

POPULAR MECHANICS MAGAZINE

WRITTEN SO YOU CAN UNDERSTAND IT

PAT. OFF.

REGD TRADE MARK GREAT BRITAIN No 410426



7 days Auto & Tractor Training FREE



How to make MORE MONEY

Thousands of untrained men are out of work. Where would you offer your services if you were out of a job—untrained, unprepared?

The Big Money today is made by the trained man. I have helped thousands to make MORE MONEY—by training them the famous Rahe-Way. Many Rahe graduates are making more than \$10,000 a year—because they know how to do one thing well. And they got into a paying business—the Auto Service Business.

YOU can make BIG MONEY. Learn Auto Mechanics the Rahe-Way. Save part of your earnings. Own a Garage. But you must make a start. Do so today.

HENRY J. RAHE

Come 7 days to a Rahe School. Spend those 7 days in the first departments of my 6 to 8 weeks course in Auto and Tractor Training. At the end of the first 7 days you will be absolutely satisfied with the training, or—

It Won't Cost You ONE CENT

This is an Absolute Guarantee. Not a penny will these 7 days cost you—you can quit—unless you are Satisfied. The success of my three schools is tremendous, overwhelming, unprecedented. So positive am I that you will use the RAHE-Way as a stepping stone to Success, that I can Guarantee you will be satisfied. This Guarantee is backed by all the resources of my 3 big schools—Kansas City, Chicago, Cincinnati—and by me personally—Largest Operator of Auto and Tractor Schools in the World.

The Famous RAHE-Way GUARANTEED!

The Rahe Complete Life Scholarship permits you to train intensively, from 6 to 8 weeks, or as long as you wish. It gives you the right to come back later for review, to stay as long as you wish, at any one of my schools without extra cost. This is the famous Rahe Course, which you have heard so much about for years. Now I GUARANTEE that if you are not satisfied at the end of the first 7 days, I'll not charge you ONE CENT. But I KNOW YOU WILL STAY. You will be convinced—like thousands of others who take the Unmatched Rahe Practical Job Method Course.

MAKE \$150 TO \$400 A MONTH!

Big Money is waiting for trained mechanics. Wires like this one must be answered: "I'll pay \$200 for good mechanic." But don't stop at the \$200 job, or even at \$400. Garage owners grow wealthy, if they are trained. Some make as high as \$40,000 to \$60,000 yearly. It's all in knowing how. I make a business of teaching you how to make more money.

Some Businesses Pay Well. Others Don't. Does Yours? Motorists spend money lavishly on their cars. This makes the Auto Service Business a Big-Pay Business. Garage owners and their assistants make Real Money—enough to live well on. Does your business pay well? If not, CHANGE NOW to a business where there is lots of money—now and all the time. Change to Auto Service Business.

Take Your Pick of 8 Big-Money Jobs

1. Battery Expert, \$40 to \$75 wk.
2. Garage Owner, \$400 to \$1500 mo.
3. Trouble Shooter, \$7 to \$15 day
4. Electrical Expert, \$40 to \$75 wk.
5. Welding Expert, \$8 to \$12 day
6. Vulcanizing, \$150 to \$350 mo.
7. Tractor Operator, \$8 to \$15 day
8. Salesman, \$200 to \$450 mo.

Rahe Auto & Tractor Schools

No Need To Delay—THIS 68-PAGE BOOK COME NOW!

The Famous Rahe Course NOW IS GUARANTEED My Special Low Tuition Rate NOW IS IN EFFECT. There is positively no reason for you to deprive yourself another day—you should get this valuable, money-making training NOW. Wire me at my expense when you will arrive. I will have room and board arrangements—everything—all ready for you. Start TODAY.

HENRY J. RAHE, Dept. 2895
CHICAGO KANSAS CITY CINCINNATI
Ontario & Michigan 22nd & Oak 9th & Walnut

If impossible to come Now, don't FREE! fail to clip the enclosed COUPON and fill it out. It will bring my 68-page book, showing how I have helped others to independence, prosperity and success. Mail the Coupon.



Rahe Masters Train You
I rolled up my sleeves and taught the first classes in the original Rahe School 14 years ago. Now I have scores of Rahe Master Instructors to help me.

Learn on Live, Running Motors



SAVE MONEY

Because in operating three schools I cut all overhead expenses to the very minimum, I am able to offer an especially Low Tuition Rate, if you ACT NOW. The most complete Auto and Tractor Training for the lowest possible price—that is my motto. You will be surprised how little it will cost you to take the Famous Rahe Course. Write NOW for Catalog and full details.

Mail This Coupon Today

Send this coupon today for my fine 68-page Catalog showing graduates' success and opportunities now open; also for details of 7-Day Offer. (Address nearest School) 2895

Name.....
Address.....
Age..... Occupation.....

LEARN MOTORS UNDER RAHE MASTERS

Victor Records

Approved by the artists
for use on the Victrola

Victor Records by the greatest artists are issued only when the artists who made them are fully satisfied that the records exactly duplicate their performances.

In judging their Victor Records for approval these artists play them on the Victrola—the instrument for which they are specially made.

It is only by using Victor Records in combination with the Victrola that you hear their interpretations exactly as the artists produced them—exactly as they expect to be heard.

Victrolas \$25 to \$1500. New Victor Records demonstrated at all dealers in Victor products on the 1st of each month.



"HIS MASTER'S VOICE"

This trademark and the trademarked word "Victrola" identify all our products. Look under the lid! Look on the label!
VICTOR TALKING MACHINE CO.
Camden, N. J.



Victor Talking Machine Co.
Camden, New Jersey

Victrola No. 130, \$350
Victrola No. 130, electric, \$415
Mahogany or oak

This One



Y168-Y05-T07J

material



IF YOU LIKE BOATS YOU'LL SURELY ENJOY THIS!

At top—Original model of the Cypress Motor Launch "Mary M.," plying in Northern Lake Waters. (Signed by the Designer.)

In Circle—Capt. John Martinek, Designer and Builder—with his own unaided hands.

In Square—Side view of stern of the Cypress Launch "Mary M."—before launching.

At Bottom—Bow view of the Cypress Motor Boat "Mary M." just before she slid into the water. (Compare with picture of original whittled model at top of page.) Aren't the lines beautiful? And isn't Old John a wizard? All figured out with his knowledge and his penknife. She is 32½ feet over all, 7½ foot beam, draught (light), at bow 13 inches, at stern 2½ inches. Seating capacity 36. 30 h.p. ALL CYPRESS except her oak keel and ribs, rail and awning frame! (Jim Johnson knows about her.)

Anybody Who Knows All About Boats Says "Cypress"

—OF COURSE. Thus spake John Martinek, who does nothing but build boats and smile on the children who come to his busy little shipyard.

The Next Thing for YOU to Do Is to Write for the Cypress Boat Book

29 PICTURES AND 16 CHARTS

It's Vol. 19 of the famous Cypress Pocket Library and its 116 pages are free on request. (Promptly, too.) We like boats as well as you do—if they're good ones, well built and of the right material, such as Capt. John knows about. *Write for free Vol. 19.*

SOUTHERN CYPRESS MFRS.' ASSN.

1219 Poydras Bldg., New Orleans, La., or
1219 Graham Bldg., Jacksonville, Fla.

Popular Mechanics Magazine

6 N. Michigan Avenue, Chicago, U. S. A.

H. H. WINDSOR, Editor

London: Hachette & Cie,
16-17, King William Street, Charing Cross, W. C. 2

Paris: Hachette & Cie,
111 Rue Reaumur

Melbourne, Australia,
The Australasian News Co.

ISSUED MONTHLY

SUBSCRIPTION:

SINGLE COPY, 25 CENTS

In United States, and its possessions, Cuba, Mexico, and Canada, per year, postpaid - \$3.00

To all other countries in the Postal Union 3.50

All subscriptions are discontinued at expiration. Please examine the date printed on your wrapper.

Entered as Second Class Matter Sept. 15, 1903, at the Post Office at Chicago, Illinois, under Act of March 3rd, 1879.
Entered as Second Class Matter at the Post Office Department, Canada.

Published monthly by POPULAR MECHANICS CO.

Copyright, 1921, by H. H. Windsor.

Copyright in Australia.

Vol. 37

Contents for January, 1922

No. 1

Air Craft Fittings, New, Made of Steel.....	80	Crankshaft and Piston Jig of Universal Quality....	77
Airplane Built for King of Belgium.....	31	Cutter, Metal, Has Horizontal Band Saw.....	31
Airplane, Small French, Has Demountable Wings....	45	Cylinder for Door Locks, Easy to Install.....	90
Airplane Stability Tests to Make Flying Safe.....	52	Dam, Irrigation, Multiple Arch Type.....	102
Altitude, High, Scientists Study Influence of on Life..	54	Dentistry—Clinics in Schools Increasing.....	105
Amplifier Makes Automobile Speak for Itself.....	25	Derricks, Texas Oil Field, Concrete Bases Needed for.....	82
Amplifiers, Gigantic, Voices Heard Four Miles by Aid of, by H. A. Lane.....	9	Desk, Collapsible, Fits in Safe.....	101
Animal, Smallest, Capturing, by Leon Augustus Haus- man, Ph. D.....	69	Desk Tray, Adjustable, Office Convenience.....	42
Arsenic, Mining and Refining in Virginia, by Phil W. Hanna.....	79	Destroyers, American, Fifty Million Dollars' Worth	25
Automobile, Berths Built in.....	75	Die Stock Takes Round Dies of Different Diameters..	106
Automobile Headlights, Glare Dimmer for.....	41	Dishwashing, Portable Machine for.....	94
Automobile, Latest English, Has "Straight Eight" Motors.....	56	Dogs, Northern Quebec, Used for Winter Travel....	59
Automobile Trailer, Horses Transported by.....	43	Draft Evaders, Few "Slackers" in List of.....	85
Automobiles, "Home Port" Plates Popular for.....	62	Draftsman, Labor Saving Instrument for.....	113
Automobiles, New European, Novel Features of....	88	Drilling Machine, Gantry, for Drilling Plates.....	97
Automobiles, Road Tests Given in Garage.....	73	Earthquakes from Deep Regions of Earth.....	40
Axles, Roller Bearing, on Railroad Cars.....	42	Electricity—100,000 Volts Carried over Berlin Streets	98
Barge, Anchored, for Anglers.....	48	Elephants Board Train at Passenger Station.....	38
Barge, Gigantic Service, for Mississippi Shipping....	57	Expedition Aims to Scale Highest Peak on Earth..	30
Barge System for Shipping Groceries, Success of....	98	Express Office, Portable, for Fairs and Exhibits....	75
Barn, Horseshoe-Shaped, Missouri Farm Has.....	104	Ferry, Suspended, Traffic Carried across English River by.....	60
Bathroom, Portable Canvas, Easy to Carry.....	110	Filters, Ordinary Cistern, Water Not Purified by....	38
Bobsled, Auto, Motorcycle Transformed into.....	41	Fireplace, Boy Scouts Study Geology from.....	94
Bones, Extra, Mistaken for Broken Ones.....	2	Football Games, Bulletin Reproduced Progress of... Footbridge Made from Old Telegraph Cables.....	48 63
Bottles and Glasses Washed by Using Brush and Motor.....	36	Forest Experiment Station Established in South....	32
Bowlders, Hammer Brings Music from.....	110	Forests, Alaskan National, Timber Wealth of.....	94
Bridge—Arch Erected in Twenty-Five Days.....	81	Furnace Gases, Instrument Records Effects of Air in Garden, Terraced, Philippine Governor's Summer Home Has.....	73 63
Bridge, Y-Shaped Three Way, Two Streams Crossed by.....	26	Gas Tank, Colossal.....	32
Broom Factory, Blind Men Run.....	104	Geese, Wild, Electrocuted in Storm.....	75
Building, Office Theater, Has Three First Floors....	107	Girl, Blind and Deaf, Wonderful Sense of Touch and Smell Developed by, by Fred L. Holmes.....	13
Buyers, Public Taste to be Studied by.....	119	Golf Course, Nine Hole, Hazards of, by H. A. Lane	67
Cable Steamer "All America," Up to Date Equip- ment on.....	4	Golf—Gun Makes Tees of Any Desired Height....	116
Canal, North Sea to Baltic, Proposal Renewed for..	106	Grain, Bulk, Loader for.....	68
Candy Industry, Permanent Exposition for.....	78	Gun, Life Line, Fired from Shoulder.....	1
Carbon Dioxide, Electrical Indicator Measures....	76	Handcar, High Speed, Section Foreman Builds....	52
Carburetors, Three, French Engine Has.....	5	Hay Stacking Machine, Time and Labor Saved by..	71
Card, Country Road Pedestrians Taught Safety First by.....	122	Hens, Laying, Automatic Nest Traps.....	30
Cars, Tank, Unloading Rack for.....	44	Hermit, Sea Life Sold to Movie Firms by.....	91
Caskets, Burial, Made of Clear Glass.....	82	Hero, Unknown, Electrical Achievements Signalize Honors of, by John W. Kean.....	19
Children's Pages.....	120	Hero, Unknown, Story of.....	17
Chimneys, Concrete, Rapid Erection of.....	37	Highway Tests Made with Tunnels beneath Road- way.....	86
Cigar Lighter for Autoists Winds on Spring Reel....	80	Homes, Port Wayne, Indiana, Families Build.....	100
Civic Features.....	108	Horse Show, Horses Perform at, by Frank B. Howe	12
Clamp, Safety, Milk Can Lid Held Tightly by.....	116	Horse Taken Aboard Steamer in Special Stall....	77
Clock for Airplanes, Electrically Wound.....	122	Hose Couplers, Automatic, for Railroad Cars.....	71
Clock, "Unbeatable," System of Symbols Used in... Coal Bill, Railroad, Constant Reminder Reduces ..	40 66	Hospital, Edward Hines, Jr., Largest Fireproof.....	58
Coal Production of 1921, Enormous Decrease Shown in.....	104	Hospital, Farthest North, Building, by Lawrence William Pedrose.....	49
Coffee Truck, Cincinnati Fire Department Operates..	66	Hospital, Largest Fireproof in World.....	58
Colors Numbered, Measured and Matched with New Instrument.....	70	Household Devices.....	114
Comment and Review, by H. H. Windsor.....	27	Humidity Readings, Instrument Gives Distant.....	116
Cot, Portable, Two Folding Chairs Make.....	112	Ice Cream Machines, Sanitary and Economical....	81
Crane, Floating, Bridge Taken to Repair Shop by....	15	Identification, Human, Improvements in Methods of..	72
		Inner Tubes, Extra, Sheet Metal Box Protects....	119
		Iron, High Grade, Produced from Magnetic Sand... Crankshaft and Piston Jig of Universal Quality....	66 77

[Continued on Page 4]

Copyrighted material

[Contents—Continued]

Island, Manhattan, Six Mile Extension Proposed for	64	Ties to be Creosoted, Machine Perforates	51
Lamp, Self-Cleaning Carbide, for Miners	116	Tire, Pneumatic, Adjustable Mold Simplifies Repairs on	85
Land Requirements, Government Scientists Will Study	57	Tower, Bronze, for Memorial Chapel	78
Lathe, Valve Refacing, Has High Degree of Efficiency	117	Tractors, Farm, Three Wheel Drive	76
Laundry Association to Have Methods Testing Plant	62	Traffic Towers, Improved, for Detroit System	44
Legion Post, American, Fitting Tribute Paid by	46	Trestles, Concrete, Southern River Swamps to Be Crossed by	98
Lifeboat Inventor, William Wouldhave, Centenary of Death of	116	Truck, New, Aggregates Handled Efficiently by	107
Light, Special, for Dentists and Surgeons	112	Truck, Telephone Repair, Novel Features of	68
Lioness, Large, Treated for Ulcerated Tooth	52	Tube, Electric Valve, Has Reversible Features	47
Lock for Spare Wheel Carrier	74	Tunnel Digging Machine Also Lines Walls	4
Micrometer, Metric as Well as Inch Readings by	76	Tunnel, Mountain Stream and Road Share	99
Milk, "Thermos" Cars and Trucks Transport	6	Typewriter Operators, Blind, Attachment to Assist	15
Motorcycle, German, Antiskid Wheels Used on	2	Uniforms, Messengers', Telegraph Company Repairs	117
Nightcaps, Electric, Cold Heads Warmed by	41	Valve, Steam Radiator, Air Humidified by	113
Nozzle, Lawn Sprinkling, Has Fan-Shaped Spray	122	Vault, Burial, Water Tightness of Tested	62
Oil Dispenser, Quick and Accurate	119	Vitamines Unnecessary for Plant Growth	44
Oil Men Strike "Gasser" Instead of "Gusher"	8	Wagon Loader with Creeper Works on Soft Ground	92
Opiate, Harmless, Prize Awarded Discoverer of	41	Warehouse System, Minneapolis Develops	65
Ox, Gigantic, Exhibited in Australia	84	War Materials, Surplus, States to Build Roads of	4
Oysters, Dredging on the Ice, by Lindsay C. Marshall	55	Water, Apparatus for Aerating in Bath tub	60
Paint, Machine Removes, from Automobile Bodies	100	Water, Phonograph Mechanism Voice Tells Height of	54
Paper Mill, Miniature, for Siamese Government	47	Welding Outfit on Motorcycle	39
Papers, Wrapping, Water, Dust, and Vermin Proof	118	Welding Plant, Electric, Novel Current Control of	74
Paris, Improving Appearance of	89	Wheels, Steel Car, Made in Revolving Mold	26
Pavement, Asphalt, Work Car Tool Digs Up	96	Windmill, Old Dutch, Is Model for Los Angeles Store	85
Peace Conference	18	Window Display, Wooden Figures Attract Attention to	106
Peace Plan, Japanese Women's	2	Window Washing, Tram System for	43
Peat, Powdered, Used as Fuel for Heating Furnaces	92	Wireless Concert, Movie Audience Hears	100
Phonograph Motor, Electric, Simple Construction of	40	Wireless Incidents, World Interest Aroused by	3
Phonograph, Record Lifting Disk for	38	Wireless Receiver Shaped like Human Ear	105
Phonograph Records of Actual Grand Opera Making	42	Workers, Industrial Rehabilitation of, by Wm. A. McGarry	33
Piers, Foundation, Epoch Making Tests of	23	Wreck, U. S. S. "Memphis," Storms Withstood by	97
Pipe Corrosion, Bureau of Standards Studies	46	X-Ray Apparatus, Midget, Immersed in Oil	30
Piping, Wooden Stave, Fire Resisting Test of	70	X-Ray Photos, New Dental Appliance Magnifies	38
Plier, Self-Locking, Constant Grip Not Required by	117	X-Rays, Atomic Structure of Matter Revealed by	111
Prince, Chinese, Automobile Frightens	78		
Pumps, Suction, Gas Tanks for Shipping Emptied by	78		
Pushball Game, Carnival Crowd Entertained by	62		
Pyrometer, Thermoelectric, Has Self-Compensation	46		
"Race, Slow," Novel Auto Test	54		
Railroad, Highest of British Empire, to Cross Rich Region	74		
Railway, Chinese, Large American Locomotives Bought by	4		
Range, Electric, Two Pilot Lamps on Switch of	45		
Rats in Europe, Endless Chain of Poison Kills	82		
Regulator to Control Gases in Operation of Torches	118		
Rice Hulls Converted into Useful Products	66		
River, Single Blast Changes Course of	58		
Rivet Forge, Oil Burning, for Portable Use	106		
Rubber, Raw, Soles of English Sport Shoes Made of	90		
Rudder, Expanding, for Self-Propelled Boats	119		
Schooner "Bluenose," Winner of Trophy	39		
Scow, Alaskan, Automobile Propels	113		
Scow, Floored, Used as Motor Car Ferry	84		
Screen, Fish Kept Out of Irrigation Ditches by	117		
Sealing Wax, Electric Device for Melting and Applying	100		
Seaplane, Mono, Rockaway Air Station Tests	105		
Seat, Double, for Golf or Garden	122		
Seawall, "Fool Proof," Built with Sharp Edged Top	47		
Seaweed, Tides Aid Collection of	90		
Sewing, Hand and Machine, Energy Required in	87		
Shaft Digging Machine and Caisson Sinker	98		
Ship, Electrically Driven, Speediest	22		
Ship, Single Deck, Converted into Oil Tanker	56		
Ship, Traffic Officer Carried on Bowsprit of	46		
Ships, Fire Regulations Safeguard	118		
Sidewalk Elevator Gates, Danger Removed by	8		
Sign, Doctor's, Pills and Corks Used to Make	122		
Signal, Electric, for Freight or Passenger Trains	36		
Signals, Railway, Improvements Insure Safety of	64		
Smokestacks, Steel, 46 Mile Wind Wrecks	102		
Soldier, America's Unknown, Final Resting Place of	16		
Spark Plug Tester, Neon Used in	118		
Standpipe, Concrete, Unusual and Artistic	64		
Star Map, Luminous, Amateur Astronomers Aided by	101		
Statue of Famous Horse Cast in Bronze	101		
Stool, Garden Weeding Made Easy by	6		
Stove Business, Prosperous, from Salvage, by Charles A. Goddard	83		
Submarine Power Plant, 10,000 Mile Radius of	102		
Surveying, Airplanes and Airships Used for	90		
Tanks, War, Germans Make Street Cars of	51		
Telephone Wires, Earth to Moon 100 Times with	110		
Theater, Outdoor, Reversible Scenery for, by John Anson Ford	95		

SHOP NOTES

Alcohol, Wood, How to Use	140
Anvil, Riveting, Handy	141
Automobile Universals, Tool for Inserting	133
Battery Service Station Aid	139
Belts, Conveyor, Speed of	138
Boiler Compound Feeder	142
Brake Lining Fixture	131
Calcimine Pail, Brush Holder on	137
Carboys, Acid, Rubber Trough for	141
Castings for Six Inch Bench Lathe	131
Compressors, Ammonia, Repairing	127
Concrete Blocks, Mold for Making	123
Counterbore for Square Bottom Hole	138
Crane, Radial Shop	131
Crankcase Bolts, Holder for	138
Crates of Maximum Strength, Making	125
Dial, Price and Quantity, Cost of Fuel to Motorists Calculated by	138
Dividers, Self-Centering	126
Draftsman's Triangle, Eyelets in	142
Drawer, Drawing Table, Novel Arrangement of	134
Ebonite, Machining and Finishing	138
File, Flat, Attachment Facilitates Use of	126
Fillets, Leather, for Wood Patterns	132
Fuels, Wood, Efficiency of	130
Gasket Lock Joint	131
Glue Pot, Deodorizing	136
Grates, Engine, Old Wagon Tires Make	124
Gravers, Gauge for Sharpening	140
Hasp Staple, Hardened, Sawing Prevented by	142
Hydrometer, Circular Stick of Wood Makes	126
Jack Made from Axle Housing	131
Jewelry, Soldering	134
Metal, Bending Large Sheets of	139
Molding, Odd-Shaped, Mitering	133
Motoring through Snow	133
Notebook, Loose Leaf, Pocket for	126
Paper, Drawing, Reel for	125
Plane Handle Made Adjustable	142
Punch Presses, Safety Device for	137
Screws, Hinge, Accurate Holes for	141
Shaft, Repairing Grooves Worn in	136
Sled, Limousine, for Winter Touring	125
Snap Ring Bending Fixture	133
Springs, Flat, Fixture for Forming	130
Square Made from Scales	137

DRAKE'S PRACTICAL MECHANICAL BOOKS

THEY WILL RAISE YOUR PAY—

ORDER ON 5-DAY TRIAL

The books listed below will perfect you in your chosen trade — pave the way to the big positions. Written in non-technical language—easy to read and understand. *Every book covers its subject completely. An entire course of instruction condensed into one volume.* Your choice sent postpaid — you benefit 5 days — money refunded in full if not entirely satisfactory. Order direct from this page.



1921
Edition
\$2.00

Automobile Books

- Automobile Ignition, by ManlyLeatherette \$2.00
- Automobile Starting and Light-
ing, by Manly.....Leatherette \$2.00
- Brookes' Automobile Handbook.....Leatherette \$2.00
- Ford Motor Car, Truck and
Tractor, by Manly.....Cloth \$1.50
- Starting and Lighting Troubles,
Remedies and Repairs, by
ManlyLeatherette \$3.00
- Automobile Battery, Care and
Repair, by Manly.....Leatherette \$2.00
- Automobile Catechism and Re-
pair Manual.....Leatherette \$1.50
- Tires and Vulcanizing, by Tuf-
ford.....Cloth \$2.00
- Gas and Oil Engine Handbook.....Cloth \$1.50
- Automobile Upkeep and Care,
by Manly.....Cloth \$1.50
- Motorcycle Handbook, by Manly.....Cloth \$1.50

Shop Practice Books

- Sheet Metal Workers' Manual.....Leatherette \$2.00
- Oxy-Acetylene Welding and Cut-
ting.....Leatherette \$1.75
- Sound Welds.....Cloth \$2.00
- Slide Rule and Logarithmic Ta-
bles.....Leatherette \$2.00

- Handbook for Millwrights.....Cloth \$2.00
- Modern Blacksmithing.....Cloth \$1.25
- Machine Shop Practice.....Cloth \$2.00
- Mechanical Drawing and Ma-
chine Design.....Cloth \$2.00
- Pattern Making.....Cloth \$1.50

Carpentry Books

- Cloth Binding
- Modern Carpentry, 2 vols.....\$3.00
- The Steel Square, 2 vols.....\$3.00
- Wooden Boat and Shipbuilding.....\$1.50
- Modern Estimator.....\$1.50
- Timber Framing.....\$2.00
- Builder's Architectural Drawing.....\$2.00
- Concretes.....\$1.50
- Practical Bungalows.....\$1.00
- Low Cost Homes.....\$1.00
- Roof Framing.....\$1.50
- Stair Building and Hand Rail-
ing.....\$1.50

Electrical Books

- Practical Applied Electricity.....\$2.00
- Alternating Current.....\$1.50
- Electric Motor Control Systems.....\$1.50
- Wiring Diagrams and Descrip-
tions.....\$1.50
- Electrical Tables and Data.....\$1.50
- Armature and Magnet Winding.....\$1.50
- Modern Electrical Construction.....\$1.50
- Modern Electric Illumination.....\$1.50
- Electricians' Operating and Test-
ing.....\$1.50
- Motion Picture Operation.....\$1.50
- Drake's Electrical Dictionary.....\$1.50
- Electric Motors, D. & A.....\$1.50
- Electrical Measurements and Me-
ter Testing.....\$1.50
- Drake's Telephone Handbook.....\$1.50
- Modern American Telephony.....\$2.00
- Easy Electrical Experiments.....Cloth \$1.25
- Wireless Telegraph and Tele-
phone Handbook.....Cloth \$1.25
- Telegraphy Self-Taught.....Cloth \$1.25

Steam Engineering

- Swingle's Handbook for Steam
Engineers and Electricians.....Leatherette \$4.00
- Examination Questions and An-
swers for Marine and Station-
ary Engineers.....Leatherette \$2.00

- Steam Boilers.....Leatherette \$2.00
- Swingle's Catechism of Steam,
Gas and Electrical Engineer-
ing.....Leatherette \$1.50

Painting Books

- Scene Painting and Bulletin Art
.....Cloth \$4.00
- A Show at Sho' Cards.....Cloth \$4.00
- Sign Painting.....Cloth \$4.00
- Strong's Book of Designs.....Leatherette \$4.00
- Signist's Alphabets.....Cloth \$1.50
- Modern Painter's Cyclopaedia.....Cloth \$2.00
- Automobile Painting.....Cloth \$1.50
- Estimates, Costs and Profits,
Painting and Decorating.....Cloth \$1.50
- New Hardwood Finishing.....Cloth \$1.50
- The Amateur Artist.....Cloth \$1.50
- New Stencils.....Cloth \$1.25

Farm Books

- Farm Mechanics.....Cloth \$1.25
- Farm Buildings.....Cloth \$1.25
- Farm Engines.....Cloth \$1.25
- Traction Farming.....Cloth \$1.50

Business and Reference Books

- Better Business Letters.....Leatherette \$1.50
- Better Business English.....Leatherette \$1.50
- Better Advertising.....Leatherette \$1.50
- Finger Prints Simplified.....Cloth \$2.00
- Practical Bricklaying.....Cloth \$1.25
- Practical Stonemasonry.....Cloth \$1.25
- Practical Plumbing.....Cloth \$1.50
- Hot Water Heating.....Cloth \$1.50
- Elementary Chemistry.....Cloth \$1.50
- Courses in Civil Service.....Cloth \$1.50
- Cyclopedia of Recipes.....Cloth \$1.50
- American Star Speaker.....Cloth \$1.50

Modern Languages

- By Prof. P. S. Allen, U. of Chicago
- French without a Teacher.....Cloth \$1.25
- Spanish without a Teacher.....Cloth \$1.25
- German without a Teacher.....Cloth \$1.25
- Everyday French.....\$1.25
- Everyday Spanish.....\$1.25

ORDER DIRECT FROM THIS PAGE—ON OUR MONEY-BACK PLAN

The books listed above are only a few of the many in our catalogue, which you will receive promptly after filling out and mailing us the attached coupon. For quick action order direct from this page—cross name of each book wanted and send in with price quoted. We prepay postage and send the books on our money-back plan.

FREDERICK J. DRAKE & CO.

PUBLISHERS

1008 Michigan Ave., Chicago

Drake Books Are For Sale at All Book Stores

FREDERICK J. DRAKE & CO.
1008 Michigan Avenue
Chicago, Ill.

GENTLEMEN:—Please send me free, postage paid, your illustrated catalogue which lists and describes over 100 Practical Mechanical Books for Home Study.

My name is

and my address

Mail Coupon For Free Catalogue
Your Guide to Home Study

NEW KIND OF HEAT!



Try It In Your Stove
30 Days Free
The OLIVER Oil-Gas Burner

Keeps home warmer. Three times the heat.
Does away with coal and wood—cheaper.
Makes your stove or range an oil-gas stove.

No fires to make. No ashes, dirt, smoke, odor, chopping, shoveling, carrying dirty coal or wood. Saves hours of work. Makes your stove heat or bake better, cleaner, quicker. Doesn't change your stove, simply sets in firebox, easily slipped in or out, absolutely safe. Lasts lifetime. Makes its own gas from coal-oil (kerosene) at small cost. Oil is cheap and getting cheaper. Gives even heat instantly, much or little, by simply turning valve. Fits any stove. Saves money, time, labor, health. **BURNS 95% AIR—5% OIL.**



FREE Attractive Book telling all about the "New Kind of Heat," sent you free, postpaid. Also amazingly low introductory-price offer, including 30-Day Trial, if you act quickly. Write today.

OLIVER Oil-Gas Burner & Machine Co.
2014-A Pine Street St. Louis
Oldest, Largest Mfrs. Oil-Gas Burners in World.

AGENTS Oliver Agents earn as high as \$500 a month—\$25 a day spare time is easy. Exclusive territory—real co-operation.

Write for full money-making details. Big season on.

WEALTH, HONOR, RICHES

Do not depend upon opportunity or intellectual brilliancy of any kind, because it is well known that uneducated people often acquire great wealth, while cultured and talented people remain in poverty.

Again, they do not depend upon capital, because many men with capital lose what they have, while others with no capital acquire phenomenal wealth.

Whatever finds a place in human experience is the result of the operation of natural laws, and the determining factors are therefore within your own control.

This may seem "too good to be true," but if you will consider that by the touch of a button or the turn of a lever science has placed almost infinite resources at the disposal of man, it becomes evident that there may be still other laws not generally known which contain even greater possibilities.

We have published a Remarkable little book, giving the conclusions of science concerning these laws, which we will send upon request. If you want to underwrite success on a magnificent scale, send for it.

MASTER-KEY INSTITUTE

210 Howard Bldg.,

St. Louis, Mo.

[Contents—Continued from Page 4]

Stains, Removing from Concrete.....	125
Tags, Case Holds Numerically.....	130
Tile, Drilling.....	139
Tinning Small Work.....	124
Tools, Valve, Combined with Tire Gauge.....	134
Trees, Big, Economic Moving of.....	135
Valve Grinder Made from Hand Drill.....	140
Vulcanizer, Vulcanizing Without.....	132
Windmill Regulator, Simple.....	136
Wrench, One, Two Taps at One Time with.....	140
Wrench, Ratchet, Convenient.....	124
Wrench, Tap, Breast Drilling Aided by.....	132

AMATEUR MECHANICS

Advertising Novelty, Toy Balloon Is.....	144
Arrow, Whistling.....	151
Automobile Fitting, Soap Dish as.....	155
Baseball, Indoor, Played with Penknife.....	146
Candle and Flag, Magic.....	156
Clotheshorse, Folding, Bracing.....	157
Clothesline, Rope, Waterproofing.....	151
Flowerpot Stand, Guard for.....	151
Furnace Register, Seat for.....	157
Hair Drier, Electric, How to Make.....	143
Helmets, New Steel Trench, Utilizing.....	147
Hydrants, Fire, Protecting from Snow.....	158
Incubator Used as Oats Sprouter.....	146
Ironing Board, Apartment.....	158
Lamp, Japanese Table.....	144
"Letter," Trick.....	145
Lever, Rocker, for Overhead Valves.....	158
Lighting Plants, Home, Silencer for.....	158
Liquids, Attachment for Pouring.....	157
Muff for Autoist's Hands.....	158
Oilcans, Finger Clips for.....	157
Photography—Print Drying Stretcher.....	145
Photography—Transferring Prints to Glass.....	155
Pictures, Hanging Straight.....	151
Spout, Engine Exhaust Cleans.....	145
Stewpan, Efficient.....	156
Stove, Coal, Made into Oil Burning Heater.....	151
Tile, Drain, Outdoor Stove Made from.....	145
Transformer, Oscillation.....	150
Typewriter Ribbon Substitute.....	157
Typewriting to Bottom of Sheets.....	149
Valves, Gas Engine, Using Old.....	150
Well Pipes, Driving.....	149
Windows, Antirattler for.....	145
Windows, Storm, Made from Shutters.....	155
Wood Turning, Novelty.....	146
Yacht, Ice, Building.....	152
Yoke, Turkey Prevented from Straying by.....	144



NAVIGATION TAUGHT BY MAIL

Hundreds of Ship Officers needed in Merchant Marine and Navy. Salaries up to \$412 monthly and living expenses. You can qualify through Captain Warren Sheppard's Home Study Course on Navigation. Chance of a lifetime to see the world as a ship's officer at a big salary. Write for free Book, "Your Future is on the Seven Seas."

World Technical Institute, Dept. 100A, Fuller Building, Jersey City, N. J.

Be an Expert Repairman



on Motors and Generators

Repair men are in big demand—particularly men expert in armature winding. Get into this well paid line.

Learn in 3 Months

—to master this work and insure yourself a permanent income and bigger opportunities—here at this Great Electrical School. In this short time you learn the theory and actually wind all types of D. C. and A. C. armatures under expert instructors.

Write for FREE Booklet

—giving full particulars of this 3-months' Armature Winding Course. Write today—you will not be obligated. Address—

SCHOOL OF PRACTICAL ELECTRICITY

Dept. PM 1, 415 Marshall St.

Milwaukee, Wis.

Let These Guides

Solve Your Problems

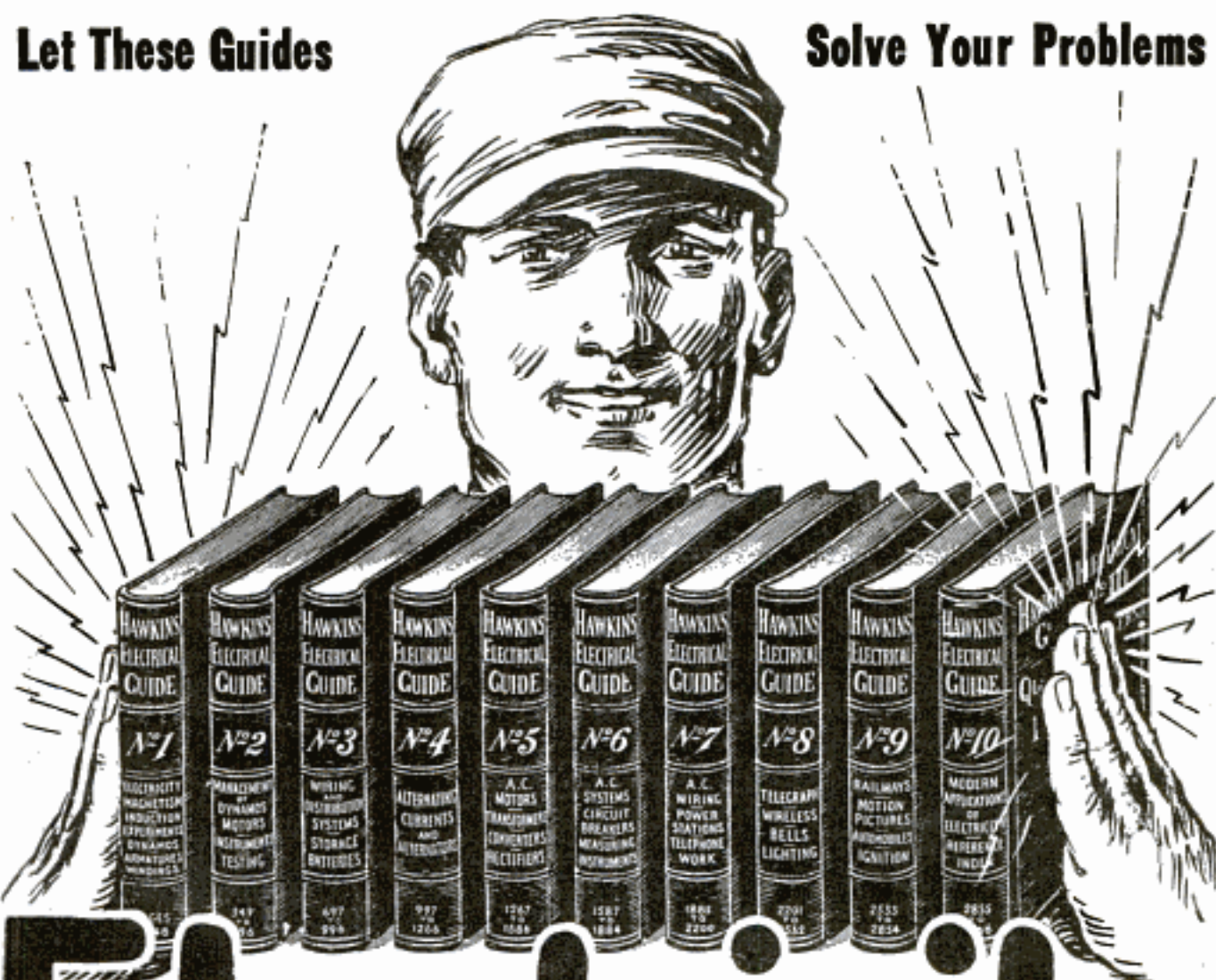

Electricity at your finger ends

HAWKINS ELECTRICAL GUIDES IN TEN VOLUMES
**3500 PAGES
4700 PICTURES**
**\$1 A VOLUME
\$1 A MONTH**
Send No Money--Send Only This Coupon

Know the facts in Electricity. They mean more money and better position for you. Hawkins Guides tell you all you need to know about Electricity. Every important electrical subject covered so you can understand it. Easy to study and apply. A complete, practical working course, in 10 volumes. Books are pocket size; flexible covers. Order a set today to look over.

LEARN ALL ABOUT

Magnetism—Induction—Experiments—Dynamoes—Electric Machinery—Motors—Armatures—Armature Windings—Installing of Dynamoes—Electrical Instrument Testing—Practical Management of Dynamoes and Motors—Distribution Systems—Wiring—Wiring Diagrams—Sign Flashers—Storage Batteries—Principles of Alternating Currents and Alternators—Alternating Current Motors—Transformers—Converters—Rectifiers—Alternating Current Systems—Circuit Breakers—Measuring Instruments—Switchboards—Wiring—Power Stations—Installing—Telephone—Telegraph—Wireless—Bells—Lighting—Railways. Also many Modern Practical Applications of Electricity and Ready Reference Index of the ten numbers.

SHIPPED FREE

Not a cent to pay until you see the books. No obligation to buy unless you are satisfied. Send Coupon now—today—and get this great help library and see if it is not worth \$100 to you—you pay \$1.00 a month for ten months or return it.

THEO. AUDEL & CO.,
72 Fifth Ave., New York City

Please submit me for free examination, HAWKINS ELECTRICAL GUIDE, (Price \$1 a number). Ship at once prepaid, the 10 numbers. If satisfactory, I agree to send you \$1 within seven days and to further mail you \$1 each month until paid.

Name

Occupation

Employed by

Home Address

Reference

PM JAN 22

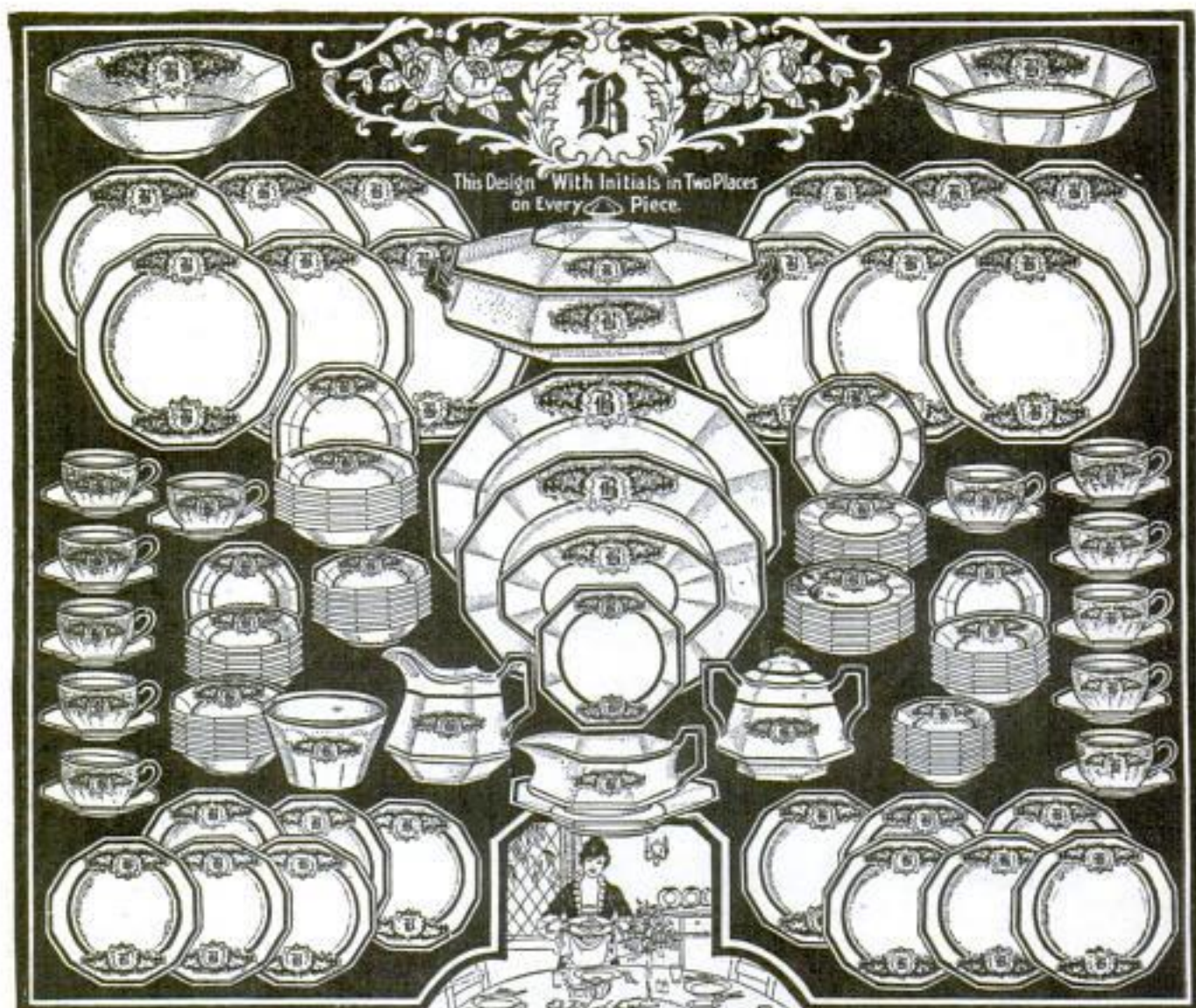

This Design With Initials in Two Places on Every Piece.

- This Superb 110-piece Set, with initial in 2 places in wreath with 5-color decorations on every piece and gold covered handles, consists of:**
- 12 Dinner Plates, 9 inches
 - 12 Soup Plates, 7 1/2 inches
 - 12 Fruit Dishes, 5 1/2 inches
 - 12 Deep Bowl, 8 1/2 inches
 - 12 Breakfast Plates, 7 inches
 - 12 Cereal Dishes, 8 inches
 - 12 Individual Bread and Butter Plates, 6 1/2 inches
 - 1 Oval Baker, 9 inches
 - 12 Cups
 - 1 Platter, 13 1/2 inches
 - 1 Sauce Boat Tray, 7 1/2 inches
 - 1 Butter Plate, 6 inches
 - 1 Gravy Boat, 7 1/2 inches
 - 12 Saucers
 - 1 Platter, 13 1/2 inches
 - 1 Vegetable Dish, 10 1/2 inches with lid (2 pieces)
 - 1 Creamer
 - 1 Sugar Bowl with cover (2 pieces)

Brings 110-Piece Gold Decorated Martha Washington Dinner Set



Send only \$1 and we ship the full set—110 pieces. Use it 30 days. Then if not satisfied, return them and we refund your \$1 and pay transportation charges both ways. If you keep them, take nearly a year to pay on easy terms.

Your Initial in 2 Places on Every Piece—5-Color Floral Decorations and Gold

Wonderful artistic effect is given by the wreath and rich design surrounding the initial. The one initial appears in 2 places on every piece.

All Handles Covered with Gold
Every handle is covered with polished gold. Shipping weight about 90 lbs.

Order No. 324DMA13. Bargain price, \$32.85. Pay \$1 now, \$3 monthly.

HARTMAN Furniture & Carpet Co.

Dept. 4153 Copyright, 1922, by Hartman's, Chicago Chicago, Ill.

ABCDEFGHIJKLMN O P Q R S T U V W X Y Z



FREE HARTMAN FURNITURE & CARPET CO. DEPT. 4153 CHICAGO, ILL.

I enclose \$1.00. Send 110-piece Golden Martha Washington Dinner Set No. 324DMA13. I am to have 30 days' free trial. If not satisfied, will ship it back and you will refund my \$1.00 and pay transportation charges both ways. If I keep it I will pay \$3.00 per month until full price, \$32.85, is paid. Title remains with you until final payment is made.

368 pages of bargains in furniture, rug, stoves, silverware, washing machines, kitchen ware, gas engines and cream separators, etc.—all on our easy terms—30 days FREE trial. Post card or letter brings it FREE.

“Let Hartman Feather Your Nest”

Name.....
Street Address.....
R. F. D..... Box No.....
Town..... State.....
State your Occupation..... Color.....
Give Initial Wanted (Any One Letter).....

I Teach You Piano In Half Usual Time

To persons who have not previously heard of my method, this may seem a pretty bold statement. But I will gladly convince you of its accuracy by referring you to any number of my graduates in any part of the world.

There isn't a State in the Union that doesn't contain many players of the piano or organ who obtained their training from me **by mail**. I have far more students than were ever before taught by one man. Investigate by writing for my 64-page free booklet, "How to Learn Piano or Organ."

My way of teaching piano or organ is **entirely different** from all others. Out of every four hours of study, one hour is spent **entirely away from the keyboard**, learning something about Harmony and The Laws of Music. This is an awful shock to most teachers of the "old school," who still think that learning piano is solely a problem of "finger gymnastics." When you **do** go to the keyboard, you accomplish **twice as much** because you **understand what you are doing**. Within four lessons I enable you to play an interesting piece not only in the original key, but in other keys as well.

I make use of every possible scientific help—many of which are **entirely unknown** to the average teacher. My patented invention, the **COLOROTONE**, sweeps away playing difficulties that have troubled students for generations. By its use, Transposition—usually a "nightmare" to students—becomes easy and fascinating. With my fifth lesson I introduce another important and exclusive invention, **QUINN-DEX**. Quinn-Dex is a simple, hand-operated moving-picture device, which enables you to see, right before your eyes, every movement of my hands at the keyboard. You actually see the fingers move. Instead of having to reproduce your teacher's finger movements from **MEMORY**—which cannot be always accurate—you have the correct models before you during every minute of practice. The **COLOROTONE** and **QUINN-DEX** save you months and years of wasted effort. They can be obtained only from me, and there is nothing else, anywhere, even remotely like them.

Men and women who have failed by other methods have quickly and easily attained success when studying with me. In all **essential** ways you are in closer touch with me than if you were studying by the oral method—yet my lessons cost you only 43 cents each—and they include all the many recent developments in scientific teaching. For the student of moderate means, this method of studying is **far superior** to all others; and even for the wealthiest student there is nothing **better** at any price.

You may be certain that your progress is at all times in accord with the best musical thought of the present day, and **this makes all the difference in the world**.

My course is endorsed by distinguished musicians, who would not recommend any course that did not maintain the highest musical standards. It is for beginners or experienced players, old or young. You advance as rapidly or as slowly as you wish. All necessary music is supplied without extra charge. A diploma is granted. Write today, without cost or obligation, for 64-page free booklet, "How to Learn Piano or Organ."

MARCUS LUCIUS QUINN
CONSERVATORY OF MUSIC

Studio PM-41, 598 Columbia Road
BOSTON, 25, MASS.



DR. QUINN AT HIS PIANO

From the Famous Sketch by Schneider, Exhibited at the St. Louis Exposition.

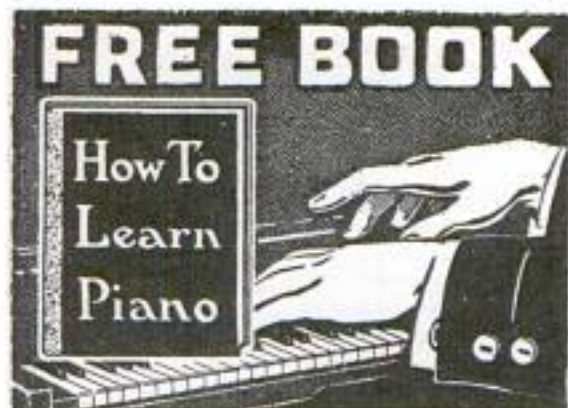

-----**FREE BOOK COUPON**-----

**QUINN CONSERVATORY, Studio PM-41,
598 Columbia Road, Boston, 25, Mass.**

Please send me, without cost or obligation, your free booklet, "How to Learn Piano or Organ," and full particulars of your Course and special reduced Tuition Offer.

Name

Address

ELECTRICITY

Two-year course in six months, in your home

Practical Electrical Engineering, a Study Course Without Higher Mathematics, now ready.

G. E. Motor Free

Upon receipt of coupon below we will send you a valuable booklet free of all charge. Also our free motor offer. We will tell you just how easy it will be for you to become a master electrical worker or engineer.

Earn \$72 to \$100 per week

A complete electrical education, and the higher positions, now within the reach of every man, young or old. The lowest priced standard electrical course, and the easiest to understand, ever constructed.

YOUR FUTURE LIES IN THIS FREE COUPON

World Technical Institute
Fuller Building, Jersey City, N. J.

Gentlemen:—

Send me free of charge your valuable booklet, also your free motor offer, and full particulars in regard to your Course on Practical Electrical Engineering.

Name

Address

PM1-22

MONEY IN POULTRY



Do you know how to MAKE MONEY from poultry? How to get most fall and winter eggs? How to select fowls for exhibition and show them how to win prizes? We can show YOU—Positively. Our officers are nationally known poultry authorities and our course the ONLY poultry correspondence course indorsed by the leading agricultural colleges. Send TODAY for new FREE book, "How to Raise Poultry for Profit."



THE NATIONAL POULTRY INSTITUTE
Dept. 312 Washington, D. C.

Is a Business Training Worth \$20 to You

ADVERTISING pays big salaries and requires little effort once you get the "knack." Learn it by mail in your spare time from a man who has been 30 years in the business. Complete course, \$20—no other expenses, no books to buy, no unnecessary studying; short course, simple lessons, easily mastered; earn while you learn. Write for particulars to

CURTIS NEWTON, Dept. 39, 818 N. Dearborn St., Chicago

ELECTRICAL Training Book FREE

Send me your name and address and I will send you my big new Electrical Training Book Free. It will show you how to qualify for high paying jobs in Electricity. Thousands now open. Prepare at home—quickly—during spare time under an Electrical Engineer. Take advantage of this unusual offer—only temporary. A. W. WICKS, President WICKS ELECTRICAL INSTITUTE
Dept. 1191 3601 Michigan Ave. CHICAGO

BLUE PRINT READING

Our new Special Courses for Machinists, Pattern-Makers, Iron-Workers, Blacksmiths, and Building Tradesmen, qualify them by mail to read blueprints and become gang-foremen.

Taught from actual blueprints—easy to learn—no mathematics—no drawing, low prices. Pay-as-you-learn Plan. Write for booklet and free sample blueprint. Dept. F. 134, Industria Correspondence University, Inc., 1504 Locust St., Philadelphia, Pa.

A FILE MAKE YOUR MIND NOT A PILE

A classified index from which you select facts, figures, names, faces. Develop concentration, self-control, overcome bashfulness, forgetfulness. Write today for FREE memory and concentration test and illustrated booklet "HOW TO REMEMBER." 21 years' experience.

PROF. HENRY DICKSON
1041 Chicago Ave. Dept. 1081-A
Evanston, Ill.

NEW SCIENTIFIC WONDER

PRICE 10c

"X-RAY" CURIO

3 for 25c

BIG FUN

BOYS You apparently see thru clothes, Wood, Stone, any object. See Bones in Feces. A MAGIC Trick Novelty FREE with each X-Ray. MARVEL MFG. CO. Dept. 47 NEW HAVEN, CONN.



WANTED

Railway Mail Clerks

\$1600 to \$2300

A YEAR

Men—Boys—Over 17—should write at once

Rapid advancement. "No lay-offs." THE POSITION IS YOURS FOR LIFE. Common-sense education sufficient. Political influence NOT REQUIRED.

Write immediately for schedule showing the places and dates of ALL coming Government examinations. Do it to-day.

FRANKLIN INSTITUTE, Dept. T176, Rochester, N. Y.



Hundreds of Railway Mail Clerks Appointed Yearly

FRANKLIN INSTITUTE (The Pathway to Plenty), Dept. T176, Rochester, N. Y.

This coupon, filled out as directed, entitles the reader to free specimen questions; a free copy of our book, "Government Positions and How to Get Them;" a list of Government positions now open, and to consideration for Free Coaching for the examination here checked.

COUPON

.. Railway Mail Clerk (\$1600 to \$2300) .. Postoffice Carrier (\$1400 to \$1800)
.. Bookkeeper (\$1400 to \$1800) .. Rural Mail Carrier (\$ 720 to \$2600)
.. Postoffice Clerk (\$1400 to \$1800) .. Customs Positions (\$1100 to \$2000)

Name

Address

Use this before you lose it. Write plainly.

WORLD'S GREATEST BOOKS ON SALE TILL MARCH 30

ONLY
10c
EACH

Here is the bargain of bargains! Grab it! Until March 30 we offer any of the following books at the unheard-of price of 10c each. Many of these books would cost from \$1 to \$3 if purchased in the ordinary way in expensive bindings. This is strictly a limited offer—on March 30 the price goes back to 25c each—the regular advertised price. If the postmark on your envelope shows that your order was mailed after midnight of March 30, we shall be obliged to return your money. Order as few or as many books as you like

—they are the best in the English language—and the entire library costs so little that you can well afford to order every book. Over three million of these books have been sold—tremendous production makes possible the extremely low price. Order by number—each book is preceded by a number—for instance, if you want *Carmen*, merely write down "21"—that makes it easy for you and insures more prompt delivery, as we handle all book orders by number. Send orders up to midnight of March 30.

Order by Number

1. Rubalyat of Omar Khayyam
2. Oscar Wilde's Ballad of Reading Jail
3. Eighteen Little Essays. Voltaire
6. De Maupassant's Stories
7. A Liberal Education. Thomas Huxley
8. Lady Windermere's Fan. Oscar Wilde
10. Shelley. Francis Thompson
11. Debate on Religion between John Haynes Holmes and George Bowne
12. Poe's Tales
13. Is Free Will a Fact or Fallacy? Debate
14. What Every Girl Should Know. Mrs. Sanger
15. Balzac's Stories
17. On Walking. Thoreau.
18. Idle Thoughts of an Idle Fellow. Jerome
19. Nietzsche: Who He Was and What He Stood For Let's Laugh. Nasby
21. *Carmen*. Merimee.
24. The Kiss and Other Stories. A. Chekhov
25. Rhyming Dictionary
26. On Going to Church. Bernard Shaw
27. Last Days of a Condemned Man. Hugo
28. Toleration. Voltaire
29. Dreams. Schreiner
30. What Life Means to Me. Jack London
31. Pelleas and Melisande. Maeterlinck
32. Poe's Poems.
33. Bran: Smasher of Shams
34. Case for Birth Control
35. Maxims of La Rochefoucauld
36. Soul of Man Under Socialism. Oscar Wilde
37. Dream of John Bull. William Morris
38. Dr. Jekyll and Mr. Hyde. Stevenson
39. Did Jesus Ever Live? Debate
40. House and the Brain. Bulwer Lytton
41. Christmas Carol. Dickens
42. From Monkey to Man
43. Marriage and Divorce. Debate by Horace Greeley and Robt. Owen
44. Aesop's Fables
45. Tolstol's Stories.
46. Salome. Oscar Wilde
47. He Renounced the Faith. Jack London
48. Bacon's Essays
49. Three Lectures on Evolution. Haeckel
50. Common Sense. Thos. Paine
51. Brune: His Life and Martyrdom
52. Voltaire. Victor Hugo
53. Insects and Men: Instinct and Reason. Darrow
54. Importance of Being Earnest. Oscar Wilde
56. Wisdom of Ingersoll
57. Rip Van Winkle
58. Boccaccio's Stories
59. Epigrams of Wit
60. Emerson's Essay on Love
61. Tolstol's Essays
62. Schopenhauer's Essays
63. Meditations of Marcus Aurelius
68. Shakespeare's Sonnets
70. Lamb's Essays

TAKE YOUR PICK AT ONLY 10c A BOOK

71. Poems of Evolution. Anthology
72. Color of Life. E. Halderman-Julius
73. Whitman's Poems
74. On Threshold of Sex
75. The Choice of Books. Carlyle
76. The Prince of Peace. Bryan
78. How to Be an Orator. John P. Altgeld
79. Esch Arden
80. Pillars of Society. Ibsen
81. Care of the Baby
82. Common Faults in Writing English
83. Marriage: Its Past, Present and Future. Besant.
84. Love Letters of a Portuguese Nun
85. The Attack on the Mill. Emile Zola
86. On Reading. Georg Brandes
87. Love: An Essay. Montaigne
88. Vindication of Thos. Paine. Ingersoll
89. Love Letters of Men and Women of Genius
91. Manhood: The Facts of Life Presented to Men
92. Hypnotism Made Plain
93. How to Live 100 Years. Cornaro
94. Trial and Death of Socrates
95. Confessions of an Opium Eater. De Quincey
96. Dialogues of Plato
98. How to Love
99. Tuffe. Moliere
100. The Red Laugh. Andreyev
101. Thoughts of Pascal
102. Tales of Sherlock Holmes
103. Pocket Theology. Voltaire
104. Battle of Waterloo. Hugo
105. Seven That Were Hanged. Andreyev
106. Thoughts and Aphorism. Geo. Sand
107. How to Strengthen Mind and Memory
108. How to Develop a Healthy Mind
109. How to Develop a Strong Will
110. How to Develop a Magnetic Personality
111. How to Attract Friends
112. How to Be a Leader of Others
113. Proverbs of England
114. Proverbs of France
115. Proverbs of Japan
116. Proverbs of China
117. Proverbs of Italy
118. Proverbs of Russia
119. Proverbs of Ireland
120. Proverbs of Spain
121. Proverbs of Arabia
122. Debate on Spiritualism. Conan Doyle and Joseph McCabe
123. Vegetarianism. Debate
125. War Speeches of Woodrow Wilson
126. History of Rome. A. F. Giles
127. What Expectant Mothers Should Know
128. Julius Caesar: Who He Was and What He Accomplished
129. Rome or Reason. Debate. Ingersoll and Manning

Order by Number

130. Controversy on Christianity. Debate. Ingersoll and Gladstone
131. Redemption. Tolstol
132. Foundation of Religion
133. Principles of Electricity
135. Socialism for Millionaires. G. B. Shaw
136. Child Training
137. Home Nursing
138. Studies in Pessimism. Schopenhauer
141. Would Practice of Christ's Teachings Make for Social Progress? Debate
142. Bismarck and the German Empire
143. Pope Leo's Encyclical on Socialism
144. Was Poe Immoral? Sarah H. Whitman
145. Great Ghost Stories
147. Cromwell and His Times
148. Strength of the Strong. London
151. Man Who Would Be King. Kipling
152. Foundations of the Labor Movement. Wendell Phillips
154. Epigrams of Ibsen
155. Maxims. Napoleon
156. Andersen's Fairy Tales
157. Marx vs. Tolstol
158. Alice in Wonderland
159. Lincoln and the Working Class
160. Ingersoll's Lecture on Shakespeare
161. Country of the Blind. H. G. Wells
162. Karl Marx and the American Civil War.
163. Sex Life in Greece and Rome
164. Michael Angelo's Sonnets
165. Discovery of the Future. H. G. Wells
166. English as She Is Spoke. Mark Twain
167. Rules of Health. Plutarch
168. Epigrams of Oscar Wilde.
169. Church Property Be Taxed? Debate
171. Has Life Any Meaning? Debate
172. Evolution of Love. Ellen Key
173. Vision of Sir Launfal. Lowell
174. Free Speech Trial of Wm. Penn
175. Science of History. Froude
176. Four Essays. Havelock Ellis
177. Subjection of Women. John Stuart Mill
178. One of Cleopatra's Nights. Gautier.
179. Constitution of League of Nations
180. Epigrams of Bernard Shaw
183. Realism in Art and Literature. Darrow
184. Primitive Beliefs. H. M. Tichenor
185. History of Printing. Disraeli
186. How I wrote "The Raven." Poe
187. Whistler's Humor
188. How Voltaire Fooled Priest and King. Darrow
189. Eugenics. Havelock Ellis
190. Psycho-Analysis—The Key to Human Behavior. Fielding
191. Evolution vs. Religion. Balmforth
192. Book of Synonyms
195. How to Keep Well
196. The Marquis. George Sand
197. Witticisms and Reflections of Mme. De Sevigne
198. Majesty of Justice. Anatole France
200. Ignorant Philosopher. Voltaire
201. Satan and the Saints. H. M. Tichenor
202. Survival of the Fittest. H. M. Tichenor
203. Rights of Women. Havelock Ellis
204. Sun Worship and Later Beliefs. H. M. Tichenor
205. Artemus Ward. His Book
206. Debate on Capitalism vs. Socialism. Seligman and Nearing
207. Olympian Gods. H. M. Tichenor
208. Debate on Birth Control. Mrs. Sanger and Winter Russell
209. Aspects of Birth Control. Medical, Moral, Sociological. Dr. Knopf.
210. The Stoic Philosophy. Prof. Gilbert Murray
211. Idea of God in Nature. John Stuart Mill
212. Life and Character. Goethe
213. Lecture on Lincoln. Robt. G. Ingersoll
214. Speeches of Lincoln
215. The Miraculous Revenge. Bernard Shaw
216. Wit of Heinrich Heine. Geo. Eliot
218. Four Essays. Jean Jaures
219. The Human Tragedy. Anatole France
220. Essays on the New Testament. Robert Blatchford
221. Women, and Four Other Essays. Maurice Maeterlinck
222. The Vampire and Other Poems. Rudyard Kipling
223. Essays on Swinburne. Sir Arthur Quiller-Couch
224. God: The Known and Unknown. Samuel Butler.
225. On a Certain Condescension in Foreigners. Jas. Russell Lowell
226. Professor Bernhardt: A Play. Arthur Schnitzler
227. Keats, the Man, His Work and His Friends
228. Aphorisms of Thomas Huxley
229. Diderot. Havelock Ellis
230. The Fleece of Gold. Theophile Gautier
231. Eight Humorous Sketches. Samuel Clemens (Mark Twain)
232. The Three Strangers. Thos. Hardy
233. Thoughts on Literature and Art. Goethe
234. McNeal-Sinclair. Debate on Socialism
235. Five Essays. Gilbert K. Chesterton
236. The State and Heart Affairs of King Henry VIII
237. Poems in Prose. Baudelaire
238. Reflection on Modern Science. Huxley
239. Twenty-Six Men and a Girl, and Other Tales. Maxim Gorki

Entire Library—239 Volumes Worth \$59.75—Only \$16.90 Until March 30

These books are recognized masterpieces. Many of them, purchased in the ordinary way in expensive bindings, would cost \$1 to \$3 each. Think of getting an entire library for the usual price of a dozen books! But your order must be mailed not later than March 30. 239 vols. for \$16.90.

Sale Ends March 30

SEND YOUR ORDER TODAY

Sale Ends March 30

While we have plenty of books to fill all orders, we advise prompt action. All books guaranteed—if you don't like them, send them back and we'll return your money. All books are clearly printed on good book paper, 64 to 160 pages each. Pocket size. Bound in heavy card cover paper. Remember this is a limited offer—closes

March 30—send your order and draft, money order or registered letter today—if you order 20 books send \$2—if 50 send \$5, and so on. Postage prepaid on cash orders. Carriage charges collect on C. O. D. orders. Add 10c to personal checks for exchange.

E. H. JULIUS, Pres., APPEAL PUBLISHING CO.

1022 Appeal Bldg., GIRARD, KANSAS

Drawing Outfit

FREE

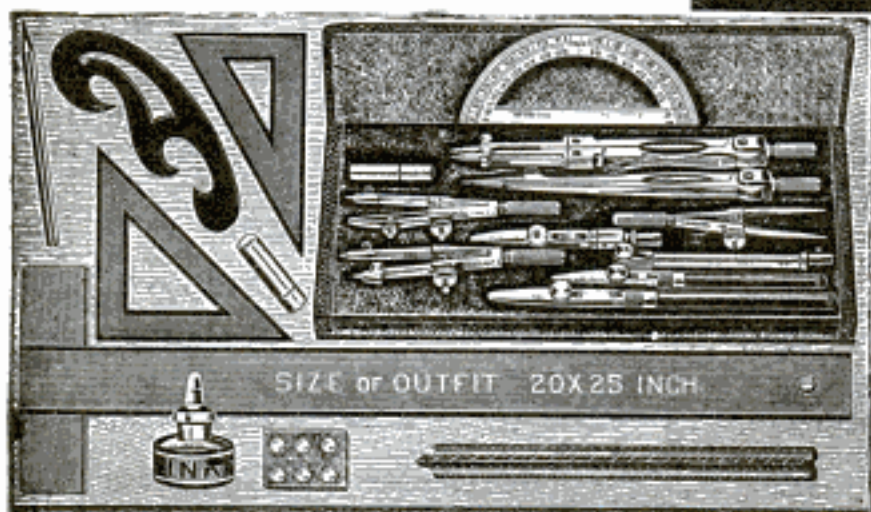

Complete Set of Drawing Instruments Delivered AT ONCE

Yes, I will give you this complete drawing outfit absolutely free. The instruments are in a handsome high class, plush lined folding case. They are regular draftsman's working instruments. Besides I will give you absolutely free, a 20 x 25 inch drawing board, a 24 inch T square, a 12 inch rule, a supply of drawing paper, two triangles, a French curve, pencils, erasers, thumb tacks, etc.

\$3600 a Year *Drafting Salary*

There is an urgent demand for skilled draftsmen. Companies are issuing calls every day for men to fill positions paying \$3600.00 a year. Work is light, pleasant and profitable.

Chief Draftsman *Will Instruct You Personally*



I am Chief Draftsman of a large and well known firm. I have been doing the highest paying expert drafting work for a quarter of a century and I know just the kind of training that is demanded from men who get the big salaries. I train you by giving you actual, practical work, the kind you must be able to do to hold permanent, big paying positions. I give you my individual instruction. If your work is right, I will advance you rapidly. If it is wrong, I will show you where and make you do it right, and do all I can to make you an expert draftsman and designer in a short time.

Write Today Without Fail!

Pay As You Wish

What I want is the *right kind* of men. Don't bother about expense. I will give you the working outfit free if you get in at once. I charge a very small fee for training you to be an experienced draftsman. You can pay the small cost as suits you best.

Chief Draftsman Dobe

Dept. 1351, 4001 Broadway, Chicago, Ill.

Without any obligation on me whatsoever, please, mail your book, "Successful Draftsmanship" and full particulars of your liberal "Personal Instruction" offer to a few students. It is understood that I am obligated in no way whatever.

Name.....

Address.....

Send Coupon For New Book!

Put your name and address on the coupon or a letter or a post card and send it to me today. I will send you absolutely free and post-paid, my new book "Successful Draftsmanship," and the great special offer that I am now making on which you get the complete Draftsman's Working Outfit absolutely free. You assume no obligations of any kind in sending in the coupon. Get in line for a big paying position. Getting the book and full particulars of the special offer is the first step.

Chief Draftsman Dobe

Dept. 1351, 4001 Broadway Chicago, Ill.

FLEXIBLE
BINDINGPOCKET
SIZE

ENTIRE SET ONLY \$12

\$1
PER
MONTH

\$10,000. Master Set AUDEL'S ENGINEERS and MECHANICS GUIDES

THE BOOKS YOU HAVE
BEEN WAITING FOR!

4750 Pages---8754 Illustrations

Just Completed—Audel's New Master Set for Engineers
and Mechanics!

Every Engineer, Mechanic and Electrical worker will
welcome this set as a sure source of advancement and higher
pay because of the complete up-to-date information that is
thoroughly and easily explained on every branch of Engineering
and Electrical practice.

Why a \$10,000 Library? Because it would cost the reader
more than \$10,000 together with years of labor and experience
to collect, plan, arrange and prepare for his own study and
ready reference, the vast fund of knowledge printed in this
Master Set.

The entire set costs you only twelve dollars—knowledge
and instruction that has cost thousands of dollars and years
of time—yours for \$12.00—\$1.00 a month.

Study This Brief Table of Contents

Theory, Practice and Operation of
ALL Steam Engines, Valves Motions—
VALVE SETTING; complete information
on ALL engines and pumps—
CORLISS ENGINES and the Theory,
Construction and Operation of all
Steam Engines, including UNIFLOW
and POPPET VALVE ENGINES,
and LOCOMOTIVES—Locomotive
Marine Engines; Turbines; Rotary
Engines—the Indicator—Lubrication—
PRACTICAL MANAGEMENT.
How to use Indicator—GAS, GAS-
OLINE, OIL, SEMI- and FULL-
DIESEL ENGINES—Arrangement and
Action—HOW TO SELECT AN
ENGINE, working instructions, draw-
ings on STREAM ENGINE DESIGN,
including rules and formulae. Theory
and Construction of ALL Steam
Boilers; Heat-Combustion; Fuel and
Flue Gas Analysis—CO₂ recorder—
Characteristics of Boilers—Materials

—Construction of all types of Boilers.
(THE LATEST PRACTICE)—Boiler
Construction—Mechanical Stokers
—Oil Burners—Setting—Chimneys—
Mechanical Drafts—HOW TO
SELECT A BOILER—Complete in-
structions and drawings on BOILER
DESIGN based on A. S. M. E. BOILER
CODE—OPERATION, including
installation, FIRING; care and repair
of Steam Boilers—Pipes, Fittings and
Pipe Fitting—Heating and Ventila-
tion—Refrigeration—Cooling Towers
—Condensers—Distilling Apparatus
—Elevators—Cranes and Hoisting
Machinery—Ropes and Cables—Splic-
ing—electric wiring in ALL branches;
compendium of practical electrical
engineering as an aid for engineers
and electricians in obtaining a license
—32 chapters—ready reference index,
covering entire field of Modern
Electricity.

Helping Hand
Books that answer
Your Questions

FREE
EXAM-
INATION



Send No Money--Send Only This Coupon

THEO. AUDEL & CO.,
72 Fifth Ave., New York City

Please submit me for free examination, AUDEL'S \$10,000
MASTER SET FOR ENGINEERS AND MECHANICS. Ship
at once prepaid, the 8 numbers, total cost \$12.00. If satisfactory,
I agree to send you \$1 within seven days and to further mail you
\$1 each month until paid.

Name.....

Occupation.....

Employed by.....

Home Address.....

Reference.....

PM JAN. '22

ELECTRICITY

In the Great Shops of

COYNE

LEARN

Electricity Opens the Whole World to You!

Get away from the deadening influences of a humdrum existence. Get out of the rut—get out onto the main highways of life where men **do** things in a big way—out where there is opportunity and big pay.

Electricity opens the way for you. Learn to be an Expert Electrician and go anywhere you wish. You will find positions open to you in any city in electrical factories, power plants, street railway plants, with contractors, out on the great hydro-electric dams, and in automobile and tractor factories and garages. Select the kind of electrical work you like best and go anywhere you wish. You can go into business for yourself.

Learn Electricity in 3 1/2 Months

We teach you practical electrical engineering from the ground up by the "learn-by-doing" method. In 98 days we teach you more about all phases of practical Electrical Engineering than you can learn about any one phase of it in years by any other method.

Earn From \$150 to \$400 a Month—and Up!

The best proof that practical Electrical Engineering is the profession and that the Coyne School is the place to learn it, is the splendid success made by Coyne graduates. Untrained men, who don't know a dynamo from a dry-cell, come to this school and after 98 days instruction under the Coyne method go out into actual work and in a short time are commanding from \$150 to \$400 a month, and, in businesses of their own, much greater sums.

No Previous Experience Necessary

You don't need to know anything at all about electricity to enter Coyne. Nor do you need to have any considerable schooling. We have no classes; use no books. We teach by the most practical methods. Our instructors, all electrical experts, work with you in the actual doing of the thing to be learned. They tell you **what** to do, **how** to do it, and **why**. You pass along from the simplest task on signal bells to the finishing work on the monster dynamo, just as fast as you can learn. (And you can spend as much time over the 98 days as you wish, without extra cost.) Here you work with your hands just as you will when you get on the job, after graduation. The Coyne method of teaching practical Electrical Engineering is not only the most efficient, but the simplest and quickest known.

All Tools and Equipment Furnished Free

Your success is assured before you start because you learn by working on the actual motors, dynamos, switchboards, batteries, electric locomotives, automobiles, etc. The Coyne Schools are the best equipped of any in the world. All the necessary electrical machinery and apparatus of the very latest approved type is here for you to work with. All tools are supplied you without cost.

BENNETT W. COOKE, President

COYNE TRADE and ENGINEERING SCHOOLS
Dept. 11 **39-51 E. Illinois St., Chicago**

IN 3 1/2 MONTHS

You Can Earn Your Way Through This Course

Don't let the lack of money stand in your way if you have ambition and determination to make your way in the world. You can work at the same time you are taking this course and earn enough to help pay your way. Our employment manager will get you a job on the side, if you need it. Hundreds of our students earn their way through this course and make brilliant successes. What they do, you can do.

A Special Offer to a Few From Each Locality

To a few young men from each locality who enroll within a limited time we have a most attractive and unusual offer. Those who act at once can get absolutely free a complete course in Business Management at America's greatest school of business, also our complete course in automobile electricity—the finest training in America on lighting, ignition and starting systems as used on autos, tractors and trucks and in battery making and repairing. Either of these courses alone is worth the price asked for all three. Write at once for full particulars.

The training in Business Management fits you to apply your knowledge of Electricity so as to get the most out of it; it assures you quick and certain success in a business of your own or in working for someone else.

Immediate Action Necessary

This offer will be open but a short time and only to a limited few from each locality. If you have the ambition to make a big success of life, to have an automobile and a home, to travel and get all the good out of life, you should take up electricity. It is the profession of big opportunity. It will bring you all these things, quickly. Send coupon now for free catalog.

Act now, and in 98 days you will be in position to command from two to ten times your present income—in 3-2 months we will equip you with that knowledge which will bring you in the equivalent of two to ten weeks' pay at your present rate for every week's work. Every day you delay will cost you \$10 or more that you could otherwise command if you were Coyne-trained in practical Electrical Engineering.

The sooner you graduate from Coyne the sooner the big pay starts. The sooner you send in the coupon the sooner you will graduate. Act!

Send Coupon NOW

You need this book. It tells you about the wonderful opportunities in the Electrical field, and of the brilliant successes which young men are making in this profession. And it tells how you can learn practical Electrical Engineering, quickly and efficiently. Write at once for full particulars governing special offer, and the big free electrical Catalog.

Bennett W. Cooke
 President,
 Coyne Trade and
 Engineering Schools,
 Dept. 11, 39-51 E. Illinois St.,
 Chicago, Illinois

Gentlemen: Send me your big free catalog with full particulars concerning your Electrical course and how I may secure your course of Automobile Electricity and the course in Business Management, free. This places me under no obligation whatsoever.

Name.....
 Address.....

MAKE \$150 TO \$400 A MONTH



This Man Earns \$83 a Day

His name is J. F. James. He left school when he was a boy. He was down, but he refused to stay down. He worked! He studied! And today he is president of the Mascot Stove Company, of Chattanooga, Tenn., at a salary of \$25,000 a year! He says that the I. C. S. "made his success possible."

Won't you let the I. C. S. help you, too? When everything has been made so easy—when so many other men are going forward to success—can you afford to let another price-less hour go to waste?

The way is easy. Without obligation or a penny of cost, mark and mail the coupon today and let us tell you how you, too, can win advancement and more money through spare-time study at home with the I. C. S.

----- TEAR OUT HERE -----

International Correspondence Schools, Box 5597-C, Scranton, Pa.

Please explain fully about your course in the subject marked X:

- | | | |
|---|---|---|
| <input type="checkbox"/> DRAFTING | <input type="checkbox"/> Electrical Engin'r's | <input type="checkbox"/> ADVERTISING |
| <input type="checkbox"/> Mechanical Engin'r's | <input type="checkbox"/> Stationary | <input type="checkbox"/> Salesmanship |
| <input type="checkbox"/> Surveying | <input type="checkbox"/> CHEMISTRY | <input type="checkbox"/> BOOKKEEPING |
| <input type="checkbox"/> Civil Engineering | <input type="checkbox"/> Automobiles | <input type="checkbox"/> Civil Service |
| <input type="checkbox"/> ARCHITECTURE | <input type="checkbox"/> STENOGRAPHY | <input type="checkbox"/> Ry. Mail Service |

Name _____

Street _____

Address _____

City _____ State _____

Earn \$35-\$125 a Wk



Your Opportunity in MECHANICAL DENTISTRY

Ambitious men of all ages can rise above small salaried positions into this profession of unlimited possibilities.

Taught by actual practice—day or evening. Three months' course. Modern laboratories. No previous knowledge or experience required. No charge for tools or equipment. The men we train are in demand. Established 29 years. Catalog free.

Address your inquiry to Dept. 2

BODEE SCHOOLS OF MECHANICAL DENTISTRY

NEW YORK
136 W. 52 St.

PHILADELPHIA
15 1/2 and Walnut Sts.

BROOKLYN
15 Flatbush Ave.

\$5,000 SALARIES

are often paid to traffic managers. Numberless traffic positions pay \$2,500 to \$5,000 per year. Millions of dollars are wasted annually because of ignorance of cheaper ways to ship. You can be a traffic expert—stop losses—make big money for yourself. Thousands of men now needed.

Learn at Home—Book Free New home study Actual Practice Method will quickly make you a Certified Traffic Manager. You can very soon qualify for a splendid traffic position. Write quick for big new illustrated book describing this wonderful training in detail. Write today. Address

American Commerce Association Dept. 101, 4043 Drexel Blvd, CHICAGO, ILL.

STAMMER

If you stammer attend no stammering school till you get my large FREE book entitled "STAMMERING, Its Origin and the Advanced Natural Method of Cure," bound in cloth and stamped in pure gold. Ask for special attention and a FREE copy of "The Natural Speech Magazine." Largest, best equipped and most successful school in the world for the cure of stammering, stuttering, etc. Nosing-song or time beat. Write today. The North-Western School, 2317 Grand Ave., Milwaukee, Wis.

"THERE'S MONEY IN IT" AT HOME LEARN TELEGRAPHY AT HOME MORSE AND WIRELESS



TEACH YOURSELF

in half usual time, at trifling cost, with the wonderful Automatic Transmitter THE OMNIGRAPH. Sends unlimited Morse or Continental messages, at any speed, just as an expert operator would. Adopted by U. S. Government, and leading Universities, Colleges and Telegraph Schools. 3 styles. Catalog free.

OMNIGRAPH MFG. CO.

26 D Cortlandt Street, NEW YORK

TIME IS MONEY ROPP'S CALCULATOR



Saves Both. Shows prices, quantities, weights, etc., of familiar commodities in any business.

Desk Size, - - \$1.50
Pocket size, leatherette, 1.00
Pocket size, cloth, .50
" " paper, .35

Postage free anywhere

WELLS & EDWARDS
852 George St. Chicago, Ills.
Send for free book catalog

4 Weeks Trial DIRECT FROM FACTORY NOT ONE CENT IN ADVANCE



Wing Pianos and Player Pianos shipped on 4 weeks' trial, freight pre-paid. Save 25 to 50 percent. 40 year guarantee. Thousands in use everywhere. The Book of Complete Information about Pianos—FREE. Write at once for new book showing 38 styles. Also latest factory prices and cash terms. WING & SON (Est. 1868), Dept. 61-F, 9th Ave. & 13th St., N. Y.

\$1,600 to \$2,300 a Year Men—Boys—Over 16—should write at once

Rapid advancement. "No lay-offs." THE POSITION IS YOURS FOR LIFE.

Country residents and city residents stand the same chance. Common-sense education sufficient.

Write immediately for schedule showing the places and dates of ALL COMING Government examinations. Don't delay. Every boy or man over 16 should write.

FRANKLIN INSTITUTE,
Dept. T177, Rochester, N. Y.

WANTED!



RAILWAY MAIL CLERKS

FRANKLIN INSTITUTE (The Pathway to Plenty) Dept. T177, Rochester, N. Y.

This coupon, filled out as directed, entitles the sender to free specimen questions; a copy of our free book "Government Positions and How to Get Them;" a list of Government positions now open, and to consideration for Free Coaching for the examination here checked.

COUPON

- | | |
|--|--|
| .. Railway Mail Clerk (\$1600 to \$2300) | .. Postoffice Clerk (\$1400 to \$1800) |
| .. Postoffice Carrier (\$1400 to \$1800) | .. Rural Mail Carrier (\$ 720 to \$2600) |

Name _____ Address _____

Use this before you lose it. Write plainly.

How I Found a \$10,000 Job in a Waste Basket

Truth is often stranger than fiction as evidenced by the fact that I found an opportunity in a wastebasket that quickly placed me in the \$10,000 a year class.

By Philip Wilson

IF anyone had told me a couple of years ago that I would be in the position I am in today it would have made me sore, because at that time my prospects did not amount to a row of beans. After ten years drudgery as a bookkeeper I was only earning \$35.00 a week. Further promotion was almost impossible and even if it came my way, it could only mean five or ten dollars more a week at the most.

From morning until night I worked on endless rows of figures, punched the clock on my arrival and again on quitting. Frankly, I was sour on life. And then, as though by a touch of magic, my entire prospects changed—thanks to a dilapidated old waste basket.

And now for the other side of the picture. At the present time I am earning about \$10,000 a year, have a comfortable home, earn enough to enjoy the luxuries that make life worth while, have a bank account that is growing each month, to say nothing of the fact that I am engaged in work that seems like play, that fascinates, thrills and enables me to live like a gentleman.

The funny part of it is that if anyone had told me two years ago that I could make good in my present profession, I would have scorned the idea as impossible.

I Suddenly Find My Big Chance

I found my opportunity in a waste basket. In my case I was eating lunch in our stock room because I could not afford to go to a restaurant. In the corner of the room I noticed a waste basket. Sticking out of it was a dirty looking old magazine. Not finding anything of interest among the articles, I idly turned over the advertising pages when something stopped me. For fifteen minutes or so I studied the page before me carefully. Then I took it over to the stock room clerk.

"What do you think of this, Jim?" I asked.

Poor Jim, who is still in that stock room, only read the headline and sniffed in contempt.

Anyway the advertisement set me thinking although my negative condition at that time made me feel somewhat the way Jim did. But anyway, I ripped that advertisement out of the magazine and stuffed it in my pocket.

Several times that afternoon I pulled it out and studied it carefully. Every time I read it my pulse quickened, because if true at all, it pointed a way for me to increase my earning power many times over, to say nothing of getting away from the drudgery of bookkeeping.

"Why couldn't I do the same?" I asked myself.

Then Old Man Negative whispered in my ear that I was foolish to even think about it—that I was not cut out for it. So I put the advertisement in my desk and for the time being I forgot it.

Several weeks later I ran across it again and this time I acted. I mailed the coupon in for particulars.

The Secret of My Success

What was responsible for my remarkable increase in earning power? What did I do to lift myself out of the low pay rut and step into magnificent earnings? I got into the great field of selling through the aid of the National Salesmen's Training Association—an organization of top

notch salesmen and salesmen, formed just for the purpose of showing men how to become master salesmen.

Through the help of the N. S. T. A., hundreds of men have been able to realize their dreams of success, health, and independence. Men without previous experience or special qualifications have learned the secrets of selling that make star salesmen—for salesmen are not "born," but made, and any man can easily master the principles of salesmanship through the wonderful system of the National Salesmen's Training Association. On record in the Association files are hundreds of letters similar to the few shown on this page. The most amazing part of it all is that these successful men had no previous selling experience before the N. S. T. A. trained them and helped them secure sales positions.

In my own case for instance, it may sound like a fairy tale but at the end of my first month I received a letter from my salesmanager congratulating me on my success. I had made a record for my territory.

Previous Experience Unnecessary

Salesmanship is not a natural gift—it is an Art and Science that is open to any man of average intelligence. There are many fundamental rules and principles that anyone can learn and put into practice. There are certain ways of doing and saying things in selling and once you are master of these selling secrets, the world is before you. The man who understands the underlying principles of salesmanship has a two fisted grip on prosperity.

A Great Book on Selling Sent Free

The interesting book "The Knight of the Grip" will be sent absolutely free to those sending in the attached coupon. This valuable book tells you all about the N. S. T. A. method of Salesmanship Training and Free Employment Service. In addition, you will read of the big opportunities open for you in the selling field and personal stories of men from all sections of the country and from all trades and professions who have suddenly stepped from small pay jobs to magnificent earnings as a result of the N. S. T. A. system.

Simply fill out and mail the attached coupon and "The Knight of the Grip" will be promptly mailed to you.

National Salesmen's Training Association, Dept. 12-A, Chicago, Illinois.

National Salesmen's Training Association,
Dept. 12-A, Chicago, Ill., U. S. A.

Please send me, without any obligation on my part, your free book, "A Knight of the Grip," and full information about the N. S. T. A. system of Salesmanship training and Employment Service. Also a list showing lines of business with openings for salesmen.

Name.....

Street.....

City..... State.....



Philip Wilson, who tells on this page how chance brought to him, from a dilapidated old waste basket, the secret that suddenly lifted him out of the rut to wonderful success and big earnings.

What Others Have Done

\$524 in Two Weeks
I had never earned more than \$60 a month. Last week I cleared \$204 and this week \$218. You have done wonders for me.—Geo. W. Kearns, 107 W. Park Place, Oklahoma, Okla.

Earns as High as \$100 a Day
I took your course two years ago. Was earning \$15 a week clerking. Am now selling many of the largest firms in the U. S. I have earned more than \$100 a day. You secured me my position. Our Sales Manager is a graduate of yours.—J. E. De-Ronia, 1628 S. Crawford Ave., Chicago, Ill.

\$1,562 in Thirty Days
My earnings for the past thirty days are \$1,562.00 and I won Second Prize in March although I only worked two weeks during that month.—C. W. Campbell, Greensboro, Pa.

Can YOU do



THE illustrations appearing on this page are but a few of the many photographs appearing in my booklet "MUSCULAR DEVELOPMENT." These are all photographs of my pupils showing the development which they have attained by faithfully following my instructions.

Chicago, Ill., Dec. 2, 1920.
My Dear Mr. Liederman,
I received my last lesson this morning and I wish to thank you for the kind, friendly interest you have shown me in the past. I have improved my condition better than I ever anticipated and you will find me always glad and willing to recommend your course to anyone.
Yours truly, Dr. J. G.

Vancouver, B. C.
Oct. 28th, 1920.
Dear Mr. Liederman,
You asked me to measure myself and I have done so. I am now happy to tell you that I have lost seven inches around my waist since taking your course and the fat around my hips and thighs is nearly all gone. I did not imagine when I enrolled with you that I could accomplish such splendid results. I think now if I lose another 5 or 10 pounds, I will weigh what I have always wanted to.
Again accept my thanks,
Yours truly, W. I.

Cleveland, Ohio, Oct. 31, 1920.
My Dear Mr. Liederman,
I received your exercises this morning and it is everything you claim it to be. It surely is the greatest muscle builder to be had, and I am mighty glad I am one of your pupils for I know you are going to make a real athlete of me. Your letters are frank and straight from the shoulder.
I am going to send you a photograph of myself in a few weeks as soon as I have time to get one taken.
Wishing you success, I am
Most Sincerely, J. McK.

Detroit, Mich., Nov. 17, 1920.
My Dear Mr. Liederman,
I received my first lesson and you cannot imagine how pleased I am with the work you outlined for me for the first week. They certainly are real muscle building exercises as you claimed they would be and I know I am going to make rapid progress. I feel stronger and better already.
Your Pupil, E. C.

Philadelphia, Pa.,
Nov. 16, 1920.
Mr. Liederman,
Dear Friend,
Received your final lesson and have completed your course. I thank you very much for the fine training you gave me. You have made a real man of me and have enabled me to defeat many of my friends in strength. I am very much pleased with your course and thank you for all your kind letters and the help you gave me.
Wishing you luck and success in your life's work,
I am, Your friend, A. C.

Cincinnati, Ohio,
Oct. 31, 1920.
My Dear Instructor,
I thought I would write you and let you know how I am getting along.
I have been following your course three weeks now and my arms have gained over an inch. I have also gained three inches on my chest and one-half inch on my neck. Your course is certainly doing wonders for me.
Looking forward with interest to the next lesson, I am
Your faithful pupil, J. F.

Earle Liederman, 203 Broadway, New York, City.

November 19, 1919.

Dear Sir:

I have recently had occasion to thoroughly investigate your splendid course, and I believe that in departing from the old time-worn methods you have worked out a system which is equalled by none.

I have found several of your original exercises to be remarkably effective. There is no reason why anyone following your instructions should not rapidly attain perfect muscular development and abounding health.

Accept my congratulations, and my best wishes for well merited success. Very truly yours,

TEX O'ROURKE.

There must be some value to my system of training when such famous men as Tex O'Rourke, who is one of the world's leading authorities on physical culture and who is undoubtedly the foremost trainer of the world's champions, recommend it.

For further particulars of Earle E. Liederman see page 143

Copyrighted material

these things?

Lift 200 Pounds or More Overhead With One Arm—Chin Yourself With One Hand—Tear Two Decks of Playing Cards—Bend and Break a Horseshoe—Expand Your Chest to 48 Inches—Flex Your Arm Until It Measures 16½ Inches

CAN YOU DO ANY OF THEM?

I can, and hundreds of my pupils can

You can do things that others cannot even attempt to do, if you follow my advice. You can feel strong—look strong—be strong. Train for strength and development at the same time. Large, well-shaped muscles will set you off and add to your personality. It is personality that brings success.

Anyone can obtain a splendid muscular development—it is simply up to themselves. I have taken hold of hundreds of weaklings and turned them into powerful athletes in a remarkably short time. I have turned hundreds of men and boys of average build into famous strong men. **Some of the strongest men of the present day are my pupils.** What I have done I am still doing every day, and if YOU—who read this, really desire to become a strong, well-developed man, I will explain how you can be one, in my latest book, "MUSCULAR DEVELOPMENT."

The best time to begin training is between the ages of 15 and 25. A young man is then growing and his muscles respond rapidly to systematic exercise. The man between 30 and 40 should not feel that he is too old, however, for at this age a man should be at his best. If he will pitch in and train systematically and determine to make the most of himself, he can positively develop and become just as strong as any YOUTH. The main thing is to do the right thing in the right way and my course has proven itself to be THE CORRECT WAY.

Hundreds of my pupils have tried other methods and failed. Why do they come to me? There must be a reason! They realize that my methods are the quickest and best for obtaining a splendid development.

I begin where others leave off. That is why I am successful. After a few weeks my pupils feel the energy and PEP that only an athlete knows.

No matter how badly you may be suffering from constipation, indigestion, nervousness, or lack of vitality, in a few weeks' time I can make A REAL MAN OF YOU; and cause you to experience the joy of living.

You just have to get strong—that is all there is to it. Going through life with a sickly, weak body will never get you anywhere. The successful man is the man with PEP—PERSONALITY—APPEARANCE—STRENGTH and ENDURANCE. That's the makings of a real American man!



LATEST PHOTOGRAPH OF
EARLE E. LIEDERMAN

The Eighth Edition of My Book **"MUSCULAR DEVELOPMENT"**

is just off the press, and I will gladly send a copy to anyone who will tear off the coupon attached and mail to me with 10c (stamps or coin) to help cover cost of postage, wrapping, etc. This little book is handsomely illustrated with 26 full page photographs of myself and of some of the well-developed men and boys whom I have trained. **Send for your copy today—now—** while it is on your mind.

EARLE E. LIEDERMAN

305 Broadway Department 2001 New York City

Mr. Earle Liederman,
Dept. 2001, 305 Broadway,
New York City.

Dear Sir:—Without any obligation on my part please send me a copy of your book "Muscular Development," for which I enclose 10 cents.

Name

Street

City State

For further particulars of Earle E. Liederman see page 143

This Complete Drawing Outfit **FREE**

You can have this complete Drawing Outfit absolutely free. It has everything needed:—A drawing board, "T" square rule, French curve, protractor, triangles, triangular boxwood scale, erasing shield, drawing ink, pencils, erasers, paper, etc. The coupon will bring you information as to how you can get this splendid outfit free.

Earn \$50.00 to \$100.00 a Week

There are few professions that offer greater possibilities than that of the expert draftsman. If you want to get into a line of work that is uncrowded—where the job will seek you—where you will earn \$50.00 a week or more, then here is your chance. Become a trained draftsman.

Thousands of Jobs Are Open

for the trained draftsman. Right now, while a great number of men of other lines of work are out of work you won't find the trained draftsman hunting for a job. The demand for men in this line far exceeds the supply. Take advantage of that fact, and without quitting your present job, in your spare time, get the preparation that will fit you for this profitable profession. **YOU NEED NO PREVIOUS TRAINING.** An hour or two after supper is all the time you need and in a few months you will have mastered this interesting job.

Our Free Employment Service

will assist you in placing yourself to the best advantage in this well-paying profession. Our improved system of practical instruction has reduced the method of becoming efficient in this work to a very simple process. It will help you to cash in quickly on your natural ability.

Don't Turn This Page Until You Have Made Up Your Mind to find out all about our free offer to you. The coupon will bring full information and our free book. Send for it today—*right now.*

AMERICAN SCHOOL

Drexel Avenue & 58th Street Dept. D-174 Chicago, U. S. A.

TEAR HERE

AMERICAN SCHOOL, Dept. D-174 Drexel Ave., & 58th St., Chicago, U. S. A.

Please send me particulars on how I can get the Drawing Outfit Free and explain how I can get the job checked. This request is to put me under no obligation.

- | | | |
|---|---|---|
| <input type="checkbox"/> Machine Drawing and Design | <input type="checkbox"/> Surveying and Topographical Drafting | <input type="checkbox"/> Structural Drafting |
| <input type="checkbox"/> Architectural Design | <input type="checkbox"/> Sheet Metal Pattern Drafting | <input type="checkbox"/> Sanitary Drafting and Estimating |

Name.....Address.....

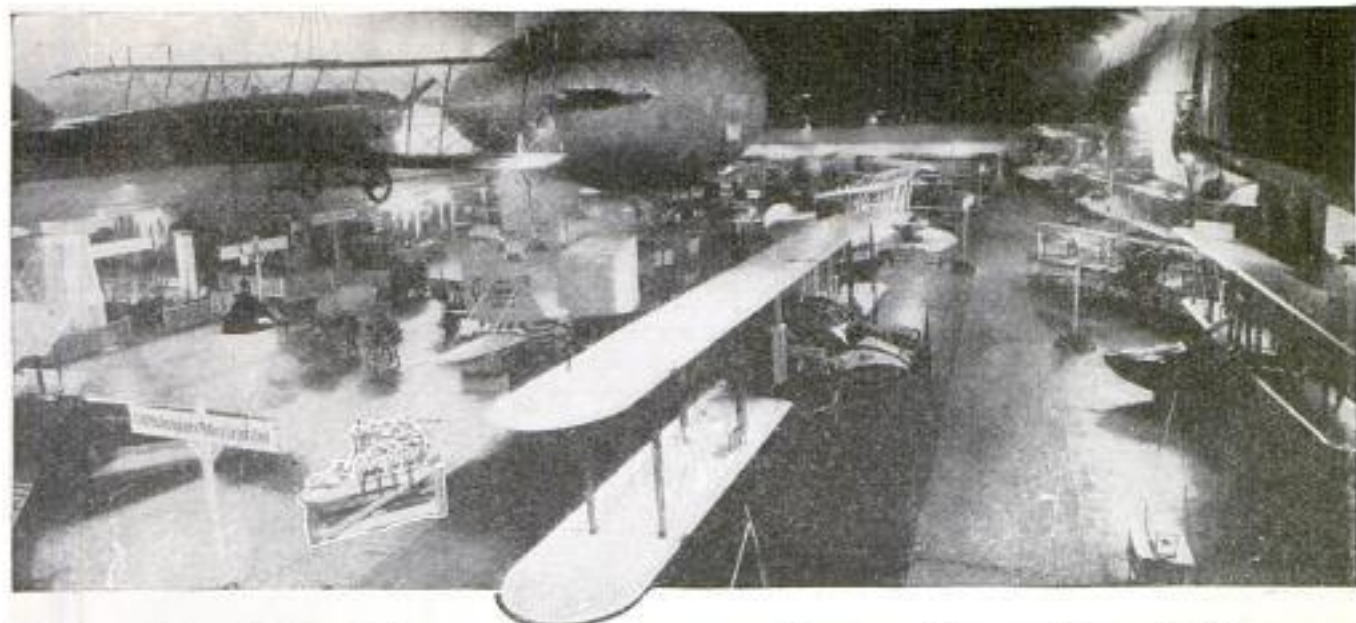

Quick Success in Aviation Fascinating—Daring—Big Paying

To young men of daring, no other field of work offers such a fascination, such high pay, nor such opportunities for quick success as the field of Aviation. As yet, aviation is practically in its infancy. NOW is the time to get in.

Amazing Opportunities in Airplane Industries

In the automobile industry and in the moving picture business hundreds of men got rich by getting in at the start. They made their success before others woke up. Today, these lines offer no greater opportunities than a hundred and one others. BUT AVIATION IS NEW. Get in while the opportunity and pay are big. All over the country there is a clamor for trained men. It is not a question of pay but of getting capable men.

Here Are Real Positions, \$50 to \$150 Per Week

Aeronautical Instructor, Aeronautical Engineer, Aeronautical Contractor, Airplane Repairman, Airplane Mechanician, Airplane Inspector, Airplane Salesman, Airplane Assembler, Airplane Builder.

A Sure and Easy Way to Learn Aviation—at Home



A New Job—The Aerial Postman

The study of aviation is almost as fascinating as the actual work. Every lesson is full of interest. That is why it is easy to learn aviation. You do not have to make yourself study—it is like reading an in-

teresting book that tells you things you have always wanted to know. Only one hour each evening will give you the basic training in a surprisingly short time. You need only a common school education.

One of my students, James Powers, Pa., says, "I am indeed surprised that such a valuable Course can be had from such practical men for so little cost."



A New Seven-Passenger Airplane

Personal Instruction by Experienced Men

Men who have had actual experience give you personal attention. They select the lessons, lectures, blueprints and bulletins. They tell you things that are essential in everyday practice. Each lesson is easy to read and understand.

BIG BOOK FREE of Opportunities

Send coupon below for New Book, just out, "Opportunities in the Airplane Industry." It is interesting and instructive. It will show you many things you never knew before about aviation. Due to shortage of paper we could get only a limited supply of these books—send the coupon before they are all gone.

AMERICAN SCHOOL OF AVIATION 3601 Michigan Ave., Dept., 1191 Chicago, Ill.

AMERICAN SCHOOL OF AVIATION
3601 Michigan Ave., Dept. 1191 Chicago, Ill.

Without any obligation, send me your Free Book, "Opportunities in the Airplane Industry," also information about your Course in Practical Aeronautics.

Name.....

Street.....

City..... State.....

How John J. Decker put down \$10— —and drew \$100!



Not only did John J. Decker pick up \$100 for every \$10 he invested, but after a few short months he stopped putting down the ten-dollar bills—and he kept right on picking up the hundred-dollar bills.

Nothing extraordinary about Decker's plan. He simply invested in the safest proposition in the world, and the one that yields the biggest dividends—specialized training. Actually within six months of his enrollment with LaSalle Extension University, he had added to his income ten times what the course had cost him.

* * * * *

If you have been putting off the time when you were going to do the one thing necessary to fit yourself for a bigger job, at least do *this* one thing **TODAY**—*find out the facts!*

Find out, for example, why it is that not a day goes by at LaSalle but what a score of statements such as these are scattered thru the morning's mail:

- "Promoted to General Manager."
- "Now Service Manager, with 476% increase."
- "Passed C. P. A. Examination. Now partner in \$20,000 firm."
- "LaSalle training enabled me to save our firm \$3,988 on a single shipment of freight."
- "Passed bar examination with highest grade

in competition with many resident school graduates."

"The most efficient and most rapidly promoted men in our whole organization are LaSalle-trained."

Ask any member of LaSalle Extension University (and LaSalle enrolls about 60,000 every year) and he will tell you that the reason such results are not at all unusual is because of the *LaSalle Problem Method of Training*. By the Problem Method, the member handles the same problems, comes face to face with the same situations, has the same questions to answer, as he would if he were actually sitting at a manager's desk. Under the personal direction of some of the ablest business men in their respective fields in America, he prepares for duties which years of everyday routine experience could not have fitted him to handle.

Mail the Coupon

Find out today about this training—learn how you can get it in the quiet of your own home, without losing an hour from work or a dollar of pay—see if it is not just what you need to increase your earning power. The coupon, mailed today, will bring you all the facts, together with particulars of our convenient-payment plan; also your free copy of the inspiring book, "Ten Years' Promotion in One." It places no obligation on you, but it brings you—*opportunity*. Mail the coupon NOW!

LaSalle Extension University

The Largest Business Training Institution in the World

INQUIRY COUPON

LA SALLE EXTENSION UNIVERSITY

Dept. 164-R

CHICAGO, ILLINOIS

Please send me catalog and full information regarding the course and service I have marked with an X below. Also a copy of your booklet, "Ten Years' Promotion in One," all without obligation to me.

- Business Management: Training for Official, Managerial, Sales and Executive positions.
- Higher Accountancy: Training for positions as Auditor, Comptroller, Certified Public Accountant, Cost Accountant, etc.
- Traffic Management—Foreign and Domestic: Training for positions as Railroad and Industrial Traffic Manager, etc.
- Railway Accounting and Station Management: Training for Railway Auditors, Comptrollers, Accountants, Clerks, Station Agents, Members of Railway and Public Utilities Commissions, etc.
- Law: Training for Bar; LL. B. Degree.

- Commercial Law
- Industrial Management Efficiency: Training for Production Managers, Department Heads, and all those desiring training in the 48 factors of efficiency.
- Modern Business Correspondence and Practice: Training for Sales and Collection Correspondents; Sales Promotion Managers, Credit and Office Managers; Correspondence Supervisors, Secretaries, etc.
- Banking and Finance: Training for executive positions in Banks and Financial Institutions.
- C. P. A. Coaching for Advanced Accountants

- Modern Foremanship and Production Methods: Training in the direction and handling of industrial forces—for Executives, Managers, Superintendents, Contractors, Foremen, Sub-foremen, etc.
- Personnel and Employment Management: Training for Employers, Employment Managers, Executives, Industrial Engineers.
- Expert Bookkeeping: Training for position as Head Bookkeeper.
- Business English: Training for Business Correspondents and Copy Writers.
- Commercial Spanish
- Effective Speaking

Name _____ Present Position _____ Address _____



Get Started RIGHT-We Will Show You How

These Books Will Help You to Fill Any of These Big-Pay Positions

Office Men

Accountants, Cashiers, Office Managers, Credit Managers—\$2500 to \$7500 per year.

Factory Men

Electrical and Mechanical Engineers, Superintendents, Foremen, Draftsmen, \$2500 to \$12000 per year.

Construction Men, Executives and Other Big Jobs!

The New Year is the time for good resolutions and the time to make up your mind to get into the big-pay class. Do it right now. Don't plod along another year waiting for a small raise that may never come. Go after the bigger pay—A. T. S. Books will help you get it. Over 200,000 men are successful today because they resolved to learn more about the work they were doing or wanted to do, through A. T. S. Books.

Every set of books listed below is the work of 15 to 35 recognized experts in that particular field. Every set contains hundreds of pictures, charts and blue prints. Everything is written in plain simple language that anyone can understand.

Any Set Sent FREE If You Clip the Coupon NOW!

You don't have to risk a single penny to examine any one of these big sets of books for seven whole days—in your office, shop or home. When you see the hundreds of charts, blueprints, formulas, figures and facts that will be at your finger ends, you will realize that the books are just what you have been looking for—at last you can bridge the gap between you and the job you want. Mail the coupon TODAY—the set of books you want will be shipped immediately.

Accountancy and Business Management—7 vols., 2700 pages, 1000 pictures. Was \$52.50. Now \$29.80.

Electrical Engineering—3 volumes, 4100 pages, 3100 pictures. Was \$60.00. Now \$34.80.

Carpentry and Contracting—5 volumes, 2158 pages, 1600 pictures. Was \$37.50. Now \$24.80.

Automobile Engineering—6 volumes, 2900 pages, 2300 pictures, diagrams, etc. Was \$45.00. Now \$24.80.

Steam and Gas Engineering—7 volumes, 3500 pages, 2500 pictures. Was \$52.50. Now \$29.80.

Law and Practice (with reading course, and standard legal forms free) 12 vols., 6000 pages, illustrated. Was \$87.50. Now \$49.80.

Sanitation, Heating and Ventilating—4 volumes, 1454 pages, 1400 pictures. Was \$50.00. Now \$18.80.

Civil Engineering—9 volumes, 3900 pages, 3000 pictures. Was \$67.50. Now \$39.80.

Machine Shop Practice—6 volumes, 2300 pages, 2500 pictures. Was \$45.00. Now \$24.80.

Telephony and Teleg. raphy—4 volumes, 1728 pages, 2000 pictures. Was \$39.00. Now \$19.80.

Employment Management and Safety Engineering—7 volumes, 1800 pages, 540 illustrations, charts and diagrams. Prepares for Employment Manager. Was \$52.50. Now \$29.80.

Drawing—4 volumes, 1578 pages, 1000 pictures, blueprints, etc. Was \$30.00. Now \$19.80.

Send No Money—Just Coupon

Here's a special offer that you must take advantage of if you want to get ahead. Just fill out and mail the coupon. There is no "red tape" about it—no strings to our offer—just mail the coupon and the books will come at once. Yours to use as you please for a whole week FREE.

AMERICAN TECHNICAL SOCIETY

Dept. X191

Chicago, U. S. A.

American Technical Society

Dept. X191 Chicago, U. S. A.

Please send me set of.....

for 7 days' examination, shipping charges collect. I will examine the books thoroughly and, if satisfied, will send \$2.50 within 7 days and \$3 each month, until I have paid the special price of \$..... If I decide not to keep the books, I will notify you at the end of seven days and return them at your expense.

Name.....

Address.....

Reference.....





GARAGE



MOTOR REPAIRING



ELECTRIC SERVICE



BATTERY

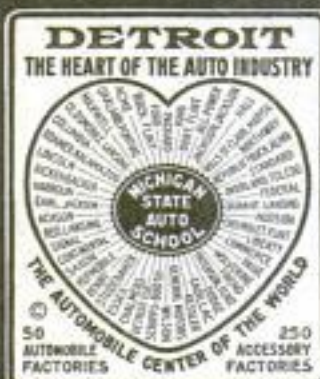

These Jobs Pay Earn More

Get into the automobile business to make big money. No limit for trained men. 10 million autos, trucks, tractors now in use. All need repairing, overhauling—millions to be rebuilt. Motorists must economize—make their cars last twice as long. 50 million tires to be re-treaded, put into longer use. Millions of batteries must be replaced. Right now this spells the greatest money-making opportunity in the world for ambitious, red-blooded, "go-getting" men.

Endorsed by Famous Factories



BUICK MOTOR COMPANY

"We believe the MICHIGAN STATE AUTO SCHOOL, Detroit, would best meet your requirements, as its course of technical training is most thorough and complete in every detail."

THE STUDEBAKER CORPORATION OF AMERICA

"We do not know of a better automobile school than the MICHIGAN STATE."



HUDSON MOTOR CAR COMPANY

DETROIT, MICH., U.S.A.

"This school is thought very highly of by the automobile men of Detroit, and is considered one of the best equipped and most efficient schools in the country. You will make no mistake in attending the M. S. A. S."

No Experience Necessary

Make a start—that's the thing! In a few short weeks, under guaranteed training, you can become a first-class, all-around, practical auto and tractor mechanic, capable of filling a garage job at bigger pay. Or, you can quickly become an Auto Electrician, and double your earnings. You can go into business for yourself—start a garage—electric service station—tire repair shop—battery station—or welding shop. You can sell cars, trucks, tractors, farm-lighting systems or engines. It's a great business—a certain money-making future.

You, Too, Can Succeed!

You have the ambition—you want success. Success is certain if you are willing to work for it. You can have independence—be your own boss—stop the plodding, get into work you like. Earn big money, be prosperous, happy and independent. You can do it just as well, or better, perhaps, than Ed. Wanhof, who writes: "I now have charge of a garage and average \$350 to \$375 a month." Thousands of similar successes. Records seem amazing, but they are only ordinary. It is all done through head and hand training at the M. S. A. S. Decide now to give yourself the training that will pay you big, and establish you in a successful life work.

Come to Detroit--The Auto Center

To the School in the Heart of the Automobile Business

Come to Detroit, to the MICHIGAN STATE AUTO SCHOOL. This is the way to get started right, up the ladder of success. Detroit, the automobile center, in the heart of the industry, is the logical place to learn the auto trade. Here a nickel car fare will take you to the great FORD plants, or the PACKARD, the CADILLAC, the HUDSON,

ESSEX, HUPMOBILE, CHALMERS, PAIGE, STUDEBAKER, MAXWELL, LINCOLN, DODGE, or to more than two hundred and fifty accessory factories—right into the very headquarters of the business—at the fountain head of this great industry. No other place can give you the same opportunity for first-hand knowledge.

MICHIGAN STATE AUTO SCHOOL

"The Detroit Auto School"



WELDING



TRACTOR OPERATING



TIRE REPAIRING



SELLING

\$200 to \$500 a Month

Money!

Train Head and Hand! By Factory Endorsed Methods

Who knows better how to teach autos, trucks and tractors than the men who build them? These men know how training should be given to make the most valuable men. The courses of the M. S. A. S. (Detroit's Auto School) are outlined with the assistance of the leaders of the Auto industry and are endorsed by them. Manufacturers here, and everywhere, supply M. S. A. S. with equipment, latest model cars, latest trucks, engines, transmissions, axles, electric equipment, etc.—everything complete to give thorough training. Everything is right up to date—the very last word in automotive training.

Detroit Trained Men Get Best Jobs

The MICHIGAN STATE AUTO SCHOOL is known the world over. Wherever autos are used—Detroit-trained men get the best jobs, highest pay. Auto, truck, and tractor factories employ M. S. A. S. graduates. Leading factories, dealers, service stations, garages, shops, and farms want men who have trained their heads as well as their hands—the M. S. A. S. Detroit-kind.

Learn in a Few Weeks-- Stay as Long as You Like

A thorough training is the thing that fills the pay envelope. You can take a full Automotive Course, or specialize in any one of its money-making branches. You can be an Auto Electrician; a Tire Expert; a Battery Service man; a Chauffeur; a Repair-Man; a Welder; a Machinist; or specialize in motorized farming, with special truck, tractor, or farm electric-lighting and farm engine training.

188-Page Catalog FREE

DECIDE NOW that you can make more money. Decide now you will forever discard the old plodding, low-pay life and make a success! You can do it! It may mean hard work, but hard work is a pleasure when you like it and are making a success. Learn all the interesting facts about this unlimited opportunity. We will send you FREE, without obligation this 188-page book that tells all about it, and what the M.S.A.S. can do for you. Book is positive proof. Don't fail to get it. Send coupon or post card today.

A. G. ZELLER, PRES. & GEN. MGR.
301 AUTO BLDG., 3729 WOODWARD AVE.
DETROIT - - - MICHIGAN



A.G. Zeller
Pres.

Money Back Guarantee

I personally guarantee that a course of training in this school, the Michigan State Auto School, will qualify you for a position as repair man, demonstrator, auto electrician, garage man, automobile dealer, tractor mechanic and operator, chauffeur or farm lighting expert; or refund your money. A similar guarantee is made with all courses. Each course includes Life Membership with privilege of our service without charge at any time.

A. G. ZELLER,
President and General Manager
MICHIGAN STATE
AUTO SCHOOL

Life Scholarship-- Start ANY TIME

Your enrollment entitles you to life-membership, with privilege of our service any time you want it. Many students come back to brush up on latest automotive ideas and new equipment. It doesn't cost a penny extra. The position of the M. S. A. S. (The Detroit Auto School) in the heart of this industry, insures most thorough, most practical, systematic training, at a cost so low any man, anywhere, can afford it.



Mail This Coupon

Michigan State Auto School
301 Auto Bldg., 3729 Woodward Ave.
Detroit, Michigan

Gentlemen: Send FREE and without obligation, your 188-page catalog and Auto School News, giving complete information and showing the opportunities and advantages of Detroit-Training to make the most money.

Name.....

Street or R. F. D.....

City.....State.....



"MY SALARY WAS RAISED"

Says James
M. Hurt,
Jr.



BE A RAILWAY TRAFFIC INSPECTOR

Position GUARANTEED or Money Refunded

READ what James M. Hurt, Jr., says: "After finishing your course in Traffic Inspection about three months ago, I was placed in a permanent position at \$110.00 per month. Several days ago my salary was raised to \$135.00 per month, and I have every reason to believe it will go higher soon if my work is satisfactory.

"Have come to the conclusion that there are very few classes of work in which the opportunities are as unlimited and at the same time, the work as pleasant as Traffic Inspection."

Earn Up to \$250 Per Mo.

There are **hundreds of openings** for trained Railway Traffic Inspectors. The work is fascinating and easy to master. Any average man can qualify. Steady employment with many opportunities to travel and see the country—or remain near home.

Start at \$110.00 per month, expenses paid—after 3 months' spare-time study at home. Advancement rapid with experience. Earn up to \$250.00 per month, expenses paid. Work brings you in contact with big railway officials and opens up splendid opportunities.



Read What Mr. W. J. Sugg Says:

"Since completing the course, I have been employed by one company in the most pleasant work that has ever been my good fortune to be engaged in. I received a raise in my salary soon after beginning with this company. Without your wonderful course, this could never have been possible. I feel I can't say too much for the Standard Business Training Institute and its good promoters."

YOU TAKE NO RISK

Our Guarantee is that after completing the course (in your spare time) if we do not provide you with a position paying at least \$110.00 a month and expenses, we will refund your enrollment fee in full. You have nothing to lose!—and the course is not expensive.

Write today for full particulars and our free Booklet No. D-580. Don't delay!

STANDARD BUSINESS TRAINING INSTITUTE
BUFFALO, N. Y.



The Technical or Scientific Book You Need

Turn to our 96-page catalog and find just the book you need on any scientific or practical subject—the latest book by the best author. This is the most complete catalog of its kind issued. You'll refer to it constantly in your work. Only 380 copies remain.

With the catalog will be sent the supplements for 1919 and 1920 and new 32-page book list for 1921. Prices are not yet entirely stabilized, but those in the supplements will be 80% correct. If there is any change in price you will be notified before your order is filled.

Send for catalog to-day. It's free. There will be no obligation for you to buy, and we want you to know our extensive book department.

Scientific American Publishing Company
Munn & Company
237 Broadway, New York City

LEARN ENGINEERING

Electrical and Mechanical Engineers receive fabulous salaries. Thousands wanted. 3 months to 2 years Practical-Technical training under experts. Not a trade school but a Practical-Technical College teaching electricity, steam, gas, auto-electric, armature winding, drafting. Extensive laboratory and shop equipment. Degrees awarded. Day and night sessions. Enroll any time. Don't judge us by size of this ad. Write for free catalog, FINLAY ENGINEERING COLLEGE, 1031 Indiana Ave., Kansas City, Mo.

PIANO JAZZ

By note or ear. With or without music. Short Course. Adult beginners taught by mail. No teacher required. Self-Instruction Course for Advanced Pianists. Learn 67 styles of Bass, 180 Syncopated Effects, Blue Harmony, Oriental, Chime, Movie and Cafe Jazz, Trick Endings, Clever Breaks, Space Fillers, Sax Slurs, Triple Bass, Wicked Harmony, Blue Obligato, and 247 other Subjects, including Ear Playing. 110 pages of REAL Jazz. 25,000 words. A Postal brings our FREE Special Offer.

Waterman Piano School, 259 Superba Theatre Bldg., Los Angeles, Calif.

Factory to Rider

Saves \$15 to \$25 on the model you select from 44 Styles, colors and sizes of Ranger bicycles. Delivered free on approval, express prepaid, direct from the makers for 30 Days' Free Trial. We pay return charges if not satisfactory.

12 Months to Pay Possession at once on our liberal year-to-pay plan. Any boy or girl can save the small monthly payments.

Tires wheels, chains, parts and equipment at half usual prices. Big Ranger Catalog FREE with marvelous new prices, 30 day trial offer and terms.

MEAD CYCLE COMPANY Dept. A-108, Chicago, Ill.



STAMMERERS

You can be cured permanently by our course of private individual lessons. Write me for free book, "How to Stop Stammering." SAMUEL A. ROBBINS, Director Boston Stammerers' Institute. Founded in 1887 246 Huntington Ave. Boston, 17 Mass.

LEARN WATCH REPAIRING



You can learn by our modern and original system of instruction every part of the Watch Repairing Trade at home as good or better than at a shop. You can earn money while learning and secure a well paying position or start in business after completing our course of instruction. Good watch repairers are always in demand and earn from \$30 to \$70 per week. For particulars apply to the WISCONSIN SCHOOL OF WATCH REPAIRING 166 Mason St., MILWAUKEE, WIS.

Check Your Present Salary



If you can't check the Black Circle

Send this Coupon now

COLUMBIA SCHOOL OF DRAFTING

Dept. 1607, 14th and T Sts., N. W., Washington, D. C.

Without obligation to me, please send me your Illustrated Book on Drafting, telling how I can secure your complete home study course and personal help in securing a position as draftsman, and enter my name for a Free Subscription to "The Compass."

Name

Address

City State

The Coupon Brings You
Our **FREE** Booklet, "YOUR FUTURE IN DRAFTING," and particulars of our Home Study Course.

And in Six Months I'll Train You to Be a Draftsman and Help You Find a Job at \$45 to \$100 a Week



ROY C. CLAFLIN,
President of the
Columbia School
of Drafting

LEARN DRAFTING

Free Drafting Outfit

We give you free—this professional drawing outfit. It's yours to keep.



Get the **RIGHT** training. I stand personally in back of the Columbia School of Drafting. You spend no time in unnecessary theories. You start on actual drawing work the day you receive your first lesson.

PROMOTION IS QUICK. I'LL QUALIFY YOU for a high-salaried position in the drafting field and keep you in touch with openings for draftsmen in the big machine shops, industrial plants, and United States Government Departments. Men who start as Draftsmen are often advanced to Chief Draftsmen, Chief Engineers, Production Managers and so on.

SUCCESS CALLS MEN OF ACTION ONLY. Show that you are a man of action. Tear the coupon off and mail it right now.

COLUMBIA SCHOOL OF DRAFTING

Roy C. Claflin, President

Dept. 1607, 14th and T Sts., N. W.

WASHINGTON, D. C.

The Letter That Saved Bob Johnson's Job

—and paved the way
for a better one!

IT was written to his employer by the International Correspondence Schools. It told how "Robert Johnson had enrolled for a course of home-study and had received a mark of 94 for his first lesson."

Bob answered the summons to the Chief's office with just a little fear and trembling, for a lot of men were being dropped—a lot more were having their pay reduced.

But as Bob came in, his employer did a surprising thing. He got up quickly from his desk and grasped Bob warmly by the hand.

"I want to congratulate you, young man, on the marks you are making with the I. C. S. I am glad to see that you are training yourself not only for your present job but for the job ahead.

"We're cutting the pay-roll. Until I received this letter, I had you in mind as one of the men to be dropped. But not now. Keep on studying—keep your eyes open—and pretty soon there'll be a better job for you around here. We're always looking for trained men."

Won't you let the I. C. S. help you, too? Won't you trade a few hours of your spare time for a good job, a good salary and the comforts that go with it? Then mark the work you like best on the coupon below and mail it to Scranton today. That doesn't obligate you in the least, but it will be your first big step towards success. *Do it now!*

TEAR OUT HERE

INTERNATIONAL CORRESPONDENCE SCHOOLS
BOX 5593-C SCRANTON, PA.

Without cost or obligation please explain how I can qualify for the position, or in the subject before which I have marked an X in the list below:

- | | |
|---|---|
| <input type="checkbox"/> ELECTRICAL ENGINEER | <input type="checkbox"/> BUSINESS MANAGEMENT |
| <input type="checkbox"/> Electric Lighting & Railways | <input type="checkbox"/> SALESMANSHIP |
| <input type="checkbox"/> Electric Wiring | <input type="checkbox"/> ADVERTISING |
| <input type="checkbox"/> Telegraph Engineer | <input type="checkbox"/> Show Card & Sign Ptg. |
| <input type="checkbox"/> Telephone Work | <input type="checkbox"/> Railroad Positions |
| <input type="checkbox"/> MECHANICAL ENGINEER | <input type="checkbox"/> ILLUSTRATING |
| <input type="checkbox"/> Mechanical Draftsman | <input type="checkbox"/> Cartooning |
| <input type="checkbox"/> Machine Shop Practice | <input type="checkbox"/> Private Secretary |
| <input type="checkbox"/> Toolmaker | <input type="checkbox"/> Business Correspondent |
| <input type="checkbox"/> Gas Engine Operating | <input type="checkbox"/> BOOKKEEPER |
| <input type="checkbox"/> CIVIL ENGINEER | <input type="checkbox"/> Stenographer & Typist |
| <input type="checkbox"/> Surveying and Mapping | <input type="checkbox"/> Certified Public Accountant |
| <input type="checkbox"/> MINE FOREMAN or ENG'G | <input type="checkbox"/> TRAFFIC MANAGER |
| <input type="checkbox"/> STATIONARY ENGINEER | <input type="checkbox"/> Railway Accountant |
| <input type="checkbox"/> Marine Engineer | <input type="checkbox"/> Commercial Law |
| <input type="checkbox"/> ARCHITECT | <input type="checkbox"/> GOOD ENGLISH |
| <input type="checkbox"/> Contractor and Builder | <input type="checkbox"/> Common School Subjects |
| <input type="checkbox"/> Architectural Draftsman | <input type="checkbox"/> CIVIL SERVICE |
| <input type="checkbox"/> Concrete Builder | <input type="checkbox"/> Railway Mail Clerk |
| <input type="checkbox"/> Structural Engineer | <input type="checkbox"/> AUTOMOBILES |
| <input type="checkbox"/> PLUMBING & HEATING | <input type="checkbox"/> Mathematics |
| <input type="checkbox"/> Sheet Metal Worker | <input type="checkbox"/> Navigation |
| <input type="checkbox"/> Textile Overseer or Supt. | <input type="checkbox"/> AGRICULTURE |
| <input type="checkbox"/> CHEMIST | <input type="checkbox"/> Poultry Raising |
| <input type="checkbox"/> Pharmacy | <input type="checkbox"/> BANKING <input type="checkbox"/> Spanish |
| | <input type="checkbox"/> Teacher |

Name..... 7 1-21

Street and No.....

City..... State.....

Occupation.....

Please Mention Popular Mechanics



Learn to Write

I Teach by Mail

I CAN make a good penman of you at your home during spare time, no matter where you live or how poorly you now write. My simplified system has shown thousands of others the way to good penmanship during the past twenty years — it **can** and **will** do the same for YOU!

Beautifully Illustrated Book
"How to Become a Good Penman"
FREE!

It contains general information, with testimonials and beautiful specimens of penmanship showing what others have accomplished by the Tamblin System. (Your name elegantly written on a card if you enclose stamp for postage.) **WRITE TODAY.** Address

F. W. TAMBLIN
 418 Ridge Bldg., Kansas City, Mo., U. S. A.

F. W. Tamblin



Does Your Wife Dress to Suit You?

Do her clothes or hats look worth the money paid for them? Every woman, or girl 15 or over, can easily, in 10 weeks' time, learn to Design and Make her own Hats, Dresses and Costumes.

DRESS DESIGNERS FREQUENTLY Get \$2,000 to \$10,000 a Year

Students often start parlors in their homes and make big money. Surprise your wife, daughter or sweetheart. Sign her name and address to the coupon and send to us for free SAMPLE LESSONS from these wonderful, fascinating courses.

Cut and Mail to
FRANKLIN INSTITUTE
 Dept. T641
 Rochester, N. Y.

Send AT ONCE to the address below, free sample lessons from the Home Study Course here checked.

Dress Designing Millinery

Name.....
 Address.....

This evening gown recently shown at a smart shop for \$55.00 can be made for \$19.00. Students design and make many such, at big savings.

BIGGER AND BETTER THAN EVER!



My policy for GREER COLLEGE OF AUTOMOTIVE ENGINEERING has always been to give our students the very best instruction and training possible. We aim to turn out *real* automobile men—**Certified Automotive Engineers.**

And now, in order to give our Students still greater advantages, we have moved into our new building. Here we have much more room, better equipment, better light—finer in every way.

BE A "C.A.E." (*Certified Automotive Engineer*)

The Greer Automobile Manual

A practical Automobile Handbook, up-to-the-minute and complete. Packed with practical information on construction, operation, care and repair of every part of the automobile. Special attention to troubles and repairs, carburetion, ignition, starting and lighting systems, batteries, etc. Chapters on Expert Driving, Rules of Road, How to secure Chauffeur's License, Selling your Services, with a Dictionary explaining automotive, mechanical and electrical words and terms.

Just what you want; fully indexed or reference. Worth many times the price to every car owner, chauffeur, salesman, garageman or mechanic. Send today. 50c prepaid.

Free Consultation Service to owners of this book

GREER COLLEGE OF AUTOMOTIVE ENGINEERING
(Book Dept.)
2024 S. Wabash Ave., Chicago

The prestige enjoyed by Greer graduates is your cue. *A Greer Diploma means something.* Graduate from *Greer College of Automotive Engineering* and *be recognized as "The Man Who Knows."* Greer students who complete the course and earn their diplomas become *Certified Automotive Engineers.*

REAL INSTRUCTION

It is not enough to merely go to some automobile school for a few weeks. You want to go to the College that makes Master Mechanics, real Certified Automotive Engineers. That means Greer College of Automotive Engineering. Here we always aim to give such instruction and training that Greer graduates will continue to be recognized as the best. Here we prepare you for success. Write for **free** catalog today.

VALUABLE BOOK FREE A new up-to-date edition of my book, "*How to Succeed*," has just been published. Full of useful and practical information. Worth \$1.00 per copy—yet sent free to anyone interested. Write today. Erwin Greer.

GREER COLLEGE
of Automotive Engineering
2024 So. Wabash Ave., Dept. 11, Chicago

GREER COLLEGE OF AUTOMOTIVE ENGINEERING

2024 Wabash Avenue, Dept. 11 Chicago, Ill.

Please send me free your big book as advertised in the January Popular Mechanics. Am interested in subjects before which I mark X.

Automobiles Vulcanizing
 Tractors Electric Starters
 Batteries Welding

Name.....

Present Occupation.....

Street or R. F. D.....

City..... State.....



A Big Raise in Salary!

Is Very Easy to Get, If You Go About It in the Right Way

You have often heard of others who have doubled and trebled their salaries in a year's time. You wondered how they did it. Was it a pull? Don't you think it. When a man is hired he gets paid for exactly what he does, there is no sentiment in business. It's preparing for the future and knowing what to do at the right time that doubles and trebles salaries.

Remember When You Were a Kid

and tried to ride a bike for the very first time? You thought that you would never learn and then—all of a sudden you knew how, and said in surprise: "Why it's a cinch if you know how." It's that way with most things, and getting a job with big money is no exception to the rule, if you know how.

We Will Show You How

Without loss to you of a single working hour we can show you a sure way to success and big pay. A large number of men in each of the positions listed are enjoying their salaries because of our help—we want to help you.

Make check on the coupon against the job you want and we will help you to get it. Write or print your name on the coupon and send it in today.

AMERICAN SCHOOL

Dept. G-174, Drexel Ave. and 58th St., Chicago

AMERICAN SCHOOL, Dept. G-174, Drexel Ave. and 58th St., Chicago, U. S. A.

I want job checked — tell me how to get it.

..... Architect	\$5,000 to \$15,000 Lawyer	\$5,000 to \$15,000
..... Building Contractor	\$5,000 to \$10,000 Mechanical Engineer	\$4,000 to \$10,000
..... Automobile Engineer	\$4,000 to \$10,000 Shop Superintendent	\$3,000 to \$7,000
..... Automobile Repairman	\$2,500 to \$4,000 Employment Manager	\$4,000 to \$10,000
..... Civil Engineer	\$5,000 to \$15,000 Steam Engineer	\$2,000 to \$4,000
..... Structural Engineer	\$4,000 to \$10,000 Foreman's Course	\$2,000 to \$4,000
..... Business Manager	\$5,000 to \$15,000 Photoplay Writer	\$2,000 to \$10,000
..... Certified Public Accountant	\$7,000 to \$15,000 Sanitary Engineer	\$2,000 to \$5,000
..... Accountant and Auditor	\$2,500 to \$7,000 Telephone Engineer	\$2,500 to \$5,000
..... Draftsman and Designer	\$2,500 to \$4,000 Telegraph Engineer	\$2,500 to \$5,000
..... Electrical Engineer	\$4,000 to \$10,000 High School Graduate	In two years
..... General Education	In one year Fire Insurance Expert	\$3,000 to \$10,000

Name..... Address.....

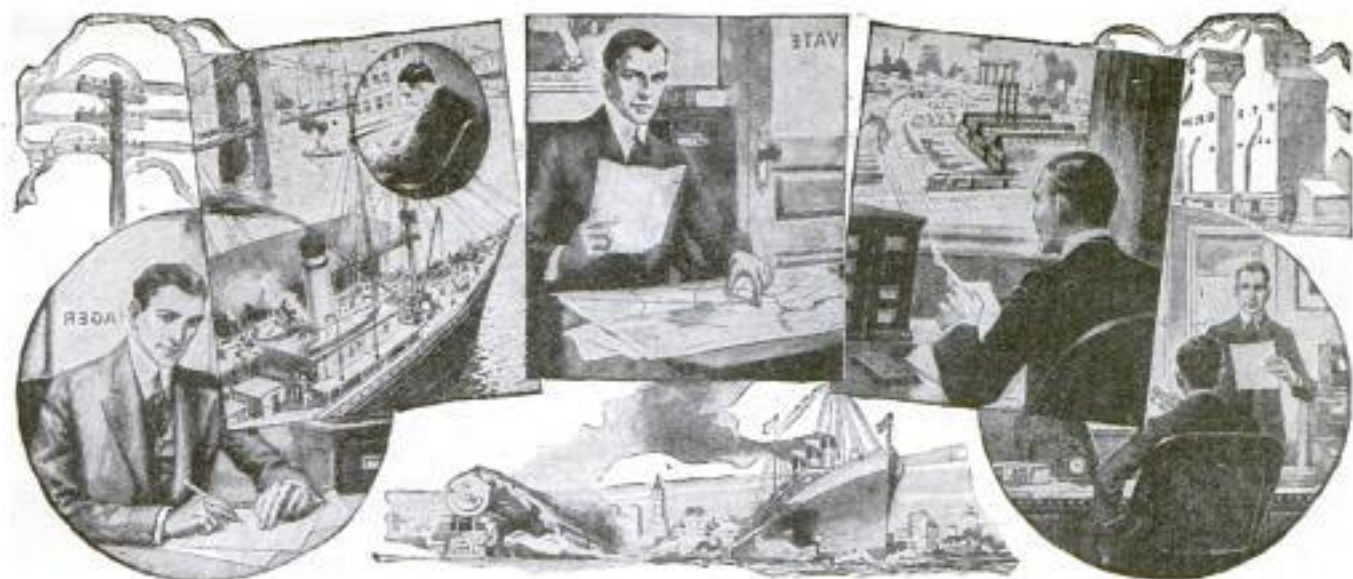

A Bigger Job Yours—If You Master Traffic Management

"We must have efficient traffic men" say manufacturers, jobbers, railroads, ship owners. Hundreds are needed where one is available. This is the chance for ambitious men to rise to higher positions—to get into an uncrowded calling—to have the specialized knowledge which commands big salaries.

If your job isn't big enough—if you haven't a prosperous future in sight where you are, become a Traffic Expert. Make your spare time count now for quick advancement and higher pay.

Train Under the LaSalle Experts

Learn from men who have held or who are among those holding the highest positions in the field—men who will train you by the famous LaSalle Problem Method—by which you actually handle the same problems that the Traffic Managers of railroads and great shippers have to meet and solve daily. Become familiar with every phase of Interstate Commerce and Traffic Management in the most practical way ever devised.

Every point concerning Freight Rates, Classifications, Tariffs, Bills of Lading, Routing, Claims, Demurrage, Express Rates, Ocean Traffic, R. R. Organization, Regulation and Management, Laws of Carriers, Interstate Commerce Rulings, etc., will be clearly explained. You will cover the entire subject and be put in line for an executive job.

How LaSalle Men Win

B. S. McMullen was a freight checker on the docks at Seattle. Two years after beginning the LaSalle Course in Interstate Commerce and Traffic Management he was appointed General Freight and Passenger Agent.

He said that it probably would have taken him 8 or 10 years to make this advance if he had depended merely upon routine work.

LaSalle experts helped him to reach the top in the space of months.

T. J. Wright, an Illinois member, reports three promotions since taking the course.

S. H. Watson, of Michigan, figures his increased earning capacity at 400 per cent.

Fred Hoffman, an Ohio member, reports 500 per cent profit on his investment in one year.

Among the many LaSalle trained men who are now Traffic Managers or Experts on Interstate Commerce are:

Wm. Ritchie, Vice-President and Traffic Manager, Philadelphia Lawn Mower Co.

F. E. Combs, Traffic Commissioner, Michigan State Farm Bureau, Lansing, Mich.

F. E. Hamilton, Traffic Manager, Retail Merchants' Association of Canada.

Mr. Hamilton says: "I cannot speak too highly of this institution. The course is up-to-date, authentic and easily understood. My only regret is that I did not take it up five years ago."

The success these men have made can be paralleled by any other ambitious man who will do as they did—train!

Send the Coupon

Your request will bring complete information about the opportunities open to traffic experts and about the LaSalle course of training. We will also send you our book, "Ten Years' Promotion in One," which has shown thousands of men the short road to promotion. Mail the coupon today.

LaSalle Extension University

The Largest Business Training Institution in the World

Dept. 164-TR Chicago, Ill.

Please send me catalog and full information regarding the course and service I have marked with an X below. Also a copy of your book, "Ten Years' Promotion in One," all without obligation to me.

Traffic Management—Foreign and Domestic—Training for positions as Railroad and Industrial Traffic Managers, etc.

Other LaSalle Training Courses

LaSalle is the largest business training institution in the world. It offers training for every important business need. If more interested in any of these courses, check here.

- | | |
|--|--|
| <input type="checkbox"/> Business Management | <input type="checkbox"/> Banking and Finance |
| <input type="checkbox"/> Higher Accountancy | <input type="checkbox"/> Modern Foremanship and Production Methods |
| <input type="checkbox"/> Railway Accounting and Station Management | <input type="checkbox"/> Personnel and Employment Management |
| <input type="checkbox"/> Law—Degree of LL.B. | <input type="checkbox"/> Business English |
| <input type="checkbox"/> Commercial Law | <input type="checkbox"/> Expert Bookkeeping |
| <input type="checkbox"/> Industrial Management Efficiency | <input type="checkbox"/> Commercial Spanish |
| <input type="checkbox"/> Modern Business Correspondence and Practice | <input type="checkbox"/> Effective Speaking |
| | <input type="checkbox"/> C. P. A. Coaching |

Name

Present Position

Address





Let \$12⁰⁰ to \$30⁰⁰ a Day
Be Your Goal

Let **ELECTRICITY**
Be Your Route
LET ME BE YOUR GUIDE

A Big-Pay Job is Waiting for You

Don't wish any longer, **BE** a success!
I'll show you how!

Be An
"Electrical
Expert"

You want to get ahead—
you want to make more money—big
money—Electricity is the field for you! It is
the big pay profession of today; but you must
be trained; you must know Electricity from every
angle to hold down a big-pay job—the job that pays.

Earn \$12 to \$30 a Day

Compare your present salary with these big pay
figures. How does your pay envelope "stack up"
with that of the trained "Electrical Expert?" Is his
pay twice, three or four times as much as you now
earn? Don't envy him, don't just wish for pay like
his—go after it yourself! You can get it because

I Will Show You How

Yes sir—right in your own home in your spare time
I will make you a Certificated "Electrical Expert"—
a "Cooke-trained man." As Chief Engineer of the
Chicago Engineering Works I know exactly the kind
of training you need and I will give you that training.
My system is simple, thorough, complete—no big
words, no useless theory, no higher mathematics,
just compact common sense written in plain English.

L. L. COOKE, Chief Engineer,
Chicago Engineering Works, Dept. 11
2154 Lawrence Ave., Chicago, Ill.

Dear Sir: Send me at once your Big Free Book, "How to Become
an Electrical Expert," and full particulars of your Free Outfit and
Home Study Course—all fully prepaid, without obligation on my
part.

Name.....

Address.....

If you are ready, I am. You don't have to know the
first thing about Electricity right now. I will train you in a
few short months so that you can step right into that big
pay business—the job you have always wanted.

"Electrical Experts" are in big demand—
more jobs than men to fill them. It doesn't
make any difference what you are doing,
or what you have been doing, if you
want to succeed—if you want big
pay—I'll show you how because
I know I can teach you Electricity.
Opportunities in Electricity,
great as they are today, are nothing as
compared to what they will be tomorrow. Get ready
for tomorrow! Get started now! Get in on the
ground floor—ahead of the other fellow—jump
from a "bossed" into a "bossing" job—jump
from \$3 to \$5 a day to \$12 or \$30 a day. I
know you can succeed, once you're a
"Cooke-trained man."

I Guarantee Satisfaction

There's no chance for failure
with me. I train you **RIGHT**
and furthermore I agree, if
you're not entirely satisfied,
to return every
penny you have paid
me. No other
school will do
this for you.

**FREE
Electrical
Outfit**

To make your
success still more
certain I give you free a splendid
outfit of tools, materials and supplies
—you do practical work right from the start
and pick up extra money doing spare-time work

Mail This Coupon Today

Save \$45.50 by Enrolling Now

If you will send this coupon today, I'll show you how to save
\$45.50. Write today for full particulars—also my big FREE book,
"How to Become an Electrical Expert." It's the first step towards
that big pay job of yours.

L. L. COOKE, CHIEF ENGINEER
CHICAGO ENGINEERING WORKS

Dept. 11 2154 Lawrence Avenue

THE "COOKE" TRAINED MAN IS THE "BIG-PAY MAN"

CLASSIFIED ADVERTISEMENTS

WORLD'S BEST WANT AD MEDIUM

Advertisements in this section, 25 cents per word, each insertion, minimum 10 words, payable in advance. To be inserted under proper classification in February issue, copy should be in our office December 25th.

AUTOMOBILE SUPPLIES

AMERICAN Garage & Auto Dealer publishes each month interesting and helpful suggestions and information on sales, merchandising, advertising, business management, accounting, welding, cutting, brazing, practical and progressive hints for office and shop for "small-town" automotive dealers, garagemen, repairmen, mechanics. Subscription price \$1.00 per year. Sample copy on request. American Garage & Auto Dealer, 1004 Lake View Bldg., Chicago.

GARAGE. Repair or Harnessmen! Write now for complete proposition that enables you to quickly and profitably make new or repair old flat belts for cars, trucks, tractors or small shop machinery. See our adv. on page 126. Lakewood Fabric Belting & Mfg. Co., 1518 W. 117th St., Lakewood, Ohio.

AUTOMOBILE parts—25%, 99% off. New and used motor gears, axles, bearings, bankrupt auto supplies; 5,000 models. Largest in New England. Brighton Auto Exchange, 321 Windsor Ave., Hartford, Conn.

INSURE Tires; double mileage. Prevent blowouts and punctures. Fully guaranteed. Fast seller. Liberal profits to agents. Auto-accessory Sales Co., Box 5, Chicago.

FIREFLY Storage Batteries for all cars, \$19 to \$27. Factory to Consumer. Iron-clad guarantee. Firefly Battery Co., Muncie, Ind.

EVERY auto owner wants beautiful auto for one dollar. State make of car. Address, Box 215, Spring Grove, Pa.

FORD Cylinders rebored, new pistons fitted, complete \$16.00. Address: Crescent Auto & Machine Co., Centralia, Ill.

COMPRESSORS, Air. Automatic, electrically operated. \$25 cash, balance terms. Hobart, Troy, Ohio.

AUTO Top Roof Recovers, easy to put on. You drive 100 tanks and save \$15 to \$40. Ford Roadster \$5.50. Touring \$8.95. Other cars \$14 and \$16, with plate glass curtain lights. Delivered at your door. Seat covers \$3.10 up. Write for catalog, samples free. Equipment Co., 20 Canal, Cincinnati, Ohio.

VULCANIZING and Repairing is a paying business. Forty million tires need repairing every day. Make big profits in tire repair. Easy to learn. Instructions free. No hard times. Always busy. Get into this money-making business quick! Plants \$200 up. Write for free catalog. Equipment Co., 1 Canal, Cincinnati, Ohio.

AUTOMOBILE Owners, garagemen, mechanics and repairmen. Our New Naco Combination Plier is the master tool of the age—Plier, pipe wrench, wire cutter and screw driver all in one. Nothing like it. Send for sample, \$1.50. Address Naco, Box 492, Galva, Ill.

PROTECT Your rights. Write for Record of Invention which contains form to establish evidence of conception of your invention. Prompt personal service. Preliminary advice without charge. J. Reaney Kelly, 612G, Columbian Bldg., Washington, D. C.

STOP that motor from pumping oil. Instructions \$1.00; eight years' experience; only successful method known; no extras to buy. Guaranteed or money returned. Alfred Bentz, Wausau, Wis., Box B.

WONDERFUL Discovery—Autolists! Combination cleaner, polish, dryer, color in one. Money-back guarantee. Sample 10c; 12-oz. \$1.00, postpaid. Flandt & Company, Wolcottville, Ind.

STORAGE Batteries \$3.00 to \$5.00. Build them yourself by a new method. Complete instructions One Dollar. Address Yates Brothers, 3403 W. Washington St., Los Angeles, Calif.

STORAGE Battery charging earns unusual profits, using HB Chargers, \$20 starts; balance payments. Hobartsons, Troy, Ohio.

AUTO Owners, avoid accidents. Latest safety article, 50c postpaid. Dobbins, 326 River St., Chicago, Ill.

AUTOMOBILE Construction and Repair—A new practical guide to the design, construction and repair of automobile mechanisms of great value to the mechanic, designer, owner and chauffeur. 736 pages, 568 illus. Price, \$3.50 postpaid. Popular Mechanics Book Dept., 6 N. Michigan Ave., Chicago.

AUTOMOBILE Parts for any car. We save you 10 to 99% and ship your order same day received. Have differential and transmission gears, drive shafts, axle shafts, transmission shafts, cylinder head gaskets, springs, Timken, Hyatt, New Departure and connecting rod bearings, pistons, rings, pins and bushings, standard and oversize, clutch leathers, steel starter gear bands for fly wheels, Connecticut, Atwater-Kent and Bemy coils and parts, Bosch, Simma, Eisenmann and other makes of magnetos. If in need of parts, write us, giving make, model and parts wanted. If convenient send in old parts to be duplicated, we will quote prices before making shipment, if you desire. We guarantee to please you or money refunded. Auto Tire & Parts Co., 501 Broadway, Cape Girardeau, Mo.

AGENTS wanted for the fastest selling accessory on the market. The only warning signal that insures safety. Has exclusive dash indicator. Sells at sight. Exclusive territory. Agents' sample, \$3.00. The Gravity Carburetor Co., 3052 E. 93rd St., Cleveland, Ohio.

CITY and County agents wanted for newly patented automobile accessory. Install it on every Ford and the money is yours, no talking or argument. Ackswell Mfg. & Sales Co., Inc., Northport, N. Y.

AIRPLANE motors for racing automobiles; see my ad under Automobiles.

SAVE 50%. Order one of our recovers for your Auto Top. Write for samples. Atlantic Auto Top Co., 3310 Atlantic Ave., Atlantic City, N. J.

TURNER spring lubricator, fits any car; speeds spring leaves and lubricates in one operation. \$2.50 prepaid. Harry Striker, Elwood, Ind.

AUTO engines for power. Best in the world—but they must be governed. We make governors and foundations. Circulars. Address Candee-Smith Governor Co., Springfield, N. Y.; 1041 So. Main St., Los Angeles, Calif.

AIR Compressor with Tank and Hose, \$48. Motor for same \$22.50. Equipment Co., 21 Canal, Cincinnati, Ohio.

INSYDE Tyres inner armor for automobile tires. Prevent punctures and blowouts. Double tire mileage any tires. Tremendous demand. Big profits. Sample and details free. American Accessories Co., B178, Cincinnati, Ohio.

AUTO Motors Supplies: Buick—Michigan—Stoddard-Dayton—E. M. F.—Cadillac—Overland—Continental and Buda Motors. All types, \$50.00 each and up. New Dixie Magnetos \$20.00. Splendor High Tension Magnetos \$10.00. Kellogg Pumps \$3.50. Auto-Lite generators, new, \$10.00. Air Gauges 65c. Bemy Ignition Coils, new, \$3.00. Electric and gas headlamps, coils, distributor heads, air compressors, etc. Write for catalog. Motor Sales Dept. 15, West End, Pittsburgh, Pa.

AUTOMOBILE Owners, Garagemen, Mechanics, Repairmen, send for free copy of our current issue. It contains helpful, instructive information on overhauling, ignition troubles, wiring, carburetors, storage batteries, etc. Over 120 pages, illustrated. Send for free copy today. Automobile Digest, 506 Butler Bldg., Cincinnati.

STANLEY Automobile Owners, include stamp for "list." Acme Welded boilers, burners, vaporizers, superheaters, engines, gauges, tubing, fittings. Everything for your Steamer. "Doc" Palma, Denver, Colo.

AUTO Owner Tire Agent wanted each locality to use and take orders for hand-made Mellinger extra ply and cord tires; guaranteed by bond for 8,000 and 10,000 miles (no seconds); shipped prepaid on approval; get your tires free; no capital or experience required; make \$100 to \$300 weekly. Write for wholesale prices and sample section, Mellinger Tire Co., 929-K Oak, Kansas City, Mo.

AUTOMOBILES

BUILD your own Auto-Bungalow Body, home comforts. Blue-print plan 25 cents (cash). Address M. Meyer, R. No. 10, Kalamazoo, Mich.

BUILD yourself a racing Automobile with Airplane Engine. Complete blue prints, instructions, etc., \$5.00. Get my list of used and new Airplane motors, 5 red stamps. Address Heber H. Hunt, P. O. Box 1043, Washington, D. C.

AUTOMOBILE Owners, Garagemen, Mechanics, Repairmen, send for free copy of our current issue. It contains helpful, instructive information on overhauling, ignition troubles, wiring, carburetors, storage batteries, etc. Over 120 pages, illustrated. Send for free copy today. Automobile Digest, 506 Butler Bldg., Cincinnati.

PATENTS—Write for our free illustrated Guide Book and Evidence of Conception Blank. Send model or sketch and description of your invention and we will give our opinion of its patentable nature. Highest references. Prompt service. Reasonable terms. Victor J. Evans & Co., 185 Ninth, Washington, D. C.

TO FORD OWNERS

PROTECT Your Motor; save time, money, clothes and temper with our superior, water-proofed, detachable belts for Fords. Regular price 50c each. Three belts sent postpaid for \$1.00. State model when ordering. Money refunded if not entirely satisfied. See our adv. on page 126. Lakewood Fabric Belting & Mfg. Co., 1518 W. 117th St., Lakewood, Ohio.

FARM with Your Ford. Do 2 days' work in 1. The Adapto-Tractor makes your Ford a tractor and power plant. Guaranteed to be as represented and not to injure your Ford or your money back. Agents wanted. Write for free circular. Geneva Tractor Co., Dept. P, Geneva, O.

FORD cover for carburetor and intake pipe, patented. Adds 25% more mileage and power. Put on any Ford motor in 2 minutes. Price \$1.50. Special price in quantities. Air Friction Carburetor Co., 9124 Madison St., Dayton, Ohio.

FORD motors completely rebuilt, \$60.00. Absolutely guaranteed. Write for information. Weyand-McMahon, Inc., 36 Goodell St., Buffalo.

MR. FORD Owner: Did you ever run out of gas? Most of us have, but never again; a Never-Out Emergency Gasoline Tank prevents it. Holds a gallon—No trouble to install—Fits at either end of regular gasoline tank—Patented spring handle holds in place—Prevents rattling. Something new and going big. Send for circular or sent postpaid on receipt of regular retail price, \$1.00. Satisfaction guaranteed or money refunded. State kind of car wanted for. Address Keith Accessories Mfg. Co., Cape Girardeau, Mo.

VICTOR Ford 4-speed transmission for standard Ford or worn truck, doubles pulling power, increases speed 40%; intermediate speed for hill climbing and heavy hauling; saves gas, motor parts. Satisfaction or money back guarantee. Special introductory price. M. L. Ford Speed & Power Equipment Mfrs., 250 West 54th, New York, N. Y.

SIMPLEX (Ford) Starter \$20.00. One agency sold 610. Easily sold. American-Simplex Co., Anderson, Ind.

FORD Necessity. Colestock Heavy Duty Timer. Eliminates 90% motor troubles. Starts easier, lasts longer. Satisfaction guaranteed. \$2.00 prepaid. Agents—Dealers coinjng money. Address Colestock Sales Co., Woodstock, Ill.

ADJUSTABLE Intake and exhaust valves for Fords increase power. For circular address: Dept. F, Steel Products Mfg. Co., Racine, Wis.

"MILESMORE," Indirect Vaporizer gives 45% more mileage per gallon. Price \$2.25. Charles Bradley, 1507 Princess, Camden, N. J.

SPEEDSTER Fans. See "Red-I-Kur" ad., page 142.

LACEY Patent Sence. See page 147.

FORD Truck Users. Your rear tire can be taken off in 15 seconds, if you have Simplex Hims; used and endorsed by Standard Oil Company, Crane Co., and individual owners all over the country. Device placed on your own rims at nominal cost. Write for dealer proposition. Address Daly Manufacturing Co., Inc., 1027-29 Santa Fe Avenue, Los Angeles, Calif.

A PATTON Body on your Ford chassis will give you the best looking car in town. Bodies \$50 and up. Illustrated folder sent on request. E. J. Patton Co., 786 Garfield Ave., Aurora, Ill.

FOR Sale, three valuable Ford accessory and machine works manufacturing same. Ralph Tyler, Muncie, Ind., Box 162.

FORD Car Repair Book sent free. This complete, well illustrated, valuable book explains in a simple way the Causes and Cures of Over-heating; Repairing Ford Timer; Curing Piston Ring Troubles; Carburetor Adjustments and Repairs; Connecting Rods; Transmission Troubles; Care and Repair of Rear Axle; Stopping Axle Grease Leaks; also covers practically every other phase of Ford Car Repairing. Send 25c coin for three months' trial subscription and get the valuable repair book free. Ford Owners' Magazine, 512 Montgomery Bldg., Milwaukee, Wis.

FORD Magnetos Recharged in the car; nothing to take apart. Simple and complete instructions. Prepaid 35c. Northwestern Service Co., 3228 Pillsbury Ave., Minneapolis, Minn.

\$30 PER day selling circulating water pumps for Ford cars. Exclusive territory. Polar Bear Pump Co., Los Angeles, Cal.

FORD Top Roof Recovering. Easy to put on. Drive 100 Tacks and save \$15. Ford Roadster \$5.50. Touring \$8.95. Parcel Post Prepaid. Equipment Co., 19 Canal, Cincinnati, Ohio.

MOTORCYCLES, BICYCLES & SUPPLIES

DON'T buy a Bicycle Motor Attachment until you get our catalogue and prices. Shaw Mfg. Co., Dept. 27, Galesburg, Kan.

WHY buy a used motorcycle? A new Cleveland costs only \$185. See page 142.

NEW motorcycles have been reduced 10%. Our prices have been reduced 35%. Send for big bargain list of rebuilt motorcycles. Western Supplies Co., 359 Hayutin Bldg., Denver, Colo.

USED motorcycles, new and used parts; write us. Mahowald Cycle Co., Mankato, Minn.

HARLEY-DAVIDSON motorcycles, slightly used or rebuilt. Write for liberal discount to rider agents. Lister Motorcycle Co., Eighteen-twenty-eight East Fifty-fifth St., Cleveland, Ohio.

INDIAN motorcycles—second-hand at extremely low prices. Howard A. French & Co., Baltimore, Md., and Washington, D. C.

PARTS, all makes. Magnetos, Generators, Carburetors, aero propellers, engines, side cars. State wants. Enclose stamp for lists. (Parts bought, exchanged.) Erickson, 8039 Farnell, Chicago.

BOYS, build your own cycle car! Send 25c for building plans and list of parts. We can supply motor with clutch and all parts at low prices. Shaw Mfg. Co., Car Dept., Galesburg, Kan.

DON'T buy a Bicycle Motor Attachment until you get our catalogue and prices. Shaw Mfg. Co., Dept. 27, Galesburg, Kan.

MOTORCYCLE Cylinders reground, fitted with new piston rings, \$8.00. Guaranteed. Muncie Piston Co., Muncie, Ind.

AVIATION

FOR Sale: Twin cylinder 1918, 12 H. P. Harley-Davidson motor, thrust bearing, propeller hub, new Supreme pusher propeller. Pushes 15-ft. boat 12 M. P. H. Best condition, \$100. Fine for sled. Herb Horstman, 614 E. 7th, Alton, Ill.

THE American School of Aviation announces a new correspondence course in Mechanics of Aviation. A thorough training in Practical Aeronautics. American School of Aviation, Dept. 1861, 3601 Michigan Ave., Chicago, Ill.

GNOME 50, slightly used, complete, ready to ship, \$300 cash. Inland Service Station, Rossmoyne, O.

AIR-COOLED Motors using Ford parts \$200. Stamp brings catalogue. Texas Aircraft Co., Rogers, Texas.

PROPELLERS for Aeroplane propulsion, small propellers for motorcycle-driven snow and ice sleds, road speedsters, and hydroplanes, 4 1/2 feet diameters \$10.00, 6 feet diameters for Fords \$15.00; others in proportion. Overhead countershafting, hub sprocket bearings and thrust, all complete, just right for installing, Ford type \$18.00, motorcycle type \$16.00. Our new ball-bearing countershafting complete for Fords \$16.00; motorcycles \$14.00. Full scale blueprints for building motorcycle snow and ice sleds 75c. Ford plans \$1.00. Prices of blueprints refunded on purchase of propeller. Crawford Motor and Aeroplane Mfr., 142 South Rampart Street, New Orleans.

NEW Standard Airplanes, without motor, \$800; new and used airplanes, motors, flying boats; wings \$125 each, JND, Canuck Standard, any part for said airplanes or OX5 motor; Canuck Propellers \$18; largest variety; lowest prices. Floyd Logan, 712 West Superior, Cleveland.

FOR Sale: Light two-seated Biplane, complete, first-class condition. Write Arthur Brown, 200 West 11th Ave., Mitchell, So. Dak.

\$80.00 TAKES 20 H. P. air-cooled Engine. Hager, Las Animas, Colo.

LEARN to fly, with America's oldest aircraft company. Six hours flying worked in with three months shop training at \$190.00. Makes our course the most complete ever offered, and an opportunity long waited for. Enroll at once. Heath Airplane Co., Chicago, Ill.

SEND for our large aeronautical supply catalog containing late ideas and low prices, 15c. Our Ford and Motorcycle Airplane Pamphlets describe the most complete little machines on the market. Propeller catalog also, 4c each. Heath Airplane Co., Chicago, Ill.

HEATH propellers represent the most efficient method of aerial drive. Each propeller individually designed for the particular work to be done, as laid out by America's oldest aeronautical engineers. Propeller catalog 4c. Heath Airplane Co., Chicago, Ill.

"FLYING Instructions on Standard Biplane" and Aircraft Construction Course, \$100. "Sportford" Biplane Plans, \$2.50. Motorcycle Engine Monoplane Plans, \$1. Knockdown Biplane, \$245. Motors cheap. Aviation Engineering Co., Lawrence, Kan.

AIRCRAFT Supplies—Bulletin 4c, 5-ft. Propellers, \$12. Motorcycle Engine Sled blueprint, 75c; Ford type, \$1. Ostergard Aircraft Works, 4269 N. Nartagansett, Chicago.

AIRPLANE motors for racing Automobiles; see my ad under Automobiles.

INVENTORS desiring patents should write for our Free Illustrated Guide Book and Evidence of Conception Blank. Send model or sketch for our opinion of its patentable nature. Highest references. Prompt service. Reasonable terms. Victor J. Evans & Co., 187 Ninth, Washington, D. C.

MODEL Aeroplanes that fly. Buy your complete outfit, scale drawings, sittings, compressed air motors and all best model aeroplane supplies from The Wading River Manufacturing Co. Established 1900. Our new 52-page catalog illustrated, 24 latest models and designs. Send 10c for your copy. Wading River Manufacturing Co., 672 A Broadway, Brooklyn, N. Y.

BIGGEST, best catalogue Model Aeroplanes, Parts and Supplies; 5c postpaid. Ideal Aeroplane Co., 67 1/2 West Houston, New York.

WELDING

ELECTRIC Grinder and tire buffer, \$25 cash, balance terms. Also Money-Making Battery Chargers. Write us. Hobart's, Troy, Ohio.

WELDING Encyclopedia, just published, is a complete Instruction Book on all Welding Processes, Oxy-Acetylene, Electric Arc, Electric Resistance and Thermit. Welding of all weldable metals fully discussed. 326 pages, 375 illustrations, clothbound. The accumulated experience of the welding brains of America is yours for \$5. Money back if not satisfied. Popular Mechanics Book Dept., 6 N. Michigan Ave., Chicago.

BOOKS AND PERIODICALS

LATEST Magic—Professor Hoffman, world-famed authority. New stunts, card tricks, sleight of hand. Handsomely bound, illustrated, \$2.15 postpaid. Spou & Chamberlain, 120 P. M. Liberty Street, New York.

INDUSTRIAL Alcohol, Wright's book everybody wants. Full directions for making with drawings of necessary apparatus, \$2.50 postpaid. Spou & Chamberlain, 120 P. M. Liberty Street, New York, N. Y.

100,000 USED and new books for sale: 35c up; all kinds; some cost \$25 new; catalogue 10c. (Moved from Chicago.) McCarthy Book House, Kellogg, Minnesota.

35 LESSONS, Original "Master Key," \$4.75. "Clairvoyance" Course, 20 lessons, \$2.10. "Keiro's Great Palmistry," 368 p., \$2.60. 5 catalogues 2c. Sovereign Company, 160 Sycamore, Buffalo.

BOOK Bargains: Fiction and non-fiction, all subjects. Catalogue free. Address Jack Marks, 193 Avenue "C," New York City.

BIG Mail Order magazine 10 cents, Riley Publisher, 1333 S. 50th Court, Cicero, Ill.

OVER 1,000,000 Industrial Facts, Calculations, Receipts, Processes and Trade Secrets for every business are contained in the 1016 page book "Moore's Universal Assistant and Complete Mechanic." 500 Engravings. Cloth Binding. Price \$2.00 postpaid. Popular Mechanics Book Dept., 6 N. Michigan Ave., Chicago.

BRINGING Up Father—Books 1 and 2. Everybody knows the funny cartoons by Geo. McManus. They may be had in book form. One volume for 35 cents or both for 60 cents postpaid. Cartoons Magazine Book Dept., 6 N. Michigan Ave., Chicago.

BACK Numbers of all magazines supplied; 12 consecutive dates of Popular, Peoples, All-Story, or Smiths, 60c. Lillstrand Agency, Alkabo, N. D.

MAIL Order books containing money-making ideas. Full particulars free. Address D. D. Green, Leslie, Mich.

FORD Joke Book and complete book catalog, 10c. Roy G. Winn, Box 132F, Clearwater, Kan.

ALL Trade magazines. List free! Toepf Magazine Agency, Middletown, N. Y.

ART Students—Special pricing of volumes 15, 16, 17 and 18 of Cartoons Magazine, bound in strong art buckram, at \$2.00 each; price was \$3.00. Have at hand the best work of Darling, McCutcheon, Kirby and others for inspiration and hunches. Each volume contains 900 pages. Order at once. Cartoons Magazine, 6 No. Michigan Ave., Chicago, Ill.

LIGHTNING Cartoonist's Book, Secrets, Tricks, \$1.00. Christman, 2925 Euclid, Kansas City, Mo.

FREE Book—"Elijah Coming Before Christ." Address, Megiddo Publishers, Rochester, N. Y.

BOOKS, Books, Books. No matter what you want in the realistic book line, I can fill your order. If you cannot find the books you want, send for my list today. Levi Bryant, 4808 Champlain Ave., Chicago, Ill.

6 DIFFERENT Business Publications covering Accounting, Advertising, Administration, Merchandising, Salesmanship and Taxation. All prepaid 25c. Value, \$1.50. Education in themselves. Waltham Company, LaFayette Bldg., Philadelphia, Pa.

BOOKS. All kinds. Lists. Address, Higene's, A-2441 Post St., San Francisco.

EVERY-DAY Facts. 75c. Particulars Free. Wittig, Dobbs Ferry, N. Y.

THIRTY-FIVE Cent Electrical and Mechanical Books. Fully illustrated. Other popular subjects. Send for complete list. Spon & Chamberlain, 120M Liberty St., New York. Publishers of Technical Books. Established 1871.

INTERESTING—Snappy, instructive essays, stories, news, poetry, formulas, money-making plans. Concordia Magazine quarterly. \$1.00 3 years' subscription. Sample 15c. 9 S. W., York, Pa.

AMBITIOUS Writers. send today for Free Copy America's leading magazine for writers of Photoplays, Stories, Poems, Songs. Instructive, helpful. Writer's Digest, 693 Butler Bldg., Cincinnati.

WHAT the World should know about Hun atrocities and their attacks on women and girls in Belgium. 50c. Belgian Specialty House, 6340 South Racine, Chicago.

INSTRUCTION Book (for shop use) on vulcanizing auto tire, boots and shoes. \$1 bill. Equipment Co., 3 Canal, Cincinnati, O.

PICTURES, POSTCARDS, NOVELTIES

"TOURS of America" afford recreation and pastime. Rates reasonable. Schedules free. Twelve interesting "colorviews" 10c. Mutual Supply Co., Bradford, Pa.

JOIN live postcard club; sample paper, list, catalog, 10c. Harvey Tvede, Decatur, Ind.

TRUE-BLUERS everywhere. Exchange posts. Organized 1908. Membership: Year, \$1.; half, 50c; quarter, 25c. Hundreds lists, 10c. Ed Ericson, 122, Elroy, Wis.

25 MAIL-ORDER Magazines and papers 25c. Address Hansen Company, Brookings, S. Dak.

"RAZORNIFF." Refillable. Handy desk tool. 25c. Dunning, Brookline 1471, Mass.

FOR Your Next Dinner Party—Try a set of the newest thing in place cards—12 illustrated and assorted cards, each one showing a different humorous picture. They start everybody talking and laughing and help you entertain your guests. Price 50 cents per set postpaid. Cartoons Magazine, 6 N. Michigan Ave., Chicago.

THIRTY Beautiful Photos in Album. Tyrol Alps, Castles, Interiors, \$1.50. Dime being samples. F. Peter, Marktgasse 5, Meran Tyrol, Italy.

A MOTTO for Mother. Hand-colored, neatly framed, ready to beautify your home. \$1.25. We also have one for Father. Eberle, 2787 3rd Ave., New York, N. Y.

TWO Dimes bring six San Diego Views and four Beach Scenes; you return for mailing "Indoor Sport." Write today. Christie Studio, 1322 5th, San Diego, Calif.

FINEST line of Christmas cards and booklets in New York. Sample, 12c; one dozen assorted, \$1.00. W. Eberle, 2787 3rd Ave., New York, N. Y.

POSTCARDS from everywhere. Membership, 25c. List, 10c. Popular Exchange, Winsor, N. C.

BEAUTIFULLY written name cards. 25c dozen. Prince, Station H, New York.

GAMES AND ENTERTAINMENT

MYSTERIOUS Wonder Shavings when dropped into water turn into fish, flowers, animals. One dozen in pretty package 15c, three 35c. Excellent for dinner party favors; they create talk. Dozen packages \$1.00. George E. Heinemann, 1424 Rosemont, Chicago.

250 PARLOR tricks 25c; big catalog 2c. Harvey Tvede, Decatur, Ind.

\$7,000.00 STOCK magical goods. Catalogues 15c. Address, Glimaglio, Morgan Park, Ill.

SNEEZE powder, greatest fun maker on earth. Ten cents per package. C. Fenner, 2491 Jefferson, Louisville, Ky.

MAGICAL Apparatus—sensational escapes, novelties, card tricks, mind reading. Latest imported jokes, illusions, books, plays, amusement goods, amateurs and professional. Write for big illustrated catalog; it's free. Buy direct from manufacturers. Lowest prices. Best service. Heaney Magic Co., Berlin, Wis.

"MARGO," a mystifying novelty that will make them all set up and take notice. Fools the wise ones. Descriptive circular free. James T. Herr, 2919 W. North Ave., Baltimore, Md.

TRICKS, Puzzles, jokes, magical apparatus, plays, stage supplies, mind-reading acts, and sensational escapes. Send 10c for 160-page illustrated professional catalogue. Oaks Magical Co., Dept. 548, Oshkosh, Wis.

FREE! "10 select pocket tricks" and illustrated catalog magic tricks, jokes, puzzles and imported novelties at reduced prices. Send today! Lyle Douglas, Station A, Dallas, Texas.

FUN! Fun!! Real joker's sporting goods—pocket novelties. Everybody wants them. Send 2c for illustrated catalogue today. Address Grandfield, 1238 Theriot Ave., Bronx, New York.

AMERICA'S Greatest Novelty. Put or Take Brass Top, 10c. \$1.00 per dozen. Richard Lavery, Asbury Park, N. J.

SAWING Lady in Half, secret, 15c. Magic Catalogue free. C. Peniz, Minneapolis.

AMAZE and mystify your friends. Big book of 250 Magic Tricks—simple—easy to perform, only 10c. Catalog of Tricks, Magic Apparatus, Novelties and Books—stamp. Send today. Henry Moody, 6674 Stoney Island Ave., Chicago.

200 KINDS iron, wood and wire puzzles. Leader and illustrated list 10c. Western Puzzle Works, St. Paul, Minn.

MAGIC—Tricks, Books and Supplies. For Amateurs as well as the great professionals. Anyone can learn through our instructions. Feature Acts in Mind Reading, Spiritualism, Rope Ties, etc. Large Illustrated Professional Catalog, 10c. Chicago Magic Co., Dept. B, 140 S. Dearborn St., Chicago, Ill.

STAMP COLLECTING

LIKE Triangular Stamps? To introduce our Sudden Service Approvals we'll send triangular Fiume, set China ships, large \$1.00 United States revenue, also packet 50 foreign, millimetre scale, perforation gauge, ruler and bargain lists for only 9c! Fennell Stamp Company, Dept. P, Fullerton Bldg., St. Louis, Mo.

1,000 MIXED, mostly Philippines, Orient, Very few United States, Europe. Many United States Surcharged Philippines and old Spanish. By-Product of our agency, saved 20 years. Postpaid 65c. 5,000, \$3.00. United States currency, United States stamps or money order accepted. Have money order favor of Burt Subscription Agency, New York. Burt Subscription Agency, Box 1341, Manila, Phil. Islands.

SNAPS—150 different stamps, 18c; 60 different United States Stamps, 12c. With each order we give free our price list of sets, packets, albums, etc., and our pamphlet which tells "How to make a collection properly." Queen City Stamp Company, Room 36, 604 Race, Cincinnati, Ohio.

FREE—New Europe, 20 diff., to applicants for my 1/2, 1, and 2c approvals; also the higher-priced stamps at 50% disc. Send reference and receive extra premium. Chas. T. Egner, 1335 Pike St., Philadelphia, Pa.

WRITE For—15 varieties Austria Jubilee and subscription to Stamp Magazine free. 40 Sweden 15c; 50 Roumania 20c. William Bettis, Box 117, Clearfield, Pa.

24 VARIETIES Cuban stamps, 10 cents. List of 6,000 low-priced stamps free. Address Chambers Stamp Co., 111P, Nassau St., New York City, N. Y.

BEST one cent approvals in America. P. P. Hand, 1117 So. 60th St., Philadelphia, Pa.

FREE packet with approvals, Postage 2c. J. Maxfield, Box 315, Amsterdam, N. Y.

FREE. New Pictorial set to approval applicants. Harry Stevens, 334 Madison Street, Brooklyn, N. Y.

FREE Packet for approval applicants. Send postage. Reid Stamp Company, Todmorden, Toronto.

FREE, big Austria packet to approval applicants. Ward, Box 57, Plainfield, N. J.

50 DIFFERENT British Colonies 10c. Weed Stamp Co., Centerville, Mich.

10,000 STAMPS Free. To the first 150 applicants for my approvals I offer the beautiful Jamaica Peace and 66 different stamps free. Requests without reference respectfully declined. Jacob Fischer, 1539 No. Lawler, Chicago.

3 COMPLETE sets stamps, Ukraina 1919; Austria 1919; Austria postage due 1917. 21 varieties, unused, 25c. Co-operative Stamp Shop, 509B Proctor Bldg., Mt. Vernon, N. Y.

15 PORTUGUESE Colonies free to approval applicants furnishing reference. Special 1000, all different, \$2.25. Bob Yorkston, Box 54, Roselle, N. J.

500 MIXED U. S., old and new, 10c. 1,000 hinges 10c. Stamp Album, 15c. Price lists free. Weatherby, Medina, Ohio.

STAMPS, Catalogue over dollar, no junk, dime. Real 50% approvals. Goodmans, 154 Wilson Block, Los Angeles, Cal.

500 U. S. and Foreign stamps and price list 10c. H. H. Carlton, 368 W. So. Temple, Salt Lake City, Utah.

NYASSA, Abyssinia, Thrace stamps, managerie packet, 250 hinges, lists only 10c. Liberty, 3974 Arsenal, St. Louis, Mo.

FREE—World's smallest stamp. To approval applicants. Postage 2c. Wifco, 919 E. 10th, Davenport, Iowa.

WANTED—Cancelled postage stamps, latest buying catalog 10c. Michigan Stamp Co., 902 Michigan Detroit.

STAMPS on approval. Books by countries. Minneapolis Stamp Shopp, 3334 Grand Ave., Minneapolis, Minn.

10c; 4 EPHRUS. Liberia 134-5. One cent approvals. Address Lloyd, 25 Cottage, South Orange, N. J.

WORLD'S Largest postage stamp free to approval applicants. Wilmar Edgar, Cherokee, Ia.

500 VAR. Packet 99 cents. Price lists free. Wilmar Edgar, Cherokee, Ia.

63 DIFFERENT U. S. including 17 Commemoratives, 34c. Dunning, Brookline (47), Mass.

FIFTEEN unused Mexican stamps, 25c. Price list free! 50% off catalog and net approvals of fine and scarce sets, picture stamps, wars, new and old issues sent to collectors giving reference. B. W. H. Poole, 412A Washington Bldg., Los Angeles, Calif.

1,000 DIFFERENT Stamps, \$2.75. 500, 85c. 300, 45c. To approval applicants, 100, 9c. Hull, 12 West 101st, New York.

AGENTS Wanted. Sell half catalog approvals, earn 25% commission. Harlan, 5367B South Marshfield, Chicago, Illinois.

100 DIFFERENT, including rare Abyssinia, 2c. Co-operative Stamp Co., 710 Pelham, St. Paul, Minn.

INDIVIDUAL Service satisfies! Twenty different Rumanians free. Progressive Stamp Co., Gloversville, N. Y.

ROUMANIA stamps, 50 different, 25c. Nickles, 122 Florida Av., Washington, D. C.

FREE! Sectional Loose Leaf Postage Stamp Album at the rate of 8 pages each month given with subscription to our monthly Journal. Send two-cent stamp for prospectus. United Stamp Co., 140 S. Dearborn St., Chicago, Ill.

1500 DIFFERENT Stamps, \$5.45; 1000, \$3.00; 500, \$1.00; 200, 20c. Michael, 5662 Prairie, Chicago.

25 U. S. FREE with approvals. Send 3 cents. St. Elmo Stamp Co., 4501 N. Ashland Ave., Chicago.

FRENCH Colonies Free—Beautiful Picture set, including Native Chiefs, Tigers, Pictorials, 2c Postage. Empire Stamp Company, Toronto, Canada.

BIG Variety Packet Foreign Stamps free for 2c postage. Gray Stamp Co., Station E, Toronto, Canada.

CANADA Packet Free—Early Issues. Maple Leaves. War Stamps. Send 2c coin. Midland Stamp Co., Toronto, Ontario.

UNIVERSAL Packet, 100 varieties, all over the world, 10 cents. Covert Stamp, 39 State, Rochester, N. Y.

25 NEWFOUNDLAND, Egypt, Transcaucasia, etc., 2c. Harland Burgett, Lima, O.

50 SOUTH and Central American, 10c. C. Deuel, Centerville, Mich.

100 DIFFERENT stamps—Nicaragua, Salvador, Brazil, Chile, Guatemala, Hong-Kong, large pictorial French colonies, etc.; album with perforation gauge, only 10c silver. Clarence Gibbs, 8925 Juniper, Los Angeles, Calif.

STAMPS sent on approval at 70% discount. Reference required. Emory Renoll, Hanover, Pa.

ALL different, 200, 25c; 300, 50c. Fred Outken, 639 79th St., Brooklyn, N. Y.

FOR 10 CENTS—Abyssinian Stamp, Guatemala Parrot Stamp, Thirty Varieties British Colonies, 250 Hinges, Large Perforation Gauge, Big Price List, and finest approvals. We buy collections. Address, Allen Sears, Inc., Dept. P, Kemper Bldg., Kansas City, Mo.

STAMPS—50 different Jamaica, Venezuela, etc., only 10c; 100 all diff., 13c; 1,000 all diff., \$4.52; 100 diff., U. S., 25c; 1,000 Hinges 10c; 50 percent approvals with every order. List free. I buy Stamps. Write L. B. Dover, Longmont, Colo.

57 DIFFERENT new and used stamps from Guatemala, Finland, Peru, India, Russia, France, Czechoslovakia, Philippines, etc., perforation gauge, millimetre scale, ruler, price lists to approval applicants. Don't wait. Send now 10c. Leader Stamp Co., Dept. P., St. Louis, Mo.

STAMPS, 50 Varieties, Africa, Brazil, Peru, Cuba, Mexico, etc., and Album, 10c. 50 Different U. S., 25c, 1000 mixed 40c, 1000 Hinges, 10c. List free. I buy stamps. C. Stegman, 5948 Cote Brillante, St. Louis, Mo.

105 CHINA, etc., stamp dictionary, list, 2c. Album (500 illustrations), 3c. Bullard, Sta. A. Boston.

55 ALL Different Stamps, including China, Japan, French Colonies, etc., given to applicants for our high-grade approval selections. Send references and 2c stamp to the Edgewood Stamp Co., Dept. H, Milford, Conn.

20 UNUSED stamps free. All different. Postage, 2c. Fisk Stamps, Toledo, Ohio.

PACKET of 23 stamps, no two countries alike. Packet hinges. Set of \$1 and \$2 U. S. Rev., all for 5c. Mention paper. Miami Stamp Co., Toledo, Ohio.

158 GENUINE Foreign Stamps—Mexico War Issues, Venezuela, Salvador and India Service, Guatemala, China, etc., only 10c. Finest approval sheets, 50 to 60%. Agents Wanted. Big 12-p. Lists Free. We Buy Stamps. Estab. 25 yrs. Hussman Stamp Co., Dept. 54, St. Louis, Mo.

STAMPS, 20 unused, all different, free. Postage 2c. Mention paper. Quaker Stamp Co., Toledo, O.

FREE 10 different Scandinavian, millimetre scale, gauge, book, lists, etc., to all sending 10c for 57 different Siam, Ceylon, Guatemala, etc. 200 different, 25c; 300 different, 60c; 100 different U. S., 25c. Hawk-eye Stamp Co., Cedar Rapids, 39, Ia.

RARE COINS

CALIFORNIA Gold 1/4, 27c; 1/2, 53c; Eagle Cent, 10c; Silver 5c, 20c. Bill Book, Southern Shipplaster, Price Lists, 10c. A. E. Bonsall, Richmond, Ind.

CALIFORNIA gold, Quarter size 27c; 1/2 size, 53c. 3c Piece and catalog, 10c. Norman Shultz, Box 146, Colorado Springs, Colo.

\$2 TO \$500 Each paid for hundreds of old coins. Keep all old money. Send 10 cents for Illustrated Coin Value Book, 4x8. Guaranteed Prices. It may mean your Fortune. Address Clarke Coin Company, Ave. 2, Le Roy, N. Y.

HIGHEST prices paid for old U. S. and foreign coins, currency, medals, etc. Send list of what you have and I will quote prices. Henri Mathewson, Jackson, Ga.

1878 TRADE dollar, \$1.35; Proof dime, 25c; California quarter, 27c; half, 32c. A. Wylie, Wheaton, Ill.

THREE old coins, 10c; coins bought, Dusso, 25 Mulberry, N. Y. City.

15 COINS 30c a package. Sample Coin Trays 35c each. C. Johnson, P. O. Box 1245, City Hall Station, N. Y. City.

DID you ever see a 10-cent greenback note? A genuine U. S. Greenback ten-cent bill? These were issued during the Civil War and are still legal tender. As a special "get-acquainted offer," I'll send you a good specimen and my 50-page Illustrated Coin Catalog for only 25c. Send NOW. B. Max Mehl, Numismatist, Mehl Bldg., Dept. P, Fort Worth, Texas. Largest rare coin establishment in the United States.

CENTS worth dollars. Do you know that coin collectors pay up to \$100.00 cash for certain old U. S. cents, as well as high premiums for all rare coins? We buy all rare coins. Send 4c. Get large coin circular. It may mean much profit to you. Numismatic Bank, Dept. H, Fort Worth, Texas.

GET my large coin-selling catalogue free. F. Stolteben, 2245 Clifton Ave., Chicago.

THREE large United States cents, 25c. Moore Coin Company, Commerce, Texas.

CALIFORNIA Gold, Quarter size and Colombia nickel coin only 30c. Italy 20 cents and catalog 10c. Homer Shultz, King City, Mo.

OLD coins, large Fall selling catalogue of coins for sale, free. Catalogue quoting prices paid for coins, ten cents. William Hesslein, 101-B Tremont St., Boston, Mass.

FOR BOYS

COMPLETE moving-picture machines, with film, \$3.00 up. Nite Mail Order & Supply Co., 609 27th St., Denver, Colo.

BOYS! Build things. Get our latest "The Boy Mechanic, Book 3." It tells how to make 809 different things, such as boys' motor car, houseboat, model monoplane, water toboggan and slide, aerial cableway, ski sled, sailing canoe, searchlight, electric locomotive, etc. 480 pages, 392 illus. Cloth binding, \$2.50 postpaid. Later on you will want the other two big books in the series, Books 1 and 2, same size, same price. Popular Mechanics Book Dept., 6 N. Michigan Ave., Chicago.

OUTDOOR Winter Sports—New 64-page illustrated book, just out, tells how to make motor-driven snow and ice sleds, ice yachts, coasting boards, bobsleds and toboggans, skis, ski gliders and ski sleds, ice gliders, portable fishing shacks, etc. 25 cents, postpaid. Popular Mechanics Book Dept., 6 N. Michigan Ave., Chicago.

MAKE Xmas toys. Wonderful illustrated book tells how. Price 10c. Hyron, 27, Station 1, New York, N. Y.

PLAY Mouth-Organ. Easy to learn. Complete instructor, 25c. G. Eisea, Bowling Green, Ohio.

CAMERAS AND PHOTO SUPPLIES

BUY the RWK Photo-Printer for results and economy. It makes photography a pleasure. Size 6 1/2 x 8 1/2, delivered in U. S. A. for \$8.50, complete with bulbs. Prices of 8x10 and 11x14 printers upon request. Write for information, R. W. Kirtledge Co., 824 W. Superior St., Chicago, Ill.

CAMERA Bargains: Get your copy of the Bass Bargain List 28 right now. More actual camera bargains listed therein than in any two lists heretofore. Save money on every purchase. Bass Camera Company, Dept. 113, 109 No. Dearborn St., Chicago, Ill.

MAKE money with your kodak. Fascinating work. Sell photographs to newspapers, magazines and advertisers. Guaranteed complete course in kodaking. Five Dollars. Address Photographic Institute, Dept. M, Wedgway Building, Schenectady, N. Y.

SEND your enlarging to specialists. One 8x10 mounted 40c; 3 for \$1.00. Haislet Bros., 5434 Broadway, Chicago, Ill.

FILMS developed 5c roll, prints 3c each. Palmgren Photo Service, 2714 E. 78 St., Chicago, Ill.

SEND negative for free sample print and price list to Phil Lundstedt, Cape Cottage, Maine.

CAMERA Repairing by expert. Prompt service. Work guaranteed, reasonable price. Send by P. M. I will write you cost. Turner, 1679 Ave. A, N. Y. City.

BIG Money Saved on Photographic Lenses and Apparatus—goods exchanged; repairing done. Ralph J. Golsen, 1128 Argyle St., Chicago, Dept. P.

TAKE your own picture. Autosnap releases camera for you. \$2.50 postpaid. Circular free. Automotive Engineering Co., Castle Hall, Indianapolis, Ind.

KODAK printing, enlarging, copying, photo stamps. Send for prices. Kodafin Shop, 387 Bellevue Place, Milwaukee, Wis.

VIEW and Advertising Postals, from any photo or film, 50, \$1.75; 100, \$3.00; 500, \$10.00; 1,000, \$17.50. Barbeau's, Oswego, N. Y.

SAMPLE Enlargement, dime, and negative (returned). Roll developed and six prints, 25c silver. Brown Studio, Lake Elmo, Minn.

MAIL us 20c with any size film for development and six velvet prints. Or send six negatives any size and 20c for six prints. Or send 40c for one 8x10 mounted enlargement. Prompt, perfect service. Roanoke Photo Finishing Co., 209 Bell Ave., Roanoke, Va.

1922 CALENDAR now ready, hand-tinted. Send your favorite Film Negative and 35c for sample now! Ax-U-Lyk-M, Bristol, Vt.

HAVE You a Camera? Write for Free sample of our big magazine, showing how to make better pictures and earn money. American Photography, 790 Camera House, Boston, 17, Mass.

JUST published—Our new complete 128-page catalog and bargain book of new and used cameras and supplies. Our goods are guaranteed finest quality obtainable. We have thousands of satisfied customers. Write at once for this bargain bulletin, just hot from the press. Address Central Camera Co., 124 S. Wabash Ave., Dept. E53, Chicago.

MOTION PICTURES

BIG Clearance sale of films. Westerns, comedies, and features \$3.00 per reel and up. Write for list. Also machines and supplies of all kinds. Monarch Theatre Supply Co., 228 Union Ave., Memphis, Tenn.

WANTED, Everyone interested in gardening to write for free copy of our beautiful Seed and Plant Guide. Our new specialties will interest you. H. W. Backbee, Rockford Seed Farms, Dept. 901, Rockford, Ill.

MOTION Picture cameras of all kinds at money-saving prices. Write Bass your needs at once. Bass Motion Camera Company, 109 No. Dearborn St., Chicago, Ill.

MOVIE Films 1c foot; 150 ft. \$1. Reels \$3 up. Send stamp for list. Address X. Sales Company, West Haven, Conn.

MOVIE Arc Generator, Eliminates Current bills, Superior projection light. Easy terms. Your engine operates. Hobbesco, Troy, Ohio.

RENT or buy Moving picture cameras. Tripods, Stereoscopes, Supplies. Catalogue, Hess, 302 E. 23d St., New York.

MOVIE Films one cent foot. Send stamps for lists. Address William Batt, West Haven, Conn.

THE Big Sacrifice. Our entire stock of 2000 reels, large assortment of the very best productions, comedies, westerns, dramas and special features, at prices far below anything offered on the market. We are almost giving them away. Our up-to-date bargain film list just off the press. Write for one immediately. Monarch Theatre Supply Co., 724 South Wabash Avenue, Chicago, Ill.

FILMS for Home Use—We sell and exchange; list free. Send \$1.00 for package Screen Coating; makes pictures 100% brighter on screen. Home Films, 736 So. Wabash Ave., Chicago, Ill.

MOVIE Projectors, \$2.50 up; \$25.00 machine shows 8x10 picture; accommodates 1000-foot reel. Films cheap. Second-hand Viascope; bargain. Werner Brothers, High Ridge, Mo.

MOTION Picture Operation, Stage Electric and Illusions—The only practical handbook and guide published for motion picture operators, theatre electricians and managers. A thoroughly practical and useful book, covering the subject comprehensively. Pocket size, cloth, 393 pages, fully illustrated. Price, \$1.50 postpaid. Popular Mechanics Book Dept., 6 N. Michigan Ave., Chicago.

BIG Profit Nightly—Moving Picture Business—small capital starts you, easily accomplished. Teach you—furnish everything. Ralph J. Golsen, 1128 Argyle St., Chicago, Dept. M.

MODERN portable electric moving picture outfit and 15 house packing reels, all like new. Rare bargains. W. Yarkington, Perum, Okla.

THOUSANDS feature films, \$2.00 to \$5.00 reel, 100 ft., 75c. Souvenir strip, six cents stamps. List free. Temple, Mason City, Ia.

SCENARIOS Wanted, any form. Screen production assured, exceptional stories. Scenario Service Corp., 527 Mason Opera House, Los Angeles.

FREE to Writers—A wonderful little book of money-making hints, suggestions, ideas; the A B C of successful story and play writing. Absolutely Free. Just address Authors Press, Dept. 12, Auburn, New York.

MAKE money writing Photo-plays; details free to beginners. No correspondence course. Producers League, 230 Wainwright, St. Louis.

EDUCATIONAL AND INSTRUCTION

FINGER Print Lesson based on Henry System included with Detective Course. Particulars free. Write George Wagner, 1968 Broadway, New York.

BOOKKEEPING self-taught in one week. Newton Duker, Fox Street Station, New York.

CIVIL Engineer, Mathematics Specialist, teaches arithmetic, algebra, geometry, Trigonometry, mathematical problems solved; private correspondence, Mondell, 280 Madison Ave., New York.

SAXOPHONE—Jazzing, Laughing, Tremolo, Triple-Tonguing Simplified, \$1.00. Guaranteed. Sterling System, Mount Joy, Pa.

FREE. Learn to write Advertisements. Accept position or work home evenings, country, city selling your "copy" by mail. I made \$100,000.00 Sample Lesson sent free. Williams, Department T, 74 Cortlandt Street, New York, N. Y.

ACT today—Learn a trade but learn a good one—Sign—Auto—Scenic Painting—Commercial Art—Decorating—Showcard Writing—Graining and Marbling—Paper-hanging—Best Paying Trades, Correspondence and resident Courses. Catalog Free. Chicago Painting School, 148 West Austin Avenue, Chicago.

MATHEMATICS taught by mail. Spare time home study courses in Arithmetic, Geometry, Algebra and Trigonometry. J. A. Harding, 76 Brighton Ave., Highland Park, Mich.

WRITE articles, stories, news, in spare time for newspapers and magazines. Big pay. Copyright book free. Press Syndicate, 552, St. Louis, Mo.

LINCOLN-JEFFERSON University, Home study in Academy College, Theological, Law, Music, Pharmacy, Business and Graduate Schools, leading to degrees. Lock Box 239-W, Chicago.

ARTIFICIAL Marble, sanitary flooring instructions, ornamental casting, concrete plaster, papier-mache decorations, garden furniture, statuary, Rubber-moulds, Electrometallurgy, particulars and 200 illustrations free. Chris Mahler, Box 122, Huntington, N. Y.

DOUBLE Entry Bookkeeping mastered in 60 hours with 8 boys; guaranteed: Diplomas. International Bookkeeping Institute, Dept. 8, Springfield, Mo.

INVENTORS—Write for our illustrated guide book and Evidence of Conception Blank. Send model or sketch and description for free opinion of its patentable nature. Highest references. Prompt attention. Reasonable terms. Victor J. Evans & Co., 147 Ninth, Washington, D. C.

HAVE a business of your own; the most fascinating, best paying business-profession in the World, a foot correctionist; easy terms for training you at home in a few weeks, a new protected system that has enabled men and women to rise in one step to greater earnings than they ever thought possible; no capital required or goods to buy, no agency or soliciting. Address: Stephenson Laboratory, 1 Back Bay, Boston, Mass.

TELEGRAPHY

TELEGRAPHY (both Morse and Wireless) and Railway Accounting taught quickly. Big salaries. Great opportunities. Oldest and largest school; established 46 years. All expenses low—can earn large part. Catalog free. Dodge's Institute, H St., Valparaiso, Ind.

TRADE SCHOOLS

MECHANICAL Dentistry—Why men are needed now; Why you can earn \$35-\$125 weekly or establish a profitable business of your own; How to enter this field of opportunity. Details free. Bodec Schools of Mechanical Dentistry, Department 2A, 132 West 52nd Street, New York (also Brooklyn and Philadelphia).

BUSINESS OPPORTUNITIES

WANT home work paying cash, requiring skill with tools; you furnish outfit at cost. Address Horst, Park Inn, Kansas City, Mo.

BUILD Yourself Profitable Business Manufacturing Fiberstone Products. Fiberstone Company, 539 N. Wolfe, Baltimore, Md.

A NEW and profitable business—Patented Cold Process making fancy glazed Tile on concrete base. Tile now the popular facing for all Mantles, Fire Places, Store Fronts, Kitchens, Vestibules, etc. Superior to burnt tile at one-fifth the cost. Non-porous, non-absorbent, resists stains. Cleaned with damp cloth. All colors. No burning or baking. You make fancy tile undersell all competitors, yet make big money. Guaranteed indefinitely. Want Licensed manufacturer in every county. Learn our patented process. We protect your territory. Send 25 cents for sample colors and particulars. Alpha Tile Co., 170A Golden Gate Ave., San Francisco, Calif.

THIS May Be Your Opportunity. A large, modern Middle Western manufacturing institution will consider proposals from inventors and small manufacturers, with a view of manufacturing on royalty basis or of buying outright. Small brass products preferred, but any high-grade proposition will be considered. Address P. O. Box 426 Kokomo, Ind.

WE Start You in Business, furnishing everything; men and women. \$30.00 to \$400.00 weekly operating our "New System Specialty Candy Factories" anywhere. Opportunity lifetime; booklet free. W. Hillier Ragsdale, Drawer 4, East Orange, N. J.

STOP, go into business for yourself. My book 1000 ways to make money explains how. Contains Practical money-making ideas. Cloth bound, postpaid \$2.00. Address Master Agency, 363 14th St., Brooklyn, N. Y.

BIG Money Painting Signs, Cards, Banners. Our patterns do the work. Complete outfit \$6, or 2 sample sets \$1. Satisfaction guaranteed. Outdoor Adv. Service, Box 438, Lockport, N. Y.

MEN make and sell improved silver cleaning cloth outside working hours. Costs \$1.20 dozen, sells \$4.80 dozen. Sample formula selling suggestions, \$1.00. Chemist, Box 158, Rahway, N. J.

"SCHEMER Magazine." Alliance Ohio, prints big profit schemes; one subscriber making \$25,000 from three; another \$10,000 from one. Try your luck. Year, only \$1.00; three months, 25c.

START a pressing, cleaning and dyeing shop; splendid field, big profits. We tell you how. Write for booklet. Ben-Vonde System, Dept. C, Charlotte, N. C.

CLEAN Wallpaper and Window Shades this fall and winter. Big demand. Take large contracts. We show you how. C. Swanson and Sons, Mankato, Minn.

A BUSINESS for yourself. Hamilton Beach Rug & Washing Machine, perfect condition; also booklets and cuts. Box 213, G. P. O., Brooklyn, N. Y.

MANUFACTURE Good Paints and Varnish, 50c to 75c Gallon. Unlimited opportunity to build large business. Utility Company, 539 N. Wolfe, Baltimore, Md.

PATENTS—Book Free. Send sketch for free opinion of patentable nature. Address Talbert & Talbert, 434 Talbert Bldg., Washington, D. C.

\$275 MONTHLY from HB Battery Charging. Fastest growing business today. Anyone operates. \$20 starts you. Profits pay balance. Hobarth, Troy, Ohio.

PAINT Pastel Pictures at Home. Money-making opportunities. Novelty framing Sample Pastel Painting 25c. Duke Bros. Studio, Three Rivers, Mich.

STATE and county rights available to men capable organizing and directing sales forces and able finance themselves to extent of \$100 to \$500. New, patented, small, low-priced, universally-useful article selling through canvassers and stores. Fast seller. No competition. Substantial profits. If you state your situation fully in first letter, we can then immediately submit definite proposition and contract. Ribbon Steel Products Corporation, 1401 Engineering Building, New York.

RESIDENT Manager wanted who can organize selling crews. \$15.00 a day. Spare time. A permanent connection. Box 441, Chicago.

START in business for yourself for \$250.00. Full time or evenings. At least \$5.00 per hour. Ex-Cell-O Tool & Mfg. Co., 1214 Beaubien St., Detroit, Mich.

\$100,000 CORPORATION wants capable man; open office; manage sales for High Class New Device. Every Home a Prospect. Big money-making possibilities for the right man. Opening in every city. Cost \$2.00, retails \$5.00. \$500 to \$2,000 necessary to finance exclusive agency. Scott Corporation, 82 W. Washington, Desk G, Chicago.

PATENTS Procured: Trade Marks Registered. A comprehensive, experienced, prompt service for the protection and development of your ideas. Preliminary advice gladly furnished without charge. Booklet of information and form for disclosing idea free on request. Richard B. Owen, 30 Owen Bldg., Washington, D. C., or 2276 R. Woolworth Bldg., New York.

START a Paying Business of Your Own. Be a business man. Any location. 8,000 new Tire Vulcanizing and Repair Stations needed. Business always good. Are you ambitious? \$200 will start you. Write at once. Wonderful opportunity. Equipment Co., 11 Canal, Cincinnati, Ohio.

IF you have about \$1,000 and capable of organizing sales force, to sell article needed by every merchant, wholesaler and retailer, which should net you \$10,000 profits first year, write Sales Director, 826 Reaper Block, Chicago.

PROTECT Your Rights. Write for Record of Invention which contains form to establish evidence of conception of your invention. Prompt personal service. Preliminary advice without charge. J. Reaney Kelly, 612 G, Columbian Bldg., Washington, D. C.

WRITE for Particulars. Best Article ever offered Men, Costs 5c, sells quick for dollar. \$20 daily easily made. Knapp, 758-15 St., Milwaukee, Wis.

MANUFACTURE "Plasto-Marble" — Equals Real Marble and Onyx for Architecture and Novelties. Secure the process for your city now. Grumman, Zanesville, Ohio.

MACHINISTS—Make extra money—Spare time work. Write for particulars. Engineering Service Bureau, Dept. 511, 56 E. Randolph St., Chicago.

MAKE money with your camera. Free information. Write Lancaster, 490B Wright-Caldwell Bldg., Los Angeles, Calif.

MONEY in mail-order business. Names of 30 supply houses 10c. Pennell Company, Covington, Ky.

ADVERTISE, 23 words 70 country town newspapers \$2.20. Pennell Company, Covington, Ky.

RAISE Rabbits!! One of the most interesting and profitable industries in the world today. You can't fail if you read Rabbidom's most authoritative book known as The 20th Century-Rabbit Guide, written by an expert of 15 years' experience. Everything about rabbits worth knowing visualized in plain and forcible style. Contains 64 pages, fully illustrated. 21,000 copies sold. Price 50c prepaid. Write today for your copy. Popular Mechanics Book Dept., 6 N. Michigan Ave., Chicago, Ill.

STEADY work! 400% profit to co-partners joining us in manufacturing a patented specialty, every man and boy should have. Machine furnished free. Send 25 cents (coin) for sample and judge for yourself. Inventors' Co-Operative Manufacturing Association, Albany, N. Y.

YOUR Chance in life to own dignified profitable business. We teach you practical real estate, insurance and business brokerage. Earn \$5,000 year, no capital required. Office at home. Representatives wanted everywhere. Stamp for booklet. Hayes Realty Association, Cincinnati, O.

INDEPENDENCE and prosperity await you in the furniture cleaning business. Course \$1.00. Circular free. Send today. Address E. M. Ellis, 110 Riverside Ave., Newark, N. J.

NICKEL-PLATING — Profitable sideline for repair shops, garages, hardware stores, etc. Complete instructions, blue print diagrams. One Dollar. Webster Engineering Co., Webster Groves, Mo.

YOUR Opportunity! Formulas solution sharpens knives — everything — like magic! Self-shaving Crème, ten others, worth hundreds. One dollar. A. Guagy, R-B, Dover, Del.

8 SANBO Starters, gross Mystic wind-shield cloths, 3 gross Gem rubber. Lot \$1.10. Retail price, \$6.88. Address, Davis Ackerly, Northport, N. Y.

HOME manufacturing—Mechanics, and household necessities. Machinery experience, or canvassing unnecessary. Enormous profits. Home Manufacturers' Association, 230 Court, Los Angeles, Calif.

START Mail Order Business. Instructions, plans, formulas, etc., 50c. Specialty Co., Harbor Springs, Mich.

GET in business yourself; \$4.00 buys marvelous Keystone Economizer. Easily attached to any make car and saves 25% to 50% present fuel consumption. Satisfaction guaranteed or money refunded. Agents make big money. Address Keystone Economizer Company, 323 Stock Exchange Bldg., Los Angeles, Calif.

I MADE \$30 a week home. French bread-making. 15 years' experience; free booklet tells. Ashbrook, 67, Marengo, O.

BE Independent. We teach by mail how to manufacture unexcelled Toilet Preparations. Earn while you learn. Results guaranteed. Particulars free. School of Cosmetics, Box K, Omaha, Nebr.

DOLLARS yearly in your backyard. No Mushroom dope. Particulars free. Metz, 313 East 89th, New York, N. Y.

\$40 WEEKLY, making rubber stamps; full instructions to build paying business 25c. Peerless Specialty, Box 101, Waterville, Maine.

MEN Wanted to earn \$1,000 to \$10,000 a year. Prepare quickly and easily through our amazing system for profitable and permanent business reclaiming waste paper for largest manufacturers in country. Boys do the work—you simply direct. Practically no investment necessary—a few dollars will start you. Simply send name for big free opportunity book—a post card will do. Write The Traub System, 303 Traub Bldg., Kansas City, Mo.

12 WAYS to Start Mail Order and Home Business, 4c. Gaylord, Publisher, Rockland, Wis.

AUTO necessity of the highest merit that sells on demonstration; profits are liberal; exclusive territory open; excellent opportunity for a business of your own. Write Service Cushion Tube Co., 4010 E. 15th St., Kansas City, Mo.

SUBSTANTIAL manufacturing corporation wants capable men to establish branch and manage salesmen; \$300 and upward necessary. Will allow expenses to Baltimore as explained. Address Secretary, 313 Courland St., Baltimore, Md.

START Mail Order Business. Our Bargain Bulletin just off the press contain hundreds of fast-selling novelties. Our low prices will surprise you. Address Circle Sales Co., Dept. 18, Moline, Ill.

MANUFACTURE Extracts, and other necessities. 200% profit; we tell you how. Write White Manufacturing Drug Co., Box 322, Cincinnati, O.

EXCEPTIONAL Opportunity for Sales Manager capable of handling state distribution. Marvelous new Adding Machine. Retail \$15. Work equals \$350 machine. Tremendous possibilities. Unlimited profits. Write quick for details. Lightning Calculator Co., Dept. B, Grand Rapids, Mich.

GET into the specialty manufacturing business. Amazing profits. We will send you free book explaining our system. Write immediately. A wonderful opportunity awaits you. National Scientific Laboratories, 624 Main, Richmond, Va.

MARBLE mixing instructions, covering wood or cement flooring 1/2 inch thick, fire-proof, waterproof, low cost, sanitary, all colors. Particulars, 200 Illustrations free. Chris Mahler, Box 122, Huntington, N. Y.

LET Me Show you how to make real money. Absolutely new proposition and new products. Materials cost \$2.00, sell for \$16.00. One man sold a thousand dollars' worth in a week. Exclusive manufacturing and sales rights to one man in each territory. Write today for booklet 5, Crouch, Chemist, 309 Broadway, New York.

LEARN the collection business. Good income, quick results. Interesting booklet, "Skillful Collecting," free. National Collectors Assn., Long St., Newark, O.

SILVERING Mirrors! My exclusive French Tartaric method opens enormously profitable business. Booklet free. H. Barstow, 514 23d Street, Oakland, Calif.

GOOD money easily earned at home, spare time silvering mirrors; no capital. Free instructive book tells how. Patterson & Co., Brooksville, Ky.

\$3,000 TO \$6,000 Yearly. Want it? Others are making it. Send check or money order today for our invaluable books "How to Sell Real Estate," \$3.00—and "How to Conduct Real Estate and Insurance Business," \$1.50. Absolute satisfaction guaranteed. Free catalogs. Realty Book Co., Dept. 52, Cleveland, O.

CHEMICAL Expert will furnish Formulas and Trade Secrets. All lines. Lists Free. W. L. Cummings, Ph.D., 228 Gordon Ave., Syracuse, N. Y.

MAIL Order Business is your opportunity. Brenner's Famous Handbooks teach how to start small, grow big. Sell merchandise, service, ideas; enormous profits. Spare time to begin. Get complete set, 11 books, \$2.50, and be posted. Brenner, 335 Walnut, Philadelphia. Descriptive Catalog and big batch interesting mail order information, 25c. None free.

ENTER a new business. Earn \$3,000 to \$6,000 yearly in professional fees making and fitting a foot specialty, openings everywhere, with all the trade you can attend to; easily learned by anyone at home in a few weeks, at small expense; no further capital required, no goods to buy, job hunting, soliciting or agency. Address Stephenson Laboratory, 11 Back Bay, Boston, Mass.

BUSINESS Brokerage pays well. Easy to understand; particulars free. Write, Eviman System, Box 617, St. Louis, Mo.

LEARN Plating, Etc. Profitable—Big Demand. Free Plans. Norman Rorick, 427 Carroll St., Akron, Ohio.

FREE—Formula Catalog, S. & H. Laboratories, Boylston Building, Chicago.

FORMULAS AND TRADE SECRETS

1,000,000 FORMULAS. Trade Secrets, Processes for Every Business, \$2.25. Ideal Book Shop, 5501ML, North Robey, Chicago.

500 FORMULAS, 20c. Luminous paint—Resilvering Mirrors—Renewing dry batteries—Mechanics' Soap—Gas Tonic—Carbon remover, Puncture Plugger, 20c each. Entire collection, 50c. Ideal Book Shop, 5501PL, North Robey, Chicago.

FORMULAS—Guaranteed, Catalogue free. Clover Laboratories, 5510CL, North Robey, Chicago.

BE Independent, learn to make Perfumes and Toilet Articles. Big profit. Commercial Laboratory, 70 So. Second, Memphis, Tenn.

NEWSHINE Auto and Furniture Polish. Best on Earth; cleans and polishes, leaves dry surface; costs 50c gallon; formula \$1, no stamps. Snyder, Box 312, Marshall, Texas.

FREE—Formula Catalog, S. & H. Laboratories, Boylston Building, Chicago.

FORMULAS of the better sort. Write for our free catalog. National Scientific Laboratories, 623 Main, Richmond, Va.

AGENTS WANTED

AGENTS: Quick sales! 350% profit. Klean-Rite magic washing wonder. Washes clothes without rubbing. Sells for 25c—you make 19c. Distributing samples free. Write quick. Besterer Products Co., 1941 K1, Irving Park Blvd., Chicago.

\$1,000 PER man per county. Get yours. Inexperienced men pulling down star salesmen's profits. Write for proof: How farmers, ministers, clerks—men in all walks of life—made big money in whole or spare time. You can do it. Amazing proposition—wanted everywhere. Exclusive territory—no sales limit. A hot or cold running water bath equipment for any home at only \$7.50. Self-heating. No plumbing nor water works required. Investigate. Terms. Send no money. Write letter or postal today. Allen Mfg. Co., 654 Allen Bldg., Toledo, Ohio.

WELCOME before you call—7 orders out of 10 hearings. Get rid of the stigma, "canvassing." We have a dignified piece of organization work we want to have done in your community, that will pay \$3,000 a year and up. Plan gets introduction for you, and if you are like our average representatives you will get 7 orders out of 10 hearings even in these dull times. Write at once for full details. Kit-chin Kit Corp., Evanston, Ill., Dept. M-1.

HOW to Sell—and What. Every issue a text book on salesmanship. Tell you how, when and what to sell. Protects you from dishonest mail order companies. Puts you in touch with most profitable fast-selling lines and reliable manufacturers. Sells for 20c an issue. Worth \$20 to anyone trying for a larger income. Three months' trial subscription, 25c. (Stamps accepted.) Address How to Sell—and What, 22 West Monroe St., Dept. AG, Chicago.

TAILORING Agents wanted in every town. We can use merchants, salesmen, foremen, barbers and cleaners who can sell ten or more suits a season. We ship free our large spring sample outfit showing over 250 all wool samples at \$15.00 and up for all wool guaranteed suit. This is an agency proposition. Write today for book or traveling. Dept. P, Jay Rose & Co., 411 E. Wells St., Chicago, Ill.

AGENTS—16,000 miles without a puncture with Insyde Tyres. Wonderful invention. Just slip inside casing before replacing tube. No tools needed. Will not heat or pinch. Positively prevents punctures and blowouts. Guaranteed double tire mileage. Old worn-out casings give 3 to 5 thousand miles more service. Biggest thing on the market. Low priced. \$8 to \$20 a day. Write for territory. American Accessories Co., B-978, Cincinnati, Ohio.

YOU can make \$12,000 a year selling well-known, standard, advertised make of hand-drawn chemical fire engines, motor fire apparatus, extinguishers, hose, and complete line of fire-fighting sundries. We have several openings in good territories. Other men are making \$1,000 a month in territories not so good as we now offer. Address Ajax Fire Engine Works, Bush Terminal Bldg., 10, Brooklyn, N. Y.

SALES district managers wanted for Dominant Polish, the new wonder that is being adopted everywhere. If you have small capital we can make you a remarkable offer, one that will put dollars in your pockets while you are making cents now. Exclusive territory granted. Dominant Products Co., 163 South St., New York City, N. Y.

SELL Minutemend for tires and tubes—cost 2c. Repair; surpasses vulcanizing, saves 500%. Every auto and accessory dealer buys. Profits amazing. Shaw made \$21 first day. Hart \$155 first week. Particulars and free sample, The Continental Rubber Co., Dept. 85, Philadelphia, Pa.

AGENTS: Minute demonstration sells one can or gross. Highly reputed among jobbers, cleaning and polishing stations, oil stations, auto owners, dealers. Heavy repeat orders always follow. Exclusive rights to men of standing only. Hellyer Steel Parts Co., 969 South Grand Ave., Los Angeles.

AGENTS—Sell rich-looking imported 36x 48 rugs, \$1 each. Carter, Tenn., sold 115 in four days. Profits, \$37. You can do same. Write for sample offer selling plan; exclusive territory. Sample rug, prepaid, \$1.39. Condon, 12 Pearl St., Boston, Mass.

AGENTS—Big money, \$8 to \$16 a day. Aluminum handle cutlery set. Brand new. You display and take orders. We deliver and collect. Pay you daily. Sample free. Try it out. Jennings Mfg. Co., Dept. 1648, Dayton, Ohio.

PORTRAIT Agents—\$50,000 is what "Picture Man Friedman" made canvassing. Free circular "Profits in Portraits" tells how. 24-hour service on prints, finished portraits, frames. Samples free. "Picture Man Friedman," Dept. 8, 127 N. Dearborn St., Chicago.

"PICTURE Man Friedman" cleared \$50,000 taking orders; he tells how in free circular, "Profits in Portraits." Samples free. 24-hour service on prints, finished portraits, frames. Address "Picture Man Friedman," Dept. 8, 127 N. Dearborn, Chicago.

AGENTS—Two real money-makers: Self-threading needles, cost 5c, sell 15c. Needle books containing 107 needles, cost 5c, sell 15c. Send for samples. Atlas Needle Works, Box 1888, Madison Sq. Sta., New York, N. Y.

SELL a Necessity—Everyone uses coffee and tea. We supply you at lowest wholesale prices packed to your order. Best quality; sure repeaters; exclusive territory. Frohman Coffee Co., 325 River St., Chicago, Ill.

\$40.00 WEEKLY (whole or part time) selling guaranteed Hose, Waterproof Aprons, Shampoo Capes, Toilet and Sanitary necessities. Credit given. Jas. C. Bailey Co., Dept. M4, Chicago.

INSYDE Tyres inner armor for automobile tires. Prevent punctures and blow-outs. Double tire mileage any tire. Tremendous demand. Big profits. Sample and details free. American Accessories Co., B-178, Cincinnati, Ohio.

MEN and women make \$100 upwards weekly selling greatest labor and money saving household necessity. Big repeater. Good crew managers' proposition. Free sample and particulars. Rolly Co., A-1, Hastings, Neb.

SELLS like hot cakes. Big profits. New ironing wax, pad and asbestos iron rest. Clamps board, perfumes clothes. Working outfit 10c. Yankee Manufacturers, 380 Atlantic Ave., Brooklyn, N. Y.

AGENTS—Our Marvel Can Opener opens a can in two seconds. Sells on sight—big profits—sample sent prepaid for 50 cents. Staples Mfg. Co., Mt. Vernon, Ind.

AGENTS! Big Sure Profits and easy fast sales with guaranteed Waterproof Aprons. No capital required. B & G Rubber Co., 618 Penn Ave., Pittsburgh, Pa., Dept. 112.

PORTRAIT Agents—A new portrait, something entirely different. Write for particulars, also catalogue and price list. Fidelity Portrait Company, Dept. 100, 3047 Harrison St., Chicago, Ill.

FREE Sample, quick-selling patented specialty. Get yours now. Also details \$5,000-year golden opportunity. Agents wanted. H. G. Martin, 51 Cliff St., New York City.

CASH in on your spare time. My novel plans tell how. No capital required; information free. Write today. 31, Stacey, 4020 Crutcher Street, Dallas, Texas.

WONDERFUL Composition, applied on wet windshield prevents rain or snow blurring. Cake form. Agents coin money. Three samples, dollar. Marvel-Wax Co., Sheboygan, Wis.

AGENTS—Salesmen and distributors—Sell polish for cleaning porcelain tubs, toilets, etc. Big demand. Money maker. Sample can 25c. Ace Mfg. Company, Portland, Me.

GALLAGHER made \$336.00 in one week selling guaranteed Collection Systems, used by all business men. Savers Cabinet Mfg. Co., 2515 Sheffield Ave., Chicago, Ill.

COPPER Pots, all sizes; also anything in copper goods desired. Write today for free catalog. Rorer & Co., 609 Reserve Bank Bldg., Omaha, Neb.

AGENTS: A sale in every home for our beautiful Utility Shopping Bags. Quick sales. Good profits. Fred Beals, 231 Mt. Vernon Ave., Detroit, Mich.

BIG Line—Big Profits—Cold Creams, face powders, perfumes, remedies, spices, extracts, pie fillers, baking powder. Catalog free. Western Laboratories, 1964 Van Buren, Chicago.

COAST to Coast campaign needs 5,000 agents. Sample and terms dime. Dept. 37, Blossom Hair Net Co., 252 Wallabout St., Brooklyn, N. Y.

EVERYBODY uses extracts. Sell Duo Double Strength Extracts. Complete line necessities. Big repeaters. Write today. Duo Co., Dept. E1, Attica, N. Y.

\$100,000 CORPORATION, manufacturing a lock guard approved by police departments and burglary insurance companies, wants capable representatives. Unlimited demand without competition. Write today. Herculo Lock Guard Company, Baltimore, Md.

START Your Ford in the morning. The Jir Manifold Heater will do it. Agents, write Jir Specialties Co., Cincinnati, Ohio.

AGENTS—300% profit selling Chemical Gas Lighters. No friction. Samples 15c. Rapid Mfg. Co., 10 E. 14th St., New York.

BIG seller. Soxneed Hose Supporters. No elastic. Send 25c for sample and proposition. Soxneed Company, 856 Pacific Bldg., San Francisco.

FLEXIBLE Key ring and name plate 25c. Stamps. Agents wanted. Monarch Sales Co., Prattburg, Steuben Co., N. Y.

AGENT'S Magazine contains many opportunities. Two big issues, including our Buyers' Guide, 25c. Harvey Teeple, Decatur, Ind.

MAKE \$50 per week this winter, making and selling Anti-Freezing compounds and polishes for Automobiles. Four formulas \$1. T. W. Engel, Box 432, Galena, Ill.

AGENTS: Big profits selling "Wunrub Polish" for furniture, woodwork, autos, etc. Fritch's Laboratories, 6451 Magnolia, Chicago.

DOLLARS Profit in our proposition. Write quick. H. Franklin Co., Shreveport, La.

AGENTS—Exclusive territory now being allotted for Tidy Furnace Clocks. Practically only thing of its kind. Retail \$6.00. It has a free field wherever there's furnaces or boilers. Every household a sure sale, for it saves getting up in cold rooms on chilly mornings. Starts itself. Every one can operate it, for it is set exactly like a clock. Guaranteed to work perfectly. Selling at top speed. Already used by thousands of homes. We can grant you absolute monopoly and start you on the road to a big income if you are the right man. You can work spare or full time and clean up big money. Tidy Heat Specialties Co., 1197 Broadway, New York.

REAL Salesmen can make real money selling our made-to-measure all-wool suits at \$26.50. You collect profits in advance and keep them. We supply finest selling outfit in America. Many exclusive money-making features. Tailoring, Raincoat and Side-Line Men, part or full time, get in touch with us immediately. Write Good-west, Inc., Dept. 1, Chicago.

GOOD income, spare time, refinishing chandeliers, brass beds, automobiles, etc., by new method; producing amazing results; every household possible customer; experience unnecessary; simple plan of manufacturing at home starts you in big money-making business. Write for free samples, showing finishes, etc. Gunmetal Finish Co., Ave. H, Decatur, Ill.

AGENTS—We want more live demonstrator-agents to demonstrate and take orders for our Ideal Fibre Cutter. We furnish advance advertising matter, folders, etc., and guarantee exclusive territory to producers. High-grade article and big profits. Write immediately for details. M. H. Trier Mfg. Co., Dept. 83, Muncie, Ind.

AGENTS—In cities where nickel phones are used in homes, agents can make big money selling Economy Slug Meter. Nothing like it. Gives user check on phone bills. Sells instantly for \$1.45—agents get 50c. Economy Slug Meter Company, Not Inc., Room 60, 39 W. Adams St., Chicago.

BIG Money Makers. Large factory offers you big profits on 150 fast sellers. Toilet Gift sets, flavoring extracts, remedies, soaps, bring you \$8.00 to \$25.00 daily. Howe of Illinois makes \$4.00 an hour. Sample outfit free to workers. Lincoln Chemical Works, Dept. 155, 2566 N. Leavitt, Chicago.

AGENTS—Sell the Plymouth Shopping bags. Leatherette Satine lined. Made to sell for \$1. Large profit for you. A 15-year-old boy sold 25 in a few days. Lady 7 in one hour. Write for particulars. Sample 75c prepaid. E. Kondon, 12 Pearl St., Boston, Mass.

MAKE and sell your own goods. Enormous profits. Experience not necessary. My System shows you how to manufacture and sell Automobile Specialties. Disinfectants, Household Goods, Food Specialties, Toilet Articles, Medicinal Preparations. No machinery required. Small investment. Particulars Free. Fred Piper, Box 764, Sacramento, Calif.

AGENTS, Mail-Order Men and Beginners: 300 to 400% profit made on four articles in constant use and daily demand. 25c in stamps for all four. Also inside information and valuable tips free. Nite Mail Order & Supply Co., 609 27th St., Denver, Colo.

AGENTS—Get our wonderful big swatch Tailoring line—119 samples at \$23.00, \$28.00, \$32.00, \$38.00 per suit, \$15.00 cheaper than store prices. \$5.00 profit and up per suit. We deliver and collect. Hustlers write D. A. Kennedy, 292A S. Green, Chicago, Ill.

AGENTS—Sell the New Naco Combination Plier—100% profit—Nothing like it. The Master tool of the age. Auto owners, Garagemen, Mechanics and Repairmen. Exclusive rights to responsible parties. Send \$1.50 for sample and full details. Address Naco, Box 462, Galva, Ill.

AGENTS! A sale in every home for our beautiful dress goods, silks and general yard goods. Quick sales! Big profits! Large book of 1000 handsome fabric samples. Write today. National Importing & Mfg. Co., Dept. 6X, 573 Broadway, New York, N. Y.

AGENTS on our staff are making \$100 to \$200 per week. You can do the same with our sanitary rubber specialties. Write immediately for particulars and exclusive territory. Paramount Rubber Co., Renshaw Bldg., Pittsburgh, Pa.

PROTECT your rights. Write for "Record of Invention" which contains forms to establish evidence of conception of your invention. Prompt personal service. Preliminary advice without charge. J. Beane Kelly, 6123, Columbian Building, Washington, D. C.

EXCLUSIVE rights to live agents on universal fabric cement, Mendis socks and clothing, rubber and leather without needle and thread. Sells to housewives and merchants. Big profits. Intersales Company, Old Whitney Bldg., Detroit, Mich.

GENERAL Agents, Something New, Whirlwind seller. "Repeat" washing powder. Washes clothes without rubbing. Women throw away washboards. Big profits. Exclusive territory. Write today, free package. Kittredge Co., 8 Putnam St., Fushkhamock, Pa.

GUARANTEED Brushes: 113 different kinds—household—commercial—auto. Tremendous sellers, everyone a prospect. Permanent business—Steady income. Write or wire Desk 6, Universal Brush Company, 181 Quincy Street, Chicago.

AGENTS: Sell Wolverine Laundry Soap; 150 other household necessities. Big line. Big profits. Quick repeaters. Free instruction. Write quick for terms. Wolverine Soap Co., 298 Water St., Portland, Mich.

AGENTS—New patented article. Enormous profits. Everyone a prospect. Sample 10c. GHS, 3561 Fifth Ave., Chicago.

RUST-I-CIDE Removes Rust—Chemically. Patented. Kills Iron and Steel's worst enemy—unlimited sales field. Booklet free. Send 20c for 35c bottle postpaid. The Rusticide Co., Cleveland, Ohio.

AMBITIOUS Agents everywhere. Complete line rubber goods. Belts, aprons, toys, household specialties; everything. Belt and other samples 35c. Nu-Line Products Co., Box 258, Akron, Ohio.

SELL articles of Universal Merit. Marvellous conveniences, absolute necessities. Hustlers make \$150.00 weekly. Exclusive territory; reliable merchandise, with no competition. Flexo Mfg. Corp., Sheboygan, Wis.

WANTED—Sales Agents. Both Sexes. Capital or experience unnecessary. Qualifications, common sense and willingness to work. Write for free details. Sanitary Mfg. Supply, Akron, Ohio.

AGENTS Wanted, to sell an improved tool that often pays for itself first time used. Address today, J. 1019 Georgia St., Los Angeles, Calif.

\$150.00 WEEKLY: Learn automobile Refinishing Business, Bonafide Practical Painting, Rehabilitating Tops, Cleaning courses. By Professional Experts. No experience required. Automobile Finishing Corp., Sheboygan, Wis.

DISTRICT Agents everywhere, for new patented low-priced time-saving office necessity. No competition; big profits. Exclusive contract. Metal Goods Corp., Dept. 100, St. Louis.

COMBINATION floor and wall broom going like wildfire. Commission over 50%. Outwears four corn brooms. Convenient shipping points. Address Harnack Co., Keene Building, Fort Worth, Tex.

PATENT for sale or Royalty. Improved Combination Tool, useful to all Mechanics. Big seller. Address Alex Miller, 132 N. Weber St., Colorado Springs, Colo.

AGENTS, sell newly invented Pie Trimmer and Crimper. 100% profit; sample and particulars 20 cents. Don Risk, 1378 W. Cedar Ave., Denver, Colo.

ONE Man wanted in each county to sell direct to user complete line of paint and paint specialties, also Kling-Tite Asbestos Roof Cement, most successful product for waterproofing any type of roof. Big demand in town and country; anyone can sell. Permanent business that will make you \$3,000 or more per year. No capital required. We ship and collect. Commission advanced. Kling-Tite Products Co., 557 Tacoma Bldg., Chicago.

\$25 DAILY. Every Demonstration means sales. Finest improved only \$1.00 Double Edge Razor. Like \$5.00 type. Standard Safety Razor Corp., Pittsburgh, Pa.

NEW—Ice-pick holder; nothing like it; needed in every home. 15 cents for sample. M. C. Wakefield, 1110 Hall, Dallas, Tex.

SELL Vic's Letter Strips. The most sensible means to learn to write. Children delighted. Parents pleased. Address Vic. Hansen, Wallace, Idaho.

YOU Can Succeed with our Formulas, Trade Secrets, Commercial Information. Particulars free. Address The Thaxly Co., Dept. 15, Washington, D. C.

AGENTS, good 50c seller; auto accessory; costs you \$1.00 per dozen postpaid. Dobbins, 326 River St., Chicago, Ill.

EASY Money Interviewing business men—Jiffys needed everywhere; new; unique; efficient; write to Jiffy Letter File, Rochester, N. Y.

WANTED—Agents; Sell Books; Catalogs 10c. McCarthy Co., Kellogg, Minn.

SELL Minutemen for tires and tubes—cost 2c. Repair; surpasses vulcanizing, saves 50%. Every auto and accessory dealer buys. Profits amazing. Shaw made \$21 first day. Hart \$155 first week. Particulars and free sample. The Continental Rubber Co., Dept. 85, Philadelphia, Pa.

\$20.00 PER DAY can easily be made at home manufacturing gold lace, and supplying wholesale and retail trade, milliners, dressmakers. Any one can do the work. Outfit complete, \$5.00 prepaid. So confident am I that you will be pleased I refund money in full to any purchaser not satisfied. Process fully explained; buy material for work anywhere; a few dollars starts you in business; this is something new, so hurry; a limited number to be sold; no orders accepted after 1st day of February until further notice. W. Brunton, 611 Yonge Street, Toronto, Canada.

AGENTS: \$60 a week selling guaranteed hosiery for men, women and children. Must wear 12 months or replaced free. All styles and colors, including finest line of silk hose. Mrs. McClure makes over \$2800 a year. Mrs. Schurman averages \$60 a month working spare time. Geo. Noble made \$35 in one day. Write for sample outfit. Thomas Mfg. Co., Class 562, Dayton, O.

AGENTS—Steady income, large manufacturer of Soaps, Perfumes, Toilet Articles and Pure Food Products, etc., wishes representatives in each locality. Manufacturer direct to consumer. Big profits. Honest goods. Whole or spare time. Cash or credit. Send at once for particulars. American Products Co., 5721 American Bldg., Cincinnati, Ohio.

O-HELL-O, why didn't I see this before. \$1 an hour selling new product. Removes iron rust, mildew, fruit, ink, medicine and grass stain. Write for free sample and terms today. C. H. Stuart & Co., 24 Broadway, Newark, New York.

AGENTS—We pay \$6 a day taking orders for New Kerogas burner. Fits any stove. Burns coal oil. No experience or capital required. Work spare time or full time. Write for demonstrating sample. Thomas Mfg. Co., Class 2642, Dayton, O.

SALES Agents. Men or women. \$200 a month. Year round position. No invents. Take orders for Jennings New Style Hosiery. Written guarantee of satisfaction or new hose free. Write for outfit. Jennings Mfg. Co., Dept. 288, Dayton, Ohio.

AGENTS: \$8 a day taking orders for Empire Tire repair. Absolutely guaranteed. Build up a big permanent business. Biggest opportunity ever offered to our Representatives. Write for territory and free sample. Parker Mfg. Co., 378 Bark St., Dayton, Ohio.

AGENTS, Wireless Umbrella. I am paying \$2 an hour, taking orders for this new invention. Send for 5-part outfit. Six-inch midgest demonstrator free. Parker Mfg. Co., 378 Dike St., Dayton, Ohio.

WRITE for money making proposition selling holiday novelty. Address Enterprise Machine Works, Spring Valley, Minn.

AGENTS—98 cents per hour. Demonstrating and taking orders. No experience necessary. Selbert, a mechanic, made \$5.00 first day out, with new patented Moore Automatic, Self-Winding Clothes Line and Reel, approved by Good Housekeeping; prevents dirt, knots and tangles—used indoors or out. Don't overlook this—let us prove it best money maker. Sample free to workers. Universal Appliance Company, Dept. 120, 425 Elm St., Cincinnati, Ohio.

ASK the Ideal Clothes Line Co., Clarksburg, W. Va., for their proposition, or send 50c for sample and particulars.

AGENTS: \$8 a day taking orders for New Heat Indicator for city and county homes. New invention. Tells exact heat in any oven. No guesswork when baking or cooking. Big seller. Every housewife wants one. Write for sample. Jennings Mfg. Co., Dept. 1268, Dayton, Ohio.

AGENTS making \$3.75 hourly. You can too; 50c specialty, 80% profit. Men, women, buy at sight. Every customer a booster. Put up under your own name, enormous repeat orders. Too busy to answer inquiries unless 20c enclosed for sample, particulars. Manager, 4035 Minnehaha, Minneapolis.

PORTRAIT Men. Lots of fine artists out of work in Chicago. Time to get best work at low prices. Frames down in price, photo pillow tops, also luminous crucifixes, too. Portrait Supply, 308 South Kilbourn, Chicago, Ill.

STOP Selling other people's goods! Big money easily earned making and selling your own products to consumers, to agents, by mail. Start small, grow big with reliable formulas and winning sales plans. Kolper, 607 Forrest Bldg., Philadelphia.

PORTRAIT Agents—Earn Big Money selling our Photo Medallions. Everybody buys. You charge \$3.00; make \$2.40 each sale. \$10 daily easy. Big variety designs. Quick service. Write Puddin' & Perry, Incorporated, Section 16, 340 Bowery, New York.

HIGHEST grade device of its kind. Something different. A rear signal for automobiles that positively insures safety. Send \$2.00 for sample and exclusive territory proposition. The Gravity Carburetor Co., 3062 E. 93rd St., Cleveland, Ohio.

BUILD Permanent Business following our Sure Success Plan introducing Guaranteed Hosiery and Underwear from factory to family. Attractive outfit assures quick sales. Large profits. Investigate for yourself. Address C & D Company, 41-B, Grand Rapids, Mich.

BIG Money—Broken arms, cranking accidents prevented by Non-Kick Device for Ford's. Burnett sold 144 in two weeks; made \$218. Write for particulars—exclusive territory. Non-Kick Co., 701A Central, Kansas City, Mo.

FASTEST Selling Sanitary Brush Line in America. Huge profit-making opportunity for live workers, with advancement. Other specialties. Get complete details. Act quick. Best season at hand. A. A. Silver-Chamberlin Co., Clayton, N. J.

AGENTS See our display advertisement on page 148 in this magazine, then write us immediately. Wide awake agents need no other line. Address, Sales Dept., The Kazo Company, Cambridge, 39, Mass.

AGENTS, Specialty Men, sell "Presto" polishing cloth on demonstration. Every housewife buys at sight, profits big, repeat orders, sample free. Premier Products Corp., 1451 Broadway, New York City.

BIGGEST, fastest sellers. Every woman buys Hawkins' High Grade Toilet and Household Necessities on sight. 100% profit. Colonial Chemical Co., 631A Penn Ave., Pittsburgh, Pa.

A BUSINESS of Your Own—Make sparkling glass name plates, numbers, checkerboards, medallion signs. Big illustrated book free. E. Palmer, 39 Wooster, O.

WE pay \$200 monthly salary, furnish rig and expenses to all who qualify introducing guaranteed poultry and stock powders. Bagler Company, X368, Springfield, Illinois.

AUTOMOBILE Accidents prevented by new invention; costs distributor \$2.50, delivered; retails at \$7; wonderful self-selling plan. Carl Brown, Manager, Dept. 32, Columbus, Ohio.

AGENTS make \$500 monthly; sell my bank pay checks, sales stimulators; no experience necessary. Get circular. Hamilton Sales Co., 316 Moffat Bldg., Detroit, Mich.

AGENTS, Salesmen, Canvassers, \$10 per day selling our Guaranteed Waterproof Aprons. \$1 per dozen; sample apron 50c. Meeker Sales, 192 Market Street, Newark, N. J.

MOVIE film souvenirs, whirlwind seller. Agents joining money, absolutely new. Great for crews. Sample, two-cent stamp. Temple, Mason City, Ia.

PORTRAIT Agents. How's this, Bromside proof prints at cost if we do the finishing. United Service Art, Station D, Chicago.

SELL "Chum" aluminum clutch pencils; cheapest on market. Big commissions. Sample 25c. Northern Specialty Company, 2053 Randolph St., St. Paul.

AGENTS, male and female, new line necessities for home, office, Auto. P. O. Box 82, East Boston, Mass.

BIG money made silvering mirrors and plating tableware. Outfits furnished. E. Decie Laboratories, 286 Fifth Avenue, New York, N. Y.

AGENTS: Self-threading needles. Every home buys. 175% profit. Sample free. Maher Co., Dover, N. J.

FREE samples to hustlers, Mustardated Creme, Aspirin Tablets, Skin Lotion, Lankes, 2313 North Kildare, Chicago.

AS side lines nothing beats our can opener, spark plug, and other live specialties. All new. Big demand. Good repeaters. Smith, 1316 North American Bldg., Chicago.

\$100 WEEKLY with 500% profit Repeater easy. K Home, 1957 Warren, Chicago.

BIG Profits Selling New \$3.50 Automatic Adding Machine. Absolutely accurate. Fully guaranteed. Quick sales. Ten daily easy. No competition. Pocket size. Business people everywhere positive customers. Thousands being sold. Tremendous demand. Here's high-grade money-maker. Bassett Co., 1458W Hollywood Ave., Chicago.

FOR the Holidays. Our Ex-Cel Luminous Crucifix which "shines in the dark" is the most appropriate gift of all. An instant to demonstrate and the sale is made. Big profits. W. G. Hannan Co., Dept B, 57 East 18th St., Chicago.

AGENTS! 1921's greatest sensation. 11-piece toilet article set selling like blazes at \$1.75 with \$1.00 dressmaker's shears free to each customer. Get lined up for Christmas rush. E. M. Davis Co., Dept. 506, Chicago.

AGENTS, Men and Women, on Farms and small towns everywhere, sell high-grade necessity. The Dabrite light demonstrates its own superiority. Moderately priced. Guaranteed. \$75.00 to \$100.00 weekly. Sample Free. Billings, 1626B West 34th, Chicago.

AGENTS—Big money taking orders overcoats, pants, blankets, direct Woolen Mill to wearer. No deliveries. No capital required. A knockout. Donahue made \$27 first day. Complete outfit free. Taylor, Wells, 2740 N. Paulina, Chicago.

AGENTS—Make 100% profit: Wonderful Milkcloth sells on sight; polishes silverware without powders or pastes; great opportunity for hustlers. Address Miller Brothers, Allendale, N. J.

WOULD good durable paints and varnish 50c gallon interest you? Then write today. Dept. 2, Emmelmann Bros. Mfg. Co., Indianapolis, Ind.

IF you need good live agents—fellows who can get the business—ask me how others are doing it. I'll gladly render the necessary assistance. J. Roy McClellan, Mgr. Classified Advertising, Popular Mechanics Magazine, Chicago.

AGENTS—Texas Remedies 200%. Address Int'l Remedy Co., 1331 Franklin, St. Louis, Mo.

AGENTS Make \$1.35 or more applying sets Lithogram Initials to automobiles, motorcycles, golf sticks, etc. Anyone can do the work in a jiffy. And everybody buys. Write today for particulars. Big money to be made. Lithogram Company, Desk 17, East Orange, N. J.

"FASTEST Selling" 50c Specialty, hotels, cafes, housewives. Sample, particulars 10c prepaid. Territory going fast. B. B. Factories, 4835 Minnehaha, Minneapolis.

AGENTS, Streetmen—Selfolite lights any fire while user sleeps, or other time, by itself. Performs surprising stunts. Newly patented; 25c, postpaid; money back. Particulars. Kaytwo Mfg. Co., Station A, Boston, Mass.

TANNING Cheap, quick way. Recipe Free. Agents wanted. R. N. Gilley, Carlton, Texas, Tanners.

SELL Something New. "The A-B-C of Business" for business men. 50c copy. Agent's terms. Forbes Kinghorn, 110 Howard St., Pittsfield, Mass.

AGENTS, Men or Women, full or spare time, earn \$25.00 to \$100.00 a week and be your own boss representing the Ho-Ro-Co Mfg. Co., manufacturers of the wonderful Ho-Ro-Co Tonic, the great blood purifier and system builder; some profit-maker. Ho-Ro-Co Medicated Skin and Scalp Soap for the baby, toilet, bath, skin and scalp; a repeater. Over 100 other fast-selling specialties, toilet preparations, perfumes, flavoring extracts, spices, medicinal preparations and household specialties. Every item a fast seller and a big profit-maker. Don't fail to ask for our free sample case offer. We furnish advertising matter and samples free of charge. Ho-Ro-Co representatives are successful. Write today. Ho-Ro-Co Mfg. Co., 154 Locust St., St. Louis, Mo.

AGENTS—Send for sample "Fretnot"—the washday wonder. Be convinced you can do a whirlwind business. You can clear at least \$20 to \$100 weekly, according to spare or whole time. You don't have to talk; if she doesn't buy at sight, leave sample; she will be looking for you long before you are able to make the rounds again. Samples furnished free. Premiums for your customers. Exclusive territory guaranteed to agents who can produce. Credits given. Don't call P. M. Motter & Sons, 20 E. Jackson Blvd., Chicago.

WONDERFUL Winter Auto Necessity invention. \$1.00 sale means 75 cents Profit for you. Experience unnecessary. Absolutely New Specialty. Hiley made \$108 three days. Stocum first hour made \$10. Every Automobilitist buys after each quick demonstration. Carried in Pocket. Prevents Accidents. Better Service. Reduces Operating and Repair Expenses. Write Quick for Exclusive Territory and Free Sample. Secretary, Box 494, Hartford, Conn.

AGENTS—New Invention. Harper's Ten-Use Brush Set and Fibre Broom. It sweeps, washes and dries upstairs windows, scrubs and mops floors and does five other things. Big profits; easy seller. Free trial offer. Harper Brush Works, Dept. X, Fairfield, Iowa.

EASY, pleasant work for Mechanics. Shop Men, Clerks, during spare hours; will add many dollars to their salaries. Also want persons who can give full time. Big wages assured. Novelty Cutlery Co., 67 Bar St., Canton, O.

GOLD Leaf Sign Letters; make and sell; profits exceed 1,000%; immense demand; particulars free. Johnston Co., Quincy, Ill.

COIN Money Selling Neterwet Shoulder Strap Waterproof Aprons. Every woman buys. Best on market. We manufacture and ship direct. Get details today. A. D. Bergen Manufacturing Company, 413 Locust St., Philadelphia.

"PEERLESS" Plate Glass Wind Deflectors give every car that "million-dollar" look. Most popular necessity ever invented. Handsome, Durable. Quickly demonstrated and attached. A fortune for live agents. Write Quick for liberal trial offer and illustrated booklet. Rapid Sales Corporation, 10-A, Grand Rapids, Mich.

ANY man handy with paint brush can start new mechanical business on nearly nothing; needed everywhere; nearly all profit; experience not required. John Braceland, 1457 So. Ninth, Philadelphia, Pa.

AGENTS—Clever Invention! Indospoon makes every pen a fountain pen. Fast office seller; big profit, demand increasing everywhere. Exclusive territory offered. Sample free. H. Marul Company, Tribune Bldg., New York, N. Y.

SELL washing tablets that are different. They work quicker, sell easier and at a greater profit. Get our proposition. Write Newton & Co., 1 Main St., Newark, N. Y.

WRITE for particulars; best article ever offered men; costs 5c, sells quick for dollar; \$15 daily; sworn statement. Beach, 22 Express Bldg., San Diego, Cal.

FREE—Formula Catalog. S. & H. Laboratories, Boylston Building, Chicago.

SELL Necessities. Everybody needs and buys the "Business Guide." Bryant cleared \$800.00 in July. Send for sample. It's free. Nichols Co., Box 4-B, Naperville, Ill.

GOLD Sign letters for stores and office windows. Photo pillow tops, portraits, frames, sheet pictures, medallions, waterproof aprons, novelties. Samples, catalogue free. Thirty days' credit. James C. Bailey Co., Desk B11, Chicago, Ill.

AGENTS Wanted—Something New—Fire Fighter sells easily. Makes a spectacular demonstration—car owners, homes, factories, stores practically buy on sight. Our men make \$10 to \$50 a day—exclusive territory. If you wish to establish a business of your own with unlimited possibilities for making big money, write us today. Fyr-Fyter Co., 163 Fyr-Fyter Bldg., Dayton, Ohio.

AGENTS make 140% profit. Iradium (luminous) crucifix shines in the dark. Sells for \$2.00. Costs 84c. Complete line religious articles, crucifixes, bulbs, switch plates, house numbers and match boxes. Novel Ornamental! Useful! Every home a prospect. Big sales. Get free demonstrating outfit. The Pioneer Corporation, 1239 W. 63d St., Chicago, Ill.

BEEES pay if kept right. Be a progressive beekeeper. We can show you how. Send \$1.00 today for Bee Primer, 9 months subscription to American Bee Journal and catalogue of bee supplies. American Bee Journal, Box 62, Hamilton, Ill.

AGENTS. Canvassers, sell Verdina Face Powder and Toilet Necessities. Big profits. Permanent repeat business. Highest quality. Lowest prices. National Products Co., A16 E. 13th St., New York.

BEAUTIFUL new map of United States showing all transcontinental highways. Profit large. Send for particulars. Standard Map Company, 129 W. Ohio Street, Chicago.

SALESMEN and District Managers for tremendously successful new office article. Two minute demonstration means sale every office; 100% repeater. A gold mine for you. Perfection Mfg., 113 South Fourth, Philadelphia, Pa.

AGENTS to sell Kerosene Burners for all purposes. Big Profits. Economy Mfg. Co., 616 W. Monroe St., Chicago.

BE Successful Agent—Free sample outfit worth \$2.25. "Quality" beauty preparations. Make big money. Extensive line. Established 50 years. Lynas Co., 216, Loganport, Ind.

WHY work for others? Make and sell your own goods. We show you how. Enormous profits. Write quick for free book explaining everything. National Scientific Laboratories, 618 Main, Richmond, Va.

SIGN letters for windows at honest prices. Genuine gold leaf. \$50 week easily made. Chicago Sign System F, 150 W. Austin Ave., Chicago.

AGENTS make 500% profit handling Auto Monograms, New Pictures, Window Letters, Transfer Flags, Novelty Signs. Catalog Free. Write Hinson Co., Star City, Ind.

AGENTS: Men and women, in spare or full time, make big money selling household necessity. Every home a prospect. Quick sales, big profit. Territory open. Write for particulars. Judd & Leland Manufacturing Company, Box 21, Clifton Springs, N. Y.

AGENTS—Steady Income. Large manufacturer of Handkerchiefs and Dress Goods, etc., wishes representative in each locality. Factory to consumer. Big profits, honest goods. Whole or spare time. Credit given. Send for particulars. Freeport Mfg. Co., 59 Main St., Brooklyn, N. Y.

STOP Making Money for Others. Manufacture These Goods Yourself From Miller's Guaranteed Manufacturer's Formulas—Profits Enormous, Investment Small, Business Quickly Established—Stamp Brings Valuable Literature Regarding Magic Windshield Cloth; Amazon Rubber Repair Laundry; Stove, Bluing Paddles, Mexican Yucca Soap, Food, Automobile, Household Specialties in all lines. Get this Valuable Literature. Miller Chemist (Old Reliable, Established 1897), Tampa, Florida.

LARGE shirt manufacturer wants Agents to sell complete line of shirts direct to wearer. Exclusive patterns. Big values. Free samples. Madison Mills, 503 Broadway, New York.

MAKE 600% Profit, Free Samples, Lowest priced Gold window letters for stores, offices. Anybody can do it. Large demand. Exclusive territory. Big future. Sideline. Acme Letter Co., 2806-D, Congress, Chicago.

AMERICO Rooster auxiliary water carburetor makes auto burn water. Eliminates carbon. Low cost; liberal profits; details free. Americo Co., Dept. 178, Cincinnati, Ohio.

AGENTS: Big Money Monogramming By Transfer Method. Catalogue Showing Over 50 Styles and Particulars Free. Motorists' Accessories Co., Mansfield, Ohio.

SELL Pudding Powders—Delicious dessert. Fast sellers; quick repeaters; big profit. Send for terms and sample. C. H. Stuart Co., 65 Union, Newark, New York.

AGENTS make one dollar per hour selling "De Luxe Art Panels." Newest thing in art. Men with automobile make forty dollars per day. Tremendous demand. Write for samples and expense money. Consolidated Portrait Co., 225 North Green St., Chicago.

\$200 WEEKLY. Free samples. Sell gold sign letters to stores, offices. No experience. Big future guaranteed. Can travel. Exclusive territory. Become our general agent. Acme Letter Co., 2800D Congress, Chicago.

MAKE \$25 to \$50 Week representing Clow's Famous Philadelphia Hosiery, direct from mill—for men, women, children. Every pair guaranteed. Prices that win. Free book "How to Start" tells the story. George Clow's Company, Desk 31, Philadelphia, Pa.

YOU can letter Automobiles, Doors, Trunks etc., without any previous experience by Transfer Process. Make \$27.50 on \$2.50 Outfit. Auto Monogram Supply Co., 16 Green St., Newark, N. J.

BEST Proposition on Earth, Kitchen Specialty Every Woman Wants. Nothing like it in existence. 200% profit. Best Novelty Mfg. Co., Dept. C, 160 N. Wells, Chicago.

AGENTS and portrait men. Crew managers. We give you more for your money. Better and quicker service. Lowest prices on frames and glass. Rejects credited. Catalog free. The Pioneer Corporation, 1239-A West 63rd St., Chicago.

FAST-SELLING Sanitary Brushes, Mops, Dusters. Positively best house-to-house line in America. Write and be convinced. Sanford Brush Co., 544 W. Lake St., Chicago.

AGENTS Make \$10 a day selling Pressurized Trouser presser and creaser. Connolly, 176 Greenwich St., N. Y.

WE Start You Without a Dollar. Soaps, Extracts, Perfumes, Toilet Goods. Experience unnecessary. Carnation Co., 201 Olive, St. Louis.

AGENTS: Big profits. Best and cheapest window letters made. Easily applied. Dime brings five samples. Particulars free. Stalbright Co., 1115 Second Ave., New York.

PORTRAIT Agents: Our goods will make you big profits. Delivery guaranteed. Rejects credited. Prompt shipments. Send for latest catalog and prices. Adam J. Kroll & Co., 602 Blue Island Ave., Chicago, Ill.

MAKE \$2 an Hour. Article that removes iron rust, grass, medicine, fruit, mildew stains. Cleans Panama and Straw Hats. Bleaches clothes. Sells Every home. Write for free demonstrating outfit and start taking orders at once. Christy, 81A Union, Newark, N. Y.

AGENTS: Big Returns, fast office sellers; particulars and samples free. One Dip Pen Co., 2 Daily Record, Baltimore, Md.

WORLD'S Fastest Selling Auto Accessory! County Distributors wanted; write today. G. L. W. Spring Oiler Co., San Diego, Calif.

AGENTS sell Laundry Tablets under your own name and brand. Free samples and circulars furnished with every order. Particulars free; sample, fifteen cents. Write today. Krebs A Products, College Point, N. Y.

PORTRAIT Agents, who want good work and prompt service and who desire to purchase their frames at factory prices, should write us at once for catalog and price list. W. G. Hannan Co., Dept. A-5, 57 E. 18th St., Chicago, Ill.

AGENTS—New patented curtain rod, necessity in every home; big profit; 4 to 10 sales at every house. Write for free sample. Home Curtain Rod Co., Providence, R. I.

CALIFORNIA Rosebuds selling like hot cakes. Agents coining money; new stuff. Big profits. Catalog free. Mission Bead Co., P31-2819, West Pico, Los Angeles.

AGENTS make a dollar an hour. Sell Mendets, a patent patch for instantly mending leaks in all utensils. Sample package free. Collette Mfg. Co., Dept. 404-B, Amsterdam, N. Y.

AGENTS—Advertising Pencils, ready sellers, excellent sideline. Write for proposition. North American Pencil Works, 501 Plymouth Court, Chicago.

YOU can be your own boss with our Key Check outfit. Good for \$5 a day stamping names on pocket key checks, fobs, etc. Sample check with your name and address, 20 cents. Pease Die Works, Dept. M, Winchester, N. H.

PATENTS—Write for our free illustrated guide book and Evidence of Conception Blank. Send sketch or model for our opinion of its patentable nature free. Highest references. Prompt attention. Reasonable terms. Victor J. Evans & Co., 163 Ninth, Washington, D. C.

WANTED—Tailoring Sales Agent—Make big money from very start—\$40.00 to \$75.00 weekly. Largest made-to-measure tailoring house, furnishing an equipment of five hundred woolsens, wants you to take orders. Satisfaction guaranteed. Biggest merchants in many towns have started with our line. If you want to establish yourself permanently in business and make big money write for full particulars, giving your experience as salesman or tailor's sales agent. H. F. Foster, Sales Manager, Lock Box 483, Chicago.

AGENTS—Best seller: Jem Rubber Repair for tires and tubes; supersedes vulcanization at saving of over 800%; put it on cold, vulcanizes itself in two minutes, and is guaranteed to last the life of the tire or tube. Sells to every auto owner and accessory dealer. For particulars how to make big money and free sample, address Amazon Rubber Co., Amazon Bldg., Philadelphia, Pa., Dept. 505.

AGENTS—If you are making less than \$300 a month our proposition on Sentinel Burglar Alarms for windows and doors will interest you. Many agents earn \$20 daily. Brand new inventions. No wires, batteries or nails. Instantly attached to any door or window. Handsomely nickel plated. Sell on sight. No competition. Provides cheap burglar insurance. Big money makers. Write today for extremely liberal terms to agents. Sentinel Alarm Co., 140 S. Dearborn St., Chicago, Ill.

AGENTS—Stamping names on Pocket Key Protectors; sample Check with your name and address, 25c. Stamping Outfits, Emblem Checks, Check Fobs, Name Plates. Hart Mfg. Co., Desk 2, 303 Degraw St., Brooklyn, N. Y.

MOST Wonderful Seller. 96c profit every dollar. No stock to carry. License unnecessary. Sample free. Mission Bend Co., 1617 Iroia, Los Angeles, Calif.

POLMET Polishing Cloth cleans all metals. Retail 25 cents. Sample free. Gale & Co., Inc., 15 Edinboro St., Boston.

BIG money and Fast Sales. Every owner buys Gold Initials for his auto. You charge \$1.50; make \$1.35. Ten orders a day easy. Write for particulars and free samples. American Monogram Co., Dept. 40, East Orange, N. J.

HIGH-GRADE SALESMEN WANTED

LEARN the secrets of Star Salesmanship and qualify for \$3,000 to \$10,000 a year as City or Traveling Salesman. Free Employment Service. Send now for free book about our amazing system, also list of lines. National Salesmen's Training Association, Dept. 128A, Chicago, Ill.

LIVE Wire Distributors and Dealers everywhere make money selling Seal-Past Inner-tube repair kits because of the unequalled efficiency and our aggressive and helpful sales promotion and advertising cooperation. Write Sales Manager for particulars. Robert M. Bowes Co., Indianapolis, Ind.

SALESMEN: Make extra money easily. Sell our Accident and Sickness policies in your spare time. \$5,000 death, \$25 weekly benefit for \$10 yearly. Address North American Accident Ins. Co., Dept. K-25, Newark, N. J.

SALESMEN—Lowry Xmas Show Window Card Signs Now Ready—35 subjects—Every Business a Prospect, 150% profit. Sample 15c. Lowry Signs, 189 No. Clark, Chicago.

OIL Gauge for Fords. Remarkable new invention. Sells on sight. Big profits easy. Exclusive distributors wanted. Address Sales Mgr. 82, Sta. C, Omaha, Nebr.

BIG Profits Easy. Duplex Transformers needed on every auto. Save gas. Easily sold. Exclusive Distributors wanted. Jubilee Mfg. Co., 22, Sta. C, Omaha, Nebr.

SALESMEN Wanted to sell Roman Spark Plugs on commission. A high-grade guaranteed plug. Side Line men desired. Write today. Roman Spark Plug Co., Rome, N. Y.

SELL 25 3-lb. Cans Yankee Hand Soap. Profit \$5.00. \$2.00 brings first dozen. Crystal Chemical Co., Newark, N. J.

SALESMEN, sell supplies boards of education. Liberal proposition. Exclusive territory. Union School Furnishing Company, 1028 Van Buren St., Chicago.

MANUFACTURER offers unusual opportunity to experienced sales manager capable of organizing crew to cover drug and grocery trade in your home territory. This is an opportunity of a lifetime for the right party. Product is fastest seller ever offered trade and the repeat business is simply phenomenal. Tremendous demand already existing with absolutely no competition. Profits should run from \$15,000 to \$35,000 per year. All replies considered confidential. State experience and qualifications fully. Beardsley Specialty Co., Rock Island, Ill., Desk P.

WANTED—Foreign and domestic representatives to sell brand-new line of guaranteed garage tools. Exclusive territory. Need \$6 for the best universal timing gear puller on the market. Try it out and see how easily it sells. Money refunded without question if you ask it. Lelin Mfg. Co., 450 Stark St., Portland, Ore.

WANTED: Reliable men to act as our District Superintendents to book orders for fruit and ornamental trees, roses, shrubs, etc. Unrestricted territory. Commissions weekly. Knight & Hostwick Nurserymen, Newark, New York State.

SELL something different: all business and professional men need it. Sells \$7.50, costs you \$1.50. Sure repeater. Exclusive territory. Sample free. Merchants Assn., Minneapolis, Minn.

TAKE Orders for Red Rooster poultry foods. Address Northwest Co., Tulare, S. D.

WANTED—Salesmen—soaps, greases, oils; old manufacturers Baum's Castorine Co., Rome, N. Y.

ACCEPT this offer if you want real money. Sweet made \$652 last month. Murphy \$636. Largest company of its kind in America. Your profit \$3 to \$8 per order. We furnish full equipment. All you do is call on our customers and take their orders for famous all-weather coats. Big, permanent proposition. Spare time or full time. No capital required. Write quick for offer that will put you on the road to success. The Comer Mfg. Co., Dept. W-56, Dayton, Ohio.

SALESMEN—Earn up to \$500 or more monthly demonstrating and selling marvelous three-pound desk adding machine. Sells on sight for \$15.00. Does work of more costly machines; speedy, accurate, guaranteed. Protected territory open. Write quick for trial offer. Pangborn Adding Machine Company, Desk 2, Grand Rapids, Mich.

LIBERAL Proposition for Live Men to act as general agent for fast selling line of food flavors, toilet articles, etc. Appoint sub-agents and receive commission on subagents' business. Write today for particulars. Address C. H. Stuart & Co., 25 Broadway, Newark, New York.

REPRESENT Corporation. No selling. Markham left \$60 weekly position to accept this. Smith making over \$8 daily; earnings \$40 to \$75 weekly. Equipment furnished. Write for portfolio. 102 White Plains Ave., New York.

SALESMEN wanted, all or part time, for nationally advertised copyright system of collection letters. The Non-Dictating System, Dept. P, Post Office Box 1919, Boston, Mass.

SPECIALTY Salesmen—In \$1,000 a month class to call on dry goods trade. Record required. Computing Yard Measure Company, 30 N Dearborn, Chicago.

FAST Selling articles appealing to colored people. Big profits to hustler. Write today. Colored agents preferred. Address Yarbrough Mfg. Co., Winston-Salem, N. C.

SALESMEN—To sell a necessity to barbers and hairdressers. Seven dollars commission on every sale. John Jorgensen Company, 120 Liberty Street, New York.

INSTANTANEOUS Calculator, wonderful seller at \$5.00. Much faster than calculating machines. Salesmen's price, \$2.40, prepaid. Instantaneous Co., 902 Michigan, Detroit.

"OUTOSITE" aluminum side suspenders, 50c. Shirt down, pants up. Enormous seller. Woods, 501 N. Seventh, St. Louis.

SALESMEN Wanted—Local or traveling, part or full time, to sell calendars, fans, fly swatters, brushes, rulers, etc. Over two hundred stock designs of paraffin signs, ice cards, etc., for all merchants. Fine side line. Liberal commission. The Harrison Company, Union City, Ind.

AN Excellent side line for men or women calling on general dry-goods, variety, notion and drug-store trade. Meritorious article, rapid seller and repeater. Big commission. Pocket samples. Magnetic Mfg. Co., 519 Corn Exchange, Minneapolis, Minn.

SIDE line salesmen: Easy selling line work pants. Advertised. Light samples. Exc. ter. Big money maker. Daniel Boone Woolen Mills, 1735 Diversey, Chicago.

VENDING Machines—Peanut, Match and Gum Venders. Excellent Line—Big Commission. Standard Adv. & Printing Company, Ft. Scott, Kans.

WONDERFUL Winter Auto Necessity invention. \$1.00 Sale means 75 cents profit for you. Experience unnecessary. Absolutely new specialty. Riley made \$108 three days. Slocum first hour made \$10. Every Automobileist buys after each quick demonstration. Carried in pocket. Prevents accidents. Better service. Reduces operating and repair expenses. Write quick for exclusive territory and free sample. Secretary, Box 494, Hartford, Conn.

EVERYBODY Eats Every Day. You can handle Sugar, Flour, Canned Goods, Dried Fruit, Coffee, and entire line of groceries, as well as Paints, Roofing, Aluminum Ware and Automobile Oils, with no rent to pay; no money invested; take large orders from samples. Goods are guaranteed and proven quality. Selling experience not necessary. Steady, profitable work for "workers." Address Hitchcock-Hill Co., Dept. 260, Chicago, Ill. Reference: Any Bank or Express Co.

57 MILES per gallon made with new patented gasoline Vaporizer. Write for particulars. Vaporizer Co., Pukwana, S. Dak.

WANTED—Salesmen now calling on Toilet Goods, Hardware, House Furnishing, Tobacco and Infants' Wear Trades to handle our different specialties—liberal commission—good territories open. E. T. Gilbert Mfg. Co., 246 South Ave., Rochester, N. Y.

SALESMEN for Patented Cigar Lighters and Cigar Case Moisteners. Sell to Cigar Stands everywhere. Thousands in use. Exclusive or side line. Start Now. Drake Mfg. Co., Dept. M, Milwaukee, Wis.

SALESMEN can make \$5.00 a day selling our Pencils, Signs, Aluminum and Celluloid Advertising Novelties, Yard Sticks, Whistles, etc. Liberal terms. Sells entire year. Fine side lines. Local and traveling Agencies. Model Calendar Co., Dept. 226, South Bend, Ind.

MAKE \$50 Daily. Something New! 400% Profit. All Business. Professional Men Need It. Sells \$5. Costs \$1. Brooks, Texas, sold 26 first day, profit \$89. Big weekly repeater. Sells quickly. Experience unnecessary. Write today for territory wanted. Sample outfit free. Federal Association, 71-D Asylum St., Hartford, Conn.

HELP WANTED

UNITED States Government Wants Men. Excellent positions at attractive salaries. Railway Mail Clerk Examination soon. Let our expert (former United States Civil Service Examiner) prepare you for this and other fine positions. Write today for free catalog P.M. Patterson Civil Service School, Rochester, N. Y.

DISTRICT Manager: 150,000 sales of a household appliance in New England have paid District Managers upwards of \$3,000 yearly. We are ready to expand. Office work entire or side line. The Reeves Co., 61 Broad Street, Milford, Conn.

SUCCEED. Be an Automotive Electrical Specialist. Learn Starting, Lighting, Ignition; Generator, Armature, Magneto Work; battery building, repairing. Greatest school. Free booklet. Johnson's Automotive Electrical School, Dept. V, 729 Broadway, Denver.

AGENTS. sell felt rugs 100% profit. Our agents making \$50 to \$75 weekly. Splendid seller. Something new. Exclusive territory. Ironclad Rug Co., 21 Myrtle Ave., Newark, N. J.

MEN—\$35 weekly for spare time, mailing letters; experience unnecessary. Send stamped addressed envelope for terms. E. Normande, 147 W. 23d St., New York, N. Y.

NATIONAL known nurseries want reliable men to sell and establish agencies. Liberal pay weekly. All or part time. Address Federal Nurseries, Rochester, N. Y.

FIREMEN, Brakemen, Baggage-men, \$140-\$200. Colored Porters by Railroads everywhere. Experience unnecessary. 810 Ry. Bureau, East St. Louis, Ill.

START Silvering Mirrors, Auto headlights, Tableware. Plans free. Clarence Sprinkle, Dept. 28, Marion, Ind.

BE a Railway Traffic Inspector! \$110 to \$250 monthly; expenses paid after 3 months' spare-time study. Splendid opportunities. Position guaranteed or money refunded. Write for free booklet CM-46. Stand. Business Training Inst., Buffalo, N. Y.

WANTED—Able-Bodied Men (White and Colored). Prepare for Railway Train service. All branches. Experience unnecessary. Good wages, steady work. Standard roads. No strike. Write, stating position wanted. Railway Institute, Dept. 35, Indianapolis, Ind.

GOVERNMENT Wants Railway Mail, Postoffice Clerks. Other positions. Salary \$135 month. Experience unnecessary. Write for information concerning positions and instruction. Columbia School of Civil Service, 411 Pope Bldg., Washington, D. C.

MEN wanted for safe work. Easy, pleasant and interesting. Excellent pay. Write Safe Expert, 913 21st Street, Rock Island, Ill.

WANTED. Men; sell books evenings; easy money; catalogs 10c. McCarthy, Kellogg, Minn.

STRICTLY Homework. We buy your product. Materials obtainable anywhere. Experience unnecessary. 135 plans, samples, formulae, dime. Co-Operative Club, Augusta, Maine.

IF you want more pay, become a draftsman. We teach you Mechanical Drawing at home in your spare time; no previous training required. Our graduates earn \$35 to \$100 a week and more as they advance. Write today for Free Book, "Your Future in Drafting," Columbia School of Drafting, Dept. 1665, Washington, D. C.

U. S. GOVERNMENT wants hundreds Railway Mail Clerks, \$1,600 first year. Quick raise to \$2,300. Vacation with full pay. Permanent-steady positions. No strikes or layoffs. Common education sufficient. Pull unnecessary. Every man or boy over 16 should become interested. Write immediately for list positions open. Franklin Institute, Dept. W3, Rochester, N. Y.

WANTED—50 men to appoint agents for fast selling line of food products and toilet preparations—212 articles. State territory wanted. Write today for particulars. C. H. Stuart & Co., 26 Broadway, Newark, New York.

MEN looking for a good paying business: Get into the battery game. Our home study method makes you an expert. Equipment furnished. Write for particulars. C. & S. Battery School, Racine, Wis.

FREE. Start Little Mail Order Business anywhere. Home employment evenings. I furnish everything. Send 2-cent stamp for free booklet and samples. Williams, Department A, 72 Cortlandt Street, New York.

U. S. GOVERNMENT wants Railway Mail Clerks. Commence \$135 month. Steady positions. Common education sufficient. Sample examination questions free. Write immediately. Franklin Institute, Dept. W21, Rochester, N. Y.

LOCOMOTIVE Firemen, beginners \$150, later \$250 monthly, for railroads nearest their homes, everywhere in United States and Canada. Address Railway Association, Desk M-1, Brooklyn, N. Y.

YOU are wanted. U. S. Government jobs. \$135-\$195 month. Hundreds openings. List free. Write immediately. Franklin Institute, Dept. W21, Rochester, N. Y.

GOVERNMENT wants Railway Mail Clerks, \$135 month. List positions open-free. Write immediately. Franklin Institute, Dept. W21, Rochester, N. Y.

BIG money made silvering mirrors and plating tableware. Outfits furnished. E. Debie Laboratories, 286 Fifth Avenue, New York, N. Y.

MEN: Become Railway Mail Clerks. \$135 month. List positions free. Franklin Institute, Dept. W21, Rochester, N. Y.

GOVERNMENT needs Railway Mail Clerks, \$135 to \$192 month. Write for free specimen questions. K-62 Columbus Institute, Columbus, O.

START a Paying Business of Your Own. Be a business man. Any location. 8,000 new Tire Vulcanizing and Repair Stations needed. Business always good. Are you ambitious? \$100 will start you. Write at once. Wonderful opportunity. Equipment Co., 175 Canal, Cincinnati, Ohio.

SILVERING mirrors, French plate taught. Easy to learn, immense profits. Plans free. Wear Mirror Works, Excelsior Springs, Mo.

WRITE Articles, stories, news, in spare time for newspapers and magazines. Big pay. Copyright book free. Press Syndicate, 553, St. Louis, Mo.

GOVERNMENT Clerks Needed soon. (men-women), \$1600-\$2300. Permanent. Few to travel. Write Mr. Ozmert, Former U. S. Government Examiner, 161 St. Louis.

SIGN Letter Agents and Painters; 500% Profit Gold and Silver Sign Letters for Stores and Office Windows. Anyone can put on. Big demand. Free samples. Metallic Letter Co., 431D N. Clark St., Chicago.

CALIFORNIA Rosebuds selling like hot cakes. Agents coining money. Absolutely new. Big profits. Catalog free. Mission Bead Co., SP2819 West Pico, Los Angeles.

SALESMEN—Become Independent. Own your business; experience unnecessary; selling our \$7,500 Accidental Death, \$50 Accident, \$25 Sick Weekly Benefits; \$12.50 yearly; other amounts proportionate. Guaranteed steady income from renewals. \$250,000 deposited Insurance Department. Registration Dept. A, Newark, N. J.

GOVERNMENT Positions are Fine: \$1400, \$1600, \$1800 at start, up to \$2300 and \$2600. Exams everywhere. Write today for full information. Patterson Civil Service School, Box 1, Rochester, N. Y.

INVENTORS desiring to secure patents should write for our book, "How to Get Your Patent," tells our terms and methods. Send sketch for our opinion of its patentable nature. Randolph & Co., Patent Attorneys, 620 F. Washington, D. C.

OUR genuine gold window sign letters are an excellent money-making proposition for handy men. Slann Sign System, St. Antoine St., Detroit, Mich.

MAKE money writing Photo-plays; details free to beginners. No correspondence course. Producers' League, 230 Wainwright, St. Louis.

WANTED: Railway Mail Clerks—\$1,600 to \$2,300. Exams everywhere. Write today for full information. Patterson, Civil Service Expert, Box 4025, Rochester N. Y.

FOR ADVERTISERS

ADVERTISE in 1,000 Corn Belt Weeklies, \$10.00 line, 25 words, 24 big Dailies, \$15.00. Booklet free. Address Union Advertising, Baltimore Bldg., Chicago.

ADVERTISE. Country town newspapers. Lists free. Pennell Company, Covington, Ky.

BATES "copy" hits the bullseye! Charges moderate—results large. Prove us. Free book to advertisers on letterhead request. Bates Better Way Advertising, Drawer 141, Springfield, Ohio.

USE Jacobus Cuts, Proofs 10c. Jacobus Advertising, Irvington, N. J.

SPECIAL!!! Inch Display Advertisement 150 Magazines Thrice \$15. Page \$200. Wood's Popular Services, Atlantic City.

INFORMATION

CHRISTMAS shopping our specialty. We secure articles or furnish information for you, 50c. Universal Service Co., 34 E. 3rd St., Brooklyn, N. Y.

LETTER SPECIALISTS

SUCCESSFUL sales letters, \$10. Results or fee returned. Free suggestions. Morse, 133 W. 103rd, New York.

ATTENTION—Gripping, desire-creating sales letters. So strenuous they have to bring business. Ewald, 200 East 87th, New York.

ADVERTISING that tells the story and gets results. Letters \$5.00. Circulars \$10.00 up. Send full particulars with order. Jackel, 3819 Warrington Avenue, Philadelphia, Pa.

SECURE the position you want. I can give you genuine assistance. Particulars free. Floyd V. Studer, Canadian, Texas.

BUSINESS SERVICE

CIRCULARS Honestly Mailed. Send samples. Box 280, North Side, Pittsburgh, Penna.

STRICTLY reliable information on mechanical and electrical problems, calculations, drawings and designs. Send in your problem and we will write you the cost. Connors & Chatto, 1010 Mass. Ave., Cambridge, Mass.

INCORPORATE. Our lawyers do the work, saving you time, annoyance and money in incorporating under the most liberal laws of Arizona. Laws and forms free. Southwestern Securities & Investment Co., Box D488, Phoenix, Ariz.

LITERARY SERVICE

WE Prepare Lectures, Speeches and original special articles. Expert Service. Manuscripts revised, placed. Herald Publicity Service, 415 Bristol Building, New York.

MAILING LISTS

MAILING lists for any place and business, multigraphing and business letters. Gissel & Blaine, Union League Bldg., Los Angeles.

TO reach Michigan's best-paid workers in Grand Rapids, Saginaw, Muskegon and Battle Creek, try our list. Two cents a word. Michigan Associated Labor Press, Houseman Building, Grand Rapids, Mich.

1,000 NAMES, general mail buyers \$1.50. Pennell Company, Covington, Ky.

THE Mail Dealers Blue Book, 1921 Edition, contains over 1,000 names. Price \$1.00. Address 363 14th St., Brooklyn, N. Y.

10,000 BUYERS, Georgia, Alabama, Florida. Address Southern Name Supply, 705 Zack St., Tampa, Fla.

TYPEWRITER AND SUPPLIES

UNDERWOOD Typewriters at far less than manufacturer's price; rebuilt, all worn parts replaced, guaranteed good as new. Cash, installment payments. Write for Catalogue 1511. Typewriter Emporium, estab. 1892, Montrose and Ravenswood Ave., Chicago, Ill.

DUPLICATORS AND DEVICES

"MODERN" Duplicators. Business Getters. \$2.25 up. 50 copies from pen, pencil, typewriter. No glue or gelatine. 40,000 in use. Free trial. Need one? Booklet Free. J. E. Durkin-Reeves Co., Pittsburgh, Pa.

"QUICK Process Duplicators." Makes 100 copies in 10 minutes. Remarkable time savers. Thousands in use. Circular Free. Hoyer Duplicator Co., 100-PM, N. Wells St., Chicago.

ADDING MACHINES

FREE Trial, Marvelous New Adding Machine. Adds, Subtracts, Multiplies, Divides, automatically. Work equals \$350.00 machine. Price only \$15.00. Speedy, durable, handsome. Five-year guarantee. Used by largest corporations. Write today for catalog and free trial offer. Lightning Calculator Co., Dept. E, Grand Rapids, Mich.

NEW \$3.50 Automatic Adding Machine. Adds, Subtracts, Multiplies. Absolutely accurate. Capacity \$999,999.99. Fully guaranteed. 75,000 pleased users. Makes adding easy, positive, quick. Eliminates Mistakes, Saves Time. Postpaid, \$3.50. Bassett Co., 1458-N Hollywood Ave., Chicago.

PRINTING, ENGRAVING AND MULTI-GRAPHING

LOWER prices for quality printing. 1,000 either 20-lb. Hammermill bond letterheads or envelopes, white, green, Cafe, blue, gold-encord, gray, russet, \$6.75. 1,000 either 6 1/2 white envelopes, noteheads, cards, tags, statements, billheads, 6x9 circulars, \$4.50. 2,000 gummed address labels, \$1.00; all postpaid. Prompt shipment. Samples and calendar, 4c. Quality Press, Clearwater, Fla.

200 BOND letterheads 6x7 and 100 envelopes, name and address neatly printed, prepaid anywhere \$1.20. Satisfaction guaranteed. Udelico, 412 Roberts Bldg., Los Angeles.

CARDS or Envelopes, 200, \$1; 500, \$2.50, Samples 2c. Address Stolte, 351 Third Ave., San Francisco, Calif.

100 IMITATION Typewritten Circular Letters, 95c prepaid. Franklin Mercantile Co., Huntington, Pa.

QUALITY Printing—500 either letterheads, envelopes, cards, \$2.75. Any printing. Superior workmanship. Samples. Address Klein Press, 6 Riverbank Pl., Rochester, N. Y.

1,000 FULL size, good quality bond letterheads, \$4.00. 1,000 good envelopes, \$4.00. Brown's Printery, 625 F Street, Southwest, Washington, D. C.

PRINTING Special: 500 Letterheads and Envelopes \$2.65, prepaid. Address Rodgers Hoggard, Printer, Windsor, N. C.

GUMMED Labels, advertising stickers. Catalogue free. Pennell-Standard, Covington, Ky.

SPECIAL Offer, 100 Bond Letterheads, 100 Envelopes, \$1.35. Economic Press, Leontia, N. J.

QUANTITY Users save 50%. Wolf Roll Labels, Sta. E, Philadelphia.

PRE-USED Printing Presses, Type and supplies. List for stamp. Popular Bargains, Richmond, Pa.

EMBOSSED business, personal stationery. Samples, stamp. Daniels Co., Pitston, Pa.

1,000 LETTERHEADS or Envelopes, \$3.00, sent prepaid. Samples Free. Monitor Press, Morrisville, Pa.

REDUCED prices for better printing. 1,000 Bond letter-heads, \$5.00; 1,000 good envelopes, \$4.25; 1,000 four-page folders, 3 1/2 x 6 1/2 inches, \$12.00. Catalogues, circulars, booklets our specialty. All printing at reduced prices. Samples free. Fantus, 525 S. Dearborn St., Chicago.

TWO-COLOR Quality Printing for price of one. Samples. Arrow Print, 333P Walnut, Waterbury, Conn.

WE print anything. Circulars, stationery. Catalogs, Samples. Commercial Press, Batavia, Ohio.

1000 FULL-SIZE Hammermill Bond Letterheads \$3.65, Postpaid. Other stationery in proportion. Business building Multigraph letters cheap. Samples free. Charles B. Hatfield, Box 353, Oswego, N. Y.

250 LETTERHEADS, 250 White Envelopes, printed and mailed, \$3.00. Samples printing free. Write Sun, Mohawk, N. Y.

200 HAMMERMILL Bond Letterheads, Envelopes, Billheads, or Business Cards, \$1.00 postpaid. Race Printing Company, Hudson, N. Y.

2,000 LETTERHEADS or Envelopes \$7.50 prepaid 3rd zone. Samples Free. Quality Printery, Marietta, Ohio.

PRINTING Outfits—Presses, type supplies, type novelties. Send stamp for catalogue. Model Press, York, Penna.

FOR MEN

I WANT to send Free to every chronic pipe smoker in the country a good, big, generous sample package of my pure, sun-cured, nature-flavored Old Green River Pipe Tobacco. No money to pay. If you are a tobacco crank, all the better. Try the pure stuff. No syrup, flavoring or dope. After you try it free, I'll show you how to cut your smoke bill one-half and get more pipe joy. Just send name and address, and say whether you want mild, medium or strong. Pete Moberly, Box 820, Owensboro, Ky.

DARK Brown corduroy vests, leather sleeves, moleskin waterproof lining, jersey wrist-bands and close fitting collars. Just right for winter and outdoor workers. Special price, \$8.50. Nite Mail Order & Supply Co., 609 27th St., Denver, Colo.

RAZORS AND BLADES SHARPENED

500 SHAVES from one hand-stropped blade. Use Simplex blade holder, \$1.00 postpaid. State blade used. Mynne Company, 77 Brighton Ave., Boston, Mass.

BLADES Resharpended 3c, any make. Guaranteed service. Straight razors \$0.50. Standard Safety Razor Corporation, Pittsburgh, Pa.

BLADES Resharpended, single edge 2c, double 3c. Guaranteed. Ideal Sharpening Works, 148 S. Sixth Ave., Kankakee, Ill.

BLADES re-sharpended. One edge 2c, double 3c each. Straight razors ground 75c. New York Edge Co., Glen Cove, N. Y.

GUNS, SPORTING GOODS, ETC.

LUGER and Mauser Pistols; Mauser Sporting Rifles, Circular ten cents. Pacific Sales, Ltd., Moscow, Idaho.

BOATS AND LAUNCHES

TURN your boat into a high speed launch with one of these twelve-cylinder Motors. Displacement 530 cu. in., 32" long, 36" wide, 30" high; 65 h. p. and up. \$985. Can replace standard parts the world over. Triple Block Motor Works, Box 233, Garfield, Wash.

12 1/2' ROWBOAT—Construction blueprint, 30c. Wee-Shu-U Co., West Market, Detroit, Mich.

DARROW Steel Boats, knockdown or finished; 100 Flatbottom Designs. You can build a steel boat by Darrow's practical plan and save half. Send for Catalogue and boat building booklet. Darrow's Boat Company, Albion, Mich.

OPTICAL GOODS

ULTRALENS Microscope, patent pending. Magnifies 10,000 times, 50c. Model with 4 changes power, 2,500 to 40,000 times, \$1.00. Guaranteed. Others up to 250,000 times. Circular P2 free. Specialty Mfg. Co., Milton, Pa.

DIAMONDS, WATCHES AND JEWELRY

WHAT is it? Watch! Send for it. Math. J. Schmitt, Box 532, Emporia, Kans.

"BLACK" Opals, Beautiful colors. Australia's National Gem. Lists free. Worldwide connection. Seward, Optician, Melbourne, Australia.

WATCH REPAIRING

WATCHES Accurately repaired and cleaned by expert watchmakers. Prompt service. Prices \$2.00 to \$4.00. William Le Gault, 2833 Warren Ave., Chicago.

ANTIQUES AND RELICS

FOR Your Den: World War relics collected Europe's battlefields. Catalogue and war photographs 10c. Address Lieut. Welsh, 50 Ft. Greene Place, Brooklyn, N. Y.

PHONOGRAPHS AND RECORDS

BUILD Your Phonograph. "Perfection" high quality spring and electric motors, tone arms, reproducers, wonderful results. Big saving. New catalog and building instructions mailed for ten cents. Hoosier Manufacturing & Supply Co., Phonograph Supply Dept., 313 Baldwin Block, Indianapolis, Ind.

FINISHED Cabinet Set Up \$28.00; Finest Motor \$12.00; Tone Arm \$6.50. Clarence Leitch, Evansville, Ind.

WONDERFUL Bargains in Phonograph Cabinets. Hunter Factory, McHenry, Ill.

SONORA Motors, Sonora reproducers, tone-arms. Prices reasonable. Frank, 1658 Washington Ave., Bronx, N. Y.

SUPERIOR Grade cabinets, tone outfits, motors, amplifiers and accessories. Superior Phonoparts Co., Erie, Pa.

BUILD a genuine Choralcon phonograph and save over half. Big profit building and selling. We furnish motors, tone-arms, full instructions and all necessary parts. Send for catalogue and free blueprint offer. Choralcon Phonograph Co., 121 11th St., Elkhart, Ind.

MAKE your own phonograph. Save dealers' and manufacturers' profit. We furnish woodwork to exact size, mechanical parts and hardware. Send stamp for blueprint and catalogue. The Carpenter & Cabinet Makers' Supply Co., Oxford Bldg., Chicago.

BELL Hood Semi-Permanent Phonographic Needle. Send 25 cents for sample and information for agency. Wonderful invention. Makes phonograph human. Sells on sight. Appel, 1404 Dixwell Ave., New Haven, Conn.

PHONOGRAPH Cabinets, 50 in. high, \$45.00, 4 spring motors, \$19.00. Write quick before they are all sold out. American Phonograph Co., 3515 North Crawford, Chicago.

DEUTSCHE Records—and Swiss—imported and American. Laendler, Marches, Yodeler, Operas, Home-Songs. Send today for Big List Free. Century Co., 1648 Second Ave., New York, N. Y.

MUSIC AND MUSICAL INSTRUMENTS

BANDMEN: You need my improved Loose Leaf Music Folio, parade size, best ever; protects music in rain. Order sample, postpaid, \$1.00. Dwight W. Godard, Aurora, Ill.

SONG Writers—Have you song poems or melodies? I have wonderful proposition. Ray Hibbeler, D110, 4040 Dickens Ave., Chicago.

NEW C Melody Saxophones, silver plated, with case, \$117.50. John T. French, 227 1/2 Erie Street, Toledo, Ohio.

RAG, Jazz, piano playing taught in 20 lessons the "Christensen" way. Christensen schools in most cities (refer to your telephone directory) or write for booklet about mail course. Teachers wanted in unoccupied cities. Christensen School, 425, 20 East Jackson, Chicago.

PIANO players, send for "Melody Waltz," a very attractive piece, 15c postpaid. Send cash. Special price to dealers in quantities. Wm. Stern, 6219 May St., Chicago, Ill.

EVERYBODY'S Singing "I Ain't Got Nothin' To Give Away." Why not you? 30c postpaid. Frederick Derrick, Music Publisher, 4434 St. Lawrence Ave., Chicago.

GET the Bohemian imported violins; best grade, pure sweet tone. Peter Boxyk, Box 63, Portland, Ore.

FLAGEOLETS \$2.00; has page 842 system. H. Bernard, Chambersburg, Pa.

SONG Poems wanted. Clarence Krause, composer and arranger of music, Box 1652, Dallas, Texas.

CORNETISTS—Trombonists—Saxophonists—Clarinetists. Send for "Free Pointers." Name instrument. Virtuoso School, Buffalo, New York.

I WANT Song Poems. Casper Nathan, Woods Theatre Bldg., Chicago.

WRITE Songs. Big money and reputation. Write for information. J. Gordon Pub. Co., 201 N. Hoyne Ave., Chicago.

"MUSIC Composed" to words. Bauer Bros. (formerly of Sousa's Band), Oshkosh, Wis.

FOR THE HOME

MAKE your own phonograph. Save dealers' and manufacturers' profits. We furnish woodwork to exact size, mechanical parts and hardware. Send stamp for blue print and catalogue. The Carpenter and Cabinet Makers' Supply Co., Oxford Bldg., Chicago.

PATENT ATTORNEYS

INVENTORS, Before disclosing your idea to others write for our "Evidence of Disclosure" form. Send sketch or model of your invention for examination and advice. Ask for free book "How to obtain a Patent." Avoid dangerous delays. Write today. Merton-Roberts & Co., 181 Mather Bldg., Washington, D. C.

EDWARD C. SASNETT, Attorney at Law and former principal examiner United States Patent Office. Sincere, personal and high-grade service at moderate rates. Address McGill Bldg., Washington, D. C.

INVENTORS: Have your invention perfected by expert draughtsmen—Patent, working drawings, free hand illustrating. Send model or sketch for estimate. Address W. H. Rockwell, Oriental Bldg., Washington, D. C.

PATENT, Trade-mark and Copyright specialist. Prompt, personal and efficient service. Advice on request. M. E. Jones, Lawyer, 509B 7th St., Washington, D. C.

PATENTS procured. Trade-marks registered. Reasonable fees. Address Theodore Willis, Registered Patent Attorney, Munsey Bldg., Washington, D. C.

PATENTS Secured. Prompt service. Avoid dangerous delays. Send for our "Record of Invention" form and Free Book telling how to obtain a Patent. Send sketch or model for examination. Preliminary advice without charge. Highest references. Write today. J. L. Jackson & Co., 244 Ouray Bldg., Washington, D. C.

PATENTS Promptly procured. Personal, careful and efficient service. Highest references. Moderate fees. Send sketch or model for actual search and advice. George P. Kimmel, Master of Patent Law, 54D Loan and Trust Bldg., Washington, D. C.

PATENT—Trademarks. Before disclosing an invention, the inventor should write for my blank form "Evidence of Conception." This should be signed, witnessed and returned to me with sketch or model, upon receipt of which I will promptly render opinion as to patentable nature and send booklet on patents. Highest references. Prompt attention. Reasonable terms. Clarence B. O'Brien, Registered Patent Lawyer, Woodward Building, Washington, D. C.

INVENTORS! Send sketch or model of your invention for opinion concerning patentable nature and exact cost of applying for patent. Book, "How to Obtain a Patent," sent free. Gives information on patent procedure and tells what every inventor should know. Established twenty-eight years. Chandice & Chandice, 426 Seventh St., Washington, D. C.

PATENTS Procured—Trade-Marks Registered. A comprehensive, experienced, prompt service for the protection and development of your ideas. Preliminary advice gladly furnished without charge. Booklet of information and form for disclosing idea free on request. Richard B. Owen, 30 Owen Building, Washington, D. C., or 2276-B, Woolworth Bldg., New York.

PATENTS — Trademarks Thirty-five years' experience. Send model or sketch for opinion as to patentability. Free "Inventors' Guide." Highest references and personal attention assure best results. Franklin H. Hough, 522 Washington Loan & Trust Bldg., Washington, D. C.

PROTECT Your rights. Write for record of invention which contains form to establish evidence of conception of your invention. Prompt personal service. Preliminary advice without charge. J. Reaney Kelly, 612G, Columbian Bldg., Washington, D. C.

MONROE MILLER, Ouray Building, Washington, D. C., patent attorney, mechanical and electrical expert. Best quality of work and results. Moderate charges.

PATENTS — Prompt, personal efficient service by an attorney-at-law, skilled in all branches of patent practice. Over 12 years' actual experience; full information upon request. B. P. Fishburne, 331 McGill Bldg., Washington, D. C.

PATENT applications filed on partial payment plan. Trade-marks, copyrights, etc. Milo B. Stevens & Co., 685 F St., Washington; 352 Menadnock Bldg., Chicago, Estab. 1894.

INVENTORS—Send for form "Evidence of Conception," to be signed and witnessed. Form, fee schedule, information free. Lancaster and Allwine, 221 Ouray Building, Washington, D. C.

KEEP up with progress. Promote your patents. Send 50c for year's subscription to best inventor's magazine, "Invention and Manufacturing." American Industries, Inc., Washington, D. C.

PATENTS, Prompt personal, efficient service. Over 15 years' actual experience. Send sketch, model or photos and description. Address Lynwood B. James, 391 McGill Bldg., Washington, D. C.

PATENTS, Trade Marks, Designs and Copyrights. Registered firm of attorneys-at-law. Careful, prompt personal service assured. Moderate fees. Full information free upon request. Address Gross & Collings, 666 Ouray Building, Washington, D. C.

PATENTS—Herbert Jenner, patent attorney and mechanical expert, 622 F St., Washington, D. C. I report if a patent can be had and its exact cost. Send for circular.

PATENTS and Trade-marks obtained. Prompt service. Write for our new book on patents. Established in 1889. D. Swift & Co., 349-7th St., Washington, D. C.

PATENTS. Booklet free. Highest references. Best results. Promptness assured. Send model or drawing for preliminary examination. Watson E. Coleman, Patent Lawyer, 624 F Street, Washington, D. C.

ROBB, Robb & Hill offer a strictly professional service to manufacturers and inventors in patenting inventions and registering trade-marks, a service which is the result of 20 years' experience. Write for free booklet and names of prominent manufacturers and inventors represented by us. Send sketch for preliminary advice, 811 McLachlen Bldg., Washington, D. C.; 1348 Hanna Bldg., Cleveland, Ohio.

PATENTS — Trademarks — Write for our free illustrated guide book and Evidence of Conception Blank. Send model or sketch and description and we will give our opinion of its patentable nature free. Highest references. Prompt attention. Reasonable terms. Victor J. Evans & Co., 166 Ninth, Washington, D. C.

INVENTORS should write for our book, "How to Obtain a Patent," which contains valuable information which every inventor should have. If you will send us a sketch, model or photograph of your invention we will promptly make search of the Patent Office records and advise you whether or not your invention is in our opinion patentable; our charge for the service being \$5.00. With an experience of over twenty years we feel that we are fitted to render you prompt, efficient service which will merit your confidence. Moderate charges. Write today. Talbert & Talbert, 422 Talbert Bldg., Washington, D. C.

FOR INVENTORS

INVENTORS, Before disclosing your idea to others write for our "Evidence of Disclosure" form. Send sketch or model of your invention for examination and advice. Ask for free book "How to obtain a Patent." Avoid dangerous delays. Write today. Merton-Roberts & Co., 182 Mather Bldg., Washington, D. C.

INVENTORS, write for free copy about designing, drawing and blue-printing. Emil T. Dahlene, Manson, Iowa.

PATENTS secured. Prompt service. Avoid dangerous delays. Send for our "Record of Invention" form and free book telling how to obtain a Patent. Send sketch or model for examination. Preliminary advice without charge. Highest references. Write today. J. L. Jackson & Co., 242 Ouray Bldg., Washington, D. C.

PATENT—Trademarks. Before disclosing an invention, the inventor should write for my blank form "Evidence of Conception." This should be signed, witnessed and returned to me with sketch or model, upon receipt of which I will promptly render opinion as to patentable nature and send booklet on patents. Highest references. Prompt attention. Reasonable terms. Clarence B. O'Brien, Registered Patent Lawyer, Woodward Bldg., Washington, D. C.

PATENTS Procured; Trade Marks registered. A comprehensive, experienced, prompt service for the protection and development of your ideas. Preliminary advice gladly furnished without charge. Booklet of information and form for disclosing idea free on request. Richard B. Owen, 30 Owen Bldg., Washington, D. C., or 2276B, Woolworth Bldg., New York.

PROTECT Your rights. Write for Record of Invention which contains form to establish evidence of conception of your invention. Prompt personal service. Preliminary advice without charge. J. Reaney Kelly, 612G, Columbian Bldg., Washington, D. C.

INVENTORS—Protect yourselves. Record idea before exposing to anyone, even to me or other attorneys. Paul M. Klein, Consulting Eng. Reg. Patent Attorney, 21 Park Row, New York, N. Y.

INVENTIONS commercialized quick. Commission only. Address Box 688, Charlotte, N. C.

INVENTORS—Will buy outright or arrange to manufacture on liberal royalty basis, patented or patentable inventions which meet our requirements. Principal parts should be of brass or steel and adaptable to screw machine production up to one inch in diameter. Complete factory fully equipped with going organization for both manufacture and sales. Submit models or drawings with complete description. Address F. H. Wellington, 1055 Riverside Drive, South Bend, Ind.

WE are interested in promoting the sales of Patented Automobile Accessories. What have you to offer? Address H. P. C., care Popular Mechanics Magazine, Chicago.

PRACTICAL Instructions to inventors and patentees written by the manufacturer and inventor, Charles Hunnicutt, covering every problem relating to inventions. Experience has shown the best means of patenting, manufacturing and marketing inventions. Written in the plain style of an honest man. No patent lawyer connections. For sale by Theo. Conant, Exclusive Agent, 1231 North Capital St., Washington, D. C. \$1 prepaid. Satisfaction or money refunded.

GET Your Own Patent. \$35 complete. Application blanks and full instructions \$1. Cutting Sons, Campbell, Cal.

PATENTS. Write for free illustrated guide book. Send model or sketch and description for free opinion of its patentable nature. Highest references. Prompt attention. Reasonable terms. Victor J. Evans & Co., 157 Ninth, Washington, D. C.

HAVE You an Invention? If so, write for our free book, "How to Get Your Patent," tells our terms and methods. Send model or sketch for our opinion of its patentable nature. Randolph & Co., Dept. 144, Washington, D. C.

PATENTS. If you have an invention which you wish to patent you can write fully and freely to Munn & Co. for advice in regard to the best way of obtaining protection. Please send sketches or a model of your invention and a description of the device, explaining its operation. All communications are strictly confidential. Our vast practice, extending over a period of seventy years, enables us in many cases to advise in regard to patentability without expense to the client. Our Hand-Book on Patents is sent free on request. This explains our methods, terms, etc., in regard to Patents, Trade Marks, Foreign Patents, etc. "Scientific American" contains Patent Office Notes. Decisions of interest to inventors, and particulars of recently patented inventions. Munn & Co., Solicitors of Patents, 623 Woolworth Bldg., New York; 625 F St., Washington, D. C.; 801 A Tower Bldg., Chicago, Ill.; Hobart Bldg., 582 Market St., San Francisco, Calif.

INVENTORS should write us for our book, "How to Obtain a Patent," which clearly sets forth what may be patented and the necessary steps to protect an invention. It describes the procedure in Patent Office and tells about assignments, licenses and trade-marks, and gives many useful facts about patents which every inventor should know. Many persons well versed in patent matters have pronounced the book the best of its kind they have ever read. It is written so you can understand it. Copy sent free upon request. Talbert & Talbert, Patent Lawyers, 433 Talbert Bldg., Washington, D. C.

"INVENTOR'S Guide," free on request; it gives very valuable information and advice. Write Frank Ledermann, 21 Park Row, New York, N. Y.

900 MECHANICAL Movements and 50 Perpetual Motions illustrated and explained in my book. Inventor's Universal Educator, 5th Edition—Tells how to procure and sell patents. Government and other costs. Covers the matter from A to Z—160 pages—Elegantly bound. Contains noted decisions of U. S. Supreme and State Courts on Patent cases. Mechanical Movements greatly assist inventors—suggest new ideas that might prove of great aid in perfecting inventions. Tells how to select an Attorney. Has valuable information regarding Patent Sharks, Selling Agents and promoters. Price, \$2. Postage free everywhere. Fred G. Dielerich, 621 Ouray Bldg., Washington, D. C.

PATENTS FOR SALE

PATENTED Envelope, for sale, royalty, or partnership wanted. Used twice for mailing or other purposes (sealed each time); also patent allowed on four-trip envelope (sealed each time). John Kuhhorn, 13 Chestnut St., Bradford, Pa.

SIX U. S. and Canadian Patents for sale. Stock punch, cow-tail holder, anti-kicking device; large demand; price reasonable. Alvah Blackburn, Alum Bank, Pa.

OUTRIGHT or royalty, new two in one screw driver. Patent pending. Address today. M. Flodin, 18 Paris St., East Boston, Mass.

PATENT outright, telescope curtain stretcher. For particulars write to Joseph Berry, 217 Sharpville Ave., Sharon, Pa.

TOTAL Patent cost divided into six payments. Ask Sterling P. Buck, 629 F. Washington, D. C.

PATENTED, Inexpensive, effective check protector, ideal advertising specialty. Bargain. B. Home, 1957 Warren, Chicago.

PATENT for No. 1,243,364, combination household article. Ed. York, 250 S. Caroline St., Baltimore, Md.

PATENT for sale, self-feeding ink-well. Clarence Rigerman, B. F. D. No. 3, Lockport, N. Y.

PATENT foldable basket. Delta C. Kimball, Wolfboro, N. H., Box 352.

PATENT No. 1,387,097. Just the thing that every Kodak owner has been looking for. Compact and portable case, for printing pictures and for carrying all necessary supplies. Investigate. Make me an offer, cash or royalty. Leo A. Kelly, 312 Broadway Street, Houston, Texas.

UNITED STATES—Canadian patents. Freight House Bill Stamp and Labeling Machine. Automatic, prints, labels, multiplex count, simple clearance. 1920 American Railroad Loss-Damage payments \$104,000,000.00. Will revolutionize present shipping methods. H. H. McFillen, 118 Ralph, Toledo, Ohio.

MILLIONS will be made—an advertising novelty of unusual merit—cheap to manufacture—convenient—sanitary. Wire and cloth. Patent pending. Royalty or outright sale. Address Henry M. Romner, Box 912, Tulsa, Okla.

SIMPLE, practical invention permits aeroplanes safely to land and start from small space like deck of ship or roof. Companies interested write to F. E. Schofield, Waterford, Conn.

PATENT for sale: Airship that will go straight up from the ground. If interested, address today. S. Hart, 150 Dean St., Brooklyn, N. Y.

FOR Sale—My invention of an automatic gasoline vending machine. Best offer accepted. Charles Drane, Jr., Clarksville, Tenn.

INVENTORS' Blue book. Patent guide free. Address, J. Kaplan, Barrister Bldg., Washington, D. C.

NOVELTY Pocket gun holder; send for drawings. Clarence Mitchell, Route 1, Petaluma, Calif.

AMERICAN and Canadian automatic wrench. Samuel Zwick, 333 Center, South Manchester, Conn.

I OFFER for sale my patent on a trouser hanger and presser combined; cheaply manufactured. For particulars, address S. Kest, Devalls Bluff, Ark.

SANITARY Fountain Shaving Brush. Patent Pending. Highest bidder. Vincent J. McNamara, 73 Clarkson St., New York City, N. Y.

RIGHTS to manufacture and sell pen-holder. Have dies. Address A. F. Rippe, Greenwich, Conn.

FOR Sale—Patent on instantly adjustable french. Automatic locking device. R. E. Dupuy, Etiwanda, Calif.

HAVE you a Patent to sell? Would you like to know what a small classified ad in this column could do for you? Ask me to send you proof of how other inventors sold their patents. J. Roy McClellan, Manager Classified Advertising, Popular Mechanics Magazine, Chicago, Ill.

MODELS AND MODEL SUPPLIES

MODEL Steam Engines, Boilers, Electric and Steam Boats, Yachts, Model Ship's Fittings and Model Makers' Supplies. Send 20c for new large illustrated catalogue and handbook. Bathe Mfg. Co., Dept. D., 5214 Woodland Ave., Philadelphia.

I IMPROVE and develop your idea. Make working blue print plans of your proposed patent. Prices right. Mathew Moratta, Princeton, Indiana.

CASTINGS, Blue Prints of Small Drill Presses, Bench Lathe, Tubes and material of all kinds Machinists' Supplies. Specialize on Experimental Work. Stamp for reply. Howard Machine Works, 2409 N. Ashland Ave., Chicago.

WORKING Models Designed and Built. Inventions Developed. Dies, Tools, Metal Stamping, Manufacturing. Wisconsin Experimental & Model Works, Madison, Wis.

EXPERIMENTAL, Model, Pattern and Machine work. Prompt service, moderate prices. Address Weiss Manufacturing Company, Brooklyn, N. Y.

MODEL makers: Do you use engines, boilers, pumps, fittings, rods, tubings, etc.? We are America's leading manufacturers. Complete catalog, 10c. Model Makers Supply, 505C Fifth Avenue, New York.

WE make working models for inventors and do experimental work and carry a complete stock of brass gears and model supplies. Send for catalogue. The Pierce Model Works, Tinley Park, Ill.

INVENTORS—Write for our free illustrated guide book and Evidence of Conception Blank. Highest references. Prompt attention. Reasonable Terms. Victor J. Evans & Co., 165 Ninth, Washington, D. C.

TO MANUFACTURERS

WANTED—Metal Stamping and Model work taken on contract basis. We are ideally located and equipped to develop patents. Meyers Company, Box 263, Bedford, Ind.

WE do all kinds of Metal Stamping—Gold, Silver, Nickel, Brass and Copper finishing. We will manufacture your article either on time or contract basis. If interested in large production, write us. When on your die work you are always welcome at our die maker's bench. Denning Mfg. Co., 1775-1777 East 87th St., Cleveland, O.

MANUFACTURING

WELL equipped machine shop, pattern shop and foundry is prepared to manufacture any automobile or garage tools or accessories, portions of which are castings, on royalty or other basis. Send us your prints and specifications for estimate. Patented articles preferred. Connersville Foundry Corporation, Connersville, Ind.

SPECIAL Devices and Machinery developed and built at reasonable rates. Jigs and fixtures designed and built for interchangeable and economical manufacturing. Punches and dies made for all kinds of metal stamping. Machine work to order. Simplex Tool Company, Woonsocket, R. I.

LET us be your factory! Write today. Logan Machine Company, 222 South Clinton Street, Chicago, Illinois.

MACHINE Work Wanted. Wood and metal patterns, stampings, and manufacturing in production quantities. Send us your machine to figure on. No jobs too large for our capacity. Lamb Co., 1938 Franklin St., Detroit, Mich.

PATENTED Articles, Models, Brass Work, Machine Construction; Dies Made. Baum's Metal Specialties, Kansas City, Mo.

RUBBER goods of all descriptions made; inventions developed. Mundell & Sons, 1459 W. 69th St., Chicago.

WIRE Goods, all kinds made to order. Cooley Mfg. Co., 524-530 N. Western Ave., Chicago.

PATTERNS, Wood and Metal Models, Tools and Dies, Brass and Aluminum Castings, General Machine Work. Write Modern Machine & Pattern Co., Terre Haute, Ind.

METAL Stamping, Punch Press Work. We manufacture articles in wood and metal. Noro Manufacturing Co., Peoria, Ill.

METAL Stamping, Dies, Tools, Special Machinery and Machine Parts Remodeled. Designed and Built, Efficiency Increased. Cylinder Grinding, Wisconsin Experimental & Model Works, Madison, Wis.

MACHINERY, TOOLS AND SUPPLIES

GAP Geared Head Lathe, 11"x15"x5", screw cutting, C. R., complete, \$260. Circular? Norton Machy. Co., Cincinnati, O.

MOTORS, Air compressors, \$25 cash, balance terms. Hobart, Troy, Ohio.

NEW Leather Belts, Four-inch single, forty-eight cents per foot; other sizes, same proportion. Louisville Belting Co., Louisville, Ky.

OTHERS have successfully sold their machinery through our columns—so can you. Ask me for proof. J. Roy McClellan, Manager, Classified Advertising, Popular Mechanics Magazine, Chicago.

AUTO engines for power. Best in the world—but they must be governed. We make governors and foundations. Circulars. Address Candes-Smith Governor Co., Springfield, N. Y.; 1041 So. Main St., Los Angeles, Calif.

CONCRETE Building Block Machines and Molds. Catalogue free. Concrete Machine Co., 112 S. Second St., St. Louis, Mo.

ENGINES, MOTORS AND DYNAMOS

MOTORS for sale, approximately 1/10 h. p., 10 to 30 volts, direct current, series wound, used but in good condition. Can be used with farm lighting plants and for experimental purposes. Price \$5.50 f. o. b. General Railway Signal Company, Rochester, N. Y.

BALL-BEARING guaranteed Motors, only \$20 cash, balance monthly payments. Write us. Hobart, Troy, Ohio.

AEROPLANE—Engines—Air-cooled for ice boats. Water-cooled for motor-boats and automobiles (use old chassis). \$100.00 up, 25 to 400 H. P. C. O. Chamberlain, 3609 Broadway, New York.

18 GOOD Used D. C. Motors. Sold only because of change to A. C. Everything from 1/2 to 25 H. P. Stock includes three generators 8 1/2 to 50 K. W. and four grinders—three bench and one stand. Prices at which these are offered, singly or in lots, will save you money. Tell us what you want. Ship anywhere in the U. S. Witte Engine Works, Dept. 5, Kansas City, Mo.

BLUE Prints 2 1/2-in. Gauge Pacific Type Locomotive, \$3.50 per set. Blue Prints and Castings, Steam and Gasoline Engines, Lathes. See our Display Adv., Rear Ad Section. Modern Engine & Supply Co., 342 Monadnock Block, Chicago.

BALL-BEARING Motors. Highest quality. Brand new. 1/4 horse, \$21.50. 1/3 horse, \$24.50. Circulars. William Boice, 23rd St., Toledo, Ohio.

AUTO engines for power. Best in the world—but they must be governed. We make governors and foundations. Circulars. Address Candee-Smith Governor Co., Springfield, N. Y.; 1041 So. Main St., Los Angeles, Calif.

ELECTRIC Motors, 500 Heavy Duty 1/2 H. P. motor, General Electric and other standard makes, 110 Volt, 60 Cycle, Single Phase. New, original packages, guaranteed perfect, \$18.00 to \$22.00. Pennsylvania Motor Exchange, Lancaster, Pa.

ALTERNATING and direct current motor bargains. New and rebuilt. All guaranteed for one year. Special prices. Get our price list before buying. Motors exchanged and repaired. Hyre Electric Co., 633-RR South Dearborn St., Chicago.

AUTOMOBILE Owners, Garagemen, Mechanics, Repairmen, send for free copy of our current issue. It contains helpful, instructive information on overhauling, ignition troubles, wiring, carburetors, storage batteries, etc. Over 120 pages, illustrated. Send for free copy today. Automobile Digest, 507 Butler Bldg., Cincinnati.

SPECIAL Garage Motors: Manufactured by the General Electric Co. 1 H. P., \$78.50; 2 H. P., \$110.00; 3 H. P., \$128.50; 5 H. P., \$166.50. All sizes, both single and Poly-phase Motors, for immediate delivery. Special charging generators, all voltages. Write for catalog. Motor Sales Dept., 15, West End, Pittsburgh, Pa.

SURVEYING INSTRUMENTS

NEW and used surveying instruments direct from factory. Satisfaction guaranteed or money refunded. Wissler, 619 Broadway, St. Louis.

ELECTRICAL

INTERESTED? Explain single pole, double pole, three-way switches for lights. Dry cells in series, etc. Diagrams 25 cents (coin). Charles Kibler, Hiedelberg, Pa.

5,000 HIGH-GRADE Electric irons, guaranteed one year, \$3.95 each. Home Service Electric Works, New Haven, Conn.

BELL Ringing Transformers, Toy Transformers, Toy Motors. Evert Electric Company, Racine Junction Station, Racine, Wis.

AIR Compressor with Tank and Hose, \$46. Motor for same, \$22.50. Equipment Co., 169 Canal, Cincinnati, Ohio.

ELECTRIC motors and supplies, including sockets, wire conduit, cleats, loom, rosettes, switches. New revised wholesale prices. Illustrated Catalog free. Hyre Electric Co., 633-GH, South Dearborn St., Chicago.

FOR MECHANICS

START in business for yourself for \$250.00. Full time or evenings. At least \$6.00 per hour. Ex-Cell-O Tool & Mfg. Co., 1214 Beaubien St., Detroit, Mich.

INVENTORS, Before disclosing your idea to others write for our "Evidence of Disclosure" form. Send sketch or model of your invention for examination and advice. Ask for free book "How to obtain a Patent." Avoid dangerous delays. Write today. Merton-Roberts & Co., 183 Mather Bldg., Washington, D. C.

STAIR Builders' Guide. Excellent treatise on construction of straight flight, platform, cylindrical and elliptical stairs. 256 pp., 358 figs. Cloth. Price, \$2.00 postpaid. Popular Mechanics Book Dept., 6 N. Michigan Ave., Chicago.

IF you want more pay—become a draftsman. We teach you Mechanical Drawing at home in your spare time; no previous training required. Our graduates earn \$35 to \$100 a week and more as they advance. Write today for Free Book "Your Future in Drafting." Columbia School of Drafting, Dept. 1606, Washington, D. C.

WANTED—Men to prepare for positions as Mechanical Draftsmen. Address, R. Breese, South Gardner, Mass.

PATENTS—Write for our free illustrated guide book and Evidence of Conception Blank. Send model for sketch and description of the invention for our opinion of its patentable nature free. Highest references. Prompt attention, Reasonable terms. Victor J. Evans & Co., 184 Ninth, Washington, D. C.

FOR THE SHOP

CARE of the Band Saw, Electric Water Heater, Modern Barn Construction, Motorcycle Trailer, Tent House, Correcting Dynamo Troubles, Homemade Metal Fence. Auto Turntable are among the hundreds of practical articles in Shop Notes, Vol. 13. Price 50 cents, postpaid. Popular Mechanics Book Dept., 6 N. Michigan Ave., Chicago.

JUST Out—Shop Notes for 1922. Bench Lathe, Electric Soldering Outfit, Jib Crane, Pump Troubles, Road Roller, Bench Grinder and Miller are among the 635 articles in this new volume. 224 pages. 50 cents postpaid. Popular Mechanics Book Dept., 6 N. Michigan Ave., Chicago.

BLACKSMITHS

BLACKSMITHS: Forge carbon into your steel with carbon compound; produces dense, tough, uniform carbon and high-speed steels; recipe and instructions \$1.00. C. F. Mills, 83 Water St., Deadwood, S. Dakota.

BLACKSMITHS, Listen: Any Handy man can make more money doing hard jobs easy. Forging and welding solid, with Toy's Modern Methods of Blacksmithing. Hardening and tempering to a standard with colored tempering charts. All for one dollar. Samples Free. W. M. Toy, Sidney, O.

FOR SALE—MISCELLANEOUS

TUBING—Soft, hard, copper, brass, aluminum—a complete line, connections and unions. Price list on request. Standard Tube & Metal Company, Dept. D, 2412 Ogden Avenue, Chicago, Ill.

FOUNTAIN Pens. Special mail order discount until Christmas on our recently perfected Lever Self-Filling Fountain Pens, with patented Auto Feeds, absolutely guaranteed, highest quality and workmanship. Three distinct styles now, \$1.75, \$2.25 and \$3.00, delivery free. Lady's pen gold-trimmed. Mention lady's or gentleman's style. Williamson Pen Co., Janesville, Wis.

BUY Thru Wholesale: \$22 value large 11-piece German Silver drawing set, nice velvet-lined case. Guaranteed, \$6.45 postpaid. Large \$3.00 drawing board; send \$1.40. Scientific App. & Chem. Co., 619 Main St., Buffalo, N. Y.

MRS. WAYMAN'S celebrated Egg producing formula, and her wet and dry wash, and water tonic; price 50c. J. F. Warner, Muncie, Ind.

ARMY-NAVY surplus. Tents, Blankets, Clothing, Camping Equipment, Boots, Shoes, Tarpaulins, Slickers. Everything for the farm, house and shop. Astounding bargains. Specify line in which interested. Nathan Frank & Sons, 317 L St., S. W., Washington, D. C.

COIL spring chart rules for figuring cutting length, spacing, tapering ends, tempering. Price \$2.25 postpaid. F. M. Athons, 440 S. St. Louis St., Los Angeles, Calif.

UNIFORM coats blue. All sizes, \$3.50 each. Jandorf, 740 West End Ave., New York City.

LUMINOUS Paint—Bottle 20c. Laboratories H. Box 316, Portland, Ore.

AUTO Tire Vulcanizing Molds, Air Compressors, Motors, Battery Charging Outfits. Reduced Prices. Write for catalog. Equipment Co., 167 Canal, Cincinnati, Ohio.

ADDRESSOGRAPHS, Letter Folders, Multigraphs, Envelope Sealers, Dupliators, less than half price. Guaranteed. Pruitt Co., 112-B N. La Salle, Chicago.

WANTED—MISCELLANEOUS

A NEW YORK Organization wishes to get in touch with manufacturers and inventors with a view to securing suitable articles for mail order purposes. Royalty or purchase considered. Full particulars. Perkins Company, 350 Broadway, New York.

AM in the market to buy press and dies for stamping and shaping small sheet metal articles in large quantities. J. B. Bradley, Box 1230, Miami, Fla.

WANTED: Durable luminous paint, or formula for making same. W. Maxwell, Bloomington, Ill.

CASH Paid. Mail us your discarded jewelry, gold crowns and bridges, watches, diamonds, silver, platinum, War Savings Stamps and old false teeth. Highest prices paid. Money sent by return mail. Packages held 4 to 12 days and returned at our expense if our offer is refused. United States Smelting Works (The Old Reliable), Dept. 71, Chicago, Ill.

WANTED: Printing presses. Any kind, size or condition. P. M. Ruddick, West Newton, Mass.

REAL ESTATE AND FARM LANDS

FREE Book of Florida Facts. Own your own orange grove in beautiful Fruitland Park. A few cents a day you now waste will buy it for you. A few dollars a month may provide you with a life income. Schnittger sold his twenty acre grove here for \$40,000—two thousand an acre. He saw the same opportunity that's offered you and planted a grove. Result—he reaped a small fortune. You have the same chance but you must act now. Write today for Free Book of Actual Photographs, Florida Facts and the interesting story of a Fruitland Park Farm. Learn of crops that help you buy it. Address today, Lake County Land Owners' Association, 93 Sunset Way, Fruitland Park, Florida.

LAND Opportunity. 20, 40, 80-acre tracts in Michigan. Rich clay loam soil, only \$15 to \$35 per acre. Very easy terms. Investigate this opportunity. Write for Free booklet today. Swigart Land Co., P-1259, First Natl. Bank Bldg., Chicago.

ATTENTION!! Let's get acquainted. Cash for your property. Farm, Hotel, factory, or retail store. Write us particulars; confidential service. Hayes Business Agency, Cincinnati, Ohio.

QUICK system to sell real estate for cash anywhere; complete plans \$1.00. Realty Publishing Co., Cincinnati, O.

OKLAHOMA Farms. Write for free agricultural booklet. Board of Commerce, Shawnee, Okla.

UNUSUAL bargain in good Minnesota wild land. Address, P. Fones, New Richmond, Wis.

TWO Thousand dollars pays fully for truck or poultry farm with house in Florida. Ask Palmetto Gardens, Orlando, Fla.

LANDLOGY, free, special number just out, containing many facts of cloverland in Marinette County, Wisconsin. If for a home or an investment you are thinking of buying good farm lands, where farmers grow rich, send at once for this special number of Landology. It is free on request. Address Skidmore-Rhie Land Co., 506 Skidmore-Rhie Bldg., Marinette, Wis.

\$500 GETS farm with 5 cows, team, 125 acres, 6-room house, barn, all \$2,500. Details page 23 Catalog 1106 Bargains. Free. Strout Farm Agency, 150P, Nassau St., New York City.

\$5.00 DOWN; \$5.00 monthly; Five acres fruit, poultry, fur farms. Riverfront: Ozarks; \$100; hunting, fishing, trapping. Address Harvey Hubbard, 1973 North Fifth, Kansas City, Kans.

WANT to hear from party having farm for sale. Give particulars and lowest price. John J. Black, 11th St., Chippewa Falls, Wis.

SELL your property quickly for cash, no matter where located. Don't pay big commissions. Particulars free. Real Estate Salesmen Co., Desk B, Lincoln, Neb.

DOGS, BIRDS, POULTRY, PETS

TOY Fox and rat terrier pups. Write, D. Robertson, Mason, Ill.

MALE and Female Airedales, 2 yrs., \$30 each. Wm. Carter, Buckland, Mass.

BREED Squabs. Book free. E. Rice, Melrose Highlands, 77, Massachusetts.

GREAT Dane Pups—For Danes that have size and intelligence write Collins Kennels, Box 109, Reedsburg, Wis.

SHOMONT'S White Collies. The all-around dog. Intelligence and beauty unsurpassed, a household companion, a guard for the home, a shepherd without equal. Eligible. Satisfaction guaranteed. Pairs not skin. The Shomont. Dept. P. Monticello, Iowa.

BELGIAN HARES, GUINEA PIGS, ETC.

RAISE Rabbits—(Siberian Fur) 50c lb. for all you raise. Breeders cheap. Book, contract, etc., free. Cross, 3845 Easton, St. Louis, Mo.

SILVERBLACK Foxes \$300.00. Skunks, Coon, Booklet dime, Arthur Schumacher, Lockland, Ohio.

RAISE guinea pigs. Pay better than poultry or rabbits; easy to raise; little space required. We guarantee market. Particulars and booklet how to raise free. Cavies Distributing Co., 3102 Grand Ave., Kansas City, Mo.

TOBACCO

TOBACCO, Natural Leaf, for mild smoking: 10 lbs. \$1.50; 20 lbs. \$2.75; will furnish free receipt for preparing. Leaf Tobacco Exchange, Mayfield, Ky., Star Route.

SMOKING! Tobacco direct from the farm, 2 1/2 lbs. \$1.00. Jim Foy, Dukedom, Tenn.

CIGARS, Christmas Specials, excellent smokes; 50 Aromas, \$2.50; Perfectos, \$3.00. Send money order or C. O. D. National Cigar Co., 410 E. 13th St., New York.

FOOD PRODUCTS

FANCY Apples, Standard boxes, Fancy Delicious Roman Beauties, Jonathans, Winesaps, \$4 per box. Fruit expressed, cut rates. Yakima Valley, wonderland for apples, pears, cherries, alfalfa, wheat and corn. Ideal climate; learn more about our fruits. Remit for one or more boxes apples at above prices. Mail Order Fruit Dealers, Yakima, Wash.

FINE Natural honey, H. Benke, Bee Keeper, Pleasantville, N. Y. (Sample 10 cents.)

KARSTADT'S Mammoth Pecan Nuts, Samples \$1.40. W. Karstaedt, Dayton, Ohio.

PERSONAL

SUCCESS or Failure! Which is your destiny? Scientific information, "Success" pointers and Personality sketch for 10c and birthdate. Thompson-Heywood, Dept. 985, Chronicle Bldg., San Francisco, Cal.

CRYSTAL Gazing Balls, 4-inch, highly polished, with stand, \$10.00. Crystal Gazing Books \$1.00. Delnora Gear, 604 N. 12th, Philadelphia.

HOROSCOPE—Send birthdate; 25c. German Society, Box 1141, Pittsburgh, Pa.

HOME Treatment for Morphine Habituation—safe, prompt, ethical; consultation invited. Box 353, Blackfoot, Idaho.

TOBACCO, Liquor and Morphine Habits can be overcome by using Hill's Three Chloride of Gold Remedies. Why not banish these Health-Destroying Habits before it is too late? Satisfactory results or money returned. Booklet sent free. Address The Ohio Chemical Works, Dept. 9, Charleston, S. C.

FREE—Stop using tobacco. We will give free information how to conquer habit easily and permanently. Results guaranteed. Anti-Tobacco League, Box K, Omaha, Neb.

TOBACCO or Snuff Habit cured or no pay. \$1.00 if cured. Remedy sent on trial. Suderba Co., TP., Baltimore, Md.

MISCELLANEOUS

5 SAFETY Keys and Novel Chain only \$1.00. Only keys of their kind in existence. Open and Test thousands of different Locks. Highly recommended. Household necessity. Invaluable for emergencies and tell you instantly if your locks are burglar-proof. Master Keys Co., Milwaukee, Wis.

ORES and Minerals. Mail us your Samples. You may have fortune. Fire assays \$1.00 each. Chemical analysis \$3.00. Prompt and reliable reports; try us. Address, Ward and Mills, assayers, 83 Water St., Deadwood, S. Dak.

HOW To Build Beautiful Homes At Small Cost. Read My Book on the Twentieth Century Building Materials. Price One Dollar. Circulars Free. Peter de Linde, Zion, Ill.

WEATHER Forecaster—Indicates rain or shine; every home needs one; sample 25c. Chemical Barometer Co., Dept. B, 131 Arlington Ave., N. W., Canton, Ohio.

CUTS anybody can make. Simple, cheap process. \$1. Specimens, particulars, 2c stamp. M. Day, Windfall, Ind.

SEA Shells Wanted—Cowrie only. T. G. Clark, 1902 S. 12th, St. Louis, Mo.

FREE—Very useful and practical article for those mechanically or mathematically inclined. Send name, address, occupation. Engineering Service Bureau, Dept. A511, 56 East Randolph St., Chicago.

LOCKSMITHS—Complete instructions for opening safes and vaults of all kinds; \$2.00. Kimball, 1140 Van Buren St., Chicago, Ill.

MUSIC rubber stamps. Rubber Type catalogue 25c. W. Karstaedt, Dayton, Ohio.

JOINT Wiping and Lead Work—A reliable guide. 89 pages, 115 illus. Cloth. Price 75 cents, postpaid. Popular Mechanics Book Dept., 6 N. Michigan Ave., Chicago.

NEW Automatic Adder, \$3.50. Postpaid. Fully Guaranteed. Bassett, 1438 V Hollywood Ave., Chicago.

ARTIFICIAL Eyes, \$3. Booklet free. Denver Optic, 559 Barclay, Denver, Colo.

LOCKSMITHS: Send \$1. get valuable chart for cutting tumbler padlock keys. Address Globe System, 136 Sixth Ave., New York.

LOCKSMITHING from A to Z—500 tricks of the locksmith trade, \$1.50—money back if dissatisfied. H. Roulson, 3406 Andover St., Oakland, Cal.

SAVE incorporating expenses and excess profit taxes and avoid personal liability by organizing your company on the Common Law Plan under a Declaration of Trust. Anyone, anywhere, can fill in Demaree Standard Forms, issue shares and begin doing business same day. Pamphlet B-53 free. C. S. Demaree, Legal Blank Printer, 613 Walnut, Kansas City, Mo.

Get This Car And the Agency In Your Territory



The World's Greatest Motor Car Value

Write NOW for full specifications and NEW REDUCED PRICES of 1922 Model

Touring Roadster **BIRCH SUPER-FOUR** and **LIGHT SIX** Sport Sedan

FIND out how you can get one of these superb cars for yourself and make money selling them to others. A big opportunity is open to ambitious men who are willing to train themselves and then get out and hustle. We pay big commissions for selling Birch Cars.

SEND THE COUPON NOW FOR FULL INFORMATION

Previous Experience Not Necessary

We require all our agents to take a brief but thorough course of training in Automobile Driving, Repairing and Selling. We have trained hundreds of others for success in this way, and we believe this is one of the reasons for the splendid success Birch Agents are enjoying. But the BIG REASON is the cars themselves. 80 per cent of all Birch Cars are in use by farmers and in small towns, and get the hardest kind of service. Mud, sand, rocks, hills and rough going have no terrors for these sturdy cars.

Send Coupon for **BIG FREE Book and Full Information** You will be astonished at the liberality of our offer. Let us put all the facts before you at once. It costs nothing to investigate, so tear off the coupon right now. Sign it and mail it to us today.

BIRCH MOTOR CARS Dept. 119, 308 N. Michigan Ave. CHICAGO, ILLINOIS
Member of Chicago Association of Commerce

4 Cyl.—37 H. P.
6 Cyl.—57 H. P.
117-in. Wheelbase
33x4 Cord Tires
Full Floating Axle
Timken Bearings
18" Steering Wheel
Boyce Motometer
Hotchkiss Drive

Choice of 10 Colors
at No Extra Charge

BIRCH MOTOR CARS

Dept. 119, 308 N. Michigan Ave., Chicago

Please send free book and full particulars as to Birch Super-Four and Agency

Name

Address



Get Expert Training in **DRAFTING** Raise Your Income

Why be satisfied with just an ordinary job when a practical knowledge of Drafting will bring you a higher salary and opportunity for advancement? Once be able to show that you are an expert and your future is clear because the man with a finished technical training always finds a call for his services. While

untrained men are scrambling for the small pay jobs, watching the "Help Wanted" advertisements, glad to take anything that will bring even a mere living income, the skilled Draftsman finds offers actually seeking him.

Today business is recovering from the shock which followed the war. New enterprises are being planned and older ones are looking toward expansion which means that more men with specialized knowledge will be needed to help build up our national industries. This is the chance for you, Master Draftsmanship. Get into a live profession that will enable you to cash in on what you know. Take advantage of the rising tide. Not only make more money but get placed where you will have an opportunity for real advancement. Expert Draftsmen earn as high as \$60 to \$150 a week.

You Can Learn in Spare Time

If you will give a few hours a week of your spare time to home study you can equip yourself to hold one of the positions which no man can hope to reach without technical training. Your future success surely makes this effort worth while and this is the time to begin. You make nothing by waiting.

Chicago "Tech" Will Give You Practical Methods

(At the College or by Mail)

Enroll with Chicago "Tech" and you are placed at once under the direction of practical men who give you the methods which they and other technical experts use in their own work. None of your time is given to "ornamental" studies or useless theories. Every Chicago "Tech" lesson, lecture and exercise gives you bedrock information which you can use in actual practice—information which puts you in the expert class. By the Chicago "Tech" method therefore you are trained for a paying position in the least time necessary to secure a thorough, dependable knowledge. If you can't come to the College you can get this training by mail. The fees are very moderate and you can pay on easy terms.

While other schools ask you to enroll and send money first, we send the free lesson first. Read it, practice the exercises and then decide for yourself whether to take the course or not.

Send the Coupon

Just put X in the beside the name of the course which interests you—then sign and mail the coupon and we will send information which may open entirely new prospects for you—just as this same information has shown other men the clear road to advancement. You incur no obligation and you make no promise when you ask for these facts. We will gladly tell you just how we train men for important jobs and send the free lesson as a demonstration of Chicago "Tech" methods. Today is the time to ask for all this. Take your pen or pencil now—fill out the coupon and get it into the next mail.

Chicago Technical College
130 Chicago "Tech" Bldg., Chicago, Ill.

Trial Lesson
FREE



FREE Outfit—set of instruments, drawing board, T square, etc., same as used in regular drafting rooms—is included with our Home Study course or credit will be given if you already have an outfit.

CHICAGO TECHNICAL COLLEGE

130 Chicago "Tech" Bldg., Chicago, Ill.

Send Free information on subject marked X:

- | | |
|---|--|
| <input type="checkbox"/> Architectural Drafting | <input type="checkbox"/> Auto. Engineering |
| <input type="checkbox"/> Machine Drafting | <input type="checkbox"/> Aero. Engineering |
| <input type="checkbox"/> Electrical Drafting | <input type="checkbox"/> Plan Reading—Buildings |
| <input type="checkbox"/> Structural Drafting | <input type="checkbox"/> Estimating—Buildings |
| <input type="checkbox"/> Sheet Metal Drafting | <input type="checkbox"/> Plan Reading—Machinery |
| <input type="checkbox"/> Topographic Drafting | <input type="checkbox"/> Plumbing, Heating, etc. |
| <input type="checkbox"/> Surveying | <input type="checkbox"/> Steam Engineering |

Name

Address

Post Office..... State.....

College or Home Study. State which.....

Free Trial Lesson Included When Inquiry Is for Drafting or Plan Reading.

LEARN AUTOMOBILE TRUCK AND TRACTOR ELECTRICITY

You have the ambition to make good in a field of highly paid specialists. You want to get out of the rut and into a profession that pays up to \$125 and more a week. Hundreds of Coyne trained men have become big successes—you can do the same.

AUTOMOBILE TRUCK AND TRACTOR ELECTRICITY

Trained men are eagerly sought after in the field of Automobile Truck and Tractor Electricity. There are plenty of mechanics, but the demand is for trained electrical experts—in garages and auto plants all over the country. We teach you this profitable and fascinating profession.

IN THE BIG SHOPS OF COYNE

The millions of autos, trucks, tractors, and lighting plants call for electrically trained men. Learn in a real electrical school—on real equipment—by the Learn By Doing method. Become well grounded in fundamental principles through actual practice. Become an expert in lighting, starting, ignition, testing, maintenance, service. No big text books—simply personal instruction, problems, directions and practice.

Own Your Own Business

We train you for the "big" jobs. No experience necessary. You can start a business of your own and make big money. Service stations offer a wonderful opportunity, but you must act now. If you want to be prosperous, successful, independent and enjoy the real things in life, study this highly paid profession in the great shops of Coyne. Established twenty-two years. Students come here from all over the world.

Send today for complete information about this Free course in Auto Truck and Tractor Electricity.

Free Free Business Course, employment department and special offer. Learn how we have helped others and how you can train for bigger pay in sixty days. Mail Coupon NOW. Don't put it off.

Bennett Wellington Cooke, President
COYNE TRADE & ENGINEERING SCHOOLS
Dept. 11A, 39-51 E. Illinois St.,
Chicago, Ill.

MAIL THIS
COUPON

Coyne Trade & Engineering Schools,
Dept. 11A, 39-51 E. Illinois St., Chicago, Ill.

Send me FREE information about your course in Auto Truck and Tractor Electricity that will help me get into the big pay class, and other information on your school, employment department and free Business Course.

Name.....

Address.....

Town..... State.....

Do you know that Clear-Tone—the wonder-working lotion—used like toilet water—

Clears Your Skin

of Pimples, Blackheads, Acne Eruptions, Enlarged Pores, Oily or Shiny Skin? *Elegant after Shaving.* Indispensable for sensitive, refined women.

GUARANTEED to banish unsightly blemishes easily and quickly, and leave the skin clear and smooth.



"A Clear-Tone Skin"

This Free Booklet tells how you can easily and quickly at home obtain a clear skin, free from all blemishes, like Nature intended you to have. Thousands of copies of this interesting book distributed monthly.

Clear-Tone is not a cure-all or a mail-order treatment, but a scientific, reliable SKIN LOTION, perfected after 15 years personal experience by Mr. E. S. Givens, who knows every embarrassment one has to suffer with a bad complexion. Endorsed and prescribed by physicians, druggists, and thousands of enthusiastic users, and sold on a direct and positive guarantee of absolute satisfaction or money back! The marvel of Clear-Tone is that it clears the complexion so quickly, no matter the cause.

Clear-Tone has had an unprecedented success as evidenced by the thousands of voluntary letters written by men and women who had very bad blemishes and tried various soaps, ointments and doctors without relief.

READ THESE LETTERS!

From U. S. Hospital--"Find myself improving wonderfully. Anyone I see that has skin trouble your wonderful Clear-Tone will be recommended. C. A. Rein, U.S. Hos. 41, Sta. Island, N. Y.

From a Barber--"Have been a barber for 30 years and never saw anything as good as Clear-Tone. All barbers should know about it." Otto Van Burin, Kansas City, Mo.

From a Musician--"I am obliged to be in public a great deal and my complexion was a great embarrassment. Clear-Tone improved me so greatly that I strongly recommend it." C. H. Lindeman, Steubenville, Ohio.

From a Lady--"I cannot thank you enough for all the good it has done me. One bottle has cleared my face wonderfully." --Miss Mary Yonka, Haverstraw, N. Y.

From a Soldier--"It is certainly wonderful." Louis Langer, Troop F, 3d Cavalry, Ft. Ethan Allen, Vt.

From a Flyer--"Cleared my face of Acne." H. J. Howald, N. H. Station, Pensacola, Fla.

People Amazed--"Has cleared my skin completely of pimples and blackheads. Everybody who sees me is amazed." R. R. Wilson, Pearson, Ga.

Thousands of Others--men and women--praise Clear-Tone. We'll gladly send copies of most interesting testimonials.

FREE! Simply send name today for FREE booklet, "A Clear-Tone Skin," telling how I cured myself after being afflicted for 15 years, and my \$1,000 guarantee to clear your skin of the above blemishes. E. S. GIVENS, 128 Chemical Bldg., Kansas City, Mo.

Please Mention Popular Mechanics

Amazing New Method Makes Drawing Easy

With This Wonderful New Graphic-Correction Method You Can Easily Learn Drawing in Your Own Home in Spare Time

NO matter what your present ability may be—no matter if you feel that you have no special "talent"—by this wonderful new method you can quickly qualify for the fascinating and highly-paid profession of Commercial Art. Even those whose work was not as good as the figure shown, have quickly and easily learned to qualify for big, highly-paid positions in this splendid uncrowded field.

From his years of experience as artist, cartoonist, illustrator and teacher one of America's foremost commercial artists has evolved a system of instruction, which cuts the time usually necessary for such training practically in half. You study at home, but it is exactly the same as if you were working in his studio.



How This Method Makes Big Artists Out of Those Who Think They Can't Draw

This remarkably easy method teaches you to draw just as you learned to write. First, straight lines and curves, then shading, action, foreshortening, etc.—it takes you step by step through all the phases of making pictures. Each step is explained in detail, and then your work is corrected and each criticism illustrated. It brings you, simply and easily, right up to the point where you are drawing pictures that bring from \$25.00 to \$300 a piece or higher.

You Learn to Draw Pictures that SELL!

And this is the great point. The Graphic-Correction Method breaks away from the old, hard-to-understand methods, which are based on "talent," and instructs you in the business of making *salable pictures* quickly and easily.

The fact that such famous artists as Frank Godwin and Wynn Holcomb (Wynn) have used this method proves its worth. (Mr. Godwin writes: "I feel that my present success is due in a great measure to your wonderful method of instruction.") And these are but two of hundreds and hundreds of successful students. Many have more than paid for their course even while they were still learning. And dozens of them have started at work at a high salary.

Alfred B. Flemming of Newark, N. J., writes: "Since the last lesson was returned, I have sold \$85.00 worth of drawings (3)."

And another, J. B. Barwell of Staunton, Va., tells us, "Have just sold the first installment of twenty drawings on a comic series."

And again,—O. B. Blake, Old Town, Me., says: "I am certain that anyone, whether he has talent or not, cannot fail to make rapid progress under your instruction."

Trained Artists Needed

Right now Commercial Artists are at a premium! Resumption of business on the old pre-war basis has caused a crying demand for them. Newspapers, advertising agencies, magazines, business concerns—all are looking for men and women to handle their art work. Designers, illustrators, layout experts are needed. Opportunities and salaries are practically unlimited. And now, through this wonderful Graphic-Correction Method, you can qualify for one of these high-salaried jobs.

Send for FREE Book

Mail the attached coupon, and we will send you our handsomely illustrated book, "How To Become An Artist," by return mail. The book tells you all about the course in detail. And shows you how the wonderful Graphic-Correction Method works. Send the coupon TODAY. Washington School of Art, Room 1752, Marden Building, Washington, D. C.

The Washington School of Art, Inc.
Room 1752, Marden Bldg., Washington, D. C.
Please send me, without obligation on my part,
your free book, "How To Become An Artist."

Name.....
(State whether Mr., Mrs., or Miss)

Address.....

SWEENEY

I PAY YOUR RAILROAD

This Is
"E. J."



Learn a Trade and Get A Good Job

I know that there is a great future for every man who will take my advice as thousands of others have. The only question is, **Are You Mechanically Inclined?** If you are, then **TODAY IS YOUR OPPORTUNITY.** No matter what you are doing—what you have been doing—I am sure that the Automotive Business offers you bigger—better—

more prosperous future. I want to see you grasp your big opportunity right now—and remember its the trained man that gets the big paying jobs.

I Will Pay Railway Fare to Kansas City

My Big Announcement this Season. You can come to this great Trade School at no more expense than if it were located in your home town, for I am rebating fares from any point in the United States to the Sweeney School. No advance in tuition. No extras. Just a fair, square rebate. No matter where you live this brings the Sweeney Million-Dollar Trade School to your door.

Thousands upon thousands of young men thought as you have been thinking about **MECHANICAL TRAINING** and they answered my advertisement, got my big Free Catalog, came here, learned the business and today, in all parts of the country **ARE MAKING GOOD.** I can give you hundreds of letters from these men that relate circumstances and hopes so like your own that you will be amazed.

Begin Right That's what I want to impress upon every man who sees the great future in the Automotive business. **COME TO SWEENEY'S**—the School of practical Experience. Sweeney Graduates are in every part of the U. S. and in foreign countries—over 46,000 of them—and they are loyal Sweeney boosters. They are proud of **THEIR SCHOOL**—their success in business is creating demand for thousands of Trained Mechanics and they look to the **OLD SCHOOL** for these men. Hundreds of letters come to my desk—these boys of mine write me personally—They want **SWEENEY GRADUATES**—every day—every week brings more openings. Again I say **START RIGHT**—come direct to the **SWEENEY SCHOOL**—and in 8 short weeks you will have a Sweeney Diploma—it commands recognition for you. Don't delay—send for my **BIG FREE BOOK** today—I want to tell you of my **Big New Special Offer**—this is in addition to my Free Railway Fare offer—it's the greatest offer that I have ever made.

EMORY J. SWEENEY, President.



LEARN A TRADE
Sweeney
SCHOOL OF AUTO-TRACTOR-AVTATION
973 SWEENEY BLDG. KANSAS CITY, MO.

SEE SWEENEY DOUBLE-PAGE AD ON NEXT TWO PAGES

SCHOOL

FARE TO KANSAS CITY

Pick the Job You Like

Chauffeurs	\$90 to \$150
Truck Driver	\$125
Tire Vulcanizer	\$100 to \$200
Welders	\$140 to \$200
Battery Man	\$150 to \$200
Auto Mechanics	\$6.00 to \$10 a day
Auto Electricians	\$225
Tractor Engineers	\$10 a day
Garage Manager	\$150 to \$400
Demonstrator and Salesman	\$150 to \$500

Hundreds of Openings for Men

SWEENEY trained men are in demand everywhere at good wages, **\$50 a week and more**, from garages, tire shops, welding concerns, auto repair shops, etc. **HERE'S THE PROOF:**

South Dakota wires: "Will pay most any price for a good man. Send him right away." Neck City, Mo., says: "Put us in touch with a first-class repair man. Excellent opening." Indiana says: "Want one more Sweeney man for my new garage. Steady work at good prices." Kansas appeals: "Send me man who understands Ford Car from A to Z. Will pay top wages." Mississippi telegraphs: "Want a post graduate mechanic. Will pay all he is worth. Wire at my expense." Florida calls: "Want head mechanic. Will pay \$50 a week. Let me hear by return mail." **Thousands of Sweeney graduates now owning their own business** in various parts of the country **naturally favor** Sweeney trained men. Sweeney loyalty is wonderful. Our daily mail is conclusive proof that the trained man with the SWEENEY diploma can secure jobs like these at **\$50 a week and more**.

The Sweeney System

THE SWEENEY SYSTEM, famous the world over, can be had only in the Sweeney School. It trains men to be mechanics by practical work. You learn by doing—no books—you do the actual work. The course takes only 8 weeks. No place in the world can you get so much real instruction—so much actual value, for so little money. If you are in earnest, there is a real job looking for you. Write me today—don't put it off—I've got some information that will open your eyes—but you must take the first step—Write for my Big Free Book.

My Big Special Offer I am offering to pay your railway fare from any point in the U. S. I have another offer—a bigger offer to make you—an offer greater than I ever made before—Mail the coupon today.

Send for My Big Free Catalog Now

GET INTO THE FASTEST GROWING BUSINESS IN AMERICA AND MAKE BIG MONEY. Thousands of good jobs go begging. There is over a quarter million dollars more invested in the Automotive business than the entire capitalization of all our National Banks. This is a business you are interested in—now is the time to make a start—reconstruction in the Automobile business is well under way—factories are getting back on full time—we're just on the eve of greater opportunities in the Automotive business than ever. Trained men—expert mechanics will be in demand as never before—they are in demand today—the SWEENEY SCHOOL stands as a great monument to thousands of successes—thousands of men who came to the Sweeney School and today are known as successful men in the business world. You can do what these men have done. The big paying jobs are open to you and This Million Dollar Trade School is now placed right at your door—no matter where you live in the U. S., for I am paying your railway fare.

Free

I will gladly send my 72-page illustrated catalog FREE. Also a free copy of Sweeney School News, a most interesting monthly school paper, published here. You will enjoy them. Read the worth-while stories of men like yourself who came to Sweeney's and found success. Read how Frank Powell and Harry Wilson built up a \$20,000 business in about two years after graduating. Read how Elbert A. Pence built up a \$25,000 yearly garage business at Clearmont, Mo. These stories and many more are told by the Sweeney students. Also I want you to learn how my students enjoy themselves after work in the swimming pool, the club and reading rooms, etc.

Send today for this free catalog. Get my big, new, special offer. See page after page of mechanical pictures. Read what students say. Note the latest ideas in auto work. Hundreds of illustrations. Learn about the jobs open—the actual present opportunities in the business for Sweeney men. **DO IT NOW.**

Yours very truly,
EMORY J. SWEENEY,
President.



Mail the Coupon Today

DO IT NOW

For Big Free Catalog Mail This Coupon.

EMORY J. SWEENEY, President
Dept. 973, Sweeney Bldg., Kansas City, Mo.
Please send me free without any obligation on my part, your 72-page catalog and your Sweeney School News. Tell me of the opportunities in the Auto and Tractor Business.

Name

P. O. State

SEE SWEENEY DOUBLE-PAGE AD ON NEXT TWO PAGES

SWEENEY

I PAY YOUR RAILROAD



E. J. SWEENEY
PRESIDENT

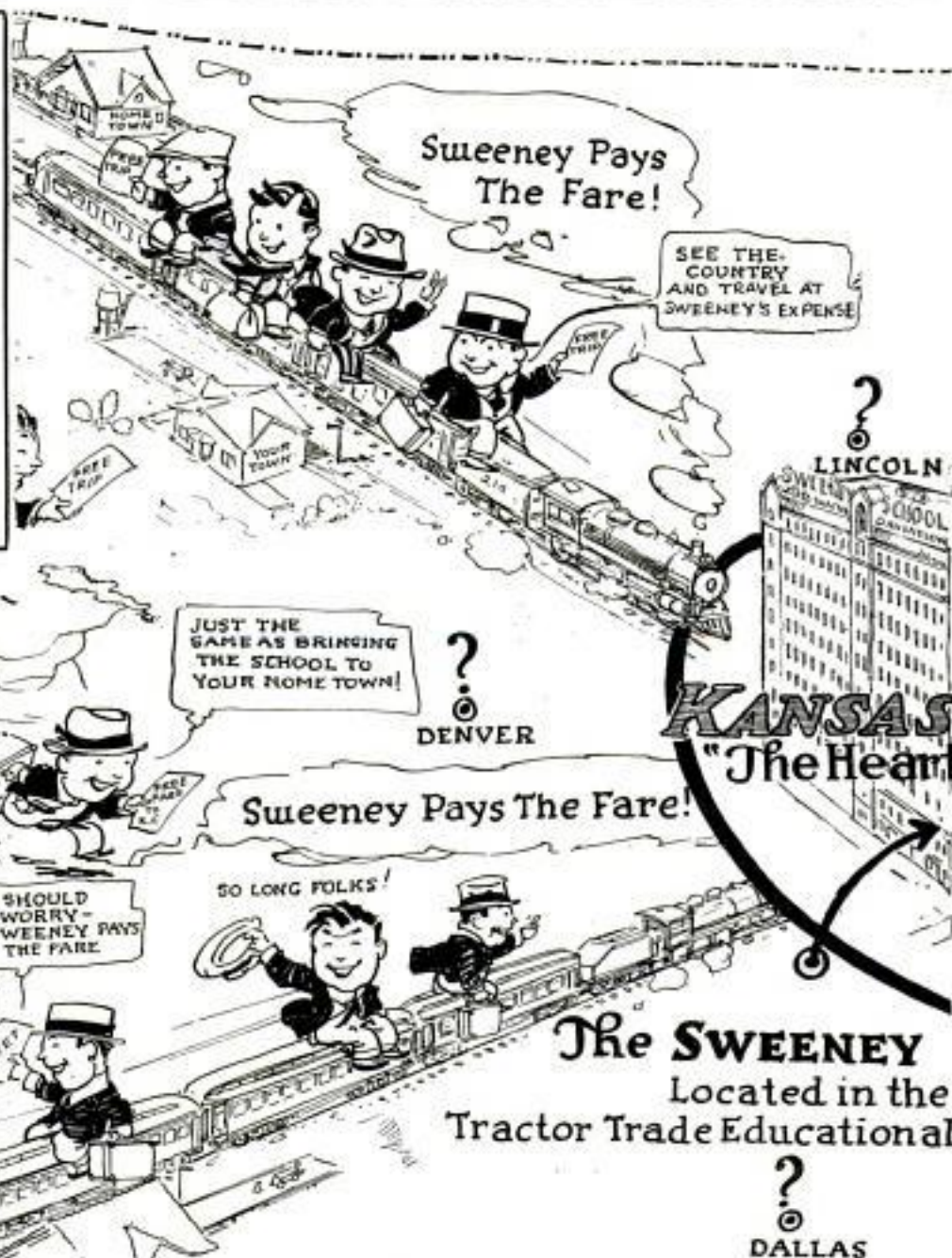

Now is the time for you to learn the world's best trade—repairing autos and tractors. Who are the millions of men out of employment? They are untrained men, or men in other industries. Auto mechanics, tire men, battery men are WANTED EVERYWHERE.

Come to the Sweeney School now and GET READY FOR A GOOD JOB. No previous experience is needed. I teach with tools not books. And let me tell you that YOU ARE NEVER TOO OLD. Henry Ford was forty years old when he STARTED THE FORD COMPANY.

Thousands upon thousands of men who read Popular Mechanics as you are reading it now, and thought as you have been thinking about mechanical training, got my big free catalog and today in all parts of the country HAVE MADE GOOD. I have the proof, hundreds and hundreds of letters from successful men asking for our graduates. These men took the first step. They GOT THE CATALOG. They tell you: "Don't make any mistake. Learn it right. Learn it at Sweeney's."

But These Men Never Had the Opportunity You Have Today

The railroad fare to Kansas City is a big item. Lots of these men had to pinch and scrape to make it. BUT I WILL NOW PAY YOUR FARE. You can come to this great school at no more cost than if it were located in your home town. No extras. No advance in tuition. Just a fair and square rebate of your railway fare. No matter where you live in the United States this offer is good. Tell your friends "SWEENEY PAYS THE FARE." Tell them that SWEENEY has another big Special Offer besides Free Railway Fare. Travel, see the world at my expense.

SEE SWEENEY DOUBLE PAGE SPREAD ON TWO PRECEDING PAGES

SAVE YOUR BODY

Conserve Your Health and Efficiency First

"I Would Not Part with it for \$10,000"

So writes an enthusiastic, grateful customer. "Worth more than a farm," says another. In like manner testify over 100,000 people who have worn it.

The Natural Body Brace

Overcomes **WEAKNESS** and **ORGANIC AILMENTS** of **WOMEN AND MEN**. Develops **erect, graceful figure**.

Brings restful relief, comfort, ability to do things, health and strength.

Wear It 30 Days Free at Our Expense

Does away with the strain and pain of standing and walking; replaces and supports misplaced internal organs; reduces enlarged abdomen; straightens and strengthens the back; corrects stooping shoulders; develops lungs, chest and bust; relieves backache, curvatures, nervousness, ruptures, constipation, after effects of flu. Comfortable and easy to wear.

Keep Yourself Fit Write today for illustrated booklet, measurement blank, etc., and read our very liberal proposition.

HOWARD C. RASH, Pres. Natural Body Brace Co.
223 Rash Building SALINA, KANSAS



For Boys and Girls Also



has enabled John G. Anderson, Aurora, Ill., to keep on the payroll since his right arm was amputated some years ago. The reproduction (from an actual photograph) shows Mr. Anderson at work on an intricate machine using his Carnes Artificial Arm.

INCONSPICUOUS - SERVICEABLE

The Best Substitute for the Natural Arm.

To see him on the street you would not realize that his right arm was artificial. Wearers of this wonderful arm find that it practically takes the place of the natural arm. With it you can dress yourself, use knife and fork, carry grips, write, pick up large and small objects—in fact, do practically everything that was possible before. Even though the amputation be at the shoulder, the **CARNES ARTIFICIAL ARM** bends at the elbow and wrist, and the fingers open and close as desired.

WONDERFUL BOOK SENT FREE Every armless man or woman should write today for the wonderful illustrated 190-page book showing with actual photographs what can be done with this invention. Write today to

CARNES ARTIFICIAL LIMB CO.
298 CARNES BUILDING KANSAS CITY, MO.

Please Mention Popular Mechanics

The Case Against Tobacco

Every tobacco user knows at times that tobacco is hurting him and would like to know just how or to what extent. The book "The Case Against Tobacco" will enable you to find your own weak spot and mark the evil effects of tobacco upon yourself. This book is authoritative; it sets forth the unbiased findings of physicians, scientists and thoughtful men of large affairs. It is absolutely free while the present edition lasts. Send a postal for it today.

H. J. BROWN MEDICINE CO., Dept. 6, Cleveland, Ohio.

Restore YOUR Pep and Power!



Resist the forces that are sapping your vital powers. Banish the weaknesses that make your life a wretched failure. Stop experimenting with dangerous dope and drugs and foolish fads. Shake off Catarrh, Constipation, Dyspepsia, Bad Blood, Rupture, Nervousness, Youthful Errors, Vital Depletion, Impotency and the other results of neglect and abuse. Rebuild your Body and Brain and fit yourself for the joys of a healthy, happy, successful life. I want to help you—I can help you.

STRONGFORTISM—The Modern Science of Health Promotion will aid Nature in Restoring your Flagging Powers and Manhood and Fit you for the Joys of Life. I guarantee it—no matter what your condition is, or what caused it.

Mention subjects on which you want special confidential information and send with 10c to help pay postage, etc., on my free book—**"Promotion and Conservation of Health, Strength and Mental Energy."** It's a man-builder and a life-saver. Send for it **Right Now.**

LIONEL STRONGFORT

Physical and Health Specialist
Department 605 Newark, New Jersey

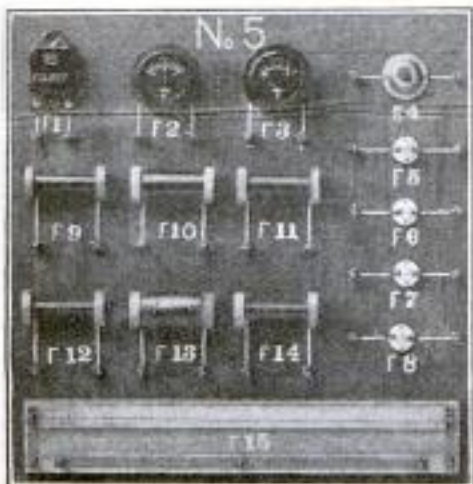
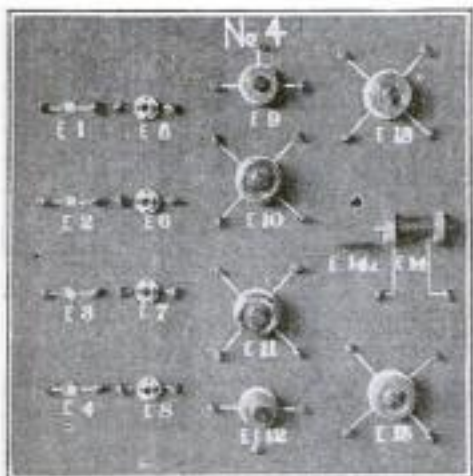
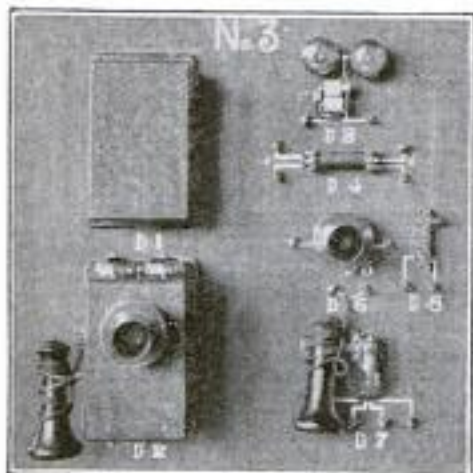
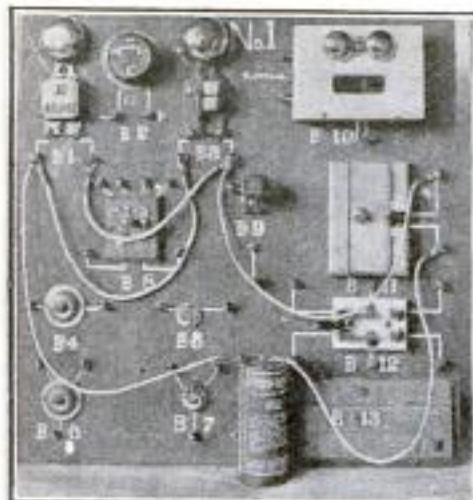

FREE — \$500⁰⁰ Electrical Outfits Sent to Your Home

to Quickly Train You to be a PRACTICAL ELECTRICIAN

Here are some of the wonderful Electrical Outfits we loan to our students. These are **our own exclusive patents** and each set costs us \$500, but **you do not have to pay one penny for them.** We send them to you — **right to your own home — FREE!** These Outfits are the **working part** of our very interesting Course on Practical Electricity. We **train you with these Outfits. You learn by doing.** You make tests and experiments with them. You get much **useful knowledge** right along with your lessons that will soon fit you to be a high grade, well-paid **Practical Electrician.**

The Master Minds' Course This is the **Master Minds' Course.** It is the combined best technical knowledge of our large faculty of University-Graduate Electrical Experts — men who are recognized authorities in the different branches they teach. It contains the **wisdom and experience** of 15 years' teaching men and boys who came to our famous Resident School from all parts of the world to get the very best electrical training, and—**they got it!** The Course is **specially prepared and arranged for home study** and written in such **plain, everyday language** that any man who can read will have no trouble at all to understand it.

We bring our wonderful school right to your home and teach you the **new way—the right way—the quick way.** We teach you all about electricity and at the same time fit you with **working knowledge** a Practical Electrician must have. Your training will be intensive—thorough—complete. You'll be agreeably surprised and delighted how quickly you can turn this knowledge into money.

This is the **greatest opportunity** you ever had and perhaps ever will have to learn Practical Electricity and learn it **right.** Now is the time to start! **Train your brain—** be a high-salaried Practical Electrician. Mail the Coupon today—**before you do another thing.** Let us tell you all about this wonderful Course on Practical Electricity with the FREE Electrical Outfit. **Send the Coupon right now.**

EXTENSION DIVISION
SCHOOL of ENGINEERING
of Milwaukee
Dept. PM-12-H
137 BROADWAY
MILWAUKEE,
WISCONSIN

**OUR SCHOOL
COMES TO
YOUR HOME**

Without obligation, please fill me all about the FREE \$500.00 Electrical Outfits You will send to my home to teach me Practical Electricity.

NAME _____
ADDRESS _____
CITY _____ STATE _____
AGE _____ OCCUPATION _____
EDUCATION _____

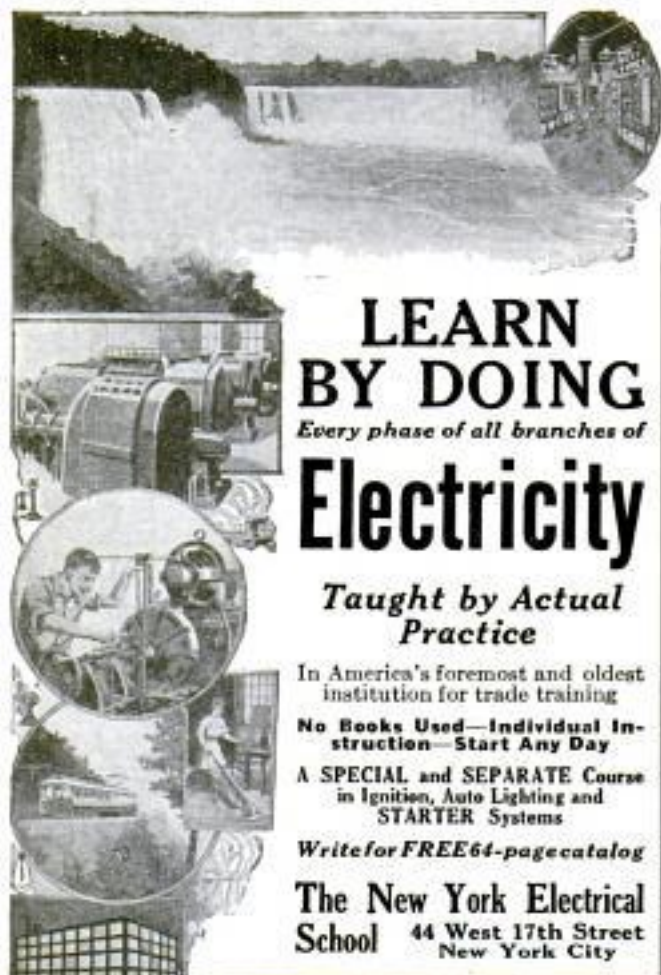

LEARN BY DOING
Every phase of all branches of

Electricity

Taught by Actual Practice

In America's foremost and oldest institution for trade training

No Books Used—Individual Instruction—Start Any Day

A SPECIAL and SEPARATE Course in Ignition, Auto Lighting and STARTER Systems

Write for FREE 64-page catalog

The New York Electrical School 44 West 17th Street New York City



Ever Get Fired?

You won't get fired or laid off if you work for Uncle Sam. When everybody else is worrying about his job or looking for work, the U. S. Civil Service Employee is earning good, steady pay in a pleasant occupation of his own selection.

\$1600 to \$2300 a Year Guaranteed

Let me train you to pass the U. S. Civil Service Examination with HIGH RATING so you can get a position QUICKEST—at \$1600 to \$2300 guaranteed. I have trained THOUSANDS and I guarantee you a position.

GET MY FREE BOOK

I was Civil Service Secretary Examiner for 8 years and KNOW how to qualify you in your spare time. My free book explains everything. Be sure to write postal for it NOW. Get into the Railway, Mail, Immigration, Internal Revenue, Rural Mail, Post Office or other Government Service right away and stop worrying about money or jobs! Write me now.



Arthur R. Patterson, Principal, Patterson Civil Service School, 31-A Wisner Bldg., Rochester, N. Y.

Improve Your Memory IN ONE EVENING

Thousands have done it through the Roth Memory Course in seven easy lessons. Be able to remember names, faces, numbers, dates, appointments, speeches, etc., on the instant. Examine the course free for five days, then decide. Price \$3 if you keep it. Otherwise no obligation. Write today to Independent Corporation, Dept. R451, 319 Sixth Ave., New York City

Whatever Your Question;—be it the pronunciation of Bolsheviki, the spelling of a puzzling word, the location of Murman Coast—the meaning of blighty, ace, tank, ukulele, etc., this Supreme Authority—

WEBSTER'S NEW INTERNATIONAL DICTIONARY

contains an accurate, final answer. 400,000 Words. 2700 Pages. 6000 Illustrations. Regular and India-Paper Editions. G. & C. MERRIAM CO., Springfield, Mass. Write for specimen pages, prices, etc. and FREE Pocket Maps per Popular Mechanics



MOVING PICTURE MACHINE FREE



This genuine New Model American made Moving Picture machine with film—ALL GIVEN for selling 20 peeps. Shine at 15c, a pkg. Write for them. We send them postpaid. When sold return \$3.00 and we send machine, film and extra premium free of set of admission tickets, postage prepaid.

BLUINE MFG. CO., 554 Mill St. Concord Junction, Mass.

LEARN WATCHMAKING

and become independent. Good-paying positions secured. Easy to learn. Send for FREE CATALOG. ST. LOUIS WATCHMAKING SCHOOL, Dept. 5, ST. LOUIS, MO



Big Money

Made by agents selling our wonderful Facial Soap, Perfumes, Toilet Articles, Spices, Extracts, etc. Free cake of soap and agents' terms mailed to any address.

LACASSIAN CO. Dept. 455 ST. LOUIS, MO.

FONTAINE FOX — makes more than \$200 a day!



for six drawings a week—more than \$80,000 a year! Clare Briggs, Sid Smith, J. N. Darling, Fontaine Fox and many others get immense incomes from simple cartooning and illustrating ideas.

These men and more than 60 others of America's leading illustrators and cartoonists comprise the Federal Staff. They teach you those secrets and methods of their success that took them years to discover and perfect. If you have talent for drawing, capitalize your ability. Make it earn big money for you. Be successful by learning drawing from men who have achieved fame and fortune through drawing.

SEND FOR OUR FREE BOOKLET—"A Road to Bigger Things." It explains the Federal method of instruction. Read of opportunities in the art world. Learn how you can qualify for a position paying big money. Your name, address and age together with 6c in stamps to cover postage, will bring this book by return mail.

Federal Schools, Inc., 213 Federal Schools Bldg., Minneapolis, Minnesota

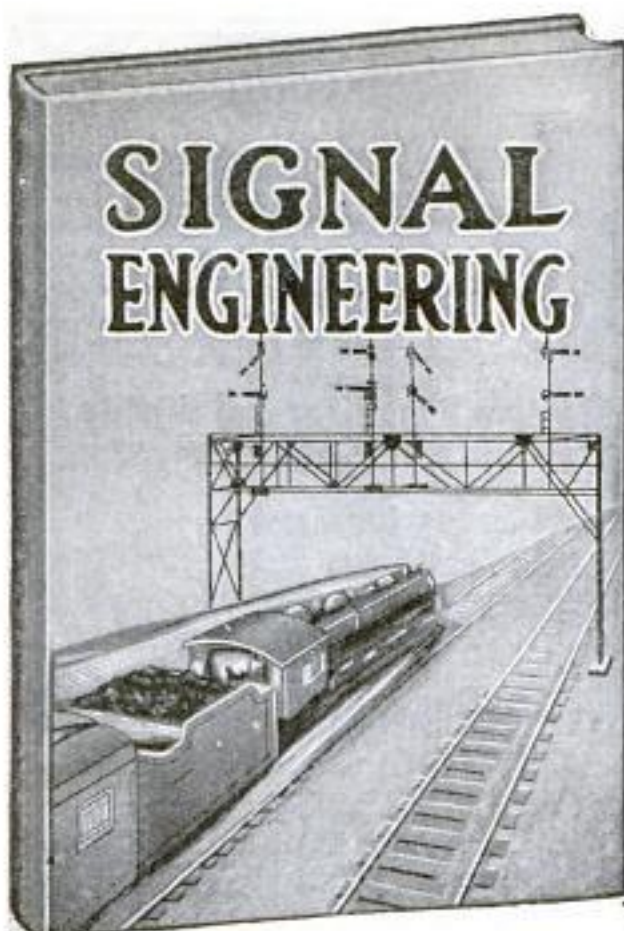

Free Book On Signal Engineering

THERE are thousands of miles of railroad that must be equipped with block signal systems. To superintend these installations men are necessary. *Golden opportunities are offered.* Every ambitious man should write for the Free Book on Signal Engineering.

Men Are Needed to Accept High Salaried Positions

When you stop to consider that, at the present time, less than one-fourth of the passenger lines in this country are equipped with automatic block signal systems—and when you read that the day is fast coming when the law will compel railroads to install them, you will realize what remarkable opportunities are offered to ambitious men in the profession of Signal Engineering. The work is big—broad—high salaries are paid. \$250.00 a month is an ordinary salary for a Signal Engineer.

Send the Coupon

Put your name and address in the coupon, or a letter or post card *Now* and get the free book about Signal Engineering. Too, we will tell you how you can get the training that you need in order to become a Signal Engineer. You will be under no obligation by writing for this free book. Do it Now.

Department
of Signaling
Dept. 1351
1924 Sunnyside
Ave., Chicago

Department of Signaling

Dept. 1351, 1924 Sunnyside Ave.
CHICAGO

Gentlemen:—Please send me absolutely free and prepaid your big new book on Signal Engineering. Also full particulars about your great special free outfit offer. It is distinctly understood that I assume no obligations of any kind.

Name.....

Address.....

Age.....Occupation.....

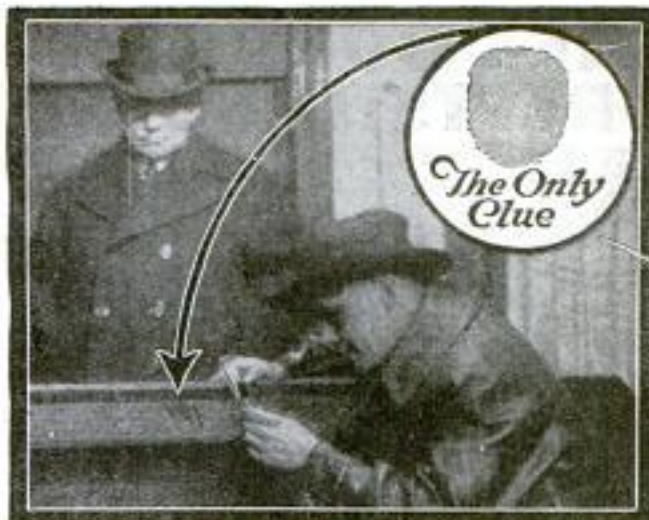

\$500 REWARD for TWO HOURS WORK

It was in answer to a request from the Chief of Police that Warren Biglow, the Finger Print Expert, arrived at the scene of the daring robbery of the T—O—Company offices. The job was undoubtedly the work of skilled cracksmen and robbers of uncommon nerve. \$5,500 in currency—the company payroll—was gone. Not a single apparent clue had been found by the police. Almost immediately after his arrival Biglow turned his attention to a heavy table which had been tipped up on its side. Examination of the glossy mahogany showed an excellent set of finger prints. The thief might just as well have left his calling card. To make a long story short, his prints were photographed and taken to Central Office, where they were matched with those of "Big Joe" Moran, a safe blower well known to the police. Moran was subsequently caught and convicted on Biglow's testimony and finger-print proof. Most of the money was recovered. In the meantime the T—O—Company had offered a \$500 reward, which was given to Biglow—his pay for two hours work.

Be a Finger Print Expert—Learn at Home in Spare Time

Could you imagine more fascinating work than this? Often life and death depend upon the decisions of finger-print evidence—and big rewards go to the EXPERT. Thousands of trained men are now needed in this great field. The finger-print work of governments, corporations, police departments, detective agencies and individuals has created a new profession. Many experts regularly earn from \$3000 to \$10,000 a year in this fascinating game. And now you can easily learn the secrets of this new science in your spare time—at home. Any man with common school education and average ability can become a Finger Print Expert in a surprisingly short time.

FREE Finger-Print Outfit and Large Illustrated Book!

For a limited time we are making a special offer of a complete Professional Finger Print outfit, absolutely free and also a *Free Course in Secret Service Intelligence*. Mastery of these two kindred professions will open a brilliant career for you. Write quickly for fully illustrated free book on Finger Prints which explains this wonderful training in detail. Don't wait until this offer has expired—mail the coupon now. You may never see this announcement again! Address

University of Applied Science Dept. 1351, 1920 Sunnyside Ave., Chicago

University of Applied Science, Dept. 1351, 1920 Sunnyside Ave., Chicago

Gentlemen: Without any obligation whatever send me your new, fully illustrated, FREE book on Finger Prints and your offer of a free course in Secret Service Intelligence.

Name.....Age.....

Address.....

Town.....State.....

Please Mention Popular Mechanics

Copyrighted material

FREE COURSE IN DRAFTSMANSHIP

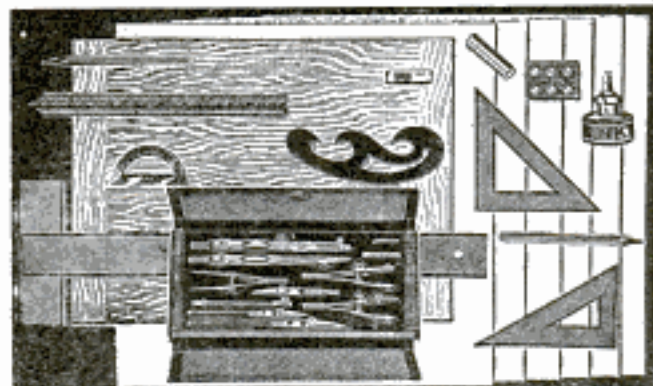

QUICK SUCCESS and MORE MONEY

Salaries up to \$100 per week. Here is your only OPPORTUNITY to get this wonderful, high-priced, Complete Drawing Outfit, including a FREE—PRACTICAL COURSE IN MECHANICAL DRAWING—now OFFERED to YOU for ONLY **\$9.98** Delivered to your address anywhere in the U. S. or Canada, **FREE**

This is a remarkable offer, with which you can build your Success in DRAFTSMANSHIP. You can put yourself in class of Trained Men whose services are always in DEMAND.

EASY TO LEARN AT HOME IN YOUR SPARE TIME

And is your one chance to earn the biggest money of your life, and will be one of the most profitable investments you have ever made.

OUTFIT CONSISTS of—Set large size Professional Draftsman's drawing instruments of Fine Nickel Silver, set into a handsome Velvet lined pocket book folding case, size 4 by 8 1-2 inches closed—also One Drawing Board 20 by 24 1-2 inches—One 24-inch T Square—One 12-inch Standard scale rule—Supply of drawing paper—Two Triangles—One French Curve—One Protractor—Pencil—Eraser—One bottle waterproof drawing ink—Thumb Tacks—and one engraved Edition FREE—A PRACTICAL COURSE IN MECHANICAL DRAWING. You cannot make a mistake by taking up drawing, so ACT NOW.

OFFER IS LIMITED—Particulars FREE
NATIONAL INSTRUMENT COMPANY

4704 North Hamilton Ave.

Chicago, Ill.

STOP USING A TRUSS

Do Away With Steel And Rubber Bands

FREE TRIAL



Inner surface is made adhesive to secure the PLAPAO-PAD firmly to the body, keeping the PLAPAO continually applied and the pad from slipping. No straps, buckles or springs attached. Soft as velvet—easy to apply.

It's the Non-Slip- ping, yet Non-Rigid Pad and What is Within It That Counts

PATD
APRIL 6
1909

FREE to 5,000 Truss Sufferers

To the extent of 5,000 sufferers who may apply I will send, ABSOLUTELY FREE, a sufficient quantity of the Plapao to positively convince them that this is the only logical, common-sense way of treating rupture. Plapao is a highly astringent medication placed within the Plapao-Pad and being absorbed through the skin, creates a wonderful feeling of relief and at the same time tends to strengthen the weakened muscles and thus permanently close the rupture opening. The process of recovery is natural, so you'll have no use for a truss—you can throw it away forever! Old and young have testified under oath that the Plapao-Pads cured their rupture—many of them long-standing, aggravated cases—without delay from work. Patent allowed in U. S. and foreign countries. Awarded Gold Medal at Rome and Grand Prix at Paris.

Send No Money—for a sufficient quantity of the Plapao is sent without charge to enable you to give it a thorough test; you pay nothing for this trial now or ever. Write for it and full information today. Address Plapao Laboratories, Block 1427 St. Louis, Mo.

The Healing Rays of this PAIN RELIEVING Sterling Lamp

make it a welcome addition to all homes, or wherever it is introduced, a practical First Aid in the instant relief of aches and pains. The Sterling Pain Relieving Lamp affords quick and sure relief to all persons suffering from Rheumatism, Lumbago, Sciatica, Neuritis, etc., soothes and induces restful sleep, heals wounds and burns.

Renews Vim, Vigor and Vitality

by increasing blood circulation, makes one more efficient. It works along Nature's lines, and follows her laws which accounts for its healing powers.

Heals Like the Beneficent Rays of the Sun

but unlike the sun, it always shines when needed, always ready, day or night, "Sunlight" in a convenient portable form, its therapeutic properties scientifically worked out, to make it possible to put this wonderful curative agent in the hands of all, for the benefit of all, at all times.

Used and Endorsed By Physicians

because of its great value in cases where, without it, some powerful drug would have to be used for quick relief of pain, in emergencies, and at other times, in the light to restore health. An invaluable aid in the sick room.



SEND FOR ILLUSTRATED BOOKLET

You will be intensely interested in reading about the authentic and wonderful cases of healing where this lamp has been used in homes, hospitals, sanitariums, etc., in all manner of cases. So simple that a child can use it. Sold under a positive guarantee of satisfaction or the money back. Write today.

STERLING PAIN RELIEVING LAMP CO.
546 Garfield Ave. Dept. 214 Chicago, Ill.

TOBACCO Or SNUFF HABIT Overcome or NO PAY!

No matter whether used in pipe, cigarettes, cigars, chewed, or used in the form of snuff. Superba Tobacco Remedy contains nothing injurious, no dope, poisons, or habit-forming drugs. Guaranteed. Sent on trial. If successful, costs you one dollar. If it fails, or if you are not perfectly satisfied, costs you nothing.

Write for full remedy today.

SUPERBA COMPANY, M-19, BALTIMORE, MD.

NO MORE BALD HEADS



WHEN our VACUUM CAP is used a few minutes daily. We accept no pay until you have tried the Cap 60 days and are satisfied. The Vacuum Cap is an appliance that draws the blood to the Hair Roots and starts a new healthy crop of hair. It stops Dandruff, stops the hair from falling out.

Bought by Doctors and men who know that it is the only reasonable HAIR GROWER known to science. No Drugs Used. Write for application blank, testimonials, and booklet on "HAIR," sent sealed in plain envelope, FREE.

THE MODERN VACUUM CAP CO.
T559 BARCLAY, DENVER, COLO.

MOTOR

AND WONDERFUL ELECTRICAL

Book-FREE

I have vastly simplified the study of Electricity for you. My practical Shop Training System of instruction divides the work up into a few MASTER IDEAS which are fully explained in plain language you can easily understand in my big **FREE** book. Send COUPON or

WRITE

for your copy of this
AMAZING Book--NOW!
Send No Money.

Announcement Extraordinary!

Fit yourself to be doing real electrical work and *earning good money* within the **NEXT FEW WEEKS.** My simplified and condensed system of Shop (type) Training—the only method fully endorsed and **ACCEPTABLE** to the largest concerns—will **QUICKLY** prepare you to do highly-paid **MOTOR MAINTAINING, BATTERY CHARGING, ELECTRO-AUTOMOTIVE ENGINEERING, HOUSE-WIRING, ILLUMINATING ENGINEERING, CENTRAL AND SUB-STATION INSTALLATION AND OPERATION, ARMATURE AND COIL WINDING, ELECTRIC TRACTION, LINE CONSTRUCTION AND WIRELESS.**



S. V. Smith
Pres. S. & H. Electrical Works

Learn to Earn \$70.00 to \$125.00 a Week at Home--or in Our Green St. Plant

Study at home or in our Green St. plant. If you prefer to train at home, I will send you a Shunt-Wound **MOTOR** and a splendid outfit of electrical instruments, materials, wire, fittings, etc., valued at about \$30.00, *freight prepaid*, and **ABSOLUTELY FREE.** I do this so you can do actual and experimental Shop-Training work right in your home and practically prepare yourself to do a modern, **WANTED** type of work. Other valuable privileges and exclusive advantages enjoyed by S. & H. trained men are: *E. T. Rating and Diploma, Strong Organization Backing, Power Plant Connection, Cash Bond Guarantee, Field Representative Position, and Money-Making Business Course.*

Shop Training at Our New Plant

We also accept a limited number of students for instruction by our wonderfully simplified and practical Shop-Training System of instruction in our Green St. plant. Students are taught through actual practice doing a commercial grade of work. They work with the aid of thousands of dollars worth of new equipment and are under the constant personal supervision of Mr. Harry Hart, the Central Power Station expert—for 21 years with Commonwealth-Edison, the largest in the world. Write, or send coupon, for particulars at once.

S. V. SMITH, President,

S. & H. ELECTRICAL WORKS, Dept. A. 1
310 S. Green St. CHICAGO, ILL.

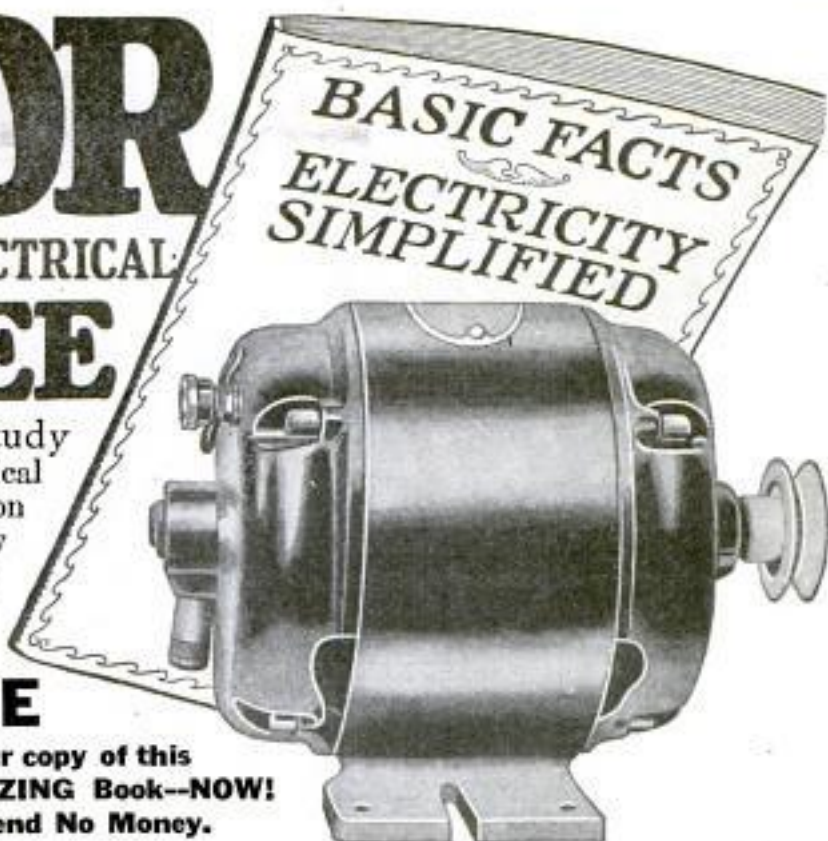

Harry Hart, E. T.
Vice Pres. and Works Mgr.

S. V. Smith, Dept. A. 1,
310 S. Green St., Chicago

Without cost or obligation to me send at once full particulars of your special offer.

Name

Address

NOTE: I check course I prefer:—
(Green St. Training) (Home Study)

Why haven't
you
clipped this
coupon

TEAR OUT HERE

INTERNATIONAL CORRESPONDENCE SCHOOLS
BOX 5592-C SCRANTON, PA.

Without cost or obligation please explain how I can qualify for the position, or in the subject before which I have marked an X in the list below:

- | | |
|---|---|
| <input type="checkbox"/> ELECTRICAL ENGINEER | <input type="checkbox"/> BUSINESS MANAGEMENT |
| <input type="checkbox"/> Electric Lighting & Railways | <input type="checkbox"/> SALESMANSHIP |
| <input type="checkbox"/> Electric Wiring | <input type="checkbox"/> ADVERTISING |
| <input type="checkbox"/> Telegraph Engineer | <input type="checkbox"/> Show Card & Sign Ptg. |
| <input type="checkbox"/> Telephone Work | <input type="checkbox"/> Railroad Positions |
| <input type="checkbox"/> MECHANICAL ENGINEER | <input type="checkbox"/> ILLUSTRATING |
| <input type="checkbox"/> Mechanical Draftsman | <input type="checkbox"/> Cartooning |
| <input type="checkbox"/> Machine Shop Practice | <input type="checkbox"/> Private Secretary |
| <input type="checkbox"/> Toolmaker | <input type="checkbox"/> Business Correspondent |
| <input type="checkbox"/> Gas Engine Operating | <input type="checkbox"/> BOOKKEEPER |
| <input type="checkbox"/> CIVIL ENGINEER | <input type="checkbox"/> Stenographer & Typist |
| <input type="checkbox"/> Surveying and Mapping | <input type="checkbox"/> Certified Public Accountant |
| <input type="checkbox"/> MINE FOREMAN or ENG'R | <input type="checkbox"/> TRAFFIC MANAGER |
| <input type="checkbox"/> STATIONARY ENGINEER | <input type="checkbox"/> Railway Accountant |
| <input type="checkbox"/> Marine Engineer | <input type="checkbox"/> Commercial Law |
| <input type="checkbox"/> ARCHITECT | <input type="checkbox"/> GOOD ENGLISH |
| <input type="checkbox"/> Contractor and Builder | <input type="checkbox"/> Common School Subjects |
| <input type="checkbox"/> Architectural Draftsman | <input type="checkbox"/> CIVIL SERVICE |
| <input type="checkbox"/> Concrete Builder | <input type="checkbox"/> Railway Mail Clerk |
| <input type="checkbox"/> Structural Engineer | <input type="checkbox"/> AUTOMOBILES |
| <input type="checkbox"/> PLUMBING & HEATING | <input type="checkbox"/> Mathematics |
| <input type="checkbox"/> Sheet Metal Worker | <input type="checkbox"/> Navigation |
| <input type="checkbox"/> Textile Overseer or Supt. | <input type="checkbox"/> AGRICULTURE |
| <input type="checkbox"/> CHEMIST | <input type="checkbox"/> Poultry Raising |
| <input type="checkbox"/> Pharmacy | <input type="checkbox"/> BANKING <input type="checkbox"/> Spanish Teacher |

Name.....

Street and No.....

City..... State.....

Occupation.....

Please Mention Popular Mechanics

3 Silk Knit TIES \$1.65



All three for the usual price of one

The narrow silk knit tie with embroidered dots is all the rage on Michigan Boulevard. Fashionable city men everywhere are wearing them. They tie up exactly right for the new stylish collars. Colors, rich brown, dark blue and black with harmonizing dots. Closely knitted. Special band insures easy tying and long wear.

SEND NO MONEY

Pay the postman only \$1.65 plus few cents postage on arrival. If they aren't the greatest tie values you ever saw, return them. We will refund your money, in full, at once. Send in your order now.

GASSMAN BROTHERS

Dept. 11-B 3014 E. 92d Street Chicago, Ill.

SPANISH LEARNED EASILY AND QUICKLY!

Also FRENCH and ITALIAN

Another language will enable you to make more money—whether you are an employer or employee, professional man or woman, boy or girl.

A Few Spare Minutes Can Increase Your Income Learning a new language by the Rosenthal Language Phone Method, is as easy as learning a new tune. Study when you are in the mood—in the comfort of your own home—on your own photograph. Soon, you can talk, read and write Spanish, French or Italian.

ROSENTHAL LANGUAGE PHONE METHOD

makes rapid progress possible

Any number of people can learn at the same time—the whole family or groups of friends.

FREE 64-Page Book. It shows how easy, interesting, and profitable it is to learn a foreign language; and explains Dr. Rosenthal's world-famous method of quick study. Also details of FREE Trial offer. Send a postal—to-day.

FUNK & WAGNALLS COMPANY
549 Hess Building, 354 Fourth Ave., N. Y.



LITTLE LEATHER LIBRARY—30 Volumes \$2.98

Write for list of World's Greatest Books. Bound in genuine limp Redcroft, pocket size—All for Only \$2.98. Write for list and illustrated circular.

Dept. 131
LITTLE LEATHER LIBRARY CORPORATION
354 4th Avenue NEW YORK CITY

BIG VALUE for 10 Cts.



6 Songs, words and music; 25 Pictures Pretty Girls; 40 Ways to Make Money; 1 Joke Book; 1 Book on Love; 1 Magic Book; 1 Book Letter Writing; 1 Dream Book and Fortune Teller; 1 Cook Book; 1 Base Ball Book, gives rules for games; 1 Toy Maker Book; Language of Flowers; 1 Morse Telegraph Alphabet; 12 Chemical Experiments; Magic Age Table; Great North Pole Game; 100 Conundrums; 3 Puzzles; 12 Games; 30 Verses for Autograph Albums. All the above by mail for 10 cts. and 3 cts. postage.

ROYAL SALES CO., Box 42, South Norwalk, Conn.

WANTED!
RAILWAY MAIL CLERKS

Examinations soon. \$1600 to \$2300 a year. Steady life-time job. Common education sufficient. No "pull" necessary. Mail coupon for Catalog

Patterson Civil Service School,
Dept. 31-F, Rochester, N. Y.

Sirs: Send me, without charge, your Catalog describing this and other fine U. S. Government positions.

Name.....

Address.....

Patterson Civil Service School,
Dept. 31-F,
Rochester,
N. Y.

He had his chance —and grabbed it!

How a young man made good after ten weeks' work at Iowa State Auto School



F. D. Hennessy, President

FROM an untrained man's low wages to a half interest in a \$12,000 business—that's the progress one man made after getting our thorough training in auto mechanics.

And this man is only one of thousands of our graduates who are making good money. His experiences show what others can do in the automobile business **with the right training.** Read this letter:—

"Dear Mr. Hennessy:—
Aurora, Ill.

I learned more at your school in ten weeks than I could in two years outside. No one going there will regret the money spent. It is an up-to-date school. I got a job next day after returning home from school last winter. Now I own a half interest in a U. S. L. Battery station, Electric Welding and Machine Shop and Garage. Since last February we have taken in \$12,000.00, and in the spring we expect to build a \$15,000 building.

The first three months I worked for this man for 65c an hour and I proved good in all my work which I learned at the IOWA STATE AUTO SCHOOL, so he has taken me as partner, now we are making good. I would like to review this winter, but too busy.

Thanking you and your instructors for your service, I will do all I can to send my friends there to school.

Respectfully yours,

Nelson Rothrock."

Are you plugging along at low pay and disagreeable work? If so, grab this opportunity to get into a business that pays \$150 to \$400 a month and up. Thousands of our graduates, men like you, are holding good-paying jobs or are making big money in business for themselves.

Iowa State trained mechanics are always in demand. Here you learn the entire trade with all its many branches, in one course at one price. You put on overalls and learn by doing—everything about the care, repair and operation of auto, truck, tractor, stationary gas engines and airplane mechanics. No unnecessary lectures. You work with the most modern equipment and motors, including the Liberty Motor.



Learn Big Shop Standards— Thoroughly in 7 Weeks

We teach you the modern, practical Big Shop Standard methods. Our test and trouble work alone is worth the price of the entire course. No education or experience required. You work with tools—not books. **Life scholarships.**

Special Business Course—Your choice of a thorough business training or complete instruction in Bookkeeping and Modern Shop Records and Management as part of regular course.

Y. M. C. A. Membership—Swimming pool, Boxing, Wrestling, Library, etc. No extra charge.

"The Quality School"

Pronounced by official inspectors,
"one of the best in the country."

BIG FREE BOOK

tells all about the opportunities in Motor Mechanics and our big shop standards of instruction. **Plan now to earn more money this spring—write today.**



F. D. Hennessy,
President and
Manager,

IOWA STATE
AUTO, TRACTOR &
ELECTRICAL SCHOOL

739 Nebraska St., Sioux City, Iowa
Please send me your big FREE illustrated Book.

Name

Address

Town State

Electrical Course

In
Book
Form

Here is the quickest, easiest, cheapest way to learn electricity. Think of it! A complete electrical course in book form. No tiresome lessons with a lot of mathematics. Just plain everyday electrical facts—the very things and the only things you need know to hold down a good paying job. Written and simplified by 27 of the biggest men in the electrical field. 8 big books—4000 pages and 3500 pictures.

Electricity Means Success

—Good Pay and a Good Job. You can succeed in electricity. It's one of the best paying fields open to young men who know. Here's your chance to learn. Study at home aided by Free Consulting Membership. Free Employment Service included. The Society helps you learn and helps you get a good job.



FREE TRIAL!

Just mail the coupon—don't send a cent. We send books for a week's free use and explain all about membership privileges. Mail coupon today—now.

American Technical Society, Dept. E191, Chicago

Send me your 8-volume set of Electrical Books for a week's free use. I will either return the books in 7 days or remit \$2.50 and pay you \$3.00 each month until a total of \$24.00 is paid. If I buy the books I get a membership in your Society free.

Name

Address

Reference

Copy this coupon on larger sheet if more convenient

PLAY THE HAWAIIAN GUITAR JUST LIKE THE HAWAIIANS!

Our method of teaching is so simple, plain and easy that you begin on a piece with your first lesson. In half an hour you can play it! We have reduced the necessary motions you learn to only four—and you acquire these in a few minutes. Then it is only a matter of practice to acquire the weird, fascinating tremolos, staccatos, slurs and other effects that make this instrument so delightful. The Hawaiian Guitar plays any kind of music, both the melody and the accompaniment.

Our complete course of 52 lessons includes FREE a beautiful Hawaiian Guitar, all the necessary picks and steel bar and 52 pieces of music.

Special arrangement for lessons if you have your own guitar.



SEND COUPON NOW
GET FULL PARTICULARS FREE

First Hawaiian Conservatory of Music, Inc.
233 Broadway (Woolworth Bldg.), New York City

I am interested in the HAWAIIAN GUITAR. Please send complete information, special price offer, etc., etc.

NAME

ADDRESS

TOWN..... COUNTY..... STATE.....

Print name and address clearly. PM-1.

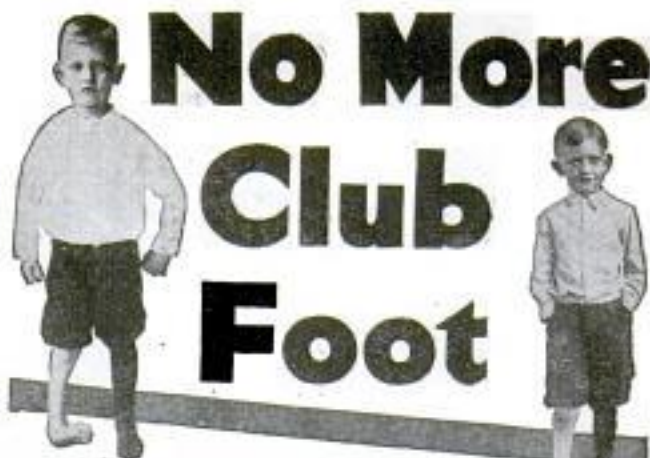

No More Club Foot

Seven-year-old Albert Albin's Club Foot was so straight that he surprised everybody when he came home from McLain Sanitarium. His parents write:

Albert's foot is in good shape. He is walking on two good feet. We are certainly proud of him and also the McLain Sanitarium. You certainly do great work. Everybody says it is more than they expected to see.

Mr. and Mrs. G. D. ALBIN,
235 Milton St., Rensselaer, Ind.

For Crippled Children

The McLain Sanitarium is a thoroughly equipped private institution devoted exclusively to the treatment of Club Foot, Infantile Paralysis, Spinal Disease and Deformities, Wry Neck, Hip Disease, Diseases of the Joints, especially as found in children and young adults. Our book, "Deformities and Paralysis," also "Book of References" sent free.

L. C. McLAIN ORTHOPEDIC SANITARIUM
902 Aubert Ave., St. Louis, Mo.

E347



Wearing Fibre Arms and Legs Gust Earns \$20 a Week

Gust Bloomquist froze his hands and feet. All were amputated. By aid of Trautman limbs, not friends and relatives, he makes his own way. Send for Gust's picture and catalog on arms, legs and braces.

RAY TRAUTMAN, MINNEAPOLIS ARTIFICIAL LIMB CO
636 Denn Building Minneapolis, Minn.

How to Get Rid of Moles



A simple, safe home treatment—
15 years' success in my practice.
Moles (Also BIG Growths) Dry Up.
Ask for Free Booklet of Full Particulars
WM. DAVIS, M. D.
124-5 Grove Ave., Woodbridge, N. J.

Don't Wear a Truss

Brooks' Appliance, the modern scientific invention, the wonderful new discovery that relieves rupture, will be sent on trial. No obnoxious springs or pads.



MR. C. E. BROOKS

Brooks' Rupture Appliance

Has automatic Air Cushions. Binds and draws the broken parts together as you would a broken limb. No salves. No lies. Durable, cheap. Sent on trial to prove it. Protected by U. S. patents. Catalog and measure blanks mailed free. Send name and address today.

BROOKS APPLIANCE CO., 126C State St., Marshall, Mich.



Surely You Can Now Afford to Own This Great Library of Knowledge

Sets of the Encyclopaedia Britannica in the Popular Handy Volume Issue, Printed on the Famous India Paper, Are Offered at Prices Within the Reach of Everybody.

ARE you one of those who do not own a set of the wonderful Encyclopaedia Britannica because you **THOUGHT** you couldn't afford it?

Have you wanted this splendid library of facts ever since you first heard about it but **NEVER INQUIRED** how easily it could be purchased?

This book will give you a tremendous advantage.

Think, too, what it will mean to you, to your children, to

have access to the **SUM** and **SUBSTANCE OF ALL HUMAN KNOWLEDGE.**

Consider what a satisfaction it will be to have at hand **THE ANSWER TO EVERY QUESTION** which comes to an active mind.

The Britannica covers the whole range of man's thought and activity and achievement—it contains more than 41,000 special articles, more than 500,000 indexed facts.

Both for profit and pleasure

THE ENCYCLOPÆDIA BRITANNICA

Is one of the best investments any ambitious man or woman can make. To briefly describe its scope is impossible. It contains hundreds upon hundreds of articles on religion, philosophy, history, art, science, literature, manufacturing, engineering, law, physics, commerce and scores of other subjects—41,000 articles in all. It abounds in everyday useful facts that satisfy the inquisitiveness of the child

mind, that enlighten the housewife, the farmer, the business man, the investigator, the educator and the lawyer.

Men and women in all walks of life are among the 200,000 owners of the Eleventh Edition.

IF YOU DO NOT OWN THE BRITANNICA, WHY NOT?

This Is Your Opportunity to Own an India Paper Set.

These sets are printed on the beautiful, genuine India paper.

As you know, this very thin but strong India paper makes this great work more convenient to handle and more inviting to read. These sets are offered at prices and terms which make the Britannica a bargain to anyone who does not yet own a set.

\$1

As First Payment Brings You This Complete Set of 29 Volumes, Containing 44,000,000 Words, 30,000 Pages, 15,000 Maps and Illustrations. The Balance Is in Small Monthly Payments.

Remember, this is an unusual offer of the complete Britannica printed on genuine India paper. Act today—**NOW**—by clipping the coupon and sending for the beautifully illustrated book telling all about the Britannica.

If you are ready to subscribe now, write an order on a piece of paper and mail with a dollar bill and we will give your order prompt attention.

Sears, Roebuck and Co.
CHICAGO

Sign and Send This Coupon Today.

Sears, Roebuck and Co., Chicago, Ill. 18X
Gentlemen: Please send me your illustrated Book giving full information about the Encyclopaedia Britannica. Also tell me what I will have to pay for a set of the Handy Volume issue of the Britannica printed on genuine India paper.

Name

Postoffice

R. F. D. Box

No. No. State

Street

and No.

BOYS



Learn Drafting

Drafting offers exceptional opportunities to boys and young men because drafting itself not only commands good pay, but it is the first step towards success in Mechanical or Structural Engineering or Architecture. And drafting is just the kind of work a boy likes to do. There is an easy, delightful way in which you can learn right at home in spare time. For 30 years the International Correspondence Schools have been giving boys just the training they need for success in Drafting and more than 300 other subjects.

Let the I. C. S. help you. Choose the work you like best in the coupon, then mark and mail it. This doesn't obligate you in the least but it will bring you information that will start you on a successful career. This is your chance. Don't let it slip by. Mark and mail this coupon now.

-----TEAR OUT HERE-----

International Correspondence Schools
Box 5591-C, Scranton, Penna.

Without cost or obligation, please send me complete information about the subject which I have checked below:

- DRAFTING
- CARTOONING
- AUTOMOBILES
- CHEMISTRY
- ADVERTISING
- SALESMANSHIP
- ELECTRICITY
- ACCOUNTING
- SURVEYING

Name

Address

Motor Car Mechanics for Beginners

105 Pages.
Cloth Bound.

Size 4 1/2 x 6 1/2 in.
Illustrated.

By GORDON W. HAYTER and
CLYDE H. PRATT, B. Sc., M. E.

The first and essential principles of motor car construction told in plain language, for the instruction of the amateur who would master this interesting and valuable subject. Written by experts and thoroughly reliable. Shipping weight 10 oz.

Price, postpaid \$1.00

The Art of Driving an Automobile

113 Pages.
Cloth Bound.

Size 4 1/2 x 7 in.
Illustrated.

By CLYDE H. PRATT, B. Sc., M. E.

To insure the greatest pleasure and safety in driving a car, every person should read and consult this book, the work of a master authority who has personally taught the art to students from every state in the Union and from many foreign countries.

Price, postpaid \$1.00

Shrewsbury Publishing Co.

5525 West Lake Street,
Chicago, Ill.

ELECTRICAL men with training are in demand. For more than a quarter of a century this school has been training men of ambition and limited time, for the electrical industries. Condensed course in Electrical

ENGINEERING enables graduates to secure good positions and promotions. Theoretical and practical Electricity, Mathematics, Steam and Gas Engines, Mechanical Drawing. Students construct dynamos, install wiring and test electrical machinery. Course with diploma, complete



Thoroughly equipped fireproof dormitories, dining hall, laboratories, shops. Over 3000 men trained.

Write for catalog. 30th year opens Sept. 27, 1922.

BLISS ELECTRICAL SCHOOL

104 TAKOMA AVENUE, WASHINGTON, D. C.

MUSIC LESSONS FREE

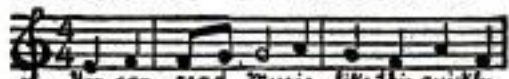

IN YOUR
OWN
HOME

You can read Music like this quickly
Piano, Organ, Violin, Mandolin, Guitar, Banjo, etc.
Beginners or advanced players. One lesson weekly. Illustrations make everything plain. Only expense about 2¢ per day to cover cost of postage and music used. Write for FREE booklet which explains everything in full.
AMERICAN SCHOOL OF MUSIC, 51 Lakeside Building, CHICAGO

FREE BOOK ON BANKING

Tells of the great opportunities in this attractive profession, and how you can learn by mail in spare time. Send for copy at once. No obligations.
EUGENE G. ALGORN, Pres.
AMERICAN SCHOOL OF FINANCE, 90 McLeane Bldg., Columbus, O.



Wonderful, new device; guides your hand; corrects your writing in few days. Big improvement in three hours. No failures. Complete outline FREE. Write C. J. Ozment, D-34, St. Louis, Mo.

LEARN WATCH REPAIRING

Be a watchmaker—you can learn this profitable trade by correspondence in a few weeks in your own home by the DeSelms Chart System. After you complete the course you will know a watch from A to Z. You will know just what the matter is and how to repair one. When you graduate you will be a practical watchmaker and repairer and competent to fill any position. Positions for our graduates.

Ask for our Free Book. It explains our system and terms.

THE DeSELMS WATCH SCHOOL
23 Perry Street ATTICA, INDIANA



Big Jobs for Big Men

The world is calling for more big, red-blooded men to qualify as Civil Engineers. Big pay is waiting for men who "know how". The civil engineer is a leader of progress. He blazes the way for civilization. He finds a path through the trackless wilderness. Towns spring up in his foot-steps. He is the pioneer of progress—the forerunner of civilization. His work is a series of achievements, full of life and interest.

Irrigation, railway, municipal and industrial development require more trained men now than ever before to direct big projects. The civil engineer is the master of all—he handles the biggest things and draws the biggest pay. Why don't you get into this great profession?

Easy to Learn At Home

It's easy to learn Civil Engineering—inexpensive too. You can learn right at home—in your spare time—keep right on with the work you are doing now—earn while you learn. The *Cyclopedia of Civil Engineering* written by 20 famous engineers will teach you everything you need to know. It will prepare you to hold such big paying jobs as Civil Engineer, Structural

Engineer, Industrial Engineer, Transitman, Estimator, Designer or Chief Draftsman.

These jobs all pay from \$75.00 to \$200.00 a week and any one of them is within YOUR reach.



Civil Engineering

9 Big Volumes Shipped Free

This is the 1920 edition and the finest books on this subject ever printed. The nine big volumes are each 8 $\frac{1}{2}$ x 5 $\frac{1}{2}$ inches with 4000 pages and more than 3000 illustrations, plans, diagrams, etc. Here is a partial list of contents. Just to give you an idea of what the books cover.

Surveying—Plotting and Topography—Highway Construction—City Pavements—Railroad Engineering—Earthwork—Steel Construction—Estimating—Statics—Roof Trusses—Specifications—Contracts—Bridge Engineering—Strength of Materials—Masonry—Reinforced Concrete—Water Supply—Sewers and Drains—Hydraulics—Water Power Development—River and Harbor Improvements—Cost Analysis Engineering—Dams and Weirs—Irrigation.

Send No Money

Just fill out and mail the coupon below. We will send all nine volumes by express collect and you can use the books a whole week as if they were your own. Go through them carefully. Give them every test you can think of and ship them back at our expense if you don't want to keep them.

If you do want to keep the books to help fit you for a fine, big-paying job or to help you on the one you have now, you can pay for them on the easiest of easy terms. Send only \$2.80 and the balance at the rate of only \$1.00 a month until a total of \$39.80 is paid. This amounts to only 75 cents a week. In these days any man can spare that much to invest in his future and never miss the money. Mail the coupon NOW.

AMERICAN TECHNICAL SOCIETY
Dept. C-191 Chicago, U. S. A.

AMERICAN TECHNICAL SOCIETY

Dept. C-191 Chicago, U. S. A.

Please send me the nine volume set of Civil Engineering books for seven days' FREE examination by express collect. If I decide to buy them I will send you \$2.80 at the end of a week and the balance at the rate of \$1.00 a month until a total of \$39.80 is paid. If I want to get along without the books I will return them within seven days at your expense.

Name.....

Address.....

City..... State.....

Reference.....

Do You Like to Draw?

Here Is a Simple, Easy Way
to Draw a Comic Face

TRY IT



Make a square with pencil, then add to it with pencil as shown in the small squares above. Erase all pencil guide lines after the drawing is completed.

We will not give you any "grand prize," if you draw this picture. Nor will we claim to make you "rich in a week." But if you are anxious to develop your talent with a **successful cartoonist**, so you can **make money**, send a copy of this picture with six cents in stamps for portfolio of cartoons and sample lesson plate, and let us explain more in detail. Some of the **most successful cartoonists** are former students of this school. It is not hard to learn to draw **originals** when you are shown how in a **practical way**.



THE W. L. EVANS SCHOOL OF CARTOONING
"The School That Has the Reputation"
821 Leader Bldg. CLEVELAND, OHIO



Learn Photography

Good-paying positions in the best studios of the country await men and women who prepare themselves now. For 25 years we have successfully taught

Photography, Photo-Engraving and Three-Color Work

Our graduates earn \$35 to \$100 a week. We assist them to secure these positions. Now is the time to fit yourself for an advanced position at better pay. Terms easy; living inexpensive. Largest and best school of its kind. Write for catalog today.

ILLINOIS COLLEGE OF PHOTOGRAPHY
Box P, 999 Wabash Ave. Effingham, Illinois

Let Me train You in AVIATION



Capt. G. F. Campbell
formerly Third Ace of the
Royal Flying Corps.

want you to take up this work. Positions are going begging because there are not enough trained men to fill them. Let me train you for these big positions. I know the game for I have been flying for years. I urge you to begin now to take a **HOME COURSE IN AVIATION** in your spare time. **GET OUT OF THE RUT.** Send today for our **FREE BOOK**, and I will write you a personal letter when it goes to you. I will give you some "inside" expert advice about how to get into this great industry. You'll join me!

Capt. Geo. F. Campbell, Chief Instructor
NATIONAL AERO INSTITUTE
Dept. 1191 916 S. Michigan Ave. Chicago

OH BOYS-GIRLS GREAT SPORT



with **CLAXOPHONE**
Under the table, back of a door, into a trunk, desk, in school, any old place. Big FUN fooling Peddlers, Policemen, Friends. Claxophone lays on your tongue unseen, always ready to use by any one. Imit. birds, etc. Claxophone with full instructions, a set of Secret Writing Tricks, also Magic Dial Trick, all for 10c., 3 for 25c. (no stamps). **10c.**
CLAXO TRICK CO., Dept. P, New Haven, Conn.

STAMMER NO MORE

Kill the fear of stammering. Re-education the key. The widely famed Hatfield Method fully outlined in an accurate, dependable, worth-while book—"HOW TO STOP STAMMERING." It has inspired thousands. Free copy today.

THE HATFIELD INSTITUTE, 109 N. Dearborn, Chicago, Ill.

FREE LESSONS EXPERT AUTO and MOTOR WORK

Men—Boys, 15 or over, can easily learn Expert Motor and Auto operation and construction during spare moments **IN 10 WEEKS**

Auto and Motor Experts frequently earn **\$40 to \$90 a week**

Send Coupon Today
COUPON Kindly send me absolutely free, single lessons in MOTOR AND AUTO OPERATION AND CONSTRUCTION. Tell me also how I can take up this work and earn while learning.

Name Address

**Play
Without
Notes**

**Be a Master of
JAZZ and RAGTIME**

Anybody Who Can Remember a Tune Can Learn to Play Jazz, Ragtime and Popular Songs by Ear, Easily, Quickly, at Very Small Cost. New Method Makes Piano Playing Wonderfully Simple.

No matter how little you know about music—even if you "have never touched a piano"—if you can just remember a tune, you can learn to play by ear. I have perfected an entirely new system. It is so simple, so easy and shows you so many little tricks of playing that it just comes natural to pick out on the piano any piece that is running through your mind. Even dull pupils grasp the idea readily and follow through the entire course of 20 lessons quickly.

Play By Ear in 90 Days

No need to devote years to study in order to learn piano nowadays. I teach you to play by ear in a small fraction of the usual time and at a smaller fraction of the cost. No tiresome scales or arpeggios to learn—no do-re-mi, no nerve-racking practice of monotonous, meaningless exercises. You learn to play what you want to play right off. No special talent is necessary. Every lesson is so easy, so interesting and fascinating that you "can't keep your hands off the piano." Just devote a part of your spare time to it and you will be playing and entertaining your friends almost before you realize how this wonderful new accomplishment has been acquired.

Experienced and talented musicians are amazed at the rapid progress of my pupils and say they cannot understand why this method was not thought of years ago. Yet it has never been used before; is not used by any other teacher or school today.

Be the Popular One In Your Crowd

One who can sit down any time without notes or music, reel off the latest jazz, ragtime and song hits and entertain the crowd is always the popular one in the crowd, the center of attraction, the life of every party, sought and invited everywhere.

Why not be the popular one in your crowd? You can learn to play as easily as hundreds of others I have taught; and you can profit by it—not only through the pleasure it provides, but also by playing at entertainments, dances, parties, etc.

Now is the time to begin. Just spend a little part of your time with my easy, fascinating lessons and see how quickly you "catch on" and learn to play. You'll be amazed, whether you are a beginner or an advanced student.

Write for my book, "The Niagara Method," describing this wonderful new method of playing by ear. I send it free.

Ronald G. Wright, Director,

Niagara School of Music, Dept. 409

Niagara Falls, N. Y.

**This Book
FREE**

SEND COUPON TODAY

NIAGARA SCHOOL OF MUSIC, Dept. 409, Niagara Falls, N. Y.

Please send me your FREE Name
Booklet describing "The Street
Niagara Method." City

Age..... Ever taken piano lessons?..... For how long a time?.....



Mechanical Engineering



Learn at Home!

EMPLOYERS everywhere are looking for men with mechanical ability. Splendid salaries and rapid advancement are offered those with special training.

There is an easy, delightful way in which you can learn right at home in spare time. For 30 years the International Correspondence Schools have been giving men and women just the training they need for success in mechanical engineering and more than 200 other subjects. Hundreds of thousands have stepped into good positions through I. C. S. help, but never were opportunities so great as now.

Let the I. C. S. help you. Choose the work you like best in the coupon below, then mark and mail it today. This doesn't obligate you in the least and it will bring you information that will start you on a successful career. This is your chance. Don't let it slip by. The most important thing you have to do is to mark and mail this coupon now.

TEAR OUT HERE

INTERNATIONAL CORRESPONDENCE SCHOOLS
BOX 5596-C SCRANTON, PA.

Without cost or obligation please explain how I can qualify for the position, or in the subject before which I have marked an X in the list below:

- ELECTRICAL ENGINEER
 - Electric Lighting & Railways
 - Electric Wiring
 - Telegraph Engineer
 - Telephone Work
- MECHANICAL ENGINEER
 - Mechanical Draftsman
 - Machine Shop Practice
 - Toolmaker
 - Gas Engine Operating
- CIVIL ENGINEER
 - Surveying and Mapping
 - MINE FOREMAN or ENG'R
- STATIONARY ENGINEER
- Marine Engineer
- ARCHITECT
 - Contractor and Builder
 - Architectural Draftsman
 - Concrete Builder
 - Structural Engineer
- PLUMBING & HEATING
 - Sheet Metal Worker
 - Textile Overseer or Supt.
- CHEMIST
- Pharmacy

- BUSINESS MANAGEM'T
- SALESMANSHIP
- ADVERTISING
 - Show Card & Sign Ptg.
 - Railroad Positions
- ILLUSTRATING
 - Cartooning
 - Private Secretary
 - Business Correspondent
- BOOKKEEPER
- Stenographer & Typist
- Certified Public Accountant
- TRAFFIC MANAGER
- Railway Accountant
- Commercial Law
- GOOD ENGLISH
 - Common School Subjects
- CIVIL SERVICE
 - Railway Mail Clerk
- AUTOMOBILES
 - Mathematics
 - Navigation
- AGRICULTURE
 - Poultry Raising
- BANKING

Spanish Teacher

Name..... 7-1-21

Street and No.....

City..... State.....

Occupation.....

Please Mention Popular Mechanics

WE TEACH COMMERCIAL ART

Properly Trained Artists Earn \$100 a week and up. Meyer Both College—a Department of the Meyer Both Company—offers you a different and practical training. If you like to draw, develop your talent. Study this practical course—taught by the largest and most widely known Commercial Art Organization in the field with 20 years' success—who each year produce and sell to advertisers in the United States and Canada over ten thousand commercial drawings. Who else could give you so wide an experience? Commercial Art is a business necessity—the demand for commercial artists is greater every year. It's a highly paid, intensely interesting profession, equally open to both men and women. Home study instruction. Get facts before you enroll in any school. Get our special booklet, "Your Opportunity"—for half the cost of mailing—4c in stamps.

MEYER BOTH COLLEGE
of COMMERCIAL ART
Michigan Ave. at 29th St.
Dept. 16 CHICAGO, ILL.

30 Days' Free Trial

Select from 44 Styles, colors and sizes, famous Ranger bicycles. Delivered free on approval, from maker-direct-to-rider, at Factory Prices. Save \$10 to \$25 on every bicycle.

12 Months to Pay Immediate possession on our liberal Easy Payment plan. Parents often advance first deposit. Energetic boys earn the small monthly payments thereafter.

TIRES Horns, wheels, lamps, parts and equipment at half usual prices. SEND NO MONEY—Ask for big free Ranger Catalog, marvelous prices and terms.

MEAD CYCLE COMPANY
Dept. A-108, Chicago, Ill.



Special offer to Rider Agents

Learn to Dance

I CAN TEACH YOU Fox-Trot, One-Step, Two-Step, Waltz and newest "up-to-the-minute" society dances in a few hours—at home—in private by the wonderful Peak System of Mail Instruction. REMARKABLE NEW METHOD. Easy—fascinating. RESULTS GUARANTEED. No music—no partner needed. Thousands taught successfully. Write me today for my interesting free book! Special low offer if you answer at once.

WILLIAM CHANDLER PEAK, M. B.
Studio 25 4737 Broadway Chicago, Ill.



Learn Autos and Tractors



Wonderful opportunities constantly offered trained men; we train you thoroughly to start your own business or make good money as motor expert, driver, shop foreman, etc.

7,000 Graduates making good. Catalog Free

Cleveland Automobile School, 1814 E. 24th St., Cleveland, O.

Be an Artist

Comics, Cartoons, Commercial, Newspaper and Magazine Illustrating, Pastel, Crayon Portraits and Fashions. Earn money; become famous. Our simple method quickly develops your talent in spare time. By Mail or Local Classes. Write for terms and list of successful students. ASSOCIATED ART STUDIOS 87-B Flatiron Building NEW YORK



SHORTHAND IN ONE MONTH

Boyd—the Wonderful, New, Easy System. Writers hold World's record. 100 to 150 words a minute in 30 days guaranteed. New Principles—dictation first week. Best for Court Reporting and Secretaries. Also Typewriting, Bookkeeping and Commercial Law. Send today for Catalog and Money-Back Guarantee. CHICAGO HOME STUDY SCHOOLS, 802 Reaper Block, Chicago, Ill.



Mounted by our student
W. T. Holcomb, Warren, Ohio



Beautiful specimens
mounted by our stu-
dent Charles Weber

Sportsmen Mount Your Own Trophies

BE A Taxidermist. Learn at home by mail to mount all kinds of specimens absolutely true to life. Save the trophies of wondrous beauty and value that you secure on your hunting and outing trips. Mount them yourself. Save Taxidermist bills, decorate your home, den or office with the choicest art in all the world. Instead of pictures of game for your dining room have actual mounted trophies. Nothing like it! Thousands now learning from our splendid mail lessons. You can learn, too. Here is a real wonderful opportunity. Do not neglect it. Send the coupon today for free books and full particulars. You positively learn to

Mount Birds and Animals

You can learn to mount *game-heads, fishes, reptiles, to tan skins* and make magnificent *rugs and robes*. You enjoy every moment given to Taxidermy. You can learn *easily and quickly at home by mail*. Adapted to everyone, men, women and boys. Learned in spare time only. Enroll in our school and be a real Taxidermist. This is the one and original school, teaching the latest and easiest methods. Over 55,000 graduates. Among our students are the most famous sportsmen, out-door lovers, statesmen, lawyers, doctors, merchants, farmers and mechanics. If you ever hunt or fish, or if you are a bird or nature lover, don't overlook this marvelous opportunity.

Learn for Pleasure and Profit

No other art is so interesting and fascinating. Men and women make Taxidermy a hobby. Nothing equals it for a delightful sparetime occupation. If you want to make big profits from your leisure time, taxidermy is just the thing. Our students easily earn from \$20 to \$35 a week from spare time alone, mounting trophies for sportsmen, and selling their own mounted game specimens. Professional taxidermists can earn \$3,000 to \$5,000 a year. You will be delighted with this marvelous art, so investigate now. Write for our free books, and see for yourself what a wonderful art Taxidermy really is.

55,000 Students Praise Our Schools and Lessons.

George Whitted, the great National League ball player (Philadelphia) says: "I am delighted with your course of lessons. I heartily recommend them".

W. A. Findlay, Edna, Texas, writes: "Have mounted over 100 specimens since taking your course. Would not take \$1,000 for them. I cannot endorse your school too highly".

Charles Weber of Cleveland says: "Your lessons are marvels of simplicity, any man or woman can learn taxidermy perfectly from your course." We have tens of thousands of such letters in our files.



Mounted by our student
J. C. Green, Sioux Falls, S. D.

Mail Coupon Today

Send the coupon today, right now, before you forget it. The coupon will bring you, absolutely free, a magnificent taxidermy book, finely illustrated with photos of game specimens, also a copy of the Taxidermy Magazine. Remember these are FREE, no obligations whatever. Mail the coupon or a postal will do. These free books will show you marvels you never dreamed of in the new and easily learned art of taxidermy.

The Northwestern School of Taxidermy
1771 Elwood Bldg., Omaha, Neb.

Our school is Patronized by Paul J. Reiney, the greatest living sportsman, by the Rockefellers, U. S. Govt., State Universities, Museums and Colleges.

Northwestern School of Taxidermy,
1771 Elwood Bldg. Omaha, Neb.

Without obligation on my part send me copies of your Free Taxidermy Book and the Taxidermy Magazine, and full particulars about your course of lessons on taxidermy.

Name.....

Address.....



"Be Wise"

Correspondence Instruction



That
Really
Meets
Your
Personal
Needs

A recent canvass, by an outside interest, of our students in Ohio showed the remarkable result of 96½ per cent thoroughly satisfied with the instruction received

This unusual showing is due to the unique features of Y. M. C. A. courses and methods.

Throughout 25 years of successful experience in spare-hour education the Y. M. C. A. has followed the personal method in instruction.

Today, in correspondence teaching, the particular needs and aims of each student are carefully considered before he is enrolled, and he receives the closest kind of personal attention from a competent, sympathetic instructor from the first lesson to the last.

The United Y. M. C. A. Schools use the latest and best text-books, so that the courses are always fully abreast of the times.

No extra charge for supplies. Even drawing instruments are furnished with drawing courses. Nothing extra to pay but postage on answers sent to your instructor for review.

A broadly organized Students' Service Department takes an active, friendly interest in all personal problems—employment, business relationships, personal development, etc.

The practical courses of the United Y. M. C. A. Schools are priced at about one-fourth less than courses of similar scope offered elsewhere. Hence, our slogan: "The most service for the least money."

Let us help you with your problems and aims. Mark and mail the coupon below. Our counsel is free.

UNITED Y. M. C. A. SCHOOLS

Dept. 2J, 375 Lexington Ave., New York City

Please tell me more about the United Y. M. C. A. Schools service. I am interested in the position or home-study course I have marked.

- | | |
|--|--|
| <input type="checkbox"/> Accountant | <input type="checkbox"/> Farm Management |
| <input type="checkbox"/> Advertising Man | <input type="checkbox"/> Farm Motor Mechanic |
| <input type="checkbox"/> Agricultural Courses | <input type="checkbox"/> Foreign Languages |
| <input type="checkbox"/> Applied Psychology | <input type="checkbox"/> Foremanship |
| <input type="checkbox"/> Architect | <input type="checkbox"/> Freehand Drawing |
| <input type="checkbox"/> Auto Mechanic | <input type="checkbox"/> Highway Engineering |
| <input type="checkbox"/> Banking | <input type="checkbox"/> Illustrator |
| <input type="checkbox"/> Better Letters | <input type="checkbox"/> Locomotive Operation |
| <input type="checkbox"/> Bookkeeper | <input type="checkbox"/> Machine-Shop Practice |
| <input type="checkbox"/> Building Construction | <input type="checkbox"/> Mathematical Courses |
| <input type="checkbox"/> Business English | <input type="checkbox"/> Mechanical Engineer |
| <input type="checkbox"/> Business Law | <input type="checkbox"/> Plumber |
| <input type="checkbox"/> Business Organization | <input type="checkbox"/> Poultry Husbandry |
| <input type="checkbox"/> Chemistry | <input type="checkbox"/> Radio Operator |
| <input type="checkbox"/> Civil Engineer | <input type="checkbox"/> Railroad Engineering |
| <input type="checkbox"/> Civil Service | <input type="checkbox"/> Salesman |
| <input type="checkbox"/> Commercial Spanish | <input type="checkbox"/> Secretarial |
| <input type="checkbox"/> Concrete Engineer | <input type="checkbox"/> Steam Engineer |
| <input type="checkbox"/> Dairy Farming | <input type="checkbox"/> Stenographer |
| <input type="checkbox"/> Draftsman | <input type="checkbox"/> Structural Drafting |
| <input type="checkbox"/> Electrician | <input type="checkbox"/> Surveyor |
| <input type="checkbox"/> Electrical Engineer | <input type="checkbox"/> Tool Designing |
| <input type="checkbox"/> English Courses | <input type="checkbox"/> Traffic Management |
| <input type="checkbox"/> Factory Management | <input type="checkbox"/> Use of the Slide Rule |

Name and Occupation.....
(Please write plainly)

Complete Address

BE AN ARTIST

We can teach you **DRAWING** in your own home during your spare time.

Our 18 years of successful teaching prove our ability. 10 Courses in Commercial and Illustrative Drawing. Teachers Normal and Applied Art. Endorsed by high art authorities. Students trained by members of our Faculty are filling high-salaried positions. Artist's Outfit FREE to Enrolled Students. Write today for Art Year

OUR HANDSOME ART YEAR BOOK FREE TO YOU!

SCHOOL OF APPLIED ART
ANNEX ART BLDG. No. 2 BATTLE CREEK MICH.

BECOME AN EXPERT STENOGRAPHER AND SPEED TYPIST

A profession that offers men and women rich rewards, fascinating work, big pay, and opens the way for promotion to high executive positions paying \$20 to \$100 a week and up. Many of America's biggest business men and women got their start because they mastered stenography. Demand for expert stenographers and typists always exceeds the supply at salaries of from \$30 to \$50 a week. The Tulloss New Way makes you an expert, one who can start in at a large salary. Complete course in shorthand and typewriting, new principles, ensures exceptional speed and accuracy. You can write shorthand the new way 125 to 150 words a minute. You can typewrite 80 to 100 words a minute, and with this speed ease accuracy and ease of operation—no fatigue as with the old way. Remarkable methods—remarkable results. You learn faster the Tulloss New Way. No previous stenographic knowledge necessary. Train at home during your spare time. Only about half usual cost—you will become a far more efficient stenographer—worth more money than the average right from the start. If already a stenographer you nevertheless need New Way training in speed typewriting, for no matter how good you are in shorthand, you can never expect the high salaried position until you get speed, real speed and accuracy on a typewriter. Quickly acquired in ten easy lessons. Will send you free our amazing book, "How to Be a Big Man's Right Hand." It tells how business men choose their private secretaries, how they advance them to executive positions. Send postal or letter and indicate whether you are interested in the complete stenography course or simply speed typewriting. No obligation—write today.

THE TULLOSS SCHOOL, 141 College Hill, SPRINGFIELD, OHIO

HOW TO PAINT SIGNS AND SHO' CARDS

Our book gives a complete course of instructions, enabling any one to learn to paint good signs. WHY NOT MAKE YOUR OWN either for your business or for others?

CONTENTS: Alphabets, Composition, Color Combinations, How to Mix Paints, Show Cards, Window Signs, Banners, Board and Wall Signs, Ready Made Letters, Gilding, Commercial Art and Tricks of the Trade—Contains 100 alphabets and designs. Cloth bound, size 7 x 5 inches, price \$1.00 postpaid.

J. S. Ogilvie Pub. Co., 577 Rose St., New York

Our Scientific Method will stop that STAMMER!

Send for free 200 page book. It tells how to permanently stop stammering or stuttering in a few weeks' time. A natural guaranteed method.

The Lewis School for Stammerers
32 Lewis Bldg., 71-77 Adelaide St., Detroit, Mich.

BE AN EXPERT Penman

FREE Particulars. "How To Become An Expert Penman," and Your Name in Fine Penmanship on two Cards. Different Colors, Embellished, Attractive Designs. ALL FREE. Write Today
T. M. TEVIE, Box 25-K, Chillicothe, Mo.

LAW High-Grade Instruction Prepares You for the Bar—Est. 1892

University Methods. Standard Text-Books. Approved by Bench and Bar. Graduates practicing in every state. Send today for Free Catalog and Rules for Admission to the Bar.

Chicago Correspondence School of Law
620 Reaper Block Chicago, Ill.



Does your English Help or Hurt you?

Does your English reveal your lack of education or does it prove that you are a man or woman of culture and refinement? Are you handicapped in your speech and writing or does your command of English rise to meet every occasion and every situation? English is the one weapon you must use every day. Here is how you can improve it almost at once.

MANY people say, "Did you hear from him today?" They **should** say, "Have you heard from him today?" Some people spell calendar "**calender**" or "**calander**." Still others say "between you and I," instead of "between you and me." It is astonishing how many people use "who" for "whom" and mispronounce the simplest words. Few people know whether to spell certain words with one or two "c's" or "m's" or "r's," or with "ie" or "ei," and when to use commas in order to make their meaning absolutely clear. And very few people use any but the most common words—colorless, flat, ordinary. Their speech and their letters are lifeless, monotonous, humdrum. Every time they talk or write they show themselves lacking in the essential points of English.

Every time you talk, every time you write, you show what you are. When you use the wrong word, when you mispronounce a word, when you punctuate incorrectly, when you use flat, ordinary words, you handicap yourself enormously. An unusual command of English enables you to present your ideas clearly, forcefully, convincingly. If your English is incorrect it hurts you more than you will ever know, for people are too polite to tell you about your mistakes.

Wonderful New Invention

For the past five years Mr. Cody has been working almost day and night on the study of the problem, "How to make correct habits in speaking and writing stick in your mind." After countless experiments he finally invented a simple method by which you can acquire a better command of the English language in only 15 minutes a day. Now you can stop making the mistakes in English which have been hurting you. Mr. Cody's students have secured more improvement in five weeks than had previously been obtained by other pupils in two years!

Learn by Habit—Not by Rules

Under old methods, rules are memorized, but correct habits are not formed. Finally the rules themselves are forgotten. The new Sherwin Cody method provides for the formation of correct habits by constantly calling attention only to the mistakes you make.

One of the wonderful things about Mr. Cody's course is the speed with which these habit-forming practice drills can be carried out. You can write the answers to fifty questions in 15 minutes and correct your work in 5 minutes more. The drudgery and work of copying have been ended by Mr. Cody. You concentrate always **on your mistakes** until it becomes "second nature" to speak and write correctly.



Sherwin Cody

Write for Free Book

Write for Free Book

A booklet explaining Mr. Cody's remarkable Course is ready. If you are ever embarrassed by mistakes in grammar, spelling, pronunciation, or punctuation, if you cannot instantly command the exact words with which to express your ideas, this book will prove a revelation to you.

A polished and effective command of the English language gives you not only the stamp of education, but it wins friends and impresses favorably those with whom you come in contact. Spare time study—15 minutes a day—in your own home will give you power of language that will be worth more than you can realize.

Write for this new free book, "How to Speak and Write Masterly English." Merely mail the coupon or a letter, or even a postal card. You can never reach your greatest possibilities until you use correct English. Write to-day for the free booklet that tells about Mr. Cody's simple invention.

Sherwin Cody School of English

51 Searle Building, Rochester, N. Y.

SHERWIN CODY SCHOOL OF ENGLISH,
51 Searle Bldg., Rochester, N. Y.

Please send me your new Free Book "How to Speak and Write Masterly English."

Mr.
Mrs.
Miss

Address

City State



High School Course in Two Years!

You Want to Earn Big Money!

And you will not be satisfied unless you earn steady promotion. But are you prepared for the job ahead of you? Do you measure up to the standard that insures success? For a more responsible position a fairly good education is necessary. To write a sensible business letter, to prepare estimates, to figure cost and to compute interest, you must have a certain amount of preparation. All this you must be able to do before you will earn promotion.

Many business houses hire no men whose general knowledge is not equal to a high school course. Why? Because big business refuses to burden itself with men who are barred from promotion by the lack of elementary education.

Can You Qualify for a Better Position?

We have a plan whereby you can. We can give you a complete but simplified high school course in two years, giving you all the essentials that form the foundation of practical business. It will prepare you to hold your own where competition is keen and exacting. Do not doubt your ability, but make up your mind to it and you will soon have the requirements that will bring you success and big money. YOU CAN DO IT.

Let us show you how to get on the road to success. It will not cost you a single working hour. We are so sure of being able to help you that we will cheerfully return to you, at the end of ten lessons, every cent you sent us if you are not absolutely satisfied. What fairer offer can we make you? Write today. It costs you nothing but a stamp.

AMERICAN SCHOOL

Dept. H-174, Drexel Ave. and 58th St., Chicago

AMERICAN SCHOOL

AMERICAN SCHOOL

Dept. H-174 Drexel Ave. and 58th St., Chicago

Explain how I can qualify for position checked:

...Architect \$5,000 to \$15,000	...Lawyer \$5,000 to \$15,000
...Building Contractor \$5,000 to \$10,000	...Mechanical Engineer \$4,000 to \$10,000
...Automobile Engineer \$3,000 to \$10,000	...Shop Superintendent \$3,000 to \$7,000
...Automobile Repairman \$2,500 to \$5,000	...Employment Manager \$4,000 to \$10,000
...Civil Engineer \$5,000 to \$15,000	...Steam Engineer \$2,000 to \$4,000
...Structural Engineer \$4,000 to \$10,000	...Foreman's Course \$2,000 to \$4,000
...Business Manager \$5,000 to \$15,000	...Sanitary Engineer \$2,000 to \$5,000
...Certified Public Accountant \$7,000 to \$15,000	...Telephone Engineer \$2,500 to \$5,000
...Accountant and Auditor \$2,500 to \$7,000	...Telegraph Engineer \$2,500 to \$5,000
...Draftsman and Designer \$2,500 to \$4,000	...High School Graduate in two years
...Electrical Engineer \$4,000 to \$10,000	...Fire Insurance Expert \$5,000 to \$10,000
...General Education in one year.	

Name..... Address.....

The Automobile Instructor

By Clyde H. Pratt, President of the Cleveland Automobile School

16 Easy Lessons

that teach you everything about automobiles. The book that tells it ALL.

The Automobile Instructor

By Clyde H. Pratt, B. Sc., M. E., Member Nat'l Society of Auto Engineers. 256 pages, 210 illustrations, cloth bound. Shipping \$7.50, \$2.00.

New edition just out. The standard work for home-study, class-room and reference, for amateur and expert. A complete course for all who desire to master this profitable profession.

LEARN AT HOME HOW TO DRIVE AND REPAIR ALL CARS

Invaluable pointers for every car owner, driver, garage man and repair man. Adopted by Cleveland and other Auto Schools and by Boards of Education as their standard text-book. The author will answer your auto inquiries FREE. This book is guaranteed to be just what you want or your money back.

Price, postpaid, - - - \$2.00

Shrewsbury Publishing Co. 5525 West Chicago, U. S. A.



& Music Lessons

UNDER MASTER TEACHERS

At Home

A Complete Conservatory Course By Mail

Wonderful home study music lessons under great American and European teachers. Endorsed by Paderewski. Master teachers guide and coach you. Lessons a marvel of simplicity and completeness.

Any Instrument Write telling us course you are interested in—Piano, Harmony, Voice, Public School Music, Violin, Cornet, Mandolin, Guitar, Banjo or Reed Organ—and we will send our FREE CATALOG with details of course you want. Send NOW.

University Extension Conservatory, 459 Siegel-Myers Bldg., Chicago, Ill.

"STAMMERING

Its Cause and Cure"

You can be quickly cured if you stammer. Send 10 cents, coin or stamps, for 288 page cloth bound book on Stammering and Stuttering. It tells how I cured myself after Stammering and Stuttering for 20 years. BENJAMIN N. BOGUE
736 Bogue Building, 1147 N. Ill. St. Indianapolis

LAW

In Your Spare Time At Home
for BUSINESS or PROFESSION
Degree of LL.B., Conferred

Only institution which gives same Course by Correspondence through Lecture System as was given for years at resident classes of this college. We coach you free to pass the Bar Examination. Complete 1921, 13-volume library. Easy terms. Organized 1910. Low enrollment fee. Write for free illustrated book, Hamilton College of Law, 431 S. Dearborn St., Dept. 61 Chicago

LEARN WATCHMAKING AND ENGRAVING



Earn while learning. Most practical watch school. Individual instructions. Graduates in great demand. Book free. Chicago School of Watchmaking, Dept. 20, State-Lake Bldg., Chicago



HOW TO BECOME A PROFESSIONAL PHOTOGRAPHER

Earning \$35 to \$125 a Week

An interesting illustrated booklet (free) on choosing a vocation, the exceptional opportunities Photography offers you and how to avail yourself of these advantages.

Motion Picture—Commercial—Portraiture

Three to six months' course. Practical instruction. Modern equipment. Day or evening classes. Easy terms. Call or write for Catalog No. 49.

N. Y. INSTITUTE OF PHOTOGRAPHY
141 W. 36th St., N. Y. or 505 State St., Brooklyn



*Says
Goodbye
to \$22 a Week*

—At 27 Earns \$4,500 a Year

"Three years ago," writes A. J. Klick, "I was just an average young man of 24, possessing a fair education, liking a (so-called) good time, occupying a bookkeeper's high stool and receiving \$1,100 a year.

"A crisis in my affairs woke me up and I began the serious study of Higher Accountancy.

"Before the year was over, I was making progress financially. Interested in my work, advancing steadily, more confident of myself, by the time I had finished the course, I had an executive position and \$3,000 a year.

"Last year I became comptroller of a good-sized corporation. My work became a pleasure; salary increased to \$3,800.

"This year I accepted a similar position with a larger corporation, with broader responsibilities and an initial salary of \$4,500. The future years are full of promise."

Unusual Opportunities in Accounting

Klick is *right*. His future years *are* full of promise!

Never in the history of business has the need for trained accountants been so great or the rewards so attractive. The files of LaSalle Extension University contain literally thousands of letters reporting rapid advancement—incomes doubled, trebled and quadrupled as the result of a comparatively few months of home-study training. Where these men were getting \$1,500 or \$2,000 a short time ago, they are earning from \$3,000 to \$10,000 today, and they are on the up-grade.

Their chance is yours—if you will take it!

Train by the "Problem Method"

Why let the *other* fellow walk away with the better job when the training you need is readily within your reach?

Right in your own home you can master Higher Accounting just as well as they! By the LaSalle Problem Method, you will be trained under the direct supervision of William B. Castenholz, A. M., C. P. A., former Comptroller and Instructor, University of Illinois, assisted by a large staff of Certified Public Accountants, including members of the American Institute of Accountants. You will be guided step by step through every phase of modern accounting practice—Auditing, Cost Accounting, Business Law, Organization, Manage-

ment, Finance and Income Tax Procedure. You will handle practical accounting problems lifted bodily from business life. You will be given special preparation for the C. P. A. examinations.

Send for further information regarding the opportunities in accounting; read the enthusiastic testimony of men still in their twenties and early thirties who have broken away from the low-pay ranks and today are expert accountants—with incomes ranging from \$5,000 to \$10,000 a year. With this information we will send you particulars of our *convenient-payment plan*; also a copy of that inspiring book, "Ten Years' Promotion in One." "Get this book," said a prominent Chicago executive, "even if you have to pay five dollars for it." We will send it *free*.

Mark—Sign—Mail the coupon—NOW.

LaSalle Extension University

The Largest Business Training Institution in the World

Dept. 164-HR Chicago, Illinois

Please send me catalog and full information regarding the course and service I have marked with an X below. Also a copy of your book, "Ten Years' Promotion in One," all without obligation to me.

Higher Accountancy

Training for positions as Auditor, Comptroller, Certified Public Accountant, Cost Accountant, etc.

Other LaSalle Training Courses

LaSalle is the largest business training institution in the world. It offers training for every important business need. If more interested in any of these courses, check here:

- | | |
|--|--|
| <input type="checkbox"/> Business Management | <input type="checkbox"/> Banking and Finance |
| <input type="checkbox"/> Traffic Management—Foreign and Domestic. | <input type="checkbox"/> Modern Foremanship and Production Methods |
| <input type="checkbox"/> Railway Accounting and Station Management | <input type="checkbox"/> Personnel and Employment Management |
| <input type="checkbox"/> Law—Degree of LL. B. | <input type="checkbox"/> Expert Bookkeeping |
| <input type="checkbox"/> Commercial Law | <input type="checkbox"/> Business English |
| <input type="checkbox"/> Industrial Management Efficiency | <input type="checkbox"/> Commercial Spanish |
| <input type="checkbox"/> Modern Business Correspondence and Practice | <input type="checkbox"/> Effective Speaking |
| | <input type="checkbox"/> C. P. A. Coaching |

Name

Present Position

Address

LEARN CARTOONING



1.

If you like to draw, develop your ability and quickly raise your income

Hundreds of others who had the same ambition have become successful cartoonists through the Landon Picture Chart Method of teaching cartooning. They are now earning from \$75 to \$400 and more per week.



2.

The Landon Course of Cartooning with the famous Landon Picture Charts teaches you how to make original drawings. As your eye follows sketch after sketch on these charts, you learn just how and where to start a drawing and place each line in completing it.



3.

You can learn during your spare time, at home—and a personal criticism service on each lesson corrects mistakes which you may make.

Celebrated cartoonists and educators everywhere pronounce Landon Picture Charts as the greatest achievement in the teaching of drawing. No other plan gives you such a thorough understanding of the fundamentals of drawing—none develops originality so rapidly.



4.

The opportunities in cartoon work were never so great as at present.



5.

Write today for sample Landon Picture Chart, long list of successful Landon students and full information showing the possibilities for you. Please state your age.

The Landon School

1438 National Bldg.

Cleveland, Ohio

ONE MAN SAW RIG

Fastest Sawing—Low Price

Here's the complete sawing outfit that you, alone, can easily operate. Saw your own wood supply—then make money sawing for your neighbors. Big market for wood in cities. Easy to move. Easy to operate. Low in price and upkeep.

4 H.P. OTTAWA One Man Saw Rig
Magneto Equipped—10-Year Guarantee
Save time and money. Get the safest saw rig built. Special friction clutch starts and stops saw or belt work while engine runs. Use the powerful 4 H.P. engine the year round for belt work. Sold on 30 days trial—Direct from factory at new low price. Cash or Easy Terms.
Write for **Free Book**
Know all about the OTTAWA before buying any machine. Your name on card will do.

OTTAWA MFG. CO.
Dept. 271 Ottawa, Kans.

LEARN PIANO TUNING

MAKING TRIALS OF TRUE TONE
By TUNE-A-PHONE



We furnish our accurate teaching device with tools, Action Model, lessons, and analysis of business advertising which makes you a master of the tuner's art. Diploma given graduates. 15 years' experience in teaching the most independent and lucrative profession by correspondence. **SIMPLER and BETTER than oral instruction.** Write today for FREE booklet and guarantee plan.

NILES BRYANT SCHOOL OF PIANO TUNING
22 Bryant Bldg. Augusta, Mich.

Get This Car And the AGENCY

In Your Territory. Drive a new 1922 Model Birch Super-Four. **Prompt shipments.** Experience not necessary. We require agents to take special course to handle Birch Agency. Write quick for full information. **BIRCH MOTOR CARS, Dept. 115, 308 N. Mich. Ave., Chicago**

MINSTRELS Musical Comedies and Revues with Complete Instructions for Staging. You can put on your own show with our books. Opening Choruses and Finales, Skits and Afterpieces, Monologues, Songs, Vaudeville Acts, How to Stage a Minstrel Show, Wigs, Make-up. Big Catalogue free. **T. S. DENISON & CO., 623 So. Wabash, Dept. 19 CHICAGO**

TELEGRAPHY

(Morse and Wireless) and RAILWAY ACCOUNTING taught thoroughly. Big salaries; great opportunities. Oldest, largest school. Endorsed by Telegraph, Railway, Radio, and Government officials. Expenses low—opportunities to earn large portion. Catalog free. **DODGE'S INSTITUTE, Dyke Street, Valparaiso, Ind.**

Learn Watchwork, Jewelrywork and Engraving.

A fine trade commanding a good salary, and your services are always in demand. Address **HOROLOGICAL, Dept. P, Bradley Institute, Peoria, Ill.,** for our latest catalog.

200 Kinds Iron, Wood and Wire PUZZLES
One of our leaders and illustrated folder, postpaid 10 cents. Ask for one difficult if desired. **WESTERN PUZZLE WORKS, St. Paul, Minn.**

BE POPULAR!

Learn to Dance Well, at home, by my new easy method. Thousands taught. You need no music or partner. I guarantee to teach you! **FREE:** To prove you can learn I will send you one lesson FREE. For mailing, etc., send 10c today! **ARTHUR MURRAY, Studio 60, 290 Broadway, New York**





Draftsman's Complete Outfit

Everything used by expert draftsmen given you absolutely free. Outfit includes "professional" complete set of fine drawing instruments with double set of compasses and dividers all in velvet lined case. Drawing board, T square, two triangles, protractor, universal curve, triangular standard scale, water-proof ink, pens, pencils and all accessories—furnished you free in this expert's complete outfit.

Easy to Learn at Home

from Great School Known All Over the World

The Coyne Home Study Course guarantees to train you. Remember, the Coyne Trade and Engineering Schools are recognized by Educators all over the world. Students come from all over the world to get Coyne training. Why. Because of the Coyne Schools' long established, tremendous reputation for successful teaching by its great staff of experts. Coyne is not a "one man" school but a great educational institution, 22 years old, an acknowledged leader and originator. Coyne originated the "Learn by Doing" method now endorsed by educators everywhere. Coyne has graduated thousands of successful, prosperous men all over the world. You can't make a mistake if you write for the Coyne free book. Coyne students say every minute of the course was enjoyable. Some students took good positions 3 months before their course was finished.

Send for FREE Book

Mail this coupon for our interesting book, "Drafting the Foundation of Industry," sent you free. It explains all about the Coyne home study method and shows you how to become a draftsman in the quickest and easiest way. You want to know all about this great institution. Don't put it off. Send for this book now. It's absolutely free, no obligation. It contains the most valuable information you will ever get in your life. Send the coupon now.

COYNE

HOME STUDY DEPT.

TRADE & ENGINEERING SCHOOLS

Recognized Producer of Successful Men

39-51 East Illinois St., Dept. 1771, Chicago, Ill.

FREE

Draftsmen Make \$225.00 to \$500.00 a Month

There is a tremendous demand for trained draftsmen. Now is the time to start. Draftsmen get good pay from the start and can work up to \$500 a month and more. Draftsmen are needed everywhere. Once you are trained you can choose your own business and work in any part of the country you please. Coyne training makes everything easy for you.

Coyne student L. T. Dubendorf writes: "Immediately after completing Coyne course I went to work for Armour & Co. Work was easy for me. Five months later I accepted a position in New York at a large increase in salary."

3 Months Course at School You can qualify as an expert draftsman by 3 months' intensive training at the school in Chicago. Living cheap. Possibilities of earning way while studying. If you prefer to come to school instead of the "Home Study" course, check coupon below and send it for complete information.

Check this coupon and mail it now

Coyne Trade and Engineering Schools,
Department 1771, 39-51 E. Illinois St., Chicago, Ill.

Dear Sirs:—Please send me, absolutely free, without obligation, your book, "Drafting the Foundation of Industry," also full information about the Course in Drafting. (Check which course you prefer.)

Home Study Course School Course

Name

Address

.....State

This Man Is Sure of His Job



HE saw the handwriting on the wall. Men in his department were being dropped right and left. He might have been the next to go but for a familiar coupon which he saw one day in a magazine. He marked it, and mailed it to Scranton.

Then one day his employer called him in.

"Young man," he said, "I have just received a letter from the International Correspondence Schools telling me you have enrolled and have received a mark of 93 for your first lesson.

"I don't mind saying that this letter has saved your job. I had you on the list of men to be dropped. But I'm going to keep you now. The man who thinks enough of his future to study his job is the kind of a man we want around here."

HOW about you? Are you sitting on the anxious bench wondering if you will be the next to go? Or are you training yourself so that you will not only be sure of your present job but will be ready for the job ahead?

No matter where you live, the I. C. S. will come to you. No matter how limited your previous education, the simply-written, wonderfully-illustrated I. C. S. textbooks make it easy to learn. No matter what career you may choose, some one of the 300 I. C. S. Courses will surely suit your needs.

This is all we ask: Without cost or obligation, put it up to us to prove how we can help you. Just mark and mail this coupon. Today is best.

TEAR OUT HERE

INTERNATIONAL CORRESPONDENCE SCHOOLS
BOX 3594-C SCRANTON, PA.

Without cost or obligation please explain how I can qualify for the position, or in the subject before which I have marked an X in the list below:

- | | |
|---|--|
| <input type="checkbox"/> ELECTRICAL ENGINEER | <input type="checkbox"/> BUSINESS MANAGEMENT |
| <input type="checkbox"/> Electric Lighting & Railways | <input type="checkbox"/> SALESMANSHIP |
| <input type="checkbox"/> Electric Wiring | <input type="checkbox"/> ADVERTISING |
| <input type="checkbox"/> Telegraph Engineer | <input type="checkbox"/> Show Card & Sign Ptg. |
| <input type="checkbox"/> Telephone Work | <input type="checkbox"/> Railroad Positions |
| <input type="checkbox"/> MECHANICAL ENGINEER | <input type="checkbox"/> ILLUSTRATING |
| <input type="checkbox"/> Mechanical Draftsman | <input type="checkbox"/> Cartooning |
| <input type="checkbox"/> Machine Shop Practice | <input type="checkbox"/> Private Secretary |
| <input type="checkbox"/> Toolmaker | <input type="checkbox"/> Business Correspondent |
| <input type="checkbox"/> Gas Engine Operating | <input type="checkbox"/> BOOKKEEPER |
| <input type="checkbox"/> CIVIL ENGINEER | <input type="checkbox"/> Stenographer & Typist |
| <input type="checkbox"/> Surveying and Mapping | <input type="checkbox"/> Certified Public Accountant |
| <input type="checkbox"/> MINE FOREMAN or ENGR | <input type="checkbox"/> TRAFFIC MANAGER |
| <input type="checkbox"/> STATIONARY ENGINEER | <input type="checkbox"/> Railway Accountant |
| <input type="checkbox"/> Marine Engineer | <input type="checkbox"/> Commercial Law |
| <input type="checkbox"/> ARCHITECT | <input type="checkbox"/> GOOD ENGLISH |
| <input type="checkbox"/> Contractor and Builder | <input type="checkbox"/> Common School Subjects |
| <input type="checkbox"/> Architectural Draftsman | <input type="checkbox"/> CIVIL SERVICE |
| <input type="checkbox"/> Concrete Builder | <input type="checkbox"/> Railway Mail Clerk |
| <input type="checkbox"/> Structural Engineer | <input type="checkbox"/> AUTOMOBILES |
| <input type="checkbox"/> PLUMBING & HEATING | <input type="checkbox"/> Mathematics |
| <input type="checkbox"/> Sheet Metal Worker | <input type="checkbox"/> Navigation |
| <input type="checkbox"/> Textile Overseer or Supt. | <input type="checkbox"/> AGRICULTURE |
| <input type="checkbox"/> CHEMIST | <input type="checkbox"/> Poultry Raising |
| <input type="checkbox"/> Pharmacy | <input type="checkbox"/> BANKING |
| | <input type="checkbox"/> Spanish Teacher |

Name.....

Street and No.....

City..... State.....

Occupation.....

If You Miss This Story You Are Out of Luck!

Good as all AMERICAN BOY stories are, we've got a new one starting in January that is a corker. "Advertising Andy," by Edward Edson Lee, is a series of stories of a boy who had an ambition bigger than driving a delivery wagon. As you read it you will learn there are worlds of fascinating things about advertising. You will understand how advertising keeps the chimneys of big factories smoking, puts merchandise onto dealers' shelves, and makes it easier for people to buy reliable goods. Through it all runs a chuckle from first to last.

Then, too, you must read "Noah's Bark," by Charles Tenney Jackson. It's a scream of a yarn about a "houn' dog" who hated water.

"Nobody's Fool," by K. P. Kempton, is a tale of a strangely matched pair in the radio shack of a big liner; Ike Palmer, haunted by the expectation of trouble, and Slim Giles, fresh from radio school. In this story they meet with a terrifying disaster at sea. It is immense!

AND ICE HOCKEY! Just how to play it is told (with diagrams) by Alfred Winsor, America's foremost college coach. "Every boy who wants to be a champion hockey player," he says, "should start young, skate and play shinny." Get in on this finest winter sport!

There's also an article about life insurance that will open your eyes. Tell your parents you want to read it—and want them to read it.

If you are not a regular subscriber to THE AMERICAN BOY you ought to be. A subscription insures you against missing any of the good stories coming. If you buy it each month you'd better stop in at your news-dealer's now and tell him to reserve the January number for you.

The subscription price is \$2.00 a year by mail—at news-stands it is 20c a copy

American Boy
The Biggest Brightest Best Magazine for Boys in All the World

THE SPRAGUE PUBLISHING CO.
No. 370 American Bldg., Detroit, Mich.

Herewith find \$2.00. Please send THE AMERICAN BOY for one year, beginning with the current issue, to

Name.....

Address.....

NAME	POSITION	SALARY
John	AUTOMOBILE ENGINEER	\$125 A WEEK
	REPAIR MAN	\$50 A WEEK
	CHAUFFEUR	\$40 A WEEK

Put Your Name On this Pay-Roll

Men like you are wanted for big-pay positions in the fascinating field of automobile engineering. We have made it easy for you to fit yourself for one of these positions. You don't have to go to school. You don't have to serve an apprenticeship. Fifteen automobile engineers and specialists have compiled a spare time reading course that will equip you to be an automobile expert without taking any time from your present work.

AUTO BOOKS 6 Volumes Shipped FREE

Now ready for you—at a big reduction in price—an up-to-the-minute six-volume library on Automobile Engineering, covering construction, care and repair of pleasure cars, motor trucks, tractors and motorcycles. Brimming over with advanced information on Lighting Systems, Garage Design and Equipment, Welding and other repair methods. Contains everything that a mechanic or an engineer or a motorcyclist or the owner or prospective owner of a motor car ought to know. Written in simple language that anybody can understand. Tastefully bound in flexible covers and gold stamped, 2700 pages and 2400 illustrations, tables and wiring diagrams. A library that cost thousands of dollars to compile but that comes to you free for 7 days' examination.

Only 10 Cents a Day

Not a cent to pay in advance. First you see the books in your own home or shop. Just mail coupon and pay express charges when books arrive. You can read them and study them for seven whole days before you decide whether you want to keep them or not. If you like the books send \$2.80 in seven days and \$3.00 a month until the special price of \$24.80 has been paid. (Regular price \$45.00.) Along with the set goes a year's membership in the American Technical Society, including consulting privileges and free employment service.

Send No Money Now

Don't take our word for it. See the books without cost. There is so much profit in this offer for you, that we urge you not to waste a moment in sending for the books. Put the coupon in the mails today. SEND NO MONEY—only the coupon.

American Technical Society
Dept. A-191 Chicago, Illinois

American Technical Society, Dept. A-191, Chicago

Please send me a set of Automobile Engineering books in 6 volumes by express collect, for a week's free use. At the end of a week I will either send the books back at your expense or send you \$2.50 as first payment and \$3.00 each month thereafter until a total of \$24.80 is paid. I understand that I will get a membership in your society, including consulting privileges and free employment service if I purchase the books.

Name.....
Address.....
City.....
State.....
Reference.....

Mail The
Coupon For
These Books

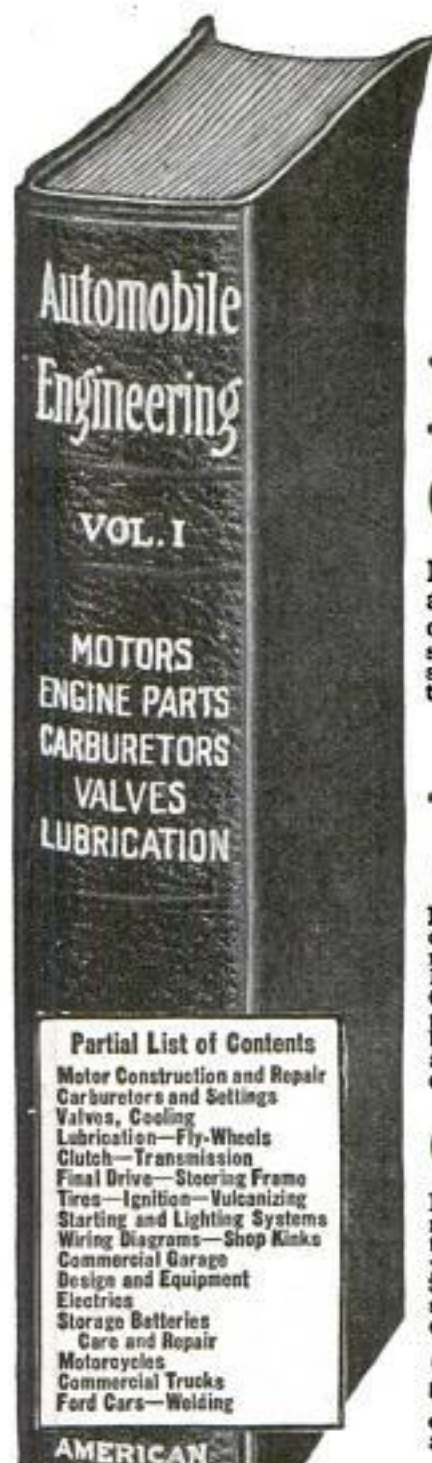

Partial List of Contents

Motor Construction and Repair
Carburetors and Settings
Valves, Cooling
Lubrication—Fly-Wheels
Clutch—Transmission
Final Drive—Steering Frame
Tires—Ignition—Vulcanizing
Starting and Lighting Systems
Wiring Diagrams—Shop Kinks
Commercial Garage
Design and Equipment
Electrics
Storage Batteries
Care and Repair
Motorcycles
Commercial Trucks
Ford Cars—Welding

AMERICAN





FREE

PROFESSIONAL TONE MUSICAL INSTRUMENTS

and lessons sent on **free** trial. Violin, Tenor Banjo, Hawaiian Guitar, Ukulele, Mandolin, Cornet, Banjo-Mandolin, Banjo-Ukulele, Guitar, Banjo-Guitar, or Banjo. Wonderful new copyrighted system of teaching note music by mail. Four lessons will teach you several pieces. Over 100,000 successful players. Do not miss this **free** trial offer. Write for booklet. No obligations.

SLINGERLAND SCHOOL OF MUSIC, INC., 1815 ORCHARD ST., DEPT. 104, CHICAGO, ILL.



Hotels Need Trained Executives

Nation-wide demand for trained men and women in all departments of hotels, clubs and apartment houses. Uncrowded field; fine living, quick advancement in the big hotels of the United States—now America's Fourth Largest Industry. Statistics show that **ONE IN EVERY TEN HOTELS WILL HAVE AN OPENING FOR A MANAGER THIS YEAR.** Thousands of other positions also open to those who qualify through training.

The Lewis School guarantees to give you the valuable knowledge that it has taken some of the most successful hotel men years to obtain—men who are now making \$5,000 to \$50,000 a year. All of your training will be under the personal direction of Clifford Lewis—a hotel expert of national reputation. A few spare-time hours a week given to the simple, clear lessons of the course will open the way to a good position, a fine living and a handsome salary. The training will in no way interfere with your present activities.

Free Coupon

LEWIS HOTEL TRAINING SCHOOL
Room 319
Washington, D. C.

Send me without obligation the FREE BOOK "Your Big Opportunity."

Name
Street
City State

Send today for FREE BOOK, "Your Big Opportunity." Don't wait a minute—you may lose the opportunity of a lifetime. Mail the coupon NOW. Your whole future may depend on it. *Founded 1916.*

LEWIS HOTEL TRAINING SCHOOL
Clifford Lewis, Pres.
Room 319
Washington, D. C.

LEARN The BUSINESS of Advertising



QUICKLY BY MAIL

We guarantee to teach you. It's **easy** to learn—and **easy** to get into! Make the start **this week.** This free book tells how.

\$75 to \$100 a Week

—frequently paid beginners. There is **no limit** to opportunities which men and women trained in advertising meet on every hand.

FREE This interesting book on advertising is sent free. Tells just the things you want to know about getting into this fascinating field. Full of facts.

PAGE-DAVIS SCHOOL, Dept. A13, Page Bldg., Chicago

WRITE NOW for Dyke's FREE Booklet

ANew IDEA OF TEACHING BY MAIL WITH DYKE'S WORKING MODELS CHARTS, MANIKINS, ETC.

tells how you can learn at home—spare time—and **Become an Auto Expert** on repairing and electrical systems.



DYKE'S SCHOOL OF MOTORING, Box 300 Granite Bldg., St. Louis, Mo. A department of the Firm: A. L. Dyke, Publisher. Original and only system of its kind. Endorsed by leading motor authorities of the world.

The WONDERFUL ERICKSON PATENT LEG

Will not chafe, overheat, nor draw end of stump.



ERICKSON ARTIFICIAL LIMB CO., 38 Wash. Av. N., Minneapolis, Minn.

\$95 to \$135 a Month

Men—boys—over 17—should write at once

Rapid advancement. "No Lay-offs." **THE POSITION IS YOURS FOR LIFE.**

Common-sense education sufficient. Political influence **NOT REQUIRED.**

Write immediately for schedule showing the places and dates of ALL COMING Government Examinations. Don't delay.

FRANKLIN INSTITUTE, Dept. T178, Rochester, N. Y.



Franklin Institute (The Pathway to Plenty), Dept. T178, Rochester, N. Y. This coupon, filled out as directed, entitles the sender to free specimen questions a free copy of our book, "Government Positions and How to Get Them," a list of Government positions now open, and to consideration for free coaching for the examination here checked.

COUPON

..... Railway Mail Clerk (\$1800-\$2200) Postoffice Carrier (\$1400-\$1800)
..... Bookkeeper (\$1400-\$1800) Rural Mail Carrier (\$ 720-\$2800)
..... Postoffice Clerk (\$1400-\$1800) Customs Positions (\$1100-\$2000)

Name
Address

Use this before you lose it. Write plainly.

Your Life May Be a Gold-Mine of Ideas for Stories and Photoplays

DOESN'T YOUR life have its stories of love, its trials, joys, surprises, partings, misunderstandings, and reconciliations? Doesn't EVERY life have its stories—and its photoplays? Don't all of us take part daily in plots and situations of comedy and tragedy? Isn't life a succession of changes, of variations, of new experiences seen, heard, taken part in?

And the stories you read, the plays you see, any one of them might well be stories of your own life changed around a bit to bring out a certain effect. "But," you say, "no one would be interested in me or my life." Right there is where you might be doing yourself a grave injustice. Just think of the countless stories starring heroes or heroines of every-day life—housewives, stenographers, mechanics, teachers, doctors, lawyers, and men and women of all stations. Every occupation has been written of and excellent story and play material made from each. Would it not be splendid to see some story of your own life amusing, thrilling, and uplifting readers and theater-goers all over the world?

The dashing buccaneer, the wild-west hero, the blood-thirsty villain, and other exaggerated, impossible characters play an extremely small part in the fiction of to-day. Small town and country folk are being featured more and more, as witness the rube roles of Charles Ray, and Sinclair Lewis's "Main Street."

So, you see, every section of the country, no matter how small or insignificant, every person, regardless of position or education, has a story, a place in the pages of our magazines and on the screens of our movie theaters.

Every day new writers spring up. Are they any different from you? The old superstition that writers were magically endowed has thankfully gone the way of so many old-fashioned and harmful prejudices. People now realize that a story is nothing more or less than a snap-shot of some particular phase of life, some incident, some character, idea, or setting. The happenings and persons making up a plot may be fictitious, but they must be true to the elemental impulses of life nevertheless.

Writing, then, has become an ordinary occupation stripped of all its fearful aspects. So many things we do not quite understand become quite simple when they are explained.

The most surprising part of it all is that editors seem

most anxious to get hold of the stories and plays of those who never even have tried to write, or even thought of it. Editors realize that the ideas of such people would flow forth in pure, fresh, natural, human, and sincere upwellings from their very hearts.

The Editor of Collier's, in sending out an appeal for new writers, says:

"There is a popular impression that the new writer has no chance—that his contributions are given scant attention. The impression would be quickly dispelled if the public could see how eagerly magazine editors go through each mail—hoping always that the great Unknown may at last have appeared."

Another famous editor makes the startling statement:

"Every editor of every magazine and studio in the United States is searching for good material. Readers in the employ of the various companies are delving hungrily, aye ravenously, for new writers, and the appear-

ance of even a gleam of genius is hailed with acclaim. It is safe to say that any well-conceived story, no matter how obscure may be the author, will not pass three editors for whom it is available before it is snapped up." AND HUNDREDS OF OTHER EDITORS HAVE MADE LIKE STATEMENTS!

People are curious by nature. They are always looking about to see what the other fellow is doing, saying, discovering. A man in Cairo is just as interested in you and your mode of living as you are in him and his circumstances. City dwellers go to the country and read stories of country life, while country and small town dwellers do the reverse. A person's interest is piqued by something that is not his. And since we are all different from each other, every person is a source of wonder to every other person.

And that is why YOUR life has its stories and photoplays which the public is so anxiously waiting to read.

There is a new book awaiting you that amazes every reader—and the most amazing thing of all is—IT'S FREE! Within its covers are surprises and revelations for doubting beginners that have caused a sensation everywhere, because it is crowded with THINGS THAT GRATIFY YOUR EXPECTATIONS—good news that is dear to the heart of all those aspiring to write; stories of success, brilliant instances of literary fame coming unexpectedly; new hope, encouragement, helps, hints—things you've long wanted to know!

"THE WONDER BOOK FOR WRITERS" tells how stories and plays are conceived, written, perfected, sold. How both men and women, young and old, suddenly realize they can write,

after years of doubt and indecision. How the scenario and story writers began. How they quickly rose to fame and fortune. How simple plots and ordinary incidents become thrilling stories and plays through New Easy Methods that simplify everything! How one's imagination may bring glory and greatness. How to really test your natural writing ability. How stories and plays are built up step by step. How to turn Uncertainty into Success.

This book and all its secrets are YOURS! You may have a copy absolutely free. You need not send a penny. You need not feel obligated. You need not hesitate for ANY reason. The book will be mailed to you without any charge whatever.

There is no need to let your laudable ambition stand still—no need to starve the Noble Flame that burns at the Altar of your Dearest Hope—no need to wait, to wish—to merely dream of being a writer. Your brilliant opportunity, your golden chance, is HERE AND NOW! Get your pencil—use the coupon below. This little act may prove the big, lucky stroke of your destiny.



Photo © by Evans L. A.

Miss Claire Windsor, famous film star.

Read her inspiring message in "The Wonder Book for Writers" sent free to anyone.



KIND OF PROOF YOU LIKE TO SEE

"There never has been such a market for good fiction as there is to-day. This is the golden age for writers. Any man or woman with an original idea or even an original way of handling an old idea, can sell their manuscripts as fast as they can turn them out."—ROBT. H. DAVIS, of Munsey's Magazine.

"It requires no literary experience or ability."—MARION FAIRFAX, writer for Mary Pickford.

"In every man and every woman there is some great moving picture scenario. There is material for screen masterpieces in the life of the dullest person you meet on the street to-day. Your neighbors are living stories that, if told naturally and spiritedly, would touch and thrill the world."—D. W. GRIF-FITH, producer of "Birth of a Nation," "Way Down East," "Intolerance."

"Original five-act plots by unknown authors sell for from \$500.00 to \$5,000.00."—JOHN EMERSON, well-known photo playwright.

"The best reading matter is as frequently obtained from absolutely new writers as it is from famous writers."—JOHN M. BIDDALL, Editor of American Magazine.

THE AUTHORS' PRESS,

Dept. 127, Auburn, N. Y.

Send me ABSOLUTELY FREE, "The Wonder Book for Writers." This does not obligate me in any way.

Name.....

Address.....

City and State.....

Gibson Instruments

Mandolin, Mandola, Mando-Cello,
Guitar, Tenor-Banjo, Mandolin-
Banjo, Cello-Banjo, Guitar-
Banjo, Harp-Guitar,
Mando-Bass -



Easy to Play
Easy to Pay

Select your Gibson now. You can soon be playing the music of the day. Your friends will be surprised and delightfully entertained. Let us help you organize a Gibson Orchestra in your community. You can increase your popularity, income and pleasure by playing for Concerts, Entertainments, Church Affairs, etc. A small down payment and then \$5 a month will soon pay for a Gibson and will furnish you with wholesome, year-round entertainment. If you have an old instrument, we will make liberal allowance on a Gibson. Write for Free Book, Catalog, Free Trial Offer, information about Wm. P. Rice, Jr. Book and Instrument you prefer.

GIBSON MANDOLIN-GUITAR COMPANY
Kalamazoo, Mich., U. S. A.

1281 Parsons Street



MAKE MONEY Make Show Cards and Signs

EARN \$10.00 to \$25.00 DAILY as salary or have own shop and independence. Easy to learn. BIG DEMAND. Complete course in 30 lessons with individual correspondence instruction, including hand lettered show cards, and 375 assortment MILLERINE COLORS and 12 BRUSHES FREE. WRITE TODAY for special offer, illustrated prospectus, price and terms. Students established in paying sign shop by our unique money-making plan in 90 days' time.

EMPIRE W. INSTITUTE OF LETTERING, 2350 Amsterdam Ave., N. Y.

10 Buys
\$100
Millions
Billions
in use
to-day



Engel
"Art Corners"

Use them to mount all kodak pictures, post cards, clippings in albums

No PASTE NEEDED
Made in Square, Round, Oval, Fancy and Heart of black, gray, green, and red gilded paper. Slip them on corners of pictures, then wet and stick. QUICK-EASY-ARTISTIC. No fuss, no fuss. At photo supply, drug and stat'y stores. Accept no substitutes; there is nothing as good. 10c brings full pkg. and samples from Engel Mfg. Co. Dept. S-A 4711 N. Clark St. CHICAGO



DRAW A BIG SALARY

as Mechanical or Architectural Draftsman

Why plod along at distasteful, hard and low-winged work, when we can qualify you in spare time at home to earn big pay in this easy, fascinating profession. Drafting is the language of construction—the open door to progress and success in

Address, Dept. E-134

INDUSTRIAL CORRESPONDENCE UNIVERSITY, Inc.

1504 Locust Street, Philadelphia, Pa.

engineering and architecture. Latest, greatest, easiest course. Famous Foster System originated by our President, the founder of mail instruction, who has made thousands of draftsmen, engineers and architects out of clerks, mechanics and salesmen. Drawing Booklet and sample plates free.

TIRES BEST VALUES EVER OFFERED

32x4-\$9. 33x4-\$9.50. 34x4-\$10.50

Used tires. Other sizes just as low. Cords and fabrics. Send no money. Return tires if not satisfactory when received. State if you want s.a. or cl. Supply limited at this price. Order quick. ROYAL TIRE & SUPPLY CO., 1461 MICHIGAN AVE., DEPT. P, CHICAGO, ILL.

From \$30 to \$1000 per Week!

This is the record of one man who read and applied the lessons in "Power of Will." Examine this great book free. Send no money. Pay \$3.00 after 5 days or return book. Address Felton Publishing Company, 13-A, Wilcox Block, Meriden, Conn.

Thousands of Positions
Waiting

Intensely Interesting
Work

BE A TRAFFIC MAN

Economical distribution is the problem confronting most concerns today in every part of the country. Only the man trained in Traffic Management has the solution to their problems. One of our students saved his concern \$90,000.00 in a single year. Many of them have saved their entire year's salary in the first month. Is it any wonder that the Traffic Manager's salary is large? The results of his work are always evident and he naturally demands a large salary.

You Can Command Salary of \$3,500.00 to \$10,000.00 Yearly

TRAINING is the difference between your job and that of the highly paid Traffic Manager. The field is uncrowded, with thousands of positions open to trained men, but you must study, prepare. You can't win by wishing. The good things of life don't come that way. The test of a man's success is his willingness to "dig" for it. Prepare yourself now for this big job. Send at once for free booklet "Traffic" and other information on this interesting uncrowded field.

Pleasant Work--Easy to Learn

Spare time study—a few hours each week will soon fit you for one of these fine positions. Our course is highly practical. Entire course is given by practical, experienced traffic men, whose advice comes from their daily experience. Each student gets personal attention. Practical assistance rendered for two years after graduation.

Post Graduate Course Free

Graduates are privileged to use this feature without extra charge. Gives actual experience at our school in rates, routing, classification and packing—an exclusive feature not offered elsewhere.

We Give You a Job at Once Earn While You Learn

We have just perfected an entirely new plan. To students who so desire, we can give a position whereby they can earn while they learn. This is an opportunity to make money that can be used to pay your tuition. The hustler can do even better. It is Traffic work, practical training every graduate needs. It is easy to do, needs no previous experience or training, can be done in spare time and helps the student in his study. This "student earning plan" is an exclusive Interstate Traffic School feature.

Think of it! You begin to earn almost as soon as you enroll. This feature together with our Post Graduate Course taken in person at our school, makes our graduates finished business getters as well as thorough Traffic men.

If You Are Out of Work

Don't ever be out of work again. Let this "hard time" be your last "hard time." Get into a business of your own—into a profession with no idle seasons or "hard time" lay-offs. Remember! You begin earning money soon after enrolling. You learn in an hour or two how to make money this new, exclusive Interstate Traffic School Way. It is the greatest and most practical feature ever given by any correspondence or residence school.

Prove your ambition.
Mail Coupon TODAY for
Full Information.

INTERSTATE TRAFFIC SCHOOL, 21 Traffic Bldg., Fort Wayne, Indiana

TRANSPORTATION
INTERSTATE COMMERCE

Clip, Sign and Mail

Interstate Traffic School
21 Traffic Bldg.,
Fort Wayne, Indiana.

Gentlemen: Without obligation, please send me booklet "Traffic" and full information about the job you can give me.

Name

Address

City State

Present Occupation

DO YOU WANT \$200 A WEEK?

The Amazing Story of How Carl A. Rowe Jumped from \$200 to \$1000 a Month

My name is Rowe—Carl Rowe. I live in a small city in New York State.

I am going to tell you an amazing story about myself. It may seem too strange to believe, but you can easily verify everything I have to say.

Two years ago I was a baker. I was struggling along, trying to make the money in my pay envelope meet the increasing expenses of our family. There was no prospect for the future.

Today, just two years later, I am a successful business man. I have plenty of money for all the things we need and want. Last month I made \$876 during my spare time, and was able to put \$200 a week in my savings account.

I am going to tell you how it happened.

Please remember that two years ago I had no surplus cash. I was in the same fix as nine out of ten other men. Expenses were constantly mounting and my salary, although it had increased, could not keep pace with the cost of living. My wife had to do without things that I knew she ought to have. We wanted an automobile, but we couldn't afford it. We wanted to buy our own home, but couldn't afford that.

It made me desperate to think of what might happen if I became sick or lost my job. I worried about it, and so did my wife. We were living from hand to mouth, and we didn't know what calamity and hardships might be lurking just around the corner.

And yet—today—I own our nine-room house. I have an automobile. I have money for books, the theater, or any other pleasures that I may want. I have the cash today to educate my son and send him through college.

Here is how it happened. One day in glancing through a magazine I read an advertisement. The advertisement said that any man could make from a hundred to three hundred dollars a month during his spare time.

I didn't believe it. I knew that I worked hard eight hours a day for \$50 a week, and I figured that no man could make that much during a couple of hours a day spare time.

But as I read that ad I found that it pointed to men who had made that much and more. In the last paragraph the advertiser offered to send a book without cost. I still doubted. But I thought it was worth a two-cent stamp, so I tore out the coupon and put it in my pocket, and the next day on my way home from work I mailed it.

When I look back to that day and realize how close I came to passing up that ad, it sends cold chills down my spine. If the book had cost me a thousand dollars instead of a two-cent stamp, it would still have been cheap. All that I have today—an automobile, my home, an established business, a contented family—all these are due to the things I learned by reading that little eight-page booklet.

There is no secret to my success. I have succeeded, beyond any dream I may have had three years ago, and I consider myself an average man. I believe that I would be criminally selfish if I did not tell other people how I made my success.

All the work I have done has been pleasant and easy, and withal, amazingly simple. I am the representative in this territory for a raincoat manufacturer. The booklet that I read was one issued by that company.

It tells any man or woman just what it told me. It offers to anyone the same opportunity that was offered to me. It will give to anyone the same success that it has brought to me.

The Comer Manufacturing Company is one of the largest manufacturers of high-grade raincoats on the market; but they do not sell through stores. They sell their coats through local representatives. The local representative does not have to buy a stock—he does not have to invest any money. All he does is take orders from Comer customers and he gets his profit the same day the order is taken. Fully half of my customers come to my house to give me their orders.

My business is growing bigger every month. I don't know how great it will grow, but there are very few business men in this city whose net profit is greater than mine, and I can see only unlimited opportunity in the future.

* * *

If you are interested in increasing your income from \$100 to \$1,000 a month and can devote all your time or only an hour or so a day to this same proposition in your territory, write The Comer Manufacturing Company at Dayton, Ohio. Simply sign the attached coupon and they will send you the eight-page booklet referred to by Mr. Rowe and full details of their remarkable proposition.



CARL A. ROWE

facturing Company at Dayton, Ohio. Simply sign the attached coupon and they will send you the eight-page booklet referred to by Mr. Rowe and full details of their remarkable proposition.

-----Cut Out and Mail-----

The Comer Mfg. Co., Dept. W-55, Dayton, Ohio.

Gentlemen: Please send me, without obligation on my part, copy of your booklet and full details of your proposition.

Name.....

Address.....

.....



"There's One Man We're Going to Keep"

"Ed Wilson, there, is one of the most ambitious men in the plant. I notice that he never fools away his spare time. He studies his International Correspondence Schools Course every chance he gets.

"It's been the making of him, too. He hasn't been here nearly so long as Tom Downey, who was laid off yesterday, but he knows ten times as much about this business.

"I'm going to give him Tom's job at a raise in salary. He's the kind of man we want around here."

HOW do you stand in your shop or office? Are you up? An Ed Wilson or a Tom Downey? Are you going up? Or down?

No matter where you live, the International Correspondence Schools will come to you. No matter what your handicaps or how small your means, we have a plan to meet your circumstances. No matter how limited your previous education, the simply-written, wonderfully-illustrated I. C. S. text-books make it easy to learn.

This is all we ask: Without cost, without obligating yourself in any way, put it up to us to prove how we can help you. Just mark and mail this coupon.

TEAR OUT HERE

INTERNATIONAL CORRESPONDENCE SCHOOLS
BOX 5595-C SCRANTON, PA.

Without cost or obligation please explain how I can qualify for the position, or in the subject before which I have marked an X in the list below:

- | | |
|---|---|
| <input type="checkbox"/> ELECTRICAL ENGINEER | <input type="checkbox"/> BUSINESS MANAGEMENT |
| <input type="checkbox"/> Electric Lighting & Railways | <input type="checkbox"/> SALESMANSHIP |
| <input type="checkbox"/> Electric Wiring | <input type="checkbox"/> ADVERTISING |
| <input type="checkbox"/> Telegraph Engineer | <input type="checkbox"/> Show Card & Sign Ptg. |
| <input type="checkbox"/> Telephone Work | <input type="checkbox"/> Railroad Positions |
| <input type="checkbox"/> MECHANICAL ENGINEER | <input type="checkbox"/> ILLUSTRATING |
| <input type="checkbox"/> Mechanical Draftsman | <input type="checkbox"/> Cartooning |
| <input type="checkbox"/> Machine Shop Practice | <input type="checkbox"/> Private Secretary |
| <input type="checkbox"/> Toolmaker | <input type="checkbox"/> Business Correspondent |
| <input type="checkbox"/> Gas Engine Operating | <input type="checkbox"/> BOOKKEEPER |
| <input type="checkbox"/> CIVIL ENGINEER | <input type="checkbox"/> Stenographer & Typist |
| <input type="checkbox"/> Surveying and Mapping | <input type="checkbox"/> Certified Public Accountant |
| <input type="checkbox"/> MINE FOREMAN or ENG'R | <input type="checkbox"/> TRAFFIC MANAGER |
| <input type="checkbox"/> STATIONARY ENGINEER | <input type="checkbox"/> Railway Accountant |
| <input type="checkbox"/> Marine Engineer | <input type="checkbox"/> Commercial Law |
| <input type="checkbox"/> ARCHITECT | <input type="checkbox"/> GOOD ENGLISH |
| <input type="checkbox"/> Contractor and Builder | <input type="checkbox"/> Common School Subjects |
| <input type="checkbox"/> Architectural Draftsman | <input type="checkbox"/> CIVIL SERVICE |
| <input type="checkbox"/> Concrete Builder | <input type="checkbox"/> Railway Mail Clerk |
| <input type="checkbox"/> Structural Engineer | <input type="checkbox"/> AUTOMOBILES |
| <input type="checkbox"/> PLUMBING & HEATING | <input type="checkbox"/> Mathematics |
| <input type="checkbox"/> Sheet Metal Worker | <input type="checkbox"/> Navigation |
| <input type="checkbox"/> Textile Overseer or Supt. | <input type="checkbox"/> AGRICULTURE |
| <input type="checkbox"/> CHEMIST | <input type="checkbox"/> Poultry Raising |
| <input type="checkbox"/> Pharmacy | <input type="checkbox"/> BANKING <input type="checkbox"/> Spanish Teacher |

Name.....

Street and No.....

City..... State.....

Occupation.....

No Better Holiday Present for \$3.00

than a year's subscription to

Popular Mechanics Magazine

Containing 3600 Pictures
and 3600 Articles

Much of it Interests Everybody
Most of it Interests Anybody
All of it Interests Somebody

Order through your Newsdealer or
address the Publisher

Popular Mechanics Co.
6 N. Michigan Avenue Chicago, Ill.

Use the coupon below

Popular Mechanics Co.

6 N. Michigan Ave., Chicago, Ill.

Enclosed find \$3.00 for which send your magazine for one year to

Name

St. and No.

City and State.....

\$150 to \$400 a Month for YOU

Putting these Auto Parts together

Easy to Learn How in 6 to 8 Weeks' Time

Read This Right Now

Come down to Washington. Drop in at the American Motor Schools. Take a look around in our big new \$250,000 school building. Watch the young men who are working and learning every detail of auto construction and repair, automobile electricity, battery building, vulcanizing, tire repairing and welding.

Many of these fellows will soon own their own garages and will be knocking out from five to ten thousand dollars a year. Many of them will soon be holding down good paying jobs like these:

Auto Mechanic	- - -	\$ 35 to \$ 70 per week
Battery Expert	- - -	175 to 300 a month
Chauffeurs	- - -	90 to 150 a month
Tire Vulcanizer	- - -	125 to 300 a month
Welder	- - -	50 to 80 per week
Auto Electrician	- - -	40 to 75 per week
Tractor Engineer	- - -	50 to 100 per week
Garage Owner	- - -	300 to 1500 a month
Auto Salesman	- - -	200 to 500 a month

The American Motor Schools with its staff of expert instructors and common sense method of instruction is getting these men started. You, too, can get your start in the same way.

See Washington, the Nation's Capital

See the sights of the greatest city in America. See the White House, the Capitol, the Monument and the other magnificent buildings. Then go right back to the American Motor Schools and join—and start to work the next day. But first

Send for FREE New Catalogue

telling you all about the equipment, the long experience of our instructors, the Advisory Board back of the School and the magnificent record made by our students. All you have to do is to clip the attached coupon. Don't wait a minute. Right now hundreds of fellows are waiting to take this step ahead of you.

Save \$50 by Prompt Action

Delays always cost money. You want to know the Auto Business. We want to teach it to you. The sooner we get together the better for both of us. To prove it we'll cut \$50 off your tuition for prompt action. Mail the coupon tonight.

AMERICAN MOTOR SCHOOLS, Inc.
Dept. 261, 16th and You Streets, N. W., WASHINGTON, D. C.

AMERICAN MOTOR SCHOOLS, Inc.
Dept. 261, 1612-22 U St., N. W.
Washington, D. C.

Without cost or obligation, please send catalogue of information on your Automobile Mechanics Course.

Name.....
Address.....
City.....State.....Age.....

Do You Want a Position

Write for My Position Offer

Today while thousands of men are looking for a position; a growing, thriving, profitable industry is looking for MEN. In this industry opportunity beckons on every hand. Its unnumbered opportunities literally force conscientious, sincere workers to success. What other industry or profession can compare with this—the Finger Print profession. Finger Print experts do not scan the want-ad columns. There is a place for you in this amazingly interesting profession. The pay is big. The future is certain. And once you have qualified, your income will be sure, certain and steady. Whatever you do will count for you. Today there are scores of successful Finger Print Experts who started without half the opportunities offered you now.

Be a Trained Finger Print Expert

Few professions are more conspicuously prominent than that of the Finger Print profession. The Finger Print expert does things. His trained and skilled abilities are essential to baffling crime detection. Finger Printing is recognized as the one infallible means of identification. Every day you read of the wonders accomplished by the trained Finger Print Expert. The Finger Print Expert achieves big pay accordingly. In addition, he shares in millions of dollars in rewards. Finger Print Experts are occupying big important positions the country over. Some head their own private bureaus. Others are drawing salaries from big corporations. You can easily learn to be a Finger Print Expert. Spare time only is required for study. If you have a position, you can continue with it until you wish to give it up. Anyone with a grammar school education can qualify as a Finger Print Expert by studying my remarkably simple and easily understood course. I explain all facts and give complete information in simple, easily understood terms. Within just a short time after you start the course, you can qualify. My course is based on practical experience. For years I was associated with the largest Finger Print Bureau in the world. I will teach you as I taught others who mastered the course without trouble or delay.

Secret Service Reports

FREE OUTFIT NOW

Send Coupon

To show you how interesting this work is, I will send you free with complete information about the course, sample Secret Service reports. These reports give you the inside facts of cases that have

startled and interested you. In addition, for a limited time only, I will give free, a complete course in Secret Service and a professional Finger Print outfit. And my course costs just about half as much as any other course offered. Before you take up any study or before you enroll in any course, get all of the facts I am willing to send you free. Asking for this information will not obligate you in any way. It may be the turning point in your life—send you up the ladder to startling success. Get the facts now, while my special limited offer holds good. Just send the coupon, and I will tell you all about my Special Low Price, Free Secret Service Reports, Free Secret Service Course and Free Professional Working Outfit. Send the coupon now.

U. S. SCHOOL OF FINGER PRINTS

Dept. 431

7003 N. Clark Street

CHICAGO, ILL.

--- Send This Coupon FREE ---

U. S. School of Finger Prints,

Dept. 431, 7003 N. Clark St., Chicago, Ill.

Please send me Free Information about your Position Offer, Finger Print Course, Free Course in Secret Service, Free Outfit for Secret Service Reports and Special Low Prices.

Name.....

Address.....

City.....

State.....



SAVE 25% to 60%

on slightly used
GRAFLEX-KODAKS

Cameras and Lenses of every description. Equal to new. Save money. Write now for **FREE BARGAIN BOOK AND CATALOGUE** listing hundreds of money-saving bargains in slightly used and new cameras and supplies. All goods sold as 10 days' free trial. Money back if not satisfied. You take no chances dealing with us. We have been in the photographic business over 16 years. Write now. **CENTRAL CAMERA CO., Dept. 11, 124 S. Wabash Ave., CHICAGO**

TYPEWRITERS



\$50 buys a brand new Corona, the Personal Writing Machine. Fold it up, take it with you, typewrite anywhere! Write for free booklet No. 8.

Corona Typewriter Co., Inc.
GROTON, N. Y.

1000 SHOT ALL STEEL MAGAZINE AIRRIFLE GIVEN **WE GIVE TO BOYS** **HAMILTON 22 CAL. HUNTING RIFLE WITHOUT COST**

Choice of Six Guns (on four easy plans) for selling our Magic Healing Wave-lets at 25c Box. **WE TRUST YOU!** Order Seven Boxes Today On Postal Card—we send promptly, Prepaid. Easy to sell—used in every home. Return money as instructed, choosing your Gun according to one of the plans shown in our Big Premium List. Also 200 other Gifts or Big Cash Commission if you prefer. If you are prompt—a special Free Gift.

WAVERLY CO. 235 Tower Bldg. Monaca, Pa.

350 SHOT REPEATER
SEND ORDER TODAY, FREE!

What 15c Will bring You From the Nation's Capital

The little matter of 15 cts. (coin or stamps) will bring you the **Pathfinder 13 weeks on trial**. The Pathfinder is a cheerful illustrated weekly, published at the Nation's center for people everywhere; an independent home paper that tells the story of the world's news in an interesting, understandable way. Now in its 29th year. This splendid National weekly supplies a long-felt want: it costs but \$1 a year. If you want to know what is going on in the world, this is your best means. If you want a paper in your home which is reliable and wholesome; if you would appreciate a paper which puts everything clearly, strongly, entertainingly, briefly—here it is. Splendid serial and short stories and miscellany. The Question Box answers YOUR questions and is a mine of information. Send 15 cts. to show that you might like such a paper and we will send the Pathfinder on probation 13 weeks. The 15 cents does not repay us, but we are glad to invest in new friends. Address: **The Pathfinder, 599 Langdon St., Washington, D. C.**

PANDICULATE FOR HEALTH

BE WELL
YOUNG
STRONG



Booklet Free

Fifteen glorious minutes on Pandicator better than two hours in gymnasium. Refreshes, rejuvenates; frees impinged, irritated nerves; corrects contracted muscles, spine ligaments; relieves congestion, improves circulation and body drainage. Doctors recommend it. No electricity, no discomfort; delightfully restful. Write now

PANDICULATOR COMPANY

Dept. E, 2807 Prospect Ave.,

Cleveland, Ohio

Mystic Skeleton

A jointed figure of a skeleton 14 in. in height, will dance to music and perform various gyrations and movements while the operator may be some distance from it. **10c & 25c pd.**

Serpent's Eggs
Box contains 12 eggs. When lit with a match, each one gradually hatches itself into a snake a foot long, which curls and twists about in a most life-like manner. Price per box, 10c ppd.

Good Luck Ring
Quint and Novel Design



A VERY striking and uncommon ring. Silver finish, skull and crossbone design, with two brilliant, flashing gems sparkling out of the eyes. Sold by many to bring Good Luck to the wearer, hence its name, **Good Luck Ring**. Very unique ring that you will take a pride in wearing. **ONLY 25 CENTS.**

JOHNSON SMITH & CO., Dept. 753, 3224 North Halsted Street, CHICAGO

He thought he could throw me—



Dear Tom: You know how Ted Brown has always been saying he could throw me with one hand tied behind him, if he wanted to. Well, yesterday, he grabbed hold of me and we had it out. Gee, I wish you'd been there. You know how much bigger Ted is than I. He thought he had me licked dead easy—

but

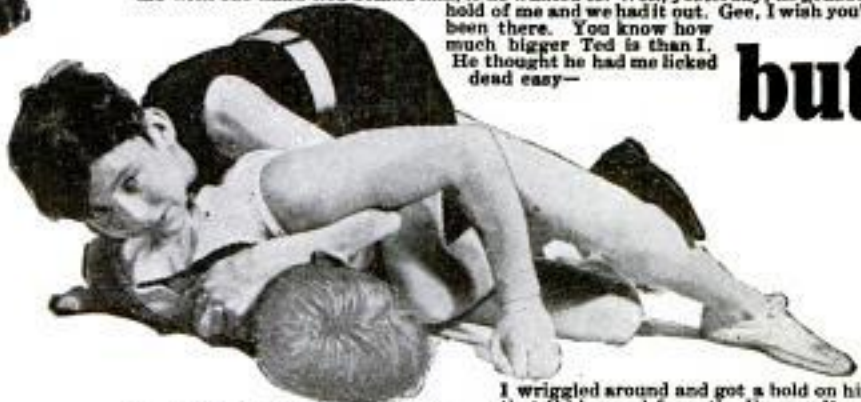

I wriggled around and got a hold on him that I'd learned from the Farmer Burns School of Wrestling. The next second — KERFLOP, and I had Mister Ted Brown on the ground, yelling for me to quit. It's a cinch to handle a fellow half as big again as you are if you know the secret holds. If I were you I'd write to Burns School for their free book about wrestling. So long—FRED.

Learn Wrestling Secrets from Worlds Champions Farmer Burns and Frank Gotch

Learn the marvelous holds, breaks, blocks and tricks that will enable you to handle big, strong men with ease. The renowned FARMER BURNS—"father of scientific wrestling"—and FRANK GOTCH the world's champion, have prepared a series of lessons in which they reveal the inside secrets of training that will make YOU, too, an expert wrestler. All the great secrets of *self-defense* and *jui-jitsu* illustrated by printed word and picture. The lessons teach you how to become a *great athlete*, and secret knowledge enabling you to throw boys and men larger and stronger than yourself.

Send for FREE Book

Our FREE ILLUSTRATED BOOK tells you all about the advantages in health, vigor and respect that being able to wrestle brings one. It tells you how to learn to become a skilled wrestler *in your spare time*. Brim full of interesting information about wrestling. Also lots of pictures. INVESTIGATE. Write today for this free book. No obligations. Tear out and mail coupon NOW!

Farmer Burns School 1771 Railway Exchange Bldg.
Omaha, Neb.

Farmer Burns School
1771 Railway Exchange Bldg., Omaha, Neb.
Please send me at once without obligation your FREE illustrated booklet on Scientific Wrestling, Physical Culture, Self-Defense, and How to Win.

Name.....

Address.....

Age.....



Build This Phonograph Yourself

TREMENDOUS SAVING IN COST
Easy, fascinating work with our SIMPLIFIED PLANS. We furnish blue prints, diagrams, motor, cabinet pieces, ready-built horn, etc. You don't need to be a cabinet maker. A few hours assembling and you will have a fine instrument at one-quarter the regular retail price. **AGENTS MAKE MONEY** making and selling these instruments. Write today for full details of our FREE OFFER. Address:—
Modern Phonograph Supply Co.
631 Springer Bldg., 315 S. Clinton St., Chicago, Ill.

PRACTICAL ELECTRICAL EDUCATION

in 6 MONTHS. We teach by scientific and original methods the theory and practice of **Electric Light Wiring, Testing, Motor Work, A. C. and D. C. Armature Winding, Transformer, Motor, Generator Repair and Maintenance.** No matter what your education, we **guarantee** to train you until competent and assist you to secure **profitable employment.** Hundreds of successful graduates and satisfied employers. Write for new ill. Book, Absolutely **FREE** to the earnest knowledge seeker.

SCHOOL OF PRACTICAL ELECTRICITY
Dept. 317 415 Marshall Street Milwaukee, Wis.

"Burgess Trained" Men Get

A large electrical plant had to "lay off" men recently—but **not a single Burgess Trained Man lost an hour**—and there are 60 Burgess Students in that plant.

Burgess Students include those with no electrical experience and men in the electrical game who want to step up to higher positions. If you have enough ambition Burgess Home Training will enable you to succeed in some branch of Electricity. Send for the Burgess Catalog No. 1. It tells how to do it.

BURGESS
ELECTRICAL SCHOOL
Dept. P1, 744 E. 42nd Street
CHICAGO, ILLINOIS

GOOD JOBS ELECTRICITY

Burgess Electrical Home Training proves its value by enabling men to get good jobs at good pay. Take "Witherspoon," for example. He was out of work and just starting the Burgess Home Training in Electricity. After completing only fifteen lessons he applied for an important electrical position. Forty other men applied for the same job but Witherspoon, the Burgess Trained man, got it. He now has 85 men working under him.

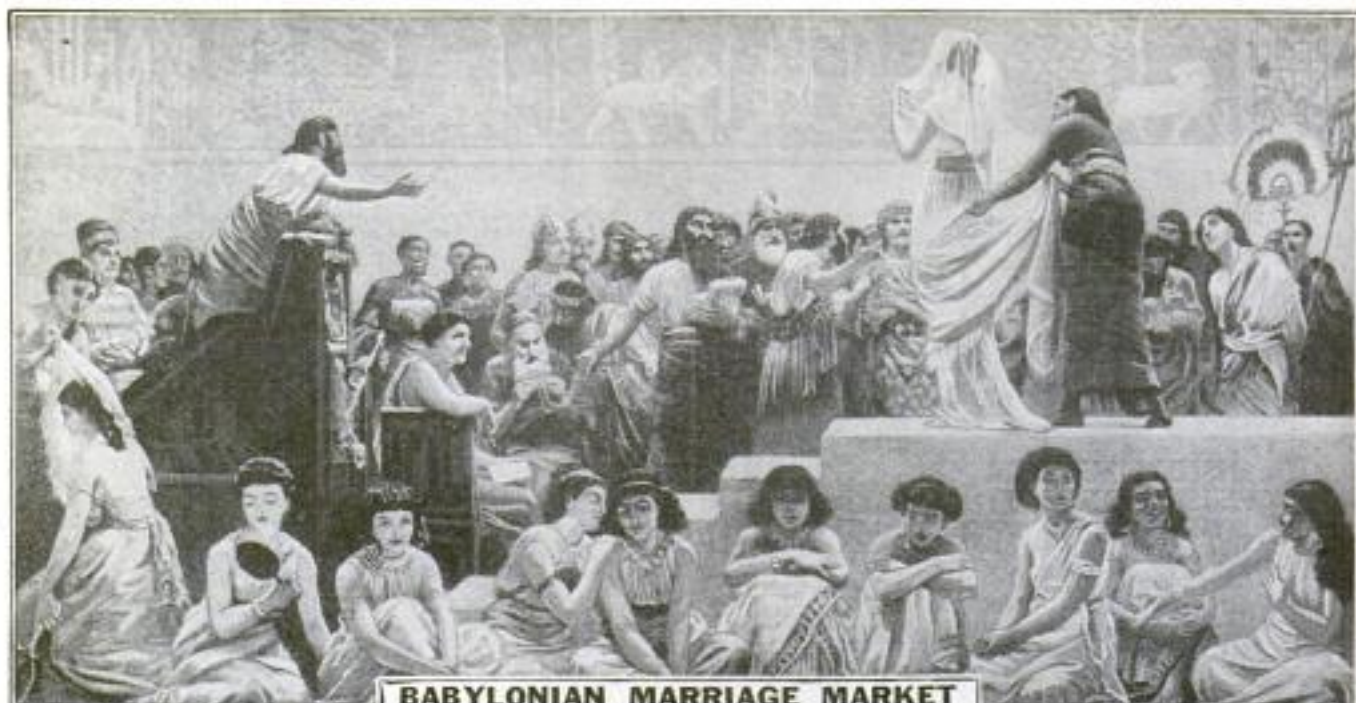

BABYLONIAN MARRIAGE MARKET

THE Babylonians are among the most interesting of ancient peoples. Here in the Valley of the Euphrates and Tigris Rivers was the cradle of civilization. The wealth and luxury and lax morals of the people finally led to their overthrow and downfall. If you would know the history of all nations and peoples, from the earliest antiquity to the present, then avail yourself of this opportunity to secure the new

Standard History of the World

WE will name our special price and easy terms of payment only in direct letters. A coupon for your convenience is printed on the lower corner of this advertisement. **Tear off the coupon,** write your name and address plainly and **mail now.** You incur no obligation whatever. The beautiful sample pages will give you some idea of the splendid illustrations and the wonderfully interesting style in which the history is written.

Free

We will mail free a beautiful 32-page booklet of sample pages from the Standard History of the World, containing pictures of great characters in history, to every reader who mails to us the COUPON.



Six Thousand Years of History

FOR hundreds of years the Pyramids of Egypt had looked down—old and still—on the activities of man at the time when the Babylonians bought their wives in the open marriage market or the Children of Israel passed through Egypt across the Red Sea—and even before that distant period begins the story of mankind. Before the separation of races, before the Assyrians were, before the gods of China, before Jerusalem was thought of—far back—begins the story; finding for you the first glimmer of light on the blackness of unknown and uncounted ages. And so this story of man, from the far beginnings, through the classic ages, through the dark centuries and Middle Ages is brought down to the recent World War. The work covers every race, every nation, every time. **Mail the coupon.**

**WESTERN NEWSPAPER ASSOCIATION
CHICAGO, ILL.**

1-22
**FREE
COUPON**

**WESTERN
NEWSPAPER
ASSOCIATION**
140 So. Dearborn St.
Chicago, Ill.

Please mail, without cost to me, your 32-page booklet of sample pages of the **Standard History of the World,** and write me full particulars of your special offer to **POPULAR MECHANICS** readers.

Name

Address

FOLD HERE, TEAR OUT, SIGN AND MAIL

LEARN WIRELESS By Practice at Home

Our Wonderful Outfit Makes It Easy Gentlemen's Work with Big Pay—\$2,400 to \$10,000 a Year

THOUSANDS of wireless operators will be needed next year. Do you want to be ready to jump into one of these big, easy jobs next Spring? Why not? All you need to start with is a common school education. You can travel or you can stay at home. Radio provides you with a valuable training and gives you a trade that will last a lifetime, and besides as a radio operator you can save big money right from the very start. It is nothing uncommon for radio men to save \$1,000 the first year they work. And why not? All expenses are paid in addition to salary. An operator's time is almost all his own with lots of spare time to study for the high positions of Radio Engineer, Technicians and Executives receiving from \$6,000 to \$10,000 a year. **You earn \$110.00 a month with your board and expenses paid. You start at that salary.** Are you making that much now? You can probably save more than you earn now in wireless.

**WE
SUPPLY
ENTIRE
OUTFIT**

If you want to work in one of the large land stations, there is plenty of room for you. Or, perhaps one of the newspapers in your home town will employ you. Next year 50% of the newspapers in this country will have wireless stations.

Be Entertained With Wireless Concerts While You Learn

The wireless era is upon us. It is wireless, wireless, wireless everywhere. Music, vaudeville and speeches are in the air at all times. You can listen to these and entertain yourself while you are learning wireless. **This entertainment is actual practice.** We supply the outfit, you learn to use it. With it you can listen in on the commercial world. Think of sitting in your warm home this winter combing messages out of the cold sky. You train yourself by practice. We supply you with four wonderful instruments. These represent four steps to a big-paying wireless job. No work could be more fascinating than wireless. No dirty hands, scarred fingers or aching back in the wireless game. You won't have to worry about getting a job. The job is waiting for you now.

**We
Supply
Entire
Outfit**

You learn at home by the aid of four wonderful inventions that have helped eight thousand other men to better-paying positions



The Natrometer is only one of the "automatic teachers" furnished with our course. You learn at home by the aid of these Four Wonderful Inventions that have helped eight thousand other men to better-paying positions.

**NATIONAL RADIO INSTITUTE
RADIO HEADQUARTERS**

Dept. 71

Washington, D. C.

Practical Spare Time Instruction By Mail

We have trained eight thousand men since 1914. Our school is at the Nation's capital, center of all wireless development. We are in touch with everything that is new. Our method of training by mail is endorsed by government officials. Our school is officially recognized. We have succeeded in bringing the subject of wireless to a point where every man who can read and write can learn this wonderful work. We have humanized the subject. Our course reads like a story. Our wireless experts will be ever ready to help you. And then, don't forget the four Wonderful Instruments that make our course so practical and fascinating. You can easily learn in four months. Next spring you will be ready to fit into a real job. Thousands have found it easy. You can too. The National Radio Institute is the oldest and largest institution of its kind in America. Our course is the greatest piece of educational literature of its kind in the world. We have sugar-coated the subject of Radio.

Four New Inventions Make Wireless Easy To Learn

With our famous short cut course are furnished Four "Automatic Teachers."

1. The Learner's Transmitter which teaches you sending and code in half the usual time.
2. The Learner's Receiver makes the most difficult part of wireless pure fun.
3. The Wonderful Natrometer (pictured below) builds up your receiving speed. Sends 600 combinations of messages at speeds varying from 3 to 30 words per minute.
4. The Westinghouse Receiving Set gives you the actual practice of taking real messages from the air.

These inventions make wireless study automatic. They make you learn in such an easy way that you will be a trained wireless man before you realize it. Then comes the big pay and the short hours. Act now. Don't permit another minute to pass. Start your training immediately.

Let Us Mail You This Big Book

Let us send you our big book free. It will tell you all about wireless, all about our course, what our students have done, and the wonderful opportunities waiting for you in Wireless. Don't put it off, mail the coupon below today.



FREE

**National Radio Institute
Dept. 71, Washington, D. C.**

Send me your FREE book, "Wireless, the Opportunity of Today." Tell me about your Home Study Course in Wireless Telegraphy and your special Short-Time Offer.

Name.....

Address.....

City..... State.....



LEARN MUSIC AT HOME!

PLAY BY NOTE

Piano, Organ, Violin, Cornet, Guitar, Banjo, Mandolin, Harp, Cello, Trombone, Flute, Clarinet, Piccolo, Saxophone, Ukulele, Sight Singing, Hawaiian Steel Guitar, Harmony and Composition, Tenor, Banjo, Drum and Traps, etc.

Music no longer difficult! New plan makes it easy to learn by home study. Positively easier than with private teacher. Faster progress. You will be able to play your favorite instrument in a few short months! More than 250,000 men, women and children have learned by our method. You, too, can learn in your spare time.

AMAZING OFFER

We want to have one pupil in each locality at once to help advertise our home study method. For a short time, therefore, we offer our marvelous lessons at practically no cost, charges amounting merely to about the cost of sheet music. Beginners or advanced pupils. Write for amazing free book giving all the facts and particulars. Send a postal today!

Instruments supplied when needed, cash or credit

U. S. SCHOOL OF MUSIC

71 Brunswick Bldg. New York City

MUSIC FROM A SAW

You can take a common carpenter's saw and produce wonderful soft and sweet music by drawing a violin bow across it or striking it with a soft hammer.



I ABSOLUTELY GUARANTEE to give you the secrets and teach you to play popular music within 7 days, classical 14 days. Very little practice is required.

Popularity follows the person who can entertain. YOUR SERVICES will be requested at Clubs, Lodges, Church Affairs, entertainments of all kinds and YOUR NUMBER will be THE HIT of the evening. Make big money playing for dances, movies, etc.

WRITE TODAY for FREE INFORMATION, "How to Play a Saw."

C. J. MUSSEHL, 234 Mack Bldg. Fort Atkinson, Wis.

FREE a Ten Lesson Course in PUBLIC SPEAKING



A postal will bring you my wonderful book, "How to Speak in Public," 1921 de Luxe edition, 300 pages, colored illustrations. Introduction by ELBERT HUBBARD. Tells secrets of oratory, how to prepare speeches, overcome bashfulness, address lodge meetings, clubs, etc. Contains ready made speeches for all occasions. Chapter by ORISON SWETT MARDEN, "Self Improvement Thru Public Speaking."

NO MONEY IN ADVANCE

Pay your postman \$2 when book arrives, this pays in full for the book. Estimate it for ten days, if not satisfied return it to me and I will at once refund your \$2.00. If you keep the book, then I will send you my Ten Lesson Public Speaking Course, with full scholarship privilege ABSOLUTELY FREE.

PROF. HENRY DICKSON

Dept. 705-P, 1941 Chicago Ave. EVANSTON, ILL.



H. S. Whitman, New York, writes: "I compliment you on your wonderful system. Did not know one note from another, but in a short time have mastered the piano and am now composing music."



C. N. Pitts, Marion, Ga., writes: "Have completed your course on violin. Now have 15 students."

BOYS! BOYS! BOYS!

THROW YOUR VOICE



Into a trunk, under the bed or anywhere. Lots of Fun fooling the Teacher, Policeman or Friends.



THE VENTRILO.

A little instrument, fits in the mouth out of sight, used with above for Bird Calls, etc. Anyone can use it. NEVER FAILS. Also a 82 PAGE BOOK which gives full instructions on Ventriloquism. Formula for Secret Writing (Invisible Ink), 12 Money Making Secrets and 10 BIG TRICKS ON MAGIC all for 10¢

ROY. NOV. CO., Dept. 349 So. Norwalk, Conn. LARGEST and OLDEST Mail Order House in Connecticut.

The Dying Pig



The most laughable novelty yet produced. Made of rubber, and you have only to blow it up and stand it on the pig on his feet, when he begins to squeal as he slowly collapses and finally lies down and dies in the most natural manner. You can blow him up as often as desired, and each time he will go through the same performance to the great amusement and delight of your friends.

Price 15 cents; 3 for 40 cents; one dozen \$1.35, mailed postpaid.

Johnson Smith & Co., 3224 N. Halsted Street, Dept. 753, Chicago

Popular Watch Charms

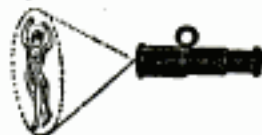

Very pretty little curiosities and decidedly novel. Fitted with Magnifying Lens that enlarges the pictures to a very surprising degree; in fact, it seems almost incredible that a clear picture could be possible in such a small compass, and how sharp and distinct they show up when you look through. Come in assorted views—Actresses, views of Panama Canal, Lord's Prayer in type, etc.

Price 15¢; 3 for 40¢; \$1.35 doz.

METEORPLANE

FLY

Young man, prepare yourself for the future. Build your own plane and learn how to construct and fly aircraft. Use your motorcycle engine. We furnish very reasonable all the parts to build this wonderful little Meteorplane. Easy to build and fly. Send \$2.50 for the complete set of blue prints, and price list of all parts.

IRWIN AIRCRAFT CO. Sacramento, Cal.

"BOW LEGS and KNOCK-KNEES" UNSIGHTLY

SEND FOR BOOKLET SHOWING PHOTOS OF MEN WITH AND WITHOUT THE PERFECT LEG FORMS

PERFECT SALES CO. 140 N. Mayfield Ave., Dept. 5, Chicago, Ill.

Buchstein's Fibre Limb

is soothing to your stump—strong, cool, neat, light. Easy payments. Braces for all deformities.

D. BUCHSTEIN CO. 113 6th St. S., MINNEAPOLIS, MINN.

\$600 to \$5,000 PROFIT FROM WASTE STORE SPACE

Business men! Send for amazing story of Butter-Kist Popcorn and Peanut Machine profits. Pays big in drug, department, candy, other stores, theatres, etc. Write

HOLCOMB & HOKE MFG. CO. 546 Van Buren St. Indianapolis, Ind.

GILBERT BOY ENGINEERING

The greatest boys' book in years, 128 pages of articles on athletic Training, Football Strategy, Flying, etc., by noted authorities. Chapters on many wonderful sciences. Contains complete catalog of Gilbert Toys. Sent at cost, 25c. Also write for free folder on Gilbert Toys.

A. C. GILBERT CO., 477 Blatchley Ave., New Haven, Conn.

ALOIS P. SWOBODA

1301 Berkeley Building 21 West 44th Street, New York City

If you need a book on some mechanical subject and do not know where to find it, write POPULAR MECHANICS BOOK DEPARTMENT 6 N. Michigan Ave., Chicago

Be a Motor Expert Learn At Home



**Make \$10,000 a year.
Be Your Own Boss. Operate
a Successful Garage**



**Expert Welder gets from
\$200 to \$400 a month**



Assembling parts in a big factory where the trained man finds real Opportunity



**Learn vulcanizing. Many men
make \$5,000 to \$10,000 a year
in this business**

Auto-Truck or Tractor

Become an automobile, truck or tractor expert. Many fine jobs are waiting for the trained man. You can secure a high-paid position in a factory or go into business for yourself after you have completed your training.

Unquestionably, you have been thinking of training yourself for this profession—but you did not like the idea of giving up many months of your time, and the expense of leaving home. Now you have the opportunity to study right in your own home and in spare time.

Just Perfected

We don't claim to be the only school that can teach you the auto, truck or tractor business. But we are the only school that is equipped to train you right in your own home. We have just completed a comprehensive course for home study, complete in every branch of the trade.

Experienced engineers and mechanics, competent and successful automobile men have helped to compile this course. They guide you, step by step, grade your papers, watch your progress, give you the benefit of personal counsel and advice. You study in the peace and quiet of your own home. You do not have to wait for slower students, or hurry your own studies to fit class requirements. You do not have to puzzle difficult questions alone, for our teachers are always anxious to answer your questions. You have careful, sympathetic, individual instruction.

A Position While You Are Studying

You can take the complete course, covering all branches of the auto, truck and tractor business, or you can take a separate course in any branch you wish.

After you have completed the fourth or fifth lesson, you can take a position in the automobile business. You gain experience and make money at the same time.

If you are already in the Automobile Business, you can add to your earning power by having a complete knowledge of the business. Just check the subject you are most interested in, send us the coupon and we will send you Special Information free.

FREE BOOK AND CONSULTATION SERVICE

Just check the subject that interests you most and send the coupon right away. We will send you a beautiful book telling about your opportunity in the auto business. And we will give you free consultation on the particular branch that you have marked. No obligation to you. Write us today. After our class quota is complete, we cannot accept any new students. Write today while our classes are open. Just clip the coupon and mail it to us—right now.

Chicago Auto Institute
Dept. 1351, 129 So. Oakley Blvd., Chicago

CHICAGO AUTO INSTITUTE,
Dept. 1351, 129 So. Oakley Blvd., Chicago.

Please send me your free book telling about my opportunity in the auto, truck or tractor business. Also free personal consultation on the subject I have checked.

- | | |
|---|---|
| <input type="checkbox"/> Complete Course | <input type="checkbox"/> Tractor Course |
| <input type="checkbox"/> Automotive Electricity | <input type="checkbox"/> Vulcanizing |
| <input type="checkbox"/> Battery Course | <input type="checkbox"/> Welding |

Name.....

Address.....

City.....

Occupation.....

COMMERCE  SPEED
FLYING IS THE ANSWER

LEARN TO FLY

In Chicago with
RALPH C. DIGGINS SCHOOL
of AERONAUTICS

Scores of graduates from our flying school are filling big-paying positions. Splendid opportunities for competent pilots are opening everywhere. Your chance is now! Get into this newest, fascinating, best paid profession.

Prepare NOW!

You can prepare now for spring and summer flying classes. Take our home study Special Extension Course, the most modern and practical course ever given, prepared by our experts right on our flying field. This course gives you thorough training in air navigation, flying, aeroplanes, motors, instruments, theory of flight, etc. Contains only what you must know to be a successful pilot. Gives you big start over the others in learning to fly a machine when you reach our field.

Easy terms. Write NOW for full information.

THE RALPH C. DIGGINS SCHOOL
of AERONAUTICS
Dept. 301, 140 N. Dearborn St., Chicago, Ill.

HOW TO MAKE DEVICES FOR OUTDOOR WINTER SPORTS

Motor-Driven Sleds—Ice Yachts—Coasting Bobsleds and Toboggans—Snow Speedsters—Skis and Ski Running—Air-Propelled Sleds and Ice Boats—Airplane Ski Gliders, etc.

64 Pages. Price 25 cents, postpaid.

Popular Mechanics Book Dept., 6 N. Michigan Ave., Chicago.

Don't Be a Wage Earner

An Hour a Day of Fascinating Study at Home
and You Can Have a Real Profession.

CHEMISTRY

offers the greatest opportunities to-day of any vocation. Chemists earn big money—salaries of \$10,000 to \$15,000 a year are quite common. If you want to know how you can learn chemistry at home. In your spare time, and obtain exactly the same chemical education that you would receive at any college or university, write to one of the foremost authorities on Chemistry, Dr. T. O'Connor Sloane, care Chemical Institute of New York, Home Extension Division 1, 140-P Liberty St., New York City. Dr. Sloane will send you full information FREE by return mail.

BRUSHES and SUPPLIES
FOR SIGN and SHOW CARD
WRITERS

Largest sign shops and studios use **BLUE HANDLE BRAND** brushes and supplies. The PIONEER has. Established 1899.

Recognized Quality—Tremendous purchasing power, and long years of practical experience, permit us to offer the highest quality supplies at the lowest prices. Thus, Cusack Co., of Indianapolis, writes: "We offer you the highest recommendation for your goods."
Write for our new 1922 catalogue, 21¢ FREE.
DETROIT SCHOOL OF LETTERING, 621 D. S. of L. Bldg.
SUPPLY DEPT., Detroit, Mich., U. S. A.



Chas. J. Stevens,
Founder

WANTED COMMERCIAL ARTISTS

If you like to draw, you are indeed fortunate. Thousands of business firms pay millions of dollars annually for good advertising drawings and designs, and commercial artists who can make such drawings earn splendid incomes.

Make Good Money--Quick



Well-trained artists earn \$50, \$75, \$100 a week and more. The Federal "Master" Course rapidly develops your ability by mail, in your spare time. It contains **exclusive lessons** by leading illustrators and designers.

You receive **individual personal criticisms** on your work. No previous training needed. Turn your spare hours into money—many students earn more than the cost of the Course while studying. Send today for "Your Future," a book telling all about this wonderful Course. It's free for the asking. Kindly state your age and occupation.

Federal School of Com'l Designing
672 Federal Schools Bldg.,
MINNEAPOLIS, MINN.

PALATIAL FLORIDA HOME

THE finest estate in that part of Florida, situated amid five acres of orange, grape fruit, sweet bay, palmetto and a large variety of semi-tropical trees and foliage. A water front of 400 feet, with entrance from a Boulevard, in a community of 30,000, affording every modern convenience. House recently completed and never occupied. Has every modern improvement, large sun parlors, sleeping porches and eight bath rooms. Inexhaustible supply of absolutely soft water; steam heat, high, light basement under entire house. This is one of the best built houses in the entire state of Florida. Surf bathing all winter within 5 minutes walk.

For full details, photographs and price, address

E. H. PECK

S. OSGOOD PELL & COMPANY
17 West 44th Street
New York City



WANTED MEN-AT ONCE

To Become Automotive Electrical Experts

The Greatest Opportunity to Make Big Money and Get Into Business That Men of All Ages Ever Faced

WHILE many are unable to find work of the sort anyone can do, the automotive industries are short of help in the trained electrical field. The pity of it is, the needed knowledge could be learned in a season!

For driving a tractor \$25 is a fair week's pay. For knowing how that tractor is ignited, fired and wired, a man is often paid \$25 a day!

What truck driver, or even mechanic, draws \$500 a month? Yet men who lay-out and inspect ignition and lighting systems make that and more.

Now Is the Time

In auto factories; branches, service shops; where tractors are made; in airplane work; with motorcycle and speed



boat makers; around lighting-plant shops; you can practically pick your job, or own your own repair shop. And there is an easy way to get experience you need.

Why, the headlight laws alone—different in every state—means big pay for



those who learn the *mechanical* requirements and how to con-

form auto lights to the regulations. Start now.

How Anyone Can Qualify

You can master this profitable line in three months! Not by digging it out of books; not by a long distance correspondence course, but *where the work is being done*. In your overalls. Doing it *yourself*. At the shops where 800 trained experts were turned out last year.

You will then know what a "troubleshooter," inspector, foreman must know. The mysteries of the "electric line" will be an open book.

While the demand is so strong, a famous resident school of electricity will make a special low tuition rate, and start new classes every few days; put you to work on the same things that ninety days later you'll be working at for money.



Act Immediately!

Send *now* for free book of facts and photographs. Explains all. Whether you are only 18, or past fifty, investigate this opportunity

If you are a *self-starter*, do not wait, but *come to Milwaukee*; we'll find you a room and have you in the thick of the work the day you arrive.

SCHOOL OF AUTOMOTIVE ELECTRICITY,
Division of School of Engineering,
415 Marshall Street, Milwaukee, Wis. (304)

Please send your FREE 48-page book telling all about your 90-day course in Automotive Electricity, without obligating me in any way.

Name.....
Address.....
City.....State.....



What's Wrong in this Picture?

It's so easy to make embarrassing mistakes in public—so easy to commit blunders that make people misjudge you. Can you find the mistake or mistakes that are being made in this picture? Can you point out what is wrong? If you are not sure, read the interesting article below, and perhaps you will be able to find out.

IT is a mark of extreme good breeding and culture to be able to do at all times exactly what is correct. This is especially true in public where strangers judge us by what we do and say. The existence of fixed rules of etiquette makes it easy for people to know whether we are making mistakes or whether we are doing the thing that is absolutely correct and cultured. They are quick to judge—and quick to condemn. It depends entirely upon our knowledge of the important little rules of etiquette whether they respect and admire us, or receive an entirely wrong and prejudiced impression.

In public, many little questions of good conduct arise. By public, we mean at the theatre, in the street, on the train, in the restaurant and hotel—wherever men and women who are strangers mingle together and judge one another by action and speech. It is not enough to *know* that one is well-bred. One must see that the strangers one meets every day get no impression to the contrary.

Do you know the little rules of good conduct that divide the cultured from the uncultured, that serve as a barrier to keep the ill-bred out of the circles where they would be awkward and embarrassed? Do you know the important rules of etiquette that men of good society must observe, that women of good society are expected to follow

rigidly? Perhaps the following questions will help you find out just how much you know about etiquette.

Etiquette at the Theatre

When a man and woman walk down the theatre aisle together, should the man precede the woman? May they walk arm-in-arm? When the usher indicates their places, should the woman enter first or the man?

Many puzzling questions of conduct confront the members of a theatre party who occupy a box. Which seats should the women take and which the men? Should the women remove their hats—or don't they wear any? What should women wear to the theatre in the evening? What should men wear? Is it correct for a man to leave a woman alone during intermission?

At the theatre, evidences of good conduct can be more strikingly portrayed than perhaps anywhere else. Here, with people surrounding us on all sides, we are admired as being cultured, well-poised and attractive, or we are looked upon as coarse and ill-bred. It depends entirely upon how well one knows and follows the rules of etiquette.

At the Dance

How should the man ask a woman to dance? What should he say to her when the music

ceases and he must return to his original partner? Do you know the correct dancing positions?

How should a woman accept a dance and how should she refuse it? How can the embarrassment of being a wall-flower be avoided? How many times may a girl dance with the same partner without breaking the rules of etiquette? Is it considered correct, in social circles, for a young woman to wander away from the ball-room with her partner?

Very often introductions must be made in the ball-room. Should a man be introduced to a woman, or a woman to a man? Is it correct to say, *Miss Brown, meet Mr. Smith* or *Mr. Smith, meet Miss Brown*? Which of these two forms is correct: *Bobby, this is Mrs. Smith*, or *Mrs. Smith, this is Bobby*? When introducing a married woman and a single woman should you say, *Mrs. Brown, allow me to present Miss Smith*, or *Miss Smith, allow me to present Mrs. Brown*?

When leaving the ball-room, is the guest expected to thank the hostess? What should the woman guest say when she leaves? What should the gentleman guest say? It is only by knowing exactly what is correct, that one can avoid the embarrassment and humiliation of social blunders, and win the respect and admiration of those with whom one comes into contact.

In the Street

There are countless tests of good manners that distinguish the well-bred in public. For instance, the man must know exactly what is correct when he is walking with a young woman. According to etiquette, is it ever permissible for a man to take a woman's arm? May a woman take a gentleman's arm? When walking with two women, should a man take his place between them or on the outside?

When is it permissible for a man to pay a woman's fare on the street-car or railroad? Who enters the car first, the woman or the man? Who leaves the car first?

If a man and woman who have met only once before encounter each other in the street, who should make the first sign of recognition? Is the woman expected to smile and nod before the gentleman raises his hat? On what occasions should the hat be raised?

People of culture can be recognized at once. They know exactly what to do and say on every occasion, and because they know that they are doing absolutely what is correct, they are calm, well-poised, dignified. They are able to mingle with the most highly cultivated people, in the highest social circles, and yet be entirely at ease.

The Book of Etiquette

There have probably been times when you suffered embarrassment because you did not know exactly what to do or say. There have probably been times when you wished you had some definite information regarding certain problems of conduct, when you wondered how you could have avoided a certain blunder.

The Book of Etiquette is recognized as one of the most dependable and reliable authorities on the conduct of good society. It has solved the problems of thousands of men and women. It has shown them how to be well-poised and at ease even among the most brilliant celebrities. It has shown them how to meet embarrassing moments with a calm dignity. It has made it possible for them to do and say and write and wear at all times only what is entirely correct.

In the Book of Etiquette, now published in two large volumes, you will find chapters on dinner etiquette and dance etiquette, chapters on the etiquette of engagements and weddings, chapters on teas and parties and entertainments of all kinds. You will find authoritative information regarding the wording of invitations, visiting cards and all social correspondence. The subject of introductions is covered exhaustively, and the etiquette of travel devolves into an interesting discussion of correct form in France, England and other foreign countries. From cover to cover, each book is filled with interesting and extremely valuable information.

Do You Know—

how to introduce men and women correctly?

how to answer a dinner invitation?

how to greet a man or woman acquaintance in public?

how to plan church and house weddings?

how to use table silver properly?

how to word invitations and acknowledgments?

how to avoid blunders at the theatre and opera?

how to do at all times the thing that is absolutely correct and cultured?

Sent Free for 5-Day Examination

Let us send you the famous Book of Etiquette free so that you can read and examine it in your own home. You are not obligated to buy if you do not want to. Just examine the books carefully, read a page here and there, glance at the illustrations, let it solve some of the puzzling questions of conduct that you have been wondering about. Within the 5 days, decide for yourself whether or not you want to return it.

We expect this new edition to go quickly. The books are now handsomely bound in blue cloth with gold lettering. We urge you to send for your set at once. The price for the complete set is only \$3.50 after 5 days. But don't send any money now—just the coupon. Keep the books at our expense while you examine them and read some of the interesting chapters.

Mail the coupon for your set of the Book of Etiquette today. Surprise your friends with your wide knowledge of the correct thing to do, say, write or wear at all times. Remember, it costs you nothing to see and examine the books. Mail the coupon NOW. Nelson Doubleday, Dept. 231, Oyster Bay, N. Y.

FREE EXAMINATION COUPON

NELSON DOUBLEDAY, Inc.
Dept. 231, Oyster Bay, New York

Without obligation on my part, and without any money in advance, you may send me the complete two-volume set of the Book of Etiquette for free examination. Within 5 days after receipt I will either return the books or keep them and send you only \$3.50 in full payment.

Name.....
(Please write plainly)

Address



*Check this square if you want these books with the beautiful full-leather binding at Five Dollars, with 5 days' examination privilege.



Become a highly paid specialist—learn quickly and easily about Automotive Electricity. Men trained in this branch are scarce and, therefore, well-paid. Thousands of big paying positions awaiting AMBU trained men.

Own a Fine Business

Great chance to start your own business—little money needed—we train you in spare time at home. Thousands of similarly trained men are drawing big salaries or running their own successful business. You can complete our course successfully even if you now know nothing of automobiles or electricity.

Salaries Up to \$6,000 Earnings Up to \$25,000

Big Corporations pay men who have the equivalent of AMBU training, up to \$6,000 per year. Millions of autos are operated, their owners are ready to patronize AMBU trained men to get expert service in Starting, Lighting, Ignition and Battery. AMBU trained men can earn up to \$25,000 yearly operating such service stations. You can do as well.

Young Dick Blake Earns \$2,600 in Own Business in Six Months

Without previous training or special experience, young Blake earned \$2,600 first six months through AMBU training. We can help you to quick success also—you don't risk a penny. Write for our "Money Back Guarantee Bond" and "Success Book"—free.

MAIL THIS NOW—
get into the Big-money Class—
Success Book tells you how.

AMBU ENGINEERING INSTITUTE
C. J. BUCKWALTER, President
130-2632 Prairie Ave. CHICAGO, ILL.

AMBU ENGINEERING INSTITUTE,
130-2632 Prairie Ave., Chicago

Send FREE your Success Book and complete information. I want to learn how to train for Bigger Money in spare time.

Write Name and Address in Space Below. Tear Off on Dotted Line

Name.....

Address.....

City..... State.....

Are you now in auto business Yes
No

Quality Fiction

100% entertainment will be found in every one of the 170 pages in the January issue of

Wayside Tales

Look over the following partial list of stories:

- "The Ward of Robbers' Roost"
By Crittenden Marriott
- "Other Men's Wives"
By S. Gordon Curwit
- "Maisie at the Crossroads"
By Vincent Starrett
- "The Matrimonial Agent"
By K. R. G. Browne
- "Christmas Up Rio Lucero"
By S. Omar Barker
- "The Hills of Home"
By Leslie Gordon Barnard
- "Both Ends Against the Middle"
By Hamilton Craigie
- "The White-Gold Gusher"
By James W. Earp
- "The Judgment of Johan Coull"
By Frederick Sleath
- "Retribution"
By R. A. Bankson

In addition to this superior fiction, we offer over fifty pages of fun, selected from the world's greatest laugh makers (artists and writers), with a generous supply of original humor never before published.

Ask your newsdealer, or send 25 cents for a sample copy, using the coupon

WAYSIDE TALES

CHICAGO

Gentlemen: For the enclosed 25 cents, please send me the January issue of your magazine

Name

Street

Town and State.....

How Cubberley Tripled His Salary

BY EUGENE FITZGERALD

The true story of a country boy's rise to industrial engineer with E. I. du Pont de Nemours Company

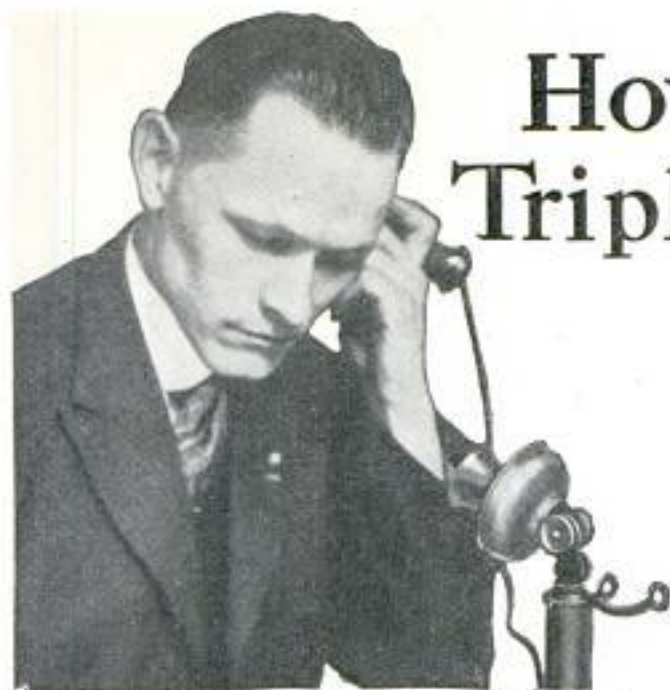

TAKE out your map or atlas and turn to the State of Missouri. Start at Jefferson City and run your finger northwest past Brunswick, Chillicothe and Gallatin until you come to the small dot that stands for Pattonsburg.

You may hardly be able to find it, for Pattonsburg is a town of only 900 inhabitants. But this unobtrusive little town was the home of A. H. Cubberley, now industrial engineer with the E. I. du Pont de Nemours Company, of Wilmington, Delaware.

When Mr. Cubberley was fifteen years old he was employed as an assistant clerk in a small hardware store at a salary as small as the position.

Fortunately, Cubberley was not satisfied. He saw that there was no future in the work he was doing, and he decided to make a new start before it was too late.

But what should he do and how should he do it? That was the question. How was he to get the special training which he knew he needed so badly?

Sometimes he would stay awake for hours thinking about it—wondering about it—Yes, worrying about it.

And then one day he found the answer!

He was reading over a magazine, just as you are doing today, when he came across an advertisement of the International Correspondence Schools. He had seen many such advertisements before and had passed them by.

But somehow this particular advertisement told of a man just like himself who had won advancement and more money through spare-time study.

The story was so real—so convincing—that Cubberley decided he could do as well. So that day he marked and mailed that familiar coupon.

It was the turn in the road for Cubberley. He studied in the spare time that he used to waste. Those practical, well-illustrated I. C. S. textbooks fascinated him. They made everything so simple—so easy to learn.

And Cubberley felt himself growing—he found that concentration on his studies and a burning zeal to conquer new fields brought greater success than any other investment he had ever made.

Today, A. H. Cubberley, who was once an assistant clerk in a small country store, is an industrial engineer for the biggest company of its kind in the world—at a salary in keeping with the position.

"I attribute much of my success to the I. C. S.," he said to me the other day. "The training I got from those textbooks was the means of changing my entire life."

"And how easy it all was! I had just as much fun as the other fellows, but instead of wasting my spare time, I put it to work for me.

"Lots of fellows laughed at me and said I was just wasting my money. Many of them are still working at small jobs and small salaries.

"My advice to young men can be summed up in one word—*Study*. It is the only thing that will make you better than the other man. The I. C. S. advanced me from a mere worker to a trained man. It will do the same for every other man with ambition."

Employers are begging for men like Cubberley—men who really want to get ahead in the world and are willing to prove it by training themselves in spare time to do some one thing well.

Prove that you are that kind of a man! The International Correspondence Schools are ready and anxious to help you prepare for something better if you'll simply give them the chance. More than two million men and women in the last 30 years have taken the I. C. S. route to better jobs and more money.

Is there any reason why you should let others climb over you when you have the same chance they have? Surely, the least you can do is to find out just what there is in this proposition for you. Here is all we ask: Without cost, without obligating yourself in any way, simply mark and mail this coupon. Then, without cost or obligation, we will send you the full story of what the I. C. S. can do for you.

TEAR OUT HERE

INTERNATIONAL CORRESPONDENCE SCHOOLS
BOX 5590-C SCRANTON, PA.

Without cost or obligation please explain how I can qualify for the position, or in the subject before which I have marked an X in the list below:

- | | |
|---|---|
| <input type="checkbox"/> ELECTRICAL ENGINEER | <input type="checkbox"/> BUSINESS MANAGEMENT |
| <input type="checkbox"/> Electric Lighting & Railways | <input type="checkbox"/> SALESMANSHIP |
| <input type="checkbox"/> Electric Wiring | <input type="checkbox"/> ADVERTISING |
| <input type="checkbox"/> Telegraph Engineer | <input type="checkbox"/> Show Card & Sign Ptg. |
| <input type="checkbox"/> Telephone Work | <input type="checkbox"/> Railroad Positions |
| <input type="checkbox"/> MECHANICAL ENGINEER | <input type="checkbox"/> ILLUSTRATING |
| <input type="checkbox"/> Mechanical Draftsman | <input type="checkbox"/> Cartooning |
| <input type="checkbox"/> Machine Shop Practice | <input type="checkbox"/> Private Secretary |
| <input type="checkbox"/> Toolmaker | <input type="checkbox"/> Business Correspondent |
| <input type="checkbox"/> Gas Engine Operating | <input type="checkbox"/> BOOKKEEPER |
| <input type="checkbox"/> CIVIL ENGINEER | <input type="checkbox"/> Stenographer & Typist |
| <input type="checkbox"/> Surveying and Mapping | <input type="checkbox"/> Certified Public Accountant |
| <input type="checkbox"/> MINE FOREMAN or ENG'R | <input type="checkbox"/> TRAFFIC MANAGER |
| <input type="checkbox"/> STATIONARY ENGINEER | <input type="checkbox"/> Railway Accountant |
| <input type="checkbox"/> Marine Engineer | <input type="checkbox"/> Commercial Law |
| <input type="checkbox"/> ARCHITECT | <input type="checkbox"/> GOOD ENGLISH |
| <input type="checkbox"/> Contractor and Builder | <input type="checkbox"/> Common School Subjects |
| <input type="checkbox"/> Architectural Draftsman | <input type="checkbox"/> CIVIL SERVICE |
| <input type="checkbox"/> Concrete Builder | <input type="checkbox"/> Railway Mail Clerk |
| <input type="checkbox"/> Structural Engineer | <input type="checkbox"/> AUTOMOBILES |
| <input type="checkbox"/> PLUMBING & HEATING | <input type="checkbox"/> Mathematics |
| <input type="checkbox"/> Sheet Metal Worker | <input type="checkbox"/> Navigation |
| <input type="checkbox"/> Textile Overseer or Supt. | <input type="checkbox"/> AGRICULTURE |
| <input type="checkbox"/> CHEMIST | <input type="checkbox"/> Poultry Raising <input type="checkbox"/> Spanish |
| <input type="checkbox"/> Pharmacy | <input type="checkbox"/> BANKING <input type="checkbox"/> Teacher |

Name..... 7 1-21

Street and No.....

City..... State.....

Occupation.....

THE SCIENTIFICALLY BUILT WATCH



1125 Waltham Mirror Clock
Antique Gilt and Polychrome
8 day 7 jewel movement
Plain Dial \$125. Radium Dial \$125



1201 Waltham Boudoir Clock
Mahogany Cross Band Case
8 day 7 jewel movement
Plain Dial \$15
Radium Dial \$40



1216 Waltham Traveling Clock
\$25 to \$35 depending on
dial and movement



1129 Waltham Boudoir Clock
Antique Gold and Bronze Case
Plain Dial \$20
Radium Dial \$45



1168 Waltham Mantel Clock
\$75 to \$200 according to the movement



1543 Waltham Willard Clock
\$85 to \$115
According to the movement

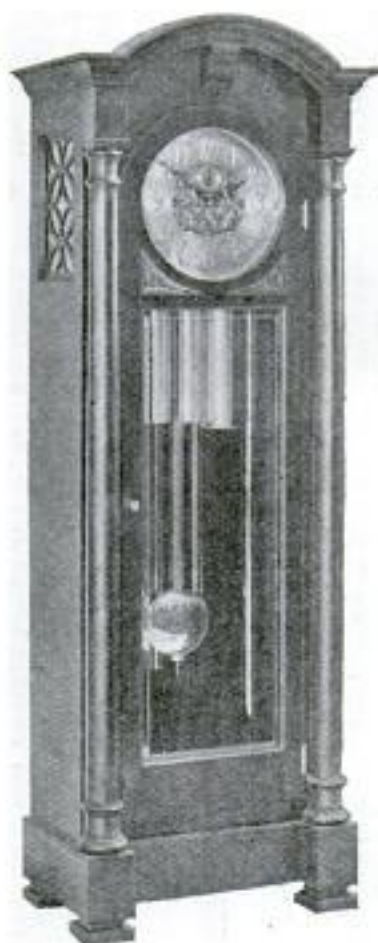

1081 Waltham Bungalow Clock
\$175 to \$735 according to
movement and chimes

A Waltham Clock is a Lasting Christmas Gift

A **DEPENDABLE** clock is a perfect Christmas gift. Its usefulness never diminishes. It is an essential household possession. It is always appreciated.

Waltham Clocks are infinitely superior to ordinary clocks because they are built by watchmakers to watch-making standards.

Waltham skill that created the tiniest watch movement in America is applied to Waltham clock-making. Waltham Clocks are remarkable for their accuracy. They are built like Waltham Watches.

Waltham Clocks can be purchased in every conceivable type and size. And at prices to suit every pocket-book. From the useful little Traveling Clock to the noble Hall Clock with its beautiful soft chimes.

Then, there are Mantel Clocks and lovely "Willard" reproductions. Also, exquisite Mirror and Boudoir Clocks which have set the fashion for exclusive furnishing. Gems of clock-making art at most reasonable prices.

A Waltham Clock is a lasting Christmas gift. It is dependable, accurate, beautiful.

If your jeweler does not happen to have the particular style of clock that you require, write the Waltham Watch Company, Waltham, Mass., and you will receive our illustrated catalog. Sent free upon request.

WALTHAM

THE WORLD'S WATCH OVER TIME

Where you see this sign they sell Waltham Watches

Popular Mechanics Magazine

REGISTERED IN U. S. PATENT OFFICE

WRITTEN SO YOU CAN UNDERSTAND IT

Vol. 37

JANUARY, 1922

No. 1

7445 Mr. B. S. A. Isaacs, Ltd. Birmingham
Life-Line Gun Fired from Shoulder
England.

GUNS for throwing life lines, used along the seacoast, have all been of the cannon type, but an English concern is now turning out a light line-throwing gun which is portable and can be fired from the shoulder. Though primarily designed for throwing life lines, it can also be used for mooring lines or, on land, for throwing lines to windows in case of fire. The line is contained in a cylinder which is slipped over the gun barrel

and held by a catch. A projectile is then attached to the line and dropped into the barrel and a cartridge inserted in the breech chamber. Ready to fire, the total weight is $14\frac{3}{4}$ lb. The recoil is about the same as that of a shotgun. A plumb-like bob on the rear sight indicates the elevation. At 30° a $\frac{3}{16}$ -in. line can be thrown 180 yd., or a $\frac{7}{16}$ -in. line 110 yd. When mounted on a base, the gun gives an even greater range.



The Portable Line-Throwing Gun in Use: No Matter Where It is Needed, It Quickly Meets the Emergency, For It Requires No Permanent Base or Other Preparation. The Box Contains Extra Cylinders of Line, Projectiles, and Cartridges, Complete Equipment for Every Need

Cont. F. S. Railey, 18 Upper Elmers
End Road, Beckenham, Kent, England.

Wide World Photos
 2 229 W. 43rd St.
 POPULAR MECHANICS
 New York City

7489
 No record makes or inventor - shown at Berlin Auto Show.

ANTISKID WHEELS USED ON GERMAN MOTORCYCLE

As an antiskid arrangement, side wheels are placed on a motorcycle recently displayed at a Berlin auto show.



The Antiskid Motorcycle with a Body Built on It, in the Act of Making a Turn: The Small Wheel to the Right is Seen Touching the Pavement, Thus Preventing a Fall or Skidding

Each side wheel is arranged at such an angle from the body as to prevent the machine from skidding or falling over when turning in either direction. These wheels also support the motorcycle when not in use. A body, similar to that of the ordinary sidecar, is built around the framework of the vehicle, and the driver rides as in a small automobile.

EXTRA BONES MISTAKEN FOR BROKEN ONES

People are like fish in that some of them have more bones than others. There are about half a dozen extra bones which occur in normal wrists and ankles, and several others are found more infrequently. Some of them may be explained by comparative anatomy. For instance, one extra bone that now and then occurs in the wrist is a regular bone in the corresponding part of lower animals right up to the monkey. They serve no useful

purpose; they are merely one of nature's distinctions, not one of her blessings. These surplus bones have a curious practical interest. It has just lately become generally realized that some of these extra bones, in X-ray photographs, resemble closely some of the ordinary fractures which result from personal injuries, and unless care is taken, wrong testimony will be given in court in damage suits. Fortunately, when these extra bones are present in one wrist or ankle they are usually in the other also, so that it is possible to identify them by taking X-ray pictures of the undamaged member.

7586
JAPANESE WOMEN'S PEACE PLAN THREE HUNDRED FEET LONG

If length counts for anything, the Japanese women have made a good start toward solving the world-wide problem of how to end all wars. The result of their efforts is a peace plan which is 300 ft. long, and is signed by 10,000 of their number. The document, which is written on rice paper, and has the signatures appearing both in English and Japanese script, was recently presented to the president at Washington, D. C. The committee which brought the interesting document was headed by a woman of 90 years.



Madame Kaji Yajima Holding the 300-Foot Peace Plan Signed by 10,000 Japanese Women and Presented to President Harding

cont. C.A. Briggs
 1521 Oak St. N.W.
 Washington, D.C.

229 W. 43rd St.
 New York City

Radio Constructed by: J. Es White
Engineering Corporation of N. Y.
WIRELESS INCIDENTS AROUSE WORLD INTEREST
43 Exchange Place



SIX of the 72 gigantic towers of the world's largest wireless station at Port Jefferson, L. I., which was formally opened by President Harding on Nov. 5, 1921, are shown here. The station, which was described by this magazine in the September 1920 issue, is operated entirely by remote-control apparatus from New York City—70 miles distant. Insert shows an artist giving a piano recital by wireless, said to be the first of this kind ever given, and estimated to have been heard by 35,000 persons between Maine and Texas.

4
7692

Above is illustrated the First of a Number of Very Large Locomotives Which are being Built by One of the American Manufacturers for Service on Chinese Railways. Hard Service on the Railroads of the United States has Proved That This Is the Highest Type of Motive Power for Heavy Freight Duty. The 16 Wheels Afford Great Tractive Power

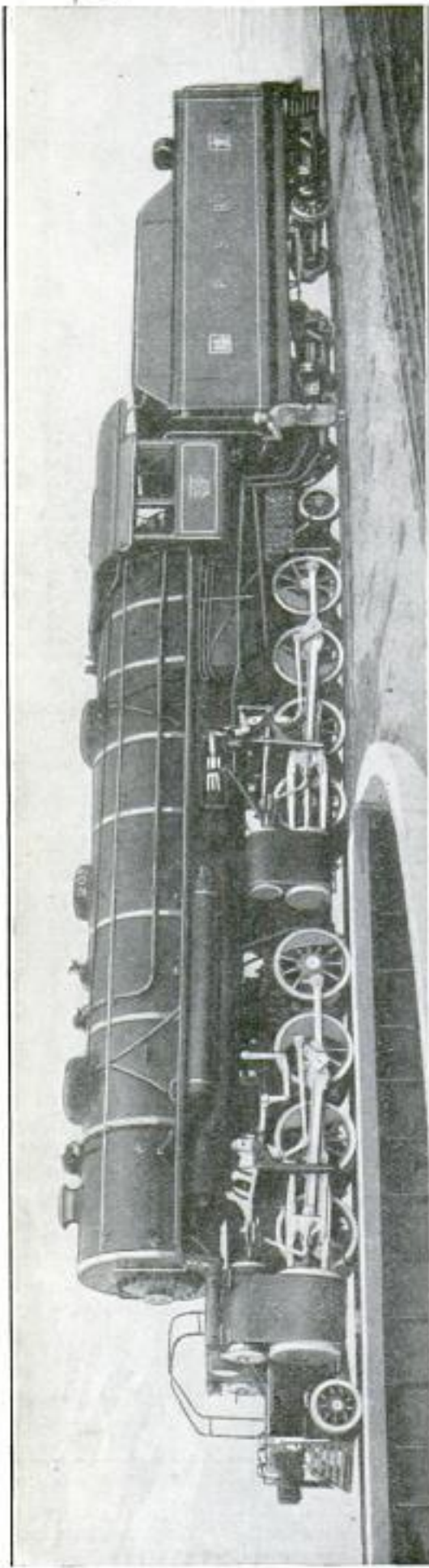

7692
CHINESE RAILWAY BUYS LARGE AMERICAN LOCOMOTIVES

What is said to be the largest locomotive in the world outside of the United States has just been shipped to China for service on the Peking-Suiyuan Railway, from the shops of one of the large American manufacturers. The length of this locomotive and tender, over all, is 94 ft. 9 in.; its total weight on track is 320 tons, and it will develop 3,000 hp. This is the first of seven such locomotives to be shipped for use on this Chinese railroad.

7685
CABLE STEAMER "ALL AMERICA" HAS UP-TO-DATE EQUIPMENT

The cable steamer "All America," built on the Tyne in England, arrived recently in New York. Its deadweight tonnage is 1,750, and it is 295 ft. long, 37 ft. wide, and draws 18 ft. There are three cable tanks forward and one aft, all of which have steel cones for coiling. The total capacity is about 14,000 cu. ft. The cable machinery is of the most improved pattern. There is a large testing room on the awning deck. There are workshops with special appliances for doing cable-repair work. The vessel is an oil-burner with two sets of triple-expansion engines. Its equipment includes electric-lighting and refrigerating plants, a wireless installation, a motor lifeboat, etc. Its trial speed was 15 1/4 miles an hour.

7685
Nauticus 11/12/21

7686
STATES GET SURPLUS WAR MATERIALS FOR ROADS

One hundred and fifty million dollars worth of surplus war materials have been turned over to the Department of Agriculture by the War Department for distribution to the various states for road-building purposes. This material and equipment include 10,000 tons of TNT, 4,500,000 tons of powder, 25,000 tons of rails, 27,198 motor vehicles, and 172 locomotives.

U.S. Dept. of Agriculture
292-2
4/10/11

7545
TUNNEL-DIGGING MACHINE ALSO LINES WALLS

Digging a tunnel, removing the earth, and lining the walls with concrete blocks as the tunneling advances, are all accomplished by a single recently developed machine. The method is claimed to be more rapid, safer, and cheaper than the open-cut or ordinary underground methods. Four revolving arms at the

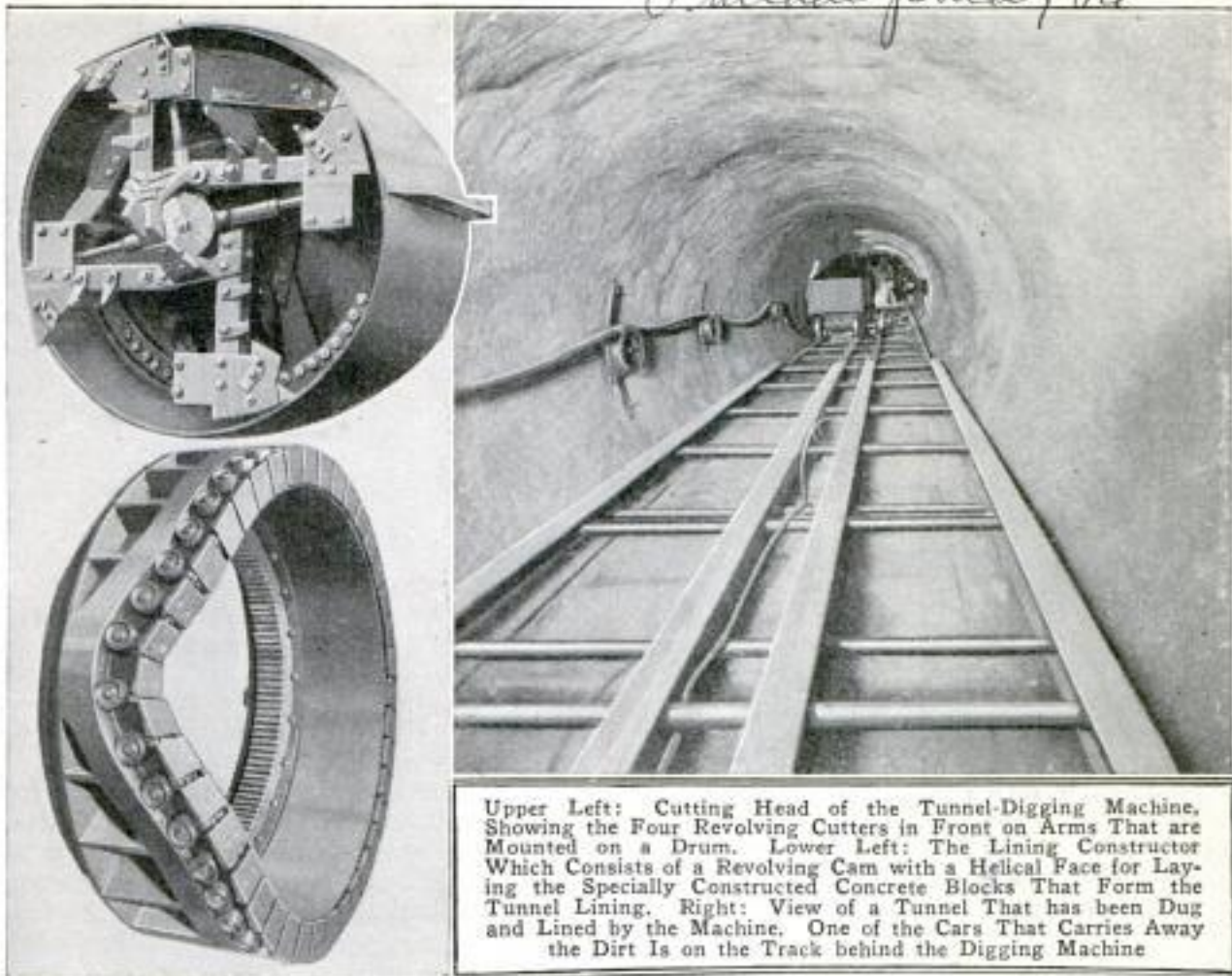

Upper Left: Cutting Head of the Tunnel-Digging Machine, Showing the Four Revolving Cutters in Front on Arms That are Mounted on a Drum. Lower Left: The Lining Constructor Which Consists of a Revolving Cam with a Helical Face for Laying the Specially Constructed Concrete Blocks That Form the Tunnel Lining. Right: View of a Tunnel That has been Dug and Lined by the Machine. One of the Cars That Carries Away the Dirt is on the Track behind the Digging Machine

front of a cutting head, mounted in a steel drum, carry the cutters which remove the earth. It is deposited, by buckets, on a conveyor belt, which carries it to cars, brought up from the rear. Behind the cutting head are the gearing and mechanism for controlling the direction of the cut. Back of this is the lining constructor, which lays concrete blocks designed so that when they are pushed into place they expand and fit tightly against the earth wall. They are laid in spiral courses, giving a forward motion to the machine, which keeps the cutting head in contact with the tunnel heading. This machine, operated by an electric motor, has constructed 18 ft. 8 in. of finished 52-in. tunnel in four hours.

THREE CARBURETORS ON ENGINE OF FRENCH MANUFACTURE

7605

Three carburetors on one engine presented an odd appearance at a French auto show recently, and was the subject of much comment. The engine is of 40 hp., and has six cylinders. When three carburetors are fitted, two of them supply independent groups of cylinders, for high power and speed, while the third sup-

plies all the cylinders at low speed, or "loafing range," as it is called. Thus, if a motor car has an engine with six cylinders, these are divided into two groups of three, and one carburetor feeds each group when high speed is desired, or when heavy power is needed, as in hill climbing. The third carburetor feeds all of the cylinders at low speed, or at times when the engine is left running while the car is stopped.

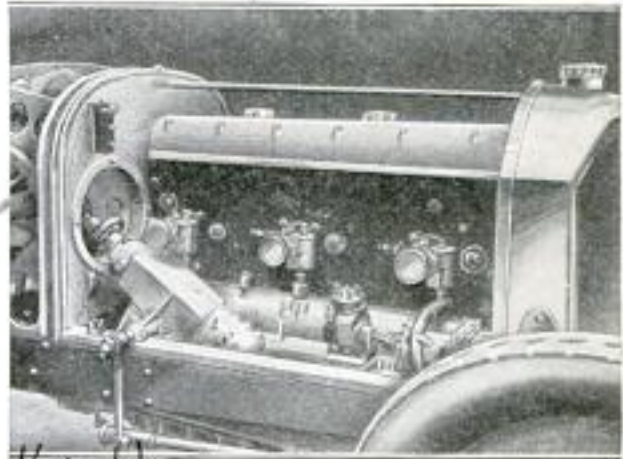

The Three Carburetors can be Plainly Seen Mounted on the Side of the Six-Cylinder Engine. These Carburetors Supply Different Groups of Cylinders at Different Speeds

esobron, France

Ans. Arthur J. Hard,
6 Wausau
Wis.

POPULAR MECHANICS

STOOL FOR WEEDING GARDENS TO PREVENT BACKACHES

Backaches and sunburn are no longer necessary consequences of weeding the garden. A combination stool and um-



Seated on a Garden Stool, Weeding Is Less Tiresome, and When the Job is Done, the Umbrella is Taken Down and the Outfit Wheeled Away

rella has been invented to make the gardener's work less of a burden. The seat is mounted on two legs and two wheels so that it may be tilted up and wheeled about like a wheelbarrow. Legs and wheel supports have a telescoping adjustment to obtain exactly the right height, and a lateral adjustment allows the stool

to be placed over rows of different widths. A large sunshade is attached to the edge of the seat and may be tilted to just the right angle. With this stool astride the rows, the gardener works in comfort, moving it along as his work progresses.

"THERMOS" CARS AND TRUCKS TRANSPORT MILK

7662

Tank cars for oil are a common sight, but tank cars for milk are something distinctly new. The first installation of this kind was made recently for a large dairy in Pittsburgh. Two 2,500-gal. steel tanks are mounted on each car. These tanks are of heavy welded plate steel with a glass lining, and are insulated with cork. Fused into the metal at extreme heat, the glass forms a smooth surface which is easily cleaned and will stand severe usage. Inside each tank is a motor-driven agitator. Run for five minutes before emptying the tank, it gives uniformity to the contents.

Milk, chilled to a temperature of 38 to 40°, is maintained at that temperature in the tanks without further refrigeration. In a 106-mile run, during the hot weather, milk has remained in these cars for eight hours with a change of only 2°

These Milk Tanks are Mounted inside of Box Cars. The Illustration Shows the Tanks through the Sides of the Cars as Though Transparent. The Space between the Tanks and the Sides of the Cars is Packed with Cork



The Pfander Co., Rochester, N. Y.

Copyrighted material

Used by Harmony Creamery Co., Pittsburgh, Pa.

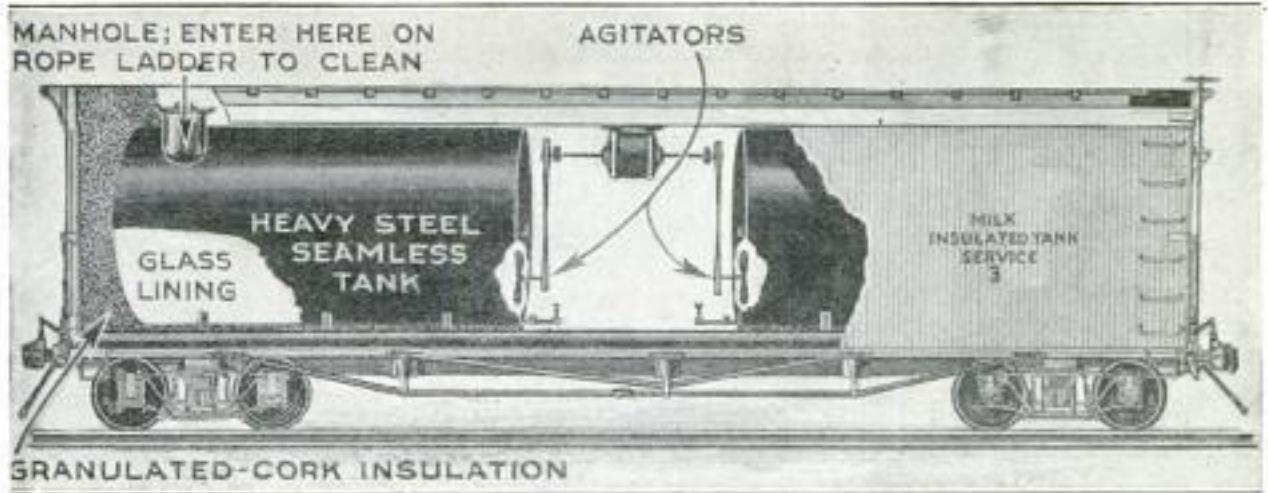

Construction of the Milk-Tank Cars, Showing the Arrangement of Tanks, Manhole for Cleaning, Agitators and Motor, and Insulation: The Milk is Transferred from These Tanks into Motor Trucks, Also with Glass-Lined Tanks, for Conveyance to the Dairy

in temperature. Perfect drainage in emptying the cars results in a loss of only 2 gal. out of 5,000, through milk clinging to the tank walls. Where cans are used, $\frac{1}{4}$ pt. clings to each 10-gal. can, a loss of 16 gal. out of 5,000. Similar tanks are mounted on wagons and motor trucks for hauling the milk from the railroad to the dairy or collecting it along country roads.

These tank cars greatly reduce the cost of han-

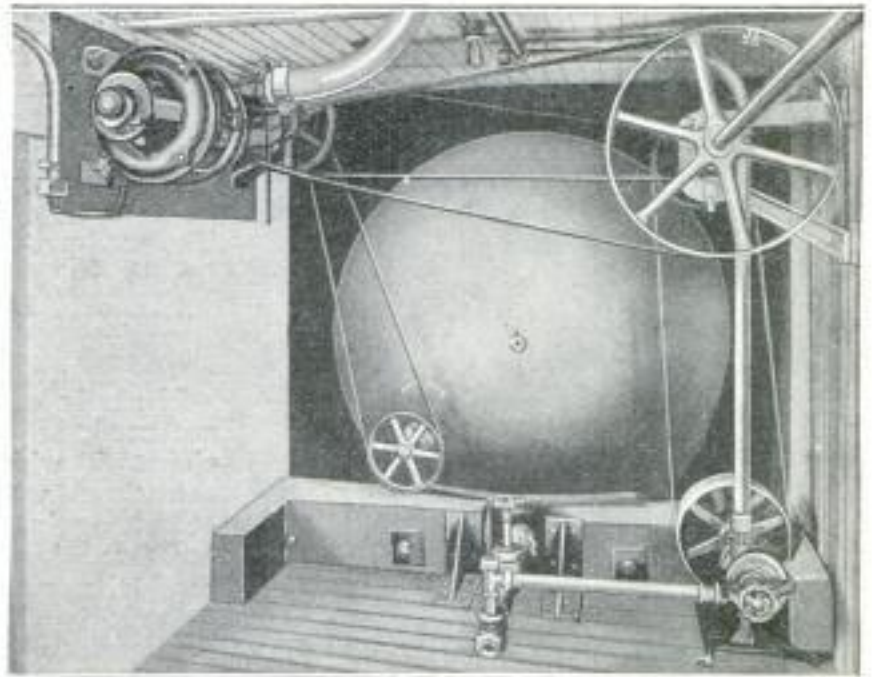

The Inside of a Car, Showing the End of One Tank, and the Motor and Gears Operating the Agitators for Mixing the Milk and Cream

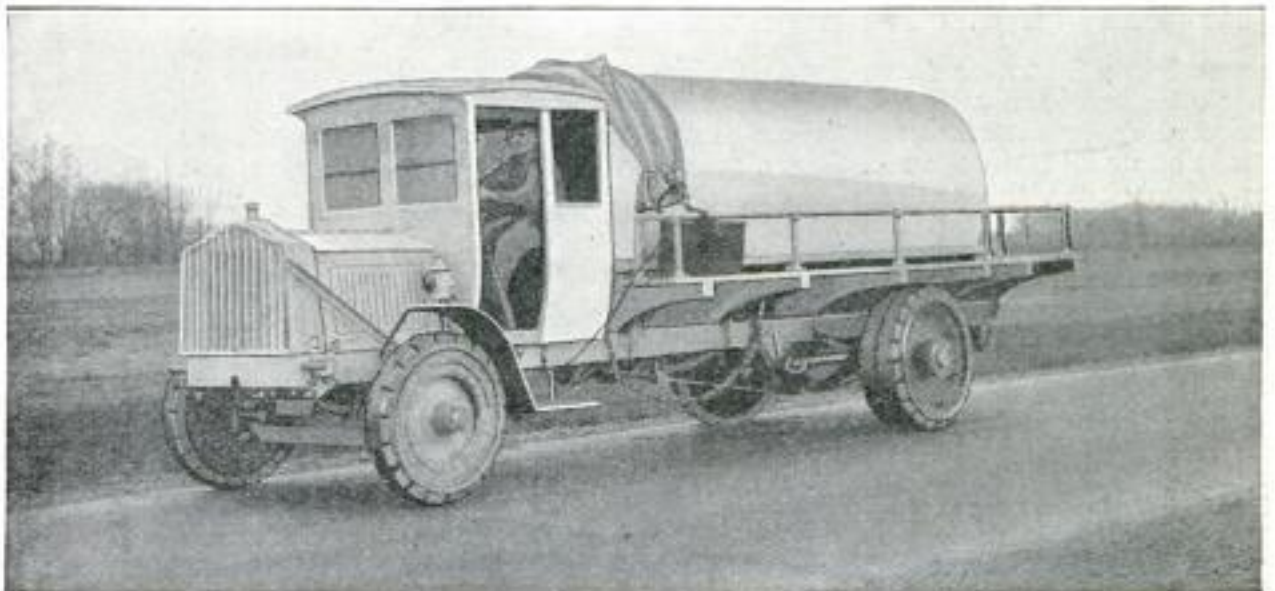

Glass-Lined Milk Tanks are Also Mounted on Trucks for Collecting Milk along Country Roads or for Long Hauls from the Railroad Tanks. With Horse-Drawn Tanks for Short Hauls, All Requirements are Met

dling milk. The Pittsburgh installation requires only three cars. Seven cars were needed when cans were used. It has done away with the services of a

3½-ton truck and seven men. It is estimated that the saving for one year will be approximately two-thirds of the original cost of the tank cars.

3480
**OIL MEN STRIKE "GASSER"
INSTEAD OF A "GUSHER"**

All sorts of unexpected things happen in the production of oil, and one of the most unusual and interesting was the

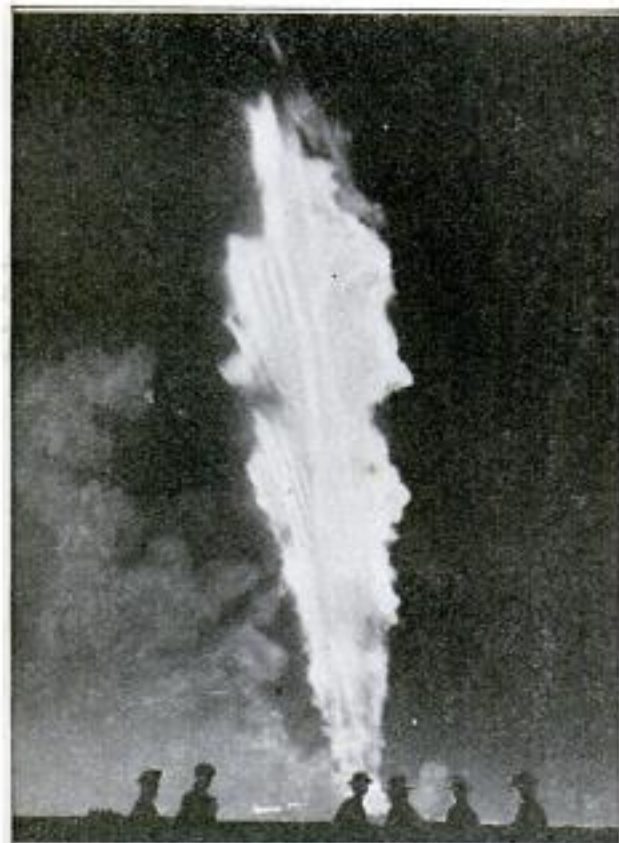

A Flame of Burning Gas, 400 Feet High, from a Well Which was Drilled for Oil: The Gas was Accidentally Ignited by a Lantern When the Well "Came In"

"gasser" in a field near Long Beach, Calif. This well had been cemented off and was expected momentarily to "come in." About one o'clock in the morning, a great explosion shook the entire city. It was the well coming in, but instead of oil it

proved to be gas. As the jet of gas struck the derrick, a lantern hanging at the top was blown off and the gas became ignited. A column of fire, 400 ft. high and several feet wide, shot into the air, illuminating the surrounding country. The roar could be heard for miles and the heat was intense. It was estimated that there were 300,000,000 cu. ft. of gas burning during a 24-hour period. For the first two hours the column of fire remained at a height of between 350 and 400 ft., and then died down suddenly for a few moments. A second explosion started it afresh, and it remained burning for two days. Pipe lines were constructed, and the well was filled with dirt, which extinguished the fire. The well proved to be a wonder.

7544
**SIDEWALK ELEVATOR GATES
REMOVE ALL DANGER**

If newly constructed guards, or gates, are used, no one need fear the sidewalk elevators which rise so suddenly, and sometimes without warning. The gates lie flat against the building when not in use, but when the elevator begins to ascend, the gates are automatically swung outward by the movement of the elevator mechanism. The descent of the elevator causes the gates to swing back against the wall of the building again, entirely out of the way of passers-by. An added feature of the gates is that they can be adjusted so as to stop the elevator if a pressure of 10 lb. or more be applied against them. Thus, should a child happen to be standing on or near the covers when the elevator starts, a slight pressure would stop the machinery and avoid accidents.

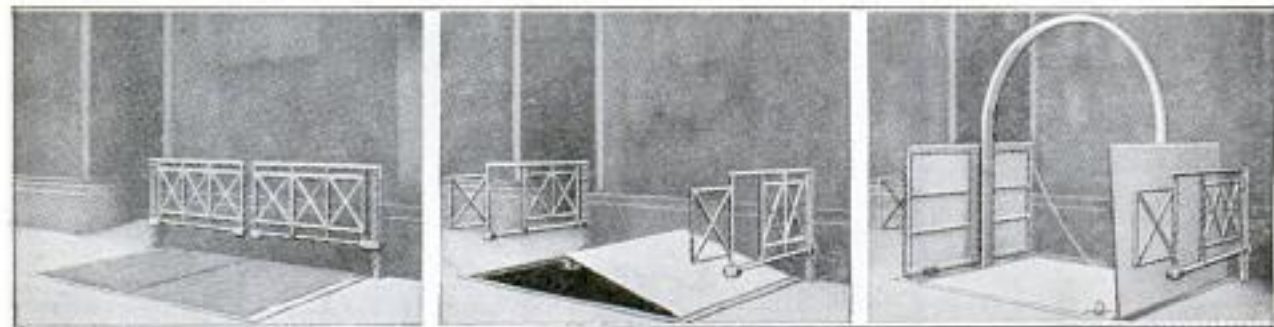

Left: The Gates Folded Back against the Building. Center: The Gates are Shown Automatically Opened by the Rising Elevator. Right: The Elevator is Seen at the Sidewalk Level

Shur-Loc Elevator Safety Co.
62 W. 45th St. New York City.

7569

Cont. John Y. Pearty

Wrigley Bldg Chicago

"DAM IS BREAKING!" — HEARD FOUR MILES

Human Voice Broadcast over Vast Area—Flood Warnings Given to Isolated Communities and Individuals—Feat Made Possible by Remarkable Tests Conducted in Catskill Mountains

By H. A. LANE

TERRIBLE disasters have been caused by the irresistible swirl of rushing floods, in which unsuspecting persons were caught without warning. In one instance, years ago, a gay party on a four-horse tallyho was enthusiastically exploring the wonders and beauties of Turkey Creek Cañon, near Golden, Colo. Gathering rainclouds failed to cast a shadow upon their high spirits, and no serious thought was given to danger from the rapidly approaching storm, because the tourists were not familiar with the characteristics of the local tempests, nor with the topography of the surrounding country.

The storm suddenly burst with great fury upon the unprepared pleasure seekers, and the deluge of water caused them quickly to abandon the tallyho and hunt for shelter. Closely huddled against the towering sides of the cañon, they soon realized, with anxiety, that they had not reckoned with the forces of nature. The terrific rush of water down the cañon sides swept them from their feet, and down to the bed of the cañon, where a torrent of water now raged. Despite their struggles, many of the party lost their lives, and those surviving were seriously injured.

Another instance was the great flood at Johnstown, Pa., which happened many years ago. Much of the disaster, and many fatalities could have been prevented if warnings had been hurled through space in advance of the cruel waters.

More recent was the disastrous flood at Pueblo, Colo., where the toll of lives, and property damage, reached enormous proportions, much of which would have been averted, had some kind of warning been given.

As a protection against such terrible events as these, a system of huge telephone transmitters and amplifiers has been produced, which will throw the human voice a distance of four miles. Extensive tests have been made with this apparatus, which have proved the practicability and success of the endeavor. These tests were conducted in the Catskill Mountains, by a specially trained group of operators. A tower, 30 ft. high, was erected to hold the gigantic amplifiers and the immense projectors which measured 15 ft. in length and 4 ft. in height.

To determine just how far the human

voice could be heard with these aids, was accomplished in rather a weird manner, because the time selected was at night. Four men took up previously agreed-upon stations, at distances of one, two, three, and four miles from the tower. As the time drew near for the experiments, the four men applied matches to specially prepared torches, which gave large flaring flames.

Meanwhile, at the tower, were gathered a party of men chosen to observe the tests, and who interestedly watched the tiny flickering torches in the distance. When the "zero hour," or time set for the tests, arrived, the operator at the tower took his place before the transmitter of the apparatus, and in a natural tone of voice, ordered the far-off men to wave their torches.

Breathlessly the watchers at the tower peered through the inky blackness at the flickering points of fire, and the nearest torch was seen to describe vigorous circles in the air. Exclamations of satisfaction came from the watchers, which rose to a shout, as the second, then the third, and finally the fourth torch was seen to dip and wave wildly in the darkness, thus showing plainly that all the men had heard the command. The operator at the transmitter then spoke to the men again, in reply to their ready signals, and bade them wait for further instructions.

The next test was made with a phonograph, which was placed before the transmitter, and several records of well-known music were produced. Before playing the machine, the operator spoke to the waiting torch bearers, telling them what the nature of this test would be, and instructing them to make a note of the tunes, and the order in which they were played. After he had delivered his orders, he again asked them to signal him if they understood the instructions. And again the four torches waved vigorously.

Several pieces were then played with the instrument, and at their conclusion the tower operator announced briefly to the far-away listeners that the experiments were completed and that they should extinguish the torches and make their way back. The party at the tower then saw the torches disappear, one by one, into the blackness of the night.

When the men returned, each was

Photographs from Oliver Morrison Center of the Transmitter 725-13 St. St. N.W. Washington, D.C.

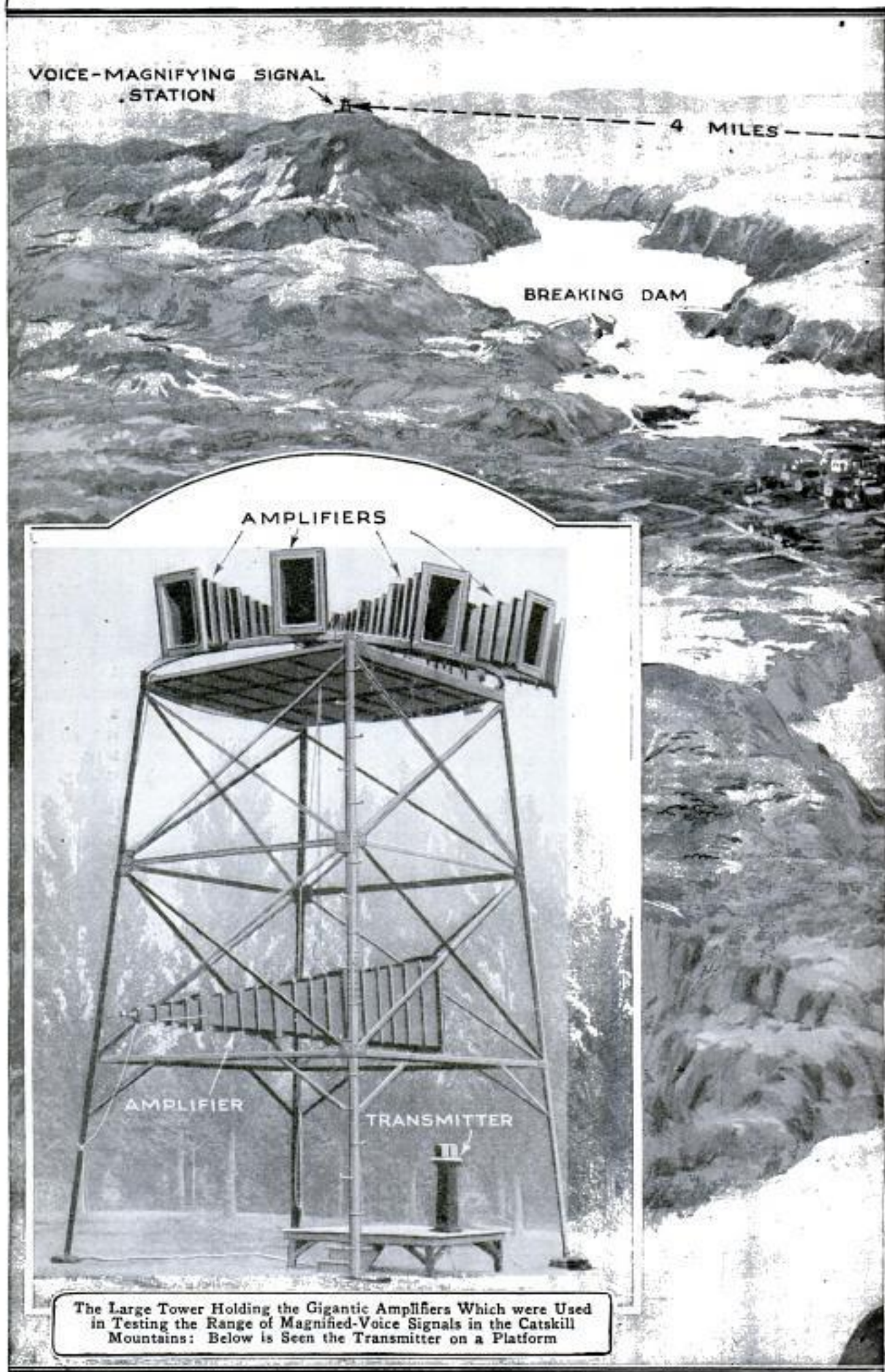

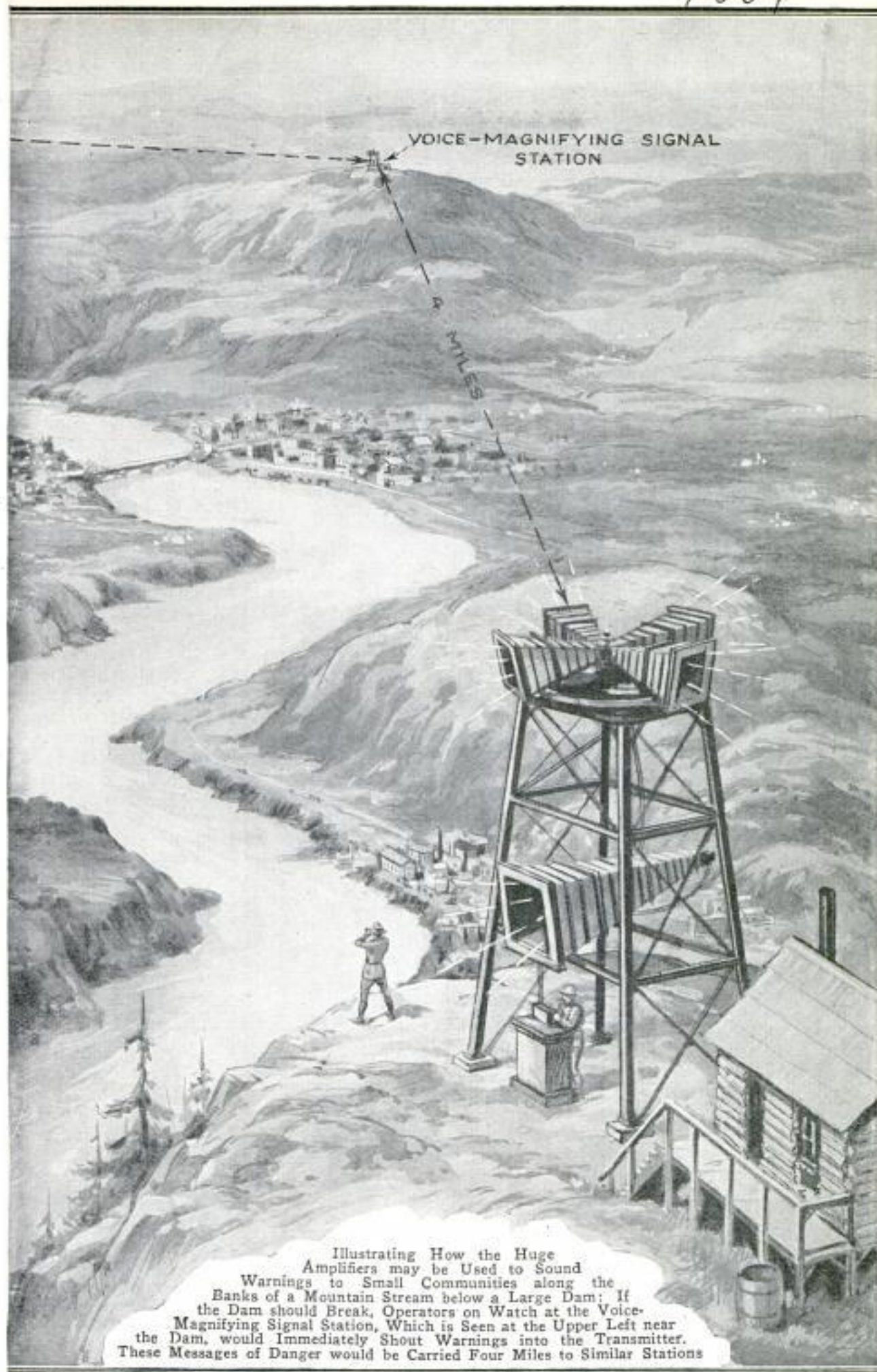

found to have a correct list of the tunes, and the order in which they were played. Thus every one of the tests proved a suc-

cess, and the time, labor, and money expended were considered small in comparison with the results obtained.

A NEW KIND OF HORSE SHOW

BY FRANK B. HOWE, *412 Mason Opera House Building Los Angeles Calif*

EVERY now and then some courageous soul, with sufficient boldness to kick over the traces and upset the estab-

recent Pacific-coast show completely upset precedent when they announced that entered horses must actually perform their specialty, instead of being led past the judges by a groom. In other words, polo ponies must play polo; saddle horses must be ridden through all the various feats that prize saddle horses are supposed to accomplish; chariot racers must draw chariots, and so on.

The innovation was a complete success, and the crowded grandstand testified to the public's approval of the change. According to psychologists, the public like

action. They got it here. Instead of the tedious procession of innumerable horses, they first saw a group of horses play polo. Then another group staged a chariot race. Some fine stallions performed various feats designated to show their intelligence. A number of cow ponies went out and showed



A Chariot Race Not Only Displayed the Merits of the Horses but at the Same Time Furnished Real Entertainment for the Spectators

lished custom, comes along and introduces an innovation in some traditional undertaking. If he can stand the criticism, he generally contributes something to humanity.

In this case the "kicking over the traces" figure is appropriate, for the subject is a horse show.

Heretofore, at such events, helpless spectators have sat in the grandstand and watched the "thrilling" spectacle of an unending procession of horses being led past a little group of judges. After some hours of this, a man with a megaphone announces that such-and-such a horse has won; the chief judge pins a blue ribbon on the animal's bridle, and the crowd departs.

Determined to make their horse show as interesting for the spectators as it was for themselves, a group of horsemen at a

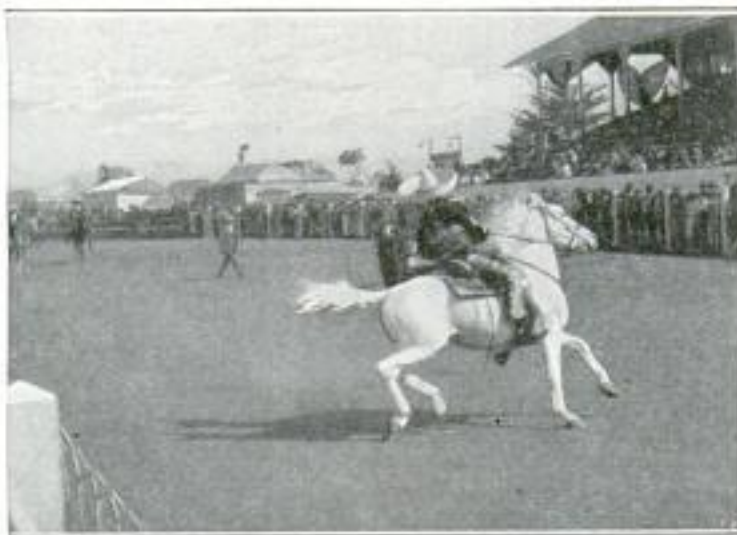

A Cowboy Putting One of the Competing Stallions through Various Paces to Test and Show Its Intelligence: Similarly, Saddle Horses and Animals of Other Classes Performed Their Specialties

how they helped their cowboy riders brand cows. After this, horse-show audiences are not likely to be content with the "procession method" of judging.

☛Tolls for a telephone call from Chicago to California, by which the purchase of a down-town Chicago building site was arranged, amounted to several hundred dollars. A 21-story office and shop building will be erected on this, and adjoining, property.

BLIND AND DEAF GIRL DEVELOPS WONDERFUL SENSE OF TOUCH AND SMELL

BY FRED L. HOLMES, 115 W. Main St., Madison, Wis.

READING the wireless telephone by the sense of touch is the new accomplishment of Willetta Huggins, age 16, the blind and deaf girl of Janesville, Wis. By placing her fingers on the diaphragm of the receiver, she gets the vibrations of the human voice and is able to understand. She has been blind and deaf for three years. Without instruction, she has developed in that time an uncanny sense of touch that seems, in a measure, to take the place of her lost faculties.

During September, 1921, the girl discovered that by placing her finger upon the diaphragm of a telephone receiver she could read conversation. She has always had the faculty of speech. With this discovery she soon learned that she could conduct a telephone conversation almost as well as any normal child of her age. But Willetta Huggins' sense of touch was to be given a new thrill. The girl was brought to Madison, Wis., on last November 1, to visit Gov. John J. Blaine. She was taken to a news-service office to ascertain if she could read the wireless telephone, and a score of persons, including Maj. E. A. Fitzpatrick, secretary of the State Board of Education; Mrs. J. T. Hooper, superintendent of the blind school at Janesville; J. G. Crownhart, newspaper correspondent and wireless operator, and a score of others were asked to be present.

Arrangements were made with Prof. E. M. Terry, head of the department of physics at the University of Wisconsin, and Malcolm P. Hansen, wireless operator, to send the girl a message

by radio telephone. No one in the room knew what the message would be. To the amazement of the audience, the blind and deaf girl with her fingers in the two receivers was able to read this message:

"My dear Miss Huggins: I am glad to have the privilege of addressing such

a remarkable girl by radio telephone. Never before have science and a wonderfully developed human sense together effected such a transmission of intelligence. Good-bye. Good luck. — Malcolm P. Hansen, Wireless Operator."

"He calls me 'dear Miss Huggins,'" declared the girl as soon as the message was

started and she laughed about it as if it were a slight embarrassment to be so familiarly addressed by a stranger.

When the message had first been received, Mr. Hansen repeated it, fearing that the girl had not received it the first time it was transmitted.

"He is repeating it," said Miss Huggins. "I know what he said the first time."

When the repetition of the message had been completed, after coaxing by Mrs. Hooper, she told the people present, almost word for word, what the operator had sent her.

But a still more striking demonstration of her sense of touch was to be given. After the message had been completed by the use of the regular telephone, it was transmitted to the receiving office and typewritten. Half an hour later, after many other experiments had been tried with the girl, success-

fully—the telling of colors by the sense of smell, and the denomination of bills



A Highly Developed Sense of Touch Enables This Girl, Who Is Absolutely Deaf, to Read a Wireless-Telephone Message by Placing Her Fingers on the Diaphragms of the Receivers



Equal to Her Sense of Touch Is That of Smell, by Which She Distinguishes Colors

by touching the numerals on them—she was handed the typewritten sheet and asked if there was a message on it. She ran her hands over the typewritten wording.

"Oh! This is the same message they



By Placing Her Hands upon Their Chests or Heads, She Is Able to Carry on a Conversation with Two Persons at the Same Time

sent to me from the university," she exclaimed.

The radiophone message sent by the university was on a wave length of 800 meters, and the instrument used in taking it off was an audion detector with a one-step amplifier with but a 50-ft. two-wire antenna on the roof of a three-story building. The audibility of the message was sufficient to enable those who were not equipped with receivers to hear the entire message while Miss Huggins read it with her delicate fingers, repeating phrases that amused her as they traveled through the ether. While the same radiophone set has been heard as far as Independence, Mo., the fact that this little girl was able to put her sensitive forefinger on the diaphragm of the receiver and thus read the message, amazed the expert physicists and wireless experimenters of the university.

Almost as marvelous as is the girl's sense of touch is her sense of smell. She can tell how many people are in the room

by this sense, and how many are strangers. Willetta Huggins was locked in a bank vault at Chippewa Falls and given six envelopes, each containing yarn of a different color. She wrote the answers on each envelope correctly.

"What is the color of my waist?" asked one girl. She smelled.

"It's white," declared the blind and deaf girl, "but the collar is edged with yellow."

"And the color of my suit is what?" asked Governor Blaine. The girl put her nose to the cloth.

"It's gray and black—a mixture," came the girl's correct answer.

Miss Huggins is a human sounding board. She places her hand on your head or shoulders and is able to conduct a conversation in rapid order, or she can conduct two conversations with two people at the same time.

Willetta Huggins was slow and plodding in her school work when a child. With failing eyesight she was sent from her home at Chippewa Falls to the school for the blind at Janesville when 10 years of age. In October, 1919, without any forewarning, she suddenly became stone-deaf. A year later she was stone-blind. For six months she groped despondently in the dark. She refused to be comforted. One day she brushed against one of her teachers who was talking and got the vibration of her voice. Then she placed her hand on the teacher's head and found that she could understand. Since then her development has been rapid.

"Willetta Huggins is a wonder," said Superintendent J. T. Hooper. "Not herself, but what she may teach to the educational world may be more wonderful than education alone. With defective sight and defective hearing, two imperfect avenues of approach to the brain, she was dull, stolid, discontented, and made no progress whatever in intellectual development. Even the work with her hands was much inferior to what it is now. When these two imperfect avenues of approach were cut off and she was forced to use the most perfect avenue of all—the sense of touch—she immediately became interested, happy, intelligent, and made very rapid progress both with her head and hands. The question arises in my mind if we are not attacking the educational problem from the wrong angle. Should not every child be made perfect in so far as possible by the physician, the nurse, and social worker before being sent to the educator?"

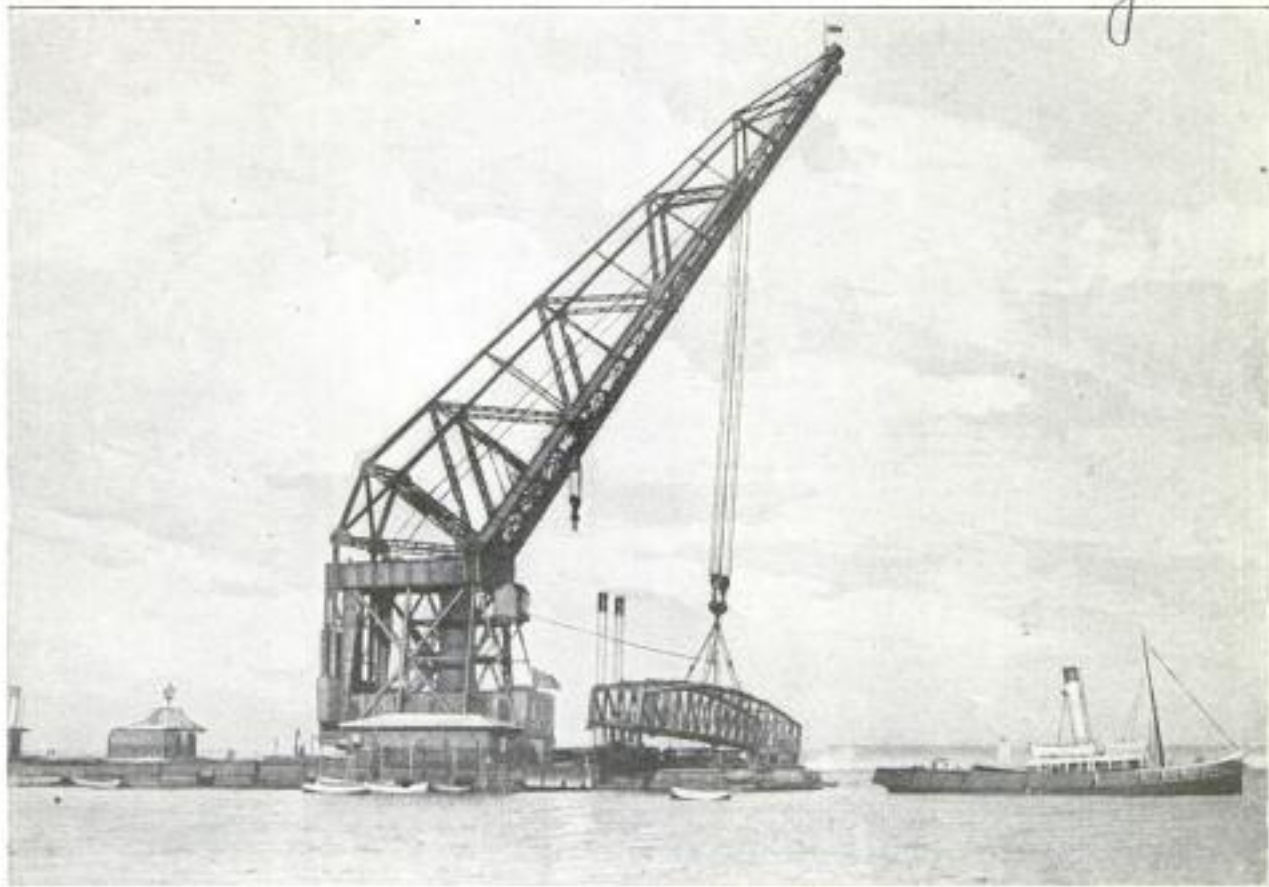

Giant Floating Crane Belonging to the Port of Liverpool, England, in the Act of Lifting from Its Abutments a 150-Ton Bridge: It Carried the Bridge down the River Mersey from New Brighton to Seacombe, a Distance of Nearly Two Miles, to a Repair Shop

7649
FLOATING CRANE TAKES BRIDGE TO REPAIR SHOP

After lifting bodily a bridge weighing 150 tons from its abutments at New Brighton, Eng., a giant floating crane carried the bridge a distance of about two miles down the river Mersey to a repair shop at Seacombe. This mammoth crane, which has a lifting capacity of even more than 150 tons, was originally intended for Russia.

7637
ATTACHMENT TO ASSIST BLIND TYPEWRITER OPERATORS

A blind Englishman, a victim of the war, has invented an attachment which enables him to operate and fully control a typewriter. Difficulty was found in determining when the end of the sheet was being reached and in taking out and reinserting sheets. The attachment that overcomes these troubles consists of a trough-shaped aluminum stamping. A flat spring, with its end wound on a spool at the top, passes through the trough and terminates in a clip. The paper is inserted in the clip and held by a screw. A projection on the clip enables one to set the

paper absolutely square. A tiny point sticks into the paper so that its exact position can be determined if taken out and reinserted. As the end of the paper



This Device, Attached to the Carriage of an Ordinary Typewriter by Means of the Bracket, Enables a Blind Person to Control the Machine

approaches, the clip operates a trip lever and rings a bell. Braille characters stamped on the side aid in the adjustment to any length of paper.

When you want anything and do not know where to get it, write Bureau of Information, Popular Mechanics, Chicago.

Mr. George Pringle, 140 Bishops Road,
Chelmsford, England.

inventor: Mrs. Lo Amble

2676

America's Unknown Hero being Laid in His Final Resting Place at the Arlington National Cemetery. Where Dignitaries from Many Countries Gathered to Do Him Homage, and While an Entire Nation Bared Its Head; In the Center of the Picture can be seen the Flag-Draped Casket of the Nameless Martyr. Flanking it on All Sides are Seen Men High in Public and Military Life and Esteem. Outside of These are Gathered the Solemn Thousands Who Followed the Simple Burial Procession from the National Capital across the Historic Potomac River to the Burial Grounds

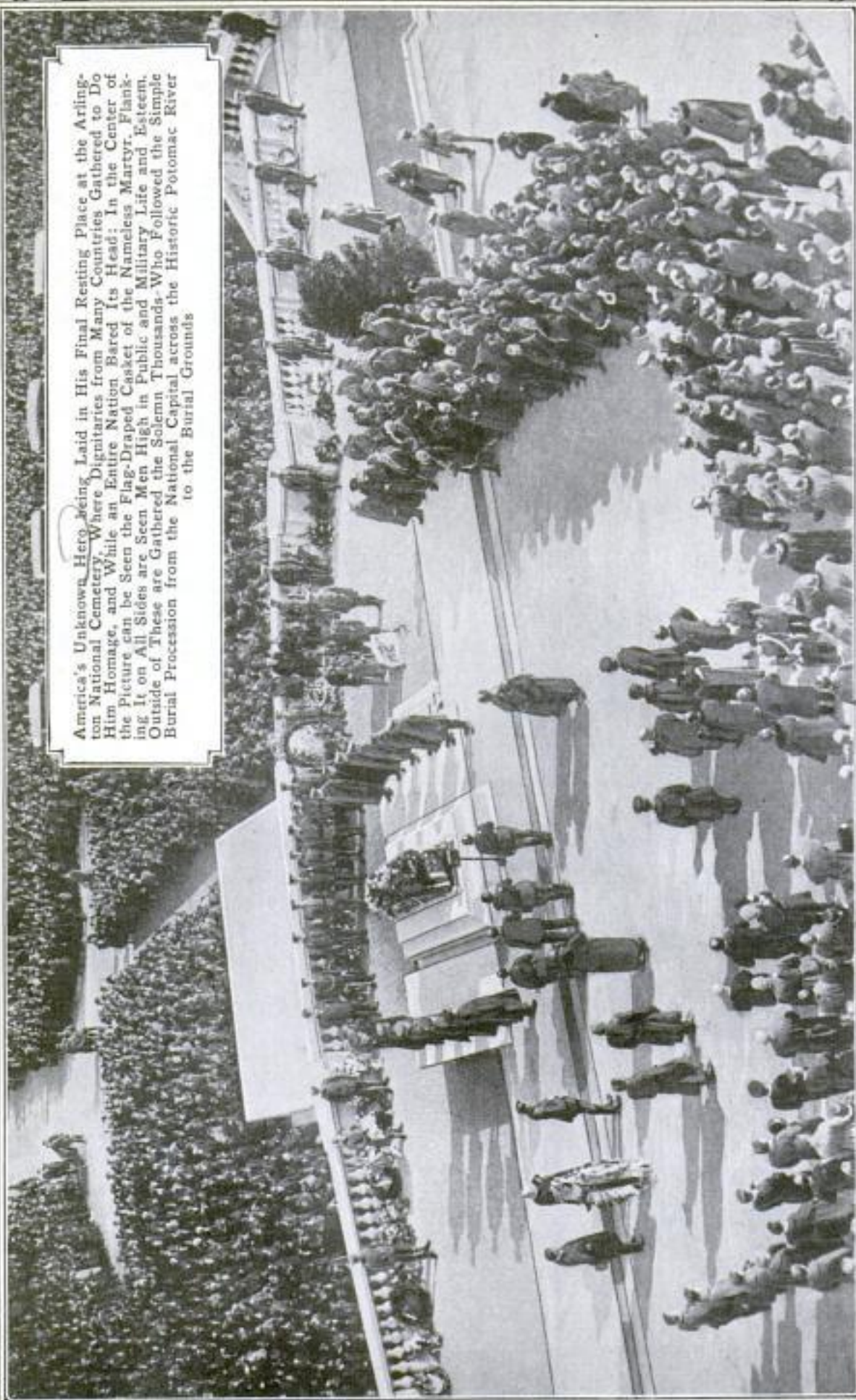

1229 W. 43rd St. New York

SEE WORLD PHOTOS

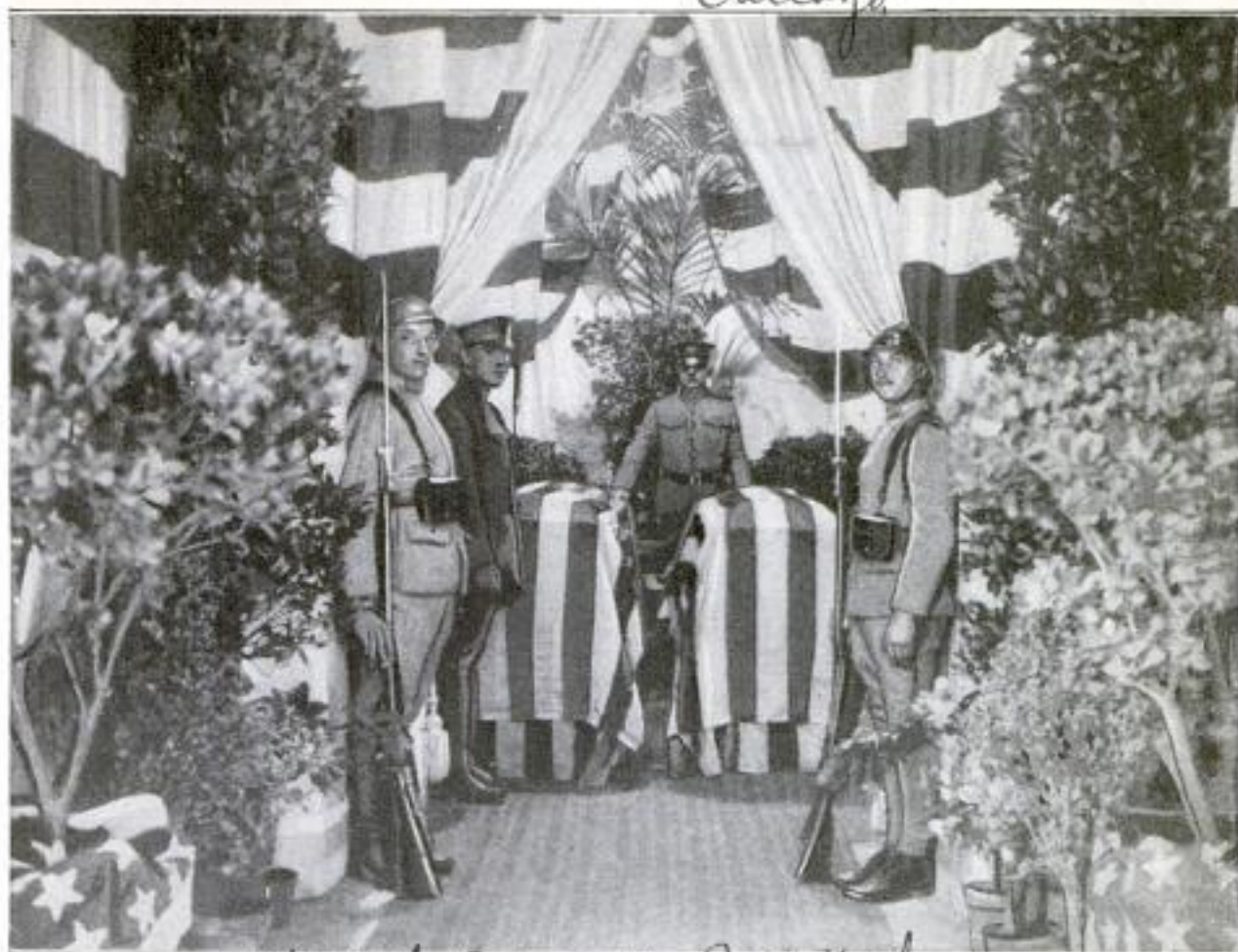

97-7th Avenue, New York
COPYRIGHT, KEYSTONE VIEW CO. In the Center are Seen the Flag-Draped Caskets Containing Four Unknown Heroes. From These Four Bodies, Exhumed in Different Cemeteries in France, One was Chosen to be Taken "Home" to Receive the Greatest Honors Ever Bestowed upon a Hero. The Honor Guard Shown Here is Composed of American and French Soldiers

THE STORY OF THE UNKNOWN HERO

IN solemn silence, on October 23, specially chosen bodyguards took up their honorary posts beside the exhumed remains of four American heroes, in as many different cemeteries, in France. From these four widely separated localities, the bodies were taken to Châlons-sur-Marne. At this city, the guards were amazed to find three other detachments of soldiers, who were guarding similar charges, because it was commonly known that only one body was to be taken to America. To add to their mystification, they were all temporarily relieved from duty.

In order that the identity of these martyrs might be forever lost to the efforts of delving historians, or selfish individual interests, measures were taken thoroughly to "unidentify" the bodies. During the night, while the guard was relieved, persons unknown to the soldiers took the remains from the caskets, and interchanged them. The caskets were also shifted about, so that when the guard was posted the following morning, none could have told which body reposed in any particular casket.

With simple solemnity, one of the bodies was then designated as the one to be prepared for the long journey back over the ocean, and "home." Not, however, to the home whence came the soldier in performance of his duty, but to a home in which he would be buried with the greatest honors ever accorded a military hero. Orders were then given to take the caskets containing the bodies of the three remaining, and thus honored heroes, to the cemetery at Romagne-sous-Montfauçon, where they were interred without ceremony.

Because of these efforts by the government to obliterate all individuality and personality from this Unknown Hero, the reverential solemnity of his burial in the Arlington National Cemetery expressed a nation's devotion to the memory of the thousands of soldiers who found eternal rest beneath the soil of France.

7735

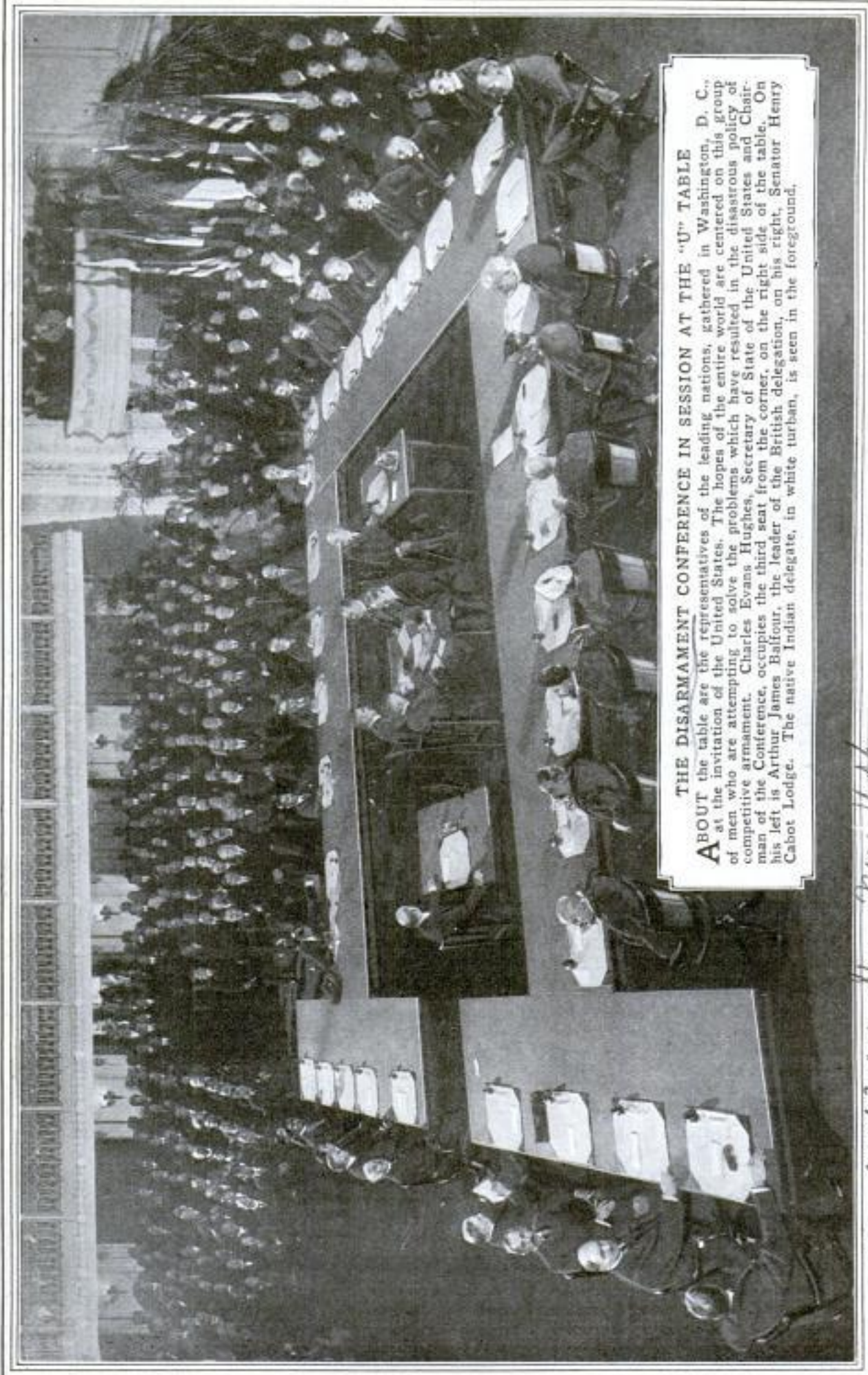

THE DISARMAMENT CONFERENCE IN SESSION AT THE "U" TABLE
ABOUT the table are the representatives of the leading nations, gathered in Washington, D. C., at the invitation of the United States. The hopes of the entire world are centered on this group of men who are attempting to solve the problems which have resulted in the disastrous policy of competitive armament. Charles Evans Hughes, Secretary of State of the United States and Chairman of the Conference, occupies the third seat from the corner, on the right side of the table. On his left is Arthur James Balfour, the leader of the British delegation, on his right, Senator Henry Cabot Lodge. The native Indian delegate, in white turban, is seen in the foreground.

APR 10 1929 W. 43 rd St. New York

7721

John W. Kean, Bureau of Navigation
Navy Department, Washington D. C.ELECTRICAL ACHIEVEMENTS SIGNALIZE
UNKNOWN HERO HONORS

BY JOHN W. KEAN

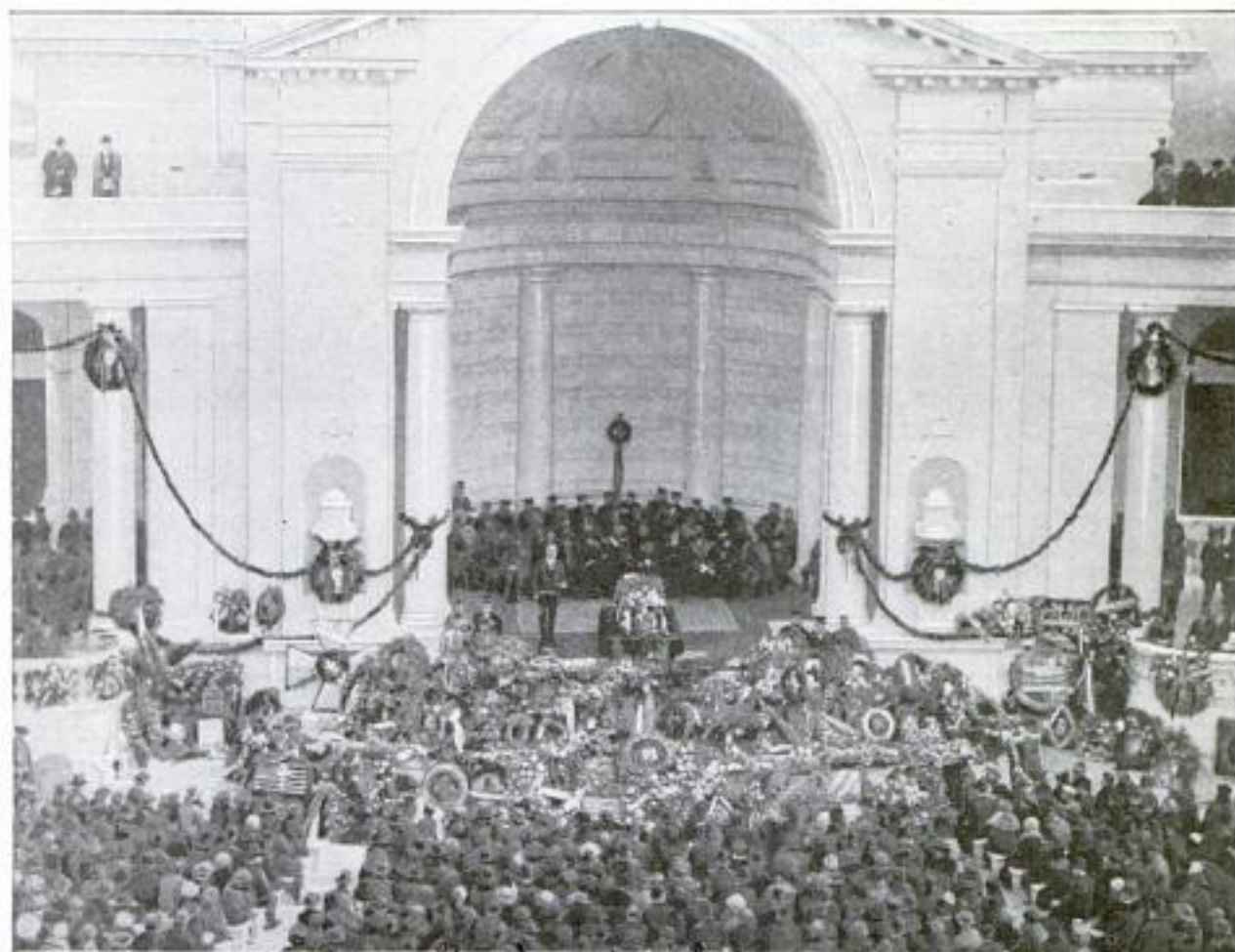
Soldier, American

WIDE WORLD PHOTOS 229 W. 43rd St. New York City
President Harding Delivering the Funeral Oration over the Remains of the Unknown Hero at the Arlington Cemetery Amphitheater: In Front of the President is Seen a Stand Which Contains a Specially Made Telephone Transmitter to Carry the Speaker's Voice to the Amplifier Room in the Basement of the Amphitheater

A MECHANICAL device, operated in connection with a highly efficient communication system, transmitted President Harding's address, delivered over the remains of the unknown soldier at Arlington Cemetery on Armistice Day, to our Atlantic and Pacific coasts. With the aid of this device thousands in and around the beautiful amphitheater at Arlington, other thousands in and around Madison Square Garden, New York City, and still other thousands in and around the Civic Auditorium at San Francisco, heard the President's every word.

While speaking, the

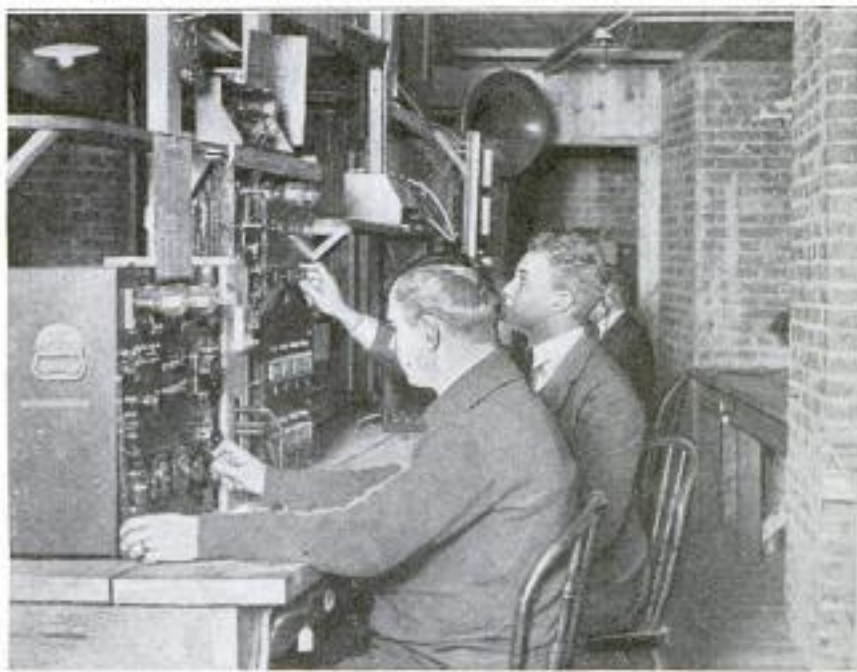

This Is the Amplifier Room in the Basement of the Arlington Amphitheater, Showing the Apparatus Used to Broadcast the President's Address to the Thousands in Attendance There as Well as to New York City and San Francisco

195 Broadway
New York City
POPULAR

MECHANICS

President stood near a small box, about 4 in. square, which rested on a little stand. In this box was a black disk like the ordinary telephone transmitter, but, in fact, a new special type of transmitter developed within the last few months by the engineers of the American Telegraph and Telephone Company, and successfully demonstrated for the first time at Arlington.

The commercial telephone transmitter is efficient for its purpose, but it has a tendency to accentuate certain tones in the voice. In ordinary conversations this is not particularly noticeable, but when used in connection with voice-magnifying devices, these improperly accented tones become very pronounced. This difficulty has been entirely overcome in the amplifier used at Arlington with the new transmitter.

Working to this end the engineers said in effect: "We are taking the voice of the speaker as sent through the ordinary transmitter, with its imperfections, and amplifying it; suppose we try reducing the sound of the voice and then amplifying it."

Following this theory they developed a transmitter with an abnormally high

frequency which transmitted the voice in a much weaker tone than the ordinary transmitter. It caught the essential vibrations, however, and maintained the character or individuality of the speaker's voice. With the aid of the amplifiers these essential vibrations were built up. The theory proved correct in practice, and the President's voice was sent out without an imperfection, to the listening thousands.

Further, to protect the new transmitter from vibrations other than those caused by the voice of the President, the little black disk was hung from the roof of the box by rubber bands, and the front of the box was covered with cheesecloth, to break any stray breeze that might wander in.

From the box, which stood near the casket of the unknown soldier, wires led to a room beneath the amphitheater stage. Here all was quiet, but the amplifiers were doing their work.

After being magnified, the electric vibrations carrying the President's address were sent over two sets of wires. One set led to telephone receivers in and around the amphitheater at Arlington, the other led to the long-distance lines

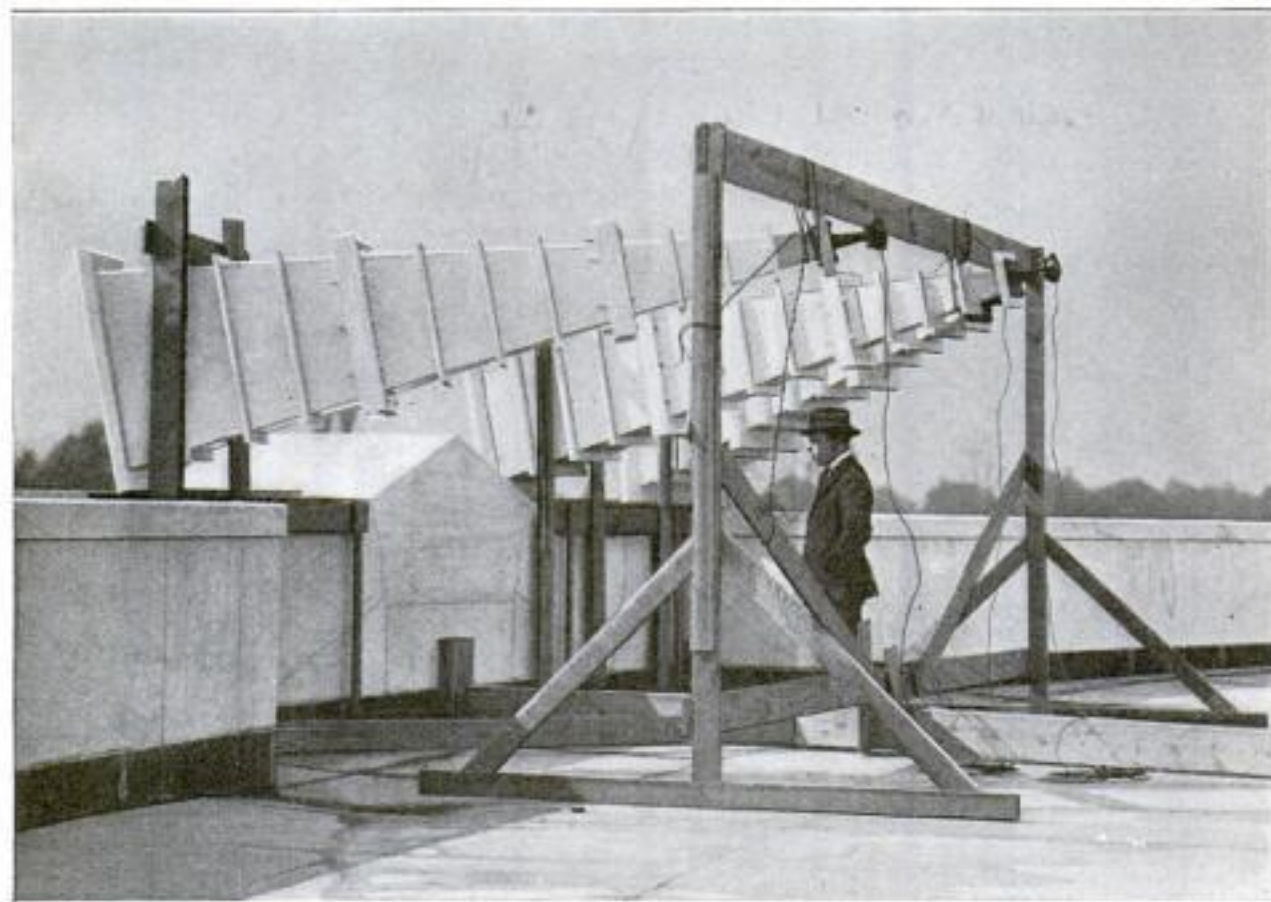

By Means of These Enormous Projectors That were Mounted on the Roof of the Arlington Amphitheater, the Thousands of Persons Surrounding the Place were Enabled to Hear Distinctly Every Word of President Harding's Speech Delivered in Honor of the Nation's Unknown Hero



Above: The Brilliant Jeweled Panel Which Forms a Spectacular Approach to the Pan-American Building Where the Limitation of Arms Conference is Held. Below: An Unusual View of the Portal with the Washington Monument Appearing in the Center. This Photo, Taken from Inside the Pan-American Building, Makes the 85-Foot Portal Towers Seem as High as the 555-Foot Monument

for transmission to receivers at Madison Square Garden, and to receivers at the Civic Auditorium, San Francisco. The diaphragms of these receivers were of specially treated linen. The electric waves passing through coils in the receiver vibrated a small armature between the coils and the poles of a permanent magnet. The vibrations of the armature

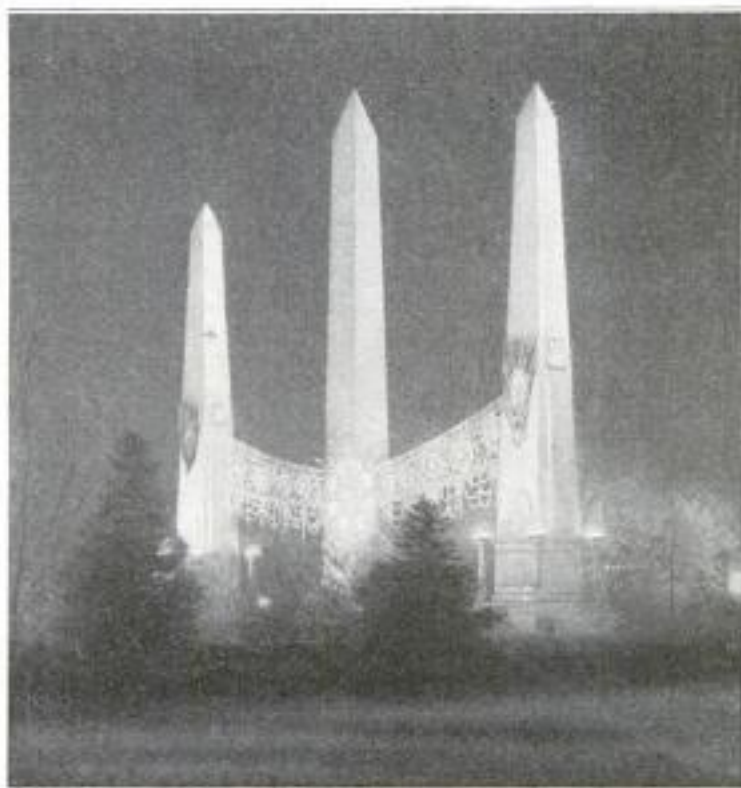

COPYRIGHT, GREEN, WASHINGTON, D. C.

carried to the diaphragm created the sound which was sent out by the horns, or as they are technically termed, projectors.

To insure that the people within the amphitheater, and at the other points, would hear the President's address without any echoing sounds, or other disturbances due to the amplifiers, many problems in the correct placing of the receivers

7721
and of the horns were satisfactorily solved. So perfectly were the difficulties overcome that it was impossible for a person to tell, no matter where he was located at Arlington, whether he was listening to the President's actual voice, or his voice after it had passed through the amplifiers.



7987
COPYRIGHT, GREEN
The Dome of the Capitol Building on Armistice Night When Added Illumination from Searchlight Batteries was Thrown on It

And to insure just as wonderful a performance for the listening thousands in New York City and San Francisco, every possible precaution was taken.

Two 25-pair cables, one to be used in case the other failed, were built especially for the occasion, and ran from the basement room of the amphitheater to a point a few blocks away, where they were connected to long-distance lines. Each of the 25 pairs in each cable made a single circuit. One pair carried the voice current; others carried telegraph circuits, over which operators at stations in the larger cities along the line kept in continual communication. At each of these emergency stations were additional sets of amplifiers to keep the voice-carrying current up to the necessary strength for its long travel.

In Washington, current was secured from the local electric-light company, adapted by special machinery for use in the amplifiers and other equipment. As a protection against loss of power from the local company, storage batteries

capable of supplying the necessary current for several hours were installed.

The Armistice Day ceremonies were symbolic. As part of those ceremonies, and also as part of the welcome to the visiting members of the Disarmament Conference, some very beautiful decorations were erected near the Pan-American Building and the Continental Memorial Building. Both buildings, and also the Red Cross Building, which is in this group, are of beautiful white marble, classic in design.

On Seventeenth Street, near the Pan-American Building, two obelisks—miniature Washington Monuments, 85 ft. high—were erected. These obelisks were covered with imitation jewels made in Austria. In refractive power they are about halfway between cut glass and diamonds.

Between the towers was swung a banner, also contrived of these jewels, 34,000 in all, in seven different colors. Woven into the banner were designs representing the flags of the nations that have sent delegates to the conference.

Armistice night, President Harding touched a button, and batteries of searchlights played on the jeweled banner. As soon as the lights were turned on, a battery of four French guns, located near the Washington Monument, fired a presidential salute—21 guns. As the smoke from the guns drifted toward the heavens, other batteries of searchlights played on them in red, white, and blue colors. Still other batteries bathed the dome of the Capitol and the Washington Monument in light. In all, these searchlights represented 4,950,000,000 candlepower.

From the President to the plain citizen, who was on hand to the number of 50,000, the illumination was pronounced a beautiful sight.

U. S. S. "MARYLAND" SPEEDIEST ELECTRICALLY DRIVEN SHIP

7707
The U. S. battleship "Maryland," at its official trials, November 14, developed a speed of 25.9 miles an hour, being a record for electrically driven ships of its class. The contract speed was 24.18 miles, which was exceeded on five high-speed runs by more than .86 of a mile. Successful anchor-gear tests were also made. The full-load displacement of the "Maryland" is 33,590 tons, with a developed horsepower of 36,673. The "Maryland's" sister ship, the "Tennessee," has never exceeded a speed of 24.6 miles an hour, and has never developed more than 30,909 horsepower.

Engineering World
Nov 1924, p. 316
Army & Navy 11/19/21

EPOCH-MAKING TESTS OF FOUNDATION PIERS

Tests of the Piers for the New Union Station at Chicago That may Revolutionize the Allowable Load on Piers and Caissons in the Future

BY HENRY S. WHITE

BY ACTUAL test, the determination of the exact conditions resulting from placing on a foundation pier three times its allowable load is a thing that has never been done as it is now being done, in connection with the new Union Station at Chicago. The results obtained will be valuable not only to the designers of this huge building, but will also be of incalculable benefit in the design of all future buildings in Chicago, or any other city with similar soil conditions.

For the purpose of carrying out these tests, two special foundation piers were sunk in the railway yard, where tracks were available for transporting the steel that was to be used and for operating the traveling crane erecting it. These piers are of 4-ft. diameter, one with a belled base and the other without one. The bottom diameter of the belled base is 8 ft. 4 in., having, therefore, an area of $54\frac{1}{2}$ sq. ft. The piers are sunk to hardpan, which is at a depth of a little over 70 ft. By city ordinance, the allowable load on hardpan is six tons per square foot. The main purpose of these tests is to demonstrate that this load can be at least doubled with

perfect safety on the foundation piers of the new station building, and, by inference, on any future buildings in Chicago. To make this demonstration more positive, the piers are being tested, not only with double, but with three times the allowable load. That means 18 tons to the square foot, and as the area of the base of the belled pier, which is the one now being tested, is $54\frac{1}{2}$ sq. ft., the load required—18 times $54\frac{1}{2}$ —is 981 tons. Therefore, in order to make the test, over 1,000 tons of steel were piled up above the pier. For the accommodation of a lifting jack, that will be described later, the steel had to be supported on two piles of wooden cribbing made of railroad ties, at an elevation of 11 ft. 4 in. above the ground level. On top of this is placed, on each pile of cribbing, a row of eight 24-in. I-beams, and on top of these are piled, crosswise, 30 layers of 130-lb. rails, 33 ft. long, to the number of about 1,400, with a total weight of over 1,000 tons—as great a weight as all the structural steel in a fair-sized office building. This load is carried by the wooden cribbing.

As much of the load as is desired is transmitted to the top of the pier by means of a 1,000-ton jack, which is

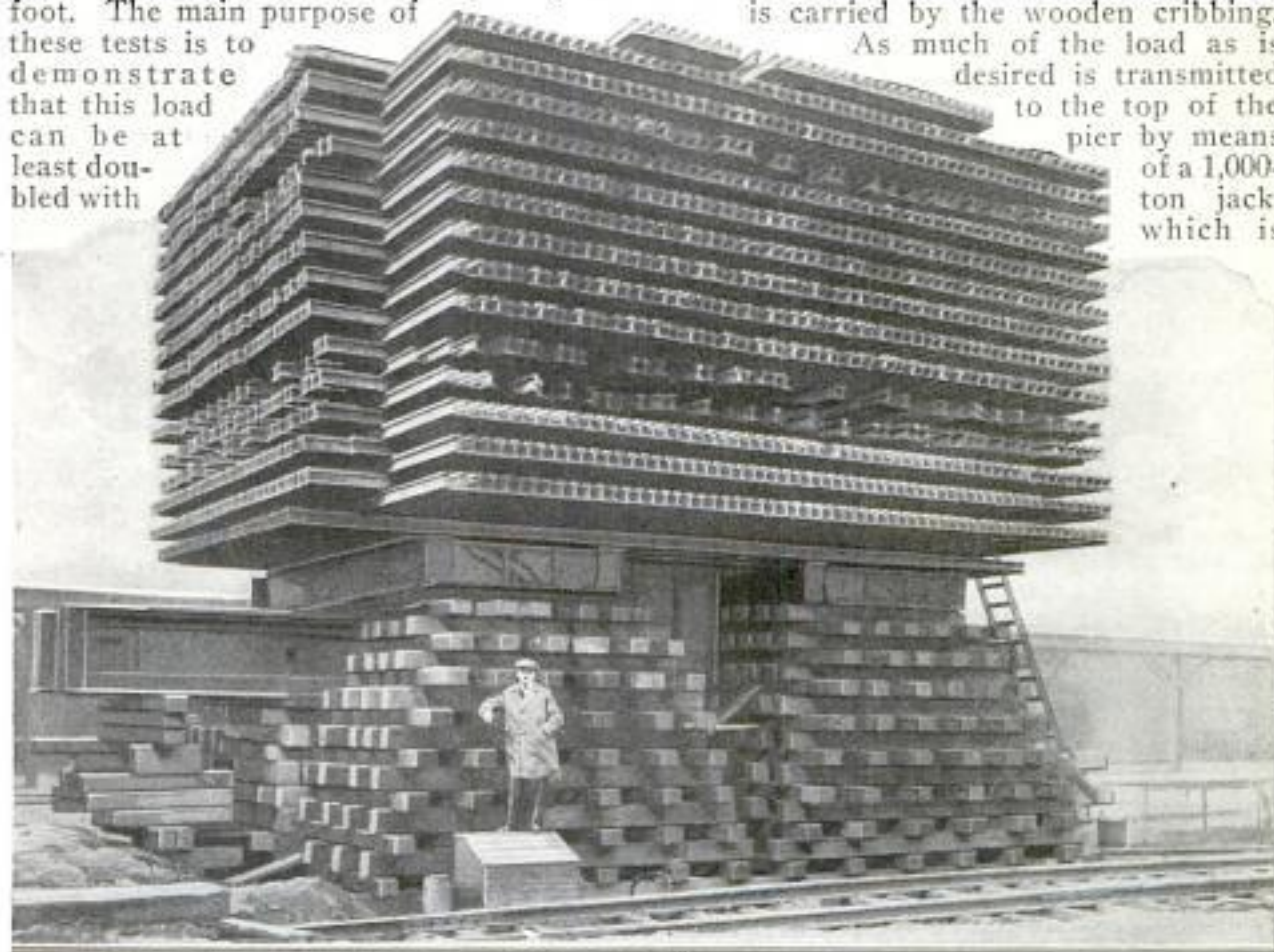

Huge Pile of 130-Pound Rails Supported on Cribbing for Testing a Foundation Pier of the New Union Station Building at Chicago: In the Pile Are Over 1,400 Rails, Which Laid End on End would Stretch Nine Miles

the first of its kind ever built. Although the jack has this enormous lifting capacity, its cast-steel cylinder operates a

a check, duplicate readings of the settlement are made with a surveyor's level.

Thus, absolutely precise data will be obtained of what happens to these foundation piers after a prolonged test of three times the allowable load, and it is expected that it will be proved to the satisfaction of the city authorities that double the allowable load can be put upon the foundation piers of the station building, all of which are now in place.

A very interesting feature in connection with these tests is an experiment that is to be made when the bearing value of the hardpan has been determined. It is then intended to sink a shaft beside the pier, and burrow out from beneath its belled base all the supporting hardpan. Observations will then be made of the load supported by the resistance of the skin friction alone between the surface of the pier and the surrounding soil. Such an investigation has never been made before, and the results will be of great value to architects and designers. At the site of the tests, hardpan is at an elevation 25 ft. above bedrock.

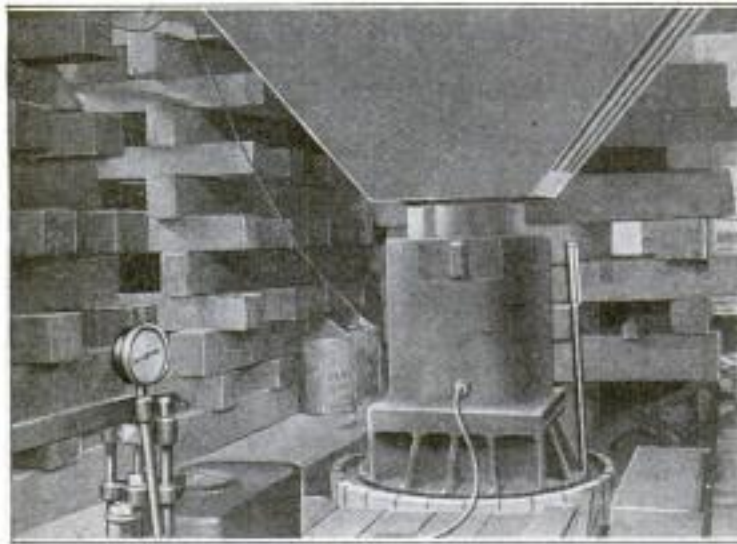

One-Thousand-Ton Lifting Jack, the First of Its Kind Ever Built: It Is between the Cast-Iron Base That Rests on Top of the Pier being Tested, and the Much Larger Casting Above That Supports the Load It Lifts

semisteel lifting ram of only 21-in. diameter. Its over-all height is 3 ft. 1 in. By calculation it will be seen that the pressure required on the ram is nearly 6,000 lb. per square inch. Connected with the jack by a heavy $\frac{1}{2}$ -in. pipe is a plunger pump that, by means of a liquid known as hydraulic oil, applies the required pressure. In the pipe line is a gauge that registers the number of tons lifted by any pressure, so that it can be seen at a glance what load is being carried by the pier. Any settlement of the pier is read on what is known as a differential draft gauge. Connected with the jack is a vertical tube containing colored alcohol, such as is used in spirit thermometers, and this is piped to the gauge, which is inclined at an angle of about 15° , so that any fall of the liquid in the vertical tube is exaggerated in the sloping gauge, and very close readings can be made. As

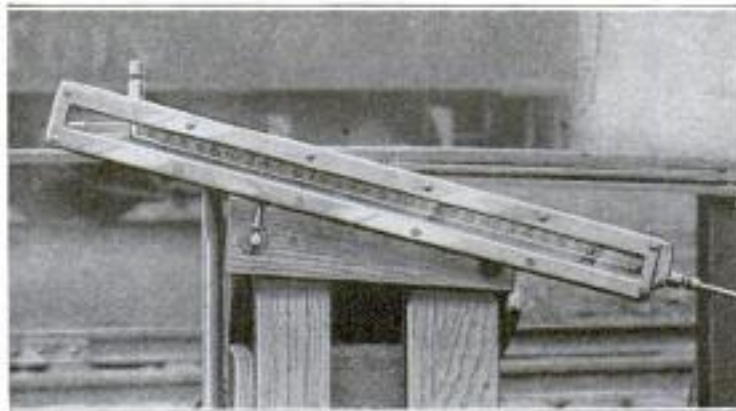

Differential Draft Gauge upon Which is Read with Great Precision Any Settlement of the Pier under Test: The Inclination of the Gauge Exaggerates the Fall of the Colored Alcohol in a Vertical Tube to Which It is Connected

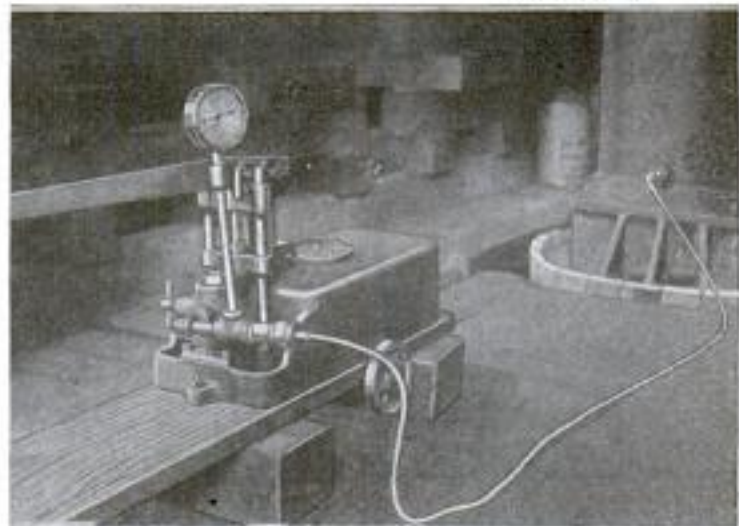

Plunger Pump That, with a Pressure of 6,000 Pounds per Square Inch, Lifts the Ram in the Jack When Loaded with 1,000 Tons

THIRTY-SIX DESTROYERS MOORED AT ONE PIER

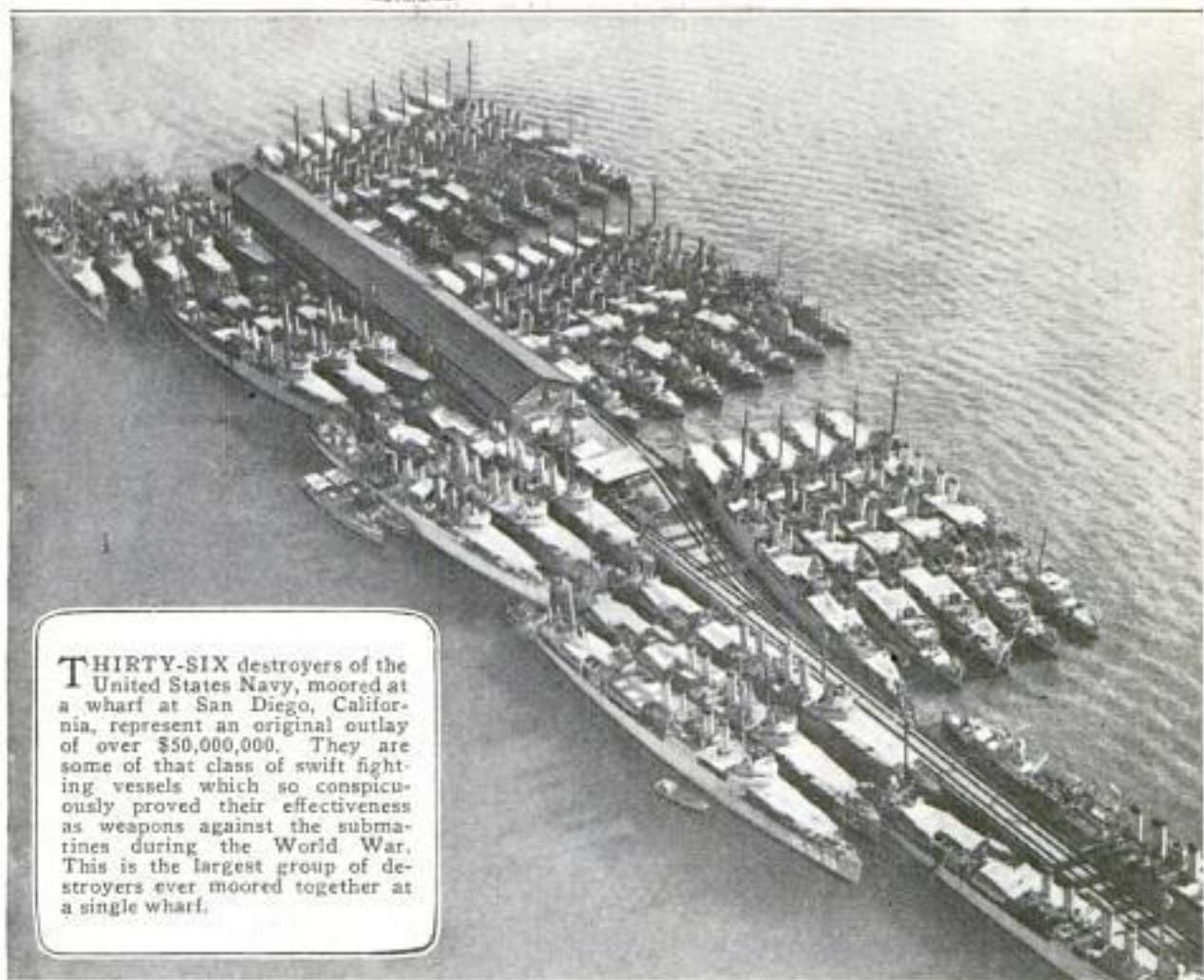

THIRTY-SIX destroyers of the United States Navy, moored at a wharf at San Diego, California, represent an original outlay of over \$50,000,000. They are some of that class of swift fighting vessels which so conspicuously proved their effectiveness as weapons against the submarines during the World War. This is the largest group of destroyers ever moored together at a single wharf.

7485

AMPLIFIER MAKES AUTOMOBILE "SPEAK FOR ITSELF"

Automobile salesmen have found a new and ingenious use for the vacuum-tube amplifier in putting over their slogan, "The Car That Speaks for Itself." A new car, with the slogan displayed on it, is parked at the curb, and the amplifier is hidden in it. A small wire, along the gutter, connects it with a transmitter in another machine, a little distance down the street. The salesmen sit, unobserved,

in the second machine and talk into the transmitter. The voice, magnified so that it may be heard for quite a distance, comes from the empty car which seems literally to "speak for itself."

Two thousand five hundred live geese recently arrived in London, Eng., coming all the way from Danzig, Poland. They composed one of the first shipments under the barter trade arrangements which for some time have been in effect between England and Poland.



A Voice, Issuing from an Empty Automobile Standing at the Curb of a City Street, Quickly Draws a Curious Crowd Which Sees and Hears Nothing but the Machine Apparently Explaining Its Own Excellence

2725 E. 14th St. Cabland Cabod: magna box co. Capt. Lodimer J. Wilson
 Apr. 21. 3406 Broadway, N.Y.C.

7675
26

Man's Wheel
Cont. E. J. Cone, 8 Ash St.
Washington, N.Y.

POPULAR MECHANICS

STEEL CAR WHEELS MADE IN REVOLVING MOLD

The manufacture of steel car wheels has grown to very large proportions, and there are now several kinds of such wheels in use on American railroads. Demand for these wheels, as distinguished from the chilled-iron wheel, has been increased by the use of the heavier steel passenger and other cars.

One of the most novel and interesting steel car wheels now being produced is a cast-steel wheel as distinguished from a solid or forged-steel wheel, and is poured in a revolving mold. The object of this is to throw the steel by centrifugal action to the outside of the

mold, where it will chill first and form the outside, or rim, of the wheel. An important feature of this process is the injection into the steel of powdered manganese in the early stages of the pouring. The addition of manganese makes the steel much harder—it really forms manganese steel in the rim of the wheel. As the mold fills up, the introduction of manganese is gradually diminished and stopped, so that the central part of the wheel is plain steel, or steel with very little manganese in it. The interesting process is now being commercially exploited on a large scale.

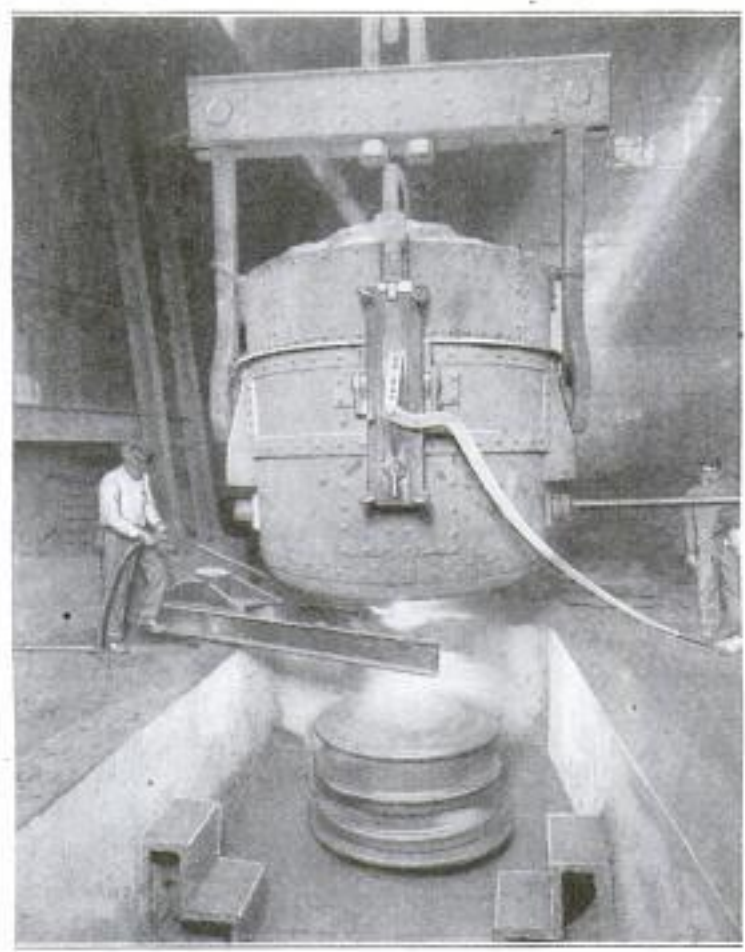

Revolving Mold in Which Steel Car Wheels are Cast: The Man with the Hose, Which is Directed under the Ladle, is Injecting Powdered Manganese into the Molten Metal As It Runs from the Ladle into the Mold

Y-SHAPED THREE-WAY BRIDGE
CROSSES TWO STREAMS

Between Fayetteville, N. C., and McColl, S. C., there is a bridge which is

unusual in the fact that it is built in the shape of a letter "Y," with roads leading in three directions. At this point two large creeks approach within 10 ft. of each other, but are separated by a solid rock ledge and do not actually come together for more than 15 miles. This 15-mile stretch between the streams is a prosperous section of land and is reached by means of the peculiar bridge, the middle pier of which stands between the two streams. One arch crosses each creek, and a gap at the side admits the road from the district below to the bridge.



The Approaches at the Left and Right Are from McColl and Fayetteville. That in the Foreground is the Road Leading from the District between the Creeks

Names and addresses of manufacturers of articles described in this magazine will be furnished free by our Bureau of Information.

Emb. B. J. Proome
Box 507, Charlotte, N. C.

COMMENT AND REVIEW

[These pages were printed November 22, 1921.]

TODAY is Armistice Day. As I write, traffic throughout Chicago and other cities is at a standstill for one minute; whistles are blowing; bells are ringing; the people are reverently, silently, facing toward the East, where lie so many of our brave young men on the fields of France. Three years have passed since the conflict ceased. Children, on that day too young to comprehend what it all was, are today old enough to understand. In only six years more the boys will be old enough to fight.

Armistice Day

Will they have to?

Is it necessary that they should?

Time lays such a subtle, comfortable blanket of forgetfulness upon us all, are not we who did understand rapidly drifting into a state of apathy in this matter? Not that those who lost sons or relatives or dear friends can ever forget, but the great majority of our people have not this personal tie. Because the volcano has exhausted itself for a time, and has ceased to pour out its molten death and stifling gases, shall those who escaped return in blind faith that such a cataclysm can never repeat itself?

In our own interest, and that of world-wide humanity, let us lend our voice and influence to every possible means which leads to ultimate international peace; and as each must sacrifice something if this result is secured, let us, with willing hearts, not hesitate to make ours.



NOT since the conference of the far-journeying shepherds to the manger cradle in Bethlehem has there assembled a gathering of as momentous portent as that now in session at Washington. Secretary Hughes' unheard-of diplomacy in presenting, at the very start, something concrete on which to work at once, was a master stroke which will live in history as a most brilliant example of statesmanship. The response from the delegations, to whom the proposal came with a suddenness which was breath-taking, was both prompt and hearty and full of promise. Events in the conference are apparently moving with progress most unusual in a gathering of this kind. Nothing more cruel or wicked can be conceived than that anyone should utter

one single word which might cause distrust or hesitation, or give personal offense to any of our visiting delegates from beyond the seas.



IT MAY seem a bit sordid to make reference to what war is costing us, you and me, today, in dollars and cents. Yet it need not be concealed. Of all the Federal taxes we pay, 93 per cent is going to pay for wars past and future. Our people surely do not realize this enormous drain, but if the war tax could only be separated, and every time a man paid his taxes he paid in at one window \$7 for all other purposes of government, and then was obliged to step to another window marked "War Tax" and pay his \$93, he would wake up and cry in real distress, "For God's sake disarm."

Our War Bill

CHARLES SCHWAB, one of the greatest steel men of all times, deserves his reputation for sincerity. The thousands of his own men, the thousands of friends—those who know him best—believe him most. It is therefore a shock to certain jingo pacifists, who so loudly shout "Wars are made and fostered by the steel interests for purposes of selfish gain," to have a man like Mr. Schwab wipe out their entire claim with one pungent sentence. Before the American Iron and Steel Institute, and in the presence of Marshal Foch, he made the public declaration. After establishing the fact that his company, the Bethlehem Steel Corporation, is the largest war-material manufacturing works in the world, and has therefore more to lose in

Setback for Jingo

the shape of steel shipbuilding yards, costly machinery, etc., than any other, he said: "If the statesmen now assembled in Washington find it possible to bring about disarmament and permanent peace I will gladly see the war-making machin-

N. Y. Evening Post
11/19/21

ery of the Bethlehem Steel Corporation sunk to the bottom of the ocean. Such a thing as financial loss can be of no consideration when compared to the inestimable boon to mankind which would be involved in the realization of that magnificent plan."



WHILE certain interests have managed to secure the defeat in Congress of a proposed sales tax of one per cent on money actually collected, the measure is one which is undoubtedly destined eventually to be adopted. It has failed at this time because public sentiment was not sufficiently roused to its support. Public sentiment failed in its support because it is either uninformed or misinformed. When once the public comes to really understand this plan of taxation, it will rise and insist upon its adoption. Under its operation goods can be made and sold more cheaply, and this without any necessary reduction in what is paid for labor. Where the purchaser of goods over a counter has been paying 23 per cent extra to anticipate an excess

The Sales Tax

profits tax, the sales tax imposes at most an average of about 3 per cent all told, from raw material to delivery wagon. It is so simple to estimate and collect, millions will be saved in determining and collecting the amount due. At the end of each month, or 12 months, each taxpayer will have a clean slate with the Revenue Department, and will not be called on to pay large sums, which as now, the Revenue Department, by means of new rulings, declares should have been paid five or six years ago, but which it declared at the time was not reportable or collectable. The annoyance, exasperation, and humiliation which are daily inflicted upon countless honest men could no longer occur. Business of all kinds would immediately know "where it was at," and would respond. With the proposed exemption of \$6,000 a year, the man of small business would pay less than now, and large interests would have no complaint at what they had to pay.

It must be admitted that a sales tax would require a good many thousand less inspectors, investigators, expert accountants, and clerks than now, for practically any boy or girl in the eighth grade could make up the report for a large corporation in a few minutes. It is natural that politicians with patronage to dispense to relatives, friends, and helpers, should oppose any measure which so largely deprives them of their perquisites. As the country weekly used to say, they "view with alarm" such a possibility. That, however, is politics, not patriotism. The time is coming when these same politicians in Congress will see something besides the sales tax to view with alarm, when they come home to tell their constituent voters about the glories of the Grand Old Flag.



DOUBTLESS, as an outgrowth of the war, when national expenditures grew from thousands into millions, and from millions into billions, a spirit of extravagance seems to have been engendered. To the men in Congress apparently anything counted in less than millions appears small and trivial.

Stop Federal Aid

Of the new national expenditures the good-roads appropriation, divided among the several states, seems to be the most practical and satisfactory. National highways have been every country's vital necessity for centuries. With thousands of miles of steam railway extending to every corner, the United States has for 75 years been able to get along without building government roads. With the advent of the automobile, however, city

and country are now agreed on state and government coöperation in road building. All parts of the country are undoubtedly in better accord on this one question than on almost any other large national expenditure.

That roast beef and pie may properly constitute two items of a good dinner is no reason for making an entire menu of either. Under Federal aid to states the government says, "Here is a fund, if you put an equal amount with it." This means an increase in taxes payable to the state, and also the state's part—and even proportionately more—of a like amount which its citizens must pay the government. Naturally the states with smaller properties to be taxed pay less than their ratio in proportion to many of the rest. In other words, certain states are thus over-taxed to help other states. This is manifestly unfair.

By literature and billboards the government constantly urges thrift and economy, but the principle of Federal aid to states works the opposite result. The

various interests which are to fatten on the vast sums spent, naturally use every effort to secure favorable action by Congress, and are organized for the purpose.

At the present moment there are pending in Congress bills for appropriating \$169,000,000 for additional state aid. This amounts to an extra tax of \$5 per average family, which, with the extra state tax, amounts to \$10 per family per year, and it is estimated this will have reached \$100 per family in 10 years, if contemplated plans are allowed to get a start.

It is always helpful to know how the same thing worked with other people. In 1843, the British national grants for aid were £244,000 (about \$1,200,000); this has grown to £65,000,000 today, or nearly \$300,000,000. As far back as 1885, Gladstone urged "a discontinuance of the system, as a burden upon labor and industry." He found, as we will, the system is a bribe to extravagance, abetted and subtly encouraged by an organized lobby and propaganda by those few who would personally benefit financially. The profiteering scoundrels of the late war would be multiplied and continued indefinitely.

All but those who expect to share in the rake-off are urged to write their senators and congressmen immediately and say, "We will not stand it."



WITH millions of the food producers starving in Russia, deprived of their live stock, and lacking even seed for planting, little surprise is occasioned at the report which shows the mining industry also paralyzed and almost extinguished.

*Idle Mines
Tell
Sad Story*

Where in the first six months of 1913 there were mined 9,000,000 tons of iron, in six months of 1921 this had dropped to 100,000 tons; copper fell from 1,000,000 to 4,400 tons, and manganese from 1,280,000 to 3,600 tons. The dark story pictures not so much the thousands of unemployed miners, but thousands of artisans which Bolshevism has slain or scattered, and hundreds of industrial plants either destroyed or partly wrecked and closed.

What is true of the farms and factories is equally so of all other lines of productive activity and business.

Aside from the natural sympathies which go out to starving men, women, and children, the world owes a debt to these helpless unfortunates whom fate has seized as the unhappy background on which to project, where all may see, the terrible results of the bolshevistic dream of a government which tried to reverse the processes of natural laws which commenced on this earth with the creation of man. From the day the attempt was made to the present moment, the path of the Russian people has been over the dead bodies of their countrymen along an ever-descending path into an awful living hell. The object lesson has been tragic to the last degree, and would have been impossible of so long endurance in any country where a free press was permitted to reach a people who could read.



WITH good roads increasing in every state, and long sections being linked up to make through routes, long-distance travel by motor has already assumed large proportions and is growing each year. The past summer, cars carrying

*Motor
Hotels*

licenses of Texas and other southern states, from the central West as far distant as the Rocky Mountains, and even from the Puget Sound country, thronged New England and Quebec. In winter, Florida is filled with cars from points as far distant as Maine and Colorado and all the states between.

With the great increase in the number of these motor travelers, it is inevitable that a corresponding increase in the number of those who desire to travel in greater comfort than at present must also result. To provide larger sleeping quarters, hot and cold water, baths, a living room, kitchen, and other conveniences, necessarily calls for larger and heavier car bodies. To accomplish this, already motor trucks with special springs have been used to carry these small one-story houses. A wealthy Frenchman has used an army truck for the purpose, and in this country trucks are being used in the same way. As the roads reduce their grades and take on a smoother surface, these combined sleeping and observation railless cars will increase.

The great majority, however, of middle-aged and younger people will not exchange their tent, cot, and sunset supper around a campfire by the side of a brook, for all the fresco-painted, satin-lined, plate-glassed movable mansions which all the trucks in the country can carry.

H. H. WINDSOR

MIDGET X-RAY APPARATUS IS IMMERSSED IN OIL

An important advance in the development of X-ray apparatus has lately been announced by Dr. W. D. Coolidge, of the General Electric Company's research



Using the Midget X-Ray Apparatus for Dental Work: The Patient is Seen Holding the Focusing Cone to Her Face to Concentrate the Rays

laboratory, pertaining to the absolute elimination of all danger from contact with the apparatus. The safety feature is accomplished by inclosing the tube, high-voltage transformer, and stabilizer, within a small oil-filled metallic case, which weighs but 20 lb. Heretofore the smallest X-ray machine weighed 150 lb., and consisted of four units. This new midget was built to give the world a tiny X-ray machine, and to eliminate the possibility of electric shock.

Physicians or dentists can now carry the X-ray machine to the bedside of the patient, for the purpose of radiographic work, as it fits into a small case no larger than the common portable typewriters require. For office use, it can be hung on a bracket arrangement. This new development is made in two units of 40,000 volts and 10 milliamperes, and 60,000 volts and 50 milliamperes. The tube is the smallest ever produced.

The Sphere, Oct. 22, 1921
 Minneapolis Journal 9/25/21
 St. Louis Dispatch 9/16/21
 MECHANICS
 7726 L & Illustration 10/29/21
EXPEDITION AIMS TO SCALE HIGHEST PEAK ON EARTH

During the last few months the first stage of the attempt to scale the peak of Mount Everest, 29,002 ft. above sea level, the highest summit on the earth, has been completed. This was the exploration and charting of the region of the mountain in the heart of the desolate Himalayas. The work was done by the Everest expedition, consisting of a small party of Englishmen, under the leadership of Col. Howard Bury, all trained mountain climbers. They were accompanied by many Chinese coolies and burden-bearing yaks, beasts that can live on scant herbage. After several months of exploration around the summit, carried out from different bases simultaneously by splitting up the party into groups, finally, at an elevation of 23,000 ft., the only way open to the summit was found in the northeast quarter of the surrounding zone. At other points there were found such obstacles as precipices towering 10,000 ft. above a huge glacier confronting the would-be climber, impassable gorges making the summit inaccessible. The most formidable task of the undertaking will be the ascent of the last 4,000 or 5,000 ft. of the summit, and this is left for the second stage of the undertaking.

7526
LAYING HENS ARE TRAPPED WITH AUTOMATIC NEST

An Iowa poultry raiser has constructed a nest, which has many good features, for the purpose of trapping laying hens. The nest is made of galvanized-iron sheeting, and is of the proper size to accommodate one hen. The laying surface is made of heavy canvas, which is stretched across the bottom and fastened to a hinged trap-door. When the hen enters the nest, her weight upon the canvas automatically pulls the door shut, and a hook arrangement holds the door closed until some



Left: The Trap Nest Empty. Center: As It Appears After the Hen has Locked Herself Inside. Right: Three Nests under One Roof

one releases the fowl. Thus the poultry raiser can get any information desired concerning the laying habits of his flock.

Wm. S. C. Belding
 Mason City Iowa
 Copyrighted material

7746
 Victor X-Ray Corp. Chicago
 236 S. Rabby St.

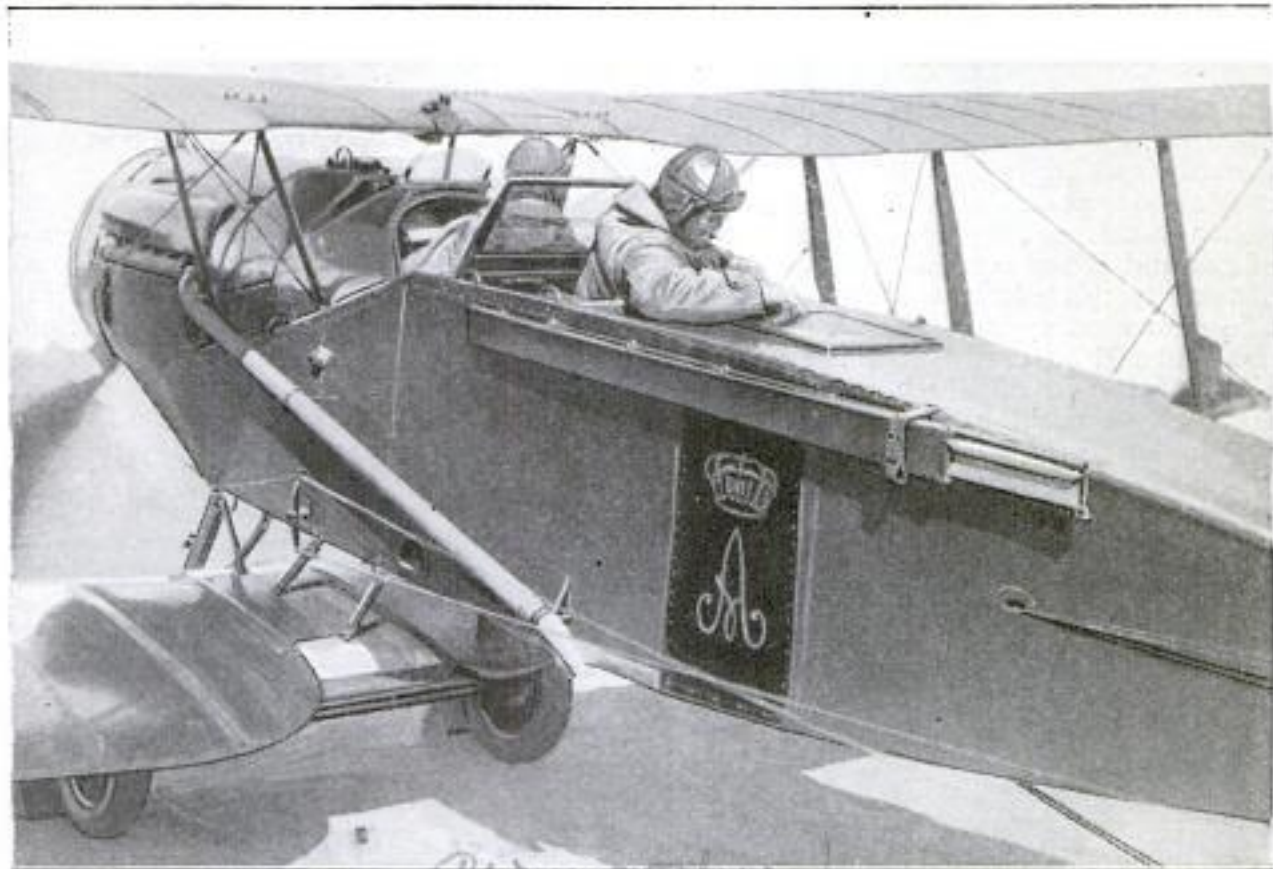

WIDE WORLD PHOTOS

FIRST ROYAL AIRPLANE BUILT FOR KING ALBERT OF BELGIUM

THIS airplane, specially built for King Albert of Belgium and bearing the king's crowned monogram on the side of the fuselage, is the first plane ever built for the use of a monarch. The Belgian King has shown a great interest in flying, and it has become a common thing for him to make trips by airplane, often flying to London and Paris. The picture was taken in Paris, as King Albert, dressed in the complete outfit of an airman, was about to take off for a return trip to Brussels, in his own machine, a two-seater biplane.

7292

METAL CUTTER HAS HORIZONTAL BAND SAW

For small capacities, not exceeding work of 4 by 4 in., a compact metal-cutting machine of the band-saw type, with the production possibilities of much larger machines, has been placed on the market recently. The band saw moves horizontally, protected by an automatic self-adjusting gravity feed which assures even cutting, regardless of varying degrees in the hardness of the metal. It is equipped with roller guides for the band saw, to insure straight cutting and freedom from vibration. The tension of the band saw is regulated by a hand adjustment on the supporting head. There is a belt-driven rotary pump, of the gear type, for wet cutting. As the cutting is done with a band saw, an exceptionally small amount of material is wasted in each cut. The machine is already in extensive use.

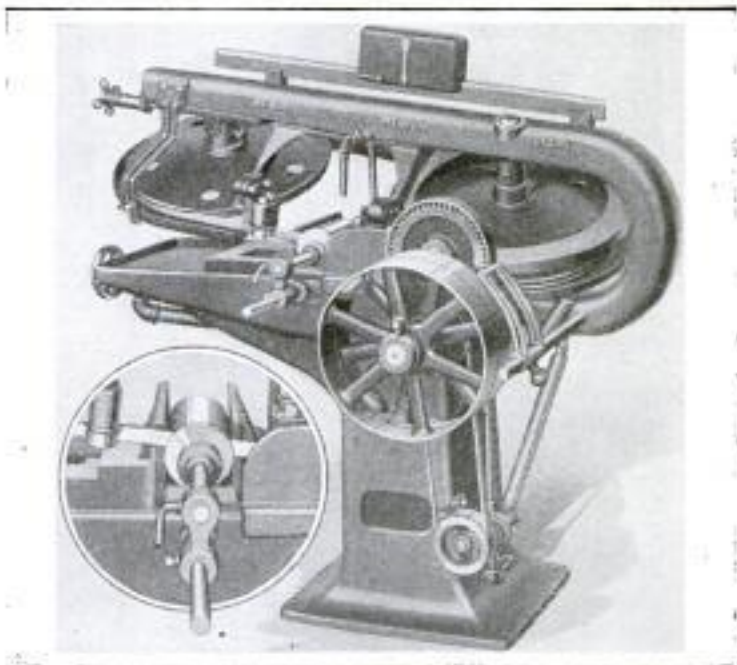

Machine That Cuts Metal with a Horizontal Band Saw, Driven by the Pulley in Front: At 250 Revolutions, the Cutting Speed Is 120 Feet a Minute. Insert: Part of the Table, Showing How Work is Held While being Cut

Metal Saw + Machine Co., Inc.
Springfield, Mass.

cont. Robert & Livingston, Suite 123,
Madison Ave., New York City.

7530

**COLOSSAL GAS TANK HOLDS
15,000,000 CUBIC FEET**

Astoria Light Heat & Power Co.
Astoria, Oregon, O. C. N.Y.

Huge things are hard to picture in the mind, and a colossal gas tank erected recently on Long Island, N. Y., comes under this head. The mammoth container has a capacity of 15,000,000 cu. ft. of gas and is the second to be completed of a contemplated plant of six such units. The enormous cylindrical sections, which rise and fall so easily with the pressure of the gas, and of which there are five, are each 48 ft. high, 300 ft. in diameter (or the length of a city block), are made of $\frac{3}{32}$ -in. steel plate, and fastened together with 2,500,000 rivets. The retaining wall at the base of the tank, which holds the water required to prevent the gas from leaking out, is 9 ft. thick at the bottom, has a height of 48 ft., and tapers to a width of 5 ft. at the top. Inside of this monstrous circular wall are confined 14,200,000 gal. of water, enough to make a good-sized lake. The gas-intake and outlet pipes are 4 ft. in diameter, and there are two for each purpose.

To the casual observer, it would appear as though, in a tank of this immense size, the raising and lowering of its sections would be very difficult because of their weight. On the contrary, the crown, or top, which weighs 4,000 tons, is very light in proportion to the lifting surface

of 60,000 sq. ft. that is exposed to the gas. Any pressure of gas greater than $\frac{1}{8}$ lb. to the square inch will raise the top. The wooden framework built to hold the crown during construction, was left inside the tank to support the top when the tank is not inflated. Three small boats were also put inside the great container to stay away from the light of day, for the use of workmen in making any repairs needed within the spacious steel walls.

7734 *service*
**FOREST-EXPERIMENT STATION
IS ESTABLISHED IN SOUTH**

Recently, a forest-experiment station was established by the Forest Service of the U. S. Department of Agriculture, with headquarters at New Orleans, La. Experiments will be conducted in the vast timber region extending from the Atlantic coast, through the southern states, to Texas. The object of the undertaking is to work out the best methods of growing and protecting the forests, thus insuring their perpetuation.

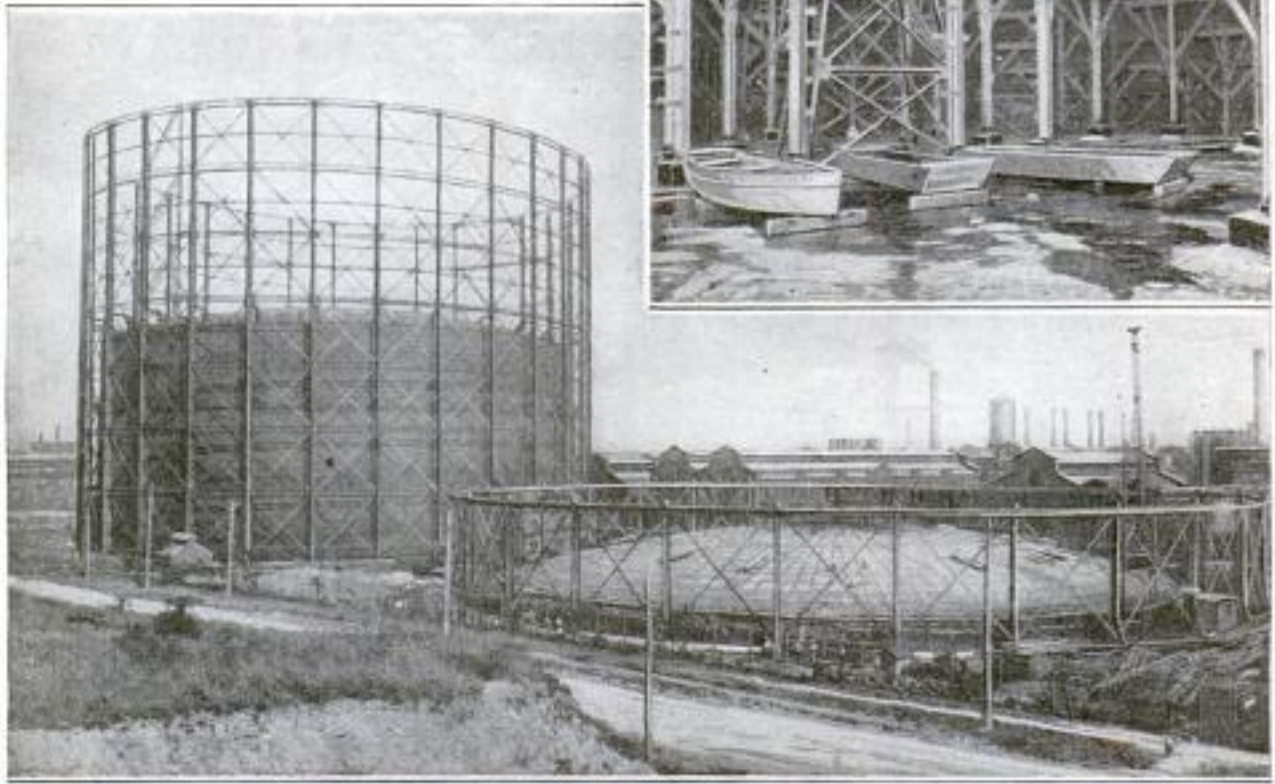

At the Right can be Seen the Mammoth Gas Holder in Process of Construction Which will Make It a Duplicate of the Completed, and Partially Inflated, Tank at the Left. The Insert Shows the Boats That were Placed Inside of the Steel Walls and Which will Remain There Forever, to be Used by the Repairmen

Bureau of Rehabilitation, Dept. of Labor
& Industry, Harrisburg, Pa. S. S. Riddle Chief.



Industrial Rehabilitation of Workers

By WM. A. MCGARRY

1033 Chestnut St.
Philadelphia Pa.

This Young Man Lost His Leg When a Sand Barge Crushed It against a Wharf but, with the Aid of the Pennsylvania Rehabilitation Bureau, He has Been Able to Get Back into Baseball as an Amateur Pitcher and has Secured the Job He had Always Wanted, in Which He Earns a Good Living. The Bureau has Made Him Independent



WHEN he was 18 years old, Joseph Meehan lost his right leg. He was working on a sand wharf and the leg was so badly crushed against the wharf by a barge that it had to be amputated below the knee. That was four years ago, and it looked as though his days as an amateur baseball star were over, but in the season of 1920 he pitched 12 games and won 10 for the team of which he is manager, and in 1921 he has made a still better record. But more important than his return to baseball is the fact that he is now earning a good living as a barber—the job he had always wanted—instead of being a cripple, dependent on relatives or charity.

The story of young Meehan's return to industry is typical of the work which is being done by the Bureau of Rehabilitation of the Pennsylvania Department of Labor and Industry, by which he was assisted. The record of that bureau, opened Jan. 1, 1920, is the story of how Pennsylvania discovered the dollar value of the individual producer, a story of deep significance to industrial America. In fairness to that state, it must be said that the bureau was not established for gain. It was strictly a social movement, an effort to repair, in part, the wreckage caused by the hundreds of thousands of industrial accidents which occur every year. But its investment return is clearly shown by the report of the first year's

operation, by S. S. Riddle, the head of the bureau.

An appropriation of \$100,000 was made to cover operating expenses for something more than a year. Statistics show that the average production of industrial workers in Pennsylvania for 1919 was about \$5,000. At the end of its first year the bureau had trained, or was training, 310 out of 750 men and women disabled in industrial accidents. Though some of these workers will never reach normal production capacity again, a conservative estimate gives them a capacity of \$1,000 a year, 20 per cent of the normal. This will increase production, the wealth of the state, by \$320,000 a year, a return of more than 300 per cent annually on the original investment.

But the really surprising thing, and one which suggests great possibilities of development, is that in scores of cases the rehabilitation experiment has made men worth more. Men considered permanent burdens on relatives or society, and incapable of ever returning to work, are now earning far more than they were ever able to earn before.

One man, who is now an engineer, had been a sort of handy man for a large corporation. He lost a leg in an accident while at work. Before he left the hospital, a representative of the bureau had learned his story and obtained a line on his experience. An artificial leg was



A Wooden Leg, and the Bureau Made a Yard Engineer of This Former Handy Man

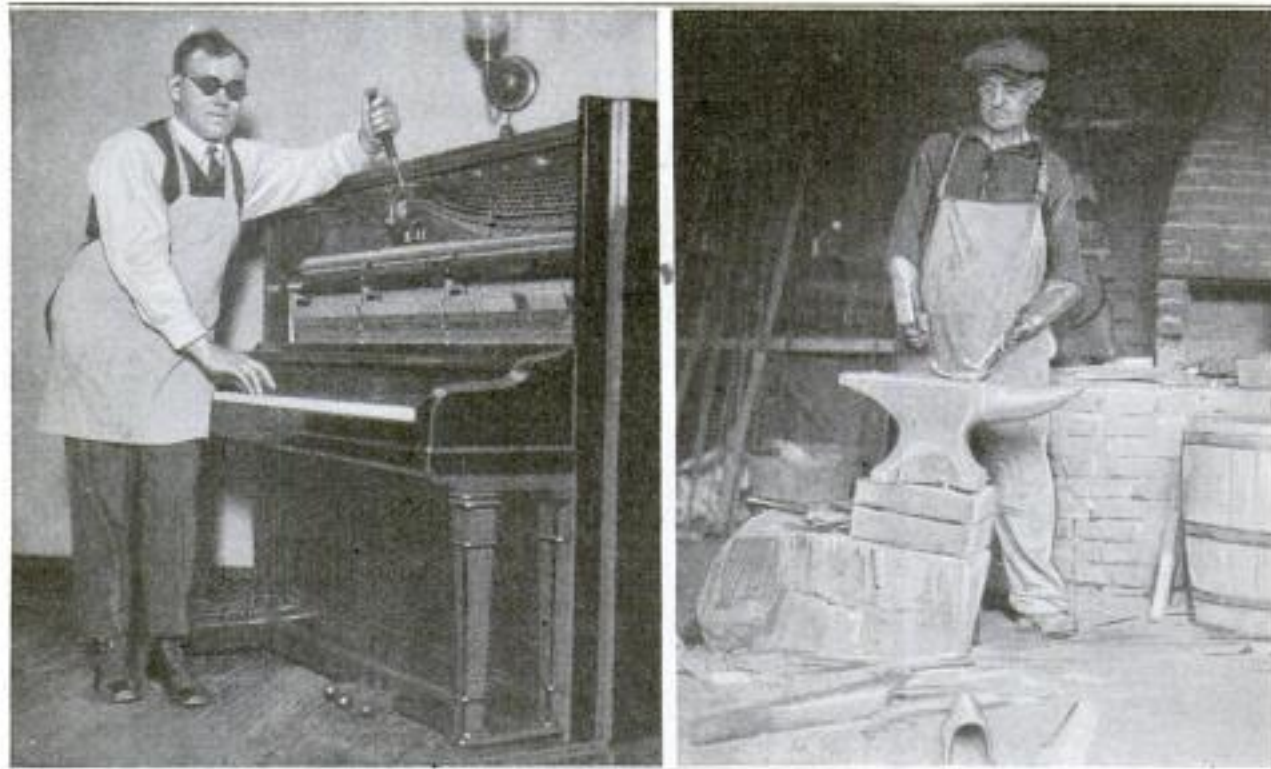

A Blind Piano Tuner and a One-Armed Blacksmith Are Two of the Men That have been Enabled to Learn New Vocations and Renew Their Earning Power after having been Forced Out of Their Former Industrial Activities through Accidents

waiting for him when he recovered, and, after consultation between the bureau and officials of the corporation, the latter agreed to give him a job as an engineer of a yard locomotive after a short period of training. He already knew the yards and was familiar with the work of the yard engine. He went back to work in a more responsible position and at greater pay than he had ever had.

In the act creating the bureau it is stated that, "rehabilitation shall mean the rendering of a physically handicapped person fit to engage in a remunerative occupation." It provides that when an injured person is unable to meet the expense of living, the bureau shall allow him a maximum of \$15 a week for maintenance during training for an occupation within his possibilities.

"The aim of our program is to render workers, disabled in industrial and agricultural pursuits, capable of earning a living at tasks they can perform without un-

due hazard," says the report, "work where advancement is possible; where their disabilities will not render them likely to lose their employment in event of a great supply of able-bodied labor; preferably at tasks for which they have a special aptitude or past experience."

From this it can be seen that the program is an individual affair. It applies to "any resident or residents of the commonwealth whose capacity to earn a living is in any way destroyed or impaired through industrial accident occurring in the commonwealth." There is no "red tape." The injured person is not compelled to apply for aid; the bureau goes to him. The law now provides that all industrial accidents be reported daily to the Bureau of Workmen's Compensation, and from there all records of permanent disability go to the Rehabilitation Bureau. While the victim is still in the hospital, he gets a questionnaire asking for information



After being Blinded, This Man, Aided by the Bureau, Learned Typewriting and Piano Tuning. He Plans to Open a Musical-Instrument Store

that will enable the bureau to decide just how it can be of help to him. When this is returned—and experience shows that it is nearly always returned—an adjuster visits the man in the hospital. He finds out not only what the patient can do but what he wants to do. The point of the training given by the bureau is often found in these desires.

Many of the men have secretly wished to be "something better" while working at hard labor or menial tasks, but have never found the chance to change. Then, in the despair of misfortune and the belief that their usefulness is ended, they admit they would like to do something different. The bureau arranges to have an examination made, often by competent psychologists. It learns whether it would be worth while to provide the training which would be needed.

In one case a young man, 20 years old, lost his arm. He told the adjuster that for a long time he had wanted to be a wireless operator. He was the sole support of his widowed mother, so arrangements were made for a lump-sum payment of his compensation award. With that he was able to start a small candy and cigar store which provided sufficient income for the two. The young man then joined an evening class,

under the direction of the bureau, to study wireless telegraphy.

The success of the bureau's activity is undoubtedly due to the fact that it



A Hand Loom in His Home, Provided by the Rehabilitation Bureau, Enables This Blinded Man to Support His Family

operates as an aid which the state owes to the injured person, not as a charity. Again and again it has awakened the desire to work in men who had become despairingly reconciled to a life of uselessness. Once these men are shown that they can be of service, they are always enthusiastic and willing to do any amount of studying to attain that end.

How this work operates for the benefit of the state is illustrated by the case of a Polish laborer who lost his right hand. The bureau provided him with a new hand, sent him to an Americanization class and procured for him a job as a hospital orderly. It was arranged to have his wife come on from her native land to join him, and finally he was put into position to rent a farm, where his past experience made him a valuable citizen.

Fully to appreciate what this kind of service means, it may be well to point out that the 310 persons assisted last year were supporting 454 dependents. A total of 166 obtained artificial appliances through the bureau, the cost being paid out of the state fund in some instances. At the end of the year, 47 were still receiving regular weekly maintenance, while studying such courses as telegraphy, motor mechanics, traffic management,



Training in the Evening Class, under the Bureau of Rehabilitation, to Achieve His Ambition to Become a Wireless Operator

salesmanship, commercial courses, including cost analysis and accounting; Braille reading and writing, piano tuning and carpet weaving, for the blind; mechanical drawing and machine design, a teachers' course in the state normal school, watchmaking, and other skilled occupations. The rest of the men had become self-supporting.

All the work done has been accomplished by the state alone. Federal funds, made available by the Industrial Rehabilitation Act of June 2, 1920, have not been utilized up to this time. When they are, it will mean an expansion of the work. The bureau has branch offices in several

cities of the state, and sends out circulars to get in touch with disabled men through labor unions and other organizations, in order that no one entitled to its services may be overlooked.

"As industrial plants have, in the past, maintained salvage departments for the elimination of needless waste of mechanical equipment, and studied the development of by-products until their value in some cases exceeds the value of the original product," says Mr. Riddle, "so must attention today be given to the human by-products of hazardous industrial processes. It is essentially a problem of human engineering."

9670

ELECTRIC SIGNAL FOR EITHER FREIGHT OR PASSENGER TRAIN

An electric train signal that has many advantages over the existing system, and that can be applied to freight as well as passenger trains, has been under test for

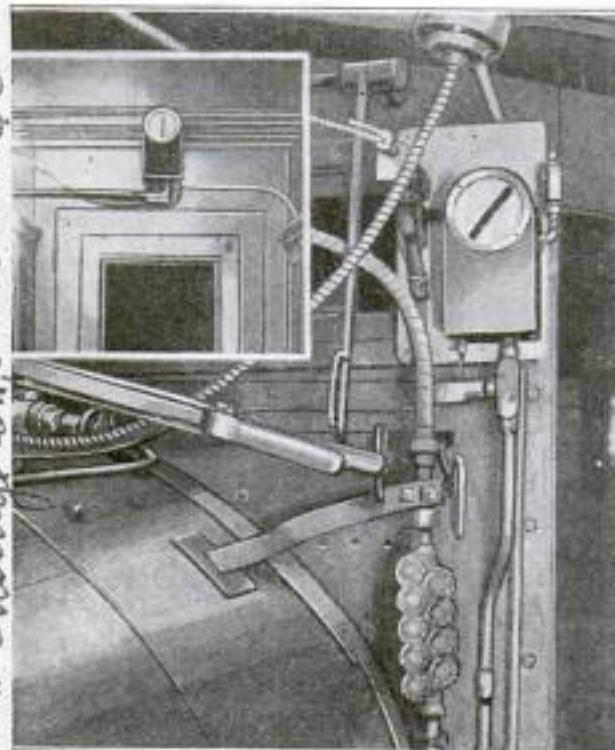

New Electric Train Signal Shown Installed on the Cab of a Locomotive, and in the Inset, on a Somewhat Smaller Scale, Shown in a Passenger Coach

more than a year on a train making a daily run in New York and Vermont. In each coach of a passenger train, and in the cab of the locomotive, a signaling instrument is installed so that it is plainly visible. It is in the form of a small metal case with a framed dial on which is pivoted a miniature semaphore that swings from a vertical to a horizontal or sloping

position to indicate danger, like the ordinary outside signaling semaphores. Attached to the case in each coach is a small hissing device, and to the instrument in the locomotive cab a loud whistle, all of which are operated by the brake air. The operation of these signals depends upon an electric circuit, the interruption of which causes instantaneously the blowing of the whistle, and the swinging of the semaphores in every instrument. Small batteries are required on freight trains, but would not be needed on electrically lighted cars. The wiring is connected between the cars by means of an insulated-wire coupling in the brake hose, thus making necessary only two hose couplings instead of three on passenger trains. An interruption of the electric circuit can be caused at will, and is caused automatically by any accident.

7638
BOTTLES AND GLASSES WASHED BY USING BRUSH AND MOTOR

An electric bottle washer is available, which consists of a brush mounted on a

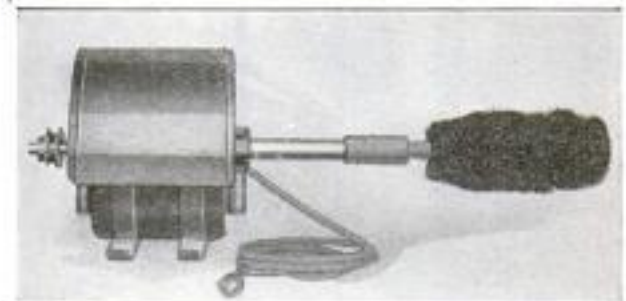

The Electric Bottle Washer, Showing the Motor with Long-Handled Brush: The Cord Attachment can Also be Seen

handle attached to the shaft of a 1/8-hp. motor. The device is placed so that the brush extends over a tub of water in which the bottles are placed. These are

*Electric Specialty Co.
Stamford, Conn.*

U. S. Train Signal Co. 97 Exchange St. Portland, Ore.

half filled with water, and pushed over the swiftly rotating brush. After cleaning, the water is poured out and the brush then acts as a drier. The motor shaft can be fitted with different-sized brushes, or with wheels to be used as buffers for silverware or other household utensils. 7534

CONCRETE CHIMNEYS ERECTED WITH GREAT RAPIDITY

Speed in construction is always considered a great asset, and a new way of building concrete chimneys certainly comes under this head. Concrete, as is generally known, requires a certain length of time after being poured to become hard, or set as it is called, and on work of this nature there is always a necessary wait before the form, or mold, is removed. To overcome this delay, a contractor has used five forms instead of one, each form being divided into four parts. When a chimney is to be erected, a wooden tower is first built, in what will be the center of the stack. This tower supports four sets of block and tackle at the top, for the purpose of hoisting the forms. The five forms are placed at the bottom, and one form is filled, or

poured, every day. On the fifth day, the lower form is hoisted to the top of the others, and again filled. Each day, thereafter, a form is raised, so that the work is never halted, and yet each form has four days in which to set, or harden.

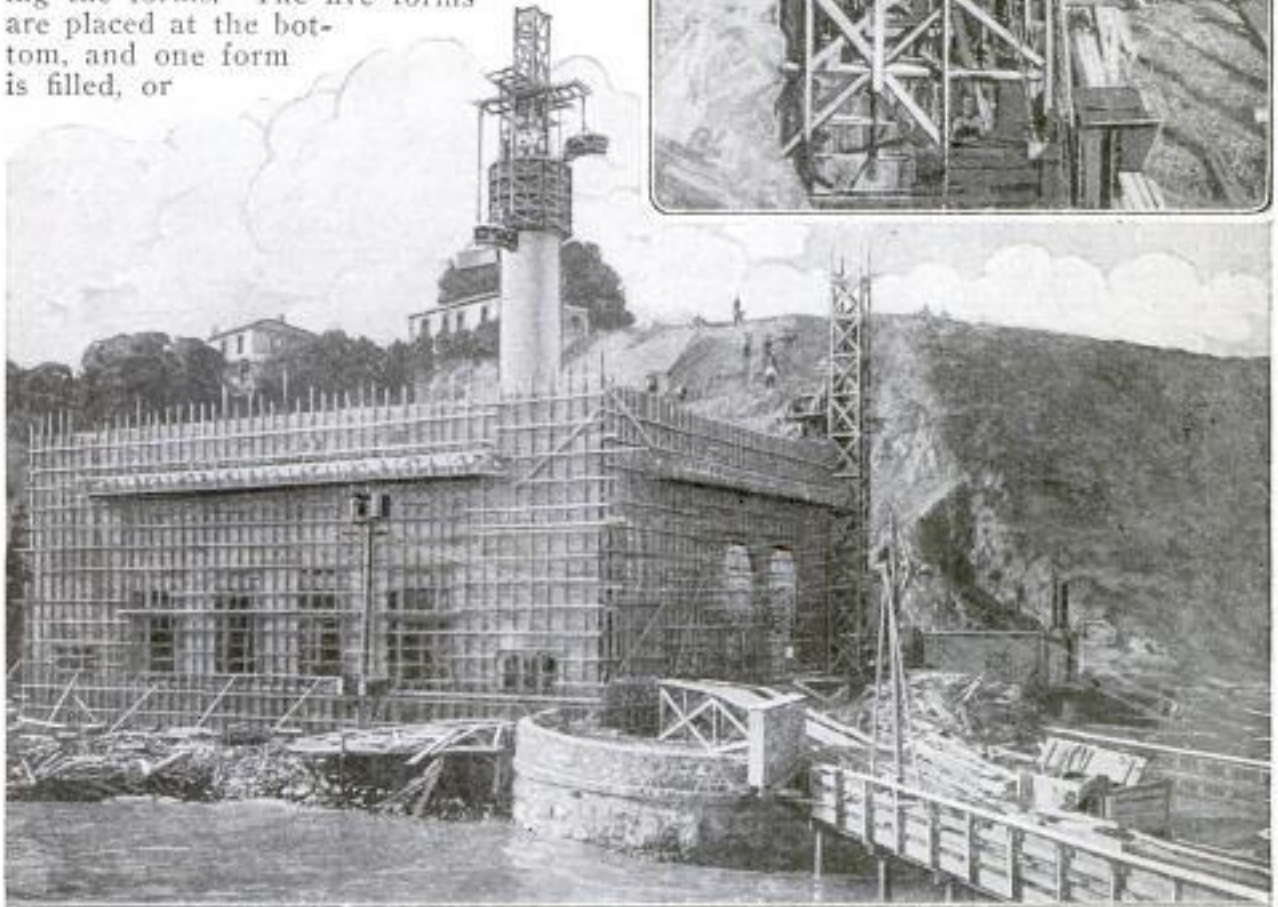
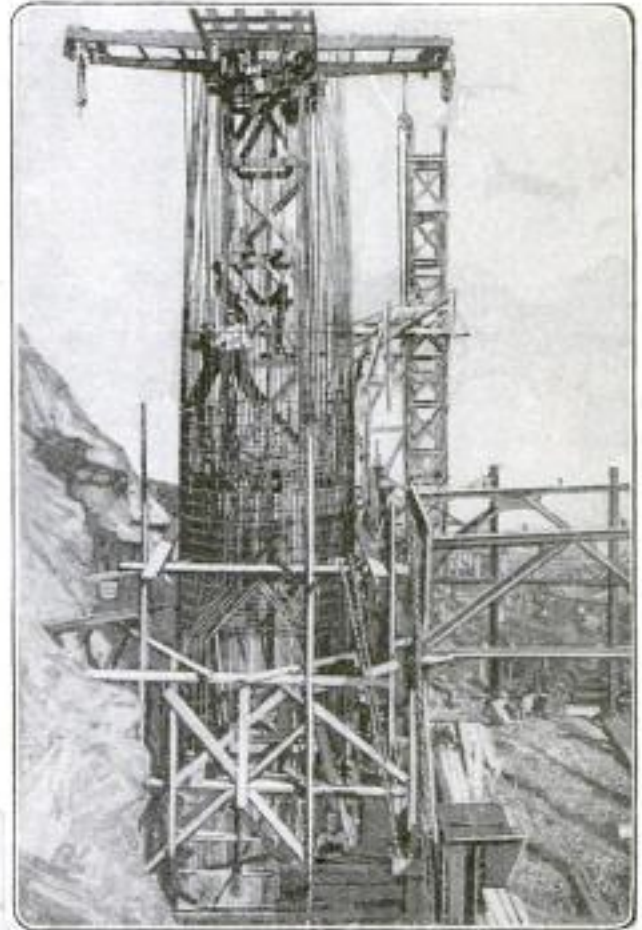

A Concrete Chimney during Construction, with the Sections of the Lower Form being Hoisted to the Top Position by Means of a Block-and-Tackle Arrangement Mounted on a Tower in the Center of the Chimney: The Upper View Shows the Method of Placing the Reinforcing Steel

Keystone View Co., 91 - 7th Ave. New York City.

7627
 d w. Walter A. Richmond
 Egg Harbor N. J.

Journal of Franklin Institute
 Nov. 1921

RECORD-LIFTING DISK LATEST PHONOGRAPH CONVENIENCE

For the convenience of phonograph users, an attachment has been invented to lift records from the turntable of the

arrangement was made for them. Two doorways, 7 ft. high, which had to be passed, caused no difficulty, though Tillie is 12 ft. tall. The animals merely knelt and crawled through without even breaking ranks.

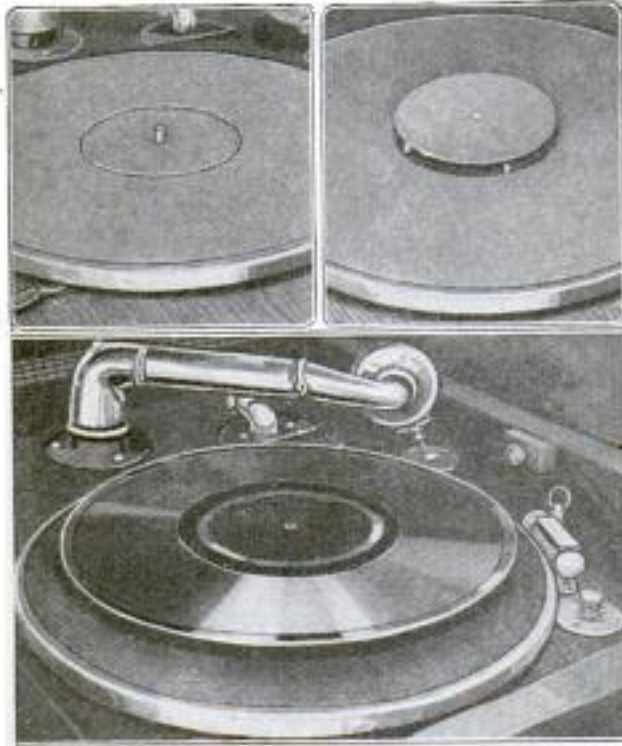

Above: A Phonograph Turntable with the Lifting Device Raised, Right, and Lowered, Left. Below: Record Lifted from the Turntable by the Device

machine. The center of the turntable is made in the form of a separate disk, which can be raised by pressing a button and plunger. The plunger is connected with the center disk by means of a series of links. This lifts the record so that it is easily removed from the turntable. When using this device, it is not even necessary to stop the machine, as the record can easily be removed while the turntable is rotating.

Circus
ELEPHANTS BOARD TRAIN AT PASSENGER STATION

Down the taxi drive of the Grand Central Station, New York City, filed four elephants one night not long ago. The excitement which their appearance created did not disturb the animals in the least. They went directly to their private car on the midnight train for Boston. Ordinarily elephants leaving the city en-train at the freight yards, but this 20-ton quartet, known as Tillie, Tony, Clara, and Pitt, could not complete their engagement at the show in time to make the train in the usual way, so a special ar-

ORDINARY CISTERN FILTERS DO NOT PURIFY WATER

7732

According to the United States Geological Survey most of the filtering methods, used to purify cistern water for drinking purposes, do not remove the disease germs, though they do make the water apparently clear. The most common method is to divide the cistern into two compartments by a brick wall. Water is admitted to one compartment and drawn from the other after it has filtered through the wall. This improves its clearness, but not its sanitary qualities. When properly purified, cistern water can be used for drinking purposes with entire safety.

X-RAY PHOTOS ARE MAGNIFIED WITH NEW DENTAL APPLIANCE

7653

Magnification of the Roentgenographs, or X-ray photos, of the teeth, to the extent of several times, is made possible with the use of a new dental appliance. The magnifier is electrically lighted and can be attached to any light socket in the usual manner. When an X-ray picture of the teeth is taken, it is sometimes impossible to detect with the naked eye the minute abscesses, or pus pockets, which have formed at the roots. Thus

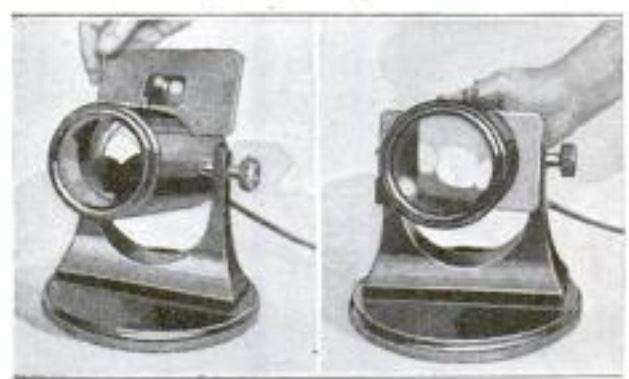

The X-Ray Photo Magnifier, Showing the Photo before being Magnified, at the Left, and at the Right, the Same Photo Magnified

the value of this instrument for dental diagnosis is very apparent, and it should prove a popular aid to this profession. The instrument can be adjusted to the proper focus for any person by means of a small thumbscrew.

New York Edison Co.
 W. 42 no N. N. Y. C.

New York Times
 11/21/21 p. 4

7601

CANADA WINS IN GREAT MARINE SPORTING EVENT

gordon

THE Canadian schooner "Bluenose" was the winner of the trophy in the International Fishermen's Race off the port of Halifax, Nova Scotia, Oct. 24, 1921. The trophy was won last year by the American schooner "Esperanto," and it was defended this year by the Gloucesterman "Elsie," which lost to the "Bluenose" in two races consecutively, in the final and decisive one by 9 min. 31 sec. Both events were characterized by a high grade of sportsmanship, and the Nova Scotians, though naturally and justifiably loud in their praises of the "Bluenose's" triumphant skipper, Angus Walters, were not without quite audible praise of "Elsie's" skipper, Marty Welch, who, the year before, had won the trophy on the "Esperanto," and who this year was a game and cheerful loser.

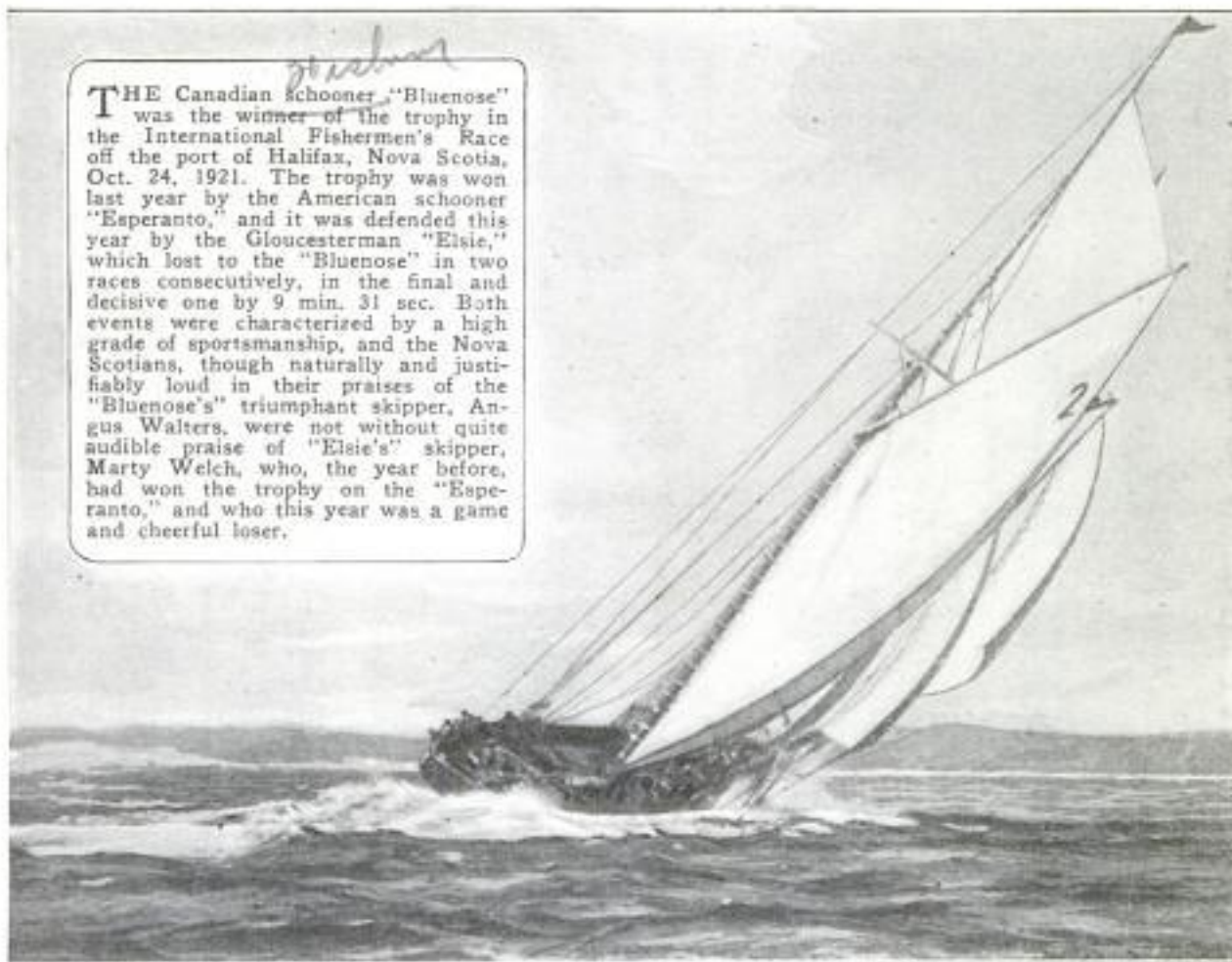

COPYRIGHT, UNDERWOOD & UNDERWOOD

7556 WELDING OUTFIT ON MOTORCYCLE

Operation costs of a welding outfit have been lowered one-half by mounting the apparatus upon a motorcycle with an improvised frame and a third wheel. The improvement is the result of the efforts of a street-railway company to obtain a welding outfit that could be moved from place to place more quickly and at less expense than was possible with the motor truck then in use. The officials of the company declare that the change has proved very beneficial, and could be profitably utilized to do similar welding for any company. The great adaptability of this small, though efficient, equipment in carrying the welding outfit

to many places that are inaccessible to a motor truck, is very apparent.

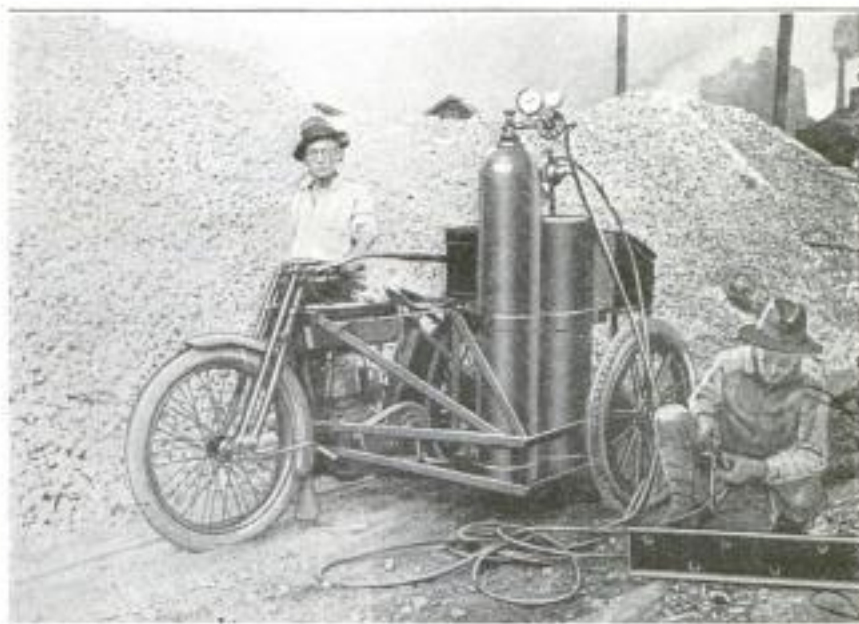

The Motorcycle Welding Outfit, Showing the Method of Carrying the Equipment, the Use of Which Requires a Driver and a Welding Mechanic

*Emt. John G. Deaty, Co. 1010
Wagon Rd. Albany*

New Orleans Railway Light Co.

J. A. Llewellyn, d. w. Oberlin Conservatory of Music 1521 Oak St. Wash. D. C.

40
7665
Oberlin, Ohio
POPULAR MECHANICS
SYSTEM OF SYMBOLS USED
IN "UNBEATABLE" CLOCK

Time clocks are usually a source of more or less trouble to the employer, because after the clock is installed, some

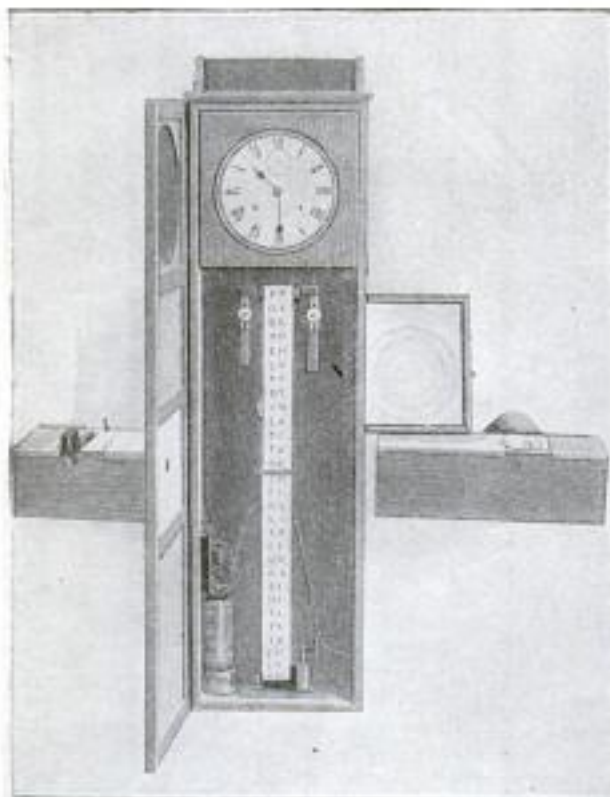

The Time Clock, Showing the Arrangement of Letter Symbols Operated by Electricity. Left Shelf: The "On Time" Register. Right Shelf: The "Late" Register

one has to be detailed to watch the employes using it, to detect any false registrations. As a means of preventing the workers from registering for each other, or from covering up "late marks," an Oberlin, Ohio, inventor has produced a new clock. Instead of complicated machinery, he uses a system of symbols, composed of letters, to compel every employe to make a correct report of his

arrival or departure. These symbols have a different combination for every two minutes of the 24 hours. By simply pressing a button, the employe has the time and corresponding symbol stamped on his time record, after which he is required to sign his name. It is claimed that the clock can be used to advantage in any line of work, or for automatic roll calls of any description.

7713
EARTHQUAKES FROM DEEP REGIONS OF THE EARTH

Earthquake waves may originate at points in the earth a considerable distance below the surface, according to the recent announcement of a scientist who has studied the existing data on the subject, and subjected it to elaborate mathematical analysis. Previously it has been assumed that such disturbances came from so near the surface that the effects of their depth could be neglected in considering problems of earth-wave propagation. It appears that the origin of some waves may be as far below the surface of the earth as one-fifth of its radius, or roughly one thousand miles, and it will be necessary to modify the interpretation which has been placed upon many of the earth's disturbances, and this may exercise an important influence upon our ideas of the stability of the earth and of its past history.

7417
ELECTRIC PHONOGRAPH MOTOR OF SIMPLE CONSTRUCTION

A new phonograph motor of extremely simple construction, and said to possess numerous good qualities, has been built along the lines of the watt-hour meter, which is installed in every electrically lighted home. Only two moving parts are used, thus assuring few breakdowns

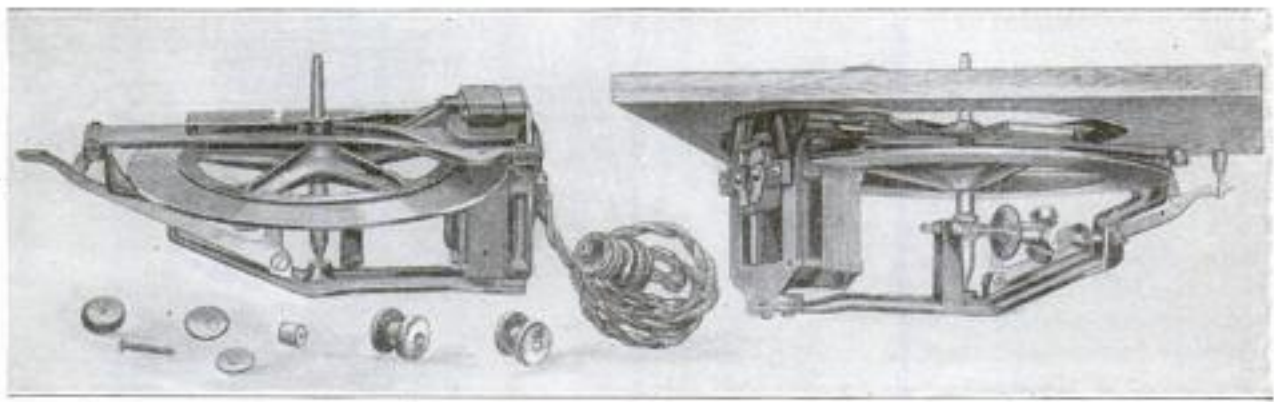

Left: The Phonograph Motor, Showing Its Simple Construction and Few Details Needed to Attach It to Any Machine. The Similarity to the Ordinary House Watt-Hour Meter can be Seen in the Flat Copper Ring Which Rotates through a Magnetic Field. Right: The Motor Attached to an Instrument

General Electric Co., Schenectady, N. Y.

Dr. J. G. Plenneth
 Berlin Conservatory of Music
 POPULAR MECHANICS
 Berlin, Ohio

Woodruff Electric Co

7652
ELECTRIC "NIGHTCAPS" USED FOR WARMING COLD HEADS

Bald-headed men can now sleep in comfort, regardless of any chilly blasts of winter which may sweep in through open



Left: How the Cap Appears on the Head. Right: The Inside of the Cap, and the Plug and Cord

windows or along open sleeping porches. The answer to the perplexing problem of cold-headed persons, lies in the production of an electrically heated warming cap. This cap is made in much the same manner as the common warming pads and blankets now on the market, and has the usual plug attachment.

5492
MOTORCYCLE TRANSFORMED INTO AUTO BOBSLED

An auto bobsled which derives its locomotion from a motorcycle engine and has a body line similar to that of a motor car, has been developed by an enterprising Indiana cyclist. The rear wheel of the motorcycle and the engine remain fitted to the cycle frame, and this in turn is fitted to the frame of the bobsled. A standard automobile wheel is used in steering, and the driving wheel is equipped with chains to prevent slipping.

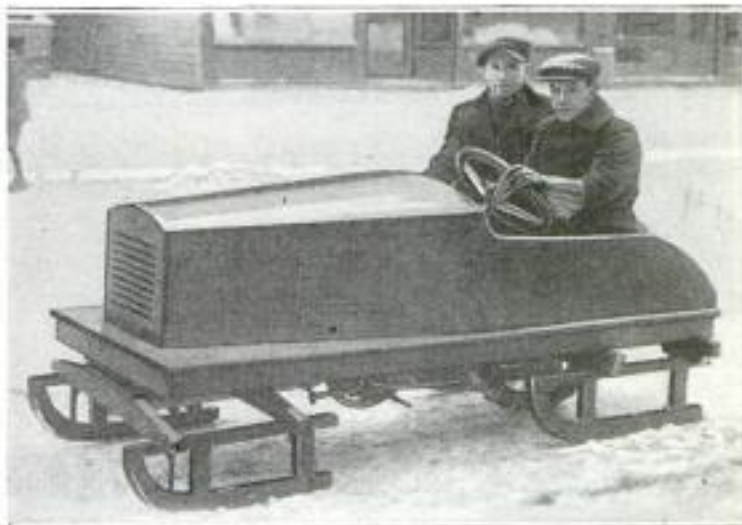

The Engine and Rear Wheel of a Motorcycle, Both Still Attached to the Cycle Frame, Form the Driving Equipment of This Auto Bobsled. The Wheel is Provided with Chains

Harley Davidson Motor Co. Milwaukee, Wis

and a corresponding longer life. The rotating element consists of a copper ring of 9-in. outside diameter and 6-in. inside diameter, having a thickness of approximately 1/4 in. This ring revolves through the ordinary electromagnetic field. It is claimed that the motor has a small power consumption due to the way its bearings are placed.

7574
AUTO-GLARE DIMMER TO END DANGER FROM HEADLIGHTS

Laws have failed to end the dangerous glare of auto headlights, but their danger is eliminated by a screen which can be instantly slipped onto the windshield of any machine. It consists of a spring-brass frame holding a very fine-meshed

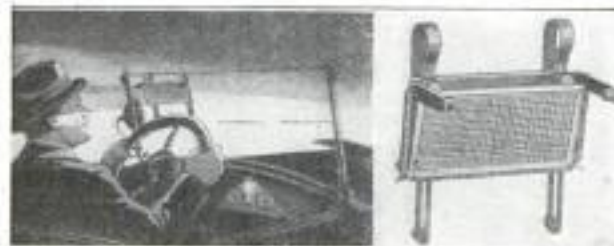

The Driver does Not Look through the Dimmer, He Looks under It. Its Shadow on His Eyes Protects Them from the Glare. Right: The Dimmer Alone

woven screening of a special-bronze wire. A slide and thumbscrews provide the adjustment for height. When not needed, it is turned up, but can be lowered by a mere touch.

7467
PRIZE AWARDED DISCOVERER OF HARMLESS OPIATE

To enable Prof. David I. Macht, of Johns Hopkins University, Baltimore, Md., to continue his research work on certain synthetic compounds which are successfully replacing opium as sedatives, the American Pharmaceutical Association has awarded him the annual grant of the association's research fund. The compounds, known as "benzyl derivatives," were first tested on animals five years ago, and their use has already saved thousands of convalescents and invalids from becoming possible drug addicts. They are fully as effective as opium derivatives, but do not form a craving or habit, such as may result from the medicinal use of opiates. The new investigations will be of benzyl compounds found in certain vegetable preparations.

Ray & Carter Co., Quarim, Ind

New York Times 10/17/21 P. 32

Cochran Roller + Ball
Bearing Axle Co., 12 1/2 S. South St.

POPULAR MECHANICS

7442
42
Mr. Vernon, d. ll.
ROLLER-BEARING AXLES
ON RAILROAD CARS

A roller and ball-bearing axle for street and railway cars has been under test now for nearly two years on a railroad car

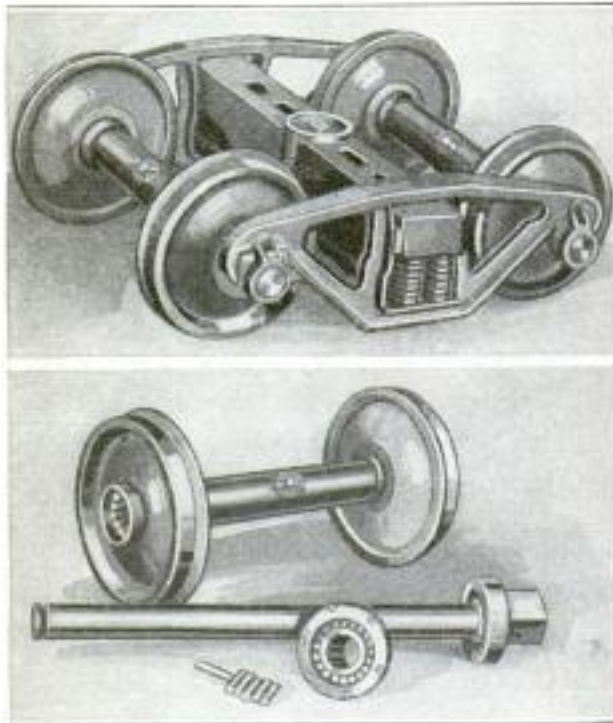

Railroad-Car Truck with Roller and Ball-Bearing Axles: The Rollers Are between the Axles and the Inclosing Sleeve That is Filled with Lubricating Grease through the Hole at the Center

with, it is said, very satisfactory results. Each journal of the stationary axle is hardened to form the inner race for a series of rollers, the outer race for which is a cylindrical extension of a rotating sleeve that incloses the axle between the wheels, and which is kept full of grease for lubricating both bearings. These rollers are directly in line with the thrust from the load on the wheels, and there is no eccentric stress as in ordinary journal boxes. All side thrust on the axle is taken up by ball bearings, which are outside the axle sleeve and contained in a cap at each end of the axle.

7444
**MAKING PHONOGRAPH RECORDS
OF ACTUAL GRAND OPERA**

Phonograph records of operatic or other singing are now made by requiring the performer, or performers, to sing into a gaping horn, standing just at the right distance, and being painfully careful just how the voice is aimed. When the recording apparatus has once been started no sound can be made by anyone but the singer, and all instructions from the director have to be made by gestures and

signs. Thus, besides the unnerving effect of the gaping horn, the singer has to keep his eye on the director, who gesticulates from behind the recorder. This is, to say the least, not exactly a stimulating form of inspiration for the singer. But, on the other hand, could these records be made when a singer is in his, or her, field of glory on the center of the operatic, or concert, stage, facing an admiring audience, surrounded by sympathetic colleagues, how much better would be the result! Plans are now under way to make records in this manner; indeed some have already been made in Chicago, where recently, for several nights, grand-opera performances have been radiophoned, to the inexpressible delight of thousands of wireless amateurs located in districts hundreds of miles away from the Chicago opera house. The records are first made, as usual, on wax master records, and everything is conventional excepting the one prime and highly important fact that the artistic temperament of the performer is not being tampered with. In connection with the enterprise there is, however, one mechanical novelty which has not yet been used in taking these operatic records. This is an entirely new form of listening device, the instrument that receives and transmits the sounds from the stage or auditorium. It is expected that it will make possible a reproduction of music on the phonograph that will surpass anything that has yet been done.

7651
**ADJUSTABLE DESK TRAY NEW
OFFICE CONVENIENCE**

Adjustable desk trays with a mounting which can be either screwed to the desk or clamped on, without marring the surface, are now on the market. The mounting consists of a grooved rod, about which the trays revolve, and the screw plate or clamp. Trays can be ad-



justed instantly to any position desired or swung entirely out of the way. They are regularly made in units of two, three, and four trays. Each tray can be removed from the rod separately.

American Electric Co.
State & 64th Sts. Chicago.

7624

AUTO TRAILER DESIGNED TO TRANSPORT HORSES

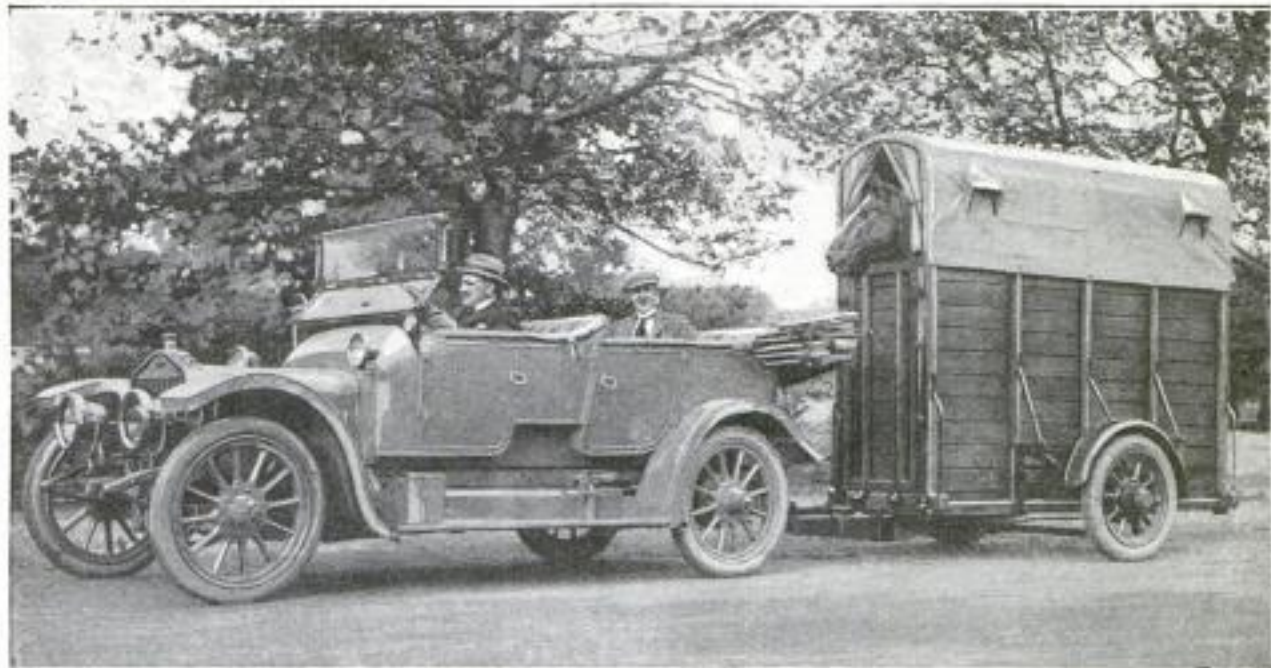

PHOTO COPYRIGHT,

Above: The Horse Trailer Loaded and Coupled to a Motor Car, Ready to Start on a Cross-Country Trip. Note the Ventilators in the Top



MODEL & NUMBER 153 & 42 no. 11
Left: The Legs Used to Support the Trailer When Standing are Shown in Use; Also the Coupling Device for Hooking to a Car can be Seen

For the purpose of transporting horses to and from races and horse shows, without the bad effects of railroad travel, an English firm is making a new kind of automobile trailer. It consists of a box body, just large enough for a horse to stand in, mounted on two pneumatic-tired wheels and covered by canvas stretched over a frame. Each end of

the box is hinged at the bottom and drops to form a platform by which the horse enters the box. Iron legs, at the ends of the box, are lowered to support it while standing, and are raised when the trailer is coupled to the rear of a motor car for traveling. Ventilation is provided by two openings in each side of the canvas top and through the ends.

4571

TRAM SYSTEM INSTALLED FOR WASHING WINDOWS

Washing the 4,600 window panes of the new Division Street pumping station of the Cleveland, Ohio, waterworks, has been made a safe job which can be done in a comparatively short time, by the installation of a tram system. A rail, around the building just below the roof, supports a light hand-propelled cage which can be raised or lowered by means of two small hand winches. The rail is inconspicuously constructed and does not detract from the appearance of the build-

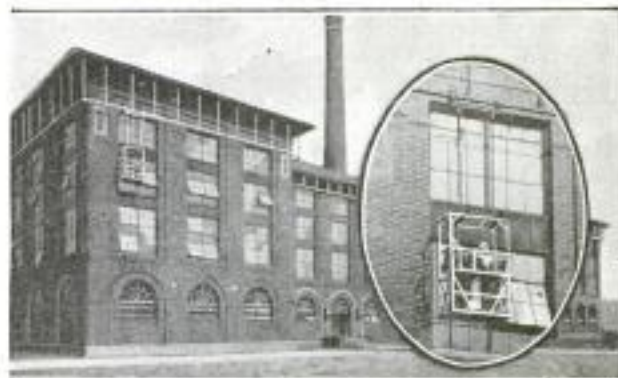

Just below the Roof is the Rail from Which the Window-Washing Cage is Hung. The Insert Shows How the Cage is Suspended

Cleveland Crane & Engineering Co
Wickliffe, Ohio
Copyrighted material

ing. Using this system, a great saving is effected in the time and cost of window washing. The tram can also be used for painting the window frames and spouting, replacing broken panes, or making any light exterior repairs.

IMPROVED TRAFFIC TOWERS FOR DETROIT SYSTEM

New and improved traffic-control towers will replace those which are being used in Detroit, Mich. The system, de-



With Traffic Towers like This, It Is Only Necessary to Have a Traffic Officer Every Four Blocks to Get Perfect Traffic Control

scribed in Popular Mechanics for June, has been so successful that it will be developed still further. The new towers are more artistic in appearance than the old ones and are equipped with a double set of lights. A telephone system has been added, and megaphones protrude through the floor of the traffic officer's box, by means of which he can give verbal directions whenever it is necessary. These towers will be used to control the traffic for four blocks in each direction, by means of three lights. A green light signals to go ahead, a red to stop, and a yellow one warns that traffic is about to be stopped.

*Cmt. C. A. Briggs
1521 Oak St. N.W.
Washington
D.C.
7704*

VITAMINES UNNECESSARY FOR PLANT-GROWTH

While it appears impossible to maintain animal life without vitamins, they are not necessary for plant growth, according to the report of a French investigator. He found that plants would reach complete growth in media known to be free of vitamins, or which were entirely of mineral composition. On the other hand, vitamins were found to be of assistance in plant growth in some cases where the plant was placed in a soil of low nutritive value, but the vitamins can be replaced perfectly by the addition of appropriate mineral salts.

7537

TANK CARS QUICKLY EMPTIED WITH NEW UNLOADING RACK

Transferring the contents of oil-tank cars to storage reservoirs, has been greatly speeded up by the introduction of a new unloading rack. The rack is constructed of 2-in. steel pipe, and is fitted with universal joints and counterweights, which make the unloading, or tank-feed, pipe, very easy to handle. The entire arrangement is controlled by a chain in the hands of an operator on the tank car, and when not in use, the counterweights cause it to lock automatically, in a vertical position. Thus the rack, when idle, is always clear of the track, which prevents any chance of accidents.

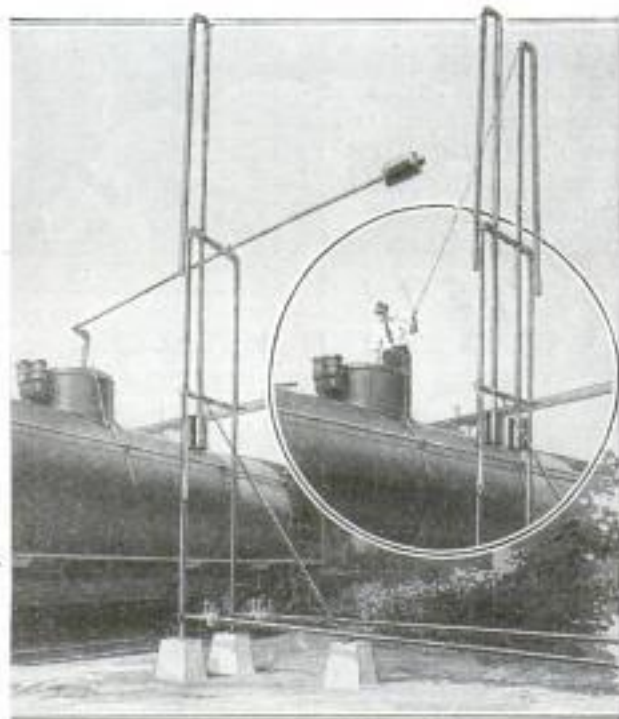

The Unloading Rack as It Appears in Use; Insert Shows the Idle Rack before being Pulled Down

*Cmt. L. L. Jellison, 250 G
Windsor Ave, Lubbock, Texas.*

*4429 Townsend Ave, Detroit Mich.
Cmt. W. A. Croser.*

*Free
cars*

Cont. No. Col. 4, Rue Richer
Paris, France

7593

POPULAR MECHANICS

45

Bueller - M. de Pishof, 3 Rue

Below is Seen the New All-Metal Biplane, Designed by the French Engineer Pishof, with Its Wings Dismounted and the Interplane Struts Removed. Only Two Minutes are Required to Dismount the Wings

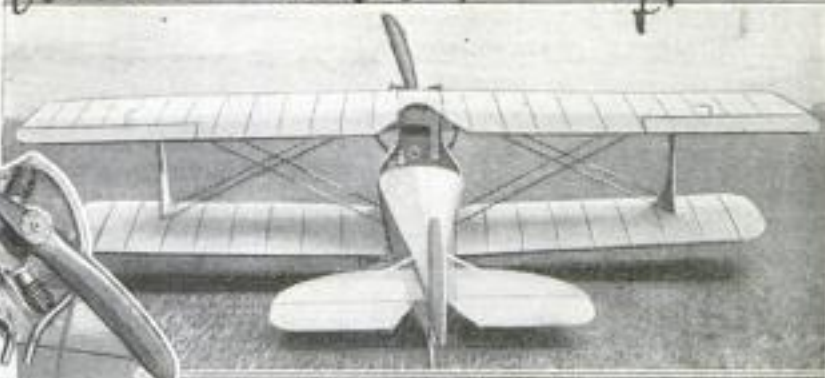
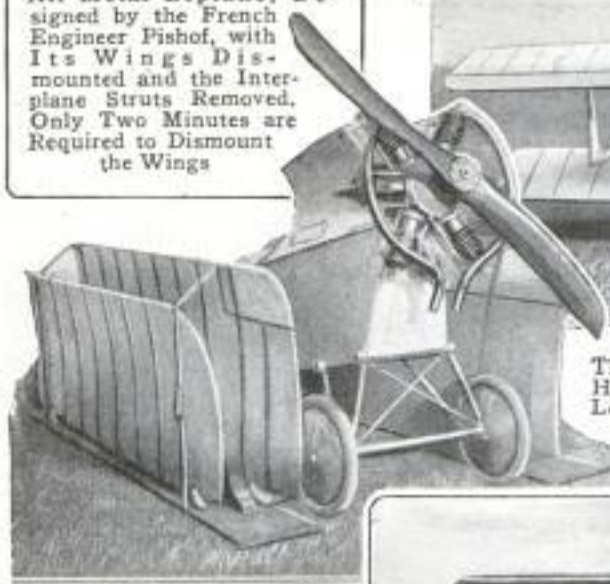
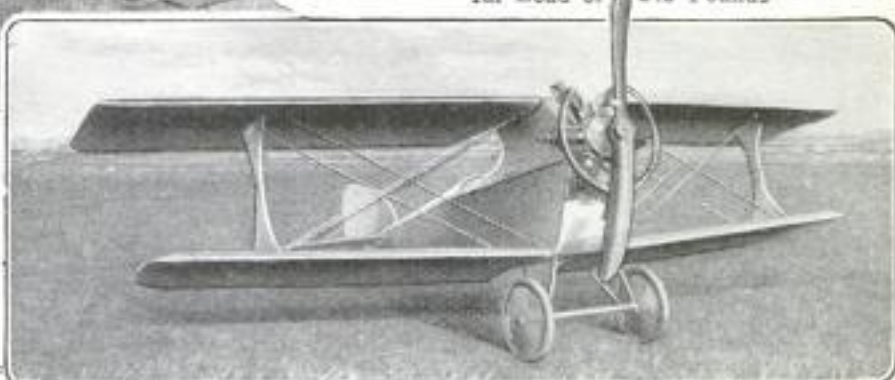

PHOTO COPYRIGHT, N. B. B.

This Small Machine is Designed to Require a Minimum of Housing, Occupying a Space Only 19 Feet Wide, 13 Feet Long, and 5 Feet 3 Inches High When Completely Assembled. With the Wings Dismounted, It Requires Even Less Space. It Weighs 418 Pounds and Has a Useful Load of 242 Pounds

The Front View of the Plane, at the Right, Shows How the Little 20-Horsepower Six-Cylinder Anzani Motor is Mounted, as Well as the System of Interplane Bracing by Means of I-Form Struts and Wires



7593

SMALL FRENCH AIRPLANE HAS DEMOUNTABLE WINGS

Wings which can be demounted in two minutes are the conspicuous feature of the new French airplane, designed by Pishof, in developing a type of plane requiring only a small hangar space. This machine is a biplane with single I-form struts at each side of the fuselage and wire bracing. It has a span of 19 ft., is 13 ft. long, and 5 ft. 3 in. high. The construction is of the all-metal type and a 20-hp. six-cylinder Anzani motor furnishes the power. Empty, the machine weighs 418 lb., and it has a useful load of 242 lb. It is credited with a speed of about 70 miles an hour.

7664

ELECTRIC RANGE HAS SWITCH WITH TWO PILOT LAMPS

Pilot lamps in a main-line switch are a new feature of electric ranges, and one which should be popular with the forgetful housewife who neglects to turn off the current. The main switch box is designed to be mounted in, or on, the wall near the stove, and contains two pilot lamps which are connected across the load side of the switch. A small knob

to operate the switch, and red lenses in front of the lamps, are set in the face of the box. When the switch is turned on, the lamps light behind their red reflectors, thus serving as a vivid reminder that the current is being used.



The Woman is Turning the Switch Handle, above Which can be Seen the Two Pilot Lamps Mounted in the Switch-Box Cover

Electrical Mfg. Co. 4149 E. 79th St. Cleveland, Ohio

bueller - M. de Pishof, Paris, France.

7690

THERMOELECTRIC PYROMETER HAS SELF-COMPENSATION

STUDIES OF PIPE CORROSION BY BUREAU OF STANDARDS

Pyrometers are used to measure exceedingly high temperatures, such as molten metals, high-pressure steam, etc.

Underground-pipe systems always suffer more or less rapid deterioration as a result of the corrosive nature of the soil,

and much study has been devoted to the problem of overcoming the trouble. Now the Bureau of Standards has taken up the subject and is making investigations, particularly with reference to gas and water mains. Forty locations representing different kinds of soils have been selected, and at each of them samples of standard iron and steel pipes will be buried.

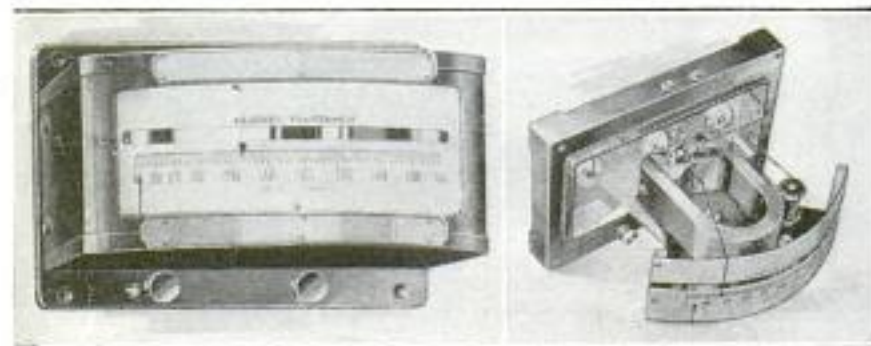

Two Views of the Thermoelectric Pyrometer Which Has Automatic Compensation for Temperature Changes of the Cold Junction: At the Left is Shown an Exterior View of the Instrument, and at the Right the Interior

Thermoelectric pyrometers have two fine wires of different metals, which are fused together at one end and called a couple. This couple is then placed in the heat to be measured. The other ends of the wires are connected through a galvanometer. The difference in temperature between the couple and the outer ends, generates an electromotive force which is approximately proportional to the difference in temperature between the heat measured and the surrounding atmosphere. The cold ends of the couple have to be kept free from any temperature changes. Heretofore they have been brought to a compensating box to insure an even temperature. By using an improved-type instrument, these ends are connected direct, and any temperature change is compensated by an adjustment on the instrument.

These will be uncovered periodically to find the rate of corrosion. When all the necessary data have been obtained, extensive laboratory tests and experiments will be made to discover a remedy.

7608

SHIP CARRIES A TRAFFIC OFFICER ON BOWSPRIT

Everyone is familiar with the small figures which often decorate the radiator caps of automobiles, but who ever heard of such a thing on an ocean-going ship? Still when the schooner "William Bowden," with a cargo of lumber from Westport, Ore., reached the port of Honolulu, H. I., one of these tiny figures, a traffic policeman, was seen perched on the end of its bowsprit. Throughout the 30-day trip he had stood there, turning and swinging his arms in response to every wind.



Standing on the Tip of a Schooner's Bowsprit, This Tiny Traffic Officer, with Swinging Arms, Responds to All the Winds of the Pacific

According to the crew, he was kept busy day and night, though the traffic on the Pacific Ocean has never been congested.

Emb. R. Clutterbuck
Box 1116, Honolulu, J. H.

FITTING TRIBUTE IS PAID BY AMERICAN LEGION POST

The Jeff Feigl Post of the American Legion has paid a fitting tribute to the man after whom the post is named, and who was the first New York officer to be killed in the late war. A bas-relief portrait, which shows him in uniform, has been made in bronze, and was recently presented to the Victory Hall Association, New York City.

Popular Mechanics Magazine does not publish the name of the maker or seller of any device described in its pages, but this information is kept on file and will be furnished, free, by addressing our Bureau of Information.

International Photo Service, New York City
226 William St., New York City

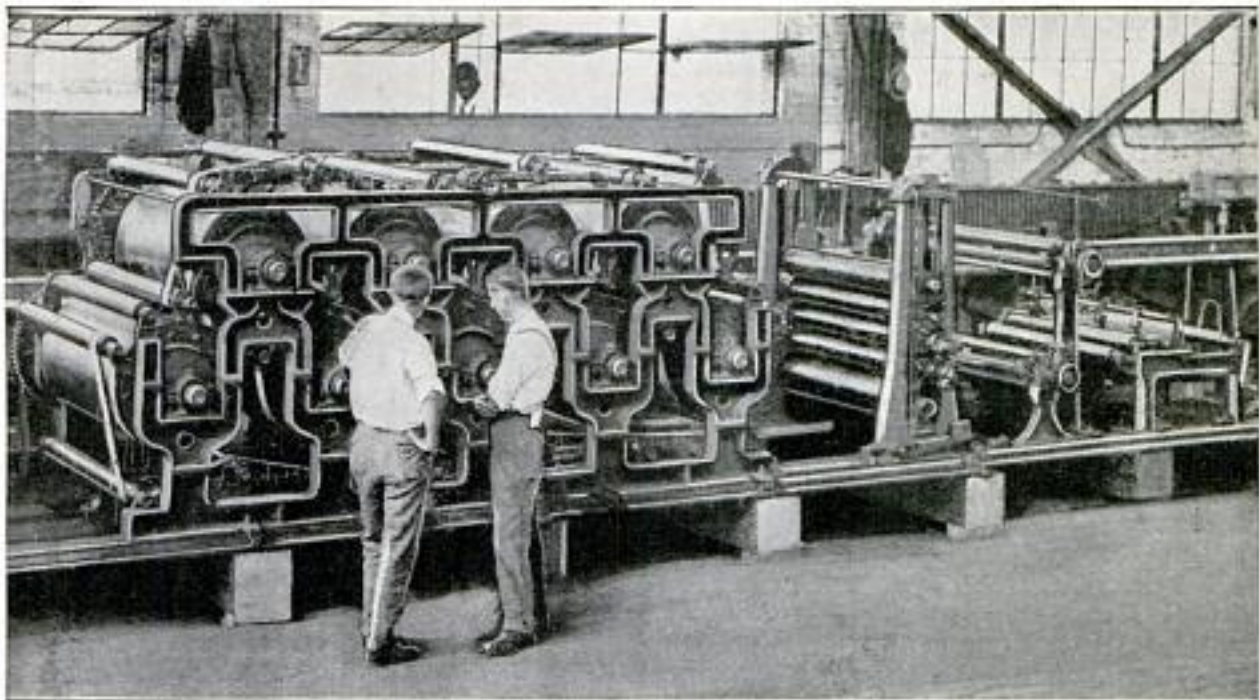

Part of the Small Paper Mill Built in This Country for the Siamese Government: It has been Shipped to Bangkok, Where It will be Installed for Experimental Work, as the First Step toward Developing the Paper-Making Industry in That Country, Which Is Exceedingly Rich in Raw Materials

7588
MINIATURE PAPER MILL SAID TO BE MOST COMPLETE BUILT

An American-built paper mill, shipped to the Siamese government for experimental purposes, is one of the most complete mills ever built. Though of small size, being only 56 ft. long, it is equipped for the manufacture of all kinds of writing and printing papers, and is patterned after the experimental mill of the U. S. Bureau of Standards. The shipment includes such essential parts as a Fourdrinier sieve, 43 in. wide and 33 ft. long, two 300-lb. wood-tube beaters, a small engine, a 600-lb. rotary beater, a cylinder duster, screen, sheet cutter, and bleaching plant, besides all fittings and accessories. Both constant and variable-speed shafts are provided. Siam became interested in the use of its abundant raw material through experiments, described in Popular Mechanics for December, made at the suggestion of their ambassador to the United States.

7645
ELECTRIC-VALVE TUBE MADE WITH REVERSIBLE FEATURE

Electric-valve tubes are usually one-way affairs as regards the current flow, but a new tube is available which possesses a reversible feature. The innovation consists of a spherical glass bulb with two cylindrical ends, each containing a short terminal wire. Between the ends is placed an aluminum tube which is insulated

Electrical World
 11/5/21

from the terminal wires by an air gap. Inside of the tube is a small aluminum ball. By tilting the tube to either side, the ball rolls down to the end, thus making contact with one or the other of the terminal wires by closing the air gap.

2557
"FOOL-PROOF" SEAWALL BUILT WITH SHARP-EDGED TOP

Tourist bathers refused to consider the danger to their necks in diving off a seawall at Waikiki Beach, Honolulu, but strove to imitate the clever Hawaiian boys, who can dive in very shallow water. The beach authorities neglected this peril until a particularly enthusiastic "thrill-hunter" banged his head upon the hard bottom with such force that his neck was broken. Signs were immediately posted to warn other rash divers, but the wall continued to be used for a diving-off place. Finally a sharp triangular concrete top was put on the wall, and this stopped the dangerous practice.



Showing the Seawall upon Which was Built the Sharp Triangular Top

Col. R. Clutterbuck, Honolulu, T.H. Box 1115

7540

PROGRESS OF FOOTBALL GAMES REPRODUCED ON BULLETIN

University of Utah football games, played away from home, were reported to the fans who could not follow the team

this year, in a way that was almost as interesting as actually seeing the games. One of the Salt Lake City newspapers devised a bulletin board by means of which every move of the games could be reproduced. The board was a zinc plate, marked off to represent a football field. An electromagnet behind the plate served to move a light metal ball about the field, as the plays were reported over a special telegraph wire. Sliding arrows indicated the team in possession of the ball and the player carrying it. Cards, slipped into slots, showed the score by quarters, the score made, the down and yards to gain, and penalties. A large slot, marked "Watch This Space," was used to display additional information, as when forward passes were made or intercepted, or the ball lost on a fumble.

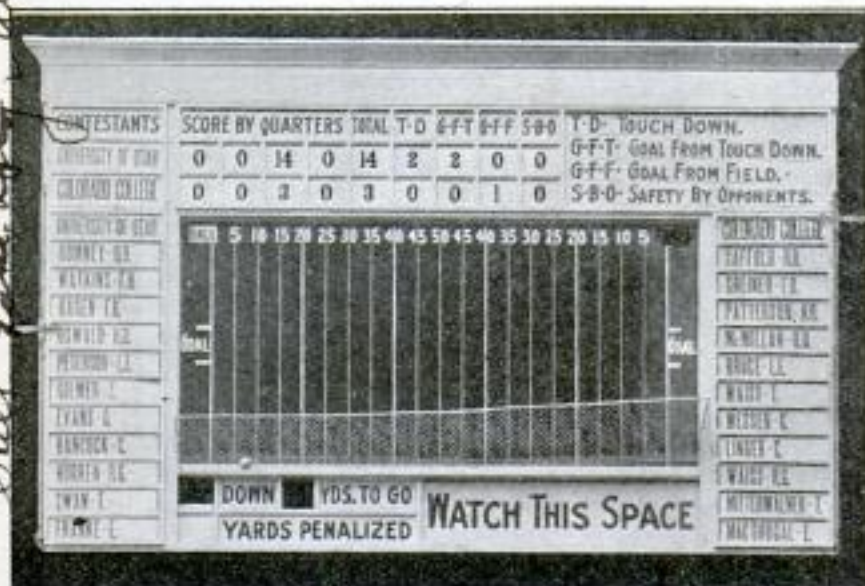

The Special Bulletin Board, Which Enabled University of Utah Football Fans to Follow the Play of Their Team during Out-of-Town Games, Showed Each Action of the Games within a Few Seconds After It Occurred

ANCHORED BARGE IS BOON TO ANGLERS

Although deep-sea fishing has long been a popular all-year-round sport in southern California, satisfactory facilities have never been provided. Recently, however, the situation has been bettered by the anchoring of a barge about two miles off

Long Beach. Here poles and lines are provided, and one may fish to his heart's content. The barge contains some small staterooms, or cabins, and a dormitory with cots. There is also a kitchen and a cook to prepare the catch, if desired. Small launches run out from Long Beach at frequent intervals to transport the anglers who may wish to return to land.

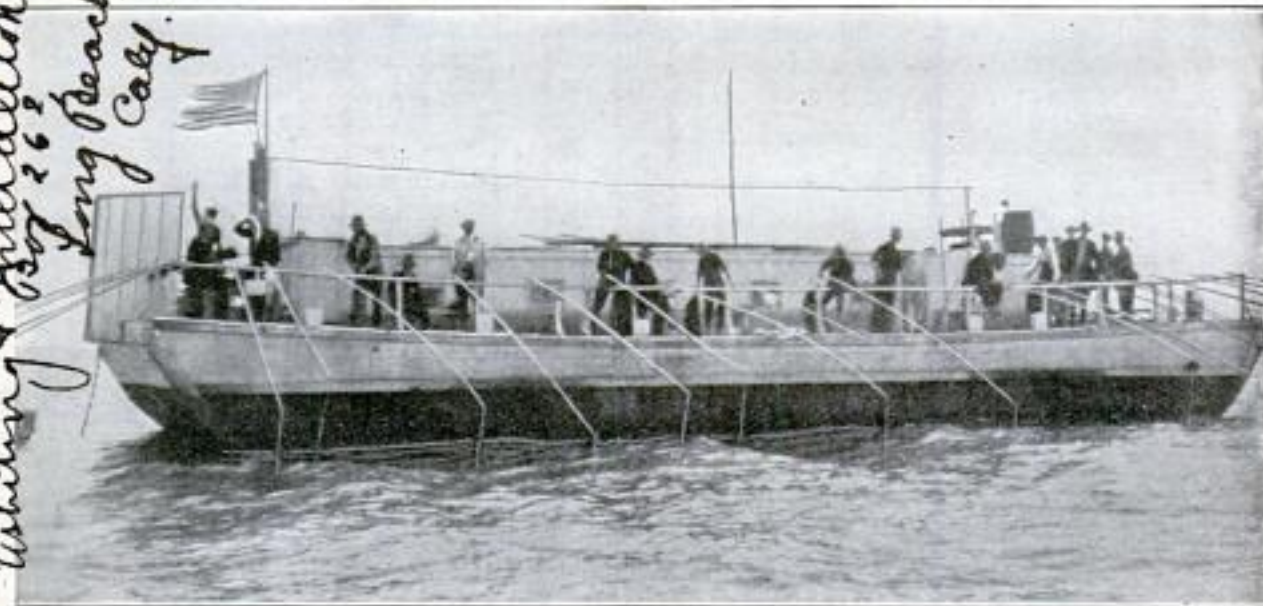

One may spend the night in a comfortable stateroom or dormitory cot aboard this barge, which has been anchored two miles off the shore for the benefit of Long Beach, California, deep-sea fishermen, and be right on the spot for the early morning fishing.

Com. Welfha Phillips, 468-20th St. San Pedro, Calif.

Com. Harold... 90... Utah

5428

Sea Products House Boat... Long Beach Calif.

7604



Some of the Residents of Point Barrow, Alaska, Greeting the First Ship on Its Arrival at Barrow, 12 Miles from Point Barrow Proper: The Woman at the Right, Carrying a Child, Is the Interpreter

BUILDING THE FARTHEST-NORTH HOSPITAL

BY LAWRENCE WILLIAM-PEDROSE

*Finchley Bldg.
Seattle, Wash.*

THERE was completed recently at Point Barrow, Alaska, the farthest-north settlement on the American continent, a modern hospital with all the facilities of an up-to-date establishment of this type. Besides being the farthest-north hospital, it serves the largest area for an institution of its kind in the world—more than 60,000 square miles.

This hospital, costing \$35,000, will require \$16,000 a year to operate. The staff consists of a surgeon-physician, a trained nurse, one or two assistants, a housekeeper, and a janitor. Point Barrow and the immediate vicinity of the hospital have a population of nine white persons, including the surgeon and trained nurse, and about 450 Eskimos. In the territory which it serves, an area 200 by 300 miles in extent, there are some 400 or 450 more Eskimos.

The medium of contact between the white doctor and the Eskimos is the wife of an American resident, a native woman who acts as interpreter.

In constructing the hospital the forces of nature had to be overcome. The materials were purchased in the States, sent

to Nome by regular steamer, and transferred at the steamship terminal to small power schooners. Despite treacherous weather, which continued through the brief summer, the materials were delivered at Point Barrow the first week in September, 1920, so that the builders could get up the frame and inclose it before the snow came, and work on the interior during the cold winter weather.



After the Frost Set In, the Chimney had to be Completed with Steaming-Hot Mortar. It Was a Source of Wonder to the Eskimos

The main building is 38 by 70 ft., and the basement rests upon ice. Within the larger basement is a sub-basement, 16 by 40 ft., which houses two hot-air furnaces, electric-light plant, and stored supplies. The floors are of two thicknesses of 1 by 6-in. flooring, with a layer of tar paper

7604
50

POPULAR MECHANICS

between. The roof consists of one layer of tar paper laid upon 1 by 6-in. tongue-and-groove lumber. Outside walls are constructed the same as the floor. The

the construction of the building is the windows. The original plan called for triple windows, to combat the cold, which ranges from 45° to 70° below zero in the winter time, but several sashes were broken in transportation, and there were left only two for each window. However, double windows serve effectually. Heat from the air furnaces is circulated by transoms over the interior doors.

The difficulties confronting the builders began when the materials were transhipped at Nome. The schooners carrying the freight became separated in a storm, and one was carried to the Siberian coast,

where it lost its propeller in the ice. Twenty-four days were required to transport the materials from Nome to Point

Barrow. Fifty-five tons of coal were carried. Two hundred tons were needed, but so severe was the weather, the balance, 145 tons, was not delivered that year, and the hospital went through the first winter sorely short of coal. Because of the danger that the Arctic

Ocean might not open to navigation every summer, it is essential that two-years' supplies be carried on hand at all times.



The Point Barrow Hospital as It Appeared When Completed Last Summer: The Building, Constructed of Wood and Tar Paper, was Finished with Two Coats of White Marine Paint

interior is finished with wood-pulp building board. Salt water and beach sand were mixed with cement to make mortar for the brick chimney.

The building has at present 12 beds, with a capacity for 70 if required. It has a well-equipped dispensary, a complete up-to-date surgery, and maternity, tubercular, and general wards. During the four summer months, a cess-pool and modern plumbing facilities are used. Sterilized snow water is utilized at all times. An interesting feature of

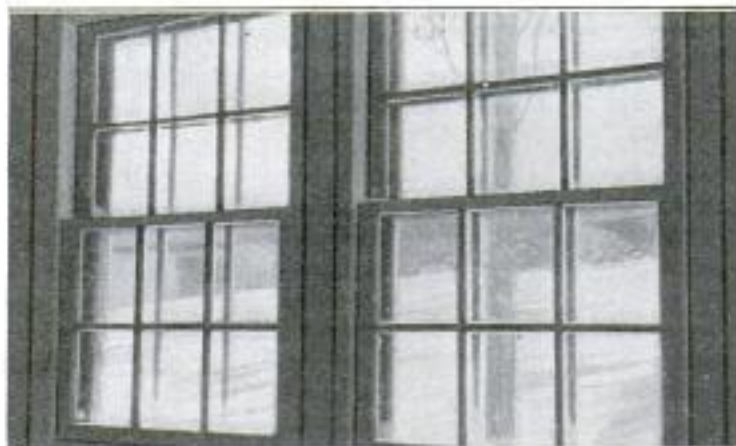

Triple Sashes were Planned, but Many were Broken in Transportation, Leaving Only Two for Each Window



The Principal Buildings of Point Barrow, the Farthest-North Settlement in North America: At the Left Is the Church, in the Center the Mission School, and at the Right the New Hospital. The Two Nearest Modern Settlements Are 300 Miles to the South and 400 Miles to the East

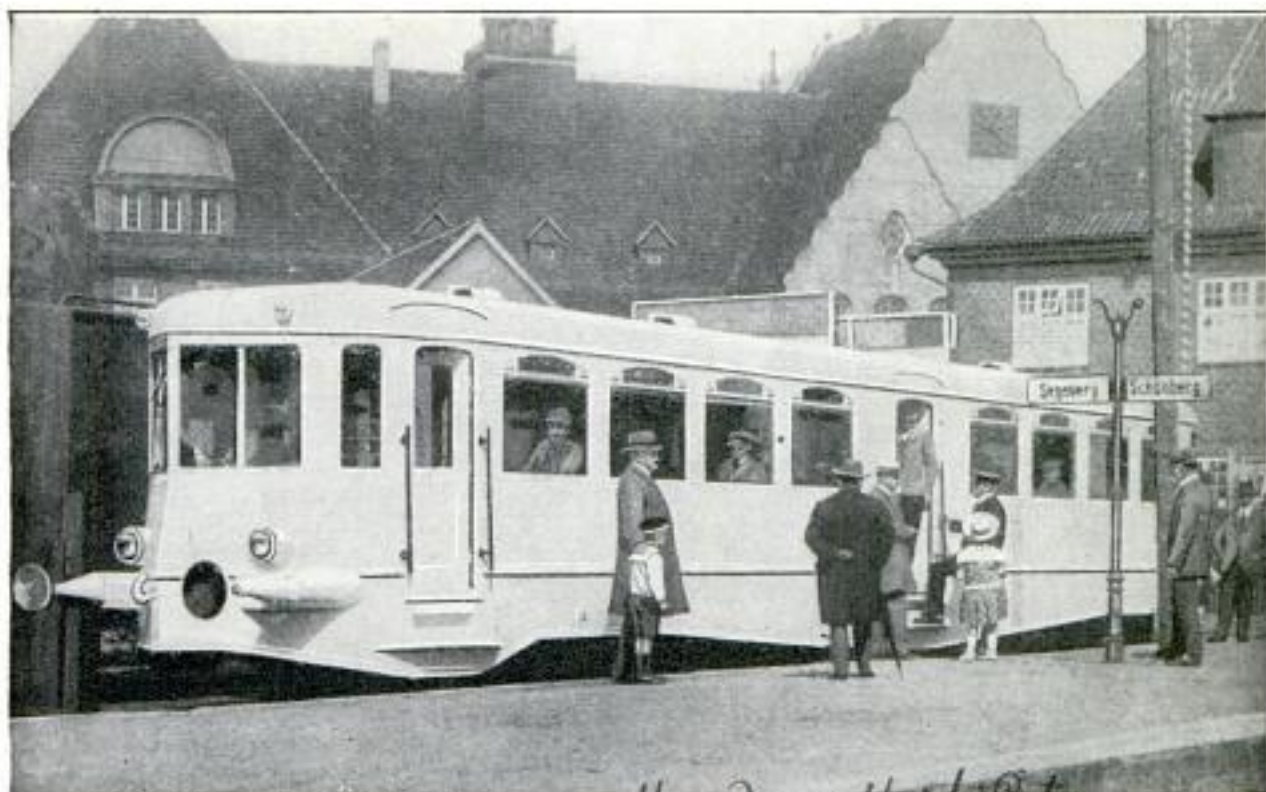

COPYRIGHT, KADEL & HERRBERT

153842 na St. New York City
 One of the Street Cars Constructed from Discarded War Material; The Interior is Finished Complete in Every Detail and the Exterior Speaks for Itself. The Two Projections Seen on the Front of the Car Are "Bumpers," Which Is a Common Feature on European Street Cars and Railway Trains. The Headlights Are Directly above the Bumpers

The foundation of the building was begun September 6. The chimney was started on the 12th. When the chimney was up 30 ft., frost set in, and it was necessary to build a bonfire around the mortar and use it steaming hot. The chimney, when completed, was a source of wonder to the Eskimos, but the electric-light plant struck them dumb with amazement and fear. However, when the natives learned the incandescent lamps were harmless, they took great delight in turning them off and on and examining various details of the plant. The hospital was completed last summer. It is planned to extend the electric-lighting system this winter to the principal houses.

All the difficulties of administering to the sick in the Point Barrow district have not been conquered by the completion of the hospital. Breaking down the prejudices of the natives is said to be difficult, for, like their white brothers, the Eskimos have a dread of the surgeon's instruments and will not take medicine unless it is disguised as a sweetmeat. Also, the native "medicine men" invoke the spirits to contest the power of the white man. However, modern science is gradually winning over the fears and superstitions of the Eskimos, and they are becoming more and more receptive to the aid which is being given them.

TANKS FROM GREAT WAR USED 7674 TO MAKE STREET CARS

The great Kiel plant in Germany, from which came so much of the war material, has now taken up more peaceable pursuits in the manufacture of street cars. These cars are made from the lumbering and rumbling tanks, and armored motor cars of all kinds, that carried explosives to the front, and which were ordered junked by the allies. They are driven by gasoline motors and are said to be complete in every detail.

MACHINE PERFORATES RAIL- ROAD TIES TO BE CREOSOTED

A machine, said to be the only one of its kind in the world, is used by a San Diego, Calif., lumber company for perforating railroad ties in connection with creosote treatment. The ties are fed into the machine between four studded steel rollers. Heavy springs press the studs into the ties, penetrating the wood about one inch on all sides. The ties are then dipped in creosote. The holes made by the studs allow the preservative to penetrate the wood more deeply than it otherwise would, and the life of the ties so treated is considerably longer than that of ordinary creosoted ties.

Char. R. Mc Cormick
 Lumber Co. San Diego, Calif.

Cont. J. R. Schmidt,
3557 St Charles Place

POPULAR MECHANICS

Cincinnati Ohio

52
7539

LARGE LIONESS TREATED FOR ULCERATED TOOTH



The Lioness Held against the Bars by the Wooden Partition: One Man Holds Her Mouth Open and the Other Injects the Medicine

One of the teeth of a large African lioness at the Cincinnati Zoological Gardens became ulcerated recently, and the animal refused to eat even juicy beef-steaks that were placed before her, until the painful tooth was treated. For treatment, the lioness was induced to enter a small cage next to hers, which had a wooden partition in it that could be pulled forward with ropes. The animal was then drawn up close to the front of the cage, and several iron rods were thrust around her and into holes in the partition, thus holding her helpless while the offending tooth was treated.

M. O'Brien
HIGH-SPEED HANDCAR BUILT BY SECTION FOREMAN

A motor-driven handcar of unusual construction has been placed in service by an Iowa section foreman. Being dissatisfied with the handcar supplied by the railroad, he decided to make one after his own ideas. A twin-cylinder motorcycle engine was used, and a three-speed transmission fitted to it. The engine is started with the regulation pedal starter common to motorcycles, and is equipped with an ignition-lighting system. As the handcar weighs but 350 lb., one man can han-

dle it, and it is claimed that a speed of 40 miles an hour has been maintained for a distance of 72 miles by the car, which is now considered a most valuable aid by the section foreman.

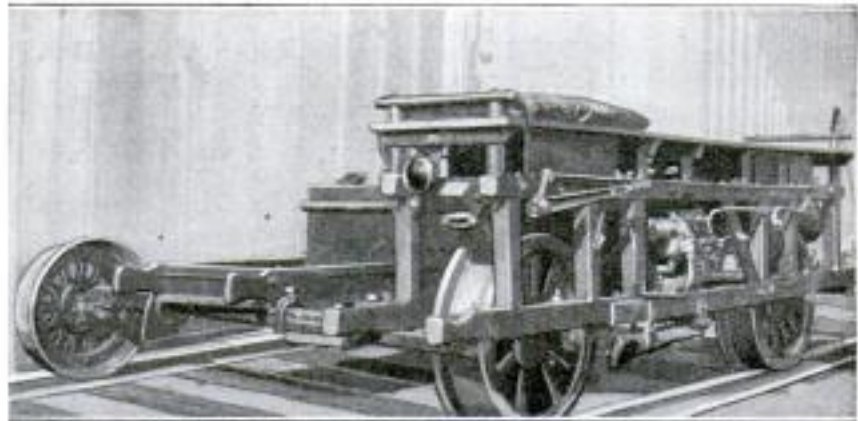

The High-Speed Handcar Placed on the Track and Ready for Use: The Engine, Taken from a Motorcycle, can be Seen Mounted at the Side, with the Exhaust Underneath. The Headlight is Seen on the End below the Seat

Harley Davidson Motor Co Milwaukee Wis
7281
Aerostudies
AIRPLANE-STABILITY TESTS TO MAKE FLYING SAFE

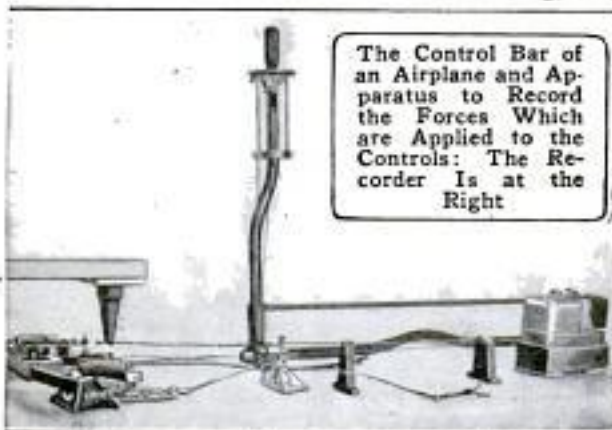

The Control Bar of an Airplane and Apparatus to Record the Forces Which are Applied to the Controls: The Recorder Is at the Right

If an airplane with its rigging intact and a capable pilot in command, responds readily to the controls, most airmen are satisfied to regard it as a stable machine. It is somewhat surprising, therefore, to learn that the standard-rigged "JN-4H," a highly satisfactory training plane, has been found to be unstable by the National Advisory Committee for Aeronautics, after a series of tests at Langley Field, Va. The stable machine is held to be one that will virtually "fly itself" with free controls, and that may be brought to the earth in safety

Jno. W. Kean, Bureau of Navigation
Navy Dept. Washington, D. C.

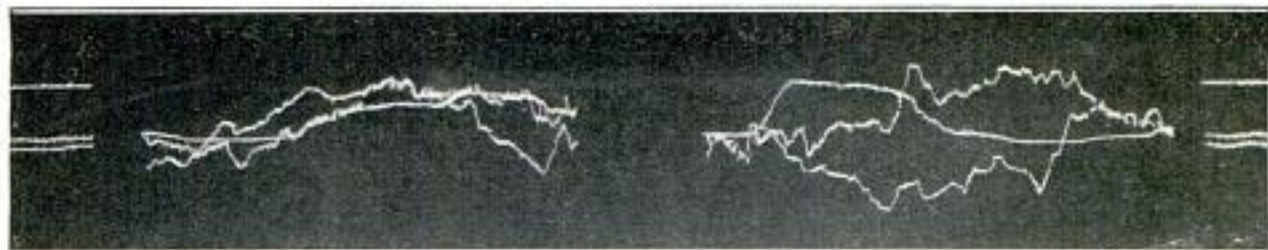

These Three Lines Represent the Variation in Forces Applied to the Controls of an Airplane in Flight as They Appear on the Recording Film in a Turn to the Left and to the Right. The Regularity or Irregularity of the Lines Indicates the Stability or Lack of Stability of the Plane

should a control wire become broken or ineffective.

The principle involved in the tests is that of a man holding a mirror which reflects a beam of light upon a moving film. Although his hand may appear perfectly steady to the eye, the unseen tremors will record a series of jagged lines on the film, not unsimilar to the record of a seismograph. In the same manner, the unconscious movements of the pilot in righting his machine against the forces of instability may be recorded.

In the application of the principle to the airplane, the control bar, or "joy stick," may be said to correspond to the hand holding the mirror. The stick has been connected with the mirror of a recording machine which reflects a constant beam of light upon a traveling film. Each movement of the controls in meeting forces is therefore translated to the film, and at the same time the force necessary to over-



A Small Parachute on a Wing Tip Gives a Drag of Known Force, and the Instrument Tells What Control Force is Required to Overcome It and How Much It Affects Stability

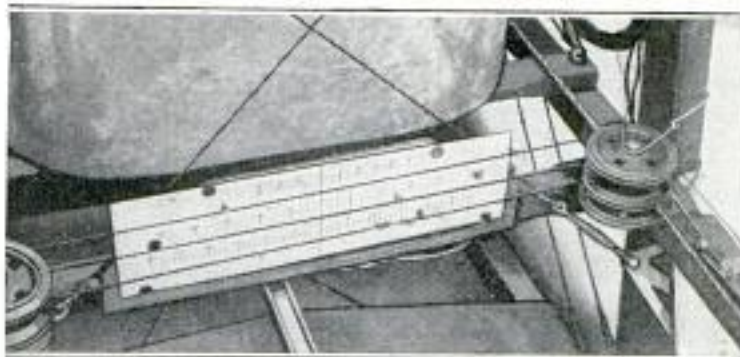

come the unstable tendency is registered on a visible scale in the cockpit.

To determine whether or not a machine is capable of righting itself in the face of weights or drags at the wing tips, ballast boxes and small para-

chutes are fixed on the underside of the lower plane. The machine is unbalanced by emptying the ballast from one of the boxes or by releasing one of the parachutes, and the force necessary to overcome the yaw or sideslip thus produced is recorded at the pilot's position.

Positions Assumed by the Controls in Meeting Forces are Read on This Scale Which is Placed in the Cockpit

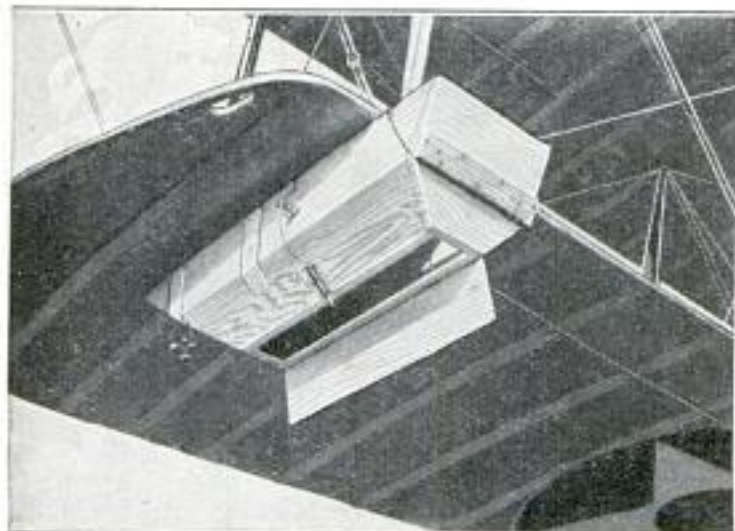

A Box on Each Wing Tip is Filled with Sand. By Emptying One Box, the Effect of Throwing the Plane Out of Balance can be Observed

☞ The copper roof on the Buddhist temple in Nagoya, one of the principal cities of Japan, is 510 years old and is still in perfect condition.

Cml. Leonard Smith

New York Times 1/16/21
P. 16

764 1 Camberwell S E 5,
33, Crofton Road
London, England. 7693

VOICE TELLS HEIGHT OF WATER BY PHONOGRAPH MECHANISM

POPULAR MECHANICS

SCIENTISTS STUDY INFLUENCE OF HIGH ALTITUDE ON LIFE

Warnings are usually given of the rise and fall of water in reservoirs, wells, tanks, etc., by the use of electrically

In the Andes, in Peru, 14,000 ft. above sea level—nearly as high as Pikes Peak—is one of the world's largest copper

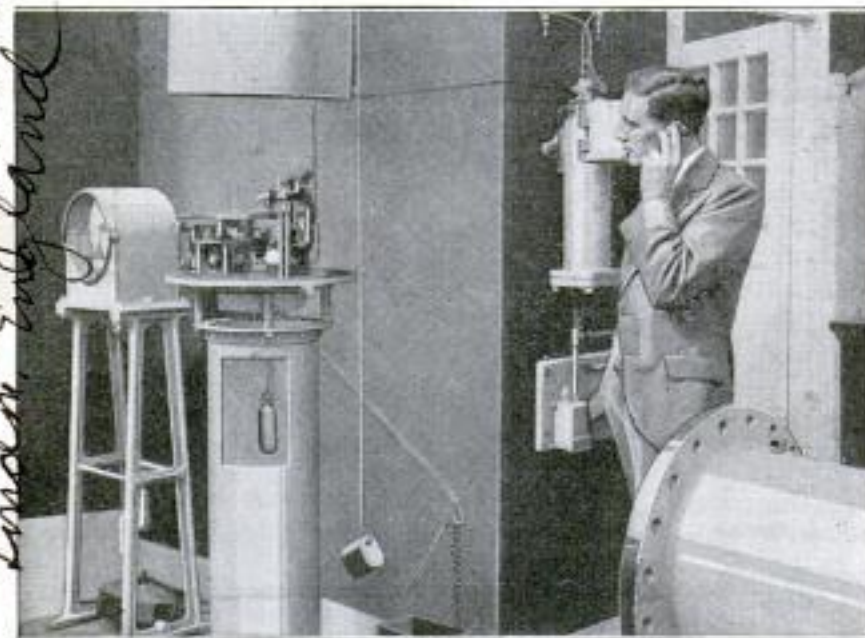

At the Left: "Visible" Water-Level Recorder. In the Center: "Audible" Mechanism. At the Right, the Man is "Calling Up" the Apparatus

operated alarm bells, but the system of bells has been improved upon by an English concern. The new apparatus, which operates after the fashion of a phonograph, has a telephone receiver placed in front of the speaking tube, and the mechanism is set in motion by the "ringing in," or connection, of a telephone operator. Thus anyone knowing the "number" of the machine, can "call up" and be connected in the same manner that any call is made. To the listener's ears comes the somewhat uncanny voice of the mechanical sentinel, saying anything from "Empty" up to "One double-nought," which means 100 feet.

The appliance has a disk record with 200 concentric grooves, so as to give the height of the water in "half feet," and 78½ ft. would be given as "seven-eight-half," etc. The height of the water regulates the lateral, or side, movement of the arm holding the needle, and the telephone connection automatically lowers the needle upon the record. The readings, or "answers," are repeated eight times, so that the chance of any mistake is reduced to a minimum, and the machine can be "asked" 100 times without being rewound.

mines, and the adjoining town of Cerro de Pasco is one of the highest towns having a substantial population. In this high altitude the air is of course exceedingly rarefied, and persons going directly from sea level to this height find physical exertion difficult, and experience other serious discomforts due to the lack of oxygen supply and diminished air pressure. Yet the natives work arduously and live in comfort. What physiological changes—what alterations of the heart, circulation, respiration, chemical composition of the blood, etc.—enable these people to

live permanently in this high altitude? Answers to these questions will be sought by eight medical scientists, five American and three British, who are now en route to Peru. It is expected that the information they will obtain will be useful in the treatment of certain diseases of the heart and lungs and also in the field of aviation.

7666 "SLOW RACE" NOVEL AUTO TEST AT CLEVELAND

It is difficult to find anything new in the way of automobile tests nowadays, but the novelty of a recent race in Cleveland, Ohio, is attracting attention. A local automobile manufacturer invited all drivers of his cars, in the city, to enter a "slow race." The course extended 2.3 miles through the city parks. Ten entrants started their cars, shifted to high, and got out before crossing the starting line. They then walked beside the cars, controlling them by the spark lever only. The winner completed the course in 46 min. 10 sec., and the second car in 40 min. 1 sec. The police department, hearing a race was to be held, sent several mounted police to the scene. They soon decided the race would not interfere with traffic, but became interested and joined the large crowd of spectators, which had gathered to watch the novel event.

Our Bureau of Information is for your benefit. Use it as often as you please.

J.K. Schmidt
90 Plain Dealer,
Cleveland, Ohio.

Miss George Kent. 199 High by Holborn, London England

5986 Cml. Lindsay C. Marshall
Cambridge, Ma.

DREDGING OYSTERS ON THE ICE

By Lindsay C. Marshall



The Men are Dragging the Oyster Dredge over the Bed from One Hole in the Ice to Another, the Rope Passing along a Narrow Slit Cut in the Ice

OYSTERS in the Maryland rivers are not safe from capture even when protected by 9 to 12 in. of ice. Ordinarily, the bivalves are won from the shallower portions of the oyster bed by means of tongs not exceeding 20 ft. in length; but about once in every five years an unusually cold winter closes to the oyster men the ordinary avenues of reaching their "game," and they are forced to resort to ice dredging. The ice, however, is not an unmitigated evil, for

it enables the men to reach the deeper portions of the beds, 40 ft. or so below the surface, and these are the more profitable because of being worked only occasionally.

The method of operating is simple but effective. A long rope is fastened to an ordinary oyster dredge, which is then lowered through a hole in the ice to the oyster rocks below. The dredge is drawn by man power to a similar hole some distance away, the rope working in a nar-



Sorting the Marketable Oysters from the Smaller Ones and the Débris Brought Up by the Dredge: The Young Oysters are Redeposited on the Bed and the Refuse Left to Disappear with the Ice



Sledding the Catch across the Ice to Market: The Difficulties Incident to Ice Dredging are Offset by the Higher Price Due to Scarcity

Great Choptank River
About 3 miles from Cambridge Md.

Nauticus
Nov 6, 1921

7642
**SINGLE-DECK SHIP CONVERTED
 INTO OIL TANKER**

row connecting slit cut in the ice. The men usually work in gangs of five.

Once on the surface, the oysters of marketable size are culled from the smaller ones and the trash included in the haul.

701
**LATEST ENGLISH CAR HAS
 "STRAIGHT EIGHT" MOTOR**

A new development of the high-priced automobile is seen in the product of an English firm. It is the first British car

By the use of specially designed tanks, an ordinary single-deck steamer has been converted into an oil tanker. The vessel, owned in Glasgow, Scotland, is of 5,522 gross tonnage, and is fitted with three main cargo tanks forward, and two abaft of the machinery space. These are constructed of four segments of cylinders attached at their ends to deep frames at the ship's side, and at their inboard ends to

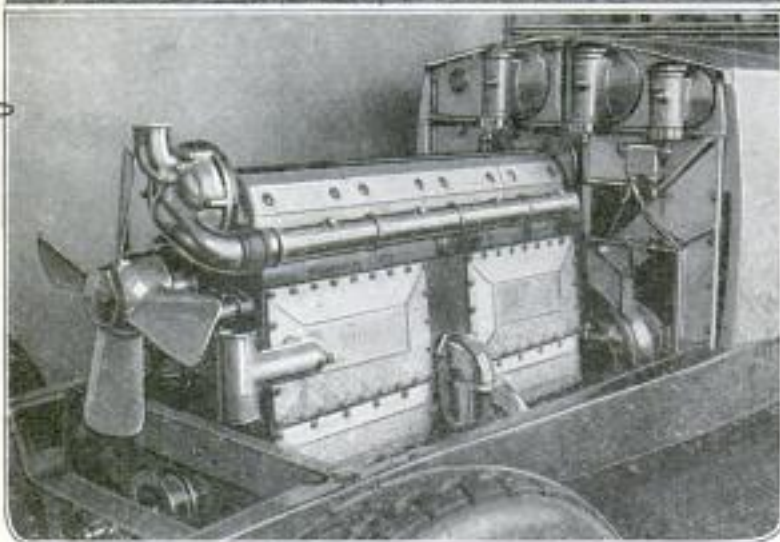
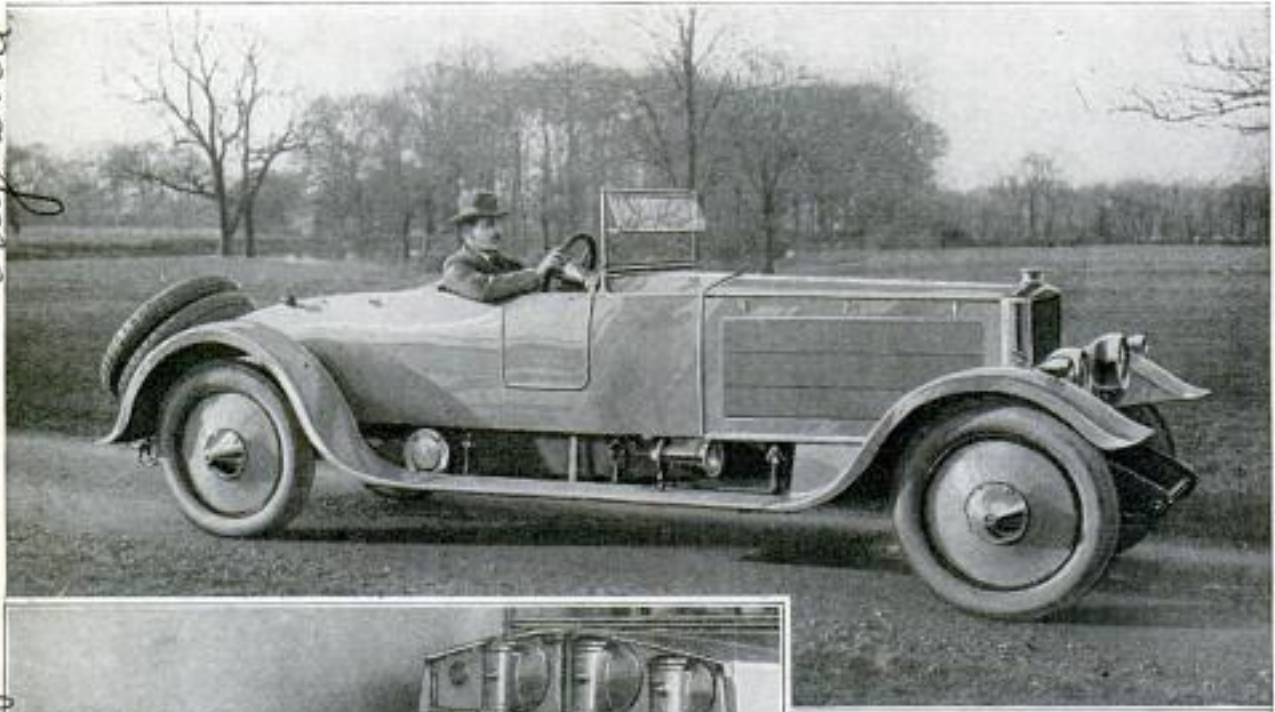

The New English Automobile, Shown Above, is Equipped with a Straight Eight-Cylinder Motor. It Is the Most Recent English Development of the High-Priced Motor Car. The Motor is Shown at the Left. The Neat, Narrow Effect of Placing the Cylinders in a Single Straight Line Instead of the Usual V-Form, can be Appreciated. It is Rated at 40 Horsepower and is Equipped with a Thermostatic System for Control of the Temperature. A Starting Motor is Built into the Gear Housing.

with eight cylinders in one line instead of the usual V-form. The engine is narrow and particularly neat in design. It has overhead valves and is rated at 40 hp., has thermostatic control of engine temperature, and a single-disk clutch. The car is provided with four speeds, and the starting motor is built into the gear housing. It has a beveled rear axle, splayed axle shafts and wheels, and an effective torsional antirolling device applied to front and rear axles.

vertical webs. The forward and aft tanks are shaped in conformity with the ship's lines. Together these tanks have a capacity equal to the vessel's full dead-weight carrying capacity, and the spaces between them, being buoyancy compartments, add to the stability. The tanks are connected to the upper deck above and to the inner bottom below, and together with the deep vertical webs between them, do away with the necessity for a center-line bulkhead.

7543

Cont. to Lawrence L. Clark
McGregor

Clava

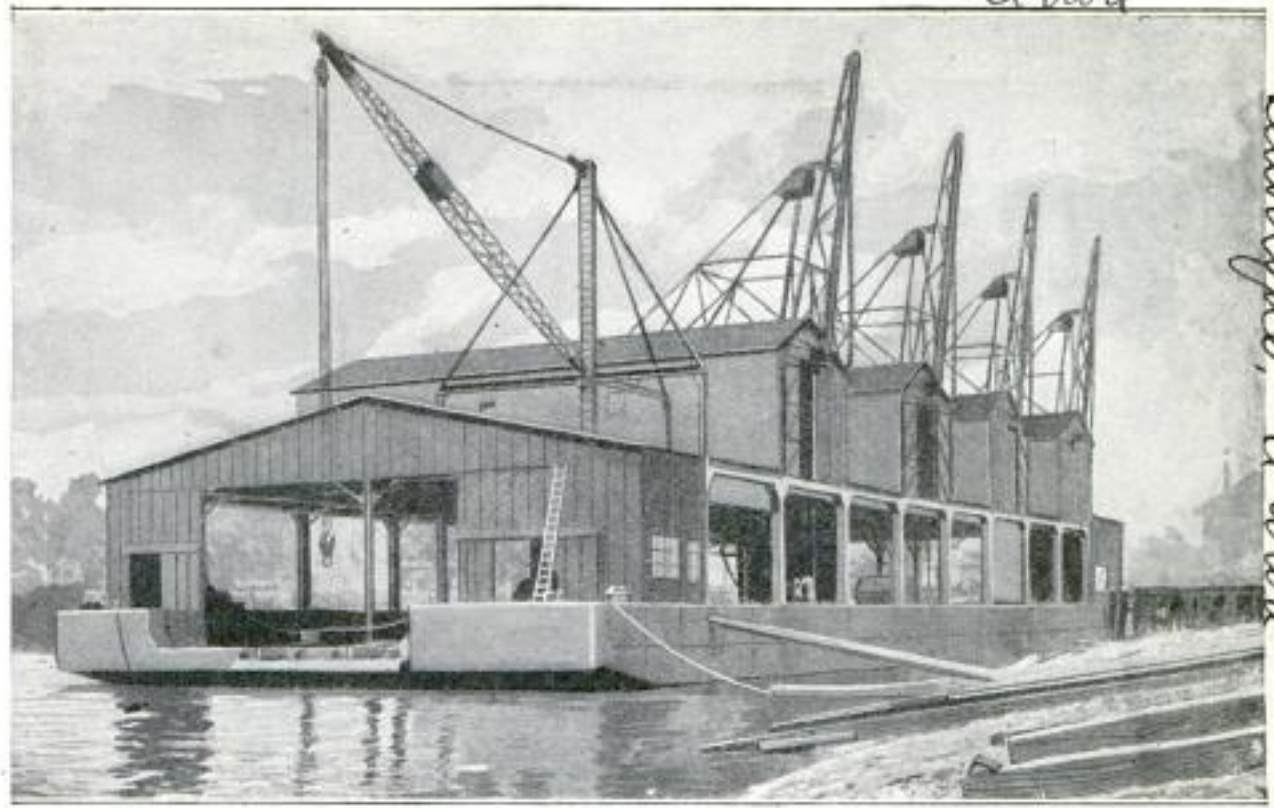

The Large Government Barge, Which Has Four Electric Cranes with 45-Foot Projecting Tracks Folded Up along the Side, and a 20-Ton Hoisting Derrick; At the Ends Are Large Openings for the Passage of Railroad Freight Cars, of Which 12 can be Accommodated on the Three Tracks of the Barge at One Time. The Inclosed Roof is Constructed of Steel

7543
GIGANTIC SERVICE BARGE FOR MISSISSIPPI SHIPPING

The singing, whistling, and happy-go-lucky negro roustabouts are being superseded by electric cranes and hoisting derricks in the handling of freight on the Mississippi River. During the late war, the government let contracts for the building of large terminal barges, and the last of this type of barge to be completed has recently been stationed for service at St. Louis. The barge is 320 ft. long, which is longer than an ordinary city block, is 75 ft. wide, which would be about twice as wide as a city street, and has an inclosed steel roof. The hold of the barge has been divided into compartments for carrying fuel oil, or similar liquid cargoes, and there are two electric pumps for transferring the liquids to boats or tank cars. Three railroad tracks are laid on the deck, and 12 freight cars can be run onto the barge at one time, to be unloaded. Four electric cranes and a 20-ton hoisting derrick are used for unloading, and the cranes have a projecting track which allows them to run out over the side for a distance of 45 ft. The projecting tracks can be folded up when not in use. The barge is electrically equipped throughout, and for night illumination, 24 clusters of lights,

aided by a row of lights along the side, have been installed. In addition, there are 16 portable clusters of lights with reflectors, which can be placed where needed. Boats plying between St. Louis and New Orleans, and St. Louis and St. Paul, will use this barge, which cost 400,000 dollars.

7669
GOVERNMENT SCIENTISTS WILL STUDY LAND REQUIREMENTS

In appointing a committee of five scientists from the Department of Agriculture to study the important problem of land utilization with regard to future requirements, Secretary Wallace called attention to several important facts. Many people believe that, with less than one-half of the national area in farms and only about one-quarter of it improved land, there is an unlimited reserve supply of farm land. By far the greater part of the 1,000,000,000 acres not yet in farms can never be used for growing crops, and land that can be made into farms will require heavy expense for clearing, drainage, irrigation, or fertilization. At the normal rate of growth, the population of the United States will reach 150,000,000 by 1950, requiring an addition of 243,000,000 acres of improved land, if the present per-capita acreage is to be maintained.

Embler - Lehighville Road + Boiler Works
 Lehighville, Clava

N.Y. Times 11/10/21
Page 3

58
7435

LARGEST FIREPROOF HOSPITAL IN THE WORLD



COPYRIGHT, UNDERWOOD & UNDERWOOD

SITUATED to the west of Chicago, near the suburb of Maywood, is what was formerly known as the Speedway Hospital. More recently its name has been changed to the Edward Hines Jr. Hospital. It got its original name from the fact that its site was formerly a speedway for automobile racing. It is a U. S. government hospital for sick and wounded soldiers and sailors, increasing numbers of whom are being cared for there. It is entirely fireproof, and is 2,040 ft. long, 50 ft. wide, and four stories high. It contains 1,284 rooms, 500,000 sq. ft. of cement flooring, and 200,000 sq. ft. of roofing. The grounds have an area of 320 acres. The surrounding scenery is somewhat bleak, but this affords the advantage of offering no obstructions to the circulation of fresh air.

7504

COURSE OF RIVER CHANGED BY SINGLE BLAST

Because of the new channel that was scoured out by the Arkansas River at a point 14 miles above Pueblo during the season of disastrous floods last year, it was found necessary to change the course of the river again to provide water for the irrigation projects. It was proposed to blast down an overhanging rock and thus form a dam that would force the water into the irrigation ditches. The lower part of the rock was sandstone, while above were thin strata of limestone and shale.

It was along the base of this rocky bluff that the new channel had been formed. Owing to the fact that, after the waters had subsided, most of the flow continued along the new channel, the head on the ditch gates was greatly lowered.

For this work of blasting, 5,000 lb. of black powder was used to shatter the rock, and considerable dynamite was mixed with the powder to insure better ignition and splitting effect. A tunnel, 6 ft. high and 4 ft. wide, was driven 35 ft.

900 Ellsworth Bldg. Chicago Ill.



Before the Blast the River Flowed in Its New Channel about the Base of This Cliff

point 14 miles above Pueblo during the season of disastrous floods last year, it was found necessary to change the course of the river again to provide water for the irrigation projects. It was proposed to blast down an overhanging rock and thus form a dam that would force the water into the irrigation ditches. The lower part of the rock was sandstone, while above were thin strata of limestone and shale.

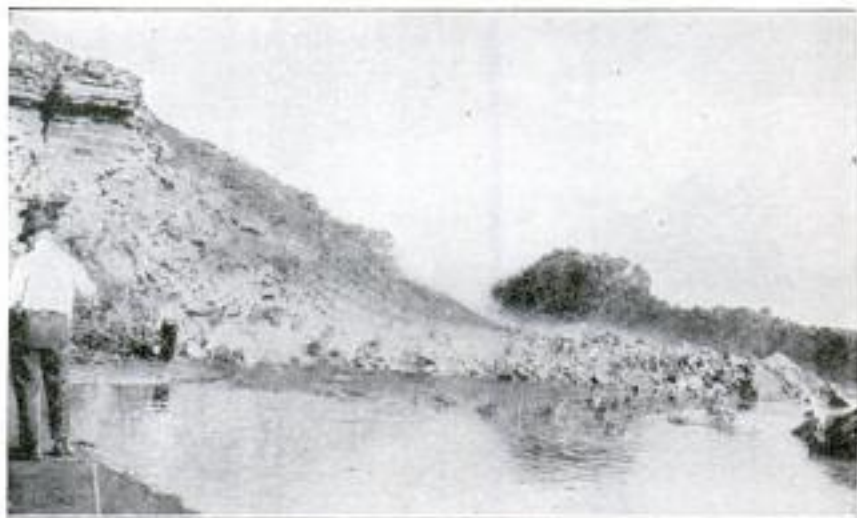

Five Thousand Pounds of Powder and Dynamite Blew the Cliff into the Channel, Effectively Damming It So That the Current was Controlled and Water Was Again Available for the Irrigation Ditches

Cmd. George J. Paul,

5842

straight into the cliff, with a 5-ft. side branch at this point, whereupon the tunnel was driven 10 ft. farther. It was in this last part that the charge was placed.

When this tremendous charge was touched off, a block of the cliff was torn off and fell, crushed into fragments, thus forming a dam across the channel and

DOGS USED FOR WINTER TRAVEL IN NORTHERN QUEBEC

At Sanford Junction, Quebec, Can., a favorite means of travel in winter is on



Dogs at Work in Northern Canada, Where They Are Most Important in the Winter Life of the People



Dogs Also Take Part in Winter Sports as Shown at the Right. Ski Riding, with a Dog to Pull the Rider, is Great Fun —for the Rider

controlling the current, as had been planned. In a short time the irrigation ditches were filled to capacity because of the 8,000,000 lb. of rock that had been dislodged in the single great blast of powder and dynamite.

☐Vessels at sea are to be supplied with a radio-news service relating to derelicts, sunken or floating wreckage of all kinds, misplaced harbor buoys, mines, ice, rafts, and any other items of interest, through an arrangement between the U. S. Navy Hydrographic Office and the Naval Communication Service.

skis, with a dog, in harness, to pull the ski rider over the frozen trails. There, throughout a large part of the year, dogs furnish the most important, if not the only, means of transportation. They are used for all kinds of hauling and some of the things they can do are surprising to a person unfamiliar with the use of dog sleds. It is a common thing for two dogs to haul a log 25 ft. long and 10 in. thick at the butt. Again, their load may be ice, to be stored for the summer, firewood, or provisions, and the passenger sled is an everyday necessity, which is ordinarily pulled by a single dog.

*Carl Henry Sanford
Sanford Station, Q. & L. St. Ry
Canada*

I. W. Chas. Weber
52 Gray St. Newark, N. J.
POPULAR MECHANICS

7334

APPARATUS FOR AERATING WATER IN A BATHTUB

Bathing in water medicated with gases, such as carbonic acid or oxygen, is a well-

known treatment for various complaints. It is claimed that water aerated by a new

device is just as beneficial. The aerating apparatus consists of a small blower direct-connected to a tiny electric motor. A hose connects the discharge port of the blower to a series of perforated pipes laid on the bottom of the bathtub. From the perforations countless little air bubbles continuously float upward through the water to its surface. The speed of the motor can be controlled to regulate the flow of these bubbles as desired. The same thing is done, but with less pressure and with only a single pipe, in aquariums.

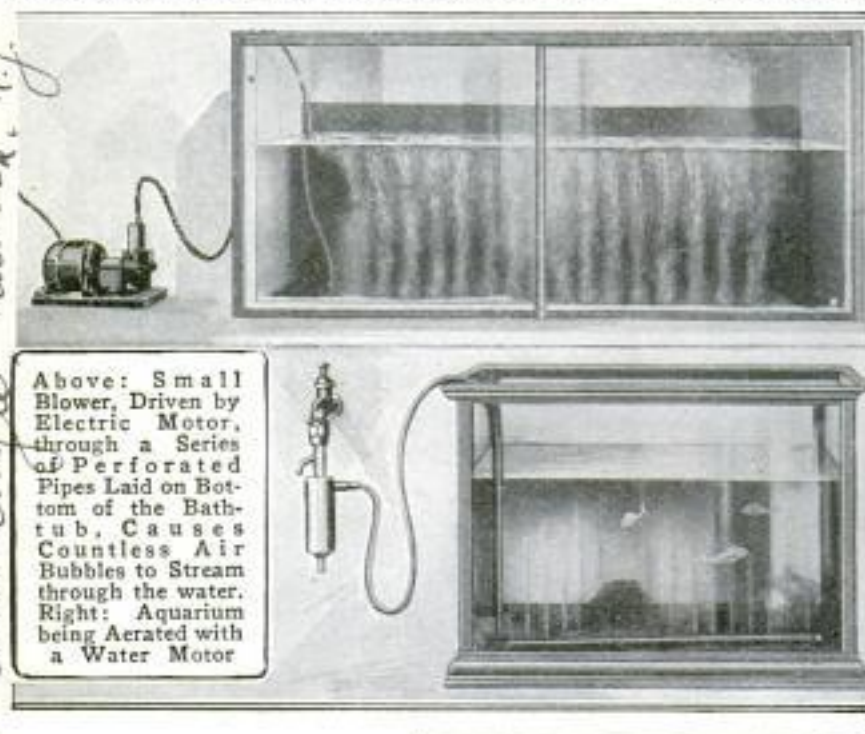

Above: Small Blower, Driven by Electric Motor, through a Series of Perforated Pipes Laid on Bottom of the Bathtub, Causes Countless Air Bubbles to Stream through the water. Right: Aquarium being Aerated with a Water Motor

SUSPENDED FERRY CARRIES TRAFFIC ACROSS ENGLISH RIVER

A NOVEL kind of bridge for transporting pedestrians and vehicles across a river, without interfering in any way with the passage of full-rigged ocean-going shipping, is in operation at the town of Newport, Eng., on the river Usk, four miles from its junction with the Severn. On account of the steepness of the banks, the great rise and fall of the tides, the length of the span, and the height of headway needed, any ordinary kind of bridge was impracticable, and therefore this special kind, called a "transporter bridge," was erected.

The stationary members of the bridge consist of a pair of supporting towers, 242 ft. high, on each bank of the river. These carry two trussed girders, 16 ft. deep and 26 ft. from center to center, across the span of 645 ft. The towers are braced, and the girders are partly supported by cables in the manner of a suspension bridge. The towers are of steel latticework, and each pair, connected above to the trussed girders and inclined outwardly at their concrete foundations, resembles closely a pair of exaggerated derrick booms. The total clearance from high-water level to the underside of the span is 177 ft. The

horizontal trussed girders are tied together and braced as in any ordinary bridge span, and their bottom chords form a track, in each case, for 15 wheels on either side of its web. These wheels are carried on steel brackets which are part of a large traveling frame, 104 ft. long, which forms the means of transporting a suspended platform or carrier. This is like a section of a bridge deck, 33 ft. long and 40 ft. wide. It has a central roadway large enough for two four-wheeled vehicles, and on each side there is a roofed-in sidewalk. The whole is electrically lighted. The suspension of this carrier from the traveling frame above is a very elaborate system of 30 cables, trussed so as to brace the carrier against swaying under any wind conditions. The traveling frame that transports this carrier is propelled by a continuous cable driven by a drum in connection with two 35-hp. electric motors in the power house near one end of the bridge. All control is operated from a pilot house on the carrier, which moves at a speed of 60 ft. a minute, taking 10 minutes to cross from bank to bank. The bridge is designed to carry safely a moving live load of 66 tons.

7559
Cmt. Leonard Smith, 33 Crofton Road
Camberwell, S. E. 5, London, England.

7559



Left: View from Water Level of the Transporter Bridge, Showing the Platform or Carrier That is Suspended from the Traveling Frame above, and Which Transports This Carrier across the River. The Central Part of the Carrier Is for Vehicles and the Covered Sidewalks Are for Pedestrians. The Elaborate System of Suspension Cables Prevents Swaying under Any Wind Conditions. The Two Inclined Towers at the Farther End Support the Trussed Girders and Their Bracing. Above: Upper View of These Trussed Girders and Their Bracing

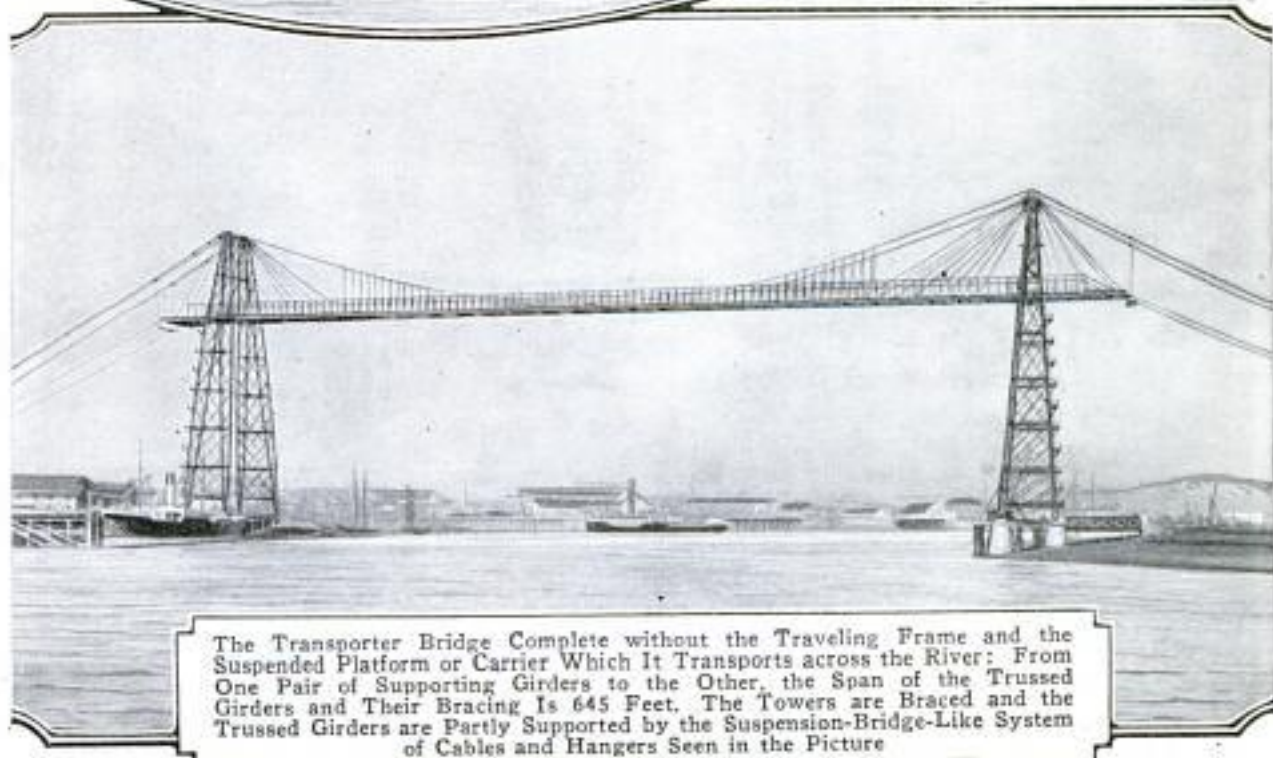

The Transporter Bridge Complete without the Traveling Frame and the Suspended Platform or Carrier Which It Transports across the River: From One Pair of Supporting Girders to the Other, the Span of the Trussed Girders and Their Bracing Is 645 Feet. The Towers are Braced and the Trussed Girders are Partly Supported by the Suspension-Bridge-Like System of Cables and Hangers Seen in the Picture

7668 Christian Science Monitor

CARNIVAL CROWD ENTERTAINED BY NOVEL PUSHBALL GAME

Among the many variations of the game of pushball that have appeared from time to time, one of the most novel

LAUNDRY ASSOCIATION TO HAVE METHODS-TESTING PLANT

An American institute of laundry-research work, for testing laundry methods, materials, and machinery, will be established by the Laundry Owners' National Association, at some town near Chicago. The association already maintains a fellowship in the Mellen Institute of Pittsburgh for chemical research, which has done much good, but it is so anxious to improve laundry methods that it intends to establish its own laboratories and maintain its own experts. The idea is not to build a model laundry. The plant will be a place where members of the association may have their individual problems worked out, or where



COPYRIGHT, RADEL & HERBERT
An Exciting Moment in the Game of Firemen's Pushball: With Spray Flying in All Directions, the Players are Taking the Ball down the Field for a Try at Their Opponents' Goal

has been the use of hose as the means of driving the ball. Such a game, played at a recent carnival at Sevenoaks, Eng., could well be called firemen's pushball, for it was played by two teams, each composed of four local firemen equipped with fire hose. The streams of water were the only means allowed for pushing the ball, and the game became fast and exciting. Of course the players were soaked, and occasional showers which sprinkled the spectators only added to the genera' merriment.

they may send members of their staffs for study and observation. The plans are already completed.

TEST MAKES BURIAL VAULT SERVE AS WATER CRAFT

Paddling down a river seated on top of a 600-lb. iron vault, is a curious method of travel, but it was used recently on the Sandusky River at Upper Sandusky, Ohio. It was not a pleasure trip, however, but a public demonstration of the water-tight character of that particular make of burial vaults. After a one-mile trip, during which the vault was in the water for one hour 55 minutes, it was found to be perfectly dry inside.



Hardly a Rival for the Birch-Bark Canoe as a Means of Travel, but a Most Effective Test of the Water-Tight Character of the Vault

*Larson Tool & Stamping Co
Attleboro, Mass
25
280 Broadway
2
Eng. Hugh A. Leamy
c/o The B. W. M. 280 Broadway
2
Life*

"HOME-PORT" PLATES POPULAR FOR AUTOMOBILES

Automobile owners in different cities throughout the country have recently been won over to the fad of carrying across their radiators, suspended from the light brace rod, neat brass or black-and-white plates bearing the names of their home towns.

Stealing a leaf from the book of ship-owners, the motorists are labeling their cars with their "home ports," and it is hinted that the plates serve a double purpose. They not only inform citizens of different communities regarding the home towns of visiting motorists, but in those towns they stamp the resident motor owner as such, and perhaps win for him a little more consideration from the police than the visitor gets.

*Beckley - Palston
can supply in
lots of 100.*

*Wojanogat Burial Vault Co
Upper Sandusky, Ohio.*

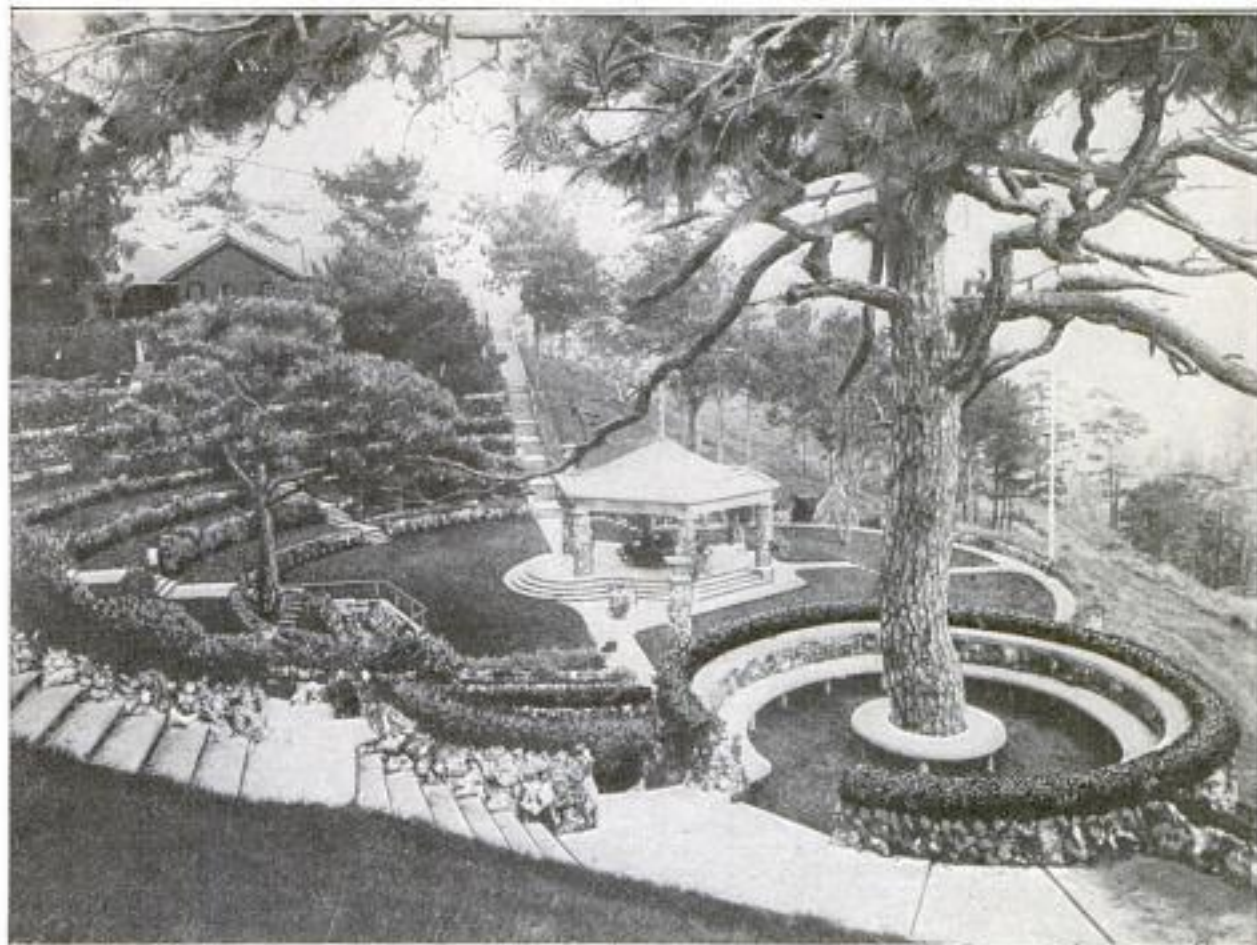

TERRACED SUMMER GARDEN FOR GOVERNOR OF THE PHILIPPINES *International*

WHEN General Wood inspected his future summer home, as governor of the Philippines, recently, he was delighted with this beautiful terraced garden, reached by many flights of stone steps from his summer residence. It was originally planned, on the hillside at Baguio, Benguet Province, by the natives, but was completed by expert Filipino landscape gardeners. The general effect of the garden is Oriental, but there is also an entirely original atmosphere about it, not to be found anywhere else in the world.

5434

OLD TELEGRAPH CABLES USED TO BUILD FOOTBRIDGE

A very interesting footbridge spans the North Thompson River in British Columbia, of which the entire superstructure is built of cables. These cables are made up of 15 strands of galvanized wire which was originally intended for use in a telegraph line that was to reach Paris from New York, over Alaska and Siberia. The project was abandoned, however, when the Atlantic cable was successfully opened. The cables and other material were then cached at various points along the proposed route of the telegraph line and were subsequently appropriated by the settlers. In

its final use as the suspension footbridge, the wire still performs important service.



Footbridge Suspended by Means of Cables Which were Originally Intended to be Used as Part of a Telegraph Line from New York City to Paris, France, by Way of Alaska and Siberia

Com. Es. P. Melrose Box 290
Kamloops, B. C., Canada.

Cml. Anthony Robinson

New York Times

Nov 28 1911

San marcial

10/21/28

64

POPULAR MECHANICS

P. 16, Vol. XVI, 168

7529

IMPROVED RAILWAY SIGNALS INSURE SAFETY IF BROKEN

In the old, and still nearly universal, type of railway signal, the semaphore or



Two Samples—One with Single and the Other with Double Semaphores—of the New Railway Signal That Rises, Instead of Falling to a Horizontal Position, to Indicate Safety

arm stands horizontally to indicate danger, and falls to a position parallel to the post to indicate safety, or line clear. The objection to this method is that in case of a break in any part of the operating mechanism the semaphore may drop by gravity



Ordinary Type of Railway Signal in Which Semaphores Hang Vertically to Indicate Safety or as Shown to Indicate Caution

to the hanging position, and thus signal safety when there might be danger. In a new form of signal, by reversing the position of the semaphore and making it stand upward instead of downward, to indicate safety, it is obvious that in case of a break of the operating mechanism the force of gravity brings the semaphore to the horizontal position, where it is stopped, indicating danger instead of

safety. This may cause some delay and inconvenience, but it will never lead to a wreck, as has actually occurred more than once with the other method.

7563

SIX-MILE EXTENSION PROPOSED FOR MANHATTAN ISLAND

About 10 years ago T. Kennard Thomson, a well-known engineer, startled New York City by a proposal to extend the area of Manhattan Island by means of built-up land. The plan, described in Popular Mechanics of August, 1911, has again been proposed, to the Broadway Association, which has been convinced of its desirability, if not of its practicability. The idea is that, by means of concrete sea walls, the island can be extended about six miles into the bay, close to the coast line of Staten Island, adding about six square miles of extremely valuable real estate to Manhattan Island. This would relieve congestion, keep the center of the city in its proper place instead of allowing it to follow the present tendency to drift north, and enormously increase the tax resources as well as debt limit of the city. Returns from such a project, if carried out, would far more than compensate for the expense involved.

7342 Water

STANDPIPE BUILT OF CONCRETE IS UNUSUAL AND ARTISTIC

A standpipe, which is both unusual and artistic in appearance, was built to furnish

a reserve supply of water to a hospital near Grand Rapids, Mich. It is constructed entirely of concrete, including the cross girders and braces, as well as the supporting columns. Even the supply pipe, which connects the tank at the top with the water mains, is of the same material. The tower is 300 ft. high and 50 ft. in diameter at the base.

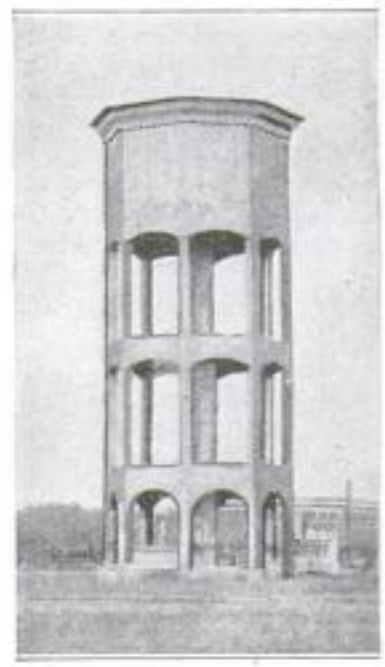

Cml. Worth C. Knowles

Atsego, Mich.

Copyrighted material

7280 Cnd. Arthur Hallam
317 Cedar Ave.
POPULAR MECHANICS

65
Minneapolis, Minn.



When the Trucks have been Loaded by the Warehouse Tenants, They are Delivered to a Tunnel by Elevators, Made Up into Trains like This, and Hauled through the Tunnel by Tractors to the Freight Station at the Other End. There Are Two of These Warehouses Now in Operation in Minneapolis, Minnesota, and More will Be Ready Shortly

7280
**TERMINAL-WAREHOUSE SYSTEM
DEVELOPED IN MINNEAPOLIS**

A new warehouse system affords facilities to manufacturers who wish to establish branch warehouses in Minneapolis, Minn. Space is rented in a series of standard warehouses, two of which are completed and in operation. At one end of the system is a joint freight station, connecting with all steam and electric railroads entering the city. Each tenant loads outgoing shipments onto small trucks and delivers them to elevators which carry them to a tunnel. An electric towing car picks up the loaded trucks and hauls them through the tunnel to the freight station, where the goods are loaded into cars. The loaded cars are pulled to the city transfer yards for distribution to the roads over which they are routed. A post office and express office, in the station, take care of shipments to be made by mail or express, and motor trucks handle city deliveries so that the tenant need not invest in trucking equipment. The small trucks, when emptied, are returned by a gravity

track to the warehouses, where tractors distribute them to the tenants' elevators. Incoming freight is handled in the same way from the station to the warehouses. A system of sidetracks and loading platforms is provided along the warehouses for handling carload shipments.

☐ We want all our readers to write us freely and often whenever they wish additional information on articles published in this magazine. Address Bureau of Information, Popular Mechanics, Chicago.

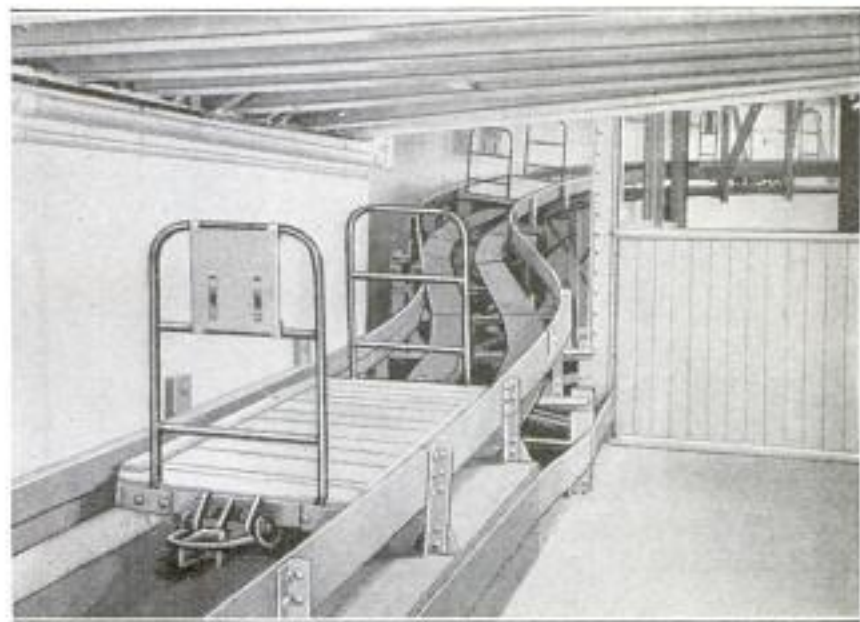

After the Trucks are Unloaded at the Freight Station, They are Placed on a Track and Run Back to the Warehouses Where They are Redistributed to the Tenants. Some of Them can be Seen Here Running Back by Gravity

Enk. J. B. Schmidt
3557 St. Charles Place

Commerce
Reports
Oct. 31, 1921

66
7523 Hyde Park, Cincinnati, Ohio

CINCINNATI FIRE DEPARTMENT OPERATES A "COFFEE TRUCK"

Firemen in Cincinnati, Ohio, will always be sure of a cup of hot coffee when fight-

RICE HULLS ARE CONVERTED INTO USEFUL PRODUCTS

The amount of waste in the rice crop has always been about one-third of the total crop, in weight, but a Berlin, Germany, inventor claims that he has solved this problem of waste and can utilize the hitherto useless rice hulls for many useful products. By a process of steam application, three-fourths of the hulls' weight can be made into cellulose for the manufacture of paper, and by another process, four-tenths of the hulls can be made into coke filter materials, such as are used in the manufacturing of sugar. Besides these, paraffin, phenol, carbonic-acid gas, carbon monoxide, hydrogen, and acetic acid can also be produced in sufficient quantities to be commercially worth while reclaiming.



Some of the Firemen of the Cincinnati, Ohio, Fire Department and Their New "Coffee Truck," Which Answers All Night Calls: The Fire Fighters will Always Have a Cup of Hot Coffee to Thaw Them Out in Freezing Weather

ing fires this winter, and will no longer have to depend on the possible generosity of some restaurant proprietor when cold and weary from their strenuous work. A "coffee truck" has been added to the department's equipment and answers all calls to big fires at night. It is a light truck with a big coffee urn mounted on the rear. A special subscription fund, to which all the city firemen contribute, keeps it going.

7516 RAILWAY COAL BILL REDUCED BY CONSTANT REMINDERS

For the purpose of constantly impressing upon its employes the virtue of saving coal, a railroad has placed many reminders along its right of way. This

7647 HIGH-GRADE IRON PRODUCED FROM MAGNETIC SAND

The process developed in New Zealand some time ago, of converting the large deposits of iron, or magnetic, sand found there into pig iron, has been adopted by the Japanese for the exploitation of their own vast deposits of this form of ore. The process consists of combining the iron sand with coke, by using hot gas flames. The product is then called ferrocoke, from which a fine grade of iron is easily produced.

Those wishing further information on anything described in the editorial pages can obtain it by addressing Bureau of Information, Popular Mechanics Magazine, Chicago.



This Shows One of the Railway Towers along the Right of Way with a "Reminder" Posted upon It That will Be Sure to Catch the Eye of the Locomotive Crew

experiment has been in effect for some time, and according to the officials of the road, has given very satisfactory results.

see Jan. 1921 - P. 32.
Century & Ill. Journal

Item from Tokio, Japan. Illinois
Crew of two Japanese

Central R.R.
Copyrighted material

Wide World Photos, 229 W 43rd St,
New York City

NINE-HOLE GOLF COURSE WITH UNUSUAL HAZARDS

BY H. A. LANE

THAT variety is the spice of life is certainly illustrated on an unusually laid-out golf course in England. Hazards, bunkers, and obstructions of all sorts, abound on this oddly constructed course, but in spite of these handicaps, it is said, a very good game is being attained. In this country, the chief hazards are sand pits, water, or uncut grass, called "the rough," and these are found upon the fairways, or in other words, the distance between the putting green of the hole ahead and the tee from which the player is driving. The putting greens are always kept smooth and free from anything that would deflect the course of a ball. The freak course in England, however, has tees elevated on boxes, and on the fairways are found nets with a small hole in them, through which the ball must be lofted. Wire screens and



This Greatly Elevated Tee Is a Very Unusual Hazard, and Is a Test of the Golfer's Ability at the First Shot of the Game



Here is Seen a Net through Which the Ball must be Driven, and Which Requires Accurate Driving with Mashie or Iron Club



View of One of the Putting Greens, Showing a Wooden-Trough Arrangement Which Makes This Hole Very Difficult to Play. Left: The Putting Green, Which is Usually Kept So Smooth and Free from Any Obstructions, Here Has a Wire Screen and Bushes upon It

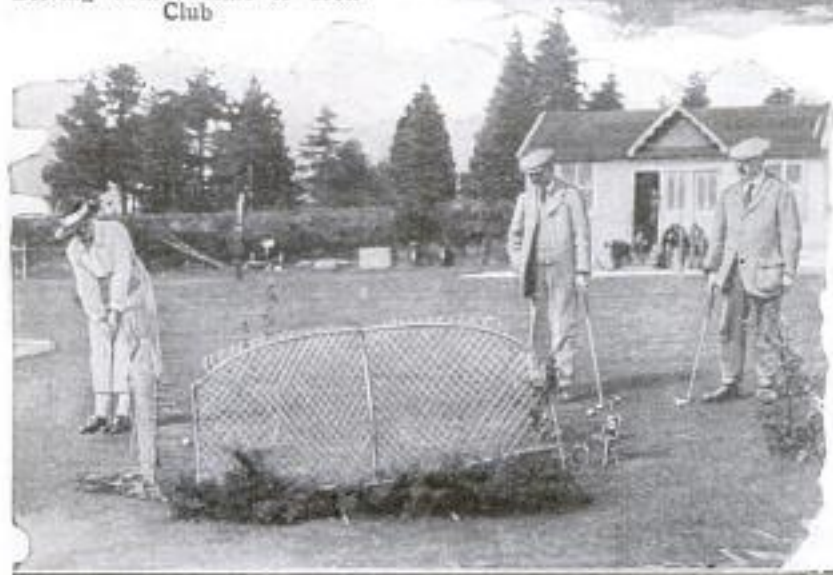

bushes are placed on the putting greens, as well as wooden-trough arrangements, which make it a very difficult task to get the ball in the hole. Those who follow the game of golf will readily appreciate the trouble that would be encountered in overcoming these unusual handicaps.

**SIMPLE BULK-GRAIN LOADER
IS INEXPENSIVE**

Simple, inexpensive equipment for loading bulk grain into railroad cars is provided

by a lately developed conveying apparatus. The loader does not provide storage space. Grain is dumped into a concrete pit, from which it goes through a regulating gate into the elevator boot. Here a bucket and belt conveyor picks it up and carries it to a hopper at the head of the elevator shaft. From the hopper the grain is carried through a metal pipe and flexible loading spout to the car, the spout serving as a nozzle to distribute it. Power for driving the conveyor is furnished by a small gasoline engine. The equipment can be installed where the expense of an elevator would be prohibitive. It is made in sizes to handle either 1,000 or 2,000 bu. an hour.



Loading a Box Car with Bulk Grain by Means of a Simple New Conveyor Device: It is Made in Two Sizes, One Handling 1,000 and the Other 2,000 Bushels an Hour, and Is Inexpensive to Operate

TELEPHONE-REPAIR TRUCK WITH NOVEL FEATURES

Several novel features are incorporated in a repair motor truck designed for a Pacific-coast telephone and telegraph company. The truck, behind the driver's cab, is of ample dimensions and can be completely inclosed with curtains.

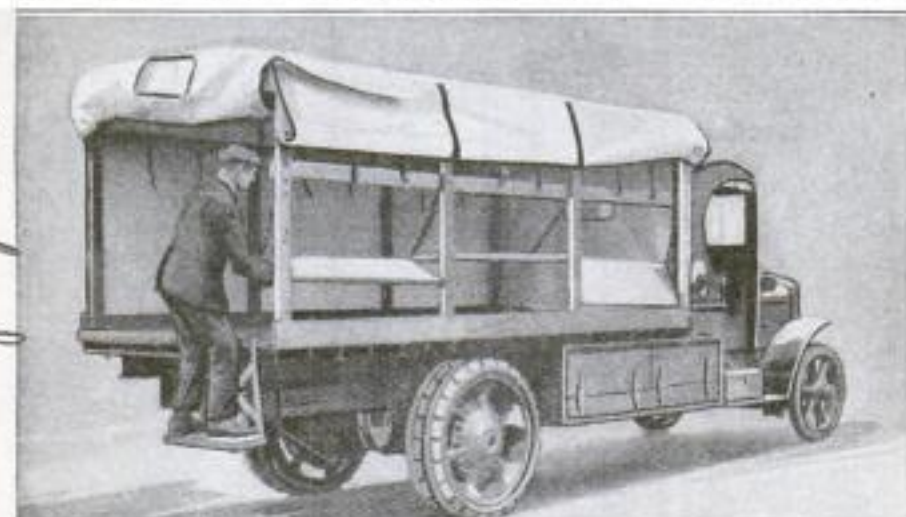

A Telephone and Telegraph-Repair Motor Truck. That can be Completely Inclosed with Curtains, as Shown to the Right, and Has Removable Seats for Workmen So That It can be Used as a Freight Truck, as Shown Above: Behind the Driver's Cab is a Winch for Winding Cables

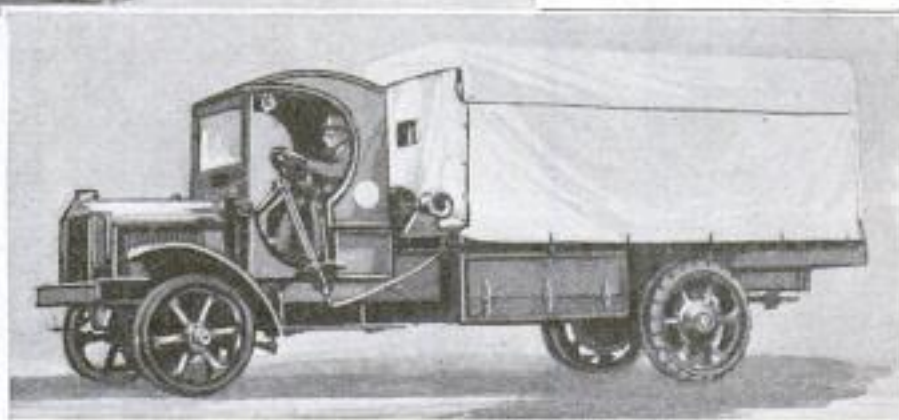

CAPTURING THE SMALLEST ANIMAL IN THE WORLD

BY LEON AUGUSTUS HAUSMAN, Ph. D.

802 University Ave., Ithaca, N.Y.

WE have become a bit blasé, during recent years, to accounts of animals of prehistoric existence, whose dimensions dwarfed those of our present animal

In diameter, along the longest axis, its body rarely reaches a length of eight or nine microns (about $\frac{1}{2,000}$ of an inch), and the writer has often found individuals

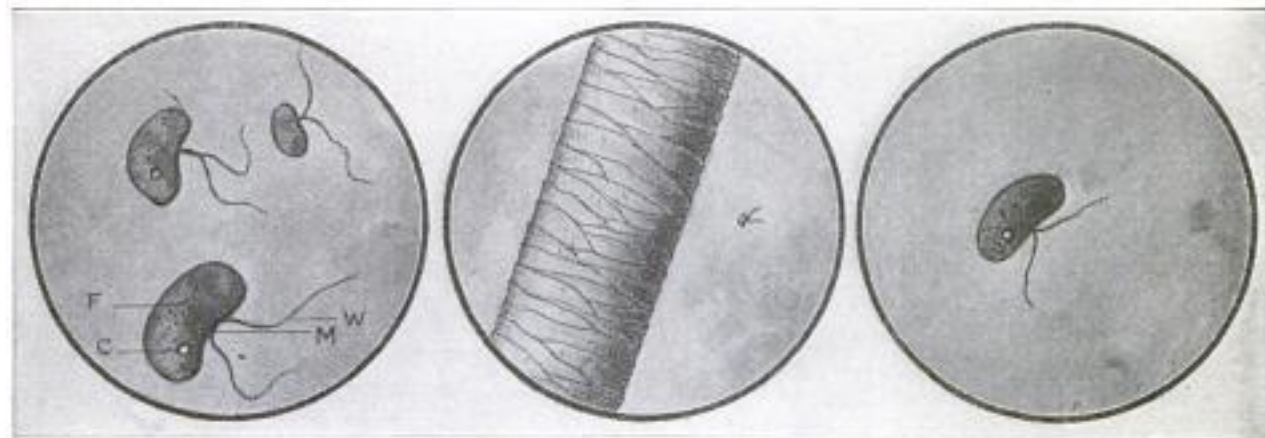

Figs. 1-3. Microscopic Views of the Smallest Animal in the World: Left to Right, Varying Shapes of Its Body, W Being the Whips or Flagellums; M, Mouth; C, Organ of Excretion, and F, Food Particles; Single Specimen beside a Piece of Human Hair, and a Specimen Photographed through Microscope

forms. Possibly then, our wearied enthusiasm for the unusual in zoölogy may be revived by a report of the capture and study of a creature which, in size, stands at the other extreme from the titanic dinosaurs of yore.

The smallest speck which can be detected by the average unaided eye, is a bit of opaque, white substance, about 50 microns (.002 in.) in diameter, seen against a black background. But the creature here under consideration is only one-twenty-fifth of this size. A graphic idea of its extreme smallness can be had by comparing it with the ordinary human hair.

In Fig. 2 is shown this, the smallest animal in existence, compared with a human hair, ordinarily averaging 50 microns in diameter. This diminutive creature, however, rejoices in a name which yields nothing in length and impressiveness to the appellations borne by the mightiest dinosaur science has to offer, for it trails after it the resounding cognomen of *Pleuromonas jaculans*.

as small as two microns ($\frac{1}{2,000}$ of an inch).

Figure 1 shows three typical individuals. The body is somewhat the shape of a kidney bean, with two long whiplike threads extending from a depression in one side. With these whips, known as flagellums, the creature makes its rather jerky way through the water in search of food, for it lives in pools and ponds amid decaying vegetation, where an ample supply of bacteria and juices from the disintegrating plant tissue is always present. These serve as its food, which is absorbed into the soft jellylike area at the base of the flagellums. The life of a single individual is usually but a few hours. At the end of that time the creature simply divides into two new individuals, both of which swim away, feed, and increase in size, and then themselves divide, and so on.

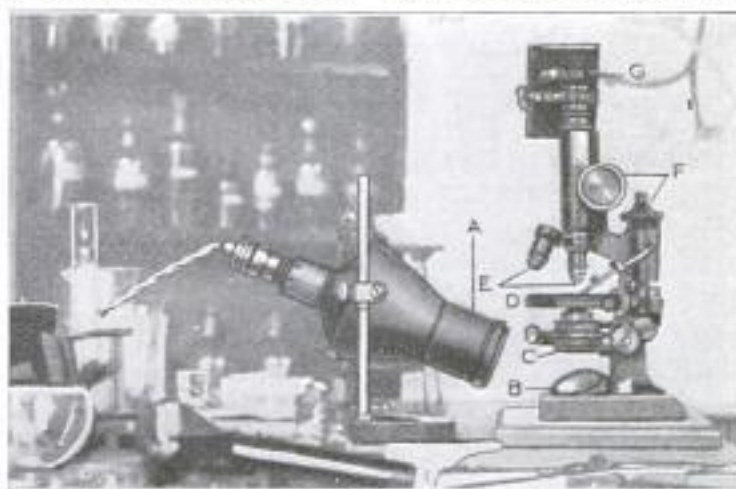

Fig. 4. The Compound Microscope for Extremely Minute Work That was Used in Obtaining the Three Views Shown in the First Illustration: A Is a Tungsten Lamp of High Power; B, the Microscope Mirror; C, the Condenser; D, the Stage; E, Objectives; F, Focusing Screws, and G, the Ocular or Eyepiece

most minute animal form of which we have record, magnified many thousand times.

The capture of *Pleuromonas*, while not involving any of the risk to life and limb which attends the capture of our largest living animal forms, the whales, still in-

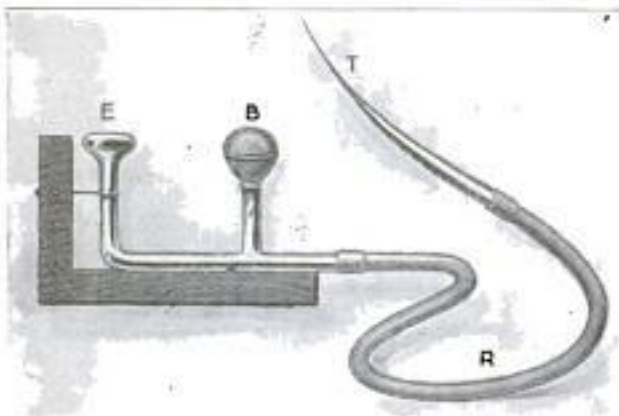

Fig. 5. Capturing the *Pleuromonas*: Laying Finger Tip on End, E, Heats Air, Driving Some through Tip, T, Which is Then Inserted into Water Drop under Microscope. Removing Finger Cools Air, Drawing into Pipette Water with One of the Creatures. Pressure on Rubber Bulb, B, through Tube, R, Deposits Object Where Desired

volves as great time, patience, and perseverance on the part of the "hunter." In Fig. 5 is shown the apparatus, devised by the author for the capture of the protozoa (the first great division of animals to which *Pleuromonas* belongs), under the microscope. By skillful manipulation of

the tip of the pipette under the objective of the microscope, it is possible to secure single individuals of *Pleuromonas*, and to transfer them either to glass microscope slides or to sterilized culture jars, to breed a new race. And many failures, either to capture or to transfer these tiny animals from one place to another, is the lot of the hunter after the smallest animal in existence.

Pleuromonas claims our interest, not only because it is the most minute form of animal life known to exist on our earth today, but because it is of actual economic value to us as well. Often bodies of water filled with putrefying plant remains will be colored a milky hue by the immense numbers of these tiny creatures, each one of which is a valuable scavenger, helping to transform decaying vegetable tissue into animal substance. The *Pleuromonas* are devoured, in their turn, by larger forms of the protozoa, or single-celled animals, which again are eaten by minute crustacea and insects. And these last constitute one of the most important supplies of fish food. In many cases, therefore, these tiniest of nature's children are the ones to take the first step in the great work of making many of our waterways sweet and pure.

7487
**COLORS ARE NOW NUMBERED,
 MEASURED, AND MATCHED**

By a new method of analysis, colors can be designated by a series of numbers after they are matched, and these numbers are then recorded, so that an exact duplicate of the color can be produced at any future time. The instrument used is called a colorimeter, and is intended for use in the factory or laboratory, for the matching of colored materials and liquids. In operating, a white light from a standard lamp illuminates one-half of the field

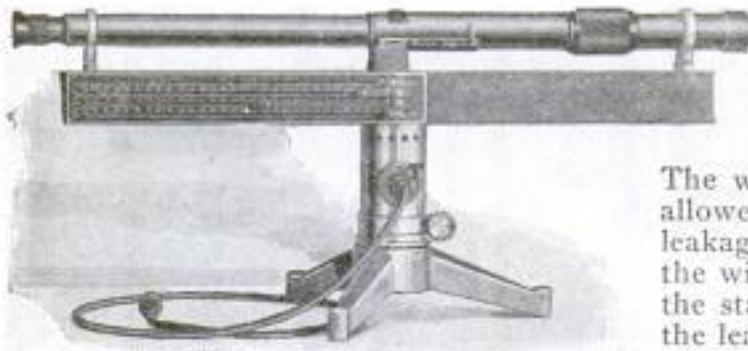

At the Top Is the Eyepiece, and Suspended from It Are the Sliding Scales Designated G, B, R, and N, Meaning Green, Blue, Red, and Neutral. Below Is the Cord Attachment for Any Light Socket

of view, and the color to be matched appears in the other half. By means of sliding gelatin wedges which are colored red, blue, green, and neutral gray, the color primaries are subtracted from the white light until the other color is matched.

7598
**WOODEN-STAVE PIPING SHOWN
 TO BE FIRE-RESISTING**

Creosoted wooden-stave piping, bound with galvanized steel wire, which formed part of a main, in Seattle, Wash., carrying water at a pressure of 125 lb. per square inch, was demonstrated by test to be fire-resisting. The test section, completely covered with fine kindling saturated with kerosene, was ignited.

The wiring expanded with the heat, and allowed the staves to separate, causing a leakage which extinguished the fire. As the wiring cooled, it contracted and drew the staves together again. In four hours the leakage had entirely stopped.

Whenever you find that you wish to know more about any article in this magazine, write our Bureau of Information.

The Engineer
 10/14/21

Eastman Kodak Co., Rochester, N.Y.

7585 Russell Bros, Winfield, Kans.

POPULAR MECHANICS
71
Inquires of Stanley Russell
Winfield, Kans



A Stack has just been Completed and Slipped Out of the Bin of the New Hay-Stacking Machine. One of the Rear Gates is Still Open, but the Nearer One has Swung Shut. The Sloping Sides of the Bin Give the Stack the Necessary Pitch to Shed Water When It Rains

7585

HAY-STACKING MACHINE SAVES MUCH TIME AND LABOR

Harvesting hay is said to require only about one-fifth of the ordinary amount of labor with a new machine, operated by six horses and two men. The hay is picked from the ground and passed to the top of a bin by a conveyor. Three sides of the bin are solid, but the rear consists of two self-closing swinging doors. The bottom, carried 6 in. above the ground, is made of slats running lengthwise. When the bin is full, a trip lever releases a support at the rear of the bottom slats, allowing them to drop to the ground. Contact with the ground causes the stack to slip from the slats and push open the rear gates as the machine passes on. Springs return the slats to position when the stack is clear.

7393

AUTOMATIC HOSE COUPLERS FOR RAILROAD CARS

It is generally admitted that the present method of coupling by hand the hose on railroad cars is objectionable, if for no other reason, on account of its danger to the life and limb of the operator. Therefore it is not surprising that there are many attempts being made to couple the hose automatically in the same manner as the cars themselves are now coupled. An automatic hose coupler that has been submitted to long and very severe tests on several railroads, is of quite simple construction, and has points about it that resemble the present standard car coupler. It is attached to a lug that is cast, or welded, to the car coupler, making a permanent union with it. It consists of only six parts and weighs 50 lb. It is made for connecting the air hose

of freight cars, and on passenger cars to connect signal and steam as well as air. The one point where failure might occur is in the coil springs that keep the

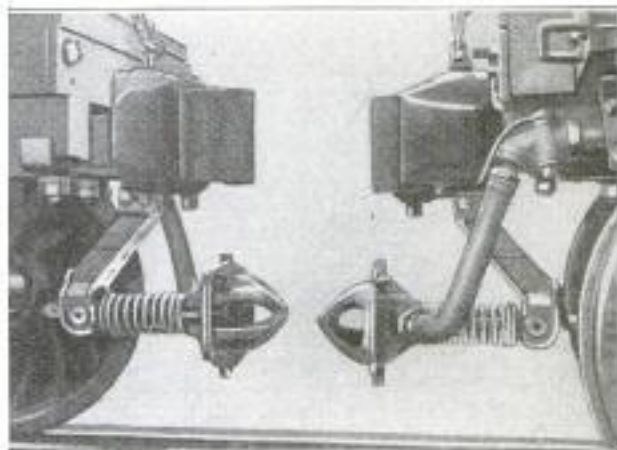

Freight Cars Fitted with the Automatic Hose Couplers About to be Coupled by Impact, When Cars and Hose will be Coupled Simultaneously

couplings pressed together, and the construction is such that upon failure of one of these springs the coupling becomes

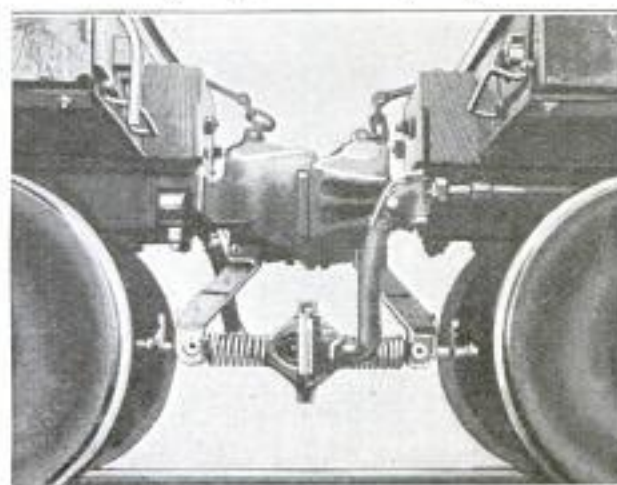

After the Impact, Showing the Freight Cars Coupled Automatically without Any of the Assistance from a Trainman That is Necessary with the Ordinary Method

American Automatic Connector Co.
235 Railway Exchange, Chicago

self-locking, and is not blown apart by the air pressure. This is demonstrated by connecting a coupling devoid of any springs. Under 120-lb. pressure the connection is maintained, and there is no air leakage.

A very interesting demonstration of this hose connector is made by a model, with a traveling track that moves at high speed, and subjects the coupling to the stresses of very sharp curves and steep grades.

IMPROVEMENTS IN DETECTION AND IDENTIFICATION MEANS

Constantly, the methods of human identification, and also the analysis of handwriting, are becoming more and more precise. In connection with the Bertillon method of identification by means of finger prints, several recent developments have occurred, one of the latest being the inclusion of the sweat pores as an element of identification. Experiments



PHOTOS BY COURTESY OF LA NATURE
The New Method That Permits Identification by Means of the 96 Sweat Pores Notated

in this connection, in France, have shown that when these finger prints are examined under a microscope there are plainly seen a series of spots in single or double lines, which were formed on the print by drops of moisture from the sweat glands. The number of these dots varies from 9 to 18 to the centimeter (.4 in.), and their position, and even their shape, which may be either round, oval, or curvilinear, are absolutely characteristic in each individual. It is indisputable



Imprint of Sweat Pores on Forearm Used for Identification When Culprit Wears Gloves

therefore, that this is an exact method of identification, for the number and the disposition of these pores are constant in the same individual from the day of birth to death. Moreover, no matter in what manner the print is taken, whether with the finger flat or rolling, the pores have the same relative position and shape. These prints are not made with ink, but with dry graphite, or light powders, such as black oxide of copper or white lead. Besides taking direct prints, the finger tips are photographed by means of a microphotometric apparatus, and the photographic and direct prints are compared. The most striking feature in connection with this method of identification is that even when a malefactor has taken the precaution of wearing gloves, an imprint of any part of the wrist or arm is sufficient for identification.

As regards the detection of counterfeit handwriting a method has been worked out that is both mathematical and scientific. It has been applied to the detection of freehand forgeries—not those made by tracing or the changing of letters which are easy to detect. It is based on the hypothesis that everybody's handwriting shows certain constants that can be measured. This method is called graphometric, and on enlarged photographic reproductions measurements are made of the height of the letters, the trace of the curvature, the slope of the downstroke, and other details, and they are compared with standards that have been established by a study of the genuine handwriting.



In Lowest Tier Are Samples of Authentic Writing; Above Are Forgeries

Political candidates were given a chance to do their electioneering by wireless in a recent mayoralty contest in Pittsburgh, Pa. Persons possessing a radio outfit could hear the aspirants tell why they should be elected, without leaving home. Each candidate was allowed a five-minutes' speech at the sending station.

Developed by Dr. Legerd,
Director, Police Laboratory,
Lyon, France

7413 Inventor, A. E. Johnson,
Minneapolis, Minn.

POPULAR MECHANICS 73
Cmt. Arthur Hallam, 317 Cedar Av. Minneapolis
AUTOS GIVEN ROAD TEST
IN GARAGE

Giving a car a road test without taking it out of the garage is a great advantage to the repairman. This is easily done

and another box that holds a two-cell battery for furnishing the current. By the admission of more or less air into the furnace, the temperature of the oxidizing element varies, and therefore brings a corresponding

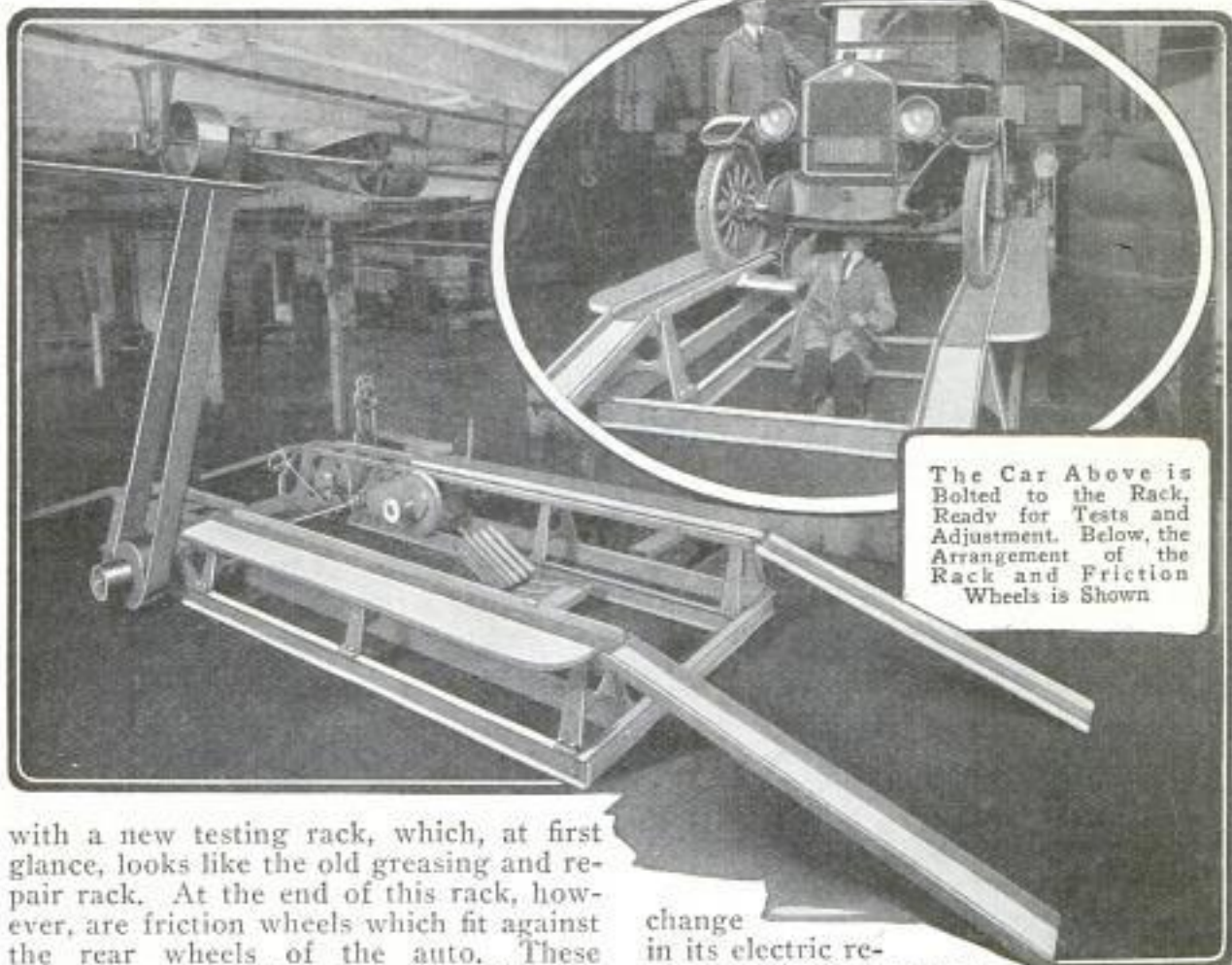

with a new testing rack, which, at first glance, looks like the old greasing and repair rack. At the end of this rack, however, are friction wheels which fit against the rear wheels of the auto. These wheels can be adjusted to give different resistances, so the equivalent of a regular road test can be given. Gauges are attached to indicate the mileage and horsepower developed. The friction wheels can also be connected to an electric motor, and the auto engine driven by this power, if desired.

7218 ——— *Does*
**INSTRUMENT RECORDS EFFECTS
OF AIR IN FURNACE GASES**

A new instrument called an "oxyscope," now in use in England, indicates the oxidizing properties of the atmosphere in a furnace. It furnishes a means for determining the amount of air that should be admitted to the furnace so that the proper temperature may be maintained in processes of heat treatment of materials. There are three parts of the instrument: a mounting that holds the oxidizing element that is introduced into the furnace; an indicator box to which this is wired,

change in its electric resistance. This change is shown on the indicator box by a needle that deflects along a graduated arc, as in an ammeter. If observations of the position of the needle are made at regular intervals of about one-half minute, the deflections of the needle will tell the rate at which the oxidation progresses can be determined, showing the oxidizing properties of the furnace gases.

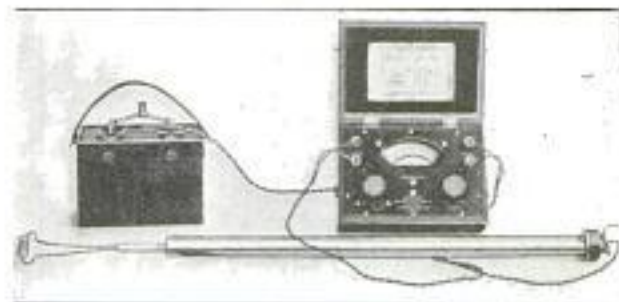

Instrument That Shows Oxidizing Properties of Furnace Gases: In Front Is the Oxidizing Member for Insertion in the Furnace, behind It, the Electric Indicator Box, and Also a Two-Cell Battery

Rudge-Whitworth Co. Birmingham
England.

7145

ARC-WELDING OUTFIT HAS NOVEL CURRENT CONTROL

A compact, portable electric arc-welding outfit has been designed and built in

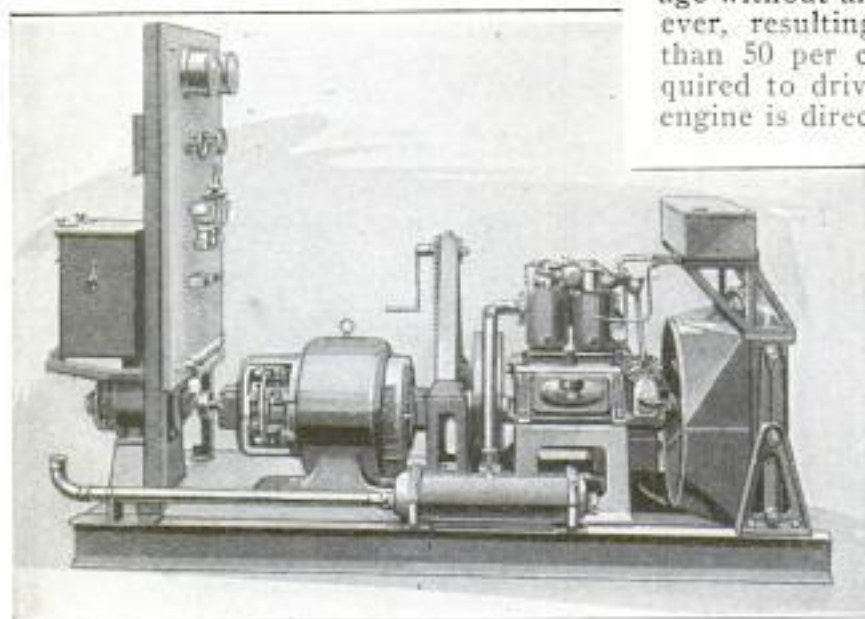

Electric-Welding Plant Which, with Switchboard, Dynamo, Rheostat, Reactance Coil, Gasoline Engine, and Its Accessories, Mounted on a Substantial Base, Forms a Very Compact and Easily Portable Outfit

England, which, it is stated, distributes the current at the required welding voltage without any mechanical control whatever, resulting in a reduction of more than 50 per cent of the horsepower required to drive the dynamo. A gasoline engine is direct-connected to the dynamo,

which is so constructed as to supply a constant current regulated by a variable rheostat. When used for welding, the dynamo is connected with the arc through a special reactance coil in the main circuit, which damps out any sudden rise in the current, and also helps momentarily to build up the current when any sudden break takes place. This plant, with switchboard, all mounted on a substantial base, weighs 2,800 pounds.

7486 Auto Access

CARRIER LOCK FOR SPARE DISK OR WIRE WHEELS

Adequate protection against spare-wheel thieves is afforded by a new lock designed for use with wheels of the disk or wire type. This lock can be installed, with the aid of ordinary tools, on any spare-wheel carrier in a few minutes. It consists of three parts, a housing, with two wing arms, made of aluminum alloy and reinforced with a hardened steel insert, a combination locking nut and washer, fitting the threaded stud of the wheel carrier, and a removable, nonpick-

able, dust-proof lock, which fits into the outer end of the housing. Two movable lugs, inside, engage a flange and hold the lock in place. The device can be quickly unlocked, by means of a key, and the wheel dismounted.

7614 Harlegon - Africa
HIGHEST RAILROAD OF BRITISH EMPIRE TO CROSS RICH REGION

The highest summit level of any railroad in the British Empire, 9,135 ft., will be attained by a new 150-mile line about to be built from Nakuru to Turbo, in British East Africa. Cutting through the heart of a rich agricultural plateau and extensive timber lands, it will form a part of a great trunk route from Mombasa on the Indian Ocean to Uganda and the Congo. Later, when the Cape-to-Cairo project becomes a reality, it will be one of the ribs of this route. The rise from Turbo, the lowest point on the line, to the summit will be 3,215 ft. Only 14 per cent of the line will be on the level, and 48½ per cent of it will consist of curves. Construction work is expected to occupy three years. The plan is to maintain an unskilled labor force of 10,000 natives. The cost will be about \$10,000,000, according to present estimates, though in view of falling prices, this figure may prove to be too large.

Clarks Co., Indianapolis, Ind.

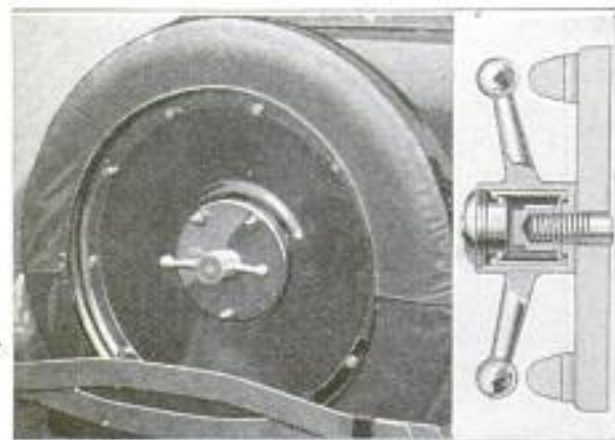

Left: A Disk Wheel Locked onto the Carrier with the New Lock. Right: Detail of Lock Construction, Showing the Barrel-Shaped Lock Housing

7280 *Enl. C. W. Isinger*

Press Club San Francisco
POPULAR MECHANICS

Calif. 75

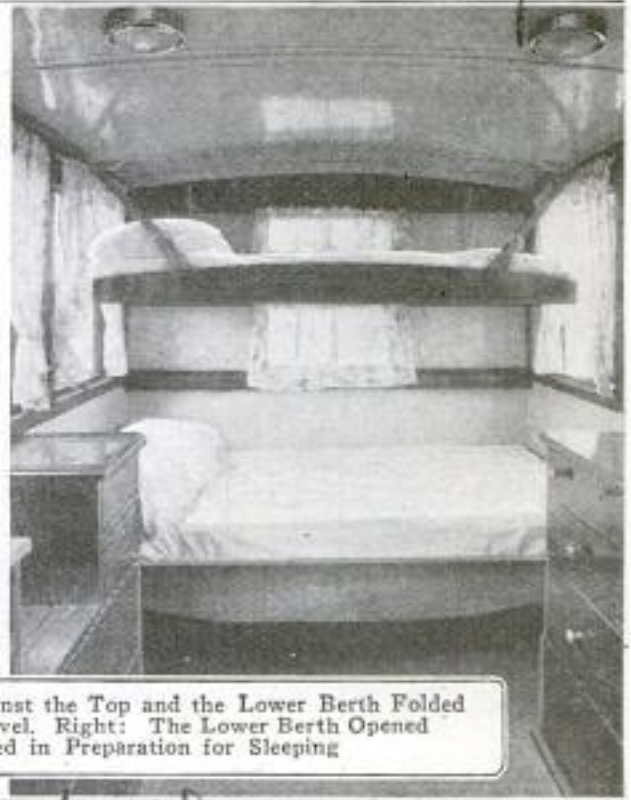
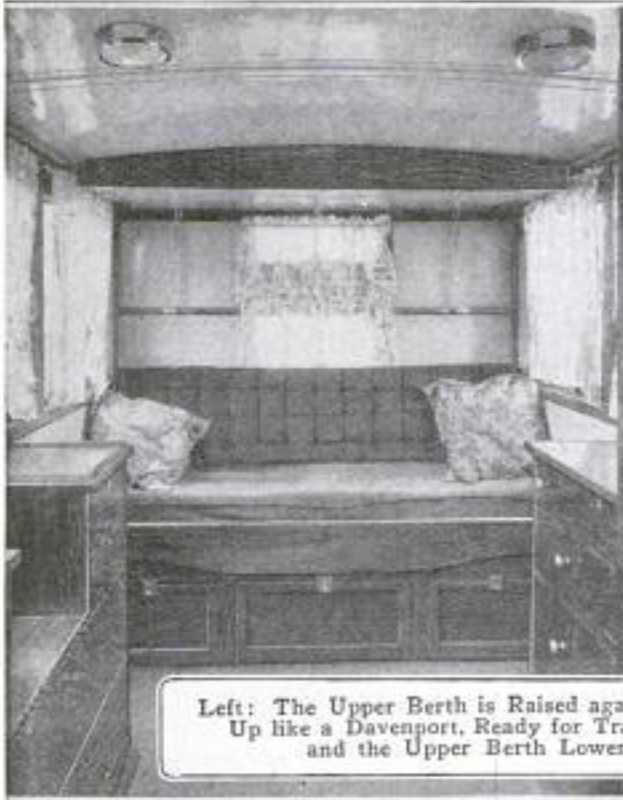

Left: The Upper Berth is Raised against the Top and the Lower Berth Folded Up like a Davenport, Ready for Travel. Right: The Lower Berth Opened and the Upper Berth Lowered in Preparation for Sleeping

7280
BERTHS ADD TO THE COMFORT OF AUTOMOBILE TOURING

A berth arrangement built into the rear of an automobile used for extensive touring affords two comfortable beds, but does not take up an unnecessary amount of space when not in use. One berth is built like a davenport against the back of the car. The other is supported against the top by hooks, during the day, and at night is lowered in a manner similar to a sleeping-car berth. In order to provide ventilation for the upper berth, the rear window of the car extends above the berth when it is lowered. A special bathtub is carried in a compartment under the lower berth.

7602
WILD GEESE ARE ELECTROCUTED IN VIOLENT ELECTRIC STORM

Although it did not "rain pitchforks," or "cats and dogs," a recent electric storm near Seattle, Wash., was featured by the queer occurrence of "raining geese." After an unusually dazzling flash of lightning, followed by a loud clap of thunder, great numbers of wild geese fell to the ground. Passers-by and residents of the vicinity took advantage of the phenomenon and immediately gathered up the fowl, which were dead and without a mark of any kind upon their bodies to indicate the manner of their death.

Rea Gilbert
40 Jefferson Co. Dan. Iles,
Ohio.

7528
PORTABLE EXPRESS OFFICE FOR FAIRS AND EXHIBITS

For convenience in handling shipments at fairs and exhibits, an expressman has introduced a portable booth, to be used as an express office. Being equipped with small wheels, it can be readily pushed where needed, and if the going proves too rough, brackets, into which handles may be slipped, are provided for carrying it. The booth is fitted with a drawer for supplies, a seat for the expressman, and also a collapsible writing shelf on each side for the shippers' use. Wiring and fixtures for electric lights, with a simple

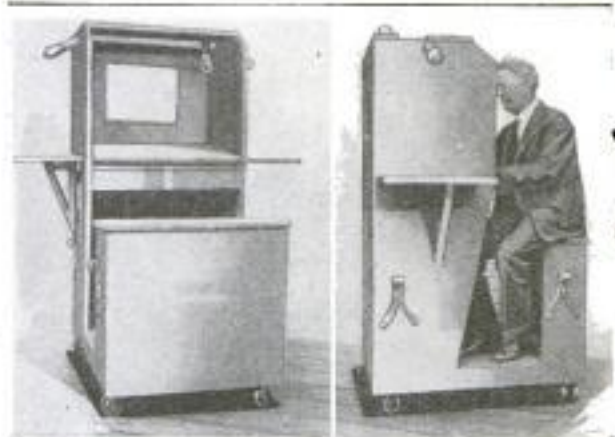

Two Views of the Portable Express Office, Showing How It Appears from the Rear and from the Side

connection which can be attached to any light socket, are also installed.

327 Ave. Strong St.
Brooklyn, N.Y.

Enl. Stanley W. Todd.

Cambridge + Paul Instrument Co

76 45 Grosvenor Place
7318 POPULAR MECHANICS
London, S.W. 1, England

**CARBON DIOXIDE IS MEASURED
BY ELECTRICAL INDICATOR**

An instrument for measuring the percentage of carbon dioxide in flue gases, is being manufactured in Europe. Two coils of platinum wire, of the same size, are inclosed in separate gas-filled cells in a metal block.



Each coil is connected to form one arm of a Wheatstone-bridge circuit, and when an electric current is allowed to flow in the circuit the coils become heated. Heat is conducted through some gases more readily than others, and when one of the cells is filled with pure gas, and the other with the flue gas to be examined, the difference in radiation of the two cells determines the percentage of carbon dioxide in the flue gas. This percentage is proportional to the deflection of the galvanometer needle, and it is a simple matter to calibrate the galvanometer scale so that it indicates this percentage directly without calculations.

readily than others, and when one of the cells is filled with pure gas, and the other with the flue gas to be examined, the difference in radiation of the two cells determines the percentage of carbon dioxide in the flue gas. This percentage is proportional to the deflection of the galvanometer needle, and it is a simple matter to calibrate the galvanometer scale so that it indicates this percentage directly without calculations.

**MICROMETER GIVES METRIC
AS WELL AS INCH READINGS**

Both inch and metric readings can be made simultaneously on a micrometer that has been introduced in England. On the stem of the micrometer, besides the usual inch graduations, there is another line of graduations with metric divisions that spirals once around the stem without crossing the inch graduations. On the thimble is the ordinary set of graduations for reading the inch measurements, and a second set for the metric readings.

**NEW FARM TRACTORS HAVE
THREE-WHEEL DRIVE**

Three-wheel-drive farm tractors, built by a middle-western concern, are credited with a number of advantages by the makers. Power, from a 35-hp. motor, is applied equally to the single front wheel and the two rear wheels. A swivel joint on the front wheel allows the tractor to make a very short turn and plow well into the corners of a field. Power on the front wheel is said to increase the efficiency of the machine, particularly in climbing hills, pulling out of ditches, and working over soft ground. A belt pulley, operated independently of the driving mechanism, does not drag on the power supply when not in use. Steering controls may be operated either by hand or by power.

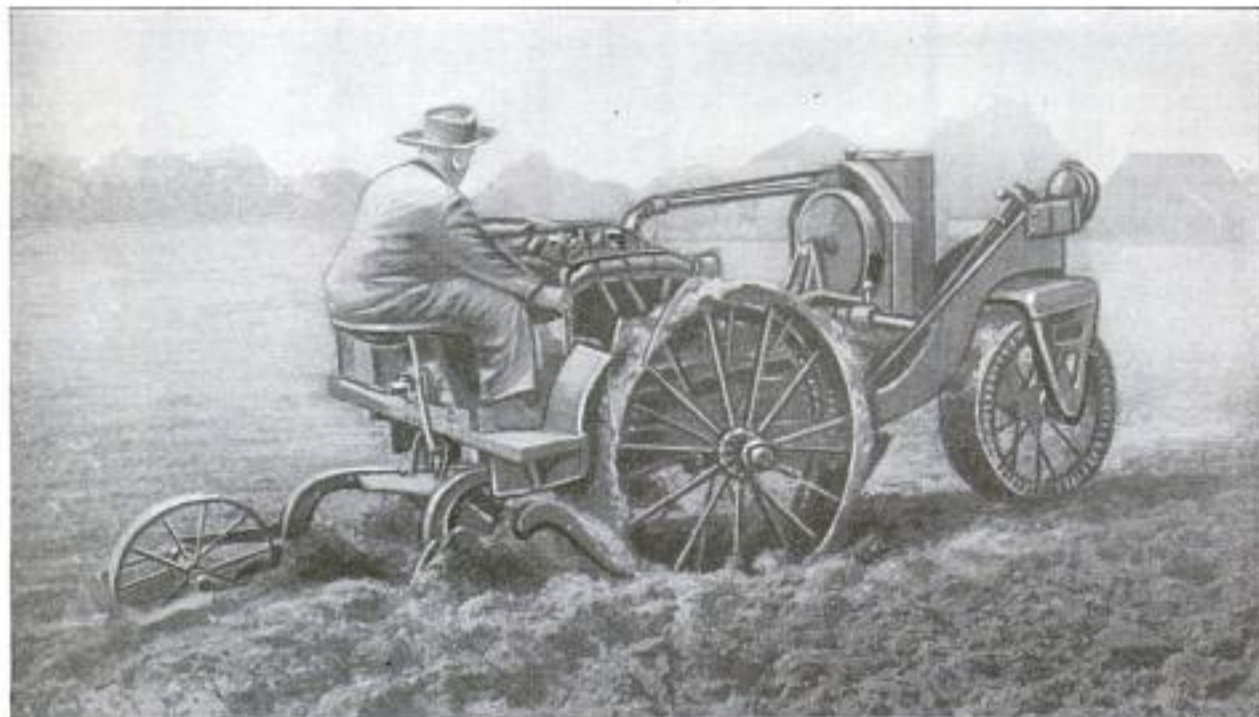

Plowing with the New Three-Wheel-Drive Farm Tractor: The Plows are Set Directly below the Driver's Seat So He can Observe Their Action and Place Any Part of the Tractor's Weight on Them. The Depth can be Regulated from Two to Fourteen Inches

Three Wheel Drive Tractor Co.
5 E. Market St. R. 206 Indianapolis Ind.

The Engineer 10/14/21

Copyrighted material

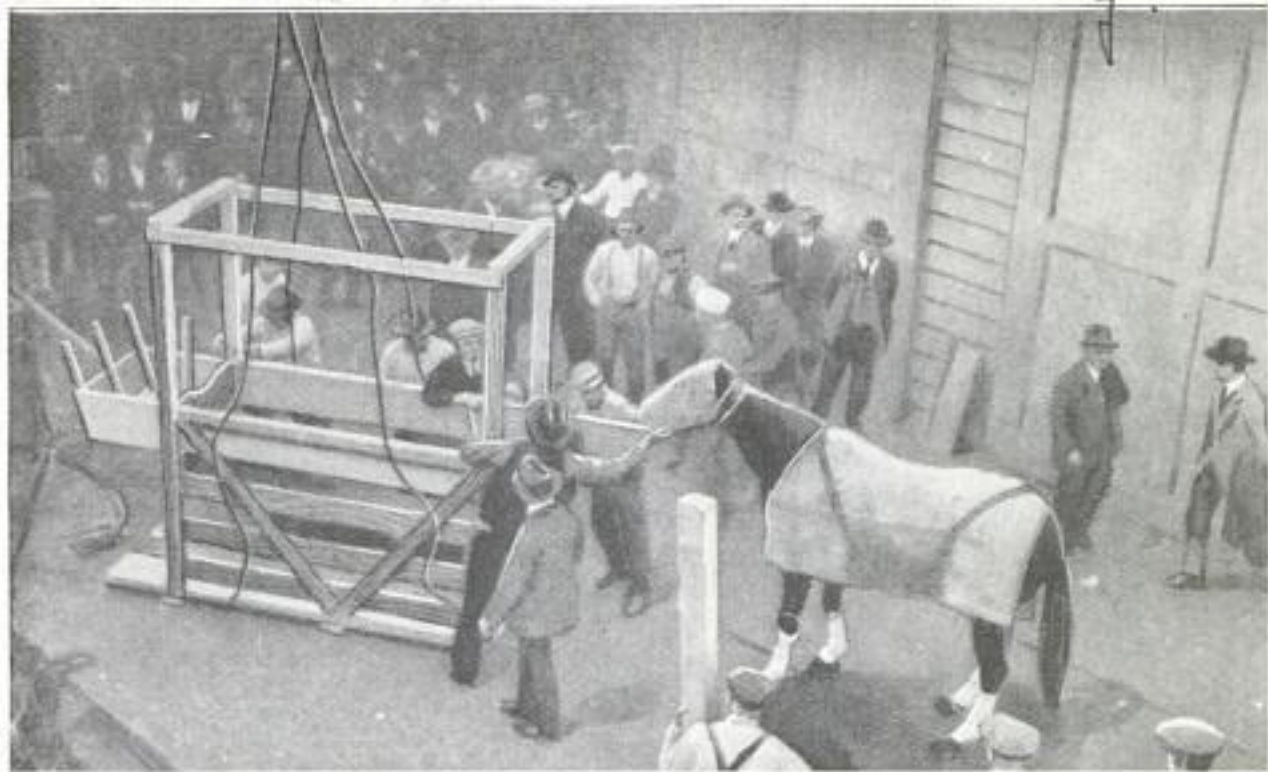

At the Left are Shown the Stall, or Crate, and the Derrick Cables with Which the Crate was Hoisted aboard Ship. Before the Horse could be Induced to Enter the Crate, His Head had to be Covered with a Sack

CRANKSHAFT AND PISTON JIG
 OF UNIVERSAL QUALITIES

HORSE TAKEN ABOARD STEAMER
 IN SPECIAL STALL

Those interested in automotive repairing will welcome a universal jig to be used in the alinement of crankshafts and pistons. The jig has three arbors, or shafts, all of the same size in the middle, but whose ends are cut down to standard crankshaft sizes, each end containing two sizes, so that 12 sizes of crankshaft can be accommodated. A sliding block at one end, to provide for different-length pistons, and a square at the other end, both move on accurate planes and are held in place by a tongue-and-groove arrangement. The total weight of the jig is 125 lb., and it is made so that it can be bolted solidly to a bench. It is claimed that this tool will handle more than 90 per cent of the truck and automobile crankshafts now made.

Horses are notoriously nervous and object to boarding cars or ships. So, when a thoroughbred animal was to be taken aboard the liner "Empire State," at



This Shows the Crate and Horse in Mid-Air as the Animal was being Lifted Bodily aboard the Ship. The Sack is Still Tied over the Eyes of the Horse

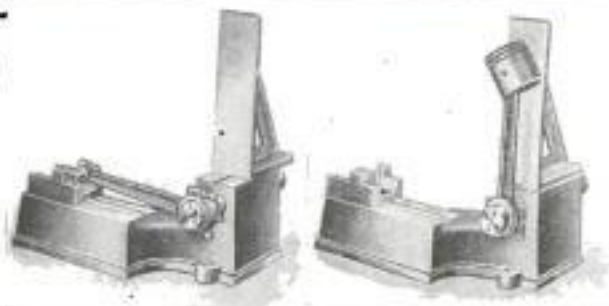

Left: Piston Shown Placed on Sliding Block. Right: Piston Alinement by Sliding Square

San Francisco, Calif., for a trip across the Pacific, a stall had to be provided for it. A light box stall was built on shore, and the horse was driven into it blindfolded. Then, with the horse in it, it was hoisted aboard the ship. Because the stevedores had difficulty in getting the horse into his stall, the sailing of the vessel was delayed for some little time.

Cmt Henry C. Copeland } Seattle
 8467 Rainier Place } Wash.

Wm. J. J. Hendricks
 Seattle, Wash.

748 4
78

Auto

POPULAR MECHANICS

*Confectionery + Alfred
Industries Exhibit,
2nd floor,
Wrigley Bldg Chicago
PERMANENT EXPOSITION
FOR CANDY INDUSTRY*

SUCTION PUMPS EMPTY MOTOR
GAS TANKS BEFORE SHIPPING

Tanks, equipped with suction pumps,
are being provided by the British automo-

7594

Candy makers and manufacturers of
candy-making machinery have rented the

entire second floor of a
large Chicago office
building, and are con-
ducting a permanent ex-
hibit for the benefit of
the wholesale buyer, the
retailer, and the manu-
facturer of any kind of
"sweet-tooth" goods.
Here, the prospective
buyer of candies, or of
machinery to make the
same, may come, and be
saved the tiresome task
of going about the city,
or the more costly one of
traveling around the
country, to look at the
displays of the many
manufacturers. The
various kinds of machin-
ery used to supply the
American public with
their favorite sweets, are
shown here in an amaz-

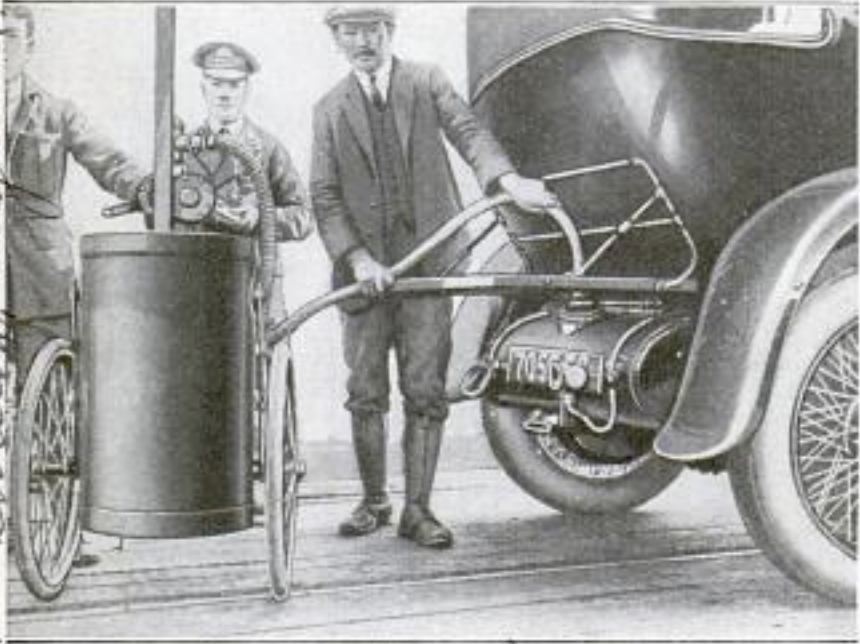

Emptying the Gasoline Tank of an Automobile to be Taken aboard Ship
at Folkstone, England: These Suction-Pump Tanks are Mounted
on Rubber-Tired Wheels and are Easily Moved about the Docks

bile association and motor union to empty
the gasoline tanks of automobiles about
to be taken aboard ships at British ports.
The shipping authorities require that all
tanks must be drained before motors can
be shipped. When tanks are drained from
the bottom, in the usual way, the gasoline
is often spilled, with dangerous results,
and the new pumps are for the purpose of
avoiding this danger.

ing array, and anything from the penny
"all-day sucker" to the glistening soda-
fountain fixtures, may be purchased at
the exhibit.

7495

ORNAMENTAL BRONZE TOWER
FOR MEMORIAL CHAPEL

An orna-
mental bronze
tower, 25 ft. in
height, is the
product of a
Minneapolis
firm, and will
be shipped to
St. Louis, to
be mounted
upon a me-
morial chapel
there. Al-
though the
tower is com-
posed of many
pieces, the
joints and
rivets are seen
only from the
inside. Thus
the work ap-
pears to be a
solid piece of
bronze.

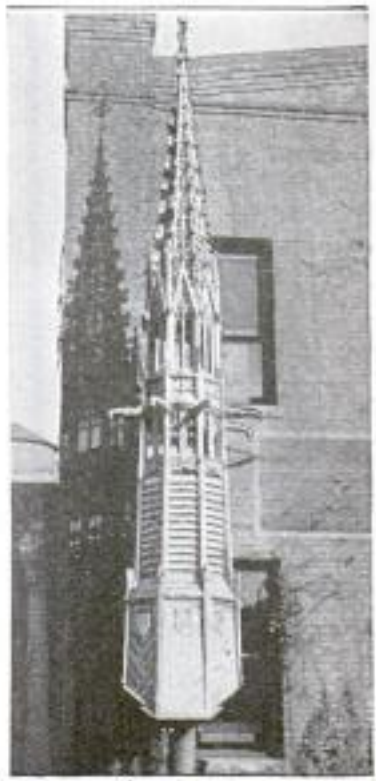

*Ornamental Iron
Bronze Co., Minneapolis, Minn.*

*Publ. Agency, 157 Fleet St. E.C.
London, England.
7615
Publicity from Plodgers Bros.
Electrical Mch.*

CHINESE PRINCE IS AFRAID
TO RIDE IN AUTOMOBILE

In sharp contrast to the establishing of
an 800-mile mail and passenger-airplane
service by China, and its interest in other
modern activities, is the experience of a
party of Americans on a trip from Pe-
king to the Ming Eastern Tombs by
automobile. A Manchu prince, who met
them at the tombs, was greatly fright-
ened when the American automobile, the
first he had ever seen, appeared. He
could not overcome his terror sufficiently
to accept an invitation to ride, and with-
drew to a safe distance. The members
of his bodyguard, armed with broad-
swords and even bows and arrows, were
both terrified and fascinated by the car.

Our Bureau of Information is for your
benefit. Use it as often as you please.

Com. H. E. Zimmerman
7264 266 Independence Ave
Kansas City, Mo



Arsenic-Refining Plant at the Little Town of Brinton, Virginia, Which has Grown Up around It as a Result of This Activity: This Is the Only Refinery in the United States, and Perhaps in the World, That is Operated Primarily for the Production of Arsenic, Which Is Usually a By-Product of Minerals

MINING AND REFINING ARSENIC IN VIRGINIA

BY PHIL W. HANNA

SEVERAL years ago, a farmer in the foothills of the Blue Ridge Mountains, in Virginia, cleared a new field for pasture. Before long his cattle became sick and one of them died. Thinking that the trouble might be caused by the water from a spring in the field, he had it analyzed. It was found to contain a large amount of arsenic, and the discovery resulted in the development of an arsenic mine and refining plant. This plant, at the little town of Brinton which has grown up about it, is the only one in the United States, if not in the world, which is operated primarily for the production of arsenic. Other refineries produce it as a by-product in refining silver, antimony, and a number of other ores. Most of those in this country are located in the mining districts of Utah and Montana. The arsenic usually appears in the ores in combination with iron as a pyrite called arsenopyrite. Pure arsenic is a steel-gray metallic substance, but it is better known in the form of an oxide, the white arsenic usually produced by the refineries.

At Brinton the ore is found in many small veins, through a gray mica-quartz formation. When taken from the mine, it is put through a crusher and then placed in an iron tube, 50 ft. long and 6 ft.

high, known as a calciner. Here it is subjected to a heat of 800° F. for 45 minutes. The resulting gases deposit the arsenic, in the form of arsenious oxide, on baffle plates in a flue, 319 ft. long, which leads from the calciner and ends in a tall stack. The deposit, a dirty-gray powder full of impurities, is then placed in a refining furnace which volatilizes 1,400 lb. in about 2½ hours, producing the pure oxide. This is ground to a powder and placed in barrels by an automatic machine, after which it is ready for shipment.

White arsenic, as this arsenious-oxide product is called, is used chiefly in the manufacture of glass, for making insecticides such as Paris green and poison fly paper, for weed-killing compounds, for a sheep dip, and for medical purposes. It was formerly used extensively in a copper compound for coloring wall paper, cloth, and toys, but has been replaced by other less dangerous coloring matter for these purposes. Contrary to what might be expected, work in the arsenic mine or refinery has no ill effect on the workmen. In fact employees seem to be benefited physically by service in the refinery.

Though arsenic is poisonous, both in the metallic form and in most of its com-

Brinton Arsenic Co., Brinton, W. Va.

pounds, a relatively large amount must be taken to be really dangerous. Arsenic poisoning results in irritation of the eyes, soreness of the mouth, skin eruptions,



White Arsenic or Arsenious Oxide Piled Up Waiting to be Barreled, at the Brinton Refinery: This White Powder Is the Form in Which Arsenic is Usually Obtained for Commercial Purposes

7525

CIGAR LIGHTER FOR AUTOISTS WINDS UP ON SPRING REEL

The drivers of motor cars will welcome a handy electric lighter, which is now

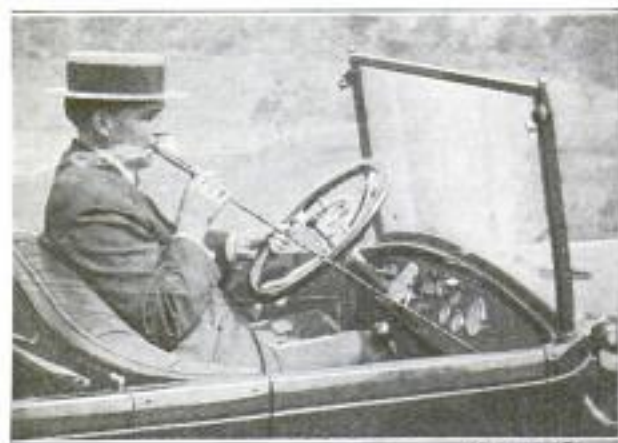

This Shows the Cigar Lighter being Used With One Hand without Removing the Other from the Steering Wheel. When the Lighter is Released, the Cord Winds Up on a Spring Reel

on the market as an automobile accessory. The autoist needs use only one

spasms, vomiting, and even paralysis. Taken in small doses, a tolerance for it can be established. Some people, notably the Styrians of Austria, develop the arsenic-eating habit, which is said to result in increased weight, strength, and appetite, and a clear complexion. It is often given to horses, in Europe, to improve their coats and make them plump and spirited. It is this quality which makes it valuable as a medicine in treating anemia and dyspepsia, its principal medicinal use. It is also used for certain skin diseases. Great care must be taken in prescribing it, as its effect on different individuals varies greatly.

About 10,000 tons of arsenic are used annually in the United States. Of this amount about 4,000 tons are imported. Most of the imported arsenic comes from Canada, Mexico, and Belgium, but small amounts are also obtained from England, France, and Germany.

hand in lighting his cigar, and after being used, the appliance winds itself up on a spring reel.

NEW AIR-CRAFT FITTINGS AND WHAT THEY ARE MADE OF

Steel shapes or fittings, required in the modern airplane to hold its various parts together, show the new demands which an invention may make, and to supply which the ingenuity of scientists and skilled men of various industries is demanded. Air-craft fittings made of steel, to be used on large machines, such as the NC's of transatlantic fame, are typical of the many structural parts which are used to connect, support, and reinforce the members of modern airplanes. Early airplane fittings were made from low-carbon sheet steel or a grade of mild alloy steel. The new giant planes, however, require a steel of high tensile strength, to avoid excessive thickness and weight. Steel of a tensile strength of 150,000 lb. per square inch is necessary.



Airplane Wing-Beam Hinges, in Various Stages of Completion, are Shown at the Left. The Smaller Forms at the Right Are Parts of a Box Fitting. After Welding, These Forms are Dip-Brazed and Heat-Treated. They must Have Great Strength and Resiliency, the Box Fitting, for Example, Carrying the Stresses from 10 Timbers

Cont. E. J. Cone, 8 Ash Street
Flushing, N.Y.

It has been found that steel having about one per cent of chromium and less than a quarter of one per cent of vanadium meets the requirements. Such a steel can be rolled successfully into sheets of the proper thickness and pliability to make the shapes, and at the same time of sufficient strength to withstand the tremendous strains to which they are subjected.

7644 — Concrete
**ARCH OF BRIDGE IS ERECTED
 WITHIN TWENTY-FIVE DAYS**

Great speed in construction was attained in the building of a 97-ft. concrete arch for a bridge in Maryland recently. The bridge spans the Little Patuxent River, near Savage, and carries the heavy traffic of the Washington Boulevard, which runs from Baltimore to Washington, D. C. Being a steel structure originally, it was wrecked by the driver of a heavily loaded five-ton truck, who disregarded the "One-Way-Bridge" signs, and attempted to pass a small car on the bridge. The two vehicles collided, which resulted in the tearing out of enough of the side supports of the structure, to allow it to collapse in the river. The State Roads Commission met the next day and called for bids on the cost of replacing the wrecked arch, and within 30 days' time, the contract was awarded at a figure of \$19,000, and work was started in five days after the accident. The wrecked steel arch was replaced by one of concrete, in 25 days, and the feat is considered quite an achievement in bridge construction.

Eng. News-Record 11/3/21

7506
**NEW ICE-CREAM
 MACHINES ARE
 SANITARY AND
 ECONOMICAL**

Two new machines, for use in the manufacture of ice cream, greatly aid sanitation as well as increase the speed of production. One of them replaces the old hand method of making brick ice cream, turning out the molds without the touch of human hands. It can be adjusted for any size of brick, made in from one to three flavors. The capacity is 20 gal. of plain, or 12 gal. of three-

layer brick, a minute. Layers produced by it are always equal in thickness and separated by a straight, even line, mak-

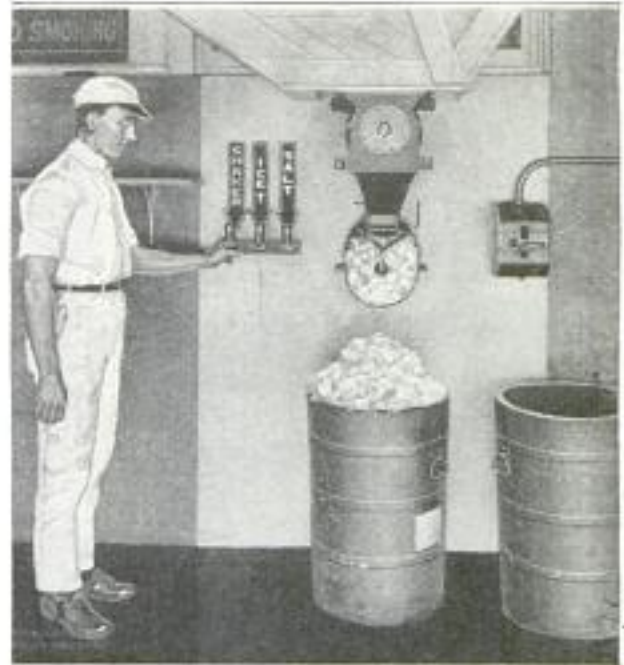

For Packing Ice-Cream Tubs with This Machine Only One Man is Required. There is No Heavy Labor and the Packing is Done Very Rapidly

ing a more beautiful brick than was possible by hand methods. The second machine is for packing tubs. Ice is crushed in a hopper, by an electrically operated rotary cutter, and delivered to the tubs with any desired proportion of salt, by moving a lever. This device has packed 199 tubs in an hour, with only one man to attend it. Formerly six men would have been required for this job.

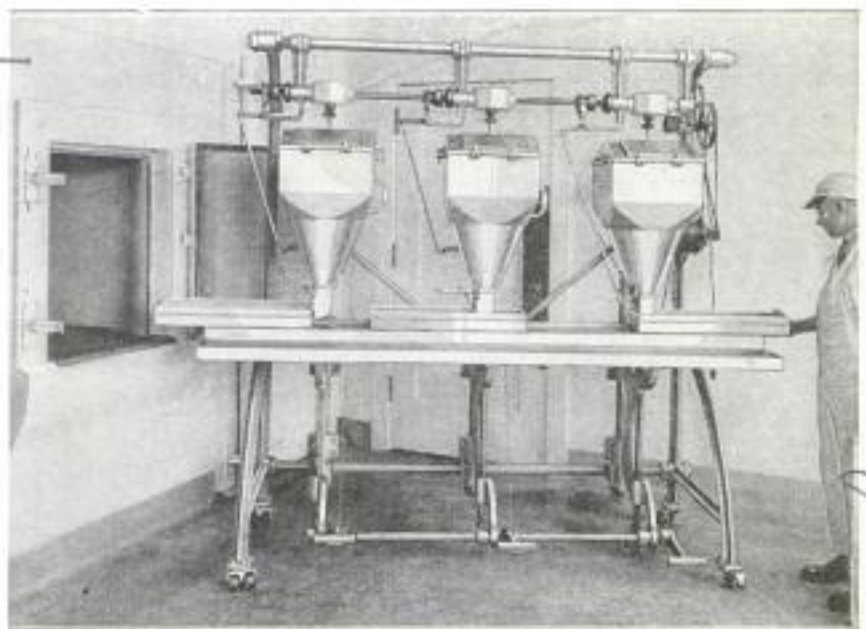

Perfect Ice-Cream Bricks of from One to Three Flavors are Turned Out by This Machine without having been Touched by Human Hands. It is More Sanitary and Rapid Than the Old Hand Method and Makes Layers of Equal Proportions

Inventors E. R. Myers &
 Geo. W. Burk, Portland, Ore.

Eng. News-Record, 5908 & Allen St., Portland, Oregon.

Glass Casket Co

82

Altoona, Pa.

POPULAR

MECHANICS

BURIAL CASKETS MADE OF CLEAR GLASS

Several unusual features have been combined in the manufacture of clear-

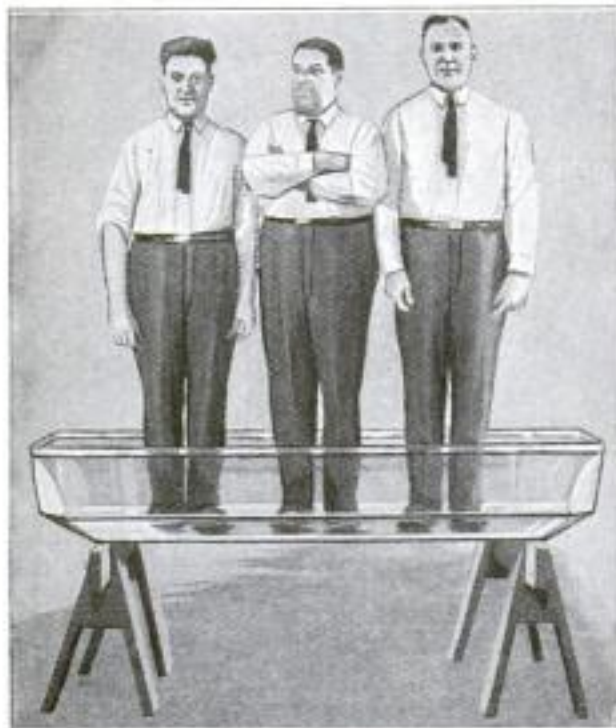

Showing a Transparent-Glass Casket That is Made Strong Enough to Hold the Combined Weight of Three Ordinary Men When Supported Only at the Extreme Ends

glass caskets, which is now an established industry. They are made strong enough to support three ordinary men standing upright in them, and the weight of both the bowl and cover of the casket is claimed to be only 260 lb. for a 6-ft.-3-in. model. Although additional weight is, of course, added in the way of trimmings, the glass casket has been found to be

Industrial Research Laboratories Bulletin

10/24/21

lighter than most of the metallic makes on the market. Glass is practically imperishable, and when made as strong as these caskets and hermetically sealed, should be proof against any underground elements.

7616

ENDLESS CHAIN OF POISON KILLS RATS IN EUROPE

Rats are being destroyed in Europe by a novel method which is said to be the only hope of finally exterminating these pests. A poisonous powder is mixed with plaster of Paris and lard, to form a paste. This is placed on the inside of rat holes and sticks to the animals' fur as they pass. When the rat licks its fur it dies. Because rats eat their dead, its carcass kills others, establishing an endless chain of destruction.

7561

CONCRETE BASES FOR DERRICKS NEEDED IN TEXAS OIL FIELD

Nine-foot concrete bases, or piers, were built to hold the derricks while drilling certain oil wells in Texas recently. The wells were drilled in the bed of the Clear Fork, which is a tributary of the Brazos River. Most of the time, the bed is almost dry, but occasionally heavy rains make it a raging torrent of water. To withstand these flood waters, the concrete piers were built, and have successfully resisted them, although a bridge located a short distance upstream was completely washed away. Special permits had to be obtained from the state in order to drill the wells in a waterway, and the state receives a royalty on the production.



At the Left is Seen the River Bed as It Looks from an Airplane and with Considerable Water in It, and at the Right, When Practically Dry; Here the Concrete Bases of the Derricks are Seen

Carl E. Reed, Box 707, Ibraham, Texas

Copyrighted material

Owner. Fred Towrest,
Los Angeles, Calif.

PROSPEROUS STOVE BUSINESS FROM SALVAGE

By CHARLES A. GODDARD

5626 Cherrington
Place Los Angeles, Calif.

EVERY day there is dumped onto a lot in a section of Los Angeles one or more ranges or stoves that offer but little promise except to the junk man. To the casual observer the rusty, bent, and broken old ranges are hopeless derelicts. To one Californian, however, they have been the means of building up a business that began with less than a shoe-string, but which today sells over 4,000 ranges a year, besides gas and water heaters, oil stoves, water tanks, lawn mowers, and many large hotel and restaurant ranges. By rebuilding what others relegated to the junk pile, this man has reached this volume of business within five years.

The business began in 1916, when, after having failed in the hardware business in the East, he started to repair lawn mowers, stoves, and ranges. As he gradually accumulated some of these, it was necessary to find a market for them, and the idea of selling rebuilt goods in these lines came to him. Prices of the new goods were high then, and the articles sometimes hard to get. Developing

the business to the point where he could afford to employ expert welders, sheet-

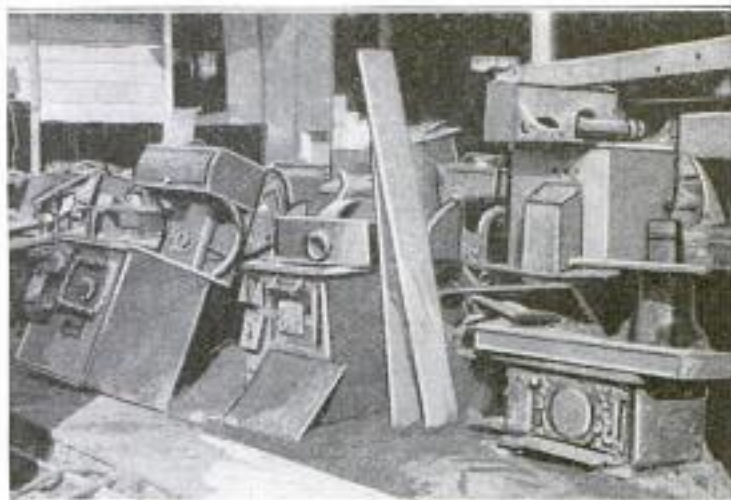

Junk to All Appearances, but Each of These Old Ranges will Either be Rebuilt into a Serviceable Piece of Merchandise or will Furnish Parts to Help Put Others into Salable Condition

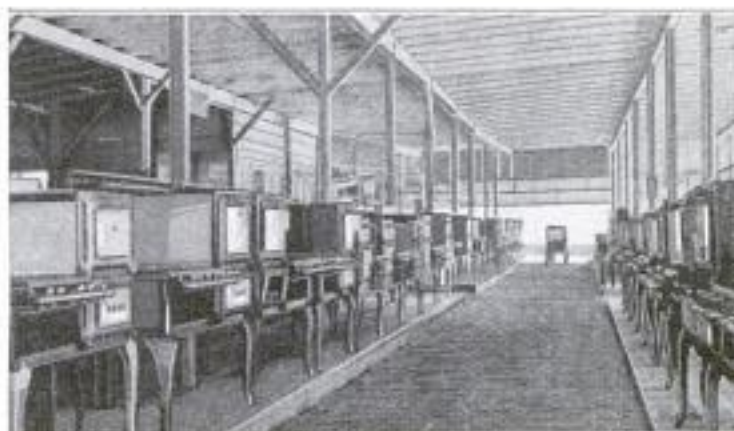

These Rows of Rebuilt Ranges Present a Striking Contrast to the Dilapidated Ones Shown in the First Picture

metal and other workers, he began to gather up the derelicts from various sources. A great number came from large downtown stores which followed the common policy of accepting old ranges or stoves as part payment for new ones. As

the business increased, many came to the plant through the trading-in plan.

A representative of the establishment visits the home where one is offered, and after examining it, proposes a price. If accepted, the range is picked up, with many others, in a truck, and on arrival examined by the experts of the plant. If the body of the range or stove is in good shape, it is scheduled for rebuilding. A new grate in a heater, an oven in a range, or some other repair, in many cases will put the article in condition to give years of satisfactory service. A "prescription" is prepared for it. The first operation is a chemical bath, given by lowering the stove or range by means of a crane into a metal vat. This removes



Section of the Plant Where Water Tanks and Heaters are Salvaged: Parts of Stoves and Ranges Which Are Still Good are Saved to Replace Worn-Out Parts in Others

rust and the greases accumulated in its years of use.

After that, the experts remove the worn parts and install new ones. When it leaves the rebuilders it is, save for appearance, a new article. This defect the finishers remedy, for they are prepared to finish its nickel and steel parts in a way to compare with the new. It may be that a range will come into the plant that is almost a total wreck; although to the plant there is no total loss. If putting it into satisfactory shape would mean practically building a new range or stove, the course of economy is followed: It is stripped of such parts as are in satisfactory condition. These are then cleaned, labeled, and sorted into the proper tills of a series of large 2-by-2-ft. pigeonholes, numbering 375 in total. The plant carries parts for every known American range or stove. Thus stripped of serviceable parts, the worn range or stove is set out to go to the junk pile for what slight revenue it will bring.

One part of these junked ranges that

finds ready service is the top and burners. With the body of the range hopeless for service, the top still can be made into a demanded article—the gas plate. These range from single burners for light house-keeping to long plates, such as restaurants use, burners from many old ranges going to make the latter.

Where the owner of an old range may place its valuation at a very low figure because of its looks and some slight handicap, the same range, refinished and repaired to produce satisfactory service, brings a good price.

Lawn mowers are handled in the same way, and a stroll through the department assigned to them is an exposition of the various makes that are for sale in this country. Hot-water tanks are corded as stove wood. Each old one is opened and the extent of the wear learned. If not too far gone, it gets a new bottom, or so, and is put up for sale. Tank heaters are also sold in large numbers, after being rebuilt and fitted to new or repaired tanks.

7399

FLOORED SCOW DOES DUTY AS MOTOR-CAR FERRY

When the owner of an automobile wished to take his machine to Westport, N. B., recently, he was forced to improvise a special ferryboat. Westport is on an island about a mile from the mainland. There are no machines on the island, and the only means of reaching it is by a motorboat ferry. A scow was obtained, floored over, and the machine run onto it. The regular ferry then towed it across. The machine was run off the scow onto the shore on planking, and for the first time a motor car appeared on the island.

7684

OX OF GIGANTIC PROPORTIONS EXHIBITED IN AUSTRALIA

An ox of gigantic proportions was exhibited last April at the Royal Sydney Show, in Australia. It was a seven-year-old, and stood 6 ft. 4 in. high. It had a girth of 14 ft. behind the shoulders, and weighed 3,700 lb. It came from New Zealand, and had arrived some days before the opening of the show. It was well proportioned in the forequarters, but its hindquarters were not nearly so robust. The Royal Sydney is one of the greatest agricultural shows in the world.

Illustration 7/2/21



At the Left: Poling the Scow Automobile Ferry to Shore after Crossing to the Island. Right: The Scow, with Its Load, was Towed across the Harbor by the Small Launch Which is Used as a Passenger Ferry

Ent. S. S. Payson
 71 Crabwey St.,
 St. John, N.B. Canada.

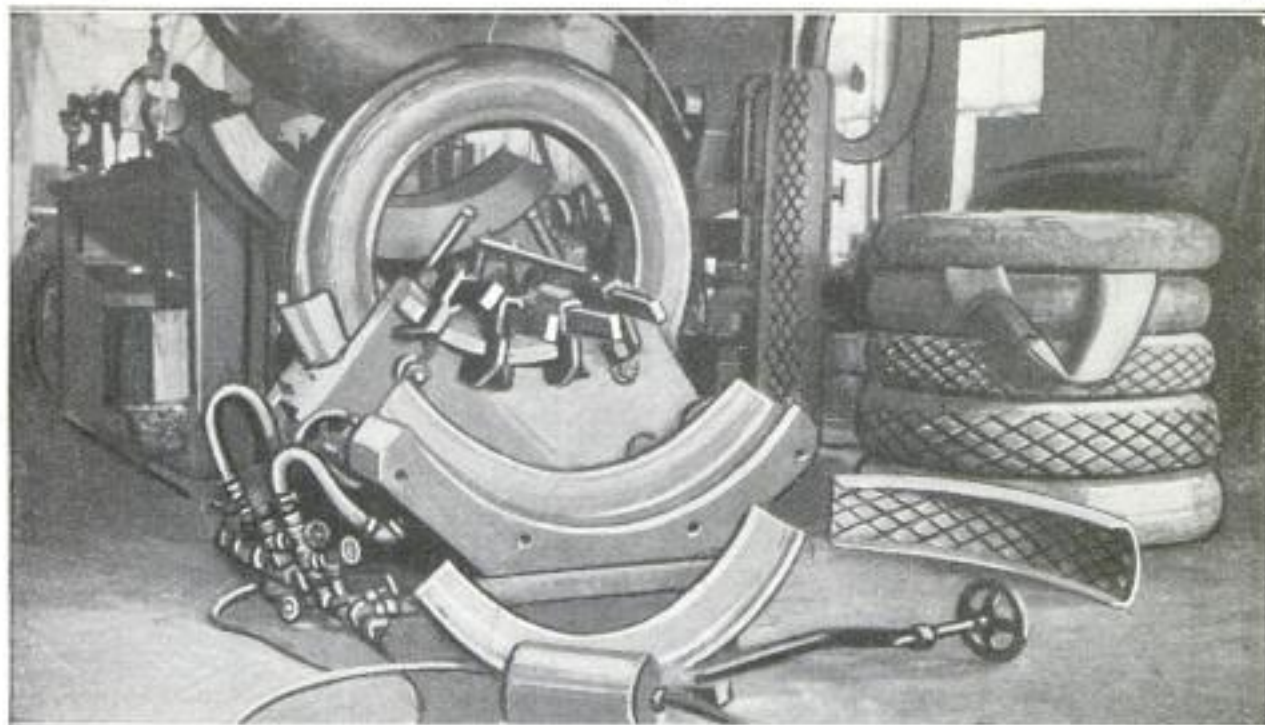

Adjustable Mold, with Interchangeable Tread Plates in the Base. That Makes Repairs on Any Size or Shape of Pneumatic Tire: Bolts Hold the Three Main Parts of the Mold Together, and are Used to Adjust It to Any Required Width. The Tire is Compressed in the Mold by Pressure on the Sandbag Plate

⁷²¹³
**ADJUSTABLE MOLD SIMPLIFIES
 PNEUMATIC-TIRE REPAIRS**

In pneumatic tires for automobiles, and especially in those for trucks, there is considerable variation in dimensions, even in cases where, made by different manufacturers, they are nominally of the same size. Therefore, in repair work on these tires, to make correct vulcanizing possible, a newly patented adjustable tire mold that will take care of tires of any shape or size, should be very helpful. It will do retread vulcanizing of any kind by means of tread plates which are interchangeable in the base of the mold. The latter is made in three parts used to adjust, by bolts, the mold sides to any width desired.

⁷⁶²⁶
**FEW REAL "SLACKERS" OF MANY
 LISTED AS DRAFT EVADERS**

Out of a list of nearly 10,000 names, submitted by the War Department to the United States district attorney in New York City, of persons supposed to be draft evaders, 3,000 cases have been investigated and only nine have proved to be cases of actual draft evasion. The lists included all persons registered for the draft who failed to send in their questionnaires. Many of those listed have not been found, and many others had served in the army or navy. Some even lost their lives in the service.

N.Y. Times 11/8/21
 P. 1

⁷⁴⁵⁵
**OLD DUTCH WINDMILL MODEL
 FOR LOS ANGELES STORE**

Advertising by means of unusual and picturesque architecture for store and shop buildings has become quite popular in many places. One example of this, the branch store of a Los Angeles bakery, which was built this fall, is a copy of an old Dutch windmill, a trade-mark of the firm. The store is a complete duplication, from the great clumsy wind vanes to the unevenly laid shingles which cover the domelike roof. Light and dark shades of Dutch blue, used in painting the building, add to the picturesque effect. The interior is equipped with the necessary counters and showcases, to make a complete little retail store.



Store in Los Angeles That Attracts Attention for Advertising Purposes by Its Unusual Architecture: It Is a Reproduction of an Old Dutch Windmill

Vande Kamp's Holland
 Dutch Bakery, 257 Verdine
 Los Angeles, Calif.

Ent. Charles Esinger, e/s Press Club,
 Powell + Sutter,
 7457
 San Francisco, Calif.

ELABORATE HIGHWAY TESTS MADE

Columbia Steel Co.

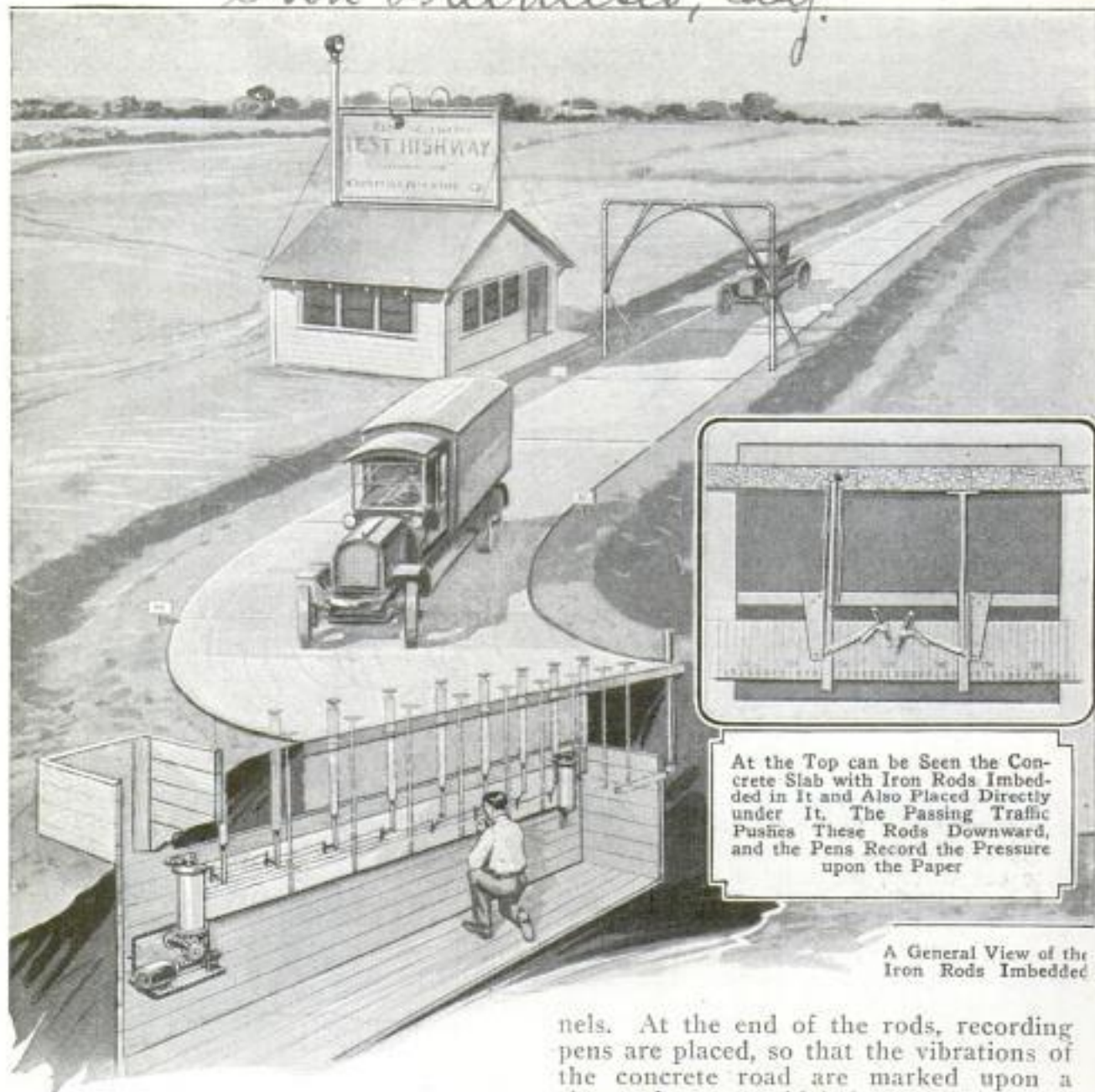

A General View of the Iron Rods Imbedded

A test highway has been built at Pittsburg, Calif., upon which a series of tests will be made to determine the good and bad features of 13 different types of concrete pavement. The types selected represent results obtained from a questionnaire which was sent to many highway engineers, asking for their views on road building, and also what features should be included in the tests.

The road is 18 ft. wide, approximately one quarter of a mile long, and is built in an oval form, much resembling a race track. Four tunnels have been dug under the roadbed, and special instruments will be used to make graphic records of the effects of the various kinds of traffic passing overhead. For these instruments, rods are imbedded in the concrete, and extend down into the tun-

nels. At the end of the rods, recording pens are placed, so that the vibrations of the concrete road are marked upon a sheet of paper, which is unrolled by an electric motor. A special grade of reinforcing steel is being tried, and the road will be used for heavy traffic until it is completely destroyed, to prove which section is the best.

The surface of the pavement has been marked off in 6-ft. sections which are numbered and lettered. A close watch will be kept, and as soon as a crack appears in any section of the road, it will be recorded upon a chart. When the test is completed, the chart will show the location of each crack and the date of its appearance. It is thought that this is the first time any highway tests have been made from under the surface of the road.

The state of Illinois has also constructed an experimental highway about 12 miles southwest of Springfield, which is divided into seven different sections, or

7457

WITH TUNNELS BENEATH ROADWAY

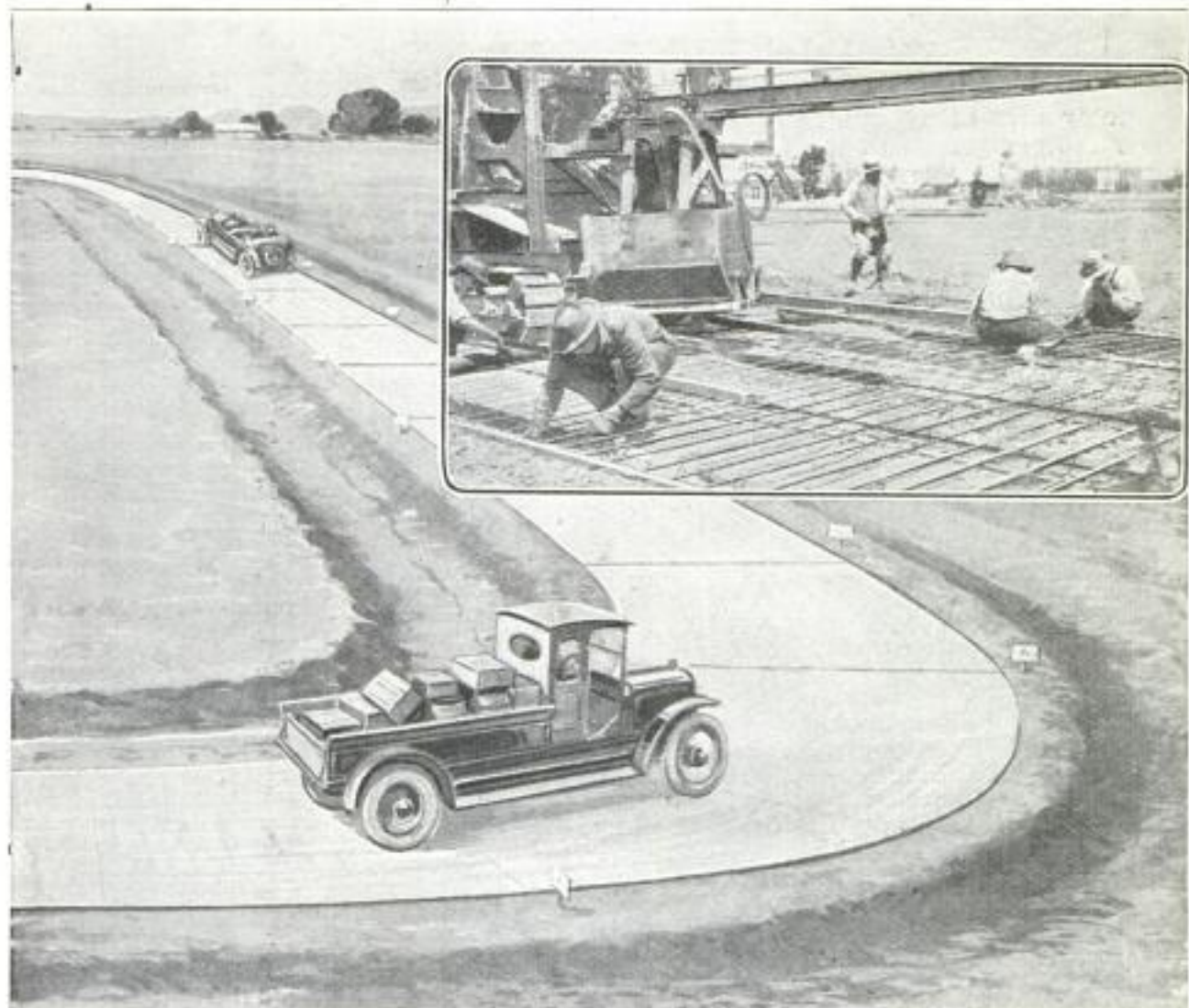

Test Highway Showing the Various Kinds of Loads being Driven over It: The Cross Section Illustrates the in, and Placed under, the Road to Measure the Varying Pressure. At the Upper Right is Shown the Placing of the Reinforcing

types, of concrete and brick-paving material. The traffic tests of the road will be accomplished by means of a battery of 10 motor trucks driven by trained operators. The loading of the trucks will be increased after each 1,000 trips over the 2½-mile highway. The maximum wheel load will not exceed 12,000 lb., which is half again as much as the legal load in Illinois. There are no curves in the road, and the grades vary from zero to .4 per cent, with an average grade of .1 per cent.

7617

ENERGY REQUIRED IN SEWING BY HAND AND WITH MACHINES

That there is a great difference in the expenditure of energy required with different ways of sewing, was demonstrated recently by scientists. Little variation was found in hand hemming on fine handkerchiefs, cotton sheets, 8-oz. cotton duck, or army blankets, but when the

speed of sewing was increased, the expenditure of energy increased in proportion. Hemming sheets on a foot-driven machine, which was discovered to be about six times as fast as doing the same work by hand, required six times as much energy, but the energy, per yard of sewing, was hardly one-half as great. When an electrically driven machine was used, the energy required per hour was not quite twice that used for hand sewing, and about one-fourth of that used for the foot-driven machine. The energy per yard of sewing was approximately one-fifth of that on the foot-driven machine, and less than one-tenth of that used in sewing by hand.

☐ Phosgene, the most deadly poison gas used in the World War, can be turned into a delicate-scented violet perfume, by means of a synthetic process which has recently been discovered by American chemists.

Science 11/4/21

Caffort Frères
125 bis, Rue du Chemin Vert,

88
7422 *70 Rue* POPULAR MECHANICS
Paris, 11^e, France.

NEW EUROPEAN AUTOMOBILES
PRESENT NOVEL FEATURES

Motor cars of a peculiar type, having their motors geared to the front instead

inches apart. This car is equipped with an ordinary steering wheel, and is supplied with various bodies for commercial and pleasure purposes. It is said to make a most economical light delivery truck.



PHOTOS COPYRIGHT, KEYSTONE VIEW CO.

Two Views of the Three-Wheeled Dutch Automobile Showing, Above, How the Front Wheel and Engine are Mounted, and the Long Steering Lever: From the Front, Below, This Machine Looks Much like a Large Motorcycle

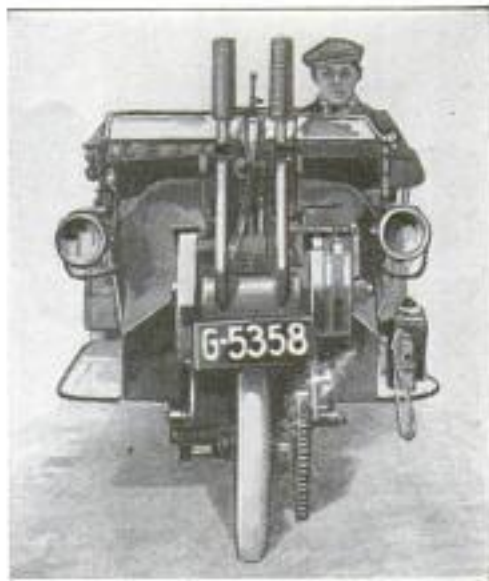

of the rear wheels, have recently made their appearance in Europe. One, of Dutch manufacture, and one French machine, are the most conspicuous examples. The Dutch car is a light three-wheeler with a single-cylinder vertical motor directly over the single front wheel. The frame of the chassis is formed into a V-shape in front and curved upward as a mounting for the motor and front wheel. Steering is accomplished by means of a long steering handle connected to the front wheel.

The French machine is said to be very economical in operation and is being used as a taxi, with rates as low as those of the horse cabs. Its frame is similar to that of the Dutch car and is attached to a fork at the front. From the side it appears to be a three-wheeled car also, but in reality has four wheels. The two front wheels are both mounted between the fork and only a few

articles of air which in the storage room becomes tainted.

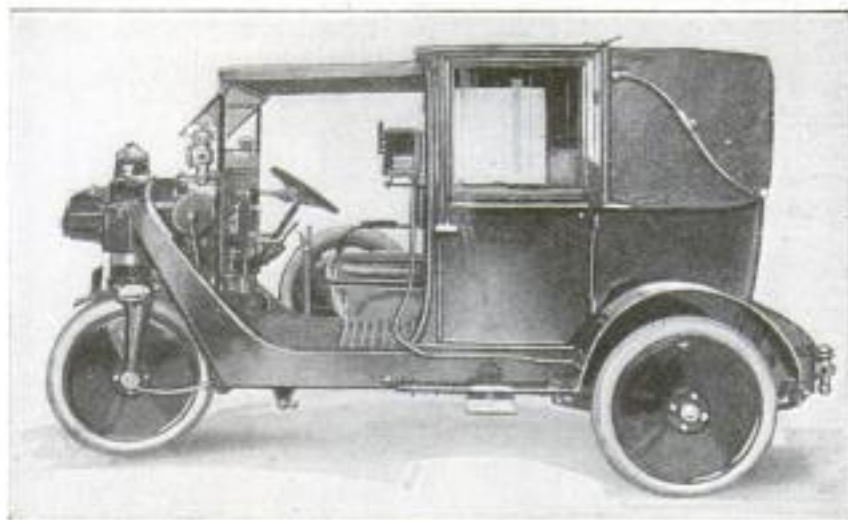

The French Machine, Equipped as a Taxicab: It Is a Four-Wheeled Car, Though from the Side It Appears to Have Only Three Wheels. The Two Front Wheels are Set Just a Few Inches Apart between the Front Fork

A two-cylinder motor is mounted just back of the front fork. All moving parts are so inclosed that a hood is unnecessary. A spiral spring around the upper part of the steering pivot is used in front, while the rear springs are of the ordinary leaf type. A conspicuous feature of this car is that either the engine or gear box may be quickly and easily removed and replaced by extra parts.

Three-wheeled motor cars were used in Sweden in 1914, but because of a tendency to tip over in turning curves, their operation was restricted in many cities.

7625

It has been found that the disagreeable flavor that is imparted to eggs by cold storage, can be prevented by immersing them in a preserving fluid. This coats the eggshells so as to make them air-tight, and thus prevents the penetration of any particles of air which in the storage room becomes tainted.

Cmd. E. H. Lemonnier 27 Rue d'Enghien, Paris, France

7415

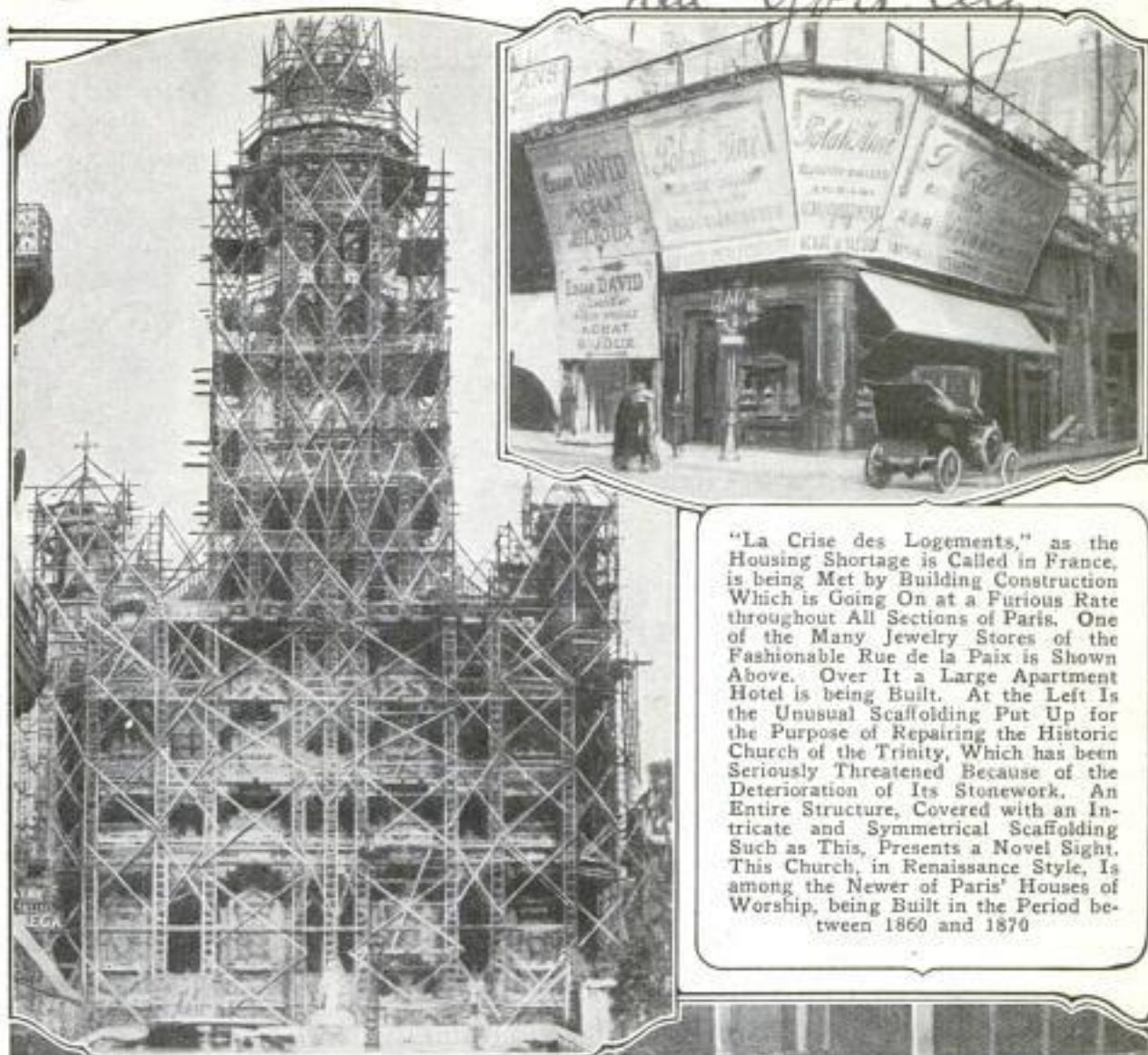
Williams Service
32 Union Square
PARIS HUSTLING TO IMPROVE ITS APPEARANCE.
New York City

"La Crise des Logements," as the Housing Shortage is called in France, is being met by building construction which is going on at a furious rate throughout all sections of Paris. One of the many jewelry stores of the fashionable Rue de la Paix is shown above. Over it a large apartment hotel is being built. At the left is the unusual scaffolding put up for the purpose of repairing the historic church of the Trinity, which has been seriously threatened because of the deterioration of its stonework. An entire structure, covered with an intricate and symmetrical scaffolding such as this, presents a novel sight. This church, in Renaissance style, is among the newer of Paris' houses of worship, being built in the period between 1860 and 1870.



Where traffic is congested, red "safety bands" are being laid in Paris streets. Motorists are required to stop while pedestrians are crossing on the bands. Workmen are shown here laying a red band.

Capt. R. F. Chapman
894 Riverside Drive

Commerce Reports
10/31/21

90

POPULAR MECHANICS
New York City

COLLECTION OF SEAWEED
AIDED BY TIDES

7597
RAW-RUBBER SOLES NOW USED
ON ENGLISH SPORT SHOES

6717

Along the south shore of Long Island, twigs anchored by means of short posts

English shoe manufacturers are preparing to make sport shoes with raw-rubber soles, since it was discovered by tennis players on Far Eastern rubber plantations, that the crêpe, or raw-rubber soles, lasted longer than those of the vulcanized variety, and were much more pliable. Rubber soles are commonly seen on different kinds of footwear, but these have undergone the vulcanizing process, which means the introduction of a certain portion of sulphur to make the rubber less liable to be affected by atmospheric changes. It is thought that the new soles can be made to sell as cheap as the



The Barriers are Built to Trap Seaweed at the Ebb of the Tide. The Weed is Then Raked into Stacks at the Farther End of Each Barrier

are used as barriers to trap seaweed between the flow and the ebb of the tide. These barriers are placed at frequent intervals, forming stalls into which the seaweed is washed at high tide. The ebbing tide, receding, drops the mass of entangled seaweed, which is then drawn out on a stack beyond the reach of the water at high tide. Large quantities of the weeds are used as fertilizer, or burned to ashes from which iodine and other chemicals are made.

vulcanized article, even though they are of pure rubber.

7524

CYLINDER FOR DOOR LOCKS
VERY EASY TO INSTALL

For door locks, an expansion cylinder that fits and adjusts itself to any thickness of door, can be installed more easily and quickly than the old-style cylinder: The cylinder has two hinged claws that move outwardly and are gripped by two setscrews, which are permanently engaged to the cylinder. It is installed by inserting it into the door hole and tightening the setscrews with a screwdriver.

SURVEYING PARTIES NOW USE
AEROPLANES AND AIRSHIPS

To gain, in five weeks, more information than the best-equipped land exploration parties could get in a year, is the goal of an Australian engineer who is using an aeroplane in his work. His task is to lay out a rough aerial survey of the best routes for the proposed railway from the north to the south of the continent. Following his trip will come an airship carrying a larger party of civil engineers, who will verify the first rough survey and make a more elaborate layout of the topography of the land. It is expected that a year's time can be saved by using this preparatory aeroplane method, and that eventually all extensive surveys will be preceded by preliminary air-craft work, thus also effecting a considerable saving in money.

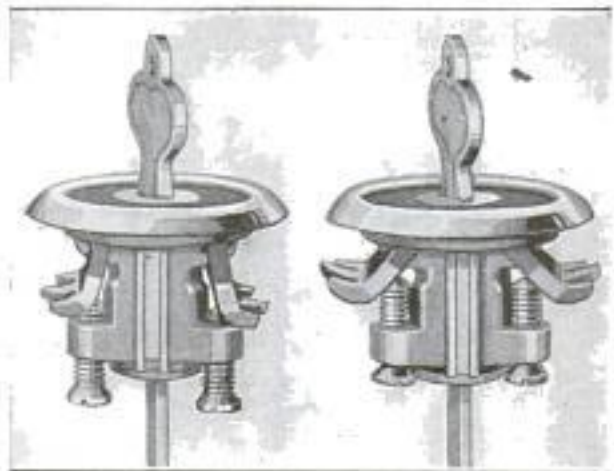

Cylinder for Door Locks That Fits and Adjusts Itself to Any Thickness of Door. Left: Before Insertion. Right: After Insertion with Setscrews Tightened

Segal Lock & Hardware Co.
155 Lenox St. New York.

Aerial Age Weekly 11/7/21

Copyrighted material



Three Views of the Hollowed-Out Sand Dune Which Is the Home of a California Hermit: The Exterior, Above, is Covered by a Desert Vine to Hold the Sand in Place. The Fireplace, at the Right, is Built of Shells and Coral. Below: Tables Holding Some of the Sea Specimens Which He Sells to Make His Living, and a Prospective Customer Examining Them



Living in a hollowed-out sand dune over which he has induced a desert vine to grow in order to keep his home from whirling away in a windstorm, a hermit residing near Santa Monica, Calif., ekes out an interesting existence in selling sea animals and plants to moving-picture producers. The stove within his humble dwelling is built of coral and sea shells which he has procured from the receding tides on the ocean beach. He has a stock of live inkfish, cuttlefish, and squids, as well as other sea monsters, which he keeps in glass tanks about the place. The motion-picture men have found it more profit-

able to buy their requirements of horseshoe crabs, starfish, seaweed, etc., from the recluse than to search the seas for them. Remuneration for his wares nets the hermit enough for clothing and food, as well as a little money on the side for his other small wants.

☐ The Popular Mechanics Bureau of Information offers its free service to all readers of this magazine. Names and addresses of manufacturers and dealers in articles described, and any other details in our possession, will be promptly furnished by addressing the Bureau.

George Haiss, Mfg. Co.
New York City - Canal Place,
 92
 7522
POPULAR MECHANICS

**WAGON LOADER WITH CREEPERS
 WORKS ON SOFT GROUND**

No more need wagons or trucks be "stuck" in the soft ground surrounding

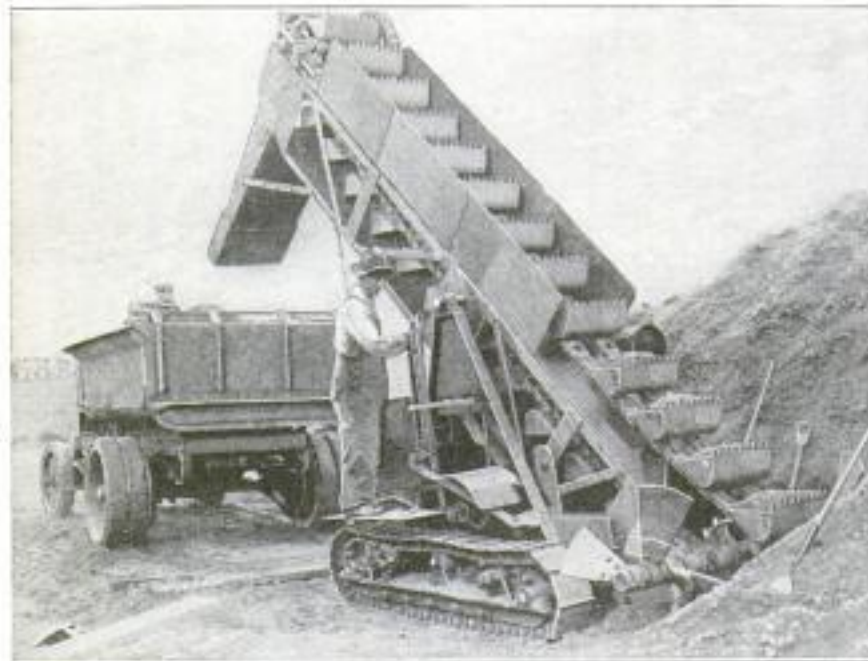

Here the Creepers are Seen, and Also the Propellers Which Push the Material into the Path of the Conveyor That Loads the Truck

the gravel or coal pile, with the use of a loader recently put on the market by a New York manufacturer. The loader, which is of the bucket-elevator type, has a distinct advantage over others in its line, because of being equipped with creepers, which provide a wide bearing surface. They are 10 in. wide and 8 ft. long, thus dividing the total weight of the machine so that the ground load is only 7 lb. per square inch. Propellers at the bottom of the conveyor force the material in toward the bucket elevator, which is driven by a 37-hp. tractor-type engine. This engine also drives the whole machine at a forward speed of 75 in. per minute, a reverse of 45 in. per minute, or a crowding, or loading speed, of 22 in. per minute, thus handling material very quickly.

POWDERED PEAT AS FUEL FOR HEATING FURNACES

Peat soils exist more or less in all parts of this country, but to the greatest extent in Minnesota. In this state there are approximately 7,000,000 acres of peat. It is therefore gratifying to learn that a stage has now been reached where plants are being erected for burning pulverized peat for heating purposes in large buildings.

heating plant in large air-tight containers carried on motor trucks. At the heating plant this powdered peat is dumped into a hopper at the road level, from which it runs to a second hopper, below, at the level of the furnaces. From this it passes through a screw conveyor into a fan blower, which drives it by means of suitable piping to the burners in the furnaces. The blower is under control so that the quantity of peat, and its force of delivery at the burners, can be regulated. In connection with the feed piping, a second system of piping is connected to a second blower for forcing additional air to the burners. The unburned peat, of which there always will be a certain amount, is blown back to the delivery hopper.

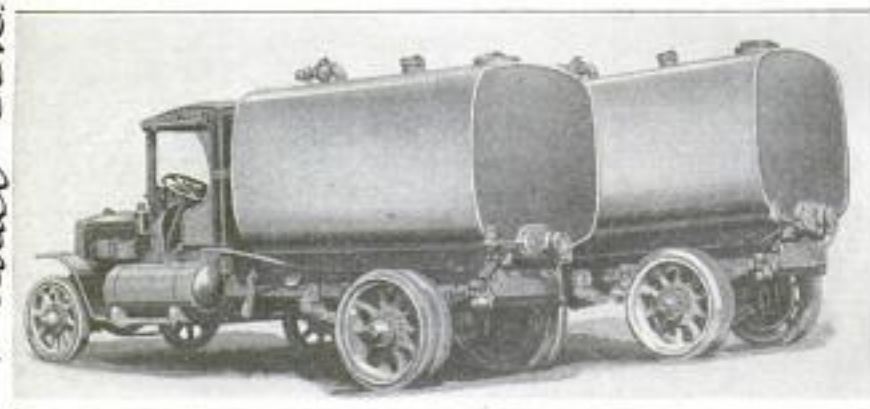

After It has been Pulverized, the Peat is Delivered to the Heating Plants in These Air-Tight Containers Mounted on the Motor Trucks. The Discharge Nipples Are at the Bottom of the Containers behind the Rear Wheels

The first operation is to pulverize the peat, after it has been thoroughly dried, to the consistency of fine flour, in a special plant, from which it is delivered to the

this type was in a university registering about 500 students. Another plant, now in course of erection, will heat a large office building.

able piping to the burners in the furnaces. The blower is under control so that the quantity of peat, and its force of delivery at the burners, can be regulated. In connection with the feed piping, a second system of piping is connected to a second blower for forcing additional air to the burners. The unburned peat, of which there always will be a certain amount, is blown back to the delivery hopper.

The first installation of this type was in a university registering about 500 students. Another plant, now in course of erection, will heat a large office building.

Emt. Arthur Hallam Minneapolis, Minnesota, 317 Cedar Ave.

7254

A. A. Halbeck

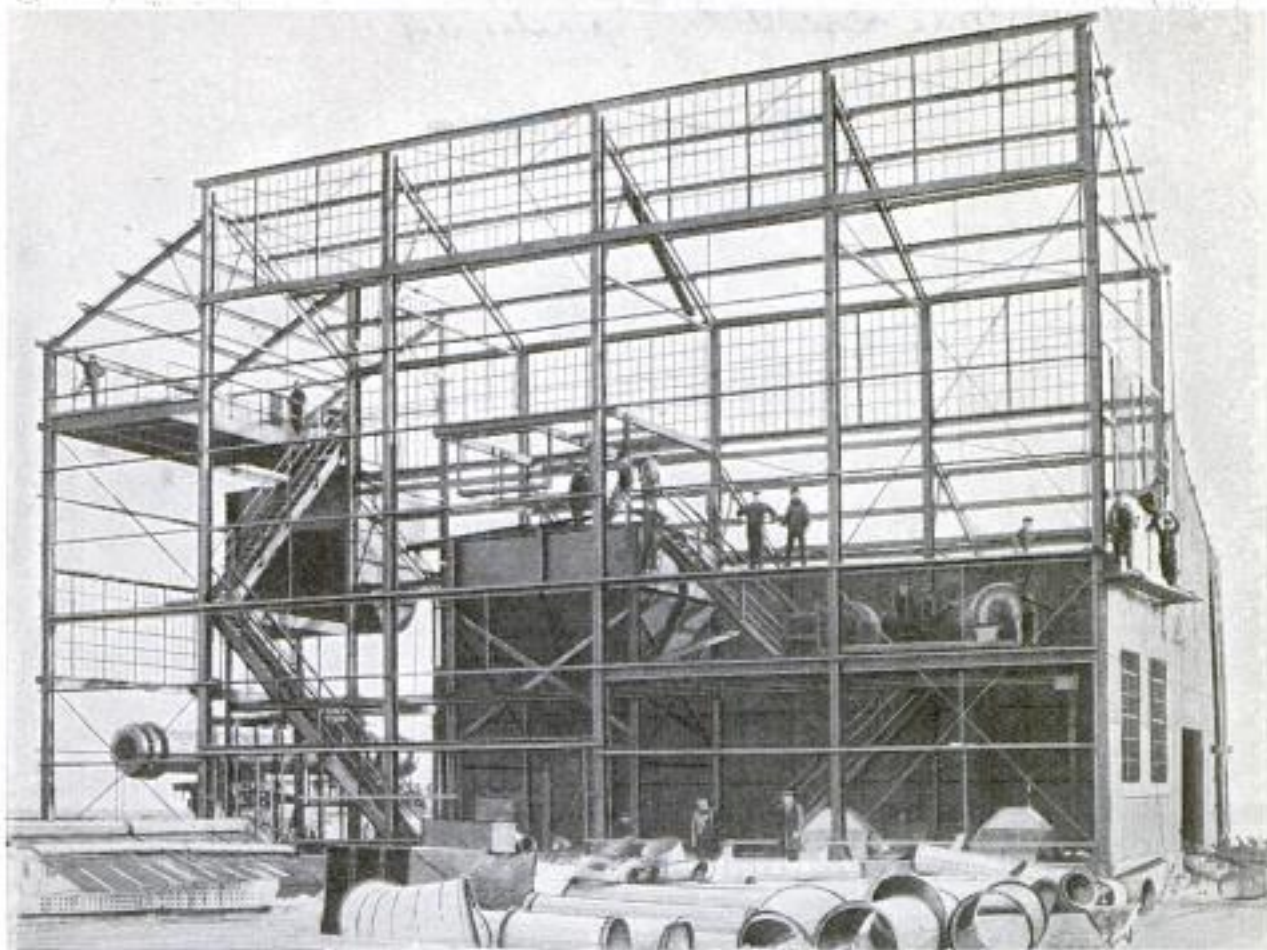

Peat-Drying and Pulverizing Plant in Course of Erection: In This Plant, When Completed, the Peat will be First Thoroughly Dried and Then Pulverized Until It is Reduced to the Consistency of Fine Flour. It Is Then Ready for Delivery to the Heating Plant in Any Building Suitably Equipped for Burning It

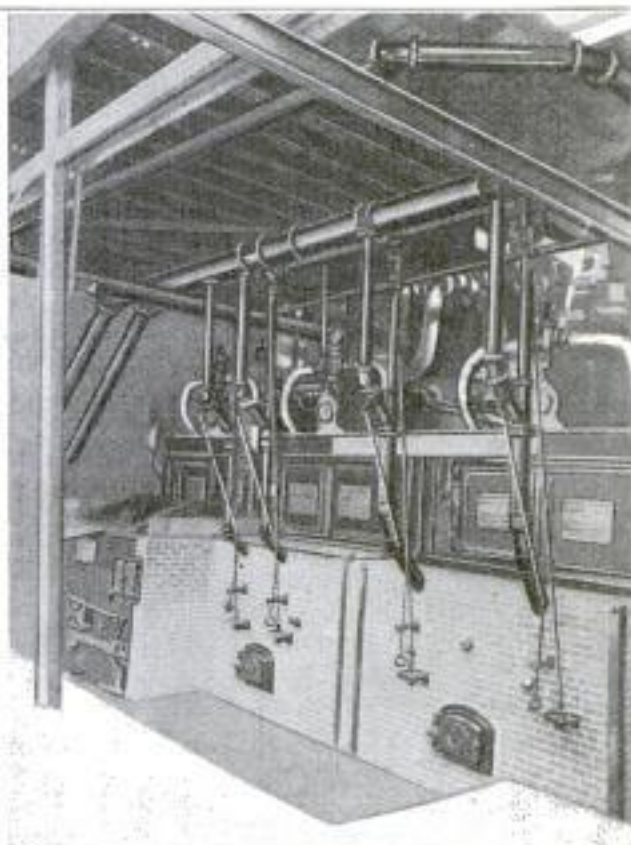
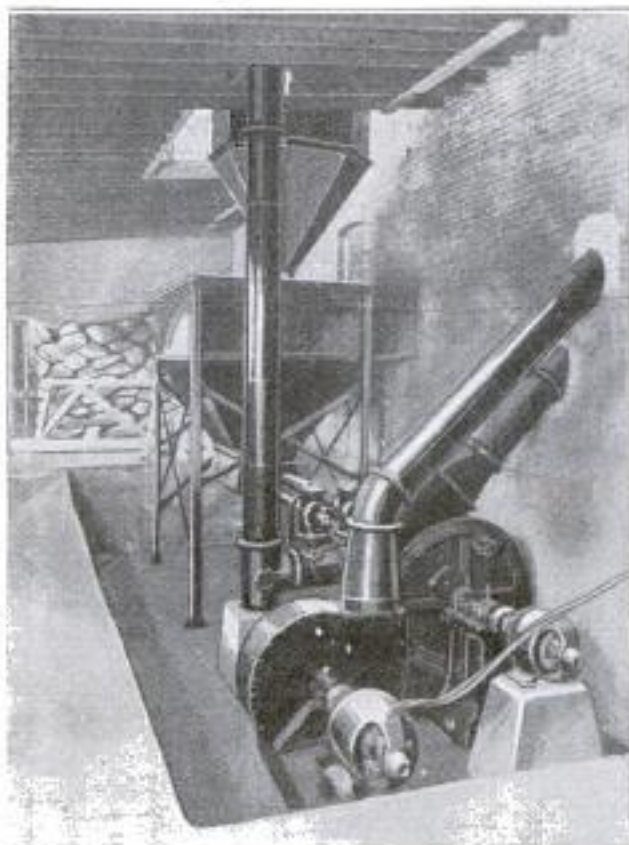

Left: In the Background Are Two Hoppers for Delivering Powdered Peat to a Blower, the Rear One of the Two Fans in the Foreground, Which Delivers the Peat to Burners in the Furnaces Shown at the Right. The Other Blower is for Forcing Additional Air to the Burners to Increase Combustion When Required

Invented by Lloyd Smith
Aerial Equipment Co

94
 7562 912 Chicago Ave. Evanston, Ill.
POPULAR MECHANICS
DISHWASHING IS PLEASURE
WITH PORTABLE MACHINE

No more frowns or sighs will accompany the task of washing the dishes,

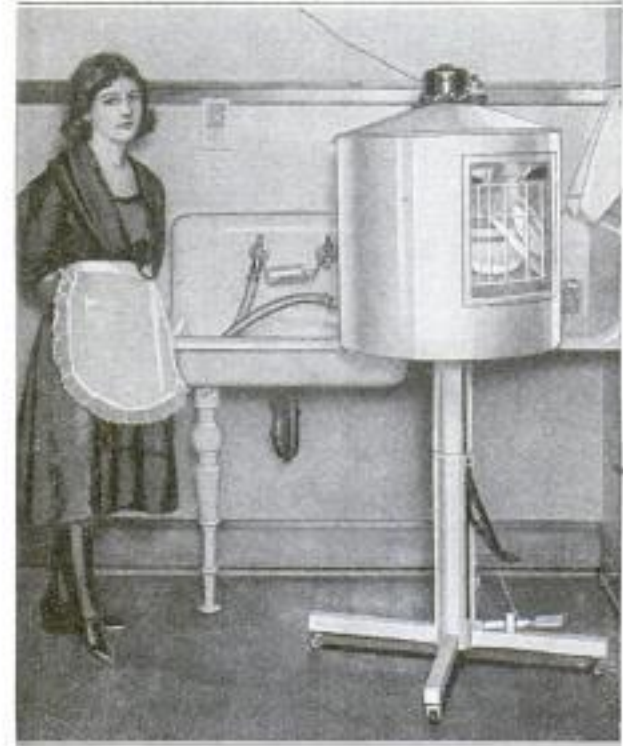

The Portable Dishwasher in Operation, Showing the Dishes Inside and the Connection to the Water Faucet: The Pedal for Raising or Lowering, and the Casters, are Seen at the Bottom

if a new portable dishwasher is used. The machine can be raised or lowered by a pedal, and is mounted on casters, so that it can be loaded at the table and then wheeled to the sink, where the water is run in. Five minutes of washing cleans the dishes, after which the dirty water is drained and hot water run in again, which rinses the dishes and cleans the washer at the same time. A small electric motor is used to circulate the water.

76 33
ALASKAN NATIONAL FORESTS
HAVE HUGE TIMBER WEALTH

The most heavily timbered section of Alaska is the western slope of the Pacific coast and the numerous islands of the archipelagos that line this coast. In this section there are two National Forests, the Tongass, which embraces what was formerly known as the Alexander Archipelago, and the Chugach, which comprises the islands of the Prince William Sound. In both cases there is included a narrow strip, at most two miles wide, of the adjacent Pacific coast. The area of the government land in these reservations is 20,579,740 acres. It has

been estimated that the Tongass National Forest contains 70,000,000,000 ft., board measure, of merchantable timber, which means there is sufficient to yield annually and perpetually wood pulp amounting to 2,000,000 tons. The enormous size of some of this timber may be judged from the fact that, in one instance, 1,500 logs scaled 1,500,000 ft., or about 1,000 ft. to the log. Western hemlock predominates, being 60 per cent of the total. The Chugach Reserve is similar to the Tongass, but is much smaller.

7505
BOY SCOUTS STUDY GEOLOGY
FROM NEW FIREPLACE

At the Evanston, Ill., headquarters of the Boy Scouts, a fireplace has been constructed for the study of geology and physiography. At the base are shown the different kinds of materials, in their relative positions, that make up the strata of the earth. At the top, many different specimens of ore are shown. Models of a lake bed, and of a river bed, are also built into the fireplace, which is ornamental as

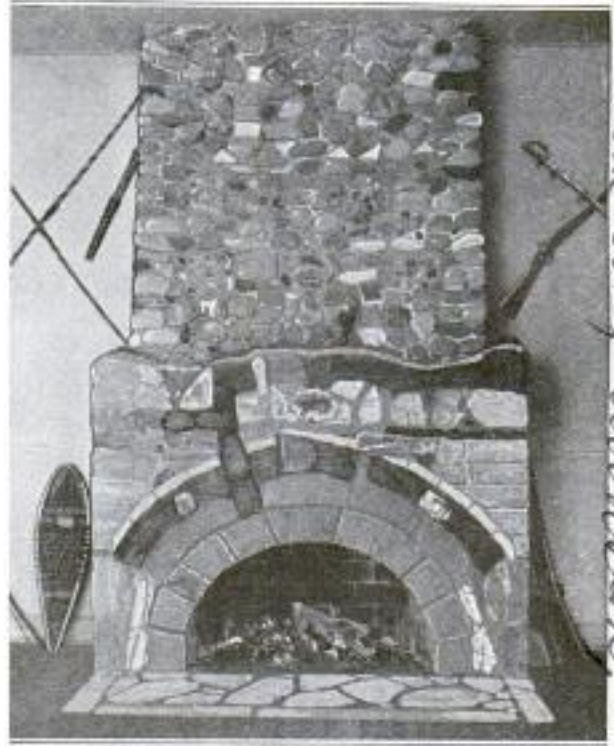

A Geological Fireplace with Many Specimens of Ore Imbedded in the Top, and the Different Kinds of Materials Which Make Up the Strata of the Earth, Built into the Base

well as useful, and it is asserted that the fireplace is the only one of its kind in the country.

Our Bureau of Information will answer all questions regarding articles appearing in this magazine.

Emf. R. 28. 7 has been all 150 5' each one 1/2" diameter of 1/2"

Christian Science Monitor 10/26/21



Reversible Scenery Arranged to Give an Indoor Effect on an Outdoor-Theater Stage: The Four Marble Settees and Massive Columns Produce a Portico Setting. By Stretching Canvas between These Columns, a Realistic Interior Scene of Any Kind can be Produced. Draperies, Rugs, Furniture, and Ornaments may be Added

REVERSIBLE SCENERY FOR OUTDOOR THEATER

By JOHN ANSON FORD,

*416 Union League
Bldg. Los Angeles, Calif.*

THE problem of providing a change of stage scenery for an outdoor theater, which did not have so much as a curtain, not to mention other stage accessories, was solved recently by producers of two Shakespearean plays in the Hollywood Bowl, a beautiful and popular community-gathering place in a suburb of Los Angeles. The need of these two plays was for one outdoor and one indoor scene. This need was ingeniously met by building a set of stage furniture and properties, each unit of which was reversible. Thus, between acts while the lights were

turned off and the stage was in semi-darkness, each unit in this novel setting was turned around, or turned upside down, according to the character of the piece. The result was a complete change of scene. The idea, which the designers worked out themselves, never having seen it applied elsewhere, is applicable to other stages where the scenery facilities are limited.

The indoor aspect of the set consisted chiefly of four massive, smooth columns with square bases, and four imitation marble settees with high backs. These,

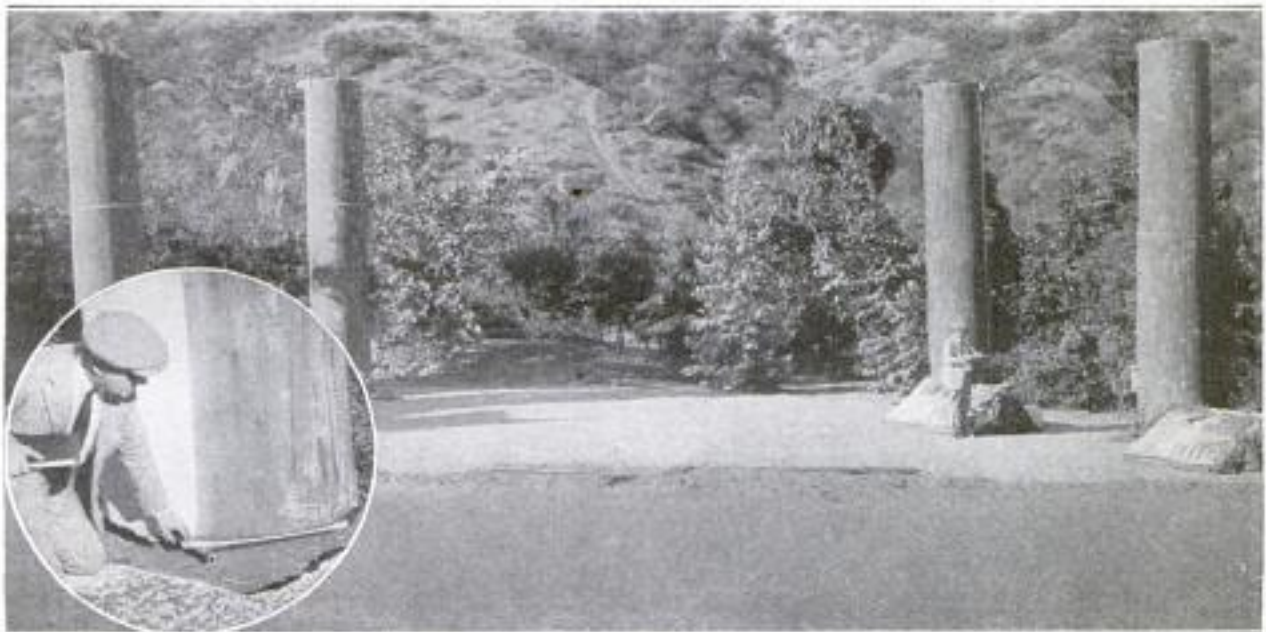

Outdoor Effects are Produced by Turning the Marble Settees Upside Down to Represent Moss-Covered Rocks, and by Giving the Columns a Half Turn to Make Them Represent Tree Trunks. Inset: Base of One of the Columns, Showing Its Support, and Casters under It to Facilitate Turning

together with other pieces of movable furniture, draperies, rugs, etc., were used very successfully in creating a portico



In the Foreground Is a Close-Up of One of the Reversible Marble-Settees. In the Background Is One That has been Turned Upside Down, and in That Position Represents a Moss and Leaf-Covered Rock

scene, and by stretching of canvas between the pillars, a palace interior could be represented.

When the play demanded an outdoor setting, it was not necessary to remove all these cumbersome articles. Instead, the pillars were turned around on their bases, each being mounted on casters, and forthwith the pillars were transformed into the trunks of huge trees. While this turning was done, branches were thrown about the bases, concealing the casters and adding to the general woodland effect. Likewise, the four settees were turned over, face forward, and became irregular, moss-covered rocks. To make the height of the settees appear less, each one was provided with a triangular addition that was placed next to the end, thus adding to the angularity of the rock. When the settees were set upright, these supplementary pieces were concealed immediately back of them, so that putting the pieces properly in place in the woodland scene was only a moment's task. Shrubbery and small trees growing at the back and sides of this outdoor stage helped materially in creating a very realistic scene, and while the tops of the trees were lacking above the massive trunks, the lighting was such at night that this was scarcely noticeable.

The construction of the settees was the easier of the two tasks, as it was only necessary to cover the back side with stage moss and canvas, properly painted to represent stone. In making the pillars, the work was less simple. Since the outdoor theater had only a natural

floor of earth and sod, it was necessary to set a wooden platform about 3 ft. square, in the earth for each of the pillars. This base was made strong enough to carry some ballast within, and heavy iron casters were screwed to the bottom so that, when placed on the wooden platform, it could be turned on its axis easily. A removable rectangular base piece, or more correctly speaking, a piece which appeared to be rectangular but in reality had only three sides, was set about the base of each pillar when it was a part of the indoor scene. When the pillar was used as a tree trunk, this base piece was removed, and boughs were scattered about it, as previously mentioned. It is expected that this scenery will prove useful in non-Shakespearean plays also.

7349 ASPHALT PAVEMENT DUG UP WITH WORK-CAR TOOL

Instead of the old way of cutting asphalt pavement, in which hammers and chisels were used, street-railway companies have put in use a great labor saver in the shape of a cutting tool which can be attached to a work car. The tool projects downward from a shoe that rides on the pavement about 18 in. from the rail. This shoe is supported by a framework which is attached to the car at three points, and which can be swung up under the car when not in use. The cutting tool depends upon the weight of the car

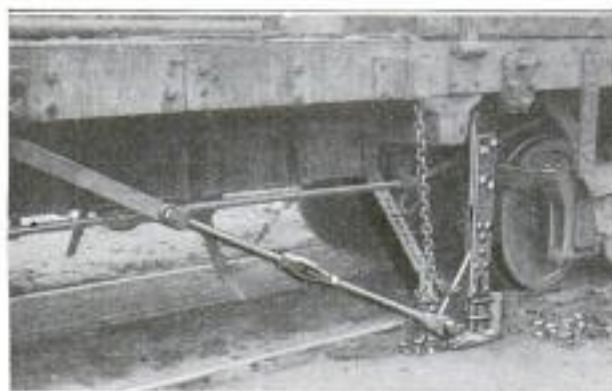

Work Car Fitted with Framework and Shoe through Which Pavement-Cutting Tool Projects

to force it into the pavement, and in cold weather it is necessary to weight the car before the tool will cut.

U. D. Chamberlin
Market St. Railway Co. San Francisco



WRECK OF U. S. S. "MEMPHIS" LITTLE AFFECTED BY FIVE YEARS' STORMS

Battleship *U.S.S.*
THIS remarkable photograph, showing the wreck of the former U. S. S. "Memphis" being battered by the equinoctial gales of September, 1921, is striking evidence of the quality of American shipbuilding. During a hurricane in August, 1916, the armored cruiser "Memphis" was driven onto the rocks of the outer harbor of Santo Domingo City, in the West Indies. For five years the vessel has withstood the terrific hammering of the waves which is so clearly shown here. The spray can be seen going completely over the tail funnels.

7009
**GANTRY DRILLING MACHINE
 FOR DRILLING PLATES**

In the manufacture of tank cars there is now being used a novel form of gantry drilling machine which is mounted on a track, the gauge of which is wide enough to straddle the tank plates in which the machine is drilling holes. Along this track the machine can be moved by means of an electric motor. A crossbeam joins, by means of flanged connections, the two parts of the machine that are mounted on the track, and from a pivotal support on this crossbeam swings a radial arm upon which is mounted the drilling head. The drill is driven by a motor mounted behind the radial arm on the crossbeam. With direct current, an adjustable-speed motor can be used, and with alternating current a multispeed motor, permitting a wide range of speeds through the combination of electrically controlled changes with the me-

chanical changes of the drill head. Two, three, or four radial arms and heads can be connected to the same crossbeam—in the case of four, two being on either side of it. The span of the drill and the gauge and length of the track can be adapted to suit any special requirements.

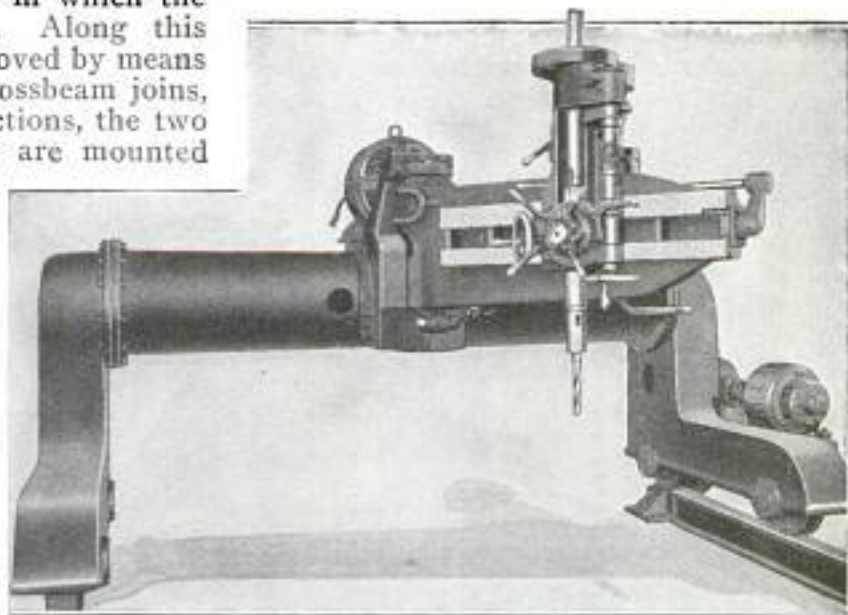

Gantry Type of Drilling Machine Which Travels on Track with Gauge Wider Than the Plates That It Drills by Means of a Drill Head Supported on a Swinging Radial Arm Connected to the Crossbeam to Suit Any Special Requirements

Crut. William K. Stamets, Pittsburgh, Pa.
Jenkins Arcade Bldg., Pittsburgh, Pa.

International Photo Service, 226 Williams St. New York City
Eng. News-Record. Bridge
 POPULAR MECHANICS
 7646 Nov 3, 1921
 100,000 VOLTS ARE CARRIED OVER BERLIN STREETS
 CONCRETE TRESTLES TO CROSS SOUTHERN RIVER SWAMPS

*7478
 Lower Electric Transmission*



Lofty steel towers carrying high-tension lines of 100,000 volts are to be seen along the streets of Berlin, Germany. The city recently decided to operate a municipal lighting plant, and thereby supply the city with illumination free.

Not one of the three rivers of South Carolina, the Santee, the Pee Dee, and the Savannah, is crossed by a bridge within 170 miles of the ocean. They have, therefore, been more of an impediment than an assistance to development of the state. Plans have now been made for a bridge of similar design over each of these rivers. The largest one will be over the Santee River, at Murray's Ferry, about 65 miles from the ocean. This river, like the others, has a very narrow channel, the greater part of its width consisting of swamps, which, at the bridge site, are four miles wide at flood water. Over the main channel there will be steel-truss fixed spans and a draw span, but the main part of the bridge will consist of approach trestles, 6,000 ft. long, built of reinforced concrete. The spans will be of two types, the pedestal type with 36½-ft. concrete beams and bents on timber piles, the other having 24½-ft. concrete beams on concrete pile bents. Construction work is now under way. The bridge over the Savannah River will be located a little below Augusta, and a fourth bridge will cross the Wateree River at Garner's Ferry. All four bridges will cost about 2,200,000 dollars.

BARGE SYSTEM PROVES SUCCESS FOR SHIPPING GROCERIES

7412

The commercial value of inland waterways is strikingly illustrated by the experience of a company in New Orleans. This concern operates 11 wholesale groceries in Louisiana and Mississippi. Several months ago a power boat was put into service to transport merchandise from New Orleans to the stores at Houma, Thibodaux, and Lockport, La. Soon after two barges were added, and recently a third, the "Interstate 3," made its first trip. This barge has a capacity of 150 tons, is 108 ft. long, 20 ft. wide, and draws only 4 ft. of water when loaded. The success of this method of transport is proved by its rapid expansion. Smaller power boats and barges are now being used to make deliveries from the various stores.

SHAFT-DIGGING MACHINE AND CAISSON SINKER

In the sinking of caissons for building foundations, as done at present by hand, men have to work continuously at the bottom of the shaft, with always an element of danger from cave-ins. There has now been developed a machine that digs the shaft and sinks the caisson more rapidly with one operator only, and with-

7481

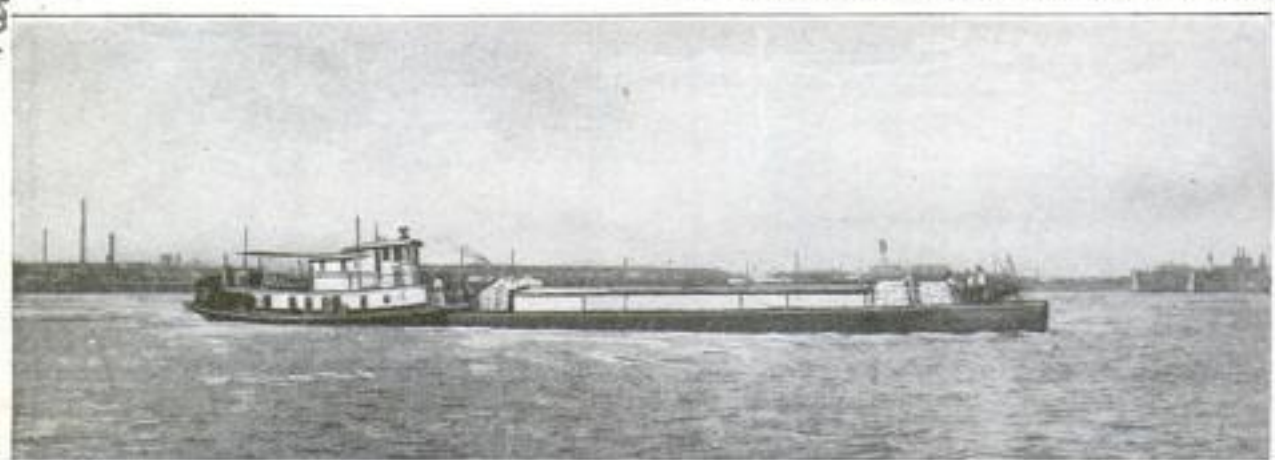

The "Interstate 3," a New Barge Which Is the Most Recent Addition to a Fleet Employed by a New Orleans Wholesale-Grocery Concern to Supply Its Branch Stores Located on Water Routes

*Emb. P. D. Spitz Garden, Orange, N. J.
 Head Office, New Orleans, La.*

7481

George W. Jackson + Fritzpatrick
 Co. 104 W. Franklin St.
 POPULAR MECHANICS

99

Chicago, Ill.

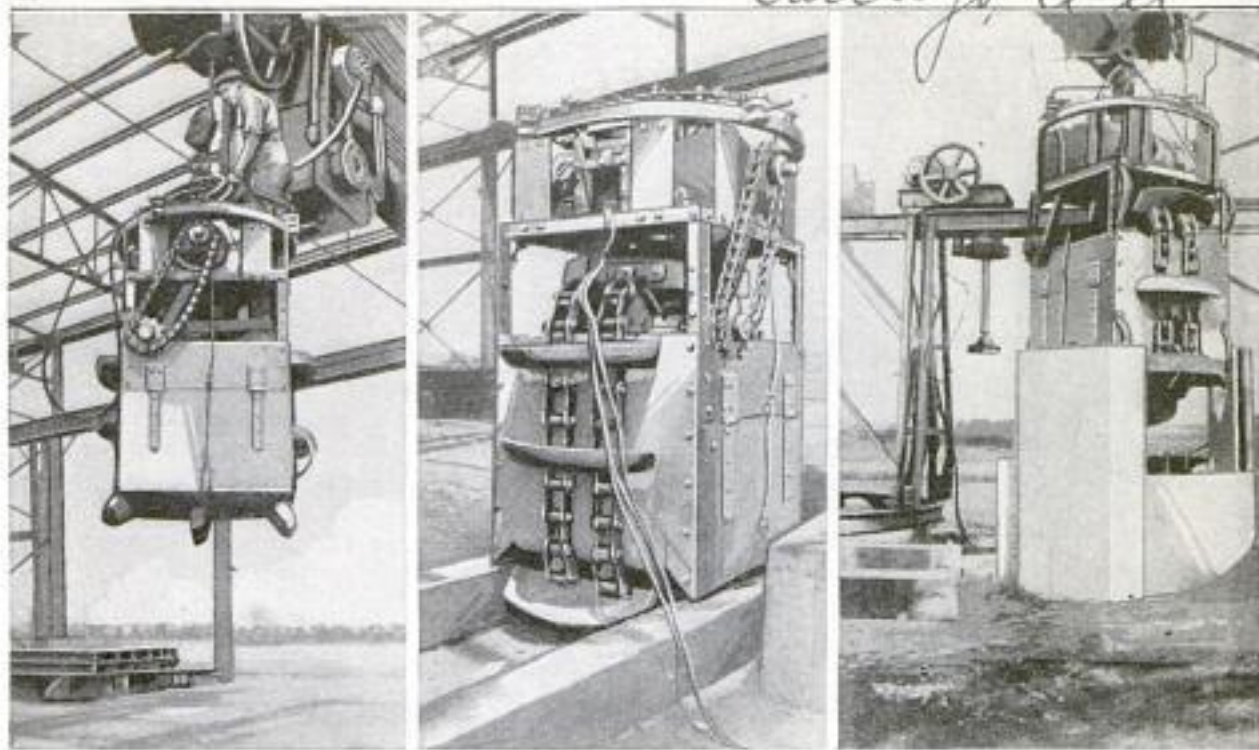

From Left to Right: Shaft-Digging Machine Shown Slung from a Crane with the Operator in Place; a Closer View of the Machine, Showing the Digging Buckets on the Endless Chain, and the Side Door for Emptying the Hoisting Bucket; Caisson Shown around the Digger with the Jack That Sinks It

out any possibility of a cave-in. Moreover, no pumping is required, which in hand-digging is always necessary.

The digger consists of a quadrangular hoisting bucket, around which runs an endless chain carrying a series of digging buckets. This is driven by an electric motor and speed-reduction outfit, which are mounted in a rigid framework above the hoisting bucket. The digger is slung from a derrick or crane, and after being filled, is hoisted and instantly emptied by raising a door on each side of the bucket. This and all other operations are under control of the bucket man, who rides on top of the machine. As the digging proceeds, the caisson is sunk into the shaft by a jack, operated above ground, that can be moved along a swinging cantilever beam to any point on top of the caisson.

rains or spring floods, the stream would no doubt occupy the highway also, regardless of the protests of delayed motorists.

520 MOUNTAIN STREAM AND ROAD SHARE TUNNEL

A tunnel that answers the double purpose of accommodating highway traffic, and forming a bed for a mountain stream, can be seen near Asheville, N. C. The tunnel was originally built by railroad engineers, to carry the stream away from the tracks, but the state highway commission laid a false concrete floor in it, thus dividing it into two parts. In dry weather, the water is easily carried in the small runway, but in the event of heavy



At the Top can be Seen the Railroad Right of Way; in the Center, the Automobile Demonstrates the Roadway, and at the Bottom, the Stream as It Is in Dry Weather

Com. A. J. Croome, Box 807
 Charlotte, N. C.

Copyrighted material

7384 Universal Paint
 Removing Co. 422 W. Liberty St.
 Louisville, Ky. Auto
**MACHINE REMOVES PAINT
 QUICKLY AND CHEAPLY**

Railroader's
 Realty Co
 201 Wayne,
 Ind.

**FORT WAYNE, INDIANA, FAMILIES
 BUILD THEIR OWN HOMES**

Tele. 1/14/23

7512

Removing paint from automobile bodies is easily and quickly accomplished with a new machine. The device consists of a

Fourteen families in Fort Wayne, Ind., with the aid of a real-estate company, have beaten the house shortage by building their own homes, doing the actual work themselves. They spent the whole summer on the job, some even camping on the ground so the whole family could work whenever possible, and they are now living in their houses. The company purchased materials, with marked instructions, from a concern selling ready-cut houses. Each prospective house owner agreed to do the labor of building in place of a first payment, and when the house was completed, to pay the cost at the rate of one per cent a month. The work was supervised by carpenters employed by the company. Many occupations were represented in the colony, which included a blacksmith, plumber,

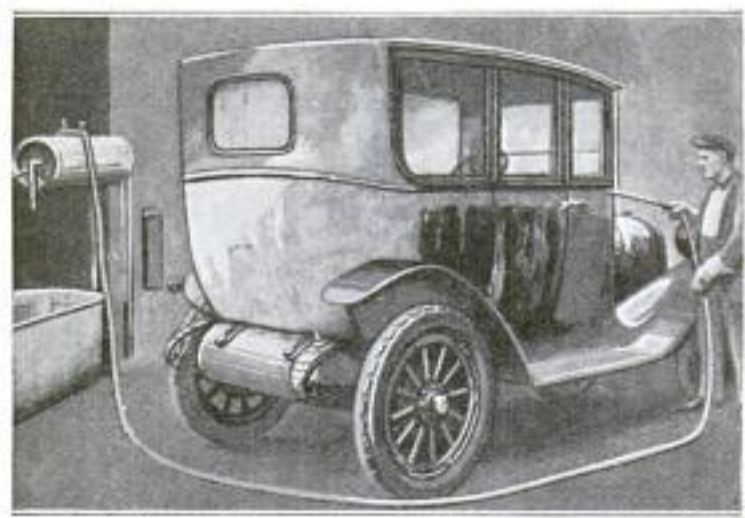

The Machine in Use Removing Paint from the Body of an Automobile: Besides Being Economical, Its Use Makes an Easy Task of One That Is Hard When Ordinary Methods are Used

tank and heater, attached to the city water main. The water is heated to a temperature of about 200° and mixed with a chemical compound in the tank. By means of a hose attached to the tank, this mixture is thrown onto the surface of the machine and completely removes the old paint. About one hour is required to clean the entire body and chassis of an automobile. This cleaner can be adapted to use in railroad shops, to prepare coaches for repainting, and is said to be economical, not only of time but also of labor and materials. Hence it should be a welcome addition to shops doing such work.

electrician, painter, railroad shopman, machinist, conductor, carpenter, mason, printer, and a salesman.

ELECTRIC DEVICE FOR MELTING AND APPLYING SEALING WAX

An electric device for melting and applying sealing wax, exhibited in Paris, France, is a small box set on a slotted base. The wax is inserted through an opening at one end and melts when the current is switched on. When a spring lever, at the opposite end, is pressed, it

Emd. As. W. Eugene
 445 W. Putnam St., Madison, Wis.

WIRELESS CONCERT HEARD BY MOVIE AUDIENCE

A wireless concert was heard by the delighted patrons of a motion-picture theater at Cedar Rapids, Ia., recently through the courtesy of the University of Wisconsin wireless station, which makes a practice of sending out all important musical entertainments given at Madison. Before each entertainment, the surrounding stations are notified regarding the time of the concert, and the wave lengths that will be used in sending it. Thus, those who wish can "listen in," and in the case of theaters, large amplifiers, or loud-speaking receivers, are used to magnify the sounds so that the audience can hear plainly anywhere in the auditorium.

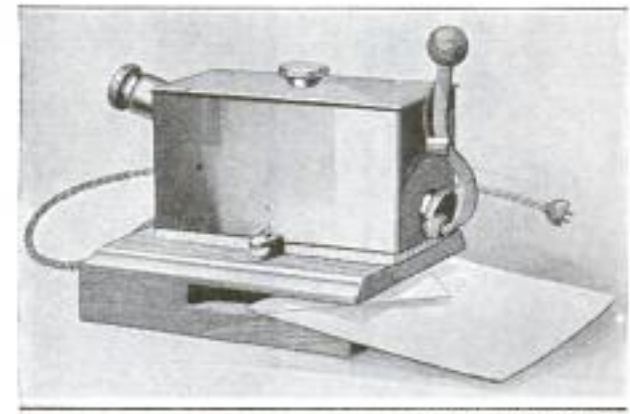

The Opening, with a Screw Cap, for Inserting Wax, Is at the Left End. The Slot Allows the Envelope to be Placed below the Other Opening

uncovers an opening from which the melted wax drops onto the flap of the envelope, inserted to the proper depth into the slot in the base.

153 E. 42nd St.
 New York City

7420

Inventor. Robert Warren
Minneapolis, Minn. no street address.

POPULAR MECHANICS

101

Emb.

Arthur

Hallam, 317 Cedar Ave
Minneapolis
Minn.



The Safe-Desk is Shown at the Right as It Appears When Closed and Locked. At the Left It has been Unlocked, the Top Swung Back, and the Desk Partly Raised by the Lever Seen on the Front of the Safe. In the Center the Desk is Completely Raised and Opened to Show the Arrangement of the Compartments

COLLAPSIBLE DESK FITS IN SAFE

A compact, complete, and fireproof bookkeeping system is a most welcome addition to garage equipment. The desk folds up, and is lowered into the safe by a lever attached to the front. The lever is then removed and the top of the safe is swung into place. A secret cabinet is located in the bottom of the safe, where valuables may be deposited. The safe is as nearly burglar-proof as is possible, being of regular safe construction and made of steel 4 in. thick. The desk comes completely stocked with standard sales books for garages.

7599

LUMINOUS STAR MAP AIDS AMATEUR ASTRONOMERS

The fascinating study of the stars is the oldest of the sciences, and one which has interested human beings for ages. The average person, who has not the time to take up this extensive study, but whom the stars interest as he gazes up at them on a clear night, is usually bewildered if he tries to distinguish one from the other. As an aid to the amateur astronomer, a star map has been drawn which shows the stars of the first five magnitudes, and the different constellation groupings. The stars of the first four magnitudes, and the lines showing the constellation groupings, are marked with radium salt, thus making them shine at night. The map is 4 ft. long, 1 ft. wide, is hinged for convenient folding, and is mounted on cloth or linen, which makes it easy to handle or carry.

Mr. E. W. Syndell
Oak Park, Ill.

STATUE OF FAMOUS HORSE CAST IN BRONZE

7497

It is not often that a horse is honored by a statue, but this tribute was paid to "Justin Morgan," the progenitor of the Morgan horses which have been famous in farm-animal history for the last century. A bronze statue of the animal was presented to the U. S. Department of Agriculture's Morgan horse farm, at Middlebury, Vt., by the Morgan Horse Club, on the centenary of its death. The figure, by a prominent animal sculptor, cost \$18,000 and stands on a granite pedestal on the lawn of the farm.



This Statue of "Justin Morgan," the First of the Famous Morgan-Breed Farm Horses, Represents the Standard of the Breed

Emb. S. O. Dyeters
702 District of Columbia
Bank Bldg Washington D C

7428. La Belle Iron & Steel Co. N.H.,
 102 POPULAR MECHANICS
 Pittsburgh Pa.
**STEEL SMOKESTACKS WRECKED
 BY 46-MILE WIND**

N.Y. Series
 4/2/21
 P. 12

Eleven immense steel smokestacks, measuring from 4 to 8 ft. in diameter and from 80 to 135 ft. in height, were completely wrecked in a 46-mile-an-hour wind, during a recent storm in Pittsburgh, Pa. The stacks, which were part of a large steel plant, fell upon the roofs of the

buildings. Fortunately no one was injured. Damage estimated at over \$100,000 was done to the stacks and buildings.

7623
**NEW SUBMARINE POWER PLANT
 WILL GIVE 10,000-MILE RADIUS**

Submarines of the newest design will have a cruising radius of 10,000 miles, owing to the installation of a new type of power plant, thus enabling them to operate for a month away from their bases or tenders. The plant, which is a combination of gas and electric propulsion, will combine the latest developments resulting from experiments conducted by naval engineers. Twelve engines with a total of 6,500 hp. can drive these 300-ft. boats, of 2,025 tons, at a surface speed of 24½ miles an hour, and a submerged speed of 11½ miles. When completed in 1923, each of the three boats now being built at the Portsmouth, N. H., Navy Yard, will be armed with a 5-in. gun which is designed to remain exposed to the water when the ship is submerged. This gun can be trained almost in a complete circle or elevated as an anti-aircraft weapon. Machine guns will be mounted on the conning-tower bridge, and storage space is planned for 16 torpedoes of 21-in. size. Forward will be four torpedo tubes, and aft, two others.

Cmt. John H. Schaefer,
 Gasogene Heights Pittsburgh Pa.



Showing the Havoc Wrought to 11 Steel Smokestacks at Pittsburgh by a High Wind: In the Foreground are Seen the Prostrate Stacks, Some of Which Smashed against and Wrecked Near-By Buildings

7374

NEW IRRIGATION DAM OF MULTIPLE-ARCH TYPE

There is now under construction on Fish Creek, near Carey, Ida., a multiple-arch dam that will have a top length of 800 ft., when completed, and a height of 125 ft. The work has been stopped temporarily, but it is expected to be renewed this winter or early next spring. It will store water for the irrigation of several thousand acres of land. It consists of a series of reinforced-concrete

triangular-shaped piers, spaced about 25 ft. apart. The upstream faces of these piers slope at an angle of 50° from the horizontal, and their downstream faces are nearly vertical. Between these piers, along the entire length of the upstream face, is a series of arches, forming, in effect, much the same kind of structure as the reinforced-concrete floors that are common in large office buildings.

Cmt. James B. Hays
 512 Franklin St Boise, Idaho

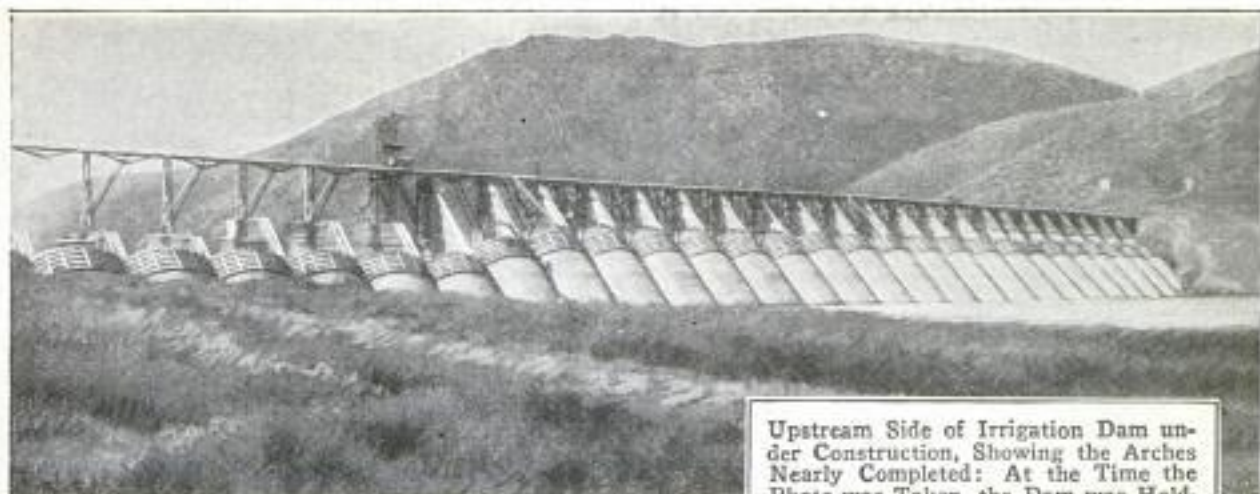

Upstream Side of Irrigation Dam under Construction, Showing the Arches Nearly Completed: At the Time the Photo was Taken, the Dam was Holding 45 Feet of Water. Above the Concrete Arches the Wooden Forms Are in Place Ready for Their Extension

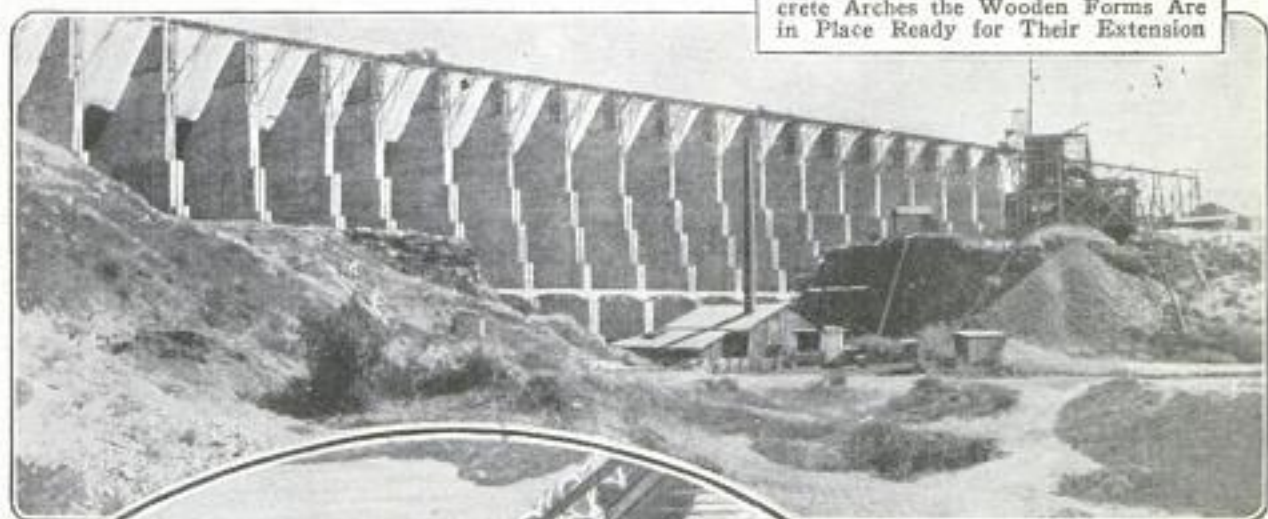

Above, the Downstream Face of the Dam Showing the Rear of the Piers with Their Slight Slope from the Vertical: Here Are the Concrete-Mixing and the Erecting Plants. In the Foreground Is the Power House, with Engine and Boiler Equipment. These Piers Are 25 Feet Apart and Are Over 100 Feet High. The View Shows the Greater Part of the Dam, but Not All of It

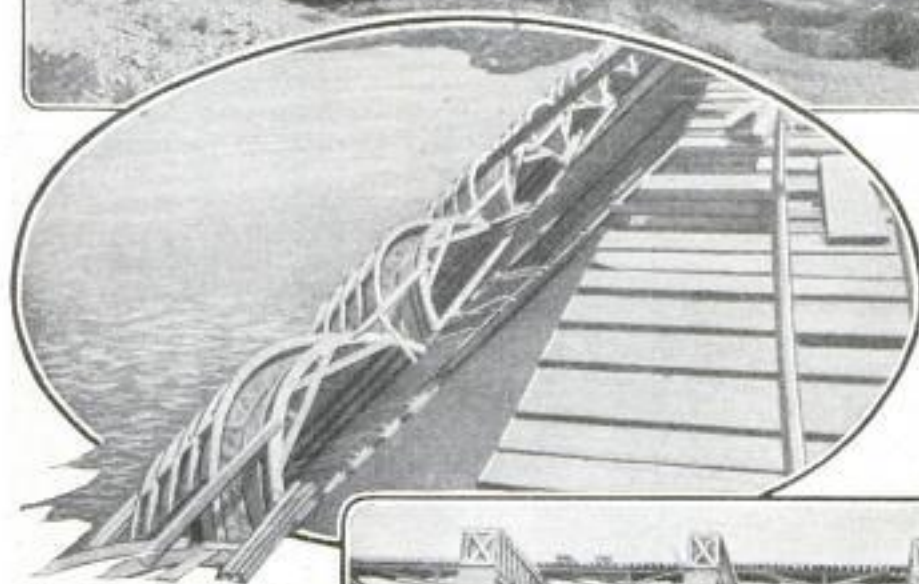

Close-Up Showing Very Distinctly the Construction of the Wooden Forms for Pouring the Concrete Arches. These are Removed after the Concrete is Poured

Looking from the Downstream Side of the Dam Directly into the Underside of the Arches That Form the Upstream Side: Here is Seen in Operation the Means of Passing the Water. There Are Several of These Discharge Valves at Different Elevations

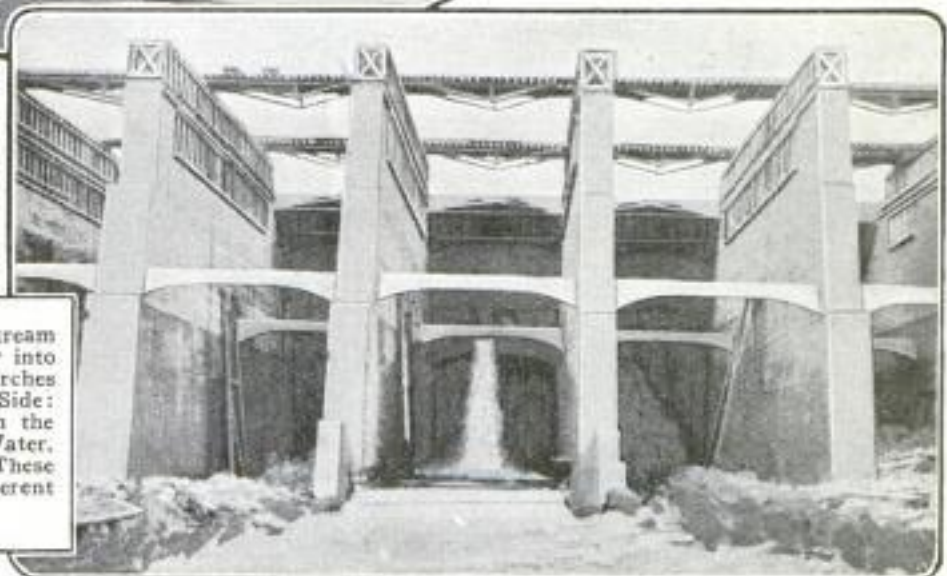

Blind

SIGHTLESS UNION MEN RUN BROOM FACTORY

A small broom factory established some time ago in Washington, D. C., with the

backing of the American Federation of Labor, is perhaps the first of its kind to

be operated exclusively by blind workmen. These are all disabled members of labor unions of recognized standing, as of course it was for the benefit and protection of its own unfortunates that the federation sponsored the enterprise. The equipment was bought, too, with money subscribed by locals of the city. Though the making of brooms is at present the only activity, it is hoped that in time the factory will be enlarged for the manufacture of belts, mops, baskets, and chairs. Were it not for this enterprise, many of these men would be hard put to make their living.

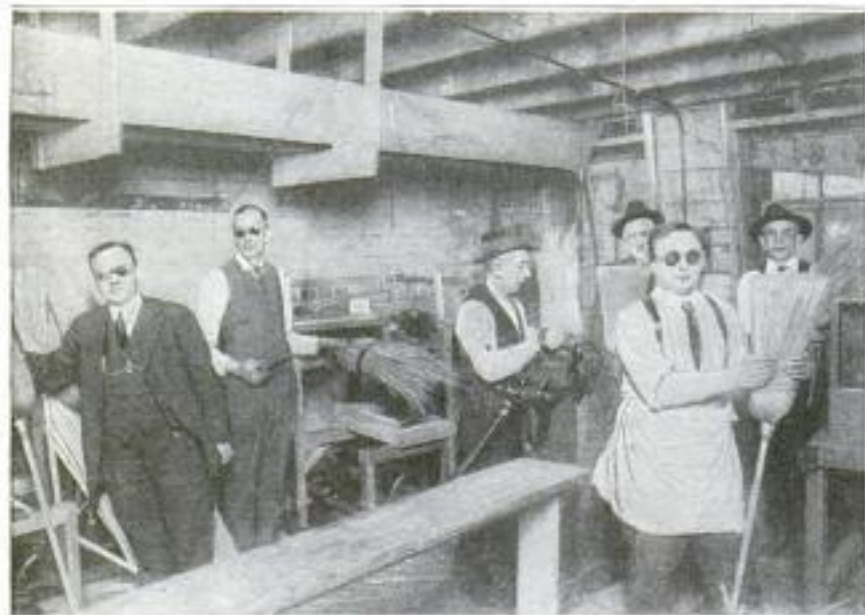

The Broom Factory, a Corner of Which is Seen Here, was Established with the Backing of the American Federation of Labor for the Benefit of Blinded Union Men

5552

HORSESHOE-SHAPED BARN BUILT ON MISSOURI FARM

On the Pickering farm, near the town of Belton, in western Missouri, there is a barn and corral which are laid out in a

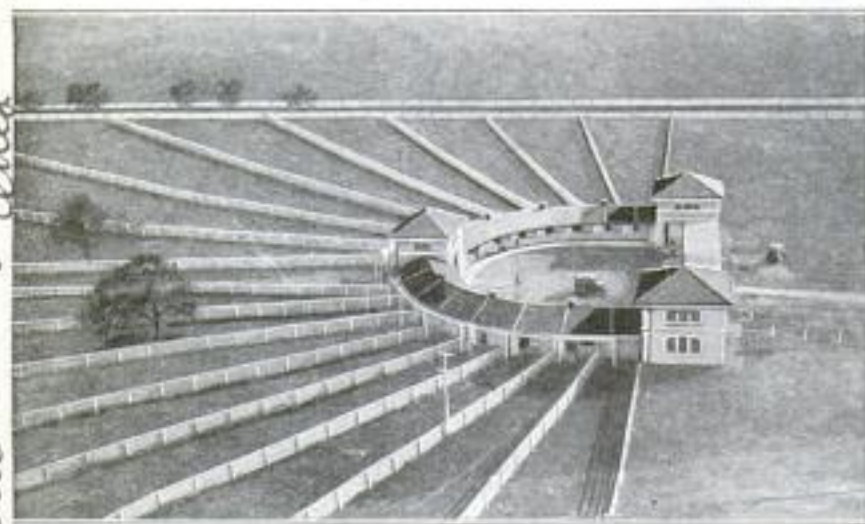

This Horseshoe-Shaped Barn, with Radiating Runways Forming the Herd-Bull Corral of a Big Farm in Western Missouri, Presents a Curious Sight

curious way. The farm is stocked with 1,000 head of cattle, and the barn and corral were built to care for the herd bulls. The barn is in the shape of a horseshoe. Fences radiate from it and inclose several acres of ground, dividing it into 17 separate runways.

7600

ENORMOUS DECREASE SHOWN IN 1921 COAL PRODUCTION

During the first six months of 1921, the world's coal production decreased enormously from the high mark attained in 1920. The total coal mined during that period is estimated by the United States Geological Survey at approximately 579,000,000 tons, or at the rate of about 1,158,000,000 tons a year. If maintained, this rate would produce, for the year 1921, 550,000,000 tons less than in 1920, and much less than in any of the preceding 10 years. The British miners' strike, lasting from April to June, and the industrial depression, affecting the manufacturing and shipping of the entire world, are considered chiefly responsible for this decrease.

Write our Bureau of Information if you wish to know who makes or sells any article described in this magazine. Send no postage; the service is free.

Ed. L. A. Tichenor, Cincinnati, Ohio, Box 16, Station 3

November 10/29/21

7423

J. M. Kean, Bureau of
Navigation, Navy Dept
POPULAR MECHANICS
Washington, D. C.

105



Above: The New Curtiss Mono-Seaplane on the Water during the Tests. Below: The Control Surfaces of the Tail Structure. At the Right: The Plane, Showing the Method of Mounting the Engine Nacelles and Cockpit, and the New-Type Pontoons

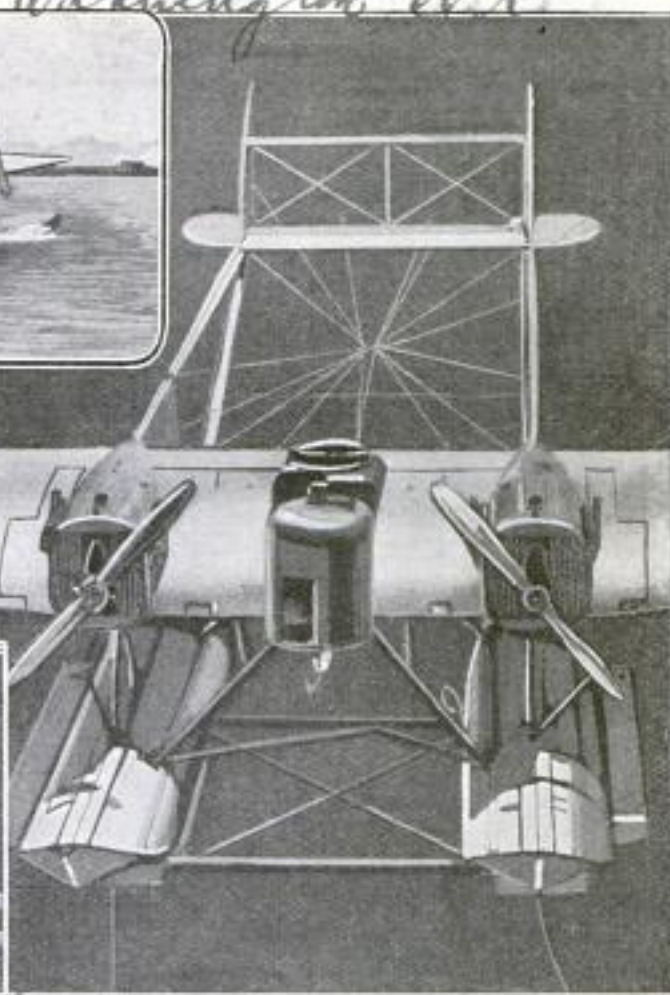
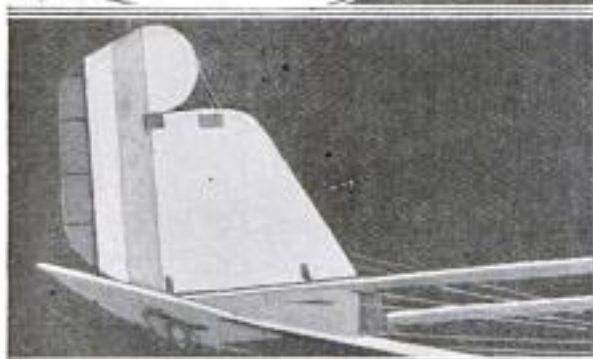

7423 aeronautics

MONO-SEAPLANE BEING TESTED AT ROCKAWAY AIR STATION

The new Curtiss mono-seaplane, except for the Loening plane which has recently demonstrated its success, represents the sole experiment with this type of machine in the United States. The Curtiss machine has been under test by the United States Navy, at the Rockaway, Long Island, air station, and the first photographs of it in flight have been obtained. The plane embodies principles of construction adapted from the JL and NC flying boats. It is equipped with two motor nacelles placed in the wing structure. Between these is the pilot's cockpit. When on the water the machine rests upon two pontoons of original design, placed directly below the engine nacelles.

7567

DENTAL CLINICS IN SCHOOLS ARE INCREASING IN NUMBER

Replies to a questionnaire recently sent out by the U. S. Bureau of Education show that in 286 cities dental clinics have been established in connection with their public-school systems. In 181 of these

N. Y. Times Oct 23, 1921
Sec. 7, Page 12

cities the clinics are supported by the local boards of education; in 33 by the city health departments; in 22 by these bodies jointly, and in 50 by the Red Cross or private donations.

7409

WIRELESS RECEIVER SHAPED LIKE HUMAN EAR

Using the human ear as a model, a remarkable wireless receiver has recently been designed. A small reproducer, similar to that of a phonograph, consisting of a permanent magnet, armature, and mica diaphragm, turns the electrical energy into sound. The sound chamber is made of a wood compound, and molded by hand in the shape of the human ear. The receiver is of the amplifying type; that is, the sound is made louder. It is claimed that a telegraph message can be received at a distance of 100 ft. with this instrument.



Copyrighted material

John A. Baird & Co. N. Y. C.
Broadway.

7456

Horton Mfg. Co
18 Tremont St.
Boston, Mass.

Times Eng. Sup.
Oct. 1921

106

POPULAR MECHANICS

**OIL-BURNING RIVET FORGE
FOR PORTABLE USE**

An oil-burning, portable rivet forge has been designed, that has folding handles, for carrying from job to job, and lifting

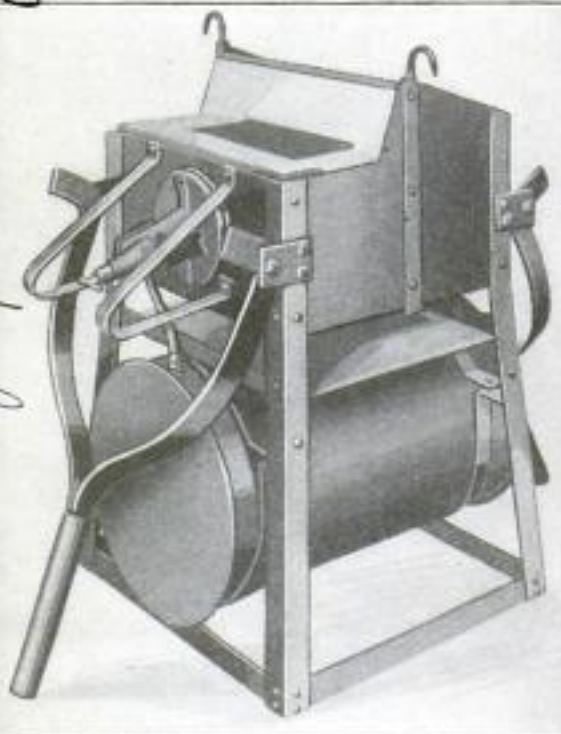

At the Top can be Seen the Rivet-Heating Chamber. The Carrying Handles Are on the Sides, and the Oil Tank is Seen at the Bottom

ears, for moving by crane. The burner is very simple to operate, as it uses low-grade fuel oils or kerosene, and will not clog nor sputter. Starting with a cold forge, it will produce rivets hot enough to drive within five minutes. No direct blast touches the rivets, which are handled from the top, and are always in plain view.

DIE STOCK TAKES ROUND DIES OF DIFFERENT DIAMETERS

A die stock that will take round dies of any outside diameter from 5/8 to 2 1/4 in., inclusive, is now on the market. The loose handle of the stock is readily adjusted to line up with the side spot hole

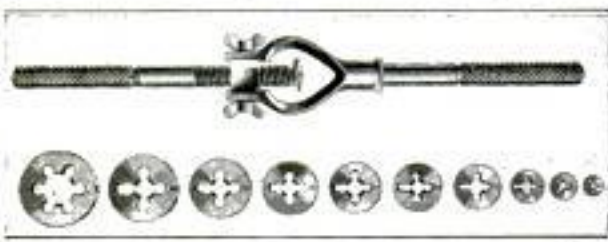

Above is Shown the Stock with the Two Thumbscrews, and Also the 10 Round Dies Ranging in Size from 5/8 Inch Up to 2 1/4 Inches

of the die by means of a sliding block which moves up or down in the jaw of the other handle, and is held in place by two thumbscrews. The pointed end of the loose handle that fits the spot hole is of hardened tool steel and resists wear. Thus the same stock can be used for as many as 10 different-sized dies, which is certainly an advantage. The only possible disadvantage is that it is much longer and heavier than the standard stock when used with the smaller dies.

7613 *Horeign*
RENEW PROPOSAL FOR CANAL FROM NORTH SEA TO BALTIC

Interest in the proposal to build a Danish ship canal from Esbjerg on the North Sea to Kolding on the Baltic has again been aroused by the reunion of North Schleswig with Denmark. The proposed route lies just north of the former international boundary. Because of the character of the country, the cost of a lock canal would not be prohibitive and it would form a valuable short cut between countries bordering on the two seas, besides opening new eastern markets for the North Sea fisheries.

7507
WOODEN FIGURES ATTRACT ATTENTION TO WINDOW

A laundry in a western city has hit upon a most unusual way of attracting

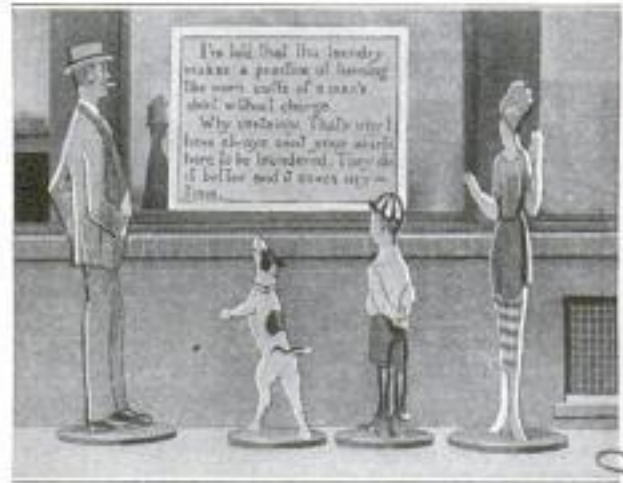

This Novel Family Group Attracts People to the Window All Day, and is Easily Carried In at Night When Its Work is Finished

attention to signs displayed in its windows. Figures of a man, a woman, a boy, and a dog, cut from 1-in. boards, fixed on wooden disks, and brightly hand-painted, are placed in front of the window, during the day, as if looking in at the sign.

Home-made by store.
Lynn M. Frink
1708 W. 23rd St.
Los Angeles, Calif.

Chicago
Decker - L. B. Burt
6233 Langley Ave. Chicago
Martin Machine Co
Turners Falls, Mass.

4005

Lowie's State Theater Bldg
Long Beach, Calif
POPULAR MECHANICS
Illustration

OFFICE-THEATER BUILDING HAS THREE FIRST FLOORS



Third-Floor Street Entrance: The Steps Lead Down to the Lower Floors



The Sloping Street, Showing How There Are Street Entrances to Three Floors

The sharp slope of the business streets of Long Beach, Calif., to the amusement area at the water's edge is responsible for an architectural novelty in the form of a large theater located on the third floor of an office building, yet with its orchestra floor at street level. The building, of recent erection, occupies the entire end of the block. The first floor



Looking down the Street at the Side of the Building from the Upper Level to the Beach: The Large Entrance Is That of the Theater

fronts on a street at the amusement-area level, the third fronts on a street of the higher, business section. The second floor is directly accessible through an entrance on the third sloping street which intersects the first two. The owners of the new building receive practically first-floor rents for the first, the third, and part of the second story.

67 1/2 Motor vs. Wheel

NEW TRUCK HANDLES AGGREGATES EFFICIENTLY

Loads of aggregate, such as sand, stone, slag, etc., generally used in the building of roads, foundations, and various other concrete constructions, are efficiently handled by a newly designed auto truck. Two end-dump hoppers, with a total load capacity of 5,000 to 6,000 lb., are located on the chassis, which has a very short wheelbase to facilitate turning. These hoppers dump their loads by gravity and are fitted with suitable springs to prevent damaging rebound, sidesway, and similar abusive shocks, and the strains caused by the loading of only one hop-

per. Trips are provided whereby the operator may dump either load as desired.

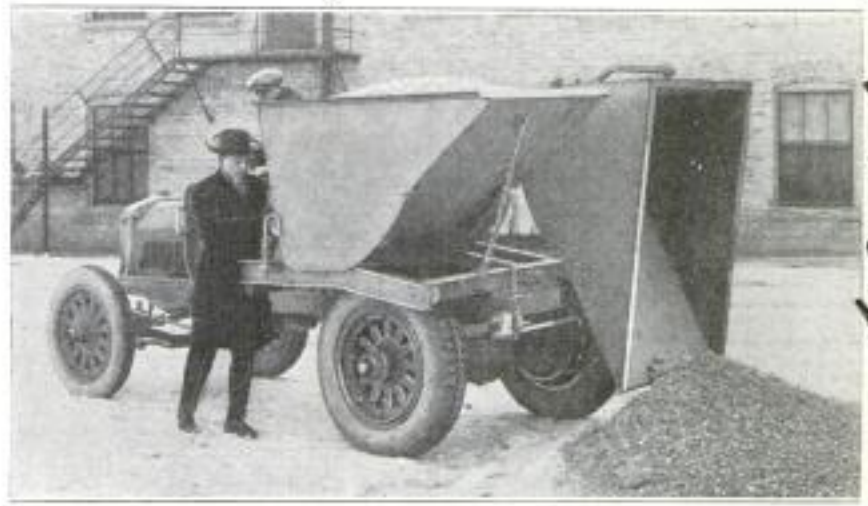

The Two-Hopper Dump Truck: The Loaded Hopper, at the Left, Is in the Normal Carrying Position. At Its Front End can be Seen the Shock-Absorbing Spring. The Hopper at the Right has Just been Dumped by Gravity

Encl. Allen B. Child
Box 73, Station 6, Kansas City, Mo.

Encl. J. B. Howe. Union League Club, Los Angeles & my home I. - - - - -

7503

Little Rock Railway & Electric Co., Little Rock Ark

CIVIC FEATURES THAT PROMOTE THE COMFORT

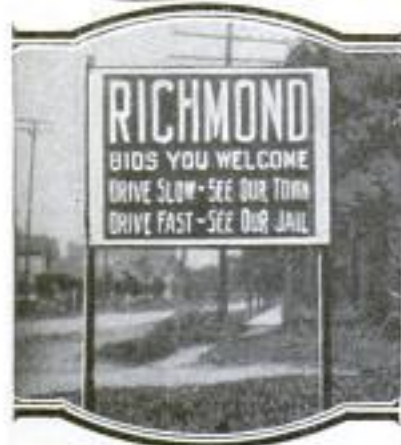

Reproduction of a Sign That Confronts the Automobile Drivers on All the Roads Leading into the Village of Richmond, Michigan: With Such a Courteous Warning, Any Driver Who Exceeds the Speed Limit Deserves to See the Village Jail, and to Continue Seeing It for a Longer Time than might Be Altogether Agreeable

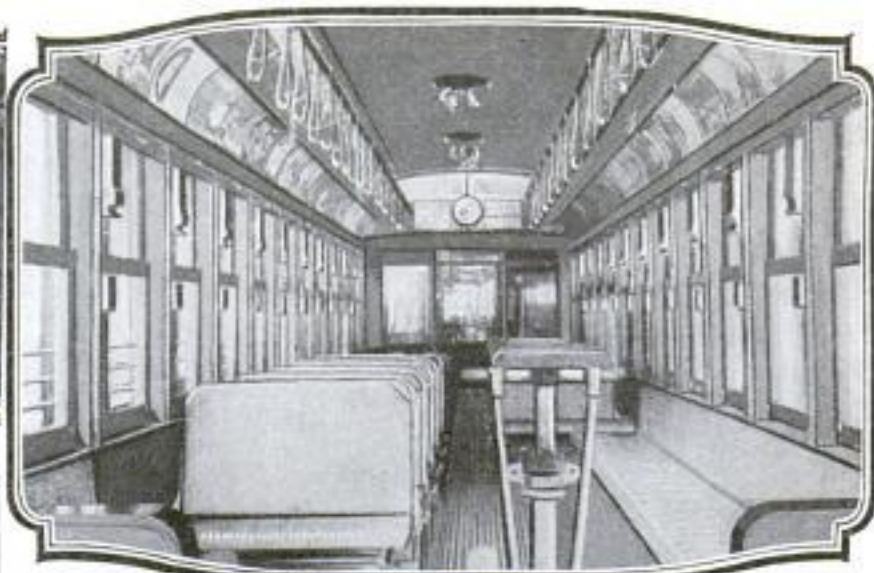

On Each of the Pilasters between the Windows of This Street Car is a Nickel-in-the-Slot Machine. These Are Gum Venders, and They are So Designed That They Prevent the Depositing of a Coin When They Are Empty, or the Insertion of a Counterfeit When They are Loaded. All the Street Cars in Little Rock, Arkansas, are Thus Equipped. About Four per Cent of the Passengers Purchase Gum

Architect - S. O'Leary, 1212 W. Madison, Phoenix, Ariz.



Municipal Band Stand in Library Park, Phoenix, Arizona: It Possesses, besides Its Architectural Beauty, Exceptional Acoustic Properties. By Actual Test It was Shown That a Match Dropped to the Floor from a Height of Five Feet could be Heard at a Distance of 150 Feet. A Speaker could be Heard at 250 Feet, and the Instrumental Music is Often Enjoyed by Citizens Seated on Their Porches Several Blocks Away. This Wonderful Transmission of Sound is Obtained by the Use of a Soundboard of Unusual Construction. It is in the Form of a Compound Curve with the Same Radii as the Curve of the Proscenium Arch, Which Has a Width of 35 Feet and a Height of 16 Feet

AND ENJOYMENT OF VISITORS AND RESIDENTS

R. J. Cornell, 6209 Lawton Ave. Detroit, Mich



One of the Little Cabins Located on the Tourists' Camping Grounds at Fergus Falls, Minnesota, Which Is on the National Park Highway: In the Little House Tourists are Furnished with Free Use of Water, Lights, and a Cookstove. At the Left is Shown One of the Signs That Direct Tourists to the Camp

Each State Trunk Highway in Wisconsin Has an Individual Number. They are All Equipped with Exceptionally Informative Direction Signs. This One, at Madison, Drawn to Scale, Shows a Temporary Detour of 20 Miles That had to be Used While Part of the Highway Was under Construction

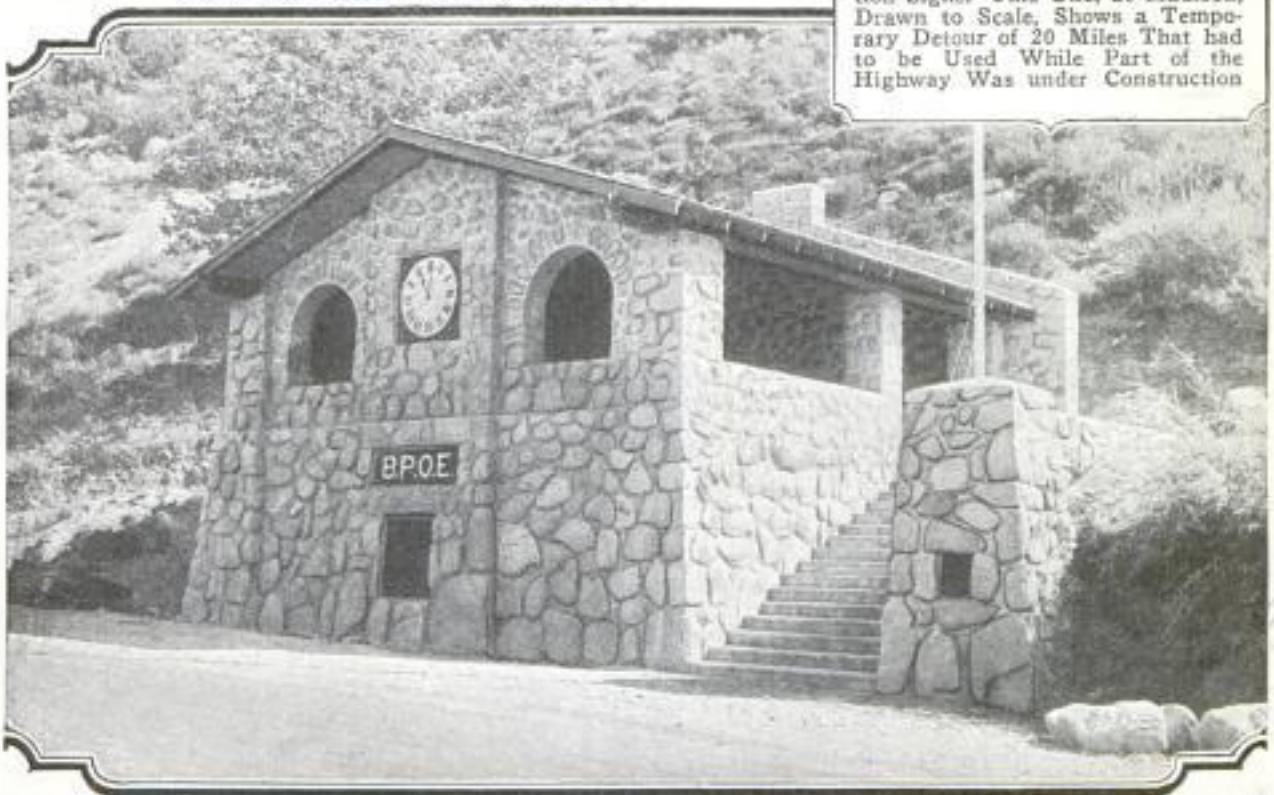

This Granite Clubhouse Is the Elks' Outpost at Camp Cajon on the National Old Trails Highway, and is Located in the Mountains 20 Miles North of San Bernardino, California. It was Erected by the Elks of Southern California for the Use of Elk Motorists Who Pass That Way

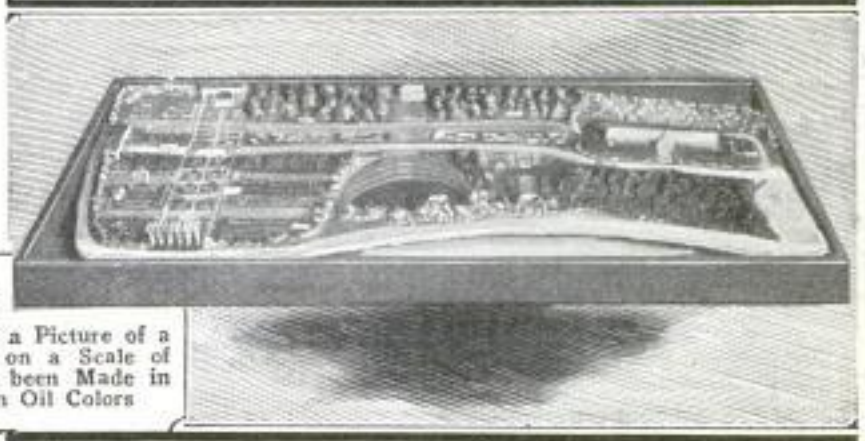

Portland, Oregon, Known as the "Rose City," Is to Have a New Municipal Rose Garden. This Is a Picture of a Model in Relief of the Garden, on a Scale of One Inch to 20 Feet, That has been Made in Plaster of Paris and Painted in Oil Colors

5 Cent. Mary Harrod Portland 483

BOWLDERS GIVE FORTH MUSIC WHEN POUNDED WITH HAMMER

The last to be expected from a rock is music. Yet, strange as it may seem,



There Is Nothing in the Appearance of These Piles of Rock to Suggest Their Peculiar Characteristic of Producing Musical Tones

melody bursts forth from a pile of rocks near Marblehead, Mass., when they are pounded in proper order with a hammer. While surveying some newly acquired property preparatory to clearing it for agricultural purposes, a farmer aimlessly tossed a rock at the neatly piled bowlders. He was surprised to find that they rang melodiously. Upon further investigation he found that each bowlder gave a different note. At once, he turned music student and learned to play tunes upon the rocks, which tourists may hear for a consideration. Many fanciful tales are current in the community as to the reason for the musical quality of the rocks, but thus far nothing in the nature of a satisfactory explanation has been given for this trick of nature.

PORTABLE CANVAS BATHHOUSE EASY TO CARRY AND ERECT

Portable canvas bathhouses are often an awkward and confusing combination of ropes, canvas, and long clumsy poles, but the latest type is simple. Four pointed, hinged poles are thrust into the ground at the corners of a 4-ft. square. They are hinged to top poles, which radi-

canvas is stretched. Folded, the bathhouse is only 42 in. long and 8 in. in diameter, and is easily carried on seashore picnics.

7533 — Equipment
EARTH TO MOON 100 TIMES WITH TELEPHONE WIRES

Although the telephone was put in use only a few years ago, the expansion of this industry has been remarkable, and the following facts will illustrate it. Enough wire has been strung to reach from the earth to the moon 100 times, making a total length of more than 23,900,000 miles. The lines of poles erected would reach around the earth nearly 15 times, a distance of 375,000 miles, and enough underground duct space has been installed for carrying cables, to reach from pole to pole through the center of the earth, more than six times, or a total length of more than 45,000 miles. Over 33,000,000 conversations take place every day.

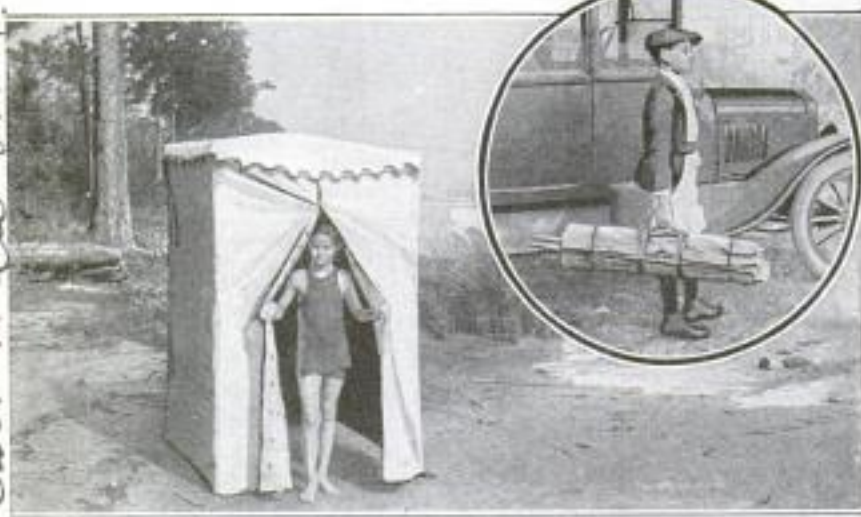

Showing the Portable Bathhouse Erected on the Beach: The 16 Square Feet of Space Inside Is Sufficient for Dressing and Undressing. The Insert Shows the House Folded and Easily Carried by a Boy

ate to the corners from a block at the center of the roof. Over this frame the

Copyrighted material

J.C. Hammond, Jacksonville Fla

X-RAYS REVEAL ATOMIC STRUCTURE OF MATTER

BY ROGERS D. RUSK, M. A.

Mc Connelsville Ohio.

THOUGH atoms of matter are far too small to be made visible to the human eye, it is now possible to discover some of the chief characteristics of their nature and structure by means of X-rays. These characteristics show in a surprising manner how the atoms of all elementary substances are closely related to one another.

In the study of atoms an entirely new property of the X-ray is made use of. Every one of the 86 substances, known as elements, is affected in a different way by these rays. Each element reflects waves of a particular wave length, and these are called the characteristic X-rays for that element. Even in complex substances, the elements still reflect their own characteristic rays. Hence it is possible to analyze an unknown substance by measuring the characteristic X-rays it reflects.

When the characteristic X-rays of different elements are compared, it is seen that they are related in a striking manner. The heavier the atom is, the shorter are the waves reflected by it. This is true in an exact ratio for the atoms of all the elements, so that the elements may be arranged in a series numbered from one to 92, according to the length of characteristic waves they reflect. There being only 86 elements, six blank places are left in the series, which presumably represent unknown elements. It is thought, if there are no heavier elements to be found beyond uranium—which is number 92—that there must be only six elements remaining undiscovered.

The comparison between the characteristic X-rays of a substance and the characteristic colors given off by the same substance in a flame, or in an electric arc or spark, is striking. When table salt (sodium chloride) is thrown into a flame, the brilliant orange-yellow color characteristic of sodium is given off. The majority of substances give off a greater complexity of colors appearing as brightly colored lines in the spectroscope, which

separates the different colors. The various spectra thus produced may contain from one or two to several thousand lines, some of which can only be detected by a photographic plate. The lines, each representing waves of a definite length, exist in complicated series, and any relationship between the elements is extremely

difficult to trace. On the other hand, the characteristic X-rays reflected by a substance are always few in number, simple in arrangement, and exhibit a definite and obvious relationship.

In Fig. 1 the chief lines in the visible spectrum are shown for gold, mercury, thallium, lead, and bismuth. The complexity and lack of

simple relation between these spectra are obvious. In Fig. 2 the X-ray spectra for the same elements are shown. The order and relationship are evident. The lines produced by these elements represent wave lengths belonging to what is called the L-series. All known elements give lines in the X-ray spectra falling in this series or in a similar series called the K-series, with the exception of those elements which give lines falling in both series. Not only is the relationship of the elements thus exhibited a qualitative one, but it is mathematically quite precise, and may be stated more scientifically

as follows: The square roots of the frequencies—or rates of vibration—of the characteristic rays are in the same ratio as the whole numbers from one to 92. The scientist who discovered the above relationship called these numbers the "atomic numbers" of the elements. When arranged by these numbers, it is found that all the

chemical and physical properties of the elements occur in a definite order, indicating the close relationship of the elements. The fact that this order is more perfect than that obtained by any other arrangement of the elements, shows it is based on something fundamental.

The reason these characteristic radi-

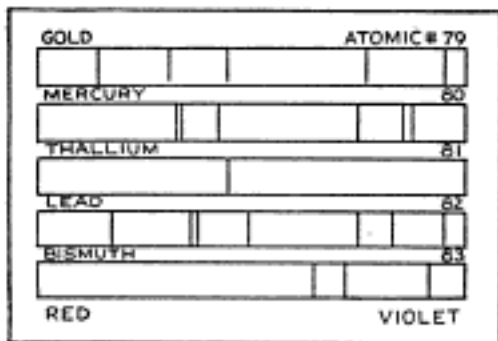

Fig. 1.—The Lines Produced by These Five Elements, When Observed in the Spectroscope, Are Complex and Unrelated

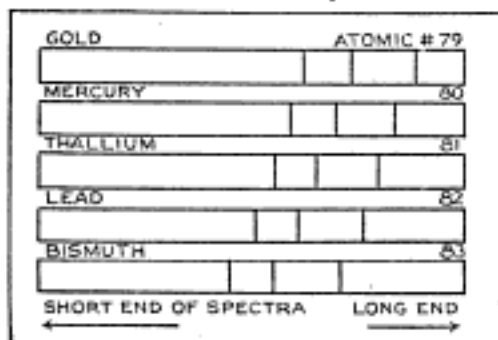

Fig. 2.—In the X-Ray Spectra of the Same Elements, the Lines Have a Distinct Relation and Fall in Regular Series

tions of the elements represent their properties so markedly is that X-ray waves are so small that instead of being reflected from the surface of the substance on which they fall, they are reflected by the individual atoms. Compared with X-ray waves, the atoms are large, and even the most highly polished surface is only a rough group of atoms. Each atom reflects a wave, but it can only reflect a wave length it is in tune with. Hence, because heavy objects will vibrate faster than light ones, the rate of vibration increases with the atomic weight of the elements, and the wave length decreases.

The relation existing between the elements is further proved by the many discoveries concerning the electrical nature of matter. It appears that the atoms of all the elements are composed of different numbers of electrical charges in different groupings. Several famous experiments even indicate that the atomic numbers are equal to half the number of free positive or negative charges in the respective atoms. And so it is that X-rays have helped us unlock the secrets of the atoms and aided us in our efforts to answer the eternal question:

What is matter?

USES TWO FOLDING CHAIRS TO MAKE PORTABLE COT

Light and portable cots have appeared on the market in several forms, but most of them are useful for no other purpose.

A Porto Rican inventor now has devised a method of using two ordinary folding chairs as the temporary frame of such a cot. The chairs are placed with their backs horizontal and turned toward each other, and rigidly connected by means of

two hinged braces of $\frac{3}{4}$ by $\frac{1}{8}$ -in. metal. A canvas strip, 6 ft. 3 in. long and 12 in. wider than the chair seats, with wooden stretchers across its ends, is then hung on the upturned front legs of the chairs, which enter slots in the fabric. The bed so made is claimed to support 600 lb. or more. It is made in various lengths for children or grown-ups.

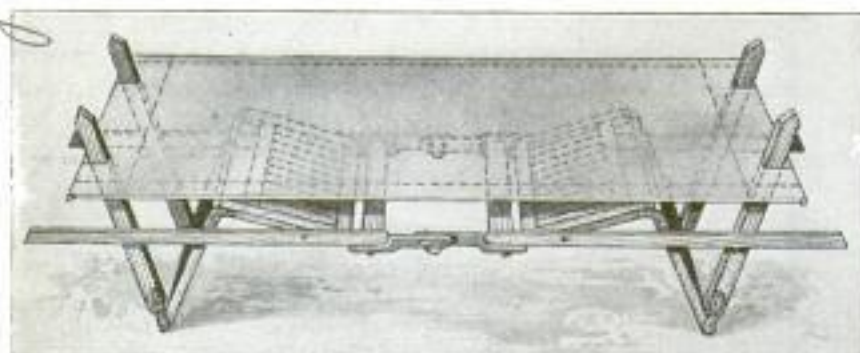

Portable Cot Made by Connecting Two Folding Chairs with Metal Braces and Hanging a Canvas Bed on the Upturned Front Legs

SPECIAL LIGHT FOR OPERATING ROOMS AND DENTAL OFFICES

An improved lighting outfit for the use of dentists and surgeons in the operating

room has recently been placed on the market. The source of light is a 100-watt stereopticon bulb, the rays from which are prevented from reaching the eyes of the operator or patient by means of front and side shields. They are directed backward toward 18 small, separate mirrors arranged in a circle, which converge the light and project it from 18 different angles onto the proper spot, thus producing an intensified light with a minimum of shadowing. The mirrors are made of blue glass to give a color value similar to daylight. The lamp is made of aluminum and is mounted on an adjustable arm.

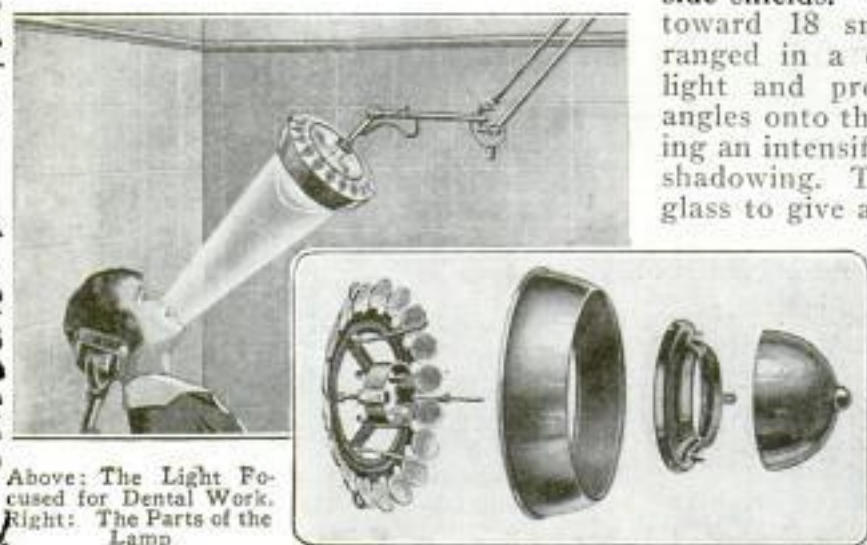

Above: The Light Focused for Dental Work. Right: The Parts of the Lamp

United States gold coins, which were taken up three years ago, will be returned to circulation to test whether people prefer gold currency.

L. Yrind & Lopez, 5 Vegetan St. upa Mayaguez, Porto Rico. 4991
The Sunlight Co. 432 Austin Place, New York. 7208

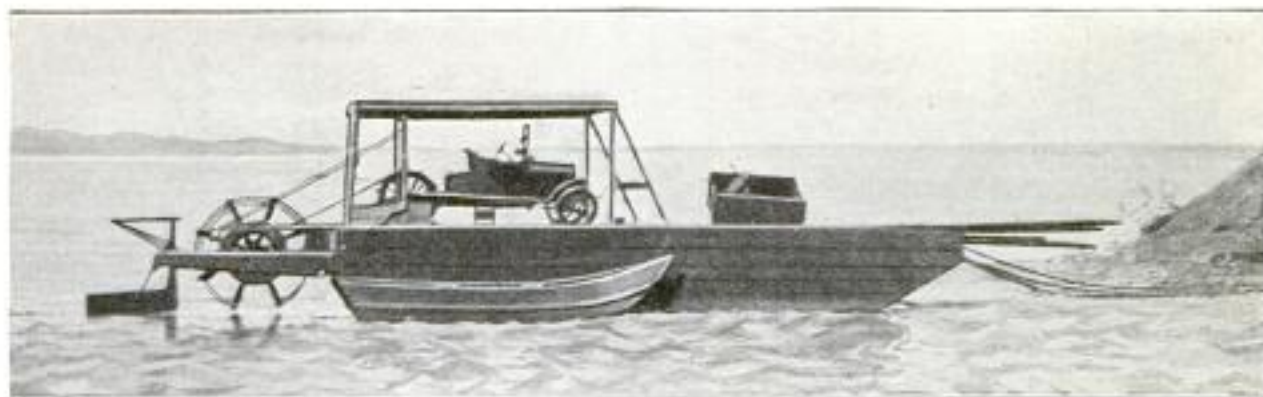

Scow That is Propelled by the Automobile near Its Stern: The Rear Wheels Have Cleats on Them like Tractor Wheels. These Cleats Engage Endless Chains That Pass over Octagonal-Shaped Pulleys on Either Side of the Paddle Wheel, and Thus Drive It

SCOWLIKE VESSEL IN ALASKA PROPELLED BY AUTOMOBILE

One automobile is frequently used to tow another, or any overland vehicle, and it is a practical idea to use an automobile for propelling a floating vessel. Such a craft is actually in operation in Alaska. The vessel is a flat-bottomed scow, decked to carry near its stern an automobile, over which is a framed housing. At the stern is a paddle wheel mounted on a shaft which is octagonal in cross section on either side of the wheel. These octagonal "drums" line up with the rear driving wheels of the automobile, which are preferably in the form of tractor wheels, having cleats that engage the links of a chain which is used for driving the paddle wheel. Astern of the latter is a rudder which is operated through a series of lines and guides by a steering wheel located near the front part of the automobile, so that it can be operated by the pilot in the driver's seat. The boat carries 30 to 35 tons of freight, and has been navigated for some time with entire satisfaction.

LABOR-SAVING INSTRUMENT FOR THE DRAFTSMAN

Every draftsman knows how much work there is in plotting or laying out an oval or ellipse. There is now on the market

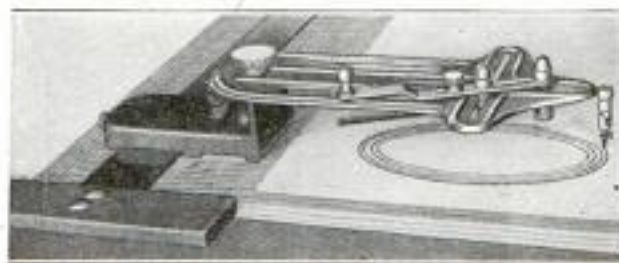

Instrument for Drawing with Pen or Pencil. Any Ellipse or Oval When Attached to a T-Square on a Drawing Board.

J. A. ...
425 S. Wabash,
Chicago.

a new ellipsograph, neat and compact in appearance, that will draw any ellipse with pencil or pen on paper, in a most satisfactory manner, and which can also be used in photographic work with a scriber or knife to cut or strip a negative. On a drawing board, it is used in combination with the T-square, to which it is attached by means of a thumbscrew. It will draw an ellipse of any size and shape within its capacity.

VALVE FOR STEAM RADIATORS HUMIDIFIES THE AIR

An attachment, in place of the ordinary air valve, on a steam radiator maintains the relative amount of moisture in the air

requisite for health and comfort in a steam-heated room. It possesses, besides, the advantage of eliminating all possibility of any hissing noise from escaping steam, or of leakage of water from condensed steam out of the valve onto the floor. A float automatically opens or closes the

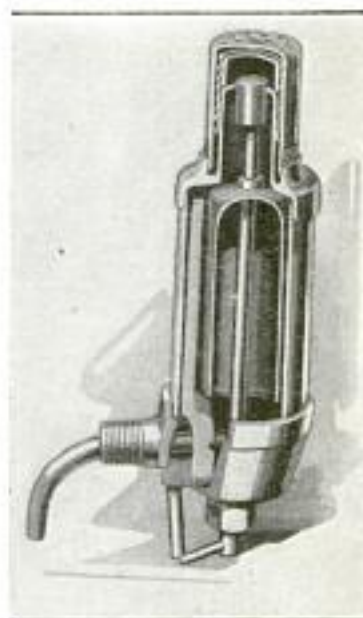

valve so that there is never an excess of steam, and just enough properly to humidify the air is allowed to escape from a perforated cap. A small tube leads from the interior through its connecting nipple downward into the radiator, into which all the condensed steam is drained.

Chicago Humidifier Co.
3214 Southport Ave
Chicago

4463

SOME NOVEL AND LITTLE-KNOWN ACCESSORIES

No data



A Notched Pole, Screwed to the Wall, is Used to Support Clothes Hangers for Infants' Wear. The Set is Enamelled and may be Had in Pink, Blue, or White



If a Bucket is Equipped with This New Spring-Compressed Roller Device, It Is Easy to Wring the Special Mop Supplied with It



To Hold a Kettle under the Faucet While Filling It, a Small Wire Device Is Convenient. It may be Fitted to Any Faucet by Tightening or Loosening the Wingnut



This One-Piece Aluminum Cake-Shell Pan Gives an Evenly Baked Shell for Fruit and Other Fillings

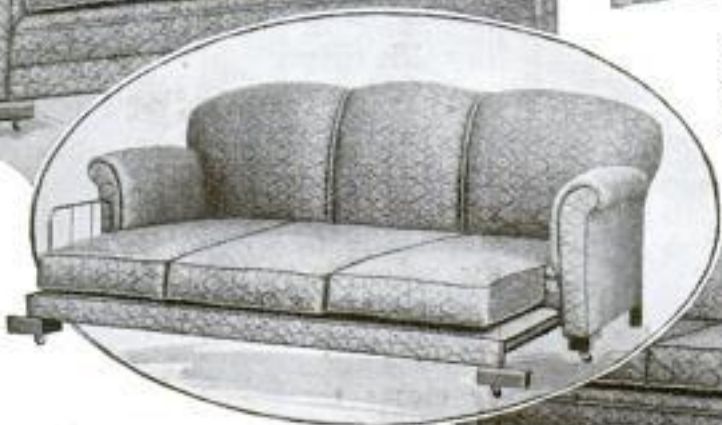

An Overstuffed Davenport Has a Sliding Shelf with Casters, to be Pulled Out at Night. The Hinged Cushions, Folded Over onto the Shelf, Make a Comfortable Bed

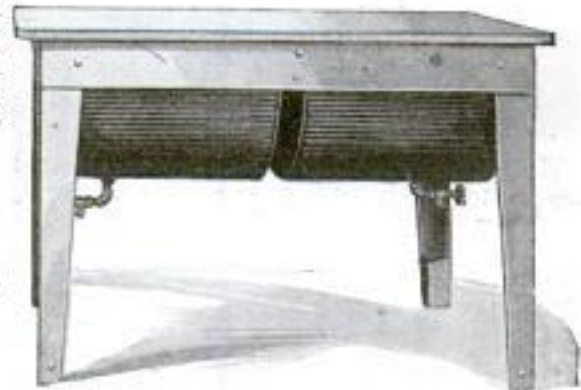

Two Galvanized-Iron Washtubs, Corrugated to Serve Also as Washboards, are Converted into a Kitchen Table by Means of a Removable Porcelain Top



INTENDED FOR THE HOME AND ITS MEMBERS



An Electric Cup That will Hold Any Bell-Shaped Glass, Heats Liquids Quickly, can be Set for Varying Degrees of Heat, and cannot Overheat



Sanitary Drinking Fountain, Water Filter, and Bottle Washer are Combined in a Rubber-Tube Fitting on the Ordinary Faucet



Vegetables are Sliced Quickly and in Uniform Thicknesses by This Machine, Which is Clamped or Screwed to the Kitchen Table. To the Right is a Rear View of the Slicer



Above: An Inverted Bottle, in a Wire Holder, Keeps a Toothbrush Clean by Allowing It Air Space for Drying



Clamped to the Edge of a Table, This Folding Ironing Board will Not Wobble, and It can be Adjusted to Any Height



Left: Dusting is Made Easy by a Small Electric Vacuum Brush. The Dust Bag, in the Handle, is Cleaned by Removing the Cap and Turning on the Motor

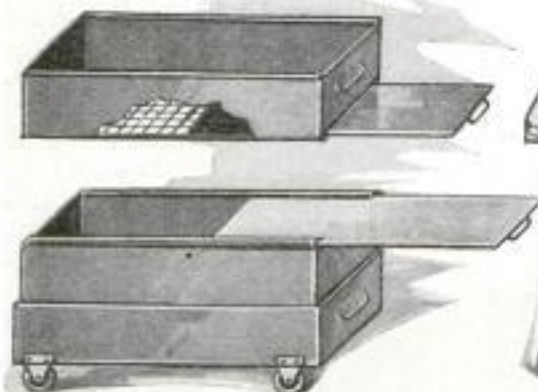

The Ash Pan with the Screen Bottom is Placed in the Stove with the Slide under the Screen. When Full, It is Set into the Other Pan and the Slide Placed on Top Till the Ashes are Sifted



Folded, This Attractive Table can be Kept in a Closet, behind a Door, or in Any Out-of-the-Way Place. The Top is Made in One Piece, of White Porcelain Enamel

Esuy & Brewster
Turner, Peace Co.

Mr. Hartman + Braun,
A. S., Frankfurt-on
Maine, Germany

116

POPULAR MECHANICS
SAFETY CLAMP HOLDS LID
OF MILK CAN TIGHTLY

A new type of safety clamp, made from three pieces of spring steel riveted together, fits tightly over the lid and neck of a milk can, holding the lid firmly down. The invention was made by a Seattle



This Simple Device Insures a Tight-Fitting Lid When Used on a Milk Can. It is Shown in Detail at the Right

milk-wagon driver, and cans have been dropped more than 10 ft. to demonstrate the efficiency of the gripping straps.

GUN MAKES GOLFING TEES
OF ANY DESIRED HEIGHT

Golfing tees are now being made with a so-called "gun," instead of in the usual



way by hand. It is said to make the tees better and more quickly. It has a short barrel which is pressed into the sand box and filled. Inside the barrel is a plunger on a spindle with a knob on top, which is used to push the tee out,

and deposit it on the ground. The plunger can be adjusted in the barrel to make the tee of any height.

THE CENTENARY OF THE DEATH
OF THE LIFEBOAT INVENTOR

September 28 was the centenary of the death of the inventor of the lifeboat, William Wouldhave, of South Shields, Eng. About 30 years previously he had, with his own hands, made his first model, which was the forerunner of the modern unsinkable lifeboat. Its unsinkability

was caused by the use of air-tight compartments fore and aft. The same principle has been applied to boats which have saved countless lives, as notably instanced, in England, in one with a record of 1,028. Wouldhave was a house painter by trade, and was in no way connected with the sea. He died, as he had lived, a poor man. At his birthplace his original model is preserved as a memorial.

7365
INSTRUMENT GIVES HUMIDITY
READINGS AT A DISTANCE

In cotton mills, refrigerating plants, storage rooms for tobacco, grain, paper, and other material affected by moisture, the exact degree of humidity existing in various parts of the plants, at any time has hitherto been ascertained by the well-known wet and dry-bulb thermometer method. A new instrument, in the nature of an electric hygrometer, is now on the market, which gives direct readings of the relative humidity at any distance from the room under control. A thermocouple, one end of which is kept wet by a muslin wick from a cup of distilled water, takes the place of the thermometer. These thermocouples may be distributed about the plant and are wired to the reading instrument, which registers directly the degree of humidity in the various rooms.

7308
SELF-CLEANING CARBIDE LAMP
NOW AVAILABLE TO MINERS

A carbide lamp that practically cleans itself, is an improvement over the old-style lamp, which required the using of a

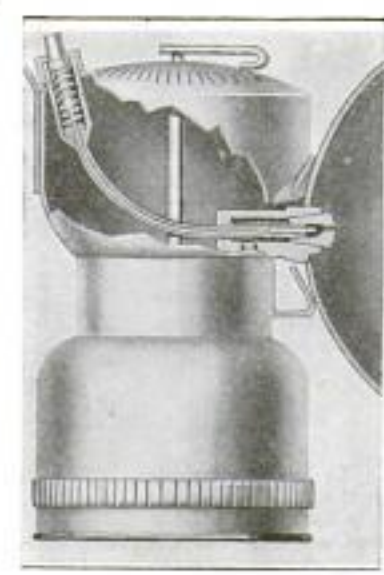

wire to clear the burner of clogging soot or carbon. On the improved lamp, the burner is cleaned by simply pressing a button. The self-cleaning lamp should be a timesaver, and should increase the efficiency of the miners, as well as avert accidents, because it does away with all danger of being caught in underground darkness.

cause it does away with all danger of being caught in underground darkness.

Similar design of padding sold by A. S. & W. Washburn, Chicago
Willebrand, N.W. London, England
W. J. Johnson, Hancock, Mich.

Electricity Works

Wm. J. Johnson + Son
Hancock, Mich.

The Sphere
Oct. 8, 1921

W. J. Johnson, Hancock, Mich.

SCREEN KEEPS FISH OUT OF IRRIGATION DITCHES

Various state laws require screens to prevent the destruction of fish through entering irrigation ditches. A new device seems to meet these requirements, and also excludes drift, without interfering with the flow of water. Fenders, on piling, part way across the main stream, deflect heavy drift past the intake, while below them a wooden float deflects any drift passing the fenders. Fish and small drift are excluded by a revolving screen set inside the intake. The water is directed to one side of a wheel, pivoted above and below, and having spokes of angle iron. Wings, of screening, attached to the spokes, are pressed against them by the flow which rotates the wheel. On the opposite side they

turn edgewise. The wheel frame is covered with screening. On each side, trash

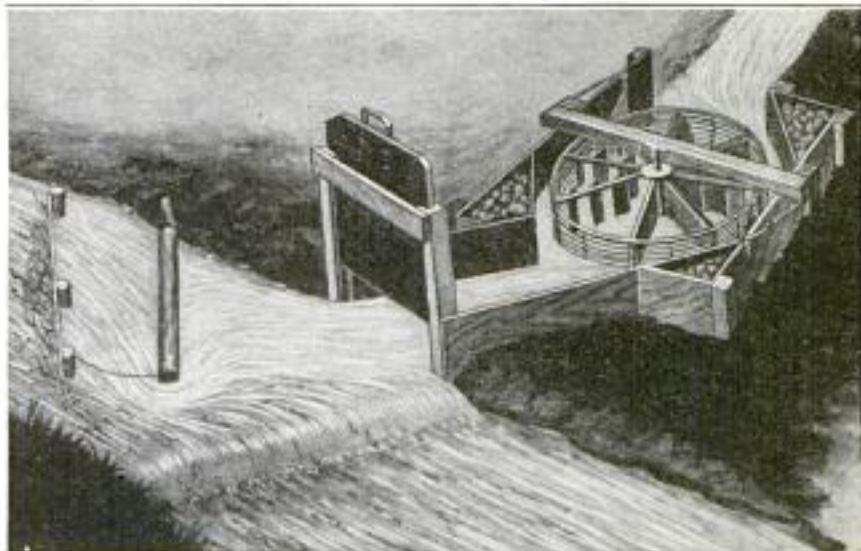

Heavy Drift is Deflected past the Intake of an Irrigation Ditch by the Fenders, on Piling, in the Main Stream, While the Revolving Wheel inside the Intake Excludes Fish and Trash

Ans. Charles W. Waizer
% Press Club, San Francisco

7518

COMPANY CLEANS AND REPAIRS ITS MESSENGERS' UNIFORMS

One of the telegraph companies keeps its messenger boys looking neat and clean by maintaining, at San Francisco, Calif., a depot where the boys' uniforms are cleaned, pressed, and repaired about once every two weeks. This depot handles approximately 5,000 suits a year, including those worn by messengers in all the cities of northern California. Suits from other cities are sent in and returned by parcel post, in cartons holding six.

CONSTANT GRIP NOT REQUIRED BY SELF-LOCKING PLIER

One grip of the hand is all that is necessary to hold securely anything grasped by the jaws of an ingenious self-locking



plier. There is no need to maintain any pressure on the handles, as in any ordinary plier. The self-lock-

ing device retains indefinitely the pressure of the first grip. To relieve this grip, the handles are opened in the usual way.

Ans. J. N. Jacobsen,
Mansfield Center, Conn.

gates, with wire fingers, continually brush the surface of the wheel to keep it clear of any obstruction.

7405

VALVE-REFACING LATHE SHOWS HIGH DEGREE OF EFFICIENCY

A simple though universally adjustable valve-refacing lathe has been developed, that shows a high degree of efficiency,

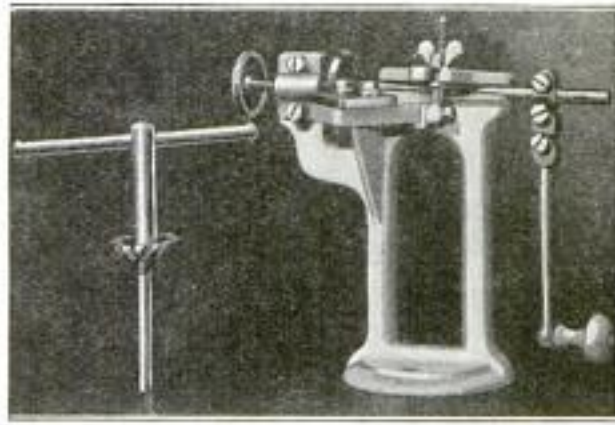

Refacing and Reseating Tools Shown with Valve Inserted and Ready for Refacing Process: The Reseating Tool is Shown at the Left

both in accuracy and speed. The lathe can be mounted upon any bench or held in a vise, and is adjustable to take any valve from 1/4 to 1/2-in. stem diameter, and any valve head up to 2 3/4 in. in diameter. Thus it has a great range of work in the automobile field, and should be a very popular tool.

Leicester, Maine
Mfg. Co. 74 Nichols St.

R. S. Whitney

7194 Safepack Mills Mfr. Air Reduction Co
 118 727 Atlantic Ave. Sales Dept. Edward J. Cassidy
 (120 Broadway New York City)

POPULAR MECHANICS
WRAPPING PAPERS ARE WATER, DUST, AND VERMIN-PROOF

The recent ruling that automobile tires must be wrapped in waterproof paper for shipping, has been largely responsible for the development of new types of paper. One of these is a paper made in two layers cemented together with asphalt cement. It is also made with cotton cord laid in 1-in. diagonals, or $\frac{3}{8}$ -in. parallels, between the layers, making it practically untearable; or with wire substituted for the cord to increase its strength. For baling purposes, the two types of corded paper are joined with asphalt cement to form a nine-ply paper, consisting of four layers of paper, two layers of cord, and three layers of asphalt cement. It is entirely proof against water, dust, moths, rats, and odors, and is said to be superior to burlap as well as cheaper.



A Nine-Ply Sheet of Paper, Cord, and Asphalt Cement for Baling

Another type of paper has two layers joined with cement and crimped to three-fourths its natural length. Being capable of stretching one-third, without breaking, it is particularly suitable as a lining for bags, barrels, and bales.



This Type of Paper will Stretch to Shape for Lining Barrels

Another type of paper has two layers joined with cement and crimped to three-fourths its natural length. Being capable of stretching one-third, without breaking, it is particularly suitable as a lining for bags, barrels, and bales.

REGULATIONS SAFEGUARDING SHIPS AGAINST FIRES

With the object of fire prevention on ships, the Board of Trade, in England, has issued a circular embodying its requirements as to the means of dealing with outbreaks of fire. Passenger ships, fitted

The Engineer, Oct. 7, 1921

for oil fuel, must have, besides the usual water service, protection in the lower part of the boiler room by means of pipes perforated for the emission of steam, controlled from outside of the boiler room. There must also be means of extinguishing fire with sand or other suitable material of that nature.

7390
RARE ELEMENT UTILIZED IN SPARK-PLUG TESTER

Neon, one of the rarest elements of the air, has the peculiar characteristic of



glowing bright red when an electric current passes through it. This has been utilized in a new spark-plug tester, consisting of a hard-rubber shell that contains

a small glass tube of neon. When the metal cap, sealing the tube, touches a spark plug, the action of the neon quickly shows whether the plug is working or not.

7340
REGULATOR TO CONTROL GASES IN OPERATION OF TORCHES

A new regulator for the control and delivery of acetylene, oxygen, hydrogen, and other high-pressure gases in connection with their use in torches, is now on the market. It maintains uniformly any predetermined pressure independently of any variation in the high-pressure source of supply, or in the consumption of the gases at the torch. The pressure is indicated on two finely graduated gauges, and is regulated by means of an adjusting key. The regulator is very simple, with few operating parts, and is exceptionally small in size and weight. Interchangeable gauges are provided that are adapted to the various gases and types of containers.

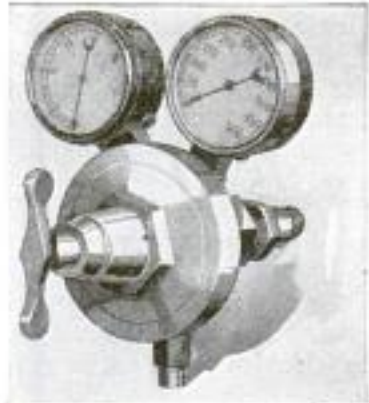

The consumption of the gases at the torch. The pressure is indicated on two finely graduated gauges, and is regulated by means of an adjusting key. The regulator is very simple, with few operating parts, and is exceptionally small in size and weight. Interchangeable gauges are provided that are adapted to the various gases and types of containers.

The Alexander Milburn Co. 1420 W. Baltimore material Baltimore, Md.

Edward J. Cassidy
 250 43rd St.
 New York City

7500

Camera Reports

7446

Handy Ailer C

POPULAR MECHANICS

Blairville

491

Auto Access

PUBLIC TASTE WILL BE STUDIED IN TRAINING OF BUYERS

SIMPLE OIL DISPENSER QUICK AND ACCURATE

Acting upon the assumption that the wholesale buyer should come in more direct contact with the needs and desires of the buying public, the University of London has instituted a three-year course, upon the students of which will be conferred the "Degree of Commerce." Under modern commercial conditions, the buying public is separated from the manufacturer by numerous distributors, wholesale and retail. The wholesale buyer must accurately gauge the wants of the buying public.

An efficient oil-dispensing outfit consists of a glass container, very much like the ordinary milk bottle, fitted with a ta-

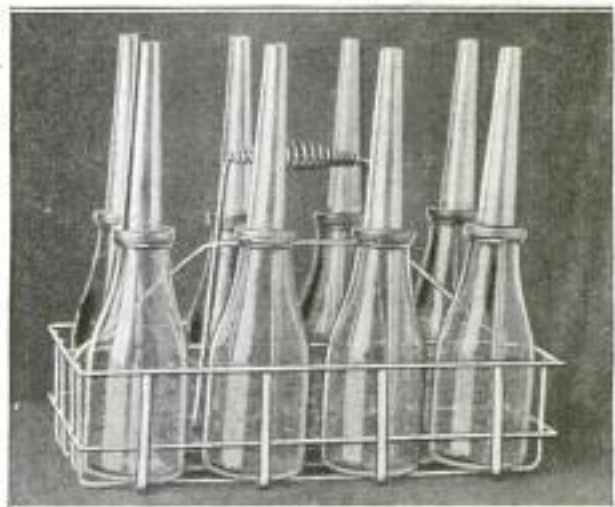

By Using an Outfit like This in an Auto-Service Station, Oil Tanks are Quickly and Easily Filled without Spilling

The degree-of-commerce course has been created for the purpose of thoroughly training the student along the lines of his particular field of buying. The advantage of this course is apparent, and it should be an innovation of benefit to the manufacturer, wholesale buyer, retailer, and to the buying public.

7388

EXPANDING RUDDER ACTS LIKE EMERGENCY BRAKE

An expanding rudder, for self-propelled boats, which when closed acts as an ordinary steering rudder, but upon being expanded stops the boat more quickly than by merely reversing the

pered metal spout. A breather tube extends from the mouth of the tube inside to the bottom of the container. This equipment gives clean, quick, and accurate service, dispensing with the unsatisfactory measuring can and funnel method.

Auto Access

SHEET-METAL BOX PROTECTS EXTRA INNER TUBES

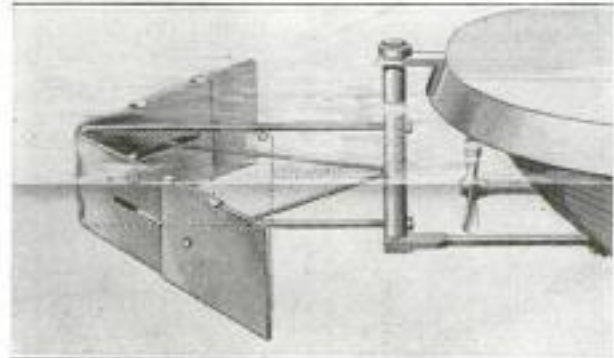

Expanding Rudder That, When Opened Out in the Manner Shown, Stops a Motorboat Much More Rapidly Than by Merely Reversing the Propeller

Extra inner tubes may be carried in the tool box, or anywhere on the automobile, and be protected from damage, dust, grease, and rotting, by placing them in a new inner-tube box. The tube is rolled up and placed in a drawn-steel shell, with the valve stem projecting. The cover, in the form of a bayonet joint, is held in place by the valve stem and a lug on the opposite side. The tube is slightly inflated to keep it from chafing.

propeller, is now being manufactured in Canada. It is particularly applicable to small motorboats, as it occupies no space inboard, and is operated by the steering wheel and a pedal near it. Connected to the rudderpost, like an ordinary rudder, is a frame, with a plate on either side of it hinged at its rear end in such a manner that each plate can be swung outwardly at an angle to the plane of the frame, and thus offer such resistance to their motion through the water that they stop the boat in much the same manner as an emergency brake stops a motor car.

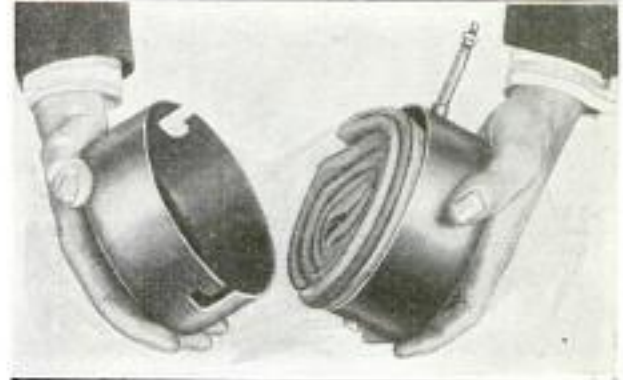

An Inner Tube in Place in the Box: The Cover is Slipped On, and a Twist Holds It Tightly

A. H. Stewart
 Sew. Steel
 Toronto, Canada.

Martin Metal Mfg Co
 Wichita, Kans.

2b

7493

CHILDREN'S PICTURE-STORY DEPARTMENT

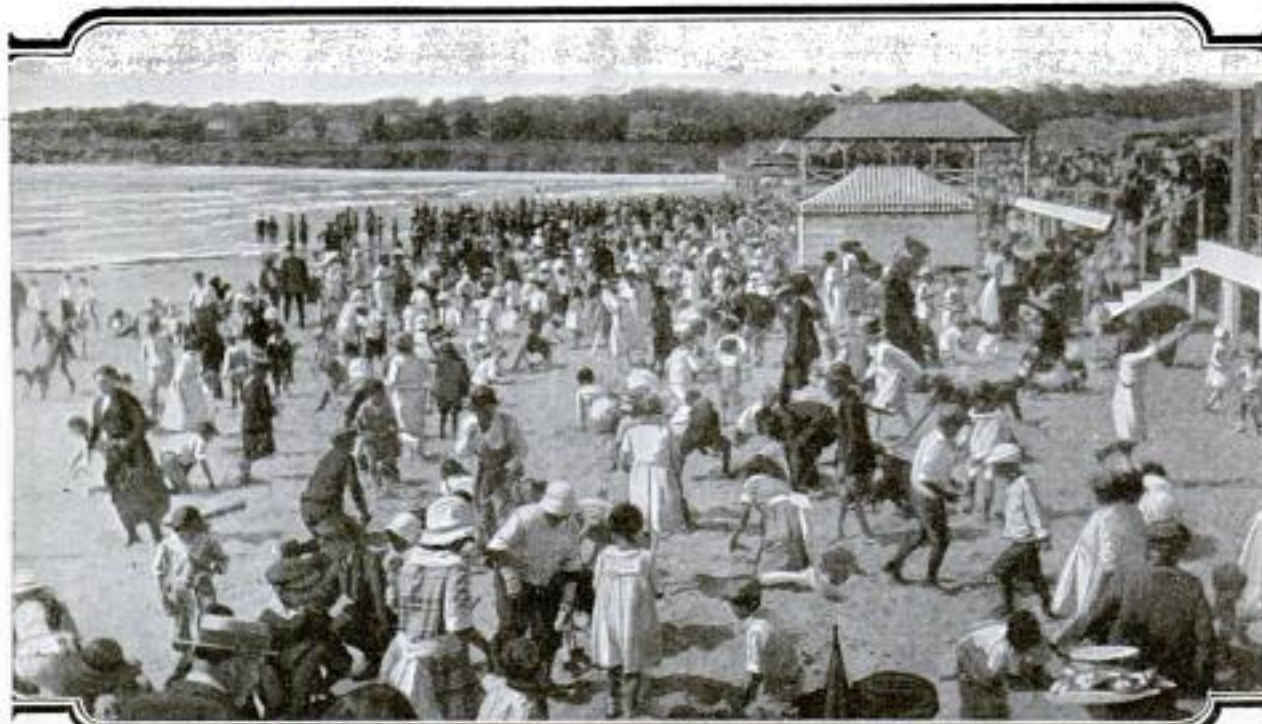

Labor Day at Newport Beach, When a Thousand Wooden Blocks, Each with a Number on It, are Buried in the Sand: The Children are Lined Up, and at a Signal Scatter over the Beach, as Seen in the Picture, and Hunt for the Blocks. For Every Block There is a Prize in the Form of a Doll, or Some Kind of Toy, and the Finders Run to the Convention Hall, Where Each Receives the Prize Corresponding to the Number on the Block. A Year Ago, a Block Which had been Buried in 1918 was Found, and the Finder Received the Present Which had Remained All That Time Awaiting Its Lucky Claimant



This Combination, When Opened Out as Seen to the Left, is a Scooter for the Kiddies, and When Closed Up as Seen to the Right, is a Walking Stick for the Grown-Ups. It is Thus Easily Transportable to a Park or Other Place Where a Child may Wish to Play with It. It is Made of Aluminum and Weighs Only Four Pounds. The Handle is in Two Parts Which Fold Downward to Form a Seat That can be Used in Scooting

no information available

7493

OF MODERN ACTIVITIES AND INTERESTS

data lost



A Game of Skill and, Therefore, Interesting: The Idea is to Move the Triangular Frame by Hand in Such a Manner That the Three Little Wire Snakes on the Bottom are Made to Wiggle from the Partly Inclosed Shamrock to the Three Points, as They are Shown in the Picture. A Wire Screen on Top Protects the Toy from Damage

This Is Not a Walrus, nor a Seahorse, nor Any Other Kind of Animal. It Is a Vegetable — a Sweet Potato That Grew in This Manner through a Buried Padlock. It was Dug from a Garden in Kansas and Photographed Just as It was Found



data lost

A Dog That Barks but does Not Bite: When the Rubber Bulb Held by the Fingers is Squeezed, the Dog's Head Snaps Its Jaws and Barks Merrily, Just like a Dog Greeting Its Master or Mistress. It Resembles the Bark of a Dog So Exactly That Everyone Who Hears It for the First Time is Surprised to See Only a Toy

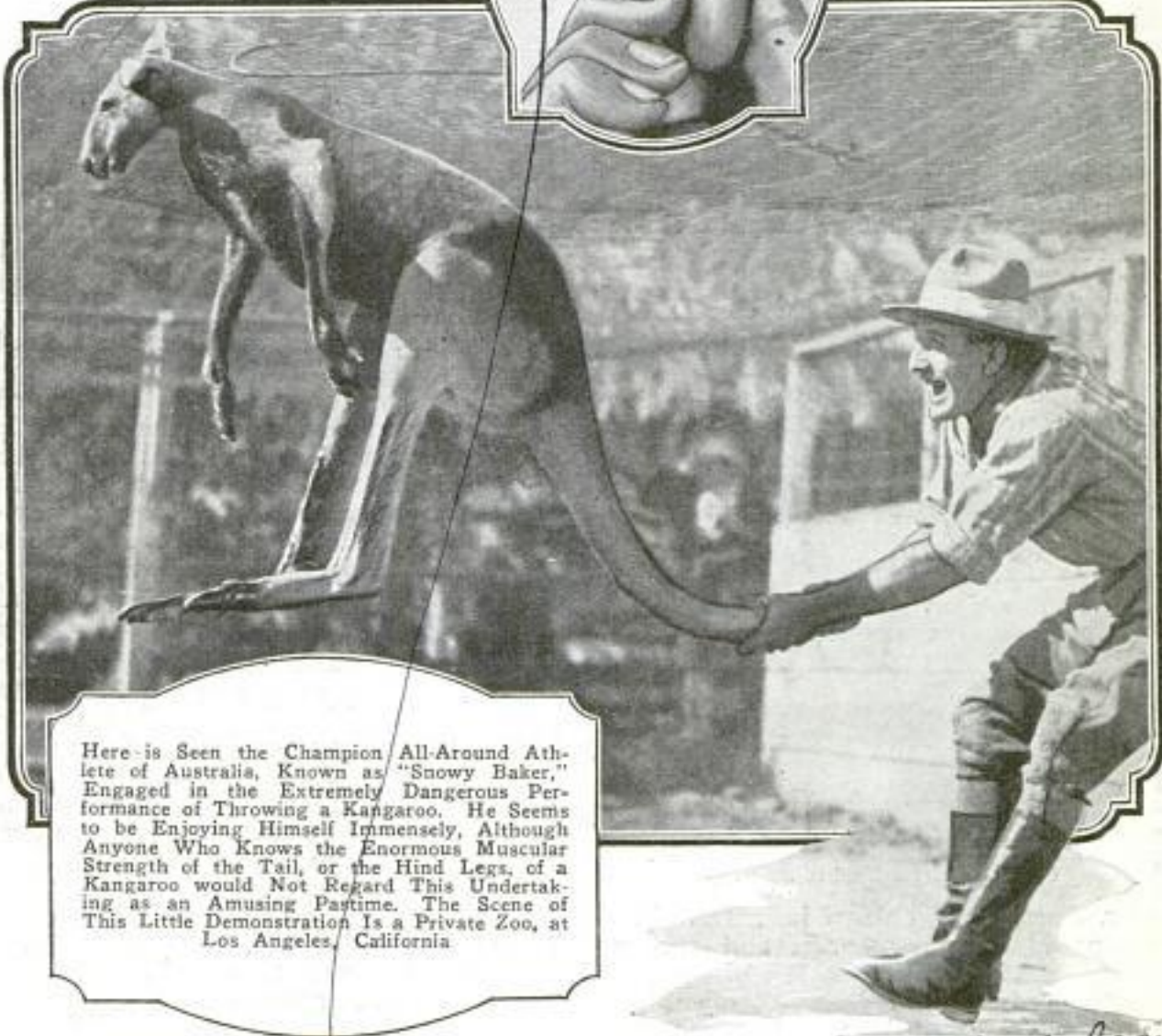

Here is Seen the Champion All-Around Athlete of Australia, Known as "Snowy Baker," Engaged in the Extremely Dangerous Performance of Throwing a Kangaroo. He Seems to be Enjoying Himself Immensely, Although Anyone Who Knows the Enormous Muscular Strength of the Tail, or the Hind Legs, of a Kangaroo would Not Regard This Undertaking as an Amusing Pastime. The Scene of This Little Demonstration Is a Private Zoo, at Los Angeles, California

COPYRIGHT, UNDERWOOD & UNDERWOOD

Embee Novelty Co. (The Museum)
 335 Broadway, New York City
 CO. 3802 Ellis
 Copyrighted material

d. w. John Spidmore Cml.
Esnelph, Ont. Canada
POPULAR MECHANICS
 7210

122
 7/188

DOUBLE SEAT IS INVENTED FOR GOLF OR GARDEN

A combination of two seats, which can be used on golf courses or elsewhere outdoors, has been invented by a Canadian.



This Seat Provides a Shelter for the Golfer from the Rays of the Hot Sun or from a Sudden Shower

An awning covers the whole, and hooks are placed upon the framework to support pails of sand, water, or other golfing necessities, which should not be exposed to the rain or sun. The awning also shades the resting golfer.

PILLS AND CORKS USED ON SIGN OF DOCTOR

A highly suggestive, ornamental, and useful sign hangs in front of the home

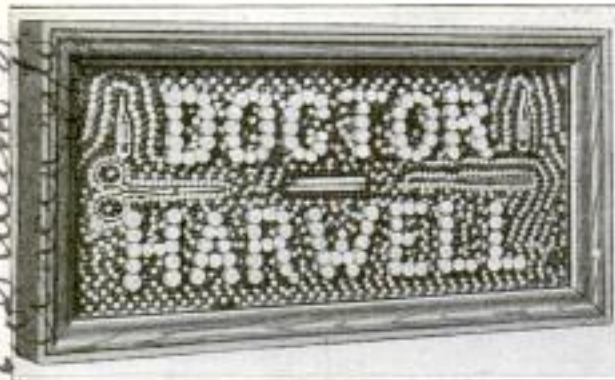

COPYRIGHT, TICHENOR NEWS PHOTO SERVICE
 This Unusual Sign of Pills and Corks Is an Entirely Homemade Article, and is Thought to Be the Only One of Its Kind in Existence

of a doctor in Poplar Bluff, Mo. It is composed of pills, corks, and surgical instruments, and is the work of the physician himself. So far as known, this is the only sign of its kind in existence.

CARD TEACHES SAFETY FIRST TO COUNTRY-ROAD PEDESTRIANS

In order to encourage safety first among people walking on country roads, Harry Park, of Portland, Ore., had a number of cards printed which he carries with him whenever he is touring. "Pedestrians should Walk on the Left-Hand Side of the Road, Thus Facing Approaching Machines—Safety Always," is printed on the cards in large black type. When he passes a person walking on the right side of the road, with his back to him, he sounds his horn to attract attention and throws out a card. Even if that person fails to pick the card up, some one will, and it will do its work in the campaign for reasonable caution. The idea does not apply, of course, to city traffic.

709 1/2 Ave. J Hastings
LAWN-SPRINKLING NOZZLE HAS FAN-SHAPED SPRAY

A lawn sprinkler for use as a hose nozzle, that has recently been introduced in the West, has some novel features.

Like other such devices, it is screwed onto a hose, and laid on the ground, resting on the ends of two supporting arms. The



outlet of the spraying nozzle has a slotted opening so shaped that it spreads the water into a semicircular fan-shaped spray, no water falling on the hose side of the nozzle. Thus the lawn can be sprinkled from the edge of a sidewalk without any danger of sprinkling passers-by, and for the same reason the nozzle is approachable from this side when it is desired to move it.

736 3
ELECTRICALLY WOUND CLOCK FOR AIRPLANES

An electrically wound clock for use in airplanes and balloons has recently been developed, and tested by the Bureau of Standards. It consists primarily of a watch movement with an electrical winding attachment operated from a three-cell, six-volt storage battery. The tests included its ability to stand severe vibration and temperature changes within a range from 120° above to 15° below zero Fahrenheit.

Bureau of Standards
Sept. 15, 1921

U. S. Patent Gazette
7/6/21

Tichenor News Photo Service
Box 16, Station 9

Canadian Patent
7/10/21
Min. for the Great North Canadian
Copyright



Mold for Making Concrete Blocks

By A. J. R. CURTIS

THE mold illustrated can be made from wood by any mechanic and used to produce concrete building blocks for quite a good-sized building. The bottom, ends, and sidepieces are made from thoroughly kiln-dried white pine, 2 in. thick, strengthened with 2-in. square cleats. The cores are merely tapered sections of 6 or 8-in. square posts. The wearing edges of the sides and ends are protected with strap iron, screws being used to attach both the cleats and strap-iron reinforcing. Handles of $\frac{1}{2}$ -in. rod

painted inside and out with any kind of light oil that will fill up the pores of the wood and keep out water. If the inside faces have been properly planed and sanded, the oil surfaces will produce correspondingly smooth surfaces on the blocks. Only enough free oil should be left on the forms to prevent the concrete from sticking, the surplus being removed with a piece of waste.

The blocks may be cast either face down or face up, as preferred, and it is recommended that only plain-face blocks

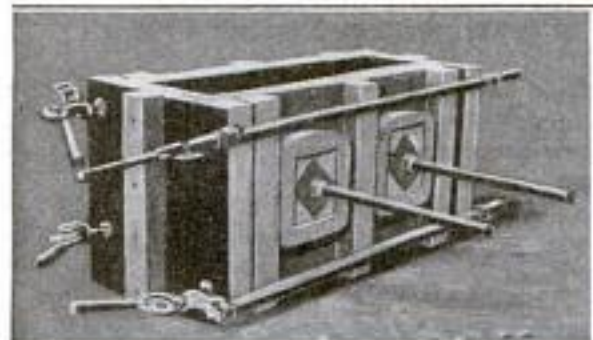
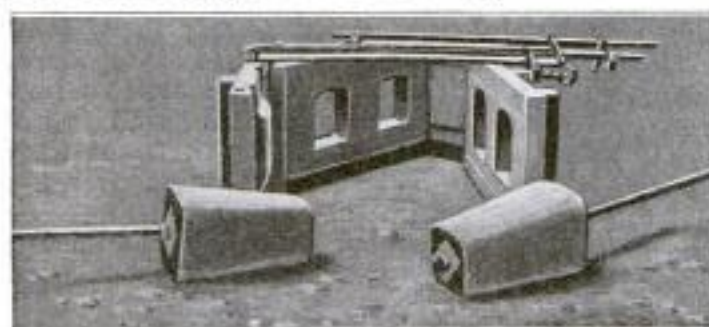

The Upper Photograph Shows the Concrete-Block Mold, Opened, with Its Cores and Clamps; Below, Left, the Clamps Applied and the Cores in Position to Cast a Concrete Block. The Face of the Block can Be at Either the Top or Bottom of the Mold. Right, One of the Blocks Cast in the Homemade Mold, Showing the Hollows at the Center. These Openings Make the Block Lighter and Improve Its Insulating Qualities

or pipe through the cores are provided, so that they can be removed from the mold after the block has been cast. Carpenters' or cabinetmakers' quick-acting clamps provide the best means for holding the parts together rigidly, although simple strap-iron hooks and wooden wedges can be used if clamps are not available.

Before using the mold, it should be

be made, as they are simpler and better-looking than the rock-face block. If the face of the block is to be down, a facing mixture is first placed in the mold to a depth of $\frac{3}{4}$ in., and the remaining space in the mold box is filled with ordinary concrete, mixed as wet as possible, yet so that it will stand up without sagging when the mold is removed. If the facing is to be placed on the upper side, the mold

is filled to within $\frac{3}{4}$ in. of the top, and struck off with a template, after which the facing mixture is placed. Of course, all the concrete must be tamped thoroughly, and this is best done with a small foundry rammer, or one so constructed that the mixture is thoroughly compacted around the cores and in the corners.

The plain-concrete backing may be made of a mixture of 1 part cement to 3 or 4 parts of clean gravel, varying in size from minute particles to $\frac{3}{4}$ -in. pieces. The facing should consist of a mixture of 1 part cement to 2 or 3 parts of white sand, marble dust, or granite, the proportion and color of the ingredients determining the color and texture of the finished article. Cement-stucco mixtures, in a variety of colors and textures, may be

obtained from building-material dealers. After the block has been thoroughly compacted in the mold and the top struck or floated off, a straight, true pallet, made from 2-in. plank and cleated on the back, is clamped to the top of the mold, which is then turned over until the block rests on the pallet. The cores are then withdrawn, the mold carefully removed, and the block set away in a warm, moist place to season. The blocks should be carefully protected against sun, draft, and frost, preferably being stored where the temperature can be kept as high as possible and where the blocks can be sprinkled frequently, commencing as soon as this can be done without injury to the block. It is almost fatal to let blocks become dry during the first two weeks.

Engine Grates Made from Old Tires

While doing some threshing, the ashes were allowed to accumulate underneath the grates of the steam tractor, the result

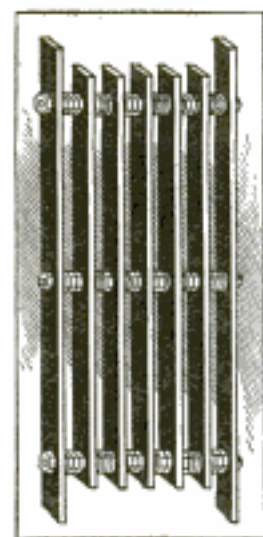

being a ruined set of grates. Not wanting to wait for several days until new grates could be received from the supply house, several old wagon tires were obtained, and, after cutting, were straightened out without heat. The iron bars thus obtained were cut into lengths to fit the grate racks, longer strips being provided at the sides for holding the grate in place. Three holes were drilled through

each piece. The separate bars were spaced by old nuts and washers, the whole being held securely together by round rods, threaded on the ends, inserted through the holes, and drawn up tight with nuts.

Tinning Small Work

The work to be tinned is placed in warm water, to which a little sulphuric acid has been added, to clean the pieces of grease and dirt. Some powdered sal ammoniac is then added to the water and vigorously stirred until entirely dissolved. The work is then removed, washed in clean water, and placed near the fire to dry. A shallow pan, such as a frying

pan, is obtained, and the bottom perforated. This pan should be small enough to allow it to be dipped into the pot of melted tin. The work is placed in the bottom of this perforated container, and a little sal ammoniac is sprinkled over the surface of the melted metal; then, after all smoke from the metal has disappeared, dip the pan containing the articles into the tin, lift it out, and shake well to get rid of the excess metal, at the same time sprinkling a little sal ammoniac over the work, to prevent too thick a coating. The articles are cooled quickly by dumping them into water, which also produces a bright finish.

A Convenient Ratchet Wrench

The original ratchet wrench of the type shown was made by using the ratchet from an old chain drill, and an elaboration of the idea resulted in a complete set of such wrenches to fit standard-size nuts.

By making the wrenches from carbon steel and casehardening, it is possible to screw or unscrew nuts and bolts that are so located as to be inaccessible to wrenches of the usual kind. The nuts are screwed down by means of a drift and hammer, as shown; to unscrew the nut the wrench is turned over so that the teeth point in the opposite direction, the hammer and drift again being used.

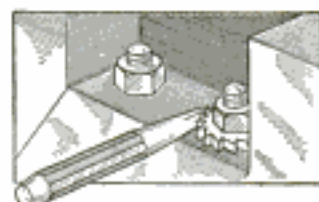

RATCHET

Removing Stains from Concrete

Stains on concrete and stucco are mostly caused by dirt and dust washed down from the windows. These can readily be removed by scrubbing with a heavy bristle or wire brush and water.

Occasionally stains are caused by iron dissolved in rain water. These are really rust stains, and come from iron piping, nails, etc. Often they resist scrubbing with plain water. In this case, a dilute solution of hydrochloric acid (muriatic acid) used with a plain bristle brush, is effective. After scrubbing, rinse well with clean water. Protect the hands with gloves when applying the acid.

A Reel for Drawing Paper

For most drafting rooms, detail paper is bought in large rolls that are heavy and awkward to handle when merely stood on end in a corner, as is quite often the case. By this system

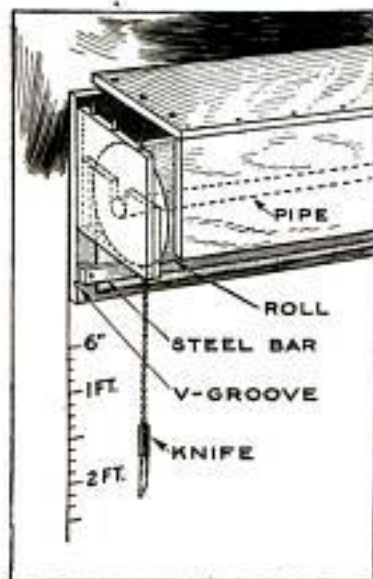

much paper is wasted through careless handling, and it was for the purpose of reducing this waste and placing the roll in a convenient position, that the reel in the drawing was devised. It was built as shown, the frame being screwed to the wall, and pieces of 1-in. material were attached inside each end as a support for the pipe roller. The top and front of the reel were made in a unit and held in place by dowels, so as to be readily removable. The paper, as it leaves the roll, runs underneath a $\frac{1}{4}$ by $1\frac{1}{4}$ -in. iron bar that serves as a guide when cutting paper from the roll, assuring a smooth, square cut, which is also greatly facilitated by the V-groove in the backboard of the reel.

The device is mounted about 6 ft. above the floor, and a scale in feet and inches is painted on the wall, making it possible to draw out a sheet of the exact size required and cut it off quickly and smoothly, with square corners.—J. H. Kay, Cleveland, Ohio.

Limousine Sled for Winter Touring

The limousine sled shown in the drawing is the product of a locality where winter comes early and stays late, and



A Limousine Sled, for Use in Localities Where Arctic Winters Are the Rule and Passable Roads the Exception at This Season of the Year

where roads, that are none too good normally, are even worse at this season. The runners of the sled are made of heavy plank, suitably crossbraced and shod with tire iron. The comfortable body is built to convenient dimensions and provided with windows on all sides, and a door. In this particular vehicle, a comfortably upholstered seat from an old automobile gives a touch of luxury.—John Hirdler, Minneapolis, Minn.

Making Crates of Maximum Strength

The annual waste and damage that are the direct results of packing and shipping goods in improperly made cases and crates amount to a staggering total. It has only been within comparatively recent times that serious thought has been given to

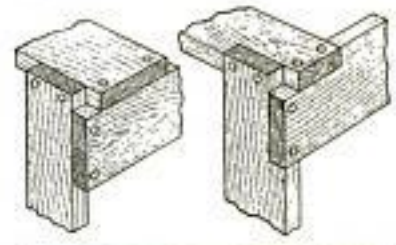

the matter of correct packing and crating. In most boxes and crates, it will be noticed that a great deal of the box is fastened together by driving the nails in parallel to the grain. This is all wrong, and should be avoided, because the nails will pull out readily. The best way to get the maximum strength at the corners of a box or crate, where it is most needed, is accomplished by arranging the pieces at the corners in either of the two ways shown in the drawing, and driving the nails into the wood at right angles to the grain.

A Stick Hydrometer

Due to the rapid evaporation of alcohol from the antifreezing solution in the automobile radiator, the owner is never quite

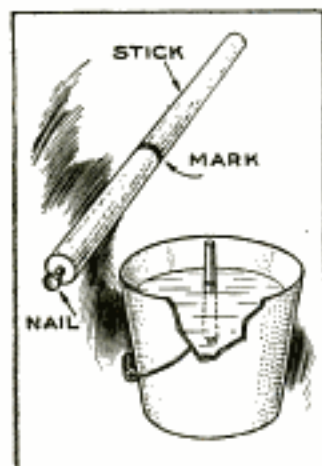

certain as to the efficiency of his alcohol-water mixture, without frequent tests.

A simple test gauge, operated on the same principle as a hydrometer, can be made from a circular stick of wood, with a nail driven into one end to hold it upright. The proper alcohol-water mixture

is made up, and the stick is inserted into the bucket, the depth to which it sinks being marked. The stick is kept either under the seat of the car or in the garage. Whenever there is any doubt as to the percentage of alcohol in the water, it is tested, and alcohol added until the test gauge sinks to the previously marked level.

Flat-File Attachment

It is not generally known that a handle placed on the front end of a flat file greatly facilitates its use. Anyone who

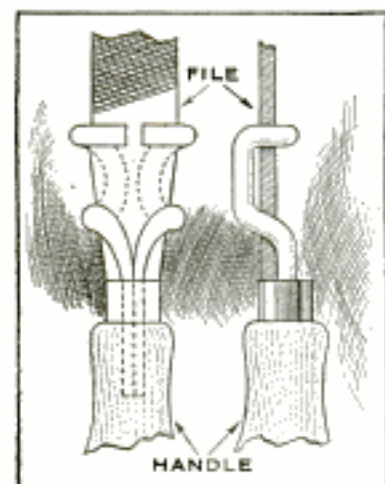

has used a flat, rough file for any length of time knows how awkward it is to keep on filing after the left hand has become sore and blistered from the continual contact with the file's rough surface. A good method of attaching such

a handle is to bend a piece of drill rod to the shape shown in the drawing. After bending, grind off half the diameter of the two ends so that when brought together they can be driven tightly into a hole drilled in the wooden handle. The piece is then split at the front to form a spring grip. The front or split part of the at-

tachment should be much narrower than the width of the file, so that when it is pushed on there will be sufficient tension to grip the file tightly. The lines showing the teeth on the end of the file have been omitted from the drawing for the sake of clearness; it is not necessary to grind off the teeth, although it may be found advisable to grind the edges of the file to a more abrupt taper. The size of drill rod to use will depend largely upon the size file with which it is to be used, $\frac{1}{4}$ to $\frac{5}{16}$ -in. stock being sufficiently heavy for 8 to 12-in. files.

Self-Centering Dividers

A pair of machinists' dividers can be made self-centering by the simple addition of a perpendicular centering rod and a link arrangement, by means of which the rod is

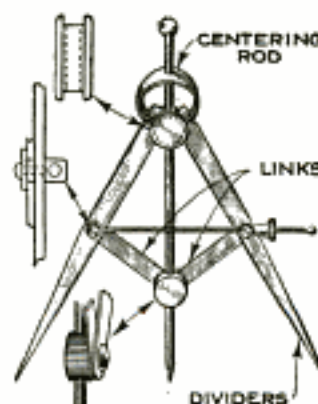

always held at the center. A hole is drilled through the spool and bow for the center rod, which is free to move vertically. This rod passes through a hole in the stud riveted at the center of the links. The links

are fastened to the legs of the dividers, and, as the adjustment is changed, move up or down the centering rod.—Albert Hochheimer, West, Ia.

Pocket for Loose-Leaf Notebook

For carrying clippings, and similar small notes, in a loose-leaf notebook, a pocket can be added to the book, which will keep them all together and prevent them from dropping out each time the book is opened.

A heavy envelope of the right size is sealed and then cut as shown, the proper number of holes to fit the notebook rings being punched in the edge. If possible, metal eyelets should be inserted in the holes to add to the strength of the pocket and prevent its being easily torn out of the book.



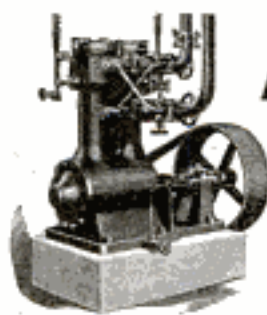

Repairing Small Ammonia Compressors

BY J. V. ROMIG

OWNERS of small ice plants are usually rather chary of undertaking the overhauling and repair of their compressors, although many are quite competent to perform the repair work if they understood just how to go about it. It is to give this instruction to owners, or repairmen unfamiliar with refrigeration equipment, that this article is written.

The first thing necessary is to go over all pipe connections, studying the plant thoroughly, until the operation of each part is completely understood, and a firm grasp of the method of controlling the ammonia obtained. It is surprising how easily the ammonia is made to do as de-

and 2 show cross-sectional views of two typical compressors; these should be studied carefully so that the instructions may be followed intelligently.

When the desired temperature has been obtained in the storage boxes, ice-cream cabinets, ice tanks, or whatever the machine may be cooling, pump a good vacuum on the system, then close the line suction valves, one of which is shown in Fig. 3, and pump down again. Stop the compressor, then close valves A and B, Fig. 3, as tight as possible. There is now no pressure on the suction side, and the pressure remaining on the high-pressure side of the cylinder may be by-passed

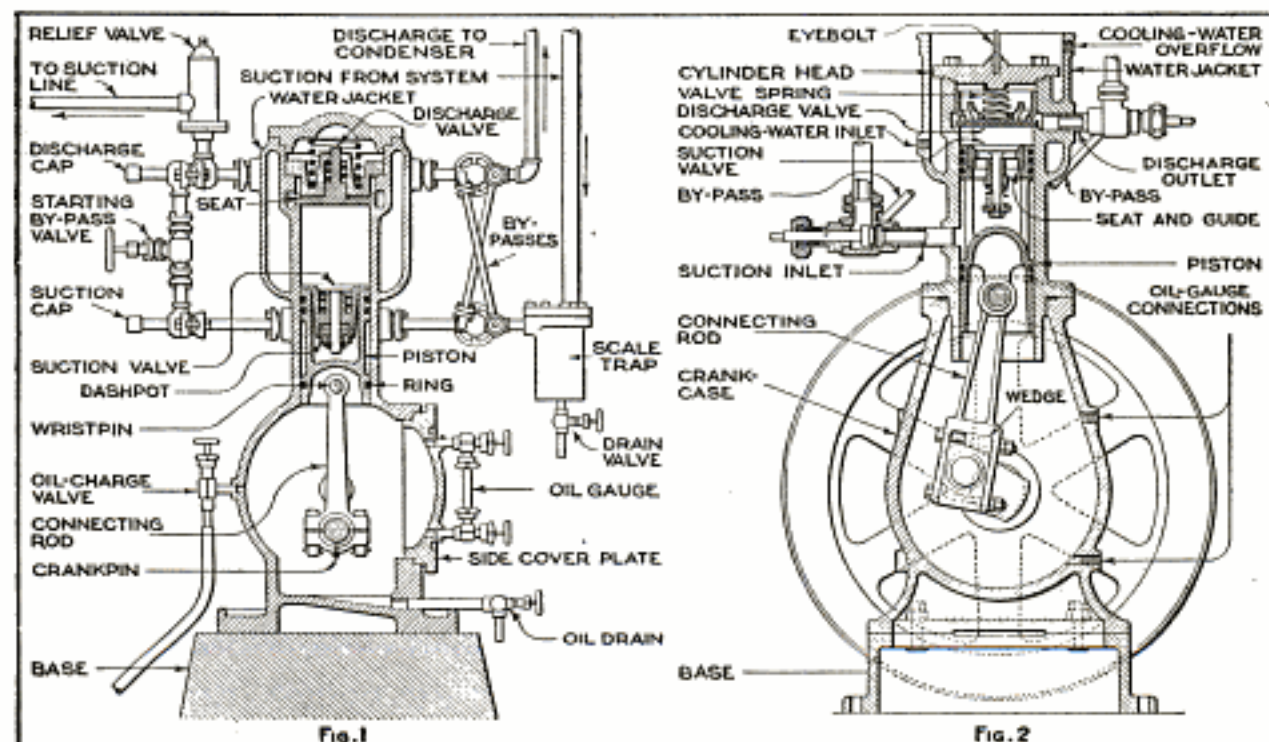

Sections through Typical Small Single-Acting Ammonia Compressors: Note Carefully the Arrangement of the By-Passes, Suction and Discharge Valves. The Cross By-Pass Valves are Closed at All Times When the Machine is Running

sired, when the operation of the system is understood.

Compressors should be thoroughly examined and overhauled at least once a year, and the winter is the best time to do this, as, once the desired temperature has been attained in the cold-storage room, it will remain at a low degree much longer than in a warmer season. Figs. 1

by opening the starting by-pass valve E, Fig. 3; the pressure will then equalize on both ends of the cylinder. Place a bucket of water below the hose on the oil-charge valve, Fig. 1, open the valve, and the ammonia in the cylinder will be absorbed by the water. Do not keep the hose in the water too long, or all the ammonia will be absorbed by the water,

and a vacuum may form in the cylinder, drawing in some of the water, and requiring subsequent sponging. Drain the oil from the crankcase, then take off the side cover plate and the cylinder heads; very little smell will be noticed if the instructions have been carried out carefully. Remove the connecting-rod nuts, caps, and shims, and turn the flywheel until the pistons are at the top of the stroke; then the discharge valve and false head, if such is fitted, can be removed, eyebolts inserted into the piston head, and the pistons and connecting rods drawn out. Carefully examine the suction-valve seats; if pitted badly, they must be reground, using fine emery and oil, as in grinding in automobile-engine valves. See also that the balancing springs on the suction valves exert just enough force to overcome the weight of the valves and dash-pot plungers; if they are too "light," remove the cage, take out the valve, and stretch the spring until the proper tension is secured; if the spring holds the valve off its seat, compress it a little. Clean out any scale or grit that may be found around the piston cavities, then take the slip ring, used to compress the piston rings when inserting the piston into the cylinder, and slip it half over each ring in turn, observing how much the ring is open at the gap when compressed. If the gap measures more than .02 in., new rings should be fitted.

Rings that have an angular oil groove

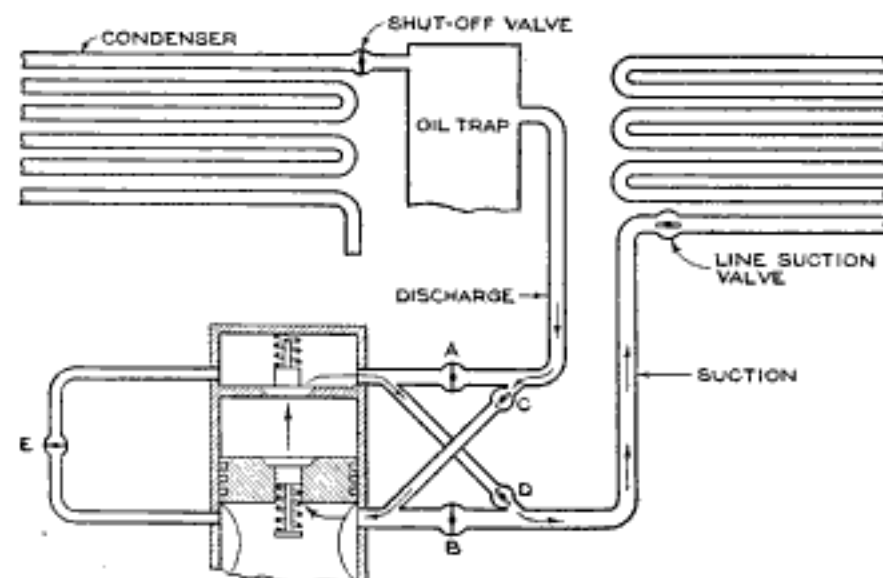

FIG. 3

Diagram of the Pipe Connections: The Arrows Show the Direction of the Gases When Pumping from the Discharge Side to the Suction Side

cut in the outer face give the best results, and should be fitted so that the gap is no wider than .006 in. "Stagger" the gaps, that is, see that the gaps are

not in line when inserting the piston into the cylinder, and that they stay staggered. Next examine the discharge valve; this usually shows some pitting, due to particles of scale getting between valve and seat; if necessary, regrind to a continuous surface with emery and oil. By a continuous surface is meant one in which there may be some pits, but which do not overlap each other, so that the valve will not leak. Too much emphasis cannot be laid upon the necessity of doing this part of the work well; the writer has found that very many cases of poor operation were due to bad high-pressure seats.

Replace the pistons in their proper cylinders, and, by turning to the top of the stroke, see how much clearance there is between the piston head and the top of the cylinder walls; if this is more than .02 in., the top halves of the connecting-rod bearings are worn, and should be replaced. Too great clearance is also a prolific source of inefficiency, as the space holds a comparatively large volume of highly compressed gas, and allows it to expand on the downstroke, partly filling the cylinder. Allow as little clearance as possible without permitting the metals to touch. All bearings should be tested for wear by placing a pinch bar under the shaft, in the case of the shaft bearings, or under the cap, in the case of the connecting-rod bearings, and, using a block as a fulcrum, raising the shaft or piston assembly; the bearings must be tight enough so that no play will be felt. If too much end play exists in the crankshaft, this can be taken up by a fiber washer, placed between the cover plate and crank web.

The key in the flywheel should be tested for shake, as it is very likely to work loose; if allowed to run when loose, it will develop a bad knock. Remove all accumulated dirt in the crankcase, and reassemble. After assembling, turn the machine over slowly to see that everything is clear, then pump out the air entrapped in the cylinder through the discharge cap, Fig. 1. If, while the machine was open, a leak in either of the main control valves A or B, Fig. 3, was noticed, it will be found neces-

sary to reseat these valves; to do this, the stems and bonnets must be removed, and the ammonia must be prevented from escaping while the valves are open. To repair valve A, proceed as follows: Close the shut-off valve between the cylinder and condenser, close also valves A and B, and open the cross-by-pass valves C and D; run the machine until the oil trap frosts up well. This pumps the gas from the discharge side, through the by-passes, into the suction side, as shown by the arrows. Close valves C and D, then the bonnet and stem may be removed from valve A.

It will probably be found that the lead seats are spun up, as shown in the center drawing of Fig. 4, which shows a double-seat valve head. To reseat, heat the head with a blowtorch until the lead melts and flows freely in the groove. Add a little new lead, and skim off the oxidized surface lead. If care is exercised, both seats may be renewed without unscrewing the two parts of the head, but the repairman with no experience in this work will probably find it better to unscrew the head and repair each seat separately. When replaced in the valve body, screw tightly in place, and use a monkey wrench on the valve wheel when seating for the first time; this will make a tiny circular impression on the new seat, and it will hold tight. If the valve has a steel disk instead of a soft seat, regrind as instructed for the cylinder valves.

To repair valve B, pump a vacuum on the system, close the line suction valves, and again pump a vacuum. Now close valve A, after stopping the compressor, and the line between the cylinder and the line suction valve will have no gas in it. Open valve E, and dissipate the gas in water as explained before; valve B can then be opened and repaired. When replaced, pump out the entrapped air through the discharge cap and replace the cap before opening valve A. These valves should be repacked when dismantled, and a little oil applied on the stem and threads. Various types of globe, angle, and expansion valves are shown in Fig. 4; with

what has been said, no trouble should be experienced in repairing any of these. One thing should be borne in mind, however; when placing valves on a line, always present the bottom of the seat or disk toward the source of the greatest pressure, that is, always have a valve shut

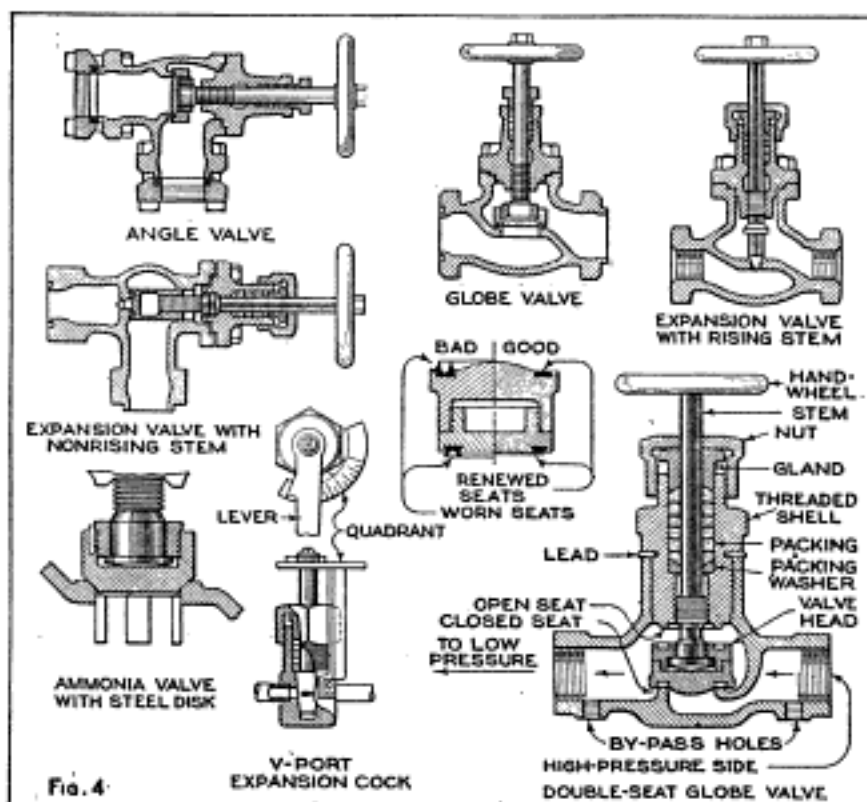

Fig. 4. Sections of Typical Globe, Angle, and Expansion Valves: The Center View Shows the Head of a Double-Seat Valve

against the pressure; if the pressure comes on top of the valve, the stuffing box will be under pressure always, and it will be difficult to keep it from leaking.

Examine the crankshaft stuffing box and repack, placing the new rings with the gaps staggered, to prevent leakage; it is well to smear the new rings with a little thin graphite grease.

Before starting up an overhauled compressor, pour in a new supply of ice-machine oil, bringing the level up to $\frac{1}{2}$ in. in the gauge glass. Be sure to get the proper kind of oil, as any oil which has not a low freezing point will cause endless trouble.

Another point worth noting is to renew all cotter pins; cotter pins may be bent more than once without breaking, but use new ones, and be safe.

Do not turn any valve, or open any part, on an ammonia compressor, without tracing over every part of the system, or without being sure what the effect will be, and also be sure that there is a near and free exit, so that a quick escape may be made if the gas comes out too strongly.

Fixture for Forming Flat Springs

The drawing shows the construction of a fixture for forming flat springs quickly, conveniently, and uniformly. A bedplate,

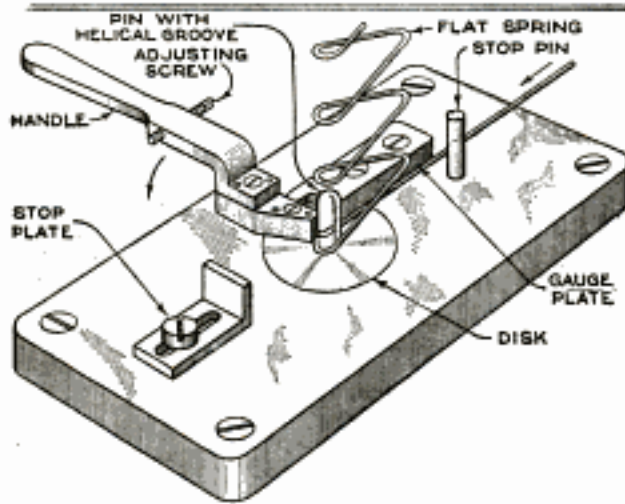

A Fixture for Conveniently and Quickly Forming Specially Shaped Flat Springs Uniformly

which may be of cast iron, is machined and provided with screw holes at the corner for attachment to bench or table, and a hole is bored out at the center to receive a steel disk, which should be a free-running fit, but without shake. A drive-fitted pin is inserted into the center of the disk. A helical groove, with a pitch equal to that desired in the spring, is cut into this central pin. A gauge plate is fastened to the plate for guiding the wire and for preventing vertical movement of the disk. A sliding, adjustable stop plate is also provided, to make the spring of uniform width. The forming handle is fastened to the disk and should stop against the gauge plate, as shown; as the handle must clear the center pin and stop plate, it should be offset, and provided with an adjusting screw which comes into contact with the stop pin, and serves to keep the coils of the spring parallel.—S. H. Johnson, Westville, Conn.

Efficiency of Wood Fuels

Two pounds of dry wood of any non-resinous species have about as much heating value as a pound of good coal. A ton of coal may be taken as the equivalent in heating value of a cord of heavy wood, $1\frac{1}{2}$ cords of medium-weight wood, or two cords of light wood.

The following is an approximation of the number of cords of seasoned wood of various kinds needed to give the same amount of heat as a ton of coal, on the basis of 80 cu. ft. of wood, with a mois-

ture content of 15 to 20 per cent to the cord: one cord of hickory, hard maple, beech, birch, oak, ash, elm, locust, long-leaf pine, and cherry; $1\frac{1}{2}$ cords of short-leaf pine, Douglas fir, western hemlock, sycamore, red gum, and soft maple; and two cords of cedar, cypress, redwood, basswood, poplar, catalpa, spruce, and white pine.

Resin gives twice as much heat as wood, weight for weight. Hence, such woods as the pines and firs have more heating power per ton than nonresinous woods. The resinous woods in the list are considered as having an average amount of 15 per cent of resin.

The fuel value of the wood depends in many cases not alone upon its heating power, but also upon such qualities as easy ignition, rapid burning, freedom from smoke, and uniform heat. As a rule, soft woods burn more readily than hard woods, and light woods more readily than heavy woods. The pines give a quicker, hotter fire, and are consumed in a much shorter time than birch, whereas birch gives a more intense flame than oak. Oak, however, gives a very steady heat.

Case Holds Tags Numerically

An adaptation of the device shown in the drawing can be used to deliver con-

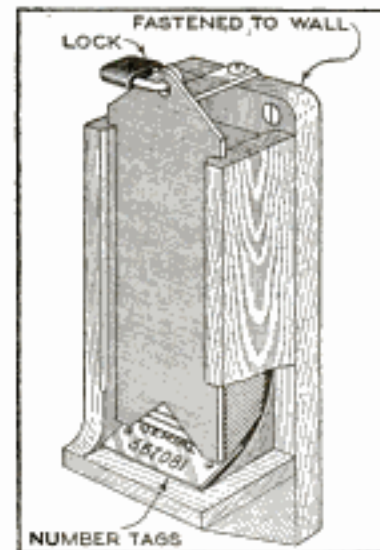

secutively numbered tags or plates, such as used for marking machinery, automobiles, and the like, and is suitable for the accommodation of plates that are made up and stored in advance of the parts being made.

The holder is made from hardwood with a compartment the exact size of the plates, the lower end of the slot being curved, as shown, so that the plates will move forward and downward as the bottom one is removed. A sliding front that fits into grooves in the sides is removable for replenishing the supply of plates; to prevent tampering with the contents, the holder can be locked.—G. A. Luers, Washington, D. C.

Castings for Six-Inch Bench Lathe

In response to our request, Mr. J. V. Romig, the author of the article on "Making a Six-Inch Bench Lathe," published in our October issue, has kindly consented to furnish the necessary castings for this lathe, to any who contemplate building one. They will, of course, be rough castings, and the price will be nominal; if machined castings are ordered, a higher charge will be made to cover the cost of the work.

Further information may be obtained by writing to the editor of this department.

A Gasket Lock Joint

When the pressure-head gasket blew out of the hoisting cylinder of an ash hoist, just at the time of day when it was most needed, a delay of several hours would have been necessary to have removed the piston-rod cables, sheaves, and other parts, to replace a solid gasket. However, by cutting the gasket joint as shown, a non-slipping splice was made, and the job completed in less than half an hour.—U. S. Sprout, Lancaster, Pa.



Jack Made from Axle Housing

Jacks around the service station are often "borrowed" without being returned. To avoid the cost of providing jacks for those lost in this manner, one station used jacks of the type shown in the drawing; these were made in their own shop. Sections of the axle housing of light automobiles were used, cutting them as shown and fitting a forged lifting bar and hook, to hold the jack in its raised position. Such jacks are always returned, as they are too large to fit in the tool box or under the seat of an auto.

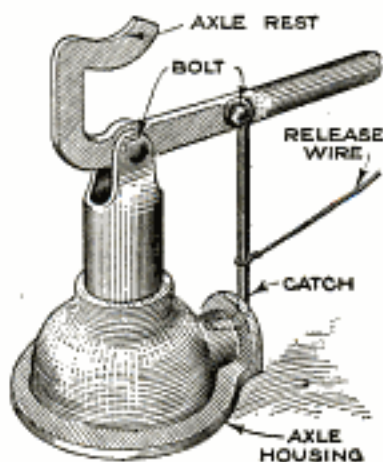

Radial Shop Crane

A crane suitable for the garage and machine shop, that involves no structural changes in roof or wall beams and re-

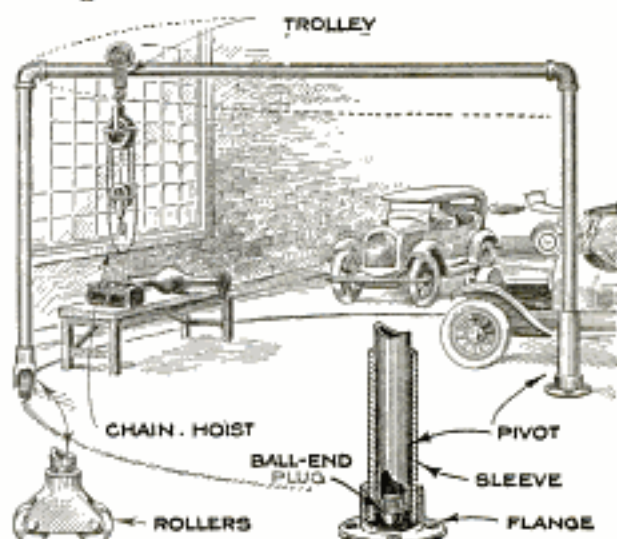

A Radial Shop Crane for the Garage and Machine Shop That can be Pushed to Any Point of Its Circular Path

quires no separate guides, is constructed, as illustrated, from pipe, making it sufficiently simple and inexpensive for any shop, even though it be used infrequently. A center pivot, consisting of a section of pipe and a closed-end floor flange, supports one end of the crane in the manner shown in the detail. The outer end of the crane is supported upon rollers so that the device can easily be pushed around.

Brake-Lining Fixture

The usual method of riveting new lining to the brake and transmission bands of automobiles consists in clamping a punch in a vise, to back up the rivet while the head is being upset with the hammer. This requires considerable effort to keep the punch and rivet together. The idea illustrated by the drawing makes the riveting job somewhat simpler and requires nothing more than a large steel ball, placed in the hardy hole of an anvil. The rivet is set on this, and the end hammered over. The first blow makes a small depression in the rivet, and the ball rests in this.

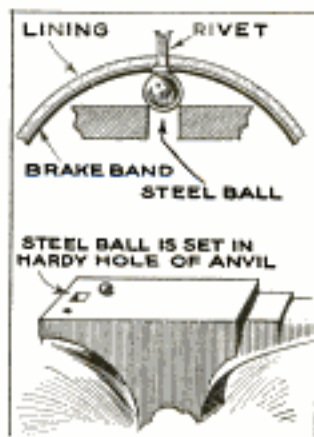

Making Leather Fillets for Wood Patterns

Leather fillets glued into the corners of wooden patterns are often used, and while they may be bought ready-made, it is oc-

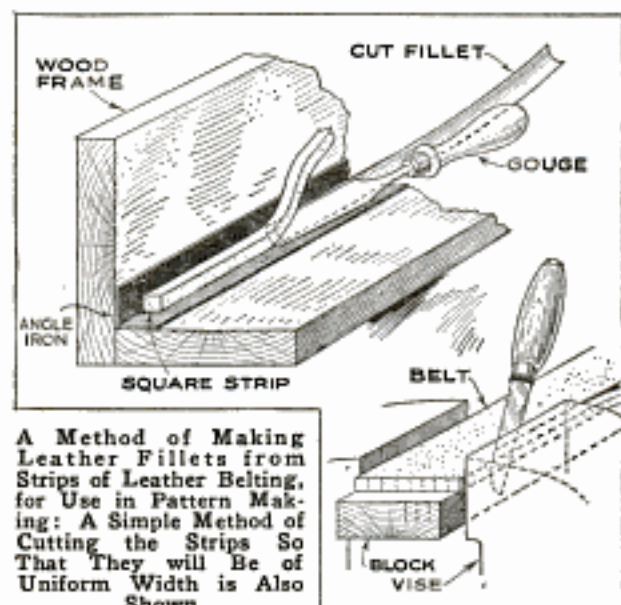

A Method of Making Leather Fillets from Strips of Leather Belting, for Use in Pattern Making: A Simple Method of Cutting the Strips So That They will Be of Uniform Width is Also Shown

asionally necessary that a special size be made in the shop.

A good method is to cut an old leather belt into strips of square cross section, in the manner illustrated in the lower part of the drawing. A wooden block, the same width as the belt, is clamped in a vise, the top of the block being lower than the tops of the vise jaws. A knife is then stuck into the block, at a distance from one of the jaws equal to the required width of the strip, and the belt is pulled through, as shown, cutting off one strip. The block is now planed down to the width of the remaining piece of belting and the operation repeated. Thus the strips will be of uniform width.

A form is then made by nailing together two pieces of board at right angles, with a right-angled strip of heavy tin or sheet iron nailed into the corner. One of the square leather strips is placed in the corner and either a gouge pushed along it while holding one end of the strip, or the gouge is held stationary and the leather strip pulled against its edge. If the resulting fillet is a little rough, it may be smoothed by wrapping fine sandpaper around a hardwood dowel and rubbing it along the surface of the leather, still held in the corner of the form; or it may be sandpapered after being glued into the pattern.

Another way to make such a fillet is to glue the uncut square strip to the pattern and hold it in place temporarily by driving

in a series of brads diagonally, allowing the heads to project. When the glue has set, the brads are pulled out, and the strip is cut with the gouge, and sandpapered. If a fillet is glued into place after being cut to shape, it is usual to press it down into position by means of a small rod, with a brass ball on the end, of the same radius as the fillet.—H. H. Parker, Oakland, Calif.

Tap Wrench Aids in Using Breast Drill

When drilling with a breast drill, to overcome the catching of the drill that necessitates backing it up, the following remedy is a good one: Take a tap holder from a set of taps and dies, slip the shank of the drill through the tap holder, and tighten down as when holding a tap. Allow enough of the drill shank to stick through to engage in the drill chuck. The tap holder now acts as a flywheel and the centrifugal motion carries the drill past the little catches unnoticed; the drilling is thus made much easier.—Orin C. Watkins, Salem, Ore.

Vulcanizing without a Vulcanizer

Repairing slits in boots, hot-water bottles, or similar rubber goods that are too large to fit into one of the small gaso-

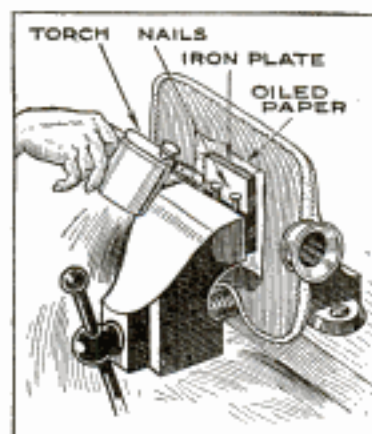

line vulcanizers, used for mending punctured automobile tubes, is done with the makeshift vulcanizing apparatus shown in the drawing. The surface around the slit is treated as in patching

a tube; that is, it is cleaned with gasoline for a generous distance around the aperture and the surface roughened slightly with sandpaper. A good coat of vulcanizing cement is applied and allowed to dry for a few seconds, and a neat patch of vulcanizing rubber is put in place and smoothed down until it adheres evenly.

Then, taking two sheets of iron, as near the size of the patch as possible, one is placed against the patch and the other on the opposite side of the article

being mended. A piece of waxed paper is placed between the plate and patch to prevent sticking. The whole is then clamped in a vise, as shown in the drawing, using a couple of nails between the vise jaw and the iron plate, to permit a free play of flame from the alcohol torch used to supply the heat. The flame is kept playing on the plate against the patch, which is kept hot for about 10 minutes, then allowed to cool for another 10 minutes before removing the work for inspection. — Harry W. Poor, Boston, Massachusetts.

Tool for Inserting Auto Universals

The tool shown in the drawing will be found of particular value in automobile garages and service stations making a specialty of light-car repairs; it is used for inserting the end of the universal joint into its socket in the transmission.

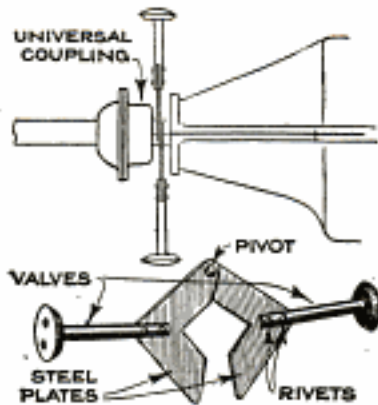

Two sheet-iron plates, triangular in shape, are hinged together at one side, as shown, and a square opening, the size of the universal-joint shaft, is cut in the center. Old valves, welded or riveted to the separate plates, are used for handles. With the tool in position around the universal shaft, the latter can be turned and centered so that it can be inserted into its socket in the transmission.

Motoring through Snow

When driving an automobile through deep snow, it is well to remember that letting some air out of the tires will give a broader traction surface; this is as efficacious in sand as in snow. While tire chains usually are effective, the wheels will sometimes spin; and it is advisable for the winter tourist to carry a pair of mudhooks for such occasions. Do not get alarmed if the radiator boils, so long as it contains enough water to cover the cylinder heads. Snow can be melted for the radiator by placing a bucket full under the radiator drain cock, and allowing some of the hot water to flow into it.

Snap-Ring Bending Fixture

The fixture shown in the drawing may be made in any machine shop at but slight cost, and will be found very useful in

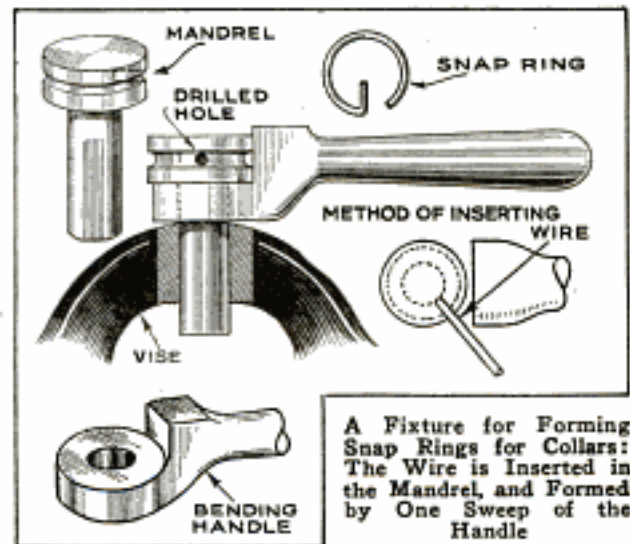

forming snap rings for collars used on small shafts, and for various other purposes. A circular mandrel is turned with a grooved collar, and a hole, slightly larger in diameter than the diameter of the wire used, is drilled in the center of the groove. Flats are filed on the mandrel shank to prevent it from turning in the vise.

A handle, the boss of which is bored to fit freely on the shank of the mandrel, is shaped as illustrated, and the fixture clamped in the vise. The wire, cut to length, is inserted in the hole in the mandrel, and one turn of the handle completes the ring.

Mitering Odd-Shaped Molding

Cutting molding that has a very narrow back, although full and round in the face, is somewhat difficult because the work rocks and slips on its narrow base. The easiest and surest way of making a correct miter, or joint, is to slip in strips of wood of suitable thickness between the sides of the miter box and the work, to provide a support for the latter, as shown in the drawing. If a great deal of molding of one style is to be cut, these strips can be permanently attached to the miter box.

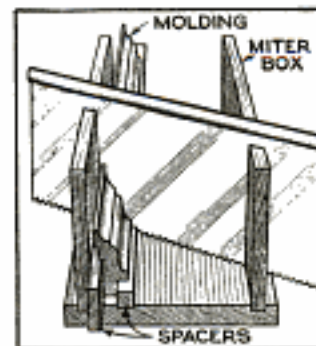

Novel Arrangement of Drawing-Table Drawer

The illustration shows a novel method of attaching a drawer to a drawing table, in which the drawer, instead of the board, is attached to the legs. The reason for

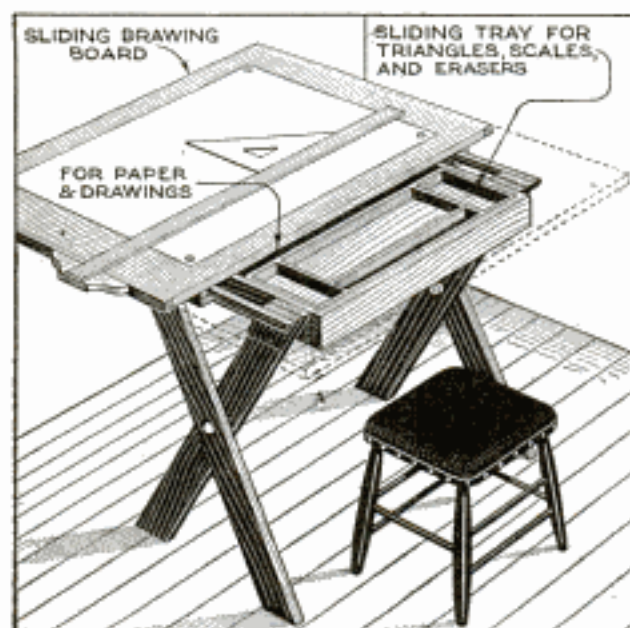

A Novel Arrangement for a Drawing Table: The Drawer is Fastened to the Legs, and the Drawing Board Moves Back over It

this is, first, that it is not necessary to move back when opening the drawer, and, second, that the drawer, being usually filled with books and paper, is much heavier to move than the top. Furthermore, the board is often tipped up at the back so that the drawer is disposed to slide out, and, as the drawer has considerable depth, the supports are more conveniently attached. A sliding tray is made to receive scales set on edge, so that one may be selected conveniently with a very slight opening of the drawer. The divisions in the sliding tray can be made to meet the requirements of individual cases.—G. M. Beerbower, Tarrytown, N. J.

Soldering Jewelry

It is of first importance that soft solder be avoided as far as possible in repairing articles of gold and silver, and even filled and plated jewelry can be repaired with hard solder. To repair a ring, the shank of which requires soldering, bury the setting in a crucible of wet sand, place a small piece of charcoal against one side, and coat the break, previously cleaned by scraping or filing, with borax; charge with solder and blow a flame against the ring until the solder runs in.

Articles that require protection against

discoloring in the process of soldering, should be coated with a mixture of burnt yellow ocher and borax, adding a little gum to make it cover the article completely. Allow it to dry, charge with borax, solder, and boil in a weak pickle composed of nitric or sulphuric acid in water. One important point is to wash the piece well in hot water, with a little ammonia added, to remove any dirt and grease, before undertaking any repairs.

If the article is made of colored gold, boil out in a pickle of muriatic acid and water, but never coat with any protecting mixture. To repair gold-filled work, melted solder is required; this may be made in the proportion of 1 oz. fine silver, and 10 dwt. hard brass wire, to which 2 dwt. of zinc is added just before pouring. Or, for strong silver use only the silver and brass.

For repairing most bright gold work, use an alloy composed of 3 dwt. fine silver, 3 dwt. gold, and 2 dwt. fine copper.

A good solder for soldering spectacle frames or other steel parts is made by melting together equal parts of silver and copper.—Geo. M. Millard, Toronto, Ont.

Tools for Valve Combined with Tire Gauge

A tire gauge, used in an eastern tire-service station, was incorporated into the three-in-one tool illustrated. This tool can be used for gripping the dust cap or valve nut, according to the end used, and is made by drilling a hole through a piece of thin steel tubing and soldering the tire pressure gauge in this hole. One end of the tubing is flattened, and a slot cut to fit around the valve nut. At the opposite end, a strip of sheet brass is riveted to form a toggle that takes a tight hold of the dust cap.

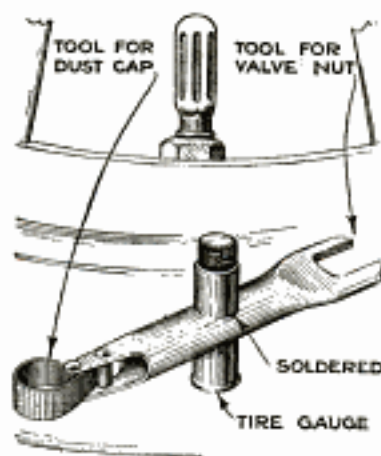

One end of the tubing is flattened, and a slot cut to fit around the valve nut. At the opposite end, a strip of sheet brass is riveted to form a toggle that takes a tight hold of the dust cap.

W. A. Luero

Pure Venetian red is the most durable color known for outside woodwork. If applied with pure linseed oil, it will last as long as the woodwork.

Moving Big Trees Economically

BY A. M. HUSTEAD

HAVING obtained a contract for moving several large trees from their original location to another, a landscape-service firm successfully accomplished the work without the use of special apparatus. For the transportation of a 16-in. hard maple, a trench was dug around the tree at a distance of about 4 ft. from the trunk and about 4 ft. deep, or to a depth sufficient to catch most of the surface roots. During the time the tree was being dug loose, it was well guyed to pre-

pulleys, cables and a check rope, to prevent a too sudden drop into the hole, as this might cause the ball to crack, with ultimate loss of the tree.

After the tree was in place, the dirt was backfilled, thoroughly tamped, and puddled in with a stream of water. It is of the utmost importance that the earth be well tamped around the ball and that no air pockets be allowed to form, as these are detrimental to root function, and will, therefore, retard the normal growth.



Showing the Method of Trenching around the Tree and the Appearance of the Root Ball: Many of the Feeder Roots are Cut in This Operation, and This Requires a Subsequent Thinning Out of the Branches



Above, the Tree being Dragged to Its New Location by a Motor Truck: The Root Ball must be Frozen So Solidly as to Avoid Splitting It or Losing Earth around the Roots. Left, Lowering the Tree down an Incline into the New Hole: A Check Rope around the Ball Prevents a Too Sudden Drop

vent it from falling over. The ball of earth around the roots was allowed to freeze until it could be moved without danger of cracking, or losing the earth from around the roots. When the ball was frozen sufficiently, the tree was tilted back and plank skids placed underneath; then, when the tree was "loaded," it was pulled out of the hole by means of suitable tackle and dragged to its new location by a truck.

The hole into which the tree was transplanted was dug with an incline from the bottom to the surface so that the tree could be slid into position by means of

In moving a tree, many of the feeder roots are necessarily cut off, and this will require thinning out the branches. From this particular tree two wagon loads of brush were removed without spoiling its original symmetry.

It is well to remember, when round holes are to be accurately sized, that the properly designed round broach has demonstrated its value for this work even in comparison with roughing and finishing reamers. The work is produced at a greater speed and a considerably lessened cost for tool maintenance.

A Simple Windmill Regulator

Many devices have been applied to windmill-driven pumps supplying water to tanks, to regulate automatically the operation of the windmill as the water in the tank becomes too high or too low.

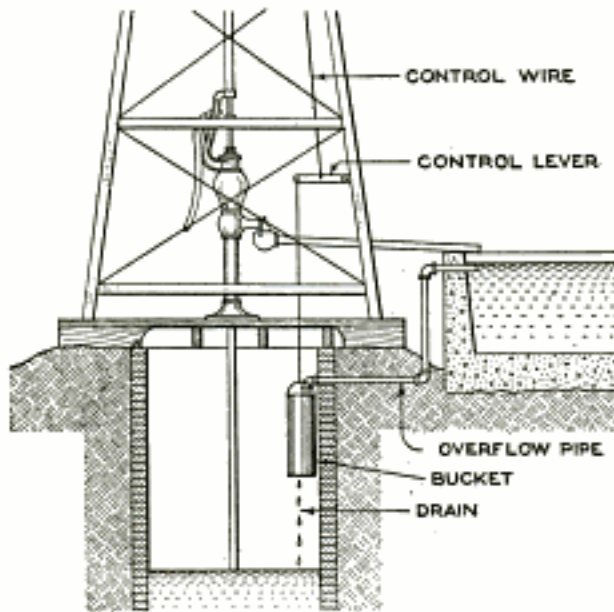

An Automatic Regulator for a Windmill-Operated Pump on the Farm That Keeps the Tank Filled with Water at All Times and Prevents Overflowing

Most of these arrangements are operated by a float or other device in the tank, and are easily rendered inoperative if the float leaks, or the mechanism rusts.

The arrangement shown in the drawing suffers from none of the shortcomings of floats. A 5-gal. cream can is suspended in the well from the end of the control lever by means of a strong wire. A small hole in the bottom of the bucket allows the water to drip out so that it is emptied about every three hours. As the weight is released, the pump clutch is automatically thrown in, and water is pumped into the tank until it reaches the level of the overflow pipe, which drains into the bucket; as the bucket is filled with water the pump is automatically disengaged, so that the container is prevented from overflowing.—S. E. Gibbs, Corydon, Ia.

Deodorizing the Glue Pot

Quite often the glue pot exudes an odor that is almost unbearable; this is often caused by bad glue, but more frequently by the brush. Copper-bound brushes are the most desirable, and, when quitting work for the day, they should be taken out of the pot and hung up until the next morning. Only a few minutes are required to soften up the brush, and

when treated in this fashion, all or most of the disagreeable odor will disappear. While in no way affecting the adhesive qualities of the glue, a few drops of some oil, like oil of sassafras, clove, wintergreen, or cinnamon in the glue pot, is very effective in purifying the vapor arising from the glue.

Repairing Grooves Worn in Shaft

When a ring-oiling box is found that continues to give trouble from heating, it is generally because one of the rings has stopped turning at some time and worn a groove around the shaft; this groove prevents the oil brought up by the ring from being properly distributed, and, of course, the bearing will not be lubricated. These grooves are not usually noticed until the machine is taken down for repairs of some sort, as they are not noticeable so long as the machine is in operation. If the box is oiled by hand, it will run properly, but if the rings are depended upon to carry the oil, the bearing cannot help but run hot.

When grooves are found in a shaft, particularly if the bearing is an important one, it is essential that they be repaired. Sometimes a new shaft may be put in, but to do this, the machine will often be shut down when it is most needed. Also, the shaft may be turned down small enough to eliminate

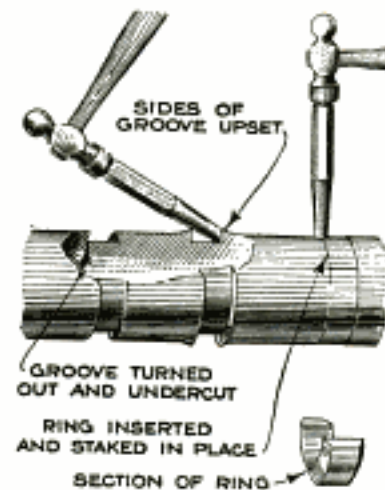

the grooves, but this makes a new bearing necessary, which is impossible in case the bearing is solid and a gear or pulley goes on the end outside the bearing.

Another method to bring the shaft back to its original condition in a short time is illustrated by the drawing. The grooves are squared out and slightly undercut, and a small punch is then used to bring the sides of the groove parallel by upsetting the metal above the surface of the shaft. A metal ring is turned up with beveled sides to fit into the dovetail groove in the shaft. The ring is sawed in half and the sections placed in the groove, the metal that was upset being staked

back in place to hold the ring securely to the shaft. If this operation is done carefully, the shaft will be the same size as before, and the ring can be turned to the exact diameter of the shaft, making it difficult to tell where the ring was applied. Small shims can be inserted to compensate for the metal removed when the ring was sawed. On very small shafts the ring can be held in place with solder, but this does not work so well on larger pieces.—James Ellis, Memphis, Tenn.

Calciminer's Brush Holder

A holder, permanently attached to the calcimine pail in such a manner that the brush may drip into the vessel,

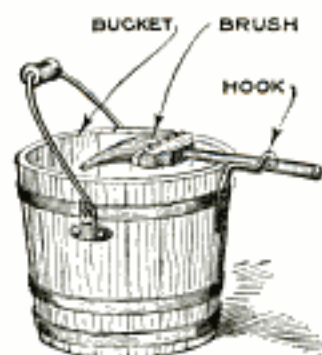

will prove of convenience to the workman. A hook is formed, as illustrated, from a piece of round iron, flattened at one end and attached to the bucket with screws, if a

wooden bucket is used, or with rivets, if a metal one. The handle of the brush rests on the rim of the pail and under the hook, where it may be instantly disengaged.—Jesse L. Blükenstaff, N. Manchester, Ind.

Making a Square from Scales

The drawing shows a convenient little clamp attachment whereby two ordinary machinist's steel scales can be converted into a square, or attached end to end to form a single long scale. The clamp is made from a block of flat steel, slotted to the desired depth to take the scales.

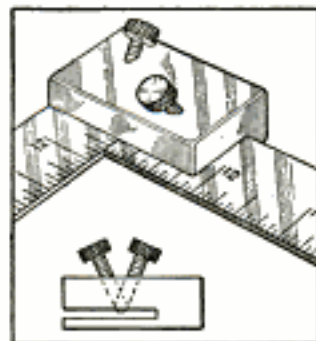

The ends of the thumbscrews are turned to a conical point of such an angle that the conical surface is parallel with the face of the scale. It will be seen that with the screws in this position, the action of tightening them rolls the edges of the scales together automatically. Both screws have right-hand threads and knurled heads.

Safety Device for Punch Presses

A manufacturer has designed and installed on his punch presses a safety device that forces the operator to use both hands to trip the press, thus making

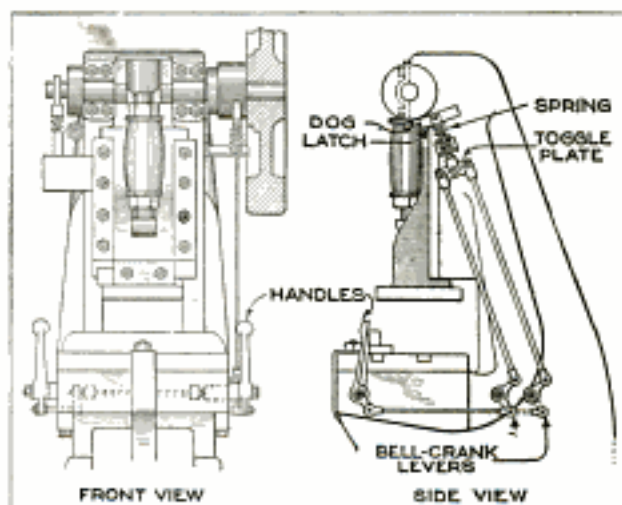

A Safety Tripping Device for Punch Presses, the Operation of Which Requires Both Hands, So That They cannot be Caught under the Descending Ram

sure that the employe's hands will not be under the ram when it descends.

The drawing shows the operating principle of the arrangement. A toggle plate, the center of which is connected to the tripping latch of the press, is controlled by rods hinged to each end. To cause the tripping lever to operate, both rods must move downward at the same time; if only one is moved, the toggle plate will turn about its center and impart no motion to the tripping latch.

Two cast-aluminum handles, one on each side of the press, are pivoted on studs screwed into the press bed. The motion of the handles is transmitted to the toggle plate by $\frac{1}{4}$ -in. cold-rolled steel rods and bell-crank levers. The handle at the left-hand side transmits its motion to the toggle through a $\frac{5}{8}$ -in. cold-rolled steel shaft extending from the left to the right side of the press. Slots are cut in the toggle plate where the connecting rods are attached, so that the operator will have to push both handles far enough to trip the latch.

This type of safety tripping device is considered more satisfactory than the air-operated device, as its action does not depend upon the use of air pressure, or any other agency but the control of the operator.—Edward H. Tingley, Dayton, Ohio.

Overprinted blueprints can be bleached by flowing very hot water over them.

Holder for Crankcase Bolts

An improvised spring holder, that facilitates the removal or insertion of the crankcase bolts on certain types of automobiles, is shown in the drawing.

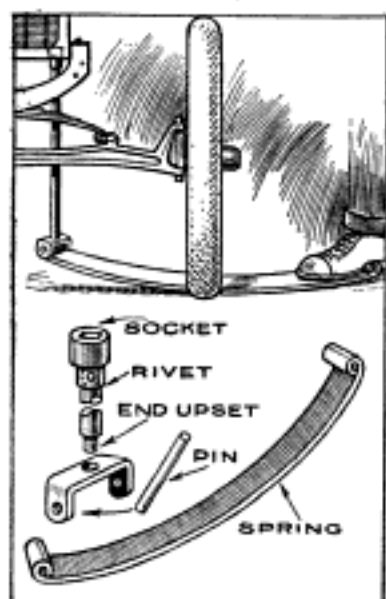

With such a tool, the bolt is prevented from turning, while both hands are free to place the nuts and washers in position and screw them down. There is nothing complicated about the device, which consists of a wrench socket, of a size to

hold the bolts, fastened to one end of an iron rod, which is hinged at its opposite end to an old auto-spring leaf.

In use, the end of the spring is held down with the foot, and this holds the wrench over the bolt head until the nut has been screwed down from above.

Counterbore for Square-Bottom Hole

The drawing shows a counterbore that was designed to make a flat-bottom hole in a case where a teat projecting from the bottom of the hole, as left by the ordinary flat-end drill, was not permissible.

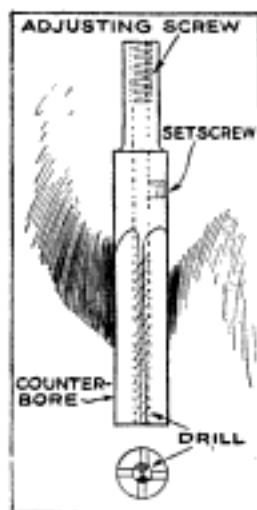

Usually, with a tool of this character, considerable trouble is encountered in keeping it sharpened, when it is made in one piece, as there is no clearance at the center. In the tool illustrated, a hole is drilled axially to accommodate a small drill, held in place by a setscrew, the thrust and compensation for wear on the drill being cared for by the adjusting screw in the top. It is no great trick to grind a drill to cut a square bottom, and the clearance necessary to grind the body is provided by the axial hole.—John Homewood, Ontario, Calif.

Speed of Conveyor Belts

The National Safety Council recommends the following speeds for belts conveying loose material, such as grain or sand: for belts under 16 in. wide, a maximum speed of 300 ft. per minute, while 450 ft. per minute should be allowed for belts of from 16 to 24 in. in width. For belts wider than 24 in., a speed of 600 ft. per minute is permissible. Belts carrying packages are generally run no faster than 60 to 100 ft. per minute.

Price and Quantity Dial Calculates Cost of Fuel to Motorists

A garage proprietor selling gasoline to motorists has installed the calculator shown in the drawing on his gasoline-measuring pump, saving his own time and that of his customers.



tained on cooling, but if the material is subsequently softened by heat it will return to its original form. In machining it, the tool must be sharp, and to prevent overheating, the cut must not be too heavy. If the tool and the work are not kept cool, the former will rapidly lose its edge and the work will be burnt. In polishing ebonite, the surface should first be rubbed smooth with powdered pumice and then buffed, using a tripoli compound, and running the cloth polishing wheel at high speed, the work being held lightly against the wheel. In making ebonite, sheet-metal foils are used as a backing for the plastic material during the process of vulcanization, and this gives the finished sheets their well-known glazed appearance. Owing to the fact that this surface is slightly metallic it should be removed when the material is used for electrical work, else the insulation will be low, owing to surface leakage.

Battery Service-Station Aid

The arrangement shown in the drawing is one of the labor-saving features of a

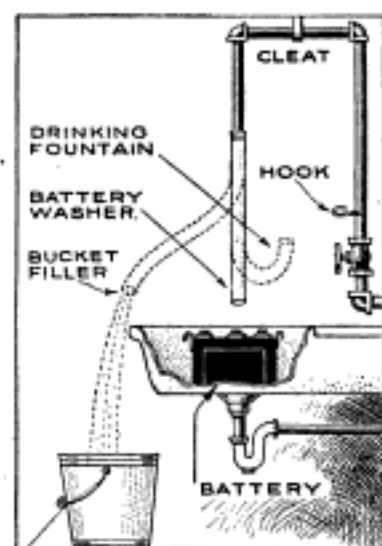

well-planned storage-battery service station. The valve is fitted close to the wall, and from it the water-supply pipe is run overhead to a point about the center of the sink. A short vertical piece of pipe has a length of rubber hose attached to it, as in the illustration. When washing out battery cells, the hose can be swung to any angle. Other conveniences of this arrangement are that the hose can be used as a drinking fountain, or to fill buckets, as indicated by the dotted lines.

☞ To remove a bolt that is "set" or "frozen," or that one has reason to believe cannot be driven out, use as large a wrench as can be handled and tighten down the nut, even if it twists off. This will stretch the bolt and reduce its diameter slightly so that it can be driven out with comparative ease.

Bending Large Sheets of Metal

In a case where several large galvanized-iron tanks were to be made, they were so large that two full-sized sheets of metal were required for the sides and bottom. These pieces had to be bent at right angles for their entire length and the ends riveted together on the bottom.

The problem was to bend these sheets to leave a square corner. To start at one end and bend as the work went along was first tried, but it was found that the metal stretched and warped, so

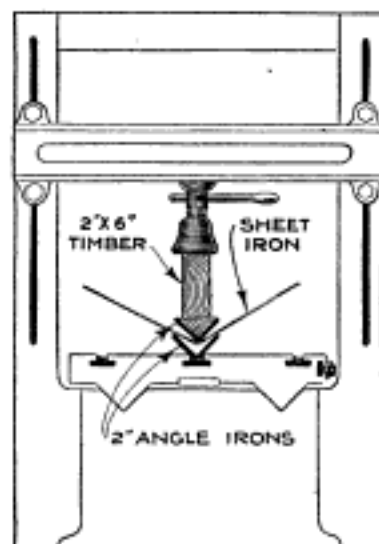

that this method would not answer. The planer was then rigged up as an angle press, and the results were perfect.

Two pieces of 2-in. angle iron were cut to the length of the sheet metal. One length was placed in the T-slot of the planer table and the stock laid on this. A triangular piece of wood was nailed to a 2 by 6-in. timber, 6 ft. long; this was placed on the second angle-iron strip, and a screwjack fitted between it and the crossrail of the machine. By turning the jackscrew, the sheet of metal was bent for its entire length in one operation, and no kinks were formed.—Edwin J. Bachman, Fullerton, Pa.

Drilling Tile

A contractor discovered that one of his men was drilling holes in tile bathroom fixtures about four times as fast as the other workers. Asked to explain his method, the worker demonstrated how cut nails were used in place of the ordinary twist drill. He filed the heads of two nails so that the nails would lie close together, and put them into his brace as he would a drill. He started the hole with the point of a screwdriver, or similar tool, and then applied the nails, which penetrated into the tile much faster and with less loss than the twist drill. When the nails become dull, they are thrown away and a new pair inserted.—Armstrong Perry, New York City.

Valve Grinder Made from Hand Drill

If an old hand drill, or breast drill, of the type in which the spindle runs up

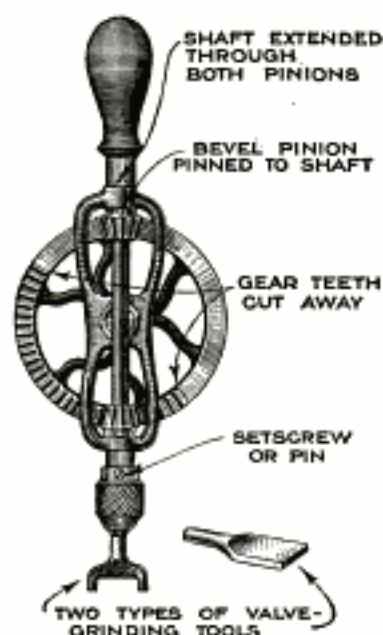

through both bevel pinions and into the handle, can be obtained, it may be converted into a tool suitable for valve grinding. The gears are removed and the upper pinion pinned to the spindle. Then, over half of the teeth on the bevel gear are filed or ground off down to the root depth; a smooth surface should be

left even with the roots of the teeth to bear against the upper pinion. Enough gear teeth must be removed to prevent interference of one pinion with the other; that is, they must clear one pinion before starting to mesh with the other. As the spindle will now continually reverse its motion as the operating handle is turned, the drill chuck is likely to loosen, so it must be pinned or setscrewed, or removed altogether, and the valve-grinding tool be fastened directly to the end of the spindle.

Using Wood Alcohol

Great caution should be observed in the use of any mixtures containing wood alcohol. This is the most deadly poison used in daily commerce; one teaspoonful has been known to cause blindness, and one ounce, death. The poison may be absorbed into the body through the nose, mouth, or skin, so that even the inhalation of the fumes, or the contact of the liquid with the hands, or any other part of the body, may cause poisoning just as though the alcohol were taken into the system through the mouth.

Sudden blindness, with vomiting and abdominal pain, should always cause suspicion of wood-alcohol poisoning, and no time should be lost in having the patient treated by a physician.

Denatured alcohol should be substituted for wood alcohol wherever possible, as this has no ill effect on the system.

It has been suggested that, in establishments using quantities of wood alcohol, the word "methanol" be used to label the liquid, as this describes the product specifically, while removing the tempting suggestiveness of the word "alcohol." This term, of course, should be accompanied by the word "Poison," as, even though the temptation to drink the liquid might be removed, the danger from absorption and inhalation would still be present.

One Wrench for Two Taps

By using a supplementary double bushing, of the type shown in the drawing, and placing this in a standard tap wrench

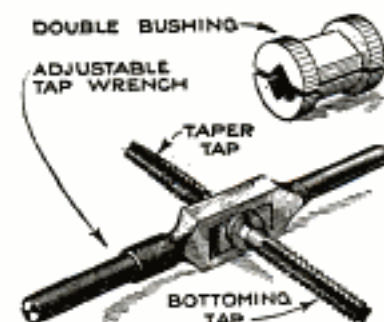

with an adjustable handle, two taps can be accommodated at one time. This is a very handy arrangement when a hole is to be rough

tapped. By using the taper tap to rough out the hole, it is only necessary to reverse the tool to complete the hole, using the bottoming tap. The bushing or holder can be made of any good grade of steel.

Gauge for Sharpening Gravers

It is a very difficult matter for users of gravers, such as those used in engraving metals, to get the correct cutting angle when sharpening them on an oilstone. This is so because the tool must be held at just the right angle, and not be allowed to rock. To overcome this difficulty, and, at the same time, make it possible to sharpen the tool at

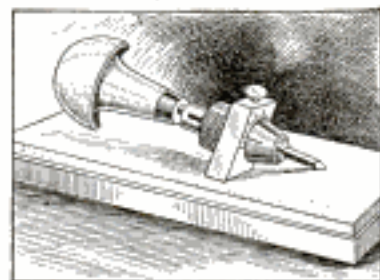

any desired angle, the tool shown in the drawing was made from a T-handle tap wrench. The handle was cut off, and a hole, large enough to accommodate the gravers, drilled along the axis of the wrench shank. A guide, made of steel, 1 in. square by $\frac{1}{4}$ in. thick, and beveled on one edge at the proper clearance angle for the gravers, was bored out to fit over

the nose of the chuck, to which it is held by a small thumbscrew, the chuck being first turned down parallel at the place where the guide fits. A zero line was scribed on the nose of the chuck, and the face of the guide graduated in degrees, as indicated.

In use, it is unnecessary to remove the graver from its handle, the tool being inserted through the hole in the center of the one-time tap wrench. The angle of the side faces of the cutting edge can be varied by loosening the thumbscrew on the guide and changing the position of the chuck with reference to the graduations on the block.—Charles E. Stark, North Attleboro, Mass.

Accurate Holes for Hinge Screws

In fastening a hinge to a door, or box, it is first necessary to drill small holes in the wood for the screws. The hinge is placed in the proper position and held there while one hole is marked off with a pencil. The hinge is then removed and the hole drilled, after which the hinge is replaced and a screw driven to hold it in place while the remaining holes are drilled, using the hinge as a template. In order to make this work a little more accurate, the device shown in the drawing was designed. It consists of an ordinary square-shank gimlet, or drill, of the proper diameter, with a spring sleeve on the outside. The sleeve is beveled at the lower end to the same angle as the countersink in the screwholes. Between the drill shank and sleeve, a spiral spring is placed; the pressure of this spring keeps the sleeve always in contact with the work so that the drilled hole is accurately centered.—Charles Homewood, Ontario, Calif.

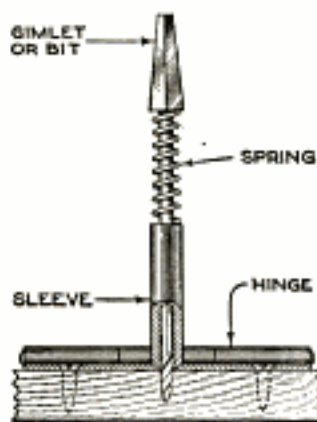

☛ An open flame should never be used for the purpose of discovering leaks in acetylene tanks. Leaks can generally be detected by the odor of the gas, and their location can be determined by applying soapy water to the surface of the tank, and watching for the bubbles formed by the escaping gas.

A Handy Riveting Anvil

Many riveting jobs require the work to be placed on an offset, to accommodate parts of the work while the rivets are being set, and this is particularly the case on channel iron and work of similar section.

An old automobile crankshaft can be utilized to make a very convenient anvil of this character, as indicated in the drawing, with very little trouble. The shaft is cut off between two crankpins and the cut face ground, or otherwise smoothed off, to provide a plane surface. The section is bolted to a suitable support by means of screws, or bolts, through the flywheel flange. An anvil of this type will prove a useful fixture in the garage for such work as relining brakes, repairing lamp casings, and other work where an opening under the face of the anvil is required.

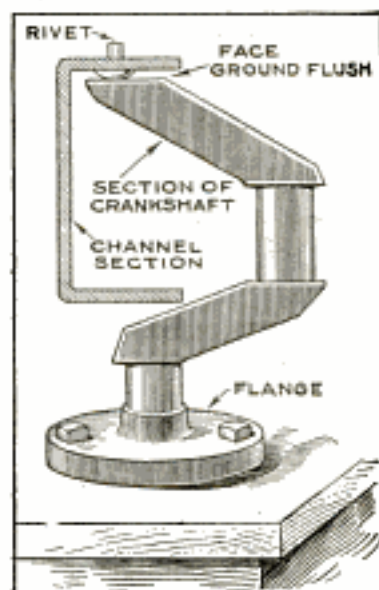

Rubber Trough for Acid Carboys

Acid carboys are bulky and difficult to handle unless they are mounted on some form of pouring device. If no device of this character is available, it is a very difficult matter to pour acid without more or less splashing and spilling, with resulting damage to clothing and surrounding objects. By using a suitable length of automobile inner tube as a trough to guide the acid, all the potential loss and damage can be prevented. A hole is cut into one end of the tube section to fit over the neck of the carboy, and the upper wall is cut away as shown, leaving the sides to guide the fluid into the receiving container.



Boiler-Compound Feeder

The steam boiler-compound feeder illustrated has features not possessed by the usual arrangement. A piece of large-

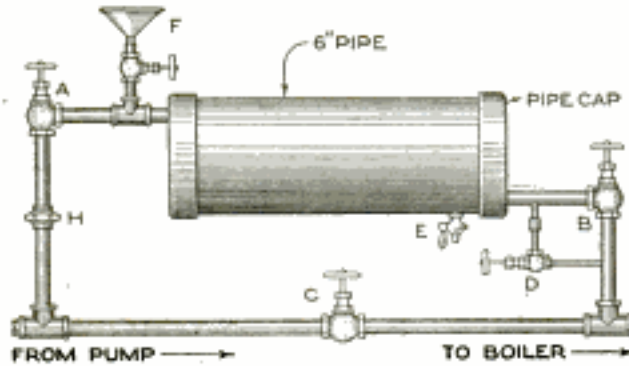

An Arrangement for Feeding Boiler-Compound Solutions into Steam Boilers with the Feed Water: The Supply of Compound can be Forced in as Fast or Slow as Desired by Proper Manipulation of the Valves

diameter pipe, closed at the ends with caps or flanges, is used as a receptacle for the solution. By opening the valves A and B and closing C, the pump discharge will be forced into the boiler, carrying the compound solution along with it. By leaving A and C open, B closed, and the $\frac{1}{8}$ -in. valve D slightly open, a slow feed of compound will be secured. It is nearly impossible to get a slow feed by leaving the valves A and B slightly opened. The tank can be emptied of water through the draincock E and filled with the compound through the valve F, the upper end of which is fitted with a funnel. Some engineers may prefer to have the union H located between the tank and valve B; a small union or right and left-hand coupling is used to connect the $\frac{1}{8}$ -in. pipes. The addition of a glass indicator on the tank, while not necessary, would be an improvement.

Hardened Hasp Staple Prevents Sawing

The staple of an ordinary padlock hasp is made of soft steel or iron, and it is usually an easy matter to saw it off and release the hasp; less trouble than to pry off the hasp or saw the lock. A way to prevent this is to make a special staple of drill rod, hardened and tempered, or of casehardened soft steel. If one is unfamiliar with casehardening, the use of drill rod is preferable, as this need only to be heated, quenched, and the temper drawn. The length of rod, which should be of the largest diameter that will pass through the slot in the hasp, is annealed, and each end is threaded. Old dies should be used if possible, as drill rod is hard on new

ones; the S. A. E. thread, as used by automobile repairmen, is preferable to the U. S. S., as less metal is removed.

Then the rod is bent to form the staple, heated bright red, and plunged into water. After testing for hardness with an old file, the piece is brightened up with emery cloth and again heated until the polished surface turns to a deep blue, when it is again plunged into water. If tempered correctly, the staple will be too hard to saw easily, but not hard enough to be brittle. After pushing the arms through the staple plate, nuts are screwed onto the ends and these are sunk into the wood beneath the plate.

Eyelets in Draftsman's Triangle

The draftsman's triangle can be arranged so that it is raised out of contact with the paper at each corner, thereby lessening the chance of blurred lines. A hole is drilled through the triangle at each corner; shoe eyelets, which can be obtained from any shoe repairer, are inserted in the holes, and heads are formed upon them. The short legs will keep the instrument from contact with the paper, but do not interfere in any way with its regular use.—C. B. Smith, Chicago, Ill.

Plane Handle Made Adjustable

The plane handle illustrated is made so that it can be pushed toward the adjusting nut to meet the requirements of different users. Ordinarily, the position of the handle with relation to the adjusting nut is such that it can be conveniently reached by only a few persons.

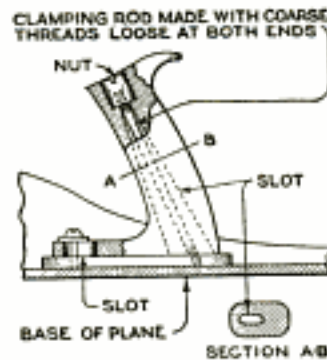

A tapered slot is cut into the handle, as indicated in the drawing. The clamping rod is made with a coarse thread at each end, and makes a loose fit in the nut and bottom of the plane. This makes possible an adjustment of the handle forward for the particular convenience of short-fingered users, or backward for the user whose fingers are long. The adjustment is made by loosening the nut, moving the handle the required distance in either direction, and retightening the nut.—M. E. Duggan, Kenosha, Wis.

material from electrical supply house



Amateur Mechanics

Information as to where to obtain any specified materials or parts for making objects described in the following pages may be had, on request, from our Bureau of Information.—Editor.

How to Make an Electric Hair Drier

By A. H. SCOTT

THE only parts of the electric hair drier illustrated that require to be made, are the blower and heating unit over which the air is driven to raise it to a temperature high enough for speedy drying.

Two pieces of sheet brass, as illustrated, will be required for the sides of the fan housing, as well as a strip of the same

half their width, as shown, are sufficiently rigid to stand without additional support. The combination blower and heater is held to the electric motor by strips screwed to the blower and to the motor shell.

To make the heating unit, obtain a porcelain insulating tube such as used in ordinary house wiring, with an out-

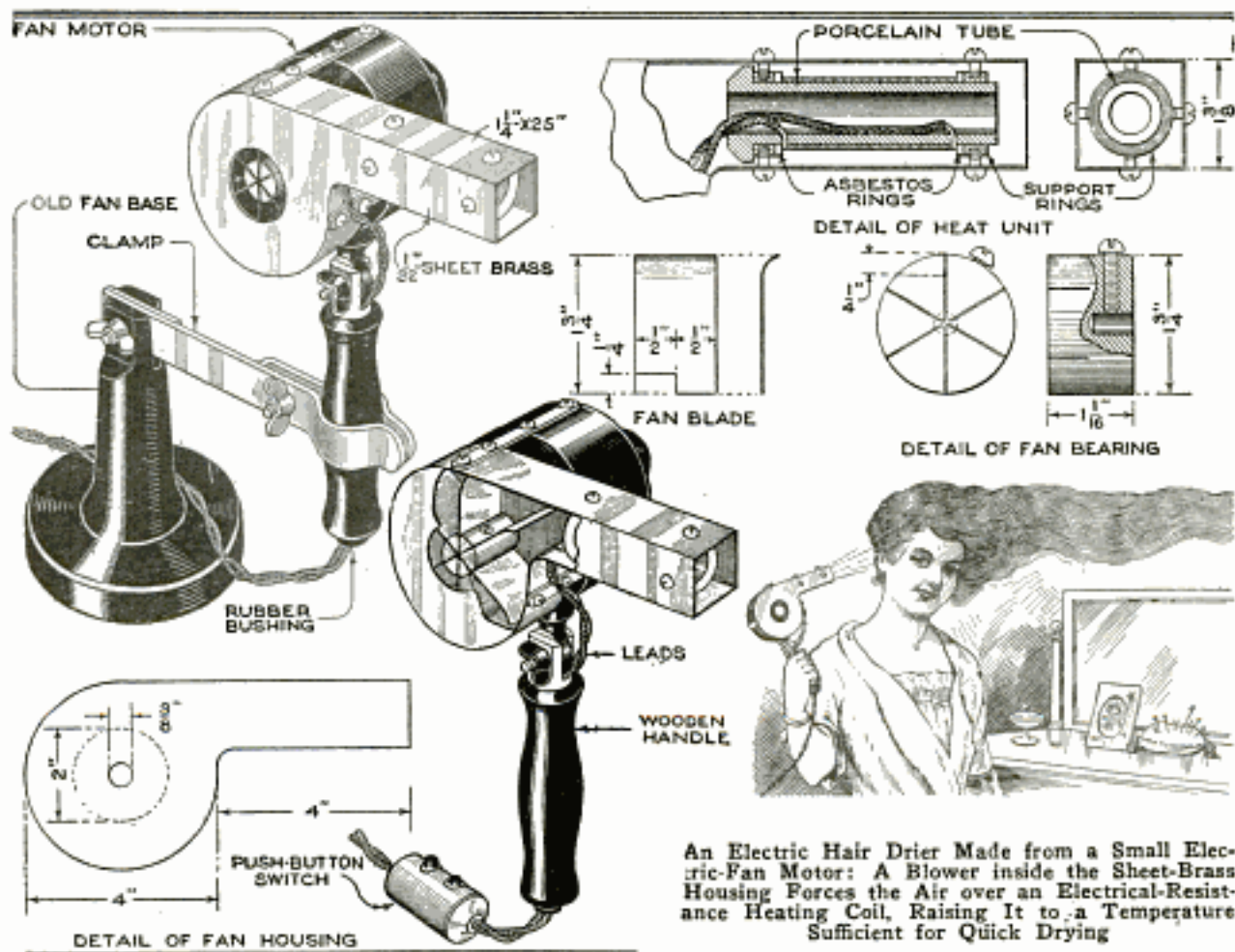

An Electric Hair Drier Made from a Small Electric-Fan Motor: A Blower inside the Sheet-Brass Housing Forces the Air over an Electrical-Resistance Heating Coil, Raising It to a Temperature Sufficient for Quick Drying

material to form the top and bottom. The fan hub, or bearing, is made from a piece of round brass or iron, slotted across one end to accommodate the six brass blades. The blades are soldered into the slots, and, although supported for only

side diameter of 1 in. This tube is cut off 3 1/2 in. from the shoulder end, and used as a core for 32 turns of .025-in. German-silver resistance wire. Wind the wire tightly so that there will be a space of 1/32 to 1/16 in. between turns, to prevent

short-circuiting. The ends of the first and last turns should be passed through $\frac{1}{8}$ -in. holes drilled through the tube. When drilling the tube, it should be plugged with wood and held in a vise, the jaws of which are protected with wood; an ordinary twist drill is used. The leads connecting the heating unit to the circuit must be asbestos-covered.

The heating unit should be centered out of contact with the blower housing. This is done with two brass rings, one at each end of the tube, cut from 1-in. brass pipe.

These rings should fit snugly over the ends of the porcelain tube and be insulated from the winding by asbestos washers. The rings are tapped at opposite sides to receive four machine screws.

When assembling the blower, care should be taken to avoid projecting screws that would catch the blades. The finished drier can be provided with a wooden handle, and this can be clamped to an iron base in the manner illustrated, so that it can be used either in the hand or upon a table.

A Japanese Table Lamp

The photograph shows a handsome Japanese-style table lamp, the principal parts of which, with the exception of the

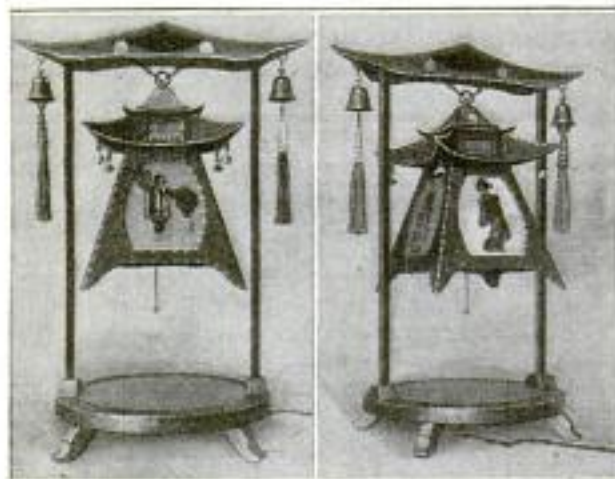

A Neat and Attractive Table Lamp Made in Oriental Style: The Principal Parts are Made of Sheet Metal

base, are made of sheet metal. The panels in the lamp shade are painted, in Oriental style, on opal glass, using transparent colors. The entire frame is painted and covered with sand while the paint is still wet, and the edges are touched up lightly with gold. The shade is wired for an electric lamp, the wires being conducted through the tubular supports and underneath the base; this is made of wood, and is supported above the table on short feet. The completed work can be decorated with small bells and tassels, as in the picture, to increase the Oriental effect.

—Louis Beagle, Los Angeles, Calif.

520 S Broadway
An Advertising Novelty

A novelty in window advertising, that will draw crowds, is very cheaply and easily made from a toy balloon.

The balloon, partly inflated, is fastened over an electric-light bulb in such a manner that air cannot escape at the point of

connection. A make-and-break socket, or some other means of opening and closing the circuit intermittently, is provided. When the current is turned on, the light transmitted through the thin rubber balloon will attract attention, and the heat from the bulb will cause the confined air to expand and distend the balloon. As soon as the circuit is opened and the light goes off, the air inside the sphere begins to contract and the balloon grows smaller. An advertising message can be painted on the balloon if desired.—Frederick C. Davis, St. Joseph, Mo.

Yoke Prevents Turkey from Straying

An Ohio farmer, whose turkey hen was continually wandering off with the young poults, devised the board yoke shown in the picture, which keeps the fowl from flying over or crawling through wire fences.



A board, about 6 in. wide and 18 in. long, of the lightest wood obtainable, was tied over the turkey's shoulders, an opening being cut in one edge of the board to conform to the outline of the back. The yoke was fastened to the bird by cords passing under the wings and across the breast.—C. M. Baker, Wooster, Ohio.

☛ A section of old inner tube, with one end cemented shut, makes a handy water pail for the motorist.

Antirattler for Windows

The flat-steel hair curlers that have taken the place of the familiar curling papers can be used to prevent a window from rattling. The curler is flattened out at the point where it is bent, and the resulting spring wedge is inserted between the window sash and frame.—Frank Jablencnik, Chicago, Ill.

A Trick "Letter"

Endless amusement will be obtained from the simple device illustrated, which

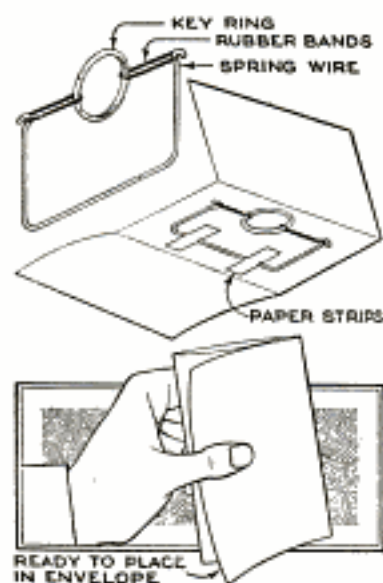

is attached to an ordinary sheet of letter paper, folded up and placed in an envelope. On opening the supposed "letter," the recipient gets something of a surprise when the ring revolves rapidly.

A U-shaped piece of spring wire is fastened to the paper by paper strips.

An iron washer, or ring of the type shown, is held across the open part of the "U" by rubber bands. In use, the rubber bands are twisted so that as soon as the letter is opened they begin to untwist and the ring to revolve, causing it to whiz and whirl as though there were something very much alive in the letter.

Using Broken Drain Tile

An outdoor stove can be made from a section of tile, for use in cooking feed, heating water, melting tar, and similar operations. A sheet-iron top, with a hole cut in it to accommodate a length of stovepipe, is provided to support the vessels. An opening in the form of an inverted "U" is chipped in the tile, at a point near the bottom edge, for the insertion of fuel.

The breakage of a small section from the flange of large-diameter sewer tiles makes them unsuitable for use in drainage systems, and they can easily be obtained by anyone wishing to use them.

Exhaust Cleans Down Spout

It happens frequently that birds' nests, leaves, and other debris collect in the eaves troughs and wash down into the conductor pipe. During a heavy rain the pipe may be so thoroughly clogged that a free flow of water to the cistern or drain is impossible.

As such obstructions are generally not accessible without a great deal of difficulty, the exhaust from an automobile engine can be used, with good results, to blow out the accumulated debris. The drawing shows how this is accomplished by connecting the rain spout to the exhaust pipe of the car with a piece of hose. By racing the engine, there will be sufficient pressure to eject all ordinary obstructions through the eaves-trough opening.—G. E. Hendrickson, Argyle, Wis.



A Print-Drying Stretcher

The commonest method of drying prints consists in the use of a cloth-covered stretcher on which the prints are placed face downward; as cheesecloth is used, there is more or less circulation of air on both sides of the print, which consequently dries very quickly and without the tendency to curl. As generally built, wooden frames are made and covered with cheesecloth, but these occupy considerable room. However, if a strip of cloth, of the length desired, is hemmed at the ends and pieces of broom handle inserted, as indicated in the drawing, the stretcher can be supported between two chairs, and rolled up into a compact bundle when not in use.—Harry G. Schultz, Teaneck, N. J.

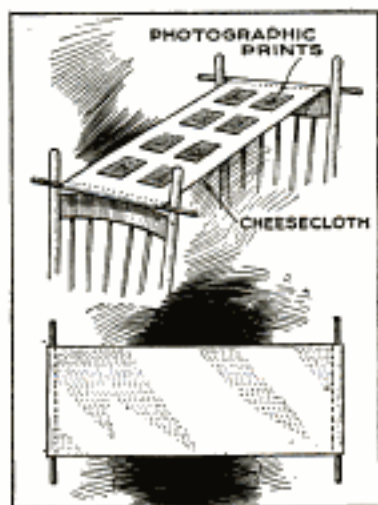

Indoor Baseball with a Penknife

A game of indoor baseball that depends for results more on pure luck than on skill, can be played with an ordinary

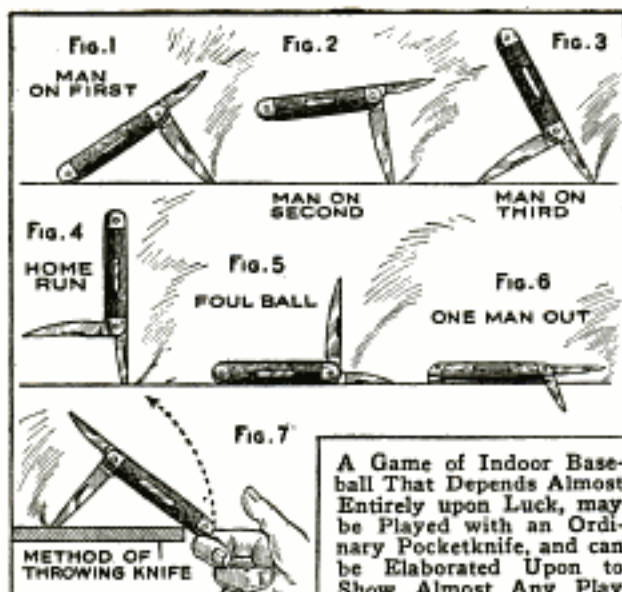

pocketknife having two blades that can be opened at right angles to each other.

The game is played on a board, or on an old table. Fig. 1 shows the position of the knife that gives the player a man on first base; when the handle is not touching the surface, as in Fig. 2, the player is on second, while to have a man on third, the weight of the knife must be resting on both blades, as in Fig. 3. A home run is scored for the player when the knife stands vertically as in Fig. 4, and the positions of the knife for a foul and a man out are shown in Figs. 6 and 7.

In playing the game, the knife is rested on the surface of the table in the manner shown in Fig. 7 and given a quick upward flip with the hand. Various other plays may be improvised with little trouble by the baseball devotee, so that the game can be made really elaborate.—W. S. Morton, Pasadena, Calif.

Incubator Used as Oats Sprouter

The value of sprouted oats as a green food for poultry has long been recognized, but the difficulty of obtaining or constructing an efficient sprouter has prevented many spare-time poultrymen from making use of the knowledge.

Any poultryman who owns an incubator that is not working during the winter months has at his command an efficient device for sprouting oats. The drawers are removed and extra strips are temporarily tacked to the sides of the

incubator, on which the trays containing the oats are placed. The trays are single wooden frames covered on one side with screen wire or burlap. About an inch of space is allowed between each tray to permit a free circulation of warm air.

The oats are moistened and placed in the trays and the incubator lamp is lighted and adjusted to maintain a temperature of about 75° F. To prevent the oats from drying out, pans of water should be placed on the floor of the incubator and the grain sprinkled each day.

If the various trays are filled at intervals of a day or so, the poultryman will have a constant supply of green food for his flock.

In placing the additional strips that are necessary for supporting the trays, very small brads or nails should be used, as there will be very little weight upon the strips, and their removal will not then be so likely to mar the appearance of the incubator.

Novelty Wood Turning

Specimens of wood turning containing rings that cannot be removed because they are smaller than the ends of the article to which they are attached, are turned out quite easily on the wood-turning

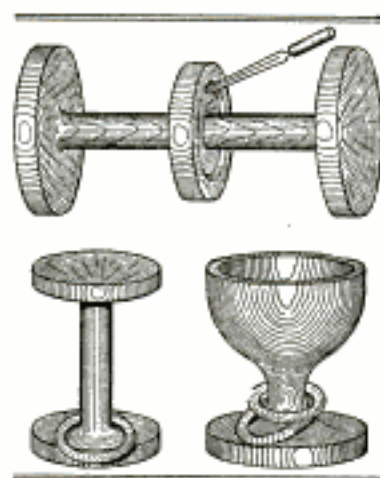

lathe, the illustrations showing two examples of this class of work.

The first operation is to turn the work to the desired shape, as shown, leaving a disk on the spindle. Next, sand and polish the disk as

though it were to remain there, and when this is done the ring can be cut from the disk in the manner illustrated. This is best done with a sharp-pointed tool, held at about the angle indicated in the drawing, cutting very slowly. When the ring is loose, the lathe must be stopped and the inner side smoothed with a file. The ring can be tied to the spindle where it will be out of the way, and one or more smaller rings can be turned off in the same manner, if so desired, or the remainder of the disk turned off flush with the spindle.—Victor Carl, Steubenville, Ohio.



UTILIZING NEW STEEL TRENCH HELMETS

Fruit Dish, Poultry Nest, and Umbrella Stand Made from Helmets

The three ideas illustrated in the large drawing, the fruit dish, poultry nest, and umbrella stand, were submitted by J. V. Romig, of Allentown, Pa.

The fruit dish is supported on feet, about 1½ in. long, turned from brass rod. These feet are inserted into holes drilled through the helmet, and riveted, the finished article being decorated in any desired manner, and then lacquered.

Parasites that infest wooden nest boxes refuse to have anything to do with metal nests. Consequently, by mounting trench helmets in the manner shown, the general condition of the flock will be improved. The steel nests are indestructible, and, having no corners or crevices, easily cleaned.

A trench helmet will make an admirable drip bowl for an umbrella stand. The frame is made from ½-in. pipe and fittings, of polished brass, nicked brass, copper, or painted iron. Holes are drilled in the rim of the hel-

met to slip over the pipe standards, where it is held in place with cotter pins. The small hole in the center of the crown may be plugged, so that, by removing the plug, water from the dripping umbrellas can be



Rats Kept Out of Corncrib by Helmets Nailed on the Posts

drained off without removing the helmet.

Helmets Keep Rats Out of Corncrib

Truman R. Hart, of Ashtabula, Ohio, who won the third prize of the contest with his idea of utilizing helmets for bird baths, also contributed another plan that makes use of them

for keeping rodents and other vermin out of corncribs and similar elevated storage bins. The idea involves nothing more complicated than capping each of the supporting posts with a trench helmet that has been drilled with two or three holes so that spikes can be driven through the plate into the post.

Fenceposts Preserved by Helmets

From saving the lives of soldiers on the battlefield, the trench helmets have been adapted by R. C. Leibe, of Chase



Helmets on Fenceposts Prolong Their Life

for keeping rodents and other vermin out of corncribs and similar elevated storage bins. The idea involves nothing more complicated than capping each of the supporting posts with a trench helmet that has been drilled with two or three holes so that spikes can be driven through the plate into the post.

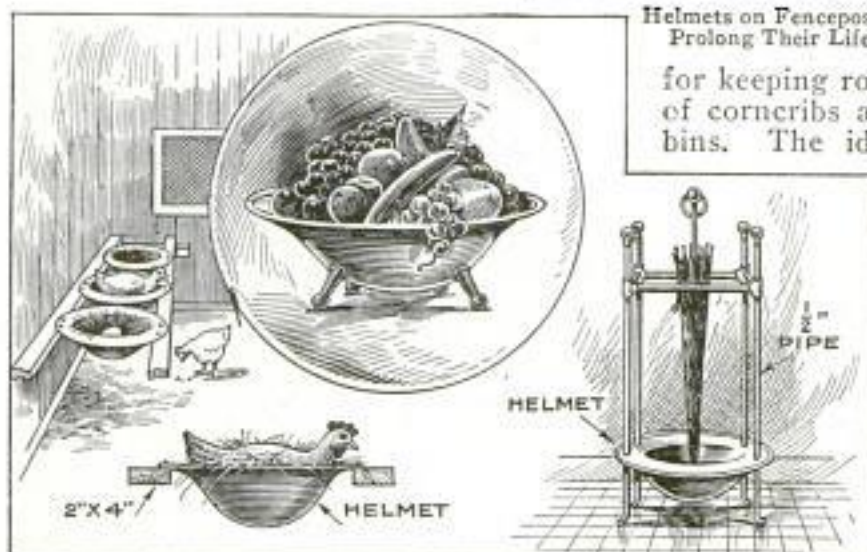

At the Left, the Helmets are Shown in Use as Sanitary Nests; in the Center, as an Attractive Fruit Dish; and at the Right, as a Drip Bowl for an Umbrella Stand

City, Va., to prolonging the life and usefulness of fenceposts on the farm. The drawing shows how each post is surmounted by a helmet that is held in place with a long spike. Naturally, this protection prevents water, that would cause the post to check and split within a comparatively short number of seasons, from coming into contact with the exposed end.

Trench Helmet as Charcoal Brazier

A rather original idea in which a trench helmet is used as a charcoal brazier in the kitchen stove



This Brazier will be Found Very Effective during the Summer

during the heat of summer, is the contribution of Roland B. Cutler, of Springfield, Vt. The crown of the helmet is perforated with $\frac{1}{4}$ -in. holes to permit circulation of air through the burning charcoal that is placed inside. In use, the helmet is set into one of the openings of the kitchen stove, and a grid from an oil or gas stove, resting upon a plate fastened to the rim, completes the arrangement.

A Helmet Drinking Fountain

From New Hartford, N. Y., Floyd A. Krenzer submitted his idea for making

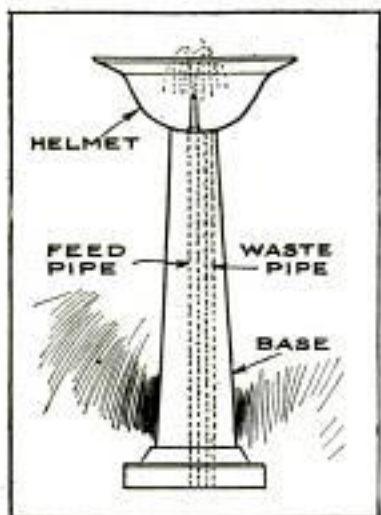

A Helmet Makes an Effective Drinking Fountain

a sanitary drinking fountain, using the trench helmet as a receptacle for catching the waste water. The water-supply pipe, with a suitable nozzle at its upper end, comes through the center of the crown, while the overflow is carried off by a waste pipe

that is arranged a little to one side of the center. The fountain is mounted on a pedestal, that can be made to correspond with its surroundings; in some instances, it might be found preferable to mount it on wall brackets.

Helmet for Stovepipe Cap

To prevent rain from blowing down a stovepipe chimney and causing it to rust to pieces rapidly, Anthony Jacobucci, Philadelphia, Pa., suggests that the army trench helmet be used as stovepipe caps in the manner shown in the drawing. A strip of flat, stiff iron is riveted around the stovepipe as a reinforcement for helmet-supporting braces, which are riveted to it and the helmet. Not only does a cap of this kind prevent entrance of rain, but, as the helmet is somewhat larger in diameter than the stovepipe, there is slight possibility of a down draft blowing the smoke out into the room below.



A Helmet Cap on the Stovepipe Prevents Rust and Down Draft

A Neat Sewing Stand

Arthur Gulbranson, of Chicago, Ill., has fashioned from a trench helmet a very substantial addition to the sewing equipment of the feminine portion of his family. As the photograph shows, feet of $\frac{1}{8}$ by 1-in. annealed brass strips, are riveted or soldered to the crown of the helmet. A combined spool rack and scissors holder, of the same material, is soldered in place, $\frac{3}{8}$ by $\frac{7}{8}$ -in. brass pins being soldered to the crossbar to hold the spools. This crossbar has small projecting ears passed through slots in the side-pieces, soldered in place, then scraped bright. A clip and socket for the scissors are also soldered to one of the side-pieces, and a small brass pin, soldered to the top of the rack,



A Substantial and Attractive Helmet Sewing Stand

makes a convenient holder for a thimble. The helmet and fittings were rubbed to a high polish with fine emery cloth and then lacquered, completing a very useful and substantial piece of work.

Trench-Helmet Washing Machine

A washing machine that can be operated by hand, or driven by electric motor, is the plan of Edwin J. Bachman, of Fullerton, Pa. He already has the hand-power machine in successful operation but plans to "motorize" it, so that it will be driven by a $\frac{1}{4}$ -hp. electric motor. The hand-power machine is simplicity itself and consists of nothing more than a lever to which the trench-helmet vacuum plunger is attached. The hand lever is fastened to the top of the wringer by means of a bolt, wingnut, and spring, while the plunger with the trench helmet attached to its lower end swings freely on the hand lever, so that the former is always in a perpendicular position. If electric current and a $\frac{1}{4}$ -hp. electric motor are available, it requires but little additional effort to make the motor do the work by following the arrangement shown in the drawing, the most important part of which is the gear and lever arrangement for reducing the speed of the motor and transmitting the motion to the helmet. The lower lever is slotted to fit over a crankpin in the larger gear; the center of the worm wheel must be directly below the center of the helmet, and the pivots on the slotted lever directly in line with those on the hand lever. Then, with the pin in the worm wheel 2 in. off center, the

stroke of the plunger will be 4 in. It will be observed that with such an arrangement there will be more or less swinging

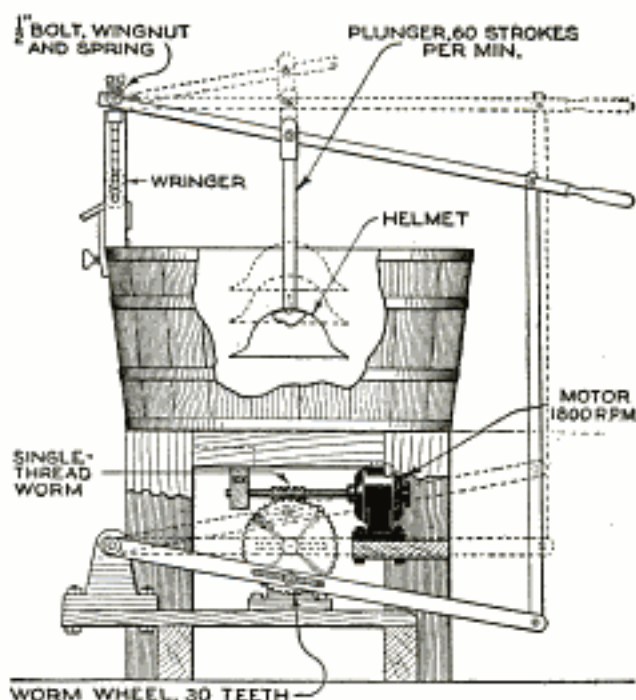

A Helmet Used as a Vacuum Plunger for a Washing Machine: The Drive Shown Is Only a Suggestion, and may be Modified in Any Desirable Way

of the plunger, whether operated by hand or power, but this is desirable because it permits the plunger to come down at a different point in the tub at almost every stroke.

Driving Well Pipes

Where water at slight depths below the surface is found suitable for household purposes, the most practical and inexpensive method of sinking a well consists in driving a screened drive point into the earth. After boring a few feet below the surface, place the pipe, with the point attached to the lower end, in the hole, and drive it down until the flow of water is reached.

In order to drive the point to the desired depth, much care is needed to avoid injuring the pipe threads. To make the work simple, and a one-man job, the hammer shown in the drawing can be used with excellent effect.

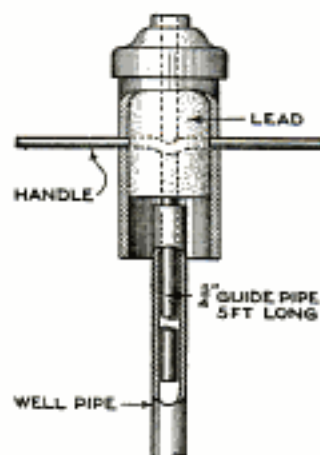

The $3\frac{1}{2}$ -in. diameter brass shell of an old pump cylinder was obtained, although a similar piece of pipe with a cap over one end will answer as well. Holes were drilled through opposite sides, large enough for a piece of $\frac{3}{4}$ -in. iron rod to serve as a handle. A piece of $\frac{3}{4}$ -in. pipe, about 5 ft. long, was screwed into the cap on the end of the pump cylinder, as in the drawing. The hammer was weighted by filling the interior with 12 lb. of melted lead. In use, the pipe guide is inserted inside the well pipe, and the hammer is lifted and allowed to drop, forcing the point deeper into the earth at each stroke. —Geo. G. McVicker, North Bend, Neb.

Typing to the Bottom of Sheets

When typewriting on postcards and envelopes, one often has occasion to write to the very bottom, but finds this impossible because the work slips out from under the feed roller. This trouble can be overcome, in most instances, by attaching the upper edge of the work to a somewhat larger sheet, with paper clips.

An Oscillation Transformer

The oscillation transformer is an important part of an efficient radio-trans-

mitter without undue heating at the gap, as experienced with the old-style helix. The pancake transformer has made possible some remarkable records in amateur stations and nearly all of the record holders use it.

The woodwork may be any variety of wood, stained and finished to the satisfaction of the maker; poplar or birch will be found easy to work, and will take a mahogany finish well. The base and uprights are cut to the dimensions given, and assembled with $1\frac{3}{4}$ -in. wood screws, driven through the bottom of the base. The brass rod is threaded and provided with a washer and nut at each end. Two wooden disks are screwed to the back of both primary and secondary crosspieces with 1-in. screws, and the crosspieces are slotted to take the required number of turns of ribbon.

This ribbon may be of either copper or brass, about $\frac{1}{16}$ in. thick by $\frac{3}{4}$ in. wide; it may be made up from a number of short pieces soldered together, or bought in one length, from any dealer in radio supplies. Clamps, in the form of light wooden strips, for holding the turns in place are fastened over the slots, so that there is no possibility of the ribbon working out of position. A binding post may be used at each outside ribbon terminal if desired, the lead wires to the condenser and aerial being soldered to standard helix clips, or clips can be used at all points. The clips from an old knife switch make ideal contacts.—F. L. Brittin, Chicago, Ill.

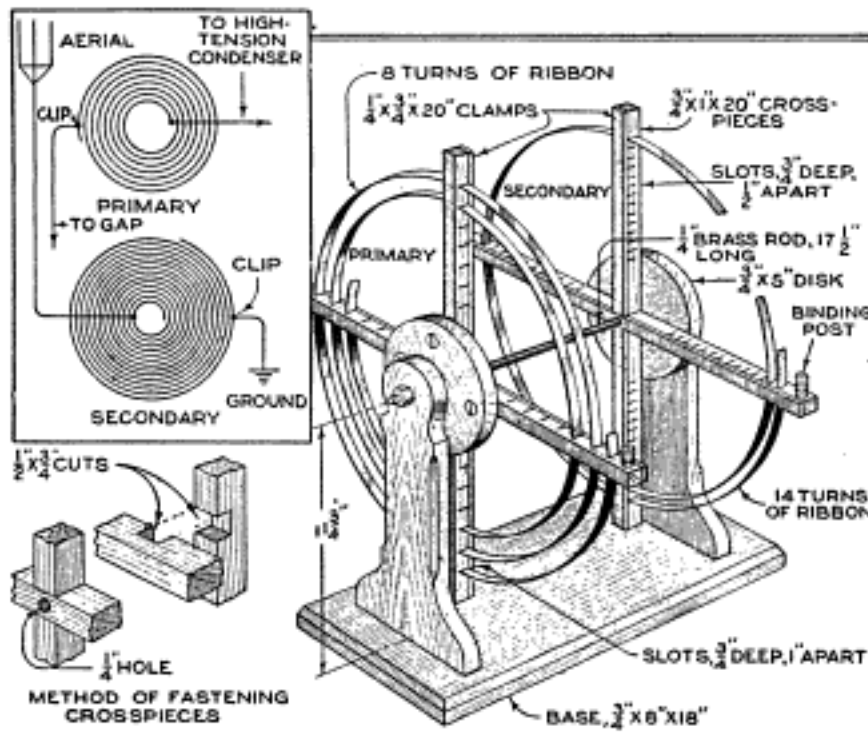

A Simple and Easily Made Oscillation Transformer, of the So-Called "Pancake" Type: All Material, with the Exception of the Ribbon, can be Picked Up around the Radio Laboratory

mitting set, and there are many types on the market; the best kind, for all practical purposes, however, is the so-called "pancake" type. This transformer is simple to make and inexpensive. The advantages of this type of transformer over the helix type are many, as it permits either direct or inductive coupling, insures a pure and sustained wave that can be sharply tuned at the receiving station, and cuts out interference. All parts of the winding are accessible to the clips, the primary and secondary slide along a horizontal brass rod that makes quick changes in coupling possible, and the full energy of the transmitter can be utilized

either copper or brass, about $\frac{1}{16}$ in. thick by $\frac{3}{4}$ in. wide; it may be made up from a number of short pieces soldered together, or bought in one length, from any dealer in radio supplies. Clamps, in the form of light wooden strips, for holding the turns in place are fastened over the slots, so that there is no possibility of the ribbon working out of position. A binding post may be used at each outside ribbon terminal if desired, the lead wires to the condenser and aerial being soldered to standard helix clips, or clips can be used at all points. The clips from an old knife switch make ideal contacts.—F. L. Brittin, Chicago, Ill.

Using Old Engine Valves

Gas-engine valves, with bent stems or warped heads, can frequently be salvaged from the scrap pile and put to further use for other purposes. Recently, in placing a concrete garage floor, the metal channel in which the doors slid was bolted down by imbedding a number of old valves in the plastic concrete, head down; of course, lining them up with the holes in the channel and threading the stems. These served as efficient anchors, as the

mushroom-shaped heads caught a firm hold in the cement. As a tube-patching fixture, a motorist inserts the stem of an old valve into a hole in his workbench. The tube to be patched is placed over the convex head of the valve, and the patch is made in the usual manner. In another instance, a similar valve was converted into a tail-lamp bracket by bending and threading the stem and drilling holes through the head so that the fixture could be bolted to the car; the head, in this case, was ground flat.

Waterproofing Rope Clotheslines

In order to make a rope clothesline waterproof and resistant to atmospheric influences, treat it in the following manner: Make two separate solutions, the first consisting of 1 lb. of soap dissolved in 5 qt. of water; the second is made by dissolving 1 lb. of ordinary alum in the same quantity of water. The soap solution is heated to about 120° F., and the rope immersed in it until the fibers have been thoroughly soaked; it is then removed, wiped free of superfluous solution, and transferred to the alum bath, in which it is allowed to remain for about 30 minutes, then taken out, and the excess solution wiped off.

This process impregnates the fibers of the rope with a soap that is insoluble in cold water, making it quite waterproof.

A Whistling Arrow

An arrow that will give a sharp and piercing whistle, when shot into the air, the tone rising and falling with the speed

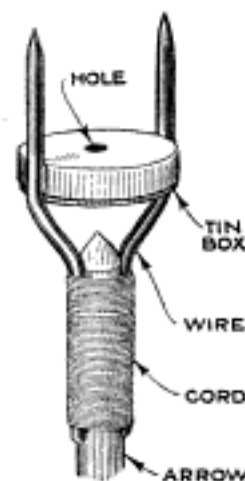

of the missile, is made as shown in the drawing. Two stout-wire prongs are bent as indicated and tightly bound to the shaft, the distance between the points being about 1 in. A small round tin box, of corresponding diameter, is obtained, and a hole, about $\frac{1}{8}$ in. in diameter, is drilled through the center, care being taken to remove any burrs or rough edges that might be around the holes. The box is placed between the prongs, to which it is held by soldering.—A. R. Mutton, Waterloo, Ia.

Hanging Pictures Straight

When framed pictures are always getting crooked, the appearance is far from pleasing, and the effect is annoying. To overcome this "shiftiness" of pictures, first hang the picture with its face to the wall. Adjust it so that it is hanging perfectly straight and then turn it around. The single twist in the cord or wire is usually sufficient to prevent it from slipping on the nail or hook from which it is suspended.

Guard for Flowerpot Stand

When flower stands that support potted plants are exposed to sudden gusts of wind, the plants are often blown from the shelves, with consequent damage to the plants and pots, and, also, in some cases, to the surroundings.

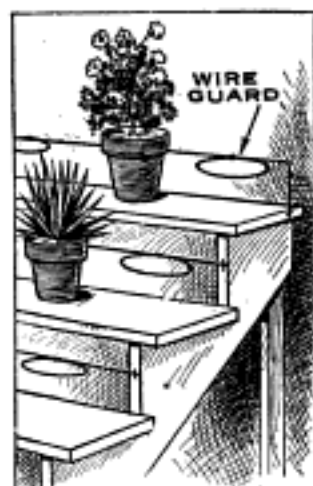

The drawing shows a neat and safe method of preventing the plants from being easily displaced. A piece of stiff iron wire has a number of loops formed in it, the ends being attached to the stand at such a height that the loops will fit the pots just underneath the shoulder.—Truman R. Hart, Ashtabula, Ohio.

An Oil-Burning Coal Stove

A resident of the Pacific coast, having on hand a kerosene burner and fuel tank, changed his wood and coal heating stove into an efficient oil-burning heater with but little trouble or cost. A burner, which was of

the vapor type, with a disk above the flame, to deflect it horizontally, was set on the stove grate. A hole was then drilled through the side of the stove to admit the fuel-supply pipe. As the heater was used in the dining room,

the feed pipe was passed through the partition into the kitchen and connected to the tank, which was supported on a shelf, as indicated in the drawing. A "gooseneck," made in the stovepipe by the use of four elbows and short lengths of pipe, permitted the escape of odors while reducing the waste of heat ascending the chimney.—Edwin M. Love, Alhambra, Calif.

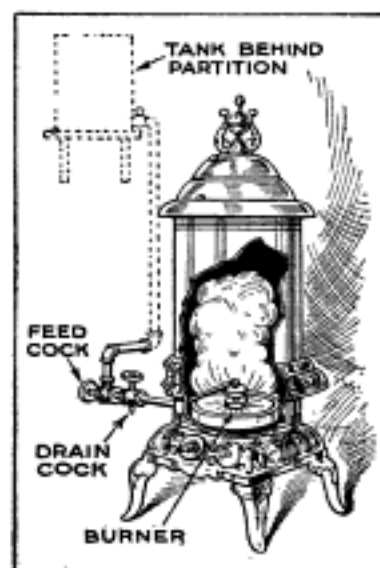

As the heater was used in the dining room, the feed pipe was passed through the partition into the kitchen and connected to the tank, which was supported on a shelf, as indicated in the drawing. A "gooseneck," made in the stovepipe by the use of four elbows and short lengths of pipe, permitted the escape of odors while reducing the waste of heat ascending the chimney.—Edwin M. Love, Alhambra, Calif.

809 N. Stoneman Ave

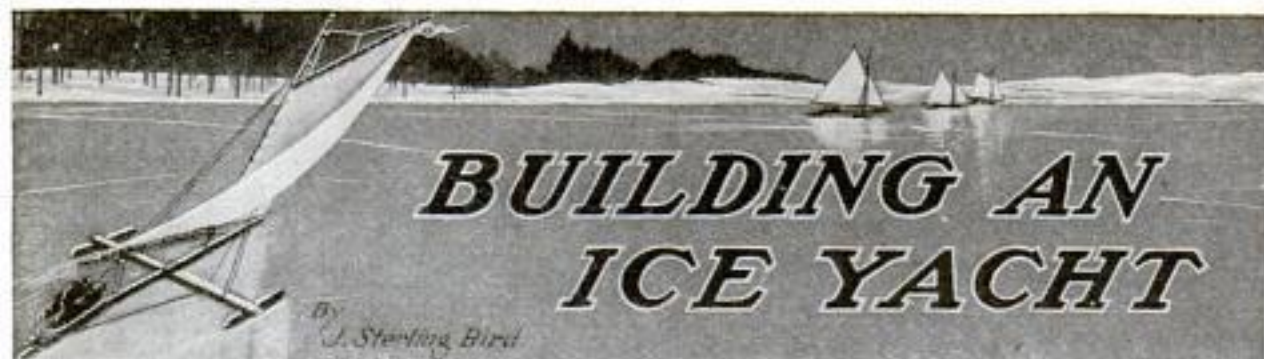

Part II—Spars, Rigging, and Assembling

ONLY the best grade of spruce is suitable for spars. Unquestionably hollow ones are lighter and stronger, but they cost a lot more. If expense is no objection, buy hollow spars, otherwise proceed as follows: For the mast select the clearest 4 by 4-in. stick to be found; for the boom and gaff a 3 by 3-in. stick, and for the jib boom, a 2 by 2-in. piece. Plane the stick for the mast fairly smooth on all four sides, then lay off a taper from a point 6 ft. from the foot, reducing the diameter to 3 in. at the heel. Plane all four sides, still keeping the stick square. From a point 5 ft. from the masthead, taper to 2½ in. Plane off all four corners, making an octagonal stick; then, with a small plane, round the spar, and finish with enough sandpaper and elbow grease—especially the elbow grease—to remove all plane marks. If any attempt is made to round the spar before tapering, it will be found impossible to keep it straight. A brass or iron ferrule, 2 in. wide, is fitted to the foot to prevent splitting, and a mortise cut to receive the mast step. Shroud cleats of apple wood or maple, of the form shown, are screwed at the points indicated, and the throat-halyard bracket and eyebolts put in place. The boom and gaff are identical in construction with the mast. The boom tapers to 2 in. at either end, with a large hole through the after end for the sail haul-out. The gaff tapers to 1½ in. at each end, with a haul-out hole at the peak, and oak jaws, fitted with a throat block, riveted at the throat. It is best to buy the jaws from a ship chandler. The jib boom is not tapered, but is rounded, and the jaws of the jib-boom shackle are riveted in place. The bridle cleats for the boom and gaff are similar to the shroud cleats, but smaller.

Wherever possible, brass or bronze should be used for fittings, although iron will do. The detail drawings show the masthead fly, throat-halyard bracket, and the two guy irons so plainly that no description is needed. The jib traveler is of ¾-in. rod, riveted and brazed to a ¼-in. plate. Ten-penny nails make excellent

cross pins for the traveler; the object of these is to prevent the sheet block from slipping around to the underside of the traveler. The two members of the mast step are also riveted and brazed. The dolphin striker is of ¼ by 1-in. stock, with a half section of pipe brazed in the lower end of the "V." The jib-boom shackle is all brass, with the end hole threaded to fit the forestay turnbuckle. The gammon-strap set cannot be made until the backbone and runner-plank parts are in place. It will probably be found advisable to cut strong paper patterns of the gammon straps for the blacksmith or machinist to work from. The bolts on the straps are riveted and brazed to the flat iron. Unless cast of bronze and turned, the rudderpost must be forged by a first-class blacksmith, it being a somewhat difficult piece of work. It is fitted with a soft-rubber bumper, which greatly relieves the shock of sailing over rough ice. Of course, the tiller must be fitted to the post so that there is no lost motion. The handle is wound with cotton cord, filled with shellac, and varnished. Plates may be used in place of the rudderpost bushings, but will soon wear, and will, in turn, wear a groove in the post, so that bronze or cast-iron bushings, of the form shown, are well worth the extra expense, as they will last forever.

As there are a number of first-class sailmakers who specialize on ice-yacht sails, one of them should be selected, and the sail plan sent to him when placing the order. Yacht twill will make strong, durable sails at a low price, but the better grades of sailcloth are more satisfactory. In giving the order, the fact that the sails are for an ice yacht should be mentioned, together with the following specifications: jib to have snap hooks for forestay, and be made to lace to the boom, or the foot will be cut as for a sailing yacht. Mainsail to have thimbles in pairs on hoist for mast-hoop lacing, and single thimbles on foot. Otherwise leave it to the sailmaker. He knows.

The cockpit cushions are made of good-quality ticking, covered with corduroy or

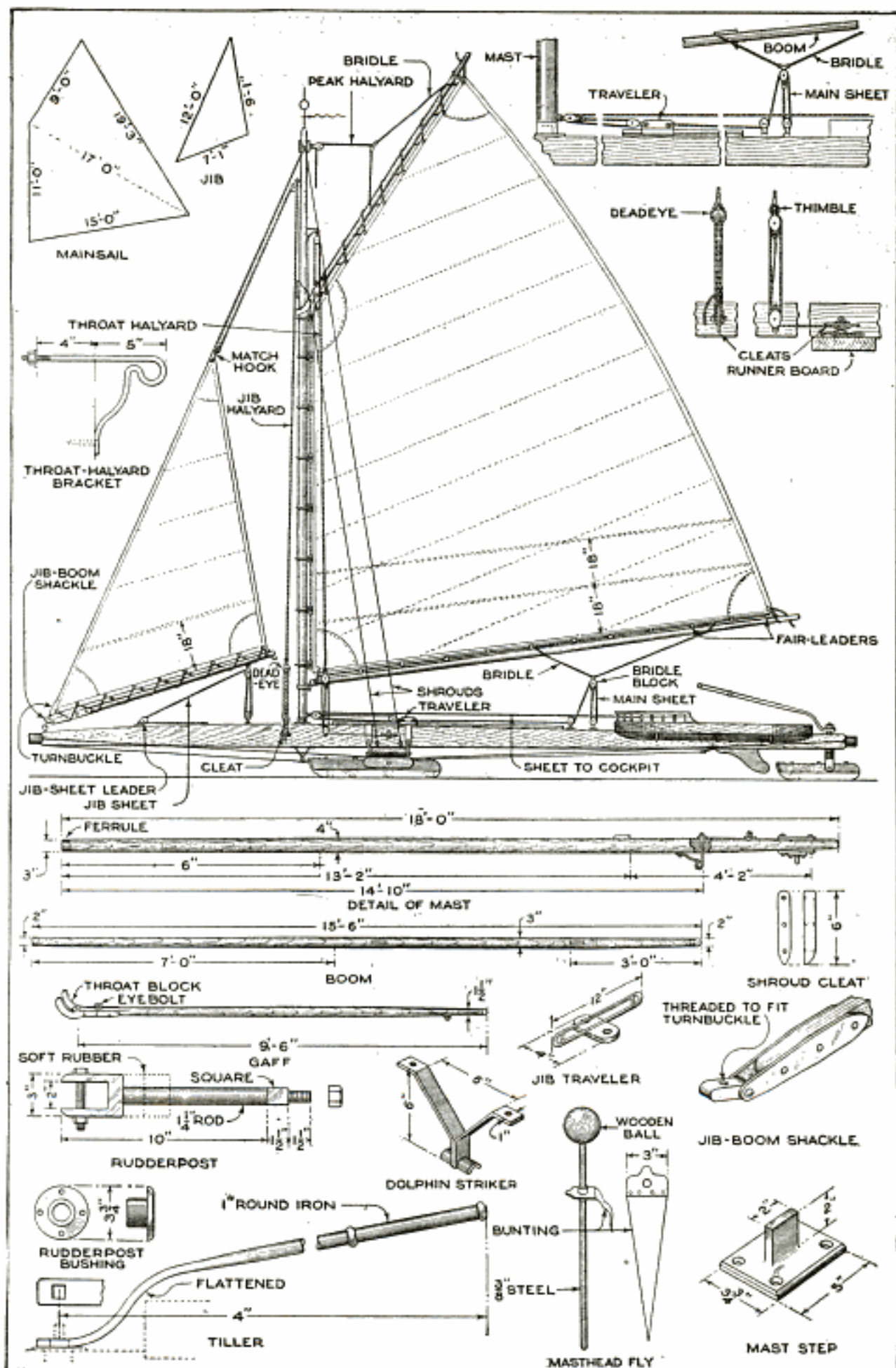

Details of Sails, Rigging, and Hull Fittings: In the Upper Right-Hand Corner Is a Detail Drawing of the Method of Rigging the Main Sheet; below This is Shown the Method of Fastening the Jib, Peak, and Throat Halyards to the Purchase Blocks

plush on the edges and one side only, and filled with upholsterer's moss, or the contents of a discarded hair mattress; $2\frac{1}{2}$ in. is sufficient thickness. In length, the covering should be 6 in. longer than the cockpit, as proper filling shortens the cushion considerably, and if made long, the finished cushions will fit tightly enough to stay in place. The buttons for tacking should be covered with the same material as the cushion.

The shrouds, forestay, and guys are made of $\frac{1}{4}$ -in. iron wire, and the bobstay of $\frac{3}{8}$ -in. wire. In making up each piece, the measurements must be taken from the boat itself to avoid mistakes. Loops to fit the masthead, and the ends of the backbone, are first spliced; then the opposite ends are spliced into $\frac{3}{8}$ -in. galvanized shackle-and-shackle pipe turnbuckles of the slot and cotter-pin pattern. (Never use any hook turnbuckles.) All turnbuckles should be fitted with wire-rope thimbles, and all loops and splices tightly served with hard cable-laid cotton cord about $\frac{1}{8}$ in. in diameter, filled with shellac, and varnished. The bobstay has an eye splice formed to fit the backbone nose; from there it runs down under the dolphin striker and aft to the anchor iron screwed to the bumper. The bridles for the boom and gaff are $\frac{1}{4}$ -in. wire, with loops finished as above. The halyards should be crucible cast steel, $\frac{3}{16}$ in. in diameter, finished as follows: The jib halyard is spliced in a pair of match hooks with wire-rope thimble for attaching to the jib, and the lower end spliced around a lignum-vitæ deadeye. The upper end of the peak halyard is spliced into a self-locking brass bridle fitted with a thimble, and the lower end around a thimble to receive the purchase block. The throat halyard has a thimble in each end, one for attaching to the eyebolt at the jaws of the gaff, and one for a purchase block at the lower end. The splices are finished in the same manner as for the shrouds and stays. All Manila rope is $\frac{3}{8}$ -in., spliced in, with free ends moused with sail thread. The main sheet proper is spliced into the becket of the bridle block at one end, and around a thimble at the other, for attaching to the main-sheet traveler by a screw shackle. This traveler is hauled along the track by a purchase attached to the foot of the mast, giving ample power to trim sail easily during a race, without luffing and losing speed. The remaining ropes are so plainly shown in the illustration as to require no further description.

The halyard blocks are of the type de-

signed for wire rope only, all others being any first-class make of bronze yacht block, with fittings suited to the work for which each block is used. Galvanized blocks will not do, nor should any have hook fittings.

Together with the rigging described above, eyebolts, mast hoops, gooseneck, cleats, lacing, and screw fair-leaders must be purchased from the ship chandler. The jib and mainsail lacing is $\frac{3}{16}$ -in. braided cotton, and the same material is used for the sail haul-outs. Fair-leaders are screwed into the top of the main boom, alternating with the thimbles on the foot of the sail, and through all is run a Manila stop, drawn very tight. Two fair-leaders are also used in the runner plank on each side of the backbone, for lashing the halyard-purchase ropes.

The whole boat, including the sails, but not the runners, should be set up complete outside the shop to prove that every part fits properly before putting it on the ice.

Always, when setting up, the gammon straps are first bolted tight, then the runner plank and backbone squared by measuring from the center of the rudderpost hole to a certain point on corresponding chocks at opposite ends of the plank, tightening the guys accordingly.

A combined sail and cockpit cover, preferably of waterproof duck and extending the full length of the boat, is necessary for protection from the elements. It should be made, in one piece, with an opening to go around the mast, and have grommets along each edge for ties to bind it down tightly to the guys and bobstay. A horse set under the boom will hold the cover up, tent-fashion. Colors for a craft of this size should be 18 by 12 in. During snow, the runners should be removed, dried, greased, and carefully put away in their box.

In many things one finds that the pleasure of anticipation and preparation far exceeds the actuality; this, however, does not apply at all to ice-yachting. For while the construction of such a craft will give the builder many happy hours' employment, the sailing of it will prove the greatest imaginable joy after the tricks of the trade are mastered, and the only way properly to master them is racing with some old hand at the game. When that incurable disease, "ice-yachting fever," attacks one's blood, the only relief is ice-yachting. While the building hardly comes under the head of woman's work, the sailing surely may be termed woman's sport as much as is running a motor car.

Transferring Prints to Glass

It is sometimes desirable to transfer photographic prints to glass, or to some other solid substance that may or may not be transparent, to obtain some particular decorative effect.

The surface of the glass, or other substance, is first coated with a half-and-half mixture of turpentine and Canada balsam, or, if obtainable, dammar varnish. The glass is set aside until the varnish has become quite "tacky;" the time required for this will vary with the dryness of the atmosphere. The print to be transferred is soaked in water until limp, and the surplus water is removed by pressing it between sheets of lintless blotter. The print is then carefully laid on the prepared surface, another blotter being used to press it into place and also to prevent the possibility of water or air bubbles being confined underneath the paper. When this is completed, the whole work is set aside until it becomes thoroughly dry, which will require from one to two days.

The next operation is the removal of the paper backing, so that only the film containing the picture will be attached to the base. The paper is removed by wetting the fingers and rubbing it off in small rolls, and it will be found, after a little practice, that this is not at all difficult.

If developing-out paper is used, a little more work will be required, as the paper stock is heavier than that ordinarily used for printing-out papers. When the paper has all been removed, the appearance and transparency of the finished work are improved by an application of transparent varnish. The same process can be applied to the decoration of opaque surfaces. However, in the latter case, the picture will be reversed, as the print is applied to the surface face down.—A. C. Cole, Chicago, Ill.

Soap Dish as a Motor-Car Fitting

A nickelplated soap dish, a familiar fitting in every bathroom, can be made to serve another useful purpose when mounted on the dash of an automobile, in front of the driver. Such a receptacle makes a convenient place for carrying matches and similar small articles.

Storm Windows Made from Shutters

A snug-fitting and easily opened storm window can be made by replacing with



Outside Shutters Converted into Neat and Substantial Storm Windows by Merely Removing the Slats and Substituting Glass Panes: Even the Old Slats can be Used to Further Advantage for the Protection of Tender Plants, as Shown at the Left

glass the slats in the outside shutters of those rooms that are difficult to keep at a comfortable temperature in the winter. The slats can easily be removed and the glass panes that take their place are held by strips of light molding. The principal advantage of using the shutters as storm windows, aside from the ability to open them easily on mild days, is that they are already cut to fit and the hardware is already in place.

Even the old slats can be used to further advantage, as shown in one of the illustrations, by using them to support sheets of glass for the protection of early spring plants. Notches are cut into the slats at each end, and these serve to hold old photographic negatives in the manner illustrated in the lower photograph.—Walter C. Harris, Brooklyn, N. Y.

The Magic Candle and Flag

This is a trick that can easily be performed by the amateur with very mystifying effect, and the necessary apparatus is simple to make. The trick is this: A candlestick, with a candle in it, is placed on a table; a cylinder is shown to be empty, after which it is placed over the candle so that the latter is concealed; the "magician" makes a few appropriate passes, at the same time saying one of the seven magic words, of which "abracadabra" is the most "potent"; when the cylinder is removed, the candle will have disappeared, and the tube is still shown to be empty. Then a flag or handkerchief

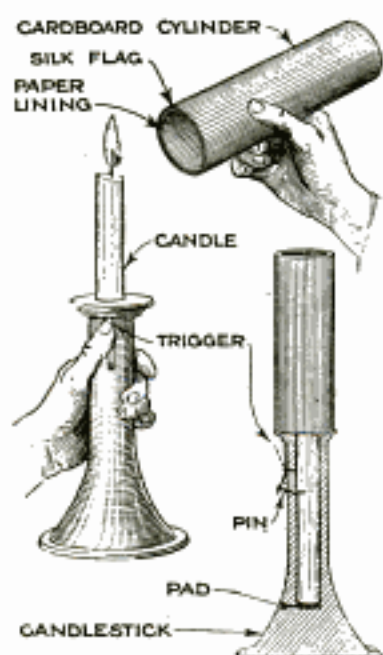

is extracted from it. While the audience is still wondering how it was done the operator reaches into a coat pocket, produces the candle lighted, and places it back in the candlestick. The apparatus required consists of the trick candlestick illustrated, two imitation candles, a cardboard cylinder, and a silk flag, or handkerchief. The base of the candlestick is hollow, and when the cylinder is placed over it, a trigger is pressed that allows the candle to drop out of sight into the hollow base. The flag is folded and placed like a lining within the cylinder, and is kept from sight of the audience by a paper lining, as indicated in the drawing. The cylinder is prepared and the second candle placed in the magician's pocket before the performance. This candle has a match head for a wick, and as it is taken from the pocket the match is struck on a piece of sandpaper that is pinned in a convenient place on the inside of the coat. The candlestick can be bought ready-made, or it may be made from wood. The hole in which the candle drops must be large enough to make a snug but free fit, and deep enough to conceal the candle entirely when resting upon the bottom. A small wire pin projects through the can-

dlestick just far enough to hold the candle in place, yet so that a very little movement will release it. A bent strip of sheet metal serves as a trigger, and this is fastened at its center to the candlestick, very loosely. When the cylinder is placed over the candle the performer presses the trigger and lets the candle fall. In this position the top of the candle should be even with the wire pin, so that when the second lighted candle is set in the candlestick it will rest on top of the first one. The candles can be made from metal, paper tubes, or wood. If tubes are used, corks are inserted into the ends to hold wicks. In any case, have a wick on one candle and a small hole for a wick on the other. Enamel them white. For the light effect in the second candle, a match end is inserted in the wick hole. The cylinder which is put over the candle to hide it can be made from cardboard or sheet metal and finished as desired. Fold the flag and place it so as to be close to one end of the tube. When taking the flag from the cylinder, hold the cylinder and the paper lining tightly together, at the end farthest from the flag, so that the latter can be pulled out without disturbing the paper.—Norman B. Taylor, Pomona, Calif.

The apparatus required consists of the trick candlestick illustrated, two imitation candles, a cardboard cylinder, and a

cardboard cylinder, and a silk flag, or handkerchief. The base of the candlestick is hollow, and when the cylinder is placed over it, a trigger is pressed that allows the candle to drop out of sight into the hollow base. The flag is folded and placed like a lining within the cylinder, and is kept from sight of the audience by a paper lining, as indicated in the drawing. The cylinder is prepared and the second candle placed in the magician's pocket before the performance. This candle has a match head for a wick, and as it is taken from the pocket the match is struck on a piece of sandpaper that is pinned in a convenient place on the inside of the coat. The candlestick can be bought ready-made, or it may be made from wood. The hole in which the candle drops must be large enough to make a snug but free fit, and deep enough to conceal the candle entirely when resting upon the bottom. A small wire pin projects through the can-

An Efficient Stewpan

The efficiency of the ordinary stewpan can be considerably increased, and at the same time, the quantity of gas required to boil the contents of the pan will be cut down. All this is done by cutting a hole, just large enough to permit insertion of the stewpan, in the bottom of an old pan, as in the



illustration. It will be noted that all the heat rising within the covered area will come into contact with the sides as well as the bottom of the upper pan. Another feature of value that commends an arrangement of this sort, is that the contents of the stewpan will not burn as quickly as when in actual contact with the stove top. As a glue-pot improvement, where gas is used for heating the pot, the same idea can be applied with excellent effect.

Typewriter-Ribbon Substitute

When the typewriter ribbon wears out and another is not easily obtainable, a sheet of carbon paper can be used with good results. The carbon paper is fed into the machine between two sheets of paper, with the carbon face in contact with the face of the letterhead. The outer sheet of paper is used to reinforce and protect the carbon paper.—Chas. N. Shaw, Jr., Gordon, Ga.

Bracing the Folding Clotheshorse

The common folding clotheshorse admirably answers the purpose it is intended

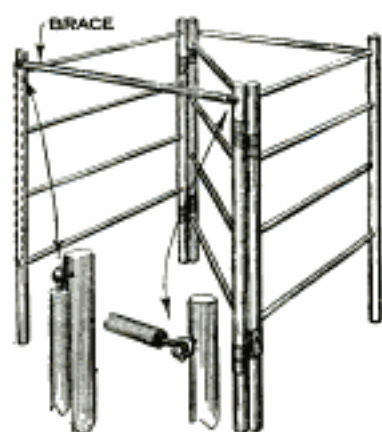

for, but suffers from lack of stability, a slight push being enough to make it fall over or close. To overcome this, the two bars or braces shown in the drawing were fitted to the clotheshorse, not only making it much more rigid, but affording additional drying space. Round-headed screws were turned into the posts as indicated, and a screw eye into each end of the braces. One of the eyes was closed, while that in the opposite end is open and free to slip over the screw.—M. E. Dugan, Kenosha, Wis.

Attachment for Pouring Liquids

One of the easiest and most effective methods of rigging a bottle for pouring liquids without removing the cork is shown in the drawing. Two pieces of glass tubing are inserted through holes in the stopper in the manner indicated. Using an arrangement of this character, the liquid will flow from the container smoothly and without bubbling.—Curtis Ralston, Chicago, Ill.

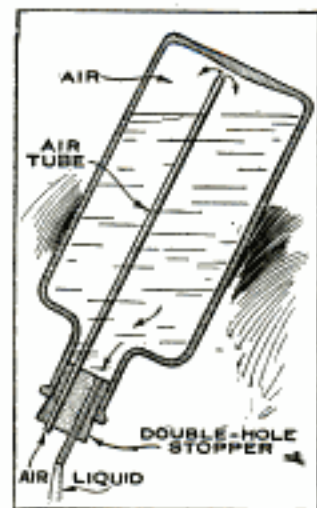

A Seat for the Furnace Register

In houses heated by a hot-air furnace, a better distribution of the warm air along the floor,

where it is most needed, can be obtained by using register boxes such as that shown in the drawing. In addition to this, it affords a convenient seat for getting warm quickly when coming from the outside cold.

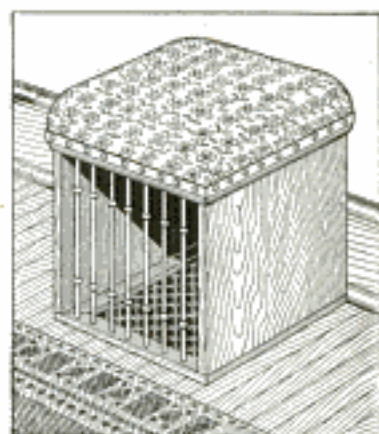

The box is a little larger than the outside measurements of the register plate, and at least one side should be open. The top may be padded and covered to match the upholstery on the furniture in the room.

Finger Clips for Oilcans

A simple device, which has been found advantageous in the handling of an oilcan of the spring-bottom type, especially

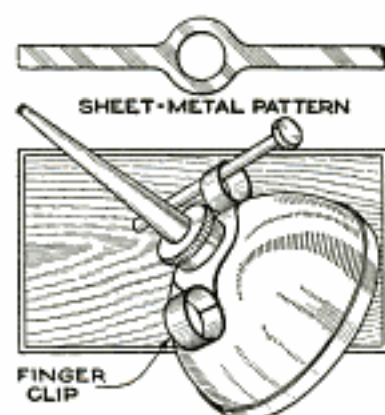

when the hands are greasy, consists of a finger clip, made and attached as indicated. The clip is made from a strip of sheet metal, with an opening at the center to fit over the neck

of the can, where it is held in place by the spout. The ends of the sheet-metal strip are formed into rings for the insertion of the first and second fingers. All edges should be finished off smoothly to prevent possibility of cutting and scratching the skin. The oilcan may also be hung up by the clip, and in this manner kept out of the way.

When playing cards become old, worn, and rough, making it difficult to deal and shuffle them with the desired speed, they can be made almost as slick as new by dusting them freely with talcum powder.

Silencer for Home-Lighting Plants

One of the objectionable features of a lighting plant, as it is usually installed in the basement of the country home, is the noise and odor of the exhaust. The drawing shows a method of muffling the

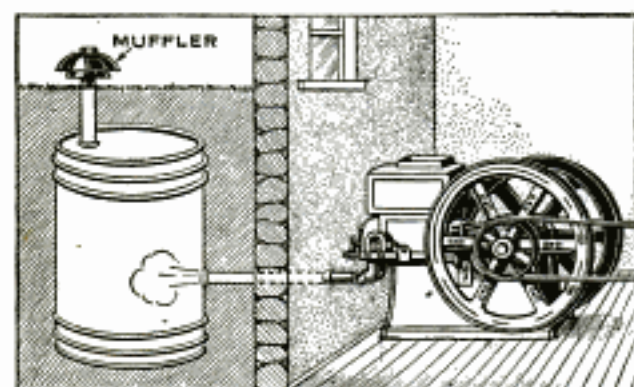

An Underground Expansion Chamber in the Form of a Barrel or Old Hot-Water Tank Receives the Exhaust from the Home-Lighting Plant and Makes Its Operation Practically Noiseless

sound of the exhaust that makes operation of the plant practically noiseless. The regular engine muffler is removed and the exhaust pipe is led to a barrel or old water-heating tank that is buried under the ground. A pipe from the tank or barrel, as the case may be, is led above the surface and the engine muffler attached, as shown in the drawing. By this method the exhaust gases are discharged into the barrel, where they expand and issue from the muffler at little more than atmospheric pressure and without the annoying noise.

Rocker Lever for Overhead Valves

A tool that expedites the removal of valves or push rods from an overhead-valve type of automobile engine, is shown in the drawing. With an average of 12 such valves to be removed from the engine, considerable time and effort are saved by the use of some form of tool

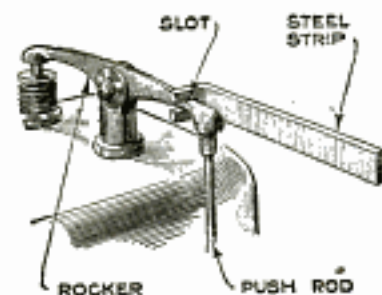

for compressing the valve spring. The tool consists of nothing more than a strip of steel, bent at right angles and slotted as indicated. The long part forms the handle, and when applied to the rocker arm, only an upward movement of the handle is necessary to raise the rocker out of contact with the push rod.

Protecting Fire Hydrants from Snow

In regions of heavy snowfall, and where the snow is likely to remain until it thaws, such as the grounds of large public institutions, the fire hydrants are quite likely to be so covered up, that valuable time might be lost in locating them. Under such conditions some way of marking the locations of the hydrants is highly desirable.

The hydrants can be effectively identified and, to a certain extent, prevented from freezing up, if, early in the winter, they are covered up with a barrel from which one of the heads has been removed. It is consequently an easy matter, in case of fire or fire drill, to lift off the barrel without having to dig the snow from around the hydrant.—James R. Noble, Portsmouth, Ont.

A Muff for the Autoist's Hands

Driving an open automobile in the winter time is far from comfortable, even when the side curtains are up, and, if the driver's hands are numbed with cold, it is easy to imagine situations where driving would be dangerous.

The drawing shows a closely woven cloth muff, in the form of a bag, made large enough to fit loosely over the steering wheel, the mouth of the bag being tied to the steering column. Openings for the hands are provided with elastics, so that the muff will be held closely to the wrists; or cuffs, such as shown, can be added to fit over the coat sleeves.

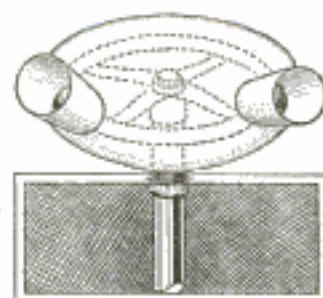

An "Apartment" Ironing Board

A convenient ironing board for the particular use of apartment dwellers, or those living in rooms where the amount of space is closely limited, can be made from an ordinary board, about 3 ft. long and 10 in. wide. This is all that is needed, with the exception of the necessary covering. In use, the drawer of the kitchen table, or a convenient drawer in a dresser, is pulled out, and the board is supported by the drawer, the end of the board being inserted inside the drawer so that it bears against the top of the opening.—R. Swedene, San Francisco, Calif.

Razor Slogan-Winner L. G. Cherry,
1200 W. Franklin Ave.

Minneapolis, Minn
* Fever & strokes for Busy Folks *
PRIZE OFFERS

7649

**CASH PRIZES OFFERED FOR NEEDLEWORK
BY STAR NEEDLEWORK JOURNAL**

Cash prizes to the amount of \$2,000 are offered for crochet, tatting, knitting, and embroidery work by the Star Needlework Journal. The contest is limited to work done with cotton thread made in America. All articles submitted must be specially made for this contest. Securely sewn to the article submitted must be a coupon which is part of a circular that contains full particulars of the many classes of work for which in each case a number of prizes are offered, varying in value from \$100 to \$1. In addition to these regular class prizes, three special prizes will be given, one of \$200 for the best piece of work entered in the contest, one of \$100 for the best original design in colored work, and one of \$100 for the best original design in white work. Competitors may enter in as many classes as desired, but will receive only one prize except those who are winners of special prizes. Work should not be sent in before December, 1921. The contest closes Jan. 31, 1922. For circulars and entry blanks, address Star Needlework Journal, 260 West Broadway, New York City.

7592

**THE SKETCH, OF LONDON, ENG., OFFERS £100
FOR BEST ANSWERS TO THREE QUESTIONS**

In the current issues of The Sketch, the well-known illustrated paper published in London, Eng., there is offered a prize of £100 for the best answers to the three questions: "What feature in The Sketch do you like best?" "What feature do you like least?" "What feature not at present published in The Sketch would you like to see introduced?" Each set of answers is to be written on a sheet of paper and signed with a pen name, accompanied by another sheet of paper bearing the pen name and the actual name and address of the contestant. The contest is open to everyone, whether a reader of The Sketch or not. Answers must reach The Sketch office, 15 Essex St., Strand, London, W. C. 2, before Jan. 1, 1922.

ed. 19, 1921

7609

**ONE MILLION FRANCS FOR BEST MOTOR
OFFERED BY AERO CLUB OF FRANCE**

The aviation commission of the Aero Club of France has now under consideration the rules that will govern a contest for a prize of one million francs (normally \$200,000), which it offers for the best motor, produced before June 1, 1923, for service on commercial airplanes. The prize will be given to the designer of the motor that proves to be the most durable, the most reliable, and the simplest and easiest to assemble and disassemble.

Paris, France

**PRIZE FOR BEST SLOGAN DESCRIBING
DURHAM DUPLEX RAZOR**

Every storekeeper handling Durham duplex razors has blanks for distribution to all applicants in connection with a prize of \$500 offered by the razor company for the best slogan of five words or less describing the shaving qualities of the razor. The contest will last until June 30, 1922. Blanks can be obtained also direct from the Durham Duplex Razor Co., 190 Baldwin Ave., Jersey City, N. J.

7711

**PRIZES FOR GEORGE WASHINGTON ESSAYS
OFFERED STUDENTS OF FIVE STATES**

With the object of encouraging a careful study of the life of George Washington, the Chicago Tribune offers a number of prizes, totaling \$11,050, for the best essays of 250 words or less upon that subject. The contest is open to every boy and girl attending grammar or high school, parochial, or private school in the city of Chicago, or in the states of Illinois, Indiana, Iowa, Michigan, and Wisconsin. The writer of the best essay submitted will receive \$2,500 in cash. Sixty other prizes ranging from \$500 to \$25 will be paid for

the best essays submitted from the six territorial divisions mentioned above, in each case as follows: first prize, \$500; second, \$250; third, \$100; fourth to tenth, \$25 each. There are also 18 cash prizes for teachers whose students submit the winning essays, as follows: in each of the six territories, \$250 to the teacher whose student wins the first prize; \$150 for the second prize, and \$100 for the third prize. All essays must be original. In case of ties, the full sum offered will be paid to each winner. The contest is now open, and will close at midnight of Washington's birthday, Feb. 22, 1922. Address: "Essays," The Chicago Tribune, 7 South Dearborn St., Chicago, Ill.

7710

**A BUNGALOW AS A CHRISTMAS PRESENT
OFFERED IN NOVEL PRIZE CONTEST**

A \$5,000 bungalow, as a Christmas present, was recently offered by the Leiter Building Stores, Chicago, Ill., in a contest of quite a novel nature. A four-room bungalow was erected inside the store, and the contestant was required to describe the best manner of expending \$2,000 in furnishing it completely with goods shown anywhere in the Leiter Stores. Everyone entering the contest had to call at the bungalow for an instruction sheet. Certainly every contestant would have to make a very thorough inspection of the goods displayed throughout this extensive department store, and doubtless the owners' recompense was this novel method of advertising their wares.

Tribune 11/20/21

CONTESTS PREVIOUSLY ANNOUNCED

Students of Railroad Engineering: Scholarships; announced March issue, 1920; closes Dec. 31; offered by the Southern Pacific.

Essays on the Life of Roosevelt: Scholarship prizes valued at \$1,000, \$750, and \$500; announced August issue, 1920; closes Dec. 31; address, Woman's Roosevelt Memorial Association.

New Methods of Testing Hardness of Metals: Prize \$1,000; announced October issue, 1920; closes Jan. 1, 1922; address, Institution of Mechanical Engineers, London, England.

Essays on Economics: Prizes, \$1,000 and \$500; announced June issue, 1921; closes Dec. 31; address, Dr. Wm. T. Foster, Newton 58, Mass.

Medals, Diplomas, and Money Awards: Announced August issue, 1921; awards offered by the Franklin Institute.

For Service to City of Philadelphia: Prize \$10,000; announced September issue, 1921; awarded in spring or summer of 1922 by Edward Bok, former editor of The Ladies Home Journal.

Orchestral-Composition Contest: Prize \$1,000; announced September issue, 1921; closes, Jan. 1, 1922; address, Carl D. Kinsey, 624 S. Michigan Ave., Chicago, Ill.

Safety-First Essays: Prizes, a trip to Washington and gold watch, a gold loving cup, a silver loving cup, and other state prizes; announced September issue, 1921; closes late in the fall; address any public-school teacher.

Essays on Cruelty of Trapping: Prizes, \$100, \$75, \$50, and 2 special prizes, \$50 and \$25; announced Oct., 1921; closes Dec. 31, 1921; address, American Humane Association, Albany, N. Y.

Research Thesis by a Woman: Prize \$1,000; announced October issue, 1921; closes Feb. 25, 1922; address, Dr. Lilian Welsh, Goucher College, Baltimore, Md.

Model in Clay by Students of Chicago Art Institute: Prizes, \$1,000, \$100, and \$50; announced November issue, 1921; closes April 15, 1922; address, Daily News Office, 15 N. Wells St., Chicago, Ill.

Best Stories of Infantry Platoons in Late War: Prizes, \$100, \$50, \$25, and \$15; announced November issue, 1921; closes Dec. 31, 1921; address, Army and Navy Journal, New York City.

11/20/21

In answering prize offers please mention Popular Mechanics Magazine

35 Ave Francisco I
Champs Elysees

Best Short Stories: Prizes, 10 of \$100 each; announced November issue, 1921; closes Dec. 31, 1921; address, True Stories Magazine, New York City.

Pulitzer Prizes and Scholarships to be Awarded Annually: Announced December issue, 1921; address, Secretary of Columbia University, New York City.

Best Canadian Novel and Story: Prizes, \$2,500, and \$500; announced December issue, 1921; closes June 1, 1922; address, Hodder & Stoughton, Limited, 263 Adelaide St. West, Toronto, Can.

Best Stories of Adventure on Naval Vessels in the War Zone: Prizes, \$100, \$50, \$25, and \$15; announced December issue, 1921; closes Jan. 31, 1922; address, Army and Navy Journal, New York City.

Postmaster-General Hays has issued orders that the resources at the command of every postmaster in the United States shall be placed at the disposal of persons in search of missing relatives or friends. In future anyone will receive all possible assistance in tracing missing men, women, or children, by applying to the postmaster of his district.

A party giving the name of J. Adams, claiming to represent the Magazine Service Co., of Chicago, is offering an atlas free and a year's subscription to this magazine at a cut rate. The Magazine Service Co. and its agents are frauds so far as having any authority to represent this magazine is concerned.

7510

ELABORATE HOUSE ON WHEELS FOR COUNTRY TOURS

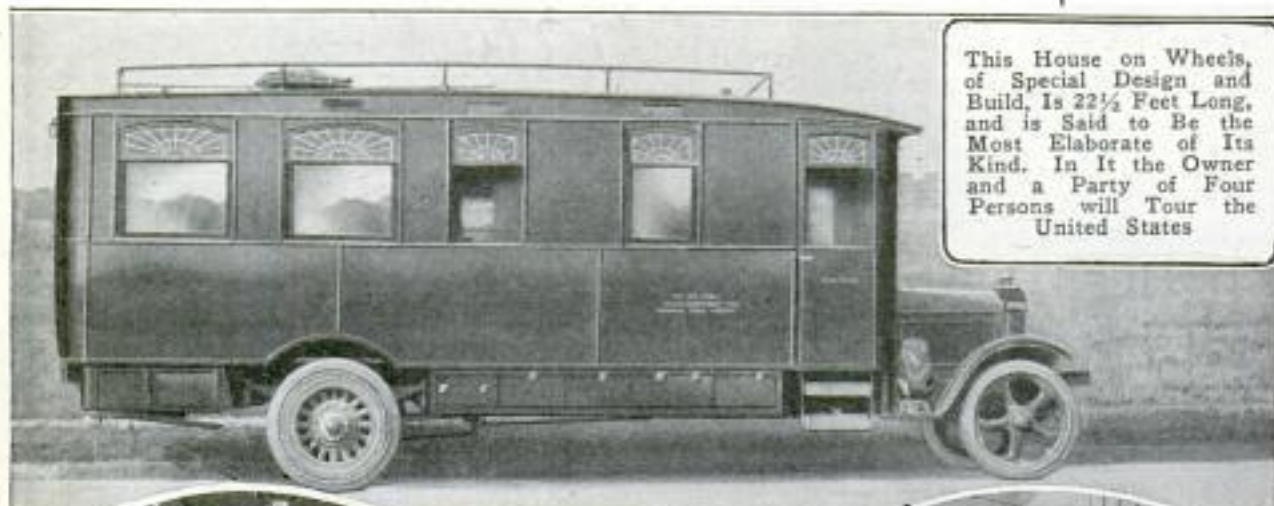

This House on Wheels, of Special Design and Build, is 22 1/2 Feet Long, and is Said to Be the Most Elaborate of Its Kind. In It the Owner and a Party of Four Persons will Tour the United States

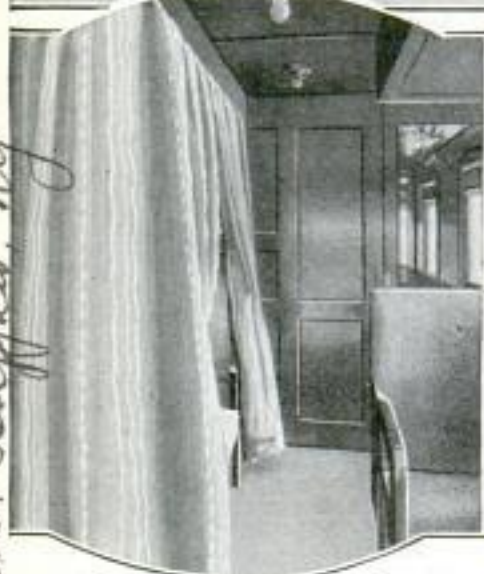

The Sleeping Compartment, Showing the Berth at the Left Ready for Occupancy, While the One at the Right is Shown Made Up for Day Travel: In the Ceiling can be Seen the Electric Fixtures



The Kitchen, Showing the Cabinets, or "Pantry," at the Right, and the Gasoline Stove, Which is Placed before the Window to Provide the Best Light and Ventilation, at the Left

Charter - Quince - Arrow Motor Car Co. Elmwood Ave. Buffalo, N.Y.

An elaborate house on wheels, containing many modern conveniences, has recently been completed. The house, or body, which is built upon a five-ton motor-truck chassis, is 7 1/2 ft. wide, and the roof is 10 ft. from the ground. All the windows are of French plate glass, and fitted with copper screens. A porch slides from beneath the body at the rear and may be

covered with an awning. The driver's compartment is a combination seat and bed, and an aisle runs from it to the rear. Off the aisle is a bathroom with modern plumbing fixtures, and a kitchen fitted with a gasoline stove, electric grill, sink, refrigerator, and hot and cold water. In the rear is a combination living and sleeping room, with four folding berths.

IN accordance with the editorial policy of this magazine never to accept compensation in any form for what appears in our reading pages, and also to avoid all appearance of doing so, we are obliged to omit the name of the maker or the seller of any article described. This information, however, is kept on file and will be furnished free, by addressing Bureau of Information, Popular Mechanics Magazine, Chicago. [Editor.]

Designer & Counsel
André Boutin, Syracuse, N.Y.

Copyrighted material

Build an Aladdin Home and Save \$200 to \$800

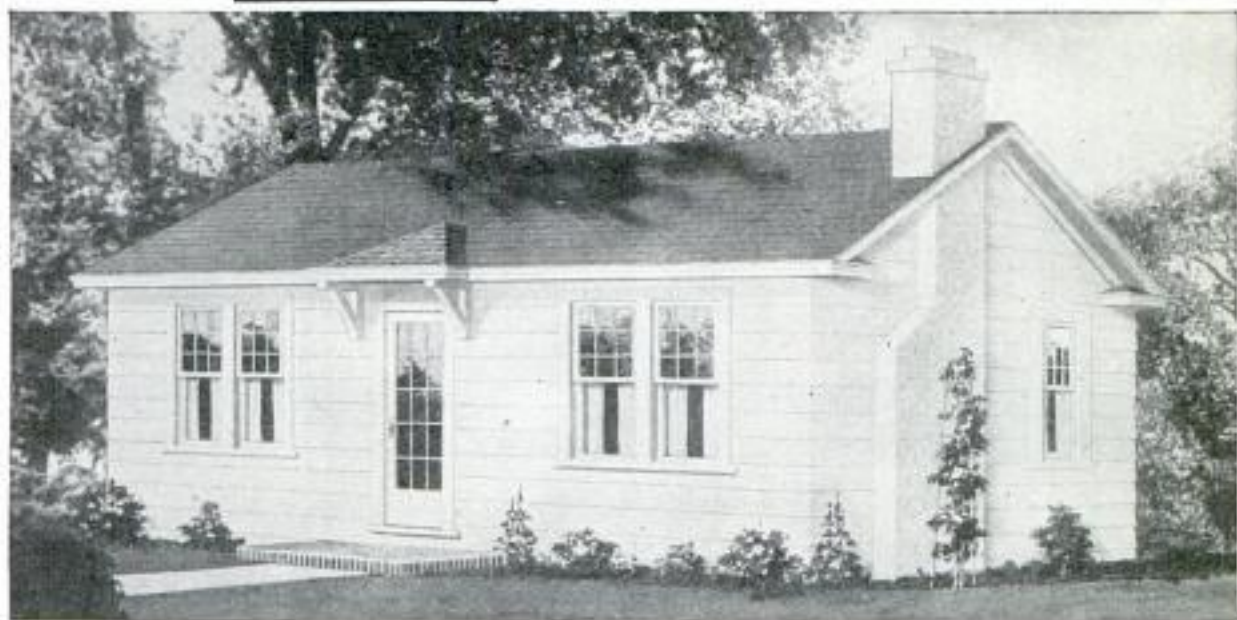

Delightful Colonial Bungalow of 5 Rooms

Aladdin success is chiefly due to the money saved for Aladdin home owners. You will save a substantial amount thru eliminating dealer's profits, saving over 18% waste in lumber and lowering labor costs in building. Aladdin homes come to you direct from one of our mills located in the nearest timber country, thereby reducing freight charges. They are built of standardized materials, saving waste, and are cut to fit, saving hundreds of hours of carpenter labor. Over a hundred beautiful and modern homes are pictured and priced in the Aladdin catalog. Send for this catalog at once.

Plan Your Spring Building NOW!

If you write for the Aladdin book now, you will have plenty of time to study the plans, learn about the savings and arrange your affairs for the spring building season. Without cost you will receive the benefit of our seventeen years' experience in building homes for American families in every state and practically every village, town and city. Start your home planning this month.

Aladdin Homes Reduce Labor and Lumber Costs

The lumber that's wasted costs just as much as the lumber that's used. Aladdin can prove to you a saving of practically every fifth dollar spent for lumber. That's surely worth while. Aladdin can prove a saving of practically every fourth dollar in labor. That's worth saving too. Will you be satisfied to build without getting the Aladdin catalog and proving these statements?

Sold Direct—No In-Between Profits

The Aladdin Company is the greatest home building institution in the world, and it does not sell through dealers. It manufactures the lumber at the edge of the four greatest timber-producing states. It prepares the house complete ready to be shipped direct to the home builder. You save the dealer's profits. Your carpenter nails the ready-cut lumber just like in any other first-class, permanent home. The catalog explains details fully.

There's an Aladdin Near You

Ask us for the name of an Aladdin home owner near you. Talk with him, inspect his home, look at the beautiful clear and knotless siding, the handsome interior woodwork, the staunch construction. Ask about the warmth in winter.

Aladdin Homes Not Portable

Aladdin homes are not portable, not sectional, not "fabricated." When erected they are exactly like any well-built, architect-designed, contractor-built home. They are guaranteed to pass the building codes of every city.

What You Get When You Buy an Aladdin Home—Aladdin homes are designed to use standard lengths and sizes of lumber so that there is practically no sawing, measuring or fitting to be done by the carpenter on the job. You receive in one shipment all the timbered frame work, millwork, the siding, outside finish, porch, shingles, windows, doors, interior woodwork, lath, glass, nails, hardware, lock sets, paints, stains and varnish. Send stamps today for catalog 1567.



A Stucco Home of 12 Rooms



Typical Bungalow of 6 Rooms

THE ALADDIN CO., Bay City, Mich.

Branches; Offices and Mills: Portland, Oregon; Wilmington, North Carolina; Hattiesburg, Miss.

Canadian Offices and Mills:

Toronto, Vancouver, Winnipeg, St. John



Coupon for Book of Homes

THE ALADDIN CO. (Send to Address of Office Nearest You)

Enclosed find stamps for your Book No. 1567

My Name _____

Street _____

City _____

State _____

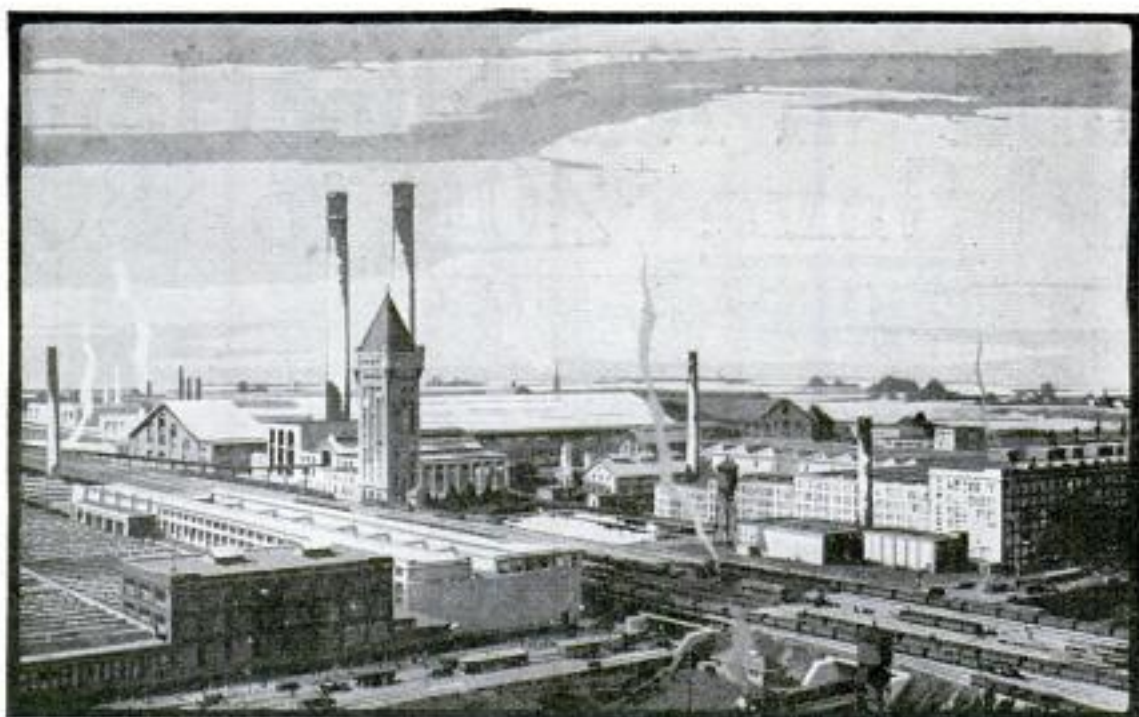

Works of the Western Electric Company; the manufacturing department of the Bell System

Economical Equipment

Forty years ago the management of the Bell Telephone System organized for a supply of the apparatus which it foresaw would be required in the development of its new industry—telephone service.

The telephone in some countries is the luxury of the rich, but in America it is used by practically all the people. This universal service is due in large measure to foresight in engineering and manufacture.

Switchboards with millions of parts, other apparatus of highest efficiency, and all necessarily of complex and intricate design, cables and wires and a multitude of technical devices enable our country to lead the world in telephone service.

All this telephone equipment is

made in a factory which is recognized throughout the world as having the largest production and the highest standards of workmanship and efficiency.

This factory, controlled through stock ownership by the American Telephone and Telegraph Company, has been for forty years the manufacturing department of the Bell System; with the result that the associated companies secure equipment of the highest development, made of the best materials, produced in accordance with the requirements of the public, and with the certainty of moderate costs.

Economy in the Bell System begins with the manufacture of equipment.

“ BELL SYSTEM ”

AMERICAN TELEPHONE AND TELEGRAPH COMPANY
AND ASSOCIATED COMPANIES

One Policy, One System, Universal Service, and all directed toward Better Service



No. 1555
(illustrated)
Length 17 in.
3-jaw chuck for
round shank
drills up to $\frac{1}{2}$
inch.

No. 555
Length 17 $\frac{1}{2}$ in.
2-jaw chuck for
round or square
shank drills up
to $\frac{1}{2}$ inch.

**Write for this helpful
tool book. It's FREE**
Numerous illustrations.
Shows how to save time
and labor. Pictures work
of a difficult nature be-
ing done easily and quick-
ly. Features of "Yankee"
Tools explained.

Some other "YANKEE" Tools

Spiral Screw-drivers	Bench Vises, removable base
Quick Return Spiral Screw-drivers	Ratchet Chain Drills
Ratchet Screw-drivers	Ratchet Bench Drills
Plain Screw-drivers, 1 $\frac{1}{2}$ to 30 in. blades	Plain Hand Drills
Ratchet Hand Drills	Plain Breast Drills
	Automatic Push Drills
	Ratchet Tap Wrenches

Dealers everywhere sell "YANKEE" Tools

NORTH BROS. MFG. CO., Philadelphia

"YANKEE" TOOLS
Make Better mechanics



Trade Mark
HANES
 ELASTIC KNIT
UNDERWEAR

Hanes Guarantee!

We guarantee Hanes Underwear absolutely—every thread, stitch and button. We guarantee to return your money or give you a new garment if any seam breaks.

Hanes 5 Big Features

- 1 HANES STAUNCH ELASTIC SHOULDERS** made with service-doubling lap seam. They fit right with give for every motion.
- 2 HANES TAILORED COLLARETTE** won't gap or roll. Fits snugly around your neck always, and keeps the wind out.
- 3 HANES ELASTIC CUFFS** are made far stronger and better than the usual cuff. They fit the wrist firmly, they won't flare or rip from the sleeve.
- 4 HANES CLOSED CROTCH** is cut and stitched a special way that really keeps it closed.
- 5 HANES ELASTIC ANKLES** hold their shape through repeated washing. They don't bunch over your shoes. They fit always.

All Hanes Union Suits made with reinforced buttonholes.

Buy Hanes Now at Greatly Reduced Prices!

Now is the time to equip yourself with Hanes Winter Underwear. You can buy it at much lower prices than at any time in recent years. There have been tremendous price reductions in the entire Hanes line. Hanes value is unsurpassed.

And remember—each Hanes garment is backed by the Hanes Guarantee. It must live up to the claims made for it or you can have your money back.

Each Hanes garment has to pass inspection by experts before it reaches you. The sterling features listed in this advertisement are all checked over.

P. H. HANES KNITTING CO., Winston-Salem, N. C.

Next Summer—you'll want to wear Hanes Nainsook Union Suits!

That's why you can rely on Hanes buttons to stay on; the reinforced buttonholes to keep their shape; the non-irritating seams to hold fast.

Have your dealer show you the Hanes winter line. You have a choice of heavy shirts and drawers, and heavy union suits in two weights; and a splendid mediumweight, silk-trimmed union suit.

Union Suits for Boys—In two weights—medium and extra heavy. Made in sizes 2 to 16 years. Two to 4 year sizes have drop seat.

If your dealer can't supply you with Hanes, write us immediately.



Be More Careful of your teeth—combat the film

If you are brushing your teeth in a wrong way, learn what this new way means.

Authorities now advise it. Leading dentists everywhere are urging its daily use. Millions of people employ it.

Make this ten-day test and let the results show you what clean teeth mean.

That dingy film

Film is that viscous coat you feel. It clings to teeth, enters crevices and stays. That is what discolors—not the teeth.

Film is the basis of tartar. It holds food substance which ferments and forms acid. It holds the acid in contact with the teeth to cause decay.

Germs breed by millions in it. They, with tartar, are the chief cause of pyorrhea.

Dental science has in late years found two ways to fight film. It has proved them by careful tests. Now they are embodied in a new-day toothpaste—called Pepsodent—for daily application.

Other new effects

Pepsodent brings three other effects, natural and very important.

It multiplies the salivary flow—Nature's great tooth-protecting agent. It multiplies the starch digestant in the saliva, to digest starch deposits. They may otherwise cling and form acids.

It multiplies the alkalinity of the saliva, to neutralize the acids which cause tooth decay.

Thus every use does five things which dental authorities now regard as essential.

You'll quickly see

A 10-day tube of Pepsodent is sent to all who ask. That shows the delightful effects. In a week you will realize that this method means much to you and yours.

Send the coupon for it. Note how clean the teeth feel after using. Mark the absence of the viscous film. See how teeth whiten as the film-coats disappear.

Watch all the effects, then read the reasons in our book. That test may lead to life-long benefits. Cut out the coupon now.

Pepsodent PAT. OFF.
REG. U.S.

The New-Day Dentifrice

A scientific film combatant, whose every application brings five desired effects. Approved by highest authorities, and now advised by leading dentists everywhere. All druggists supply the large tubes.

10-Day Tube Free

776

THE PEPSODENT COMPANY,
Dept. 515, 1104 S. Wabash Ave., Chicago, Ill.
Mail 10-Day Tube of Pepsodent to

Only one tube to a family.

A Great Year to Succeed!

A renowned predictor has said: "In 1922 success is due."

Success to those who are MASTERS OF THEIR TIME.

You can only be master of your time when you possess a thoroughly reliable, reputable high grade watch. There is no watch made that excels THE SANTA FE SPECIAL in reputation, reliability or workmanship. He who owns one always knows his time.

We expect to put this Great Watch into the pockets of 50,000 men who are on the road to success in 1922. With this as our goal we have made our margin of profit on the sale of a watch so small it defies competition.

Will you be one of the 50,000? If you expect to succeed you must act—ACT NOW! If you want a great watch with a life-time guarantee, do not delay—order a SANTA FE SPECIAL this minute! You do not have to pay cash—we trust you. ACT NOW!

Senator Capper O. K.'s

Santa Fe Special
I am glad to say that your "Santa Fe Special" Watch has given entire satisfaction, and I believe is the very best watch value for the money I have ever seen.

ARTHUR
CAPPER,
United
States
Senator.



Always Thrive

Pres., Santa Fe Watch Co., Topeka, Kans.

The ILLINOIS Famous \$
Santa Fe Special 3.50
2 JEWEL RAILROAD WATCH 3 A MONTH

The Standard Railroad Watch

that is GUARANTEED FOR A LIFE-TIME OF SATISFACTORY SERVICE. These watches are now in service on practically every rail-

road in the United States and in every branch of the Army and Naval Service. Thousands of them are distributed around the world. Your name or monogram and any emblem you may desire will be engraved in the case to suit your own ideas.

Save One-Third to One-Half Your Money

Save One-Third to One-Half the price you pay for a similar watch made by other manufacturers. Most Liberal Offer Ever Made. Our "Direct-to-You" low wholesale terms and Extra Special Distribution Plan is fully explained in the New Santa Fe Special booklet just off the press. The "Santa Fe Special" Plan means a big saving of money to you and you get the best watch value on the market today.

Send Your Name Today

Clip the coupon, fill out and receive the beautiful FREE 52-page, 4-color art watch book. All the newest watch case designs are shown. Read our easy payment offer. READ the so-called secrets of watchmaking and the jewelers' trade—tells how we can sell Railroad watches at practically half the price charged by retail jewelers. READ our great "Direct-to-You" offer. DON'T BUY A WATCH UNTIL YOU HAVE SEEN THE "SANTA FE SPECIAL."

Watch sent for you to see without one penny down.

SANTA FE WATCH COMPANY
16 Thomas Bldg., TOPEKA, KANS.

A letter, post card or this coupon will bring my beautiful Watch Book FREE

Santa Fe Watch Company
16 Thomas Bldg., Topeka, Kans.

Please send me your New Watch Book with the understanding that this request does not obligate me in any way.

Name.....

Address.....

State.....



Your Choice, On Trial

THE Wurlitzer plan gives you *any instrument* with a complete musical outfit for a week's Free Trial in your own home. No obligation to buy. Return the instrument at our expense at the end of the week, if you decide not to keep it. Trial won't cost you a penny.

Monthly Payments

Payments are arranged in small monthly sums. A few cents a day will pay for your instrument and complete outfit. The Wurlitzer plan gives you all at direct cost. You get the outfit and instrument practically for the cost of the instrument alone.

Artistic quality of Wurlitzer instruments is known all over the world. Wurlitzer instruments have been used

by artists and in the finest orchestras and bands for years. The house of Wurlitzer has made the finest musical instruments for more than 200 years.

Complete Outfits

The new plan includes with the instrument everything that you need—velvet and plush lined carrying case with lock and key, all accessories and extra parts, self instructor, book of musical selections, etc.

A Wurlitzer Outfit

This shows the Wurlitzer Violin Outfit. Case is professional style, beautifully finished. Complete outfits like this are now furnished with all Wurlitzer instruments.

Every musical instrument known, including Pianos and Victrolas, is embraced in the Wurlitzer plan.



Send for New Catalog

Every known instrument illustrated and fully described in detail with prices, monthly payments and free trial blank. More information and pictures of instruments than in any other book published. (Also complete catalog of accessories, repairs, strings and all needs for replacements for any instrument made. Instant mail service.) Book is absolutely free. No obligation. Send the coupon now.

The Rudolph Wurlitzer Company

Cincinnati, Ohio Chicago, Illinois New York, N. Y.

Copyright 1921, The Rudolph Wurlitzer Co.

THE RUDOLPH WURLITZER CO., Dept. 1771
117 E. 4th St., Cincinnati; 700 Jackson Blvd., Chicago; 120 W. 42nd St., New York

Send me your new catalog with illustrations in color and full description of the Wurlitzer Complete Outfits and details of the free trial and easy payment offer.

Name.....

Address.....

(State musical instrument in which you are especially interested)



WHEN Joseph R. Brown gave the world the invention of the Vernier Caliper in 1851, he established a world-wide Standard of Accuracy—over 70 years ago he brought out *these first precision tools*.

Today, as then, Brown & Sharpe Machinists' Tools represent the accuracy and fine workmanship which only pride in product and experienced master craftsmen can accomplish—they help you work your best.

See these superior tools—over 1000 of them, in our Catalog No. 28—send for it today

The first precision tools in America were Brown & Sharpe Tools
They are the best tools today



BROWN & SHARPE MFG. CO.

Providence, R. I., U. S. A.

The tool with
the 5 Big
Bull-Dog
Features

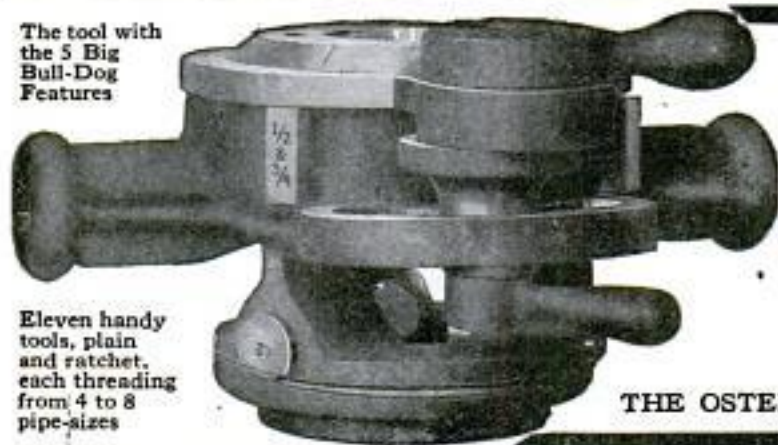

Eleven handy
tools, plain
and ratchet,
each threading
from 4 to 8
pipe-sizes

OSTER
BULL-DOG DIE-STOCKS

Write for Folder 31-B
illustrating and de-
scribing modern sim-
plified pipe-threading.

THE OSTER MFG. CO., 2100 E. 61st Place, Cleveland



Your Home Is Within Your Reach When You Buy From Us

NOW is the time to build your Harris Home!

And here is a mighty organization of thirty great departments ready to serve you. Managed by expert material buyers, designers and practical builders. We have vast stocks bought at huge quantity price savings which are now at your command. Our sole aim and purpose is

To help you get a home that will prove entirely satisfactory at a price that will mean a substantial saving in actual dollars of your money.

The combined efforts of these great departments in experimenting and testing materials and methods of construction have produced for you a GUARANTEED home, expert machine cut, bundled and marked—the last word in building economy.

Not One Penny in Advance

So sure are we of the super-excellence of our material and our GUARANTEED Ready-Cut System that we will ship you any HARRIS HOME without the payment of one cent down. Our Plan Book explains our liberal terms fully.

FREE Plan Book

The latest edition is waiting for you, contains our FREE PLAN OFFER and photographic reproductions, with floor plans and specifications of 100 beautiful homes. Mail coupon today.

Building Material of All Kinds

For over a quarter of a century, thrifty wise buyers have realized that here is the "open door" to real economy, whether it be a brand new home or material for improvements or repairs. Our big stocks of brand new building material, all purchased in tremendous quantities at savings that are passed along to you are ready for quick and complete shipments.

"PRESTO-UP" Patented Bolt-together Buildings!

The wonder buildings of the age. Guaranteed buildings, for quick industrial housing. Individual Homes, etc., extra strong, practical and suitable for all year 'round habitation in any climate. 50 different plans. They come to you in easily handled sections—painted and stained, ready to bolt together and move in.

Plumbing and Heating!

Hot water and heating systems, warm air heating plants, pipeless furnaces and plumbing material of every kind—the product of America's leading makers. Our mammoth plumbing stock offers unlimited possibilities for you to save money. Our heating plants are guaranteed to heat your home in any weather with big fuel economy. Mail the coupon for our Plumbing and Heating Book and get the benefit of our Expert Engineering Service.

Department NM-7

HARRIS BROTHERS CO.
1349-1525 W. 35th St., CHICAGO

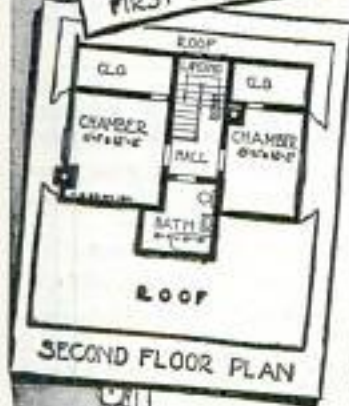
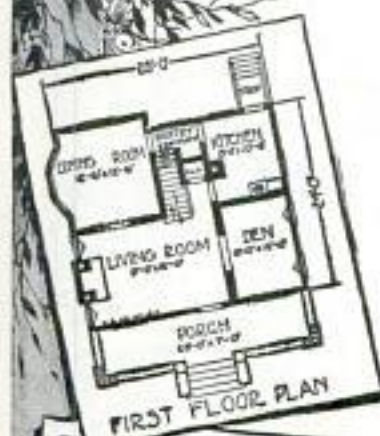

FREE BOOK of Plans

HARRIS BROTHERS CO.
Dept. NM-7, Chicago

These books are FREE and sent post paid. Mark an "X" in the squares to indicate which ones you wish.

- | | |
|--|--|
| <input type="checkbox"/> Harris Home | <input type="checkbox"/> Book of "Presto-up" |
| <input type="checkbox"/> Book of Plans | <input type="checkbox"/> Houses and Garages |
| <input type="checkbox"/> Building Material | <input type="checkbox"/> Plumbing and |
| <input type="checkbox"/> Catalog | <input type="checkbox"/> Heating Book |

Name.....

Address.....



The 1922 Elto is now ready—

Ole Evinrude's new motor, his greatest achievement! Two-cylinder construction, only 47 pounds. Practically vibrationless, starts easily, tilts automatically; 19 exclusive features explained in the Elto booklet. Write for it today.

ELTO OUTBOARD MOTOR CO.
OLE EVINRUDE, Pres.
Dept. A, Mfrs. Home Bldg.
Milwaukee, Wis.

Comfortably
Portable

Elto

Light Twin Outboard Motor

Always Plenty of Stretch

—no rubber to rot



in Nu-Way
and
EXCELLO

RUBBERLESS
SUSPENDERS

Guaranteed One Year—Price 75¢

Ask your dealer for
Nu-Way or Excello

Guaranteed Suspenders, Garters and Hose Supporters
Accept no substitutes—Look for name on buckles.
Nu-Way Stretch Suspender Co., Mfrs., Adrian, Mich.



This Book Free

"Success in Music and How to Win It"

Sousa and nine other world-famous musicians tell how you can quickly learn to play saxophone, cornet, trombone, clarinet, any band or orchestra instrument and double your income and pleasure.

Free Trial Any Conn Instrument

Used by greatest bands and solo artists.

Highest honors at world expositions.

Easiest of all to play. Send post card

for free book and details of free trial plan.

C. G. Conn, Ltd.

131 Conn Bldg. Elkhart, Indiana
World's Largest Manufacturers of High
Grade Band and Orchestra Instruments



—action

—with the New Stromberg Carburetor is as quick as thought. A rush of power instantly follows the demand on your engine. Efficiency is always on its finest edge. On the traffic choked boulevard or out in the open stretches, you are master. You can slow down to a snail's pace—surge ahead at express speed—stop—start, at will—your machine is under control.

In addition to this—you get most miles per gallon. These are facts—proved absolutely by service and fully explained in literature, which will be sent you upon request. Write for it. State name, year and model of your car.

Stromberg Motor Devices Co.
64 East 25th Street
Chicago, Illinois
Dept. 114



New **STROMBERG** Does it!
CARBURETOR

ADD TO YOUR INCOME

\$5 TO \$10 A DAY MADE EASY

The New Improved Am. Jr. No. 2 is
A Wonder



Sharpens and stropps ordinary razors. Sharpens razor blades, scissors, etc.

Complete outfit for only \$85
AM. SHARPENING MACHINE CO.,
Dept. 1 184 Washington St., Chicago

CAMERAS

Over a Hundred Styles and Sizes
Send for new illustrated catalog showing
latest reduced prices. It's Free.

10 days' trial given

SENECA CAMERA MFG. COMPANY
300 Central Avenue Rochester, N. Y.



A LATHER THAT SOOTHES

Palmolive Shaving Cream gives a full, creamy lather that makes the beard wobble. The razor moves smoothly. Palmolive is also a lotion. Contains both Palm and Olive oils. Write for free trial tube. Large size tube at drugists 35c.

THE PALMOLIVE COMPANY, Milwaukee, U. S. A.
PALMOLIVE SHAVING CREAM

Try This Typewriter 5 Days FREE



\$4 DOWN—Ten Months to Pay!

Save more than half on any standard make. Every machine rebuilt in our own factory. Guaranteed to be in perfect condition. Try for 5 days at our expense. Write today for Big Special Offer. A postcard will do. Send now!

WYNN TYPEWRITER EXCHANGE, 7 Reliance Bldg., Kansas City, Mo.



Actual photo
of one of
our rebuilt
Underwood
Typewriters.

\$3
DOWN

And It's Yours

Standard Underwood

Rebuilt like new. Every typewriter is factory rebuilt by typewriter experts. New cases—new nickeling—new lettering—new plates—new key rings—new parts wherever needed—making it impossible for you to tell it from a brand new Underwood. An up-to-date machine with two-line ribbon, back spacer, stencil device, automatic ribbon reverse, tabulator, etc. In addition, we furnish FREE, waterproof cover and a special Touch Typewriter Instruction Book. You can learn to operate the Underwood in one day.

From factory to you

Yes, only \$3 brings you this genuine Rebuilt Standard Visible Writing Underwood direct from our factory, and then only small monthly payments while you are using it makes it yours; or, if convenient pay cash. Either way, there is a big, very much worth-while saving, too. Genuine new Underwood parts wherever the wear comes

—genuine standard four row, single shift keyboard—thoroughly tested—guaranteed for 5 years.

\$3 Puts It in Your Home

You don't even have to scrimp and save to pay cash. Instead, you pay only a little each month in amounts so conveniently small that you will hardly notice them, while all the time you are paying,

you will be enjoying the use of and the profits from the machine.

10 Days' Free Trial

Remember, you don't even have to buy the machine until you get it and have used it on 10 days' free trial so that you can see for yourself how new it is and how well it writes. You must be satisfied or else the entire transaction will not cost you a single penny.

Typewriter Emporium Shipman-Ward Mfg. Co.

2121 Shipman Bldg., Montrose and
Ravenwood Aves., Chicago, Ill.



All shipments made direct to you from our big modern factory (shown above)—the largest typewriter rebuilding plant in the world

Use Coupon

Now is the time when every dollar saved counts. Let us save you many dollars. Don't delay. Get this wonderful easy payment bargain offer now, so you can send for and be sure of getting your Underwood at a big saving—and our easy terms or for cash.

**Act Now—
Send Coupon Today!**

FREE TRIAL COUPON

Typewriter Emporium Shipman-Ward Mfg. Co.

2121 Shipman Bldg., Montrose and
Ravenwood Avenues, Chicago, Illinois

Send by return mail Bargain Offer No. 2121 of a Standard Visible Writing Underwood. This is not an order and does not obligate me to buy.

Name.....

Street
& P. O. No.....

Post
Office.....State.....

\$375.75 One Day!

Ira Shook, of Flint, Did That Amount of Business in 1 Day

—making and selling **Popcorn Crispettes** with this machine. He says in letter dated March 1, 1921: "I started out with nothing, now have \$12,000.00 all made from **Crispettes**." Others have amazing records: Gibbs says: "Sold \$50.00 first night!" Erwin's little boy makes \$35.00 to \$50.00 every Saturday afternoon. Meixner reports \$600.00 business in one day. Kellogg writes: "\$700.00 ahead first two weeks." Master's letter says: "—sold \$40.00 in four hours." During March, 1921, Turner was offered \$700.00 clear profit above cost of his investment to sell. **There is money—lots of money—in Crispettes.**

Times make no difference for most of these records were made in 1921—were made while people are crying hard times and are looking for jobs! Location makes no difference. It's common for **Crispette** machines to make \$10.00 to \$25.00 profit daily in small towns!

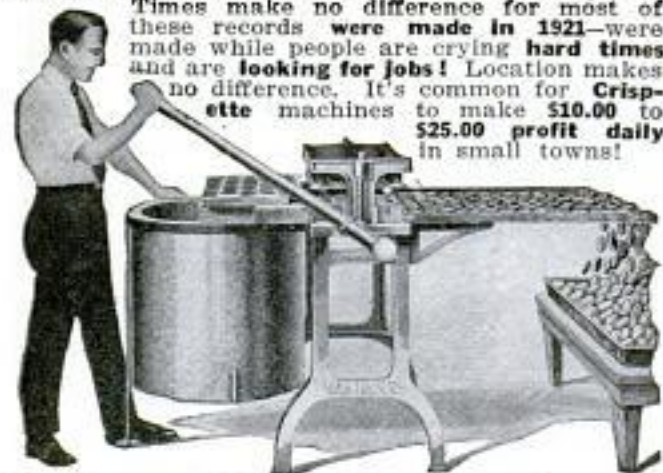

I Start You In Business

Write me—get my help. Begin now. Others are making money selling **Crispettes**. You can, too! You don't need much capital. Experience not necessary. I furnish everything—secret formulas, equipment for shop or store, full directions, raw materials, wrappers, etc. Splendid chances galore everywhere! Crowded streets, amusement parks, concessions, wholesaling and stores!

\$1,000.00 Monthly Easily Possible

Crispettes are a delicious, delightful confection. People never get enough. Always come for more. Raw materials are plentiful and cheap. You make enormous profits. Trade grows by leaps and bounds. It's an easy, pleasant and fascinating business. Send post card for illustrated book of facts. Contains enthusiastic letters from men and women who have quickly succeeded. Tells how to start. Explains most successful methods. Gives all information needed. It's FREE! Write Now! Address

LONG EAKINS COMPANY

128 High Street,

Springfield, Ohio

TWO YEAR GUARANTEED BATTERIES SAVE 50%



Famous "Royal" Batteries—highest quality made—now selling direct from factory to car owner. You save just about half. We give written 2 year guarantee—longest on any battery made. Big responsible organization backs guarantee. Batteries for any car, tractor or gas engine.

Send no money! Save time. Order from this ad. Battery shipped immediately—by express C. O. D. You run no risk. Our location saves for eight years.

Free Booklet If you want descriptive matter first, send for free booklet. Gives full details of this superior battery. Get this booklet before you buy any battery. Write today! Give year and model of your car.

K - E BATTERY CO., Dept. 56
14 E. Jackson Blvd., Chicago

SPECIMEN PRICES
Ford-Dart - - \$18.80
Overland-Buick 21.85
Maxwell-Dodge 25.60
All Other Cars Supplied
at Equally Low Prices

Largest Exclusive Mail Order Battery House in America

Please Mention Popular Mechanics

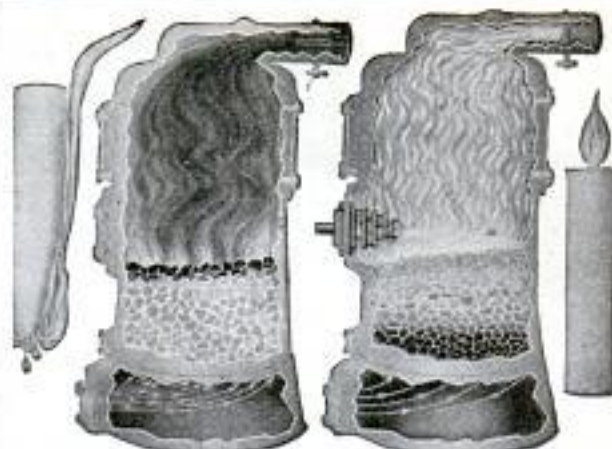

Rich Gases Unburned, Wasted Up the Chimney—WRONG WAY. Pre-Heated Air Injected Turns Gases into Intense Heat—RIGHT WAY.

Big Money in a Business of Your Own

CROWN Fuel Saver distributors are cleaning up to the tune of \$250-\$500 a month clear, solid profits, selling fuel economy to owners of furnaces and heating boilers. No experience needed—we train you in salesmanship, back you up with real service and business-getting selling helps, put all the resources of the strongest company in the field behind you.

This wonderful device has for six years and more been converting every sort of heater into a hot blast furnace, saving two tons of coal out of every ten, with less labor, soot, smoke, clinkers and ashes. **Sells readily everywhere.**

Exclusive territory now open to men with grit and gumption. Extra liberal contract—earnings constantly growing better. Write for proposition today—this may be your big opportunity.

CFSCO, 15 N. 10th St., RICHMOND, IND.

LAKWOOD FAN BELT FASTENERS



MAKE or repair your own flat belts for Autos, Trucks, Tractors, Electric Washers and small Shop Machinery with Lakewood Quick attachable Fasteners. Two sizes— $\frac{1}{2}$ in. and 1 in.; used alone and in combinations handle eight widths flat belting. Simply square up ends, rivet half of fastener to each end, slot together and go. Belt can be removed from pulleys instantly, but can't open in driving. Complete Fastener with rivets, 15c per set; 2 for 25c; 6 for 60c; or 12 sets in neat slide box for \$1.00. Specify size wanted. Sent postpaid same day order received. Fine proposition for Garage, Repairmen, and Dealers.

LAKWOOD FABRIC BELTING & MFG. CO.
1518 W. 117th St., Lakewood, Ohio



FREE

The first person in every community who purchases a **SUNRAY** Lamp, will receive a **300 Candle Power Lantern** worth \$8.50 absolutely **FREE**. Lights up the yard or barn like a searchlight. Cheap to operate.

No Wicks to Trim

No Smoke

No Smell

300 CANDLE POWER

SUNRAY lamps and lanterns operate 30 hours on a few cents' worth of kerosene or gasoline. Better than gas or electricity. Whitest light ever produced. Nothing to wear—simple—safe. **15 days' trial.** Satisfaction guaranteed. Write for special offer on **FREE** lantern and agency proposition. Act Now.

KNIGHT LIGHT CO.

Dept. F481

Chicago, Ill.



\$10,000 a Year

Because He Knows Law!

Are you *in earnest* when you say you would like to increase your income—qualify for the management of big affairs?

Then there is one thing you should do just as quickly as possible—**STUDY LAW!**

No *guess work* about this, mind you; it's the verdict of the most prominent executives in America—the very men who are naming *other* men for positions paying from \$10,000 to \$50,000 a year.

"What must I do?" asked Leonard Livingstone, when Percy H. Johnston (now President of the great Chemical National Bank of New York) told him that the man who *prepared* would go along with him to bigger responsibilities.

"Study law!" replied Mr. Johnston.
"A good sound knowledge of the law," writes D. P. Kingsley, President of the New York Life Insurance Company, "is becoming more and more necessary. I would advise any man who intends to equip himself for the management of large business interests not to consider his training complete until he has taken a law course."

"Whether I went thru college or not," advises William Maxwell, Vice-President of Thomas A. Edison, Inc., "I should surely study law."

"In looking over the field," writes a prominent Eastern manufacturer, "I find that nearly all the positions commanding a salary of \$10,000 or more are filled by men who have studied law."

Be a Law-Trained Man

Why stand stand still while other men are steadily preparing for the job you want? *You can train just as well as they!*

Right in the quiet of your own home, under the LaSalle Problem Method, you can study the same cases you would read at the resident universities, master the fundamental principles of law set forth by some of the most eminent authorities in the profession, develop under their direction a sound understanding of business relationships, a power for keen and logical thinking, a facility for analyzing *business* problems that in later years will make *you* the man the directors pick for an important and high-salaried position.

LaSalle text-books, "lesson talks," lectures, quizzes and examinations have been prepared by leading members of the American bar—prominent practitioners, judges, law professors in the great universities. You graduate with the degree of LL. B.—possessed with all the advantages of a thoro legal training as a foundation for independent practice or for a responsible position with one of the big corporations.

Prepare Now to Double Your Income

During the past few years literally thousands of ambitious men have doubled and tripled their earnings as a result of specialized business and professional training under the LaSalle Method. We will send you, if you like, the names and

addresses of 1,089 LaSalle members reporting definite salary increases during a three months' period. Read these typical statements from their letters:

"Passed the bar examination with second highest honors in a class of 71."

"Three years ago I was earning \$22.00 a week. Today I am comptroller of a good-sized corporation with an initial salary of \$4,500."

"Promoted to General Manager."

"Now Service Manager, with 466% increase."

"Passed bar examination in 'Class A', in competition with five graduates of resident universities."

Sign the Coupon

Whether you aim to practice law as a profession or to use it as a stepping stone to the big rewards in business, opportunity is fairly thumping on your door. It stands revealed in the coupon at the foot of the page. This coupon, signed and mailed, will bring you full information regarding the training you are interested in, together with details of our convenient-payment plan: also your free copy of that inspiring book, "Ten Years' Promotion in One."

Mail the coupon NOW and make TODAY your starting point toward big success.

LaSalle Extension University

The Largest Business Training Institution in the World
Dept. 164-LR Chicago, Illinois

Gentlemen: Send without obligation to me information regarding course indicated below:

LAW, Degree of LL. B.

LaSalle is the largest business training institution in the world. It offers training for every important business need. If more interested in any of these courses, check here:

- | | |
|--|--|
| <input type="checkbox"/> Business Management | <input type="checkbox"/> Modern Business Correspondence and Practice |
| <input type="checkbox"/> Higher Accountancy | <input type="checkbox"/> Modern Foremanship and Production Methods |
| <input type="checkbox"/> Traffic Management—Foreign and Domestic | <input type="checkbox"/> Personnel and Employment Management |
| <input type="checkbox"/> Railway Accounting and Station Management | <input type="checkbox"/> Expert Bookkeeping |
| <input type="checkbox"/> Commercial Law | <input type="checkbox"/> Business English |
| <input type="checkbox"/> Industrial Management Efficiency | <input type="checkbox"/> Commercial Spanish |
| <input type="checkbox"/> Banking and Finance | <input type="checkbox"/> Effective Speaking |
| | <input type="checkbox"/> C. P. A. Coaching |

Name

Present Position

Address

Hear the Wireless Concerts at Home

from far and near. The Latest News, Market and Weather Reports now broadcasted by radio by our Government.

Ever since the year 1909 Duck's Radio Catalog has blazed the way with everything worthwhile and dependable in radio.

This catalog eclipses all previous editions. It is all other catalogs in one. No other is even half as large. Over 50 pages of diagrams and data on radio.

Complete sets sell for as little as \$20.00—some even less.

Stations all about you.

Duck's 275-Page No. 16 Radio Catalog—Just Out. Send 12 cents in stamps or coin for your copy of this wonderful catalog. Not sent otherwise.

You could spend \$3.00 for text books and other catalogs and then not have the contents of this catalog.



THE WILLIAM B. DUCK CO., 223-227 Superior St., Toledo, O.

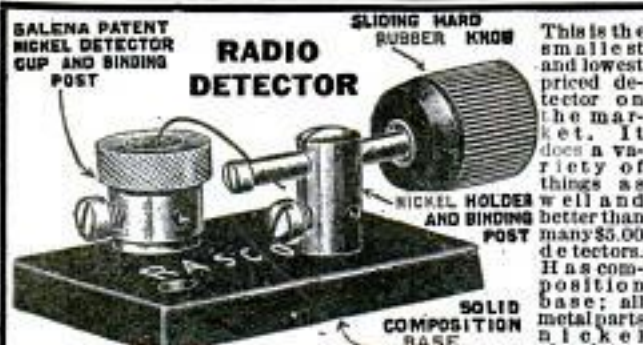

RADIO DETECTOR

This is the smallest and lowest priced detector on the market. It does a variety of things as well and better than many \$5.00 detectors. It has composition base; all metal parts nickel plated; furnished complete with galena crystal. Study illustration and notice new features. Note particularly patent nickel detector cup and binding post. Size 1 1/4 x 1 1/4 x 1 inch. Sent prepaid anywhere. Price complete

50c

If you build your own radio set you must have the RASCO catalog containing 185 illustrations and 30 vacuum tube connection diagrams—the greatest collection published in any catalog. Catalog contains the greatest assortment of parts and raw materials in U. S. Send 10c in stamps or coin for this catalog. "Radio Has It."

RADIO SPECIALTY COMPANY, 98E Park Place, N. Y. City

REAL MOVING PICTURE MACHINE AS LOW AS \$3.00!!

that anyone can operate anywhere
Uses big theatre films

Six wonderful guaranteed models to choose from.

Every boy in the land can now run his own movie shows at home.

HAVE FUN—MAKE FRIENDS—EARN MONEY

The Ideal Gift That Lasts

We also sell genuine films of best subjects as MARY PICKFORD, CHARLIE CHAPLIN, etc., etc.

Write to-day for big free illustrated catalogue and film price list.

PARAMOUNT MFG. CO.

Dept. M,

P. O. Box 1371, Boston, Mass.



THE MOVIEGRAPH

(patented)

Model 260—Wt. 8 1/4 lbs.

WIRELESS CATALOGUE

Whether you are interested in a complete radio receiving outfit, or a half a dozen binding posts, you'll find the particular instrument, best for your needs, in Corwin's Catalogue. Send 10 cents, (credited to your first order) for your copy to-day. Where's the nearest mail box?

A. H. CORWIN & CO. Newark, N. J.
4 West Park St. Dept. M

4 Weeks Trial

DIRECT FROM FACTORY NOT ONE CENT IN ADVANCE

Wing Pianos and Player Pianos shipped on 4 weeks' trial, freight prepaid. Have 25 to 50 percent. 40 year guarantee. Thousands in use everywhere. The Book of Complete Information about Pianos—FREE. Write at once for new book showing 55 styles. Also latest factory prices and easy terms. **WING & SON (Est. 1868), Dept. G-1-R, 9th Ave. & 13th St., N. Y.**



WRITE TODAY for Our 168-PAGE FREE BOOK on Deafness

and learn how Perfect Hearing is now being restored in every condition of deafness or defective hearing. Our "Little Wireless Phones for the Ears" require no medicine, but effectively replace what is lacking or defective in the natural ear drums. They are simple devices, which the wearer easily fits into the ears, where they are invisible. Soft, safe and comfortable.

WILSON EAR DRUM CO., Incorporated
295 Inter-Southern Bldg. LOUISVILLE, KY.



\$17.50 ALL WOOL SUIT

Made to your measure, payable after received.

Perfect fit, fine goods and tailoring, \$20 saving, all guaranteed or no pay. **SAMPLES FREE.** Every man should write at once for our beautiful free book of cloth samples and correct fashions, explaining everything. Write letter or postal; just say, "Send me your samples," and get everything by return mail **FREE.** Important to every man. Write today sure.

PARK TAILORING COMPANY
Dept. D 100-L, CHICAGO, ILL.

DIAMONDS

ONE CARAT \$195.00

Former retail cash price \$325.

New low prices 40% discount.

1/2 carat \$148.25;

3/8 carat \$97.50;

1/4 carat \$48.75. If satisfied, pay 20% down; balance

in 10 monthly payments.

10 MONTHS TO PAY

Genuine sparkling

blue-white diamonds

now sold direct to you

by **DIAMOND IMPORTERS**

on credit at 40% discount.

14 Kt. solid gold ring included free. We guarantee to satisfy you or return your money. **30 DAYS FREE TRIAL!**

Order direct from advt. or write for 128-page bargain catalog, sent free.

\$1,000,000 and 42 years' experience are back of our guarantees

B. GUTTER & SONS Div. 363, NEW YORK

172 NASSAU STREET

Div. 363, NEW YORK

Guaranteed \$13⁵⁰ 1/4 H-P. A.C. MOTOR

F.O.B. Chicago

Think of it—a new, latest type, 1/4 hp, single phase, alternating current motor, guaranteed for one year, for \$13.50!

This is lower than the before-war price. Motor is 110 volt, 1740 rpm, 60 cycle, split-phase, fan-cooled induction type. Suitable for running washing machines, churns, cream separators, ventilating fans, blowers, lathes, drills, etc. Furnished in two styles—with cord and plug as illustrated; or with binding post terminal (reversible type).



Motor weighs 24 lbs. bare, 33 lbs. boxed. It is the latest type of a large, responsible manufacturer, who guarantees every motor shipped, for one year, and attaches to each a **guarantee service tag**, serially numbered, which entitles owner to a new motor, by express prepaid, should defects develop within a year. Repair parts are always available at low cost; but motor is so sturdy and has so few parts that repair expense is negligible. Price complete, boxed, f.o.b. Chicago . . .

\$13⁵⁰

Quantity Discounts: On 3 motors ordered in 1 shipment, price is \$13.00 each; six motors \$12.50 each; 12 motors \$12.25 each; 25 motors \$12.00 each.

Send Cash with Order

or we will ship by express C. O. D. if you prefer

GRINDER and BUFF \$25⁰⁰

Above motor, equipped with 6 in. Norton No. 60 abrasive wheel, and 6 in. Hanson & Van Winkle Cotton Buff, complete with off-and-on switch and cord and plug.

Machine weighs 38 lbs. bare, or 52 lbs. boxed. It is ideal for the home, garage or workshop, for grinding tools and cutlery and for polishing silver and plated ware, also adapted to the heavy work of hotels and restaurants for the same purposes, and for general machine shop service. Speed 1740 r.p.m. Price, f.o.b. Chicago, **\$25⁰⁰**



This price is less than half the usual charge for a tool of this size and capacity.

Send Cash with Order

or we will ship by express C. O. D. if you prefer. Descriptive circular on application.

NORTHWESTERN ELECTRIC COMPANY
408 So. Hoyne Ave., Chicago

DIAMONDS WATCHES ON CREDIT

Genuine Diamonds GUARANTEED

PRICES LOWER
THAN THE LOWEST

Send for Catalog

Write for Free Wonderful Bargain Catalog today. Credit Terms fully explained. Amazing money-saving prices on Diamonds, Watches and Jewelry. **Diamond Rings, \$25 up.** Satisfaction guaranteed. Liberty Bonds Accepted. **Lady Louise Diamond Ring, Solid 14-K Green Gold; Diamond set in Solid White Gold. \$125 Value, \$83.33 Cash or Credit.**

Wrist Watch
Solid
18-K White
Gold, engraved; looks like genuine platinum. Full Jeweled Imported movement. Guaranteed. Silk Ribbon Bracelet. **Special at \$35.** Other Solid Gold Wrist Watches, \$25 up. Gold filled, \$15 up. Men's Watches, Guaranteed, \$17.50 up.



OPEN
A
CHARGE
ACCOUNT

USE YOUR CREDIT

SEND FOR FREE HOLIDAY CATALOG

THE NATIONAL CREDIT JEWELERS

Dept. H-894

108 N. State Street, Chicago, Ill.

Stores in Leading Cities

LOFTIS
BROS & CO. ESTD 1850

GREAT INTERCHANGEABLE-TYPE TYPEWRITER

Hammond

MULTIPLY

A NEW
FOLDING
MODEL
Full Capacity

Write for Free Booklet. Hammond Typewriter Co., 569A East 69th St., New York

Shoot Without Noise

BUY A
**MAXIM
SILENCER**

For your
Rifle or
Target
Pistol

The Most Interesting of all Gun Accessories. Reduces Noise and Recoil and Eliminates Flash. One of the Wonderful Inventions of our time. Made in every caliber from 22 to 45. Ask any hardware or sporting goods dealer to show you one, or send 6c. in stamps for catalog and BOOKLET of astonishing experiences of Silencer users.

THE MAXIM SILENCER CO.
93 Homestead Ave., Hartford, Conn.

Hand
Forged
Razor Steel
Blades, No. 57



A GENUINE \$2 KNIFE
FOR
\$1.38 POSTPAID

Direct at Factory Prices

This \$2 KNIFE \$1.38 Postpaid

Hand Forged Razor Steel Blades

Handy shaped blade makes this knife best for mechanics, sportsmen and farmers; light but strong; re-sharpened easily. Stag handle. German silver finish; blades file tested, hand forged from razor steel and warranted.

Sample \$1.38, 3 for \$3.60 postpaid.

Send for our 100 page List and "HOW TO USE A RAZOR" **FREE**

MAHER & GROSH CO., 106 A. St., Toledo, Ohio

THE AJAX EYELET FASTENER

Binds Papers Quickly and Permanently

It Saves Time by
Punching the Hole,
Feeding the Eyelet
and Clinching it
in One Operation.

Drop the eyelets into the magazine and go right ahead. Order from your stationer or direct.

Write for our catalogue of office tools



MACHINE APPLIANCE CORPORATION
351-353 Jay Street ★ Brooklyn, N. Y.



KEEP WARM

by wearing Russell's Outing Clothing. Here are a few genuine bargains:

Sheeplined Coats, 34 inches long.....	\$ 2.75
Sheeplined Moccasins.....	1.00
All wool Army Underwear, suit.....	2.50
Heavy wool Army socks.....	.45
Wool flannel Army shirts.....	3.55
Coat style, wool, Army Sweaters.....	5.00
Army wool blankets.....	3.50
Aviator's leather helmet.....	3.50
U. S. Navy Pen Jackets.....	16.00

We have a complete assortment of Army and Navy Uniforms, insignia and equipment. Also all winter sporting goods.

Write for FREE CATALOG 112 containing over 2000 Army, Navy, and Sporting Goods specials.

RUSSELL'S (Incorporated)

245 West 42nd Street

Formerly Army & Navy Store Co., Inc.

New York

ASBESTOS

We are miners and shippers of Crude Asbestos in any quantity. We produce all grades at our world-famous BELL ASBESTOS MINES, in Canada. We also card fibres, spin yarns, weave cloths, and make all sorts of Asbestos products.

For anything you want in Asbestos, turn to

KEASBEY & MATTISON COMPANY

Dept. S-3, AMBLER, PENNA., U.S.A.

Owners of the world's largest Asbestos Mines

MONEY IN MUSHROOMS

NOW TIME TO START
BIG DEMAND. HIGH PRICES BEING PAID

An uncrowded occupation. Exceptional opportunities for live men and women. Raised at home. Only small space needed. Small expenditure will start you in a practical money-making enterprise. Big profits. Booklet telling all free. Write **Nat'l Spawn Co., Dept. 17, Waban, Mass.**

STRUCTO TOYS The most perfect copies of real Automobiles, Trucks, Tractors and Tanks. Ask your Toy Dealer to let you see them.

**Practical
Training**



**Expert
Instruction**



Auto Mechanics Step Into Bigger Pay

Here is a secret of success. 9 out of 10 auto mechanics are weak on electrics, while 75% of car troubles come from the electrical end. Moral: **Learn the electrical end of the auto business and get bigger pay.** Why putter along knowing only part of the business? Why not check up your knowledge and prepare yourself for a step ahead? Big-pay jobs are open for men who know. Special advanced training at the MICHIGAN STATE AUTO SCHOOL, in Detroit, the auto center, will make you an Expert Auto Electrician, the step ahead for auto mechanics.

Be An Expert Auto Electrician

Special Course for Garage Men

More Auto Mechanics must go after the electrical end and master it to meet the need. Everywhere experts are wanted who can tell definitely what is wrong with the electrical system of cars, trucks, and tractors, and can make the repairs properly and quickly. M. S. A. S. now offers a special **Advanced Electrical Course**. This is not elementary instruction but highly specialized advanced work for a specific purpose—to train electrical experts. So great is the need for real automotive electricians that we have increased our training capacity and added a big three-story building. Up-to-date electrical equipment is here for you to work on. Expert instructors are here to give you individual instruction. You train head and hand in a few weeks.



What We Teach

The course includes scientific teaching and experiments of electrical operation, induction, magnetism, regulation, circuits, etc. The student has actual practice in testing, wiring, and adjusting every part of starting, lighting and ignition system; also over-hauling all systems; tearing down and assembling; operating them on live motors; trouble shooting on live cars; building and repairing of storage batteries; armature winding; farm lighting systems. This course is advanced work, and will enable experienced mechanics to do better work and earn better salaries—to reach the top.

Life Scholarship in Factory-Endorsed School

Life membership with privilege of our service free at any time, is included with your enrollment here. Our position in the center of the Auto Industry, and the co-operation of the leaders in this industry, enable us to offer quality training at a lower cost than less efficient training is given for. Ask about this—

Big 188-Page Catalog—**FREE**

MAIL COUPON TODAY

This book tells in detail about M. S. A. S. training, methods and equipment. It includes letters from graduates telling what this training has enabled them to do, and letters from leaders in the auto and tractor industry endorsing our methods. There is no obligation in sending for this catalog. It will tell you more about the opportunities for trained men in the great automobile business, and what the M. S. A. S. can do for you. It's FREE. Send your name and address today. Use coupon or post-card. But write NOW!

Catalog Coupon

MICHIGAN STATE AUTO SCHOOL
21 Auto Bldg., Detroit, Mich.

Please send me your FREE 188-Page Catalog, and special information on the advanced electrical course.

MICHIGAN STATE AUTO SCHOOL

The Factory-Endorsed School

A. G. ZELLER, President

21 Auto Bldg., 3729 Woodward Ave.
DETROIT, MICHIGAN

Name

Street or R. F. D.

City..... State.....



Be a better Musician

If you want to be a better musician; if you want to gain a reputation as an artist—then you must play the most perfect instrument obtainable—and that means a "King". The best musicians admit the superiority of a King.

For a quarter century, King Band Instruments have maintained their world-wide reputation. Each instrument is a masterpiece built by expert workmen in our own, modern factory.

Now Sold Direct from Factory on Easy Payments

Once, King Instruments were sold only for cash to famous players, and were considered expensive. Now, anybody can afford to buy a King on our easy payment plan.

When you buy direct from us, you save all the middlemen's profit and positively get a brand-new, perfect instrument. And with every new King goes our famous free factory-service and guarantee.

Big Stock of Used Instruments

Thousands of musicians have turned in good instruments as part payment on new and better Kings. These used instruments we sell for cash at very low prices. They are refinished and look like new. Send for our latest complete catalog and list of these bargains before they are gone. Ask for details of easy payment plan on new instruments.

THE H. N. WHITE CO.
5239 Superior Ave., Cleveland, Ohio



TYPEWRITERS

All Makes. Save \$25 to \$50

rebuilt at the factory by the well-known "Famous Young Process." Sold for low cash—installment or rented. Rental applies on purchase price. Write for full details and guarantee. Free trial.

YOUNG TYPEWRITER CO., Dept. 148, Chicago



WINDOW SIGNS

AGENTS 500% PROFIT

Gold and Silver Sign Letters

For store fronts, office windows and glass signs of all kinds. No experience necessary. Anyone can put them on and make money right from the start.

\$75.00 to \$200 a Week!

You can sell to nearby trade or travel all over the country. There is a big demand for window lettering in every town. Send for free samples and particulars. **Liberal Offer to General Agents.**

METALLIC LETTER CO.

433B North Clark Street

CHICAGO, ILL.



Imperial Sanitary Floor

Put on like Plaster
Wears like Iron
-waterproof
-fireproof
-resilient
-noiseless
-dust-less

Base and Floor
one solid piece

A composition material easily applied in plastic form over practically any kind of floor. Laid about $\frac{1}{8}$ inch thick. Imperial Floor does not crack, peel or come loose from foundation. A continuous, fine grained, smooth, non-slipping surface. No crevices to gather grease, dirt, dust, disease germs or moisture.

Ideal Floor for Kitchen, Pantry, Bath Room, Laundry, Porch, Garage, Restaurant, Theatre, Hotel, Factory, Office Building, Railroad Station, Hospital—wherever a beautiful, substantial floor is desired. Several practical colors. Full information and sample FREE of your first and second choice of color.

Imperial Floor Co., 39-41 East Ave., Rochester, N.Y.

A Success for 15 Years



"Best" Hand Lantern

A powerful portable lamp, giving a 300 candle power pure white light. Just what the farmer, dairyman, stockman, etc., needs. Safe—Reliable—Economical—Absolutely Rain, Storm and Bug proof. Burns either gasoline or kerosene. Light in weight. Agents wanted. Big Profits. Write for Catalog.

ADOPTED BY THE U. S. GOVERNMENT

The Best Light Co., 324 E. 5th St., Canton, O.

MUSIC LESSONS FREE



IN YOUR OWN HOME

You can read Music like this quickly

Piano, Organ, Violin, Mandolin, Guitar, Banjo, etc. Beginners or advanced players. One lesson weekly. Illustrations make everything plain. Only expense about 2c per day to cover cost of postage and music used. Write for FREE booklet which explains everything in full.

AMERICAN SCHOOL OF MUSIC, 50 Lakeside Building, CHICAGO



SELF-FILLING INK PENCIL

"INDEPENDENT"

Meets all requirements. Self-filling, non-leakable, safety cap. Attached clip. Smooth writing gold style point.

Guaranteed Improved Fountain Pen. Eliminates fatigue. Promotes efficiency. Writes uniform. A business necessity.

\$2 By Mail

Your Name in Gold—35 Cents Extra

AGENTS WANTED

J. C. ULLRICH & CO., 161 Washington St., New York



SEND NO MONEY

If You Can Tell it from a GENUINE DIAMOND Send it back

To prove our blue-white MEXICAN DIAMOND cannot be told from a GENUINE DIAMOND and has same DAZZLING RAINBOW FIRE, we will send a selected 1 carat gem in Indian Solitaire Ring, (Cat. price \$5.25) for Half Price to introduce, \$2.63, or in Gentle Heavy Tooth Belcher Ring (Cat. Price \$6.50) for \$3.25. Our finest 12K Gold Filled mountings. GUARANTEED 20 YEARS. SEND NO MONEY. Just mail postcard or this ad, State Size. We will mail at once. When ring arrives deposit \$2.63 for Ladies ring or \$3.25 for Gents with postman. If not pleased return in 7 days for money back less handling charges. Write for free catalog. Agents Wanted.

MEXICAN DIAMOND IMPORTING CO., Dept. ET, Las Cruces, N. Mex.
(Exclusive controllers Mexican Diamonds)

Help Wanted

We require the services of an ambitious person to do some special advertising work right in your own locality. The work is pleasant and dignified. Pay is exceptionally large. No previous experience is required, as all that is necessary is a willingness on your part to carry out our instructions.

If you are at present employed, we can use your spare time in a way that will not interfere with your present employment—yet pay you well for your time.

If you are making less than \$150 a month, the offer I am going to make will appeal to you. Your spare time will pay you well—your full time will bring you in a handsome income. It costs nothing to investigate. Write me today and I will send you full particulars by return mail and place before you the facts so that you can decide for yourself.

ALBERT MILLS, Gen. Manager Employment Dept.
5515 American Bldg., CINCINNATI, OHIO

We pay \$8 a Day

taking orders for New Kerogas Burner. Makes any stove a gas stove. Burns kerosene (coal oil). Cheapest fuel known. Fits any stove. Burns like gas.



Clean
Odorless
No
Smoke

Easy to get orders on account of high price and scarcity of coal. Work spare time or full time. Write for sample.
THOMAS MFG. CO. B-848 DAYTON, OHIO

MAKE \$15 A DAY: EVERY HOME NEEDS IT
Wonderful Easy Knife, Scissors and Tools sharpener. Sells 50cts. 200% profit to agents.

Write for particulars
PREMIER CO.
806 E. Grand Blvd.
Detroit, Mich.

Sample sent for 25c
coin or stamps.

**BIG CHANCE
FOR YOU**



Send for a Complete Catalogue of
**MASONIC BOOKS
Jewelry and Goods**
REDDING & CO.
Publishers and Manufacturers
Dept. D 200 Fifth Avenue, New York



Moore Push-Pins
Glass Heads—Steel Points
Moore Push-less Hangers
To hang up things
Ask your dealer to show them
Sold Everywhere **10¢** per packet
Moore Push-Pin Co.
Wayne Junction Philadelphia

FREE TRIAL

Cut out this ad and mail it to us, with your name and address (no money), and we will send you our **FAMOUS KARNAK RAZOR** by return mail, postpaid. You may use the razor for 30 days **FREE**; then if you like it, pay us \$1.85. If you don't like it, return it. — **SEND NO MONEY** —

MORE COMPANY Dept. 355 ST. LOUIS, MO.



High School Course in Two Years!

Lack of High School Training has kept thousands of men and women from attaining **business and social position**. Without this training you are absolutely barred from a successful business career, from the leading professions, from well-paid civil service jobs, from teaching and college entrance. In fact, all **preferred positions** are closed to you without this vital training. You can't stand this heavy handicap nor do you have to. The American School can give you the valuable training you missed.

Put Your Idle Hours to Work You can complete our simplified High School Course within two years by spare-time study. Then you will be mentally equipped to handle a worthwhile position. This Course, prepared by some of America's leading professors, will broaden your mind, give you a wider outlook and make you keen, alert and capable.

Remove Your Handicap

Whether you need High School Training or specialized instruction in your chosen line — **NOW** is the time to remove your handicap. You must know the **HOW** and **WHY**. Over 50,000 students owe their success to training received from the practical, money-making Courses in the coupon below. Let us tell you about this training — about the Course you are interested in. Check and mail the coupon.

Try Ten Lessons FREE At our expense — not yours — try ten lessons in any Course before deciding. If you are not completely satisfied you are not out one cent. **We guarantee satisfaction.**

AMERICAN SCHOOL

Dept. H-174-X Drexel Ave. and 58th St., Chicago

AMERICAN SCHOOL

Dept. H-174-X, Drexel Ave. and 58th St., Chicago
Send me full information on how the **PROMOTION PLAN** will help me win promotion in the job checked.

- | | |
|------------------------------|----------------------------|
|Architect |Lawyer |
|Building Contractor |Machine Shop Practice |
|Automobile Engineer |Photoplay Writer |
|Automobile Repairman |Mechanical Engineer |
|Civil Engineer |Shop Superintendent |
|Structural Engineer |Employment Manager |
|Business Manager |Steam Engineer |
|Cert. Public Accountant |Foremanship |
|Accountant and Auditor |Sanitary Engineer |
|Bookkeeper |Surveyor (& Mapping) |
|Draftsman and Designer |Telephone Engineer |
|Electrical Engineer |Telegraph Engineer |
|Electric Light & Power |High School Graduate |
|General Education |Fire Insurance Expert |

Name

Address

1/2 SAVED
BUY
DIRECT
GET BIG BOOK



DO YOUR OWN PLUMBING & HEATING AT LOW COST

Send for our big instructive 256-page well-bound **HANDY MAN** Book-Catalog. Every homeowner, contractor, farmer, mechanic, institution, etc., needs it. Shows over 10,000 fixtures and supplies in plumbing and heating at wholesale; how to save skilled labor, hard work and unnecessary material by our new



Pipeless Furnace

Cut-To-Fit Method

This wonderful encyclopaedia on plumbing and heating helps you select and install the proper plumbing, water system, hot air, water or steam plant. Besides being our wholesale catalog, it has many practical plans, diagrams, sketches, elevations, handy links, etc., showing how to do the work this newer easy way. Any handy man with a few tools can do his own installing with the aid of this

Big Handy Man Book

We have spared no effort, and have gone to a GREAT EXPENSE to compile this valuable book, and to keep from sending it to uninterested persons, we request 25c, which will be refunded on your first order, or send for our free bulletin.

Write today and save.

HARDIN-LAVIN CO.

50 Years at 4547-4557 Cottage Grove Avenue, CHICAGO

\$500,000 Plants Behind Our Guarantee



Hot Water Boiler



"Lighting Fixtures"

READY TO HANG

(Direct from Manufacturers)

Completely wired, including glassware. New designs. Send for catalogue No 20.

ERIE FIXTURE SUPPLY CO.

STA. A. ERIE, PA.

KEITH'S \$2.50 OFFER



3 Plan Books, showing 100 designs of artistic bungalows, cottages, or two-story houses—in frame, stucco and brick—with floor plans and descriptions, and 8 months' subscription to Keith's Magazine, all for \$2.50.

Keith's Magazine for over 20 years an authority on planning, building and decorating homes—25c a copy on newsstands. With its help and Keith's Plans you can get the most distinctive, comfortable and satisfactory home with greatest economy. **Set of 3 plan books (260 plans) and Keith's for 12 months—\$4.50** Keith Corporation, 527 Abbay Bldg., Minneapolis, Minn.

Marvelous Invention Gives More and Better Light from Kerosene and Gasoline

WIZARD AUTOMATIC CLEANING NEEDLE makes possible more and a continuous light as brilliant as electricity. Cost of operation as low as six hours for one cent for 300 candle power of light. No smoke. No wicks to trim. No odor.

WIZARD

Lamps and Lanterns

Used in every part of the world on farms, cottages, homes, barns, stores—every place where sure, dependable, low-cost light is needed. Beautifully finished, light in weight, portable. Unlimited guarantee.

Quicklit

gasoline lamps and lanterns are lit with a common match like city gas.

Agents Making \$15 to \$25 a Day

We have an exceptional sales plan for capable salesmen. \$15 to \$25 a day and more can be made easily. Permanent connection with old, well-established concern. Write today for full particulars.



The Nagel-Chase Mfg. Co.

285-289 E. Erie Street, Chicago, Ill.



The "BEST" LIGHT

Positively the cheapest and strongest light on earth. Used in every country on the globe. Makes and burns its own gas. Casts no shadows. Clean and odorless. Absolutely safe. Over 200 styles. 100 to 2000 Candle Power. Fully Guaranteed. Write for catalog. AGENTS WANTED EVERYWHERE.

THE BEST LIGHT CO., 324 E. 5th St., CANTON, O.

Beautiful HOUSES \$900 and BUNGALOWS

CAN BE BUILT FOR AND UP This and many others in my new book, Building Plans for Modern Homes, will save you hundreds of dollars. One of the most complete and comprehensive books of plans ever published by any architect. New edition just off the press. Nearly 500 floor plans and photographs of bungalows, Colonial houses, etc., costing from \$200 up; gives sizes and cost to build. Sent postpaid for \$2.00



FREDERICK H. GOWING
ARCHITECT

18 Tremont St., BOSTON, MASS.

WHITE FLAME

BURNERS make your old kerosene lamps and lanterns give a brilliant white light better than electricity or gas. Doubles your light. Saves oil. **NO MANTLE TO BREAK.** Guaranteed Safe and Reliable. Delights every user. Send now for complete sample postpaid 50 cents, stamps or coin. 3 for \$1.25. Money Back if Not Satisfactory. Live Representatives Wanted. Exclusive Territory. **WHITE FLAME LIGHT CO., 68 Clark Bldg., Grand Rapids, Mich.**



HAWAIIAN IM. DIAMONDS



No. 9110
Special Price \$2.98

The Greatest Discovery the World Has Ever Known. Just to advertise these famous Im. diamonds we will send you one of these 14kt gold rings, postage paid. When it arrives pay postpaid \$2.98 C.O.D. charges to cover cost, etc. Only 10,000 rings given away. Money refunded if you can tell it from a genuine diamond. Send size of finger.

KRAUTH & REED
Dept. C
Masonic Temple Chicago



No. 9111
Special Price \$2.98

MAKE MONEY Building Phonographs

Make Big Money Building Phonographs

Ask for Our Sure-Fire Plan and Free Blue Print Offer

You can make hundreds of dollars easily. Ask us. We tell you how and help you. We have started many others. We can start you. Pleasant, easy work. N. J. Adams, Michigan, says: "Just sold my phonograph which I built from your plans and parts at nearly \$100 profit. Only took about a week working evenings to build it. Those who have heard it say that it is better than phonographs they have seen and heard at \$200."

We furnish everything—blue print plans—case material, tone arms, motors, full instructions. You can easily make \$100 to \$200 a month in spare time. Even boys of 14 make them. They play any record. Wonderful tone—equal to any you ever heard. Sell to friends and neighbors. Write now for free blue print offer.

Become a Home Dealer—Wonderful Plan

Our dealers' proposition on our ready-built Phonographs will appeal to you. It's the best thing yet. No canvassing—no work—no capital needed. It works every time. We give you full particulars and show you how to make sure, easy money. Remember, we are the old reliable house-originators of the home building and home dealers idea. Write today. Get our proposition. Have a fine phonograph at half price and make money besides.

Choraleon Phonograph Co.
121 1st Street ELKHART, IND.



PLAN YOUR FUTURE HOME NOW



Send for Stillwell Building Books with Economy Plans of new California Styles suitable for any climate. Famous for comfort and beauty

- "Representative Cal. Homes"
50 Houses—7 to 10 Rooms, \$1
- "The New Colonials"
60 Houses—6 to 10 Rooms, \$1
- "West Coast Bungalows"
50 Houses—6 & 7 Rooms, \$1
- "Little Bungalows"
75 Houses—3-4-5 Rooms, \$1

SPECIAL OFFER: Send \$2.50 for any three of these books and get Garage Folder **FREE**

Money back if not satisfied.

E. W. STILLWELL & CO., Architects, 781 Calif. Bldg., LOS ANGELES



SAXOPHONE MUSIC Catalog

Just out—complete catalog of latest jazz hits, also standard saxophone solos, duets, trios, quartettes—2000 selections. Largest general dealers of saxophone music and supplies in the world. *Expert repairing.* Send for free catalog today.

SAXOPHONE SHOP, 427 S. Wabash Ave., Chicago

AGENTS: \$72 A WEEK

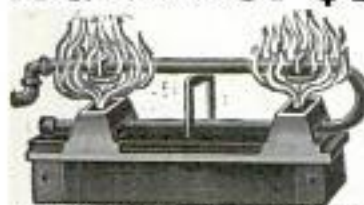

New Can't Clog Coal-Oil Burner Newest Invention

Most perfect burner ever invented. Intense blue flame. Can't clog up. Turns any coal or wood stove into a gas stove. Heats oven to baking point in ten minutes. Cheapest fuel known. Low priced. Sells everywhere. Nothing else like it. Not sold in stores. Write quick for agency.
PARKER MFG. CO., 578 Coal Street, DAYTON, OHIO



Enders
SAFETY RAZOR

Ask him
Why
Shaving with
an Enders
is—

**“Just like
wiping
your face
with a
towel”**

ENDERS
sells for \$1,
with six
blades, at
all up-to-
date dealers
everywhere.
Extra blades,
package of 5
—35c.

Blades — hand-stropped and hand-tested

ENDERS SALES COMPANY
105-111 West 40th Street
NEW YORK



TRADE MARK
PAT. MAY 2, 1906

Please Mention Popular Mechanics

"I Saved \$90⁰⁰ on My Engine



by Selecting a Dependable OTTAWA,"

Writes John H. Henneke of Waukomis, Oklahoma.

"I am well pleased with my OTTAWA 7 H-P. Engine and I am sure I saved \$90 by buying direct from you over what they asked for the same size here. The OTTAWA is easy to start and develops steady, even power at all the different speeds."

You, too, can save money and get a better engine by selecting an OTTAWA now. My prices are down to bed-rock—lower than are now made on any reliable engine. My Special Offer saves you \$15 to \$200. Write for full information TODAY.

OTTAWA ENGINES

KEROSENE—GASOLINE—DISTILLATE—GAS.

1½ to 22 H-P. Built in and sold direct from the same mammoth factory as the world famous OTTAWA Log Saw. Built carefully, by skilled workmen and of highest grade material.

The OTTAWA is the standard by which engines are judged for dependability, Easy to start, Easy to operate.

90 Days' Trial: Three whole months to test the OTTAWA at your own work. Every engine shipped on this offer.

10-Year Guarantee: Every OTTAWA Engine Must Make Good My Binding Guarantee.

Special Offer Now! Send me your name and address for my Big Special Offer and valuable book: "How To Know Better Engines."

H. C. OVERMAN, Gen'l Mgr.

OTTAWA MFG. CO. 518-A King Street, OTTAWA, KANSAS.

Get my New Lower Prices and Easy Payment Plan before you select any engine. **H. C. OVERMAN, Gen'l Mgr.**

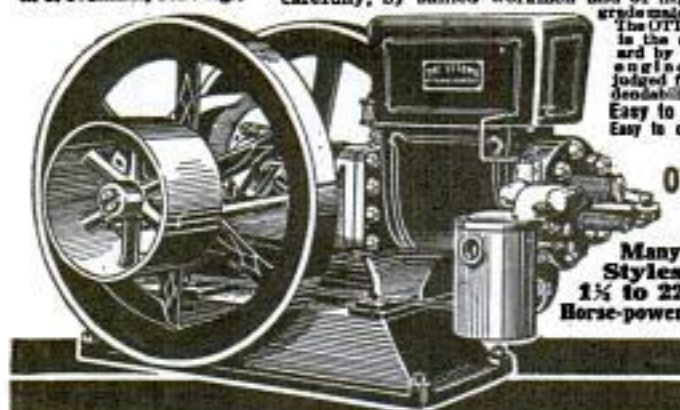

Many Styles
1½ to 22
Horse-power

LOOK!
1½ H-P.
NOW ONLY
\$35.50
2 H-P. \$38.50
Other Sizes
Proportionately Low

This Fine
ENGINE BOOK
FREE!
Send TODAY.

How to Know
BETTER
ENGINES



The OTTAWA Gives Dependable Shop Power

Cash
or
Easy
Terms



For Pumping and All Farm Uses

ADD \$5.00 A DAY TO YOUR PROFITS BY QUICKER, CHEAPER AND BETTER WORK

The TORIT No. 13 ACETYLENE TORCH goes the big. The latest invention for the speedy repairing of radiators, for heating, tempering, sweating, all kinds of soldering, light brazing, etc.

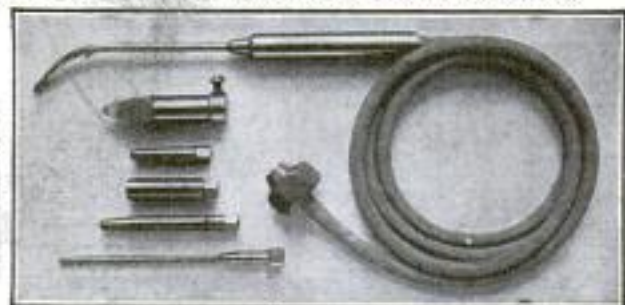

The **HANDY** works for the garage, electrician, and general repair shop. **QUICK, CHEAP, DEPENDABLE**, and will return to the purchaser in a short while. Heavy times its cost. Furnished complete with 4 tips, **SOLDERING COPPER**, tubing and equipment for Presto Auto Tank. Price \$7.50. Order **now TODAY**.
St. Paul Welding & Mfg. Co., 177 W. 3rd St., St. Paul, Minn.

TIRRO

the ideal mending tape of a thousand uses—sticks to anything and stays stuck. For sale at all druggists. A Bauer & Black product.

1/4 H. P., 110 volts,
A. C., 60 cycles,
single phase,
1750 R. P. M.

MOTORS

LARGE QUANTITIES NEW WASHING MACHINE MOTORS

These are of standard manufacture and carry the full factory guarantee. Shipped in original boxes. Complete as ret. Suitable for operating Coffee Grinders, Cream Separators, Bottle Washers, Air Compressors, Small Lathes, Etc.

Mail \$1.00 check or money order. We will send C.O.D. subject to full examination. Money Ref. Secured.

\$22.75 Each

MANUFACTURER'S DISTRIBUTOR

GRAS. H. JOHNSTON - Box 15 W. E., Pittsburgh, Pa.

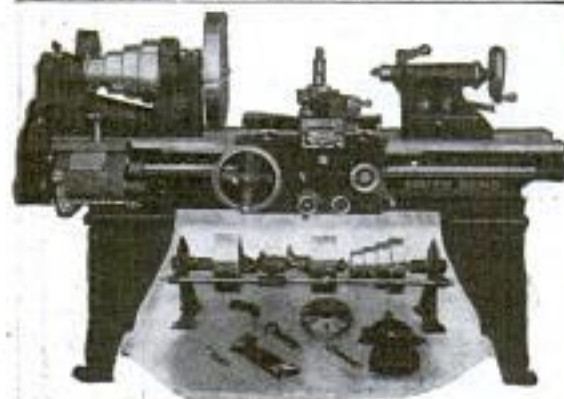

REDUCED PRICES

Back to Normalcy -- 20% Further Reduction

"SOUTH BEND" LATHES

	Standard Change Gear	Quick Change Gear		Standard Change Gear	Quick Change Gear
9"x3' Lathe	\$176.00	\$216.00	16"x8' Lathe	\$452.00	\$512.00
11"x4' Lathe	228.00	273.00	18"x10' Lathe	656.00	721.00
13"x5' Lathe	304.00	354.00	21"x12' Lathe	848.00	923.00
15"x6' Lathe	376.00	431.00	24"x14' Lathe	1140.00	1230.00

64-page Catalog No. 75 for 1922 sent free to any address.

ESTABLISHED 1906

SOUTH BEND LATHE WORKS,
625 E. Madison St. **SOUTH BEND, IND.**

How to Run a Lathe An 80-page book, postpaid to any address for ten cents, silver or stamps accepted.

FOR SMALL POWER USERS

1 H.P.

1/2 H.P.

Light-
Weight
Compact
Reliable

Over
200,000
now in
operation

Maytag Multi-Motor

If you build any machine or device that is operated by a small power unit—especially for places where electricity is not available—get the facts about this remarkable gas engine. Made in 1/2 h.p. and 1 h.p. sizes. Air cooled. Operates on gas or gasoline. Equipped for battery or magneto ignition.

Our Engineering Department can help you with the details of your power problem. Special prices to manufacturers using large quantities. Write for information.

MADE BY

THE MAYTAG CO., Dept. X, Newton, Iowa



It is the well known quality of CRESCENT machines that justifies you in selecting one of them each time you have need for wood working machinery. The CRESCENT line is better than ever and will always give you satisfaction in every particular. Ask today for catalog of hand saws, saw tables, jointers, shapers, planers, bores, planers and matchers, swing saws, disk grinder, cut off table, hollow chisel mortiser, variety wood worker, Universal wood workers.

THE CRESCENT MACHINE CO., 93 Columbia Street, Leetonia, Ohio

Little Giant Drill Press

Just the thing for small shop and experimental work. Mechanically right and well made. Size 0 to 1/4 in. drill. Weight 23 pounds. Price \$15.00.

Send for circular.

SYPHER MANUFACTURING CO.
Dept. "D" Toledo, Ohio

Speed Lathe \$10.50

Swing 7 in. 24 in. Metal Bed

Longer Bed \$1.00 per additional foot.
3 1/2 in. Face Plate \$1.25. Spur Center for Wood Turning \$1.00

Head has 3-speed cone, No. 1 Morse Taper Shank Centers, 3-8 in. hole thru spindle. Tail Stock has screw feed spindle and No. 1 Morse Taper Blank Center.

Immediate Delivery

CENTRAL MANUFACTURING CO. We manufacture a bench hand saw FAIRFIELD, IOWA

AGENTS—A REAL MONEY MAKER

High-Grade Assortments of 14 Knives, All German Silver-Nickel Bolsters, Brass Lined. No seconds. \$6.70. Boards extra \$1.00. Write for Descriptive Circular and Price List. 20% Cash with order, balance C. O. D.

THE GOLDEN RULE CUTLERY COMPANY
212 North Sheldon St., Chicago, Illinois
Est. 1900 Dept. 311

Men Wanted to become Draftsmen

Salary \$250 to \$300 a month when competent. Chief Draftsman will train you personally until you are placed in high salaried position. The day you start I will give you absolutely FREE a draftsman's complete working outfit. Thousands of draftsmen are needed. Big pay, clean work.

Write Today Send your name and address for my booklet "Successful Draftsmanship." It carries a vital message to you. Sent free. No obligation. Write today. CHIEF DRAFTSMAN DOBE Dept. 8353 4001 Broadway Chicago, Illinois

Going to Build Remodel or Repair?

DON'T think of planning a new home or repairing an old one without copies of our two free books.

Our Building Material Catalog shows latest ideas and most advanced styles for everything in building. We ship everywhere everything in the way of high grade lumber roofing, doors,



Material Complete for Houses from \$500.00 Up

windows, porchwork, screens, builder's hardware, paints, wallboard, interior woodwork, plumbing, heating and water supply outfits—all at money saving prices direct to you. Plan Book shows skillfully planned homes of all kinds, bungalows, city houses, suburban residences, country homes, barns. Tells you how to get building plans FREE. Write today. No obligation.

Let us develop plans from your rough sketches. Send your material list for free estimate price.

Catalog of 6000 Price Bargains

Beautifully Illustrated PLAN BOOK

CHICAGO MILLWORK SUPPLY CO., 1444 W. 37th St., Chicago, Ill.
PLEASE SEND ME YOUR FREE BOOKS.

Name _____
Town _____
State _____
Occupation _____

St. No. _____

Books
Are Free



Thanks to a good dealer you can get
**WHITING-ADAMS
 BRUSHES**
 Buyers of them always get
 good deals, no discards - -

Send for Illustrated Literature
JOHN L. WHITING-J. J. ADAMS CO., Boston, U.S.A.
 Brush Manufacturers for Over 112 Years and the Largest in the World

MONARCH JUNIOR LATHES

"The Biggest Little Lathe Built"

A real engine lathe—small, sturdy, compact, low-cost—guaranteed to do all small work with 1/1000 of inch accuracy. Built with the same care and precision that made **MONARCH ENGINE LATHES** the world's standard of quality and efficiency.

THE MONARCH JUNIOR is ideal for beginners. Occupies small space in your own home or shop. Easy and economical to operate. Simple and trouble-proof, automatic safety features. Fully equipped.

The Greatest Achievement in Lathe Building History

Monarch Junior 9 in. Engine Lathe \$225 With Bench Legs

Full particulars and a Monarch Junior Catalog will be sent you on request.

THE MONARCH MACHINE TOOL CO.
 200 Oak Street Sidney, Ohio

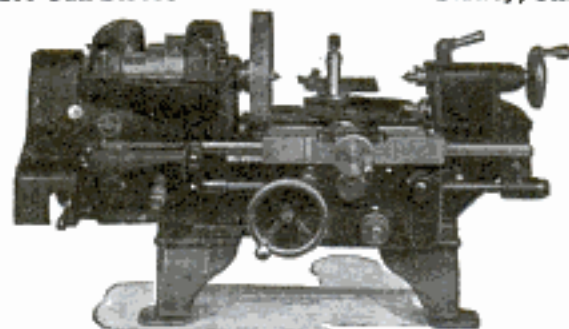

One Man Saw Rig

Cuts Faster—Pays for Itself

Saw your own wood for winter. Make big money cutting wood for market. New **OT-TAWA One-Man Saw Rig** saves time and labor. Easily moved. Magneto equipped. No extras to buy.



MYERS WONDERFUL SEWING AWL

Tools in Handle



A complete repair shop in itself. Sews anything heavy or light, leather, shoes, harness, buggy tops, canvas, belts, etc. \$1.00 Postpaid. **C. A. MYERS COMPANY, 6339 Woodlawn Ave., Chicago, Ill.**



\$4 or \$5 a month **WILL BUY**
 A Standard, Guaranteed
TYPEWRITER
 With Every Modern Writing Convenience
 Write Today For Illustrated Circular
 Explaining Try-Before-You-Buy Plan
SMITH TYPEWRITER SALES CO.,
 (Harry A. Smith) 910-218 No. Wells St., Chicago, Ill.

HOME LOVERS' BARGAIN BOOK FREE

Showing Over 10,000 Furniture Bargains
 All selections loaned free for a month. Take a year to pay if satisfied, paying little by little almost as you please.
SPIEGEL, MAY, STERN CO., 1108 W. 35th St., Chicago

Delivered to You Free

for 30 days' trial on approval. Your choice of **44 Styles, colors and sizes** of famous **Ranger Bicycles.** **Factory-to-Rider** lets you buy at wholesale prices, express prepaid, direct from maker.

12 Months to Pay lets you enjoy your **Ranger** at once. Many boys and girls easily save the small monthly payments. The **Ranger** is a better bicycle than you can buy anywhere at any price. **TIRES** lamps, horns, wheels, parts and equipment at half usual prices.

Send No Money Simply write for our Big, Illustrated Free **Ranger** catalog with lowest prices and terms. Also special **Rider** Agent Offer.
MEAD CYCLE COMPANY
 DEPT. A-108 CHICAGO, ILL.



5 Safety Keys \$1.00

Only keys of their kind in existence—open and test thousands of different locks. Thousands of sets in use among locksmiths, realtors, policemen, detectives, firemen, mechanics, hardware men, travelers, hotel men, etc. Endorsed by all as an invaluable household necessity and convenience in emergencies. Tell you instantly if your locks are burglar proof. Novel chain **FREE** with keys. Send \$1.00 today. We prepay postage.



MASTER KEY CO., 306 Manhattan Bldg. Milwaukee, Wis.

DIAMONDS, WATCHES ON CREDIT

The James Bergman Jewelry Book is Full of Many Bargains
 DIAMONDS, WATCHES, JEWELRY.
 Select any article desired, have it sent to you, all charges prepaid, no interest charged, no security required.

8, 10 or 12 Months TO PAY

WRITE TODAY For Big Illustrated Catalogue No. 3. It tells about our low prices and binding guarantee. **JAMES BERGMAN** 27-29 Maiden Lane, N.Y. City, Est'd, 1896



The only stitcher that works with or without bobbin. A valuable feature. Saves refilling.

STEWART-SKINNER CO.

26 Green St.
Worcester,
Mass.



Accurate Measurements

Inside or outside made instantly. Rule slides in and out; no slow folding.

Interlox
MASTER SLIDE RULE

Strong; brass trimmed. Any length, 2 to 8 feet.

If not at dealer's, sent postpaid.

MASTER RULE MANUFACTURING CO., INC. 841-43 East 136th Street
NEW YORK CITY



Dealers and agents: request attractive proposition.



Save Money On Your Tools!

Save your tools—prevent damage—discourage "borrowing"—have your tools in order and increase your efficiency.

A style, size and price to suit your trade and purse. Catalog free.

The Gerstner & Sons

747 Columbia Street DAYTON, OHIO

BURN YOUR NAME ON TOOLS

WITH
ARKOGRAF

Protect your tools from theft. Write any name, engrave any design on metal with electricity as easily as writing on paper with pen or pencil. Complete outfit \$3.50, prepaid anywhere. Circular and sample of work free. Write today. Agents Wanted. Arkograf Pen Company 895 Capitol Ave. Portland, Oregon



MECHANIC'S POCKET SECRETARY

Constructed of finest steel. Just push the button and out comes the article you require. Worth \$1.00. Postpaid

25c

See One To-day



25c

10 in 1 —

Adjustable Pencil, pen, paper knife, ink eraser, pencil sharpener, nail file and cleaner, mechanic's marking point, fine compass with screw attachment, foot rule.

Universal Co. Box 300, Stamford, Conn.

DISSTON SAWS

"The Saws Most Carpenters Use"

HENRY DISSTON & SONS, INC.

Philadelphia, Pa. Canadian Works, Toronto, Can.

SANDS LEVELS

Spirit Levels of Aluminum, Walnut and Pine, plain or brass bound. All sizes for all workmen on every kind of work. Descriptive folder price list free.

J. SAND & SONS

4851 Rivard St.

Detroit, Mich.

DEAFNESS IS MISERY

I know because I was Deaf and had **Head Noises** for over 30 years. My invisible Antiseptic Ear Drums restored my hearing and stopped Head Noises, and will do it for you. They are Tiny Megaphones. Cannot be seen when worn. Effective when Deafness is caused by Catarrh or by Perforated, Partially or Wholly Destroyed Natural Drums. Easy to put in, easy to take out. Are "Unseen comforts." Inexpensive. Write for Booklet and my sworn statement of how I recovered my hearing.

A. O. LBONARD, Suite 226, 70 5th Avenue, New York City



"Red Devil" Pliers made in 100 styles—one for every need. Known and used the world over. Style 1024—6 1/2 inch shown here. From dealers or from us, \$1.25.

Red Devil

Reg. U. S. Pat. Off.

Corrugated Lock Washers

Stop Loosening and Rattling—Reduce Wear and Tear—Insure Longer Life and Greater Safety



USED wherever nuts and bolts are subject to vibration—automobiles, trucks, tractors, stationary and marine engines, farm implements and machinery. They hold on like grim death.

"Red Devil" Lock Washers Have Six Points of Contact

—others have only two—three times the gripping power of others. It requires 1 1/4 turns to loosen them, while others will loosen with a 3/4 turn. That means 66 2/3% greater efficiency.

Put up in bags in assorted sizes from 1/8" to 3/4" in the following quantities: 30 in a bag, 15c; 50 in a bag, 20c; 90 in a bag, 25c. Also put up in an assortment of 530 washers in nine of the most practical sizes, in a handy tin box. Send for circular. From dealers or from us.

Mechanics' Tool Booklet FREE.

SMITH & HEMENWAY CO., Inc.

Manufacturers of "Red Devil" Tools
260 Broadway, New York, N. Y.

"Red Devil" Glass Cutters—the glaziers' standard tools of the world. "It's all in the wheel." Made in 40 styles. No. 024 shown here, 30c.



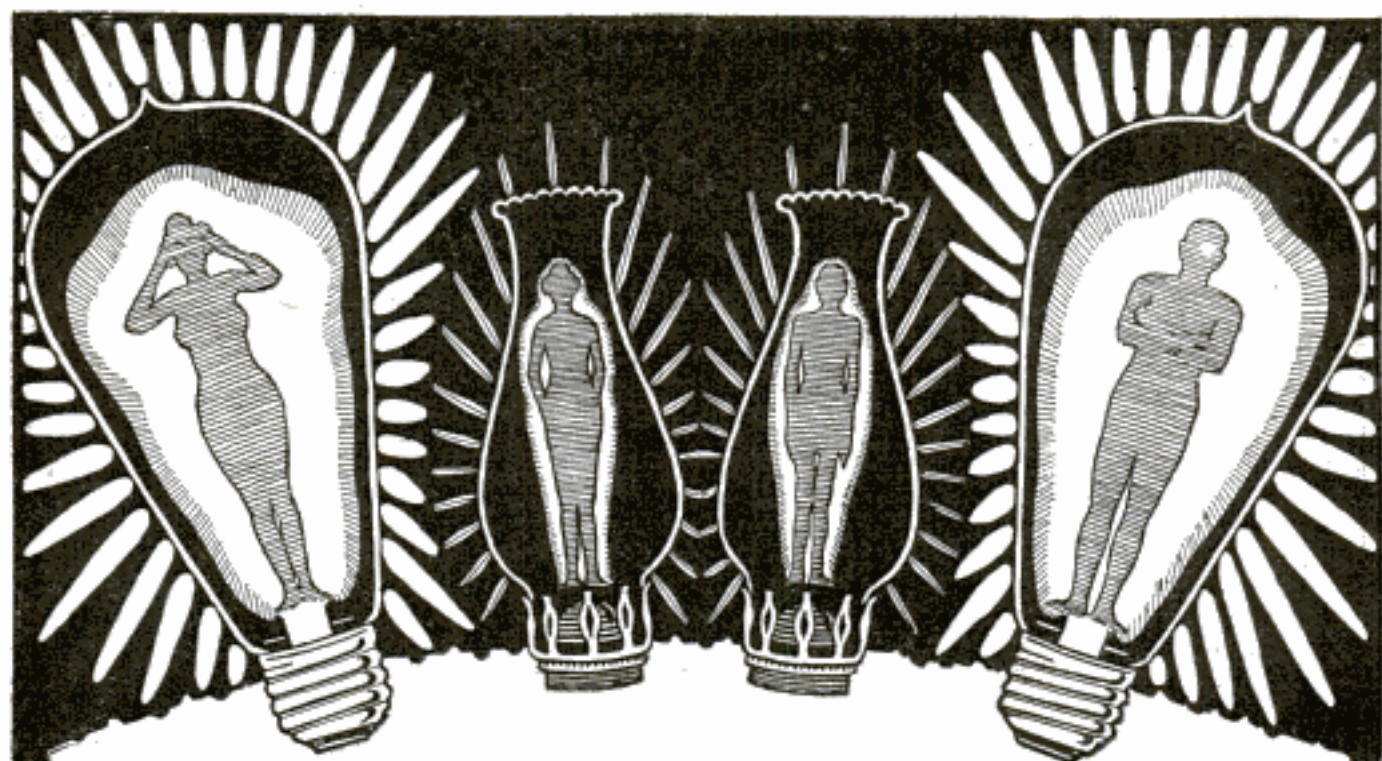

Do You Glow With Health?

Build Up Personality, Magnetism, Vitality with

VI-REX VIOLET RAYS

Some people are dull, drab, uninteresting and sickly! Others are vital, compelling and magnetic! WHICH ARE YOU? It is all a matter of vitality and health. The greatest discovery in years is that of VIOLET RAYS, electricity in a curative, medical form. Violet Rays put new life into over-taxed and sluggish tissues; penetrate and invigorate all the muscles and nerves of the body; give new tone and vitality to the entire body.

Learn the Secret of Physical Perfection

Learn how you can multiply your energy and vim! Learn how to banish those pains, aches, and ailments that run down your system, drain your personality and ruin your looks. WHAT IS PHYSICAL MAGNETISM? It is PERFECT HEALTH—plus the keen mentality based on perfectly balanced nerve centers. We will be glad to send you on request the most interesting book ever published on this subject.

Treat Yourself at Home for Asthma, Constipation, Headache, Rheumatism, Neuritis, Neuralgia, Catarrh, Pimples, Blackheads, Dandruff, Goitre, Pains, Skin Diseases.

Write Now for Startling Book and Free Trial Offer

VI-REX ELECTRIC CO.

Dept. 21

326 W. Madison St., Chicago, Ill.

Please send me your free book and particulars of your Trial Offer of the Vi-Rex Violet Ray Machine.

Name

Address

City State

Just write postal or mail coupon for wonderful free 52-page book explaining in detail. Read how Violet Rays massage every cell in the body. Read letters from users. See what physicians, sanitoriums, home-users say.

Why suffer? Why be satisfied with less than your full share of health and beauty? See what wonderful Violet Rays will do for you.

Mail coupon or write postal for free book and 10 days Trial Offer. Do not miss this offer. Address NOW



VI-REX ELECTRIC CO.

Dept. 21, 326 W. Madison Street,

Chicago, Ill.

For New York City ONLY Address 47 W. 34th, New York City, N. Y.

Swear Off Tobacco

Tobacco Habit Banished Let Us Help You

Quick Results

Trying to quit the tobacco habit unaided is often a losing fight against heavy odds, and may mean a serious shock to your nervous system. So don't try it! Make the tobacco habit quit you. It will quit you if you will just take **Tobacco Redeemer** according to directions.

It doesn't make a particle of difference whether you've been a user of tobacco for a single month or 50 years, or how much you use, or in what form you use it. Whether you smoke cigars, cigarettes, pipe, chew plug or fine cut or use snuff—**Tobacco Redeemer** will positively remove all craving for tobacco in any form in a few days. Your tobacco craving will usually begin to decrease after the very first dose—there's no long waiting for results.

Tobacco Redeemer contains no habit-forming drugs of any kind and is marvelously quick, scientific and thoroughly reliable.

Not a Substitute

Tobacco Redeemer is in no sense a substitute for tobacco, but is a radical, efficient treatment. After finishing the treatment you have absolutely no desire to use tobacco again or to continue the use of the remedy. It helps to quiet the nerves, and will make you feel better in every way. If you really want to quit the tobacco habit—get rid of it so completely that when you see others using it, it will not awaken the slightest desire in you—you should at once begin a course of **Tobacco Redeemer** treatment for the habit.

Results Absolutely Guaranteed

A single trial will convince the most skeptical. Our legal, binding, money-back guarantee goes with each full treatment. If **Tobacco Redeemer** fails to banish the tobacco habit when taken according to the plain and easy directions, your money will be cheerfully refunded upon demand.

Let Us Send You Convincing Proof

If you are a slave of the tobacco habit and want to find a sure, quick way of quitting "for keeps" you owe it to yourself and to your family to mail the coupon below or send your name and address on a postal and receive our free booklet on the deadly effect of tobacco on the human system, and positive proof that **Tobacco Redeemer** will quickly free you from the habit.

Newell Pharmacal Company
Dept. 300 St. Louis, Mo.

Free Book Coupon

NEWELL PHARMACAL CO.,

Dept. 300

St. Louis, Mo.

Please send, without obligating me in any way, your free booklet regarding the tobacco habit and proof that **Tobacco Redeemer** will positively free me from the tobacco habit or my money will be refunded.

Name.....

Street and No.....

Town..... State.....



Tobacco Tells on
Nervous System



Tobacco Ruins
Digestion



Tobacco Stunts
Boy's Growth



Tobacco Robs
Man of Vitality



Tobacco Steals
from You the
Pleasures, Com-
forts, Luxuries
of Life



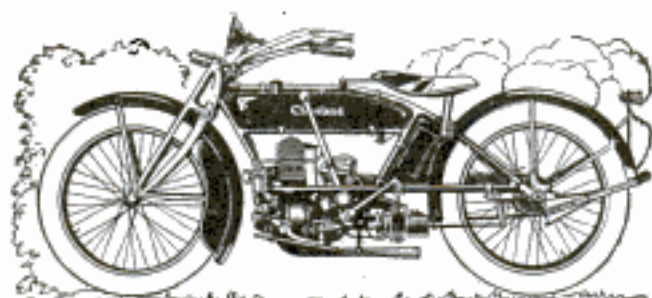

PRICE
\$185

**America's
Best Motorcycle Value**

Not a bicycle with power attachment, but a **real** motorcycle with a two-stroke motor!

A safe, sensible motorcycle with satisfying speed and power. No heavy drain on the purse for operation and upkeep. Averages 75 miles to the gallon of gas—15,000 miles on tires! Lowest priced real motorcycle you can buy.



Write for catalog "M." Can you recommend a "live" man for Cleveland dealer in your town?

CLEVELAND MOTORCYCLE MFG. CO. 7th
CLEVELAND, U.S.A. YEAR

MOTOR CYCLE
Cleveland

12 Months to Pay

Enjoy your 1922 "Ranger" at once. Earn money for the small monthly payments on our **Easy Payment Plan**. Parents often advance first small payment to help their boys along. **FACTORY TO RIDER** wholesale prices. Three big model factories. 44 Styles, colors and sizes in our famous Ranger line. **DELIVERED FREE ON 30 DAYS' TRIAL.** We ship by prepaid express. Select bicycle and terms that suit—cash or easy payments—you take no risk.

TIRES lamps, horns, wheels, parts and equipment at half retail prices. **SEND NO MONEY**—Simply write today for big FREE Ranger catalog and marvelous prices and terms.

MEAD CYCLE COMPANY
Dept. A-108, CHICAGO, ILL.



Special offer to Rider Apr '22.

MAKE FORD INTO THIS SPORT CAR \$ ONLY 6.40

Other types down to \$3.50. **Patents** sure fit. **Rebuilt** Re-size patterns and simple instructions show all details. You can easily convert your Ford into this fast, snappy Sport Car as hundreds have done with a few dollars worth of material from the hardware store. No need to lay up the car. The "P.A.I." with optional disc wheel patterns. **Pressed Metal Streamline Rear** only \$6.40 delivered. Built low, rides wonderfully easy. Order NOW while we can make good delivery. Send for our illustrated prospectus of Sport Bodies, "Judy" Toys and "Gorham" Woodstock Co. Kuenzle Co., 57 Kuenzle Bldg., Guttenberg, Iowa

MOTORCYCLE BARGAINS

Save 25% to 65%

on Slightly used and Rebuilt Motorcycles, Side Cars, Johnson Motor Wheels, Evans Power Cycles, Bicycles. Send for Free Bargain Bulletin and Money Saving Message, listing hundreds of bargains in used, rebuilt and new machines, supplies, accessories, etc.

AMERICAN MOTOR CYCLE CO.
Dept. 181 2047 W. Chicago Avenue, CHICAGO



\$20 STARTS YOUR BATTERY CHARGING BUSINESS



Start Now to make **BIG PROFITS** charging auto batteries with HB Charger. Winter brings biggest demand for reliable battery charging service.

\$150 to \$300 a month clear profit easily made. \$20 cash brings you an HB Charger—long easy terms on balance, easily paid by your profits. Sizes for 8, 10, 16, 32 or 70 batteries. Let us recommend size to make biggest profits for you. Write us today.

HOBART BROS. CO., Box M17, Troy, Ohio



6 Big Improvements



Here are six big improvements in the **Auto-Wheel Coaster** and the **Auto-Wheel Convertible Roadster**:

1. Disc Wheels, rubber tires
2. Disc Wheels, steel tires
3. Self-contained roller bearing
4. Hub cap inscribed with word "Auto"
5. Hound support brace
6. Axle clip.

Our new catalog tells all about these new improvements as well as other unusual features of the **Auto-Wheel** wagons. Write for the catalog. If you do, and if you send us the names of three dealers, telling which ones sell the **Auto-Wheel** wagons, we will send you a Dime Bank FREE and a year's subscription to our magazine "**Auto-Wheel Spokesman**."

The Auto-Wheel Coaster Co., Inc.

137 Schenck Street, In Canada Preston, Ont. N. Tonawanda, N. Y.
Export Office: 365 W. 23rd St., New York City

Auto-Wheel

REPAIRER WILL SAVE
\$40 **BIG MONEY SAVINGS FOR YOU**
Use and rebuild motorcycles, single and twin, \$25 to \$100. Used bicycles, \$5.00; tandem, \$10. All machines guaranteed in good working order. New bicycles and motorcycles at Factory prices. You save dealers' profits. Motorcycles and automobile tires too, \$3.00. Complete line of parts and supplies.
Deninger Cycle Co., Rochester, N.Y.
YOU 25 TO 50 DOLLARS

You Can Save \$50.00

By recovering your old auto top frame yourself. We make these covers to fit all makes and models of cars. Any person that can drive a car can put it on. We furnish instructions. Roof and quarters sewed together with rear curtain, fasteners, welts and tacks. All complete. Give us the name, year and model number of your car, and we will send you our catalogue with samples and quote you exact price.
LIBERTY TOP & TIRE CO., Dept. E7, Cincinnati, O.



VITALIC Bicycle Tires

TRADE MARK REGISTERED
Tougher Than Elephant Hide

THE CORBIN DUPLEX COASTER BRAKE is the standard brake equipment, assuring absolute control. Equip it now. Send for 1921 catalog.
THE CORBIN SCREW CORP. The American Hardware Corporation, Successor
NEW BRITAIN, CONN. BRANCHES: New York, Chicago, Philadelphia

Start the New Year Right

Does 1922 Mean Success or Failure?

It is up to you right now to decide. If you had started right one year ago you would be on the high road to success this minute. Don't let another year pass by. It is within your power to make yourself what you will. Let this be the beginning of a new life and a better one.

I Will Give You Wealth—Health— and Happiness

I will take that body of yours and make it physically perfect. I will make a new man of you. I will fill out your chest so that every breath means increased life, purifying your blood and sending vim and vitality throughout your entire system. I will broaden your shoulders, and give you the large muscular arms and legs of an athlete. I will strengthen your back and every vital organ within you. You will be bubbling over with life, having the keen alert brain, the bright flashing eyes and the spring and step of youth. Passers by will stop and admire you for your physical make up; and you will be the favorite in both the business and social world—you will be a leader of men, and the good things in life will naturally come your way.

I CHALLENGE THE WORLD

If a man stood on the house-tops and shouted to the people that he was the strongest man on earth, it would avail him nothing. Someone would make him come down and prove it. But records speak for themselves. I will gladly show anyone personal letters from the leading strong men in the world today that my course is absolutely the best and the quickest to acquire physical perfection. Come on then and make me prove it—I like it. I have the means of making you a perfect physical specimen of manhood, of making you a successful leader of men. You will be a credit to your community. I have done this for thousands of others. What I have done for them I will do for you. I don't care what your present condition is. The weaker you are, the more noticeable the results. Come on then. **START THE NEW YEAR RIGHT.**



LATEST PHOTOGRAPH OF
EARLE E. LIEDERMAN

Send for My New Book "MUSCULAR DEVELOPMENT" IT IS FREE

It tells the secret. Handsomely illustrated with 26 full-page photographs of myself and some of the world's best athletes whom I have trained. Also contains full particulars of my splendid offer to you. The valuable book and special offer will be sent on receipt of only 10c stamps or coin, to cover cost of wrapping and mailing.

Don't miss this opportunity. Sit right down now and fill in the coupon. The sooner you get started on the road to health the easier it will be to reach perfect manhood. Don't drag along one day longer—mail the coupon today.

EARLE E. LIEDERMAN
Department 2001, 305 Broadway, New York

EARLE E. LIEDERMAN,

Dept. 2001, 305 Broadway, New York City

Dear Sir:—I enclose herewith 10 cents, for which you are to send me, without any obligation on my part whatever, a copy of your latest book, "Muscular Development." (Please write or print plainly.)

Name

Address

City.....State.....

See pages 18 and 19 for photographs and letters of Earle E. Liederman's pupils

PATENTS TRADE-MARKS AND COPYRIGHTS

SPECIAL OFFER—Free Opinion as to Patentable Nature

Before disclosing an invention, the inventor should write for our blank form "Evidence of Conception." This should be signed and witnessed and if returned to us together with model or sketch and description of the invention, we will give our opinion as to its patentable nature.

Our Three Books Mailed FREE to Inventors



OUR ILLUSTRATED GUIDE BOOK

HOW TO OBTAIN A PATENT

Contains full instructions regarding Patents, Trade-Marks, Foreign Patents, Our Methods, Terms, and 100 Mechanical Movements illustrated and described; Articles on Patent Practice and Procedure, and Law Points for inventors.

OUR TRADE MARK BOOK

Shows the value and necessity of trade-mark protection and gives information regarding unfair competition.

OUR FOREIGN PATENT BOOK

We have direct agencies in all the principal foreign countries and secure foreign patents in the shortest possible time and at the lowest cost. Write for our illustrated Guide Book on Foreign Patents, sent free to any address.

Specialization—Our Staff

The field of invention is so vast that it is impossible for any one man to become an expert in all the different classes of invention. Only those practically skilled in the class to which the invention relates are capable of rendering efficient service. For this reason Victor J. Evans & Co. employ a number of patent lawyers and mechanical experts who have been selected for their special knowledge and ability in certain lines of invention. Each case is placed in charge of experts in the classes to which the invention relates.

THE VALUE OF YOUR PATENT

will depend much upon the skill and care with which your case is prepared and prosecuted in the United States Patent Office. This work will receive the benefit of skill and experience acquired by a long and successful practice. We spare neither time nor pains to secure the broadest possible patents that the inventions will warrant. That every case intrusted to us receives our best efforts, and that our work is done consistently, skillfully, and thoroughly is evidenced by the many unsolicited letters of commendation that we receive constantly from our clients. We will furnish upon request lists of clients from any State in the Union for whom we have secured patents.

Our New York, Philadelphia, Pittsburgh, Chicago and San Francisco Offices

Owing to the growth of our business we have established for the benefit of our clients Branch Offices in New York City, Philadelphia, Pa., Pittsburgh, Pa., Chicago, Ill., and San Francisco, Cal. These branch offices being located in these large commercial cities together with our Main Office located near the U. S. Patent Office, in Washington, enables us to more promptly handle the business of our clients, particularly as the branch offices are in constant touch with the Main Office and fully equipped to handle patent business in all its branches.

Highest References—Prompt Attention—Reasonable Terms

—FREE COUPON—

VICTOR J. EVANS & CO., Patent Attorneys

NEW YORK OFFICES
1007 Woolworth Building

CHICAGO OFFICES
1114 Tacoma Building

PHILADELPHIA OFFICES
135 South Broad Street

PITTSBURGH OFFICES
514 Empire Building

SAN FRANCISCO OFFICES
Hobart Building

MAIN OFFICES: 765 9TH STREET, N.W., WASHINGTON, D. C.
Gentlemen: Please send me FREE OF CHARGE your books as described above.

Name Address



PATENTS

Booklet Free

Highest References

Promptness Assured

Best Results

Send drawing or model for preliminary examination

ALL BUSINESS GIVEN PROMPT AND PROPER ATTENTION

WATSON E. COLEMAN, Patent Lawyer, 624 F St., Washington, D. C.

PATENTS

To the Man with an Idea

I offer a comprehensive, experienced, efficient service for his prompt, legal protection and the development of his proposition.

Send sketch, or model and description, for advice as to cost, search through prior United States patents, etc. Preliminary advice gladly furnished without charge.

My experience and familiarity with various arts frequently enable me to accurately advise clients as to probable patentability before they go to any expense.

Booklet of valuable information and form for properly disclosing your idea free on request. Write today.

Richard B. Owen, Patent Lawyer
9-303 Owen Building, Washington, D.C.
2276-E Woolworth Bldg., New York City

U.S. PATENTS



DON'T LOSE YOUR RIGHTS TO PATENT PROTECTION

Before disclosing your invention to anyone send for blank form "EVIDENCE OF CONCEPTION" to be signed and witnessed. A sample form together with printed instructions will show you just how to work up your evidence and establish the same before filing application for patent. As registered patent attorneys we represent hundreds of inventors all over the United States and Canada in the advancement of inventions. Our schedule of fees will be found reasonable. The form "Evidence of Conception," sample, instructions relating to obtaining of patents and schedule of fees sent upon request. Ask for them—a post card will do.

PATENTS AND TRADE MARKS

LANCASTER & ALLWINE

204 Ouray Bldg. Washington, D. C.
Originators of forms "Evidence of Conception."

PATENTS If You Have an Invention and Desire to Learn How to Secure a Patent

Send for our Guide Book, **HOW TO GET A PATENT**, sent Free on request. Tells our terms, methods, etc. Send model or sketch and description of your invention and we will give our opinion as to its patentable nature.

RANDOLPH & CO.
600 F St., N.W., Washington, D. C.

NAME.....

STREET.....

CITY..... STATE.....

PATENTS PROMPTLY PROCURED TRADEMARKS REGISTERED

Send disclosure of invention, design, or trademark for actual search of U. S. Patents and novelty report. Validity and infringement investigations. Patent and trademark suits prosecuted and defended anywhere in the United States. Discriminating clients appreciate my efficient service. No literature will be sent you as this is a professional service, *individual* and *Personal*. Specific information and advice given regarding each individual case. Specialize in prosecution of pending cases that have been previously rejected by the Patent Office. Specialize also in unfair competition litigation before the Federal Trade Commission.

George P. Kimmel, Master of Patent Law
53-O Loan & Trust Bldg., Washington, D. C.

PATENTS

C. L. PARKER
Formerly Member Examining
Corps., U. S. Patent Office
PATENT LAWYER
MCGILL BLDG.
WASHINGTON, D. C.

Patents, Trade Marks, Copyrights, Patent Litigation

Handbook for Inventors, "Protecting, Exploiting and Selling Inventions," sent free upon request.

PATENTS Secured

Prompt service. Avoid dangerous delays. Send for our "Record of Invention" form and Free Book telling How to Obtain a Patent. Send sketch or model for examination. Preliminary advice without charge. Highest references. Write TODAY. J. L. Jackson & Co., 243 Oursy Bldg., Washington, D. C.



Dandy proposition selling Chewing Gum to dealers. Clean, profitable, spare-time work. Write at once.

**SELL
GUM**

HELMET GUM MFG. CO., Cincinnati, O.

Can You

think of a simple, practical idea that will fill one of the many requests we have on file for new inventions? It may mean a fortune for you. Thousands of things are needed **right now**. Your brains can help. Send today for our great new book—

"Inventions and Trade-Marks, Their Protection and Exploitation"

and learn more about making money from ideas than you ever knew before. It tells many things that are wanted, too.

**A postal will do—
It is free**

We Help Our Clients

without charge, to get the dollars out of their ideas—having facilities none others possess. Advice free. Don't delay—get the book at once.

American Industries, Inc.
200 Patent Dept.
WASHINGTON, D. C.

Patents Advertised For Sale Free

in Invention and Manufacturing Supplement

Published for the man with an idea. Send for free sample copy. One year's subscription, 50c.



**PROTECT
YOUR
RIGHTS**

WRITE TODAY FOR FREE BOOK ABOUT PATENTS and "RECORD OF INVENTION" for establishing evidence of conception. The book tells how to proceed, the usual cost of obtaining a patent, and contains good sound practical advice every inventor should know. "RECORD OF INVENTION" should be filled out, signed and witnessed before you disclose invention to anyone. Send rough sketch or model and description for free report upon patentable nature and cost to Patent, etc. **Prompt, personal service.** Reasonable fees. Partial payment plan. Preliminary advice without charge.

J. REANEY KELLY
PATENT LAWYER

612-COLUMBIAN BLDG. WASHINGTON, D.C.

Please Mention Popular Mechanics

Inventors

in all cities and many towns in the United States and Canada have secured patents through us. We secure patents in delayed, neglected, and

Rejected

cases. Write giving data. Our fee will be contingent on success.

Abraham Lincoln in an Address to Law Students said:

"As a rule, never take your fee in advance, nor any more than a small retainer. When fully paid beforehand, you are more than a common mortal if you can feel the same interest in the case as if something was still in prospect for you, as well as your client; and when you lack interest in the case, the job will very likely lack skill and diligence in the performance."

Engaged in Patent Soliciting exclusively since 1875, we have procured more than 40,000

Patents

Send us a model, drawing or photo with description of invention, remit \$5.00 for search in U. S. Patent Office. If we report invention patentable, we will back our judgment and keep no attorney's fee unless patent is obtained.

Our booklet on patent protection at home and abroad sent free. Write Dept. N or come to us.

C. A. SNOW & Co., Patent Attorneys
710 8th Street, Opp. North Front of U. S. Patent Office
WASHINGTON, D. C.



PATENT-SENSE

The Book for
INVENTORS and
MANUFACTURERS



SIXTH EDITION

PATENTS

A Hand-Book of Essential Information and Advice relative to Patents, Trade-Marks; Assignment, Sale or Licensing of Rights; Abstracts from Leading Decisions; State Laws on Patent and Trade-Mark Property. FREE! Write

LACEY & LACEY
Established 1869
Dept. A Washington, D. C.

INVENTORS

Send sketch or model of your invention for advice. Write for Book on Patents FREE.

Merton-Roberts & Co., 184 Mather Bldg., Washington, D. C.



PATENTS

Send us sketch or model for patentability opinion and exact cost of patent. Our book "How to Obtain a Patent," Sent Free on request. It tells how to apply for Patents, Trade Marks, Foreign Patents, Copyrights, etc.; gives information on Patent Procedure; tells what every inventor should know. Thousands of Inventors, who are our clients, are our references. Chandlee & Chandlee, 25 Years Experience. 422 7th St. Washington, D. C.



GEARS ALL KINDS SMALL

The most accurate made and prices reasonable. We carry a complete line of gears in stock for immediate shipment. Can also quote on special gears of all kinds. Send us your inquiries. WRITE FOR CATALOGUE.

CHICAGO STOCK GEAR WORKS
105-109 S. Jefferson St., CHICAGO

PATENTS

IF YOU HAVE AN INvention which you wish to patent you can write fully and freely to Munn & Co., for advice in regard to the best way of obtaining protection. Please send sketches or a model of your invention and a description of the device, explaining its operation.

All communications are strictly confidential. Our vast practice, extending over a period of seventy years, enables us in many cases to advise in regard to patentability without any expense to the client. Our Hand-Book on Patents is sent free on request. This explains our methods, terms, etc., in regard to Patents, Trade Marks, Foreign Patents, etc.

If you are a reader of the SCIENTIFIC AMERICAN

you are probably aware of the fact that it has a special appeal to the inventor. Each issue contains a description of a large number of recently patented inventions. Pending patent legislation as well as the most recent rulings of the Patent Office and the courts are considered in its columns.

MUNN & CO.

SOLICITORS OF PATENTS

672 Woolworth Bldg., NEW YORK
627 F Street, WASHINGTON, D. C.

801 A Tower Bldg., CHICAGO, ILL.

582 Market St., SAN FRANCISCO, CALIF.



A WIRELESS STATION

complete for \$21.00

LISTEN in on the world's news by wireless. This Climax Unit picks up both wireless telegraph and telephone. Simple to operate, sure of results. No battery, no license, no experience needed. Send five cents today for your copy of the new bulletin describing the complete line of

CLIMAX

RADIO RECEIVING UNITS

You can put up a working station, and get results in less than an hour. Address:

Wireless Equipment Co., Inc.
Dept. P1 Newark, N. J.

GEARS FOR ALL CARS

GUARANTEED NEW NICKEL STEEL

TRANSMISSION and DIFFERENTIAL GEARS; FLY-WHEEL GEAR RINGS, DIFFERENTIAL PARTS and AXLE SHAFTS in stock for over 1,000 models.



BIG DISCOUNT

To Repairmen and Garages

Our prices are lower than factory lists. We save you money. Get our prices today. Our new nickel steel

gears are sold with a money back guarantee. **Buy direct from us.** Largest stock of new automobile gears in America.
MECHANICS GEAR WORKS, 1446 Catalpa Ave., Service Dept. 1, Chicago, Ill.

Silk Knit TIE 55¢

Line quality silk knit ties, 55¢ each. \$1 to \$1.50 value. Fast colors. Dark brown, dark blue, black. Harmonizing silk embroidered dots. Closely knit to give long wear. **Send No Money.** Give name, address and color wanted. Pay postman, only 55¢ each, plus a few pennies postage. Complete satisfaction or money back. *Order one or more today*
CASSMAN BROTHERS, Dept. 11-B, 3014 E. 92d St., Chicago

Different from all others—the NEW BENJAMIN

AIR RIFLE

Made on a different principle from all other Air-Rifles. The Benjamin is really a strong air-pump used to compress the air in the air chamber to any degree of power desired. From one to six strokes of the pump give all the force necessary. Each additional stroke gives increased power. The Benjamin works on the same principle as all air-drills and air-hammers—with this difference:

You control the shooting force as you desire. Look at this block of hardwood. It shows how Benjamin power is regulated as you wish.

You can't have accidents with a Benjamin. It's safe, always, because you control the power. The Benjamin never loses shooting force, and has no springs to get out of order or shake your aim. Write us for an interesting folder about this wonderful air-gun.

For sale by all dealers.
Price \$5.00.

BENJAMIN
AIR-RIFLE & MFG. CO.
615 N. Broadway, St. Louis, Mo.

Ask your dealer for demonstration.

Pacific-Coast Representatives:
McDonald & Liferth,
Call Bldg.,
San Francisco

A PERFECT POLISH WITH CLEAN HANDS



KAXO
SHOE BRUSH

POLISH DAUBER and BRUSH combined in one convenient article. Polish is in a tube enclosed in metal case on top of brush, and when tube is used up, new ones may be obtained at leading stores everywhere, 25 cents. Buy of your dealer or order direct, stating whether black tan, mahogany or white is desired. Fine opportunity for agents.

Postpaid anywhere \$1.25
Address Sales Dept.
The Kaxo Co., Cambridge, 39, Mass.



The Midget "FIVE-IN-ONE" Slide Rule is a combination Mannheim, Log-Log, Add and Subtract, Polyphase and Binary Slide Rule. It will instantly add, subtract, multiply and divide any combination involving whole numbers, fractions, decimals and mixed numbers. Gives every possible foot and power of every quantity. The graduations are printed on metal, coated with white celluloid and are green and waterproof. While it is the most versatile calculator ever invented, its operation is simple and easily understood. Diameter 4 inches. Price with 16-page instruction book, \$1.50. Leatherette carrying case 50¢ extra. Catalog free. Your money back if you are not satisfied.
GILSON SLIDE RULE CO., Niles, Mich.



RAISE BELGIAN HARES

New Zealand Reds - Flemish Giants - American Blues. **BIG PROFITS, WE PAY \$1.50 TO \$8 EACH.** Also Corvies, Milk, Stunk, Fox, Muskrat, Etc. Easily raised anywhere. **FREE!** page Catalog and Contract. Illustrated book "COMMON SENSE RABBIT RAISING," quarterly journal, and copy of America's leading small stock magazine, all for 10 cents. Address Outdoor Enterprise Co., 1005 O. E. Bldg., KANSAS CITY, MO.



HAND FORGED RAZOR STEEL BLADES
Indestructible Handles, Liberty Silver Bolsters, Brass Liners, Razor Steel Blades, File Test. Warranted. **EASY TO BUY. EASY TO SEND. A JOY TO RECEIVE**

FOR HIS XMAS GIFT

Buy him a beautiful PHOTO HANDLED knife with his name and address on one side, and the COMPLIMENTS OF THE SEASON on the opposite side.

DIRECT TO YOU AT FACTORY PRICES

This \$2.25 knife (3 blades) mailed Postpaid for \$1.50, 3 for \$3.75
2 blades for \$1.35, 3 for \$3.50

SOUTH BEND CUTLERY COMPANY
Dept. 30, South Bend, Ind.



Tom Brown as he appears in "Top-Top"

Be the "Tom Brown" of Your Town

You may have the talent to develop into a Saxophone wizard like Tom Brown, of the famous Tom Brown's Clown Band, the highest priced musical act, and enjoy this most pleasant of vocations. True-Tone Musical Instruments have helped make famous Tom Brown, Art Hickman, Clyde Doerr, Donald Clark, Clay Smith, Guy Holmes and thousands of others. \$500 to \$1000 weekly for but two hours a day is not uncommon for musicians of such ability to earn.



TRUE-TONE SAXOPHONE

It is the easiest of all wind instruments to play and one of the most beautiful. Three first lessons sent free. You can learn the scale in an hour's practice and play popular music in a few weeks. Practice is a pleasure because you learn so quickly. You can take your place in a band within 90 days, if you so desire. Unrivalled for home entertainment, church, lodge or school. In big demand for orchestra dance music. A Saxophone will enable you to take an important part in the musical development of your community. It increases your popularity and your opportunities, as well as your pleasure.

Saxophone Book Free

Tells what each Saxophone is best adapted for; when to use singly, in quartettes, sextettes, octettes, or in regular band or Saxophone Band, and how to transpose for cello parts in orchestra. Send coupon for free copy.

BUESCHER BAND INSTRUMENT CO.
Makers of Everything in Band and Orchestra Instruments
2541 Buescher Block Elkhart, Indiana

Free Trial—Easy Payments

You may order any Buescher Saxophone, Cornet, Trumpet, Trombone or other Band or Orchestral Instrument without paying in advance, and try it six days in your own home, without obligation. If perfectly satisfied, pay for it on easy payments to suit your convenience. Mention the instrument interested in and a complete catalog will be mailed free.

Buescher Band Instrument Co.
2541 Buescher Block, Elkhart, Ind.
Please send me a free copy of "The Origin of the Saxophone."
Name
TownState
Street Address.....
Mention any other instrument in which you are interested.

THE HANDIEST TOOL in the WORLD

THE OLSON MAGAZINE SCREW DRIVER

Large enough to hang a door. Small enough to fix a bell. Used by—Carpenters, Machinists, Farmers and Automobile men.

Three blades and one awl guaranteed. Dealers and agents write for special proposition.

Only 5 1/4" long.

\$1.25
Prepaid



Olson Mfg. Co., 52 Commercial St., Worcester, Mass.

HOW TO KEEP TOOLS

Tool wise machinists, carpenters, plumbers, garage mechanics, electricians and others keep them in Union Tool Chests. Furnished in every style or size needed. ANY price you can afford. Write for free descriptive booklet.

UNION TOOL CHEST CO.
22 Mill St., Rochester, N. Y.

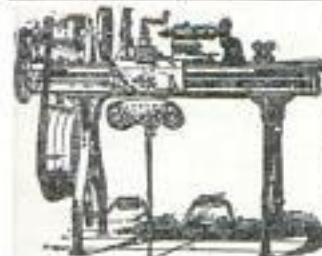

LATHES

9 to 18-inch Swing

List price \$165 and up according to size. When ready to buy send for Lathe Catalog and prices.

W. F. & John Barnes Co.
100 Ruby Street, ROCKFORD, ILL.



Six Machines in One

—bench grinder, polisher, buffer, sander, drill and saw, for working in wood and soft metals.

Handles 4" and 5" grinding wheels, 6" saws 6" and 8" sand discs, and 3-8" chuck. Top easily removed. Mountable on separate base with motor. Extremely compact; highly serviceable; decidedly practical. Not a toy. Height 19". Weight 31 lbs. Easily driven with 1-4 hp motor. Sailed for Painters, Cabinet and Pattern Makers, Musical Inst. Mfrs., Furniture Repairmen, Shipping Dept., Mental Training Schools, Laboratories, Private Shops, etc.

Machine fully guaranteed.

ONLY \$3785

Write for circular

W. & J. Boice, 114 23rd St., Toledo, Ohio

Send No Money

21 Jewel Illinois

The greatest watch value ever offered. Unequaled for beauty, accuracy and reliability. 21 ruby and sapphire jewels—adjusted to positions, temperature and isochronism, 20 year gold-filled case.

10 Days' Free Trial

Wear it for 10 Days at our risk. Note its absolute exactness. If at the end of ten days you are not satisfied, just send it back at our expense.

Knife and Chain Free

We are offering for a limited time this handsome gold-filled knife and chain ABSOLUTELY FREE.

ONLY 11c A DAY

Just send your name and address. The watch, chain and knife come to you, prepaid. Give the expressman \$8.50 as a deposit. If after 10 days, you do not wish to keep them, return at our expense; your deposit will be refunded instantly. Trial is absolutely free. If you keep the watch pay \$3.40 a month until full price of \$42.50 is paid. This splendid watch will cost you less than 11c a day. Act at once. De Luxe catalog of Diamonds, Jewelry, etc., sent free. Address Dept. 62-F.

CAPITAL \$1,000,000

"The House of Quality"
L. W. SWEET, INC.
1650-1660 Broadway New York



Please Mention Popular Mechanics

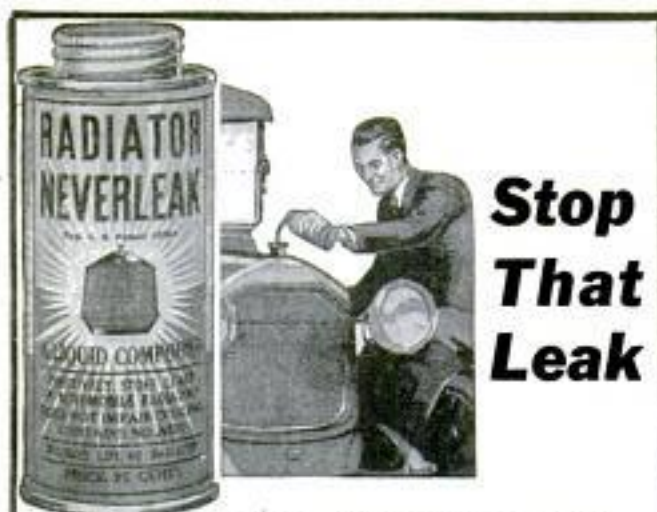

RADIATOR NEVERLEAK

Stop That Leak

RADIATOR NEVERLEAK

poured into the water in your radiator will permanently mend leaks anywhere in cooling system in less than 10 minutes. Don't lay up your car or spend money for costly repairs. Radiator Neverleak will do it. Quick, sure, safe. Cannot clog or injure cooling system in any way. Our

Million Dollar Guarantee

protects you, for Radiator Neverleak must do everything we claim, must be entirely satisfactory in every way or your money will be refunded. A 75c can does the trick.

Carry a can in your tool kit,
ready for that unexpected leak.

BUFFALO SPECIALTY COMPANY
BUFFALO, N. Y.

Auto Owners WANTED!



To introduce the best automobile tires in the world. Made under our new and exclusive Internal Hydraulic Expansion Process that eliminates **Blow-Out—Stone-Bruise—Rim-Cut** and enables us to sell our tires under a

10,000 MILE GUARANTEE

We want an **agent** in every community to use and introduce these wonderful tires at our astonishingly low prices to all motor car owners.

Write for booklet fully describing this new process and explaining our amazing introductory offer to owner agents.

Hydro-United Tire Co.

Dept. 100 Chicago, San Francisco, Pittstown, Pa.

DRIVE 100 TACKS AND SAVE \$25.00

Easy to put on. We furnish instructions. We tailor top coverings for all cars, and guarantee them to fit. Ford Roadster, \$5.50; Touring, \$6.95; other cars, \$12.00 to \$16.00, delivered at your door. Sent covers \$3.10 up.

Write for Catalog and Samples.
AUTO EQUIPMENT CO., 32 Canal St. East, Cincinnati, O.

\$5.50 DELIVERED

\$20 Brings an H B Battery Charger



Start a Business That Makes \$150 to \$300 Profit Every Month

Profits easily pay small monthly terms and big earnings besides. Now's the time to start money-making Battery Charging. Winter's best paying business. HB Charger brings you biggest profits, pulls trade from other shops. No expenses needed with HB. No renewals or repairs. A size for every shop. Write me today.

W. H. HOBART, V. Pres.

HOBART BROTHERS COMPANY, Box M1722, Troy, Ohio



MAKE YOUR OWN SCOOTERS



BOYS

FULL SIZE TOYS AS PICTURED ABOVE, built with Wheel-A-Way Combination Steel Fittings, using empty boxes, odd sticks or pieces of board. Makes most any toy that runs on wheels. For Real Fun—Make 'em Yo' self—NO TOOLS BUT A HAMMER. Make a Different toy whenever you want it. Kids going wild over them. Wheels, Brackets, Bases, Axles, Yokes, Etc., Highly Expanded. Packed complete in a box. Sent anywhere in U. S. for \$1.25 prepaid. Wheel-A-Way Mfg. Co., 614 Nibonian Bank Bldg., Los Angeles, Calif. Get your set now. Become one of our boy demonstrator Agents. Big money for you.



A. I. D. FOR FORDS

The A. I. D. Airnit pumps a Ford tire in less than 5 minutes. Aero Fan keeps motor cooler—any one can attach. A Real Tire Pump—no gears, cams, chains or noise.

Agents Wanted. Send for Circular
A. I. D. Inc.
1352 Beacon St., Boston 47, Mass.

An Easy Way to Make Money

Don't be content to plod along on a small salary. Be independent. Go in the tire repairing business and make \$60 or more a week. One man made \$45 the first day he received his outfit. Others are making \$25 a day and hundreds of wide-awake men are making \$200 to \$500 a month.

No experience needed. We teach you how. Very little capital required. But slight risk, as every car owner in your town is a possible customer. Jobs are plentiful because tires blow out and puncture every day. Business is good the year round.

SHALER Tire Repair Outfit, \$75

Will do as much and as perfect work as the big \$250 to \$500 vulcanizing outfits. A boy can vulcanize perfectly with this simple machine. It's the only vulcanizer that has Automatic Heat Control. It must vulcanize just right. It can't undercure or overcure a tire. Requires no watching or regulating. You can learn to do expert tire vulcanizing in half an hour with the Shaler.

WRITE FOR FREE BOOK "HOW TO OPEN A TIRE REPAIR SHOP" and complete Catalog, which gives full information.

WRITE QUICK BEFORE SOME HUSTLER GETS AHEAD OF YOU.

C. A. SHALER CO., 2012 Fourth Street, WAUPUN, WISCONSIN



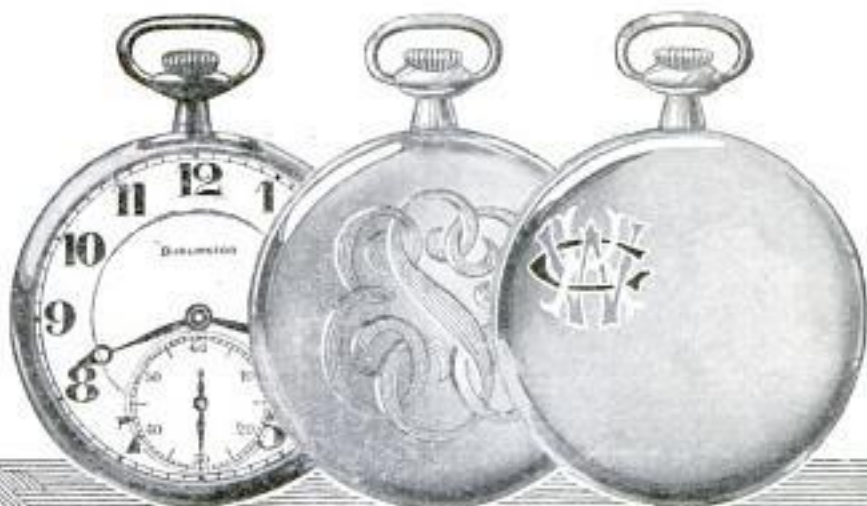

Burlington 21 Jewels

A FEWER number of jewels not worthy of the name Burlington. The masterpiece of watch manufacture—Adjusted to the Second—Isochronism—and Positions—25-Year Gold Strata Case.

Sent On Approval

We will send you the 21-jewel Burlington for your approval (without any obligation on your part to buy) and besides we offer you very special terms, after Free examination, of small monthly payments. A 21-jewel Burlington watch sold to you at a price much lower than that of other high-grade watches. Send for the most complete watch book ever produced. The book is free. Send now.

We send the 21-jewel Burlington for you to look at and examine carefully before you buy. This is the only way a Burlington Watch is ever sold. Send for the free book now.

See It First

BURLINGTON WATCH COMPANY
Dept. 1351, 19th St. and Marshall Blvd., Chicago
Please send me your free book on watches with full explanation of your approval offer on the Burlington Watch.

Name

Address

Only \$45.00 For This Job Complete

Save exorbitant freight rates and one-half original cost by buying Ford Speedster Bodies knocked-down. Simple, complete instructions furnished, all parts cut to exact fit. Any one can assemble this job. Complete with hood, radiator shell, instrument board, upholstery, metal parts, wood parts, bolts, screws, etc. Fiat radiator shell furnished made up. Designed low with lack of wind resistance. Price set at \$40, further particulars on request.



Not Paper Patterns
All Parts Complete

The Central Auto Supply Co. Eng. Dep. 120, Louisville, Ky.

STAR AUTO BATTERY 2-Year Iron-Clad Guarantee



Star Auto Battery plates are hand pasted and grouped with straps having threaded pillar posts. Assembled with specially treated leaded separators in Goodrich rubber jars. Hardwood battery box. Only high grade battery on market with 2-year written guarantee at saving of 50 per cent. Highest quality of materials and workmanship. 25 per cent more power. Shipped fully charged direct from factory ready for instant use.

We make batteries for all cars, trucks and tractors
HOW TO ORDER: Send \$2.00 and we will make shipment C. O. D. for balance. Examination allowed on express and freight shipments if requested. P. P. rules do not permit crates to be opened or examined. Reference any bank or trust company in Chicago.

STAR BATTERY CO., Dept 17
1825 S. Michigan Ave. Chicago
Highest Quality—Lowest Priced Battery in America

PRICES:
Ford-Chevrolet, \$16.95
Bach-Overland, 20.50
Dodge-Maxwell, 24.50

Used Motorcycles

\$40⁰⁰ and up
Bulletin FREE

ALL MAKES

ASH MOTOR CORPORATION ROCHESTER, N.Y.

Profit and Protection \$7.75

Carry this revolver and be always fully protected. This handsome firearm is the style of weapon adopted by the police and secret service of many cities. The most accurate and dependable of firearms. Has popular break cylinder. Made of extra fine nickleed steel by expert mechanics. Shoots five times before reloading.

Send No Money

Order to-day. Just send your name and address and state which style revolver you want. Pay Postman our price and postage on arrival. Money back if not completely satisfied after examination.
No. 2014 is 32 cal., 3 1/4-in. barrel. Pay Postman \$7.75 and postage on arrival.
No. 2514 is 38 cal., 3 1/4-in. barrel. Pay Postman \$9.00 and postage on arrival.

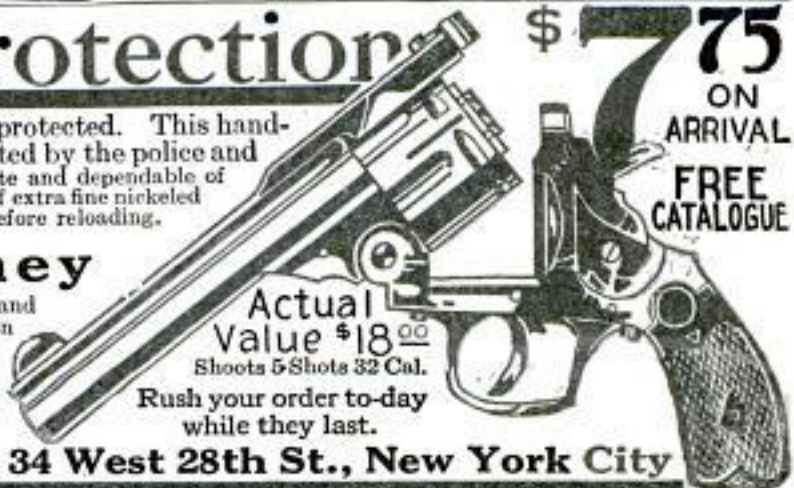

Actual Value \$18.00
Shoots 5 Shots 32 Cal.

Rush your order to-day while they last.

Paramount Trading Co., 34 West 28th St., New York City

Indian Motorcycles for 1922

The Standard Motorcycle
of the World

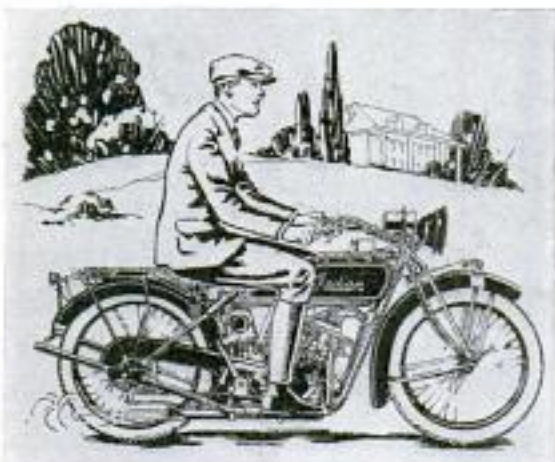

Adopted by governments, cities
and towns for protection and utility.

Used as an economical and sport
machine generally.

Write for literature covering
the 1922 models.

Numerous improvements.

Two brand new models.

Substantial price reductions.

Address Dept. 37

Hendee Manufacturing Company

Largest Motorcycle Manufacturer
in the World

Springfield

Mass.

FORD and CHEVROLET SPEED BODIES

Dealers:
Write for Accessory
Catalogue

MAKE DRIVING
A PLEASURE



Copyright 1921—F. M. S. Co.
Equip your old Ford or Chevrolet
Chassis with one of our new distinctive
modern bodies. Up-to-date Roadster, Touring and
Speedster designs. Ford bodies as low as \$29.50 and up. Territory
open for live wire dealers and agents. Make real profits.
Buy Direct from Factory.

FEDERAL MOTOR SUPPLY CO., Inc.
2626 So. Michigan Blvd. Chicago
CANADIAN DISTRIBUTORS
Federal Auto Body Co., Toronto, Ont.; Campbellton, N. B.

10c CHARGES STORAGE BATTERY

FROM A LAMP SOCKET AT HOME OR BUSINESS WITH AN F-F

BATTERY BOOSTER, which is a Magnetic
Booster for 105-125 Volt 60 cycle A. C. Leave battery
just as it is in your car. Snap Charger Clips on battery
terminals. Turn Switch, look gauge, showing battery
will be charged in morning. METER shows amount of
current flowing. Everything Complete in Compact Self-
Contained Portable Charging Unit. No skill required.
Lasts a Life Time. A Fully Charged Battery Starts
Cars and Trucks quickly in the coldest winter weather
and thus lower expensive replacement Storage Batteries
must be bought, when kept Fully Charged. So it actually
Costs Less to Buy a Booster than to be without one.
Do not think your battery is dead and worn out
simply because it will not start your car. Buy a Booster.
Fill it with Life and hear Engine spin! By Buying
a Booster You Save Money. PRE-WAR PRICES:

Booster Type 6 charges 6 volt Battery at 6 amperes \$15
Booster Type 12 charges 12 volt Battery 3 amperes \$15
Type 160 charges 6 volt Battery at 15 amperes \$24
Type 1812 charges 12 volt Battery at 7 amperes \$24
Type 1826 Combination Type charges both 6
and 12 volt Batteries at 12 and 7 amperes... \$35

CHARGING SERVICE
The Latest Types are recommended for heavy batteries, or where time is limited.
Shipping Weights Complete with AMMETER & BATTERY CLIPS, 12 to 15 Pounds.
Mail Check for Prompt Express Shipment. Or if for Parcel Post Shipment add Postage
& Insurance charges. Or Order us to forward the Type you desire C. O. D.
Order Now or Write Immediately for FREE DESCRIPTIVE BOOSTER BULLETIN 24.
For GROUP CHARGING write for Free ROTARY RECTIFIER BULLETIN 24-A.
Real Economy in First Cost & in Service. It charges up to 30 Cells. Automatically.
THE FRANCE MFG. CO., CLEVELAND, OHIO, U. S. A.
Canadian Representatives: Battery Service & Sales Co., Hamilton, Ontario, Canada.

Oh Boy! BUILD THIS CAR

This tiny little car driven
by gasoline motor, can be
built by any boy.
New plans, bigger,
better than
ever, now ready.
Send 50c for building
plans and price
list of parts showing
how to build
this kid's car.

SYFHER MFG. CO.
146 Sypher Bldg. TOLEDO, OHIO

For **FORD CARS** Any Year, Any Model
Genuine **HEINZE-SPRINGFIELD** \$49.75
Starting and Lighting System---
Limited supply—latest improved type! Price includes Ammeter,
Dash and Tailights, Switch Lock and new high-grade battery
of standard make. Quick, sure start—bright, steady lights. Easy-
ly attached to any Ford. Order direct from this ad or write for
literature.

The Service Products Co., Dept. 9. - Springfield, Ohio

AUTO DRIVERS

Can make big money in spare
time or devote entire time to
introducing and taking or-
ders for our

IMPROVED CORD TIRES

Highest quality. Sensa-
tional prices. Big profits.
Permanent business.
Write today for catalog and
agent's special offer.

LANGAN & PHILLIPS
Dept. 104 CHICAGO

NEW INVENTION!

Makes winter starting easy. Attaches to carburetor. Hot electric coil heats gasoline. Vapor fills manifold and cylinders. Two turns of starter and motor starts with rush.

SURE-START VAPORIZER DOES IT!

Slightest spark ignites. It's fully guaranteed. Absolutely safe. Makes starting sure on coldest day. Saves battery. Saves gas. Saves temper. Saves time. It's a marvelous invention. Motorists wild about. Write for name of nearest dealer.

DEALERS OR AGENTS -- BIG MONEY!

Sell right and left in your town, \$15 to \$20 day easy. Exclusive Territory. Easily attached. Take out drain cock and insert vaporizer—that's all. Get our proposition.

THE SURE-START VAPORIZER COMPANY
145 Tenth St. Toledo, Ohio

MAKE MORE MONEY

Get the Agency for **BUSH Automobiles for 1922**



6 and 4 cyl.

Open and closed cars. Start today to make more money in 1922 than you did in 1921. You can with good cars at low prices. Get all information quick. Write TODAY.

BUSH MOTOR CO.
Dept. 121, Bush Temple, Chicago

Knife-Pistol
SHOOTS 22-calibre cartridges. Automatic safety. Large, keen blade, made of best cutlery steel—finished in nickel. **SEND NO MONEY.** Rush name and address and we will immediately forward this **Defender Pocket Knife-Pistol.** Deposit only \$4.95 with postman on arrival. **Money Refunded if Not Satisfied.** Special proposition to agents.

ALEXANDER SALES CO., 208 Alexander Ave., Dept. P.M., N.Y.C.

We Pay \$8 a Day

taking orders for Insyde Tyres—inner armor for automobile tires. Positively prevents punctures and blowouts. Guaranteed to give double tire mileage.

We Want 2000 Representatives

Easy to get orders. Every auto owner a prospect. Old worn-out casings will give three to five thousand miles more service. Use over and over again. Demand enormous. Write quick and get started.

AMERICAN ACCESSORIES CO., B-1876, Cincinnati, O.

Our **BUREAU OF INFORMATION** will answer all questions regarding articles appearing in this magazine. Address Bureau of Information, Popular Mechanics Magazine, Chicago.

Ford OWNER Agents Wanted!

In each locality to use and introduce
NON-KICK DEVICE

Prevents Broken Arms—Cranking Accidents.

Make big money, part or full time. Burnett sold 144 in two weeks—made \$218. Big Field—our folder, "How to Make Money With Non-Kick Device," will prove it. Almost 5,000,000 old Fords without starters. 70% 1921 Fords sold without starters, or 875,000 out of 1,250,000.

Try a "Non-Kick" 10 Days at Our Risk

See for yourself how it disengages the clutch, allowing motor to reverse without danger to person who cranks. Thousands of satisfied users. Easy to install; only one nut to remove; slips right on over handle; a child can put it on in two minutes. With a "Non-Kick" on your Ford you will never have a broken arm or cranking accident, with suffering, doctor bills, inconveniences, lost time, etc. Send \$2.50 for sample "Non-Kick" Device (or, we will send it C. O. D. and when it arrives pay postman \$2.50) and if after 10 days trial it isn't as represented get your money back. Be the first in your locality to order—and ask about our attractive exclusive territory offer to agents.

NON-KICK DEVICE COMPANY

774 Central Street

Kansas City, Mo.



Jiffy

KNOCK-ABOUT SUIT

No Button, Lightning Hookless
Fastener Front

Here's the ideal garment for every man whose work or hobby necessitates the protection of his ordinary clothing. Whether you wear it all day, or just put it on for a few minutes you can't beat it for speed in putting it on and taking it off, or for its thorough protection when fastened.

See that "slide"? It's the lightning hookless fastener. One upward sweep of the hand and it closes the suit—dust-tight. One downward sweep and the suit is opened—ready to step out of. The **Jiffy Suit** is a wonder to all who see it and a great satisfaction to all who wear it.

No Trouble to Wash and Wring

The **Jiffy Suit** is just as easy to wash as any other garment. The flexible fastener is rust-proof, can be handled in any washing machine, and will go through the wringer with less trouble than buttons. You need a **Jiffy Suit** for the time it saves—the absolute protection it affords—and its positive efficiency as a handy garment in the house, factory, work-shop or automobile.

**It Is Rust-Proof,
Dust-Proof and
Scratchless**

Get a **Jiffy Suit** to-day and enjoy real comfort. If your dealer cannot supply you send \$5.00, with your size, and address, and we'll send you a **Jiffy Suit** by return mail.

JIFFY GARMENT CO.

Saint Paul, Minn.



Do it with the

ONE-HAND-Y



Weight
3 lbs.

Capacity
 $\frac{1}{4}$ in.

**The ONE-HAND-Y Electric Drill
Rapid, Economical, Indispensable**

Application

The ease with which holes may be drilled in metal or wood with the ONE-HAND-Y makes it one of the most desirable tools in existence.

Ease of Operation

Its light weight—3 pounds—insures rapid, economical and accurate work, as it can be moved about easily, and can be used constantly without tiring the operator.

Cost

The ONE-HAND-Y is the lowest priced, most economical electric drill on the market.

Motor

Westinghouse, Universal Type, 110, 220, and 32 volt AC and DC. Air cooled. Ample power controlled by switch always under thumb.

Guarantee

The ONE-HAND-Y—the lightest electric drill on the market—is guaranteed against defective workmanship and material.

Write nearest office for details

Knight Engineering & Sales Co.

30 West Walton Place,
Chicago, Ill.

210 W. Seventh Street,
Los Angeles, Calif.

DIAMONDS For a Few Cents a Day

Send No Money

We will send you—upon your simple request—your choice of diamond bargains—the greatest in America! Do not send a penny in advance. When the ring comes, examine it. You are the judge. If it is not, without exception, the greatest value you have ever seen, send it back—at our expense! If you decide to keep it, it is yours—for a few cents a day. You may order direct from this advertisement if you wish. Don't send a cent. You do not risk a penny.

Charge-Account Plan

By our new charge-account plan, you may pay for your choice of hundreds of pieces of exquisite jewelry in sums so small that you would never think of saving them. You are also guaranteed 8% yearly dividends—and a 5% bonus may be earned.

Send for Bargain Book

Send your name and address today for our new 125-page book, showing hundreds of unmatched diamond bargains. Sent absolutely free. It explains the dividend offer and bonus plan. Write today to Dept. 1771

J. M. LYON & CO.
1 Maiden Lane, New York N.Y.

PATENTS

TRADE-MARKS

COPYRIGHTS

Send for our free book of patent information.

Beale & Park

802 F St., Washington, D. C.
16 S. Broad St., Philadelphia, Pa.

9 CORDS IN 10 HOURS



BY ONE MAN. It's KING OF THE WOODS. Saves money and backache. Send for FREE catalog No. B115 showing low price and latest improvements. First order gets agency. FOLDING SAWING MACHINE CO., 161 West Harrison St., Chicago, Ill.

NEW LAMP BURNS 94% AIR Beats Electric or Gas

A new oil lamp that gives an amazingly brilliant, soft, white light, even better than gas or electricity, has been tested by the U. S. Government and 35 leading universities and found to be superior to 10 ordinary oil lamps. It burns without odor, smoke or noise—no pumping up, is simple, clean, safe. Burns 94% air and 6% common kerosene (coal oil).

The inventor, L. D. Johnson, 609 W. Lake St., Chicago, is offering to send a lamp on 10 days' FREE trial, or even to give one FREE to the first user in each locality who will help him introduce it. Write him today for full particulars. Also ask him to explain how you can get the agency, and without experience or money make \$250 to \$500 per month.

Motorize Your Bike With a SHAW Motor Attachment

IT'S quick and easy to do—Prices have been smashed—they are way down—lower than ever before. Everybody—can now afford to own a Shaw Attachment at these New Reduced Prices. Save Money! The Shaw Attachment will make your old bike take on new life. The powerful $2\frac{1}{2}$ Horse-Power Motor will save you many dollars in time and expense. Enjoy all the pleasures of motorcycling at about *one-fourth* the cost.

Easily and Quickly

Attached—The Shaw Motor Attachment complete can be attached to any bicycle frame in 30 minutes time. No special tools or knowledge required—just a screw driver and wrench. No boring or brazing. Fits any single or double bar frame. Thousands of Shaw Motors are now in daily use in every state in the Union and many foreign countries.

90 to 125 Miles

Per Gallon—This is the mileage you get from the Shaw Attachment. The Shaw motor is either battery or magneto equipped. Lunkenheimer bronze fuel mixer give almost unheard of mileage. Runs 1500 to 1800 miles on a gallon of oil. Nothing complicated to get out of fix. The simplest, most compact motor ever built.

**Prices
Greatly
Reduced**

SHAW Motorbicycles

WE also manufacture the Complete Shaw Motorbicycle. A light weight machine having the powerful Shaw $2\frac{1}{2}$ H-P. Motor, Chain Drive, Free Engine Clutch. Grip Control. Special low introductory price if you write NOW!



Climb
the
Steep
Hills
Without
Pedaling

Takes You Anywhere—

Your old bike with the Shaw Attachment takes you anywhere. Spin up the steepest grades or over rough roads without any effort. Distance is no barrier, if your bike is Shaw equipped. You can go anywhere, at any time, quickly and at small expense. The Shaw brings pleasure and enjoyment every minute.

Special Offer

Now! We want every Boy or man interested in motorcycling to write at once for our **Big Special Offer and New Reduced Prices**. The big saving will surprise you. Use the Coupon NOW!

SHAW MFG. CO.

Dept. 37,
Galesburg, Kansas.

FREE!

Send for complete literature illustrating and describing SHAW Attachments and SHAW Motorbicycles. Use the Coupon. **Send today.**

MAIL THIS NOW!

SHAW MANUFACTURING CO.,
Dept. 37, Galesburg, Kansas.

Please send me your Special Offer, New Lower Prices and Complete Literature on SHAW Motor Attachments and Motorbicycles.

NAME.....

ADDRESS.....

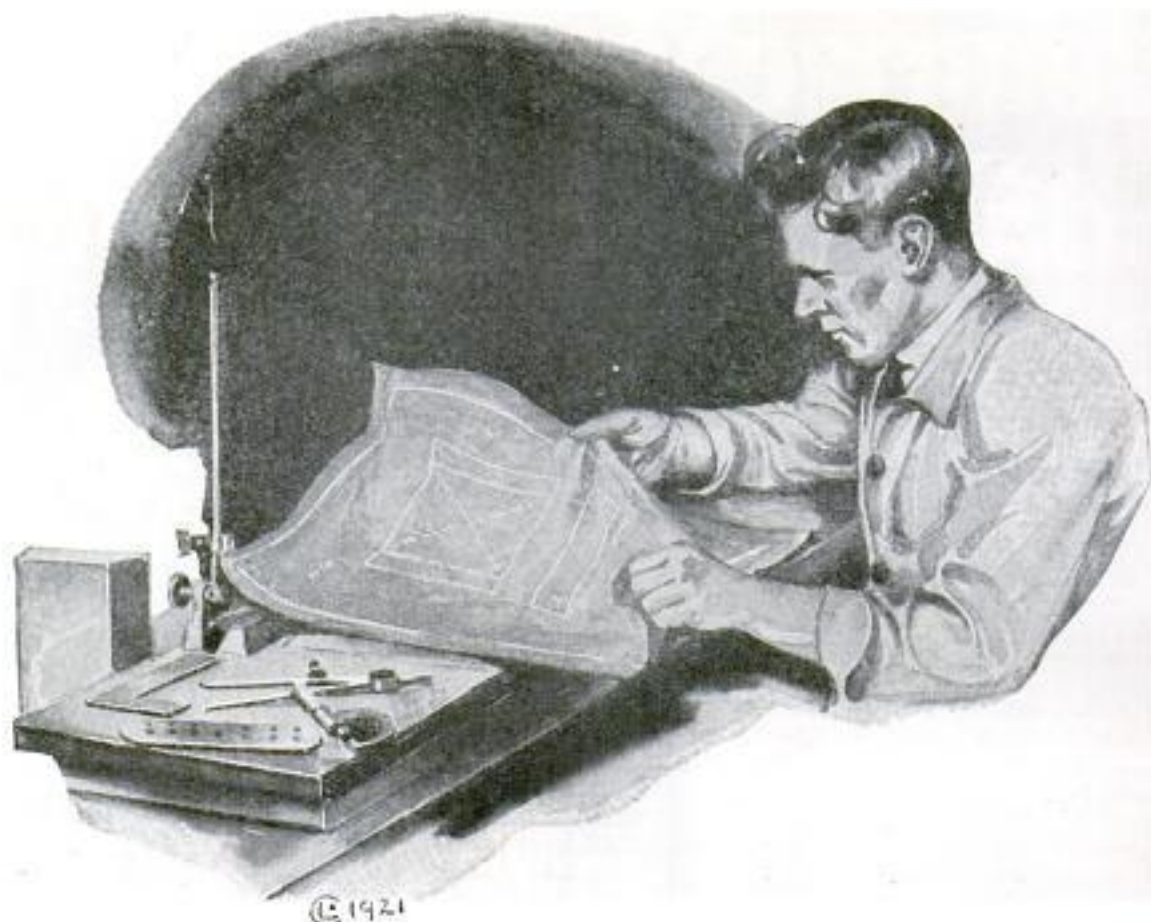

THE superior accuracy and quality of Starrett Tools is shown by the fact that toolmakers as a class prefer them. These men know the importance of using precision tools of the highest accuracy. The worth of Starrett Tools to men of lesser skill is even greater—because they need the aid that only fine tools can give.

Write for free copy of Starrett Catalog No. 22 "AP" describing and illustrating 2100 Fine Tools

The L. S. Starrett Company

The World's Greatest Toolmakers
Manufacturers of Hack Saws Unexcelled

Athol, Mass.

42-255



Use Starrett Tools

Copyrighted material

Cuts 36 Cords a Day With His OTTAWA LOG SAW

The Standard Log Saw of the World

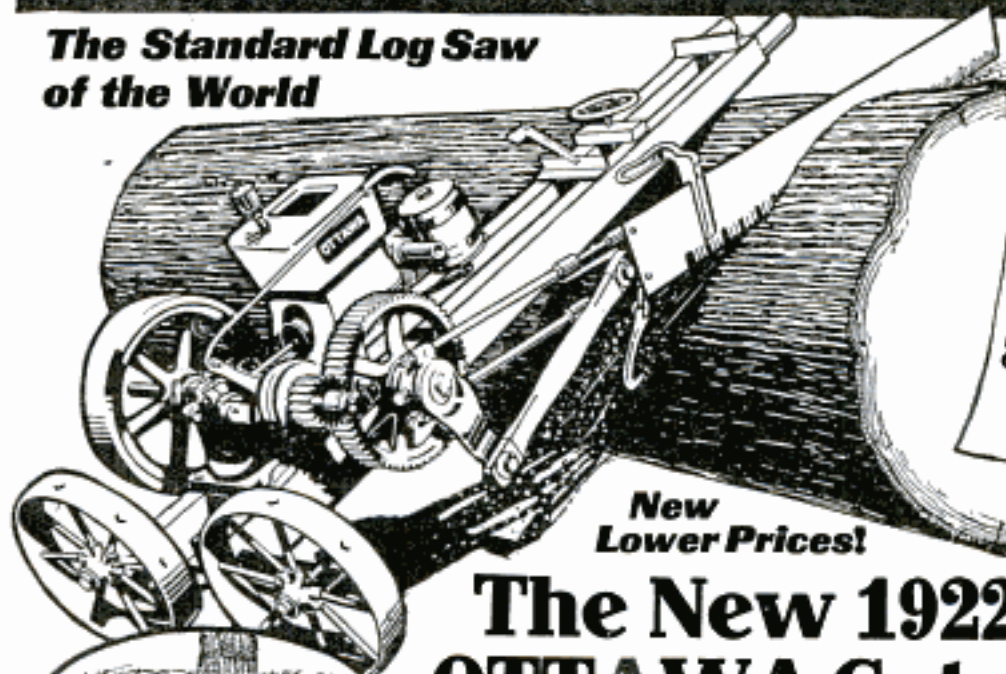

New Lower Prices!

The New 1922 Model OTTAWA Cuts Faster

MR. MARTINS' report is the best proof I can offer to make good the claim that the OTTAWA Log Saw is the Fastest-Cutting One-Man Outfit ever made. And the 1922 Model is still faster! As for making money with the OTTAWA—T. O. Shurson, Eagle Grove, Ia., banked \$255.25 extra in two months. These men have the older model. The New OTTAWA does more work quicker.

350 Cuts a Minute That's the rate at which the New 1922 OTTAWA saws through the toughest log. More than 6 cuts a second! And every cut is made the human way because of the **Power Force Feed**.

Magneto Equipped: No batteries. The New 1922 OTTAWA comes all ready for use. 4-H.P. Motor. Nickel Chrome valves—just like high priced automobile motor. All power needed for sawing and belt work. Wide, long wearing bearings.

Cash or Easy Terms New Lower Prices and Easier Terms of Payment enable any worthy man to own an OTTAWA.

Send for FREE Book **Mail Coupon Right Now**

Wood Sawing Encyclopedia

MAIL THIS TODAY

H. C. Overman, Gen. Mgr.
OTTAWA MFG. CO., 1748-P Wood St.
Ottawa, Kansas.

Send me your New Book and Special Money-Saving Offer on New 1922 Model OTTAWA Log Saw.

NAME

ADDRESS

READ THIS

Withee, Wisc.,
Sept. 20, 1922

Gentlemen:
Our Ottawa Log Saw certainly works fine. I saw 36 cords a day with the Ottawa and never have any trouble.
Will start sawing again this week. It is no work at all with our fast-cutting Ottawa.

Your friend,
FELIX MARTINS

Quick change to Tree Saw and back to Log Saw.



Cut Up Branches

Limb or Buzz Saw sold alone or with Log Saw.

Free My New Book in colors describing the New 1922 Model OTTAWA and showing how hundreds have paid for their outfits while sawing, is ready for mailing. It will include New Lower Prices and Special Money-Saving Offer if you write at once.

H. C. OVERMAN, Gen. Mgr.
OTTAWA MFG. CO.
1748-P Wood St., Ottawa, Ks.

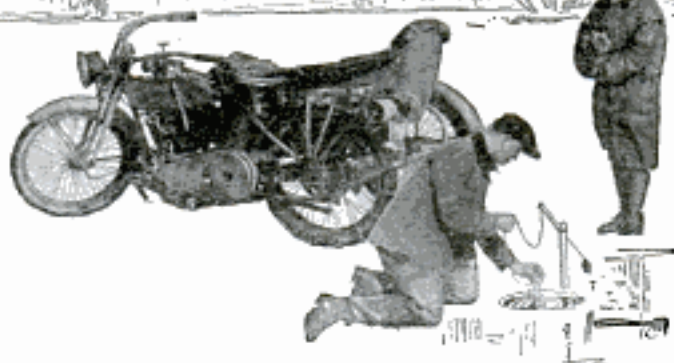

Fishin' Pals

ACROSS the lake in a jiffy to the place where the big fellows lurk the year 'round—then scooting for home and breakfast, so swiftly you leave the wind behind!

While your neighbor's automobile stands on four jacks, your Harley-Davidson and side car are exploring snow-clad paths, hunting for rabbit tracks, carrying you and your pal with the speed of an ice-boat to toboggan slide, ski jump or skating party.

And it's inexpensive sport, too. A dollar will pay for 50 miles—gas, oil, tires and all. Who can't afford a motorcycle?

Harley-Davidson prices have been cut 25%. Ask your dealer for free demonstration, or write us for literature

Attractive dealer proposition for open territory. If interested, address Desk A-2
HARLEY-DAVIDSON MOTOR CO., MILWAUKEE, WIS.

Harley-Davidson

World's Champion Motorcycle

Tycos Room Thermometers

Stand between you and ill health; help you save coal; assure comfort throughout winter months. One of many thermometers—oven, candy, bath, fever—made by world's largest manufacturers of temperature instruments. Booklet telling right home temperatures free.

Taylor Instrument Companies
 Rochester, N.Y., U.S.A. T-191



BIG PROFITS 3 IN 1 COMBINATION

Hand bag, change purse, and shopping bag. Made of heavy auto leather. Price \$8.00 per dozen. Send 75c for sample.

LEATHER PRODUCTS CO.
 165 W. Monroe St., Chicago, Ill.

CATALOG No. 21 IS READY Get Yours NOW

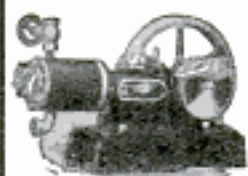

Small Steam Engines and Boilers, Gas and Gasoline Engines, 1/4 H. P. and up, Pumps, Gears, Model Makers' Supplies.

Catalog No. 21 sent postpaid or 15c (coin preferred) or stamp.
Modern Engine and Supply Co.
 342 Monroeville Block, CHICAGO



SEND NO MONEY

Try this Portable Typewriter 10 Days FREE

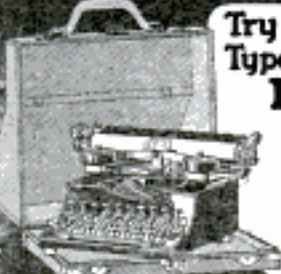

10 Months to Pay

Now you can buy famous, 9-pound National Typewriter direct from the factory, after 10 days' trial—absolutely free. You be the judge. Then we give you

10 MONTHS TO PAY

Same machine as used by thousands of doctors, lawyers, bankers, salesmen, students, writers and business men in 31 countries. Every feature of best, standard size machines. 28 keys.

84 characters. Brand new—not a rebuilt typewriter. Neat, compact carrying case free with every machine. Send today for our 10 Days' Free Trial offer and 10 Months' Easy Payment Plan.

NATIONAL TYPEWRITER CO.
 Dept. 7A. Fond du Lac, Wis.



DIAMONDS

Here at 60% of Market Price

This blue white perfectly cut diamond, 7-8 - 3-32 ct. at \$22.50 among bargains last list. Many other big values in our lists. Buy **HERE**. Loan values the price basis, not market values. This 75 year old diamond banking firm has thousands unpaid loans and other bargains we must sell NOW.

Why Pay Full Prices

Any diamond sent for absolutely free examination at our risk. No obligation. No cost to you.

Send for Latest List

Diamond Bargains described in detail. Tells of guaranteed loan values, unlimited exchange privilege, details of free examination. No obligation. Just send name.

JOS. DEROY & SONS
 Only Opposite Post Office

1922 DeRoy Building
 Pittsburgh, Pa.

Easy to Get Winter Eggs



Use the
Coupon
below!

"A Family of Five Can Live on the Work of Fifty-four Hens. That Sized Flock Will Pay the Bills of the Family and Permit It to Live Decently!" says a practical poultry raiser before the U. S. Commission on Unemployment at Washington, D. C.

Simple Methods Guarantee Success

To enjoy this success you must treat your hens right. There are real secrets you must know in order to avoid loss of money and time and disappointment. You must **know** these secrets and **know** how to apply them. T. E. Quisenberry, one of the world's most successful poultry raisers, outlines all anybody need know in his new book, "Dollars and Sense in the Poultry Business," sent free to readers of THE COUNTRY GENTLEMAN. The book is based on 25 years' actual experience and covers a multitude of subjects, among which are the following:

- How to Tell Males or Females that Breed Good Layers.
- How to Get Eggs in Coldest Weather.
- How to Get More Eggs and Save Feed.
- How to Cull Out Non-Layers.
- How to Tell Poor Layers at a Glance.
- How to Tell Good Layers at a Glance.
- How to Prevent White Diarrhoea and Bowel Trouble.
- How to Feed Chicks from Start to Finish.

Dollars
and
Sense
in the
POULTRY
BUSINESS

by T. E. QUISENBERY

Capitalize Your Back Yard

Nothing hard about Poultry Raising. This **FREE BOOK** shows you how you can have plenty of fresh eggs for home use and to sell when prices are highest.

Get This Book at Once!

Use the coupon or a post card and mail today. This Book will be sent postpaid without obligating you.

Address:
T. E. QUISENBERY,
Dean,
American Poultry School
Dept. 185
KANSAS CITY, MO.

FREE Book Coupon

American Poultry School,
Dept. 185, Kansas City, Mo.

Send me "Dollars and Sense in the Poultry Business," written by Prof. T. E. Quisenberry, without obligation.

Name.....

Address.....



Know How to
Double Your
Egg
Yield!

American Poultry Journal

OLDEST, LARGEST and BEST
4 MONTHS' TRIAL 25 cents

1 Yr. 75c. 2 YEARS \$1 5 Yrs. \$2

Averages over 100 pages per issue—tells how to feed, house and breed; how to secure high egg production; how to hatch and rear poultry successfully. Established 1874. Only 25 cents for 4 months. Stamps accepted.

American Poultry Journal, 14-523 Plymouth Ct., Chicago

GREIDER'S FINE CATALOG

of fine bred poultry for 1922; all choicest breeds illustrated and described; information on poultry, how to make hens lay, grow chicks—all facts. Low price on breeding stock and hatching eggs. 30 years in business. This book only 10c.
B. H. GREIDER, Box 19. RHEEMS, PA.

PLANS FOR POULTRY HOUSES!

All styles. 150 illustrations; secret of getting winter eggs, and copy of "The Full Egg Basket." Send 25 cents.
INLAND POULTRY JOURNAL, Dept. 74, Indianapolis, Ind.

64 BREEDS

Most Profitable pure-bred ducks, geese, turkeys. Fowls, eggs, incubators at reduced prices. 29th year. Largest plant. Large valuable poultry book and catalog free.
R. F. NEUBERT Co., Box 916 Muskoka, Minn.

SQUAB BOOK FREE

Squabs are selling at the highest prices ever known. Breed them and make money. Write at once for free book, prices, etc.

Phonick Rock Squab Co., 634 Howard St., Melrose Highlands, Mass

World's Best Poultry Journal

You be the Judge!
4 Months' Trial 20c
Subscription 20c

SEND U. S. STAMPS
Tells how to keep poultry with greatest profit; 100 to 168 pages monthly; 27th year. Best articles; expert advice; profusely illustrated. 1 Yr., \$1.00; 3 Yrs., \$2.00.
Reliable Poultry Journal Pub. Co., Dept. 118, Quincy, Ill.

Grow Dollars From Dimes

I'll help you.

Get my big, free book about

Old Trusty Incubators and Brooders.

Mail a postal for your copy today.

Also ask for 1922 low prices

on Old Trusty Incubators and

Brooders. Nearly a million

owners. Harry Johnson,

"Incubator Man."

M. M. JOHNSON CO.
Clay Center Nebraska



Send No Money for this 25 Cal regulation blue steel Automatic Revolver



Pay the Postman only

\$9.75

and postage when the revolver is delivered. We guarantee full satisfaction or money back after examination.

Keep one of these brand new safety revolvers in your home and be fully protected against burglars, thieves and hold-up men. It's a terrible fright to wake up in the night—hear noises down stairs or in the next room—and realize your neglect has left you wholly UNPROTECTED. One of these revolvers will fully protect you.

Shoots Quick—7 Shots in 3 Seconds



Just pull the trigger. Each shot automatically ejects the cartridge and loads ready for the next shot. This revolver HAS DOUBLE SAFETY and is practically "fool-proof" against accidents. Perfect grip, accurate aim. Handsome blue steel gun metal finish. Rifled barrel, checkered grips, safety lever. Holds 7 cartridges. Small, compact, fits in vest pocket, lies flat and will not bulge out pocket. Shoots famous Colt Auto Cartridges. Fine for target practice.

SEND NO MONEY

Order today. Just send your name and address and say which revolver you want.

- No. 405 is 25 cal. 7 shot. Regular price \$22.50. Our price... **\$9.75**
- No. 3528. Same style as above only 32 cal. 7 shots. Regular price \$25. Our price only... **\$11**
- No. 4502. 25 cal. genuine Mauser. The only 25 calibre automatic that shoots ten shots. Blue steel finish. Value \$35. Our price only... **\$14.50**
- No. 5002. 32 cal. genuine Mauser automatic. Shoots 9 shots. Blue steel finish. Value \$40. Our price only... **\$15.50**

- No. 805. 32 cal. automatic military model, 10 shot, extra mag. FREE, 19 shots in all. Special price **\$12**

Genuine LUGER

No. 4018. 30 cal. genuine Luger. Don't be misled by a gun that looks like a Luger. We are selling this wonderful world famed automatic at such ridiculously low prices because of our ability to purchase in quantities. Shoots 9 shots. Has automatic magazine ejector. Latest model with safety attachment. Regular value up to \$60. Our special price, while they last, **\$28.50** only.

Don't wait. Order these bargains today. You take no risk. Write clearly your name, address and the Number of the Revolver you want. Send No Cash. We ship by return mail. Pay Postman on arrival our price, plus postage. Send for free catalogue.



HOLSTER for any of above revolvers. Genuine leather, \$1.50

GUARANTEE We guarantee absolute satisfaction after examination or your money back. Rush your order today.

PARAMOUNT TRADING CO.
34 West 28th St., New York, N. Y.

New 300 Candle Power Lamp



Make \$60 to \$100 a Week
Introducing this wonderful new lamp. Gives soft, brilliant, glowing light; restful to eyes; ideal illumination.

Burns Kerosene or Gasoline
Clean, odorless, economical. Burns 96% air, 4% fuel. Absolutely safe. Lights with match. 100 times brighter than wick lamps. Patented. Greatest improvement of the age. Table lamps, hanging lamps, lanterns.

No Capital Required
Work all or spare time. You simply take orders. We deliver by Parcel Post and do collecting. Commissions paid same day you take orders. No experience necessary. We give free selling instructions. Get started at once. Big season now on. Write today for catalog and special agents offer.

AGENTS Send for FREE Offer

THE AKRON LAMP CO.
101 Lamp Bldg., Akron, O.

Mend Your Own Utensils With SOLDERALL

Patented Oct. 3, 1911

A Paste That Turns Into Metal When Heated **Our New Improved Torch \$1.50**



25c per tube

A match will do it, but best results can be obtained by using our new improved torch. Requires no acid or soldering iron. Joins or repairs wires, metal or metalware. Sold by Hardware and Electrical Stores, or sent by us postpaid.

COMBINATION SET \$1.75
Tube and Torch Complete
SOLDERALL CO., Dept. P
129 Sussex Avenue NEWARK, N. J.
Dealers Send for Quantity Prices
Beware of Imitations with Similar Names



5.00 DOWN **23 JEWELS**
14 KT. SOLID GOLD

30 days free wear to test it. Take 10 months to pay. Easily worth \$45.00, our price only \$25.00—men's full size.

\$2.00 A MONTH

Send \$5.00 deposit with order. We will refund your money if you are not satisfied. Send for 128-page bargain catalogue.

B. GUTTER & SONS.
34-36 NASSAU ST., NEW YORK

Do Your PRINTING

Cards, circulars, labels, tags, book, menus, paper, Press, \$12. Larger \$15. Job Press \$150 up. Save money. Print for others, **BIG PROFITS**. All easy, rules sent. Write factory TODAY for press catalog. TYPE, cards, paper. **THE PRESS CO D-37, MER DEN, CONN.**

Cut Price!

Save money. Try this wonderful range at **OUR RISK. We pay the freight. Over 150,000 in use. All sold on THIRTY DAYS' FREE TRIAL.**

Great Fuel Saver. Wonderful Baker!
Housewives delighted with results. Amazing demand. Many exclusive features. **Oder Hood**—carries all odors up chimney. **Ash Sifter**—sifts ashes right in range. No dust. **Stone Oven Bottom** absorbs and holds heat. Makes baking sure and successful. **GUARANTEED. Will last for years.** You can buy this wonderful range **DIRECT FROM FACTORY at WHOLESALE PRICE**—our only selling plan. New 1922 design has white enamel front. Handred other styles from which to choose. **Easy Credit Terms** if desired. Write today for big FREE catalog.

THE IMPERIAL STEEL RANGE COMPANY
569 Detroit Avenue Cleveland, Ohio

A New Evinrude— 21 Pounds Lighter!

AMERICA'S sportsmen who have long awaited a truly dependable outboard motor of greater portability, will welcome the latest Evinrude achievement—the new, 50-pound "Lightweight."

With light, strong aluminum alloys replacing many bronze and malleable parts, this Evinrude sport model scales just under 50 pounds *complete*, ready to run. The lightest practical row boat motor ever built. It matches in power and speed the standard 2 H. P. model. While not designed for such rugged service, it is a true Evinrude in sturdy dependability.

Fishermen, hunters—particularly motorists—who wish to carry boat-power with them, will find the "Lightweight" ideal—so easy to handle in car, train or trolley.

The Evinrude "Lightweight" is priced the same as the standard motor, which is now back at the pre-war price of \$100. See these motors at your sporting goods or hardware dealer's. Or write for catalog.

EVINRUDE MOTOR CO.

605 Evinrude Building, Milwaukee, Wis.

Distributors:

69 Cortlandt St., New York, N. Y. 440 Market St., San Francisco, Calif.
780 Commonwealth Ave., Boston, Mass. 211 Morrison St., Portland, Ore.

EVINRUDE "LIGHT-WEIGHT" DETACHABLE MOTOR FOR WATERCRAFT



New! Just Out!

PILLIOD General Service Case

Heavy copper-plated over zinc. Brass-plated hardware. Handsome, durable, great for machinists, repair men, motormen, autoists, etc. Will last a lifetime.

Illustrated Folder Free
THE PILLIOD LUMBER CO.
Dept. 1 SWANTON, OHIO

SAVE HAND WORK & WASTED STEPS

by using Wallace Bench Saws and Planers. They are portable, motor driven machines—take them to the job. Their speed and accuracy saves time and labor. Send for catalog and prices.

J. D. WALLACE & CO., 1418 W. Jackson Blvd.
CHICAGO, ILL.

START IN BUSINESS

Make Real Money on Small Capital

All over the U. S. and Canada we are establishing Vulcanizing Service Stations. Start one in your town. Make \$10 to \$30 per day on a \$350 investment. We instruct you and furnish the **Most Modern Methods and Equipment**—

THE ANDERSON Known the World Over

We have 34 Schools in U. S. and 4 in Canada. One is near you. School pays you \$5 per day while learning to operate your station. Write for full particulars—TODAY.

THE ANDERSON STEAM VULCANIZER CO.

Manufacturers of Modern Tire Repair Equipment,
103 Williams Bldg., Indianapolis, U. S. A.



Race Electric Grinder \$16⁵⁰

Complete With 3" Emery Wheel, Grooved Pulley and Electric Cord

F. O. B. CHICAGO

For sharpening tools, polishing or grinding, the Race Motor Grinder will prove a great convenience in the Carpenter Shop, Machine Shop, Garage, at Home, or on the Farm; it is a practical machine that will prove its value to every mechanic. It is portable, plugs into any electric light socket, push button start and stop, operates on either A. C. or D. C. current of 110 to 130 volts, or 25 to 60 cycles. Weighs only 7 lbs.

These small Grinders are dependable in every respect and satisfactory service is guaranteed to the extent that if you are not entirely pleased after ten days' use, the Grinder may be returned to us and your money will be cheerfully refunded.

A neat adjustable tool rest can be supplied for \$1.50 extra if desired.

RACINE UNIVERSAL MOTOR CO., 4642 Ravenswood Ave., Chicago, Ill.
ATTRACTIVE DEALER PROPOSITION

Do You Love Violins?

Then let us send you the latest edition of our Violin Catalog, describing and pricing many types and models of Violins, Violas, Violoncellos, Basses and Accessories. If you are particularly interested in rare old violins, please mention this especially—our large collection embraces the finest masterpieces grouped together in America.

In moderate-priced high quality modern violins, our own *Crematone Viola* offers the best value obtainable. It may now be bought on a special small monthly payment plan. Fill out coupon and mail to us for details.

Name.....
Address.....

I am interested in a New Violin.....Old Violin.....at \$.....Price.

If a violin teacher, let us include your name in our revised teachers' list now being compiled.

We take used violins in exchange. Write today. Leading Music Stores sell Lyon & Healy Musical Instruments.

LYON & HEALY

Everything Known in Music

76-86 Jackson Blvd. Chicago



WINTER CAP \$1.65



Smartest cap you ever saw. Genuine imported all-wool, Scotch Tweed. Beautifully tailored, extra large and full. The kind for which City haberdashers ask \$3.00 or more. Extra heavy peak. Just the thing for zero weather, yet nothing smarter will be seen on Michigan Boulevard or Fifth Ave.

VELVET LINED EAR-LAP

Extra long, wide ear-lap, lined with long-nap, heavy silk, black velvet, resembling seal. Fits tight to head and ears. Keeps out cold. Folds out of sight when not used. Fine for driving.

SEND NO MONEY

Just your name, address and head size. Pay postman only \$1.65 plus a few pennies postage when delivered. If you don't say it's the most wonderful cap bargain you ever saw, return it and we will refund your money in full. Order today.

GASSMAN BROTHERS Dept. 11-C, 3014 92nd St. CHICAGO

Be A Floor Surfacing Contractor

Make \$5,000 to \$15,000 or More—Yearly



New, uncrowded field. Architects and general contractors know the American Universal and prefer its work. They prefer to subcontract the floor surfacing contract, as it is a big business in itself. Business comes easily the American Universal Way. We furnish office forms, advertising, etc.—in fact we practically set a man up in a business of his own.

RE-SURFACING OLD FLOORS

Every building, large or small, is a prospect. Hundreds of floors right in your own vicinity need resurfacing. The owners will be glad to have you do it when you show them how easy and quickly the work can be done the American Universal Way. Old floors made like new—new floors made perfect.

Don't ever get caught out of work again—get into a big paying business of your own. Floor Surfacing Contractors pay for machines first month and make big profit besides. WRITE TODAY for full information. Act NOW

American Floor Surfacing Machine Co.

Originators of Floor Surfacing Machines
523 South St. Clair St., TOLEDO, OHIO, U. S. A.

Build and Fly Model Aeroplanes



Build a Model Aeroplane that will fly like a real one. With IDEAL Scale Drawings and Building and Flying Instructions you can easily build exact 1/4 ft. duplicates of Big Aeroplanes. Send now for Drawings and Instructions for the one you will build!

Curless JM40-2 Training Plane, De Havilland Battle Plane, NC-8 Naval Seaplane, Curtiss Military Tractor, Sturtevant Monoplane, Newport Monoplane, Taube Monoplane, each Postpaid Catalog of 1088 Model Aeroplanes and Instructions, by Postpaid.

IDEAL AEROPLANE & SUPPLY CO.
159 Woolster St., Cor. W. Houston, N. Y. C.

25c

LOOK 50¢ LOOK

Wonderful Instrument. Greatest thing yet. Nine separate articles in one. Everybody delighted with it. Odd, curious and interesting. Lots of pleasure as well as very useful. It is a double Microscope for examining the wonders of nature. It is also an Opera Glass, a Stereoscope, a Burning Lens, a Reading Glass, a Telescope, a Compass, a Pocket Mirror, and a Laryngoscope—for examining eye, ear, nose and throat. It is worth all the cost to locate even one painful cinder in the eye. Folds flat and fits the pocket. Something great—you need one. Don't miss it. Sent by mail, with 300 page Novelty Catalog, ONLY 50c or 3 for \$1.25. JOHNSON SMITH & CO., Dept. 753 3274 N. Halsted St., CHICAGO

New Land Clearing Book

Written by the greatest land clearing experts. It will mean hundreds, maybe thousands of dollars extra income to you. Tells how you can convert waste land into extra bushels. Your richest virgin bumper crop soil is under your stumps. Remove them. This book explains the different methods and tells which is best for your own job. Write today. It's free.

FREE

80 pages in Colors fully illustrated

A. J. KIRSTIN CO.
3203 Lud St.
Escanaba, Mich.

LAND-CLEARER'S GUIDE



Wonderful New Razor

Blade slides from side to side as you shave, cutting beard cleanly without scraping or irritation. 30 days' free trial. Write for booklet. LEE RAZOR MFG. CO., Dept. 100, 154 W. Whiting St., Chicago

STEADY WORK

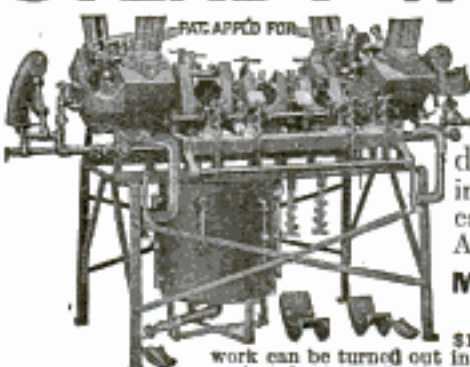

in a fast growing business. With Vanderpool latest improved Vulcanizer made in America you can MAKE MORE MONEY

\$100 to \$150 worth of work can be turned out in a day with the five cavity plant—profit about one-half. VANDERPOOL VULCANIZER CO., Dept. P1, Springfield, Ohio
F. H. Dibb, Agent for the British Isles, 26 Fairfield Rd., Winchester, England

Baby Grand Lathes

Not a Toy—Just Like a Big One

For either metal or wood working—ideal for auto and electric repair shops, pattern and model shops. Because of their simplicity and compactness, we are able to build into each Baby Grand Lathe the same sturdiness that characterizes the finer types of big lathes—and at a price within the reach of everyone, everywhere.

Put One on Your Bench at Home

Baby Grand Lathes develop talents, make more producers and provide a means of carrying out your ideas right in your home. Do your own work on either metal or wood. **WONDERFUL FOR THE BOY.**

They are so light, compact and simple to operate, but at the same time so sturdy that the highest quality of work is produced. Manual Training teachers endorse the Baby Grand. It is a wonderful help to the student at home. The lowest priced **GOOD LATHE** ever produced.

6 In. Swing

12 In. Between Centers

20 In. Base

Write for Prices and Details

THE WATSON MFG. CO.
Post St., Toledo, Ohio

AUTO SUPPLIES WHOLESALE

SEND FOR BIG NEMCO BARGAIN BOOK

Bargain Book **FREE!**



Fidelity Bodies for Fords & "Chevrolet"

SAVE MONEY ON YOUR SPRING REPAIRS
Repair parts for Fords and general accessories for all cars—Fenders, Radiators, Tops, Wheels, Axles, etc. Know the lowest wholesale prices before you buy. Send today for your copy of this great Nemco Bargain Book, listing 3,000 latest price reductions in this line.
NEMCO BARGAIN SUPPLY HOUSE, 1015 Jackson Blvd., Chicago

Every boy loves boats and trains

Send 10 cents to The Ives Manufacturing Corporation, Bridgeport, Conn., for complete catalog of Boats and Trains.
IVES TOYS MAKE HAPPY BOYS

\$2,500 Monthly for Miller

With Willey Universal Vulcanizer

Walter J. Miller invested \$175 in 1919, came to our plant for instructions for three weeks. Since that time he has bought his own home. He is now doing \$2,500 worth of business per month, employing two men and making big money.

Sold on Installments

Tire repair business is all cash. Only small investment necessary. We give you practical training in our plant and shop or by mail **FREE**. The machine burns coal, wood, kerosene or gas. Economical to operate. Set up in a few minutes. **FULLY** guaranteed.

WILLEY RUBBER BOOT AND HALF SOLE MACHINE

Can be connected to regular vulcanizer or set up separate. Repairs auto tubes, water bottles, boots, rubbers—in fact anything made of rubber.

Write for complete catalog and Free Training Offer—all free.
WILLEY UNIVERSAL VULCANIZER CO.
21 WILLEY BLDG. BATTLE CREEK, MICH.



A Home and Income For You in Sunny Florida



Be Independent—Own a Grapefruit and Orange Grove—A Truck or Poultry Farm. Increase Your Income

You Can Start a Grove Today Under Our New Plan

Develop a profit-earning fruit farm without leaving your present position—provide for your future. A small payment now and a few dollars invested each month.

A profit-producing fruit grove is a permanent investment and provides protection against old age.

THE RIGHT LAND IN THE RIGHT LOCATION AT THE RIGHT PRICE

We Have It—Any Size Farm

These splendid lands are suburban to Tampa, the metropolis of South Florida. Here you find the most healthful, the most delightful climate in North America. For Ten years we have been right here helping develop Hillsboro—the banner agricultural County of Florida, and we are still here to serve you and to help you obtain the farm you want, on very easy payments extending over 2 or 3 years' time to suit.

Groves Developed for Non-Residents

If you want to remain in your present position for a few years we can develop a grapefruit and orange grove for you. When you are ready we will clear your land, furnish fruit trees, plant and care for your grove until you are ready to look after it.

We Raise Our Own Guaranteed Citrus Trees in Our Own Nurseries

This insures every purchaser the best fruit trees that can be grown. This also insures a successful grove. We can save you money on planting and caring for your grove.

\$300.00 to \$500.00 Per Acre Profit

This is not an unusual return for truck farmers in the Famous Tampa district. All kinds of vegetables can be grown. Big prices are paid for early potatoes, Winter cabbage, Bermuda onions, tomatoes, celery and dozens of other vegetables during the Winter and early Spring, when the north is covered with ice and snow. Strawberries, Melons, and other small fruits also yield large profits.

Write for Facts About Sunny Florida

IT COSTS YOU NOTHING TO LET US PROVE TO YOU that we have the land you want—in the location you want—at a price you can afford to pay and on the easiest terms you can imagine. Let us show you.

Fill out and mail us the coupon today and receive our large descriptive book **FREE!**

NORTH TAMPA LAND CO.

Suite 522 Monon Bldg. CHICAGO

Coupon for **FREE** Book on Florida

NORTH TAMPA LAND CO.
Suite 522 Monon Bldg., CHICAGO

Please send me your large Illustrated Book "The Call of the Southland" on choice Citrus Fruit and Truck Farms suburban to Tampa, Florida, and information on how I can have a grove developed on the monthly payment plan. P.M. 1-1-22

Name

St. No.

City

State

GET FACTORY PRICES ON GALVANIZED ROOFING



EDWARDS "REO" Metal Shingles

Absolutely rust-proof — edges as well as sides. Not the space of a pin point exposed to weather. Also fire and lightning proof. Reduces insurance. Outlast building. Need no repairs — end all roofing expenses. Easy to lay — one man can do the work — hammer and nails only tools needed. Lay over old shingles if desired. Patent Interlocking Device makes water tight seams — all nail heads covered — no rust or leaks possible.

Exclusive "Tightcote" Process
Put all Edwards Galvanized Roofing in a class by itself. Bend, twist, strike it with a hammer as much as you like — you can't loosen or scale off the galvanizing — due to our "TIGHTCOTE" process which practically makes the covering a part of the metal sheet. No other galvanized roofing can withstand this test.

FREE Roofing Book Don't buy roofing until you get our big free book, describing Edwards famous "Tightcote"



Patent Side Lock
No nail heads in sight or exposed to the weather



Brick Siding

Roofings, Sidings, and Ceilings, and our lowest factory prices. We sell you direct and save you in-between dealers' profits. Write for Roofing Book No. 100.

Low-Priced Garages

Lowest prices on Ready-Made Fire-Proof Steel Garages. Not up any more. Send postal for Garage Book showing styles.



THE EDWARDS MFG. CO.
110-150 Pike St. CINCINNATI, O.

MOTORCYCLES

RELIABLE STANDARD MAKES that you can DEPEND on.

Enjoy the glorious experience of going wherever you like—whenever you like. The price is within your means—35% to 50% less than others. These machines are slightly used, thoroughly overhauled or rebuilt. Send for catalogue.



MYEROW BROS.,
258 Columbus Ave., Boston, Mass.

MASCOT



\$100⁰⁰ Weekly Profit

Agents—Specialty Men—Premium Users
BIG MONEY—SELL

MASCOT The Portable Keyless Lock
Fits any door or window without tools (carry in a vest pocket). Absolutely new. No competition. Fire and jenny proof. Our agents averaging 1,500 Mascots a month. Send 50c for sample and literature. \$38 in gross lots (25c each). Shipped C. O. D.
Milbruck Products Corporation
311 5th Avenue, Dept. "P" New York

CONORD AUXILIARY TRANSMISSION

Six-Speed Forward Power Speed for all Fords.

CARS - - \$100
TRUCK - - 110

SEND AT ONCE FOR DETAILS

ELIZABETH AUTO PARTS MFG. CO.
Dept. C, 716 Broadway ELIZABETH, N. J.



"For Your Backache"

"Use Sloan's"

Splendid for every sort of external ache and pain, rheumatism, neuralgia, sciatica, lumbago, stiff joints and sore muscles, sprains and strains, and the after effects of weather exposure.

Sloan's penetrates without rubbing. At all druggists, 35c, 70c, \$1.40.

Keep it handy
Sloan's Liniment Pain's enemy

BLANK CARTRIDGE PISTOL

PRICES
50c.
\$1⁰⁰

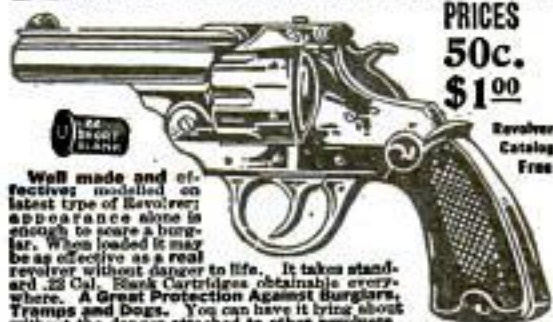

Revolver Catalog Free

Well made and effective; modeled on latest type of Revolver; appearance alone is enough to scare a burglar. When loaded it may be as effective as a real revolver without danger to life. It takes standard .22 Cal. Blank Cartridges obtainable everywhere. A Great Protection Against Burglars, Tramps and Dogs. You can have it tried without the danger attached to other revolvers.
PRICE 50c Postpaid. Better make and superior quality for \$1.00. Blank Cartridges .22 cal., shipped extra 50c per 100.
JOHNSON SMITH & CO., Dept. 753, 3224 N. Halsted St., CHICAGO

OLD KENTUCKY HOMSPUN TOBACCO

Direct From Our Farms To You

Kentucky's finest, natural leaf tobacco—mellow as moonlight, fragrant as the rose—tobacco users the world over swear by its inimitable smoking and chewing qualities.

REDUCE YOUR TOBACCO BILL 75%
5 lbs. trial order \$2.98 prepaid; 10 lbs. \$5.85 prepaid. Send no money. Pay on arrival, try for 10 days. If for any reason you are dissatisfied, send it back and your money will be refunded. Order Today.

TOBACCO GROWER'S ASS'N OF KENTUCKY, Warehouse 323, Mayfield, Ky.

STOP! LOOK!! LISTEN!!!
BIG REDUCTION IN PRICE

FORD SPORT BODIES



4 Speed Transmissions
Wire and Disc Wheels
Crankshaft Counterbalances

16 Valve Heads	Price	Now
Foot Accelerator	\$ 2.00	\$ 1.10
3:1 Differential Gears	15.00	7.95
2 3/4:1 Differential Gears	18.00	9.75
87 Underlugs Fenders	20.00	11.95
Milwaukee Water Pump	12.00	8.95
Steel Disc Set (4)—give size, style wheel	15.00	7.50

Limited number at above prices. Terms: 30% with order; balance upon delivery. **SATISFACTION OR MONEY BACK GUARANTEE.** Complete cars from \$225 to \$1295. On account of ever changing stock we can furnish no description by mail. Variety of models always on our floor. Call in person or telephone.

N. O. FORD SPEED & POWER EQUIPMENT MANUFACTURERS
250 West 54th St., New York. Telephone Circle 612. Cable FORDSPEED

Please Mention Popular Mechanics



4-oz. Set **70c** | 6-oz. Set **\$1.00** | 8-oz. Set **\$1.35**

West of Denver add 10c. Sent anywhere Parcel Post, Stamps or C. O. D.

Here's just what you have wanted. A Fin Hammer and a Riveting Hammer with Hard Steel Heads and a Brass Mallet. All three with Steel Shanks and Wood Handles. Worth three times as much if bought separate, but now you get the set of three for the price of one.

Special offer to dealers

UP-TO-DATE MACHINE WORKS

2914 So. Wabash Ave.

CHICAGO, ILLINOIS



Cook Stoves and Ranges

How's This for Saving Money?

Compare this price with prices in your local stores. Isn't the saving worth while? Write and get similar money-saving prices on Kalamazoo Heaters, Furnaces, Washing Machines, Paints, Shoes and many other articles in our catalog. Now is the time to save money and we can help you do it. Ask for Catalog No. 473. Cash or easy payments. Quick Shipment. Money-back Guarantee.

KALAMAZOO STOVE CO., Mfrs.
Kalamazoo, Michigan

"A Kalamazoo Direct to You"
Trade Mark Registered

Learn Drafting

Individual study at home may be successfully engaged in with the aid of our new enlarged book

A Practical Course in Mechanical Drawing

Cloth, 160 Pages, 157 Drawings. Price, 50c Postpaid.

POPULAR MECHANICS BOOK DEPT., 78 East Madison St., CHICAGO

BANG! You Can't Beat OUR PRICES on these PISTOLS \$ **8.75** prepaid

25-Calibre Regulation 7-shot, Blue Steel, Handsome Automatic; accurate and reliable; highest grade material and workmanship; double safety attachment makes accidental discharge utterly impossible; perfect grip; small, compact; you need this gun for your protection. Regular value \$22; get one now. No. 109, while they last... \$8.75

\$25 Military Model Automatic for ... \$10.75

Just like they used "Over There." A MAN'S gun, built for hard service. .32-calibre, with EXTRA magazine free. A 10-shot gun, regularly sold for \$25.00. Our price NOW, for .32-calibre No. 209, while they last... \$10.75

\$14.00 Genuine German MAUSER

Latest model; 9-shot Automatic. The World-Famous Most Powerful Weapon known; shoots COLT'S cartridges; is perfectly balanced with substantial and comfortable grip; accurate and efficient; two safety attachments; it is flat-shaped; has no sharp edges or projections and does not bulge the pocket; it is solidly and simply constructed from blue steel; can be dismantled and reassembled in a few seconds.

Regular Value \$35 25-Cal., No. 809..... \$14.00
32-Cal., No. 809-A..... \$15.00

ALL OUR MERCHANDISE IS BRAND NEW

Order one of these Specials NOW

Mail Orders Promptly filled upon receipt

of Cash or Money Order, or if you prefer

SEND NO MONEY

We ship by return mail. You pay Postman on arrival. Full satisfaction guaranteed or money back. Bank references.

We also carry a complete line of Field Glasses, Binoculars, Pistols and Shotguns at Prices that cannot be equalled.

IMPORT TRADING COMPANY (Dept. 9), 258 Broadway, New York

LUMINOUS PAINT

Make Your Watches, Clocks, Etc., Visible by Night

The very latest discovery in the scientific world... this paint, practically on obtainable except at an exorbitant price, we have at last succeeded in producing this remarkable LUMINOUS PAINT, which applied to the surface of any article, emits rays of white light, rendering it perfectly visible in the dark. THE DARKER THE NIGHT, THE MORE BRILLIANT IT SHINES. Quite simple to use. Anyone you can do it. A little applied to the dial of your watch or clock will enable you to tell the time by night. You can coat the push buttons or switch plates of your electric lights, watch boxes, and innumerable other articles; make your own Luminous Clocks, Luminous Hoopoes, etc. Small bottle, price 25c. Larger sizes, 50c and \$1 postpaid. Johnson Smith & Co., 1124 N. Halsted St., Dept. 712, Chicago

WE GUARANTEE OUR AGENTS \$60 A WEEK

FOR ONLY FOUR \$5 ORDERS A DAY

No Delivering—Commissions Same Day You Take Orders

AT LAST

A Simple Practical

Dependable Fire Extinguisher for only

\$5



FUGO Automatic Fire Extinguisher

MILLIONS OF PEOPLE want a handy, reliable fire extinguisher but they've held off paying \$15 or \$20. The FUGO AUTOMATIC—just patented—costs only \$5 and is just as efficient, just as dependable as the highest priced. Everyone can afford one—agents take orders on every call. Nothing like it at the price—a 5 minute demonstration sells it—no talking—no arguments. An inexperienced agent can take 4 orders a day—others book 10 orders—easily. No competition—the field is unlimited. Customers so pleased they tell others—sales multiply fast.

NO EXPERIENCE NEEDED Our proved instructions guide you—you can't go wrong—a 5 minute demonstration and it's sold. Your neighborhood fire department will recommend it—boost it—push it.

EXCLUSIVE TERRITORY Become our licensed agent—employ sub-agents—each one brings you a good profit. You take no risk—you don't invest a penny. We deliver—you receive commission same day you take orders.

THE OHIO INSTRUMENT MFG. CO.
9412 St. Catherine Ave. Cleveland, Ohio

Get Our Plan—TODAY

You don't hear of an invention like this every day—don't delay. Trained agents will jump at this opportunity. Write now for full particulars showing big possibilities for YOU. Sample Fugo Automatic FREE.

AGENTS \$150

THIS IS
A GOLD MINE at
Only 20 Boxes a Day Means \$18 Daily Profit



Lucky 'Leven Combination in Display Case

Full size of box 6 1/2 x 13 1/4 ins. Each article full drug store size. Retail value \$1.25; you sell for \$1.50-\$2.00; costs you only 60c. Think of it! The array of fine toilet goods (that always appeals to lady's heart) will dazzle her eye, and when at the end of your spiel you state the low price of \$1.50 for these 11 articles, the money is yours, even if she has to borrow, or beg it.

Act Now! Sells like hot cakes—men and women coming in to \$10 dollars a day—a lady could sell "Lucky 11." Don't delay a minute. Each day's delay means big money to you. Sample outfit including Display Case will be sent postpaid for \$1.50. Write for full details. Hurry! before it's too late. Act NOW.

E. M. DAVIS PRODUCTS CO., 2351 Davis Building, Chicago

A Quality Hatcher At The Lowest Price "Successful" INCUBATORS & BROODERS

Mail a postal—Get our offer. Poultry lessons free to every buyer. Booklet, "How to Raise 48 out of 50 chicks," 10c. Catalog FREE. Make green egg-making feed in "SUCCESSFUL" Grain Sprouters.

Des Moines Incubator Co.
689 Second St., Des Moines, Ia.



29 Years of
Big Success

Guaranteed 8000 Miles!

Against **BLOW-OUT** and **STONE-BRUISE**

Not second-hand or rebuilt—these wonderful tires BRAND NEW, direct from factory. Famous Vacuum Non-skid tread. Tough, oversize, made to stand up on bad roads. Sensational guarantee at least 8000 miles without blow-outs, or stone-bruises. All adjustments on 8000 mile basis.

Look at These Prices!

Sizes	8000 Mile Tires	2 Year Tubes
32 x 3 1/2	\$11.50	\$1.95
31 x 4	12.35	2.00
32 x 4	14.25	2.10
33 x 4	15.25	2.15
34 x 4	15.75	2.25
34 x 4 1/2	19.75	3.00
35 x 4 1/2	20.45	3.10
36 x 4 1/2	21.25	3.25

Send No Money!

and express back if you're not from this ad. Do it NOW!

GARFIELD TIRE CORP.
3935 Washington Blvd. Dept. 167, CHICAGO, ILL.

Hurry! At these world-beating cut prices our big stock can't last long—so order at once and Make Sure of getting the sizes you want.

Pay factory price when tire arrives. Money satisfied. Order right

YOURS FOR ONLY \$1.00 CASH

ONE DOLLAR BILL PAYS IN FULL for complete directions, plans and blue print of Home Made Stump Puller. This powerful Puller will pull your largest stumps easily. \$1.00 for plans, etc., and materials found on nearly every farm, are all you need for this new Stump Puller. NOW you can afford to clear your land. Send dollar bill or stamps for complete plans, blue prints, etc.—today.

Money Back If Not Pleased. Plans may be returned in five days and we will return dollar.

Home Made Stump Puller
Box 3291 Gladstone, Mich. Adv. X



NEW STUMP PULLER

Gets Big Play New Gum Vending Machine

This machine is making \$10 to \$20 day profits for many store owners.

Install one in your store or any public place and get this easy profit. Requires no attention. Always works. Machine's profits pay the rent.

Write us about rebuilt penny and nickel machines. Finished like new. In excellent running order. Pay their cost in 10 days.

Write or wire today for full particulars. \$25 down payment. Balance C. O. D.

Mints \$30 per case—2,000 5 cent packages. Single boxes, 100 5 cent packages, \$2.50.

SILVER KING NOVELTY CO.
400 Williams Bldg. Indianapolis, Ind.



Silver King

HOW TO BUILD A FORD RACER



is the title of this new book. It tells in plain, simple language just how to lower the frame, strengthen steering, change gear ratio, body design, etc. This information has been collected from men who have had years of experience in the racing game. You cannot afford to be without this book if you contemplate building a Ford speedster. It will save hundreds of dollars as well as give assurance of a job that will be classy and should be capable of 80 miles per hour or better.

Send Postpaid Anywhere Upon Receipt of \$1.50
CENTRAL AUTO SUPPLY CO., Dept. 220, Louisville, Ky.

MADE TO YOUR ORDER \$1.95

Pants

NO EXTRA CHARGES Postage Prepaid

Send no Money We make this special offer for 30 days, to prove the wonderful value, style and fit of Progress tailoring. We will tailor to your special order, a pair of these stylish \$6.00 pants, send them to you postage prepaid and guarantee two years' solid wear or money back for only \$1.95.

AGENTS WANTED—Earn \$30 extra every week, taking orders from your friends and neighbors for our high-class tailoring. No experience necessary.

Big Sample Outfit FREE
Drop us a line today and we will send you absolutely free, our big assortment of woolen samples, style book and special wholesale prices, on our made-to-measure suits—\$12.48 up and made-to-measure tops—\$1.95 up. Full details of this offer sent FREE.

The Progress Tailoring Co., Dept. A-145, Chicago, Ill.

Please Mention Popular Mechanics

Copyrighted material

Tire Agents Wanted

\$4,000. a year taking orders for Mellinger Tires!

I want exclusive agents, all or part time, to handle Mellinger Extra Ply and Cord Tires under the Mellinger Plan. Thousands upon thousands of owners say Mellinger Tires are the finest, most serviceable made.

Guarantee Bond Up To 10,000 Miles

behind my Extra Ply and Cord Tires. The exclusive Patented Tread gives you a tire that competitors can't offer (Patent Office award No. 68612). Mellinger agents sell these highest grade tires at prices that knock competition sky high. A Mellinger Agency puts you in a business of your own—makes you independent, prosperous. Auto owners save big money on Mellinger Tires. **My new low prices amaze everybody!** Why pay dealers, jobbers, garages profits? Tires shipped prepaid on approval.

I Guarantee Your Profits

Mellinger Tires are sold by the phenomenally successful Mellinger Plan. So confident am I that you can earn money under my plan that I literally guarantee your profits. I don't ask you to carry a big stock—to risk **ONE CENT** of an investment. My **BIG FREE BOOK** tells all about the **Mellinger Plan** that is giving auto owners **BETTER TIRES FOR LESS MONEY**—and giving my agents in all parts of the country big bank accounts. This book tells all about tires—facts of construction—how tires are sold—inside figures—explains manufacturers', jobbers', retailers' profits. Get the amazing figures. Learn what **REAL WHOLESALE PRICES ARE**. I send this book free without cost or obligation. The Mellinger Plan is an amazing and simple plan of big money-making opportunities, a plan never before offered to tire agents. Write for this book today. Free tires for your car to one user in each locality! Be first to write quick for **special introductory offer**.

Prove It for Yourself

SEE these tires on your own car! See these amazing values before you buy anyone's tires. Think of buying a splendid cord tire for less than the old fabrics used to cost. Tires cost 90c a pound. Get the facts! Read what others say about these super-quality tires. Read what my agents say about their success under the **Mellinger Plan**. Their re-orders! Throw away your old tires and ride on a brand new set of Mellinger Tires that I will give you for a little of your time and good will. Try a Mellinger Cord or Fabric Tire on your car at my risk! Send no money. Just send name and address—post card will do. Sample sections furnished.

B. L. MELLINGER, Pres.

**MELLINGER TIRE &
RUBBER COMPANY**
1015 Oak St., Kansas City, Mo.

My Amazing Offer

Just send your name and address—post card will do. I want to make you an amazing offer! I appoint only one exclusive agent in each locality. Send your name today and get my offer. Get my **big free book**. My wholesale prices. Look into the money that hundreds of others are making. Tweedle, of Maine, sells \$1436 in a few short weeks. A. R. Amigo, of Santurce, Porto Rico, sold \$4024 in seven months. Keithley, of Idaho, says: "I have sold \$900 worth of tires since I took the agency and all have given good satisfaction." Hundreds of other agents making big money. You can do as well. You can make \$4000 a year. You can have better tires at wholesale prices. The **Mellinger Plan** explains it all. Fill in and mail the coupon today.



**THE
MELLINGER
PLAN**

**MAIL
COUPON
NOW!**

**Mr. B. L. Mellinger, Pres.,
Mellinger Tire & Rubber Co.,
1015 Oak Street, Kansas City, Mo.**

Without obligation, send me details of the Mellinger Plan, Free Book and Wholesale Prices and how, without investing any money, I can become your authorized agent.

Name

Address

NEW EXCELSIOR SOLAR TELESCOPE

And Microscope Combined

WITH ADJUSTABLE SOLAR EYEPIECE



OVER 3 FT. LONG
NEARLY 6 IN. 'ROUND

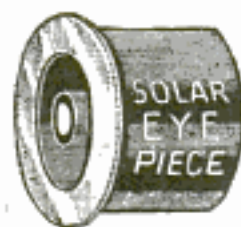

GUARANTEED SCIENTIFICALLY PERFECT

Only **\$1.85** Postpaid

THE NEW EXCELSIOR SOLAR TELESCOPE is a large and serviceable instrument, well made and accurately fitted, and marvelously cheap. A Telescope with an adjustable Solar Eyepiece for observing Eclipses of the Sun and examining the very interesting and mysterious Sun Spots, has never before been obtainable for less than several times the price charged; in

fact, such an eyepiece alone usually costs more than the price charged for this complete Telescope. The lenses are well ground and adjusted, and the five sections are perfectly fitted. There is a metallic cap to protect the object glass from injury and to exclude dust. The section with the eyepiece can be withdrawn and used separately as a magnifier or microscope. The Telescope when fully extended is about 3 feet 6 inches in length, and when closed it measures almost a foot. Tourists, residents at the seaside, farmers and others able to enjoy wide and extended views should have this excellent and wonderfully cheap Telescope. For a limited time only we are offering this Telescope, complete, at the remarkably low price of ONLY \$1.85, packed in a box and carriage paid to any address in the world. Our 300-page Catalog of domestic and imported novelties, many of them unobtainable elsewhere, given free with every order.

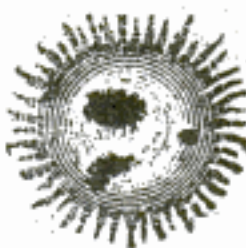

SUN SPOTS

JOHNSON SMITH & CO., 3224 North Halsted Street, Dept. 753, CHICAGO

Our BUREAU OF INFORMATION will answer all questions regarding articles appearing in this magazine. Address Bureau of Information, Popular Mechanics Magazine, Chicago.

STARK PRECISION BENCH LATHES

and BENCH MILLERS



The original Spring Chuck Bench Lathe. Six sizes, with attachments for Turning, Screw Cutting, Milling, Drilling, Grinding, etc. The best for laboratory, experimental and manufacturing purposes. Prices, No. 4, with Milling Attachment like cut, \$365.00. Plain Lathe \$155.00. Catalog free. **STARK TOOL CO., Waltham, Mass.**
Established 1882

CHEMCRAFT Makes Any Boy an Amateur Chemist

Fine Outfits: \$75c to \$10.00 **SOLD BY ALL TOY STORES**



TWO GREAT FUN MAKERS

The dog head is made of metal, with rubber bulb. When you squeeze bulb the dog barks and it's a wise dog that can tell the difference from the real thing. The cat is worked the same way, only the sound is produced by a bellows within neck. This cat's meow will fool any cat or your friends. Both are small enough to be concealed in the pocket. Thousands of these have been sold in Chicago. **The Two Sent Postpaid For Only 25 Cents**
The Flasmus Co., Dept. 30, 3802 Ellis Av., Chicago, Ill.



Health-Strength-Beauty Thru

RenuLife

VIOLET RAY

Treatments at Home

STIMULATE AND STRENGTHEN your vital organs, develop your body and steady your nerves by applying the powerfully corrective and upbuilding RenuLife Violet Ray. Spray thousands of volts of high-frequency electricity into any weak, sluggish or painful organ or muscle. Feel the flood of warm, rich blood it brings to the treated parts, driving out aches and pains and washing nature to build healthily new tissue.

THOUSANDS OF USERS have found in RenuLife Violet Ray a quick and positive means of relieving pain and suffering, correcting nervous disorders and building the vital energy and strength that comes from perfect health.

Get **"HEALTH" Book**

—sent for the asking. Tells of the wonderful benefits derived from RenuLife treatments in more than a hundred diseases, weaknesses and chronic disorders.

RENULIFE ELECTRIC CO.
1101 Newberry Bldg., Detroit, Mich.
In Canada:
Netting Bldg., Windsor, Ont.
Sales Agents, write for attractive plan



Portable Power Plant



For every use where power is needed. 60 H. P., 12 cycle, 530 cubic inch Piston displacement. Electric Starter. Non-Vibrating Motor. Very economical. Anybody can operate it. Standard parts for replacement can be obtained the world over. Price \$985. Run your Saw Mill, Thrasher, or turn your Launch into a Speed Boat. **TRIPLE BLOCK MOTOR WORKS**
Box 233 Garfield, Wash.

YOU Can Make This Engine WITHOUT a LATHE



Also Other Engines
Power Boats, Sail Boats

COMPLETE
PARTLY FINISHED
ROUGH SETS

Catalog free

THE H. E. BOUCHER MFG. COMPANY
154 Lafayette Street
New York

I Earned \$2200 IN FOUR MONTHS



THIS is Richard A. Oldham. He earned \$2200.00 in four months with a Haywood Tire Repairing outfit. For 20 years he was telegraph operator on the Illinois Central Railway. He is now 58 years old. He answered my advertisement—quit his job—bought a plant and opened a business. He just wrote me: "I have made more in eight months than 2½ years as operator." There are now 500 stations where tire repairing is neglected.

I Must Have 500 Men To Fill These Positions

I have a Big interesting Book to send you. It tells all about tires—gives inside figures and profit. Send for it! What Oldham and others are doing You can do. \$2500.00 to \$4,000.00 per year is conservative. Like Mr. Oldham—One machine will start you. Then open a shop. You can see business all around you. Put out a Haywood Sign and business will come to you. Now get started. Send for the Big Book and start making money.

M. HAYWOOD, Pres.
Haywood Tire & Equipment Co.
964 Capitol Avenue Indianapolis, Ind.



\$85 to \$100 WEEKLY FOR AGENTS



Wonderful ROBINSON FOLDING BATH TUB. Only 3 sales a day earn you \$90.00 a week. No plumbing needed; self-emptying; folds into small roll; guaranteed 10 years. Best has sold over 100. Best sold 23 in 16 hours. You can get Demonstrating Tub FREE. Write quick.

ROBINSON HOUSEHOLD MFG. CO., 905 Factories Bldg., Toledo, O.

2 Tires for \$11.25

FREE Tube with Each Tire

Most sensational used tire offer of the year! Two tires for less than the usual cost of one—and a free tube with each tire! This is a special lot—all standard makes—selected for record-breaking sale. No double treads or seced tires. Our big volume means best tire values! Thousands of steady customers everywhere are getting full mileage out of these tires and you, too, can get

8000 Miles

Size	1 Tire	2 Tires	Size	1 Tire	2 Tires
30x3	\$ 7.00	\$11.25	32x4 1/2	\$13.50	\$22.50
30x3 1/2	7.95	13.65	33x4 1/2	13.95	23.45
32x3 1/2	9.00	15.45	34x4 1/2	14.45	23.90
31x4	10.00	16.90	35x4 1/2	14.95	24.45
32x4	11.50	19.75	36x4 1/2	15.45	25.45
33x4	12.25	20.90	35x5	15.90	26.15
34x4	13.25	22.45	37x5	16.45	26.55

SEND NO MONEY! Shipment C.O.D. Express or Parcel Post. Examine tires on arrival and if not fully satisfied return same at our expense and your money will be promptly refunded, including shipping charges. State whether Straight Side or Clincher. **DON'T DELAY! ORDER NOW!**

ALBANY TIRE & RUBBER COMPANY
2721 Roosevelt Road Dept. 164 A Chicago, Illinois.



Note the renewable cutting blades. There's the reason why Neverslips will outcut and outlast any plier made.

They're Always Sharp!

YOU can't make a pair of pliers that will always stay sharp from one piece of metal. It takes time. And it takes special steel.

Neverslip Pliers and cutting edges are made separate—from different kinds of metal. High carbon crucible steel is used for the cutting blades. That's one reason why they will outlast and outcut any plier made.

But here's another and more important one. You know that even with high carbon steel the cutting edges are bound to become worn under the severe punishment you give them. So we've made Neverslips with renewable edges. As soon as the edges become worn just replace them with a set of brand new sharp ones. It's done in a jiffy—no bother or trouble.

Just go into any hardware store and ask to see a pair of Neverslip Pliers. If your dealer doesn't stock them send us his name and we'll see that you are supplied.

THE NEVERSLIP WORKS
NEW BRUNSWICK NEW JERSEY

NEVERSLIP
side cutting pliers

Neverslip Pliers are furnished in 6-7 and 8 inch sizes.

Please Mention Popular Mechanics



\$215⁰⁰ In One Day

New Invention Sweeping Country Like Wildfire!

NO wonder this amazing new invention is bringing fortunes to agents. All over the whole country this new device is doing away with old-fashioned methods of heating with coal stoves, ranges and furnaces. Already over \$1,000,000 worth have been sold.

You can readily understand why this new invention—the Oliver Oil-Gas Burner—is sweeping over the country like wildfire. It does away with all the expense of coal—making every stove a modern oil-gas burner. Saves money, time and drudgery. Three times the heat of any other method. No wonder agents are riding in on the tide of big Oliver profits!

These men know the secret of big money. They know a good thing when they see it and they know that the time is ripe for this new Oliver improved Oil-Gas Burner. They know that this age of high-priced coal and wood makes it necessary for some substitute. They see ships and locomotives being run by oil and big buildings being heated by it. And they know that

an invention that makes use of this cheap fuel for every home—and yet does it so as to give more heat than coal or wood—is the thing they want to tie up to.

AGENTS Are Making Fortunes

Big Profits Quickly Made

You too can use this secret of big money. You do not need to be a high-powered salesman. The Oliver's amazing features sell it for you. When people see it they know at once that it is the thing they want. You will realize that this is a proposition that will pay you as big money as it does others. We have a definite number of open territories which we are ready to dispose of to those who act quickly. Every territory allotted is filled with big-money opportunities. And this big money comes easily. Because not only does this invention practically sell itself on sight but when you have sold **one** this one will sell several others as soon as your customer's friends and neighbors see it. And thru our special plan you get credit and commissions for every sale in your territory.

You can also make big money just by using your spare time. Note how N. B. Chelan made \$43 in one evening.

Coupon Brings Full Offer

If you want to make at least \$5,000 a year easily, mail this coupon now for our offer. We are not making any extravagant claims about this. We do not have to. We believe that your common sense will indicate a good proposition to you when you know about it. We want to give you the facts. Won't you write us? And by doing so quickly you will be allotted an exclusive territory with private selling rights.

The coupon will bring you the facts and will save you writing a letter. But mail the coupon at once.

It Sells Itself

Agents find it no work at all to sell this amazing invention—the Oliver new improved Oil-Gas Burner. They just show it—taking only one minute to connect it—then light it. And the sale is made! This new invention is its own salesman. It sells itself! The Oliver Oil-Gas Burner is the most timely thing that could be put out. It dispenses entirely with coal and wood when both are now high-priced. It burns the cheapest fuel—oil. It saves a woman work now in times when she is looking for just such things. Just as much or as little heat as wanted, off and on instantly by simply turning a valve.

The Secret of Big Money

Of course, now that you know the facts you yourself can understand why this new invention is going over like wildfire! And you can understand why F. W. Bentley made \$215 in one day. Why J. Carnegie made \$1,000 in one month and why hundreds of other agents are cleaning up big too.

SAYS F. W. Bentley of Philadelphia

"Ye Gods—some seller! I made \$215 today!"

Buy's Car with Profits

"Have earned enough in one month to buy me a new auto."
S. W. Knappen, Cal.

\$7 Profit per Hour

"I started out and made \$21.50 in about 3 hours. The Oliver does the work. It certainly is the real thing."
L. Zucker, Ohio.

"Sells Like Beer in a Dry Town."

"Am sending today for 7 Oliver's. This is one day's orders (\$85 profit). Selling like beer in a dry town."
W. H. Drew, Mich.

Mr. T's 28th Order in Six Months

"Ship 52 Oliver's: 10 No. 20; 6 No. 1; 12 No. 2; 24 No. 4." (Mr. T's profit on this order alone is \$711).
G. T., Ottawa, Ont.

Russel Earned \$3300 in Five Months

"Have averaged \$660 profit a month for last six months."
A. M. Russel, Conn.

Carnegie— \$1000 a Month

"Am making \$1000 per month. I have made big money before but did not expect so much. Your Burner is just the thing."
J. Carnegie, B. D.

Berger— \$258.50 per Week

"Send following weekly hereafter: 10 No. 1; 8 No. 2; 4 No. 5."
R. Berger, Ont.

\$11.75 in Ten Minutes

"I took order for a neighbor, \$11.75 profit in ten minutes."
Mrs. N. B., Hattiesburg, Miss.

\$43 in One Evening

"I made \$43 last night selling Oliver Burners."
N. B. Chelan, Wash.

Oliver Oil-Gas Burner and Machine Co.

2014-M Pine Street, St. Louis, Mo.

Please send me full facts about how I can make at least \$5,000 a year representing you in my territory. Also your plan if I just wish to make big money in my spare time.

Name.....

Address.....

OLIVER OIL-GAS BURNER AND MACHINE CO.
2014-M Pine Street, St. Louis, Mo.



ENGINE PRICES

All Sizes—2, 3, 4, 6, 8, 12, 16, 22 and 30 H-P.
All Styles—Kerosene, Gasoline or Gas.
Stationary, Portable or Saw-Rigs.

SMASHED

NOW is the time to get your WITTE

Engine—while prices are lower than they have been for years. You need engine power to reduce labor costs, do more and earn more. Tell me what you want, Engine, Power Saw, BuzzSaw, Log Saw or Tree Saw, and I will send you special information, catalog, and lowest direct-from-factory price. To give an idea how low prices are, this

WITTE

2 H-P Engine

\$39⁹⁵ F.O.B. K.C.

From Pittsburgh, \$5 More.

Here is a chance to get your power plant, any size, up to 30 H-P., at a big saving. I can make immediate shipment, guarantee safe delivery. Engine shown is shipped on skids, ready to operate. Easy to set and use. Easy to buy now.

Liberty Bonds Same as Cash

If you are short of cash, I will take your Liberty Bonds—any issue—full face value, or I will sell you on easy terms at the regular payment price, if you wish terms.

90-DAY TEST—Lifetime

Guarantee All WITTE Engines, Saw Outfits, Log and Tree Saws sold on 90-Day Test and Life Guarantee against defects.

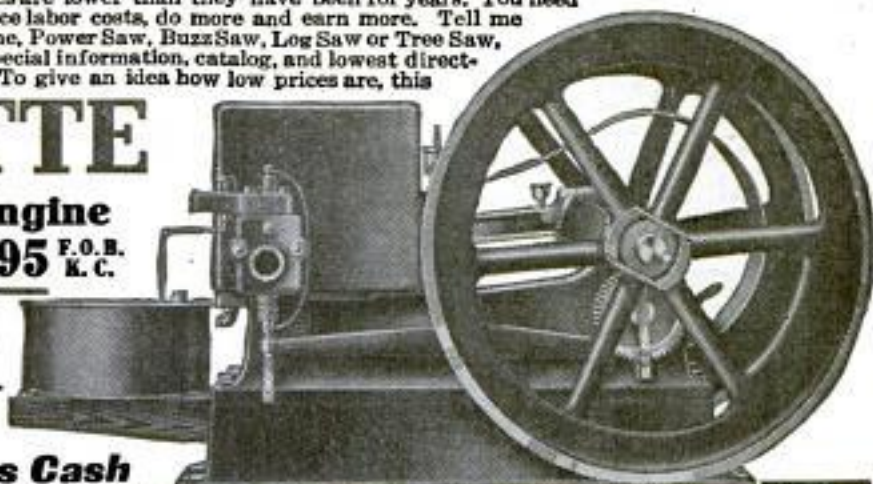

Write For Engine Catalog No. 49—FREE

It tells about Stationary and Portable Engines, or if you want to know about Saw Outfits, write for Saw Catalog No. 17.

WITTE ENGINE WORKS,

1745 Oakland Avenue,
1745 Empire Building,

Kansas City, Mo.
Pittsburgh, Pa.

"The War IS Over"

Special FREE Offer



WITTE

Latest Out Log Saws
Run Steady—Cut Faster.
Shipped Complete—Engine
and Saw as Shown—Ready to Use.

For a Short Time Only

We will include regular \$35 Tree Saw equipment FREE with every WITTE Log Saw.

You Get Both for Only

\$99⁵⁰ F.O.B. K.C.

From Pittsburgh, \$6.00 more.



90-DAY TEST—Lifetime Guarantee

The WITTE Log Saw is a Big Capacity, strongly built outfit—Easy to operate. Runs all-day on 2 gallons of fuel. Positive Lever Control. Start or stop saw while engine runs. Only Arm Swing Log Saw with Interchangeable Tree Saw Parts. Makes Log Saw a fast-cutting Tree Saw as shown. Change in 5 minutes. Clamps to tree below saw in 10 seconds. Most practical—lightest—easiest to use treesaw equipment built. Big 3-color catalog tells all about it—Free. Don't buy any log or tree saw until you know about the WITTE. Sold direct—Cash or Easy Terms. Write today.

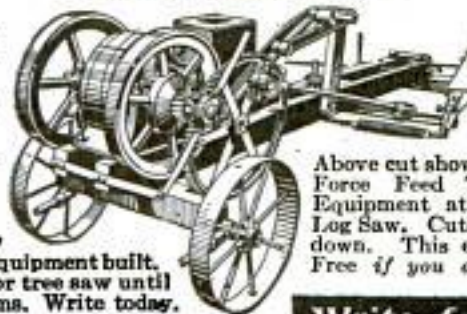

Above cut shows WITTE Force Feed Tree Saw Equipment attached to Log Saw. Cuts tree clear down. This equipment Free if you order now.

WITTE ENGINE WORKS

1743 Oakland Ave., Kansas City, Mo. 1743 Empire Bldg., Pittsburgh, Pa.

Write for big Log and Tree Saw Catalog Free



His Letter—

"It has been about eight years ago since I blew into Chicago, more or less broke, but with a strong determination to learn the automobile business. I dropped in at the office of Greer College. You took me in and in about ten weeks I had a practical working knowledge of automobiles that has since been the means of making me a successful automobile man. I am just 40, but have made enough that I will retire from business and spend the rest of my life just taking things easy. Greer College was at the bottom of my success. In less than 10 years, I have done better than many men do in an entire lifetime. I had no special advantages not possessed by other men. Every student who enters Greer College has the same chance that I had, and today the chances are even better than when I began. I consider Greer College the best school of its kind in the country—bar none. As you know, I have sent you a great many students and there are more coming. I am proud of my school and never pass by an opportunity to do it a good turn."

E. M. HAGAR.

Broke! -Then Enters Big-Money Field That Soon Enables Him to Retire

How Would You Like to Retire in Just a Few Years from Now? The Actual Story of E. M. Hagar (as told in the letter above) Points a Way for You to Make Big Money Quickly Too. Let Us Tell You About It.

"Have made enough and will retire from business and will spend the rest of my life just taking things easy."

Surely E. M. Hagar from a town in Illinois was not a man to stand by while a business was expanding by leaps and bounds. Just a few years ago he knew that one person out of every fifty had a car—then one out of every thirty—then one out of every twenty! And still the amazing growth continued. One out of every fifteen, ten, nine and eight! And finally he saw the time when one person out of every seven in the United States owned an automobile.

Were those merely statistics to him? Did he just whistle at the amazing story that they told? No! He said to himself, "If one out of every seven people in this country owns a car, then there's big money—millions of it—going to be spent in keeping them up. And I'm going to get my share!" And, as you know, he did, quick!

How Much of Those Millions for You?

E. M. Hagar made his pile. How about you? There's plenty more waiting. The automobile business is here to stay—and to grow even bigger. More than 3½ million automobiles were made in 1920. What's your share going to be of the millions that will be spent in keeping these cars working and looking right?

You know how our American folks are. They're proud of their cars. They want them always to be good to look at—and good to drive. They want these things and they'll pay for them, and pay well. You can be the man to do what they want done right. This big-money field is waiting for you to step into. Trained, thoroughly capable men are needed everywhere.

Greer College of Automotive Engineering,
2014 Wabash Ave., Chicago.

Please tell me all about the automobile business and how I can make big money in it too. And send me your 64-page book, "How to Succeed in the Automobile Business" also.

Name.....
Address.....

Ask a dozen experts—men who know—and you would get the same answer: "The expansion of the automobile business has only just started!" How, in justice to yourself, can you stand by while big automobile profits are just pouring into the laps of others?

Why Not Move On to Easy Street?

Get your share. Learn the automobile business thoroughly from A to Z. Learn how to give the automobile owner the kind of service he is glad to pay good money for. Learn, thru a fascinatingly interesting new way, all about ignition, repairing, overhauling, automotive electricity and mechanics—and how to establish your own automobile business. Be an Automotive Engineer. Then in a short time you can do as Mr. Hagar did—Move On to Easy Street!

Your Own Eyes Give You Proof

Look around you. What do you see? Automobiles, Auto Trucks, and Tractors by the thousands. Your own eyes give you daily proof of the big money you can make. In every city, town and village, good automobile experts are needed. Big money is paid—and paid gladly. Nothing is to be made by merely wondering who is getting the big profits for keeping them in shape. Step in and get your share! Don't fail to write to this school that will do as much for you as it did for Mr. Hagar of Illinois!

Don't Detour—Send for This Free Book

All your life you've wanted to come to Chicago! This is your chance. Come to Chicago—and at the same time learn the automobile business thoroughly from the ground up. Greer College will teach you to repair and make every part pertaining to the automobile, truck and tractor. We teach you by actual practice.

Don't detour! Send for the book of the oldest automobile school in America—the school that started with the automobile in 1902 and is abreast of its development in 1922. Write today.

GREER COLLEGE
of Automotive Engineering
2014 Wabash Ave., Chicago, Ill.



11 Reasons Why Greer Brings You Big Money as Automotive Engineer

1. Greer College—the pioneer automobile school—began with the automobile in 1902 and has grown and developed step by step right with it.
2. Thorough equipment covers every possible branch of the automobile, truck, tractor, and aeroplane business.
3. Special method of instruction qualifies you thoroughly in shortest possible time—you learn by doing, not merely by being shown.
4. Full staff of foremost automotive experts give you their personal attention and instruction.
5. Our service in finding you a job. The Greer College has never failed to place any competent student who wanted work.
6. No cut-and-dried, machine-like instruction. We do not turn out "graduates" as a factory would turn out bolts. Our instruction is personal, individual, and based on the needs of each single student.
7. Greer Diploma given to graduates is recognized in the automobile industry as unquestioned evidence of its holder's ability.
8. Our location in Chicago, America's second largest city. Not only a pleasant and interesting place for you to get your training but also keeps you in touch with the big activities in the automobile business.
9. Greer College occupies the entire new building pictured above containing floor area of 190,000 square feet—located right in the heart of the automobile district of Chicago.
10. 50,000 Greer Graduates. And every one thoroughly, carefully, individually trained—just as we will train you.
11. Money-Back Guarantee. We absolutely guarantee to fulfill every promise made to the prospective student or to refund the money paid without question or quibble.



1 \$

**Brings
HARTMAN'S
Richly Upholstered
7-Piece Suite**

Quarter-Sawed and Solid Oak
Send only \$1 for this complete suite of library, parlor, or living room furniture. Use it 30 days on Free Trial.

If you don't say that it is even more than you expected, ship it back and we return your \$1 and pay transportation charges both ways.

A Full Year to Pay

Only by seeing this splendid quarter-sawed and solid oak suite can you realize how it will add to the appearance of your home. Only by examining it can you appreciate what a record-breaking bargain it is at our **smashed price**. Furniture like this can be bought nowhere else at near our price. **Handsome Fumed Finish!** TABLE, solid oak with top 24x36 in. ARM ROCKER, solid oak with quarter-sawed top panel and rounded arm rests; seat 18x19 in. SIDE ROCKER, solid oak with quarter-sawed oak top rail, seat 16x14 in. ARM CHAIR, 37 in. high and SIDE CHAIR, 36 in. high, with seat 16x14 in. Table and chairs stand on noiseless glides. Ornamented backs and seats upholstered in durable, imitation Spanish brown leather. Comfortable spring seats. TABOURETTE, 16 1/2 in. high with 10 in. top, is solid oak. BOOK BLOCKS, heavy enough to support a liberal number of volumes. Shipped (fully boxed, "knocked down" to lessen freight charges) from factory in Central Indiana, Western N.Y. State or Chicago warehouse.

Order No. 112DMA7. Reduced Bargain Price \$37.95. Send \$1.00 now. Pay balance \$3.00 per month.

FREE Bargain Catalog

368 pages of the world's greatest price smashing bargains. Everything you need in Furniture, rugs, linoleum, stoves, watches, silverware, dishes, washing machines, sewing machines, aluminum ware, phonographs, gas engines, cream separators, etc.—all sold on our easy monthly payment plan and on 30 days' FREE Trial.

Post card or letter brings this big bargain book Free.

"Let Hartman Feather YOUR Nest"

HARTMAN

Furniture & Carpet Co.
Dept. 4152 Chicago, Ill.

Copyright, 1922, by Hartman's, Chicago



Upholstered Backs and Seats Comfortable Spring Seats



HARTMAN Furniture & Carpet Co.
Dept. 4152 Chicago, Illinois
Enclosed find \$1.00. Send the 7-piece Living Room Suite No. 112DMA7 as described. I am to have 30 days' free trial. If not satisfied, will ship it back and you will refund my \$1.00 and pay transportation charges both ways. If I keep it, I will pay \$3.00 per month until the full price, \$37.95, is paid. Title remains with you until final payment is made.

Name.....
Street Address.....
R. F. D..... Box No.....
Town..... State.....
State Year.....
Occupation..... Color.....

YOU TOO Can Learn to Boss This Job

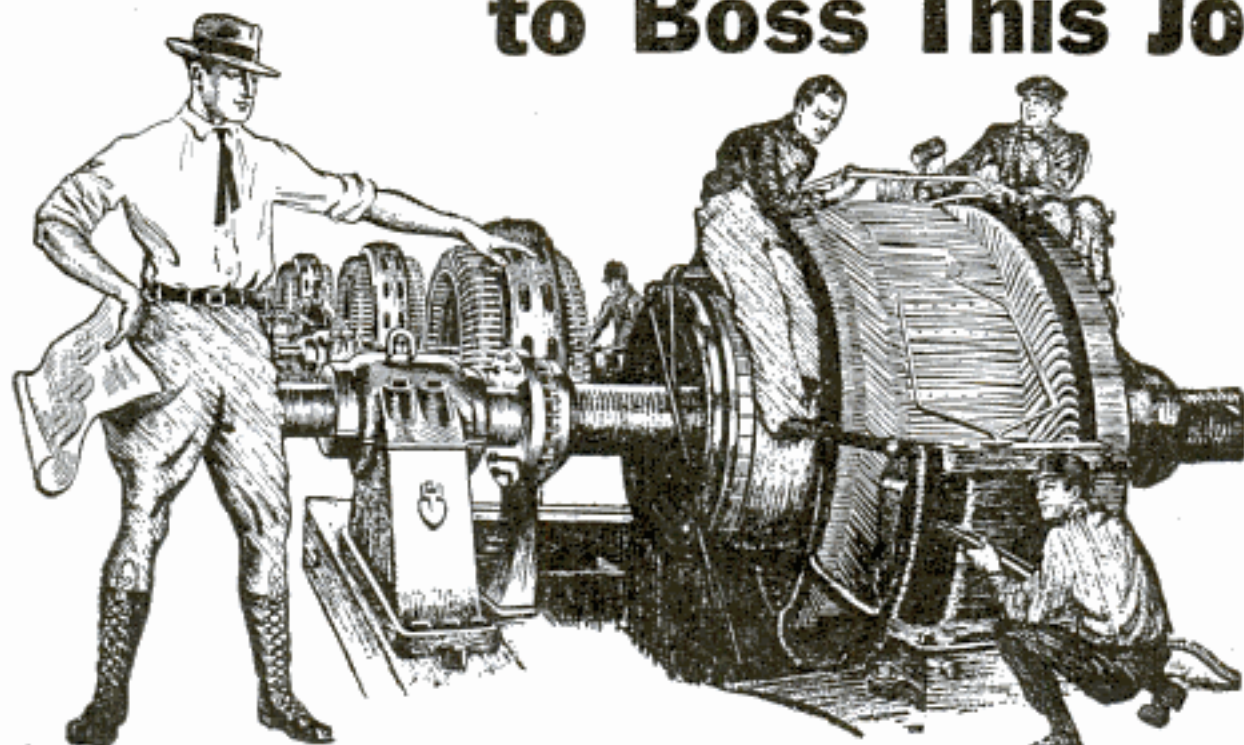

“Electrical Experts” Earn \$12 to \$30 a Day WHAT’S YOUR FUTURE?

Today you are probably earning \$3, or \$4, or \$5 a day—\$18 to \$30 a week. In the same six days, as an “Electrical Expert,” you can make from \$70 to \$200 a week, and make it easier—not work half so hard.

Why, then, remain in the “small pay” game—in a line of work that offers **no Big Promotions—no Big Income—no Big Future?**

Fit Yourself for a REAL Job—Be an “Electrical Expert!”

Today even the ordinary electrician—the “screw driver” kind—is making money—big money. But it’s the “trained man”—the man who knows the whys and wherefores of Electricity—the “Electrical Expert”—who is picked out to “boss” ordinary electricians—to “boss” the big jobs—the jobs that pay.

\$3,500 to \$10,000 a Year

You don’t have to work for less. Enroll NOW for my easily-learned, quickly-grasped, right-up-to-the-minute, Spare-time, Home-Study Course in Practical Electricity. It’s the Short Cut to Success—To Big Pay.

Age or Lack of Experience No Draw-Back

You don’t have to be a College Man; you don’t have to be a High School graduate. My Course in Electricity is the most simple, thorough, and successful in existence, and offers every man, regardless of age, education, or previous experience, the chance to become, in a very short time, an “Electrical Expert,” able to make from \$70 to \$200 a week.

EARN AS YOU LEARN

Don’t let money matters worry you. My terms are easy—And with me, you **Earn as You Learn**—and have money to spare. Some of my students are averaging as much as \$25 a week in spare-time electrical work.

“Money Back” Guarantee

Under Bond, I positively guarantee to return every penny paid me, if you are not entirely satisfied with my instruction. And back of me, in my guarantee, stands the Chicago Engineering Works, Inc., a Million Dollar Institution.

FREE—Electrical Outfit—FREE

After the first few lessons with me you start right in to WORK AT YOUR PROFESSION in a practical way. For this you need apparatus and I give it to you, ABSOLUTELY FREE. This complete set of equipment also helps you to make money doing Electrical jobs on the side.

WRITE ME—MAIL COUPON TODAY

Success in the Electrical field is sure—you can’t fail if you are a trained man. Use Coupon below and get the Vital Facts, and my Free booklet, “How to Become an Electrical Expert.” Don’t hesitate—DO IT NOW. MAIL THE COUPON TODAY.

L. L. COOKE, Chief Engineer

CHICAGO ENGINEERING WORKS

Incorporated

Dept. 11-A, 2154 Lawrence Avenue, Chicago, Ill.

L. L. Cooke, Chief Engineer,
 Chicago Engineering Works, Inc.
 Dept. 11-A, 2154 Lawrence Ave., Chicago, Ill.

Dear Sir: Send me at once full particulars of your Free Outfit and Home Study Course; also Free Booklet on “How to Become an Electrical Expert.” No obligation on my part.

Name.....

Address.....

The “Cooke” Trained Man is the “Big Pay” Man

\$50 SAVED Rahe's

Complete **AUTO AND TRACTOR** Training Course

REDUCED FROM \$150 to \$100



If You Are Not Earning
What You Should—Come to

RAHE

I want to be frank and plain. If you are making \$400 a month or more, and like your work, stick to it. That is always my advice to men who already are making big pay.

But if you are \$400 calibre, and are making only \$100 to \$300, you'd better break away NOW or you never will. **BREAK AWAY from LOW PAY, DISAGREEABLE WORK, NO FUTURE.** Fill out the Coupon today. This is the greatest offer I ever made to **AMBITIOUS MEN.**

AMBITIOUS MEN—Here is the greatest offer I ever made. For immediate acceptance, a complete Rahe Life Scholarship, reduced from \$150 to \$100. If you **ACT NOW** you can **SAVE \$50** (enough to pay your railway fare and leave you money for room and board). Think of it—three great schools to choose from—Chicago, Kansas City and Cincinnati—each one of them a complete automotive training institution teaching students the famous **RAHE-WAY**. Most complete training I have ever offered. Was \$150. Now only \$100—

And I add this Ironclad Guarantee:

7 days free (SEE INSIDE FRONT COVER)

The RAHE-WAY is Guaranteed. We must be satisfied we can train you. So must you. Come now under this famous Rahe 7-Day Guarantee. You take no chance when you buy guaranteed clothing or food. And you take no chance here—the Rahe Auto and Tractor Training Course is GUARANTEED.

No need to delay a minute. You know my tuition rate and my course is *guaranteed*, so **COME NOW.**

Office Men, Clerks, Mechanics, Farmers! Three Billion Dollars will be spent this year for automobile upkeep alone. Millions more for Tractor and Aviation. \$3,000,000,000—and a part of it can be yours. A big part, too, for RAHE-Trained men are in demand, and receive big money.

Become An Auto or Tractor Expert

If you have been undecided, if you have put off coming, if you lacked the \$150—break away NOW. Come to a RAHE School. Come—prepare for Big-Pay Positions—Independence, PROSPERITY. Send for Catalog TODAY.

HENRY J. RAHE Dept. 2897

Three Big Schools

CHICAGO, ILL. Ontario and Michigan Blvd.
KANSAS CITY, MO. 22d and Oak Sts.
CINCINNATI, O. 9th & Walnut Sts.



FREE! Use attached coupon, or just a post card will do, and get my 68-page Catalog. Sent free to you. Let me prove the big opportunities open to you. Get all particulars FREE. Send Today—NOW!



Mail This Coupon Now!

Send this coupon today for my fine 68-page Catalog showing graduates success and opportunities now open. (Address nearest School.)

2897

Name.....

Address.....

Age..... Occupation.....

JOHNSON'S WOOD DYE



How to Finish Woodwork

The finishing of woodwork—old or new, is just a matter of using the proper materials. The Johnson Line of Artistic Wood Finishes is complete—it includes Johnson's Wood Dye, Perfectone Enamel and Undercoat, Varnishes, Prepared Wax, Paste Wood Filler, Crack Filler and everything necessary for woodwork, floors and furniture.

Johnson's Wood Dye is the proper material to use for staining wood—old or new—soft or hard. For the popular enamel finish on either new or hard work use Johnson's Perfectone Undercoat and Enamel. Made in White, Ivory and French Gray.

For refinishing old woodwork, floors and furniture in color where you do not care to go to the trouble or expense of removing the old finish, apply one coat of Johnson's Sani-Spar Varnish Stain. Made in four beautiful shades.

This Book on
Home Beautifying

Free!

This book gives complete instructions for finishing all wood—hard or soft, old or new. Tells how inexpensive soft woods may be finished so they are as beautiful and artistic as hardwood. Explains just what materials to use and how to apply them. Includes color card—gives covering capacities, etc. Use coupon.

S. C. Johnson & Son, Dept. PA 1, Racine, Wis.

Please send me, free and postpaid, your Instruction Book on Wood Finishing and Home Beautifying.

NAME.....

ADDRESS.....

CITY & STATE.....

Dealer's Name.....

Are You Building?

If so, you will find our book particularly interesting and useful. It will tell you how to do the work yourself or enable you to talk intelligently on the subject to your architect and contractor. Our Individual Advice Department will give a prompt and expert answer to all questions on interior wood finishing—without cost or obligation.

S. C. JOHNSON & SON, Dept. PA 1, Racine, Wis.

"The Wood Finishing Authorities"

Canadian Factory—Brantford

This Letter Saved Me Half on a New Typewriter

Chicago, Nov. 2, 1921.

Dear Henry:

I hear that you are down in New York to open a branch office for your firm. You'll be buying a lot of things for the office, not the least important of which will be typewriters.

And that's what I want to talk to you about—typewriters. I want to give you the benefit of an experience I had some time ago, and thereby, I hope, save you some real money.

About a year ago I decided to buy a typewriter for home use. My first thought was to purchase one of the makes we were using in the office, which had been put in before I became buyer for the house. But when it came to digging up a hundred dollars for the machine—I just couldn't. Somehow or other it looked like too much money to me.

Then I thought about picking up a second-hand machine, but the price was about as high, and I had no assurance of service.

I was undecided as to what to do, when one evening at home I ran across an Oliver Typewriter ad in a magazine. I remembered then having read the advertising before and being impressed with the story.

"Why pay \$100 for Any Typewriter"—"When You Can Buy a New Oliver for \$49.50?" read the ad—then it went on to explain how The Oliver Typewriter Company had cut the price by selling direct and eliminating costly selling methods. It was clear to me as an experienced buyer how they could well afford to lop off \$50.50 of the \$100 by their new economical selling plan.

The ad brought out the fact, too, that I could pay \$49.50 cash, or \$55 in easy installments—\$3 after trial and then \$4 per month.

But the thing that decided me was their free trial offer. Without my sending or depositing a penny, they would ship me an Oliver for five days free trial. I could use the typewriter for five days just as if it were my own, and if I wasn't satisfied, all I had to do was to ship it back at the Oliver Company's expense. Well, I mailed in the coupon and got an Oliver for free trial. To make a short story shorter, I was more than pleased with the Oliver. I fully agreed with The Oliver Typewriter Company that if any typewriter was worth \$100 it was this splendid Oliver.

**A Finer Typewriter at a Fair Price
Over 900,000 Sold**

Well, later when we found it necessary to replace some of the typewriters at the office, you may be sure I put in Olivers, saving the company a nice \$50.50 on each. At first the girls were reluctant about changing machines, but after a week or two with the Oliver, they wouldn't have any other.

Naturally now we are all Oliver enthusiasts—that's why I write this letter to you.

You just give the Oliver a trial and you'll be more than willing to buy me a good dinner when I arrive in New York next month.

Yours, J. B.

**FREE
TRIAL**

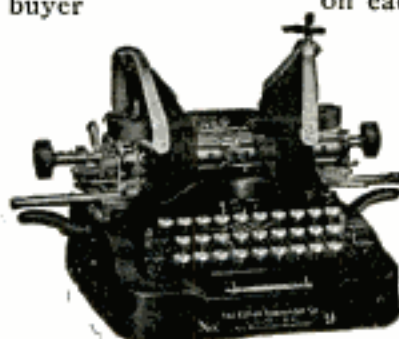

**Now
\$49.50**

That is the letter that saved me \$50.50 on each of my typewriters. I not only equipped the office with the Oliver, but, like my friend, I also bought one for home use. Yes, I am more than willing to buy my friend a good dinner for his valuable advice.

Any reader may order an Oliver direct from this ad by mailing the coupon. No money in advance. No deposit. No obligation to buy. Return or keep the Oliver as you decide after five days free trial. If you decide to keep the typewriter, you can pay cash or you may take over a year to pay at the easy rate of \$4 a month. Mail the coupon today—NOW.

Canadian Price, \$79

**The OLIVER
Typewriter Company**

1091 Oliver Typewriter Bldg.
Chicago, Ill.

**Save
\$50.50**

**THE OLIVER TYPEWRITER COMPANY,
1091 Oliver Typewriter Bldg., Chicago, Ill.**

Ship me a new Oliver No. 9 Typewriter for five days' free inspection. If I keep it I will pay \$55 as follows: \$3 at the end of trial period and then at the rate of \$4 per month. The title to remain in you until fully paid for. If I make cash settlement at end of trial period I am to deduct ten per cent and remit to you \$49.50. If I decide not to keep it, I will ship it back at your expense at the end of five days.

My shipping point is.....

Do not send a machine until I order it. Mail me your book—"The High Cost of Typewriters—The Reason and the Remedy," your de luxe catalog and further information.

Name.....
Street Address.....
City.....State.....
Occupation or Business.....

Williams' ^{PATENTED} Holder Top Shaving Stick

A mechanical problem cleverly solved by the "Holder That Holds"—the Perpetual Stick.

The threaded METAL collar gives the hold



There is just one sure way to prevent the loosening and wobbling of the stick in the holder resulting from changing climatic conditions.

It is to put a threaded METAL collar on the stick and to screw this into the threaded holder. This gives you METAL to METAL—a dead sure hold. The user is thus freed from all the petty exasperations caused by

the holder that does NOT hold.

See for yourself how neatly this little problem has been solved. Send us 10 cents in stamps for a trial size Holder Top Stick in a large *reloadable box*. The Re-Load makes it the perpetual stick.

As to the soap itself, it yields the Williams' lather.

THE J. B. WILLIAMS COMPANY
GLASTONBURY CONN., U. S. A.