

December
15 Cents

NOTICE TO READER: When you finish reading this magazine place a 1-cent stamp or notice, hand same to any postal employe and it will be placed in the hands of our soldiers or sailors at the front. NO WRAPPING—NO ADDRESS. A. S. Burleson, Postmaster General

POPULAR MECHANICS MAGAZINE

WRITTEN SO YOU CAN UNDERSTAND IT

REG. U.S. PAT. OFF.





HARRIS HOMES

\$811

Buys the Material
To Build
This Beautiful
Home No. GX426
Others as Low as
\$483



No. GX131, \$759



No. GX109, \$673



No. GX89, \$1,450

Build The Harris Way—

and secure the utmost possible in Quality, Economy and Service. Profit directly—immediately—by our 24 years' experience. Get the benefit of our practical knowledge FREE.

"The Harris Way" Has exclusive merits—special advantages for the shrewd and careful Home Builder, possessed by no other plan or method. It is the best, safest and most sensible way to build your ideal home right without sacrifice of quality or the waste of a single penny! Thousands have built "THE HARRIS WAY" with profit.

\$10,000,000 Capital Stock and Surplus
Stands back of our guarantee to
Every Harris Home Buyer—you cannot lose.

Advance in Prices Our prices are so low that it will be impossible to maintain same for any length of time. They are bound to advance. If you are needing a house, either for investment purposes or for a home, write now. Do not delay another moment if you wish to make a saving.

The Material Used in building all Harris Homes is prepared by us complete for your use in a way that is instantly and easily understood. It is sensibly cut-to-fit with absolute accuracy and positive elimination of all waste.

\$10,000 Book of Plans

Be sure to mail free coupon for the latest edition of our famous \$10,000 PLAN BOOK, now ready. Contains 100 Modern Harris Home Designs, with Floor Plans, specifications, prices, etc., and explains how we save you \$25.00 to \$50.00 on plans alone. Think twice before you pass this opportunity. Free to all Readers in the United States.

- Dept. GX7.
Harris Bros. Co., Chicago, Ill.
Please send me Free—without the slightest obligation—the following books checked:
- Book of Plans,
 - Plumbing and Heating,
 - Paints
 - "Presto-Up" Sectional Houses and Garages.

Name
Address State

FREE Plan Offer

\$2.00 brings complete Blue Print Plans for these or any Harris Homes in our Plan Book. Specifications and Material List tell exactly what is furnished with each Home. If you purchase material of us, plans are FREE.

"Presto-Up" SECTIONAL HOUSES



A "Presto-Up" (Patents Pending) Sectional, Ready Made or Portable House is the most wonderful building of its kind to be had today. Guaranteed from foundation to roof. In use by U. S. Government, Aero, Radio and War Depts. and large industrial companies. Scientific Construction, handsome in appearance, lasting in quality and low in price. Stronger than the ordinary method of building. Prices, \$150.00 and upward. Garages, \$85.00 and up.

HARRIS BROS. CO. CHICAGO

Victrola XVII, \$250
 Victrola XVII, electric, \$300
 Mahogany or oak



Will there be a Victrola in your home this Christmas?

To hear the world's best music is a pleasure every one enjoys, and the artists who entertain you on the Victrola are the artists every one wants to hear. The world's greatest artists—and they make records for the Victrola exclusively.

Caruso, Alda, Calvé, Culp, de Gogorza, De Luca, Farrar, Gadski, Galli-Curci, Gluck, Hempel, Homer, Journet, Martinelli, McCormack, Melba, Ruffo, Schumann-Heink, Scotti, Sembrich, Tetrizzini, and other famous singers of the opera and concert stage. Elman, Kreisler, Paderewski, Powell, Zimbalist, and other noted instrumentalists. Sousa's Band, Pryor's Band, Conway's Band, Victor Herbert's Orchestra, and other bands and orchestras of world-wide renown. Harry Lauder, Nora Bayes, Raymond Hitchcock, and a host of other favorite entertainers.

Get a Victrola this Christmas. There are Victor dealers everywhere, and they will gladly play your favorite music for you and demonstrate the various styles of the Victor and Victrola—\$10 to \$400.

Victor Talking Machine Co., Camden, N. J., U. S. A.
 Victor Gramophone Co., Montreal, Canada Distributors

"Victrola" is the Registered Trade-mark of the Victor Talking Machine Company designating the products of this Company only. Warning: the use of the word Victrola upon or in the promotion or sale of any other talking Machine or Phonograph product is misleading and illegal.

Victor Supremacy

Important Notice. Victor Records and Victor Machines are scientifically coordinated and synchronized by our special processes of manufacture, and their use, one with the other, is absolutely essential to a perfect Victor reproduction.



To insure Victor quality, always look for the famous trademark, "His Master's Voice." It is on all genuine products of the Victor Talking Machine Company. New Victor Records demonstrated at all dealers on the 1st of each month.

Please Mention Popular Mechanics

Does Cypress ^{"The Wood Eternal"} Last?!

Study These Photographs of an "Ingrowing Fence"



WITHOUT A NAIL
OR A PEG IN IT.

Below is a glimpse down a country highway ("de big road," as Uncle Remus called it) near Monroe, Louisiana. That fence has no posts. It was built by forcing split Cypress boards between sapplings. This occurred so many years ago that nobody knows when it was, nor who was the labor-saving genius who did it. Then the trees grew, and grew, and grew.

NOW, PLEASE, study the larger photograph and see in detail how the fence looks today. Note the size of the tree, and how deeply are embedded the ends of those old Cypress rails—no one can tell how deep they extend in. Note, also, how weathered they are, yet they ring as true and sound under a hammer as though just hewn. Were those old Cypress boards somebody's money's worth? Why should not YOU do as well with your lumber money—whether you are building a beautiful home or just patching up the old place? (USE CYPRESS.)



"THE PROOF OF THE FENCING IS IN THE LASTING."

"Build of Cypress Lumber and You Build but Once."

Let our "ALL-ROUND HELPS DEPARTMENT" help YOU. Our entire resources are at your service with Reliable Counsel.

SOUTHERN CYPRESS MANUFACTURERS' ASSOCIATION

1219 Hibernia Bank Bldg., NEW ORLEANS, LA., or 1219 Heard National Bank Bldg., JACKSONVILLE, FLA.

INSIST ON TRADE-MARKED CYPRESS AT YOUR LOCAL LUMBER DEALER'S. IF HE HASN'T IT, LET US KNOW.

Please Mention Popular Mechanics

Copyrighted material

Popular Mechanics Magazine

6 N. Michigan Avenue, Chicago, U. S. A.

EDITED BY H. H. WINDSOR

London: The International News Co.,
5 Beams Bldg., Chancery Lane

Paris: Messageries Hachette & Co.,
111 Rue Reaumur

Melbourne, Australia:
The Australian News Co.

ISSUED MONTHLY

SUBSCRIPTION:

SINGLE COPY, 15 CENTS

In United States, and its possessions, Cuba and Mexico, per year, postpaid - - - \$1.50
To Canada - - - - - 1.75
To all other countries in the Postal Union - - - - - 2.50

All subscriptions are discontinued at expiration. Please examine the date printed on your wrapper.

Entered as Second Class Matter Sept. 15, 1903, at the Post Office at Chicago, Illinois, under Act of March 3rd, 1879.
Entered as Second Class Matter at the Post Office Department, Canada.

Published monthly by POPULAR MECHANICS CO.

Copyright, 1917, by H. H. WINDSOR.
Copyright, in France.

Contents for December, 1917

Accident—Car, Buckling Freight, Causes Odd Wreck.....	838
Accident—Railroad Wreck, Serious, Narrowly Averted.....	864
Aeroplane Engines Tested in Vacuum Chamber.....	836
Aeroplane Propeller, Pitch of, Regulated in Flight.....	871
Aeroplanes, Fast, Lock Horns in Air and Kill Pilots.....	918
Aiming Device Teaches, without Use of Shot.....	911
Airmen Fly from Italy to England.....	814
Animals, Wild, Vacation Resort for, Maintained by Denver.....	881
Armchair, Mammoth, Made of Paper Fiber.....	871
Auto Oil, Paper Cone Containers for.....	845
Automobile—Car Fitted Up Like Home.....	837
Automobile Lamp, New Lens Prevents Glare of.....	910
Automobile—Motor Bus, Safety First, Used by Land Firm.....	860
Bed, Porch, Concealed in Room during Day.....	826
Beehives, Odd, Solemn Statues Serve as.....	892
Bell, Class Erects Memorial Shelter for.....	894
Block, Cement, Resembles Thirteen Brick.....	918
Boat and Cargo, Sunken, Double in Value.....	905
Boat, Pleasure, High School Girl Makes Own.....	825
Boiler House Consumes Sawmill Refuse.....	919
Bomb, Antisubmarine, Made to Explode at Any Death.....	913
"Book of Reprisals," France Compiles.....	912
Books for the Blind, Methods of Manufacturing.....	800
Bottle, Metal Hot Water, Is Form Fitting.....	917
Bridge, Quebec, Builders of Triumph at Last.....	837
Buckets, Toothed, Fertilizer Loader has.....	901
Buffalo, Crossing with Beef Cattle.....	884
Building, Big Apartment, Has Japanese Aspect.....	898
Cabinet, Portable Steel, for Valuable Files.....	916
Camouflage, Overcoming with Hued Screens.....	880
Camp, A Prison, for Enemies of Our Country.....	874
Camp Stove Derives Heat from Blowtorch.....	894
Camps, Big Army, Scrap Lumber is Saved at.....	844
Canals, Scow Makes Artificial Current in.....	891
Canals, Trolley Boat Keeps Ice from Jamming.....	907
Capitol, At Work on Historic Frieze in.....	877
Carrier with Which Two Can Move Hospital Bed.....	922
Cars, Special Narrow Gauge, Guns Carried on.....	890
Chair, Revolving Rocking, for Car or Home Use.....	865
Chicken Yard on Hotel Roof a Success.....	828
Christmas, Will Bethlehem Observe as of Old?.....	903
Church, All Steel, Houses Members Temporarily.....	868
Civic Features Promote Comfort.....	909
Clipper, Power Driven, New Barber Shop Accessory.....	868
Clipping Machine a Boon to Red Cross Workers.....	823
Coal Pile, Railway's Big, Represents Heavy Loss.....	846
Coal Pile So Huge that Trains Climb Over It.....	808
Crutches, New, Fasten to Wearer's Belt.....	873
Desk, Convertible Office, Serves Different Needs.....	833
Dirigible Balloons, Navy's New, Make Good Showing in Trials.....	816
Engine is Rushed across Country by Express.....	892
Excavator, Steam, Kicks Itself Up an Incline.....	904
Fence, Artistic Prison, Serves Two Purposes.....	907
Fire, Car, Use Water from Railroad Tank to Fight.....	904
Fires, Big, Lives Lost and Food Destroyed in.....	843
Fish Hatchery, Bugs Lessen Food Bill at.....	896
Flag, Device Prevents Folding of about Staff.....	827
Flood, Unexpected, Alaskan Cities Damaged by.....	908
Flour, Cottonseed, Sausages and Cakes Made with.....	906
Freight Cars, Loading Appeal Posted on.....	815
Garage, Four Story, without Elevators, by Montgomery Evans.....	861
Garage, Japanese, Sign in Seven Languages for.....	841
Garages, Bodies of Service Cars Resemble.....	884
Garages, New Cylinder Grinding Machine for.....	894
Gears on New Tractor All Run in Oil.....	919
Germination Tests, Seed Counter Serviceable in.....	815
Glycerin, Manufacture of from Sugar War Triumph.....	892
Gold Extracting Machine, New Portable.....	880
House Moving in Japan a Simple Process.....	876
Industrial Discoveries, Late German, Reported.....	822
Insane, Simple Games and Occupations Help.....	895
Iron and Steel Protected by Pore Filling Oxide.....	902
Kitchen, New Army, Makes Excellent Showing in Test.....	840
Kitchen Table, Electric, Lessens Domestic Work.....	823
Kitchen, Well Planned, Convenient Corner Found in.....	866
Labor Saving Methods, Large Gravel Plant Uses.....	885
Lamps in Hudson Strait Mark Route to England.....	886
Lamps, Powerful Gas, Light Guarded Dam.....	894
Launch, Seven Passenger, a Spare Time Product.....	825
Lead Pencil Industry in Japan, War Aids.....	828
Library, Plan of, Adapted to Odd Sloping Site.....	870
Library, Public, Index to Community Taste.....	860
Life Preserver, New, Steamship Line Adopts.....	880
Lightning Breaks Dish Holding Steel Beads.....	868
Limbs, Broken, Adjustable Support for.....	879
Locomotive, Big War, Built in Three Weeks' Time.....	814
Locomotive Deserted Far from Railroad.....	877
Locomotive—Engine, Decorated, Heralds Pilot's Patriotism.....	860

[\(Continued on Page 6\)](#)

Popular Mechanics offers no premiums; does not join in "clubbing offers," and employs no solicitors to secure subscriptions. It is for sale by nearly every newsdealer in the United States and Canada.

This One



95RC-QX2-SJQEpyrighted material

[Contents—Continued]

Machine, Bulk Powder is Divided into Doses by ..	842
Massage, Women Study to Aid the Maimed....	813
Memorial Building, Marble, Tribute to McKinley	833
Mine, New Floating, Wrecks Only Enemy Vessels ..	880
Miners' Clothing Dried between Shifts	888
Mining, Desert, Tractors Revolutionize	872
Monument—Newsboys Erect Pyramid to Friend's Memory	873
Motor Car, New, Railway Uses for Branch Line ..	835
Motor, Novel Electric, Made Like a Wheel	922
Motor Outfit, Woman's, Comfort and Grace Mark	839
Motor, Synchronous, Used with Simple Rectifier	900
Motorboat, Shallow Draft, Driven by Air Column	911
Motorboats, New Type of, for Shallow Waters ..	922
Motorcycle Events, Unusual, Command Interest ..	889
Motorcycle with Automobilelike Body	802
Mountain—Climbs Mt. Hood on Hands	811
New Testament in Khaki for Fighters	808
Novelties for the Home and Its Members	914
Nozzle, New Fire Hose, Has Numerous Uses ..	844
Ore Crushing Mill of Novel Type	835
Oven, Gas Heated, Motorist Prepares Meals in ..	890
Parrots, Sheep Killing, Escape into America ..	802
Patrols, Cold Ocean, An Eskimo Navy for, by Fitzhugh Green	901
Photograph, Ten Foot, Made by Ingenious Patchwork	823
Photos, Print on Silver by Secret Process	838
Piles, Lumber, Flood Unsets Hundreds of	898
Planer, Large, Constructed for Use at Navy Yard	832
Plates Reveal Position of Advancing Troops ..	918
Post Hole Digger Driven by Old Auto Engine ..	900
Poultry, Forceful Feeding Device to Make Fat ..	810
Power, Free and Unlimited, Promised by Inventor	847
Press, Fast Platen, Prints Four Jobs at Once ..	886
Pulley, Variable Speed, All Gears Eliminated in	809
Race, Thrilling, Down Dark Tunnel Ends in Deep Pool	901
Radio Receiver, Delicate, Has Startling Features	839
Red Cross, Junior, Formed for School Children ..	829
Red Cross, Urgent Needs in France Met by	910
Reflector Gives Bright Light without Glare	916
Regulator, Temperature, for Auto Engines	918
Revolution, Russian—Machine Guns Rattle in Nevsky Prospect	848
Rice, Water Wheels in Japan Used to Pound	905
River Bottom, Steps Lead to Short Cut across ..	902
Saloniki, Overturned Pot of Oil Destroys	840
Santa Claus, Some Strange Visits He Has Made	920
Scholarships, Red Cross, for Trained Nurses ..	872
Scissors Grinder's Odd Homemade Outfit	908
Screen, Sun, for Beach Use Has Convenient Features	873
Semaphore, Ticket Vending, for Way Stations ..	810
Sidocar De Luxe Equipped for Camp or War Use	808
Sign, Café, Live Fish in, Attract Business	880
Sign's Moving Manikin Helps Money "Drive" ..	844
Sleeper, New, Eliminates Familiar Discomforts ..	917
Soldiers, Our Wounded, Government to Re-educate	876
Soldiers, War Department Perfects Plan of Paying	900
Sole Leather is Tested by New Apparatus	818
Speed Recorder, Motor Car, Keeps Permanent Record	870
Station, Training, Open Air Eating Place at	888
Stump Puller, Powerful, Operated by One Man ..	878
Submarine, Interior of, Vividly Portrayed	904
Submarines, Wireless System for Detection of ..	801
Sulphite Lye Exploited by Swedish Industries ..	810
Targets, Range, and How They are Operated, by E. F. Ingals, Jr.	897
Tea Wagon, New, Equipped for Electric Dishes ..	841
Teeth, Crowned, New Porcelain Facing for	864
Textbooks, Expunging, a Big Task	808
Theater, Greek, City Eyecore Transformed into ..	885
Tourniquet, Steel, Devised for Surgical Uses ..	916
Tractor Runs Driverless for Five Days	828
Tractor with Only One Wheel has Many Uses ..	879
Trailer, Handy Two Wheel, for Coal Dealers	893
Trenches, When Popular Mechanics Reaches the	892
Truck, Meter, Simplifies Work in Light Plant ..	878
Truck Seller, No Lost Time in Program of	836
Typewriter Feeder Saves Operator's Time	841
Valve Grinder, Pneumatic, of Aluminum and Steel	811
Vegetables, Fresh, Hotels Urged to Freeze	827
Volcano a Monstrous Steam Boiler, by Lewis R. Freeman	803
Waistcoat, Backless Dress, Designed for Dancing	815
War, World:	
At Zero Hour	817
Bombs, Sound, London Uses as Air Raid Warning	835
Hospitals in France, Flying Huns Bomb	848
Masks, Leather, Used by German Fighters	842
Observer's Post Resembles Tree	834
Opportunity for American Gas and Flame Fighters	846
Phases Shown in Photographs Taken at Random	809
Prisoners, Tubercular, Given Sun Treatment ..	856
Russian Troops Shamed by Girls and Tommies	850
"Spirit of France" is Undying	857
Training Camps Here and across the Water ..	852
Warship, Rolling "Tank" of the Sea, Sensational	834
With Italian Land, Aerial, and Naval Forces ..	854
Warfare, Submarine, Increases Demand for Skilled Divers in Navy	867
Warnings, Fog, Radio Telephone Used for	841
Water Tank, Utilize Boulders Picked Up on Ranch to Build	893
Water Wheel, Picturesque, Operates Churn	814
Weather Observatory, Wind Sweeps from Peak ..	824
Windmill, Revolving Cylinders Are Feature of ..	910
Wireless Controlled Torpedoes to Bring Victory ..	812
Wireless Operators, Free School for in Boston ..	832
Yeomen, Girl, Common Sight at Our Navy Yards	891

SHOP NOTES

Auto Used as Power Plant without Altering Car ..	940
Band, Brake, Repaired with Spring Steel Strap	938
Barrels, Old, Make Inexpensive Concrete Culvert Forms	933
Bench Stop and Wedge Clamp, Combination	931
Bushings, Inserting in Motorcycle Connecting Rods	928
Caliper, Special Sliding, Useful on Many Jobs ..	937
Cap, Leather, Remedies Loose Auto Engine Valve	942
Capstan, Makeshift, House Moved over Snow with	929
Cartridges, Electrical Fuse, Test Box for	925
Clip, Safety Pen, Fitted on Nose Glass Pocket Case	932
Clockface, Large, Fitted on Small Clock	932
Disk, Bronze, Takes Up Thrust Wear in Pump ..	935
Gauge, Door Lock Mortise, That Saves Time	931
Gauge Pins, Printing Press, Made of Paper	940
Gear, Slip, Minimizes Breakage of Teeth	925
Hand, Moving, Draws Attention to Window Display	936
Holder, Revolving Check, for Lunch Rooms	941
Hook, Pulling, with Safety Finger Hold	932
Illuminating Units, Selection of for Home or Office	935
Ladle, Solder, Arranged as Crucible Carrier	934
Lamps for Stock Room Shifted along Horizontal Wires	937
Lathe, Centering Halved Pattern Work in a	936
Lathe, Wood Turning, Enlarging Diameter Capacity of	934
Lever, Knee, Actuates Shift Key of Typewriter ..	937
Lug, Stove Lid Lifting, Repaired with Wire	942
Messenger, Novel Method of Strapping Money Satchel to	930
Paint Brushes, Old, Provide Small Tool Handles	940

[Contents Continued on Page 8]

IN accordance with the editorial policy of this magazine never to accept compensation in any form for what appears in our reading pages, and also to avoid all appearance of doing so, we are obliged to omit the name of the maker or the seller of any article described. This information, however, is kept on file and will be furnished free, by addressing Bureau of Information, Popular Mechanics Magazine, Chicago. [Editor.]

Diamonds

\$69.75 Per Carat

This is the lowest price at which genuine diamonds have ever been offered. You will never have this opportunity again. Act on it, here and right now.

This Acquaintance Offer Limited Positively to This Importation—

We make this offer to "get acquainted." Never before were you offered such a bargain in genuine diamonds; never again will you have this chance. No other importer can meet this sensational price. We handle better grades of diamonds, described in our big catalog. But a genuine diamond at \$69.75 the carat can be bought only now.



No. P101—Brilliant, genuine diamond, full one-carat weight, set in 14k solid gold Tiffany mounting, hand made. Attractively boxed. Mounting, \$3.75. Price, complete..... **\$73.50**



No. P102—Genuine diamond, 1/4 carat, \$15.00. 14k solid gold Tiffany mounting, \$3.75. Price, complete..... **\$18.75**



No. P103—Genuine diamond, 1/2 carat, \$25.00; 14k solid gold Tiffany mounting, \$3.75. Price, complete..... **\$28.75**



No. P104—Genuine diamond, 3/4 carat, \$34.75. 14k solid gold Tiffany mounting, \$3.75. Price, complete..... **\$38.50**



No. P105—Genuine diamond, 1 carat, \$43.75. 14k solid gold Tiffany mounting, \$3.75. Price, complete..... **\$47.50**



No. P106—Genuine diamond, 1 1/2 carat, \$52.00. 14k solid gold Tiffany mounting, \$3.75. Price, complete..... **\$55.75**

We Send These Diamonds for Free Examination—Our Written Buy-Back Bond Protects You if You Purchase!

Upon your simple request, we will send your diamond for free examination. Your order to Basch is not a promise to buy. You are not obliged to purchase. We pay all charges. If you *do* buy, our written guarantee allows you to exchange your purchase, *at any time*, for full value. It also guarantees to buy back your diamond for full purchase price less 10% within a year. You are absolutely protected.

Big, New 1918 Book *FREE!*

Send for our large De Luxe Diamond and Jewelry Book—new edition just out. Save one-third to one-half through this bargain book. But if you want a diamond ring at this startling price of \$69.75, order now from this advertisement. When present supply is sold, this offer ends. Our catalog offers diamonds in five grades, from \$97.50 upward—the lowest prices by far, quality considered. Send the coupon now for free book.

L. BASCH & CO.

State and Quincy Sts., Dept. P3470, Chicago, Ill.

COUPON—CLIP IT NOW
 L. BASCH & Co., State and Quincy Streets, Dept. P3470, Chicago
 Please send your 1918 De Luxe diamond book with cover and special pages in colors.

Name.....

Street No.....

P.O.....

State.....

Please Mention Popular Mechanics

Don't Delay
Write Today
Now!

LEARN THE AUTO-MOBILE TRADE

at home—spare times

WITH

**Dyke's Working Models
and Simplified Instructions**

On these models you see the actual operation and learn more than you could from the auto itself—it's easy and quick. An Auto Repairman is not a machinist—his work consists of adjustments and refitting worn parts: "knowing the principle," that's the thing.

IF we PROVE to you that we've actually given instructions by mail and then assisted our students in getting into the automobile repair business—you must admit we can do the same for you.

WRITE NOW For Dyke's FREE 32-Page Booklet

It is interesting and instructive in itself. Learn how you can get all this training for only \$15. The knowledge gained will be worth a hundred times its cost. Fill out below or write a postal—but do it now.

Dyke's Correspondence School of Motoring
Box 198, Granite Bldg., St. Louis, Mo.

Send me your free 32-page booklet about your New Idea Working Model Course and testimonials and proofs. It is understood I am under no obligations in sending for this.

HOW
TO
GET INTO
THE
AUTO
BUSINESS
AND ITS
OPPORTUNITIES

Name

(WRITE PLAIN)

Town

Street.....State.....

This school is a department of the firm A. L. Dyke, Publisher and Importer. Dyke's system is endorsed by leading motor authorities of the world. Dyke's Books are used by the Government and by High Schools in some of the largest cities.

SPECIAL INSTRUCTION on Six, Eight, Twelve Cylinder Engines.
Electric Starting and Generating Systems Simplified.

Learn in Spare Time to be a CIVIL ENGINEER

Earn \$1500 to \$5000 Yearly

Here's your big chance to become a full-fledged Civil Engineer! With this set of books you can fit yourself to make big money, in the greatest outdoor profession on earth! Offer fully explained in coupon. Good only within boundaries of U. S. and Canada.

Great Books Shipped FREE

50c a Week if you keep them after 7 days' FREE TRIAL.

Nine big leather-bound volumes; 3900 pages, 7x10 inches; 3000 plates, maps, diagrams, etc. Written by world's greatest civil engineers. Books tell you—

ALL ABOUT surveying; highway construction; railway engineering; earth work; specifications; estimating contracts; bridge engineering; masonry; reinforced concrete; water supply; sewers and drains; water power equipment; irrigation engineering—etc., etc. Written in simple language—every point made plain.

Consulting Service Free

A \$12 Consulting Membership solves your difficult problems for a whole year. FREE with the set of books.

SEND NO MONEY—JUST THE COUPON!



AMERICAN TECHNICAL SOCIETY
Dept. C-1199
Chicago, U. S. A.
Please send Library of Civil Engineering for seven days' examination, express prepaid. I will send \$2.00 within seven days and \$2.00 a month until I have paid \$29.00 or notify you and hold books subject to your order. Title not to pass until fully paid.

Name.....

Address.....

Reference.....

(Contents—Continued from Page 6)

Pencil Held to Teeth Detects Knocks in Inclosed Machine	936
Pit, Small Floor, Convenient for Sheet Metal Work	938
Plane, Bead, Made of a Wood Screw and Block	934
Plugs, Wooden Expansion, for Screws Easily Made	940
Press, Substantial Power Drill, Made of Pipes and Fittings	923
Pump, Drainage, Improvised on the Job	936
Rack, Disassembling, Keeps Engine Parts in Order	924
Rack, Portable Tool, for Mill Room	925
Racks for Pipes and Cigars Aid "No Smoking" Enforcement	941
Runway over Oil Tanks Saves Lifting of Barrels	939
Scooter, A Long Island	926
Scraper for Removing Ice and Snow from Cornice	933
Seat, Square Wrench, Fitted on Tank Filler Cap	940
Setscrews, Collar, Made from Ordinary Setscrews and Nuts	930
Shafting, Overhead, Polishing	930
Soldering Granite Ware, Simple Method of	924
Spring, Long Coil, Holds Auto Starting Crank	934
Stock, Devices for Gripping Accurately in a Vise	929
Stoppers, Sink, Rubber Covered Instrument Knobs Made from	938
Tapline, Handy One Man Method of Using	942
Tongs, Blacksmith's, Made of Iron Strips Bent Cold	930
Treatment, Electrical Sinusoidal Current at Home	932
Truck, Shop, with Folding Upper Deck	931
Wall, Foundation, Built of Tile and Concrete	934
Wrench, Pipe, Made from Rope and Wooden Strip	938

AMATEUR MECHANICS

Balls, Old Tennis, Provide Typewriter Cushions	958
Bicycle Supported from Pulleys for Storage and Repairing	959
Bicycles Driven as Three Wheel Tandem after Breakdown	954
Cabinet, Sportsman's Gun and Equipment, for Automobile	950
Camera, Film, Using Plates in	945
Canteen, Large, Tipped Handily When Suspended from Tree	945
Canvas, Waterproofing with Paraffin	946
Chain, Quickly Detached Nonslip, for Shoes	958
Clips, Wire, Weight Paper in Typewriter	949
Clock Case and Electroliers Made of Marble and Onyx	950
Cruiser, Model Battle, Built by Boy	951
Dishwasher, A Homemade	955
Eggs, Boiling in Steam	953
Eyes, Open Screw, Handy for Use on Wall Hooks	958
Fence, Poultry, Construction Economical of Netting	949
Flag, Chain Weight Prevents Whipping of	949
Fort Built of Snow Blocks Made in Box Form	949
Guard Keeps Baby's Playthings on High Chair	946
Guides, Index, Quickly Made	958
Gun, Toy Machine, That Fires Wooden Bullets	948
Holder, Plate, Using as Printing Frame	948
Holder, Suspended Twine, Made from Funnel	953
Keys, Photographic Prints of, Handy for Making Duplicates	950
Lock, Electric Bolt, Made from Bell Ringer	945
Machine, Compact Electric Photograph Printing	953
Oilcup, Glass, Used as Electric Mast Light	951
Pedal for Opening a Drawer	959
Pendulum, Electric Time, for Experimental Work	952
Polisher, Flannel Shoe, Made from Barrel Hoop	944
Rack Protects Sprayer Used in Barn	952
Rims, Tightening, on Shell Nose Glass Frames	944
Safe, Match, Soldered to Pocket Tobacco Can	950
Shovel, Two Man Snow, for Heavy Snowfalls	943
Sidecar for a Parcel Delivery Bicycle	947
Silver or Filigree Work, Brightening and Cleaning	959
Sled with Runners Made of Wagon Wheel	944
Spring Relieves Hands of Motorcycle Driver	951
Stand, A Double Cabinet Sewing	956
Submarine, Toy, Propelled by Rubber Motor	955
Table, Rustic, with Polished Top Crosscut from Log	953
Target, Moving, for Practice with Air Rifle	944
Theaters, Movie, Call Service for Patrons of	959
Toboggan Made of Old Buggy Shafts	954
Toy, Horse and Rider	957
Tractor, Model Steam, Made by Boy	954



The Partition of Poland was the greatest national tragedy in history. The country was divided between Austria, Russia, and Prussia, shown herewith by the three crowned eagles. Poland is shown by the fallen soldier, the flag of his country trailing in the dust, while the Goddess of Liberty is defending the nation. It is altogether probable this ancient nation may again be re-established as a result of the present European War. All the underlying causes of this mighty struggle and every conflict or achievement in history may be learned from the pages of the famous publication

Ridpath's History of the World

DR. John Clark Ridpath is universally recognized as America's greatest historian. Other men have written histories of one nation or period; Gibbon of Rome, Macaulay of England, Guizot of France, but it remained for Dr. Ridpath to write a history of the entire World from the earliest civilization down to the present day.

Notice Before Advance in Price

ON account of the tremendous increase in the cost of paper and leather, occasioned by the European War, it becomes necessary to advance the price in order to cover the increased cost of manufacture. This is your last opportunity to buy Ridpath's History of the World at our present low price and easy terms of payment. We will name this low price only in direct letters to those who mail us the coupon below. Tear off the coupon, write your name and address plainly and mail now before you forget it. You incur no obligation whatever. We employ no agents as our low price does not permit the payment of an agent's commission. The beautiful sample pages will give you some idea of the splendid illustrations and wonderfully beautiful style in which the history is written.

Six Thousand Years of History

RIDPATH takes you back to the dawn of History, long before the Pyramids of Egypt were built; down through the romantic troubled times of Chaldea's grandeur and Assyria's magnificence; of Babylonia's wealth and luxury; of Greek and Roman splendor; of Mohammedan culture and refinement to the dawn of yesterday. He covers every race, every nation, every time, and holds you spellbound by his wonderful eloquence.

The European War

IF you would know the underlying causes which have led up to this conflict, the great racial antipathies, the commercial rivalries, the sting of past defeats, the vaulting ambitions for world empire, then embrace this opportunity to place this History in your home.

Ridpath's Graphic Style

RIDPATH pictures the great historical events as though they were happening before your eyes; he carries you with him to see the battles of old; to meet kings and queens and warriors; to sit in the Roman Senate; to march against Saladin and his dark-skinned followers; to sail the southern seas with Drake; to circumnavigate the globe with Magellan. He combines absorbing interest with supreme reliability.

**WESTERN NEWSPAPER ASSOCIATION
CHICAGO**



FREE COUPON
WESTERN NEWSPAPER ASSOCIATION
H. E. SEVER, Pres't.
140 SO. DEARBORN ST.
CHICAGO, ILL.

Please mail, without cost to me, sample pages of Ridpath's History of the World, containing photographs of Napoleon, Caesar and other great characters in history, and write me full particulars of your special offer to Popular Mechanics readers.

FOLD HERE, TEAR OUT, SIGN AND MAIL

NAME

ADDRESS

Please Mention Popular Mechanics

Every Electrical Man

Wants These Books
and we ship them
for your inspection
FREE



10 Volumes
3500 Pages
4700 Pictures
\$1 Per Volume
\$1 Per Month

Flexible Covers
Handy Pocket-Size Volumes

Just what you need to know to succeed in ELECTRICITY

Please Mention Popular Mechanics

EVERY electrician, every engineer, every mechanic should know about these wonderfully helpful instructive books, which give in plain words a complete working knowledge of electrical engineering in all its phases. You run into some new electrical

What Electrical Men Say About—

Helped Him Make Good
 "It is only right for me to recommend highly the Hawkins Guides, for they have been of the greatest assistance to me in placing me in my present position as Superintendent of Construction Department of one of Ohio's largest Electrical Companies. I would like to see every man have a set of Hawkins Guides." Geo. Karsch, Columbus, Ohio.

The Trouble With Them
 "The only trouble I find with the Hawkins Guides is that everybody is always borrowing them. My set was even borrowed by a high school instructor for reference work in a physics class."
 Carl Hueschle, Hettinger, N. D.

First Aid
 "Number 10 Guide arrived all O. K. and complete the set, which I am very proud of. I don't think it would be possible to find a better set for either the beginner or the professional electrician."
 Elmer A. Stevens, Elmer, N. Y.

In the Naval Electrical Dept.
 "The Hawkins Guides are great help to me in the Naval Electrical Department, which they cover very thoroughly."
 C. J. Cornell, U. S. Receiving Ship, Brooklyn, N. Y.

Handy to Carry
 "The great beauty of them is that you can carry them in your pocket. That suits me, for I never want to be without them."
 F. S. Collins, Richardson Engineering Co., Hartford, Conn.

Saved Him Money
 "Hawkins Guides saved me just \$3.50 the first time I looked through No. 10 Book. I had a spark coil played out, and that book showed me how to rewind it; and I made it as good as new. Hawkins Guides are the best ever."
 H. F. Ramsey, Foodmont, Mo. Superintendent

**I am now superintendent of the Dunnville Hydro-Electric Systems, and Hawkins Guides were a great help to me in holding down a responsible position."
 W. E. Swartz, Dunnville, Ontario.**

Even in College
 "I am attending Cornell University, but I use the Hawkins Guides every day for general information which I cannot in recitation work or in laboratory experiments. I'll always speak a good word for the 'every-ready Guides'."
 J. Winfield Kurtz, Joannas, Berke Co., Pa.

Wireless Operators
 "I have worked wireless for ten years—but I wish I had these books years ago, as they have saved me a great deal of trouble."
 H. Marshall, Steamer M & B No. 2, Walkersville, Ont.

problem almost every day. It may be some trouble that you can't locate, or some electrical principle that you don't know just how to apply. It's up to you to find the right way out. There's no need to spend hours trying to "dope it out," no need to ask somebody else, or do a makeshift job. The information you need to help you in your every day work is in

HAWKINS ELECTRICAL GUIDES

These books place electricity at your finger ends. They cover every imaginable subject, principle, theory, problem, trouble, and way of doing things electrically. Every subject is indexed so that you can turn right to it. They are a study course and a reference guide in one, written in plain every day language—no wasted words—only what you need to know—chock full of up-to-the-minute electrical knowledge. The guides are a complete course in electrical engineering. They will help you in every detail of the day's electrical work. You can't ask an electrical question that Hawkins Guides can't answer.

Pocket-Size Flexible Covers

The books are small enough to slip into your coat pocket—handsomely bound in flexible black covers. You can carry each volume with you until you have mastered its contents. 3,500 pages of actual information and 4,700 illustrations. Once you see these books and put them into actual use you will never again want to be without them. Try it at our expense.

SEND NO MONEY

It will cost you nothing to receive these books—to look them over—ask them all the questions you can think of—use them in your work—study them—pick up some information that will increase your earning ability. We will ship you the entire set of 10 volumes entirely FREE. This is a sign of our confidence in the guides. Pure gold does not object to being tested. Keep them for seven days and if you do not decide that you can't get along without them, return them to us and owe us nothing. When you decide to keep them you only have to pay \$1.00 down and remit the balance of \$9.00 on the easy payment of \$1.00 a month till paid for. Use this coupon to get the books. It will pay you many times over.

THEO. AUDEL & CO.
 New York, N. Y.
 72 Fifth Ave.



Read This Partial List of Contents

- No. 1** Contains 348 pages, 388 illustrations. Electrical signs and symbols—static and current electricity—primary cells—conductors and insulators—resistance and conductivity—magnetism—induction coils—dynamo principles—classes of dynamo—armatures—windings—commutators—brushes, etc.
- No. 2** Contains 348 pages, 394 illustrations. Motor principles—brake horsepower—selection and installation of dynamo and motor—galvanometer—standard coils—current measurement—resistance measurement—voltmeters—wattmeters—watt hour meters—operation of dynamo—operation of motors, etc.
- No. 3** Contains 330 pages, 473 illustrations. Distribution systems—wires and wire calculations—inside, outside and underground wiring—sign flashers—lightning protection—rectifiers—storage battery systems, etc.
- No. 4** Contains 270 pages, 370 illustrations. Alternating current principles—alternating current diagrams—the power factor—alternator principles—alternator construction—windings, etc.
- No. 5** Contains 330 pages, 614 illustrations. A. C. Motors—synchronous and induction motor principles—A. C. commutator motors—induction motors, transformers; losses, construction, connections, tests—converters—rectifiers, etc.
- No. 6** Contains 298 pages, 473 illustrations. Alternating current systems—switching devices—circuit breakers—relays—lighting projector apparatus—regulating devices—synchronous condensers—indicating devices—turbines—power factor indicators—wave form measurement—switch boards, etc.
- No. 7** Contains 316 pages, 370 illustrations. Alternating current, wiring power stations—turbines; management, selection, location, erection, testing, running, care and repair—telephones, etc.
- No. 8** Contains 322 pages, 627 illustrations. Wireless—electric bells—electric lighting—photometer, etc.
- No. 9** Contains 322 pages, 627 illustrations. Electric railways—electric locomotives—car lighting—trolley car operation—miscellaneous applications—motion pictures—gas engine ignition—automobile self-starters and lighting systems, electric vehicles, etc.
- No. 10** Contains 513 pages, 669 illustrations. Elevators—cranes—pumps—air compressors—electric heating—electric welding—soldering and brazing—industrial electrolyzes—electroplating—electro-therapeutics—X-rays, etc.

Also a complete 126-page ready reference index of the complete infactory I agree to send you \$1 within seven days and to furnish them mail you \$1 each month until planned to reader easily accessible all the vast information contained in the 10 electrical guides. There are over 13,500 cross references. You find what you want to know instantly.

Signature.....
Occupation.....
Business Address.....
Residence.....

Since we have not yet had the pleasure of business relations with you, we shall appreciate your giving us some reference on line below.

Reference..... P. M. Dec. '17

Home Study Books Spend 50¢ a Week—

Big Reductions in Price for Limited Time Only

The great book offers on the opposite page open the way for any ambitious man to break into the big-pay class by studying at home in his spare time. Each set is a sensational bargain.

These complete, practical Home Study Books cover the fourteen leading professions and trades—**one of which is right in line with your talents.**

Don't fail to grasp this great opportunity for self-improvement. The technically trained man is the man of the hour. Every industry is bidding for his services.

Get started quickly, while books can be purchased at a bargain price, on very easy terms. Trained men are drawing record-breaking salaries these days—**why don't you "get in the game?"**

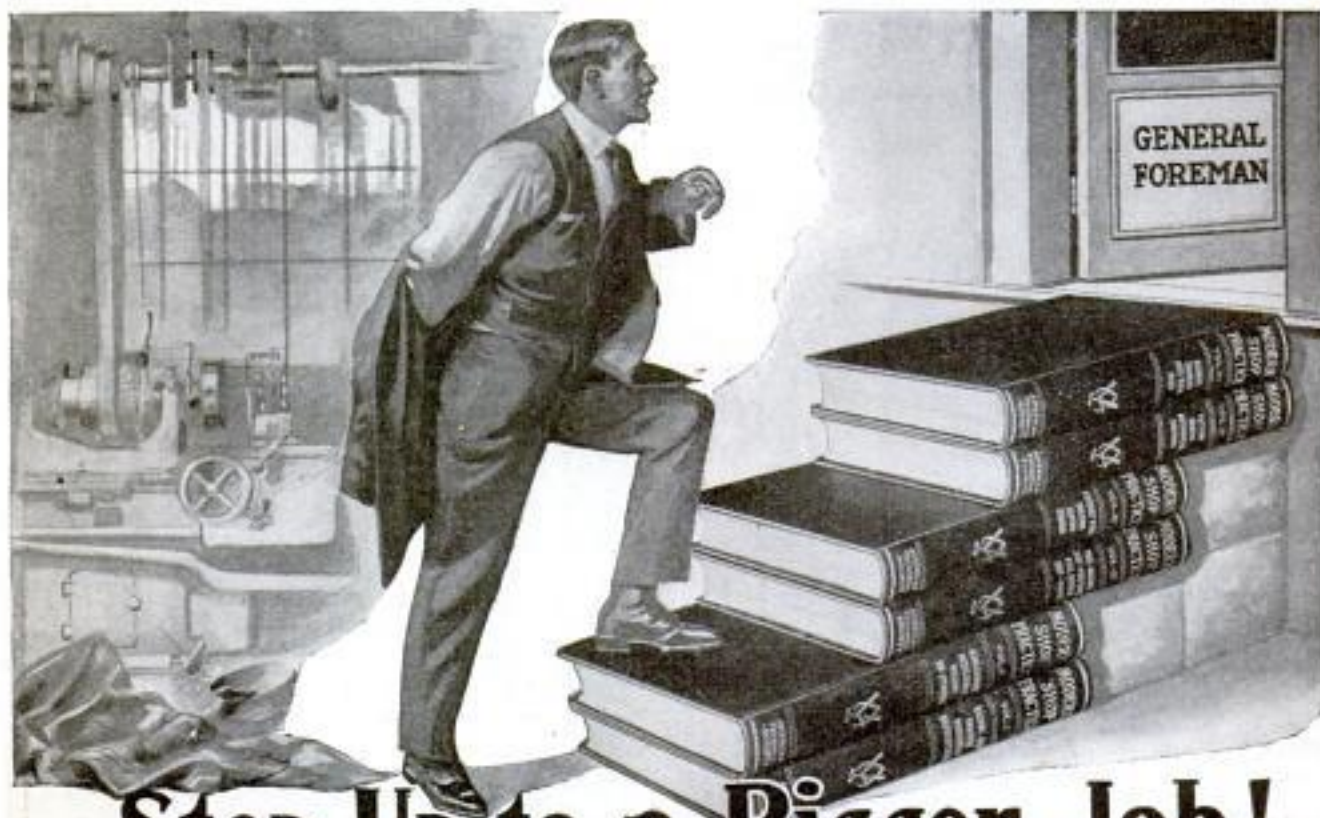

Step Up to a Bigger Job!

to Boost Your Pay! and Half an Hour a Day.



Here's your chance to get—at a bargain price—a set of pay-raising books that will fit you for a bigger, better job. Yes, and you may pay the bargain price at the rate of **only 50 cents a week**. This is a special offer. Act on it at once! The rising cost of paper and binding materials won't permit us to continue it indefinitely.

No matter what your occupation, one of the sets listed below is bound to suit your needs. They are written in easily-understood language by recognized authorities, and contain thousands of photographs, full-page plates, diagrams, etc., that make difficult points as simple as A-B-C. Handsomely bound

in half or full morocco leather, gold stamped.

Shipped for 7 Days' Free Trial

We'll gladly send any set of books to you for seven days' free examination, shipping charges fully prepaid. Examine them carefully—use them at your work for an entire week. If, at the end of that time, you feel they aren't worth many times what we ask, send them back to us. If you keep them, pay the specially-reduced price on the easy terms explained below.

Practical Home Study Books

	Vols.	Pages	Size of Page	Illus.	Reg. Price	Spec'l Price
Civil Engineering	9	3900	7x10	3000	\$45.00	\$29.80
Architecture, Carpentry and Building	10	4760	7x10	4000	50.00	24.80
Accountancy and Business	10	3680	7x10	1987	50.00	24.80
Applied Electricity	7	3000	7x10	2600	35.00	19.80
Automobile Engineering	5	2400	5½x8¾	2000	25.00	17.80
Telephony and Telegraphy	4	1728	7x10	2000	20.00	12.80
Modern Shop Practice	6	2300	5½x8¾	2500	30.00	18.80
Heating, Plumbing and Sanitation	4	1600	7x10	1600	20.00	14.00
Mechanical and Architectural Drawing	4	1720	7x10	1037	20.00	12.00
Motion Picture Work	2	600	7x10	300	12.00	6.00
Law and Practice (with Reading Course)	13	6000	7x10	24	72.00	39.80
Steam Engineering	7	3300	7x10	2500	35.00	19.80
Fire Prevention and Insurance	4	1500	7x10	600	20.00	15.80
Practical Accounting	4	1840	7x10	800	20.00	12.80

Only 50c a Week

Not only can you buy these books at a rock-bottom price, but we offer them to you on the easiest of monthly payments. If, after seven days' examination, you decide to keep the set you have selected, simply send us \$2 and then \$2 a month until the present low price has been paid. Have you ever heard of a more generous offer?

Don't wait. This means money in your pocket if you act now. Remember, you take no chances whatever—it costs nothing to inspect and you are not obliged to keep the books if you do not care to buy. This offer is open to every man living within the boundaries of the U.S. and Canada. Mail the coupon now—before you turn the page!

AMERICAN TECHNICAL SOCIETY
Dept. X-1199 CHICAGO, U. S. A.

SPECIAL DISCOUNT COUPON

AMERICAN TECHNICAL SOCIETY, Dept. X-1199, CHICAGO, U.S.A.

Please send me set of.....

for 7 DAYS' FREE examination, express prepaid. I will examine the books thoroughly and, if satisfied, will send \$2 within 7 days and \$2 each month until I have paid the special price of..... If I decide not to keep the books, I will notify you at once and hold them subject to your order. Title not to pass to me until the set is fully paid for.

NAME.....

ADDRESS.....

REFERENCE.....

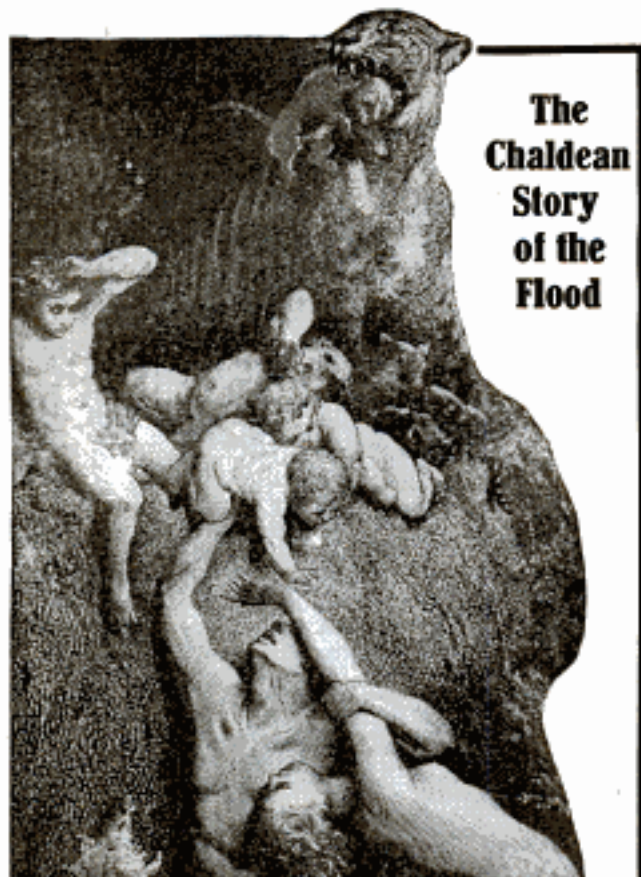

The Chaldean Story of the Flood

Dug Up from the Ruins of Ancient Chaldea

DO YOU KNOW that there has been dug up from the ruins of old Chaldea a complete story of the Flood—the same in every detail as Moses' account in Genesis—and that it was written thousands of years before his version appeared? Hardly one in a million has ever had an opportunity of seeing this startling story—**HAVE YOU?** But it is one of the many thousand curiously interesting accounts in

The Library of Original Sources

now for the first time available to the general public. By purchasing the entire unsold edition from the publishers we secured it at an absolutely unheard of reduction. We offer a few sets to Popular Mechanics readers at a

GREAT BARGAIN Send us the attached coupon AT ONCE, and we will tell you how to get the Library on EASY MONTHLY PAYMENTS, and Mail you FREE a book of rare documents showing curious inscriptions of the Ancients. Act quickly. Mail the coupon NOW. The book is FREE.

OVER 100 RESEARCH SPECIALISTS spent 10 years gathering the contents of this great work. Ancient and remote civilizations in all parts of the globe, age-buried hieroglyphics on monuments, tablets and sun-baked bricks yielded their secrets; untiring workers ransacked the hidden literature of every age to find these "original documents." Nothing like it has ever been attempted or thought of before. You'll be amazed at the wealth of information this unique library contains.

MAIL THIS COUPON FOR FREE BOOK

UNIVERSITY RESEARCH, Dept. G, P.M.12-17
Milwaukee, Wis.

Send me the FREE book of rare documents showing inscriptions of the Ancients and tell me of your easy payment offer. I assume no obligation; the book and all you send me is to be free, and no salesman is to call.

Name.....

Address.....

How to Read a Blue Print



You must know how to read Blue Prints to get a good job and to succeed at your trade. Secrets of the Blue Print are now made plain. Simple and easy. Be the master of your work. Learn quickly. New, easy, practical method of the School of Metal Trades. Write to-day for particulars and special small price.

Secret of Success

When you know the secret of the Blue Print you know the big secret of success in your trade. Send for all particulars and special introductory price on short practical course. Write to-day.

Earn Big Money

Be a thinker on the job. Act now. You must know the Blue Print secrets to get the best pay. Send for free booklet on the Master secrets of the Blue Print. Open the door of opportunity. Write to-day for Blue Print Booklet. Free.

Special Offer For a limited time we will make a special low price offer on the short, easy, practical course. Learn quickly in your leisure hours. Be a success. Write today for introductory special low price. Book on Blue Print Free. Send for it.

SCHOOL OF METAL TRADES

Dept. 5244, P. O. Box 163, CHICAGO, ILL.



PAY \$75 to \$150 MONTH

U. S. GOVERNMENT WANTS
Railway Mail Clerks—City Mail Clerks—Postoffice Clerks—Clerks at Washington, D. C.
HUNDREDS MEN AND WOMEN WANTED

Common education sufficient. Send coupon immediately. We coach candidates free. This coupon, filled out as directed, entitles the sender to (1) free sample examination questions; (2) a free copy of our book, "Government Positions and How to Get Them;" (3) free list of positions now easily obtainable; and (4) to consideration for Free Coaching for the examination here checked.

.. Railway Mail Clerk	[\$900 to \$1800]	.. Customs Positions	[\$900 to \$1500]
.. Postoffice Clerk	[\$800 to \$1200]	.. Internal Revenue	[\$700 to \$1800]
.. Postoffice Carrier	[\$800 to \$1200]	.. Stenographer	[\$1100 to \$1500]
.. Rural Mail Carrier	[\$500 to \$1200]	.. Clerk in the Departments at Washington	[\$900 to \$1500]
.. Bookkeeper	[\$900 to \$1800]		

Name.....

Address.....

Use this before you lose it. Write plainly. J 103

Please Mention Popular Mechanics

(Just Issued)

the New Library of Practical Electricity

—A New McGraw-Hill Home Study Course

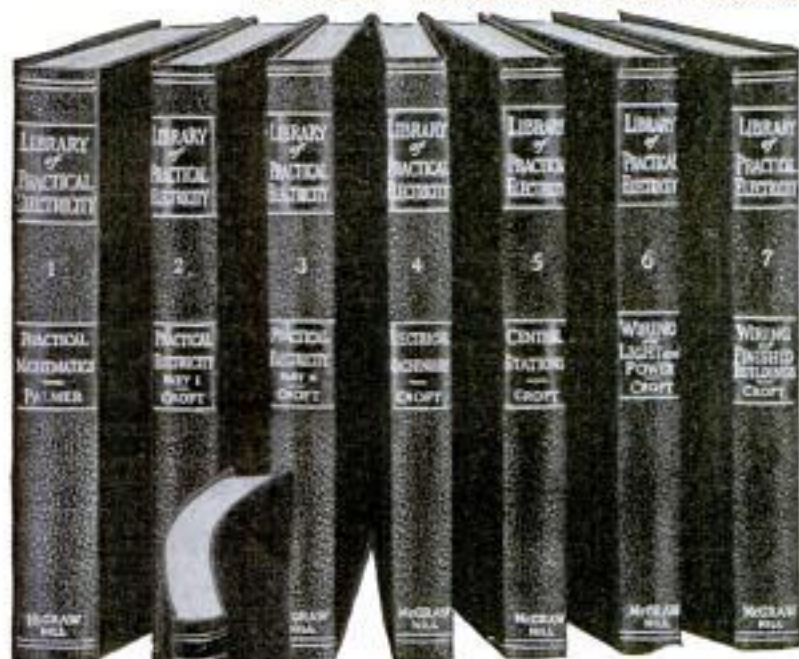

The New Library of Practical Electricity by Terrell Croft marks a new era in electrical literature.

The great field of electrical engineering, with its limitless possibilities of earning power, is brought to you in a form that makes the conquest easy. Yet the Library is a creation—an achievement that is without parallel in technical literature.

Terrell Croft, author of seven of these volumes, stands without peer in his field. He rose from dynamo tender, through the ranks, to electrical engineer with the Westinghouse Company. He gained his experience with his sleeves rolled up. He gives it to you in books that are technically of the highest order, yet free from involved theory and complex mathematics. And in the excellence of the illustrations and printing, the flexibility and convenience of the thin paper, pocket-size volumes, and the richness of the morocco grained Karatol binding, they are fittingly dressed for this great achievement.

Not a Correspondence Course

The New Library of Practical Electricity contains all the facts you will ever need in electrical work—vastly more than you could gain by experience. Yet all this valuable information on modern electrical practice is now yours for the small sum of 50c per week or \$16 for the complete course—payable \$2 per month. An hour or less per day with the Library will give you a thorough working knowledge of the whole field.

Vol.
8

The Secrets of Practical Electricity

Sent for 10 Days' Free Examination

Only \$2 per month

8 vols. Complete
\$16 for the Course

This New Library of Practical Electricity will do everything to help you succeed in electricity. Here are 8 books flexibly bound in rich, morocco-grained Karatol, pocket-size, containing just the facts you must know to succeed—all in practical, handy form for instant reference. The course contains nearly 3000 pages, size 4 3/4 in. x 7 3/4 in., with as many illustrations made specially for this flexibly bound, thin paper edition—3000 pages of actual PRACTICE.

Send No Money Examine this new Library for 10 full days at our expense, and find out for

yourself why they improve working methods and form a sure, short-cut to BIGGER PAY. The coupon below is for your convenience in examining these practical books. It obligates you in no way; on the other hand it may easily mean permanent success for you in the well paid field of practical electricity—so mail the coupon today—right now if possible.

McGraw-Hill Book Co., Inc.
239 W. 39th St.
NEW YORK

McGraw-Hill
BOOK CO., Inc.
239 W. 39th St.
NEW YORK

GENTLEMEN:
Please send me the Library of Practical Electricity (shipping charges prepaid) for 10 days' free examination. If satisfactory, I will send \$2 in ten days and \$2 per month until \$16 has been paid. If not wanted I will write you for return shipping instructions.

Name

Home Address

City and State

Name of Employer

His Address

Your Position (P. M. Dec. '17)

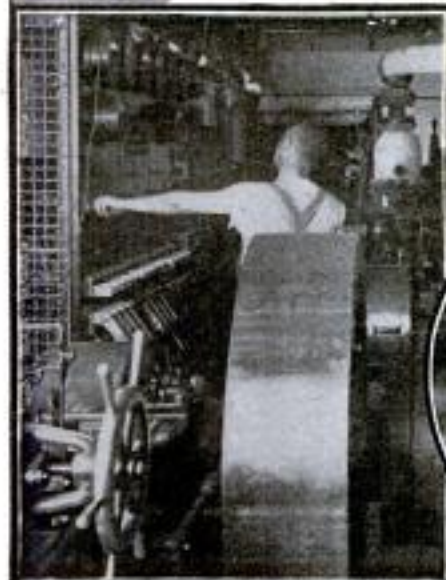

Copyright Underwood & Underwood, N.Y.

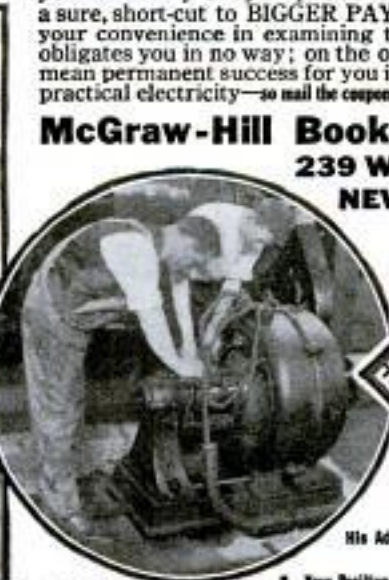

Copyright Brown Bros., N.Y.



High School Course in Two Years!

Here's a thorough, complete, simplified High School Course that you can complete in **two years**. A liberal education, of incalculable value, by spare time study, at home. Course prepared by leading professors in Universities and Academies.

Meets Entrance Requirements of Colleges and Universities

Fits you for Harvard, Yale, Princeton and other institutions of highest standing. Helps you to win in business and social life. Spend the hours you would otherwise waste, in profitable study of this fascinating course.

The man who knows is the leader. Knowledge gives you assurance, turns your natural ability into actual power.

This course gives you the key to success and power.

Don't Stop Growing

Keep on going! Train your brain! Broaden your mental vision! Make the most out of your life before too late. Cash in "on your natural ability."

Choice of 20 Courses

We have helped 50,000 men and women to win! Let us help you, too.

SEND COUPON TODAY

for **FREE** Book and Full Information

American School of Correspondence, Chicago, U.S.A.

Dept. P-1199. Gentlemen: Please send me booklet and tell me how I can fit myself for the position marked X.

- | | |
|---------------------------|------------------------------|
| High School Course | Shop Superintendent |
| Electrical Engineer | Lawyer |
| Telephone Engineer | Business Manager |
| Architect | Auditor |
| Draftsman | Certified Public Acc't |
| Building Contractor | Stenographer |
| Structural Engineer | Bookkeeper |
| Mechanical Engineer | Fire Ins. Adjuster |
| Civil Engineer | Sanitary Engineer |
| Steam Engineer | Automobile Engineer |

NAME.....

ADDRESS.....

Please Mention Popular Mechanics

DRAKE'S NEW Mechanical Books FOR HOME STUDY

Send for our complete catalog of the best and most practical books for Engineers, Marine and Stationary; Electricians, Automobile Repair Men, Railroad Men, Builders, Carpenters, Sign Painters, Scene Painters, Card Writers, Designers, and Other Mechanics. It is **FREE**

These books are all up-to-date and range in price, post-paid, from 50c to \$3.00—the lowest priced books ever made considering quality and usefulness. They are written in plain language. You can understand them.

These Books Will Increase Your Earning Power



Just Published

Automobile Painting

By F. N. Vanderwalker

This new book shows you every detail of the process of automobile painting. It offers a great opportunity to any painter who desires to enter the field as an off-season business; shows the owner or garage man how to paint a car, new or old. Tools and materials are described and illustrated. Working methods for priming, surfacing, rubbing and varnishing are made perfectly plain. Factory processes are also explained. 12mo. 209 pages fully illustrated. Price, postpaid - - - \$1.25

All First-Class Book-Stores Carry Our Full Line

Frederick J. Drake & Co., 1008 Michigan Ave., Chicago

Be An ARTIST

Earn \$25 to \$100 a week as Cartoonist—Illustrator—Commercial Artist. Learn quickly at home by new instruction method. Easy terms. Outfit FREE to new students. Write today for handsome Booklet, free, and Special Offer NOW. WASHINGTON SCHOOL OF ART, 1298 H St., N. W., WASHINGTON, D. C.

\$25 TO \$40 A WEEK

Hundreds earn it. You can too. Typewrite 80 to 100 accurate words a minute. Double or treble your salary!

NEW WAY IN TYPEWRITING

Totally New system. Based on Gymnastic Finger Training! Only 10 easy lessons. Learn while working. Results from first day. Write for full particulars illustrating and explaining all, showing letters from hundreds earning Big Money. Write postal NOW!



THE TULLOSS SCHOOL
132-B College Hill SPRINGFIELD, OHIO

LEARN MUSIC

AT HOME

MUSIC LESSONS FREE

Become most popular person in your set! LEARN TO PLAY BY NOTE—Piano, Organ, Violin, Banjo, Mandolin, Trombone, Flute, Guitar, Ukulele, Saxophone, Clarinet, Piccolo, Cornet, Harp, Cello, or to sing. Special Limited offer of free weekly lessons. You pay only for music and postage, only 12 1/2 cents a week. No extras. Beginners or advanced pupils. Everything illustrated, plain, simple, systematic. Free lectures each week, 19 years' success. WRITE POSTAL TODAY for Free Booklet. Over 200,000 successful pupils all over the country.
U. F. SCHOOL OF MUSIC, 712 Brunswick Bldg., New York



Opportunity Is Calling the Interstate Commerce and Traffic Expert

Large business organizations and railway companies today need the expert who can handle their transportation problems. They need the man who knows interstate commerce rulings and the laws of carriers, who can see that classifications are correctly made, who can secure fair claim adjustments and who is acquainted with all the technicalities of freight rates, bills of lading, etc. Opportunities are almost boundless for the man who is competent to fill the position of Commerce Counsellor or Traffic Director. Fully half a million concerns require service of this kind—and the demand is daily increasing for men trained in this important profession.

The ambitious man who is tired of being in the ranks, and who sees the prospect for advancement in this new profession can get a thorough training in Interstate Commerce through the home study course offered by

LaSalle Students and Graduates

can now be found employed in the executive departments of practically all the large railroads, business houses and commercial organizations in the United States. Many prominent business concerns can be named in each of which 100 to 900 or more LaSalle students or graduates from our several specialized departments are employed in responsible positions. For instance—

Pennsylvania R. R. . . .	319
American Telegraph & Telephone Company . . .	359
U. S. Steel Corporation . . .	359
Baltimore & Ohio R. R. . . .	351
Armour & Company . . .	342
Chicago & N. W. Ry. . . .	332
Ford Motor Company . . .	322
Swift & Company . . .	317
Standard Oil Company . . .	310

Among the numerous firms and corporations employing 50 to 100 or more LaSalle students or graduates are the following:

Western Electric Company
International Harvester Co.
B. F. Goodrich Company
Wells Fargo Express Company
Goodyear Tire and Rubber Co.

and every important railroad company in the United States.

More than 125,000 men in active business life including a large number of corporation officials have been enrolled and are reaping the benefits of LaSalle training and service. Over 20,000 new students now enroll annually. The LaSalle organization consists of 800 people including a staff of 300 business experts, professional men, text writers, special lecture writers, instructors and assistants. LaSalle students and graduates occupying responsible positions can be found throughout the entire English speaking world.

Send the Coupon

Your request will bring our large illustrated catalog with all information about practical training in traffic management, rates, etc.—also our valuable book, "Ten Years' Promotion In One". Write for this today. Use the coupon.

LASALLE EXTENSION UNIVERSITY

"The World's Greatest Extension University"

This course was prepared by some of the most eminent railway and industrial traffic experts—men holding the high positions in the Traffic Departments of railways and great business organizations—men who are recognized as authorities on this subject.

Enrolled here, you will study directly under men who know every phase of Interstate Commerce. They will give you in a short time, the benefit of the experience which they have obtained in actual practice. You will gain more than you could acquire in years of your own experience because as soon as you master one subject you advance to another. You will be thoroughly trained

in every detail pertaining to Freight Rates, Classifications, Tariffs, Bills of Lading, Routing, Claims, Demurrage, Express Carriers, Ocean Trade, Railway Organization, Regulation and Management, Laws of Carriers of Goods, Interstate Commerce Rulings, Accounting, Statistics, etc. Every point will be made clear by individual instruction step by step as you go along.

Free Consulting Service

As a LaSalle student, you will also be entitled to the free use of our Business Consulting Service which gives you the privilege of calling on our staff of experts in any department at any time you need special help or counsel. LaSalle Extension University is a clearing house of business

information and through its many highly specialized departments is organized and equipped to render a practical and distinctive service which cannot be supplied by any other institution of similar character. It is a service for which outside consulting experts would charge large fees.

Study By Mail

You can get this expert training in your spare time while holding your present position as the instruction is all given by mail. And you can pay for the course a little each month if you wish. The coupon will bring full information about this.

LASALLE EXTENSION UNIVERSITY

"The World's Greatest Extension University"
Dept. 1264-C Chicago, Illinois

Without cost or obligation on my part, please send me Catalog describing your Home Study Training in Interstate Commerce and Railway Traffic and your Business Consulting Service. Also a copy of your valuable book for the ambitious man, "Ten Years' Promotion In One."

Name.....

Present Position.....

Address.....



Please Mention Popular Mechanics

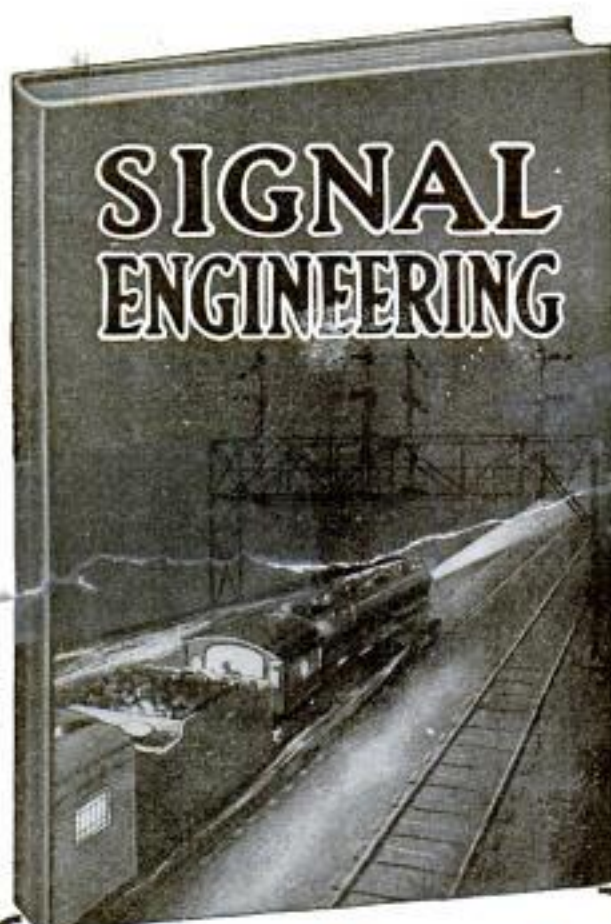

Free Book On Signal Engineering

THERE are thousands of miles of railroad that must be equipped with block signal systems. To superintend these installations men are necessary. Golden opportunities are offered. Every ambitious man should write for the free book on Signal Engineering.

If you join the army or navy before you have completed the course, your course of study may be resumed upon your return without any additional fees.

Men Are Needed to Accept High Salaried Positions

When you stop to consider that, at the present time, less than one-fourth of the passenger lines in this country are equipped with automatic block signal systems—and when you read that the day is fast coming when the law will compel railroads to install them, you will realize what remarkable opportunities are offered to ambitious men in the profession of Signal Engineering. The work is big—broad—high salaries are paid. \$250.00 a month is an ordinary salary for a Signal Engineer.

Department of Signaling

Dept. 1199, 1810 Wilson Ave.
Ravenswood Station, Chicago

Gentlemen:—Please send me absolutely free and prepaid your big new book on Signal Engineering. Also full particulars about your great special free outfit offer. It is distinctly understood that I assume no obligations of any kind.

Name.....

Address.....

Age..... Occupation.....

Send the Coupon

Put your name and address in the coupon, or a letter or post card. Now and get the free book about Signal Engineering. Too, we will tell you how you can get the training that you need in order to become a Signal Engineer. You will be under no obligation by writing for this free book. Do it Now.

Department of Signaling

Dept. 1199
1810 Wilson Ave.
Ravenswood Sta.
Chicago

Mr. A. R. Patterson, whose advertisement appears below, was for eight years a Civil Service Secretary-Examiner, and is well qualified to help YOU secure a Government Position.

WANTED! MEN FOR CIVIL SERVICE

Send for Free Book

Show Your
Patriotism

By
Working for
Uncle
Sam.



Men in Civil Service do as great a service as those in the field of battle. Positions pay \$75 to \$150 a month. Short hours. Easy work. No strikes, no hard times, no layoffs. No petty bosses. No politics—no pull. Ordinary education sufficient. 15 and 30 day vacations each year with full pay. Sick leave with full pay. Positions for life.

**RAILWAY MAIL CLERK, POSTAL CLERK,
REVENUE OFFICER, CUSTOMS SERVICE**

and many other divisions of Government Service offer splendid opportunities for big pay and rapid advancement. If you are an American Citizen, 18 or over, send in your name for all facts about Government Positions and how to get one.

NEW BOOK FREE!

Mr. Patterson was U. S. Civil Service Secretary-Examiner for 8 years, and has students and graduates in practically every State in the Union in all branches of Government Service. You can qualify. Don't delay. Mail postal NOW for Free Book and special 30-day Offer! Address

PATTERSON CIVIL SERVICE SCHOOL
812 News Bldg., Rochester, N. Y.

Be an Artist

Comics, Cartoons, Commercial, Newspaper and Magazine Illustrating, Pastel and Crayon Portraits. By Mail or Local Classes, 10 FREE LESSONS. Write now. ASSOCIATED ART STUDIOS 30A Flatiron Building, New York

CIVIL SERVICE

positions are in all parts of the country. Good pay, steady work, life positions, congenial surroundings, promotions on merit, short hours, annual vacation and sick leave with pay. Many thousands appointed yearly. Both sexes. No political pull. Nearly 300,000 classified positions. Common school education sufficient. Full information and questions used by the Civil Service Commission free.

COLUMBIAN CORRESP. COLLEGE, WASHINGTON, D.C.

COPY THIS SKETCH

and let's see what you can do with it. Cartoonists and illustrators earn from \$20.00 to \$125.00 or more per week. My practical system of personal individual lessons by mail will develop your talent. Fifteen years' successful work for newspapers and magazines qualifies me to teach you. Send sketch of Uncle Sam with 6c in stamps for test lesson plate; also collection of drawings showing possibilities for YOU. State your age.

The Landon School of Illustrating
and Cartooning
1429 SCHOFIELD BUILDING, CLEVELAND, O.



Voice Thrower 10c

Learn to throw your voice into a TRUNK, under the bed, out in the hall or anywhere. Lots of FUN fooling the Teacher, Janitor, Policeman, Parents, Neighbors, or Friends.

THE VENTRILO

is a little instrument that fits into the mouth out of sight. BOYS or GIRLS can use it. NEVER FAILS! A 32 page book on Ventriloquism sent with the VENTRILO for TEN CENTS.

Royal Novelty Co., Dept. 92, So. Norwalk, Conn.

5000 FIRMS WRITE IN FOR SALESMEN!

Salaries of \$50 to \$200 a Week Offered to Trained Men; How to Qualify, at Home!

This photograph shows part of a stack of 5000 letters sent in by firms all over the country, in every line of business, almost begging for qualified traveling salesmen. Never before in the history of American commerce have so many men been needed, and never before have such salaries been offered. Yet it is only a hint of opportunities yet to come. For salesmen are the producers of business—and during bad times as well as good times no one is more needed than the man who keeps the wheels going by bringing in orders!

How Others Have Succeeded

The greatest salesmen in the country today were developed—not born. Usually they came from other lines of work. Clerks, farmers, mechanics, bookkeepers and other poorly paid workers become high powered salesmen with earnings of \$2500 to \$10,000 a year. For example, E. C. Kessler of Rockford, Ill., worked for a railroad at \$75 a month, took up salesmanship and has earned \$375 a month. C. W. Birmingham of Dayton, Ohio, earned \$600 a year as a clerk and now, a year later, earns \$125.00 a week, as sales manager. Geo. W. Kearns of Salina, Kansas, used to earn \$60 a month but since becoming a salesman has earned as high as \$306 in one week. P. W. Broedel, Woodhaven, N. Y., is earning \$92 a week as a salesman where formerly his salary was but a fraction of that amount.

And so it goes—men who have been slaving away at a desk or bench turn to salesmanship and their earnings enable them to ride around in their own cars, own their homes and really enjoy life.

Become a Star Salesman

All of the instances cited above are the result of studying the course of scientific salesmanship issued by the National Salesmen's Training Association. Instruction, which is of the highest order, is given by mail and the results border on the miraculous. In an amazingly short time, you can learn every detail of successfully selling any line of merchandise, the problem of securing a position, methods of getting orders and receive special training necessary to successful salesmanship. The Association is now more than 10 years old and has already successfully trained thousands of men who never before sold a dollar's worth of goods. In addition, thousands of men who have spent years in selling merchandise have taken the course with the greatest profit.

FREE EMPLOYMENT

One of the advantages of joining the Association is the Free Employment Service. Thousands of firms, realizing the superiority of the N. S. T. A. type of salesmen, write in asking the Association to supply members for positions paying up to \$10,000 a year. There is no charge for this service.

64-Page Book Free

The National Salesmen's Training Association has issued a remarkable book which will be sent free, on request, to every man who is dissatisfied with his present position. Regardless of how little ability you now have as a salesman, regardless of how impossible you may think it is for you to become a successful salesman, write for this book today. It tells everything you want to know about the opportunities in salesmanship for you, about the amazing system of instruction and what N. S. T. A. Training and Service has meant to thousands of others. Do not wait until tomorrow for you may miss the greatest opportunity of your life. Send in a post card or the coupon below right NOW. ADDRESS nearest office—NATIONAL SALESMEN'S TRAINING ASSOCIATION, Dept. 12-W, CHICAGO—SAN FRANCISCO—NEW YORK.

National Salesmen's Training Association,
Dept. 12-W, Chicago—San Francisco—New York
Please send me your Big Free Illustrated Book, and list of lines in which positions are open. No obligation on my part. Address nearest office.

Name.....

Street.....

City.....State.....

Please Mention Popular Mechanics

Be A Certificated ELECTRICIAN

Your Future

is in Electricity—Obey that "Hunch."

Get a Move on Yourself—Here's Your Chance—

If You Act Quick I Will Give You Special Personal Training at Home.

Only a Limited Number of Students Can Secure My Special Instruction—**ACT NOW.**



CHIEF ENGINEER
Your Instructor

Qualify at Home
—With My Help

STUDY BY MAIL

My New Course and a Common School Education All You Need.

Fit Yourself in Spare Time to Earn \$45.00 to \$175.00 a week.

SPECIAL

Earn While You Learn

Right After You Are Enrolled I Will Give You a Short Course in Quick Money-Making Electrical Branch—**FREE.**

MY OFFER TO YOU:

If you act quick I will accept you among a few more students to complete Home Study class now forming. Grasp this wonderful opportunity. Fit yourself by a few months' fascinating Home Training to be a **REGULAR CERTIFICATED ELECTRICIAN.**

I have a splendidly attractive proposition for you. I **GUARANTEE** you satisfaction in the study of this great profession. Decide to enter it while you can do so on terms especially advantageous to you. Plan a glorious future. Secure for yourself the assured independence, the handsome income, the agreeable working conditions, the easy professional hours and the unlimited opportunities of trained and experienced Electrician.

FREE ELECTRICAL OUTFIT

For the next 30 days I am giving each student an Outfit of Electrical Testing Instruments, Tools, Electrical materials and Motor absolutely Free.

My instruction is by practical methods and this outfit is used in working out the lessons. Practical training with the theory makes perfect.

I am Chief Engineer of the Chicago Engineering Works, and I can give you the training that will land the big jobs and hold them.

I haven't the space here to tell you all the advantages, benefits and privileges **GUARANTEED** to my students. If you are ambitious to make a big success in the greatest profession on earth—if you are ready to start right in and study Electricity the "easy" way—at home—mail me the **FREE "OUTFIT"** coupon without delay. I will send you full particulars of my personal instruction plan, my splendid laboratory and educational facilities, my wonderfully complete and fascinating course of bed-rock lessons, and my thoroughly practical method of making Electricity easy to understand and master. Write me **NOW.**

L. L. COOKE

CHIEF ENGINEER
Chicago Engineering Works
Room 12, 441 Cass Street, CHICAGO, ILL.

L. L. Cooke,
CHIEF
ENGINEER

Room 12, 441 Cass St.
Chicago, Illinois

Without obligation on my part kindly send at once, fully prepaid, particulars of your complete Practical Home Study Course in Electricity.

NAME.....

ADDRESS.....

TOWN..... STATE.....

USE THIS FREE "OUTFIT" COUPON

CLASSIFIED ADVERTISEMENTS

WORLD'S BEST WANT AD MEDIUM

We have records to prove that a classified ad in these columns will find a buyer for almost anything which can be sold. Doubtless you have some article of value to some one else which you no longer need. Why not turn it into money?

Advertisements in this section, 18 cents per word, each insertion, minimum 10 words, payable in advance. To be inserted under proper classification in the January issue, copy should be in our office November 25th.

Popular Mechanics Magazine, Chicago, Ill.

Gentlemen: By actual test I have been able to find no better medium for classified advertising than Popular Mechanics Magazine. Not only has this section brought inquiries at a small cost, but a very large per cent of them have been buyers. For the person or persons starting in a small way or conducting a small business, your classified section is unsurpassed. If there is a market for your product this section will find it.

Sincerely yours,

WILL WAND.

AUTOMOBILES

AUTOMOBILE Repairs—Automobile owners, Garages and Repairmen should subscribe for the Automobile Dealer and Repairer; 150-page illustrated monthly devoted exclusively to the care and repair of the car. The only magazine in the world devoted to the practical side of motoring. The "Trouble Department" contains five pages of numbered questions each month from car owners and repairmen which are answered by experts on gasoline engine repairs, \$1 per year; 15c per copy. Canadian subscription, \$1.50. Postals not answered. Charles D. Sherman, 50 Windsor Road, Hartford, Conn.

PAINT your own car for \$5. Use it next day. Nine colors. Free booklet "B" and color card tells how. Autonomel Company, Rochester, N. Y.

THE Modern Gasoline Automobile—Most complete and up to the minute automobile book published. Recognized as the standard book on construction, operation, maintenance and repair, showing every recent improvement. Over 700 pages, 500 illustrations. Cloth. Price, \$2.50 postpaid. Send for complete description of this and other reliable automobile books. Popular Mechanics Book Dept., 6 N. Michigan Ave., Chicago.

CYLINDERS reground, new pistons and rings fitted. Restores lost power. Write for prices, giving make and model. The Ervarts Machine Co., Hartford, Conn.

PATENTS for Automobile Improvements are in great demand. We have special Automobile Department in charge of experts who are in touch with demands of trade. Write for "What To Invent and List of Patent Buyers," sent Free. Victor J. Evans & Co., 158 Ninth, Washington, D. C.

AUTOMOBILE SUPPLIES

AUTO Tops at one-half usual price. Fit any car. Prices \$6.25, \$8.00, \$11.50 without frame. One-man Tops complete \$20.00 and up. Seat covers for Fords \$8.25, \$11.50, \$12.25 up. Overlands \$9.25, \$12.00, \$18.25 up. Buicks \$8.25, \$10.50, \$18.25 up. Others similar prices. "Frost King" Asbestos Insulated Radiator and Engine Covers \$2.75, \$3.25, \$5.00 up. Repair broken light in ten minutes with "Stik-tite" Window. Our local representative will give you expert advice free and save you money. Write for his address, free catalog and samples. Limited territory still open for a few more exclusive agents. Write, The Cincinnati Auto Specialty Co., Dept. MA 127, Elm St., Cincinnati, Ohio.

DOUBLE Service tires. Guaranteed to give good service. Size 30x3, \$5.50; 30x3½, \$6.00; 30x4, \$9.00; 31x4, \$9.00; 30x4½, \$10.00; 30x5, \$11.00; 37x5, \$11.00; Non-skid \$1.00 extra. 10% required on all C. O. D. orders. State if Q. D. straight side or clincher type. 5% discount if cash accompanies order. Also special discount to dealers. I. Jaffess, 1319 5th Ave., New York. Branch, 211 West 34th St., New York.

INSYDE Tires, inner armor for Automobile tires, double mileage and prevent punctures and blowouts. Quickly applied. Cost little. Demand tremendous. Profits unlimited. Details free. American Automobile Accessories Co., Dept. P2, Cincinnati, O.

VULCANIZE auto tires. Make big money. Learn with our book \$1.00. Vanderpoels, Springfield, Ohio.

HEAVY car type Non-Skid Tires. 28x3, \$7.05; 30x3½, \$10.05; 30x4½, \$23.55. All sizes. F. T. Snyder, "Maclay," Harrisburg, Pa.

CONSERVE Gasoline, price is advancing. Cold hard-starting engines are causing trouble. "Gldz" overcomes these conditions. Registered United States Patent Office Aug. 3, 1915, as follows: ("Gldz") a fuel for Increasing Efficiency of Gasoline Engines. Experts endorse "Gldz" as gasoline saver and carbon preventative. One Dollar can be prepaid mail will convince you. Fine Dealer's proposition. Quick action means quick profits. Write today, "Gldz," Galesburg, Illinois.

AUTOMOBILE Parts for most all makes of cars: Buick 10, 27, 17, 19, 29, 39 and 43. Maxwells, E. M. F., Studebakers, Flanders, Paige 25 and 36. Overlands, 37, 38, 42, 51, 59 and 80. Cadillacs '09 to 1912. Parry, Regals, '09 to 1913. Oakland, Jeffrey, Mitchells '07 to 1913, also 1915. Empires, Elmors, Chalmers '09 to 1913. Auburn, Jackson 35 and 42. Interstate, Marlon, Cole, Moline, Stearns-Knight, Rambler, Howard, Thomas, Imperial, Lexington, Detroit, Moon 30 and 40. Staver, Hudson 20 and 33. Everett, Kline, Stutz, Reo, Fal. Kissell, Hupp 20, Bergdoll, Ohio and many others. Pistons, connecting rods, cam shafts, crank shafts, cylinders, axles, bearings and gears for most any make of car. Write us your need, satisfaction guaranteed. Auto Parts Company, 4116-18 Olive Street, St. Louis, Missouri.

FOR Sale—One E. M. F. 33 motor complete with carburetor, magneto, clutch and fan; A-1 condition, \$47.50. One Model 38 Overland motor, complete with carburetor and magneto—good as new, \$42.50. F. M. McGraw, Payne, Ohio.

REINFORCED Unbreakable Porcelain Insulator for spark plugs or other insulators. Price reasonable. John Sayer, Stone Lake, Wisconsin.

TIRES—Double Tread Guaranteed for good service. Absolutely Puncture-Proof. Big—Strong—Extra heavy, 30x3 tire, \$5.50; 30x3½, \$6.50; 30x4, \$9.00; 34x4, \$9.50; 30x4½, \$12.00; 37x5, \$13.00. Big saving on other sizes and tubes also. Trade in your old tires. Discount to dealers. 10% deposit required on C. O. D. orders. Send for list now! State size and bead of tire. Max Liben & Co., 205B West 48th Street, New York.

GEARS for all purposes; transmission gears, bevel-drive gears, sprockets, axles. Special machine work. Must have old parts or drawing. Turley Gear Plant, 1505 N. 10th St., St. Louis, Mo.

MOTORS, magnetos, coils, carburetors, radiators, axles, transmissions, etc., cheap. Badger Motor Co., Milwaukee, Wis.

BATTERY Charging pays big Profits. City current or gas engine operates. Easy terms. Hobarts, Troy, Ohio.

PAINT your own car for \$4. Use next day. Any color. Instructions free. Gill Company, Grand Rapids, Wisconsin.

TIRES—Send for our price list of fine guaranteed tires. American Tire Co., Oelwein, Iowa.

BARGAINS—Ignition Coils, Repair Parts and Supplies. Guaranteed Coils \$3.50 up. Smythe Ignition Co., 1453 Laurel Ave., St. Louis, Mo.

MAGNETOS—Boech, all sizes and types, \$10.00 up. Remy and Spaldorf \$3.50. Coils—Steering Wheels—Auto accessories all kinds. Write for list. Johnston, West End, Pittsburgh, Pa.

BESCOHOL—New substitute for Alcohol in Radiators. Good for 20 Below Zero. Write for territory and particulars. Sample, 25 Cents. Beardsley Specialty Laboratories, Rock Island, Ill.

BEST Valve Tool on the market. Sent Post Paid \$1.65. Write for circular. L. C. Ryan & Sons, Pacific Grove, Calif.

AUTOMOBILE Repairing Made Easy—The most needed and useful book on automobiles ever written. Only book of its kind—just out. Covers every phase of automobile repairing practice. 1,056 pages (5½x8 in.), 1,900 engravings. Cloth. Price \$3.40 postpaid. Send for complete description of this and other reliable automobile books. Popular Mechanics Book Dept., 6 N. Michigan Ave., Chicago.

OFFICIAL Auto Wiring Guide—Just Out. The most valuable book ever offered to the automobile world. Contains 430 pages; 448 of which are guaranteed accurate blueprint diagrams showing complete wiring circuits of all makes of gas and gas-electric cars, dating back as far as 1912. Miscellaneous wiring diagrams covering all starting and lighting systems are shown as well as diagrams for re-wiring cars, both grounded and multiple systems. Price \$7.50 prepaid. Send for 8-page descriptive circular. Popular Mechanics Book Dept., 6 N. Michigan Ave., Chicago.

JUST Out—Modern Starting, Lighting and Ignition Systems—A new book on automobile electricity without an equal. Nearly 400 Pages. 250 Engravings. Cloth. Price \$1.50 postpaid. Complete description sent on request. Popular Mechanics Book Dept., 6 N. Michigan Ave., Chicago.

A JOKE on the Spark Plug. Pronto Spark Gaps, patented, will fire any Plug, any condition. Our wonderful new combination Plug and Gap, now ready. Convincing demonstration. Everybody welcome, write us. Pronto Manufacturing Co., Omaha, Nebraska.

AUTO Motors—4-cylinder, water-cooled, \$35.00 up. Buick 10-24-30 and 17, Mitchell-Everett 30—Hup 20—Flanders 20—Continental and Buda motors all sizes. Johnston, West End, Pittsburgh, Pa.

TIRES—At Wholesale; send at once for our price list of first quality guaranteed tires and tubes. We ship C. O. D. subject to examination without one cent deposit. Overton Tire Co., Box 5, Oelwein, Ia.

AUTO Top Roof Covers Save you two-thirds price of new top; tailored to fit any car; easy to apply; \$6 to \$15, prepaid post paid; seat covers \$5 and up; catalog and samples free. S. & H. Top Co., 439 Hunt St., Cincinnati, O.

TO FORD OWNERS

MODERNIZE Your Ford. The Famous Lawson V-shaped hood and hood fits all models. Price, \$17.50. Ospeco slanted hub-caps, \$5.75 per set of 4. Ospeco ventilating windshield—parts complete, \$5. Write for circular. Ospeco Mfg. Co., Inc., Ford Bldg., Detroit, Mich.

BE our agent. Buy a Safety Ford Starter for \$5.00. Retail for \$15.00. Try one, write for particulars. Safety Ford Starter Corporation, Columbia Theater Bldg., New York.

PEUGEOT Type Ford Speedster life-size patterns, blue prints, instructions, \$5. Photographs 10c. Peugeot Type Ford Speedster Pattern Co., Omaha, Ill.

FORD car owners wanted in every county, to demonstrate my Ford Truck Unit, \$50 to \$100 weekly. Write for territory to Fred E. Lane, Keene, N. H.

SUNLIGHT System. Headlight switch fits in place of regular switch. Bright light, controller, dimmer \$1. Sunlight System, Dept. Y, 1503-10 Lytton Bldg., Chicago.

L-H FORD Gasifier: \$3.50. Distributors Wanted. No bonuses. Lincoln Holland, Los Angeles.

"WINTER Starter" heats manifold, gives warm starting mixture, \$1.85. Fifteen days' trial. F. Whitmore, Gilman, Montana.

SLEEP in your Ford in McMillin Auto Bed, \$8.50. Other small cars \$10. Free booklet on auto camping. Auto Bed Company, Box O, Bellingham, Wash.

SPLENDID up-to-date Roadster or Speed Bodies for Ford. Exceptional bargain. J. C. Edwards, Box 216, Aurora, Ill.

FORD Tops \$17.00 to \$24.00. Seat Covers \$4.30. Top Coverings \$5.50. Commercial Bodies \$11.40. Radiator Covers \$1.80. Write for prices. B. & S. Co., Station V., Cincinnati, Ohio.

FORD Top Roof Cover \$6 and up. Easy to apply. You save two-thirds price of new top. Seat covers \$5 and up. Samples and catalog free. S. & H. Top Co., 429 Hunt St., Cincinnati, O.

FORD ACCESSORIES

NEW 300-page book on the Ford car for every Ford owner, dealer and repairman. Deals fully with construction, operation and repair. 103 engravings. Best and most complete Ford book published. Price, \$1.00 postpaid. Also Ford Engine Chart, 25x58 in. Location of engine troubles made easy. Price, 25 cents postpaid. Popular Mechanics Book Dept., 6 N. Michigan Ave., Chicago.

MOTORCYCLES, BICYCLES & SUPPLIES

FORCED Sale! 300 Motorcycles sacrificed. Heavily overstocked. 1917 Harley-Davidson Three Speed, \$105.00; Powerplus Indian, \$85.00; 1917 Excelsior, \$60.00; Four Horsepower Excelsior, \$20.00. Hundreds of big bargains. Write for list. Tires, Accessories, Motors, Frames, at half price. What do you need? Clip this ad. It is worth \$3.00 on any machine. W. E. Wandersee Company, 1561 Woodward Ave. Branch, 129 Grand Ave., Detroit, Michigan.

LARGE stock of rebuilt motorcycles, new parts for all makes 25% discount; second-hand parts, good as new, 50% discount. Motorcycle Paris Mfg. Co., Chicago.

DON'T buy a Bicycle Motor Attachment until you get our catalogue and prices. Shaw Mfg. Co., Dept. 27, Galesburg, Kans.

BICYCLES \$7.50 up. Fine tandems \$15. Circular free. McDougald, 309 North Fifth Ave., Chicago.

HARLEY-DAVIDSON Twin Motorcycle—clutch, magneto, engine; overhauled. Price \$50. Clayton Williams, Reed, Ky.

MOTORCYCLES \$25 Up—25% to 50% lower than you can buy anywhere. Splendid new list, 100 bargains to select from. All makes. Write today, get your copy free. Western Supplies Co., 259 Hayutin Bldg., Denver, Colo.

END-SEASON bargains in used motorcycles. Now is the time to buy a slightly used motorcycle. Our stock consists of over 75 motorcycles of all makes, perfect condition, included are the well known Indians, Harley Davidsons, Excelsiors, Hendersons, etc. 1916 and 1917 models, prices \$35 up. If you want a real bargain in a good machine send today for our bulletin No. 6 describing in detail all machines we have, with prices. Gotham Sporting Goods Company, 57 Warren St., New York City.

WANTED: We pay cash for used motorcycles or take them in on exchange for new machines. Write with complete description, State condition of tires, frame, motor, make and model. Shaw Manufacturing Co., Dept. 137, Galesburg, Kans.

MOTORCYCLE Owners. Our No. 100 Catalog now ready. Contains all accessories and hundreds of parts at big saving to you. World Cycle Company, 47 Gateway Station, Kansas City, Mo.

EASY Terms on new and rebuilt motorcycles, side cars, tandems, and lighting outfit. Motorcycle Investment Co., Brockton, Mass.

INVENT something. Your ideas may bring wealth. Free book tells what to invent and how to obtain a patent through our credit system. Talbot & Parker, 4638 Talbot Building, Washington, D. C.

FOR Sale—1917 Four-Cylinder Henderson Motorcycle. Guaranteed first-class condition. Headlight, Tandem, \$245. Ross Fox, Shady Grove, Ky.

OVERSTOCKED—100 Used Motorcycles, all makes, must be sold at once. Write for our latest catalog. Myerow Bros, 149 Berkeley St., Boston, Mass.

1917 EAGLE Motorcycles now ready. Get circular M-12 and agency proposition. Eagle Motorcycle Company, Brockton, Mass.

HUNDRED Motorcycles \$40—\$175; Autos \$75 up. Agents Wanted. Knights, 3323 Locust, St. Louis, Mo.

MOTORCYCLE cylinders reground, fitted with new piston and rings, \$5.00, guaranteed. Muncie Piston Co., Muncie, Ind.

I SAVE you half on parts and accessories for all makes. Jones, "The Paris Man," Box 691, Brockton, Mass.

GET your Motorcycle or Bicycle at your price. Motorcycles \$25.00 up. Bicycles \$5.00 up (Guaranteed). Parts for all motorcycles and bicycles carried in stock; repairing. Send for big Bargain Bulletin. American Motorcycle Co., Chicago.

MOTORCYCLES, Side Cars and Cycle-cars. Their Construction, Management and Repair—The only complete work published on this subject. The dealer, mechanic and rider will find this an excellent treatise. 550 pages, cloth, 350 illus. Price, \$1.50 postpaid. Complete description sent upon request. Popular Mechanics Book Dept., 6 N. Michigan Ave., Chicago.

MOTORCYCLES, all makes, Harley-Davidsons, Indians, Excelsiors, Thors, Reading Standards, Flying Merks, Cleveland Lightweights, all prices. Write for descriptive catalogue 8-B with pictures. Carl W. Bush Co., 518 Broad Street, Newark, New Jersey.

BIG bargains in second-hand motorcycles, \$35 up. Indians, Harleys, Thors, Excelsiors and Merks. Write for description. Howard A. French & Co., Baltimore, Md.

BIG bargains in good motorcycles we have taken in exchange on new ones. Send for special bargain list. Shaw Mfg. Co., Galesburg, Kansas.

BARGAINS in used motorcycles—all machines guaranteed and in A-1 condition ready for use. Write for terms and new bulletin. Photos free. Harley-Davidson Sales Company, Birmingham, Alabama.

SHORT-coupled Harley Racer. Like new. \$75. Box 1689, Atlanta.

TWIN Indian, \$60.00. Good condition. Photo furnished. Rubel, Mobile, Ala.

WELDING

WELDING Plants \$25.00 to \$300.00. Designed for all purposes, small cash payment, balance three to six months. Every mechanic or shop should have one. Bernco Co., Omaha, U. S. A.

DON'T Scrap Aluminum Parts. Save them with So-Lumium. New welding solder for aluminum. So-Lumium is a perfect substitute for acetylene welding—4 time and cost—no flux—use gasoline or blowtorch or soldering iron. Sample bar and directions \$1.00, \$3.00 per lb. Booklet 12. Lo-Lumium Manufacturing Co., 1790 Broadway, New York, U. S. A.

WELDING—Automobile Welding with the Oxy-Acetylene Flame—Just Out—167 pages, fully illustrated. Price, \$1.00 postpaid. Explains the actual welding of all automobile parts in a manner understandable by everyone. Popular Mechanics Book Dept., 6 N. Michigan Ave., Chicago.

OXY-ACETYLENE Welding and Cutting. Electric and Thermit Welding. Brand new book of practical instruction in this process. The workman will find all necessary information for handling any kind of welding. 215 pages, fully illus. Cloth, \$1.00; Leather, \$1.50 postpaid. Popular Mechanics Book Dept., 6 N. Michigan Ave., Chicago.

SIMPLE Soldering, both hard and soft—82-page book telling how to join metals. Do your own repairing. 52 illustrations. 25c postpaid. Popular Mechanics Book Dept., 6 N. Michigan Ave., Chicago.

AERONAUTICS

MEN or Women wanting to learn Aviation—Government or exhibition—write Moler Aviation School, Inc., 195 S. 5th Ave., Chicago. Winter field, Jacksonville, Fla.

BE an Airplane Engineer. Enormous demand for trained men. \$2,000.00 to \$10,000.00 a year. Famous Aviator and Engineer will train you personally in airplane factory. Extraordinary opportunity offered first-comers only to finish tuition payments when earning \$10.00 day. Bud Morris Airplane & Motor School, 2848 B. Broadway, Chicago.

FRENCH Aeroplane Co. Manufacturers of Aeroplanes, Aeronautical and Model Aeroplane Supplies. 908 Wells St., Chicago, Ill.

AVIATION Dictionary, \$1; cloth \$1.50. Languages, 143 West 47th, New York.

AEROPLANE mechanics wanted; thousands needed right now. Will give thorough, practical training course on modern machines for \$110. No book study, actual work only. U. S. Aero, 38 Park Row, N. Y. C.

AEROPLANE accessories, propellers, fittings, etc. Dependable parts at the right prices. Illustrated catalog eight cents postpaid. Chicago Aeronautical Supply Co., Chicago.

AVIATION Motors, all makes, up to 150 H.P., \$250 up. Complete aeroplanes, all types, \$500 up. State your needs. Aero Exchange, 38 Park Row, N. Y. C.

LET Heath supply your aeronautical needs. Your small or large order will receive the same attention and quality we give to government. Heath Aeroplane Co., 2046 Broadway, Chicago.

BUILDING and Flying an Aeroplane—160-page handbook covering the building of small models and full-sized gliders and machines. In both biplane and monoplane models the well-known Curtiss and Bleriot types are followed. Fully illustrated with detail drawings. Price, \$1 postpaid. Popular Mechanics Book Dept., 6 N. Michigan Ave., Chicago.

MODEL Aeroplanes, material and supplies. Compressed Air Motors. Practical course in Aeroplane construction. Send 5c for catalogue. Wading River Mfg. Co., 550 Mason St., Brooklyn.

BUILDING and Flying an Aeroplane—160-page handbook covering the building of small models and full-sized gliders and machines. In both biplane and monoplane models the well-known Curtiss and Bleriot types are followed. Fully illustrated with detail drawings. Price, \$1 postpaid. Popular Mechanics Book Dept., 6 N. Michigan Ave., Chicago.

BI-PLANE Glider, full size, how to make—Our book "Amateur Mechanics No. 2" contains a complete detailed description of how to make one and also over a hundred other interesting articles. Price, 25c postpaid. Popular Mechanics Book Dept., 6 N. Michigan Ave., Chicago.

HEATH propellers for land and water produced by America's oldest aeroplane factory. Let us supply the right propeller and you will travel efficiently. Heath Aeroplane Co., 2856 Broadway, Chicago.

PATENTS Wanted in Aeronautics—U. S. Government spending millions in this class for Army and Navy. Our Aeronautics Department will give full information on this subject upon inquiry. Write for "What to Invent," sent free. Victor J. Evans & Co., 169 Ninth, Washington, D. C.

AVIATION Motors, all makes, up to 150 H.P., \$250 up. Complete aeroplanes, all types, \$500 up. State your needs. Aero Exchange, 38 Park Row, N. Y. C.

BOOKS AND PERIODICALS

HENDRICKS' Commercial Register for Buyers and Sellers. The twenty-sixth annual edition of Hendricks' Commercial Register of the United States for Buyers and Sellers has just been published. This standard publication is especially devoted to the interests of the architectural, engineering, contracting, electrical, hardware, iron, mechanical, mill, mining, quarrying, railroad, steel and kindred industries. Full lists are included of producers, manufacturers, dealers and consumers, listing all products, from the raw material to the finished article, together with the concerns handling these products. From the producer to the consumer. There are 2269 pages of text matter and the index to trade classifications numbers 151 pages, covering over 50,000 trade references. The list of trade names, brands, titles of identification, etc., numbering 1212 pages, furnishes ready reference to distinctive products manufactured by concerns listed in the work. The alphabetical section is included for the first time and contains in one alphabetical list the name, trade description and address of every concern appearing in the book. S. E. Hendricks Company, Inc., 2 W. 13th St., New York City. Price \$10.00.

FIND Out for Yourself what to invent and how to procure and sell a patent for the same. My book, "Inventor's Universal Educator," covers the matter from A to Z. 140 pages, elegantly bound. Also contains 600 mechanical movements and 50 perpetual motions. Price \$1.00, postage free. F. G. Dieterich, 651 Ouray Bldg., Washington, D. C.

MAGAZINES at rock bottom prices. Send today for our free catalog "P." S. C. Hanson Magazine Agency, 4929 Kinzie, Chicago.

100,000 SECOND-Hand books for sale, 25c each; costly bindings; some cost \$25.00 new; Medicine, Surgery, Agriculture; Mechanical; chemistry, philosophy, encyclopedias, law; scientific; technical; mathematics; history; fiction; religious; text; school, etc. Send 10c stamps for big catalogues (none free). McCarthy, 219 South Dearborn St., Chicago, Ill.

"GENEVIEVE de Brabant," most sensational novel ever written, \$1.00. "Semam," the spirit voice of the mysterious Hindoo mystic, 25c. Sovereign Pub. Co., 160 Spcamore, Buffalo, N. Y.

BOOKS—Novelists! Catalogue So. Vim Co., Box 108-M, East St. Louis, Illinois.

WORLD-ROMIC Languages — Masterkey, 56c. Languages, 143 West 47th, New York.

BINDER for Popular Mechanics magazines. Best adjustable magazine binder on the market made especially to hold any number from one to six copies of this magazine with name "Popular Mechanics" in gold letters on front cover. No laces or cutting or perforating of pages necessary. Simple, unique adjustment; handsome, durable and neat. We buy in quantities and can offer our readers this regular \$1.50 binder for \$1.25, all shipping charges prepaid. Address Popular Mechanics Book Dept., 6 N. Michigan Avenue, Chicago.

WANTED — International Correspondence School Books. McCarthy, 219 So. Dearborn, Chicago.

ENGINEERS' questions and answers for license by Hobson, for twenty-five cents, postpaid. Send stamps. Betty's Book Store, Philadelphia, Pa.

USED Books, Bargains. Catalog. Higgins's, A-2441 Post, San Francisco. (Books Bought.)

U. S. ARMY Infantry Drill Regulations, 58 cents. Field Service Regulations, 80 cents. Cavalry Drill Manual, 80 cents. Small Arms Firing Manual, 80 cents, cloth, postpaid. Also send for complete list of over fifty standard military and naval books. Popular Mechanics Book Dept., 6 N. Michigan Ave., Chicago.

NEW 1917 Catalog of Latest and Best Books on Mechanical, Electrical and Industrial Subjects, comprising 128 pages and adequately describing more than 400 works. Sent free upon request by Popular Mechanics Book Dept., 6 N. Michigan Ave., Chicago.

EDUCATIONAL AND INSTRUCTION

SHORTHAND—Uncle Sam and business houses need thousands of stenographers at once. Learn Gregg at home. Special war rates. Write for catalog. Fairfield School of Shorthand, 190 Davis Bldg., Fairton, New Jersey.

ELECTRICAL instruction given by practical engineer. Learn this wonderful profession at home by practical instruction. By my improved method of learning you can become a Certified Electrician in a few months. Satisfaction guaranteed. Electrical outfit of instruments, tools and materials furnished free to each student. Earn money while learning. Write me for Electrical book and full particulars. Everything free if you answer now. Chief Engineer, Chicago Engineering Works, 437 Cass St., Chicago.

BE a Finger Print Expert—\$25 to \$50 a week in this new and fascinating profession. Write—find out how you can learn at home to supply the big demand for finger print experts in banks, big factories, detective agencies, etc. Special limited offer—write while it lasts. Evans University, Finger Print Dept., Room 1189, 1772 Wilson Ave., Chicago, Ill.

A RAPID Handwriting easily learned in spare time. For particulars write Courtney's Writing School, Box A, 492 Detroit, Mich.

ARITHMETIC Master key to short rules; 25c brings you 32-page book. Shultz, 1920 Arch St., Phila., Pa.

DRAFTING — Increase your earnings. Private lessons Architectural and Mechanical drawing. Write C. W. A., Box 403, Des Moines, Iowa.

COMPLETE "Memory Course," 20c. "Photoplay," 30c. Barry, 2409 Pac., Atlantic, N. J.

LEARN at home: Bookkeeping, Salesmanship, Civil Service, Shorthand and Typewriting. Earn \$20.00 to \$50.00 a week. Mention courses that interest you most, and ask for Free Home Study Book. Brown's Home Study School, 809 Brown Building, Peoria, Illinois.

ARTIFICIAL Marble, sanitary flooring, complete instructions, \$1. Ornamental casting, concrete, plaster, papiermache, decorations, garden furniture, statuary, rubber moulds, electrometallurgy. Particulars, 200 Illustrations free. Mahler, D-721 Woodland Ave., Woodhaven, L. I., New York.

FREE Tuition by Mail; Normal Grammar School, High School, Bookkeeping, Shorthand, Typewriting, Civil Service, Agricultural, Drawing, Domestic Science, Engineering, Automobile, Salesmanship, Law and Real Estate Courses thoroughly taught by mail. Membership Fee, \$10.00; tuition free. For "Free Tuition Plan," address, Carnegie College, Rogers, Ohio.

BOOK-KEEPING, Expert Auditing, Rapid Arithmetic, Garfield Commercial School, 1916 Germantown Ave., Philadelphia.

FINGER Print Instructor—A text book for the guidance of finger print experts and an instructor for persons interested in the study of finger prints. Book based on the Henry System and prepared by an expert. Cloth, 155 pages, illustrated. Price, \$2.00 postpaid. Popular Mechanics Book Dept., 6 N. Michigan Ave., Chicago.

STENOGRAPHY or P. o. k. e. e. p. i. n. g. 25c. Self-instructive Books, 100 different subjects. Marr, B285, Nashville, Tenn.

FRENCH Pronunciation—Masterkey, 37c. Spanish, 37c. Languages, 143 West 47th, New York.

NEW Invention, Writing Device, improves penmanship immediately. Sample \$1.50. Use it before buying. Particulars, Francis Company, 635 North Clark, Chicago.

IDEAL Atlas—Just Published—Contains large scale maps, yet is a book of handy size. Has special maps of all war zones in addition to all regular maps found in a good atlas. Is self-revising, that is, contains a certificate entitling the purchaser to a supplement of new maps after the war is over. Genuine flexible leather binding. 512 pages, 256 pages of maps, 254 pages of text. Price, \$2.50. Cloth binding \$1.65 postpaid. Popular Mechanics Book Dept., 6 N. Michigan Ave., Chicago.

ROPP'S Calculator and Short-Cut Arithmetic—Shows the answer as quickly as a watch shows the time to all problems likely to occur in office, store, shop, bank, farm or factory. Over two million sold. Price, vest pocket size, 50 cents; leather, pocket size, \$1.00; large, desk size, \$1.25 postpaid. Complete description sent upon request. Popular Mechanics Book Dept., 6 N. Michigan Ave., Chicago.

REPORTS; Just what I've been looking for, getting along fine, wonderful success, send six more medals. Ask Mr. Spahr about Photography and Pres. Wilson Medallions. F. B. Spahr, York, Pa.

WANTED—New Ideas. Write for list of Patent Buyers and Inventions Wanted. \$1,000,000 in prizes offered for inventions. Our Four Books sent free upon request. Victor J. Evans & Co., 167 Ninth, Washington, D. C.

MOULD making for ornamental casting, particulars, 200 illustrations, free. Mahler, Woodhaven, N. Y.

ARMATURE Rewinding—Learn at home easily by our plain simple course for Automobile Electric Starting Motor and Generator Armatures. We furnish working model, etc. Good armature winders earn big pay. Free literature. S-A Electric Works, 1906 Emmet St., Omaha, Nebraska.

TRADE SCHOOLS

LIBERTY Bonds Accepted as payment. Learn now. Sign painting, showcard writing, paper hanging, graining, decorating. Catalogue 5 free. Chicago Painting School, 131 No. 5th Ave., Chicago.

ELECTRICITY, Plumbing, Bricklaying, Mechanical, Architectural and other Drafting Courses. Motion Picture Operating taught by practical work. Largest, best equipped practical trade school in America. Short time to learn. Small cost, easy payments. Write for big illustrated book; it's free. Coyne Trade and Engineering Schools, Dept. 1899, Chicago, Ill.

HILE'S Watchmaking and Engraving School, the largest and best equipped school in the West, 717 Market Street, San Francisco, Cal.

TELEGRAPHY

CORRESPONDENT Course in telegraphy; instruments free. (Wireless and station). \$35. Maynard Blaine, Barre, Vermont.

TELEGRAPHIC—both Morse and Wireless, also Station Agency, taught quickly. Tremendous demand—much greater than supply—permanent positions secured. Big salaries—recently raised. Ideal working conditions—short hours, vacations with pay, sick and death benefits etc., prevailing. Great opportunities for advancement. Women operators also greatly desired by Railway and Western Union. Tuition reasonable. Cheap living expenses—can be earned. Oldest and largest school—established 43 years. Endorsed by railway, Western Union, and Marconi Telegraph officials. Large illustrated catalogues free. Correspondence courses also. Write today. Enroll immediately. Dodge's Institute, 15th St., Valparaiso, Indiana.

TELEGRAPHY — Morse and Wireless — taught at home in half usual time and at trifling cost. Omnigraph Automatic Transmitter will send, on Sounder or Buzzer, unlimited messages, any speed, just as expert operator would. Adopted by U. S. Govt. and used by leading Universities, Colleges, Technical and Telegraph Schools throughout U. S. Catalog free. Omnigraph Mfg. Co., 41-G Cortlandt St., New York.

THE Telegraph Instructor — Sixth and Revised Edition, just from the press—containing 348 pages of valuable information pertaining to railway and commercial telegraphy. Many illustrations showing how to erect a line, the different telegraph instruments, switch-boards and their different connections; numerous colored illustrations of train movements and semaphore signals as used by all railroads. Complete in every detail and written in language easily understood. Used by many telegraph schools as a text book. No student of telegraphy or telegraph operator can afford to be without this book. Price \$1.25 postage prepaid. Money returned if it doesn't please. Popular Mechanics Book Dept., 6 N. Michigan Ave., Chicago.

PICTURES, POSTCARDS, PENNANTS

NATIONAL Post-Card Exchange covers the World, membership 15c. Wallace, Box 535-P, Erie, Penna.

VIEWS of European Cities 10c each. Rizzo, 1189 Mack, Detroit, Mich.

SAMPLES high grade Cards; Club membership 10c. Six months 25c. Jolly Card Exchange, Decatur, Indiana.

MOVIE Star Postcards; 25 different and novelty catalogue 25c postpaid. Charles Crane, Racine, Wisconsin.

WOULD you like to exchange postcards; stamps, coins (state which) with some of our 17,500 members in many countries? Membership 15c. Halegon, Box 183-P, Erie, Pa.

CROSS-SECTIONAL view of ocean liner "Britannic," showing interior arrangement of ship in colors, size, 14x20 inches, on heavy plate paper for framing or hanging; Very interesting. Reproduced from front cover design of July, 1914, Popular Mechanics. Will be sent postpaid to any address in the world on receipt of 4 cents in stamps to cover packing and mailing; Popular Mechanics Magazine, 6 N. Michigan Ave., Chicago.

PRETTY view cards from everywhere. Membership and 6 pretty cards, 10c Riverside Club, Knoxville, Md.

OPTICAL SUPPLIES

WE duplicate broken lenses accurately. E. Pfeiffer, 549 No. Robey St., Chicago.

CAMERAS AND PHOTO SUPPLIES

FILMS Developed, 10c. All Sizes—Prints 2 1/4x3 1/4, 3 1/4x4 1/4, 4c. We give Profit-Sharing Coupons. Work guaranteed. Send negatives for samples. Girard's Comm. Photo Shop, Holyoke, Mass.

ENLARGED photos, 8x10, from films, 25c. Order yours now. Goldman, Photographer, Cleveland, O.

FILMS Developed 10c roll. Six prints free. Ask for descriptive booklet. Roanoke Photo Finishing Company, 209 Bell Avenue, Roanoke, Virginia.

FILMS developed 10c; prints, 3c to 5c. A reputable incorporated company conducting largest existing plant. Price list and special offer. Enlargements our specialty. Chicago Photo Finishing Co., 54 W. Lake St., Dept. A, Chicago.

BIG Money Saved on Photographic Lenses and Apparatus—goods exchanged; repairing done. Ralph J. Golsen, 5123 Kenmore Ave., Chicago, Department F.

INVENTIONS Wanted in Motion Pictures and Photography. Special department for these classes of invention. Advice, What to Invent and List of Patent Buyers Sent Free. Victor J. Evans & Co., 139 Ninth, Washington, D. C.

SPECIAL—10% discount on all Eastman Kodaks, Graflex, Cameras brand new, latest type. Every outfit sent prepaid right to your home, amounting to \$3.00 or over. Send at once for our complete catalog and Bargain Book, the most complete in America listing everything worth while in Cameras, Kodaks, Lenses and supplies of every description. All we ask of you is to compare our prices with others and we know you will be convinced that we offer real bargains. "A few slightly used Bargains"—\$6 Eastman Vest Pocket Autographic Kodak \$3.50; 3 $\frac{1}{4}$ x4 $\frac{1}{4}$ Autographic Kodak, Zeiss Tessar 2B f:8.3 Anastigmat Lens, Volute Shutter \$49.50; 2 $\frac{1}{4}$ x4 $\frac{1}{4}$ IA Autographic Kodak Junior R R Lens \$9.50; No. 6 Circuit Camera, Turner-Heich Lens, \$129.50; 4x5 Auto Graflex Camera, 1c Tessar f:4.5 Lens \$66.50; 2 $\frac{1}{4}$ x3 $\frac{1}{2}$ Goerz Coat Pocket Tenax Camera, Dagor f:6.8 Lens, six holders, one adapter \$65.50; No. 3 Eastman Folding Pocket Kodak \$11.25; IA Folding Brownie Camera \$4.25. Every item guaranteed. Money back if unsatisfactory after ten days' free trial. Central Camera Co., 124 So. Wabash Av., Dept. E-7, Chicago, Ill.

OUR 1918 Camera Catalog contains many wonderful bargains in cameras and supplies. Every article guaranteed and backed by 19 days' Free Trial. All standard makes—new, right from the factory, and slightly used cameras, at a saving of 10% to 50%. Write for the catalog and save money. No. 2 V-P Ansco, f:7.5 Anastigmat lens, extra speed Bionic shutter, \$15.00. New V-P Seneca, Universal Focus, \$5.95. New Autographic V-P Kodak, \$5.30. Slightly used Jearett Model A-P 6.8 lens, compound shutter, \$23.00. 5x7 New Improved Seneca View, \$17.50. 2 $\frac{1}{4}$ x3 $\frac{1}{2}$ Eastman Folding Cartridge Promo Meniscus, Achromatic lens, \$3.75. Get your copy now and save money. See our display advertisement on page facing third cover. David Stern Company, "Everything in Cameras." In business since 1885. 1218 Davesco Bldg., 1627 Madison St., Chicago.

CAMERA Money buys most here. Make us prove it. Send for Bass book of 1,001 camera bargains showing America's biggest 1,400 Photographic values. Everything required in the taking and making of good pictures—standard, reliable goods made by Eastman, Ansco, Rexo, Bausch-Lomb, Wollensak, Goerz, Universal motion-picture cameras. 10 days' free trial on everything and everything guaranteed. It will pay every camera buyer to write today. Bass Camera Co., Dept. 59, 169 Dearborn St., Chicago.

PRINTS and postcards 2 $\frac{1}{2}$ c; 8x10 enlargements 25c; 5, \$1.00. Guaranteed. Emil Spranger, Hamilton, Ohio.

FILMS Developed, 13c, all sizes. Prints 2 $\frac{1}{2}$ x3 $\frac{1}{2}$, 5c; 3 $\frac{1}{4}$ x4 $\frac{1}{4}$, 4c. We give you Profit Sharing Coupons, 24-hour service, all work guaranteed. Send negatives for samples. Girardi's Com'l Photo Shop, Holyoke, Mass.

SEND for free booklet containing Price list of Kodak Finishing. Enlarging and hand coloring; also how to get Photographic Magazine one year free. Camera Shop, Box 69, Ann Arbor, Michigan.

\$100.00 TO \$1,000.00 yearly; sell your exhausted solutions. Mr. Photographer, Profits absolutely sure. Artistic Finishers, 959A Lockwood, Chicago.

MOTION PICTURES

\$75.00 BUYS complete Moving Picture Machine, Film and Outfit. Write for particulars. Feature Film Exchange, 228 Union Ave., Memphis, Tenn., Dept. P.

ELECTRIC Arc Generator halves expense. Your engine operates. Easy terms. Hobart, Troy, Ohio.

MOTION Picture Operation, Stage Electrics and Illusions—The only practical handbook and guide published for motion picture operators, theater electricians and managers. A thoroughly practical and useful book, covering the subject comprehensively. Pocket size, leather. 393 pages, fully illustrated. Price, \$2.00 postpaid. Popular Mechanics Book Dept., 6 N. Michigan Ave., Chicago.

MAKE a complete Motion Picture Camera and Projector from instructions given in our book Amateur Mechanics No. 4. Full details given. Not hard to construct. Words of enjoyment taking and exhibiting subjects dear to the heart. Price of book only 25c, postpaid. Popular Mechanics Book Dept., 6 N. Michigan Ave., Chicago.

MAKE money writing Photo-plays; details free to beginners. No correspondence course. Producers League, 239 Wainwright, St. Louis.

BIG Profit Nightly—Moving Picture Business—small capital starts you, easily accomplished. Teach you—furnish everything. Ralph J. Golsen, 5123 Kenmore Ave., Chicago, Dept. M.

BUSINESS OPPORTUNITIES

DO you want to know about conditions in any trade or business? Do you want to know how war will affect your trade or situation? Do you want to know about any college or method of obtaining an education? Have you questions to ask regarding scientific business or commercial problems? Ask us—Our experts know. Kent System, Dept. 4, Cambridge, Mass.

PATENTABLE Ideas Wanted—Send for 4 free books. R. B. Owen, 30 Owen Bldg., Washington, D. C.

PATENTS for Sale, covering inventions of merit which can be manufactured with a moderate outlay. State manufacturing line interested in. Particulars free. Trade-marks registered. Lancaster & Alwine, Washington, D. C.

"BOOKS for Inventors" free. Patents sold and for sale. Patent News, Washington, D. C.

HAVE a business of your own; manufacture name plates, numbers, etc.; big illustrated book sent free. E. E. Palmer, Wooster, Ohio.

PRINT pencils and advertising novelties; we teach you how to make the press; costs only about 20c; has been in use by us for 25 years. L. Box 615, Wellsburg, W. Va.

SUGAR Puff Waffle Parlor. This new and alluring business earns steady, handsome income every month in cities and towns. We furnish everything. No skill or experience, and only small capital needed. Talbot Mfg. Co., St. Louis, Mo.

I START Men Manufacturing important household articles. Big demand. Only small capital needed. Profits 250% to 300%. Free book tells all. Write Protecto Co., 5014 Dorchester Ave., Dept. 112, Chicago, Ill.

LEARN the real estate business; our enlarged instruction book teaches listing, appraising, management, salesmanship, insurance, brokerage, advertising, renting, agency, estates, titles, rights, forms, etc.; revised edition; 240 indexed subjects; excels \$25 correspondence course; buckeye cover, \$1; silk cloth, \$1.25, postpaid. Realty Book Co., Dept. No. 29, Cleveland, Ohio.

3,380 FORMULAS, Trade-secrets, etc., in "Encyclopedia Business Opportunities," 3 Volumes. Worth \$3. Special offer \$1. 500 Formulas including resilvering mirrors—renewing dry batteries—luminous paint—25c. "The Ideal," Box 543-BL, Chicago.

SILVERING Mirrors! My exclusive French Tartaric method opens enormously profitable business. Booklet Free. H. Barstow, 514 23rd Street, Oakland, Calif.

GOOD Monthly Income Easy in Spare Time, manufacturing letters for signs. Free particulars. J. F. McPherson, 677 Brown Ave., Butler, Pa.

ADVERTISERS, Mail Dealers. Our New Rate Book lists 2,000 Principal Publications, rates, circulation. Includes 30 Mail-Order Plans. Free. Dearborn Advertising Agency, 310 Franklin Bldg., Chicago.

MONTHLY income paid those writing lists of names for us at home, spare time; no supplies to purchase; no investment, expense or other work required; postal brings particulars. National Exchange, Box 1401, New York.

WHY work for others? Earn big money; open your office at home; learn the Real Estate, Insurance, and business brokerage from successful brokers. No capital required. Representatives male and female wanted. Booklet free. Hayes Realty Association, 235 W. Fourth St., Cincinnati, Ohio.

BB Business Broker; Earn big income; little capital needed. Details free. Eydman System, 1327 Chemical Bldg., St. Louis.

MANUFACTURE "Gas-Inc." Saves one-third of the gasoline. Every motorist your customer; big profits; easy work; formula and instructions \$1. Particulars, stamp. Hile Company, Carey, Ohio.

WE Analyze everything. Guaranteed formulas furnished by experts. No lists. Laboratories, 332 South St., Jamaica, New York.

CONDUCT a profitable Candy Kitchen; very small capital required; booklet free. Kenyon School, 569 Wells St., Dept. A, Chicago.

WE will start you in the cleaning and dyeing business, little capital needed, big profits. Write for booklet. Ben-Voede System, Dept. C., Charlotte, N. C.

RAISE Valuable Goldenseal for Us. Plants; Cash Buyers; Directions; Furnished. Wooten, Morristown, Tenn.

GET into business, operate non-commission Real Estate Agency, Capital and Experience unnecessary. Write, Non-Commission Agency, Lima, Ohio.

WILL Buy Patented or Patentable Ideas on a practical device for army, home, office or store use; for example machine that will correctly measure and calculate cloth sales. O. Whaley, 704 Boyce Bldg., Chicago, Ill.

SLOT Machines—Headquarters for premium machines. 1016 Germantown Ave., Philadelphia.

MAKE Sell Carbo-Cide—Efficient, Reliable Automobile Gasoline Intensifier. Increases Mileage, Eliminates Carbon, Results Guaranteed. 800% Profit—Unlimited demand everywhere. Formula for Tablet and Liquid Form. Exclusive territory. Latest Formula Lists and Valuable Information, Stamp. Miller, Ph. D., Tampa, Fla.

INVENT Something. Your Ideas may bring wealth. Free book tells what to invent and how to obtain a patent through our credit system. Talbert & Parker, 4671 Talbert Bldg., Washington, D. C.

ANYBODY can make \$3 a day at home, spare time, growing mushrooms in cellars, sheds, barns, boxes. Success guaranteed. Free illustrated booklet. Hiram Barton, 324 West 45th, New York.

WE start you in business furnishing everything; men and women make handsome income weekly operating our "New System Specialty Candy Factories" home or small room anywhere; no crossing. Opportunity lifetime; booklet free. W. Ragdale Co., East Orange, N. J.

ENTER a new business. Earn \$3,000 to \$6,000 yearly in professional fees—making and fitting a foot specialty, openings everywhere, with all the trade you can attend to; easily learned by anyone at home in a few weeks, at small expense; no further capital required, no goods to buy, job hunting, soliciting or agency. Address Stephenson Laboratory, 11 Back Bay, Boston, Mass.

MANUFACTURERS, Promoters and Patent Buyers are invited to write us stating the line of invention in which they are interested, as we can supply their wants in any class of patents. Victor J. Evans & Co., 162 Ninth St., Washington, D. C.

INVENTORS: We develop and perfect inventions, make models, dies, tools. Metal stamping and special manufacturing. Gerding Bros., Lion Bldg., Cincinnati, O.

START a Vacuum Clothes and Carpet Cleaning business, \$125.00 for machinery required. Write today. General Compressed Air & Vacuum Machinery Co., St. Louis.

EXPERT Chemical Service. Commercial Analysis, Instructions, Formulas, Processes and Trade Secrets. Manufacturing problems solved. Satisfaction guaranteed. Write for Lists and Valuable Information. W. L. Cummings, Ph. D., 127 Standart St., Syracuse, N. Y.

BIG money in promoting inventions. Write Adam Fisher Mfg. Co., 2061D Railway Exchange, St. Louis, Mo.

NOW is the time to develop your oil property, mining property, quarry, or other natural resources. What have you? H. Sanders, 114 W. Van Buren St., Chicago.

MAIL-ORDER SUPPLIES

INCREASE your sales. Place your proposition before the readers of "Cartoons Magazine," 25,000 copies guaranteed every month. Classified rate 5c per word. Mail in a trial ad today. Cartoons Classified Dept., 78 E. Madison St., Chicago.

TO MANUFACTURERS

I NEED different articles to sell through agents in offices, homes. Send full particulars to Diego J. de la Garza, Apartado 2293, Havana, Cuba.

WANTED: Something to Sell. What Have You? Anselco, 11216 Itaska, Cleveland, Ohio.

FOR ADVERTISERS

ADVERTISE in 140 Syndicate monthlies, 25 words three issues \$1.50. Southwestern, 1413-1 Berendo, Los Angeles.

20 WORDS in 101 publications \$1.00. Circulation 113,000. National Opportunity, Stratford, Wis.

TWENTY-WORD advertisement in 140 monthlies \$1.00. American System, Hollywood, California.

ADVERTISE your goods in Russia. Anton Leliep, San Francisco, Calif.

SPECIAL Offer—25-word advertisement in 100 magazines, \$1; three, \$2. Inch display, \$1; three, \$8. Page, \$133; three, \$268. Universal Syndicate, Atlantic City.

BUSINESS SERVICE

ANALYSIS of Products attended to on definite charge basis. Processes developed. Write up your requirements for full report. The Import & By Products Co., Inc., Trenton, N. J.

HAVE a New York Broadway Office. Good effect on letterhead for big business. We receive and forward your mail with use of eight telephone numbers on stationery. \$3 monthly. Duane, 309 Broadway, New York.

ADVERTISING by Motion Pictures is the book of the hour for the business man who is seeking up-to-date methods, whether he be manufacturer, wholesaler or retailer. The first and only practical book to deal with this immensely important subject. Each one of the 48 chapters teems with snappy new ideas pertaining to a great many different lines of business. 255 pages. Cloth. Price \$1.50 postpaid. Popular Mechanics Book Dept., 6 N. Michigan Ave., Chicago.

BOPP'S Price Marking Tables and Profit Indicator make price fixing an exact science. With the assistance of this book any merchant can instantly mark any item costing from 1c to \$100.00 with an accurate selling price which will cover any desired percentage of profit and at the same time include the percentage of overhead expense. Avoid the rock on which many a promising business founders. Price \$2.00 postpaid. Money back if not satisfied. Popular Mechanics Book Dept., 6 N. Michigan Ave., Chicago.

INCORPORATE. Our lawyers do the work, saving you time, annoyance and money in incorporating under the most liberal laws of Arizona. Laws and forms free. Southwestern Securities & Investment Co., Box D488, Phoenix, Ariz.

COLLECTIONS

DEBTS Collected Anywhere, Quickly! Established 25 years. William H. Dodd, 87 Nassau Street, New York.

AGENTS WANTED

AGENTS: Big Hit: Our 5-Piece Aluminum Set is all the rage. Cheaper than Enamel Ware. Sells like wildfire. Guaranteed 20 years. Retail value \$5.00. You sell to housewives for only \$1.98. Biggest seller of the age. 9 sure sales out of every 10 shown. Others cleaning up \$10.00 to \$20.00 a day. Answer this quick to secure your territory. Div. G55, American Aluminum Mfg. Co., Lemont, Ill.

550 WEEKLY and up selling Mexican Diamonds. Exactly resemble genuine. Same Rainbow Fire; Stand tests; sell at sight; Repeat orders. Write quick for Sample Case offer free. Mexican Diamond Importing Co., S. W. Las Cruces, New Mexico.

MAKE a big monthly income. Agents and garagemen are clearing as high as \$150 a month selling automobile body polish made from my exclusive formula. Going like wild fire wherever introduced. The formula is yours for only \$5. There is no limit to the profits you can make. For full particulars, address B. Sonntag, Waco, Texas.

MARVELOUS new winner—the Daylite Mantle Oil Light. Different from all others. Better light than electricity. Five times more efficient than common lamps. Uses common kerosene. Burns over 50 hours on 1 gallon. Guaranteed five years. Elegantly finished. To show it is to sell it. Men with rigs and autos making as high as \$25 every month. No money—no experience needed. You can start on our capital. We furnish stock of lamps on credit to reliable men. Sample lamp free. Exclusive territory. Write quick for particulars free. Daylite Company, 646 Daylite Building, Chicago, Illinois.

MAIL-ORDER System for beginners. Pendleton, Box 1003, Atlantic City, N. J.

AGENTS: The Ford Automatic Trousers Stretcher sells at sight. Big money selling to dealers or to every man who wears trousers. See advertisement in this magazine. A gilt-edge line for traveling men calling on Tailors, Clothing, Hardware or General Merchandise dealers. Do it now. Ford Automatic Mfg. Co., 1325 Michigan Ave., Chicago, Illinois.

AGENTS, Salesmen, Demonstrators, Streetmen. Soap Books sell on sight to stores, factory-hands, travelers, soldiers, everybody. Earn \$50 week easily. Sample, 10c; dozen, 60c. Prove it. Moore Company, 288 Greenwich St., New York.

AGENTS—Wonderful repeater! "Egg-ette" (The original egg substitute). Replaces eggs in all kinds of Baking and Cooking. Sells rapidly to Homes, Stores, Bakeries, Restaurants, etc. Guaranteed Pure Food Product. 10c package equals 12 eggs. Money-making proposition free. Write quick. Bestever Products Co., B-12, Douglas Park Station, Chicago.

\$1,000 PER Man per county. Strange invention startles world—agents amazed. Ten inexperienced men divide \$40,000. Korstad, a farmer, did \$2,200 in 14 days. Schlicher, a minister, \$195 in first 12 hours. \$1,200 cold cash made, paid, banked by Stomachian in 30 days; \$15,000 to date. A hot or cold running water bath equipment for any home at only \$6.50. Self-heating. No plumbing or waterworks required. Investigate. Exclusive sale. Credit given. Send no money. Write letter or postal today. Allen Mfg. Co., 311 Allen Bldg., Toledo, Ohio.

25% PROFIT selling Jubilee Spark Intensifiers to automobile owners, garages. Sure cure for Spark Plug troubles. Sells like wildfire. Brand new. Exclusive territory. Write today. Jubilee Mfg. Co., Dept. M-3, Omaha, Nebraska.

AGENTS: You can make big money taking orders for our fine made-to-measure clothes, so write quick for 60 beautiful cloth samples. 32 smart styles in rich colors, wholesale and retail price lists, lowest prices and best offer to agents. \$5.00 to \$10.00 a day easy. Big outfit, over 250 samples free to live wires. No experience needed—no capital. We furnish everything free—pay postage or express charges—back you, boost you, show you how and clearly explain everything. Costs nothing to try. Let us make you a stylish suit to measure to prove our fine quality and style. Send postal or letter today. Paragon Tailoring Co., Dept. 1214, Chicago.

ANY Man or Woman can make \$35 or more weekly selling Puritan Brushes to every household. Big profits, easy work. Exclusive territory. Special method for making sales easy. Puritan Co., Dept. M, 1966 Broadway, New York.

AGENTS Part or all time, take orders for Gold, Silver, Nickel, Brass Plating. Lots of plating all around you. Many do not know where to send. Can build stable business. General Plating Works, Youngstown, Ohio.

AGENTS, good profits for spare time selling shirts direct from maker to wearer. Nizem Shirt Co., 4650 Third Ave., New York City.

A \$2.50 PREMIUM with every \$1.98 sale and 70 cents profit for you means big daily profits. Free sample. Box 509, Shreveport, La.

YOUR name brings copy Money-Making Ideas. The great 32-page agent's and mail dealer's magazine. A. H. Kraus, 395 Kraus Bldg., Milwaukee, Wis.

AGENTS make quick money. "Gem Motor Wrench." \$1.00 prepaid. J. H. Ferguson, 762 Carlisle Ave., Dayton, O.

DISTRIBUTORS to market gasoline saver, guaranteed 25% fits any automobile. Excellent proposition for right man. Dayton Vaporizer Sales Co., Dayton, Ohio.

SELL guaranteed made to measure raincoats. Agent's price \$2.50 delivered. Make \$50 weekly. Outfit free. Standard Raincoat, 395 Broadway, New York.

AGENTS \$50 weekly. Wonderful Winter automobile fuel reduces operating expenses half. Outfit free. L. Bailway, Dept. 189, Louisville, Ky.

WRITE for liberal free sample—Get posted on biggest Money-Making Combinations and specialties. Guaranteed tremendous sellers. Samples furnished free to distribute. Special large profit offers made now. T. A. Newberry, 210 Peoria, Chicago.

"GOLDINE" Sign Letters—1,000% profit. Particulars free. Johnston Co., Quincy, Ill.

AGENTS—100% profit selling wonderful article. Send 10c for small size and proposition. J. D. Toblen, 3309 N. Madison, Peoria, Ill.

AGENTS—New Invention. Pneumatic Butter Blender. Every housewife wants one. Makes butter at half price. Quick seller. Big profits. Special offer. Waco Mfg. Co., Kansas City, Mo.

AGENTS, salesmen, dealers to sell wonderful patriotic novelty. Lang, 5042 N. Albany Ave., Chicago.

STRETCHING Cuff Links, remarkable convenience, invisible. Laundry saver. Opens and closes instantly when cuffs are raised or lowered. No unbuttoning. Meritorious. Guaranteed. Sell like wildfire. Large profits. District representatives wanted. Master Jewelers' Corporation, Sheboygan, Wisconsin.

YOU get one dollar for every book you sell. Carroll Book Co., St. Louis.

CANVASSERS—Men and Women. High Grade Household Necessity. Millmore Corporation, South Bend, Ind.

AGENTS Wanted—Tolliver Guaranteed Puncture-Proof Inner Tubes sell easily—our Agents make \$5.00 to \$50.00 a day net profits—no competition. If you wish to establish a business of your own that has unlimited possibilities for profit, write us for complete details. Tolliver Tube & Tire Co., 123 Tolliver Bldg., Denver, Colo.

AGENTS: Big profits. Best and cheapest window letters made. Easily applied. Dime brings five samples. Particulars Free. Stalbrit Co., 1115 Second Ave., New York.

HEL-MIT the Kaiser Pin—Latest war novelty—Biggest Hit Out; oxidized silver; thousands being sold; simple matter handling them out and taking money; sample with agents' terms, 10c. O. Finch, 1403 S. Iowa Ave., Grand Rapids, Michigan.

PRE-USED Printing presses, Type, Supplies, cheap. List for stamp. Popular Bargains, Richland, Pa.

\$10.00 DAILY Selling "Self-Lite." Latest wonder. Lights gas without matches, rubbing, alcohol; contact with gas causes instant flame. Sample 15c. Particulars free. Michael Bientz, Mgr., Cutler St., Newark, N. J.

SELL to Automobile Owners. Quickest selling proposition; costs you \$1.00, sells for \$1.50; sold you in case lots only for \$12.00; your profit \$6.00; a case or more easily sold per day. Act quickly. Money back proposition. Frenalene Co., Clinton and Monroe Streets, Chicago.

NOTICE: Year Soldier Boy's Photo enlarged on beautiful (18x18) pillow top. 98c. Water colors, \$1.25. Send photos. Xmas coming! Box 210, Ridgewood, N. J.

AGENTS, \$50 a week to travel by automobile and introduce our 306 candle power coal-oil lantern. Write for particulars of our auto offer. Thomas Co., 862 North St., Dayton, Ohio.

AGENTS to Travel by Automobile to introduce our fast selling, popular priced household necessities. The greatest line on earth. Make \$10 a day. Complete outfit and automobile furnished free to workers. Write today for exclusive territory. American Products Co., 3339 3rd St., Cincinnati, O.

NACMA repeat order household products are big money makers. Catchy selling plan gets and holds the business. Free selling helps and samples. Exclusive territory. The Nacma Co., Dept. D-7, 20 W. Lake, Chicago.

NINETY Per Cent of Your Calls Turned into Sales! Wonderful Enthusiasm Follows Every Demonstration! Write at Once for Full Particulars of Our Line of Eradium (Luminous) Articles. Startling! Mysterious! Everlasting! Novel! They Shine in the dark. Crucifixes, House Numbers, Bulbs, Match Boxes, Pictures, Sewing Plates. Sole Manufacturers, The Pioneer Corporation, 1259 W. 63rd, Chicago.

AGENTS: Big profits selling our latest model \$2.50 Automatic Adder. Does work of expensive machines. Pocket size. Absolutely guaranteed. Sells quickly. Ten daily, easy. No competition. Every business man buys. Demonstrates in two minutes, sales clinched on the spot at once. Bassett Company, 5921A Indiana Ave., Chicago.

EASY, pleasant work for Mechanics, Shop Men, Clerks, during spare hours, will add many dollars to their salaries. Also want persons who can give full time. Big wages assured. Novelty Cutlery Co., 67 Bar St., Canton, Ohio.

AGENTS, \$1.00 Commission every call. Greatest household money saver ever invented. Housekeepers buy on sight. Samples free. Ovee Mfg. Co., 189 Ovee Bldg., Louisville, Ky.

AGENTS! Make \$25 to \$50 a week. Sell gasoline saving tablets to auto owners. Every owner a prospect. Fosco, Box 373, Nashville, Tenn.

LUMINOUS Paint. Shines in the dark. Make and sell your own Luminous Articles: Watches, Clocks, Switch Plates, Bulbs, Crucifixes, etc. (Everlasting.) Only 25c bottle. Luminous Paint Co., B-24, Douglas Park Station, Chicago, Ill.

AGENTS: Brand new Whirlwind seller. Sample and particulars 15c. Chas. Webster Co., 2935 N. Clark St., Chicago, Ill.

AGENTS—Take orders for Christmas packages and other fast sellers. Send dime for samples and price list. Harit Sales Agency, Grafton, W. Va.

INK Pencils are outselling fountain pens. Big field untouched. Write, Colonial Manufacturing Company, Woodhaven, N. Y.

AGENTS: Write quick. Something new. Whirlwind seller. \$10.00 daily easy. Riley Weaver, Michigan City, Ind.

AGENTS—Handle the "Multiseller." Latest and Sensational improvement on Sales Boards. Declared Legal. Can be used anywhere. Our line of Sales Boards and Specialties are sure repeaters. Gordon Specialty Agency, Dept. B, 52 West Chippewa, Buffalo, N. Y.

AGENTS make 500% profit handling Auto Monograms, Patriotic Pictures, Holiday Decorations, Window Letters and Changeable Signs. Catalog free. Hinton Co., 6142 40th Court, Chicago, Ill.

EXCLUSIVE territory. Wonder knife sharpener. Just out. Big seller in Chicago. Send 25c sample. Big Christmas proposition. Lovedall, 8 So. Dearborn St., Chicago.

A \$15 CHECK protector for \$8.75. Bankers Check Protector Co., Atlantic City.

AGENTS. We have a good proposition for you. Write for particulars and samples. Chicago Agency Co., 838 Altgeld St., Chicago.

SELLS like hot cakes. New ironing wax. Perfumes clothes with lasting violet. Working outfit 5c. New offer. Perfume Gloss, 11 Water St., New York.

AGENTS: Get the winner's Perfection sheet holder, Daisy Hope Fasteners. Quick sales, large profits, particulars free. Moore Company, 4138 Jerome Ave., Cincinnati, Ohio.

MEN and women with spare time—Whether employed or not employed—can make a lot of extra money with our all profit advertising offer. No goods to buy or sell. No deliveries. No collections. National, Dept. D-15, 18 W. Lake St., Chicago.

PHOTO Pillow Tops, Portraits, Frames, Sheet Pictures, Medallions, Patriotic Pictures, Pennants. Refects credited. Prompt shipments; samples and catalogs free to agents; 30 days' credit. Jaa. C. Bailey Co., Desk G, Chicago.

GOOD income spare time, refinishing chandeliers, brass beds, automobiles, etc., by new method; producing amazing results; every household possible customer; experience unnecessary; simple plan of manufacturing at home starts you in a big money-making business; write for free samples showing finishes, etc. Gunmetal Co., Ave. H, Decatur, Ill.

BIG Profit for Agents. You can easily earn \$5 a day and more taking orders from our sample case for our fast-selling well-known nationally advertised line of Soaps and Toilet Preparations. Easy, pleasant work. No experience necessary. Write today for our sample case offer and full particulars. Crofts & Reed Co., Dept. C-254, Chicago.

WORLD'S fastest selling auto accessory. County distributors wanted; good profits; write today. G. L. W. Spring Oiler Co., San Diego, California.

TAILORING Agents Wanted—Big complete sample outfit and case, nearly 300 large cloth samples, 3 piece lists and everything needed for canvassing or use in store, free to live agents. \$25.00 to \$50.00 a week; may make more. Write us today for free elegant outfit to begin, cloth samples, wholesale prices, special offer on a suit for yourself and full information—see our wonderful values, beautiful fabrics and styles. Established 28 years. Every garment made to measure—everything guaranteed and express prepaid. Just send a postal. American Woollen Mills Co., Dept. 1214, Chicago.

WANTED Reliable People—Place Eggs in stores and appoint agents. Takes place of eggs in baking and cooking at 9c doz. Large package and particulars 10c postpaid. Morrissey Company, 4403-5 Madison, Chicago.

"RADIO" Luminous Paint at Wholesale. Quarter Pints 50c stamps. Highest Power, Sole Manufacturers. American Luminous Products Co., Huntington Park, California.

AGENTS—Get Particulars of the best paying proposition ever put on the market; something no one else sells; make \$4,500 yearly. Address E. M. Feldman, Mgr., 5139 3rd St., Cincinnati, O.

PORTRAIT Agents: Our goods will make you big profits. Delivery guaranteed. Refects credited. Prompt shipments. Send for latest catalogue and prices. Adam J. Kroll & Co., 602 Blue Island Ave., Chicago, Ill.

AGENTS, 500% Profit. Sign-Letters for office and store fronts. Samples and particulars free. Inter-States Letter, 2424 N. Halsted St., Chicago.

AGENTS: A Live Wire accessory for Ford Cars. Sells on sight to dealers and car owners. Nothing else like it, no competition, appeals to every Ford car owner whether his car is driven by himself, his family or an employee. Bill Manufacturing Co., 101 Factory St., La Porte, Ind.

\$15.00 MADE first day by 13-year-old boy with shomescope. Woman made \$6.00 first hour. Particulars free. Shomescope Mfg. Co., 4923 Montgall, Kansas City, Mo.

\$1,000.00 REWARD if my High-Grade Formulas are not Money-Makers for those who Manufacture various Big Selling Specialties from them. Latest Food Products, Washing Tablets, Automobile Specialties, Tube Flavors, Dry Cleaners, Rust Soap, Luminous Paint, Polishes, No Trash. Valuable Information and latest lists—Stamp. Established 20 years. Miller, Analytical Chemist, Tampa, Florida.

AGENTS wanted to sell Egnit—a pure food substitute for eggs. Easy selling article—big profits—quick repeater. Stuart & Co., 16 Main St., Newark, N. Y.

BIG value Xmas package. Cards, booklets, tags, seals, everybody buys. Good profits. Sample 10c. Ufert, 236 W. 41st, New York.

AGENTS: A golden opportunity selling Yanoco "Quality Ivory" combs, brushes, mirrors and other toilet requisites. Ten to forty dollars weekly. Best season now. Ideal holiday line. Sells on sight. Yanoco Ivory Co., Leominster, Mass., Ave. P.

"We start you in business, furnish everything; men and women; make good weekly income." Majestic Printing Co., 3044 Leeward, Los Angeles, Cal.

AGENTS: Even if you were deaf, dumb and blind you could sell our Aluminum Utensil Cleaner. Every housewife grabs it on sight. Steady trade and big money in protected territory. Write quick. Div. Pol. American Aluminum Mfg. Co., Levent, Ill.

FREE sample with particulars. No splashing water strainers. Easy seller. Returns big. Experience unnecessary. Union Filters Co., New York.

AGENTS, \$50 a week. Will show you how. Genuine Gold Leaf Window Letters. Chicago Agency Co., 842 Altgeld St., Chicago.

AGENTS—Stamping names on Pocket Key Protectors; sample check with your name and address, 12c. Stamping Outfits, Emblem Checks, Check Fobs, Name Plates. Hart Mfg. Co., Desk 2, 303 Degrav St., Brooklyn, N. Y.

SIGN Letter Agents and Painters: 500% Profit Gold and Silver Sign Letters for Stores and Office Windows. Anyone can put on. Big demand. Free samples. Metallic Letter Co., 404 N. Clark St., Chicago.

HUGE profits selling Nibco Sanitary Brushes, Auto Washers, Brown Beauty Adjustable Floor Mops, Dustless Dusters, and other specialties. Big line. Fast sellers. Write today. Silver-Chamberlain Company, Department M, Clayton, New Jersey.

AGENTS sell Reliable Custom-Made Raincoats and Gabardines. Big commission. Complete sample line free. Temple Raincoat Company, Templeton, Mass.

RAINCOATS—Direct from factory. Agent's price \$2.95 delivered. Retail price \$5.00. Agents average six coats daily. Rainy season now here. W. Lewis Raincoat Co., Cleveland, O.

AGENTS: Sell "Ironslide." Great new starch enamel. Wonderful success. Women delighted. Free samples. Big profit. 25 other articles. All winners. Write today. G. H. Brummund, Horicon, Wis.

AGENTS for H & H Solder Cement; Mends Aluminum and all metals; applied cold or with heat; indispensable for household, automobiles and motorboats; neither heat nor water affect it; send 10c for sample and agents' proposition. H & H Sales Co., Orange, N. J.

RELIABLE people wanted. Place Hall's sore throat remedy in stores and appoint agents. 20c for sample. Hall Drug Co., Mifflinburg, Pa.

NINETY Per Cent of Your Calls Turned into Sales! Wonderful Enthusiasm Follows Every Demonstration! Write at Once for Full Particulars of Our Line of Eradium (Luminous) Articles. Startling! Mysterious! Everlasting! Novel! They Shine in the dark. Crucifixes, Home Numbers, Bulbs, Match Boxes, Pictures, Switch Plates, Sole Manufacturers. The Pioneer Corporation, 1259 W. 63rd, Chicago.

KEROSENE Gas Burners in Cook Stoves or Ranges stop use of wood or coal. Recently patented. Money-maker for Agents. The Vapor Gas Burner Co., Desk 8, Columbus, Ohio.

AGENTS: Sell Neverfail Iron Rust and Stain Remover. Always seasonable. Huge Profits. Big line. Credit. Sample. Sanford-Beal Co., Inc., Newark, New York, Dept. C.

MAN Wanted in each country community and every small town, to wear beautiful new tailored-to-order suits of clothes and be Agent in spare time among friends, relatives and neighbors. Confidential wholesale prices given, good profit on each order. No experience required, we teach you all you need to know. Write at once and get gorgeous, illustrated book of cloth samples free, and full instructions. Banner Tailoring Co., Dept. 695, Chicago.

CONVEX Portraits, frames, pillow tops. Lowest prices. Liberal Terms. Free catalogue. Brewer Art Co., Shelbyville, Ind.

AGENTS wanted. Economy Kerosene Burners for cooking and heating stoves. Big profits. Exclusive territory. Economy Mfg. Co., 1323 N. Dearborn St., Chicago, Ill.

AGENTS. "Eggite," the guaranteed substitute for fresh eggs, means eggs at 8 cents per doz.; enormous demand everywhere; big profits; sample free. Thomas Dougherty, 157 East 47th St., New York.

YOU can be your own boss with our Key Check outfit. Good for \$5 a day stamping names on pocket key checks, fobs, etc. Sample check with your name and address, 15 cents. Pease Die Works, Dept. M., Winchester, N. H.

1917'S GREATEST Sensation! 11-piece toilet goods combination selling like blazes at \$1.00 with \$1.00 Carving Set Free. Everybody buys. Engle's profit first week \$51.00. Great crew proposition. P. Pierce Co., 992 Lake St., Chicago.

MAKE and Sell Your Own Goods. Machinery unnecessary. Expert Chemists advice. Special attention to beginners. Formula Catalog for Stamp. Blake Mystic Company, Washington, D. C.

AGENTS. Something new; Free sample. Foreign inquiries invited. Famous Products Co., Decatur, Illinois.

EVERY home on farm, in small town or suburb needs and will buy the wonderful Aladdin kerosene (coal-oil) Mantle Lamp. Five times as bright as electric. Tested and recommended by Government and 34 leading Universities. Awarded Gold Medal. One farmer cleared over \$500 in six weeks. Hundreds with rigs or autos earning \$100 to \$100 per month. No capital required; we furnish goods on time to reliable men. Write quick for distributor's proposition and lamp for free trial. Mantle Lamp Co., 528 Aladdin Bldg., Chicago, Ill.

INSYDE Tyres, inner armor for Automobile tires, double mileage and prevent punctures and blowouts. Quickly applied. Cost little. Demand tremendous. Profits unlimited. Details free. American Automobile Accessories Co., Dept. P, Cincinnati, O.

GET Davis' Latest Proposition. \$15.00 daily a cinch. No matter how many times you have answered my ads in last 20 years, write again. E. M. Davis, Dept. 506, 990 Lake, Chicago.

LARGE Manufacturer wants representatives to sell shirts, underwear, hosiery, dresses, waists, skirts, direct to homes. Write for free samples. Madison Mills, 593 Broadway, New York City.

NEW Patriotic War Atlas Free with my 1917 "Business Guide." Sells everywhere. Beginners clear \$7 daily. 50% commission. Outfit free. Prof. Nichols, Box P. M. 3, Naperville, Ill.

DO you want to travel at our expense? We want good men and women for traveling general agents. Must have fair education and good references. Will make contract for three months, six months or year at salary \$22.50 per week and necessary expenses. Can assign most any territory desired. For full particulars address George G. Clows Company, Philadelphia, Pa., Dept. 4-1.

\$19 A DAY Profit—manufacture Harley Crisp; new confection; 5c package costs you 1c; machine, instructions complete, \$1.50 prepaid; send 15c for samples. Harley Crisp Company, 1267 Broadway, San Francisco.

AGENTS—Make a dollar an hour. Sell Mendota, a patent patch for instantly mending leaks in all utensils. Sample package free. Collette Mfg. Co., Dept. 401B Amsterdam, N. Y.

AGENTS—Send for sample "Frotnot"—the wash day wonder. Be convinced you can do a whirlwind business. You can clear at least \$20 to \$100 weekly, according to spare or whole time. You don't have to talk; if she doesn't buy at sight, leave sample; she will be looking for you long before you are able to make the rounds again. Samples furnished free. Premiums for your customers. Exclusive territory guaranteed to agents who can produce. Credit given. Don't call. P. M. Motter & Sons, 3213 Warren Ave., Chicago.

AGENTS make 500 per cent profit selling our Auto Monograms and Initials, Window Sign Letters, Changeable Signs, and Show Cards. 1,000 Varieties. Enormous Demand. Sullivan Co., 1123 Van Buren St., Chicago, Ill.

DECALCOMANIA Transfer Initials and Flags: You apply them on automobile while they wait. You can make \$1.38 profit on \$1.50 job; free particulars. Auto Monogram Supply Co., Dept. 1, Niagara Bldg., Newark, N. J.

DISCOVERED! Extraordinary New Proposition. Supreme Opportunity. \$200 per week Easy, demonstrating marvelous Adding Machine. Retail \$7.50. Work equals \$300 machine. Subtracts, Multiplies, Divides, automatically. Whirlwind in speed. Guaranteed Five Years. Used by U. S. Government. Sells everywhere. Amazing profits. Write quick for exclusive territory. Calculator Corp., Dept. PM, Grand Rapids, Mich.

NEW invention, fast seller to all classes. Popular price, many buy dozens, no competition. Big profit. Dandy mail-order proposition. The Clark Co., Clark Building, Jacksonville, Fla.

WANTED. General Agent to represent us in your locality. Exclusive territory. Big inducements. Chicago Agency Co., 849 Altgeld St., Chicago.

WANTED—New Ideas. Write for list of Patent Buyers and Inventions Wanted. \$1,000,000 in prizes offered for inventions. Our Four Books sent free upon request. Victor J. Evans & Co., 163 Ninth, Washington, D. C.

AGENTS — Ho-Bo-Co Skin Soap and Toilet Goods plan beats everything for agents' profits. "Ho-Bo-Co." 112 Locust St., St. Louis, Mo.

AGENTS: \$30 to \$100 a week. Free samples. Gold sign letters for Stores and Office Windows. Anyone can do it. Liberal offer to general agents. Metallic Letter Co., 407 N. Clark, Chicago.

CALIFORNIA Flower Bead Necklaces beat anything for quick sales and profits. Absolutely new. Write for agent's proposition. Mission, 2819 PM, West Pico, Los Angeles, Calif.

AGENTS. Make Big Money; fast office seller; particulars and samples free. One Dip Pen Co., Dept. 2, Baltimore, Md.

AGENTS — \$5 daily selling our Handy Tool, 12 articles in one. Lightning seller. Sample free. Thomas Mfg. Company, 762 North St., Dayton, Ohio.

HOSIERY and Underwear Manufacturer offers permanent position supplying regular customers at mill prices. \$50.00 to \$100.00 monthly. All or spare time. Credit. D. Parker Mills, 2735 No. 13th St., Phila., Pa.

AGENTS — Sell rich-looking imported 36x68 rugs, \$1 each. Carter, Tenn., sold 115 in 4 days. Profit, \$57. You can do same. Write for sample offer selling plan; exclusive territory. Sample rug by parcel post prepaid, 98c. E. H. Condon, Importer, Stonington, Maine.

FEATHER Flowers, the all-purpose Home flower. Business clean, attractive, profitable. Sample fifteen cents. De Witt Sisters, Route Ten, Battle Creek, Mich.

GAS Fire in any cook stove from common coal oil. Agents coin money. Wonder Burner Company, Columbus, Ohio.

AGENTS make \$100.00 monthly selling our 500 Handy Household Articles; Catalogue free. Scheff Company, Desplaines, Ill.

AGENTS—Steady Income. Large manufacturer of Handkerchiefs and Dress Goods, etc., wishes representative in each locality. Factory to consumer. Big profits, honest goods. Whole or spare time. Credit given. Send for particulars. Freeport Mfg. Co., 59 Main St., Brooklyn, N. Y.

GRAB Territory on our new specialties. Full line samples and terms \$2.00. Money back if wanted. Adam Fisher Mfg. Co., 2661-G, St. Louis, Mo.

AGENTS—Make and sell your own goods. 24 valuable manufacturing formulas and big formula catalog 10c. "The Ideal," Box 543-A, Chicago.

AGENTS—Year's Biggest Seller—everybody making big money. Protective territory. Write immediately. Bestever Products Co., B-14, Douglas Park Station, Chicago.

AGENCIES WANTED

GENERAL Agencies, Manufacturers' Distributors, Sale Promoters, Consignments, Mail Orders. Guaranteed Articles Only. The R. W. Slater Co., 2326 First Avenue, Seattle.

SALESMEN WANTED

WERE You Ever Offered a Grocery Store? Our Proposition is Better. Let us tell you how you can handle Flour, Canned Goods, Provisions, an entire line of groceries, as well as Paints, Bookings, Stock Foods, Automobile and Machinery, Oils and Greases. No rent to pay. No investment in stock. Large orders taken from samples. Goods of guaranteed and proven quality. Selling experience not necessary. Very profitable work for "workers." Address Hitchcock Hill Co., Dept. 208, Chicago, Ill. Reference: Any bank or express company.

SALESMEN—Get our plan for Monogramming Automobiles and motorcycles by transfer methods. Very large profits. Motorists' Accessories Co., Mansfield, O.

HIGH-GRADE salesmen, experienced in electrical lines, to sell much needed specialties to doctors and others, no competition. Unlimited opportunities. Only men of unquestionable ability and integrity need apply. Western Coil & Electrical Co., Racine, Wisconsin.

SALESMEN Wanted Jan. 1st—Excellent line Signs and Novelties. Traveling expenses advanced. Liberal commissions. Exclusive territory. Give age, height, weight, road experience and three late business references. Stanford-Crowell Co., Ithaca, N. Y.

\$7.50 COMMISSION each sale and repeat orders; traveling salesmen among general mercantile trade; every State; weekly settlements; no competition; pocket sample. Toledo Cable Co., 443 Davis Bldg., Toledo, Ohio.

BRAINS, ability, experience can connect with Management and American dollars. New National Corporation, Howard Smith Co., Washington, Penna.

SALESMEN: Every man buys. Retail \$1.00. Costs 5c. Oscar Hanson, Mentor, Minn.

TRAVELING Salesmen Wanted—Experience unnecessary. Earn while you learn. Hundreds of good positions open. Write today for large list of openings and testimonials from hundreds of members who have placed in positions paying \$100 to \$500 a month. Address nearest office. Dept. 125-W, National Salesmen Training Association, Chicago, New York, San Francisco.

WHEN tired of "Get rich quick schemes," write for our line of standard auto supplies; build a business among garages and dealers. \$10 daily easily made. Auto Equipment Co., "Manufacturers," Roxborough, Philadelphia, Pa.

SALESMEN calling on Manufacturing and Factory Trade to sell High-Grade Legitimate product as a side-line. No samples to carry. Liberal commission proposition. Write North American Linseed Products Co., Cleveland, Ohio.

SALESMAN—\$6,000 Accidental Death. \$30.00 Weekly Accident Benefit. \$25.00 weekly Sick Benefit. \$10.50 yearly, half amount \$5.50. \$250,000 deposited Insurance Department. Experience Unnecessary. Become independent—own your business. Guaranteed steady income from renewals. Registration, Dept. B, Newark, N. J.

WANTED—Representatives everywhere. Exclusive territory. Gold sign letters for stores and office windows. Any one can put on. Write today for free sample. Metallic Letter Co., 403 N. Clark St., Chicago.

SALESMEN—Acquainted with grocery trade. Large demand; liberal commission; pocket sample. Wirth Salesbook Co., Dept. P., Chicago.

EARN \$5,000 to \$20,000 yearly. New business necessary. Retail \$5 to \$200. 100-200% profit. Purchaser satisfied or money refunded. No competition. Exclusive territory. Free samples. Sayers, 408 Wainright, St. Louis.

HELP WANTED

FOREMEN, Shopmen, and Office men Wanted to work spare time as special representative of large well-known mail-order house, selling Watches, Diamonds, and Jewelry on Credit. Liberal commissions and exclusive sales rights granted. No investment or deposit required for outfit or samples. Write at once for details. Address S. D. Miller, Dept. 24, Agency Division, Miller Bldg., Detroit, Mich.

UNCLE SAM has thousands of jobs open this year. I will help you get one. Write for my big Free book, DX-29. Earl Hopkins, Washington, D. C.

I HAVE an opening for a man who is honest, capable and industrious. Prefer one with previous sales experience. Will pay \$25.00 per week to the man who can make good. One bank and two business references required. Address C. A. Nudson, 717 Capital Bldg., Topeka, Kans.

WANTED Immediately: Men—Women. Government war jobs. \$100 monthly. List free. Franklin Institute, Dept. J-21, Rochester, N. Y.

GOVERNMENT Examinations. Most thorough preparation, \$5; returned if not approved; particulars free. American Civil Service School, Washington, D. C.

GOVERNMENT Positions are easy to get. My free booklet BY-29 tells how. Write today—Now. Earl Hopkins, Washington, D. C.

FIREMEN, Brakemen, all railroads, everywhere, \$100-\$150 monthly, experience unnecessary, position guaranteed. Railway Association, Dept. 254, Brooklyn, N. Y.

RAILWAY Mail Clerks wanted immediately. Men 18 up. \$75 month. List positions free. Franklin Institute, Dept. J-21, Rochester, N. Y.

CARTOONING, Sign and card writing made easy. D. Freeburn System, Hicksville, Ohio.

DO you want a position for life, with big pay, short hours and sure advancement? Then work for Uncle Sam. My free illustrated book DK-29 tells how to get an appointment. Earl Hopkins, Washington, D. C.

WANTED ambitious, able salesmen to sell high grade oil securities, large commission. Knapp, 1599 Singer Building, New York.

HUNDREDS Government War positions open. Men—women wanted. \$100 month. Write immediately for list. Franklin Institute, Dept. J-21, Rochester, N. Y.

GOVERNMENT pays \$900 to \$1,800 yearly. Prepare for coming "exams" under former Civil Service Examiner. New Book Free. Write Patterson Civil Service School, Box 3020, Rochester, N. Y.

FREE Illustrated Book tells of about 300,000 protected positions in U. S. service. Thousands of vacancies every year. There is a big chance here for you, sure and generous pay, lifetime employment. Just ask for booklet CS-29. No obligation. Earl Hopkins, Washington, D. C.

PICK up some easy money gathering butterflies, insects. I buy 750 kinds. Some \$1-\$7. Intensely interesting. 2c stamp brings prospectus. Get posted. Sinclair, Box 244, D6, Los Angeles, Cal.

WANTED—Telephone Switchboard Installers. Steady employment. Good wages. Bonus. Liberal sickness, disability and pension plan. Ages 19 to 35 years. High-school education preferred. Experience not necessary. We will teach beginners at our expense. Address, Western Electric Company, Inc., Department No. 6592, Hawthorne Station, Chicago, Illinois.

WANTED—Civil Service examinations open the way to good Government positions. I can teach you by mail at small cost. Full particulars free to any American citizen of eighteen or over. Write today for booklet CE-29. Earl Hopkins, Washington, D. C.

FOREMEN for tank factory, to take charge of factory in K. C. Manufacturing stock tanks, hog troughs, grain bins and other sheet metal products. Must be competent to handle men, and be able to read plans, make estimates. Good opportunity. State age, experience and other qualifications; strictly confidential. H. J., Room 990, 78 E. Madison St., Chicago.

WANTED—Skilled mechanics in all lines, for Detroit and other cities. Highest wages. Send for registration blank. It's free. Earl Conway, 299 Antoine St., Detroit, Mich.

GET a sure Job with big pay, steady work, short hours, regular vacations, rapid advance. Thousands of positions open with Uncle Sam. I will prepare you in a few weeks at small cost. Write immediately for big free book DU-29, with special offer. Earl Hopkins, Washington, D. C.

MAKE money writing Photo-plays; details free to beginners. No correspondence course. Producers' League, 239 Wainwright, St. Louis.

INVENT something. Your ideas may bring wealth. Free book tells what to invent and how to obtain a patent through our credit system. Talbert & Parker, 4192 Talbert Building, Washington, D. C.

WANTED—Men to become chauffeurs, \$25 week. Earn while learning. Franklin Institute, Dept. J-302, Rochester, N. Y.

U. S. GOVERNMENT wants help. Men—Women, 18 or over. \$80 month. War means many vacancies. Write for list positions obtainable. Franklin Institute, Dept. J-21, Rochester, N. Y.

WANTED—Men and women to qualify for Government positions. Several thousand appointments to be made next few months. Full information about openings, how to prepare, etc., free. Write immediately for booklet CG-29. Earl Hopkins, Washington, D. C.

FIREMEN, Brakemen, Baggage-men, 8 hours, \$140. Colored Porters wanted everywhere. Experience unnecessary. 810 Ry. Bureau, East St. Louis, Ill.

MEN wanted to make Toy Soldiers, Army, Navy, Patriotic emblems and novelties. Spare-time homeworkers and manufacturers. Enormous demand, big business. War stopped importation. We buy the whole output or all surplus over sales, the whole year. Experience or tools not necessary. Casting form outfit from \$2.50 up. More than 300 made complete per hour. Greatest chance for industrious people. Booklet and Information free. Toy Soldier Manufacturing Company, 32 Union Square, New York.

MEN—Become U. S. Railway Mail Clerks, \$75 to \$150 month. Every second week off with pay. Education unnecessary. Sample examination questions free. Write immediately. Franklin Institute, Dept. J-21, Rochester, N. Y.

MEN wanted to learn automobile business in Detroit. Experience not necessary. Can earn good salaries, with excellent chances for advancement. Address National Service Bureau, 136 Woodward Ave., Detroit, Michigan.

RAILROAD Traffic Inspectors Wanted. \$125 a month and expenses to start; short hours; travel; three months' home study under guarantee; we get you position. No age limit. Ask for booklet L-4. Frontier Prep. School, Buffalo, N. Y.

RAILWAY Mail Clerks wanted, \$75.00 month. Examinations soon. Also Salesmen wanted. Civil Service and Salesmanship Courses by mail. For "Free Tuition Plan," address Carnegie College, Rogers, Ohio.

THE Way to Get a Government Job is through the Washington Civil Service School. We prepare you and you get a position or we guarantee to refund your money. Write to Earl Hopkins, President, Washington, D. C., for book PK-29, telling about 292,296 government positions with lifetime employment, short hours, sure pay, regular vacations.

STOP that daily grind. Take nose off grindstone; be no man's slave, punch no body's time clock. Own your business. I start you silvering mirrors, plating tableware home. Sure income. Plans free. Clarence Sprinkle, Dept. 28, Marion, Ind.

WANTED—An Idea! Who can think of some simple thing to patent? Protect your ideas; they may bring you wealth. Write for "Needed Inventions" and "How to Get Your Patent and Your Money." Randolph & Co., Patent Attorneys, 620 F Street, Washington, D. C.

BE a Mirror Expert. Good income; spare time home at first; no capital; we train, start you making and silvering mirrors; French method. Free prospectus. W. P. Derr, Pres., 579 Decatur, Brooklyn, N. Y.

WANTED

WANTED—Old False Teeth. Don't Matter if Broken. We pay up to \$15 per set. Cash sent by return mail. Goods held 10 days subject to sender's approval of our offer. Mazer's Teeth Specialty, 2007 S. 5th St., Phila., Pa.

\$3.00 TO \$60.00 per set paid for old, broken, false teeth. Bridgework 40c a tooth. Morrison, 510 West 144th St., N. Y. City.

WANTED, good mail order propositions. Medina Merchandising Co., Medina, Ohio.

FOR SALE

EDISON Motion Picture Outfit for sale. Simpkins, 333 Church, Roanoke, Virginia.

TIME Clock—International Second Hand Now in use. Wilson & Bennett Mfg. Co., Chicago, Ill.

ARMY and Navy Men, Attention! Field, Marine, Day and Night Glasses with case, 25-mile adjustment, only \$9.50. Money back if not satisfactory. We'll's Curiosity Shop, 20 S. Second St., Philadelphia, Pa.

6X TURNER-REICH Binoculars, \$35.00; **6X B & L Stereo Binoculars,** \$50.00; **Bush Prisma Monocle,** \$15.00; **8X Turner-Heich Binoculars,** \$35.00; **8X Bush Prisma Binoculars,** \$35.00. David Stern Company, in business since 1885, 1027 Madison Street, Chicago, Ill.

MEDICAL Books, Typewriter, Handcuffs, Shackles, Chains, Spirit Locks, etc. J. Trudell, 524 Moody, Lowell, Mass.

10 MILL'S Floor Vendors, \$14 to \$22, **Operator's Bells,** \$12, **Miscellaneous machines,** \$1 to \$5, for quick sale. All like new. Auto Vending Co., Minneapolis, Minn.

3" BARDOU Telescope. Equatorial movement. Angle and 3 other eye-pieces; also other equipment, like new, \$225.00. David Stern Company, 1027 Madison Street, Chicago, Ill.

UNIVERSAL Knitting Machines. Many styles, hand or power. For Catalogue, address, Daniel Booker, Prabhody, Mass.

TYPE and Printing Material at bargain prices. Now is the time to buy. All sizes rebuilt Job Presses very cheap. Catalogue free. Philadelphia Printers' Supply Co., 14 So. Fifth St., Philadelphia.

FOR Sale—Buffalo Lap Robe, in first-class condition. L. M. Birely, Union Bridge, Md.

SALE OR EXCHANGE

HAVE you anything to sell or exchange. Books, motors, dynamos, cameras, bicycles and miscellaneous objects? Advertise in "The Market for Exchange," a magazine which offers a market to everyone, everywhere. Rate 3 cents a word. Send 10 cents for sample copy to Publisher, Market for Exchange, 141 Milk Street, Boston, Mass.

GUNS, SPORTING GOODS, ETC.

BARGAINS. Will trade, buy or sell Guns, Rifles, Revolvers. Send Stamp for Bargain List. Oldest, most reliable Dealer in Country. Wm. E. Burkhardt, 143 East Fourth Street, St. Paul, Minnesota.

BUY, sell, exchange old-time and modern Fire-arms. Antiques wanted. Stephen Van Rensselaer, 895 Madison Avenue, New York.

MACHINERY, TOOLS AND SUPPLIES

"RED DEVIL" Mechanic's Plier (drop-forged steel); most efficient, 5 inch size, 66c. Style 50, Tool circulars free. Smith & Hemenway Co., 97B Coit Street, Irvington, N. J.

PULLEYS, Gears, Sprockets, Shafting, Hangers. See page 146. W. A. Jones Foundry & Machine Co., Chicago.

FOR Sale—20 H. P., two-cylinder gasoline engine, heavy planetary transmission, tractor wheels, bevel drive, auto axle, portable drill, lever punch, 22" Walcott geared shaper. Aris Veenschoter, Pella, Iowa.

WIRE—all sizes— 1/2 to No. 18. Coppered, tinned, galvanized and plain steel wire for sale. Cooley Mfg. Co., 553 W. Monroe St., Chicago, Ill.

MILLING machine, back geared, Lincoln type, with arbor and vise, overhauled, \$90. Photo. Lucas & Son, Bridgeport, Conn.

ENGINES, MOTORS AND DYNAMOS

ELECTRIC Motors, 110 Volts, 60 cycle, A. C., Single phase, 1750 Speed, 1/4 HP, \$22.00, 1/2 HP, \$42.00. Brand new, never unpacked, guaranteed perfect. Lincoln Supply Company, Lincoln, Penna.

ENGINE User Agents Wanted to use, demonstrate and sell "Big Ben," wonderful new 2 1/2 H. P. gasoline engine. Free introductory offer and free details. C. Benninghofen & Sons, Dept. P, Hamilton, Ohio.

EXCEPTIONAL values, alternating and direct current motors from 1/30 H.P. upwards. All guaranteed for one year. Motors bought and repaired. Tell us your needs. Illustrated catalog supplies and motors. Hyre Electric Co., 633-AB South Dearborn St., Chicago.

ELECTRIC Motors, 110 Volts, 60 Cycle, A. C., Single Phase, 1750 Speed, 1/4 HP, \$22.00, 1/2 HP, \$42.00. Brand new, never unpacked, guaranteed perfect. Lincoln Supply Co., Lincoln, Pa.

GENERATORS, Ball-bearing, 32 volt, 11 to 35 amperes, complete with base and pulley. Prompt shipments. Goodie Company, Indianapolis, Ind.

SMALL Motors and Generators—Quantity 1/4 H. P. A. C. Motors—110 volts—slightly used, \$14.00. Small generators—charging—lighting—moving picture Arc machines, \$10 each and up. A. C. Motors 1 and 3 phase up to 5 H. P. for immediate delivery. Write for Bankruptcy Stock sheet. Johnston, West End, Pittsburgh, Pa.

FLOUR & FEED MILLING MACHINERY

SPECIAL bargains in second hand Attrition mills, burr mills, crushers, corn shellers, bran dusters, dust collectors, purifiers, reels, double, single, 2 and 3-pair high roller mills, sieve bolters, receiving separators, scourers, etc. Write for description and prices. Sprout, Waldron & Co., P. O. Box 429, Muncy, Pa.

FOR MECHANICS

PATENTS Wanted. Write for list of Patent Buyers who wish to purchase patents and what to invent with List of Inventions Wanted, \$1,000,000 in prizes offered for inventions. Send Sketch for free opinion as to patentability. Write for our free Guide books sent free upon request. Patents advertised free. We assist inventors to sell their inventions. Victor J. Evans & Co., 184 Ninth, Washington, D. C.

BLACKSMITHS

BLACKSMITHS, Listen! Prepare for big wages in Navy and Arsenal with Toy's Modern Methods doing hard jobs easy. Forging and making solid welds, hardening and tempering to a standard, with colored tempering charts. All for one dollar. Samples free. W. M. Toy, Sidney, Ohio.

ELECTRICAL

ILLUSTRATED catalog, just issued. Electrical supplies and motors, wire, switches, boom, plugs, tape, rosettes, lamps, fuses, sockets. Send for free copy today. Hyre Electric Co. 633-WF South Dearborn St., Chicago.

PRactical Electrics—Universal handy book on every-day electrical matters, alarms, batteries, bells, carbons, connections, coils, dynamos, wires, lamps, motors, telephones, etc. 135 pages, 126 illustrations. 25c postpaid. Popular Mechanics Book Dept., 6 N. Michigan Ave., Chicago.

STORAGE Batteries Simplified—A complete new treatise on action—maintenance—repair—use. Describes fully the Exide, Edison, Gould, Willard, U. S. I. and other forms. Only complete and up-to-date book on subject. 329 pages, fully illustrated. \$1.50 postpaid. Complete description sent upon request. Popular Mechanics Book Dept., 6 N. Michigan Ave., Chicago.

STAMP COLLECTIONS

61 ALL Different Foreign Stamps, including Honduras, Mexico, China, Peru, Australia, Egypt, Japan, Chile, Russia, Argentina, Brazil, Cuba, India, Portugal, etc. Only 7 cents. Royal Stamp Company, 368 N. 53rd St., Philadelphia, Penna.

STAMPS—12 different from warring nations, 10c; 10 different foreign coins, 15c; 20 Belgian stamps, 10c. Lists free. Toledo Stamp Co., Toledo, Ohio.

FREE! 75 Different foreign to applicants for approvals. Postage, 2c. Nickles, 122 Florida Ave., Washington, D. C.

FREE—Choose One. 200 different International. 100 United States. 50 Sweden. Remit 25c six months' subscription. McKeloe's Stamp Weekly, Beverly, Mass.

STAMPS sent on approval at 70% discount. Reference required. Emory Bennell, Hanover, Pa.

FREE—25 different United States, with 60% approvals. Enclose 2c. Seidenberg, Rocher, Ill.

TRY Pauline's 'Provals and improve your purchases. Premiums. Big discounts. References. Pauline, Townsend, Montana.

FREE—60 different stamps, including Newfoundland, China, Japan, Mexico, etc., to applicants for our high-grade approvals. Send 3c stamp for return postage. The Edgewood Stamp Company, Dept. H, Millford, Conn.

STAMPS will be sent 2 U on approval, for satisfactory reference. Premium, 2 Jamaica War Stamps. Mrs. Louise Kellogg, West Hartford, Conn.

FREE—Dandy Packet of Foreign Stamps to Approval Applicants. Litten, Rock Island, Illinois.

STAMPS, 61, all different, free. Postage, 2c. Mention paper. Quaker Stamp Co., Toledo, Ohio.

FREE—Choose one. 200 different foreign; 100 United States; 25 Persia with McKeloe's Stamp Weekly, Beverly, Mass., six months. Remit 25c.

FREE—Ten unused stamps. Send 15c for 3 months' trial subscription to Collectors Journal, Minneapolis, Minn.

PACKET "A" 100 varieties foreign stamps, 20c. F. J. Pope, Charlotte, Vermont.

105 CHINA, etc., stamp dictionary, list, 2c. Album (500 illustrations) 3c. Bulhard, Sta. A., Boston.

PACKET of 23 stamps; no two countries alike, 500 hinges. Set of \$1 and \$2 U. S. Rev., all for 5c. Mention paper. Miami Stamp Co., Toledo, Ohio.

20 UNUSED stamps free. All different. Postage, 2c. Fisk Stamps, Toledo, Ohio.

500 MIXED U. S., old and new, 12c. Weatherly, Medina, Ohio.

STAMPS—500 fine foreign incl. Mex. War, Salvador, incl. officials, Guatemala, China, etc., only 10c. Best App. Sheets 60 to 80% dia. We give valuable extra presents free! Big 120 pg. catal. free. We buy stamps. Hussman Stamp Co., St. Louis, Mo.

24 VARIETIES Cuban stamps, 10 cents. List of 6,000 low-priced stamps free. Chambers Stamp Co., 111 P. Nassau St., New York City.

FOR THE SHOP

SHOP Notes for 1917, a book containing 524 Articles, 422 Illustrations, 224 Pages. Easy Ways to do the Hard Things in every trade and calling. Price, 50 cents, postpaid. Also all previous numbers in Shop Notes series Volumes 1 to 12 inclusive at 50 cents each, postpaid. Send for description. Popular Mechanics Book Dept., 6 N. Michigan Ave., Chicago.

RARE COINS

OLD Coins. Large Fall Coin Catalogue of Coins for Sale, free. Catalogue quoting prices paid for coins, ten cents. William Hessein, 101 Tremont St., Boston, Mass.

COINS, bills, stamps, pistols, relics. List free. Collectors' Exchange, 1585 Wellington Street, Philadelphia.

TEN Different Old Bills 50c. Coin Lists free. Moore Coin Company, Commerce, Texas.

CALIFORNIA Gold—quarter size, 27c; 1/2 size, 58c; dollar size, \$1.10. Large cent before 1821, Columbian nickel coin and catalogue, 19c. Norman Shultz, King City, Mo.

WAR has not changed our prices. Send stamp for catalog. Coin Exchange, New Rochelle, N. Y.

WILL pay \$100.00 for Trade Dollar 1855; \$7.00 for 1853 Quarter without arrows; \$750.00 for certain \$5.00 gold without motto. Cash premiums for rare coins to 1912. Get posted. Send 4c. Get our Large Coin Circular. Numismatic Bank, Dept. H, Fort Worth, Texas.

\$4.25 EACH Paid for U. S. Flying Eagle Cents dated 1856. We pay cash premiums on hundreds of Old Coins. Send ten cents at once for New Illustrated Coin Value Book 4x7. It may mean your fortune. Clarke & Co., Coin Dealers, Box 15, Le Roy, N. Y.

GAMES AND ENTERTAINMENTS

MAGIC—Tricks, Books and Supplies. For Amateurs as well as the Great Professionals. Any one can learn through our instructions. Feature Acts in Mind Reading, Spiritualism, Rope Ties, etc. Large illustrated Professional Catalogue, 19c. Chicago Magic Co., Dept. B, 72 West Adams St., Chicago, Illinois.

NOVELTIES to surprise and entertain everybody. Rank tricks, puzzles, jokers. Goods to amuse yourself and your friends. Snuff powder, tich powder, small bombs. 3 for 25c. Shooting fountain pen 25c postpaid. Send 4c for large illustrated catalogue. Retail and wholesale. Grandefeld, 1238 Theriot Ave., Bronx, New York.

WAR—War, about, shoot! All the latest shooting novelties, tricks and jokers' goods. Send 2c for illustrated catalogue. Grandefeld, 1238 Theriot Ave., Bronx, New York.

TOYS—Complete set of American soldiers for 25c postpaid. Send money order. G. Hollinshead, New Baltimore, Mich.

PLAYS for amateurs; Monologues, Recitations, Drills, Minstrel and Vaudeville Jokes and Sketches; Home amusements; ideas for all kinds of entertainments. Send for free catalog. Dramatic Pub. Co., 542 S. Dearborn St., Chicago.

SMALLEST Bible on Earth. Size of postage stamp, 200 pages illustrated. 15c, 10 for \$1.00. Catalog of Novelties and special offer free. P. & S., 1318 Spaight, Madison, Wis.

TRICKS, Puzzles, Jokes, Magical Apparatus, Plays, Stage Supplies, Mind-reading Acts, Sensational Escapes, and Illusions. Free large illustrated 1917 catalog. Oaks Magical Co., Dept. 476, Oakbrook, Wis.

MAGIC—Card Tricks—Books—Sensational Escapes. Catalog just off press, free. Heaney Magic Co., Berlin, Wisconsin.

CARD in egg trick and handkerchief vanish \$1.00. Catalog for stamp. Magic Emporium, 644 East Ave., Oak Park, Ill.

2 DOZEN Assorted Wire and Steel Puzzles. Best 10c Sellers. Postpaid for 50c. Western Puzzle Works, St. Paul, Minn.

PEERLESS Minstrel Book, Recitations, Monologue, 15c each. All 30c. Catalogue plays, farces, 2c stamp. Stanton Amusement, Norwich, New York.

1,000 STAGE and Parlor tricks. Illustrated Catalog 10c. Small Catalog free. Second-Hand Apparatus bought or exchanged. Hornum Magic Co., Sta. 10, 470 8th Ave., New York.

"THE Magical Bulletin." For magicians and entertainers only. Published monthly. Sample 10 cents. F. G. Thayer, 225 S. San Pedro, Los Angeles, Cal.

PLAYS, Vaudeville Sketches, Monologues, Dialogues, Speakers, Minstrel Material, Jokes, Recitations, Tableaux, Drills, Musical Pieces, Entertainments for all occasions. Make-up Goods. Large Catalog Free. T. S. Denison & Co., Dept. 11, Chicago.

BEST Magic Magazines, 10c. New Magic Catalogue free. Eagle Magician, Minneapolis, Minn.

THEATRICAL GOODS

SCENERY supplied. Anywhere. Everywhere. Moderate Rental. Amelia Grain, Philadelphia, Pa.

FOR BOYS

BOYS! Big 1918 illustrated mischief and magic catalog and Para Trick mailed anywhere for stamp for postage. Southham, 415-B Holland Bldg., St. Louis, Mo.

JUST Issued—Amateur Mechanics No. 8. How to make 152 different interesting things such as electric fountains, bird houses, model monoplanes, porch swing, kites of various kinds, fishing rods, camp outfits, scarecrow, stocking machine, etc. 128 pages, 254 illus. Price 25 cents, postpaid. Also all preceding numbers in the series at same price. Popular Mechanics Book Dept., 6 N. Michigan Ave., Chicago.

BIG New Book for Boys—The Boy Mechanic, Vol. II—Just out—A sequel to, but containing nothing found in Vol. I. Tells all about 1,000 interesting things to make and do. 480 pages; 995 illus. Cloth. Price, \$2.00, postpaid. Send for descriptive circular. Popular Mechanics Book Dept., 6 N. Michigan Ave., Chicago.

RAZORS AND BLADES SHARPENED

SAFETY razors sharpened; two cents each. Guaranteed. Blade box free. Electro Strapping Co., 134 Shelby St., Detroit, Mich.

FOR MEN

SHAVING and Toilet outfit, specially arranged for Soldiers, 14 articles, including Khaki Folding Case with embroidered National emblem; consists of Razor, Strop, Brushes, Soaps, Powders, Trench mirror, etc., all of A-1 quality, only \$4.50. Same outfit, but Razor with gold-filled handle having space for initials, and extra special Strop, this outfit \$9. Booklet, "Shaving Made Easy," 25c, sent Free with outfit orders. C. M. Marriott, Box 11936, Los Angeles, Calif.

KNIFE very tough, for cutting Rawhide, etc. Price, Postpaid 50c. Heber Hancock, Taylor, Arizona.

RAZOR Honing. Smooth keen edge put on your razor, 25c, return postage paid. Lot second-hand razors, best makes, values to \$3.50 for 75c and \$1.00. Howard, 4325 Greenwood Ave., Chicago.

FOR THE HOME

"EGGETTE" (the original egg substitute) takes the place of eggs in all kinds of baking and cooking. Simple to use—always fresh. Guaranteed pure food product. Makes delicious cakes, cookies, puddings, etc. 10c package equals 12 eggs. Send 10c for a package today. (Agents Wanted.) Bestever Products Co., B-13, Douglas Park Sta., Chicago, Ill.

DIAMONDS, WATCHES AND JEWELRY

UNREDEEMED Watches and Jewelry good as new—save three-fourths of new price. 7-Jewel Elgin or Waltham fully guaranteed watch, \$3. Other exceptional values. Tell us what you want. We have it and can save you money. David Stern Company, 1627 Madison St., Chicago, Ill.

GUARANTEED Solid gold ring 35c. Big value. Satisfaction guaranteed. Oscar Hanson, Mentor, Minn.

21-JEWEL Watch, \$3.95. If you want a watch, any price or make, write us for confidential inside price on it. We understand them all. Agents wanted. Rex Company, Andover, O.

PHONOGRAPHS AND RECORDS

"KIDS Delight" Phonograph. A real phonograph, plays 10c records. Speed regulator and stop. Amuses the old as well as the young. Complete with 3 records \$2.80. The Nite Mail Order & Supply Co., 2603 So. Penn. Ave., Denver, Colo.

VICTOR and Columbia Records and all make Talking Machines. We buy or exchange for new ones your selection. Send parcel post or express prepaid. Satisfaction guaranteed or goods returned. Record Exchange, 2017 South Street, Philadelphia.

TALKING Machines and Records, Records for Victor, Columbia, Edison, disc or cylinder talking machines bought, sold. Edison Standard 6c, Blue Amberol 25c, Victor 15c up. Send 5 cents in stamps for Record List. Well's Curiosity Shop, 20 S. Second St., Philadelphia, Pa.

WANTED—Victor and Edison Disc Records in good playing condition. Bought and Exchanged. Buffalo Record Exchange, 50 West Chippewa, Buffalo, N. Y.

BUILD your Phonograph. Highest quality motors, tone arms, reproducers, cabinets. Big Saving. Handsome catalog free. Indiana Phonograph Supply Co., Indianapolis, Indiana.

BUILD your Phonograph—any type. Big saving. Works \$5.00 and up. Full instructions, blue-prints, parts—price list, 25c. Circulars free. Arlon Phonograph Supply, South Bend, Indiana.

BUILD Your Own Phonograph. Any type. Big saving. Patents expired. Profits making and selling them. We furnish parts you can't make. Full instructions, dimension drawings, illustrations, parts—price-list only 25c. Circular Free. Associated Phonograph Co., Dept. F, Cincinnati, O.

MUSIC

"GO! My Son, God Bless You." Greatest March Song Success, 20c; orchestration, 30c. Sovereign Pub. Co., 160 Sycamore, Buffalo, N. Y.

SONG-WRITERS and Musicians: Any one can play instantly with our Rotary Music Scale. Helps you arrange song poems to music. This musical marvel complete only \$2.00. Write Needham Music Co., D61, St. Louis, Mo.

FORMULAS AND TRADE SECRETS

1,000 FORMULAS 25c. Luminous paint—gas tonic—carbon remover—puncture plunger—mechanics soap—resolving mirrors—renewing dry batteries 20c each. Entire collection 50c. "The Ideal," Box 543-FL, Chicago.

GOLD and silver plating is easy and profitable. 6 formulas 50c. L. Higginson, Virginia, Ill.

MORE Eggs! Wonderful Egg-Producing formula, 10c. Wm. Waelder, Hannibal, Mo.

10,000 SELECTED scientific, chemical, technological and practical recipes and processes, including hundreds of so-called trade secrets for every business, alphabetically arranged in one large volume of 800 pages. Price \$3 prepaid. Large descriptive circular sent upon request. Popular Mechanics Book Dept., 6 N. Michigan Ave., Chicago.

\$10,000 FORMULAS \$3—Circular descriptions. Claus, 1864 Harman St., Brooklyn.

TYPEWRITERS AND SUPPLIES

STARTLING Values in Typewriters, \$10 to \$15, up. Factory rebuilt. All makes. Shipped on trial. Write for our special offer. No. 126-L, Whitehead Typewriter Co., 186 North LaSalle St., Chicago.

TYPEWRITERS, all makes factory rebuilt by famous "Young Process." As good as new, look like new, wear like new, guaranteed like new. Our big business permits lowest cash prices, \$10 and up. Also, machines rented—or sold on time. No matter what your needs are we can best serve you. Write and see now. Young Typewriter Co., Dept. 328, Chicago.

LARGEST Stock of Typewriters in America. Underwoods, one-fourth to one-half manufacturer's prices; rented anywhere, applying rent on purchase price. Free trial. Installment payments if desired. Write for catalogue 70, Typewriter Emporium, estab. 1892, 34-36 W. Lake St., Chicago, Illinois.

NEW Rebuilt and Slightly Used Typewriters, 3 up. Portable Machines, \$10 up. Write for our catalog 50-P. Bevan Typewriter Co., 58 W. Washington St., Chicago.

419. NUMBER Three Oliver visibles, factory rebuilt, like new. Guaranteed three years. Will express three days' trial. W. D. Knowles, 513 Plymouth Ave., Buffalo, N. Y.

UNDERWOODS, Oliver's, Remingtons, \$15 to \$45; terms to suit; free trial. Typewriter Co., 188 N. Dearborn, Chicago.

UNUSED Display Typewriters, 1/2 manufacturer's prices! Adopted by big corporations since 1895. Investigate. Free Trial (name typewriter preferred). Co-operative Union, Covington, Kentucky.

DUPLICATORS AND DEVICES

\$125.00 SUPERIOR or Automatic Card Press, like new, for quick sale; our price \$55.00. David Stern Company, 1027 Madison St., Chicago, Ill.

\$390 MULTIGRAPH like new for \$160. Guaranteed. Russell Baum, Philadelphia Bourse, Philadelphia.

"MODERN" Duplicator—a Business Getter. \$1 up, 50 to 75 copies from pen, pencil, typewriter; no glue or gelatine. 35,000 forms use it. \$3 days' trial. You need one. Booklet Free. J. E. Durkin & Reeves Company, Pittsburgh, Pa.

OFFICE EQUIPMENT

SAVES time, money, labor—costs less than the average mistake. The Ray adds with speed and accuracy of highest priced machines. Also directly subtracts. Used by U. S. Government, International Harvester Co., B. & O. Ry., business and professional men everywhere. Complete for \$25.00. Handsome desk stand free. Send no money, but write for 20 day free trial. Ray Company, 1632 Power Bldg., Richmond, Va.

PRINTING, ENGRAVING AND MULTI-GRAPHING

ADVERTISERS—Get 100% efficiency from your letters. Our perfect imitation typewritten letter will bring better returns, save time, labor and money. No better advertising medium than personal letters. Samples 10c. A. Mercado Brothers, Box "A," Tyrone, Penna.

BIG Bargains in Printing. Samples free. Willamette Printery, Multnomah, Oregon.

200 LETTERHEADS or envelopes 80c postpaid. Samples free. Barney Golden, East Tallapoosa, Ala.

GOOD Printing at low prices. 1,000 good letterheads, envelopes, cards, billheads, labels, circulars, \$2.50. Samples free. Catalogues, booklets and circulars our specialty. Ernest L. Fantus Co., 323 S. Dearborn St., Chicago.

SOMETHING classic. 50 visiting cards, your name and address printed in gold bronze 25c. Postpaid. Makes a splendid Xmas Present. R. Wiese, Atlantic, Iowa.

500 LETTERHEADS \$1.50. 500 Cards and Card Case \$1. Parcel Post Press, Girard, Kansas.

1,000 GUMMED Labels 50 cents. Samples free. Edward Harrison, General Printing, Baltimore.

250 LINEN Letterheads and envelopes \$1.75 prepaid. Laborer's Printery, Mansura, La.

AT Last! Beautiful Lithography for small users. 1,000 Letterheads, 1,000 Billheads and 1,000 Statements, \$8.90. Engraving Free. Kaydee Lithographing Co., 764 Teutonia, Milwaukee.

PRINTING Outfits — Presses, type, supplies, type novelties. Send stamp for catalogue. Model Press, York, Penna.

100 6% ENVELOPES printed to order, 65c prepaid. Samples, Lincoln Novelty Co., Rochester, N. Y.

QUALITY Printing Prepaid. 500 either envelopes, noteheads, cards, statements, \$1.35; 1,000, \$2.25; 500 linen-finished letterheads or envelopes, \$2.25; 1,000, \$3.50. Prepaid. Typewriter letters. Stamp brings samples. Model Company, Manchester, Iowa.

500 LETTERHEADS, Envelopes to match, \$3.40. Frank Emerson, Brooklyn, Mich.

ENVELOPES, Statements, Billheads. Cards printed \$1.75 per thousand. Other printing low. Samples free. J. M. Hunt, Lambertville, N. J.

500 R. C. CARDS assorted colors, size 3 1/4 x 1 1/4; 1 1/2 x 3 1/4 \$1.25, cash with order. One color ink. Other printing in proportion on quotation. Girard Job Shop, B2, Girard, Kans.

YOUR name on fifty "Styloprint Cards" 35c. Card case free. Bridgen Company, Waltham, Mass.

PERFECTION Letter Company, Muncie, Indiana. Multigraphs 500 purple letters with black letter heads, \$2.15. Samples for stamp.

3,000 GUMMED Labels for \$1.00—size 1 1/2 x 2 1/2. Circular free. Catalogue 2c Stamp. The Helmers Company, Hoboken, New Jersey.

PATENT ATTORNEYS

PATENTS Promptly Procured. Send Sketch or Model for Actual Search. 1917 Edition. 99 page Patent Book Free. My patent sales service gets full value for my clients. It should never require more than 2 days to report upon the patentability of your invention; nor longer than 10 days to prepare your case for filing. Longer delay amounts to gross neglect. For prompt personal service write George F. Kimmel, 53-L, Barrister Bldg., Washington, D. C.

PATENTS Secured or Fee Returned. Books and advice free. Send sketch for free search. We help market your invention. A. M. Buck & Company, 539 7th St., Washington, D. C.

PATENTS that Protect. Write us for new Book Patent Sense, worth more than all other patent books combined. Free. R. S. & A. B. Lacey, 104 Barrister Bldg., Washington, D. C. Est. 1869.

INVENTORS: Let us sell your patent. Send for our liberal proposition. Atlantic Supply Co., Long Branch, N. J.

INVENTORS: Write our Patent Dept. Adam Fisher Mfg. Co., 2061 C Railway Exchange, St. Louis, Mo.

INVENT Something. Your Ideas May Bring Wealth. Free book tells what to invent and how to obtain a patent through our credit system. Talbert & Parker, 4622 Talbert Building, Washington, D. C.

PATENTS obtained through D. Swift being promptly sold to manufacturers. Write today for free books of "Inventions Needed" and surpassing references. D. Swift, 317 Seventh St., Washington, D. C.

DON'T lose your rights to patent protection. Before proceeding further send for our blank form Evidence of Conception to be signed and witnessed. Book, suggestions and advice free. Lancaster & Allwine, 221 Ouray Bldg., Washington, D. C.

PATENT what you invent. It may be valuable. Write me. No attorney's fee until patent is allowed. Estab. 1882. "Inventor's Guide" free. Franklin H. Hough, 522 Loan & Trust Bldg., Washington, D. C.

PATENTABLE Ideas Wanted—Send for 4 free books. R. B. Owen, 59 Owen Bldg., Washington, D. C.

PATENTS without advance attorney's fees. Send sketch for free report. Books free. Frank Fuller, Washington, D. C.

PATENT applications filed on partial payment plan. We help sell the patent. Trade-marks, copyrights, etc. Milo B. Stevens & Co., 685-333 F St., Washington, D. C.; 353 Monadnock Bldg., Chicago. Estab. 1864.

"BOOKS for Inventors" free. Patents for sale. Patent news, Washington, D. C.

PATENTS on easy payments. Send model or sketch for Free Search and certified Registration of Your Invention for Your Protection. Free Book Tells What to Invent and How to Obtain a Patent on Easy Payments. C. C. Hines & Co., 561A Loan & Trust Bldg., Washington, D. C.

FETHERSTONHAUGH & CO., 490 Victor Bldg., Washington, D. C. A 35 year old firm composed of young men for energy and push and older men for counsel—all trained patent lawyers. Free booklet.

FITZGERALD & CO., Patent Lawyers, 803 F St., Washington, D. C. Est. 1889. "The Old Reliable Firm." Free Handbook.

PROTECTIVE patents procured promptly. 104-page blue book on patents sent on request. Trade-marks registered. Robb & Robb, 211-215 Southern Bldg., Washington, D. C.

PATENTS explained in my free books, telling what you should know—what to invent—what not to invent—how to sell your patent, etc. Write today. H. L. Woodward, 302 G St., Washington, D. C.

PATENT Your Ideas. Books, "How to Obtain a Patent," and "What to Invent," sent free. Send rough sketch for free report regarding patentability. Manufacturers constantly writing us for patents. Patents advertised for sale free. Established 20 years. Address Chandlers & Chandlers, Patent Attorneys, 455 7th St., Washington, D. C.

THE Patentsome is free. An education in obtaining patents. Established 1865. Anderson & Son, Attorneys, 707 7th St., Washington, D. C.

PATENTS. R. Morgan Elliott & Co., Patent Attorneys, Mechanical, Electrical and Chemical Experts, 713-721 Woodward Bldg., Washington, D. C.

PATENTS Bring Riches; Protect Your Invention. Attorney's Fee payable when patent allowed. Plain advice and "Patent Facts" free. Trade-marks registered. Jaynes & Jaynes, 653 Kellogg, Washington, D. C.

PATENTS that protect and pay. Advice and books free. Rates reasonable—highest references; best results. Watson E. Coleman, Patent Lawyer, 624 F St., N. W., Washington, D. C.

PATENTS—Herbert Jenner, patent attorney and mechanical expert, 606 F St., Washington, D. C. I report free of charge if a patent can be had and its exact cost. Send for circular.

PATENTS Wanted. Write for list of Patent Buyers who wish to purchase patents and what to invent, with list of inventions wanted. \$1,000,000 in prizes offered for inventions. Send Sketch for free opinion as to patentability. Write for our four Guide books sent free upon request. Patents advertised Free. We assist inventors to sell their inventions. Victor J. Evans & Co., 186 Ninth, Washington, D. C.

"PATENTS and Patent Possibilities" is a 72-page treatise which tells all about patents, what to invent and where to sell it. It gives honest advice to inventors and tells about the successes of some of my clients, also explaining what are frequent causes of failure. Manufacturers are constantly writing for protective patents upon all kinds of sound inventions. Can you help supply their wants? The book is free. Write for it today. H. S. Hill, 905 McLachlen Building, Washington, D. C.

KEEP Up with Progress. Promote your patent. Send \$1.00 for year's subscription to best Inventor's Magazine, "Invention and Manufacturing." United States Patent Corporation, Washington, D. C.

PATENTS—Send sketch for free search and report. Books on patents and book of reference letters sent free. John S. Dufflo & Co., 610 F St., Washington, D. C.

MAILING LISTS

GENERAL store, Minnesota, Dakotas, Montana, Five Dollars per Thousand. Reliable. A. O. Welz, 3026 Harriet Ave., Minneapolis, Minn.

FOR INVENTORS

INVENTIONS commercialized on cash and royalty basis. Patents secured. Models, experimental work and contract manufacturing. Inventors should write at once, Adam Fisher Mfg. Co., 2061C Railway Exchange, St. Louis, Mo.

INVESTOR will buy patents. Write details. 602 Caswell Block, Milwaukee.

EXPERIMENTAL work, special machinery, automobile inventions, expert assistance to inventors, drawings, models, etc. L. Henden, 1926 Broadway, N. Y.

SEND patent copy and price. Howard Smith Co., Washington, Penna., Originators of New Things.

ADVICE on patentable ideas. Confidential electrical and mechanical information furnished to inventors at low rates by expert engineers. We send on receipt of your inquiry our guarantee giving absolute protection of your ideas. Investigate our offer. Sandborn & McKaig, Engineers, 174 West 85 Street, New York City.

INVENT Something. Your Ideas May Bring Wealth. Free book tells what to invent and how to obtain a patent through our credit system. Talbert & Parker, 4289 Talbert Building, Washington, D. C.

INVENTIONS—Patenting and Promoting. A book containing practical advice and directions for inventors and manufacturers. Book, suggestions and advice free. Lancaster & Allwine, 221 Ouray Bldg., Washington, D. C.

PATENTABLE Ideas Wanted—Send for 4 free books. R. B. Owen, 20 Owen Bldg., Washington, D. C.

NO Attorney fees until patent allowed. Send sketch for free report. Books free. Frank Fuller, Washington, D. C.

"BOOKS for Inventors" free. Patents sold. Patent News, Washington, D. C.

INVENTORS—Do you contemplate prosecuting your own applications? If so, read "Patents and the Preparation and Prosecution of Applications by Applicants Themselves." A paper read before the Examining Corps of the United States Patent Office. Price \$1.00. Address George R. Ide, 644 D Street, N. E., Washington, D. C.

INVENTORS—We specialize in manufacturing new patented articles—make models—dies—and do experimental work. Leo J. Gerding Mfg. Co., Dept. D, Opera Place, Cincinnati, O.

WANTED—An Ideal Who can think of some simple thing to patent? Protect your ideas; they may bring you wealth. Write for "Needed Inventions" and "How to Get Your Patent and Your Money." Randolph & Co., Patent Attorneys, Dept. 144, Washington, D. C.

LET Government expert make your drawings. Skilled designer and engineer. Valuable advice. Engineer, 3222 Park Pl., Washington, D. C.

GREAT opportunities exist for inventors, but a patent is not everything. My free books tell what you should know. Horace L. Woodward, 902 G, Washington.

INVENTIONS—How to protect, sell and buy them. If you are inventive, read this book. 108 pages. 25c, postpaid. Popular Mechanics Book Dept., 6 N. Michigan Ave., Chicago.

PATENTS on easy payments. Send model or sketch for free search and certified registration of your invention for your protection. Free book tells what to invent and how to obtain a patent on easy payments. C. C. Hines & Co., 591A Loan & Trust Bldg., Washington, D. C.

HAVE You An Idea? If so, you should protect it by a patent. Send us a model or sketch for free opinion as to patentability. Write for our Four Books sent free to any address. Victor J. Evans & Co., 157 Ninth St., Washington, D. C.

INVENTORS: Invent for profit. Write for list of needed inventions. Sanders, 7 Webster Bldg., Chicago.

PATENTERS—Incorporate and market your patent. H. Sanders, 114 W. Van Buren St., Chicago.

PATENTS FOR SALE

PATENT Buyers are invited to address our sales department for information on any class of Patents they wish to purchase or lease on a royalty. We have secured a number of valuable patents in all lines of invention. Mail Order, Department Store and Household Novelties a specialty. Victor J. Evans & Co., 169 Ninth St., Washington, D. C.

FOR Sale. Improved "Safety first" brake beam hangers. Henry Miller, Bristol, Pa.

WE have some money-making inventions for placing on royalty; outright sale or trade. Write Adam Fisher Mfg. Co., 2061B Railway Exchange, St. Louis, Mo.

POSITIVE and quick control of Search Light for enclosed Automobiles and other motor conveyances. C. E. Rice, 4941 W. Superior St., Chicago, Ill.

OUTDOOR Electric Lamp Bracket—absolutely weatherproof and circuit proof. Approved by National Board of Fire Underwriters. Reasonable offer accepted. T. Nelsen, 2808 Lyndale St., Chicago.

FOR Sale—Patents—Sugar Beet Topper and Digging Machines, Gasoline or Horse Power. Make Me Offer. John M. Sherer, Owner, America, Ala.

OVERSHOE and Rubber Retainer. Positively holds overshoes and rubbers in proper position and prevents slipping off. Manufactured at low cost. Sells for 10c at big profit. Box 41, Telford, Penn.

FOR Sale—Inventor will sell patent for novel laundry device. Model has proven its practicability. Address Ralph E. Gray, R-x 1113, Salt Lake City, Utah.

U. S. PATENT for sale, No. 1,219,142, electric tool for grinding valves in gas engines. Reasonable offer accepted. L. O. Clamptitt, 330% West 46th St., Los Angeles, Cal.

STEERABLE Sled—U. S. Patent 1,166,130. Outright cash. Steerable as a bicycle. Large market awaits a really steerable sled. F. Bennett, Nutley, New Jersey.

SELL patented improvement on Automobile Gas Engine. Manufacturing cost very small. Largest profit, no substitute; sale no limit. Charles Reuter, Mobile, Ala.

FOR Sale—Patent on Height Gauge Attachment for Square. A small tool for Tool, Die, and Metal Pattern Makers, and Machinists. Boyd Thompson, 844 Franklin St., S. E., Grand Rapids, Mich.

U. S. PATENT. Emergency brake for street-cars. Johnson & Johnson, 6849 S. Green St., Chicago, Ill.

PATENT 1,206,737, foldable ironing board that fits a suit case for use of traveling people. Outright or royalty. A. Laurent, 293 West 102nd St., N. Y.

WILL sell "Patented Attachment"—turns "Headlights" on Automobiles automatically—light follows path car is moving. D. Fornbraseo (owner), Klamath Falls, Ore.

PATENTS: Our practice before the Patent Office extends over seventy years. It pays to employ an attorney of reputation, as a poor patent is a bad investment. Ability and Reliability are our special partners. We are also the publishers of the Scientific American and all patents secured by us are described without cost in the Scientific American. Your invention is thus brought to the attention of thousands of intelligent readers especially interested in such matters. To procure like publicity in any other manner would cost you many times the patent fees. Our Hand Book on Patents sent free on application. Munn & Co., Patent Attorneys, 643 Woolworth Building, New York, 625 F St., Washington, D. C.

PATENT: Interchangeable Sectional Tire No. 1,233,853 for automobiles. The only practical one in the United States. Too big for owner to handle. Name your price. Address: James Drummond, 437 South Laundale Ave., Kansas City, Mo.

SPORTING Goods Manufacturers and others. Shoelace makes any shoes a pair of spikes in a jiffy; light, strong. Patent cheap at \$30,000. Will consider any reasonable offer. Write, Alfred Schrader, Box 135, Surrey, N. Dak.

SPLENDID Opportunity. For Sale—Patent for Hose Clamp. Ready for Manufacture with Dies. E. Heynemann, 1926 Broadway, New York City.

STOPPING Apparatus for motor cars. No. 1,121,404. Practical and efficient. A boon to auto manufacturers. Reasonable offer considered. H. C. Ruf, Easton, Pa.

INVENTIONS—For sale, lease or trade. Mutual Service Bureau, Cincinnati, Ohio.

NEW Invention—Real warfare—trench, sandbags, soldiers, cannon, but harmless. Keeps children busy for hours. Mellon (inventor), Times Bldg., Chicago.

FOR Sale—Patent convertible chair. 12 in one. F. Goetz, Keyport, N. J.

BEFORE buying any patent write us explaining your wants. We will put you in touch with a number of valuable patents now for sale or lease, including the following: No. 10,519, Road Drag; No. 10,253, Combined Tobacco and Match Box; No. 10,244, Improved Match Box; No. 10,697, Improved Shade Bracket. Talbert & Parker, 4687 Talbert Bldg., Washington, D. C.

CROSS arm for telephone and electric light wires, 100% stronger than wood. Will last 100 years. As light as wood arms. Saving to users enormous. United States and Canadian Patents. O. P. Magellan, Westerville, Ohio.

OUTRIGHT or Royalty. Cuspidor Handing Device to clean, empty and carry cuspidor without touching with the hand. Patent pending. Bernard Leffoy, 1237 Miller St., Zanesville, Ohio.

SAFETY Elevator. Complete, provided with compound concussion chambers, operated automatically. Patent No. 1,101,686; no price asked, but any reasonable offer considered. Benjamin Ocker, Marion, Pa.

PATENTED Novelty Scrap-Basket with removable and changeable fabric covering, collapsible, can be shipped flat, quick and cheap to manufacture, possibilities unlimited. Adine Kunath, 830 Broadway, New York City.

FOR Sale—Gollings automobile light reflector. Patented July 3, 1917. A. H. Gollings, 839 Boulevard, Akron, Ohio.

OUTRIGHT or Royalty—Heater attachment for oil-lamps. New; practical. Excellent for agents and mail-order trade. Address C. S. Ferguson, New Melle, Mo.

OFFER cash U. S. patent camera attachment No. 92,510, patent pending. Write inventor, Alfred Freitas, 513 Gorham St., Lowell, Mass.

WAVE motor, power almost unlimited. Indestructible. Would like party to develop invention. For interest in the patent 1,170,038, or will sell patent outright. Henry Schaser, Sierra Madre, Cal.

PATENT for sale, household article universal demand, hardware line. Suitable general trade, department store, premiums, agent or mail order. Smithers, 61 Hooker, Detroit, Mich.

FOR Sale—U. S. patent, outright or royalty, handy tool for electricians and auto shops. Outright preferred. For particulars write, Jos. H. Courtney, Box 152, Magdalena, N. Mex.

PATENT on Improved Article-Carrier for sale on cash or royalty basis. Reasonable terms. For full particulars address, Joseph Falls, Gunn, Wyoming.

MODELS AND MODEL SUPPLIES

INVENTIONS Developed. The specialists who develop Auto accessories, gasoline engines, automatic cigarette-making machines; weighing, tending, photography and lead pencil printing machines; electric scales; turbines; air, electric and steam motors and other intricate devices are at your service. They'll handle your development drawings, experimental work, patterns, models, special tools, dies, stampings, castings, plating, forging and spinning in our big plant—covers two acres. Make any metal novelty. Complete organization for developing, manufacturing and selling. Advice backed by 30 years' experience free. Send drawings or samples. The Wm. Gent Machine Co., Cleveland, Ohio.

MODELS, Punches and Dies. Patents Perfected. The Sachs-Lawler Co., Inc., Established 1881. 1543 Larimer St., Denver, Colo.

PERFECT models sell inventions. We make them. Write Adam Fisher Mfg. Co., 2061E Railway Exchange, St. Louis, Mo.

WE make working models for inventors; also dies and stamping of specialties, and carry a complete stock of brass gears and model supplies. Send for catalogue. The Pierce Model Works, 3465 Pierce Ave., Chicago, Ill.

WANTED—New Ideas. Write for list of Patent Buyers and Inventions Wanted. \$1,000,000 in prizes offered for inventions. Our Four Books sent free upon request. Victor J. Evans & Co., 145 Ninth, Washington, D. C.

MANUFACTURING

DIES, Tools, Experimental Machinery, Special Machinery, Stamping, Screw Machine Work, Manufacturing, Models, Drafting and Development of Inventions; two Shops, one Engineering Laboratory, Expert Workmen. Our exceptional facilities, skill and experience at your command. Write today. R. G. Clyde Machine Works, 318 Eighth St., St. Louis, Mo.

WIRE Goods, all kinds, made to order. Cooley Mfg. Co., 553 W. Monroe St., Chicago.

INVENTIONS manufactured under contract. Write Adam Fisher Mfg. Co., 2061F Railway Exchange, St. Louis, Mo.

WE manufacture spring motors, window displays and all kinds of patented devices. High-class work. Prompt service. Let us estimate. Imperial Clock Company, 3425 Rutger Street, St. Louis.

WE will commercialize and manufacture that electrical or mechanical invention for you. Confidential development and experimental work. Precision Engineering Co., 2914 Woodburn Ave., Cincinnati, O.

LET us build your light machinery, dies, tools and castings. We can solve your problems. Standard Machine and Tool Co., Yale Ave., Columbus, Ohio.

REAL ESTATE AND FARM LANDS

FOR Sale—Timber and farming land. 3,500 acres, almost solid body, one mile to trunk line railroad, two miles to Suwanee river, three to good town; all pine timber is long leaf yellow pine; land is excellent for general farming, fruits and pecans, almost perfectly level; no waste; no overflow; no palmetto; land alone worth more than my price for both; timber worth \$10,000 now, and is increasing in value every day; no safer investment anywhere and one offering every assurance of great value increase; only \$2.50 per acre, half cash. J. W. Blume, Live Oak, Fla.

FARMS—5,000, all sizes, to exchange; located in Kansas, Missouri, Colorado, Arkansas, Iowa, Texas and Oklahoma; let us know your wants. Goodman, 517 Commerce Bldg., Kansas City, Mo.

CALIFORNIA little farms near Los Angeles for sale on easy payments. Write E. H. Waite, Shawnee, Oklahoma.

LOCATE in Los Indios, Isle of Pines, where "Just Naturally the Best" Grapefruit grows. Climate unsurpassed for citrus fruits and vegetables. Growers netting big returns. No hail! No frost! No sheet! No snow!!! Pay for your 10, 20 or 40 acre farm with small monthly payments. Titles Guaranteed. Protect your family with this kind of life insurance. Further information cheerfully furnished. Address B. G. Allen, Room 712, 117 Wisconsin St., Milwaukee, Wis.

MONEY-MAKING Farms—15 states, \$10 an acre up; stock, tools, and crops often included to settle quickly. Write for Big Illustrated Catalogue. Strout Farm Agency, Dept. 3043, New York.

VIRGINIA and North Carolina Farms \$15 Per Acre and up. Easy payments. Fruit, Dairy, Stock, Climate, Schools, Churches, Roads, Markets and Neighbors of the best. Get our Farm Lists, magazine and other interesting literature, all free. Address—F. H. LaBaume, Agri. Agt., N. & W. Ry., 250 N. & W. Bldg., Roanoke, Va.

MISSISSIPPI—Madison County—First Prize, State Fair, 1917. More Northern families than any three counties in State. Excellent schools, graveled roads, ideal climate, fertile lands. Ten to forty dollars per acre. Tip Ray, Canton, Mississippi.

\$3.00 DOWN, \$5.00 monthly; seven-acre fruit, poultry, fur farm; river front; Ozarks; \$100.00. Hunting, fishing, trapping. Harvey Hubbard, 1973 North Fifth, Kansas City, Kansas.

A SMALL California Farm earns more money with less work. Raise the crops you know about—alfalfa, wheat, barley, etc.—also oranges, grapes, olives and figs. Ideal for dairying, pigs, and chickens. No cold weather; Rich soil; low prices; easy terms; good roads; schools and churches. Enjoy life here. New comers welcome. Write for our San Joaquin Valley, also Dairying and Poultry Raising Illustrated folders, free. C. L. Seagraves, Industrial Commissioner, AT&SF Ry., 1933 Railway Exchange, Chicago.

SELL your property quickly for cash, no matter where located. Don't pay big commissions. Particulars free. Real Estate Salesmen Co., Desk B, Lincoln, Nebr.

OWN your own Orange or Grapefruit grove in beautiful Fruitland Park. Let me tell you how melons, peaches, hay, your first crops, should pay for your land and grove. J. G. Lloyd, Desk 93, Fruitland Park, Florida.

ANTIQUES AND RELICS

POMO Indian Star Baskets. Prices free. Gilham, Highland Springs, Cal.

DOGS, BIRDS, POULTRY, PETS

SQUABS are raised in one month, they sell for fancy prices. Write at once for big free book telling how to make money breeding squabs. Plymouth Rock Squab Co., 634 Howard St., Melrose Highlands, Massachusetts.

EARN big money raising Belgian hares. Particulars 10c. Anderson's Rabbitry, 2421 Ogden, Denver, Colorado.

HOUNDS for any game, guaranteed. Three States Kennels, Somerset, Ky.

AIREDALES—Collies—Scottish Terriers. Send for free lists. State wants. P. L. Savage, St. Charles, Ill.

FOR Sale—Foxhounds, trained and untrained. Several litters of foxhound pups. Registered in United Kennel Club. R. A. Schuchard, Hammond, Minn.

FOR Sale. Fox, Coon, Skunk, Opossum Hounds sold on 20 days' trial. Stamp for prices. Yellow Creek Kennels, St. Catharine, Mo.

THOROUGHBRED Belgian Hare-bucks. \$5 each. Bloomsburg Belgian Hare Farm, Bloomsburg, Pa.

BIG Money in Pigeons and Squabs. Free book tells you all about it. Write today. Start profitable business of your own. Demand unlimited. Investment is small. Write today for Free Book. Indiana Squab Co., Dept. 1199, Terre Haute, Ind.

RAISE Guinea Pigs, more profitable than poultry. Big demand. Thousands needed. Experience unnecessary. Send for our money-making proposition and big free illustrated book, explains all. Laboratory Supply Co., Dept. K, 2841 Ridge Ave., Phila., Pa.

SQUAB Journal, treats on raising and marketing of squabs. Four months' trial, 25c. Sample 10c. Squab Journal, Warrenton, Mo.

AIREDALE pups for sale. W. Bebee, 4290 4th Ave., Des Moines, Iowa.

BEAUTIFUL white Collies. Pets, workers or companions. Attractive, beautiful, refined and useful. Address, The Shomont, Dep't E, Monticello, Iowa.

RAISE Guinea Pigs for us. We buy all you raise. Pay better than poultry. Contract, particulars, booklet how to raise free. Cavies Distributing Co., 3102-A Grand Ave., Kansas City, Mo.

TRAINED beagles, rabbit hounds, foxhounds, coon, skunk dogs, ferrets, catalogue 10c. Brown's Kennels, York, Pa.

RAISE Belgian Hares for us. New Zealand and Flemish Giants. Profits Large! We supply stock and pay you \$3.00 each. Also Cavies, Squab Breeders, and Fur Bearing Animals. Instruction Books, Contract and prospectus for dime. None free. Outdoor Enterprise Co., Box 99, Holmes Park, Mo.

HANDSOME Dog Collar Name Plates, Dog's Name, Your Name and Address, 25c. Sullivan, Engraver, 190 Abbott Ave., Fitchburg, Mass.

YOU can make a good living in your back yard raising Belgian Hares. Particulars free. Mark Twain Stock Ass'n, 101 Hannibal, Mo.

RAISE skunks in city or country. Odorless method. Illustrated circular P free. Skunk Development Bureau, Chicago.

PERSONAL

THE oldest, largest, most reliable private concern in Chicago. Money loaned on Watches, Diamonds, Jewelry, Silverware, Furs, Clothing, Cameras, Lenses, Victrolas, Hand Bags, Suit Cases, Fine tools, Musical Instruments and all other Goods of Value. Our own fire-proof Vaults on the premises. Highest cash prices paid for old Gold, Silver and Platinum. David Stern Company, in business since 1885, 1027 Madison Street, Chicago, Ill.

BROTHER—Discovered pleasant root, chewed like gum, quickly overcomes tobacco habit. Gladly send particulars. Franklin Stokes, Mohawk, Florida.

STOP Using Tobacco. Complete treatment \$1. Sincerely Bros., Des Moines, Iowa.

ILL-SMELLING, swollen and sweaty feet can be most successfully treated with "Odorgone." the powder that permanently dispels any trace of bad odor. Put up in shaker top tins. Sent anywhere for 50c coins or stamps. Money-back guarantee. The Odorgone Co., Box 823, Station "W," Seattle, Wash.

FREE—Stop using tobacco. We will give free information how to conquer habit easily and permanently. Results Guaranteed. Anti-Tobacco League, Box 370, Omaha, Nebr.

MISCELLANEOUS

LUMINOUS Paint. Shines in the dark. Our Luminous Paint, coated on any article, makes them visible at night. Watches, clocks, electric switch plates, crucifixes, match boxes, etc., can be coated with splendid results. (Everlasting.) Only 25c bottle. Luminous Paint Co., Douglas Park Station, B-25, Chicago, Ill.

GRANDFATHER'S Clock Works \$5.00. Build your own cases from our free instructions. Everybody wants a hall clock. You can make good profit building artistic clocks for your friends. We replace worn-out works in old clocks with works having chimes at money-saving prices. Write for folder describing the most beautiful hall clock ever sold at \$25.00. Clock Co., 1673 Ruffner St., Philadelphia, Pa.

FORMULAS—all kinds. Valuable collection and big catalog 10c. "The Ideal," Box 348-M, Chicago.

SHELLS, 1,600 named varieties in cabinets (glass-covered drawers), \$4.00. C. R. Orcutt, 1795 Broadway, San Diego, California.

FOR Sale. Ten acres irrigated land, Yakima Valley, Wash., or will trade for Wisconsin property. L. P. Kunz, Oconomowoc, Wis.

CUTS anybody can make. Simple, cheap process, \$1. Specimens, particulars, 2c stamp. M. Day, Windfall, Ind.

USED Stamps Wanted—Common kinds, 20c hundred. Particulars, 2c. "Elaea," Owaso, Mich.

PICK up some easy money gathering butterflies, insects. I buy 750 kinds. Some \$1-\$7. Intensely interesting. 2c stamp brings prospectus. Get posted. Sinclair, Box 244, D-6, Los Angeles, Cal.

THE Modern Gasoline Automobile—Most complete and up to the minute automobile book published. Recognized as the standard book on construction, operation, maintenance and repair, showing every recent improvement. Over 700 pages, 500 illustrations. Cloth. Price, \$2.50 postpaid. Send for complete description of this and other reliable automobile books. Popular Mechanics Book Dept., 6 N. Michigan Ave., Chicago.

OFFICIAL Auto Wiring Guide—Just Out. The most valuable book ever offered to the automobile world. Contains 430 pages; 448 of which are guaranteed accurate blueprint diagrams showing complete wiring circuits of all makes of gas and gas-electric cars, dating back as far as 1912. Miscellaneous wiring diagrams covering all starting and lighting systems are shown as well as diagrams for re-wiring cars, both grounded and multiple systems. Price \$7.50 prepaid. Send for 8-page descriptive circular. Popular Mechanics Book Dept., 6 N. Michigan Ave., Chicago.

AUTOMOBILE Repairing Made Easy—The most needed and useful book on automobiles ever written. Only book of its kind—just out. Covers every phase of automobile repairing practice. 1,056 pages (5½ x 8 in.), 1,000 engravings. Cloth. Price \$3.00 postpaid. Send for complete description of this and other reliable automobile books. Popular Mechanics Book Dept., 6 N. Michigan Ave., Chicago.

PATTERN Makers! A book devoted to the principles of pattern and core making and molding. Written by G. H. Willard, a practical pattern maker of years' experience. This book, just published, treats the subject in a much more simple, direct and effective manner than most books along this line. 224 pages, 312 illustrations. Price, \$1, postpaid. Popular Mechanics Book Dept., 6 N. Michigan Ave., Chicago.

MISSION Furniture—Make your own at little expense. Complete instructions, working drawings and stock lists for 96 different pieces. Price \$1.50 postpaid for set of three books. Send for complete descriptive matter. Popular Mechanics Book Dept., 6 N. Michigan Ave., Chicago.

FINGER Print Instructor—A text book for the guidance of finger print experts and an instructor for persons interested in the study of finger prints. Book based on the Henry System and prepared by an expert. Cloth, 155 pages, illustrated. Price, \$2.00 postpaid. Popular Mechanics Book Dept., 6 N. Michigan Ave., Chicago.

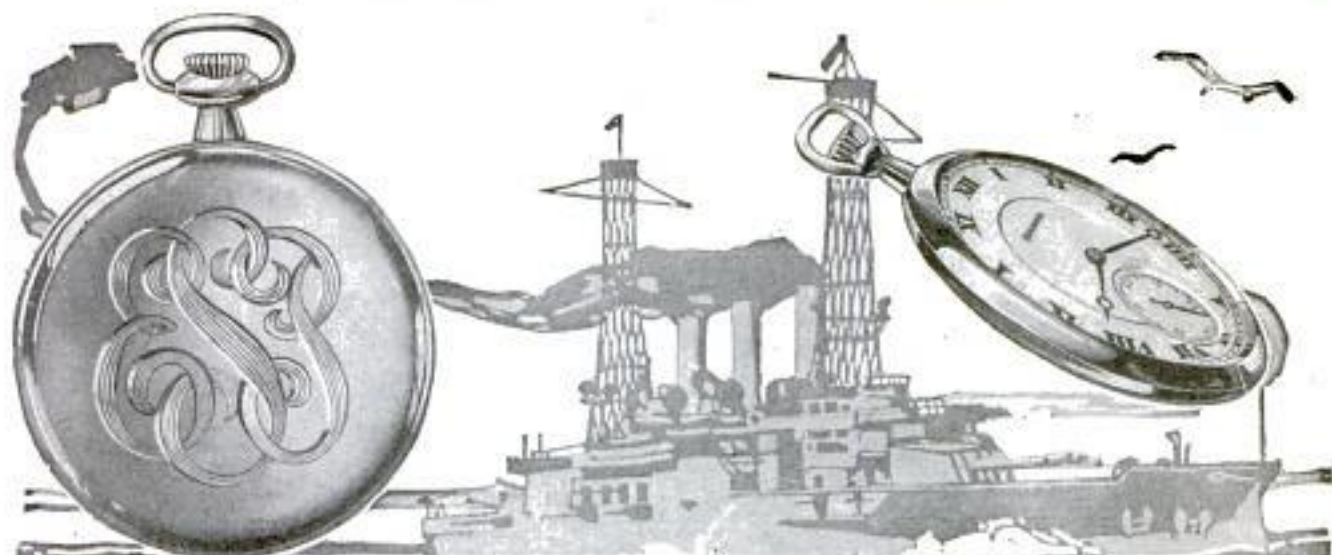

6,003 Burlingtons in the U. S. Navy—

A WATCH has to be made of sturdy stuff in order to "make good" on a man-of-war. The constant vibration, the extreme heat in the boiler rooms, the cold salt air and the change of climate from the Arctic to the Tropical are the most severe tests on a watch. If a watch will stand up and give active service aboard a man-of-war, it'll stand up anywhere.

6003 Burlingtons have been sold to the men aboard the U. S. battleships. Practically every vessel in the U. S. Navy has a Burlington aboard. Some have over 100 Burlingtons. The victory of the Burlington in the U. S. Navy is testimony to Burlington superiority.

21-Jewel \$2⁵⁰ Burlington A Month

And yet you may get a 21-jewel Burlington for only \$2.50 a month. Truly it is the master watch, 21 ruby and sapphire jewels, adjusted to the second, temperature, isochronism and positions. Fitted at the factory in a gold strata case, warranted for 25 years. All the newest cases are yours to choose from. You pay only the *rock-bottom-direct-price*—positively the exact price that the wholesale dealer would have to pay.

See It First! You don't pay a cent to anybody until you see the watch. We ship the watch to you *on approval*. You are the sole judge. No obligation to buy merely because you get the watch on approval.

Write for Booklet!

Put your name and address in the coupon or on a letter or post card now and get your Burlington Watch book free and prepaid. You will know a lot more about watch buying when you read it. Too, you will see handsome illustrations in full color of all the newest cases from which you have to choose. The booklet is free. Merely send your name and address on the coupon.

Burlington Watch Company,
19th St. & Marshall Blvd., Dept. 8199, Chicago, Ill.

Burlington Watch Co., Dept. 8199
19th Street & Marshall Blvd., Chicago, Ill.

Please send me (without obligations and prepaid) your free book on watches with full explanation of your cash or \$2.50 a month offer on the Burlington Watch.

Name

Address

Continued from Page 32

BINDER for Popular Mechanics magazines. Best adjustable magazine binder on the market made especially to hold any number from one to six copies of this magazine with name "Popular Mechanics" in gold letters on front cover. No laces or cutting or perforating of pages necessary. Simple, unique adjustment; handsome, durable and neat. We buy in quantities and can offer our readers this regular \$1.50 binder for \$1.25, all shipping charges prepaid. Address Popular Mechanics Book Dept., 6 N. Michigan Avenue, Chicago.

ROPP'S Calculator and Short-Cut Arithmetic—Shows the answer as quickly as a watch shows the time to all problems likely to occur in office, store, shop, bank, farm or factory. Over two million sold. Price, vest pocket size, 50 cents; leather pocket size, \$1.00; large desk size, \$1.25 postpaid. Complete description sent upon request. Popular Mechanics Book Dept., 6 N. Michigan Ave., Chicago.

IDEAL Atlas—Just Published—Contains large scale maps, yet is a book of handy size. Has special maps of all war zones in addition to all regular maps found in a good atlas. Is self-revising, that is, contains a certificate entitling the purchaser to a supplement of new maps after the war is over. Genuine flexible leather binding. 512 pages, 256 pages of maps, 256 pages of text. Price, \$2.50. Cloth binding \$1.65 postpaid. Popular Mechanics Book Dept., 6 N. Michigan Ave., Chicago.

OH, Skin-ny! The Days of Real Sport. Famous cartoons by Clare Briggs with appropriate verse by W. D. Nesbit. Here is a book for young and old. One you will enjoy reading and even more enjoy giving to others. Price, \$1.50, postpaid. Cartoons Magazine, Book Dept., 78 E. Madison St., Chicago.

THE Telegraph Instructor—Sixth and Revised Edition, just from the press—containing 318 pages of valuable information pertaining to railway and commercial telegraphy. Many illustrations showing how to erect a line, the different telegraph instruments, switch-boards and their different connections; numerous colored illustrations of train movements and semaphore signals as used by all railroads. Complete in every detail and written in language easily understood. Used by many telegraph schools as a text book. No student of telegraphy or telegraph operator can afford to be without this book. Price, \$1.25 postage prepaid. Money returned if it doesn't please. Popular Mechanics Book Dept., 6 N. Michigan Ave., Chicago.

MAKE a complete Motion Picture Camera and Projector from instructions given in our book Amateur Mechanics No. 4. Full details given. Not hard to construct. Worlds of enjoyment taking and exhibiting subjects dear to the heart. Price of book only 25c, postpaid. Popular Mechanics Book Dept., 6 N. Michigan Ave., Chicago.

MOTION Picture Operation, Stage Electrics and Illusions—The only practical handbook and guide published for motion picture operators, theater electricians and managers. A thoroughly practical and useful book, covering the subject comprehensively. Pocket size, leather, 393 pages, fully illustrated. Price, \$2.00 postpaid. Popular Mechanics Book Dept., 6 N. Michigan Ave., Chicago.

FAVORITE Old Home Songs—No home in the land should be without this book of 290 of the familiar old songs everybody loves. Words and music complete in a substantial volume 9 1/2 x 7 inches in size. Price 50 cents postpaid. Popular Mechanics Book Dept., 6 N. Michigan Ave., Chicago.

ROPP'S Price Marking Tables and Profit Indicator make price fixing an exact science. With the assistance of this book any merchant can instantly mark any item costing from 1c to \$100.00 with an accurate selling price which will cover any desired percentage of profit and at the same time include the percentage of overhead expense. Avoid the rock on which many a promising business founder. Price \$2.00 postpaid. Money back if not satisfied. Popular Mechanics Book Dept., 6 N. Michigan Ave., Chicago.

ADVERTISING by Motion Pictures is the book of the hour for the business man who is seeking up-to-date methods, whether he be manufacturer, wholesaler or retailer. The first and only practical book to deal with this immensely important subject. Each one of the 48 chapters teems with snappy new ideas pertaining to a great many different lines of business. 253 pages. Cloth, Price \$1.50 postpaid. Popular Mechanics Book Dept., 6 N. Michigan Ave., Chicago.

SHOP Notes for 1917, a book containing 524 Articles, 422 Illustrations, 284 Pages. Easy ways to do the Hard Things in every trade and calling. Price, 50 cents, postpaid. Also all previous numbers in Shop Notes series Volumes 1 to 12 inclusive at 50 cents each, postpaid. Send for description. Popular Mechanics Book Dept., 6 N. Michigan Ave., Chicago.

HAVE you a Patent to sell? You'll be interested in my proposition. Write now for free particulars. Don't call. F. W. Johnson, 6 N. Michigan Ave., Chicago.

MISSION Furniture—Make your own at little expense. Complete instructions, working drawings and stock lists for 94 different pieces. Price \$1.50 postpaid for set of three books. Send for complete descriptive matter. Popular Mechanics Book Dept., 6 N. Michigan Ave., Chicago.

A LAMP WITHOUT A WICK

A new lamp, which experts agree gives the most powerful home light in the world—better than gas or electricity—and a blessing to every home, on farm or in small town, is the latest achievement of W. H. Hoffstot, 530 Factory Building, Kansas City, Mo. This remarkable lamp gives 300-candle power at one cent a night. It has no wick and no chimney, and is absolutely safe. A child can carry it. It gives such universal satisfaction that he is sending it on Free Trial. Mr. Hoffstot wants one person in each locality to whom he can refer new customers. Take advantage of his free offer. Agents wanted. Write him today.—*Adv.*



ACORN UNI-LITE FREE OFFER

Turns night into day. 300 candle-power. Carry as a lantern; use anywhere as a lamp. Weather proof. For house, barn, garage, camp and around the farm. Write for big, free offer. Special opportunity to farmers, stockmen and motorists. Agents make big money.

WRITE TONIGHT for new 1916-1917 offer.
ACORN BRASS MFG. CO., 122 Uni-Lite Bldg., Chicago

If you need a book on some mechanical subject and do not know where to find it, write
POPULAR MECHANICS BOOK DEPARTMENT
6 N. Michigan Ave., Chicago

We Send Prepaid,
No Money Down,
10 Nights' Free Trial

See it, try it, test it in any way you want in your own home, alongside any other light. Then if you feel like parting with it send it back at our expense. The trial costs you nothing. We take all the risk.

U. S. GOVERNMENT report shows mantle oil light more than 3 times as efficient as ordinary lamp. The Daylite is whiter and brighter than gas or electric, at 1/4 the cost. Pays for itself in a few months in oil saved. No smoke, no dirt, no odor. Uses common wick and is lighted same as ordinary lamp. Simple and safe, cannot explode. Only oil light guaranteed for 5 years. Only mantle light with telescoping tubes; full details in complete illustrated catalog—It's FREE.

AGENTS WANTED. No money—no experience—needed. Five out of six buy the Daylite the minute they see it. Wanted in every home. No talking necessary. Sells itself. No capital required. We supply stock, all necessary equipment, and protected territory. Men with rigs or autos are making \$6 to \$15 every day, month after month.

WRITE NOW FOR LAMP—FREE for ten nights' trial. Tell us if you have a rig or auto, whether you can work spare time or steady, your age, occupation, what territory you want and when you can start.

DAYLITE COMPANY, 335 DAYLITE BUILDING, CHICAGO, ILLINOIS

SENT FREE! JUST OUT
Model 8 Daylite

Whiter-Brighter Than Gas or Electric, at 1/4 the Cost

BURNS
KEROSENE



WEBSTER'S NEW
INTERNATIONAL
DICTIONARY

G. & C. MERRIAM CO., SPRINGFIELD, MASS.

Whatever your question;—be it the pronunciation of a new term; the spelling of a puzzling word; the location of Nigeria, the meaning of tractor, white coal etc.—this New Creation contains a clear, accurate, final answer.

REGULAR AND INDIA-PAPER EDITIONS

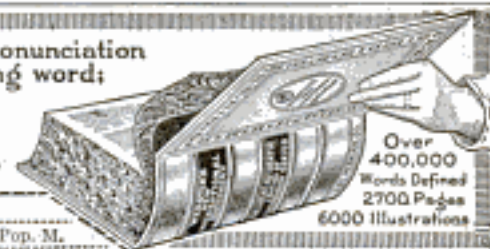

Over
400,000
Words Defined
2700 Pages
6000 Illustrations

Please send me specimen pages and
FREE POCKET MAPS

NAME

ADDRESS

Pop. M.

Please Mention Popular Mechanics



Amazing Opportunities in the AIRPLANE INDUSTRY

Never before have ambitious men had such a glorious chance as is offered today in this wonderful new industry. The war news only proves that the Airplane has come to stay—that thousands and hundreds of thousands of airplanes will be demanded for commercial uses when peace returns.

Meanwhile an army of trained men must be found to man the new aeroplane factories that are now being built everywhere. This makes the big chance for you—a chance of a lifetime. Enroll NOW for our complete Course of training in Practical Aeronautics and the Science of Aviation and prepare yourself in a few short months to double or treble your present salary.

We Teach You By Mail In Your Spare Time at Home

Our new, scientific Course has the endorsement of airplane manufacturers, aeronautical experts, aviators and leading aero clubs. Every Lesson, Lecture, Blue Print and Bulletin is self-explanatory. You can't fail to learn. No book study. No schooling required. Lessons are written in non-technical, easy-to-understand language. You'll not have the slightest difficulty in mastering them. The Course is absolutely authoritative and right down to the minute in every respect. Covers the entire field of Practical Aeronautics and Science of Aviation in a thorough, practical manner. Under our expert direction, you get just the kind of practical training you must have in order to succeed in this wonderful industry.

Special Offer NOW

Send This Coupon Today

It is our duty to help in every possible way to supply the urgent need for graduates of this great school. We have facilities for teaching a few more students and to secure them quickly we are making a remarkable Special Offer which will be withdrawn without notice. Write today—or send the coupon—for full particulars. Don't risk delay. Do it now.

Prepare for one of these positions

Aeronautical Instructor	\$80 to \$150 per week.
Aeronautical Engineer	\$100 to \$300 per week.
Aeronautical Contractor	Enormous profits.
Aeroplane Repairman	\$90 to \$75 per week.
Aeroplane Mechanician	\$80 to \$90 per week.
Aeroplane Inspector	\$50 to \$75 per week.
Aeroplane Salesman	\$600 per year and up.
Aeroplane Assembler	\$40 to \$25 per week.
Aeroplane Builder	\$75 to \$200 per week.



AIRPLANE BUILDER



AIRPLANE MECHANIC



AIRPLANE ENGINEER



INSPECTOR

American School of Aviation
431 S. Dearborn Street, Dept. 119C, Chicago, Ill.

**AMERICAN
SCHOOL
OF AVIATION**
431 S. Dearborn Street,
Dept. 119C
Chicago, Illinois

Without any obligations on my part, you may send me full particulars of your course in Practical Aeronautics and your Special LIMITED Offer.

Name.....

Address.....

Please Mention Popular Mechanics

Let These "Shop Books" RAISE YOUR PAY

Learn at Home, in Spare Time!

Send no money—just the coupon—and get the "Pay-Raising Shop Books" that have helped thousands to get better jobs. Record-breaking demand for machinists everywhere—big pay, too!

10,000 QUESTIONS ANSWERED IN MODERN SHOP PRACTICE

6 VOLS.—2300 PAGES—2500 ILLUSTRATIONS
Leather bound—page size 5½ x 8½—a vast fund of facts on shop methods, machinery, tools, etc.

Shipped FREE ON 7 DAYS' TRIAL—JUST SEND COUPON

Study at home. Fit yourself for a bigger job.
50c a Week Only \$2 a month if you decide to keep them. Coupon explains special offer, good only within bounds of U. S. and Canada.
Free Consulting Service solves your difficult problems for an entire year—(Regular Price \$12)—free with the set.

RUSH THIS COUPON

NAME: _____ ADDRESS: _____
SHOP PRACTICE _____ SHOP PRACTICE _____
PRACTICE PRACTICE PRACTICE PRACTICE PRACTICE PRACTICE

American Technical Society
Dept. M1199, Chicago, U. S. A.

Please send Modern Shop Practice for seven days' examination, express prepaid. I will send \$2.00 within seven days and \$2.00 a month until I have paid \$18.50 or notify you and hold books subject to your order. Title not to pass until fully paid.

Name.....
Address.....
Reference.....

Typewrite the New Way.

80 to 100 Words a Minute GUARANTEED
Totally new system. Based on Gyroscopic Finger Training! Brings amazing speed—perfect accuracy—BIG SALARIES. Easy for anyone. First day shows results. Learn while working. Write postal today—NOW—for full particulars. **THE TULLOSS SCHOOL, 132-A College Hill, Springfield, O.**

BE AN ARTIST

We can teach you **DRAWING** in your own home during spare time.

Our 18 years of successful teaching prove our ability. 10 Courses in Commercial and Illustrative Drawing.

Endorsed by high art authorities.

Students trained by members of our Faculty are filling high-salaried positions. Artist's Outfit FREE to Enrolled Students. Fully equipped Residence School. Write today for Art Year Book.

OUR HANDSOME ART YEAR BOOK IS FREE TO YOU

SCHOOL OF APPLIED ART
APPLIED ART BLDG. NO. 2 BATTLE CREEK MICH.

What 15 cts. Will Bring You From the Nation's Capital

Washington, the home of the Pathfinder, is the nerve-center of civilization; history is being made at this world capital. The Pathfinder's illustrated weekly review gives you a clear, impartial and correct diagnosis of public affairs during these strenuous, epoch-making days. The little matter of 15c in stamps or coin will bring you the Pathfinder 13 weeks on trial. The Pathfinder is an illustrated weekly, published at the Nation's center, for the Nation; a paper that prints all the news of the world and tells the truth and only the truth; now in its 24th year. This paper fills the bill without emptying the purse; it costs but \$1 a year. If you want to keep posted on what's going on in the world at the least expense of time or money, this is your means. If you want a paper in your home which is sincere, reliable, entertaining, wholesome, the Pathfinder is yours. If you would appreciate a paper which puts everything clearly, fairly, briefly—here it is. A dollar bill mailed at our risk will bring you the Pathfinder for a full year, or simply send 15c to show that you might like such a paper and we will send the Pathfinder on probation 13 weeks. The 15c does not repay us, but we are glad to invest in new friends. **PATHFINDER, Box 8, Washington, D. C.**

Earn \$100 to \$200 a month DRAFTSMEN Get the BIG Pay

Study at home to be a Draftsman and earn \$100 to \$200 a month. We have successfully trained hundreds of beginners now filling big-paying positions. Manufacturers and the U. S. Government are desperately in need of trained Draftsmen. We have numerous requests at all times for competent men; fine positions with big salaries and excellent opportunities. The demand will probably be even greater when you finish our course.

Drafting Outfit Given FREE!

to every new student for a limited time. Send today for FREE BOOK which explains the remarkable opportunities offered through Drafting. Let us tell you about our practical method of giving thorough, INDIVIDUAL instruction by mail, and send you proof of the success of our graduates. Act quickly and qualify yourself to command a big salary as a trained Draftsman.



COLUMBIA SCHOOL OF DRAFTING
143 McLachlen Bldg., Washington, D.C.

EARN WHILE YOU LEARN

IN FACTORY AND LABORATORY
Become an Electrician in one year, Commercial Engineer in two years, Electrical Engineer in three years. ½ day lectures and experiments in our completely equipped laboratories; ½ day employment in leading electrical concerns. Day and evening classes. **New Term Opens January 2.** Write for free illustrated catalog. Mention age, education and course interested in.



School of Engineering of Milwaukee 356 Stroh Building Milwaukee, Wis.

Driver Agents Wanted

Five-Pass., 34.7 H. P. Drive and demonstrate the Bush Car. Pay for 18 out of your commissions on sales, my agents are making money. **Bush Cars guaranteed or money back.** Write at once for my 64-page catalog and all particulars. 1918 models now ready. Address: **H. Bush, Pres., Dept. 1217, 115-inch Wheelbase, Delco Ignition—Elect. Ste. & Ltg.**

RUSH MOTOR COMPANY, Bush Temple, Chicago, Ill.

FREE BOOK ON BANKING

Tells of the great opportunities in this wonderful profession, and how you can learn by mail. Six months' term. Diploma awarded. **EDGAR G. ALCOORN Pres., AMERICAN SCHOOL OF BANKING 490 East State St., Columbus, Ohio**

JEWELRY ENGRAVING

We teach you, by our new and original method of instruction, this clean, fascinating and profitable business right at your home, and furnish you all tools needed absolutely free. Write for free book to the **WISCONSIN SCHOOL OF ENGRAVING, Stroh Bldg., MILWAUKEE, WIS.**

I TEACH Penmanship BY MAIL

I won the World's First Prize for best course in Penmanship. Under my guidance you can become an expert penman. Am placing many of my students as instructors in commercial colleges at high salaries. If you wish to become a better penman, write me. I will send you Free one of my Favorite pens and a copy of the Ransomorian Journal. **G. W. Kansom, 325 Essex Bldg., Kansas City, Mo.**



Free Test Lesson in Draftsmanship



Special offer now. Pay nothing for this Test Lesson in Drafting prepared by the experts of the Chicago Technical College. Learn from a study of this lesson how well equipped you are to take up drafting as a profession. Also see from it how clearly the Chicago "Tech" Course in Draftsmanship explains every point—and how it will give you a practical training in Architectural, Electrical, Structural Steel, Machine Drafting or any other branch of Drafting in which you may be interested. No charge whatever for this lesson. We invite every ambitious man to send for it. To ask for it places you under no obligation. Get it while the offer holds good and let it show you whether or not you are a man who can study this technical calling to advantage. Just sign and mail coupon. Send no money.

\$25⁰⁰ to \$100⁰⁰ a Week

Positions are always open to competent draftsmen and the war conditions are sure to create an extra demand. These positions pay good salaries and the well trained man always has the best opportunity for advancement. Our course gives this training in the shortest time consistent with thoroughness. Its practical value is proved by the success of our graduates. If you are in a position where the future looks doubtful, if you want to be a technical expert, if you want to be master of a calling which will make you independent, at least get the Free Lesson and the information we send upon request.

Come to the College or Study at Home

You need not leave your present occupation to get this expert training in Draftsmanship. We will teach you by mail and you can study at home in your spare time. The work is the same as given in our Day and Evening Classes at the College here in Chicago. Your instruction will be given directly by men who are engaged in the very work they teach. They will teach you how to do just what is being done in the drafting rooms of big organizations where Chicago "Tech" graduates are always in demand at good salaries.

Easy Payments

Pay for the course as you go along. The fee is so small the terms so easy that no matter how moderate your income may be, you can afford to get this training in Draftsmanship which will prepare you for an important paying position. Catalog and all particulars sent free with the Test Lesson.

See For Yourself

This Free Lesson is an absolute test, pure and simple. Send for it today. In the privacy of your home study it, then you will know for yourself whether you are proper material for a successful Draftsman. Other institutions will ask for your money first. You find out later at your own expense, whether you can adapt yourself to the work and succeed in the profession.

We do not charge you one cent for the Test Lesson, either now or later. It is absolutely FREE. Nor do we obligate you in any way whatever by writing for the Free Test Lesson, so send coupon or write postal request today. If you do nothing else but secure the Free Test Lesson you will gain such valuable knowledge as will be beneficial to you through life, for the Free Lesson gives the very fundamentals of draftsmanship which are helpful to every man. Mail the coupon.

CHICAGO TECHNICAL COLLEGE
1230 Chicago "Tech" Building Chicago, Ill.

FREE Instruments

Every student of the Chicago "Tech" Course in Draftsmanship receives this set of instruments, or a cash credit in case he already has a set. We start our students at once in practical work with necessary equipment.



Builders' Course

Men in the Building Trades whether working now as mechanics or contractors should get information about our Courses in Plan Reading and Estimating. We teach men how to make money through knowing more about their business. We want to tell carpenters, bricklayers, stone masons, and other men engaged in building work about these courses. Write for free Lesson in Plan Reading, Builders' Catalog and other instructive information.

Chicago Technical College,
1230 Chicago "Tech" Building, Chicago

Without obligation to me, please send me your FREE Test Lesson in Draftsmanship and other interesting literature covering the subject indicated below.

Mark X opposite work in which you are specially interested.

- | | |
|---|---|
| <input type="checkbox"/> Architectural Drafting | <input type="checkbox"/> Builders' Course |
| <input type="checkbox"/> Machine Drafting | <input type="checkbox"/> Plan Reading |
| <input type="checkbox"/> Electrical Drafting | <input type="checkbox"/> Estimating |
| <input type="checkbox"/> Structural Drafting | <input type="checkbox"/> Surveying |
| <input type="checkbox"/> Sheet Metal Drafting | <input type="checkbox"/> Map Drafting |

Name.....

Address.....

City..... State.....

College or Home Study? State which.....

Please Mention Popular Mechanics



Come to Detroit The Automobile Center and

LEARN THE AUTOMOBILE BUSINESS

DETROIT
trained men get
preference and get jobs
quickly. No other city can give
what Detroit offers. Think what it
means to learn in the Michigan State Auto
School. Factories endorse our school, glad to em-
ploy our graduates or offer them territory in which
to sell cars and start garages. Unlimited opportunities.
71% of Automobiles are made in Detroit. You're right in the Heart of the Auto
Industry. Men are needed everywhere as testers, repairmen, chauffeurs, garage
men, and salesmen. Hundreds of our graduates start in business for themselves.

Earn \$75 to \$300 a Month

We teach you to handle any auto proposition. You graduate in from ten to twelve weeks. Our equipment is new, up-to-the-minute, and complete. No old, obsolete motors, chassis or electrical equipment used. Students actually build cars from start to finish, getting factory training in assembling, block-testing, road-testing, everything. Special complete course in Oxy-Acetylene brazing, welding and cutting, separate from regular course. Learn to time motors, rebore cylinders, adjust carburetors, magnetos, valves and bearings quickly and accurately. Six-cylinder Lozier, Chalmers "8," Detroit "6," Overland, and 8-cylinder King

are used for road instruction. We have the following completely equipped chassis:
Chalmers "6-30" 1917 chassis
Detroit "6-45" 1917 chassis
Buick Light "6" 1917 chassis
Willis-Knight 1917 chassis
Studebaker "6" 1917 chassis
Hudson Super-Six 1917 chassis
Cole "8" 1917 chassis
King "8" 1917 chassis

We have the following completely equipped chassis:
Metz "4" 1917 chassis
Detroit Electric 1917 chassis
G. M. C. 2 Ton Truck
Saxon "6" 1917 chassis
Maxwell 1917 chassis
Oldsmobile "8" 1917 chassis
Winton "6" chassis
Packard Twin "6" 1917 chassis
Chalmers "4" 1917 chassis

All completely equipped for students to work on. We have more than 20 motors in our block test department—2 cyl., 4 cyl., 6 cyl., 8 cyl., and 12 cyl. Our electrical department is complete, having every standard starting, lighting, and ignition system, including Delco System as used in Buick, Hudson, and Packard Twin "6,"

33,000 sq.ft. Additional Floor Space

Follow the Crowd to the Michigan State Auto School. Come to Detroit



THIS IS ONE OF THE FEBRUARY 1917 CLASSES

Detroit Is the Place to Learn—Start Any Time

There are 44 auto factories in Detroit and vicinity and 140 accessories and parts factories. Our students have the privilege of going through any or all of them. We operate Starting, Lighting, Ignition Service Station. This has added thousands of dollars worth of equipment and makes our electrical department unequalled. Students get actual experience in handling all kinds of electrical auto equipment and taking care of trouble. We have just installed a Sprague Electric Dynamometer for block-testing purposes for students' use. Ours is the only Auto

school having this equipment. Auto factories need Dynamometer men constantly. Factories and garages are paying big salaries to men who know how to handle electrical equipment quickly and properly. Detroit is the automobile center. You get practical instruction. School open all the year. Enter classes anytime, any day. Three classes daily: morning, afternoon, evening. All instructors are members of the Society of Automobile Engineers (S.A.E.) There is a great demand for Michigan State Auto School students. Auto factories write and phone for men constantly.

Money-Back Guarantee

We guarantee to qualify you in a short time for a position as chauffeur, repair man, tester, demonstrator, auto electrician, garage man, or automobile dealer, paying from \$75 to \$300 monthly or refund your money. We have constantly more requests for Detroit trained men at GOOD salaries than we can supply.

SEND THIS COUPON TODAY

MICHIGAN STATE AUTO SCHOOL
312 Auto Bldg., 687-89-91 Woodward Ave.
DETROIT, MICHIGAN, U. S. A.

Gentlemen: Send me absolutely FREE literature on Aeroplane Motor Mechanics Course, "Auto School News" and New Catalog, or better still, you can expect

me about.....

Name.....

Street.....

Town..... State.....

Automobile Factories Endorse Our School

The Leading Automobile factories in Detroit, as well as in other cities, endorse our school. They have been watching our school and graduates for years and are satisfied. They are putting their latest model, complete chassis in our school for students to work on. They are employing our graduates in their factories and service stations and assisting them in opening garages and salesrooms. They allow our students to go through their factories. They need trained, competent men and are asking for more of our graduates constantly. The Michigan State Auto School in Detroit, the heart of the Auto Industry, is endorsed by the Leading Auto Factories, is receiving their hearty co-operation. What better endorsement could you ask?

Act Quickly—NOW!

Fill in the coupon; get literature on aeroplane motor mechanics, "Auto School News" and New 128-Page Illustrated Catalog. All absolutely free. Or better still, jump on the train, as hundreds have done, and come to the "Heart of the Automobile Industry," and learn right. We have no branches. Write or come direct to this school.

MICHIGAN STATE AUTO SCHOOL
The Old Reliable School A. G. ZELLER, Pres.
312 Auto Building, 687-89-91 Woodward Ave.
DETROIT, MICH., U. S. A.



The War Will Be Won In The Air

Aeroplane Motor Mechanics Needed



CURTISS
200 Horse Power
Aeroplane
Motor

The war will be won in the air. A course in Aeroplane Motor Mechanics is now being taught at the Michigan State Auto School. We have secured, by special permission, Curtiss Aeronautical Motors for practice and study purposes. We have also arranged with the Curtiss Aeroplane Company for a complete Aeroplane and a great quantity of the aeroplane material. Students will be given practical instruction on the Aeroplane motor and will secure complete knowledge of the plane in general.

Aeroplane Motor Course Started October 1st

The course is under direct supervision of a Curtiss expert who is an authority on aero-motors and aeroplanes as well as hydros and flying boats. Weeks have been spent in perfecting this course which is entirely separate from our Automobile course. Our plans are complete. A special price is made to those who enroll before November 15, 1917.

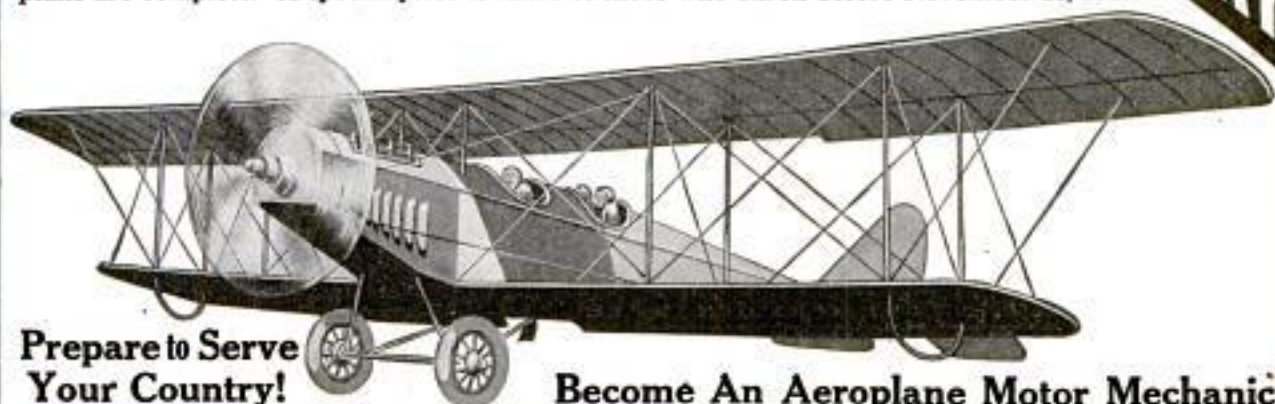

Prepare to Serve
Your Country!

Become An Aeroplane Motor Mechanic

Aeroplanes will win the war. They are the eyes of the army. They must be in perfect running condition. Thousands of keen, well-trained men are needed by the Government to care for the aeroplanes and aeroplane motors. Men are needed in the aeroplane factories. Trained Aero-motor mechanics will get the preference.

Get Into This New Industry Now

The men who become trained Aeroplane Motor Mechanics now will be big men in the aeroplane business. Only a short time ago the automobile business was starting, the men who got in then are now the Big Men. The Aeroplane business is in its infancy. The war will give it a big start. The men who train now will be the Big Men in the near future. The work is extremely interesting and will grow in interest as the business develops. Aeroplanes and Sea-planes will be used for every purpose. Trained Aero-motor mechanics will always be in big demand.

THE CURTISS AEROPLANE CO. AEROPLANES, HYDROAEROPLANES FLYING BOATS, AERONAUTICAL MOTORS BUFFALO, U. S. A.

September 17, 1917.

MR. A. G. ZELLER,
Michigan State Auto School, Detroit, Mich.
Dear Mr. Zeller:

In accordance with our conversation I have asked the Sales Department to send you a collection of motor and aeroplane parts which you can use in connection with your aeroplane mechanics' school. You will find, I think, a sufficient number of parts so that you will have no difficulty in explaining to your students the general principles of construction and operation.

These models, together with the literature which you now have will, I believe, furnish a valuable background upon which your new school work can be based. There is going to be a big demand for good aeroplane mechanics and for that reason we believe that your activity along this line is very timely and commendable.

Very truly yours,

THE CURTISS AEROPLANE CO.
F. L. FAUROTE (Signed) F. L. FAUROTE,
W. F. W. Advertising Manager.

Special Price Up to November 15th

As a special inducement to those who enroll before November 15th, 1917, we will make liberal discount in the price of the Aeroplane Motor Mechanics' Course. The rate will be raised after that date.

Don't hesitate; get into this new industry now. The far-sighted, keen fellows who enter at once will reap the big benefits.

Write Now for literature and use the coupon on opposite page.

No matter whether you join the colors or stay at home, you can do your bit best as a trained man.

The Old
Reliable School

Michigan State Auto School

A. G. ZELLER
President

312 Auto Bldg., 687-89-91 Woodward Ave.

DETROIT, MICHIGAN, U. S. A.

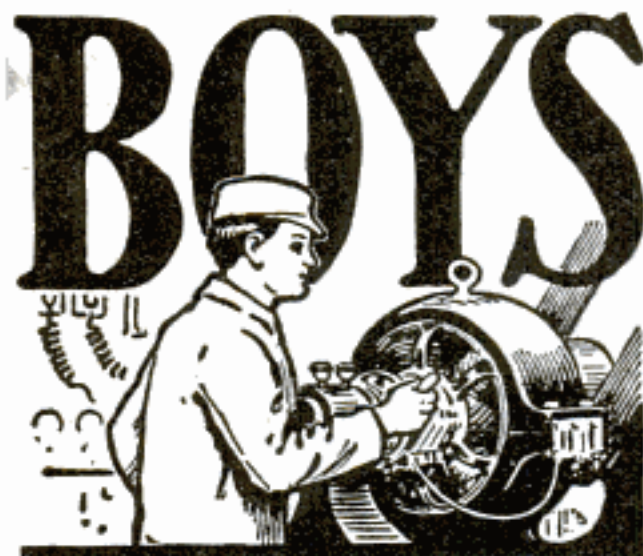

Big Money in Electricity

The Electrical industries offer wonderful opportunities to boys with a liking for Electricity. The salaries paid to trained men are large, promotion comes rapidly and, best of all, the work is fascinating.

The discovery and development of new lines (such as wireless telegraphy and telephony), from time to time, promise attractive and paying fields to those who wish to specialize. The *will to do* and *Special Training* will bring success to you.

The International Correspondence Schools can help you to become an expert in electrical work, no matter what branch you like best. Thousands of young men have already won success through I. C. S. help. You can do as well as anybody, *if you try*. Everything is made so clear that you can learn in your spare time, regardless of where you live or what your work. No books to buy.

There's big money in Electricity. Get after it by marking and mailing the Coupon today. *Finding out costs you nothing.*

INTERNATIONAL CORRESPONDENCE SCHOOLS

Box 5623, SCRANTON, PA.

Explain, without obligating me, how I can train for the position before which I mark X.

- ELECTRICAL ENGINEER
- Electrician
- Electric Wiring
- Electric Lighting
- Electric Car Running
- Electric Machine Designer
- Telegraph Engineer
- MECHANICAL ENGINEER
- Mechanical Draftsman
- STEAM ENGINEER
- GAS ENGINEER
- CIVIL ENGINEER
- Structural Engineer
- CHEMICAL ENGINEER

- ARCHITECT
- Architectural Draftsman
- Mine Foreman or Supt.
- Business (Complete)
- Bookkeeper
- Stenographer
- Advertising Man
- Salesmanship
- Window Trimmer
- Civil Service
- AGRICULTURE
- Poultry Raising
- AUTOMOBILES
- Auto Repairing

Name _____

Present Occupation and Employer _____

Street and No. _____

City _____ State _____

If name of Course you want is not in this list, write it below.

16 Easy Lessons

that teach you everything about automobiles. The book that tells it ALL.

The Automobile Instructor

By Clyde H. Pratt, B. Sc., M. E., Member Nat'l Society of Auto Engineers. 256 pages, 210 illustrations, cloth bound. Shipping wt., 22 oz.

New 1917 edition just out. The standard work for home-study, class-room and reference, for amateur and expert. A complete course for all who desire to master this profitable profession.

LEARN AT HOME HOW TO DRIVE AND REPAIR ALL CARS

Invaluable pointers for every car owner, driver, garage man and repair man. Adopted by Cleveland and other Auto Schools and by Boards of Education as their standard text-book. The author will answer your auto inquiries FREE. This book is guaranteed to be just what you want or your money back. (Auto schools, write for quantity prices.)

Price, postpaid \$1.50

Shrewsbury Publishing Co., 5525 South Boulevard, CHICAGO, U. S. A.

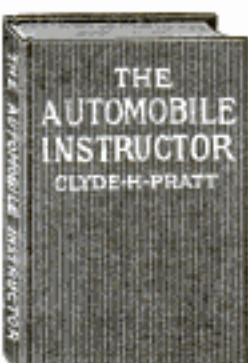

Motor Craft Encyclopedia illustrated. Tells how to build and operate Motor Boats. Best book on boats. Price, \$1.00. 5525 South Boulevard, CHICAGO, U. S. A.



SHORTHAND IN 30 DAYS

Boyd Syllable System. Easy to learn, based on New Principles; all difficulties of old line systems eliminated; amazing results. Prepare for a Government position paying \$900 to \$1200 a year, or for office work, court reporting or private secretaryship. Writers hold highest records. 100 to 150 words a minute in 30 days guaranteed.

The World's Greatest System

No longer necessary to spend six months in learning shorthand. You can become an expert writer in 30 days at your own home by the Modern, Up-to-Date Boyd System. Boyd writers command highest salaries. A course in Touch Typewriting prepared by experts—winner of 15 Consecutive Championship Contests—given FREE as a part of the course. Send today for Catalog, Special Offer and Sample Lesson.

CHICAGO HOME STUDY SCHOOLS
504 Reaper Block Chicago, ILL.

MUSIC TAUGHT FREE

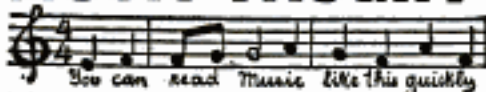

IN YOUR OWN HOME

You can read Music like this quickly
Piano, Organ, Violin, Mandolin, Guitar, Banjo, etc.
Beginners or advanced players. One lesson weekly. Illustrations make everything plain. Only expense about 2c per day to cover cost of postage and music used. Write for FREE booklet which explains everything in full.

AMERICAN SCHOOL OF MUSIC, 51 Lakeside Building, CHICAGO



BE A BANKER

Prepare by mail for this high profession, in which there are great opportunities. Six months' term. Diploma awarded. Send for free book, "How to Become a Banker," by EDGAR G. ALGORN, Pres. AMERICAN SCHOOL OF BANKING, 419 East State Street, COLUMBUS, OHIO



Better Your Position

\$125—\$250 A MONTH

Are you under 55? War has taken the youth of the country. Railroads demand Traffic Inspectors—young men, old men, but trained men. \$125 a month and expense to start. What is a Traffic Inspector? Briefly, he roams the continent in a Pullman to safeguard our lives and his Company's money. He is in a position to grasp opportunities. If he is efficient he is bound to gain positions of trust. Hundreds wanted now. There is no excuse for failure today. This is your chance. You can do this with proper training. F. P. S. qualifies you in 3 months' home study, and arranges for position. Write for explanatory booklet K-2.

Frontier Preparatory School
BUFFALO, N. Y.

Please Mention Popular Mechanics

FREE BOOK



How To Learn Piano

This Interesting Book

shows the keen delight and personal satisfaction which a musical training will bring you; and how you can obtain this training easily and thoroughly in your own home at one-quarter the usual cost.

It tells how this most prized of social accomplishments greatly increases your own enjoyment of life and the enjoyment of others. It tells of the concert career which may be open to you, and how you can increase your earning power by giving musical instruction in your spare time. Send for your copy of this valuable book today!

Dr. Quinn's Famous WRITTEN METHOD has revolutionized the study of music. By the use of Dr. Quinn's remarkable device, the **COLOROTONE** (patented), you save three-quarters of the time and effort usually required for learning piano or organ. You play chords immediately and a complete piece within a few lessons. The method is scientific and systematic, yet practical and simple. It is endorsed by leading musicians and heads of state universities. Equally effective for children or adults, beginners or experienced players. Practice in spare time, whenever convenient. Successful graduates everywhere. Diploma granted. Special reduced terms this month. Investigate without cost or obligation by writing today for free book, "How to Learn Piano and Organ."

Marcus Lucius Quinn Conservatory, Studio KY, Social Union Building, Boston, Mass.

Learn Watchwork, Jewelrywork and Engraving. A fine trade commanding a good salary, and your services are always in demand. Address **HOROLOGICAL**, Dept. P, Bradley Institute, Peoria, Ill., for our latest catalog.

TRAFFIC

Men Needed Everywhere

Big salaries. "Bankers" hours. Dignified position. Your own boss. Work easily learned in few weeks at home. Course guaranteed. Satisfaction assured. Graduates coached free for two years after in position. You can't fail. Practical experience in actual Traffic office offered graduates. Student E. W. Fish appointed General Traffic Manager fifteen million dollar corporation after six months' study. His salary to start \$3000. Complete training inexpensive. Easy terms. Write today and save \$25.00. Opportunity knocks but once. Too important to lay aside.

INTERSTATE TRAFFIC SCHOOL, 32 TRAFFIC BUILDING, FORT WAYNE, IND.

Learn How to WRESTLE

In Your Own Home
By Mail



Yes, learn to become an expert wrestler right in your own home, by mail, from the greatest wrestler the world has ever known. Be an athlete, be strong, be healthy. Learn how to throw and handle big men with ease. Learn to defend yourself. All taught in our course of lessons, and illustrated with hundreds of charts and actual photographs by

Farmer Burns and Frank Gotch

Farmer Burns, "the grand old man of the mat," taught Frank Gotch, the present World's Champion, all he knows about wrestling, so Gotch says. He will now teach you Scientific Wrestling—Physical Culture—Jiu-Jitsu—Self Defense. Every man and boy in America, no difference what age, needs this wonderful course of lessons. Write today—your name, age and address on a postcard or letter brings you our free book absolutely free—no obligations of any kind. A splendid book on wrestling and physical culture. Write today stating your age.

Farmer Burns School of Wrestling, 1199 Range Bldg., Omaha

This Wrestling Book FREE



Their Jobs Are VACANT

Great numbers of skilled **ELECTRICIANS, DRAFTSMEN, PLUMBERS** and **BRICKLAYERS** have quit their jobs to join the fighting forces. Who will take their places? They **MUST** be filled. The nation's business must be speeded up to meet the greatest emergency in history. Trained men **MUST** do it. If ever there was an opportunity for **YOU** to become a success, for you to help your country, it is **NOW** and it is through this wonderful institution that all this is possible. We train you in a few weeks in our big shops.

COYNE TRADE AND ENGINEERING SCHOOLS

You Men Liable to Be Drafted

If you are between the ages of 21 and 31, with a liability of being drafted later on, come to Coyne now and let us train you in one of these big trades and professions. By so doing you offer your government the services of a skilled man in a much needed line, instead of a man that can do nothing but carry a gun and go into the trenches. Here is your opportunity to be patriotic, to furnish your government one of the half million skilled men it needs.

Men Wanted for These Trades



Our Own Building

**Electricity
Drafting
Plumbing
Bricklaying
Motion Pic. Opr.**

We teach all these big paying trades under actual working conditions. We do not have classes, do not use books, do not teach by correspondence. Each man is instructed individually right in our big shops. Drafting, Estimating and Plan Reading included in all courses. We charge a small tuition fee which can be made in easy payments if desired. All tools, equipment and material is furnished by the school, **FREE**. Our institution is open Day and Evening. Many of our students earn a part or all of their expenses while attending. Our employment bureau is always ready to help a man to earn expenses, without charge.

SEND COUPON FOR FREE BOOK

Be a man of action. Send today for our book of trades—fully illustrated. It costs you nothing and shows how you can earn more money, make a bigger success than you ever dreamed of. If you live near come over and go through our shops—visitors are always welcome.

Bennett Wellington Cooke
Director
Coyne Trade and Engineering Schools
Dept. 1199
39-51 E. Illinois St., Chicago, Ill.

FREE COUPON

Coyne Trade and Engineering Schools
Dept. 1199

39-51 E. Illinois St., Chicago
Please send me your big new Manual of Trades. I am interested in the trade checked below.

Electricity Drafting
 Plumbing Bricklaying
 Motion Picture Operating

Name.....

Address.....

ORDER BOOKS BEFORE ADVANCE IN PRICE

SEND TODAY—SAVE 50%

The present low price on this great work will be withdrawn when the few sets left are sold. Quick action saves 50%.

10-VOLUME LIBRARY OF ARCHITECTURE Carpentry and Building

4760 Pages, 7 x 10—4000 Plates and Diagrams

These books answer 10,000 questions on carpentry and building. Written by 26 architects, contractors, carpenters, and engineers.

50c. a Week

Only \$2 a month if you decide to keep them. Coupon explains special offer, good only within the boundaries of U. S. and Canada.

Shipped FREE on 7 Days' Trial

Consulting Service Free
Solves your difficult problems for entire year—(regular price \$12)—free with the set. Rush the coupon today.

American Technical Society
Dept. 31199, Chicago, U. S. A.

Please send Architecture, Carpentry and Building for seven days' examination, express prepaid. I will send \$2.00 within seven days and \$2.00 a month until I have paid \$24.80 or notify you and hold books subject to your order. Title not to pass until fully paid.

Name.....

Address.....

Reference.....

STUDY LAW 30 Days FREE

Let us prove to your entire satisfaction, at our expense, that the Hamilton College of Law is the only recognized resident law school in U. S., conferring Degree of Bachelor of Laws—LL. B.—by correspondence. Only law school in U. S. conducting standard resident school and giving same instruction, by mail. Over 500 class-room lectures. Faculty of over 30 prominent lawyers. Guarantee to prepare graduates to pass bar examination. Only law school giving Complete Course in Oratory and Public Speaking. School highly endorsed and recommended by Gov. Officials, Business Men, Noted Lawyers and Students. Send today for Large Handsomely Illustrated Prospectus and Special 30-Day Free Trial.

HAMILTON COLLEGE OF LAW, 1255 Advertising Bldg., Chicago, Ill.



Do You Like to Draw? Cartoonists Are Well Paid

We will not give you any grand prize if you answer this ad. Nor will we claim to make you rich in a week. But if you are anxious to develop your talent with a successful cartoonist, so you can make money, send a copy of this picture, with 5c in stamps for portfolio of cartoons and sample lesson plate, and let us explain.

The W. L. Evans School of Cartooning
821 Leader Bldg., Cleveland, O.

LEARN WATCHMAKING

and become independent. Good-paying positions secured. Easy to learn. Send for FREE CATALOG.

ST. LOUIS WATCHMAKING SCHOOL, Dept. 5, ST. LOUIS, MO.

EARN \$100 A WEEK

Send in now for amazing free book of facts about wonderful opportunities open to you. Read how to become a Certified Public Accountant, Cost Accountant, Banker, Broker, Corporate Secretary, Business Organizer, Advertising, Sales and Real Estate Expert. Learn at home, in spare time through remarkable, easy methods. State course which interests you.

UNIVERSAL BUSINESS INSTITUTE
75 Madison Avenue New York

SHORTHAND IN 30 DAYS

We absolutely guarantee to teach shorthand complete in only thirty days. You can learn in spare time in your own home, no matter where you live. No need to spend months as with old systems. Boyd's Syllabic System is easy to learn—easy to write—easy to read. Simple. Practical. Speedy. Sure. No ruled lines—no positions—no shading as in other systems. No long lists of word signs to confuse. Only nine characters to learn and you have the entire English language at your absolute command. The best system for stenographers, private secretaries, newspaper reporters and railroad men. Lawyers, ministers, teachers, physicians, literary folk and business men and women may now learn shorthand for their own use. Does not take continual daily practice as with other systems. Our graduates hold high grade positions everywhere. Send today for booklets, testimonials, etc.

Chicago Correspondence Schools
969 Unity Bldg., CHICAGO, ILL.

ENGINEERING MECHANICAL ELECTRICAL

One Year Practical Courses. Day and Evening classes. Splendid equipment and instruction. Low tuition. For particulars address

DETROIT TECHNICAL INSTITUTE
Box 308, Y. M. C. A. Building, DETROIT, MICH.

Come to Akron, Ohio The Tire Center and LEARN THE TIRE REPAIR BUSINESS



Big money made in this field. Tires need constant repairing. Profits large, work comes easily. Locations everywhere.
EARN \$100 to \$500 MONTHLY
There is no limit to what you can make. Start business with small capital. We teach you everything about auto tires. School open all year. Start any day. Write for school literature, etc., Now. ALL FREE.
Akron Tire Repair School, 72 Tire Bldg., 46-48 N. Main St., Akron, O.



Marvelous FREE Book Sent

You can now learn Taxidermy, the wonderful art of mounting birds, animals, taxidermy skins, etc. Learn at home, by mail. The free book tells how. Mount your own trophies. Decorate home and den. Hunters, trappers, nature lovers, you need taxidermy. Interesting, fascinating, big profits. Join our school. 55,000 students. Success guaranteed. Get our free book without delay. Send right now—today.
N. W. School of Taxidermy, 9179 Elwood Bldg., Omaha, Neb.

LEARN LANGUAGES BY LISTENING ON YOUR OWN PHONOGRAPH



at home with Disc Cortinaphone Language Records. Write to us for FREE booklet today; easy payment plan.
Endorsed by leading universities.
CORTINA ACADEMY OF LANGUAGES
Suite 2201, 12 East 40th St., New York.

Spanish-French-English-Italian-German

Encyclopaedia Britannica

"HANDY VOLUME" ISSUE
Printed on India Paper

AT HOME Learn TO SING

HARVEY SUTHERLAND, 1832P 49th St., BROOKLYN, N. Y.



LEARNED BY ALMOST ANYONE AT HOME SMALL COST

Send today 2c stamp for particulars and proof.
O. A. SMITH, Room D 157, 823 Bigelow St., PEORIA, ILL.



F. D. HENNESSY
Pres. and Gen'l Mgr.

Let Me Help You Get Ahead

WHAT wonderful opportunities there are today for any man, young or old, who likes machinery and yet how hard it is to awaken these men to this fact. Why do you hesitate?

The Automobile and Tractor World is Crying for Help

There is absolutely not a single chance to fail. Think of it—not a chance of failure, if you are properly trained. It costs next to nothing to be properly trained and takes but seven weeks, at my complete automobile and tractor school. It does take a little ambition and determination, I know; but if you haven't got either of these, you never will succeed in anything. The whole world is a field for a man trained in the Gas Engine business.

Everything Simplified—Everything Thorough—Everything Complete—Everything Practical—Everything for One Price—Life Scholarship Privileges—Complete Tractor Course Without Extra Charge.

Lowest priced complete Gas Engine course in the country. Send in attached coupon for free catalog now.

Iowa State Automobile and Tractor School Biggest and Best in the Whole Northwest
Dept. 8, 306 Pearl St., Sioux City, Ia.

Every day we have calls for help. Our students get first chance at these jobs. Mine is one of the best schools in the country, and in one of the cleanest and most progressive cities in the country. Over 20,000 square feet of floor space filled with latest equipment. Every instructor from myself down has had years of experience teaching men, young and old, the gas engine business.

MAIL TODAY

Iowa State
Automobile and
Tractor School
306 Pearl St., Dept. 8
Sioux City, Iowa
Please send free Catalog.

THESE ARE OUR BOOKS



VULCANIZING



MOTORS



ELECTRIC STARTERS

Name

Address

LAW High-Grade Instruction by CORRESPONDENCE

Prepares You for the Bar—Est. 1893

Four Courses: College, Post-Graduate, Business Law and Bar Ex. Review. Classes begin each month. Approved by Bench and Bar. University Methods, Unabridged Text-Books, Cases. Course in Oratory, Public Speaking and Moot Court FREE with regular course. Graduates now practicing in every State. Write today for Catalog and Rules for Admission to the Bar. CHICAGO CORRESPONDENCE SCHOOL OF LAW, 528 Racine Bldg., CHICAGO



A GOOD POSITION

with UNCLE SAM is most desirable. Life positions, pleasant surroundings, good pay, steady work, short hours, promotions on merit. Both sexes. No political pull. Thousands of appointments yearly. Most thorough preparation \$5. Returned if not appointed. Full information and questions used by the Civil Service Commission free.

AMERICAN CIVIL SERVICE SCHOOL

WASHINGTON, D. C.

NATIONAL TRADE DENTAL SCHOOL

506 S. Wabash Ave., CHICAGO, ILL.

LEARN MECHANICAL DENTISTRY—DEMAND UNLIMITED

Earn \$1200 to \$4000 yearly in mechanical dentistry. A big and growing demand everywhere for mechanical dentists—like a gold mine, unexplored. Attend this school any time of the day or evening; be taught individually and learn by actual practice, without book study. Our System, the most complete in the world, is used exclusively in this school. We are constantly called upon to fill high-salaried positions. Why not qualify for one? Be fair to yourself; find out more about exceptional opportunity we offer. Visit the school or write for booklet.

Learn to PAINT SIGNS and SHOW CARDS

I teach you personally, by mail, in a short time. Oldest and largest School. Big field, work interesting. You can EARN \$18 TO \$45 A WEEK

Prattner, Minn., writes: "Did job after first lesson, got \$10, profit \$7.00." Crawford, E. C., says: "Earned \$200.00 while taking course." Get literature, samples, guarantees—all FREE.

DETROIT SCHOOL OF LETTERING
Established 1899. 212 D. S. of L. Bldg. DETROIT, MICHIGAN



Music Lessons

Book Sent FREE Wonderful home-study music lessons under great American and European teachers given by the University Extension Method. The lessons are a marvel of simplicity and completeness, endorsed by Paderewski and other great authorities. You, too, can now quickly and easily satisfy your musical ambitions.

Any Instrument or Voice

Write, telling us the course you are interested in, age, how long you have taken lessons if at all, etc., and we will send you our Free Book containing text and illustrations covering Lessons in PIANO (students' or teachers' courses) by the great Wm. H. Sherwood, HARMONY by Dr. Protheroe and Rosenbecker, VOICE COURSE (with aid of Phonograph) by Crampton, PUBLIC SCHOOL MUSIC by Frances E. Clark, VIOLIN, CORNET, MANDOLIN, GUITAR, BANJO, BANJO, REED ORGAN, CHORAL CONDUCTING, by equally eminent teachers.

Send NOW for Free Book and learn how easily you can become a fine singer, or a skillful player. See how quickly you can become successful. Our Free Book tells you how. Write for it today. A few Special Introductory Scholarships now being awarded by our faculty. Full particulars sent with Free Book. Investigate without cost or obligation. Write today.

University Extension Conservatory

Proprietor Siegel-Myers School of Music
3181 Siegel-Myers Building Chicago, Ill.

Please Mention Popular Mechanics



What are you kicking about?

—You men who think you're underpaid

The men who get big pay are those who are *trained* to earn it. Your pay is small because you have no special training—and *you only are to blame.*

You can *learn to earn* more. No matter what your job, where you live or how old you are, nor how limited your education, the International Correspondence Schools can train you for a *better position and bigger pay.*

If you want to get out of the ranks of the "hard-ups" and *be* somebody, prove your ambition by marking and mailing the coupon on this page today. Thousands of others *just like you* who have used this coupon are now occupying positions of power and high pay. You can join them. *Grit your teeth, say "I will" and mail the coupon NOW.*

I. C. S., Box 5625, Scranton, Pa.

INTERNATIONAL CORRESPONDENCE SCHOOLS Box 5625, SCRANTON, PA.

Explain, without obligating me, how I can qualify for the position, or in the subject, before which I mark X.

- | | |
|---|--|
| <input type="checkbox"/> ELECTRICAL ENGINEER | <input type="checkbox"/> SALESMANSHIP |
| <input type="checkbox"/> Electric Lighting | <input type="checkbox"/> ADVERTISING MAN |
| <input type="checkbox"/> Electric Car Running | <input type="checkbox"/> Window Trimmer |
| <input type="checkbox"/> Electric Wiring | <input type="checkbox"/> Show Card Writer |
| <input type="checkbox"/> Telegraph Expert | <input type="checkbox"/> RAILROADER |
| <input type="checkbox"/> MECHANICAL ENGINEER | <input type="checkbox"/> ILLUSTRATOR |
| <input type="checkbox"/> Mechanical Draftsman | <input type="checkbox"/> DESIGNER |
| <input type="checkbox"/> Machine Shop Practice | <input type="checkbox"/> BOOKKEEPER |
| <input type="checkbox"/> Gas Engineer | <input type="checkbox"/> Stenographer and Typist |
| <input type="checkbox"/> CIVIL ENGINEER | <input type="checkbox"/> Cert. Public Accountant |
| <input type="checkbox"/> Surveying and Mapping | <input type="checkbox"/> Railway Accountant |
| <input type="checkbox"/> MINE FOREMAN OR ENGINEER | <input type="checkbox"/> Commercial Law |
| <input type="checkbox"/> Metallurgist or Prospector | <input type="checkbox"/> GOOD ENGLISH |
| <input type="checkbox"/> STATIONARY ENGINEER | <input type="checkbox"/> Teacher |
| <input type="checkbox"/> Marine Engineer | <input type="checkbox"/> Common School Subjects |
| <input type="checkbox"/> ARCHITECT | <input type="checkbox"/> CIVIL SERVICE |
| <input type="checkbox"/> Contractor and Builder | <input type="checkbox"/> Railway Mail Clerk |
| <input type="checkbox"/> Architectural Draftsman | <input type="checkbox"/> AGRICULTURE |
| <input type="checkbox"/> Concrete Builder | <input type="checkbox"/> Textile Overseer or Supt. |
| <input type="checkbox"/> Structural Engineer | <input type="checkbox"/> Navigator |
| <input type="checkbox"/> PLUMBING AND HEATING | <input type="checkbox"/> Poultry Raising |
| <input type="checkbox"/> Sheet Metal Worker | <input type="checkbox"/> AUTOMOBILES |
| <input type="checkbox"/> CHEMICAL ENGINEER | <input type="checkbox"/> Auto Repairing |
| | <input type="checkbox"/> Spanish |
| | <input type="checkbox"/> German |
| | <input type="checkbox"/> French |
| | <input type="checkbox"/> Italian |

Name _____

Occupation
& Employer _____

Street
and No. _____

City _____ State _____

If name of Course you want is not in this list, write it below.

Make Alcohol

It Is
the Coming
Fuel



Get Wright's Book.
It gives full directions
for making
and De-Naturing.

Fully Illustrated. 283 Pages. Cloth. By Mail \$1.15

SPON & CHAMBERLAIN
120 P. M. Liberty Street NEW YORK



Learn a Paying Profession

that assures you a good income and position for life.
For twenty-four years we have successfully taught

PHOTOGRAPHY

Photo-Engraving and Three-Color Work

Our graduates earn \$20 to \$50 a week. We assist them to secure these positions. Learn how you can become successful. Terms easy—living inexpensive. Write for catalogue—NOW!

ILLINOIS COLLEGE OF PHOTOGRAPHY, Box P, 999 Wabash Av., Effingham, Ill.

LEARN WATCH REPAIRING

Be a watchmaker—you can learn this profitable trade by correspondence in a few weeks in your own home by the DeSelms Chart System. After you complete the course you will know a watch from A to Z. You will know just what the matter is and how to repair one. When you graduate you will be a practical watchmaker and repairer and competent to fill any position. Positions for our graduates.

Ask for our Free Book. It explains our system and terms.

THE DeSELMS WATCH SCHOOL
23 Perry Street ATTICA, INDIANA



Draw Pictures that MOVE

The demand for animated cartoonists far exceeds supply. Get into this new, *unprecedented* profession now and

EARN \$25 TO \$200 A WEEK

Anyone with ordinary ability can quickly learn at home, in spare time. Write today for free book.

HARRY PALMER STUDIOS
29 VANDERBILT AVE., NEW YORK CITY.



IF YOU STAMMER

attend no stammering school till you get my large FREE book and special rate. Largest and best school in the world curing by natural method. Write today.

Lee Wells Millard, Pres., North-Western School, Inc.
2317 Grand Avenue Milwaukee, Wis.

Typewrite the New Way

80 to 100 Words a Minute Guaranteed

Totally new system. Based on *Gymnastic Finger Training!* Brings amazing speed—perfect accuracy—**BIG SALARIES.** Easy for anyone. First day shows results. Learn while working. A revelation as to *speed* and *salary* possible to typists. Write for particulars NOW. A Postal will do. Address **Tulless School of Typewriting, 132 College Hill, Springfield, Ohio**

Please Mention Popular Mechanics

Get This Car

And the Agency
In Your Territory



Six cylinder valve-in-head motor, 116 in. wheelbase, Remy Ignition, Stewart Vacuum Gasoline Feed, electric lights and starter

Write now for full specifications of new 1918 Model

BIRCH LIGHT-SIX

Find out how you can get one of these superb cars for yourself and make money selling them to others. A big opportunity is open to ambitious men who are willing to train themselves and then get out and hustle. Hundreds of cars will be sold this year in every county in the United States. Millions of dollars will be paid to automobile agents. We pay big commissions for selling Birch Cars. Probably you know right now anywhere from six to ten people who are going to buy automobiles in the near future. Make some of these sales yourself. Get our proposition quick. **Mail the coupon.**

Previous Experience Not Necessary

We want men of character and ability and high standing in their communities to represent us. Previous experience in the automobile business unnecessary. We require all our agents to take a brief but thorough course of training in Automobile Driving, Repairing and Selling, which will fit them to represent us in a manner creditable to us and profitable to them. We have trained hundreds of others for success in this way, and we be-

lieve this is one of the reasons for the splendid success which Birch Agents are enjoying. But of course the BIG REASON is the cars themselves, and the remarkable records they are making in the hands of satisfied owners all over the United States. Eighty per cent of all Birch Cars are in use by farmers and in small towns, and get the hardest kind of service. Mud, sand, rocks, hills, and rough going have no terrors for these sturdy cars.

Send **COUPON** for Big **FREE BOOK** and Full Information Get all the details at once. We have agents in every state in the Union now, but we want an agent in every county. You will be astonished at the liberality of our offer. Let us put all the facts before you at once. It costs you nothing to investigate, so tear off the coupon right now. **Sign it and mail it to us today.**

BIRCH MOTOR CARS
Dept. 1219, 81 E. Madison St., CHICAGO, ILL.

Member of Chicago Association of Commerce

Sign and
Mail this
Coupon

BIRCH MOTOR CARS
81 E. Madison St., CHICAGO, ILL.
Dept. 1219

Please send me your big free booklet and full particulars as to how I can get a Birch Light-Six and the agency.

Name.....

Street No. or R. F. D.....

P. O..... State.....

Please Write Plainly

Stronger, Clearer Voice for You!



Weakness, huskiness and harshness banished. Your voice given a wonderful strength, a wider range, an amazing clearness. This done by the Feuchtinger Method, endorsed by leading European musicians, actors and speakers. Use it in your own home. Simple, silent exercises taken a few minutes daily impart vigor to the vocal organs and give a surprising quality to the tones. Send for the facts and proofs.

Do YOU Stammer?

The famous Perfect Voice Institute Method is invaluable to those who stammer or lisp. A special course of training for those with an impediment in their speech has been prepared by a famous European director. It will give you command of muscles and cords which reproduce vocal sounds. You should not hesitate for one minute to secure this valuable training. It will give you the self-confidence so necessary to your business and social success. Write at once for special offer.

WRITE

Send the coupon and get our free book and literature. We will tell you just what this method is, how it is used and what it will do for you. No matter how hopeless your case may seem, the Feuchtinger Method will improve your voice 300%. No obligation on you if you ask for this information. Just mail coupon.

Perfect Voice Institute
Studio 1199—1772 Wilson Ave., CHICAGO

Send me the book and facts about the Feuchtinger Method. I have put X opposite subject that interests me most.

Singing Speaking Stammering Lipping

Name

Address

A 'Steel Trap' Memory

One that takes a tight grip on facts, figures, names, details of every kind and hangs onto them through life—that's the kind of memory you ought to have and the kind you can have if you will give me ten minutes of your spare time daily for a few weeks. I will make your mind an infallible classified index of the things it is to your advantage to remember—give you power to concentrate, overcome self-consciousness, enable you to think on your feet, and address an audience intelligently without hesitancy and without notes.



Henry Dickson, Principal, Dickson School of Memory

The Key to Success

Stop Forgetting

During the past 23 years I have trained thousands of people to STOP FORGETTING—aided them to greater business and social success—I know positively that the person with a strong, tenacious memory, though he be far behind at the beginning of the race for success, advances and soon outdistances his forgetful rival. The demands of commercial and professional life are so exacting in their details of facts and figures to be remembered, that to succeed or even hold your own you simply must possess a good memory.

Get My Remarkable Memory Test Free

I've had this test—most ingenious and most exclusive memory test ever devised—copyrighted. I'll send it to you, free, also a copy of my book "How to Remember" and tell you how to obtain a copy of my De Luxe edition, "How to Speak in Public," a handsomely illustrated \$2 book, absolutely free.

HENRY DICKSON, Principal,
Dickson School of Memory, 1105 Hearst Bldg., Chicago

LEARN TELEGRAPH

Morse and Wireless—R. R. Accounting (Station Agency) also taught. Tremendous Demand—much greater than supply—Permanent Positions Secured. Big Salaries—regularly raised. Ideal Working Conditions—short hours, vacations with pay sick and convalescence, etc.—prevailing. Great Opportunities for Advancement. Women Operators also greatly desired by Railways and Western Union. Tuition reasonable. Cheap living expenses—can be earned. Oldest and largest school—two large school buildings, investment exceeds \$2,000,000—established 43 years. Endorsed by railway, Western Union and Marconi Telegraph officials. Large illustrated catalogue free. Correspondence courses also. Write today. Enroll immediately.

Dodge's Telegraph, Ry. & Wireless Institute
6th Street, Valparaiso, Ind.



If you are earning less than
\$50.00 PER WEEK
and like to draw — you should study
COMMERCIAL ART

Leading Art Managers—the men who know—recommend us and employ our students. We will guarantee to make you successful—Learn at home in your spare time—or in our resident school—Day or evening. Write for FREE illustrated catalogue. Commercial Art School, 720, 116 So. Michigan Ave., Chicago, Ill.

LEARN WATCHMAKING AND ENGRAVING

Earn while learning. Most practical watch school. Individual instructions. Graduates in great demand. Book free. Chicago School of Watchmaking, 63 E. Van Buren St., Chicago

ELECTRICAL men with training are always in demand. Having trained over 2000 young men in the past 23 years in the fundamentals of Applied Electricity, The Miles Electrical School, with its well-equipped shops and laboratories, is particularly well qualified to give a condensed course in Electrical

ENGINEERING

Including Mathematics, Steam and Gas Engines, Mechanical Drawing, Shop Work, and Theoretical and Practical Electricity, in all branches. Students actually construct dynamos, install wiring and test efficiency of electrical machinery. Course, with diploma, complete



IN ONE YEAR

For practical young men with limited time, 25th year opens Sept. 20th. Catalogue on request, 104 Takoma Ave., Washington, D. C.

These Are The Hours That Count



MOST of your time is mortgaged to work, meals and sleep. But the hours after supper are yours, and your whole future depends on how you spend them. You can fritter them away on profitless pleasure, or you can make those hours bring you position, money, power, *real success* in life. Thousands of splendid, good-paying positions are waiting in every field of work for men *trained to fill them*. There is a big job waiting for you—in your present work or any line you choose. Get ready for it! You can do it without losing a minute from work or a wink of sleep, without hurrying a single meal, and with plenty of time left for recreation. You can do it in one hour after supper each night, right at home, through the International Correspondence Schools.

Yes—You Can Win Success in an Hour a Day

Hundreds of thousands have proved it. The designer of the Packard "Twin Six," and hundreds of other Engineers, climbed to success through I. C. S. help. The builder of the great Equitable Building, and hundreds of Architects and Contractors, won their way to the top through I. C. S. spare-time study. Many of this country's foremost Advertising and Sales Managers prepared for their present positions in spare hours under I. C. S. instruction.

For 25 years men in offices, stores, shops, factories, mines, railroads—in every line of technical and commercial work—have been winning promotion and increased salaries through the I. C. S. Over 130,000 men are getting ready *right now* in the I. C. S. way for the bigger jobs ahead.

Your Chance Is Here!

No matter where you live, the I. C. S. will come to you. No matter what your handicaps, or how small your means, we have a plan to meet your circumstances. No matter how limited your previous education, the simply written, wonderfully illustrated I. C. S. textbooks make it easy to learn. No matter what career you may choose, some one of the 280 I. C. S. Courses will surely suit your needs.

Make Your Start Now!

When everything has been made easy for you—when one hour a day spent with the I. C. S. in the quiet of your own home will bring you a bigger income, more comforts, more pleasures, all that success means, can you afford to let another single priceless hour of spare time go to waste? Make your start right now! This is all we ask: Without cost, without obligating yourself in any way, put it up to us to prove how we can help you.

Just Mark and Mail This Coupon

TEAR OUT HERE

INTERNATIONAL CORRESPONDENCE SCHOOLS

BOX 5622. SCRANTON, PA.

Explain, without obligating me, how I can qualify for the position, or in the subject, before which I mark X.

- | | |
|---|---|
| <input type="checkbox"/> ELECTRICAL ENGINEER | <input type="checkbox"/> SALESMANSHIP |
| <input type="checkbox"/> Electric Lighting | <input type="checkbox"/> ADVERTISING |
| <input type="checkbox"/> Electric Railways | <input type="checkbox"/> Window Trimmer |
| <input type="checkbox"/> Electric Wiring | <input type="checkbox"/> Show Card Writer |
| <input type="checkbox"/> Telegraph Engineer | <input type="checkbox"/> Sign Painter |
| <input type="checkbox"/> Telephone Work | <input type="checkbox"/> Railroad Trainman |
| <input type="checkbox"/> MECHANICAL ENGINEER | <input type="checkbox"/> ILLUSTRATING |
| <input type="checkbox"/> Mechanical Draftsman | <input type="checkbox"/> Cartooning |
| <input type="checkbox"/> Machine Shop Practice | <input type="checkbox"/> BOOKKEEPER |
| <input type="checkbox"/> Gas Engine Operating | <input type="checkbox"/> Stenographer and Typist |
| <input type="checkbox"/> CIVIL ENGINEER | <input type="checkbox"/> Cert. Public Accountant |
| <input type="checkbox"/> Surveying and Mapping | <input type="checkbox"/> TRAFFIC MANAGER |
| <input type="checkbox"/> MINE FOREMAN OR ENGINEER | <input type="checkbox"/> Railway Accountant |
| <input type="checkbox"/> Metallurgist or Prospector | <input type="checkbox"/> Commercial Law |
| <input type="checkbox"/> STATIONARY ENGINEER | <input type="checkbox"/> GOOD ENGLISH |
| <input type="checkbox"/> Marine Engineer | <input type="checkbox"/> Teacher |
| <input type="checkbox"/> ARCHITECT | <input type="checkbox"/> Common School Subjects |
| <input type="checkbox"/> Contractor and Builder | <input type="checkbox"/> Mathematics |
| <input type="checkbox"/> Architectural Draftsman | <input type="checkbox"/> CIVIL SERVICE |
| <input type="checkbox"/> Concrete Builder | <input type="checkbox"/> Railway Mail Clerk |
| <input type="checkbox"/> Structural Engineer | <input type="checkbox"/> AUTOMOBILE OPERATING |
| <input type="checkbox"/> PLUMBING AND HEATING | <input type="checkbox"/> Auto Repairing <input type="checkbox"/> Spanish |
| <input type="checkbox"/> Sheet Metal Worker | <input type="checkbox"/> Navigation <input type="checkbox"/> German |
| <input type="checkbox"/> Textile Overseer or Supt. | <input type="checkbox"/> AGRICULTURE <input type="checkbox"/> French |
| <input type="checkbox"/> CHEMIST | <input type="checkbox"/> Poultry Raising <input type="checkbox"/> Italian |

Name _____
 Present Occupation _____
 Street and No. _____
 City _____ State _____

Please Mention Popular Mechanics

Best of all your Christmas Gifts—



THE AMERICAN BOY

"the biggest, brightest, best magazine for boys in all the world"



Get the folks to give you The American Boy for Christmas and then watch the other fellows forget their presents and say—"you got the best of all." You'll like it so well, you'll let all your other gifts alone until you've read it clear through.

In 1918, The American Boy Magazine will be crammed full of live, inspiring literature. There will be published, in serial form, the seven best books of the year. Funny, fat Mark Tidd will be there; Dan Beard will tell you about outdoor life; you'll get true and exciting Indian stories; stories of Pirate days; stories about Baseball, Football, Camping, the Army and Navy, and many others. Fascinating articles on Poultry Raising, Mechanics, Electricity, Aviation, Automobiling; easy ways to earn money; jokes, comic pictures and lots of other good reading matter.

Yes, sir, Fellows, The American Boy is the finest Christmas gift anybody could give you. And all it costs is

\$1.50 a year

15 cents a copy on news-stands

Think of it! For \$1.50 you get 12 big, bright issues of The American Boy regularly from this Christmas to next. You can't beat that for price and enjoyment. Make sure you get The American Boy this Christmas. Show this advertisement to the folks at home or to some friend and tell them you want this boy's publication for Christmas. Tell them to send their subscriptions to

THE SPRAGUE PUBLISHING CO.
108 American Building, Detroit, Mich.

THE AMERICAN BOY

Please Mention Popular Mechanics

This Fob FREE

Are you interested in the mechanical side of an automobile, its proper operation and economical maintenance?

Owners—Garagemen—Chauffeurs

The *American Chauffeur* is a live monthly magazine featuring articles in common sense language, by "men who know," on instructive topics, which will be interesting and of great value to every auto owner, chauffeur and garageman.

FREE OFFER

To introduce the *American Chauffeur*, we are offering this plated lacquered watch fob, with seal grain leather strap, as illustrated, ABSOLUTELY FREE, with a 3 months subscription to the *American Chauffeur* at the regular price of 25c.

Your money refunded if either the magazine or fob does not come up to your expectation.

THE AMERICAN CHAUFFEUR

62 Butler Bldg., CINCINNATI, OHIO

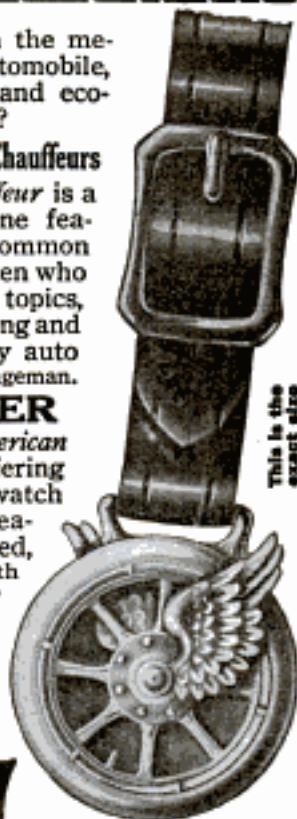

This is the exact size

Increase Your Income

Learn Show Card Writing and Lettering



A complete course (32 lesson plates) size 11x15, mailed for \$1.00. Guaranteed to suit you or money refunded if returned at once.

Send for descriptive circular.

ALPHA COLOR COMPANY, Inc.
31 E. 125th Street, New York

The University of Chicago

HOME STUDY

in addition to resident work, offers also instruction by correspondence.

For detailed information address

24th Year U. of C. (Div. V) Chicago, Ill.



Michell Tower

FREE 10 Lessons In Public Speaking

Write for particulars of this extraordinary offer. 10 lessons in public speaking absolutely free. Remarkable opportunity. Become a powerful speaker in spare time by mail. Overcome "stage fright," enlarge your vocabulary, train your memory, gain self-confidence. Increase your earning power, get results. We have trained hundreds.

Offer Limited This offer is made strictly for advertising purposes and may be withdrawn at any time. Write at once, while this free lesson offer lasts. Big saving if you act now.

North American Institute, 119C Manhattan Bldg., Chicago, Ill.

LEARN WATCH REPAIRING



You can learn by our modern and original system of instruction every part of the Watch Repairing Trade at home as good or better than at a shop. You can earn money while learning and secure a well paying position or start in business after completing our course of instruction. Good watch repairers are always in demand and earn from \$20 to \$35 per week. For particulars apply to the Wisconsin School of Watchmaking, Strub Bldg., Milwaukee, Wis.

414 PAGES 145 ILLUSTRATIONS

I.C.S.
ELECTRICAL ENGINEERS
HANDBOOK

50¢

ELECTRICITY!

HERE'S just the book on Electricity that you need to answer your many questions—to solve your knotty problems, to teach you new kinks, to be your memory for tables, rules, formulas and other Electrical and Mechanical facts that some people try to carry in their heads—and fail.

With this "Little Giant" I. C. S. Electrical Engineer's Handbook in your pocket, tool chest, on your work bench, drawing table or desk, an hour or a day need not be lost "digging up" some forgotten rule, some unfamiliar fact; you'll just turn to the very complete index and get it "in a jiffy." Just a few of the subjects treated are:

Electricity and Magnetism; Electrical Symbols; Batteries; Circuits; Magnets; Direct and Alternating Currents; Dynamos and Motors; Belts; Shafting; Electroplating; Electrical Measurements; Meters; Arc and Incandescent Lamps; Mercury Arc Rectifiers; Transformers; Insulation; Electric Cars; Single and Multiple-Unit Control; Transmission; Rail Welding; Tables of Wires—Sizes, Capacities, etc.—Mathematical Rules, Formulas, Symbols; Tables of Constants, Equivalents, Roots, Powers, Reciprocals, Areas, Weights and Measures; Chemistry; Properties of Metals; Principles of Mechanics; First Aid, etc.

The Electrical Engineer's Handbook is one of 22 I. C. S. Handbooks covering 22 Technical, Scientific and Commercial subjects, all crowded with value. They have the contents of a full-size book condensed into pocket-size ready to go with you anywhere and be at your instant command. They are substantially bound in cloth, red edges, goldleaf stamping, printed from new, clear, readable type on good quality book paper. There is an illustration at every point where a picture will help. Hundreds of thousands have been sold on a money-back guarantee of satisfaction.

The former price of these Handbooks was \$1.25, but **THIS MONTH** you can buy **50c** each, the ones you want for only **50c** postpaid

(For 10c extra we will send a cloth-covered protecting case.)

You Run No Risk! Money Back if Desired!

International Correspondence Schools
Box 5629, Scranton, Pa.

INTERNATIONAL CORRESPONDENCE SCHOOLS

Box 5629, SCRANTON, PA.

I enclose \$_____ for which send me postpaid the Handbooks marked X, at 50c. each. I may return any or all and get my money back within ten days from receipt:

- | | |
|--|---|
| <input type="checkbox"/> Electrical Engineer's | <input type="checkbox"/> Advertiser's |
| <input type="checkbox"/> Teleph. and Teleg. Enginner's | <input type="checkbox"/> Business Man's ★ |
| <input type="checkbox"/> Mechanic's | <input type="checkbox"/> Bookkeeper's |
| <input type="checkbox"/> Steam Engineer's | <input type="checkbox"/> Steno. and Correspondent's |
| <input type="checkbox"/> Westinghouse Air Brake | <input type="checkbox"/> Salesman's |
| <input type="checkbox"/> Civil Engineer's | <input type="checkbox"/> Window Trimmer's |
| <input type="checkbox"/> Coal Miner's | <input type="checkbox"/> Cotton Textile Worker's |
| <input type="checkbox"/> Concrete Engineer's | <input type="checkbox"/> Farmer's |
| <input type="checkbox"/> Building Trades | <input type="checkbox"/> Poultryman's |
| <input type="checkbox"/> Plumber's and Fitter's | <input type="checkbox"/> Mariner's |
| <input type="checkbox"/> Chemist's | <input type="checkbox"/> Automobile |

Name _____

Street and No. _____

City _____ State _____

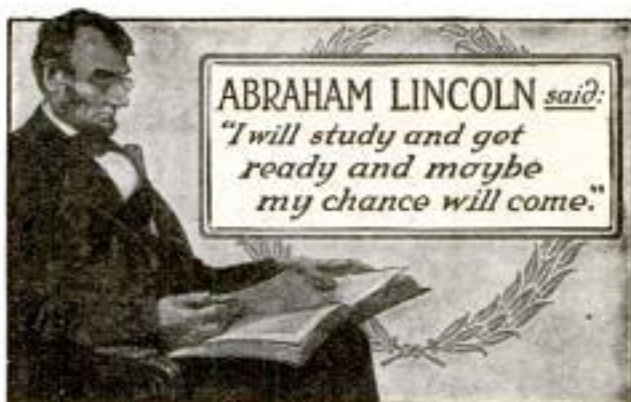

ABRAHAM LINCOLN said:
"I will study and get ready and maybe my chance will come."

YOUR Chance Will Come

Born in a log cabin, Abraham Lincoln had little chance to acquire an education. But he was determined to succeed. "Some day," he said, "my chance *will* come." So he studied and got ready. And his chance *DID* come.

Your chance will come. Some day you'll be considered for promotion or for a good job in some other line of work. If you are ready, you'll go up.

And you *CAN* get ready. No matter if your schooling was limited—if you do have to work long hours. If you really want a better job, the International Correspondence Schools can train you for it at home during your spare time.

Every month more than 400 I. C. S. Students voluntarily report promotions or salary increases due to I. C. S. help. What the I. C. S. have done for these men they can do for *YOU*. Mark and mail the coupon NOW.

INTERNATIONAL CORRESPONDENCE SCHOOLS, Box 5627, Scranton, Pa.

INTERNATIONAL CORRESPONDENCE SCHOOLS BOX 5627, SCRANTON, PA.

Explain, without obligating me, how I can qualify for the position, or in the subject, before which I mark X.

- | | |
|--|---|
| <input type="checkbox"/> ADVERTISING MAN | <input type="checkbox"/> ELECTRICAL ENGINEER |
| <input type="checkbox"/> Salesmanship | <input type="checkbox"/> Electric Lighting |
| <input type="checkbox"/> Commercial Law | <input type="checkbox"/> Electric Car Running |
| <input type="checkbox"/> BUSINESS (Complete) | <input type="checkbox"/> Electric Wiring |
| <input type="checkbox"/> Certified Public Accountant | <input type="checkbox"/> Telegraph Expert |
| <input type="checkbox"/> Higher Accounting | <input type="checkbox"/> Practical Telephony |
| <input type="checkbox"/> Bookkeeper | <input type="checkbox"/> Railroad |
| <input type="checkbox"/> Stenographer and Typist | <input type="checkbox"/> Mine Foreman or Engineer |
| <input type="checkbox"/> Railway Accountant | <input type="checkbox"/> Metallurgist or Prospector |
| <input type="checkbox"/> WINDOW TRIMMER | <input type="checkbox"/> ARCHITECT |
| <input type="checkbox"/> Show Card Writer | <input type="checkbox"/> Contractor and Builder |
| <input type="checkbox"/> Outdoor Sign Painter | <input type="checkbox"/> Architectural Draftsman |
| <input type="checkbox"/> Common School Subjects | <input type="checkbox"/> Concrete Builder |
| <input type="checkbox"/> Good English | <input type="checkbox"/> Structural Engineer |
| <input type="checkbox"/> Teacher | <input type="checkbox"/> Plumbing and Heating |
| <input type="checkbox"/> Civil Service | <input type="checkbox"/> Sheet Metal Worker |
| <input type="checkbox"/> Railway Mail Clerk | <input type="checkbox"/> CHEMICAL ENGINEER |
| <input type="checkbox"/> CIVIL ENGINEER | <input type="checkbox"/> Illustrator |
| <input type="checkbox"/> Surveying and Mapping | <input type="checkbox"/> Designer |
| <input type="checkbox"/> MECHANICAL ENGINEER | <input type="checkbox"/> Agric. Overseer or Supt. |
| <input type="checkbox"/> Mechanical Draftsman | <input type="checkbox"/> AGRICULTURE |
| <input type="checkbox"/> Machine Shop Practice | <input type="checkbox"/> Navigator |
| <input type="checkbox"/> Stationary Engineer | <input type="checkbox"/> Poultry Raising |
| <input type="checkbox"/> Gas Engineer | <input type="checkbox"/> AUTOMOBILES |

Name _____

Present Occupation _____

Street and No. _____

City _____ State _____

If name of Course you want is not in this list, write it below.

Please Mention Popular Mechanics

LEARN AUTOS

WHERE AUTOS ARE MADE



Enlarged
Facilities

Freely Endorsed by
Automobile Manufacturers

Detroit is the training camp for men who make good in the automobile and allied lines. Never has the call for men skilled as mechanics, testers, inspectors, repair-men, bearing scrapers, welders, chauffeurs and salesmen been as great as it is today — and the demand is growing.

The Y.M.C.A. Auto School

is organized to train men. A Course in this School will quickly fit the beginner to do well-paid work, and get in line for advancement in the rapidly growing automobile industry. Tuition fees go to procure the highest class of instructors and best of equipment.

Growth Brings Added Facilities

The Y.M.C.A. Auto School is now in its New Building. Among the manufacturers who have contributed liberally toward our equipment are: Studebaker, Buick, Hupp, Chalmers, Ford, Packard, Hudson, Gray & Davis, Delco, Cutler-Hammer, Zenith, and many others. Can you ask stronger proof of the school's standing than the fact that men who know give freely of their time and money to co-operate with us.

Tuition includes membership in the "Y" and free service of **Employment Bureau** for one year. Our big Club House, adjoining our New Building, is at your disposal. Reading rooms, lounging rooms, gymnasium, swimming pool, billiard and pool tables, bowling alleys, with five floors of dormitories and restaurant at low rates. You are assured of not only thorough and competent instruction, but good companionship and clean living conditions with the comforts of home and club life combined. **Don't Visit Detroit Without Seeing Us.** You want to consider everything carefully before you enroll for any course of instruction. Come and look us over, whatever purpose brings you to Detroit. Get all the particulars of this school, get the records of our instructors, hear what auto factories and automobile men have to say about us, see for yourself our comfortable quarters and big equipment. We will be glad to see you and show you around whether you enroll or not. Day and night classes. Start at any time.

Write today for full particulars. Address

**EDUCATIONAL
DIRECTOR**

Box 305, Y.M.C.A., DETROIT, MICH.

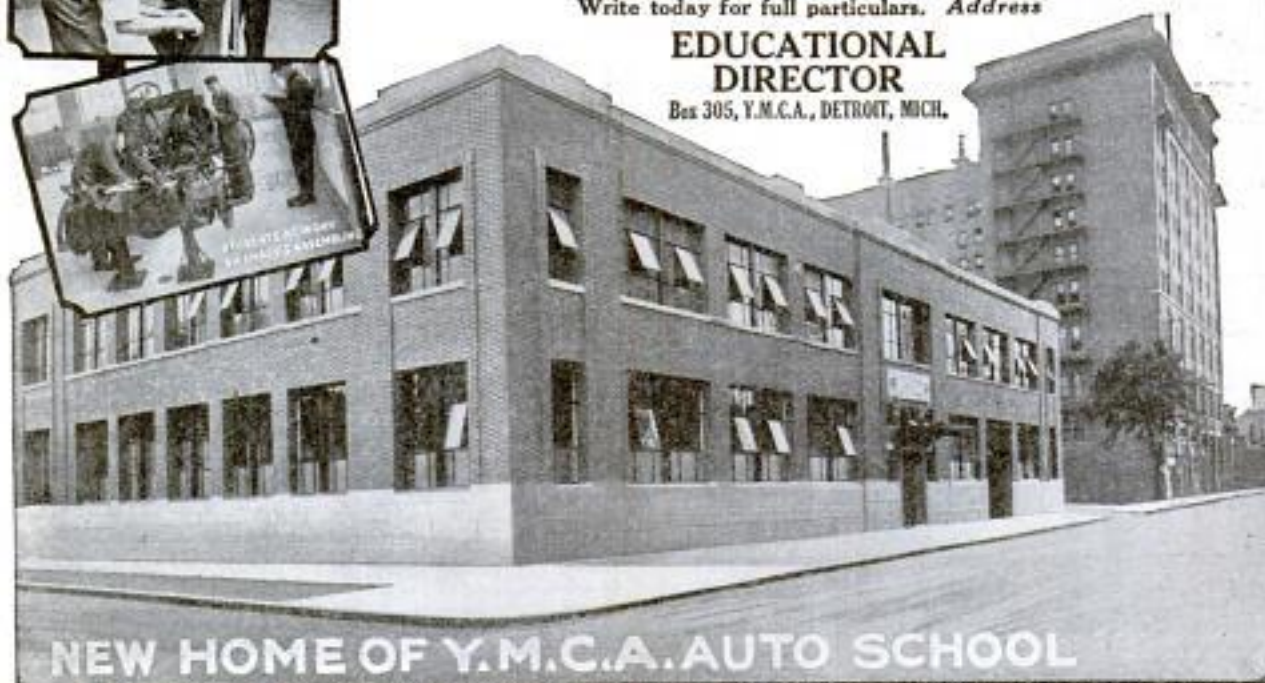



Be An Expert Accountant

- The Man Who Directs

Everywhere in business there is need for the man who knows Higher Accounting. To meet the competitive conditions that exist today, waste must be eliminated, accurate cost systems must be installed, economies must be put into effect and the management must have the whole situation charted and shown in figures whenever wanted. The book-keeper cannot do this. To analyze a business, a man must be to accounting what the highly trained lawyer is to the legal aspects of commerce. Over 500,000 American concerns today need the services of Expert Accountants. That shows where opportunity is. Write today for information about the course in Higher Accounting given by the LaSalle Extension University.

La Salle Students and Graduates

can now be found employed in the executive departments of practically all the large railroads, business houses and commercial organizations in the United States. Many prominent business concerns can be named in each of which 100 to 500 or more LaSalle students or graduates from our several specialized departments are employed in responsible positions. For instance—

Pennsylvania R. R.	917
American Telephone & Telegraph Company	259
U. S. Steel Corporation	250
Baltimore & Ohio R. R.	554
Armour & Company	163
Chicago & N. W. R. R.	393
Ford Motor Company	122
Swift & Company	187
Standard Oil Company	149

Among the numerous firms and corporations employing 50 to 100 or more LaSalle students or graduates are the following:

Western Electric Company
International Harvester Co.
B. F. Goodrich Company
Wells Fargo Express Company
Goodyear Tire and Rubber Co.

and every important railroad company in the United States.

More than 125,000 men in active business life including a large number of corporation officials have been enrolled and are reaping the benefits of LaSalle training and service. Over 20,000 new students now enroll annually. The LaSalle organization consists of 800 people, including a staff of 300 business experts, professional men, text writers, special lecture writers, instructors and assistants. LaSalle students and graduates occupying responsible positions can be found throughout the entire English speaking world.

Free Consulting Service

As a LaSalle student, you will also be entitled to the free use of our Consulting Service which gives you the privilege of calling on our staff of experts in any department at any time when you need special help or counsel. LaSalle Extension University is a clearing house of business information and through its many highly specialized departments is organized and equipped to render a practical and distinctive service which cannot be supplied by any other institution of similar character.

Learn Higher Accounting By Mail

Our staff of experts in the Science of Accounting will give you their direct personal instruction by mail, guiding you step by step until you have mastered this paying profession. You will study text books, lectures and accounting methods prepared by authorities—men who are actually employed or retained as expert advisers by leading industries. The underlying principles and the most modern methods of Business Analysis and Organization, and the Principles of Accounting, Auditing, Commercial Law and Scientific Management all made clear. You will be given special preparation for the C. P. A. examinations and made ready to command a higher salary or to enter business as a Consulting Accountant. You can get all this in your spare time while you hold your present position. How better could you use your hours of leisure?

Easy Terms

No large fees. No large sum to pay down. This instruction is offered on a convenient monthly payment plan. Our courses are for the ambitious man no matter how small his present income. Send the coupon below for full, detailed information.

Mail The Coupon Today

Make the knowledge of these LaSalle experts yours. At least send for information about this course which has helped so many men to rise quickly to positions of greater profit and prestige and which you can easily master by home study. No matter where you may be or what position you may hold, LaSalle Extension University can put you on the road to greater success. This has been proved by the record of its students and graduates. The information we will send will tell you just what knowledge you require to become proficient in Higher Accounting and how we will teach you in the shortest possible time. It will point out the possibilities that are wide open to the man who has the training demanded by large business organizations. We will also send valuable book "Ten Years' Promotion In One." Mail coupon now.

LASALLE EXTENSION UNIVERSITY

"The World's Greatest Extension University"

Dept. 1264-H

Chicago, Illinois

Without cost or obligation on my part, please send me particulars regarding your Home Study Course of Training in Higher Accounting and your Consulting Service. Also a copy of your valuable book for ambitious men, "Ten Years' Promotion In One."

Name.....

Address.....

City.....State.....



Please Mention Popular Mechanics

Here's Health and Power—Vim and Vigor



Do you want them?

Strength that is more than mere muscular strength. The strength of better health, abundant nerve force. The strength of keen relish. Write and find out what vibration will do for you. Nine out of ten people are only half alive. How about yourself? Do you feel just right? If you haven't that vigorous "go ahead" feeling all the time, don't fail to send the free coupon today for our big new book that will tell you all about

THE WHITE CROSS ELECTRIC VIBRATOR



Our Combination Outfits give you three of the greatest curative

agents—Vibration, Faradic and Galvanic electricity. We will send this wonderful machine to you on free trial. See it—try it—feel its health-giving vibrations for yourself. White Cross Electric Vibrators can be connected up as easily as electric lamps, or, if your home is not wired for electricity, they will operate on their own dry cells.

Vibration Is Life

In vibration there exists many of the secrets of life. The safest, surest and quickest way to recover normal health is by scientific manipulation of the organs affected and in this way stimulating them to perform their duties, whether it be those of digestion, respiration, circulation, or the nervous system. The rich, red blood will be sent coursing through every vein and artery. Write today—now—for our free book.



Send the Free Coupon

Lindstrom, Smith Co.
1100 S. Wabash Av.
Dept. 1199, Chicago

Please send me, absolutely free and prepaid, your new book, "Health and Beauty" and full particulars about the White Cross Electric Vibrator. I assume no obligation of any kind.

Name.....

Address.....

My Electrical Dealer's Name is.....

Just your name and address on the free coupon or a letter or a post card is enough. We will send you absolutely free and prepaid, our new book, "Health and Beauty." It's free. No obligations of any kind. Write today—at once.

Lindstrom, Smith Company
1100-1110 So. Wabash Ave.
Dept. 1199 Chicago, Ill.

We also manufacture White Cross Electric Stoves, Irons, Hair Dryers, Electric Lanterns, Electric Fans, Electric Automobile Horns, Electric Curling Irons, Heating Pads, Small Motors, etc., etc.

DEALERS WRITE

STOP CHEATING Yourself Out of Health and Life

I can prove to you that you are only half as alive as you must be to realize the joys and benefits of living in full. I can show you how, without drugs or medicines or dieting, without excessive exercise, without giving up any of the pleasures of life, you can revitalize, re-energize, restore every cell, tissue and organ of the body and become a giant in health and mind.



Send for My Book — FREE

The secret of wealth, health and happiness is fully explained in Swoboda's new book, "Conscious Evolution." In it, hundreds of pupils tell what this great discovery has meant to them in increased earnings, increased ability to live the well-rounded, wholly successful life. This great book will be sent free to all who are interested in greater health and mental power. Write today—now—before you forget. **ALOIS P. SWOBODA, 2077 Berkeley Bldg., New York City**

FREE!

A flying model aeroplane and all materials to build your own scale model, *Free* with our great Home Course in the Principles of Aviation. Write at once—before this offer is withdrawn. Learn the Science of Aviation at Home—under guidance of Experts. Tremendous demand for men who know aviation. Wonderful future. Prepare now. Write us today. **NATIONAL AERO INSTITUTE, Dept. 9193, Morton Bldg., CHICAGO**



Drums FREE



We teach you by mail and give you a professional orchestra drum absolutely *Free*. You pay weekly for lessons as taken. Drum comes with first lesson. Motion pictures analyze the beats. We teach and supply all brass band instruments. Write

INTERNATIONAL CORNET SCHOOL, 120 Federal St., Boston, Mass.

150 Parodies on Latest Songs 10c



Newly, Arab, Old Green River, Come Back Dixie, Bomb Bom Bay, Down Home in Texas, Down Among the Sheltering Palms, Tulip Time in Holland, Dublin Bay, It's a Long Way to Tipperary, I Didn't Raise My Boy to be a Soldier, Tokyo, Little Spark of Love, When You Were a Tulip, Michigan, Night in Jerusalem, Mandrake, International Rag, In My Harem and 131 others, including Comic Dialogues. Complete 10c; 3 for 20c.

J. C. DORN, 731 S. Dearborn Street, Dept. 18, CHICAGO, ILL.

Folding DOUBLE X-RAY



With this X-RAY you can apparently see thru cloth or wood, see bones in the body, makes the flesh look transparent. Lots of fun. 10 cts by mail. **THE ARDEE CO., Box 213, STAMFORD, CONN.**



WANTED—Railway Mail Clerks

Commence \$75 Month Increase to \$150

Common Education Sufficient

Sure Pay, Life Job, Pull Unnecessary.

Franklin Institute
Dept. J105, Rochester, N.Y.

Size: Send me, without charge, (1) sample Railway Mail Clerk Examination questions; (2) schedule showing places of examinations; (3) list of other government jobs now easily obtainable and (4) free book describing them.

NAME.....

ADDRESS.....

Please Mention Popular Mechanics

The MILLION DOLLAR AUTOMOBILE and TRACTOR SCHOOL

You Want to Succeed

It is just as easy to be a successful man in a live business as it is in one that holds little opportunity or chance for you. A man that thinks, knows that the automobile and tractor business is the liveliest business in the world. It has grown faster and has made more men big money and opened good positions for them than any other, and the best part of it is that the field is not crowded. In fact there are more chances for the average man today than in any other line of business.

Get in the Game!

There's money, lots of it, to be made, and you might as well make it along with the rest of the live men. Let this successful school, the one that has the reputation of turning out competent mechanics who are making good, give you the training that will start you toward success. It's easy. All it needs is determination and backbone.

I started teaching the automobile business nine years ago, with \$60 and a training in mechanics, the best which was to be had in those days. My success has been that

I came out with the idea that no man could learn a mechanical business without actually doing the work. Textbooks and charts and lectures are all right for some lines of education, but not in mechanics. Here you get right down in the work, and you know as well as I do that when you once do a thing, you know it.

My School Today Represents an Investment of \$1,000,000

I have 7 acres floor space and up-to-date equipment in every department of my school. In my Starting and Lighting System room I have every known make of starter. The same way in my battery room. When you get all through my course, then I put you in my garage, where you prove up what you know. It gives you self-confidence, and you can go out and tackle any kind of work, because you know that you can do it, as you have already done it.

Don't Experiment Get in a business with a future, and learn it where success is assured. All it needs is application on your part.

Write Today for My Big, Fully Illustrated Catalog

showing pictures of every department in my school and just how we teach you this business, and then decide your future. This is the day of big opportunities for mechanically inclined men. Write to me today. I will show you a sure road to success.

E. J. SWEENEY, President

SWEENEY AUTOMOBILE AND TRACTOR SCHOOL

The Opportunity School for Mechanically Inclined Men
312 Union Station Plaza KANSAS CITY, MISSOURI

Mail This Coupon

Sweeney
Auto and
Tractor School
312 Union Sta. Plaza
Kansas City, Mo.

Send me Free
Illustrated Cat-
alogue of your
School and how you
teach the Automobile
and Tractor Business.

Name.....

Address.....

Please Mention Popular Mechanics

Copyrighted material



Wanted— Men Who Know the Science of Aviation!

The fact that the United States government plans to send 30,000 flying men to Europe and spend possibly a billion dollars in aviation means something more than a big demand for flying men.

It Means the Sudden Building Up of a Vast New Industry!

There will be urgent need for thousands of men who thoroughly understand the science of aviation—men who can serve as airplane designers, builders, engineers, assemblers, salesmen, repairmen, mechanics, contractors, inspectors, instructors.

Learn at Home!

Start now to master the science of aviation. Help to meet this tremendous demand for trained men. You can learn at home, in your leisure time, without giving up your employment—and you do not need a college education.

The National Aero Institute offers you a mail course of 33 lessons in the principles of aviation. Your training will be under the supervision of aeronautical experts—men like Walter L. Brock, the famous aviator who won the great London to Paris race. While you cannot, of course, learn to fly by mail, this great home course gives you all the ground work which is so necessary to successful flying—and all the basic training needed to fit you for any of the positions mentioned above.

When you have completed the course you will need only actual working experience to make you an aviation expert. Aviation experts command big salaries.

This Course Gives You

all the basic training needed to fill such positions as:

Airplane Designer;
Builder; Salesman;
Assembler; Contractor;
Repairman; Inspector;
Mechanic

Authorities agree that after the war aviation is bound to become a vast means of transportation—passenger—freight—mail. Orville Wright says, "There is no means of transportation that is so safe." Be a pioneer in this great new industry. Pioneers have the best chance of being leaders. The sudden rise of the automobile industry turned poor men into millionaires. You may be the future "Henry Ford" of aviation!

Write at Once For Special Offer

National Aero
Institute
Dept. 1199
Morton Bldg., Chicago, Ill.

Gentlemen:—Please send me, free and prepaid, full particulars of your mail course in the principles of aviation, and details of your special limited offer.

Name.....

Address.....

Send for our special limited offer. Just now we are offering this Complete Mail Course in the Principles of Aviation at a greatly reduced price. We also furnish free, to every student who enrolls now, a complete flying model and all materials for a scale model. Tear out the coupon and mail it at once—before this offer is withdrawn. Do it right away—NOW.

NATIONAL
Aero Institute
Dept. 1199
Morton Bldg., CHICAGO



Do You Like to Draw?

Whether your ambition is to become a second Bud Fisher or whether you draw merely for your own amusement—you will find lots of inspiration in

CARTOONS MAGAZINE

It contains each month the cream of caricature, and cartoon art the world over. The foremost American cartoonists are represented, together with the most famous of the Parisian artists and cartoonists of Berlin, London, Petrograd, and Rome.

Either as an art student or a student of current events you will enjoy seeing how cartoonists are portraying world history in the making. "Cartoons" is a monthly review, but doesn't take itself too seriously.

There are pictures by Ethel Plummer, stories by Helena Smith-Dayton, comics by King, Webster, and others, and Parisian sketches by the artists of Fantasio and La Baionnette. It also tells what the big fellows in the cartoon world are doing.

A two-bit piece together with the following blank filled out, will bring you post haste a sample copy.

CARTOONS MAGAZINE,
6 North Michigan Avenue, CHICAGO

Enclosed find 25 cents for which send me a sample copy of your magazine.

Name.....

Street and No.....

City..... State.....



H. J. RAHE
President

The Training For YOU!

Come to the School of Complete Equipment

— and let me train you to earn big money in the Automobile and Tractor Business. The supply of men to fill the many open positions and waiting opportunities is far short of the demand. Now is the time to start. I'll help you — I'll train you **right**. My success in training thousands of ambitious men is known throughout the country. I have been right here in Kansas City for a number of years and I rightly claim more successful graduates than any similar institution in the world. I am always ahead with complete equipment — with plenty of floor space and more expert instructors. My graduates earn from

This twin-six motor is block mounted.

Then there are the Eight and many other motors for my

students' special training and experience. These motors are in the practice room. All types of lighting and self-starting devices — full equipment, so that you learn all easily. Tire vulcanizing, Oxy-Acetylene welding — training and experience in all branches of the automobile business. My students do practical work. They handle welding torches under the guidance of master-welders. Don't bother with any training that gives you only a little — come here and I'll hand you a kit of tools — not printed books.

All types of motors — block-mounted. Easy to get around.



\$90 to \$300 a Month

YOU CAN DO THE SAME if you have ambition and determination to learn. **Rahe's Original Practical Method of Automobile Training and Experience** is everywhere recognized as the most efficient method of training ever devised. Remember — it's not theory — there are **no books or printed lessons**. My training is unique and distinctive — **it's the actual doing** — getting into overalls and starting at the bottom under the guidance of expert instructors.

Only a Few Weeks Required

That's all — just a few weeks and you will have a thorough understanding of the basic principles of this wonderful business. You will then be ready for a position, paying good money right from the start — with a world of opportunity before you. My original practical method is all simple and easy. You get the full instruction in easy stages and you have the wonderful advantages of complete equipment — Automobiles, Tractors, Welding Plants, Big Drill Presses, Power Lathes, Forges, etc. Two big garages and repair shops. Cars of all kinds for my students' practical use. Every type of motor is represented in my equipment — block mounted so they are easy to get around, easy to take apart. It's the Rahe method —

Practical — Efficient — Complete



17 Complete Welding Outfits. Big demand for Expert Welders.



Both Types of Tractors, Kerosene and Diesel Oil, Bang Pumps, Big Practice Field

\$50 Tractor Course Free

I want to enroll the full capacity of my school a month earlier this year, and to all students enrolling now I am giving a free scholarship for complete instruction in **Tractor Engineering, Power Farming, Gas and Stationary Engineering**. The development of the farm tractor and its growing popularity is second only to the automobile itself. Come and see my large tractor practice field and complete tractor and farm equipment. With this added knowledge you can reap new profits in an entirely new field. Remember — it's **FREE** when you enroll for my automobile course.

Get My 80-Page Catalog

Use the coupon below or post card, but send now for my new catalog. Filled with Copper Engravings of men at work in the various departments — views of equipment — four big buildings and big tractor farm. Let me start you. **Let me help you to be the success you can be** — if you have backbone and ambition. Send for the book at once and read letters from men like yourself — who came to me without previous experience and are now earning big money.

H. J. RAHE, President,
Rahe's Automobile and Tractor School

(World's Greatest Auto Training School)

2895 Oak St. Kansas City, Mo.

OPPORTUNITY COUPON

H. J. RAHE, Pres.,
Rahe's Automobile and Tractor School,
2895 Oak St., Kansas City, Mo.

Send me your new 80-page catalog, fully illustrated, telling of your Practical Training and big money opportunities in the Automobile and Tractor Business.

Name.....

Town.....

Street or R. F. D..... State.....



"Think Beyond Your Job!"

"There is not a man in power at the Bethlehem Steel Works today," says Charles M. Schwab, in the American Magazine, "who did not begin at the bottom and work his way up. Eight years ago Eugene Grace was switching engines. His ability to *out-think* his job, coupled with his sterling integrity, lifted him to the presidency of our corporation. Last year he earned more than a million dollars. . . . Jimmie Ward, one of our vice-presidents, used to be a stenographer. The fifteen men in charge of the plants were selected, not because of some startling stroke of genius, but because day in and day out, they were *thinking beyond their jobs.*"

If you want to be somebody, to climb to a position of responsibility, *get ready for it.* Do what you are doing now better than the men beside you, and *train for the job ahead.* You can do it—in spare time—through the International Correspondence Schools.

For 25 years men with ambition and I. C. S. help have been making spare hours the stepping-stones to successful careers. Last year more than 5,000 reported that their studies had won for them advancement and increased salaries. Over 130,000 men in offices, shops, stores, mines and mills and on railroads all over America are preparing in the I. C. S. way to take the next step upward.

Join them! All you need is just ordinary brains, the will to do, and the firm resolve to *think ahead of the job you now hold.* The I. C. S. are ready to make the rest easy. Make your start. Mark and mail this coupon.

INTERNATIONAL CORRESPONDENCE SCHOOLS BOX 5628, SCRANTON, PA.

Explain, without obligating me, how I can qualify for the position, or in the subject, before which I mark X.

- | | |
|---|--|
| <input type="checkbox"/> ELECTRICAL ENGINEER | <input type="checkbox"/> SALESMANSHIP |
| <input type="checkbox"/> Electric Lighting | <input type="checkbox"/> ADVERTISING |
| <input type="checkbox"/> Electric Railways | <input type="checkbox"/> Window Trimmer |
| <input type="checkbox"/> Electric Wiring | <input type="checkbox"/> Show Card Writer |
| <input type="checkbox"/> Telegraph Engineer | <input type="checkbox"/> Sign Painter |
| <input type="checkbox"/> Telephone Work | <input type="checkbox"/> Railroad Trainman |
| <input type="checkbox"/> MECHANICAL ENGINEER | <input type="checkbox"/> ILLUSTRATING |
| <input type="checkbox"/> Mechanical Draftsman | <input type="checkbox"/> Cartooning |
| <input type="checkbox"/> Machine Shop Practice | <input type="checkbox"/> BOOKKEEPER |
| <input type="checkbox"/> Gas Engine Operating | <input type="checkbox"/> Stenographer and Typist |
| <input type="checkbox"/> CIVIL ENGINEER | <input type="checkbox"/> Cert. Public Accountant |
| <input type="checkbox"/> Surveying and Mapping | <input type="checkbox"/> TRAFFIC MANAGER |
| <input type="checkbox"/> MINE FOREMAN OR ENGINEER | <input type="checkbox"/> Railway Accountant |
| <input type="checkbox"/> Metallurgist or Prospector | <input type="checkbox"/> Commercial Law |
| <input type="checkbox"/> STATIONARY ENGINEER | <input type="checkbox"/> GOOD ENGLISH |
| <input type="checkbox"/> Marine Engineer | <input type="checkbox"/> Teacher |
| <input type="checkbox"/> ARCHITECT | <input type="checkbox"/> Common School Subjects |
| <input type="checkbox"/> Contractor and Builder | <input type="checkbox"/> Mathematics |
| <input type="checkbox"/> Architectural Draftsman | <input type="checkbox"/> CIVIL SERVICE |
| <input type="checkbox"/> Concrete Builder | <input type="checkbox"/> Railway Mail Clerk |
| <input type="checkbox"/> Structural Engineer | <input type="checkbox"/> AUTOMOBILE OPERATING |
| <input type="checkbox"/> FLUHING AND HEATING | <input type="checkbox"/> Auto Repairing |
| <input type="checkbox"/> Sheet Metal Worker | <input type="checkbox"/> Navigation |
| <input type="checkbox"/> Textile Overseer or Supt. | <input type="checkbox"/> AGRICULTURE |
| <input type="checkbox"/> CHEMIST | <input type="checkbox"/> Poultry Raising |
| | <input type="checkbox"/> Spanish |
| | <input type="checkbox"/> German |
| | <input type="checkbox"/> French |
| | <input type="checkbox"/> Italian |

Name _____

Present Occupation _____

Street and No. _____

City _____ State _____

Please Mention Popular Mechanics

JUST OUT

OXY-ACETYLENE WELDING AND CUTTING

ELECTRIC AND THERMIT WELDING

By H. P. MANLY

Chief Engineer

Americas Bureau of Engineering

215 pages, Fully Illustrated.
Cloth, Price \$1.00; Leather,
stamped in gold, red edges,
Price \$1.50 (each postpaid).

The extensive use of the oxy-acetylene flame in welding and cutting has created an active demand for a practical book explaining this process. In addition to the oxy-acetylene welding are included electric and thermit welding, also a chapter

on hand forging and welding. In order to make a complete book on welding, the following subjects have been included: annealing, tempering, hardening, heat treatment, and the restoration of steel.

Much practical information is given on the uses and characteristics of the various metals. Thus, in this book the manufacturer and the workman will find all necessary information and data required in handling any kind of welding.

Sent postpaid upon receipt of price by

POPULAR MECHANICS BOOK DEPT.
6 N. Michigan Ave., CHICAGO

No Better Christmas Present for \$1.50

[than a year's subscription to

Popular Mechanics Magazine

containing 3600 Pictures and 3600 articles

Much of it interests Everybody

Most of it interests Anybody

All of it interests Somebody

Order through your newsdealer or address the publishers, POPULAR MECHANICS, CHICAGO

The Ford Motor Car

and Truck and Tractor
Attachments

By H. P. MANLY

A complete Instruction Book on every feature of the Ford car, including Truck and Tractor Attachments. It covers the Ford power plant; transmission system; running gear; control; adjustment and repair; upkeep and care; trouble symptoms and remedies; driving; starting and lighting; truck attachments; tractor attachments.

FULLY ILLUSTRATED

Limp cloth, prepaid - \$1.00

Leather, prepaid - - 1.50

POPULAR MECHANICS BOOK DEPT., 6 N. Michigan Ave., CHICAGO

LEARN AUTOS the Big Money Making Business



Our
New School
Just Completed



You Pay Nothing if We Fail

If you are mechanically inclined come to Cleveland and learn the auto business, under our Guaranteed instruction. Here in this new modern equipped building is every facility to give you a thorough, up-to-the-minute training. 4,000 graduates of the Cleveland Auto School in Factories, Garages, and in business for themselves in all parts of the country. The demand for Cleveland Trained Men is enormous, greater than we can supply.

Earn \$75 to \$200 a Month

No Previous Experience Necessary

With a few weeks' training under our capable instruction you can step right out and make \$75 to \$200 a month. We Guarantee to qualify you for a position as Chauffeur, Tester, Garageman, Expert Repairman, Shop Foreman, Auto Electrician, Auto Salesman, Demonstrator, Truck Driver, or fit you to start in the Auto business for yourself. If you desire you can take special training in Oxy-Acetylene Welding and Cutting, or Tire-Repairing, on the latest and modern machines made for the purpose.

Every one a member of firm and personally interested in your Success. All are members of the Leading Societies of Automotive Engineering. They put you on the right track—show you the "short-cuts" of the business. You learn by practice, not books. When you have finished your course you are trained, capable, and a man we are proud to recommend.

Act Now—Mail Coupon—Write Today

Get our big FREE Catalog and complete details. Remember your country needs men trained in this business. They are giving them positions in the Quartermasters' Department, Signal Corps, and Aviation Service. Whether you join the colors or not, investigate. Send the coupon. Write a letter or send a post card today, or if you prefer, come to Cleveland and see us. New classes starting every few days so you can start at once.

CLEVELAND AUTOMOBILE SCHOOL

Clyde H. Pratt, President

Dept. 12

1814 East 24th St.
Cleveland
Ohio

Fill Out TODAY!

Cleveland Automobile School
Dept. 12, 1814 East 24th St.
CLEVELAND, OHIO

GENTLEMEN: Send me free catalog and full details of your Automobile Training School.

Name.....

Address.....



Tire
Repairing



Garage Owner or
Manager



Chauffeur



Motor
12 Cyl.
Motor



One of
Our Classes

Please Mention Popular Mechanics

Never Mind How **STRONG**
You are—
What d'ye Know?



Today it's a battle of wits—and *brains win*. Muscle and brawn don't count so much as they used to.

The great question now is "What do you Know?" It draws the line between failure and success.

What do *you* know? Have you special ability in any one line? Could you "make good" in a big job right now?

For 25 years the International Correspondence Schools have been helping men to get ready for better work and bigger salaries. They can do the same for YOU. No matter where you live, what hours you work, or how little your education—the I. C. S. can train you for a more important and better-paying position.

Mark and mail the attached coupon—it won't obligate you in the least—it won't cost you anything to find out how you can get this salary-raising ability right in your own home, during your spare time.

MARK THE COUPON NOW

TEAR OUT HERE

INTERNATIONAL CORRESPONDENCE SCHOOLS

Box 5624, SCRANTON, PA.

Explain, without obligating me, how I can qualify for the position, or in the subject, before which I mark X.

- | | |
|---|--|
| <input type="checkbox"/> ELECTRICAL ENGINEER | <input type="checkbox"/> SALESMANSHIP |
| <input type="checkbox"/> Electric Lighting | <input type="checkbox"/> ADVERTISING MAN |
| <input type="checkbox"/> Electric Car Running | <input type="checkbox"/> Window Trimmer |
| <input type="checkbox"/> Electric Wiring | <input type="checkbox"/> Show Card Writer |
| <input type="checkbox"/> Telegraph Expert | <input type="checkbox"/> Outdoor Sign Painter |
| <input type="checkbox"/> Practical Telephony | <input type="checkbox"/> RAILROADER |
| <input type="checkbox"/> MECHANICAL ENGINEER | <input type="checkbox"/> ILLUSTRATOR |
| <input type="checkbox"/> Mechanical Draftsman | <input type="checkbox"/> DESIGNER |
| <input type="checkbox"/> Machine Shop Practice | <input type="checkbox"/> BOOKKEEPER |
| <input type="checkbox"/> Gas Engineer | <input type="checkbox"/> Stenographer and Typist |
| <input type="checkbox"/> CIVIL ENGINEER | <input type="checkbox"/> Cert. Public Accountant |
| <input type="checkbox"/> Surveying and Mapping | <input type="checkbox"/> Railway Accountant |
| <input type="checkbox"/> MINE FOREMAN OR ENGINEER | <input type="checkbox"/> Commercial Law |
| <input type="checkbox"/> Metallurgist or Prospector | <input type="checkbox"/> GOOD ENGLISH |
| <input type="checkbox"/> STATIONARY ENGINEER | <input type="checkbox"/> Teacher |
| <input type="checkbox"/> Marine Engineer | <input type="checkbox"/> Common School Subjects |
| <input type="checkbox"/> ARCHITECT | <input type="checkbox"/> CIVIL SERVICE |
| <input type="checkbox"/> Contractor and Builder | <input type="checkbox"/> Railway Mail Clerk |
| <input type="checkbox"/> Architectural Draftsman | <input type="checkbox"/> AGRICULTURE |
| <input type="checkbox"/> Concrete Builder | <input type="checkbox"/> Textile Overseer or Supt. |
| <input type="checkbox"/> Structural Engineer | <input type="checkbox"/> Navigator |
| <input type="checkbox"/> PLUMBING AND HEATING | <input type="checkbox"/> Penitry Raising |
| <input type="checkbox"/> Sheet Metal Worker | <input type="checkbox"/> AUTOMOBILES |
| <input type="checkbox"/> CHEMICAL ENGINEER | <input type="checkbox"/> Auto Repairing |

Name _____

Occupation & Employer _____

Street and No. _____

City _____ State _____

If name of Course you want is not in this list, write it below.

Please Mention Popular Mechanics



**1000 Interesting Things
For Boys to Make and Do**

are described in this great book

The Boy Mechanic, Vol. II

(A sequel to, but containing nothing found in Vol. I.)

480 Pages. Size 6 $\frac{3}{4}$ x 9 $\frac{3}{4}$ x 1 $\frac{3}{4}$ in. 995 Illus.

Cloth Binding. Price \$2.00 Postpaid.

Boys! Build Things!

This Big Book Tells You How to Make

- | | |
|-------------------------|-------------------------|
| Aerial Gliders | Merry-Go-Round |
| Aeroplane Kite | Mile-O-View Camera |
| Art Craft Work | Model Aeroplane |
| Bicycle Horn | Model Boat |
| Blowgun | Monorail Sled |
| Boats | Motion-Picture Camera |
| Boat Landing | Muskrat Trap |
| Bobbeds | Paddle-Wheel Boat |
| Camps | Pea-Shooting Gun |
| Camp Furnishings | Photographic Appliances |
| Cartridge Belt | Pushmobile |
| Castamaran | Pushmobile for Ice |
| Cyclemobile | Reed Furniture |
| Disk Pistol | Roller Coaster |
| Dog Exerciser | Sail for Wagon |
| Electric Fishing Signal | Scarecrow |
| Electric Fountain | Skates of Wood |
| Electric Horn | Skiff |
| Electric Motor | Skis |
| Ferris Wheel | Snowball Thrower |
| Fish Attractor | Snowshoes |
| Fishing Tackle | Spot-Light Lantern |
| Flymobile | Springboard |
| Footboats | Steam Turbine Boat |
| Games on Ice | Steam Turbine Engine |
| Grape Arbor | Steering Sled |
| Houses of Poles | Stilts |
| Hurdle | Sunlight Flasher |
| Ice Boats | Surveying |
| Ice Gliders | Swimming Raft |
| Indoor Games | Tricks |
| Kites | Vaulting Pole |
| Lawn Tennis Marker | Water Wheel |
| Live Bait Pail | Windmill |

And 932 Others

Sent postpaid to any address upon receipt of price by the publishers.

POPULAR MECHANICS BOOK DEPT.
6 N. Michigan Ave. CHICAGO

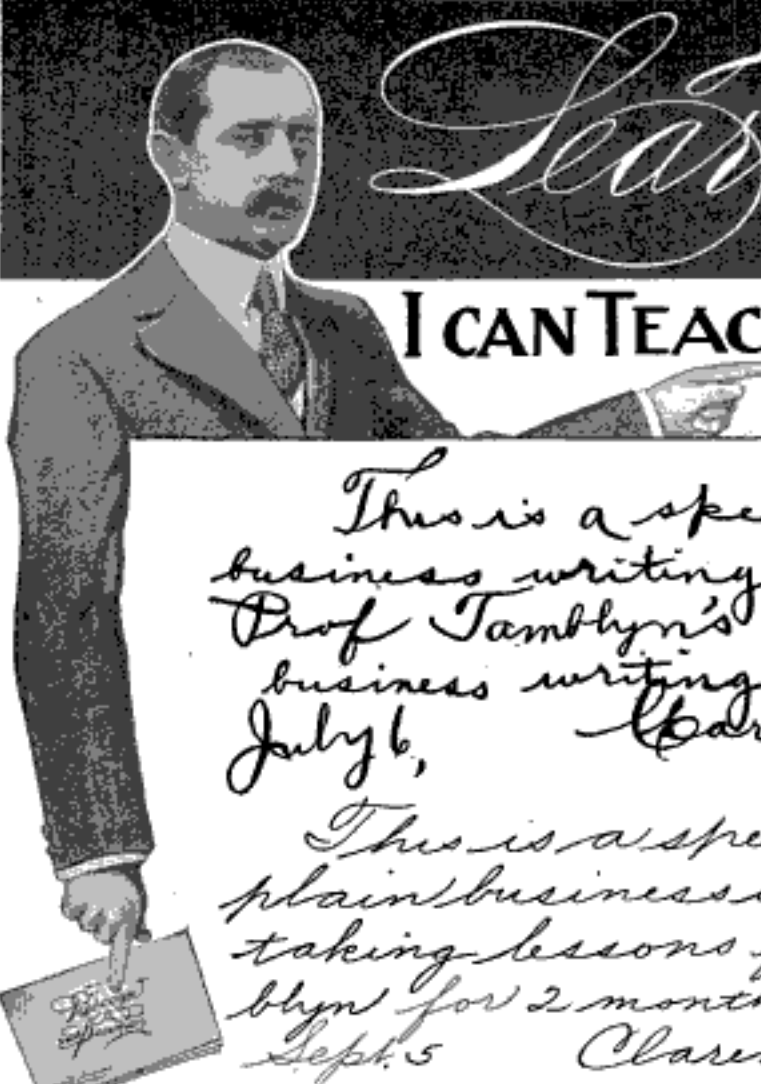

TO
Learn to Write

I CAN TEACH YOU AT HOME
During Spare time

This is a specimen of my business writing before taking Prof Tambllyn's course in business writing
July 6, Clarence P. Weber.

This is a specimen of my plain business writing after taking lessons from F. W. Tambllyn for 2 months
Sept. 5 Clarence P. Weber.

FREE BOOK

My 32-Page book "How to Become a Good Penman" is FREE to anyone who wants to write better. Contains copies and information that will help you, and beautiful specimens that will make your eyes twinkle with delight.

WRITE FOR IT—use the coupon below—or a postal will do—but

Send at Once!

If you enclose a stamp, I will write your name on a card with white ink, making one of the prettiest specimens of penmanship you ever saw

"A Wonderful Bargain" "It is now about two months since I began your course, and while I am not quite half through with Business Writing, I am delighted with my improvement, which is quite marked as you will see by comparing my present writing with the specimen written when I began. My parents objected to my taking it up, but now see I'm getting a wonderful bargain."

— CLARENCE P. WEBER, Middletown, Del.

Good Writing Is the Very Foundation of Business Success

I can make a good penman of you at your own home, in your spare time, no matter where you live or how poorly you now write. Ever fail to secure a good position because of poor penmanship? Ever know of better positions you could have stepped into if you only wrote a good hand? If not, you're an exception. The advantage of good penmanship is seen all around us.

I have been teaching penmanship by mail over 20 years. I know that any ambitious person can master penmanship just as quickly and thoroughly by my system at home as if in a schoolroom under the personal instruction of the teacher.

BEGIN NOW to learn good handwriting and be ready for the next better position that comes your way. Learn right at home—in your own room, outside of working hours. Your spare time is all I ask.

I teach *Spelling and Letter Writing* also.

Mr. Weber's wonderful improvement shown in the specimens above was made in 2 months. Hundreds and hundreds of others in all parts of the country are doing the same.

YOU CAN DO AS WELL

This Brings FREE BOOK

F. W. TAMBLYN, 418 Ridge Bldg., KANSAS CITY, MO.

I am interested in improving my penmanship. Send me your Free Book, "How to Become a Good Penman," postpaid.

Name

Address

F. W. TAMBLYN

418 Ridge Bldg., KANSAS CITY, MO., U.S.A.

These Books Answer Ten Thousand Questions About Automobiles!



You Need Them in Your Business

Every Mechanic, every Garage man, every Dealer, every Repairman, every Car Owner needs these complete, practical, *helpful*, up-to-the-minute auto books. They tell you *instantly* everything you want to know about automobiles.

Automobile Engineering

5 Volumes, Flexibly Bound in
Genuine Morocco Leather, Gold Stamped

The final authority on automobiles, 2400 pages (5¼ x 8¼) and 2000 illustrations, tables, diagrams, etc.

Everything About Automobiles
Including Explosion Motors, Welding, Motor Construction and Repair, Carburetors and Settings, Valves, Cooling, Lubrication, Fly-Wheels, Clutch, Transmission, Final Drive, Steering Frames, Tires, Vulcanizing, Ignition, Starting and Lighting Systems, Wiring Diagrams, Commercial Garage Design and Equipment, Electrics, Storage Batteries.

American Technical Society
Dept. A1199, Chicago, Ill.

Please send me the 5 volume Automobile Engineering for 7 days' free examination, express prepaid. If I decide to buy, I will send \$2.00 within 7 days and the balance at \$2.00 a month until \$17.80 has been paid. Then you send me a receipt showing that the \$25.00 set of books and the \$12.00 Consulting Membership are mine and fully paid for. If I think that I can get along without the books after the 7 days' trial I will return them at your expense.

Name.....

Address.....

Reference.....

50c a Week If You Decide to
Keep Them

Just your name and address on coupon brings entire set for 7 days' free use, express prepaid. If you decide to keep them send only \$2.00 within 7 days and then \$2.00 a month—50c A WEEK—until special price of \$17.80 has been paid. This offer open to all within the boundaries of United States and Canada.

FREE CONSULTING SERVICE

With each set we give you free, a year's Consulting Membership in the American Technical Society. The regular price is \$12. Put your problems up to our Experts, for one entire year.

Free on 7 Days' Trial
Send Coupon



Imported Drawing Instruments Free!!

YES, I will give you this exquisite set of imported drawing instruments absolutely free and I will give you a 20 x 25 inch drawing board, a 24-inch T square, a 12-inch rule, a supply of drawing paper, 2 triangles and a French curve, pencils, erasers, thumb tacks, etc. The instruments come in a superb plush lined leather case—they are genuine working instruments and I don't think you could duplicate this outfit for less than \$15. But I give it away *absolutely free* to the men who get my personal instruction.

Be a Draftsman!

Draw \$125 to \$175 Per Month

There is an urgent demand for skilled draftsmen. Companies are issuing calls every day for men to fill positions paying from \$125.00 to \$175.00 per month. I will give you just the training you need to hold one of these big jobs—right in your own home. Write now.

Chief Draftsman Will Instruct You Personally

I am Chief Draftsman of a large and well known firm. I have been doing the highest paying expert drafting

**Pay As
You Wish**
I want ambitious men. Don't worry about the small charge I make for my instruction. Write today.

work for a quarter of a century and I know just the kind of training that is demanded from men who get the big salaries. During my spare time I will train a few ambitious men to hold big jobs, while they remain in their own homes. You will get actual work to do—practical instruction until you consider yourself competent regardless of how long it takes. Write to-day—now—set at once.



Chief
Draftsman Dobe
Engineer's Equipment Co.
Div. 1199, CHICAGO, ILL.

Send the Coupon for Big New Book

Without any obligations on me whatsoever, please mail your book "Successful Draftsmanship" and full particulars of your liberal "Personal Instruction" offer to a few students. It is understood that I am obligated in no way whatsoever.

Write me personally for my new book on drafting—sent free. Send the coupon now.

Chief Draftsman
Dobe

Engineer's
Equipment
Co., Inc.
Div. 1199
Chicago,
Ill.

Name.....

Address.....

Why \$5,000 Salaries are Common in this New Two Billion Dollar Industry

By M. B. Sackheim

A CONCERN in South Chicago had been shipping, daily, about 200 cars of Coke from Connellsville to their smelters. Some time ago a traffic expert succeeded in getting a rate judgment which resulted in a saving of about \$5.00 on each car. Thus, on this one item alone a saving of over \$300,000 a year was effected.

In St. Louis, through misrouting of freight, errors in reconsigning cars and undercharges on shipments, a railroad lost over \$27,000.

A traffic expert discovered that freight rates paid by the Meeker Coal Co. were exorbitant. A ruling secured from the Interstate Commerce Commission resulted in a refund of \$122,000.

An oil shipper in Kansas was losing over \$30 every day—\$700 monthly—because he did not know of certain tariff regulations entitling him to lower rates.

These are but a few instances of what is occurring every day in the traffic industry. Tens of thousands of concerns, without realizing it, are losing fortunes every year because they do not know that there are countless classifications, special freight services and rate combinations which legally entitle them to rates that would amaze them if they but knew.

Is it any wonder that competent traffic experts are paid \$2,500 to \$10,000 and even up to \$25,000 and \$40,000 a year? Is it any wonder that firms are glad to pay a percentage of what traffic managers save? The man who can do it is in high command and instead of finding himself in the position of ever asking for a raise generally has several firms bidding for his services. Why not? It's no hardship to pay a big salary out of losses turned into profit.

Traffic—The Life-Blood of Business

Transportation is the second largest and the most important business in the country. More than two billion dollars annually are spent in freight rates, yet it has been estimated that eight out of every ten shippers are losing money because of the scarcity of trained traffic men.

Every dollar wasted in freight charges represents a dollar of wasted profit or a dollar of wasted opportunity. In business today freight charges are a vital factor in governing prices. By accepting every existent advantage in rates, a concern, or a city, can vastly undersell its competitors who waste traffic dollars.

So vital is this element of freight charges that the Chicago Board of Trade pays its traffic manager about \$12,000 a year to protect the members of the board from freight-rate losses.

By having rates properly based, competent railroad-traffic managers influence shipments over their lines, and for this work they are paid from \$6,000 to \$45,000 annually.

There are about 50,000 large business corporations and about 400,000 smaller shippers which must be protected by competent traffic men. These concerns have freight expenses running from a few thousand dollars to many thousands of dollars monthly. Yet in the entire country there are only a few hundred men actually competent to save the money now being wasted through lack of efficiency in applying the Government Freight Rate System. It is estimated that over 100,000 more traffic experts are needed at once.

Become a Traffic Expert

Heretofore, there has been no simple way to master the details of traffic management. Realizing the crying demand for trained traffic experts, and seeking relief, the American Commerce Association—a National organization OF traffic men, FOR traffic men, BY traffic men, offers to give men the training required to make them competent to handle the problems of most economical distribution. The instruction is given by mail and can be studied in sparetime, at home. Though the most complete and thorough training is given, the Course is remarkably easy to master.

Through its Advisory Council, every member of the American Commerce Association receives the help of such men as T. Albert Gantt, traffic manager, Corn Products Co.; Wm. Scott Cowie, freight agent Erie R. R.; Samuel G. Lutz, general traffic manager Stone & Webster Engineering Corporation; A. C. Westfall, traffic manager Cadillac Motor Car Co.; T. T. Harkrader, traffic manager American Tobacco Co.; as well as nearly 200 others of equal prominence.

Wonderful Book, Free

The Course in Traffic Management is adjusted to beginners as well as to those already engaged in traffic work. The instruction has been endorsed by such men as Robt. H. Forbes, traffic manager Butler Bros., New York; J. F. Brown, manager transportation department Chicago Board of Trade; H. G. Wilson, traffic manager of the Toledo Board of Trade; Ira S. Bassett, traffic commissioner Pittsburg Commercial Club; W. H. DeWitt, Eastern traffic manager Western Electric Co., and hundreds of others equally prominent.

It is impossible to go into details in this limited space, but the Association has published a remarkable book for free distribution which explains the instruction in detail and tells how anyone may quickly learn the cheapest rates in existence on all kinds of shipments, the fastest methods of shipment, the best methods of protecting shipments from loss and damage, and how to organize and manage a traffic department for maximum results. The book also tells what hundreds of other men have accomplished as a result of the study.

The new profession of traffic management is in its infancy. The possibilities today—great as they are—are nothing compared to what they will be a year from now. If you are at all interested in getting into this highly profitable field, paying salaries of \$2,500 to \$10,000 and more, be fair to yourself and write for the remarkable book now offered free by the Association. In writing, please state whether you are a beginner or whether you have had previous traffic experience, and give your present age and occupation. Address, American Commerce Association, Dept. 1012, 206 S. Wabash Ave., Chicago, Ill. (American Commerce Building.)



"I propose
to fight it out
on this line if it
takes all summer"

— Gen. U.S. Grant

Resolve to Win!

Determination made Grant one of the greatest generals in history. The world knows his story. It knows, too, the stories of thousands of other determined men, who succeeded because they had a purpose and stuck to it.

Do you want to succeed? Do you want that better job? Do you want that increase in pay?

If you *do* want to get out of the rut—if you *are* determined to make something of yourself, send the International Correspondence Schools the attached coupon. Tell them what kind of position you want and they will show you how you can fit yourself to get it.

More than 100,000 determined men and women are getting ready for better positions right now through I. C. S. training. They are securing this training in their own homes, at small cost and without losing an hour from their everyday work.

**Determine to mark and
mail the coupon to-day**

YEAR OUT HERE

INTERNATIONAL CORRESPONDENCE SCHOOLS BOX 5626, SCRANTON, PA.

Explain, without obligating me, how I can qualify for the position, or in the subject, before which I mark X.

- | | |
|---|--|
| <input type="checkbox"/> ELECTRICAL ENGINEER | <input type="checkbox"/> SALESMANSHIP |
| <input type="checkbox"/> Electric Lighting | <input type="checkbox"/> ADVERTISING |
| <input type="checkbox"/> Electric Railways | <input type="checkbox"/> Window Trimmer |
| <input type="checkbox"/> Electric Wiring | <input type="checkbox"/> Show Card Writer |
| <input type="checkbox"/> Telegraph Engineer | <input type="checkbox"/> Sign Painter |
| <input type="checkbox"/> Telephone Work | <input type="checkbox"/> Railroad Trainman |
| <input type="checkbox"/> MECHANICAL ENGINEER | <input type="checkbox"/> ILLUSTRATING |
| <input type="checkbox"/> Mechanical Draftsman | <input type="checkbox"/> Cartooning |
| <input type="checkbox"/> Machine Shop Practice | <input type="checkbox"/> BOOKKEEPER |
| <input type="checkbox"/> Gas Engine Operating | <input type="checkbox"/> Stenographer and Typist |
| <input type="checkbox"/> CIVIL ENGINEER | <input type="checkbox"/> Cert. Public Accountant |
| <input type="checkbox"/> Surveying and Mapping | <input type="checkbox"/> TRAFFIC MANAGER |
| <input type="checkbox"/> MINE FOREMAN OR ENGINEER | <input type="checkbox"/> Railway Accountant |
| <input type="checkbox"/> Metallurgist or Prospector | <input type="checkbox"/> Commercial Law |
| <input type="checkbox"/> STATIONARY ENGINEER | <input type="checkbox"/> GOOD ENGLISH |
| <input type="checkbox"/> Marine Engineer | <input type="checkbox"/> Teacher |
| <input type="checkbox"/> ARCHITECT | <input type="checkbox"/> Common School Subjects |
| <input type="checkbox"/> Contractor and Builder | <input type="checkbox"/> Mathematics |
| <input type="checkbox"/> Architectural Draftsman | <input type="checkbox"/> CIVIL SERVICE |
| <input type="checkbox"/> Concrete Builder | <input type="checkbox"/> Railway Mail Clerk |
| <input type="checkbox"/> Structural Engineer | <input type="checkbox"/> AUTOMOBILE OPERATING |
| <input type="checkbox"/> PLUMBING AND HEATING | <input type="checkbox"/> Auto Repairing |
| <input type="checkbox"/> Sheet Metal Worker | <input type="checkbox"/> Navigation |
| <input type="checkbox"/> Textile Overseer or Supt. | <input type="checkbox"/> AGRICULTURE |
| <input type="checkbox"/> CHEMIST | <input type="checkbox"/> Poultry Raising |
| | <input type="checkbox"/> Spanish |
| | <input type="checkbox"/> German |
| | <input type="checkbox"/> French |
| | <input type="checkbox"/> Italian |

Name _____
Present Occupation _____
Street and No. _____
City _____ State _____

Please Mention Popular Mechanics

Learn



LAW

—At Home

The opportunity to get a legal training without leaving your present position is now yours. By our simplified Home Study Course we bring professors, text books, lectures, cases, personal suggestions, etc.—a complete legal training—right into your own home, where you can study in your spare time.

Our plan of instruction gives you a complete university training in law. We facilitate your progress by placing you under the direction of the ablest legal minds. The cost of the tuition is moderate and you can pay a little each month if you wish. Investigate.

LAW-TRAINED MEN

Rule in Business and Public Life

It will pay you to take up law. Lawyers, as a class, enjoy a distinction and prestige unsurpassed in any other profession. There is a vast field open in court practice, in public life and in business. Since every business transaction involves a knowledge of law, the law trained man is always in demand by the great commercial interests. Prepare to profit by these opportunities.

We guarantee that if, after graduation, you do not pass the bar examination we will give you free coaching until you meet the requirements.

14 Volume Law Library Given Free

to students. All branches fully covered. Also Course in Public Speaking given free to students enrolling now.

Write Now for our free book "Evidence" and "Law Catalog", which point the way to a successful career in law. Send for these two books today. They will tell how you can study law at home and all about the opportunities open to you as a law-trained man. Send today.

LaSALLE EXTENSION UNIVERSITY

"The World's Greatest Extension University"

Dept. 1264-F

Chicago, Ills.

7 DAYS

LIGHTENTAG PARAGON
SHORTHAND

In your own home, during the evenings of just one week, you can learn the famous

Then Practice Brings the Speed

Used in Government service; also in Court Reporting. Adopted by cities for High Schools. Wonderfully easy to read. Speed capacity practically unlimited. Positive proof before you enroll. Send for it TODAY.

PARAGON INSTITUTE, 652 COLISEUM PLACE, NEW ORLEANS, LA.

Learn SHOW CARD WRITING

Fascinating profession pays big money. Opportunities everywhere.

EARN \$20 TO \$75 A WEEK

Become an expert in spare time at home. Earn while you learn. **FREE** Complete Show Card Writer's Outfit to new students. Write postal for amazing offer and free booklet.

Lithonia System of Lettering
412 Flatiron Bldg., NEW YORK, N. Y.

Check the Job You Want!

Thousands War Jobs Open

... Railway Mail Clerk	\$900 to \$1800	... Customs Positions	\$ 600 to \$1500
... Postoffice Clerk	\$800 to \$1200	... Internal Revenue	\$ 700 to \$1800
... Postoffice Carrier	\$800 to \$1200	... Stenographer	\$1000 to \$1500
... Rural Mail Carrier	\$600 to \$1200	... Clerk at Washington	\$ 900 to \$1500

Name

Address

Sign your name and address and send us this coupon immediately. We will immediately send you (1) a full description of the position checked, (2) a list of many U. S. Gov't Jobs now easily obtainable and directions telling how to get free coaching for the position checked.

Franklin Institute, Dept. J97, Rochester, N. Y.

"Spare Time Study Does It"

ELECTRICAL ENGINEERING

IN 18 MONTHS!

Study our thorough, simplified, practical, complete course in Electricity in spare time for 18 months.

Train for a career as Electrical Engineer. The work is intensely fascinating.

You do the experiments yourself just as if you were actually engaged in the work.

You learn theories and their practical application.

ELECTRICITY

The Eleven Billion Dollar Industry

offers wonderful opportunities for experts. Training is absolutely essential for the big electrical manufacturing companies and Light and Power Plants cannot turn over their costly equipment to incompetents.

\$2500 to \$5000

A Year, For You

Others are earning these big salaries and so can you. It's simply a matter of training. And the training you need to put you in one of these positions can be obtained right in your own home.

Send The "Success" Coupon

American School of Correspondence

Dept. E-1199,
CHICAGO, U. S. A.

Please send me your free book on Electrical Engineering.

Put your name and address on the coupon or send letter or postcard for big free book that points the way to success in Electrical Engineering.

Hundreds of splendid positions open

Mail the Coupon

NOW

Name.....

Address.....

How to Succeed In the Automobile Business

BY ERWIN GREER

THIS BOOK FREE

Get this ←

Make Money! Never before were there such splendid money making opportunities as the automobile business offers you now, possibly right in your own community. With the business growing so rapidly, and the Government calling for many thousands of chauffeurs, mechanics and repairmen, there are not nearly enough trained men in the country.

You can be an experienced auto man and command big pay, after a few weeks at

GREER COLLEGE OF MOTORING

We train Repairmen, Chauffeurs, Garage Managers, Auto Salesmen—18 branches. Here you learn by doing the actual work under the direction of experts. You get individual instruction—no over-crowding. Special attention is given to all *Lighting and Starting Systems, Acetylene Welding, Brazing, Vulcanizing, Machine Shop work, etc.* Here you get *actual experience*, and are ready to start in business for yourself if you wish. Most men finish in 8 to 10 weeks. Diplomas are awarded and employment is secured for competent graduates.

Valuable Auto Book—FREE

This is a big, really valuable book, containing much useful information. *Sent free; tear off the coupon and mail or write today.*

Do not enroll in any school until you have read our literature. Gives reasons why you should come to Chicago and attend the GREER COLLEGE OF MOTORING.

GREER COLLEGE OF MOTORING

Dept. 2
1519 Wabash Ave.
CHICAGO

COUPON

Dept. 2
Greer College of Motoring
CHICAGO

You may send me absolutely free, the Big Auto Book you advertised. This does not obligate me in any way.

Name.....

Address.....

City.....State.....

Please Mention Popular Mechanics

The New York Men of All Ages Electrical School

Whether Sixty or Sixteen, you are assured absolute success in the future if you attend the only school devoted to teaching every angle of Electrical Industry by a method of "actual practice." All ages enter this school on the same level, are shown "how" and "why," and make rapid progress under the watchful eye of a staff of highly trained and experienced men. No preparation needed to take this course and you can start any day of any week throughout the whole year.

At this "Learn by Doing" School a man acquires the art of Electrical Drafting; the best business methods of Electrical Contracting; together with the skill to install, operate and maintain all systems for producing, transmitting and using electricity.

Write for illustrated booklet and "be shown" what the N. Y. Electrical School can do for YOU.

44 WEST 17TH STREET, NEW YORK

30 DAY COURSE IN TIRE REPAIRING FREE

Write Today for attractive particulars about our free course in tire repairing. Let us show you how to make \$3,000 to \$8,000 a year. RELIABLE TIRE REPAIR SCHOOL, 112 Reliable Bldg. DETROIT, MICH.

Short Story Writers Wanted!

There is a tremendous demand for short stories, photo plays, magazine and newspaper articles. 24,000 publications buy short stories. \$3,000.00 a year is a small income for a writer. You can be successful. Jack London said so. He and other great writers have endorsed our course. Learn at home during your spare time. Write Today for FREE BOOK. Our free book, "How to Write," tells you about it; also gives details of the special introductory offer that is being made for a limited time. Don't lose this opportunity. Write today. Hoosier Institute Short Story Dept., Dept. 1199, Fort Wayne, Ind.

BART CHALK-TALK
OF PATRIOTIC NUMBERS ANYONE CAN DO
You can't fail to make a big right away with this EASY PROGRAM OF UP-TO-THE-MINUTE NUMBERS. That you may become acquainted with chalk-talk possibilities, make a start with this PATRIOTIC PROGRAM. Write for new price list of art and entertainment materials and stunts of all kinds.
BART SUPPLIES, 521 Marquette Avenue, MINNEAPOLIS

FINLAY ENGINEERING COLLEGE KANSAS CITY, MO.

Practical, Technical, only school of its kind in the West. Mechanical, Electrical Engineering, including Auto. Fully equipped shop and laboratory. No entrance exams. Enroll any time. NIGHT AND DAY SESSIONS from one week to two years. Write for catalogue X.

STAMMERERS

Our course of private lessons will correct your impediments. BOSTON STAMMERERS' INSTITUTE
Founded 1867. Samuel D. Robbins, Principal.
246 Huntington Ave. BOSTON, MASS.

Make this car your office—

there is \$900.00 to \$1800.00 a year in it for you

Examinations will likely be held everywhere soon

Rapid advancement to higher Government Positions. "No layoffs" because of STRIKES, FINANCIAL FLURRIES or the WHIMS OF SOME PETTY BOSS. THE POSITION IS YOURS FOR LIFE. Country residents and city residents stand the same chance for immediate appointment. Common-sense education sufficient. Political influence NOT REQUIRED.

We will prepare 25 candidates FREE! Write immediately for schedule showing the places and dates of all coming Gov't examinations. Don't delay. Every day you lose means the loss of just so much coaching before the rapidly approaching examinations.

FRANKLIN INSTITUTE, Dept. J96, Rochester, N. Y.



Government Wants Hundreds Men — Women Clerks for War Work

COUPON

Franklin Institute (The pathway to plenty), Dept. J96, Rochester, N. Y.

This coupon, filled out as directed, entitles the sender to (1) free specimen questions, (2) a free copy of our copyrighted book, "Government Positions and How to Get Them," (3) a list of positions now easily obtainable, and (4) to consideration for Free Coaching for the examination here checked.
 Railway Mail Clerk (\$900 to \$1800) Customs Positions (\$800 to \$1500)
 Postoffice Clerk (\$800 to \$1200) Stenographer (\$1000 to \$1500)
 Postoffice Carrier (\$800 to \$1200) Clerk in the Departments
 Rural Mail Carrier (\$900 to \$1100) at Washington (\$900 to \$1500)

Name..... Address.....
Use this before you lose it. Write plainly.

Mathematics Made Easy by ROPP'S CALCULATOR AND SHORT-CUT ARITHMETIC

Shows the Answer as Quickly as a Watch shows the Time to all Problems likely to occur in the Office, Store, Shop, Bank, Farm, or Factory.



Over 2,000,000 Sold

Explains and simplifies every principle in Arithmetic, Mechanics, and Mensuration.

PRICES, POSTPAID
Desk Size.....\$1.25
Leather, Pocket Size.....\$1.00
Leather, Vest Pocket Size.....\$0.50
Pocket Size.....\$0.50

Send for 4-page description of this work

Popular Mechanics Book Dept., 6 N. Michigan Ave., Chicago



Latest Model No. 5

Over 600 of these visible L. C. Smith and Bros. Typewriters are used in the great Larkin offices to serve our two million customers.

L. C. Smith Typewriters

Write today for details of our Factory-to-Family care-to-pay offer on this latest model machine. Easy Payments. Desk \$198. 217 30 Days' Trial Larkin Co. BUFFALO, N. Y.

LITHOGRAPHIC MODELS IN COLORS

show and name every part of the following: Mallet Compound Locomotive—Atlantic Type Locomotive—Automobile—Steamship—Steam Engine—Steam Turbine—Dynamo—Gas Engine—Wireless Telegraph. Size 10x14 in. PRICE 50c EACH. Set of Nine Models \$4.00 Postpaid

POPULAR MECHANICS BOOK DEPT., 6 North Michigan Ave. CHICAGO



REACH UP AND HELP YOURSELF!

Train for a Better Job---Attractive Salaries in Many Trades and Professions Await Claimants

— Electrical Engineer, \$2000—\$5000	— Mechanical Engineer, \$2000—\$5000	— Architect, \$2000—\$7000	— Draftsman and Designer, \$1500—\$2500
— Steam Engineer, \$1500—\$2500	— Lawyer, \$2000—\$5000	— Sanitary Engineer, \$2000—\$5000	— Automobile Engineer, \$2000—\$5000
— Civil Engineer, \$2000—\$5000	— Telephone Expert, \$2000—\$5000	— Fire Prevention Expert, \$2000—\$5000	— Bookkeeper and Accountant, \$1500—\$2500
— Shop Superintendent, \$2000—\$5000	— Business Manager, \$2000—\$10,000	— Contractor and Builder, \$2000—\$5000	— Certified Public Accountant, \$2000—\$10,000

(Mark with an X the position you prefer)

Opportunity thunders at the door of every man who has ambition and natural ability. Industrial America is undermanned. War activities, on a scale so vast as to stagger the imagination, necessitate the quick training of a great secondary army of technical experts. These men must also help rebuild the world after the war is over. Get in training for one of the Big Jobs by taking an American Home Study Course in any one of 32 trades and professions.

We Have Trained 50,000 Winners!

We offered them their chance — they grasped it! We helped them to better positions, larger incomes, broader opportunities, because they helped themselves. You — today — have a better chance.

Now the position seeks the man and salaries for high-class men are more liberal than were ever known before.

Mail This Ad for Free Book and Personal Analysis

Send us your name and address on the coupon. Just check the job that you want to hold and mail this advertisement to us.

We will tell you how you can get just the training you need, right in your own home. We will tell you how to line up your natural talents with your practical experiences.

Write today for the personal examination blank and bulletin of American home study courses. Do it now — you'll be under no obligations.

American School
of Correspondence, Chicago, U.S.A.

Dept. G 1199

Please tell me how I can qualify for the position marked X.

Name

Address

The Brunswick

ALL PHONOGRAPHS IN ONE



Your Problem is Solved Because The Brunswick Plays ALL Records

WITH each Brunswick come two reproducers. These are instantly interchangeable. So for every type record you may use the proper needle: Steel, sapphire ball, jewel, etc. This great achievement, with others equally advanced, makes The Brunswick the final type phonograph—all instruments in one.

All records are at your command, all artists, bands, orchestras, ALL MUSIC. The Brunswick alone—of the finer phonographs—offers this unrestricted selection. This includes the wonderful Pathe Discs,

Heretofore few were permitted to enjoy the famous Pathe star, Muratore, and other Pathe artists.

Brunswick tone is unmatched because of the all-wood sound chamber, built like a violin.

Who, now, is content with a one-record phonograph, or with lesser attractions?

Hear The Brunswick first—then compare. Note all its advanced and exclusive features.

You'll say, too, that it is the one phonograph you've always wanted.

The Brunswick-Balke-Collender Company

Branch Houses in Principal Cities of the United States

Please Mention Popular Mechanics

Copyrighted material

Inventor: Roy B. Ashbrook

Box 285 - Chamberlain, Calif.

Popular Mechanics Magazine

REGISTERED IN U. S. PATENT OFFICE

WRITTEN SO YOU CAN UNDERSTAND IT

Vol. 28

DECEMBER, 1917

No. 6

Warfare
Submarine
Snack

Wireless System for Detection of U-Boats

TO assist naval airmen in detecting the presence, and then determining the position of enemy submarines, a delicate instrument of considerable ingenuity has been produced. An adequate conception of its character is afforded without necessarily discussing its technical details, which for obvious reason are withheld. Roughly, it consists of a compact buoy that carries a receiver which converts the sound waves from a submarine's propeller into electrical energy. When thrown overboard by an airman, it floats on the surface of the water. Upon the approach of a submarine within a certain radius of it, the antenna attached to the buoy sends out

wireless signals which are in turn picked up by receiving instruments installed in the air craft. The presence of a boat within this area is thus an-

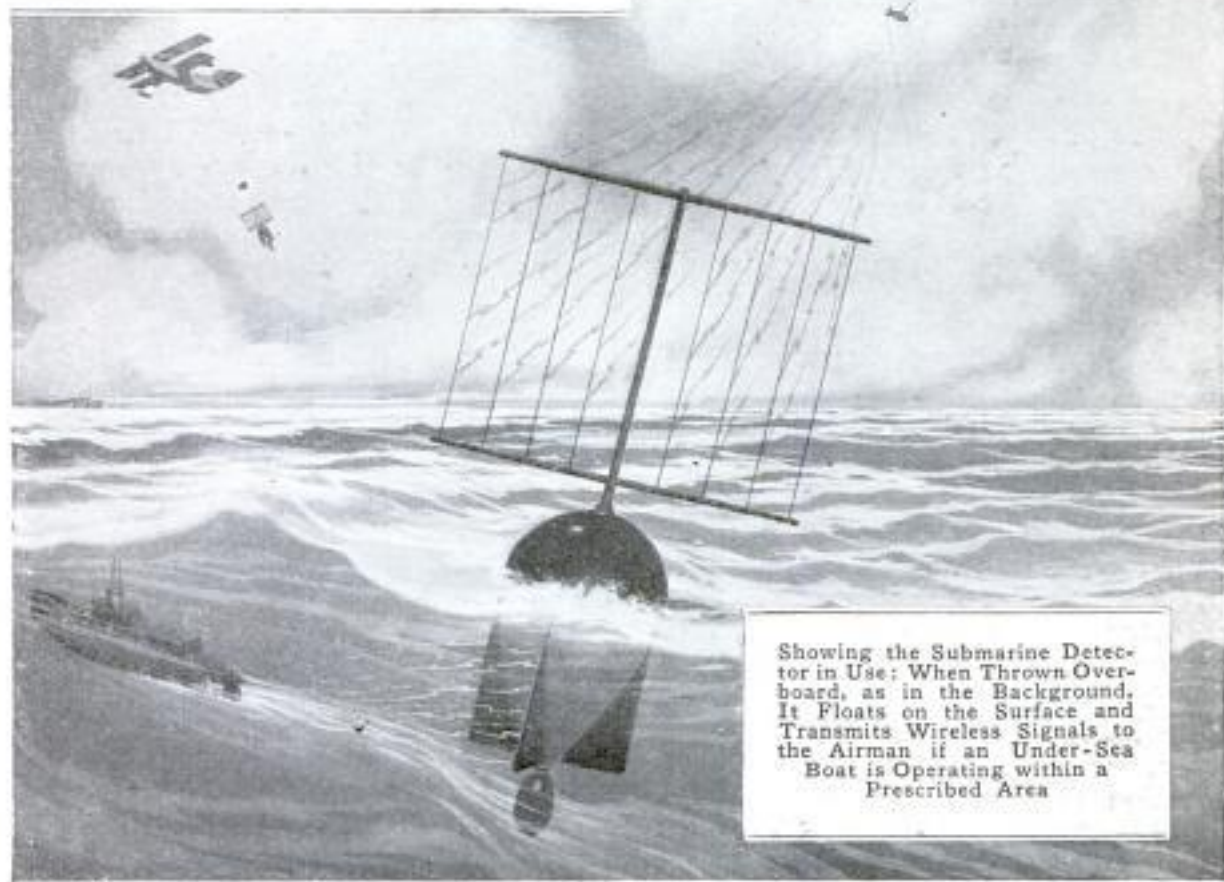

Showing the Submarine Detector in Use: When Thrown Overboard, as in the Background, It Floats on the Surface and Transmits Wireless Signals to the Airman if an Under-Sea Boat is Operating within a Prescribed Area

*The Moore Car Corp. of Amer. } Letter recd
14th & N. West St. } 6/15/23*

802

POPULAR MECHANICS

Dear Sirs. Ind
nounced. Its general position in relation to the buoy, as well as its movements, are indicated by the intensity of the signals. Assisted to this extent, the airman's search for the vessel is greatly simplified. After locating it, destruction can be carried out with aerial torpedoes or bombs that explode at predetermined depths.

In scouting for submersibles, a number of the buoys would be carried. One would be dropped overboard as the flying boat passed out of range of a detector previously launched. In this way a large area would be patrolled. It would, of course, devolve upon speed boats to retrieve the buoys. Gratifying tests of the device have been made.

**ODD TWO-WHEELED VEHICLE
5349 FOR CITY STREETS**

There is a hybrid among the season's new vehicles. It is a cross between a motorcycle and an automobile, and in design closely follows the latter in some of its details. It is mounted on two wheels and at the back equipped with a pair of large casters that are adjustable and hold it erect when it is not in motion. A unit power plant with

stability. Starting and stopping are accomplished without requiring the operator to place his feet on the ground.

**SHEEP-KILLING PARROTS
5361 ESCAPE INTO AMERICA**

Not long ago no little consternation was created by the escape at San Francisco of two keas, or sheep-killing parrots, which were being shipped from Australia to the Smithsonian Institution, at Washington. The birds liberated themselves by splintering the slats of their wooden crates with their powerful beaks. The federal authorities offered a reward of \$100 for each bird taken dead or alive. This species of parrot has made itself an enemy of man in both Australia and New Zealand by slaying sheep for

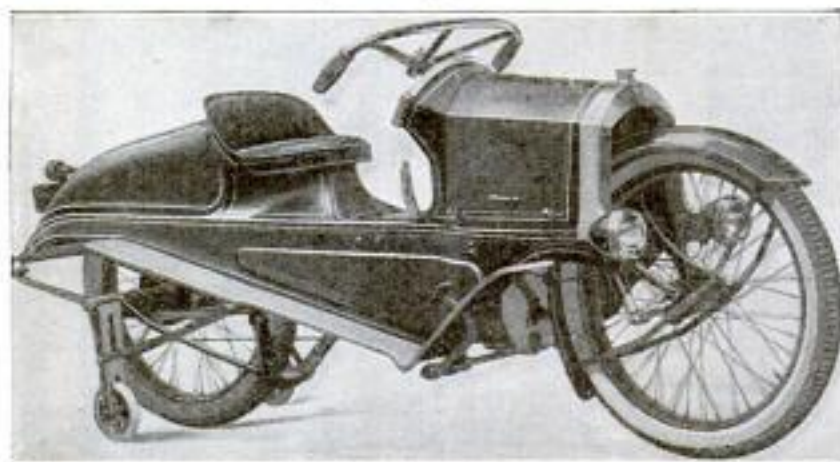

Features of Both the Motorcycle and Automobile are Found in This New Two-Wheeled Machine

three-speed, selective gear transmission is employed. A radiator and hood, an instrument board, a racing-car seat, and running boards give the contrivance an attractive and automobilelike appearance. All parts are completely covered so that the driver is protected from grease and dirt. Fuel is carried in two concealed tanks on opposite sides of the rear wheel. The turtle back also hides a folding seat which, when raised, offers accommodation for a passenger. Pressed-steel construction gives the machine strength and lightness and indicates

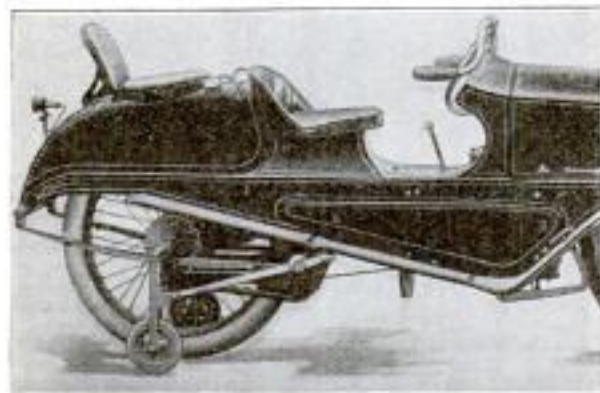

When Folded within the Turtle Back the Extra Seat is Completely Concealed from View

the sake of eating parts of the flesh, of which it is very fond, and there bounties are paid for killing the birds.

Mr. J. E. Nagg.

VOLCANO A MONSTROUS STEAM BOILER

LIGHTS DISTANT CITIES AND DRIVES THEIR TROLLEY CARS

THE MOST REMARKABLE POWER PLANT IN THE WORLD

By LEWIS R. FREEMAN

Special War Correspondent for Popular Mechanics Magazine

28 Montague St. Russell Sq. London E.C.

Glaciers and Volcanoes Produce Same Power

IT was while going over one of the great munition plants near the west coast of Italy early in the war that the manager called my attention to the fact that the machinery of the three newest units was entirely electrically driven.

"The power for each of the three units has a different origin," he said, "and here, for the first time in history, you may see working, almost side by side, machines driven by electricity generated from a steam plant, by electricity generated from water power, and by electricity generated from the heat of the earth. It is the latter which runs the newest unit, and the supply of it, though it comes from a source a hundred miles away, is capable of being increased to such an extent that we contemplate drawing on it for any extensions we may be called upon to make to our plant in the future. It is a strange contrast, is it not, the latent power of Alpine snows sending a current to run the plant on our right, and the latent power of some sputtering hot springs sending a current to run the one on our left?"

Tapped Earth's Stores of Solar Heat

This was the first occasion on which I heard of a practical system for the generation of power from the heat of the earth, though I seemed to recall an article or interview, published some years previously, in which a distinguished American engineer had suggested that the inexhaustible heat reservoirs of the earth might be tapped by driving a bore the size of a wagon wheel through—or at least a great distance into—the outer crust. The plan was no more than a dream, and nothing, so far as I ever heard, has come of it. But some Italian engineers, with the direct practicality and common sense, of which the world is now having so remarkable an example in the war organization of their country, instead of wasting their time in boring into the solar heat, simply sought out a place where the solar heat had bored its way out to them—nothing more or less than just such a mineral hot-springs area as one encounters in so many parts of Europe, America, and other parts of the world. Here they carried out a series of exhaustive experiments in harnessing the steam which had been blowing to waste for so many centuries, and the same rare talent of inventiveness which enabled one Italian to solve the forerunning problems in long-distance transmission, and another to send the first wireless messages, again achieved ultimate and complete success. Some time before the outbreak of the war the principles of the exploitation had been worked out, so that when once Italy had thrown her weight into the great struggle and an unprecedented demand for power for munition manufacture arose, all that remained to do was to apply those principles; to do commercially what had been proved feasible by experiment.

World Event Unknown outside Volterra

One transmission line is much like another, and, in this instance, there was nothing to differentiate the tower-to-tower-swung cables of aluminum that led off from the steel and concrete power house by the glacier-fed torrent in the Alps from those which went off in the opposite direction from another—probably very similar—power house standing in the steam of the hot springs of Volterra. Much as I should have liked to follow the latter line to the miracle which has been wrought at the other end of it, I could not spare the time from an already scheduled visit to the Alpine front to make the journey to the remote, and by no means readily accessible, mountain region to which it led. In the months that followed I met no one at the front, or in any other part of Italy, who knew anything about the hot-springs electrical plant, and many there were who even ridiculed the practicability of the thing, saying that I must have misunderstood the description of the works, and that no such epoch-making discovery could have been made without its being noised to the ends of the world. But it was only another instance of an event of world-wide importance being obscured, or eclipsed, by the battle cloud of Armageddon. A few weeks ago—again on my way to the Italian front—I was stopping over in Florence, which chances to lie on the opposite side of a mountain range and something like 150 miles distant from the munition works which I had visited the previous year. From the terrace of the village of Fiesole, where I was staying, we were watching the evening searchlight drill above the valley of the Arno, when my host happened to remark that the power behind the questing beams might very well come from the new installation among the geysers of Volterra, as a transmission line had recently been completed connecting it with Florence. Beyond this, he knew nothing of what work had been done, or how it had been done, but as the fact that power was being distributed to the east as well as to the west indicated an extension of the scheme, I decided that no better use could be made of the two days that still remained to me before leaving for the front than by putting them in visiting the installation which had for so long been the object of my interest.

VOLTERRA is one of the finest and most perfectly preserved of the old Roman mountain towns, and, as a consequence of the power development at the hot springs in the near-by suburb of Larderello, there is perhaps no other place in the world where the ultramodern can be seen thrown into such striking contrast against the background of the truly ancient. The nearest thing to it which occurs to me offhand, is the hydroelectric plant near Damascus, situated at the foot of a waterfall fed from a spring said to have leapt forth from the mountainside at a stamp of the foot of the patriarch Abraham.

To the leeward of the "soffioni" (the Italian name for the hot steam jets of the Volterra region) the wind-blown fumes of sulphureted hydrogen recall that same odor-of-ancient-egg welcome extended to the visitor by the Norris geyser basin of the Yellowstone, the mud-volcano plain of the Colorado delta, and the great geyser area of Maoriland. It is only when the weird region comes into view that one envisages a scene which, with many details about it to suggest other places he has seen, still presents an ensemble that must be quite unique for the simple reason that there is nothing else in existence like it. The soffioni of this central Italian infernal region run more to steam and less to jets of solid water than do the similar eruptions of the Yellowstone, northern California, and New Zealand. The effect, however, is not unlike that of the upper geyser basin of the Yellowstone on a crisp fall day when the active geysers are resting and the cold air is condensing in thick white clouds the steam from the countless pools of boiling-hot water. The later volcanic formation of the Volterra area is doubtless responsible for the fact that the steam—where no attempt has been made to confine it by artificial means—tends to rise, in wavy tufts and plumes of cotton wool, from sinuous cracks, where that of the Yellowstone—as in most other hot-springs areas—spouts out through separate vents.

It is in the development, however—the things man has done—that the principal differentiation occurs. In the first place, the power house itself—though, as I had surmised, differing in no important essential, inside or out, from the box-shaped steel-and-concrete structures that one expects a modern power house to be in any part of the world—loomed up as a strange, almost a jarring, feature in a landscape where one had been accustomed to look for nothing more businesslike than tourist hotels and bathing establishments. The squat wooden derricks and the miles of large pipe running along the top of the ground suggested an oil field so strongly that the eye almost unconsciously sought for storage tanks or reservoirs; but I had already learned enough of the way in which the "harnessing" was being done to know that the derricks were employed in connection with drilling holes for steam vents, and that the pipes were for carrying the steam itself. Flat-topped, tapering octagonal structures, dotted plentifully about the exploited portion of the area, were unlike anything I had ever seen before, and it was in these, as I learned afterward, that were carried on the distinctive processes of converting the raw and mineral-charged steam into a medium which could in turn be utilized in the generation of electrical energy.

The manager received us kindly, and although certain of the processes are still being perfected, seemed quite willing to show and explain to us all there was to be seen. It is from what I saw and heard on this brief visit, and from the summary of a technical report by the distinguished Professor Luigi, D. Sc., consulting engineer of the company, that the following description is written. Professor Luigi himself, to whom, I am told, the principal credit for the solving of the intricate technical problems connected with the scheme belongs, I missed—by only a few hours—meeting in Florence.

The existence of the hot springs near Volterra is repeatedly mentioned in various Roman records, and there are indications pointing to the fact that in

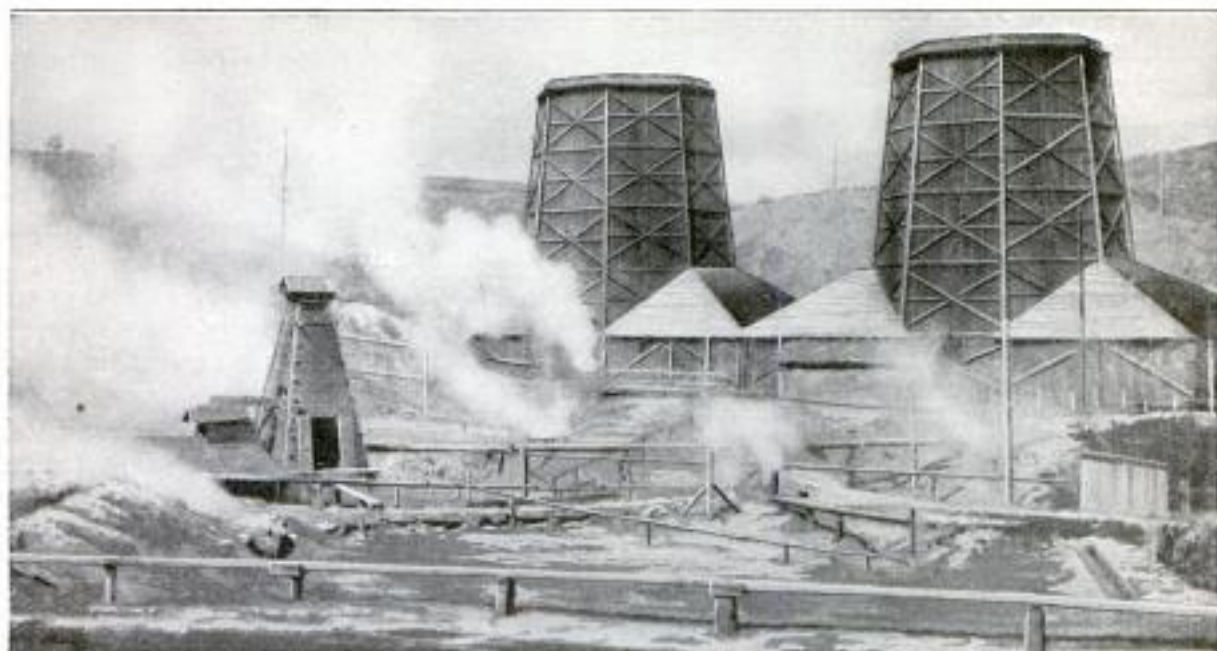

In the Queer, Tapering, Flat-Topped, Octagonal Buildings at the Hot Springs, the Mineral-Charged Steam Superheats Generated Steam That Drives the Turbines

very ancient times an oracle was "operated" there, the future being read by the sibyl in the trance following her apparent strangulation in a jet of hot steam. The later Romans founded a spa at the place, though it does not appear that the waters are possessed of any notable curative properties. The Florentines came there to collect the incrustations of boric acid deposited by the evaporating waters, but it was not until something like a hundred years ago that a process was worked out by a French engineer for extracting that increasingly valuable product in commercial quantities. That process, strangely—in that it made the heat of the steam itself do the work—was the forerunner of the present system by which that same steam is turned into electrical energy.

The concession for exploiting this soffioni area has been held for a number of years in the distinguished Ginori-Conti family, and the present prince of that name has been for some time the president of the "Societa Boracifera di Larderello," which has been engaged in the production of borax and boracic acid. Improved processes of extraction had made this in itself a very lucrative industry, but up to about 1903 no use was made of the heat of the

steam itself save in evaporating the borax-impregnated water and in warming the houses of the workmen in the little village of Larderello. In that year Prince Ginori-Conti began a series of experiments which have culminated in the present 15,000-hp. electrical plant and the first practical solution of the problem of utilizing the heat of the earth.

The first experiment consisted in applying as strong a jet of the steam as was available to a rotary motor, but with only sufficient success to encourage the continuance of the investigation. The next contrivance—a jet of steam applied to a small reciprocating engine connected to a dynamo—proved that the principle was correct, and ultimately enough power was generated in this manner to light a part of the works. Two facts had by now been demonstrated: first, that steam much hotter and under much greater pressure than that escaping from the fissures in the earth must be made available, and, second, that this steam itself was far too heavily impregnated with minerals to make its direct use in boilers or turbines practicable for steady operation. As there was no use to bother about the latter problem until the matter of the proper steam supply was settled, it

was this question to which the first attention was directed. Luckily, an entirely satisfactory method of effecting this end was hit upon at the outset.

The source—the reservoir, so to speak—of the steam was under an impervious stratum of hard rock from 300 to 500 feet beneath the surface, and the plan decided upon was to drive large bores down to this level and conduct the steam to the surface in iron pipes. The scheme worked admirably. The holes varied in size from 12 to 20 inches in diameter and, with the force of the steam concentrated where before it had been diffused in open fissures, a pressure of two, three, and even as high as five, atmospheres was obtained. The temperature of the steam issuing from these bores varied from 150° to 190° C., or from 50 to 90 per cent hotter than the usual boiling point of water, 212° F. The question was now whether or not this entirely satisfactory heat and pressure could be expected to be maintained, and to this end experiments extending over several years were conducted. At the end of this time it was apparent that none of these bores was likely to show any diminution in capacity provided no new holes were put down within 50 feet of them. With a continuous and practically unlimited supply of steam definitely assured, the next thing to do was to find a practical system of converting the latent energy of that steam into some form in which it would be commercially useful.

One more attempt was made, in 1906, to utilize the steam direct. An ordinary steam engine of about 40 hp. was used for this purpose, but while the thing worked admirably so far as the mechanical power of the steam was concerned, the boracic salts, sulphuric acid, and the sulphureted-hydrogen gas carried by the steam, set up a corrosive action which was fatal to the iron parts of the engine. After an exhaustive series of experiments, this difficulty was finally overcome by—to use Professor Luigi's words—"applying the superheated steam, not directly to the engine, but to a boiler; that is, by applying it instead of fuel to an ordinary

multitubular boiler, in which steam was produced at a pressure of two atmospheres, then passed through a superheater, and afterward used for driving a 300-hp. steam turbine, directly connected with a triphase electric generator." The latter provided enough power for lighting the works and the villages around Larderello. It had been in operation successfully for several months when Italy entered the war, and it was the tremendous increase in the price of coal and oil—neither of which that country produces in more than negligible quantities—which gave impetus to the project of increasing the installation to a size sufficient to allow the production of power for transmission to Leghorn, Pisa, Florence, and other not far-distant industrial centers. Perhaps the most astonishing fact in connection with what followed is that, although the system was hardly out of its experimental stage, an installation capable of generating 15,000 hp. of electrical energy was designed, completed, and put into operation at less cost, and in less time, than a similar installation run by water power could have been built. For the sake of accuracy, I shall follow closely Professor Luigi's technical description of this epoch-making plant.

Acting on the advice of a Legano firm which had long specialized in steam turbines and alternating electrical generators, Prince Ginori-Conti ordered three groups of condensing turboelectric engines, each of 3,000 kw., working with superheated steam at one and one-half atmospheres, generated in specially constructed multitubular boilers, the latter arranged vertically and with aluminum tubes, both for better utilization of the heat and better resistance to the corrosive action of the steam from the soffioni. This steam, it is worth while to repeat, is used instead of combustible. It loses part of its heat in the boiler, reducing its temperature from 356° F. to about 248° F., and is then utilized for the borax industries.

The steam thus generated in the boilers is ordinary water steam, which



In the Background, Partly Clouded, Is One of the Squat Derricks, and in the Foreground a Pipe Line That Carries Subterranean Steam to the Power Plant

on its way to the turbine passes along aluminum pipes heated outside by a current of superheated natural steam, at 356° F., and thus gets in turn superheated to about 302° . After passing through the turbine this steam is discharged into a surface condenser, the circulating water of which is in its turn cooled in an ordinary cooling tower. The condensed steam of the turbines is, of course, pumped back into the

boilers, and thus no natural steam ever comes in contact with the turbine. By this arrangement corrosion was completely avoided. This was the real difficulty to be overcome.

The 4,500-volt triphase electric current is stepped up through an oil transformer to 36,000 volts, and transmitted to Florence, Leghorn, Volterra, Grosseto, Cecina, and a number of the smaller towns of Tuscany. The long-

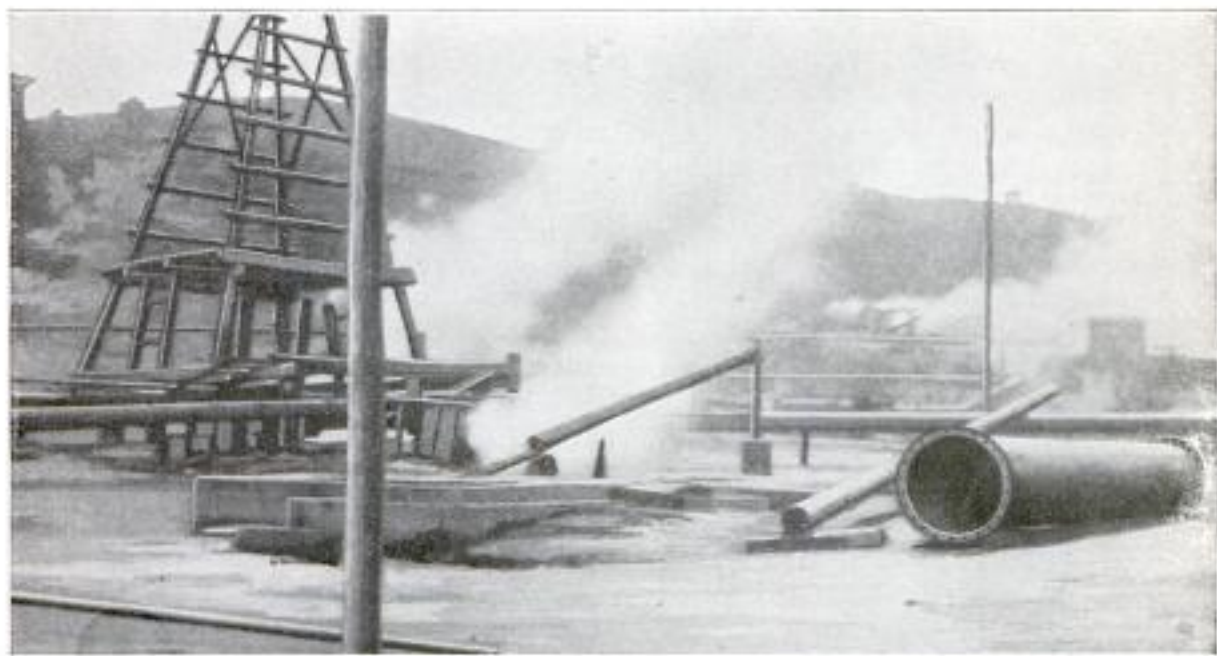

Close View of a Derrick That is Drilling through an Impervious Rock Stratum to the "Reservoir" of Natural Steam Some 500 Feet beneath the Surface of the Ground

est distance to which it is transmitted at the present time is something less than a hundred miles, and it is probable that a market for all power likely to be developed in the near future will be readily found within that radius. The principal uses of the power at present are in munition making, running tram lines, and lighting.

Careful experiments have shown that each of the bores put down in this region can be depended upon to produce steam of a temperature of from 312° to 392° F. At the average rate of 33,000 to 55,000 lb. per hour, this gives a theoretical horsepower of from 1,000 to 2,000 for the same period. On the basis of these figures, Professor Luigi estimates that hundreds of thousands of horsepower can be produced in the Larderello region, as the soffioni area covers many square miles. He also be-

lieves that in the "Campi Flegrei" region, near Naples, where the ground, at even so slight a depth as 100 ft., has been found red-hot, a similar utilization of volcanic heat can be made.

As neither of these regions is of anything approaching the extent of the geyser countries of the Yellowstone Park or of New Zealand, or, indeed, many other hot-springs areas which are known to exist in both of the Americas as well as in Asia and Africa, the vista of possibilities opened up by this latest of the great scientific problems Italians have solved for the benefit of the world, fairly staggers the imagination. It must certainly be numbered among the greatest, if it is not actually the greatest, of the gifts to humanity that have been brought about by, or at least greatly accelerated through, the war.

EXPUNGING TEXTBOOKS

A BIG TASK

5292

In these days textbooks, as well as press dispatches, are being censored and in some of the large cities the task



Women Engaged in Eliminating Objectionable Passages from German Textbooks Used in the Cincinnati Public Schools

of altering the former, to comply with new or more accurate conceptions of truth, has been a big one because of the large number of books to be handled. In Cincinnati a special board of censors barred seven German texts formerly used in the high school, and ordered that passages in four others

be eliminated. To carry out this ruling six women were employed to go through all the partly objectionable books and make them suitable for use. In some cases they tore out whole pages and in others the obnoxious passages were covered with thick white paper.

ALASKAN CITIES DAMAGED BY UNEXPECTED FLOOD

534

Considerable damage was done to the new government railway and other public and private property early last fall when a serious flood swept Seward, Valdez, and intermediate Alaskan points contiguous to Prince William Sound. The deluge was the result of a heavy unseasonable rain that lasted three days and ended with a cloudburst. In the vicinity of Seward much of the railroad was inundated and sections of it were washed away. Residences and buildings in the two cities met with similar fate, several of them being completely demolished. The lighting plant at Seward was flooded and the city left in darkness, while, to make matters worse, the pipe line that supplies the community with water



One of the Points at Seward, Alaska, Where the Government's New Railway Line was Washed Out by the Raging Torrents That Swept through the City

was washed out at several points. It was only by heroic work on the part of all the inhabitants that the business section was saved. Men worked day and night constructing wing dams and dynamiting log jams. Every available motor car and horse was commandeered for the work.

ALL GEARS ARE ELIMINATED IN VARIABLE-SPEED PULLEY

5279 One of the outstanding advantages of a variable-speed pulley of distinctive pattern lately developed is that it enables an operator to make minute variations in the speed ratios of the driving

and driven shafts without any interruption of power transmission. Another striking point is that all gearing has been eliminated. Only a few parts are employed. The pulley is adapted to a wide range of uses and is said to be capable of governing the speed of a delicate mechanism as perfectly as that of a powerful stamping press. Essentially the member consists of a pair of flanges, a set of steel segments that forms the face of the pulley, and six slotted and notched vanes. The latter are mounted on the shaft and arranged to work in and out of the flanges and effect the expansion and contraction of the spring segments, thereby changing the diameter of the pulley.

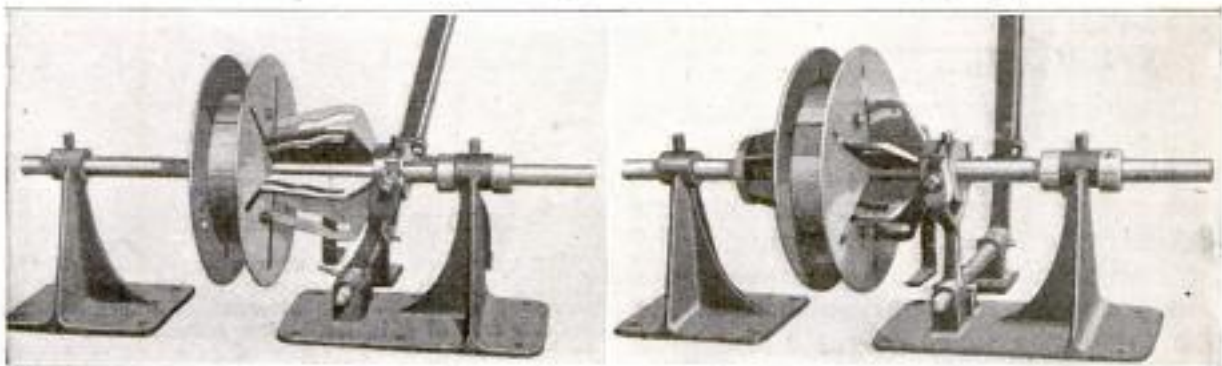

The Circumference of the Pulley is Changed by Moving the Vanes In or Out: This may be Understood by Comparing the Picture at the Left with That at the Right

Mfd. by Mr. B. Dunbar

Sydney Australia

Amf. of
E. F. McIntyre - 220 N. Murray St.
Madison, Wis.
 810

Inv: C. E. Reynier
Camp. Newton
St. Paul, Kas.

POPULAR MECHANICS

**FORCIBLE-FEEDING DEVICE
 TO MAKE POULTRY FAT**

528

Forcible feeding, besides being resorted to as a means of counteracting



Forcibly Feeding a Fowl with a Machine Recently Invented in Europe: By Filling Its Crop Once Daily with the Proper Food a Chicken Fattens Rapidly

the effects of "hunger strikes," is also employed to make chickens fat. Recently a machine for this purpose, similar to one lately devised in Europe, has been employed with success in this country. It consists essentially of a cylinder placed horizontally on a tripod and having a plunger that is operated by a foot lever. The cylinder is filled from a pail mounted just above it. After inserting a discharge pipe in the mouth of the fowl to be treated, the lever is pressed down slowly, filling the crop with the fattening material. One such feeding daily will cause a confined fowl to put on weight rapidly.

**SULPHITE LYE EXPLOITED
 BY SWEDISH INDUSTRIES**

5360

Considerable importance is attached to the discovery in Sweden of a practicable means of removing the water from residual lye obtained in sulphite manufacture. Since the beginning of the war there has been demand for the substance as a coal-tar substitute. It also takes the place of resin and glue for cementing purposes, is valuable as raw material in the production of dye-

stuffs, and is useful in the manufacture of alcohol. It contains about 90 per cent water, and the difficulty of concentrating it has heretofore interfered with its use. By the new method, the water is frozen and in that way removed. The organic substances are to be separated so that they can be used in a number of different industries. It is estimated that 800,000 tons of valuable matter has been wasted annually in Sweden alone and that the new scheme of separation will convert loss into profit.

**TICKET-VENDING SEMAPHORE
 FOR WAY STATIONS**

5300

At Kansas City an electric inter-urban railway has tried out, with gratifying results, a coin-operated semaphore intended for way stations where cars do not stop unless signaled. To operate the signal, one places a nickel in the slot and presses a lever. This actuates the semaphore arm, ignites a red lamp, and issues a five-cent ticket to the prospective passenger. The device eliminates the necessity of patrons striking matches and lighting newspapers when trying to flag a car at night.

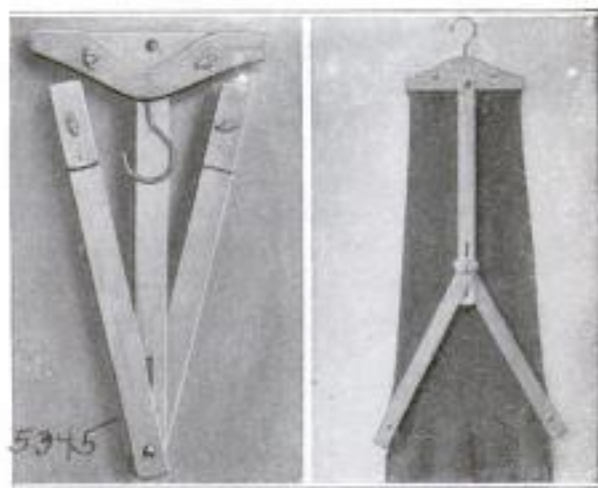

FOLDING TROUSERS STRETCHER

By means of clamps at the extremities of this folding wooden frame a pair of trousers can be stretched as shown and, after a few hours, will be entirely free of wrinkles. After fastening the clamps in place the frame is extended as much as desired and then locked by means of a nut and bolt at the center of the stretcher. Folded, the device occupies little space in a suitcase.

1. cl. in 1. 2. 3. 4. 5. 6.

Hord Automatic Mfg. Co.
1325 S. Michigan Ave
Chicago.

WALKS ON HANDS TO SUMMIT OF WHITE-CLAD PEAK



The Legless Newsboy and His Wife Resting for a Moment on Their Way to the Summit of Mount Hood: At the Right They are Shown Again with Other Members of the Party at the Forest-Service Lookout Station



On His Way to Establish a World's Record in Mountain Climbing, Joe Harty, His Companions, and the Pack Train: The Arrow Indicates the Newsboy



Snow-capped Mount Hood, a difficult, exhausting climb for the seasoned sportsman, has been scaled by a legless newsboy. The story of the young fellow's accomplishment offers a wealth of material for the moralist, for from beginning to end it is a lesson in ambition and perseverance. His name is Joe Harty and he sells papers in Portland, Ore., where the white slopes of the distant peak offer an inspiring picture on clear days. For years the desire to climb the mountain obsessed his mind. A few weeks ago, accompanied by two guides, a forest ranger, and his wife, the newsy's determination won out. He did what hundreds of strong, normally constituted men have failed in their attempts to do: he reached the uppermost pinnacle of Mount Hood. Part of the trip was made on horseback, but when the steep grades were encountered it was every man for himself. The newsboy was equipped with an improvised sled and blocks studded with heavy spikes. These implements, however, proved more of a hindrance than help and were discarded. Raising himself on his abnormally strong arms, he flung his body up the inclines several feet at a time and often made bet-

ter progress than others of the party. When ropes were used, Harty was in his element, for his strength enabled him to clamber along with remarkable ease and swiftness. The descent of the snow-packed slopes was a hilarious experience. A guide would precede him a hundred feet or more and catch him as he slid down at a fast clip. He afterward said, "I tell you, that part was fun!" As might be expected, the climb has made Harty and his news stand famous.

PNEUMATIC VALVE GRINDER OF ALUMINUM AND STEEL

A labor-saving device which has recently come into commercial use is a pneumatic valve grinder made of die-cast aluminum and hardened steel, the latter being used for the working parts. It is so designed that it operates with an oscillating motion. The grinder is easy to handle because it weighs only 2 1/4 lb. An air pressure of 10 lb. is sufficient for ordinary operation, but by increasing it, 1/4 hp. can be developed.



Mfg. by: W. E. Veltum
 763 Olive St.
 Eugene, Oregon

WINGED VICTORY IS HOVERING

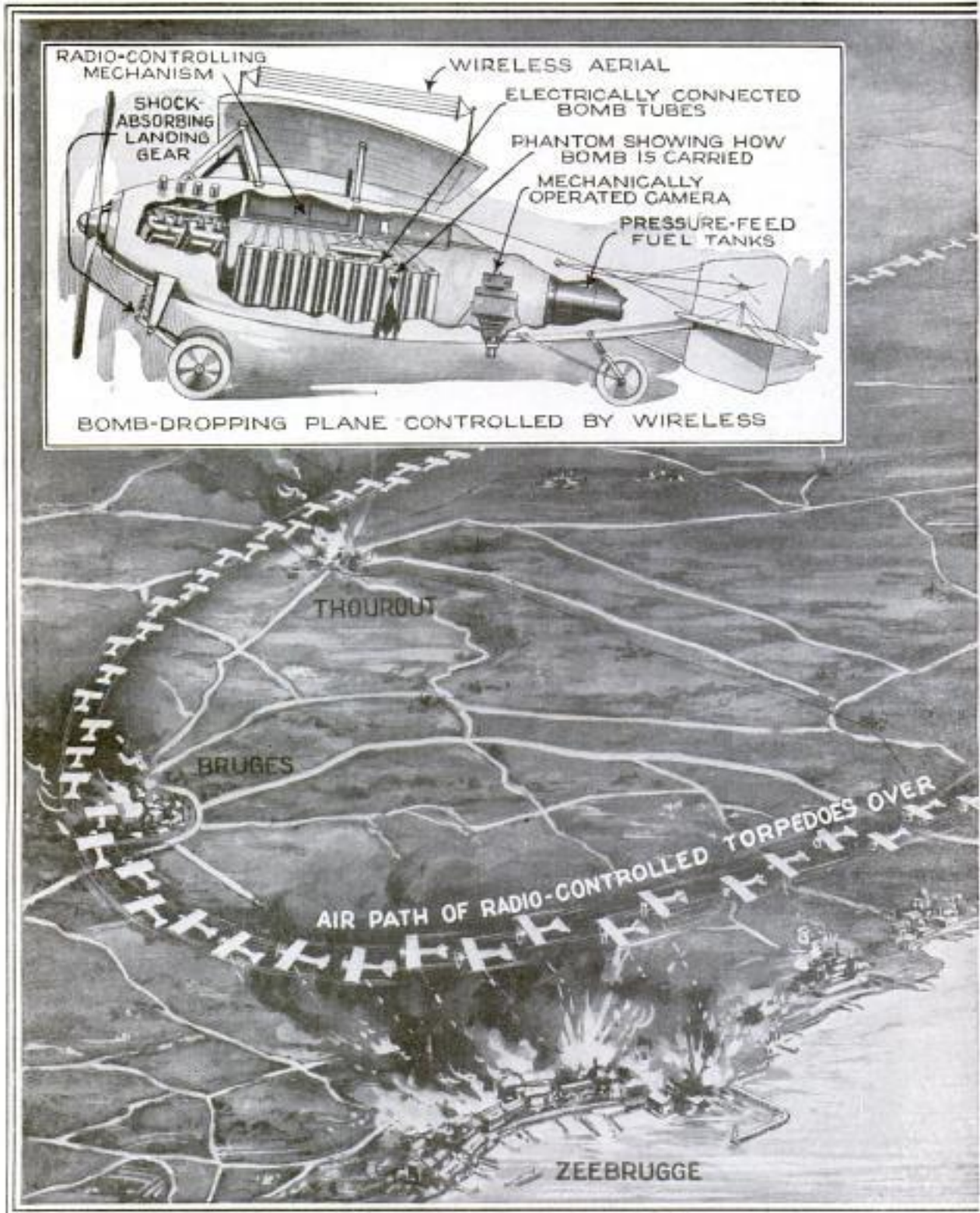

TO combine the submarine's torpedo, the aeroplane, and the wireless telegraph into one irresistible engine of annihilation has for months been the dream of a group of inventors, among whom are a few men in the forefront of science. Our "liberty motor" was built "overnight" behind bolted doors in a Washington hotel! Will the radio bombing plane and the flying torpedo be similarly evolved in time to crumble the fortresses of autocracy along the Rhine?

Presented above is a graphic illustration of how pilotless air craft directed from Dunkirk might bomb Zeebrugge, Bruges, and Thourout without the loss of a single flier. It portrays aerial warfare with the human element eliminated. A number of these weird projectiles are launched from a station safely removed from the actual battle zone. Directed by wireless, they follow a given circuit, auto-

Torpedos

WITHIN THE GRASP OF SCIENCE

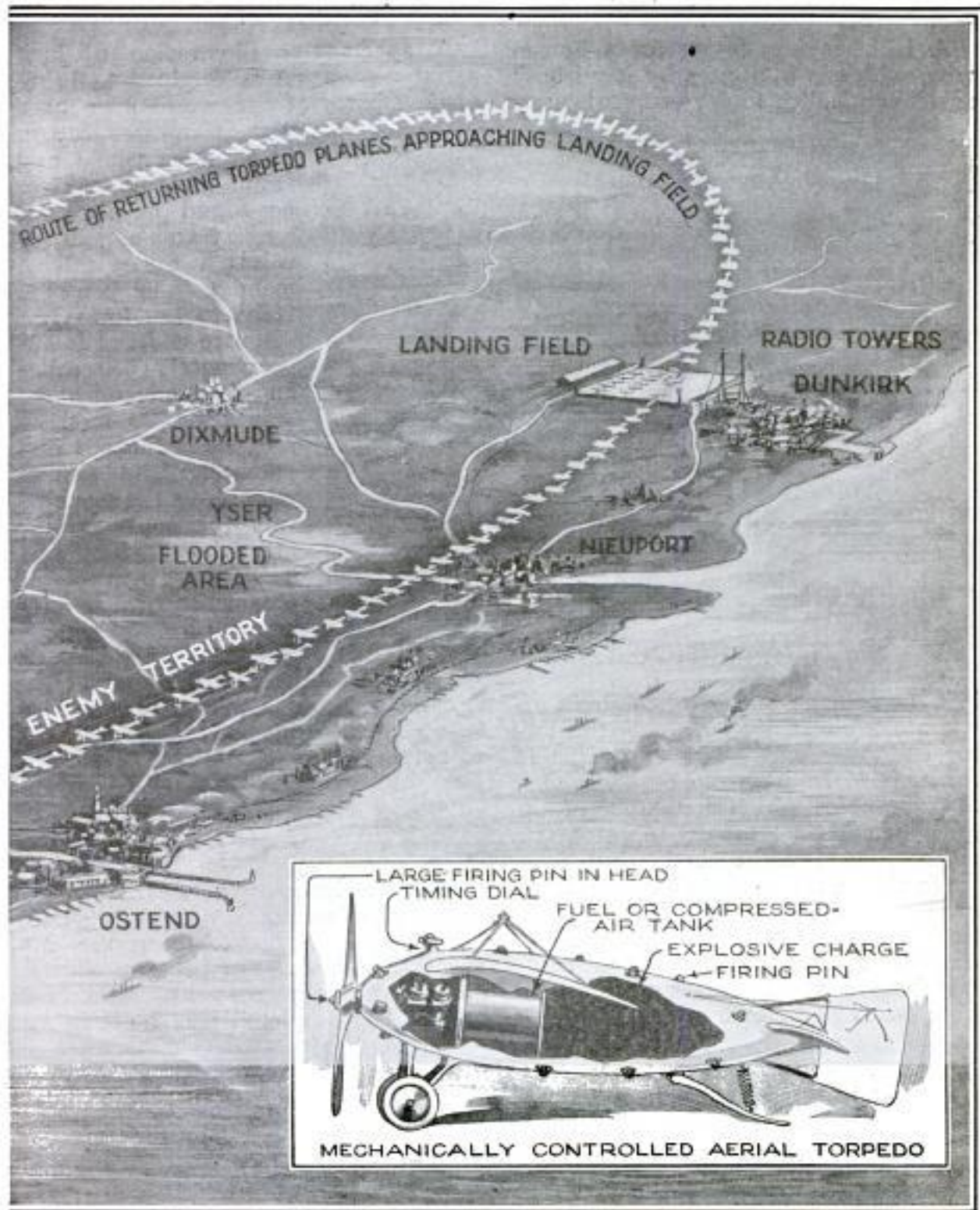

matically dropping powerful bombs on the enemy strongholds. Previously, machines of the same type have made photographic records of the enemy-controlled territory from which the points of attack have been determined and the timing mechanism for releasing the bombs set accordingly. General details of this type of machine are suggested in the upper left-hand insert. The insert on the right shows another idea for a winged torpedo, not radio-operated, but driven by compressed air, gasoline, or clockwork. It could not carry as much explosive as the first and its operating radius would be more limited, but for certain work it would be quite as effective. While to the conservative mind a multitude of difficulties forestall the realization of this scheme, it must be admitted that they are chiefly matters of adaptation rather than of principle.

PICTURESQUE WATER WHEEL

5214 OPERATES CHURN

A labor-saving device for a housewife, which is in a class by itself both as to originality and picturesqueness,



Water Wheel Made by a Farmer's Wife from a Few Articles Found Close at Hand: It Revolves the Churn 60 to 90 Times a Minute

is a homemade water wheel built to operate a churn by revolving the latter end over end. The apparatus is constructed from an old buggy wheel, to the rim of which a number of tin cans have been attached to catch the falling water, while at the hub is a crude wooden frame in which the churn can be securely fastened. The wheel is mounted just beneath a little stream of water that flows from a spout protruding from a stone wall, and revolves from 60 to 90 times a minute.

AIRMEN FLY FROM ITALY

5346 TO ENGLAND

A spectacular illustration of how aerial navigation is destined to bring distant parts of the world into more direct communication than steamships and trains have done, is to be found in a recent aeroplane journey which two Italians made from Turin, Italy, to London. The distance covered is approximately 650 miles and the time consumed was 7 hr. 22 min. 30 sec., according to dispatches. The airman who drove the machine was the same skilled flier who not long ago flew from Turin to Naples and back, a distance of over 900 miles. The Alps were crossed at an altitude of 12,000

ft., and the course was determined by following the routes of certain railways to northern France.

manufacturer

BIG WAR LOCOMOTIVE BUILT
5343 IN THREE WEEKS' TIME

At one locomotive works where 25,000 men are employed, 30 big battleship-gray engines bearing the insignie "U. S. A." are being produced daily for the government. The first one to be completed was built in 20



Only 20 Working Days were Spent in Building This, the First of the Government's New War Locomotives Destined for Use on Our Military Lines in France

COPYRIGHT, COMMITTEE ON PUBLIC INFORMATION

*Mfg. G. G. Jackson,
Welloughby Blair
Chicago*

working days. Six hundred and eighty of similar type and some 9,000 standard-gauge freight cars are under contract. Each of the locomotives, including its tender, weighs about 275,000 lb. and costs \$43,000. The equipment is being constructed for use on the American military railways that are now being established by our engineers in France.

**BACKLESS DRESS WAISTCOAT
DESIGNED FOR DANCING**

5338

Those who dance will readily appreciate the design of a dress waistcoat that has been introduced for men of discrimination in matters of apparel. The model is distinctive in that it has no back and therefore affords comfort and perfect freedom of movement. Relaxation is requisite for graceful dancing, but difficult of attainment when one is bound in a tight-fitting garment.



The new waistcoat is without armholes and cannot bind the shoulders. It is held in position by a band of medium width that crosses the small of the back. The garment fits snugly and is supposed not to have a tendency to ride the collar. Obviously there is no material that can bunch and destroy the hang of a coat.

URGENT APPEAL POSTED

5275 **ON FREIGHT CARS**

In such a routine matter as loading and unloading freight cars the progress of the war can be furthered or hindered by the speed of the workmen, because nowadays there is need for every car, every hour of the day, and at best, there are scarcely enough cars to go around. This fact has been well emphasized in a poster that the Santa

Fe Railroad is tacking to the doors of its freight cars, the wording of which



A Patriotic Appeal, Decorated with Red, White, and Blue Stripes, Which is being Posted on Freight Cars Belonging to the Santa Fe System

is shown in the accompanying illustration. Red, white, and blue stripes adorn the top of the notice.

**SEED COUNTER SERVICEABLE
IN GERMINATION TESTS**

4416

When testing seeds, it is necessary to count them and then space them evenly on moist sheets of blotting paper. If done manually this is a slow operation. A device has been developed, however, which does the work accurately and quickly.



Counting and Spacing of Seeds, When Making Germination Tests, Is Unnecessary if the Suction Instrument is Employed

It is used in conjunction with a vacuum pump operated by exerting pressure on a foot pedal, and consists of a metal contrivance having a square, flat surface with 100 small perforations. When this is brought in contact with a quantity of grain and a partial vacuum

Santa Fe System

*Inv: Prof. H. W. Hughes
Iowa State College
Iowa*

created, the suction draws a kernel over each of the orifices. By then placing the instrument on a blotter and releasing the pressure, the seeds are deposited in regular order on the sheet. Any error is readily apparent and can be immediately corrected.

SOLE LEATHER IS TESTED BY NEW APPARATUS

For determining the wearing quality of sole leather, a machine that subjects samples to conditions approximating

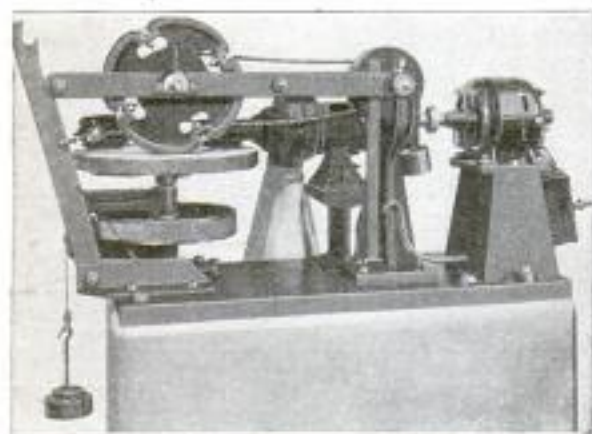

Bureau of Standards' Leather Tester: Four Samples are Applied to the Face of the Cam, Which by Contact Drives the Abrasive Horizontal Disk

those encountered by boots and shoes in actual use has been developed by the Bureau of Standards. One of the essential parts of the apparatus consists of a clover-leaf cam, about 11 in. in diameter, to the face of which four test pieces may be applied. It is mounted vertically between parallel bars pivoted at one end, and rests on a 15-in. horizontal disk which has a cement-mortar surface. The point of contact is $5\frac{1}{2}$ in. from the center of the latter member. The cam revolves at a speed of about 30 revolutions a minute and while doing so drives the abrasive disk, the axle of which is equipped with a brake wheel that provides, through application of weights, any desired resistance to rotation. The cam, in bringing the leather samples in contact with the rough surface, subjects the material to a moderate impact, a shearing action under pressure, and an abrasive action. Forty thousand revolutions produce about the same wearing effect as a 20-mile walk. The samples are weighed before and after the test. The loss in weight indicates the amount of wear, and that in turn gives an index to the quality of the leather.

NAVY'S NEW "BLIMPS" MAKE GOOD SHOWING IN TRIALS

In official tests of the first of a group of flexible dirigibles under construction

portable margin some weeks ago. Prolonged flights covering speed, altitude, endurance, quick ascent and descent

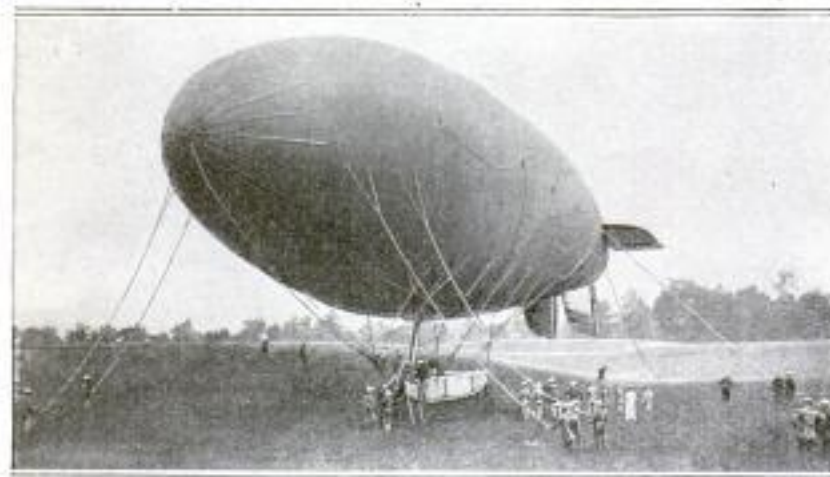

One of the Navy's New "Blimps" Ready to Make an Ascent during the Official Trials Recently Conducted: The Dirigibles are to be Used for Coast and Harbor-Patrol Duty

were made with completely satisfactory performances. The craft are of a type that in Great Britain and France has been used almost exclusively and are popularly known in the former country as "blimps." Our navy will use them for coast and harbor-patrol duty, for which they are better suited in many respects than planes. Pontoons are mounted

for the Navy Department, government requirements were exceeded by a com-

beneath the nacelle so that descent can be made either on land or water.

*Goodyear Tire & Rubber Co.
Akron, Ohio.*

World war

AT ZERO HOUR



(As told to E. T. B. by the sole survivor of the incident related in the second anecdote.)

5319

I COUNTED four of them, and all I could see at any one time was about 80 yards of trench. The truth of it was that we all were near the border line of insanity from the suspense, and these four were weaker links that couldn't stand the stress. All along the line it was just the same, for every man knew IT was coming, and yet did not know when. IT stood for "zero hour," the moment our big attack was to start.

First was a chap by the name of Peters from somewhere out in Ontario. He had been gassed at Massiges—took a good sniff of chlorine, not enough to kill him, you understand, but sufficient to put him back in the base hospital for two months.

At any rate, he wasn't up to par when he joined us at Rheims. He was a good-looking chap too, blond and broad-shouldered, though rather short; his face, when I saw him, was lined and rather set in expression. He looked rather as I imagine a man might look who has gone over Niagara Falls in a keg, but no one paid any particular attention, for among the number of us who had been punctured, shocked by the big shells, gassed,

broiled by "flammenwerfer," blinded by tear bombs, and kept awake for long periods of time, there were many blank dominoes.

It was two o'clock on a Friday afternoon when Peters broke. The sun was beating down from a clear sky, and except for what we all knew was coming we were quite comfortable, though warm. Our artillery was making mincemeat of the German batteries, placing three shells to the Teutons' one. Everyone but the sentries was under cover, for our work would be heavy enough when it came.

Of a sudden a cry of surprise ran down the trench. A row of heads poked up, their owners gaping at the deadly ridge above, the border of No Man's Land. I stared too, for up there, striding along as unconcernedly as if it had been the corridor leading to his private bath, was Peters, clad only in

"'Four o'clock is zero hour,' was the message from headquarters, and all along the trench men clasped hands silently, or patted each other on the back."



"They [the Germans] were so dumfounded, that the corporal . . . had time to grab a rope, make a noose in it, and try to lasso poor Peters as he came by."

a scanty towel which he had tucked around his middle!

We yelled at him, but the poor idiot paid no attention whatever. The desultory rifle fire from the German trenches 70 yards away ceased abruptly, and I knew that they were staring also, unable to comprehend what this strange new maneuver might mean.

They were so dumfounded that a corporal in the company next beyond mine had time to grab a rope, make a noose in it, and try to lasso poor Peters as he came by. The rope fell short, however, and the next instant came "Br-r-r!" from a German machine gun, and Peters toppled over.

Somehow or other an incident like that brings home the hideous reality of war stronger to me than even the ear-breaking thunder of heavy shells, for it emphasizes the strain that we all are having to bear. One sees every detail, while in the more active mo-

ments of conflict the mind is blessedly oblivious to most everything but the footing and the aim.

And the worst of it is that these weak ones that go under often take others with them. Ches Wight finished himself and Carney, and I thought for two hours that I was gone, too. The three of us went over the top one night—Monday morning about three o'clock, to be exact—to deter-



mine whether or not the Germans had evacuated their first-line trench. We had reason to suspect that this was the case, for not even the Huns could mistake what was coming. Our batteries had concentrated their fire—a huge preponderance—for eight days already; we had rehearsed the whole program behind the lines twice, and were all set for the signal.

Wight, Carney, and I crept out. Heavy clouds covered the whole sky, not even letting the glimmer of a star through, so the time was ideal for reconnoitering. We had covered about 40 of the 70 yards, and were beginning to hear gutturals now and then, when suddenly I smelled garlic—not garlic cooking, but the stench that comes from the breath of a person who has been eating it.

I touched Carney on the leg and he signaled to Wight, who was just beyond. That same instant we saw him, a hulking shadow, creeping toward us and very near. The three of us put an end to his scouting duty quickly and without much noise. We just made sufficient, however, in choking him, to arouse the trench ahead of us. Stealthy sounds came up of many men scrambling to the edge.

We could have no further doubt that the trench still was occupied, so Carney and I started back without more ado. We could not see Wight, but thought, of course, that he was at the side of us. Just as we were 20 feet from home, however, we heard a blood-curdling yell behind us. Outlined roughly against the lesser blackness of the sky came Wight, running and waving his arms.

A commotion arose in our trench. As Wight charged on, our sentries, evidently mistaking him for the van of a German surprise attack, opened fire and brought him down. Carney and I both lost our heads for a second and started up. That was enough for Carney. He went down with four Canadian bullets through him. One shot cut through the skin on my arm just above the elbow, and it brought back sense to me. I dropped flat.

For the next two hours I remained without moving, afraid to attempt to make the trench before the dawn guard was posted. I tried to call the attention of one of the earlier sentries, but to no avail. I knew that the barrels of 30 rifles and two machine guns were hanging over the edge, pointed in my general direction, waiting for more Germans.

With the first streaks of dawn I gathered all my courage and called my captain by name, and then each of the officers in turn. Then I crawled in, to be met by a very suspicious sentry, who had great difficulty in recognizing me.

Three days later I found out that Wight had apparently gone daft upon overcoming the German we met out on the waste. He had stopped to

search the body, and then had donned the helmet of our adversary, and started a charge all by himself—and in the direction of our trenches.

The twist of psychology is hard to understand, perhaps, but it is common. Once in a big university football match I saw the captain lose his head in this manner, and forget which goal his own team was defending, but it always seems to border on the spooky to me.

Kegley's case was much on this order. He was a member of a "bombing party" from our trench. The squad of six set out much as had Wight, Carney, and myself. Their object was not secrecy, however, after they had covered half the distance to the German trench, for at this point they all let fly with their missiles. Their stint was to get rid of the eight grenades carried by each, and then to scurry back to our trench before the Germans could get them.

This program was carried out, except for Kegley. He apparently got badly mixed as to directions in the semidarkness, and when he ran for cover he ran directly toward the German trench! Three or four bayonets rose to meet him as he scrambled over the edge.

The saddest case of all these that we ascribed to the suspense of waiting for the "big push" was that of a young lieutenant whom I shall not name. He was a city lad who had obtained his commission the Lord only knows how. He was a nice enough boy, all right, but made of the material from which officers never should be chosen. He was slim, youthful, nervous, sensitive, and temperamental. I suspect that deep down in his heart he thought himself a coward. I know that he shrank from the roughness of the men, and kept himself well within his shell all of the time.

It was just the day before the long-awaited signal really did come when he went out. And I'll say for him that he did a good job of it. He was not content with shooting himself in the left hand, the stunt adopted by many of the German privates to escape serv-

ice, but shot himself through the heart, shortly after noon mess.

When, about six the next evening, our phone operator jumped to his feet and whispered the thrilling message, we rejoiced, and all the suspense was forgotten. Action was coming! "Four a. m. is zero hour!" said the message from headquarters, and all along the trench men clasped hands silently, or patted each other on the back. After two weeks of waiting there seems to be nothing in the world that seems so delightful as the prospect of real action.

You see, we all knew our parts as thoroughly as if the bit of entertainment we were to give the Germans consisted of a bit of movie slapstick, all timed to be photographed within the space of two reels. The program given to us had been simple, for we formed part of the first wave in the eight-wave attack. We knew that when zero hour should arrive, whistles would blow, and we would scramble out of our protecting trench and walk—not run—to the first-line German trench. As we emerged, our barrage fire would be bursting 50 yards ahead of us. It would lift 25 yards every 10 seconds. Our stint was to take full advantage of it without walking into it ourselves.

Close behind us would come the "trench cleaners" or "moppers-up" of our wave, and then closely behind, advancing at an absurdly moderate pace, the other seven waves.

In respect to this attack, I scarcely can describe it from its actual happening, for any one man's part in a push which extends over a front of 12 miles is ultramicroscopic. I did see a great deal of it as it was being rehearsed, however—they put us through it all twice, far back of the trenches—and I know that this was the method employed, for we gained every objective.

When the rehearsals took place, they were enacted on ground which was an exact replica of that which lay before us across the waste of No Man's Land. Every trench was there, every clump of bare poles—that once had been trees—

was indicated, every house and barn was marked, and every German battery that our aeroplanes could chart was placed on our eight-mile-deep map. These were "dress rehearsals" in every sense of the word.

We were placed in formation exactly as we would be at zero hour; that is, every wave and every man in that wave had his position determined and his time schedule of advance.

One wave was almost exactly like another, so I shall describe the unit of which I was a member.

On the 12-mile front first came three continuous lines of grenadiers, spaced in skirmish formation, which means that each soldier was three yards from the next man to him. The men in these first three lines carried nothing but hand grenades.

Behind these came two lines, also as skirmishers, which were alternated in equipment. Taking a regiment as the unit, the first man on the left carried a machine gun. Then came three rifle grenadiers, another machine gun, three rifle grenadiers, and so on down the length of these two lines.

On the heels of these followed two lines of riflemen with fixed bayonets, whose duty it was to give the "rebel yell" and charge calculated to demoralize the enemy.

Immediately after these came an aggregation, two lines deep, that to me seems the most interesting of all in modern warfare. These were the "trench cleaners" or "moppers-up" that I mentioned previously. Imagine, if you can, a team of champion Rugby or American football players—a team of 8,000 such men, spread out in two lines over a 12-mile front—with every man a broad-shouldered husky capable of handling a small piano single-handed, and you have a flash of the appearance of the trench cleaners. This formidable assemblage was armed with weapons that remind one strongly of the police exhibits at yeggman trials—sticks, cudgels, shillalahs, black-jacks, poniards, sandbags, two-handed swords, battle-axes, tomahawks, brass knuckles—anything and everything

that the lower strata of civilization has found useful in personal combat since the days of the first Ptolemy and Lief the Lucky. One thing only seemed lacking: the trench cleaners carried no firearms of any kind.

This assemblage of "knock-down-drag-outers" follows upon the heels of the bayonet charge, and has for its duty the extermination of all pig-headed Teutons who cannot escape and will not surrender. There really are many such



"As Wight charged on, our sentries, evidently mistaking him for the van of a German surprise attack, opened fire and brought him down."

men who become fired with the flame of battle until they lose all reason and sense of proportion. Because it is highly dangerous to an advancing army to have small detachments of the enemy creating a disturbance when the van has passed on, the trench cleaners are carried to do literally what their name suggests.

And this constitutes one of the eight waves of a normal infantry attack nowadays. It has a definite objective which it must not miss and cannot exceed. For instance, as was the case with us, the time card may say succinctly, "Zero hour, advance rapid walk. Barrage twenty-five in ten seconds. Take first trench 0:20." Or, in the case of the second wave, the card

may read exactly the same up to the last sentence. From this point it goes, "Pass first trench 0:23. Take second trench 0:35." The third wave is instructed to take the third trench, and so on, for as many lines as the enemy possesses. The fifth, sixth, and seventh waves will have instructions similar to this, "Occupy Hill 137, 12:45," or "Dig in behind clump of trees, 15:08." In each of these, zero hour is understood, the first numbers standing for minutes and the second for the seconds. The whole affair may take two or three hours to be completed, but the units proceed to their specific assignments strictly according to the prepared schedule.

On the morning which I have described, the period of our nervous tension was over sharp at four a. m. Whistles shrilled along the whole front, and we proceeded to attack behind our barrage just as I have described. From that point until nearly a half hour later, I saw only that part of the fight which was within 30 yards of myself. I was one of the machine gunners, and though we managed to take the trench assigned to us, we en-

M. Gorodess
585 Atlantic ave

822

POPULAR MECHANICS

Brooklyn N. Y.

countered stiffer opposition than we had anticipated.

At seven o'clock all was over, however, and the Germans had dug in again in positions eight miles back of their previous front lines.

TEN-FOOT PHOTOGRAPH MADE BY INGENIOUS PATCHWORK

Quite an interesting piece of photographic handiwork has been fabricated by a photographer who is as clever



At Work on the Big Panorama, Which Since Completion has Often Passed as a Legitimate Photograph

with scissors and paste as he is with the camera. He has made a 10-ft. panoramic view that shows a tremendous crowd blocking the streets in the vicinity of an eastern newspaper office while watching a baseball score board. The work was produced by taking 24 separate panoramas, enlarging them, and then, by ingenious cutting and fitting, grouping them into a composite picture. Except when closely scruti-

Dispatches stated it all very prosaically, "This morning the Canadian and British troops succeeded in penetrating the German lines to a distance of eight miles along a 12-mile front east of Rheims."

nized, the finished panorama has the appearance of being an enormous enlargement, rather than well-executed patchwork.

LATE GERMAN INDUSTRIAL DISCOVERIES REPORTED

According to commercial reports that have reached this country, a number of very interesting industrial discoveries have lately been made by the Germans. Viscous, golden-yellow mineral oils have been obtained by treating coal with liquid sulphurous acid. By heating naphthalene under pressure and in the presence of aluminum chloride, an illuminating oil has been produced as a kerosene substitute. Insoluble carbon compounds in coal have been converted into soluble ones by an ozone treatment, the chemical value of which is not as yet known. A new process for extracting nitrates from the atmosphere has increased efficiency of about 80 per cent. Strides have been made in producing substitutes for copper, brass, and bronze. In this connection special mention is made of zinc and lead alloys. In smelting copper schists it has been found possible to reduce the workable limit from 2.5 to about 0.7 per cent. A scheme of removing aluminum from clay has proved so successful that it is stated Germany will hereafter be independent of foreign bauxite. The rubber situation has been improved by the development of a method of regenerating old material.

CA recent dispatch announces the completion, in connection with the Cape-to-Cairo Railway, of the railroad to Bukama, on the navigable Congo. Thus another important step has been taken in providing "the dark continent" with modern transportation.



Tractor at a Country Fair with Front Wheels Cramped by Means of a Wire so That It could Run in a Circular Path without a Driver

TRACTOR RUNS DRIVERLESS 5278 FOR FIVE DAYS

An exhibitor of a tractor at a country fair succeeded in attracting more than the usual amount of attention to his machine by holding its front wheels in a cramped position by means of a wire and allowing it to run five successive days without a driver. Hour after hour it traveled around a beaten circular path without human guidance. As a result, the name of the machine and its ability to turn around in a small area were brought to the attention of many who otherwise might never have observed the exhibit.

ELECTRIC KITCHEN TABLE LESSENS DOMESTIC WORK

5327 To the servantless housewife an electrified kitchen table offers inestimable convenience. One recently designed embodies a number of real labor-saving features that will appeal to most women who do their own work. Housed in a cabinet at the top is a small motor that drives various appliances through flexible shaft and belt connections. A closed compartment provides storage space for the utensils at the times they are not in use. When a food chopper, bread mixer or kneader, or ice-cream freezer is to be employed,

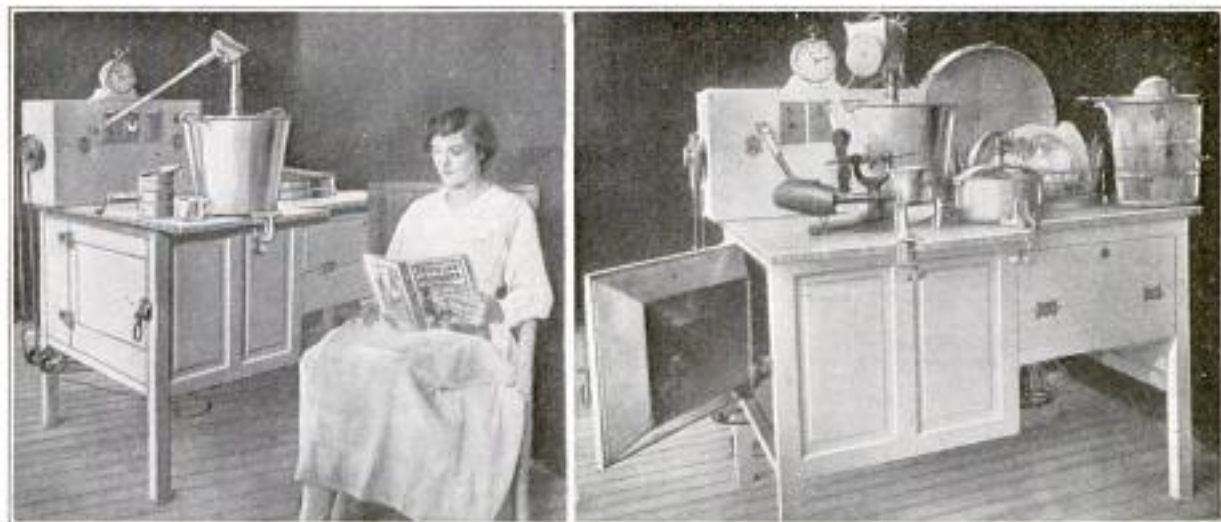

Showing the Electrified Kitchen Cabinet in Use: At the Left, Bread is being Mixed, While at the Right a Food Chopper is Shown Connected, and the Dishwasher with Some Other Appliances Are Visible.

Mfg. by B. R. Helter
365 N. Central Ave.
Phoenix, Ariz.

it is fastened to the table top by means of clamps provided for the purpose, and connected with the motor. Pressure of a button accomplishes the rest. A clock breaks the circuit at the desired moment, so that constant attention to the work in hand is not required. At the right end of the table is a built-in dishwasher which practically eliminates what usually is the most disagreeable part of kitchen work. Silver-polishing equipment, an emery wheel, and similar accessories are also included in the outfit.

WIND SWEEPS OBSERVATION STATION FROM PEAK

Complete destruction of the government's lookout station on Strawberry Mountain, Malheur National Forest, has been reported. The house was built by rangers during the summer of 1916 and, although of part steel construction, it proved incapable of withstanding the heavy winds of the following winter. It stood at an elevation of about two miles on the pinnacle

of one of the highest peaks in eastern Oregon. Weeks of difficult and dangerous work, and considerable money, were spent in establishing the post, which was thoroughly equipped with weather-recording apparatus and fire-finding instruments. The building was 12 ft. square, surmounted by a lookout tower of half that size, and glazed on all sides. During the past winter observers discovered that the station was no longer visible through binoculars. That led to the belief that heavy snows had entirely covered it. The coming of warm weather, however, showed this to be a mistaken assumption. All that could be found of the building, when the peak was scaled, were twisted pieces of steel scattered along the slopes. Apparently the structure was destroyed by a cyclone.

Customs officials in New York recently discovered that some wire nails in a large lot consigned to Sweden were provided with lead caps. This fact has aroused the grave suspicion that lead secured in this manner might really be destined for Germany.



The Station as It Appeared Shortly after Completion: It Occupied the Topmost Pinnacle of One of the Highest Peaks in Eastern Oregon

Right: Pack Train Arriving at Mountain Summit with Material and Men for Erection of Government Lookout Station and Weather Observatory



Forest Rangers Breaking a Trail through the Mountain Snows and Driving the Pack Train to the Summit: The Work was Undertaken Late in the Summer and was Attended with Much Difficulty and Some Danger



*Summit of Strawberry Mountain,
Malheur Nat. Forest, Oregon*

HIGH-SCHOOL GIRL MAKES OWN PLEASURE BOAT



An Inviting Rowboat and Its Long and is Fitted Up Ingeni

Builder: The Craft Is 15 Feet ously for Long River Journeys

By the building of a handsome rowboat in which she and her chums have taken delightful river trips, a high-school girl, who prefers manual training to domestic science, has attracted more than local attention. The trim little craft which was fashioned by her own hands is quite original in design and furnishings. It is 15 ft. long, has a 40-in. beam, and is 18 in. broad at the ends. A daintily scalloped awning, supported by four posts, gives the boat a touch that is quite feminine. By care-



The Feminine Boat Builder Ready for an Outing in Her Own Craft

ful planning, available nooks and corners in the shallow body have been utilized to excellent advantage. Under the seat in the prow is a clothespress and beneath the middle seat is a place for provisions. Built into the stern is a water cooler consisting of a galvanized tank, with a spigot, incased in wet sawdust. An automobile lamp serves as a searchlight, and inner tubes are carried as life preservers. The seats have adjustable backs, and the bedding may be used as cushions.

BALL MILL OF NOVEL TYPE BUILT IN SECTIONAL FORM

At some of the western mines a new type of ball mill for crushing gold ore has been installed. Certain engineers who have seen the equipment in use have indicated that it is as efficient as it is novel in design and operation. To facilitate its transportation to remote places difficult of access, the unit has been built in sections which are easily

handled and assembled. In shape the mill is circular and, in one size, about six feet in diameter. A steel groove encircling the basin holds seven chilled-iron balls that are 16 in. in diameter and weigh 500 lb. each. An inverted groove, similar to the aforementioned one, rests on top of the balls and encompasses the cylindrical upper section of the mill, to which the driving power is transmitted by a broad horizontal belt. A 10-hp. motor

In: Ellis Ball Mill; 29 Monadnock Bldg. San Francisco

gives the mill about 50 revolutions a minute and at that speed, it is claimed, two tons of ore can be handled hourly.

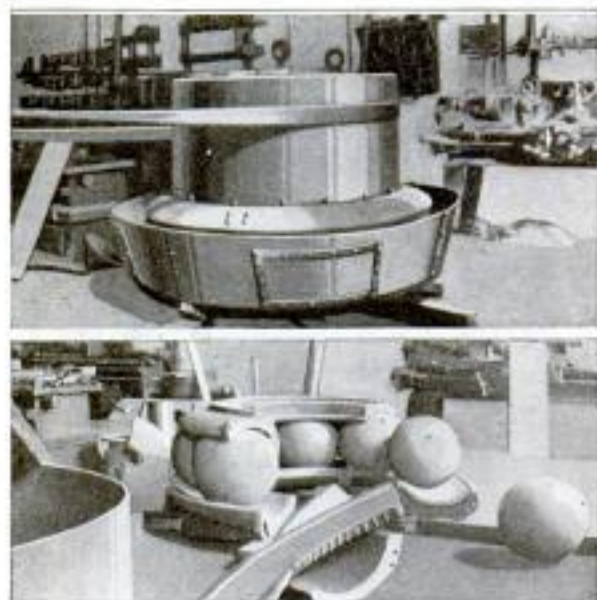

At the Top the Mill Is in Operation, While Below It is Disassembled to Show the Arrangement of Some of Its Parts and the Size of the Balls Used

Since there are no shafts, boxes, or bearings, there is little to get out of working order. Provision is made for the quick renewal of worn parts.

CHICKEN YARD ON HOTEL 52/87 ROOF A SUCCESS

A few months ago a hotel manager in a large city was presented with a crate of young chickens by relatives in the country and, instead of killing them, he decided to utilize the gravel roof of the hotel as a poultry yard and raise the little flock. The fowls have thrived in their lofty home and seem altogether



A Flock of Chickens Which have been Confined for Some Weeks on a Hotel Roof and have Thrived

satisfied to scratch for food that is scattered upon the gravel of the roof. It is asserted that the rooster's early-morning call, when delivered from certain points of vantage, has not been without its beneficial effect on guests who are late risers. The owner has considered increasing the size of his flock.

JUNIOR RED CROSS FORMED 521 FOR SCHOOL CHILDREN

The children of the United States are to share in the great war, not in the fighting forces, of course, but in a very vital way nevertheless. With the approval of the president, the Red Cross has undertaken the organization of the country's millions of school children into the Junior Red Cross. Among the tasks they will undertake, under the guidance of their teachers and others, are the making of knitted articles, saving of garden seed for use in rehabilitating France, making cretonne rest pillows filled with snippings from odds and ends of material, making crutch pads of unbleached muslin, and the saving of tin foil, old kid gloves, etc., to be sold for the benefit of the Red Cross fund. In an executive message, which is unusual in that it is addressed directly to the children, the president says: "It will teach you how to save, that suffering children elsewhere may have a chance to live."

5195 PORCH BED IS CONCEALED IN ROOM DURING DAY

By means of unusual features in plans and furniture, narrow balconies are made available as sleeping porches for occupants of a large Y. M. C. A. dormitory. Each of the rooms in question is provided with French windows opening onto a narrow, railed porch, and is furnished with a bed mounted on wheels so it can be drawn out on the balcony when desired. Beneath a closet and wardrobe in one corner of each room is a low recess in which the bed is usually concealed during the day, the head of the bed being in the

Hotel Savoy, Roof
Salt Lake, Utah.

Y.M.C.A.
Los Angeles, Calif.

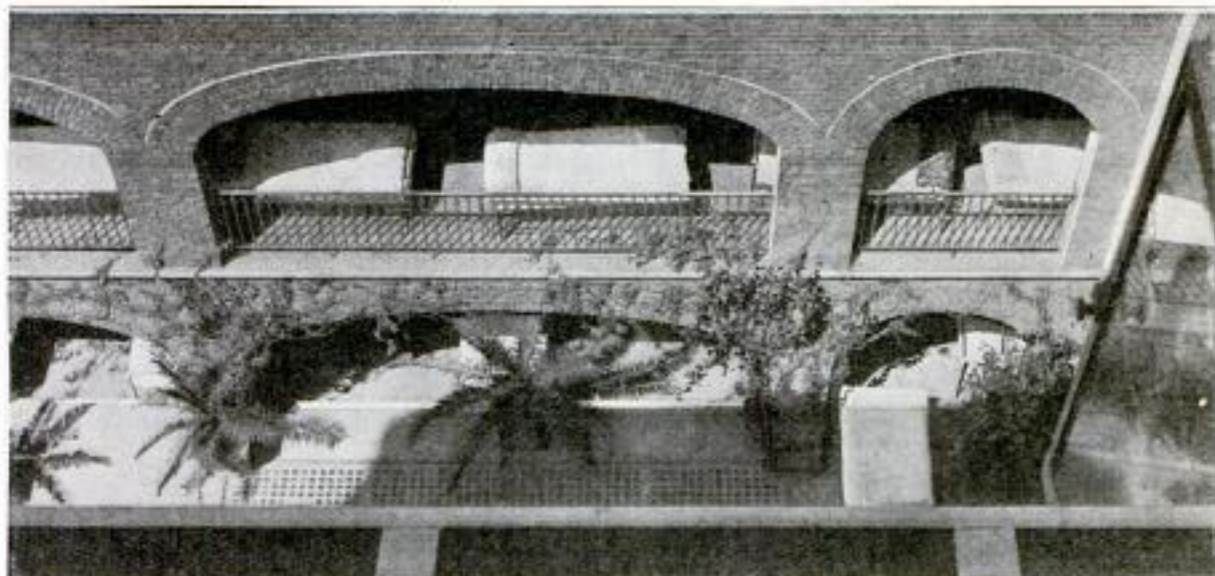

Above Is a View Looking Down on the Balconies Which Serve as Sleeping Porches in a Y. M. C. A. Building. Usually the Beds are Kept in the Rooms during the Day



View of One of the Bedrooms as It Appears in the Daytime: The Panel beneath the Wardrobe in the Far Right-Hand Corner Is the Head of the Bed

form of a panel which completely closes the entrance to the recess. This arrangement provides the equivalent of an attractive living room for day use and an open-air sleeping apartment at night.

5339 HOTELS URGED TO FREEZE FRESH VEGETABLES

Restaurant and hotel owners who have facilities for freezing and cold storage have been advised by specialists to freeze fresh vegetables and berries to preserve them for winter use instead of canning them. This would somewhat relieve the canning plants which are under unusual pressure this season. Among the articles which are said to have been kept successfully by freezing are sweet corn on the cob, string beans, lima beans, beets, aspara-

gus tips, peas in the pod, parsnips, and spinach. Among the fruits are strawberries, gooseberries, cranberries, blueberries, currants, plums, and cherries. These foods, when preserved by freezing, should be used within a few hours after being thawed out.

5245 DEVICE PREVENTS FOLDING OF FLAG ABOUT STAFF

A good deal of annoyance is often caused by a flag wrapping itself around the staff when the emblem is displayed from a window or doorway with the pole in a horizontal position. This difficulty is overcome by attaching to the emblem a light metal rod provided with a clamp at either end. One clamp fastens to the corner of the flag next to the end of the staff and the other clamp to the edge of the cloth about midway between the ends. This prevents the banner from folding itself about the pole and, at the same time, permits it to wave freely.



5213

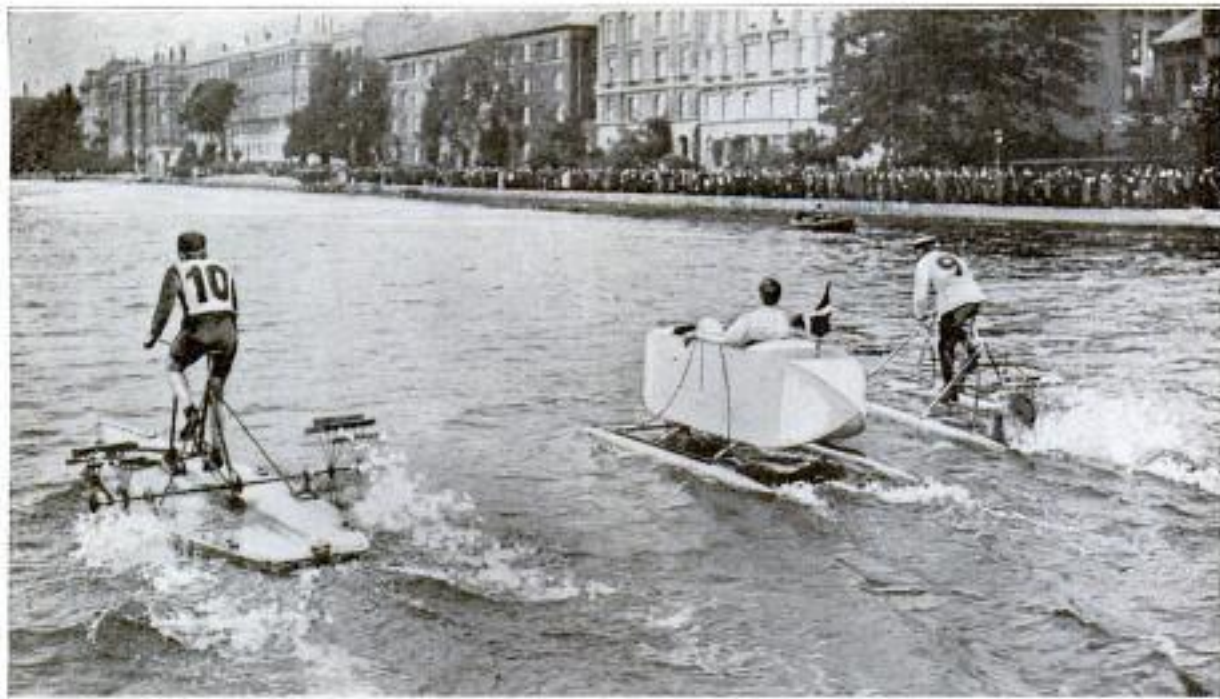

COPYRIGHT, UNDERWOOD & UNDERWOOD

ODD CRAFT RACE ALONG THE STRANDVEI AT COPENHAGEN

WHEN the annual water carnival was held recently at Copenhagen, many strange-looking craft took part in the racing events. The picture presented herewith shows a few of the queer contrivances skimming along the water before immense crowds lining the Strandvei. The two outer entries are alike in that they are equipped with bicycle frames and gearing and propelled by paddles. One of them, it will be noticed, is a side-wheeler, while the other, of pontoon construction, has a single wheel at the stern. The craft in the middle is built on pointed air cylinders and provided with a more or less streamline body. The festival, always a popular event, was attended by the Danish royal family.

CLIPPING MACHINE A BOON TO RED CROSS WORKERS

5289

Women in Red Cross groups who have blistered their hands making clippings from cloths with which to fill fracture pillows for our army hospitals will welcome a new machine that clips about eight times as fast as a person can with a pair of shears. It is provided with four knives, mounted



like the spokes of a wheel, which are turned on an axis by means of a handle. As they revolve they pass a stationary blade across which torn strips of the proper width are fed by means of two rollers. By means of a clamp the cutter can be securely fastened to the edge of a table.

\$2.00 each of Rockwell
\$3.50 Post
Special Rates in Quantities, RED CROSS

WAR AIDS LEAD-PENCIL INDUSTRY IN JAPAN

5356

The war has proved a great stimulus to the production of lead pencils in Japan. During the last quarter of a century that country imported these articles in increasing amounts, until in 1911 the total for the year was 65,000,000 pencils, most of which came from America and Germany. But with the opening of the European conflict German sources of supply were cut off and native manufacturers, who had been producing only in comparatively small quantities, seized their opportunity and made the most of it. In 1914 Japan exported over 9,000,000 pencils and in 1916 the number had increased to 168,000,000. There is strong indication that many of the markets won by the orientals will be held by them after the war, for they have the advantage of very cheap labor. Most of the lead which they use is imported from India and this country.

Inv: Miss L. M. Sepinae
6816 McPherson St
Pittsburgh Pa

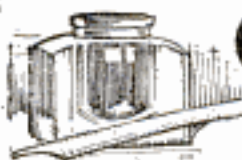

COMMENT AND REVIEW



RECENTLY motoring through a small seaport town, I stopped to watch a fire which had already gained considerable headway in a large warehouse which was built upon a dock, near the main business street. The local fire department, a volunteer organization common to places of that size, made its first appearance 15 minutes after the fire was well under way. Its members came from offices, stores, workshops, and their homes. None was in uniform; some were bareheaded and coatless. The water supply was inexhaustible, the apparatus fairly good, what there was of it, but a second trip had to be made before enough hose was available to reach the fire. There was the usual crowd, with the usual excited efforts, everybody wanting and trying to help, and working at cross-purposes and in each other's way. A small gale was blowing, and for a time it seemed as though the town was doomed. Then suddenly the wind shifted, and though the warehouse and all its contents were destroyed, and a good part of the expensive dock, the fire eventually burned itself out.

Universal Military Training

We in this country have the greatest property in the world. We have built up and accumulated with an energy, and daring, and effectiveness, such as no other nation has ever displayed. And we have done it all under conditions of personal liberty and opportunity far more priceless than all our material wealth. But what of our foresight in safeguarding all these? Since our armies disbanded at the close of the Civil War, up to the present moment, we have, comparatively speaking, been far less prepared for a world conflagration than the little seacoast town with its dock fire. We cannot, must not, rely upon some hoped-for shift in the wind, when enemy countries threaten to consume us.

For three years past we pursued our daily walks in the false belief that if that impossible time ever came, we would spring to arms overnight. Millions of otherwise sane thinkers really believed this. Today we know the truth. A modern army—and none other has the slightest value—can no more be produced in a day, or week, or month, than a crop of corn or wheat. On proper provocation 10,000,000 men would spring to arms between sunrise and sunset, but they would be a mob, not an army.

World life has changed; the volunteer system—always most unfair—is obsolete; as obsolete as the whale-oil lamp compared to the electric light, the messenger to the telephone, the oxcart to the limited express. If we are to continue our existence as a free people we must modernize our system of national protection, and that means universal military training. The greater our abhorrence of war, the greater reason for equipping ourselves to avoid it. The thief and slugger and assassin seldom attempts his wickedness in the presence of an officer of the law. Other nations will hesitate to attack us if we are thoroughly prepared; and as the policeman has no use for his club and gun in the presence of only the law-abiding, so we, too, would never use our military arms except in self-defense.

Last April there was introduced in the Senate, the Chamberlain bill. Briefly, it provides for six months' intensive military training for every young man: in the first year of the act, of those between the ages of 19 and 23, inclusive, and thereafter on reaching the age of 19. If temporarily exempted, then the training can be taken up to and including the age of 26. Exemptions provide for those who are members of the permanent military or naval forces of the United States; persons physically unfit for any military or naval service whatever; persons on whose earnings a father, mother, brother, sister, wife, or child is wholly dependent for support. Members of a religious sect whose creed forbids the bearing of arms will not be trained in the bearing or use of arms, but will be trained in some noncombatant branch of military or naval service. As far as practicable, the person will be assigned to train in the department and branch of the service of his choice. The expense of transportation to and from the place of training, and subsistence, clothing, and medical attendance while there, will be paid by the government. Having completed the training, each person will receive a certificate and rosette.

It includes every young man, rich or poor; there is to be absolutely no substitute or subterfuge; all will be treated exactly alike. Provision is made

for the separate training of the vicious and criminal. The result of the recent draft has already shown conclusively that an average increase in efficiency, physical and mental, of at least 25 per cent can be secured through this training. That alone is sufficient to warrant the plan, for what a tremendous asset to the country does 25 per cent added efficiency mean! It will teach respect for authority without incurring vassalage; it will serve as the great refiner of what the melting pot has already produced. It will create self-respect where self-respect does not exist; it will teach love of country where it is weak or wanting. The period, six months, is no handicap and does not interfere with the learning of a trade, or a college course. Records show such a training as is contemplated actually increases the length of life of the average man by five years. Ample provision is made to surround the training camps with even greater safeguards, moral and physical, than exists in the life of the boy living at home.

Aside, therefore, from all questions of necessity, the undertaking has everything to recommend it, as a means to making Real Americans and Real Men.



DOES it not seem a bit inconsistent to teach the German language in our public schools? Why should we require our boys and girls to spend months in learning a language which is the language of a nation with which the world is at war, and, whatever of literature and science it once stood for, is now the language of hate? And why teach German and not Scandinavian and Bohemian, Russian, Japanese, Spanish, and Polish? French is a more polished language, and Italian is a tongue of art and opera. Is it fair to the millions of our taxpayers who came to these shores from other lands than Germany, to pay tribute that the language of any other foreign country than their own native

*Cut Out
Study of
German*

tongue be taught in public schools? There are riches in German literature it is true; the medical and scientific works in German contain much of value to future writers, doctors, and chemists, but the proportion of these three to the whole number of scholars is very small. The study of German properly belongs in colleges and universities, and even there it is in most cases, if not all, now made an optional study. The small number of our boys and girls who enter high schools, and the still smaller number who go on to college work, make it imperative that the few years of study possible to the great majority should be devoted to necessary practical studies, including a better knowledge of our own country and its government, city, state, and national. Far better might the time spent in the study of German be devoted to that largely neglected and old-fashioned accomplishment of learning how to spell correctly.

Now is a good time to cut out German from our public schools, and use the time in a better study of that language in which was penned the Declaration of Independence.



AND why, also, when the time comes that merchant ships can again sail the seas in safety, and the several thousand vessels flying the German flag seek foreign shores loaded to the guards with goods of German manufacture—why then should the nations of the world buy the German exports? One surely cannot expect the mothers in England, France, Australia, and Canada to buy and wear garments made by the very hands which dropped bombs on the hospital in which lay their wounded sons! To do so would be sacrilege. And why should we in this country, whose women and helpless children went down on the "Lusitania," whose sons and brothers and fathers are already near or on the firing line—why should we forget all these things in days to come, and exchange our gold for German-made goods merely because they are offered us for a little less money than the same articles can be manufactured here? And why should the South American countries encourage imports of German goods when by doing so, every dollar serves to strengthen the arms of a nation which would crush them all in its plan of world dominion?

*Made-in-
Germany
Goods*

Why should India, and Japan, and China, help rebuild an export trade, the rapid growth of which, and whose enormous profits, fed the fires of avarice with the dream of controlling the factories and workshops of the whole world?

The very money which for years has flowed into Germany from France, and England, and Italy, is this very moment going back to them in the form of deadly gases and monster shells, and all the hideous implements of which the Huns are proud. Money which this country exchanged for German goods is being spent on our own soil in a propaganda by which hate, distrust, and maliciousness are planted and nurtured. Our own dollars were and still are being spent to foment hate between this country and Japan, and Mexico; it was some of our own money which paid for dishonor of the Bernstorff type; which has blown up our mills and ships and docks; which has made the I. W. W. what it is. Shall we then in time resume the exchange of our money to a foe who will ere long approach us with smiling face and explain no harm was meant when he stopped at no barrier and recognized no code of faith or morality? Will we be so craven as to forget all this? Or will we demand that Congress pass a law requiring that every article imported into this country shall (under penalty of confiscation) be plainly marked, showing the country of its origin? And then may all good Americans show their loyalty and never hesitate one instant between going without an article or buying one bearing that mark of iniquity "Made in Germany."



A FASCINATING sight it is, to stand on the seashore and watch the ebbing tide. Each succeeding wave recedes just a little beyond its predecessor, yet compared with a half hour before, great stretches of beach are revealed which were recently submerged. Compared with two years ago, one year ago, six months ago, six weeks ago, the tenor of the German war office has receded. It has not gone very far at that, and the boat which in fancied security drops anchor at this stage will find itself in a short time stranded on the beach. The tide must ebb a long way yet before low-water mark is reached.

*Lasting
Peace
or
None*

Our ocean frontage extends over 5,000 miles, with countless bays and coves, inlets and river mouths. All of these are carefully charted, the result of two centuries of patient sounding and survey. With these charts the navigator may cruise for the first time along the coast, or into harbors where he never sailed before; and in confidence and safety, for on these charts is set down the depth of water at low tide. With sufficient water at low tide, he can disregard any other stage.

There are now unmistakable signs that Germany's tide, which four years ago burst upon Europe with the suddenness and intensity of a tidal wave, has begun to ebb. Its high-water mark has been reached. Like the tide, it could not remain always at that point. The ebb was inevitable. It has already begun. As yet it is slow, just as the recession of a tide is at first almost imperceptible, but the ebb flow has begun. It is ours and our Allies' to follow that ebb steadily and resistlessly, until it has reached the low-water mark. And having reached its lowest point, then will be the time to make charts which may serve through future generations as guides by which the nations of the earth may pilot their ships of state in safety and security.

And not before.



CONGRESS has at last adjourned and its members are now at home, "mending fences" where some other aspirant for congressional honors has been ingratiating himself with the voters. The voice of the congressman will be heard in places where men congregate, in hall and park and picnic wood. He will wave the "Dear Old Flag" in a fervor of emotion; he will thrill his hearers with the story of our destroyers as they fight the deadly submarine; he will paint a glowing picture of great battleships from whose mastheads fly the Stars and Stripes, as they convoy our soldiers and munitions through the danger zones; he will recount the assembly of our thousands of young men, the

*An
Unpatriotic
Congress*

flower of the land, as they fill great cantonments created as by magic; he will

fill the heavens with an imaginary fleet of air craft, so great as to darken the very sun; he will appeal to fathers to exhaust their last dollar in the furtherance of this holy war; and exhort mothers, wives, and sweethearts to rejoice in the sacrifice of their most precious of all earthly possessions. Tears even will fill his eyes, and his voice will grow husky and fade away into breathless silence like a dying sunset on a lofty mountain top.

All this will he do. And the band will play "My Country, 'tis of Thee."
But when the war tax is paid next June, he will not pay his part, for he has voted to exempt himself.
Oh, patriotic congressman!

H. H. WINDSOR

October 25th.



LARGE PLANER CONSTRUCTED FOR USE AT NAVY YARD

Seven railway cars were recently required for transporting an enormous planer across the continent to the Mare

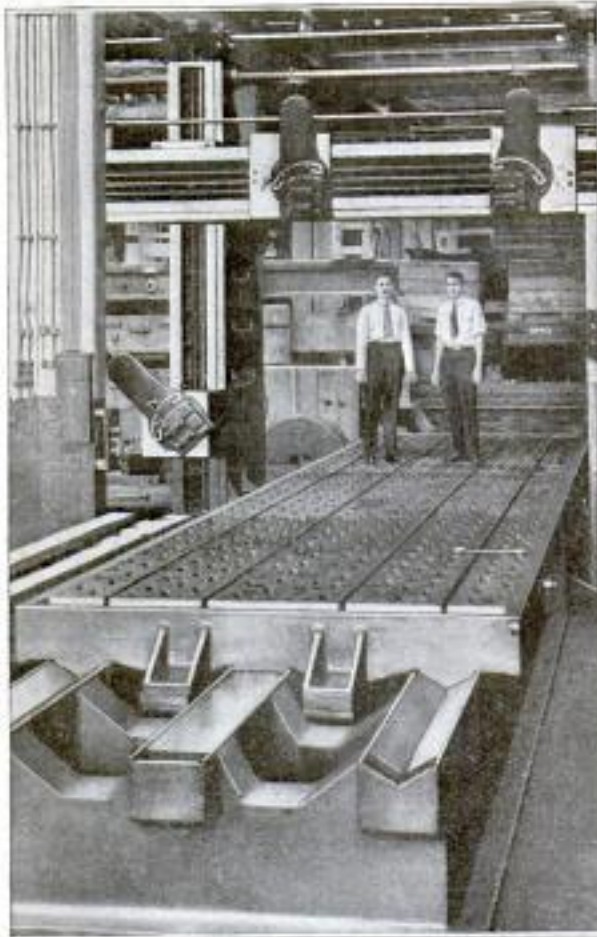

Showing the Big Planer Assembled at the Factory Where It was Erected: Obviously It had to be Completely Dismantled for Shipment

Island Navy Yard where it is to be used in the construction of battleship turbines. Among other things, the machine is interesting because of its size and weight. It occupies a space 25 ft. wide and 80 ft. long, and has a height of about 19 ft. Its weight aggregates approximately a half million pounds. A 100-hp. motor is used in operating it. Engine castings 35 ft. long, 15 ft. wide, and 9 ft. high will be handled.

FREE SCHOOL FOR RADIO

OPERATORS IN BOSTON

With the passing of the first congressional appropriation for a merchant marine it became apparent to men interested in the subject that there would be a large demand for radio operators when the new vessels were completed. With this idea in mind, two radio inspectors in Boston have been instrumental in establishing a free wireless school under government auspices. The promoters' resources were limited and they were compelled to rely for the most part on donations or loans of material and apparatus from various sources, such as the Bureau of Navigation, a wireless-telegraph company, and Boston authorities. Facilities for instructing 40 men have been acquired and classes enrolling almost that number meet three nights a week.

*mfg: Dietrich & Harvey Plant
of Bethlehem Steel Co.
Baltimore, Md.*

MARBLE MEMORIAL BUILDING TRIBUTE TO MCKINLEY

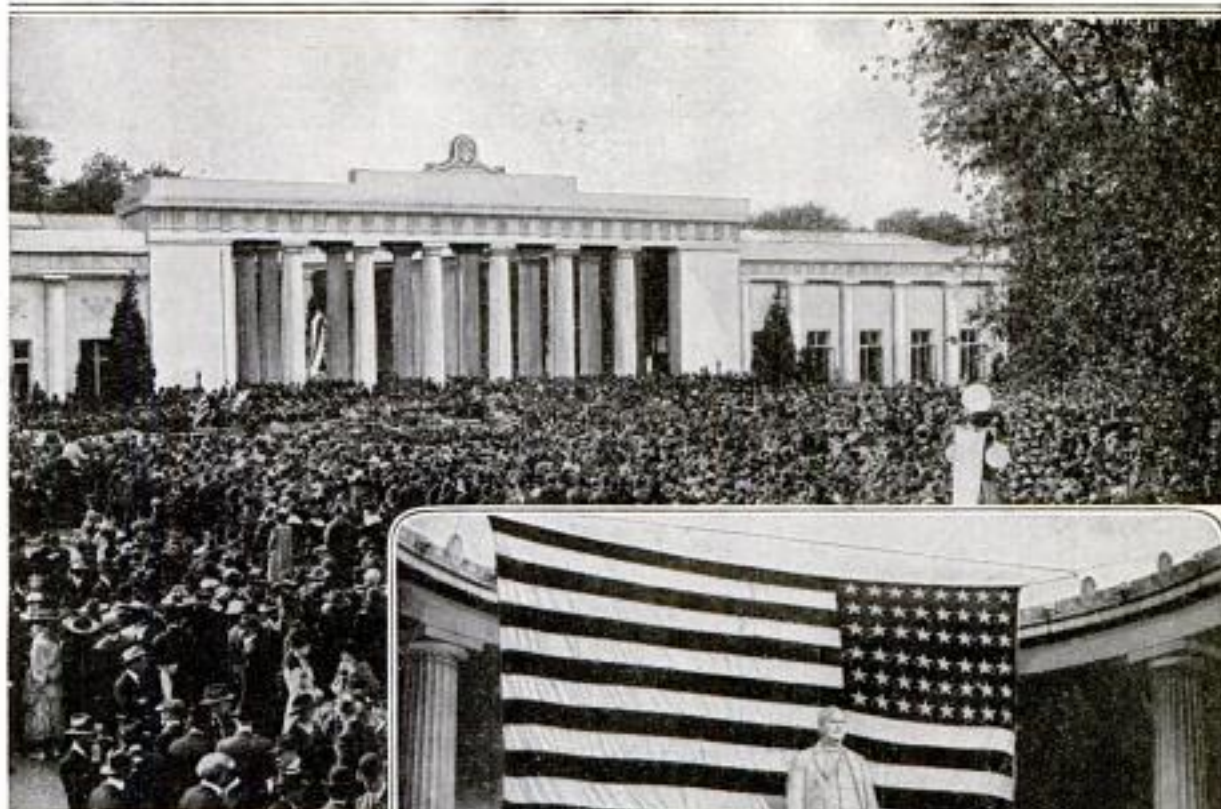

Thousands of Persons Attended the Dedication of the William McKinley Memorial Building at Niles, Ohio, a Few Weeks Ago. The Picture Above Gives Some Idea of the Appearance of the Edifice



The Marble Statue of McKinley, Which Occupies the Central Position in the Court of Honor at the Entrance of the Memorial Structure



Workmen Spent Six Months in Quarrying and Finishing This Massive Roof Stone. The Building is Situated in a Small Park in the Heart of the Town Where the Late President was Born

Men of international prominence participated in the dedication of a magnificent memorial building that has been erected as a tribute to the late President William McKinley at Niles, O., his birthplace. Thousands of persons attended the exercises, which

were made particularly interesting by the unveiling of J. Massey Rind's new marble statue of the deceased executive. The work occupies the central position in the Court of Honor at the entrance of the structure. It is 12 ft. high and weighs approximately 35 tons. The building is situated in a small park near the middle of the town. It is constructed of marble and is 232 ft. long, 136 ft. in depth, and 36 ft. high. The interior plan includes an auditorium, a library, a museum, Grand Army rooms, and other space to be used for educational purposes.

*In: J. L. Newell
539 E. 60 St. Chicago*

5367 **OBSERVER'S POST OF SHEET METAL RESEMBLES TREE**

Observation posts made of lumber and sheet metal to look like tree trunks are among the latest disguises employed on the battle front to deceive the enemy and enable watchers to occupy



In the Center of This Picture is Shown a Battle-Front Observation Post Made of Sheet Metal and Lumber, Cleverly Fashioned and Colored to Resemble a Tree Trunk

positions of advantage. About a tall framework of wood not much larger in diameter than the body of a man is placed a sheath of sheet metal, pressed and painted to resemble bark. A structure of this sort standing amid tree trunks that have long survived artillery fire is almost sure to escape detection by the enemy. Only on close

inspection does one discover the seams that mark the overlapping of the metal sheets.

539 **ROLLING "TANK" OF THE SEA SENSATIONAL WARSHIP**

Plans for one of the strangest war vessels ever proposed have been submitted to the Council of National Defense. The craft is an enormous ocean-going water wheel that is intended to perform much the same service for the navy as the British and French "tanks" have for the allied armies. It has been conceived as an offensive machine for assisting landing parties in coast attacks. Although highly visionary and entirely untried, it has novelty and potential power that draws attention. In addition to being amphibious to a certain degree, it is theoretically capable of great speed. Essentially it consists of two big connected cylinders that are supplied around their outer rims with adjustable paddles. The horizontal axis offers space for a crew and is gyroscopically stabilized to support a fighting mast. Opposite ends of the axis are utilized as gun turrets. Powerful motors mounted on heavily weighted sliding platforms in the lower part of each drum engage cogged rings encircling the inner circumference of the cylinders. In tending to climb the latter they impose weight that revolves the drums and causes the paddles to send the craft forward. By driving the cylinders in opposite directions, the craft can be turned around quickly.



Theoretically Capable of Great Speed, the Sea "Tank" Represents One of the Most Unusual War Vessels Yet Proposed

5-388

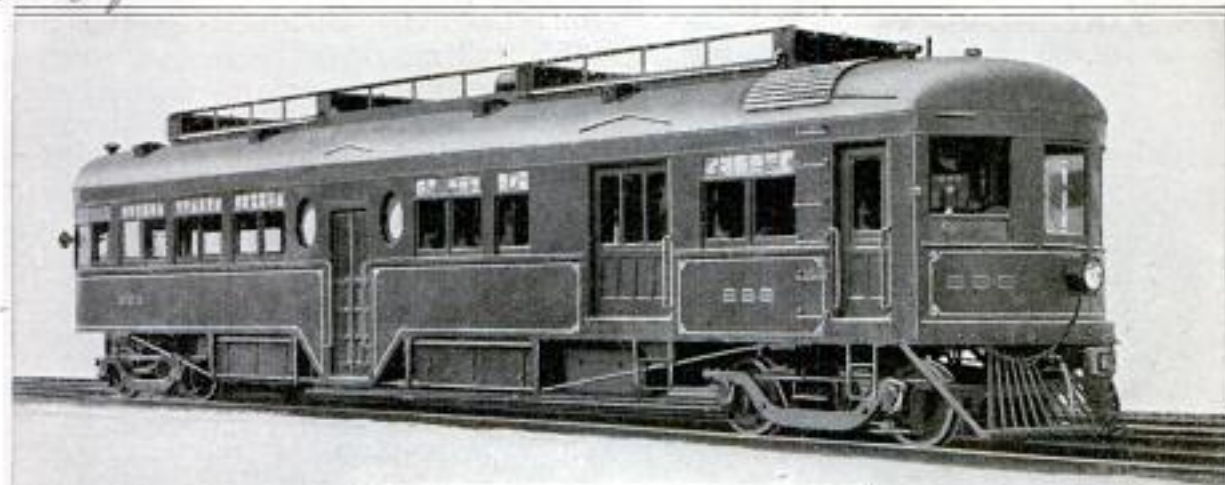

Showing the Exterior Appearance of the New Oil-Electric Motor Car Recently Built for the Nashville, Chattanooga & St. Louis Railway

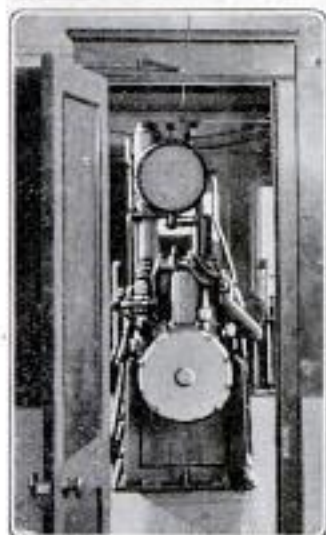

Left: Looking Forward from the Passenger Compartment into the Engine Room, Showing the Power Plant. Right: The Seating Arrangement and the General Interior Plan Are Similar to Those of Electric Interurban Cars

RAILWAY USES NEW MOTOR CAR FOR BRANCH LINE

To reduce operating costs on branch lines that have light passenger traffic, the Nashville, Chattanooga & St. Louis Railway has put in service an oil-electric motor car that is of late development. The points of chief interest are found in the power plant. Kerosene is converted into a fixed gas and fed to a 150-hp. marine-type engine that uses a mixture of one part fuel and six parts air. A 250-volt direct-current generator is turned at a constant speed of 1,000 revolutions a minute and delivers unused energy to a storage battery. The latter is able to supply 400 hp. for a five-minute period or 93 hp. for an hour, and automatically assists the

generator when the car is accelerated or heavy grades encountered. The battery also supplies energy for the lights and starter and in addition is an auxiliary source of power in the event of engine trouble. For a limited period, it will drive the car at a speed of about 30 miles an hour.

LONDON USES SOUND BOMBS AS AIR-RAID WARNING

The London authorities have recently begun using sound bombs, or rockets, as a means of warning the populace of approaching air raiders. These bombs consist of cylinders about eight inches long, weighing 1 lb. each, which are fired from small mortars by

pulling a lanyard attached to a fuse at the nose. They rise some 300 feet in the air. More than 200 of them were



A Magazine Containing Six Sound Rockets, and a Mortar from Which They are Fired: The Police Display "Take Cover" Notices at the Same Time the Warnings are Given



PHOTOS COPYRIGHT, INTERNATIONAL FILM SERVICE
Firing One of the Sound Rockets Recently Introduced to Warn London of Approaching Air Raiders

sent up from 79 fire stations the first time they were used and the result was pronounced very satisfactory. The public was informed about the rockets in advance so that the significance of the peculiar sound which they produced was understood.

5311 TEST AEROPLANE ENGINES IN VACUUM CHAMBER

The government's recent activity in producing new aeroplanes lends special interest to a small building on the Bureau of Standards grounds in which is a vacuum chamber for testing aeroplane engines. In this room, measuring 6 by 6½ by 15 ft. and having 12-in. concrete walls, various atmospheric conditions similar to those found in altitudes up to 20,000 ft. and higher, can be reproduced for the purpose of ascertaining how a motor will act when driven swiftly or slowly to vari-

ous heights. Undoubtedly the new "liberty" motor, of which so much is expected in the war, was tested in this or a similar chamber.

Not only is apparatus provided here for reducing the pressure as desired, but arrangement has been made for the exhaust of the engine and for discounting the heat which would be dissipated during actual flight. In the building inclosing the testing compartment are many pieces of apparatus for measuring heat, air pressure, and the volume of air used by the engines.

NO LOST TIME IN PROGRAM 529 OF THIS TRUCK SELLER

There is so little waste time in the schedule of a certain truck and tractor salesman that his methods should delight the most exacting efficiency expert. This energetic man drives from place to place in one of the trucks which he is selling and since his machine is well loaded, he is ready at all times to demonstrate its capacity for service. The load consists of a tractor for which he also takes orders. With this double outfit he is able to make his trips count to the best advantage, visits to several prospective buyers of one or both machines being possible within a short time. Two heavy planks are used as inclines down which the tractor can be driven from the truck under its own power.



Salesman's Double Demonstration Outfit: While Carrying the Tractor to a Farm Where It is to be Tried Out, He Is Able to Display the Merits of the Truck, for Which He Also Takes Orders

Inf. by Geo. Stevens
Blankenhorn University
Club, Milwaukee, Wis.

Over St. Lawrence River Quebec

5312 QUEBEC BRIDGE BUILDERS TRIUMPH AT LAST

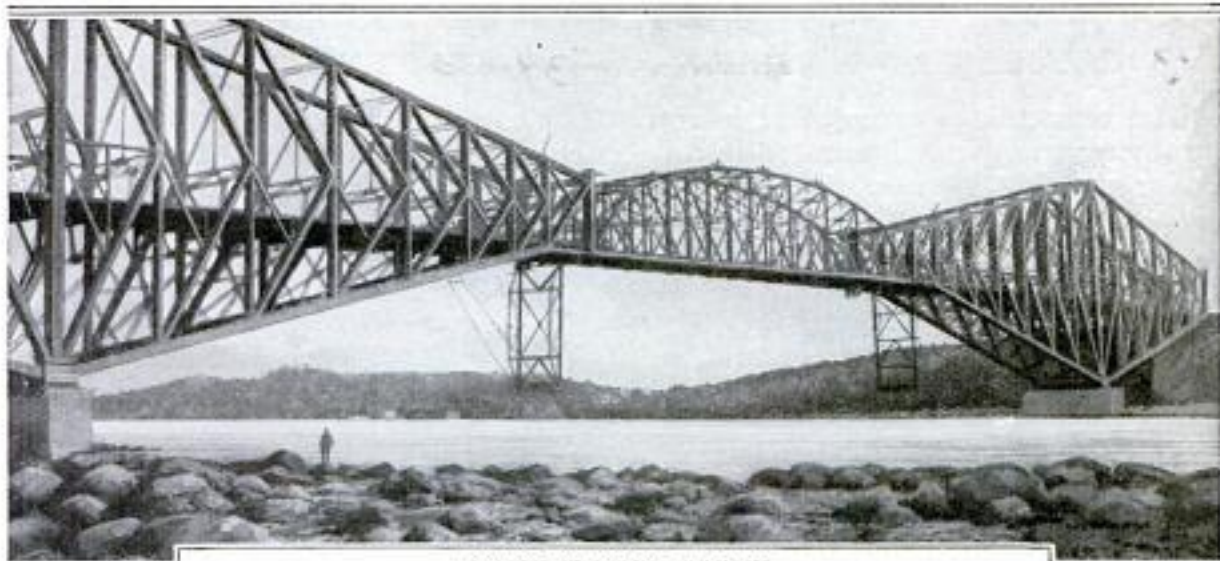

COPYRIGHT, INTERNATIONAL FILM SERVICE

The 640-Foot Central Span of the Mighty Quebec Bridge in Place: Undismayed by Tragic Failures in 1907 and 1916, the Builders have at Last Achieved One of the Greatest Triumphs in the History of Bridge Building

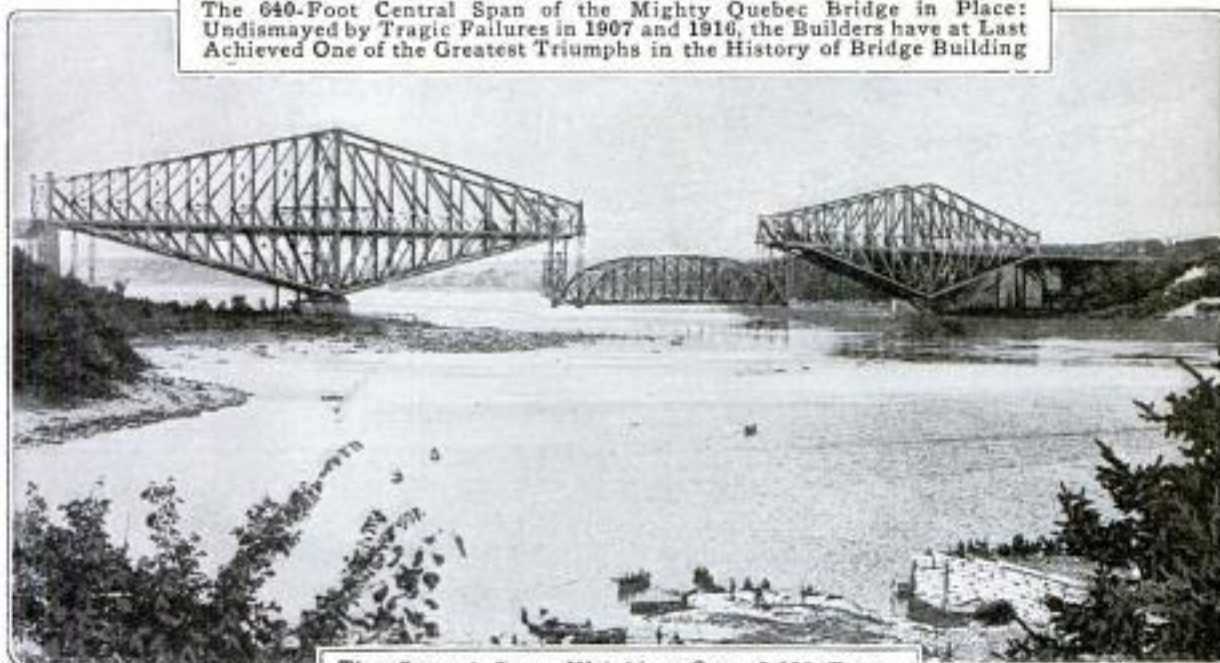

The Central Span, Weighing Over 5,000 Tons, being Raised by Practically the Same Method as was Employed Last Year, with Certain Added Precautions



Ready for the Hoist of 150 Feet: The Span is About to be Lifted from Its Pontoons by Means of Hydraulic Jacks and Chains, Composed of Massive Bars of Steel. The Raising Occupied Practically Four Days

Sept '13, 1917 - at
Newburgh, N.Y.

BUCKLING FREIGHT CAR

5293 **CAUSES ODD WRECK**

The tremendous cumulative force of a moving train was illustrated in a peculiar wreck which occurred in New-

PRINT PHOTOS ON SILVER

5394 **BY SECRET PROCESS**

Photographs which are printed on silver plates instead of paper and are practically indestructible are now being

produced by a chemist who has been working five years to perfect his invention. The chemical formula used in making the likenesses is a secret. A remarkable feature claimed for the new pictures is that the impression of each seems to penetrate the silver so that if the printed side of a plate is ground down on a buffing wheel the picture is not obliterated but shows on the new surface. In some instances, too, the natural colors of the objects photographed, such as pink and blue, have appeared on the plates, but the inventor is not able to explain this phenomenon nor can he always reproduce the colors when he wishes. Other uses of the new discovery

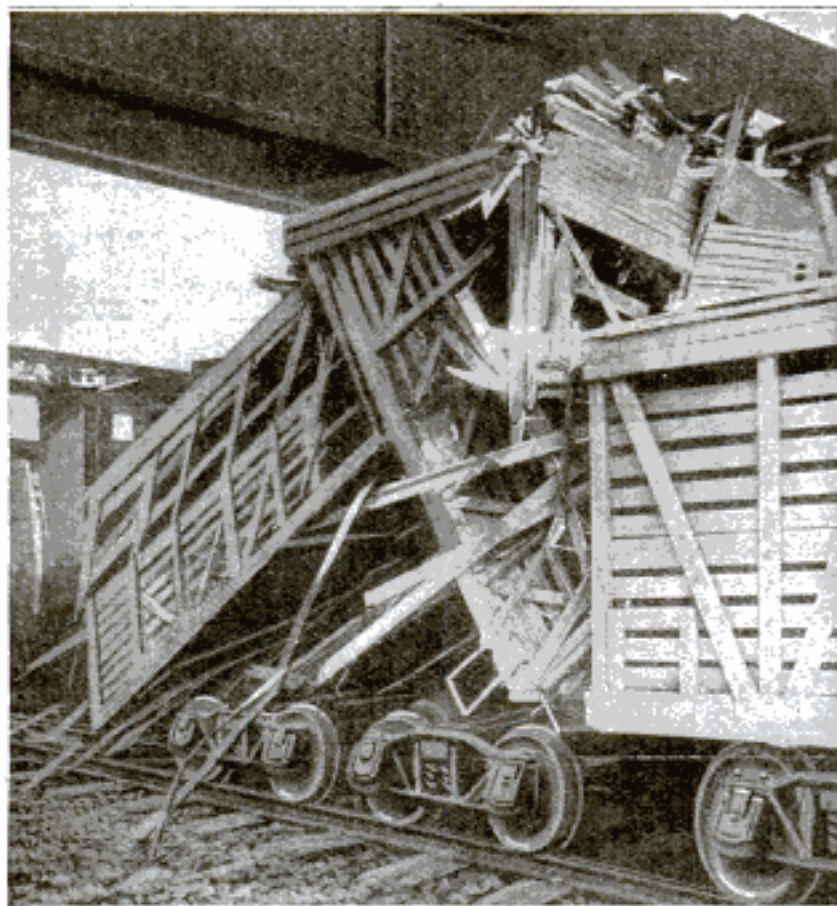

Stock Car Which Buckled beneath a Trestle When the Brakes were Suddenly Applied to the Train, Subjecting This Car to Too Great Pressure at Either End

burgh, N. Y., recently. As a result of suddenly applying the air brakes to a line of some 75 empty cars, those in the center were caught between one section of the train which was still moving under its own momentum and one section that had been brought to a quick stop. Under this strain a stock car buckled and was broken in two, the body being torn from the front and rear trucks, which were jammed against one another. By coincidence this car was passing beneath a trestle when the crash came and part of the wrecked mass was forced up against this overhead structure. In spite of the smash-up the wheels did not leave the rails.

having far-reaching possibilities are suggested by the fact that with this process portraits can be made on plate glass, and invisible impressions can be made on glass which can only be brought out by use of the secret solution.

5381
**CONVERTIBLE OFFICE DESK
SERVES DIFFERENT NEEDS**

In a flat-top desk have been incorporated the features of a filing cabinet, a directors' table, and a roll-top desk. The top is divided into three sections. The middle one is the largest and connects the pedestals, while those on either side of it are counterbalanced

In: C. S. Marcellis
vs Lincoln P.
Orange, N.J.
Copyrighted material



Ends Moved Outwardly, Uncovering Compartments in Which Files and Pigeonholes are Provided

When Closed, the Desk, as Shown at the Top, Conceals Its Character. Below It is Shown Opened as a Directors' Table

and arranged to slide outwardly and expose two compartments supplied with letter and card files and inclined pigeonholes. When desired, the arm rests may be inserted in the openings thus formed and a six-foot directors' table provided. To make the changes, the top can be opened or closed almost as easily as a drawer.

DELICATE RADIO RECEIVER HAS STARTLING FEATURES

For more than a year complete secrecy has shrouded the technical details of a highly sensitive radio receiver that is understood to be of remarkable character. It was originally designed for commercial purposes, but before being publicly announced gained the scrutiny of the Navy Department. Coincident with our entrance into the world war, the invention was turned over to the government. Whether actual use is to be made of it remains to be seen. The instrument is intended for long-range receiving and at a distance of 3,000 miles succeeded in picking up signals from Panama even before it had been perfected to its pres-

ent stage. The outfit can be dismantled or assembled in 15 minutes and operated in a closed room without employing exterior aerials, according to information at hand. The antenna consists of a series of wires arranged in rectangular form on opposite walls of the operating room, which must not be in a building of steel construction. The wires, if desired, may be concealed from view.

5363

COMFORT AND GRACE MARK WOMAN'S MOTOR OUTFIT

In the striking woman's motor costume shown herewith, the use of Morocco leather as the principal material, and ample provision for the warmth and general comfort, have not prevented the maker from producing an outfit whose lines and general appearance are genuinely feminine and graceful. This in spite of the fact that the coat is cut man-fashion and the bifurcated skirt has been gathered about the ankles like breeches. The low-heeled comfortable shoes are a detail not determined by accident. Such a costume is suitable for flying and motorcycling, as well as automobiling.



COPYRIGHT, INTERNATIONAL FILM SERVICE

Radio Engineering Co
728 Security Bldg. Minneapolis



OVERTURNED POT OF OIL DESTROYS SALONIKI

COPYRIGHT, UNDERWOOD & UNDERWOOD

SALONIKI, known to travelers as one of the most interesting and metropolitan cities of the Mediterranean, is a graveyard of tottering walls and ashes. The smoke-clouded picture of the water front, reproduced above, was taken the morning after flames had swept the port and made it the homeless resort of 100,000 miserable persons of all nationalities. The fire occurred several weeks ago. Its origin reminds one of the great Chicago fire, caused by a cow kicking over a lamp. A high wind held Saloniki in its teeth and the water supply was scant. The Jews had closed their shops, for it was the day of Sabbath. An old woman in a decrepit wooden shanty was cooking a meager meal in a pot of boiling oil over an open fire. She made a clumsy movement and overturned the pot. Nothing could stop the roaring flames. Saloniki burned.

ARMY KITCHEN MAKES EXCELLENT SHOWING IN TEST

Great capacity and efficiency are the principal claims that are made for a new mobile field kitchen lately attached to the 102nd infantry for demonstration purposes. With two cooks it has shown itself capable of replacing two complete kitchen units of 80 men and 40 horses. At Yale field a few

outfit has been developed by a hotel manager who visited Plattsburg two summers ago and determined to design an army kitchen that would obviate the wasteful and insanitary methods of food preparation that he found in use there. It is mounted on the chassis of a four-ton truck and consists of an upright 10-hp. boiler, a pair of 90-gal. stew, soup, or pot-roast kettles, and two 50-gal. coffee urns. The truck has a road speed of about 15 miles an hour.

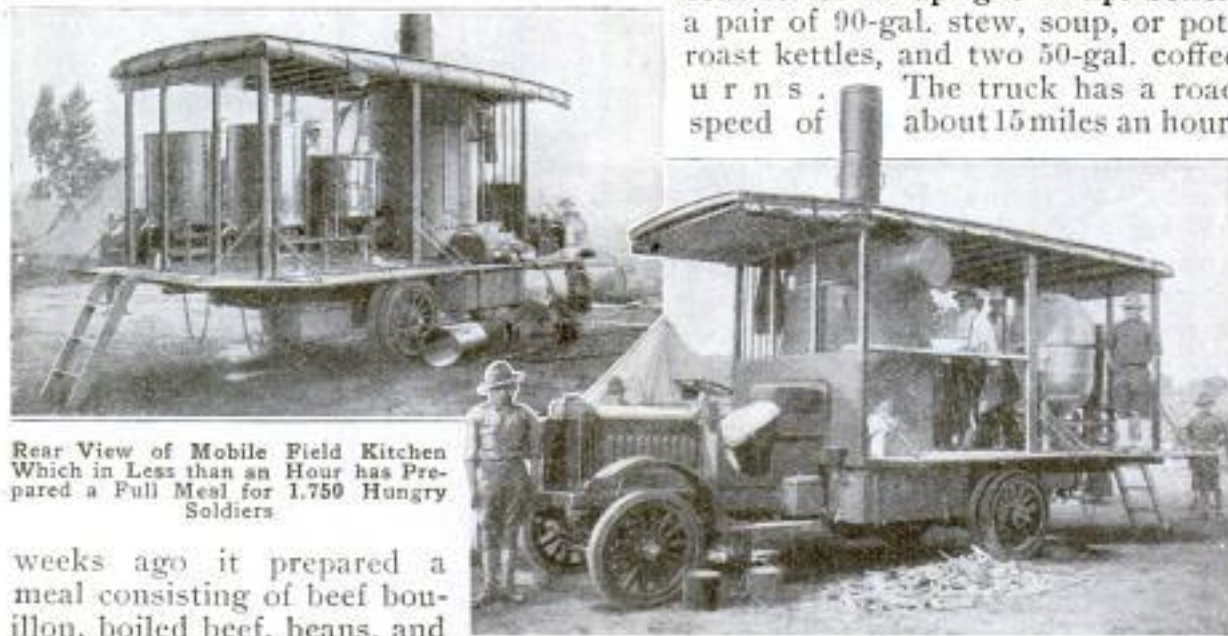

Rear View of Mobile Field Kitchen Which in Less than an Hour has Prepared a Full Meal for 1,750 Hungry Soldiers

weeks ago it prepared a meal consisting of beef bouillon, boiled beef, beans, and coffee for 1,750 men, in less than one hour's time. The

Two of the Units, It has been Demonstrated, are Adequate to Meet the Needs of an Entire Regiment of Men

Locomobile Company
Bridgport, Conn.
 Copyrighted material

*Davidson Mfg. Milwaukee, Wis. 841
111 N. Market St. Chgo.
TYPEWRITER FEEDER SAVES*

RADIO TELEPHONE USED FOR FOG WARNINGS

5318

Fogs on the ocean, as is well known, often play strange tricks with warning sounds, leading sailors to destruction, and lighthouse lights are often obscured by the heavy mists, but greater reliability, it is hoped, will characterize a new type of signal which has been installed at Point Judith Light to warn mariners who in bad weather pass through, or near, Block Island Sound, at the east end of Long Island. The new signal is a radio telephone and any vessel equipped with an ordinary wireless receiver, when within a radius of several miles, can pick up the words, "Point Judith Light," that are repeated every five seconds. To every third call this warning, with a two-mile radius, is added: "You are getting closer. Keep off!" If the peculiar difficulties involved in operating signals of this type can be overcome, it is believed that eventually they will be installed all along the coast.

SIGN IN SEVEN LANGUAGES

5172 **FOR JAPANESE GARAGE**

Though the number of automobiles in Japan is not large, one enterprising garage owner in Yokohama is taking no chances on missing possible customers, foreign or native, because of their ignorance of languages not their own. In seven different languages he repeats the statement that he has cars for rent. This polyglot sign is printed on cut-outs resembling automobiles which line the top of a near-by fence.



Cars-for-Rent Sign of Yokohama, Japan, Garage Owner in Seven Languages

Garage, Yokohama Japan

5351 **OPERATOR'S TIME**

To increase the output of a typist engaged in addressing envelopes and filling in form letters, an automatic feeder for typewriters has been developed. It conserves the effort and time usually spent in picking



As a Finished Sheet is Withdrawn from the Machine, a Fresh One is Automatically Pulled around the Platen and into Position

up paper, inserting it in a machine, and adjusting it to the proper position. The appliance is geared to the typewriter so that the feeding is accomplished with precision. Some 50 letterheads or envelopes are placed in a rack mounted above the machine at the back and are fed down one at a time as needed. The act of withdrawing a sheet of paper from the platen automatically pulls a fresh one into position. Because the attachment operates on its own track and is separate from the carriage, it does not retard a typewriter.

NEW TEA WAGON EQUIPPED FOR ELECTRIC DISHES

5312

One of the newest types of tea wagons is designed especially for use in connection with electrically heated cooking utensils, being provided with a flexible 10-ft. cord which rolls up on a reel, concealed beneath the top of the

W. C. Lamb & Co. Ottawa, Ill.

wagon. The reel operates like a window-shade roller so that the cord can be drawn out the desired distance and connected with a near-by socket without being under tension all the time. The cord is



A Mahogany Tea Wagon Equipped with a Concealed Flexible-Cord Reel and Two Switch Plugs, Making the Use of Electrically Heated Utensils Especially Convenient

suitably joined with two shorter ones attached to the sides of the wagon and is provided with switch plugs to be inserted in the base of the dishes to be heated.

BULK POWDER IS DIVIDED INTO DOSES BY MACHINE

To facilitate the pharmacist in preparing prescriptions, a device has been contrived that divides a quantity of powder into the desired number of equal portions quicker and more accurately, it is claimed, than is usually done with a spatula. The mechanism employs a series of blades spaced equidistantly along a shaft and so arranged that when they drop into a trough, through which powder is evenly distributed, they separate the whole into



The Instrument Is of Compact Size, and Proportions Powder for a Druggist More Quickly Than Does a Spatula

several parts. When a lever controlling a spring is pressed, all the blades are moved forward one space. This causes a portion of powder to be delivered. By releasing the spring, the blades are raised and returned to their original position. The process, which is similar to the depression and release of a typewriter key, is then repeated. Regulation of the machine is easily accomplished so that an ordinary amount of powder can be divided into as many portions as is required.

LEATHER GAS MASKS USED BY GERMAN FIGHTERS

Two interesting respirators of German origin, one of unusual character, were picked up not long ago by Canadian soldiers operating in the vicinity of Lens. Presumably because of the scarcity of rubber, the flexible parts of the mask attached to one of the devices had been made of light-weight leather. The other appliance merely consisted of a cylindrical box provided with a mouthpiece and nose clamp. According to



Above: New Type of Respirator Supposedly Used by Trench Runners. Right: German Mask Made of Leather Instead of Rubber Fabric

CANADIAN OFFICIAL PHOTOGRAPHS

incomplete information emanating from the official Canadian War Records office, this type of hoodless respirator is probably used by trench runners who apparently do not employ goggles. Except for this version, which because of its source must be fairly accurate, it would seem that the appliance had been torn from a mask like the first.

Brooklyn N.Y.

LIVES LOST AND FOOD DESTROYED IN BIG FIRES

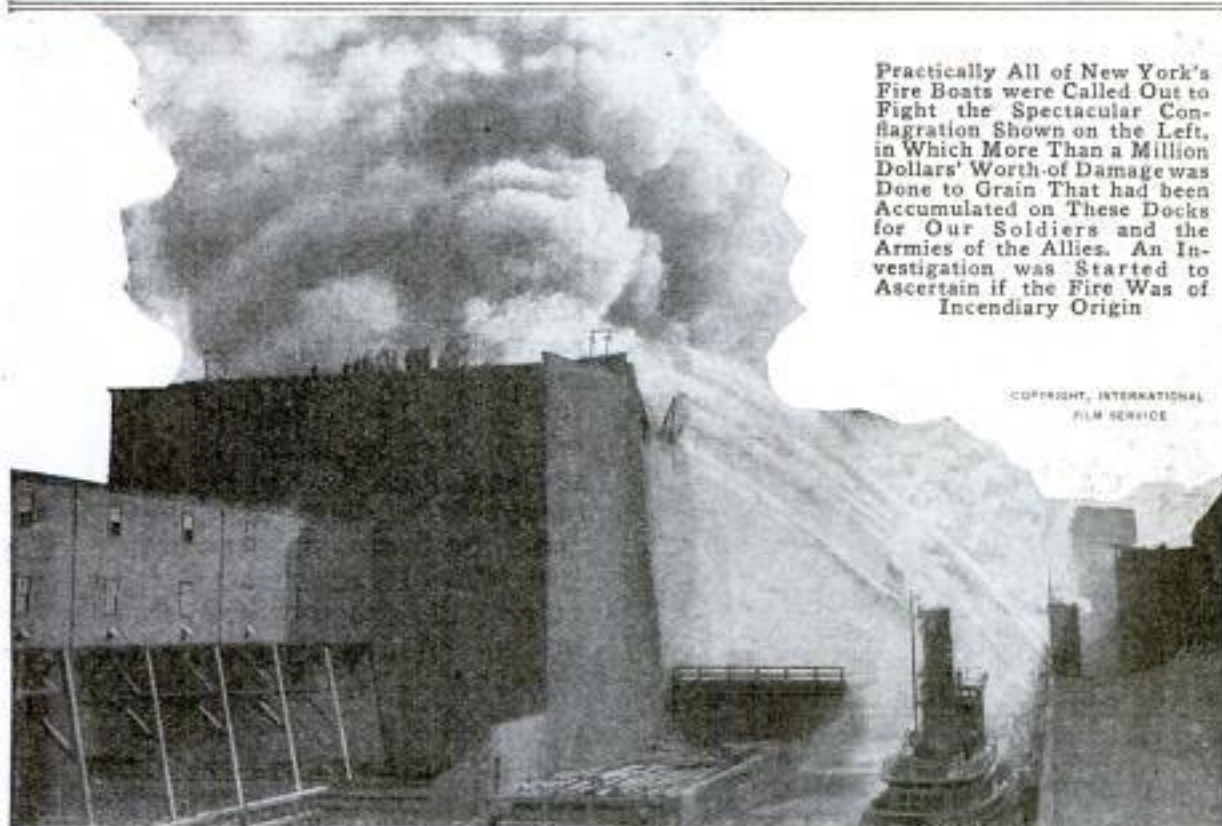

Practically All of New York's Fire Boats were Called Out to Fight the Spectacular Conflagration Shown on the Left, in Which More Than a Million Dollars' Worth of Damage was Done to Grain That had been Accumulated on These Docks for Our Soldiers and the Armies of the Allies. An Investigation was Started to Ascertain if the Fire Was of Incendiary Origin

COPYRIGHT, INTERNATIONAL FILM SERVICE



Removing the Body of One of the Firemen Killed in a San Francisco Lodging-House Fire: Three Minutes After the Fire Chief had Ordered His Men from the Burning Structure It Collapsed, the Falling Walls Killing Three and Injuring a Score of His Fighters Who were Standing Near

San Francisco, Calif

SIGN'S MOVING MANIKIN HELPS MONEY "DRIVE"

539

The effective means employed in stimulating public interest in a financial "drive" in Seattle recently con-



Sign in a Seattle Thoroughfare Showing the Movable Boy Scout Figure Used to Indicate the Progress of a Money-Raising Campaign

sisted of a huge banner from which was suspended a Boy Scout manikin. The banner was stretched across a principal thoroughfare and was divided into sections representing \$1,000 each. It also bore these words: "Help This Boy Scout Across the Street," and as the campaign progressed the figure was moved along to a position corresponding to the amounts pledged.

SCRAP LUMBER IS SAVED AT BIG ARMY CAMPS

536

Though immense piles of scrap lumber have accumulated at the various cantonments during the construction of the buildings to house the National

Army, the waste of materials has not been as great as might appear at first. At Camp Funston, Fort Riley, Kan., for example, a crew of men with a buzz saw were set to work trimming the discarded pieces so that many of them were made available for building purposes. It sometimes happened that in the truck loads that were almost constantly being added to the piles, some perfectly good lumber was included by mistake. This was sorted out and returned to the carpenters. The pieces which were left after the scrap heaps at Camp Funston had been gone over, amounted to many tons and were set aside for firewood. At another camp two officers were arrested for not requiring their men to use scrap lumber instead of new lumber in making some shelving.

NEW FIRE-HOSE NOZZLE HAS NUMEROUS USES

525

In designing a new hose nozzle, the inventor, who is an experienced fireman, has sought to provide a single piece of equipment that is capable of producing any kind of a discharge desirable for fire fighting. It consists of an adjustable bell-shaped sleeve which incloses a member resembling a plain nozzle, except that it is provided with a special valve by which it can be opened or closed. Spray can be produced with or without a central straight stream by various adjustments of the sleeve. The misty discharge can be made either in the form of a beam several inches in diameter, which is less destructive than a plain



One of Two Immense Piles of Scrap Lumber Accumulated While Erecting Buildings at Camp Funston, Fort Riley, Kansas: At the Right can be Seen a Crew of Men with a Buzz Saw Engaged in Sorting and Trimming the Good Pieces

Camp Funston,
Fort Riley, Kas.

Inv. Clyde F. Hughes
63 E. 28 St. No.
Portland, Oregon



A Water Curtain is Shown Above, Accompanied by a Straight Stream. With This Protection a Fireman can Stand Close to Hot Flames

A Close View of the Nozzle Showing the Central Member with Its Separate Valve, and the Adjustable Bell-Like Sleeve with Which Spray is Produced

A Cone of Fine Spray: This Form of Discharge is Most Valuable in Driving Smoke from a Room or in Quickly Dampening a Large Area

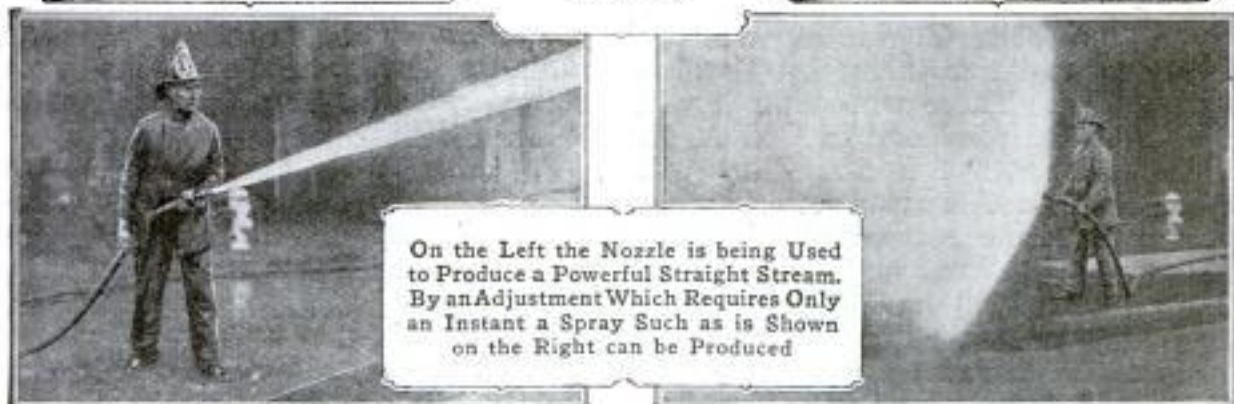

On the Left the Nozzle is being Used to Produce a Powerful Straight Stream. By an Adjustment Which Requires Only an Instant a Spray Such as is Shown on the Right can be Produced

stream, or in the form of a cone whose diameter can be varied at will without shutting off the water. A cone-shaped spray is often of great value in clearing a room of smoke or dampening a large area quickly without causing serious water damage. The nozzle can also be adjusted to produce a well-defined circular curtain of water which issues almost at right angles from the end piece and is a great protection when one is working close to the flames.

PAPER-CONE CONTAINERS

5-702) FOR AUTO OIL

A cone-shaped container has been devised which is a special convenience for the motorist who desires to carry an extra supply of oil for his car. The cones are made water and oil proof and have a capacity of one quart each. A case holding four containers is provided, if desired. To empty a cone, a safety cap is removed, after which the apex is cut off with a pocketknife.

Used receptacles may be made to serve as funnels by removing the bottoms.

The new containers will appeal especially to those traveling in sparsely settled regions where auto stations are far apart.

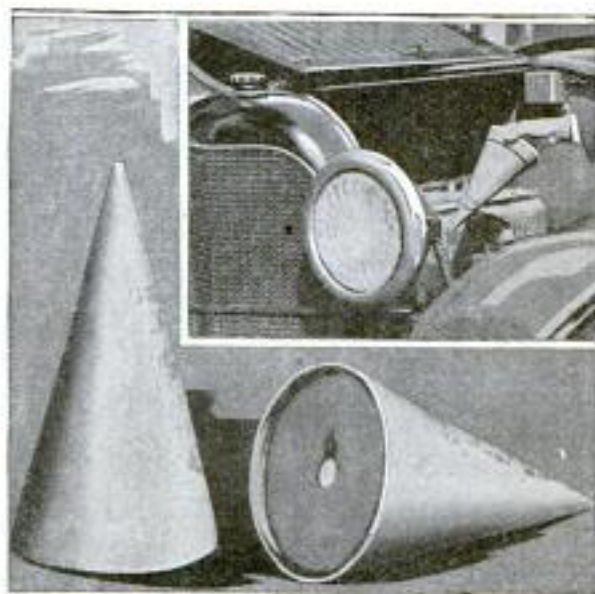

Light and Durable Quart Containers Made of Paper, for Automobile Oil: The Insert Shows a Cone Used as an Oilcan

Mitrolene Oil Co., Los Angeles, Calif.

Major Carl J. Stinson
30th Engineers Camp
POPULAR MECHANICS

American University
D.C.

846

5401

GAS AND FLAME

Chemists and Mechanics Have Big Chance to Choke Kaiser in America's Spring Offensive

Several days remain in which expert mechanics, chemical workers, and those skilled in certain other lines can enter the Gas and Flame service regiment. Only red-blooded, well-built fellows who can take care of themselves can qualify.

Men who enlist now will be leaders in the spring offensive.

The pioneer Gas and Flame regiment, the 30th Engineers, will be ready to go "over there" by Thanksgiving Day. Those who enter it will be under the command of Col. A. A. Fries, now at the front. They will supervise the American offensive in Gas and Flame service and instruct men along the front in this important work. They will be in the thick of things where they will have to assume responsibilities and act upon their own initiative and individual judgment.

There will be opportunities for commissions, especially as the service is expanded.

Here are the men who are wanted: Chemists, chemical workers, powder men, gas men, machinists, automobile repairmen, gas and steam engine experts, pipe fitters, electricians, designers, interpreters, carpenters, blacksmiths, plumbers, boiler makers, and chauffeurs. They must be of good muscular development and alive with energy. Men between 18 and 40 years of age are eligible.

To enlist, apply at the nearest recruiting station, state your qualifications and desire to join the 30th Engineers (Gas and Flame). All men must enlist as privates. Accepted men will be enlisted immediately and sent to the regiment's headquarters at Camp American University, D. C.

5307

RAILWAY'S BIG COAL PILE REPRESENTS HEAVY LOSS

Foresight may prove more disastrous than beneficial at times if the fortune of a western railway company is conceded to be a criterion. In antici-

pation of the fuel shortage, a 28,000-ton coal pile was established on an open prairie in Iowa by the company. Some time later spontaneous combustion caused serious loss and made it necessary to remove some 3,000 tons of the coal as a fire-fighting measure.



Removing Coal from the Prairie Where It had been Stored in Anticipation of Shortage and High Prices

C. R. J. & P. Revue
Centerville, Iowa



Left: Interior View of the Car, Showing the Berths, Gas Stove, Refrigerator, Bureau, and Cupboard; Folding Dining Table and Chairs are Also Provided. Right: Automobile Truck Equipped Like a Pleasure Yacht Which Began a Transcontinental Journey a Few Weeks Ago

LOFT LIGHT, LINDBERG & CO., & UNL. BRADDO

Prolonged exposure and heavy rains caused considerable deterioration. As a result it is estimated that the company has lost \$50,000 in the venture.

Traveling Truck
CAR FITTED UP LIKE HOME

5292 FOR OVERLAND TRIP

All the conveniences of a seagoing pleasure yacht have been provided for in a one-ton truck which started on a journey from Boston to Seattle a few weeks ago. Immediately back of the driver's seat is a steel framework supporting three spring beds, one above the other. To the rear of the beds the body of the car takes on the aspect of a kitchen and dining room combined. On one side is a gas stove, a set of drawers, a sink, and a cupboard. On the opposite side is a bureau with eight drawers, and an ice box with a capacity for 50 lb. of ice. Beneath the body are three gas tanks which supply fuel to the gas stove and to a jet which lights the room brilliantly. Two other tanks are situated beneath the car, one with a capacity for 45 gal. of gasoline, and the other a 60-gal. container for water which can be drawn upon at any time by means of a pump located beside the sink. Pneumatic tires make the truck very easy-riding.

5395 FREE AND UNLIMITED POWER PROMISED BY INVENTOR

Soon, perhaps, a group of five scientists and the secretary of the interior will determine whether man's eternal riddle, the production of power without cost, has been solved. Just before its adjournment, Congress laid aside all other matters long enough to pass, at the request of the patents committee, a bill that will enable a little-known inventor to demonstrate to the first-mentioned body a machine that is supposed to utilize "free fuel." Utmost secrecy conceals all details of the apparatus, except its purpose. The fact that the patents committee witnessed a demonstration before taking its action has caused many potential critics to maintain discreet silence. The invention is not a perpetual-motion scheme, but there is no basis for conjecture as to its true nature. The claim is made that the device will permit aeroplanes to be heavily armored, carry enormous burdens, and fly until they fall apart, without having to descend for fuel. One congressman, who knows something of the mechanism has stated: "This invention will win the war."

ⒸThe Dutch authorities are reported to have recently tested and found practical a device for steamships invented by one of their naval officers, which cuts anchor chains of floating mines and prevents the latter from coming in contact with a vessel passing through a mine field.



MACHINE GUNS RATTLE IN NEVSKY PROSPECT

A REMARKABLE memento of the revolutionary outbreak that occurred at Petrograd last July: A picture that vividly portrays the terror that reigned in Nevsky Prospect when the ultra radicals and anarchists trained machine guns on people in the streets. Rifles were mounted on the top of the library building visible in the background. The dead are shown scattered along the pavement and wounded victims are to be seen here and there crawling on their hands and knees to cover. Action tells the rest of the story.

FLYING HUNS BOMB HOSPITALS IN FRANCE



During the Raid on the Hospital One of the Enemy's Planes was Felled. The Observer Escaped with Slight Wounds and is Shown on the Way to a Hospital That, Fortunately for Him, He Failed to Destroy



To Those Who Find Excuses for the Invasion of Belgium and the "Lusitania's" Destruction, This Picture of the Holocaust at Vadelaincourt is Submitted. It Shows the Twisted Metal Beds That Held Wounded Soldiers in the Hospital for Three Hours the Target of German Incendiary Bombs



End of a Kultur Vulture: The Wrecked Plane and Its Dead Pilot after the Bombing of Vadelaincourt's Hospital. Of Late Months the Teutons have Conducted a Systematic Campaign against Hospitals, Attacking, among Others, Those at Belrupt, Monthairon, and Dugny, and Two American Bases

SPIRITLESS RUSSIAN TROOPS ARE SHAMED



The Accompanying Photographs Show the Demoralization of Russian Troops in Different Sectors. Above, Officers with Drawn Revolvers have Stopped a Truck Loaded with Fleeing Soldiers and Forced Them to Leave the Car. In the Foreground Is a Russian Captain Who is Attached to the British Armored Cars as Interpreter



Here One Russian Fellow with Spunk is Using the Butt of His Rifle to Stop a Pair of Retreating Soldiers. Such Scenes have been Tragically Common in Many Sectors along the Eastern Front



British Soldiers in the Russian Trenches Endeavoring to Stem the Tide of Defeat: Members of the Armored Motor-Car Corps Fought Valiantly to Meet the Grave Crisis



A Truly Remarkable War Document: Russians in Complete Rout. Upon Hearing a Rumor That the German Cavalry had Broken through the Lines, Panic Seized the Men and They Ran Like Terrified Children, Many of Them Abandoning Their Rifles

BY HEROIC GIRLS AND BRITISH TOMMIES



Assisted by Men Who Remained Loyal to the Cause, English Officers Attached to the Russian Army are Shown Stopping Retreating Slavs and Forcing Them to Turn and Face the On-Coming Germans



DRAWN BY F. NATANIA FOR THE SPECTATOR, LONDON. COPYRIGHTED IN THE UNITED STATES BY THE NEW YORK HERALD CO.

Although Betrayed by Her Men in the Hour of Need, Russia has Received Marvelous Support from Her Women, Whose Patriotism and Bravery are Destined to Fill a Glorious Page in the History of the Twentieth Century. Above is a Picture That Tells an Inspiring Story without the Assistance of Words and Stock Phrases. It might Fittingly be Entitled "Womanhood"

WITH OUR BOYS IN THEIR TRAINING



It Took a Circus Rider to Master the Nervous Little Broncho That is Entertaining the Crowd at the Side. It was Received by a Massachusetts National Guard Unit and before the Circus Came to Town Succeeded in Sending Four Young Fellows to the Hospital

Thanks to a Group of Admiring Young Women, the Second Battery, Sixth Field Artillery, Stationed at Fort Myer, Now Has a Chummy Brown Cub, "Miss Liberty," as Its Mascot and Overseas Chaperon



TROISIEME LEÇON

Quand l'on dit "Bonjour" on dit "Salut"
Après "Vive la France" on dit "Vive la République"
Après "Mille Bonsoirs" on dit "Bonne nuit"
Après "Bonne nuit" on dit "Bonne nuit"
Après "Bonne nuit" on dit "Bonne nuit"
Après "Bonne nuit" on dit "Bonne nuit"

J'ai le fusil / J'ai le pistolet
Tu as le fusil / Tu as le pistolet
Il a le fusil / Il a le pistolet
Elle a le fusil / Elle a le pistolet
On est en France / On est en France
On est en France / On est en France
On est en France / On est en France
On est en France / On est en France

QUATRIEME LEÇON

Mais quel est le fusil que tu as?
C'est un fusil de guerre.
Mais quel est le pistolet que tu as?
C'est un pistolet de guerre.

On est en France / On est en France
On est en France / On est en France
On est en France / On est en France
On est en France / On est en France
On est en France / On est en France
On est en France / On est en France

PREMIERE LEÇON

Est-ce le fusil?
Non, c'est le pistolet.
Est-ce le pistolet?
Non, c'est le fusil.
Est-ce le fusil?
Non, c'est le pistolet.
Est-ce le pistolet?
Non, c'est le fusil.

On est en France / On est en France
On est en France / On est en France
On est en France / On est en France
On est en France / On est en France
On est en France / On est en France
On est en France / On est en France



Open-Air School at Governor's Island Where Soldiers are being Taught the Language of Pöllu: Intensive Instruction is Given in Conversational French. Apparently Male Tourists after the War will Encounter Embarrassing Questions in Paris if Unfamiliar with "Soldiers' French"

CAMPS HERE AND ACROSS THE WATER



In the Photograph Above, Passed by the Signal Corps Censor, a Group of Veteran Chasseurs Alpines are Shown Instructing a Number of American Soldiers in the Approved Etiquette of the Bayonet, a Weapon They Use Most Proficiently



After a Hard Workout, Lasting from Sunrise until Noon, Many of the Soldiers are Making the Best of an Opportunity for a Brief Nap

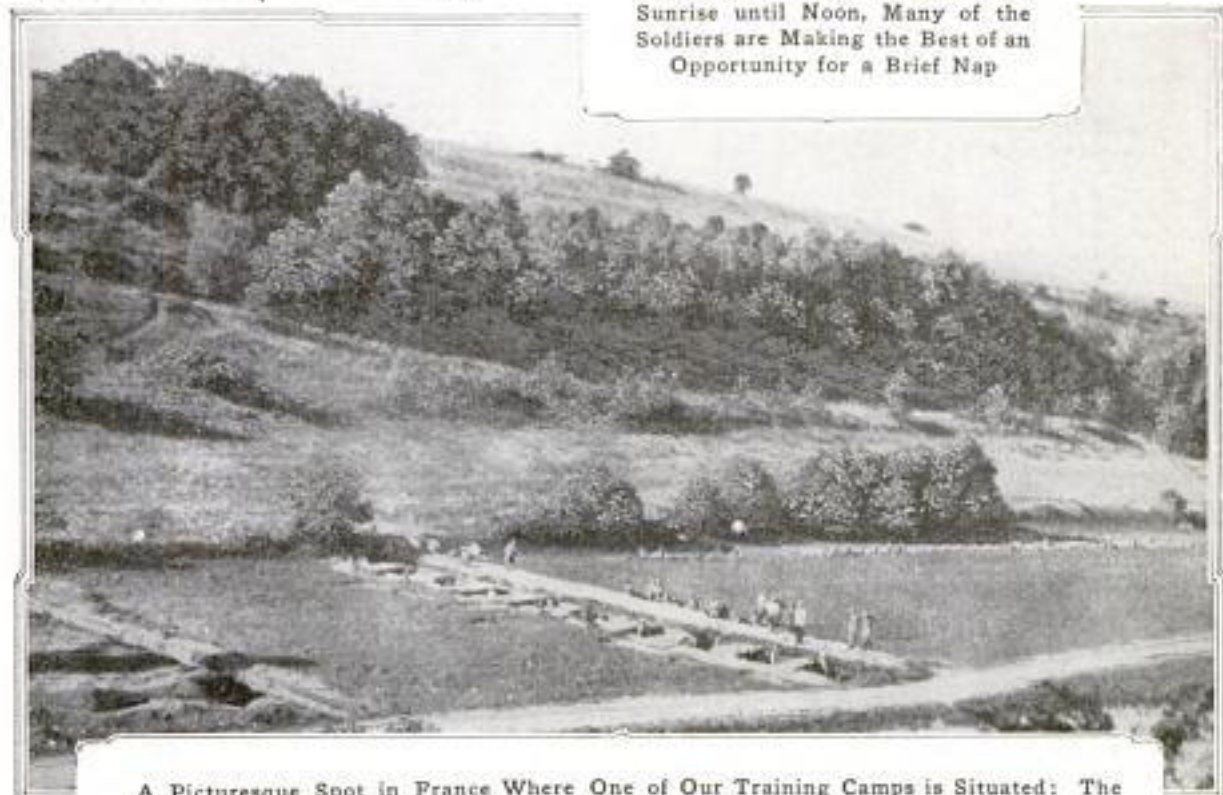

A Picturesque Spot in France Where One of Our Training Camps is Situated: The Picture Shows American Boys Schooling Themselves in the Use of the Hand Grenade While Taking "Enemy" Trenches under the Tutelage of Experienced Fighters. The Photograph has been Passed by the Censor

IN THE WAR THEATER WITH THE GALLANT



COPYRIGHT UNDERWOOD & UNDERWOOD

Under the Best of Conditions the Lot of the Wounded Soldier Is a Hard One, but in the Mountain Regions Where the Italians are Fighting It Is Often Pitiful, Owing to the Difficult Problem of Transportation. Here, Wounded Fellows Who have Marched a Long Distance to Reach the Road are Patiently Awaiting the Arrival of Ambulances



COPYRIGHT UNDERWOOD & UNDERWOOD

The Water Cart Drawn by Sturdy Dogs is a Familiar Sight at the Italian Front. In Many Places the Troops are Entirely Dependent upon These Faithful Fellows for Their Water Supply



At the Hands of the Austrians Some Italian Cities have Fared Little Better than Many of Those in Northern France and Belgium. In This Picture a Detachment of King Emmanuel's Troops is Bivouacked in the Midst of Buildings Apparently Wrecked by Aerial Bombs

ITALIAN LAND, AERIAL, AND NAVAL FORCES



A Speedy Motorboat in the Service of the Italian Navy Patrolling the Coast Line and Maintaining a Constant Vigil for Enemy Fliers: The Craft Mounts a High-Angle Quick-Fire Gun at the Forward End of the Cockpit and Also Supports a Radio Mast. Such Vessels as This One have Proved Valuable throughout the War, and Many of Similar Character are Now Guarding Our Own Waters

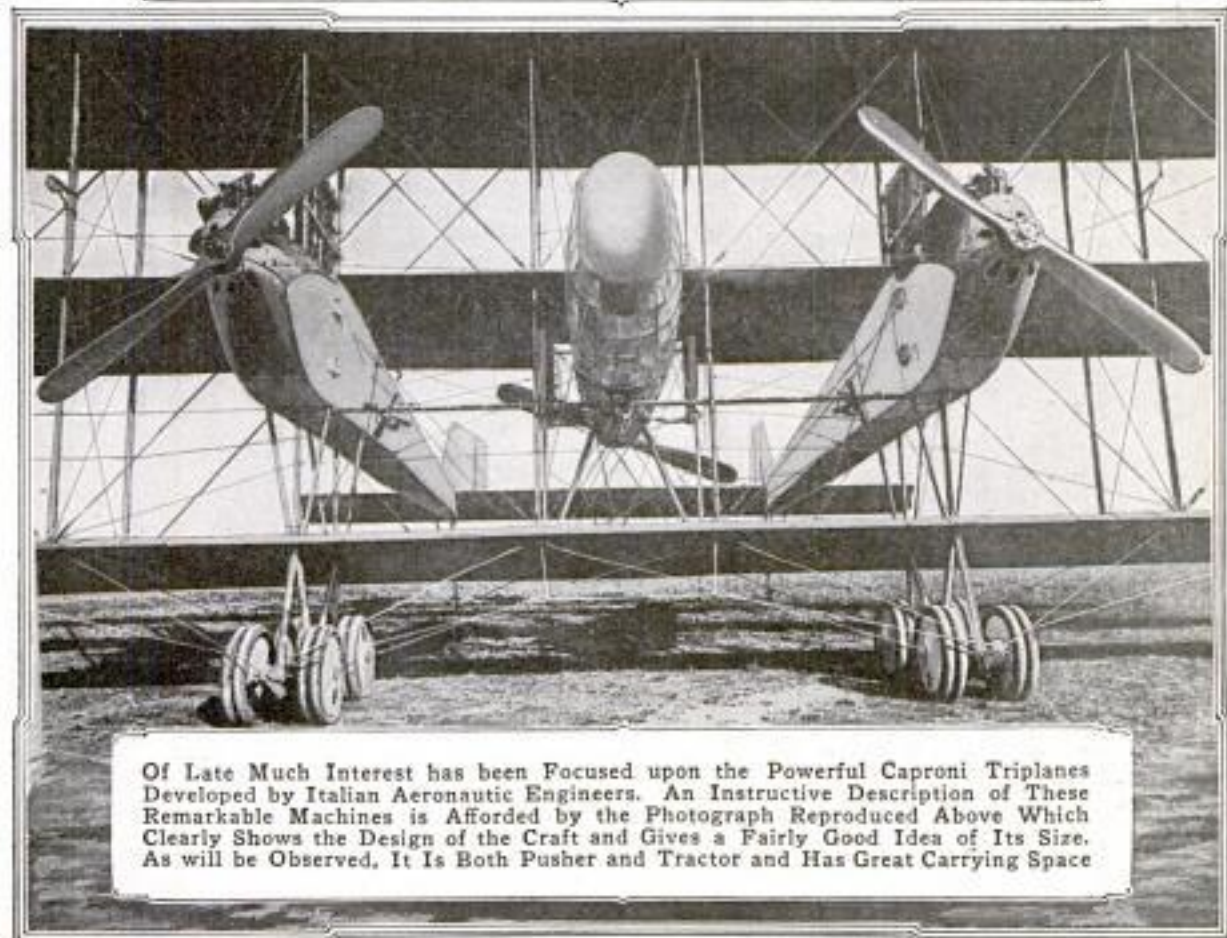

Of Late Much Interest has been Focused upon the Powerful Caproni Triplanes Developed by Italian Aeronautic Engineers. An Instructive Description of These Remarkable Machines is Afforded by the Photograph Reproduced Above Which Clearly Shows the Design of the Craft and Gives a Fairly Good Idea of Its Size. As will be Observed, It Is Both Pusher and Tractor and Has Great Carrying Space

TUBERCULAR PRISONERS GIVEN SUN TREATMENT

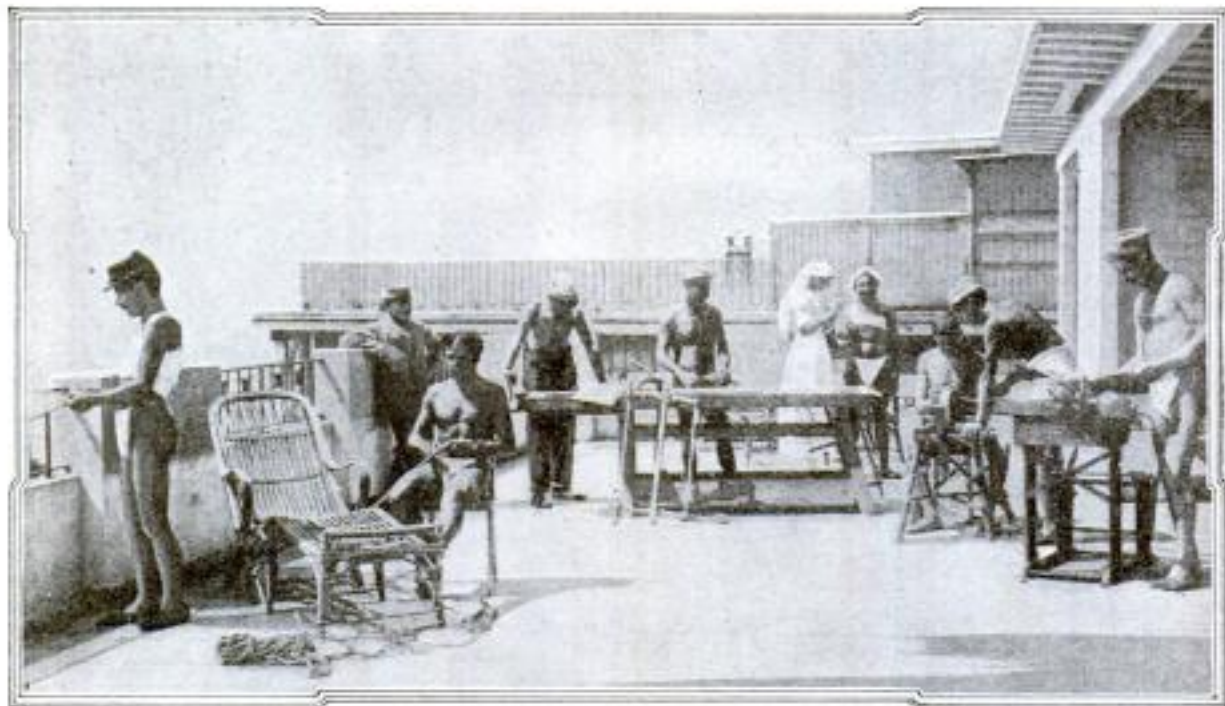

MANY cases of tuberculosis have been found among invalided prisoners of war held in Switzerland. Such men are being sent to the widely famed sanitarium at Leysin for treatment. There, near the Rhone River a few miles above Lake Geneva, the fellows are divested of clothing and exposed to the sun's rays for hours each day. Those who are weak, or prevented from moving because of wounds, occupy cots on roofless balconies. For others, various forms of labor are provided in the open so that they may utilize their energies and fill their minds enjoyably. The photograph above shows a number of the men at work, and that below gives a glimpse of one of the cot-lined balconies.

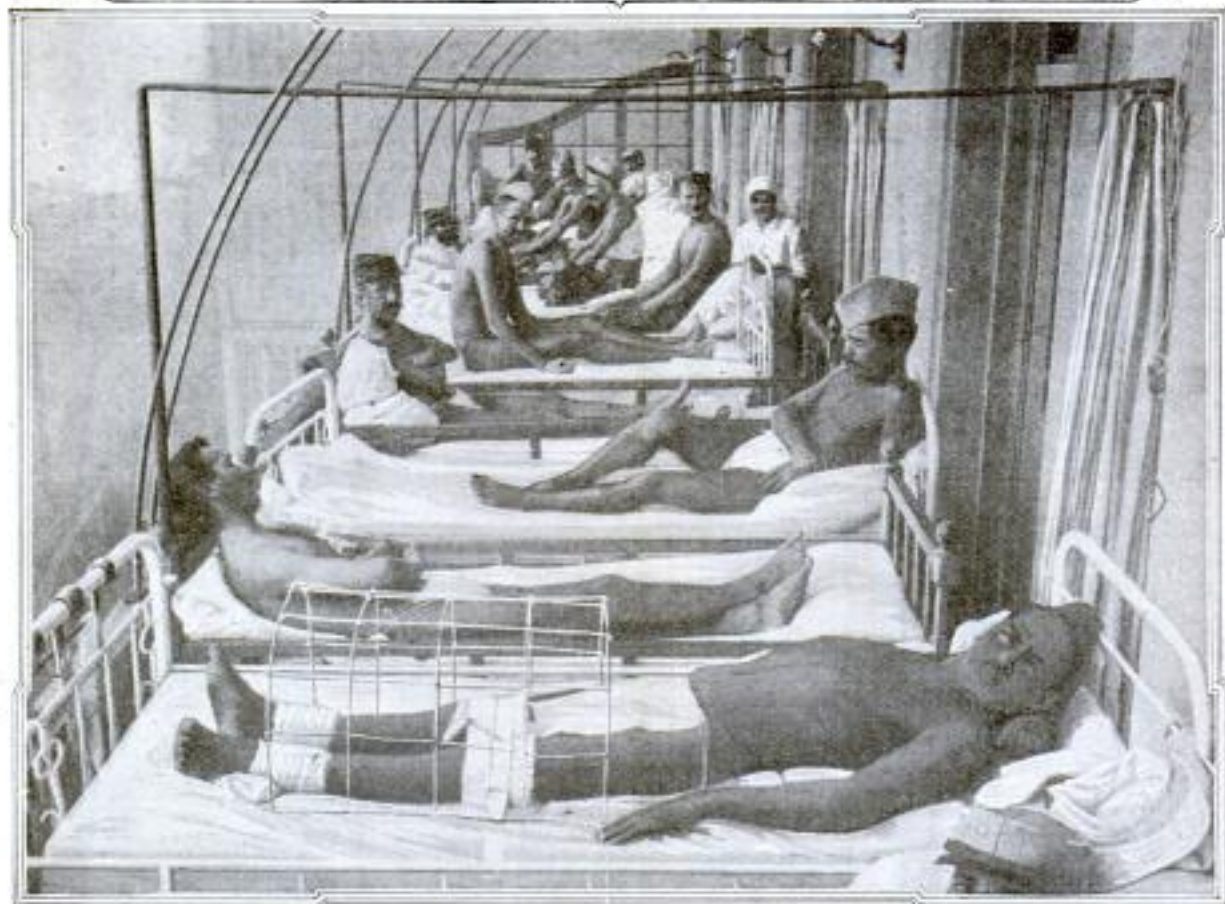

WHERE THE "SPIRIT OF FRANCE" IS UNDYING



FRENCH OFFICIAL PHOTOGRAPH

"A Soldier of France to His Mother," Perhaps, or Possibly a Poilu Posing for the Convenience of a French Official Photographer: Anyway We Get an Intimate Glimpse of Life in a Trench Dugout Where Comforts Are Few and Brave Hearts Many. At the Left will be Noticed a Well-Filled Rifle Rack



Here Is Camouflage with a Vengeance: The Picture is Said to Show a French Communication Trench Covered with Canvas and Verdure to Conceal It from Airmen. To Us It Looks Like the Interior of an Improvised Greenhouse



This Is Not a Pleasure Resort or a Sanitarium in the Strict Sense, but Nevertheless It Is Both. It Is a Camp near the Marne in Which Soldiers after a Trying Turn in the First-Line Trenches are Given Opportunity to Rest for Two or Three Days, Recover Lost Sleep, and Get Glimpses of Something besides Earthen Walls, Sandbags, and Shell Pits. The Narrow-Gauge Railway Carries Supplies to the Front

FRENCH OFFICIAL PHOTOGRAPH

ODD AND STRIKING PHASES OF GREAT WAR



Wheat Destined for France being Weighed at One of the Receiving Depots Established by the Colonial Office in Morocco: The Work is Done under the Supervision of French Army Officers

FRENCH OFFICIAL PHOTOGRAPH

Bearing an Extremely Unwieldy Burden: A Camel Belonging to the British Army's Supply Train in Palestine



FRENCH OFFICIAL PHOTOGRAPH

Bird's-Eye View of One of the Military Camps Established in the Moroccan Wheat Belt to Protect It against Possible Depredation by the Enemy: Similar Posts are Maintained Elsewhere in the Country for a Like Purpose. The Grain Fields of Northern Africa have Been of Tremendous Value to France and the Loss of Their Crops would Prove a Staggering Blow

SHOWN IN PHOTOGRAPHS TAKEN AT RANDOM



Englishwomen at the Front: Showing Two Ambulance Drivers in Service Uniforms at a Shell-Wrecked Church in France: Their Steel Helmets Indicate That They Are in the Firing Zone



The Two Canadian Soldiers are Leaning against One of the Spike-Studded Platforms Used by the Germans during Their "Victorious Retreat" Last Spring to Hamper Pursuit. They were Placed in Trenches and along Important Roads



At the Left Are American Serbs and Croats, Attached to the Serbian Army, at a Training Camp in Tunis: The Arrow Points to Sergeant Flora Sanders, a Young Englishwoman Decorated by King Peter



Preparing Nets with Which to Ensnare German Submarines: The Picture was Taken Aboard a British Boat and Shows Seamen Engaged in Covering Buoys, Used for Supporting the Big War Seines in the Water, with Wire Netting

Used on B. & O. R. R.
bet. Phila. & Wash. D. C.

DECORATED ENGINE HERALDS

5303 PILOT'S PATRIOTISM

What might be termed a patriotic locomotive, a big engine with the stars and stripes liberally emblazoned on it,



Philadelphia-Washington Locomotive Dressed Up with American Flags to Demonstrate the War Views of Its Crew

has been operated between Philadelphia and Washington since our entrance into the world war. At the outset of hostilities, the locomotive was put in one of the company's shops and decorated by an employe of German birth. Old Glory was painted on the front and side of each of the steam chests and large five-pointed stars placed on the cylinder heads.

5357 METHODS OF MANIFOLDING BOOKS FOR THE BLIND

A method of manifolding books with raised letters for the blind, which has recently been brought into use in Europe, possesses special interest because of its simplicity. In this process a sheet of paper is placed between two frames having openings corresponding to the letters to be punched. An oiled, waterproof paper is stretched underneath and the letters are punched with an instrument having some resemblance

to a ticket punch. When the perforating has been completed a sort of pulp containing dextrin, starch, and rubber is spread over the frame. This dries in a short time and, when removed, reveals the letter in relief on one face. With this matrix, printing can be done at home if desired.

NEW PORTABLE MACHINE FOR EXTRACTING GOLD

457 There has recently been put into operation a machine for extracting gold from gold-bearing sand which, it is claimed, allows only a very small fraction of the precious metal to escape. It measures 4½ ft. long, 5 ft. high, and 30 in. wide, and is so constructed that it can be taken apart or put together in a few minutes. With it old beds, as well as new ones, can often be worked with profit. The sluice box consists of two upright end members containing traps, connected by two inclosed sets of riffles, one above the other and slanting in opposite directions. The sides of the machine are of glass so that its working parts can be viewed at all times. No power is required to operate the apparatus, the gold-bearing sand, which has previously been separated from the coarser materials by a screening process, being carried

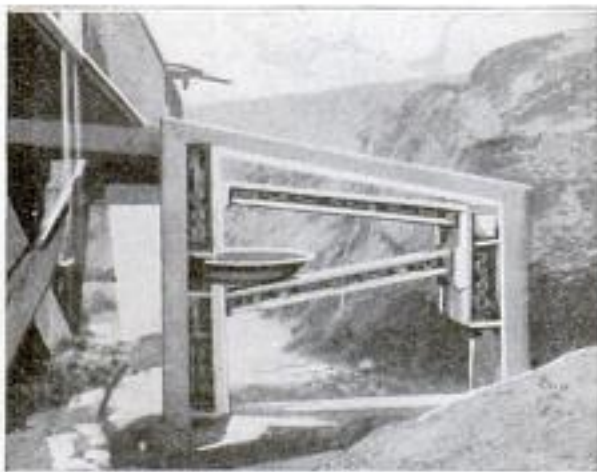

The New Sluice Box Showing the Glass Sides behind Which Are the Traps and Riffles Retaining the Metal

through the various traps and over the riffles by the force of the water. The machine's capacity is claimed to be 200 tons per day.

Inv: H. B. Halling, Pres.
Western Mining
Exploration Co. Ltd. 2015 City Bldg

5310 - Hudson Garage - N.Y.C.

A Four-Story Garage Without Elevators

by Montgomery Evans

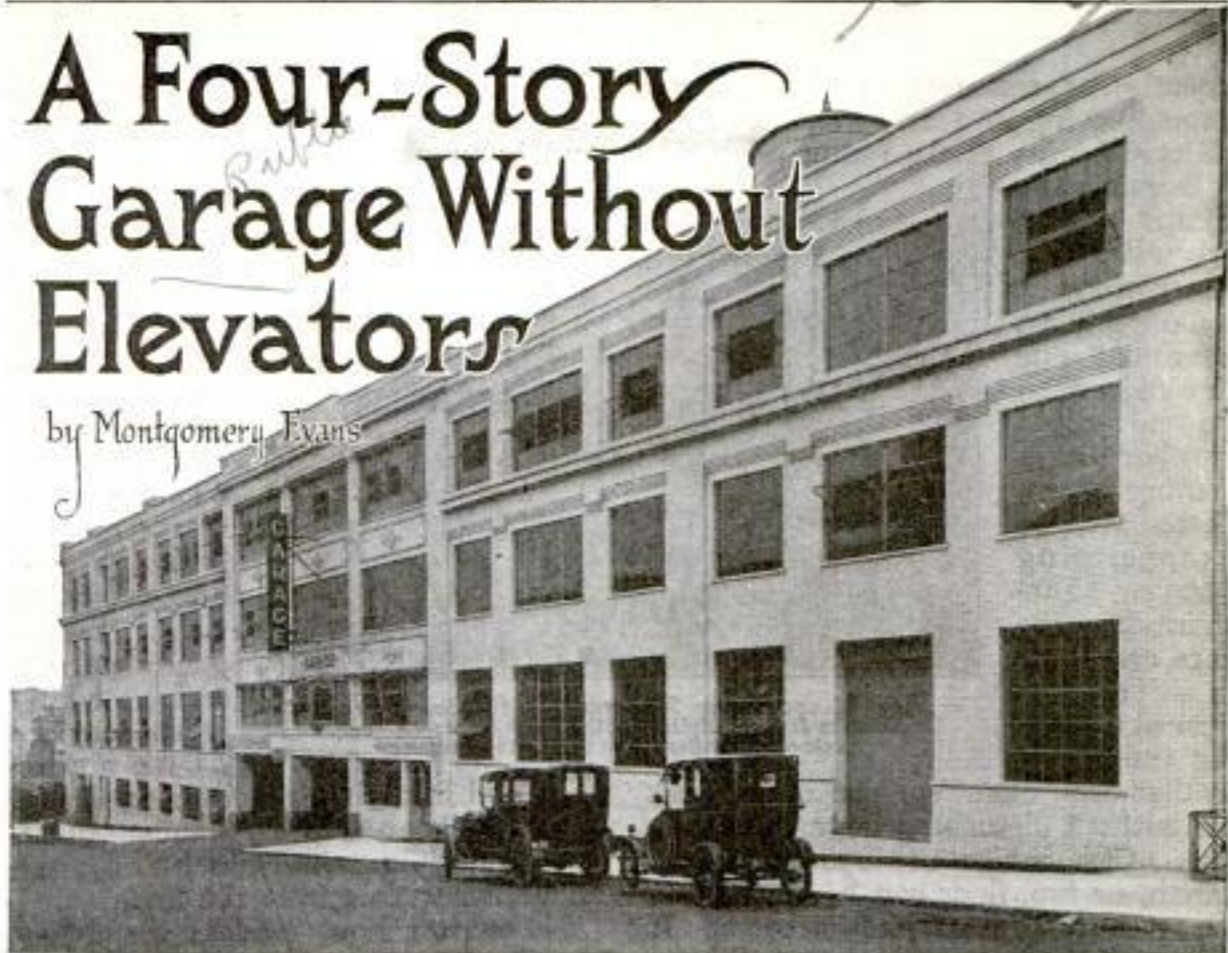

Exterior View of One of the Most Modernly Equipped Garages in the Country: It Has a Capacity for 600 Cars on Its Four Floors and is Provided with Two-Way Inclines Instead of Elevators—an Arrangement That Is Very Convenient for the Patrons and Economical for the Proprietors

A GARAGE which in point of novel features, equipment, and general service outclasses any other in the country, has been recently completed in New York City. Six hundred cars can be accommodated in 164,000 sq. ft. of the total floor area of 205,000 square feet.

Although the garage is four stories high, two-way inclined concrete ramps take the place of elevators and effect a saving of about \$18,250 in annual

overhead expense. The ramps extend from floor to floor of the structure and take up the same amount of space as elevators, but the cost of constructing

them is the only expense connected with them, for it costs nothing to operate them. The architect of the building has figured that the minimum cost of each trip of an elevator is 10 cents and that it would require at least 250 trips each day to serve the 600 cars accommodated. Conse-

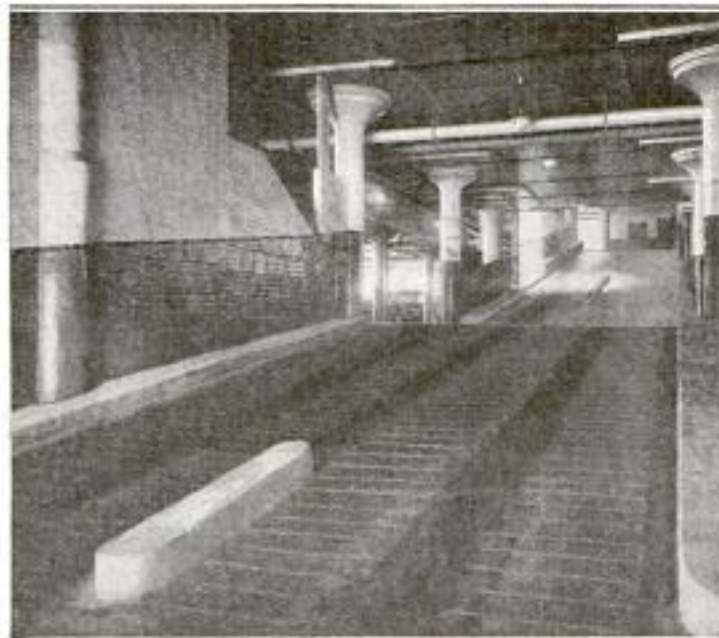

Looking up the Wide Ramps to the Third Floor from the Entrance: These Inclines can Easily Accommodate Two Lines of Cars

quently he calculates that an initial annual saving of nearly \$19,000 will be effected by use of the ramps.

Because the ramps are 18 ft. wide, and therefore wide enough to permit one line of cars to go up while another line is coming down, there are no exasperating delays. Furthermore, the cars are automatically spaced apart on the floors

so that each chauffeur can operate his car without disturbing the cars next to him. Cars which are spaced on the fourth, or top, floor can be brought to the street in from 10 to 15 seconds. It is impossible for machines to collide on the ramps, for concrete guides, or curbs, in the middle of each ramp restrict the cars to separate paths.

The ground floor of the garage is devoted entirely to the storage of cars and is reached by a short ramp, as the entrance is slightly below the street level. The second floor is reached by a short ramp which continues straight up to the third floor, where it turns to the left and continues along the back of the building to the fourth floor. The grade of the inclines is 15 per cent, which is not too steep for the average car to climb on second gear, nor so steep that the average car would have difficulty in descending with poor brakes.

One of the biggest improvements

that has ever been made in garage construction consists of concrete guards and bumpers in the car stalls. Most



A View of the Safety Platforms That Prevent Careless Drivers from Colliding with Other Cars: At the Back of Each Stall Are Concrete Bumpers

up - to - date garages assign the positions of cars by means of whitewash lines, but this in no way eliminates the element of danger of backing into an adjoining car. In the garage described, whitewash lines are done away

with and in their place are substituted concrete boat-shaped islands, 10 ft. long and 49 in. wide, which are raised about five inches from the floor.

No matter how careless the driver may be, he cannot bump into adjacent cars when driving in or out. As each car enters its stall from the aisle it is backed up until its rear wheels strike

the curved end of the island. This guides the car automatically into its correct position, allowing a leeway of from three to four inches one side or other of the car. Thus each car can run into or out of its stall without disturbing its neighbors. The worry of damaging other cars or one's own by the dangerous backing operation is thus entirely eliminated. Near the rear of each island is a concrete bumper, 2 ft. long, 6 in. wide, and 6 in.

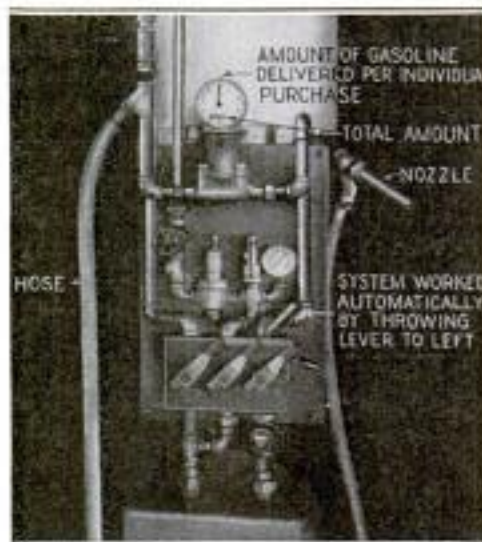

Gasoline is Delivered to Each Floor by Means of Apparatus of This Character, Which Includes a Gauge Showing the Amount of Fuel Supplied to the User

high, which serves as a stop for the rear wheels of the car. The width of the car space is $7\frac{1}{2}$ ft. and the minimum distance between running boards



General View of One of the Floors Showing the Movable Wash Rack Suspended from Overhead Tracks: The Rack is Placed above a Car That is to be Washed and Curtains are Drawn Down from It to Inclose the Automobile so That Near-By Cars will Not be Splashed

is 14 in. All the aisles are 18 ft. in width.

In most other garages, when cars are to be washed, they have to be moved out of their stalls and taken to the washer. In the model garage described a traveling, overhead wash rack is brought to each car. In other words, each car is washed in the aisle directly in front of its confined space. The washing of each car is done as follows: The car is pushed straight out into the aisle, the washer is rolled over, canvas curtains hung from the frames on the sides are pulled down like ordinary window shades to prevent splashing adjoining cars, and the aisle sides are left open for light and air. The hose is suspended from two corners of the wash rack, and there is a light at each corner to illuminate the car, as well as air and vacuum connections. Each square in which the washing is done is provided with a drain and the floor slopes gently toward it. The wash rack itself is merely a wooden frame to carry the hose, lights, and curtains.

For cleaning the interior of cars and polishing them, women are employed. They are said to be more conscientious, more reliable and faster workers than men employed for the same kind of work. They are paid \$2 a day, which is the same salary paid to male cleaners and polishers.

Another noteworthy feature of this new garage is a pressure system for distributing gasoline to various points on all the floors. This eliminates delay and makes for better service in every way. There is also a vacuum system for cleaning the interior of cars. Pipe connections are located on posts and the dirt is drawn to a pump in the basement of the building. Thus dirt is eliminated instead of being scattered over adjacent cars, as is the case in the majority of garages available for automobile owners at the present time.

There are few garages where satisfactory facilities are afforded chauffeurs for doing minor repairs on their cars. In most cases the cramped quarters and the ever-moving stream of

Dr. W. J. Brown
1288 Southern Blvd

864

POPULAR MECHANICS

Brooklyn, N.Y.

cars prevent a man from working on his car. In this new garage there is a workshop on the third floor where cars may be repaired by their owners or by chauffeurs. The room is 42 by 75 feet.

Although the tipping evil is abolished and no commissions are paid to chauffeurs, everything is done to compensate for this lack. There is a reading room, barber shop, billiard and pool room, and lunch counter, all in one unit on the top floor. Big, roomy

lockers are furnished to patrons. Each locker is fitted with a tire compartment, clothes space, robe rail, tool box, and letter box.

To enable the car owner or his chauffeur to examine the soaps, oils, and greases for his car, a testing laboratory, fully equipped with the necessary apparatus, is maintained by the garage. Charges for runabouts and touring cars are \$35, and for inclosed cars, \$40 a month.

NEW PORCELAIN FACING FOR CROWNED TEETH

A porcelain-jacket crown for a tooth is commonly preferred to a gold crown, particularly if the artificial member is conspicuously located, but the former is costly and difficult to mount. As a substitute for the common type of porcelain-jacket crown a dentist has invented a porcelain facing that can be easily fitted to a metal jacket set on

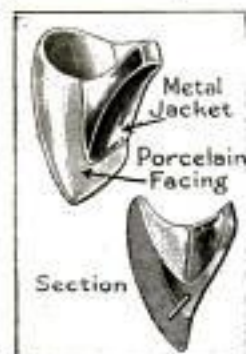

the natural tooth. Each of these new facings is provided with four depressions on its inner surface and protruding near the cutting end is a T-shaped anchor. After a facing of the desired color and shape has been selected it is held next to the tooth to be crowned while a wax jacket is fashioned around the latter, the wax filling the depres-

sions in the facing and inclosing the anchor. Then the facing and wax jacket are removed and placed in a plaster mold, after which the wax is melted and metal poured in its place. In this comparatively simple manner a perfect-fitting jacket, with a well-matched facing, is produced.

SERIOUS RAILROAD WRECK 5-288 NARROWLY AVERTED

While a passenger train on a trans-continental line in Minnesota was endeavoring to make up for lost time, the front truck of the engine tender jumped the tracks and ran along the ties for about 1,500 feet. What probably would have been a far more serious accident was averted by the fact that the engine and tender finally broke loose from the cars and the latter came to a stop while still on the track. Had they been drawn much farther they might have been derailed and plunged into a ravine close by.



Left: Railroad Bridge Showing Rut in the Sheet-Iron Covering Made by a Derailed Tender Truck. Right: This Photograph Shows the Point at Which the Cars Came to a Stop After the Engine and Tender Broke Away from Them; had This Not Happened the Whole Train Might have been Plunged into a Ravine

Great Goodies, All

Isbury, Meant
Copyrighted material



Once an Unsightly Gravel Pit—Now a Municipal Outdoor Theater That Is a Benefit and Pleasure to the Entire Community

5147 CITY EYESORE TRANSFORMED INTO GREEK THEATER

It has remained for a progressive little city in the West to find a real use for an abandoned gravel pit and convert it into an attractive institution of benefit to the whole community. It was discovered that a large excavation in one side of a hill situated in a public park at Pomona, Cal., had excellent acoustic properties, and a movement was subsequently launched to employ it as the site for an open-air theater of classic design. The scheme was carried out at a cost of about \$20,000 and all of the amount was raised by subscription. Reinforced concrete was used in the construction of an imposing stage 140 ft. in width and 40 ft. deep. In front of it is an arena, rising above which are crescent-shaped tiers of seats that accommodate, at present, 2,500 persons. Provision is to be made soon for additional seats so that approximately 15,000 individuals can attend the outdoor entertainments that are given at fairly frequent intervals during pleasant weather.

5184 REVOLVING ROCKING CHAIR FOR CAR OR HOME

A rocking chair which revolves on a circular base has been invented for use either in railway chair cars or the home. The rockers are fastened by coil springs to the upper half of a turntable which resembles a fifth wheel. The lower half is bolted to the floor of the car or to a movable base, accord-

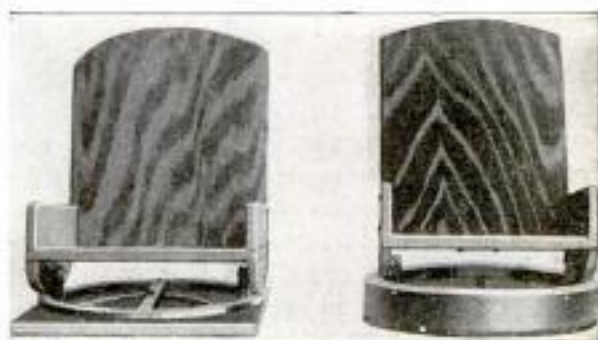

Two Designs of a New Revolving Rocking Chair: The One on the Left Is for a Chair Car and the Other for Home Use

ing to the place in which it is used. If desired, ball bearings can be employed, permitting the chair to revolve more easily.

Wm. E. Albion
 45 Clark St.
 Paterson, N. J.

Mrs. Mary S. Cook,
Cambridge, Mass.

866

CONVENIENT CORNER FOUND IN WELL-PLANNED KITCHEN

4966 One housekeeper who makes her white-enameled kitchen an inviting



An Arrangement That Saves Steps and Time
in Doing Housework

culinary laboratory instead of a hot, stuffy workshop, has planned a sunny corner of the room most attractively. Between two windows, and placed several feet above the floor, is a built-in bookcase in which a small library of cookbooks, menu calendars, and useful magazines is kept behind glass doors ready for reference. Beneath is a closet in which sewing is kept. The top of this compartment forms a convenient shelf for bread jars, a toaster, and other things. A comfortable rocking-chair stands adjacent. The corner not only offers a pleasant place to rest occasionally, but also saves time and steps. The next day's meals may be planned, or a bit of sewing done, during odd moments that might otherwise be wasted. In this manner the maximum is accomplished with a minimum of effort.

☞The German state railways are in serious straits, according to press dispatches, because of a fuel shortage and to curtail traffic heavy excess fares on express passenger trains are being levied.

571 SIDECAR DE LUXE EQUIPPED FOR CAMP OR WAR USE

A sidecar de luxe for motorcycles, which serves equally well as the usual carrier for two passengers, as an ambulance, or as a very complete camping outfit, has been designed by an English inventor. It consists of an attractive metal body divided into three compartments. In one there is room for two passengers. Another, at the front end, consists of two lockers, and the third occupies the lower portion of the car and is equipped with a special removable case, or portmanteau. This container is composed of two halves hinged together in such a way that they can be opened out to form a table suitable for emergency use by a surgeon. One portion contains drawers in which supplies may be stored, and blankets or clothing may be kept in the other half. A small folding table, together with the two camp

chairs that are provided to support the case, are carried strapped to the rear of the body.

The sidecar is provided with a folding top, while the rear of the car is so made that it can be let down to permit the loading or unloading of a patient. A stretcher, with wheel supports, which folds up and is carried inside the body, is a part of the outfit and on camping trips serves as one of three beds, the other two being the portmanteau and the sidecar itself, which has removable upholstery that is covered with leather on one side and with cloth on the other. This serves very satisfactorily as a mattress. Another important article provided with the car is a thoroughly waterproof tent with a frame composed of telescoping parts. It measures 14 by 10 ft. and is divided by a curtain into two rooms.

Inv: F. W. Mercer

177 Concord Rd. Mass. Made in England



An Elaborately Equipped Sidecar That is Well Suited for Ambulance Service, as Shown Above and at the Left; In the Latter View a Patient can be Seen Lying Full Length in the Car. The Stretcher, Which is of the Folding Type with Wheel Supports, is a Part of the Outfit

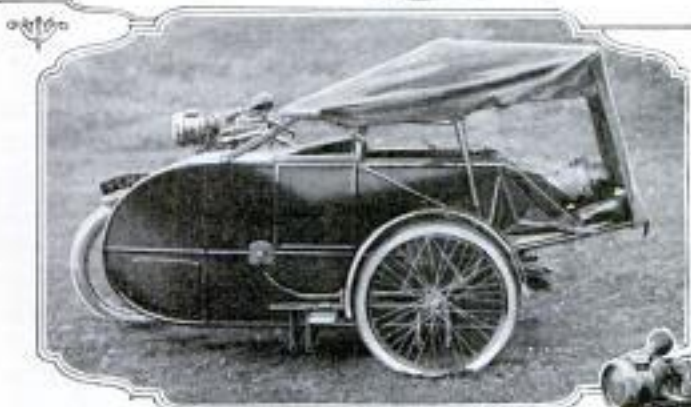

Though Only One Passenger is Shown in the Sidecar as Pictured at the Right, It Has Ample Accommodations for Two. The Fact That a Baby can be Carried Comfortably in the Bottom of the Compartment near the Front End, Makes the Outfit Particularly Desirable for Family Outings



At the Left, the Portmanteau has been Set Up to Serve as an Operating Table. The Drawers may be Used by a Surgeon to Hold His Instruments, or by Campers for Storing Supplies. The Camp-Chair Supports and the Camp Table are Carried Strapped to the Rear of the Car

Thoroughly Waterproofed Material is Used in Making This Tent, Which is Carried as a Part of the Outfit. It Measures 10 by 14 Feet and the Frame is Composed of Telescoping Parts That can be Packed into Small Space. A Curtain Divides the Tent into Two Rooms. At the Right the Portmanteau is Shown Standing on Edge. The Capacity of the Car is Sufficient to Carry All the Utensils and Bedding Necessary for Camping Out



mfg. The Moore Electric Corp.
648 - 20th Century Bldg.
 868 *Chicago*

POPULAR MECHANICS

POWER-DRIVEN CLIPPER NEW

520 **BARBER-SHOP ACCESSORY**

LIGHTNING BREAKS DISH

522 **HOLDING STEEL BEADS**

Hair cutting by electricity is a barber-shop innovation that has lately made its appearance. The equipment



employed consists of a power-driven clipper that is intended to displace the time-honored shears. Better and quicker work is claimed to be the advantage gained by installation of the apparatus, which has already been adopted by a number of high-grade tonsorial emporiums in

large cities. An enameled-iron stand with cross arms at the top for supporting the motor, and also the clipper when it is not in use, is supplied as a part of the outfit. Power is transmitted by a flexible shaft of sufficient length to afford freedom of action for the barber. When desired, the clipper may be disconnected from the shaft and a vibrator attached in its place.

Because of the scarcity of leather, Dutch military authorities are to experiment with army shoes having wooden soles.

During a recent thunderstorm in New York state surprise and wonder were caused in a certain home by an unusual accident that accompanied a sharp bolt of lightning. The latter struck very close to the house in question, causing the telephone to "snap" so that those in the room heard it distinctly. Following this report a glass dish containing some steel beads, standing on a table about 12 feet from the telephone, broke into pieces, scattering the beads on the floor. The apparent explanation for the phenomenon is that when the lightning caused the spark at the telephone there was a discharge of electricity into the room and that the beads, being of polished steel with numerous sharp edges, offered a path of least resistance to the discharge, which, seeking a ground, burst the dish.

ALL-STEEL CHURCH HOUSES MEMBERS TEMPORARILY

An all-steel church edifice is a novel, but serviceable, religious structure that has been built in Detroit to house a congregation temporarily. The walls are of steel panels which interlock in an ingenious way so that they can be taken apart readily when this building is moved to make room for a permanent sanctuary. The doors, window sash, and roof are also of steel. The interior is well lighted and has an attractive appearance. The exterior is painted light gray.



An All-Steel Church. Built for Temporary Use: Its Walls are Composed of Interlocking Panels Which can be Readily Taken Apart When the Time Comes to Move It to Make Room for a Permanent Structure

Grace Episcopal Church
Detroit Mich

4968



Thirty or More Persons may be Carried Comfortably in This Big Bus, Which Embodies a Number of Interesting Safety Features



The Bar Prevents Operation of the Gear-Shift Lever When the Door Is Open



A Glimpse of the Seating Arrangement is Given by the Picture in the Lower Left-Hand Corner. In the Middle, the Door is Shown Closed with the Steps Swung beneath the Car, While at the Right the Entrance Is Open.

SAFETY-FIRST MOTOR BUS USED BY LAND FIRM

Seating space for 30 or 35 persons is provided in a motor bus used by a real-estate firm for conveying prospective purchasers to and from tracts of land that are being marketed. The vehicle was especially designed for this purpose and embodies a number of interesting features. The arrangement is such that practically all the available space is utilized without cramping the passengers. Cross seats wide enough for at least three persons are spaced along one side of the car. On the opposite side a long seat extends from the front and rounds the rear. Between the two is an aisle that gives access to the exit, which is immediately behind the driver's seat. The door and the steps leading to it are operated simultaneously by means of a lever. Except when the former is open, the steps are beneath the machine, out of the way. In the interests of safety, a mechanical connection has

been made between the door and the gear-shifting lever so that the car cannot be started until the exit has been closed, or the latter opened while the machine is in motion.

NEW TESTAMENT IN KHAKI 57¢ FOR FIGHTERS

Through the efforts of the National War Work Council of the Young Men's Christian Association, a million copies of a special army and navy edition of the New Testament are to be provided for American boys composing our fighting forces. The volumes are of pocket size and neatly bound in khaki so that they will withstand a certain amount of exposure and may be carried conveniently, whether the soldier is in camp or in the trenches.



COPYRIGHT, AM. PRESS ASSN.

The Auto Speed Recorder Co
3034 N. Highland Ave. Chgo.

4713

MOTOR-CAR SPEED RECORDER KEEPS PERMANENT RECORD

For motor cars a permanent-record speed and mileage register has been developed which has features of inter-

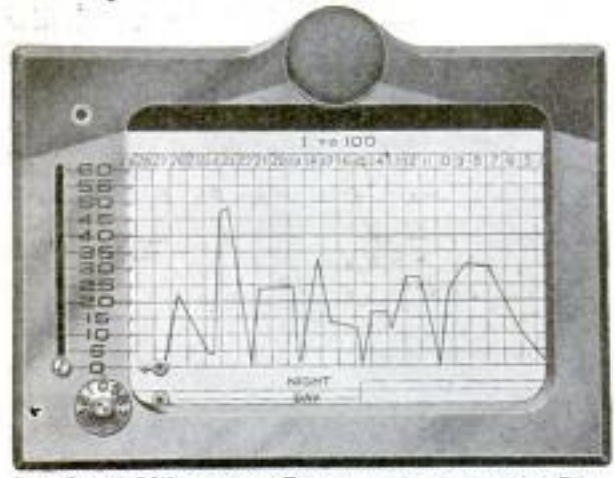

Speed and Mileage are Permanently Recorded, Day and Night Driving Differentiated, and the Maximum Speed Controlled by This Register

est to drivers. The distance traveled and the rates of speed at which a machine proceeds while covering the mileage, are registered on plotting paper by a stylus. In a similar manner day and night driving is indicated. The perpendicular lines on the record sheet indicate miles of travel, while each horizontal one measures speed in multiples of five. The roll is of sufficient length to record trip and season mileage to 5,000, and at all times enough of it is visible to show the record for the 25 miles last traveled. By setting an indicator, the maximum speed may be limited to any desired rate, and when this is reached, ignition is automatically cut off and a warning bell sounded. The instrument offers employers an opportunity to keep a constant check on the drivers of their delivery and service cars, and also to prevent speeding.

4967

PLAN OF LIBRARY ADAPTED TO ODD SLOPING SITE

A branch public library has been completed in a suburban district of Los Angeles, in the building of which unusual architectural and landscape problems were solved. The site se-

sloped at one side toward the lower street. The entrance walk extends from the front of the building down to the street intersection, ending in circular steps which take up the slight difference in street levels at that point. An auditorium on the lower library floor has a rear entrance level with the lower street. The doorway, with sloping lawn on either side, is partially hidden.



Front View of Library Showing How Circular Steps in Foreground Take Up the Difference in Street Levels: Note That the Building's Plan Conforms to the Shape of the Lot

lected was V-shaped being bounded by two converging streets, one of which slopes downward from the intersection past the site, while the other slopes upward past the site. The building faces the point of the lot and is surrounded by a lawn which has been skillfully leveled in front and



Rear View Showing the Street-Level Entrance to the Library Auditorium: The Steps on the Far Side Lead to the Higher Street Level

Location:
Carvanca, Highland Ch. Los Angeles
Calif.



Showing Propeller and Hub, and Indicating Position of One Pin



Above, the Blades are Set at a Pitch of Four Feet Eight Inches



High Pitch, Showing Collar in Different Position than at Left



By Turning the Screw the Collar is Shifted and Pitch Changed

PITCH OF PLANE PROPELLER

4913 REGULATED IN FLIGHT

In an attempt to increase flexibility and efficiency, an adjustable-pitch propeller has been developed for aeroplanes. Both block and flying tests have been conducted and satisfactory results reported. Complicated construction has been avoided and positive control provided. A pilot can change the propeller pitch while in full flight and thus make compensation for whatever atmospheric condition is encountered. He accomplishes this even more easily than a motorist shifts the transmission gears of his car. In purpose and effect the two operations are practically analogous. Accurate adjustments are made by turning a screw which moves a collar mounted on the propeller shaft forward and backward. The angularity of two pins, which are hinged to the latter member and pass through holes in the bases of the propeller blades, is changed in this manner. Since the blades are mounted on roller bearings in the opposite ends of an aluminum hub, they are directly affected by changes in the angularity of the pins. When a plane is navigating in heavy atmosphere at a low altitude one minute, and soaring in thin air at a high elevation a few minutes later, different propeller pitches can be used and the motor protected from severe strains.

MAMMOTH ARMCHAIR MADE

5744 OF PAPER FIBER

The mammoth armchair shown in the accompanying illustration was built for advertising purposes and is made of twisted paper fiber reinforced with steel cores. It stands 7 ft. 2 in. high,



An Armchair, Seven Feet Two Inches High, Made of Paper Fiber Reinforced with Steel Cores

and the cretonne cushion is 4 ft. square and 6 in. thick. The boy scout standing in the chair is 4½ ft. tall.

**TRACTORS REVOLUTIONIZE
DESERT MINING**

Perhaps nowhere has transportation by motors brought greater changes than in desert mining. Rich fields which have long lain idle, or nearly so, because of the almost insuperable difficulties of carrying supplies and ore, have suddenly been transformed into scenes of big-scale industry by the coming of motors and tractors. The con-

trasted belts which enable the machines to pull through the sand without sinking. In many districts such trains make trips to and from "civilization" on a regular schedule.

**RED CROSS SCHOLARSHIPS
FOR TRAINED NURSES**

The Red Cross has recently offered a number of scholarships to qualified nurses for an eight months' course in public-health nursing. It is pointed out that thousands of nurses are ready and willing to respond to a call from the Red Cross for war service, while comparatively few are prepared for constructive community health work, so important in conserving the interests of the home. It is particularly difficult to obtain



The Old Way: Eight Burros and Two Pack Animals Which can Carry Perhaps Two Tons 10 Miles per Day across Hot Desert Sands

women with adequate hospital training who are willing to go to the smaller communities. The scholarships, which are valued at \$250 each, have been donated by various organizations and schools in eastern and middle-western states. The Red Cross offers to supplement the scholarships with loans of an equal amount. An appeal is being made to various local bodies to encourage nurses to enter this important but neglected field. Women engaged in the town and country nurs-

trast in transportation methods is strikingly presented in the accompanying photographs. The outfit with the team of eight burros and two pack animals is typical of a day that is passing rapidly. With it a miner could transport but two tons of ore across the hot sands of the desert, traveling only about 10 miles per day. Instead of such primitive means has now come the tractor, hauling trailers which can carry 25 tons 20 miles per day. The rear wheels of these engines operate in endless cor-



The New Way Which has Made Possible the Development of Many Desert Mining Fields: A Tractor and Its Trailers can Carry 25 Tons 20 Miles per Day

ing service, as this branch of Red Cross work is called, are not subject to call for other Red Cross duty outside their community.

scoping tubes of steel fitted with aluminum sockets at the belt. They are

NEWSBOYS ERECT PYRAMID TO FRIEND'S MEMORY

5243

Unusual interest attaches to a massive pyramidal monument which was recently dedicated in a Toledo, Ohio, cemetery to the memory of a man long known in that city as a friend of the newsboys. As a testimonial of their regard the paper sellers, together with school children and many of the deceased man's admirers throughout the world, contributed the stone from which the monument was constructed



COPYRIGHT, INTERNATIONAL FILM SERVICE
British Soldiers Wearing Recently Designed Steel Crutches Which are Hinged to a Broad Belt Worn Just above the Waist

designed to give the wearer greater freedom in using his arms.



Recently Dedicated Monument in Toledo, Ohio, Constructed of Stone Contributed by Newsboys as a Tribute to Their Friend Who Lies Buried Here

and also funds for building it. At the dedication exercises the mayor of the city and other citizens made addresses.

SUN SCREEN FOR BEACH USE HAS CONVENIENT FEATURES

Excellent for those who frequently motor to the beach to spend an afternoon on the sand and in the surf is a collapsible sunshade that folds into a compact, flat parcel, small enough to be stowed in the tonneau of a car. The striped canvas that forms its tent-shaped top is held on spring rollers so that it may be disposed of like an ordi-



The Canvas Covering of This Beach Screen is Mounted on Spring Rollers Like Those of Window Shades

NEW CRUTCHES FASTEN

5038

TO WEARER'S BELT

Wounded British soldiers have recently been provided with crutches of a new type which represent a decided departure from those commonly in use and are believed to possess special advantages. Instead of resting in the arm-pits, these artificial supports are hinged at either side of the body to a broad leather belt worn slightly above the waist. The crutches consist of tele-

nary window shade. Since it is provided with four legs, it holds its own quite well in a strong breeze.

*Swanwick Patent & Co. Inc. Copyrighted material
Los Angeles Calif*

5228 - War *St. Douglas, Utah.*

A PRISON CAMP FOR ENEMIES OF OUR COUNTRY



The Group of Prisoners Shown Above are Engaged in Carpenter Work for a Y. M. C. A. Building Which is Designed to be a Combined Theater, Music Hall, Gymnasium, Chapel, and General Assembly Room



Dishes Ready for the Noonday Meal are to be Seen on the Left; Bread from the Same Oven That Supplies the Soldiers in a Near-By Camp Goes Also to the Prisoners. The Variety of Vegetables is Large

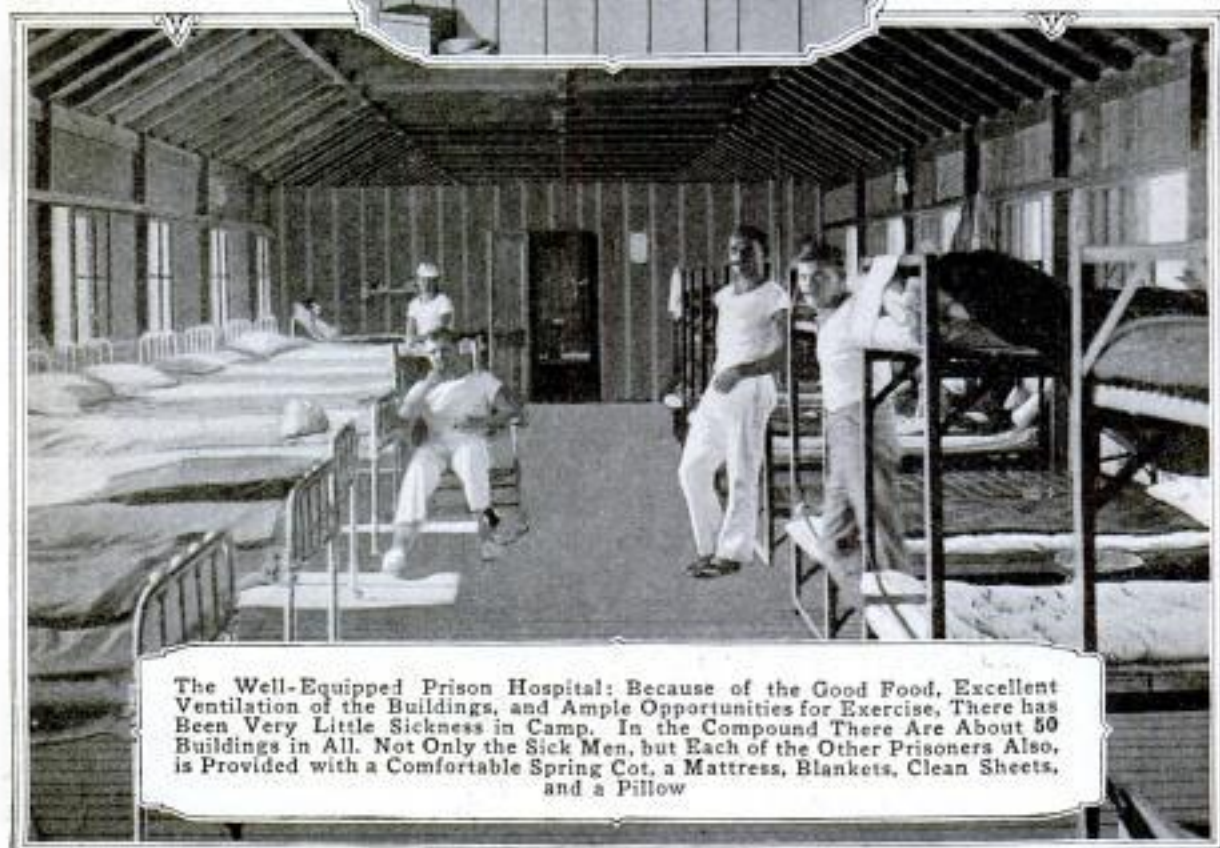

The Well-Equipped Prison Hospital; Because of the Good Food, Excellent Ventilation of the Buildings, and Ample Opportunities for Exercise, There has Been Very Little Sickness in Camp. In the Compound There Are About 50 Buildings in All. Not Only the Sick Men, but Each of the Other Prisoners Also, is Provided with a Comfortable Spring Cot, a Mattress, Blankets, Clean Sheets, and a Pillow

IN WHICH NO "FRIGHTFULNESS" IS TO BE FOUND



A Street Scene in the Prison Camp at Fort Douglas, Utah, Where 320 Prisoners from the Commerce Raider "Cormoran" and about 60 Alien Civilians are Confined: Here can be Seen Some of the Little Fences Made by the Men from Scraps of Lumber to Inclose Their Beds of Flowers and Vegetables. As These Pictures Help to Show, Principles of Humanity Govern the Treatment of the Men



On the Left Is the Camp's Octagonal Bulletin Board, Resembling a European Kiosk, on Which are Posted Official Notices, Censored News Clippings, and Contributions by Prisoners



A Mess Hall in the Camp: The Men are Given Plenty of Wholesome Food, Including Vegetables They have Raised and Fresh Meat Issued in the Same Rations as to Our Soldiers. German Cooks Belonging to the Interned Crew Prepare the Meals. The Officers of the "Cormoran" Have Quarters Separate from the Men and the Routine of Camp Discipline is Maintained Largely through Them



One of the Few Inmates in the Camp Hospital—and He so Well He is Able to Weave Souvenirs during Odd Moments: The Hospital is in Charge of the "Cormoran's" Surgeon, and under the Supervision of Our Own Medical Officers. When Advisable, Special Diets are Provided for the Sick

*Los Angeles Bureau of
Power & Light. - L.A. Calif.*

876

POPULAR MECHANICS

METER TRUCK SIMPLIFIES 5 94 WORK IN LIGHT PLANT

Increased efficiency in the electrical department of a municipal light and

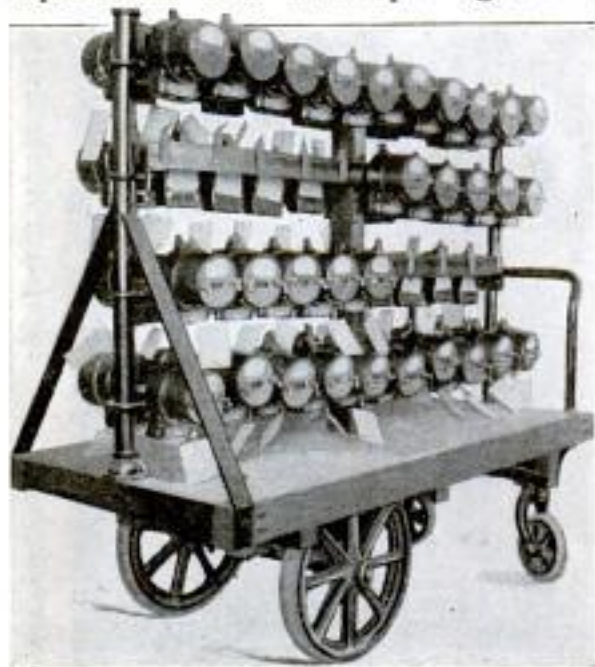

A Truck Designed by an Electric-Lighting Plant Superintendent Which Enables One Man to Move a Number of Meters Quickly and with Little Risk of Getting Them Out of Order

power company has resulted from the use of a truck designed by the superintendent for carrying electric meters. The carrier is pushed by hand, has four rubber-tired wheels, and supports a steel rack with four crosspieces, on each of which 20 meters can be securely hung. The delicate instruments when transported in this way are less apt to get out of order than when carried about the plant in boxes, as is frequently done. It is obvious, too, that one workman can transport a large number of meters on this rack quickly and with little effort.

5259 GOVERNMENT TO RE-EDUCATE OUR WOUNDED SOLDIERS

Our soldiers and sailors who may be maimed in this war are to be cared for more scientifically than has ever been attempted in previous conflicts, thereby showing that we have advanced not only in methods of fighting, but also in our conception of the nation's obligation to those who fight for

it. In other wars wounded soldiers were kept in army hospitals until their wounds healed and then released to shift for themselves, aided by such pension money as they might obtain from congress. Now the government proposes to equip and reeducate every wounded man, after healing his wounds, so that he can return to a useful civil life. The best that surgery and the science of education have to offer will be employed in his behalf.

The first step in this splendid program will be the erection of "reconstruction hospitals," sites for which have been tentatively chosen in a score of large cities. Workshops will be provided in the hospitals where the convalescent soldiers' weary hours may be made more bearable and in some cases financially profitable. In addition, arrangements will be made with outside industries where more elaborate training can be carried on, and an employment bureau will be established to place these trained men in various parts of the country.

HOUSE MOVING IN JAPAN

5 174 A SIMPLE PROCESS

House moving as practiced in rural districts in Japan is a far more simple procedure than it is in America. If an owner of one of the little houses typical of Japan's agricultural regions decides to change its location, it is only necessary to call in a score of neighbors, or as many laborers, and they will accomplish the task in short order, carrying



A Group of Natives in Japan Moving One of the Simple Houses Which Are Common in the Rural Regions of That Country

off the whole of the habitation on their shoulders, and incidentally illustrating an attractive aspect of the simple life.

5-169



COPYRIGHT, INTERNATIONAL FILM SERVICE

AT WORK ON HISTORIC FRIEZE IN CAPITOL

AN historical frieze, begun in the rotunda of the national capitol years ago by men no longer living, is now being completed by a well-known American artist. The railed platform shown here is suspended from the rotunda balcony, giving the artist access to the wall on which his predecessors have pictured scenes of early historic events. It is interesting to note that the additions now being made, subject to the approval of Congress, give generous recognition to American engineering and commercial achievements. Among the subjects treated are the application of steam to travel, the building of the Panama Canal, the harnessing of electricity, and the development of the modern battleship and aeroplane.

415' LOCOMOTIVE DESERTED FAR FROM RAILROAD

When a western river overflowed some time ago and flood water washed away \$15,000 worth of track, a small locomotive that had been used in railway-construction work was marooned in a desert. Recovery of the engine will not be attempted, for its value is less by several thousand dollars than the cost of re-laying the rails to it. The locomotive has been stripped of some of its parts and abandoned. It presents a singular

appearance, standing forlornly as it does, away from all vestige of habitation.



Abandoned Locomotive in Western Desert: It Is Too Far from a Permanent Railroad Line to Make Its Recovery Financially Practicable

Geo. Ayer & Lepple, Salt Lake City, U.S.A. Copyrighted material

5/15
SEE CAP

POWERFUL STUMP PULLER

OPERATED BY ONE MAN

An excellent feature of the powerful stump puller shown in the accompanying illustration is that it can be oper-

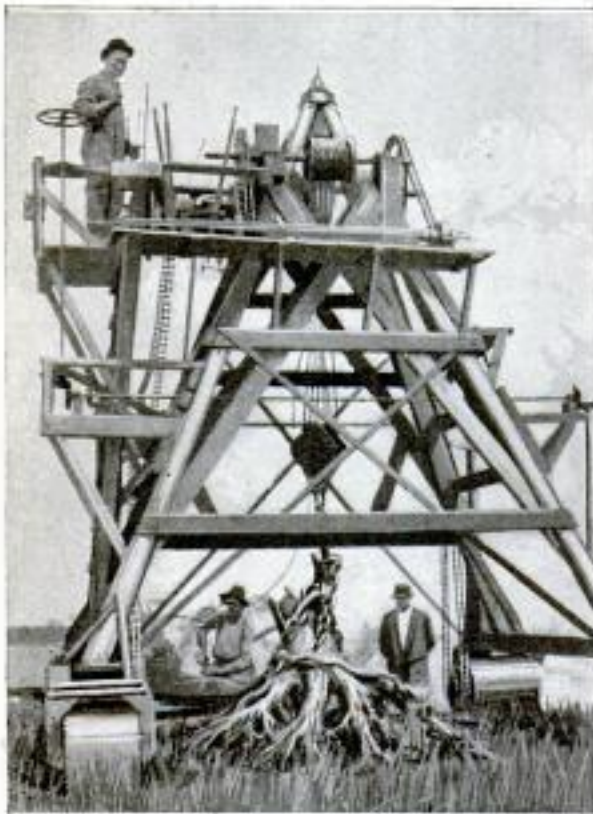

Powerful Stump Puller Which can be Driven and Operated by One Man: Not More Than Five or Six Minutes are Required to Set the Machine and Extract a Stump

ated by one man who stands on a platform near the apex of the pyramidal wooden framework, some 15 or 18 feet above the ground. The machine is

mounted on four broad-tired wheels and is driven by a gasoline engine that is also used to operate the block and tackle provided for pulling the stumps from the ground. The operator from his high platform steers the machine like an automobile, moving with fair speed from place to place. Not more than five or six minutes is required to set the outfit over a stump and extract it. The fact that the apparatus exerts a pull straight upward instead of sideways enables it to remove a large proportion of the roots.

5/15

SEVEN-PASSENGER LAUNCH A SPARE-TIME PRODUCT

The seven-passenger gasoline launch pictured in the accompanying illustration shows what an industrious carpenter with some mechanical ability was able to construct for his family's pleasure with a very small cash outlay. The craft was built during the owner's spare hours, three weeks being required to complete the 22-ft. wooden hull. A satisfactory gasoline engine was constructed from parts secured at junk shops and secondhand machinery shops. Installed, it proved to have ample power to drive the stern paddle wheel. An oilcloth top and side curtains enable the carpenter and his family to enjoy excursions on the near-by river in sunshine or rain. The total cash expenditure for the launch was \$48, including hired help.



A 22-Foot Gasoline Launch Constructed by a Carpenter during His Spare Hours and Driven by an Engine Made from Parts Purchased from Junk Dealers and in Secondhand Machinery Shops

Dr. Jerry Dyke
Miami, Okla.

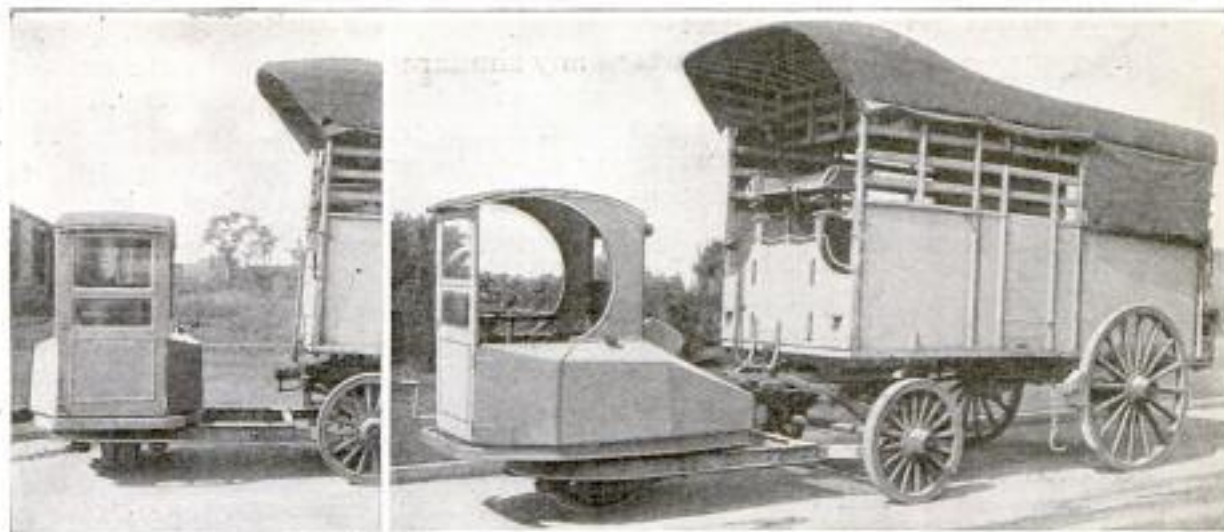

The Tractor is Provided with a Single 34-Inch Drivewheel, Is Capable of Pulling a Five-Ton Load, and, as Shown at the Left, can be Turned Around without Moving Its Trailer

TRACTOR WITH ONLY ONE WHEEL HAS MANY USES

5248

Many uses suggest themselves for a one-wheel tractor which has just been put on the market and is capable of pulling loads up to five tons. It is designed to be coupled to any wagon of the horse-drawn type, making it unnecessary to discard such vehicles when giving up the use of horses. The tractor is equipped with a four-cycle gasoline engine inclosed in a small metal body, of which an upholstered cab for the driver is a part. The unit rests on a 34 by 10-in. drivewheel and is so mounted on the steel frame, with which a coupling is made to the vehicle behind, that it can be turned completely around without moving the load. This feature, together with the fact that it occupies less space than a team, makes the tractor very serviceable for any hauling which involves maneuvering in cramped quarters. It is claimed that the engine can operate more efficiently than the ordinary motor truck because it pulls its load instead of pushing it, as is the case when power is delivered to rear wheels.

Candles, designed especially for soldiers in the field, are now being manufactured which have a base so broad that they can stand alone. This feature makes the use of holders unnecessary.

ADJUSTABLE SUPPORT FOR BROKEN LIMBS

5168

Tests of a new limb support which have been made in a hospital in this country have proved so satisfactory that a Red Cross unit will take one of the devices to France, together with specifications for making others if desired. It consists of a hammocklike sling suspended from a steel arm that can be attached either to a bed or a wheel chair. Its special feature is the freedom of movement that it affords the patient. By means of a rope and pulleys the sling can be raised or lowered, while the supporting arm permits it to swing from side to side.



A Special Advantage of This Support for an Injured Limb Is That It can be Raised, Lowered, or Swung to Either Side. The Method of Attaching It to a Bed is Also Shown

Dr. Chas. H. Burton
 Salt Lake City, Utah

LIVE FISH IN CAFE SIGN**ATTRACT BUSINESS**

Originality and unusual effectiveness have been displayed by a café owner who has incorporated a fish bowl containing live fish in an electric sign above the entrance to his establishment.



The eating house makes a specialty of fish and by displaying lively sea bass in such an unusual place the public's attention is sure to be arrested. Three pipes are connected with the aquarium, one supplying clean water, another air to aerate the water, and a third serving as an overflow. At night the sign is illuminated with flashing light bulbs. The fish are supplied with food by means of a small cup attached to the end of a long pole.

**NEW FLOATING MINE WRECKS
ONLY ENEMY VESSELS**

Our government has under consideration a marine contact mine of an unusually interesting type. It may, or may not, prove to be suitable for general adoption, but at any rate it has the merit of ingenuity and therefore is worth notice. Unlike ordinary mines, this one operates on a selective principle. In other words, it is designed to destroy enemy vessels without endangering the friendly ones that collide with it. Technical details of the invention cannot, of course, be divulged, but a general description is permissible. The outer shell of the mine is built of pressed steel and equipped with a group of magnetic disks, which are employed in place of the firing pins customarily

used. The instant that steel, iron, or any similar metal comes in contact with one of the disks, a clock motor, housed within the buoy, is set in motion. It in turn operates a trigger and causes the discharge of a fulminate cap that detonates the explosive. Thus any unprotected steel vessel would explode the mine on contact. In order, however, that our war and merchant vessels and those of our allies might safely proceed through a field strewn with such weapons, the inventor has provided a simple means of protection which prevents explosion of the mine upon contact with a so protected vessel. The magnetic disks covering the outside of the mine are made of a special metal, the character of which is withheld from publication. It is easily procured in large quantities and is understood not to be of excessive cost.

**STEAMSHIP LINE ADOPTS
NEW LIFE PRESERVER**

A life preserver made in the form of a vest that can be worn continuously if desired, has been marketed recently. One article of this sort is now being issued to each passenger on one of the large transatlantic steamship lines. Encircling the vest is an inflatable belt which lies flat when not filled with air, causing the wearer no inconvenience. It can be inflated in any emergency merely by blowing into a rubber-tube attachment with which it is provided. The mouthpiece of the tube is a valve which can be opened and closed as desired. A heavy strap is attached to the back of the garment, and it is claimed that when the belt is inflated it is capable of supporting three persons in the water. The protection against cold which the vest affords is also an excellent feature.



W. B. H. Hermann
504 Hubbard Ave
Hapakonela, Ohio.

City of Denver, Colorado



Part of a Herd of Elk Cows and Yearling Calves in Genesee Mountain Park, 22 Miles from Denver: Because of the Exceptional Natural Advantage Offered by This Large Game Preserve, That City Is Able to Maintain Unusually Fine Herds of Wild Animals

VACATION RESORT FOR WILD ANIMALS MAINTAINED BY DENVER

4 981
UNTIL two years ago governmental efforts to conserve the nation's game supply had been limited to laws and reservations created by acts of Federal or state governments. At that time the city of Denver entered the game-preservation movement as a development of her mountain-park system. So marked has been the success of the movement that it opens an important war-time possibility for cities that wish to supplement their meat supply. Denver's game sanctuary has not been developed with this idea in view as yet, but has reached a stage where such a movement could be quickly carried out.

Denver's mountain game preserve includes 400 acres of fenced land in Genesee Mountain Park, 22 miles from the city. The preserve is well timbered, and consists of rolling meadows, deep ravines, and rocky points, jutting forth from the sides of Genesee peak, 8,270 ft. in elevation.

Five varieties of western game ani-

mals, representing types from prairie to mountain peak, have been introduced and have thrived. The buffalo and antelope of the prairies, the elk and deer of the mountain forests, and the big horn of rocky peaks above the timber line, are all found within the preserve. The elevation, ranging from 7,500 to 8,000 ft., has agreed with all. Increase in the herds has been even more pronounced than under natural conditions, for the predatory lions and

wolves cannot enter the Genesee preserve. The elk have shown great reproductive power, the herd increasing as readily as cattle. The yield from the cows, even with some immature animals in the lot, has been about 75 per cent of their total number.

The improved vitality of the animals after reaching the mountains is noticeable even to the unpracticed eye. Results have shown that this improvement has extended to increased productiveness and stronger individuals among the young.



Buffalo Swimming through a Vat Filled with a Disinfecting Bath: This Precaution is Taken so That These Animals will Not Transmit Disease to the Park Herds

Surplus ruminants, born in the city zoo, are sent to the mountains as soon as they are able to care for themselves. Indeed, the city now keeps only three or four of each species of ruminants in the zoo, revitalizing the stock by interchanging individuals as soon as the zoo specimens begin to show the effects of close confinement. The result of this policy is that the Denver zoo specimens of big game are always in the finest possible condition.

A tremendous saving in feed bills has been an indirect result of the creation of the preserve. Formerly the city kept 20 buffalo and about 40 elk in its city park. This number has been reduced until about a half dozen of each species are now in the city, the remainder being in the mountains. The Genesee elk herd now numbers about 100 animals. The native grass and shrubs in the preserve are so abundant that the animals require no hay except after a very heavy snowstorm. One ton of hay a winter for 10 animals is about the amount consumed by the Genesee herds during an average winter.

Some of the animals are visible at all

times of the day from the road that skirts the preserve, or from that branch which passes directly through it, dividing it into two sections. The pleasure afforded motorists by such sights is one of the strong attractions of the mountain-park drive.

Construction of the fence, transportation of the animals, and trapping of new specimens have developed some ingenious devices. The fence is constructed of heavy stock wire, strung upon iron



The Truck in Which the Wild Animals are Transferred to the Mountain Game Preserve: A Tarpaulin Covers the Crate so That the Creatures will not be Unduly Frightened

pipes from the boilers of discarded locomotives. These pipes, bored with holes for attachment of the stock wire, are each sunk in 2-ft. concrete bases, and have withstood charges from buffalo and elk without a sign of weakness. The pipes were bought at \$7 a hundred, but surrounding stockmen adopted the idea eagerly, with the result that the price rose to \$14 a hundred by the next summer. This was before the war prices seriously affected scrap iron such as that utilized.

A unique feature of the preserve is a subway built beneath the auto road that bisects the inclosure. Some doubt was expressed as to whether the ani-



Some of the Park's Fine Specimens of Buffalo Which have Sought Out the Snow-Covered Uplands for Food: Even in Winter They Are Able to Obtain Most of Their Food Themselves

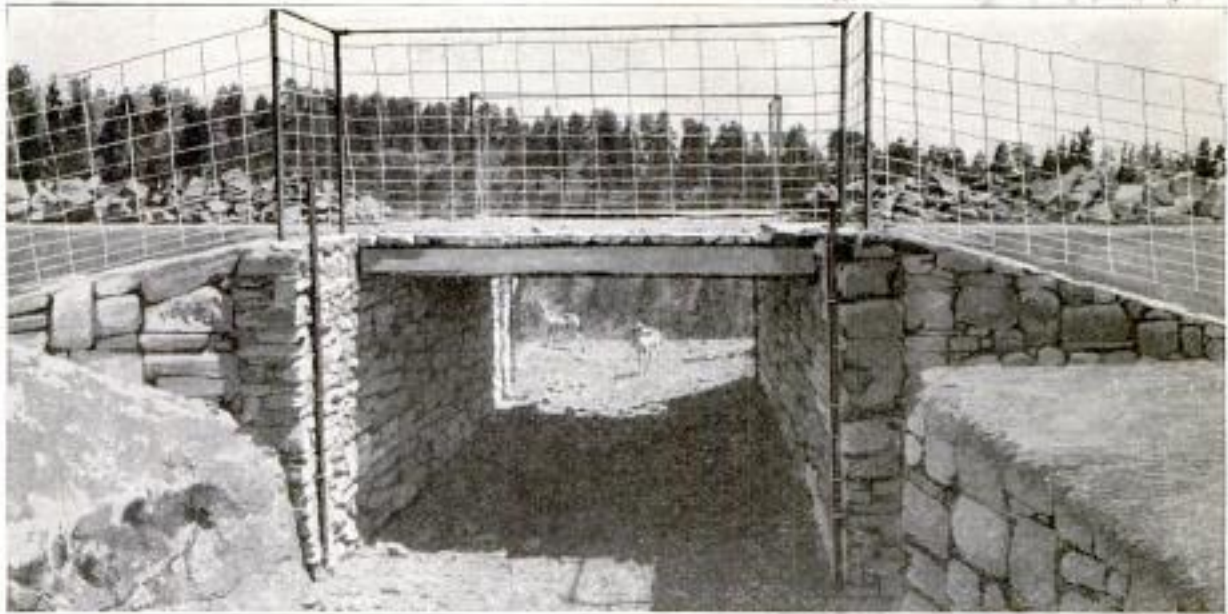

The Viaduct beneath the Automobile Road That Cuts the Preserve in Two: Contrary to the Predictions of Some, the Wild Animals Use This Passageway Freely. An Antelope is Shown About to Enter It

mals would use this, but they speedily justified the faith of the zoo superintendent by passing through freely. The subway is walled on either side with rough stone and may be closed to create a winter range if a drought should make this desirable.

No animals are introduced into the game sanctuary, whether taken from the zoo yards or the wild, without first having undergone two dippings at an interval of 10 days. This is to eradicate any skin disease the animal might have contracted. A concrete vat at the city yards is used for the purpose. Animals are driven through a high board chute into the vat, which contains warm water into which eight pounds of carbolic acid has been mixed. After the second dipping the vat is boarded over, a motor truck backed against the end of the chute and the animals are driven into it. An immense

wooden crate, built upon the truck, holds the animals securely. Partitions in the crate prevent the animals from crowding to the rear end and injuring one another as the truck ascends the mountain grades, while tarpaulin is drawn upon the crate to shut out the sights of the road. Wild animals are nervous creatures and might easily injure themselves against the walls of the crate if frightened.



Trapping Mountain Sheep: The Gate Uphill is Sprung When Sheep Enter and These are Then Driven into the Cabin Below, Which is Heavily Padded to Prevent the Animals from Injuring Themselves

The latest addition to the game preserve is a bunch of six mountain sheep, trapped at Ouray, Colo. The sheep entered the trap to secure hay and were held by a spring gate. The secret of the trap's success lies in the fact that its entrance is uphill. The sheep always flee upward when pursued and will enter no trap where they cannot see an unobstructed road to their peaks. The five ewes captured each yielded two lambs.

Motorists Service Assn.
3393 Bejelow St
 884
Pittsburg Pa.
POPULAR MECHANICS

**BODIES OF SERVICE CARS
 5156 RESEMBLE GARAGES**

For the accommodation of motorists of an eastern city and its environs, a new automobile service, based on an



The Service Cars Are Distinctive, for They Embody the Association's Motto, "We Bring the Garage to You"

interesting plan, has been instituted. Conducted as an association, the firm makes members of its patrons and, for a prescribed annual fee, renders emergency service to stalled cars whenever summoned. The company's motto is, "We bring the garage to you," and in carrying it out, the service cars have been equipped with bodies that resemble small brick buildings. The machines, of course, carry fuel, oil, water, tire pumps, and various tools in addition to whatever parts or accessories may be needed by the machine requiring assistance. If a member's car becomes stalled in the mud near the city, has engine trouble, a flat tire, uses up all of its gasoline or oil, a call sent to the station brings immediate help.

**CROSSING THE BUFFALO
 4438 WITH BEEF CATTLE**

Efforts made during the last 25 years to produce a hybrid, domestic animal, by crossing the native buffalo with the black Galloway, or polled Angus, strain

and their characteristics carefully watched by the experimenters. The largest herd is located on the isolated, uninhabited "Arizona strip," north of the Grand Cañon. While the herd roams free, as did the buffalo, without herder or any special attention except at breeding and calving times, the catalo submits readily to confinement and domestication when desired to do so. Like the buffalo, it requires little water and is successful in evading beasts of prey. Its roving habits prevent fattening and the meat resembles buffalo meat, though a little better. The cows produce only sufficient milk for their young. Catalo sell for park-exhibition purposes at \$500 to \$750 apiece,



A Yearling Catalo, or Cross between a Buffalo Bull and a Galloway Cow: These Hybrid Animals, Bred in the West, Submit to Confinement and are Sold to Parks, While Their Hides Furnish Better Robes and Rugs than the Original Buffalo

of beef cattle, can now be summarized. The hybrid is known as the "catalo." A considerable number have been bred

and their black-haired hides bring from \$50 to \$250 each, for use as robes and rugs.

Gumbo. only male offspring of lion and domestic cow. Raised on Grandview Ranch, Colville Wash



Above: The Mouth of Tunnel Extending under Piles of Material. Below Is a View of the Shovel That Pulls Itself on Skids



The Extensible Conveyor Platforms over the Piles are Shown Above. Below Is a Rear View of the Steam Shovel in the Arroyo



End View of a Dump Car, Showing the Manner in Which It is Automatically Tilted to Discharge Its Load into the Crusher



LARGE GRAVEL PLANT USES 516/ LABOR-SAVING METHODS

Interesting labor-saving methods of handling large quantities of sand and gravel are practiced by a concern obtaining its material from an arroyo which is dry nine months of the year. Low-cost storage is particularly essential for this plant because large stores of materials must be gathered to last through the wet season when the arroyo is flooded. The unsorted stone is dug up by a steam shovel mounted on skids. By means of an extra winch mounted on the shovel, together with a pulley anchored at the proper distance, and a cable connecting the two, the shovel is able to pull itself along, bringing new gravel deposits within reach. Thus no time is lost in using rollers.

The dump cars, which deliver stone to the plant's crusher, are drawn up an incline by a cable and dumped automatically at the top. Two small sup-

plementary wheels are mounted on the extended ends of each car's rear axle. On reaching the top of the incline these wheels start to travel up slanting beams and so tilt the load forward. At the same time a catch holding the door at the front end is released and the stone is discharged. For the purpose of providing conveyors whose range can be extended as the piles of sorted material grow, sets of cables have been stretched from the crusher to points beyond the piles. Frame sections are laid on these wires to form suspended supports, to the end of which the sand or stone is carried and dumped.

In order that the sorted material may be easily loaded for delivery to purchasers, a tunnel has been built beneath the piles, its top and sides being reinforced with 8-in. square beams. Into this passageway the delivery trucks are driven and then loaded by opening a slide and letting the desired amount of sand and gravel fall through into the vehicle.

Lagerman Press Co
Liberup Bldg.
New York City

886

POPULAR MECHANICS

FAST PLATEN PRESS PRINTS

5247 FOUR JOBS AT ONCE

Of late a printing press capable of handling four separate jobs at once and feeding stock that varies in thickness

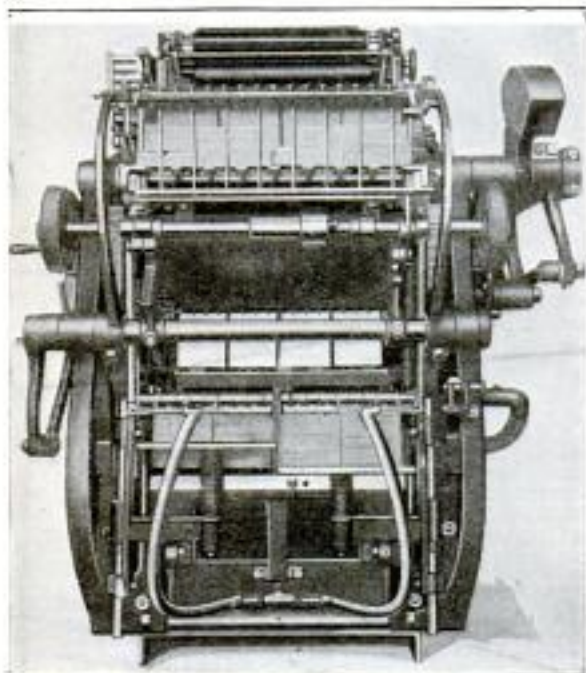

The Feeding Device, as Shown Above, Is Capable of Four Subdivisions. It Also Permits Paper of Two Different Thicknesses to be Run Simultaneously

from thin tissue to four-ply cardboard, has been introduced in this country. It is said to do three-color process work as well as cylinder presses, and produces solid tints that show no mottling. In addition to being of simple enough construction that any pressman can familiarize himself with the mechanism in a few days, it will turn out from 2,500 to 3,200 impressions an hour, the speed depending, of course, upon the class of work in hand. The feeding device is capable of four subdivisions and permits two different thicknesses of paper to be run at the same time. Delicate regulation of the suction force obviates the chance of more than one sheet of paper being fed at once when tissue is used. Two gripper arms convey the printed sheets from the platen to the delivery board, where they are jogged into even stacks. The board is arranged at a convenient height so that an operator can inspect the work as it is run off, without stooping. The machine

is driven almost noiselessly by a one-horsepower motor. With the aid of a helper to handle the stock, one pressman can operate two of the presses simultaneously.

OVERCOMING CAMOUFLAGE 534 WITH HUED SCREENS

An American physicist believes that the advantages of camouflage—or at least certain kinds of camouflage—can be overcome by an opposing army by providing its airmen and other scouts with colored glasses or screens of contrasting colors to use with field glasses. When the colors of these screens are properly selected, uniforms and other objects may be made to appear in contrast, instead of in harmony with their surroundings, he claims. Camouflage as practiced in many cases is accomplished largely by the use of paint, objects being given shades that blend with the landscape. In spite of certain difficulties that would arise, it is believed that such efforts at concealment could be rendered quite ineffectual by the means stated.

5152 LAMPS IN HUDSON STRAIT MARK ROUTE TO ENGLAND

The completion of the railroad line to Port Nelson on the west coast of Hudson Bay has opened a new direct route from western Canada to England through Hudson Strait. The accompanying illustration shows one of the mast lights which are being installed in these straits, pending the erection of more permanent lighthouses. It is anticipated that henceforth much of Canada's wheat crop will travel via this route to the motherland, as will also Canadian oil for the great British war fleet.



Lots Island

SUBMARINE WARFARE INCREASES DEMAND FOR SKILLED DIVERS IN NAVY

THIS is a war of the fishes. Not only great armored submarines but man himself must go alone into the mysterious depths of the sea if he would win. Formerly each battleship carried its divers and diving outfit for use only in an emergency. Simple underwater repairs to the bottom or propeller were sometimes necessary after grounding or other accident. Survey of the damage could thus be made and temporary patches put on.

Then torpedoes came into general use in the fleet. While a few ran and floated, the majority wobbled and sank. They are worth about \$10,000 apiece. To avoid vast unnecessary expense, special divers were trained to look for lost torpedoes. Only an expert can handle one of these grease-slimed bodies under water. At a touch from an unpracticed hand it may leap away with knifelike propellers spinning at terrible speed. Also the "stink pot," or torch, in the nose is likely to burn a hole in the diver's suit and drown him before he can be hauled to the surface.

In the past few years submarines have come to the front—lately they have made the front! Our own navy has had very few casualties with them. Year before last, Lieutenant Ede, U. S. N., took his ill-fated boat down in the harbor of Honolulu, never to rise again. Her horizontal rudders jammed and she sank in over 150 ft. of water. Divers heard men inside hammering—apparently trying to fix the pumps that she might be floated; all, however, were suffocated.

England, France, and Germany have paid the penalty of their submarine activity. Collisions and explosions have caused the loss of many boats,

their crews dying like cats in a bag. Divers were always sent down, but frequently the water was too deep for rescue work of either men or submarine.

Submarine nets now set new problems for the diver. He must be plumber and fitter and general mechanic under water to a degree of skill never before thought possible. The latest nets are too heavy for quick hoist. When a section needs repair the shortest method is by divers armed with pliers, hammer, and even anvil, lowered over the side.

Resistance of the water impedes all movements of the diver. Quick blows or sharp wrenches are beyond any but the most powerful men. One may notice in the accompanying photograph that the man's hands are bare. His wrists and arms are covered by only the thinnest rubber in order to give him all possible freedom.

The suit proper is of rubber and in one piece. The helmet is attached by clamps lined with metal-protected gaskets; the boots are heavily weighted with lead plates, and the line for lowering and signals is attached to the shoulders and carries with it the air hose.

In the United States Navy, submarine crews receive \$5 a month extra and \$1 for each day during any part of which they have been below the surface of the water. Divers earn a bounty of \$1.20 an hour or fraction thereof while at work.

Diving is like flying: easy, interesting, and pleasant until something goes wrong. Then, "Cross your fingers, Jack, or your name is Mud!" River mud, for the crabs and little fishes.



A Modernly Equipped Diver Ready for the Descent: His Suit Proper Is of Rubber and in One Piece. For the Sake of Freedom of Movement His Hands Are Bare

OPEN-AIR EATING PLACE
522! AT TRAINING STATION

Eating in the sunshine under a blue sky is the delightful year-around priv-

ilege of the young men of the naval training station at San Diego, Calif. Here in a broad plaza bordered on either side by shrubbery and, at one end, by one of the exposition buildings, long tables are set for the future sea fighters, several hundred of whom can be seated at once. The structure shown in the illustration was formerly the Fisheries Building and is now used as a bathhouse.



Beautiful Spot in San Diego, California, Where Sailors in Training Have Mess the Year Around: The Exposition Building in the Background is Used as a Bathhouse

¶An exceptional record in shipbuilding was made recently at Kobe, Japan, when a 9,000-ton steamer, complete with engines and masts on board, was launched in two months and 27 days after laying the keel.

4604 MINERS' CLOTHING DRIED BETWEEN SHIFTS

It is no longer unusual for a mining company to provide a respectable

to suffer in the end if men are allowed to work in damp clothing, or are not enabled to replace wet, mud-soaked garments with dry ones before leaving for their homes. At one mine the change house is equipped with shower baths, stationary laundry tubs in which dirty clothes may be washed, and other serviceable facilities. When a miner removes his working apparel, he attaches it to a hanger fixed on a chain that passes around a pulley near the ceiling and hoists it overhead. Steam pipes in the upper part of the room keep the atmosphere hot, so that by the time the clothing is needed, it is dry.



One Section of a "Change House" in Which Provision is Made for Drying the Work Clothes of Miners

"change house" for the convenience of its employes, since production is known

Quaker Hill & Sullivan Camp House
Bellogg, Id.

5190 *Motor Race*
UNUSUAL CYCLE EVENTS COMMAND INTEREST



Signal-Corps
 Dispatch Rider
 Winning One-Mile
 Deep-Sand Race in
 the Remarkable
 Time of One Minute
 22½ Seconds,
 a Contest That
 Severely Tested
 Both Machine and
 Operator



Thrills Galore are
 Afforded When a Motor-
 cycle is Substituted for
 a Roller-Coaster Car.
 The Two Pictures Give
 Glimpses of One Fellow
 Who has Learned It to
 His Own Satisfaction
 without Mishap



While the Tug of War Lasted, the Little
 Machines Roared, Bucked, and See-Sawed,
 Throwing Sand High in the Air Until Their
 Rear Wheels had Cut Such Deep Ruts That
 Traction Was Out of the Question. The
 Picture Above Gives an Idea of This



Motorcycle Tug of War between Two Teams
 of Six Riders Each; The Machines were
 Hitched in Tandem at Opposite Ends of a
 Heavy Rope. The Contest Lasted 10 Minutes,
 and the Winning Team Pulled the Losing
 One 12 Feet 8 Inches

J. S. Kernetz
Grand Rapids Mich
Auto & Mechanical

**MOTORIST PREPARES MEALS
IN GAS-HEATED OVEN**

527

When on cross-country tours a resourceful motorist cooks his meals by utilizing the heat radiated from the ex-



When Camp is Pitched after a Long Drive, It is Comforting to Raise the Hood of the Car and Find a Meal Ready to Serve

haust manifold of his engine: For doing this he has a metal box heavily lined with asbestos mounted beneath the hood. The manifold passes directly through it. Potatoes packed solidly in the oven thus formed are baked to a turn in two hours. Canned beans are piping hot and ready to serve in even less time than that. A couple of hours before mealtime, the motorist fills the oven with food so that when the time comes for his wayside repast it is ready for him.

**GUNS CARRIED ON SPECIAL
NARROW-GAUGE CARS**

527

For transporting heavy guns at the front, rolling stock of interesting character has been supplied for the French artillery. It is designed to operate on tracks of about 24-in. gauge that are laid with very light rails built in sections on pressed-steel ties. Special all-steel, four, six, and eight-wheel trucks are employed. For heavy duty they are coupled in pairs, equipped with gun and swivel supports, and connected by telescoping reach bars. A car of this type is able to run over uneven track and around sharp curves while carrying a considerable load. Furthermore it is of exceedingly simple construction and therefore burdened with no unnecessary weight. The length over the buffers of the six-wheel trucks is about six and a half feet and the width slightly under four feet. Being of heavy capacity they may be arranged in groups for carrying any heavy material. A pair, for instance, may have swivel supports, be connected by reach bars, and used to transport either timber or steel. Two pairs, in turn, each connected by a platform surmounted by swivel supports, may be joined with lengthened reach bars and made to carry approximately an 80,000-lb. load. Eight-wheel trucks are of heavier construction and correspondingly greater capacity. Because of this they are particularly suited for handling long, heavy timbers and materials of similar size and length. Steel bodies are used on some of the chassis.

Below Is One of the Cars with Six-Wheel Trucks, Gun and Swivel Supports, and Reach Bars. It is Designed to Operate on Tracks of 24-Inch Gauge Built of Very Light Rails

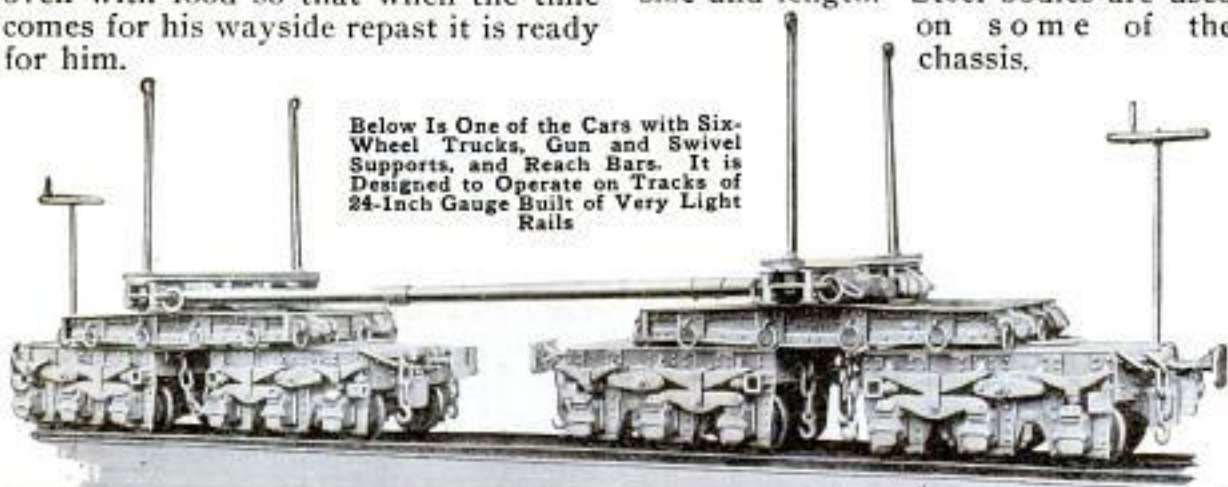

Mfg. National Steel Car Co. Ltd.
Hamilton, Ont. Can.
for French Government



An Anchored Scow with Which Water is Kept Moving through a System of Canals by Driving the Rear Paddle Wheel at Full Speed: Scum and Débris are Collected in a Net Stretched across the Channel

**SCOW MAKES ARTIFICIAL
CURRENT IN CANALS**

5086

The water in a system of canals, which serves as a substitute for streets at an ocean resort in California, is kept clean and wholesome by means of a current created by a paddle wheel on an anchored scow. This craft is 36 ft. long and 16 ft. wide, while the paddle, mounted at the rear and driven by a 25-hp. engine, is 4 ft. in diameter and 8 ft. wide. Spuds hold the scow stationary while the engine is run full speed ahead, thereby causing the water to flow swiftly. A net stretched across the canal catches the débris and scum. The canal system is directly connected with the ocean, but gates are employed to prevent the variation in water level which the tides would cause and so the channels are not cleansed by natural means. A small clamshell bucket mounted on the scow is used for minor jobs of dredging which must be undertaken from time to time to keep the artificial waterways at the proper depth.

Work has begun on the strengthening of the southeast pier in the transept of St. Paul's Cathedral, London. The southwest pier, which has been under repair for nearly four years, will, it is hoped, be relieved of its disfiguring scaffolding soon.

**GIRL YEOMEN COMMON SIGHT
AT OUR NAVY YARDS**

5240

Since our entrance into the world conflict many young women have enlisted in the navy as yeomen and been detailed to navy yards and recruiting headquarters for clerical work. The uniform provided for them consists of a short skirt and blouse of blue, and a white cap. These girls are executing shore work that relieves a corresponding number of youths for service afloat and so are doing their "bit."



Ahoy! My Lads. Three Jolly Jack Tarettes: They Are Yeomen Assigned to the Charlestown, Massachusetts, Navy Yard Where There Is Much Clerical Work to be Done. The Uniform Is "Regulation"

*Charlestown Navy Yard
Charlestown, Mass.*

Shipped from Jersey City
San Francisco

ENGINE IS RUSHED ACROSS COUNTRY BY EXPRESS

When quick delivery of a large oil-burning marine engine became im-



Transferring the Engine from a Truck to the Express Car Preparatory for the Fast Transcontinental Trip

perative recently, it was dispatched across the continent by express. The motor, as shipped, weighed about 25,000 lb. and was loaded through the opened end of an express car, securely blocked, and sent on its journey.

MANUFACTURE OF GLYCERIN FROM SUGAR WAR TRIUMPH

Government chemists working in cooperation with the Council of National Defense have evolved a process for obtaining glycerin from sugar. The discovery is one of immense importance, for it not only offers a way of conserving our supply of fats, but also cuts the cost of manufacture to approximately one-fourth the current figure. With sugar at the present market price, glycerin can be produced for about 25 cents or less a pound. Lack of some such process as this has been a serious embar-

rassment to the enemy, for the need of glycerin in the manufacture of explosives has been largely responsible for the great consumption of fats vitally needed for food and other purposes. Germany has even been forced, for this reason, to discontinue the manufacture of soaps and other articles of necessity.

SOLEMN STATUES SERVE AS ODD BEEHIVES

A quaint, solemn row of statues representing Moses, the apostles, high priests, monks, and other ecclesiastical personages, constitutes what is undoubtedly a

very picturesque set of beehives. These figures which house many swarms of bees are the cherished possession of a landowner in a little village in Silesia, Germany, and had their origin in the sixteenth century. Efforts have been made by collectors of antiques to purchase them at various times, but their possessor has always refused the tempting offers. A long wooden shed open at one side protects the figures from the weather.



These Quaint Representations of Biblical and Ecclesiastical Characters Are Beehives and Are the Prized Possession of a Landowner in Silesia, Germany

Laboratory of
Internal Revenue
Bureau
Wash. D.C.

Owner - Hermann Vogt
Doge, Silesia, Germany
Copyrighted material

HANDY TWO-WHEEL TRAILER

5123 FOR COAL DEALERS

To the coal dealer who fills many small orders of a ton or less, a new two-wheel trailer should make a special appeal because it is light, easily emptied, and can be quickly attached to the rear of a runabout. The wheels are rubber-tired, while the metal body is V-shaped and mounted on curved flanges bolted to either side—an arrangement which permits it to be tilted backward for instant dumping. Chains wound on a ratchet-controlled drum hold the body upright. The trailer is attached to the rear of a runabout by means of a fifth-wheel coupling which is installed after removing the rear deck of the car. When the trailer is not employed,

the part of the coupling permanently attached to the automobile can be concealed by replacing the deck. This trailer can be drawn many places where a regular truck cannot, such as



A One-Ton Coal-Carrying Truck That can be Quickly Attached to a Runabout: The Illustrations Show How It Dumps and Also How Coal in Sacks can be Carried

in narrow alleys, across thinly cemented driveways, and the like.

UTILIZE BOWLDERS PICKED

5110 UP ON DESERT RANCH

Boulders collected on a large ranch in a semiarid region were used to excellent advantage in building a serviceable and inexpensive support for a tank that was a part of the water system on the property. The walls, composed of stone set in concrete, are 2½ ft. thick at the base and 1½ ft. thick at the top. The roof is reinforced with steel beams to help support the tank above.

Periscopes have been installed in a power plant recently, with no hostile intent, however. In the past, in order to read the temperature of the oil in the transformers it has been necessary to mount a ladder, but with the new apparatus that inconvenience is overcome.



By Utilizing Boulders Picked Up on His Land a Rancher Was Able to Build a Tank House at Low Cost

*Inv: J. O. Gould
801 1/2 Main St.
Stockton, Calif*

*Mfg: Ry. Hoade
Machene Co - 5616
Curtis Ave Cleveland Ohio*

894

POPULAR MECHANICS

**POWERFUL GAS LAMPS LIGHT
5223 GUARDED DAM**

Several portable gasoline searchlights of about 25,000 cp. were recently constructed for use in illuminating at night an important dam in the West which is constantly guarded. The lamps are assembled in compact form and might be employed for any of a number of different purposes in districts where electricity is not easily available. The projector is mounted above



an oblong case that incloses the fuel and pressure tank and all operating valves. A 14-in. silvered reflector backs a group of ordinary gas mantles. A brilliant flood of light is thrown in a wide angle. The unit is about eight feet in height and can be moved without difficulty by one man. In operation it is comparatively inexpensive, for its gasoline consumption only amounts to about a gallon and a half for an all-night period.

an oblong case that incloses the fuel and pressure tank and all operating valves. A 14-in. silvered reflector backs a group of ordinary gas mantles. A brilliant flood of light is thrown in a wide angle. The unit is about eight feet in height and can be moved without difficulty by one man. In operation it is comparatively inexpensive, for its gasoline consumption only amounts to about a gallon and a half for an all-night period.

**CAMP STOVE DERIVES HEAT
5251 FROM BLOWTORCH**

By attaching an ordinary blowtorch to a boxlike oven surmounted with suitable grating, an inventor has devised a portable camp stove whose flame will not blow out in the wind and which produces a quick, intense heat. The flame is conducted from the torch through a flue terminating under the grating in two funnel-shaped outlets. Dampers are provided by which the amount of heat



conducted from the torch through a flue terminating under the grating in two funnel-shaped outlets. Dampers are provided by which the amount of heat

*Mfg: Frank Keefer
120 West Ave, #3
Los Angeles Calif*

issuing from these vents can be regulated. A quart of gasoline will feed the stove for three hours, it is said. An additional advantage of the outfit is that it provides a blowtorch which is always available for repair work on the road.

garage
**NEW CYLINDER-GRINDING
5175 MACHINE FOR GARAGES**

Well suited to the needs of the average garage is a cylinder-grinding machine which has recently been put on the market. It stands 6 ft. high, occupies small floor space, and does not require the services of an expert operator. The table and the upright arm carrying the movable spindle are one casting, a feature which promotes accuracy of alignment. Located on the front of the machine, within easy reach, are all the operating levers, including those controlling the up-and-down feed and the speed of the spindle. When desired, the latter can be adjusted to move eccentrically while revolving on its axis. The cylinder block to be ground is bolted to a sliding plate which travels on ways underneath the table and can be brought into position by means of simple gearing. An elongated hole in the table gives easy access to the bores.



the market. It stands 6 ft. high, occupies small floor space, and does not require the services of an expert operator. The table and the upright arm carrying the movable spindle are one casting, a feature which promotes accuracy of alignment. Located on the front of the machine, within easy

reach, are all the operating levers, including those controlling the up-and-down feed and the speed of the spindle. When desired, the latter can be adjusted to move eccentrically while revolving on its axis. The cylinder block to be ground is bolted to a sliding plate which travels on ways underneath the table and can be brought into position by means of simple gearing. An elongated hole in the table gives easy access to the bores.

After much expense of time and labor the Coast and Geodetic Survey has completed a revised chart of New York harbor. Something of the work involved in bringing the chart up to date is shown by the fact that in one year there were 253 items of change to be made, requiring 233 days for compilation and engraving.

Municipal Hospital, Phila Pa

SIMPLE GAMES AND OCCUPATIONS HELP INSANE

3826



Moderate Forms of Open-Air Exercise, Even Such as the Boyish Game of Leapfrog, Are Highly Beneficial to Those Whose Mental Apparatus is De-ranged. Importance is Attached to This Fact at the Philadelphia Municipal Hospital, Where These Pictures were Obtained



When the Mind Is Weak, Idleness Promotes Brooding. This Condition is Combated by Keeping the Patients Employed and in the Open Air as Much of the Time as Is Possible. When the Weather Is Unpleasant, Indoor Exercises and Tasks are Arranged. Above, the Men are Modeling Clay



Usually Women Are More Gentle and Patient than Men and Get Readier Response from Those Whose Mental Processes Fail to Function Normally. The Women Pictured Here are Explaining the Rules of a Game to a Group of the Inmates



Only Games and Tasks of the Simplest Possible Character are Indulged in at the Outset. Gradually, as Improvement Warrants, Slightly More Difficult Pastimes are Employed. If Interest Lags, a Change is Made in the Program. In This Way Progress is Attained and Persons Who have been Listless and Morbid for Years are Brightened and Strengthened. The Picture Above Shows Some of the Women Patients Engaged in Outdoor Exercise

**COAL PILE SO HUGE THAT
TRAINS CLIMB OVER IT**

A coal pile so huge that the trains used to add to its size climb up over it



Partial View of a Railroad Company's Huge Coal Pile Surmounted by a Coal Train Which is Adding to the Mass

on temporary tracks, is to be found in a yard of a railroad which is making preparation against a possible coal famine. As the level of the coal rises,

the tracks are lifted up in much the same manner as in ordinary track-elevation work.

**BUGS LESSEN FOOD BILL
AT FISH HATCHERY**

A change recently instituted by the warden of a Kansas state fish hatchery would seem to indicate that the food-conservation movement has extended to the feeding of the fish in that institution. The change consists in installing electric lights above the fish ponds, with the result that large numbers of bugs and smaller insects are attracted to the vicinity at night. Eventually many of these fall into the water and are fed upon by the fish. In the past the cost of food for the finny creatures has been about \$1,000 per year, but it is predicted that under the present arrangement this expense will be reduced.

FLOOD UPSETS HUNDREDS OF LUMBER PILES

A strange spectacle was presented when a flood occurred at St. Maries, Ida., recently which totally covered low land, utilized as a lumber yard, with 16 ft. of water. Piles aggregating 30,000,000 ft. of lumber were set topsyturvy in a most fantastic fashion by the rise of the water. Timbers of all sizes were tossed into heaps that suggested games of

giant jackstraws. When the water subsided, about 80 per cent of the piles righted themselves, and the owners of



The Dark Rectangular Patch in the Flooded Area is Composed of Floating Piles Aggregating 30,000,000 Feet of Lumber



A Close View of the Lumber Yard at St. Maries, Idaho, Set Topsy-Turvy by a Flood

the yard were able to save considerably more than had been expected when the river began to rise to such an unusual height. Fortunately the current among the piles was slight.

Melwaukee Lumber Co.

St. Maries, Idaho



Students in Training at an Officers' Reserve Camp Learning to Shoot on a Rifle Range: The Targets at Which They are Aiming Are 50 Yards Away

4523
RANGE TARGETS AND HOW THEY ARE OPERATED

By E. F. INGALS, JR. -55-40 Woodlawn Ave Chicago

FEW men, other than those who have had experience on an outdoor rifle range, know in what manner the targets are worked and scored so that the man on the firing line knows just what he is doing. An onlooker watching rifle practice on an outdoor range hears the crack of the rifle, he sees the target change, he sees certain disks or flags come up in front of the target and descend, and he hears the marksman remark, "a four at seven o'clock." What does it all mean? Only the initiated can tell.

The targets are mounted behind a large mound or ridge of earth which is about eight feet high, and are set perhaps five feet behind the ridge. This affords the target men ample room to walk in front of the targets and still be sheltered from the rifle fire. The targets, which are about six feet square, are mounted in pairs so that when one target is up above the protecting ridge or embankment, the other one is down behind it. As one target is pushed up into place, the other target drops down. The target that is used at 500 or 600 yards has a black circular area in its center measuring 20 in. in diameter. This is called the "bull," or the bull's-eye. Around this black center are two black circular lines, the first line having a diameter of about 40 in., and the second line having a diameter of about 60 in.

These lines mark off the "four" and "three" rings respectively. If a shot lands in the black center, namely the bull, it adds five points to the marksman's score. If it strikes outside the bull, but still within the boundary marked off by the first line, it counts as four points. Outside of that, but still within the boundary of the second line, the shot counts three points. If the bullet strikes anywhere else on the target, it counts as two; and if it misses altogether, the score is zero.

The handling and scoring, however, is the interesting part. Let us begin with the firing. After a shot is fired, the fresh target is raised into position while the other one is lowered. The target men examine the lowered target carefully until the bullet hole is located. Then the target is scored, and after the scoring the man on the firing line is at liberty to fire again. While he is firing his next shot, a small piece of paper about the size of a postage stamp is pasted over the bullet hole in the lowered target so that succeeding shots on that target can be identified. Squares of black paper are used over holes in the bull, while white squares are used over other holes in the target. If for any reason it is desired that firing should cease, a red flag is placed squarely in front of the exposed target, and until the flag is removed, no firing on that target is permissible.

Let us come back to the scoring of the targets. When the bullet hole is located in the bull's-eye, for example, a white metal disk, 10 or 15 inches in diameter, is raised to such a position as to indicate the location of the bullet hole on the target. If the bullet hole had been found in the "four zone" a red metal disk would have been raised in a similar manner. In scoring a shot counting three, a disk is used which shows a black cross on a white background. A black disk is used in scoring a "two" on the target. If the shot should miss the target altogether, a red flag is waved in front of the target to indicate a miss. Frequently, however, the bullet strikes the ground in front of the target and then glances upward as a flat stone might do when skipping on water. If, perchance, the bullet should strike the target in so doing, the score that it made would be counted as a regular hit. In marking, however, besides the regular scoring, a ricochet flag would be waved in front of the target at the same time. A ricochet bull would be scored by both the white disk and the ricochet flag. A ricochet miss is scored by waving both the red flag designating a miss and the ricochet flag. This flag is white with a red square in its center.

But back at the firing line we hear the marksmen speaking of "fours at three o'clock" and of "threes at nine-thirty." What are they referring to? It is like this: As you face the target,

just imagine it as the face of a clock with imaginary figures indicating the hours in their respective places. Now a "four at three o'clock" would mean that the bullet had struck the target in the ring that scores four points, and had struck directly to the right of the bull, or over toward the imaginary figure three on our imaginary clockface. A "three at nine-thirty" means that the bullet landed in the three ring still farther from the bull, and had struck a little high of directly to the left, or halfway between our imaginary nine o'clock and ten o'clock. By this means the rifleman can always locate his shots accurately. Likewise, in speaking of the direction of the wind, one will hear it said that a "five-o'clock wind is blowing." In this case, however, our imaginary clockface is laid flat on the ground with the target as 12 o'clock and the marksman as six o'clock. On the whole this system makes a very good means of keeping a record not only of one's scores, but also of the wind conditions under which one has been shooting.

4789 **BIG APARTMENT BUILDING HAS JAPANESE ASPECT**

The extremes to which architects can go in adapting Japanese and Chinese architectural features to American buildings are illustrated in the apartment house shown herewith. The exterior presents quite a bewildering array of low roofs, broad eaves, and

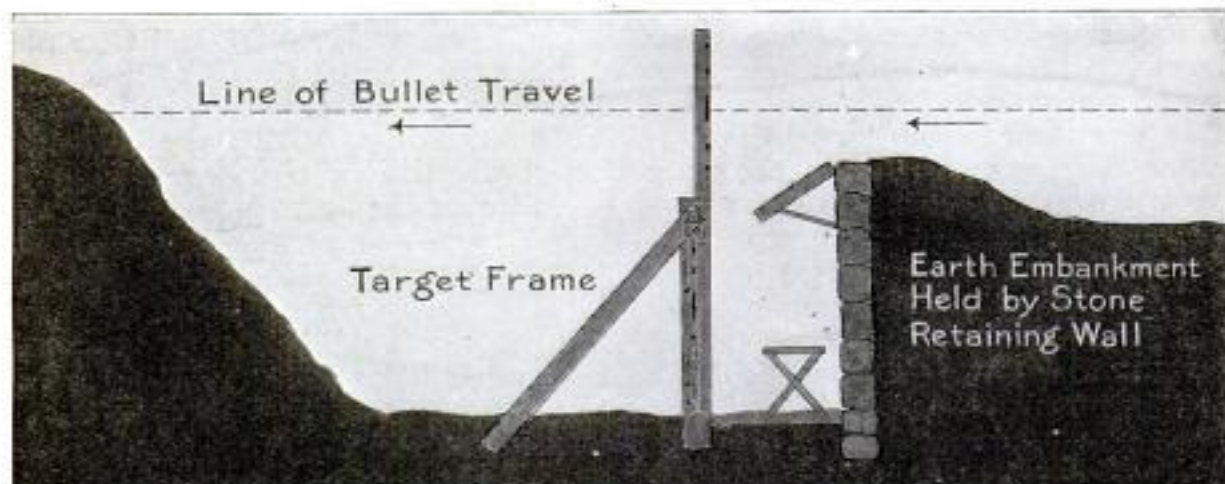

A Diagram Showing the Arrangement of the Range Targets: The Gallery in Which the Score Keepers are Located is to the Right of the Target Frame



An Apartment House Decidedly Unconventional in Its External Aspect: In His Effort to Find Something Distinctive in Design the Architect has Provided a Type of Roof, Eaves, and Balconies That Suggests Japanese Architecture

overhanging balconies, so designed as to produce an oriental effect. The interior differs but little from that of other apartment houses.

world-wide publication in the thick of things, I am sending this [picture] along. . . ." All of which tends to

5213
WHEN POPULAR MECHANICS REACHES THE TRENCHES

News from the outside world is as eagerly sought by the fellows at the front as are the cocoa and wafers that are served at Y. M. C. A. canteens in the trenches. Tasteful refreshments, something to smoke, and a good magazine or a letter from home; these are among the things that go far toward breaking the monotony of trench life and making the leisure hours of soldiers enjoyable. Perhaps this is best illustrated by a letter lately received from a lieutenant with the Canadian engineering corps in France, in which was inclosed the photograph reproduced herewith. Referring to Popular Mechanics Magazine he writes: "I can assure you it was with the greatest pleasure that we received the copy shown and got a bit of an idea of what was going on outside. You can get the expression of interest in my pal's face. Thinking you might be interested to know we are getting a copy of your



In the Trenches of France with a Magazine from Home

show that war is not so absorbing to those actually engaged that it stifles interest in normal civil activities.

5249 POST-HOLE DIGGER DRIVEN BY OLD AUTO ENGINE

The ingenuity of a ranch owner has enabled him to construct a power-driven post-hole digger at compara-

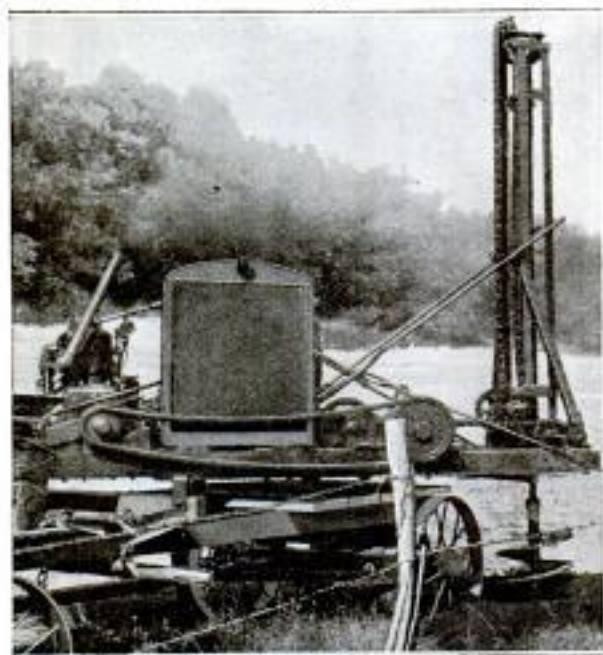

A Post-Hole Digger Driven by an Engine Taken from a Wrecked Automobile

tively little cost. The outfit is mounted on a ranch wagon and is driven by an engine taken from a wrecked automobile. A big auger is held in a vertical position at the end of the wagon and is connected with the engine by improvised chains and gearing. The digger can be moved quickly from point to point and will make a post hole in a short time.

4883 WAR DEPARTMENT PERFECTS PLAN OF PAYING SOLDIERS

American soldiers are to be paid monthly in a way which will protect United States money from the danger of being captured or sunk by the enemy. A large credit has been established in France so that each disbursing officer can draw directly on the government. The plan is particularly convenient and advantageous for the boys at the front.

A soldier will have the choice of being paid in French currency or by check on the treasury. Each month announcement will be made of the exchange rate at which payment will be made. If, for example, the rate were set at 5.70 and some subsequent economic development sent the exchange higher, the soldier would profit. On the other hand, if the exchange fell so that banks were willing to give 5.80 francs for each dollar, a soldier could obtain a check instead of accepting the paymaster's fixed rate. A fighter is thus offered the chance of winning by a change in the money market, but at all times is protected against loss.

4150 SYNCHRONOUS MOTOR USED WITH SIMPLE RECTIFIER

Interesting construction is embodied in a new rectifier that has been developed particularly for transforming electric current from alternating to direct for motion-picture purposes. It is also employed for charging storage batteries. The important feature of the outfit is a synchronous motor that keeps a two-segment commutator revolving at the proper speed to reverse the current, which is reduced to the desired voltage by a special transformer. Changes in the voltage and frequency of the current are taken care of without the

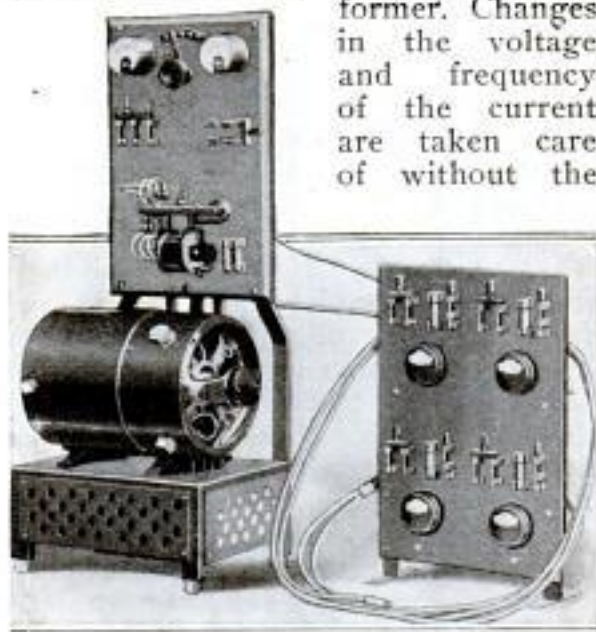

This Rectifier, Which Operates with a Synchronous Motor, is Especially Intended for Motion-Picture Work and Storage-Battery Charging

Imperial Electric Co.
Union City, Ind.

use of auxiliary devices, and as a result high efficiency is claimed to be obtained. The apparatus can be installed without difficulty in any projection booth, for it requires only 10 by 14 in. of floor space.

FERTILIZER LOADER HAS TOOTHED BUCKETS

Steel buckets whose edges are fitted with rows of sharp teeth are a special feature of the loading machines used to handle hard acid phosphate in certain large fertilizer-storage plants. So hard does this substance become that drills are used to break it up, after which the machine elevates it to a hopper to be ground. Following this process it is discharged into wheelbarrows at the

5114 **THRILLING RACE DOWN DARK TUNNEL ENDS IN DEEP POOL**

Reports have been received of a strange subterranean trolley accident that occurred some weeks ago in a railway tunnel under construction in New Zealand. The bore has about a three-per-cent down gradient. Shortly after a car carrying four men entered the tunnel, its acetylene headlight became extinguished. While engulfed in darkness, something else went wrong and control of the car was lost. Two of the men jumped, but before the others could follow, the trolley gained headway and thundered through the black passage at express-train speed, headed for a blank wall that terminated the excavation. By odd good fortune, it happened that the pumps were out of order and the lower end of the tunnel was filled with water. This acted as a buffer and the men were hurled into the pool.



Machine for Loading Acid Phosphate: The Fertilizer Is So Hard That Drills are Used to Break It Up. The Loader's Capacity Is a Ton a Minute

rate of a ton a minute, in some instances. A loader such as is shown in the illustration saves the work of six men.

AN ESKIMO NAVY FOR COLD OCEAN PATROLS

BY FITZHUGH GREEN

5196. The Navy Department is spending more than \$4,000,000 on winter clothing for its bluejackets. In the past our fleet has wintered among the West Indies, where the balmy average temperature of about 83° F. required only ordinary summer garb.

deck force will be provided with cold-weather apparel. Scouts and patrols will have at least half their men similarly equipped; destroyers, who will suffer most in the northern ice lanes above Scotland and Ireland, can draw full costumes throughout.

A percentage of each battleship's

The following list of articles has been

published to the service: wind-proof shirt with hood; wind-proof trousers; blanket overshirt, wool, with a hood; four pairs each of heavy socks and mittens; one pair of high leather sea boots.

The wind-proof suit may well be noted by farmers and others who suffer so much from exposure through our cold western and northern winters. It is of light, close-woven material, such as high-grade duck or khaki. Sleeves and body are full to permit plenty of woollens underneath. The attached hood fits closely about the face and forehead, and can be closed by a drawstring. Tapes are also fitted at the waist and wrists.

The design is that of a North Greenland Eskimo's costume adapted to a

sailorman's activity. Blanket shirts worn directly beneath the wind-proof are of an identical pattern, only slightly smaller. Common army or navy blankets will be used for economy's sake.

An Eskimo fortifies himself against the endless blizzards of the arctic regions by a thick padding of clothing which is always surmounted by some thin, light layer impervious to wind and snow alike. This idea forms the basis for the Navy Department's plans. The costume will be cheap and durable. Its lightness will be a great factor in a man's freedom of movement. What this means one can imagine who has seen an almost helpless fisherman weighted down by a vast bulk of poorly insulated clothing that hampers every movement he makes.

STEPS LEAD TO SHORT CUT ACROSS RIVER BOTTOM

In arid regions of the West and Southwest many rivers are not rivers



The Steps in This River Wall Enable Pedestrians to Cross the River Bed at This Point during the Dry Season Instead of Walking Several Blocks to a Bridge

at all nine or ten months of the year, but merely hard gravel-strewn bottoms. In such instances bridges are more of a nuisance than a convenience if they afford the only means of crossing these

dry channels. This accounts for the fact that when a concrete wall was erected along one of the arroyos to confine the occasional floods that sweep through it, flights of steps were built into the barrier every few hundred feet for the convenience of those living in the neighborhood. During the months that the river is dry these stairs enable pedestrians to take short cuts across the river bottom and thus avoid walking several blocks to a bridge.

IRON AND STEEL PROTECTED BY PORE-FILLING OXIDE

Iron and steel are said to be permanently protected against rust by a process of treatment that is now being used commercially. The material is placed in an oven and heated to a temperature of 1050° F., while subjected to the action of certain gases. Dry steam is introduced and an oxide formed that penetrates the pores and covers the outer surface of the metal. After an hour in the oven, the material is removed and permitted to cool gradually. It is then submerged in heated paraffin oil, which neutralizes the chemical deposit and produces a permanent black finish, after which it is dried in sawdust.

along the bank of the
Arroyo, ca.
Inglewood, Calif

Rust Resisting Black
Finish Co.
Bridgeport, N. H.

4266

WILL BETHLEHEM OBSERVE CHRISTMAS AS OF OLD?



FOR many years the Turks have grudgingly permitted Christians in Palestine to observe solemn rites in places Christendom holds sacred, notably in Bethlehem. Here a patriarch of the church can be seen entering that city in state on Christmas Eve. But this year the "City of David" is in the path of the on-coming British forces, and who can forecast what solemn or tragic scenes will take place in these streets on Christ's natal day?

To Los Angeles Calif

USE WATER FROM RAILROAD TANK TO FIGHT CAR FIRE

5234

A fire, which had started in an express car attached to one of the trans-



Putting Out a Fire on the Roof of an Express Car in a Transcontinental Train with Water from a Railway Water Tank

continental trains, was recently extinguished by means of water from a railway water tank at Mobridge, S. D. The blaze was discovered in the roof of the car in time to prevent serious results, for instead of the engine backing for water, the train was pulled up sufficiently to utilize the big stream from the tank in putting out the flames.

CLASS ERECTS MEMORIAL SHELTER FOR BELL

A beautiful and distinctive memorial has been erected on the Scott High School grounds in Toledo, Ohio, by



the class of 1917 in the form of a shelter for a bell which is one of the school's prized relics. Formerly this bell hung in the Central High School building, serving as a school and fire signal from 1853 to 1895, when the structure was destroyed by flames. It was taken from the ruins badly cracked and now

*Toledo High School
Toledo, Ohio*

has been installed in a carved-stone shelter having arched openings on four sides. The memorial cost \$2,995 and in design is in harmony with the architecture of the school near which it stands.

STEAM EXCAVATOR KICKS ITSELF UP AN INCLINE

5154

After a deep excavation had been completed with a self-propelled steam shovel it was found that the machine could not be driven up the steep embankment to the street level, even though its own power was supplemented by that of two motor trucks. The difficulty was finally overcome by repeatedly driving the bucket into the ground at the lower end of the machine



Steam Shovel Pushing Itself Out of an Excavation: The Jets of Escaping Steam Show That the Machine is Prepared for Maximum Effort

and, by a series of short pushes or kicks, forcing the excavator up the incline foot by foot.

INTERIOR OF SUBMARINE VIVIDLY PORTRAYED

5130

In spite of the peculiar difficulties involved, the interior of a submarine has been made the scene of a play that portrays undersea warfare with remarkable realism. The stage is occupied with what appears to be a cross section of a submarine that is searching for the German fleet. The craft's varying depth below the surface is indicated on a large dial in full view of the audience. When the order is given to turn on the periscope, what appears to be a reflected periscopic view of the

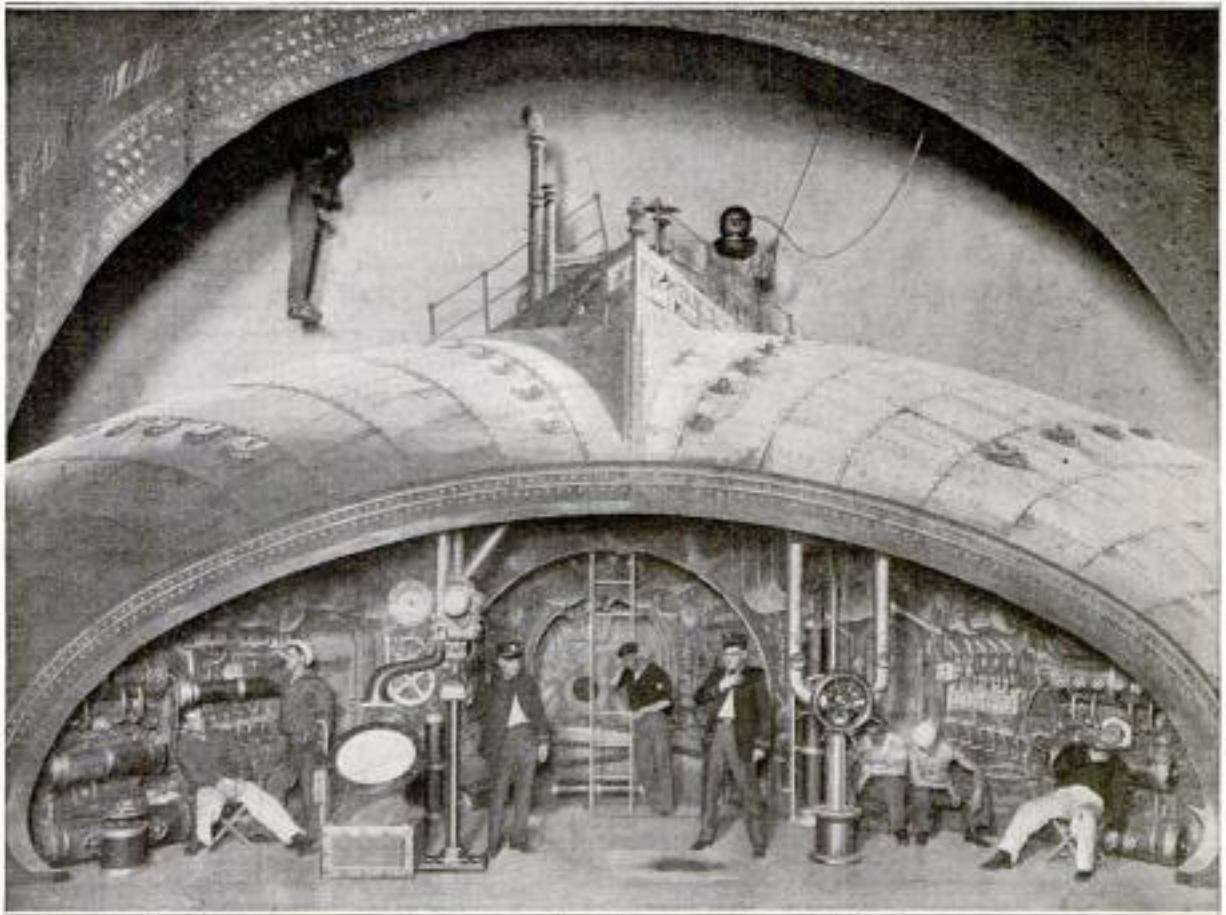

A Stage Setting Showing the Interior and Exterior of a Submarine: This Scene Represents the Moment When the Boat is Supposed to be Sinking and the Crew has Collapsed. Earlier in the Play What Purports to be a Reflected Periscopic View of the Sea's Surface is Thrown on the White Disk at the Left by Means of a Motion-Picture Projector

ocean's surface is shown on a large frosted glass plate beneath the end of the periscope tube. The changing scene is in natural colors and is produced by a large motion-picture projector located beneath the glass. The climax of the play comes when the enemy's fleet, clearly shown on the

glass, fires on the submarine and, as indicated by the dial, the underwater craft sinks lower and lower. Members of the crew are overcome and collapse at their posts. At that instant, divers descend from a friendly vessel to the sinking boat, saving the vessel and its crew as well.

SUNKEN BOAT AND CARGO

5370 DOUBLE IN VALUE

The recent salvaging of a steel ship of 4,764 gross tons which sank in Georgian Bay, Ontario, in the latter part of 1915, furnishes striking evidence of the remarkable rise in the values of vessels which has taken place since that date. When the vessel went down it was carrying a hull insurance of more than \$200,000 and was valued at between \$350,000 and \$400,000. The persistence of a wrecking company in the face of unusual difficulties finally

brought the vessel to the surface, and when it has been repaired it will be worth \$750,000 or more, according to estimates.

WATER WHEELS IN JAPAN

5113 USED TO POUND RICE

In spite of the rapid advance in mechanical lines which Japan is making, much primitive machinery is still found in that country. The accompanying street scene was photographed in a mountain village in the island empire and shows some of the big water

Japan

wheels, driven by a stream, which operate wooden pestles for pounding rice.

used with success in making bread and cake and at a recent luncheon for men interested in the cottonseed business, ginger snaps and jumbles made from this flour were served and much enjoyed.

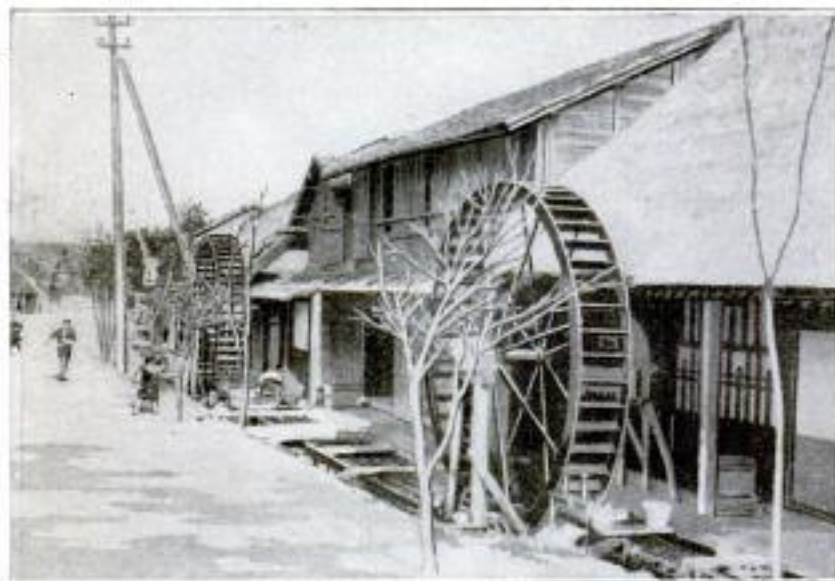

Street Scene in Japanese Mountain Village Showing Two of 27 Water Wheels on This Thoroughfare Employed in Pounding Rice

There are 27 of these picturesque, but crude, wheels on this one street.

SAUSAGES AND CAKES MADE WITH COTTONSEED FLOUR

5296 A new food product which vegetarians may well claim represents a partial victory for the meatless diet is the cottonseed sausage, made somewhat after the manner of peanut sausages that are now supplied to German troops. The new product is not all or chiefly vegetable, however, since it contains three parts sausage meat to one part cottonseed flour. Because of the low cost of the latter it is claimed that the new sausage is eight cents per pound cheaper than the usual kind. Special effort is now being made to show the public the food value of cottonseed flour, emphasis being placed on the fact that its protein content is much in excess of that of meat. This flour has been

back of the front wheel and is driven with pedals and a chain, the operator sitting on a seat just above the two rear wheels. A box for the grinder's tools is mounted above the rear axle, while a frame for holding saws to be filed is attached to the front end of the frame. No means is provided for propelling the tricycle by foot power, though a few alterations would make that possible. Included in the outfit is a hollowed block which is placed on one wheel to keep the machine steady while grinding is being done.



Two Views of a Homemade Grinding Outfit Constructed from Bicycle Parts: Pedals are Used to Drive the Grindstone but are Not Employed to Propel the Conveyance

5153 — SCISSORS GRINDER'S ODD HOME-MADE OUTFIT

An itinerant scissors grinder has constructed a very serviceable outfit for himself by combining parts of two bicycles into a three-wheeled conveyance which he pushes along the street. The grindstone is mounted just

3940 TROLLEY BOAT KEEPS ICE FROM JAMMING CANALS

During the winter months a small electric-trolley boat is employed to prevent ice from jamming the intake canals at the big Niagara Falls power plants. The craft, as its name implies,

tween the posts are of iron. Every seventh post is taller than the rest and is surmounted by an



The Little Steel Boat, Driven by an Electric Motor, Breaks into the Ice Packs and Keeps the Intake Canals Open during Winter Months

is quite an unusual one and is driven by a 75-hp. motor which receives current from a pair of overhead conductor wires strung above the water. At the top of a short mast there is a swivel arrangement through which connection is made with the insulated cables extending to the double trolley that travels along the transmission wires. This enables the vessel to move freely without continually tangling the feeders while it is engaged in attacking big cakes of ice and sending them on their way downstream.

ARTISTIC PRISON FENCE

5792 SERVES TWO PURPOSES

In place of forbidding walls and gratings which unhappily mark the boundaries of many penal institutions' grounds, the prisoners' ward of a county hospital in the West has been surrounded with an artistic fence in which light standards have been incorporated. The posts are of concrete while the portions of the barrier be-

electric-light globe so that the whole fence is well illuminated at night-time.



This Artistic Fence around a Prisoners' Inclosure Is in Pleasing Contrast to Many Prison Barriers. Every Seventh Post Serves also as an Electric-Light Standard

Fence builders - H. O. Casley Co. Los Angeles, Calif.
Lighting by Southern Calif. Edison Co.

5271
CIVIC FEATURES THAT PROMOTE THE COMFORT



For the Convenience of Bathers and Others This Clock has been Installed at the End of a Promenade at Coronado, California. It Hangs beneath a Pleasing Gabled Shelter Several Feet above the Rail and Bears the Advertisement of an Enterprising Jeweler



By Making Direct Connection with One of the Outlets of a Fire Hydrant This Convenient Drinking Fountain has been Installed in Galion, Ohio, at Slight Expense. The Overflow Leads to a Sewer Below



This Floating Band Stand with a Thatched Roof of Palm Leaves Is a Special Attraction in a Los Angeles Park. It is Often Occupied by a String Orchestra and on These Occasions Pleasure Seekers Are More Ready to Rent Boats That They may Row Out and Hear the Music Better. Thus the Owner of the Stand and Boats Increases His Revenue Materially



Every Student at the State University of Iowa, at Iowa City, Knows This Bench. The Fine View Obtainable from This Spot Is Suggestive of a Favorite School Song Which Appears on the Bronze Tablet on the Back of the Seat

In These Times of High Food Prices Train Luncheons Are More Popular Than Ever with Travelers. For That Reason Inclosed Lunch Wagons Like This, Which are to be Found at Various Stations on the Northern Pacific and Elsewhere, are Well Patronized. With Them Fruit, Sandwiches, and Light Lunches can be Brought within Reach of the Car Windows



AND ENJOYMENT OF RESIDENTS AND VISITORS



For Several Seasons the Chamber of Industry at Cleveland, Ohio, has Held Its Displays in Tents, but This Year It Secured This More Substantial Structure, Consisting of a Steel Frame Composed of Numbered Parts That can be Fitted Together Quickly or Packed into Small Space. The Sides are Covered with Canvas and the Top with Roofing Paper



Traffic Officers in Grand Rapids, Michigan, can Now See Two Ways at Once. Mounted on Each Signal Post Is a Cube Having Sides Composed of Mirrors, as Shown Here. These Are a Great Help in Watching Traffic Conditions

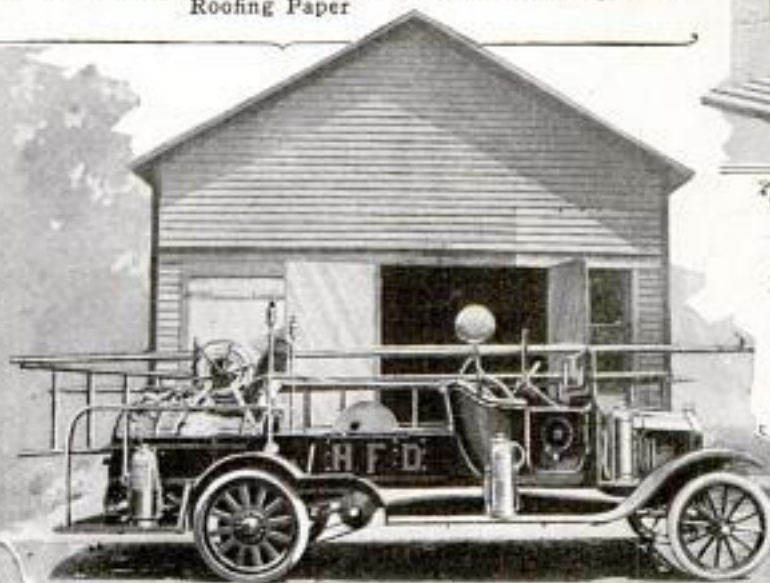

At Hollansburg, Ohio, the Motor Car has Brought Better Fire Protection to the Countryside as Well as to the Town. This Village Secured the Cooperation of Farmers within a Three-Mile Radius in Purchasing This Fire Truck, Equipped with Chemicals, Ladders, and Tools. Now, in Case of Fire, It Speedily Responds to Their Phone Calls



The White Club Which This Vancouver, British Columbia, Policeman Carries Is Not a Mere Novelty, but Is of Decided Assistance in Indicating the Direction Traffic may Travel. A Stick of This Color, It has been Found, is More Easily Seen by Drivers Than One of a Darker Hue



Though Unable to Raise Their Salaries, Pueblo, Colorado, Helped Its Policemen Meet the Mounting Cost of Living by Granting Them "Free Water" for Irrigating Their Gardens, While a Corporation Loaned the Men 10 Acres of Land. How Well the Force Utilized These Novel Substitutes for More Pay, is Shown Here

Inw. Jno. B. DuMont
811 South Erie St
910
Soleds Ohio

1657 **REVOLVING CYLINDERS ARE
FEATURE OF WINDMILL**

A novel type of windmill has been invented which consists of a cylindrical metal housing, mounted on a tower and having two openings opposite each other. The housing contains two cylinders set vertically and fitted with wind vanes which cause the cylinders to revolve, one to the right



Powerful Windmill
with Two Revolving
Cylinders

and one to the left. By means of gearing they operate a perpendicular shaft which may be connected with a pump or machinery. The front opening of the housing is kept to the windward by means of a tail which swings the mill on its axis. Power is shut off by setting the tail at right angles to its normal position. In a storm, automatic governors perform the same function, so that a rounded section of the housing faces the wind.

5219 **URGENT NEEDS IN FRANCE
MET BY OUR RED CROSS**

The war council of the American Red Cross, since its appointment last May, has appropriated more than \$12,000,000 for work in Europe, of which over \$10,000,000 has been spent in France. How splendidly this body, acting in behalf of the American peo-

ple, is meeting the great task confronting it is shown in a recent report. While the main object of the organization is to care for our army and navy, it has found time and means to render valuable aid to our allies on the continent, particularly the French and Belgians. A wonderful work has been done in caring for and educating destitute children, and in caring for sick and wounded soldiers. While it is not the policy of the Red Cross to rebuild the villages of France, many of the population have been given shelter until they could return to their homes, and large numbers in the devastated areas have been aided with food, clothing, and agricultural implements.

It is estimated that some 500,000 persons in France have contracted tuberculosis as a direct result of the war. Our Red Cross has done valiant work in fighting this disease, not merely for the sake of France, but to obtain better health conditions for our own soldiers. The sum of \$1,000,000 has been appropriated for the relief of sick and wounded French soldiers and their families. More than a dozen base hospitals organized by the American Red Cross are now doing active service in France and others are rapidly being made ready for foreign duty.

5251 **NEW LENS PREVENTS GLARE,
FITS ANY AUTO LAMP**

A new lens designed to eliminate the glare of automobile lamps, is so constructed that it can be easily attached to a headlight on any car. It is cup-shaped and encircles the bulb so that all light striking the reflectors first passes through the lens. The inner surface is ribbed and the outer surface covered with rounded elevations, the purpose being to produce a broad beam of strong, but diffused, light.



Stewart Warner
Speedometer Corp.
1870 Newberry Bldg. Chgo

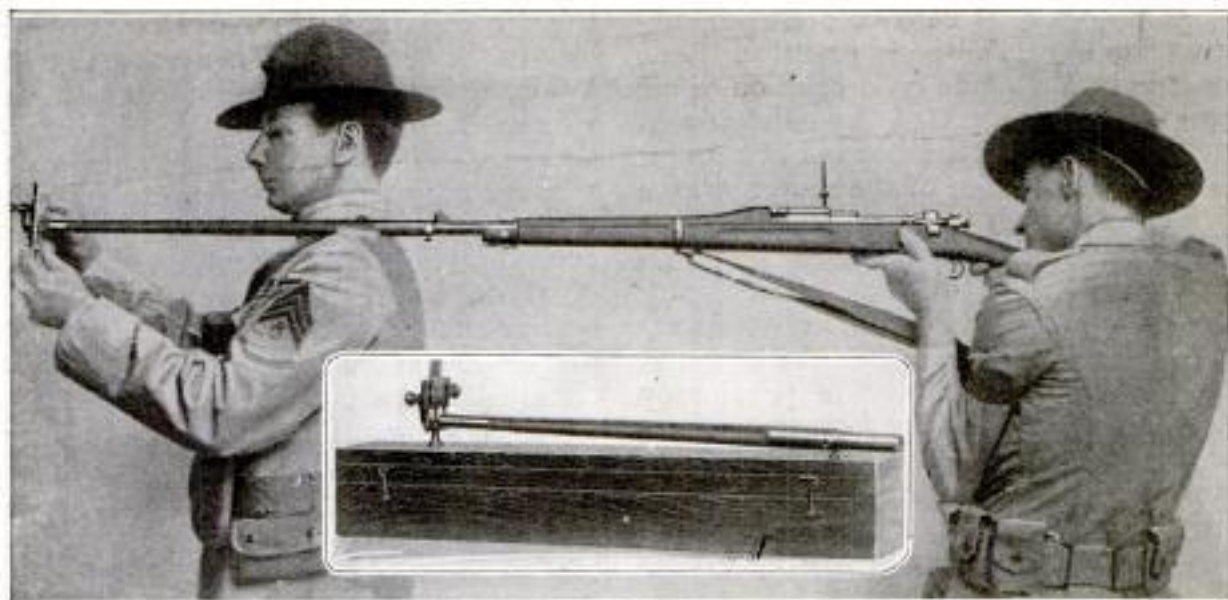

An Instructor is Here Shown Adjusting the Miniature Target on an Aiming Device According to the Pupil's Directions. On Word from the Pupil the Officer Registers the Aim with a Dotter. A Close View of the Attachment is Given in the Insert

5201
**DEVICE TEACHES AIMING
 WITHOUT USE OF SHOT**

A new device with which instruction in aiming a rifle can be given, without the use of ammunition, has recently been tried out in teaching recruits the use of firearms. It consists essentially of a wooden rod, 16 in. long, with a metal end which is slipped on and fastened to the muzzle of the rifle. The outer end carries an arrangement in which miniature celluloid targets are placed. There are also screws for moving the target up or down and to the right or left. On this end, too, is a small dotting apparatus and a place for cards to be dotted by it. In learning to aim, the pupil rests his rifle on the

instructor's shoulder and directs the latter to move the target as he, the pupil, deems to accord with proper aim. When the man aiming believes that the sights and bull's-eye are in proper alinement he calls out "mark," and the instructor, by means of a finger key, actuates the dotter. The latter makes a mark on the card which serves as a record of the aim.

5215
**CRAFT OF SHALLOW DRAFT
 DRIVEN BY AIR COLUMN**

Radical features are embodied in a hydroplane that has been designed particularly for the navigation of shallow streams. Outstanding among them is the means of propulsion, a pneumatic

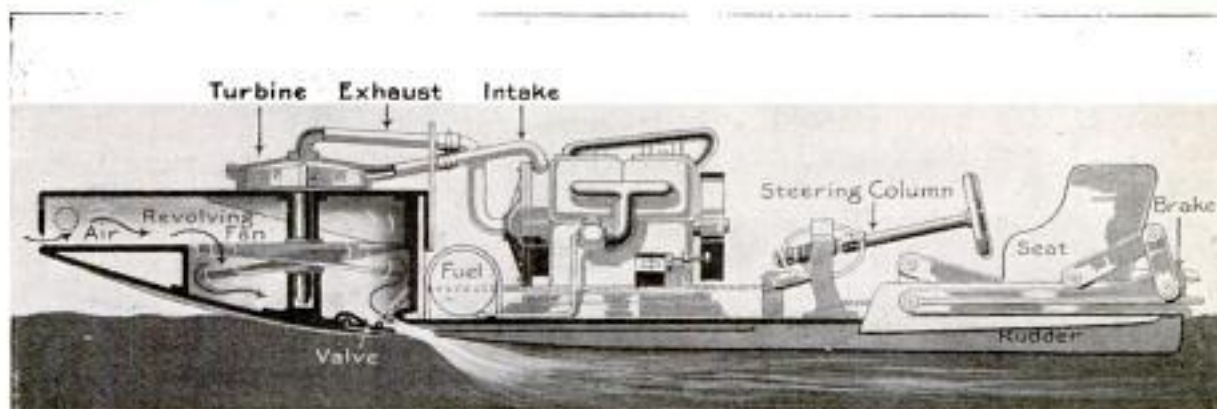

New Boat for Shallow Water Designed to Ride on Air and be Propelled by Air Pressure Instead of a Screw

Inventor: Capt. C. A. Allogg
 22 Chamber St.
 Jamestown N. Y.

system that represents a wide departure from established practice. The boat is built to ride on a cushion of air and to be propelled by air forced through ports in the bottom at a point slightly in advance of the motor, where the chief load is borne. The engine is connected with a centrifugal pump that operates a turbine. The latter drives a propeller which draws in air through a large opening at the bow and discharges it through the previously mentioned ports. The bottom is convex, while the knife-edge sides taper toward the stern, where they slant inwardly until nearly flush with the rest of the hull. This arrangement prevents

the air column from escaping, except by traveling the length of the vessel. While doing so it forms a cushion on which the hydroplane rides. It is apparent that head resistance is cut to the minimum by the air intake at the bow, while friction is reduced by causing the craft to glide over the water instead of through it. The arrangement, as will be seen, provides only for forward propulsion and because of that, a mechanical brake is required. There is an interesting problem in determining whether the loss of energy through power transmission in this case is offset by the reduction in friction attained by pneumatic propulsion.

FRANCE COMPILES A "BOOK OF REPRISALS"

German "frightfulness" is being turned less and less, nowadays, against France. The Teutons have found that it does not pay.

The reason for the comparative immunity which France now enjoys—so far as shelled hospitals, ambulance trains, cathedrals, and peaceful villages are concerned—is to be found in a system of impartial retribution which our Gallic allies adopted approximately one year ago, and which they have pursued unceasingly ever since. Now even Bavarian denseness has grasped the idea.

Driven by the fact that the Germans always have been distinguished for uncivilized acts like suddenly dropping five 60-mm. (about 2½-in.) shells into a Red Cross hospital, a village green outside the real fire zone, or into an edifice like Rheims cathedral—that even a Vandal would have respected—the French quietly have printed a little book, the like of which probably never existed before.

This volume lists all the possible German atrocities—at least it lists all that the Germans have thought of to date—and then in opposite columns, it tersely recommends the reprisal that should be made.

At first, the idea was simply to discourage these atrocities, so when

a Teuton battery dropped five 60-mm. shells at once in a Red Cross hospital, a French battery immediately replied with 12 shells of the same or larger caliber. The French did not exactly adopt the "eye for an eye" method, since even in revenge they could not descend to wanton cruelty. They placed their shells just as near to the German battery which had committed the outrage, as was humanly possible—the idea being to wipe out the malefactors as an instant lesson to their comrades in arms.

Three months of this, with the French batteries methodically dealing out reprisals, each on the basis of two to one, and a growing reluctance became visible on the German side. It is discouraging to the worst bad man to find that the chap he is trying to dishearten is handing back just twice as much as he receives. And the Germans found themselves exactly in this position, for the French were always ready, willing, and able to retaliate.

ⒸThe rapidity with which fighting armies destroy each other's signal equipment is shown by the fact that the signal officer on General Pershing's staff has recommended that provision be made for \$1,000,000 worth of wire alone, for each month of service.

Hart House SE
University Grounds
Toronto, Ont. CAN

Int: Jos. A. Stearns
Morris Bldg
Philadelphia Pa

WOMEN STUDY MASSAGE

ANTISUBMARINE BOMB MADE

5255 TO AID THE MAIMED

5044 TO EXPLODE AT ANY DEPTH

An important lesson which this country can learn from Canada and our allies in Europe is that the masseuse can be of great service in working cures among the wounded soldiers, supplementing in an important way the work of the surgeon. Early in the present year the Canadian government, seeing the excellent results obtained along this line in hospitals at the front, opened an institution in Toronto for instruction in massage and remedial gymnastics. Women from all over the Dominion volunteered for the course. Those who enter are paid \$25 per month during the six months' period of instruction, and the government reserves the right to reject any student at the end of the first month. On completing the course the salary is \$75 per month and the graduate is subject to military orders. Refinement, tact, a good physique, and a fair education are required of those entering the work. With their treatment, which supplies a need not filled by the work of surgeons, these trained young women are able to restore the use of hands and feet, and even to restore the faculty of speech to many of the men.

ⒸThe Post Office Department has announced that it is not permissible to add the words "Compliments of," together with a blank for the name and address of the sender, to the imprint which states that a magazine can be sent unwrapped and unaddressed to our soldiers.

As one method of dealing summarily with Germany's U-boats, an American inventor has proposed to use bombs of

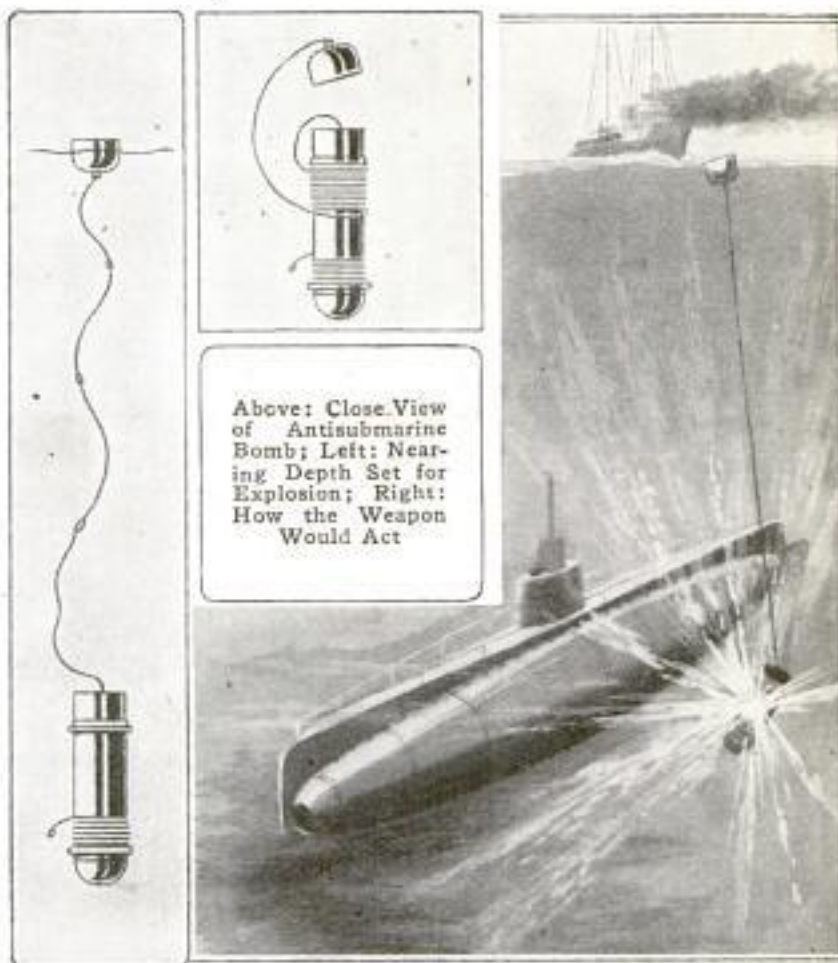

a special type designed to explode at any desired depth when thrown into the sea. The missiles would be dropped from air craft or submarine chasers when an enemy boat was sighted beneath the water or seen to submerge. The bomb is connected by a light cable to a buoyant chamber that floats on the surface. As it sinks, the line, which is wrapped around it, unreels until a predetermined depth is reached. The jerk that then occurs actuates the detonator and discharges the explosive. When submerged at any considerable depth, a submarine is under an enormous pressure. An explosion, such as that of a high-power bomb, occurring in close proximity to it would cause it to collapse.

SOME NOVEL AND LITTLE-KNOWN ACCESSORIES



Adjustable Shower Attachment Requiring No Curtain, and Adaptable to Persons of Different Heights: Convenient, Also, for Rinsing Hair after a Shampoo, as the Inset Shows. Price \$10



Unsealing Tin Can without Injuring It so That Subsequent Use Is Possible: Ring, When Heated, Melts Solder Permitting Cap to be Lifted after being Punctured. Price about 50 Cents



For Blind Persons and Those with Impaired Sight, a Head-Conforming Guide That Enables the Hair to be Parted Neatly without the Assistance of an Attendant. Price 25 Cents



Soft-Rubber Guard for Nursing Bottle That Affords Good Protection against Breakage

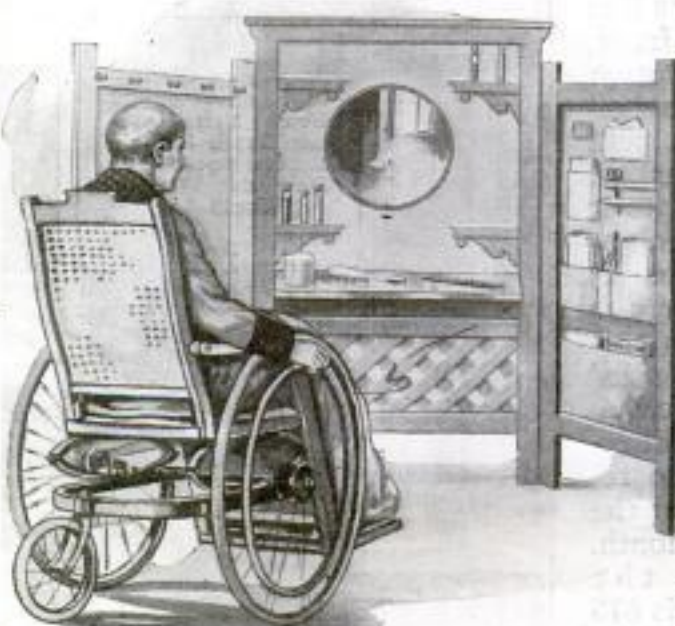

Portable and Folding Dressing Screen of Service in Homes Where There Are Invalids: It may be Placed beside a Bed, or Carried from One Floor to Another as Needed



A Gift Suggestion for Those Who Knit: A Silver-plated Yarn Holder of Attractive Appearance and Serviceable Form. Price \$3.50



Between the Metal Base and Asbestos Top of This Flat-iron Mat Is a Layer of Waxed Felt That Keeps an Iron in Good Condition



Artistic Aquarium of Plain Glass Supported on a Substantial Wrought-Iron Stand. Price \$7.50

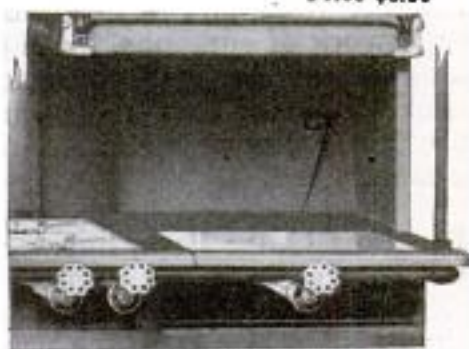

Gas Range with Built-In Hot Plate or Griddle: The Ovens Are Immediately Above and the Open Burners at the Left

INTENDED FOR THE HOME AND ITS MEMBERS

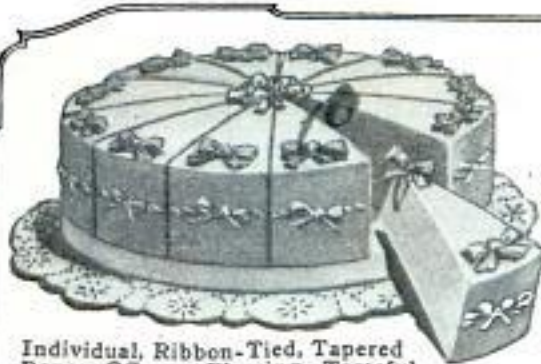

Individual, Ribbon-Tied, Tapered Boxes Offer a Pleasing, Tasteful Way of Serving Cake. All Colors, \$5



Rubber Washbasin Intended for Motorists and Campers: Hot Water does Not Injure It and When Not in Use It may be Folded Compactly



Leather Pouch with Two Openings, the Smaller of Which Permits Tobacco to be Poured into the Bowl of a Pipe without Needless Waste. Price 50 Cents

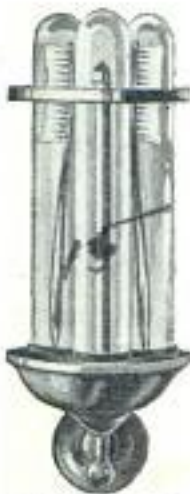

Sanitary Toothbrush Holder: Glass Tubes with Ventilating Holes at Top are Open at the Bottom and Mounted on a Revolving Base, Inside of Which a Volatile Disinfectant is Kept



All-Metal Shoe Tree of Light Weight That Folds Compactly and Occupies Little Space in a Traveling Bag. Price 50 Cents

Among the New Accessories for the Sewing Room is This Mahogany-Finished Lamp Equipped with Hooks and Pegs for Scissors, Needle Cushions, Thread, and Other Articles



Especially Suited for a Newel is This Striking Lamp Made of a Three-Inch Shrapnel Case. An Opalescent, Projectile-Shaped Globe is Used. Price \$10



Folded One Way the Broiler Holds Thin Strips of Bacon Firmly; Reversed, It Receives Thick Steaks. Results Shown Above: (1), Raw Bacon; (2) & (3), Broiled; (4), (5), & (6), Fried; Originally Each Was of Corresponding Length. Price 50 Cents

used by
Rockford Electric Co
916

for: National Lamp Works
Cleveland Ohio

**PORTABLE STEEL CABINET
FOR VALUABLE FILES**

5140

The steel case shown in the accompanying illustration was made for an electric-light company which desired a container for its meter-record cards that would be fireproof. The case is of such a design that it would be serviceable in any office having similar card files. It contains sixteen 5 by 8-in. drawers, and eighteen 3 by 5-in., and stands 41 in. high. It is mounted on two heavy rubber-tired wheels and two swiveled casters, while at either end are handles so that it can be easily moved to and from the safe daily.

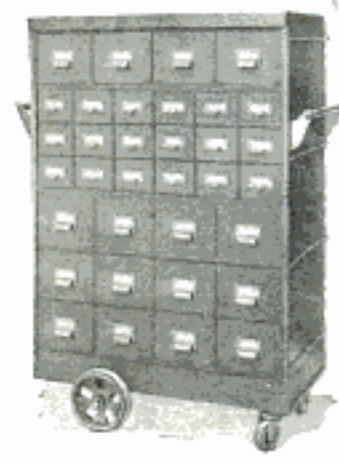

**STEEL TOURNIQUET DEvised
FOR SURGICAL USES**

5064

Intended for war and ordinary emergency purposes as well as for the use of the surgeon when performing certain operations, a tourniquet has been devised that may be applied to the neck as well as to other parts of the body. It consists of a steel band that may be fastened about an arm or lower limb somewhat in the manner of a handcuff. Attached is a thumbscrew with a plug swiveled to its inner end. When this is pressed firmly against an artery, it controls the flow of blood without affecting the venal system unless the band is tightened for such a purpose, according to the inventor's claims.



**REFLECTOR GIVES BRIGHT
LIGHT WITHOUT GLARE**

5131

The shape and construction of a new electric-lamp reflector are such that a strong light is produced, unaccompanied by a glare or sharp shadows, thus making it a desirable fixture for industrial illumination. This reflector is designed for use only with clear bulbs having the light filament concentrated in a small coil at the end. Over the end of the bulb is placed a metal cap silvered and polished on the inside. This throws a large part of the rays back into a porcelain reflector which roughly resembles an inverted pan, 20 in. in diameter, with wide-spreading sides. What corresponds to the bottom of the pan has a special concave shape which re-directs the rays reflected to it by the cap, to the sides of the reflector, whence they are thrown into the room. The diffusion thus produced without dimming the light is what gives the reflector its distinctive character.



**TEMPERATURE REGULATOR
FOR AUTO ENGINES**

4365

A new model of a temperature regulator for the cooling medium of automobile engines is installed in the bottom water line of the radiator system, instead of the top line. It contains a corrugated-metal vessel containing a volatile liquid. When heated, this liquid is converted into vapor, and the metal vessel expands or contracts according to the temperature of the liquid, which is affected by that of the water in the cooling system as it passes through. By means of valves the regulator allows just enough circulation to keep the temperature of the cooling medium constant.



Dr. Henry H. Hammer
Box 198 - Augusta, Me.

Gulton Company
Copyrighted material
Anokville, Tenn

Invt. Jas. S. McFetty, Minneapolis

Office in
Monadnock Bldg. City

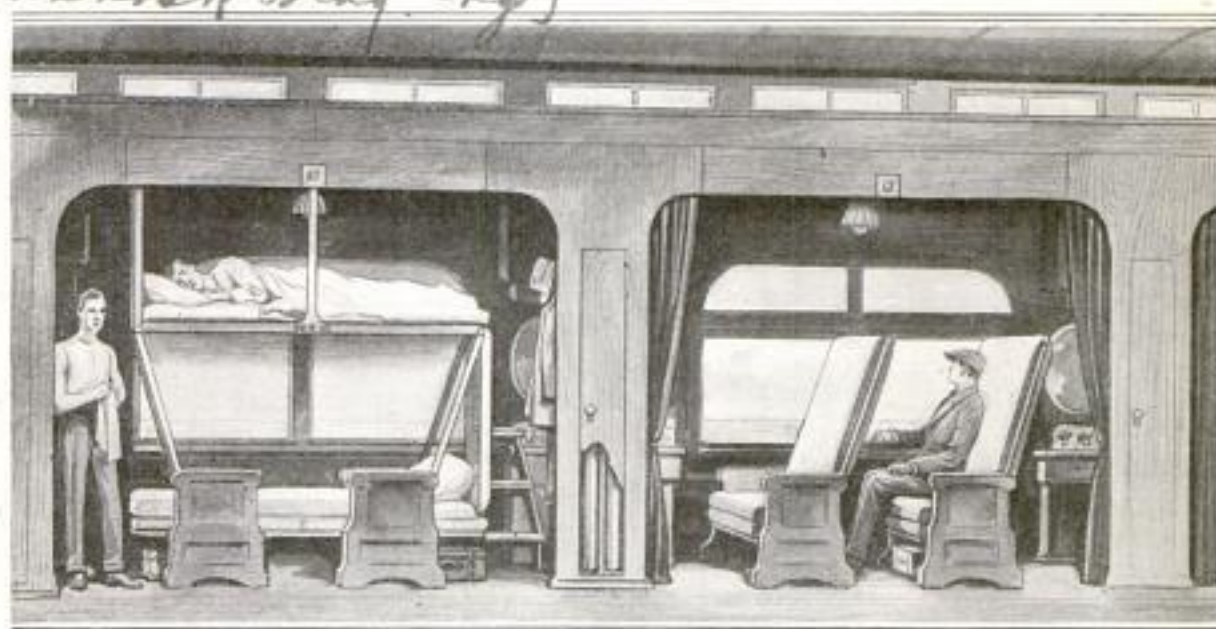

A View Showing Two Sections of a Proposed Design for a Sleeping Car: The Arrangement of the Berths Which are Entered from Their Respective Dressing Rooms at Either End, is Shown at the Left. A Section as It Appears for Day Service is Pictured at the Right

Railroad car
NEW SLEEPER ELIMINATES FAMILIAR DISCOMFORTS

A recent invention, designed to eliminate the various inconveniences occasioned by the present type of sleeping car, provides for a sleeper with 24, instead of 32 berths, each of which is entered with ease from the end rather than from the aisle, thus affording greater privacy. In this car an upper and a lower berth constitute a section divided from the adjoining ones by a partition and a narrow closet for holding the bedding in the daytime and the traveler's belongings at night. At the end of each section is a narrow dressing room furnished with a washstand, mirror, rack, etc., one for the upper berth and the other for the lower. In the former a set of steps is provided for the convenience of the occupant. The seats are made with high backs and can be faced either way for day service so that no passenger need ride backward.

To make up the berths the two seats are placed facing each other, the frames of the backs serving as a support for the upper berth. Each back, as well as each seat bottom, is composed of two upholstered parts that fold together. The backs are so hinged to

the frame that they can be used as end partitions and as a base on which the upper mattress rests, while the two seat bottoms are opened up to serve as a support for the lower-berth mattress. The inventor has reduced the amount of weight carried near the roof of the car, thereby tending to lessen the swaying of the coach.

METAL HOT-WATER BOTTLE 5700 IS FORM-FITTING

For hospital and household use a metal hot-water bottle, curved to conform to the abdomen and chest, has lately been introduced. It is made entirely of aluminum and is supplied with loops that accommodate a belt by which the device may be strapped and held firmly in place regardless of the posture assumed by a patient. The capped opening is an inch and a half in diameter and permits the receptacle to be filled either with hot water or crushed ice.



Sterling Aluminum Co.
Copyrighted material

Artillery

**PLATES REVEAL POSITION
OF ADVANCING TROOPS**

4763 It is quite certain that the world will not know until the war is over, if even then, how many lives have been sacri-



Charging Soldiers Wearing "Back Plates" of Shining Metal Which Reveal the Position of the Men to the Gunners at the Rear

ficed because artillerymen have failed to keep their curtains of fire ahead of advancing infantry comrades. When telephone lines and aeroplanes fail, such tragedies are possible because the dull-colored uniforms of the charging soldiers are easily lost sight of when blended into the landscape. To prevent losses of this sort British infantrymen are now being equipped with "back shields" when they engage in a charge. These are merely shining oval disks of metal that are attached to the knapsacks.

The light that they flash back enables the gunners at the rear to follow the men's advance more closely and to regulate the artillery fire accordingly.

Castor oil, much used to lubricate aeroplanes because it is little affected by heat and cold, has doubled in price, so the government is to raise its own castor beans from which to extract the oil.

5253 **FAST PLANES LOCK HORNS
IN AIR AND KILL PILOTS**

Two student airmen met instantaneous death at the North Island army aviation field, San Diego, when their machines, traveling at a high rate of speed, met in a head-on collision a few weeks ago. The accident was one of the most spectacular aeroplane wrecks that has occurred since our entrance into the world war. While flying at a blind angle, which prevented the pilots from seeing each other, the craft struck at an elevation of about 1,200 ft. The tremendous impact locked the engines of the two tractor biplanes so rigidly that they failed to separate when, far below, they landed on sun-baked adobe that was nearly as hard as concrete. Both fuel tanks exploded, shattering the machines and hurling the debris in a shower of fire. One airman was climbing for altitude and proceeding eastward. As he emerged from a cloud bank, according to one version, the other pilot, traveling toward the west, turned the nose of his craft downward, preparatory for descent. The collision followed instantly. Although the airmen had the entire field to themselves, the tragedy was purely accidental, but scarcely unavoidable. Fortunately it was one of a character that is exceedingly rare.

Cement

5139 **CEMENT BLOCK RESEMBLES
THIRTEEN BRICK**

A very serviceable design for cement building blocks is shown in the accompanying illustration of a unit which is



fashioned to resemble 13 brick laid in four tiers, the ends of adjacent blocks being such that they dovetail into each other. Blocks of this sort are particularly suited for covering frame houses with a veneer. The resemblance of these cement units to brick can be made nearly perfect by facing them with suitably colored material.

*Installed at Seattle
Construction & Dry Dock
Co's Plant - Seattle, Wash.*

BOILER HOUSE CONSUMES

3145 SAWMILL REFUSE

The boiler house of a shipbuilding plant at Seattle is a circular steel structure, in which the 12 drum boilers, each 30 in. in diameter, are arranged on end in a steel framework around a central fire pit. Besides extensive machine shops and shipyards, the plant includes a large sawmill, and the boiler house also serves as a consumer of all the refuse from this mill, which is picked up by traveling conveyors and finally dumped into the consumer through a chute passing over the ring of boilers to the fire pit. The inside of the boilers and the through tubes come in contact with the fire and burning gases, while the outside is lagged with asbestos covered with canvas. The boiler house furnishes steam for generating the electricity used in the plant, power for the sawmill, and power for

air and hydraulic compressors. When the fire is once started beneath the boilers, it is said practically to take care of itself by the consumption of the sawmill refuse continually dumped in from the conveyor above. The ar-

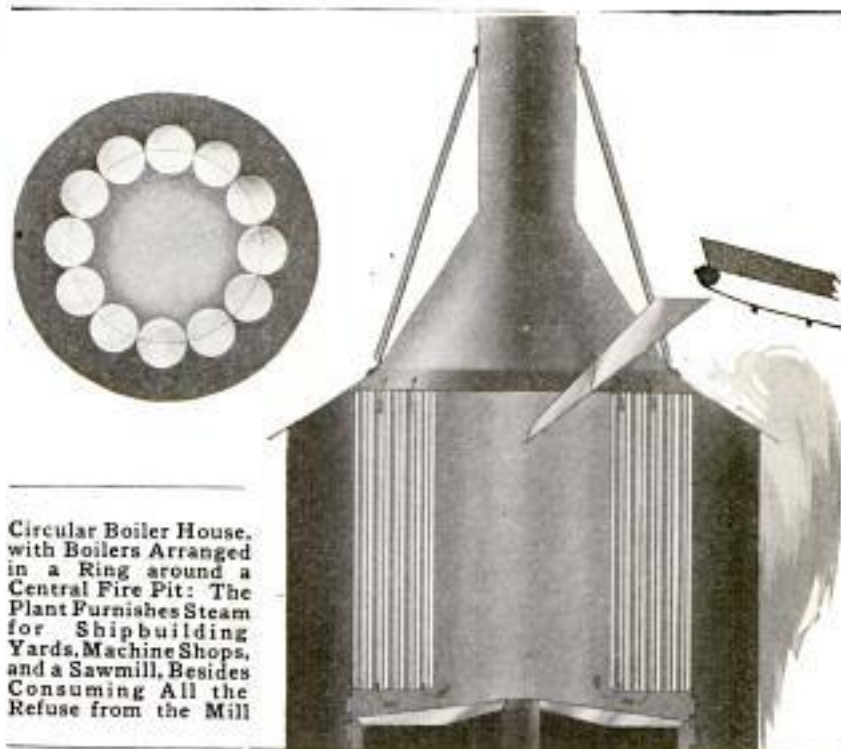

Circular Boiler House, with Boilers Arranged in a Ring around a Central Fire Pit: The Plant Furnishes Steam for Shipbuilding Yards, Machine Shops, and a Sawmill, Besides Consuming All the Refuse from the Mill

arrangement, it is claimed, solves the refuse problem which is a matter of concern in sawmills handling large quantities of timber.

GEARS ON NEW TRACTOR

5784 ALL RUN IN OIL

By designing a tractor all gears of which are inclosed in oil, a concern has provided a farm machine whose transmission cannot become clogged and

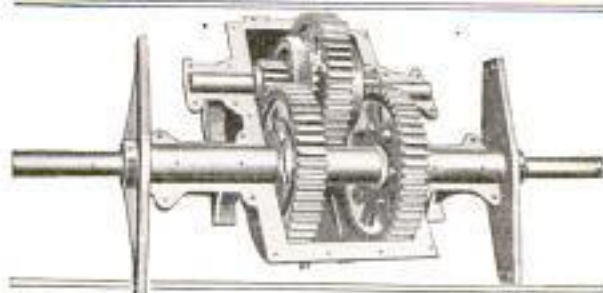

Driving Gear of New Farm Tractor with Top of the Gear Case Removed: The Cogged Wheels on the Axle are Mounted Free but are Bolted to Sleeves That are in Turn Bolted to the Drivewheels

worn by dirt as is common with many tractors. The improvement makes the engine 25 per cent more efficient, it is claimed. In this transmission a conventional train of gearing carries the power to an ordinary differential. In delivering the power from this point on, special features are introduced. The differential actuates two identical sets of gears, one for each drivewheel. Each set terminates in a cogged wheel mounted free on the rear axle but rigidly connected with one drivewheel by means of a sleeve placed about the axle. The case inclosing the gearing, which by this arrangement is confined in quite small space, is partly filled with oil that needs replenishing infrequently. All bearings have dust-tight casings.

*Mfg. The Deere & Co.
Motor Implement Co.
Cedar Rapids, Ia.*

5266

SOME STRANGE VISITS SANTA CLAUS HAS MADE

Every Mother and Child in This Picture Is a "Christmas Opportunity" for Some One Who Is Ready to Help Santa Claus. These Are a Few of Many French Peasants Sent from the War Zone to Southern France, by Way of Switzerland. The Swiss are Shown Helping Them as Best They Can, but, as They Are so Far from Home, Their's will Be a Sad Holiday Time Unless Kind Folks Remember Them



Very Deep Snow Enabled Bishop, California, to Have a New Kind of Municipal Celebration Last Year. A Big Christmas Tree was Mounted on a Wagon and Drawn through the Streets by a Tractor, While Santa Claus Distributed Gifts along the Way

Already the Children in the French Villages have Made Friends with Our Soldiers. Here They are Getting Acquainted with—What do You Suppose?—a Baby Lion Which Is a Pet of Some American Boys. If You will Look Carefully, You can See Where the Cannon Shells have Battered the Walls of These Village Homes and, of Course, Some of the Shells have Made Hearts in These Homes Sad. Here, Then, Is a Job for Santa Claus so Big That He will be Glad of Everybody's Help

AND STRICKEN FOLKS HE SHOULD NOT FORGET



When the Tired French Mothers with Their Babies Reached Switzerland on Their Roundabout Journey to Southern France the Good Red Cross Nurses Thought First of the Littlest Travelers. So Far as They Were Able, They Gave Them Clean Clothes, as You See Them Doing Here, and Nice Warm Baths. But the Red Cross Says It Has Not Near Enough Garments to Go Around and It Needs All the Baby Clothes That American Folks can Give



The Boy Scouts Pledge Themselves to Do a Good Turn Every Day and Those in Salt Lake City Surely Lived Up to That Ideal When They Started Out to Collect Shoes Which are to be Sent to War Victims, Young and Old, in France and Belgium. Everyone was Asked to Contribute Footwear Which a Little Repair would Make Serviceable. When the Lads Cooperating in the Scheme Completed Their Task, They had Gathered 15,000 Pairs of Shoes—Enough to Fill Several Rooms! One of Their Receiving Counters and Some of the Shoes are Shown Here



Many Modern Buildings Have No Fireplaces with Wide Chimneys for Santa Claus' Entrance, but as He Is a Very Persistent Old Santa He Is Sure to Find a Way In. Here He is Scaling the Wall of a 14-Story Hotel in San Francisco, Just Like a Steeple Jack, While Thousands Below Watch Him Breathlessly

*Inv. Chas. C. Powers,
P. O. Box 152 - Williams,
Army*

5-042
**CARRIER WITH WHICH TWO
CAN MOVE HOSPITAL BED**

In a hospital which shelters a large number of wounded soldiers a simple carrier has been devised with which a

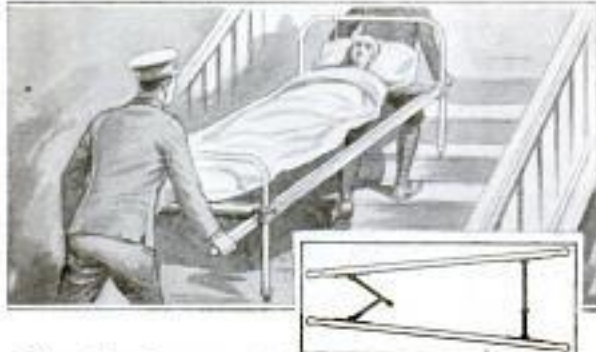

Collapsible Frame with Which Two Men can Carry a Hospital Bed and Patient with Ease

patient and his bed can be moved easily by two attendants, whereas four were formerly required for the task. It consists of a collapsible frame composed of two stretcher handles, 8 ft. 8 in. long, united by two jointed cross-pieces of iron hinged to the handles at a distance from each other equal to the length of a bed. This frame can be placed underneath a bed and then opened up so that it fits tightly between the legs and will not permit its burden to slide about while it is being carried.

4884
**NOVEL ELECTRIC MOTOR
MADE LIKE A WHEEL**

Novel features are to be found in a newly patented electro-magnet so designed that it can be used singly or in multiple as a motor to turn a shaft, or for other purposes. The core is of iron and is ring-shaped, composed of sections insulated from each other. This ring is supported by a spider, giving it a wheel-like construction. The coil surrounding the core is wound on a bobbin, in shape resembling an automobile tire casing, there being a slot extending along its inner periphery, as illustrated



herewith, which permits the core to revolve around its center. The bobbin is covered with wire, looped back and forth around pins arranged along either edge of the slot. Alternate loops of the wire are drawn close to the bobbin, while the others are wound more loosely. By energizing successive sections of the coil the core can be made to revolve or oscillate, as the specific use of the machine may require.

4082
**NEW TYPE OF MOTORBOATS
FOR SHALLOW WATERS**

A company has been organized in New Jersey to build power boats of a new type, designed by a resident of that state for use in shallow waters. The design is novel as to both hull and driving power, and was recently patented. It shows a boat of the flat-bottom type, but with a well in the bow, where the power for propulsion is located, instead of in the stern. Two paddle wheels work in the well on separate shafts, opposite each other and pitched at an angle of 60°, being driven by a worm gear operating in a

grease-filled casing. An opening or channel leads from the water line under the bow to the well, and the paddle wheels draw the water through this channel and discharge it beneath

Side View of New-Type Boat for Shallow Waters. Showing the Well in Which Paddle Wheels Operate: At the Right Is a Cross Section Showing Position of the Wheels

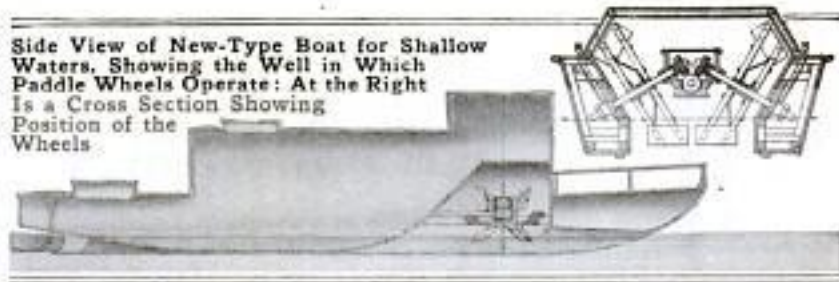

the hull, where it is prevented by two outside keelsons from causing side wash to canal banks and levees, being discharged in a straight line at the stern. The engine exhaust is discharged into the well.

*Inventor Fred W. Doty
Ocean City, N.J.*

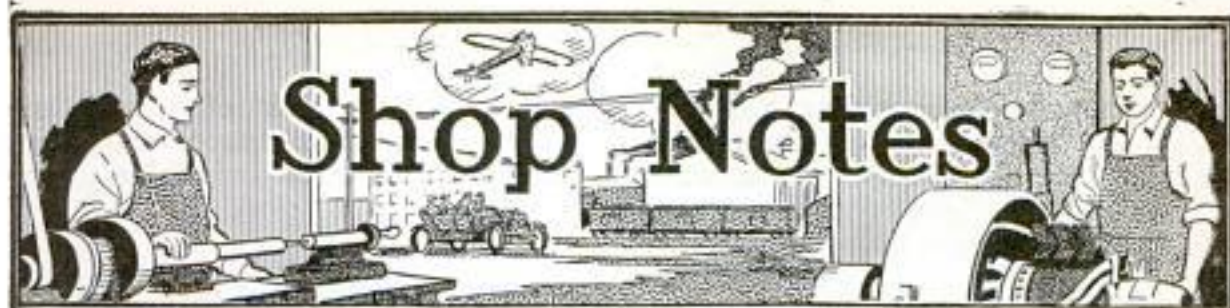

Substantial Power Drill Press Made of Pipes and Fittings

By RAY F. KUNS

PRACTICAL mechanics who build small machines for use in their workshops, often make use of pipes and fittings and usually get fair results. By carefully working out a design for a drill press, which is suitable for construction with these standard parts, and giving special attention to the machining and joining of the various members, the drill press shown in the

photograph and detailed in the working drawings, was made. It gives very satisfactory service, and compares favorably with standard machines of its size, though the cost was comparatively slight. It has stood up well under very hard service in a school machine shop. The design can easily be adapted to a smaller-size machine, or revised for special classes of work.

It will carry a drill up to 1 in. in diameter. It has four changes of speed, ranging from 84 to 666 revolutions per minute.

The main support is a 3-in. extra-heavy pipe. The height from the floor to the center of the spindle arm is 4 ft. 4 in.; from the floor to the center of the upper arm is 5 ft. 10 in.; from

the center of the main support to the center of the spindle is 15 in. The arm which carries the table is adjustable on the pipe support, the latter being turned to a good finish. The tee, which slides on the post, is bored out to fit the latter, and is clamped by means of a threaded handle. The bottom of the main post is split, spread, and bolted to an iron plate. This is

imbedded in the concrete base, as shown in the side view.

The tee under the drive pulley at the upper end of the spindle shaft has a bearing made from a piece of 1 $\frac{1}{4}$ -in. gas pipe. This is first bab-bitted, then scraped, and the holes for the set-screws drilled and threaded. The same type of bearing is used in the hangers, four of which are required, two for the upper and two for the lower counter-shafts. The hangers are forged, as

shown in the drawings, from 1 $\frac{1}{2}$ -in. gas pipe.

The gear wheel in the spindle feed is $\frac{3}{4}$ in. thick and 1 $\frac{1}{4}$ in. diameter. The teeth, 12 in number, are made from $\frac{1}{4}$ -in. cold-rolled steel, set into tapped holes. The hollow spindle, which is



This Substantial Drill Press was Made by Boys in a School Shop. Pipes and Fittings Being the Chief Materials Used. It has Withstood Hard Wear

made from 1½-in. gas pipe, has a row of ⅝-in. holes drilled in the side, to form a rack for the gear to work in.

is considerable risk of getting the parts mixed, making successful operation of the assembled machine almost

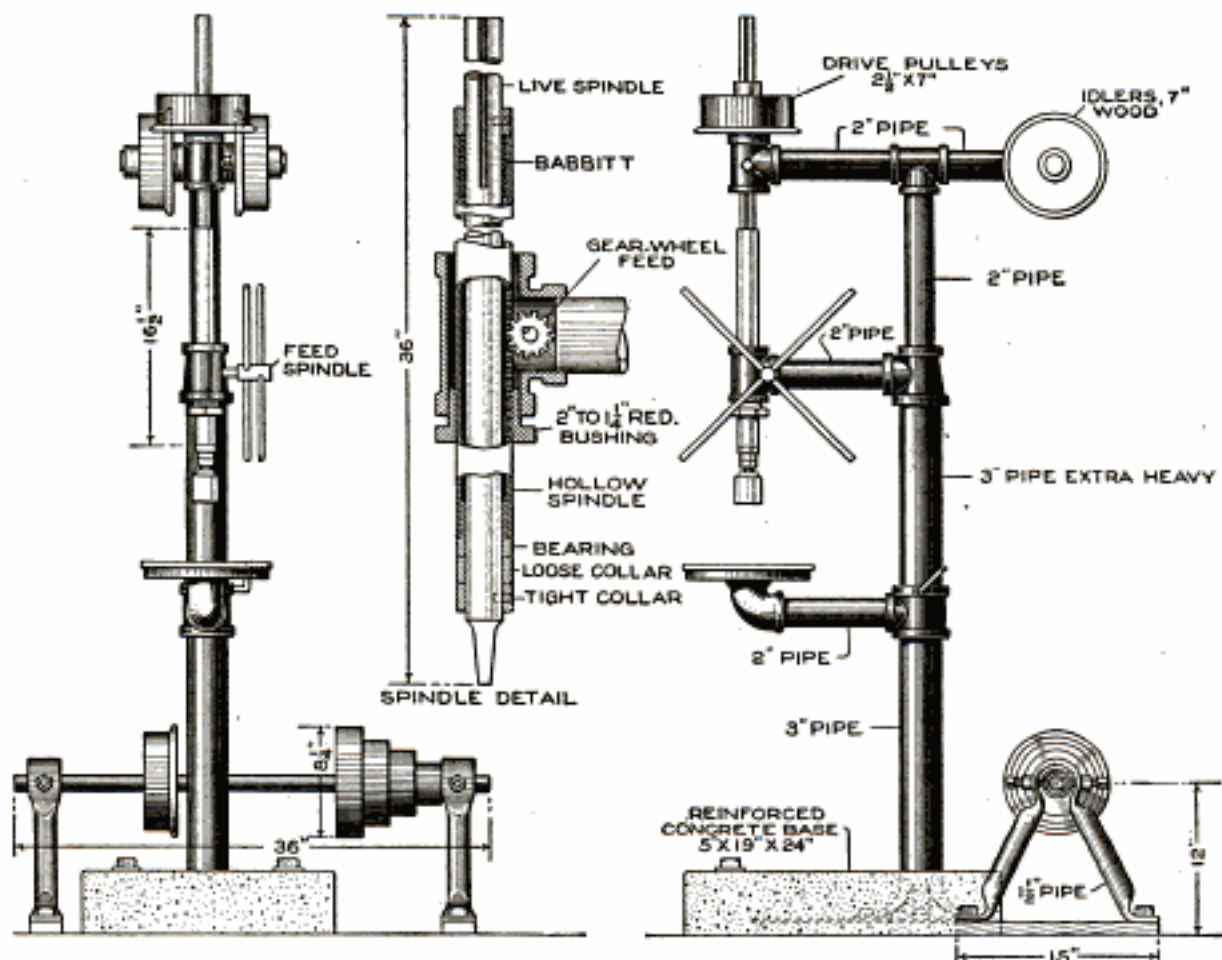

While the Cost of This Drill Press is Comparatively Slight by Reason of the Use of Pipes and Fittings, the Service It Gives Compares Favorably with Standard Machines of This Type and Size

The chuck should be procured before working up the live spindle, that these parts may be fitted properly.

Disassembling Rack Keeps Engine Parts in Order

When taking apart an engine, especially one of several cylinders, there

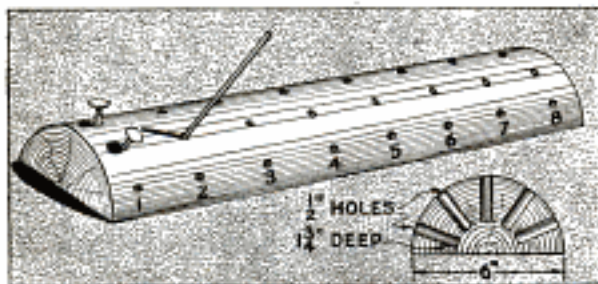

The Engine Parts are Placed Systematically on the Rack When Disassembling, Thus Insuring against Mixing Up the Parts Easily

impossible. A simple method of caring for the parts is to place them on a disassembling rack made of a heavy piece of wood, cut to the shape shown and provided with numerous holes in which pins are inserted for small parts having center openings, and providing also for various kinds of rods. Each cylinder has a separate row on the rack, numbered as indicated.—J. J. Green, Chicago, Ill.

Simple Method of Soldering Granite Ware

Many persons have the impression that it is almost impossible to repair a leak in a piece of granite ware, but if the following method is tried, the amateur will have perfect success. With a sharp file cut away the porcelain, and

buff the exposed metal until it is shiny. Apply soldering acid, and with a hot iron apply half-and-half solder, the same as one does in soldering tin. The solder will repair the leak permanently, for we have pieces of granite ware mended in this way in our kitchen, and they have been in use several months since repairing.—John F. Robinson, North Adams, Mich.

Slip Gear Minimizes Breakage of Teeth

On many kinds of machinery where inexpensive cast gears are used, as well as in some other cases, a type of gear has been found useful for preventing undue breakage of the teeth. Heavy strain is caused on the gear teeth by sudden stopping, starting, or reversing, and a gear in which the hub is separate from the rim, the two sections being held together by slip rings as shown in the illustration, gives the proper relief to the gear teeth. The slip rings are bolted securely with tension springs. When the strain becomes too great, the outer ring revolves, and the hub re-

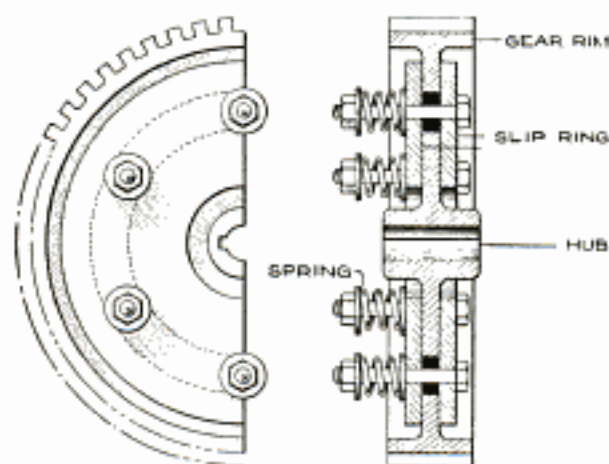

When the Strain on the Gear Teeth Becomes so Great that Breakage may Result, Damage is Prevented by the Slipping of the Rings

mains stationary until normal conditions obtain.—C. Van Den Berg, Jr., Gadsden, Ala.

CA coating of paraffin oil should be applied to the surface of freshly cleaned iron to protect it from oxidation before the paint is applied.

Test Box for Electrical Fuse Cartridges

For testing electrical fuses of the cartridge type, to determine whether or not they were serviceable, a small

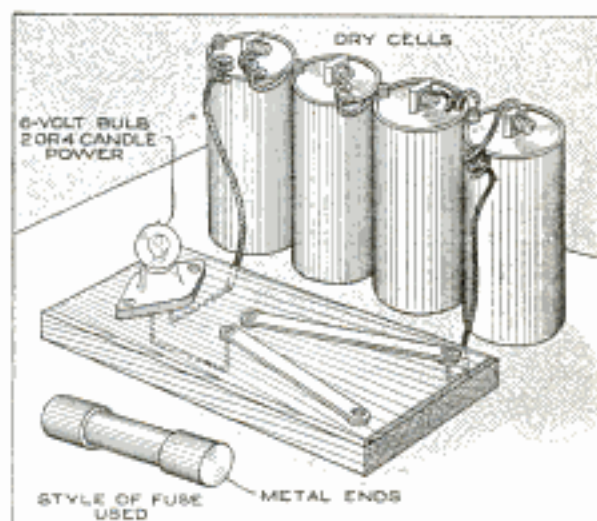

The Fuses are Placed in Circuit by Setting Them across the Brass Strips, and the Bulb Lights as the Current Passes through a Serviceable Fuse

outfit was rigged up as shown. Brass strips were mounted on a board with screws so that fuses of various lengths could be tested by setting them across the strips with the metal ends of the fuse in contact with the brass. If the fuse is good, the small electric bulb is lighted when in circuit with the dry cells.—A. E. Rounds, Milwaukee, Wis.

Portable Tool Rack for Mill Room Aids in Checking Up Tools

It was customary in a certain plant to "clean up" the mill room every Saturday afternoon. Upon the arrival of the mill hands on Monday morning it was discovered that various tools, such as squares, rules, straightedges, etc., were missing, and it was only after lengthy search that the tools were found in obscure corners or drawers. To overcome this, an A-shaped tool rack was constructed, 5 ft. long and 2½ ft. high, and provided with casters. On "clean-up" day various tools are placed on hooks on the rack, which is pushed around the shop, and finally taken to the tool room.—Joseph Plogmann, Cincinnati, Ohio.

A Long Island Scooter Driven by a Motor Aero-Propeller



By L. B. ROBBINS

A craft that affords much sport for the ice speed enthusiast is the "Long Island Scooter," which gets its name from the fact that it has long been popular on the waters of Long Island Sound. It is something of an amphibious boat-sled, and can sail on the ice, on ice-covered land, or on broken ice with stretches of open water. The original scooter is a sailing craft, rigged in various ways, like an ice sailboat. With the power from a gasoline motor of about 4 hp. applied to an aero-propeller of 3-ft. sweep, the scooter has a much wider range, and is practically independent of wind and weather during its season. It is controlled from the driver's seat at the steering wheel, like an automobile or speed motorboat, as shown in Figs. 3 and 6. The installation for the motor and control mechanism is arranged convenient to the steering post, within easy reach. The engine is set well forward in the cockpit, and the steering wheel on the port side, leaving room for a passenger, or cargo, on the starboard side.

The strong iron runners make the scooter ride easily, and also stiffen the hull. The iron prow aids in climbing over rough areas, and prevents the bow from crawling under ice ledges, when leaving open water. The engine may be of various types, and that indicated is a double-cylinder motor of about 4 hp., air-cooled, developing 500 to 700 r. p. m. on the main drive shaft, and 1,500 to 1,800 r. p. m. on the propeller shaft. The driving mechanism is suggestive only, since many mechanics prefer to devise these features to suit the materials and facilities at hand. This installation may also be left to a

professional gasoline-motor mechanic, only the hull and minor fittings being homemade.

Begin the construction by making the framework, shown in Fig. 1. The sides are of $\frac{7}{8}$ -in. pine, cut 12 in. wide at the middle, 8 in. at the stern, as shown in Fig. 3, and 2 in. at the junction with the wagon-wheel rim, at the bow. The use of a wagon-wheel rim, of oak, which can be obtained of a wheelwright, makes it unnecessary to do the tedious work of steaming and bending this heavy material. The rim is bolted to the sides. The ribs are of hard pine, $\frac{7}{8}$ by 2 in. in section. The stern transom, as detailed, is fastened into place with galvanized-iron screws, which are to be used throughout, instead of plain iron screws, as they withstand the water better. The keel, of pine, 1 by 8 in. in section, is laid on the ribs and fastened with screws.

Place the frame, bottom side up, on sawhorses, and plank the bottom with $\frac{1}{2}$ -in. pine, or cypress, boards. Set the nail heads and clinch the nails well on the inside. Plane the bottom off smooth and apply a coat of priming paint to the hull. Next cut the deck beams, as detailed, for the various stations. These beams may be steam-bent or cut, 2 in. wide, from a good quality of $\frac{7}{8}$ -in. stock. Nail the beams into place, as indicated in Fig. 2. Beams Nos. 5 and 6 are set 5 ft. apart, to make a frame for the cockpit, with the beams at the side coaming set 6 in. from the sides. Plank the deck with $\frac{3}{8}$ -in. cypress, or pine, and cover it with canvas, if desired. Boards for the floor, of $\frac{1}{2}$ -in. stock, may be fitted into place, but should not be nailed down until the

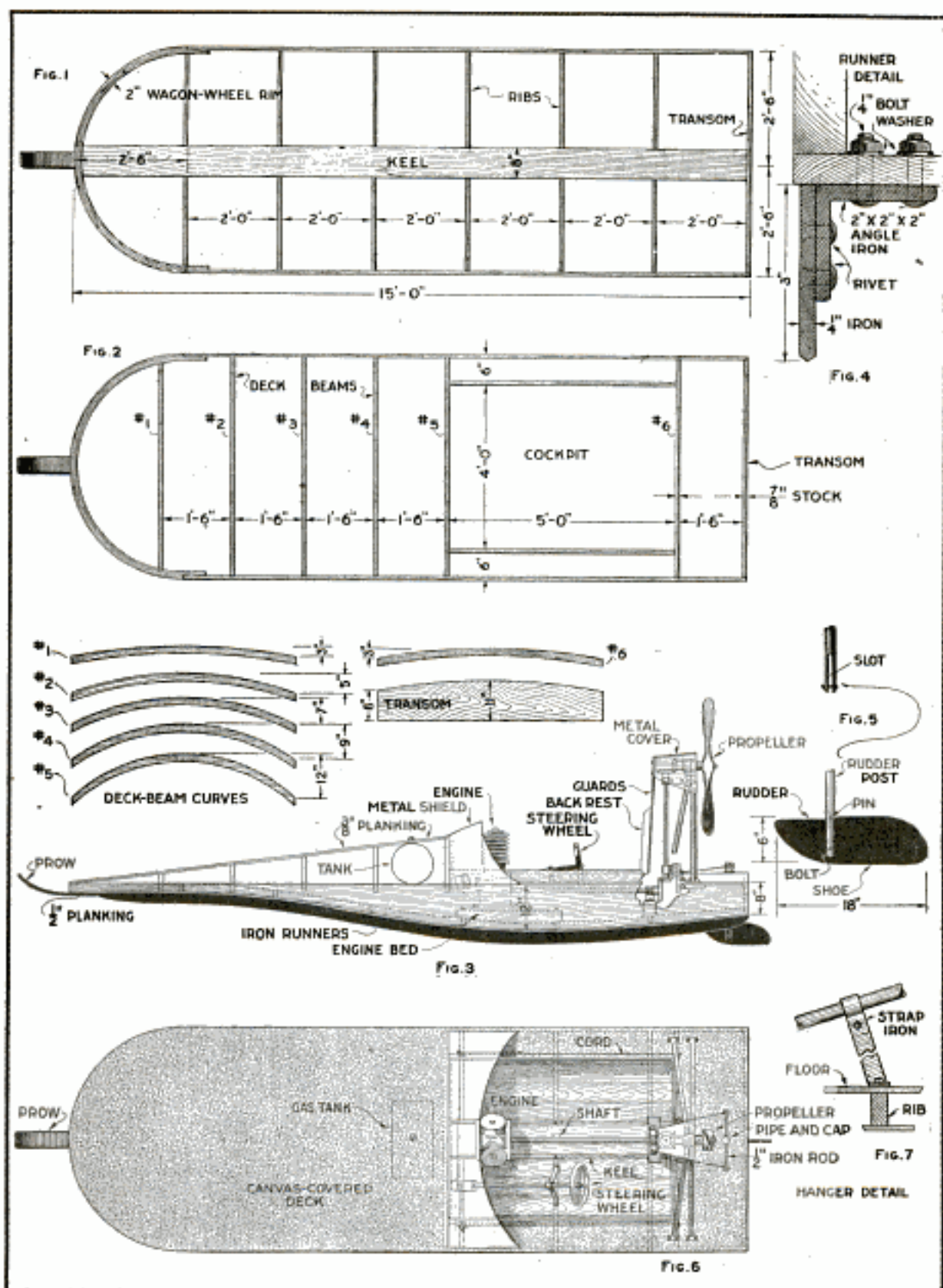

The Scooter is an interesting Mechanical Construction for the Winter Speed Enthusiast. The Craft may be Made and Installed Complete by the Builder, or He may Make Only the Hull and Its Fittings Other Than the Power Plant and Driving Mechanism. Fig. 1 Shows the Hull-Framing Plan; Fig. 2, the Deck-Framing Plan; Fig. 3, a Side Sectional Elevation; Fig. 6, an Assembly Plan, and the Other Figures, Details of Construction

other interior fittings have been placed finally. Fit the supports under the after deck, for fastening the machinery fittings, and set blocks for strengthening the hull at the rudder post, as de-

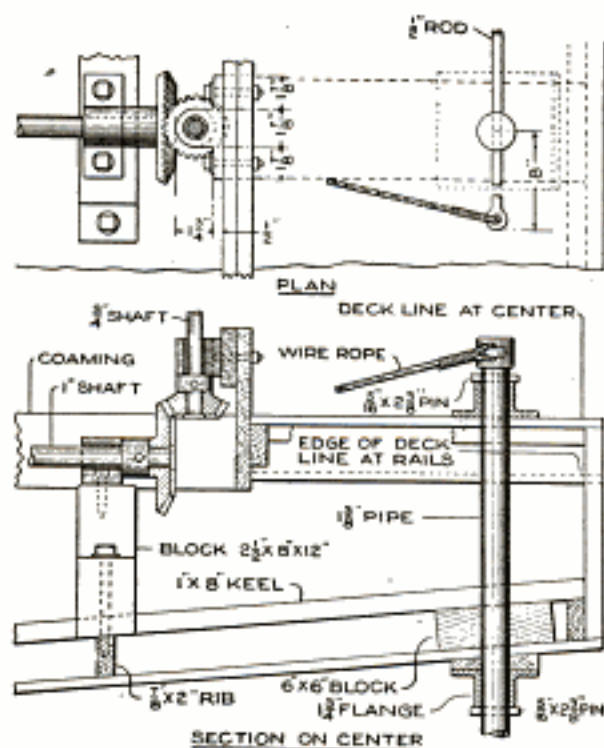

Fig. 8
Details of Construction at the Stern: The Section on the Center Shows the Fitting of the Gears and Connections of the Main Drive Shaft and the Vertical Shaft, and the Fitting of the Rudder Post. The Plan Shows a View from Above

tailed in Fig. 8. Fasten the coaming around the cockpit, and build a suitable base for the engine. The metal shield, in front of the engine, can be fitted handily before the machinery is installed, and laid aside until finally needed.

The metal fittings of the hull, apart from the power-plant installation, may be considered next. The runners are shaped, as indicated in Fig. 3 and in the detail drawing, Fig. 4, from $\frac{1}{4}$ by 3-in. sheet iron. The stern end is tapered off, and the bow end is tapered and curved in, to match the curve of the rim. The runners are fastened by means of angle irons, as detailed, and bolted through the floor, or the floor and iron straps, hung over the top edges of the ribs, adjoining the inner sides of the hull. A metal prow, $\frac{3}{16}$ by $4\frac{1}{2}$ in. in section and hammered to a slight dished effect crosswise, extends 15 in.

beyond the bow rim, and is bolted to the bottom and keel. The rudder is of sheet iron, as detailed in Fig. 5. The lower edges of the runners and the rudder are sharpened slightly to give a good grip for steering the craft on the ice.

The installation of the steering mechanism is shown in plan in Fig. 6, in a side elevation in Fig. 3, and in detail, as to the steering-post fitting, in Fig. 8. The crossbar of the rudder is fastened to a pliable steel cable, $\frac{3}{16}$ in. in diameter, and this is reeved through suitable pulleys to carry it around the cockpit coaming, as shown in Fig. 6. The cable passes through the coaming at each side near the front end of the cockpit, and is wound about five turns around the 3-in. wooden drum, fixed to the steering post. The steering post is of pipe, $1\frac{1}{4}$ in. in exterior diameter. Its lower end is set into a metal flange, its upper end is shouldered with a threaded collar, and the steering wheel screwed on and suitably capped. The steering post is braced by a hanger of $\frac{1}{4}$ by $1\frac{1}{4}$ -in. strap iron, as detailed in Fig. 7.

The details of the rudder post are shown in Fig. 8, which also shows the details of the gearing shafts and bear-

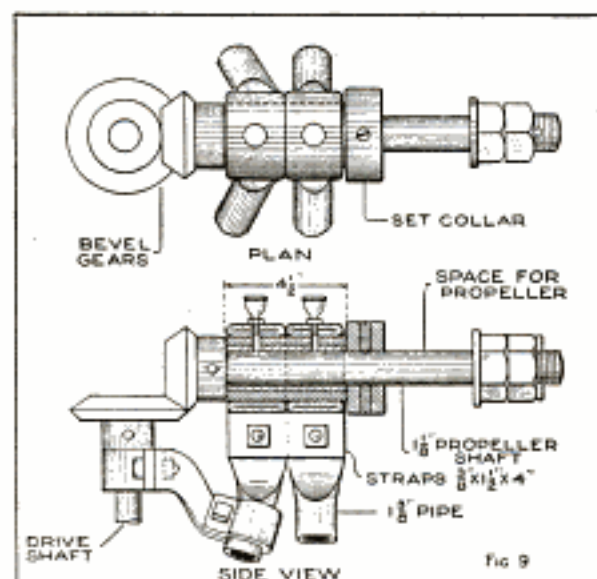

Fig. 9
Details of Construction at the Propeller Shaft: The Supporting Standards are Forged around the Propeller-Shaft Bearing, and the Vertical Shaft is Held Rigid, at Its Bearing, by a Strap-Iron Bracket,

ings at the junction of the main drive shaft and the vertical connecting shaft.

The rudder post is a pipe of $1\frac{3}{8}$ -in. exterior diameter. It is carried at its ends in pipe flanges bored out to a snug fit. Two round steel pins hold the post in position. A pipe cap at the upper end carries the rudder crossarm, as detailed in the plan. The main drive shaft is carried in a solid bearing, suitably bab-bitted, or provided with a bronze bushing. The bearing is bolted to a heavy block, as shown. The bevel gears are of machine steel, and are in a ratio of two to one, the smaller gear being of 3-in. pitch diameter. The vertical $\frac{3}{4}$ -in. shaft is carried in a similar smaller bearing, bolted to the reinforced coaming.

The general arrangement of the propeller shaft and its connections and supports is shown in Figs. 3 and 6, and in detail in Fig. 9. A bevel gear of $4\frac{1}{2}$ -in. pitch diameter transmits the power from the $\frac{3}{4}$ -in. vertical shaft to the 3-in. bevel gear on the $1\frac{1}{8}$ -in. propeller shaft. The latter is carried in a bearing made from a seamless steel tube, provided with a suitable bronze bushing and oil cups. A set collar and jam nuts, as well as a keying, or other standard device employed on aero-propellers, hold the propeller in place. The bearing is held solidly in a housing forged into the standards of $1\frac{3}{8}$ -in. pipe, which

support the propeller shaft and connections from the stern deck. The forged pipes are fitted snugly around the bearing, and clamped to it by means of two straps of iron, and bolts, as shown. The vertical shaft is carried in a bearing similar to that used at its connection with the main drive shaft, as indicated in Fig. 8. The bearing is supported rigidly by a brace of $\frac{5}{16}$ by $1\frac{1}{2}$ -in. strap iron, bolted to the forward pipe standards. The lower ends of these standards are split and forged to provide a flange for secure bolting at the reinforced points of fastening on the deck.

The gearing, etc., of the propeller shaft is covered by a sheet-metal hood, as shown in Figs. 3 and 6, as a safety measure, and also as a protection for the machinery. The hood is braced in front by two iron guard rods, as shown in Fig. 3, which support the back rest for the driver and passenger. This rest is also essential in guarding the occupants from the machinery, and the main drive shaft should also be guarded. The driving mechanism, and especially the gearing connections and sizes, are suggestive only. They must be worked out according to the requirements of the power plant used. The propeller may be made or purchased complete.

Devices for Gripping Stock Accurately in a Vise

When gripping work which is rough in a vise, a frequent source of trouble is that the vise grips on one corner only. In milling or planing, the work is likely to be torn from the vise. To overcome this, the vise can be equipped with a simple jaw which equalizes the grip on the work. A jaw adapted to gripping rough stock is shown in Fig. 1. A is the fixed jaw and B the movable jaw. Attached to the movable jaw is the piece C, held in position by two screws D. This movable piece butts against the movable jaw, at E, and as the jaw is tightened by the screw F, the movable piece pivots at E, adapting itself to the work.

Another method of gripping the work is shown in Fig. 2. The purpose of the pin is to insure against the jaws

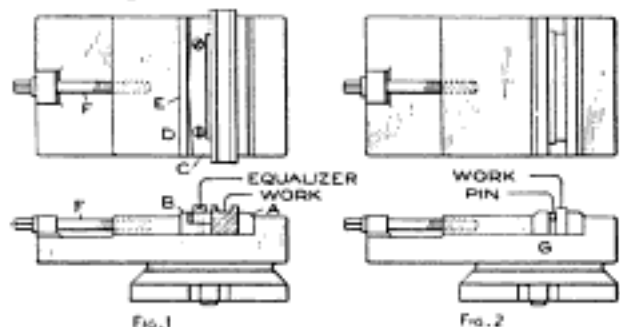

These Simple Methods of Gripping Work in Vises Are of Wide Use

pinching on the lower edge of the work G, causing chattering. These methods are good when gripping finished work that is not parallel.—H. M. Frank, New York, N. Y.

Novel Method of Strapping Money Satchel to Messenger

A paymaster, who carries a small satchel for his money and accounts, has devised a novel method of strapping



the satchel around his shoulders, as shown in the sketch. A strong strap is fastened to the handle of the satchel and passes up his sleeve, around the right shoulder, and back to the sleeve across the chest. This gives him the free use of both arms in his work, as well as in defense against attack in an emergency.

Blacksmith's Tongs Made of Iron Strips Bent Cold

When a pair of heavy tongs are needed for an occasional job of forging,



and blacksmith tongs of the usual pattern are not at hand, a substitute can be made quickly of two iron strips bent to the form shown in the sketch. No forging is necessary, as the metal can be drilled for a bolt and then bent cold making proper allowance for the size of work to be handled.—J. A. Ryan, Buffalo, N. Y.

Polishing Overhead Shafting

In a large factory the brightly polished overhead shafting was quite noticeable. The method used to keep the shafting clean and free from rust was this: A pad covered with emery cloth and fastened to a long pole was held against the revolving shafting.

The workman, reaching up with the pole, pressed the emery surface against the shafting, as desired, a fine polish resulting.—F. M. Ball, Kansas City, Missouri.

Centering Halved Pattern Work in a Lathe

The centering of pieces for halved, or split, patterns in the lathe is often done inaccurately, so that the halves are not equal, and have to be thrown away. A good method is to plane one surface

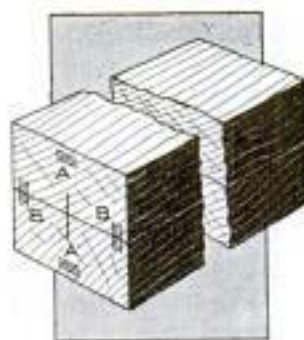

parallel with the parting surfaces, and square up the ends from it. Fasten the pieces together, and with dividers, scribe lines on both ends, as at A and B. When putting the work in the lathe, center

as usual, but do not drive the centers home. Turn down to the outer series of lines, and stop the lathe. The slightest error will be easily detected, as some of the lines will be nearer the cut than others. Tap the wood to center it properly, and set the dead center in slightly. Turn down a small portion, and examine the work, setting it so that it is accurately centered.—D. D. Gurnee, Hempstead, N. Y.

Collar Setscrews Made from Ordinary Setscrews and Nuts

Fifty collar screws were needed in the shop, and not being able to obtain them locally, we made them as follows: A setscrew of the required size was taken, and a nut screwed very tight up to the head, with a wrench. The screw was then put in a spring collet in a lathe. The corners were broken with a tool, and then smoothed off with a file. This makeshift served the purpose exactly as well as the real article, and could not be noticed by a casual observer. The saving in time was considerable.—S. B. Royal, Baltimore, Md.

A Door-Lock Mortise Gauge That Saves Time

In setting a number of door locks, a gauge is desirable, and is preferable to a template. The door-lock gauge shown in the illustration will do as good work on the hundredth door as on the first. It centers the bit with accuracy every time, does away with the use of a clamp, and is rapid in action. A vertical strip is used, 1 in. thick, of the same width as the thickness of the door, and of a length to the height of the lock from the floor. Small holes are bored through the longitudinal center line of the face of this strip, and at a distance corresponding to the diameter of the bit to be used. Short nails are driven through these holes, as shown. The heads of these nails are covered by a nailed strip beveled. The sides, containing the nail points for marking the hole centers for the shank and the keyholes, are then nailed to the beveled sides of the vertical strip, the bevel spreading them so that the nail points will not scratch the door when the gauge is slipped on.

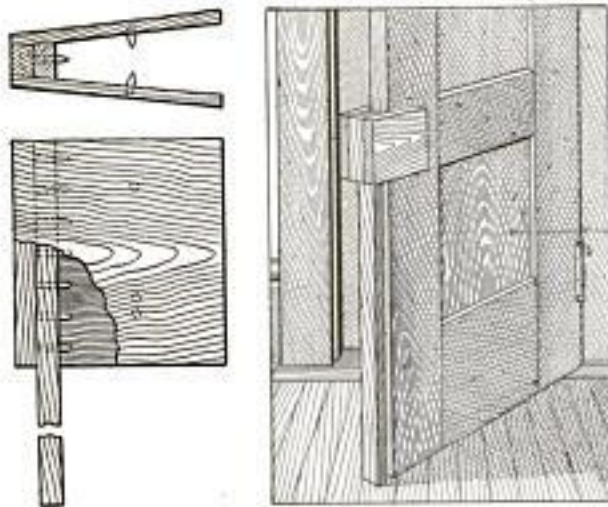

The Centers for the Bit in Boring Mortises and Fitting Holes for Door Locks are Accurately and Quickly Marked with This Gauge

To operate, simply set the gauge on the floor, push it against the door, and then strike sharp blows on the back and sidepieces. The holes will be sharply centered, ready for the bit to follow.

Shop Truck with Folding Upper Deck

A truck that has many uses in manufacturing establishments was developed in a shop where automobile

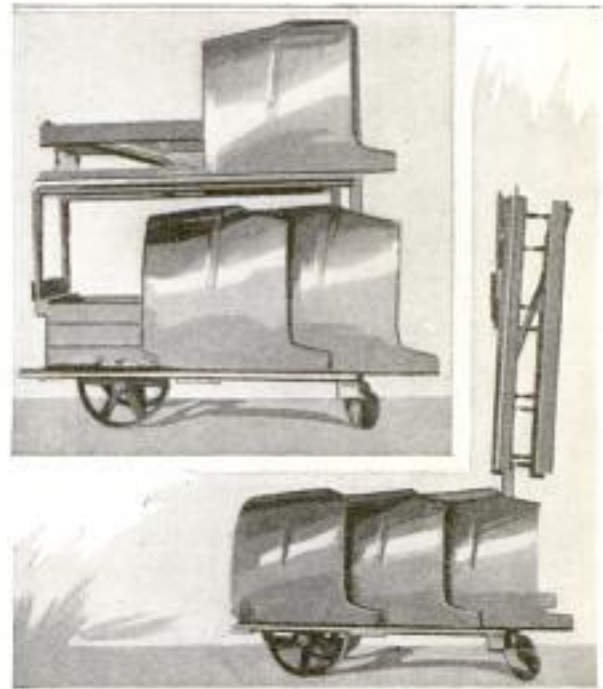

A Large Load is Carried on This Double-Deck Truck, and the Pieces are Not Easily Marred While being Loaded and Unloaded.

cowls are finished. The pieces are piled or nested on the lower deck when the upper deck is raised, as shown. This minimizes the marring of the cowls. The upper deck is then folded down and the load stacked on it.—Alfred J. Bell, Detroit, Mich.

Combination Bench Stop and Wedge Clamp

A bench stop that is firmly fastened to the top of the bench is often in the way, and it is sometimes undesirable to provide a metal one that is mortised into the bench top. The stop shown in the sketch overcomes these objections, and has the added features that it is widely adjustable and can be made quickly. The adjustable wedge portion of the clamp consists of two parts, A and B, sliding in a tongue-and-groove joint. This tends to keep the pieces in place and to prevent them from springing up from the bench when

in use. The front piece B is fixed to the bench by means of two screws driven into it from below. Two holes are bored in the bench top and slots extended from them, as shown at F.

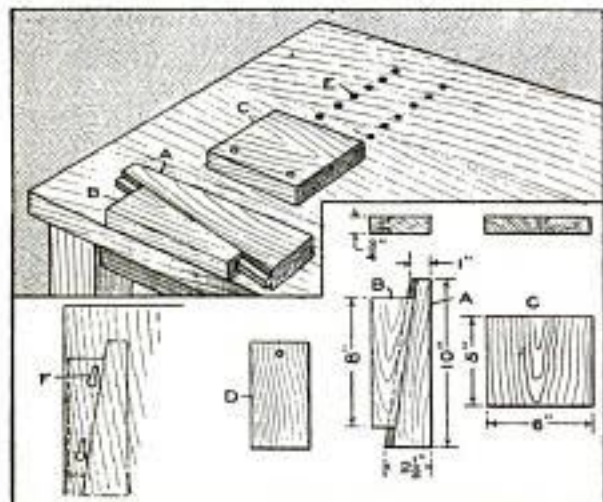

This Homemade Bench Stop Is Adjustable to a Wide Variety of Work

The piece B is set in place, and flat-head screws are driven into it from the two holes in the top. By pushing the strip forward it is held firmly in the grooves. The screws may be adjusted to give the block B the proper tension. The block A should be planed off slightly on its lower side so as to slide properly. A double row of holes is drilled in the top of the bench, as at E, and a block, C, made to fit them by means of pegs. This block may be adjusted according to the width of the piece being clamped. For use with irregular-shaped pieces, a block, D, having only one peg, is useful.—Henry Simon, Laguna Beach, Calif.

Large Clockface Fitted on Small Clock

Desiring a large clock with a face 2 ft. in diameter, I easily constructed one by using a dollar clock to operate the hands. First I took the glass and hands from the clock and put brass extension tubes on the posts of the hour and minute hands. These extension tubes give the necessary projection through the large clockface to accommodate the large hands. Each tube should snugly fit its post, one inside the other, the inner tube being half

an inch longer than the outer one. For the face, I cut a disk 2 ft. in diameter from tin, and painted it white with hour figures in black. Directly behind this I fastened the dollar clock. The large hands were cut from thin aluminum strips, and fastened to the tubes. This clock serves the purpose, and keeps good time, saving the cost of a large wall clock.—W. H. Raymond, Boston, Mass.

Safety Pen Clip Fitted to Nose-Glass Pocket Case

Mechanics in the shop and on the job, who wear glasses occasionally and keep them in a pocket case much of the time, find it difficult to keep the case from falling from the pocket. A simple remedy is to fit an ordinary clip, of the type slipped over a fountain pen, to the case, riveting the clip into place. The two wings of the clip which grip the barrel of the fountain pen, are flattened out to fit against the back of the case, which is usually of metal. The lining of the case is removed sufficiently to permit riveting, and then glued back into place.—A. D. Fleck, Yonkers, N. Y.

Sinusoidal-Current Electrical Treatment at Home

Sinusoidal electrical current is used extensively in sanitariums for treatment, and can be provided at home as handily as that from the common medical coil. Graphically, a sinusoidal current is represented by a smooth wave

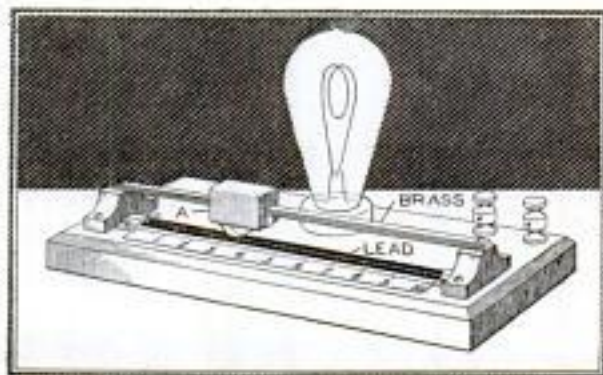

The Intensity of the Current is Regulated by Moving the Contact A along the Lead Strip

form, whereas the current from an induction coil is very irregular, and consequently comparatively unpleasant. A much stronger current of the sinusoidal variety can be "taken" at the usual handles provided.

A true sinusoidal current for home use—therapeutic or experimental—can be provided inexpensively where the usual alternating-current supply is available. The main element in the apparatus is the lead removed from a carpenter's pencil. These leads, of good quality, have about 200-ohms resistance. Connect this lead in series with an incandescent lamp, as shown, and then make temporary connection with a pair of handles. The current felt in the arms should become quite strong, and finally unbearable as the point A is moved to the right. By means of the sliding contact, a source of current

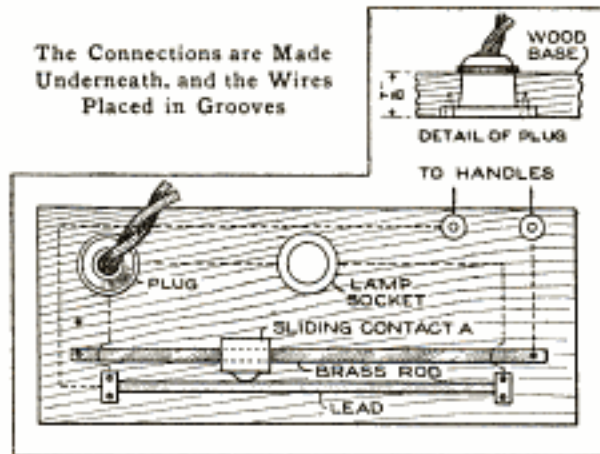

supply controllable from zero to the maximum is available.

The illustration shows the construction. The base is of wood, 4 by 9 in. long. A porcelain lamp receptacle is set in as shown, and directly above the lead, which is held down by a strip of brass at each end, is placed a square rod of brass carrying a sliding contact, A, such as is used in wireless apparatus, or made from a block of wood or fiber. Two binding posts make connection with one end of the lead and the sliding contact. The supply cord is connected by means of a screw plug. All connections are made underneath, the wires being placed in grooves, and felt is pasted over the bottom.—John D. Adams, Phoenix, Ariz.

Old Barrels Make Inexpensive Concrete-Culvert Forms

Vinegar casks, or other heavy barrels, provide excellent concrete forms for small culverts, or concrete drains.

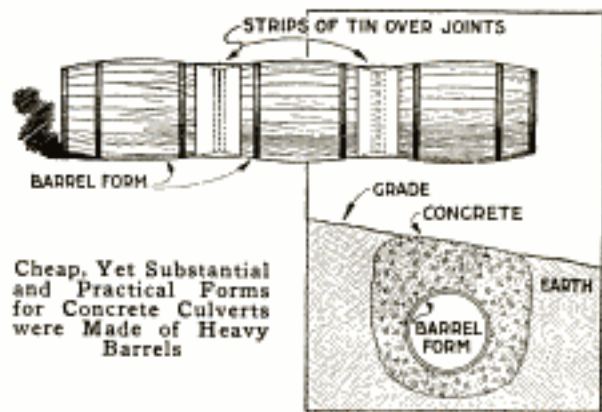

Both ends of the barrel are left in place before concreting, to give stability to the form, and strips of sheet iron are nailed over the joints between the barrels, to close them. To remove the form after concreting, knock out the ends and remove one stave in each barrel, and the rest of the form comes away easily.—Roy H. Poston, Flat River, Mo.

Scraper for Removing Ice and Snow from Cornice

The eaves of a flat-topped roof were cleared of icicles and snow quickly and easily in the following manner: A scraper was constructed as shown. The crosspiece acted as brace and guide, and the upper piece as a handle. The man doing the cleaning walked along the edge of the roof, holding the device by the handle, and pushed it along, the brace bearing against the cornice. The lower piece cut off the icicles.—B. L. Dobbins, Attleboro, Massachusetts.



Foundation Wall Built of Tile and Concrete

For various small buildings on the farm, a foundation wall built up of hard-glazed 6-in. tile and concrete has been found effective. Its first cost is reasonable, and the foundation can be built easily by unskilled labor, in a short time.



The tile are set on end, close together in a row, as shown, to form the outer side of the wall. The inside row of tile is set staggered with the first row, as shown, and filled with loose, dry sand and gravel. The intervening spaces are filled with cement grouting. The outer tiles can be filled with concrete, or a mortar made up with stones and gravel.—T. J. Hubbard, Mendota, Ill.

Enlarging Diameter Capacity of Wood-Turning Lathe

Having a number of pieces to be turned out on a wood lathe that were too large in the rough to be placed in the machine,

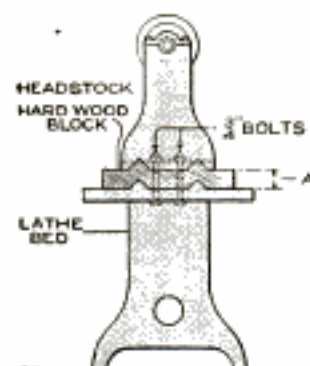

I hit upon the scheme shown in the sketch for raising the headstock and tailstock sufficiently to overcome this difficulty. The arrangement consists of two hard wood blocks, shaped to fit between the headstock and bed frame and between the tailstock and bed frame, and of sufficient thickness to accommodate the work. The width and length of the wooden pieces are suitable to the parts under which they rest. The wooden pieces are held in position by bolts, as shown.—H. P. Roy, Kansas City, Mo.

Long Coil Spring Holds Auto-Starting Crank

The starting crank of an automobile is sometimes lost or damaged when left to hang from its pivot. By supporting it with a long, light coil spring, fastened neatly with cords or wire across the front of the frame, it is kept from rattling, and is not easily damaged or lost.—E. T. Coyne, Buffalo, New York.

Bead Plane Made of a Wood Screw and Block

Often the home woodworker, or even the mechanic in the small shop, requires a bead on a strip for a door stile, or similar uses, when he has no bead plane at hand. A quick method of making beads at the edges of such strips, is by means of a wood screw, set into a block as shown. The width of the bead can be regulated somewhat, and the depth cut to the limit that the screw head will permit, as indicated in the detail diagram.—E. K. Wehry, Cedar Rapids, Iowa.



Solder Ladle Arranged as Crucible Carrier

A convenient addition to an ordinary ladle used for pouring solder or babbitt, is a small hook riveted on the front edge of the ladle, as shown. This makes a safe holder for the solder pot or handled crucible. Combining the ladle feature with the carrier saves time and prevents accidents that may result from using makeshifts.—A. Gemmell, Ansonia, Conn.

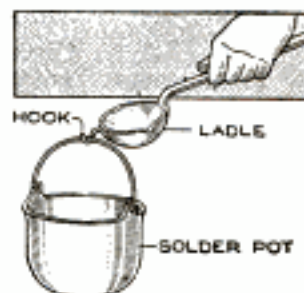

The Selection of Illuminating Units for Home or Office

By K. M. COGGESHALL

The first rule to be remembered in planning artificial lighting is to avoid the use of a very bright spot in a poorly illuminated room. Such a condition prevents concentration, as the eye involuntarily fixes itself on the bright light. There should be a general illumination with additional lamps for local use, if necessary. It is best that only reflected light reach the eye; the source of illumination should be so placed that the direct rays are thrown on the work, and not in the eye. Precautions should also be taken to hang the light unit above the working plane in such a position that distracting shadows are not cast by the furniture or office fixtures, as indicated in one of the sketches, at A and B, as compared with C and D. The higher lights provide better light for both desks, No. 1 and 2, without shadows.

The illumination of a home is perhaps of first importance. If the rating used by manufacturers in classifying standard tungsten lamps is employed, the reception room, library, or living room should have an intensity of .9 watt per square foot of floor space. For instance, if the library is 12 by 16 ft. the floor area is 192 sq. ft. At .9 watt per square foot, about 173 watts are necessary for proper illumination. This value is approximated by using three 60-watt tungsten lamps.

The dining room should have a general illumination of about .4 watt, while the den should have at least .85 to .95 watt per square foot. It is necessary that the latter room be well lighted, as it is generally used for reading, writing, or playing games. Hallways, pantries, and closets should have an illumination of .2 watt. For the sake of sanitation, the illumination of the kitchen should be at least 1.3 watts per square foot. The lamps should be grouped under a cheap, yet efficient, 12-in. white-porcelain reflector near the ceiling. For the bedrooms .3 watt per square foot is satisfactory.

For the average office, an illumina-

tion of 1.3 watts per square foot of floor space is sufficient, except in instances where a great deal of stenographic or copy work is done, when

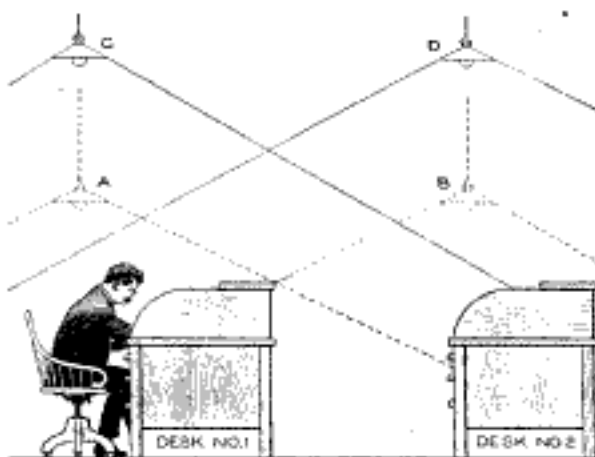

The Higher Lights Provide Better Light for Both Desks, and without Troublesome Shadows

the factor is 1.45 to 1.7 watts. For drafting work the range is 2.45 to 2.75 watts. The subject of spacing of the units is important. It presents a problem which cannot be entirely solved by mathematics; the answer is influenced by individual judgment and the cost of installation. The room should be laid out in sections of equal area, as shown in the other sketch. After the total watts per room have been determined, each section should be allotted its share. Standard lamps should then be installed in the center of each section. For the office, these lamps should be hung 12 to 14 ft. from the floor, while in drafting rooms, mountings as high as 16 ft. are sometimes desirable. Where

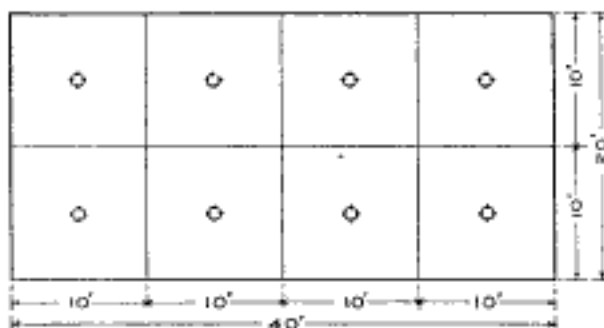

The Room is Laid Out in Squares and Each Section Allotted Units for Proper Illumination

the ceiling is low, limiting the available mounting height, it is desirable to use smaller spacing, and more lamps of smaller candlepower each.

Drainage Pump Improvised on the Job

On an excavation job where water was struck, and had to be removed quickly, a drainage pump was made in short order, and did the work. First a square box for the barrel of the

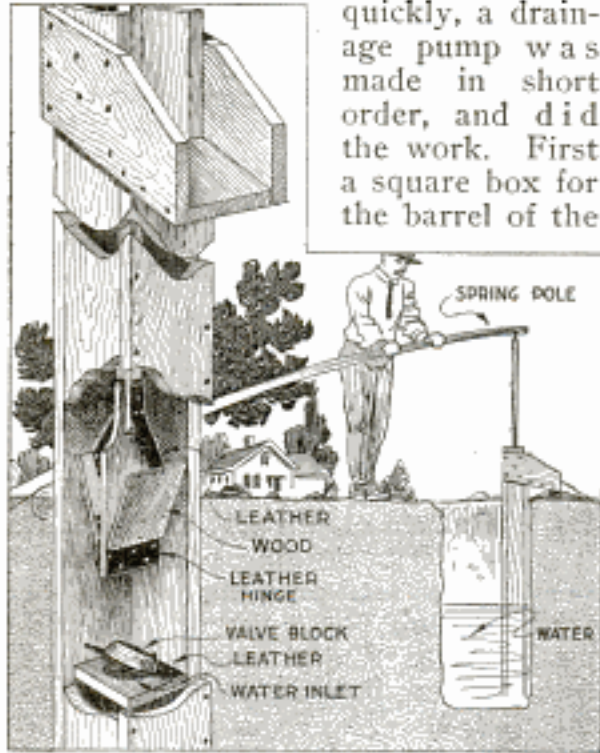

This Crude Form of Plunger Pump was Rigged Up on the Job When Water was to be Removed from an Excavation Quickly

pump was made, and a valve block with a leather-and-wood valve cap, as shown, was fitted into the pump near the lower end. A spout was fixed near the upper end. The plunger was made of a square pole, at the lower end of which a water lift was rigged, as indicated. Two sections of wood were hinged to the central piece and braced by straps. When the pump plunger is lifting a load, the wooden hinge pieces are weighted down and form a close contact against the sides of the pump barrel. When the plunger is lowered into the water these pieces fold back against the center piece. The parts must be fitted closely to give good results. A spring pole was attached to the upper end of the plunger, and fastened at one end by means of logs.

Pencil Held to Teeth Detects Knocks in Inclosed Machine

When part of an inclosed machine, for example a blade in a centrifugal pump, is pounding slightly, the affected locality needing adjustment can often be found without removing the casing. The operator touches the casing with a hard pencil point, the butt of the pencil being against his front teeth. The vibrations due to the pounding will attract his attention to the place to be adjusted without removing the casing to locate it.—R. Z. Kirkpatrick, Washington, D. C.

Moving Hand Draws Attention to Window Display

Moving objects in window displays are good means of advertising, as they command attention. A printer having a sample case built directly underneath his show window, had a large hand painted on tin, on which was inscribed "Look at These Samples." He then fastened a wheel to the pointing finger, and connected it to the arm of a printing press near by, by means of a series of grooved pulleys and a string. It was adjusted so that at each revolution the hand would be raised pointing to the samples in the case. As the press

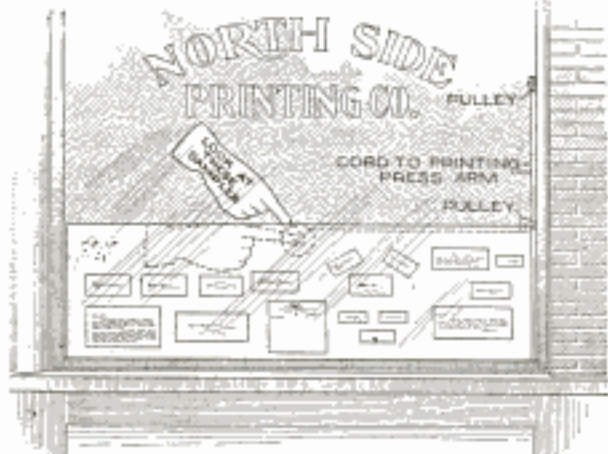

The Hand is Connected to a Near-By Printing Press by a Cord and Pulleys, so That It is Raised and Lowered by the Revolution of the Press Shaft

reaches dead center, the hand remains stationary for a moment, and then disappears from view.—M. J. F. Schramm, Brooklyn, N. Y.

Special Sliding Caliper Useful on Many Jobs

The usefulness of a sliding caliper can be extended by making the legs pointed and providing the end leg with a vertical adjustment, as shown. A typical example is in scaling the distance between two points not in the same plane, as the points A and B. The body C of the caliper is made of machine steel. The legs D and E are made of the same material and shaped as indicated. The slides on the legs are made by riveting two strips of sheet metal, F, and a third, G, to the leg, as detailed. A thumbscrew through G clamps the leg. The leg E is constructed as shown, a small strip being riveted on the front. The legs may also be machined from solid pieces, the slots being drilled and filed. The leg D may

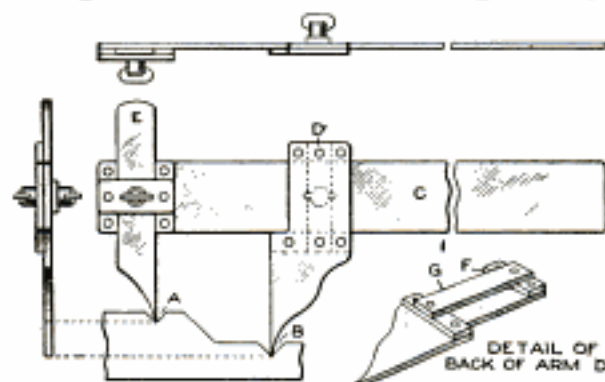

This Homemade Tool Has a Wide Range of Usefulness on Work Not Practicable with an Ordinary Caliper

also be made with a vertical as well as a lateral adjustment.—William A. Robinson, Waynesboro, Pa.

Knee Lever Actuates Shift Key on Typewriter

An unskilled typist, of the "two-finger" school, found that time was lost in striking the shift key, as this operation took one of the two fingers. In order to save this lost motion, he bored a small hole through his desk directly below the machine, and ran a cord through it, the upper end of which was hooked over the shift key of the typewriter, as indicated. A knee pedal was arranged as shown. The upper end of the pedal was connected with the

string, which passed through an eye, to give a straight pull on the key. To strike a capital, the knee is pressed

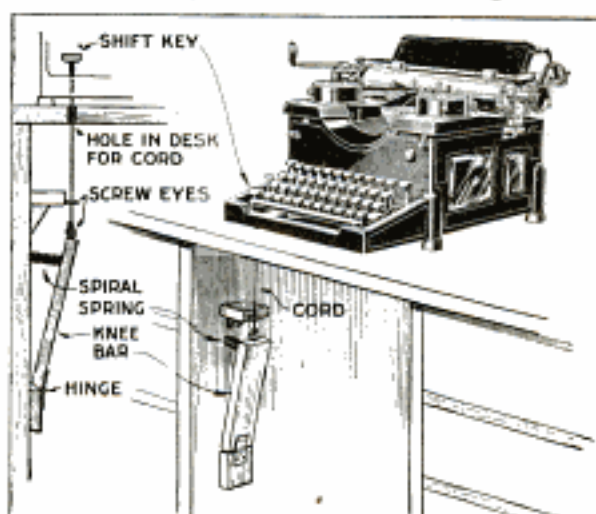

Greater Speed can be Attained on the Typewriter if One or More of the Shift Keys are Controlled by Pedals

against the pedal, giving the operator greater speed. This arrangement is practical even for a skilled typist.—John D. Gilbert, Eugene, Ore.

Lamps for Stock Room Shifted along Horizontal Wires

Below long rows of shelves or racks in stock rooms, it is sometimes necessary to install an electric-lighting system. The method generally used is to have an incandescent lamp on a long cord, the latter dragging on the floor, as the lamp is moved from one portion of the room to another. A better plan is to stretch a steel wire down the center of the aisle, high enough above the

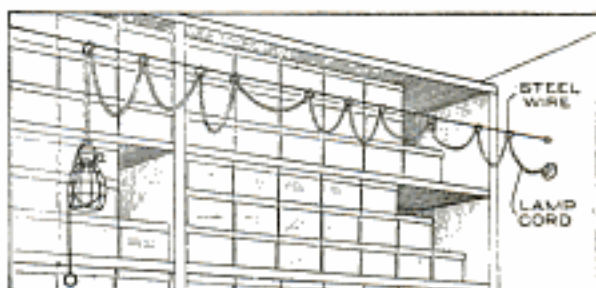

The Light is Moved Along the Wire, and the Cord does Not Drag on the Floor

floor to be over the heads of the clerks. At points 2 ft. apart, rings are fastened, as shown. The lamp cord will be out of the way, and protected from injury.—B. E. Waller, Omaha, Neb.

Brake Band Repaired with Spring-Steel Strap

The point at which the brake band of an automobile usually breaks is opposite the opening, as shown in the sketch. I found that, by making a repair at this place with a strap of spring steel riveted into place as detailed, the brake band was stronger than when originally fitted. The spring steel at the break gives the band elasticity, and its strength is equal to, if not greater than, that of the metal where the break usually occurs. When I bought two new brake bands, I had them sawed in half at the point where the break usually occurred and joined by this method.—C. H. Thomas, Kennett Square, Pa.



Rubber-Covered Instrument Knobs Made from Sink Stoppers

The furnishing of suitable knobs for rotating shafts on small instruments, and similar constructions, is often a problem to experimenters. Many forms of cheap and attractive insulated handles, or knobs, can be made by fitting rubber sink stoppers, or even chair-leg tips, to common wooden, or other, knobs. The addition of these soft-rubber coverings is desirable where a firm grip for turning a shaft is necessary.—R. U. Clark, III, Newton, Mass.



Small Floor Pit Convenient for Sheet-Metal Work

In a shop where much cutting was done with large hand shears, it was found that the most convenient way to do this work was to provide a pit in the floor, about 30 in. deep and 4 ft.

square, in which the workman stands. This gives him a large working area on the floor around the pit. The work is brought to a good level for convenience in cutting, and where long strips are to be cut, the large floor area is desirable. The tiresome stooping to the floor is avoided, a feature which appeals to the man on the job.—Lee M. Delzell, Maroa, Ill.

Inserting Bushings in Motorcycle Connecting Rods

An easy method of inserting bushings in connecting rods of motorcycle engines is to pass a machine bolt of sufficient size and length through the bushing and connecting rod, as shown. Run the thread up to within 1 in. of the head. Place a $\frac{3}{8}$ -in. washer on the bolt next to the head. Put the bolt through the bushing and connecting rod. Then put a large washer next to the connecting rod. Put a nut on the bolt and draw it up, until it pulls the bearing into place, and without marring the bearing surfaces.—Walter B. Raynor, Patchogue, N. Y.

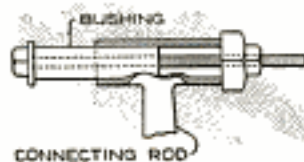

Pipe Wrench Made from Rope and Wooden Strip

When a pipe wrench is needed for turning or holding pipe, and none is at hand, a substitute can be made of a wooden strip and a piece of rope. Lay the strip across the pipe as shown, and wind the rope around the pipe and over the strip, so that the latter acts as a lever. The rope should, of course, be fastened so that the pull is in the desired direction.—C. M. Hall, St. Louis, Missouri.

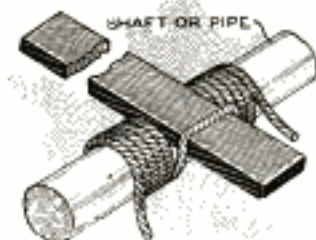

Bronze Disk Takes Up Thrust Wear in Pump

The oil pump of a gasoline engine revealed a gradual drop in pumping capacity and an examination showed that the driven spur gear was subjected to a great longitudinal thrust due to the action of the driving worm. This thrust resulted in the inner wall of the pump case becoming worn, allowing the oil to leak past the gear teeth so that the pump lost a great amount of its pumping force.

A repair was necessary and it was accomplished in the following manner: The pump was dismantled and found to be worn out in the casing wall to a depth of $\frac{1}{16}$ in. A hole equal in diameter to the outside diameter of the gear and $\frac{1}{4}$ in. deep, was bored in the casing on the side subjected to the thrust, and a bronze disk inserted in the hole. This was held in position by two $\frac{1}{4}$ -in. headless machine screws.

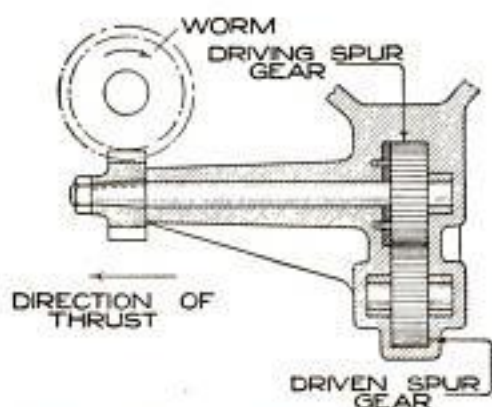

The Cavity Worn in the Casing was Filled by a Bronze Bearing Plate

The disk acted as a sort of thrust plate and instantly brought the pump up to its normal pumping capacity. A new disk replaced the worn one from time to time, so that the least bit of wear was quickly counteracted.

House Moved over Snow with Makeshift Capstan

On a house-moving job here recently, the movers rigged out a capstan that did the work in first-rate shape, and as will be seen from the photographs it was quite crude as compared with the

usual capstan for this purpose. A fork of a tree was strongly braced to a heavy timber foundation, and a vertical drum for the capstan was mounted in it. This made a more convenient arrange-



The Building was Moved Nearly One-Half Mile over Rough Ground by the Use of This Makeshift Capstan Built of a Large Tree Fork

ment than the usual support of two or four upright pieces braced together. The building was moved nearly one-half mile in 40 hours, over very rough and hilly ground, by two men with the aid of one team.—W. E. Covert, Grande Prairie, Alta., Canada.

Runway over Oil Tanks Saves Lifting of Barrels

Shops using several grades of oil will find it convenient to build a runway or track above their oil-storage tanks, as shown in the photograph. When it is necessary to renew the storage supply,



The Barrels or Drums are Rolled into Position and the Contents Transferred

the barrels, or drums, in which the oil is shipped, are rolled up an incline to the track, and thence along the track to the tank to be filled. A saving of many hours of labor resulted from the adoption of this plan in a large shop, as compared with the pump or dipping method of filling the tanks.—K. M. C., Webster Groves, Mo.

Square Wrench Seat Fitted on Tank Filler Cap

The filler cap on the gasoline tank of an automobile was of circular shape, and was extremely hard to remove when it was necessary to refill the tank. I decided to improve it in some manner so that a wrench could be used. I took four square-headed machine screws and set them in the top of the cap, as shown in the illustration. The wrench could then be applied with ease, and the cap was quickly removed.—Adolph Klein, New York, N. Y.

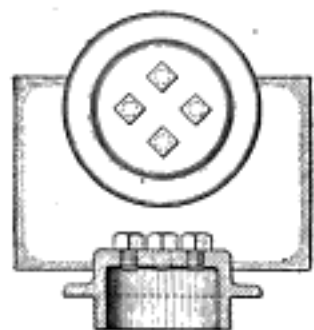

Wooden Expansion Plugs for Screws Easily Made

A wooden expansion plug for holding a screw or bolt in a concrete wall may be made quickly, as shown in the sketch. A round wooden 1-in. plug is sawed diagonally, so that the cross section will show three parts, A, B, and C. The plug is placed in the drilled hole in the wall, and the screw started in the wedge end of B, expanding it tightly against the other sections. The wedge tends to press A and C more tightly against the walls of the hole under an outward pressure. The plugs are best uniformly machine cut.

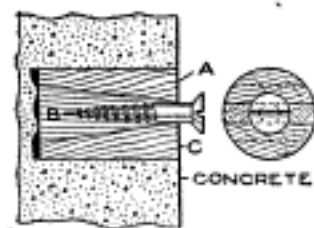

Old Paintbrushes Provide Small Tool Handles

When paintbrushes become worn out they are usually thrown away or burned. By saving the handles of these brushes, especially those of the heavier round type, the home mechanic can keep his tool box well stocked with extra handles for small files and other tools. The brush handle can be quickly trimmed to shape with a jackknife, and the end cut for a ferrule, flattened to an oval if necessary.—Frank Jablecnik, Chicago, Ill.

Printing-Press Gauge Pins Made of Paper

Printers, when doing work with narrow margins, often find that the gauge pins they commonly use are in the way of the grippers. Instead of using a regular-style gauge pin, a homemade substitute, which is perhaps better since it can be flattened out by the tympan clamps with each impression without doing it any harm, can be used. It is made from a piece of light cardboard, or stiff paper. The paper is folded, as shown, and the ends A and B are pasted at C and D, along the line where the paper will be fed.—Joseph Thalheimer, Jr., Venice, Calif.

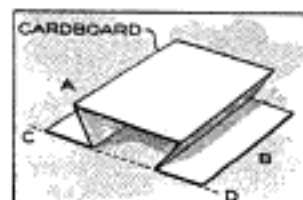

Auto Used as Power Plant without Altering Car

An automobile may be utilized to furnish power for operating small machinery without altering the car in any way, by the use of the driving rigging shown. All that is necessary is to back the automobile up the slight incline, and leave the gears in mesh with the engine running. The tires transmit the power to the 6-in. rollers, and they, in turn, to a belted drive pulley. The wooden rollers are 6 ft. long. Each end is fitted with an axle, 1 ft. long, suf-

ficiently heavy to bear the weight of the automobile used. Two wooden bearing boxes are built of 3-ft. pieces of 2 by 4-in. hard pine, bolted together and bored through the middle, for bearings, where the two faces come together. Small holes are also bored down through the top piece for lubrication. The rollers are assembled with ring washers against their ends, and the bearing boxes are bolted together with two braces. The pulley on the projecting end of the driving axle is set with a setscrew.

A slanting platform, as shown, makes it easy to back up the car on the rollers. The distance between the rollers depends on the diameter of the wheel of the car being used, but for general purposes a space of 18 in. between the two sets of bearings will give ample

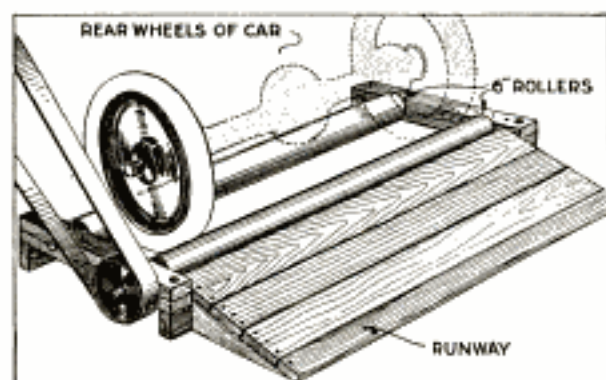

The Rear Wheels of the Automobile are Run onto the Rollers, and Transmit Power to the Drive Pulley

room for the average auto wheel to come well down between the rollers and insure good traction.

Revolving Check Holder for Lunch Rooms

Instead of having a person at the door to hand out checks during the busy hours, a lunch room uses several holders of a type shown in the sketch. They are filled by the cashier during the part of the day when the patronage is light. As the patrons enter they pick their own checks from the holder, the arrow indicating which end the check should be taken from. The cardboard box in the center, on which the directions are marked, is lifted off, and

the rack for the tickets replaced as required. The rack is pivoted on the

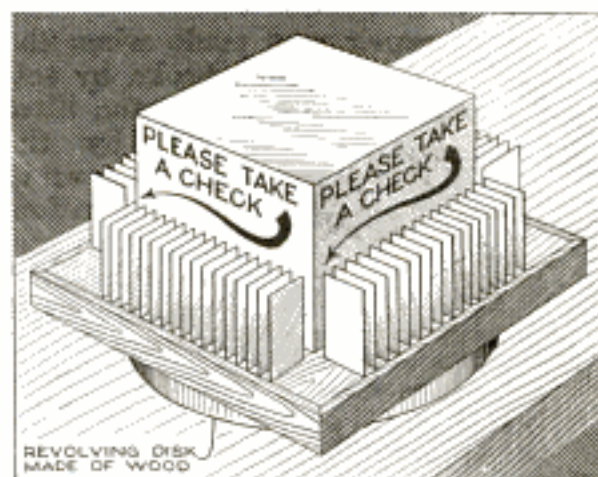

The Patrons Take Their Checks from the Holder Which is Provided with a Filled Rack as New Checks are Needed

center of the wooden base with a bolt. —L. E. Turner, Brighton, Mass.

Racks for Pipes and Cigars Aid "No Smoking" Enforcement

Considerable trouble was experienced in a large factory where smoking was forbidden in certain of the departments, because lighted cigars, pipes, and cigarettes were carried by persons entering the room to remain only a short time. As a result, racks made of sheet metal, as shown, were provided at the doors, and a suitable sign placed over them. The rule against carrying

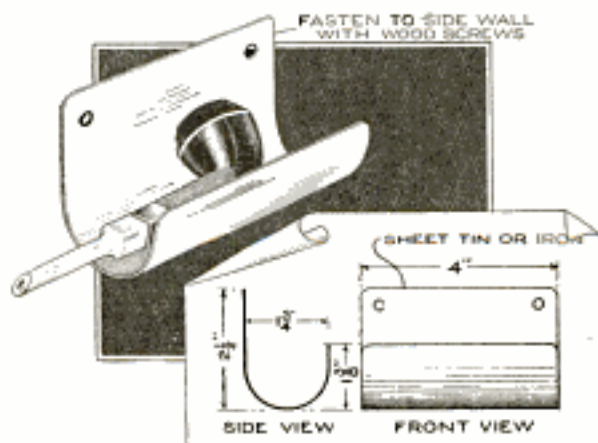

Before Entering the Room Where Smoking is Forbidden, the "Smoke" is Placed on a Rack at the Door

lighted tobacco in various forms was rigidly enforced and hearty cooperation of the men was gained.

Stove-Lid Lifting Lug Repaired with Wire

A neat repair was made when the cast lug on a stove lid broke, by setting a piece of wire across the lifter socket, by the method shown in the illustration. The hole was chipped clear, and holes for the wire were drilled through the sides, at a slight angle, as indicated. The wire was driven through from below, cut off to the proper length, and hammered into place. The bend which the wire must be given to fit into the holes, can be determined easily by a test, the wire being bent with the aid of pliers.—Edwin J. Bachman, Jr., Fullerton, Pa.

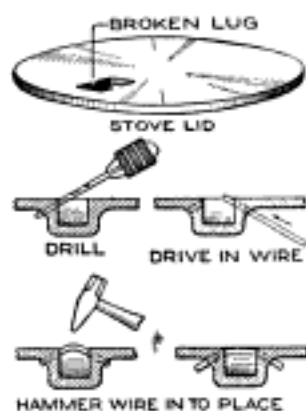

A Pulling Hook with Safety Finger Hold

Where hooks of the ordinary design are used on the end of a chain, or line, for pulling objects around by power, on cranes, etc., accidents occur frequently. The man whose work it is to engage the tackle may try to place the hook in the hole, or fitting, "on the fly," and smashed fingers may result. The safety-first hook shown has a finger hole whereby it may be held without danger. The proportions of such a hook will vary in accordance with the work to be handled. The size of the finger opening should be about 1½ by 4 in. Where the service is not too severe, these hooks may be cut and forged from sheet-steel plate.—E. D. Clifford, Chicago, Ill.



Handy One-Man Method of Using Tapeline

If proper care is taken, measurements can be made with a tapeline by one man with as much accuracy as if an assistant were setting the end of the line. A 6-in. brad awl is set carefully at the mark from which the measurements are made, the point passing through the end loop of the tapeline. While the device is especially useful on wooden structures, it can also be used handily on brickwork, by making the measurements from wooden trimmings, and deducting the lengths which are not to be included in the measurements.

Leather Cap Remedies Loose Auto- Engine Valve

When the valve guide and valve stem became worn on an automobile engine, an extra amount of air was sucked in, weakening the mixture coming through the carburetor, thereby causing much trouble. To eliminate this, I shaped a piece of soft leather to fit on the inside of the valve spring. I put a piece of wire around the top to stiffen it and attached the cap to the valve stem at its lowest point of motion. Grease was added, as shown, acting as a lubricant and aiding in keeping out the air. The device is held in place by the pressure of the valve spring, and the leather, being soft, allows for the movement of the valve.—A. Elting, New York, N. Y.

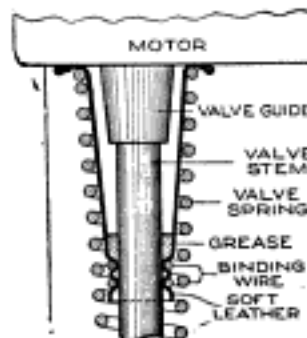

When drilling holes in small pieces of metal, especially where a brace or breast drill is used, and no vise is at hand, hold the piece with a monkey wrench, so as not to harm the hands, or weight the wrench, if both hands are needed for drilling.

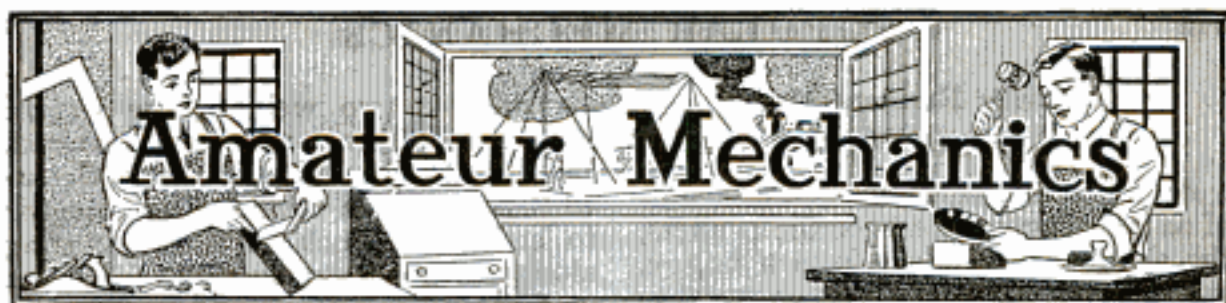

A Two-Man Snow Shovel for Heavy Snowfalls

By R. S. EDWARDS

WHEN three feet of snow fell in as many days, we found it difficult to keep a reasonably wide path cleared from the house to the roadway, to say nothing of paths to the other buildings, and along the main sidewalk.

Ordinary snow shovels were inadequate, so we built a two-man—or rather two-boy—shovel that did the work in a hurry. The making of this interesting outfit also was fun. It operates like a derrick. The man at the shovel takes on a load of snow, and his partner raises the load, and pivots the upper part of the outfit to one side, so that the load can be dumped easily.

The construction is simple, and the materials used can be obtained easily, or substitutes devised. The runner is a flat piece of board, curved at the ends, and braced with two cleats. A wooden box is nailed to the runner, as shown. A pivot block is fastened on top of it, at the middle, and a bolt is fitted through the block and the lower strip of the pivot frame. On the ends of this strip are blocks through which an axle

is set, to provide for the vertical motion of the derrick feature. The latter is built up of strips, strongly braced with boards, cleated together. A strong rope is fastened to the two sections of the derrick feature, as shown, and then

connected to the shovel proper by a two-cord yoke. This is set in line with the shovel handle, so as to make it easy to tip the load, without interference.



In a Very Heavy Snowfall, When Ordinary Snow Shovels Proved Inadequate, This Novel Two-Man Outfit was Built to Handle Large Loads Quickly

Filing Popular Mechanics Magazine Compactly

To economize space in filing away my copies of Popular Mechanics Magazine, I first remove both front and back covers with a knife, leaving the back intact. I remove the index and advertising sections carefully, and hammer down the staples. Next

I paste the index on, and cover the back edges over the staples, with a pasted strip of paper. A uniform style of title, indicating the month and year of issue, is put on the back. I cut out the advertisements I want to preserve, and file them.—W. J. Parks, La Salle, Illinois.

Sled with Runners Made of Wagon Wheel

An unusual homemade sled was built of an old wagon wheel for the runners, the shafts being taken from a buggy,



This Novel Sled was Made Largely of an Old Wagon Wheel and Packing Boxes

and the seat made of packing boxes. The runners are merely the tire and rim, and the spokes are the uprights supporting the bed. This construction was made possible by straightening out the wheel rim, and setting it up, one-half for each runner. The sled takes the place of one that would be rather costly and is quite serviceable, as the photograph shows.—M. W. Behrmann, Fairfield, Wash.

Moving Target for Practice with Air Rifle

An interesting device, which a boy can make, and which will give him good practice with an air rifle, is a mov-

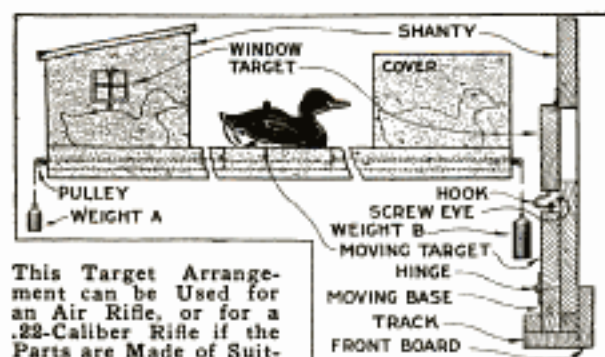

This Target Arrangement can be Used for an Air Rifle, or for a .22-Caliber Rifle if the Parts are Made of Suitable Metal

ing target, arranged as shown. The duck is fastened behind the shanty and held in place lightly by a hook, as detailed in the sectional diagram. The window target is hinged at the top and when struck folds back, releasing the duck. The base of the duck is

attached to two weights, the weight A being lighter, and when released, the duck is drawn along the track until it reaches the cover. The object is to strike the duck as it is traveling along the track, causing it to fold back on its hinge. Other cords can be arranged easily so that the duck can be raised when folded back, and the heavier weight lifted by the marksman from a distance, so that the duck will be drawn back to its place in the shanty. If the hook on the window target is properly bent, it will drop into the screw eye at the top of the duck when the latter is drawn back behind the shanty.—G. P. Lehmann, Brooklyn, N. Y.

Flannel Shoe Polisher Made from Barrel Hoop

A good method of obtaining a high polish on shoes is to rub the leather surface with a strip of cloth, such as felt or flannel. A

convenient means of polishing the shoes with such material is to cut a small section of a wooden hoop so that the span across the arc is about 18 in., and secure a strip of felt or flannel, 3



by 20 in. long, to it, as shown. By grasping the hoop as a handle and moving the strip of cloth over the shoes, an excellent polish will result, with minimum labor and little soiling of the hands.

Tightening Rims on Shell Nose-Glass Frames

In extremely hot or cold weather, or under rapid changes of temperature, lenses in nose glasses and spectacles, having shell, celluloid, or similar frames, frequently become loosened and in danger of falling out. This is usually due to the variance in the ex-

pansion or contraction of the glass and the rim. The remedy lies in fitting the loose parts together, and shrinking or expanding them to a closer fit. In cold weather the rim is likely to contract more than the lens, sometimes snapping off, if left near a window. The glasses should, therefore, not be exposed to extreme cold. In very hot weather the rim expands more than the lens, permitting the lens to fall out. The lens can be replaced by manipulating it and the frame in warm water. When removed from the water, the rim will shrink, holding the lens securely.—C. P., Chicago, Ill.

Large Canteen Tipped Handily When Suspended from Tree

Campers in the mountains of southern California usually keep water cool for camp use by hanging a two or three-gallon evaporation-cooled canteen in a tree. The canteens are somewhat difficult for the women in the camp to handle. A method that was improvised on a recent trip, and which proved popular, judging from the smile of the fair user, is shown in the photograph. The filled canteen is hung up by its carrying strap, so that it swings 2 ft. clear of the trunk of the tree from which it is supported. A stout cord



is tied to the bottom lugs of the canteen and strung over a hook set in the trunk of the tree above the can. It is only necessary to draw on the cord to pour the water easily.—John E. Hogg, Alhambra, Calif.

Flowers and decorations, cut from good-quality crepe-paper napkins, make neat ornaments for place cards, programs, etc., when pasted on white cards.

An Electric Bolt Lock Made from Bell Ringer

An interesting piece of construction that the amateur will find useful is a bolt lock for drawer or door operated

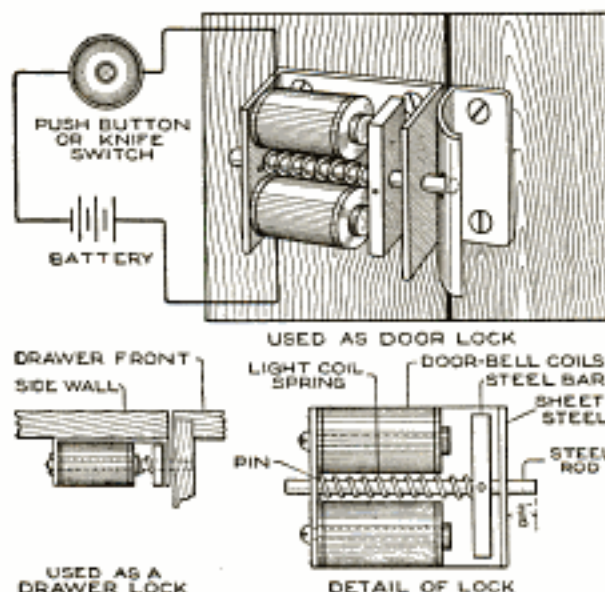

Details of the Electric Bolt Lock, and Methods of Installing It on a Drawer and a Door

from a distance. It can be made easily from an old bell-ringing magnet. The magnet is mounted on a strip of sheet metal, bent into a U-shape, and the steel rod for the lock bolt is mounted in the end of this piece. It is free to slide within limits set by a pin near one end and a steel bar fastened to it near the other end. The steel bar is held in place, in its locked position, by a light coil spring. When the push button, or knife switch, set in the circuit, is closed, the steel bar is drawn against the magnet coils, opening the lock. On the cutting of the circuit, the spring forces the lock into its closed position.

Using Plates in a Film Camera

Those owners of film cameras who often wish to proceed with the developing and printing of an exposure without an indefinite wait for the remainder of the roll of film to be exposed, will appreciate the following suggestions. The use of a plate solves the difficulty. A plate may be fastened in a film camera by the simple methods indicated. The operations are, of course, con-

ducted in the dark room, under red-light illumination, and the camera is empty of film. If the camera has a detachable back that clamps on, then

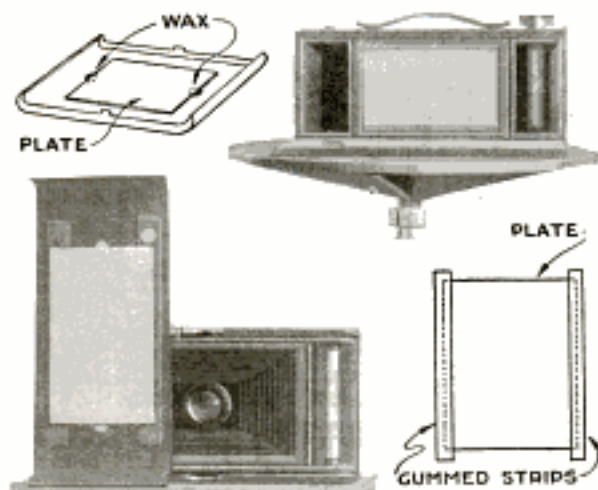

By the Use of These Simple Schemes, Single Exposures may be Made in Cameras Usually Requiring Roll Films

two pellets of beeswax may be stuck against the inside surface of the back, and a photographic plate may be pressed firmly against them. The back may then be clamped into position, the exposure made, and the plate removed and developed.

If the back slides in guides, the plate may be held in the rectangular opening in the back of the camera, using gummed binding strips. Prepare a plate as indicated, then stick two binding strips upon the back of the plate, allowing half the width of the strips to project beyond the edge of the glass. After moistening the projecting gummed surfaces, fit the plate into the rectangular opening at the back of the camera, and press the sticky surfaces down firmly upon the frame. Slide the cover into place, make the exposure, and then free the plate for the developing process. A number of plates may be equipped with the strips and stored in a box for ready use.—L. Pyle, St. Louis, Mo.

Waterproofing Canvas with Paraffin

A handy method of waterproofing canvas is as follows: Melt 1 lb. paraffin in a dish. Remove the melted paraffin a safe distance from the fire, and

pour it into a gallon of gasoline. Stir the gasoline as the paraffin is put in so that it will mix well, and keep the gasoline as well as the mixture away from the fire. The heating should be done out of doors.

Hang the material to be waterproofed over a line. With a clean paintbrush, apply the liquid like paint. The gasoline carries the paraffin into the fabric. In a few hours the gasoline will have evaporated, leaving the canvas smooth, clean, and flexible. After being treated in this manner, the canvas will be insured against mildew, as well as being impervious to water.—Joseph T. Sproule, Watkins, N. Y.

Guard Keeps Baby's Playthings on High Chair

Baby, with his small and mischievous hands, often drops playthings from the table of the high chair to the floor, keeping his fond parents busy picking them up. To prevent this I built a slanting guard around the high-chair table. This also keeps baby's toys within reach, for they slide back down the inclined edge, should they be thrust out of reach. Basswood, $\frac{1}{4}$ in. thick, was used to build this guard. It is held in place by four small hooks, at the edge, and easily and quickly attached or taken off.—J. E. Malden, San Francisco, California.

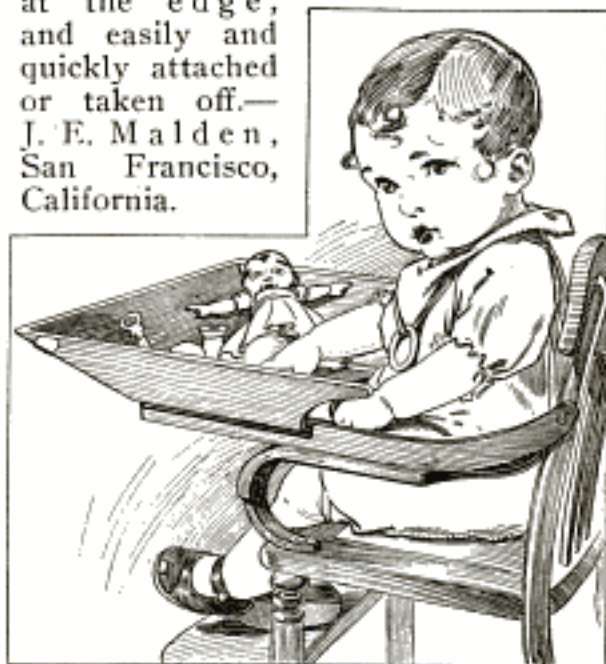

This Guard for the High Chair Keeps Baby's Toys within Reach

Sidecar for a Parcel-Delivery Bicycle

By P. P. AVERY

QUICK delivery of small packages within a two-mile radius can be accomplished with a bicycle by a sturdy

should be strongly fastened, tongue-and-groove boards being used, and the side corners should be fitted with iron

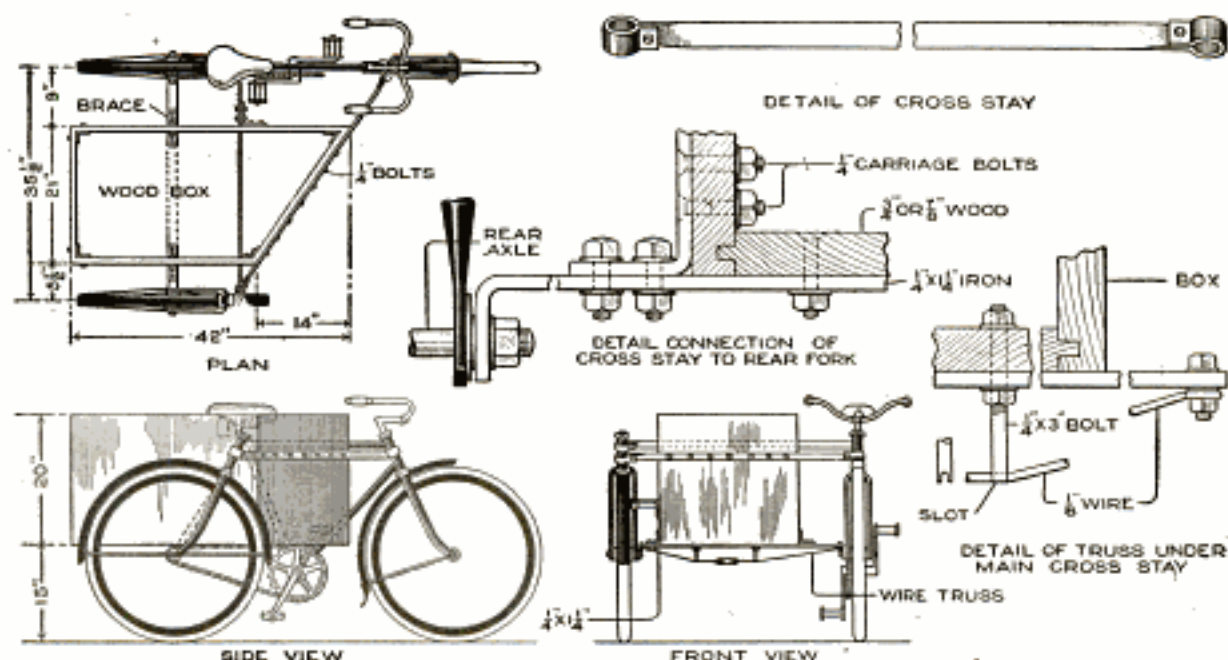

An Ordinary Strong Bicycle can be Made into a Substantial Delivery Car by the Addition of a Body and a Third Wheel

boy. An ordinary bicycle is used, preferably one with coaster brake and mudguards. Iron braces, $\frac{1}{4}$ by $1\frac{1}{4}$ in., are shaped to make the framework, and the ends are looped to fasten around the frame of the bicycle and the supporting fork of the third wheel. This wheel is a bicycle front wheel with a fork. A mudguard on the third wheel is desirable. Make the iron parts as detailed, and fasten them into place. The body is made of $\frac{7}{8}$ -in. wood, preferably oak. The upper portion of the body is cut to receive the top brace, which is not in the way in loading or unloading the packages. Fasten the box with $\frac{1}{4}$ -in. carriage bolts, using a spring washer under the nut wherever a joint is made between wood and iron. A canvas cover can be cut to fit the top and secured at one end only, with three catch knobs on the sides and corresponding eyelets in the canvas, keeping the dust and rain from the interior of the body.

It is a good plan to stiffen the body with corner braces, using $\frac{1}{8}$ by $\frac{3}{4}$ -in. band iron. The floor of the body

braces at the bottom. The body may be extended farther over the rear, if more loading space is required.

One coat of priming and one of paint finishes the box, and with the name of the merchant on the front and rear, the whole makes a neat advertising feature. Regarding the selection of a bicycle, since great speed is not essential, the lower the gearing is, the easier it will be to propel the load, and for ordinary work, where only small grades are covered, a gear of about 65 will be found efficient.

Handy Use for Adhesive Tape

Adhesive tape is useful in the shop and for the home mechanic, for many purposes: to mend broken handles temporarily; to bind up a cut finger; to prevent a hammer or ax handle from slipping in the hands, by applying tape around the handle; for making a ferule for an awl, chisel, etc.; around the nail set it will keep that tool from jarring the hand; around a lead pencil in the vest pocket as a guard.

A Toy Machine Gun That Fires Wooden Bullets

For use in the mimic battles which most boys like to stage in this war time, an interesting mechanical toy that a boy can easily make of materials picked up in the workshop, is a machine gun having a magazine for wooden bullets, and which can be made as a single or a double-barrel gun. The construction of the single-barrel arrangement is detailed in the sketch and the modification for a double-barrel gun is shown in the smaller diagram. It is a duplicate of the first type, suitably mounted as shown. The gun is fired by turning the crank on the wheel and the bullets can be quickly replaced in the magazine at the top.

The support for the gun is made of

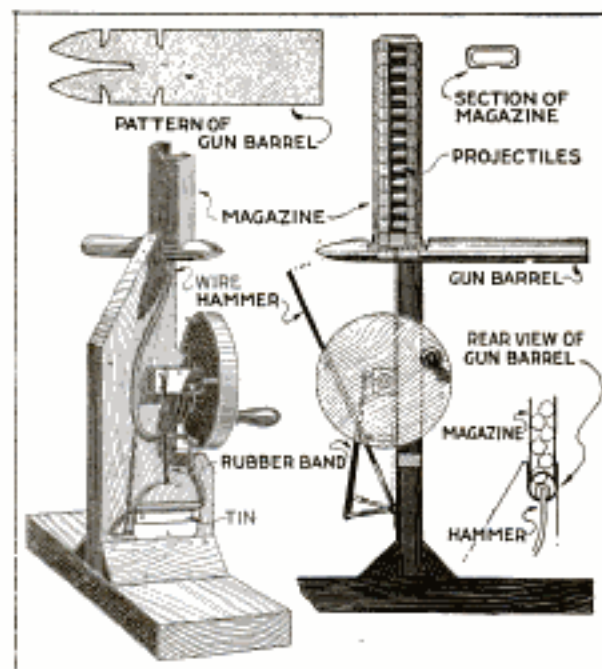

The Machine Gun is Fired by Turning the Crank at the Wheel, the Pins on the Latter Drawing Back the Hammer, Which is Hooked Up with a Rubber Band

wood and braced strongly at the base. The gun proper is set into the top of the vertical piece, as shown, and the

magazine, which is bent from a piece of tin to the shape detailed in the sectional view, fits on top of the breach of the gun. The hammer, which drives the bullets, is made of a piece of stiff wire bent to the shape shown. The lower curved end is connected to a small nail set on a block at the shaft of the wheel. To fire the gun, the hammer is drawn back by contact with the small nails set into the side of the wheel. As the wheel is turned, the nails grip the hammer and then suddenly release it, driving out the lowest bullet each time. The bullets are piled in the magazine, as shown in the detailed view at the right, where the rear view of the gun barrel is indicated.—Edward R. Smith, Walla Walla, Washington.

Using Plate Holder as Printing Frame

A cumbersome part of a commercial photographer's equipment when "on the road" is his set of printing frames. Amateur photographers who have cameras using plates of more than one size find these frames an expensive part of their outfits. A method that is practical and inexpensive for these requirements in many cases, is as follows: Place the sensitized paper in the plate holder with the emulsion side up. Then put the plate in the holder in the same way as if about to expose it in a camera, but with the emulsion side down, so that the sensitized side of the paper and the emulsion side of the plate are in contact. The paper and plate are thus held in close contact without the use of springs, as in the regular printing frames. The plate and paper can be removed by pressing the spring catch at the bottom of the holder, and the plate is not easily moved while in place.—Francis W. Clinton, Brooklyn, New York.

Leaks in garden hose may be repaired by wrapping several layers of adhesive tape over the break, lapping the edges carefully.

Wire Clips Weight Paper in Typewriter

Three wire paper clips linked together make a good weight for typewriter sheets that keep rolling or blowing back over the carriage, into the operator's way, in a breezy office or where a fan is not properly stationed. They may be quickly applied to the end of the sheet, or batch of paper and carbon sheets, and removed as easily, saving time and annoyance.—H. P. Roy, Kansas City, Mo.

Chain Weight Prevents Whipping of Flag

A length of chain, sewed into a hem at the lower edge of a flag makes an inconspicuous and effective weight to prevent whipping of a flag suspended from a horizontal staff. A piece of cord can be threaded through the links of a chain to prevent it from rattling, if necessary.

Poultry-Fence Construction Economical of Netting

Not wanting to put a high poultry netting on my fence to keep my poultry at home, I devised the method shown, and was thus enabled to use 24-in. wire instead of 48-in., thereby effecting a saving, as well as not marring the appearance of the fence. Chickens will not attempt to fly over this wire but once or twice, as they endeavor to alight on the pickets of the fence instead of the wire, and consequently are thrown back by striking the wire. The wire



should be supported at each post, as shown in the sketch.—Roy H. Poston, Flat River, Mo.

A Fort Built of Snow Blocks Made in Box Form

What boy does not enjoy a regular snowball fight—a battle, in fact—especially when he has a fort of his own



The Making of the Snow-Block Fort Is Nearly as Much Fun as Daring the Enemy to Come and Capture It or Capturing the Enemy's Barricade

building to defend, and his friends have one which he wants to capture? A way to build a snow fort that will not crumble easily when the enemy charges it is to pack the snow into a box form and build the structure of the snow blocks, as shown in the photograph. Portholes can be provided and when the snow melts slightly, and freezes again, a very solid wall results. The form for the block, as detailed in the sketch, is made of a box, arranged so that it is hinged at one corner and has a catch at the corner diagonally opposite. The form is set on a wooden board and when the snow is packed in solidly, the catch is opened and the form lifted away from the block. It is then carried into position and another block made on the same board. Several boards are handy in making the block quickly.—H. S., Chicago, Ill.

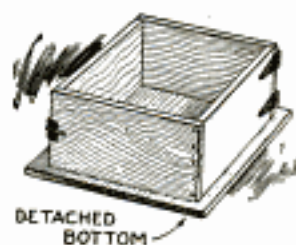

Ⓒ In applying varnish over an old wood surface, or on new wood that has become soiled, care should be taken to remove all traces of oil or grease with benzine.

Match Safe Soldered to Pocket Tobacco Can

A homemade tobacco can and match holder for the pocket, which has proved handy, was made in a few minutes, as shown in the sketch. An ordinary tobacco can, of the kind that fits the pocket nicely, was cut off at the top about an inch below the cover. This portion was then soldered to the lower end of a similar can, and the cover at this end was fitted tightly by making several center punch marks into the edge. Matches are kept in the small end and tobacco in the larger end.—O. S. Billings, Ruskin, Fla.



Sportsman's Gun and Equipment Cabinet for Automobile

The sportsman who makes it a custom to load his guns and outfit into his automobile for occasional trips knows that he is likely to forget some of the hundred and one articles needed, to say nothing of the inconvenience of handling the various objects. To avoid this I built a cabinet in which I keep my hunting paraphernalia packed compactly and safely for auto transportation. The cabinet, as shown in the illustration, fits into the rear compartment of the machine, and is supported from the robe rail by straps. It is built of pine boards, and is 14 in. wide, 16 in. deep, and 50 in. high. It



is divided into two equal compartments by a partition, one side being the gun cabinet and the other the equipment case. The guns are strapped into racks and the equipment is packed in convenient drawers and pockets. The full-length doors are provided with locks and set flush with the edges, making a cabinet that is flat and smooth on all sides.—F. E. Brimmer, Dalton, New York.

Clock Case and Electroliers Made of Marble and Onyx

As a pastime for spare moments, my father made the clock case and electroliers shown in the photograph from bits of onyx and marble. All the work was done by hand, with the exception of the round portions, which



were turned in a lathe and then polished. The polishing was finished by hand and the various parts, such as the bases, shafts, etc., were cemented together. The centers of the electroliers were bored out $\frac{5}{8}$ in. and fitted with small electric-light bulbs, giving a translucent effect when the light is on.—Howard Scott, Jersey City, N. J.

Photographic Prints of Keys Handy for Making Duplicates

Being in possession of only one set of keys for the safe and cash register. I thought it would be a good plan to have a perfect imprint of the keys, so that new ones could be replaced with the least trouble in case any keys were lost. The process is simple: Make a print on photographic paper, using the keys as a negative; place the side of the key which has the sharpest edge in contact with the



paper, and use a rather soft pad to force the paper into contact with every part of the edge. Develop and fix the print as usual. To make a duplicate key, cut out the pattern, place it in the vise with the key blank, and file the notches, following the pattern carefully.—A. J. Viken, Waterloo, Iowa.

Spring Relieves Hands of Sidecar Motorcycle Driver

Steering a motorcycle equipped with a sidecar is, at best, a tiresome task, which takes a good deal of pleasure from this sport. Such a machine has a tendency to steer toward the sidecar, and, as a result, there is constant strain on the wrists of the driver while driving straight ahead. An effective way to overcome this is to attach a $\frac{1}{2}$ -in. screen-door spring to the handlebar, opposite the sidecar, and to the horizontal bar of the frame. The tension of the spring can be adjusted to counteract exactly the inward pull of the sidecar, relieving the driver of undue strain on his wrists, and giving him greater freedom and safety.

Glass Oilcup Used as Electric Mast Light

Wanting a small top light for decoration on the top of a mast flagpole on a launch, I found an oilcup that had been used for a stationary engine and rigged it up as a fixture for the light. I cleaned and polished the oil cup, and cut out the center pipe, which was used for the oil flow, and placed a small electric light receptacle in the bottom. The wires from the battery were run through the bottom hole to the receptacle connections. By sealing the oilcup, it was made weatherproof.—P. D. Baker, San Francisco, Calif.



☞ A triangle placed under tracing cloth when making an ink erasure, will prevent the cloth from buckling.

Model Battle Cruiser Built by Boy

Numerous features of construction and automatic operation, not evident from an exterior view, make this model battle cruiser interesting and suggestive for amateur mechanics. It is driven by an electric-battery motor and twin propellers. The equipment includes most of the common fittings of a large battleship, above decks. The guns in the turrets have mechanical controls, and can be turned sidewise as well as vertically. At the stern of the ship, back of the

second turret, are two torpedo tubes. On the upper deck near the funnels are two cranes, one on each side. Six smaller guns are set on each side, and two smaller guns just below the funnels. An aerial gun is mounted in the crow's nest on the conning tower. Other deck equipment is two anchors operated by chains on capstans, and eight lifeboats. The length of the craft is 47 in., width 16 in., and height 26 in. It weighs 44 lb. without the sand ballast. The

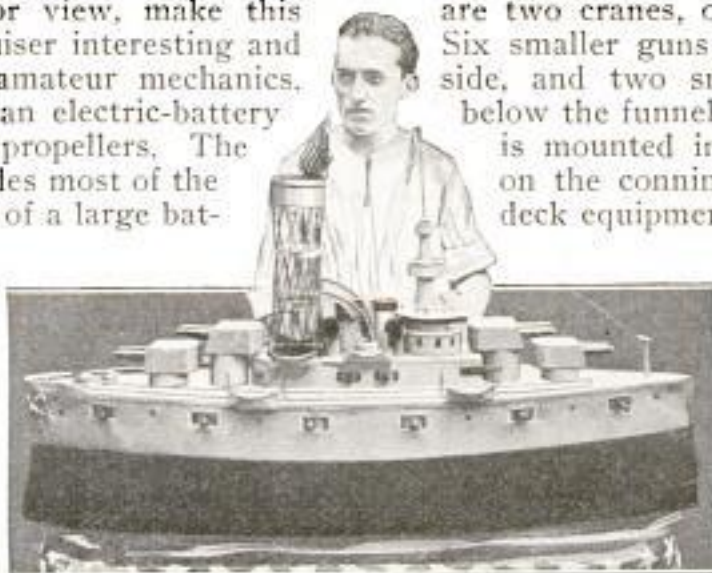

This Electrically Driven, Twin-Propeller Model Battle Cruiser was Equipped by Its Boy Builder with Many of the Features of a Genuine Cruiser, Including Torpedo Tubes

draft is 7 in. when in ballast. The hull was made of tinned sheet metal and the frame of maple and cypress.—Ralph Dengler, Lebanon, Pa.

An Electric Time Pendulum for Experimental Work

Many experimenters find much use for a device that will beat the time in seconds, or fractions of a second, in

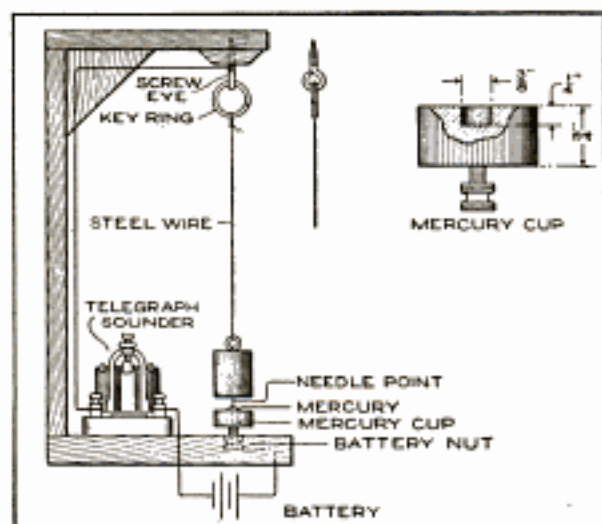

The Pendulum Swings and Makes Contact with the Mercury, Completing an Electrical Circuit and Operating a Buzzer

experiments involving the element of time. For this purpose, an arrangement in which use is made of the swinging of a pendulum was found satisfactory. The materials required to make the apparatus are possessed by most experimenters. The cup to hold mercury, as detailed, was made by cutting off the end of an old dry-cell carbon, and drilling a hole in it. The bob need not be of lead, or of the size specified. The heavier and bigger the bob, however, the longer the pendulum will swing when once started. A good bob was made by drilling a 1½-in. hole, 2 in. deep, into a block of wood. In the center of this hole a needle was set, and around it, sand to a thickness of ½ in. Melted lead was poured into this hole, and while the lead was still in a liquid state, a screw eye was fixed in it. The steel wire was of the size used for the E-string of a mandolin. The length of this wire is determined from the formula for the period of a simple

pendulum, and for one swing in one second is 3.26 feet.

In assembling the instrument the pendulum is suspended to swing freely. The cup is to be mounted on a board directly below it, setting it about two-thirds of the way into the nut. When it is in this position, and the pendulum is set to swinging, the needle should make contact with the mercury, causing the sounder to tick. Adjustment is made at the nut, suitable electrical connections being made as indicated.—C. S. Cierpik, Chicago, Ill.

Rack Protects Sprayer Used in Barn

To provide a safe and convenient place for the hand sprayer, which was employed frequently in the stable and barn for spraying horses and cattle, I made the rack shown in the sketch. It has more than paid for itself in the saving of time, as the sprayer is always in place, and in the cost of new sprayers. The rack should be made of a size suited to the sprayer used, and the dimensions given are suggestive only. The construction should also be varied to suit special needs, but the general plan of using two brackets with a back

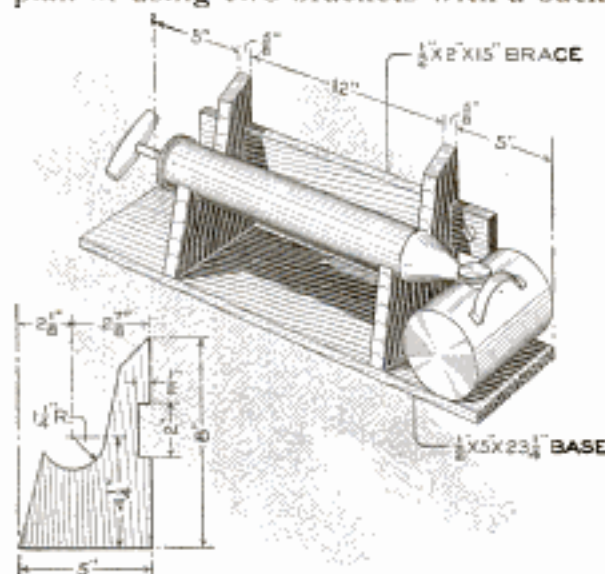

By Keeping the Sprayer in a Rack It is Protected from Undue Wear and Denting, and Is Always at Hand When Wanted

and bottom piece will usually be found suitable.—T. H. Linthicum, Annapolis, Maryland.

Suspended Twine Holder Made from Funnel

A handy container for a bundle of twine, used in tying parcels, is a funnel suspended by its upper edge from the wall or ceiling. Three strings or wires are attached to the rim of the funnel and brought together into one cord, by which it is suspended. The drawstring of the ball of twine is drawn from the small end of the funnel.—Abel Greenstein, New York, N. Y.

Rustic Table with Polished Top Crosscut from Log

A workman watching the felling of a large maple tree, and noticing that the wood was sound to the core, obtained a slice of the butt, 2 in. thick, and made it into an unusual top for a rustic table. He smoothed off the slab with a plane, on both sides, and finished one side very carefully, to serve as the top. He fitted it with rustic legs, and worked the top to a piano finish, showing off the beautiful annual rings to advantage. The other parts were varnished, the bark being smoothed only slightly.—Dale R. Van Horn, Milton, Wis.



Boiling Eggs in Steam

Boiling eggs in steam not only saves time but is also economical. Use only enough water to cover the surface of the pan thoroughly; about $\frac{1}{8}$ in. deep is sufficient. This small quantity will boil in a few seconds, and when boiling, place the eggs in the pan and cover with a close-fitting lid. The eggs will be cooked, or boiled, in steam, without the necessity of heating a large quantity of water.—F. Ball Pinkus, La Crescenta, Calif.

A Compact Electric Photograph- Printing Machine

An electric photograph-printing machine which practically does away with a dark room is a great convenience to the amateur photographer. The two lower drawers, as shown in the illustration, are large enough to hold the materials necessary, and the cabinet is built the height of an ordinary table, so that the operator can be seated, and work conveniently.



The top is fitted with a sheet of clear plate glass, 10 in. square. Hinged to the back and one side of the top, are two felted pads. The rear one is raised a trifle to allow for printing plates, the one on the side being used for films.

A sheet of ground, or opal, glass, for diffusing the light, is inserted 5 in. below the glass top. Halfway down the front of the box is a light shelf, and to the front of it, a spring-hinged door, which closes the entire upper compartment. Wire the space under the opal glass for five electric light sockets, four for 25-watt lamps, and one for a ruby light, not over 8 cp. The two switches on the side are for the ruby and white lights, which work independently of each other. The wooden pocket, under the switches, holds the paper while printing. Build the two drawers to fit the bottom compartment. The upper one is fitted with partitions.—L. B. Robbins, Attleboro, Massachusetts.

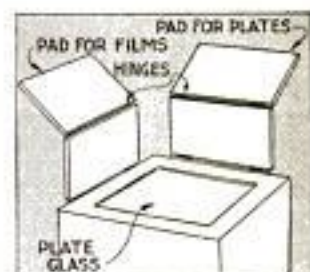

Model Steam Tractor Made by Boy

Boys, and others who like to make models, may be interested in a small steam tractor I designed and built of

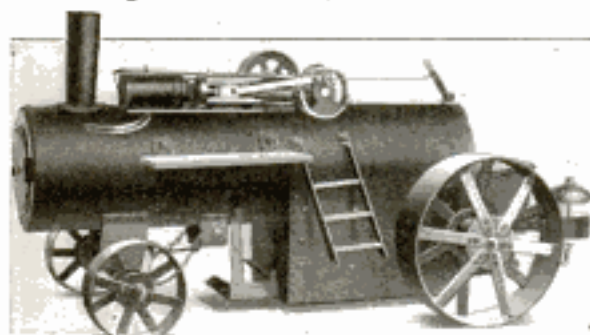

This Model Steam Tractor Is 28 Inches Long and Drives Itself, Wood and Coal being Used as Fuel

scrap materials around the farm shop. I used only the ordinary tools on hand in such a place. The steam engine and tractor run smoothly, and the engine propels the tractor just like a large machine of this kind. The tractor is 28 in. long and 14 in. high, and the boiler holds $1\frac{1}{4}$ gal. The bore of the cylinder is $\frac{7}{8}$ in. and its stroke $1\frac{3}{4}$ in. It was made from an old iron window weight. I use wood and coal to fire the boiler, and steam can be got up in a few minutes.—Albert H. Bennington, Park River, N. D.

Toboggan Made of Old Buggy Shafts

A method of making a strong toboggan sled by nailing a suitable bottom

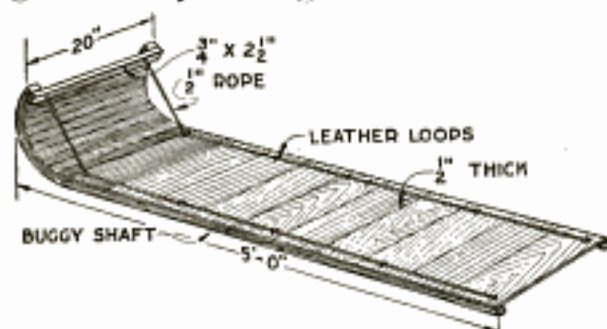

This Toboggan with Stout Runners Made from Buggy Shafts can be Used like One of the Ordinary Type, but Works Best on Frozen Snow

over sections cut from old buggy shafts, as shown in the sketch, can be adapted easily for use with poles of

about the same size. They can be steamed and bent at the ends and the construction otherwise made as shown. The shafts were cut to the length indicated, the curved front end being sawed off. The bottom was carried up around the curved rear end, and a strong bracing strip was bolted across them. One-half-inch rope with leather loops provided handholds, and was also used as a brace at each side of the front of the sled. Twisted wire may also be used for this purpose. Cushions of the usual type can easily be made for the toboggan.

Bicycles Driven as Three-Wheel Tandem after Breakdown

On a bicycle trip, when about five miles from town, the front axle of my partner's bicycle broke, and as neither of us wanted to walk, we had to find some way of getting us both home.



When the Front Wheel of One of the Bicycles Broke Down, They were Rigged into a Tandem, and a Distance of Five Miles to Town was Covered

We removed the front wheel from one of the bicycles, and set the front fork on the rear axle of the undamaged machine, as shown in the sketch. The axle was just long enough so that the sides of the fork could be bolted securely. By careful riding we made the distance to town with only the slight inconvenience of my partner having to carry the extra wheel on his back.—J. F. G., Mountain Grove, Mo.

Do not touch the inner surface of a tent or shelter in the rain, as the water will drip from the spot touched.

Toy Submarine Propelled by Rubber Motor

A submarine which is not as deadly as those that infest the waters of the war zone, but which will give any boy who makes it considerable fun, is shown in the illustration. It is driven by a rubber-band motor made up of a number of rubber bands linked together, or from the strands of rubber used to drive a model aeroplane. The motor is wound up by turning the propeller, which is held until the submarine is dropped gently into the water. The water should be still and at least a foot deep. The craft will gradually submerge and travel along slightly below the surface of the water until the motor gives out. The balancing rudder, shown near the stern, is necessary to counteract the action of the rotating propeller.

Make the main piece of oak, 16 in. long, as shown in the side view. The cigar-shaped upper float is of pine, $\frac{3}{4}$ by $6\frac{1}{4}$ in. long. The shaft for the propeller is made of a

piece of wire bent into an eye at one end. It is fitted into a small bearing made as detailed, from a strip of tin. Beads, or small washers, are fitted between the bearing and the propeller.

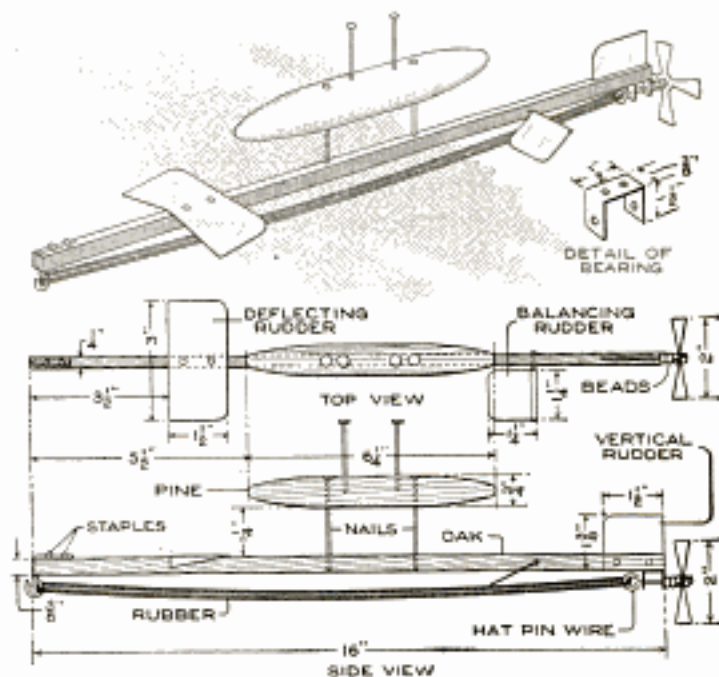

The Toy Submarine, Driven by a Rubber Motor, Submerges Itself in Still Water and Travels Slightly below the Surface Until the Motor Gives Out

The dimensions of the other parts are plainly shown in the drawings.—Howard R. Cassler, Somerset, Pa.

A Homemade Dishwasher

A DISHWASHER which is simple in design, easily constructed, and requires only a small amount of material, is shown in the illustration. It will do the work in less than half the time ordinarily required, and built on a larger scale, it could be used to advantage in a restaurant or any other place where there are many dishes to be washed.

The tank is made of matched boards, preferably hard pine, put together with brass screws. Measured inside, it is 14 in. square and 18 in. deep. The sides are cut 19 in. to allow for overlapping the bottom. White lead is used in the joints to make them watertight. A 1-in. hole, for letting out the water, is bored near the bottom and

fitted with a plug. Give the tank two good coats of linseed oil and allow it to

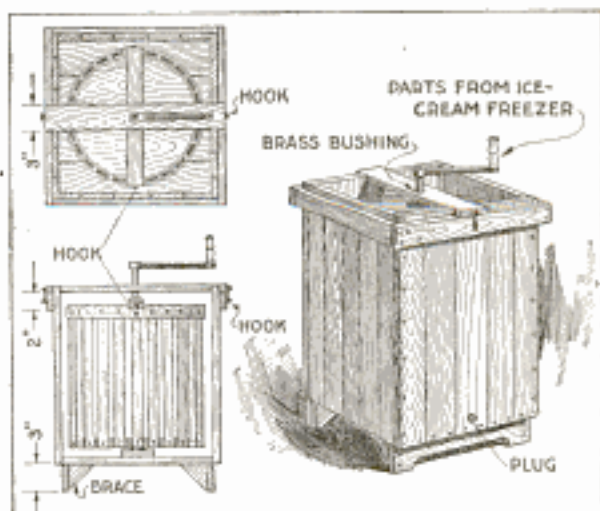

Time and Energy can be Saved in the Large Home or Farm Kitchen by the Use of This Dishwasher

dry thoroughly before it is used.

The revolving drum for the dishes is made of strips 14 in. long, 1 in. wide, and $\frac{1}{2}$ in. thick, spaced 1 in. apart. The bottom is 11 in. in diameter. To make it, cleat two 6-in. boards together with $\frac{1}{2}$ by 2-in. cleats. First, cut this disk eight-sided, and then trim it circular. The strips are held, at the top, between two barrel hoops, with offset joints, and fastened with screws. The top crosspiece of the drum is 2 in. wide. The drum revolves on a $\frac{1}{4}$ -in. bolt. Place a large washer between the bottom of the drum and the block at the bolt.

The crank and fittings were taken from an ice-cream freezer, and others suitable can be devised easily. A piece

of brass tubing was put through the crank bar for a bushing. This bar is held in position by hooks, as shown.

To use the dishwasher, the dishes are first placed in the drum, the plates being set on edge, and the others so the water can circulate freely around them. Pack them in as securely as possible. Fill the tank with hot, soapy water, and hook the two crosspieces in place. Turn the crank about 20 revolutions, and then reverse the direction. Repeat until the dishes are clean. Then drain the tank, and fill it with clean water, having it as hot as possible. Revolve the dishes a few times to rinse them, run off the water and set them out to dry.—Clifford A. Butterworth, Newton Center, Mass.

A Double-Cabinet Sewing Stand

A useful and artistic sewing cabinet of cedar, walnut, or any wood that is easy to work, and which can be stained to match the furniture in the room, may be made, as detailed, by anyone handy with woodworking tools. The front, back, sides, and top are paneled.

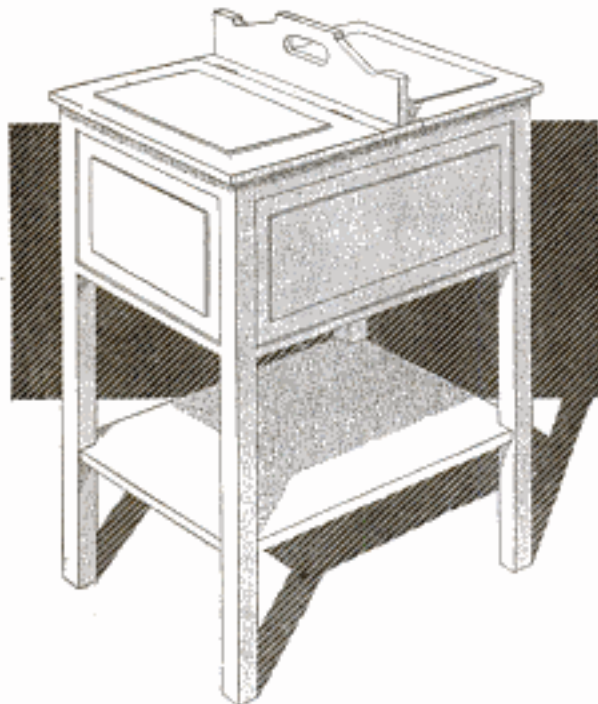

The Sewing Materials and Articles in Use are Kept in the Hinged-Lid Compartments, and the Cabinet can be Carried Easily.

The cabinet can be made more attractive by selecting the wood for the panels so the knots or figures come near the center. Similar construction may also be used, and the cabinet portion made without panels. The cabinet is 27 in. high, 18 in. wide, and 11 in. deep. The legs are made of straight-grain wood.

The panels are cut in one board, the total length of the front, back, sides, and top, allowing for saw cuts and poor wood, by rabbeting out the edges. When the sides of the board are rabbeted, the board is cut into lengths, and the ends of each panel are rabbeted. The top rail above the panels is fastened to the legs with dovetail joints, as detailed. The cover strip is mitered at the corners.

In assembling the parts, nails are used only where they do not show from the outside. The panels are glued into the legs, as shown. The bottom of the cabinet, lower shelf, and handle are fastened with glue, and then nailed. The nails are set and the holes plugged with a mixture of glue and sawdust, sandpapered smooth when dry. When the hinges are fitted, the cabinet is ready for the finish. If cedar is used, brush light-mahogany oil stain on the

light streaks in the wood. A coat of stain, an equal mixture of light-mahogany oil stain and turpentine, is then

of the horse carefully on paper and then transfer them to the wood. Note that the rider is made principally of one

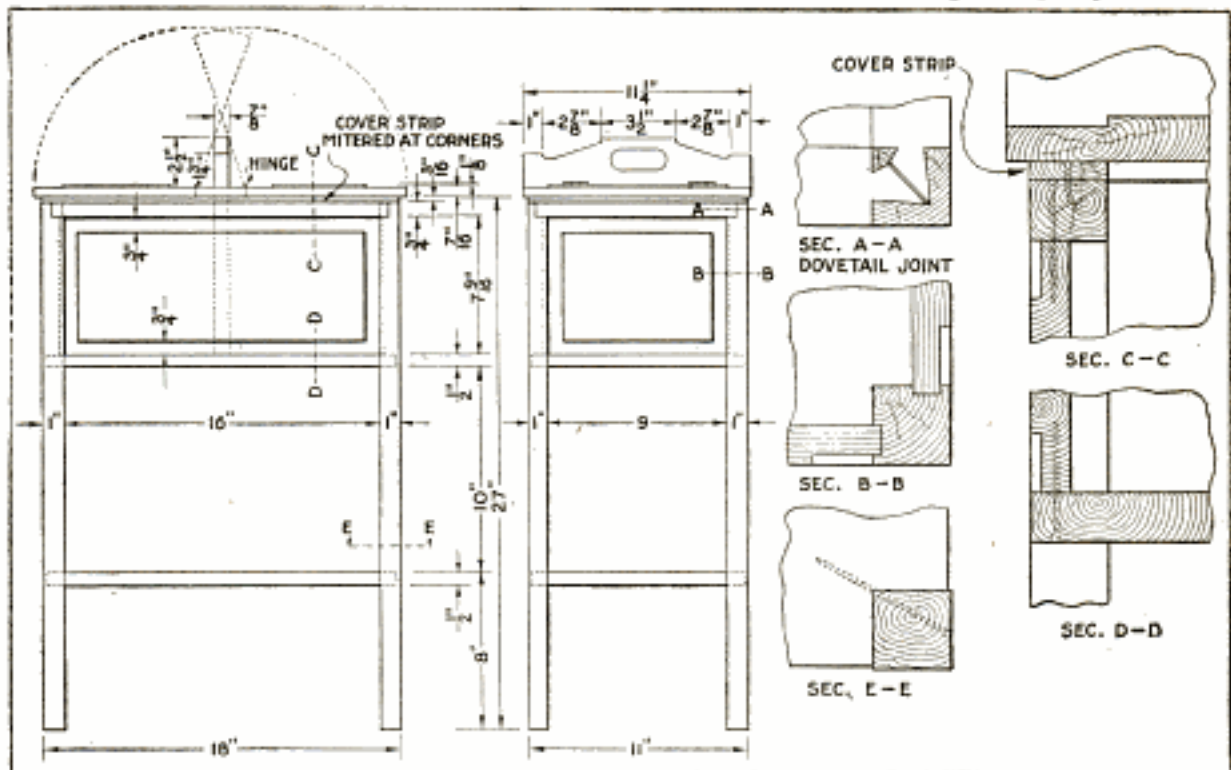

Details of the Construction: The Pieces are All Readily Cut and Shaped. Plain Panels may be Used

applied, followed, in a day, by a coat or two of shellac, each coat rubbed with steel wool when dry. Two coats of wax give a good outer finish. The inside of the cabinet is left unfinished, to preserve the spicy cedar odor.—A. F. Krueger, Champaign, Ill.

A Horse-and-Rider Toy

An interesting toy which a boy can make from 1/4-in. wood is a horse and rider which have lifelike movements, actuated by a swinging lead ball. The rider and his mount are set on a small bracket shelf which can be fastened to the wall. Make patterns of strong paper, shaping them as shown in the illustration. First cut out the parts for the shelf, using a fine coping saw or a jig saw. Nail the shelf parts together and bore holes in the top of the shelf for the pegs which hold the horse in position. Cut a slot through the middle of the shelf so that the string, on which the lead ball hangs, has room for play. Mark the shape of the parts

piece, including the head, body, and arms. The legs of the rider are painted on the side of the horse, and the upper and lower ends of the legs should be shown on the pattern from which the shape of the horse's body is marked on the wood. The head and tail are made separately and fit between the two sidepieces of the body. The head and

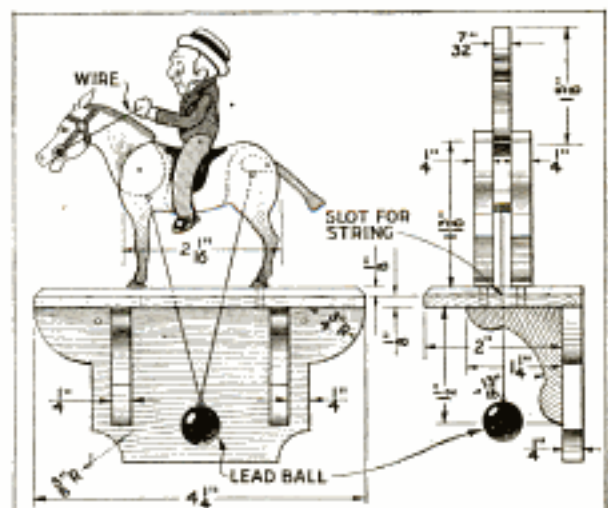

The Horse and Rider Have a Lifelike Action When the Lead Ball is Swung on the Cord

tail are pivoted on brads and the lead ball is suspended from a string, one end of which is fastened to the horse's neck and the other to the tail, as shown.—Harry B. Mowery, New Holland, Pa.

Quickly Detached Nonslip Chain for Shoes

A safety shoe chain, which I have used to good advantage on hard snow and slippery ice, can be adjusted on the shoes in a few minutes and as quickly removed. I took a piece of chain about as long as the width of the sole of the shoe, and looped a buckskin lace through the ends of it, as shown in the sketch. The chain is tied in the buckskin so that it hangs loose under the sole, and can readily adjust itself to irregularities in the ice or snow. The lace is slipped over the heel of the shoe, and tied with a convenient slip-knot.—Glenn Brown, Salt Lake City, Utah.



through the ends of it, as shown in the sketch. The chain is tied in the buckskin so that it hangs loose under the sole, and can readily adjust itself to irregularities in the ice or snow. The lace is slipped over the heel of the shoe, and tied with a convenient slip-knot.—Glenn Brown, Salt Lake City, Utah.

Index Guides Quickly Made

Making card guides for a file is usually tedious work, and often unsatisfactory. A practical method, which provides index tabs with a minimum of cutting, is shown in the sketch. The first card is cut as at A, the second as at B, and so on. These are then used

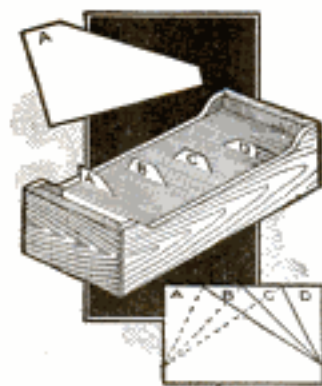

as patterns and the other cards cut in series from them. A good method is to cut all the cards of one shape at the same time by clamping them between boards and using a sharp knife.—L. E. Turner, Brighton, Mass.

as patterns and the other cards cut in series from them. A good method is to cut all the cards of one shape at the same time by clamping them between boards and using a sharp knife.—L. E. Turner, Brighton, Mass.

Open Screw Eyes Handy for Use on Wall Hooks

In hanging up small tools and other articles, such as brushes, buttonhooks, etc., it is a nuisance to locate the wall hook on which the eye or screw eye, set in the end of the handle, is threaded. A good kink is to open the screw eyes sufficiently so that they may be hooked over the wall hook at the opening. Several articles can thus be placed on the same hook, without the necessity of removing those in front to take off the others.—M. T. C., Chicago, Ill.

Electric-Light Cord Adjuster Made of Curtain Roller

A device for adjusting an electric-light cord over a bench lamp that is as convenient as rolling a window shade, was made of an old curtain roller using the same end fittings.

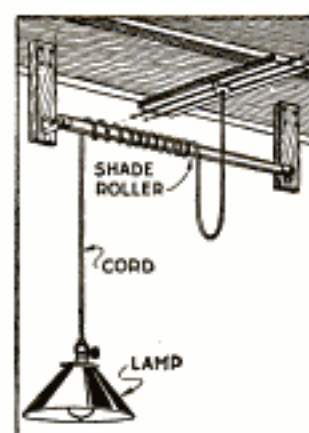

The roller was mounted on two strips fixed to the joist overhead, as shown, and the cord wrapped around it. The lamp is raised and lowered by drawing on its cord just as the shade is adjusted.

The lamp is raised and lowered by drawing on its cord just as the shade is adjusted.

Old Tennis Balls Provide Typewriter Cushions

To deaden the noise of a typewriter, and to protect it from its own racking vibrations, take two "dead" tennis balls, cut them into hemispheres, and at the top point on the curve of each half, cut a hole to accommodate the feet of the typewriter. Then set the typewriter on these, placing the feet in the holes in the tops of the hemispheres. The vibration is taken up in the rubber cushions formed.—A. S. Allen, La Belle, Mo.

Brightening and Cleaning Silver or Filigree Work

To clean silver or filigree work make up a paste of cream of tartar with water, and rub it well into the crevices. Then wrap the piece in flannel and let it remain for five or six days, after which the paste may be removed by washing with warm water. If the filigree silver has become black and dull, wash it thoroughly in hot potash water, which will cleanse it and restore its brightness. Rub the flat surfaces with a soft toothbrush, and then place the piece in the following solution: one part of alum, one part of table salt, two parts of saltpeter, and four parts of water. Soak in this for about five minutes, rinse thoroughly in clear, cold water, wipe dry, and polish with chamois.—A. A. Kelly, Malvern, Pa.

A Pedal for Opening a Drawer

With both hands filled with cooking utensils, one has difficulty in opening the drawers in the kitchen or work table. A pedal, A, fitted beneath the drawer E, as shown, was thus found convenient. To a rod of wood, F, pivoted between the rear legs, at G, a lever was nailed. A cord, B, was run

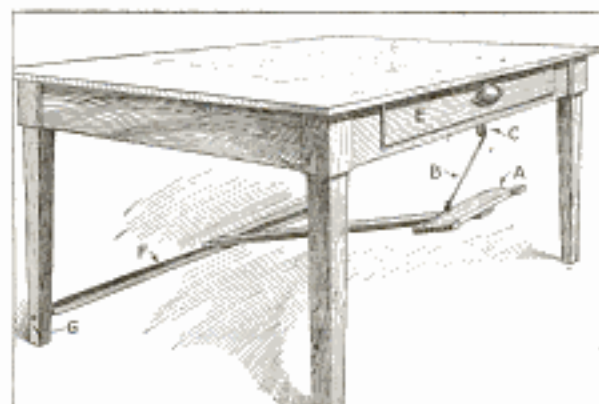

The Drawer is Opened by Stepping on the Pedal

from the pedal over a pulley C, fastened to the table frame and to the back of the drawer. To open the drawer, the pedal is stepped on; to close it, the drawer is pushed.—R. E. Landon, Seattle, Wash.

Bicycle Supported from Pulleys for Storage and Repairing

The storage of a bicycle as well as a handy arrangement for repairing it, is provided by suspending the machine

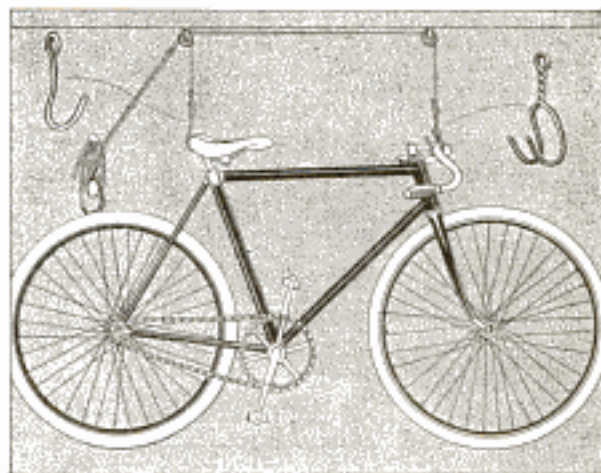

By Supporting the Bicycle on a Rope-and-Pulley Arrangement, the Tires are Kept from the Floor, and Convenient Access in Repairing is Afforded

from ropes fitted with suitable hooks and pulleys, as shown. The bicycle should not be stored with its weight on the tires, and this method takes care of that feature. The pulleys are arranged at the ceiling with a double rope, so that either end of the bicycle can be raised or lowered, as desired, for convenient repairing. By the use of both ropes the height can be varied, even to bring the lower working parts several feet above the ground, which is often a great convenience.

Call Service for Patrons of Movie Theaters

When a person in the audience is wanted at the box office, or on the telephone, the moving-picture machine operator in a certain theater writes the name of the person wanted on a piece of glass, and holds the glass in front of the projector, so that the name is thrown on the screen. If one expects a call, he has only to leave his name at the box office. Black drawing ink and an ordinary steel pen are used for writing on the glass, and the writing is wiped off after the message has been shown, so that the same glass can be used many times.

PUBLIC LIBRARY INDEX TO COMMUNITY TASTE

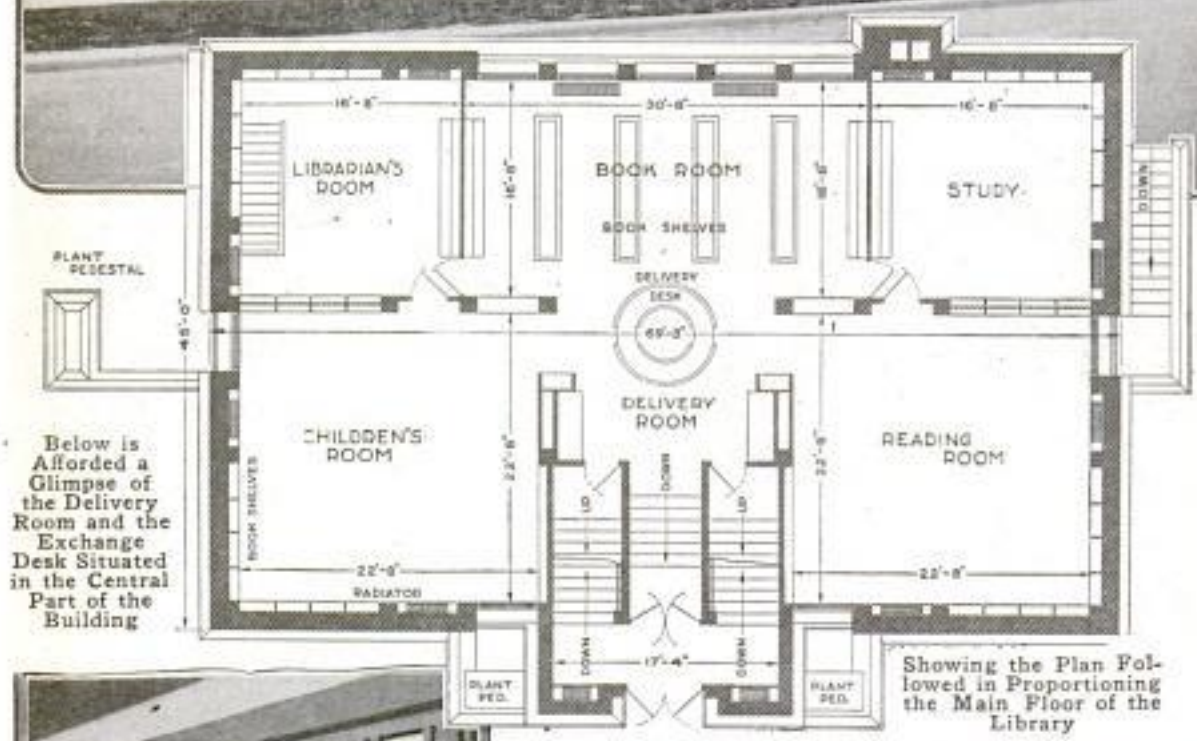

Below is Afforded a Glimpse of the Delivery Room and the Exchange Desk Situated in the Central Part of the Building

Showing the Plan Followed in Proportioning the Main Floor of the Library



PUBLIC buildings of distinctive and artistic architecture always reflect credit upon the intelligence and progressiveness of a community. For that reason Anna, a small Illinois town, which boasts a library of unusual lines and commanding appearance, possesses an asset of considerable value to its citizens. The structure, illustrated herewith, indicates what can be accomplished in almost any small municipality at an expense of about \$25,000. It is fireproof and constructed of native limestone, concrete, and steel. The interior walls are finished with rough plaster and tastefully tinted, while the trim is of heavy fumed oak. As will be observed, the outdoor aspect of the window scheme is striking. Inside it is even more effective, for the long, narrow openings on either side of each window break

the blank wall space attractively. Stained, leaded glass is used. Adequate description of the practical arrangement of the main floor is supplied by the plan presented above. A large part of the basement, which is nearly level with the ground, is equipped as an auditorium. In addition there is enough room for storage space, wardrobes, toilets, janitor's quarters, and the heating plant.

\$988 for this 7-Room ALADDIN



Your Own Home—Build It This Year

HERE is your opportunity to own a home and dodge high building prices. You can do it even though building prices are going up! **THE ALADDIN READI-CUT SYSTEM** of building stands between you and present high prices. It offers you this ideal home or one hundred other attractive homes at substantial savings in price. Think of the home pictured above containing large living room and dining room, large kitchen, three large bedrooms and porch for \$988 for complete material, readi-cut. This is only one of a hundred homes with prices from \$200 to \$8000 shown in the handsome book. Let us send you a copy of this book entitled "Aladdin Homes." Send stamps today for your copy.

Why Pay \$1200 for a Home That You Can Buy for \$988

Why hand over two hundred dollars of your savings to a contractor when you can **keep that money** by having any carpenter put up your Aladdin Read-Cut Home? Your staunch, beautiful Aladdin Home comes **all ready for building**—complete to the last lock screw in the front door. It saves you money because the lumber is cut by **machinery**—the materials bought at **wholesale**. The daily capacity of our mills is 40 Aladdin Homes—we get 18% more out of our lumber than any builder. This great saving becomes **YOURS**.

What You Get Aladdin price includes all lumber, mill-work, flooring, outside and inside finish, doors, windows, shingles, lath and plaster, hardware, locks, nails, paint, varnishes. Your home is shipped in a sealed box car, complete, Read-Cut, ready to erect. Safe arrival of the complete material in perfect condition is guaranteed. Floor plan arrangement and complete description of the house shown above will be found in the Aladdin Book of Homes. Send stamps today for the book, "Aladdin Homes," No. 180.



Here is the Floor Plan of Home Shown at Top of Page

The Aladdin Company

Homebuilders to the Nation
Canadian Branch, C. P. R. Bldg., TORONTO, ONT.

1468 Aladdin Ave., Bay City, Mich.



How Four Pitiful Failures Discovered the Road to Fortune

NOTE: *Men are asking—"How can I earn more money—what shall I do to reach the turning point in my life?" These remarkable instances of how four failures found the answer may point the way to you.*

By Stanley D. Hopkins

A YOUNG man in the East had an article for which there was a nation-wide demand. For twelve years he "puttered around" with it, barely eking out a living. Three years ago he began to analyze himself. He discovered that his one great fault was his inability to come to a quick, definite decision. Time and again he had tried, in a half-hearted way, to market his goods. This time he steeled himself to fight a winning battle. He began to develop his strength of will so that no imaginary mountain could turn him aside from his purpose.

From \$30 to \$1,000 a Week

Today this young man is worth \$200,000. He is building a \$25,000 home—and paying cash for it. He has three automobiles. His children go to private schools. He goes hunting, fishing, motoring or traveling whenever the mood strikes him. His income is over a thousand dollars a week and he attributes his amazing success to his super-developed power of will.

A School-Teacher's Rise

A teacher in a little town just outside of Chicago was so "down and out" that he couldn't pay a \$10 debt which he had contracted months before. Every cent he had scraped together had been lost through an investment in a corporation that failed to make good. Discouraged, sick at heart, he was forced to do something quickly to recoup his losses. He secured a position in a small private school, and in a remarkably short time was the owner of it. As he says, "I am the owner of a business worth many thousands of dollars and owe no man a cent."

Talk to him and he will tell you what his newly revived strength of mind has done for him!

A Failure at 60—Then Sudden Success

In a little town in New York lives a man who two years ago was pitied by all who knew him. From the time he was 14 he had worked and slaved—and at 60 was looked upon as a failure. Without work, in debt to his charitable friends, with an invalid son to support, the outlook was pitchy black.

Then, suddenly, things began to happen. He went to the owner of an old vacant factory, secured the place at a ridiculously low rent, with the first three months' rent free. He almost *demand*ed a loan of \$500 with which to begin some experiments. In three weeks he was out for business. In three months his plant was working day and night to fill orders. During 1916 the profits were \$20,000. During 1917 the profits, it is estimated, will run close to \$40,000. And this genial 62-year-young man is enjoying pleasures and comforts he little dreamed would ever be his.

Ask him what made the remarkable change in his life and he will tell you that it was his life-and-death determination to whip *his own mind*—so that he could do the things he wanted to do without being hampered by a weak, milk-and-water will.

Former Newsboy Heads \$1,000,000 Business

From "peddling papers," to the management of a concern doing business of over a million dollars a year, is a far cry indeed. Yet

Please Mention Popular Mechanics

that is the remarkable achievement of a 26-year-old youth from the West. Born of Russian parents, raised in a tenement, with no education save that gained in the ordinary grade school, this young business giant forced his way to the front rank of his profession. For a while after he stopped selling papers he drifted around from job to job. Two years ago he made his present connection. Today he drives around in his own motor-car, his income is almost unbelievable when one considers the handicaps he had to overcome, and his prospects for "five-figure" yearly earnings are exceedingly bright. He disclaims all credit for his success—stating that it was only through systematically developing his personality and will-power that he was able to make his way so rapidly.

Their Guide to Wealth

These are but a few of the hundreds of achievements brought about through systematic will-power development. Regardless of what a man may be—what failures he may have gone through—he can have practically anything he wants out of life if he will but use and develop his God-given power of will. For will-power is the secret of every great achievement. It makes weak men strong. It makes leaders out of followers. It makes doers out of dreamers. It makes dominating personalities out of cringing wrecks of humanity. It makes successes out of failures. It makes dollars jingle where only pennies clinked before.

And the most wonderful thing about a strong will is that it may easily be acquired by anyone. Prof. Frank Channing Haddock—a scientist whose name ranks with James, Bergson, and Royce—after 20 years of research, investigation and study, has prepared a remarkable set of actual exercises, lessons and new methods which have already revolutionized the lives of over 200,000 men and women in all parts of the world. This book, called "Power of Will," is issued by the Pelton Publishing Co. of Meriden, Conn. Mr. Pelton has authorized me to say that any reader who cares to examine the book may do so without sending any money in advance. In other words, if after a week's reading you do not feel that this book is worth \$3, the small sum asked, return it and you will owe nothing.

When you receive your copy for examination I suggest that you first read the articles on: The law of great thinking; how to develop analytical power; how to perfectly concentrate on any subject; how to guard against errors in thought; how to drive from the mind unwelcome thoughts; how to develop fearlessness; how to use the mind in sickness; how to acquire a dominating personality.

No Money in Advance

Some few doubters will scoff at the idea of will-power being the fountainhead of wealth, position and everything we are striving for, and some may say that no mere book can teach the development of the will. But the great mass of intelligent men and women will at least investigate for themselves by sending for the book at the publisher's risk. I am sure that any book that has done for thousands what "Power of Will" has done, is well worth investigating.

It is interesting to note that among the 200,000 owners who have read, used and praised "Power of Will" are such prominent men as Supreme Court Justice Parker; Wu Ting Fang, ex-U. S. Chinese Ambassador; Lieut.-Gov. McKelvie, of Nebraska; Assistant Postmaster-General Britt; General Manager Christeson, of Wells-Fargo Express Co., E. St. Elmo Lewis; Governor Arthur Capper of Kansas, and thousands of others.

As a first step in will training, I would suggest immediate action in this matter before you. It is not even necessary to write a letter. Use the form below, if you prefer, addressing it to the Pelton Publishing Company, 13-W Wilcox Block, Meriden, Conn., and the book will come by return mail. This one act may mean the turning point of your life, as it has meant to me and to so many others.

PELTON PUBLISHING COMPANY,

13-W Wilcox Block, Meriden, Conn.

I will examine a copy of "Power of Will" and I agree to remit \$3 or remail the book in five days.

Name

Address

.....

Please Mention Popular Mechanics

WHITE MONOPLANE

**A
Proved
Success**

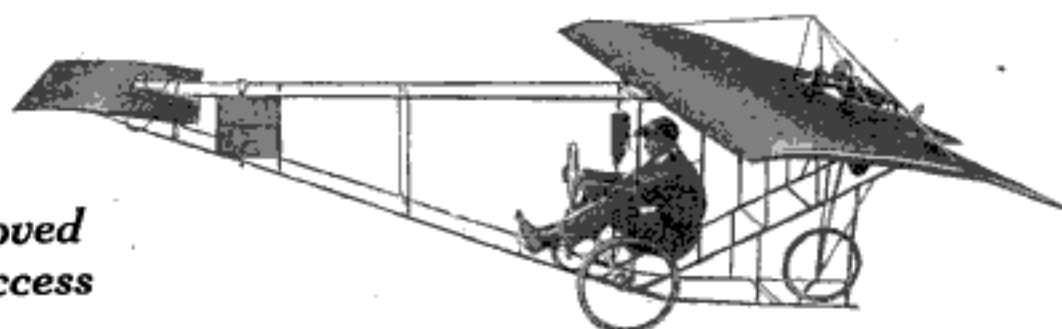

FLIES WITH MOTORCYCLE ENGINE

Think of flying with an ordinary twin cylinder motorcycle engine! This is the only aeroplane that will do it. It is the smallest and most efficient of all aircraft. No longer is flying the sport of acrobats and millionaires. Men and boys! Build one of these remarkable aeroplanes with ordinary tools in a few weeks and learn to fly at home with safety. No shop is needed. If you can use a hammer, saw and a pair of pliers and have a shed, barn, a basement or a back yard you can build one of these remarkable flyers for a few dollars and in spare time if necessary. Costs less than 1/50 the cost of the average aeroplane and can be built for less than a fifth the cost of going to a flying school. It is the smallest, simplest, safest and most successful aeroplane in the world.

YOU CAN BUILD IT

Remember, this is not a toy or an experiment, but a thoroughly perfected man-carrying aeroplane with 18 foot spread and a speed of 30-60 m.p.h. Lifts 190 pound man with twin cylinder motorcycle engine. Flights of several hours can be made. Hundreds are already in use in the United States, Canada, Mexico, South America, England, Australia and the Philippine Islands. Hundreds of amateurs are building and flying these aeroplanes, men and boys who knew absolutely nothing about aeroplanes and flying before. It is the simplest and safest flyer in the world. Any make of motorcycle engine can be used.

WHAT OTHERS SAY:

POPULAR MECHANICS says:

"Undoubtedly the smallest successful monoplane in the world."

AERIAL AGE says:

"One of the most interesting machines yet to be developed."

SCIENTIFIC AMERICAN says:

"A unique type of monoplane."

L. A. EVENING HERALD says:

"Has solved the problem of producing small machines at a cheap price for universal service."

USE THIS COUPON

George D. White,
Dept. 14, 3832 So. Main St.,
Los Angeles, Calif.

DEAR SIR: I am enclosing \$2. Send me a full set of working drawings of your famous monoplane, charges prepaid.

Name.....

Address.....

Working Drawings \$2

Send \$2 at once for a complete set of working drawings of this wonderful monoplane showing all details and dimensions in a simple manner so you can easily understand everything. Here is your chance to get into the greatest of all industries. Thousands of experienced flyers and builders are needed.

Don't Miss This Chance! Send \$2 Now!

GEORGE D. WHITE

DEPT. 14

3832 South Main Street, LOS ANGELES, CALIF.

The Men The Navy Needs Now

DURING the first few weeks after the United States entered the Great War, many thousands of patriotic young Americans responded to the call of the United States Navy. So many of these fine young men offered their services who had no special qualifications for the work on board ship, that the capacities of the training stations were soon overtaxed. It shortly became necessary to restrict the enlistments of unskilled men by raising the minimum age limit of apprentice seamen, and to suspend enlistments in certain trades which were in excess, such as shipwrights, shipfitters, blacksmiths, boilermakers, plumbers, printers, painters, general electricians and yeomen (or clerks).

The Navy still needs men, but desires to fill the remaining vacancies in its authorized complement with men who are most needed in the fleet.

There is a demand now for competent machinists, ages 21 to 35; for cooks and bakers, 21 to 35 (or landsmen for cooks and bakers, 18 to 25); and for radio operators, 18 to 25.

Other ratings which are still open to enlistment are apprentice seamen, musicians, coppersmiths, firemen, hospital apprentices, mess attendants, and men specially qualified for machinists in the Navy Flying Corps.

An attractively illustrated booklet explaining the naval service, together with circulars describing special branches of the Navy, will be sent upon request.

ADDRESS

RECRUITING DIVISION
NAVY DEPARTMENT **WASHINGTON, D.C.**

There is a Navy Recruiting Office in every large city

[NOTE— This page contributed by Popular Mechanics Magazine.— Editor.]

CORONA

The Personal Writing Machine

IT'S a pleasant task to make up arrears of correspondence with Corona, amid the quiet of familiar surroundings—or even to catch up with office overloads or odds and ends of personal business.

For Corona is truly the *personal* writing machine. It fits the home atmosphere, the home mood—even fits into your favorite nook as cosily as a comfortable chair. Light in weight, readily portable, and never in the way, for it *folds* into small compass—yet sturdily built and thoroughly practical, as a hundred thousand users will testify. Also exceptionally simple to operate.

Corona weighs but six pounds; complete with neat traveling case, it costs fifty dollars. A useful gift, for men or for women, and one that steadily grows in value. Fully described in Booklet No. 13. Also supplied with smart special luggage, made by Likly.

CORONA TYPEWRITER CO., INC., GROTON, N. Y.
 NEW YORK CHICAGO SAN FRANCISCO
 AGENCIES IN ALL PRINCIPAL CITIES



-fold it up-take it with you-typewrite anywhere

Please Mention Popular Mechanics

No. K 5



*"—and here's
our present to you, Dad"*

Just imagine how happy dad would be with a KEEN KUTTER Tool Cabinet. Think of all the odd jobs he does about the house for mother—an extra shelf, a door to hang, a new cupboard or closet and a hundred and one little things around the barn and garage.

Give him a KEEN KUTTER Tool Cabinet for Christmas and he'll always be prepared to tackle any little odd job about the house—know right where to find every tool.

And he'll know that KEEN KUTTER Tool Cabinets are filled only with highest grade, tested tools because every tool is guaranteed to give satisfaction—or your money back. Ask your dealer to show them to you.

SIMMONS HARDWARE COMPANY

Manufacturers and Distributors

St. Louis New York Philadelphia Toledo Minneapolis Sioux City Wichita

No. K5 Price \$35.00

Complete with 28 Highest Grade Tools and 12 other miscellaneous articles.

"The recollection of QUALITY remains long after the PRICE is forgotten."

Trade Mark Registered

—E. C. Simmons

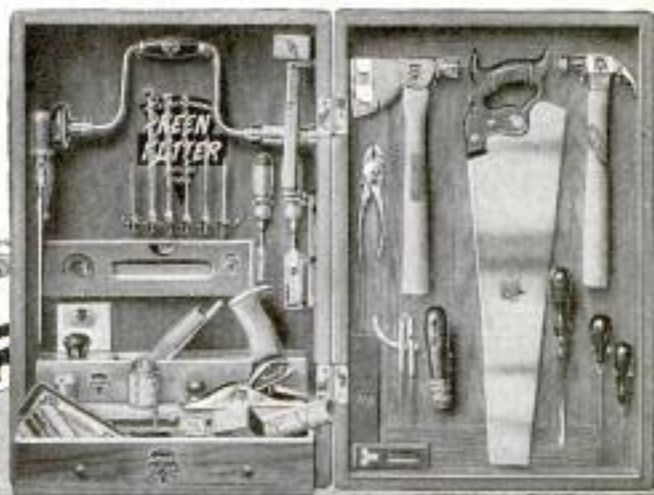

Please Mention Popular Mechanics

Copyrighted material



Look, Boys!

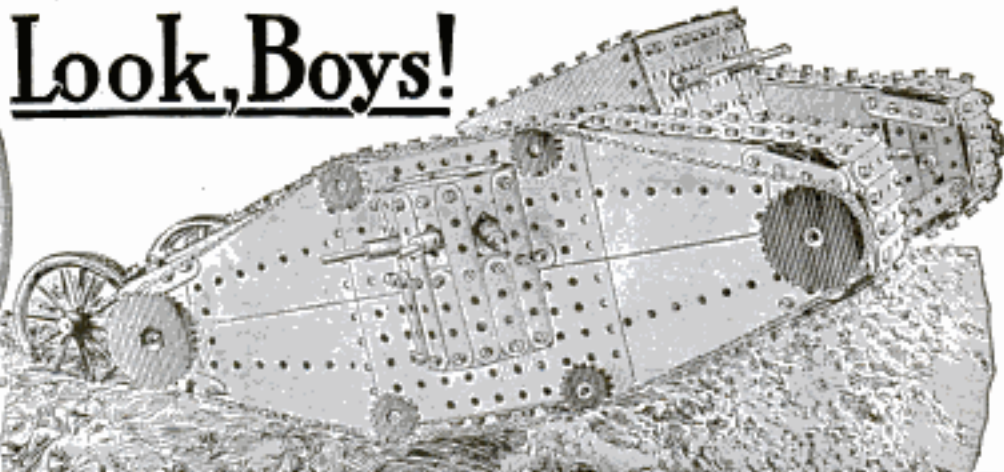

A set of Meccano is just like a Magic Box of fun!

You Can Build This TANK with MECCANO

Toy Engineering for Boys

Think of the never-ending joy of building with Meccano! You can construct Towers with electric elevators, Cranes that lift loads, Bridges that open and close, Steam Shovels that dig, Looms that weave, Clocks that keep time.

Or—you can reproduce the machines you see everywhere around you. There's no limit to what you can do. Why, it's almost magic! You can actually have a new toy every day.

The "Tank" shown above is a perfect working model of the wonderful machines which crawl over trenches and shell-holes, knock down trees and houses, and climb right over them. Yet it's only one of the hundreds pictured in the Meccano Manuals, which come with the Meccano sets. Each page is a fund of wonder; each model an inspiration.



Send For Meccano Wonder Book

Send the name and address of yourself and three boy friends and you will receive the Wonder Book, telling all about Meccano; a free trial subscription to "The Meccano Engineer" and terms of \$1,000 Prize Contest. Send now, so you and Dad can decide on your present.



A bully Field Gun

You can make a new model every day with Meccano if you want to. You never get tired of Meccano, and it never wears out.

Be Sure the Name "MECCANO" is on the Box

A few of the Hundreds of Models Any Boy can Build With Meccano.

A regular Army Aeroplane



Insist on Meccano for Christmas Because:

—Meccano Building is True Engineering.

—No Other Toy will make such Fascinating Models.

—Meccano Models operate like Real Machinery.

—You don't need to Study; the Fun begins when you open the box.

—There is no Limit to the Number of Models any Boy can Construct.

—Each Set is Complete; nothing more to Buy.

—You can Win a Big Cash Prize.

BE SURE YOU GET MECCANO

Be sure to get MECCANO. There isn't anything else just as good or just the same. So say the name over to yourself—MECCANO—MECCANO—MECCANO. Then tell Mother and Dad why nothing else will give you as much fun.

Prices of MECCANO Sets

MECCANO sets include various sizes of dandy girders, plates, and perforated strips; also nuts, bolts, wheels, gears and scores of other parts—all cut from shining steel and brass, as accurately as the works of a clock. Each regular outfit, from No. 60 to No. 6, is complete with tools and full instructions. Nothing more to buy. Sets numbered 1X, 2X, 3X contain the powerful MECCANO Electric Motor. Any set sent postpaid upon receipt of price, if not at your dealer's.

No. 60....	\$1.00
No. 6....	1.50
No. 1....	3.00
No. 1X....	4.50
No. 2....	6.00
No. 2X....	7.50
No. 3....	9.00
No. 3X....	12.00
No. 4....	15.00

And up to \$40.00

MECCANO COMPANY, Inc.
Building 10H, Bush Terminal, Brooklyn, N. Y.



Make this Christmas "the best ever" for your boy

You remember, don't you, how much you wanted a gun, how discontented you were till you got it? And will you ever forget how proud and happy you felt the first time you fitted the stock of your *own* Winchester to your shoulder and fired your first shot? Well, that lad of yours wants a rifle of his own just as badly as you ever did and—

Now's your chance to make him happy

Christmas is the time to make his most cherished dream come true, and that Winchester .22 will give him more pleasure this year than a whole arsenal of them could possibly give him five years from now. So make him happy while you have such a good chance.

A rifle is a wise gift, too, because it brings out the man in him; it teaches him responsibility, self-control, self-reliance; it develops in him the invaluable qualities of concentration and perseverance.

Every boy knows the reputation behind the name "Winchester," so get him the rifle he can be most proud of.

What the name "Winchester" means

The name "Winchester" stands for the

best in gun making. For over half a century Winchester has been the standard of pioneers and sportsmen.

The Winchester Company today is an organization of expert gun makers with 50 years of gun-making reputation behind it.

Every gun or rifle that bears the name "Winchester" is fired many times for smooth action and accuracy, and is fired with excess loads for strength.

Get the rifle now

Your dealer will help you to decide which one of the fine .22 Winchesters will best suit your boy. Now is the time to select it—while there are still plenty in stock. You will be surprised to find what a fine gun you can get for a low price. Get the rifle now and make the boy happy.

There is a place near you, either out in the open or at a club, where you can shoot. If you do not know where to shoot, write to us, and we will tell you where and how you can, or we will help you organize a club.

WINCHESTER REPEATING ARMS CO.
Dept. 145 New Haven, Conn.



Boys and Girls Winchester Medals for skill with the rifle

The Gold Plated "Sharpshooter" Medal goes to the boy or girl under 18 who makes the first grade score with a Winchester .22 rifle and Winchester ammunition.

The Silver Plated "Marksmen" Medal goes to the boy or girl who makes the second grade score.

Go to your dealer today; he will give you a sample target and booklet explaining the full conditions of the contest. This booklet also tells you how to get the best results from your Winchester. The dealer will also supply you with targets.

If your dealer cannot supply you, write to Winchester Repeating Arms Co., Dept. 145, New Haven, Conn.



MODEL 66. Take-down Repeating .22 caliber rifle, 21-inch round barrel. Shoots three sizes of ammunition. The most popular .22 caliber repeater ever placed on the market.

Take-down .22 caliber single shot rifle. A low priced, light-weight gun made in two sizes.

WINCHESTER

World Standard Guns and Ammunition

Please Mention Popular Mechanics

Science Gave Us Radiolite

Radium is a comparatively new scientific discovery. Now the world's greatest watch factories have utilized Radium to make a substance for illuminating Ingersoll hands and figures. This substance has been named Radiolite. The only watches that can be Radiolites are Ingersoll Watches.

Radiolite hands and figures double the usefulness of the Ingersoll Watch—and the Ingersoll has long been the utility watch of the world.

Radiolite glows brightly at night. It makes the hands

and figures of Ingersoll Radiolite Watches plainly visible in pitchy darkness. It is self-luminous—unlike phosphorescent paint, which can only absorb light and later throw it off.

Buy an Ingersoll Radiolite Watch. Own a proven time piece that has been perfected by one of the greatest discoveries in the history of science. Let radium tell you every minute of every hour of every night at a glance.

Look for Ingersoll on the dial—for only Ingersolls are Radiolites.

ROBT. H. INGERSOLL & BRO.

New York

Boston

Chicago

San Francisco

Montreal



Radiolite—\$2.25
In Canada \$3.50
The regular Ingersoll with
a radium-lighted dial



Waterbury Radiolite \$4.50
In Canada \$4.50
A small, handsome jeweled
watch

Ingersoll

RADIOLITE WATCHES

\$2.25 to \$4.50

Illustrations three-fifths actual size

Please Mention Popular Mechanics

**FREE
TRIAL
OFFER**

Be Your Own Salesman and Save \$51—

New Oliver Typewriters for \$49

Let us send you a brand new Oliver Nine—the world-famous typewriter—for five days' free trial. Keep it or return it.

That is our plan in a nutshell. Our new plan—besides saving you \$51—makes it easy for every one to convince himself of Oliver superiority. No red-tape—no money down—no C. O. D. No salesman to influence you. No need to ever pay \$100 for a typewriter again.

But here is a warning— all advertisements for *brand new* Oliver Nines at \$49 must be signed by the Oliver Typewriter Company.

**Prices
Cut in
Two—
and Why**

With greater production and huge financial resources, the Oliver Typewriter Company is the pace setter.

Its officials seek to relieve the public of a useless tax. In the past, it has cost \$51 to sell typewriter through an expensive sales force—high rents for offices in 50 cities—and other frills. All are wasteful from an economic viewpoint. That is why Oliver Nines are shipped direct from the factory to the user—on free trial. This permits us to wholesale machines to you for \$49. You get the saving. No middlemen with their tolls.

This plan, we feel sure, is in keeping with modern demands. All will welcome such a sincere effort to reduce the High Cost of Typewriters.

10 Cents a Day

Easy payments of \$3.00 per month. This in addition to our cutting the price in two. Could any one go further? Yet we offer this free trial without obligation on your part. The plan is daring—but we believe discerning people will respond.

This is the first time in history that a new, never-used \$100 typewriter of the latest model has been offered at the price of cheaper or second-hand machines. It is cheaper to own than rent.

No Money Down

Simply send in the coupon properly filled in. There is no red tape—no salesmen—no collectors—no bother. Keep the Oliver for \$3.00 per month. Or return it. It is up to you.

Mail the coupon today.

The Oliver Typewriter Company
1099 Oliver Typewriter Bldg., Chicago

This Is Our Offer

No Money Down. No C. O. D.

Easy Monthly Payments

Maker and user deal direct. You are your own salesman. You pay yourself the \$51. Own this master typewriter at the rate of \$3.00 per month.

The Oliver Nine itself must convince you. It is the greatest, the most durable, the most successful typewriter ever built. No finer can be bought for any price. It is a twenty year development.

There is no need now to ever pay \$100 again for a new typewriter. The Oliver rebellion gives everyone an opportunity to own an Oliver. And at lowest time payments.

This is the same machine used by the largest concerns. It has all the latest improvements. For speed and fine workmanship, it can't be beat.

If after trial of 5 days, you are not satisfied—ship it back at our expense.

MAIL TODAY

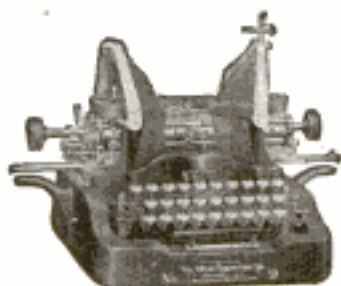

Over 600,000 Sold

Do Not Confuse

This \$49 Oliver is *not* a second-hand machine—but brand new, direct from the factory to you. It is not a special model—but the identical machine that was \$100. Reduced selling expenses saves you \$51.

Some of the big concerns using Oliver's are: U. S. Steel Corp., Standard Oil Co., Nat'l City Bank of N. Y., Montgomery Ward, Pennsylvania R. R. The Oliver is famous the world over. You can now own one for 10¢ per day.

FREE TRIAL COUPON

THE OLIVER TYPEWRITER CO.

1099 Oliver Typewriter Bldg., Chicago

You may send me a new Oliver Nine on approval. I will keep it five days. Then, if I decide to buy it, I will pay \$49 at the rate of \$3 per month. The title to remain in you until fully paid for.

If I decide to return it, I will turn it over to the express company, properly packed and addressed to you.

Name

Address

References

Please Mention Popular Mechanics

Copyrighted material



"With mirth and laughter let old wrinkles come"

Shakespeare

The key to a keen and cheerful old age is vigor.

ANHEUSER-BUSCH'S
Malt-Nutrine

REG. U.S. PAT. OFF.

TRADE MARK

Liquid-Food-Tonic

is strengthening. It benefits the old and weak — aids digestion and nourishes without overburdening the system. Is there a birthday in *your* home whose celebration crowds the cake with candles? Malt-Nutrine should be taken at each meal and before retiring.

All Druggists—Most Grocers

Malt-Nutrine declared by U. S. Internal Revenue Department to be a pure malt product — not an alcoholic beverage. Contains 14.50 per cent malt solids—1.9 per cent alcohol.

Interesting booklet on request.

ANHEUSER-BUSCH ST. LOUIS, U. S. A.

The key to
the situation



Please Mention Popular Mechanics

Copyrighted material



The *BEST* Solution of the Youngsters' Christmas Gift Problem

NOT a soon-forgotten toy or worthless trinket, but an economical, practical, body-building, muscle-making 1918 *Electrically Equipped*

Indian Bicycle

Any boy or girl will glory in the possession of this most popular bicycle. Large Electric Light with Reflector, a necessity in those States requiring that bicycles be lighted; Tank Battery Holder, Triple Stem Forks, Indian Crank Hanger, motorcycle style lines throughout. Everything in equipment a bicycle should have.

Eleven other models in the 1918 Indian line, ranging in price from \$27.50 to \$50. All backed by the Indian nameplate and guarantee.

1918 Indian Light Twin Motorcycle—Easily-

handled, safe, dependable, mechanically simple motorcycle of modified speed and power. Has all the qualities of Indian super-construction and excellence, plus the Indian's recognized features of operating and upkeep economy. Priced to make it available for anybody who can afford any sort of high-grade two-wheel vehicle.

Give the youngsters what they want—**Indians**. Practical, economical, healthful, they furnish fun and happiness and splendid outdoor exercise the year round.

Send for illustrated Bicycle or Light Twin Catalog, or both

HENDEE MANUFACTURING COMPANY, 711 State Street, Springfield, Mass.
(Largest Manufacturers of Motorcycles in the World)

Please Mention Popular Mechanics

SUGAR 4c a Lb

Only one of the hundreds of Sensational offers in highest-grade, guaranteed quality, staple groceries in our amazing new Price-Wrecking Catalog. To save all mailing expense and to avoid all waste distribution of this remarkable catalog, we send it ONLY to new customers who send us their order for the SPECIAL "Get Acquainted" assortment listed below. Catalog packed in every shipment.

FLOUR Per bbl. \$9⁶⁰ — **SUGAR** 100 lbs. \$4⁰⁰

Stop paying exorbitant prices for groceries. National necessity demands that you buy carefully and waste nothing. Establish yourself with the great Consumers' Wholesale Grocery Co. and cut the high cost of living. Rush your order today. Make your own selections for all future orders—large or small. Sugar 4c a lb.; Flour \$9.60 a bbl. with orders. Use the coupon.

Save 1/3 to 1/2

What Our Customers Say

"Goods received, and they are all O. K. Will send another order at once."—Ed. A. Dehme, Prop. The Horicon House, Horicon, Wis.

"Groceries received in good shape and am well pleased with the goods. I consider that I have saved about \$4.00. Will order more soon."—J. W. Chester, Kent, Ind.

"I received my order of groceries all right. They are fine—as good as any I have ever used."—R. Donovan, Lyndon, Wis.

We Ship You This \$4.21 "Get Acquainted" Order for \$2.53 **\$1⁶⁸**
YOU CAN SAVE

\$0.50	5 lbs. Our Best Granulated Sugar . . .	\$0.20
.16	2 Bars American Family Soap09
.08	1 Pkg. Gold Dust Washing Powder03
.12	1 Large Pkg. Quaker Oats06
1.50	3 lbs. Our Special Blend Coffee96
.50	1 lb. Special Pure Baking Powder40
.40	1/2 lb. Black Pepper20
.40	1/2 lb. Cinnamon20
.55	1 Bottle Pure Vanilla Extract, 4 oz. . .	.39
	Usual Retail Price	
\$4.21		Our Rock-Bottom Price \$2.53

HURRY MAIL THIS TRIAL ORDER COUPON NOW

ORDER BLANK COUPON

CONSUMERS WHOLESALE GROCERY CO.,
1403 to 1409 W. Congress St., Dept. 586
CHICAGO, ILL.

GENTLEMEN—Enclosed please find \$2.53, for which please send your Special Bargain Grocery Order and include free your new Price-Wrecking Grocery Catalog. It is understood that if I am not thoroughly pleased with the goods I receive I can return them and you will refund my money.

Name.....

Address.....

City..... State.....

Do not delay. Start today to cut your living expenses. Fill out and mail this coupon with \$2.53. Your order will be shipped the same day received. Our money back guarantee is your protection. You take no risk. Send now.

CONSUMERS WHOLESALE GROCERY CO.
1403 to 1409 W. Congress St.
Dept. 586, CHICAGO, ILL.

MONEY-BACK GUARANTEE

We positively guarantee the weight, quality and quantity of every article listed in our catalog. If you are not perfectly satisfied with the goods, return them and we will promptly return every cent of your money.

Mail Coupon for STAG SHARPENER OUTFIT

and get **TRENCH
MIRROR** →



SHARPENS ALL SAFETY BLADES

HONING—STROKE FORWARD

SHARPENS ALL SAFETY RAZOR BLADES

Yes sir, sharpens them sure and fast and better than you ever thought a safety razor blade could be sharpened. No experience necessary—a child can use the Stag Sharpener. Makes old blades like new—makes new blades better. Can't possibly use it wrong—just a few strokes and you have the best shaving edge you ever saw. A head barber's shave all the time with your Safety if you use the Stag Sharpener. The regular price on the Stag Sharpener is \$1—it is worth many times that. Here is a special offer for this month—may not be repeated again.

Complete, including unbreakable Trench Mirror,
\$1 postpaid to you on this special offer

Stag Sharpener

with barber's hone and strop
and Trench Mirror complete.

\$1

Free Trial

We are so sure that the Stag Sharpener must please you that we want you to use it ten days entirely at our risk, and our expense, then if you are not delighted, send it back and get your money back in full. We gladly assume the risk and welcome your order on this liberal Free Trial Money Back Guarantee. Just fill out the coupon above and send on the dollar today.

Ideal Christmas Gift for the Soldier Boy

Uncle Sam says his soldier boys must be clean shaved every day. What better gift than the Stag Sharpener outfit with the Trench Mirror. Remember, the outfit includes a hone and strop, and also the Trench Mirror described above, all packed in attractive kit box. It is a splendid gift for the soldier boy or for any other man. Nothing could be more appreciated. Just fill out the coupon, send the dollar, and if you are not satisfied with the outfit all you have to do is return it and ask for your money back. Don't delay, though, for this offer is extremely special and cannot be held open indefinitely. Be sure to write your name plainly on the coupon.

THE STAG COMPANY

329 Plymouth Ct., Dept. 5244, Chicago

SPECIAL \$1 COUPON

Hone, Strop and Trench Mirror Free

THE STAG COMPANY

329 Plymouth Court, Dept. 5244, Chicago

GENTLEMEN: Wishing to take advantage of your 10 days' free trial and money-back guarantee, you may send a Stag Sharpener, hone, strop and Trench Mirror complete. I am sending herewith \$1.

Name.....

Address.....

For Trench Mirror alone send only 25c

FREE!



TRENCH MIRROR FREE

Handiest, dandiest, finest thing for the soldier boy you ever saw. Trench Mirror positively can't break. Gives a perfect mirrored reflection. Takes practically no room in the soldier's kit. The soldier boys are wild about them. It is absolutely free with the Stag Sharpener outfit. Just mail the coupon above with \$1—get Stag Sharpener, hone, strop and Trench Mirror free.

NOTE: If you want the Trench Mirror alone enclose only 25c. It will be sent to you postpaid.

25c

Order one for every friend you have in the service, either in the army or the navy. They will appreciate it.

Sold on Our Money Back Guarantee

Just mail the coupon above, get the Stag Sharpener, test it thoroughly. If it does not do more than we say for it, just send it back and it costs you absolutely nothing, as every Stag outfit is sold positively on

Dealers

Dealers the country over tell us the Stag Sharpener outfit is the fastest seller they have. Put in your order now—get the benefit of the great national advertising campaign just starting. Write today for dealer proposition. If you have not seen a Stag outfit yet, mail coupon above.

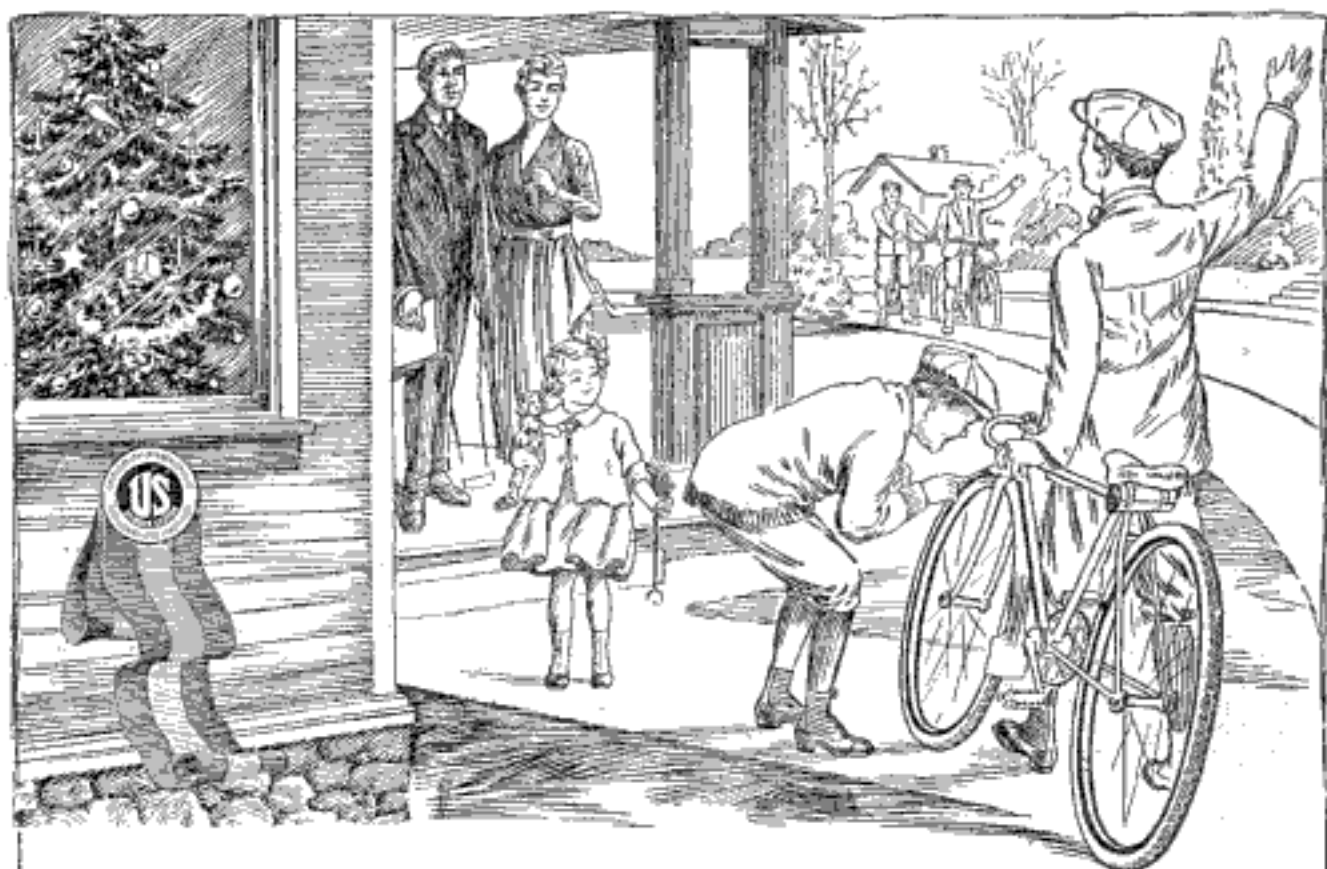

The Tires on That Christmas Bicycle

are important. You know what the other fellows with bikes say about United States Tires. They're not only the snappiest looking tires made, but, what's a lot more important, they wear longer and better on both city pavement and country roads.

Ten different treads from which to pick the one that you think will best fit your road requirements.

So, when you ask Dad or Mother for a new bike for Christmas, don't forget to tell them you want it equipped with United States Tires.

United States Bicycle Tires
Are Good Tires



STRUCTO

BOYS' ENGINEERING OUTFITS



The Greatest Toy Ever Invented for Real Boys

Structo is a miniature of the mechanical world for boys. Structo enables you to make regular working models, engines, battleships, bridges, sky-scrapers, pile drivers, and hundreds of other things—just like famous engineers and inventors make. Then you connect your motor and they work just like the real machines do. The Structo book shows you how to make hundreds of working models. You can design many other models yourself.

POWER ELECTRIC MOTOR

Given free with outfit Nos. 4, 5, 6 and necessary outfit No. 3-A. Equipped with standard shafting, which is interchangeable with Structo gears and pulleys.



STRUCTO GEARS are wonder gears—drop out—sure to work.

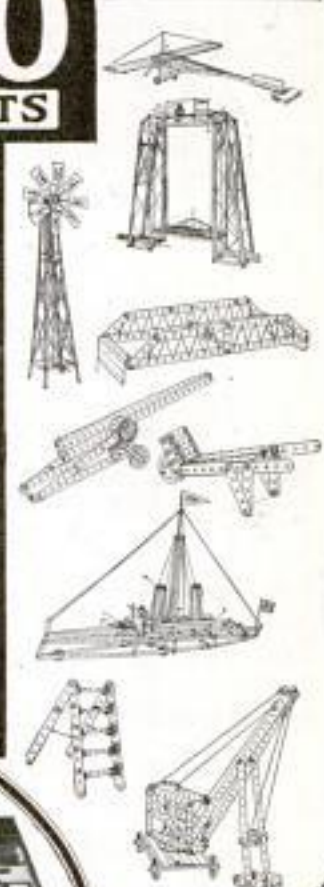

STRUCTO AUTO BUILDER



A Toy That Includes All the Mechanical Principles of a Real Automobile

Has a triple unit motor, a real steering apparatus—transmission with three speeds—first, second, reverse and brake. Also a differential gear that is a duplicate of the gears used in regular automobiles. You build it yourself into a real working automobile.

STRUCTO Engineering Outfits

Cadet Outfit...	\$ 1.00
No. 1 Outfit...	1.50
No. 2 " " "	2.50
No. 3 " " "	3.75
No. 4 " " "	6.00
No. 5 " " "	12.00
No. 6 " " "	25.00
Junior Engineer...	4.00
Structo Engineer...	6.00
Chief Engineer...	12.00
Multi-Gears, 1/2 doz...	.60
Multi-Gears, doz...	1.00

Structo Pays the Postage

Structo Manufacturing Company
Freeport, Ill.

Write Us Today for Full Particulars

Send This
Coupon
TODAY

Structo
Mfg. Company
Freeport, Ill.

Please send me free your Structo Auto Builder Book and full information and prices on your Structo Outfits.

Name.....

Address.....

City or Town.....

State.....

Father's Name.....



How Many Hides
Has A Cow?

Uncle Sam Knows the Real Answer:
NOT ENOUGH!
SAVE LEATHER
For Soldiers

TO make America's hide supply go as far as possible, hides are being split into five or more thin sheets; but, even this saving scheme fails to meet the requirements for soldiers' shoes, harness, equipment, ship upholstery, factory needs, etc., chiefly because too much hide leather is used by the public in places where high grade leather substitutes will serve as well or better.

Uncle Sam Has Set the Pace

The new U. S. motor trucks and ambulances will be upholstered in leather substitutes. For several years the standard for book binding in the Government Printery has been Du Pont Fabrikoid.

The upholstery specifications for the new Merchant Marine call for



For
Automobile
Seats and
Upholstery



For Boat
Cushions and
Upholstery



For Furniture
Upholstery



For Bags,
Trunks and
Suit Cases



For Book
Binding



For Home Decorations,
Novelties, Belts, etc.



REG. U. S. PAT. OFF.

Craftsman Quality

What Uncle Sam has found by experience and tests good enough for the Government's severe requirements should be good enough for every loyal American.

How You Can Help

If you are a manufacturer using leather probably part or all of your requirements can be met by some grade of Fabrikoid. While not feasible for every use of leather, the illustrations herewith show its wide range of utility.

If you use leather in your home for any purpose, try the proper grade of Fabrikoid instead.

When buying an automobile, boat or piece of furniture prefer Fabrikoid upholstery. Help the manufacturer conserve leather by patronizing those who use good leather substitutes like Fabrikoid.

Every hide displaced by a good substitute helps supply our armies with shoes, our farms with harness and our factories with belting—it helps win the war.

Manufacturers! write us your requirements and let us co-operate with you.

Americans everywhere! write for samples and names of manufacturers, of the article you want, who use Fabrikoid and of stores near you selling it by the yard.

Du Pont Fabrikoid Company, Wilmington, Delaware

World's Largest Manufacturers of Leather Substitutes

Factories at Newburgh, N. Y.; Fairfield, Conn.; Toronto, Ont.

DU PONT

Please Mention Popular Mechanics

Men, Snuggle Up to This Bang-up Underwear—It's a Downright Bargain

You can bet your last cent that Hanes will give you more real value for your money than any other buy. No frills, no fol-de-rols—just downright value and a heaping lot of it, too.

Hanes is form-fitting, elastic and comfortable. The fleecy-warm cotton is mighty fine protection from the cold—and it feels mighty good, too. Pre-shrinking keeps it true to size and shape.

Greatest
Winter
Underwear

HANES

Sold at
Popular
Prices

ELASTIC KNIT UNDERWEAR

And just read about these special features over there in the illustration. No more high-priced underwear for the man who sees Hanes. It's just the popular price for everybody and the underwear everyone should wear.

Mothers, Fathers — Get this Big Bargain

A jam-up boy's union suit, chock-full of all the big features on the men's suits. Downy-soft, warm and everlastingly fine, its value can't be duplicated. You sure ought to buy this splendid underwear for your youngsters. See if it doesn't put it all over anything you ever tried at twice the price!

**P. H. HANES KNITTING
COMPANY**
Winston-Salem, N. C.

Warning to the Trade—Any garment offered as Hanes is a substitute unless it bears the "Hanes" Label.

This Label on
Every Garment



Buy None
Without It

Please Mention Popular Mechanics



The Best Proof of Witte Quality

"I have run gas, gasoline and kerosene engines for several years, but I have never found an engine that equals the WITTE Engine for power, reliability and saving of fuel."
—W. W. Demorest, Lamar, Ark.

"I find the engine is complete in every way, very still running and powerful. It is very sensitive to the governor and runs with even motion. If I was to buy another engine it would be a WITTE sure."
—H. I. Spott, Breadloaf, Vt.

"I know it would be a pleasure for Mr. Lackey to recommend the WITTE Engine, as ours is doing such excellent work and giving such splendid service. He had such a time with engines and spent so much on them before he got a WITTE, that it is truly a pleasure to have one so satisfactory."
—Mrs. H. R. Lackey, Chautauque, Kans.

"I have never had a bit of trouble with my WITTE Engine. All I have to do to start it is just turn the wheel and she is off."
—W. M. Land, Lardo, Idaho.

"My 4 H. P. WITTE certainly worked fine, doing the work of a 6 H. P. It has as much power as any 6 horse engine I ever saw."
—Richard Hoffman, Arlington, Ill.

"If you will allow me to say a few words for your engine: I call it the WITTE Common Sense Engine, for any man with common sense can run one, and it has all the power you claim, and about one-third more."
—W. L. Hawk, Barton, Ala.



ED. H. WITTE

I Can Make You The Best PRICE

On a Kerosene Engine

Sell You a Better Engine—Save You \$15 to \$200

Not an experiment! Hundreds in Use! Better and more powerful than ever! Starts as easily as a gasoline engine! Will use any fuel that can be used in a Kerosene engine! You get three times as much power for the money at present fuel prices! Your own terms! Cash, Deposit, Payments, or No Money Down! If you are in the market, write me today! I CAN MAKE YOU THE BEST PRICE—Sell You a BETTER Engine—Ship At Once! Any Style—Stationary or Portable.

WITTE ENGINES

Kerosene and Gasoline—2 to 22 H-P.

are made in the largest exclusive direct selling engine factory in the world. I make nothing but engines. Over 30 years success proves quality—immediate shipment proves superior factory equipment and business methods—just as my engines are superior. You can see the high quality in every line and curve. Look at the long solid base affording absolutely solid footing. See how cleanly-built—no cumbersome overweight of metal—no cylinder hanging out behind—no interior packing—vertical valves and many other special features that make WITTE Engines high-grade, better, and more desirable. 90-Day Trial will fully convince you of superior quality. Write for latest prices and free book, or come to factory and see them—You are welcome. Ed. H. Witte,

FREE



WITTE ENGINE WORKS

1749 Oakland Ave., Kansas City, Mo.

1749 Empire Bldg.,
Pittsburgh,
Pa.

Write for this Beautiful 3 Color Illustrated FREE BOOK Today! Yours for a Post Card—by Return Mail.

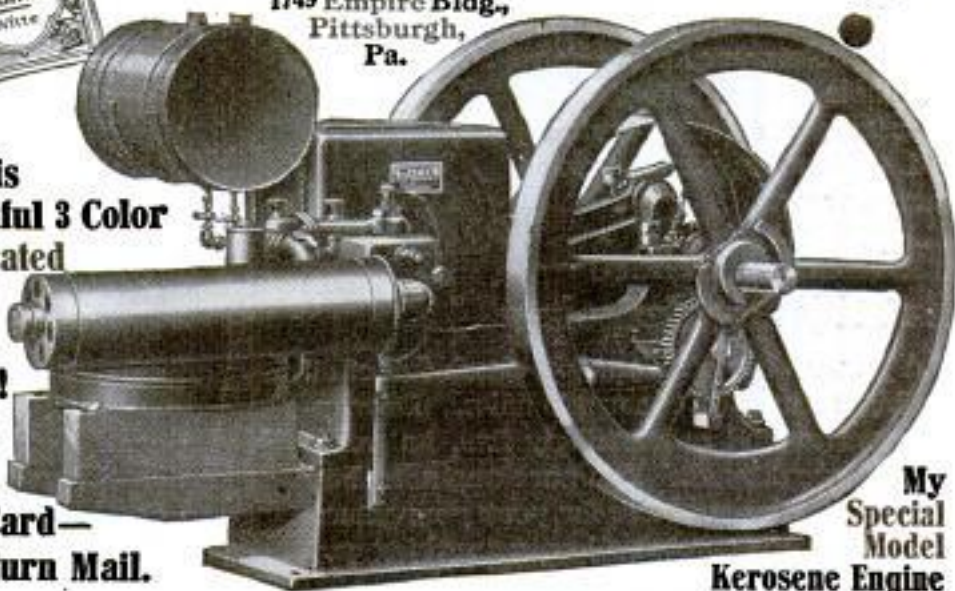

My Special Model Kerosene Engine

OR MAIL THIS SLIP

With Name and Address and I will send postage paid "How to Judge Engines" and "How to Make Money."

No. 1749

NAME.....

TOWN..... STATE.....

I Will Save You More Than 1/2 on a \$100 UNDERWOOD

E. W. S. SHIPMAN, President

EVERYONE knows the reputation of the Underwood Typewriter. I will send you on **TEN DAYS' FREE TRIAL** a High Grade No. 4 Visible Writing Underwood, with Back Spacer, Tabulator, Stencil Attachment, Two-color Ribbon, Waterproof Cover and Special Touch Typewriting Instruction Book, that will teach you to operate this simple Underwood in one day. I will give you a **written** guarantee of **FIVE YEARS' SERVICE** from date of sale and I will save you much more than one-half the manufacturer's price.

25 Years' Experience—Confidence of 200,000 Customers

I am the largest typewriter re-builder in the world, employing the most expert workmen in the typewriter business. I handle only Underwoods, obtaining all my machines and all new parts direct from the Underwood Company.

How I Double the Life of An Underwood

Do not confuse me with a second-hand dealer. I put each machine through a process that I have spent 25 years perfecting. Each machine is taken apart and re-built from top to bottom.

The frame is re-named, the bright parts re-nickled. All parts unfit for further service are discarded and replaced by new parts purchased from the Underwood Company. Every machine is equipped with new type, new platen, new ribbon vibrator, front scale, feed roll, ribbon, space bar, key rings, key glasses, rubber feet, etc. Expert mechanics re-adjust and re-align each machine. It will stand any mechanical typewriter test.

You May
RENT APPLYING RENT ON PURCHASE PRICE
OR
BUY FOR CASH OR ON EASY PAYMENTS

My Five Year Guarantee—Ten Days Free Trial

I personally stand back of every machine that goes through my factory with a **WRITTEN FIVE YEAR GUARANTEE OF SERVICE**. I guarantee to send you a genuine Underwood, exactly as illustrated and described herewith. You don't even have to buy the machine at the time you get it. You can try it for ten days **FREE** and then, if you conclude the machine I send you does not look, work and write like new, you may return it and I will refund any deposit or charges paid by you. This guarantee affords you complete protection.

Rent or Buy Mail coupon or post card today for special low price and terms. You can **RENT**, applying six months' rental on purchase price, buy on easy terms or secure discount for cash.

Our Other Plan Brings Underwood FREE

A new plan—our agency plan. You are not asked to do any canvassing or soliciting for orders. You simply co-operate with us, becoming part of our nation-wide organization. You can easily get your Underwood **FREE** in this way. Send name and address on coupon today and learn about Offer No. 62.

E. W. S. SHIPMAN, President
Typewriter Emporium
CHICAGO

Five
Year
Guarantee

Ten
Days'
Free Trial

SEND AND MAIL COUPON TODAY
TYPEWRITER EMPORIUM, 34-36 W. Lake Street, CHICAGO
Send me immediately full facts about your Special Offer No. 62.

Name

Street or R. R. No.

City

State

Please Mention Popular Mechanics



"Not the name of a thing, but the mark of a service"

No lamps can ever be marked MAZDA unless they embody MAZDA Service standards of excellence

4632



The Meaning of MAZDA

MAZDA is the trademark of a world-wide service to certain lamp manufacturers. Its purpose is to collect and select scientific and practical information concerning progress and developments in the art of incandescent lamp manufacturing and to distribute this information to the companies entitled to receive this Service. MAZDA Service is centered in the Research Laboratories of the General Electric Company at Schenectady, New York.

The mark MAZDA can appear only on lamps which meet the standards of MAZDA Service. It is thus an assurance of quality. This trademark is the property of the General Electric Company. :: :: :: ::



RESEARCH LABORATORIES OF
GENERAL ELECTRIC COMPANY



The curtain call

with all its wit and responsiveness, is no more interesting than the fireproof curtain itself. This moving fire-wall that protects both audience and stage from panic and disaster is of fabric woven from rock and adorned by the artist's brush—

JOHNS-MANVILLE Asbestos

Resistant to heat,



water, wear and weather

No magic wand turned it into theatre curtains, table mats, coverings for pipes, linings for furnaces. Only the ceaseless research and labor of a national institution—Johns-Manville—has developed Asbestos. And now Asbestos is a necessity to the

COVERS
THE CONTINENT

large manufacturer and the standby of housewives on ironing day—the roof of huge buildings and the cap for tiny nerves in a sensitive tooth. This is the work of Johns-Manville—hundreds of J-M Products pour into every avenue of life.

H. W. JOHNS-MANVILLE COMPANY
New York City

Branches in 55 Large Cities

Asbestos Fabrics, Packings, Roofings, Shingles, Brake Linings, Building Materials, Electrical Devices, Heat Insulations, Refractory Cements, Waterproofing.

The Motor Car



The Farm



The Home



Industry



Power Plants



Transportation



Roofings



When you think of Asbestos you think of
Johns-Manville

Please Mention Popular Mechanics

Oxy-Acetylene Welding and Cutting

Most Metal Manufacturers Can Save by Welding

THE manufacture of metal beds strikingly illustrates the advantages of oxy-acetylene welding—the decided savings of time, labor and materials. Parts formerly riveted required boring, which decreased strength and increased labor costs. By welding, these parts are now fused into one piece of uniform strength. The welding process, as used today, has virtually revolutionized metal bed manufacture.

Stronger, neater products, simplified production, lower costs and *minimized material waste*—these all-important factors are open to every manufacturer of metal products.

Oxy-acetylene welding has proved its value in nearly every line of metal manufacture from the making of delicate jewelry to massive locomotives. It is, in many instances, supplanting the bolt, rivet and threaded joint, when two pieces of metal are to be joined.



One of the oxy-acetylene welding operations employed in metal bed manufacture by The Simmons Company factories at Kenosha, Wisconsin

Prest-O-Lite

PROCESS

Insures better welds, quicker work and lower operating costs. Offers a simple, inexpensive welding outfit for all classes of work. Prest-O-Lite Dissolved Acetylene is furnished in convenient cylinders, making the welding outfit portable for use inside or outside the shop. The Prest-O-Lite System of exchanging empty cylinders for full ones insures universal, perpetual service. Avoids large initial investment and depreciation.

Millions of dollars' worth of valuable castings, machine parts and tools are being reclaimed from the scrap-heap by this process. Railroads, foundries, mines, machine shops and garages—using it exclusively for repair work—are realizing big returns. One quick repair may save the entire cost of a Prest-O-Lite outfit by avoiding a tie-up through the break-down of an important machine. Wherever metal parts are to be joined, welding merits investigation.

Our literature shows hundreds of profitable uses for the Prest-O-Lite Process, in manufacturing, construction and repair work. Write for it.

A Profitable Business for Garages and Repair Shops

The substantial profits to be made on oxy-acetylene welding work present a splendid opportunity to enterprising service garages and repair shops. The demand for welding is large and growing fast. The cost of necessary equipment is low. Send for full details—today.

The Prest-O-Lite Co., Inc.

U. S. Main Offices and Factory
816 SPEEDWAY, INDIANAPOLIS
Canadian General Office
Dept. U TORONTO, ONT.

59 Branches and Charging Plants



World's Largest Makers of Dissolved Acetylene

The Craftsman Deserves Good Tools



CABINET work calls for clever hands and painstaking craftsmanship. It is poor economy to jeopardize the result by using inferior tools. Most cabinet-makers, whose living depends upon the quality of their work, use Disston saws. They don't guess about their tools—they KNOW.

The name Disston on a mitre-box saw, a web saw, or any other tool means that it was made by experts who know just what qualities such a tool should possess—and how to put those qualities into it. You can saw to the line with Disston saws because they are built right and balanced right. You know how a job is coming out if you begin it with a Disston.

Disston trowels, files, screw-drivers, levels, bevels, gauges, squares, and other tools are all of the same Disston quality.



Send for our free "Hand-Saw Booklet." It tells you how to select, use, and care for saws and other Disston tools.

HENRY DISSTON & SONS, Incorporated
PHILADELPHIA, U. S. A.

Canadian Works: Toronto, Canada

CHICAGO
MEMPHIS

CINCINNATI
NEW ORLEANS

VANCOUVER, B. C.

BOSTON
SEATTLE

SIDNEY, AUSTRALIA

SAN FRANCISCO
PORTLAND, ORE.

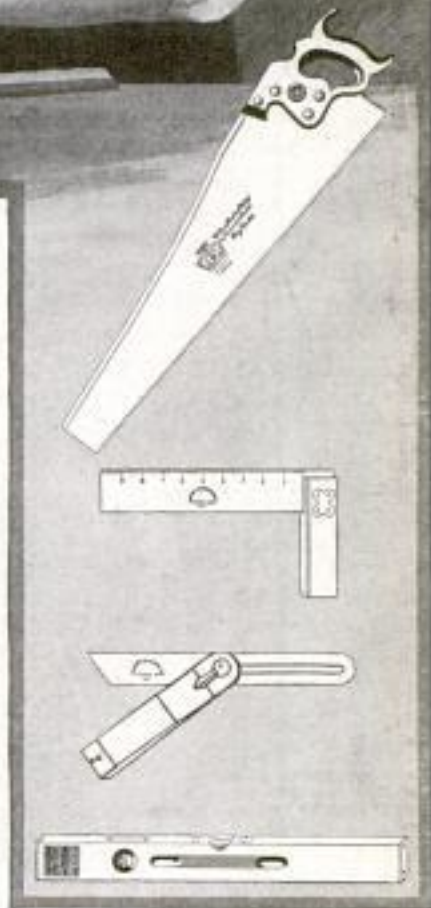

DISSTON

SAWS AND TOOLS

Please Mention Popular Mechanics

WANTED! WE WANT 300 AGENTS AT \$35 TO \$70 A WEEK

NEW INVENTION—just out. Needed in every home every day. Patent just applied for. Nothing else like it. Supplies what every housewife has wished for for years. Perfected after long experimental work by mechanical experts. Low priced—anyone can use it—**sells on sight**. We want three hundred representatives at once—men or women hustlers—to advertise, accept orders and manage deliveries for our new **Quickedge Knife and Shear Sharpener**. Sharpens any kitchen knife, paring knife, carving knife, bread knife or shears and scissors in **ten seconds**. Agents are taking orders at every house—**wiring for rush shipments**. Write today for this opportunity to make \$10 to \$20 every day.

MAKE \$300 NEXT MONTH

This little machine is a mechanical masterpiece. A child can use it. Just put knife in slot—turn crank—**grinds automatically**—draws blade to keen, sharp, perfect, lasting edge **at absolutely correct bevel for daily use**. Nothing to adjust—nothing to change, nothing to get out of order—**absolutely guaranteed**—will last for years. Once they see it and use it, women will not do without it for several times its cost. One agent wrote: "It was easier for me to learn to sell the **Quickedge** than it was to learn to tear open my pay-envelope in my former dollar-a-day job." Get out of the dollar-a-day class. Get this position, where profits start the first day.

No Experience Required

Just take one of the machines to any house and show it—give a ten-second demonstration upon the dullest knife in the house; **the order is yours right on the spot; instantly**. No talking necessary. No argument. The machine simply sells itself, **and stays sold**. Every customer becomes your friend. They tell others, your profits double and multiply. Leave one hundred on trial over night. Collect the cash for every one of them next day. **The machine will do its own talking**; it is so easy to operate, no explanations or instructions are necessary. Secure your county now; **free**. Get started right now and

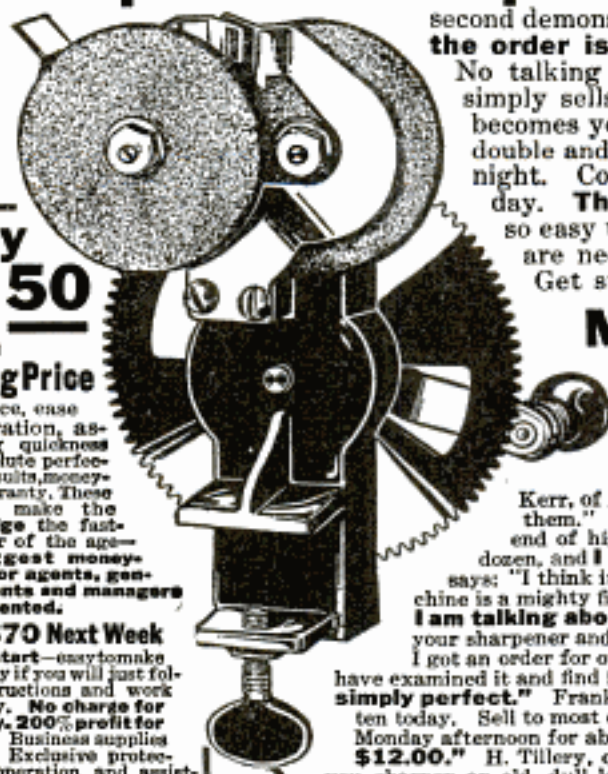

Only
\$1.50

Selling Price

Low price, ease of operation, astonishing quickness and absolute perfection of results, money-back guarantee. These things make the **Quickedge** the fastest seller of the age—the **biggest money-maker for agents, general agents and managers ever invented**.

Make \$70 Next Week

Easy to start—easy to make big money if you will just follow instructions and work faithfully. **No charge for territory. 200% profit for agents.** Business supplies capital. Exclusive protection, co-operation and assistance. Failure impossible. Nothing to risk. Success assured.

Easy to demonstrate—and every woman is anxious to see it work—then she would not do without it. No talking necessary. Just show the machine and take the order—**one dollar profit on every call you make**.

Send for application blank and complete information today—**free**. Investigate. **Get the proof**. Don't delay. Write a postal card or letter right now. **Territory is being assigned very fast**. Get your county now—**free**. Write today.

The
**Quick-
edge
Knife
and Shear
Sharpener**

Grinds any Kitchen Knife
or Shears in 10 Seconds

Absolutely Guaranteed

Make as Much Money Next Week as These Men are Making Now

J. C. Lewis, of Kansas, says: "**I have sold one hundred Sharpeners in four days.**" Hobart Kerr, of Md., writes: "The women can hardly wait till they get them." Herbert Cain, of Ky., sold nine after supper. At the end of his first day, J. W. Gordon, of Pa., writes: "I sold two dozen, and **I sold to every one I saw.**" Wm. G. Hall, of N. J., says: "I think it is great. I sold six in about one-half hour. The machine is a mighty fine proposition. **I am a mechanic and I know what I am talking about.**" Peter Courland, of Mich., writes: "I received your sharpener and opened it in a barber shop. I ground his shears and I got an order for one right on the spot." H. A. Henkel, of Va., says: "I have examined it and find it a wonderful little machine. **The workmanship is simply perfect.**" Frank King, Colo., says: "Sample received Saturday. Sold ten today. Sell to most every house." Forest Webb, of Pa., says: "Went out Monday afternoon for about three hours and received one dozen orders. **Profit \$12.00.**" H. Tillery, of Tenn., wrote: "I took three orders first hour. When you sharpen an old, dull knife, dull as a hoe, in less than a minute, **they sit up and look.**" Ray Carter, of Mass., writes: "I went out two days and have orders for thirty sharpeners." **Profit \$30.00 for first two days.** John Durr, of Wis., also says: "**I have sold thirty in two days.**"

You can make this money. **Send now. Territory free.**

GET BUSY. WRITE TODAY.

The Quickedge Sharpener Company

No. 696 Sharpener Building
215 N. Desplains St., Chicago, Ill.



10c a Day

You can have your choice of over 2,000 musical instruments for one week's trial in your own home. Then, if you decide to purchase, you can pay the rock-bottom price at the rate of a few cents a day. If you do not want the instrument, send it back. The trial won't cost you a penny.

But first mail the coupon below for our new 194 page catalog illustrating every known musical instrument. You will be astonished at the the low prices and at the liberal offer we are now making.

We Offer—

- the best instruments that can be made.
- rock bottom manufacturer's prices.
- one week's trial at our expense.
- triple silver-plated cornet for only 10c a day.
- your choice of over 2,000 instruments.

WURLITZER

200 years of instrument making

Wurlitzer has supplied the United States Government with Trumpets for 55 years

The name, "Wurlitzer", stamped on musical instruments has stood for the highest quality for nearly two centuries. We are manufacturers or importers of every known musical instrument — every one sold to you at direct-from-the-manufacturer price.

Play It a Week—At Our Expense

Try out the instrument of your choice in your own way before you decide to buy. Compare it with other instruments. Test it. Use it just as if it were your own. Then, after one week's trial, either pay a little each month or send it back. The Cornet, Violin, Saxophone and Snare Drum, illustrated here, are but four of many real bargains in instruments which we offer at a few cents a day.

Send the Coupon

Just put your name and address on the coupon now and get our big, new catalog absolutely free. Please state what instrument you are interested in and we will send you the big 176-page book, free and prepaid.

The Rudolph Wurlitzer Co.
Dept. 1199
E. 4th Street, Cincinnati, Ohio
S. Wabash Avenue, Chicago

The Rudolph Wurlitzer Co.
Dept. 1199

East 4th Street, Cincinnati, Ohio
South Wabash Avenue, Chicago, Ill.

Gentlemen:— Please send me your 176-page catalog, absolutely free. Also tell me about your special offer direct from manufacturer.

Name.....

Address.....

I am interested in.....

(Name of instrument here)

Starrett Hack Saws are unexcelled just as Starrett Tools are unexcelled

You buy Starrett Tools because you know that you can get none finer, none more accurate, none more dependable.

It's the same with

Starrett Hack-Saws

Whether you buy these saws in large quantities for a big shop, or in smaller numbers for occasional use, you buy more than a good hack saw — you also buy the right saw, the one best fitted for the job.

The right saw cuts quicker, thereby saving valuable time. It lasts longer — doesn't dull as quickly, doesn't break as easily — thereby saving money because fewer are required.

Our Catalog No. 21 AP describes the Hack Saw that is Unexcelled and tells you how to pick the number of saw that will do the best work on any given job.

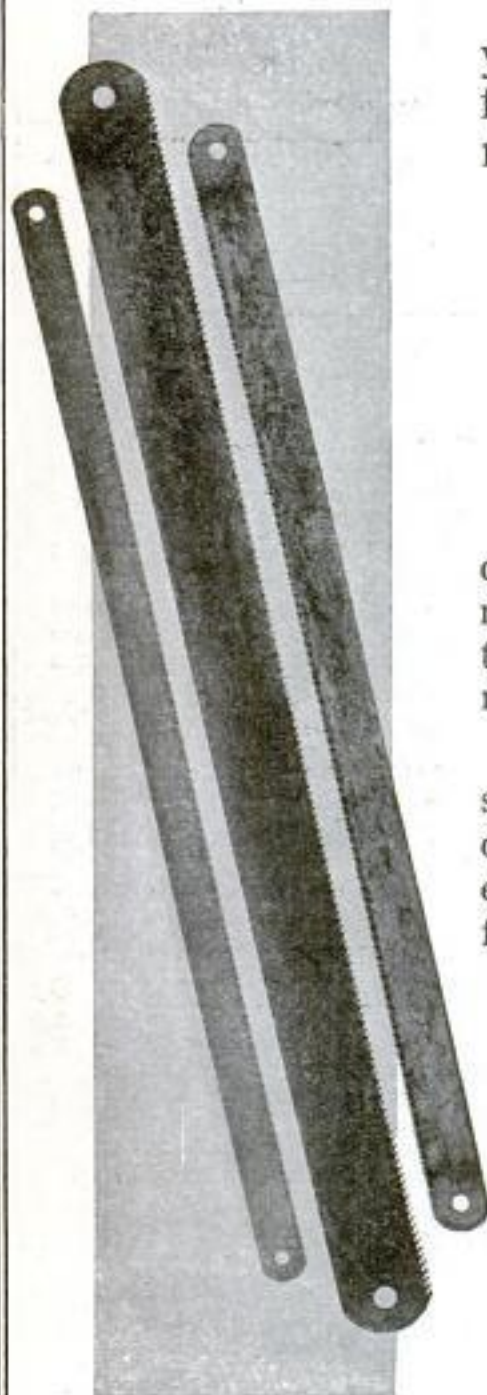

THE L. S. STARRETT COMPANY

The World's Greatest Toolmakers
ATHOL, MASS.



42-700

*The Haywood Tire
Repair Shop of
Paul R. Fredricks
Wallingford, Conn.*

*Now doing an aver-
age business of
\$450 a week.*

YOU TOO CAN MAKE BIG MONEY

We need immediately, more men like Paul R. Fredricks to manage Haywood Tire Repair stations. "Just a year in the business and now doing \$400 to \$450 a week at a good round profit" tells the story of this ambitious young man's rapid rise to fortune. Scores of men like Fredricks have found their independence in the Tire Repair business, have opened Haywood shops and are making big money. The coupon below or a post card with your name and address will tell you how to start. Send today.

Tire Repairing Revolutionized!! Motorists To Save Millions in Tire Expense

The Haywood method of tire repairing is different—Scientific. It strikes a new chord in tire economy. It is efficient—saves tires—increases mileage—lasts. It has required years of experience to develop it. Practical tests have proven it. Its superiority is acknowledged—accepted by those who know, as a *Triumph*.

30 Million Tires to Repair

The demand for tire repairing is now so great that more Haywood stations must be established at once throughout the country. We want capable, energetic, ambitious men in charge of each—men who are dependable—competent. You can have this opportunity—share in the Haywood success—become a link in a mammoth chain of a country-wide, thoroughly efficient Tire Repair Service.

Make \$3,000 a Year or Better! You Own Your Own Business! Keep Your Own Profits!

Haywood equipment is sold outright. We teach you Haywood Scientific Tire Repairing in our Laboratory especially equipped for this purpose. Here you learn all about tires—the inner mechanism of construction—how to repair scientifically every tire injury. This training is thorough—practical and equips you to give Haywood Service of the standard we advertise nationally and are so careful to maintain—the Service that saves motorists millions of dollars in tire up-keep.

A Wonderful Opportunity

The coupon—your name and address, brings full particulars. How to start. How to tie up with the Haywood Service. We'll give inside facts and figures about costs and profits. Explain in detail our Co-operative Business Building Plans. Write today without fail. Learn how you can start at once.

Haywood Tire & Equipment Co.
658 N. Capitol Ave. Indianapolis, Ind.



*Haywood
Tire Repair
Plants
Are Big
Money Makers
for
Ambitious Men.
Investigate.*

Mail this Today

HAYWOOD TIRE & EQUIPMENT CO.
658 N. Capitol Avenue, Indianapolis, Ind.

Gentlemen:—

Please send full particulars of your Scientific Tire Repair Service and details of your Co-operative Business Building Plans.

Name

Address



Like Taking an Axe to a Corn

Some methods of removing corns suggest an axe. They are harsh. They attack live tissue as well as the corn. And soreness often follows.

Some are mussy. Some require frequent applications. All were uncertain, all unscientific, until Blue-jay came.

Now, with Blue-jay, you apply a thin protector, which stops the pain at once. In the center—acting on the corn alone—is a gentle, efficient wax. And a tape wraps the toe while it acts.

Blue-jay is applied in a jiffy. When applied, you forget the corn. In two days you find it gone.

About one corn in ten needs a second application. But no corn can resist this new-day method.

At least a million corns a month are ended in this easy, gentle way. Users of Blue-jay apply it as soon as a corn is felt. And it never pains again.

Try it tonight—on any corn, old or new. What it does to that corn, it will do to all. And that means lifetime freedom. You will be amazed to know how easily this trouble can be ended.

Blue-jay Corn Plasters are sold by all Druggists. Also Blue-jay Bunion Plasters.

B&B Blue-jay
Corn Plasters

Stop Pain Instantly
End Corns Completely
25c Packages at Druggists

BAUER & BLACK, Makers of Surgical Dressings, Etc., Chicago and New York

How Blue-jay Acts



A is a thin, soft pad which stops the pain by relieving the pressure.

B is the B&B wax, which gently undermines the corn. Usually it takes only 48 hours to end the corn completely.

C is rubber adhesive which sticks without wetting. It wraps around the toe, to make the plaster snug and comfortable.

Blue-jay is applied in a jiffy. After that, one doesn't feel the corn. The action is gentle, and applied to the corn alone. So the corn disappears without soreness.

Don't Wear a Truss

Brooks' Appliance, the modern scientific invention, the wonderful new discovery that relieves rupture will be sent on trial. No obnoxious springs or pads.

Brooks' Rupture Appliance

Has automatic Air Cushions. Binds and draws the broken parts together as you would a broken limb. No salves. No lies. Durable, cheap. Sent on trial to prove it. Protected by U. S. patents. Catalogue and measure blanks mailed free. Send name and address today.

C. E. BROOKS, 126A State St., Marshall, Mich.

Please Mention Popular Mechanics



Deafness Is Misery

I know because I was Deaf and had Head Noises for over 30 years. My invisible Anti-septic Ear Drums restored my hearing and stopped Head Noises, and will do it for you. They are Tiny Megaphones. Cannot be seen when worn. Easy to put in, easy to take out. Are "Unseen Comforts." Inexpensive. Write for Booklet and my sworn statement of how I recovered my hearing.

A. O. Leonard, Suite 226, 150 5th Ave., N. Y. City



Send for my book STRONG ARMS and MILITARY SHOULDERS

for 25c coin or stamps

Illustrated with 20 full-page half-tone cuts, showing exercises that will quickly develop, beautify and gain great strength in your shoulders, arms, and hands, without any apparatus.

PROF. ANTHONY BARKER
Studio 641, 127 West 42nd Street, New York

Our 21 Jewel SMASHES PRICES



Every fighting vessel in the U. S. Navy has the Burlington Watch aboard. Many have over 100 Burlingtons—a few over 200. This includes every torpedo boat—every submarine as well as the big Dreadnaughts.

Send Your Name on This Free Coupon

Get the Burlington Watch Book by sending this coupon now. You will know a lot more about watch buying when you read it. You will be able to "steer clear" of the over-priced watches which are no better. Send the coupon today for the watch book and our offer.

Burlington Watch Co.

19th St. & Marshall Blvd., Dept. 9199 Chicago, Ill.

Look!

- 9 21 Ruby and Sapphire Jewels—
- 9 Adjusted to the second—
- 9 Adjusted to temperature—
- 9 Adjusted to isochronism—
- 9 Adjusted to positions—
- 9 25-year gold strata case—
- 9 Genuine Montgomery Railroad Dial—
- 9 New Ideas in Thin Cases.

Only \$2.50 A Month

And all of this for \$2.50—only \$2.50 per month—a great reduction in watch prices—direct to you—positively the exact prices the wholesale dealer would have to pay. Think of the high-grade, guaranteed watch we offer here at such a remarkable price. And, if you wish, you may pay this price at the rate of \$2.50 a month. Indeed, the days of exorbitant watch prices have passed.

See It First

You don't pay a cent to anybody until you see the watch. You don't buy a Burlington Watch without seeing it. Look at the splendid beauty of the watch itself. Thin model, handsomely shaped—aristocratic in every line. Then look at the works! There you will see the masterpiece of the watch makers' skill. A perfect timepiece adjusted to positions, temperature and isochronism.

Burlington Watch Co.

19th Street and Marshall Blvd.
Dept. 9199 Chicago, Ill.

Please send me (without obligation and prepaid) your free book on watches with full explanation of your cash or \$2.50 a month offer on the Burlington Watch.

Name _____

Address _____

Please Mention Popular Mechanics

DIAMONDS WATCHES & JEWELRY

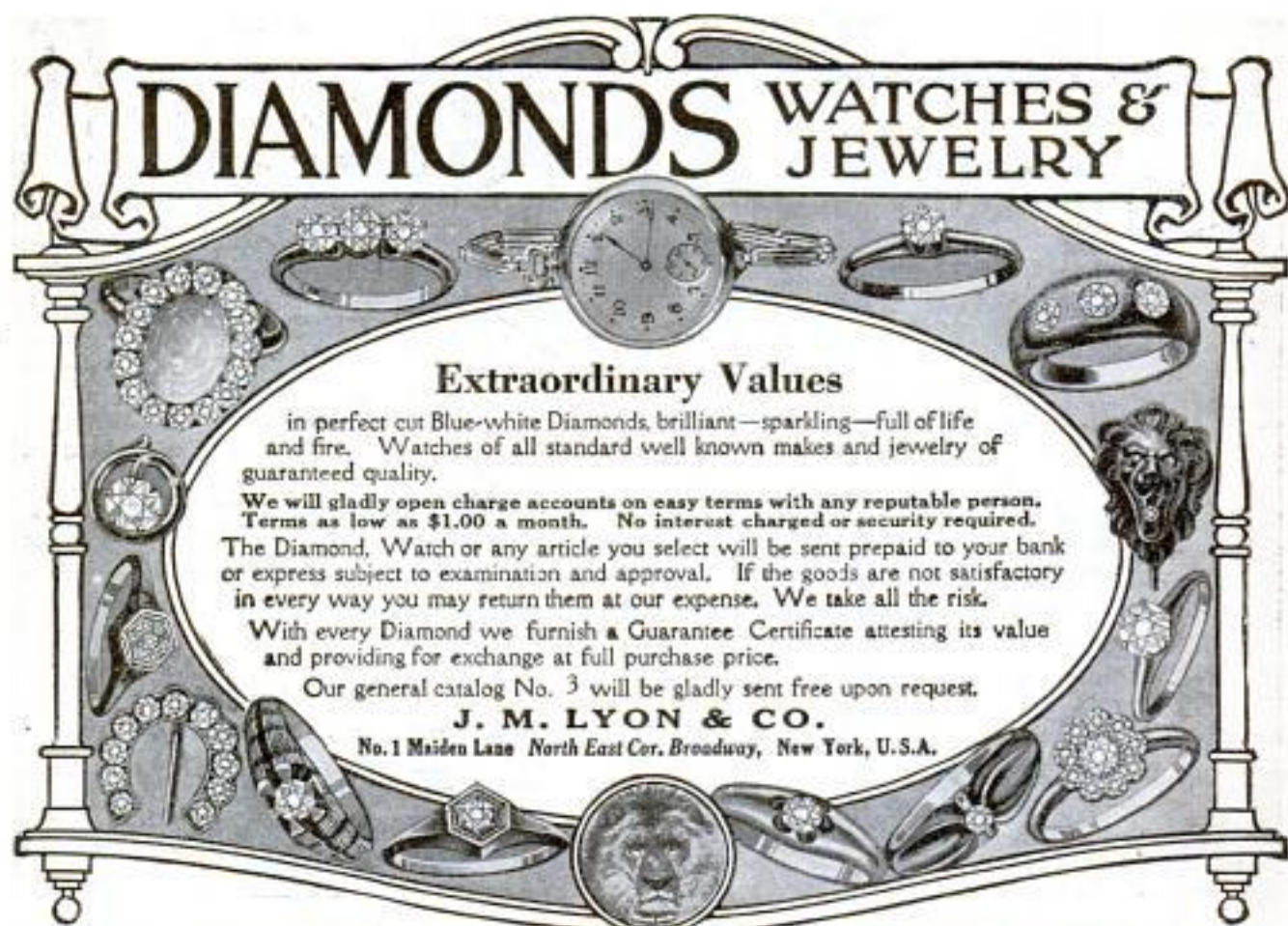

Extraordinary Values

in perfect cut Blue-white Diamonds, brilliant—sparkling—full of life and fire. Watches of all standard well known makes and jewelry of guaranteed quality.

We will gladly open charge accounts on easy terms with any reputable person. Terms as low as \$1.00 a month. No interest charged or security required.

The Diamond, Watch or any article you select will be sent prepaid to your bank or express subject to examination and approval. If the goods are not satisfactory in every way you may return them at our expense. We take all the risk.

With every Diamond we furnish a Guarantee Certificate attesting its value and providing for exchange at full purchase price.

Our general catalog No. 3 will be gladly sent free upon request.

J. M. LYON & CO.
No. 1 Maiden Lane North East Cor. Broadway, New York, U.S.A.



**Make Yourself as
Healthy and Attractive
As You'd Like to Be**

Enjoy vigorous, glorious health. Wonderful new invention—most scientific, successful, natural way of acquiring beauty and health. Users astonished at results.

The Violetta

most advanced design of Violet Ray Instruments. Fairly saturates system with beauty and health-giving life. Enriches blood with ozone. Massages tissues with action of Violet Ray. Strengthens entire body. Brings glow of natural lasting, irrefragable beauty and health. A delight to use. No shocks. Remarkably speedy results.

No other method of Beauty or Health Culture compares with it. Wonderfully effective in treatment of skin affections and scalp diseases. The most successful means of relieving ailments of any nature. Send now for free booklet that shows how to make yourself as attractive as you'd like to be.

BLEADON-DUNN CO.
Dept. C, 13 So. Desplaines St., Chicago, Ill.



"I Would Not Part with it for \$10,000"

writes an enthusiastic, grateful customer. "Worth more than a farm," says another. So testify over 100,000 Men and Women who have worn it.

The Natural Body Brace

Develops erect, graceful figure. Brings comfort, health, strength and pep.

Makes You Feel Good and Look Good

Replaces and supports misplaced internal organs; reduces enlarged abdomen; straightens shoulders; relieves backache, curvatures, nervousness, ruptures, etc., in both sexes. Fine after operations. Write today for illustrated booklet, measurement blank and our very liberal free trial proposition.

HOWARD C. RASH, President
Natural Body Brace Co., 223 Rash Building., Salina, Kans.

Does The Socket Chafe Your Stump?



Sold on easy payments to tired people. D. Buchstein
Co., 113 6th St. S., Minneapolis, Minn.

**BUCHSTEIN'S VULCANIZED
FIBER
LIMB**

which is soothing to your stump, cool, neat, light, walls not much thicker than a silver dollar, strong
Guaranteed 5 Years!

Mammoth Jubilee Book Free

Picturing 5152 Home Things
Make your own Credit Terms—1 to 3 years' time,
SPIEGEL, MAY, STERN CO., 800 W. 35th St., Chicago



MEN

Raise Mushrooms Profits Astonishing

Easy to grow in spare time at home, in cellars, barns, sheds, boxes, etc. I furnish market. Success guaranteed. Free illustrated booklet. Read how a beginner took \$131.50 from cellar bed. Write today.

HIRAM BARTON
Desk 2, 329 W. 48th St., New York

WOMEN

GREEN AUTOMATIC MACHINE



Let This Machine Grind Out Money for You

THE GREEN AUTOMATIC MACHINE \$10 A DAY AND UP

Sharpens, Honors and Strops all kinds of safety razor blades in one operation, from four to six blades in one minute. For both quality and quantity this machine is in a class by itself. There is nothing like it on the market. Let us send you our free booklet explaining everything, including the "AMERICAN" Key Cutter—cuts square, angular or round slots. Liberal proposition to State Agents.

AMERICAN SHARPENING MACHINE CO. (Inc.), 184 W. Washington St., Dept. 12, CHICAGO



Do This

Before you put a tool away treat it to a little 3-in-One.



Oil the action parts of automatic tools. Wipe all tools and their wooden handles with a soft cloth moistened with 3-in-One. Then you'll find your tools in perfect working condition the next time you use them. This is a small thing to do, but every tool user will find it produces great big results.

3-in-One



is the one right oil for tools. Lubricates automatic drills, screw-drivers, brace-and-bits to perfection. Never gums or collects dirt. Prevents rust on edge tools. Makes saws work much easier. Cleans and polishes the wooden handles. Try it.

3-in-One is sold at all stores—in 25c Handy Oil Cans and in 15c, 25c and 50c bottles.

FREE—Generous sample of 3-in-One Oil and Dictionary of Uses—both free for the asking.

Three-in-One Oil Co.
165CANT. Broadway, New York

TOOL CASES

For Up-to-Date TOOLMAKERS and MACHINISTS

We carry the finest and most complete line of mechanics' toolcases and tools in the country. We guarantee to please you or refund money. Write for free catalogue.

J. M. WATERSTON
75 Woodward Ave., DETROIT, MICH.



Has
to
be
on
the
list

The ONLY Interlocking, sliding rule made

Interlox

MASTER SLIDE RULE

Here is the Exact INSIDE Measurement

Best, quickest, most accurate rule for outside measurements, too.

If not at dealer's send his name and 20c per foot (any length 2 to 8 ft.), and we'll send rule prepaid.

DAHL MFG. CO., 51C E. 42nd St., N. Y.

Liberal Proposition for Dealers and Agents

Here
is
the
Other

FOR HIS CHRISTMAS—\$1.30

will purchase one of our patented Compound Lever VEST POCKET SNIPS. They are 7 inches long and stamped from the same grade of crucible tool steel that our larger shears are made from.

Guaranteed to cut 24 gauge metal. Highly polished and packed in individual boxes. Sent postpaid in U. S. or Canada upon receipt of price. If desired we can furnish in nickel-plated finish for 50 cents additional.

DROP-FORGED Snips \$2 to \$4.60 FOR HIS XMAS

Made for hardest service. Highly tempered crucible tool steel, drop forged. Outs keen. Holds the edge. Cuts 18-gauge metal at point easily—cutting power three times that of ordinary straight snip.

For sale by dealers or sent postpaid in the United States at these prices:

8-inch \$2.00
10-inch 3.00
12-inch 4.00
14-inch 4.60

FOLDER ON REQUEST
BARTLETT MFG. CO., 20 E. Lafayette Ave., Detroit, Mich.



BROWN & SHARPE TOOLS

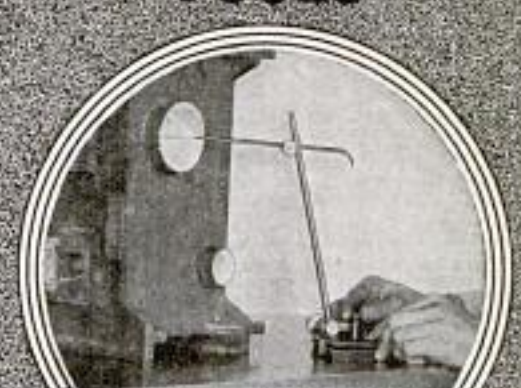

Easier, Better Work Naturally Follows

the use of B & S Tools because they're handy to use, accurate and adaptable to even the most adverse shop conditions. Every one of the difficulties you have to contend with in measuring or laying out work was considered in the designing of B & S Tools. Our tool designers have always worked with first-hand information as to the needs of the man in the shop. Their laboratory has been our shop, where practically every variety of measuring and laying-out tools are used in manufacturing our extensive line of machinery. Their efforts have ever been

Directed Toward Greater Accuracy & Greater Efficiency

in the machine shop. The world-wide preference for B & S Tools is proof of their success.

Catalog 27, listing our complete line, sent on request. Get one for your tool kit.

Brown & Sharpe Mfg. Co.
Providence, R. I., U. S. A.

ACCURACY

Please Mention Popular Mechanics

Every Builder and Contractor Needs this Level

10 Days' Free Trial

We have been makers of transits and levels since 1883 and our instruments are the standard of the world. Prove the superior quality of the Aloe Convertible Level by giving it a 10 days free trial. Use it on your every-day work laying out buildings, leveling up foundations, walls and floors, aligning, shafting walls, piers, etc., for getting angles or levels anywhere.

Easy Monthly Payments

If you decide to keep it, the instrument will earn its way while you make monthly payments so small that you hardly feel them. Costs no more than to pay all cash. No red tape about it, no embarrassing questions, everything confidential.

Aloe Convertible Level

is the finest instrument ever offered at anywhere near its price. Permits taking of sights both above and below the horizontal. For taking vertical sights it is provided with a special convertible bracket rigidly and permanently attached to the cross bar. The telescope is fitted with permanent axis which rests in bracket bearings and is held by clamps easily and quickly released.

Aside from being a level, it is a modified transit that permits a much wider range of work than is possible with the ordinary architect's level. With it the man without technical training can obtain the same absolutely accurate results as the expert. Write today for descriptive circular.

A. S. ALOE CO.,
620 OLIVE ST., ST. LOUIS, MO.



Save Money, Time and Worry

GET A UNION TOOL CHEST

Save money—keep tools clean, safe, free from rust.
Save time—keep tools in place.
Save worry—you know immediately if one is borrowed or misplaced.

Built of selected plain or quartered oak, or mahogany. Some leatherette covered. Perfectly fitted drawers—19 styles and sizes. ONE FOR YOU.

Write for our catalog and prices. Chest guaranteed to give entire satisfaction or money refunded.

Union Tool Chest Works
22 Railroad St., Rochester, N. Y.

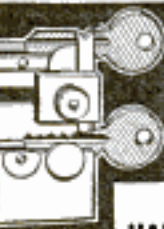

Duplicate Keys

for all Yale and similar Locks made in one minute with Harrison M. L. P. Key Filing Machine. No misfits. Thousands in use. \$3.50 net. Special diamond-shaped files for angular cut keys, 40c each. Harrison C. K. Key Clamp duplicates all common and lever keys without a caliper. Price, \$1.50. Parcel post prepaid.

Money returned if not satisfactory.

HARRISON & CO., 81 New St., New York

Wonderful New Kerosene Light FREE

Beats Electric or Gasoline

We want one person in each neighborhood to whom we can refer customers. Takes very little time and no investment. The new Aladdin kerosene mantle light **Burns 50 Hours on One Gallon**



common kerosene. No odor, smoke or noise, simple, no pumping up, no pressure, won't explode. Tests by U. S. Government and thirty-five leading universities show the Aladdin gives **three times as much light** as best round wick flame lamps. **Won Gold Medal** at Panama Exposition. Over three million people already enjoying this powerful, white, steady light, nearest to sunlight. Guaranteed. And think of it—you can get it **without paying out a cent**. All charges prepaid. Ask for our 10-day Free Trial Offer and learn how to get one Free. **AGENTS WANTED**
MANTLE LAMP CO., 412 Aladdin Building, CHICAGO, ILL.
Largest Kerosene (Coal Oil) Mantle Lamp House in the World

For Light That Never Fails "Storm King" Lantern

Use the 350 C.P.

Burns Kerosene or Gasoline—Gives Powerful, Bright, Sure, Satisfying Light. Learn how easily and cheap you can obtain the "Storm King" and other Lamps and Lighting Systems. Write now.

BIG PROFITS FOR AGENTS
NATIONAL STAMPING & ELECTRIC WORKS
Dept. 4 410-424 S. Clinton St. CHICAGO



FOR XMAS—A TYPEWRITER!

Show the Xmas Spirit in a big way for little money. Our **Factory Rebuilt Typewriters** are ideal Xmas Gifts for children, students, business people. They save you \$25 to \$75 on your purchase. Standard Makes, thoroughly rebuilt, trademarked and guaranteed the same as new. Branch stores in leading cities give prompt service. Send today for catalogue.

American Writing Machine Co., Inc., 339 Broadway, N. Y.



WHITE VALLEY GEMS
Look and Wear Like Diamonds
Brilliance guaranteed 25 years. Will cut glass. Stand acid and fire tests and scratch a file. Any style 14-K solid gold ring, pin or stud, (regular diamond mounting) sent for **Free Examination. No Money in Advance.** Write today for special prices and free catalog.

WHITE VALLEY GEM CO., Mfg. Jewelers
827 Wulsin Building Indianapolis, Indiana

LOCKSMITHS Be an expert. How to unlock cylinder and all locks. 100 Tricks of the Trade, \$1.00. Money back if not perfectly satisfied. Don't miss this opportunity.
ROUTSON, 576 42nd Street, OAKLAND, CALIF.

GOODELL PRATT

1500 GOOD TOOLS

FOR 10c—A GENUINE Red Devil GLASS CUTTER



With it you can make and repair many odds and ends in the household—windows, picture frames, etc. Useful in the tool chest, laboratory, making condenser plates, etc. Glass cutter booklet free.
SMITH & HEMENWAY CO., Inc. 97 Coit Street IRVINGTON, N. J.



Home Plan
No. 1364—
Has an interior
arrangement
that fully equals
the beauty of
the outside.
Complete
wholesale.
\$2570

Gordon-Van Tine Saved Me \$390

Let us save for you, too. Despite war conditions, Gordon-Van Tine building material prices are still exceptionally low. You can save money by building NOW! Get our wholesale prices. No extras, no additions. Ready-Cut Houses—\$300 up. No high-priced labor needed—everything cut to fit—save time and waste of material. Not Ready-Cut if wanted. ALL highest standard material. Send for Book, "Gordon-Van Tine Homes," 200 plans, photos, prices. 100,000 customers. Safe shipment anywhere. Use coupon NOW.

Gordon-Van Tine Co.

Satisfaction Guaranteed or Money Back

Established Half a Century

6514 Case Street, Davenport, Iowa



GORDON-VAN TINE CO., 6514 Case Street, Davenport, Iowa

Send me Free the Books checked:

Gordon-Van Tine
Home Plans

Garages

Greenhouses and Hotbeds
for the Home Grower

Summer
Cottages

NAME.....

ADDRESS.....

Be Sure It's "POROSKNIT"
GENUINE SUMMER UNDERWEAR
Cool, elastic, comfortable—GUARANTEED
Chalmers Knitting Co., 78 Washington St., Amsterdam, N. Y.

FREE POWERFUL AIR GUN
Big lever action rifle free for selling 25 Art and
Religious Pictures or 25 tags. Post Cards at 10c. Order your choice.
GATES MANUFACTURING COMPANY, Dept. 879, CHICAGO, ILL.

The Patriotic Pictures
Encourage your boy to display them on
the walls of his room by using
MOORE PUSH-PINS
Glass Heads, Steel Points
Moore Push-less Hangers, the Hanger with
a Twist, for framed pictures, mirrors, etc.
10c
At Stationery, Hardware, Drug and Photo
Supply stores. In Canada 11c. Sample
and Booklet Free. Write Dept. 36.
MOORE PUSH-PIN CO., Philadelphia, Pa.

LYON & HEALY
57-67 East Jackson Street, CHICAGO
Will mail, free, their Cata-
logs of Band Instruments
and Equipments. Hundreds
of Fine Illustrations describing
every article required by Bands
or Drum Corps. Reasonable prices.
The new Lyon & Healy "Own Make"
Brass Band Instruments are the finest made.

SAXOPHONES Sold on easy payments.
WRITE TODAY, stating
what instrument you have in mind.

Williams' Shaving Soaps

STICK, POWDER, CREAM, LIQUID
The J. B. Williams Co., Glastonbury, Conn.

"ACTUAL PIPE-THREADING EXPERIENCES" free



Threads
pipe,
nipples,
bolts

3 DAYS' work a month is all that is re-
quired by an Oster to pay a definite divi-
dend over hand-threading or thread-
ing "purchased outside." Small
in floor space, but wide in capacity

OSTER COMBINATION THREADING MACHINES

save you time, labor, money. Why not find out from
this book what Oster users think of it?—a free
copy will be gladly sent by return mail. Write today.

THE OSTER MFG. COMPANY

2100 East 61st Street

CLEVELAND, OHIO



Please send
me "Actual
Pipe-
Threading
Experiences."

Name.....

Address.....

City.....

State.....

Occupation..... (2100)

Christmas Bicycles

Choose from 44 styles, colors, and sizes in the famous "RANGER" line of bicycles. All are pictured in natural colors in our big new catalog. There are many other models also—in fact the most complete line of bicycles in the world, all at FACTORY PRICES, from \$16.75, \$17.75 up. There is a Mead bicycle to suit the taste of every rider—electric lighted Motorbikes models, Racers, Juniors for children; Ladies' models too—all at prices made possible only by our Factory-direct-to-Rider selling policy.

Delivered to You Free We send the "RANGER" bicycle, FREIGHT CHARGES FULLY PREPAID TO YOUR TOWN, for 30 days free trial—actual riding test. We pay return charges if you decide not to keep it, and make no charge for wear and tear during trial. We make no effort to influence your decision. The trial is all at our expense.

Factory-to-Rider Back of your "RANGER"—if you decide to keep it—is the oldest and most successful bicycle concern in the world, with a Service department that cares for the parts and repair needs of more than a million riders. With every "RANGER" we ship, goes a Certificate of Guarantee for Five Years.

Parts & Repairs Lamps, Horns, ready-to-use front and rear wheels, Inner Tubes, Tool Kits, etc., etc. Repair parts for all bicycles and coaster-brakes, all accurately pictured and described in the sundry pages of the big new Ranger Catalog. All the latest imported and American novelties in equipment and attachments at prices so low they will astonish you.

Rider Agents wanted everywhere to ride and exhibit "RANGER" bicycles. Select the model you prefer and, while you ride and enjoy it, make money by taking the orders of your neighbors who want a bicycle like yours.

Send No Money but write today for this big new catalog, also full particulars of the great new offer to send, all charges prepaid, the "RANGER" bicycle you select for 30 Days Free Trial. You cannot afford to buy a bicycle, tires or sundries without first learning what we offer.

MEAD CYCLE COMPANY
Dept. K-108 CHICAGO, U.S.A.

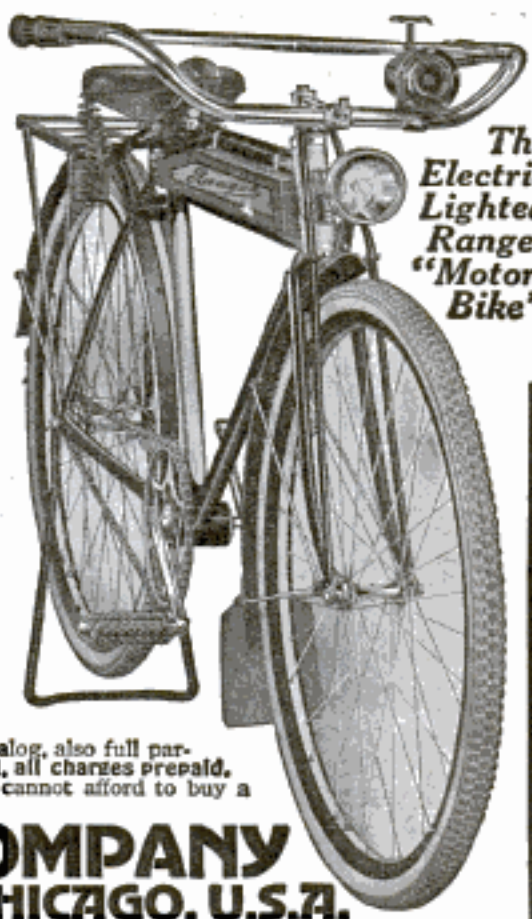

The Electric Lighted Ranger "Motor-Bike"

Vitalic Bicycle Tires Deluxe

\$8 a pair, Brigadier \$6 a pair—made for endurance
Continental Rubber Works, 1964 Liberty St., Erie, Pa.

EDWARDS STEEL BUILDINGS



Many Styles and Sizes
Garages—Barns—Factories, Etc.
Put up or taken down in a jiffy. Save time and labor. Have a strong, permanent, fireproof building, any size, smallest to largest, for any purpose. Made of steel. Ready to erect.
FREE Catalogs with prices and plans for the building or buildings you need. Write for them.

THE EDWARDS MANUFACTURING CO.
METAL ROOFING, METAL LOCKERS, ROLLING DOORS, ETC.
370-370 EGGLESTON AVE. CINCINNATI, OHIO

Champion Toledo

Dependable Spark Plugs

Champion Spark Plug Co., Toledo, Ohio

The Harley-Davidson "Master 17"



It sets the pace for 1917. Has more power, more speed, greater flexibility, faster getaway. Equipped with hand-operated, auxiliary brake in addition to regular service brake. Finished in beautiful military drab. Write for 1917 catalog.
HARLEY-DAVIDSON MOTOR COMPANY
509-B Street Milwaukee, Wis.
Producers of High-Grade Motorcycles for More Than Fifteen Years

An Easy Way to Make Money

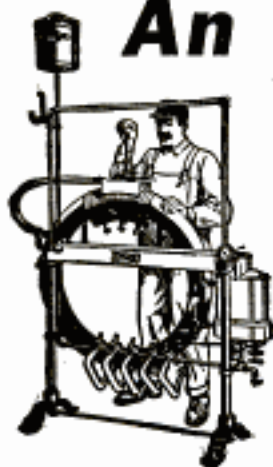

Don't be content to plod along on a small salary. Be independent. Go in the tire repairing business and make \$60 or more a week. One man made \$45 the first day he received his outfit. Others are making \$25 a day and hundreds of wide-awake men are making \$200 to \$500 a month.

No experience needed. We teach you how. Very little capital required. But slight risk, as every car owner in your town is a possible customer. Jobs are plentiful because tires blow out and puncture every day.

SHALER Tire Repair Outfit, \$65

will do as much and as perfect work as the big \$250 to \$500 vulcanizing outfits. A boy can vulcanize perfectly with this simple machine. It's the only vulcanizer that has Automatic Heat Control. It must vulcanize just right. It can't undercure or overcure a tire. Requires no watching or regulating. You can learn to do expert tire vulcanizing in half an hour with the Shaler.

WRITE FOR FREE BOOK "HOW TO OPEN A TIRE REPAIR SHOP" and complete Catalog, which gives full information.

WRITE QUICK BEFORE SOME HUSTLER GETS AHEAD OF YOU.
C. A. SHALER CO., 2011 Fourth Street, WAUPUN, WIS.

The New EXCELSIOR Military Model

The Master Motorcycle

*Pre-eminent on the hills,
Supreme in speed,
Reliability and Endurance
proven in public tests
and private service*

In the new model is embodied all the details of motorcycle perfection that have been developed in the production of a powerful and dependable machine for Army service which simply means power and stability to meet all possible road conditions without weakness at any point and the least possible necessity of repairs or adjustment.

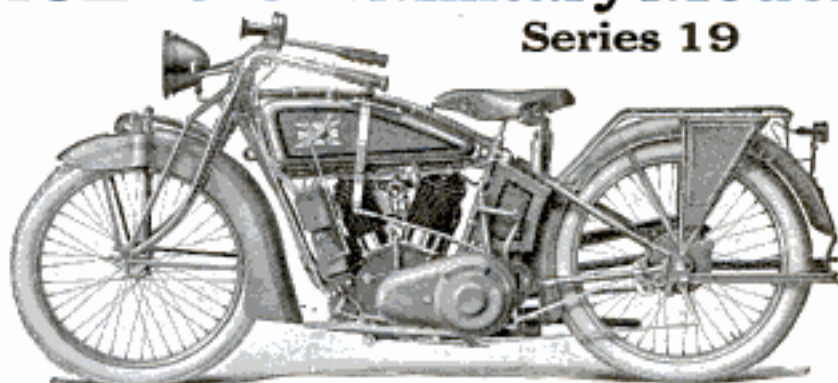

Standard Equipment \$290.00 — Electrical Equipment \$320.00

SOME OF THE SPECIAL FEATURES

Extra Large, Roller Bearing, Multiple Disc Clutch, with removable bearing faces.

Double Truss, Military Type Front Fork, the strongest fork ever put in a motorcycle.

Excelsior Cushion Sprocket equalizes the pull and conserves every ounce of power delivered by the motor.

Removable Center Bar permits quick and easy access to the motor and removal of cylinders without interference with any other part of the power plant.

See the dealer or write us for new catalog describing the Military Model, Excelsior Lightweight and Sidecar

EXCELSIOR MOTOR MFG. & SUPPLY CO., 3702 Cortland Street, CHICAGO, ILL.

Inclosed Clutch and Motor Drive Chain, protects these important parts from dirt and road grit.

Foot Starter and Automatic Compression Control, assure a quick and easy start always — in any kind of weather.

Tubular Steel Luggage Carrier with Steel Tool Box.

Rustproof, Military Olive Drab Finish, including hubs, spokes, etc.

THE CORBIN DUPLEX COASTER BRAKE

is the standard brake equipment assuring absolute control. Equip it now. Send for catalog.

THE CORBIN SCREW CORP. The American Hardware Corporation, Successor
NEW BRITAIN, CONN. BRANCHES: New York, Chicago, Philadelphia

\$40 Motorcycle Bargains

Single and Twins, Hendersons, Harleys, Indians, Excelsiors, Kultures, Emblems, Thors, Popes. All makes guaranteed. A-1 shape, tuned up ready to ride. \$35 to \$100. Motorcycle tires \$3. Lamps \$5. Automobile tires \$3. Bicycles \$5. Tandems \$20. Bicycles and motorcycles

at Factory Prices. Old motorcycles taken in trade. Highest prices allowed for them. Swap in yours. Send for Catalog, Free DENINGER, THE PRICE CUTTER, Rochester, N. Y.

STANWELD Cold Drawn Seamless Steel TUBING

Lightest, smoothest, strongest Steel Tubing made. World's largest manufacturers of bicycles, motorcycles and automobiles use it exclusively. Send for Folder "A."

THE STANDARD WELDING COMPANY
Main Office and Factory CLEVELAND, OHIO

TIRES ^{1/3} LESS

There's a way to obtain high-grade tires at manufacturers' prices. Write and we'll tell you. Freshly made tires, every one

Guaranteed 6000 Miles

(No seconds). All sizes, non-skid or plain. Shipped prepaid on approval. This saving on guaranteed quality will open your eyes. State size tires used.

SERVICE AUTO EQUIPMENT CORPORATION
911 Westover Building, Kansas City, Missouri

35 MILES PER HOUR

IS RECORD OF THIS CAR

Built by a boy from Junior parts furnished by us. Parts very cheap. Send 26 cents



for blue prints and price list of parts, showing how to build this speedy little car.

Any boy can build this car

SYPPER MANUFACTURING CO., 146 Warren St., Toledo, O.

MAKE YOUR BIKE A MOTORCYCLE

at a small cost, by using our attachable outfit. Fits any Bicycle. Easily attached. No special tools required.

"Used His Four Years"

Harry A. Hyatt, of Boreas River, New York, writes: "About four years ago I received my motor attachment, and wish to say that I am satisfied with it in every way, for it has certainly given me good service. Anyone wanting a motorcycle or attachment, I would recommend them to the Shaw Manufacturing Co."

FREE BOOK Write today for bargain list and free booklet, fully describing the SHAW Bicycle Motor Attachment. Motorcycles all makes, new and second-hand, \$35.00 up.

SHAW MANUFACTURING CO.
Dept. 6 GALESBURG, KANSAS



New **STROMBERG** Does it!
CARBURETOR

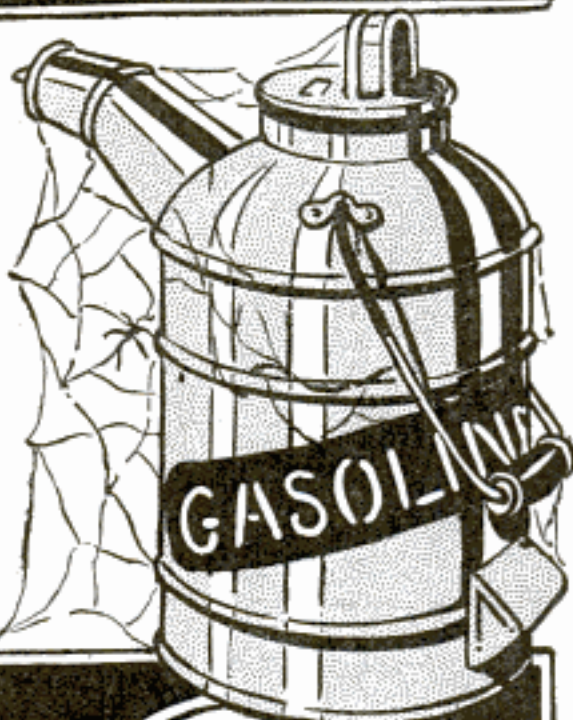

**Gives Your
Gas Can Less to Do
—Saves Big on Fuel Bills**

37 4/10 miles on a gallon of gasoline — that's the world's greatest official Ford economy record. Made by a Stromberg-equipped Model T 1915 Ford Touring Car, carrying three passengers and weighing 2170 lbs.

You can secure similar substantial savings—because that wonderful feat was made under ordinary road conditions—by an ordinary stock Ford Car. Such savings as those run up into tremendously big totals in a short time—put a big dent in cost of operation—make fuel bills less of a burden.

But that's not all that is accomplished by the

**New Stromberg Carburetor
FOR FORDS**

It whips your engine along at a faster speed clip. It produces power that pulls your Ford through roads you now consider impassable. It abolishes cold weather cranking bothers—shoots your car away with a quick, clean start—no matter where the mercury stands. It gives the greatest range of flexibility—smoothest acceleration. Pays no attention to weather or road conditions—requires least attention—fewest adjustments.

10-Day Money-Back Trial

Order today. Enclose purchase price—\$18. Test it for ten days. No risk. Money back if you want it. Send Now. Out fuel costs. Roll up mileage. Save money. Stop waste and engine worry. Realize the full satisfaction of greatest power, speed and surety of smooth motor efficiency at all times. Descriptive matter free on request.

**Stromberg
Motor Devices Co.
Dept. 1214, 64 E. 25th St.
Chicago**

Please Mention Popular Mechanics



The Smile of Satisfaction

Every motorist who uses Twin Fire Spark Plugs experiences keen satisfaction, as they put an end to trouble. No more need of cleaning plugs every few days or weeks. The only plug that fires a two series spark. If one gap is short-circuited, the other point still fires and the continuous explosions clean the fouled one.

TWIN FIRE

Spark Plugs intensify the spark without increasing the consumption of current. Make combustion complete, and aid in cold weather driving. Twin Fire Plugs require less attention and cost no more than others, but give more dependable service. Get a set from your dealer or write to us direct.

Price One Dollar

For the Dealer Twin Fire Plugs mean large sales with little effort. The demand is spreading rapidly. Write for our attractive selling plan.

**Twin Fire Spark Plug Co.
660 Woodward Ave., Detroit, Mich.**

Fires
Two
Distinct
Sparks



Mobiloils

A grade for each type of motor

Wilmo Manifold
Gives More Miles From Any Gasoline

A. A. A. tests show 42% to 54% greater mileage.
Price \$7.50 to \$15, according to make of car.

THE WHITTIER COMPANY
First National Bank Bldg. Dept. 8012 Chicago, Ill.

America's Tested Tires

GOODRICH

BLACK SAFETY TREADS

THE B.F. GOODRICH COMPANY, Akron, Ohio

Buy an Akron-Williams

Tire Repair Outfit. Get into this profitable business with the same equipment that is used and endorsed by 90 per cent of the big tire manufacturers and successful repair shops. Write for book giving full details.
**The Williams Foundry & Machine Co.
50 Cherry Street AKRON, OHIO**





The Sweet, Mellow Tone of "Gibson" Instruments has made many a "Sammy" Departure easier to bear.

5¢ A DAY BUYS A GIBSON

Terms as low as \$1.00 down—\$1.50 per month. Mandolin or Guitar sent on approval. Liberal allowance on old instruments in exchange for the "Gibson." The wonderful new Gibson violin construction has set the whole Mandolin and Guitar world talking. Get our new FREE BOOK—112 pages—111 illustrations, a valuable fund of information for player and teacher. Also FREE treatise on "HOW TO PRACTICE."

Exclusive Features That Make Every Gibson Matchless: Stradivarius arching—scientific graduation from thickest to center to thinnest rim, securing strength—sensitivity—free vibration of entire sounding board. Tilted neck, high bridge with extension string holder, securing increased string pressure that vibrates a larger sounding board, producing a richness of tone never before realized. Reinforced, non-warpable neck—elevated guard plate or finger rest—easy action—adjustable string-bearing at bridge overcoming sharpening of heavier strings in upper positions.

Make \$1800 to \$5000 or More a Year Teaching and Selling the Gibson

Become a teacher. Splendid opportunities for either sex in every locality for private and class instruction and the sale of Gibsons. Gibson instruments have "made" many a teacher, professionally and financially. We have a permanent teaching and business opportunity now open for either sex. Other positions pending. WRITE PROMPTLY. A. C. Brockmeyer, Esq., Lewis, Mo., Teacher and Director, writes: "Will do \$10,000 business in 1917; did \$7,000 in 1916." G. A. Templeman, teacher, Sioux City, Ia., writes: "I did \$4,600 gross business for the year." Wm. Place, Jr., America's Greatest Mandolin Virtuoso, Star Soloist for Victor Talking Machine Co., UNQUALIFIEDLY ENDORSES THE GIBSON.

Do Business on Our Capital Become our agent. We help sell. Agents' territory protected. Stock furnished. We pay the advertising. You make the profit. You pay for goods when sold; return goods not sold. Try our "6000 Hunt," FREE to those interested, our new \$1.00 book "The Organization, Direction and Maintenance of the Mandolin Orchestra," by America's most successful director, Wm. Place, Jr. Write now for Catalog, Treatise, "How to Practice" Psychologically Explained," all free. Don't wait! ACT NOW. FILL IN THE COUPON.

Gibson Mandolin-Guitar Co., 172 Parsons St., Kalamazoo, Mich., U.S.A.



"Everyone a 'Gibson'ite" The Asolian Mandolin Quartet



"Everyone a 'Gibson'ite" Thompson's Mandolin Orchestra

GIBSON MANDOLIN-GUITAR CO., 172 Parsons St., Kalamazoo, Mich., U.S.A.

Gentlemen: Without obligation, send me free book complete Catalog, free treatise, also information about the Wm. Place, Jr., book and instrument checked. If teacher check here

- Mandolin
- Mandolin-bass
- Mandola
- Guitar
- Mandolin-cello
- Harp-guitar

Name

Address

Be sure you have checked instrument.

\$40 Motorcycle

We have the largest line of new and used motorcycles in the country at the lowest prices. Every machine guaranteed. Send for catalog. We are the largest and only exclusive motorcycle supply house in the world. Repairs a Specialty. Send us your machine to be overhauled. Motors and castings for airplanes and railway velocipedes. WE EXCHANGE MOTORCYCLES.

HARRY R. GEER CO., 888 McLaren Ave., St. Louis, Mo.

Make a Warm Friend by Presenting a CHASE Plush Motor-Car Robe

Convert Your Bicycle into a Motor-Cycle

Motor fits any wheel. BEST, MOST RELIABLE. Best hill climber. More STEFFEYS in use than all others. Stamp for circulars. STEFFEY MFG. CO., 5007 Brown Street, PHILA., PA.

Rémoh Gems

Look and wear like diamonds. Brilliance guaranteed forever. Stand file, acid and fire like diamonds. Have no paste, foil or backing. Set only in 14 karat solid gold mountings. About 1-30th the price of diamonds. A marvelous synthetic gem—will cut glass. Guaranteed not as imitation, and to contain no glass. Sent G.O.D. subject to examination. Write today for our illustrated catalog. It's free.

Rémoh Jewelry Co., 656 Washington Ave., St. Louis, Mo.

SHINE YOUR OWN SHOES AND SAVE MONEY

IT IS VERY EASY WITH OUR ADJUSTABLE ALL METAL BRACKET

For Men, Women and Children's Shoes

LASTS A LIFE TIME

PAYS FOR ITSELF FIRST MONTH

No Soiled Hands

No Bending

Holds Any Size Shoe

Sent prepaid for \$1.50

In Canada the price is \$2

F. S. KAY CO.

1733 Republic Bldg. Chicago

FOLDING TRUCK BODY

Butler Product

Open, it's a strong, serviceable, practical, economical, light truck. Closed, it's an attractive roadster. No tools needed to change. Nicely finished in black enamel. Lettering does not show when folded. Easily attached. Low in price. For Ford or Chevrolet. Write for free circular giving full description. Also shows other style bodies.

BUTLER MANUFACTURING CO.

804 Butler Bldg., Kansas City, Mo.

899 Sixth Ave. S. E., Minneapolis, Minn.

60 SECONDS MAKES THIS CHANGE—

Direct at Factory Prices

This \$2 KNIFE 88c Postpaid Hand Forged Razor Steel Blades

Handy shaped blade makes this knife best for mechanics, sportsmen and farmers; light but strong; re-sharpened easily. Stag handle, German silver finish; blades file tested, hand forged from razor steel and warranted.

Sample 88c. 3 for \$2.12 postpaid.

Send for our 100 page List and "HOW TO USE A RAZOR" FREE

MAHER & GROSH CO., 106 A. St., Toledo, Ohio

The slightest cut,
received while
working with tools,
may become infected.

LISTERINE

The Safe Antiseptic



should always
be at hand, so
it may be ap-
plied promptly
to cuts and
small wounds
to prevent in-
fection.

Motor Perfection



is what you get in Watkins Class "B"
all iron motors. Especially fine for canoes
and light boats. Constant and efficient.

3 H. P. single cylinder . . . 45 lbs.
6 H. P. double cylinder . . . 85 lbs.
12 H. P. four cylinder . . . 155 lbs.

Are light at the same time strong,
accomplished by using semi-steel castings, high carbon
steel shaft, bronze bearings, high class workmanship.

THE WATKINS MOTOR CO.

837-839 W. 6th Street

Cincinnati, Ohio

EVINRUDE



Detachable rowboat and canoe
motors. Magneto—Built-In Fly-Wheel
Type. Silencer and Automatic Reverse.

CATALOG FREE USED BY 25 GOV'TS. OVER 80,000 SOLD

EVINRUDE MOTOR COMPANY

563 Evinrude Block Milwaukee, Wis.

Infantile Paralysis



left 8-year-old Evelyn Olson so
crippled she had to crawl on her
knees. Five months' treat-
ment at the McLain Sanita-
rium restored her feet and
limbs to the satisfactory

condition shown in the lower picture. Her
mother has this to say:

We feel it our duty to recommend your sanitarium. Evelyn was
stricken with Infantile Paralysis in August 1915. March 1, 1916,
we carried her to you. Five months later she could walk without
crutches or braces. Words cannot express our
thanks.

MR. and MRS. JOHN OLSON,
R. D. 7, Grinnell, Iowa

For Crippled Children

The McLain Sanitarium is a
thoroughly equipped private In-
stitution devoted exclusively to
the treatment of Club Feet, In-
fantile Paralysis, Spinal Diseases and
Deformities, Hip Disease, Wry Neck, etc.,
especially as found in children and young
adults. Our book, "Deformities and
Paralysis," also "Book of References," free
on request.

**The McLain
Orthopedic Sanitarium**
902 Aubert Ave. St. Louis



Stem wind and set watch, guaranteed
5 years, for selling 25 art and religious pictures or
25 pgs. post cards at 10c each. Order your choice.
GATES MFG. CO., Dept. 479, Chicago



Print Your Own Cards, Circulars,
programs, labels, books, newspaper,
5c PRESS, Larger \$20. Rotary \$70.
Save money. Print for others, BIG PROFIT. All easy
rates sent. Write factory TODAY for catalog pressos,
TYPE, paper, cards etc. IT WILL PAY YOU.
THE PRESS CO., D-37, MERIDEN, CONNECTICUT

Mullins Steel Boats Can't Sink

When you think of buying a boat,
whether it be a 16-foot Runabout,
a big 20-foot Auto Boat, or some-
thing in between—remember that
Mullins Steel Boats are guaranteed
for life. They cannot sink, leak,
water-log, dry out or open at the

seams—never require caulking.
Designed by America's foremost
naval architects—built in the largest
boat factory in the world. More
than 65,000 in use. Big catalog of
steel or wooden motor boats, row-
boats or canoes, on request.

THE W. H. MULLINS CO., 52 Franklin Street, SALEM, OHIO

The Santa Fe
SHATTERS
WATCH PRICES

SEE
THIS
WATCH
FIRST



Don't Send a Penny
Examine Watch Free

SPECIAL CHRISTMAS OFFER Write today and take advantage of our New Dis-
tribution Plan, the greatest money saving event
now before the public. 5000 watches now being distributed on **VERY SPECIAL TERMS at ROCK BOTTOM PRICES.**
Santa Fe Watch Company, Dept. D-6, Topeka, Kans. Home of the Great Santa Fe R. R.

The **ILLINOIS** Famous \$
Santa Fe Special **2.50**
21 JEWEL RAILROAD **A**
WATCH **MONTH**

—the one standard railroad watch "That's Guaranteed for
Life," thin model, all sizes, adjusted to positions, adjusted to
isochronism, adjusted to temperature, adjusted to the second.

Write for FREE Souvenir and Watch Book

shows newest watch case designs in 4 colors. Read the so-called Secrets of
watch-making. Read how you can save from One-Third to One-Half of your
money—Buy "Direct," cut out the wholesale jeweler's profit.

"Dead!"

A keen eye, steady aim and gun with quick action, score "dead."

HOMOL

TRADE MARK

The Real Sportsmen's Oil

In the patented can with the disappearing spout—the slickest oil in the world for gun actions, reels, tackle, traps, typewriters, phonographs and all household uses.

Lubricates, polishes, prevents rust.

If your dealer hasn't Homol yet, send us his name and a quarter and we'll send you a 5-ounce can, carriage prepaid.

William Peterman, Inc., 200 Fifth Ave., New York City



Engine User-Agents Wanted

Men wanted in every county to sell, demonstrate and sell "BIG BEN"—wonderful new gasoline engine for every work. Big demand. Liberal profits. Free details and introductory offer. C. Beaminghofen & Sons, Department 511, Hamilton, Ohio.

WRITE FOR FREE BOAT BOOK



Build your own boat—From \$3 up for full-sized patterns—\$33 buys complete frame, 12-pas. 23-ft. Motor Boat. Write today. BROOKS MFG. CO., 8212 Rudin, Saginaw, Mich.

Universal MARINE MOTOR

9-12 H.P. 4 Cycle 4-Cyl. inder. Speed range 300 to 1800 R.P.M. Adapted to boats from 14 to 30 feet. Write to

UNIVERSAL MOTOR CO. OSHKOSH, WIS. Dept. P

For Bulletin No. 25 giving full description

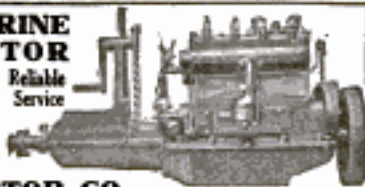

GET THIS CATALOG

FULL OF VALUABLE INFORMATION TO EVERY BOAT OWNER ON

RACING PROPELLER WHEELS, REVERSE GEARS AND MARINE ACCESSORIES

LARGE CATALOG FREE. SEND TODAY

MICHIGAN WHEEL CO. 1139 MONROE AVE., GRAND RAPIDS, MICH.



1/2 and 1 H.P. Multi-Motor



Most powerful and simplest little engine made. Economical and dependable power for farm and home. Burns gas or gasoline. Light, indestructible, low-priced. Write for folder and factory-to-you price.

THE MATTAG CO. Dept. 230 Newton, Iowa

Yes Sir - I Can SAVE YOU Money on that ENGINE



I will put you on the "inside" in the engine question. I'll make it possible for you to buy your engine at wholesale—yes, and even less because I sell direct-to-you from my immense engine factory and save you 25% to 30% on just the engine you want. I guarantee satisfaction or money back. I have been building gasoline engines for fourteen years and my engines have

Because of rapidly rising costs my low prices cannot last. Act now!

Proved Quality in 110,000 Users Hands

Everywhere, in all parts of the country, on all kinds of work you'll find Galloway Engines on the job delivering 100% service. I make all kinds—from the small 1 3/4 horse-power—to the big, powerful horse drawn—16 horse-power. For every kind of a power work there is a Galloway Engine just built to do it.

Mail Coupon for Book and Low Price

and full information. It explains my special engine features and improvements; Valves in the head, like high class automobile motors—Economy carburetor—cuts down fuel bills—makes easy starting in all weathers—frust-proof cylinder and water pot; my blower spark magnets and new make and break igniter which never misses fire. Write today. Mail Coupon below for low prices.

WM. GALLOWAY CO., Box 965, Waterloo, Iowa

1 3/4 H.P. to 16 H.P.

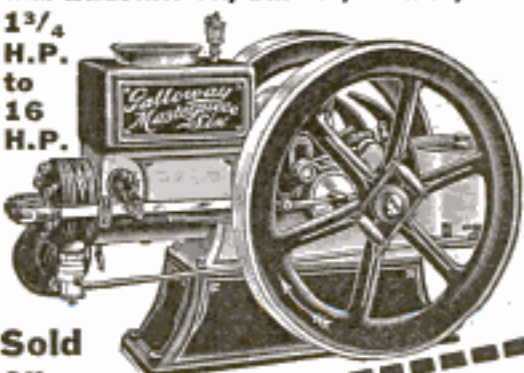

Sold on 90 Days Trial Test

MAIL ME THIS!

WM. GALLOWAY CO.

Box 965, Waterloo, Iowa

I am interested in Gas Engines—send me your Book and low prices.

Please Mention Popular Mechanics

Copyrighted material



Ives Toys
Make Happy Boys

Here you are, boys! Throw open the throttle of that big powerful Ives locomotive, with its long, low, streamline body — the very latest type. Watch the big driving wheels spin. She's off! See her pull that train along. Now work that switch! She's crossing over! Press it again! She's slowing up! Now she's stopping at the station.

Get an Ives Train and track. Ask your folks for one for Christmas. Passenger cars, freight cars, coal cars, cabooses — just like real. Electric and mechanical locomotives — bridges and signals, etc.

Write for **FREE FOLDER** today, and name of Ives dealer near you.

THE IVES MANUFACTURING CORPORATION
202 Holland Ave., BRIDGEPORT, CONN.

Boys! Get This Book
A really gorgeous book, with big pictures of trains in real colors and colored designs used on the cars. Tells about electricity and history of Ives Toys. Send five 2 cent stamps for it to pay postage, packing, etc.



RADIO BLINKER SIGNAL SET
Pat. Sept. 4, '17

For individual instruction and practice in sending or receiving messages by means of sound (Radio) or light (Blinker) signals. Officially adopted by U. S. Navy, Massachusetts Institute of Technology and Boy Scouts of America. Used by U. S. Army and U. S. Marine Corps.

Price **\$5.00** Net Weight 1 lb. 6 oz.

Manufactured solely by Frank B. Perry & Sons, Newton Center, Mass.

Searles Lake, Neb., is estimated to contain 20,000,000 tons of potash, an amount sufficient to supply the needs of the country for 15 years.

DUCK'S BIG 300-Page No. 11 CATALOG
Electrical and Wireless

Mailed on receipt of 8 cents in stamps or coin, which may be deducted on first dollar purchase. Great cost of catalog and low prices prohibit distribution otherwise. Catalog contains 160 pages of wireless apparatus and 140 pages of electrical supplies. No bigger or better values are obtainable elsewhere.

THE WILLIAM B. DUCK CO., 223-227 Superior St., TOLEDO, OHIO

Super-Sensitive Microphone Only **\$7.50**

This instrument is offered at an extremely low price. It is excellent for building your own amplifier. Can also be used in many experiments where a sensitive microphone is required.

Delectograph, \$15

This detecting instrument of marvelous sensitivity can be used for detecting secret conversations. Outfit consists of Sensitive Transmitter, 25-ft. Black Cord, Receiver, Headband, Case and Battery.

Send for One Today and Convince Yourself.



Delectograph, \$15

THE \$15 MICROPHO DEAF-PHONE

is a super-sensitive instrument which has been developed to meet the demands for a practical and efficient hearing device at an extremely low price. It is equal to any \$35 instrument made and superior to most of them. The outfit consists of One Super-Sensitive Transmitter with cord connector; One Super-Sensitive Ear Piece with small black cord; One Black Single Headband; Black Case and Two Batteries. Write today for free booklet.

MICROPHO-DETECTOR COMPANY
Gaston Boissonault, President
25 DEY STREET NEW YORK
Makers of Super-Sensitive Microphone Apparatus

Thordarson Improved

TOY Transformer

An ideal Christmas gift for a live boy. Runs a dozen toys at once. Connects direct to light circuit, going away with heavy, expensive batteries. Large capacity—11 different voltages; absolutely safe. Economical. Lasts forever. **PRICE, \$3.00.**

Write Today for Description

THORDARSON ELECTRIC MFG. CO.
501 S. Jefferson Street CHICAGO

TELEGRAPH INSTRUMENTS

\$1.10 to \$21

This Set \$1.90

Learn telegraphy at home on one of our instruments. Our Catalog of Electrical Merchandise illustrates and describes high quality keys, sounders, private line sets, relays, learner's outfits and automatic telegraph transmitters, and quotes low prices. It is a book every boy interested in telegraphy should have. Send for your copy today. Ask for Electrical Merchandise Catalog No. 80P18.

SEARS, ROEBUCK AND CO.
CHICAGO

Please Mention Popular Mechanics

This NEW ELGIN ON 30 DAYS FREE TRIAL



Adjusted
17 Jewel Elgin

This New Thin Model 17 Jewel Elgin is absolutely supreme where Reliability is a factor. Double sunk dial—Double Roller Escapement—Double strata 25 year Gold case. It's just the watch you've always wanted.

Send No Money! \$1.50
—A—
MONTH

Easy Credit Terms As Low As
Just send your name and address for this New Elgin with our Special \$5 Gold Chain Free, and our bed-rock confidential price will surprise and delight you.

Sent on Approval You do not risk a cent. We send this Watch and \$5 Chain complete on your own approval—also our 160 page **FREE CATALOG**, showing all kinds of Watches, Diamonds, etc., all on smilingly easy terms. **Send your name and address today.**

The House That Sells More Elgin Watches Than Any Other Firm in the World.

HARRIS-GOAR CO., Dept. 252
KANSAS CITY, MO.
WE DO AS WE ADVERTISE!



Power for YOU!

Power from within! Strength that is **more** than mere muscular strength—the strength of better health, abundant nerve force—the strength of the perfect man. Don't you want it?

Nine people out of every ten are only **half alive!** How about yourself.

All the Exhilarating Joys of Life Strength Youth

Do you feel just right? If you do not—if you haven't that vigorous "go ahead" feeling all the time—don't fail to send the coupon for full particulars about the White Cross Electric Vibrator. In vibration there exists many of the secrets of life. You now have an opportunity of seeing what vibration will do for you—how every nerve, every fibre in your whole body will fairly tingle. Try this remarkable instrument for yourself—test it. Now is the time for YOU to send for the free book, "Health and Beauty." Thousands have received it. You are invited to write for it, too.



The White Cross Electric Vibrator

is the result of years of work and experiment. If you have your house wired for electricity, you connect it up as easily as an electric lamp; if not, we can supply you with models operated on their own batteries.

With our Combination Outfits, you may give yourself Swedish Movement, Vibrating Chair Treatments, Electric Baths, Faradic or Galvanic Treatments—right in your own home.

Special Offer for a Limited Time

For a short time only we are making a remarkable Special Introductory Offer on the White Cross Electric Vibrator. In order to place at least one of these splendid instruments in every city, town, village in the country.

Free Book Sign the coupon and mail it today. Get our splendid big

FREE book telling you all about the marvels of **Vibration**. Read what scientists say. Post yourself on what it will do for you. Learn all about the **White Cross Electric Vibrator** and our limited offer. No obligations at all—send the coupon or a post card or letter today.

Send for This Book

LINDSTROM, SMITH CO.

1100 S. Wabash Avenue
Dept. 9199 Chicago, Ill.

Without any obligations on my part, please send me, free and prepaid, your free book on Vibration, full particulars of the White Cross Vibrator and your Special Offer.

Lindstrom, Smith Co.
1100 South Wabash Avenue
Dept. 9199 Chicago, Ill.

We also manufacture White Cross Electric Stoves, Irons, Hair Dryers, Electric Lamps, Electric Fans, Electric Automobile Horns, Electric Carrying Irons, Heating Pads, Small Motors, etc. Dealers write.

Name.....

Address.....

My Electrical Dealer's Name is.....

BENJAMIN

Speaking of air rifles why not buy the best and safest.

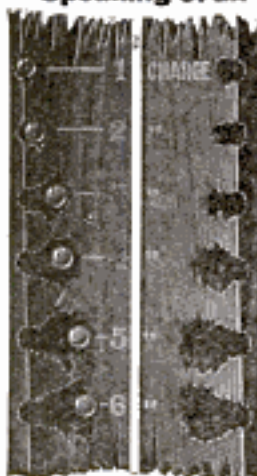

Only real pump gun ever invented. Unlike all others, it never loses shooting force.

Man and boys gun for target practice and small game hunting.

This perforated inch block of wood shows the various degrees of shooting force. This is a feat no other air rifle can duplicate.

Descriptive folder on request. Ask your dealer for demonstration.

BENJAMIN AIR RIFLE & MFG. CO.
605 N. Broadway St. Louis, Mo.

LE PAGE'S
CHINA
CEMENT
STANDS HOT AND COLD WATER

Please Mention Popular Mechanics

Oh BOY! *if you want* FUN

Lionel Trains are patterned after the big electric trains. They have fine, high-power, electric motors and are full of dash and go! Built with the weight close to the track; handsomely enameled — unbreakable — good for years of fun. Operate economically on batteries, or on house current with Lionel Transformer.

Send for Big Free Catalog

— showing complete line of freight and passenger sets. Over 100 fascinating pictures. Tell Dad or Mother what you want and if not at your dealer's, I'll ship prepaid on receipt of price.



Ask Dad for a
**Lionel Electric
Train**
for Christmas

\$5
Up

J. Lionel Cowen, Pres. The Lionel Mfg. Co., 48-G, E. 21st St., New York City

LIONEL ELECTRIC TOY TRAINS

& Multivolt Transformers

Electric
Armored
Car
\$5

NEW!



Price includes 8 sections "0" Gauge Track

LIONEL MULTIVOLT TRANSFORMER

Runs All Kinds
Of Electric
Trains And Toys

ATTACHES to your house current, operates all electrical appliances; any regulation of power from 2 to 80 volts. This special \$3.40 transformer is Lionel quality, high grade, all time. Absolutely safe. If not at your dealer's order direct giving us his name. We will ship, charges prepaid. Other models up to \$8.00; send for catalogue.

The Lionel Mfg. Co.
48-G, East 21st Street NEW YORK CITY



\$3.40
*Cheaper
than Batteries*

Rifle won't Bruise Shoulder

Because the Maxim Silencer absorbs 75% of the recoil. Increase the pleasure of home practice or hunting trip with a

Maxim Silencer

It will make you a better marksman — prevents flinching and nervous tension. Teach your family target practice at home or camp. Boys, girls, grown-ups like it. Send for Free Book — full of stories.

**This
Book
Free.**

THE MAXIM SILENCER COMPANY
93 Homestead Avenue HARTFORD, CONN.

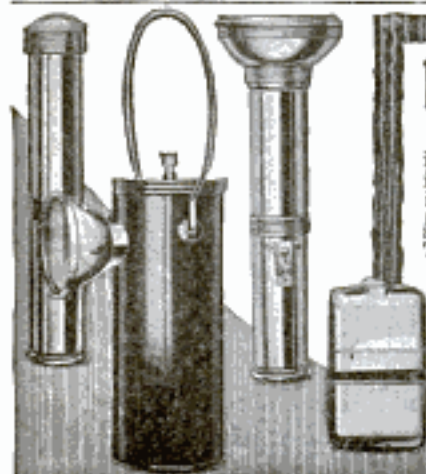

Kwiklite Has All Improvements

Always look to Kwiklite for improvements in flashlights. For instance, the new Seamless Battery (no soldering whatever), which is guaranteed for 25% longer burning life. Then there is the original "Telescopic Construction" which strengthens the case and permits easy withdrawal of the battery for inspection or renewal. The Self Locking Switch allows continuous or intermittent light as desired. The Improved Reflector gives clearest light, free from rings or blotches.

Sold by Hardware, Drug, Electrical and Sporting Goods Dealers. Send today for Booklet 41 which tells all about the 88 different models including several new ones just out.

The Usona Manufacturing Company New York, Toledo
San Francisco

Renew any Flashlight with KWIK-LITE Seamless Batteries—
25% longer service guaranteed.



I'm Ready for Action

24 inches long
9 inches high
30 shots a minute



I Am Big Dick

American Boys Attention!

I never miss fire. I shoot thirty-six (36) wooden bullets as fast as you can turn the firing-crank. I shoot true as your aim and my strong iron base keeps me from "jumping."

For indoor war play I have no equal and will give you and your friends exciting fun storming the German Breast-works you can easily build.

If you are a real live American Boy you will want me.

Tell mother and father I am not dangerous and just whisper to them that Christmas is coming.

You will find me at most toy dealers and well worth the \$3.00 asked. If you don't find me at your dealers send the price to my builders and they will send me direct to your home.

Don't forget!

"BIG DICK"

Milton Bradley Company

(Builders of BIG DICK)

Department B SPRINGFIELD, MASS.

Makers of the World's Best Games

Start a Big-Paying Business of your own with a BADGER TIRE REPAIR OUTFIT

THE man who's equipped to supply the tremendous demand for auto tire repairs can make an assured income of \$200 to \$300 or more per month. The famous Badger Solid Pad System with its strong array of improved features insures your customers quick, economical, high-grade repair jobs, the kind that build up steady trade. We teach you how. Write for Catalog and details.

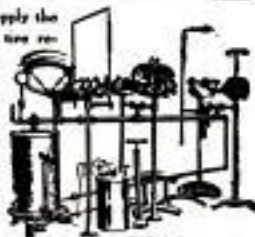

TIRE REPAIR EQUIPMENT CO. 610 Johnson St. APPLETON, WIS.

FREE!—GENUINE EASTMAN PREMO

FILM PACK CAMERA, Size 2 1/2x3 1/4, for selling 25 Art and Religious pictures, or 25 postage post cards at 10 cents each. Order your choice. Sent PREPAID. GEO. GATES CO., Dept. 1579, CHICAGO

Effecto FINISHES AUTO

MAKE OLD AUTOS NEW

\$500 REWARD

We will pay \$500.00 reward to anyone who can permanently dim the brilliancy of the RAJAH Im. diamond without destroying the stone.

RAJAH Im. Diamonds

They stand all diamond tests—fire, acid, file, and glass cutting. Their brilliancy is eternal. Guaranteed for a lifetime. Set in solid gold, and sent to you on 30 Days' Free Trial. If you can tell it from a real diamond return it. Send today for our beautiful, FREE illustrated jewelry catalog in color. Write now. KRAUTH & REED, 159 N. State St., Dept. P-2 CHICAGO, ILL.

A YEAR
TO PAY



3 Promotions in 5 Months!

This Coupon Did It

THIS coupon brought George Yeck of Dixon, Cal., advancement beyond his expectations. This is what he wrote to the school the other day: "The first month I had to do all the hard work. I think that the Signal foreman and supervisor wanted to find out what I was made of, but the second month I got promoted with a raise in salary. On May 18th, I got promoted again with another raise in salary. On Sept. 7th I was again promoted with another raise in salary. Now I am one of the highest paid men in the Signal gang and am Assistant Signal Repair man, thanks to your wonderful course." And what Mr. Yeck did, you can do.

Men Are Needed

There are thousands of miles of railroads that must be equipped with block signal systems. Many states already passed laws that require automatic block signals on all railroads. To expedite these installations and maintain the systems now in use, thousands of men are necessary. Golden opportunities are offered. The work is big and broad—high salaries are paid—\$200.00 a month is an ordinary salary for a Signal Engineer.

You can learn at home during your spare time. It is not necessary to give up your position to take up this profitable profession. Just a little time in the evening—it does not interfere with your work during the day. Put your spare time to advantage.



If you join the army or navy before you have completed the course, further payments will be postponed until you return.

Free Book

Put your name and address in the coupon, in a letter or on a post card now and get the free book about Signal Engineering. It will be sent to you prepaid—without obligation. Every ambitious man in America should get this book on Signal Engineering. Find out about the opportunities that are offered you. You are under no obligations in sending this coupon—so write at once—today.

Department of Signaling,

Dept. 9109—1810 Wilson Ave.
Ravenswood Station, CHICAGO, ILL.

Gentlemen:—Please send me, absolutely free and prepaid, your big new book on Signal Engineering. Also full particulars about your great special free outfit offer. It is distinctly understood that I assume no obligation of any kind.

Name

Address

Occupation..... Age.....

Please Mention Popular Mechanics

Inventors Badly Needed Now

**Big Demand for Almost Any Invention
The "Man with an Idea" Is Important Personage
Today. Must Solve Both War and Domestic Problems**

NEVER before has the demand for something—almost anything—in the way of a new invention been as great as it is today. In the past, many of our small manufactured articles came from abroad—most of them from Germany—and this supply is of course completely cut off. American manufacturers must supply these things now, and many others besides. Naturally, in meeting competition they want something a little better than the public has been getting and something that they alone can manufacture. This is where the demand for newly patented articles comes in—and it spells Opportunity for the inventor. Now is the time for the "Man with an Idea" to come forward and "cash in" on his brains.

"The demand for patented inventions, today, seems to be almost unlimited," said a Washington patent attorney in an interview recently. "Our firm is flooded with inquiries for good articles in all lines.

Reason for Demand

"I attribute the demand to the fact that farsighted manufacturers who are now making war supplies want to be ready to jump in with something else as soon as war stops, and of course they are making their plans now. If the inventor sells his patent, it makes no difference to him, of course, when the articles are made—and it is the man who has something good to offer right now who is going to 'get in on the ground floor.'

"But there are other reasons for the present demand. Our supplies from abroad have stopped, and American manufacturers have got to get busy. They don't want to imitate the old foreign articles—especially the German ones; they want something new and American to make—something better than we have been getting from Europe. And our American inventors can give it to them!

Patents Actually Asked For

"Then there is the importance of time and labor saving inventions—often only slight improvements in old machines but in these days of high wages and high costs, the inventor who makes a machine to save a few moments or a little material is an important man.

"Here are a few of the requests we have

had: One man wants anything good to handle through agents, but especially something in milking machines. Another wants good things in household specialties. Another is interested in an improved tooth brush, tire pump or speedometer. Another wants a machine that can be used by the purchaser to base a business on—something like the Crispette Machine, the Photo-button Camera, a new vulcanizing plant, etc. Another wants a toothbrush, mail box, spark plug, folding crate, cigar lighter, pipe threader and general kitchen articles. Another asks for patents on toys; another wants counting and measuring devices; another wants automobile specialties—and so on and on, through almost everything that Americans may have invented, or might invent with a little thought.

How to Find Out What is Needed

"The trouble with inventors is that they are usually careless of their own interests. They invent something, but they put off patenting it, and the first thing they know someone else has gotten ahead of them. I know a man who thought of the tire chain for autos five years before they were made, but he didn't have enough energy to protect his idea and lost out. The company manufacturing them has made millions.

"Anyone of an inventive turn who is in earnest and who wants to find out what is needed, need only write to our firm and we will send him a list of things for which we have received from one to twenty-five requests. We mail this free, and we send him, too, our book, 'How to Obtain a Patent,' which will give him full information. If he has an invention, and will send us a sketch or model and a description of it, we will tell him without charge, whether it is proper subject matter for a patent, and if he applies for a patent through us, we put him in touch with manufacturers who want patents. We also advertise his patent for sale without charge to him.

"Our business is to get patents for our clients but it is also our business to help our clients to make money from their inventions and this is what we are trying to do. Our firm name is Chandlee & Chandlee and our address is 537 Seventh Street, Washington, D. C."

PATENTS TRADE-MARKS AND COPYRIGHTS

LARGEST PATENT FIRM
IN THE WORLD

SPECIAL OFFER

Free Opinion as to Patentability

Before sending your invention to any attorney or manufacturer or disclosing your invention, write for our free blank form **PROOF OF CONCEPTION** in order to protect your invention and secure your rights. This should be signed and witnessed and returned to us, together with a model or sketch and description of your invention, and we will give a **FREE OPINION** as to the patentability of the invention. If we report the invention patentable we will furnish a Certificate of Patentability.

VICTOR J. EVANS

This Certificate of Patentability, together with our blank form Proof of Conception will protect the inventor and serve as proof of the invention until the case can be filed in the U. S. Patent Office.

Obtaining Assistance for Inventors—Our certificate is of great assistance to inventors who require financial aid to obtain patents.

OUR FIVE BOOKS MAILED FREE

(See Coupon Below)

to any address. Send for these books—the finest publications ever issued for free distribution.

How to Obtain a Patent

Our illustrated eighty-page Guide Book is a book of reference for inventors and contains 100 mechanical movements, illustrated and described. Tells how to invent for profit.

What to Invent

Contains a valuable list of inventions wanted and suggestions concerning profitable fields of inventions; also information regarding prizes offered for inventions amounting to

One Million Dollars

Millions in Trade-Marks

Shows the value of Trade-Marks and information regarding unfair competition.

We Advertise Our Clients' Inventions Free in a list of Sunday newspapers, in manufacturers' journals and in World's Progress. Sample Copy Free. We save you time and money in securing patents. After the patent is granted we assist you to sell your patent.

WANTED NEW IDEAS

Prepare Now to meet the Demands of Industry in All Fields for New Ideas and New Inventions. We are constantly receiving requests from manufacturers who consult us when purchasing patents for inventions in all lines. We invite manufacturers and promoters to address our Sales Department regarding the purchase or leasing of a number of meritorious patents secured by us.

List of Patent Buyers

Contains requests from manufacturers, mail order houses and promoters for patents secured by us and suggestions as to **New Ideas** they wish to purchase. We place our clients in touch with capital free of charge. We have recently received over 300 requests from manufacturers.

Foreign Patents

We have direct agencies in all the principal foreign countries and secure foreign patents in the shortest possible time and at the lowest cost. Write for our illustrated Guide Book on Foreign Patents, sent free to any address.

VICTOR BUILDING

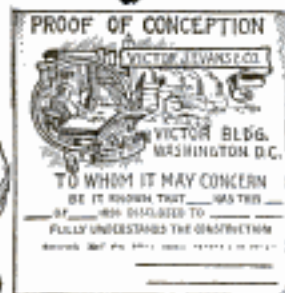

FREE COUPON!

VICTOR J. EVANS & CO.

New York Offices:

1007 Woolworth Bldg.

PATENT ATTORNEYS

Pittsburg Offices: 514 Empire Bldg.

Philadelphia Offices:

1429 Chestnut St.

Main Offices: 765 Ninth St., N. W., WASHINGTON, D. C.

Name..... Address.....

Please Mention Popular Mechanics

AMERICA NEEDS YOUR IDEAS

SUBMARINES, torpedoes, flying machines, machine guns, immense howitzers, the British "tanks," and an untold number of other products of American brains, are dominant factors in the Great War. We are just starting, our—your—ingenuity must lead to Victory. Uncle Sam—the whole civilized World—is seeking ideas that will aid in the fight. Can't you help with even one of thousands of simple things that will win recognition—perhaps fortune—for you?

The need is for inventions of peace, too. Never before was there such a demand for new ideas of all kinds—never before have so many manufacturers, and other patent buyers, written me for good things protected by Owen Patents. There is, today, a market for thousands of ideas—including yours. Write for my free booklets and see—read for yourself the hundreds of requests recently received.

A simple request will bring to you at once, my four free books:—"Successful Patents," a 72-page guide telling how to proceed, gives references, etc.; "Stepping Stones," tells the truth about prizes for inventions, gives hundreds of hints of inventions wanted, etc.; "Patent Buyers" publishes over 400 requests of manufacturers and others who want Owen Patents, together with ideas they want; "Patent Promotion," tells you how to sell, why some inventors fail, discusses the value of your idea, etc.

Write for these books today. I will send you a signed agreement that will protect you before you disclose your invention.

You incur no obligation by writing me. My advice costs nothing and I make no charge for an opinion as to patentability of your idea. If my opinion is favorable, I will back it up by a **GUARANTEE CONTRACT** which protects you fully. If you want to sell your invention, I will help you, and will advertise it, free of charge, in "Invention and Manufacturing."

RICHARD B. OWEN Patent Lawyer

9-303 Owen Bldg Washington D.C. 2276 E Woolworth Bldg New York

PATENTS SECURED OR ALL FEES RETURNED!
THAT PAY ACTUAL FREE SEARCH of Patent-Office Record as to Patentability of your invention
"Trade Mark" With each favorable report we issue a Contract to Return All Fees!

Send data at once by registered mail and we will promptly advise how OUR CLIENTS PROCEED TO MAKE FORTUNES. Over \$627,212.00 made by clients.

Patents Sold FREE: Read "Patent Sales Department" of our 190-page Guide Book, FREE!

Don't miss this book. Mail postal today.

E. E. VROOMAN & CO., 871 F Street, WASHINGTON, D. C.

Send for **FREE BOOK** { WHAT TO INVENT
WHAT NOT TO INVENT
HOW TO SELL YOUR PATENT
Nearest Patents and report in each case to be filed—no charge
H. L. WOODWARD, 9th and G Sts., WASHINGTON, D. C.



**"The book
the Inventor
KEEPS"**

Worth more than
all other patent
books combined.
FREE. Write

R. S. & A. B. Lacey
116 Barrister Bldg.
Washington, D. C.
Established 1869

Protective Patents

Procured Promptly. No fee refund, no guarantee certificate, no so-called prize or free search schemes used in our business. Inventors 104 page Blue Book sent on request.

Robb & Robb, 211-215A Southern Bldg., Washington, D. C.



Patent Secured or Fee Returned

Hundreds of inventions sold yearly. We help market yours without cost. Our new book is FREE. Send model or sketch for free opinion.

A. M. BUCK & CO.

204 2nd Nat'l Bank Bldg., Washington, D. C.

PATENTS **C. L. PARKER**
Formerly Member Examining
Corps, U. S. Patent Office
PATENT LAWYER

MC GILL BLDG.
WASHINGTON, D. C.

Patents, Trade Marks, Copyrights, Patent Litigation

Handbook for Inventors, "Protecting, Exploiting
and Selling Inventions," sent free upon request.

PATENTS

THAT PROTECT AND PAY
Books and Advice Free

Send sketch or model for search. Highest References.
Best Results. Promptness Assured.

WATSON E. COLEMAN, Patent Lawyer
624 F Street, N. W. Washington, D. C.

Please Mention Popular Mechanics

Wanted—Ideas

Inventors! Send for these Remarkable FREE BOOKS, Today



"Inventions Needed"

This book lays before you a description of the active and profitable field of invention. It tells you the inventions the world needs today, the devices manufacturers are seeking for their business, the ideas for which the public will pay big money.

"How to Get Your Patent"

This book is a guide to the inventor. If you have invented something and desire to learn what it will cost you to get your patent and what you must do to find your market, read this book.

"Special Bulletin of Patent Buyers"

This bulletin contains letters from men who are seeking to purchase patents. We act as intermediary without one cent of charge, between the man who invents and the man who invests.

Send Model or Sketch and description of your invention for Free Opinion as to patentability

*Rejected and Difficult
Cases are Our
Specialty*

RANDOLPH & CO.

600 F St., N.W., Washington, D.C.

RANDOLPH & CO.
600 F St., N. W., Washington, D. C.

Gentlemen: Please send me without obligation on my part, the books indicated on margin of this coupon. (Write on margin of coupon, names of books desired.)

NAME
STREET.....
CITY.....STATE.....

PATENTS

Send me your ideas. Manufacturers want patents I procure. Prompt, confidential, personal service by successful patent attorney with highest references. Honest advice and "The Truth About Patents" Free.

J. R. KELLY, 743 Woodward Bldg., WASHINGTON, D. C.

Patents on Easy Payments

Send sketch for free opinion as to patentability. Write today for our new book on what to invent and how to protect your invention under our NEW EASY PAYMENT PLAN.

C. C. HINES & CO.

591a W. L. & T. Bldg., WASHINGTON, D. C.

U.S. PATENTS



REGISTERED ATTORNEYS

LANCASTER & ALLWINE

204 OURAY BLDG. WASHINGTON, D. C.

Don't Lose Your Rights

We publish forms called "Evidence of Conception" by which you can establish your rights before sending the invention to anyone. It is your best protection. We issue up-to-date bulletins of improvements wanted; aid inventors to promote their rights; render reliable opinions free of charge and secure valuable patents and trade marks on reasonable terms. Personal service assured by our Service Guarantee Contract. References: 2nd National Bank, Washington; John P. Roth Packing Co., Cincinnati.

SIMPLY MAIL COUPON

LANCASTER & ALLWINE, 204 Ouray Bldg., Washington, D. C.

Send me free book "Inventions—Patenting and Promoting," Bulletin of Improvements Wanted and blank forms, "Evidence of Conception."

Name

Address

Please Mention Popular Mechanics



PATENTS

Send Sketch or Model of Your Invention for Free Opinion as to Patentability

Our Certificate of Patentability is Evidence

of Conception of your invention and may prove valuable to you. Our Credit System enables you to file your application for Patent and proceed without delay. Every case receives personal attention of one or both members of the firm.

Patents we secure advertised at our expense in Popular Mechanics Magazine.

Write today for Free copy of 104-page book, "How to Obtain a Patent and What to Invent"

Talbert & Parker, Patent Lawyers
4683 Talbert Bldg. WASHINGTON, D. C.



**GENUINE
DIAMONDS**

**FROM THE DIAMOND
CUTTERS DIRECT
TO YOU BY MAIL
AT THE DIAMOND
CUTTER'S
PRICES**

\$70

PER CARAT



A125 \$8.95
Solid Gold laval-
liere and chain. 3
fine diamonds \$8.95

A127 14K Ear screws
2 blue-white diamonds.
Per pair..... \$10.00

A128 \$25.00
14K stud. 1/2 carat
diamond

\$39.00. A126
14K cluster platinum
top. 7 blue-white dia-
monds. Complete \$39.00

A129 \$16.75
14K ladies' solitaire
1/4 carat diamond.

\$57.50
A130 14K man's sol-
itaire. 1/2 carat dia-
mond. Complete \$57.50

\$36.65
A132 14K ladies'
solitaire. 1/2 carat
diamond. Com-
plete..... \$36.65

\$2.75.
A133 14K ladies'
belcher solitaire. 1
diamond. Com-
plete..... \$2.75

\$25.00
A131 14K cluster
scarf pin. 7 blue
white diamonds.
Complete. \$25.00

FREE EXAMINATION—NO OBLIGATION

To convince you beyond the shadow of a doubt that our values are absolutely unequalled, we will gladly forward you any article from this ad or from our Catalog, care of your bank or express office, for your examination and approval. We prepay all charges.

**YOUR MONEY BACK IN FULL
ANY TIME WITHIN ONE YEAR**

Our ironclad guarantee gives you the right to return the diamond to us any time within one year and we give you back the full price you paid without even one cent being deducted. This guarantee is final evidence of the superior values we offer.

BIG 1918 CATALOG FREE

This new 1918 Catalog is a wonderful guide to the selection of Christmas Gifts and gifts for all other occasions. It contains 244 pages of intensely interesting and valuable information written by recognized experts on Diamonds, Watches, Jewelry, etc., and quotes thousands of money-saving prices. Write us a letter or postcard for this book NOW.

FREE! We will mail you, postpaid, a beautiful Red, White and Blue Enameled Flag Button with our Catalog, free, if you mention this magazine.

I. PRESS & SONS
IMPORTERS AND CUTTERS OF DIAMONDS
WHOLESALE JEWELERS
901-C CHESTNUT ST.
PHILADELPHIA, PA.

INVENTORS AMAZED!

PATENT
KNOWLEDGE
for
INVENTORS

FREE BOOK!

You who would like to invent something—you who have inventions in mind—you who have been disappointed in your plea for a patent—write today for a book that will open your eyes! My new 90-page book. The most complete patent book ever published for free distribution. A straightforward revelation of valuable information. Altogether different from the usual stuff sent out to inventors. Free to you. Send a postcard.

My New Kind of Patent Service

I entered the patent field with the idea of giving a superior service to inventors. My policy has won out big. My free book explains my personal service to inventors. I do not entrust your interests to assistants. Fair, square advice in your ideas.



Send Me Your Sketch or Model

Send me sketch, photograph or model of your invention for prompt report. Let me prove to you what a high-class patent attorney service really means.

GEORGE P. KIMMEL, Patent Lawyer
54-L Barrister Building, WASHINGTON, D. C.

COMPETENT PATENT SERVICE

BY A FORMER EXAMINING OFFICIAL
OF THE U. S. PATENT OFFICE

NORMAN T. WHITAKER

LAWYER AND ENGINEER

27 WHITAKER BLDG., WASHINGTON, D. C.

INQUIRIES INVITED

THE DAWN PATENTS OF INVENTION AND - PATENT - POSSIBILITIES -

THE WAR opens a virgin field to inventors. Submarine Destroyers, Torpedo Carriers, Airships, etc. are needed. Help your country meet the emergency.

AFTER THE WAR, Tanks, Agricultural Machinery, Railway Appliances, etc., will be needed. Patents can be made supplying these demands. Prepare now for the future.

Get the right man by sending for free book "Patents and Patent Possibilities." It tells how to obtain a patent and where to sell it. Write for it today.

H. S. HILL, 802 McLaughlin Building, Washington, D. C.

R. MORGAN ELLIOTT & Co.

PATENT ATTORNEYS

MECHANICAL, ELECTRICAL & CHEMICAL EXPERTS

713-721 WOODWARD BUILDING

WASHINGTON, D. C.



Press One Pair While You Wear the Other

The real Military Knife Blade crease without heat or wear on the material.

Applied in two minutes and removed in one.

Presses over night or will preserve the crease as long as you like.

The well-dressed man wins every time and no matter what the cost or quality of your trousers you are not well dressed with baggy knees.

THE FORD AUTOMATIC Trouser Stretcher

PRICE \$1.00

does the work right and at no expense whatever. If your dealer does not carry them send us one dollar and we will immediately mail you one, prepaid. Do it now and enjoy the self-respect of the well-dressed man.

FORD AUTOMATIC MFG. CO.
1323 S. Michigan Avenue CHICAGO, ILL.



GEARS ALL KINDS SMALL

The most accurate made and prices reasonable. We carry a complete line of gears in stock for immediate shipment. Can also quote on special gears of all kinds. Send us your inquiries.

WRITE FOR CATALOGUE.

CHICAGO STOCK GEAR WORKS
16 S. Fifth Av. CHICAGO



MECHANICAL
SUPPLIES AND MATERIAL
of all kinds.

EXPERIMENTAL AND
LIGHT MACHINE WORK
to order.

132 MILK STREET. BOSTON

**Models
and
Gears**

Experimenters—Inventors

Developing inventions and making working models our specialty. Well equipped shop and staff of experts at your service. Carry complete stock of gears. Shipments same day order received. ESTABLISHED 1882.

UNION MODEL WORKS, 121 S. Clark St., CHICAGO

HURRY! HURRY! HURRY!

The 1918 FRIDGER output is almost contracted.

FRED W. WOLF, Manufacturer

Wells Street Bridge Building CHICAGO, ILLINOIS

AGENTS \$200 A MONTH

New Automatic Adjustable Wardrobe. Patented. Fits any wall or corner. Takes up no floor space. Put up or removed in five seconds. Self-Supporting.

No nails, no screws. Sells in homes, offices, halls, stores, shops, garages—every place. Best and easiest seller ever offered. Write quick for sample. A postal will do.

A demonstration means a sale. Dozen can be carried. No competition. Women delighted.

THOMAS MFG. CO., 5248 Gay Street, DAYTON, OHIO



"I'll Play the 7-Ball!"

A combination! Good position if he makes it, with a chance to clear the table. If he misses, disaster! Every shot is a fresh problem, a new test of skill, judgment and nerve. That's why everybody likes to play Billiards and Pool.

BURROWES

Billiard and Pool Table

Burrowes Tables are correct in every detail. The most delicate shots can be made with the utmost accuracy. Some of the leading experts use them for home practice. Burrowes Regis High-Speed Rubber Cushions are unquestionably the finest cushions made. The new 1918 models, now ready, are the finest Portable Billiard and Pool Tables ever produced.

\$1.00 DOWN

Prices of Burrowes Tables range from \$15 up, on terms of \$1 or more down and a small amount monthly. Cues, balls, etc., free. Sizes range up to 4 1/2 x 9 ft. (standard), with smaller sizes for smaller rooms.

No Special Room Needed

You can put up or take down your Burrowes Table in a moment. Mount it on your dining or library table or on its own legs or folding stand.

FREE TRIAL—No Red Tape

On receipt of first instalment we will ship Table. Play on it one week. If unsatisfactory return it, and on its receipt we will refund your deposit. This insures you a free trial. Write for illustrated catalog, giving prices, convenient terms of payment and full information.

THE E. T. BURROWES CO.

167 Spring St., Portland, Me.

Burrowes Tables are now on sale in many cities and towns. You can inspect them before ordering if you wish.

San Francisco and Los Angeles Offices



Earn
\$ **15 to \$50**
Per Day



Thousands of dollars' worth of show cards, signs and bulletins are bought yearly in every community by merchants, theatres, hotels, restaurants, clubs, churches, schools, etc., at a cost of 50c to \$3.00 per card.

You can now make beautiful signs at an average labor and material cost of 2½ cents, which ordinarily sell at 25 cents to 75 cents apiece, superior to all other signs, equal to the work of the best printing press. 1½ to 8 minutes per card. Any bright boy or girl can do it.

PRINTASIGN
"ONE LETTER AT A TIME"

The marvelous giant typewriter—the only sign, show card and bulletin printing machine ever produced. Not a stencil machine, but prints in any two colors from copper-faced type, one letter at a time. No type to set up or distribute. The Printasign automatically inks each type and spaces between letters—a different space for each character. No one can compete with your Printasign

prices and quality. Just show your samples and you ought to get 100 to 200 regular customers, each buying 5 to 20 signs at a time. Selling only 50 signs at 50 cents each, your daily net profit would be \$23.75. Let us tell you how to build up a good full-time or part-time permanent business. A big money-making chance for some one in your community. Don't let another beat you to it. Write today.

AMERICAN PRINTASIGN CO., Borland Building, CHICAGO, ILL.

SEND for CATALOG P 28

It will be pocket size, 8x4½ and will contain 248 pages with over 1,100 illustrations, describing in plain, clear language all about Bells, Push Buttons, Batteries, Telephone and Telegraph Material, Electric Toys, Burglar and Fire Alarm Contrivances, Electric Call Bells, Electric Alarm Clocks, Medical Batteries, Motor Boat Horns, Electrically Heated Apparatus, Battery Connectors, Switches, Battery Gauges, Wireless Telegraph Instruments, Ignition Supplies, etc.



Send for a copy now.

Manhattan Electrical Supply Company, Inc.

New York, 17 Park Place St. Louis, 1106 Pine St.
Chicago, 114 So. 5th Ave. San Francisco, 604 Mission St.

THERE IS BIG MONEY IN CARD PRINTING
of all kinds if done with an **Automatic Press**

Send for our Free Booklet No. 6
S. B. FEUERSTEIN & CO.
Manufacturers
542 Jackson Blvd., Chicago



Prints While You Wait
100 Cards a Minute Any Size

BATTERY CHARGING PAYS BIG PROFITS



The 500 watt H-I equipment guarantees quick charging and large profits. Recharges one to seven batteries at cost of about 15c per battery. You get from 70c to \$1.50 from autoist. Hundreds of garage owners are clearing \$20.00 to \$50.00 every month.

\$15 PUTS THIS MONEY-MAKER IN YOUR GARAGE
Balance in 5 monthly payments of \$20 each. Easily paid from savings and great profit business. Every outfit fully guaranteed. Tear out this ad and mail with name for full particulars. **DO IT TODAY!**
HOBART BROTHERS COMPANY, Box M 12, TROY, OHIO

DIAMONDS - WATCHES ON CREDIT

Eight Months To Pay
Wear a Pure, Blue-white Diamond or Watch while paying for it on easy terms, **20% DOWN - 10% A MONTH**. Any honest person given credit. No security required. All transactions confidential. Goods sent prepaid subject to approval. Binding Guarantee with each Diamond covering quality and value and providing for exchange at full purchase price. 10% DISCOUNT allowed for cash. Write today for **FREE CATALOG No. 5** containing 4000 photographs of Diamonds, Watches, Jewelry, Silverware, etc. No obligation to buy.

Dept. (A)

7088 \$75
7079 \$45
7070 \$25
7071 \$25
7072 \$25
7073 \$25
7074 \$25
7075 \$25
7076 \$25
7077 \$25
7078 \$25
7079 \$45
7080 \$25
7081 \$25
7082 \$25
7083 \$25
7084 \$25
7085 \$25
7086 \$25
7087 \$25
7088 \$75
7089 \$75
7090 \$75
7091 \$75
7092 \$75
7093 \$75
7094 \$75
7095 \$75
7096 \$75
7097 \$75
7098 \$75
7099 \$75
7100 \$75
7101 \$75
7102 \$75
7103 \$75
7104 \$75
7105 \$75
7106 \$75
7107 \$75
7108 \$75
7109 \$75
7110 \$75
7111 \$75
7112 \$75
7113 \$75
7114 \$75
7115 \$75
7116 \$75
7117 \$75
7118 \$75
7119 \$75
7120 \$75
7121 \$75
7122 \$75
7123 \$75
7124 \$75
7125 \$75
7126 \$75
7127 \$75
7128 \$75
7129 \$75
7130 \$75
7131 \$75
7132 \$75
7133 \$75
7134 \$75
7135 \$75
7136 \$75
7137 \$75
7138 \$75
7139 \$75
7140 \$75
7141 \$75
7142 \$75
7143 \$75
7144 \$75
7145 \$75
7146 \$75
7147 \$75
7148 \$75
7149 \$75
7150 \$75
7151 \$75
7152 \$75
7153 \$75
7154 \$75
7155 \$75
7156 \$75
7157 \$75
7158 \$75
7159 \$75
7160 \$75
7161 \$75
7162 \$75
7163 \$75
7164 \$75
7165 \$75
7166 \$75
7167 \$75
7168 \$75
7169 \$75
7170 \$75
7171 \$75
7172 \$75
7173 \$75
7174 \$75
7175 \$75
7176 \$75
7177 \$75
7178 \$75
7179 \$75
7180 \$75
7181 \$75
7182 \$75
7183 \$75
7184 \$75
7185 \$75
7186 \$75
7187 \$75
7188 \$75
7189 \$75
7190 \$75
7191 \$75
7192 \$75
7193 \$75
7194 \$75
7195 \$75
7196 \$75
7197 \$75
7198 \$75
7199 \$75
7200 \$75

JAMES BERGMAN Est'd. 1896. **37-39 MAIDEN LANE NEW YORK CITY**



NEW-SKIN
First Aid
For Cuts and Scrapes

Keeps out germs.
Protects from infection.

Have it on hand
for emergencies.

In two sizes, at all druggists.
NEWSKIN CO., NEW YORK

Taxidermy Book FREE

Mount Birds

We teach you by mail to stuff and mount all kinds of **Birds, Animals, Game Heads**. Also to tan skins and make rugs. Be your own taxidermist. Decorate your home with your beautiful trophies or increase your income selling specimens and mounting for others. Easily, quickly learned in spare time by men and women. Highest endorsements by thousands of students. Write today for our great free book "How to Mount Birds and Animals" Free—write today.

N. W. School of Taxidermy, 1199 Elwood Bldg., OMAHA, NEB.

Get this LA Engine Book



— it gives valuable information about motor boat engines. It also describes the full line of L-A motors and tells of the 30 days' free trial plan. Write for your copy today.

LOCKWOOD-ASH MOTOR CO.
1430 Harton Ave. Jackson, Mich. (27)

RAISE BELGIAN HARES For U.S.

HUGE PROFITS easily and pleasantly made. We furnish stock and pay you \$5.00 a pair and express charges for all you raise. Contract and book "Fortunes in Hares," \$2.00. Nothing free.

NATIONAL FODD & FUR ASSOCIATION
Dept. 40, 557 12th St., MILWAUKEE, WISC



New Vamping Card

No Teacher Needed
Surprisingly Simple System

PIANO PLAYING MADE EASY

Persons having neglected their Musical Education need not despair, for with the aid of our new **VAMPING CARD** (placing the card upright over the piano keys), you can at once Vamp away to thousands of Songs, Ballads, Waltzes, Rag Time, etc., etc., equal to a Professional Musician. No knowledge of music is required. After using it a few times, you will be able to dispose with the Vamping Card entirely. The price of this very clever invention is only 18 cts. postpaid.

JOHNSON SMITH & CO., Dept. 93, 54 W. Lake Street, CHICAGO



RADIANT VIOLET RAYS ENERGY

STOP

Living in ignorance. Learn at once about nature's new phase of energy, so beneficial to all forms of life. You owe it to yourself to learn more about those sources of nature whence all truth springs. Read about atomic radiant electricity in the form of violet rays—health-giving and health restoring. Violet-Ray energy is the closest approach to artificial vital force so far produced by science. Learn how to relieve suffering, how to increase your physical strength, improve your circulation and general well-being and how to assist nature in her own way to give you the healthy bloom of a natural complexion and splendid bearing of a perfect physique.

VI-RAY-O

is the name of the famous Home Violet Ray Instrument. A scientific little apparatus, simple and safe to operate from any lamp socket or from dry batteries. It has now been used



for four years with the greatest success by the medical profession. Medical authorities endorse it and 40,000 satisfied users recommend it. Vi-ray-o is not a vibrator. It benefits by painless electricity. It instantly relieves pain and aches, rheumatism, lumbago, headaches, asthma, nervous troubles, reduces swellings and relieves chronic ailments in most instances. It ozonizes the blood by carrying oxygen into the tissues. It is excellent for skin and scalp diseases, restores hair to natural color and removes facial blemishes. Go to your electrical store and ask for a demonstration or send today for the Free Book and our 30 days' free trial offer. Fill in the coupon and mail it to us.

Western Coil & Electrical Co.
Box 29, Racine, Wis.

SEND FOR THIS FREE BOOK NOW

WESTERN COIL & ELECTRICAL CO., Box 29, RACINE, WIS.

Please send me your book on health, beauty and strength. Also details of your 30 day trial offer.

Name.....
Street.....
Town..... State.....

A REAL
X'MAS
GIFT

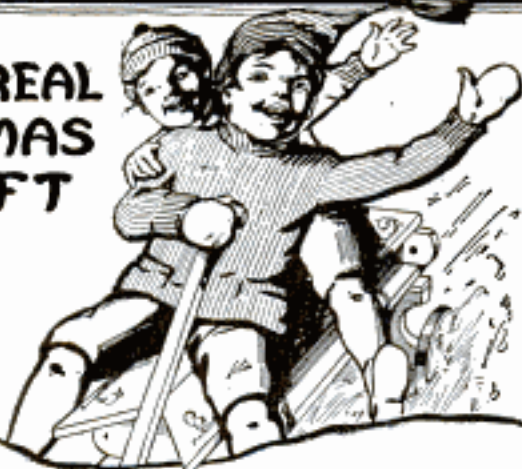

AUTO-WHEEL CONVERTIBLE ROADSTER

*There's nothing a real boy likes
better than a real Coaster Wagon*

HIS COASTER is his side partner almost everywhere he goes, in almost everything he does. His play centers around it. His work is often made more pleasant because of it.

The Auto-Wheel Convertible Roadster is the very latest thing in wagons. Every boy who sees the Auto-Wheel wants one because of its two-in-one construction.

It's both a roadster and a coaster. To change from one to the other means simply pulling up the sides or turning them back.

Get your boy an Auto-Wheel Convertible. Made with ball-bearing wheels, dust-proof hub caps, steel axles—just like the famous Auto-Wheel Coaster. Don't take a substitute.

BOYS! Get a FELT PENNANT, FREE. Send us names of three Coaster Wagon Dealers and we'll mail you the Pennant. Ask Dad or Mother to get you an Auto-Wheel Convertible FOR CHRISTMAS.

BUFFALO SLED COMPANY

137 Schenck St.

N. Tonawanda,
N. Y.



In Canada:
Preston, Ont.

The Cleveland Lightweight

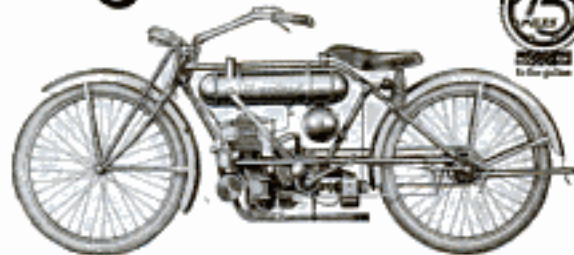

It Dominates —

Where elegance and refinement are essential, the Cleveland Lightweight is in marked evidence.

In its ultra-distinctiveness, it enjoys that reputation which places it wholly apart from the ordinary.

Cleveland Dealers are making money

We will gladly talk the Agency proposition with you.

\$175 F.O.B. Cleveland, O., U.S.A.

Cleveland Motorcycle Manufacturing Co.
7209 Platt Avenue, Cleveland, Ohio

FREE STEEL SHOE BOOK SAVES \$20



Tells all about my Celebrated Steel Shoes. One of the greatest inventions in footwear the world has ever known. Over a million people now wearing them. Wear as long as three to six pairs of leather shoes. Easiest, most comfortable shoes you ever had on your feet. No cold, wet feet, therefore Colds, Rheumatism, Grip, Lumbago, Lamé Back, and other ailments prevented. No corns, bunions or tender, tired feet. Write today for my free book.

Address: RUTHSTEIN, Steel Shoe Man, Dept. 32, RACINE, WIS.

WEBER Throttle-Governed VALVE-IN-HEAD KEROSENE ENGINES

WILL SAVE YOU HALF IN FUEL COST. All 1917 Weber Engines are equipped with that great engine improvement, the "Weberator."
Makes Kerosene as convenient to use as Gasoline. Saves 50% on fuel.
Write today for full details and 60 day trial offer. Sold direct to user at factory prices.
WEBER ENGINE CO.,
Dept. 1779 KANSAS CITY, MO.

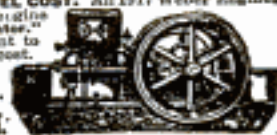

WE ARE READY TO PROVE THE SUPERIORITY OF OUR BREECHLOADER Over All Other PEACE Producers

Our Claim That It IS THE FIRST and ONLY Positively DRY "JUICELESS", "HEELLESS", "CLOGLESS", SWEET, SANITARY, OPEN SAFETY Smoking Pipe Ever Devised IS Backed By Our BONA FIDE GUARANTEE To Make Good Or REFUND The Purchaser's Money UPON DEMAND.

Such A Proposition Precludes Further Parley. The Practical Man Cannot Fail To See Generousness And Feasibility In This NEW SIMPLE Method. HOW DOES IT LOOK TO YOU? Surely GOOD ENOUGH TO Try With All CHANCE ELIMINATED.

THE BREECHLOADER

IS EXTREMELY SIMPLE, Most Substantial and Practical; Neat and Unique in Design; A Very Desirable Size; 5/8 in. long With Graceful Curves; A Little on the "Chubby" order, Half Bent; Considerably Lighter, Holding about one-fourth more Tobacco than the ordinary pipe of the same size. The bowl and Breech Plug are made of FIRST QUALITY, GENUINE FRENCH BRIAR; Given a Rich, Natural, Friction Finish; Solid Rubber Stem; Sterling Silver Mounted With Aluminum Clog Eliminator Shield. Price, including Nickel Plated Pipe Companion \$1.50 Postpaid. Or Write For Free Booklet.

THE BREECHLOADER PIPE COMPANY, Inc.
SUITE B B, 335 BROADWAY, NEW YORK, N. Y.



Belber

TRAVELING GOODS

For Christmas—a bag or suitcase—a Belber bag or suitcase—made of Du Pont Fabrikoid, Craftsman Quality—fitted complete with a toilet set of beautiful Ivory Py-ra-lin—and doubly guaranteed.



It is the ultimate in Christmas gifts. Nothing could give more lasting pleasure or better convey the Christmas sentiment.

At all good dealers and department stores

THE BELBER TRUNK AND BAG CO.
Turner and Mascher Sts. Philadelphia, Pa.

681 F—Black
685 F—Brown
Made in handsome, small cross grain. Fitted as illustrated.
20 inch size - - \$12.00
22 inch size - - 13.00
24 inch size - - 14.00



3 YEARS TO PAY

Meister Piano 30 days' free trial in your own home
\$1 A WEEK or \$5 A MONTH Price \$210.00

No cash payment down. No interest—no extras. Piano stool and scarf free.

ROTHSCHILD & COMPANY
Dept. K16 CHICAGO, ILL.

Drilling Wells is a Year Round Business

Drilling Water Wells is a profitable, healthful, year-round business. There are wells all around you to be drilled. Don't you want to get into a money-making business for yourself? Write for particulars.

STAR DRILLING MACHINE CO.
664 Washington St. AKRON, OHIO

Net Prices To You!



Wonderful offer. Get our best net prices on superb diamonds. Rings in all styles of setting, Tiffany, Belcher, etc., brooches, La Vallieres, pins, etc. Splendid diamond clusters in elegant platinum mountings. \$2.50 a month and up. And free examination first.

Write for illustrated *Diamond Book*, net price list and liberal credit terms. All particulars free. Get this great offer. Write today—now.
Burlington Watch Co., Dept. 1199, Chicago

DODGE BROTHERS MOTOR CAR



Equal to Any \$125 Machine—COSTS LESS THAN HALF

Every family should have a real Phonograph for Christmas. Investigate this wonderful instrument and easy-payment offer.
FULL YEAR TO PAY

THE LIBERTY is 45 inches high—a big, massive, magnificent piece of furniture. Has All Features—Multiple Spring Worm Gear Motor, Speed Regulator, Automatic Stop, Universal Tone Arm, All-Wood Sound Chamber, Individual Record Rack—in fact, every feature of machines costing TWICE as much.

THE LIBERTY plays all records without extra attachments—Victor, Columbia, Edison, Pathé and any other disc record—with a clearness and roundness of tone that the most expensive machines cannot improve upon.

Free Booklet Just send us your name and address at once and get the handsome Liberty Booklet FREE! *Admission*

National Talking Machine Co., 329 N. Second St., St. Louis, Mo.

Please Mention Popular Mechanics

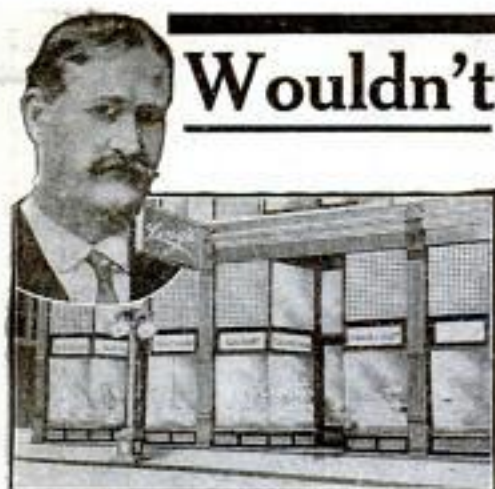

Wouldn't You Like to Own a Store

Like This?

me. The very same proposition that made me, should do the same for you. Long winter months are ahead. Don't slave them away for someone else. **Start in the Crispette Business for yourself.** Build a business of your own as I did. Get a window—a small store—a cozy nook where the rent is low. Keep all the profits. I'll teach you the Crispette business—tell you how to succeed—show you how to make Crispettes by my special secret formula. I'll do it right here in Springfield—personally or by mail. But the thing for you to do is to

Wouldn't you like to be proprietor of a money making business? Once I was just a struggling candy maker. The profits from Crispettes, the new, delicious popcorn confection, built this big business for me. The very same proposition that made me, should do the same for you. Long winter months are ahead. Don't slave them away for someone else. **Start in the Crispette Business for yourself.** Build a business of your own as I did. Get a window—a small store—a cozy nook where the rent is low. Keep all the profits. I'll teach you the Crispette business—tell you how to succeed—show you how to make Crispettes by my special secret formula. I'll do it right here in Springfield—personally or by mail. But the thing for you to do is to

Come to See Me at My Expense

Don't say you're coming. Just drop in quietly. Call on any banker or merchant. Ask them about Long—about my store—my crispette business. Ask children—parents—old folks. One sale always means two—two means four. So it goes. It's a great business. I found it so—so should you. **Send for my big free book "How to make money in the Crispette Business"—48 pages illustrated—complete information and story of how I built my business. Read it and then come to Springfield.**

them if what I say isn't the truth—right from the shoulder. Look into my reputation. See if folks think I'll give you a square deal. Then come and see my store—see that it's just like the picture. See the machine. See crispettes made—make a batch yourself. Learn the business. Get my pointers on how to succeed. Up to a distance of 300 miles I'll pay all your traveling expenses, if you buy a machine. You'll see—know—learn everything. It's simple—easy. Won't take you a day. I'll be glad to see you—glad to show you the store and have a good talk with you. You'll go home ready to make more money than you ever made in your life.

Every Nickel You Take in Nets You Almost Four Cents Profit

Think of it! Think of the fortunes made in 5 cent pieces. It's one business in a hundred. Everybody likes crispettes—children—parents—old folks. One sale always means two—two means four. So it goes. It's a great business. I found it so—so should you. **Send for my big free book "How to make money in the Crispette Business"—48 pages illustrated—complete information and story of how I built my business. Read it and then come to Springfield.**

W. Z. LONG, 1377 High Street, SPRINGFIELD, OHIO

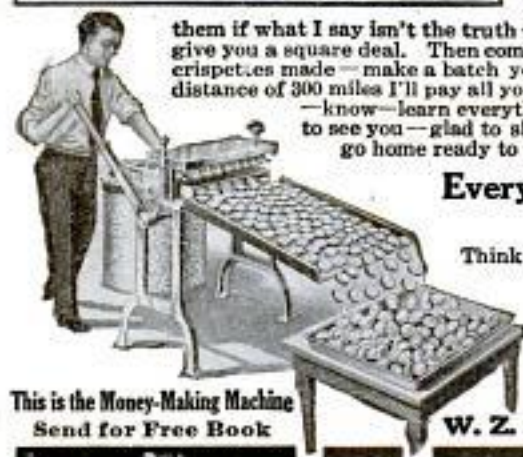

This is the Money-Making Machine
Send for Free Book



This is a recent picture of the man who made \$1500 in one month with a Long Crispette machine, in a store window.

WONDER Pipe Bender



Saves the cost and waste of elbow joints. Bends 2" pipe cold to 90 degrees in 2 minutes.

Bends steel, iron, brass or copper pipe—without heating, treating, filling, cracking or crimping.

Used by United States, Canadian, French and English Governments.

No job too big—no shop too small.

3 SIZES: $\frac{1}{8}$ " to 1" — $\frac{3}{8}$ " to 2" — $2\frac{1}{2}$ " to 4"

Write for complete catalog.

American Pipe Bending Machine Company
49 Pearl St., Boston, Mass. 003

Caille Family Motor-Electric Starter



A motor for all members of the family. As completely equipped as a modern motor car. Electric starter. Starting, controlling, steering, all in easy reach from one position. **THE DEPENDABLE MOTOR** for women and children this motor is unequalled. It gives constant service. Write for catalogue this motor and our entire line.

Caille Perfection Motor Co.
32 Caille Bldg., Detroit, Mich.

For Ford Cars

The Light that never Fails
HENRICKS
Electric Lighting Outlets
Perform a double duty: give you brilliant steady light for your car and sure-fire ignition for your engine. Simple, strong, positive. Come ready for work; easy to install; low in price.
Write Today for Booklet
Henricks Magneto & Electric Co.
1202 St. Paul Street, Indianapolis, Indiana



Does Red Meat Cause

RHEUMATISM?

Send now for FREE copy of Dr. R. L. Alaker's article published in The Independent, September 1925. Frank E. Morrison, Publisher, 805 St. James Bldg., New York.

THE "LITTLE PET" ENGINE

An Ideal Xmas Present.—War may take your men away, but a "Little Pet" motor will do much of the work they leave. These little machines are designed to do the home work, from running the washing machine to the cream separator and pumping. They are entirely enclosed, safe and compact. Any woman or child can run them when once set up, and they are silent and cleanly enough to use right in the house. Gas or gasoline can be used for fuel at a cost of from $\frac{1}{2}$ to 15c per hour when developing full H. P. Every engine is complete with starter and geared countershaft. You Don't Have to Crank Them.

Send for Our Booklet "A"
ELGIN GAS MOTOR COMPANY, ELGIN, ILL.



Please Mention Popular Mechanics



The Light You Need

YOU need Prest-O-Lite to give you pleasure and safety in night riding. No other lighting system is more efficient, dependable or trouble-proof—none more economical.

With your machine equipped with Prest-O-Lite you have a light that is brilliant, steady and reliable. And it is the most economical lighting system you can buy. Its first cost is small and the upkeep expense is practically nothing.

Experienced riders everywhere insist on Prest-O-Lite when buying a new machine. They know it fully meets every lighting need. More motorcycle riders use Prest-O-Lite than all other systems combined.

Easy to Install on Any Machine

No matter what make of machine you have or intend to buy, your dealer can fit you out with Prest-O-Lite. All you need is a style M C Prest-O-Lite gas tank, a good acetylene head-lamp and rubber tubing to connect the two.

On this combination of equipment your dealer can make you an attractive price. See him about it today.

Write for our literature on acetylene lighting systems for indoor and outdoor use. Prest-O-Lite is also the ideal fuel for soldering and brazing.

The Prest-O-Lite Co., Inc.

The World's Largest Makers of Dissolved Acetylene
U. S. Main Office and Factory, 365 Speedway, Indianapolis, Ind.
Canadian General Office, Dept. N-8, Toronto, Can.
Prest-O-Lite Exchange Agencies Everywhere

"The Gas of a Thousand Uses"

Please Mention Popular Mechanics

ANY WATCH YOU WANT on CREDIT



1918 Models

**WALTHAM
HAMILTON
ELGIN
SOUTH BEND
Illinois, Howard**

Sent on **30 Days Free Trial**

No Money Down

Express Prepaid in Advance by Me

You take no chances with me. I am "Square Deal" Miller and I trust the people. That is why I am doing the greatest Credit Watch, Diamond and Jewelry business in the country. Suppose you want any one of the country's best makes of watches? Name any one, I have it for you. No money Down, Express Prepaid. A full month to carry it in your pocket and the easiest of Long Time Payments. That's the best that tells. All these watches **GUARANTEED 25 YEARS**

I Smash the Terms

No References Demanded

My terms are made to suit you. You get unlimited credit, with no red tape, notes or collectors. All unnecessary detail left out.

An "Open Charge" Account

the same kind of credit you get from your grocer. No matter where you live or what your income is, you can now own the finest watch, a beautiful diamond or any rare jewelry and never miss the money.

Costly Catalog FREE

Send me your name and address so I can mail you, Free and postpaid, the most beautiful catalog of its kind ever printed. I want you to have this book. It's a gem. It illustrates all makes of valuable Watches, Elegant Genuine Diamonds, and a vast assortment of Beautiful Jewelry, all on the easiest and most liberal terms

Square Deal MILLER

PRES.

950 Miller Bldg., Detroit, Mich.



**BE THRIFTY
BUY A DIAMOND
PAY MONTHLY**

**MONEY REFUNDED
IF YOU CAN BUY
CHEAPER FOR CASH.**



SQUARE DEAL

MILLER

PRES.

Fine Diamonds

Our diamonds are all perfect cut beautiful stones, white in color and lots of size.

Fine Diamonds

You cannot buy by mail better diamonds at any price than we are selling on credit.

FREE CATALOG COUPON

SQUARE DEAL MILLER, Pres.
950 Miller Bldg., Detroit, Mich.

Please send me your 1918 Catalog and explain fully your 30 Day Trial Plan and Easy Terms.

Name.....
Address.....

Are You Mechanically Inclined?

If so, this list of Practical, Up-to-Date Electrical and Mechanical BOOKS at **25c each, postpaid**

WILL INTEREST YOU

Each one is a complete, dependable treatise and worth the price several times over

	Pages	Illustrations
Practical Electrics	135	126
Study of Electricity for Beginners	88	54
Dry Batteries, Their Construction	59	30
Modern Primary Batteries	105	55
Electric Gas Igniting Apparatus	101	57
Alternating Currents	90	33
Electrical Circuits and Diagrams—Part I	72	217
Electrical Circuits and Diagrams—Part II	80	78
Magnets and Magnetism	94	49
Small Electrical Measuring Instruments	90	59
Woodwork Joint	101	178
How to Build a Bi-Plane Glider	60	31
Model Vaudeville Theatres*	90	34
Windmills and Wind Motors	83	76
A. B. C. of the Steam Engine	30	6
Steam Engine Design	102	34
Inventions, How to Protect, Sell and Buy Them	108	1
Simple Soldering, Both Hard and Soft	82	52
Induction Coils, How to Make and Use Them	75	35
Experimenting With Induction Coils	73	26
Wimshurst Machine, How to Make and Use It	112	30
Simple Experiments in Static Electricity	72	51
Making Wireless Outfits	61	27
Wireless Telephone Construction	74	43
Telegraphy for Beginners	63	19
Small Accumulators, How to Make and Use	80	40
Wiring Houses for Electric Light	93	42
Low Voltage Electric Lighting	92	23
Electric Bells, Annunciators and Alarms	95	70
Magneto Telephone	86	23

A uniform series, size 5x7 inches. Paper cover. You will be surprised at how much good reliable information 25 cents will buy.

Any of the above books sent postpaid to any address upon receipt of price by

Popular Mechanics Book Dept.
6 N. Michigan Ave., CHICAGO

DOES YOUR STOMACH BALK?



STRONGFORT
The Perfect Man
An athlete of whom Dr. Sargent of Harvard University has said: "He is unquestionably the finest specimen of physical development ever seen."

ARE you afraid of it? Is it a mystery? What do you know about it? What service is it giving you? You are no stronger than your stomach! Your capacity for work, your endurance, your mental keenness, are all dependent upon whether your stomach functions soundly and does its share in producing pure blood for the heart to send to all parts of the body, energizing the mind and putting "Pep" in every thought and action.

Does Your Heart Murmur, Skip and Flutter?

Do you know that your heart is also menaced by a deranged stomach? If, instead of properly digesting your food, it is allowed to remain in the stomach to sour and ferment, the gases thus generated by the decomposition will swell your abdominal region unnaturally, interfering with all the organs and bringing the pressure thus caused principally against the heart. It is this condition that is responsible for many of the fatal, so-called cases of Heart Failure.

You Can Correct This with Strongfortism—But Not with Drugs and Pill Piffle!

If your stomach is in good condition you can digest anything, and then your natural appetite will call for the food your body needs. The stomach is a muscular organ and its perfect functioning depends upon maintaining a normal muscular activity. This is where

YOU NEED MY HELP!

This is where my study of anatomy and the internal organs becomes so valuable. I have devised methods which bring about such an internal muscular development so that the functioning can be controlled, thus giving you full control of your health. It is not what you eat, but what you are able to digest that gives you the vitality to do things. Stop pampering your stomach. It is the STRONGFORT Methods that you need, based on the true principles of Nature's laws of health and body building.

I Am a Builder of Men

YOUR whole body can be rebuilt. I will show you how to help Nature and replace the old worn, decaying cell life and rebuild it with new vital tissue. No matter what your weakness may be, whether it has been brought on by indigestion, gassy stomach, nervousness, or by youthful indiscretions, my natural methods will correct it. If you are SKINNY, run down, bilious, always tired and sleepy, have headaches, rupture, no "Pep," you need the STRONGFORT Methods. Every bodily ail gives way to the gentle, healing and building influences of my System. Mark the statement that interests you most on the coupon below and I will send you personal information that will help you. It will cost you nothing to consult me—it may save your life. Send TODAY for my book, "Intelligence in Physical and Health Culture." It is a liberal education on the subject and will show you the way to perfect Health, Long Life, Success and Happiness. It is free. Send 6c in stamps to cover mailing expenses. Write now.

LIONEL STRONGFORT Master of Physical Culture
364 Park Building, NEWARK, N. J.

Personal consultation by special appointment only

FREE CONSULTATION COUPON

Dear Strongfort:—Please send me your book "Intelligence in Physical and Health Culture," for postage of which I enclose 6 cents in stamps. I have marked (X) below the subject in which I am interested and should like you to send me a personal talk on this subject.

- | | | |
|---------------------------------------|---|---|
| <input type="checkbox"/> Thinness | <input type="checkbox"/> Colds | <input type="checkbox"/> Lung Trouble |
| <input type="checkbox"/> Obesity | <input type="checkbox"/> Catarrh | <input type="checkbox"/> Alcohol |
| <input type="checkbox"/> Nervousness | <input type="checkbox"/> Poor Circulation | <input type="checkbox"/> Tobacco or Other |
| <input type="checkbox"/> Insomnia | <input type="checkbox"/> Rheumatism | <input type="checkbox"/> Bad Habits and |
| <input type="checkbox"/> Biliousness | <input type="checkbox"/> Heart Weakness | <input type="checkbox"/> Weaknesses |
| <input type="checkbox"/> Indigestion | <input type="checkbox"/> Headache | <input type="checkbox"/> Dependancy |
| <input type="checkbox"/> Constipation | <input type="checkbox"/> Skin Disorder | <input type="checkbox"/> Poor Memory |
| <input type="checkbox"/> Neuritis | <input type="checkbox"/> Round Shoulders | <input type="checkbox"/> Flat Feet |
| <input type="checkbox"/> Short Wind | <input type="checkbox"/> Stoop Shoulders | <input type="checkbox"/> Increased Height |
| <input type="checkbox"/> Torpid Liver | <input type="checkbox"/> Deformity | <input type="checkbox"/> Muscular Development |
| <input type="checkbox"/> Flat Chest | <input type="checkbox"/> Rupture | <input type="checkbox"/> Great Strength |

Name.....(364)

Street.....

City.....State.....

Buy Xmas Gifts Today—Eight Months to Pay



Why pay cash when you can get "Sweet" diamonds and jewelry on credit at cash prices? WE TRUST YOU—no security—no guaranty—no red tape—WE TRUST YOU.

20% Down — 10% Monthly Free Examination

Anything you select from our complete gift Catalog 6F, will be sent at our expense. You see before you buy. Only if you are satisfied do you pay one-fifth down, and the balance in equal monthly payments. "Sweet" diamonds are superior quality, perfect cut, blue-white gems.

Our Unusual 7 1/2% Profit Sharing Guarantee

Invest in a "Sweet" diamond. Each gem is guaranteed by us for quality and value. Our binding guarantee protects you.

We accept diamonds bought from us in exchange for larger gems at full price, plus 7 1/2% annual increase.

Get Your Copy of Gift Jewelry Catalog 6F Today

Over one thousand gifts to select from—gifts suitable for everybody. Diamond rings, pins, lavallieres, watches, etc.; silverware, French ivory toiletware, cut glass; also cameras and photographs.

L. W. SWEET & CO., Inc., 2 & 4 Maiden Lane, 6F, NEW YORK CITY



Give HIM This Wonderful Gift!

Give the "lucky man" a fishing rod and reel outfit **Write for Illus. "Bristol" and Meek Catalogues** and study for yourself all the fine points of these prize winners.

For Bait Casting, "Bristol" De Luxe, \$25, and Meek No. 3, \$33; or "Bristol" No. 33, \$12, and Meek Blue Grass Reel No. 25, \$12. **For Fly Casting**, "Bristol" De Luxe, \$25.00 and Meek Reel No. 2, \$32, or "Bristol" No. 8, \$4.50 to \$6.25 and Meek Blue Grass Reel No. 33, \$7.50. **The All Purpose Rod**—"Bristol" No. 11, \$4.50 to \$6.25 and Meek Blue Grass Reel No. 5, \$15.00—or any combination made up of our offering of over 60 different "Bristol" Rods and Meek and Blue Grass Reels. If your dealer cannot supply you, we will fill your order at catalogue prices.

The Horton Mfg. Co. 196 Horton St. BRISTOL, CONN.

Build a \$100 Phonograph



Assemble your own phonograph. Do it yourself easily. Have the finest machine. Astonishing saving. **We give you the phonograph secrets.** Complete instructions. See our page of on page 183, June issue.

Electro Mechanical Parts Co. 164 North 5th Ave., Chicago



Gray Hair? Use BARBO

A preparation of great merit for streaked, faded or gray hair.

You Can Make It Yourself

Get a box of Barbo Compound at any drug store. Directions for making and use come in each box. Costs little and easy to make.

\$1800 to \$5000 This Year

We want one thousand local agents for townships and counties, also general agents—at once—all or spare time. Wonderful new business. No risk. No experience required. Success assured. \$1800 to \$5000—cash—this year. **Act today.**

AMAZING NEW HOME INVENTION

The Shafer Ventilated Chemical Indoor Closet revolutionizes living conditions in country and village homes. Banishes the obnoxious outdoor closet. **No plumbing—no waterworks—no cesspool.** Absolutely odorless, sanitary, germproof. Tested and proved in 2000 homes. Now offered to the public. Endorsed by physicians, health and sanitary authorities. Every home needs it—buys on sight. "I unhesitatingly and continually recommend these closets. I wish they were in every home," says Dr. Thomas H. Turner, (Health Officer). Big illustrated descriptive book free. Do not delay. **Investigate!**

Territory and Agent's Outfit Free Send no money. Exclusive county agency free. One man made \$112 cash first day. Another sold nine first three hours—profit \$72.00 cash. 1,000,000 will be sold, making agents rich. You can place 1000 in your county. Your profits start first day. **Act now.** Write today giving name of your county.

THE SHAFER MFG. CO., 495 Colton Building, TOLEDO, OHIO

No Waterworks No Plumbing



Chemicals and air currents do the work automatically.

Do ^{YOUR OWN} Plumbing or Heating
Our New **EASY WAY**
Buy From Us Direct—Save ½



Send for Our Big Valuable
"Handy-Man" Book

Shows over 10,000 different fixtures and supplies in plumbing and heating goods at Wholesale, with our new easy adjustable installing features.

OUR HANDY-MAN BOOK shows and tells you how to properly install our new cut-to-fit STEAM, HOT WATER, or HOT AIR HEATING PLANTS, or plumbing outfits, and how to make any plumbing or heating repairs. Any handy man with a few ordinary tools, and the help of our free planning service, can properly do the work himself.

"Our New Hardin Easy Way"

To avoid sending this large 236 page, well bound, valuable book broadcast, we ask a temporary deposit of 25c, which will be refunded on first order. Or if you are not satisfied, return book, and we will refund your money at once.

Every home owner, contractor, farmer, institution, etc. needs this BIG HANDY-MAN BOOK. WRITE TODAY.

HARDIN LAVIN CO.
40 Years at
4540-501 Cottage Grove Avenue
CHICAGO, ILL.



TEAMSTERS MUST INSPECT BRIDGES IN KANSAS—An old Kansas law provides that when a teamster with a heavy load reaches a bridge, he must examine it before driving on it, and if necessary lay planks for his wheels. Recently a teamster had failed to do this with the result that his wagon broke through a bridge floor, and when he sued for damages, his case was thrown out of court.

Mechanics, Engineers and Firemen



TRADE MARK

Wanted to manufacture Straight-line Metallic Packing for Steam, Air, Gas, Water and Ammonia. Learn an art that will not interfere with your present position, which will help you earn money on the side. This is an entirely new field and is not only a money-maker but a great chance to secure a better position. Write J. G. Strack, Drawer "F," E. Liberty Sta., Pittsburgh, Pa.

TYPEWRITERS—



**\$10 and Up. ALL MAKES
SAVE \$25 TO \$50**

on rebuilt at the factory by the well known "Young Process." Sold for low cash—installment or rented. Rental applies on purchase price. Write for full details and guarantee. Free trial.
YOUNG TYPEWRITER CO., Dept. 517, Chicago

Has The Motor Boat Bug Got You?



Health and happiness are assured with one of the new popular priced Gray motors in your boat. Select your boat from our 1917 Boat Builders Catalog showing products of 200 leading boat builders. Select your engine from our new complete Engine Catalog. Both books FREE. Send today.
GRAY MOTOR COMPANY
1246 Oakland Ave., DETROIT, MICH.



Ask
Santa
Claus
for the
new

**Flexible
Flyer**

Boys and Girls!

Here's the fastest sled on the hill.
You'll be the winner in
every race with the new

**Flexible
Flyer**

The Famous Steering Sled with Non-Skid Runners

It's a real "snow-mobile." With its grooved runners of chrome nickel steel, it steers on ice and snow without skidding. Its new all-steel front acts as shock-absorber to keep the wooden seat and hand rails from splitting. It's the *strongest* sled made stronger. The *safest* sled made safer. The *easiest steering* sled made to steer still easier.

Outlasts Three Ordinary Sleds

Tell mother and father that you don't have to drag your feet steering the Flexible Flyer, or get them wet and wear out shoes. It prevents colds and saves doctor's bills. Finest quality of construction—selected ash for the wood work. Tough steel for the front and runners. Handsomely decorated. Finished with three coats of high-grade varnish. Keeps its beauty year after year.

Nine sizes, 3 to 8½ ft.

Sold by hardware and department stores

S. L. ALLEN & CO., Box 1101G, Philadelphia

Insist on the genuine. Unless it bears this trade-mark it isn't a Flexible Flyer.

Free Offer Send postal or letter for cardboard model showing how Flexible Flyer steers. Free.



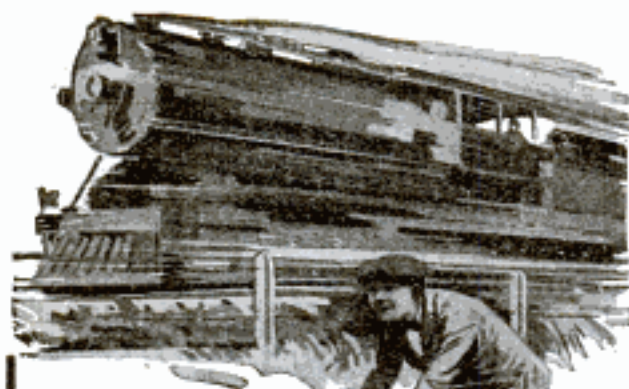

It requires ten minutes for a locomotive to develop its maximum speed, yet owing to the tremendous power of the Air Brake it can be brought to a complete stop within 22 to 24 seconds.



What the Air Brake is to the Locomotive the Corbin Duplex Coaster Brake is to the Bicycle

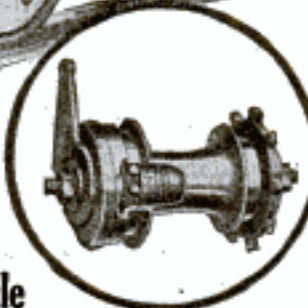

Experienced cyclists the country over can testify to the reliability of this most famous of all coaster brakes. For seventeen years it has been recognized as the standard brake equipment and during that time it has been developed to the highest state of brake efficiency.

The Corbin Duplex answers every demand the rider may make on it. With Corbin equipment he has at all times complete control over his bicycle. No grade is too steep and no corner too sharp. Complete ball bearings throughout minimize friction and assure that smooth, easy action for which the Corbin Duplex has always been noted. The large brake surface provides a powerful grip, enabling the bicycle to be brought to an instantaneous or gradual stop as the occasion demands.

A slight pressure of the foot is all that is required. When coasting, the feet remain at rest and always in a convenient position to apply the necessary control.

Carefully constructed, handsomely finished, the Corbin Duplex will outlive the sturdiest bicycle and stand up under the most rigorous service.

When purchasing your new bicycle specify and insist upon the Corbin Duplex. Now is the time to do it. Equip it to your old wheel—it makes all the difference in the world.

Corbin Control Means Safety Assured

BOYS send today for this handsome Liberty Pin—It is **FREE**

Fill in the coupon as indicated and send it to us and by return mail we will send you this attractive souvenir.

Write for this pin today. You will be delighted with it as is every boy who has seen it.

Just out! The new 1918 fully illustrated catalog. You should have one. Write for it.

The Corbin Screw Corporation, The American Hardware Corporation, Successor, 200 High St., New Britain, Conn.

Dear Sir: Please send me handsomely colored Liberty Stick Pin.

The name of my bicycle is.....

My name.....

Street.....

City.....

State.....

Please Mention Popular Mechanics

Money Grows

if rightly planted

Florida Grapefruit and Orange Groves

Earn Large Incomes

You Can Start a Grove Today Under Our New Plan

Develop a profit earning fruit farm without leaving your present position—provide for your future. A small payment now and a few dollars saved and invested each month should reap large and increasing dividends from year to year.

We furnish the land—We develop it for you—We plant your trees—We care for your grove—You can pay for all in small easy monthly or quarterly payments. We will give you four or five years' time if you want it.

Nothing in this world can be so safe an investment as highly improved, well located farm land. Land prices are bound to advance with the continued high prices of all farm products.

A profit producing fruit grove is a permanent investment and provides protection against old age. These splendid lands are suburban to Tampa, the metropolis of South Florida, the most healthful, the most delightful climate in North America. This, then, is your opportunity. Write today for full details.

NORTH TAMPA LAND CO.
804 No. 6 N. Michigan Ave., CHICAGO

\$1 A Week

for the

Black Beauty

Great Christmas offer; easy payment plan; best built and classiest "bike" in all cycle-dom. Firestone Non-Skid Tires; "finger" grips; B. B. Spocket. 18 exclusive features.

Guaranteed 5 years.
SHIPPED ON APPROVAL
direct from factory, freight prepaid. You risk nothing. Returnable at our expense. Keep it and pay small deposit, then \$1.00 a week.

HAVERFORD CYCLE CO. (Est. 1896), Dept. F4, Philadelphia



Write Today for Christmas offer and FREE CATALOG of Black Beauty models.

A Tickling Throat

—the cause is irritation; irritation makes you cough; coughing leads to hoarseness and loss of voice. Soothe and relieve throat and voice with

BROWN'S

Bronchial

TROCHES

Promptly helpful to the vocal cords and bronchial passages. An effective and pleasant throat remedy—not a confection. Unexcelled for coughs, hoarseness and loss of voice. Before the public for over 70 years.

At all Druggists 10c, 25c, 50c, \$1

If your dealer cannot supply you, we will mail any size upon receipt of price.

JOHN L. BROWN & SON, Boston, Mass.

SLIGHTLY USED CAMERAS

Why pay full list price for a good camera? Our latest Bargain List No. 4 is chock full of the best bargains ever offered in slightly used machines. Get a camera equal to new and save nearly half. Look at this list below. We have hundreds like these.

GOOD AS NEW!

\$20.00 3A Eastman Kodak R. R. lens, slightly used.....	\$11.00
\$125.00 3A Graflex, Tessar Ser. 1C F4.5 lens, slightly used...	75.00
\$52.00 3A Eastman Kodak, Rodenstock Anastigmat F4.5 lens in Compound shutter.....	32.00
\$6.00 Eastman V. P. Kodak, slightly used.....	4.00
\$20.00 3A Anso No. 9, Roll Film R. R. lens, Auto Shutter, slightly used.....	\$8.50
\$5.00 2 1/4 3 1/4 Prentice Jr., likewise	3.65
\$35.00 3 1/4 4 1/4 Graflex, Tessar Ser. 1C F4.5 lens, latest model	69.50

AND HUNDREDS OF OTHERS

SAVE NEARLY 1/2!

FREE! The Famous Bass Book of 1001 Bargains. New and Used Cameras and Lenses and everything for the taking and making of good pictures. Also our latest and best Bargain List No. 4. Write for them today. 10 Days' Free Trial and our powerful protective guarantee go with every purchase.

SERVICE IS OUR SPECIALTY

BASS CAMERA COMPANY
107 DEARBORN ST. CHICAGO**Build Your Own PHONOGRAPH***It's Easy With Our Help*

A few hours' interesting work saves many dollars and gives you a machine exactly to suit your ideals. We furnish motors, tone arms, case material, blue prints and full instructions. Plays any record. You can make fine profit building phonographs for your friends.

Agents Wanted for Our Ready-Built Choralions

Write Today for Our Free Blue Print Offer

CHORALEON CO.
112 Monger Bldg., Elkhart, Ind.

**SAVE OVER HALF****Four Weeks' Trial**

Piano or Player Piano



Yes, we will ship you on four weeks' absolutely free trial direct from our own factory your choice of 38 new styles of the highest-grade Wing Piano or Player Piano.

No Money Down

Nothing on arrival; no freight either way; no deposit.

Use it and enjoy it four full weeks; then, if you wish, slip it back to our expense. You alone are the judge. You will be amazed at our rock-bottom, direct price on the superb Wing, guaranteed 40 years. Easy monthly payments or cash—but first 4 weeks free trial. Write today.

Valuable Book—FREE "The Book of Complete Information About Pianos" sent free and postage d. Valuable 140-page book. Tells how to judge pianos. Beautiful art cuts; also sent and particulars of great Free Equipment Offer. Write today—now. Wing & Son (Est. 1868), Wing Building, 9th Ave. & 13th St., Dept. 1199 New York

Diamonds and Tifnites**"As Like as Two Peas"**

See these wonderful Tifnite Gems—sent direct on our special Free Wear offer. Wear one and your friends will say that it's a diamond. Tifnites have the pure white color and the flash and fire of the diamond—stand all diamond tests, fire, acid and diamond file. No backing, no paste, no foil, full of fire and sparkle. Only an expert can distinguish between them—and yet they cost so little. Don't miss this great offer. Send the coupon now and let us send you your choice of these three superb rings or scarf pin to wear free for ten days. Send no money. Just the coupon—now while this special offer holds good.



Flat Belcher Ring
No. 1. Solid gold mounting. High class design with flat wide band. Almost a carat, guaranteed genuine Tifnite Gem. Price \$12.50, only \$3.50 upon arrival. Balance \$5.00 per month.

Solid Gold Mounting

Every Tifnite Gem is set in the most fashionable, most artistic mounting—guaranteed Solid Gold. Send the coupon and see for yourself what wonderful gems these are.



Ladies' Ring
No. 2. Solid gold Tiffany mounting. Has a guaranteed genuine Tifnite Gem almost a carat in size. Price \$12.50, only \$3.50 upon arrival. Balance \$5.00 per month.

FREE!**For 10 Days' Wear**

Scarf Pin
No. 3. Solid gold open circle design. 1-2 K. Tifnite Gem. Price \$12.50, \$3.50 on arrival. Balance \$3.00 a month.

Select the ring you want or the stick pin and send the coupon. When it comes, pay only \$3.50 on arrival. Wear it 10 days. If fully satisfied, pay balance on easy terms as given under the illustrations. Otherwise return the ring or pin to us and we will refund any money you have paid. You risk nothing by accepting this offer. So send while it holds good.

Send No Money

Neither money nor references. Just the coupon brings wonderful Tifnite Gem mounted in solid gold. For size cut a strip of heavy paper so that ends exactly meet when drawn tightly around second joint of finger on which you wish to wear ring. Don't let it overlap. Send this with coupon. Send now and take advantage of this liberal free trial offer. Satisfy yourself about these dazzling gems.



Tooth Belcher Ring
No. 3. Solid gold six-prong tooth mounting. Guaranteed genuine Tifnite Gem almost a carat in size. Price \$12.50, only \$3.50 upon arrival. Balance \$3 per month.

THE TIFNITE GEM CO.

Rand McNally Bldg., Dept. 289, Chicago

Send me.....No.....on 10 Days' approval. If satisfactory, I agree to pay \$3.50 on arrival and balance at rate of \$3.00 per month. If not satisfactory, I will return same within 10 days.

Name.....

Address.....

Please Mention Popular Mechanics

Kodak Camera

is the Most Desirable and Useful of
CHRISTMAS GIFTS
Our Prices are the Very Lowest
SPECIAL

As there is a great shortage of all Photographic Goods, we suggest to

ORDER NOW

while our stock is complete. If you do not want your selection forwarded at once, we will gladly place same in reserve until you submit further instructions for shipment. All Cameras and Kodaks sent prepaid and packed in **Holly Boxes**. A lot of people are going to be disappointed. We hope you won't be one of them. Therefore we again repeat

ORDER NOW

while we have a good supply of everything on hand. This Season is going to be one of the greatest Camera Gift-Giving Seasons ever experienced. **Don't you want to remember some Soldier or Sailor?**



No. 0 Anaco Vest Pocket Camera takes pictures 1 1/2 x 2 1/4, fitted with a high grade Achromatic Lens and Shutter of various speeds. Very light and compact.

\$6.75 Same Camera equipped with an f7.5 Anastigmat Lens and Actus..... **\$14.40**



No. 2 Anaco Vest Pocket Camera takes pictures 2 1/4 x 3 1/4, fitted with a high grade Anastigmat Lens working at f7.5 and extra Speed Bionic Shutter working from 10th to 200th part of a second. Can easily be carried in hip pocket.

\$16.50 Same Camera equipped with the f6.3 Lens..... **\$24.50**



3A Kodak Eastman Autographic. This is the most popular machine on the market. Takes full Post Card size pictures. Equipped with a first class RR Lens, Kodak Ball Bearing Shutter, Cable Release covered with fine grain leather. The most compact Kodak for the size picture it takes.

\$19.95 Same Kodak with f7.7 Anastigmat Lens..... **\$24.25**



2A Ksmell. This Camera takes pictures 2 1/4 x 4 1/4, fitted with a good grade of Achromatic Lens and Shutter for time and instantaneous exposures. Covered with imitation leather, leather handle. This is the most wonderful camera for the price.

\$3.15 Same Camera in postal card size..... **\$4.95**

These Cameras and Kodaks use the standard roll films, and are just a few of our Bargains. We carry a complete line of all standard makes of Cameras, Kodaks, Lenses and supplies of every description.

Send for our free Bargain Book and Catalog
the most complete in America

Listing hundreds of new cameras at extraordinary low prices.

SPECIAL

For those that are not particular about a brand new outfit we have a large assortment of used machines from **Vest Pocket to Graflex**, which we are offering at remarkable saving prices. Therefore, **don't delay** sending for your copy now. Compare our prices with others and we know you will be numbered amongst our thousands of satisfied customers. Every item sold on our

10 Day Free Trial Guarantee or Money Back in Full if Unsatisfactory

Established in the photographic business for the past 18 years. If you are in doubt about making a selection, do not hesitate to consult our expert service department regardless of whether you purchase or not.

CENTRAL CAMERA CO. 124 So. Wabash Ave., Dept. 109
CHICAGO, ILLINOIS

TEMCO

Pays Its Way Every Day
The speedy, dependable and durable portable electric drill—taking the place of hand work in thousands of machine shops, garages, factories, ship yards, public buildings, etc. A wonderful tool enjoying a wonderful and fast increasing popularity.

EXECUTIVES AND SUPERINTENDENTS—investigate this money and time saving tool. **IT PAYS ITS WAY EVERY DAY.**

MECHANICS—ask the boss to get a TEMCO. Show them you are alive to good things. Five sizes—9 to 19 pounds. Capacities to 1/2" drilling in steel.

Also Temco Drills, Grinders, Buffers, etc., of larger capacity.

At leading Dealers and Jobbers Everywhere.
Write for our catalog.

The Temco Electric Motor Company
145 Sugar Street LEIPSIK, OHIO
Makers also of TEMCO-Afts Shock Absorbers and TEMCO Shock Absorbers, Master Vibrators and Lock Switches for Ford.

Drills by electricity anywhere—direct or alternating current

TEMCO

THE TOOL OF MANY USES

ROBERTSON HORSESHOE MAGNET HAMMERS

The Hammer Holds the Tack
Tacks or small nails are held by magnet end of hammer, so you can drive them anywhere within reach. A handy tack hammer for home or workshop. Strong, permanent magnet; warranted fine steel. Price 50c. Write for price list of other special purpose hammers.

At your hardware dealer, or mailed postpaid, for 50c, coin or stamp.

ARTHUR R. ROBERTSON, 144 Oliver St., Boston, Mass.

INDOOR CLOSET

More Comfortable, Healthful and Convenient than the Out-Door Closet

Eliminates the out-door closet and open vault. They are breeding places for germs. Have a warm, sanitary, odorless toilet right in your house. No going out in cold weather. A boon to invalids. Endorsed by State Boards of Health.

W. M. Davis writes: "Your indoor closet is giving absolute satisfaction. It is certainly the thing for a home without sewerage."

Absolutely Odorless Put It Anywhere in the House

The germs are killed by a chemical process in water in the container, which you empty once a month. **Absolutely no odor.** No more trouble to empty than dishwasher. **Best sanitary guarantee.** Write for full description and price.

Agents Wanted—Big Profits Wonderful opportunities in every town, village and in the country. Best season just at hand. Every home is a good prospect. Sell eight out of every ten you call on. Ernest Hildesheim writes: "Have ten orders." G. A. Deeman says: "Ship at once twenty closets and fifteen washstands. Sold them all in one community." Sell itself. Everybody takes the outdoor closet. Everybody wants a Ro-San Indoor Closet. Write quick for territory and full particulars. We are prepared to ship promptly any quantity of closets—no waiting.

ROWE SANITARY MFG. CO., 12612 6 St., Detroit, Mich.
Ask about the Ro-San Washstand—Hot and Cold Rinsing Water Without Plumbing

Send for it Now

A PREPAREDNESS GIFT

Huntsman Sporting Knife and Pistol

Combined Hunting Knife and .22 Caliber Pistol for the boys who are away—and those who are "doing their bit" at home.

NOT A TOY

Size 3 3/4 inches long, 1 inch wide

The Constitution of the United States

Article II reads: "A well regulated militia being necessary to the security of a Free State, the right of the people to keep and bear arms shall not be infringed."

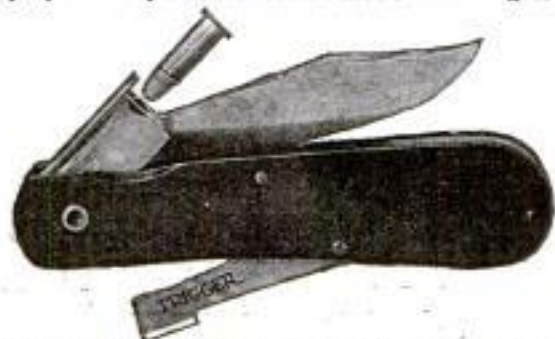

The "HUNTSMAN" is for the outdoor man or woman—also a protection for every home. Discharges the standard .22 caliber long cartridge as effectively as any pistol. Automatic safety makes it absolutely without danger to user. High class workmanship—large, keen blade made of best cutlery steel—finished in nickel—handsome in appearance—put up in fine chamois skin pouch with button fastener and packed in neat box.

Price \$5, postage prepaid

Send cash or money order

U. S. Small Arms Co., Inc.

First National Bank Bldg. CHICAGO, ILL.



Entirely New Signal Positive—Pleasing—Penetrating

Wonderful improvement in warning devices. Sure. Safer. Most economical. So superior to other signals—now standard equipment on many leading cars. Operated directly by explosion through prying cap—opening in cylinder. Not an exhaust whistle. Vastly better. Easily installed. Never fails. Clear, sweet-toned warning note cuts through noisest traffic confusion. Guaranteed for life. Sold on Trial. Low first cost only cost. Write quick for circular. Big money-making proposition for agents and dealers—ask for it.

THE BUELL CO. 1610 Michigan Ave. CHICAGO

Pay as You Wish

We'll send you a genuine Lachnite for you to wear for 10 full days. If you can tell it from a real diamond send it back at our expense. Costs but 1.00 as much. If you decide to keep it you pay only a few cents a day. Write for catalog.

Genuine Lachnite Gems

keep their dazzling fire forever. Set in solid gold. Cut by world renowned diamond cutters. Will stand fire and acid tests. All kinds of jewelry at astonishing low prices. Easy payments. WRITE TODAY. 11 Lachnite Co., Dept. 1199, 12N. Michigan Ave., Chicago



The Ideal Gift



FITS ANY FAUCET

Give This Practical Gift of Lasting Pleasure KNICKERBOCKER Bath Spray-Brush

Shower-Massage-Shampoo-Rub-Down-ALL IN ONE

Enjoy the Delights of a REAL Tonic Bath

You'll feel renewed—different than

after any other bath you've ever had.

Hundreds of hollow rubber teeth

massage and cleanse the impurities from

every pore. Stimulates circulation.

Invigorates. Makes your whole body

glow. You bathe in fresh running water—

at temperature desired—the only sanitary

way. Great for children—and everybody.

It's "so" health and cleanliness. For shampooing

the Spray-Brush is unexcelled. Its

staunch, flexible teeth penetrate the head—

hair, massage the scalp, and clean, flow

the water away as you wash, dirt and dandruff

is quick—so easy to fix. This hard—flexible

body. Wear only prevents. Lasts for years.

\$1.75, \$2.50, \$3.50, \$5 — De Luxe Set \$6

Don't wait. Get one today—at Dealers or order direct.

KNICKERBOCKER MFG. CO.

231 West Schiller St., CHICAGO

SEND FOR FREE BOOKLET—"A Knickerbocker

Bath." It tells how and when to bathe.



Name

Address

City.....State.....

WATER FLOWS
THROUGH HUN-
DREDS OF HOLLOW
RUBBER TEETH

Russel Internal Gear Drive Axle



The most serviceable and economical motor truck axle made. Write for convincing reasons why your truck should be equipped with the Russel Axle.

RUSSEL MOTOR AXLE COMPANY, Central Ave., North Detroit



For Boys and Girls

The Ideal and Practical Christmas Present

Father, that boy will jump out of his skin with joy if you give him an **American Junior** Auto for Christmas. Boys—get dad interested. Tell him the many ways you can help pay for it, running errands, delivering bundles, messages, etc. Say to him, "Dad, you get the machine and I'll turn in my earnings and pay you back as much as you say. I'll take you to work in the morning and get you at night."

American Junior Automobiles

are just the thing for boys and girls from 12 to 18. **American Junior**, shown above, propelled by motor wheel attached in rear. Simple and safe. No complicated parts. Price \$175.00. **American Flyer No. 2**, shown at right, is the cheapest and best motor propelled vehicle of its kind ever produced. Climbs hill like the big fellows—has a speed up to forty miles per hour, makes from forty to fifty miles per gallon of gasoline. Price \$200.00. Two cylinder, four cycle opposed type engine with magneto and carburetor. The slickest thing you ever saw. Simple in construction—easily started from the seat—oiled by splash system—develops maximum power on minimum amount of gasoline. Four horse power, brake test, ample to propel car with two passengers over any ordinary road. **American Motor Vehicle Company, Lafayette, Ind.**



Write today for
free catalog and
full description

SUGAR—4c



MAIL order houses waste thousands of dollars daily, sending expensive catalogs to people that don't mean business. We eliminate this waste and sell for less by sending our catalogs only to people that prove their sincerity by taking advantage of the big saving offered in the following trial assortment.

HERE is your opportunity to become a customer of a Real Wholesale Grocery that can save you big money on groceries every day in the year. Indications point to unheard of high prices on all lines for the winter months. Our customers can be protected. Send your trial order and get our catalog. It's brim full of bargains that you need and want. Get it today and lay in a supply for the winter.

NOTE! We reserve the right to limit each customer to only two assortment orders

GUARANTEE Each and every item we sell is guaranteed to be exactly as represented—the best that money can buy. You cannot buy the same quality of goods at such low prices from any other firm on earth. However, should you be in any way dissatisfied simply return the entire shipment and get your money back. We guarantee that you will never lose a penny in your dealings with us.

DON'T FORGET We send our catalog only to those who buy this special assortment. We do not sell a part of the order or any item in it separately, but our Big Bargain Catalog contains hundreds and hundreds of these great bargains which you are privileged to buy in any amount you want. Get this catalog and save money. Send your trial order today. Simply enclose money order or check for \$2.99 and say "Send assortment number E-89."

Moneyworth Wholesale Grocers

Dept. E-89

14th and Ashland

CHICAGO, ILL.

NOTE:—The above firm is reliable. Send them your order. Independent State Bank, Chicago

BEST PATENT FAMILY FLOUR 190 Lb. BBL. **\$8.50**

IN GROCERY ASSORTMENTS

Money Back If You Are Not More Than Pleased

GROCERY ASSORTMENT No. E-89

Approximate Retail Price	Our Wholesale Price to you
Approximate Weight, 19 lbs.	
\$0.50—5 lbs. Best Pure Granulated Sugar . . .	\$0.20
.12—1 Large Size Package of Quaker Oats06
.08—1 Package Uneda Biscuits02
.08—1 Bar Ivory Toilet Soap03
.15—1 Can Campbell's Tomato Soup08
.07—1 Bar Kirk's Flake White Laundry Soap02
.07—1 Bar American Family Soap02
.25—1 Can Sanlines, French Style14
.90—2 lbs. Moneyworth Brand Coffee70
.80—1 lb. Tea, highest grade, uncolored Japan57
.50—1 lb. Guaranteed Baking Powder30
.30—1 Bottle Concentrated Blueing23
.60—1 lb. Pure Breakfast Cocoa33
.50—1/4 lb. Pure Ground Cinnamon20

\$5.01—Our Special Catalog Free!
OUR WHOLESALE PRICETO YOU \$2.99
Approximate Saving to You of \$2.02

Let Me Ship You An Engine To Earn Its Own Cost While You Pay For It!



Notwithstanding the war-time high prices of iron and steel, and engine materials, I am still shipping Ottawa Engines for low prices. My factory has large stocks of materials, and plenty of engines. I make prompt shipments besides saving you money in the price.

GEO. E. LONG

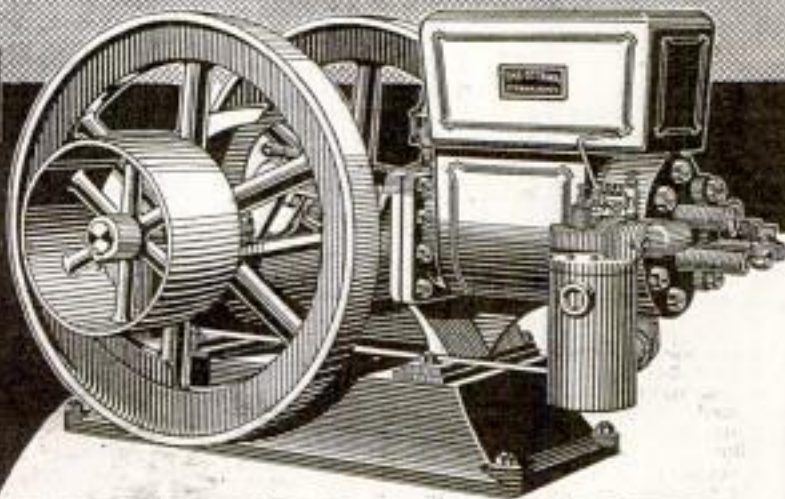

Kerosene Engines

Kerosene is the economical engine fuel now. While gasoline may go still higher, kerosene oil will continue to be cheap, because of the great proportion more of Kerosene made while forcing the production of gasoline for the great needs of the war. Get an OTTAWA Kerosene Oil Engine and have continuous reliable power for the future, and at less than one-third the cost of gasoline.

OTTAWA ENGINES

Thousands of men all over this country, in shops, elevators, mills, factories, and on farms, have made my engine pay for itself while they used it. My money-saving terms of purchase make it easier to own an engine than to be without one. Having the largest number of sizes to choose from, you can find a size of engine just suited to your work, and you have your choice of the fuel, for my engines use

Kerosene Oil, Gasoline, Distillate, and Gas

My kerosene oil engine is easy to start and as easy to operate as any gasoline engine. With it, you get more power from a gallon of 6 or 8-cent kerosene, than you can get from a gallon of 20 or 25-cent gasoline in any gasoline engine. All sizes are easy to start, easy to understand and manage, and with my lower prices and fuel saving engines, you get the greatest amount of dependable power for years to come, for the small amount of money you put into your engine.

90 Days' Trial — 10 Year Guarantee

You have 90 days in which to try my engine at your own work. I have always given my customers this right. Years ago I was the only engine manufacturer selling direct from my factory and the only one who sent every engine out on trial. You take no chances in selecting an Ottawa engine.

Cash or Easy Terms My money saving plan of selling makes it easy for you to own an OTTAWA engine, on terms by which the engine cost can be paid for by the earnings of the engine. No need now to trade your savings for 2 years to own a good engine.

Send for Free Book You should have a copy of my new book—the most up-to-date book on engine building. Explains how easy my engine starts; how little it costs to operate; how easy to keep it running; cut out coupons and mail to-day and I will tell you the complete story by return mail.

GEO. E. LONG
OTTAWA MFG. CO.

539 King St.
Ottawa, Kansas

GEO. E. LONG, Pres.
OTTAWA MFG. CO.
539 King St., OTTAWA, KANSAS

Without obligation to me, I would like to receive your latest and finest book "How to Know Better Engines," and your liberal plans of selling.

Name

Address

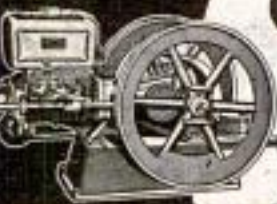

The Ottawa gasoline engine on iron subbase equipped with magnets requiring no batteries

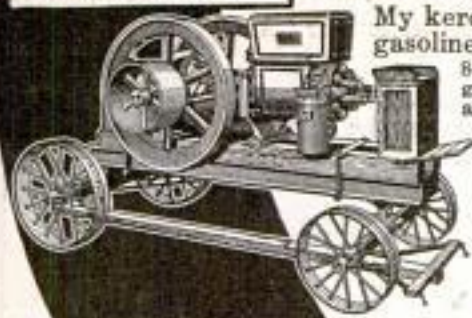

The OTTAWA Kerosene engine on heavy trucks with complete equipment

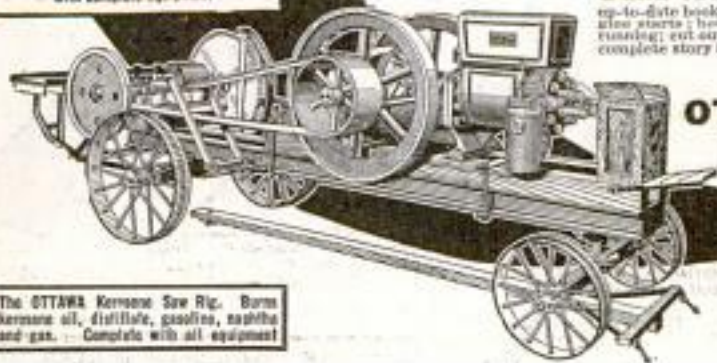

The OTTAWA Kerosene Saw Rig. Burns kerosene oil, distillate, gasoline, naphtha and gas. Complete with all equipment

Please Mention Popular Mechanics

IVER JOHNSON

For the
HOME DEFENDER



THE GIFT OF PROTECTION

Make home defence a reality by giving the man of the house a *safe* revolver for Christmas.

The gift of an Iver Johnson Revolver is a gift of complete protection for your family.

The Iver Johnson is the perfect weapon for home defence. It gets off the first shot because there is nothing to do but pull the trigger—no complicated safety buttons or levers to adjust—or forget. There is nothing to fear from an Iver Johnson for the man who owns one. It is the safe small firearm—you can "Hammer the Hammer." It is accident-proof.

At all sporting goods and hardware stores. Or send for FREE Booklet "A" telling all about Iver Johnson Revolvers and Shotguns.

Iver Johnson's Arms & Cycle Works, 307 River St., Fitchburg, Mass.
99 Chambers Street, New York

717 Market Street, San Francisco



Hammer Model with
"Perfect" Rubber Grip, \$8.75



Hammerless Model with
Regular Grip, \$8.75



Hammer Model with
"Western" Walnut Grip, \$9.25

Please Mention Popular Mechanics

LAST Chance

to get the
Genuine New Edison
 at the
Old Price

Here's your chance, and it's the last one. The very last announcement that will be made in this paper before the big increase in price of the New Edison.

Orders for the increase have come from Mr. Edison himself. High costs of materials and labor have made it necessary. Mr. Edison regrets the necessity of this price raise but conditions make it essential. So, if you want a New Edison now is the time to get it. Don't put it off.

Still Only
\$1.00



after free trial

Yes, we will send you the New Edison, the product of the world's greatest inventor's genius, the phonograph with the wonderful diamond stylus reproducer and your choice of the latest Diamond Amberol Records on *free trial without a penny down*. On this offer, you can have the genuine Edison, the instrument which gives you real, life-like music, the finest and best

of all phonographs at a small fraction of the price asked for imitations of Mr. Edison's great instrument. *Seize this opportunity.* Send the coupon now for free catalog.

Rock-Bottom Offer

Direct If, after the free trial, you decide to keep Mr. Edison's superb new instrument, send us only \$1. Pay the balance on the easiest kind of monthly payments.

Think of it—a \$1 payment, and a few dollars a month to get this wonderful new style outfit—Mr. Edison's great phonograph with the Diamond Stylus reproducer, all the musical results of the highest price outfits—the same Diamond Amberol Records—yes, the greatest value for \$1 down, balance on easiest monthly terms. Convince yourself—free trial first! No money down; no C. O. D., not one cent to pay unless you choose to keep the instrument.

New Edison Catalog Free

Your name and address on a postal or a letter (or just the free coupon) is enough. No obligation in asking for catalog. Find out about Mr. Edison's great new phonograph. Get the details of this offer—*while this offer lasts.* Write today—now!

F. K. BABSON, Edison Phonograph Distributors
 1199 Edison Block, Chicago, Ill.

Canadian Office: 355 Portage Avenue, Winnipeg, Manitoba

Hurry or You Will Be Too Late

Thousands of people are going to lose out on this offer unless you hurry—hurry. Don't fail to let me send you the Edison Catalog giving you all the details of the big price increase. You will have just time now, and no more than time, to let me tell about the big opportunity you have and get your order in. So "make hay while the sun shines" and rush in coupon. There is absolutely no reason why you shouldn't save this money. You will always blame yourself if you do not. So mail the coupon now. This isn't a matter which can be put off. Remember, now or never.

To F. K. BABSON

Edison Phonograph Distributors

1199 Edison Block, Chicago

Gentlemen: Please send me your New Edison Catalog and full particulars of your free trial offer on the new model Edison Phonograph.

Name.....

Address.....



Ignatius Barnard
President



The Barnard \$45
7 Diamond Solitaire
(trade mark registered) the size of a 1 carat diamond. Finest Blue White Wessolton absolutely perfect diamonds. Set in platinum to resemble a beautiful solitaire. Retail value \$75. Barnard import price, only \$45.00 Men's Mounting \$3.00 Extra.

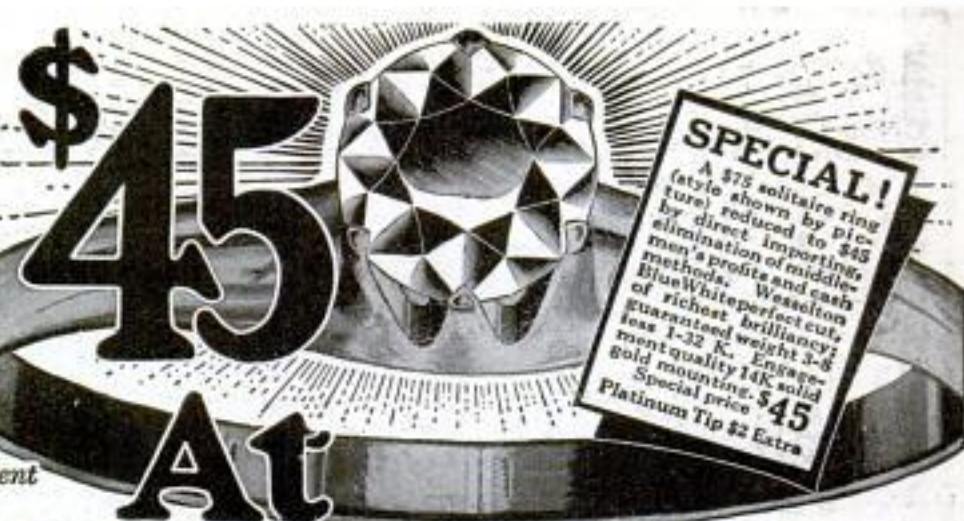

At Barnard & Co. Diamond Headquarters

Yes, only \$45 brings either the splendid Solitaire or the exquisite cluster ring. Or you can choose from hundreds of amazing values in other superb diamonds. These offers made possible because I import from European cutters and sell direct to you. No middlemen to pay. A positive saving of 35 per cent on retailers' prices or you can send the diamond back. Judge for yourself before you buy. Free examination of any diamond you select. Be sure to get my De Luxe Book of Diamond Bargains now. Select Christmas gifts from my wonderful collection.



Fine Italian Coral Cameo in hand made dinner ring. 1 fine Diamond. \$20 quality and value. Barnard price. \$10.88

Send No Money!

Merely send for my beautiful Diamond Book—select the diamond and mounting of your choice, and I'll ship it for your inspection—at my expense and without obligating you to buy. As we get all our business in this way our success proves our prices lowest by comparison.

Bankable Money Back Guarantee

The only bankable Money Back Guarantee in the diamond business. You can take it to any bank and cash in on your diamond investment if you want to. The only guarantee without red tape, delays or evasions. It is also a legal certificate of carat weight, quality and value of the diamond. Allows you to exchange it at full value at any time.

1918 De Luxe Book of DIAMONDS FREE

Profusely illustrated in colors. Shows thousands of the greatest bargains in diamonds. Tells you all about diamond qualities, colors, imperfections. Shows every fashionable and popular style of mounting in 14K solid gold and platinum at actual factory cost. Also all sizes of diamonds in 7 different qualities at import prices. Free for the asking.

Ignatius Barnard, Pres.



Solid Gold Necklace, brand new and stylish. 16-inch chain. 5 fine quality Blue White Diamonds. Very fine design and workmanship. \$40 value. Barnard price \$24.88

BARNARD & CO., Dept. 3488-C
N. W. Cor State and Monroe Sts., Chicago
Without expense or obligation, please send me, Free, postage paid, 1918 De Luxe Diamond Book.

Name
Address
City State

14K Solid Gold
1-4C Steel Blue White \$30.00
2-8C Extra Blue White \$41.50
3-8C Rare Steel Blue \$62.50



14K Solid Gold
1-8C Wessolton Blue White \$79.50
1-2C Jaguar Blue Perfect \$121.50
3-4C Extra Blue White \$80.00



14K carved rose finish ring.
3-8C Blue White Diamond \$35.88
1-8C Steel Blue Diamond \$59.88



14K Solid Gold Ring.
6-8C Steel Blue White Diam \$109.88
8-8C Rare Steel Blue Diamond \$172.50

\$88
Per Carat.
Blue White, perfect cutting, extra brilliancy. Worth \$150 per carat.
1-2 C \$15.00
1-3 C \$18.00
3-4 C \$4.35

\$133
Per Carat.
Extra Blue White, perfect cutting, extra brilliancy. Worth \$200 per C.
1-4 C \$22.50
1-2 C \$9.00
3-4 C \$8.00

\$177
Per Carat.
Wessolton Steel Blue White, perfect cutting. Right perfect.
1-4 C \$27.00
1-3 C \$7.00
3-4 C \$28.00

\$233
Per Carat.
Victor Blue, perfect cutting, first quality eye perfect.
1-4 C \$30.00
1-3 C \$8.00
3-4 C \$25.00

\$288
Per Carat.
Rare Jagged-Violet Blue, absolutely perfect and better than first quality.
1-4 C \$42.00
1-3 C \$12.00
3-4 C \$28.00

Barnard & Co. N. W. Cor. State
Diamond Headquarters and Monroe Sts.
Dept. 3488-C
Chicago, Ill.

Please Mention Popular Mechanics

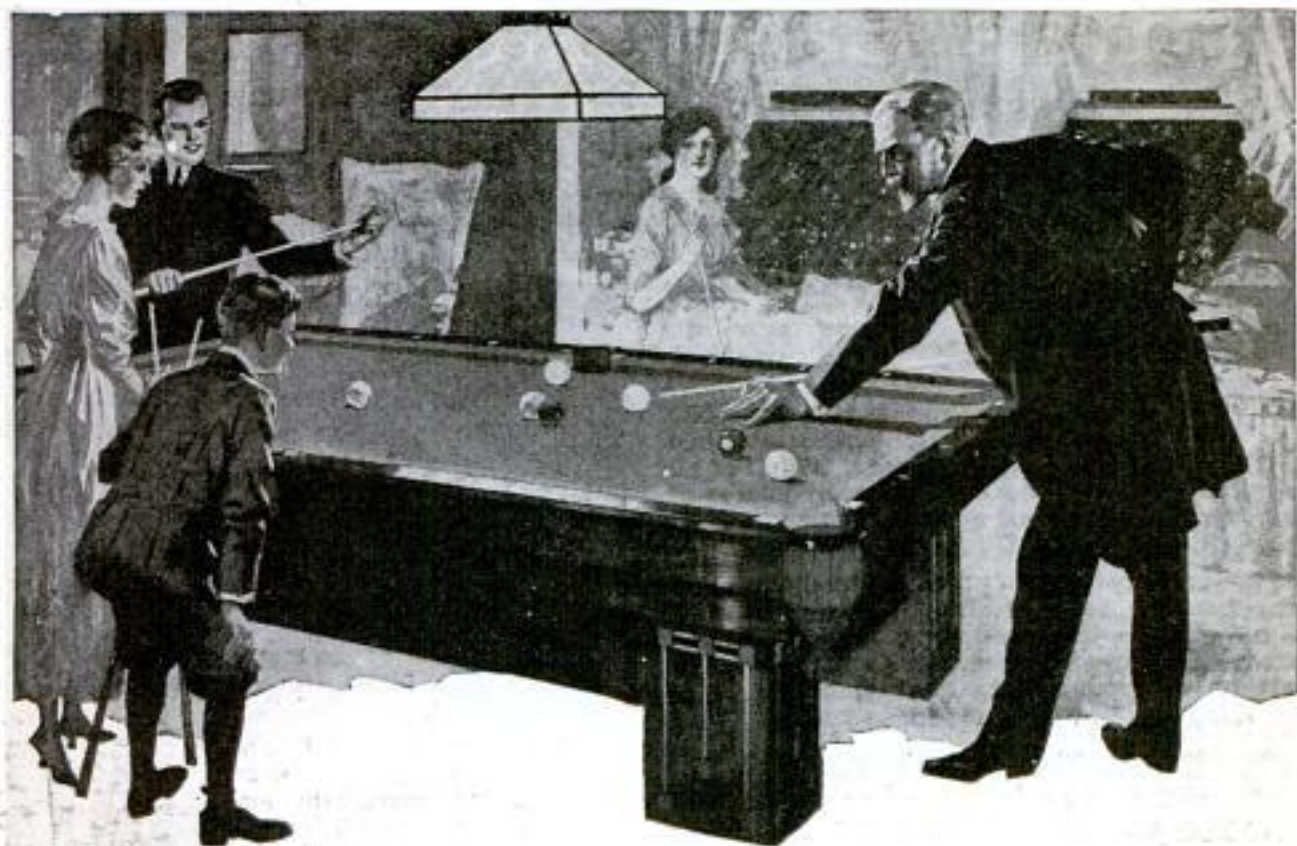

Play Billiards!

Keep the Home Fires Burning

Carom and Pocket Billiards are an all-year sport—brimful of fresh surprises every game! This is not forced exercise, but healthful fun; and it brings to players life-long benefits.

Shared by boys and girls, and mothers and "old boys"—billiards instills the love of home in all. With practice you can soon control the balls, but not the merry flow of jest that often makes the best of players lose.

Give your home Carom and Pocket Billiards—not "some-time," but NOW—this Christmas. A small part payment puts a scientific Brunswick Table in your home. Pay the balance monthly—as you play.

BRUNSWICK HOME BILLIARD TABLES

Life, speed, accuracy and lightning action—beautiful cabinet work in rosewood, mahogany, oak and walnut. Brunswick "Quick Demountable" Tables fit all size rooms, and are easily folded when not in play.

"Baby Grand" home-size regulation styles for spare-rooms, lofts, basements, or private billiard rooms. Balls, Cues, Rack, Markers, Tips, Cue-Clamps, expert book of 33 games, etc., all included free.

Write at once for handsome color-book—"Billiards—The Home Magnet" and pick out the size and style best fitted to your home.

Low prices, easy terms and home trial offer included. Mail the coupon for this interesting book at once.

THE BRUNSWICK-BALKE-COLLENDER CO.

Dept. 58-J, 623-633 S. Wabash Avenue, Chicago
Dealers, Write for Attractive Agency Proposition

Send
Your Address
For Billiard
Book FREE

THE BRUNSWICK-BALKE-COLLENDER CO.

Dept. 58-J, 623-633 S. Wabash Avenue
Chicago, Ill.

Send me one of the free color-books—
"BILLIARDS—The Home Magnet" and
tell me about your home trial offer.

Name _____

Address _____

Please Mention Popular Mechanics

Xmas Camera Gifts

At Less Than Manufacturers' Prices!

New Cameras—From Factory Direct to You—All Makes

THE camera is a superb Xmas gift. Everyone will welcome such a gift. That soldier boy will find one a great pleasure. Think of all the pictures he will be able to bring home—of comrades—of camps—of even foreign shores and sights! Send him one for Xmas!

You needn't pay the high prices regularly charged. You can save money by dealing direct with us. And get brand-new—just from the factory Cameras—Lenses—Kodaks—Supplies, too. Furthermore, you can't be disappointed in quality, either. For everything you buy of us is sent to you on

10 DAYS' TRIAL Money-Back Guarantee

And back of that guarantee is our record of over 32 years of honest, above-board dealing. Any bank—any mercantile rating agency will assure you that we are reliable. Over 18,000 camera users, all over the world, know by experience that we can—and we do—save big money for all our customers. Send for

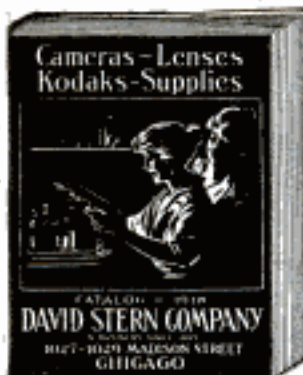

Big Book Packed with Camera Gifts Free at Low Prices

It's a big, handsome, illustrated 96-page book that knocks the props from under high prices. Its facts are startling. Its offers are genuine. Get this book immediately. Ask for it on the coupon that you mail us today. Also—

**Order Direct From This Ad
Don't Delay! Xmas is Near!**

These are all special Xmas offers. Every one of them saves money for you. Simply write your order on the coupon—attach Money Order and mail to us. We will rush your order to you.

DAVID STERN COMPANY

In Business Since 1885
Everything in Cameras
1027-29 Madison Street
1210 Davaco Building
CHICAGO,
ILLINOIS

David Stern Company, 1210 Davaco Bldg., Chicago
Please send me a copy of your catalog. I also attach Money Order for... for which please ship me immediately the following:

Name.....
St. or R.R. No.....
City.....
State.....

\$64.00
Graflex Junior
F:4.5 Velostigmat Lens
Our Xmas Price
\$54



\$18.50 V. P. Ansco No. 2
F:7.5 Anastigmat Lens—Extra
Speed Bionic shutter.
Our Xmas Price
\$15

\$6.00 V.P. Autographic Kodak
Our Xmas Price
\$5



\$20.00 3A Ansco Jr.
A folding pocket
camera fitted with high
grade F:7.5 Anastigmat
lens fully corrected.
Our Xmas Price
\$18

\$12.00 2c Folding Scout
The new size—2 $\frac{3}{4}$ x4 $\frac{1}{4}$ -in.
—uses roll film and slips
easily into coat pocket.
Our Xmas Price
\$10.25



Xmas Prices on Supplies

Imp Flashlight Gun—takes action pictures at
night—\$1.75.

Genuine Metol-Quinol Tubes—6 for 25c.

Davaco Acid Fixing Mixture—per lb.—15c

Wait-a-Minute Shutter Tripper—Enables
you to get into the pictures yourself—90c.

Leather Album—7 x 10—removable
leaves—\$1.00.

The Showscope—One of the lat-
est and greatest photographic
inventions—93c.

Send For Our
Catalog
It's Free

\$5.00
Folding
Cartridge
Promo Our
Xmas Price
\$3.75



Please Mention Popular Mechanics

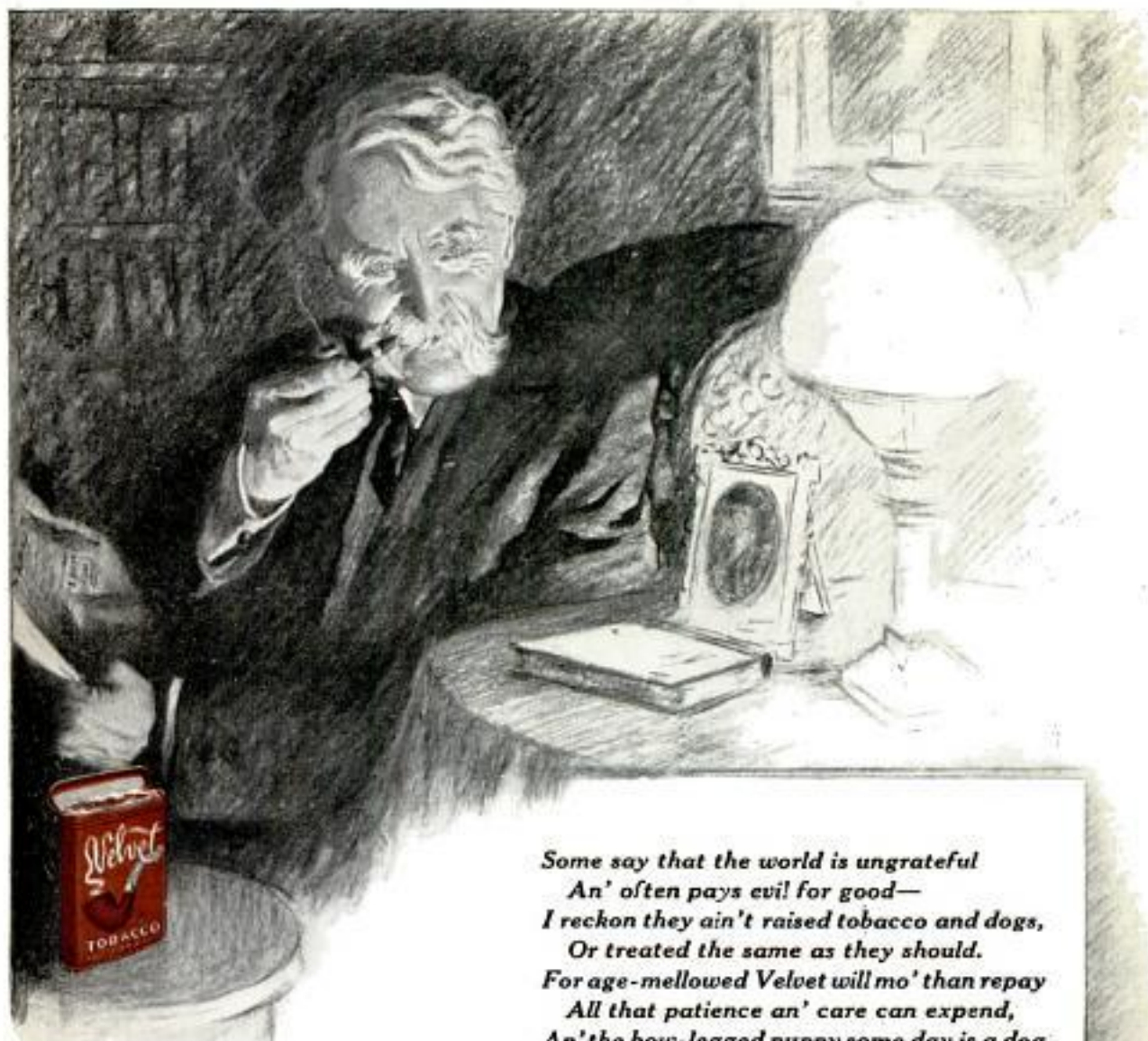

*Some say that the world is ungrateful
An' often pays evil for good—
I reckon they ain't raised tobacco and dogs,
Or treated the same as they should.
For age-mellowed Velvet will mo' than repay
All that patience an' care can expend,
An' the bow-legged puppy some day is a dog
That would lay down his life for his friend.*

Velvet Joe.

Time is money—two years that Velvet spends slowly ageing in huge wooden hogsheads represents a heavy expenditure. But how richly Nature repays that investment.

Those two years make Velvet mild and mellow, cool and smooth, and bring out the flavor of the rich Kentucky Burley tobacco to its utmost.

Fill your pipe with Velvet and let it prove what we can only tell.

Liggett & Myers Tobacco Co.



M. LEONE
BRACKER.

W. P. HALL PRINTING COMPANY, CHICAGO

Copyrighted material



Wonderful Construction Blocks of Real Stone

A whole toyland of fun for boys and girls—and an industrial art education as well—are to be had with these scientifically made blocks of real stone—in three natural colors. They are the finest construction toy a boy or girl could have. There are no parts to rust or to get hurt with, none to shrink or swell or fall apart. At all times, in all climates, these blocks are unchanging, correct, clean and everlasting.

Castles, battlements, bridges, forts, arches and towers rise as by magic under the child's hand. Each block is made architecturally exact and mathematically accurate. They are easy to put up and easier to take down—no pegs or screws or nuts or bolts—and with one set of Anchor Blocks you can build an almost endless number of models. Books of designs furnished free with every set.

RICHTER'S ANCHOR BLOCKS

Each block fits perfectly on the other blocks so that it is possible to buy additional pieces or regular supplementary boxes at any time to add to the set so that larger models or several models can be built. Anchor Blocks develop initiative and the constructive side of a boy or girl's nature.

They broaden the mind and the imagination. They lead to higher ambitions. Buy a set now for that boy or girl of yours, or get one for Christmas. Prices 50c to \$5.00. Fortress sets for building modern forts at \$1.50, \$3, \$6 and \$12.00.

Write for illustrated catalog today. Just mail us the coupon below, writing your name and address plainly or send money order if you wish to order now.

F. AD. RICHTER & CO. 74 Washington Street NEW YORK CITY
Dept. 202

FREE COUPON!

Send me your booklet giving full particulars about Anchor Blocks.

Name

Address

City

State



BUILT WITH ANCHOR BLOCKS — FORTRESS SETS