

July

See Page 21

15 Cents

POPULAR MECHANICS MAGAZINE

WRITTEN SO YOU CAN UNDERSTAND IT

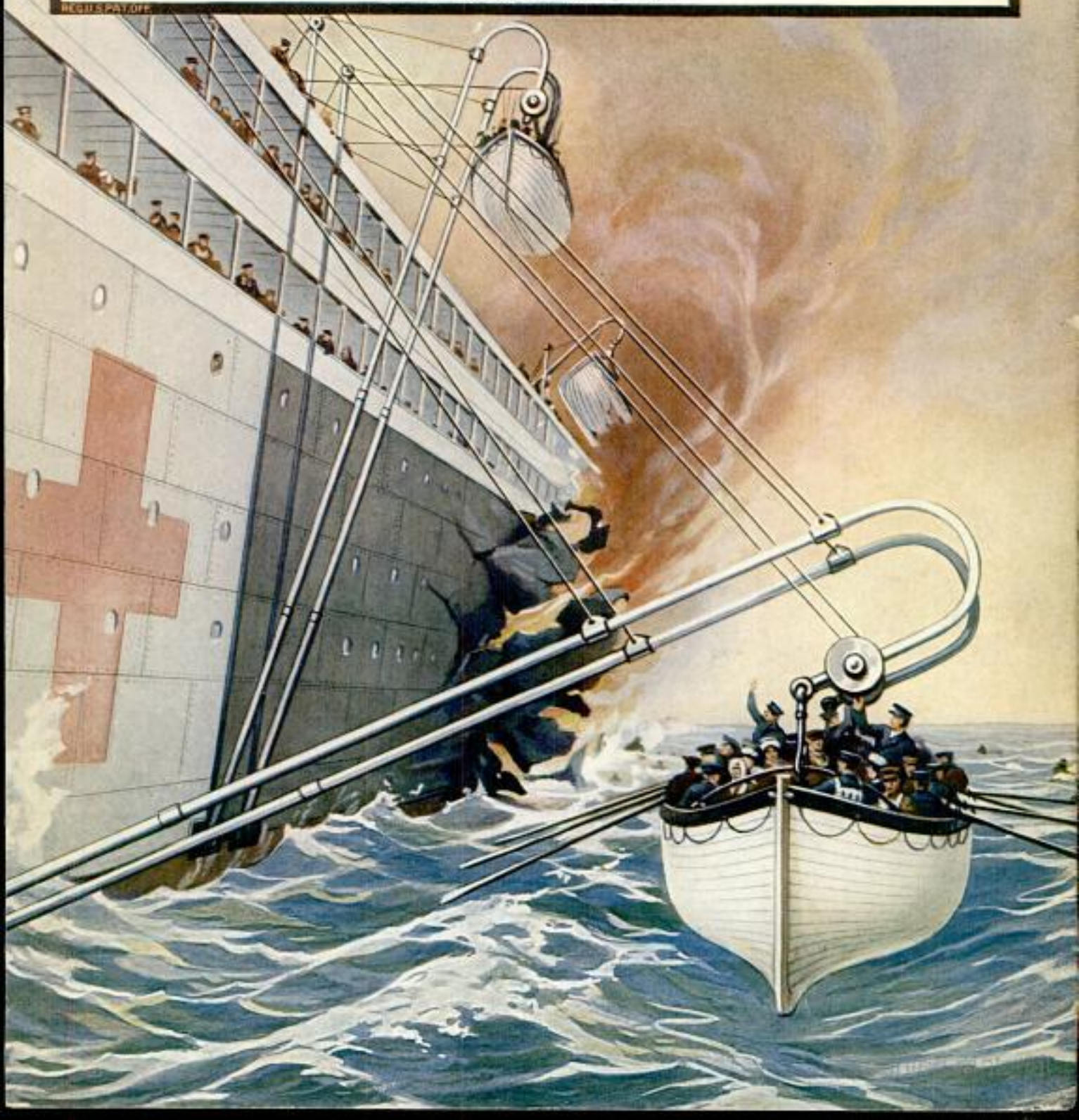



\$705 Buys the Material to Build this Home!

NO MONEY IN ADVANCE!

When you "Build-To-Stay—The Harris Way," you secure the *utmost possible* in Quality, Economy and Service. Why? Simply because you profit directly—*immediately*—by our 24 years' experience. You get the benefit of our practical knowledge as the *originators* of the "Direct-to-You" Home Building Industry. We were the *first* to sell Lumber and Material direct to Home Builders at one small profit. We were the *first* to reduce this vitally important industry to a *perfect system* and extend the benefits uniformly to the people of the nation. *The splendid Harris Home above has 5 rooms, bath, pantry and reception hall in an excellent arrangement. The size is 22 ft.x 26 ft.*



"THE HARRIS WAY"

has exclusive merits—special advantages for the shrewd and careful Home Builder—possessed by no other plan or method. It is the best, safest and most sensible way to build your ideal home *right* without sacrifice of quality—or *the waste of a single penny!* Thousands have built "THE HARRIS WAY" with profit and satisfaction.

SEND LUMBER BILLS

Our ten million dollar buying power gives Harris customers an overwhelming price advantage. We can—and do—undersell all others. The *proof?* Easy! Just send us your lumber bills—for any kind of building you may be planning and get *our* prices. Compare them item for item, and let the *test* be the *proof.* Write us today!

BUY YOUR HOME SENSIBLY CUT-TO-FIT—SHIPPED ALL COMPLETE IN ONE CAR

The material used in building all Harris Homes is prepared by us, complete for your use in a way that is instantly—and easily understood. It is sensibly cut-to-fit with *absolute accuracy* and *positive elimination of all waste.* You pay for nothing you do not get—you pay our bed rock low, one-small-profit bargain price *only* for what is needed to do the work *right*—"THE HARRIS WAY."

Our mammoth material stations, in the heart of the finest lumber tracts are always filled to overflowing with brand new, quality material. These stations are centrally located for quick and economical deliveries, "DIRECT-TO-YOU," no matter where you live, at the *lowest possible freight charge.*

Free Beautiful New \$10,000 Book of Over 100 Harris Homes

Be sure to mail free coupon for the latest edition of the famous \$10,000 HARRIS HOME PLAN BOOK, now ready. A golden guide to Quality, Service and Economy in Home Building. Explains—fully and freely—everything about building economy. Contains 100 modern Harris Home Designs, with descriptions, material, specifications, prices, etc., and explains how we save you \$50 to \$75 on our Special Free Architect's Plans. Think twice before you pass this opportunity.

Harris Bros. Co.
Dept. FH-7, CHICAGO
Please send me free—without the slightest obligation—the Harris Home Book of Plans, and show me how to save big money in building my home.

Name

Address

Harris Brothers Co. Dept. FH-7 35th & Iron Streets Chicago



To insure Victor quality, always look for the famous trademark, "His Master's Voice." It is an easy Victor and every Victor Record. It is the identifying label on all genuine Victrolas and Victor Records.

The right partner, a smooth floor and the Victrola!

The instrument that is always ready to oblige with the best dance music;

—that plays itself and permits every one to dance;

—that keeps right on playing as long as any one wants to dance.

Are you familiar with the delights of dancing to the music of the Victrola? Go to any Victor dealer's and ask to hear some Victor Dance Records. He will gladly play the newest dance music for you, and demonstrate the various styles of the Victor and Victrola—\$10 to \$400.

Victor Talking Machine Co.
Camden, N. J., U. S. A.

*Berliner Gramophone Co., Montreal,
Canadian Distributors*

"Victrola" is the Registered Trade-mark of the Victor Talking Machine Company designating the products of this Company only.

Warning: The use of the word **Victrola** upon or in the promotion or sale of any other Talking Machine or Phonograph products is misleading and illegal.

Victor Supremacy

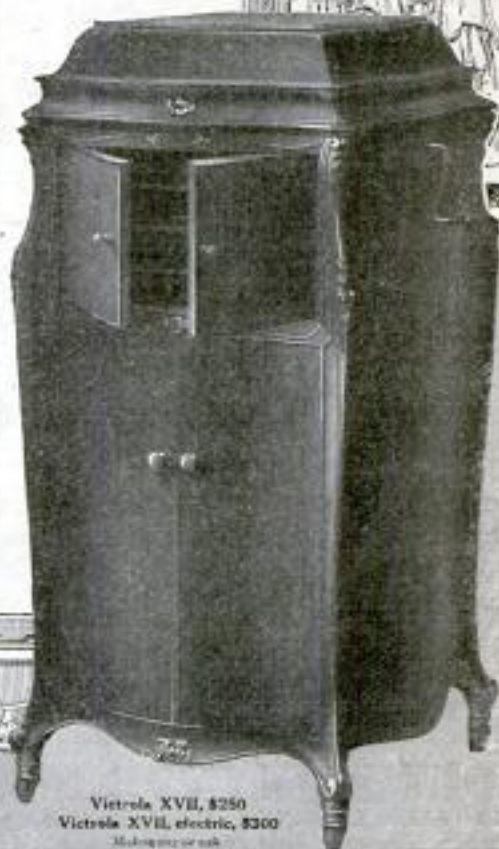

Victrola XVII, \$250
Victrola XVII, electric, \$300
Manufactured in U.S.A.

New Victor Records demonstrated at all dealers on the 28th of each month

"Anonymous" Cypress Good Enough?

(WOULD YOU TAKE AN UNSIGNED CHECK? NO? THEN WHY UNSIGNED CYPRESS?)

Of course you want Cypress, "the Wood Eternal," for all uses where it represents the highest utility and ECONOMY. But—how do you know that what you get is *Cypress*? And, if it *is* Cypress, how can you tell that it's genuine

"Tide-water" Cypress

? How can you be sure that it grew in the regions near enough to the coast to produce the true "Wood Eternal"? And how can you tell that the Cypress you buy was *properly manufactured, sufficiently dried* before shipment, and then *scrupulously graded and counted*? There's ONE WAY to be

Sure About *Everything*

It is simply to INSIST on SEEING the registered Cypress Association Trade-Mark on *every piece* (or bundle). Buy by the Cypress Arrow."

**"TIDE-WATER" CYPRESS
MANUFACTURED BY
ASSOCIATION MILLS
IS IDENTIFIED BY
THIS TRADE-MARK**



You don't buy diamonds of a casual solicitor—nor expect pure foods in unidentified packages; why not be equally careful in guaranteeing yourself your money's-worth in Cypress lumber? The undersigned Association licenses its registered trade-mark only to those Cypress saw-mills whose location, business methods and responsibility guarantee delivery to the consumer "as per specifications." The kind of Cypress you want IS TO BE HAD. It is up to you to SEE THAT YOU GET IT by simply insisting on SEEING that CYPRESS ARROW on EVERY BOARD (or bundle) you pay for

Let our ALL-ROUND HELPS DEPARTMENT help YOU MORE.

Our entire resources are at your service with Reliable Counsel

SOUTHERN CYPRESS MANUFACTURERS' ASSOCIATION
1219 HIBERNIA BANK BLDG., NEW ORLEANS, LA., or 1219 HEARD NAT'L BANK BLDG., JACKSONVILLE, FLA

INSIST ON TRADE-MARKED CYPRESS AT YOUR LOCAL LUMBER DEALER'S.

IF HE HASN'T IT, LET US KNOW

Please Mention Popular Mechanics

Popular Mechanics Magazine

6 N. Michigan Avenue, Chicago, U. S. A.

EDITED BY H. H. WINDSOR

England: The International News Co.
5 Beams Bldg., Chancery Lane, London, E. C.

Australia:
The Australasian News Co.

ISSUED MONTHLY

SUBSCRIPTION:

SINGLE COPY, 15 CENTS

In United States, and its possessions, Cuba and Mexico, per year, postpaid - - - \$1.50
To Canada - - - - - 1.75
To all other countries in the Postal Union - - - - - 2.50

All subscriptions are discontinued at expiration. Please examine the date printed on your wrapper.

Entered as Second Class Matter Sept. 15, 1903, at the Post Office at Chicago, Illinois, under Act of March 3rd, 1879.

Entered as Second Class Matter at the Post Office Department, Canada.

Published monthly by POPULAR MECHANICS CO.

Copyright, 1917, by H. H. WINDSOR.

Copyright, in France.

Contents for July, 1917

Accident, Strange, Kills War Nurses.....	46	Comment and Riview, by H. H. Windsor:	
Acetylene Refuse Used for Plastering.....	104	Vacation on Farms.....	34
Airman, Famous, Death of Loss to Army.....	14	Work, Everybody Work.....	35
Alfalfa Luncheon Served to Farmers.....	104	Concrete Railway Ties, Hollow, Test of.....	62
Armor Plant, Federal, To Build in West Virginia.....	90	Cooler, Evaporation Food, Made of Concrete....	122
Automobile Show for Used Cars in Chicago.....	18	Corn, Tall Sappy, Experts Condemn.....	38
Automobile Thieves, Guard Posts to Capture....	119	Cotton Bales, Powerful Compress Makes Smaller	79
Automobiles, Center of Road Parking System for	20	Crib, Folding, for Use in Car or Camp.....	107
Automobiles, Quick Acting Vacuum Brake for..	87	Cripples, War, Show Ability to Do Farm Work..	24
Barn Plan, Sun Parlor for Cows in.....	98	Dam, Citizens String Boom to Save.....	84
Baseball Player, Cuban, "Bones" His Bat.....	28	Dam, Suction Kills Two Men in Gallery of.....	113
"Birds" and "Beasts" Made from Seeds and Pods	40	Davits, Ship, Hold Boat Far from Side.....	21
Blueprinting Machine Operates at Low Cost....	94	Desk Sets Ornamented with Brocade Panels....	7
Bombs, Imperiled Boston Public Studies.....	31	Dredge, Mammoth Gold, Has Two Stackers....	6
Booth, Observation, for Traffic Officer.....	96	Ear Defenders, Artillery, Worn by Mill Workers	106
Boy Scouts to be Taught First Aid to Autos....	102	Electric Directory Helps Hotel Guests.....	24
Brick Repress, Automatic Feeder for.....	41	Electric Lamp of High Efficiency.....	85
Bricklayer's Raker Suited to All Needs.....	122	Electric Light Bulbs Supplant Potatoes in Odd	
Bricks, "Soft Mud," Machine for Making.....	92	Race.....	21
Building, Argentine, at Exposition Demolished..	105	Electric Lights, Propose for Lincoln Highway..	11
Building—Bungalow Built on Top of Garage....	97	Elk, Yellowstone, Deep Snows Cause Death of..	74
Building—Skyscraper to be Center for Buyers		Elevator Gate Operates on Two Floors.....	80
and Sellers.....	18	Elevator Regulation, Indicator System Devised	
Cabinets, Folding Light Bath, for Home Use....	87	for.....	113
Camera, Airman's Folding, Shield Protects....	11	Engine, Donkey, Steams across Slough.....	32
Camera and Projector, Combined Movie.....	27	Engines, Duplex, Solve Traffic Problem.....	45
Camp, Permanent Army, Built in Ten Days....	15	Farms for War Veterans, Railway Prepares....	95
Can, Caster Mounted, for Printer's "Dead" Metal	78	Farms, Numbering by Clock System.....	117
Can Labeling Machine Operates by Gravity.....	80	Ferrule, Coil Spring, for File Handle.....	98
Cancers, New Light on Nature and Origin of..	40	Fire Whistle, Town, Blown by Soda Water Gas..	66
Cane Used as Container and Staff for Flag....	79	Fish Guide for Systems of Irrigation.....	118
Carbon Deposit Removed by Cold Water Device	24	Fish—Sea Bass Caught with Big Mouthful....	102
Carriage, Bullock, Used in Madeira.....	70	Fish—Smelt, Oregon Folk Catch Quantities of..	62
Caskets and Vaults Made of Reinforced Cement..	14	Fish Trap, Service Pipe, for Water System....	116
Castings, Heavy, are Made for Powerful Machine	75	Flag, Novel Ways of Displaying and Draping..	42
Cave, Mammoth, Lighted by Electricity.....	12	Flagpoles, Nonfouling Halyard Top for.....	122
Charts on Farm Subjects for Country Schools....	10	Flats, Model, for Small Industrial Centers....	160
Chemical Testing Outfit for Laundrymen.....	27	Floor Polisher Has Two Detachable Units.....	71
Children's Activities of Unusual Interest.....	120	Floor, Refrigerator Car, Insures Ventilation....	96
Cisterns, Device for Cleaning While Full.....	14	Forceps, Surgical Sewing, Saves Operator's Time	83
Civic Features for Comfort of Residents and		Furniture, Latest Trends in Designing.....	108
Visitors.....	76	Gardening, Novices Study, in Skyscraper.....	46
Cliff Dwelling, Lofty, Food Found in.....	104	Goats, Developing Commercial Possibilities of, by	
Clock, Big, without Hands Tells Time by Figures	78	Albert Marple.....	67
Clock, Time Switch, Used to Control Lights....	116	Gun Mount, New Machine, with Periscope.....	63
Combustion Data, Pocket Indicator Gives.....	116	Gun, Pneumatic, Used to Destroy Trenches....	113
Comment and Review, by H. H. Windsor:		Harbor, Great, Making at Los Angeles.....	44
A Slacker Congress.....	37	Harrow Evener, Improved, with Wide Swath....	23
Buy a War Bond.....	34	Heaters, Street Car, Thermometer Control for..	75
Germany does Not Understand Us.....	36	Horn, Rear, Operates When Car is Backed....	89
Save, but do Not Hoard.....	33	Horse, Operation and Odd Shoes Save.....	86
The War No Passing Effort.....	35	Hose Clamp for Use on Any Automobile.....	122

[Continued on Page 6]

Popular Mechanics offers no premiums; does not join in "clubbing offers," and employs no solicitors to secure subscriptions. It is for sale by nearly every newsdealer in the United States and Canada.

This One



RHW5-Y5X-E57X

Copyrighted material

[Contents—Continued]

Hospital, Modern, Operating Room Devices in..	110	"Stairway" Built for Weak Fish to Aid Spawning	30
House, Artistic Chicken, Looks Like Dwelling..	71	Stamps, Cancellation, on Mail to Boost War Bonds	22
House Boat Life Enjoyed in River Colonies....	25	Styles, Latest, War Spirit Reflected in	39
Hydraulic Test Machine for Boiler Tubing....	93	Swing, Three Seated Porch, with Crib Feature..	64
Joint, Universal, Designed for Stanchness....	112	Telephone Rates, Special, for Vacationists....	13
Kerosene Used as Fuel in Galley Range....	118	Tent and Bed, Combination, Has Many Uses....	66
Kettles, Steam Heated, in Hospital Kitchen....	29	Theatrical Laboratory for Testing Plays, by M. W. Meier	8
Lace, Lobbyist's, Records Deeds of Legislature..	4	Tire Cover Safeguards against Collisions....	30
Lamp and Magnet, Long Handled, for Motorists	64	Tires, Huge Truck, Have Fourteen Inch Tread..	44
Lanterns, Chinese Erect for Spirits of Drowned	17	Tires, Truck, of Heavy Cord Construction....	117
Lathes, Engine, Indexing Attachment for....	4	Torpedo—New Naval Weapon Idea of Great Scientist	2
Level, Aluminum Line, for Builders....	111	Tower, Windmill, Houses Auto and Chauffeur..	103
Lighting—Mormon Temple Lighted at Night....	95	Towns, Out-of-the-Way, Moving to Railroad....	93
Lily Beds, Vast, Beautify Mississippi River....	19	Tractor, Farm, Pumps Water from Cellar....	72
Lunch Service, Wagonette, on Trains....	22	Tractors, Survey of States Shows Many in Use..	22
Map, Relief, of Caribou National Forest....	10	Tray Outfit, Adaptable, for Sorting Letters....	78
Marimba, Primitive, may Become Popular Here	101	Trees, Quaking Aspen, for Paper Making....	103
Markets, Roadside, of Southern California, by J. E. Hogg.....	99	Truck, Auto Ladder, Built by Firemen....	29
Massage Machine, Vacuum, Operated by Faucet	28	Typewriters, Mechanical Device Tests Speed of	73
Megaphone, Coxswain, Used by College Girls....	12	Valve, Helpful Check, Made for Suction Flask..	102
Milk, Malted, New Dispensing Machine for....	75	Violin, Tailpiece Designed to Improve Tone of..	19
Mine, Alaska Gold, Wrecked by Sea....	5	Volcanoes Found to Be Hottest on Surface....	46
Motor Busses Give Relief to Chicago Strap-hangers	71	War:	
Motor Truck Brakes, Ability of Shown by Tests	30	Airmen at Home and Abroad, With Our.....	47
Motor Truck Loads Itself with Heavy Mains....	65	American War Workers, Here and There with	59
Motor Trucks, Army, Carry Big Mess Hall....	72	Automobiles, American Armored, in Sham	60
Motorcycle as Adjunct to Aeroplane	86	Fight	60
Motorcycle Chain Tool of Nutcracker Type....	112	British and French Missions at Washington's	56
Motorcycle Conquers Hill of Precipitous Grade..	13	Tomb	61
Moving Picture Shows on Edge of Grand Cañon.	73	France, Northern, Work of Vandals in.....	61
Mower Driven by Engine from Low Priced Car..	8	French Hot upon Heels of Retiring Enemy...	58
Novelties for the Home and Its Members....	114	Food for Fighting Forces and Civilians....	57
Oil Burner, Improved, of Rotary Type....	94	Naval News, Recent, Pictorial Accounts of..	49
Olive Grading Device, New, Replaces Hand Sorters	92	Russia Pays Tribute to Revolution's Dead....	54
Painters and Decorators Go to School....	88	Russian Revolution, Camera Glimpses of....	53
Paper Holder, Folding, for Display Purposes....	118	Russia's Masterly Underground Defenses....	55
Paper, Moisture Proof, for Wrapping Goods....	118	Russia's Revolutionary Council in Session....	52
"Pig Clubs," Organize to Increase Meat Supply	32	Ship That Fired Our First Shot in War....	50
Pigeon Lofts, Strange Egyptian Towers Serve as	17	Side Lights on Our Entrance into War....	48
Platinum, New Source of Found in Siberia....	6	Water Systems, Two, Unusual Connection for..	119
Play on Bare Stage, Blind Soliders "See"....	38	Water Tower, Big, Wrecking from a Raft at Its	1
Pliers, Insulated, Resist High Voltage....	106	Top	1
Pliers—Tool, Combination, Forest Ranger	107	Waterway Improvements Planned by Germany..	84
Devices	107	Wells, Deep, Give Islands Pure Water....	64
Porto Ricans Celebrate Grant of U. S. Citizen-ship	101	Wreck—New Automobiles Strwn along Track..	41
Press, Hydraulic Multiple, for Wet Materials....	74		
Railroad Ballast Cleaner Kills Track Growths..	110		
Railroad Freight Train Switched by Four Horses	85		
Railroad Freight Trains, How Account is Kept of	87		
Railroad Plans to Employ Women	31		
Railroad Track, Test by Backing into Flood....	66		
Reacher Gives Access to High Shelves....	11		
Reindeer Team Driven through City Streets....	65		
Reservoir Dragged with Cable to Remove Moss..	111		
Restaurant, Theaterlike, Has Terraced Floor....	7		
Road, Alaska, Has Clear Ice Foundation....	11		
Road Repair, Method of Saves Manual Labor..	88		
Rustproofing Bath for Iron and Steel....	89		
Saw, Coarse Toothed, for Pruning Trees....	62		
Selenium Proves Valuable in Cable Telegraphy..	28		
Ship, Cattle, Giant Dredge Now Used as....	18		
Ship, Clipper, to Become Powered Tanker....	106		
Ships, Wooden, Hasten to Fill Need for....	90		
Shock Absorbers, New, Aid Auto Springs....	116		
Shrapnel, by Reginald Trautshold....	81		
Signals, Safety, Nailed to City Pavements....	23		
Snake That Eats Other Serpents Friend of Man..	20		
Spectacles, Indian Chief Starts Fad of Wearing..	45		
Spitting Habit Cured by Painting Corners White	74		
Spring, Auto, Pads Make Self-Lubricating....	40		

[Contents Continued on Page 8]

IN accordance with the editorial policy of this magazine never to accept compensation in any form for what appears in our reading pages, and also to avoid all appearance of doing so, we are obliged to omit the name of the maker or the seller of any article described. This information, however, is kept on file and will be furnished free, by addressing Bureau of Information, Popular Mechanics Magazine, Chicago. [Editor.]

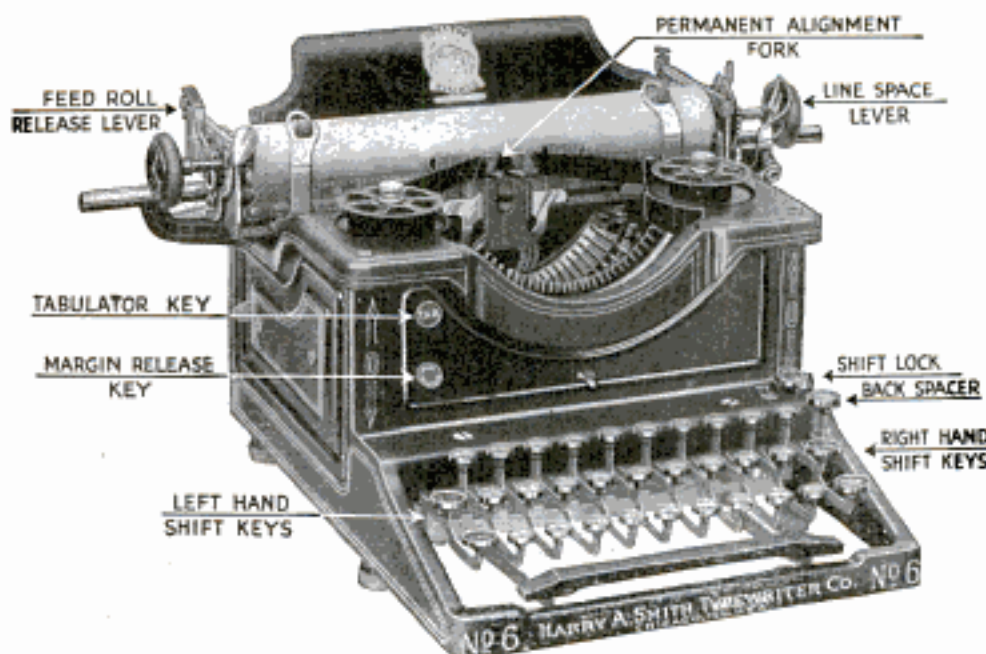

I want, through this advertisement, to establish as friendly business relations with you as I possibly can. I want you to realize also that it is my earnest effort and intention to give you full honest value for every dollar that you spend with me. This is the only way I can succeed. My advertisement has appeared in this magazine continuously for more than four years.

I am building up my business on the foundation of good value and square dealings. I am saving thousands of satisfied customers thousands of dollars, by supplying perfect—late style—visible writing—typewriters, at remarkably low prices.

All my transactions are handled throughout by personal correspondence. I assure you every courtesy and consideration in your dealings with me. Your order will have my prompt, careful, personal attention. I will be glad to do business with you.

Harry A. Smith

TYPEWRITER SENSATION

Free TRIAL—Use As You Pay

Send me only \$2.00 a month until the low total price of \$34.15 is paid, and the machine is yours

This is absolutely the most generous typewriter offer ever made. Do not rent a machine when you can pay \$2.00 a month and own one. Think of it—Buying a \$100.00 model for \$34.15. Cash price, \$32.30. Never before has anything like this been attempted.

Standard Visible MODEL No. 6

Perfect machines, Standard Size, Keyboard of Standard Universal arrangement, writing 84 characters—universally used in teaching the touch system. The entire line of writing completely visible at all times, has the tabulator, the back spacer; in fact, every late style feature and modern operating convenience. Comes to you with everything complete, tools, cover, operating book and instructions, ribbon, practice paper—nothing extra to buy. You cannot imagine the perfection of this beautiful reconstructed typewriter until you have seen it. I have a thousand of these perfect latest style Model No. 6 typewriters at this bargain price, and each purchaser fortunate enough to secure one of these beautiful machines must try it out in home or office for five days before deciding to buy. I will send it to you F. O. B. Chicago for five days' free trial. It will sell itself, but if you are not satisfied that this is the greatest typewriter bargain you ever saw, you can return it at my expense. You won't want to return it after you try it—you cannot equal this wonderful value anywhere.

You Take No Risk—Put In Your Order Now

When the typewriter arrives deposit with the express agent \$6.15 and take the machine for five days' trial. If you are convinced that it is the best typewriter you ever saw, keep it and send me \$2.00 a month until my bargain price of \$34.15 is paid. If you don't want it, return it to the express agent, receive your \$6.15 and return the machine to me. I will pay the return express charges. This machine is guaranteed just as if you paid \$100.00 for it. It is standard. Thousands and thousands of people own and use these typewriters and find them the best ever manufactured.

The supply at this price is very limited, the price will probably be raised when my next advertisement appears, so don't delay. Fill in the coupon today—mail to me—the typewriter will be shipped promptly. There is no red tape. I employ no solicitors—no collectors—no chattel mortgage. It is simply understood that I retain title to the machine until the full \$34.15 is paid. You cannot lose. It is the greatest typewriter opportunity you will ever have. Do not send me one cent. Get the coupon in the mails today—sure.

HARRY A. SMITH, 510-231 N. Fifth Ave., Chicago

H. A. SMITH
Room 510-231 N. Fifth Ave.
CHICAGO, ILL.

Ship me a No. 6 Smith F. O. B. Chicago, as described in this advertisement. I will pay you the \$28.00 balance of the SPECIAL \$34.15 purchase price, at the rate of \$2.00 per month. The title to remain in you until fully paid for. It is understood that I have five days in which to examine and try the typewriter. If I choose not to keep it I will carefully repack it and return it to the express agent. It is understood that you give the standard guarantee for one year.

Name

Address

.....Pop. Mech. July

Learn the Automobile Business



More help needed and big pay

No other business offers such opportunities. It's easy to learn. An Auto Repairman is not a machinist—his work consists of adjustments and refitting worn parts; "knowing the principle," that's the thing.

If we prove to you that we've started others you must admit we can do the same for you.

DYKE'S NEW IDEA OF TEACHING BY MAIL WITH WORKING MODELS

On these models you get actual practice, see the actual operation and learn more than you could from the auto itself—it's easy and quick. You don't have to study hard with this system—we teach through the eye—a new idea. Mr. Dyke is the originator of the system of teaching by mail with models—therefore beware of imitators. Some of the divisions of the U. S. Army: TRUCK, AVIATION, MOTORCYCLE, are using Mr. Dyke's instruction book.

FREE Mr. Dyke's 32-Page Booklet WRITE FOR IT—NOW!

It is interesting and instructive in itself. Learn how you can get all this training for only \$18. Fill out below or write a postal—but do it now.

Dyke's Correspondence School of Motoring
Box 198, Ree Bldg., St. Louis, Mo.

Send me your free 32-page booklet about your New Idea Working Model Course and (optional) and proofs. It is understood I am under no obligations in sending for this.

HOW TO GET INTO THE AUTO BUSINESS AND ITS OPPORTUNITIES

Name

Town

Street.....State.....

This school is a department of the firm A. L. Dyke, Publisher and Importer. Dyke's system is endorsed by leading motor authorities of the world.

SPECIAL INSTRUCTION on Six, Eight, Twelve Cylinder Engines. Electric Starting and Generating Systems.



"To be frank, you're short on headwork. You are good at packing and nailing up boxes, but many of our men can do as well. What we need right now is a Traffic Manager—a man who knows freight and express rates, classifications, and routing of shipments. Such a man could save us thousands of dollars every year, and we could well afford to pay him a good salary. But you can't fill that job—you haven't the training. If you had looked ahead of your job and prepared in spare time for such work, there would be a good position with a good salary open to you right now."

For 25 years the International Correspondence Schools have been a good friend to men situated like Jim. No matter where you live, what your work, how little education or spare time you have, the I. C. S. can help you get ready for advancement and better pay. Without obligating yourself, just mark and mail the coupon and find out how.

TEAR OUT HERE

INTERNATIONAL CORRESPONDENCE SCHOOLS, Box 5592, Scranton, Pa.

Explain fully about your Course in the subject marked X:

- | | | |
|---|--|---------------------------------------|
| <input type="checkbox"/> TRAFFIC MANAGEMENT | <input type="checkbox"/> ADVERTISING | <input type="checkbox"/> SELLING |
| <input type="checkbox"/> Business Law | <input type="checkbox"/> Bookkeeping | <input type="checkbox"/> Stenography |
| <input type="checkbox"/> Architecture | <input type="checkbox"/> Civil Service | <input type="checkbox"/> CHEMISTRY |
| <input type="checkbox"/> Architectural Drafting | <input type="checkbox"/> Ry. Mail Service | <input type="checkbox"/> Illustrating |
| <input type="checkbox"/> Electrical Engineering | <input type="checkbox"/> Steam Engineering | <input type="checkbox"/> Farming |
| <input type="checkbox"/> Mechanical Engineering | <input type="checkbox"/> Civil Engineering | <input type="checkbox"/> Poultry |
| <input type="checkbox"/> Mechanical Drafting | <input type="checkbox"/> AUTOMOBILES | <input type="checkbox"/> Languages |

Name

Address

(Contents—Continued from Page 6)

Hoist, Homemade Power, for Loading Hay in Barn	125
Horn, Warning, at Sidewalk Garage Door	125
Horseshoe Calks, Preventing Rapid Wear on	134
Joints, Mortise and Tenon, Hand Tool for Making	142
Lamps, Incandescent, Used in Stereopticon Lantern	131
Landscape, Miniature, Built Up of Concrete	123
Micrometer, Direct Reading Lever	133
Nuts, Brass Thumb, Hammering Tightens	136
Oil, Excess, in Cylinders, Beveled Piston Ring Overcomes	139
Palette, Artist's, Supported by Easel	123
Plier Vise, Handy, Used in Piston Rings	135
Plumb Bob, Drop, of Weighted Tubing	126
Pump, Temporary, for Cooling Gas Engine Water Jacket	141
Rack Safeguards Surveyor's Instruments	129
Reamer, Large, Repairing	128
Reaming a Bushing or Collar without Reamer	130
Reel, Roller Bearing, for Electrical Wire	141
Ropes Fed through Floor from Basement	138
Sash, Emergency, for Railroad Car Doors	135
Screw Rivets for Woodwork, Hidden	132
Screwdriver, Toothed End Prevents Slipping	134
Skimmer for Removing Slag from Molten Metal Soldering Auto Radiators, Tool for	134
Soldering Iron, Bushing in Handle of	129
Spider for Cutting Large Pipe in Lathe	138
Springs, Coil, Hints on Making and Use of	124
Sprinkler, Barrel, for Oiling Roadway	132
Steel, Shop Bin Economizes Short Lengths of	129
Stool, Folding Metal Cushion Seat	137
Tapeline, Rapid and Accurate Repair of	137
Tires, Valve and Stand for Inflating	131
Washer Holds Bolt from Turning in Clamping Grooves	134
Washer, Thin, Filing Down	128
Window Cleaning Seat, Safety	124
Wood Turning Tools, Holder for	138
Wrapping Small Articles of Uniform Size, Device for	130

AMATEUR MECHANICS

Aluminum Ware Cleaner, Steel Wool as	146
Belt for Sprocket Drive Made of Brass Strips	144
Billfold, Craftsman Leather	156
Boats, Model Paddle Wheel	153
Broom, Moving Heavy Objects with	155
Coaster Steering Gear Made from Cream Freezer Drive	145
Corks, Pad for Glass Vessels Made of	145
Desk Light Arm Folds into Pigeonhole	151
Easel or Support for Copy, Quickly Made	149
Electric Light, Automatic, on Talking Machine Cabinet	146
Film Holder for Photographic Developing	151
Fishline Nibble Spring Automatically Released	149
Handlebar Grips, Rubber, Reinforcing Ends of	151
Hoe or Rake, Second Handle on Saves Stooping	144
Hooks, Overhead, Device for Suspending Parcels from	146
Hoop, Child's Bell Ringing	159
Ironing Board, Extension on for Large Pieces	150
Kite, Eight Pointed Star	143
Knife, Pruning and Brush Cutting	159
Lamp and Mirror, Shaving, for Camp	146
Lawn Mower Sharpened with Simple Rigging	158
Mail Box, Homemade Residence	150
Memo Device, Order, for Delivery Routes	153
Moth Ball Puzzle as Window Novelty	154
Motorcycle or Bicycle, Rear Seat for	156
Phonograph, Record Cleaning Pad Fixed to	155
Phonograph Record Covers, Diagonal Corners on	152
Photo Copying Lens Increases Angle of Camera	144
Pictures, Transferring to Glass	153
Poultry House Door Latch, Spring Roost Releases	156
Rain Alarm with Drop of Water Contact	145
Rubber Pads for Opening Screw Watch Bezel	158
Safety Pins, Novel Uses for	155
Scale, Funnel, Live Poultry Weighed on	152
Sink, Old, Installed as Dish Draining Basin	151
Stoves, Emergency Camp, Quickly Made	159
Swimming Machine Made in the Home Workshop	147
Thresher, Small, of Practical Use	154
Wheels, Changing Equalizes Wear on Baby Cab Tires	156
Writing, Simple Machine for Transmitting	152

How to Learn Piano The Modern, Scientific Way

You Save Time, Effort, Money—
and Play More Artistically

Notable improvements have recently been made in teaching piano or organ. Difficulties which for generations have delayed beginners and troubled even experienced players have now been swept away through the scientific discoveries of experts. If you are already taking lessons or are thinking of doing so, be sure to investigate **at once** by writing for free 64-page book, "How to Study Music."

Short Lesson with Expert Better than a Dozen Other Lessons

This is the age of **EFFICIENCY**—in music just as much as in any other Art or Science. Now, more than ever before, your teacher must be an **EXPERT**, or you will waste months and years of time practicing in out-of-date ways. Your teacher must possess more than mere playing ability—**much** more. He must know **MUSICAL SCIENCE** as well—and such knowledge is very rare even in the largest cities. The old-fashioned system of studying with a "private teacher" is rapidly being abandoned. And anybody can see why. If you want the **entire** attention of your teacher, but can afford only a dollar or two for each lesson, you can get only **third-rate-instruction**. Whereas, if you join a **class** at a Conservatory, you can secure the services of a **real expert** at the same or **even less cost**—and you learn **correctly** and thus **more rapidly**.

Learn Right at Home—By Scientific, Guaranteed Method

Dr. Quinn's famous Written Method brings right to your home, **wherever you live**, all the great advantages of Conservatory study. You obtain a complete Course of Music Lessons which has been prepared according to the **latest developments** of scientific teaching and has been successfully used by **thousands** of men and women. **Satisfaction is Guaranteed.**

Easy to Understand—Music Furnished Free

The Course is fully illustrated with photographs showing every position and movement of the fingers, hands and arms. You can refer to these photographs at any time, day or night. You are **certain** of practicing correctly. Verbal instructions, given by a "private teacher," are unsatisfactory, because, even if correct, it is impossible to remember them **in full** when you practice. Dr. Quinn instructs and guides you at every step. You cannot go wrong, and no matter how far you continue your music you will never have anything to unlearn. All necessary music is included **FREE**. A diploma of internationally-recognized value is granted. Progress as rapidly or as slowly as you wish.

For Beginners or Experienced Players

The Course is entirely different from any other that you have ever seen or heard of. In thoroughness and in the subjects covered it corresponds to the usual three-year term of study. Yet it can easily be mastered in seventy-five weeks and some students finish it in less than a year. These prompt results are because the Course is systematic, and is carefully planned in advance; **not** because anything is omitted. Not a minute of your time nor an ounce of your effort is wasted. Nothing is forgotten or needlessly covered twice, because errors such as this would have been discovered and corrected long ago. Men and women who have failed by all other methods have quickly and easily attained success when using Dr. Quinn's method. It brings the same surprising results to either beginners or experienced players.

Endorsed by Distinguished Musicians

Among our graduates are thousands of accomplished amateur players, as well as prominent professional players, successful teachers and leading composers. We have enrolled more students so far in 1917 than in 1916 and 1915 combined. This is due to the remarkable results we have produced. The Course is endorsed by many distinguished musicians, educators and men of affairs who would not recommend any Course but the **best**.

Investigate Without Cost—Special Offer

Write today, using postcard, letter, or Free Book Coupon, for our new 64-page book, "How to Study Music." It is the most complete explanation of modern teaching methods ever published by a Conservatory. It tells how much the lessons cost, gives the records and opinions of our students and much other valuable information. Our Tuition Fee is greatly reduced just now on account of our Twenty-Fifth Anniversary Offer. Investigate without cost or obligation **NOW**.

Marcus Lucius Quinn Conservatory of Music
Studio KT, Social Union Building, BOSTON, MASS.

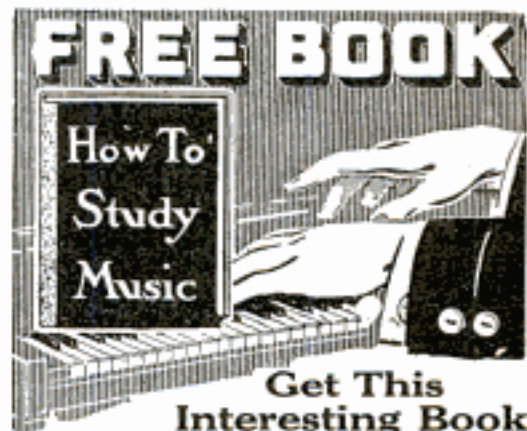

Get This
Interesting Book

It explains how we teach you piano or organ in your own home by scientific methods which cut the time and the cost in half.

FREE Book Coupon

QUINN CONSERVATORY
Studio KT, Social Union Bldg., Boston, Mass.

You may send me without obligation or expense your 64-page Free Book, "How to Study Music," which describes Dr. Quinn's WRITTEN METHOD of teaching piano or organ at home in 142 lessons. Also tell me how much the lessons cost at the reduced Tuition Fee allowed this month as a Twenty-Fifth Anniversary offer.

NAME

ADDRESS

HAWKINS ELECTRICAL GUIDES

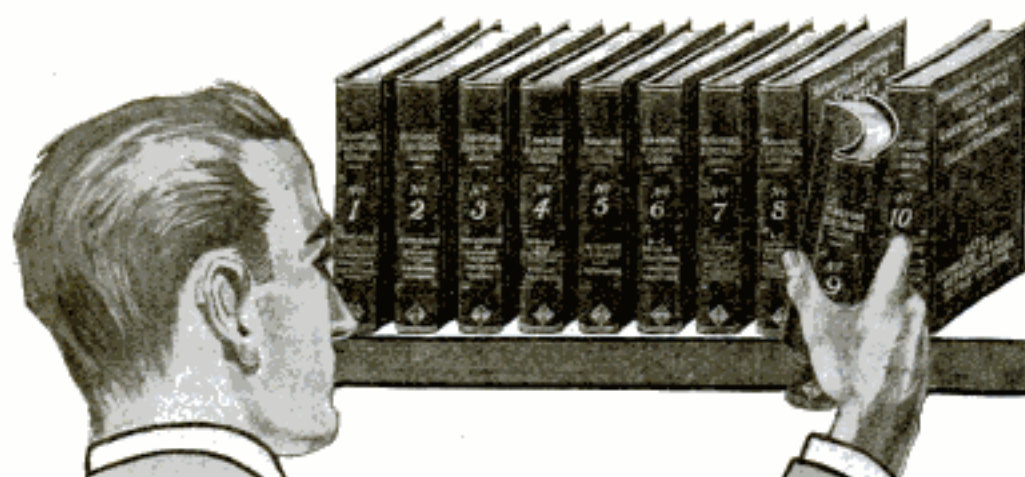

10 Volumes
3500 Pages
4700 Pictures

—
Pocket Size
Flexible Black
Covers

—
\$1 Per Volume
\$1 Per Month

An advertisement written entirely by men who have pushed ahead to greater success in Electricity through owning and using the Guides.

Helped Him Make Good

"It is only right for me to recommend highly the Hawkins Guides, for they have been of the greatest assistance to me in placing me in my present position as Superintendent of Construction Department of one of Ohio's largest Electrical Companies. I would like to see every man have a set of Hawkins Guides." Geo. Knecht, Columbus, Ohio.

A Man Who Arrived

"I am a machinist—I never professed to be an electrical machinist. But I received an unsolicited offer of a position in the Steel Works here (by the largest stockholder). And I want to say that I got my 'Juice' from Hawkins Guides. They are the only books for a man who wants to learn without having to wade first thru a lot of technical phrases he doesn't understand."

W. R. Hammer, Connellsville, Pa.

Up the Ladder

"While in Cuba, I applied for the position of Chief Electrician for the Government. I secured it, and though only a machinist I pulled through with the wonderful help of the Guides. With a repair shop, full supplies and three men, I had 100 telephones to care for, part of the system being under water. I also had the lighting system for shops and residences and wiring for power. Before that time I had never taken a transmitter or receiver apart. Owing to the climate, I later left there and have secured a fine position in the Westinghouse Electric Co."

William Cardell, Newark, N. J.

In the Naval Service

"I wish to state to you that I have resigned the position of Chief Electrician of Sears-Roebuck plant here in Dallas, and joined the U. S. Navy as an Electrician. Made a good grade which was largely aided by the Guides of Hawkins. I can highly recommend them."

Frank E. Lane, Dallas, Tex.

Saved Him Money

"Hawkins Guides saved me just \$3.50 the first time I looked through No. 10 Book. I had a spark coil played out, and that book showed me how to rewind it; and I made it as good as new. Hawkins Guides are the best ever."

H. F. Ramey, Piedmont, Mo.

Superintendent

"I am now superintendent of the Dunnville Hydro-Electric Systems, and Hawkins Guides were a great help to me in holding down a responsible position."

W. E. Swartz, Dunnville, Ontario.

Even in College

"I am attending Cornell University, but I use the Hawkins Guides every day for general information which I cannot get in recitation work or in laboratory experiments. I'll always speak a good word for the ever-ready Guides."

J. Winfield Kurtz, Joanna, Berke Co., Pa.

Wireless Operators

"I have worked wireless for ten years—but I wish I had these books years ago, as they have saved me a great deal of trouble."

H. Marshall,

Steamer M & B No. 2, Walkersville, Ont.

HAWKINS ELECTRICAL GUIDES

Help

"My work lately has comprised the supervision of four trucks and other cars; also the wiring and electrification of sundry buildings on our place—the C. W. Munson Farm Assn., Roslyn, L. I., including the Packing House, Hot Houses, etc. There's never a point comes up that Hawkins Guides do not help me to solve."

Jacob Weiss, Port Washington, L. I.

The Trouble With Them

"The only trouble I find with the Hawkins Guides is that everybody is always borrowing them. My set was even borrowed by a high school instructor for reference work in a physics class. I find them highly instructive."

Carl Hasenwinkle, Hettinger, N. D.

First Aid

"Number 10 Guide arrived all O. K. and completes the set, which I am very proud of. I don't think it would be possible to find a better set for either the beginner or the professional electrician."

Elmer A. Stevens,

U. S. S. Nebraska, Postmaster, N. Y.

In the Naval Electrical Dept.

"The Hawkins Guides are great help to me in the Naval Electrical Department, which they cover very thoroughly."

C. J. Cornell,

U. S. Receiving Ship, Brooklyn, N. Y.

Handy to Carry

"The great beauty of them is that you can carry them in your pocket. That suits me, for I

never want to be without them." F. S. Collins,
Richardson Engineering Co., Hartford, Conn.

Look Through This List of Subjects:

No. 1 Contains 348 pages, 388 illustrations. Electrical signs and symbols—static and current electricity—primary cells—conductors and insulators—resistance and conductivity—magnetism—induction coils—dynamo principles—classes of dynamos—armatures—windings—commutation—brushes, etc.

No. 2 Contains 348 pages, 304 illustrations. Motor principles—armature reaction—motor starting—calculations—brake horsepower—selection and installation of dynamos and motors—galvanometers—standard cells—current measurement—resistance measurement—voltmeters—wattmeters—watt-hour meters—operation of dynamos—operation of motors, etc.

No. 3 Contains 300 pages, 423 illustrations. Distribution systems—wires and wire calculations—inside, outside and underground wiring—sign flashers—lightning protection—rectifiers—storage battery systems, etc.

No. 4 Contains 270 pages, 379 illustrations. Alternating current principles—alternating current diagrams—the power factor—alternator principles—alternator construction—windings, etc.

No. 5 Contains 320 pages, 614 illustrations. A. C. Motors—synchronous and induction motor principles—A. C. commutator motors—induction motors—transformers—losses, construction, connections, tests—converters—rectifiers, etc.

No. 6 Contains 298 pages, 472 illustrations. Alternating current systems—switching devices—circuit breakers—relays—lightning protector apparatus—regulating devices—synchronous condensers—indicating devices—meters—power factor indicators—wave form measurement—switch boards, etc.

No. 7 Contains 316 pages, 379 illustrations. Alternating current, wiring power stations—turbines: management, selection, location, erection, testing, running, care and repair—telephones, etc.

No. 8 Contains 332 pages, 436 illustrations. Telegraph—simultaneous telegraphy and telephony—wireless—electric bells—electric lighting—photometry, etc.

No. 9 Contains 322 pages, 627 illustrations. Electric railways—electric locomotives—car lighting—trolley car operation—miscellaneous applications—motion pictures—gas engine ignition—automobile self-starters and lighting systems, electric vehicles, etc.

No. 10 Contains 513 pages, 599 illustrations. Elevators—cranes—pumps—air compressors—electric heating—electric welding—soldering and brazing—industrial electrolysis—electro-plating—electro-therapeutics—X-rays, etc.

Also a complete 126-page ready reference index of the complete library. This index has been planned to render easily accessible all the vast information contained in the 10 electrical guides. There are over 13,500 cross references. You find what you want to know instantly.

SEND NO MONEY

The entire set of 10 Volumes

SHIPPED TO YOU FREE

EASY PAYMENTS

Accept the offer now—mail the coupon today. If you decide to keep the books you can make settlement at only \$1 per month until paid for.

Send no money. Examine the books first. Use them for seven days in connection with your work, and decide for yourself that they are the most complete, the most helpful and the clearest written electrical books ever published.

This unusual offer is a sign of our confidence in the Guides.

THEO. AUDEL & CO.
72 Fifth Ave., New York, N.Y.

THEO. AUDEL & CO.
72 Fifth Avenue
New York, N.Y.

Please submit me for examination Hawkins Electrical Guides (price \$1 each). Ship at once, prepaid, the 10 numbers. If satisfactory I agree to send you \$1 within seven days and to further mail you \$1 each month until paid.

Signature.....

Occupation.....

Business Address.....

Residence.....

Since we have not yet had the pleasure of business relations with you, we shall appreciate your giving us some of reference on line below.

Reference..... P. M. July '17



33,000 sq. ft. of Additional Floor Space

Come to Detroit

The Automobile Center and

LEARN THE AUTOMOBILE BUSINESS

DETROIT trained men get preference and get jobs quickly. No other city can give what Detroit offers. Think what it means to learn in the Michigan State Auto School. Factories endorse our school, glad to employ our graduates or offer them territory in which to sell cars and start garages. Unlimited opportunities. 71% of Automobiles are made in Detroit. You're right in the Heart of the Auto Industry. Men are needed everywhere as testers, repairmen, chauffeurs, garage men, and salesmen. Hundreds of our graduates start in business for themselves.

Earn \$75 to \$300 a Month

We teach you to handle any auto proposition. You graduate in from ten to twelve weeks. Our equipment is new, up-to-the-minute, and complete. No old, obsolete motors, chassis or electrical equipment used. Students actually build cars from start to finish, getting factory training in assembling, block-testing, road-testing, everything. Special complete course in Oxy-Acetylene brazing, welding and cutting, separate from regular course. Learn to time motors, rebore cylinders, adjust carburetors, magnetos, valves and bearings quickly and accurately. Six-cylinder Lozier, Chalmers "6," Detroit "6," Overland, and 8-cylinder King are used for road instruction. We have the following completely equipped chassis:

Chalmers "6-30" 1917 chassis	Detroit Electric 1917 chassis
Detroit "6-45" 1917 chassis	G. M. C. Truck
Buick Light "6" 1917 chassis	Saxon "6" 1917 chassis
Willys-Knight 1917 chassis	Maxwell 1917 chassis
Studebaker "6" 1917 chassis	Oldsmobile "8" 1917 chassis
Hudson Super-Six 1917 chassis	Winton "6" chassis
Cole "8" 1917 chassis	Packard Twin "6" 1917 chassis

All completely equipped for students to work on. We have more than 20 motors in our block test department—2 cyl., 4 cyl., 6 cyl., 8 cyl., and 12 cyl. Our electrical department is complete, having every standard starting, lighting, and ignition system, including Delco System as used in Buick, Hudson, and Packard Twin "6."

Detroit Is the Place to Learn—Start Any Time

There are 44 auto factories in Detroit and vicinity and 140 accessories and parts factories. Our students have the privilege of going through any or all of them. We operate Starting, Lighting, Ignition Service Station. This has added thousands of dollars' worth of equipment and makes our electrical department unequalled. Students get actual experience in handling all kinds of electrical auto equipment and taking care of trouble. We have just installed a Sprague Electric Dynamometer for block-testing purposes for students' use. Ours is the only Auto school having this equipment. Auto factories need Dynamometer men constantly. Factories and garages are paying big salaries to men who know how to handle electrical equipment quickly and properly. Detroit is the automobile center. You get practical instruction. School open all the year. Enter classes any time, any day. Three classes daily; morning, afternoon, evening. All instructors are members of the Society of Automobile Engineers (S.A.E.) There is a great demand for Michigan State Auto School students. Auto factories write and phone for men constantly.

Follow the Crowd to the Michigan State Auto School. Come to Detroit

MONEY-BACK GUARANTEE

We guarantee to qualify you in a short time for a position as chauffeur, repair man, tester, demonstrator, auto electrician, garage man, or automobile dealer, paying from \$75 to \$300 monthly or refund your money. We have constantly more requests for Detroit trained men at GOOD salaries than we can supply.



THIS IS ONE OF THE FEBRUARY 1917 CLASSES



DETROIT THE HEART OF THE AUTO INDUSTRY

Additional Building and Equipment

Thousands of dollars' worth of new equipment, plenty of room for students to work, at 687-89-91 Woodward Ave., in addition to our building at 11-19 Selden Ave. Our school has grown by leaps and bounds, students come from all over the world. We are constantly adding new equipment. Our electrical department is thorough and complete.

Factory Co-Operation

We have completed arrangements with the Auto factories to put them in touch with men who intend going into business for themselves. Men who know the auto business from A to Z are in biggest demand. Remember, the price of course is based on giving full value. Graduates in the complete auto course are competent to handle farm tractors.

Auto Factories Endorse Our School

The Leading Automobile factories in Detroit, as well as in other cities, endorse our school. They have been watching our school and graduates for years and are satisfied. They are putting their latest model, complete chassis in our school for students to work on. They are employing our graduates in their factories and service stations and assisting them in opening garages and salesrooms. They allow our students to go through their factories. They need trained, competent men and are asking for more of our graduates constantly. The Michigan State Auto School in Detroit, the heart of the Auto Industry, is endorsed by the Leading Auto Factories, is receiving their hearty co-operation. What better endorsement could you ask?

Act Quickly—NOW!

Fill in the coupon; get full particulars, "Auto School News," and New 128-Page Illustrated Catalog. All absolutely free. Or better still, jump on the train, as hundreds have done, and come to the "Heart of the Automobile Industry," and learn right. We have no branches. Write or come direct to this school.

Michigan State Auto School

The Old Reliable School
307 Auto Building
687-89-91 Woodward Ave.

A. G. ZELLER, Pres.
DETROIT, MICHIGAN, U. S. A.

SEND THIS COUPON TODAY

MICHIGAN STATE AUTO SCHOOL
307 Auto Bldg., 687-89-91 Woodward Ave.
DETROIT, MICHIGAN, U. S. A.

Gentlemen: Send me absolutely FREE "Auto School News" and New Catalog, or better still, you can expect me about.....

Name.....

Street.....

Town..... State.....

Our Country needs competent trained
Auto Mechanics in the
Quartermaster's
Dept. and Signal
Corps



A Packard Truck
Used By The
U.S. Government

The United States needs thousands of truck, transport, aeroplane and motorcycle drivers. Trained competent men are needed, men who can take care of the machines, men who know how to keep them in service. Any piece of motor driven machinery the government owns or will own must be in service. Preference will be given to trained men. No matter what service the Army is doing it must be fed. If it is on the firing line it will need thousands of rounds of ammunition. The importance of trained men is very evident. Food and ammunition must be delivered regularly. Then too, the army must often be transported.

Quartermaster Department and Signal Corps Needs Trained Men

The Michigan State Auto School trains men thoroughly.

Every student learns pleasure cars, trucks, motorcycles and gasoline motors of every kind from A to Z. Graduates of the Michigan State Auto School are in big demand by the leading Automobile plants in Detroit. These factories know from actual experience that our men are thoroughly, completely and practically trained. No matter what happens to a truck or pleasure car, a Michigan State Auto School graduate is competent to repair it. Cars in the care of a graduate give highest efficiency.

This is the kind of men Our Government wants and is daily enlisting. Trained men who will be efficient themselves and keep every bit of motor driven equipment in the most serviceable condition.

This branch of the Army Service pays good salaries. There are wonderful opportunities for clean, clear headed, trained men to advance in the service and certainly now is the time to train.



Aerial View of Motor Truck Group at Ft. Sam Houston, Texas. Major F. H. Pope, Cavalry, Commanding

This view gives an idea of the large number of transport trucks that will be used in our Army. Thousands of trained men are needed and will be needed to care for these machines and keep them operating up to their highest efficiency. Trained men will be given preference and men who graduate from the Michigan State Auto School are now and have been holding big, responsible jobs in Detroit and over the country and will be able to serve their country in the most efficient way.

You Can Serve Your Country Best as a Trained Man

TRAINED Auto and Motor Mechanics are always in big demand. Men who have learned motor mechanics from beginning to end at the Michigan State Auto School can take care of every type of motor, motorcycle, automobile, truck, motor boat, aeroplane and stationary engines, and are capable of filling any of the positions in the Army where competent men are needed.

You can serve your country better as a trained man and draw more money. You can complete your course in from 10 to 12 weeks and there will be a place waiting for you. Trained men are needed most and will be paid highest salary. You can serve both your country and yourself best

and certainly in these times of preparation, you should do your part. Men who can drive and keep up motor transport trucks are needed by the Quartermaster Department.

Motorcycle and Auto Mechanics and drivers will be needed by the Signal Corps and in every branch of the service as chauffeurs for officers' cars and as messengers. Motor Mechanics will be needed for Aeroplane work — this branch of the service is very important.

Motor Mechanics will be needed on the "Mosquito Fleet" of "U boat chasers," "Tanks," tractors and trench digging machines will need Trained Motor Mechanics.

Train NOW to do your part right.

Learn a Business That You Can Use When Peace Comes

By training to serve Your Country best you are preparing yourself in one of the best paying businesses of today. You can readily see your country's need. After Peace comes you will find plenty of jobs — and hundreds of good locations to go into business for yourself. There will always be Automobiles in abundance — trucks of every size are being used more and more each year, the newspapers are full of

advertisements asking for men who know their business.

The men get from \$75.00 to \$300 a month and many foremen and superintendents get more. Good pay is the rule but the best pay always goes to the trained man.

The work is interesting as well as profitable — new things are coming on the market continually; there are hundreds of new, interesting problems coming up in the work.

TRAIN NOW AND SERVE YOUR COUNTRY BEST

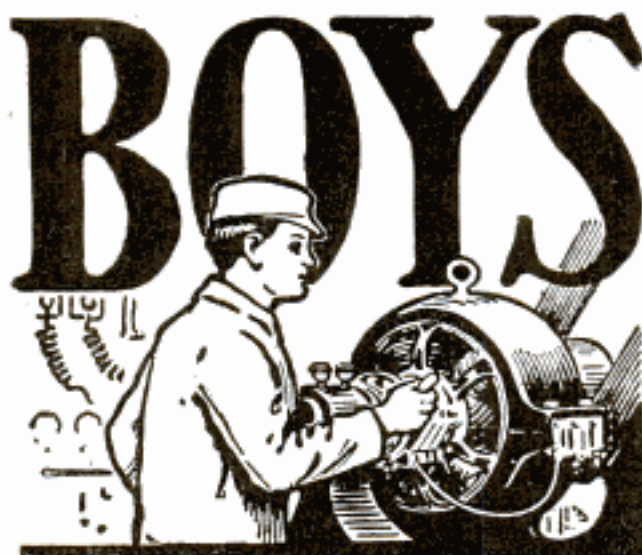

Big Money in Electricity

The Electrical industries offer wonderful opportunities to boys with a liking for Electricity. The salaries paid to trained men are large, promotion comes rapidly and, best of all, the work is fascinating.

The discovery and development of new lines (such as wireless telegraphy and telephony), from time to time, promise attractive and paying fields to those who wish to specialize. The *will to do* and *Special Training* will bring success to you.

The International Correspondence Schools can help you to become an expert in electrical work, no matter what branch you like best. Thousands of young men have already won success through I. C. S. help. You can do as well as anybody, *if you try*. Everything is made so clear that you can learn in your spare time, regardless of where you live or what your work. No books to buy.

There's big money in Electricity. Get after it by marking and mailing the Coupon today. *Finding out costs you nothing.*

INTERNATIONAL CORRESPONDENCE SCHOOLS

Box 5588, SCRANTON, PA.

Explain, without obligating me, how I can train for the position before which I mark X.

- ELECTRICAL ENGINEER
- Electrician
- Electric Wiring
- Electric Lighting
- Electric Car Running
- Electric Machine Designer
- Telegraph Engineer
- MECHANICAL ENGINEER
- Mechanical Draftsman
- STEAM ENGINEER
- GAS ENGINEER
- CIVIL ENGINEER
- Structural Engineer
- CHEMICAL ENGINEER

- ARCHITECT
- Architectural Draftsman
- Mine Foreman or Supt.
- Business (Complete)
- Bookkeeper
- Stenographer
- Advertising Man
- Salesmanship
- Window Trimmer
- Civil Service
- AGRICULTURE
- Poultry Raising
- AUTOMOBILES
- Auto Repairing

Name _____

Present Occupation and Employer _____

Street and No. _____

City _____ State _____

If name of Course you want is not in this list, write it below.

Please Mention Popular Mechanics

16 Easy Lessons

that teach you everything about automobiles. The book that tells it ALL.

The Automobile Instructor

By Clyde H. Pratt, B. Sc., M. E., Member Nat'l Society of Auto Engineers. 256 pages, 216 illustrations, cloth bound. Shipping wt., 2 1/2 oz.

New 1917 edition just out. The standard work for home-study, class-room and reference, for amateur and expert. A complete course for all who desire to master this profitable profession.

LEARN AT HOME HOW TO DRIVE AND REPAIR ALL CARS

Invaluable pointers for every car owner, driver, garage man and repair man. Adopted by Cleveland and other Auto Schools and by Boards of Education as their standard text-book. The author will answer your auto inquiries FREE. This book is guaranteed to be just what you want or your money back. (Auto schools, write for quantity prices.)

Price, postpaid \$1.50

Shrewsbury Publishing Co. 5525 South Boulevard CHICAGO, U. S. A.

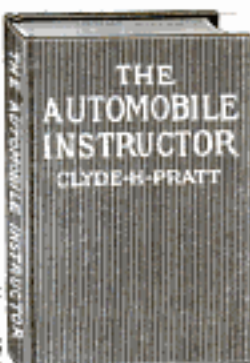

Motor Craft Encyclopedia illustrated. Tells how to build and operate Motor Boats. Best book on boats. Price, \$1.00.

This House and many others in my new book "Building Plans for Modern Homes"

will save you hundreds of dollars. One of the most complete and comprehensive books of plans ever published by any Architect. Fifth edition just off the press. One hundred and fifty floor plans and photographs of Colonial Houses, Bungalows, etc., costing from \$250.00 up; gives sizes and cost to build.

Sent postpaid for \$1.00



Frederick H. Gowling ARCHITECT
19 Tremont St., Boston, Mass.

REVERSIBLE
"Linene"
TRADE MARK



SEND 2 CENTS

in United States stamps to pay postage and we will send you FREE a SAMPLE COLLAR of our New Style "Copley." State size wanted. REVERSIBLE COLLAR CO., Dept. U, BOSTON, MASS.

NATIONAL TRADE DENTAL SCHOOL

506 S. Wabash Ave., CHICAGO, ILL.

LEARN MECHANICAL DENTISTRY—DEMAND UNLIMITED

Earn \$1200 to \$4000 yearly in mechanical dentistry. A big and growing demand everywhere for mechanical dentists—like a gold mine, unexplored. Attend this school any time of the day or evening; be taught individually and leave by actual practice, without book study. Our System, the most complete in the world, is used exclusively in this school. We are constantly called upon to fill high-salaried positions. Why not qualify for one? Be fair to yourself; find out more about exceptional opportunity we offer. Visit the school or write for booklet.

DRAWING

Learn by Mail in YOUR OWN HOME

Newspaper, Magazine and Commercial Illustrating, Cartooning, Water Color and Oil Painting. Learn drawing or painting for profit and pleasure. We can develop your talent. This school has taught thousands. Free Scholarship Award—special limited offer. Your name and address brings you full explanation and our handsome illustrated Art Annual by return mail. Don't delay, write to-day.

Fine Arts Institute, Studio 56Y, Omaha, Neb.



IF YOU STAMMER

attend no stammering school till you get my large FREE book and special rate. Largest and best school in the world curing by natural method. Write today.

Leo Wells Millard, Pres., North-Western School, Inc.
2317 Grand Avenue Milwaukee, Wis.

LEARN WATCH REPAIRING



You can learn by our modern and original system of instruction every part of the Watch Repairing Trade at home as good or better than at a shop. You can earn money while learning and secure a well paying position or start in business after completing our course of instruction. Good watch repairers are always in demand and earn from \$20 to \$35 per week. For particulars apply to the Wisconsin School of Watchmaking, Stroh Bldg., Milwaukee, Wis.

Stop Forgetting!



Prof. Henry Dickson

America's foremost Authority on Memory Training, Public Speaking, Self Expression, Lecturer and Principal of the Dickson Memory School, Hearst Building, Chicago.

The Executive



Mr. William H. Weeks, District Attorney of Putnam County, N. Y., writes:

"After a thorough trial of your method of mental and memory training, I find it to be not only first class—simply wonderful. I can truthfully say that I would not be again without the benefits I have received from your study for \$10,000."

The Salesman



O. G. Wehmeier, of the American Miner's Accident Association, Indianapolis, Ind., writes:

"I can honestly and truthfully say I am a new person. I have more friends than I really expected I could have. Everyone who has known me says that a wonderful change has come over me in the last six months. It is all due to the Dickson School of Memory."

Perfect Your Memory and You Can Command What Salary You Will

Your salary—what it is today—what it will be tomorrow—depends very much on your memory. Tricky memories—wandering minds—unable to grasp detail—have thwarted thousands in their battle for success—have held them down to bare living wages—working long hours with slight prospect of advancement—subordinates for life.

The Ability to Concentrate, to Think and Express Yourself Clearly Means Everything to Your Success

America's men of power—in business, social or public life—are uniformly men of **trained memories**. Train your memory properly and you will find yourself able to concentrate absolutely on matters at hand—to think and speak connectedly—to develop self control, to overcome self consciousness—to make your **PERSONALITY DOMINATE**. Think what this means—a better position—bigger pay—social and business success—the **EFFICIENT LIFE**.

Give Me 10 Minutes a Day and I Will Give You a "Steel Trap" Memory

That is all I ask—just ten minutes a day for a few weeks and I will train your memory just as I have trained the memories of 50,000 others. I will make your mind an infallible classified index from which you can instantly select facts, figures, faces, arguments. No matter what your age—your education—your vocation—your place of residence—I can make you "forget proof"—can train your memory for **SUCCESS**.

Special Offer!

"How to Speak in Public"—FREE!

For a limited period I am offering "How to Speak in Public," a de luxe edition, handsomely bound book—regularly priced at \$2.00—FREE to every student enrolling in my course. Full particulars of this unusual offer—together with a copy of my famous Memory Test and my remarkable book "How to Remember" will be sent FREE—simply for the mailing of the coupon or a postal. This is YOUR opportunity—mail it NOW.

The Public Speaker



Carl F. Schader, one of California's biggest men, writes:

"I have been surprised physically and mentally beyond my own expectations by the continued study of your course. Every business man, especially those called upon to talk at Chambers of Commerce, realty boards, advertising clubs and other meetings should take your course. I unhesitatingly recommend it to my many friends."

In Social Life



Roland Miller, of New York City, writes:

"What I have gotten from your method has advanced me both socially and financially and I feel it my duty to tell you of these excellent results."



The Key to Success

Stop Forgetting

**Prof. Henry Dickson, Prin. Dickson School of Memory
1705 Hearst Bldg., Chicago, Ill.**

Please send me free of charge and without obligation your booklet, "How to Remember"; also your remarkable copyrighted "Memory Test." Give me facts on your special offer of a free copy of "How to Speak in Public."

Name

Street and No.

City State

Auto Books

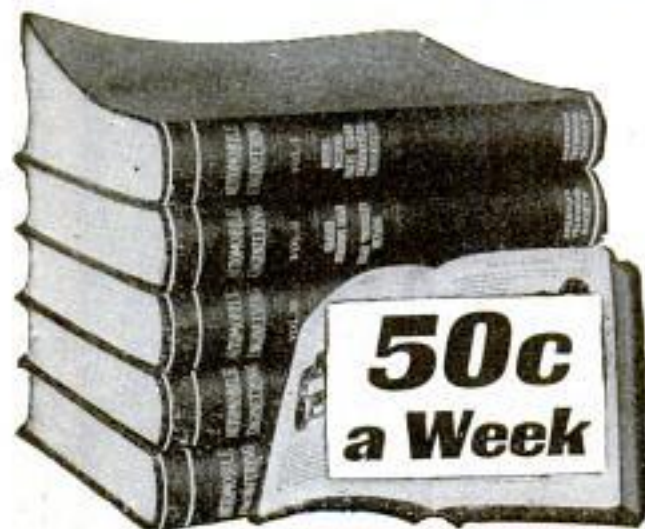

Just Out

A great automobile library is just off the press. It is called **Automobile Engineering**, and in it you will find everything about modern automobiles. Hundreds of pages explain all the new systems of ignition, starting and lighting. Welding, vulcanizing, and commercial garage equipment and operation is thoroughly covered. Five thick volumes, 5½x8 inches, flexibly bound in genuine morocco leather, gold stamped, 2,200 pages; 2,000 illustrations, tables and diagrams. Written in simple, easily-understood English, and carefully cross-indexed for quick reference.

Shipped Free

Don't send a penny. Just put your name and address in the coupon and we'll send all five volumes to you, express prepaid. Read them—study them—examine them carefully before you decide to buy. If you don't like them after 7 days—write us and we'll take them back at our expense. If you keep them, send only \$2.00 within 7 days, and then \$3.00 a month—50c a week—until the introductory price of \$16.50 has been paid. The regular price of this set will be \$25.00.

Partial List of Subjects
Motors, Welding, Motor Construction and Repair, Carburetors, Valves, Cooling, Lubrication, Flywheels, Clutch, Transmission, Final Drive, Steering, Tires, Vulcanizing, Ignition, Starting and Lighting Systems, Wiring Diagrams, Shop Kinks, Commercial Garage Equipment, Electricity, Storage Batteries, Motorcycles, Commercial Trucks, Glossary.

Consulting Service FREE

In addition to the books you get free of all charge a \$12.00 Consulting Membership. If any question puzzles you—write us. Our corps of auto experts will solve any auto problem. Ask all the questions you want for a whole year. This service is absolutely free.

American Technical Society
Dept. A119B, Chicago, U.S.A.

Please send me a set of Automobile Engineering for 7 days' free examination. If I decide to buy, will send \$2 in 7 days and balance \$2 a month until \$16.50 has been paid, when books and Consulting Membership will be mine. Otherwise will notify you and hold books subject to your order. Title not to pass until fully paid.

NAME.....

ADDRESS.....

REFERENCE.....

MAIL This Coupon

See these books before you decide to buy. Remember—don't send us a penny. Just fill in and mail the coupon. This offer is open to any person living within the boundaries of the U.S. and Can.

AMERICAN TECHNICAL SOCIETY
Dept. A119B
CHICAGO, U. S. A.

Please Mention Popular Mechanics



Learn to FLY

Build Your Own Glider

Many of the famous Aviators learned to fly with a GLIDER. It is the FIRST step in aviation. Cost of material and the ease with which such a machine can be built places it within the reach of everyone.

Send to-day for copy of book "How to Build a 20-ft. Glider." Full particulars, with detailed drawings—Postpaid.....

60 cts.

Send for our list of Military books on Preparedness.

SPON & CHAMBERLAIN
120 P. M. Liberty St., NEW YORK

BE AN ARTIST

We can teach you **DRAWING** in your own home during spare time.

Our 18 years of successful teaching prove our ability. 10 Courses in Commercial and Illustrative Drawing.

Endorsed by high art authorities.

Students trained by members of our Faculty are filling high-salaried positions. Artist's Outfit FREE to Enrolled Students. Fully equipped Residence School. Write today for Art Year Book.

OUR HANDSOME ART YEAR BOOK "FREE TO YOU"

SCHOOL OF APPLIED ART
APPLIED ART BLDG. No. 2 BATTLE CREEK MICH.

STUDY LAW 30 Days FREE

Let us prove to your entire satisfaction, at our expense, that the **Hamilton College of Law** is the only recognized resident law school in U. S., **Conferring Degree of Bachelor of Laws—LL. B.—by correspondence.** Only law school in U. S. conducting standard resident school and giving same instruction, by mail. Over 500 class-room lectures. Faculty of over 30 prominent lawyers. Guarantee to prepare graduates to pass bar examination. Only law school giving **Complete Course in Oratory and Public Speaking.** School highly endorsed and recommended by Gov. Officials, Business Men, Noted Lawyers and Students. Send today for Large Handsomely Illustrated Prospectus and Special 30-Day Free Trial.

HAMILTON COLLEGE OF LAW, 1255 Advertising Bldg., Chicago, Ill.

LEARN WATCHMAKING AND ENGRAVING

Earn while learning. Most practical watch school. Individual instructions. Graduates in great demand. Book free.

Chicago School of Watchmaking, 63 E. Van Buren St., Chicago

A GOOD POSITION

with **UNCLE SAM** is most desirable. Life positions, pleasant surroundings, good pay, steady work, short hours, promotions on merit. Both sexes. No political pull. Thousands of appointments yearly. Most thorough preparation \$5. Returned if not appointed. Full information and questions used by the Civil Service Commission free.

AMERICAN CIVIL SERVICE SCHOOL WASHINGTON, D. C.

New Book Free

Write today for the book that tells about the opportunities in the profession of Signal Engineering. Men are needed. Learn, too, how you can get the training that you need to fill the big job.

\$125 to \$300 a Month

The free book will give you just the information you want. Write for it now—immediately. Here is a golden opportunity.

Dept. 8119—1610 Wilson Ave. Riverwood Station, Chicago, Ill.

Aviation

PRACTICAL AERONAUTICS BY MAIL

EARN \$50 to \$500 a Week!



BUD MORRISS, Chief Instructor American School of Aviation

HERE is the one inexhaustible gold mine of opportunity and here is the man

who will lead you to it. It is the most extraordinary condition ever presented, owing to the sudden world-wide demand for aeroplanes. High class positions by the thousand calling for trained men—fame and fortune actually thrust at them. Salaries of from \$50 to \$500 a week are awaiting men who can fill these positions. And now, for the first time in history, a practical, home-study course in practical aeronautics is open to every man at a trifling expense. No matter what your occupation, you can prepare for a better position with big pay. Now is your opportunity.

Enter a practically untrodden field—a new profession. Seize the opportunity that has burst upon the country with tremendous force. Hustle ahead with the rapid development of the aeroplane industry which is outrivaling that of automobile and motion picture, as the quick and sure road to financial independence.

Conducted by Famous Aviators and Aeroplane Builders

The Course has been prepared by men of international reputation. Mr. Bud Morriss, the well-known aviator, is Chief Instructor and personally guides the progress of each student. He is assisted by a distinguished staff of Aviators, Aeroplane manufacturers and Aeronautical Engineers. Every Lesson, Lecture, Blue Print and Bulletin is self-explanatory, in plain terms for quick understanding. The Course is absolutely up-to-the-minute with every known fact concerning Aeronautics. You get practical, working knowledge of the very highest merit. Now is the time and this is your opportunity to step right into fame and fortune. You are needed. Where there's a will here's the way.

What Our Students Say:

Mr. Stanfield Fries

Fort Bliss, Tex.
My estimation of the new course is excellent; it could positively not be any better.

Mr. Z. Purdy

Shreveport, La.
It is hard to believe that lessons on such a subject could be gotten up in such an interesting manner.

Mr. Lloyd Royer

Haigler, Neb.
I can hardly thank you enough for the way you have personally taken up my enrollment.

Mr. Mayne Eble

Manistee, Mich.
I believe I learn more from my lessons than an aviator who takes his first lesson with an airman in a aeroplane.

Prepare NOW
for these positions

- Aeronautical Engineer
- Aeronautical Instructor
- Aeronautical Contractor
- Aeroplane Repairman
- Aeroplane Mechanic
- Aeroplane Inspector
- Aeroplane Salesman
- Aeroplane Assembler
- Aeroplane Builder

Write Now for Our Great Offer

Send the coupon for full particulars of our remarkable special offer open to you now. Find out all about the marvelous opportunities that are opening in the Aviation game. This offer is the greatest stepping stone to bigger opportunities ever known. Write today for complete literature, all free and prepaid. You are not obligated in any way. Do not waste time in thinking about it. Act! Send the coupon or a letter or a post card will do. Write at once.

American School
of Aviation
431 So. Dearborn St.
Dept. 1197
Chicago, Ill.

Gentlemen: Please send me free and without obligation, full particulars of your Course in Practical Aeronautics and your Special Offer to those who write at once.

American School of Aviation
431 So. Dearborn Street, Dept. 1197, CHICAGO, ILL.

Name.....

Address.....

Please Mention Popular Mechanics

YOU CAN DO

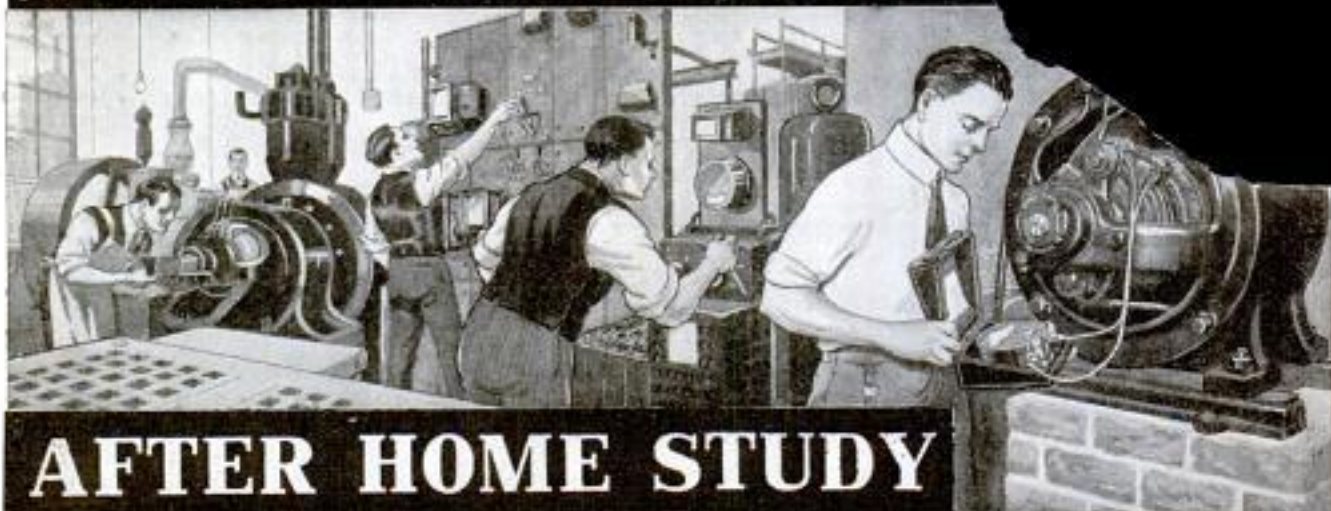

AFTER HOME STUDY

\$36⁰⁰ TO \$100⁰⁰ A WEEK

You can earn \$36 to \$100 a week and more as an Expert Electrician. If you have a common school education I can train you in a few months at home. Big lighting and power companies, municipalities, and manufacturers are always seeking trained men to handle their Electrical problems.

I Guarantee Satisfaction

Every student receives our Sealed Guarantee Bond, which guarantees to return every penny of his money if he is not entirely satisfied. No other school has made this wonderful offer, but I know the success I have brought to hundreds of my students, and I know what I can do for any ambitious young man who will give me a little of his spare time each day.

FREE ELECTRICAL OUTFIT

For the next 30 days I am giving each student an Outfit of Electrical Testing Instruments, Tools, Electrical materials, and Motor absolutely Free. My instruction is by practical methods and this outfit is used in working out the lessons. Practical training with the theory makes perfect. I am Chief Engineer of the Chicago Engineering Works, and I can give you the training that will land the big jobs and hold them.

If you are in real earnest I want to send you my new Book—"How to Become an Electrical Expert." It's free. No matter how many other schools you write to I want you to have my book—It's different because it's practical—Write today.

CHIEF ENGINEER COOKE
CHICAGO ENGINEERING WORKS
 423 Cass Street, CHICAGO, ILL.

CHIEF ENGINEER
 Chicago Engineering Works
 423 Cass St.
 Chicago, Illinois

Without obligation on my part kindly send at once, fully prepaid, particulars of your complete Practical Home Study Course in Electricity.

Name

Address

Town.....State.....

USE THIS FREE "OUTFIT" COUPON

CLASSIFIED ADVERTISEMENTS

WORLD'S BEST WANT AD MEDIUM

We have records to prove that a classified ad in these columns will find a buyer for almost anything which can be sold. Doubtless you have some article of value to some one else which you no longer need. Why not turn it into money?

Advertisements in this section, 18 cents per word, each insertion, minimum 10 words, payable in advance. To insure ads being inserted under proper classified head in the August issue, copy must reach this office not later than June 30th.

Minneapolis, Minn.

Popular Mechanics Magazine, Chicago, Ill.

Gentlemen: I am very much pleased with the results I have received from my ad in your magazine. I am leaving for the east to take a share in Allstone Kennels, Bound Brook, N. J. As soon as I am settled will see that an ad is put in your magazine to stay. I shall also pass the word to a couple of reliable breeders here. Thanking you for your service, I am, yours respectfully,

(MRS.) RUTH J. DARE,
2225 Fillmore St., N. E.

AUTOMOBILES

SOMETHING entirely new in automobiles. Junior cars for boys and girls. Real cars with real engines, 35 to 50 miles to the gallon of gas. Also special cars for cripples. Prices range from \$130 to \$250. Dealers and agents wanted for open territory. Catalog free. American Motor Vehicle Co., Manufacturers, Box 271, LaFayette, Ind.

PAINT Your Own Car for \$5. You can paint your own car as perfectly as an expert. Autoneel is not a paint—paint requires skill. Autoneel is color and luster both in one. Dries over night. Jet black and eight colors. Free Booklet "B." Autoneel Company, Rochester, N. Y.

INVENT Something; your ideas may bring wealth; free book tells what to invent and how to obtain a patent, through our credit system. Talbot & Parker, 4657 Talbot Bldg., Washington, D. C.

HOW to operate and repair Automobiles. Book 10c. Dertine, M409 W. Division St., Chicago.

THE Modern Gasoline Automobile—Most complete and up to the minute automobile book published. Recognized as the standard book on construction, operation, maintenance and repair, showing every recent improvement. Over 700 pages, 500 illustrations. Cloth. Price, \$2.50 postpaid. Send for complete description of this and other reliable automobile books. Popular Mechanics Book Dept., 6 N. Michigan Ave., Chicago.

STORAGE Batteries Simplified—A complete new treatise on action—maintenance—repair—use. Describes fully the Exide, Edison, Gould, Willard, U. S. L. and other forms. Only complete and up-to-date book on subject. 320 pages, fully illustrated. \$1.50 postpaid. Complete description sent upon request. Popular Mechanics Book Dept., 6 N. Michigan Ave., Chicago.

GET into the Automobile business, as salesman, chauffeur, garage manager, mechanic. Automobile instruction in four weeks' residence course. Send for booklet P. M., West Side Y. M. C. A. Auto School, 318 West 57th St., New York.

CYLINDERS reground, new pistons and rings fitted. Restores lost power. Write for prices, giving make and model. The Everts Machine Co., Hartford, Conn.

PATENTS for Automobile Improvements are in great demand. We have special Automobile Department in charge of experts who are in touch with demands of trade. Write for "What To Invent and List of Patent Buyers," sent free. Victor J. Evans & Co., 158 Ninth, Washington, D. C.

AUTOMOBILE SUPPLIES

SAVE 50 to 75% on auto parts: Pope-Hartford, Columbia, Peerless, Chalmers, Cadillac, Knox, Thomas, Maxwell, Buick, Pierce-Arrow, Overland and all others. Remy magnetos \$5.00, Splittdorf \$10.00, Bosch high tension \$15.00 up. Prest-O-Lite tanks \$6.00. Conn. Auto Parts Co., 1670 Main St., Hartford, Conn.

GET into biggest money-making end automobile business—replacing necessary equipment. Live, ambitious men wanted as special factory representatives, exclusive territory, taking orders for tops, top coverings, seat covers, "Stik-Tite" Windows. No experience necessary. No capital required. No competition. Copyrighted system protects you. Free catalog, samples, full details. Cincinnati Auto Specialty Company, Dept. MA-77, Cincinnati, Ohio.

233% PROFIT selling Jubilee Spark Igniters to automobile owners, garages. Sure cure for Spark Plug troubles. Sells like wildfire. Brand new. Exclusive territory. Write today. Jubilee Mfg. Co., Dept. N-5, Omaha, Nebraska.

ENGINES, Transmissions and Parts. State your requirements. Bertschy, Omaha, U. S. A.

ENGINES, all makes, Carburetors, Magnets, Steering Wheels, Repair Gears, Tires and Tubes for all cars. Parts required at cheapest prices. Write Haviland Supply Co., Long Branch, N. J.

WELDING—Automobile Welding with the Oxy-Acetylene Flame—Just out—167 pages, fully illustrated. Price, \$1.00 postpaid. Explains the actual welding of all automobile parts in a manner understandable by everyone. Popular Mechanics Book Dept., 6 N. Michigan Ave., Chicago.

DOUBLE Service Tires. Guaranteed to give good service. Size 30x3 \$5.50, 30x3 1/2 \$6.00, 33x4 \$8.80, 34x4 \$9.90, 36x4 \$9.90, 36x4 1/2 \$11.00, 36x5 \$12.10, 37x5 \$12.10. Non-skid \$1.00 extra, 10% required on all C. O. D. orders. State if Q. D. straight side or clincher type. 5% discount if cash accompanies order. Also special discount to dealers. J. Jaffes, 1319-5th Ave., New York. Branch—241 West 54th St., New York.

MAGNETOS—Bosch, all sizes and types, \$10.00 up. Remy and Splittdorf \$3.50. Coils—Steering Wheels—Auto accessories all kinds. Write for list. Johnston, West End, Pittsburgh, Pa.

SAVE 50% to 75% on your next tire purchase. Our tires are practically blow-out and puncture-proof. Guaranteed for 3,500 miles. Send for illustrated catalog No. 4 and Price List, Taxedo Auto Tire Exchange, 306 W. 54th St., New York City.

PEUGEOT Type Ford speedster patterns, blueprints, instructions \$2.00. Photographs 10c. Will Wand, Omaha, Ill.

MOTORISTS, Save Money! Chicago user writes: "Your 'Glix' reduced my gasoline consumption better than 1/5, and keeps carbon out of my machines." "Glix" \$1 postpaid. Agents wanted. Repeat proposition. Write today. "Glix," Galeburg, Illinois.

10% PROFIT—Sell Carbon Remover; no valve grinding. Auto owners want it. \$1.00 per can. Rosenthal Mfg. Co., Milwaukee, Wis.

5,000 AUTOS Test Gas-Saver Tonic with wonderful results. More power—more speed—more mileage, average 23 miles per gallon on heavy roads. That knocking—poor ignition—lost power vanishes as Carbon erasorate by using this chemical wonder. Absolutely harmless, 10-gal. test 10c. C. P. Winegar, West Fort Ann, N. Y.

TIRES—Double Tread Guaranteed for good service. Absolutely Puncture-Proof. Big—Strong—Extra heavy. 30x3 tire, \$5.00; 30x3 1/2, \$6.00; 33x4, \$9.00; 34x4, \$9.25; 36x4 1/2, \$12.00; 37x5, \$13.00. Big saving on other sizes and tubes also. Trade in your old tires. Discount to dealers. 10% deposit required on C. O. D. orders. Send for list now! State size and bead of tire. Max Liben & Co., 265B West 48th Street, New York.

AUTOMATIC Gear Cutting. Exchange your stripped fly wheel for one with steel ring gear attached. All kinds of gears made. We wreck all makes cars, sell the parts. No catalogues. Kent Auto Parts, Denver, Colo.

VULCANIZER for shop. Bargain. Vanderpool's, Springfield, Ohio.

AUTO Motors—4-cylinder, water-cooled, \$35.00 up. Buick 10-24-30 and 17, Mitchell-Everett 30—Hup 20—Flanders 20—Continental and Buda motors all sizes, Johnston, West End, Pittsburgh, Pa.

BATTERY chargers earn big profits. Engine or city current operates. Electrical knowledge unnecessary. \$15 places money-maker in your Garage, balance easy terms. Hobarts, Box MCT, Troy, Ohio.

EXPLOSION Whistle—Plts pining cup. First whistle adopted as standard equipment on any automobile. See display ad. Page 102, Buell Co., 1610 Michigan Ave., Chicago.

AUTOMOBILE Parts for most all makes of cars: Buicks, 16, 17, 19, 27, 29 and 25; Maxwells, E. M. P., Flanders, Paige 25 and 26; Overlands, 37, 38, 42 and 59; Cadillacs, '09 to 1912, Parry, Regals '09 to 1913; Oakland, Jeffery, Mitchells, 1907 to 1913; Empire, Elmore, Chalmers, '09 to 1913; Auburn, Jackson 35; Interstate 30, Hudson 20 and 33, Hupp 20, Ohio, Staver, Marion, Halladay, Velle, Ico, Peerless, Empire 25, Abbott, Lexington and many others. Pistons, connecting rods, Cam Shafts, Crank Shafts, Cylinders, Axles, Bearings and gears for most any make of car. Write us your needs. Satisfaction guaranteed. The Auto Parts Co., 4116-18 Olive St., St. Louis, Mo.

INSIDE Tyres, inner armor for Automobile tires, double mileage and prevent punctures and blowouts. Quickly applied. Cost little. Demand tremendous. Profits unlimited. Details free. American Automobile Accessories Co., Dept. P2, Cincinnati, O.

JUST Out—Modern Starting, Lighting and Ignition Systems—A new book on automobile electricity without an equal. Nearly 400 Pages, 250 Engravings. Cloth. Price \$1.50 postpaid. Complete description sent on request. Popular Mechanics Book Dept., 6 N. Michigan Ave., Chicago.

UNUSUAL Bargains in Automobile Repair Parts, Axles, Bearings, Carburetors, Complete Engines, Cylinders, Differentials, Magnets, Pistons, Radiators, Springs, Valves, Wheels and other parts for Buick, Cadillac, Chalmers, Interstate, Maxwell, Mitchell, Moon, Overland, Packard, Peerless, Regal, Studebaker, Thomas and other cars, at a discount of 50% to 75% off manufacturer's list price. Maxwell Bros., 3331 Olive St., St. Louis, Mo.

SPARK Plug or Tire Troubles? Pronto Spark Gaps, either separate or Plug and Gap as one construction, eliminate all missing, new designs. Pronto Inner-tube Patches repair any puncture or blow-out instantly. Big profit and sellers. Real Salesmen write quick. Pronto Manufacturing Co., Omaha, Neb.

AUTO Top Roof Covers Save you two-thirds price of new top; tailored to fit any car; easy to apply; \$6 to \$15, parcel post paid; seat covers \$5 and up; catalog and samples free. S. & H. Top Co., 430 Hunt St., Cincinnati, O.

GEARS for all purposes; transmission gears, bevel-drive gears, sprockets, axles. Special machine work. Must have old parts or drawing. Turley Gear Plant, 1505 N. 10th St., St. Louis, Mo.

POWER increased; carbon eliminated; results guaranteed. Write for folder. Automobile Accessories Co., (G.) Baltimore, Md.

LOW priced, fast selling auto necessity. State, local and Canadian agents write. Schulz Manufacturing Co., 105 W. Monroe St., Chicago.

TO FORD OWNERS

SAVES Wear—Stops Rattling. King Spindle Joint Anti-Rattler for Fords. Attached without detaching spindle joint. Saves trouble and prevents vibration of steering wheel. Price, \$1.00. King Manufacturing Co., Inc., 301 Washington St., Brookline, Massachusetts.

FORD Top Roof Cover \$6 and up. Easy to apply. You save two-thirds price of new top. Seat covers \$5 and up. Samples and catalog free. S. & H. Top Co., 429 Hunt St., Cincinnati, O.

GASOLINE Shut-off for Fords, stops gas leaks and prevents theft. Installed in ten minutes without tools. By parcel post \$1.00. J. H. Crawford, P. O. Box 294, Schenectady, N. Y.

L-H, GASOLINE Saver: Fords and Metz cars. No machine work; instantly applied; \$3.50 list. Sample postpaid, \$1.85. Agents wanted. Lincoln Holland, Los Angeles, Calif.

FORD Car Owners Everywhere: Demonstrate the \$10 Ajax Ford Starter. \$30 to \$50 weekly. Write for territory to Ajax Ford Starter Co., Keene, N. H.

BE our agent. Buy a Safety Ford Starter for \$5.00. Retail for \$15.00. Try one, write for particulars. Safety Ford Starter Corporation, Columbia Theatre Bldg., New York.

SLEEP in your Ford in McMillin Auto Bed \$8.50. Other small cars \$10. Free booklet on auto camping. Auto Bed Company, Box O, Bellingham, Wash.

FORD ACCESSORIES

I CAN improve your Ford 1,000%—attach Irreversible Worm Steering Gear, style used on all high-priced cars. Prevents "turning turtle," "losing the road," etc.—makes your Ford safe. Also absorbs shock and strain on driver. \$12. Satisfaction or money back. Thousands in use. Attach one now. Sell them in your locality. Good proposition. Wire or write E. H. Sprague Mfg. Co., Dept. 5, Omaha, Neb.

1,000 NEW oversize Ford pistons fitted with Gaslight rings and bushings complete, special price to Garages. John D. Silberzahn, Toledo, Ohio.

NEW 399-page book on the Ford car for every Ford owner, dealer and repairman. Deals fully with construction, operation and repair. 100 engravings. Best and most complete Ford book published. Price, \$1.00 postpaid. Also Ford Engine Chart, 25x38 in. Location of engine troubles made easy. Price, 25 cents postpaid. Popular Mechanics Book Dept., 6 N. Michigan Ave., Chicago.

MOTORCYCLES, BICYCLES & SUPPLIES

MOTORCYCLES \$50.00 and up. We are cleaning up all 1916 stock and offer you a real bargain in every machine listed. The first check or money-order gets each machine, no reserving. 23 single cylinder 1916 Flying Merkle Machines, complete, each \$120.00, 6 twin cylinder 1916 Flying Merkle Machines complete, each, \$165.00. Two-speed for either item, \$20.00 extra. All the above have regular catalog specifications with Firestone or Federal Tires, 50 Model 15, 1916 design. Miami Power Bicycles, catalog specifications, all guaranteed, each \$90.00. 5 twin chain Merkle, second hand with Spillidorf Mag. and Fed. Tires, worked over models, better than new, each \$110.00. 1 twin belt Merkle, second hand, with same specifications as above, in A-1 condition, \$85.00. 1 1913 Harley twin, chain drive, single speed, not run over 100 miles, a good buy at \$90.00. 1 Special Overhead Valve. Twin Chain Drive Merkle, motor built for racing. Has gone 80 miles per hr., \$135.00. Remember every machine is in first-class condition and the first money order received for each machine takes it. Specify a substitute in ordering. The Miami Cycle & Mfg. Co., 1520-1536 Grand Ave., Middletown, Ohio.

1917 EAGLE Motorcycles now ready. Get Circular M7, and agency proposition. Eagle Motorcycle Company, Brockton, Mass.

MOTORCYCLES: Twin Harleys; twin Indians; nineteen-sixteen models; dependable; prices right; supplies at cost. Maurice Schwartz, Windsor, Detroit, Michigan.

MOTORCYCLES Bargains—Big new list, over 100 real snags. All rebuilt, guaranteed, first-class machines from \$20 up. Write today, save 25% on your motorcycle. Western Supplies Company, 168 Hayutin Bldg., Denver, Colo.

INDIAN twin, equipped, perfect repair, \$55 cash. Rural 50, Webster, Mass.

EASY Terms on new and rebuilt motorcycles, side cars, tandems, and lighting outfit. Motorcycle Investment Company, 800 Centre St., Brockton, Mass.

1913 INDIAN twin, just overhauled, worn parts replaced, two-speed, electric starter, light and horn, new tires, speedometer, cradle frame; like new. Price \$180. Leslie Rogers, Stewartville, Minn.

SEND for our catalog. Hundreds of Used and Rebuilt Motorcycles \$25 up. Myerow Bros., 149 Berkeley St., Boston, Mass.

I SAVE you half on parts and accessories for all makes. Jones "The Paris Man," Box 691, Brockton, Mass.

1913 INDIAN Twin \$75, 1913 Excelsior Equipped \$75. 1915 Single Cylinder Pierce 5 Horsepower, \$50. 50 other makes motorcycles. Write for our latest catalog. North End Cycle Co., 9 Cooper St., Boston, Mass.

BARGAINS in used motorcycles—all machines guaranteed and in A-1 condition ready for use. Write for terms and new bulletin. Photos free. Harley-Davidson Sales Company, Birmingham, Alabama.

DON'T buy a Bicycle Motor Attachment until you get our catalogue and prices. Shaw Mfg. Co., Dept. 27, Galesburg, Kans.

MOTORCYCLES from \$25 up—New and second hand—easy terms—large list to choose from—all makes. Send 4 cents stamps for Bulletin "K." Peerless Motorcycle Co., Boston, Mass.

WANTED—Secondhand motorcycles. Send description and lowest price. Harry R. Gier Co., 888 McLaren Ave., St. Louis, Mo.

"FLYING Merkel"—1917; just overhauled, \$85. Orville Nelson, Freeman, Mo.

MOTORCYCLES. Side Cars and Cycle-cars. Their Construction, Management and Repair—The only complete work published on this subject. The dealer, mechanic and rider will find this an excellent treatise. 550 pages, cloth, 350 illus. Price, \$1.50 postpaid. Complete description sent upon request. Popular Mechanics Book Dept., 6 N. Michigan Ave., Chicago.

MOTORCYCLES—New 12-H. P. Peerless Twin. Direct chain drive—sensation of the year—1918 Models ready only \$79 with the order—balance easy monthly payments. Send 6 cents stamps for Catalog and special proposition. Peerless Motorcycle Co., Boston, Mass.

LARGE stock of rebuilt motorcycles, new parts for all makes 25% discount; second-hand parts, good as new, 50% discount. Motorcycle Parts Mfg. Co., Chicago.

BIG bargains in second-hand motorcycles, \$25 up. Indians, Harleys, Thors, Excelsiors and Merckles. Write for description. Howard A. French & Co., Baltimore, Md.

BIG bargains in good motorcycles we have taken in exchange on new ones. Send for special bargain list. Shaw Mfg. Co., Galesburg, Kans.

A REAL bargain in second-hand motorcycles. We have an overstock of all makes, such as Indians, Harley-Davidsons, Excelsiors, Pops, Merckles, and 4-cylinder Hendersons. All are in A-1 condition and fully equipped. If interested in buying a motorcycle write for our Bargain Bulletin No. 5 giving description and prices from \$35 up. Gotham Sporting Goods Co., 57 Warren St., New York City.

MOTORCYCLE cylinders reground, fitted with new piston and rings, \$5.00, guaranteed. Muncie Piston Co., Muncie, Ind.

WANTED: We pay cash for used motorcycles or take them in on exchange for new machines. Write with complete description. State condition of tires, frame, motor, make and model. Shaw Manufacturing Co., Dept. 157, Galesburg, Kans.

WANT to sell your motorcycle? I have a method which has sold many. Write me today for free information. F. W. Johnson, Room 900, 78 E. Madison St., Chicago.

ONE Hundred Motorcycles, \$20.00, \$30.00, \$40.00. Being overstocked will sacrifice Indians, Harleys, Excelsior, Yales, Thors. Lifetime chance to get a machine cheap! Fifty Police Hendersons and Harleys \$100.00 up. No reasonable offer refused. Write for illustrated bargain sheet. Tires half price. Money refunded if not satisfied. W. E. Wanderses Company, 129 Gratiot Ave., 1561 Woodward Ave., 2996 Woodward Ave., Detroit, Mich.

1915 HARLEY-DAVIDSON Speedster, \$160.00. 1914 Two-speed Harley-Davidson, equipped, \$70.00. Box 1685, Atlanta.

BICYCLES \$7.50, tires \$1, tandems \$15. Repairing. McHughald, 300 N. Fifth Ave., Chicago.

WELDING

DON'T scrap aluminum parts—trial bar 50c. So-Luminum, new great welding compound for aluminum. Perfect substitute for acetylene welding. $\frac{1}{2}$ time and cost. Use gasoline or blow torch. Booklet 1 and directions, \$3.00 per pound. So-Luminum Mfg. Co., 1790 Broadway, New York.

SIMPLE Soldering, both hard and soft—82-page book telling how to join metals. Do your own repairing. 52 illustrations. 25c postpaid. Popular Mechanics Book Dept., 6 N. Michigan Ave., Chicago.

ONY-ACETYLENE Welding and Cutting, Electric and Thermit Welding. Brand new book of practical instruction in this process. The workman will find all necessary information for handling any kind of welding. 215 pages, fully illus. Cloth, \$1.00; Leather, \$1.50 postpaid. Popular Mechanics Book Dept., 6 N. Michigan Ave., Chicago.

AERONAUTICS

THE American School of Aviation offers new and complete Courses in Aviation. Exceptional opportunities open for men who write today for our Special Reduced Price Offer. American School of Aviation, Dept. 7927, 431 South Dearborn St., Chicago.

AEROPLANE Instruction—Thousands of aeroplane mechanics needed, right now. Will give 4 weeks' course on full-sized airplanes for \$110. No book study, but actual work. G. P. O., Box 1186, N. Y. C.

THE National Aero Institute offers you the opportunity to learn the principles and mechanics of Aviation in your spare time at home. Hundreds—yes, thousands—of men are wanted in this new field at once. Opportunity is ripe. Fame and financial independence await you. Write for free particulars of the training we offer. You can save time and money—you can put yourself ahead of the men who must go through apprenticeships on aviation fields—by equipping yourself as an Aviation expert in short time at home. Very limited introductory offer now in force. Write for details while it lasts. National Aero Institute, Dept. B119, Morton Bldg., Chicago, Ill.

GET our latest Aeroplane Book containing full information about "Ideal" Model Aeroplanes, parts, plans, etc. 5c postpaid. Ideal Aeroplane Co., 82½ West Broadway, N. Y.

TANDEM Monoplane Glider, full size, how to make—Our book "Amateur Mechanics No. 6" contains a complete detailed description of how to make one and also over a hundred other interesting articles. Price, 25c postpaid. Popular Mechanics Book Dept., 6 N. Michigan Ave., Chicago.

BI-PLANE Glider, full size, how to make—Our book "Amateur Mechanics No. 2" contains a complete detailed description of how to make one and also over a hundred other interesting articles. Price, 25c postpaid. Popular Mechanics Book Dept., 6 N. Michigan Ave., Chicago.

BUILDING and Flying an Aeroplane—160-page handbook covering the building of small models and full-sized gliders and machines. In both biplane and monoplane models the well-known Curtiss and Bleriot types are followed. Fully illustrated with detail drawings. Price, \$1 postpaid. Popular Mechanics Book Dept., 6 N. Michigan Ave., Chicago.

AVIATION. Send for free and prepaid literature on Aviation. Courses in Practical Aeronautics and Flying. Learn how you may prepare yourself for this fascinating and big paying profession at home. Special Limited Offer to all who write immediately. American School of Aviation, Dept. 7917, 431 South Dearborn St., Chicago.

WORKING drawings of small tractor biplane, latest model, 16 to 25 H. P. complete in every detail. You can build your own aeroplane easily at a very low cost. Wood or metal aeroplane parts at a reasonable price. Write for particulars. Northern Aircraft Co., Bay City, Mich.

ONLY \$2.00 brings you Hayward's "Practical Aeronautics," including "Building and Flying an Aeroplane." If not satisfactory, return in five days and get your money back. 750 pages; 210 illustrations. American Technical Society, Chicago.

INVENT Something; your ideas may bring wealth; free book tells what to invent and how to obtain a patent, through our credit system. Talbert & Parker, 4659 Talbert Bldg., Washington, D. C.

"LEARN to Fly." No books, all lessons given in air. Ecker School of Flying, Syracuse, N. Y.

AVIATION dictionary, \$1; cloth, \$1.50. Languages Publishing Company, New York.

HEADQUARTERS for airplane supplies. See our catalog before you order. Eight cents postpaid. Chicago Aeronautical Supply Co., Chicago.

HEATH Aerial Products and Supplies. Why are they the best and cheapest? It's the old story—quantity production. Aeronautical supply catalogue, 6 red stamps; propeller catalogue, 3 red stamps. Heath Aeroplane Co., formerly Heath Aerial Vehicle Co., Chicago.

AVIATION Motors, all makes, up to 150 H.P., \$250 up. Complete aeroplanes, all types, \$500 up. State your needs. Aero Exchange, 38 Park Row, N. Y. C.

PATENTS Wanted in Aeronautics—U. S. Government spending millions in this class for Army and Navy. Our Aeronautic Department will give full information on this subject upon inquiry. Write for "What to Invent," sent free. Victor J. Evans & Co., 169 Ninth, Washington, D. C.

BOOKS AND PERIODICALS

100,000 **SECOND-HAND** books all kinds for sale, 25c each; leather, velvet, cloth and other costly bindings; some cost \$25.00 new; Medicine, Surgery, Agriculture; Mechanical; chemistry, philosophy, encyclopedias, law; scientific; technical; mathematics; history; fiction; religious; text; school, etc. Send 10c stamps for big catalogues (none free). "M." McCarthy, 1236 Arthur Ave., Chicago, Ill.

WORLD-ROMIC, Languages Masterkey, 50c. Languages Publishing Company, New York.

MAGAZINES at rock bottom prices. Send today for our free catalog "P." S. C. Hanson Magazine Agency, 4926 Kinzie, Chicago.

REESE Publishing House, Mt. Pleasant, Pa., can supply any book published. Catalogs free.

PATRIOTIC War Atlas, Wilson Message, etc., 25c. Stovers, Millersburg, Pa.

CORRESPONDENCE Lessons, Books, etc. Social and professional. Literature free. Science Institute, MC1336 Morse, Chicago.

AM selling brand-new technical books at reduced prices and on easy terms. Send for list of sets on Shop Practice, Carpentry and Building, Plumbing, Automobile Repairing, and Electrical, Steam and Civil Engineering. C. H. Ward, Room B119, Drexel Ave. and 38th Street, Chicago.

UTILIZE Your Table Scraps. Learn how to turn scraps into profits. Eat more poultry and eggs. Little space, big returns. Practical magazine tells how to house, feed and raise poultry at minimum cost. Only 50c a year. Sample copy 5c. Big Four Poultry Journal, 442 So. Dearborn, Chicago, Ill.

ENGINEERS' questions and answers for license by Hobson, for twenty-five cents, postpaid. Send stamps. Reilly's Book Store, Philadelphia, Pa.

BINDER for Popular Mechanics magazines. Best adjustable magazine binder on the market made especially to hold any number from one to six copies of this magazine with name "Popular Mechanics" in gold letters on front cover. No laces or cutting or perforating of pages necessary. Simple, unique adjustment; handsome, durable and neat. We buy in quantities and can offer our readers this regular \$1.50 binder for \$1.25, all shipping charges prepaid. Address Popular Mechanics Book Dept., 6 N. Michigan Avenue, Chicago.

NEW 1917 Catalog of Latest and Best Books on Mechanical, Electrical and Industrial Subjects, comprising 128 pages and adequately describing more than 400 works. Sent free upon request by Popular Mechanics Book Dept., 6 N. Michigan Ave., Chicago.

U. S. ARMY Infantry Drill Regulations, 58 cents. Field Service Regulations, 80 cents. Cavalry Drill Manual, 80 cents. Small Arms Firing Manual, 80 cents, cloth, postpaid. Also send for complete list of over fifty standard military and naval books. Popular Mechanics Book Dept., 6 N. Michigan Ave., Chicago.

FIND Out for Yourself what to invent and how to procure and sell a patent for the same. My book, "Inventor's Universal Educator," covers the matter from A to Z. 140 pages, elegantly bound. Also contains 600 mechanical movements and 50 perpetual motions. Price \$1.00, postage free. F. G. Dieterich, 651 Ouray Bldg., Washington, D. C.

USED Books, Bargains, Catalog, Higgins's, A-2441 Post, San Francisco. (Books Bought.)

EDUCATIONAL AND INSTRUCTION

WILL-POWER and body efficiency developed. Insure success. "From a failure to success in one year." \$1.00 for course I followed. Send 10c for helpful autobiography letter and particulars. S. M. Massett, Dept. 4, 241 Meade St., Glendale, Long Island.

MASTERKEY to Spanish Pronunciation, 37c. Languages Publishing Company, New York.

THOUSANDS have tried soldering and failed. I teach you for one dollar in four lessons the art of soft soldering tin, brass, etc. Fine in experimental model work. Established 1888. Reference—Chamber Commerce. Schultz, 511 Walnut, Cincinnati, Ohio.

YOU can learn Cartooning, Commercial Art, and Lettering, from my original hand drawn examples. Particulars free. D. Freeburn, Hicksville, Ohio.

SHORTHAND—The Gregg writer is first choice everywhere. Modern system, thoroughly dependable. Gregg writers are a success. Let us tell you of some. Fairfield School of Shorthand, Davis Bldg., Fairton, New Jersey.

MORRIS' "DE Bookkeeping and Stenography Billed Down," 50c; practical home study. B285, Nashville, Tenn.

ARTISTS in big demand. \$50 paid for one drawing. Learn quickly at home, in spare time. Commercial Art, Cartooning, Illustrating, Designing. Artist's Outfit Free to new students. Handsome book free explains. Write now. Washington School of Art, 1147 H St., N. W., Washington, D. C.

"SUCCESS" Natural and Scientific Laws governing Success in Life's affairs. 158 pages, 50c. Circular free. Aellig Company, PM1518 Belfield, Atlantic City, New Jersey.

ELECTRICITY—Learn it at America's largest and best equipped trade and Engineering School. Here you are taught by practical work on finest equipment. No books, no classes, no useless subjects to waste your time. 18 years of success. Write for our big free book of trades. Course Trade & Engineering Schools, Dept. 719Y, Chicago, Ill.

GOOD Opportunities for Veterinarians. Send for Catalog. Grand Rapids Veterinary College, Grand Rapids, Michigan, Dept. Z.

WAR Atlas—Large 20-page (11x15 in.) Atlas of the War in Europe, containing large colored scale maps of the Battle-ground, showing Europe, Austria, Servia, Germany, England, Belgium, France, Russia, Italy, Greece, the World, etc. Special data showing comparison of armies and navies involved, pictures of rulers, etc. Price 20 cents postpaid. Popular Mechanics Book Dept., 6 N. Michigan Ave., Chicago.

IDEAL Atlas—Just Published—Contains large scale maps, yet is a book of handy size. Has special maps of all war zones in addition to all regular maps found in a good atlas. Is self-revising, that is, contains a certificate entitling the purchaser to a supplement of new maps after the war is over. Genuine flexible leather binding. 512 pages, 256 pages of maps, 256 pages of text. Price \$2.50, cloth binding \$1.65 postpaid. Popular Mechanics Book Dept., 6 N. Michigan Ave., Chicago.

FINGER Print Instructor—A text book for the guidance of finger print experts and an instructor for persons interested in the study of finger prints. Book based on the Henry System and prepared by an expert. Cloth, 155 pages, illustrated. Price, \$2.00 postpaid. Popular Mechanics Book Dept., 6 N. Michigan Ave., Chicago.

MOULD making for ornamental casting, particulars, 200 illustrations, free. Mahler, Woodhaven, N. Y.

SHORTHAND—The New Way. Boyd System. The Wonder of the Age. Learned in 30 Days in Spare Time. 100 to 150 words a minute. Writers hold World's Record. Send today for Special Offer. Catalog and Sample Lesson, Chicago Home Study Schools, 551 Reaper Block, Chicago, Illinois.

WANTED—New Ideas. Write for list of Patent Buyers and Inventions Wanted. \$1,000,000 in prizes offered for inventions. Our Four Books sent free upon request. Victor J. Evans & Co., 167 Ninth, Washington, D. C.

ARTIFICIAL Marble, sanitary flooring, complete instructions, \$1. Ornamental casting, concrete, plaster, papiermache, decorations, garden furniture, stationary, rubber moulds, electrometallurgy. Particulars, 200 illustrations free. Mahler, D-721 Woodland Ave., Woodhaven, L. I., New York.

ROPP'S Calculator and Short-Cut Arithmetic—Shows the answer as quickly as a watch shows the time to all problems likely to occur in office, store, shop, bank, farm or factory. Over two million sold. Price, vest pocket size, 50 cents; leather, pocket size, \$1.00; large, desk size, \$1.25 postpaid. Complete description sent upon request. Popular Mechanics Book Dept., 6 N. Michigan Ave., Chicago.

LEARN Drafting—One of the most practical subjects, and indispensable in many occupations. Individual study at home without an instructor may be successfully carried on with the aid of our book. "A Practical Course in Mechanical Drawing," 160 pages, 157 drawings. Cloth. Price 50 cents postpaid. Popular Mechanics Book Dept., 6 N. Michigan Ave., Chicago.

TRADE SCHOOLS

ELECTRICITY, Plumbing, Bricklaying, Mechanical, Architectural and other Drafting Courses. Motion Picture Operating taught by practical work. Largest, best equipped practical trade school in America. Short time to learn. Small cost, easy payments. Write for big illustrated book; it's free. Coyne National Trade Schools, Dept. 189Y, Chicago, Ill.

HILES' Watchmaking and Engraving School, the largest and best equipped school in the West. 717 Market Street, San Francisco, Cal.

LEARN Decorating, Paperhanging, Graining, Sign Painting, Showcard Writing by Practical Training. Catalog Free. Chicago Painting School, 131 North Fifth Avenue, Chicago.

TELEGRAPHY

TELEGRAPHY—Learn at home. Our semi-automatic teaching machine with correspondence course turns the trick. Write for particulars. Simplex Company, Station A, Jacksonville, Florida.

THE Telegraph Instructor—Sixth and Revised Edition, just from the press—containing 348 pages of valuable information pertaining to railway and commercial telegraphy. Many illustrations showing how to erect a line, the different telegraph instruments, switch-boards and their different connections; numerous colored illustrations of train movements and semaphore signals as used by all railroads. Complete in every detail and written in language easily understood. Used by many telegraph schools as a text book. No student of telegraphy or telegraph operator can afford to be without this book. Price \$1.25 postage prepaid. Money returned if it doesn't please. Popular Mechanics Book Dept., 6 N. Michigan Ave., Chicago.

TELEGRAPHY—Morse and Wireless—taught at home in half usual time and at trifling cost. Omnigraph Automatic Transmitter will send, on Souther or Buzzer, unlimited messages, any speed, just as expert operator would. Adopted by U. S. Govt. and used by leading Universities, Colleges, Technical and Telegraph Schools throughout U. S. Catalog free. Omnigraph Mfg. Co., 41-G Cortlandt St., New York.

TELEGRAPHY—Morse and Wireless—also Station Agency taught. Graduates assisted. Cheap expense—easily learned. Largest school—established 42 years. Correspondence courses also. Catalog Free. Dodge's Institute, 15th St., Valparaiso, Ind.

PICTURES, POSTCARDS, PENNANTS

MAKE friends by exchanging postcards. Membership only 10c. Universal Exchange, 77 Franklin St., Jersey City, N. J.

POSTCARD Collectors, attention! If you wish to secure a fine collection of postcards, try our dainty card exchange. Membership 10c. Rose Postcard Society, Portland, Oregon.

IF you really want to exchange postcards, try our splendid club. Lists circulate in many countries. Membership, 10c. Halcyon Club, Box 133, Erie, Pa.

BARGAIN—16 assorted post cards only 10c. This ad with order brings a gift. Florence Ackerman, Plainville, Kans.

EXCHANGE Postcards, Best Club, 10c. Jolly Card Exchange, Decatur, Indiana.

CROSS-SECTIONAL view of ocean liner "Britannic," showing interior arrangement of ship in colors, size, 14x20 inches, on heavy plate paper for framing or hanging. Very interesting. Reproduced from front cover design of July, 1914, Popular Mechanics. Will be sent postpaid to any address in the world on receipt of 4 cents in stamps to cover packing and mailing. Popular Mechanics Magazine, 6 N. Michigan Ave., Chicago.

PATRIOTIC NOVELTIES

THE Declaration of Independence. Fac simile of the original. 19x28 inches for framing. 10 cents, postage paid. Lincoln Publishing Company, Dept. A, Cincinnati, O.

ALLED flag pins. Something new, American, English, French, 15c. "Niseo," Peru, Indiana.

"THE President's War Message," Booklet form, postpaid, 5c (postage). Miller, 2133N-10th, Philadelphia.

TRANSFER American flag emblems; beautiful design; sells for \$1.00; sample 25c. J. Cifra, 2628 Marion Ave., Cleveland, O.

TRANSPARENT American Flags for auto lamps, windows and wind-shields. Two for 25c. Harry Wardell, Sea Bright, N. J.

CAMERAS AND PHOTO SUPPLIES

CAMERA—Kodak Bargains. New—right from the factory—Eastman 2 C Autographic Kodak Jr. with B. R. lens \$14.00 model—our price \$11.85. Anseo No. 2 V.P. with f: 7.5 lens regular \$18.00 model—our price \$15.00. 3A Rexo Jr. with B. R. lens and special Ilex shutter \$12.00 model—our price \$10.80. Our big camera catalog shows now—right from the factory—and slightly used articles at from 10% to 50% saving. Every item guaranteed—10 days' free trial to insure your complete satisfaction. Save money—write for catalog now. See our display ad on page 113. David Stern Company. Everything in Cameras—in business since 1885. 718 Davaco Bldg., 1047 Madison St., Chicago.

REAL Bargains—in Kodaks, Graflex, Anseo Rexo and Premo Cameras; also Lenses of every description. Save 25 to 60% on slightly used equipments fully as good as new. Money back if unsatisfactory after ten days' free trial. Write at once for our free Bargain Book and Catalogue listing hundreds of slightly used and new cameras; also supplies at extraordinary low prices. \$22.50 3A Autographic Kodak \$13.25. \$6 Vest Pocket Kodak \$3.25. \$67 5x7 Goerz Dagor in Compound Shutter \$43.75. No matter what Camera you want, we can save you money. Our prompt and fair dealing will please you. Central Camera Co., Dept. E-2, 124 So. Wabash Av., Chicago, Ill.

ENLARGEMENTS made from your negatives at low prices. Write for particulars and catalogue on photo supplies. Fahrenwald Bros. & Co., Kildare & Cortland, Chicago.

EVERY Amateur needs "Experiments with a Camera."—New, interesting book. \$1.00. Sparrow Publishing Co., Mesaba Block, Duluth, Minn.

FREE. Send negative for sample print. Film developed 5c per roll, print 2 1/2 x 3 1/4 3c each; 3 1/2 x 4 1/4 4c each. 8x10 enlargement 25c each for your own negative. Send for price list. M. A. Leese, 611 9th St., Washington, D. C.

PRINTS, any size, 3c each, first-class work only. Films developed 10c per roll. Prompt Service. Postage paid. Grant Co., 336 Brandeis Theater, Omaha, Nebr.

AMATEURS—For next sixty days will develop any six exposure roll under 4x5, make prints and one 8x10 enlargement for 4c. We make slides, and are specialists. Motion Picture Products, 3238 Harrison, Chicago, Ill.

SAVE Camera Money. Deal with Specialists. Everything in Photography. A thousand and one Camera Bargains always on hand for you to choose from. You save nearly half. Everything Guaranteed. Bass Camera Co., Dept. 55, 169 N. Dearborn St., Chicago.

FILMS developed, 10c; prints, 3c to 5c. A reputable incorporated company conducting largest existing plant. Price list and special offer. Enlargements our specialty. Chicago Photo Finishing Co., 54 W. Lake St., Dept. A, Chicago.

FILMS developed 5c, any size. Prints 3c each, all sizes. Free enlargement with first \$1.00 order. Johnson's Studio, Oswego, N. Y. 3 months' instruction in Photography \$10.00 at studio.

MAKE Beautiful transparent photos on watch dials, cases, etc. Complete process and working instructions 25c. C. Johnson, 4519 N. Whipple St., Chicago.

FILMS Developed, 10c, all sizes. Prints 2 1/2 x 3 1/4, 3c; 3 1/2 x 4 1/4, 4c. We give you Profit Sharing Coupons. 24-hour service, all work guaranteed. Send negatives for samples. Girard's Com'l Photo Shop, Holyoke, Mass.

TRIAL Offer. Roll Films Developed and 8 prints, or 8 reprints for 8 cents. Joe O'Hern, Hannibal, Mo.

"ECONOMIZE." Attach a film Economizer to your camera; use all of film for exposure and get seven pictures on six-exposure film. Pays for self many times over. Price One Dollar. State name of camera, film used and size. Satisfaction guaranteed. Voigt Mfg. Co., Sheboygan, Wis.

FILMS developed, 10c roll. Packs 20c; Prints, Brownies, 2c; 1a, 3x4, 3x5 and Post Cards, 3c. Returned next day. Prepaid. Kodak Film Finishing Co., 112 Merchants Station, St. Louis.

FILMS Developed, any size 5c. Any size prints 3c. 8x10 enlargements 25c. Work returned same day received. Address Camera Shop, Box 69, Ann Arbor, Michigan.

SENSATIONAL discovery—Autol develops and fixes films or plates in one operation. Automatic and sure; develops until just right, then fixes. Make it, use it, and supply your county. Formula \$1.00. Be the first. Chromatoseope Company, Norwalk, Conn.

INVENTIONS Wanted in Motion Pictures and Photography. Special department for these classes of invention. Advice. What to Invent and List of Patent Buyers Sent Free. Victor J. Evans & Co., 159 Ninth, Washington, D. C.

No. 2 HARVEY Exposure Meter for Kodaks, Graflex and other Cameras. New Exposures and Films, Plates, Interiors, Portraits and Night Photography. \$1.25. Ask your dealer or G. Harvey, 105 S. Dearborn, Chicago.

BQUIP your camera or Kodak with a Wollensak lens and shutter and obtain the best possible results. Beautiful descriptive catalogue "B" sent on request gratis. Wollensak Optical Co., Rochester, N. Y.

BIG Money Saved on Photographic Lenses and Apparatus—goods exchanged; repairing done. Ralph J. Golsen, 5123 Kenmore Ave., Chicago, Department P.

NEAT Permanent Finishing. All postage paid. Prompt service. Mailing boxes furnished. Get prices and Samples free. C. Grant Myers, Summit, New Jersey.

OPTICAL SUPPLIES

EYEGLASSES made clearer and weak eyes improved by using the "Chamois" eye-glass cleaner. Fits any hand. 10c each postpaid. Knapp Mfg. Co., 1428 N. Ashland Ave., Chicago, Ill.

MICROSCOPE, magnifies 3,600 times. Every microscope guaranteed to give a clear and perfect definition of objects. Price 25c. Catalogue for stamp. Specialty Mfg. Co., 31, Box 144, Milton, Pa.

MOTION PICTURES

WRITE Moving Picture Plays; constant demand; big prices paid; past experience or literary ability unnecessary; details free. Glesco Co., 318 Whiteman St., Cincinnati, Ohio.

MOTION Picture Operation, Stage Electrics and Illusions—The only practical handbook and guide published for motion picture operators, theater electricians and managers. A thoroughly practical and useful book, covering the subject comprehensively. Pocket size, leather, 393 pages, fully illustrated. Price \$2.00 postpaid. Popular Mechanics Book Dept., 6 N. Michigan Ave., Chicago.

WRITE for Free Copy "Hints on Writing and Selling Photoplays, Short Stories, Poems." Atlas Publishing Co., 271, Cincinnati.

MAKE Big Money in moving-picture business. We start you and furnish guaranteed outfit on easy payment plan. Easy to accomplish. Catalog free. Monarch Film Service, 228 Union Ave., Dept. P, Memphis, Tenn.

MAKE a complete Motion Picture Camera and Projector from instructions given in our book Amateur Mechanics No. 4. Full details given. Not hard to construct. Worlds of enjoyment taking and exhibiting subjects dear to the heart. Price of book only 25c, postpaid. Popular Mechanics Book Dept., 6 N. Michigan Ave., Chicago.

ARE You a Movie Type? Many of the greatest stars were discovered by accident. You want to know if you have the natural qualifications that bring \$51,000 salaries. The book Motion Picture Acting tells you this, also 191 screen favorites show you how they register 499 human emotions. Use of cosmetics, costume requirements and color schemes also treated. Price cloth 75 cents postpaid. Popular Mechanics Book Dept., 6 N. Michigan Ave., Chicago.

JUST Out—Concise book of facts. Teaches you to plan, write and market Movie Plays, including sample scenario, 25c in coin. Benacott Booklet Co., 8 Spring Lane, Boston, Mass.

MAKE money writing Photo-plays; details free to beginners. No correspondence course. Producers League, 230 Wainwright, St. Louis.

BIG Profit Nightly—Moving Picture Business—small capital starts you, easily accomplished. Teach you—furnish everything. Ralph J. Golsen, 5123 Kenmore Ave., Chicago, Dept. M.

BUSINESS OPPORTUNITIES

ERECT chain six-foot Advertising Thermometers in public places. Each nets you \$120 first year; \$170 succeeding years. Valuable "Opportunity" booklet telling how sent for dime. Winslow Cabot Company, 22 Congress Bldg., Boston, Mass.

BIG monthly income for anyone operating Premium vending machines. Circulars free. Premium Vending Co., 3470 Scranton Rd., Cleveland, Ohio.

BUILD a profitable business of your own. Let us start you in the collection business. No capital needed; big field. We teach secrets of collecting money; refer business to you. Write today for Free Pointers and new plan. American Collection Service, 101 State Street, Detroit, Mich.

CONDUCT a profitable Candy Kitchen; very small capital required; booklet free. Kennon School, 509 Wells St., Dept. A, Chicago.

INDEPENDENCE and fortune quickly attained in the Manufacturing Mail Order business. I furnish Formulas, Manufacturing processes and Trade Secrets in all lines. Sold under positive guarantee; 18 years' practical experience, Revision and improvement of Formulas and Processes—reduction of manufacturing cost—utilization of waste materials, etc., a specialty. Booklet, Formula List, and Valuable Information Free. W. L. Cummings, Ph. D., 127 Standard St., Syracuse, N. Y.

"MAIL Order News"—America's Only Exclusive Mail Trade Magazine. Established 1905. Noted for its fearless and impartial policy. Teaches truth about Mail Order Business. Replete with money-making opportunity plans. The Guidepost for beginners. Has saved for its readers thousands of dollars. Countless numbers of readers admit this magazine would have saved them time and money had they known of it sooner. Start right. Profit by their mistakes. New readers can have one 50c sample copy for 25c. Send quarter today and receive free a truthful cycloper as premium. Mail Order News Corporation, Dept. A, Newburgh, N. Y.

500 FORMULAS, including Resilvering Mirrors—Renewing Dry Batteries, Luminous Paint, Luminous Ink, 25c. Ideal Book Shop, 3315-C7, Belleisle Ave., Chicago.

PATENTS and Inventions for sale or on royalty. My clients have valuable inventions for market. No better investment for manufacturers or individuals. Full information without charge. Mention line of invention interesting you and data will be sent. Richard B. Owen, Patent Lawyer, Owen Building, Washington, D. C.

TERRITORIES for sale—European File Renewing Process. Costs less than half cent per file to sharpen. Send us a sample worn out file. Universal File Renewing Co., 1246 East Jefferson Ave., Detroit.

SLOT Machines, Headquarters for premium machines. 1016 Germantown Ave., Phila.

SILVERING Mirrors—My exclusive French Tartaric Method opens enormously profitable business. Booklet Free. H. Barstow, 514 23rd St., Oakland, Calif.

WOULD a paying, independent business of your own (not a mail order or agency scheme), appeal to you? If so, ask for proposition of Fourpoint Co., Sturgis, Mich.

PATENTABLE Ideas Wanted—Send for 4 free books. R. B. Owen, 30 Owen Bldg., Washington, D. C.

MAKE Music Rolls for profit and pleasure, with simple perforator. Splendid opportunity. Particulars free. The Lesbarjan Mfg. Co., Hamilton, Ohio.

MAIL Order Dealers. Let the 4 in 1 coupon plan increase your profits. Sell valuable instruction systems by cut price coupon under money back guarantee. Big margin. Small selling expense. Complete plan, sample coupons and bargain bulletin sent on request. Mail Dealers' Coupon System, 519 So. Dearborn St., Chicago.

\$46,000 PER annum net profits rentals each 100 machines costing \$125. Moving picture melody producer. Perfect synchronization. Illustrated June Popular Mechanics. Open to propositions. Carl Brown, Columbus, Ohio.

MANUFACTURERS, Promoters and Patent Buyers are invited to write us stating the line of invention in which they are interested, as we can supply their wants in any class of patents. Victor J. Evans & Co., 162 Ninth St., Washington, D. C.

BIG money in promoting inventions. Write Adam Fisher Mfg. Co., 2061D Railway Exchange, St. Louis, Mo.

ENTER a new business. Earn \$3,000 to \$6,000 yearly in professional fees making and fitting a foot specialty, openings everywhere, with all the trade you can attend to; easily learned by anyone at home in a few weeks, at small expense; no further capital required, no goods to buy, job hunting, soliciting or agency. Address Stephenson Laboratory, 11 Back Bay, Boston, Mass.

WE start you in business furnishing everything; men and women make handsome income weekly operating our "New System Specialty Candy Factories" home or small room anywhere; no canvassing. Opportunity lifetime; booklet free. W. Ragsdale Co., East Orange, N. J.

INVENTORS: We develop and perfect inventions, make models, dies, tools. Metal stamping and special manufacturing. Gerding Bros., Lion Bldg., Cincinnati, O.

ADVERTISERS, Mail Dealers. Our New Rate Book lists 2,000 Principal Publications, rates, circulation. Includes 30 Mail-Order Plans. Free. Dearborn Advertising Agency, 210 Franklin Bldg., Chicago.

LEARN the real estate business; our enlarged instruction book teaches listing, appraising, management, salesmanship, insurance, brokerage, advertising, renting, agency, estates, titles, rights, forms, etc.; revised edition; 240 indexed subjects; excels \$25 correspondence course; buckeye cover, \$1; alk cloth, \$1.25, postpaid. Realty Book Co., Dept. No. 25, Cleveland, Ohio.

SILVERING Mirrors—Recharging Dry Batteries—Gas Tonic—Orange-ade Powder—Straw Hat Cleaner—Luminous Paint. This valuable collection of formulas 25c. C. Johnson, 4319 N. Whipple St., Chicago.

STEADY income on the side. Manufacturing Carbo-Cide. Guaranteed successful gasoline interfilter-decarbonizer. Increases mileage, saves gasoline. Fibro-Vac, absolutely Perfect Automobile Puncture Plugger. Unlimited possibilities. Exclusive territory. Formulas supplied for those and twenty other automobile specialties. Particulars, stamp. Miller Analytical Chemist, Tampa, Florida.

BIG money in Home Town while learning. Success guaranteed. Experience unnecessary. Be first. P. D. Q. Sign System, Calgary, Alberta.

3,380 FORMULAS, Trade Secrets and moneymaking plans in "Encyclopedia Business Opportunities." 3 volumes. Worth \$5. Special offer \$1. Ideal Book Shop, 3315-K-7, Belleplaine Ave., Chicago.

MAIL-ORDER SUPPLIES

INCREASE your sales. Place your proposition before the readers of "Cartoons Magazine," 20,000 copies guaranteed every month. Classified rate 5c per word. Mail in a trial ad today. Cartoons Classified Dept., 78 E. Madison St., Chicago.

FOR ADVERTISERS

ADVERTISERS—Here's your opportunity. Your proposition placed before the readers of "Cartoons Magazine" for only 5c per word. Circulation 20,000 copies guaranteed. Send a trial ad for our next issue. Cartoons Classified Dept., 6 N. Michigan Ave., Chicago, Ill.

BUSINESS SERVICE

CLEVELAND, Ohio, office ten dollars yearly. Sixth City Service, Schofield Bldg.

INCORPORATE. Our lawyers do the work, saving you time, annoyance and money in incorporating under the most liberal laws in Arizona. Laws and forms free. Southwestern Securities & Investment Co., Box D488, Phoenix, Ariz.

COLLECTIONS

COLLECTIONS on commission. Beacon Collection Agency, Cedar St., N. Y.

DEBTS Collected Anywhere, Quickly! Established 25 years. William H. Dodd, 87 Nassau Street, New York.

AGENTS WANTED

LARGE Cleveland Million-Dollar Corporation will pay you \$20 to \$30 weekly for your spare time, or as high as \$100 weekly if you prefer to devote your entire time to representing a widely known and nationally advertised product in your community. Furthermore we will furnish you absolutely free a full and complete course in salesmanship. You do not have to pay one penny—you do not have to invest a single cent in our products. This course is the equal of any \$50 course in the country. Only one course given to each community. We are particularly desirous of securing inquiries from small towns having electricity. Write at once for full particulars. The Franitz Premier Company, World's Largest Makers of Electric Cleaners, Dept. 136, Cleveland, O.

TAILORING Agents Wanted—Big complete sample outfit and case, nearly 300 large cloth samples, 3 piece lists and everything needed for canvassing, or use in store, free to five agents. \$25.00 to \$40.00 a week; may make more. Write us today for free elegant outfit to begin, cloth samples, wholesale prices, special offer on a suit for yourself and full information—see our wonderful values, beautiful fabrics and styles. Established 28 years. Every garment made to measure—everything guaranteed and express prepaid. Just send a postal. American Woolen Mills Co., Dept. 114, Chicago.

AGENTS: Biggest moneymaker ever put on the market. "Eggette," the original egg substitute. Takes place of eggs in baking and cooking at less than ten cents per dozen. Sells rapidly to homes, stores, bakers, etc. A Guaranteed pure food product. Good opportunity to build permanent business with big income. No competition. Regular size package 10c, equal to 12 eggs. Attractive moneymaking proposition free. Write quick. Bestever Products Co., R-2 Douglas Park Station, Chicago, Ill.

AGENTS, stop looking for free automobiles. Make \$75 to \$100 weekly selling our guaranteed custom-made raincoats. We deliver and collect. 1917 outfit free. "Aero." Desk P, 175 E. B'way, New York.

AGENTS—Stamping names on Pocket Key Protectors; sample Check with your name and address, 12c. Stamping Outfits, Emblem Checks, Check Fobs, Name Plates, Hart Mfg. Co., Desk 2, 303 Degraw St., Brooklyn, N. Y.

Sign Letter Agents and Painters: 500% Profit Gold and Silver Sign Letters for Stores and Office Windows. Anyone can put on. Big demand. Free samples. Metallic Letter Co., 404 N. Clark St., Chicago.

HUGE profits selling Nibco Sanitary Brushes, Auto Washers, Brown Beauty Adjustable Floor Mops, Dustless Dusters, and other specialties. Big line. Fast sellers. Write today. Silver-Chamberlin Company, Department M, Clayton, New Jersey.

FREE sample with particulars. No splashing water strainers. Easy seller. Returns big. Experience unnecessary. Union Filters Co., New York.

AGENTS, Castrassers—100% profit selling Hartemex for the skin and complexion. The beautiful package makes first sales. The cream positively makes others. Exclusive territory. Sample free. Address J. F. Hartman, 67 Wordworth St., East Boston, Mass.

LUMINOUS Crucifix—Heatless Trouser Press: Toledo sold 60 Crucifixes in 10 days. Old Paducah, Paducah, Ky.

AGENTS—\$10 a day introducing wonderful new water filter for farm and city homes. Renders water pure and safe. Prevents typhoid and other diseases. Simple and easy to use. Low price, big profits. Write quick for territory and sample. Thomas Mfg. Co., 1702 North St., Dayton, Ohio.

OUR Representatives are getting rich with marvelous new household commodity. Free samples get over 100 orders daily. Big profits. Exclusive territory going fast. Join our successful organization of prosperous agents and send today for free samples and particulars. E. O. Andrews, Merrill Bldg., Milwaukee, Wis.

RARE Opportunity for State Representatives, General Agents and Agents. Latest Invention prevents hairpin loss. Sensation of 1917. Write quick. Loss Preventing Device Co., Gardena, Calif.

AGENTS—Our brand-new seller will get the money for you every time. Particulars free. Slevers & Frank Sales Co., Box 12, Chicago Heights, Ill.

MOTH Proof Garment Bags; High Grade Specialties. Money Makers. Utility Sales Co., Dayton, O.

MANUFACTURE a Necessity needed in every home. Big demand. Brand new. Particulars free. Mains, Box 22, Port Matilda, Pa.

AGENTS: Guaranteed Line; Big Repeater. 200% profit. Send 25c for Mailing Sample. Deel Mfg. Co., 932 N. LaSalle St., Chicago.

"MO-BE-CO" Agents make \$10 per day easily selling toilet preparations. Moen-Berg, Fosston, Minn.

MAN Wanted in each country community and every small town, to wear beautiful new tailored-to-order suit of clothes and be Agent in spare time among friends, relatives and neighbors. Confidential wholesale prices given, good profit on each order. No experience required, we teach you all you need to know. Write at once and get gorgeous, illustrated book of cloth samples free, and full instructions. Banner Tailoring Co., Dept. 605, Chicago.

STATE Representatives and Agents—We want men of known ability for best line of Cutlery offered for salesmen. Extremely liberal margins. Dept. P, Aerial Cutlery Manufacturing Company, Marinette, Wisconsin.

AGENTS! Sell Tiffany Quality Raincoats. Highest commission. Sample coat and outfit free. Write for particulars. Tiffany Raincoat Co., 1647 Heiden Ave., Chicago.

LARGE Manufacturer wants representatives to sell shirts, underwear, hosiery, dresses, waists, skirts, direct to homes. Write for free samples. Madison Mills, 503 Broadway, New York City.

GET into biggest money-making and automobile business—replacing necessary equipment. Live, ambitious men wanted as special factory representatives, exclusive territory, taking orders for tops, top covers, seat covers. "Stik-Tite" windows. No experience necessary. No capital required. No competition. Copyrighted system protects you. Free catalog, samples, full details. Cincinnati Auto Specialty Company, Dept. MC-77, Cincinnati, Ohio.

AGENTS make 500 per cent profit selling our Auto Monograms and Initials, Window Sign Letters, Changeable Signs, and Show Cards. 1,000 Varieties. Enormous Demand. Sullivan Co., 1123 Van Buren St., Chicago, Ill.

AGENTS: Big profits selling our New \$2.50 Automatic adding machine. Quick sales. Ten a day easy. No competition. Anyone having adding to do is positive customer. You'll be glad you wrote us. Bassett Company, 5921 Indiana Ave., Chicago.

AGENTS—Send for sample "Pretnot"—the wash day wonder. Be convinced you can do a whirlwind business. You can clear at least \$20 to \$100 weekly, according to spare or whole time. You don't have to talk; if she doesn't buy at sight, leave sample; she will be looking for you long before you are able to, make the rounds again. Samples furnished free. Premiums granted to agents who can produce. Credit given. Don't call. P. M. Motter & Sons, 3213 Warren Ave., Chicago.

AGENTS—To travel by automobile introducing our Big Line of fast summer sellers. The greatest line on earth. Make \$10 a day easy. Complete outfit and automobile furnished to workers. Write at once for exclusive territory. American Products Co., 8539 Third St., Cincinnati, O.

AGENTS—One man made 100 sales from 100 demonstrations to auto owners. 100% profit. You can, too. Details free. Dept. P. O. Box 286, Cincinnati, O.

AGENTS: Greatest money-making proposition out. Stopleak Seals Tire Punctures instantly. Increases life of tire and tube. Birks Supply House, 5214 Lake Park Avenue, Chicago, Ill.

PORTRAIT Agents, new and old, write us. We know what you want and need. Established 17 years. Pioneer, 1252 W. 63rd St., Chicago.

23% PROFIT—\$2.80 on each set sold. Newly invented Jubilee Spark Intensifier. Banishes spark-plug trouble forever. Sells on sight. Huge profits. Exclusive territory. Hurry! Jubilee Mfg. Co., Dept. M-8, Omaha, Neb.

WASHING Compound Agents—Ho-Loi-Hu-Na, Great Hawaiian Washing Secret (Improved)—Washday Wonder of the Age. Become District Sales Agent and make \$2,500 to \$5,000 a year. Cinch exclusive territory now. Get twice the money for your work. Opportunity is knocking. Adam Fisher Mfg. Co., Agency Dept., 2961, Ry. Exch. Bldg., St. Louis, Mo., U. S. A.

SAFETY paper cutter. Holds any razor blade. 400% profit. Sample 25c. Write E. P. Wilson Co., 828 Francisco St., Los Angeles, Calif.

AGENTS. New summer phonograph—the **Portophone.** Built into a carrying case. Ideal for automobiles, canoes, campers, etc. Wonderful tone. Low price. Big profits. Write for demonstrating sample. Orchestra Co., 1602 North St., Dayton, Ohio.

YOUR Name brings a copy of **Money Making Ideas.** The great 32-page agent's and mail dealer's magazine. A. Kraus, Kraus Bldg., Milwaukee, Wis.

AUTOMATIC Sash Lock—Newest home invention, now ready for agents. Locks either sash any position. Prevents burglary. permits ventilation; stops rattling. Sells on sight wherever people live. Big repeater. Handy, business-pulling demonstrator free. To prove it's the greatest agent's article we'll postpay 25c sample and "No-talking" sales plan for 10c. Try it—then you'll order a gross. Stonaker Co., 1410 Standard Theater, Cleveland.

NINETY Per Cent of Your Calls Turned into Sales! Wonderful Enthusiasm Follows Every Demonstration! Write at Once for Full Particulars of Our Line of **Eradium (Luminous) Articles.** Startling! Mysterious! Everlasting! Novel! They Shine in the Dark. Crucifixes, House Numbers, Bulbs, Match Boxes, Pictures, Switch Plates. Sole Manufacturers, The Pioneer Corporation, 1239 W. 63rd, Chicago.

AGENTS. We have a good proposition for you. Write for particulars and samples. Chicago Agency Co., 838 Altgeld St., Chicago.

AGENTS. Best seller yet. Every man a customer. Retail \$1. Write today. Curtis Co., Bement, Ill.

AGENTS. Sell patriotic felt novelties. Send stamp for full particulars. Schroeder, 770 Central St., Paul, Minn.

OLD Glory can be seen at night as in the day. Sell our beautiful ever-lasting luminous American flags. Good profits. Send 25c for sample. Luminous Flag Co., 1317 46 Street, Brooklyn, New York.

AGENTS—Big Hit. 6 Piece Aluminum cutlery set; new specialty delights housewives; good profits; 2 premiums clinch sales. Aluminum Cutlery Co., Div. 25, Sag Harbor, N. Y.

A \$2.50 PREMIUM with every \$1.98 sale and 70 cents profit for you means **Big Daily Profits.** Free Sample. Box 509, Shreveport, La.

LUMINOUS Paint! Shines in the dark. Big seller to hotels, garages, etc. Any article can be coated with splendid results, watches, clocks, electric switch plates, crucifixes, match boxes, etc. (Everlasting.) Only 25c a bottle. Luminous Paint Co., B-16 Douglas Park Station, Chicago, Ill.

"BE a Winner." Arnold made \$112 last week without investing a cent. Sell for large manufacturers finest to-order "Rex" raincoats and bathrobes. Sensational demand. We deliver and collect. American Mercantile Co., 31 W. 124th St., New York.

AGENTS for newly invented article, novel, useful. In demand among all classes everywhere. Fast seller, popular price, no competition, big profit. The Geo. W. Clark Co., Clark Building, Jacksonville, Fla.

AGENTS financially responsible who understand heating plants to sell **Blaske Fuel-Saving Devices** on monthly payment plan. Every heating plant a prospect. Guaranteed to save 20%. Evaporation tests at two universities average 25% saving. Wolf Fuel Saver Company, 14 East Jackson, Chicago.

MAN or Woman to travel for old-established firm. No canvassing; \$1,170 first year, payable weekly, pursuant to contract. Expenses advanced. G. E. Nichols, Philadelphia, Pa., Pepper Bldg.

YOU can be your own boss with our **Key Check** outfit. Good for \$5 a day stamping names on pocket key checks, fobs, etc. Sample check with your name and address, 15 cents. Pease Die Works, Dept. M., Winchester, N. H.

NO fortune, but a clean living. New household specialty. Carry in pocket. Write or enclose 10c for sample. Arco Sundry Co., 37 Liberty St., New York.

AGENTS: Stop Here—Dryola Chemical Dry Cleaner for all clothing, silks, feathers, furs, gray shoes, etc. sells to every woman after explaining merits. Five Dollars per hour profit. Write today for sample and particulars. Archart Chemical Co., Rosholt, So. Dak.

AGENTS—Handle Bonanza Sales Boards. Can be used for any purpose desired. Gordon Specialty Agency, Dept. B, 52 West Chippewa, Buffalo, N. Y.

GASOLINE Saver for Ford's: New Principle; Saves 20% Gasoline; increases power; reduces carbon. No moving parts. Put on with wrench in ten minutes. Price \$1.50. Guaranteed. 100% proposition to agents. The Little Cyclone Accessories Co., Dayton, Ohio.

AGENTS: 100% profit. Every railroad man wants one. Sample 7c. "Rhymes of the Rail," Box C-216, St. Paul, Minn.

NEW Patriotic War Atlas Free with my 1917 "Business Guide." Sells everywhere. Beginners clear \$7 daily. 50% commission. Outfit free. Prof. Nichols, Box P. M. 3, Naperville, Ill.

AGENTS: Write immediately for our proposition. Unlimited possibilities. Custe Lessire Cooker Co., 4191 LaCrosse Ave., Chicago, Ill.

AGENTS Wanted. To Handle Our **Free Hair and Fibre Broom** that Takes the Place of the High-Priced Corn Broom. Write for Protected Territory. 100% Profit. J. H. Hergensrather & son, 57 E. 43d St., Chicago.

RELIABLE People Wanted to Place Our **Orangeade Powder** in stores and appoint agents. Makes the most delicious drink you ever tasted by just adding cold water and sugar. Enough for 10 glasses and particulars 10c postpaid. Chas. A. Morrissey Co., 4417 Madison St., Chicago, Ill.

INVENT Something; Your ideas may bring wealth; free book tells what to invent and how to obtain a patent, through our credit system. Talbert & Parker, 4663 Talbert Bldg., Washington, D. C.

GAS Fire in any cook stove from common coal oil. Agents coin money. Wonder Burner Company, Columbus, Ohio.

AGENTS, \$50 a week. Will show you how. Genuine Gold Leaf Window Letters. Chicago Agency Co., 842 Altgeld St., Chicago.

MERCHANTS Buy at Sight. New changeable letter sign for window advertising. Large metal sign with 270 letters. Sells \$1.50. 500% profit. Greatest seller ever invented. Write for proposition. Changeable Sign Co., E. 162, Cleveland.

AGENTS: Automatic Automobile Signal just patented; enormous seller; big profits. Territory reserved. Write: Jordan, 1920 9th St., Washington, D. C.

EXCLUSIVE county rights. Sell Tankli; modern auto fuel. Profitable. Tankli Chemical Co., Cleveland, Ohio.

MARVELOUS Expanding Cuff Buttons. Presto, slip your cuffs up on forearm without unbuttoning same. Cuffs positively stay where placed. Lowered they close automatically. A real convenience and laundry saver. Wanted—High-grade agents to sell direct, as well as side-line salesmen to sell to the trade. We also have fifty popular-priced canvassing agents' specialties. Flexo Mfg. Corporation, Sheboygan, Wisconsin.

\$61.50 WEEKLY. Introducing and selling a new gas light burner for kerosene lamps. Beautiful light. No chimney. No mantle. Samples free. Lusher Manufacturing Co., Dept. 312, Cincinnati, Ohio.

SELLS like hot cakes. Brand new ironing wax. Perfumes clothes with lasting violet perfume. Working outfit 5c. Perfume Gloss, 13 Water St., New York.

DECALCOMANIA Transfer Initials and Flags: You apply them on automobile while they wait; cost 2c each; profit \$1.38 on \$1.50 job; free particulars. Auto Monogram Supply Co., Dept. 1, Niagara Bldg., Newark, N. J.

GOOD income refinishing chandeliers, brass beds, automobiles by new method, producing amazing results; no capital or experience necessary; particulars free. Gunmetal Co., Ave. H, Decatur, Ill.

"WASHWHITE" makes easy sales. Big profit. Sure repeat business. Genuine Rogers Siltorsare free to your customers, and valuable Premiums for you. Free printed matter and Sales Course. Free samples with every order. Cleans clothes without rubbing, and without injury to the finest fabric. 7 big washings for 15 cents. Sales Guaranteed. Write for Our Offer. The Nacma Co., Dept. L-7 20 W. Lake St., Chicago.

AGENTS—Handle perfection floor oiler; for oiling any kind of floor. Write Perfection Oiler Co., 620 K. of P. Bldg., Indianapolis, Ind.

AGENTS: 50 Calling Cards 10c. F. Shepard, Rome, N. Y.

RUSH postal for Free Sample "Spik & Span." Wonderful new washing tablet. Washes clothes spotless, without rubbing. Tremendous seller. 200% profit. Free Samples to boost sales. Newbury Co., 212 Peoria, Chicago, Ill.

MAKE and Sell Your Own Goods. Machinery unnecessary. Expert Chemist's advice. Special attention to beginners. Formula catalog for stamp. Blake, Mystic Company, Washington, D. C.

SELL. Guaranteed made-to-measure raincoats. Agent's price \$2.50 delivered. Make \$75 weekly. Outfit free. Standard Raincoat Co., 393 Broadway, New York.

AGENTS: You can make big money taking orders for our fine made-to-measure clothes, so write quick for 60 beautiful cloth samples, 32 smart styles in rich colors, wholesale and retail price lists, lowest prices and best offer to agents. \$5.00 to \$10.00 a day easy. Big outfit, over 250 samples free to live wires. No experience needed—no capital. We furnish everything free—pay postage or express charges—back you, boost you, show you how and clearly explain everything. Costs nothing to try. Let us make you a stylish suit to measure to prove our fine quality and style. Send postal or letter today. Paragon Tailoring Co., Dept. 714, Chicago.

PHOTO Pillow Tops, Portraits, Frames, Sheet Pictures, Photo Plates, Pennants. Rejects credited. Prompt shipments; samples and catalogues free to agents; 30-days' credit. Jas. C. Bailey Co., Desk P, Chicago.

OUR New Pocket Check Protector does work of \$25 machine. Sells for 50c. Big profits. All writers of checks ready customers. 50c brings sample and full particulars. Gray Mfg. Co., 300½ Main, Fort Worth, Texas.

WANTED. General Agent to represent us in your locality. Exclusive territory. Big inducements. Chicago Agency Co., 840 Altgeld St., Chicago.

"1916's SENSATION!" Eleven piece toilet article set selling like blazes at \$1.00 with \$1.00 carrying set Free! Enormous profits! Tremendous hit! Engle made \$31.00 first week. Write quick! Pierce Co., Dept. P, 906 Lake St., Chicago.

SOFT Drinks in Powder. Just add water—delicious, refreshing, healthful. Everyone buys—big profits. Enough for 10 glasses Orangeade and particulars 10c postpaid. Chas. S. Morrissey Co., 4417 Madison St., Chicago, Ill.

INSULATED Tyres, inner armor for Automobile tires, double mileage and prevent punctures and blowouts. Quickly applied. Cost little. Demand tremendous. Profits unlimited. Details free. American Automobile Accessories Co., Dept. P, Cincinnati, O.

BIG Profits for You! Manufacture Barley Crisp. New Confection. 5c package costs you 1c. Machine instructions complete \$7.50 prepaid. Send 10c for samples. Barley Crisp Co., 1295 Broadway, San Francisco.

GET Davis' Latest Proposition. \$15.00 daily a pinch. No matter how many times you have answered my ads in last 20 years, write again. E. M. Davis, Dept. 506, 903 Lake, Chicago.

MEDALLIONS—300% profits. Make up your own goods and be independent. Catalogue free. Resag Co., 1235 Randolph St., Chicago.

AGENTS—Our gold window letter proposition beats 'em all. Stairbrite Co., Dept. P, 1115 Second Ave., N. Y. Established 1905.

AGENTS make 500% profit handling Auto Monograms. Patriotic Pictures, Flag Novelties, Window Letters and Changeable Signs. Catalog free. Hinton Co., 6142 40th Court, Chicago, Ill.

AGENTS: Big Hit: Our 5-Piece Aluminum Set is all the rage. Cheaper than Enamel Ware. Sells like wildfire. Guaranteed 20 years. Retail value \$5.00. You sell to housewives for only \$1.98. Biggest seller of the age. 9 sure sales out of every 10 shown. Others cleaning up \$10.00 to \$20.00 a day. Answer this quick to secure your territory. Div. GG7, American Aluminum Mfg. Co., Lemont, Ill.

SNYDER'S Toilet Preparations and Household necessities are big values; big profit makers; sell themselves; Start making money immediately. T. H. Snyder & Co., Dept. M., Cincinnati, O.

RELIABLE People Wanted—Place Engine in stores and appoint agents. Takes place of eggs in baking and cooking at 9c doz. Large package and particulars 10c post-paid. Morrissey Company, 4403-5 Madison, Chicago.

WHO wants to make more money selling brushes that every household needs? Special method of getting entrance to demonstrate. Fuller Sanitary Brushes are nationally advertised—largest output—best terms and prices—western distributing stations. Your territory is valuable. Write, Fuller Brush Company, Hartford, Conn.; Hook Island, Ill.

THEY sell themselves; big profits. Wire Products Co., Scranton, Pa.

AGENTS: \$30 to \$100 a week. Free samples. Gold sign letters for Stores and Office Windows. Anyone can do it. Liberal offer to general agents. Metallic Letter Co., 407 N. Clark, Chicago.

EXCEPTIONAL opportunity selling Sanitary Brushes. Large profits, no permanent capital required. Every home a customer. Special selling help for agents. Proposition free. Sample ten cents. Puritan Sales Company, Dept. M, 1366 Broadway, N. Y.

DISCOVERED! Extraordinary New Proposition. Supreme Opportunity. \$200 per week Easy, demonstrating marvelous Adding Machine. Retail \$7.50. Work equals \$300 machine. Subtracts, Multiplies, Divides, automatically. Whirlwind in speed. Guaranteed Five Years. Used by U. S. Government. Sells everywhere. Amazing profits. Write quick for exclusive territory. Calculator Corp., Dept. PM, Grand Rapids, Mich.

\$50 WEEKLY and up selling Mexican Diamonds. Exactly resemble genuine; Same Rainbow Fire; Stand tests; sell at sight; Repeat orders. Write quick for Sample Case offer free. Mexican Diamond Importing Co., S. W. Las Cruces, New Mexico.

AGENTS. Make Big Money; fast office seller; particulars and samples free. One Dip Pen Co., Dept. 2, Baltimore, Md.

EXCLUSIVE selling rights given for our Wonderful Triples Folding handbag and other sellers. None sold in Stores. Write for terms and catalogue. Diamond Bros., 35 West 21st Street, New York.

CALIFORNIA Flower Bead Necklaces beat anything for quick sales and profits. Absolutely new. Write for agent's proposition. Mission, 2819 PM, West Pico, Los Angeles, Calif.

"GOLDINE" Sign Letters—1,000% profit. Particulars free. Johnston Co., Quincy, Ill.

MARRIED Salesmen and Agents—Wives to demonstrate in dept. stores, on salary. Easy sales to jobbers, dealers, consumers. All or part time, or side line. Appoint sub-agents. Silveron, the Silver-plating polish—needed in every home, hotel, restaurant, and garage. Guaranteed to Deposit Pure Silver. Write for proposition and sample. Exclusive territories open. Silveron, 157 Cedar St., N. Y.

AGENTS—Ho-Ro-Co Skin Soap and Toilet Goods plan beats everything for agents' profits. "Ho-Ro-Co." 112 Locust St., St. Louis, Mo.

WANTED—New Ideas. Write for list of Patent Buyers and Inventions Wanted. \$1,000,000 in prizes offered for inventions. Our Four Books sent free upon request. Victor J. Evans & Co., 163 Ninth, Washington, D. C.

AGENTS Wanted: Sell Polishing Cloths, Rust Remover, Food Flavors, etc. 130 household necessities, guaranteed line, big profits, quick repeater, permanent business. Stuart & Co., 18 Main St., Newark, N. Y.

\$1,000 PER Man per county. Strange invention startles world—agents amazed. Ten inexperienced men divide \$40,000. Korstad, a farmer, did \$2,200 in 14 days. Schleichler, a minister, \$195 in first 12 hours. \$1,200 cold cash made, paid, banked by Stoneman in 30 days; \$15,000 to date. A hot or cold running water bath equipment for any home at only \$6.50. Self-heating. No plumbing or waterworks required. Investigate. Exclusive sale. Credit given. Send no money. Write letter or postal today. Allen Mfg. Co., 311 Allen Bldg., Toledo, Ohio.

EASY, pleasant work for Mechanics, Shop Men, Clerks, during spare hours, will add many dollars to their salaries. Also want persons who can give full time. Big wages assured. Novelty Cutlery Co., 67 Bar St., Canton, Ohio.

AGENTS, 500% Profit. Sign-Letters for office and store fronts. Samples and particulars free. Inter-States Letter, 2424 N. Halsted St., Chicago.

AGENTS sell Reliable Custom-Made Raincoats and Gabardines. Big commission. Complete sample line free. Temple Raincoat Company, Templeton, Mass.

PORTRAIT Agents: Our goods will make you big profits. Delivery guaranteed. Refunds credited. Prompt shipments. Send for latest catalogue and prices. Adam J. Kroll & Co., 602 Blue Island Ave., Chicago, Ill.

WAR! Go if you must—but first start a manufacturing business for the home folks. Big income assured and easy with Miller's Guaranteed Formulas for manufacturing biggest advertised selling specialties: Wizard Washing Tablets—no wax, lime lye. Egg-O-Lene, pure food egg substitute. Tube Flavors. Putnam's Dry Cleaner. Zeeru-Salz, preserves eggs indefinitely (powdered). Carbo-Cide, automobile decarb nizer—increases mileage, saves gasoline. Fibro-Vac, wonderful tire puncture plugger—exclusive territory being rapidly taken. Latest money making propositions. Lists, information, stamp. Lise M. Miller, Chemist, Tampa, Florida.

SAMPLE—5c for 15c water filter; be first; catalogue free. Suvio, 606 East 161st St., New York.

"QUICKSELLERS"—Self-threading needles, assorted sizes 10c, three packages 25c; skeleton key, opens doors 10c, ten all different 50c, twenty, including premium \$1.00; unbreakable "Brightlight" inverted gas mantle 15c, two 25c. Ernest Benninghofen, Anderson, Indiana.

DANDELIONS destroyed easily, grass uninjured. Wonderful seller wherever there is a lawn. Exclusive territory to good agents, large profits. Nebraska Chemical Co., Dept. G, Benson, Nebraska.

AGENTS are making \$5 to \$10 daily selling our illustrated novelty shoe cards. Mornings, 23 1/2 Ave. 81., New York.

OUR line of sanitary brushes, mops and dusters is a winner. So is our proposition. Rich territory waiting. Agents wanted now. Sanford Brush Co., 544 W. Lake St., Chicago.

POWER tire pumps for Fords. Retail for \$5.50. Agents wanted everywhere. Big profits. Write for particulars. Universal Auto Specialty Co., Bates and Atwater Sts., Detroit, Mich.

SALESMEN WANTED

SALES Agents for widely advertised electric lighting outfit for farms and country homes. Exclusive territory to right man with automobile. No other capital needed. Fidelity bond required. Address the Western Electric Company, 195 Broadway, New York City, or 509 South Clinton St., Chicago, Ill.

SALESMAN Wanted—A dandy side line for salesmen calling on Auto Supply Jobbers, Dealers, Garages. Samples free; pocket size. Send for particulars. King Manufacturing Company, Brookline Mass.

NEW York Auto Specialty Manufacturers seeking agencies complete line selling accessories, want salesmen to handle city, county, state agencies. Gorman Company, 47 W. 42nd St., New York.

\$60.00 OR more can be made weekly selling staple moderate priced line to the general trade. Experienced salesman preferred; permanent position. Unusual opening now. Continental Jewelry Co., 351 Continental Bldg., Cleveland, O.

BIG opportunity for travelling salesmen for side line to establish agencies for a fuel-saving device. University tests show 25% saving. Commission basis. Wolff Fuel Saver Co., Lytton Bldg., Chicago.

WANTED—Salesmen \$25 to \$40 weekly. Clothing, tailoring, or retail experience or men who have taken orders for made to measure suits or raincoats. Take charge of agency to be placed in each county—No investment—new proposition—profitable, permanent. P. M. Nelson, 241 W. Van Buren, Chicago.

WANTED—Salesmen everywhere. 3,500 mile factory guaranteed tire. Large commission for exclusive territory. Opportunity. References. W. & G. Tire Co., Flatiron Building, New York.

WANTED—Representatives everywhere. Exclusive territory. Gold sign letters for stores and office windows. Any one can put on. Write today for free sample. Metallic Letter Co., 403 N. Clark St., Chicago.

EARN \$5,000 to \$20,000 yearly. New business necessity. Retail \$5 to \$20, 100-200% profit. Purchaser satisfied or money refunded. No competition. Exclusive territory. Free samples. Sayers, 408 Wainright, St. Louis.

SALESMEN—Acquainted with grocery trade. Large demand; liberal commission; pocket sample. Wirth Salesbook Co., Dept. P., Chicago.

SALESMEN—Get our plan for Monogramming Automobiles and motorcycles by transfer methods. Very large profits. Motorists' Accessories Co., Mansfield, O.

HELP WANTED

SALES Manager—Big manufacturer desires to connect with a live wire Sales Manager to handle on a big commission basis several splendid lines of automobile accessories. Will grant good territory to right man who can produce results. Address Wallace C. Hood Service Bureau, 1199 Woodward Avenue, Detroit, Mich.

DO you want a position for life, with big pay, short hours and sure advancement? Then work for Uncle Sam. My free illustrated book DK-29 tells how to get an appointment. Earl Hopkins, Washington, D. C.

GOVERNMENT War Positions Open. \$100.00 month. List free. Franklin Institute, Dept. D-21, Rochester, N. Y.

A POSITION is open for you in the Government service after we have helped you qualify. My money back offer guarantees it. Write quick for big free book DA-29. Earl Hopkins, Washington, D. C.

RAILWAY Mail Clerks Wanted, \$75.00 month. Sample examination questions free. Franklin Institute, Dept. D-21, Rochester, N. Y.

GOVERNMENT Examinations. Most thorough preparation, \$5; returned if not appointed; particulars free. American Civil Service School, Washington, D. C.

GOVERNMENT pays \$900 to \$1,800 yearly. Prepare for coming "exams" under former Civil Service Examiner, New Book Free. Write Patterson Civil Service School, Box 2920, Rochester, N. Y.

CIVIL service examinations lead to good government positions. Railway mail pays up to \$1,300; postoffice clerk, carrier, \$1,200; customs, \$2,500; internal revenue, \$2,190; bookkeeper, \$2,500; stenographer, \$1,800; clerk, \$1,800; technical, \$4,900; rural carrier, \$1,200; women, \$1,800; guard, \$840 up. I can coach you by mail at small cost and give bond guaranteeing success or money refunded. Particulars free to American citizens over seventeen. Ask for booklet QE-29, naming position wanted. Earl Hopkins, Washington, D. C.

MEN, 18 or over, wanted. Government Railway Mail Clerks, \$75 month. List Government jobs open, free. Franklin Institute, Dept. D-21, Rochester, N. Y.

CASH paid for butterflies, insects. Some \$1 to \$7 each. Easy work. Even two boys earned good money with mother's help and my pictures, descriptions, price list, and simple instructions on painless killing, etc. Send 2c stamp at once for prospectus. Sinclair, Box 244, D 6, Los Angeles, Cal.

THE way to get a Government Job is through the Washington Civil Service School. We prepare you and you get a position or we guarantee to refund your money. Write to Earl Hopkins, President, Washington, D. C., for Book FK-29, telling about 292,928 Government Positions with lifetime employment, short hours, sure pay, regular vacations.

FACTORY Superintendent. The leading firm in its field, manufacturing a nationally used product, is seeking the right man for Factory Superintendent. This man not only will possess a practical knowledge of efficiency methods, but will also have that indispensable knack of leadership that inspires his men to better work. He will know how to meet emergencies and to get things done with a minimum of friction. In fact he must have a proven record along all these lines. If you are interested just send us your name and address and we will identify ourselves to you and enter into confidential correspondence. Address, B. B., Room 990, 78 E. Madison St., Chicago.

\$125.00 PER month and all traveling expenses! Railway Traffic Inspectors in great demand, due to 8-hour law and congested conditions; new profession, promotion sure; demand for our graduates far exceeds supply; three months' course during spare time, thoroughly prepares intelligent men. Ask for Booklet A-13, Frontier Prep. School, Buffalo, New York.

GET a sure job with big pay, steady work, short hours, regular vacations, rapid advance. Thousands of positions open with Uncle Sam, I will prepare you in a few weeks at small cost. Write immediately for big Free Book, DU-29 with special offer. Earl Hopkins, Washington, D. C.

TECHNICAL Men are wanted for the federal civil service. We coach by correspondence for many of these examinations. Write for free booklet QF-29, Washington Civil Service School, Washington, D. C.

\$100 MONTH. Get Government Jobs. Men and Women Wanted. List of positions open—free. Franklin Institute, Dept. D-21, Rochester, N. Y.

WANTED. Men and women to qualify for Government positions. Several thousand appointments to be made next few months. Full information about openings, how to prepare, etc., free. Write immediately for booklet CG-29. Earl Hopkins, Washington, D. C.

FREE Illustrated Book tells of about 200,000 protected positions in U. S. Service. Thousands of vacancies every year. There is a big chance here for you, sure and generous pay, lifetime employment. Just ask for booklet CS-29. No obligation. Earl Hopkins, Washington, D. C.

WILL \$50 weekly income satisfy you? Best proposition with surest results ever offered solicitors. Outfit free. No selling, delivering, or showing samples. Address—Room 343, Wells Building, Quincy, Illinois.

GOVERNMENT Positions are easy to get. My free booklet BY-29 tells how. Write today—now. Earl Hopkins, Washington, D. C.

WANTED—Men. Become Automobile experts. \$25.00 week. Learn while earning. Franklin Institute, Dept. D-801, Rochester, N. Y.

WORK for Uncle Sam. He is the best employer. Big pay, sure work, easy hours, long vacations, rapid advance. Thousands of jobs open this year. I will help you get one. Write for my big free book, DY-29, today. Earl Hopkins, Washington, D. C.

INVENT Something; your ideas may bring wealth; free book tells what to invent and how to obtain a patent, through our credit system. Talbert & Parker, 4192 Talbert Bldg., Washington, D. C.

DO you want a sure job with big pay, easy hours and rapid advance? Write for my big free book, DW-29, which tells you how you can get a good Government position. Earl Hopkins, Washington, D. C.

GOOD income refinishing chandeliers, brass beds, automobiles by new method, producing amazing results; no capital or experience necessary; particulars free. Gummetal Co., Ave. G, Decatur, Ill.

CIVIL Service Examinations open the way to good Government positions. I can coach you by mail at small cost. Full particulars free to American citizens of eighteen or over. Write for Booklet CE-29, Earl Hopkins, Washington, D. C.

CIVIL Service Examinations everywhere soon. War causing thousands of vacancies. Men desiring Clerkships, Departmental, Postoffice, Railway Mail, Customs, write for free particulars, to J. O. Leonard (Former Government Examiner), Kenosha Bldg., Washington.

THOUSANDS Men—Women, 18 or over, wanted immediately. Government positions. \$100 month. No layoffs. Write for list positions open. Franklin Institute, Dept. D-21, Rochester, N. Y.

UNCLE Sam has thousands of jobs open this year. I will help you get one. Write for my big free book, DX-29. Earl Hopkins, Washington, D. C.

WREDS Wanted. Many common ones worth 2c to 75c pound. Dept. F, National Drug Co., North Yakima, Wash.

FOREMEN, Shopmen, and Office-men Wanted to work spare time as special representative of large well-known mail-order house, selling Watches, Diamonds and Jewelry on Credit. Liberal commissions and exclusive sales rights granted. No investment or deposit required for outfit or samples. Write at once for details. Address S. D. Miller, Dept. 14, Agency Division, Miller Bldg., Detroit, Mich.

BE a Mirror Expert. Good income; spare time home at first; no capital; we train, start you making and silvering mirrors; French method. Free prospectus. W. P. Derr, Pres., 379 Decatur, Brooklyn, N. Y.

MAKE money writing Photo-plays; details free to beginners. No correspondence course. Producers' League, 230 Wainwright, St. Louis.

WANTED—An Idea! Who can think of some simple thing to patent? Protect your ideas; they may bring you wealth. Write for "Needed Inventions" and "How to Get Your Patent and Your Money." Randolph & Co., Patent Attorneys, Dept. 14, Washington, D. C.

EARN One Dollar every hour during spare time, calling on doctors, coal dealers, general stores. Nothing to sell. Everything furnished. No money needed. National Credit Reporter, Delphos, Ohio.

FOR SALE

POWERFUL Marine day and night glasses with case, 25-mile adjustment, \$9.50. Satisfaction or money returned. Wells Curiosity Shop, 29 South Second Street, Philadelphia, Penna.

UNIVERSAL Knitting Machines. Many styles, hand or power. For Catalogue, address Daniel Becker, Peabody, Mass.

SALE OR EXCHANGE

WANT to Swap? Send 10 cents for "The Market for Exchange" to Pierre Notley, 141 Milk Street, Boston, Mass. It gives a long list of those who have things to trade or sell. Send list of things you have to trade or sell.

AIR Compressor to sell or exchange for small gasoline engine. Garage, Potter Brook, Pa.

FLOUR & FEED MILLING MACHINERY

SPECIAL bargains in second hand Attrition mills, burr mills, crushers, corn shellers, bran dusters, dust collectors, purifiers, reels, double, single, 2 and 3-pair high roller mills, sieve bolters, receiving separators, scourers, etc. Write for description and prices. Sprout, Waldron & Co., P. O. Box 423, Muncy, Pa.

MACHINERY, TOOLS AND SUPPLIES

RED Devil mechanic's plier (drop-forged). Most efficient, 5-inch size 86c. Style 58. Tool booklet free. Smith & Hemenway Co., 37 B Chambers St., New York.

BARGAINS—Two \$16 block machines; one silt machine; one 5-hp machine; two 18" tile molds. W. A. Morse, Pocomoke City, Md.

SEND for circular, 12" Quick Change Gear, Screw Cutting Lathe, Compound Rest, Power Cross Feed, Complete, \$200.00. W. P. Trotter, 818 Union Trust Bldg., Cincinnati, Ohio.

PULLEYS, Gears, Sprockets, Shafting, Hangers. See page 139. W. A. Jones Foundry & Machine Co., Chicago.

TOOLS—for shop, factory, garage and home—many high-class tools attractively priced in our "Odds and Ends" pamphlet—which is mailed free on request by Montgomery & Co., Inc., 105 Fulton St., New York City.

WIRE—all sizes— $\frac{1}{8}$ to No. 16. Coppered, tinned, galvanized and plain steel wire for sale. Cooley Mfg. Co., 533 W. Monroe St., Chicago, Ill.

LANGDON feeder 40 in., carpenter wings, 2 Florence weighers, new drive belt 150 ft., 9 in. 3 ply. A. J. Strassmann, Hutchinson, Minn.

ENGINES, MOTORS AND DYNAMOS

SMALL Motors and Generators—Quantity $\frac{1}{2}$ H. P. A. C. Motors—110 volts—slightly used, \$14.00. Small generators—charging—lighting—moving picture Arc machines, \$10 each and up. A. C. Motors 1 and 3 phase up to 5 H. P. for immediate delivery. Write for Bankruptcy Stock sheet. Johnston, West End, Pittsburgh, Pa.

EXCEPTIONAL values, alternating and direct current motors from $\frac{1}{2}$ H.P. upwards. Tell us your needs. Fans. Illustrated catalog supplies and motors. Hyre Electric Co., 617-AK South Dearborn St., Chicago.

GENERATORS, Ball-bearing, 32 volt, 11 to 35 amperes, complete with base and pulley. Prompt shipments. Goodlite Company, Indianapolis, Ind.

5 HORSEPOWER, two phase, 220 volt, 60 cycle, 1,200 revolution, Alternating electric motor, new—\$75. 8 horsepower Arme gasoline engine with magnets, used slightly—\$100. Parker, 1800 N. Francisco Ave., Chicago.

FOR Sale. Dynamo and four gasoline Engines. Valan, Alaska, W. Va.

REBUILT Engines—We have rebuilt "Buffalo" Engines, guaranteed, at greatly reduced prices. Write for bargain list. Buffalo Gasoline Motor Co., 1293-1305 Niagara Street, Buffalo, N. Y.

FOR MECHANICS

HAND Cleanser, wonderful remover of dirt and grease. Guaranteed not to contain injurious substances and to last 1 year, 25c. Hand-cleanser Co., 173 Ulland Ter., N. E., Washington, D. C.

TOOL Cases. For Carpenters and Machinists. Write for catalog. Keystone Case Co., 4920 Lake St., Chicago.

FOR THE SHOP

PATTERN Makers! A book devoted to the principles of pattern and core making and molding. Written by G. H. Willard, a practical pattern maker of years' experience. This book, just published, treats the subject in a much more simple, direct and effective manner than most books along this line. 224 pages, 312 illustrations. Price, \$1, postpaid. Popular Mechanics Book Dept., 6 N. Michigan Ave., Chicago.

SHOP Notes for 1917—Just Published—524 Articles, 422 Illustrations, 224 Pages. Easy Ways to do the Hard Things in every trade and calling. Price, 50 cents, postpaid. Also all previous numbers in Shop Notes series Volumes 1 to 12 inclusive at 50 cents each, postpaid. Send for description. Popular Mechanics Book Dept., 6 N. Michigan Ave., Chicago.

CEMENT

CONCRETE Building Block Machines and Molds. Free catalogue. 221 So. Main St., St. Louis, Mo.

BLACKSMITHS

BLACKSMITHS, Listen! Prepare for big wages in the navy and arsenals with Toy's Modern Methods doing hard jobs easy. Forging and making solid welds, hardening and tempering to a standard, with colored tempering charts. All for one dollar. Samples Free. W. M. Toy, Sidney, Ohio.

ELECTRICAL

ILLUSTRATED catalog, just issued. Electrical supplies and motors, switches, wire, tape, plugs, loom, cutouts, fuses, rosettes, lamps, sockets. Send for free copy today. Hyre Electric Co., 618RL South Dearborn St., Chicago.

DRY Batteries and Their Construction for All Purposes. A practical handbook of 66 pages with 30 illustrations dealing with batteries for automobiles, gas engines, medical and coil work, electric bells, alarms, telephones, experiments, etc. Price, 25 cents postpaid. Popular Mechanics Book Dept., 6 N. Michigan Ave., Chicago.

PRACTICAL Electric—Universal handy book on every-day electrical matters, alarms, batteries, bells, carbons, connections, coils, dynamos, wires, lamps, motors, telephones, etc. 135 pages, 126 illustrations, 25c postpaid. Popular Mechanics Book Dept., 6 N. Michigan Ave., Chicago.

STAMP COLLECTING

FREE—60 different stamps, including Newfoundland, China, Japan, Mexico, etc., to applicants for our high-grade approvals. Send 2c stamp for return postage. The Edgewood Stamp Company, Dept. H, Milford, Conn.

SELL Old Glory stamps; big profits; sample 10c. Queen Novelty Co., Sta. F, Cincinnati, Ohio.

40 DIFFERENT U. S., 10c. Free stamps on approvals. Lutzke, Bay City, Mich.

STAMPS sent on approval at 70% discount. Reference required. Emory Renoll, Hanover, Pa.

44 GOOD U. S. Postage Stamps 8c, postage free. Gem Stamp Co., 1111 Washington Building, Los Angeles.

FREE! Two stamps cataloging 30c to all approval applicants enclosing postage. B. Garnett, Rt. Elgin, Illinois.

STAMPS—500 fine foreign incl. Mex. War, Salvador, incl. officials, Guatemala, China, etc., only 10c. Best App. Sheets 60 to 80% dis. We give valuable extra Presents free! Big 120 pg. catal. free. We buy stamps. Hussenman Stamp Co., St. Louis, Mo.

PACKET of 23 stamps; no two countries alike, 500 hinges. Set of \$1 and \$2 U. S. Rev., all for 5c. Mention paper. Miami Stamp Co., Toledo, Ohio.

500 MIXED U. S., Old and New, 12c. Weatherby, Medina, Ohio.

STAMPS—12 different from warring nations, 10c; 10 different foreign coins, 15c; 20 Belgian stamps, 10c. Lists free. Toledo Stamp Co., Toledo, Ohio.

THE way to build your Stamp Collection. Send 50 cents for one of my approval Books. Select the stamps you want, to the value of Fifty Cents, and return me the Book. F. J. Pope, Charlotte, Vermont.

24 VARIETIES Cuban stamps, 10 cents. List of 6,000 low-priced stamps free. Chambers Stamp Co., 111 P. Nassau St., New York City.

STAMPS, 75, all different, free. Postage, 2c. Mention paper. Quaker Stamp Co., Toledo, Ohio.

105 CHINA, etc., stamp dictionary, 1st. 2c. Album (500 illustrations) 3c. Bullard, Sta. A., Boston.

20 UNUSED stamps free. All different. Postage, 2c. Fisk Stamps, Toledo, Ohio.

RARE COINS

WILL pay \$75.00 for 1884 Trade Dollar, 10 cents for 1912 nickels, 8. mint. We buy for cash premiums all rare coins, bills and stamps to 1912—all rare cents to dollars. Send now 4c. Get our Large Descriptive Circular. Numismatic Bank, Dept. H, Fort Worth, Texas.

CALIFORNIA gold, quarter size, 27c. $3\frac{1}{2}$ size, 53c. \$1.00 size, \$1.10. Large cent before 1821, Columbian Nickel and Catalogue 10c. Norman Schultz, King City, Mo.

VILLA Money. Have just returned from Mexico; will send package of \$5 and \$1 bills assorted, postpaid for 15c. Maurice Grossman, E. 102, Cleveland.

FIVE Villa Coins and Bills, 35c. Moore Coin Company, Commerce, Texas.

\$100 VILLA (seven bills), postpaid 35c. Border Tradepost, Albuquerque, New Mexico.

OLD coins wanted; 24-page buying catalogue, 5c. A. Kraus, Kraus Bldg., Milwaukee, Wis.

ALL for 30c, a 25c California gold token, 5 foreign coins and price list. V. Walter, New Rochelle, New York.

OLD Coins. Large Spring Coin Catalogue of Coins for Sale, free. Catalogue quoting prices paid for coins, ten cents. William Hesselein, 101 Tremont St., Boston, Mass.

\$4.25 EACH Paid for U. S. Flying Eagle Cents dated 1856. We pay cash premiums on hundreds of Old Coins. Send ten cents at once for New Illustrated Coin Value Book 4x7. It may mean your fortune. Clarke & Co., Coin Dealers, Box 15, Le Roy, N. Y.

GAMES AND ENTERTAINMENTS

MAGIC—Escapes—Illusions—Catalog of Parlor Tricks Free. Professional Catalog with 500 Illustrations, 1,000 Tricks, 10c. Hornmann Magic Co., Sta. 10, 470 8th Ave., New York.

SCHOOL of Magic. Join now. No trash to sell. Learn magic as performed on the stage. Sample lesson 3 tricks 10c. Kellison School of Magic, 905 E. 70 St., Cleveland, Ohio.

ESCAPE from handcuffs, boxes, etc. Secrets of ten sensational escapes 50c. Blippy Magic Co., 2527 Ocean View Ave., Los Angeles, Calif.

MAGIC—Tricks, Books and Supplies. For Amateurs as well as the Great Professionals. Any one can learn through our instructions. Feature Acts in Mind Reading, Spiritualism, Rope Ties, etc. Large Illustrated Professional Catalogue, 10c. Chicago Magic Co., Dept. B, 72 West Adams St., Chicago, Illinois.

TRICKS, Puzzles, Jokes, Magical Apparatus, Plays, Stage Supplies, Mind-reading Acts, Sensational Escapes and Illusions. Free large Illustrated 1917 catalog. Oaks Magical Co., Dept. 412, Oshkosh, Wis.

THEATRICAL GOODS

SCENERY for Hire and Sale. Amelia Grain, 819 Springgarden Street, Philadelphia, Pa.

FOR MEN

SEND 50c for pair most wonderful soft shirt cuff buttons yet invented. If not satisfactory, return and get money. E. Riddle, Dunsmuir, Calif.

CLEVER invention. Samples free. 100, 10c. DeLoof, G-247 Harrison, Detroit.

FOR THE HOME

"EGGETTE" (the original egg substitute) takes the place of eggs in all kinds of baking and cooking. Simple to use—always fresh. Guaranteed pure food product. Makes delicious cakes, cookies, puddings, etc. 10c package equals 12 eggs. Send 10c for a package today. (Agents Wanted.) Best-ever Products Co., B-3, Douglas Park Sta., Chicago, Ill.

MISSION Furniture—Make your own at little expense. Complete instructions, working drawings and stock lists for 96 different pieces. Price \$1.50 postpaid for set of three books. Send for complete descriptive matter. Popular Mechanics Book Dept., 6 N. Michigan Ave., Chicago.

RAZORS AND BLADES SHARPENED

MAKE shaving a pleasure. Mail your razor and 25c. returned in two days. J. Motz, Expert Honer, 235 Amber St., Pittsburgh, Pa.

SAFETY Blades Resharpened. Double 3c; single 2c. Mevntzen, Beaumont, Texas.

SAFETY razors sharpened; two cents each. Guaranteed. Blade box free. Electro Strapping Co., 134 Shelby St., Detroit, Mich.

PIANOS AND MUSICAL INSTRUMENTS

YOU can tune and keep your own piano or player piano in perfect condition. Van Atta's book on The Piano and Player Piano not only tells you but shows you every movement in their care, repair and tuning. 156 Pages. 51 Illustrations. Cloth. Price, \$1.50 postpaid. Popular Mechanics Book Dept., 6 N. Michigan Ave., Chicago.

BEERIE Violins, deep, mellow tone, easy payments. Colored photo and particulars. 130 Clinton St., Muskegon, Mich.

MUSIC

"SWEET Luana" and "Honolulu Pa-hika," popular Hawaiian songs. 25 cents brings both. Money refunded if dissatisfied. Request catalog. Quincke Company, Majestic Theater Bldg., Los Angeles, Cal.

FAMOUS Century Edition Sheet Music, 10c per copy. Catalog free. New Jersey Sales Co., Dept. F, Box 217, Passaic, N. J.

BEAUTIFUL Song Free with catalog of latest music, popular and high-class. Send 4c. Roy Linwood, Box 2232, Dept. M, Boston, Mass.

PHONOGRAPHS AND RECORDS

VICTOR, Columbia, Edison Disc and Cylinder Records bought and sold. Victor and Columbia 15 cents up. Edison Standard 9 cents. Blue Amberol 25 cents. Send for record list. Wells Curiosity Shop, 20 South Second Street, Philadelphia, Penna.

BUILD your Phonograph. Highest quality motors, tone arms, reproducers, cabinets, lowest prices. Circulars free. Central Music Exchange, Indianapolis, Indiana.

BUILD Your Own Phonograph. Any type, Big saving. Patents expired. Profits making and selling them. We furnish parts you can't make. Full instructions, dimension drawings, illustrations, parts—price-list only 25c. Circular Free. Associated Phonograph Co., Dept. P, Cincinnati, O.

MANUFACTURING

PATENTED Articles, Molds, Brass Work, Machine Construction; Dies Made. Baum's Metal Specialties, Kansas City, Mo.

WANTED, Metal Specialties, Novelties 1. Manufacture on contract. Stellar Mfg. Works, Batavia, N. Y.

WIRE Goods, all kinds, made to order. Cooley Mfg. Co., 533 W. Monroe St., Chicago.

WOOD and Metal Patterns, Iron, Brass, Aluminum Castings. Metal Specialties Manufactured on Contract. Welch Bros., North Chicago, Ill.

INVENTIONS manufactured under contract. Write Adam Fisher Mfg. Co., 2061F Railway Exchange, St. Louis, Mo.

ANTIQUES AND RELICS

OLD mahogany furniture, china, antiques, all kinds. C. W. Unger, Pottsville, Pa.

ANCIENT Indian arrow heads. Send for lists. A. Ruby, Middletown, Pa.

POMO Indian Star Baskets. Prices free. Gilham, Highland Springs, Cal.

FORMULAS AND TRADE SECRETS

1,600 FORMULAS, 25c. 75 Manufacturing Secrets, 10c. Resilvering Mirrors—Renewing Dry Batteries—Gas Tonic—Mechanics Soap—Luminous Paint—20c each. Entire Collection, 50c. Satisfaction guaranteed. Big Catalog, 2c. Ideal Book Shop, 3315-F7 Belleplaine Ave., Chicago.

FOR Sale—Formula and Machinery for manufacture of best Greases on market. Quincy Lubricating Grease Co., Quincy, Ill.

10,000 SELECTED scientific, chemical, technological, and practical recipes and processes, including hundreds of so-called trade secrets for every business, alphabetically arranged in one large volume of 800 pages. Price \$3 prepaid. Large descriptive circular sent upon request. Popular Mechanics Book Dept., 6 N. Michigan Ave., Chicago.

LUMINOUS Paint—16 formulas—different colors, 25c. "Puncture Plugger"—automatically seals punctures on the run, complete formula 25c. "Carbon Remover," carbons worst enemy, 25c. All sent for 50c. C. Johnson, 1319 N. Whipple St., Chicago.

20,000 FORMULAS, \$1, Postpaid. Complete list 4c stamps. Edm Bromley, Watervliet, N. Y.

TYPEWRITERS AND SUPPLIES

TYPEWRITERS—Prices wrecked. All Makes, Nearly New and Rebuilt, \$5.00 up. Coronas and other portable machines, \$10.00 up. Write for catalog 30K. Beran Typewriter Co., 58 W. Washington St., Chicago.

STARTLING values in Typewriters, \$10 to \$15, up. Factory rebuilt. All makes. Shipped on trial. Write for our special offer No. 126G. Whitehead Typewriter Co., 186 N. La Salle St., Chicago.

L. C. SMITH, Remington—\$38. Underwood—\$40. Fresh typewriters; modern improvements. Investigate Free Trial (name typewriter). Co-operative Union, Covington, Kentucky.

SEND for list of Typewriter Bargains, new and rebuilt; cash, time or rent. 10 days' Free trial. American Typewriter Exchange, 14 N. Dearborn St., No. 4, Chicago.

LARGEST Stock of Typewriters in America. Underwoods, one-fourth to one-half manufacturer's prices; rented anywhere, applying rent on purchase price. Free trial. Installment payments if desired. Write for catalogue 79. Typewriter Emporium, estab. 1892, 34-36 W. Lake St., Chicago, Illinois.

DUPLICATORS AND DEVICES

"MODERN" Duplicator—a Business Getter. \$1 up. 50 to 75 copies from pen, pencil, typewriter; no glue or gelatine. 35,000 forms use it. 30 days' trial. You need one. Booklet Free. J. K. Durkin & Reeves Company, Pittsburgh, Pa.

\$390 MULTIGRAPH like new for \$100. Guaranteed. Russell Baum, Philadelphia Bourse, Philadelphia.

OFFICE EQUIPMENT

THE Ray Adding Machine—Complete for \$15, handsome desk stand free. Adds with speed and accuracy of highest priced machines—also actually subtracts. Saves time, money, labor. Convenient to have on desk or to carry wherever needed. Used by Hershey Chocolate Co., Barrett Manufacturing Co., etc. Order today. Money returned at end of 30 days if not satisfactory. Or write for further information. Ray Company, 1430 Power Bldg., Richmond, Va.

MAILING LISTS

1,000 ILLINOIS Farmers' names \$1.50, 98% correct. Miss Lawrence, 245, Lincoln, Ill.

115 RELIABLE firms that buy names \$1.00. Liebau, Drawer 585, Erie, Penna.

250,000 NAMES of Iowa Farmers Classified by Counties. Write. L. C. Scott, Bloomfield, Iowa.

PRINTING, ENGRAVING AND MULTIGRAPHING

1,000 IMITATION typewritten letters, heading black, body purple, \$3.50; envelope slips, \$1.00; 6x9 circulars, \$1.50. Elegant samples free. Good's Printery, Harrisonburg, Va.

500 LETTERHEADS or envelopes \$1.25. Weaver's Print Shop, Michigan City, Ind.

NEW large catalog of attractive gummed Labels and Advertising Stickers Free. 3,000, 75c upwards. Royal Label Company, 419 Cherry, Philadelphia.

500 BOND Letterheads, \$1.25. Satisfaction guaranteed; samples free. Southern Systems, Mansura, La.

CIRCULARS—1,000, 3x6, 90c; 4 1/2x6, \$1.15; 6x9, \$1.75. Chas. Walter, Lancaster, Ohio.

"SHOW Your Colors." Flag labels 75c per 1,000 or 100 samples 10c. Helmers Company, Hoboken, N. J.

GUMMED Labels! Any size! Catalog free. Edward Harrison, Baltimore, Maryland.

QUALITY Printing Prepaid. 500 either envelopes, noteheads, cards, statements, \$1.35; 1,000, \$2.25; 500 linen-finished letterheads or envelopes, \$2.25; 1,000, \$3.50. Prepaid. Typewriter letters. Stamp brings samples. Model Company, Manchester, Iowa.

PRINTING of every description, large modern plant. Get our prices. A. Kraus, Kraus Bldg., Milwaukee, Wis.

PREPAID: Name and address 50 elegant cards, 15c. Commercial printers, samples free. Majestic Printing Co., 3944 Leeward Ave., Los Angeles, Cal.

PERFECTION Letter Company, Muncie, Indiana. Multigraphs 500 purple letters with black letter heads, \$2.15. Samples for stamp.

500 SWELL Linen-Finish Letterheads printed two colors, \$2.50, Bond \$2. Price list. Samples 2c. Starb Printing Co., Hamilton, Ohio.

PRINTING Outfits—Presses, type, supplies, type novelties. Send stamp for catalogue. Model Press, York, Penna.

AT Last! Beautiful Lithography for small users. 1,000 Letterheads, 1,000 Billheads and 1,000 Statements, \$9.99. Engraving Free. Kaydee Lithographing Co., 764 Teutonia, Milwaukee.

PRE-USED Printing presses. Type, Supplies, cheap. List for stamp. Popular Bargains, Richland, Pa.

GOOD Printing at low prices. 1,000 good letterheads, envelopes, cards, billheads, labels, circulars, \$2.50. Samples free. Catalogs, booklets and circulars our specialty. Ernest L. Fantas Co., 323 S. Dearborn St., Chicago.

LABEL Catalog "A" free. Irvin Wolf, 2126 Jagger Street, Philadelphia.

AMERICAN Flag Gummed Seals our specialty. Samples free. Wetzel, Box 101A, Madison Square, New York City.

PATENT ATTORNEYS

PROTECTIVE patents procured promptly. 104-page blue book on patents sent on request. Trade-marks registered. Robb & Robb, 211-215 Southern Bldg., Washington, D. C.

PATENTS Secured or Fee Returned. Actual search free. Send sketch or model. 1917 Edition, 90-page patent book free. My patent sales service sets full value for my clients. It should never require more than two days to report upon the patentability of your invention; nor longer than ten days to prepare your application for filing. Longer delay amounts to gross neglect and the jeopardizing of your rights. For prompt personal service write. George P. Kimmel, 212 Barrister Building, Washington, D. C.

"PATENTS and Patent Possibilities" is a 72-page treatise which tells all about patents, what to invent and where to sell it. It gives honest advice to inventors and tells about the successes of some of my clients, also explaining what are frequent causes of failure. Manufacturers are constantly writing for protective patents upon all kinds of sound inventions. Can you help supply their wants. The book is free. Write for it today. H. S. Hill, 905 McLachlen Bldg., Washington, D. C.

PATENTS without advance attorney's fee. Send sketch for free report. Books free. Frank Fuller, Washington, D. C.

PATENTS—Send Sketch. Free Search and Certificate of Patentability. Free Book. "How to Obtain a Patent and What to Invent." Patents secured through Credit System. Talbert & Parker, Patent Lawyers, 4622 Talbert Bldg., Washington, D. C.

PATENTS Secured or All Fees Returned. See E. E. Vrooman & Company's advertisement, page 149.

PATENT What You Invent. It may be valuable. Write me. No attorney's fee until patent is allowed. Estab. 1882. "Inventor's Guide" Free. Franklin H. Hough, 522 Loan & Trust Bldg., Washington, D. C.

HIGH-VALUE Patents. See R. S. & A. B. Lacey's advertisement on page 147.

PATENTS Bring Riches; Protect your Invention. Attorney's fee payable when patent allowed. Plain advice and "Patent Facts" Free. Trademarks registered. Jaynes & Jaynes, 633 Kellogg, Washington, D. C.

PATENTS—Herbert Jenner, patent attorney and mechanical expert, 606 F St., Washington, D. C. I report free of charge if a patent can be had and its exact cost. Send for circular.

PATENTS that protect and pay. Advice and books free. Rates reasonable—highest references; best results. Watson E. Coleman, Patent Lawyer, 624 F St., N. W., Washington, D. C.

PATENTS: Send model, sketch or drawing. Advice. 100 Mechanical Movements and 50 Perpetual Motions, Free. Fred G. Dieterich & Co., 61 Ouray Bldg., Washington, D. C.

H. L. WOODWARD—Safe methods. Paying patents. Write today. 902 G St., Washington, D. C.

PATENT Your Ideas—\$9,000 offered for certain inventions. Books, "How to Obtain a Patent," and "What to Invent," sent free. Send rough sketch for free report as to patentability. Manufacturers constantly writing us for patents we have obtained. We advertise your patent for sale at our expense. Established 20 years. Address Chandler & Chandler, patent attorneys, 1090 F St., Washington, D. C.

DON'T lose your rights to patent protection. Before proceeding further send for our blank form "Evidence of Conception" to be signed and witnessed. Book, suggestions and advice free. Lancaster & Allwine, 221 Ouray Bldg., Washington, D. C.

PATENTS. R. Morgan Elliott & Co., Patent Attorneys, Mechanical, Electrical and Chemical Experts, 713-721 Woodward Bldg., Washington, D. C.

PATENTS Wanted. Write for list of Patent Buyers who wish to purchase patents and what to invent with List of Inventions Wanted. \$1,000,000 in prizes offered for inventions. Send Sketch for free opinion as to patentability. Write for our Four Guide books sent free upon request. Patents advertised Free. We assist inventors to sell their inventions. Victor J. Evans & Co., 166 Ninth, Washington, D. C.

PRACTICAL Patent Service such as comes only with the mature judgment and years of experience of an old established firm, you can secure from Fetherstonhaugh & Co., 400 Victor Building, Washington, D. C. 35 years in U. S. and Canada. Free Booklet.

KEEP Up with Progress. Promote Your Patent. Send \$1.00 for Year's Subscription to Best Inventor's Magazine, "Invention and Manufacturing," United States Patent Corporation, Washington, D. C.

THE Patentome is free. An education in obtaining patents. Established 1865. Anderson & Son, Attorneys, 767-7th St., Washington, D. C.

PATENTS obtained through D. Swift being promptly sold to manufacturers. Write to-day for free books of "Inventions Needed" and surpassing references. D. Swift, 517 7th St., Washington, D. C.

PATENT applications filed on partial payment plan. We help sell the patent. Trade-marks, copyrights, etc. Milo B. Stevens & Co., 685 F. St., Washington; 358 Monadnock Bldg., Chicago, Estab. 1864.

PATENTABLE Ideas Wanted—Send for 4 free books. R. B. Owen, 30 Owen Bldg., Washington, D. C.

PATENTS on Easy Payments. Send model or sketch for Free Search and Certified Registration of Your Invention for Your Protection. Free Book Tells What to Invent and How to Obtain a Patent on Easy Payments. C. C. Hines & Co., 591A Loan & Trust Bldg., Washington, D. C.

PATENTS—Send sketch for free search and report. Books on patents and book of reference letters sent free. John S. Duffie & Co., 610 F St., Washington, D. C.

INVENTORS: Write our Patent Dept. Adam Fisher Mfg. Co., 2061 C Railway Exchange, St. Louis, Mo.

FOR INVENTORS

INVENTORS: Invent for profit. Write for list of needed inventions. Sanders, 7 Webster Bldg., Chicago.

WANTED, to buy Inventions, State price and full particulars. Howard Smith Company Inc., Washington, Penna.

INVENT Something; Your Ideas may bring wealth; free book tells what to invent and how to obtain a patent, through our credit system. Talbert & Parker, 4280 Talbert Bldg., Washington, D. C.

PATENTS secured or all fees returned. See E. E. Vrooman & Company's advertisement, page 149.

HIGH-VALUE Patents. See R. S. & A. B. Lacey's advertisement on page 147.

INVENTORS—Write quick, learn difficulties about selling patents before spending money to get them. O. d. Inventor, Box 3079, Boston, Mass.

INVENTORS: My patent made a fortune. Let me sell yours. Send description. Eugene Pearl, 23 Union Square, New York.

NO Attorney fees until patent allowed. Send sketch for free report. Books free. Frank Fuller, Washington, D. C.

WANTED—Patent. Magnetic Ore Locator. 13 E. 7th, Portland, Ore.

WILL buy or finance any good patent on an aeroplane stabilizer or safety device. Write Mr. Beaton, care of First National Bank, Imogene, Iowa.

WISH to communicate with inventor having good patent for sale. Burns, 1227 Walnut, Cincinnati, Ohio.

MANUFACTURER wants inventions that can be commercialized on royalty basis. Automobile preferred. J. A. Hedges, 5423 Prexel Ave., Chicago.

HAVE You An Idea? If so, you should protect it by a patent. Send us a model or sketch for free opinion as to patentability. Write for our Four Books sent free to any address. Victor J. Evans & Co., 157 Ninth St., Washington, D. C.

INVENTORS—We specialize in manufacturing new patented articles—make models—dies—and do experimental work. Leo J. Gerding Mfg. Co., Dept. D, Opera Place, Cincinnati, O.

INVENTIONS—Patenting and Promoting. A book containing practical advice and directions for inventors and manufacturers. Book, suggestions and advice free. Lancaster & Allwine, 221 Ouray Bldg., Washington, D. C.

INVENTIONS commercialized on cash and royalty basis. Patents secured. Models, experimental work and contract manufacturing. Inventors should write at once. Adam Fisher Mfg. Co., 2061A Railway Exchange, St. Louis, Mo.

PATENTS, Trade-Marks and Copyrights. Our handbook on patents will be sent free on request. All patents secured through us are described without cost to the patentee in the Scientific American. Munn & Co., Patent Attorneys, 623 Woolworth Bldg., N. Y. Washington, D. C., office, 623 F. St.

PATENTABLE Ideas Wanted—Send for 4 free books. R. B. Owen, 30 Owen Bldg., Washington, D. C.

PATENTS on easy payments. Send model or sketch for Free Search and Certified Registration of Your Invention for Your Protection. Free Book Tells What to Invent and How to Obtain a Patent on Easy Payments. C. C. Hines & Co., 591A Loan & Trust Bldg., Washington, D. C.

WANTED—An Idea! Who can think of some simple thing to patent? Protect your ideas; they may bring you wealth. Write for "Needed Inventions" and "How to Get Your Patent and Your Money." Randolph & Co., Patent Attorneys, 623 F. St., Washington, D. C.

INSURE Success. Skilled designing, automatic and special machines. Practical working drawings. Tipnash, Box 4708, Philadelphia, Pa.

PATENTS FOR SALE

IMPROVED patented speedometer for automobiles. Shows mileages, trip mileage, speed, controls speed and locks car. J. H. Core, 690 3rd Ave., North Nashville, Tenn.

METALLIC Railroad Tie. Simple and efficient. Conveniently supports rail and holds it securely. Prevents rail from separating at any time. Patent is pending. Will consider good royalty offer or sell outright. Write Daniel I. Cowgill, R. F. D. No. 5, Lexington, Ky.

PATENTED improved "Article-Carrier." Cash or royalty basis. Reasonable terms. U. S. Patent No. 1,177,692. Canadian Patent No. 175,789. For full particulars address Joseph Falls, Gunn, Wyoming.

FOR Sale Cheap—Patent 1,297,339, Car Window Shelf, Headrest Draft Shield, Combination. Box 613, Ely, Nevada.

CASH or royalty Patent No. 1,138,943. Mouse trap. Investigate. Duncan, R. J., Box 834, Inglewood, California.

PATENT, outright or royalty, simple, new parallel ruling instrument. N. Chida, 1329 Willow St., Los Angeles, Calif.

HOUSEHOLD necessity. Bath-tub-seat. Sell cheap for cash. Tanaka, Japan Trading, 331 4th Ave., New York.

PATENT—Self-Stock Feeder—particularly hogs. Wm. T. Halligan, Emmett, Kansas, R. 1.

SALE or Royalty, Patent 1,151,538. Tool-holder with swivel head, 3 tools in one. Geo. H. Mason, Lubec, Me.

PATENT on game board for sale. Address E. Leonard, Thompson, Pa.

FOR Sale—1917 Patent-pending Automatic Pipe and Monkey Wrench. Joseph P. Ruffeno, Opelousas, Louisiana.

PATENT lock for garage and barn gate for the use of locking and drawing tight. Joseph Buchek, 1935 S. Wisconsin Ave., Oak Park, Ill.

TOWEL, napkin and drapery hanger. Latest household invention. B. Anderson, 1191 W. 39th St., Chicago.

PATENT for Sale, Railway Switch whereby engineer close open switch. Train at any speed from either direction. B. O. Markham, Alma, Mich.

FOR Sale—Patented household necessity. Granted Feb. 21, 1917. Housewives will buy upon demonstration. Maurice M. Ely, Clinton, Iowa.

PATENT Spring Fork—New idea in construction—very simple—for bicycles and motorcycles. For particulars, address Geneva, 614 Fordham Road, New York City.

PATENT secured or fee returned. Free Patent Book and Selling Guide. We will promote your patent. Write Sues & Co., Attys., 559 7th St., Washington, D. C.

PATENT covering new features in double acting pump cylinder; no gears; very simple; working model for demonstration. Sell outright or royalty. T. B. Yetter, Fountain Green, Ill.

PATENT issued June 13, 1916. Self-fitting truss. Will sell on account of other business. Address A. D. Caywood, 1741 Walnut St., Chicago, Ill.

SHOE fastening device, gloves, leggings, etc. U. S. and Canadian patent. Cash or royalty. Simple constructed, inexpensive, efficient. J. Peterson, Bourne, Oregon.

DRAWING board. U. S. patent for sale. Cheap manufacturing, hence splendid opportunity. Nagy, Woodlawn Inn, Pittsfield, Mass.

PATENT for sale, issued 1917. The handiest household necessity ever invented. Best offer takes it. Mrs. Della Woolard, 416 N. Cherry, Ontario, Calif.

FOR Sale, cash or royalty, patent No. 935,269, safety brake for elevators. 111,378, adjustable butter cutter for restaurant use. Lawrence Givulinovich, 913 E. Terrace, Seattle, Wash.

OUTRIGHT or Royalty. Patent Pending. Metal adjustable pen pencil ring. Practical, efficient. Great Mail-order article. Nicholas O. Guss, Jr., Entwistle, Alta., Canada.

ORIGINAL, effective Bumping Foot Device, patented in thirty days. Railroad Engineers approve it. Deriving your exclusive time means fortune. Reason for selling: war rush in my business. Patents, 511 Walnut, Cincinnati, Ohio.

VALUABLE Patents for Sale or Lease—Cash or Royalty. Our No. 10,162, Non-Reliable Bottle; 10574 Plow; 10,125, Combined Hammer, Nail Puller and Wrench. Write us regarding these and other late patents. Ask for Free Copy of our 164-page patent book. Talbert & Parker, 4687 Talbert Bldg., Washington, D. C.

PARTNER wanted to manufacture fire-escape. Made of steel with endless rope. Tested and demonstrated so forty persons can go down a minute. Is regulated and works by compressed air cylinders. Made on small truck for shops and any style cabinet for any room in buildings. Joseph Bonford, Linwood, Mass.

PATENT—For sale or royalty, to prevent hot boxes on car-wheel axles, called Self-Lubricator. Wm. King, Padmexter, Ky.

ENGINE Shaft Coupling used on engines intended for pulling threshing machinery successfully. Great saver of grain. Patent No. 1,183,681. F. W. Schipper, New London, Iowa.

TRUNK, spring bed, bureau, table and chair combined in one article. Any offer considered. Particulars unsolicited. D. Hornstein, 105 Alberman St., Baltimore, Md.

REINFORCED Concrete Fence Post. Securely holds wire. Great boon to farmers. S. G. Gillespie, Box 29, Charleston, W. Va.

METAL Shield to protect pneumatic tubes from puncture. Partner for promotion. S. G. Gillespie, Charleston, W. Va.

PATENTED Metal Shingle for ventilating roof. Unique idea. D. W. Millsaps, 835 North Main St., Greenville, S. C.

PATENT for Sale—No. 34629, combined pistol and saber which cuts and shoots. Sale for \$5,000. S. Przepiolka, 133 Gulf St., Medina, N. Y.

SIMPLE new Carnival Toy. Practical novelty. Royalty or outright. J. L. Castillo, 1360 Hyde St., San Francisco, Calif.

PATENT Buyers are invited to address our sales department for information on any class of Patents they wish to purchase or lease on a royalty. We have secured a number of valuable patents in all lines of invention. Mail Order, Department Store and Household Novelties a specialty. Victor J. Evans & Co., 160 Ninth St., Washington, D. C.

FOR Sale—Agricultural tool, rake and fork. Ingenious device. Convertible, one blade. B. A. Arnold, Box No. 2, Trough, S. C.

We have some money-making inventions for placing on royalty; outright sale or trade. Write Adam Fisher Mfg. Co., 2601B Railway Exchange, St. Louis, Mo.

OFFER Cash or Royalty; U. S. Patent No. 1,189,266, Improved, Profitable kite. Big field for this. Further particulars furnished on request. J. M. Moreira, 57 Hanover St., Lowell, Mass.

WANTED

WANTED—Victor, Edison and Columbia Records. Give price, title and quantity. Address, N. T., Room 925, 78 E. Madison St., Chicago.

MODELS AND MODEL SUPPLIES

MODELS, Punches and Dies, Patents Perfected. The Sachs-Lawler Co., Inc., Established 1881, 1543 Larimer St., Denver, Colo.

WANTED—New Ideas. Write for list of Patent Buyers and Inventors Wanted. \$1,000,000 in prizes offered for inventions. Our Four Books sent free upon request. Victor J. Evans & Co., 165 Ninth, Washington, D. C.

We make working models for inventors; also dies and stamping of specialties, and carry a complete stock of brass gears and model supplies. Send for catalogue. The Pierce Model Works, 3405 Pierce Ave., Chicago, Ill.

PRODUCERS of Results: Inventions developed. Models, Experimental work, anything special in metal to order, novelties, spinning, forging, castings in any material, electrical devices, patterns of all kinds, plating, general manufacturing, designing, special tools, punches and dies, stampings. Send drawing or sample. Expert information free. The John's Machine & Stamping Works Company, Dept. C, Cleveland, Ohio.

PERFECT models sell inventions. We make them. Write Adam Fisher Mfg. Co., 2601B Railway Exchange, St. Louis, Mo.

REAL ESTATE AND FARM LANDS

LAKE Shore frontage and cottages on Northern Wisconsin most beautiful lakes. Small or large tracts, good fishing, hunting, boating, bathing, camping in heart of sportsman's paradise. Write, tell us what you want. Pearson and Jenks, Minong, Wis.

SEVERAL improved farms for sale at reasonable prices. Owner, Wm. Voigt, Grand Rapids, Wisconsin.

OWN your own Orange or Grapefruit grove in beautiful Fruitland Park. Let me tell you how melons, peaches, hay, your first crops, should pay for your land and grove. J. Q. Lloyd, Desk 33, Fruitland Park, Florida.

FOR Sale—25-acre truck farm; new house; full equipment for working farm; Ford car, Bargain quick sale. Harry Green, Georgetown, So. Car.

FREE Homesteads on Government land. New law allows each homesteader 640 acres. Send 25 cents for digest laws and map state. Parker Co., Fort Sumner, N. M.

IRRIGATED 80-acre Wyoming farm. Fine location, close in. Healthy climate. Low price. Terms. Alfred Clark, Lansing, Mich.

PROFITABLE little farms in Valley of Virginia, 5 and 10 acre tracts, \$250 and up. Good fruit and farming country. Send for literature now. F. H. LaBaume, Agri. Agt. N. & W. Ry., 250 Arcade Bldg., Roanoke, Va.

BEAUTIFUL Seashore Homesites Only \$20. Special sale lots at Alamo Beach, Texas, famous Bayshore resort. First 100 lots \$20. Terms \$1 cash, \$1 monthly. Lots 50x140 feet. No endowment. Write for free literature and views. Alamo Beach Company, 422 First National Bank, Houston, Texas.

FOR Sale by owner 160 acres improved farm in Perkins County. Guy Courtright, Grant, Nebr.

100 ACRES of land with splendid 8-room house, barns and sheds, plenty of fruit, 10 s of timber, good water, fine climate, only \$16 per acre. Owner must sell. Other farm bargains. F. W. DeLong, Louisa, Va.

FOR Sale—20 acres of Orange and Grapefruit land, close to Clearwater, Fla. Pinellas County. Plenty of fishing, boating. Write for price and booklet. H. E. Tooker, Clearwater, Fla.

GOVERNMENT Lands Free Booklet. Joseph Clark, Sacramento, California.

SELL your property quickly for cash, no matter where located. Don't pay big commissions. Particulars free. Real Estate Salesman Co., Desk B, Lincoln, Nebr.

A **SMALL** farm in California will make you more money with less work. You will live longer and better. Delightful climate. Rich soil. Hospitable neighbors. Good roads, schools and churches. Write for our San Joaquin Valley illustrated folders free. C. L. Sengraev, Industrial Commissioner, AT&SF Ry., 1933 Ry. Exch., Chicago.

MONEY-MAKING Farms, 15 states, \$10 an acre up; stock, tools, and crops often included to settle quickly. Write for Big Illustrated Catalogue. Strout Farm Agency, Dept. 3045, New York.

FLORIDA. Choice farms near Jacksonville. Ernest Bennighofen, Anderson, Ind.

DOGS, BIRDS, POULTRY, PETS

RAISE Guinea Pigs for us. We buy all you raise. Pay better than poultry. Contract, particulars, booklet how to raise free. Cavies Distributing Co., 2102-A Grand Ave., Kansas City, Mo.

YOU can make a good living in your back yard raising rabbits for us; we will pay you from \$1 to \$2 each for young hares; breeders furnished at reasonable prices; send dime for contracts, circulars, etc. Thorson Rabbit Co., Aurora, Colo.

SEND for our expert advice on home gardening. If you have a garden now or ever expect to have one, you need these instructions. Write to-day for details. H. Balch, 327 Barclay Ave., Grand Rapids, Michigan.

AIREDALES, Irish and Scotch Terriers, fine pedigree stock, \$20 up. Allston Kennel's, Bound Brook, N. J.

RAISE Belgian Hares for us, Flemish Giants and New Zealand. Profits large. We supply stock and pay \$3.00 each. Also Cavies, Squab Breeders and fur-bearing animals. Instruction book and contract for dime. None free. Outdoor Enterprise Co., Box 13, Main St., Holmes Park, Mo.

FULLBLOOD Russian wolf-hound puppies. Pure white, white and tan, and white and brown spotted. \$20 each. Satisfaction guaranteed. Geo. E. Hineman, Dighton, Kansas.

BEAUTIFUL White Collies—Registered. Satisfaction guaranteed. Thos. Shower, Monticello, Iowa.

RAISE skunks in city or country. Odorless method. Illustrated circular P free. Skunk Development Bureau, Chicago.

SQUARES are raised in one month, they sell for fancy prices. Write at once for big free book telling how to make money breeding squabs. Plymouth Rock Squab Co., 634 Howard St., Melrose Highlands, Massachusetts.

RAISE Belgian Hares for Us. Big profits. We furnish stock and pay you \$2.00 each. Also Cavies, mink, skunk, fox, squabs, frogs, etc. Two booklets and contract for dime. None free. Address the Belgian Hare, 31 Main Street, Holmes Park, Mo.

SQUAB JOURNAL, treats on breeding and marketing of squabs. Four months' trial. 25c. Sample 10c. American Squab Journal Dept. O, Warren, Mo.



“We Need More Men Like Joe”

“Men, we are giving Joe a better position and a good increase in salary. He deserves it. Joe looked ahead of his job. He studied during his spare time with the International Correspondence Schools and today he *knows*, forwards and backwards, just the things he *must* know to hold down the job he is going into. I’m telling you this because there are *other* positions here for men who know. We need *more* men like Joe.”

Are you looking ahead of your job? Are you using your spare time in getting ready for something better? If not, now is the time to begin. Don’t delay. Don’t put it off. Lincoln said to himself, “I will study and get ready and sometime my chance will come.” It did. Your chance will come, too. Be ready for it. Study. Train yourself. You can do it at home, in spare time, through the I. C. S., just as more than 100,000 men are doing right now. You have every chance they have. You needn’t sacrifice an hour or a dollar from your present work. Simply use your spare moments.

Every shop, factory, store and office needs its “Joe.” Wherever you are, whatever your chosen line of work, if you *know* what you want to become, the I. C. S. will help you. Let us show you what we are doing for others and what we can do for you. The way to find out is easy. Use this coupon. Use it now. You will never regret it. Choose your career from the list it contains, then mark and mail it today.

TEAR OUT HERE
INTERNATIONAL CORRESPONDENCE SCHOOLS
 BOX 5585, SCRANTON, PA.

Explain, without obligating me, how I can qualify for the position, or in the subject, before which I mark X.

- | | |
|---|--|
| <input type="checkbox"/> ELECTRICAL ENGINEER | <input type="checkbox"/> SALESMANSHIP |
| <input type="checkbox"/> Electric Lighting | <input type="checkbox"/> ADVERTISING |
| <input type="checkbox"/> Electric Railways | <input type="checkbox"/> Window Trimmer |
| <input type="checkbox"/> Electric Wiring | <input type="checkbox"/> Show Card Writer |
| <input type="checkbox"/> Telegraph Engineer | <input type="checkbox"/> Sign Painter |
| <input type="checkbox"/> Telephone Work | <input type="checkbox"/> Railroad Trainman |
| <input type="checkbox"/> MECHANICAL ENGINEER | <input type="checkbox"/> ILLUSTRATING |
| <input type="checkbox"/> Mechanical Draftsman | <input type="checkbox"/> Cartooning |
| <input type="checkbox"/> Machine Shop Practice | <input type="checkbox"/> BOOKKEEPER |
| <input type="checkbox"/> Gas Engine Operating | <input type="checkbox"/> Stenographer and Typist |
| <input type="checkbox"/> CIVIL ENGINEER | <input type="checkbox"/> Cert. Public Accountant |
| <input type="checkbox"/> Surveying and Mapping | <input type="checkbox"/> TRAFFIC MANAGER |
| <input type="checkbox"/> MINE FOREMAN OR ENGINEER | <input type="checkbox"/> Railway Accountant |
| <input type="checkbox"/> Metallurgist or Prospector | <input type="checkbox"/> Commercial Law |
| <input type="checkbox"/> STATIONARY ENGINEER | <input type="checkbox"/> GOOD ENGLISH |
| <input type="checkbox"/> Marine Engineer | <input type="checkbox"/> Teacher |
| <input type="checkbox"/> ARCHITECT | <input type="checkbox"/> Common School Subjects |
| <input type="checkbox"/> Contractor and Builder | <input type="checkbox"/> Mathematics |
| <input type="checkbox"/> Architectural Draftsman | <input type="checkbox"/> CIVIL SERVICE |
| <input type="checkbox"/> Concrete Builder | <input type="checkbox"/> Railway Mail Clerk |
| <input type="checkbox"/> Structural Engineer | <input type="checkbox"/> AUTOMOBILE OPERATING |
| <input type="checkbox"/> PLUMBING AND HEATING | <input type="checkbox"/> Auto Repairing |
| <input type="checkbox"/> Sheet Metal Worker | <input type="checkbox"/> Navigation |
| <input type="checkbox"/> Textile Overseer or Supt. | <input type="checkbox"/> AGRICULTURE |
| <input type="checkbox"/> CHEMIST | <input type="checkbox"/> Poultry Raising |
| | <input type="checkbox"/> Spanish |
| | <input type="checkbox"/> German |
| | <input type="checkbox"/> French |
| | <input type="checkbox"/> Italian |

Name _____

Present Occupation _____

Street _____

and No. _____

City _____ State _____

Please Mention Popular Mechanics

Power Plant Engineering

Steam, Electrical, Turbine and
Refrigerating Engineering

Now Easily Learned

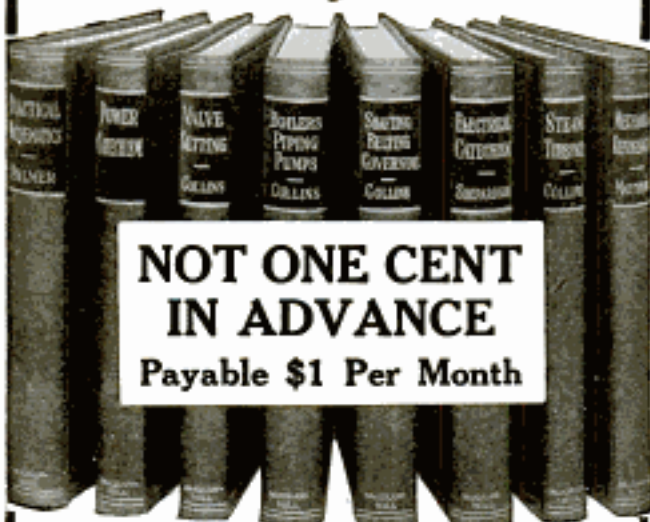

**NOT ONE CENT
IN ADVANCE**
Payable \$1 Per Month

These Books Have Revolutionized the Study of Up-to-Date Power Plant Practice

The Power Plant field is one in which a man's salary depends entirely upon himself—his training. The responsibilities are increasing in this field daily, likewise the income. This is a field in which the demand for competent training is never fully met.

Facts Compiled by Experts

It is no longer possible for a man to climb to a responsible position in power plant engineering by experience alone. He must study; inform himself on the latest practice, through books on power plant subjects, written by experts in the field—practical men only. The Power Plant Library is just THIS. It is the most used engineer's library in existence, because it is the best.

Every phase of power plant work is covered; it is a complete reference—study course in Mathematics, Engine Running, Valve Setting, Boilers, Piping, Pumps, Shafting, Belting, Governors, Electricity, Turbines, Refrigeration, etc.

10 Days' Free Examination

If you are a power plant engineer or expect to become one, any one of these eight volumes will be worth the small price we ask for the entire Library. Nothing is omitted. Only facts compiled by experts are included. Upon receipt of the coupon below we will send you this set for ten days' free examination, and you will be under no obligation to purchase.

FREE EXAMINATION COUPON

McGraw-Hill Book Co., Inc., 239 W. 39th St., New York

Gentlemen:—Ship the Power Plant Library, eight volumes, for my inspection. If satisfactory after examination, I will send you \$1 in ten days and the balance at the rate of \$1 per month until I have paid the price of the books, \$12. If not satisfactory I will write for shipping instructions.

SIGNATURE.....

RESIDENCE ADDRESS.....

CITY AND STATE.....

NAME OF EMPLOYER.....

REFERENCE.....

ADDRESS.....P.M. July '17



Be A Traffic Manager

Over a half million ship pers need men who know how to route shipments, obtain shortest mileage and quickest deliveries; how to classify goods and obtain lowest rates. These are two vital factors in business competition. The man who can classify commodities and figure routings most economically can name practically his own salary. Concerns gladly pay competent men

\$35 to \$100 a Week

Many pay a great deal more, because the knowledge of a Trained Traffic Expert saves them many times his salary. Train to enter this new, uncrowded profession. Positions are permanent; work is pleasant; salary is large. Give yourself a chance.

We Train You By Mail

In your spare time—at home—while holding your present position. The LaSalle Course is endorsed by railroads and big concerns everywhere. Covers thoroughly every phase of shipping and transportation. Write at once for Big Free Traffic Book and full details. We will also send you a valuable book—

"Ten Years' Promotion in One" Free

A prominent business man said—"It would pay every ambitious person to get this book even if it cost him \$5.00." Free with literature explaining how easily you can qualify for a Big Traffic job. LaSalle Extension University Dept. 764-C Chicago, Ill. "The World's Greatest Extension University."

ENGINEERING MECHANICAL ELECTRICAL

One Year Practical Courses. Day and Evening classes. Splendid equipment and instruction. Low tuition. For particulars address

DETROIT TECHNICAL INSTITUTE
Box 308, Y. M. C. A. Building, DETROIT, MICH.



H. L. WELLS, Pres.

Earn \$80 to \$400 a Month

Earn what you are worth. Get the good jobs where pay is big. Get into business where money is plentiful. Double your present salary.

LEARN THE AUTO BUSINESS

Study at home in spare time. You learn everything thoroughly. I. M. I. Course is complete. Earn while you learn. Get salary increase after first few lessons. Special instructions in Auto Electric. Write for Free Offer and Catalog, all Free.

INTERNATIONAL MOTOR INSTITUTE
27 Kesner Building CHICAGO, ILLINOIS

SHORTHAND IN 30 DAYS

We absolutely guarantee to teach shorthand complete in only thirty days. You can learn in spare time in your own home, no matter where you live. No need to spend months as with old systems. Boyd's Syllabic System is easy to learn—easy to write—easy to read. Simple. Practical. Speedy. Sure. No ruled lines—no positions—no shading as in other systems. No long lists of word signs to confuse. Only nine characters to learn and you have the entire English language at your absolute command. The best system for stenographers, private secretaries, newspaper reporters and railroad men. Lawyers, ministers, teachers, physicians, literary folk and business men and women may now learn shorthand for their own use. Does not take continual daily practice as with other systems. Our graduates hold high grade positions everywhere. Send today for booklets, testimonials, etc.

Chicago Correspondence Schools
969 Unity Bldg., CHICAGO, ILL.

414 PAGES 145 ILLUSTRATIONS

I. C. S.
ELECTRICAL ENGINEER'S
HANDBOOK

50¢

ELECTRICITY!

HERE'S just the book on Electricity that you need to answer your many questions—to solve your knotty problems, to teach you new kinks, to be your memory for tables, rules, formulas and other Electrical and Mechanical facts that some people try to carry in their heads—and fail.

With this "Little Giant" I. C. S. Electrical Engineer's Handbook in your pocket, tool chest, on your work bench, drawing table or desk, an hour or a day need not be lost "digging up" some forgotten rule, some unfamiliar fact; you'll just turn to the very complete index and get it "in a jiffy." Just a few of the subjects treated are:

Electricity and Magnetism; Electrical Symbols; Batteries; Circuits; Magnets; Direct and Alternating Currents; Dynamos and Motors; Belts; Shafting; Electroplating; Electrical Measurements; Meters; Arc and Incandescent Lamps; Mercury Arc Rectifiers; Transformers; Insulation; Electric Cars; Single and Multiple-Unit Control; Transmission; Rail Welding; Tables of Wires—Sizes, Capacities, etc.—Mathematical Rules, Formulas, Symbols; Tables of Constants, Equivalents, Roots, Powers, Reciprocals, Areas, Weights and Measures; Chemistry; Properties of Metals; Principles of Mechanics; First Aid, etc.

The Electrical Engineer's Handbook is one of 22 I. C. S. Handbooks covering 22 Technical, Scientific and Commercial subjects, all crowded with value. They have the contents of a full-size book condensed into pocket-size ready to go with you anywhere and be at your instant command. They are substantially bound in cloth, red edges, goldleaf stamping, printed from new, clear, readable type on good quality book paper. There is an illustration at every point where a picture will help. Hundreds of thousands have been sold on a money-back guarantee of satisfaction.

The former price of these Handbooks was \$1.25, but

THIS MONTH you can buy **50c** each, the ones you want for only **50c** postpaid

(For 10c extra we will send a cloth-covered protecting case.)

You Run No Risk! Money Back if Desired!

International Correspondence Schools

Box 5586 Scranton, Pa.

INTERNATIONAL CORRESPONDENCE SCHOOLS

Box 5586 SCRANTON, PA.

I enclose \$_____ for which send me postpaid the Handbooks marked X, at 50c. each. I may return any or all and get my money back within ten days from receipt:

- | | |
|--|---|
| <input type="checkbox"/> Electrical Engineer's | <input type="checkbox"/> Advertiser's |
| <input type="checkbox"/> Teleph. and Teleg. Engineer's | <input type="checkbox"/> Business Man's ★ |
| <input type="checkbox"/> Mechanic's | <input type="checkbox"/> Bookkeeper's |
| <input type="checkbox"/> Steam Engineer's | <input type="checkbox"/> Steno. and Correspondent's |
| <input type="checkbox"/> Westinghouse Air Brake | <input type="checkbox"/> Salesman's |
| <input type="checkbox"/> Civil Engineer's | <input type="checkbox"/> Window Trimmer's |
| <input type="checkbox"/> Coal Miner's | <input type="checkbox"/> Cotton Textile Worker's |
| <input type="checkbox"/> Concrete Engineer's | <input type="checkbox"/> Farmer's |
| <input type="checkbox"/> Building Trades | <input type="checkbox"/> Poultryman's |
| <input type="checkbox"/> Plumber's and Fitter's | <input type="checkbox"/> Mariner's |
| <input type="checkbox"/> Chemist's | <input type="checkbox"/> Automobile |

Name _____

Street and No. _____

City _____ State _____



"What y' Doin' Now, Bill?"

You don't have to ask that question of a *trained* man, because you *know* his position is a permanent one—that he is not at the mercy of conditions that affect the *untrained* man.

You can always be sure of a good position and a good salary if you have the *special training* that puts and keeps you in demand. The International Correspondence Schools will bring *special training* to you, no matter where you live, or how little spare time or spare cash you have.

To learn *how* the I. C. S. can help you, and how you can easily qualify for success in your *chosen occupation*, mark and mail the attached coupon today. Doing so costs you only the postage. You assume no obligation. If you *think* you're ambitious, marking the coupon will *prove* it. Do it NOW.

I. C. S., Box 5587, Scranton, Pa.

INTERNATIONAL CORRESPONDENCE SCHOOLS

Box 5587, SCRANTON, PA.

Explain, without obligating me, how I can qualify for the position, or in the subject, before which I mark X.

- | | |
|---|--|
| <input type="checkbox"/> ELECTRICAL ENGINEER | <input type="checkbox"/> SALESMANSHIP |
| <input type="checkbox"/> Electric Lighting | <input type="checkbox"/> ADVERTISING MAN |
| <input type="checkbox"/> Electric Car Running | <input type="checkbox"/> Window Trimmer |
| <input type="checkbox"/> Electric Wiring | <input type="checkbox"/> Show Card Writer |
| <input type="checkbox"/> Telegraph Expert | <input type="checkbox"/> RAILROADER |
| <input type="checkbox"/> MECHANICAL ENGINEER | <input type="checkbox"/> ILLUSTRATOR |
| <input type="checkbox"/> Mechanical Draftsman | <input type="checkbox"/> DESIGNER |
| <input type="checkbox"/> Machine Shop Practice | <input type="checkbox"/> BOOKKEEPER |
| <input type="checkbox"/> Gas Engineer | <input type="checkbox"/> Stenographer and Typist |
| <input type="checkbox"/> CIVIL ENGINEER | <input type="checkbox"/> Cert. Public Accountant |
| <input type="checkbox"/> Surveying and Mapping | <input type="checkbox"/> Railway Accountant |
| <input type="checkbox"/> MINE FOREMAN OR ENGINEER | <input type="checkbox"/> Commercial Law |
| <input type="checkbox"/> Metallurgist or Prospector | <input type="checkbox"/> GOOD ENGLISH |
| <input type="checkbox"/> STATIONARY ENGINEER | <input type="checkbox"/> Teacher |
| <input type="checkbox"/> Marine Engineer | <input type="checkbox"/> Common School Subjects |
| <input type="checkbox"/> ARCHITECT | <input type="checkbox"/> CIVIL SERVICE |
| <input type="checkbox"/> Contractor and Builder | <input type="checkbox"/> Railway Mail Clerk |
| <input type="checkbox"/> Architectural Draftsman | <input type="checkbox"/> AGRICULTURE |
| <input type="checkbox"/> Concrete Builder | <input type="checkbox"/> Textile Overseer or Supt. |
| <input type="checkbox"/> Structural Engineer | <input type="checkbox"/> Navigator |
| <input type="checkbox"/> PLUMBING AND HEATING | <input type="checkbox"/> Poultry Raising |
| <input type="checkbox"/> Sheet Metal Worker | <input type="checkbox"/> AUTOMOBILES |
| <input type="checkbox"/> CHEMICAL ENGINEER | <input type="checkbox"/> Auto Repairing |

Name _____

Occupation & Employer _____

Street and No. _____

City _____ State _____

Please Mention Popular Mechanics

LEARN AUTOS

WHERE AUTOS ARE MADE



Enlarged
Facilities

Freely Endorsed by
Automobile Manufacturers

Detroit is the training camp for men who make good in the automobile and allied lines. Never has the call for men skilled as mechanics, testers, inspectors, repair-men, bearing scrapers, welders, chauffeurs and salesmen been as great as it is today — and the demand is growing.

The Y.M.C.A. Auto School

is organized to train men. A Course in this School will quickly fit the beginner to do well-paid work, and get in line for advancement in the rapidly growing automobile industry. Tuition fees go to procure the highest class of instructors and best of equipment.

Growth Brings Added Facilities

The Y. M. C. A. Auto School is now in its New Building. Among the manufacturers who have contributed liberally toward our equipment are: Studebaker, Buick, Hupp, Chalmers, Ford, Packard, Hudson, Gray & Davis, Delco, Cutler-Hammer, Zenith, and many others. Can you ask stronger proof of the school's standing than the fact that men **who know** give freely of their time and money to co-operate with us.

Tuition includes membership in the "Y" and free service of **Employment Bureau for one year.** Our big Club House, adjoining our New Building, is at your disposal. Reading rooms, lounging rooms, gymnasium, swimming pool, billiard and pool tables, bowling alleys, with five floors of dormitories and restaurant at low rates. You are assured of not only thorough and competent instruction, but good companionship and clean living conditions with the comforts of home and club life combined.

Don't Visit Detroit Without Seeing Us. You want to consider everything carefully before you enroll for any course of instruction. Come and look us over, whatever purpose brings you to Detroit. Get all the particulars of this school, get the records of our instructors, hear what auto factories and automobile men have to say about us, see for yourself our comfortable quarters and big equipment. We will be glad to see you and show you around whether you enroll or not. Day and night classes. Start at any time.

Write today for full particulars. Address

EDUCATIONAL DIRECTOR
Box 305, Y. M. C. A., DETROIT, MICH.

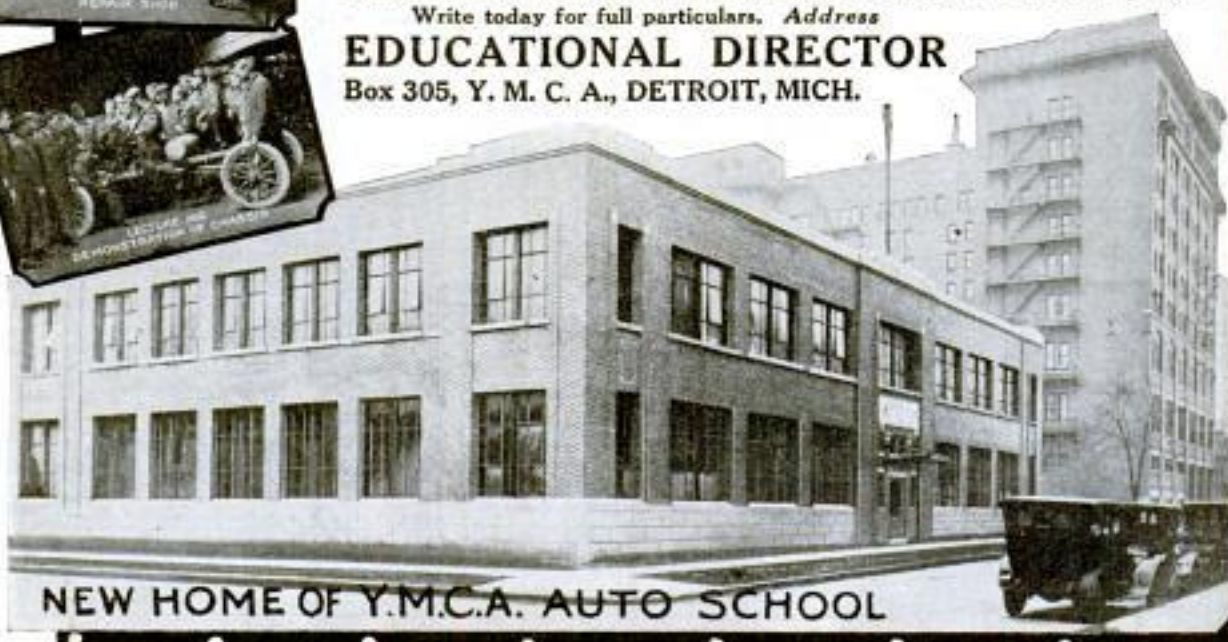

NEW HOME OF Y.M.C.A. AUTO SCHOOL

Please Mention Popular Mechanics

Be a Big Man In the Office

The Expert Accountant is consulted in all business affairs. He is a confidential adviser in all matters of finance. His reports and recommendations are sought after by every business man. He is highly paid. Many certified public accountants earn \$10,000 to \$25,000 a year. Think of this in planning your future.



BECOME AN EXPERT ACCOUNTANT

The Profession that Pays Big Incomes

Never before have there been so many splendid opportunities for Trained Accountants. The tremendous commercial growth of this country has created a rich field for the expert. There are only 2000 Certified Public Accountants to do the work of the half million concerns needing their services. The Expert Accountant is also needed today in every executive organization. We train you by mail for one of these big positions.

Knowledge of Bookkeeping Unnecessary

to begin. Our course is under the personal supervision of Wm. Arthur Chase, Ex-Sec'y Ills. State Board of Accountancy, and other experts who will give you whatever instruction or review on the subject of bookkeeping you may personally need—and without any extra expense to you. Our FREE Book on the Accountancy profession fully explains how we train you from the ground up according to your individual needs.

Send now for full information regarding our Home Study Course in Accountancy, our money-back guarantee, C. P. A. Examinations, State Regulations, Salaries, how you can qualify for a high-grade accounting position; and how you can pay for it, a little each month if you wish. We have helped over 125,000 ambitious men—learn what we can do for you.



LaSalle Extension University, Dept. 764-H Chicago
"World's Greatest Extension University"

The University of Chicago

HOME STUDY

in addition to resident work, offers also instruction by correspondence. For detailed information address

25th Year U. of C. (Div. V) Chicago, Ill.



EARN TELEGRAPH

Morse and Wireless—R. R. Accounting (Station Agency) taught. Splendid opportunities. Positions secured. Marconi Co. contracts to employ graduates. We own and exclusively occupy two large modern buildings equipped with R. R. and Western Union wires and complete 2 K. W. Marconi Wireless Station. Largest school—established 42 years. Investment \$20,000. Endorsed by Railroad, Marconi and Western Union Officials. Expert practical teachers. Low living expenses; easily earned if desired. Tuition low, easy payments. Correspondence courses also. Catalogs Free.

Dodge's Telegraph, Ry. & Wireless Institute
8th Street, Valparaiso, Ind.

STAMMERERS

Our course of private lessons will correct your impediments.
BOSTON STAMMERERS' INSTITUTE
Founded 1867. Samuel D. Robbins, Principal.
246 Huntington Ave. BOSTON, MASS.

Learn Watchwork, Jewelrywork and Engraving.

A fine trade commanding a good salary, and your services are always in demand. Address HOROLOGICAL, Dept. P. Bradley Institute, Peoria, Ill., for our latest catalog.

CIVIL SERVICE

positions are in all parts of the country. Good pay, steady work, life positions, congenial surroundings, promotions on merit, short hours, annual vacation and sick leave with pay. Many thousands appointed yearly. Both sexes. No political pull. Nearly 300,000 classified positions. Common school education sufficient. Full information and questions used by the Civil Service Commission free.

COLUMBIAN CORRESP. COLLEGE, WASHINGTON, D. C.



A. B. Payne

Die, Thou Villain!

He had thought of being a great Indian Chief, or a soldier—but the biggest idea of all had come to him. He would be a Pirate!

Now his future lay plain before him. His name would fill the world and make people shudder. And, at the zenith of his fame, how he would suddenly appear at the old village and stalk into church, brown and weather-beaten, in his black velvet doublet and trunk, his great jackboots, his crimson sash, his belt bristling with horse-pistols, his crime-rusted cutlass at his side, his slouch hat with waving plumes, his black flag unfurled, with the skull and crossbones on it! His career was determined.

Remember the days when you dreamt of being a Pirate?—when you thought you would be a black avenger of the Spanish Main?

Get back the glamour of that splendid joyousness of youth. Read once more of Tom Sawyer, the best loved boy in the world; of Huck, that precious little rascal; of all the small folks and the grown folks that make Mark Twain so dear to the hearts of men and women and boys and girls in every civilized country on the face of the globe.

Mark Twain

At first it seems a long way from the simple, human fun of Huckleberry Finn to the spiritual power of Joan of Arc, but look closer, and you will find beneath them both the same ideal, the same humanity, the same spirituality, that has been such a glorious answer to those who accuse this nation of being wrapped up in material things.

There seems to be no end to the things that Mark Twain could do well. When he wrote history, it was a kind of history unlike any other except in its accuracy. When he wrote books of travel, it was an event. He did many things—stories, novels, travels, history, essays, humor—but behind each was the force of the great, earnest, powerful personality that dominated his time, so that even then he was known all over the face of the globe. Simple, unassuming, democratic, he was welcomed by kings, he was loved by plain people.

If foreign nations love him, we in this country give him first place in our hearts. The home without Mark Twain is not an American home.

The Centennial Half Price Sale Must Close

Mark Twain wanted these books in the hands of all the people. He wanted us to make good-looking, substantial books that every man could afford to own. So we made this set, and there has been a tremendous sale on it.

But Mark Twain could not foresee that the price of paper, the price of ink, the price of cloth, would all go up. It is impossible to continue the low sale. It should have closed before this. Because this is the one hundredth anniversary of the founding of Harper & Brothers, we have decided to continue this half-price sale while the present supply lasts.

Get your set now while the price is low. Send the coupon today before the present edition is all gone.

HARPER & BROS., NEW YORK

1817-1917

Send me, all charges prepaid, a set of Mark Twain's works in 25 volumes, illustrated, bound in handsome green cloth, stamped in gold, with untrimmed edges. If not satisfactory, I will return them at your expense. Otherwise I will send you \$1.00 within 5 days and \$2.00 a month for 12 months, thus getting the benefit of your half-price sale.

Pop. Mech. 7-17

NAME.....

ADDRESS.....

For our beautiful red half leather edition change the above terms to \$2.50 on delivery and \$3 a month for twenty months.

Please Mention Popular Mechanics



“Think Beyond Your Job!”

“There is not a man in power at the Bethlehem Steel Works today,” says Charles M. Schwab, in the American Magazine, “who did not begin at the bottom and work his way up. Eight years ago Eugene Grace was switching engines. His ability to *out-think* his job, coupled with his sterling integrity, lifted him to the presidency of our corporation. Last year he earned more than a million dollars. . . . Jimmie Ward, one of our vice-presidents, used to be a stenographer. The fifteen men in charge of the plants were selected, not because of some startling stroke of genius, but because day in and day out, they were *thinking beyond their jobs.*”

If you want to be somebody, to climb to a position of responsibility, *get ready for it.* Do what you are doing *now* better than the men beside you, and *train for the job ahead.* You can do it—in spare time—through the International Correspondence Schools.

For 25 years men with ambition and I. C. S. help have been making spare hours the stepping-stones to successful careers. Last year more than 5,000 reported that their studies had won for them advancement and increased salaries. Over 130,000 men in offices, shops, stores, mines and mills and on railroads all over America are preparing in the I. C. S. way to take the next step upward.

Join them! All you need is just ordinary brains, the will to do, and the firm resolve to *think ahead of the job you now hold.* The I. C. S. are ready to make the rest easy. Make your start. Mark and mail this coupon.

INTERNATIONAL CORRESPONDENCE SCHOOLS BOX 5589, SCRANTON, PA.

Explain, without obligating me, how I can qualify for the position, or in the subject, before which I mark X.

- | | |
|---|--|
| <input type="checkbox"/> ELECTRICAL ENGINEER | <input type="checkbox"/> SALESMANSHIP |
| <input type="checkbox"/> Electric Lighting | <input type="checkbox"/> ADVERTISING |
| <input type="checkbox"/> Electric Railways | <input type="checkbox"/> Window Trimmer |
| <input type="checkbox"/> Electric Wiring | <input type="checkbox"/> Show Card Writer |
| <input type="checkbox"/> Telegraph Engineer | <input type="checkbox"/> Sign Painter |
| <input type="checkbox"/> Telephone Work | <input type="checkbox"/> Railroad Trainman |
| <input type="checkbox"/> MECHANICAL ENGINEER | <input type="checkbox"/> ILLUSTRATING |
| <input type="checkbox"/> Mechanical Draftsman | <input type="checkbox"/> Cartooning |
| <input type="checkbox"/> Machine Shop Practice | <input type="checkbox"/> BOOKKEEPER |
| <input type="checkbox"/> Gas Engine Operating | <input type="checkbox"/> Stenographer and Typist |
| <input type="checkbox"/> CIVIL ENGINEER | <input type="checkbox"/> Cert. Public Accountant |
| <input type="checkbox"/> Surveying and Mapping | <input type="checkbox"/> TRAFFIC MANAGER |
| <input type="checkbox"/> NINE FOREMAN OR ENGINEER | <input type="checkbox"/> Railway Accountant |
| <input type="checkbox"/> Metallurgist or Prospector | <input type="checkbox"/> Commercial Law |
| <input type="checkbox"/> STATIONARY ENGINEER | <input type="checkbox"/> GOOD ENGLISH |
| <input type="checkbox"/> Marine Engineer | <input type="checkbox"/> Teacher |
| <input type="checkbox"/> ARCHITECT | <input type="checkbox"/> Common School Subjects |
| <input type="checkbox"/> Contractor and Builder | <input type="checkbox"/> Mathematics |
| <input type="checkbox"/> Architectural Draftsman | <input type="checkbox"/> CIVIL SERVICE |
| <input type="checkbox"/> Concrete Builder | <input type="checkbox"/> Railway Mail Clerk |
| <input type="checkbox"/> Structural Engineer | <input type="checkbox"/> AUTOMOBILE OPERATING |
| <input type="checkbox"/> PLUMBING AND HEATING | <input type="checkbox"/> Auto Repairing |
| <input type="checkbox"/> Sheet Metal Worker | <input type="checkbox"/> Navigation |
| <input type="checkbox"/> Textile Overseer or Supt. | <input type="checkbox"/> AGRICULTURE |
| <input type="checkbox"/> CHEMIST | <input type="checkbox"/> Poultry Raising |

Name _____
Present Occupation _____
Street and No. _____
City _____ State _____

Please Mention Popular Mechanics

Learn to PAINT SIGNS and SHOW CARDS

Get into this interesting, profitable and fascinating business where the field is not crowded. Thousands of cards used weekly. Department stores, clothiers, movie shows, etc., pay big prices—work done quickly and easily—profits large—hundreds of jobs all around you. My students can more than pay for course doing jobs in spare time while studying. Increase your salary, get a better job or go into business for yourself.

Earn \$18.00 to \$45.00 a Week—Easily
I will train you to fill a big salaried job. I personally correct every lesson. 17 years' successful teaching. Thousands of successful graduates all over the world. No town too small, no job too big for my graduates. Get my training—start now.

Big Money in Card, Sign and Bulletin Business

No other profession pays such profits—work comes to you in abundance—no job will stamp you—my students learn all. All the newest, swiftest designs, how to run the business, how to hire men, how to keep records, in fact gives you a complete training. You can finish my course in a short time. Read my guarantee—don't be out of a job or work at low wages any longer—**Get Started Now.**

FREE Outfit
Write now for special literature and prices on 5 courses—terms, testimonials, sample lesson and Free Outfit offer. **All Free—Don't delay, act quickly.**

Guarantee
I guarantee to place competent graduates at \$25.00 to \$75.00 monthly. The demand for trained competent men is far greater than the supply.

Detroit School of Lettering, Dept. 207, Detroit, Mich.

MUSIC TAUGHT FREE

IN YOUR OWN HOME
You can read Music like this quickly

Piano, Organ, Violin, Mandolin, Guitar, Banjo, etc. Beginners or advanced players. One lesson weekly. Illustrations make everything plain. Only expense about 20 per day to cover cost of postage and music used. Write for FREE booklet which explains everything in full.

AMERICAN SCHOOL OF MUSIC, 51 Lakeside Building, CHICAGO

FREE This Complete Set of Drawing Instruments



\$15.00 Draftsman's Complete Working outfit free to students. They do not cost you a penny on this offer. Write today for particulars. Do it NOW! **\$150 to \$300 a Month**
My graduates are earning from \$150.00 to \$300.00 a month and more. **WRITE TODAY.** Send for my free book on drafting. No obligation. Write now. **Chief Draftsman Dobe, Div. B119 Engineer's Equipment Co., Chicago**

7 DAYS LIGHTENTAG PARAGON SHORTHAND

Then Practice Brings the Speed
Used in Government service (also in Coast Reporting. Adopted by cities for High Schools. Wonderfully easy to read. Speed capacity practically unlimited. Positive proof before you enroll. Send for it TODAY.
PARAGON INSTITUTE, 393 COLISEUM PLACE, NEW ORLEANS, LA.

Advertising Manager—\$5000 a Year

YOU CAN BE ONE
If our Vocational Director will accept you, then you can succeed in advertising. Ten practical business men will teach you. Write for booklet, "Poverty to \$10,000 a Year" and "Free Personal Analysis blank."
BRYANT & STRATTON COLLEGE, 1023 Bryant & Stratton Bldg., CHICAGO, ILL.

ARTISTS AND ART STUDENTS!

We have a series of 40 9x12 technique plates. Just what you have been wanting—and the entire set, over 400 drawings, for \$3. The **STUDENTS ART MAGAZINE** publishes cash art assignments, lessons and articles on practical art and one animal plate each issue. 10 cents a copy, \$1 a year. 40 animal plates and magazine for a year, **\$3.50—SEND NOW to the editor.**

G. H. LOCKWOOD
Dept. 249, Kalamazoo, Mich.

Go LOCKWOOD PRACTICAL TECHNIQUE STUDIES

BIRDS AND ANIMALS
40 Plates \$3.50

SATISFACTION GUARANTEED

YOU CAN SAVE \$60 BY JOINING NOW

Price of Tuition for full course after
July 9 will be \$120

We are just completing an immense new building—owned and used exclusively by us—fully equipped with all the best and most modern appliances for learning the auto business *from the ground up*.

Our course—always recognized as the most thorough and practical—will be increased *many times* in value, and we must make a moderate increase in Tuition rates.

Our Graduates are regularly earning from \$100 to \$300 and more per month as Race Drivers, Expert Engineers, Final Testers, Shop Foremen, Tractor Experts, Chauffeurs, Sales-

men, Garage Owners and Managers, House-Lighting Experts; and many are in Government employ as Aviators, Truck Drivers and Dispatch Bearers—all because of the *practical* training we give.

Opportunities for *practically* trained men were never better. We have constant calls for more men than we can furnish.

Cleveland Auto School

Established 1903
Individual Instruction

Up-to-date Equipment
13 Years of Success

Over 4,000 Graduates Making Good OUR EQUIPMENT

includes all types of motors, including Knight type, and 4, 6, 8 and 12 cylinder; a dozen cars at the disposal of students; latest starting and lighting equipment; Akron-Williams tire repair outfits, oxy-acetylene welding and cutting outfits; all the latest electrical testing outfits; and everything necessary to give you a thorough and practical training.

CLEVELAND LEADS

in the manufacture of parts, accessories and high grade cars, and is gaining faster than any other city in new factories. Up-to-date training in 4 to 8 weeks; board and room only \$6 per week near school; we help you get located in congenial surroundings and feel at home. We Absolutely Guarantee to qualify you for a good paying position in the Auto business on completion of our course.

Join Now!

If you intend to take the course on or before December 1st, it will pay you well to make a deposit *NOW*—Write at once for full particulars.

Cleveland Automobile School

CLYDE H. PRATT, President, Dept. 7, 2338 Euclid Ave., CLEVELAND, OHIO

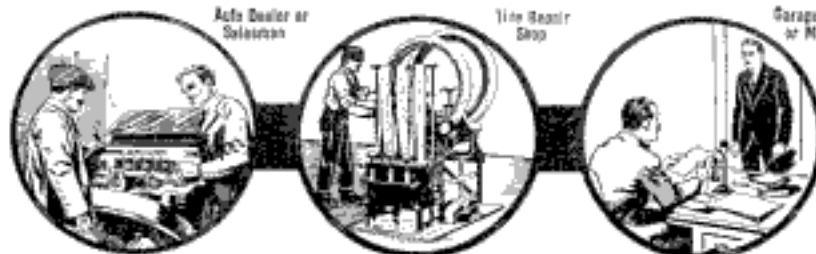

Auto Dealer or Salesman

Tire Repair Shop

Garage Owner or Manager

We Teach



Race Driver



Tester



Master of 12-cyl. Motor



Private Chauffeur

Your Own Business

Call
or write
us
TODAY

Please Mention Popular Mechanics



Music Lessons

Book Sent FREE Wonderful home-study music lessons under great American and European teachers given by the University Extension Method. The lessons are a marvel of simplicity and completeness, endorsed by Paderewski and other great authorities. You, too, can now quickly and easily satisfy your musical ambitions.

Any Instrument or Voice

Write, telling us the course you are interested in, age, how long you have taken lessons if at all, etc., and we will send you our Free Book containing text and illustrations covering Lessons in PIANO (students' or teachers' courses) by the great Wm. H. Sherwood, HARMONY by Dr. Frothero and Rosenbecker, VOICE COURSE (with aid of Phonograph) by Crampton, PUBLIC SCHOOL MUSIC by Frances E. Clark, VIOLIN, CORNET, MANDOLIN, GUITAR, BANJO, REED ORGAN, CHORAL CONDUCTING, by equally eminent teachers.

Send NOW for Free Book and learn how easily you can become a fine singer, or a skillful player. See how quickly you can become successful. Our Free Book tells you how. Write for it today. A few Special Introductory Scholarships now being awarded by our faculty. Full particulars sent with Free Book. Investigate without cost or obligation. Write today.

University Extension Conservatory

Proprietor Siegel-Myers School of Music

2891 Siegel-Myers Building Chicago, Ill.



PAY \$75 to \$150 MONTH

U. S. GOVERNMENT WANTS

Railway Mail Clerks — City Mail Carriers — Postoffice Clerks — Clerks at Washington, D. C.

Common education sufficient. Send coupon immediately. We are coaching candidates free.

SEND COUPON BELOW

FRANKLIN INSTITUTE

Dept. D 97, ROCHESTER, N. Y.

This coupon, filled out as directed, entitles the sender to (1) free sample examination questions; (2) a free copy of our book,

"Government Positions and How to Get Them;" (3) free list of positions now easily obtainable; and (4) consideration for Free Coaching for the examination here checked.

COUPON

.. Railway Mail Clerk	(\$900 to \$1800)	.. Customs Positions	(\$800 to \$1500)
.. Postoffice Clerk	(\$800 to \$1200)	.. Internal Revenue	(\$700 to \$1800)
.. Postoffice Carrier	(\$800 to \$1200)	.. Stenographer	(\$800 to \$1500)
.. Rural Mail Carrier	(\$500 to \$1200)	.. Clerk in the Departments at Washington	(\$800 to \$1500)
.. Bookkeeper	(\$900 to \$1800)		

Name.....

Address..... D 97

Use this before you lose it.

Write plainly.

ENGINEERING



AND

Mechanical Trade Schools

of Highland Park College, Des Moines, Iowa
SCHOOL YEAR OPENS SEPT. 11, 1917

Civil, Electrical and Mechanical Engineering — Standard four-year courses completed in three years of forty-eight weeks each, and one-year courses in Civil, Electrical and Mechanical Engineering. Graduates holding some of the best engineering positions in the country.

Machinist and Auto-Machinist Courses — One-year Machinist and Auto-Machinist courses. Elaborately equipped machine shops and skilled mechanics for teachers. Graduates secure positions as journeymen mechanics.

Garage and Traction Courses — Twelve weeks' courses in automobile repairing and Traction engine shop work. Everything taught pertaining to the automobile and Traction engine — gas or steam.

Mechanical Drafting — One-year course, which fits students for any sort of drafting work. One of the largest and best equipped engineering and mechanical Trade schools in the country. Expenses most reasonable. Write for catalog. State course in which you are interested. Address

HIGHLAND PARK COLLEGE, 121 Euclid Ave., Des Moines, Iowa

Learn Mechanics of Aviation

Write today. See how you can learn the principles of Aeronautical Construction and Engineering in your spare time at home. Save all the time and expense of laborious field training. Big opportunities now for trained Aviation Experts in different branches of the service. \$50.00 to \$250.00 a week.

Write At Once! Big tuition reduction offer now open. Write for details while this offer lasts. No obligations. American School of Aviation, Dept. 1797 431 S. Dearborn St., Chicago, Ill.

LAW High-Grade Instruction by CORRESPONDENCE

Prepares You for the Bar—Est. 1892

Four Courses: College, Post-Graduate, Business Law and Bar Ex. Review. Classes begin each month. Approved by Bench and Bar. University Methods, Unabridged Text-Books, Cases. Course in Oratory, Public Speaking and Moot Court FREE with regular course. Graduates now practicing in every State. Write today for Catalog and Rules for Admission to the Bar. CHICAGO CORRESPONDENCE SCHOOL OF LAW, 520 Ruper Block, CHICAGO



VENTRILOQUISM

LEARNED BY ALMOST ANYONE AT HOME SMALL COST

Send today 2c stamp for particulars and proof. O. A. SMITH, Room D 152, 823 Bigelow St., PEORIA, ILL.

LEARN WATCH REPAIRING

Be a watchmaker—you can learn this profitable trade by correspondence in a few weeks in your own home by the DeSelms Chart System. After you complete the course you will know a watch from A to Z. You will know just what the matter is and how to repair one. When you graduate you will be a practical watchmaker and repairer and competent to fill any position. Positions for our graduates.

Ask for our Free Book. It explains our system and terms.

THE DeSELMS WATCH SCHOOL
23 Perry Street ATTICA, INDIANA





I am having the biggest demand in the history of my school for capable graduates to fill the hundreds of waiting positions in the varied branches of the automobile and tractor business. Join me here and get Practical Training — then your future is assured.

H. J. RAHE,
President

Auto Experts Wanted

This is the biggest year in the history of the automobile business. Millions of new cars, trucks and tractors are being manufactured and sold this year, creating positions for thousands of expert salesmen, demonstrators, repair men, starting and lighting experts, garage managers, chauffeurs, etc. My graduates are in demand because the big employers of all kinds of automobile experts know that my graduates are practically trained in all branches of the business.

This Is the School of Complete Equipment

The Rahe Original Method of Practical Automobile Training and Experience is recognized as the standard and thousands of my graduates in all parts of the world recommend my method as the **most efficient, most thorough, most complete.** I teach you to handle any kind of an auto repair job. You get the benefit of a completely equipped automobile training school with plenty of floor space, expert instructors, all the worth-while equipment and thousands of successful graduates. Students in this school get genuine repair shop training and experience that enable them to step into waiting positions at big pay—or to go into business for themselves. My graduates earn from

\$75 to \$300 a Month!

You can do likewise if you are **properly trained**—but **half trained** will not do. Come to this school of complete equipment—don't bother with any training that is not the result of years of experience, that has not stood the test of time, that has not produced thousands of successful graduates.



My Training Includes All

Students in this school become thoroughly familiar with every branch of the business—repairs, vulcanizing and welding, forging, machine shop work, piston ring fitting, babbitt-ing, battery work, magnetos, ignition, self-starting, etc., etc. In addition to this complete training, my students get the same practical training and experience on farm tractors. My big farm is fully equipped with tractors of both types—kerosene and gasoline and power farming machinery. I own and operate two of the largest garages in the entire west. All kinds of cars and commercial trucks for my students' training and practice.



\$50 SCHOLARSHIP FREE

For Tractor, Stationary, Gas Engineering, Power Farming

To Those Who Enroll at Once for My Full Course in Auto Repairing

Limited number of Free Scholarships available. Tractor business growing at a tremendous rate. Big demand for Tractor Experts, Operators, Salesmen, Repairmen, etc.

My 80-Page Catalog Sent Postpaid

My newest and best book filled with fine copper engravings, showing men at work in my big machine shops making repairs of all kinds, the three big buildings, detailed views of equipment, tractor farm and equipment—the finest book ever issued on the subject. Just use the coupon and mail today.

H. J. RAHE, President

Rahe's Auto Training School 589 E. 11th St.
Kansas City, Mo.

Mail This Quick—TODAY!

H. J. RAHE, President

RAHE'S AUTO TRAINING SCHOOL
589 E. 11th St., KANSAS CITY, MO.

Send me your 80-Page Catalog Free and Postpaid—also reserve a Free Tractor Scholarship without obligations on my part.

Name.....

Postoffice.....

Street or R. F. D.,.....State.....

World's Greatest Auto School. Thousands of Successful Graduates

Please Mention Popular Mechanics

Take a Pencil and make an "X"

A LITTLE X, like the one shown here, has marked the starting point for a good many big successes. It's an easy thing to make. Your pencil will make it in a jiffy BUT it may mark the turning point in your life.

These days the thing that puts a man above his fellows is TRAINING.

And this little "X" when marked on the coupon below will bring you a handsome free book that will tell just exactly how YOU can get the training that has put THOUSANDS of men into high positions. It won't be necessary for you to leave your home to get this training. For twenty years the American School has been giving ambitious men practical training that started them on the road to success

Send the Coupon

Take a pencil now and mark an X before the position for which you want to qualify yourself. Let us tell you how we have given other men the training that enabled them to hold these positions. Let us tell you how you can get THIS VERY TRAINING right in your own home during your idle hours. You will be under no obligations by sending the coupon.

Find out for yourself what the American School will do for you. Make your mark in the coupon now for the sake of your ambition and the man you want to be. Opportunity is calling. Your ambition is saying, send the coupon. Do it now.

American School
of Correspondence, Chicago, U.S.A.
Dept. G119B, Chicago, U.S.A.

American School of Correspondence, Dept. G119B Chicago, U.S.A.

Gentlemen: Without obligation please send me booklet and tell me how I can qualify for position marked X.

- | | |
|--------------------------------|----------------------------|
|Electrical Engineer |Business Law |
|Elec. Light & Power Supt. |Business Manager |
|Hydroelectric Engineer |Auditor |
|Telephone Engineer |Accountant |
|Architect |Cert'd Public Acc't |
|Architectural Draftsman |Stenographer |
|Building Contractor |Bookkeeper |
|Building Superintendent |Fire Ins. Inspector |
|Structural Engineer |Fire Ins. Adjuster |
|Structural Draftsman |Fire Ins. Expert |
|Mechanical Engineer |Sanitary Engineer |
|Mechanical Draftsman |Master Plumber |
|Civil Engineer |Heat and Vent. Eng. |
|Steam Engineer |Plumb. and Heat. Est. |
|Shop Foreman |Reclamation Engineer |
|Shop Superintendent |Automobile Engineer |
|Sheet Metal Draftsman |Automobile Repairer |
|Lawyer |High School Course |

We also prepare for civil service examinations in all engineering subjects.

Name.....
Address.....

Mark
an X
and
Mail
Today

Learn



LAW

-At Home

The opportunity to get a legal training without leaving your present position is now yours. By our simplified Home Study Course we bring professors, text books, lectures, cases, personal suggestions, etc.—a complete legal training—right into your own home, where you can study in your spare time.

Our plan of instruction gives you a complete university training in law. We facilitate your progress by placing you under the direction of the ablest legal minds. The cost of the tuition is moderate and you can pay a little each month if you wish. Investigate.

LAW-TRAINED MEN

Rule in Business
and Public Life

It will pay you to take up law. Lawyers, as a class, enjoy a distinction and prestige unsurpassed in any other profession. There is a vast field open in court practice, in public life and in business. Since every business transaction involves a knowledge of law, the law trained man is always in demand by the great commercial interests. Prepare to profit by these opportunities.

We guarantee that if, after graduation, you do not pass the bar examination we will give you free coaching until you meet the requirements.

14 Volume Law Library Given Free

to students. All branches fully covered. Also Course in Public Speaking given free to students enrolling now.

Write Now for our free book "Evidence" and "Law Catalog", which point the way to a successful career in law. Send for these two books today. They will tell how you can study law at home and all about the opportunities open to you as a law-trained man. Send today.

LaSALLE EXTENSION UNIVERSITY
"The World's Greatest Extension University"
Dept. 764-F Chicago, Ills.



Wm. H. ARBELGER, Milwaukee Motor School, 217-21 Seventh St., Milwaukee, Wis.

Men Wanted To Learn Automobile Business

EARN BIG MONEY — \$75 to \$300 Per Month

Only a few weeks required to train you. In six weeks I teach you to run and repair properly any automobile made. Learn to be repairman, demonstrator, garage manager and salesman. I teach thoroughly, practically and personally on real automobiles in everyday use. No books used. Tools furnished free. Actual practice on big, powerful cars brought here for inspection and repairs. **SEND FOR BOOKLET, "Making You Master of the Auto,"** Free upon request.



**Do You Like to Draw?
Cartoonists Are Well Paid**

We will not give you any grand prize if you answer this ad. Nor will we claim to make you rich in a week. But if you are anxious to develop your talent with a successful cartoonist, so you can make money, send a copy of this picture, with 5c in stamps for portfolio of cartoons and sample lesson plate, and let us explain.

The W. L. Evans School of Cartooning
821 Leader Bldg., Cleveland, O.



FINLAY Engineering College
KANSAS CITY, MISSOURI

ONLY SCHOOL OF THE KIND IN THE WEST

Specialties: Electricity, Steam, Gas. Six weeks, three months, year, and two year courses. Auto-Tractor, Armature Winding, Conduit Work, Lathe Work, Oxy-Acetylene Welding, Corliss Valve Setting, Operation of Steam, Gas Electric Machinery. Anything you want, any time you want it, night or day, from a week to two years. Write for Catalog T.

SPEAK A FOREIGN LANGUAGE !!!



The War has created unlimited opportunities for those who know Spanish, French, German or Italian. Better your position or increase your business. You can learn quickly and easily, at home, during spare moments, by the

LANGUAGE-PHONE METHOD
And Rosenthal's Practical Linguistry
(Highest Award Panama-Pacific Exposition, 1915)

You listen to the living voice of a native professor pronounce the foreign language, over and over, until you know it. Our records are all talking machines. Write for Booklet, particulars of Free Trial. The Language-Phone Method, 561 Putnam Bldg., 2 W. 45th St., N.Y.

Please Mention Popular Mechanics

LEARN ELECTRICITY

at America's Largest Trade School

MAIL TODAY

Name.....

Address.....

U. S. Needs Trained Men—Big Pay

The demand for trained men is enormous. Uncle Sam needs thousands of skilled Electricians, Plumbers, Draftsmen, Bricklayers, at big pay. There are also thousands of vacancies in civil life for trained men—and there will be thousands more vacancies through enlistments. Men trained in the trades we quickly teach can serve the country better and while serving draw big pay. Whether you work for Uncle Sam or in civil life, we can quickly train you to do better work for yourself and your country. Our experts instruct and coach you in fully equipped shops. No books or correspondence. All practical training. **Tools and Material FREE.**



Practical Instruction in ELECTRICITY, DRAFTING, PLUMBING, BRICKLAYING, MOTION PICTURE OPERATING

More and more trained men are needed everywhere to fill the big paying positions in these trades. We teach all of them through practical methods. Our graduates are in demand everywhere. As soon as you finish your course you can get a job paying up to \$8.00 a day. Or, you can go into business for yourself and make from \$3,000 to \$7,500 a year. We teach you drawing, estimating, plan-reading, contracting—everything so you can handle the biggest jobs. Free employment bureau helps you to get position. School open all the year. Enter any time. Day and evening sessions. Students' ages range from 15 to 50 years. Many earn part of their expenses while learning. If necessary, we help you secure a position, so you can do this.

LEARN QUICKLY—SMALL EXPENSE

In order to supply these trades with trained men we are charging only a very small tuition fee. We have made the payments so amazingly easy that all may learn. Remember, all equipment and tools are furnished free. All instruction is individual, under the personal guidance of well-known experts of long experience. This enables you to master a trade thoroughly and quickly. Send the coupon today for your copy of "Manual of Trades." See the wonderful opportunities awaiting you. Read how you can master one of these big trades quickly—how you can make a bigger success than you ever dreamed of. Don't fail to state which trade you are most interested in! Mail the coupon today—now.

BENNETT WELLINGTON COOKE, Director

Coyne Trade and Engineering Schools

Engineers and Contractors Desiring Practically Trained Men Should Communicate With Our Graduate Employment Bureau.

39-51 E. Illinois Street
Dept. 119Y, CHICAGO, ILLINOIS

BENNETT WELLINGTON COOKE,
Director

Coyne Trade and Engineering Schools
39-51 E. Illinois St., Dept. 119Y
Chicago, Ill.

Without cost or obligation to me,
send your Manual of Trades gov-
erning the trade checked below:

- Electricity Bricklaying
 Builders' Course
 Plumbing Drafting
 Motion Picture Operating

READ THIS

April 10, 1917.
B. W. Cooke, Director,
Dear Sir:—I want to
thank you for the in-
terest shown me while
at your school. Sorry
I could not quite finish
my course in plumbing
as I have enlisted in
the Army as a
plumber. Am getting
along fine and expect
to be made Sergeant
Plumber in a short
time. Yours sincerely,
J. J. VIGANUS, Jef-
ferson Barracks, Mo.



MAIN BUILDING

LEARN WATCHMAKING

and become independent. Good-paying positions secured.

Easy to learn. Send for FREE CATALOG.

ST. LOUIS WATCHMAKING SCHOOL, Dept. 5, ST. LOUIS, MO.

AT HOME
Learn TO SING Send 2-cent Stamp
for Helpful Book-
let, "The Voice
Made Beautiful."
HARVEY SUTHERLAND, 1832P 49th St., BROOKLYN, N. Y.

POWER of WILL By FRANK CHANNING
HADDOCK
contains 28 fascinating lessons on how to strengthen
the Will. Write for free trial offer. Pelton Publishing
Company, 13 Wilcox Block, Meriden, Conn.

Be An ARTIST

Earn \$25 to \$100 a week as Cartoonist—Illustrator—Com-
mercial Artist. Learn quickly at home by new instruction
method. Easy terms. Outfit FREE to new students. Write
today for handsome Booklet, free, and Special Offer NOW.
WASHINGTON SCHOOL OF ART, 1097 H St., N. W., WASHINGTON, D. C.

Are You Earning Less Than \$3000 Yearly?

If you are,—you're on the wrong job. You're in
a rut. Why waste a lifetime working for animal
wages,—when it's so easy to get into a Man's
Job and earn a Man's Salary?

Be a Traffic Manager

Get into a new—clean—fascinating—high salaried—dignified
profession that assures you a place on Easy Street. Traffic Man-
agers needed everywhere. Field can't be crowded for years
to come. A POSTAL BRINGS FULL INFORMATION.

INTERSTATE TRAFFIC SCHOOL 27 TRAFFIC BLDG FT WAYNE IND

Mr. A. R. Patterson, whose advertisement appears below, was for
eight years a Civil Service Secretary-Examiner, and is well qualified
to help YOU secure a Government Position.

FREE BOOK OF GOV'T POSITIONS

Earn \$75 to \$150 a Month

WRITE TODAY

Be a Railway Mail Clerk, Post Office
Clerk or Carrier, Rural Mail Car-
rier, Internal Revenue Officer,
Clerk at Washington, D. C., or
Panama Canal, or accept any
other good Civil Service position
with Uncle Sam, world's
greatest and best employer.

**Good Pay, Easy Work, Vacations,
Position for Life**

Earn \$75 to \$150 a month from the start.
Rapid advancement. Work 8 hours or less
a day. 15 to 30 days vacation with full pay.
No strikes, no "lay-offs," no "straw bosses."
No politics, no "pull" needed. Ordinary education sufficient.
American citizens 18 or over WANTED.

PATTERSON PREPARES YOU

Only school offering help of former Civil Service Sec'y-
Examiner. Quick appointment certain. Sure position or no
pay. Send coupon or postal NOW for book free.

FREE! Tells what positions are open. How to
prepare easily and quickly for job you
like best. Don't be satisfied
with a mail per, uncertain
job. Write for book of Uncle
Sam's positions and
get on easy street.
Mail coupon or postal
NOW. Address

PATTERSON CIVIL SERVICE SCHOOL
87 News Bldg., Rochester, New York

HOW To Get a GOV'T Position

Send me Free Book of Govern-
ment Positions.

Name.....
Address.....

Please Mention Popular Mechanics



\$100⁰⁰ EARNED BY YOUNG ARTIST IN TWO DAYS

Conscientious, careful training by members of our Faculty made this possible. You, too, should succeed — *with the right training.*

Earn \$25, \$35, \$50, \$75 a Week and More

Become a Commercial Designer. The business world pays big prices for good designs and illustrations. Learn to draw during your spare time by the "Federal" home-study method — a course endorsed by high authorities.

Easy to Learn, Easy to Apply Write today for "Your Future," a book every young man and woman should read before deciding on their life work. Free for the asking.

Federal School of Commercial Designing, Inc.
621 Warner Building Minneapolis, Minn.

The Salaries

of TRAINED TRAFFIC MEN range from \$2,500 to \$10,000 a year. There are thousands of positions open. Train yourself to be a Traffic Manager—in your spare time—at home. Our experience method of training—our traffic library, compiled through the co-operation of more than 300 Traffic Experts of national reputation—the members of our association will make it easy for you to qualify yourself for one of these positions.

Write TODAY for Free Particulars. We will show you how

THE AMERICAN COMMERCE ASSOCIATION
Dept. 141 206 South Wabash Ave. CHICAGO, ILL.

Abdominal MASSAGE

with the wonderful new **KOLON MOTOR** brings health, strength and energy. Banishes chronic constipation. Write for interesting booklet—"Colon Cleanliness"—mailed free. Send a postal.

MARTIN'S METHOD, Inc., Dept. 80, 50 E. 31st St., NEW YORK

Get This CAR And the AGENCY For YOUR Territory



Drive a new 1917 Model Birch Motor Car. Pay for it out of your commissions and make big money on sales. Special offer now. Write quick for Big Free Book and full information. Address

Ralph Birchard, Pres.

Birch Motor Cars, Dept. 719, 81 E. Madison St., Chicago

JUST PUBLISHED

AUTOMOBILE WELDING

With the Oxy-Acetylene Flame

167 Pages Price \$1 Fully Illustrated
POSTPAID

Explains in a simple manner apparatus to be used, its care, and how to construct necessary shop equipment. Proceeds then to the actual welding of all automobile parts, in a manner understandable by everyone. Aluminum, cast iron, steel, copper, brass, bronze and malleable iron are fully treated, as well as a clear explanation of the proper manner to burn the carbon out of the combustion head.

POPULAR MECHANICS BOOK DEPT.
6 North Michigan Avenue, CHICAGO

"The U.S. Navy"

Pictured by E. MULLER, Jr.
Foreword by Rear-Admiral Bradley A. Fiske, U. S. N.

Camera Studies of Our First Line of Defense

Most complete and impressive presentation of

Uncle Sam's Fighting Ships in Action

and
The Activities in the Daily Life on Board a Fighting Ship

142 Halftone Reproductions of Official Photographs. Board Cover in Colors. Size 9¼ x 12¼.

Postage 10c Extra PRICE \$1.00 Postage 10c Extra

For Sale by
POPULAR MECHANICS BOOK DEPT.
6 N. Michigan Ave., CHICAGO

JUST OUT—Official Auto Wiring Guide

Price Prepaid
\$7.50

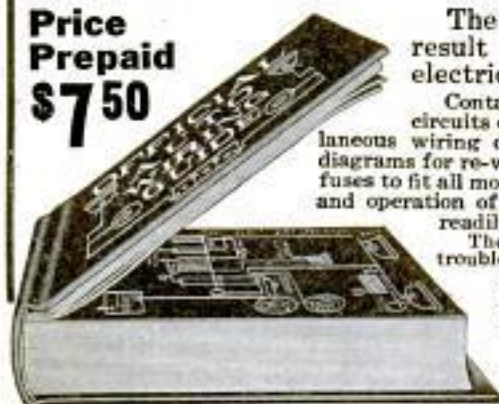

The most valuable book ever offered the automobile world. The result of nearly three years' work of several of the best known electrical experts in the country.

Contains 448 guaranteed accurate blueprint diagrams showing complete wiring circuits of all makes of gas and gas-electric cars, dating back as far as 1912. Miscellaneous wiring diagrams covering all starting and lighting systems are shown, as well as diagrams for re-wiring cars, both grounded and multiple systems. In addition there is a list of fuses to fit all models of gas cars and a complete and practical treatise covering the care, repair and operation of storage batteries, so written that any man, even the newest mechanic, can readily understand it.

The Official Auto Wiring Guide will pay for itself on each and every job where the trouble is electrical, through the saving of from one to five hours' time usually required in tracing wiring circuits preparatory to locating and remedying troubles in the electrical system. This means greater efficiency and profit, and better service to your customer and the building up of your reputation as an expert in ignition, lighting and starting systems.

Send for 8-page descriptive circular.

Popular Mechanics Book Dept., 6 N. Michigan Ave., CHICAGO

Learn Electricity at Home!



New, Easy System

Amazingly simple, quickly learned at home in spare time. Big openings everywhere for trained men. Or go into business for yourself anywhere. No text books used. Don't miss this extraordinary opportunity.

TWENTY LESSONS FREE!

We are making this sensational offer to a limited number of new students to advertise our remarkable new, easy method and prove to you that you can become an expert electrician by a few months' home study in spare time. Pay nothing if you *should* fail. No previous experience or study required if you can read and write.

Send This Coupon NOW!

Tomorrow may be too late to profit by this amazing offer of 20 lessons FREE. Act now. You risk nothing. Fill out the coupon and mail it today — sure. Or send a postal to

ALBERT W. WICKS Bachelor of Science and E. E.,
Pres., Wicks Electrical Institute
Dept. 487, 81 W. Randolph Street, CHICAGO, ILL.

ALBERT W. WICKS
Bachelor of Science and E. E.,
President, Wicks Electrical Institute
Dept. 487

81 W. Randolph St., Chicago, Ill.

Without any obligation on my part, please send me full particulars of your 20 Free Lessons Offer and all other information about your wonderful new system for teaching Electricity at home.

Name.....

Address.....

Be an Artist

Comics, Cartoons, Commercial, Newspaper and Magazine Illustrating. Pastel and Crayon Portraits. By Mail or Local Classes. Write for terms, list of successful pupils. **ASSOCIATED ART STUDIOS** 30A Flatiron Building, New York

60 BOOKS Bound in Leather \$100 AFTER TRIAL

Balance in small payments each month. Not a penny in advance. The masterpieces of Kipling, De Maupassant, Stevenson, G. Bernard Shaw, Victor Hugo and dozens of others. Each book bound in genuine limp leather, pocket size. Write postal now for offer. **LITTLE LEATHER LIBRARY, 110 Mercantile Bldg., 23rd St., New York**



Come to Washington Work for the Government

War conditions have created thousands of new positions at big pay in the U. S. Civil Service. Men wanted in all branches at Washington and elsewhere. If you are an American over 18, we can prepare you quickly at home to pass examinations. We are placing hundreds in splendid positions. Let us help you. Write now for book telling all about jobs open and how to qualify. **International Correspondence Schools, Box 5593 Scranton Pa**

War Creates Big Demand for Railroad Inspectors

**\$125 A MONTH
And All Expenses**

"Do your bit" by helping prevent accidents and traffic congestion.

War supplies and the new 8-hour law have created a tremendous demand for trained Traffic Inspectors at \$125 a month and all expenses.

A New Profession with Wonderful Opportunities for Advancement and Travel

Demand for our graduates far exceeds the supply—from railroads throughout America. Three months course, during spare time, thoroughly prepares intelligent men of fair education. Ask for our illustrated Booklet G-2. Address

FRONTIER PREP. SCHOOL, BUFFALO, N. Y.

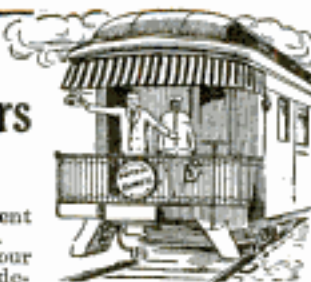

WAR JOBS

★ "UNCLE SAM" ★
★ WANTS HELP ★
★ \$800⁰⁰ to \$1800⁰⁰ a Year ★

★ Many of the U. S. Government departments are now overloaded with war work. ★

★ Hundreds clerks, stenographers, bookkeepers, etc., must be appointed at once to help on this work. ★

★ You can now easily get a big paid, permanent position, and at the same time help your country in this time of need. ★

★ Common sense education sufficient. Men, women, 18 or over, eligible. ★

★ Rapid increase in pay. Pull unnecessary. Fill out address coupon. Do it now. ★

★ **SEND COUPON BELOW** ★

..... **FRANKLIN INSTITUTE** Dept. D103, Rochester, N. Y.
This coupon, filled out as directed, entitles the sender to (1) free sample examination questions; (2) a free copy of our book, "Government Positions and How to Get Them;" (3) free list of positions now easily obtainable; and (4) to consideration for Free Coaching for the examination here checked.

..... **COUPON**

..... Railway Mail Clerk (\$900 to \$1800) Customs Positions (\$800 to \$1500)
..... Postoffice Clerk (\$800 to \$1200) Internal Revenue (\$700 to \$1800)
..... Postoffice Carrier (\$800 to \$1200) Stenographer (\$800 to \$1500)
..... Rural Mail Carrier (\$900 to \$1200) Clerk in the Department at Washington (\$800 to \$1500)
..... Bookkeeper (\$900 to \$1800)

Name.....

Address..... D103

USE THIS BEFORE YOU LOSE IT
Please Mention Popular Mechanics

This Fob FREE

Are you interested in the mechanical side of an automobile, its proper operation and economical maintenance?

Owners—Garagemen—Chauffeurs

The *American Chauffeur* is a live monthly magazine featuring articles in common sense language, by "men who know," on instructive topics, which will be interesting and of great value to every auto owner, chauffeur and garageman.

FREE OFFER

To introduce the *American Chauffeur*, we are offering this plated lacquered watch fob, with seal grain leather strap, as illustrated, ABSOLUTELY FREE, with a 3 months subscription to the *American Chauffeur* at the regular price of 25c.

Your money refunded if either the magazine or fob does not come up to your expectation.

THE AMERICAN CHAUFFEUR
87 Butler Bldg., CINCINNATI, OHIO

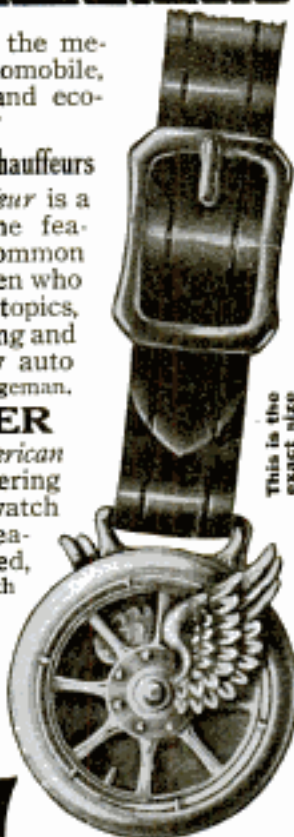

This is the exact size

There's Money in the Automobile Business—Big Money—

and all it takes to get it is experience.



We give you the experience. Eight weeks in our school is worth more than two years of figuring it out for yourself. The cost is light, the reward great—there's a job waiting for you as soon as you're through. Don't delay—Act now.

Uncle Sam Needs 150,000 Experienced Automobile Men

Think of the openings that makes for you—either in the army or in the place left vacant by the man who goes. Start now to qualify.

Indianapolis Motor School, 107 Southeastern Ave., Indianapolis, Ind.

Wonderful Camera Bargains

High grade Cameras shipped for one full week's examination and approval. You use the Camera and test it out for one full week and pay only if you choose to keep it. Satisfaction guaranteed.

Wholesale Prices

We ship direct from factory to consumer, eliminating all middlemen's profits. The Camera must serve as its own salesman. Our prices are so low and our terms of payment so easy that no one may be deprived of the pleasure of owning a splendid camera.

Write for Free Catalog

We will mail our latest catalog sheets free to all who ask for them. Write at once. A postal card will do. These catalog sheets show the latest sizes and low prices on the most beautiful line of cameras ever offered.

H. E. Sever & Co., 140 So. Dearborn St., Chicago



Learn to Write

I Teach by Mail

I CAN make a good penman of you at your home during spare time, no matter where you live or how poorly you now write. My simplified system has shown thousands of others the way to good penmanship during the past twenty years—it can and will do the same for YOU!

Beautifully Illustrated Book "How to Become a Good Penman" FREE!

It contains general information, with testimonials and beautiful specimens of penmanship showing what others have accomplished by the Tamblin System. (Your name elegantly written on a card if you enclose stamp for postage.) WRITE TODAY. Address

F. W. TAMBLIN
418 Ridge Bldg., Kansas City, Mo., U. S. A.



FREE!



A flying model aeroplane and all materials to build your own scale model, furnished FREE with our great Home Course in Aviation. Write at once—before this offer is withdrawn. Learn the Science of Aviation at Home—under guidance of our Experts. Tremendous demand for men who know aviation. Wonderful future. Prepare now. Write us today. NATIONAL AERO INSTITUTE, Dept. 8915, Morton Bldg., CHICAGO



Learn MOTION PICTURE Reporting

Trained operators needed in every locality. Profitable, fascinating employment out of doors for "live" men and women.

We train you. Write for free book. MOTO-GRAPH SYNDICATE
Clark and Halsted Sts., CHICAGO, ILL.

THE DESTRUCTIVE WORK OF A SUBMARINE

can be best understood by studying our Chart of a Modern Submarine, size 14x28 inches; printed on plate paper and showing and naming over 200 parts. This chart is a cross-sectional view (lengthwise) and shows the entire construction and operation; is really an encyclopedia of a submarine; educational and worth many times its cost.

PRICE 25 CENTS POSTPAID
POPULAR MECHANICS BOOK DEPT.
6 N. Michigan Ave., CHICAGO

30 DAY COURSE IN TIRE REPAIRING **FREE**

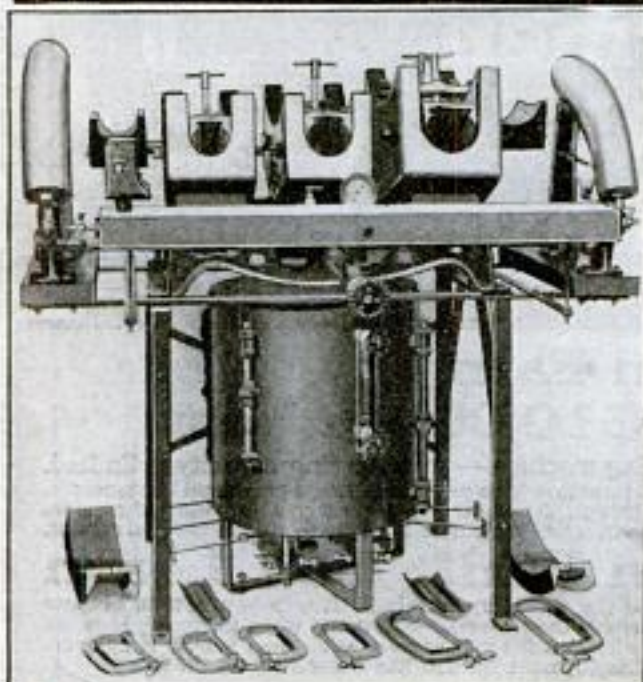

Write Today for remarkably low price and particulars about our free course in tire repairing. Let us show you how to make \$3,000 to \$8,000 a year.

RELIABLE TIRE REPAIR SCHOOL 107 Reliable Bldg.
DETROIT, MICH.

Stop Eating Poison! Wrong food combinations are poisonous and destroy health—right combinations build health. Eugene Christian's 24 lessons in Correct Eating tell how to eat for health, strength and efficiency. Send for Free Trial No Money in Advance offer. Write today. **Corrective Eating So., Dept. 50, 450 Fifth Ave., New York City**

Electrical Meter Engineering

"The Profession With a Future"

Now learned at home. Big demand for competent men. Pleasant, interesting, fascinating employment all the year 'round, with exceptional opportunities for advancement. Success guaranteed. High salaries offered. No experience necessary.

Special Offer! In order to get more men to train for good positions, we are making a great special offer to a limited number. Write today for full particulars—FREE. No obligations. Be a Meter Engineer, the man who fixes, not the one who is fixed. Be boss. Write today. **Fort Wayne Correspondence School** Dept. B119 Fort Wayne, Indiana

**40
hours**

—be an Expert
Book keeper—

Average bookkeeping courses are too elementary and theoretical, too involved, too impractical—to fit you as a successful bookkeeper.

Guaranteed Simplified Method

Our course is so simple that you can easily master its lessons, so practical that you can solve the most intricate bookkeeping problems **40 hours** after you begin to study. And you can learn at less than **one-third** the cost of other courses.

Endorsed by Treasurer of Pennsylvania

The State Treasurer of Pennsylvania, business men, bankers, and successful students everywhere have endorsed this practical course.

Write at once for free literature, learn how quickly and cheaply you can better your life-career.

HOFFMAN CORRESPONDENCE SCHOOL OF BOOKKEEPING
506 Dispatch Bldg. 5th Ave. Pittsburgh, Pa.



"Instruction by correspondence is the cheapest and best way for the poor man"

Thomas Edison

Edison is Right!!!

You admit the International Correspondence Schools are a good thing. You'd take a course right now "if"—"except"—

"If" what? If you weren't so "overworked," with such "long hours," or had more strength and energy? Wasn't it Edison who stayed up half the night educating himself in spite of every handicap you could ever have?

All big men who have made their mark in the world had the *ambition*—the *determination*—to improve their spare time, to train themselves for big work. You, too, can possess power, money and happiness if you'll only make the effort. The reward is great—it's worth it.

Here's all we ask: Merely mail this coupon. Put it up to us without paying or promising. Let us send you the details of others' success through the I. C. S., and then decide. Mark and mail this coupon now. **I. C. S., Box 5591, Scranton, Pa.**

INTERNATIONAL CORRESPONDENCE SCHOOLS BOX 5591, SCRANTON, PA.

TEAR OUT HERE

Explain, without obligating me, how I can qualify for the position, or in the subject, before which I mark X.

- | | |
|---|--|
| <input type="checkbox"/> ELECTRICAL ENGINEER | <input type="checkbox"/> SALESMANSHIP |
| <input type="checkbox"/> Electric Lighting | <input type="checkbox"/> ADVERTISING |
| <input type="checkbox"/> Electric Railways | <input type="checkbox"/> Window Trimmer |
| <input type="checkbox"/> Electric Wiring | <input type="checkbox"/> Show Card Writer |
| <input type="checkbox"/> Telegraph Engineer | <input type="checkbox"/> Sign Painter |
| <input type="checkbox"/> Telephone Work | <input type="checkbox"/> Railroad Trainman |
| <input type="checkbox"/> MECHANICAL ENGINEER | <input type="checkbox"/> ILLUSTRATING |
| <input type="checkbox"/> Mechanical Draftsman | <input type="checkbox"/> Cartooning |
| <input type="checkbox"/> Machine Shop Practice | <input type="checkbox"/> BOOKKEEPER |
| <input type="checkbox"/> Gas Engine Operating | <input type="checkbox"/> Stenographer and Typist |
| <input type="checkbox"/> CIVIL ENGINEER | <input type="checkbox"/> Cert. Public Accountant |
| <input type="checkbox"/> Surveying and Mapping | <input type="checkbox"/> TRAFFIC MANAGER |
| <input type="checkbox"/> MINE FOREMAN OR ENGINEER | <input type="checkbox"/> Railway Accountant |
| <input type="checkbox"/> Metallurgist or Prospector | <input type="checkbox"/> Commercial Law |
| <input type="checkbox"/> STATIONARY ENGINEER | <input type="checkbox"/> GOOD ENGLISH |
| <input type="checkbox"/> Marine Engineer | <input type="checkbox"/> Teacher |
| <input type="checkbox"/> ARCHITECT | <input type="checkbox"/> Common School Subjects |
| <input type="checkbox"/> Contractor and Builder | <input type="checkbox"/> Mathematics |
| <input type="checkbox"/> Architectural Draftsman | <input type="checkbox"/> CIVIL SERVICE |
| <input type="checkbox"/> Concrete Builder | <input type="checkbox"/> Railway Mail Clerk |
| <input type="checkbox"/> Structural Engineer | <input type="checkbox"/> AUTOMOBILE OPERATING |
| <input type="checkbox"/> PLUMBING AND HEATING | <input type="checkbox"/> Auto Repairing |
| <input type="checkbox"/> Sheet Metal Worker | <input type="checkbox"/> Navigation |
| <input type="checkbox"/> Textile Overseer or Supt. | <input type="checkbox"/> AGRICULTURE |
| <input type="checkbox"/> CHEMIST | <input type="checkbox"/> Poultry Raising |
- Spanish
 German
 French
 Italian

Name _____

Present Occupation _____

Street and No. _____

City _____ State _____

Please Mention Popular Mechanics



Salesmen Get the Big Pay



The Man Who Makes the Goods
—and the Man Who Sells Them

Salesmen Earn \$2,000—\$5,000—\$10,000 a Year

Inside workers are a part of a non-business producing machine — their earning capacity is limited. Men who can sell, who have the power to persuade people to purchase their products, always command big incomes. They are the direct producers of profits — the life blood of any concern. It is the trained Salesmen who bring in the orders — whose services thousands of concerns today are seeking — and to whom they are willing to pay large commissions and salaries.

Be a Salesman—Earn While You Learn

Our Home Study Course in Scientific Salesmanship gives you the necessary training. It tells you how to prepare a "Selling Talk" — how to approach the prospect — how to manage the interview — how and when to close. It is the one system of practical training that links ability to opportunity and fits you to **earn while you learn**. Employers everywhere recognize the value of N. S. T. A. training. Our Employment Bureau has constantly on file more requests for salesmen than we can possibly fill.

64 Page Book Write today for Free book "A Knight of the Grip" and list of hundreds of good openings offering opportunities to earn Big Pay while you learn. Address nearest office. Dept. 5077. **FREE**

NATIONAL SALESMEN'S TRAINING ASSOCIATION
 CHICAGO NEW YORK SAN FRANCISCO



COPY THIS SKETCH

and let's see what you can do with it. Cartoonists and illustrators earn from \$20.00 to \$125.00 per week or more. My practical system of personal individual lessons by mail will develop your talent. Fifteen years' successful work for newspapers and magazines qualifies me to teach you. Send sketch of Uncle Sam with 6c in stamps for test lesson plate; also collection of drawings showing possibilities for YOU. *State your age.*

The Landon School of Illustrating and Cartooning
 1428 SCHOFIELD BUILDING, CLEVELAND, O.



What the WAR means to Electrical MEN

"The Nation needs each man in the endeavor that will best serve the common good. The Nation is being served only when the sharpshooter marches, and the machinist remains at his levers," said President Wilson in his proclamation of May 17th.

Men with electrical training are needed now more than ever before, both at home and at the front. But America needs experts in electricity—not dabblers. You can't learn electricity out of a book.

The Only Way to Learn Electricity

The only way you can become an expert is by doing the very work, under competent instructors, which you will be called upon to do later on. In other words, *learn by doing*. That is the method of the New York Electrical School.

Our concentrated work with actual apparatus under actual conditions will put you ahead of men with from 5 to 10 years' experience in the electrical field. 4,500 of our students have gone forth into electrical success.

Learn by Doing This method makes you an expert, able to command a high salary. All instruction is individual. You go ahead as fast as you can learn. Good students complete the course in seven months. Send today for FREE 64-page book. Tear out this advertisement and mail it with your name and address.

NEW YORK ELECTRICAL SCHOOL
 44 W. 17th Street, NEW YORK, N. Y.



YOU ARE ONLY HALF ALIVE I Can Prove It

I can prove to you that you are only half as alive as you must be to realize the joys and benefits of living in full. I can show you how, without drugs or medicines or dieting, without excessive exercise, without giving up any of the pleasures of life, you can revitalize, re-energize, restore every cell, tissue and organ of the body and become a **Giant** in health and mind.

Send for My Book — FREE

The secret of wealth, health and happiness is fully explained in Swoboda's new book, "Conscious Evolution." In it, hundreds of pupils tell what this great discovery has meant to them in increased earnings, increased ability to live the well-rounded, wholly successful life. This great book will be sent free to all who are interested in greater health and mental power. Write today—**now**—before you forget. **ALOIS P. SWOBODA, 2050 Aetolian Hall, New York City**



WANTED—Railway Mail Clerks

Commence \$75 Month
 Increase to \$150 "

Franklin Institute
 Dept. D105, Rochester, N. Y.

Common Educa-
 tion Sufficient

Sure Pay, Life
 Job, Pull Un-
 necessary.

Sirs: Send me, without charge, sample Railway Mail Clerk Examination questions; schedule showing places of examinations; list of other government jobs now easily obtainable and free book describing them.

NAME.....

ADDRESS.....

A New Book on the Ford

PUBLISHED JUNE 15, 1917

The Ford Motor Car

AND

Truck and Tractor Attachments

By H. P. MANLY

Author "Automobile Starting and Lighting," "Oxy-Acetylene Welding and Cutting."

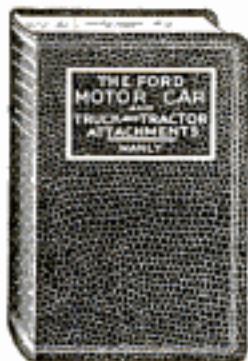

A complete instruction book on every feature of the Ford car, including Truck and Tractor Attachments. It covers the Ford power plant; transmission system; running gear; control; adjustment and repair; upkeep and care; trouble symptoms and remedies; driving; starting and lighting; truck attachments; tractor attachments. Fully illustrated.

Limp cloth, prepaid - - - \$1.00

Leather, prepaid - - - 1.50

Send for our catalogue of practical mechanical books for Electricians, Engineers, Telephone Men, Machinists, Railroad Men, Automobiles, Carpenters, Plumbers, Sign and Card Writers, Scene Painters, etc. It is **Free**
FREDERICK J. DRAKE & CO., 1008 Michigan Ave., CHICAGO

Co-Operative Electrical Education *Earn While You Learn*

We can prepare you in a comparatively short time to secure and hold a responsible, good-paying position with wonderful chances for advancement.

No matter what your former education, we start you at the point where you are competent to begin. "Earn While You Learn." We furnish you with a position in an electrical or manufacturing concern for half a day at good wages, and the remaining half day you get regular instruction in our extensive laboratories, testing and class-rooms.

Clip this ad and return for free illustrated book.

Mention age, education and course interested in.

One-Year Practical and Theoretical

Electrician Course - D. C. & A. C.

Two-Year Commercial Engineering.

Three-Year Electrical Engineering.

ENTER AT ANY TIME. ADDRESS

School of Engineering of Milwaukee, 324 Stroh Bldg., Milwaukee, Wis.

Learn to Concentrate

Prof. Theron Q. Dumont's famous 20 Lesson Course in Concentration, now sent in handy book form, for 5 days' FREE examination. Gives every principle and method. Also practice exercises. Tells you just how to concentrate. Get it now—while offer lasts. Send no money. Read it 5 days. Then, if satisfied, send only \$2. Otherwise return to us. Write for it today on this FREE offer.
ADVANCED THOUGHT PUB. CO., Dept. 739, 168 N. Michigan Ave., Chicago

Public Speaking

Taught at Home

Write for our special offer. Become a powerful speaker in spare time by mail. Overcome "stage fright", enlarge your vocabulary, train your memory, gain self-confidence. Learn how and when to use gestures; how to suit the speech to the occasion. Increase your earning power—become more popular. We have trained hundreds of successful speakers by mail at home.
Write Now for Special Offer Send quick for details of our special limited offer. No obligation. Write while this offer lasts.

Public Speaking Dept. American Correspondence School of Law, 1197 Manhattan Building, Chicago, Ill.

Attend
Chicago
TECH

New college building, new equipment. Location in America's leading industry center affords opportunity for inspection and research work. 2-year courses, Special Short Courses, Day and Evening Classes, Home Study subject and course interests you.
CHICAGO TECHNICAL COLLEGE
 730 Chicago "Tech" Bldg. Chicago, Ill.

Day and EVENING
Classes

No special entrance requirements. Low tuition. Experts in charge of big work instruct you in all branches of

ARCHITECTURE
ENGINEERING
DRAFTING

Machine Shop Practice Complete

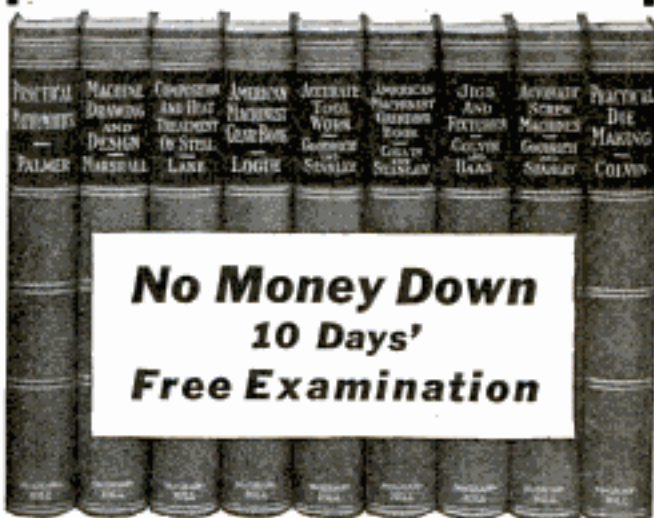

No Money Down
10 Days'
Free Examination

The Standard in America

The Machine Shop Library is the standard work on machine shop practice in America—accepted as such because it is complete in all respects and easily understood.

Nine volumes—6x9 in., 3000 pages, 3000 illustrations. Handsomely bound in morocco grained cloth with titles in gold.

3000 Pages of Experience

The Machine Shop Library affords you one of the surest means of entering the machine shop field fully prepared for a better position. It teaches you as in practice, saving long months of apprenticeship at low wages.

Nine authorities tell you in 3000 pages that which took them years to learn in the leading shops of the United States and England.

Now Is the Time to Get Ready

Machine shop workers now make higher wages than ever before. Begin now and prepare yourself for a well paid machine shop position. An hour or less of your time each day is all that is necessary to place yourself in direct line for promotion. We will send the books direct to your home without deposit on receipt of the coupon below, for a free ten-day examination, and we will also pay the return charges if you feel you do not need this training under expert authority. Now is the very best time to begin where these machine shop specialists left off. Merely fill out the coupon below and return to us at once.

-Free Examination Coupon-

McGraw-Hill Book Co., Inc., 239 W. 39th St., New York

Gentlemen:—I am interested in your Machine Shop Library. You may send me the nine volumes, charges paid, for my inspection. If satisfactory I will send \$2 in ten days and \$2 per month until I have paid the price of the books, \$16. If the books are not what I want, I will write you for shipping instructions.

SIGNATURE.....

RESIDENCE ADDRESS.....

CITY AND STATE.....

NAME OF EMPLOYER.....

REFERENCE.....

ADDRESS.....P.M. 7-17

Please Mention Popular Mechanics



Serve Your Country Where

The Heart of Our President's Proclamation:

"The Nation needs all men; but it needs each man, not in the field that will most please him, but in the endeavor that will best serve the common good.

"Thus, though a sharpshooter pleases to operate a triphammer for the forging of great guns, and an expert machinist desires to march with the flag, the Nation is being served only when the sharpshooter marches and the machinist remains at his levers.

"The whole Nation must be a team in which each man shall play the part for which he is best fitted. To this end Congress has provided that the Nation shall be organized for war by selection and that each man shall be classified for service in the place to which it shall best serve the general good to call him.

"The significance of this cannot be overstated. It is a new thing in our history and a landmark in our progress. It is a new manner of accepting and vitalizing our duty to give ourselves with thoughtful devotion to the common purpose of us all.

"It is in no sense a conscription of the unwilling; it is, rather, selection from a Nation which has volunteered in mass. It is no more a choosing of those who shall march with the colors than it is a selection of those who shall serve an equally necessary and devoted purpose in the industries that lie behind the battle line."

Our Nation Needs All Men, but in the Capacities They Are Best Fitted or Trained to Fill!

You want to show your loyalty, but how can you best do it?

MECHANICS NEEDED AS MUCH AS SOLDIERS

Mechanics are needed as much as soldiers. We must have truck and ambulance drivers to go to the front with our army. To equip an army of 1,000,000 men, we will need 35,000 trucks and 75,000 trained drivers and repair men. Our navy needs mechanics in the shipyards and machine shops. Our aeroplane factories must have mechanics to make and assemble the motors used in these machines. Our munitions plants need mechanics to make shells and guns, and the greatest need of all is for mechanics in our home industries to take the places of those that prefer active service. Our automobiles and tractors must be sold and repaired, and we will need mechanics and garage men at home to do this.

Sweeney Automobile
1165 E. Fifteenth St.,

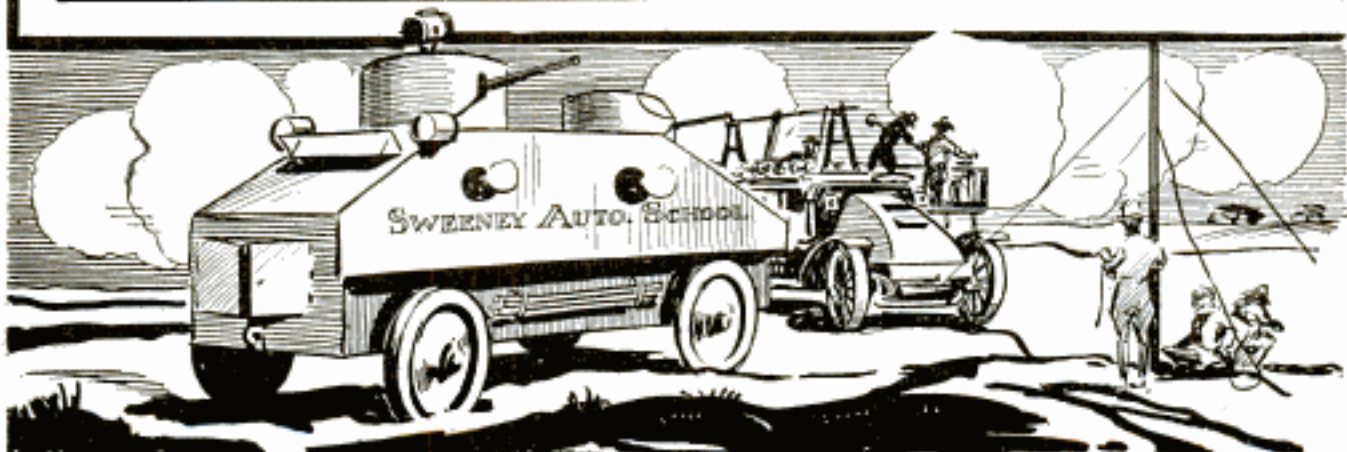

Please Mention Popular Mechanics

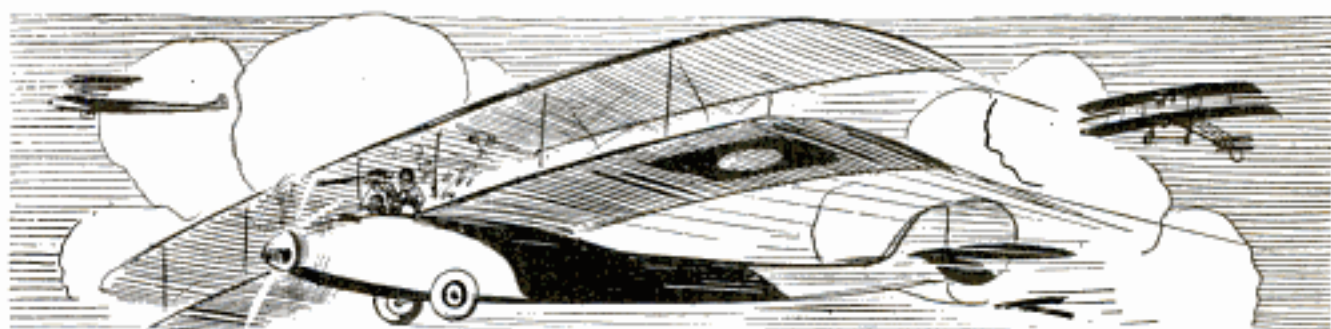

You Can Serve It Best.

It is not the desire of the Government to put a mechanic in the trenches or the man with no trade or training in our machine shops or on our farms. Every man to his place.

The significance of this part of our President's proclamation should appeal to all men. Every man must do his duty, not only the man of military age, but those over or under the conscription age.

TRACTOR OPERATORS IN BIG DEMAND

The man that can go on our farms and operate our tractors is doing his duty just as much as the man carrying a gun, and our Government has recognized this fact. Selective conscription means taking men that will least disturb normal conditions to carry the guns and put in the trenches. If you are a mechanic, you will be called to fill a mechanic's place, not a soldier's.

LEARN TO DO THINGS UNTRAINED MEN CAN'T DO

It is not a question of loyalty or bravery if you prefer to serve your country other than as a soldier. Get the training that will enable you to do something that the untrained man can't. **THE SWEENEY AUTOMOBILE AND TRACTOR SCHOOL** can train you in a short time to fill the place where your services will prove of real value to your country. If you are mechanically inclined, come here and get the training that fits your inclinations. Then you will make good.

GET INTO THE RIGHT JOB

Remember, selective conscription means fitting the man to the place, not the place to the man. A misfit always gets the worst of it. If you are in the wrong job, get out of it and into one that fits you.

Thousands of our automobile and tractor mechanics are going to war. Let the **SWEENEY SCHOOL** train you to fill their places at home. Somebody will have to. It might as well be you.

and Tractor School KANSAS CITY, MO.

Write today for my catalog; better still, wire me you are coming. Your country needs mechanics. Be one.

E. J. SWEENEY, President

Sweeney Automobile and Tractor School
1165 E. Fifteenth Street, KANSAS CITY, MO.
Send me FREE Catalogue.

Name

Address

State

Country

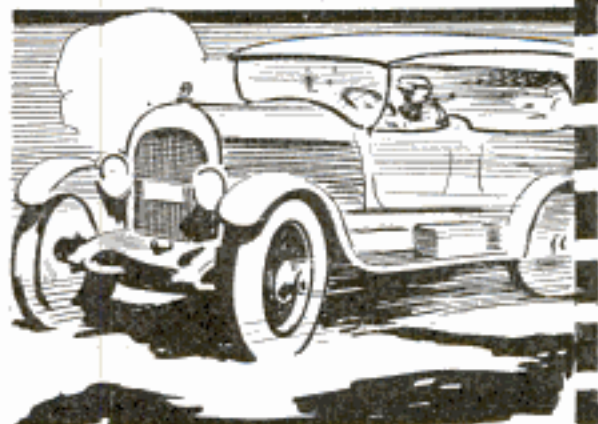

Please Mention Popular Mechanics



The Natural Beauty of Wood

is a most important consideration when choosing the material for the interior finish and trim of your home. That beauty is dependent principally on the texture and "grain"—the varied arrangement of the fibers in individual pieces.

Because of its close, even, velvety texture and its wonderfully varied and pleasing grain, the ideal wood for interior trim is

Southern Yellow Pine

Southern Yellow Pine not only makes a handsome appearance finished in its natural color, but because of its light tint, it is especially suited to staining. It takes stains, varnishes, paints and enamels perfectly, and there is absolutely no effect of color or tone that cannot be obtained with its use.

Futhermore, its extremely moderate cost makes it the most ECONOMIC of finishing woods.

INVESTIGATE—We will gladly send you gratis a handsome booklet, illustrated with color plates, entitled "Directions For Finishing Southern Yellow Pine". Suppose you send for it NOW!

Southern Pine Association

5003 INTERSTATE BANK BLDG.

NEW ORLEANS, LA.



Please Mention Popular Mechanics

Popular Mechanics Magazine

REGISTERED IN U. S. PATENT OFFICE

WRITTEN SO YOU CAN UNDERSTAND IT

Vol. 28

JULY, 19 17

No. 1

Wrecking a Big from a Raft

WHEN the dismantling of a large steel standpipe, that for years had served as a pressure reservoir for the municipal water system in one of Chicago's suburbs, was undertaken some time ago, it was found necessary to adopt an unusual method of attack. The tank extended to an elevation of about 120 feet and stood within two yards of a new pumping plant that had been completed only a short time. Partly on account of the close proximity of the building, it was considered impracticable to fell the pipe by loosening it at the base and pulling it over with the aid of tackle. Therefore another, and more interesting, plan was instituted.

A circular platform of approxi-

Workmen Carried
on a Floating
Platform While
Cutting Down a
Steel Standpipe
with Oxyacety-
lene Torches

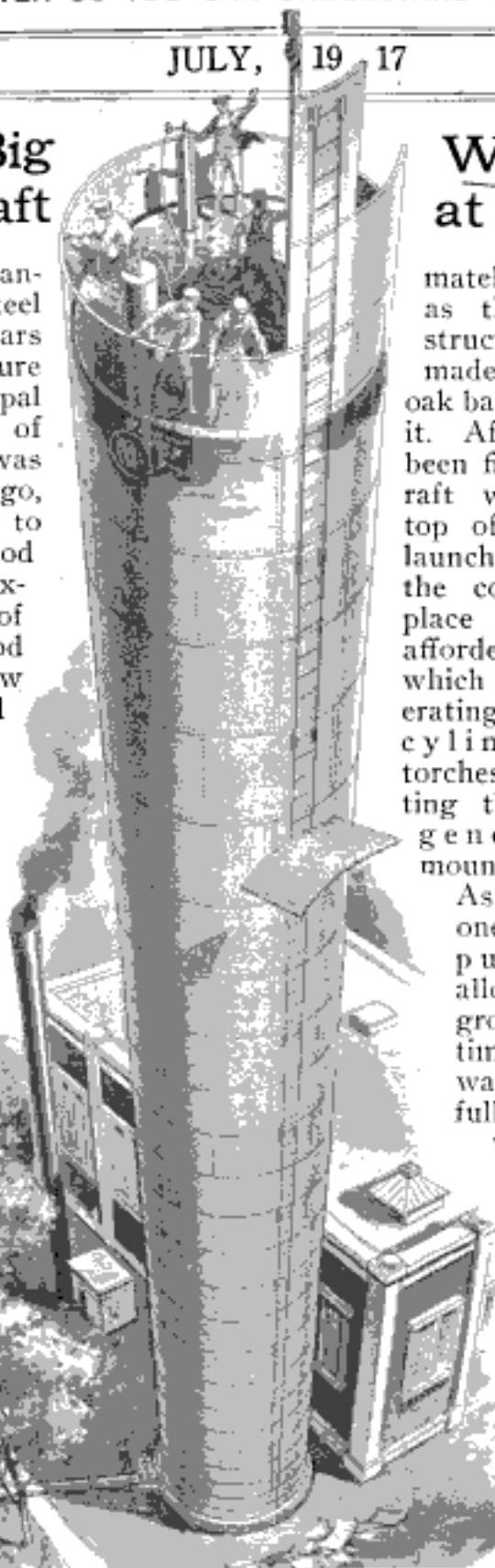

Water Tower at Its Top

mately the same diameter as the tank, was constructed and provision made for attaching four oak barrels to the bottom of it. After the standpipe had been filled with water, the raft was hoisted to the top of the structure and launched on the surface of the column. With it in place the workmen were afforded a platform on which to stand while operating inside of the steel cylinder. Oxyacetylene torches were used in cutting the metal, and two generating outfits mounted on the platform.

As the plates were cut, one by one, they were pushed outward and allowed to fall to the ground below. At all times the column of water had to be carefully regulated so that the raft would not float too near the top of the tank as the plates were removed. This was successfully accomplished by opening a cock in the drain pipe at the bottom of

Newsdealers will have the August issue of Popular Mechanics Magazine on sale July 20th.

the tank and discharging proportionate volumes of water as each of the sections was removed. Thus the platform dropped four or five feet at a time as the wrecking progressed.

Throughout the operations painstaking care had to be observed to safeguard against accidents. A number of contractors declined to undertake the work because of its precarious nature. The tower rocked considerably when struck broadside by strong gusts of wind. At times the swaying became so great that some of the workers could not restrain expression of their fears. On such occasions the only thing that kept them from abandoning their

efforts was their appreciation of the danger involved in attempting to make a descent on the slender ladder extending up one side of the pipe. The strength of the wind made it seem more dangerous to undertake the downward climb than to stick it out at the top. This condition, of course, decreased as the work progressed and the height of the tower was lessened. In many places the plates had corroded until they were only half their original thickness. Had it not been for the stabilizing effect of the water, it is said, the swaying might easily have become great enough to cause the tank to buckle and crash to the earth.

STRANGE NEW NAVAL WEAPON IDEA OF GREAT SCIENTIST

ONE of America's greatest electrical engineers, whose reputation extends throughout the world, has developed what he terms an aeromarine torpedo. It is intended as a weapon for destroying hostile war vessels. Essentially it consists of a torpedo freely suspended by cables beneath a skiff, or pontoon. The latter is connected, by means of a long piano wire, with a flying boat, which tows it through the water at high speed until

it strikes its target. The device is interesting because of the eminence of its inventor, who in this instance has departed from his accustomed field of endeavor and built a machine

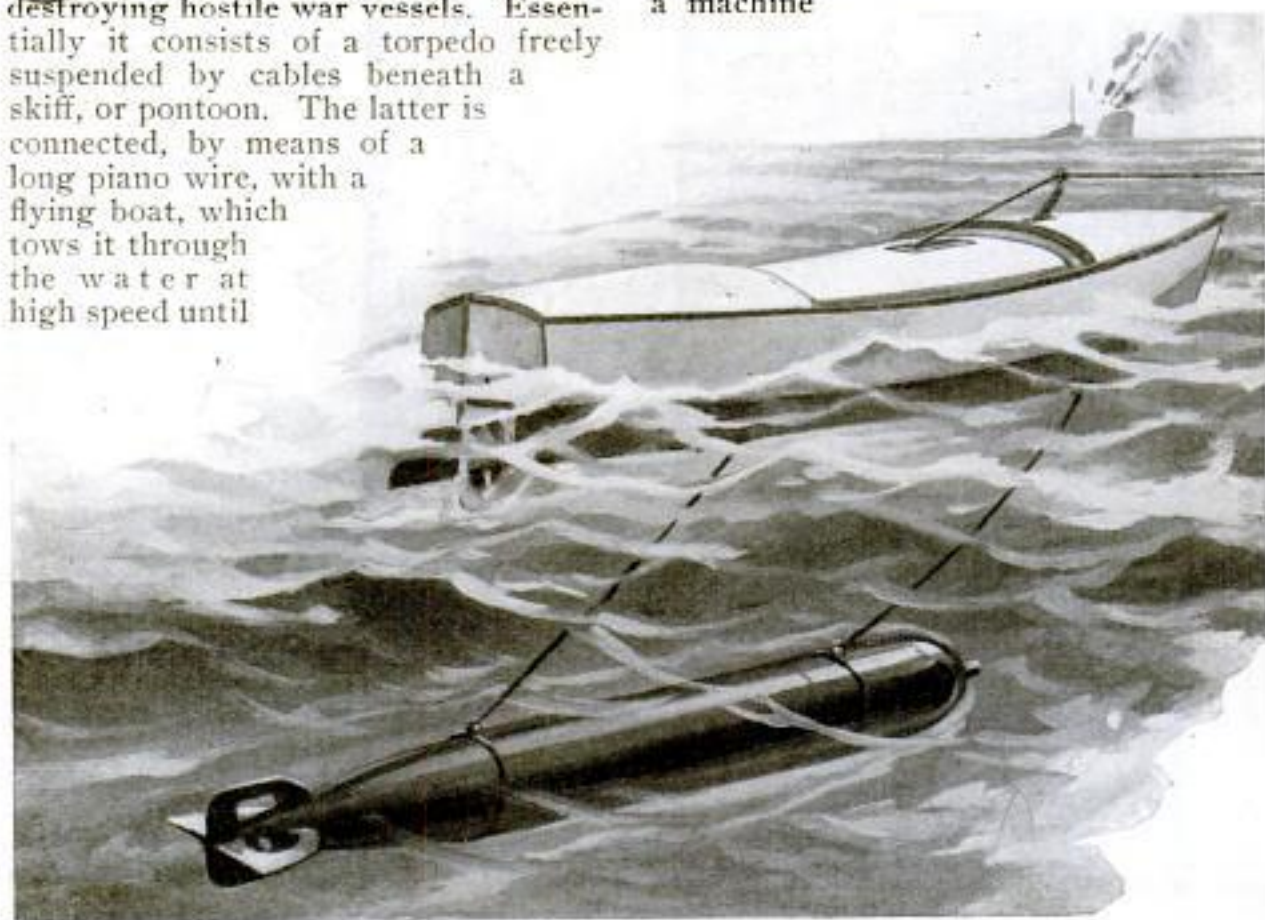

that is entirely mechanical in construction and in operation. The wire, which serves as a towline, passes through an eye in the handle of a lever and is wound about a drum installed in the skiff. While the flying boat is skimming across the water, the towline assumes a low angle. This depresses the lever, which in turn locks the drum against movement so that needless unreeling does not occur. When the pilot craft ascends into the air, however, the drum revolves as the wire is drawn out. This motion is transmitted to a propeller, and the forward propulsion of the skiff thus aided.

In attacking a vessel, an airman would leave the water and attempt to cross the enemy's path, dragging the torpedo carrier after him. The missile would be sus-

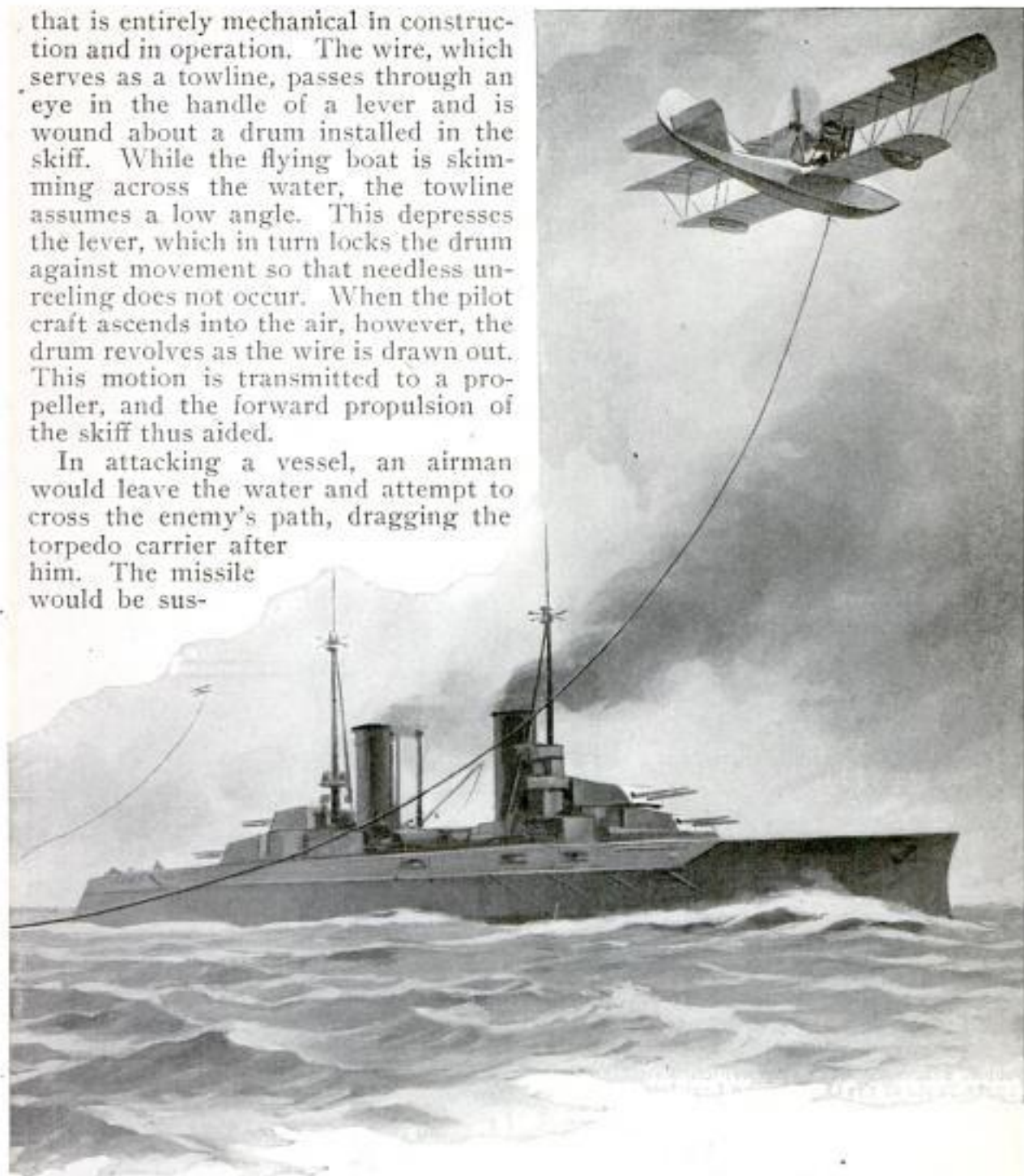

The Aeromarine Torpedo Pictured in Use against an Enemy War Vessel: This Peculiar Mechanical Weapon Is the Invention of a World-Famous Electrician Which has Only Lately been Made Public

ended far enough beneath the bottom of the skiff to pass below a net, should one be encountered at the side of the ship. The towline, of course, would fall across the radio aerial, or across the deck, of a vessel. The continued pull upon it by the air craft would bring the torpedo, it is assumed, against the vessel with considerable force. To

gunners who can hit the periscope of a submarine in a choppy sea, a flying boat traveling at a low elevation would appear to be an excellent target. There are possibly important phases of the invention, however, that have not been made public, and if such be true, the time is not ripe for surmises as to their nature.

LOBBYIST'S LACE RECORDS DEEDS OF LEGISLATURE

A woman lobbyist who attended sessions of the last Oregon legislature for five weeks demonstrated by some



Lace Crocheted by Woman Lobbyist While Attending Oregon Legislature; the Figures in Order and What They Represent Are: Bow, Frances Willard Day Made Legal Holiday; Pear, Bill for Spraying Fruit; Chinese Pheasant, Law Pertaining to Its Protection; Sheep-Killing Dog, Severe Law against Same; Cow, Law against Live Stock Running at Large; Stork, Illegitimate-Child Law; Woman at Washtub, Widows' Pension Law; Two Men with Umbrellas, Candidates for Governorship; American Flag, Indorsement of Severance of Relations with Germany; Juggler, Legislative "Juggling"; Dancing Couple, Satirizing Manner in Which Male Members Sought Favor of the One Woman Legislator; Church, Proposal to Tax Churches

unique crochet work that on entering politics she had not lost her skill in handicraft. Practically all of the woman's spare time while at the sessions was occupied by crocheting lace in which she worked a symbolical record of what the legislature did. When a bill was passed pertaining to illegitimate children a stork was crocheted to signify the event. Two prospective candidates for governor, both members of the legislature, were represented by two figures, each ringing a bell to attract attention and carrying

an opened umbrella as an indication that he was a "dry." An American flag was worked into the lace on the day resolutions were passed indorsing the severance of diplomatic relations with Germany. A white bow, the emblem of the W. C. T. U., was incorporated in the lace when Frances Willard Day was made a public holiday. Other symbols were: a juggler, emblematic of the "trading" that went on, particularly during the last days of the session; a church, suggesting the proposal to make churches pay taxes, and a sheep-killing dog, signifying severe legislation against the implied menace.

INDEXING ATTACHMENT FOR ENGINE LATHES

A useful attachment for engine lathes, or other machine tools in which the work is rotated, quickly locks the rotary part of the machine so that the work may be indexed or marked for drilling holes or other operations before removing it from the machine. With one row of 60 holes drilled around the large drive gear of the lathe, the new device is capable of accurately locating 42 different indexes, or sets of divisions. It is of very simple construction and can be readily operated by any machin-

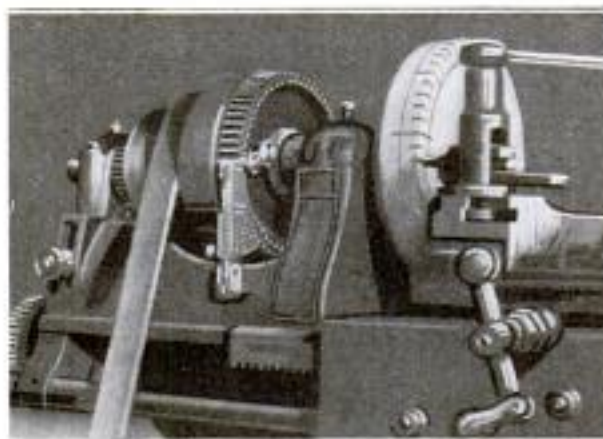

Engine Lathe with Newly Patented Attachment on the Large Gear Wheel, for Indexing Work before Removal from the Tool

ist with the utmost accuracy. It is secured to the large gear wheel by thumbscrews and may be attached or detached in a few seconds.

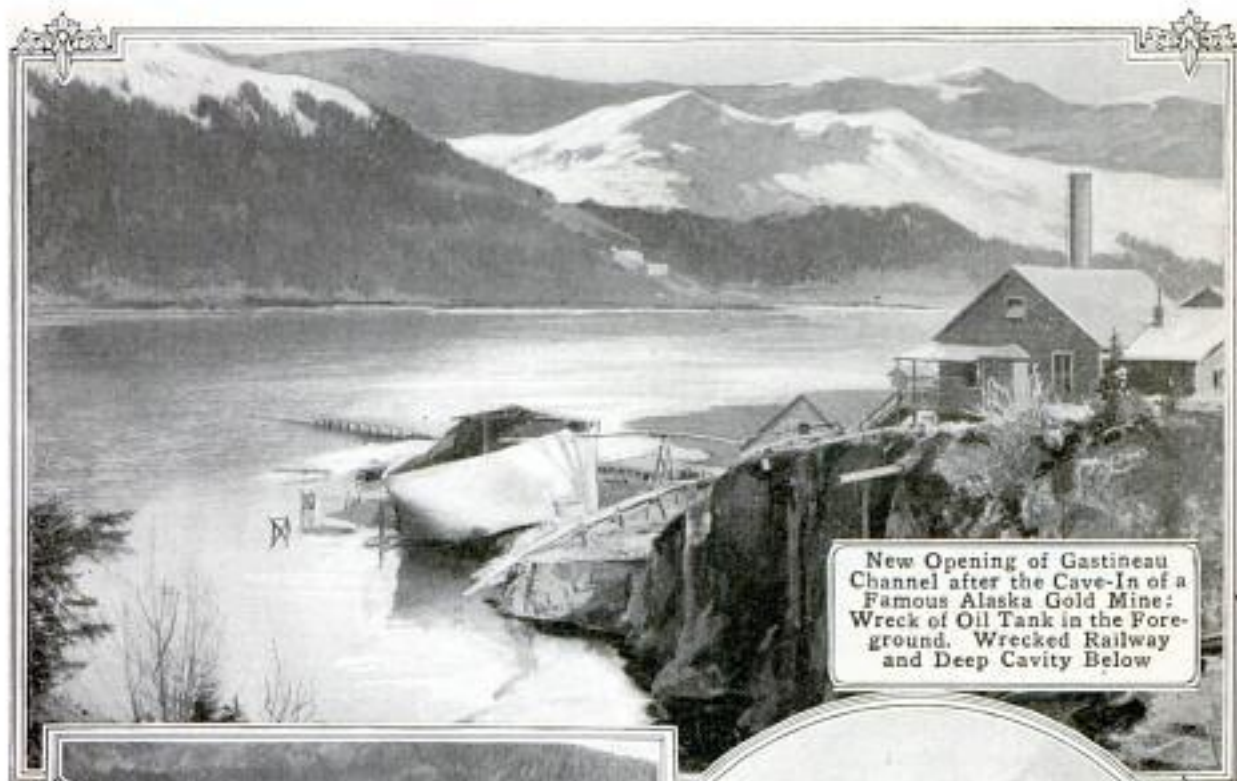
FAMOUS ALASKA GOLD MINE WRECKED BY THE SEA

New Opening of Gastineau Channel after the Cave-In of a Famous Alaska Gold Mine; Wreck of Oil Tank in the Foreground. Wrecked Railway and Deep Cavity Below



Gold-Mining Camp on Douglas Island, Alaska, before the Recent Disaster: In the Center Is a Noted Gold-Quartz Quarry That Has Produced Millions

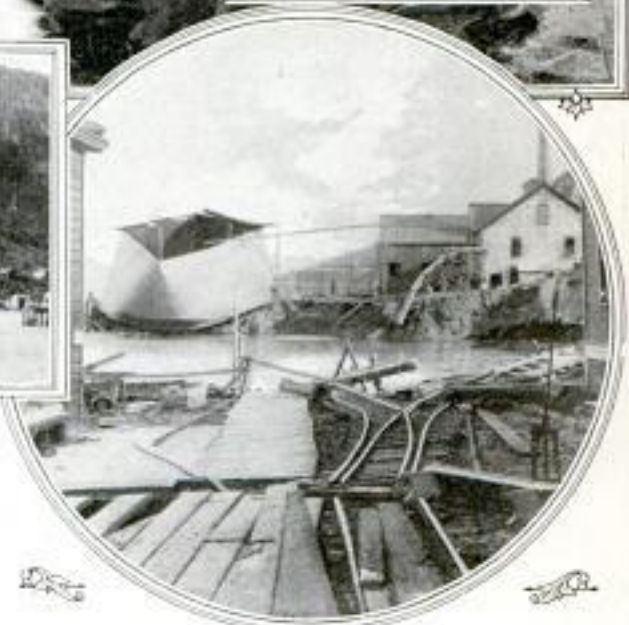

Damage estimated at \$15,000,000 was caused when the under-sea workings of a noted group of gold mines on Douglas Island, near Juneau, Alaska, were invaded by the icy waters of Gastineau Channel, on the night of April 21-22 last, with disastrous results. Only a thin skin of rock had separated the upper workings from the channel stream. When water broke through this in a thin trickle, the alarm was given, the miners at work on the night shift ran for the lifts, and only one human life was lost, although some of the workings extended to a depth of 2,000 ft. below the sea. An hour afterward, the intruding waters had flooded the mine and drove a spout through

the main shaft 200 ft. into the air. Then came a surface cave-in which destroyed a number of the mine structures, including a costly steel oil tank and the company gymnasium and bathhouse, some of the buildings falling into the great cavity created by the disaster. An immense quantity of ore and of mining machinery was lost, and 1,300 miners were thrown out of work. Attempts will probably be made to mine the ore under the flooded diggings by deep tunneling beneath Gastineau Channel.

MAMMOTH GOLD DREDGE HAS TWO STACKERS

A dredge company contracted with the United States government not long ago to build flood-restraining levees on either side of the Yuba River, Calif., and to do it free of charge, the condition being that the company be allowed to dredge for gold while fulfilling its contract. Accordingly a gold dredge, costing \$500,000, was built which is said to be the largest of its kind in the world. An unusual feature of the mammoth floating machine is that it has two arms, each 225 ft. long, instead of one. These are provided with 44-in. belt conveyors that deposit the tailings on either bank of the stream as the dredge moves along. The digging ladder is equipped with steel buckets of 18-cu.-ft. capacity, which can dig to a depth of 80 ft. The hull which supports all this machinery is entirely of steel and is 165 ft. long and 68 ft. wide. The gold-saving tables have an area of 8,000 square feet.

NEW SOURCE OF PLATINUM FOUND IN SIBERIA

An interesting discovery of a new source of platinum is reported from Siberia, where the valuable metal is now being extracted by a Russian mining engineer from the conglomerate rock known as dunite. This rock contains chrome-iron ore, and it is from this ore that the platinum is obtained by processes of grinding and washing. Immense quantities of dunitic rock are found in Siberia, the Nizhni-Tagilsk district alone embracing an area of this formation estimated at 11.7 square miles. This is the scene of the experiments now being made in platinum extraction. The method is to grind the dunite under runners, in order to separate the chromitic slack, which is then subjected to further grinding until the pure platinum can be washed from it. A recent experimental grinding of chromitic slack yielded over 200 oz. of platinum out of 9,720 lb., and plans are being made to work the deposits of dunite on a large scale.

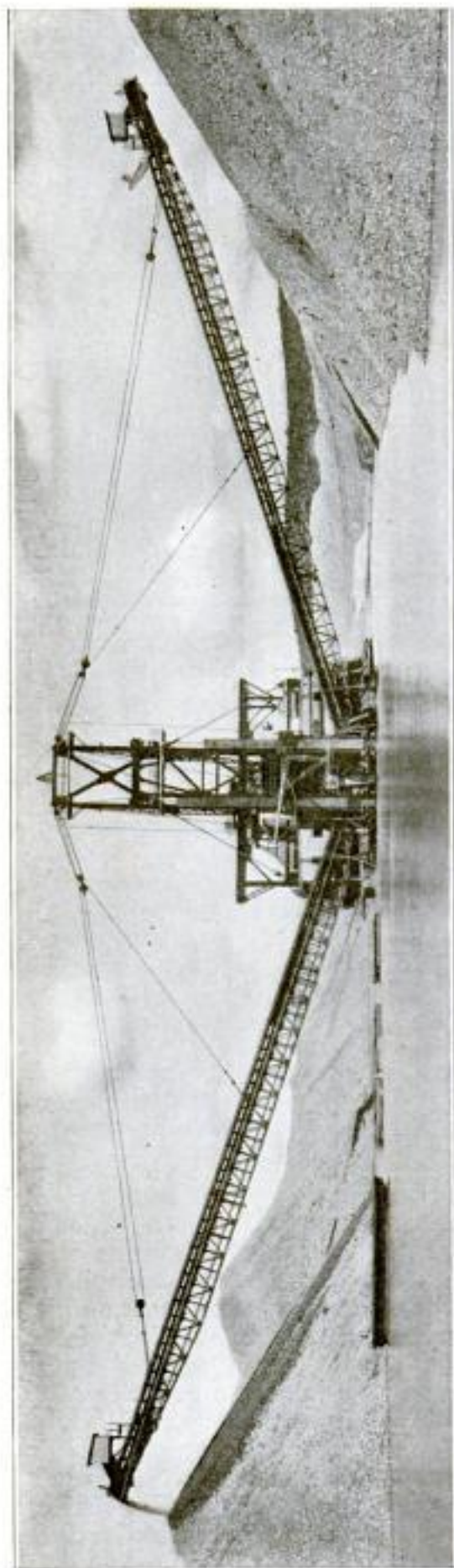

Gold Dredge on the Yuba River, California. Which Cost \$500,000: The Two Arms Are Each 225 Feet Long and the Steel Buckets, Having a Capacity of 18 Cubic Feet Each, can Dig to a Depth of 80 Feet below the Water

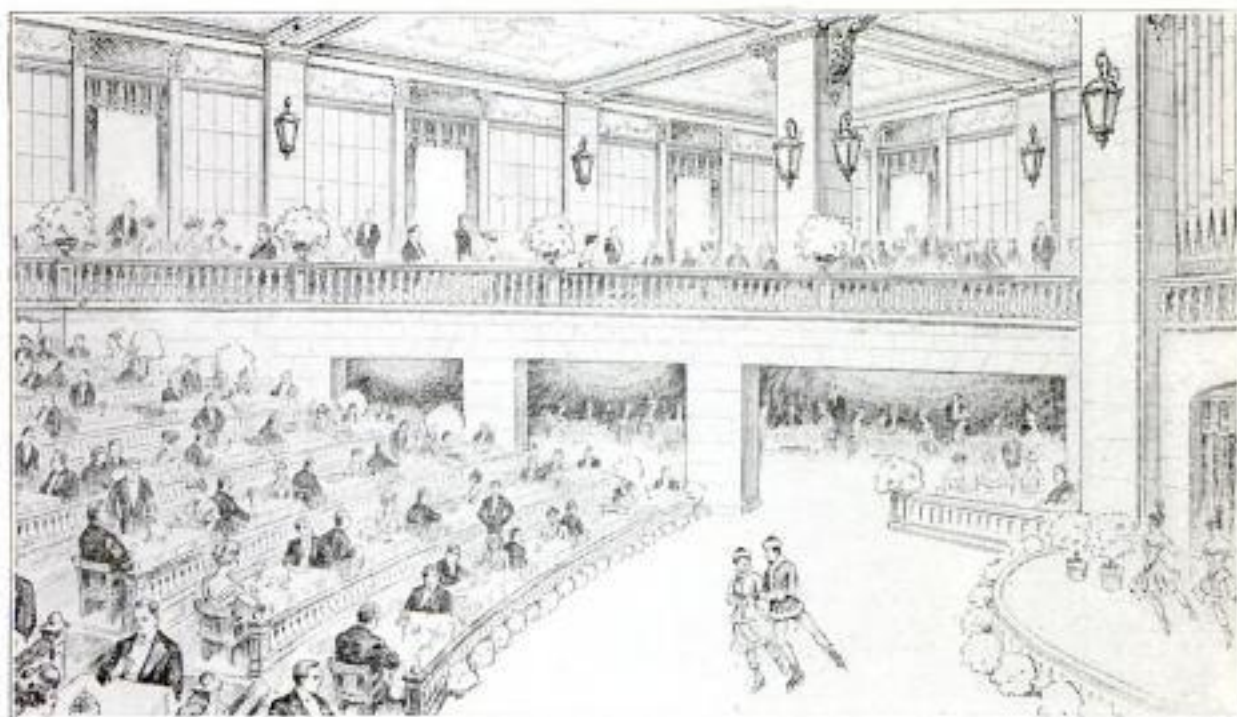

New Chicago Restaurant Built Like a Theater, with Tables Arranged Tier above Tier on Terraces: Every Seat Affords a View of the Stage and Ice Rink. The Room Measures 100 by 100 Feet and can Accommodate 1,200 Diners at One Time

THEATERLIKE RESTAURANT HAS TERRACED FLOOR

The basement of one of Chicago's new hotels is occupied as a dining room which is really a restaurant and theater combined. Tables accommodating 1,200 diners are arranged in a balcony and on seven semicircular terraces that rise one above the other in front of a stage. Between the terraces and the stage is a skating rink, the ice for which is kept in condition by a special refrigerating system. Though this dining room measures 100 by 100 ft., the ceiling is so made that there are no pillars to obstruct the view, save close to the sides. The paging of guests is done silently, the names of persons wanted being shown on a large screen with the aid of a telautograph. A \$30,000 pipe organ is situated at the back of the stage.

Since the sale of opium in the open market became illegal throughout China a few weeks ago many poppy fields have been converted into wheat fields—a fact that will undoubtedly increase the use of wheat flour by the Chinese.

DESK SETS ORNAMENTED WITH BROCADE PANELS

A manufacturer of novelties has placed on the market writing-desk sets of brass, bronze, etc., each article of which is decorated with slightly padded panels of brocade, or other fabrics. This combination of cloth with the hard surfaces gives a warmth and color which other desk sets of metal only, even if very ornate, cannot possess. The variety of effects that can be obtained is only limited by the variety of fabrics available. These panels of cloth are so attached to the flat sides and tops of the articles that no seams, folds, or means of fastening are visible.

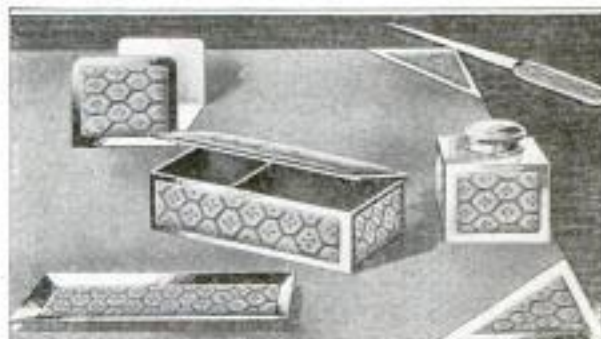

Bronze Writing-Desk Set Attractively Decorated with Slightly Padded Panels of Brocade so Attached to the Metal That No Fastening Is Visible

*The Walker Power Harvester Co.,
204 Mining Exchange Bldg.
Colorado Springs, Colo.*

8

POPULAR MECHANICS

MOWER DRIVEN BY ENGINE FROM LOW-PRICED CAR. *Colo.*

A gasoline-driven mowing machine is to be placed on the market

by a Colorado company in which parts similar to those in an ordinary mower are combined with the engine and other portions of a well-known low-priced automobile. The machine is mounted on three iron wheels, and the operator sits at the rear with all controlling levers within easy reach. It is claimed that it will do twice the work of a horse-drawn mower and that the gasoline consumption is low.

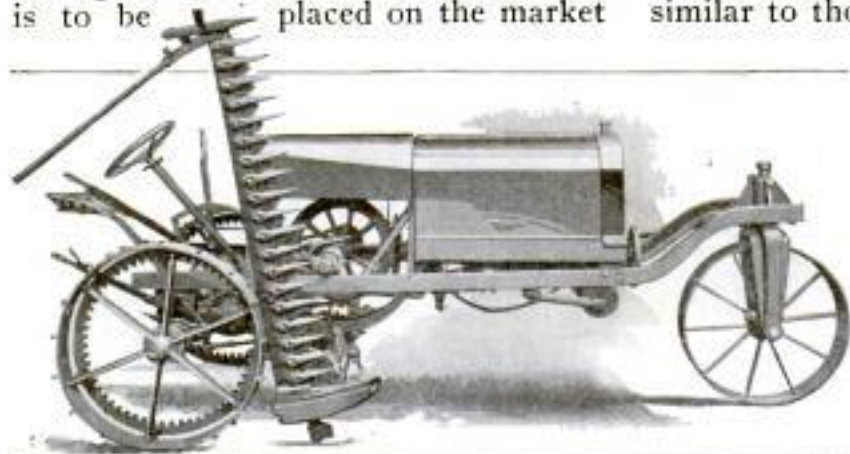

Gasoline-Driven Mowing Machine Said to Do Twice the Work of a Horse-Drawn Mower and at Low Cost

A THEATRICAL LABORATORY FOR TESTING PLAYS

By M. W. MEIER

IN its "Player's Workshop," founded by a woman, Chicago has what is perhaps the only organization of its kind in the world. It is a sort of theatrical laboratory, where one-act plays are tested out before being offered to the general public. Its location is in the 57th Street art colony and it has a membership of over 100 playwrights and actors.

Every month three or four plays written by members are produced, and if successful in the eyes of the spectators are offered to theatrical managers for public production. Great care is given to scenic, lighting, and costuming effects. Each new play is carefully studied by experts in these lines, who then plan how it can best be presented.

New wrinkles and devices are continually being tried and injected into productions. The stage is quite small, only 17½ ft. wide by 15 ft. deep, and the staff is often handicapped for lack of space. The auditorium seats 90 and on six nights a month it is packed with members to witness the try-out performances. The actors are chosen from the organization, and the training

is so rigid and good that few of them can be called amateurs. Simplicity and originality are the keynotes of every performance. Nothing that is old or hackneyed is ever used, provided a new substitute can be found.

All stage and lighting effects are handled by an expert who, from an all too meager switchboard, brings forth a great variety of light effects. No footlights are used, all illumination coming from wing and border lights. Flood and spotlights are frequently utilized, but not so much as in other theaters. Here the play is the thing, and not the actors. The scenery is always strikingly beautiful and novel. Futurist touches are often added to good advantage. A well-known etcher has charge of all scene work, and is also the originator of many of the unusual costumes that are used.

Practically all the scenery is made up in flat sets, the height of the stage being too scant to permit the use of drops. For this reason also, the curtain is drawn from side to side rather than up and down as is customary. No set of scenery is ever used twice, a new one being painted for every play.

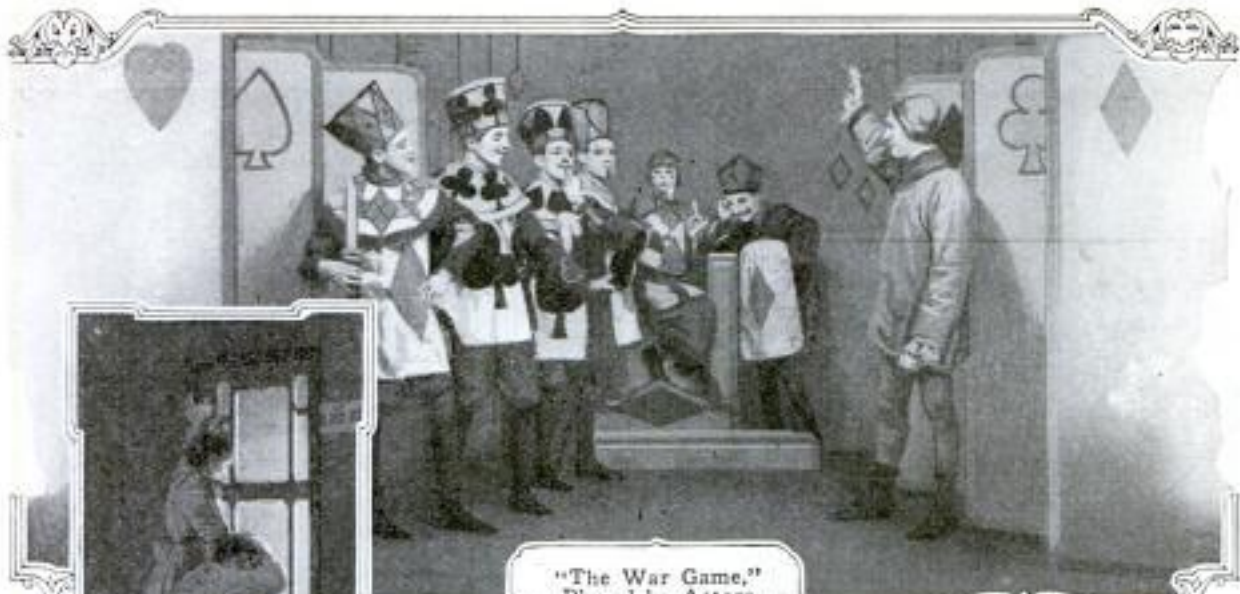

"The War Game,"
 Played by Actors
 Representing Suits of
 Cards: A Typical
 Scene from One of the
 Plays Produced in the
 "Player's Workshop,"
 Where Members of the
 Chicago Art Colony
 Give Frequent Entertainments to Introduce
 the Work of Local
 Playwrights



A Scene from
 "Civilization":
 Two Characters
 in the Play are
 Watching, from
 a Darkened
 Hospital Ward,
 Executions in the
 Courtyard Below



Pierrot in the Light
 of the Moon: The
 Lighting Effects,
 Like All the Other
 Accessories of These
 Unique Productions,
 are Worked Out by
 Club Talent

Skeletons Out of the Closet: Another
 Scene Realistically Played by Members of
 the Organization. Costumes and Scenery
 are All Designed by the Talent of the
 "Workshop," and would Reflect Credit on
 Experts of the Professional Stage



Apparition of Christ in a Window
 to a Discouraged and Forlorn
 Character in a Playlet Called
 "Dregs," Written by a Member of
 the Organization and Produced
 with Striking Effects in the
 "Player's Workshop": The Scene
 Tells Its Own Story, of the Renewal
 of Hope in a Mind Driven Near to
 Desperation, but Encouraged to
 Fresh Effort by the Miraculous
 Image of the Savior



Making a Relief Map of a National Forest: At the Left, Foresters Working on the Clay Model; at Right, Putting the Finishing Touches on the Plaster Map

RELIEF MAP OF CARIBOU NATIONAL FOREST

Using a method devised by a professor of the Agricultural College of Utah, members of the Forest Service stationed at Ogden in that state have just completed a noteworthy relief map of the Caribou National Forest, Idaho. The map is 13 ft. 9 in. long, 5 ft. 3 in. wide, and weighs



The Finished Map of the Forest Area, Showing the Relative Elevations, Also Streams, Roads, and Towns

several hundred pounds. Three copies have been made from the original clay model, one of which will be used for exhibition purposes on a railroad car. The horizontal scale of the map is two inches to the mile, the vertical scale being doubled to make the mountains appear to the eye as seen in nature. In making the map, a large vat was filled with clay on the smooth surface of which the 500-

ft. contours of the forest—which comprises 699,828 acres—were traced from a topographic map. The clay was then cut down into steps and

smoothed off to show the correct elevations; after which the relief was shaped into a close representation of the country, the clay being kept moist. It took over three months to make the model. A plaster-of-Paris negative cast was then taken, and from this the three positives were made. These contain a large percentage of macerated paper money, furnished by the Treasury Department. On the painted surface streams, roads, and towns are shown, and the forested areas are indicated by a sprinkling of green sawdust and cornmeal.

CHARTS ON FARM SUBJECTS FOR COUNTRY SCHOOLS

Lecture charts and lantern slides on agricultural subjects are furnished with appropriate printed lectures for the use of school superintendents and teachers in rural districts, who usually plan a circuit of neighboring schools for systematic study. The lectures deal with soils, crops, poultry, live stock, weeds, flies, home economics, and other interesting subjects which directly concern agriculture, the home, or the business of the country. The charts are 70 in. long, 63 in. wide, and can be read at a distance of 100 ft. or more. The set on each subject contains 10 to 15 cloth charts, mounted on an oak crosspiece, with an iron stand which can be used either indoors or in the open air, as desired. The sets are loaned for one or two weeks to rural schools or organizations.

4155

PROPOSE ELECTRIC LIGHTS FOR LINCOLN HIGHWAY

The lighting of Lincoln Highway by electricity from coast to coast is the ultimate aim of a movement set on foot recently in Ohio. The Stark County members of the Joyian League, which is a national organization composed of men connected with the electrical trade, have proposed that this order, through its branches located in various parts of the country, indorse and work for such an improvement. The plan has been well received in many quarters. Its originators estimate that the cost of illuminating the 33 miles of the highway which lie within Stark County would be \$4,000 per year.

SHIELD PROTECTS AIRMAN'S FOLDING CAMERA

An airman, who is also a photographer of considerable experience, found that he could not use his folding



Airman with Folding Camera Fitted with Shield to Protect It from Wind Pressure: The Shutter is Operated by a Thread



The Shield Is of Aluminum and is Made Like a Collapsible Carton so That It can be Folded Up and Carried in the Pocket

REACHER GIVES ACCESS TO HIGH GROCERY SHELVES

Easy access to cans or packages on the upper shelves of a grocery may be had by using a reacher consisting of a long arm, at one end of which are two rubber-covered jaws that can be clamped about the desired article. The jaws are controlled by either of two handles, one at the middle and the other at the lower end of the arm.



The Chicago municipal pier, which is 3,000 ft. long, is being converted into barracks for a regiment of reserve engineers who expect to drill as well as live there.

camera for taking pictures from an aeroplane because the wind pressure flattened out the collapsible portion of his instrument. Accordingly he devised an aluminum camera shield that can be fitted around the extended part of a camera in a few seconds, thereby giving it ample protection.

ALASKA ROAD HAS A CLEAR-ICE FOUNDATION

A hillside road recently built by the board of road commissioners for Alaska has at one point a foundation of many feet of ice. Mining operations at this point disclosed the fact that below a surface layer of 2 ft. of moss and tundra, there were 40 ft. of clear ice and then 6 ft. of gravel on the bedrock. A corduroy road of willow was therefore laid on the tundra and surfaced with gravel.

COXSWAIN MEGAPHONE USED BY COLLEGE GIRLS

The latest style of megaphone for coaches and coxswains of rowing crews



has been adopted by the oarswomen of several colleges. It is an 8-in. instrument of heavy fiber, and has a pair of light metal arms attached to an elastic band which goes round the head.

MAMMOTH CAVE LIGHTED BY ELECTRICITY

Electric illumination of important parts of the Mammoth Cave, Kentucky,



Electric Lighting Plant Newly Installed in the Mammoth Cave of Kentucky, Hitherto Lighted by Oil Lamps

is now an accomplished fact, a lighting plant having been recently installed at the edge of the Rotunda, which is the first main chamber of the cave. This chamber is at the end of a passageway, about 500 feet long, leading in from the entrance, the passage being lighted by electric lamps strung along the walls. The

Rotunda itself, which is 200 or 250 feet across, with a dome roof from 60 to 75 feet above the floor, is lighted by batteries of electric lamps set in shallow reflectors, placed on poles so that the lamps themselves are unseen. From the Rotunda two avenues lead off into the recesses of the vast cave, hitherto lighted only by dim, smoky oil lamps and the torches of guides. In one of these avenues is what is known as the Banquet Hall, containing a wooden inclosure with tables and equipment for serving the banquet customary when a large convention visits the cave in a body. This hall is now lighted with 2,135 electric lamps.

In the Rotunda, besides the reflector banks on poles, there is a large tripod carrying a 600-watt lamp, used to throw a particularly strong light on various features of the walls and roof of the cave. As the visitor receives at this point his first impression of the vastness and beauty of the great natural wonder, the installation of electric lighting has added to the effect produced by the subterranean scene, endowing the stalactite and stalagmite formations with prismatic colors never displayed by the old oil lamps. It is a distance of 380 yd. from the entrance through the Rotunda to the far end of the Banquet

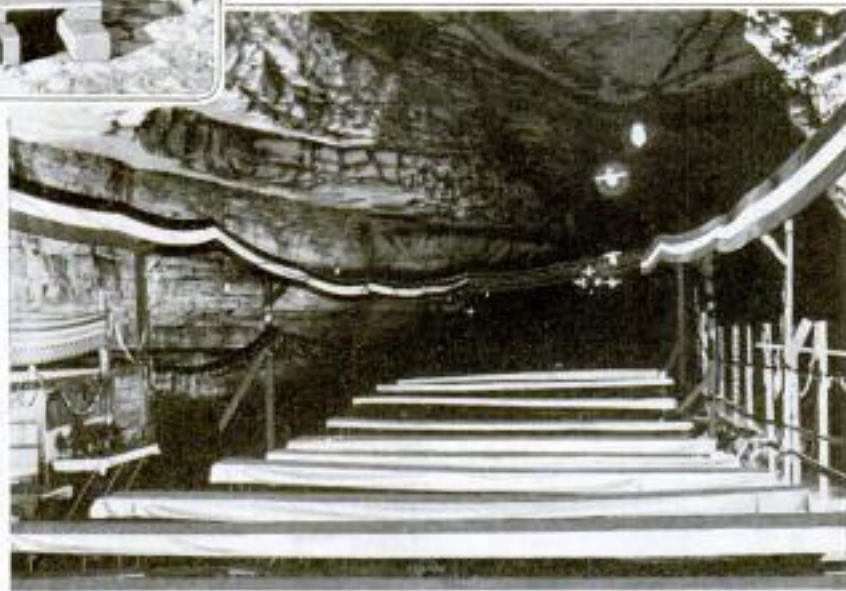

Banquet Hall in the Mammoth Cave, Where Large Conventions are Often Entertained: Now Lighted by 2,135 Electric Lamps That Display the Natural Beauties of the Cave as Never Before. Showing Wonderful Prismatic Effects



Winner of Spectacular Climbing Contest Approaching the Most Difficult Stretch on the Steep Hillside

Hall, and this is the only portion lighted at present by the electric plant, while there are in all about 15 miles of passageway in the cave.

SPECIAL PHONE RATES FOR VACATIONISTS

When a telephone subscriber in Lincoln, Neb., goes on a vacation, or otherwise has no use for his phone for a temporary period of more than 30 days, the company will, upon request, make a special disconnect rate during the discontinuance of service. This is half the regular rate, and a valuable feature is that when a disconnect-rate phone is called, the call is taken by an information operator who states that the party called is away from home and tells where he is staying, also when he expects to return, this information being kept in a card index in the exchanges.

On the Humboldt National Forest in Nevada there are 315,740 sheep, the largest total to be found on any one of the national forests, while the largest number of cattle—75,818—is found on the Tonto National Forest in Arizona. The average annual value of the meat product of these two tracts is estimated at \$2,000,000.

MOTORCYCLE CONQUERS HILL OF PRECIPITOUS GRADE

During a spirited contest recently conducted in southern California, one motorcycle out of a number of entries succeeded in negotiating what is stated to be a 76-per-cent grade. Several thousand persons from various sections of the state witnessed the event. The cycle that carried away the honors was geared 16½ to 1 and made two triumphant dashes up the steep incline between rows of cheering spectators. The feat was made possible by the fact that the winning machine did not



depend upon an ordinary tire for traction. A demountable motor-car rim, about the circumference of which deep steel cleats had been riveted, encircled the rear tire and thus prevented the driving wheel from spinning. The competing machines were not similarly equipped, and therefore were unable to reach the top of the hill.

DEVICE FOR CLEANING CISTERNS WHILE FULL

A cistern can be cleaned quite thoroughly without pumping off any of the water, by using a simple device recently invented.



It consists of a galvanized-iron can, 5 in. in diameter and 10 in. long, to one end of which is attached a long extensible handle. The bottom of the can is provided with a large leather intake valve and in the upper end is a small hole fitted with a cork, designed to keep the air in the cylinder until it reaches the bottom of the cistern. A rod projects from the upper end of the cork and is bent so that it extends, through eyelets, down the outside of the can and about an inch below the lower end. When the cleaner is immersed in the water it remains filled with air until the end of this rod strikes bottom. This forces the cork out, allowing the air to escape, while dirt and muddy water rush in

through the leather valve. The cleaner can then be withdrawn, filled with deposit, and the process repeated.

through the leather valve. The cleaner can then be withdrawn, filled with deposit, and the process repeated.

FAMOUS AIRMAN'S DEATH A LOSS TO OUR ARMY

A fatal aeroplane accident which resulted in a loss that the United States can ill afford, particularly in this time of national emergency, occurred May 9 when Victor Carlstrom and a student flier were killed at Newport News, Va. Within sight of several hundred persons the famous airman was taking his companion on the latter's first flight and had ascended to a height of 3,500 ft. when the aeroplane was seen to crumple and plunge to earth. Both men were killed instantly. Carlstrom was one of the best known fliers in the United States and had won many honors. Last November he attracted nation-wide notice by making a new cross-country nonstop record for America during a flight from Chicago to New York. However, a few days later his achievement was surpassed by Miss Ruth Law. Only a few weeks ago Carlstrom received an appointment as first lieutenant in the army aviation reserve corps, and he had begun a most valuable service to the country by instructing a large class in flying.

CASKETS AND VAULTS MADE OF REINFORCED CEMENT

Reinforced cement is now being used with success in the construction of

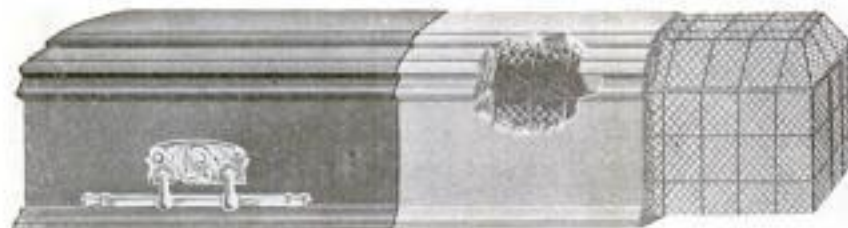

View of Cement Casket. Showing Cloth Covering, the Finished Cement, and the Reinforcing, Consisting of Wire and Rods

burial vaults and caskets of the most durable sort. Each casket is reinforced with sets of rods, that intersect at frequent intervals, and with strong wire

mesh. The cement used is thoroughly treated with waterproofing. The cover, like the rest of the receptacle, is able to withstand great weight. It fits into a V-shaped groove that extends around

the rim of the vault. Before it is put in place for the last time the groove is filled with liquid cement so that when the casket is closed it is hermetically sealed. In each cover is a plate-glass panel over which a small cement lid is sealed.

The vaults, the tops of which are more rounded, are made in much the same manner as the caskets.

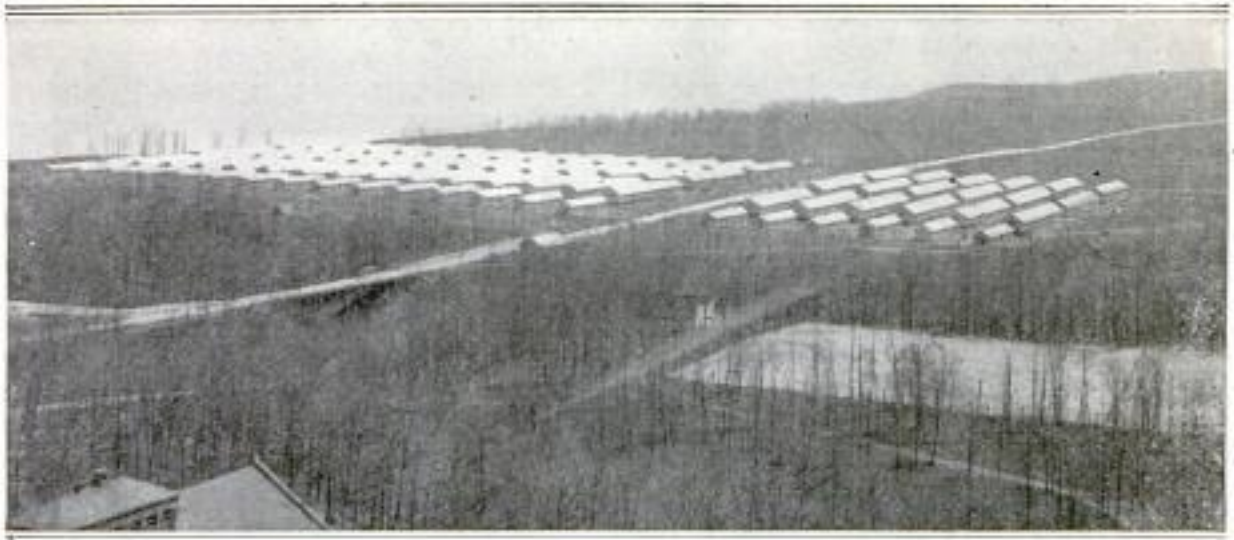

Bird's-Eye View of Cantonment Erected at Fort Sheridan, Illinois, to Accommodate Some of the Several Thousand Men Now in Training at the Post: The 85 Buildings Shown in the Picture were Constructed in 10 Days

PERMANENT ARMY CAMP BUILT IN TEN DAYS

IN ten days of actual work, a bald knoll on the army reservation at Fort Sheridan, Ill., was converted into a well-planned cantonment with accommodations for 3,500 men attending the officers' training camp. The speed of the construction made this a feat perhaps unsurpassed in the Middle West, if not in the entire country.

Eighty-five separate one-story frame buildings were erected. They consist of 42 barracks, 20 by 126 ft.; 21 mess halls and kitchens, 20 by 112 ft.; 21 bathhouses, 14 by 63 ft., and a telephone-exchange building. The structures were built side by side in four long rows.

Organization and competent supervision accomplished the work. Materials were rushed to the grounds by special trains and motor trucks. Special trains also shuttled a large part of the force of 600 or 700 men between Chicago and the army post morning

and night. Approximately 1,250,000 ft. of lumber were used. All of this was delivered in about three days' time.

The romance of the undertaking swells as the details of its accomplishment are unfolded. Plans and specifications for the cantonment were received from Washington late on Saturday, April 28. Their complete revision by Monday morning was necessary to fit them to local conditions. This fell to Josiah L. Rice, the government's superintendent of construction at Fort Sheridan, who acted as director of works while operations were under

way. The general contract, awarded to a Chicago construction company, was signed on Sunday and dated for the following day. Rain fell on Monday, when work was supposed to be launched. Because of this, a time extension of one day was



Looking down the Street Separating the Bathhouses from One Row of Barracks and Showing a Trenching Machine at Work Cutting a Ditch for a Sewer Conduit: At the Time the Picture was Taken All of the Buildings were Nearing Completion

granted, and real building activity began on Tuesday, May 1. In this period

all orders had been placed, the necessary deliveries made at the grounds, 25 miles north of Chicago, and several hundred workmen collected.

From the instant operations started, until the final nail was driven, work was pushed at fever heat. The clatter of hammers and the hum of circular saws blended in a staccato rumble that was heard several miles on all sides. Yet, brief as was the time allotment, and great as was the work, system ruled and there was little confusion. Excitement prevailed, but it was the excitement of a hard game closely fought.

Khaki was in the foreground of the animated scene. Four officers and two "noncoms" of Company B, Ohio Engineers, played important rôles in supervising the construction race. While on their way to Camp Perry the soldiers were ordered to Fort Sheridan to lend their assistance in the work. And this, their first battle of the war, they won with honors and composure. The list embraced Captain Fred P. Troyan, First Lieutenants James H. Reding and John C. Reitz, Second Lieutenant Harry D. Churchill, and Sergeants John Vohs and Roy D. Burdick.

While the structures were springing up like pen-and-ink houses in a movie cartoon, water-supply mains, sewer conduits, telephone cables, and electric-

light feed wires were extended to the cantonment, which is situated across ravines several hundred yards from the old buildings at the post. Steam and gasoline trench diggers crept between the rows of growing shelters, cutting ditches for the drainage pipes, while others ate their way across the reservation to the site, making an underground pathway for the water line. Overhead, cables and wires were stretched as quickly as poles were tamped in place.

Thirteen days were allowed for the installation of all plumbing. Thus three days after the buildings were finished, shower baths, lavatories, and other toilet fixtures were ready for 3,500 men in 21 concrete-floored bath-houses. In addition, there was the plumbing in an equal number of kitchens. Fire hydrants, and near them coils of hose for protective purposes, were also supplied.

The work was a remarkable achievement, well done.

CA gold-palladium alloy has been put on the market as a substitute for the more expensive platinum-iridium alloy much used by chemists. Tests by the Bureau of Standards indicate that this new alloy can be used for many laboratory purposes in place of platinum.



If This Picture could Talk, It would Scream, for It Shows One of the Power-Driven Saws That Shrieked from Morning until Night for 10 Days. Standing in the Foreground near the Middle Is Lieutenant James H. Reding, One of the Ohio Engineers Who Assisted in Supervising the Work

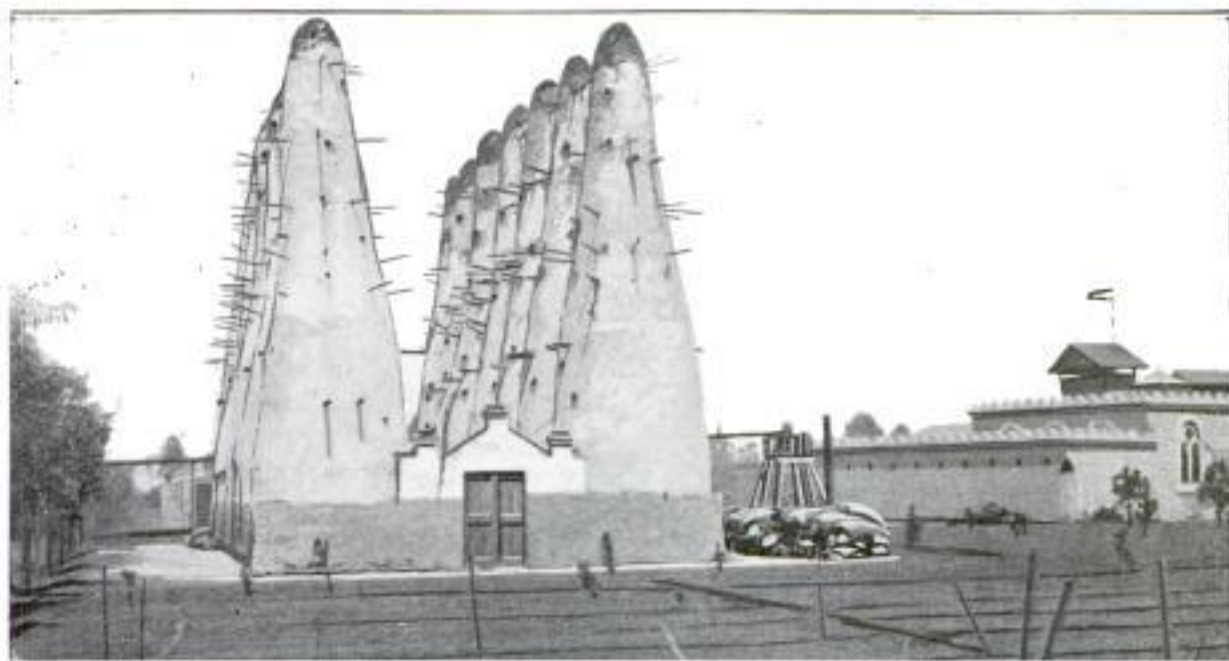

COURTESY OF THE JOURNAL OF HEREDITY
 Fourteen Towers on a Large Egyptian Estate Which House Thousands of Pairs of Pigeons: Each Tower is Made by Piling 1,200 Clay Jars Tier upon Tier with Their Openings Facing Inward

STRANGE EGYPTIAN TOWERS SERVE AS PIGEON LOFTS

Pigeon raising is carried on by the proprietors of certain large estates in Egypt on a scale that is truly astonishing to most Americans. For example, the owner of the 14 strange-looking towers in the accompanying illustration started with 250 pairs of pigeons and in a few years these had increased to 8,000 pairs. About 1,200 clay jars are utilized in building each tower. These are laid tier upon tier with their openings facing inward. In addition to the birds raised, nearly 250 bu. of guano are produced annually.

CHINESE ERECT LANTERNS FOR SPIRITS OF DROWNED

Suspended from tall poles that are to be found on the banks of rivers in China are quaint lanterns that sway back and forth in the wind, adding a picturesque touch to the landscape by day and weird illumination by night. Each of these lanterns has been placed by relatives of some person who has been drowned in the near-by stream, in the hope that the spirit of the deceased may see the light as it journeys

in search of heaven. Many are too poor to erect these supports and so, by paying a suitable sum, are permitted to utilize other people's poles. This accounts for the presence of seven lanterns on the one shown in the accompanying photograph.



Picturesque Lanterns Hung beside a River in China by Relatives of Persons Who have been Drowned in the Stream, so That the Spirit of the Deceased may See the Lamp during His Journeyings in the Other World

SKYSCRAPER TO BE CENTER FOR BUYERS AND SELLERS

When a \$2,000,000 building, now under construction in New York, is completed it will no longer be necessary for a buyer visiting that city to travel through miles of congested streets to inspect stocks of goods, for it is proposed to house in this skyscraper permanent exhibits maintained by many producers in each of numerous lines. One floor will contain artistic booths occupied by shoe manufacturers. Another will be equally representative of the toy interest, another will be devoted to groceries, and so on. Here, also, buyers will find club accommodations, a restaurant, and an information bureau that will supply credit data, shopping news, and the like. Special provision is being made for the convenience of women also.

AUTO SHOW FOR USED CARS HELD IN CHICAGO

An automobile show in which used cars formed the bulk of the exhibits was held in Chicago during a recent week, and the novelty proved a success. Directed by a committee of dealers, the show was an experiment, looking to a solution of the problem of disposing of

secondhand cars, this being a trade problem in every city. About 50 dealers engaged space in the huge Coliseum—scene of the regular annual automobile shows—and some 200 used cars of a large variety of makes were exhibited daily. Each car was tagged with a certificate of inspection and serviceability, after undergoing a strict examination by a committee of mechanical experts appointed by the dealers' association, and was also plainly marked with its selling price. Sales were made direct from the floor, the exhibitors being allowed to remove cars and refill their space twice daily. Prices ranged from less than \$200 for some of the used small cars to \$1,800 for secondhand models of expensive make. Purchasers were numerous and the used-car show will probably become an annual event in Chicago.

GIANT DREDGE IS NOW USED AS CATTLE SHIP

Of late the seagoing dredge "Caribbean," which for several years did remarkable work in certain sections of the Panama Canal, has been converted into a cattle ship. This novel change in the vessel's status comes after an interesting career. It was constructed at Sparrows Point, Md.,

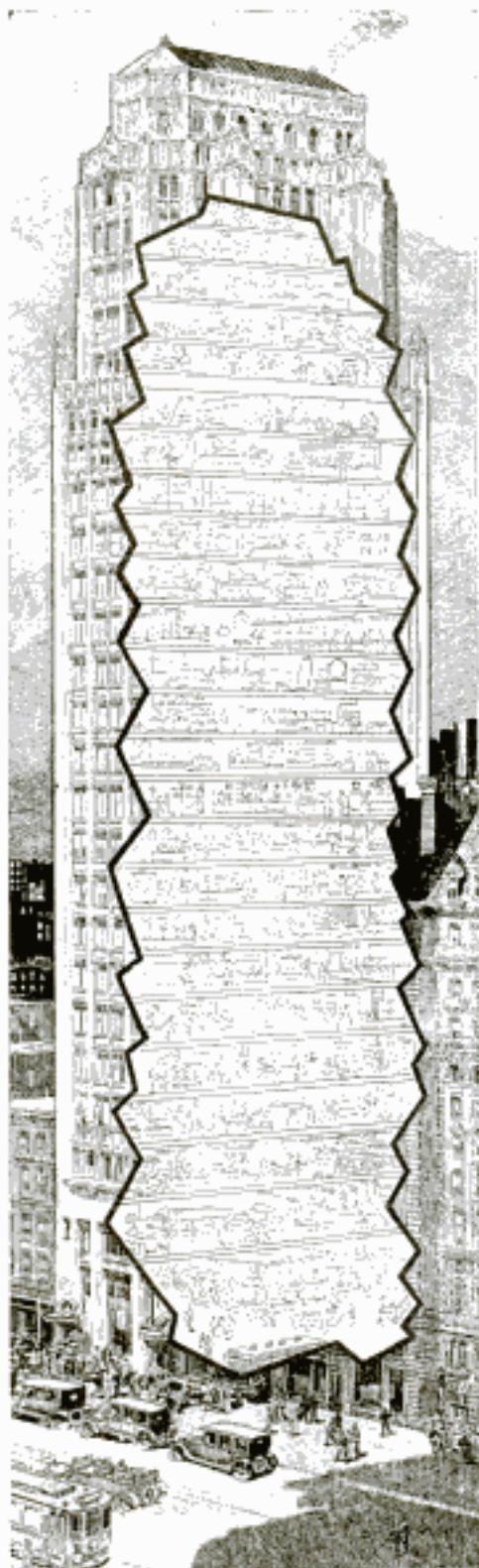

Two-Million-Dollar Building Which is Designed to House Permanent Exhibits of Hundreds of Manufacturers, so That Visiting Buyers can Place Their Orders with a Minimum of Inconvenience

in 1907, and taken to the Canal Zone, where it is estimated to have moved more than 10,000,000 cubic yards of material and dumped it at sea. When this work was finished the serious slides developed at Gaillard Cut. The purchase of an expensive plant for operating air drills used in blasting the slipping earth, was avoided by installing two high-power compressors aboard the "Caribbean." The latest alteration came when the dredge was fitted for live freight. Its suction and overflow pipes were removed, the hopper and dumping doors sealed, bulwarks erected, additional living quarters constructed, and a complete wooden deck provided. Loading apparatus, and feed and water troughs, were also installed, and the decks divided into pens. The boat now plies between Colon and Central and South American ports.

VAST LILY BEDS BEAUTIFY MISSISSIPPI RIVER

Some of the most beautiful and extensive natural water-lily beds in the world are to be found along the upper Mississippi. During the summer months persons come from miles around to look upon these vast exquisite displays. When the river is low portions of its bed, in some cases scores of acres in extent, are covered with shallow water, or wholly exposed. In such places the white and yellow lilies, sur-

rounded by their shining green leaves, are to be found, some of the beds stretching as far as the eye can see.

TAILPIECE DESIGNED TO IMPROVE VIOLIN'S TONE

Improvement in tone, it is claimed, is obtained by equipping a violin with a tailpiece so made that the four strings



The Tailpiece on the Right-Hand Violin Differs from the Ordinary One Shown at the Left so That the Strings are Separated Almost as Widely at Their Ends as at the Bridge. They Are Also Less Apt to be Cut by This Tailpiece

are tied about a rounded bar which forms the end of the piece. The bar is long enough to permit the strings to be spread as far apart at their ends as at the bridge—an arrangement which the designer believes produces better musical tones. Furthermore, strings tied in this manner press against no sharp edges and therefore are less apt to break.



COPYRIGHT, F. W. BICKEL

One of Many Large Water-Lily Beds to be Found along the Mississippi River: Some of these Fields of Natural Beauty Are More than 100 Acres in Extent

REPTILE THAT EATS OTHER SNAKES A FRIEND OF MAN

Strange as it may seem, the larger of the two reptiles pictured in the accompanying illustrations is regarded

an adept at doing the thing illustrated here so vividly, namely swallowing other snakes. This reptile is immune to the bites of venomous serpents and frequently makes its meal on them, swallowing them head first. The fact

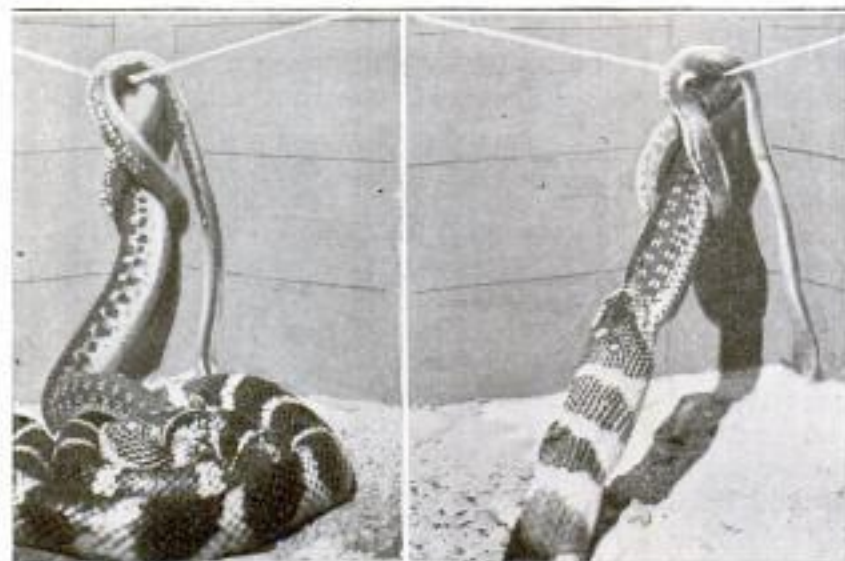

King Snake, Regarded as a Friend of the Farmer in the Southwest, Beginning to Swallow a Garter Snake Almost as Long as Itself

The Meal in Progress: The King Snake Took Three Hours to Swallow Its Adversary, Which Wound Itself about the Suspended Cord in an Effort to Escape

that it devours mice, gophers, and other field pests, adds to its popularity and its usefulness on farms, so that an effort is being made in southern California to prevent the extermination of this and other harmless snakes, as was told in Popular Mechanics Magazine for April. The creature which was devoured, as shown in the illustrations, was a garter snake nearly as long as its adversary. Though the doomed reptile fought hard and twisted itself about a

cord and nail in an effort to escape, the swallowing process continued for three hours, when the tip of the tail disappeared in the mouth of the king snake.

cord and nail in an effort to escape, the swallowing process continued for three hours, when the tip of the tail disappeared in the mouth of the king snake.

CENTER-OF-ROAD PARKING SYSTEM FOR AUTOS

In an attempt to find a satisfactory way of parking automobiles the city of Phoenix, Ariz., is now trying a system that is apparently well adapted to any street of the required width. Along the middle of a 100-ft. thoroughfare has been outlined in white paint a double row of parking spaces, each 15 ft. long and 8 ft. wide, with passageways marked at the ends of each area. All the cars in one row are required to face one way, while those in the

other row face in the opposite direction. It is planned to replace the painted lines with inlaid cement of light color so that the re-marking of the rectangles will be unnecessary.

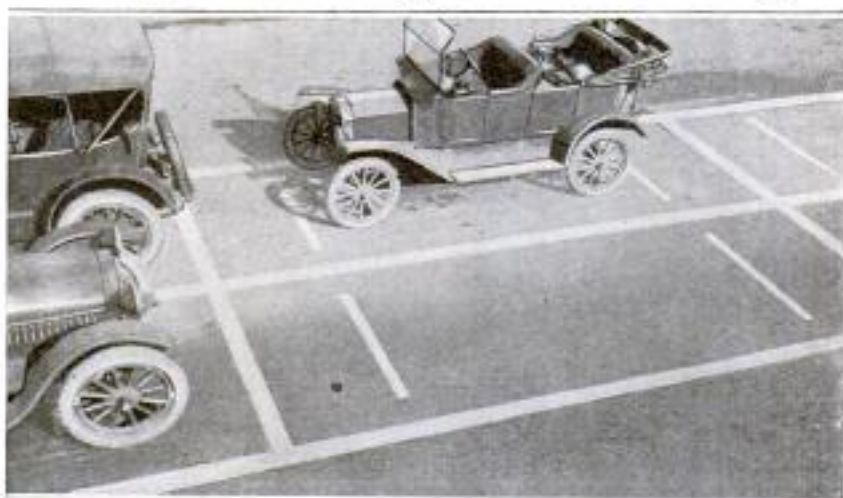

System of Parking Automobiles in the Center of a Principal Street in Phoenix, Arizona: The Two Rows of Cars Face in Opposite Directions

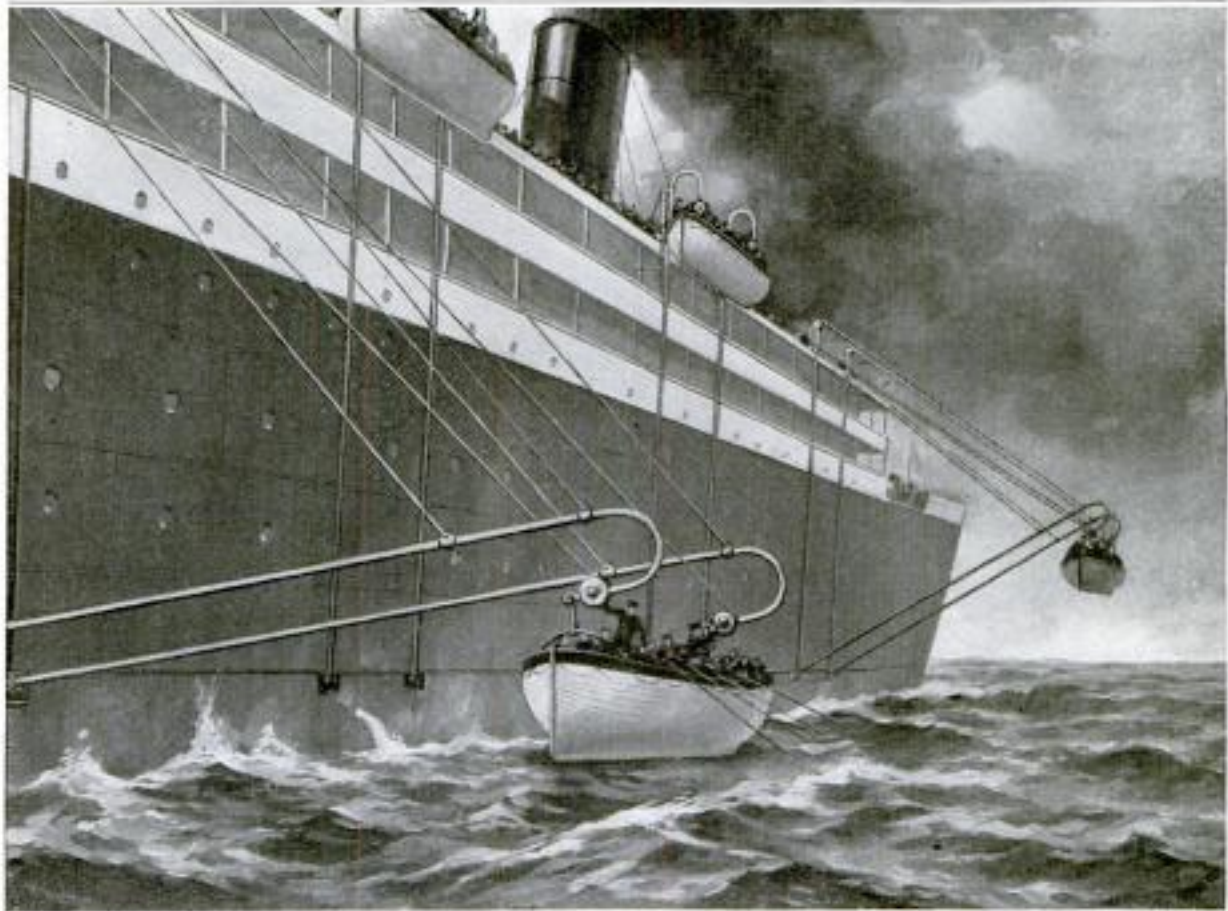

Launching a Lifeboat by Means of Patent Davits of Recent Invention: The Long Arms are Pivoted in the Side of the Ship and Hold the Boat Out from the Side, to Lessen Danger of Swamping, While It can be Lowered Either from the Deck or by the Occupants

SHIP DAVITS HOLD BOAT FAR FROM THE SIDE

One of the numerous new forms of ship davits recently patented in this country and abroad, as a result of the frightful marine casualties of late years, is the invention of a Mobile, Ala., man and embodies a novel idea. His davits in normal position rest on pivots in the side of the ship and extend vertically in channels to the top or boat deck. The arms are of such length that, when lowered on the pivots by means of gear and tackle, they carry a suspended boat out far from the side, much as the arm of a movable crane would do; thus enabling a lifeboat to be launched when the ship has a considerable list to the opposite side, and also lessening the danger of the boat being carried down by the suction of a sinking vessel. Means are provided whereby the boat can be lowered either from the deck or by the occupants themselves.

LIGHT BULBS SUPPLANT POTATOES IN ODD RACE

A contest of two or more persons, each screwing electric-light bulbs into a suitably mounted row of sockets laid on the ground, has proved a novel substitute for the old-fashioned potato race. The new game is suitable for either indoor or outdoor festivities.



Modern Substitute for Old-Fashioned Potato Race: The Man Who Inserts Six Bulbs into Their Sockets First Wins the Race

WAGONETTE LUNCH SERVICE ON SOUTHERN TRAINS

Coach passengers on a southern railway who may not desire a meal in the



Wagonette Used in a New Lunch Service for Coach Passengers on a Southern Railroad: After Loading It in the Diner, the Attendant Pushes It from Car to Car

dining car are catered to by a "wagonette service," an innovation that is being given a thorough test. A small, light, and neatly built wagonette, of the domestic tea-wagon type, with three shelves, is loaded in the dining car with simple and inexpensive lunch material, and hauled or pushed through the coaches by a white-clad attendant, who serves passengers in their seats with whatever they wish. The freight of the white-enameled wagonette is temptingly displayed and includes sandwiches, lunch boxes, cold meats, pies, fruit, milk, and hot coffee and chocolate in vacuum bottles, with the necessary crockery and silverware.

1315 SURVEY OF STATES SHOWS MANY TRACTORS IN USE

A census of the number of farm tractors, gasoline and kerosene, which are in use in the United States at the present time shows a total of more than 34,000 machines. While the figures for some of the more sparsely settled states may not be quite accurate, neverthe-

less the compilers believe the survey gives a very fair idea of the widespread use of tractors for agriculture. Illinois leads all the states with 3,202 machines, while Kansas is second on the list with 2,287. Two other states, Iowa and Texas, are listed as having just a few more than 2,200, while North Dakota has 2,137. Arizona and Nevada are credited with 23 and 19, respectively, and 1,210 is the total for New York State.

CANCELLATION STAMPS ON MAIL BOOST WAR BONDS

Terse patriotic appeals, incorporated in the stamps used to cancel postage on letters, etc., have been employed with marked success by the Canadian government in advertising its war bonds. Practically every one in the Dominion who receives mail is confronted again and again with such legends on his letters as, "Save Your Money: Lend It to Your Country," and "Help to Win the War: Buy War Savings Certificates." The United States government has seen the tremendous advertising power of such a plan, the cost of which is comparatively little, and is to popularize its "liberty loan" in a sim-



Canadian Government's Method of Obtaining Dominion-Wide Advertising of Its War Bonds, Practically without Cost: These Cancellation Stamps Are Sure to be Read by Practically Every Canadian

ilar manner, it is announced. Letter boxes and post-office walls are to be placarded for the same purpose.

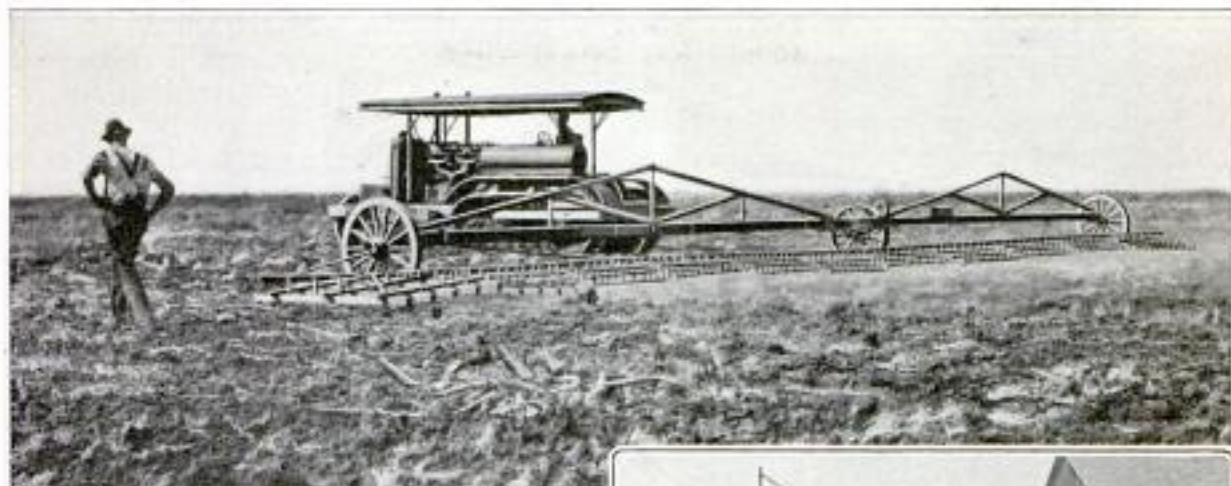

New Harrow Evener, Which Covers a Swath of 80 to 100 Feet, at Work in the Field

IMPROVED HARROW EVENER WITH A WIDE SWATH

An extra-wide swath is made, with a consequent saving of labor, by an improved harrow evener recently patented. This device provides means for holding together a large number of separate harrow sections in alinement, so that they may be drawn along the ground by a tractor. It also folds up, when the harrow sections are removed, in such a way that the whole implement can be transported like a vehicle from one point to another, as required, with the harrow sections piled upon the rear end. A total width of from 80 to 100 feet of ground sown to seed, or newly broken, can be harrowed or evened at one passage of the machine over it, when extended with the harrows assembled in place. There are three carrying wheels, the central one supporting a horizontal ring of metal on which two long trussed arms pivot, with a ground wheel at either end. The harrow sections are connected to and drawn by these long arms.

SAFETY SIGNALS NAILED TO CITY PAVEMENTS

Small metal disks nailed to the street pavement so as to form words of command and warning are used as signals to motorists in Los Angeles. The disks are about 1½ in. in diameter, of



The Harrow Folded Together at the Central Wheel for Transportation

bright metal, and the system appears to be proving more satisfactory than the painting of signals on the pavement, as paint quickly wears off where traffic is heavy. One advantage of the pavement signal, such as "Stop," is that it not only brings the motorist to a halt but shows him just where to stop his car, and pedestrians can govern themselves accordingly. By the Los Angeles system a safety zone is provided for persons crossing the street, the limits of this zone being also plainly marked in the pavement.

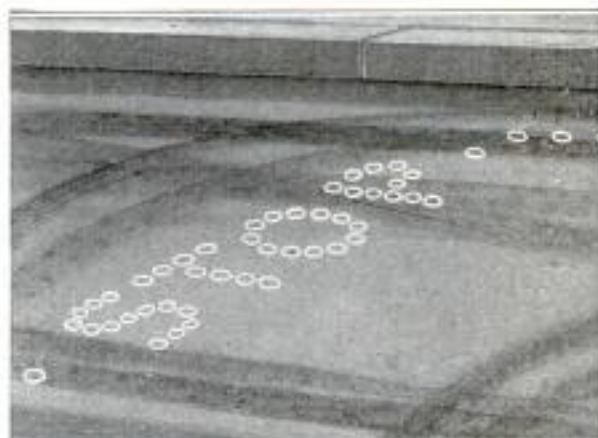

This Shows the Signal to Motorists, "Stop," Marked in the Pavement with Metal Disks Arranged so as to Spell the Word. Paint Wears Out, but the Metal Retains Its Brightness and Visibility

ELECTRIC DIRECTORY HELPS HOTEL GUESTS

Several hotels in New York have installed in their lobbies an electric directory for the guidance of their



COPYRIGHT, THE ELECTRIC DIRECTORY CO.

Using an Electric Directory in the Lobby of a New York Hotel: Pushing a Numbered Button Lights Up the Section One Wishes to Visit and Shows How to Get There

guests to points they wish to visit in the city. A metal directory board exhibits a city map, divided into 56 numbered sections, each lighted by a six-volt lamp controlled by a push button with a corresponding number. An index book gives the visitor the number of the section in which any street, building, or point of interest is located, as well as the name of the proper transportation line; and pushing the button of that number lights up the section on the board and shows its relative position and distance from the hotel.

ONE-ARMED SOLDIERS SHOW ABILITY TO DO FARM WORK

As a result of a scientific study of the effectiveness of artificial limbs made by certain European investigators it appears that men with crippled arms are becoming so proficient that they can do almost a normal amount of certain kinds of labor. According to

recent statistics agricultural laborers make up a large percentage of the war cripples. It is asserted that all those who have been farm laborers and have retained as much as one-third of an injured arm can, and should, resume agricultural pursuits, after suitable reeducation with artificial attachments. In a competition in digging, several men, each of whom had lost an arm, actually got through quicker than those who had lost a forearm and even quicker than two-armed men. The zest of the contest, which was not of long duration, is considered in part responsible for the gratifying showing. In harvesting, those who had lost an arm or a forearm each, reaped slightly more than what would be considered a normal man's work for the same short period of time. In reaping, which continued for three days, four one-armed patients accomplished very nearly as much as regular laborers would accomplish.

Arthur Allen

CARBON DEPOSIT REMOVED BY COLD-WATER DEVICE

Automobile troubles arising from deposits of carbon in the motor may be cured by a small cylindrical brass device recently



placed on the market, which is claimed to perform the fourfold function of a decarbonizer, a primer, a preventive of backfire, and an automatic "breather," or auxiliary air intake. The device is inserted between the carburetor and the intake manifold, and in operation is connected by a rubber hose to a supply of cold water. The motor being started, its suction draws water through the decarbonizer into the combustion chambers, where it is turned into vapor and breaks up the carbon to be carried out by the exhaust.

to be carried out by the exhaust.

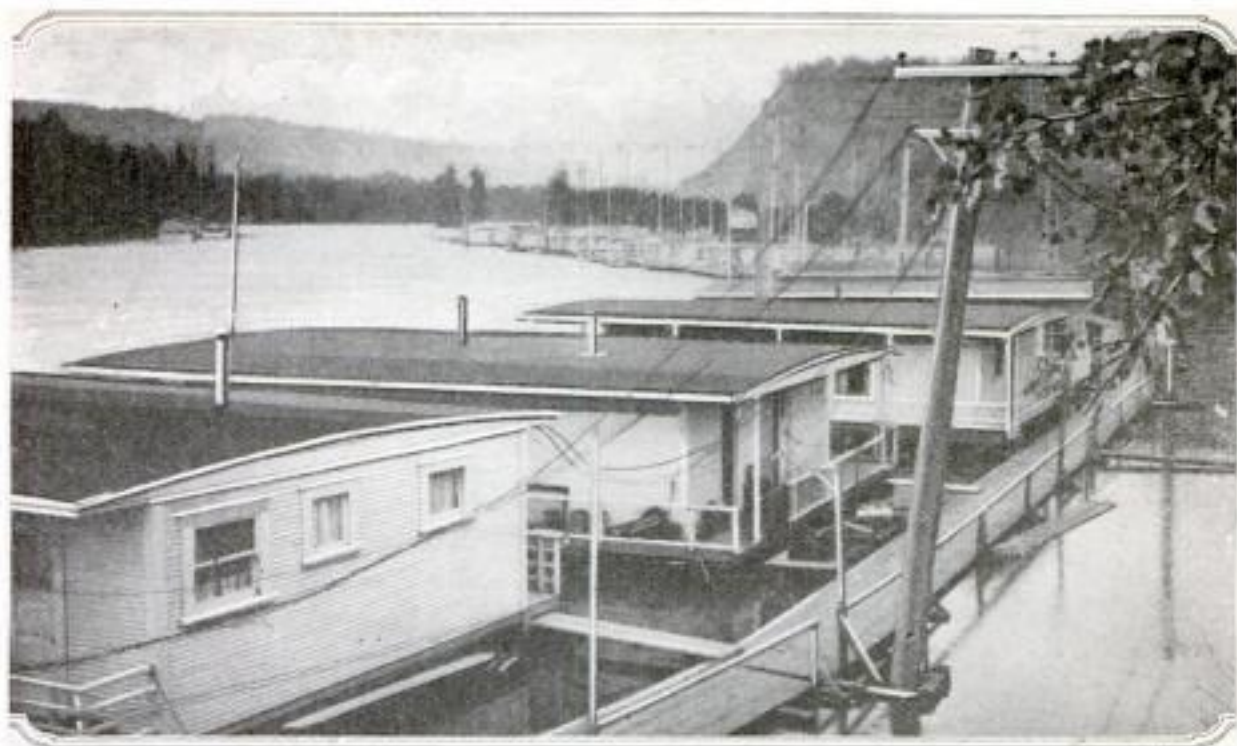

General View of a House-Boat Colony on the Willamette River at Portland, Oregon, Where Many City Folk Make Their Homes during the Summer in Floating Abodes Like These

HOUSE-BOAT LIFE ENJOYED IN RIVER COLONIES

SEVERAL colonies of house boats along the Willamette River at Portland, Ore., afford the occupants an enjoyable mode of life during the summer season and some of the boats are used as dwellings all the year round. They are moored side by side along the river bank, sometimes connected by board walks, and are within easy reach of the business center by car lines. Young women engaged in business offices and



Fishing for Breakfast from the Rear Porch of a Willamette House Boat: Before Going into the City for the Day's Work in an Office, the Young Woman in the Photo is Trying Her Luck in Momentary Expectation of a Good Catch



After the Daily Business Grind in Portland, the Fair House-Boat Resident Enjoys the Evening Swim

stores, as well as young men, find the house-boat life most attractive, healthful, and economical, and club together to meet the expense of purchasing a boat and keeping house. A simply furnished house boat in an inexpensive colony may cost anywhere from \$100 to \$500, while in the more pretentious river colonies there are two-storied boats costing \$1,500 and



Typical House Boat of the Willamette River Colonies: This One Has Four Rooms and Bathroom. Entrance from the Board Walk Is at the Rear. Note the Ideal Diving Platform, the Flower-Bedecked Porch, and the Big Logs on Which the House Floats

upward. Furnishings have a similar range of adaptability to the owner's pocketbook, but the clear waters of the Willamette are free to all, the driftwood of the river furnishes fuel, electric light is obtained from the city system, and the usual moorage charge is \$3 or

\$3.50 a month. The harbor patrol keeps a keen lookout for fires among the house boats. Most of the boats are built on a platform of logs, and nearly all have screened front porches that are used as living rooms during the hot weather. The early morning or evening swim can



At the Left Is a Screened-Porch Living Room; at the Right the Kitchen and Pantry of a House Boat, All Displaying the Comforts of a Real Home

be enjoyed by simply diving off one's porch. Sometimes, when the fish are biting, breakfast or dinner can be taken from the river, and many of the house-boat folk find that while enjoying all the comforts of home and city life in their floating abodes, they

can at the same time cut the high cost of living very materially. In the summer many of the boats are floral bowers, being almost covered with flower boxes and hanging baskets.

COMBINED MOVIE CAMERA AND PROJECTOR

Motion pictures can be both taken and projected by anyone without previous experience, according to the claims made for a new machine that is a combined camera and projector. The construction is almost as simple as the operation and the invention is especially intended for home and business uses, such as filming the baby or one's friends in social activities, or demonstrating the operation of machinery to prospective customers. The cost of the combined machine brings it within general reach. Completely equipped, the camera weighs about five pounds and has a magazine capacity of 200 ft. of film. Standard film is used, also the usual finder, side focusing device, automatic footage register, and speed regulation. The change to a projecting device is made in about two minutes, including the substitution of lenses, adjustment of film reels, and attachment of a lamp house with a 400-watt electric lamp, supplied with current from any lighting circuit. The same crank is used in taking and projecting pictures.

"SUITCASE" LABORATORY FOR LAUNDRYMEN

A chemical testing outfit that can be carried in a container no larger than a suitcase has been designed especially for laundrymen, so that



Compact Chemical Testing Outfit Designed Especially for Laundrymen, with Which They can Make Tests of Their Cleaning Materials, Thus Avoiding the Cost of Analyses by Chemists

they themselves can test the cleaning materials they use and thus avoid the cost of analyses by chemists. Holders are provided in the case for each bottle, tube, etc. One side of the portable

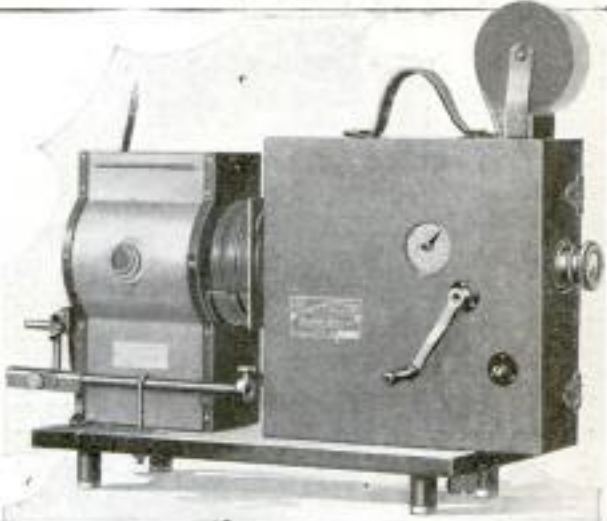

Taking a Motion Picture with a New Combined Camera and Projector: At the Right Is a View of the Camera with the Lamp House Added for Projecting a Picture

4430 Helen St
Pittsburg

of Industrial
Copyrighted material

cabinet can be folded down into a horizontal position to serve as a shelf. The top of this shelf is hard and white and attached to its center is a metal base in which an upright, provided with adjustable clamps, can be inserted. This standard is used to hold tubes while tests are being made. The outfit includes bottles of standard solutions for testing the hardness of water, the presence of chlorine, of alkali, and of acid.

VACUUM MASSAGE MACHINE OPERATED BY ANY FAUCET

Water flowing from a faucet supplies the power for a new massage machine now on the market, which stimulates



A Massage Device Which Stimulates Circulation of the Blood by Creating a Vacuum in the Rubber Cup Held against the Skin

the skin by creating a vacuum in a cup held against the flesh. It is claimed that it does not pound and jar as an electric vibrator does and that in many instances the cost of operating it is considerably less than that of the electric machines. This apparatus consists of a cylinder, 6 or 7 in. long, open at one end, and having at the other a rubber cap which fits over a faucet. Projecting from the side of the cylinder is a rubber tube, to the end of which a rubber cup, or cone, of any desired size, is attached. As the water flows through the cylinder the air is drawn in through the cup and tube, and when the former

is held against the face the resulting suction brings the blood to the surface, stimulating the skin.

SELENIUM PROVES VALUABLE IN CABLE TELEGRAPHY

Of late years many important uses have been found for metallic selenium, and the true value of its properties are daily becoming more apparent. The element is a vital part of a recently announced invention that is reported to more than double the capacity of submarine cables. According to trustworthy information, the apparatus in use on some of the Atlantic cables has increased by about 125 per cent the speed of handling commercial messages. Selenium cells operate a siphon recorder and amplify the signals to such an extent that more than twice the usual transmission speed is obtained without lessening the legibility of the graphic records. Intense illumination of the cells is provided by a special arrangement which enables the concentration of 45 separate light beams upon a galvanometer mirror. The apparatus has increased the transmission speed in one Atlantic cable from 200 to 450 letters a minute, it is reported. Even better showings have been made in special tests.

CUBAN BASEBALL PLAYER "BONES" HIS BAT

A Cincinnati baseball player, a Cuban by birth, has been the subject of not a little good-natured banter because he "bones" his bat, that is, he rubs it with a calf's bone to fill up the crevices. This, he claims, is much to be preferred to scraping a bat with a piece of glass, as many players are in the habit of doing.



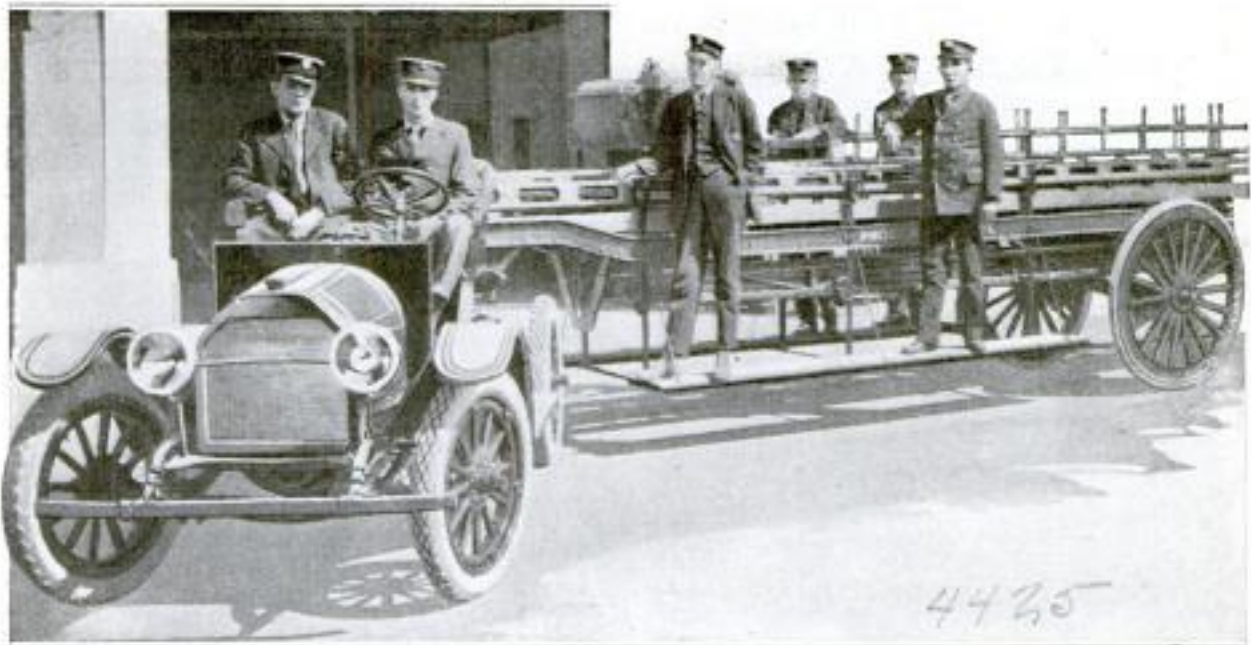

Auto Ladder Truck Built by Firemen from a Discarded Patrol Wagon and an Old Horse Truck

AUTO LADDER TRUCK MADE BY CITY FIREMEN

When the fire chief of a western city found that he needed an \$8,000 auto ladder truck, while his appropriation was exhausted, the loyal firemen at one of his stations came to the rescue by making a very creditable piece of apparatus of the kind desired, mostly of material that had been junked by the city. The motive power and forebody were furnished by an old four-cylinder patrol wagon, discarded by the police. This was dissected and rebuilt as good as new, with the addition of an electric starter and extra-large gas tank. An old horse-drawn ladder truck was hauled out of the city's scrap heap, lengthened and strengthened, furnished with rubber-tired wheels and a swivel connection to the auto forepart, and the final result was a well-equipped and efficient ladder truck costing \$675 instead of \$8,000.

STEAM-HEATED KETTLES IN HOSPITAL KITCHEN

An example of up-to-date equipment for a hospital kitchen is to be found in the accompanying photograph which shows a battery of steam-heated aluminum kettles in the Cook County Hos-

pital at Chicago. Each kettle is covered and is partly inclosed by a jacket into which steam is injected. By this means the food in each vessel can be brought to any temperature desired. Odors from the cooking are carried out of the room by pipes.



Battery of Aluminum Kettles in Kitchen of a Chicago Hospital; These Vessels are Partly Inclosed in Jackets into Which Steam is Injected to Heat the Contents of the Kettles

4357

greatest

Access

"STAIRWAY" BUILT FOR WEAK FISH TO AID SPAWNING

What might be designated as a stairway for weak and small fish of those families which go upstream to spawn



Runway in a Nevada Stream, Comprising a Series of Low Artificial Falls Constructed so That Small or Weak Fish can More Easily Make Their Way Upstream to Spawn

has been constructed in connection with a diversion dam on the Truckee River, Nev., the object being to provide waterfalls or rapids which are not so steep or high that they will prevent the smaller and weaker fish from ascending. This run consists of several steps formed by concrete gates built one above the other and about three feet apart. The concrete walls either side of the gaps through which the water rushes when the headgate is open, help to form comparatively quiet eddies in which the fish can rest before making the next leap to a higher level. Owing to the character of the ground the run was constructed at comparatively low cost.

ABILITY OF AUTO-TRUCK BRAKES SHOWN BY TESTS

The large number of accidents in New York City which have been caused by motor trucks recently led to an interesting test of motor-truck brakes, which was participated in by the police, the object being to ascertain in how short a space one of these heavy vehicles could be brought to a stop. Seven trucks, ranging in capacity from one to six and one-half tons, were tested both empty and full on a dry asphalt pavement. The heaviest machine, loaded, when running five miles an hour, was brought to a stop in 1 1/2 seconds and traveled 8 ft. after the brakes were set. When running 14 1/2 miles per hour it traveled 20 ft.; the one-ton machine when going five miles an hour with a full load, went 5 ft. 4 in., and when its speed was 20 miles per hour it traveled 44 ft. 11 in., all after the brakes had been set. Tests were also made at 10 miles per hour. The records of the other machines, generally speaking, corresponded with those given.

Auto Access

TIRE COVER SAFEGUARDS AGAINST COLLISIONS

A motorist has painted the spare-tire cover, attached to the back of his car, with black and white stripes. This makes the case very conspicuous even at night and so serves as an extra safeguard against rear-end collisions, which are now so frequent.



CA Japanese scientist is reported to have invented a submarine magnet with the aid of which thousands of projectiles have been recovered from the comparatively shallow water into which they have been fired during target practice.



Above is Shown a Coal Hod Shattered by a Bomb Explosion Which Occurred in Boston Courthouse, Killing Two Men. The Other Fragments were Collected in an Effort to Learn the Identity of the Bomb Maker. At the Right is a View of the Wash Room After the Explosion Occurred. The Bronze Door Knob Shown at the Left was Pierced by a Flying Piece of Metal

IMPERILED BOSTON PUBLIC STUDIES BOMBS

Because of a recent fatal explosion in the Boston courthouse and the discovery of infernal machines in other Massachusetts cities, effort is being made, in Boston particularly, to familiarize the public with the appearance of bombs of various sorts. The state chemist has prepared an exhibit consisting of a suitcase containing imitation bombs, to show what bombs look like and how they are carried, so that people generally will be cautious about handling strange packages. Two men were killed in the blast referred to, which took place in a lavatory near the room in which the supreme court was sitting. One theory is that some vengeful person left a suitcase containing a bomb in the lavatory and that a

janitor, who was one of the two killed, found it and, ignorant of its contents, was carrying it away when the charge went off. The bodies of the two men killed were blown to pieces and the near-by rooms wrecked. Soon after this an unexploded bomb was found near a Plymouth, Mass., factory, and some time since one was found near the statehouse. Some of the bombs seemed to have had a common source.



Exhibit Consisting of Suitcase, Containing Imitation Bombs Prepared by the Massachusetts State Chemist so That the Public could Familiarize Itself with the Appearance of a Common Type of Infernal Outfit

RAILWAY PLANS TO EMPLOY MANY WOMEN

Many of the great industries of the country have already begun to lay plans for the employment of an increased number of women to meet the scarcity of male employes which the war is creating. The Pennsylvania Railroad, for example, has notified the general superintendents on its lines east of Pittsburgh, to

ascertain the occupations in which women and girls can be employed and the probable number of places they could fill. No men will be dropped from the pay roll, the railroad has announced, but some may be called on to change their occupations. The proposed changes will not affect clerical work merely, but very probably will include some of those engaged in telegraphy, telephony, signaling, train dispatching, ticket selling, light machine-shop work, and car cleaning.

4400 DONKEY ENGINE STEAMS —ACROSS A SLOUGH

A donkey engine employed in clearing land on the lower Columbia River, Ore., made a record for itself by crossing a deep slough under its own steam not long ago, when no scow was available for its transportation to a new setting. The slough was 160 ft. across, several feet deep, and had rather steep banks and a soft bottom, but the engine forded it safely, although the water at one point reached the crown sheet of the fire box. The steam gauge showed 150-lb. pressure when the engine was fired up for the trip, and 15 lb. of steam was left when it landed on the opposite bank.

ORGANIZE "PIG CLUBS" TO INCREASE MEAT SUPPLY

As a means of increasing our meat supply the Department of Agriculture is urging bankers to aid boys and girls in the forming of "pig clubs." These groups, which already have a membership of over 30,000, are engaged in raising pigs. The assistance provided by banks is in the form of money loaned to the boys and girls for the express purpose of enabling them to buy pigs. The regulations of these groups vary, but all include an agreement on the part of the children to exercise proper care in the raising of the animals. The written consent of the parents is secured when a child obtains money from the bank, and the parents agree not to claim any right in the pig purchased. In some cases the club member gives a promissory note, payable when the pig is sold. Another method, called the "endless-chain plan," is for the child to cancel its debt in part by giving the banker two gilts from the first litter, to be put out to other boys and girls.

☐ Bicycle riding is very popular in Palm Beach, Fla., the hotels there having some 2,000 bicycles which they rent to guests.

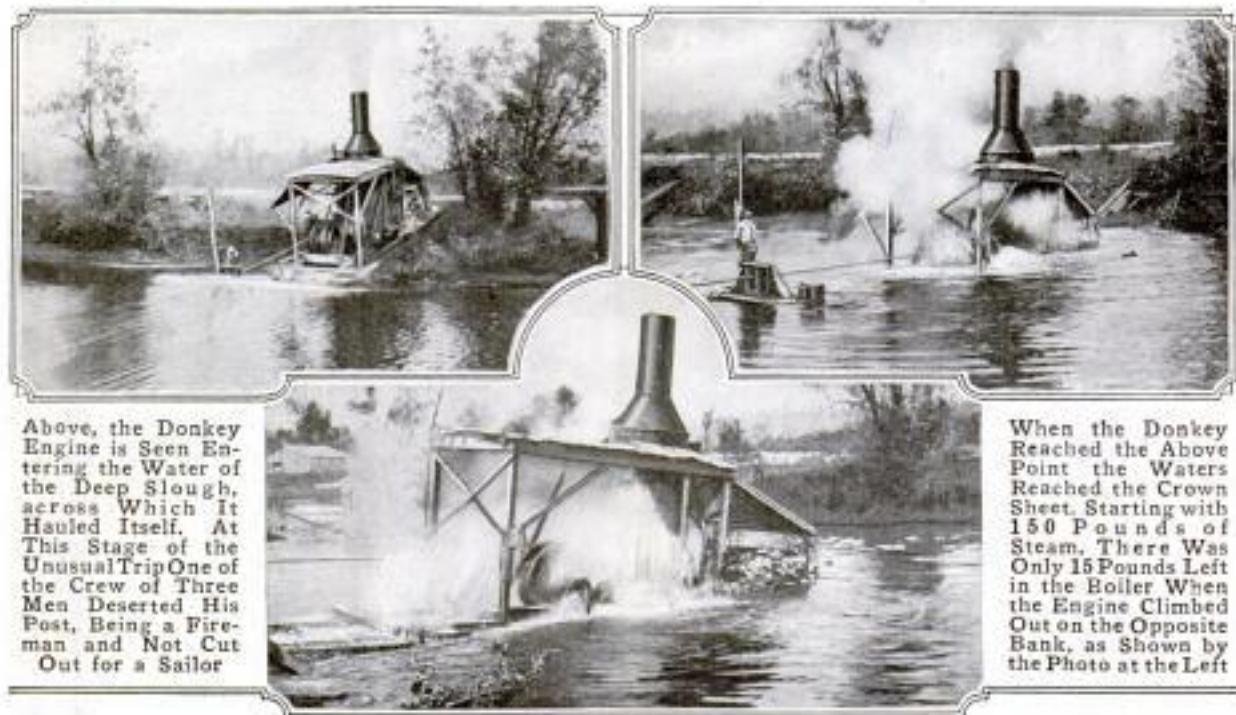

Above, the Donkey Engine is Seen Entering the Water of the Deep Slough, across Which It Hauled Itself. At This Stage of the Unusual Trip One of the Crew of Three Men Deserted His Post, Being a Fireman and Not Cut Out for a Sailor

When the Donkey Reached the Above Point the Waters Reached the Crown Sheet. Starting with 150 Pounds of Steam, There Was Only 15 Pounds Left in the Boiler When the Engine Climbed Out on the Opposite Bank, as Shown by the Photo at the Left

COURTESY OF THE TIMBERMAN

COMMENT AND REVIEW

WHEN the word first went out to our people to stop wasting, it was repeated so rapidly and so often that in a few hours the message had lost its original meaning. The necessity to husband our food supplies and exercise every caution against needless waste still confronts us, and will until one year after the war ends. But automatically to stop the usual, normal expenditures for other ordinary necessities and requirements is quite another matter.

*Save, but
do Not
Hoard*

Will anything short of actual food restriction bring our people to realize the tremendous, wicked waste of food? It would be a sad comment on our intelligence if so. The food waste, to which every one of us must plead guilty, is so great that every day in the city of Chicago alone 1,250,000 lb. of food-stuffs are dumped into the city's garbage cans, while the waste in the entire United States would sustain life for every man, woman and child in our thirteen largest cities. Here is where we can all help, even the children.

In the city of Philadelphia is a very wealthy man, now retired, who started life as a poor boy. His father had died, leaving the mother and several children. These children were allowed to have sufficient food, but her constant admonition was, "Never take onto your plate more food than you intend to eat." So thorough was this training that all through life he has observed it, and with all that money can buy at his command, he today never takes upon his plate more than he is certain he will eat. Every boy and girl can help in this, and at the same time enlist their parents in a reform which does not restrict the quantity of food, but does stop a wicked waste.

We should cultivate the spirit of saving, but not carry it to the extreme of hoarding which, when general, upsets all the machinery of business life. Nor is there need of it, for never in the history of this country has so much money been spent in the same length of time as will go into circulation by reason of war preparation. Every farm, factory, industry, mill, shop and railroad will be called on to exert its utmost efforts. Many establishments will run night and day and then be unable to keep pace with the demand. Everyone, man and woman, who is willing to work will be employed at good wages.

Just now we are in the position of the swimmer who has plunged into very cold water: It takes his breath away, and for a moment he hesitates. Then comes the exhilaration, and with conscious strength he strikes out boldly in full confidence of what he is doing.

The billions which the Government is already spending and will expend practically all go immediately into circulation here in payment for services and material, and extend to the most remote points. Markets for every sort of produce and goods, the yield of mine and forest, the output of every kind of manufactured thing, will be alive with activity; and while no thought of stimulated industry entered into our decision to fight for universal freedom, the result will be a period of unusual material prosperity. As the President aptly says: "It is evident to every thinking man that our industries, on the farms, in the

shipyards, in the mines, in the factories, must be made more prolific and more efficient." We need more business, not less. Now is the time to open the throttle.

Don't waste; don't hoard; be normal; get busy.



EVERYONE who can possibly do so should buy one or more of the war bonds known as the Liberty Loan. Banks, capitalists and other investors are already doing so with liberal subscriptions, but the loan should be as widespread as possible. In England, as soon as the war bonds were issued in small denominations, the general public took bonds amounting to millions of dollars. Certainly our citizens will be no less patriotic. These bonds are issued in units as small as \$50 each, and throughout the country banks and trust companies are arranging to furnish these bonds on the partial-payment plan. Let everyone who can save and is willing to help, do his bit by taking his part of the Liberty Loan.

*Buy
a
War Bond*



HUNDREDS of thousands of city workers who are allowed a vacation this summer should plan to spend it on a farm. The shortage of help on our farms is greater this year than ever before, due partly to the patriotic effort of our farmers to plant every available acre. Two weeks of outdoor life on a farm will be not only a new and pleasant experience to those who have never tried it, but will do wonders in building up physically for the entire year. It is not so much the time spent in idleness which constitutes a real vacation as a complete change in one's everyday work. Farm work is much lighter than formerly, owing to the general adoption of labor-saving machinery, and a large part consists in riding where a few years ago the operator walked. While the city man may not be qualified to perform properly all kinds of farm work, there is plenty he can do, and when given the chance is likely to surprise his farmer employer by his readiness to learn and efficiency shown. Aside from the satisfaction of doing something worth while for our country, the return in health and strength which outdoor exercise affords, and the money earned instead of spent at a resort, there is a positive asset in this getting together of the city and the country man. Each will be surprised to discover what a lot of valuable experience the other fellow has, and how much each can learn from the other to mutual advantage. The farmer will find out the city boys are not all "dudes," and the city lad will realize the modern farmer is anything but a "rube." There will be some disappointment, of course, but the majority on both sides will make good. Don't wait until the last minute, but get in touch with some farmer at once. This can easily be done through the bureaus conducted by daily papers in all cities. You may raise a few blisters on your hands, but you will raise a tremendous appetite at the same time, and the rich

*Vacation
on
Farms*

tan and fresh blood will more than compensate for a few lame joints the first day or so. Many will know for the first time the joy contained in an old oaken bucket, and that new-mown hay has a fragrance which no amount of money can purchase at the perfumer's.



NOW is the time for work; work for men and women, boys and girls; for earnest, energetic, useful work. Leisure has its attractions, and easily becomes enervating; luxury is alluring to the onlooker, and trails a host of ills and pains; but work, real work, is the key to a happy mind and a sound body. With unprecedented prosperity and fortunes made as by magic, it is high time as a nation we restore good, old-fashioned manual labor to the dignity and respect it deserves and formerly had. He or she,

*Work,
Everybody
Work*

young or old, who speaks sneeringly of honest work with their own hands, or anybody else's hands, should themselves be sneered at and snubbed as snobs. It is by no means those of largest wealth who deserve rebuke in this respect — Marshall Field III, the richest boy in the United States and barely old enough to vote, enlisted a few days ago as private in the United States Cavalry.



APPARENTLY few people in this country have begun to estimate the war at anything like its full significance. When the war opened it was generally believed, even in parts of England, that six months would see its end. The late Lord Kitchener was roundly criticised when his first public comment was uttered that the war would last fully three years. Were he alive today he would doubtless feel justified in extending his prediction two or three years longer.

*The War
No Passing
Effort*

On this side the public, with only their hopes as a basis of judgment, declared it would not only be soon over, but could never involve the United States. Time has now prolonged the struggle into nearly three years, and the United States is itself in the war. We must not allow our own sanguine hopes, which are steadily fed with suitable propaganda from Germany, to longer deceive ourselves. Germany has today 9,000,000 soldiers. Our own Ambassador Gerard tells us that while Germans do not have as many foods as in peace times, nor as much, a condition of starvation there is a very remote possibility. And he declares the world will look in vain for a revolution similar to that in Russia, at least during the period of the war.

On the other hand, German intriguers in every country, large and small, are working at supreme effort in sowing seeds of discord. Those who know the South are well aware of the effort put forth the past few months in all the southern states to incite the colored people to an uprising against the whites, one of the many rewards promised being that laws would be passed authorizing marriage between black and

white, in that near future when Germany should be in control here. That the colored people of the South refused to be disloyal to their country is creditable to their good sense and patriotism, but the attempt did not fail for want of earnest efforts on the part of our enemies.

While the clash of arms is yet beyond a wide ocean, the sun does not set on an idle enemy, whose long-cherished plans of two generations for world domination are daily being unfolded.

A large number of our easy going, who assume to be informed but are far from it, still refuse to consider these plans seriously. They are the same careless thinkers who in August, 1914, confidently declared the war would not last six months.



GERMANS in Germany do not understand us. They think they do, but they don't. At this writing war with Germany has been declared some six weeks. Although practically in a state of war with this country for months, Germany has not considered the incident as worth acknowledging by a similar official declaration on her part. The German administration smiles indulgently and says we are only bluffers — there is no backbone or substance to us.

*Germany
does Not
Understand
Us*

At the head of a great daily in Berlin was a man named Doctor Dernburg. From this position he was called by the kaiser for special service, part of which was a visit to this country two years ago. He came on an errand of propaganda, but so clumsily did he work that he was soon requested to depart. While here, during a private conference, he spoke at considerable length on the instability of our national life, and based it on the "fact" (!) that we were only a nation of monumental bluffers. "Why," said he in proof of this, "your national game is poker, which is essentially a game of bluff." Parenthetically it might be proper to remark that if some of the poker-playing boys in the neighborhood of the Rocky Mountains ever happen to stray over toward the front their arrival will not have to be announced.

We are not deceived about ourselves, however. We are intensely unprepared. Because our people repudiated even the thought of conquest, we entertained a lovely but mistaken theory that all other nations felt the same. Now we know better. In characteristic American fashion we bend all our energies to getting ready, even at a late day. Germany had one million fully equipped soldiers actually on the march within three hours after war was declared. Our inability to put half that number under arms in three months is creditable to our heart, but not our head. Only the other day 1,500 college men from Harvard, Yale and Princeton assembled at Marblehead, without any preparation whatever having been made to receive them, and they had to go back where they came from. We have only begun to organize. Such mistakes as Marblehead will be ironed out. Every day will bring order out of confusion, and we soon will be in shape. So far as we are prepared we are well prepared, as, for instance, the United States destroyer squadron which crossed the Atlantic and

before anchors had scarcely touched bottom replied to the British admiral: "We are ready now."

The American young man can learn fast, think quickly, and act instantly; he can be depended on to do all these now his country needs him. Events will surely give the Prussian occasion to revise his opinion of us as a nation of arrogant bluffers and mere dollar makers.



SIX weeks ago Congress declared war. What it has done since, or rather failed to do, is anything but creditable to itself or the country. Many members have impeded the passage of bills with artificial

*A
Slacker
Congress*

debate; they have resorted to all manner of technicalities; they have burdened good bills with bad riders and jokers, and, in short, have blocked the wheels of legislation at every opportunity. Their excuse for their unpatriotic action is this or that personal hobby: It is to be hoped they are at least sincere in this, and that their action comes from lack of judgment and not from lack of loyalty. The fact remains, however, that some in support of their personal views have consistently rendered service to the enemy to a degree which strains the patience of patriotic Americans. The conviction is certainly taking root that the 88-per-cent professional (more accurately, politician) contingent in the two branches of Congress will eventually have to be replaced with 88-per-cent sound and successful business men. The latter may not count for much on the stump, but when it comes to sawing wood are the real thing. A good business man, for instance, would hesitate in these times of excessive taxes to vote a pork bill of \$27,000,000 for rivers and harbors, when on March 1, 1917, there was \$32,000,000 still unspent from the previous year for the same purpose. Yet this is precisely what Congress is trying to do, and then justifying the startling precedent of a retroactive tax because, as one of them writes me, "Uncle Sam needs the money." As the Chicago Post says: "Why not repeal the appropriation for rivers and harbors, flood control and public buildings, all largely pork bills, and without which the country can easily get along a few years more?" This country has admittedly been long-suffering and kind with its politicians, but even a politician may easily go too far.

H. H. WINDSOR

May 19.



BLIND SOLDIERS "SEE" PLAY GIVEN ON BARE STAGE

A curious, not to say pathetic, spectacle was presented in London recently when a well-known play was enacted

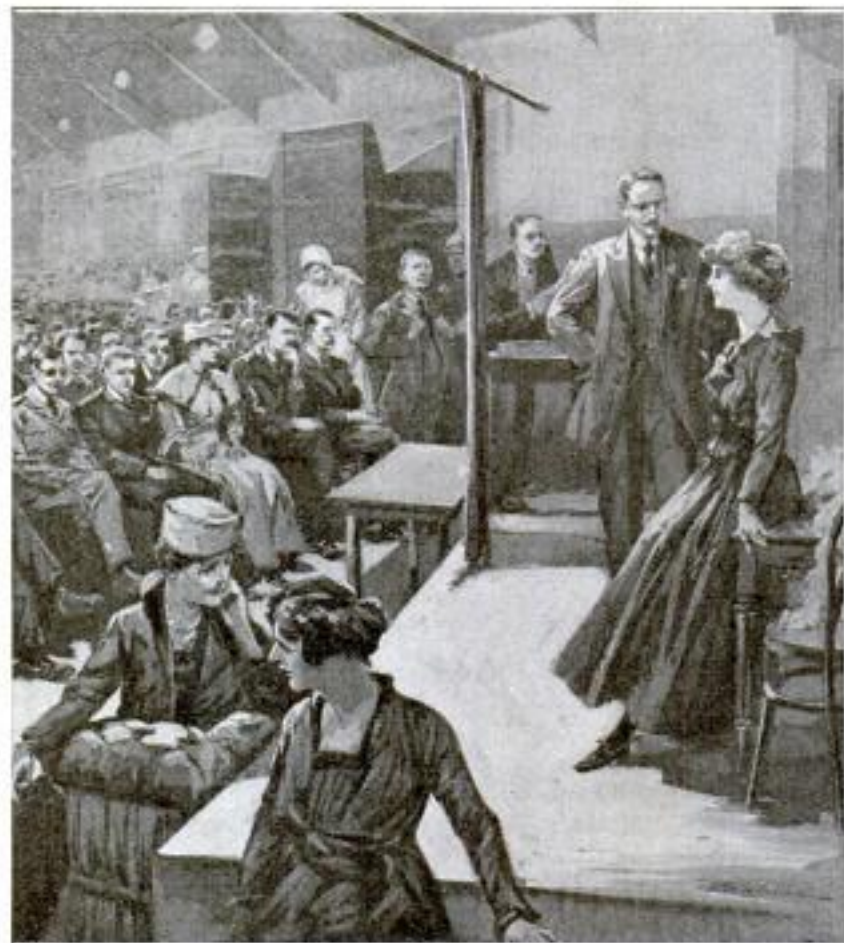

COPYRIGHT, ILLUSTRATED LONDON NEWS
Strange Theatrical Performance Given in London for the Entertainment of Blind British Soldiers: The Players Wore Their Street Clothes Instead of Costumes, the Stage Was without Scenery, and a Teacup and a Telephone Bell Served as the Properties

before a large audience by actors who wore their street clothes instead of costumes and played on a stage utterly bare of scenery. The only properties used, aside from one or two pieces of furniture, were a teacup and a telephone bell. The explanation of this strange performance lies in the fact that the audience, with a few exceptions, was composed of soldiers who had lost their sight. To them stage settings, costumes, and lighting effects meant nothing, but every sound and the most subtle inflections of the players' voices were detected by the hearers with extraordinary readiness. That the

afflicted men were able to follow the action closely was indicated by their quick response to tragic and humorous lines. The action in one scene called for the breaking of a teacup, and in another the ringing of a telephone bell, hence the presence of these articles on the stage.

EXPERTS CONDEMN TALL SAPPY CORN

The growing of very tall corn—once a feat in which the farmer took special pride—is no longer looked on as desirable, according to the Department of Agriculture, for the producer is discovering that tall, coarse stalks add much weight to the load of fodder that he hauls to the feed lot, and that a large part of this excess is water. Additional unprofitable labor is necessary in hauling back to the field the uneaten stalks, along with the manure. Large, sappy stalks are not as profitable even for silage, experts say, as corn that has been planted early and is al-

most mature. As to the variety that is best to plant, it is pointed out that there is very little in a name because different lots of the same variety may produce quite different results. It is recommended that one use seed grown in one's own section, which has been properly selected and cared for.

☞ One person in every 25 in this country owns an automobile, making a total of 4,000,000 automobiles in the United States, according to statisticians. In their opinion these figures indicate that nearly every person who can afford a car now possesses one.

WAR SPIRIT REFLECTED IN LATEST STYLES

Clathery Women

Pringle's Co. N.Y.C.

Lord & Taylor N.Y.C.



A Brilliant Costume of Military Cut, Showing How Fashion is Reflecting the War Spirit: The Long Cape Is of Blue Serge and the Smart Shoulder Cape is Lined with Turkey Red. With This Garment the Military Sombrero Is Altogether Appropriate



More Distinctly Military and Plainer Than the Hat in the Central Picture Is This One of Pearl-Gray Felt, with the Brim Tilted Up in Rough-Rider Fashion and Held in Place by an Artillery Insigne and a Chin Strap of Black Patent Leather



Quite in Keeping with Military Clothes for Women Is This Cowboy Hat of Rich Golden-Brown Felt. The Broad Brim and Soft Crown are Adorned with Thongs of Patent Leather Laced In and Out, While Two American Flags Add a Patriotic Touch

Lord & Taylor N.Y.C.



The Three-Cornered Shape, Suggestive of Revolutionary Days, and the Red, White, and Blue Rosette are Happily Combined in This Black Velvet Hat to Typify Patriotism. Gold Braid is Used at Edge of Brim



In the Face of War-Time Scarcity of Leather the Resourceful Shoemakers have Turned More and More to Cloth. A Beautiful Example of Their Latest Products Is This White-Striped Pair of High Shoes

W. J. ... N.Y.C.

N.Y.C.

Photo Courtesy: Uncredited & Uncredited

PADS MAKE AUTO SPRING SELF-LUBRICATING

A new automobile spring is made self-lubricating by means of round, oil-saturated pads imbedded under the ends of the leaves. From these the oil is spread between the steel parts by capillary attraction, thereby preventing rust, squeaks, and undue stresses. The supply of oil is replenished through ducts provided in the ends of the leaves.



NEW LIGHT ON NATURE AND ORIGIN OF CANCERS

New and important data regarding the origin and growth of tumors and cancers have been secured by a scientist connected with the Department of Agriculture, who lectured on his investigation before the recent meeting of the National Academy of Sciences in Washington. The author expressed the belief that there is a very close relation between crown gall, a plant disease, and cancer in animals and human beings, and that both are of parasitic origin, which, so far as cancer is concerned, is contrary to the present

commonly accepted theory. During 16 months of study the investigator discovered a new type of crown-gall tumor which he has been able to produce at will by inoculating plants in particular places. This newer type corresponds to the most complex of malignant tumors in men and animals, he said. The scientist also believes that he has shown for the first time that tumors are due to chemical products of bacteria slowly liberated within the cells of the attacked plants.

"BIRDS" AND "BEASTS" MADE FROM SEEDS AND PODS

Ingeniously devised creatures of all sorts, made from seeds, cones, leaves, pods, bark, etc., are the product of a new woodcraft which is proving of fascinating interest to both children and adults. The variety of articles that can be made, and for which there is a market both in kindergartens and curio shops, is limited only by the ingenuity of the maker. By using halves of pine cones for wings, whole cones for bodies, burs strung on wires for legs, eucalyptus-seed pods for feet, and cantaloupe seeds for ears, these new craftsmen evolve groups of figures that include eagles with spread wings, ostriches, chickens, etc. Little pigs and opossums are made from camphor-tree pods. Hollow-tree crotches serve as rustic flowerpots. A little paint and shellac add to the attractiveness and durability of the articles.



Cleverly Fashioned Products of a New Woodcraft: Two Collections Showing the Interesting Objects That can be Made from Seeds, Cones, Pods, and the Like. The Flowerpots at the Right are Made from Hollow-Tree Crotches and the Pins on the White Cards are Made of Shellacked Leaves, Assembled to Look Like Flowers

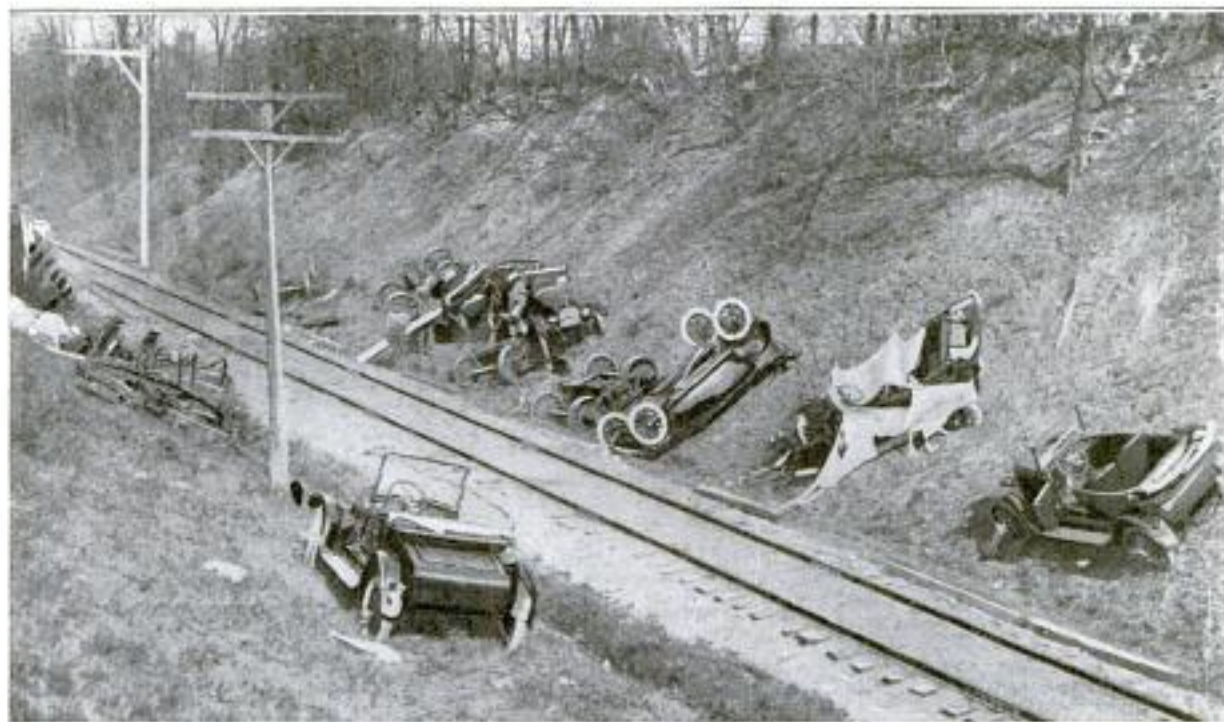

NEW AUTOMOBILES STREWN ALONG A RAILWAY TRACK

WHEN an axle broke on the rear car of a Norfolk & Western freight train near Cincinnati recently, and the car was overturned, the resulting wreck strewn along the track a number of the new automobiles with which the train was loaded. The photograph shows the odd sight presented when the single track was cleared of the wreckage, valuable autos and freight-car trucks being scattered on both sides of the right of way. Some of the autos sustained little damage; others were wrecked beyond repair.

AUTOMATIC FEEDER FOR BRICK REPRESS

A comparatively simple machine, especially suited for use in small or medium-size brick-yards, has been designed automatically to feed brick to a repress. The freshly cut brick are discharged, one at a time, from a chute onto an endless conveyor. The latter stops at stated intervals to allow a lever arm, called a shover, to push the two foremost bricks from the belt. As fast as the bricks are brought into position the process is repeated. The machine is intended to be so placed that it feeds directly into the repress, thus dis-

pensing with the transfer of bricks by hand, as is done in some cases. The inventor's plans also call for machines equipped with two or three shovers which will take brick from a single belt

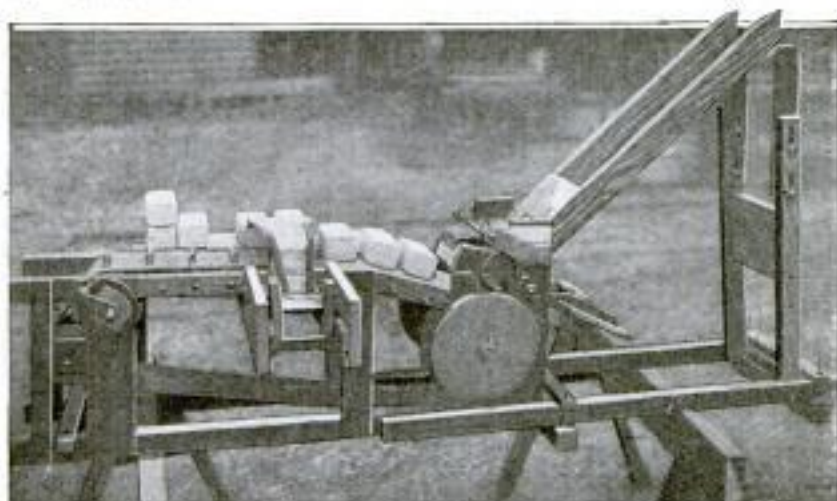

Hand-Operated Model of a Machine Designed to Feed Brick Automatically to a Repress: As Fast as the Brick are Brought in Front of the Arm Projecting over the Belt, the Arm Shoves Them Off into the Repress

and feed two or three represses at the same time.

MANY NOVEL WAYS IN WHICH THE NATION

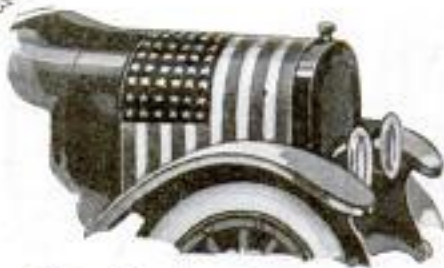

View Showing One of Two
Flags Covering an Auto Hood,
the Other Being the French
Tricolor

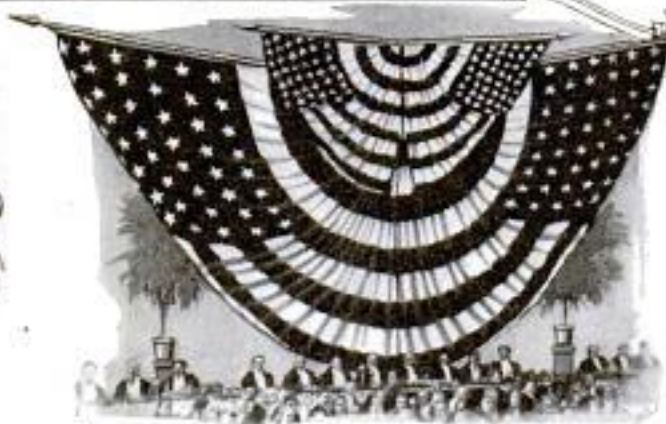

Four Flags, Very Artistically Gathered,
That Formed an Imposing Decoration Back
of, and above, the Speakers' Table at a
Banquet



Old Glory
between
French and
British
Ensigns on
Auto Hood



Fine Example
of Draping
about a Shield,
Worthy of
Careful Study

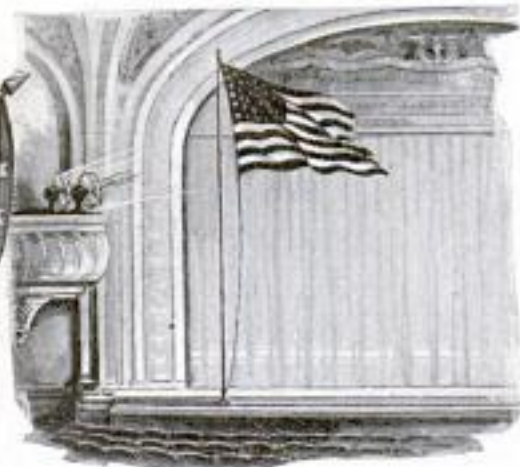

Emblem of Patriotism Effectively Dis-
played on a High-School Stage: An
Electric Fan Makes the Flag Fly as
If It Were Out of Doors



Two Flags Serve as a Pleasing
Substitute for the Usual
Draperies at the Rear Window
of This Limousine

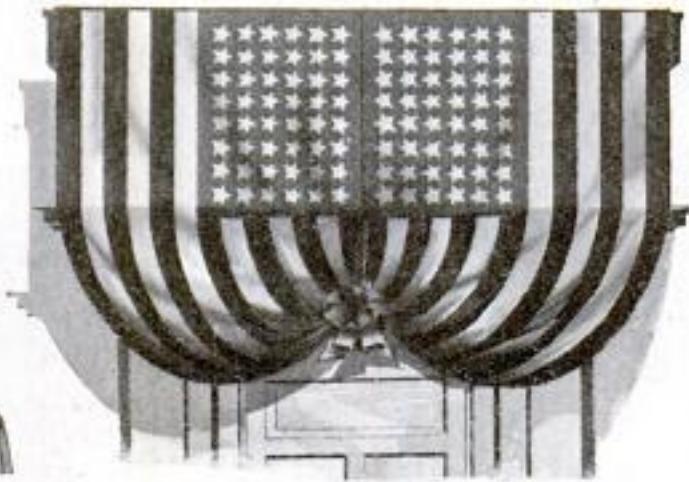

The Proper Arrangement of Blue Fields,
When Two Flags are Hung Vertically
Side by Side, is Shown in This
Doorway Decoration

IS DISPLAYING AND DRAPING THE FLAG

American

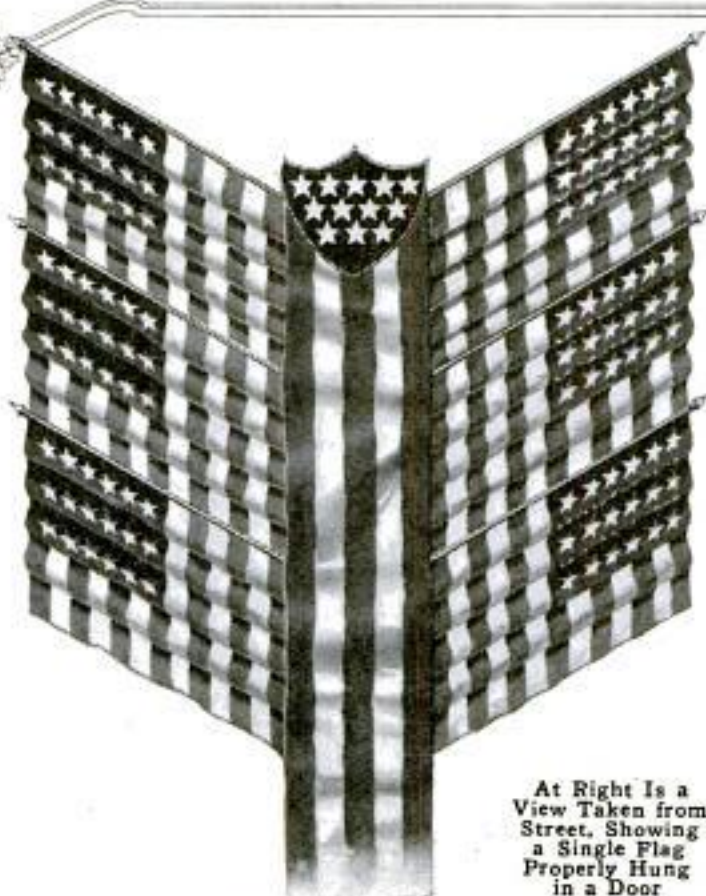

An Odd Decorative Effect for a Display Window, Produced by Placing Flags Containing Many Tucks Either Side of Ribbon Streamers



Auto Flag in Celluloid-Walled Case, Lighted by Bulb Concealed in Base



At Right Is a View Taken from Street, Showing a Single Flag Properly Hung in a Door

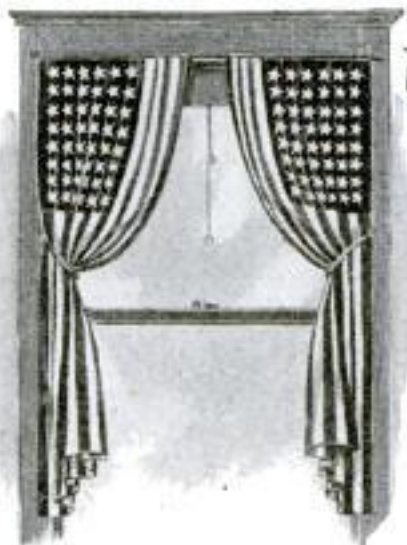

Here a Housewife has so Decorated a Window with Flags That They Take the Place of Curtains



Flag on Under Side of This Aeroplane Tells Its Own Story



COPYRIGHT INTERNATIONAL FILM SERVICE
Flag Made of 2,500 Blossoms: Carnations Compose the Stripes and Blue Field Is of Cornflowers, Set with Starlike Cape Jasmine

HUGE TRUCK TIRES HAVE FOURTEEN-INCH TREADS

The demand for wide solid-rubber tires for six and eight-ton trucks, that are resilient and yet sufficiently

lasting, has resulted in the production by an Ohio company of 42-in. tires that are 14 in. wide. These are among the largest truck tires made. Careful study has shown that excessive internal stress on the rubber, as well as friction, is a destructive factor in the life of a tire. Narrow solid tires are able to expand at the sides at the point where the weight rests and so do not suffer undue internal stress. To make the same lateral expansion possible with this wide tire its tread is provided with three parallel grooves. These also aid in preventing skidding. A machine has been invented for regrooving these tires after they are worn down, without removing them from the rims.

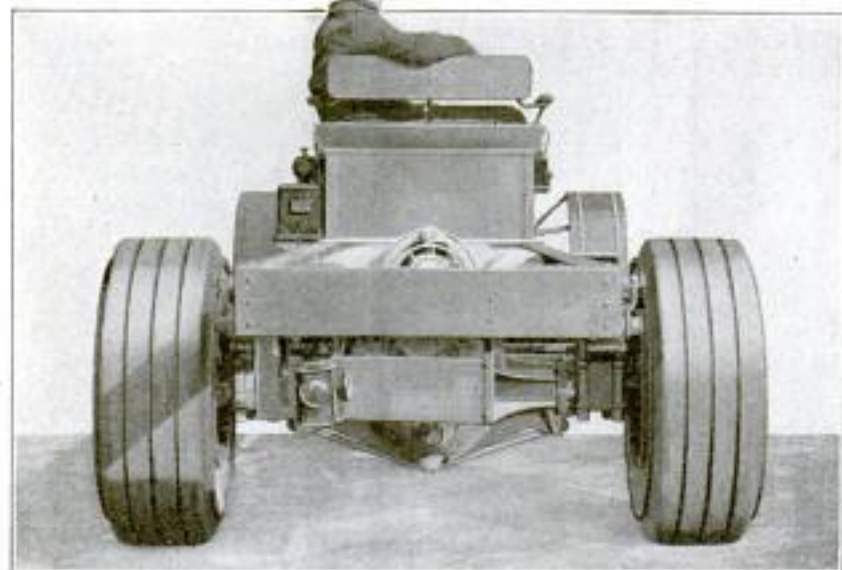

Six-Ton Truck, Equipped with 42-Inch Tires Having 14-Inch Treads: The Grooves are Designed to Permit Lateral Expansion of the Rubber at the Point of Greatest Stress. They Also Aid in Preventing Skidding

MAKING A GREAT HARBOR AT LOS ANGELES

Harbor improvements at Los Angeles are keeping pace with the phenomenal growth of the city's commerce, and plans now being carried out are expected to make the harbor within five years one of the first five seaports in the world. The first of a series of new transit sheds, just built

by the city, is 1,800 ft. long, 100 ft. wide, and fitted with the latest machinery for handling cargo freight. It

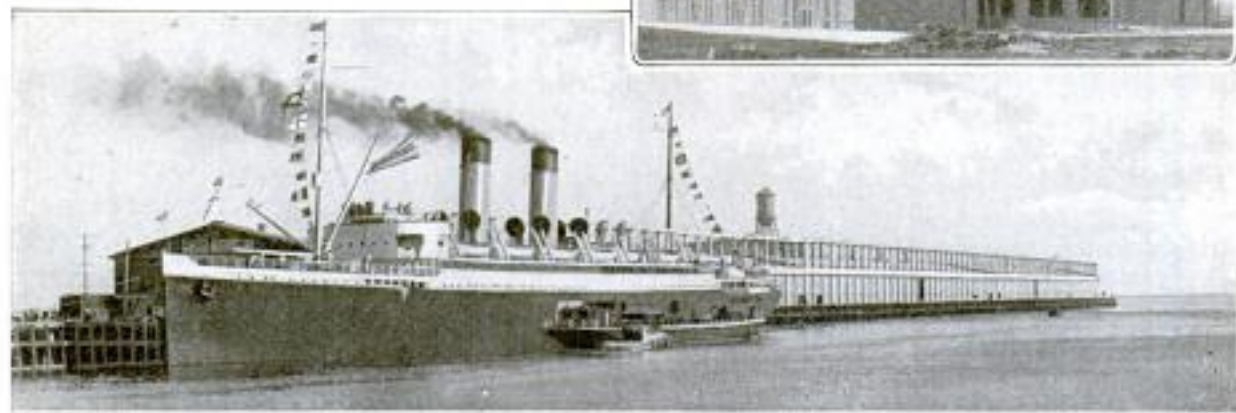

Pacific Steamship "Great Northern" at Its Dock in Los Angeles, alongside the First of the New Municipal Transit Sheds: At the Right is Shown, Nearing Completion, the First of Six Municipal Warehouses Planned in Connection with Great Harbor Improvements



One of the "Duplex" Locomotives of the Southern Railway, Made by Mounting the Tender on the Running Gear of an Old Light Locomotive, Thus Making an Auxiliary Tractor Which is Supplied with Steam from the Engine Boiler

is constructed of concrete and steel, and cost \$250,000. A series of six concrete-and-steel municipal warehouses is also being built at a cost of \$440,000 each. The first is nearing completion. Besides interior electric elevators, each warehouse will have 16 powerful outside hoists for handling goods from floor to floor. The dimensions of each will be 160 by 480 ft., with 11 acres of floor storage space. Thousands of acres are being reclaimed from the sea in carrying out the harbor developments.

DUPLEX ENGINES SOLVE A TRAFFIC PROBLEM

By placing the running gear of a discarded light engine behind one of their standard locomotives, mounting the tender on the running gear, and connecting the gear by a flexible steam coupling with the superheater of the engine, the mechanical department of the Southern Railway made what the officials called a duplex engine, the tender serving as an auxiliary tractor. This solved a troublesome problem of operation on a 68-mile line of single track, where the grades are heavy and traffic often became congested. The "tractors" were fitted to seven locomotives, and have proved very satisfactory on short, steep grades. The average increase of tonnage hauled by the engines with the tractor tenders, over similar engines without tractors,

is approximately 30 per cent. The parts taken from the discarded locomotives to make the tractors included the wheels, axles, frames, cylinders, side rods, and valve motion. Special steel castings were made to carry the connections between engine and tender.

INDIAN CHIEF STARTS FAD OF WEARING SPECTACLES

Members of the Ute tribe of Indians in Utah have recently acquired the habit of wearing spectacles, much to their own delight and to the profit of an optical salesman who was in their vicinity. A chief started the style by purchasing a pair of yellow-lens glasses from the white man and in a few days so many Indians demanded similar adornments that the drummer's supply was exhausted and he had to send for more. It is said that there are nearly 200 men, women, and children in this tribe who now possess spectacles. Some indicate their social position by wearing three pairs at a time. Glasses with heavy tortoise-shell rims have



proven popular. These Indians were on their way to attend a powwow in New Mexico, and it is thought that they wanted their new adornments especially for this occasion.

STRANGE ACCIDENT KILLS AMERICAN WAR NURSES

As a result of an accident without parallel in our navy's history, two Red Cross nurses on their way to France aboard an armed vessel, were among the first in United States service to lose their lives in the great war. A third nurse was seriously injured at the same time. These young women with many other nurses were seated on deck watching a test of guns and ammunition. When the third shot from a 6-in. gun was fired, a brass attachment of the powder charge, called a mount cup, struck the water and, flying back, hit a stanchion near the

nurses. The impact broke it into fragments which produced the fatal results stated above. The gun causing the accident was of a type for which the shell and powder are loaded separately. The powder charge is contained in a brass case and is there held in place by various parts, including a brass mount cup. When the gun is fired this cup invariably is thrown forward into the water without danger to anyone, but for some unaccountable reason, on this occasion it ricocheted and hit the ship.

CA military airman, Capt. W. A. Robertson, Jr., stationed at San Diego, recently ascended with one passenger in an army battleplane to a height of approximately 16,400 feet, thereby surpassing the American altitude record of 16,225 ft., for an airman and one passenger, held by the late Victor Carlstrom.

NOVICES STUDY GARDENING IN A SKYSCRAPER

Miniature gardens have been laid out in a Cincinnati skyscraper for the pur-



One of Several Miniature Gardens Which have been Laid Out in a Cincinnati Skyscraper to Aid in Teaching City Folks How to Raise Vegetables

pose of teaching city folks how to plant and cultivate vegetables. Here in the midst of offices, at neat little garden plots placed on tables, novices under the guidance of instructors learn how to make foodstuffs grow.

VOLCANOES FOUND TO BE HOTTEST ON SURFACE

Notwithstanding what schoolbooks have said, it now appears that a volcano

is hottest on its surface rather than below it. This is the conclusion drawn by a scientist who has made extensive investigations in craters in Hawaii and has obtained samples of gases and lava before they reached the air. Laboratory studies of these samples make it appear probable that much of the heat required to keep an open lava basin in fluid condition is supplied by the chem-

ical action of the gases. From these investigations the scientist concludes that in times of great activity the temperature at the surface of a volcano undoubtedly is higher than that below the surface.

WITH OUR AIRMEN AT HOME AND IN FRANCE

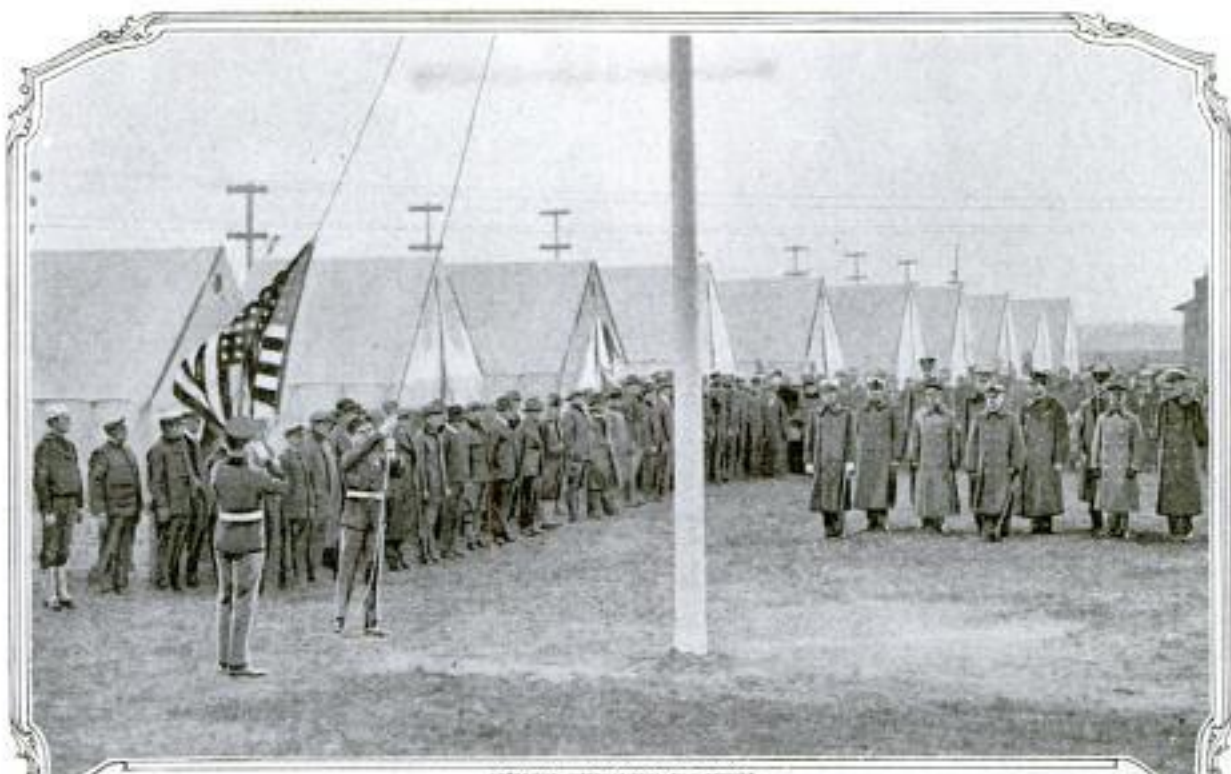

COPYRIGHT, INTERNATIONAL FILM SERVICE

Raising the Stars and Stripes above the New Aviation Field in Massachusetts, When the Training Camp was Turned Over to the Government Recently: The Post was Organized and Equipped by the Naval Forces Committee of the Public Safety Committee, and the Formal Presentation of the School Made in the Presence of Several Hundred Persons. The Key to the Field was Given to the Commandant of the First Naval District. Student Fliers will be Trained Here for the Navy Reserve Flying Corps



Before the Open Grave of Corporal Genet of the Lafayette Escadrille: The First American Airman Killed in the War against Germany since Our Entrance into the Conflict. The Picture Shows a French Officer Standing beside the Flag-Draped Casket While Eulogizing the Service Performed by the Deceased Pilot. While Flying over the German Lines, Genet was Wounded. He Managed to Drive Back to the Vicinity of Ham, Where He Died a Few Hours Later

SIDE LIGHTS ON OUR ENTRANCE INTO WAR



COPYRIGHT INTERNATIONAL FILM SERVICE

Hundreds of Persons Crowded about the Statue of George Washington in the Place d'Iena in Paris on the Fourth Sunday of Last April, Designated in France as American Day, to Hear Addresses Delivered by Representatives of the French Government and Ambassador Sharp. The Occasion Was One of Enthusiastic Rejoicing on Account of Our Entrance into the World War on the Side of Democracy and Justice. The Stars and Stripes was Displayed with the Tricolor, and Cries of "Vive l'Amerique" Filled the Air



COPYRIGHT UNDERWOOD & UNDERWOOD

So Unusual a Sight Is the Real American in His Native Dress, That When Chief Eagle Horse, Garbed in Buckskin and War Bonnet, Stood Erect before the Public Library and Appealed to New Yorkers to Rouse to the Country's Cry for Fighters, His Patriotic Words Carried a Deep Meaning to the Assembled Crowd

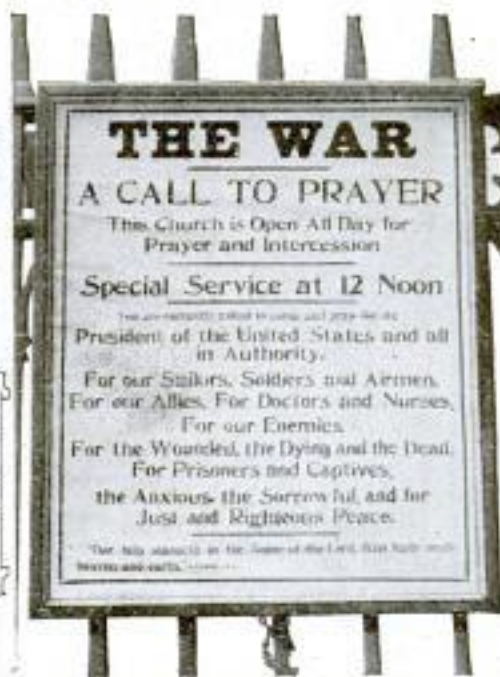

THE WAR A CALL TO PRAYER

This Church is Open All Day for
Prayer and Intercession

Special Service at 12 Noon

President of the United States and all
in Authority.

For our Sailors, Soldiers and Airmen,
For our Allies, For Doctors and Nurses,
For our Enemies.

For the Wounded, the Dying and the Dead,
For Prisoners and Captives,
the Anxious, the Sorrowful, and for
Just and Righteous Peace.

The Holy Scriptures in the Name of the Lord, God, Father, Son,
and Holy Spirit, Amen.

The Poster Reproduced Above Appears before Trinity Church on Broadway, in New York, and Admonishes the Ceaseless Throng of Passers-By to Enter the Edifice and Pray for Humanity and Righteous Peace. The Sign is Conspicuously Displayed and Attracts Many to the Doors of the Church

PICTORIAL ACCOUNTS OF RECENT NAVAL NEWS

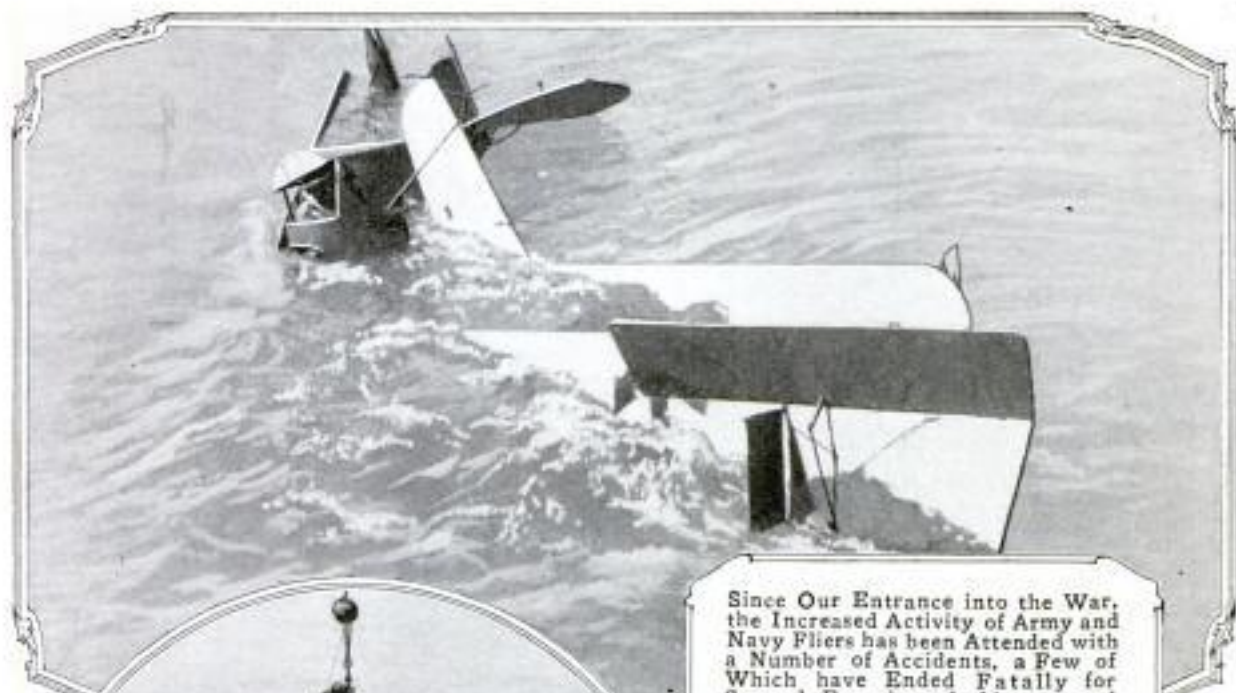

Since Our Entrance into the War, the Increased Activity of Army and Navy Fliers has been Attended with a Number of Accidents, a Few of Which have Ended Fatally for Several Experienced Airmen and Some Students. Pictured Above is the Wreck of a Navy Seaplane That Fell Recently

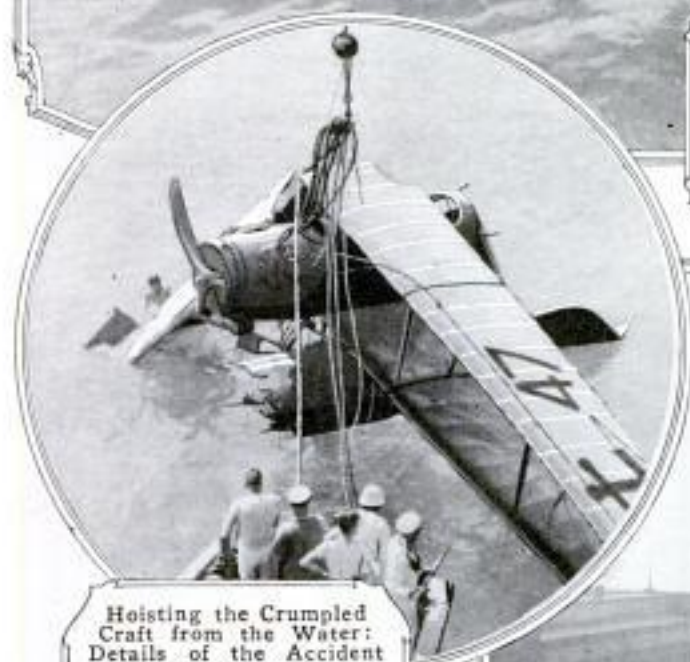

Hoisting the Crumpled Craft from the Water: Details of the Accident have been Censored and It is Not Known Where It Occurred or Whether It Resulted in Fatalities. The Right Wing may have Collapsed in the Air, or Broken When the Machine Plunged into the Ocean. It Appears to have been a Tractor Seaplane

The French Cruiser "Admiral Aube" Tied Up at New York after Putting In from Hampton Roads on May Day: The Vessel is One of the Fighters That Convoys the French Mission to This Country for the War Conference. Members of Its Crew were Feted and Given a Royal Welcome in Gotham

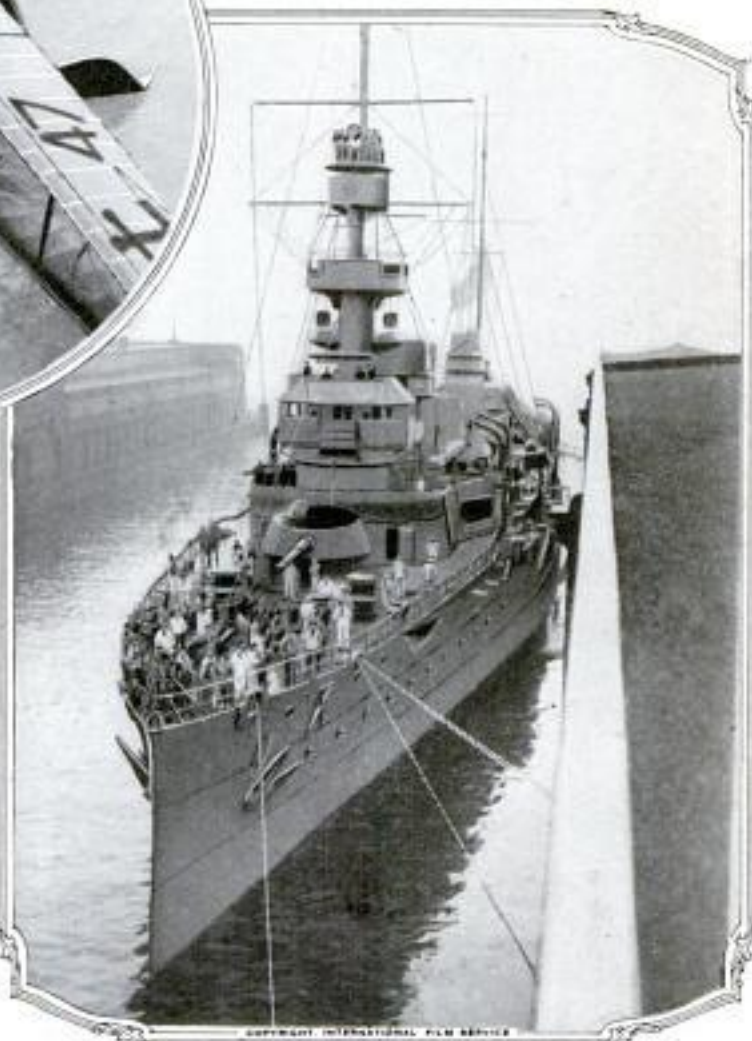

SHIP THAT FIRED OUR FIRST SHOT IN WAR



COPYRIGHT INTERNATIONAL FILM SERVICE

To the American Steamship "Mongolia" Belongs Credit for Firing Our First Shot in the War against German Ruthlessness. The Projectile Smashed the Conning Tower of a Teuton Submarine and Killed the Vessel's Commander. Contrary to the First Belief, the U-Boat did Not Sink, but Managed to Limp into Kiel. A Second Unsuccessful Attack was Made upon the "Mongolia" May Fourth as the Ship was Returning to an American Port

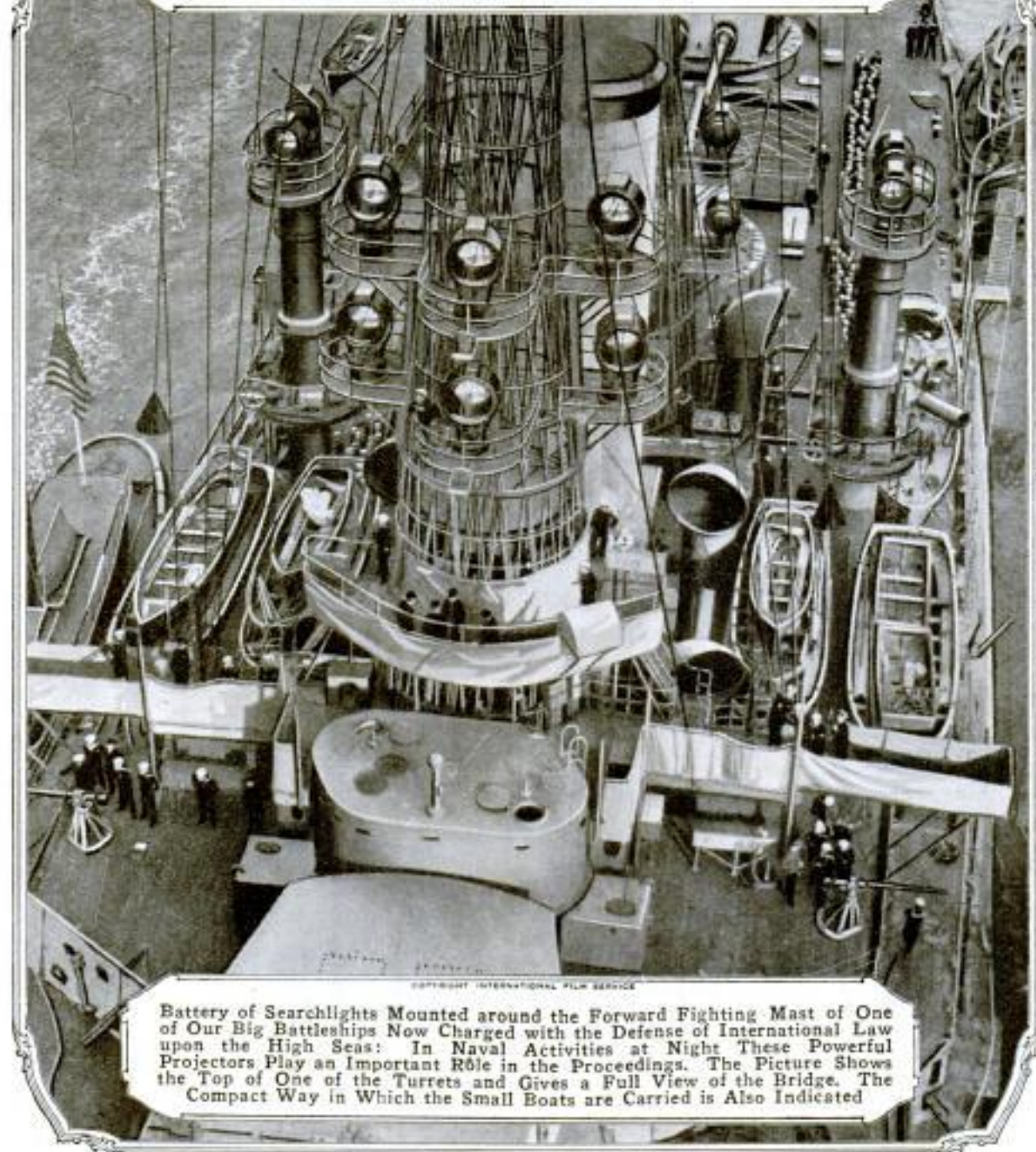

COPYRIGHT INTERNATIONAL FILM SERVICE

Battery of Searchlights Mounted around the Forward Fighting Mast of One of Our Big Battleships Now Charged with the Defense of International Law upon the High Seas: In Naval Activities at Night These Powerful Projectors Play an Important Role in the Proceedings. The Picture Shows the Top of One of the Turrets and Gives a Full View of the Bridge. The Compact Way in Which the Small Boats are Carried is Also Indicated

AND OTHER VESSELS OF CURRENT INTEREST

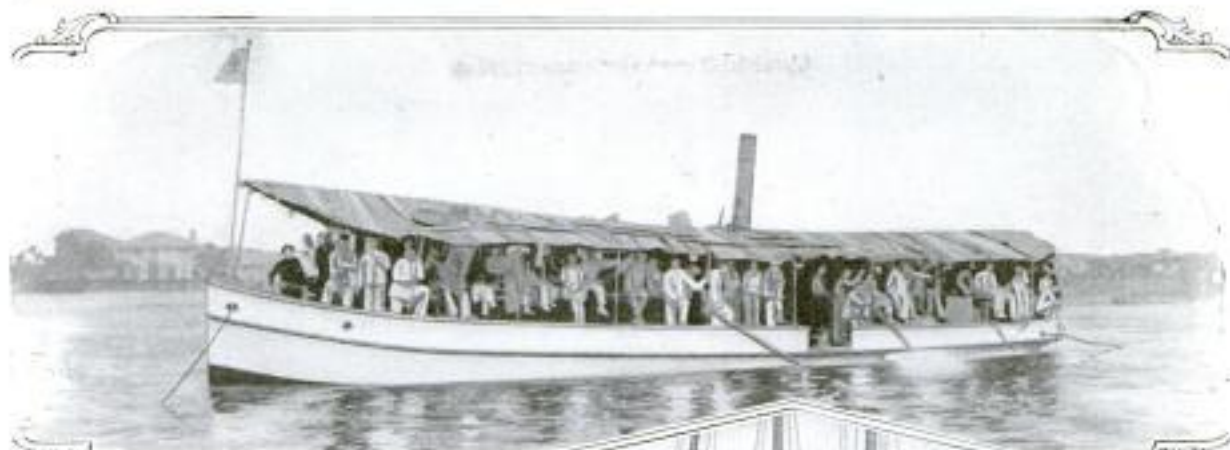

When Chinese Troops are Moved from One Point to Another on Water Almost Any Kind of a Vessel That Happens to Be Available is Used as a Transport. Above, for Instance, is a 90-Foot Tug Loaded with 110 Soldiers. Boats of This Type Often Tow as Many as 15 of the Junks Pictured at the Right. The Latter are Usually Crowded beyond the Safety Limit, from 100 to 120 Men being Consigned to Each of Them. The Tent Visible on One of the Junks Illustrated is Used by the Commanding Officer



Following the Break in Diplomatic Relations between Vienna and Washington Last April, United States Customs Officials Seized 14 Austrian Merchantmen at Different American Ports. Armed Guards were Placed Aboard Them and Their Officers and Crews Taken to Concentration Camps. At the Left, Austrian Seamen are Seen being Escorted from One of the Vessels, and Above, on Their Way to a Government Revenue Cutter



COPYRIGHT, UNDERWOOD & UNDERWOOD

RUSSIA'S REVOLUTIONARY COUNCIL IN SESSION

The Council of Soldiers' and Workingmen's Delegates in Session in the Chamber of the Duma at the Taurida Palace, Petrograd: The Body, It Appears, Is the True Revolutionary Parliament of the New Republic. Instead of a Small Self-Chosen Coterie Bent upon Usurping Power, Without Professing Executive Rights, It Maintains a Vigil in the Interest of the Masses, Opposing the Seizure of Undue Dominion by the Provisional Government for the Middle-Class Liberals. Each Regiment of Russia's Enormous Army is Represented in the Council, as is Likewise Every Factory, Large or Small

CAMERA GLIMPSES OF RUSSIAN REVOLUTION



COPYRIGHT, INTERNATIONAL FILM SERVICE

Revolutionary Soldiers Corraling Reactionaries in One of the Streets of Petrograd Preparatory to Incarcerating Them in the Cells of St. Peter and St. Paul That Formerly Held Political Prisoners, Included in the Group of Captives Are Police Officials



COPYRIGHT, UNDERWOOD & UNDERWOOD

In the Entrance of a Church, Soldiers and Students Firing across the Moika Canal at Police Who, Armed with Pistols and Machine Guns, are Hidden in the Buildings Flanking the Opposite Bank: Sniping Such as This Continued for Several Days at the Capital and Caused Many Casualties



COPYRIGHT, UNDERWOOD & UNDERWOOD
The Red Flag of the Revolution: The Standard of Radicalism and Democracy during the Eventful Days in March When Freedom was Achieved in Russia. The Picture Shows Soldiers on the Fenders and Runboards of a Motor Car



COPYRIGHT, UNDERWOOD & UNDERWOOD

Staff and Soldiers of the Russian General Likhvitsky, Fighting in France, Listening to Their Commander Reading the Duma's Proclamation of the New Government: Subsequently a Chaplain Administered the Oath of Allegiance, to Which All of the Officers and Men Swore. It Was in This Way, Also, That the News of the Revolution and Its Triumph Reached the Troops Defending the Eastern Front

RUSSIA PAYS TRIBUTE TO REVOLUTION'S DEAD



The Crowd, Composed of Workers, Students, and Soldiers, in Nevsky Prospect at Petrograd Making Its Way to the Duma: In This Street the First Shots of the Revolution were Fired and Liberty Born to Russia. It Was Close to This Place That Soldiers, upon being Ordered to Fire into the Throng, Killed Their Officers and Joined the People. Because of Its Width, Nevsky Prospect has Always Been a Gathering Place for the Populace, and Therefore the Setting of Many Historical Events

Soldiers, Workmen, and Students, Pallbearers of Those Who Died in the Uprising: The Funeral of the Revolutionists was Made an Occasion of Great Demonstration. Thousands, Headed by Regiments of Soldiers, Marched Solemnly to the Burial Place. Everywhere Were the Red Banners and Flags of the Revolution, Many of Them Bearing Significant Phrases



High Officials, Including Prince Lvoff, President of the Provisional Government, and M. Miliukoff, Foreign Minister Who Later Resigned, Mingled with the Masses before the Open Graves of Those Who Died for Russia's Liberation. The Ministers are Standing Adjacent to the Post at the Right

RUSSIA'S MASTERLY UNDERGROUND DEFENSES

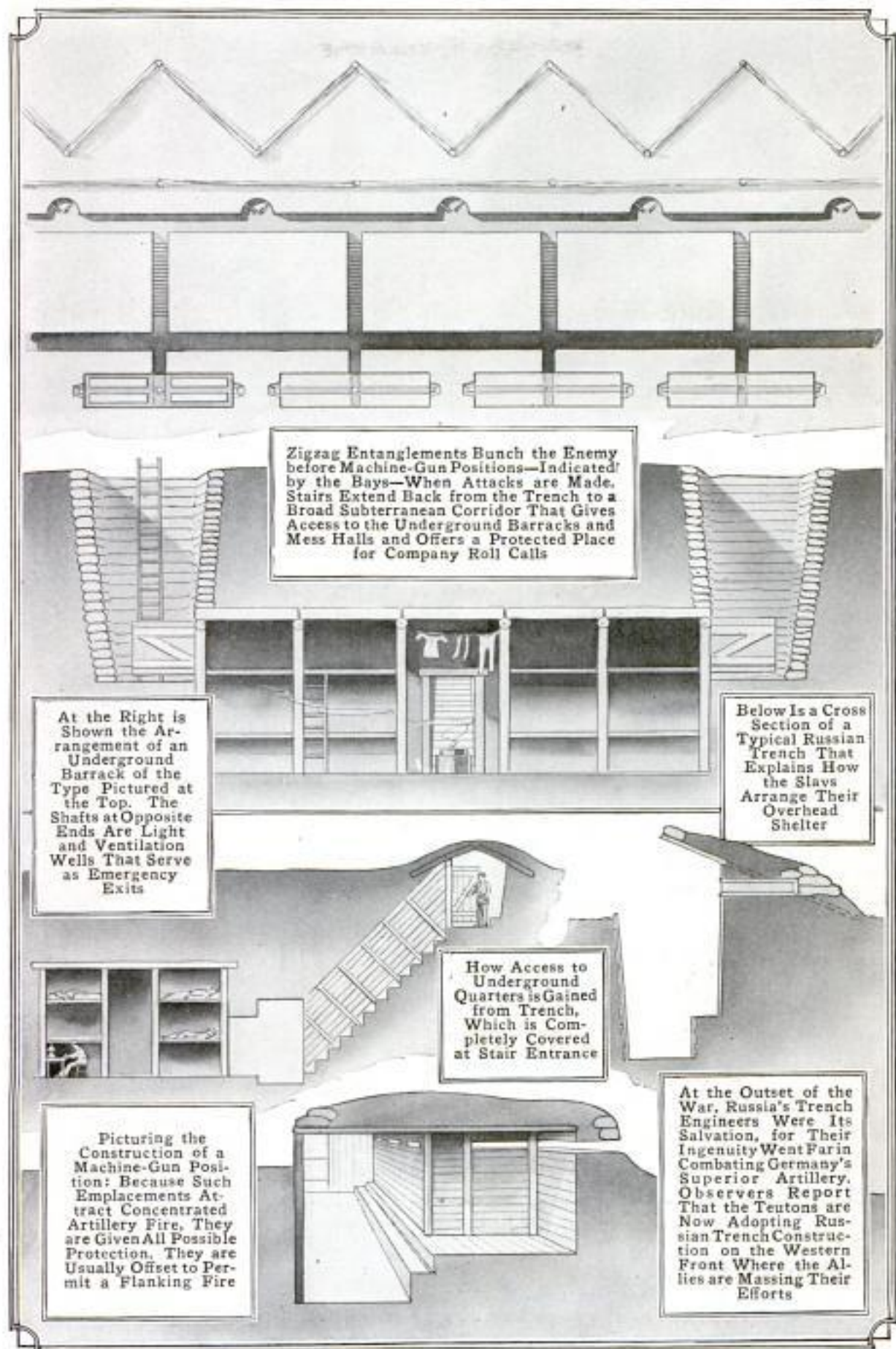

Zigzag Entanglements Bunch the Enemy before Machine-Gun Positions—Indicated by the Bays—When Attacks are Made, Stairs Extend Back from the Trench to a Broad Subterranean Corridor That Gives Access to the Underground Barracks and Mess Halls and Offers a Protected Place for Company Roll Calls

At the Right is Shown the Arrangement of an Underground Barrack of the Type Pictured at the Top. The Shafts at Opposite Ends Are Light and Ventilation Wells That Serve as Emergency Exits

Below is a Cross Section of a Typical Russian Trench That Explains How the Slavs Arrange Their Overhead Shelter

How Access to Underground Quarters is Gained from Trench, Which is Completely Covered at Stair Entrance

Picturing the Construction of a Machine-Gun Position: Because Such Emplacements Attract Concentrated Artillery Fire, They are Usually Offset to Permit a Flanking Fire

At the Outset of the War, Russia's Trench Engineers Were Its Salvation, for Their Ingenuity Went Far in Combating Germany's Superior Artillery. Observers Report That the Teutons are Now Adopting Russian Trench Construction on the Western Front Where the Allies are Massing Their Efforts



OUR ALLIES PAY TRIBUTE TO WASHINGTON

Issues That Once Arrayed France and the United States against Great Britain were Obliterated and the Alliance of the Three Nations in the Interest of Human Rights and Liberty Impressively Solemnized. When the British and French Missions Visited Mount Vernon and Paid Reverent Tribute to the Memory of George Washington. For the First Time the Union Jack and Tricolor were Draped with the Stars and Stripes over the Tomb of the First President. As Officials of the Three Sisters in Arms Stood before the Entrance of the Sepulcher with Bared Heads, Marshal Joffre, Hero of the Marne, Entered the Vault and Laid a Bronze Wreath upon the Sarcophagus. He was Followed by the Right Honorable A. J. Balfour, Head of the British Mission, Who Placed a Large Floral Piece beside the French Token

FOOD FOR FIGHTING FORCES AND CIVILIANS



Mobile Field Kitchens of the Latest Type are Supplied with Insulated Heat-Retaining Compartments That Keep Food Piping Hot for Hours at a Time. A Unit Such as is Pictured Above is Adequate to Serve the Needs of 250 Hungry Soldiers



Placing Food in a Heat-Retaining Compartment of One of the New Kitchen Outfits: In This Way Victuals can be Prepared While an Army is Marching. General Efficiency is an Outstanding Feature of the Equipment



One of the United States Army's Big Tractors Drawing a Supply Train of Many Tons: Machines of This Type are among the Most Powerful Built, and, Armed by the British, are the Famous "Tanks" of the Western Front



In These Days of Food Scarcity, the Hoe is Taking the Place Proverbially Ascribed to the Pen and is Becoming Mightier than the Sword. This Shows a Patriotic Society, Armed with Gardening Implements, Marching to a 10-Acre Plot Which It has Undertaken to Make Productive

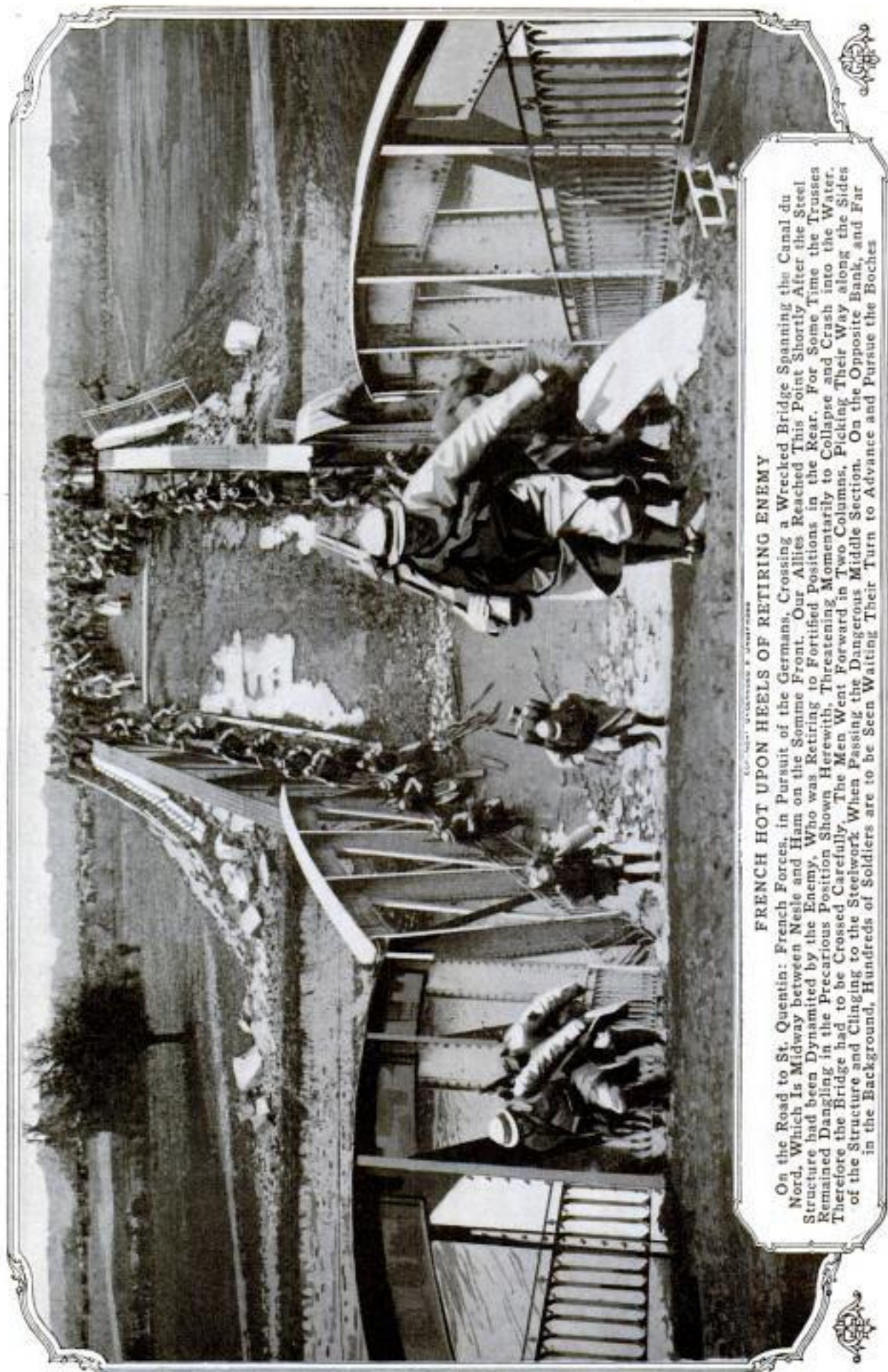

FRENCH HOT UPON HEELS OF RETIRING ENEMY

On the Road to St. Quentin: French Forces, in Pursuit of the Germans, Crossing a Wrecked Bridge Spanning the Canal du Nord, Which Is Midway between Nele and Ham on the Somme Front. Our Allies Reached This Point Shortly After the Steel Structure had been Dynamited by the Enemy, Who was Retiring to Fortified Positions in the Rear. For Some Time the Trusses Remained Dangling in the Precarious Position Shown Herewith, Threatening Momentarily to Collapse and Crash into the Water. Therefore the Bridge had to be Crossed Carefully. The Men Went Forward in Two Columns, Picking Their Way along the Sides of the Structure and Clinging to the Steelwork. When Passing the Dangerous Middle Section, on the Opposite Bank, and Far in the Background, Hundreds of Soldiers are to be Seen Waiting Their Turn to Advance and Pursue the Boches

HERE AND THERE WITH AMERICAN WAR WORKERS



Entertaining a Crowd in Boston Common: The Strong Man of the United States Navy Holding His Own against the Combined Efforts of a Dozen Husky Lads. The Muscular Seaman Is a First-Class Fireman aboard the "Virginia"



This Is a Steeple Jack's Way of Risking His Life for the Stars and Stripes: Untangling Old Glory on a Staff Jutting Out from the Twenty-First Story of the Municipal Building at New York. The Man Accomplished His Work, Although Hampered by a Stiff, Snow-Laden Wind



Recruiting Fighters in the Rural Districts of California: A Roadside Scene. The Expedition was Sent Out by a Western Newspaper—Not by the Government—and Operated through a Territory Adjacent to San Francisco, Sounding the Call to Arms



Red Cross Worker Employing an Electric Machine That Cuts Gauze into Bandages of Various Widths: Many Thicknesses of the Flimsy Material are Cut Smoothly and Quickly in a Single Operation by This Machine Driven from an Ordinary Lighting Circuit



All of the Men and Women Employed at the Bronx Park Zoo, New York, are Doing Their Bit in One Way or Another. While a Hundred Women Gather in One of the Animal Houses and Sew for the Red Cross, the Men Devote Their Energies to a 15-Acre Garden Plot

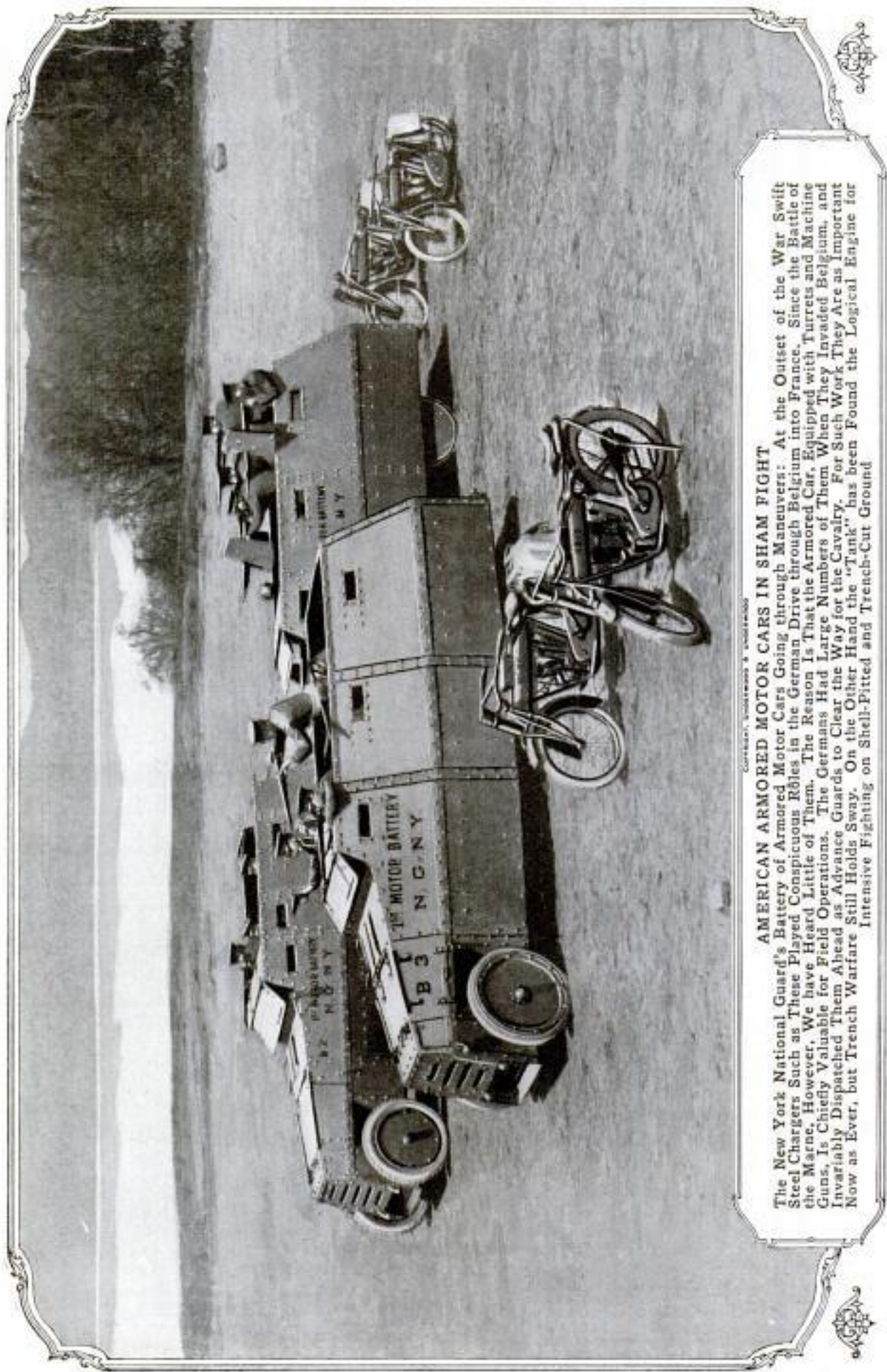

AMERICAN ARMORED MOTOR CARS IN SHAM FIGHT

The New York National Guard's Battery of Armored Motor Cars Going through Maneuvers: At the Outset of the War Swift Steel Chargers Such as These Played Conspicuous Rôles in the German Drive through Belgium into France. Since the Battle of the Marne, However, We have Heard Little of Them. The Reason is That the Armored Car, Equipped with Turrets and Machine Guns, is Chiefly Valuable for Field Operations. The Germans Had Large Numbers of Them When They Invaded Belgium, and Invariably Dispatched Them Ahead as Advance Guards to Clear the Way for the Cavalry. For Such Work They Are as Important Now as Ever, but Trench Warfare Still Holds Sway. On the Other Hand the "Tank" has been Found the Logical Engine for Intensive Fighting on Shell-Pitted and Trench-Cut Ground

WORK OF THE VANDALS IN NORTHERN FRANCE

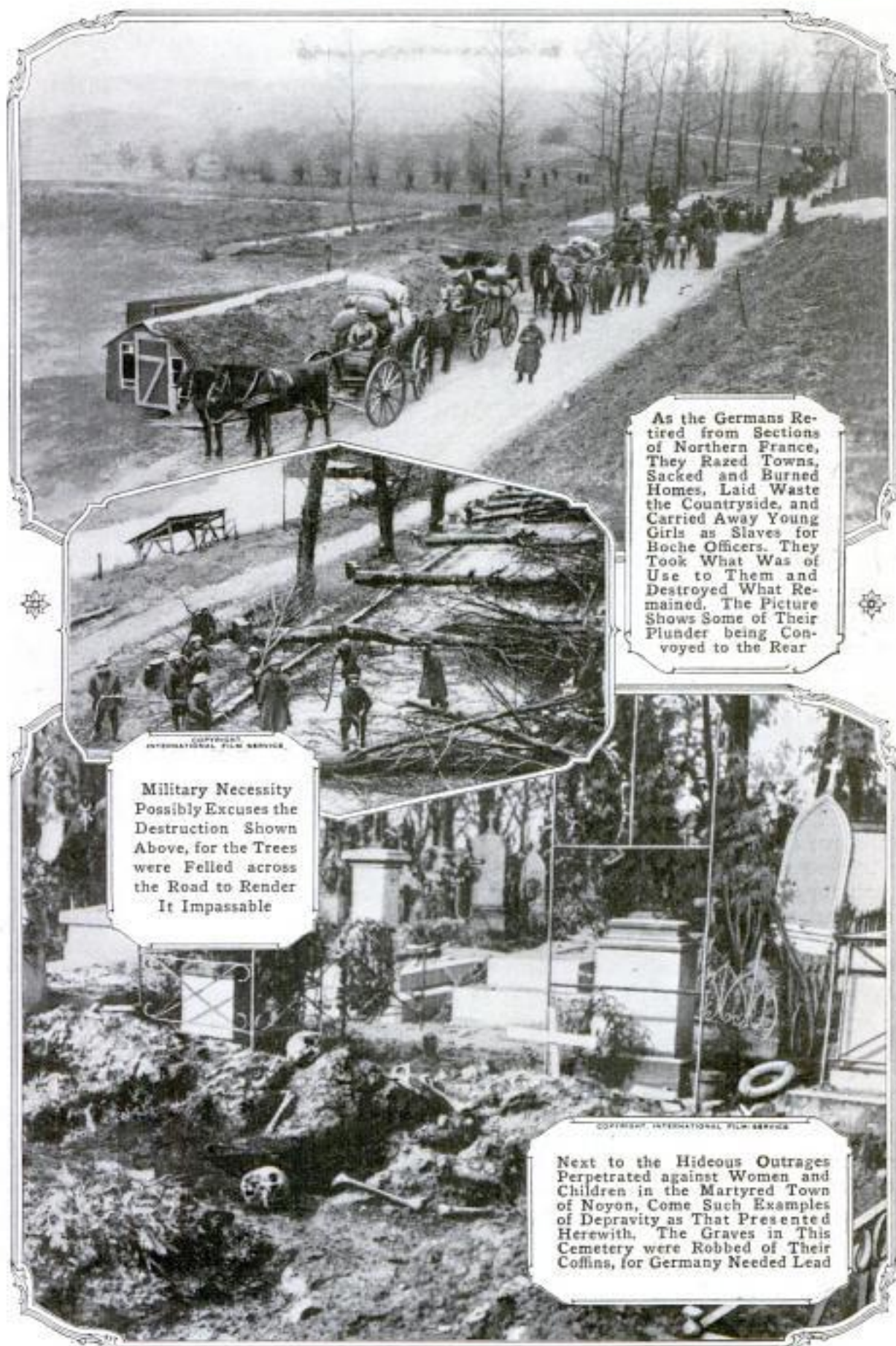

As the Germans Retired from Sections of Northern France, They Razed Towns, Sacked and Burned Homes, Laid Waste the Countryside, and Carried Away Young Girls as Slaves for Boche Officers. They Took What Was of Use to Them and Destroyed What Remained. The Picture Shows Some of Their Plunder being Conveyed to the Rear

Military Necessity Possibly Excuses the Destruction Shown Above, for the Trees were Felled across the Road to Render It Impassable

Next to the Hideous Outrages Perpetrated against Women and Children in the Martyred Town of Noyon, Come Such Examples of Depravity as That Presented Herewith. The Graves in This Cemetery were Robbed of Their Coffins, for Germany Needed Lead



Scene Showing the Shores of the Sandy River, near Portland, Oregon, Lined with Hundreds Who Turned Fishermen during a Recent Unprecedented Run of Smelt; Such Vast Numbers, as Shown on the Right, were Caught That the Price Dropped to One Cent a Pound



OREGON FOLK CATCH VAST QUANTITIES OF SMELT

Millions upon millions of smelt filled the Sandy River near Portland, Ore., recently during an unprecedented run in that stream and enabled hundreds of persons to lay in stores of fish which will supply them for months. So great was the multitude of swimming creatures during the two weeks that the run lasted, that they could be scooped up by the hundred with ordinary dip nets. Two men in a boat, using two small nets, secured 1,500 lb. in a few hours. Such large quantities were offered for sale that the market price dropped to one cent a pound. Many people improvised smokehouses in which to preserve what they caught, while others salted the fish down in barrels and jars.

COARSE-TOOTHED SAW FOR PRUNING TREES

In pruning trees having either large or small limbs to be cut, one can work to the best advantage with a short



Saw Designed Especially for Pruning Trees: It Is 26 Inches Long and Has Three Teeth to the Inch

large-toothed saw, such as has been put on the market recently. This saw is 26 in. long and has three teeth to the inch.

TEST OF HOLLOW CONCRETE RAILWAY TIES

A prolonged test is being made on a 200-ft. stretch of railroad track at Riverside, Calif., of hollow concrete ties recently patented. The ties are said to have stood up well under the strain of an interurban high-speed electric service, with an intermittent service of heavy steam-railway trains. In outward shape the hollow concrete ties resemble those of wood, so that replacements can be easily made. They are 7 by 8 in. in cross section, 8½ ft. long, and have 1½-in. walls, thickened to 2 in. under the rail seats. Flat steel plates are used under the rails, instead of standard tieplates, with screws through the tie to cushion plates of oak inside the hollow space. Each tie has 32 lb. of steel-rod reinforcement, and additional reinforcement of wire cloth and netting is contemplated in the design. The tie weighs 320 lb. and can be handled by two men. The objects of lightness and resilience are claimed to be secured, and the tests will be continued.

NEW MACHINE-GUN MOUNT WITH PERISCOPE

An improved machine-gun mount designed by an American inventor for use of the allies in the European trenches, was turned over to the ordnance department of the United States Army when diplomatic relations with Germany were severed. Without material rearrangement it will carry any machine gun used by the army. The mount weighs 150 lb. and can be completely disassembled in 10 seconds. In case of retreat it could be carried to the rear by five men, the separate units weighing not over 35 lb. each. A gun on this mount can be operated in safety by one man, who could be concealed from 2 to 20 ft. below the level of the gun. The weapon can be aimed in a complete horizontal circle for straight blanket fire, or at any angle from direct overhead fire to a muzzle depression of 45° .

A periscope feature gives the gunner in trench fire complete sight of the field, while himself entirely concealed from view, and he can fire at will from his concealed position.



New Machine-Gun Mount with the Gun at 45-Degrees Muzzle Depression, Commanding Streets from a Roof



This Shows the New Mount Carrying a Machine Gun Operating at 90-Degrees Perpendicular Fire, against Air-Craft Attack. It will Carry Any Machine Gun Used in the Army

HYDRAULIC TEST MACHINE FOR BOILER TUBING

A new testing machine for boiler and other tubing is designed to exert in-

or a power-driven pump. The machine consists of a frame with two rectangular tie bars, with a stationary abutment at one end and at the other a carriage mounted on rollers, forming a moving abutment. The tube to be tested is adjusted between these abutments, the carriage being then secured to the side frame by pins. The tube being filled with water, pressure is applied by the hydraulic pump to the desired point, which is indicated on a gauge.

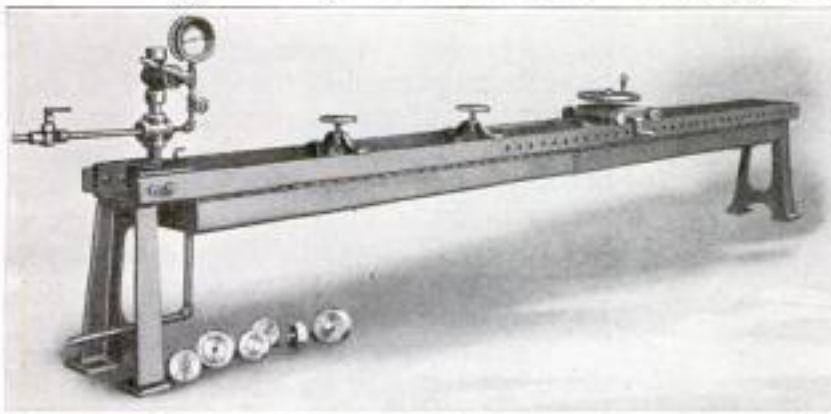

New Hydraulic Boiler-Tube Testing Machine: The Tube being Filled with Water When Fixed in the Machine, Pressure is Applied by a Pump and Indicated on the Gauge

ternal hydrostatic pressure upon the tube and to be used with either a hand

THREE-SEATED PORCH SWING WITH CRIB FEATURE

A novel porch swing, recently patented, has three adjustable armchair seats, the middle chair and either of



Triple-Seated Swing Which Is Convertible into a Children's Crib, as Shown, Leaving a Seat for Mother

the outer ones being turnable so as to face each other. When latched in this position the arms form a safe crib for young children, leaving the third chair for the mother or nurse. The chairs are secured in the position desired by turning a thumb nut. In making the crib, the middle chair is moved in either direction, so that the arms will join, its clamping bolt projecting through a longitudinal slot in the seat board for this purpose.

LONG-HANDLED LAMP AND MAGNET FOR MOTORISTS

Automobilists will find very convenient a combination inspection lamp and magnet with which dark recesses in a motor can be examined easily. Mounted on the end of an 18-in. flexible handle is a 4-cp. bulb and a magnet 1 in. in diam-



The Little Lamp at the End of This 18-Inch Handle Is Convenient in Examining a Motor. The Magnet Enables One to Pick Up Small Metal Parts Easily

eter, which is convenient for picking up small metal parts. Current for the tool is supplied through a light cord.

DEEP WELLS GIVE ISLANDS SUPPLY OF PURE WATER

Although still far from ideal, the water-supply situation in the Philippines is most encouraging, especially when compared with the unspeakable conditions that prevailed at the time of the American occupation. Years and considerable money have been spent in providing artesian wells and educating the people to use them. Two years ago there were more than 1,000 deep wells publicly and privately owned in different provinces, and since then many others have been drilled. The importance of this work, from the standpoint of sanitation, is tremendous, but according to experts connected with the Bureau of Sciences at Manila, there is much yet to be done. In some districts the natives even now are dependent upon surface waters. In some other places where pure water is available, many, because of ignorance and indifference, fail to make use of it, preferring instead to obtain their supplies from more conveniently located sources that often are seriously contaminated. In 1915 there were more than 50 water systems in operation and as many more planned by communities of various sizes. All of which gives an idea of the extent of the progress. The entire cost of all unsuccessful deep wells for public use, and two-thirds of the expense incurred in providing satisfactory ones, has been borne by the insular government. In addition to this, manual and power-drilling outfits have been provided by it to all of the provinces. This arrangement has naturally been responsible for the results accomplished. In many localities good water is found at depths ranging from 200 to 300 ft., but in others it is necessary to go even three times as far. In only one instance has fresh water been encountered at a depth greater than 1,000 ft. Some of the deep wells have natural flows, and the largest of them, a gusher struck at Bayambang, Pangasinan, delivers 1,000,000 gal. daily. Before a new well is made public, its water is tested by experts.



The Picture Above, Showing the Reindeer being Driven along a St. Louis Thoroughfare, was Taken When the Fleet Little Animals Were Less than a Year Old



Harnessed to a Buckboard: The Reindeer as They Now Appear When Driven in the Streets. Never do They Make Their Appearance without Attracting a Great Deal of Attention

REINDEER TEAM IS DRIVEN THROUGH CITY STREETS

Many a youngster who dreams of Santa Claus and loves some of the fascinating old nursery tales with Lapland settings, would delight in seeing a reindeer team that frequently appears in the thoroughfares of St. Louis. The animals are young and thoroughly broken for city driving. Harnessed to a light sulky, or buckboard, they are fleet and picturesque. Never are they driven without attracting notice, as might well be surmised.

TRUCK LOADS ITSELF WITH HEAVY MAINS

When confronted with the problem of how to unload a car filled with water-main sections, each weighing a ton or more, employes of the city of Glendale, Calif., devised means where-

by an automobile truck did most of the work. The big castings had to be lifted from a gondola car and then lowered onto the truck. A telephone pole was set 4 ft. into the ground close by the railway car, and a pulley fastened to its upper end and another one near its base. A rope, after being attached to the truck, was run through the pulleys and fastened to one or two of the pipes. After distances had been properly gauged the truck was driven forward a few yards, thereby hoisting the pipe out of the freight car. To lower it onto the truck, the latter was carefully backed up with the aid of another pulley and rope fastened to a well-anchored car some distance away.

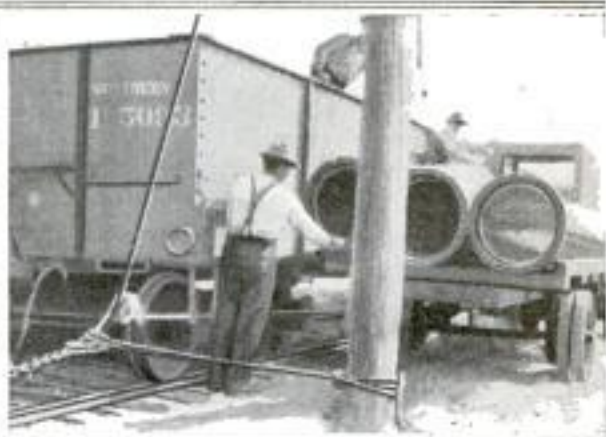

Two Views Showing the Way in Which an Automobile Truck was Employed to Hoist Heavy Water Mains from a Gondola Car and Then Lower Them onto Itself

NEAT COMBINATION OF BED AND TENT HAS MANY USES

The problems of camping are greatly simplified for the motorist, canoeist, hunter, or boy scout by means of a new

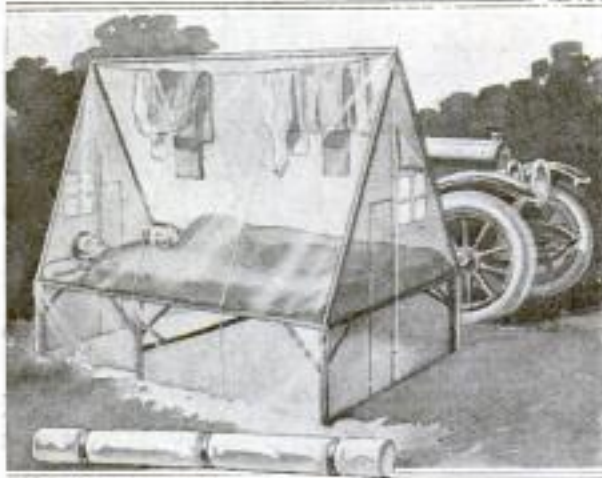

Combination Tent and Bed That Folds into a Small Bundle and can be Easily Carried on the Running Board: It can be Set Up in Five Minutes, and with It the Motorist Is Independent of Hotels

combination tent and bed in which a number of good features are united. The outfit requires no tent stakes or ropes and is provided with a light folding frame so that it can be erected in a few minutes. The bed measures 4 1/2

ft. wide and 6 ft. 4 in. long. At either end of the tent are screened ventilators and the walls are provided with supplementary flaps that keep out mosquitoes, flies, etc. Rolled up, the entire outfit forms a bundle only 8 in. in diameter and 4 1/2 ft. long. The bed can be used in the home without the tent, if desired.

TOWN FIRE WHISTLE BLOWN BY SODA-WATER GAS

A little town of southern Oregon, Ashland by name, claims the distinction of possessing the only fire alarm in the United States—probably the only one in the world—operated by carbonic-acid gas, the kind familiarly used in soda water. The town alarm, formerly a bell, is now a whistle and it is blown by gas pumped into the town from a distant well under heavy pressure, to make an effervescent water. A 2-in. pipe connects the gas line with the whistle on top of the fire hall, and the former bell rope is used to operate a valve which admits the compressed gas to the whistle when its alarm is required.

TEST TRACK BY BACKING CARS INTO FLOOD

Fearing that a section of track in Portsmouth, Ohio, which was covered

weakened, a crew of railroad men cautiously investigated its condition in the manner shown in the accompanying photograph. A train composed of an engine, a caboose, and a hopper car, arranged in the order named, was backed onto the submerged track very slowly. Men were stationed on the open car and were able to watch conditions to advantage. They were prepared to stop the train at a moment's notice and to "retreat," leaving the end car if necessary. In places the water rose almost to the car floors.



Railroad Men Investigating Condition of Submerged Track by Backing a Short Train onto It Very Cautiously

with several inches of flood water, had been washed away or was seriously

ing the end car if necessary. In places the water rose almost to the car floors.

Widemann Goat Milk Co.,
King City, Monterey Co.,
Calif.



Part of the Herd of 3,500 Goats on a Single Ranch in Monterey County, California, Where Goat's Milk is Now Evaporated and Canned on a Commercial Basis for the First Time, Making It Available for City Dwellers. The Photo Shows a Fine Lot of Milkers

DEVELOPING THE COMMERCIAL POSSIBILITIES OF GOATS

By ALBERT MARPLE

IF the aims and objects of some of the leading ranchers and dairymen of California materialize, the thoroughbred milk goat will be an important factor before long in the lives and health of the people of the United States. Although the goat has been one of the most important domestic animals in Europe, we on this side of the Atlantic seem to be reluctant to grasp the real worth of this little chin-whiskered creature. We have, in some measure, made use of the common or "Mexican" goat, but not until very recently has goat's milk been handled here in a commercial way.

During the past few months a number of goat ranches or dairies have sprung up in southern California, appearing in true mushroom style, and tending to show that when the real value of the milk of the goat is known, it is bound to receive a warm welcome. These ranches sell the goats'

milk fresh, as does the ordinary dairy, the average price received being 25 cents a quart. And in addition to selling the milk in this way a considerable quantity of goat cheese is manufactured in that section.

There is one company, however, which for the first time in the history of the goat-milk business, is evaporating that product under vacuum, after which it is canned and presented to the consumer in very much the same condition as evaporated cow's milk. The object is to make this product just as accessible to those living in the heart of the large city, where a goat is never seen, as to the farmer or suburbanite. To evaporate goat's milk, as is claimed to be the



Thoroughbred Doe on the Milking Platform: This Goat Averages About Five Quarts of Milk Daily, Worth 25 Cents a Quart

case with cow's milk, increases its keeping and digestible qualities, also its purity, as well as ease of transportation.

This innovation in the goat-milk industry has just been introduced by a

concern in Monterey County, Calif., about 100 miles south of San Francisco.



A Week-Old Kid Taking One of Its Last Natural Meals before being Weaned by the Aid of a Bottle

The ranch of this company, five miles from King City, consists of 5,000 acres of the prettiest rolling country imaginable, while its herd of goats at this writing numbers about 3,500, these being divided as follows: 2,500 does of the milk-producing age; 750 between the ages of three and six months; 200 babies, and 50 bucks.

The work of raising the babies on this ranch is of unusual interest, for the process is practically

identical with that necessary for the raising of the human infant. For about a week following birth the kid is permitted to remain with its mother, after which the mother is turned into the herd of "milkers," and the kid is fed by hand. For this purpose an ordinary feeding bottle and nipple are used, it taking about two days to wean the babies. A mixture of half goat's and half cow's milk is fed at the start, after which the percentage of goat's milk is

gradually lessened. For a week or 10 days the kids are fed by hand; then they are taught to feed from nipples arranged along the sides of long pans. This nipple feed continues for about three months, when the little ones are further weaned by being fed, for a space of about three weeks, on one meal of grain and one of milk

daily, after which the milk is eliminated entirely.

The does on this ranch are divided into two herds, the "dries" and the "milkers." They are kept in separate corrals and are fed from different parts of the range. The milkings occur at 4:30 in the morning and the same time in the afternoon. At 9:30, after the morning milking, both the dries and the milkers are taken out upon their respective feeding grounds, accompanied by a herder, and they return to the corrals



Teaching the Little One to Drink: An Ordinary Feeding Bottle and Nipple are Used, with Half Goat's and Half Cow's Milk



Nipple Feeding from Long Milk Pans: The Kids Soon Learn to Use This Method, which is Continued for About Three Months

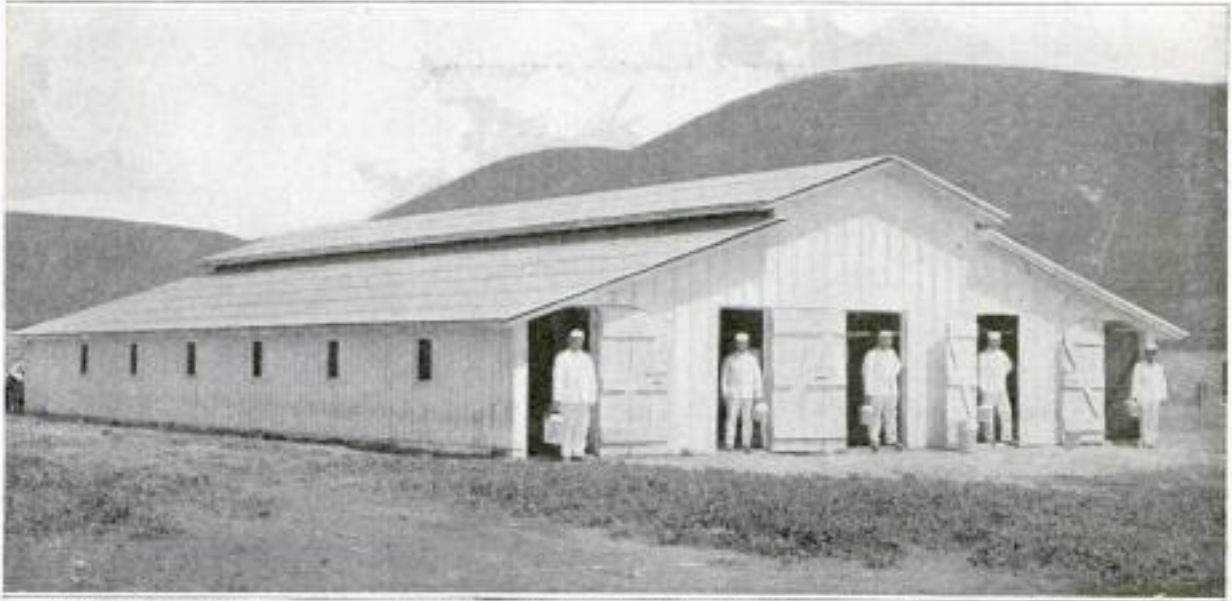

The Milking Shed on a Large Goat Ranch: Twice a Day 400 Goats at a Time are Milked in This Barn. The Milkers Sit behind the Animals, Instead of at the Side as in Milking Cows, and the Goats Stand on Wooden Platforms

just before milking time in the afternoon. For the milking process a large barn has been provided, and shifts of 400 goats each are arranged. During milking, the goats stand upon wooden platforms and eat from clean mangers, while the milkers sit behind the animals, rather than at the side as in milking cows. From the milking barn the milk is taken to the milk house, where it is cooled, poured in sanitary cans, and loaded on auto trucks, bound for the condensary in King City.

As has been stated, the condensing of this milk and the canning of it are entirely new to the goat-milk industry,

and the method of treating the milk at this condensary is of interest. After being unloaded from the trucks the cans containing the milk are arranged in rows upon the concrete floor. When everything is in readiness the milk is poured from the cans into a mammoth copper heating kettle, which has a capacity of 200 gal., or 2,000 lb., and while in this kettle, it is heated to at least 160° F., after which it is drained by vacuum to the copper vacuum boiler, where the condensing process takes place. This consists of reducing the quantity of milk about 50 per cent, the portion taken away being entirely



A Goat Kids' Playground on the Ranch: The Young Animals Are Just as Playful as Kids Ought to Be, and Special Apparatus Like the Above is Provided for Their Amusement

water. The condensing process takes about 40 minutes, after which the milk is drawn to the hot-milk tank or reservoir, and from this it is pumped to and over a tubular cooler, from which it is piped to the filling tank. This tank is in reality the reservoir of the filling machine, which has a capacity of two dozen cans at a time.

After being filled the cans are crimped in a sanitary manner, packed in the cases in which they are to be shipped and taken to the sterilizer, which holds 60 dozen cans at one filling. This device is in the form of a drum, within which the cases are fastened. When the cans are in place, the lid of the drum case is closed and locked, and the drum is then revolved at a fair rate of speed, during which operation live steam is injected into it. The interior of the device is brought to a temperature of 240° F., and permitted to remain at that heat for at least one hour. The cans and their contents, after being taken from the sterilizer, are permitted to cool. Then, if necessary, they are placed in the shaker. The purpose of the shaker is to bring whatever portion of the milk may have become thick, due to the rich quality of the milk, back to its original

condition. The shaker moves back and forth at a rate of 50 trips per minute, this operation being continued from 10 seconds to 5 minutes, according to the requirements of the milk. From the shaker the milk is taken to the store-room, where the cases are turned over once each day for two weeks, this operation revealing the leaks, if any, in the cans; then the cans are labeled, after which the milk is ready for shipment.

The goats on the ranch are of the kinds that are considered the best milking strains in the world, namely, the Toggenberg (Swiss), Anglo-Nubian (English), and Saanen (Swiss). A good milk goat will produce twelve times her own weight of milk in a year, while the cow is considered as doing very well if she produces about four times her weight. At present the goat milk is being produced solely for infants and invalids, although it is the object of these dairymen to widen the field as rapidly as possible. One of the most important points about the goat is that it is considered free from tuberculosis, while the United States officials condemned, because of tuberculosis, in the year 1914 alone, 29,738 cows out of those slaughtered for food purposes.

BULLOCK CARRIAGE USED IN MADEIRA

Until recently almost the only means of conveyance in the island of Madeira was the bullock carriage known as the

"carro." A popular form of this vehicle carries four passengers in two opposite seats of wickerwork, nicely upholstered, with low side entrances and a canopy top, the body of the carro being mounted on springs on a pair of strong wooden, steel-shod runners with upcurved ends which sustain the weight. A driver walks beside or behind the vehicle, occasionally dropping a greased rag in front of first one runner and then the other, to lubricate them as they pass over it, while a boy walks in front of the team of oxen, directing them with strange cries.



This Slow but Comfortable Vehicle Called a "Carro," Is a Familiar Sight in Madeira, on Streets Paved with Smooth Pebbles from the Ocean Beach



Motor Busses are being Operated in Chicago for the First Time. Although the Popular Demand for Them has Been Urgent for Several Years. The Pictures Show Two of the Machines Carrying and Discharging Passengers at Different Points along the North Shore. Service to the South Side is Expected to be Instituted in the Fall

MOTOR BUSES GIVE RELIEF TO CHICAGO STRAPHANGERS

After several years' negotiations, motor busses have finally been admitted to Chicago boulevards and are now carrying north-shore residents to and from the loop district. Although a fair schedule is maintained, there are as yet hardly enough of the machines in use noticeably to lessen congestion on north-side transportation lines during the rush hours. This effect, however, is expected to result as the size of the flotilla is increased. Service to the south side is to be inaugurated in the fall. The cars are of the usual double-decked type.

NEW FLOOR POLISHER HAS TWO DETACHABLE UNITS

A motor-driven floor-polishing machine, which has just been offered to the trade, can be operated with either two or four revolving disks according to the requirements of the job. Each disk is connected with a vertical driving shaft by a universal joint so that pressure is applied directly to its center even on an irregular surface. The polishing is done by four carborundum blocks attached to each disk. The two detachable revolving units are provid-

ed with a separate metal framework and gearing, and when a machine of larger capacity is desired they can be quickly attached to the original unit. No previous experience is required to operate the polisher.

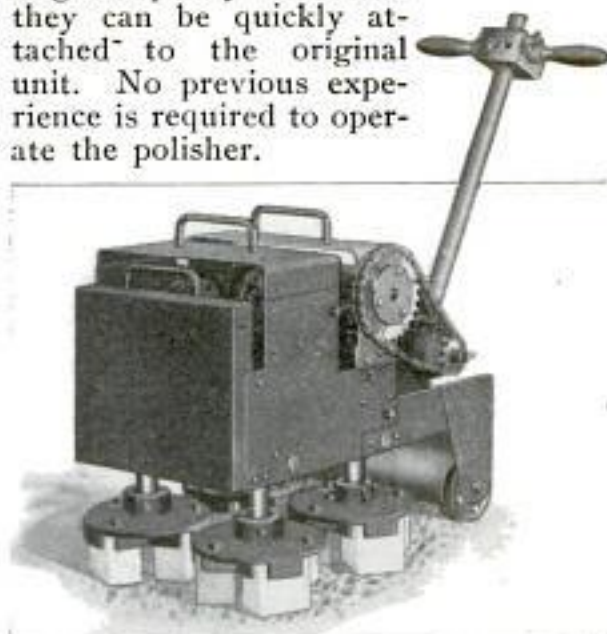

Floor-Polishing Machine with Four Revolving Units, Two of Which can be Detached: The Machine is Driven by a One and One-Half Horsepower Motor and Weighs 325 Pounds

ARTISTIC CHICKEN HOUSE LOOKS LIKE A DWELLING

Strangers passing the artistic structure shown herewith, which is situated on an estate in southern Wisconsin, have sometimes mistaken it for a concrete dwelling, but as a matter of fact



This Well-Built Structure, Which at a Glance Looks Like a Dwelling, Shelters Chickens on an Estate in Southern Wisconsin

it is a chicken coop of the most up-to-date and elaborate sort. The smooth white outer walls, the diamond-paned windows, and the gambrel roof give it quite the appearance of a home for folks instead of for a few score fowls of which the wealthy owner is fond.

FARM TRACTOR PUMPS WATER FROM CELLARS

A farm tractor rendered excellent, though unusual, service in Norfolk, Neb., recently, when it aided in pumping water



This Farm-Tractor Engine is Driving a Pump for Drawing Water from a Flooded Cellar in Norfolk, Nebraska

motor trucks to an unusual task not long ago when they employed them in

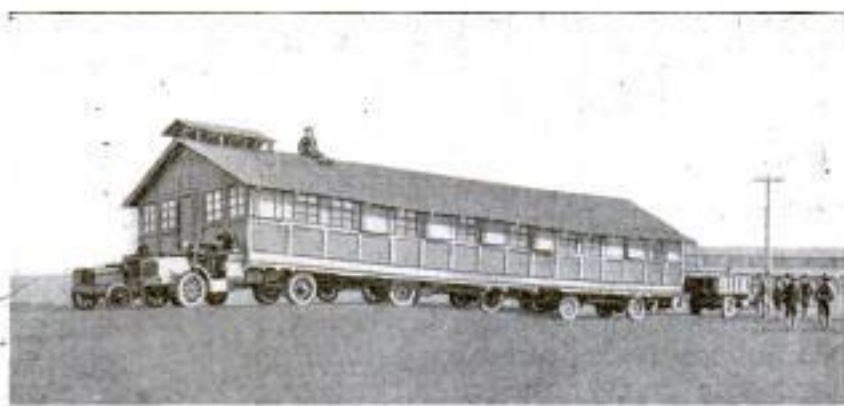

Novel Method of Moving Frame Structure: Army Mess Hall at Camp Wilson, Texas, Mounted on Motor Trucks Which Carried It About a Mile to a New Site

moving a large wooden mess hall about a mile to a new site. After suitable temporary construction had been provided within the building, it was raised up and a number of the trucks were placed beneath it. The two foremost machines were so placed that their forward ends, including the front seats, projected beyond the building, enabling the drivers to see the road ahead. In transit the big frame building looked like an ark on wheels.

from flooded cellars in the town. High water had practically tied up business and power was scarce, so the tractor was brought to the scene and connected by a belt with a pump. This outfit was able to draw off the water at a rapid rate.

ARMY TRUCKS CARRY BIG MESS HALL A MILE

Army engineers at Camp Wilson, Tex., put

MOVIE SHOWS ON THE EDGE OF GRAND CAÑON



This Building on the Edge of the a Motion-Picture Theater Seats and Giving Shows

Tourists visiting the Grand Cañon of Arizona recently have been surprised to find a motion-picture theater built on the very edge of the cañon, at a point from which one of the world's most wonderful views is obtained. The little theater seats about 50 people and shows are given four times a day during the tourist season. It is owned and managed by an explorer-photographer widely known for his work in the cañon. Light



Power House in the Cañon That Furnishes Electric Light for the Movies, 50 Feet Above

Grand Cañon of Arizona Contains Seating About 50 Tour- Four Times a Day

for the projecting machine is obtained from a dynamo and gasoline engine, located in a small galvanized-iron shed about 50 ft. below the theater, but controlled from the operator's booth, where the wife of the explorer reigns supreme. From the back porch of the picture house,

which is propped against a slope of the cañon in the big horseshoe cut near El Tovar, the tourist looks down 2,000 ft. into the bed of the cañon.

MECHANICAL DEVICE TESTS SPEED OF TYPEWRITERS

One of the large typewriter concerns of the country employs a mechanical device, in preference to expert operators, to test the speed of each machine turned out. The small motor included in the apparatus drives a cylinder a foot in diameter, on the surface of which are rows of projecting teeth. As the cylinder revolves it trips rubber-tipped hammers, which in turn strike the keys of the typewriter being tested. Each machine is operated by a device of this character for half an hour, at the rate of 560 strokes per

minute, and if it fails to respond properly, is sent back to the assembling room.

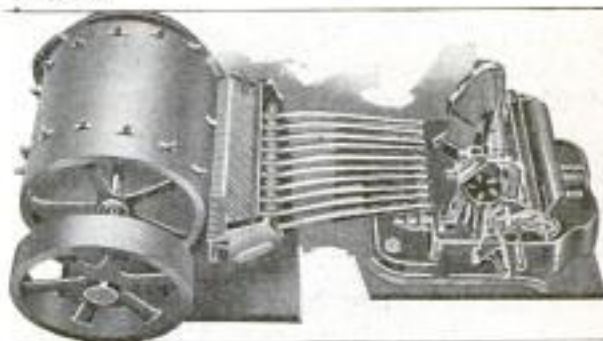

Speed Tester for Typewriter: The Revolving of the Cylinder at the Left Operates the Hammers, Which in Turn Strike the Keys of the Typewriter. Each Machine is Tested for 30 Minutes at a Rate of 560 Strokes per Minute

(Incr.) 74

HYDRAULIC MULTIPLE PRESS FOR WET MATERIALS

A new form of hydraulic press, with multiple pressing compartments, has been devised for the removal of mois-

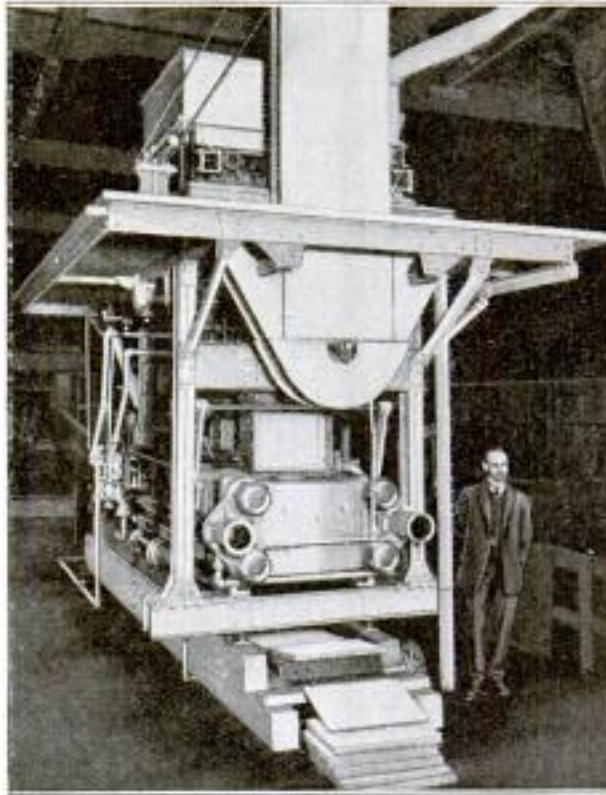

Automatic Hydraulic Press, with Multiple Compartments, for Removing Water from Wood Pulp: Pressed Pulp Cakes are Seen Coming from the Machine in the Foreground

ture from all kinds of wet or pulpy materials, such as wood pulp, or any process requiring great and steady pressure. The multiple-compartment system consists of a plurality of compression chambers, operated simultaneously and automatically, their movements being timed and controlled by a special governing device. Thus a number of cakes of a compressed product may be in process of compression at once, and there is a consequent saving of power. A series of compression cylinders is carried backward and forward so that their pistons receive in turn the pressure of a hydraulic ram, this pressure being applied to the material confined in the compression chambers, which are charged and discharged automatically.

DEEP SNOWS CAUSE DEATH OF YELLOWSTONE ELK

Many of the elk in the two principal Yellowstone herds perished through the conditions which existed this year, due to an exceptionally heavy winter snowfall and the late oncoming of spring. Deep, crusted snow prevented the elk from getting at their usual feed, and the weakened animals, especially the calves, died rapidly in spite of the large supplies of hay provided by the government for such emergencies, which were soon exhausted. One of the herds, numbering more than 20,000 elk, usually winters around Jackson's Hole, in Wyoming, and is known as the southern herd. The Biological Survey had provided over 600 tons of hay for feeding them, but the losses amounted to possibly one-third of the entire number, including practically all last year's calves. The northern or park herd is estimated to contain over 30,000 elk, and these were widely scattered in search of food, with considerable losses probable.

SPITTING HABIT CURED BY PAINTING CORNERS WHITE

Employees in a certain Boston factory, who had acquired the insanitary habit of spitting in the corners of the room, were cured of the practice when the floor and walls adjacent to the corners were painted white. This simple expedient also served as an inducement to the janitor to be particularly careful when sweeping and mopping in the corners.

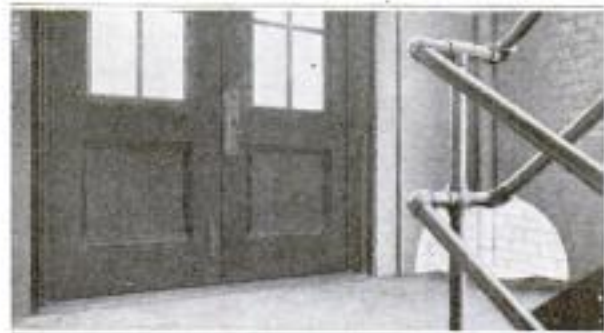

Corner in Boston Factory Painted White so That Employees would Be Less Apt to Expectorate in It

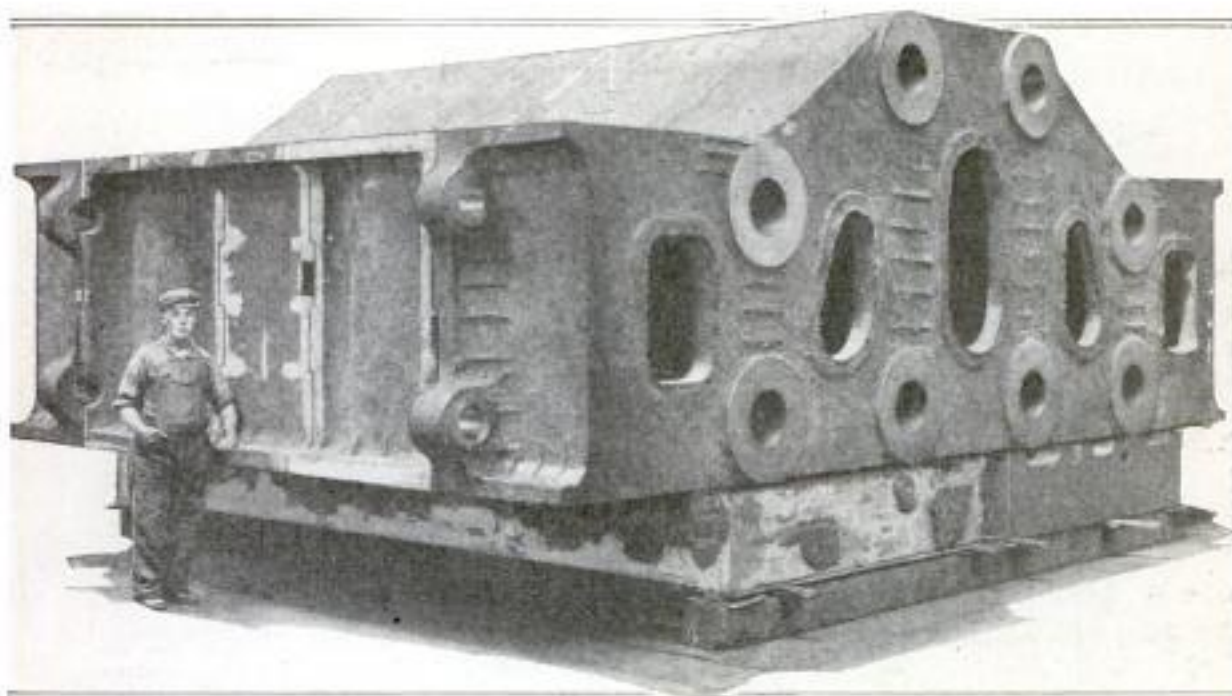

Showing the Five Castings, Each Weighing About 96,000 Pounds, Assembled

HEAVY CASTINGS ARE MADE FOR POWERFUL MACHINE

Five castings, having a total weight of 480,000 lb., were recently made at a Pennsylvania steel plant for a 9,000-ton forging press. Neither the individual parts nor the machine itself is record-breaking in size, but both are sufficiently large to be of interest, particularly to the layman. At the same plant a single casting weighing 400,000 lb. was produced some time ago.

THERMOMETER CONTROL FOR STREET-CAR HEATERS

To save a great deal of the electric current usually wasted in heating electric cars, the street-car systems of Chicago and other cities are being rapidly equipped with a new device which appears to give a simple and reliable form of thermostatic control of the heating. The regulator is mounted in a steel box, which is usually placed on the wall of the car vestibule. It is connected by two wires to an accurate mercury thermometer in a perforated metal case, mounted inside the car. The wires connect with two special platinum points fused into the glass of

the thermometer, one near the bulb and the other at a specified temperature point on the tube, usually between 50° and 52°. The mercury completes the electrical connection of the contacts. When the temperature in the car reaches 50°, say, a circuit is formed which opens a switch in the regulator

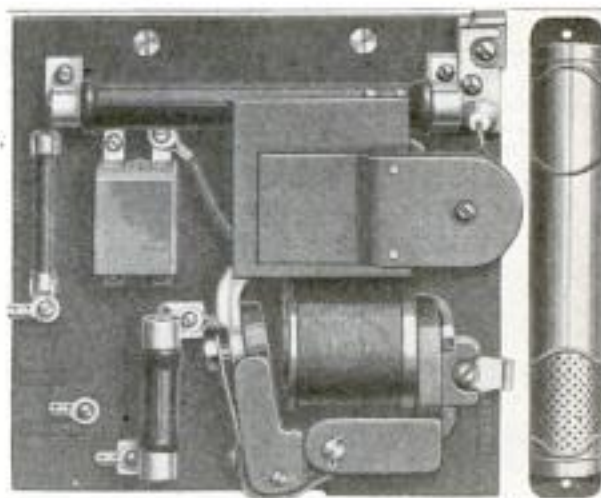

Regulator Panel of New Device for Thermostatic Control of Electric-Car Heaters; This Panel Connects with a Thermometer in the Car

and shuts off the heating current. As soon as it falls below that point, the heat is similarly turned on. Thus an equable temperature will be maintained in the car.

CIVIC FEATURES THAT PROMOTE THE COMFORT



The Call of Outdoor Life is Made More Alluring by Many Convenient Ovens Like This Provided on the "Sky Line Drive," near Cañon City, Colorado



Umbrellalike Concrete Shelter for Street-Car Patrons in a Salt Lake City Suburb: Panels are Provided in the Post for Street Signs



An Example of the Provision Made for Visitors in Its Beautiful Mountain Parks by the City of Denver: Stone and Undressed Pine have been Used Very Effectively in This Shelter



A Rustic Fountain in Sioux City, Iowa, Having as Much Charm as an "Old Oaken Bucket": The Hollow Knot That Serves as a Bowl, to Which Concealed Pipes Lead, is Cement-Lined



Because of Its Queer Shape They Call This Six-Sided Seat a Tub. It Stands on an Ocean Pier at Venice, California

AND ENJOYMENT OF RESIDENTS AND VISITORS



In These Tree Pots of Concrete Small Trees can Grow Despite Hard Pavements



Graceful Traffic Guide at Modesto, California, Adorned with Potted Plants: On the Sides Are Signs "Keep to Right," At Night Red Lights are Shown



At Denver's Civic Center, Where a Dozen Car Lines Converge, Stands This Inviting Many-Windowed Waiting Room, with Flower Beds about It. Street-Car Patrons Feel That the \$469 Which It Cost has Paid Big Dividends

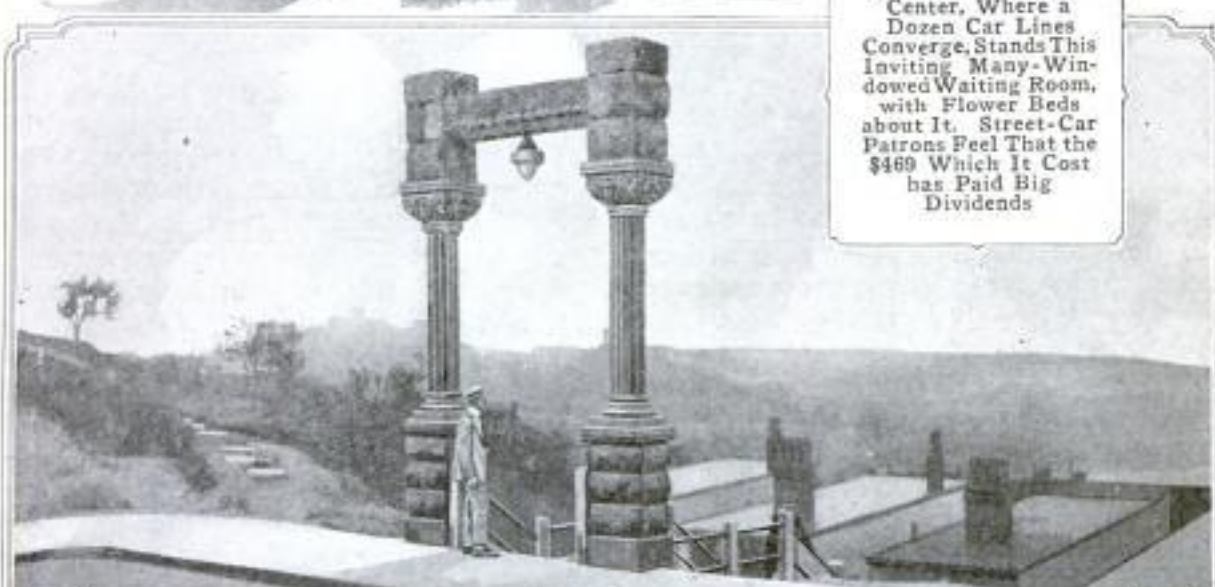

When Cincinnati's Old Courthouse was Torn Down Two of Its Marble Columns were Used to Make This "Gateway to the City." From This High Point of Vantage One Obtains an Impressive Panoramic View of the City's Business District and Many Public Buildings

BIG CLOCK WITHOUT HANDS TELLS TIME BY FIGURES

In the tower of the Union Station of Nashville, Tenn., is a great clock which is believed to be different from any other tower clock in many respects. Instead of the usual circular dial with revolving hands, the time is shown by white figures 28 in. high, mounted on endless flexible bands, which move across the face of the clock, changing every 60 seconds. Figures of this height can, of course, be read much



farther than those on an ordinary clock dial occupying the same space. At night they are illuminated. The clock is operated by weights, aggregating several hundred pounds, which are wound up automatically by electrical power. This remarkable timepiece was constructed by a resident of Louisville, Ky., who devoted his spare time to the task for a number of years. In seeking to construct a clock of the peculiar type demanded, he was confronted with many mechanical difficulties which had to be solved along original lines.

ADAPTABLE TRAY OUTFIT FOR SORTING LETTERS

A new outfit for offices, designed to make the sorting of correspondence easier, consists of four trays held one above the other in staggered positions, a short distance apart, by a standard having a broad base and



notches in one side of its upright portion, into which the trays can be inserted so that they are held securely.

Any or all of the units can be taken out or rearranged merely by tilting them up, thus releasing them from their support.

CASTER-MOUNTED CAN FOR PRINTER'S "DEAD" METAL

A large galvanized-iron can, equipped with casters and handles, has been put on the market and is proving a great convenience in printing shops as a receptacle for "dead" metal. It saves the printer's time because it can be drawn close up to the case or stone to receive old matter when it is being thrown out, and its transfer to the casting room can be accomplished without any lifting. Dirt is not apt to collect around the can since it can be moved easily.



NEW DISPENSING MACHINE FOR MALTED MILK

A malted-milk dispensing machine has been designed for soda fountains which discharges a carefully measured amount of powdered milk at each operation, thus preventing waste and at the same time serving as a sanitary container. The upper part of the apparatus constitutes a hopper in which the supply of material is kept. By pressing down a lever projecting from the side of the machine the desired amount of powder is discharged from a measuring device into the glass placed to receive it. This measuring device can be set for any one of eight different amounts.



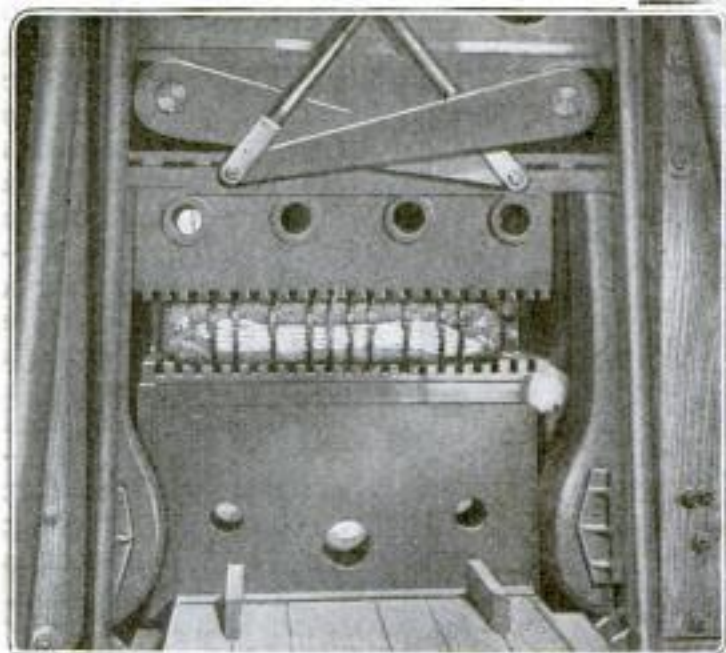

Bale of Cotton in the New Machine being Compressed to a Density of 34 Pounds per Cubic Foot

POWERFUL COMPRESS MAKES COTTON BALES SMALLER

By compressing cotton bales to a far greater density than has been common heretofore, it is now possible to increase by nearly 50 per cent the capacity of freight cars, warehouses, and steamships, as regards cotton. A powerful press of a new type has shown during recent tests in New Orleans' huge new warehouse that it can easily compress cotton bales to a density of 34 lb. per cubic foot, whereas with the older presses 20 to 22 lb. per cubic foot was the limit. The new equipment is said to be capable of increasing the density to as much as 50 lb. Arrangements have been made to install a number of these high-density compresses in the warehouse, with a view to attracting much additional land and water traffic to New Orleans. About 73 bales of the reduced size can be loaded into a 36-ft. freight car, whereas between 50 and 60 of the regular-size bales are a capacity load.

Ⓒ Powdered glass is said to be used as a filling between two layers of thin armor plate on German armored cars, thus forming a protection against rifle bullets that is very effective.



General View of New High-Density Compress in New Orleans' Huge Cotton Warehouse

CANE USED AS CONTAINER AND STAFF FOR FLAG

A walking stick, in which a flag may be carried when not displayed, is a recently patented invention of special interest in these days of patriotic demonstrations. The cane is hollow and by removing the head a flag, which is tightly rolled up, may be withdrawn. Means are provided for attaching the emblem to the end of the stick, which thereupon serves as the flagstaff. Carried in the cane, the flag is not wrinkled and is protected from the weather.



Hollow Cane in Which Tightly Rolled Flag can be Carried, Protected from the Weather; By Removing the Head the Flag can be Withdrawn and Attached to the Cane, Which Thereupon Serves as a Flagstaff

CAN-LABELING MACHINE OPERATES BY GRAVITY

A labeling machine for gallon-size cans, which operates entirely by grav-

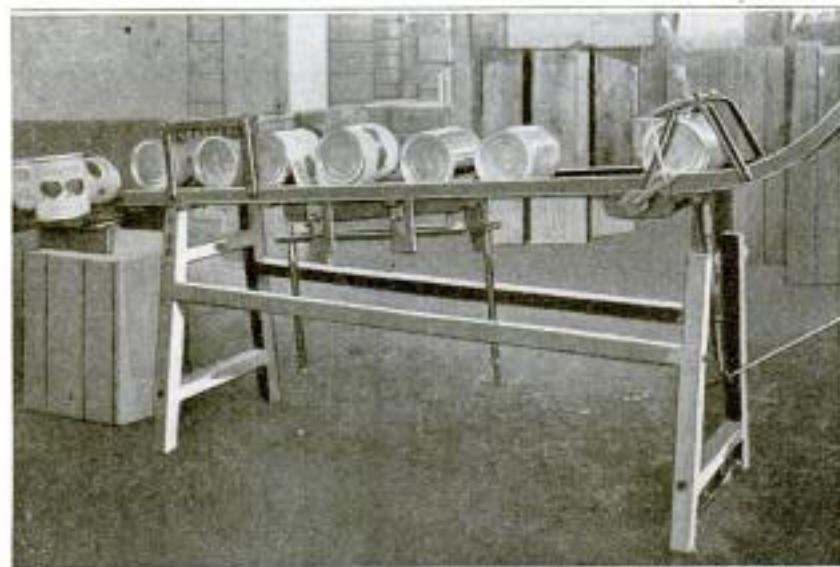

Gravity-Operated Machine for Labeling Cans: As Containers Roll down the Incline Each Receives Sufficient Paste to Enable It to Pick Up a Label. It Then Passes beneath Brushes Which Smooth Out the Wrapping

machine costs practically nothing to operate and is less complex than a power-driven piece of equipment. The cans to be labeled are placed at the upper end of an incline, down which

they roll of their own weight, passing over a tray containing adhesive and then over a stack of labels. While rolling along enough paste is acquired by a can to pick up a label from the pile. The adhesive is so placed that it comes in contact with only the two ends of the paper strip, which is automatically wrapped around the can. At the end of the incline the container passes under brushes which complete the labeling process by

ity, has been built to do work now done by hand in many factories. The

smoothing out and pressing down the wrapper.

ELEVATOR GATE OPERATES ON TWO FLOORS

The proprietor of a motorcycle warehouse has designed and installed an elevator gate that serves to close the shaft entrances on either floor of the two-story building when the elevator is at the other floor. This is accomplished by hanging the gate in a steel groove by chains that run over pulleys at the top of the shaft and then are securely fastened to the floor of the elevator on its rear side. Thus the gate operates somewhat like a counterweight. When the elevator is at the first floor, the gate is in position before the opening on the second floor. When

the elevator goes up, the gate comes down to the first floor. Movements of the elevator are signaled by an electric gong, and with the gate device the shaft cannot be left open. The cost of

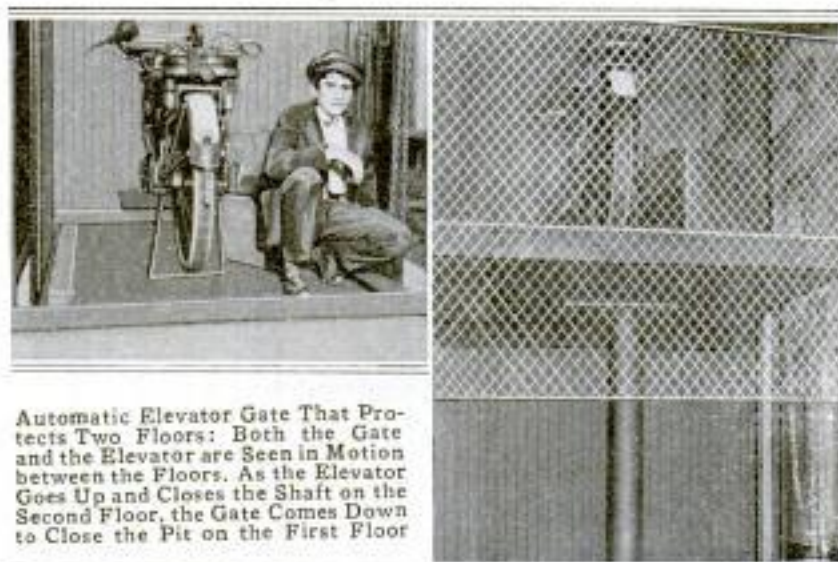

Automatic Elevator Gate That Protects Two Floors: Both the Gate and the Elevator are Seen in Motion between the Floors. As the Elevator Goes Up and Closes the Shaft on the Second Floor, the Gate Comes Down to Close the Pit on the First Floor

installation was less than that of other gates in common use.

SHRAPNEL

By REGINALD TRAUTSCHOLD, M. E.

A SHORT time ago, a man was haled to the police court for having under his arm a package containing a shrapnel, incorrectly referred to as a shrapnel shell. It is safe to assume that had passers-by known the contents of the package, at least one side of the street would have been shunned, while had the package dropped to the sidewalk a wild panic might readily have ensued. As a matter of fact the package the man carried was as safe as a box of candy, for shrapnel without a fuse is harmless and the fuse is fitted to the shrapnel only on the battle field. We hear a great deal of talk about "shrapnel" and read more, but, as this incident shows, we really know mighty little about it.

While all artillery projectiles are not shrapnel, the word is often incorrectly used, even by men who have been under artillery fire and who are very often apt to describe as effects of shrapnel what are in fact effects of high-explosive shells. Then, what is shrapnel?

The dictionary defines shrapnel as "a shell filled with bullets and having a bursting charge to explode it at any time in its flight." This definition is credited to a British officer, but, while accurate, is somewhat misleading. It describes the inside of a shrapnel well enough, as shown in Fig. 1—a view which has become quite familiar in the past three years. The bullets, technically shrapnel, are imbedded in rosin and fill the steel casing above the diaphragm which closes up

the powder pocket in the base of the casing. In this powder pocket is confined the powder charge which "explodes" the shrapnel. A timing device, from which emanates the flash which ignites the powder charge at some predetermined instant, caps the shell casing and forms the nose of the shrapnel. All this has become familiar enough to many within the last few years, with the possible exception of the timing device and its operation.

So much for what a shrapnel is. What a shrapnel does is clouded by even more general misunderstanding.

Consulting the dictionary again, we note that the shrapnel carries a bursting charge to explode it, and the general belief is that this charge, carried in the powder pocket in the base of the casing, shatters the steel shell and scatters the charge of shrapnel bullets. Even the head of a prominent concern engaged in the manufacture of war munitions, in describing the powder pocket, uses the expression, "which contains the necessary amount of powder to explode the casing." This may happen at times, but it is not what a shrapnel is designed to do, nor what a properly built shrapnel will do.

On firing a gun loaded with shrapnel, the cartridge case is left behind, just as is the shell when discharging an ordinary shotgun. The complete shrapnel, with its time fuse, etc., is projected at a high rate of velocity, revolving rapidly in its

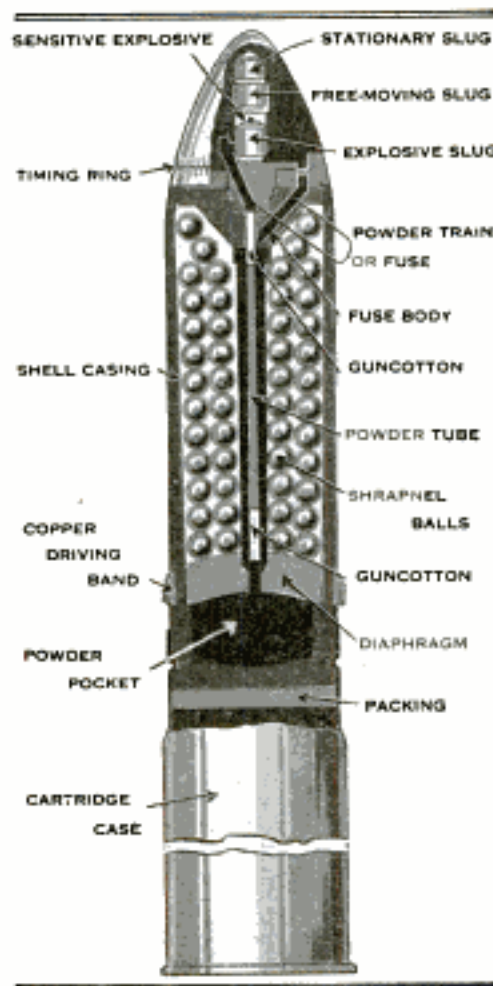

Fig. 1—Section of a Shrapnel: A Three-Inch Size Contains from 240 to 250 Bullets, Varying to Give Exact Weight

flight, and travels as a unit until such instant as the flash from the fuse reaches the powder pocket. When ignition of the powder charge occurs, the diaphragm, separating the powder pocket from the section containing the shrapnel balls, is driven forward. This strips the fuse body from the end of the shell casing, while the forward travel of the casing is seriously retarded, if not arrested or reversed. On issuing from the casing, the diaphragm plows through the mass of shrapnel balls and scatters them in all directions, the rosin which bound them together having been melted by the heat of the explosion and the friction created in driving the collection of shrapnel and partly melted rosin from the shrapnel casing.

The blast of the gases formed by the explosion of the powder charge on issuing from the open end of the casing scatters the shrapnel still further and imparts to the balls a velocity which makes them very destructive within a radius of about 60 feet of where the shrapnel "breaks." Part of the gases generated in the powder pocket are apt to escape through the powder tube and this strips the fuse cap from its body, or, if the fuse body is stripped from the shell casing before this takes place, the fuse body is pulled from the end of the powder tube. After the break of a shrapnel, the head of the projectile continues in advance, with a certain accelerated speed, followed by the diaphragm, powder tube, etc., and the spread of scattering shrapnel. The casing, having lost much of its momentum, drops to the ground (Fig. 2).

Should the force of the explosion within the powder pocket not be suffi-

cient to strip the threaded connection between the fuse body and the shell casing, the steel shell would explode, but only in such a case. To retain the effectiveness of the shrapnel, the fracture would be limited to a section near the mouth of the casing, where its walls are comparatively thin, and the shrapnel would be scattered from the

remainder of the casing as before. The shattering of the steel casing takes place only when a shrapnel fails to break properly. It is not what a shrapnel does ordinarily, but what it may do in the case of an emergency.

A shrapnel which breaks properly during flight simply scatters shrapnel balls, not fragments and pieces of jagged shell such as fly from an exploding high-explosive shell. When a shrapnel, through failure of the time fuse to respond, does not explode until it comes in contact with the ground or some other firm object in its path, then, and only then, the steel shell is fractured and pieces scattered in all directions. Damage frequently described as caused by flying pieces of shrapnel casings, therefore, is more probably correctly to be ascribed to fragments of high-explosive shells.

A properly built shrapnel can be timed to break accurately at any predetermined distance in its flight, notwithstanding the fact that on leaving the muzzle of the gun it may be traveling at a speed of close to 2,000 ft. per second. The time fuse controlling this all-important function is carried on the end of the shell casing and forms the nose of the projectile. Different types of fuses are employed, but the one depicted in Fig. 1, a combination detonator and time fuse, is simple and

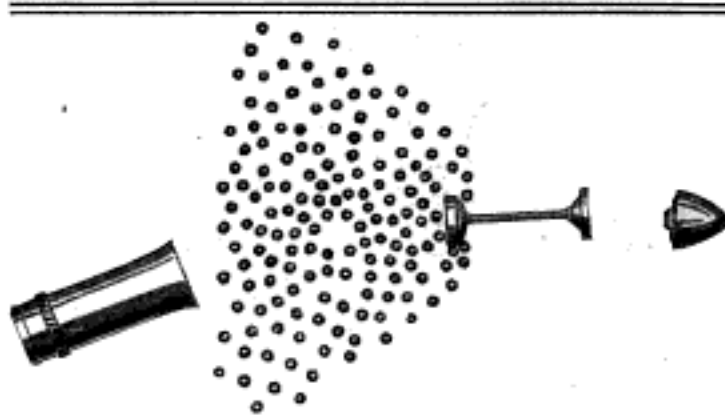

Fig. 2—What Happens When a Shrapnel Breaks Properly: During Flight, at the Time Set, the Powder Charge is Ignited, the Balls are Scattered by the Diaphragm Plowing Forward, and the Head of the Projectile Flies in Advance

well illustrates the principle involved. The cap of the fuse contains three slugs, or pellets, the upper one of which fits firmly into the nose of the cap and serves primarily as a cushion against which the center free-moving slug rebounds on the discharge of the gun. The free-moving slug fits loosely in the cap, so that on the instant the shrapnel leaves the cartridge case on firing it is thrown forcibly against the lower slug. This explosive slug carries on its upper end a small quantity of ignitable and highly explosive substance which is instantly exploded with a flash when struck by the free-moving slug. This ignites a powder train, or fuse, encircling the inside of the timing ring and connecting with the lower of the two powder trains shown in the illustration as leading to the guncotton in the upper end of the powder tube. The flash from the ignited upper section of guncotton is transmitted with lightning rapidity, through the central powder tube, to the guncotton in the lower end of the powder tube, and the powder charge in the powder pocket is thus ignited.

Adjustment of the timing ring regulates the time required for transmitting the flash of the sensitive explosive on

the end of the explosive slug to the powder under the diaphragm, so that the shrapnel will break at any predetermined point in its flight. This regulation is accomplished by simply increasing or decreasing the length of fuse which has to be consumed between the point at which it is ignited by the flash from the explosive slug and its connection to the train leading to the guncotton.

Should the free-moving slug stick, however, and fail to strike the explosive slug when the gun is discharged, the shrapnel will not break, but explodes when it strikes a firm object. On striking, the explosive slug is thrown violently forward by the concussion and in moving forward opens communication to the upper of the two powder trains, so that the flash of the sensitive explosive ignites this more direct train. This explodes the powder charge in the pocket instantly, as no time is wasted in the preparatory consumption of the encircling fuse within the time ring.

A shrapnel is in fact nothing but a kind of smooth-bore cannon charged with bullets, which is shot off while in flight and explodes as a bomb only when it fails in its mission.

SURGICAL SEWING FORCEPS SAVES OPERATOR'S TIME

For the more rapid and regular sewing up of wounds and incisions, a surgeon has designed an instrument which has the general character of a pair of forceps and is handled similarly. It carries a needle at one end of the curved blades. When the handle of the device is closed, the needle passes through the flaps of tissue, carrying the thread with it, and is automatically seized and held by the opposite blade. Then the handles are closed again and by pressing a thumb catch near the middle of the forceps the needle is released from its position in the second blade and returns to its original place in the first blade, ready for another stitch. The stitches are made in an in-

stant of time, much more rapidly and with greater regularity of spacing and of tension than is usually possible by hand.

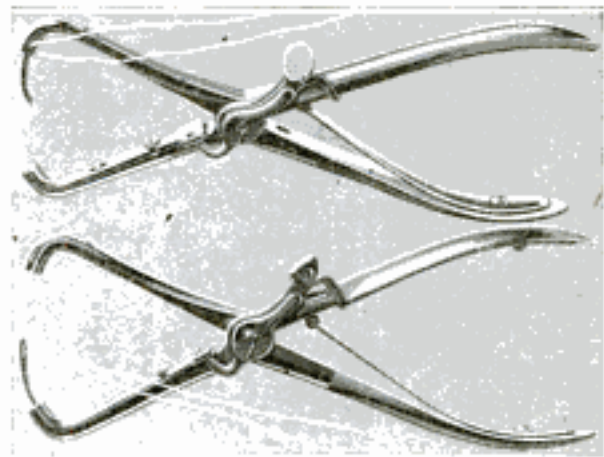

First and Second Positions of the Needle in New Surgical Sewing Forceps: It Passes from One Blade to the Other in Making the Stitch

CITIZENS STRING BOOM TO SAVE A DAM

When the dam that furnishes power to run the municipal lighting plant of a



Scene When the Mazeppa, Minnesota, Dam was Expected to Give Way, After Part had been Torn Out, as Shown

Minnesota village was repaired last summer, the authorities failed to replace an ice boom that protected the dam. As a result, when the ice went out in a sudden thaw this spring, part of the dam was carried away. To save the rest and avert a calamity, a few citizens volunteered to string the boom across the river, and this they did in four hours, saving the dam at the risk of their lives.



Citizen Volunteers Stringing a Boom across the River to Save the Dam from Further Damage by the Ice

another. Not only is it proposed to undertake extensive works of this character after the war, but certain projects are under way at the present time. Today Germany has more than 8,000 miles of navigable waterways. This total includes open rivers, rivers made navigable, canals, and navigable lakes.

The Rhenish papers, it is said, are talking freely of building a canal from Antwerp to Aix-la-Chapelle and Cologne, thus making a navigable waterway from the Scheldt to Constantinople. It is proposed, also, to greatly improve the canal facilities from Strassburg to Basel, a distance of 79 miles. The Mosel is to be regulated

so that the ore deposits in Lorraine and Luxemburg can be transported by water. The Elbe is being improved and the Moldau, its principal tributary in Bohemia, will be canalized as far as Prague. The



The River and Dam Next Day, After Danger had Passed: The Boom Held the Ice in Check and Saved the Village Thousands of Dollars

WATERWAY IMPROVEMENTS PLANNED BY GERMANY

In the midst of war Germany has found time to plan numerous important extensions to its inland-waterway system, including the improvement and construction of canals and the regulation of streams. In fact, the present conflict has tremendously increased the need of making all possible improvement in facilities for transporting materials from one part of the empire to

Oder is to be improved also, and with certain tributaries which connect with the Bromberg Canal, will be well joined with the Vistula.

ⓄThe war has entirely shut off the European trade in fireworks, out of Hongkong.



Two Teams of Percheron Horses Switching a Train of 19 Cars Loaded with Hemlock Logs in the Yards of a Wisconsin Paper Mill: Note the Team "Hanging to the Pull"

FREIGHT TRAIN SWITCHED BY FOUR HORSES

When a yard switch engine broke down at Eau Claire, Wis., recently, a train of 19 flat cars, carrying hemlock logs for a paper mill, was switched by two teams of heavy Percheron horses belonging to the paper company. The freight load moved was 118,000 ft. of timber, weighing 944,000 lb., in addition to the weight of the cars. The teams weighed 3,400 lb. each.

arc

LAMP OF HIGH EFFICIENCY UNUSUAL IN DESIGN

Intense illumination that is hardly distinguishable from daylight, so far as color is concerned, is said to be produced by a new incandescent lamp of radical design. Practically all of the light developed by it emanates from a small ball of fused tungsten which forms one electrode of an arc. Because of this, the light source is easily and effectively controlled with lenses and reflectors. It is intended particularly for use in projection lanterns and provides an almost perfect disk of light, which, when thrown upon a screen, is reported to be free from blurs and other inequalities. The lamp differs from ordinary incandescent ones in that it is an inclosed arc which strikes

between tungsten electrodes in a nitrogen atmosphere. In intrinsic brilliancy, its range is between 400 and 30,000 cp. to the square inch. In addition to being adapted for projectors, it can be used advantageously in microphotographic work, for matching colors under artificial light, and for similar purposes. Its life is about 500 hours. At present only direct-current

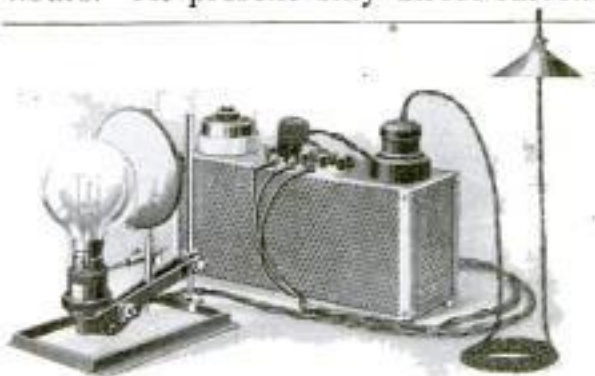

Practically All of the Light That is Developed by This Inclosed-Arc Lamp Emanates from the Small Globule of Fused Tungsten

lamps of this type are available. A resistance box allows current of any voltage from 100 to 250 to be used.

According to a table tentatively adopted by the state highway department of Michigan, the number of vehicles for which 9-ft. gravel roads are economically suited is up to 200 per day, while the number for 16-ft. concrete roads is from 500 to 2,000 per day.

Umi

on

OPERATION AND ODD SHOES SAVE FAITHFUL HORSE

The faithfulness of a work horse was rewarded some time ago by giving it expensive surgical aid when it became

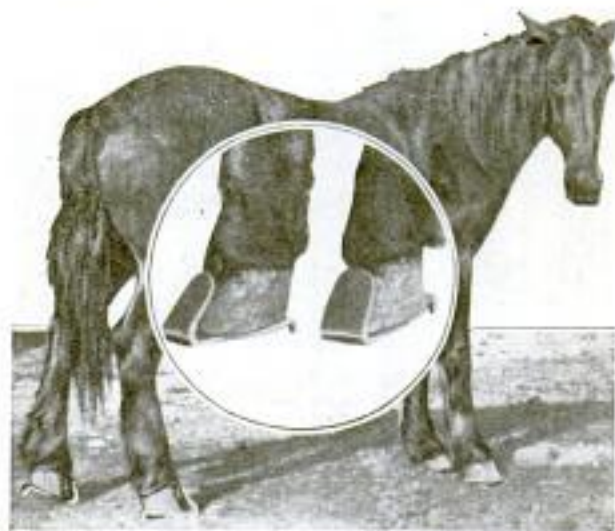

Work Horse Operated on Twice for Lameness: Insert Shows the Horse's Hind Feet Shod with Special "High-Heel" Shoes, Having Protectors in Front Which Enabled It to Walk without Stumbling

very lame. The tendons of the animal's hind legs had contracted so that it could stand only on the front edge of its hind hoofs. To remedy this the horse was operated on twice. The first time the tendons were almost severed

in several places between the fetlock joints and the hock, and the second time, above the hock. After being in a sling for several weeks the animal was able to walk, but with its hoofs still tilted forward a little. It was then provided with special rear shoes, having heel calks an inch high and broad "bumpers" that curved up in front of its feet so that it would not stumble. Now it walks and works almost as well as ever. The owner says he has never regretted the expense, which amounted to several hundred dollars.

MOTORCYCLE AS ADJUNCT TO AN AEROPLANE

In a recent aeroplane flight in California an airman carried with him, besides a passenger, a fully equipped motorcycle. After flying more than 100 miles, part of the time at an altitude of over 6,000 feet, a landing was made and the motorcycle was used to obtain gasoline at a garage two miles from the spot. The motorcycle was then replaced on the aeroplane for the return flight, which was made in safety. A number of army and navy officers witnessed the test, among them an army airman whose recent experiences when lost in the Mexican desert suggested the idea of carrying a motorcycle for use in emergencies.

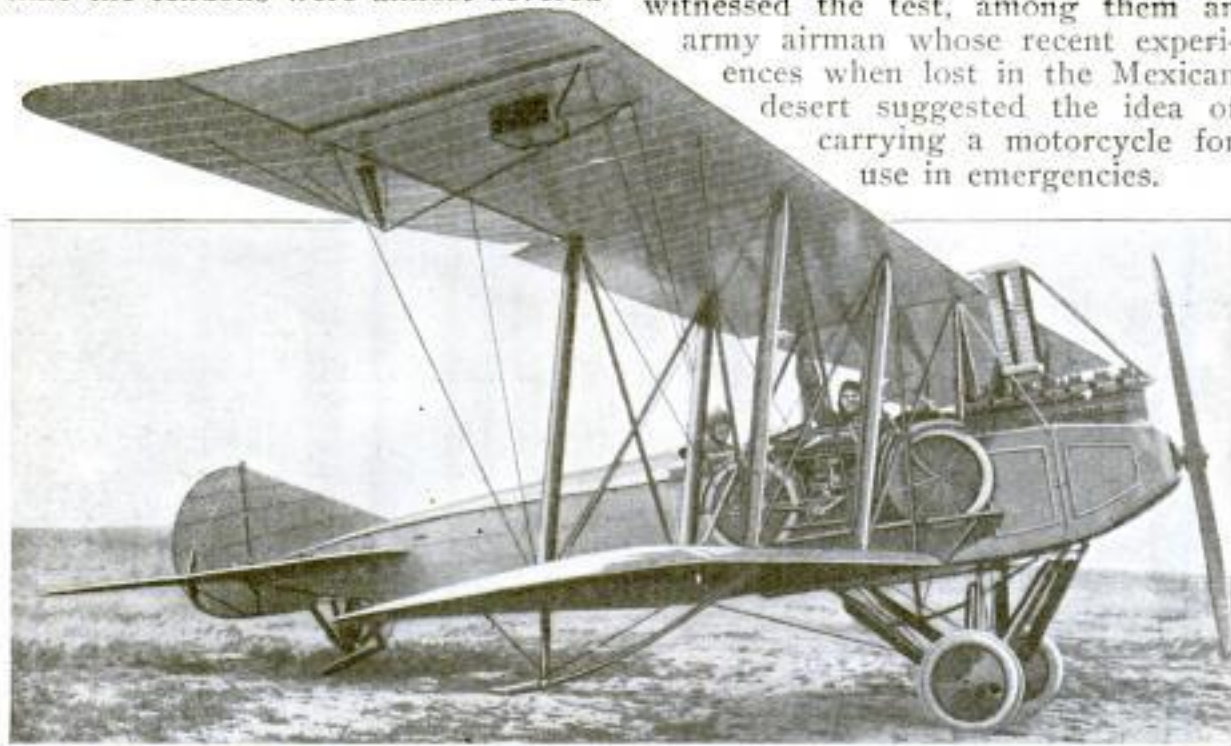

Motorcycle Mounted on an Aeroplane: During a Recent Flight in California the Cycle was Used to Get Gasoline from a Distant Garage

QUICK-ACTING VACUUM BRAKE FOR AUTOS

The latest automatic brake for automobiles is somewhat similar in action to the air brake in railway use. Instead of operating by the force of compressed air, however, the auto vacuum brake operates wholly by the normal suction of the engine. Like the air brake, it has a cylinder and piston connected to the brake rods. The cylinder is small and may be mounted on the frame or any convenient cross member of the chassis. There is a copper-tubing connection to the intake manifold of the engine, and in this is located a simple valve, controlled by a lever or button convenient to the hand or foot. For hand control, the lever is placed on the steering column; for foot

control, a button on the toe board is provided. A slight touch is sufficient to apply the brake, either to bring the car to a gradual stop or to stop it instantly, as the intake vacuum will exert as much as 1,000-lb. braking

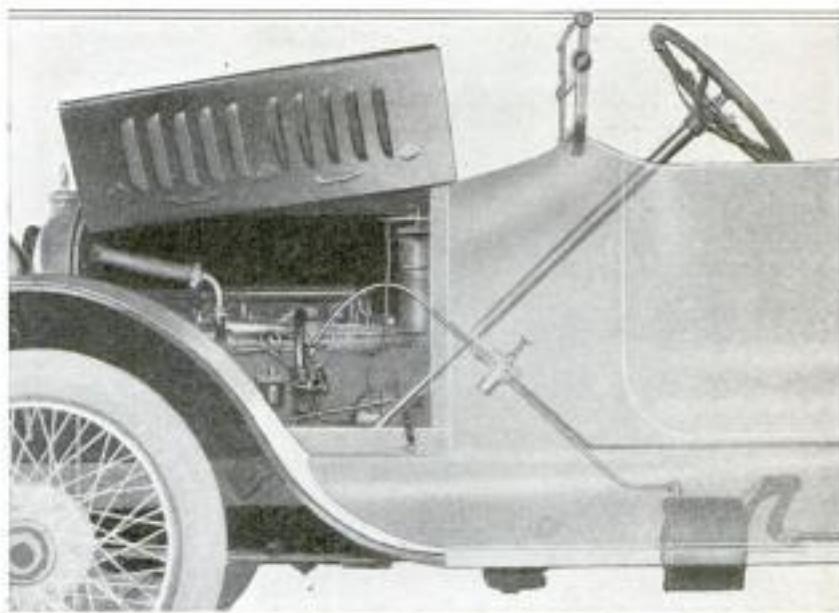

Mechanism of New Auto Vacuum Brake, Which Operates by Suction of the Engine through a Special Cylinder and Piston Connected to the Brake Rods

power at the rear wheels. It operates even on the slowest engine speed.

FOLDING STEEL LIGHT-BATH CABINET FOR HOME USE

Collapsible, pressed-steel cabinets outfitted with electric equipment comparable with that installed in the large stationary models used in hospitals and sanitariums, are being constructed to facilitate the administration of light baths in the home. One type is provided with ball-bearing hinges, an automatic roll top, and folding panels, so that it closes compactly and may be stored conveniently in a small closet or toilet room. The operation of opening and closing the cabinet is a simple one which requires little physical effort, while the matter of moving it from one room to another through narrow doors presents no difficulty whatever, since it is supplied with casters and is only 8½ in. thick when folded. The lighting equipment con-

sists of 44 lamps wired in four circuits and arranged on special shields in such a way as to protect a person from the danger of being burned. Double walls provide the necessary thermal insulation. The cabinet is supplied with a

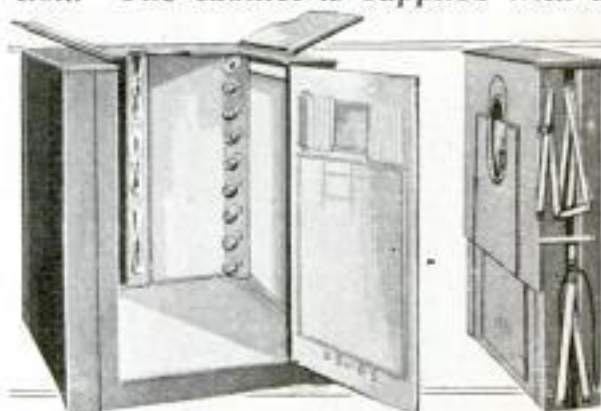

Occupying Little Space When Not in Use, This Folding Cabinet is Provided with Essentially the Same Equipment as the Large Stationary Models Intended for Hospitals

wide door so that a large or feeble patient may enter or leave it easily.

PAINTERS AND DECORATORS GO TO SCHOOL IN IOWA

In several cities in Iowa painters and decorators are going to school. Iowa State College, at Ames, Ia., seeking to give practical aid to men of the painting trade, now employs experts who offer two courses in this line of work. One is conducted at the college and lasts four weeks. The other is a two-weeks' course and is given in several cities during the slack season, so that men can take advantage of it with a minimum of inconvenience. The size of the classes is limited for the sake of efficiency, and while half of the

men spend the morning doing wall work, the other half do graining, for example, and in the afternoon the two groups change about. The evenings are occupied with general discussions and lectures. The equipment used includes a large number of doors and panels on which the men work under the supervision of the instructor. In some cases, too, men are assigned to practical jobs in houses or elsewhere. One painter, after he had taken the short course, redecorated without cost a home that he had previously decorated, because what he had learned made him dissatisfied with his previous work.



METHOD OF ROAD REPAIR SAVES MANUAL LABOR

Machinery
A

The shortage of unskilled labor which has been felt increasingly since the war began has caused contractors to adopt many labor-saving practices, one of which is shown in the accompanying illustration. In this case a self-propelling crane is employed to remove crushed stone from a gondola car

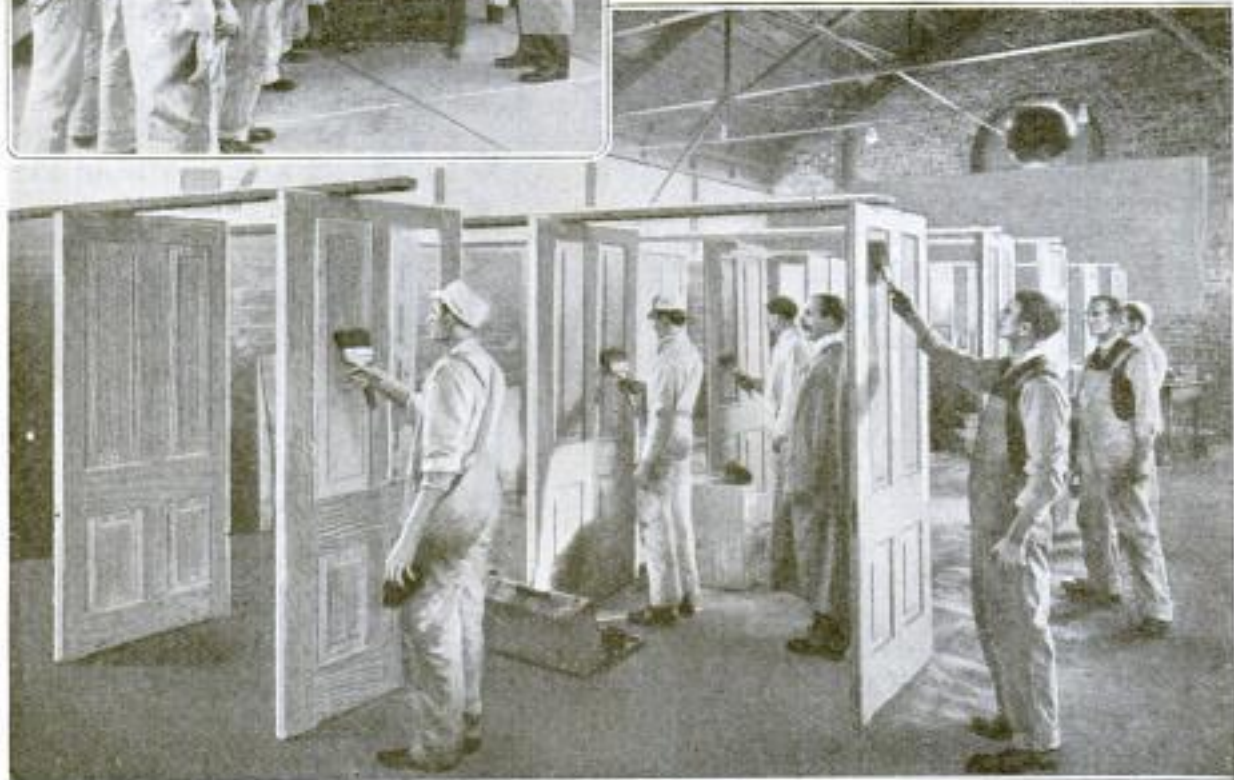

Painters Learning to Better Their Work: These Men are Enrolled in a Course in Painting and Decorating Offered by Iowa State College. Above: College Instructor, an Expert Decorator, Explaining the Fine Points of Mahogany Graining



Spreading Crushed Stone with a Minimum of Manual Labor: The Gravel Car and a Self-Propelling Crane Move Along Side by Side, While the Stone is Deposited in Piles, and Spread by a Scraper

and dump it directly on a road under repair. An electric locomotive slowly draws the car along a trolley line which parallels the road, while the crane moves forward on the highway, depositing the material in piles as it goes. The contractor has further lessened the manual labor involved in spreading the crushed stone, by attaching a wheeled scraper behind the crane. As the road implement is drawn along, it smooths out the piles, so that little shoveling is required to finish leveling it off.

RUSTPROOFING BATH FOR IRON AND STEEL 4297

A chemical bath for rustproofing iron, and steel parts of all sorts, against atmospheric attack has been developed by an American firm. Many automobile concerns are said to be using the process. It gives the metal a dull, etched appearance and does not prevent its use in the ordinary way, it is said. Springs, for example, can be made to function as usual without affecting their rustproof qualities. The articles to be treated, after being cleaned, are immersed in a boiling bath containing phosphate salts and are kept there for about two hours. After the chemical treatment has been completed, the parts are removed, dried, and dipped in oil. They then can be painted or enameled.

REAR HORN OPERATES WHEN CAR IS BACKED UP

Because not a few automobile accidents have occurred while cars were being backed up, a young woman has patented a rear-end horn, designed to prevent such mishaps. The reversing of the transmission causes the signal to operate automatically. The horn is situated at the back of the car just beneath the body. The electric wiring with which it is connected extends to the gear shift and is attached to a brass contact arm that is fastened in a horizontal position to the base of the brake lever. This brass projection is so placed that when the transmission is thrown into reverse, the gear lever strikes it and causes the horn to operate. By having the tone of the horn entirely different from that of signals now used, the device is made more effective.

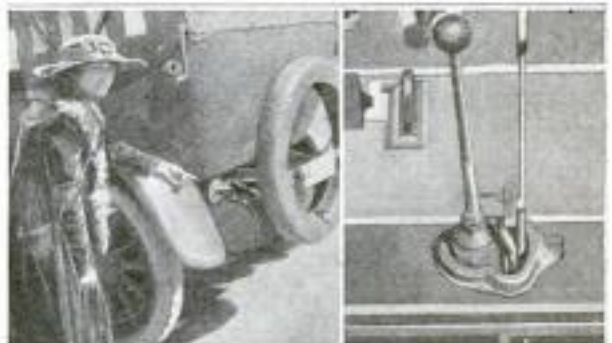

Rear Horn Which Sounds a Warning When the Car is Backed: Projecting from the Base of the Brake Lever Is a Brass Arm Which Makes a Contact with the Gear Lever When the Transmission is Reversed

*Warrant W. Varian (L.A. Cal.)
The Parler Rustproof Co
Detroit, Mich.*

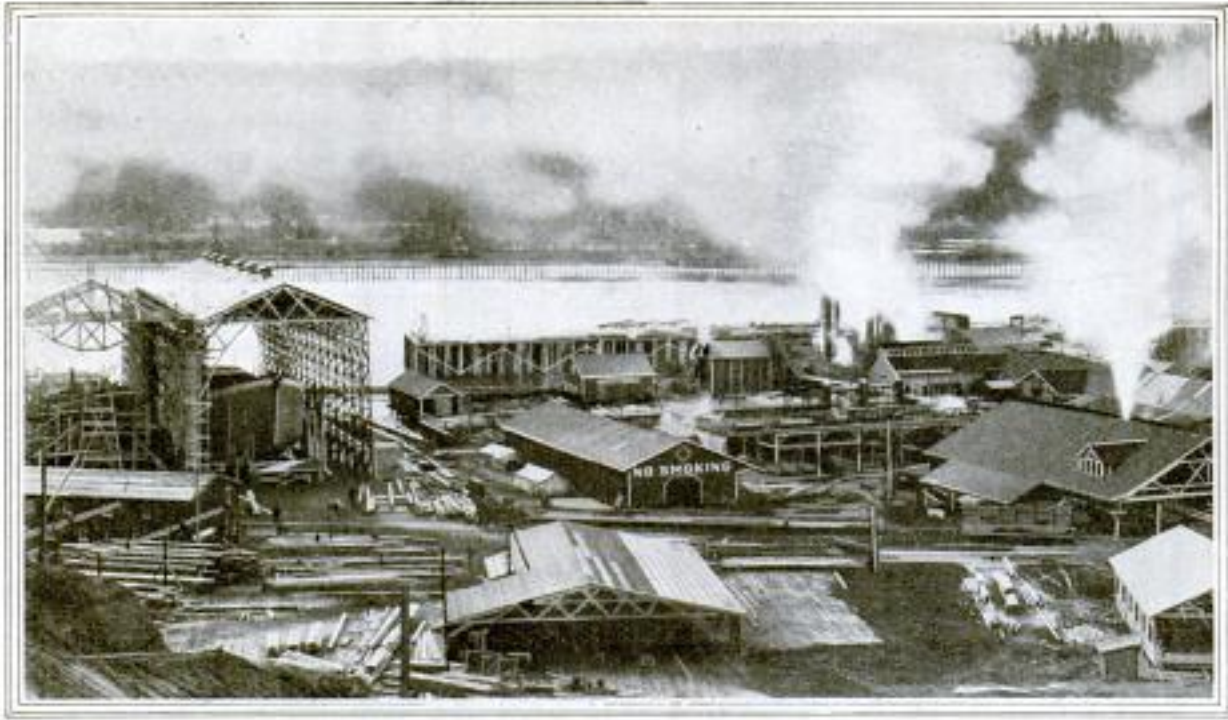

General View of a Shipyard in Portland, Oregon, Showing Two of Seven Ways: One of the Two has been Roofed so That Work can Go On the Year Round

4141

BUILDERS HASTEN TO FILL NEED FOR WOODEN SHIPS

In response to England's recent declaration that the present great need of the allies is "ships, and always ships," the United States is now bending every energy to supply that want, so far as it can, with modern steel craft. But the need is enormous and use can be found for every type of bottom that can sail the seas, whether steel or wooden. This emergency has created a great opportunity for the builders of wooden vessels of small tonnage particularly, and shipyards on our east and west coasts have become scenes of feverish activity. Old yards in Maine, long since idle or almost so, are now working to their capacity. Builders of wooden ships in Washington and Oregon, like those in Maine, are taking advantage of the vast timber resources at their very doors, and are turning out boats at a rapid rate. It is interesting to note that Oregon alone, according to estimates, possesses one-sixth of the standing timber of the United States. Government authorities now realize that though powered wooden vessels cannot be profitably utilized so extensively as has been advocated recently, nevertheless there is need for all wooden ships that can

be built, for they relieve by just so much the excessive demand for steel vessels. The Federal authorities have organized a \$50,000,000 corporation, headed by the ablest engineers and shipbuilders in the country, and within a few months this government-owned concern expects to be turning out hundreds upon hundreds of vessels.

TO BUILD FEDERAL ARMOR PLANT IN WEST VIRGINIA

The government's great armor-plate and projectile plant, for which congress has appropriated \$12,700,000, is to be located in a rugged part of West Virginia, namely at Charleston. This city was selected by a special navy board after it had personally inspected more than a score of cities and carefully considered their respective claims. Charleston, the board decided, offers an ideal combination of military safety and accessibility to the materials that will be needed. The city tendered to the government several desirable sites free of cost, on one of which the plant will be erected. One of the protected gorges in the region will be converted into a proving ground.

Schooner Recently Launched at Camden, Maine: This Vessel, a Fine Example of Wooden Construction, Is 158 Feet Long and Has a 36-Foot Beam. It is Valued at \$80,000. A Decade Ago It Could Have Been Built for Perhaps Half That Sum

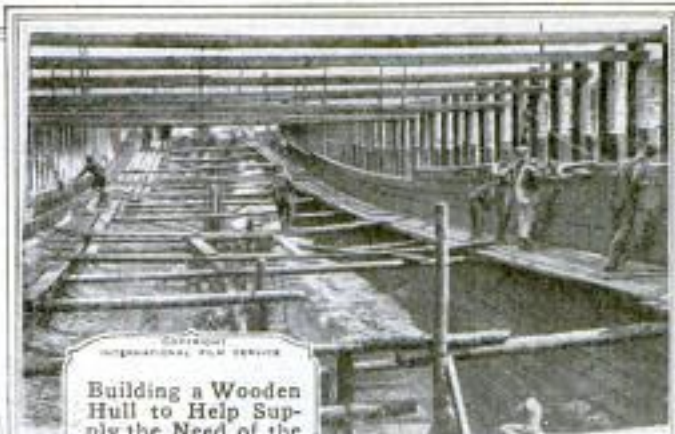
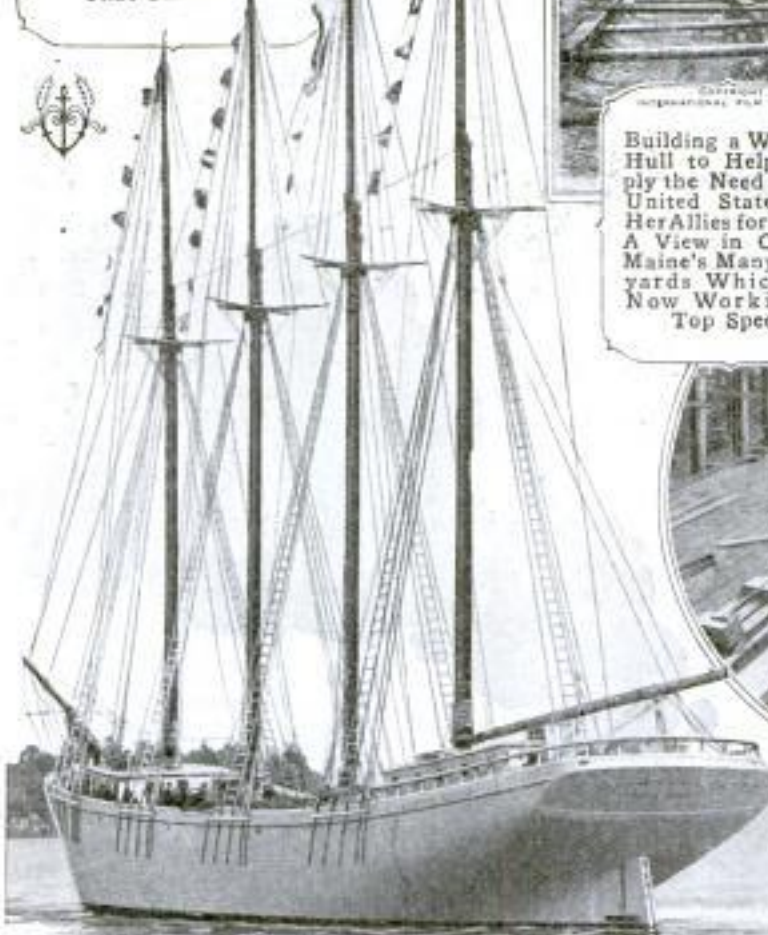

Building a Wooden Hull to Help Supply the Need of the United States and Her Allies for Ships: A View in One of Maine's Many Shipyards Which are Now Working at Top Speed



A Pacific Coast Shipyard: Three Timbers, Each 124 Feet Long, being Prepared to Do Keel Service

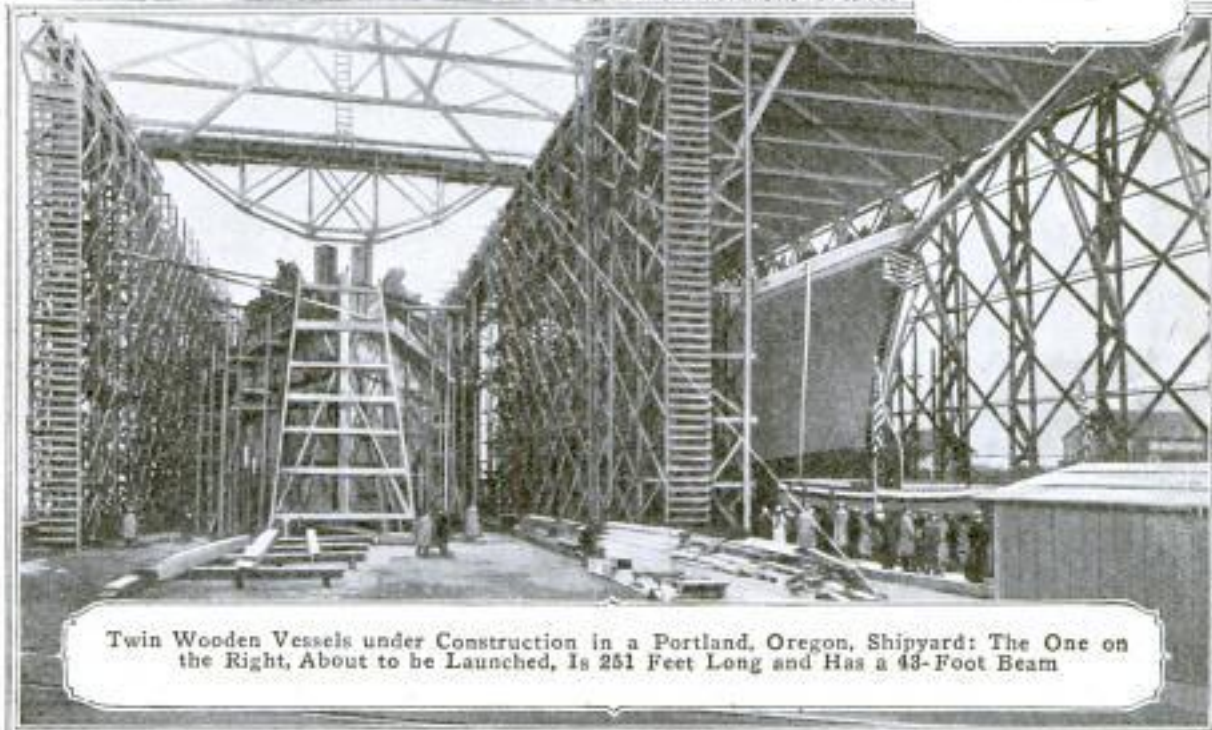

Twin Wooden Vessels under Construction in a Portland, Oregon, Shipyard: The One on the Right, About to be Launched, Is 251 Feet Long and Has a 43-Foot Beam

NEW OLIVE-GRADING DEVICE REPLACES HAND SORTERS

Satisfactory work is apparently being accomplished with a lately invented olive-sorting apparatus installed

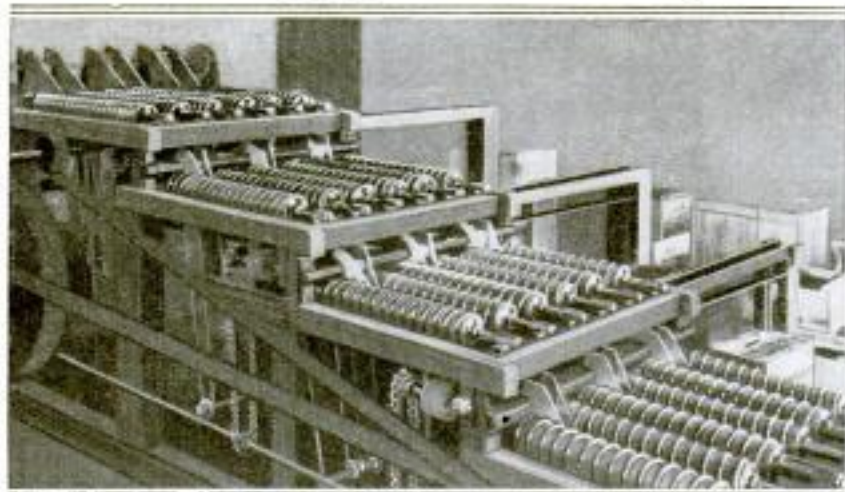

The Rollers in Each Tier of This Olive Sorter are Spaced Differently, so That the Smallest Olives Drop Through at the Outset and the Largest Ones Last

in a large pickling plant, where heretofore the grading has been done by hand. The machine consists in part

of four stepped tiers of spiral rollers, arranged in pairs that revolve away from each other. At the rear end of the machine small bucket conveyors lift ungraded olives from a large bin and discharge them between

the rollers composing the first battery. The spacing of the rollers is such as to permit the smallest fruit to drop into a bin below, while the rest is carried to the next tier, and so on until the intermediate sizes have been sorted out and the largest olives delivered into a receptacle at the front of the machine. In this way various grades of olives are quickly separated.

When the fruit drops into the sorting bins its fall is broken by canvas so that the danger of bruising is overcome.

ROTARY MACHINE FOR MAKING "SOFT-MUD" BRICKS

Approximately 50,000 bricks are molded in a single day with an odd

near Mt. Vernon. The apparatus is locally known as a wheel machine, and

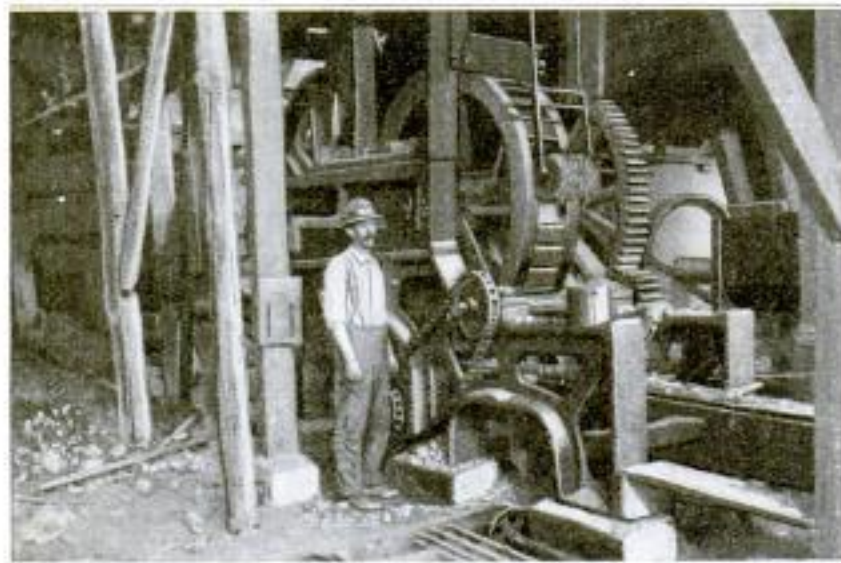

COPYRIGHT, HARRIS & EATING

Queer Brick-Molding Machine Employed in a Yard near Mt. Vernon

machine used in a plant located on a part of the original Washington estate,

dropped onto a belt conveyor at the bottom and transferred to drier cars.

although apparently uncommon elsewhere, is used at a number of yards in the vicinity of Washington. The device consists essentially of two large wheels or drums, one of which has 42 forms arranged about its circumference. The clay is fed into a hopper at the top of the machine and forced into the various molds as they come into the proper position. As the two wheels revolve in contact, the clay is tightly compressed. The molded bricks are



Moving an Oklahoma Town to a New Town Site on a Railroad: The Buildings are Hauled by Tractors, as Shown, Sometimes to Distances of 10 or 20 Miles from Former Sites

MOVING OUT-OF-THE-WAY TOWNS TO A RAILROAD

By J. R. HENDERSON

In the silver and gold-mining camps of the West, when a rich "strike" is made, a small city of tents and shacks springs up almost within a night. One town may be practically deserted in favor of a new one; but whoever heard of moving the town—post office, stores, dwellings, and all—for a distance of 10 or 20 miles?

It could not be done—the nature of the land, rough and hilly, would not permit it. Instead, tents and huts are erected; then, after a time, more pretentious buildings, and finally comes a railroad, with a box car for a depot. That's a "boom town" in the West.

On the level plains of Oklahoma they do things differently. Instead of slowly building up a new town in a very desirable locality (in the oil or zinc fields, for instance), the people simply move the old town to the new location.

Every few weeks a whole town moves its location. Enterprising Oklahomans think little of moving a whole city. Healdton moved recently and is now known as New Healdton. The people of Staunton moved their town 20 miles to a railroad. Cornish did the same thing, though not quite so far.

So did Hewitt, Walters, Bottsford, and many others.

The railroads are the greatest cause of this town-moving. They are in the town-site business themselves, and are far more concerned in selling building lots on new sites than in developing tonnage in old towns. Wherever they wish to have a town, perhaps near some newly discovered oil pool or lead and zinc deposit, they throw down a track, build a nice depot, and a little advertising brings not only new buildings, but perhaps some town 10 or 12 miles away, which moves to the new site. Many such towns are not doing very well, and have no prospect of a railroad coming to them, so they pick up and move, houses and all, to the railroad, be it 5 or 25 miles away.

Some of the larger buildings may take three or four tractors to move them, but move them they do, and in quick order. The largest of these towns will usually move completely within a week or less. It is a common thing to have one or more traveling shows doing a thriving business on the new town site within five or six days after the first building of an old town starts for the new location.

BLUEPRINTING MACHINE OPERATES AT LOW COST

Simplicity, speed, and low cost of operation are special features of an electrically driven blueprinting machine

that is now being used by architects and others. The blueprint paper may be stored

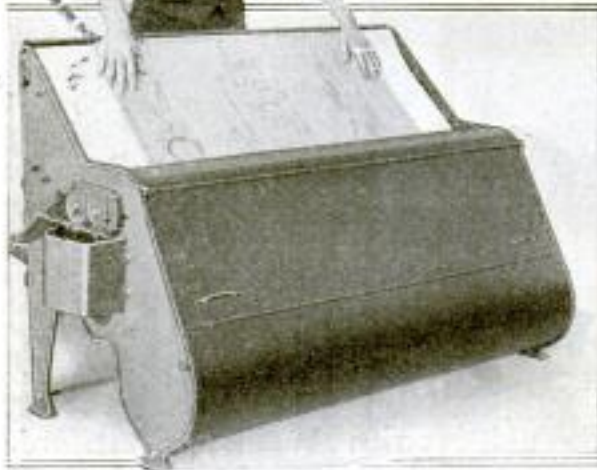

Blueprinting Machine So Simple an Office Boy can Run It: When Operated at a Rate of One Foot per Minute the One in Charge can Print, Trim, Wash, and Dry Prints without Stopping the Machine. No Dark Room is Required

in a chamber in the front of the apparatus. In printing on a continuous roll, the paper is fed from this chamber down an incline table, and is carried along by an endless belt, with the tracing placed over it. The belt is guided by rollers which cause it almost completely to encircle a printing cylinder made of wire, wound spirally. Within the cylinder is a mercury-vapor tube so situated that the paper passes within 2 in. of the light. After the paper and tracing have followed the belt almost around the cylinder, the paper is delivered into a light-proof chamber at the back, and the tracing to the operator. Any width of paper up to 48 in. can be used.

A telephonic device, with a microphone attached, has been invented in Norway, which when lowered into the water enables fishermen to detect the presence of near-by schools of fish, it is said.

IMPROVED OIL BURNER OF ROTARY TYPE

Crude oil may be readily substituted for coal as fuel for steam-heating boilers, and other purposes, by means of an improved rotary oil burner recently patented. In this burner a small electric motor is direct-connected to a blower and oil atomizer. The atomizer is composed of a number of thin disks, over which the fuel oil is carried by centrifugal force and then thrown off in a finely divided spray into an annular stream of low-pressure air furnished by the blower. The oil and air enter the combustion chamber in the form of an inflammable vapor, which ignites close to the burner and is readily adjustable to a large or small fire as desired, by regulation of the supply of air and oil. The entire apparatus takes up hardly more than a square foot of space and rests on the floor in front of the boiler, the oil atomizer entering the boiler

through what was formerly the ash-pit door. The electric motor need be of only one-fourth horsepower. With this arrangement the total heating surface of the boiler is exposed to the heat of the oil flame.

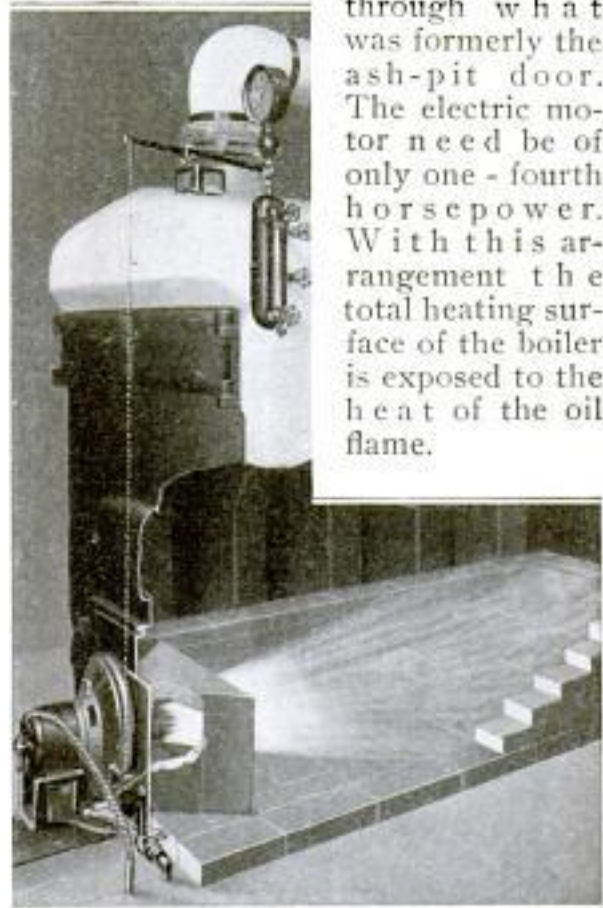

View of Multiple-Disk Rotary Crude-Oil Burner at Work in a Steam-Heating Boiler Converted from Coal Burning, the Coal Grates being Removed and Fire Brick Set in the Ash Pit

RAILWAY PREPARES FARMS FOR WAR VETERANS

Returned war veterans of the Dominion, who are capable of agricultural work and wish to engage in it, are to be assisted in a material way by one of the Canadian railroads. At a cost of about \$3,500,000 the company is outfitting a thousand farms which will be offered to successful applicants at low prices on a 20-year payment plan with six per cent interest. Irrigated tracts consist of about 80 acres, while others embrace a quarter section. Each farm is being fenced and provided with a comfortable house, a barn, implement shed, and well. Forty acres of land is broken for a tenant, and fireguards plowed about the buildings. When necessary, the company provides a purchaser with a team, two cows, a sow, some poultry, a wagon, plow, harrow, disk, \$25 worth of small implements, seed for 40 acres, and credit for freight and incidentals to the amount of \$50. If it is clear that a colonist cannot otherwise support his family during the first year, cash advances, not exceeding one-half the value of the constructive work done by him, will be made. The farms are being grouped in colonies and will be under the jurisdiction of expert superintendents situated at central control stations, where additional implements and male live stock will be kept for community use at a moderate charge. Another scheme enables veterans to acquire 320 acres of unimproved land in certain districts.

MORMON TEMPLE LIGHTED AT NIGHTTIME

For the first time since its completion 24 years ago, the Mormon temple at Salt Lake City, Utah, was illuminated at night during a recent church-



First Illumination of the Mormon Temple, Salt Lake City: Flood Lights of 150,000 Candlepower were Focused on the Central Statue. The Blur in the Sky Records the Progress of the Moon While the Photograph was being Taken

conference week, and presented a striking picture. A system of flood lighting from adjacent buildings was used, the light from several massive projectors, aggregating about 150,000 candlepower, being concentrated on the brass-and-gold statue of the angel Moroni (son of Mormon), which surmounts the central tower of the giant façade. The lighting was experimental, but proved so successful that the projectors will be kept in service for gala occasions.

NOVEL OBSERVATION BOOTH FOR TRAFFIC OFFICER

A traffic booth of novel character has been designed by a Dayton, Ohio, policeman and is used at a street intersection in that city. It consists of a wooden shelter having a large glass window on each side so that the officer stationed within has a full view of traffic in all directions. The roof of the booth is somewhat like a pagoda. Beneath the overhanging eaves of the upper section are narrow windows in which appear in turn the words "Go" or "Stop," according to the officer's desire. The refuge is heated and lighted by electricity derived from one of the wires that pass overhead.



Comfortable Shelter for Traffic Policeman in Dayton, Ohio: The Booth is Lighted and Heated by Electricity

A resolution has been introduced in the senate authorizing the Secretary of the Interior to take the proper steps to make the so-called Rittman process of manufacturing gasoline available to the public. This method, described in Popular Mechanics Magazine in June, 1915, greatly reduces the cost.

REFRIGERATOR-CAR FLOOR INSURES VENTILATION

Ventilated flooring is desirable in refrigerator cars carrying fruits, vegetables, and dairy products, and the common method has been to use sections roughly made of two-by-fours, which were thrown out when the trip was ended. A new patent auxiliary flooring is permanently installed in the car, and can be raised to the roof with one hand, by a small windlass, when not required. It affords better ventilation than the old-style sectional flooring, being constructed of slats supported on small trusses. Two sections complete the floor of a car, and the side cables used in raising them are inclosed. It is claimed that the new flooring will save its cost in lumber in a short time. It is also possible to use the auxiliary floor, when hoisted half-way to the roof and there secured, to make a double-decked car for some kinds of freight. In either hoisted position the floor may be supported on brackets.

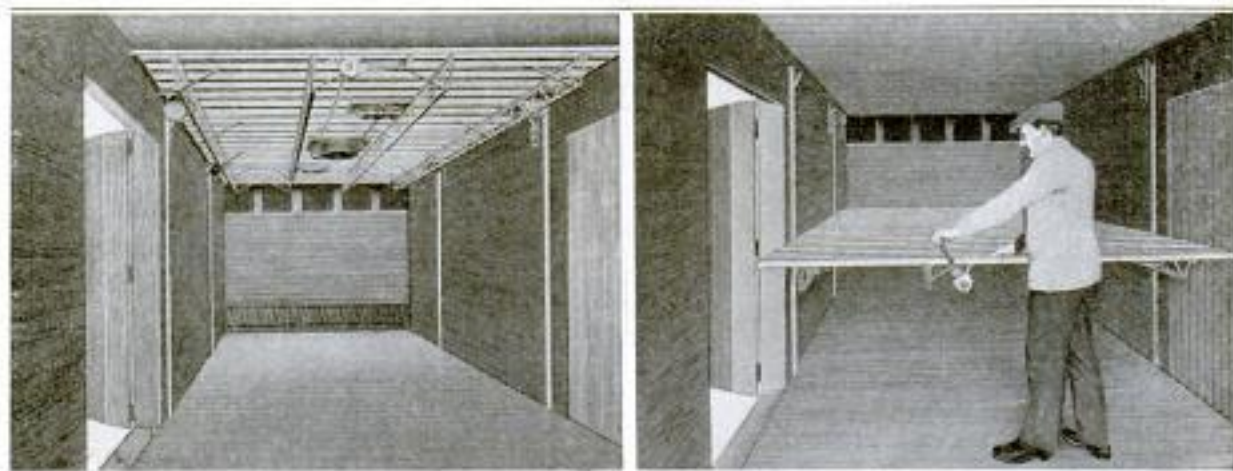

Ventilated Flooring for Refrigerator Cars: It can be Raised to the Roof When Nonperishable Freight is Carried, or Makes a Double-Decked Car When Double Floor Space is Required

HOW CONSTANT ACCOUNT IS KEPT OF FREIGHT TRAINS

One of the big problems of railroad-ing which has been solved ingeniously has to do with keeping track of the freight trains in transit, as well as of every car, the nature of its load, its destination, etc. The means employed by one of the great roads in the Southwest includes a large wall board marked off with vertical rows of rectangles, each row representing a station from which train crews report, or track between stations. Each train is represented by a curious-looking little box that can be hung in front of any of the rectangles by hooking it into a hole provided.

As the movements of the trains from place to place are reported by wire to the headquarters where this device is located, the train boxes, as they are called, are moved along to corresponding rectangles. The upper surface of each box is perforated with holes in which round-headed pegs are inserted. Each peg represents a freight car and its position designates the car's posi-

tion in the train. A tag attached to each train box bears notations regarding the train's departure, etc., while a sticker on each peg shows by its color and by data recorded on it, the nature

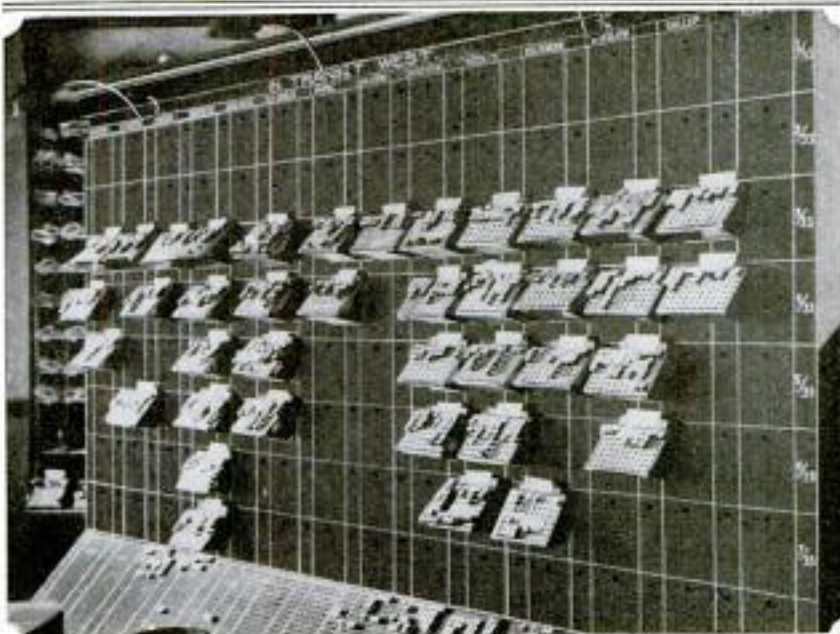

Each of the Curious Boxes on This Board Represents a Freight Train in Transit. A Close View of One Train Box, with a Peg for Each Car in the Train It Symbolizes, is Shown at the Right



of the car's load, its destination, and the car's symbol. Each car must be accounted for in every report until it reaches the end of its journey. The great advantage of this ingenious board is that it visualizes the traffic condition of the whole route.

BUNGALOW BUILT ON TOP OF GARAGE

By erecting what is virtually a bungalow on top of his place of business, a garage owner in Los Angeles found a very satisfactory means of utilizing a single building lot for both business and residence purposes. The garage portion of this structure measures 60 by 42 ft. and abuts on the street. The rear half of the building was made two stories in height, the upper part resembling a bungalow in almost every particular. At the rear is a screened

porch and in front the sloping roof is extended to form a wide veranda that overlooks the graveled roof of the garage. This level space serves very



A Los Angeles Garage Surmounted by an Apartment Which Resembles a Bungalow in Almost Every Particular, Even to the Style of Roof and Porch

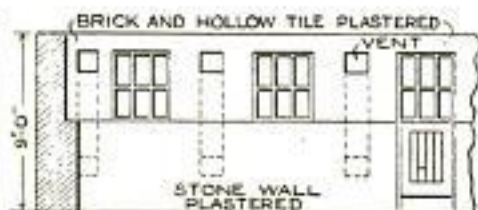

INTERIOR ELEVATION

In the New Jersey Stock Barn Pictured at the Left, a Sun Parlor for the Cows is a Distinctive Feature, Occupying the Space at the Right of the Building

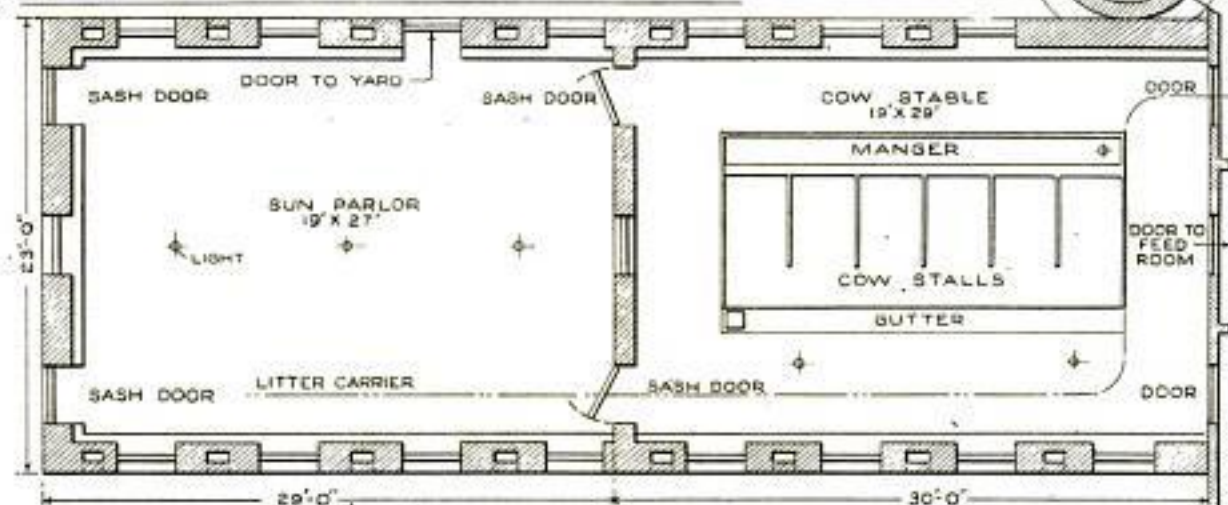

Floor Plans and Interior Elevation of the Stock Barn, Showing the Large Relative Space Allotted to the Sun Parlor and the Arrangement of the Stable for Six Valuable Cows

well as a yard in which, for example, clothes may be dried. The owner finds his apartment quiet, especially well lighted, and the air free from dust.

COIL-SPRING FERRULE FOR FILE HANDLE

A removable handle for a file has been devised, which is protected with a special ferrule to prevent the handle from splitting. The ferrule consists simply of a tightly wound coil spring that can be slipped onto the end of the wooden holder. The latter is slotted about the hole in which the end of the tang is inserted so that the aperture can be expanded to receive the iron member. When the tool is submitted to twisting or other strain the coiled ferrule tends to bind more tightly and will not expand or give way to pressure exerted from within.



SUN PARLOR FOR COWS IN A BARN PLAN

Plans for construction of a new barn on a stock farm in New Jersey provided for a space 19 by 27 ft. which is practically a sun parlor for six valuable cows housed in the barn, although the owner does not call it by that name. This space is fitted on three sides with double-glazed windows and communicates with the adjoining cow stable. The barn is a model farm structure, 224 ft. long, with wings at each end, forming a three-sided court. Stone construction was used to a height of 6 ft., with brick and timber above, and the cost of the barn, including a silo, was \$27,000. The six cows have exclusive use of the sun parlor.

(Since the outbreak of the war 17 of Great Britain's prisons have been closed and the male prison staff reduced from 3,001 to less than 2,000.

THE ROADSIDE MARKETS OF SOUTHERN CALIFORNIA

By JOHN EDWIN HOGG

ESSENTIALLY the outgrowth of motor-vehicle traffic, thousands of roadside markets selling from the producer to motorist consumer have sprung up along the highway system of southern California. The new institution, which to all appearances flourishes by diverting to itself profits which formerly went to the middleman, has also been carried out to some extent along the highways of the East.

Any ranchman of southern California who chances to dwell along one of the main arteries of vehicular traffic may enter into the

roadside-market business with but little effort and almost no investment. The mechanics of the roadside market

are seldom more elaborate than some form of roof to offer protection from the sun, a few racks for displaying the products, and a wheelbarrow, pushcart, or other conveyance for carrying the stock into the market from the ranch in the background on which it is produced.

Sunday, when the highways are thronged with thousands of motor cars, and the motoring population of the larger cities seek the open country, is the harvest day



A Roadside Floral Market in Southern California: These Markets Are a Natural Outgrowth of Automobile Traffic in a Benign Climate with Good Roads



Ripe Oranges are Sold for Ten Cents a Dozen in a Wire Basket at This Roadside Market, near Eagle Rock, California. The Market House Consists of a Roof, Thatched with Palm Leaves

for the roadside markets. The advent of the institution has also developed the southern California Sunday into the market day of many motorists who seek to combine their Sunday's outing with the opportunity to purchase their next week's supply of fresh food-stuffs at prices representing a considerable saving over city-market prices.

The ranchmen have learned that it is easier and essentially more profitable for them to dispose of their produce, or even a portion of it, at their very gates than to be put to the expense of hauling to the city markets and then accepting a narrower margin of profit. Simultaneously the motoring public has learned that it is more logical to secure fresh produce which has come from the tree or garden on the day it is purchased, and at minimum prices, than to buy from the city mar-

kets produce which stock several days

may have been in and in the retail price of which a multitude of middlemen's profits must necessarily be included.

No such institution as a roadside market existed in southern California three years ago. The first ones began as small stands where the ranchmen thought only to sell an occasional watermelon to passing motorists. From the sale of watermelons the field evolved into the marketing of cantaloupes, oranges, strawberries, casabas, and other ready-to-eat fruits. Then came vegetables, nuts of all sorts, butter, eggs, milk

and cream, honey, live poultry and rabbits, and even orange marmalade, jams, and preserves. Each addition to the stock adds popularity to the service, which would be sorely missed were it discontinued.



In This Roadside Establishment Sweet Peas, Violets, and Carnations are Offered for Sale Side by Side with Vegetables Fresh from the Adjoining Ranch



A Large Roadside Fruit Market near Glendale, Where Practically Every Variety of Fruit Produced in Southern California may be Purchased by the Passing Motorist

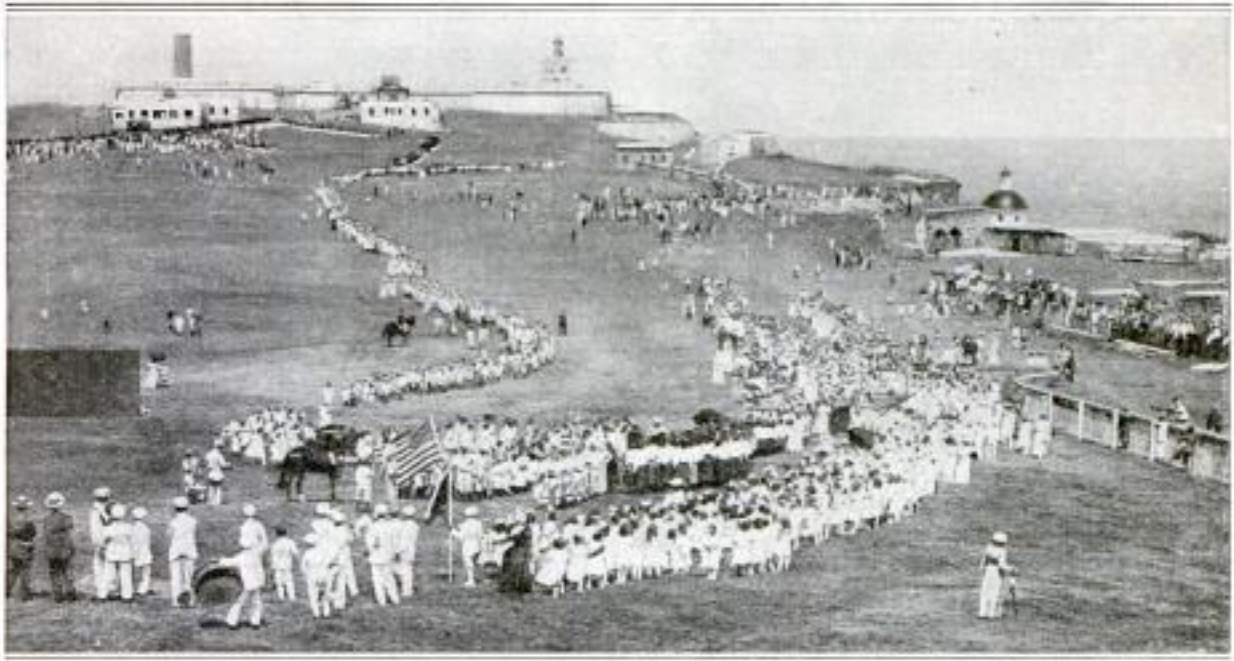

PORTO RICANS CELEBRATE GRANT OF UNITED STATES CITIZENSHIP

CHILDREN of the schools of San Juan marched in the Campo del Morro and participated actively in the public demonstration recently given by Porto Ricans in celebration of their new citizenship. Although the Stars and Stripes was unfurled in the island nearly 20 years ago, the inhabitants have been in the peculiar position of being an unrecognized part of a republic. America's occupation of the island until now has deprived the inhabitants of the franchise enjoyed in the dark days of Spanish rule when their deputies were seated in the Cortes at Madrid. Hereafter, the government is to be headed by a governor appointed by the president, and a council named jointly by both. Also there will be a dual-branch legislature which will select a commissioner to congress who, however, will not be seated as a delegate. The laws made by the insular legislature will be subject to the approval of congress and the president.

PRIMITIVE MARIMBA MAY BECOME POPULAR HERE

Since Americans have shown such phenomenal fondness for the Hawaiian ukulele, perhaps they will develop a similar liking for the "marimba," another musical instrument found among primitive peoples, which has been introduced into this country. A picturesque type of marimba is made in Angola, Africa. It is provided with a set of hardwood keys attached to a semi-circular framework. Fastened to the under side of the keys are hollow gourds arranged according to size. Each gourd, besides its mouth, has a small hole in its side, covered with

a membrane taken from spiders' nests that appears to be essential to the sounding quality. The instrument is played with rubber-tipped sticks. The marimbas made in South America have wooden sound boxes instead of gourds.

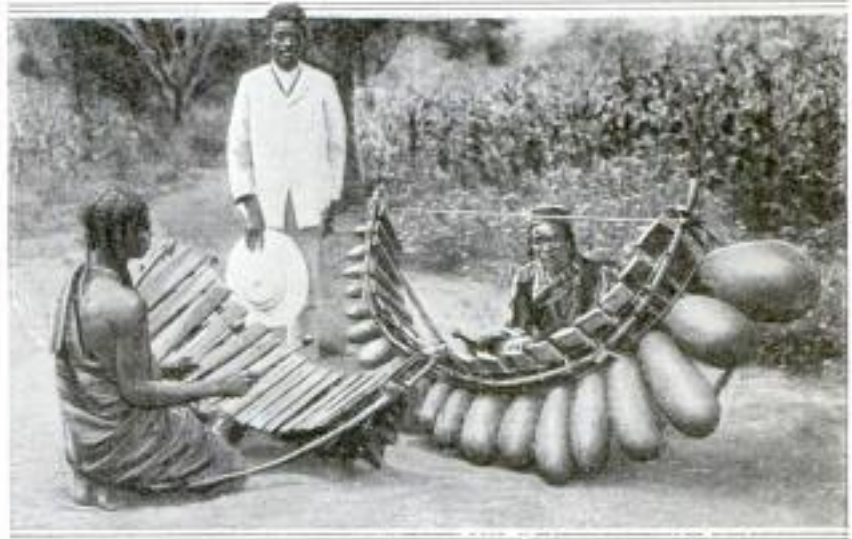

African Natives Playing Marimbas, Which Have Hollow Gourds for Sound Boxes. South American Marimbas have been Heard in This Country and Phonograph Records have been Made of Selections Played on Them

SEA BASS CAUGHT WITH A BIG MOUTHFUL

Those who doubt the voracity of the sea bass, or question the fact that it



Any Doubt That the Sea Bass Attacks Its Own Kind should be Set at Rest by This Photograph from the Texas Coast

preys upon its own kind, may be convinced by the photograph of an unusual catch reported from Texas. An 8½-lb. sea bass was taken in the act of swallowing another fish of the same species and not

very much smaller, as the camera shows beyond possibility of doubt.

BOY SCOUTS TO BE TAUGHT FIRST AID TO AUTOS

A movement has been started to give systematic instruction in auto-repair work to the Boy Scouts of the country, so that they may be able to render practical first aid to motorists who are stalled by the roadside on account of minor troubles. Two classes of instruction will be given, with the cooperation of scoutmasters, each consisting of a series of three lessons. The first series will be elementary and specially designed for the younger

scouts, while the second or advanced course of lessons is intended for the older members of the organization. Scoutmasters will be provided with printed instruction sheets from the headquarters of the movement, and the lessons may be supplemented by lectures by automobile experts to the scout companies of their respective communities.

HELPFUL CHECK VALVE MADE FOR SUCTION FLASK

One of the chemists connected with the Department of Agriculture has devised an effective check valve that obviates the interruptions commonly encountered when filtering is being done through Gooch crucibles with the aid of suction. It is inserted near the bottom of a suction flask and allows the accumulated filtrate to drain off automatically when a stopcock, that cuts off the vacuum force and restores normal pressure within the container, is turned. In laboratories devoted to analytical chemistry it is not infrequent that from 10 to 50 filtrations must be completed in rapid succession. It is in such cases that the new valve proves valuable. By the usual method it is necessary to disconnect the vacuum system and displace the crucible holder before emptying a flask. This is a source of much inconvenience, especially when quick work is imperative. The details of the valve are explained by the accompanying illustration.

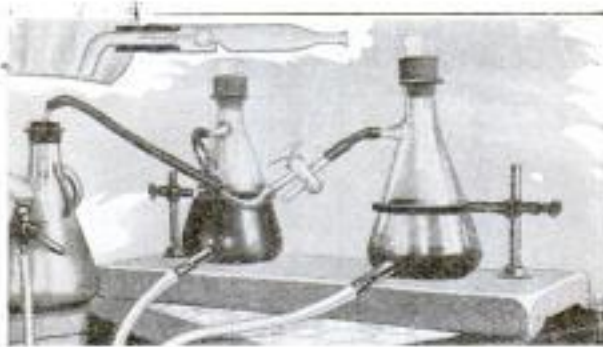

Detailed Construction of the Check Valve is Indicated at the Top, While the Main Part of the Illustration Shows Its Use with Suction Flasks



Among the Quaking-Aspen Trees of Utah, Which Now Serve Little Useful Purpose but may Prove a Valuable Source of News-Print Paper Supply, as It is Proposed to Use Them for Pulp

QUAKING-ASPEN-TREE PULP FOR PAPER MAKING

Shortage of the paper supply has directed attention to the possibilities of using the quaking-aspen trees of Utah for reduction to pulp for paper manufacture. These trees cover approximately 100,000 acres of the slopes in northern and central Utah. Their usefulness is limited to serving as a cover for young evergreens, although to a certain extent they aid in controlling stream flow and are therefore conserved by foresters. The timber is soft and valueless commercially at present, but without denuding the aspen areas, the mature trees, it is claimed, would furnish an annual paper supply sufficient for the news-print needs of the entire West. It grows rapidly, maturing at 20 to 40 years of age, in large areas on the gentler slopes and flat regions where it could be easily and cheaply gathered for the pulp mills. Only trees of three inches or more in trunk diameter would be taken. Paper making from aspens is not new to the people of the state, the Mormon pioneers having produced a

fair grade of news print from wood pulp and rags in Salt Lake City prior to the days of railroad transportation.

WINDMILL TOWER HOUSES AUTO AND CHAUFFEUR

In a suburban yard near Chicago an old inclosed windmill tower, from which the wheel and machinery have been removed, serves as a garage. Above the place where the car is kept is a room for the chauffeur. Vines partly cover the odd-shaped structure.



A butter-dispensing machine has been invented that discharges a piece of butter of a certain size with each operation of a lever. The invention is designed to save labor and material for the restaurant owner.

*Inventor: Nikolaus Kargus
my
no et ad. given*

FOOD FOUND IN LOFTY CLIFF DWELLING

Though settlers have lived in Nine-mile Cañon, near Harper, Utah, for perhaps a third of a century, it was



Primitive Structure High Up in a Cañon Wall in Utah, Which was Found to Contain Several Ears of Well-Preserved Corn and Other Seeds

only recently that a primitive structure built high up on the almost perpendicular wall of the gulch, was explored. The building, which is regarded as the work of cliff dwellers, is made of adobe and stone and occupies a niche in the rugged wall, 60 ft. above the floor of the cañon, and is practically inaccessible. After letting down over 100 ft. of rope from the top of the wall, an investigator descended by this precarious means and gained access to the primitive shelter. Here he found several ears of well-preserved flint corn, such as is

now grown on many arid western farms, and a quantity of seeds resembling squash seeds. Neither rodents nor birds had molested this supply. The dry climate doubtless aided in preventing its decay. Poles extending across the top were built into the masonry and probably once formed a part of a larger structure. It is thought that the primitive people used this, together with other shelters in the cañon, as reserve storehouses, and that access to them was gained with the aid of ladders and poles.

ALFALFA LUNCHEON SERVED TO KENTUCKY FARMERS

Alfalfa was served to Kentucky farmers in the form of hot biscuits, doughnuts, cake, and candy, at a luncheon during the recent annual farmers' week exhibition of the Agricultural College at the state university. The progressive young women of the domestic-science department took care of the cookery and convinced their farmer guests that very palatable products may be obtained for the table from their alfalfa crops. The flour of alfalfa is of a creamy tint before cooking and a light green afterward, and while pea-green biscuits may not at first appeal to the average housewife, the flavor is regarded by many as rich and delicious. Food requirements may easily result in greatly increased use of alfalfa for flour in the near future. The recipes used in cooking it are about the same as those for wheat flour. Alfalfa candy is made from a glucose pressed from the stalk.

ACETYLENE REFUSE USED FOR PLASTERING

Commercial uses have been found recently for the accumulations of acetylene ash, hitherto regarded as worthless and dumped into sludge pits at hundreds of gas storage-tank charging stations throughout the country. It has been discovered that the material can be utilized to make plaster and whitewash, and as a substitute for



Sludge Pit of an Acetylene-Gas Charging Station, Containing the Slaked-Lime Residue of Calcium Carbide. Now Used for Plaster and Whitewash: Such Pits Are Sometimes Several Feet Deep

marble dust in surfacing roads, the former waste product has acquired a market value of at least 50 cents a ton at the sludge pits, some of which cover several acres and are 8 to 10 feet deep. As acetylene gas is derived from calcium carbide, and the residue is practically nothing but slaked lime

and water, the sludge makes good plaster and is said to harden almost like rock. Its disposal has long been a problem at every charging station and it has usually been dumped on a piece of low ground. When this was filled, a new dumping place had to be procured.

Panama-Pacific

ARGENTINE BUILDING AT EXPOSITION DEMOLISHED

A cloud of dust, thousands of flying fragments, and a resounding crash gave a spectacular aspect to the falling of the beautiful dome of the Argentine building in the San Francisco exposition grounds—one

of the last of many artistic structures to be laid waste. An alert camera man, standing near by, obtained a most unusual photograph of the graceful dome, just as its crumpling supports were hurling it to earth.

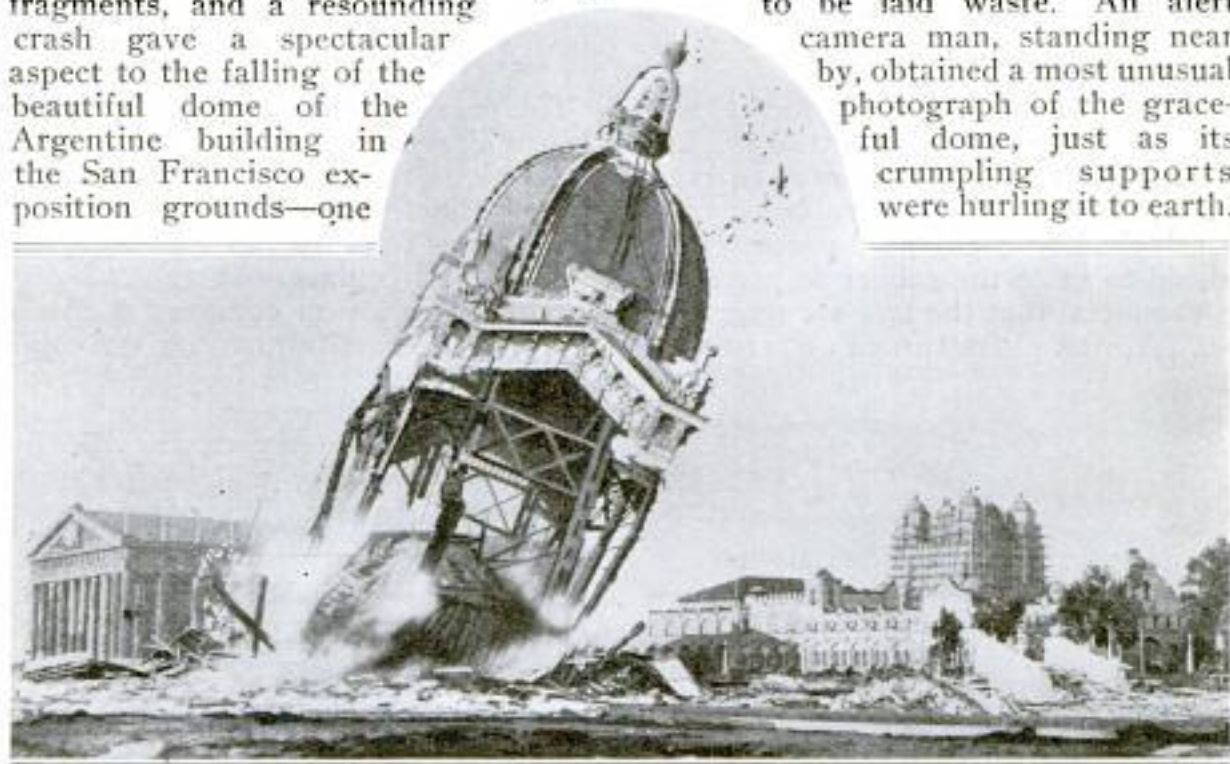

Remains of Beautiful Argentine Building at San Francisco Exposition Photographed Just as the Big Ornamental Dome was Topping to the Ground

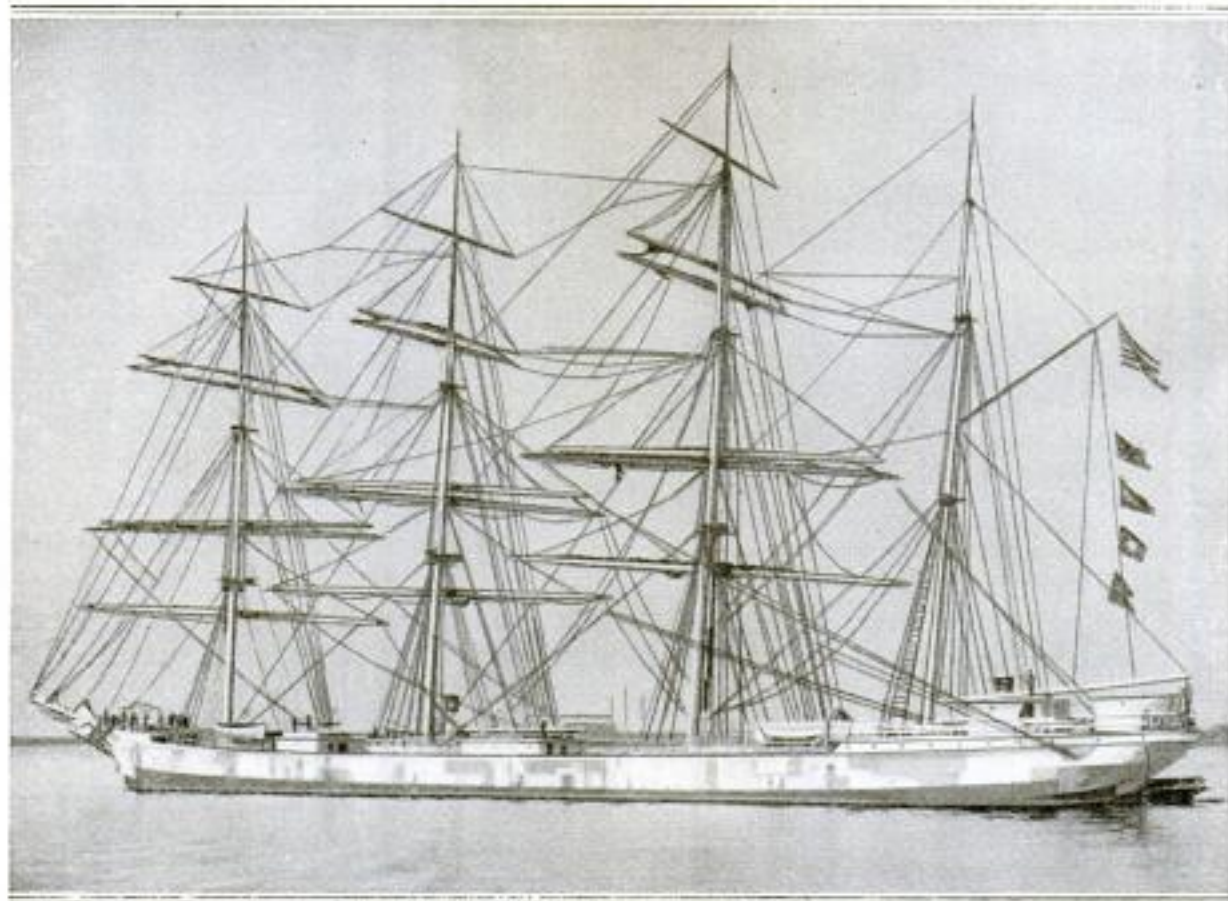

The "Edward Sewall," One of the Few Remaining American Clipper Ships: Its Four Sky-Scraping Masts will Soon be Removed, for It has been Bought by an Oil Company and will be Equipped with Power as a Prosaic Tanker

INSULATED PLIERS RESIST HIGH VOLTAGE

Metal pliers, insulated for 10,000 volts, have been placed on the market recently. The handles are covered with a thick coating of rubber which is attached by a patented process that is said to unite the rubber so perfectly to the metal that the two are inseparable. All the pliers turned out are sub-



Metal Pliers for Electrical Workers, with Rubber-Covered Handles Insulated for 10,000 Volts

jected to laboratory test. They are intended for use by automobile repair men, and the like, as well as linemen and others engaged in various kinds of electrical work.

CLIPPER SHIP TO BECOME A POWERED TANKER

The passing of the American clipper ship will soon be emphasized by the conversion of the "Edward Sewall," one of the few remaining vessels of that famous rig, into an oil tanker, propelled by oil engines. It was recently purchased by an oil company with no eye for the beautiful, and on the completion of its present voyage out of Galveston its towering spars with their wealth of snowy canvas will be removed, machinery will be installed, and the sightly hull will become a tank.

ARTILLERY EAR DEFENDERS WORN BY MILL WORKERS

Ear defenders, such as were designed by artillerymen in Europe, are being used by workers in stamp mills in South Africa. These protectors, consisting of small hard-rubber plugs that resemble

chess pawns, are worn in the ears. A passage extends lengthwise through each plug, and at the enlarged bell mouth is a fine wire screen that breaks up the sound waves. Workmen provided with these devices can more readily detect unusual noises, as for example, those caused by broken machinery.

FOLDING CRIB FOR USE IN CAR, CAMP, OR HOME

Its all-around serviceability is one of the important features of a new folding crib which can be set up in an automobile and affords a safe resting place for a baby when taken on a motor trip. One side of the little bed attaches to the back of the front seat, while straps attached to the ribs of the car top, support the other. If desired, the legs and sides can be folded against the mattress frame so that it forms a bundle but $4\frac{1}{2}$ in. thick. In camp or in the home the crib stands on its own legs. One of the side rails can be turned down and the crib used as a seat. This feature makes it particularly convenient for camping.

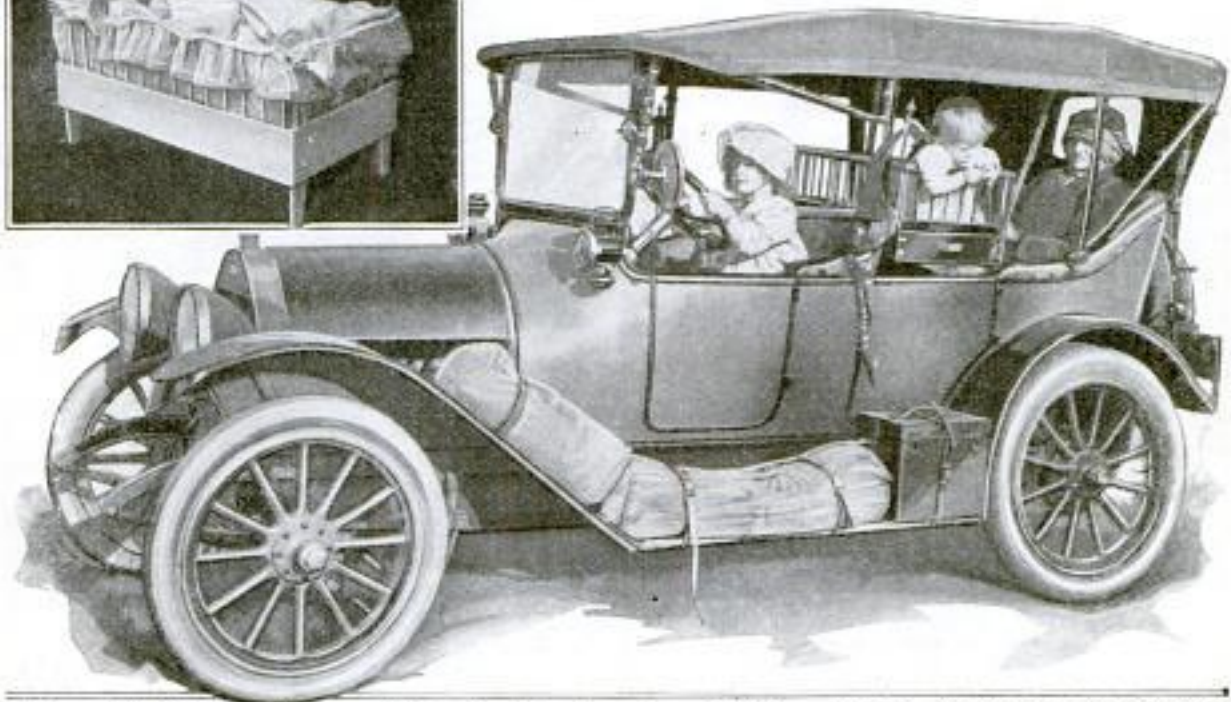

Folding Crib Which can be Installed Back of the Front Seat of a Car or Used in the Home in the Ordinary Way: When One Side is Turned Down It can be Used as a Seat, if Desired

FOREST RANGER DEVISES COMBINATION TOOL

A forest ranger whose duties involve much repair work on telephone lines of the Forest Service has devised an improved type of pliers which consists of ordinary pliers with a broad, flat hook forged onto one end of one handle. This addition is especially serviceable in splicing or bending wires. The improved tool serves such a variety of purposes that it enables the rangers to get along with a much smaller number of implements than they carried formerly. The useful hook adds little to the tool's weight.



CA specimen of spruce has been found which the Wisconsin state geologist estimates is 500,000 years old.

SELECTED PIECES OF ARTISTIC FURNITURE

Near 5th av., N.Y.C.



10
Its Availability as a Lounge or as a Bed Makes This Mahogany Day Bed Especially Serviceable in an Apartment or Small House

2
Out-of-the-Ordinary Book and Magazine Rack That Stands on or beside a Reading Table

3
Semi-Indirect Light on This 74-Inch Customer Gives It Added Utility

4
The Attached Lights and Open Shelves of This Dressing Table Are Features That Count for Beauty and Convenience

8
Reed Tea Wagon of Unconventional Type: The Low Wheels Make the Large Space below the Top Easily Accessible

9
Folding Table for Tea or Breakfast Use: It is Made to Stand Alone When Folded

13
Spacious Phonograph-Record Cabinet with Sliding Top Which Affords Easy Access to Records Arranged on Edge

Peterson Art Furniture Co.

Peterson Art Furniture Co. Fairbanks, Minn.

Flexible Distributing Co. 527 So. La Salle St.

Keywood Bros & Wakefield Co. Chgo

ILLUSTRATING LATEST TRENDS IN DESIGNING



7

Peterson Art Furniture Co.

An Artistic Attached Light and Inkstand and Two Raised Drawers Make This Writing Table Distinctive



Bookcase with Handy Open-Shelf Space at Top, Designed Especially for a Bedroom



5

Peterson Art Furniture Co.

R. Williams Co. Wash. D.C.



Very Decorative Lamp and Flower Holder Combined with Mother-of-Pearl Shade and Cut-Glass Vase

High-Grade Phonograph of New Type: Sound Issues through Screened Grill. Albums Hold 119 Records. Turntable Compartment Closes Like an Organ



6

Unusual Drop-Leaf Desk, Finished in French Gray with Decorations in Old Rose, Soft Blue, and Ivory



Substantial and Ornamental Chaise Longue Made Up of Armchair and Bench That can be Used Separately

Erskine-Danforth Corp'n Stamford Conn.

OPERATING-ROOM DEVICES IN A MODERN HOSPITAL

Many improved devices have found their way of late years into the operating rooms of the modern hospital.



One of the Rooms in the Operating Pavilion of a Cincinnati Hospital: Note the Studio-Lighting Effect, and the Wheeled Furniture Which can be Moved without Handling

At a great new hospital in Cincinnati, for instance, all the rooms in the operating pavilion are lighted on the studio plan, which gives the surgeons a maximum of light for their work. All the tables, receptacles, and other articles of furniture are on ball-bearing wheels, making them easily movable by a slight motion of the foot, without touching them with the hands. Small clamps hold the wheels of the operating tables firm during an operation, and are released by the foot when the table is to be moved. Even in the stationary sinks, the water is turned on or off without handling faucets, by means of nicked valves underneath, manipulated by the knee of a doctor, nurse, or attendant.

RAILROAD-BALLAST CLEANER KILLS TRACK GROWTHS

On railroad lines where a great deal of grain is hauled every year, much trouble is experienced with grain growing through the stone ballast between

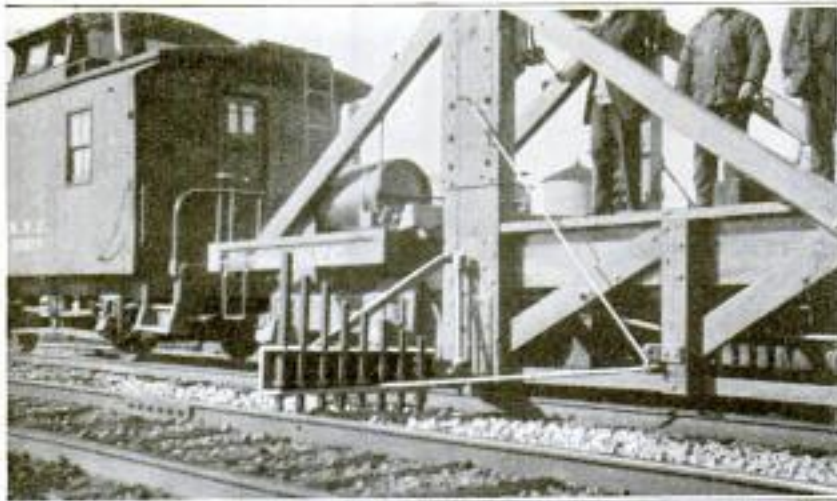

This Device Kills Vegetation between Railway Tracks by Stirring Up the Ballast with Its Steel Prongs as It is Drawn along the Line

the tracks, from seed dropped in transit. The New York Central lines have recently adopted a device which is used to kill such vegetation. It consists of a metal frame holding pointed steel rods of graduated sizes in a vertical position at the side of a work car, so as to form prongs that loosen and displace the ballast, sending all the finer material to the bottom. The cleaner is securely braced to the car at the required level when in operation, but can be swung in or out in about 10 seconds, as well as raised or lowered, by air pressure from the car on which it is fastened. It is drawn at a speed of from 8 to 10 miles an hour.



The Man in the Rowboat is Laying the Cable in a Loop Extending Out into the Lake. One End being Held Fast on Shore by Means of the Rod



The Cable Used in Accumulating the Moss is Wound on a Reel. Here Shown Mounted on a Rowboat, from Which It is Payed Out into the Water



Cutting the Moss from the Cable as It is Pulled Ashore: This View Gives Some Idea of the Way the Revolving Line Accumulates the Undesirable Vegetation



Team of Horses Pulling in the Cable about Which the Moss has Accumulated: The Long Steel Line is Divided into Sections by Swivels Which Permit the Various Parts to Revolve Freely as They are Drawn Across the Bottom of the Reservoir

RESERVOIR DRAGGED WITH CABLE TO REMOVE MOSS

The engineers in charge of Denver's water supply have found it most desirable to remove the moss which grows in portions of the big water reservoir, both because it clogs the screens and filters and because it is thought to foster the growth of algæ. The novel means used to get rid of the moss is to drag the bed of the lake by laying a 1,000-ft. cable in a loop extending out from shore and then drawing it in to land, and repeating this process until the entire bottom has been traversed.

The cable is wound on a reel and placed in a boat. After one end of the line has been anchored on shore, the boat is rowed out about 400 feet and then back to within 100 ft. of the starting point, the cable being payed out as the boat moves along. The steel line is then run through a pulley and hitched to

a team of horses which draws it ashore, bringing moss with it. Larger quantities are secured in this way than might be supposed, for the cable is divided by swivels into several sections which revolve freely, binding the weeds about them. Additional moss, torn up by the roots, floats to the surface and eventually is blown ashore, after which it is gathered into piles and burned with the rest.

ALUMINUM LINE LEVEL FOR BUILDERS

A small aluminum line level of recent invention is designed to replace the 16-ft. wooden straightedge long used by the building trades to secure level construction of walls and other parts of a building. It is of pocket size, furnished with hooks for hanging on a

taut line stretched from the point which serves as a guide level, and is put up in a leatherette case, the outfit including a 40-ft. line and a spring clamp with which the level can be at-

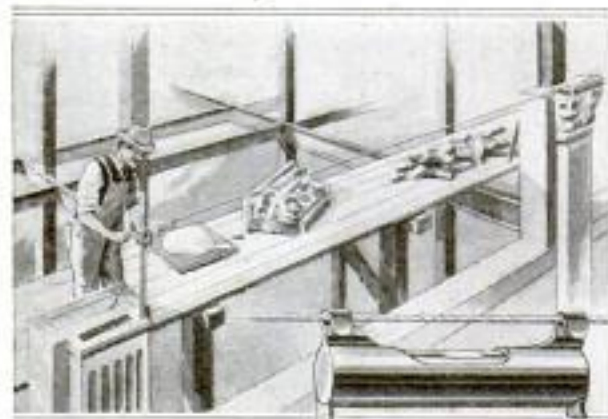

Using a New Builder's Level Which is Hung on a Line Stretched from the Guide Point

tached to a steel square or pocket rule, thereby serving as a plumb rule or bench level. In use, the line from the guide point is tightened with the right hand at any distance up to 40 ft., while the level is placed on the line with the left hand, the hooks being turned outward.

UNIVERSAL JOINT DESIGNED FOR STANCHNESS AND LIFE

Because of the large bearing surface provided by its design, great strength and durability are proclaimed advantages of a new three-piece universal joint that is being brought out by a western manufacturer. The parts are incased in a grease-tight steel housing that keeps out grit and other foreign

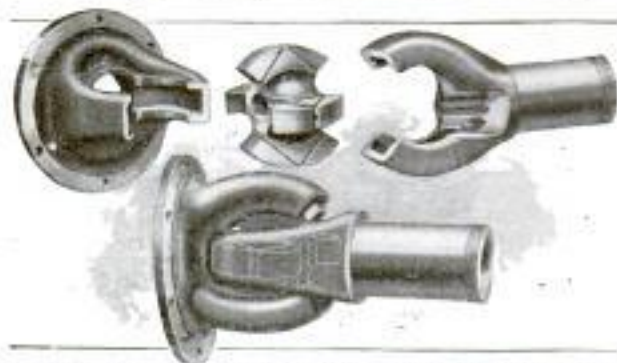

The Three Working Parts of the New Universal Joint: When Assembled the Members are Inclosed in a Grease-Tight Steel Housing That Retains the Lubricant and Keeps Out Dirt

particles. Lubrication is accomplished by centrifugal force, instead of being defeated by it. Two grooved yokes hold the center block in such a way that no pin, rivet, or bushing is required to retain it in its proper position. It is the intention to provide the device in sizes which will meet all demands for universal joints.

MOTORCYCLE CHAIN TOOL OF NUTCRACKER TYPE

Motorcyclists will welcome the appearance of a new chain tool of very convenient size and weight, which will be marketed very soon. Most of the chain tools now in use work on the screw principle and force out the chain pin by screwing down on it, which is often a slow process. The new tool

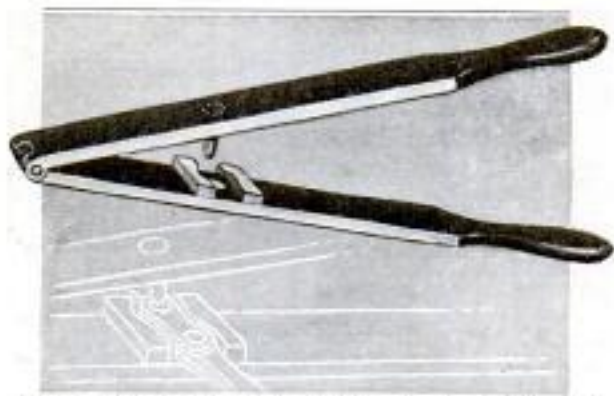

Convenient New Tool for Taking Apart a Motorcycle Chain by Punching Out the Pin from Any Link, with Action Like That of a Nutcracker

works like a nutcracker, and a motorcycle chain can be taken apart with it almost instantly. The two parts of the tool hinged together are of drop-forged steel, the outer ends forming handles. On the inside of the lower part, at an appropriate distance from the hinge, there is a rack for holding the chain link and a hole through the body of the drop forging, in such a position that the chain pin may be forced down through the hole by a hardened steel spike which is welded into the upper part of the tool. The length of the tool for motorcycle use is 9 in. and its weight 18 oz., so that it can be carried in the kit. Larger sizes will probably be made for motor-truck and other heavy driving chains.

SUCTION KILLS TWO MEN IN GALLERY OF BIG DAM

A strange accident, illustrating the tremendous suction created by water rushing over the Elephant Butte dam in New Mexico, occurred recently in a gallery in that great water barrier. An attendant on coming to work was unable to find the fellow employe he was to relieve and so went through the gallery in the dam looking for him. At an air-inlet chamber of one of the valves he found the missing man and a companion standing with their faces against the wall, dead. Their bodies apparently were held in place by the suction through the air-inlet tube. The theory advanced regarding the strange accident is that the two men inadvertently approached too close to the opening, and that their bodies practically closed it, so that the suction due to the vacuum in the tube held them secure and they could not escape. The pressure on the exposed portions of the two human forms was estimated at 6,000 lb. To release the bodies the attendant had to close the valve.

INDICATOR SYSTEM DEvised FOR ELEVATOR REGULATION

For regulating elevator service in large buildings, an electric indicator system has been developed to afford operators a tangible way of preventing cars from becoming bunched. It also informs a starter, or general supervisor, regarding the position of each lift and, when necessary, enables him to communicate with any of the elevator men. A signal box installed in each car shows, by illumination of numerals, the locations of all the lifts in a battery as they pass from one floor to the next. An indicator at the manager's desk sup-

plies the same information. When a car is delayed and unable to keep its



In Each Elevator There Is an Indicator That Shows the Operator the Positions of All the Cars. Only the Progress of the Pursuing Car Need be Watched to Keep All of the Lifts in the Proper Order

position, the runner can flash the pursuing elevator to take the lead. Likewise, signals can be transmitted to any car from the manager's desk. The system has been tried out for some time in a southern office building.

PNEUMATIC GUN USED TO DESTROY TRENCHES

Correspondents with the German forces in France report that the British are bringing into service a new type of gun which appears to be pneumatic. It produces no noise when fired, thus making it possible to use it at points close to the front. The missiles discharged are said to explode like mines, working destruction over a considerable area.

SOME NOVEL AND LITTLE-KNOWN ACCESSORIES



A Time-Saving Tool for the Small Gardener. Supplied with Three Disks of Different Sizes. Price \$1.50



Odd Foot Rule Made of Twelve Distinct Kinds of Native Wood, Such as Maple, Gum, and Ash. Price 75 Cents



Pasteboard Indicator Shows Dairyman How Much Milk, Cream, or Butter is Desired



Glass-Lined Bowl, Intended Particularly for Fruit Salads, Which Has Separate Compartment for Chipped Ice. In London. \$17.50



Laundry Rack Supplied with Eight Parallel Rods Equal to Many Feet of Clothesline: It is Attached to the Ceiling and Readily Raised or Lowered. Its Purpose is to Save Steps and Lessen the Drudgery of the Family Wash Day. Clothes Go from Wringer to Rack and from There to Ironing Board



Trick Novelty Which Detonates a Percussion Cap: It is Loaded and Put beneath Some Object. When the Latter is Lifted the Cap Explodes. Price 10 Cents



Light, Canvas-Covered Parcel-Post Laundry Box Intended for Student: The Reversible Top Flaps Overlap and Carry Home and College Addresses. Price \$1.50



Electric Attachment for Oil Lamp: Socket Fits in Place Like Chimney. The Change may be Made in a Minute. Price \$2



Bracelet Consisting of Miniature Portraits of Movie Favorites Mounted in Gilt Frames Threaded on Strap. Price \$1



Lawn or Porch Swing with Adjustable Back and Top: The Latter may be Used as a Sunshade or Windbreak for Either Front or Back Side



Rapid-Working Pitter Feeds Fruit, Removes Stones, and Delivers Seeded Cherries and Pits into Separate Receptacles. Price \$1.50

DATA JULY NOVELTIES

- SEEDER-- Osmundson Spade Mfg. Co., Perry, Ia.
- RULE-- Biltmore Estate Industries, 10 Plaza, Biltmore, N. C.
- MILK INDICATOR-- Invt. by William S. Bowen, 506 Buttonwood St., Nerristown
- SALAD BOWL-- Goldsmiths & Silversmiths Co., 112 Regent St., London
- BINGO-- S. S. Adams Co., Plainfield, N. J.
- LAUNDRY BOX-- Mfg. by Charles T. Geowey, S. Bend, Ind.
- Laundry Rack-- Overhead Clothes Dryer Co., 471 W. 145th. ST., N. Y. C.
- LAMP ATTACHMENT-- Harvey Hubbell, Inc., Bridgeport, Conn.
- MOVIE BRACELET-- F. B. Warner Co., Chambers St., N. Y. C.
- COUCH HAMMOCK-- Invt. by C. F. Waldman, 1514 W. 7th. St. Los Angeles.
- CHERRY SEEDER-- New Standard Hardware Works, Mount Joy, Pa.
- ROBE CLIPS & MONOGRAM-- Parks Mfg. Co., 236 Aborn St., Providence, R. I.
- BANDAGE-- Invt. by W. Hayden, M. D., Marshfield, Ore.
- DICTIONARY SET--Mark Cross, N. Y. C.
- CANOPY PLUG RECEPTACLE-- Hart & Hegeman Mfg. Co., Hartford, Conn.
- PENCIL CLIP--- Reeta-Hunt Corp., Putnam, Conn.
- WALKING STICK--Mendel Bros., Chicago
- STANDARD SPRAY PUMP--- Standard Stamping Co., Marysville, O
- CHECK-PROTECTOR CHECK BOOK--- Feldman Check Protector Co.,
108 W. 34th. St. *n.y.*
- FOLDING CRIB-- Barri, 72 Baker St., London
- PRISCILLA SEWING RACK-- Invt. by Mrs. ^A Alice Kent Trimpey, Baraboo, Wis.

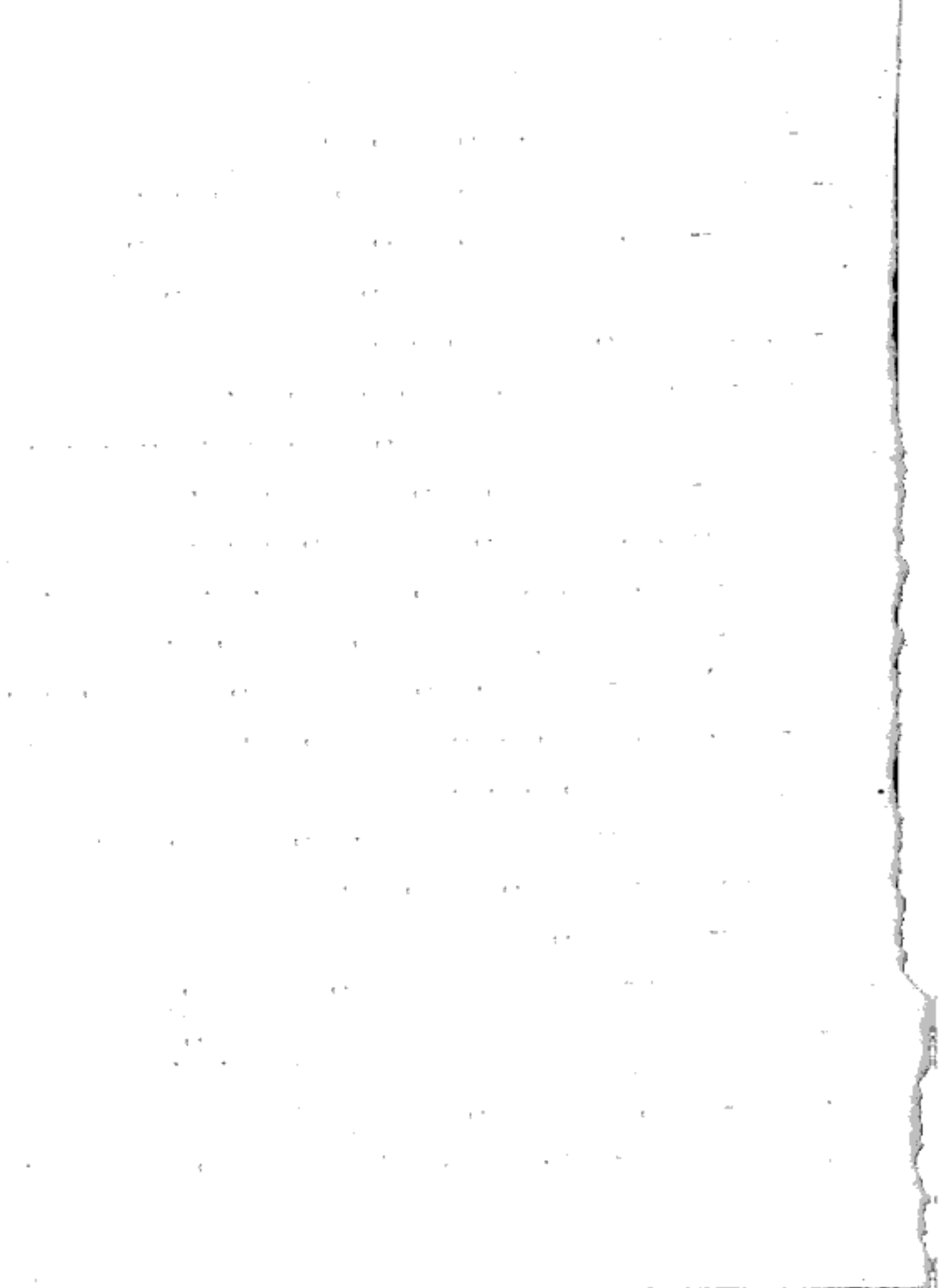

INTENDED FOR THE HOME AND ITS MEMBERS



Stanch Clips, Connected with a Heavy Curb Chain, Hold a Robe Firmly in Place on a Rail. Price \$5. The Monogram Plate Costs \$3



A Glazed-Morocco Dictionary Set for Library Table, Consisting of English, English-French, and English-German Volumes. Price \$9.50



Pencil Clip That may be Attached with Equal Facility to a Work Apron or Coat Pocket. Price 5 Cents



Dainty Folding Crib That may be Fitted into the Waterproof Case, Shown at End, for Traveling



For the Summer Girl, a Smart Walking Stick with Three-Compartment, Dark-Green Leather Bag Attached. The Price is \$14



An Adhesive Tab Attached at the Free End Permits This Antiseptic Bandage to be Applied Easily with



One Hand. Price About 15 Cents



Showing the Installation of a New Wall Plug Finished to Match the Canopy of a Bracket Fixture



Efficient Portable Spraying Outfit with Tank Designed to be Strapped to Gardener's Shoulders: It is Supplied with a Direct-Acting Force Pump and Shown Here with a Nozzle for Spraying Potatoes. Price \$7.50



Check Protector of Sensible and Convenient Form for Private Depositor: It maybe Had with Name and Address Lettered in Gold on Cover and Printed on Blanks. With 250 Checks, Price \$2.50

Adjustable Metal Sewing Rack That may be Attached to Window Casing: It Holds All Necessary Articles for Mending and Darning. Price 50 Cents



POCKET INDICATOR GIVES COMBUSTION DATA

A compact apparatus has been devised for the use of engineers, superintendents, and operators of power plants in ascertaining the percentage of carbonic-acid gas resulting from the combustion of coal, gas, oil, or any other fuel. A knowledge of this percentage is a reliable indication of the character of combustion in furnaces. The higher the percentage can be raised, the greater is the fuel economy—hence the importance of such tests. The new indicator does the work of a bulky apparatus formerly required, and is contained in a small portable case, requiring no setting up or preparation for immediate use. From 17 to 20 analyses of combustion gases can be made in an hour with this instrument, the reagent used being a solution of potassium hydroxide in water.

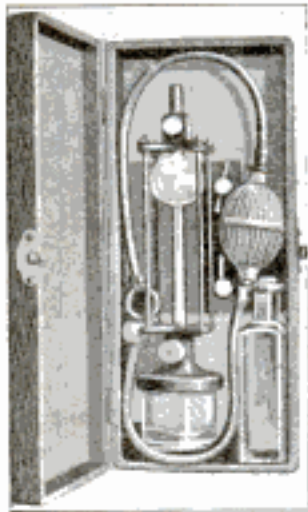

TIME-SWITCH CLOCK USED TO CONTROL LIGHTS

Electric lights in a show window or outside a store can be turned on or off automatically at any time desired by means of a time-switch clock recently placed on the market in Chicago. It has a standard eight-day movement with 12-in. dial for timekeeping purposes, but is provided with a special switch attachment by which night lights are controlled without re-



quiring the services of an attendant. In operation, the indicators of a small dial on the clockface are set at the respective hours at which the lights are to be turned on and off each night, and the switch then works automatically, operating at the same hours every night until the indicators are changed.

NEW SHOCK ABSORBERS AID AUTO SPRINGS

Small jolts, jars, and vibrations of a motor car, to which the regular springs are not sensitive, are taken up, it is claimed, by a new form of shock absorbers, adjustable to any make of car with full or three-quarter scroll elliptic rear springs. The construction includes a pair of coiled tension springs attached to an arrangement of cantilever bars mounted at the end of the rear springs, where they respond to all actions of the axle.

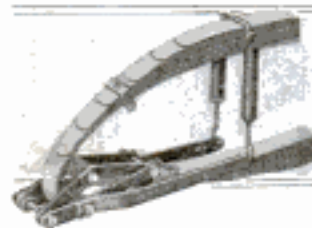

NEW SERVICE-PIPE FISH TRAP FOR WATER SYSTEM

Small fish, shells, and other foreign matter, occasionally pass through water mains into the service pipes of industrial plants and business houses, clogging the pumps, drains, and faucets, and sometimes causing considerable trouble. A trap designed to prevent difficulties of this kind may be connected with a supply pipe. It is an iron casting with a globular basin that catches whatever is stopped by a nipple-shaped strainer installed above its mouth. The trap is thoroughly flushed by opening a valve in the bottom of the basin. If wished, the latter may have a direct connection with a sewer pipe.



NUMBERING FARMS BY THE CLOCK SYSTEM

A Colorado farmer has devised a method of locating farms by numbers, which he calls the "clock system," the numbers being allotted according to the general plan of a watch or clock dial. A rural directory based on this system was recently issued to cover a district of which Fort Collins, Colo., is the center, and by its aid any farm within a given distance of this center can be readily found. In an accompanying map 12 dotted radiating lines are drawn out from the central town so as to make 12 spaces between them, and these are used to indicate the direction of the farms lying within them. If a farm number begins with 11 or 12, it indicates that it is situated north of the town. To fix the distance, circles are drawn around the common center at distances of one mile apart. Thus, if a farm is numbered 122, for example, it indicates that it lies north and two miles from the town. The number 63 would indicate that the farm is south of the town and in the third mile sector—the figure 6 being south on the clock dial—and so on for the rest of the

farms in the district. Each town can be made a directory center in this way, and letters added to the numbers serve to identify the farmhouses still further.

TRUCK TIRES OF HEAVY CORD CONSTRUCTION

Cord tires of the pneumatic type are now built for motor trucks as well as for pleasure cars, the construction being similar, but the truck tires are much larger and stronger, with greater numbers of plies of cords. The tread is specially designed to prevent skidding of heavy loads, and the tubes used with the tires are of course extra heavy. These big cord tires are especially adapted for trucks ranging from $\frac{3}{4}$ to $2\frac{1}{2}$ tons, for auto busses, sight-seeing cars, and fire apparatus. They are made in sizes from 36 by 6 in. to 42 by 9 in., with from 10 to 16 plies of cords, according to their size.

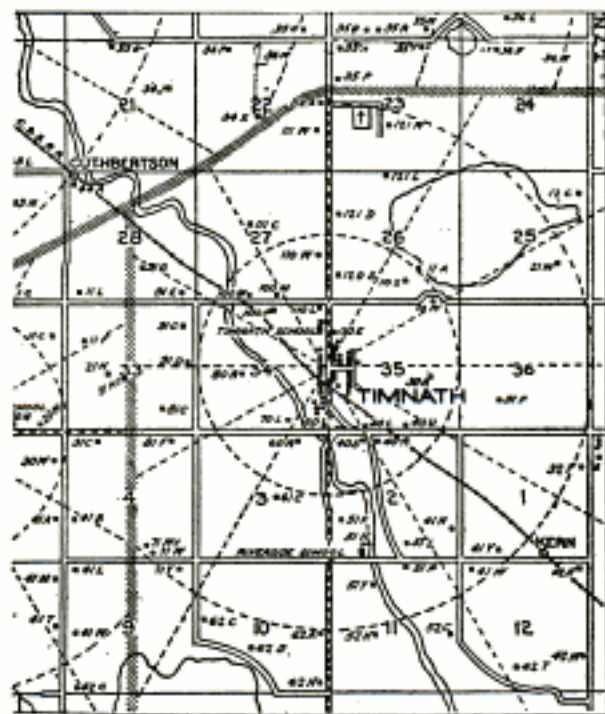

COPYRIGHT, U. S. R. D. CO.

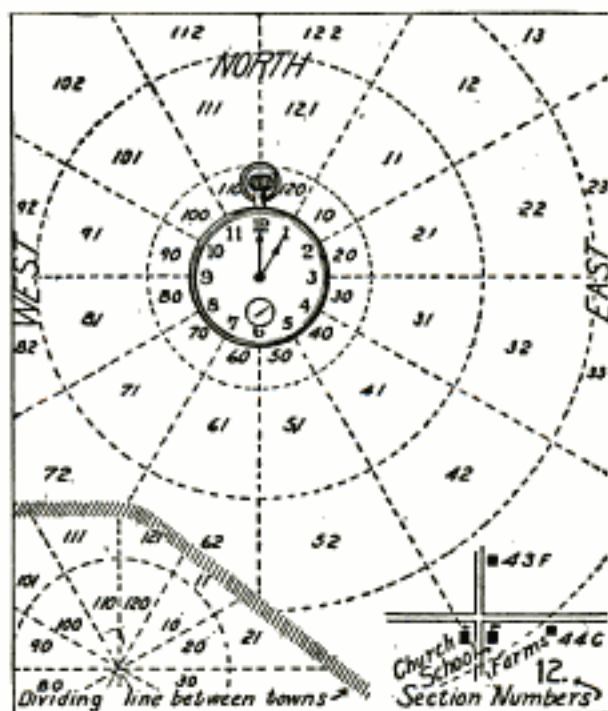

At the Left Is the Map of a Colorado District of Which Timnath Is the Center, with Its Farms Indicated by Numbers and Letters According to the Clock System, Which is Explained by the Diagram at the Right

FOLDING PAPER HOLDER FOR DISPLAY PURPOSES

An inexpensive pyramidal holder for display purposes has been devised which is made of cardboard and when

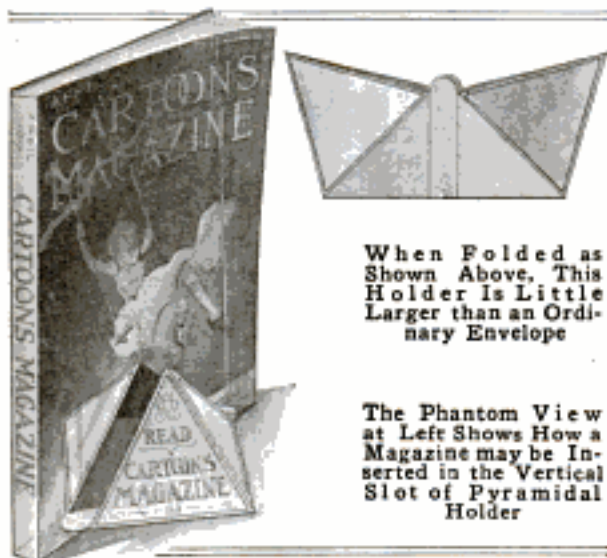

When Folded as Shown Above, This Holder Is Little Larger than an Ordinary Envelope

The Phantom View at Left Shows How a Magazine may be Inserted in the Vertical Slot of Pyramidal Holder

not in use can be folded flat. Opened, it has a square base with four slanting triangular sides, forming a pyramid which is divided into halves by a vertical slot. A book or magazine inserted in this gap is held securely in a vertical position.

FISH GUIDE FOR SYSTEMS OF IRRIGATION

A method of preventing fish from entering the flumes or ditches of an irrigation system has been devised by

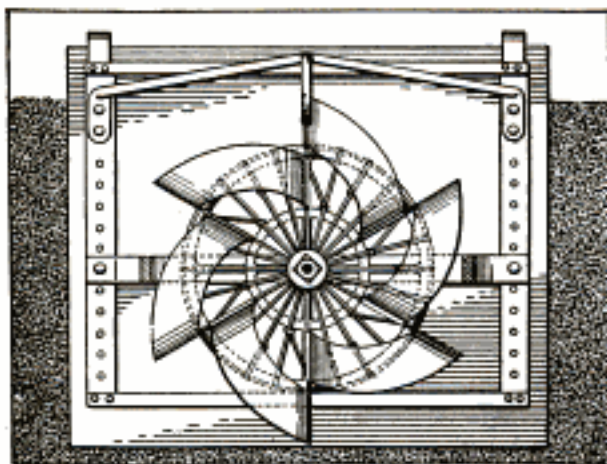

This Revolving Machine, Placed at the Head of an Irrigation Flume, Protects Fish by Keeping Them in the Main Stream

a North Dakota inventor. It consists in placing at the head of each flume a 22-in. wire cage with V-shaped fans over the wires, the cage being supported on a stationary shaft held by an outside brace and frame. When the water is allowed to flow into the flume, its action revolves the cage and fans, thus scaring the fish and keeping them in the main supply stream. The object is to protect the fish from dying in the shallow flumes when these are drained.

KEROSENE USED AS FUEL IN A GALLEY RANGE

For twelve months past kerosene has replaced coal as fuel in the galley range of a government lighthouse tender, with satisfactory results. The oil reservoir was a standard type of tank used with vapor lamps. This was connected to an oil-engine starting torch, located horizontally with its nozzle just inside the door of the fire box. Passing through a hole in the front fire brick, the flame was deflected by a curved fire brick to the top of the fire box. False brick was installed to fill up the space between the grate and the burner. The range was heated for cooking in from 7 to 10 minutes, about one quart of kerosene per hour was consumed, and meals were prepared much quicker than with coal.

MOISTURE-PROOF PAPER FOR WRAPPING GOODS

Package goods, and merchandise which should reach the hands of the consumer free from dust, grease, moisture, or the effects of atmospheric changes, may be protected by a new waterproofed lining and wrapping paper which resembles a thin parchment in appearance and texture. It can be soaked in water or crumpled in the hand without losing its strength, although it cuts or tears readily to any size required. It comes in sheets 24 by 26 in. and 25 by 40 in., the smaller size weighing 26 to 27 lb. per ream of 480 sheets.

GUARD POSTS TO CAPTURE AUTO THIEVES

More than \$800,000 worth of automobiles having been stolen in southern California during the past year, local authorities have arranged for a series of guard posts at each of the seven mountain passes by which alone stolen cars can be removed by land from the Los Angeles district, where thefts have been most numerous. Guards stationed at each post will check the number of every car that attempts to pass. Being promptly furnished with the numbers of stolen cars, they will arrest the driver of any car bearing one of such numbers, detaining the car for its owner. Anyone attempting to pass without stopping when ordered, will find himself in a

trap. Hitherto most of the autos stolen in the district have been driven to a distance through the passes, it is claimed, and the new guard-post system is expected to prove efficient in wiping out this "foreign market"



Guard Posts to Intercept Stolen Autos will be Maintained in the Mountain Passes around Los Angeles at the Points Indicated in the Map by Crosses

thievery. It will cost \$30,000 a year to maintain the guards, but there are about 120,000 automobiles to be protected in Los Angeles territory.

UNUSUAL CONNECTION FOR TWO WATER SYSTEMS

Two neighboring Ohio towns, Dover and New Philadelphia, recently discussed the erection of an additional pumping station to be used in emergencies. Instead of going to that expense, however, it has been proposed to install a rather novel connection between the water systems of the two communities, so that in case of special need one can supply the other with water and the amount furnished can be measured accurately. This connection, as provided for in the plans, con-

sists of two parallel pipes united at one end to a Dover main and at the other to a New Philadelphia main. In each of these parallel pipes would be a check valve, one of which would swing toward Dover and so allow water to flow through it only in that direction, while the other valve would swing in the opposite direction, permitting only a current in the direction of New Philadelphia. Set in proper relation to each check valve would be a meter, enabling each town to know how much water it supplied to its neighbor. The cost of such a connection would not be large.

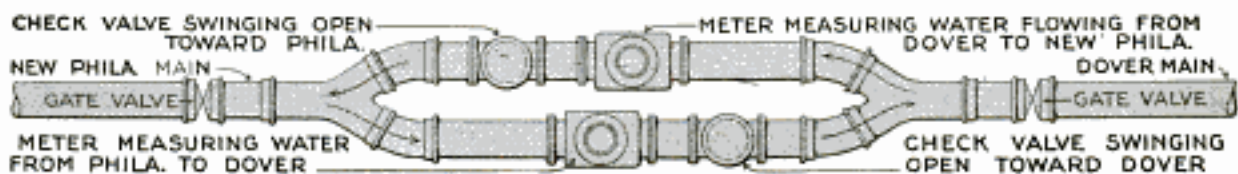

Diagram of a Proposed Connection between the Water Systems of Two Communities, Showing Valves and Meters Arranged in Such a Way That Water Flowing in Either Direction can be Accurately Measured

STRANGE PICTURES OF BIRDS AND ANIMALS, AND



A Policeman in Memphis, Tennessee, When Angry, Broke This Stray Dog's Leg with a Club and Then Threw Him into a Garbage Can. Later Kind Folks Rescued and Cared for the Dog, Whom They Call "Fido." The Officer was Fined and Discharged, Showing That Not Even a Policeman can Afford to Be Cruel



Baby Lion Sees His Reflection in Top of Table, in Mayor's Office, Boston



Photo Courtesy, International Film Service

Even Giraffes, with Their Long Necks, Sometimes Have Sore Throats Like Folks, and That Is Just What Happened to This Giraffe, Whom They Call "Goliath." So the Circus Men Had to Bundle His Neck All Up—and It must have Taken Yards and Yards of Cloth

On the Right Are Some Weaver Birds in a Boston Park and the Wonderful Nests Which the Skillful Little Creatures have Woven with 40 Balls of Twine. It Took Them Two Months to Make Their Interesting Homes

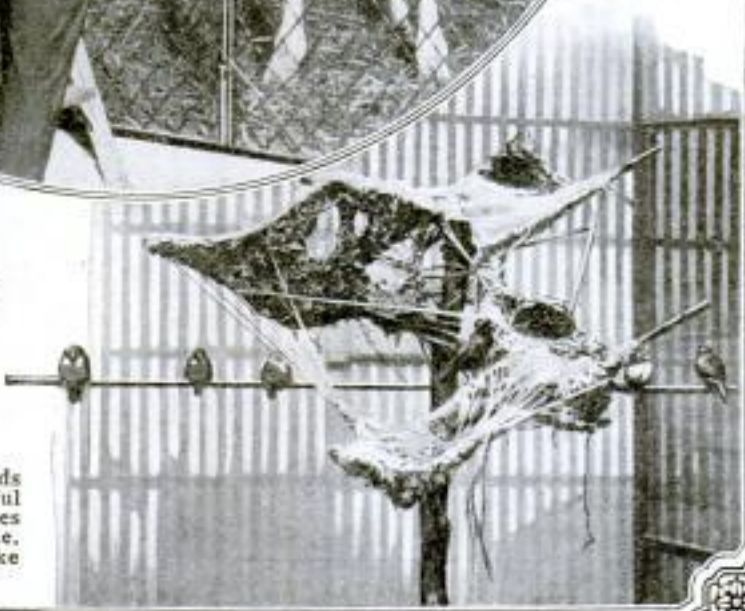

CHILDREN'S ACTIVITIES OF UNUSUAL INTEREST

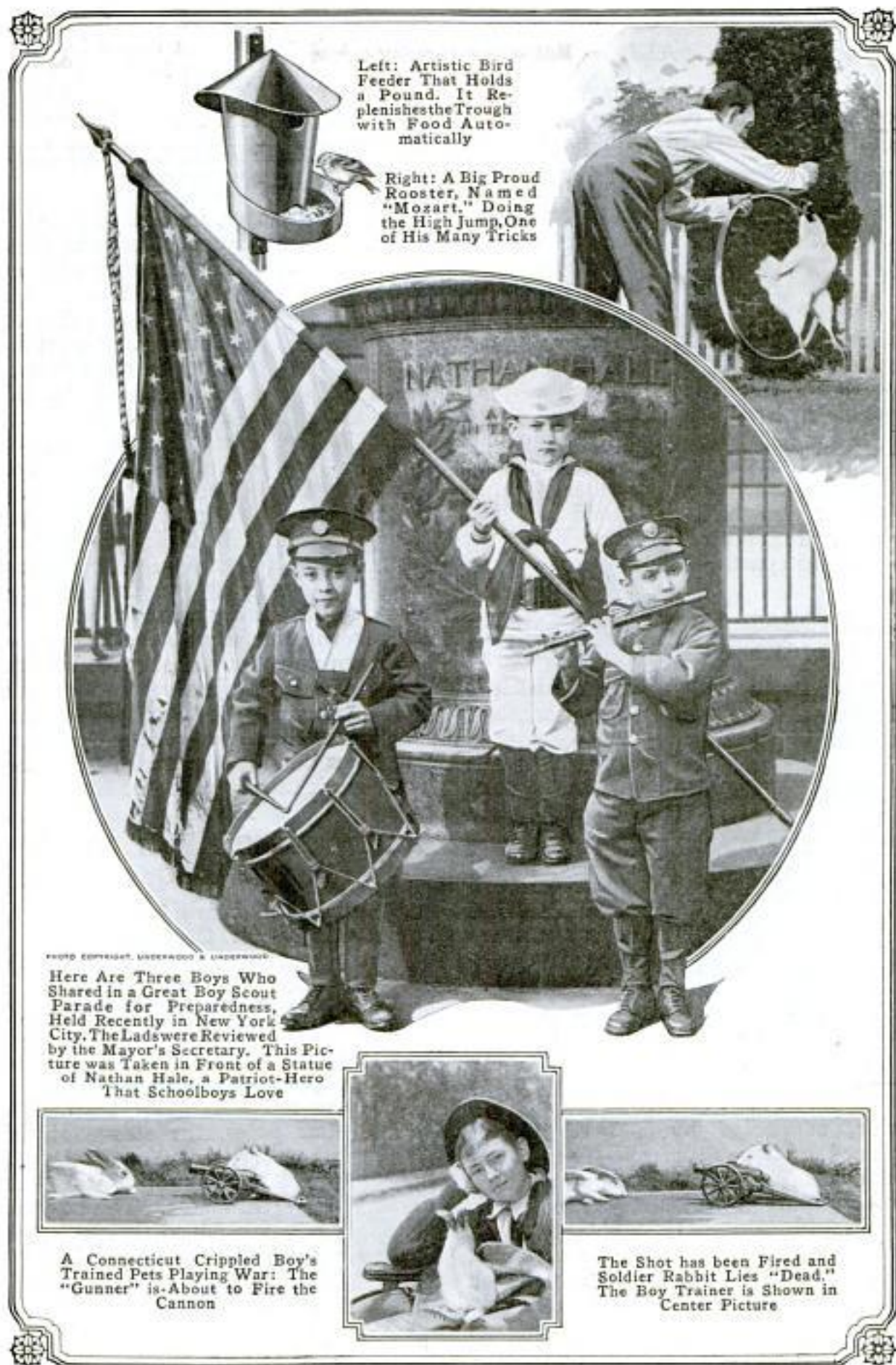

Left: Artistic Bird Feeder That Holds a Pound. It Replenishes the Trough with Food Automatically

Right: A Big Proud Rooster, Named "Mozart," Doing the High Jump, One of His Many Tricks

PHOTO COPYRIGHT, UNDERWOOD & UNDERWOOD

Here Are Three Boys Who Shared in a Great Boy Scout Parade for Preparedness, Held Recently in New York City. The Lads were Reviewed by the Mayor's Secretary. This Picture was Taken in Front of a Statue of Nathan Hale, a Patriot-Hero That Schoolboys Love



A Connecticut Crippled Boy's Trained Pets Playing War: The "Gunner" is About to Fire the Cannon



The Shot has been Fired and Soldier Rabbit Lies "Dead." The Boy Trainer is Shown in Center Picture

NEW BRICKLAYER'S RAKER SUITED TO ALL NEEDS

A new raker for bricklayers is more convenient than the ordinary tool because it is provided with four points



of as many different sizes. The head, or blade, is square and is pivoted at its center to a suitable handle. Projecting from each side of this revolvable part is a slightly up-turned point.

The width of these projections ranges from $\frac{1}{4}$ in. to $\frac{1}{2}$ in. so that the tool is suited to raking mortar from between brick laid various distances apart.

EVAPORATION FOOD COOLER MADE OF CONCRETE

A concrete food container, which is kept cool by evaporation, represents a recent improvement on coolers with canvas walls built on the same principle.



This chest stands about five feet high and is cylindrical in shape, with small screened ventilators in the sides and a narrow door in front. Four circular, revolving shelves are provided inside, supported by a vertical pipe placed in the center. The cooler stands outdoors and rests on a raised base having a projecting edge that is fashioned into a trough and, when filled, serves as a barrier to ants, etc. On the top is a reservoir from which water drips through valves into a surrounding groove and then overflows down the sides of the container. The

resulting evaporation keeps the interior cool. The thick walls retain the cool air and withstand the heat of the sun well.

HOSE CLAMP FOR USE ON ANY AUTOMOBILE

A garage owner, instead of keeping in stock hose clamps of several sizes to be used on different makes of cars,



will find a single style of patented clamp very convenient, because it can be adapted to all sizes of hose. It is a straight strip of metal, in which are 13 holes, $\frac{5}{8}$ in. apart. The metal band is pliable and can be bent around

the hose easily. By inserting a threaded bolt through the proper holes and screwing on a nut, the clamp can be drawn up tight. It only remains to break off the projecting end of the band by bending it back and forth a few times. Small perforations between the holes help to make possible an even break at any point desired.

NONFOULING HALYARD TOP FOR FLAGPOLES

A patent ball-bearing halyard top, now available for flagpoles of either



steel or wood, revolves with the slightest shift of the breeze and keeps the flag from fouling in any kind of wind. It can be attached to any wooden pole by means of screws, and when used with steel poles, the sleeve of the revolving top is wedged securely into the hollow pole. The halyard sheave wheel is protected from moisture by a bonnet, carried on a shaft which runs on ball bearings and is topped with a gilded ball or a weather vane.

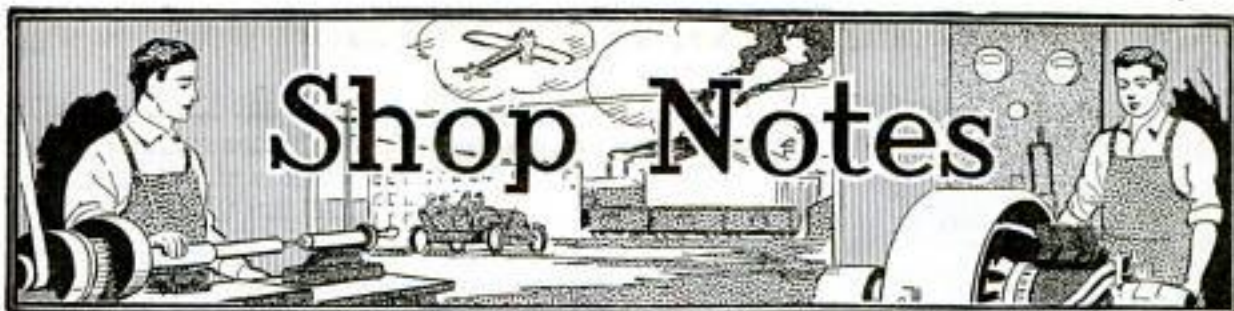

Miniature Landscape Built Up of Concrete

By A. J. VIKEN

AN interesting use of concrete is in the making of models of landscapes, for practical uses as well as for pastime or in scientific work. One of the widest applications of this form of model construction is for display and advertising purposes, where small lakes and picturesque natural effects are desired. The photographs show a miniature landscape which I made principally of reinforced concrete. It measures 20 by 30 in. and is built in a box 5 in. deep. The trees are Japanese air plants. The log cabin is built of matches and toothpicks. Window wire screen was used for fences and bridge railings. In the lake are gold fish, a submarine, a row-

boat, and a ship. The lower photograph shows the size of the log cabin and people compared with a match and a 16-size watch.



The Match and Watch Give a Basis for Comparison with the Cabin

boat, and a ship. The lower photograph shows the size of the log cabin and people compared with a match and a 16-size watch.

The mountain and hills, as shown in the sectional diagram, were built on a skeleton of iron wire, and wire screen,

to make the landscape as light as possible. The bottom of the lake was also formed with the aid of wire screen and the concrete put on top of it. After the concrete had dried, the whole landscape was painted in natural colors. The bot-



General View of the Rugged Mountain Lake

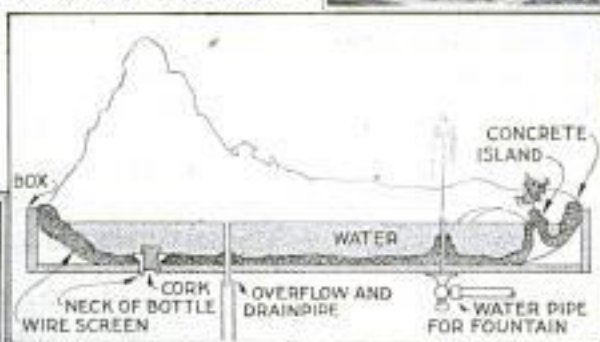

Sectional Diagram of the Construction

tom of the lake was given two coats of dark-gray paint, and when thoroughly dry, a coat of paraffin wax was added to make it waterproof, and to prevent the paint from affecting the water. The whole landscape is mounted on a stand like a rectangular mission table.

An Artist's Palette Supported by the Easel

Artists and others who sketch out of doors can make good use of a palette which hooks to the easel and is supported by a stick, as shown. The shelf keeps within easy access the several articles of a painter's outfit, while he is working. It eliminates some of the distractions of outdoor work. The hand

is free from holding the usual thumb-hole palette, a comfort appreciated



The Artist can Work More Freely When His Materials are Kept on the Palette Shelf, Making a Thumb Palette Unnecessary

especially in hot or cold weather, and in mosquito-infested regions.

The palette consists of shellacked canvas tacked on a wood stretcher. Hooks on the easel and screw eyes on the palette provide a support. The brace is inserted in a slot, and held by a large screw eye.—Phil Bierdemann, Chicago, Ill.

A Safety Window-Cleaning Seat

In the home, and in many shops or buildings where window washers are not employed and the usual safety de-

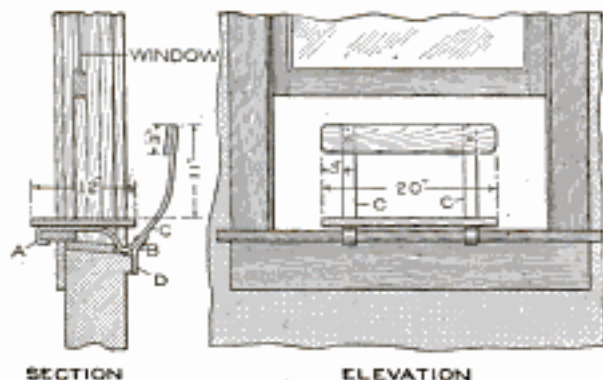

This Homemade Seat Is Comfortable for Window Washing and Insures Reasonable Safety

✓ vices are not used, a small window-cleaning seat is practical as a safety

measure. One like that shown can be made easily by the home mechanic. It hooks over the window stool, at A, and rests on the sill, at B. The main supports C are of $\frac{1}{4}$ by $1\frac{1}{2}$ -in. band iron, shaped as shown, and riveted to a seat of wood, 12 by 20 in., and braced at the top with a wooden rest, 3 by 20 in. The safety strips D are of $\frac{1}{8}$ -in. band iron, riveted to the pieces C. The position of these strips should be determined carefully for the windows on which the seat is used. The back rest makes the work of window cleaning easier.

Hints on the Making and Use of Coil Springs

The experimenter or mechanic often spends time trying out springs that could not possibly do the work expected of them, owing to a lack of knowledge on this important subject. First as to coil springs: Compression springs have open coils and the pressure on each end is toward the center. Tension springs have their coils wound close together; the working pressure on their ends is away from the center. A compression spring of greater strength is made by increasing the size of the wire; making fewer coils per inch of length, or decreasing the outside diameter of the coils.

When this kind of spring is compressed, its outside diameter is slightly increased. Where a spring fits in a hole, this should be allowed for. A given weight will compress a long spring more than a short spring, otherwise of the same dimensions. In building a mechanism with a spring that is to be compressed, see that in the extreme closed position there is room left for the spring itself.

A stronger tension spring is made by increasing the size of the wire, or by decreasing the outside diameter of the coils; and a weaker one by changes in the opposite direction. A compression spring of fair quality may be made from a tension spring by spreading the coils with a screwdriver. The loop on the end of a tension spring can be made,

P. P. Avery,
38 Millard av.,
Garfield, N. J.

with pliers, from the end of the spring wire. Springs may be coiled from spring wire, brass or steel, or from piano wire. Spring wire comes annealed or tempered; if the former is used, the spring has to be tempered after coiling.—Donald A. Hampson, Middletown, N. Y.

Homemade Power Hoist for Loading Hay in Barn

Having a gasoline engine for use on the farm, I rigged it up to aid in loading hay into the barn, by building a hoist for it. An ordinary hay carrier, or fork, was used, with the same tackle commonly used with a team in hoisting the hay into the mow. I built a frame of 2 by 4 and 2 by 6-in. lumber, bolting it together strongly, as shown. The check reel from a corn planter was mounted in it as a drum. On the end of the center shaft a drive pulley was mounted and belted to the engine, which was set in the barn on its usual skid. The clutch for checking the hoisting of the load quickly was on the engine. The arrangement proved more

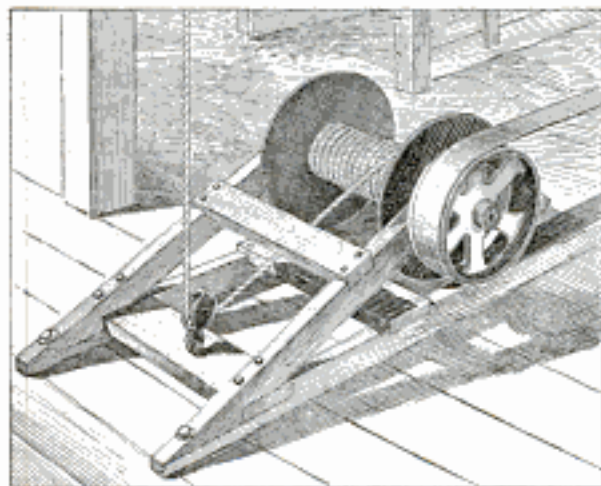

This Hoisting Arrangement was Devised on the Farm for Use with an Engine, in Putting Hay into the Mow

dependable than horses and made it unnecessary to unhitch the team, or to use an extra team for the hoisting.—Ralph A. Page, Urbana, Ill.

CA worn broom can be used handily for cleaning corners by cutting it to a sharp point at one side.

Warning Horn at Sidewalk Garage Door

A garage, situated on a much-traveled street, uses an effective scheme



The Warning Horn Set in the Metal Window Pane Is Effective in Safeguarding Pedestrians

to warn pedestrians on the sidewalks when a car is about to leave the garage. A circular hole was cut in a sheet-metal pane set in one of the sections of a window at the doorway, and a large electric automobile horn was set into it. The mechanism of the horn is supported on a bracket, fixed to the wall. When a car is ready to leave, the employe, who opens the sliding door, touches a push button, sounding the horn. Passers-by "wake up" without fail at the blast, whereas the car horns, sounded inside, cannot be heard readily outside.—John Miller Bonbright, Philadelphia, Pa.

Cementing Gaps around Machinery Tension Keys

There are usually unsightly gaps around tension keys used to hold together sections of large flywheels, and other heavy machinery parts. If this space is filled with neat cement, a smooth, workmanlike finish is obtained that will not crack nor crumble. After painting it the same color as the machinery, the joint is hardly discernible. The cement can be chipped out when desired.—H. P. Roy, Kansas City, Mo.

A Drop Plumb Bob of Weighted Tubing

A plumb bob which may be dropped so that its point will indicate a "plumb spot" is handy as a part of the equipment of a home tool chest. An easy way to make a plumb bob of this type is as follows: Cut a piece of $\frac{3}{4}$ -in.

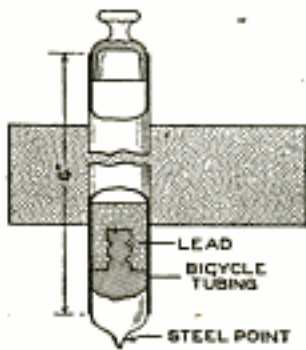

bicycle tubing 6 in. long. Turn a piece of steel to fit the bore of the tube and point it for the bottom of the bob. Turn the other end of this plug with several grooves around it, so that

when the lead is poured into the tube with a point in place, the grooves are filled with lead. Pour in about 3 oz. of lead, holding the tube perfectly vertical. Turn a metal plug, as shown, for the upper end of the tube. Secure it by a rivet through the tube. It is best to make this plug so that it can be removed and the plumb line knotted through a vertical hole.—J. H. Beebe, Rochester, N. Y.

Shelf for Order Books on Auto Dash

A shelf, made from $\frac{5}{8}$ -in. surfaced stock, painted to match the dash of a



delivery, or collector's, automobile, makes an excellent place for order books and the like. The books are always in convenient position; they cannot easily be bounced out of the car and lost,

nor thrown on the floor and walked on, becoming soiled and dog-eared. The shelf is set across the dash at an angle, so that the books lie nearly vertical, in a slotlike rest.—Francis W. Nunenmacher, Berkeley, Calif.

Indicator for Centering Faceplate Work

Some means for accurately locating the center of faceplate work in the lathe is a great convenience to machinists or tool makers. An effective device for this purpose is shown in the sketch. The rod A is of $\frac{1}{8}$ -in. cold-rolled steel, 12 in. long. One end is turned to $\frac{3}{32}$ in., for a length of $1\frac{3}{4}$ in., and pointed to an included angle of 60° . The other end is filed to a sharp point, and both ends are casehardened. Two $\frac{5}{16}$ -in. bearing balls, B, are annealed, and drilled $\frac{3}{32}$ in. to fit the end. The spring C is made from .020 music wire $\frac{5}{8}$ in. long, and wound on a $\frac{3}{32}$ -in. core. The inner ball is free to slide, while the outer one is fastened to the rod with a pin, the spring separating them.

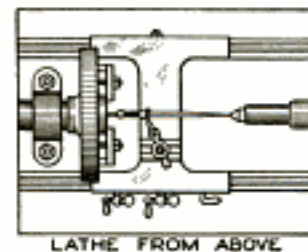
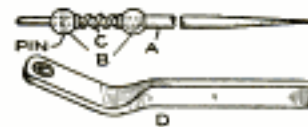

The stock D, for holding the testing bar, is used in a tool holder, and is made of $\frac{5}{16}$ -in. square cold-rolled steel. A $\frac{7}{32}$ -in. hole is drilled and chamfered in the flattened end. The view of the lathe as seen from above shows the tester in use. The stock is fastened in the tool holder, the bar A is pushed through the $\frac{7}{32}$ -in. hole in the flattened end, and the carriage advanced until the 60° end of the bar is in contact with the job. This pushes the loose ball against the spring and holds the end against the work. By starting the lathe and observing the relation of the pointed end to the tailstock center, it is easy to determine how much the piece is off center.—William E. Jewett, Jersey City, N. J.

Time may be saved in drafting I-beams, and other duplicate parts, by making a triangle having special angles, or a hole in it, for marking these standard shapes.

Structural-Steel Sliding Base for Motors and Machinery

By A. L. FENTON

A STRUCTURAL-STEEL sliding sub-base is often convenient for belt-drive electric motors and machinery, and may be arranged substantially as shown in the photograph and detailed in the sketches. These sub-bases are desirable especially where the service is severe, and the belt requires frequent tightening. Provision is usually made on the bases of belt-drive motors to permit take-up for belt tightening, but in some cases the adjustment provided by the manufacturer of the motor is not sufficient. Where a sub-base of the type shown is used, the base can be made long enough so that any reasonable amount of take-up will be provided.

The structural-steel members of the base are I-beams, held together with plates, riveted to their lower flanges, as detailed in Figs. 1 and 2. Holes for the anchor bolts are provided in the plates. Channels may be used instead of I-beams with a decrease in cost, but an I-beam has two flanges as against one for a channel, and hence is capable of being riveted more securely to the

In installing the structural-steel sub-base, it is mounted on top of the foundation prepared for the motor, as shown

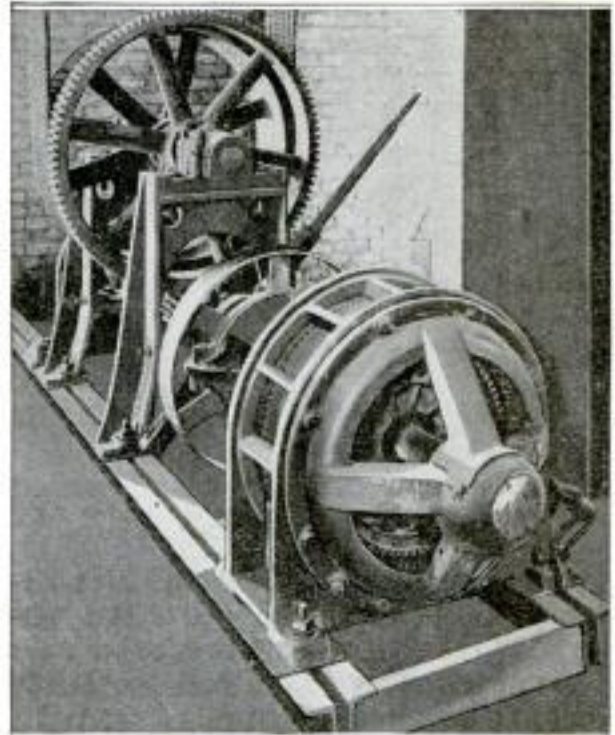

A Substantial Foundation for Motors and Machinery Which Permits of Easy Adjustment or Removal of the Machines

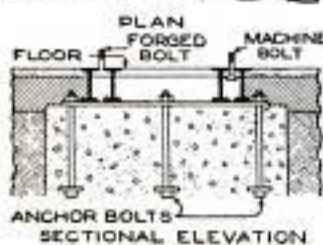
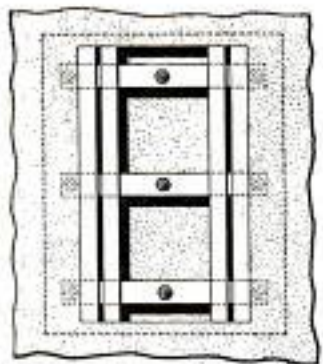

Fig. 1

The Frame is Built Up of I-Beams to Which Steel Plates are Riveted

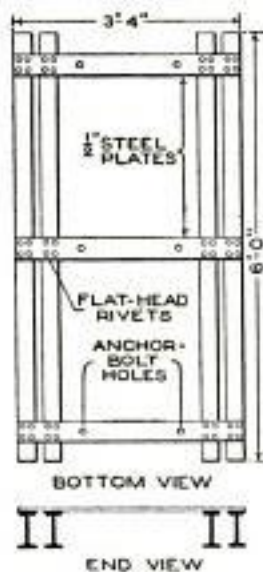

Fig. 2

plates, and held more rigidly upon the top of the foundation where it is to be installed.

in Fig. 1. The height of the foundation should be such that the top faces of the I-beam members will, after the sub-base has been installed, lie flush with the face of the top floor. The surfacing of the floor should be built up close to the sub-base, as indicated in the sectional elevation.

The motor base is bolted to the sub-base by means of bolts set in the slot between the pairs of I-beams, as shown in two forms in Fig. 1. The bolts for this purpose are made as detailed in Fig. 3, or ordinary machine bolts can be used in combination with a casting similar to that shown in Fig. 4. The casting is shaped to fit the I-beam flange, and the head of the bolt is held in a recess, preventing the bolt from turning. The T-bolt is forged by welding a piece of stock of suitable dimensions to the head end of an ordinary machine bolt. The under side of the T-head should be given a 6 to 1 pitch to correspond with the pitch on the

flanges of the I-beam, or channel members, in the sub-base, against which it is clamped. The thickness *T* of the head should be such that the

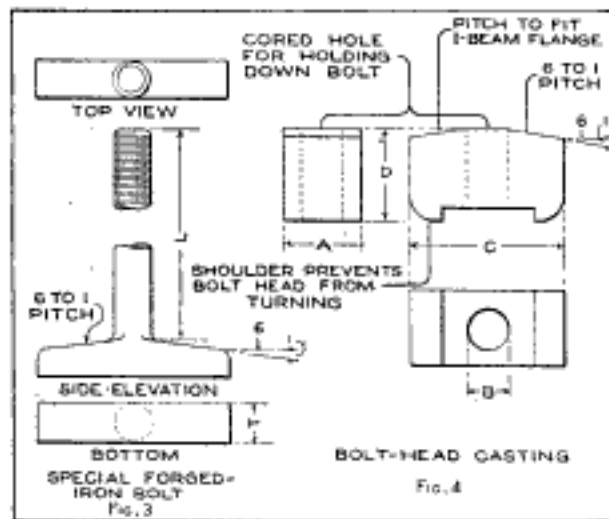

A Forged Bolt with a T-Head, or a Machine Bolt, may be Used to Secure the Machine Bases

bolt can be dropped into the slot between the I-beam members of the sub-base, so that if a bolt breaks, a new one can be substituted, and so that it will not be necessary to place the bolts in the sub-base until all of the rough work involved in building the foundation and setting the sub-base has been completed. The length *L* of the bolt will be determined by the thickness of the motor base, and by the general proportions of the particular installation.

Where a bolt-head casting, like that of Fig. 4, is to be made, its thickness, *A*, should always be such that the casting can be inserted in the slot between the I-beams in the sub-base. Hence, these I-beams must be spaced a little farther apart than the thickness *T* of the head of the forged bolt. The diameter *B* of the hole should be just large enough to produce a good sliding fit on the bolt. The length *C* should be about twice the thickness, and the height *D* proportioned as shown.

Filing Down a Thin Washer

It is difficult to hold a thin washer in a vise while filing it on the face, and a good method of accomplishing this is to file the washer flat on the bench, or on a block. Drive a nail into the bench

top, or into a block, so that its head is just below the surface of the washer, and place the latter over it. Lay the file flat across the washer, a little to one side of the center. File with a forward stroke only, causing the washer to turn slowly. An even cut will be removed from all parts of the surface.—Walter B. Raynor, Patchogue, N. Y.

Repairing a Large Reamer

An apprentice drove the expansion screw of an expensive, large hand reamer in too far, causing the reamer to crack, as indicated at *A*. A satisfactory repair was made by first removing the pin *B*, separating the shank *D* and the body. The screw *C* was then taken out, and a tight push-fit collar, *E*, was forced on the blades, to hold down the broken ones. The reamer was put on centers in the lathe, and the groove *F* was ground in. The portion between the new groove and the old one at *G* was ground down to a diameter slightly smaller than before. A steel bushing, *H*, was made, the hole in it being .003 to .004 in. smaller than the newly ground part at *G*. The bushing was heated and shrunk on the reamer, the old groove beside it being made as wide as the original one, at *A*. The bushing held down the broken blades, and was

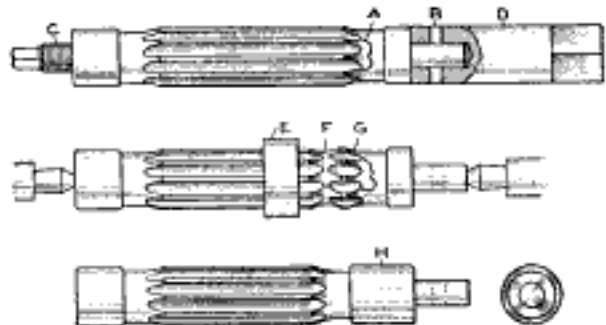

An Expensive, Large Reamer was Saved by Making a Skillful Repair for It

ground down to the size of the shank *D*. The reamer was then reassembled.—Richard H. Jehlicka, Worcester, Massachusetts.

ⒸA machine bolt is usually screwed down $2\frac{1}{2}$ times its diameter.

Machine Clamps Made from Hexagon Nuts

I made a set of hexagon clamps which are strong and useful for many kinds of small work, by fitting 1-in. cold-pressed nuts with thumbscrews, as shown in the sketch. One side of the nut is cut away and a $\frac{5}{16}$ -in. knurled thumbscrew, provided with an adjustable cap at its lower end, is fitted to it, as shown. These clamps may be laid flat on work and can be used like parallel clamps in many cases.—J. Harger, Honolulu, Hawaiian Islands.

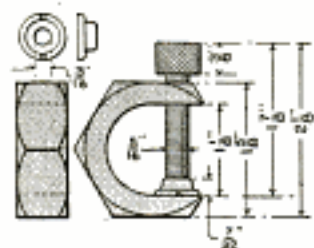

One side of the nut is cut away and

a $\frac{5}{16}$ -in. knurled thumbscrew, provided with an adjustable cap at its lower end, is fitted to it, as shown. These clamps may be laid flat on work and can be used like parallel clamps in many cases.—J. Harger, Honolulu, Hawaiian Islands.

Fans on Machine Shafting Cool Workman

Lacking an electric, or other common power fan, an ingenious workman in a machine shop attached two ordinary paper hand fans to the line shafting, securing them with cord, as shown. The result was a rather unique fan, which cooled him at his machine, nearly as well as the boss's elegant brass fan cooled him, in his private office.—M. J. Doyle, Cleveland, O.

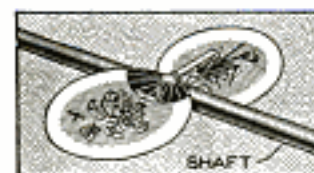

in a machine shop attached two ordinary paper hand fans to the line shafting, securing them with cord, as

shown. The result was a rather unique fan, which cooled him at his machine, nearly as well as the boss's elegant brass fan cooled him, in his private office.—M. J. Doyle, Cleveland, O.

Skimmer for Removing Slag from Molten Metal

In using molten lead or other metal, especially in the workshop where it is gathered in many small pieces, it is important that the slag be skimmed off carefully. A handy tool for this purpose was made by hammering a piece of iron rod out to the shape shown in the sketch,



A handy tool for this purpose was

made by hammering a piece of iron rod out to the shape shown in the sketch,

the small end serving as a handle, and the rounded edge of the skimming end fitting against the curve of the ladle in which the metal is melted.—E. K. Marshall, Oak Park, Ill.

Device for Wrapping Small Articles of Uniform Size

A block for wrapping small articles, such as typewriter ribbons, in tin foil, can be made from wood with metal fittings, as indicated. The hole in the top is cut $\frac{1}{16}$ in. larger than the width of the article to be wrapped. The foil is laid on the

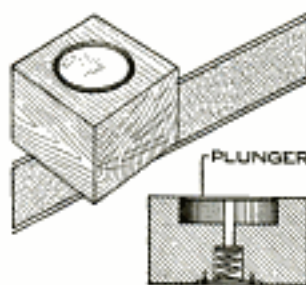

top of the block, then the article is pressed down, and the foil drawn from the sides and pressed with the palms of the hand. When released the article rises above the top, so that it can be handled easily. Articles wrapped in this form are neater and more uniform than when wrapped by hand. The shape of the hole in the block can be varied to suit special needs.—A. H. Hale, Brooklyn, N. Y.

Reaming a Bushing or Collar without Reamer

To enlarge a bushing properly, where a reamer is not obtainable, take a round rod, or a piece of wood, somewhat smaller than the bushing; wrap emery cloth around the rod and place one end in a vise. Place the bushing over the emery cloth. By coiling a cord twice around the bushing, and pulling on the ends of the cord, first one, then the other, the bushing is dressed to a perfect fit. In reaming a bushing by this method, for piston pins, etc., it should be made to fit rather loosely, because of the tendency to tighten when in place.—J. W. Reynolds, Mason, Ill.

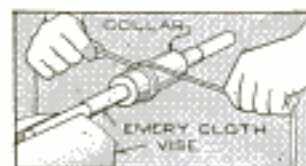

Saving Overall Buttons That Pull Through

The buttons used on mechanics' overalls and jumpers sometimes pull out. Examine the buttons used; if in the center two bent wires hold on the button, they can be sewed on again. With a pair of cutting pliers cut off the rivet head of the button that pulled through the cloth; remove the wires from the center of the button, and it may then be sewed on. If it is the type of button that shows a round rivet-head center, it cannot be so used again. Keeping these buttons saves hunting up other suitable ones.—John Hoeck, Alameda, Calif.

Incandescent Lamps Used in Stereopticon Lanterns

The electric arc lamp has been used to a great extent in stereopticons and moving-picture apparatus, where an intense light is essential. However, the newer high-candlepower incandescent nitrogen lamp, from 300 to 1,000 watts,

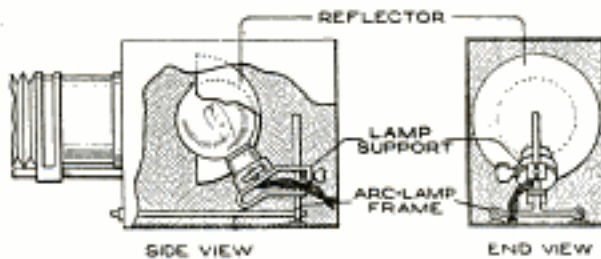

The High-Power Nitrogen Filament Lamp Is Safe and Efficient for Use in Stereopticon Lanterns

provides a satisfactory substitute for the arc lamp. The former requires little attention, and is more economical of current. It is also safer than the arc lamp, and is easily adapted to stereopticon equipment.

A special support of $\frac{1}{8}$ -in. sheet iron is provided for the arc lamp, as shown, and is clamped on the vertical rod. A 300-watt lamp is satisfactory for small stereopticons, and the 500-watt size for larger ones. Round-bulb lamps are used, and a reflector, placed behind the lamp, increases the light efficiency. The old housing and lamps are used.—E. A. Binney, St. Louis, Mo.

Valve and Stand for Inflating Tires Quickly

Much time is spent in inflating tires in automobile factories and garages, and the device described reduces this opera-

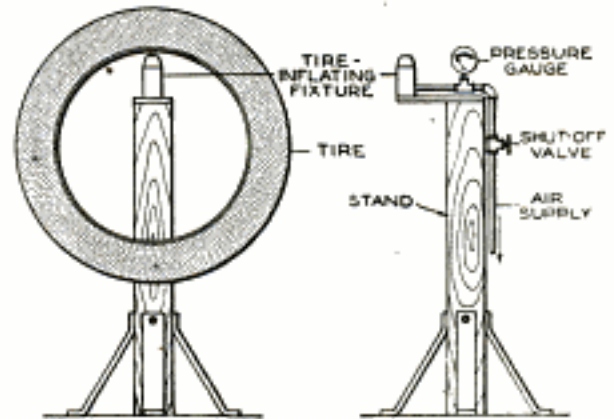
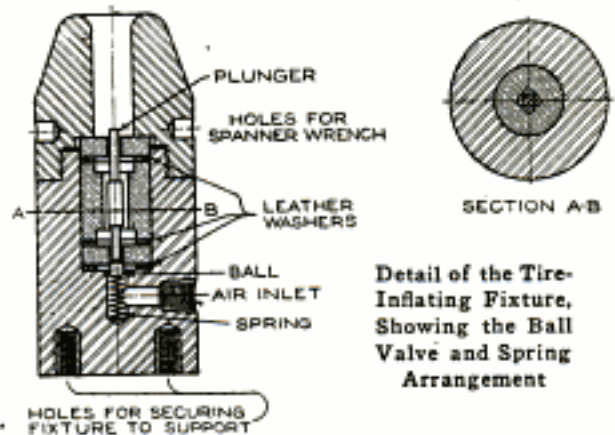

Fig. 1

The Tire is Inflated After It is Mounted on the Rim, and Before the Rim is Placed on the Wheel

tion to a minimum. The tire is inflated after it has been placed on the rim, and before the latter is placed on the wheel. A stand is used, as shown in Fig. 1, and a special valve is arranged on the tire-inflating fixture. This is shown in the detail sketch. The weight of the tire and rim presses down the plunger, which bears, at its lower end, on a ball and a spring, controlling the air at the inlet. The air passes around the spring and the ball and up into the tire valve. A pressure gauge and a shut-off valve



Detail of the Tire-Inflating Fixture, Showing the Ball Valve and Spring Arrangement

are provided in the air line, so that the air may be regulated easily.—William J. Outcalt, Detroit, Mich.

ⒸA piece of tin, fixed to the lower edge of an ax handle at the head, saves wear.

Barrel Sprinkler for Oiling Roadway

In summer, the suburbanite is often confronted with dusty driveways and walks that are easily improved with a



Occasional Oiling of Roadways with a Homemade Sprinkler will Keep Down Dust around the Home

homemade oil sprinkler, like that shown. A steel frame, mounted on wheels, was rigged up to hold an ordinary oil barrel. Inserted in the bung is a short piece of pipe equipped with a shut-off. To this is attached the sprinkling pipe, having perforations, about $1\frac{1}{2}$ in. apart, of sufficient size to allow the oil to flow freely. The cart may be drawn, or pushed, the latter being more convenient, discarded shoes being worn, and a thin layer only applied.—J. C. Grindell, St. Louis, Mo.

A Solderless Extension Drill Rod

In using an extension drill, a common practice is to sweat the shank of the drill into a brass tube, or a rod bored

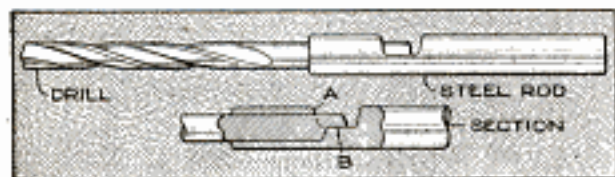

The Drill is Held in the Extension Rod by the Shoulder Joint

out. This process fixes the drill more or less permanently in the rod or tube, and requires special heating for the

soldering. By making a special drill rod with a simple chuck arrangement, as detailed in the sketch, it is unnecessary to solder the drill into place. The end of the drill rod is bored out to receive the drill, and a groove, A, is filed across the rod and into the drilled hole. This provides a small, slightly beveled shoulder, B, which grips a corresponding shoulder on the end of the drill. The fastening is very strong if carefully made, and the drill can be quickly removed.—V. Arkin, Chicago, Illinois.

Hidden Screw Rivets for Woodwork

When one has done a fine bit of gluing, as on the neck of a violin, some not unsightly reinforcement is often desirable. I proceeded in the following manner in making such a repair: Using No. 17 brass escutcheon pins of a suitable length, I cut off the heads, and gripped the pins in the chuck of a small hand drill, and threaded them. Taking another light hand drill, and with a drill about two sizes smaller than the pin, I bored through the glued parts as many holes as were necessary. I cut off the point of the pin, and, with it still in the hand drill, screwed it into the hole. To hide the screw pins, I cut them off on the top side and dressed it smooth. Carefully pricking a center mark, and taking a drill the size of the brass wire, I drilled out a little of the end. By waxing these holes and staining the spots properly I had a strong and neat job.—L. M. Drake, Daytona, Fla.

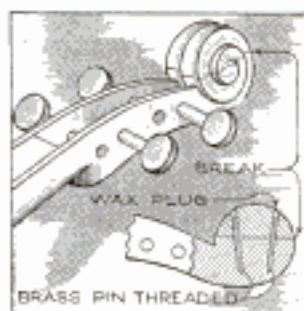

Ⓒ A bearing for moderate speeds and light duties should be of a length at least two diameters of the shafting. High-speed shafts should have bearings of a length four times the diameter of the shaft.

A Direct-Reading Lever Micrometer

By H. L. WILEY

THICKNESSES of paper, sheet metals, rubber and cloth fabrics, wire, and similar materials, can be read directly to .0001 in. with this lever mi-

ried on fine needles thrust through them at points M and L. The levers work through slots cut in the supports H and J. To keep the levers from

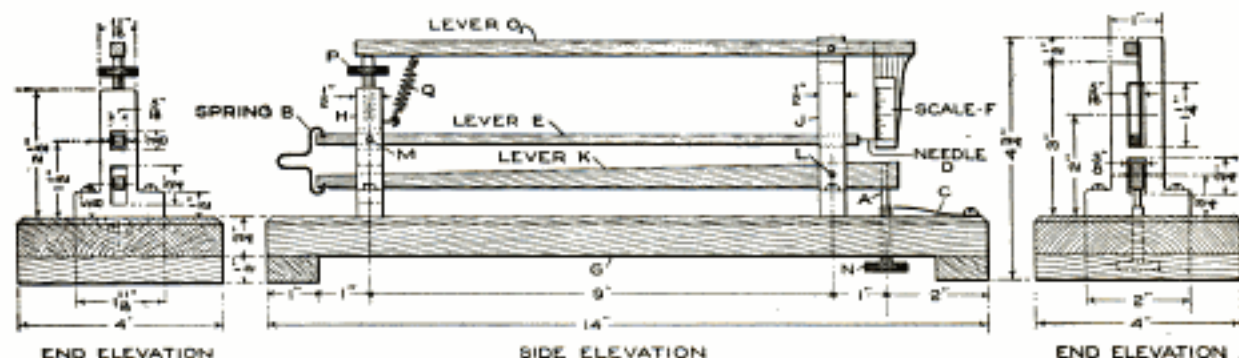

When the Operator becomes Accustomed to This Homemade Lever Micrometer, He can Read to Minute Accuracy with It

rometer. It can be operated much more rapidly than a screw micrometer of the usual type, over 30 readings per minute being possible after a few minutes' practice. To operate the micrometer, the anvil A is raised by placing the finger lightly upon the spring link B, the object to be measured being guided to its position under the anvil by means of the guide spring C. When the object is between the jaws of the micrometer, the spring link B is released, and the needle D, at the small end of the lever E, immediately indicates the thickness of the object upon the scale F. Upon the base G are mounted two supports, H and J, through which run the levers K and E. These levers, K and E, work respectively on the pins L and M. The upper anvil A is set into the end of the lever K, and forms a contact with the lower anvil, which is the end of the screw N. The small end of lever K is connected to lever E by means of the spring link B, which is made out of a piece of clock spring, or other thin, flat spring steel. The small end of the lever E terminates in a fine needle, working close to the scale F. This scale is carried on the end of lever O.

Base, supports, and levers are made of cedar, or other light-weight wood, as the machine is delicate in its action, and superfluous weight in the moving parts, especially in lever E, should be avoided. The levers K and E are car-

touching the sides of the slots in the supports, washers, or fillers of fine glass beads, can be used on both sides of the levers.

The scale F is 1 in. long, graduated to hundredths of an inch. If desirable, a reading glass can be mounted on support J, directly focused upon the scale. With the upper and lower anvil jaws in contact, the reading on the scale should be zero. If such is not the case, adjustment is made by means of the screws N and P. Both of these screws work directly in the wood. In placing them, holes, slightly less in diameter than the screws, are drilled into the support H, at the top of which is located the screw P, and into the base G, through which passes the screw N. The coarse adjustment, by means of which the indicator needle D is brought within .01 in. of the zero line on the lower end of the scale F, is made with the screw N. The finer adjustment is made with the screw P. The lever O is held lightly against the screw P by means of the small coil spring Q.

This machine is accurate, by close observations, to .00001 in. and will stand considerable hard use without requiring adjustment. As soon as the operator becomes accustomed to its use he can read to $\frac{1}{50,000}$ part of an inch without difficulty. The machine will indicate the thickness of a pencil mark on paper.

Tool for Soldering Automobile Radiators

An attachment made in the shop to be used with a common gas-and-air torch is the best arrangement for soldering automobile radiators I have ever used. When the leak occurs in the cells of a honey-comb radiator, little difficulty is experienced in soldering it. A tube radiator can also be soldered, without moving the webbing.

The soldering iron is made of $\frac{1}{4}$ -in. round-iron stock, bent as shown in the sketch, ground square and slightly tapering from the curve to the point. The length of the iron depends on the depth of the place to be soldered, 3 in. being practical. The torch unscrews at A, allowing the device to be slipped on through the $\frac{3}{8}$ -in. hole in the clamp, provided with setscrews.—Charles G. Moon, Des Moines, Ia.

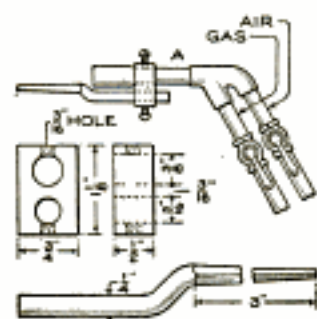

Boxes for Small Hardware Display Contents

A convenient way to keep nails, screws, and other small parts, is to place them in tin boxes of uniform size, which may be stacked without the use of shelving. It is desirable to mark the boxes so that the contents may be identified easily.

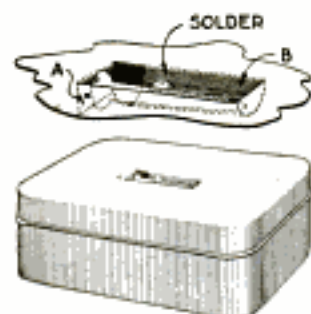

A good way to do this is to make a depression in the top or front of the box, large enough for one of the articles contained. The sketch shows how a screw was fastened in the top of the box. The part A was bent to hold the head, and the part B hammered in.—H. K., West Nyack, N. Y.

Washer Holds Bolt from Turning in Clamping Grooves

To keep the head of a bolt from turning in the clamping grooves of a planer, miller, or other shop machine, on which machine parts are bolted down while in process, take a washer of the same size hole as the bolt diameter, and turn over two opposite edges of it so that the head of the bolt fits between them. Then slip the washer under the head of the bolt, so that it rests in the clamping groove, almost as a part of the bolt head. This takes up the looseness.—J. Fast, Denver, Colo.

Preventing Rapid Wear on Horseshoe Calks

An efficient method of fixing a horseshoe calk so it will stay sharp is

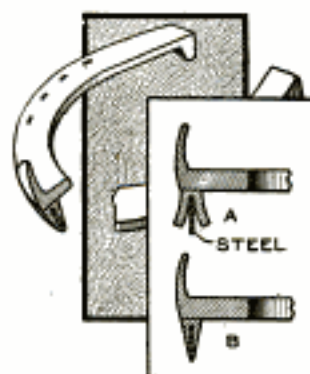

to have the blacksmith split the toe calk lengthwise and insert a strip of steel cut from a worn-out mowing-machine knife. This is done after the calk is welded to the shoe. The inserted strip of steel, ready for welding, is shown at A, and the calk with the strip of steel welded in place, at B. The hard steel will not wear away as fast as the softer part of the calk, hence the calk wears in a V-shape, remaining comparatively sharp.—Clarence H. Green, Columbus, Ohio.

Toothed End Prevents Screwdriver from Slipping

The troublesome slipping of an automatic screwdriver, often experienced when driving is unusually light or hard, can be avoided by filing small teeth in the edge of the blade. About 24 teeth to the inch, or about seven teeth to a medium blade, is suitable, and they should be kept sharp as saw teeth.

Handy Plier Vice Used on Piston Rings

An effective method of securing additional usefulness from an ordinary combination adjustable plier, is to drill two elongated holes through the handles, inserting a $\frac{3}{16}$ by 3-in. screw or stove bolt, as shown. A thumb nut controls the adjustment, providing a hand vise that is useful for light work. A C-clamp fastens the plier quickly on an automobile running board, for roadside repairs.

One of the many novel uses to which the vise may be applied is as an aid in a one-man method of inserting pistons in the cylinders of a gas engine. A wire band of the diameter of the piston is made, as shown, with loops at the ends for the nose of the plier. The vise in position, as indicated, compresses the piston ring and holds it clamped until the piston is slid forward into the cylinder. The end of one handle of the plier is forged and filed into a convenient automobile-

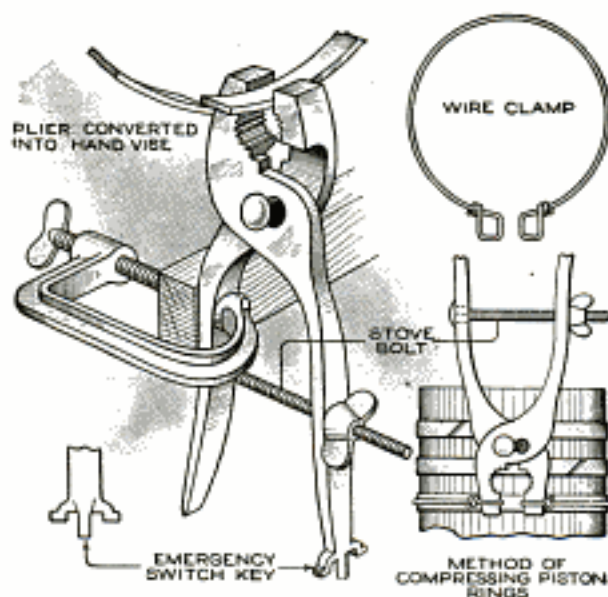

The Automobilst and Mechanic can Make Better Use of a Plier by Applying These Simple Kinks

starting switch key, which cannot easily be mislaid.—George A. Luers, Washington, D. C.

☞ A few drops of oil applied to the joints of a folding rule greatly facilitate its use.

Emergency Sash for Railroad-Car Doors

Window sashes are frequently broken on railroad coaches, and it has been

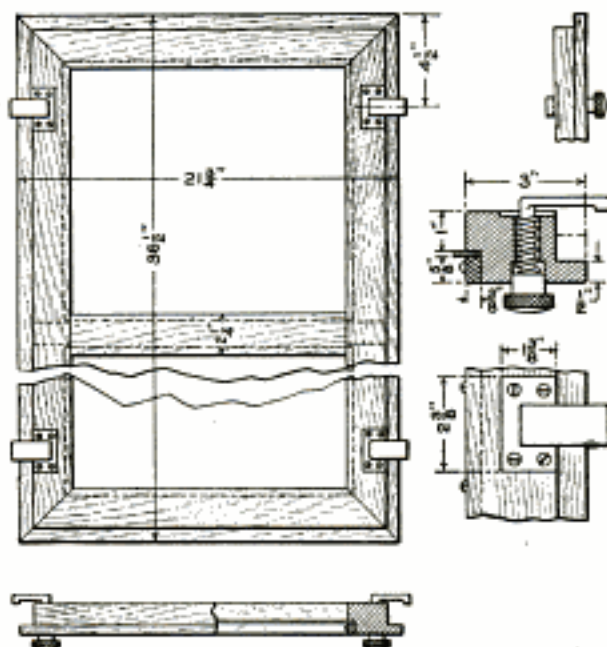

This Emergency Sash was Designed for Use on Railroad Coaches

found desirable to have emergency sashes on hand at the repair shops of divisions. The sketch shows the detailed construction of such a sash that can be installed in a few minutes. The glass is held in a wooden frame which is locked in place by means of four catches. The latter are shown in detail in the sketches at the right. The catch consists of a brass fitting, cast with an angle plate at one end and a round rod at right angles to it. The rod is machined and fitted to a plate fixed to the sash. A spring acting against a knurled knob, sliding over the end of the rod, draws the angle end firmly against the window casing.—John W. Shank, Renovo, Pa.

Boiler-Furnace Stokers' Inspection Glass

A piece of blue glass, about 4 in. square, mounted in a small frame having a handle, is useful for stokers in examining the condition of the fires in large boiler furnaces, which require close and repeated inspection to maintain efficiency.

Self-Opening Garage Door

It is often annoying, especially in rainy or winter weather, to get out of an automobile at the garage in order

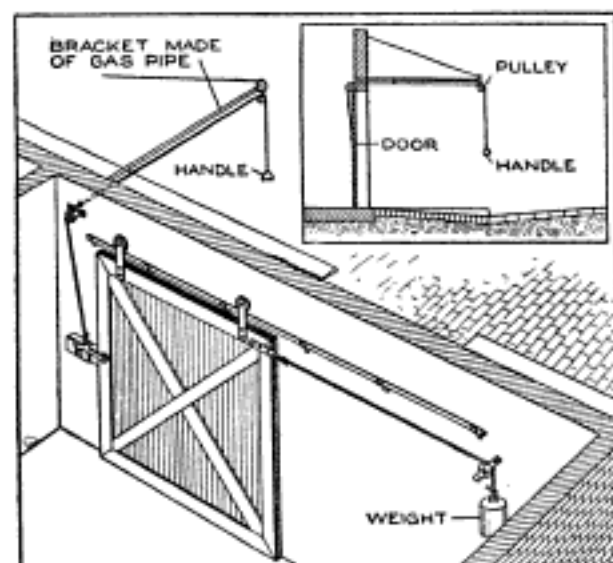

The Driver of the Car Pulls on the Handle, Releasing the Catch, and the Door Opens Automatically

to open the door. Customers at a public garage usually toot their horns until the door is opened, and in order to make this unnecessary I built a self-opening arrangement for the garage door. The auto driver pulls on the handle suspended in front of the door, releasing the door catch. The door is then automatically opened by the counterweight. The garage attendant can easily close the door, and adjust the catch for the next patron. This device is also handy on private garages. A section of gas pipe, braced with strong wire, was used to support the pulley and the unlocking cord.—R. S. Matzen, Fort Collins, Colo.

Hammering Tightens Worn Brass Thumb Nuts

When brass thumb nuts used on drawing instruments, and for similar purposes, become worn, they may be tightened by hammering them slightly to make the threaded hole smaller. Place the nut on a metal plate and strike it a level blow with a hammer. Try the nut in its original position, and repeat the hammering until a tight fit results.—E. C. Griess, Grand Forks, N. D.

Shop Device for Addition of Fractions

Draftsmen, machinists, and many other mechanics, will find the home-made instrument shown in the sketch almost indispensable after giving it a trial. A disk, A, of heavy white cardboard or opaque celluloid, is graduated as indicated. A smaller transparent disk of celluloid, with small holes drilled in it to correspond to the graduations on the disk A, is riveted to the latter, at C, permitting the disks to turn. The arrow is scribed on disk B.

To add two fractions, such as $\frac{5}{16}$ and $\frac{7}{32}$, set B so that the arrow is at 1, place a pointed, pencil-like stick in the hole in the arrowhead and turn this disk until the arrow is at the fraction $\frac{5}{16}$; then place the stick in the hole now opposite 1, and turn B until the stick is at $\frac{7}{32}$. The arrow will then be at $\frac{17}{32}$, which is the sum of the two fractions. This process may be carried on indefinitely, and each time the arrow passes the unit graduation, 1 is added to the sum. To subtract two fractions the operation is reversed. The arrow is placed at the larger fraction; the stick is placed in the hole opposite the smaller one, and disk B is turned back to 1. The arrow will then be found to point to the difference of the two. Disk A may be graduated to suit the uses

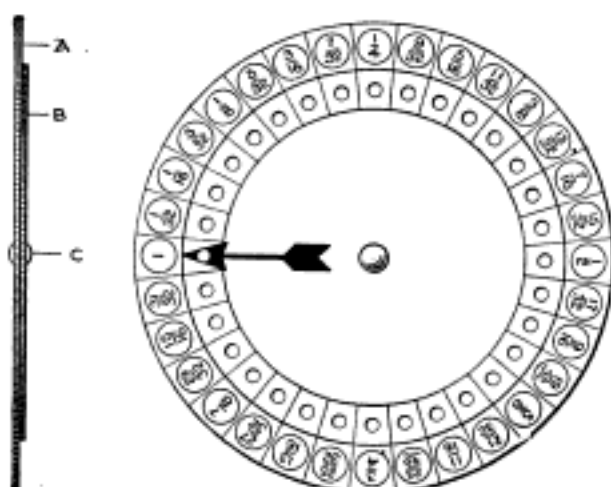

Much Time is Saved and Errors Minimized by the Use of This Handy Adding and Subtracting Device

for which it is intended, and decimal equivalents to the fractions placed underneath them.—James F. Boyd, Detroit, Mich.

Rapid and Accurate Repair of Broken Tapeline

When the only available steel tapeline on a job broke it was necessary to make a repair immediately. A piece, about 1 in. long, was broken out and it was replaced and a good joint made as follows: A piece of steel was cut from an old stovepipe, to the same width as the tape and 3 in. long. It was marked carefully to correspond to the broken part, and riveted into place with ordinary carpet tacks, cut down to the proper length.—P. A. Midland, New York, N. Y.

Removing Dents from Auto Fenders or Sheet Metal

A simple and effective means of removing dents from automobile fenders

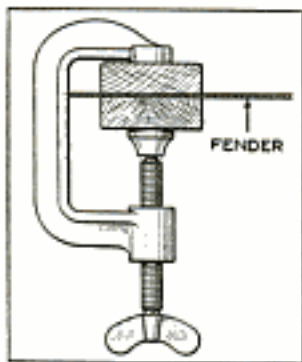

or sheet metal is to clamp the damaged part between two wooden blocks, as shown in the illustration. An iron cabinetmaker's clamp is best suited for this purpose, but various other

means of applying pressure may be used. Where the damage is considerable, this method will, of course, restore the surfaces only partly.—Arthur E. Miller, Evansville, Ind.

Cushion-Seat Folding Stool of Metal

This compactly folding stool was made of high-grade materials shaped by the use of a forge. If softer metal is used the parts may be bent cold. Strap iron, $\frac{3}{16}$ in. thick, was used for the pieces A and B. The brace C is a bolt. The pieces D and E are made to snap together, the shoulders on the ends of each checking the motion of the other. The upper supports are made similarly of $\frac{5}{16}$ -in. cold-rolled steel. The rigidity of the stool depends on the care with which these

parts are made and fitted. The padded top is built up around a wooden frame, one of the upper supports being hinged to it, as shown in the bottom view.

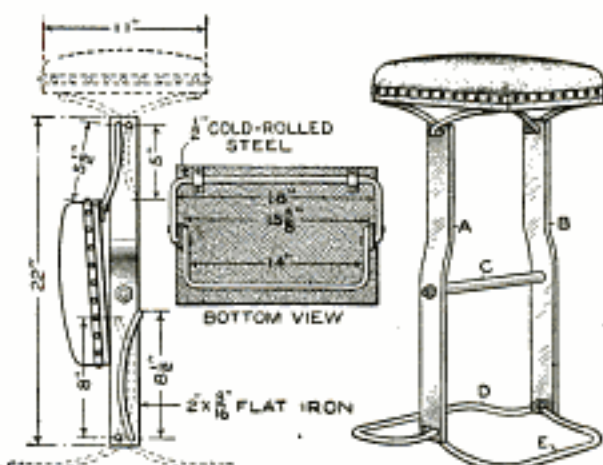

The Upper and Lower Supports Brace Each Other, and the Stool can be Folded Compactly

The method of folding the stool is indicated at the left.—Hubert Kann, Pittsburgh, Pa.

Repairing Broken Teeth in Fiber or Paper Gears

A repair of broken teeth in gear wheels made from fiber or compressed paper, by replacing the broken teeth with lead reinforced by screws, proved satisfactory. The broken tooth stub was dressed down with a file, and holes for machine screws were drilled as indicated in the sectional views. The bolts were given a brushing with soldering acid, and the tooth was built up on them, with solder and a soldering copper. After roughing in the tooth, it was finished with a file. The heads of

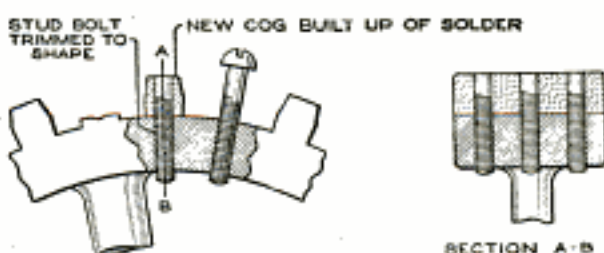

The Broken Teeth were Replaced by Building Up New Ones of Solder around Machine Screws

the bolts were cut off flush with the curved surface of the gear. Such a repair, properly made, will last practically as long as the other teeth.—Logan E. Anderson, Cove, Ore.

Spider for Cutting Large Pipe in Lathe

A machinist in our shop, having to turn out a lot of 8-in. pipe for coup-

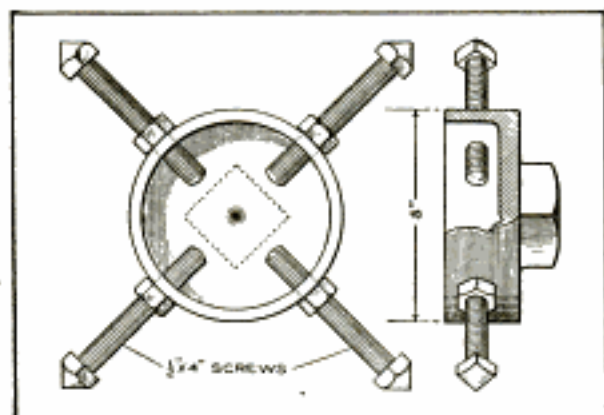

The Work was Turned Out in Record Time with This Tool

lings, had no tool large enough to center the pipe in the lathe. He obtained a 5-in. plug and drilled four holes in it, and tapped them out for $\frac{1}{2}$ -in. screws, as shown. Taking four $\frac{1}{2}$ by 4-in. machine screws, he ground the heads to a point, leaving just enough to put a wrench on. He fitted four locknuts to the screws, and put them in place. The tool is inserted into the end of the pipe, adjusted, and centered, and the locknuts tightened up. The other end of the pipe fits into the chuck of the lathe.—Charles K. McCluskey, Wheeling, W. Va.

Holder for Wood-Turning Tools

Instead of having handles for each wood-turning tool, a mechanic made a

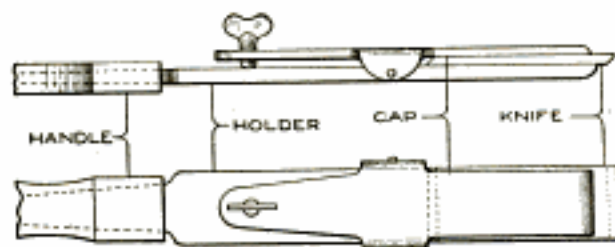

This Holder Provides for a Number of Knives or Bits for Wood Turning, with a Single Handle

simple holder which makes it necessary to have only a single handle and a number of bits, which are inserted as required. The bits, or knives, are thin, making it easier to grind them to

various shapes. The detailed construction of the holder is shown in the sketch. A sheet-metal clamp is pivoted over the main support of the holder and clamps the knife by means of the thumbscrew.—M. E. Duggan, Kenosha, Wisconsin.

Copper Covering Transmits Heat to Auto Intake Manifold

A practical means of heating the intake manifold of an automobile from the hot exhaust manifold, to increase the efficiency, is to cover the entire intake manifold, and part of the exhaust manifold, with No. 20 gauge copper, bending well around each, and making it meet in the rear of the intake manifold. This copper plate is held in place

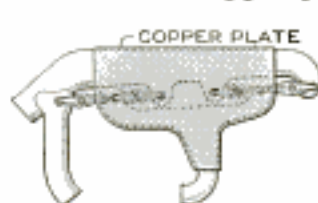

by boring holes through it to correspond to the bolts on the engine block, slipping it over these bolts, and then setting the pipe clamps in place, tightening them with the nuts, as usual. The copper plate conducts the heat from the hot exhaust manifold to the intake manifold. After running the engine 10 minutes, the intake manifold becomes so hot that the hand cannot be held safely on it, thus preheating the gas, and making it more combustible.—Charles A. Pettit, Rossville, Md.

Ropes Fed through Floor from Basement Stock Room

Coils of different-sized rope lying around the main floor of a hardware store look untidy, to say nothing of the valuable floor space they occupy and the dust they collect. A good way to do away with this nuisance is to place the coils in the basement on a shelf, bore holes in the floor for the different sizes, and pull the rope through, as required. A single loose knot will prevent the rope from sliding back. A measuring scale is laid out from the hole, the rope being pulled out and measured off in one operation.

Filing Cork in a Lathe

Cork cannot be turned in a lathe in the usual manner, but can be cut down quickly by filing it, much as metal spindles are finished in a speed lathe. A coarse file, preferably of the type used for filing wood, is used for the roughing out. Special care must be taken that the file is applied only on the forward or cutting stroke. If the cork is of a fairly solid texture, it can be worked quite smoothly. To finish the surface, apply a fine file, gradually applying greater pressure. To give the cork a polished surface, burnish it with a smooth piece of steel.

Beveled Piston Ring Overcomes Excess Oil in Cylinders

Many automobile and similar motors have a tendency to pump oil into the compression chamber, which causes rapid accumulation of carbon. I have found the first cylinder usually the worst. After some experimenting I filed off the lower, outer corner of the piston ring at the bottom of the piston, beveling it slightly. The ring was replaced in its normal position, and reduced the pumping of oil. The opening around the corner of the ring prevents the oil from being sucked up into the cylinder. When a piston fitted quite loosely, an oversized piston was substituted with very good results, the lower ring being beveled as described.—J. W. Reynolds, Mason, Ill.

Remover and Wall Receptacle for Bottle Caps

In a store, or other place, where drinks or bottled goods are sold in bottles having metal caps, a convenient way to remove the caps and prevent them from falling on the floor is to install an arrangement like that detailed in the sketch. The caps are removed quickly by means of the small device fastened to the wall, and dropped into a chute and a box made of cigar-box or other thin wood. The box is suspended on screws and can be quickly

removed and emptied. The cap remover, as detailed, is made of a strip of galvanized sheet iron, bent over a

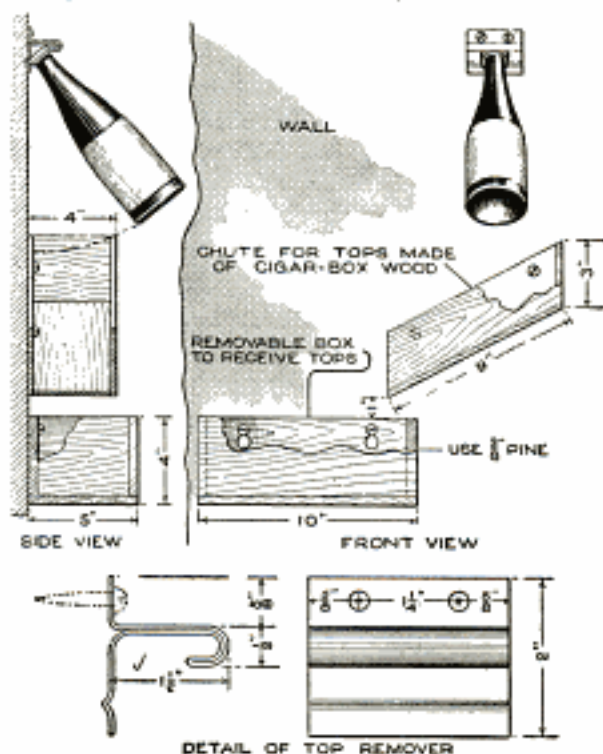

The Bottle Caps are Quickly Removed and Dropped into the Receptacle, Avoiding the Danger of the Slippery Caps on the Floor

$\frac{1}{2}$ -in. pipe held in a vise. It is fastened with screws.—P. P. Avery, Garfield, New Jersey.

Belt Guard Pivoted for Easy Removal

A belt guard on some machines, while desirable for safety, is considered a necessary evil, especially when it interferes with making quick adjustments of parts of the machine, which it makes inaccessible. A swinging guard that can be moved out of the way in an instant is shown in the sketch. It is supported by a pipe column, which may extend from the floor to the ceiling, if desired.—J. J. O'Brien, Buffalo, N. Y.

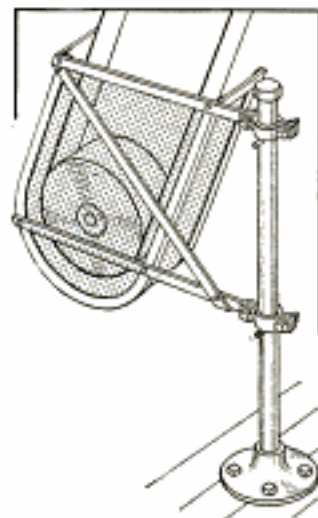

Suggestions on the Care of Automobiles and Motorboats

By HAYES BIGELOW

INEXPERIENCED automobile and motorboat owners may find the following suggestions helpful: Almost all nuts, bolts, and screws have right-hand threads. They tighten as the hands of a watch turn, and loosen in the reverse direction. If a nut or bolt fails to turn on applying moderate pressure, remove the wrench, and tap the part firmly, several times, with a hammer. By using wrench and hammer alternately, almost any "frozen" nut or bolt may be started. With slotted screws, tap on the head of the screwdriver with a block. When the screwdriver shaft is square a wrench or pliers may be used.

The application of oil, or, in some cases, heating the surrounding metal, facilitates the work. Be sure the wrench fits snugly, and does not cause burrs. Left-hand threaded nuts are usually placed on axles, or other bearings, where the motion might tend to remove a right-hand threaded nut. Propeller-shaft stuffing boxes in boats may have left-hand threads. A left-hand thread loosens as a right-hand thread tightens, and vice versa.

Graphite, No. 1 or finer, is often useful. Mixed with oil or grease and applied to threads, it prevents sticking, and is particularly useful in making up pipe joints and union nuts which will be subjected to heat. Candle wicking, rubbed full of grease and graphite, makes a good packing for propeller-shaft stuffing boxes, setting up little friction—a good point to remember when dealing with a hard-starting, two-cycle engine not equipped with a clutch. Plain graphite, thoroughly rubbed over wheel rims, tends to prevent rusting.

Shellac is not dissolved by gasoline. Always use shellac on the threads of gasoline connections. Gasoline-supply tubing sometimes develops leaks suddenly; a cloth soaked in shellac provides a temporary repair when wrapped around the leaky pipe. Tire tape will

not hold gasoline long unless shellacked. Soap is a fair substitute when shellac is not at hand. Gasoline cuts the oil in white and red lead, and many kinds of varnish.

Storage batteries need distilled water frequently, and lack of water ruins them. Some cells lose water more rapidly than others in the same battery. Sulphuric acid weakens slowly, and should never be introduced into the cells except by an expert. Acid fumes rise from the cells, and if given a chance to work on battery connections, will cause corrosion, which may put a self-starter, operated from the battery, out of commission. All connections should be bright, and assembled with vaseline, which is impervious to acid fumes. Corroded bolts and lead-cased nuts can be cleaned by boiling them in a solution of cooking soda and water. Such connections, if corroded, are likely to stick very tight, and can best be loosened by applying a pair of hot tongs to the nut before attempting to twist it.

If the self-starter operates sluggishly, run it 30 seconds and then feel its battery and line connections. If a connection is warm, its contact is either loose or corroded, and the full current is not able to pass through it. Generator armatures should be clean and not sticky, and the brushes free and smooth.

Blue smoke pouring from the exhaust indicates too much cylinder oil, and this condition produces carbon trouble. Only a stiff, new engine justifies the use of much oil, and even then the smoke should be a trail rather than a cloud. Black smoke indicates too much gasoline in the carburetor mixture, and will result in sooted and irregular sparking plugs. If the engine chokes and emits black smoke when suddenly given more throttle, the carburetor is usually at fault, and it is best to consult an expert carburetor adjuster.

When descending steep hills, shift into middle or low speed, cut out the spark, and let the car operate the engine, as much brake wear is thus avoided. With practice it is possible to see reasonably well around a corner. Show windows frequently afford reflections of the side street.

On motorboats, carry adequate life-saving apparatus at all times when the craft is in commission. Even though willing to assume a dangerous risk, it is well to remember the government requirements, and that inspectors are paid to guard boat owners from their own recklessness in disregarding dangers.

Have at hand in the automobile, or motorboat, the following items of equipment: Shellac, tire tape, graphite, rubber and asbestos packing, cotton wicking, waste, overalls, hand soap, towel, dry-battery tester, extra spark plugs, matches, and a trouble lamp. Lastly, know the rights on the water or the road, use caution, and have consideration for the "other fellow." Happily, friendliness and rendering of assistance are quite common among drivers of gasoline motors on the road as well as on water.

Temporary Pump for Cooling a Gas-Engine Water Jacket

A pumping engine for flooding a cranberry bog at a critical time was put out of commission by the breaking down of the circulating pump supplying the water jacket. The owner devised a substitute as follows: Two barrel heads were nailed together so the beveled edges formed a grooved pulley wheel, as shown. The pulley was then mounted on a pipe shaft in a wooden framework, and lined up with one end of the engine flywheel shaft. The belt was a piece of spliced rope.

A pitcher pump outside the engine house was driven down, as indicated, opposite the wooden pulley, and a wooden arm was bolted to the pulley. The upper end of the arm was slotted to fit the pump handle, this arrangement giving a 2-in. stroke to the pump.

The old circulation pump was disconnected, and the water pumped was

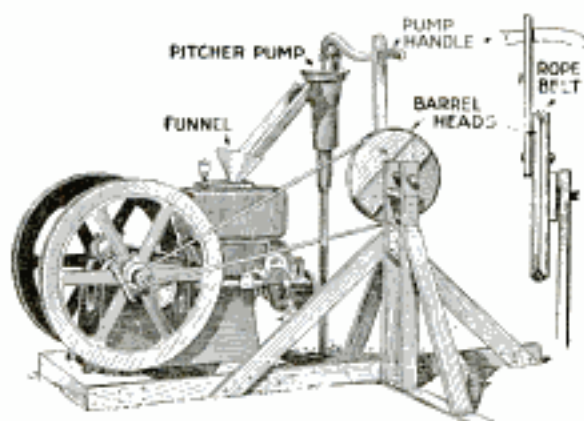

This Emergency Water Supply for a Gas-Engine Water Jacket Proved Serviceable for Several Months

conducted to the engine by means of a trough.—L. B. Robbins, Harwich, Massachusetts.

Roller-Bearing Reel for Electrical or Other Wire

To replace cumbersome horizontal-drum wire reels on his various jobs, an electrical contractor designed the reel shown. It feeds out the wire in various directions without jamming. The framework is a wooden cross, and rods serve as a drum for the wire coil. Casters are provided to operate on a disk of heavy sheet iron, bolted to a wooden foundation. The reel is held

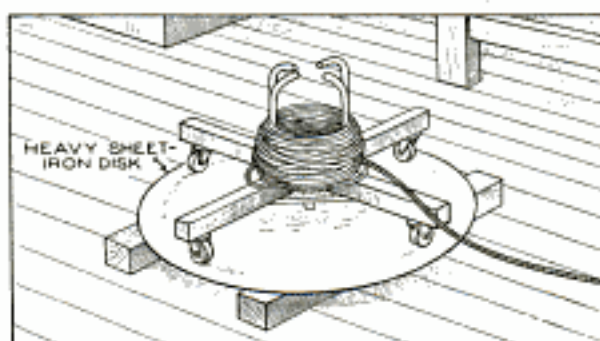

The Wire may be Drawn from the Reel Easily in Various Directions

in position by a long bolt, and is free to turn. The coil is placed in position quickly, and the device is readily portable.

A pocket in the front cover of a schoolbook is convenient for carrying notes and papers.

Artist's Cabinet Made from Old Sideboard

The great miscellany of material, tools, paper, sketches, etc., with which



Instead of Using Various Makeshifts, an Artist Rebuilt This Cupboard to Suit His Special Needs

an artist works were cared for economically by providing a cabinet for them, which was adapted from an old sideboard, or china cabinet. Adjustable shelves were fitted into the upper cupboard for books, tools, etc. Three shallow drawers were built into the center section, which was an open shelf. At the right of this shelf a roll of paper was mounted in a holder. The lower section was provided with a hinged door to which the cupboards for mats, paper, etc., were fixed.—John T. Bowe, Chicago, Ill.

Hand Tool for Making Mortise-and-Tenon Joints

One of the chief causes of failure in home woodworking by intelligent, though inexperienced, persons is lack of knowledge in the proper use of chisels in making joints, particularly the common mortise-and-tenon variety. This joint must be exact in its con-

struction or it is almost worthless. Having to build with the aid of inexperienced helpers, several pieces of furniture in which were many mortise-and-tenon joints, to be made by hand, I made a device that did the work rapidly and accurately.

First, I had made two tools, A and B, of $\frac{1}{2}$ -in. tool steel, grinding them carefully. Tool holders of maple, as detailed, were made, the screws D preventing splitting, when the wing screw, which holds the cutter, is tightened. The $1\frac{1}{2}$ -in. hole is an outlet for chips. The various steps in making a mortise and tenon with this router are: First, saw and chisel for the tenons, as detailed, leaving strips E as bearings for the router and removing them later. Trim both sides of the tenon at one setting of the tool.

To make the mortise, use the tools as shown: The two tools make it possible to cut both sides of the mortise from the same side of the piece. Make all of the similar cuts with one setting of each of the tools, using a chisel for

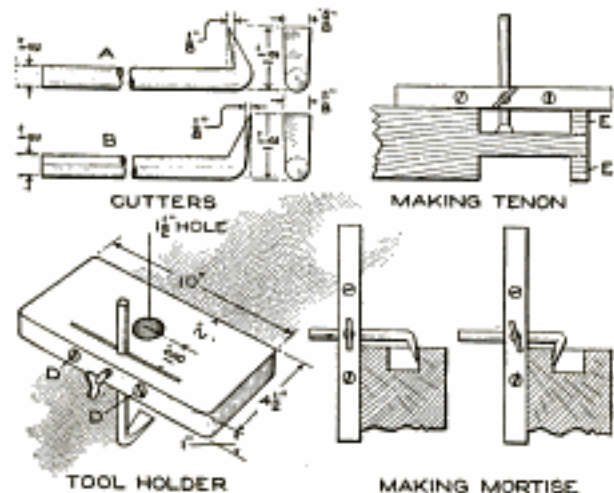

By the Use of This Homemade Router Mortises and Tenons were Cut Quickly and Accurately by Inexperienced Workers

preliminary work, as usual, to within a scant $\frac{1}{16}$ in. of the lines.—D. D. Gurnee, Hempstead, N. Y.

Indicators having a metal point require a specially coated paper of good quality. Apply a thin coating of this mixture, by weight: 1 part zinc oxide, 4 parts water, $\frac{1}{10}$ part gum arabic. Permit it to dry thoroughly.



An Eight-Pointed Star Kite

By CHARLES M. MILLER

NEARLY every boy can make kites of the several common varieties without special directions. For the boy who wants a kite that is not like those every other boy makes, an eight-pointed star kite, decorated in an original and interesting manner, in various colors, is well worth while, even if it requires more careful work, and extra time. The star kite shown in Fig. 1 is simple in construction, and if carefully made, will fly to a great height. It is balanced by streamers instead of the common type of kite tail. Any regular-shaped kite should be laid out accurately, as otherwise the error appears very prominent, and unbalances the poise of the kite.

The frame for this star kite is made of four sticks, joined, as indicated in Fig. 5, with strings running from one corner to the second corner beyond, as from A to C, from C to E, etc. A little notching of each pair of sticks lessens the thickness of the sticks at the center crossing, and strengthens the frame. The sticks are $\frac{1}{4}$ by $\frac{1}{2}$ in. by 4 ft. long. They are set at right angles to each other in pairs, and lashed together with

cord, and also held by a $\frac{3}{4}$ -in. brad at the center. The strings that form the sides of the squares, A to G, and B to H, must be equal in length when tied. The points where the strings forming the squares cross each other and the sticks are also tied.

The first cover, which is put on with paste, laying it out on a smooth floor or table as usual in kite making, is plain light-colored paper. The darker decorations are pasted onto this. The outside edges of the cover are turned over the string outline, and pasted down. The colors may be in many combinations, as red and white, purple and gold, green and white, etc. Brilliant and contrasting colors are best. The decoration may proceed from the center out,

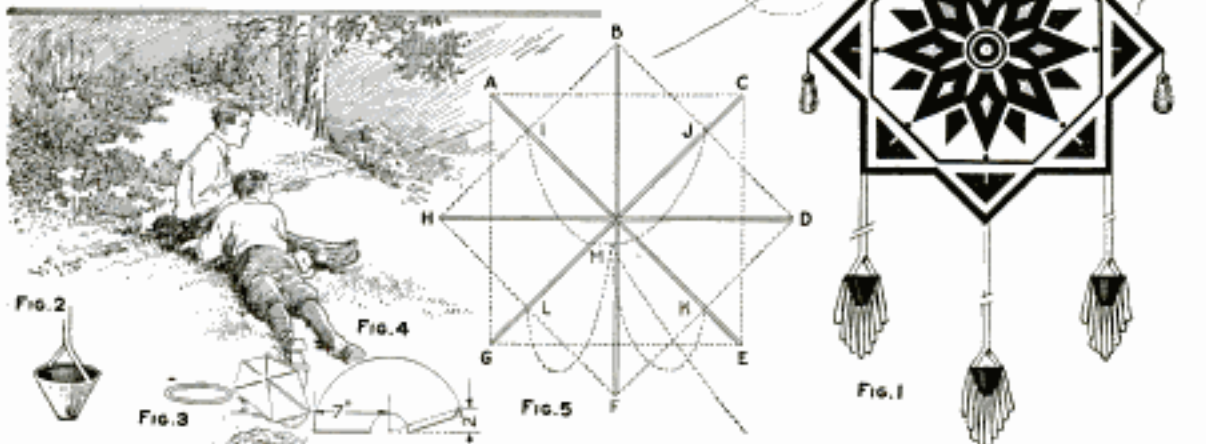

The Boy Who Makes a Star Kite of This Type will Have a Construction Different from the Common Run of Kites, Especially If He Decorates It in an Attractive Manner

or the reverse. The outside edge in the design shown has a $1\frac{1}{2}$ -in. black stripe. The figures are black. The next octagonal black line binds the design together. The points of the star are dark blue, with a gilt stripe on each. The center design is done in black, dark blue, and gilt.

The flags are tied on, and the tassels are easily made of cord. The outside streamers are at least 6 ft. long, and balanced carefully. Ribbons, or dark-colored lining cambric, are used for them. The funnel-shaped ends balance the kite. They are shown in detail in Figs. 2, 3, and 4, and have 1-in. open-

ings at the bottom, through which the air passes, causing a pull that steadies the kite. They are of dark blue, and the cloth fringe is of light blue. A thin reed, or fine wire, is used for the hoop which stiffens the top. Heavy wrapping or cover paper is used to cover the hoops. It is cut as shown in Fig. 4 and rolled into shape.

A four-string bridle is fastened to the frame at I, J, K, and L, as shown. The upper strings are each 18 in., and the lower ones 32 in. long, to the point where they come together, and must be adjusted after the kite line is fastened at M.

Second Handle on Hoe or Rake Saves Stooping

Anyone who has used a hoe or rake for days at a time will appreciate the labor saved by the attachment for the



Much of the Tiring Labor in Using a Hoe or Rake is Overcome by This Simple Homemade Attachment

handle shown in the illustration. It is adjustable to various-sized persons by means of the holes at the front end of the horizontal piece. The two parts are each made of strips joined at the middle portions, and arranged to clamp on the handle of the hoe or rake. In hoeing around shrubs and large plants, the handle may be set to one side.—A. S. Thomas, Amherstburg, Ont., Canada.

Photo-Copying Lens Increases Angle of Camera

Trying to take some indoor pictures, I found the angle of my ordinary lens was insufficient to "get in" the various objects I desired. Not having a wide-angle lens, I decreased the focal length of the lens by using a copying attachment. The results were quite pleasing, and while there is some distortion and less of the plate is covered than usual, there is a remarkable increase in the angle of view. To obtain definition, it is necessary to stop the lens down, but the pictures are very clear.—Samuel L. Pickett, Denver, Colo.

Belt for Sprocket Drive Made of Brass Strips

Being unable to purchase a small driving chain for sprockets made by cutting out every other tooth in gears taken from a clock-work, I used a brass strip, properly punched, and found it satisfactory. The

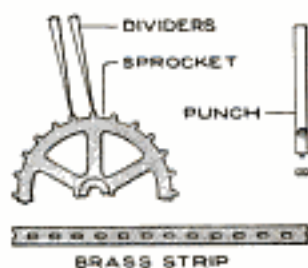

strip was .005 in. thick and the points where the holes were to be punched out were indicated by dividers set from the gears. I made a punch from a nail, leaving a small center on it as shown,

and grinding the end to an oblong shape. I used a piece of sheet lead as a die, on which to punch the strips. The marks made by the dividers provided spots on which to set the center of the punch, making the result quite accurate.—Edward M. Davis, Philadelphia, Pa.

Rain Alarm with Drop-of-Water Contact

An annunciating device, which awakens a person sleeping in a room with the window open and warns him that it is raining, so that he may close the window, is an interesting bit of electrical construction. On the outside of the house, as detailed, is a funnel fixed to the wall. At its small end, two separate wires have their terminals. The wires enter the room at the frame of the window, and connect to an electric bell, and a dry cell. A drop of water entering the funnel, flows down to the small end, falling on the terminals of the wires, and acting as a conductor, completes the circuit, ringing the bell. A

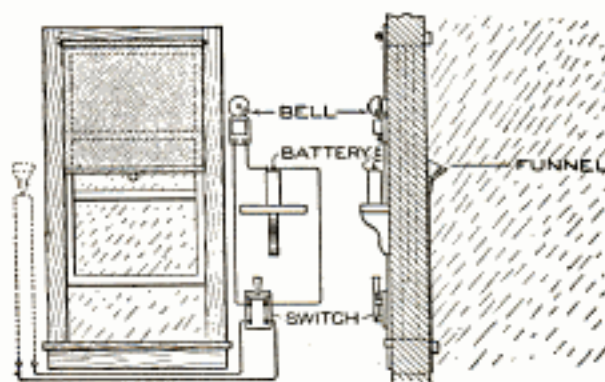

INSIDE VIEW OUTSIDE
A Drop of Rain Water Completes the Bell Circuit,
Thus Giving Warning of the Rain

switch inside cuts out the circuit, stopping the bell's ringing.—John M. Chabot, Lauzon, Quebec, Can.

Coaster Steering Gear Made from Cream-Freezer Drive

In rebuilding a wagon into an automobile coaster, I used the driving rod and gears from an old ice-cream freezer, and found that it worked so well that perhaps other boys might be interested

in the job. The front of the coaster was covered with a hood, and the steering wheel was set back of it, as shown. The center rod of the freezer was used

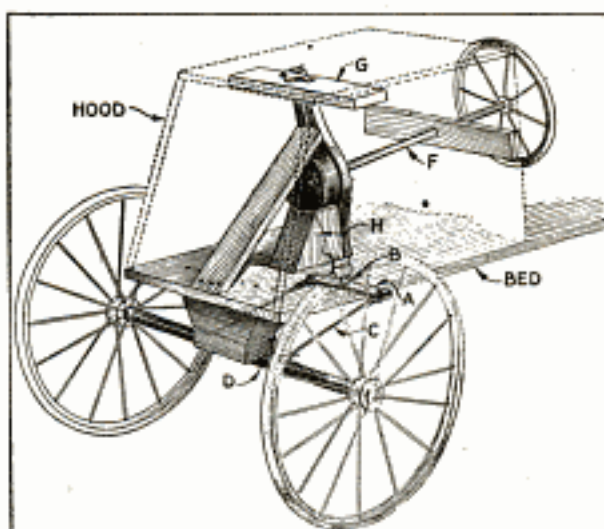

A Steering Rig That Works Almost Like That on an Automobile was Made Out of the Driving Parts of an Old Ice-Cream Freezer

for the steering post F, and an old rubber-tired wheel was made into a steering wheel. The casting from the top of the freezer, with the gears in it, and the rod on which the turning crank was fastened were set on a block, H, and braced, as shown. The shaft where the crank was fastened, at B, was set through the wagon bed. A crosspiece of iron, A, was wired to the axle D with wires C. A heavy block was used for a turntable. The top end of the casting was fastened to the hood with a brace, G, and the block H steadies the rigging also.—L. Chester Bryant, El Dorado, Ark.

Pad for Glass Vessels Made of Corks

In the kitchen, shop, laboratory, and other places where glass or other fragile dishes or vessels are used, a convenient pad on which to rest them can be made by stringing corks on a strong cord or wire in the form of a ring. Several rings of corks may be used to make a mat, or rings slightly larger in diameter than the bottle or vessel may be made for certain sizes of containers. If desired, the corks may be cut to fit closely on the radial joints, making the resulting ring more secure.

A Shaving Lamp and Mirror for the Camp

To make shaving possible in camp at night, or with little daylight, a small mirror was provided with an electric flash light. The mirror was set to swing free, in a wooden support. The light was fastened slightly above and behind the mirror, and swings at its base, so that it can be tipped upward or downward, throwing the light correspondingly. A piece of wood,



1¼ by 3½ in., and as long as the mirror frame is wide, serves as a base. The arms will hold the mirror far enough in front of the lamp to allow room in which to swing. The body of the lamp is set on a block, and held between two wooden pieces, into which a band of iron was set near the top. The uprights move in an arc, pivoting at their lower fastening, on screws.—C. L. Meller, Fargo, N. D.

Automatic Electric Light on Talking-Machine Cabinet

In many homes the phonograph is placed where little light is available in changing the records, setting the needle, etc. An electric light which is lighted only while the cover of the phonograph is raised, is well worth installing. A metal arm, A, supports the open cover of the cabinet. When the cover is closed, this arm passes through a slot and takes the position shown by the dotted line. A

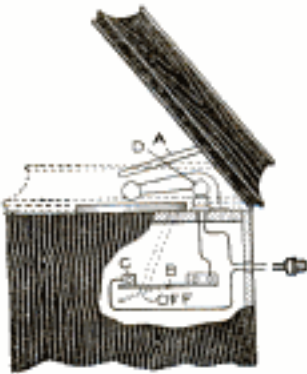

strip of spring brass, B, is fastened to the inside wall of the cabinet, in the path of the arm, so that it will be pushed down to the off position, as indicated. When the arm releases the strip B, the latter presses against the contact C. A small electric lamp, D, is set in the corner, and electrical connection made to it through B and C, the plug connections passing through the back of the cabinet. When the cover is down, the electric circuit is open, and the moment it is raised, connection is made at C, and the lamp lights. The backs of most phonograph cabinets may be removed easily to make these changes.—M. C. Ball, Kansas City, Mo.

Device for Suspending Parcels from Overhead Hooks

To hang small sacks or other articles out of reach overhead, so that they may be easily taken down, I use a double-eye hook which I made of wire. A single piece of wire is used, and twisted into two loops, as shown, and then formed into a twisted hook.

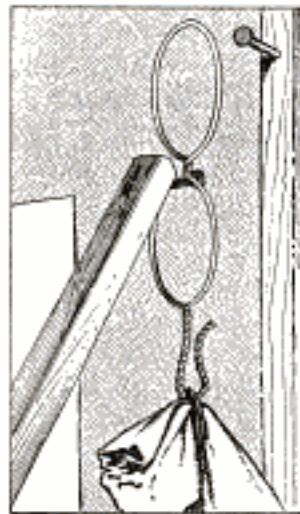

I use a pole with a nail, hooking it into the lower loop, to raise the parcel; this leaves the upper loop free to be hooked on the nail above.—E. B. Warren, Garnet, Mont.

Steel Wool as Aluminum-Ware Cleaner

It takes little trouble to keep aluminum pots and pans shining if they are cleaned frequently with steel wool, water, and a nonalkaline soap. Use a very fine grade of the wool, and give the utensils a few rubs frequently, rather than attempt to clean them only occasionally, when much soiled.—L. P. Langan, Denver, Colo.

A Swimming Machine

Made in the Home Workshop



By T. S. CHESNUTT

PROPELLED by the hand-power driving mechanism and the folding flippers driven by the feet of the rider, this novel swimming machine attains a speed of from 5 to 12 miles an hour. The operator lies prone on the main board A, with the chest on the slanting rest C, Fig. 2, near the front, and the feet in the loops N. The cranks are turned with the arms, and the feet are drawn forward and back, moving the crossbars E to which the flippers M are attached. The cranks drive the propeller I, by means of the gears G and the shaft H. The flippers are hinged to the pieces F, and fold up on each forward stroke, reducing the resistance greatly. The feet are drawn forward alternately, causing the crossbars to pivot on their center bolts, yet maintaining their parallel relation. Thus, while the flippers on the right side are in action, those on the other side are being drawn forward, folded up by the action of the water. The galvanized iron tanks D and O float the operator, and make it impossible to sink the machine unless the tanks are punctured. The body of the operator is completely submerged, as shown in the headpiece illustration. When he becomes tired, it is only necessary to retain a good hold, and lie on the board A. The machine is steered by means of the rudder, controlled by the feet, at the crossarm J, Fig. 2, similar to that at K, Fig. 1, and detailed in Fig. 4. The construction is simple, and the parts may be easily obtained or made.

The construction is begun by making the wooden parts. Make the main

piece A $\frac{5}{8}$ by 9 in. by 11 ft. 5 in. long, with the lower edge of the bow beveled slightly; the keel B, $\frac{5}{8}$ by $5\frac{1}{2}$ in. by 8 ft. 2 in. long. The piece C is made to fit the incline, which is 8 in. high and 2 ft. 2 in. long, on the base, and supported by a wooden bracket. The tanks, as shown in Figs. 1 and 2, are of two sizes, the front one being deeper and wider than the rear one. They are made of galvanized iron, soldered water-tight, and supported on brackets of $1\frac{1}{2}$ -in. strap iron. The wooden main portions are fastened together with brass screws, countersunk carefully. Note that the keel is not on center, but that it is set slightly to one side, as detailed in Fig. 6.

The driving mechanism of the propeller is shown in bottom and side views in Figs. 1 and 2. The bevel gears G are 5-to-1 ratio, the larger one being about 8 in. in diameter. They may be varied in size, according to the gears available, which may be obtained from machine shops, or from old machinery. The propeller shaft is a $\frac{3}{8}$ -in. steel rod, and is supported by wooden hangers with strap-metal bearing caps, fastened with bolts, or screws, as detailed in Fig. 1. They are made to suit the shaft, the center of which is $1\frac{3}{4}$ in. below the under side of the board A. The shaft may be supported along the keel by metal straps, if desired. The propeller, shown in detail in Figs. 5 and 6, is of bronze, 7 in. in diameter, and may be one of several standard patterns. It may also be made of sheet metal, the blades set into a metal collar.

The rudder L, and the rudder support and control K, are shown in Figs.

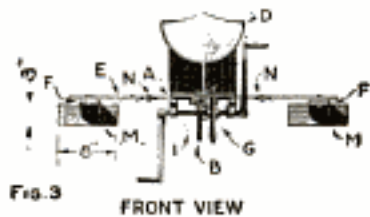
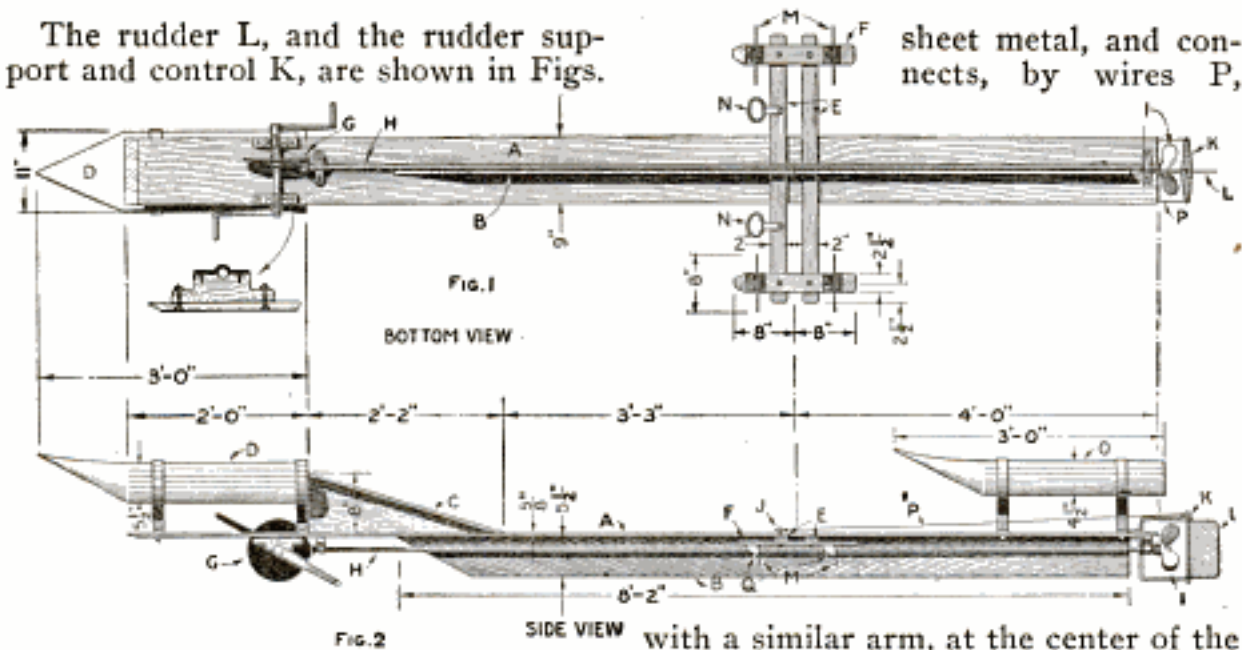

Assembly Views Showing the Main Details of Construction and the Arrangement of the Parts

4, 5, and 6, in detail. The rudder is of sheet metal, fixed to an iron rod, or post, at the top of which the rudder control K is fixed. The arm K is of

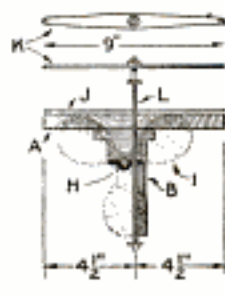
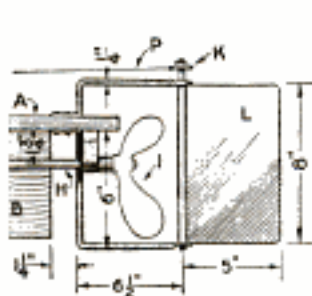
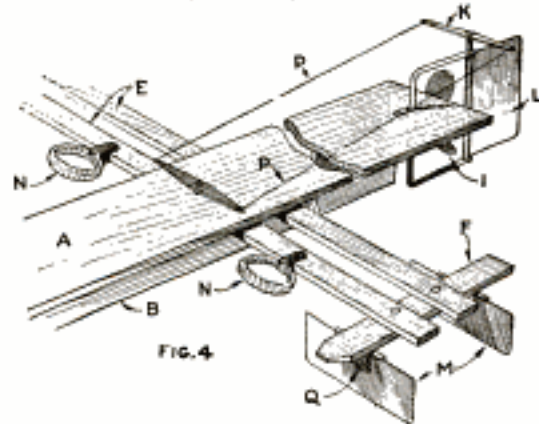

The Perspective Sketch, Fig. 4, Shows Clearly the Arrangement of the Parts of the Flipper and Crossbar Mechanism as Well as the Stern and Its Fittings, Which are Detailed in Figs. 5 and 6

sheet metal, and connects, by wires P,

with a similar arm, at the center of the forward flipper crossbar E. The rudder support is made of $\frac{1}{4}$ -in. round iron, flattened at the ends for fastening with bolts.

The flipper mechanism is shown in Figs. 1 and 2, and in detail in Fig. 7. The loops N, for the feet, are made of strap iron, $\frac{1}{16}$ by 1 in., wrapped with cord. The loop ring is pivoted to the crossbar E by means of a U-shaped strap of iron, bolted into place, and riveted to the ring. The crossbars and the other wood parts are of ash. The bars are $\frac{3}{8}$ by $2\frac{1}{2}$ in., by 3 ft. 6 in. long. The pieces F are $\frac{5}{8}$ by $2\frac{1}{2}$ by 16 in., and centered 3 in. from the ends of the crossbars E. The flippers are 3 by 8 in., of No. 22 gauge sheet iron. They are hinged to a piece of sheet metal by means of a roll made over a $\frac{3}{16}$ -in. rod. The portion forming the upper half of the hinge fits between the two end rolls of the hinge, and its side edges are shaped in a quarter circle, and bent down as stops for the flippers on the back stroke, as indicated at Q, Fig. 7.

The upper edge of the keel is notched to receive the crossbars, sufficient play being allowed to give a satisfactory forward and backward limit for the stroke. Bolts are used for the fastenings wherever possible, especially at the pivotal points. The nuts should be set to prevent them from coming off easily, by riveting over the ends of the

A Homemade Residence Mail Box

Mail boxes installed in residences are often not of sufficient size to accommodate packages and magazines, and to meet this need, this mail box was

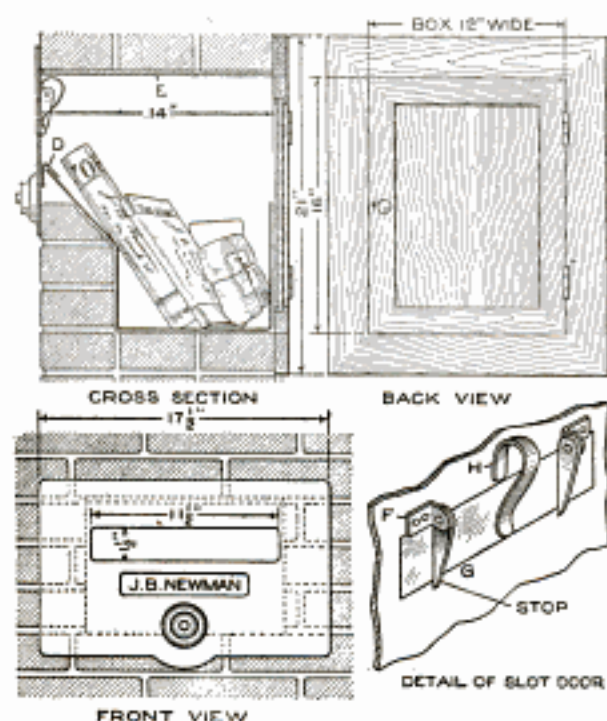

This Substantial Mail Box Is Large Enough to Care for Magazines and Small Parcels as Well as Letters

designed. The contents are removed by unlocking a small door on the inside of the house, or on the opposite side of the wall in which the box is set. The views of the box show its construction, the dimensions being suggestive only, since they vary with local conditions. The cross section shows the method of setting the box in a brick wall. The front view shows the bell, the metal name plate, and the deposit slot, provided with a spring-hinged door. The wooden casing and the inside door are shown in the back view.

The box and opening in the metal plate on the front should be broad enough to accommodate the larger magazines, and the box should be deep enough so that the magazines may stand on end in it. A metal box of the proper size is placed inside of the opening, as shown in the sectional view. A small lip, D, is soldered on the front edge to prevent any mail from falling

down between the box and the wall. A $\frac{1}{4}$ -in. metal plate, E, supports the brick forming the wall above the opening.

A suggestion for a means of mounting the door to the slot in the front plate is shown in the detail sketch. The door is supported on angles, F, and pieces, G, forming hinges. A spring, H, keeps the door closed. The lower ends of the pieces G extend below the lower edge of the door, serving as a stop.—M. P. Norton, Chicago, Ill.

Extension on Ironing Board Supports Large Pieces

An attachment for the ironing board that prevents large pieces from falling to the floor and becoming soiled is a worth-while addition to the kitchen equipment. Strips of pine, $\frac{3}{8}$ by $1\frac{1}{2}$ in., were used for the frame, which is 18 in. wide, and of a length to suit the ironing board. It is attached to the under side of the ironing board by means of slides. Across the front edge of the frame, tack a shallow muslin bag to hold the unironed portion of the article on the board. By sliding the frame backward, the support holds the ironed part smooth, and away from the

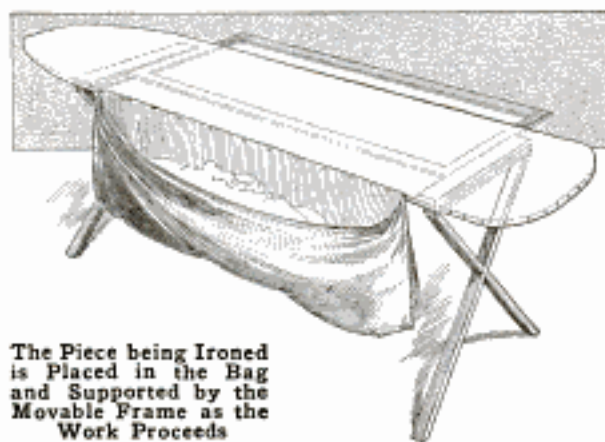

The Piece being Ironed is Placed in the Bag and Supported by the Movable Frame as the Work Proceeds

floor. When not in use, turn the bag back against the board, and slide the frame into place.—J. E. McCoy, Philadelphia, Pa.

⌋ Instead of a soft rubber, use gasoline applied with a soft cloth, to clean dirt and pencil marks from tracing cloth.

Reinforcing the Ends of Rubber Handlebar Grips

The flexible rubber grips used on bicycles and motorcycles have good shock-absorbing qualities, but they have a tendency to break off at the end of the handlebar. They may be reinforced by a small stick projecting from the end of the handlebar tubing. One end of the stick is cut to fit tightly in the opening, and the other to fit the flexible end of the grip.—George M. Zimmerman, Fort Sumner, N. M.

Film Holder for Photographic Developing

The amateur photographer who uses roll film and who does his developing by the tray method, will find this device a simple and reliable means for holding the film spool while removing the film, duplex paper, autographic carbon paper, gummed labels, etc. Once the spool is properly placed in the holder, there is little danger of its dropping. The holder takes various sizes of film spools. The side fingers are $\frac{3}{16}$ by $\frac{3}{4}$ by 23 in. long. A small peg is set in each finger, $1\frac{1}{8}$ in. from the end, to engage the spool. The upper ends of the fingers are nailed to a tapered block of wood, $\frac{7}{8}$ by $3\frac{1}{4}$ and $2\frac{1}{2}$ in. wide, and 8 in. long. The holder can be conveniently fastened to a wall, door casing, or to the under side of a shelf in the dark room.—John Hoeck, Alameda, Calif.



Old Sink Installed as Dish-Draining Basin

An added convenience for the housewife is the installation, in the place of the drain board customarily attached to the kitchen sink, of a second sink, with waste connections. Light wooden slats in the sink bottom give it all the utility of a drain board, without the danger of

dishes slipping off onto the floor. A sink, of the old-fashioned kind used,

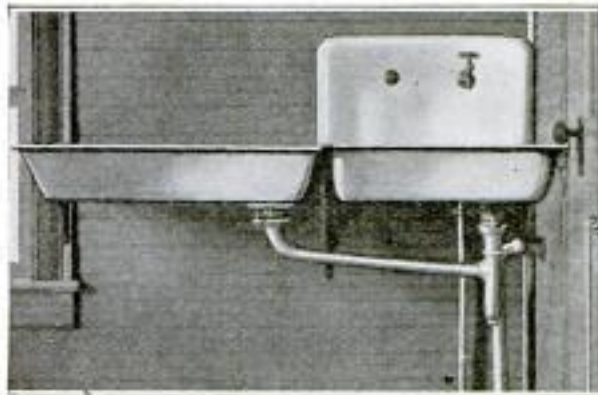

The Extra Sink Replaces the Drain Board and Does Its Work More Effectively

can be purchased about as cheaply as a good drain board.—E. C. Blomeyer, Waco, Tex.

Desk-Light Arm Folds into Pigeonhole

The extension arm for an electric lamp shown in the illustration was made of strips from steel building toys. I installed it in my writing desk, and fastened it with one screw to the back of the desk inside the pigeonhole. When collapsed the arm measures $7\frac{1}{2}$ in. from the fastened end to the front end of the socket, leaving only the globe protruding. Extended, it measures $16\frac{1}{2}$ in. The lamp cord is taken through a hole in the back of the desk. If a very rigid arm is wanted, the strips can be doubled. I used screws with two nuts, but rivets can be used also, leaving the joints to move freely. The

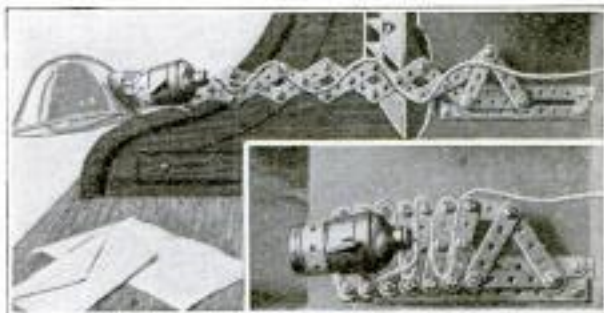

This Desk Lamp and Holder Folds Up into a Pigeonhole When Not in Use

sliding feature at the inner end adds about 2 in. to the length of the arm when extended.—A. J. Viken, Waterloo, Ia.

Simple Machine for Transmitting Writing

An interesting and novel construction for amateur or boy mechanics is a telautograph or writing telegraph

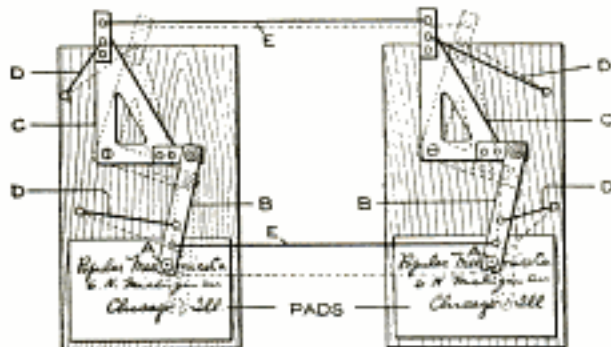

A Message Written on the Pad with a Pencil is Transmitted to the Other Pad at a Considerable Distance Away

machine. The instruments, as shown, are duplicates with the exception of the placing of the rubber bands. They can be made in different sizes, and satisfactory results were obtained by making the base 7 by 12 in., the arm B 5 in. long and $\frac{3}{4}$ in. wide, and the triangle C 6 in. by $3\frac{1}{2}$ in. A hole is bored in the arm B, slightly smaller than the pencil to be used and a slot sawed from the edge to hole, so that when the pencil is forced into the hole it will be tightly gripped, as at A. The arm B is fastened to triangle C, to move freely. The triangle is fastened to the base, and can also move freely.

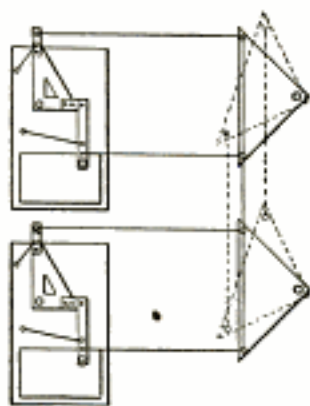

The larger diagram shows the instruments placed in parallel position. The smaller diagram shows how they can be placed one above the other. An unruled pad is fastened to the base of each instrument with thumb tacks. The operation may be traced by noting the successive action of the parts when the

rubber bands D are stretched tightly to hold the moving parts in position. The strings E should be strong, and stretched taut.

The larger diagram shows the instruments placed in parallel position. The smaller diagram shows how they can be placed one above the other. An unruled pad is fastened to the base of each instrument with thumb tacks. The operation may be traced by noting the successive action of the parts when the

pencil on the pad at the left is moved in writing a message. The pivoted triangle communicates the action to the string E, which actuates the other triangle and its lever system. The rubber bands serve to steady the action. The instruments may be arranged a short distance apart for play or experimental purposes or set in rooms on different floors, by making suitable pulley connections for the cords E.—William Freebury, Buffalo, N. Y.

Diagonal Corners on Disk-Record Covers

Having been bothered with the edges of square paper covers of disk records curling,

making it unhandy to place them in a file, I remodeled them as shown in the sketch. The covers without the lower corners were so convenient that I made others by folding and pasting paper of the shape shown in the pattern.

It was found desirable to use a good quality of paper for the new envelopes, as this gave added protection.—J. H. Moore, Hamilton, Ontario, Can.

Live Poultry Weighed Handily in Funnel Scale

A deep funnel, or cone, made of sheet metal and attached to an ordinary platform weighing scale or a draw scale, is useful especially in weighing live poultry. The fowl is placed in the funnel head first and remains quiet while being weighed, which is not the case in most common methods of weighing. The funnel is mounted on three legs, for use on a platform scale, and suspended from a ring by chains, from the hook of a drawspring scale.—C. W. Reemtsen, Des Moines, Ia.

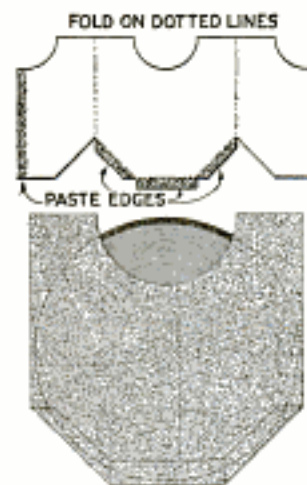

Transferring Pictures to Glass

The surface of glass on which pictures are to be transferred must be thoroughly clean. A coat of nearly colorless varnish is applied, and permitted to dry overnight in a room free from dust. Wet the picture, soaking it in clear water for about 10 minutes. Place it on blotting paper with the front side down, leaving the back wet. Varnish the glass again, and place the picture face down on the varnished surface, pressing out the bubbles, working from the center out. Rub on the back of the transfer paper until the picture is transferred to the varnished surface, and remove the paper carefully. Permit the picture on the glass to dry, and then varnish it.

An Order-Memo Device for Delivery Routes

A milk driver who had many extra orders of milk and cream to deliver had considerable difficulty in keeping track of the orders. He overcame this difficulty by the use of a clip attached to the steering wheel of his truck. He got a spring clothespin, wired one side of it to one of the spokes of the steering wheel, and now places his extra orders in a ring attached to the clip, as they come on his route. When he makes a delivery, he moves the memo on the ring, bringing the next order before him. This method can be used in many other businesses, where articles such as newspapers are delivered on routes.—Francis W. Nunenmacher, Berkeley, California.

☞To counteract mildew on canvas, coat the parts with soap and rub well with powdered chalk or whiting.

Model Paddle-Wheel Boats

Only a few boys have ponds of their own, in a pasture, perhaps. But there

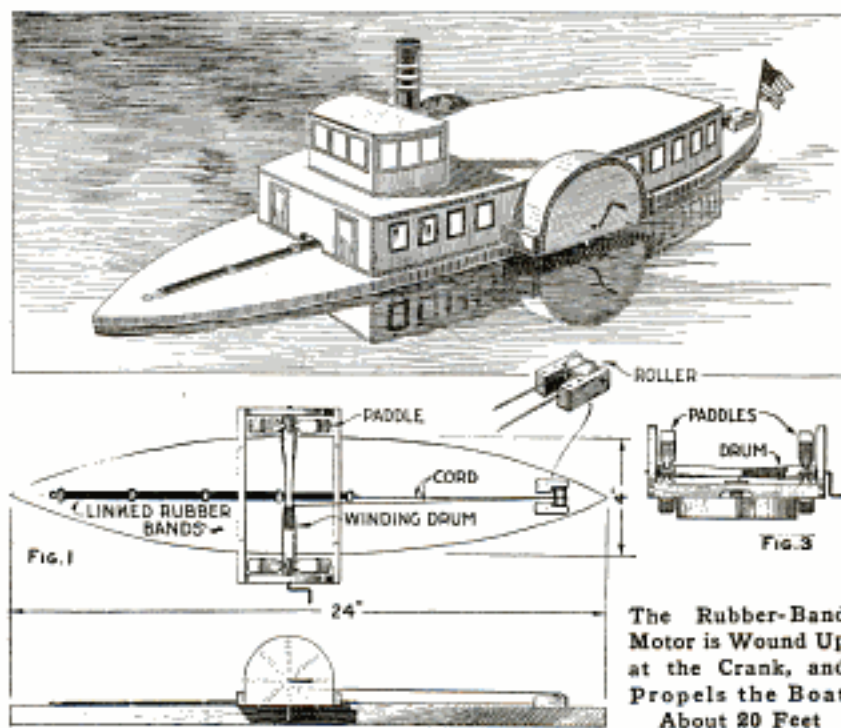

The Rubber-Band Motor is Wound Up at the Crank, and Propels the Boat About 20 Feet

are miniature lakes in our city parks, pools at our summer camps, and old water holes in the woods; if all of these fail, a boy can still sail his ships on the bathtub sea. A simple side-wheeler, built of wood, is shown in the sketch. It winds up with a crank and runs 15 to 20 ft. A float is made by pointing the ends of a thick board, the dimensions of which are given in Fig. 1. On this the paddle-wheel frame is nailed, as shown in the top view, Fig. 1, the

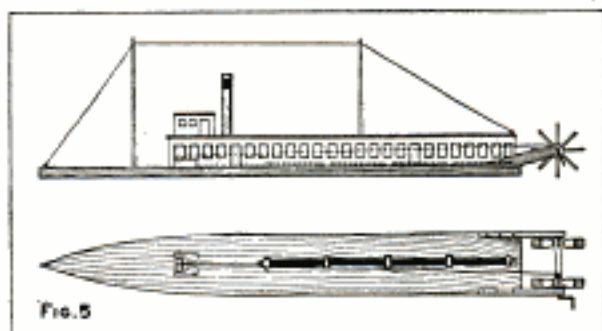

The Stern-Wheeler Is Similar in Construction to the Side-Wheeler as to Driving Mechanism

side view, Fig. 2, and the end view, Fig. 3. It is made of thin wood. A broom-handle section, just long enough

to slip into this frame, is whittled to form a winding drum, and fitted with paddles, wire axles, and a crank. A second shorter section of the broom-handle, set between blocks nailed to the stern, serves as a roller for the rubber bands. These, linked together and tied to a length of heavy cord, as shown in Fig. 1, are fixed to the bow

and run over the roller to the drum. The addition of a top, or lid, of cardboard, wood, or tin, and painted to resemble cabins and pilot house, and fitted with masts and a smokestack, completes the model. Fig. 5 shows a similarly built stern-wheeler with the stern-wheel shaft set on brackets.—E. R. Smith, Walla Walla, Wash.

A Small Thresher of Practical Use

Buckwheat, oats, wheat, morning-glory seeds, and other grains and seeds, were successfully cleaned with a model

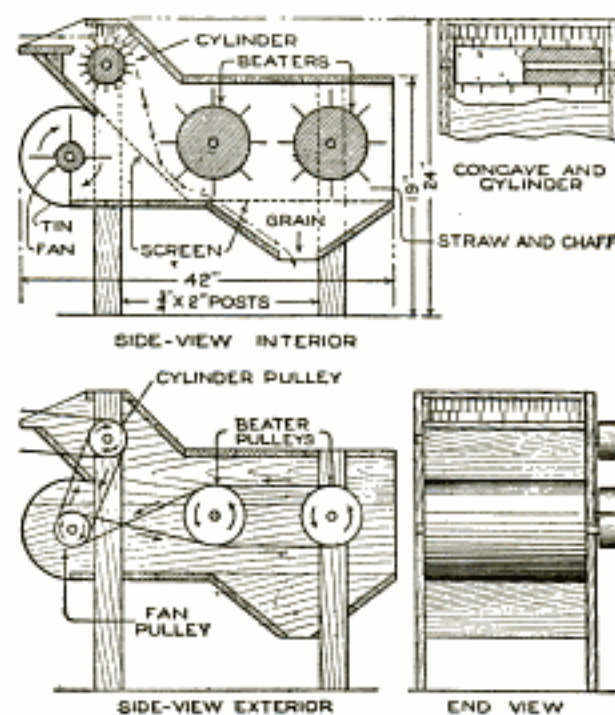

Made as a Model, This Small Thresher Proved Useful for Various Grains and Seeds

thresher of simple design which I made from materials picked up in and around the farm workshop. It is 24 in. high, 14 in. wide, and 3½ ft. long. For a cylinder, I used a roller, 3 in. in diameter and 1 ft. long. The teeth are nails driven spirally about the cylinder in rows that alternate with similar teeth in the concave, the nails being driven ½ in. apart. The fan consists of a small roller upon which four pieces of tin are nailed. The beaters are larger rollers, into which wooden teeth are set. To hold the cylinder, fan, and

beaters in place, four posts and two crosspieces were used, as shown.

The power used is an 8-ft. windmill that I constructed, using a buggy wheel as the frame. The cylinder must be run at a fairly high speed, the fan nearly as fast, and the beaters may be run much slower; this is taken care of by the relative size of the pulleys. The screen between the fan and beaters must be of small mesh so that grain will not fall through into the fan chamber. The sieve through which the grain drops must be the proper size for grain, and can be varied for the different kinds of grain or seed threshed. It is better to put only the heads of grain into the thresher, as long straws twist about the rollers. The material to be threshed is fed into the cylinder in the usual manner, and takes its course as indicated by the arrows, the grain falling to the spout at the bottom, and the straw and chaff being blown out at the exhaust for it. Soft wood was used in the construction, 7/8-in. stock for the heavier pieces, and 3/8 or 1/4-in. stock for the other parts. The curved housing for the fan was made of tin. Leather or rope belts, fitted tightly, may be used. The power is applied on the cylinder pulley, hand or other power being suitable.—F. E. Brimmer, Dalton, N. Y.

Moth-Ball Puzzle as Window-Advertising Novelty

A druggist recently puzzled thousands with a novel window display. A small white ball in a 1-in. glass tube, about 10 in. long, displayed in a show window, would sink to the bottom, then

slowly ascend, only to sink as before. A sign reading "What Makes It Move?" kept the crowd guessing. The tube was apparently filled with water. The construction is simple. The tube is about three-quarters full of carbonated soda water. The white ball is an ordinary moth ball. The ball sinks, and when it becomes soaked gradually as it lowers, bubbles of gas cling to it, carrying it to the top of the solution. There the gas escapes, destroying the ball's buoyancy, and causing it to sink again. This process is repeated over and over.—David J. Lonergan, Minneapolis, Minnesota.

Record-Cleaning Pad Fixed to Talking Machine

By providing a practical method of keeping talking-machine records free



from dust automatically, as they are played, the life of the record is prolonged and the reproductions are more clear, and free from scratching sounds. A felt pad supported on a fixture made of a strip of brass does the work nicely. The pad is clamped in a clip at the end of the brass strip, and the entire device is held in place by the spring action of the upper clip, which fits over the end of the reproducing arm. The pad or the whole device can be slipped out of place quickly.

Novel Uses for Safety Pins

It is surprising to note how many uses can be made of an ordinary safety pin, both as an emergency-repair device, and for other purposes. I found 40 simple uses for safety pins, a few of which are shown in the illustration. Some of the many other uses are as a chain, a candle holder, a spring, a cover

holder for a kettle, and as a pencil clip. Most of these can be made by twisting

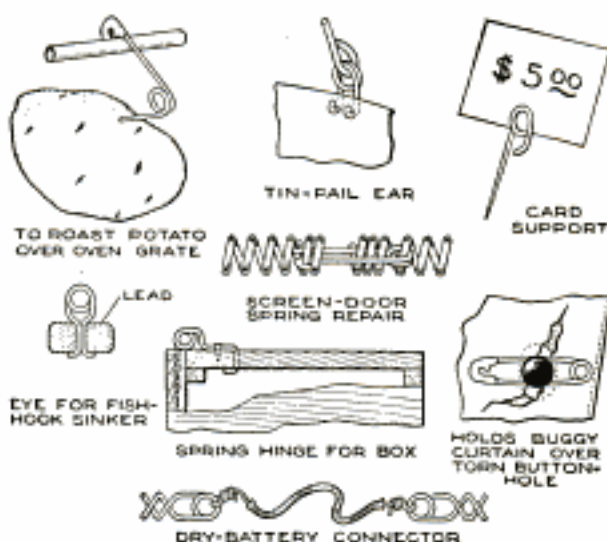

These Eight Examples of How an Ordinary Safety Pin can be Used for Practical Purposes Are Suggestive of Many Others

the safety pin with a small plier. By using a cutting plier, many more useful kinks can be devised.—George G. McVicker, North Bend, Neb.

Moving Heavy Objects with a Broom

After trying to move a heavy trunk alone, the attempt is usually given up until some friend can be called in to lend a hand, because a truck



The Broom Is Slippery and Rides over the Floor or Even Carpets without Trouble

or other means of handling such heavy objects is not at hand. An ordinary sweeping broom will serve as a sled to move a stove or similar object in the home without heavy lifting. The straw in the broom is slippery and can be drawn over carpets without injuring them. In handling a stove, the legs must of course be removed, one person drawing the load and the other steadying it.—Samuel H. Avery, Chicago, Ill.

Rear Seat for Motorcycle or Bicycle

A rear seat mounted on a light support that can be quickly attached to a

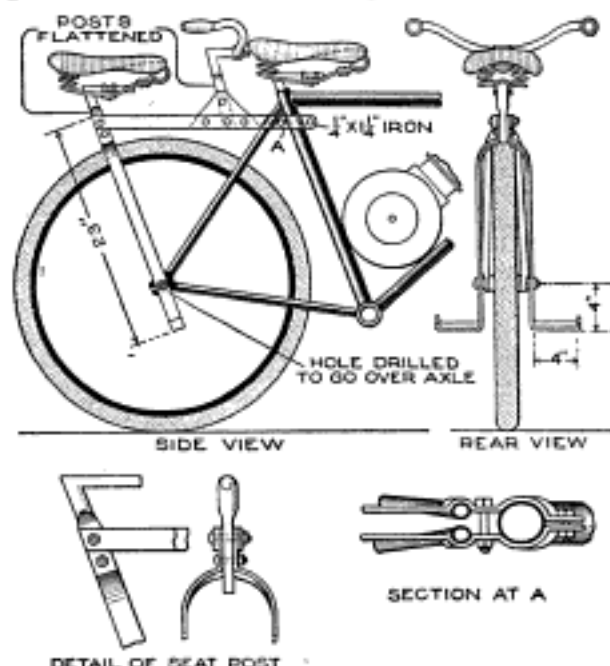

DETAIL OF SEAT POST
This Light-Weight Homemade Rear-Seat Fixture Is a Convenience for a Strong Bicycle or Motorcycle

strong bicycle or a motorcycle is handy, and one like that shown in the sketch can be made in the home workshop.

The supporting frame, consisting of two main sections forming a fork over the rear axle, and a brace extending to the bicycle frame, are made of $\frac{1}{4}$ by $1\frac{1}{2}$ -in. strap iron. The seat and the handlebars are supported on posts of the usual type, flattened at their lower ends, and riveted to the fixture. The lower ends of the fork are bent to form foot rests. The detailed construction of the seat post and the method of clamping the brace at A are shown in the smaller sketches. The fastenings of the seat and handlebar posts are made with rivets or bolts.—P. P. Avery, Garfield, N. J.

Changing Wheels Equalizes Wear on Baby-Cab Tires

The front and rear wheels of a baby cab are usually of the same size and the tires on the rear wheels are worn much more rapidly than those on the front wheels. By changing the position of the wheels, the wear on the tires is equalized, making it unnecessary to renew them until all are worn out.—J. Cecil Alter, Cheyenne, Wyo.

A Craftsman Leather Billfold

By LIVINGSTON HAVILAND

The making of a billfold is easily within the range of an amateur in

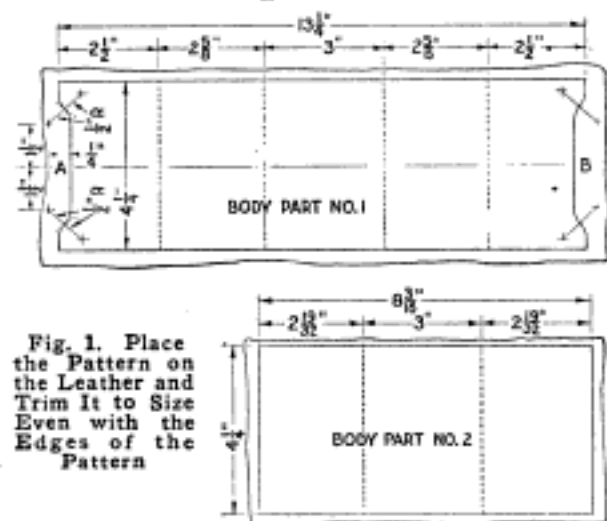

Fig. 1. Place the Pattern on the Leather and Trim It to Size Even with the Edges of the Pattern

leather work, who will observe the instructions carefully. Seal, morocco,

pigskin, and ooze sheep are satisfactory. Skiver, or thin leather, and silk moiré make suitable linings. When the processes involved in the making of the billfold are mastered, numerous other small articles in leather will suggest themselves, and can be made similarly.

The finished billfold is shown with the cardcase side up; folded, and with the bill compartment open, in Fig. 2. Begin the making of it by cutting a pattern of stiff cardboard for the main portion, or body part No. 1, as shown in Fig. 1.

Make a second pattern for body part No. 2, as shown in Fig. 1. Trim the leather to fit the patterns, a straight-edge of metal being placed over the pattern as a guide for the knife. A

close-grained hardwood board, or a piece of sheet zinc, is suitable as a base for cutting the leather.

Cut pieces of lining slightly larger than the patterns. If skiver is used, it must be glued to the leather with a good quality of leather glue, which should be pliable so as not to crack the leather. Do not stretch the lining, but merely smooth it gently, as otherwise it may cause the leather to buckle. Place the glued parts under a light weight to dry. In fitting the silk lining into place, apply a thin stripe of glue around the edges only, and permit them to extend beyond the leather. Then trim them off neatly.

Part No. 1 is to be folded to form the back of the billfold and also the two pockets for cards. The parts are glued as shown in Fig. 3. Weight the billfold and permit the glue to dry. The sewing may then be undertaken.

The neatness of the billfold will depend largely on the care with which the sewing is done, and the finish on the

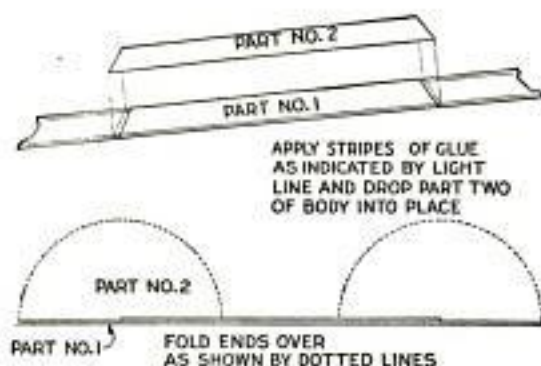

Fig. 3. Glue the Parts Together Carefully along the Edges, and Fold the Ends as Indicated

edges. Draw a straight line with a blunt-point tool along the edges to be

sewed, $\frac{3}{16}$ in. from them. Mark the spacing for an inch of the stitches on a strip of paper and transfer them to the stitching line. Punch the holes, making certain that each is made with the awl held vertical, as shown at D. Back



Fig. 2. The Photographs Show the Cardcase Side, the Folded Billfold, and the Silk-Lined Money Compartment

the open ends with strips of cardboard when punching holes in them. Heavy,

waxed silk of a color to match the leather is used for the sewing. The work may be done by hand without a holder, clamped between two boards. Thread the two needles and start them from the right side, as at E. Pass the needle from the first hole through the second as at F. With the needles then in position, as at G, continue this stitch. Tie the ends of the thread neatly at the end of the stitching. Trim the edges and tool them to a smooth finish with a suitable metal tool, or rod, heated moderately, applying water with the finger tip.

⌄The taper of a key is generally $\frac{1}{8}$ in. per foot of length, and keys having a head are preferable because of greater ease in removing them. The width of a key is usually $\frac{1}{4}$ the diameter of the shaft, plus $\frac{1}{8}$ inch.

Lawn Mower Sharpened Efficiently with Simple Rigging

With this device, one can quickly sharpen the lawn mower, or perhaps earn money sharpening the neighbors'

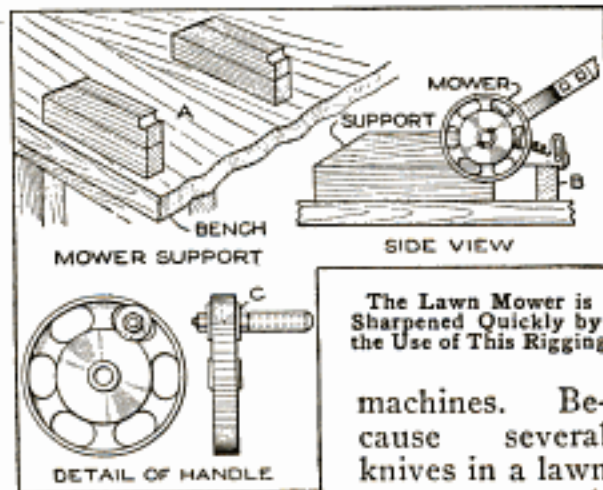

machines. Because several knives in a lawn mower work against the cutting blade, it is difficult to sharpen a mower satisfactorily with a file or stone. A usual method is to reverse the cutting-wheel cogs, turn the mower upside down, and run it backward over the ground. By the use of grinding paste on the cutting blade the cutting wheel tends to sharpen itself. This process can be improved by supporting the mower, as shown at A, the blocks permitting the mower's driving wheels to rest outside them. A block, B, supports the wooden roller. Remove the driving wheels, and the gears which turn the cutting wheel. Take the gear from one end and put it in the other end, replacing the driving wheel. By revolving the latter backward, the cutting wheel will also turn backward. Apply a paste of emery powder and lubricating oil to the cutting blade, and adjust the blade so that it comes fairly into contact with the cutting wheel. Turn the driving wheel backward, and gradually tighten the adjustment until a good edge on the cutting blade and the knives is produced.

A handle fixed on the driving wheel, as shown at C, makes turning it easier. After sharpening, replace the gears, clean the bearings thoroughly, and replace the driving wheels.—Ed. M. Hawes, Everett, Wash.

Rubber Pads for Opening Screw Watch Bezel

The modern screw case for watches is primarily for the purpose of keeping dust from getting into the delicate works. Unless one is possessed of a strong grip, it is hard not only to set the case tight enough to keep out dust, but also to open the watch when adjustment is necessary. To make this work easy, a jeweler has, as a part of his tool kit, several rubber dies to fit the different sizes of watch cases. He made them from old rubber heels, cut to fit the watch cases closely. Danger of breaking the crystal is also overcome.—C. E. Drayer, Cleveland, Ohio.

Spring Roost Releases Poultry-House Door Latch

Those in the habit of shutting their poultry houses at night to prevent disturbance or loss by night-prowling animals, will be interested in a contrivance that makes this unnecessary. The principle of the mechanism, as illustrated, is that the opening to the poultry house is closed after the fowls have gone to roost, and in the morning when they descend from the roost, the door automatically opens, and they are free to go out. The spring door opens inside, with hinges at the side, and a suitable

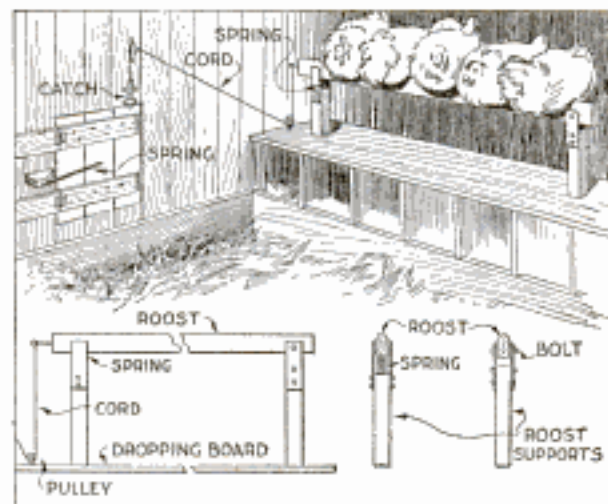

The Door is Opened Automatically When the Fowls Leave Their Roost

bumper. The spring has just sufficient tension to cause the door to open when the catch is released.

The roost is fitted up as shown in the detail. One end is held by a bolt, while the other rests on a coil spring compressed by the weight of the fowls on the roost. A cord is attached at the spring end, passing through pulleys to the door, where it is fastened to the end of the bolt catch. The door is closed after the fowls are on the roost. The spring end is compressed to a level position, by their weight. The instant the birds leave the roost, it rises and pulls the cord, releasing the catch, and permitting the door to open.—George S. Brown, Norwich, Conn.

A Child's Bell-Ringing Hoop

In making this useful toy, first, a wheel from an old baby carriage was



stripped of the tire; then two laths were fastened together at one end, and the wheel inserted between them, at the other end, and held by a bolt. A strong cord was passed around the groove in the wheel, and around a spool, nailed so as to

turn on the side of the lath when the wheel is rotated. Driven into the rim of the spool are three nails, which strike against the old alarm-clock bell, fastened as indicated.—W. F. MacGregor, Toronto, Can.

Emergency Camp Stoves Quickly Made

While conducting a boys' camp in summer we experienced a severe sleet storm. Our tents were not equipped with stoves and I faced a double problem: to keep the boys warm and to keep them contented. The difficulty was solved by having them construct emergency camp stoves, as shown, using iron stovepipe, and other mate-

rial at hand. One length of pipe is laid under the side of the tent about 4 in. in the ground, as in Fig. 1. An elbow mounted in sod connects with the chim-

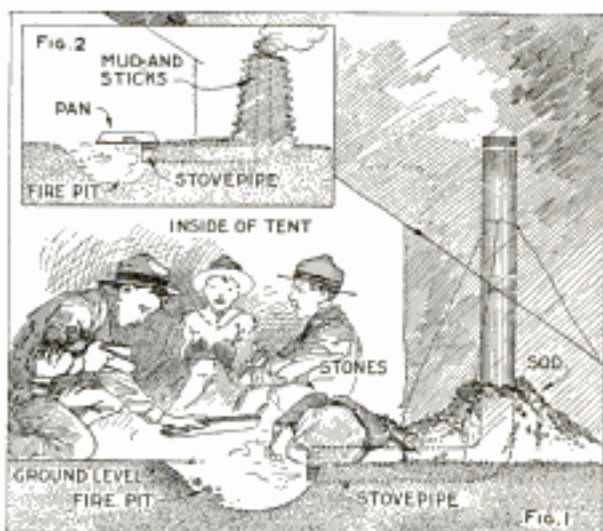

Boys at a Summer Camp Kept Themselves Busy during a Cold Spell by Making These Stoves

ney. A stone at the front of the stove regulates the draft, and stones placed upon the pipe hold the heat. The arrangement diagrammed in Fig. 2 is built with one length of pipe or a stone conduit. A hole is dug into the ground, about 10 in. deep. Over this is placed a pan, and an opening is made at the front for the fuel. The chimney is made of stones and sticks picked up around the camp, and plastered with mud. Coffee may be boiled or small cooking done on this stove.—William H. Leach, Alden, N. Y.

Pruning and Brush-Cutting Knife

With the blade of an old beef cutter and a stout wood handle, I fashioned

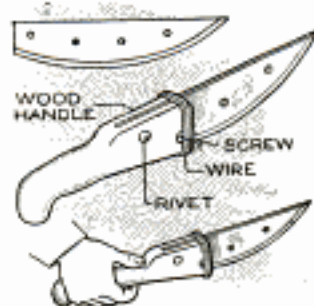

a brush knife that is superior to a sickle for cutting down heavy weeds. The blade was secured in a slotted handle by a screw and rivet, and the top of the handle wired

as an additional security. A blade of this sort is handy, also, for pruning purposes.—J. M. Kane, Doylestown, Pa.

MODEL FLATS FOR SMALL INDUSTRIAL CENTERS



TO provide sanitary, attractive residence quarters for low-paid workers in small manufacturing communities is the aim of the architect who originated the open-stair model tenements, which have gained the financial support of New York millionaire philanthropists. The adaptation of the same type of apartment building to conditions prevailing in factory and industrial towns where land is available at moderate prices, is suggested. It is hoped to obliterate the long rows of dismal, barnlike hovels, such as are shown above, by erecting three-story tenements around the sides of large plots of ground, as pictured



below. Since the separate units are set at an angle of 45°, instead of square with the sidewalk, air and light are assured. Grass plots and garden spaces are allowed for all tenants. Each apartment has its private entrance on an open-stair landing, not in a dark, inclosed hall. Outside rooms, toilet facilities, electricity, gas, hot and cold water, and steam heat supplied from a central plant, make each of the suites comfortable. Country tenements of this type could be rented for \$1.10 a week for each room. Three-story buildings accommodating three families on each floor could be built for about \$12,000 each.

The Open Stair Eliminates the Hallway of the Tenement, and Increases the Privacy of Each Apartment

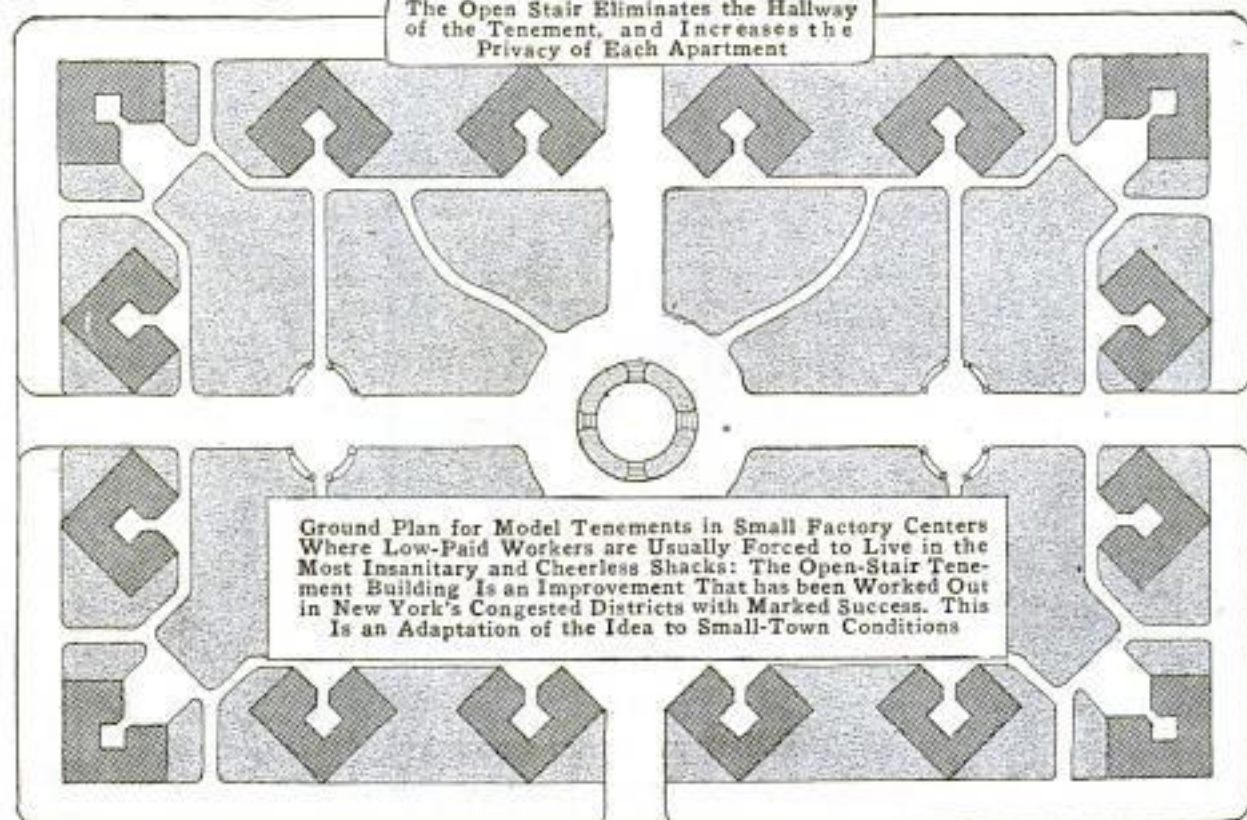

Ground Plan for Model Tenements in Small Factory Centers Where Low-Paid Workers are Usually Forced to Live in the Most Insanitary and Cheerless Shacks: The Open-Stair Tenement Building is an Improvement That has been Worked Out in New York's Congested Districts with Marked Success. This is an Adaptation of the Idea to Small-Town Conditions

VIEWS COPYRIGHT BY HENRY ATTERBURY SMITH, ARCHITECT

Business as Usual — Uncle Sam *Building as Usual* — Aladdin

Save 10 to 25%

Shrewd buyers are placing their orders for Aladdin Homes at present low prices. They are not going to take a chance on the future when the big demand comes for building materials in the European countries. You can save from \$300 to \$1,000 by building *Now*. Aladdin prices are considerably below the present market. Send for a copy of the big book "Aladdin Homes" showing over 100 homes, many in colors.

Aladdin Bungalows, Dwellings, Garages

The material for a complete home is furnished from a single source and at a single fixed price—eliminating extras. All of the lumber, framing, sheathing, building paper, shingles, siding, porch work, outside finish, flooring, windows, doors, stairways, interior woodwork, nails, glass, paints, varnish, stains, and lath and plaster are included in one price and shipped together at one time. Delays usually experienced waiting for deliveries of material are thus done away with.

Aladdin lumber, millwork and interior finish are all of the very highest grades and highest quality to be found in the forests. All exposed lumber inside and outside is clear and free from knots.

The Aladdin Book of Homes illustrates and describes over one hundred modern homes, priced from \$100 to \$6000—bungalows, two-story dwellings of stucco, siding and shingle exteriors, summer cottages, barns and garages. If you expect to do any building, you should certainly have a copy. Send stamps for Aladdin Book of Homes No. 180.

**THE ALADDIN CO. 1463 Aladdin Avenue
BAY CITY, MICH.**

This Home
\$643



This Home
\$758



This Home
\$898



This Home
\$1205



Westinghouse

SMALL MOTORS, FANS, ELECTRIC WARE FOR THE HOME

Your Unseen Servant

He comes at your bidding, but you do not see him.

You turn a switch or put a plug in a socket, and instantly he is at work.

He lights your lamps, cooks your meals, washes and irons your clothes, sweeps your rooms, gives you a breeze on hot summer nights, freezes your ice-cream, warms your bed, heats the baby's milk, runs your sewing-machine, polishes your silver, grinds your knives, transports you to your office and carries you up or down in the elevator.

He works for small wages and is at your service twenty-four hours a day.

But you would not have this universal servant—at an expense anyone can afford—except for the work of many engineers who have made possible the economic generation of electric current and provided the means of turning that current into light, heat and power.

When you use your Westinghouse Electric Iron or Toaster-Stove or Sew-Motor, you owe the lightening of your household tasks not alone to these appliances, but to many other types of electrical apparatus in the origination and perfection of which Westinghouse engineers have played a leading part.

These include the turbo-generators in the power-house miles away, that generate the electricity, and the switchboards, meters, transformers, rectifiers, regulators and more that make possible the control, distribution and use of this great force.

And Westinghouse engineering has been accompanied at every step by complete manufacturing facilities and high manufacturing standards.

Thus Westinghouse quality is the same, whether in a great 15,000 horsepower blooming mill motor, a 75,000 kilowatt generator or little fan motors and electric irons in a million homes.

WESTINGHOUSE ELECTRIC & MANUFACTURING CO.

East Pittsburgh, Pa.



A Westinghouse Electric Fan keeps the home comfortable in hot weather for a few cents a day.



A Westinghouse Electric Iron eliminates the hot stove, saves steps and is ready any time anywhere there's a lamp-socket.



Westinghouse Electric Waffle for the table provides a quick, easy and efficient way to prepare breakfast and supper.



A Westinghouse Sew-Motor makes an electric machine of any ordinary sewing-machine, abolishing the toil of treading.

Please Mention Popular Mechanics

Westinghouse

COMPLETE EQUIPMENT FOR CENTRAL STATIONS

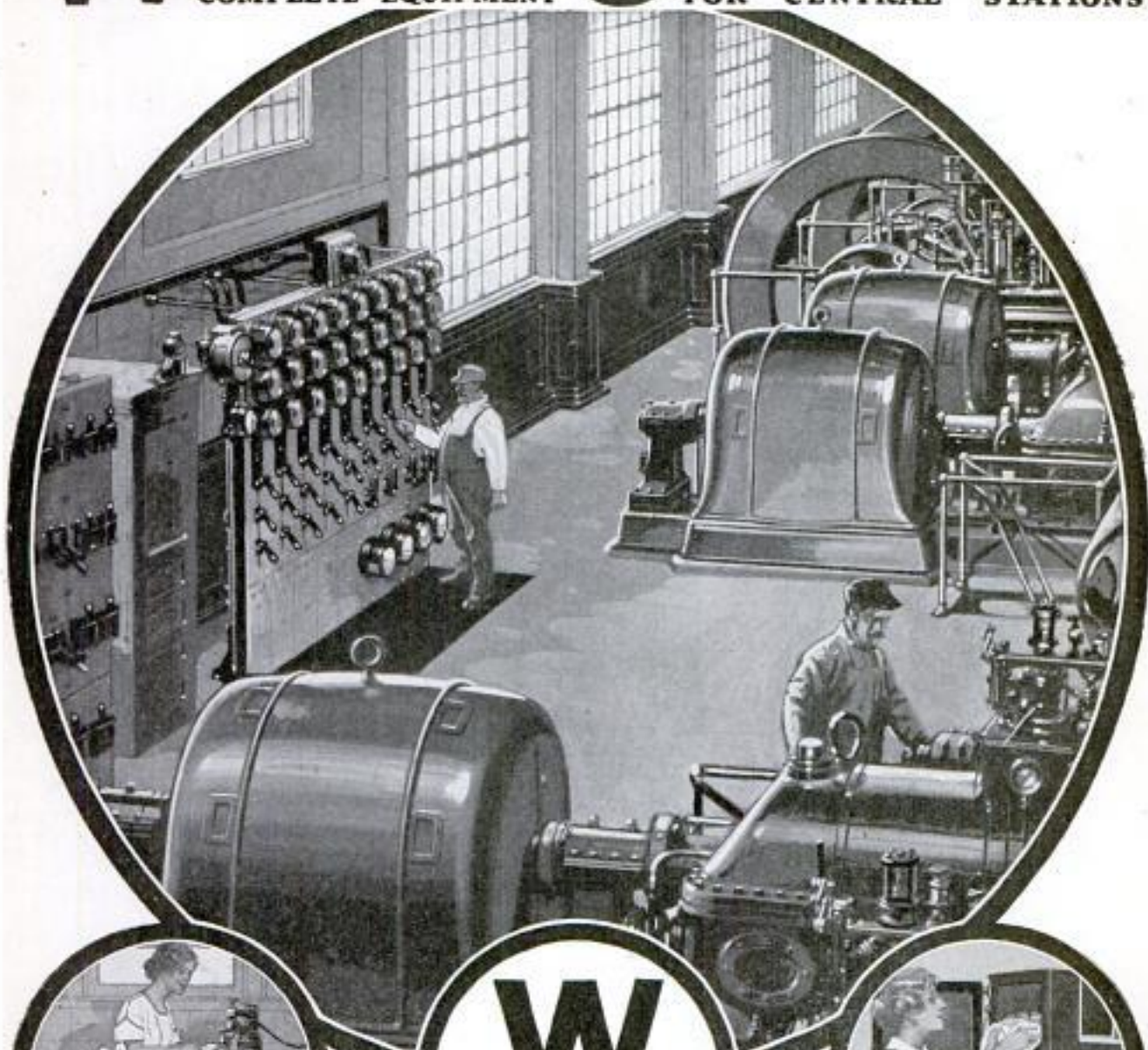

An electric washing-machine, equipped with a Westinghouse Motor, saves time, labor and wear-and-tear on the clothes.

A Westinghouse Electric Milk-Warmer heats baby's milk quickly at the turn of a switch. Can be attached wherever there's a light-socket.



W

WESTINGHOUSE
ELECTRIC



With a Westinghouse Automatic Electric Range the dinner is ready to serve when you come home after an all-day absence.



An electric vacuum cleaner, driven by a Westinghouse Motor, ends tiring, unsanitary, inefficient sweeping with a broom.

Please Mention Popular Mechanics

BLUE STREAKS

TRADE MARK REG. U. S. PAT. OFF.



Why Some Dealers Goodyear Blue

Bicycle riders have been paying too much for their tires. And the tires have not been good enough.

High profits have been to blame.

And, too many brands of tires, too.

But now Goodyear comes out with a really good tire—the Blue Streak—which costs the rider only \$3.25 each. It is as good as some other tires that cost \$5.00 each, and better than most that equal it in price.

It means big savings for the rider.

Long Wear Pleases Dad

You will find your Goodyear Blue Streaks wearing a good long time. There are many miles of happy travel in these tough, rugged tires, built with two stout reinforcing strips of fabric beneath the tread. The strong two-ply tire body has wonderful durability. Such a long wearing tire is most economical.

Springy Tires Make Pedaling Fun

No boy likes to push a bicycle with heavy, clumsy tires. So Goodyear Blue Streaks are made of fine two-ply fabric carried in lively rubber. That gives you strength and extreme lightness in your tire. Such a resilient tire makes pedaling easy. The tire shares the job with your legs.

GOODYEAR

AKRON

Please Mention Popular Mechanics

BLUE STREAKS

TRADE MARK REG. U. S. PAT. OFF.

Do Not Handle *Streak Bicycle Tires*

Naturally, some dealers refuse to handle Goodyear Blue Streaks. They want a higher profit on each tire.

But those dealers who *do* sell you Blue Streaks—and there are many of them—place your satisfaction ahead of their own profit.

Find the Goodyear dealer in your town. The fact that he has Blue Streaks for sale means he is a square deal merchant.

Boys everywhere are wearing Goodyear Bicycle Caps. Ask your dealer. They're especially popular with Bicycle Clubs—name of club printed on the cap.



When a gypsy peddler sells you a horse, he probably does not plan on seeing you again. He wants to make one sale—and plenty of profit. Never mind about your satisfaction.



The Goodyear dealer sells you better bicycle tires cheaper. He wants to see you again—often. He wants to keep you as a permanent customer. Goodyear Blue Streaks help him do this.

Non-Skid Treads Save Side-Slipping

Goodyear Blue Streaks are made with sharp-edged blocks of rugged rubber that bite the ground like teeth, in travel. Side-slipping is prevented. Besides, these stout rubber blocks add to the life of the tire. Press your thumb on a Blue Streak Tread. You can feel the "bite."

See your Goodyear Dealer or write The Goodyear Tire & Rubber Co., Akron, O., for his address.

Handsome Tires—Show Your Friends

Blue Streaks are good-looking as well as long-wearing and easy-riding. They put your bike on parade—make it look like new. You will know Goodyear Blue Streaks by the smart Blue Streak on each side of the tire.

GOODYEAR

AKRON

Please Mention Popular Mechanics

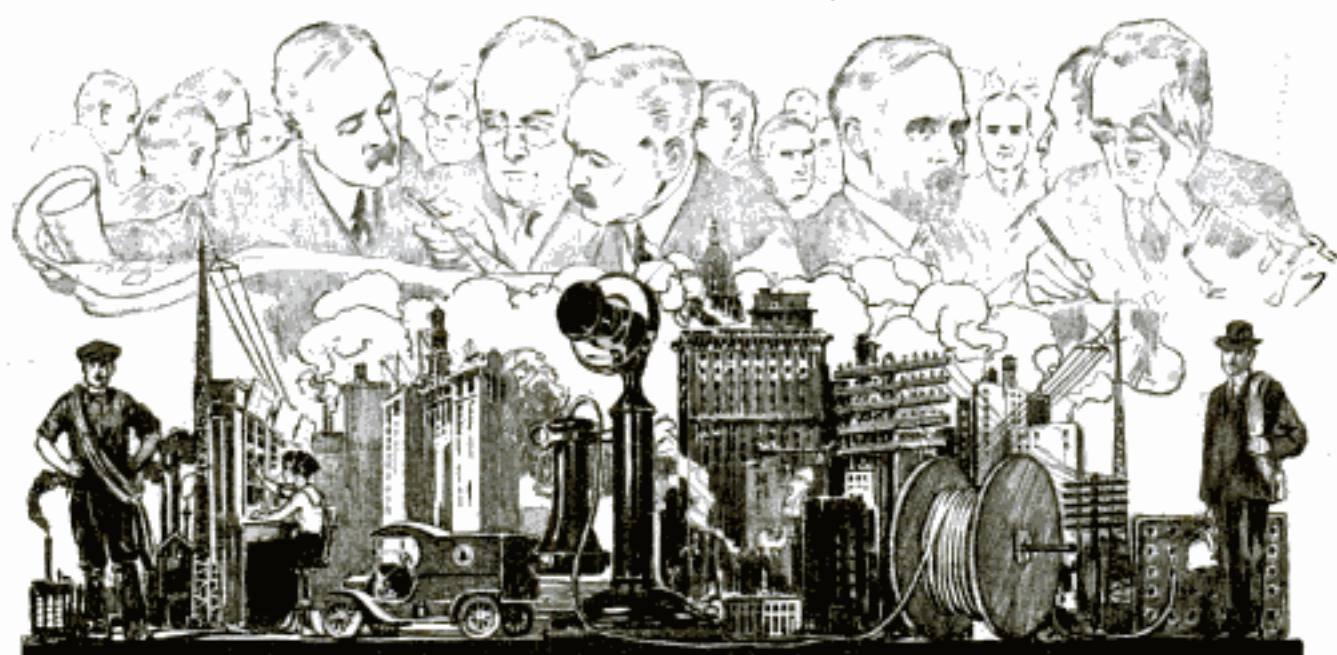

Our Real Reserves

Grim war today drags whole nations in its wake. The organized machinery of the government and the army and the navy in all their power cannot fight unaided. They constitute only in small part the country's real forces.

The bones and sinews of campaigns are supplied by our developed farms and specialized farm machinery; our highly organized steel industry, factories and mines; our facilities of transportation and communication. Railroads, telephone and telegraph systems link together and speed up the many activities of the nation.

But these material resources are not the whole. Back of each industry and activity there must be organizations of human beings, requiring years of patient training and actuated by the spirit of loyal service.

This spirit and training for service in the common welfare constitutes above all else the real strength of a Republic and insures victory. Joining all the country's resources is a fine spirit, a thorough training, a great, sustained concentration of real effort typified by the Bell Telephone System.



AMERICAN TELEPHONE AND TELEGRAPH COMPANY
AND ASSOCIATED COMPANIES

One Policy

One System

Universal Service

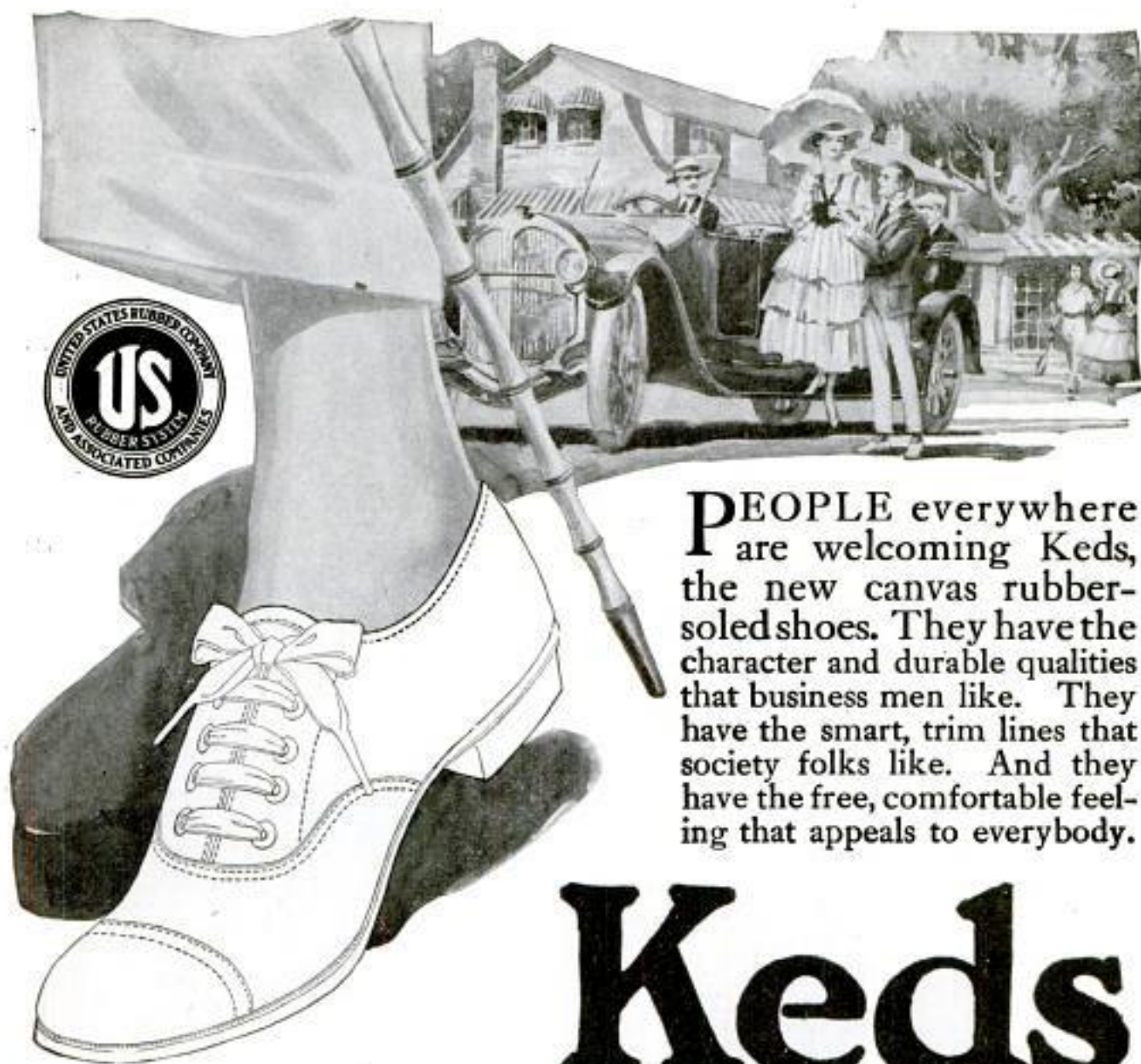

POPLE everywhere are welcoming Keds, the new canvas rubber-soled shoes. They have the character and durable qualities that business men like. They have the smart, trim lines that society folks like. And they have the free, comfortable feeling that appeals to everybody.

Keds

Wear Keds to work and make every step every day light and springy. You can get any style you like—high or low heels with low tops or high tops. There are Keds for every fancy.

Ask your dealer to show you the three leading brands of Keds for each member of the family.



**\$1.50
up**



**\$1.25
to
\$2.00**



**\$1.00
to
\$1.50**

You can get a better balance of comfort, style and economy in Keds than in any other shoe you can buy. Every pair carries the reputation of the largest rubber manufacturer in the world.

United States Rubber Company

New York

Please Mention Popular Mechanics



DODGE BROTHERS CLOSED CAR

Its uncommon beauty appeals
to feminine good taste

The convertible coupe is well
designed, well finished, well
upholstered, roomy—and
suited for use the year 'round

Coupe or Sedan, \$1265. In Canada, \$1800
Touring Car or Roadster, \$835. In Canada, \$1185
All prices f. o. b. Detroit

DODGE BROTHERS, DETROIT

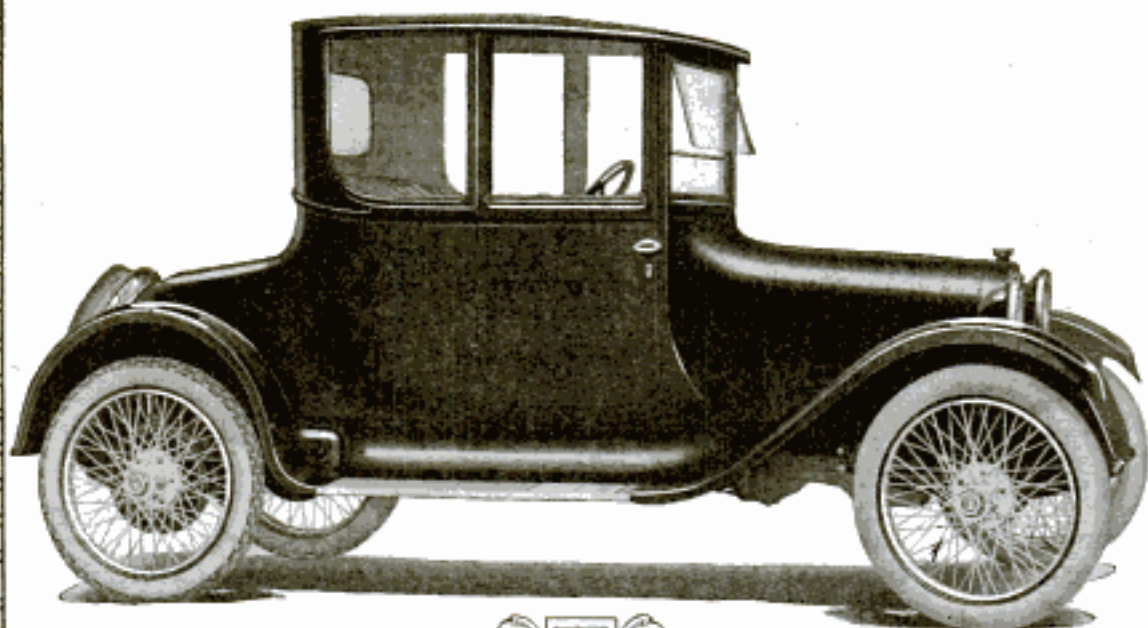

Please Mention Popular Mechanics

The Dominant One-Ton Truck Unit



\$350 and Up
F.O.B. Chicago

will convert a Ford or other car into a One or Two-Ton Dearborn Truck that has the Quality, Stability and Carrying Capacity of a Standard Truck costing \$1500 to \$2500 or more.

Dearborn Universal One or Two-Ton Units

are now made to fit ALL makes of Cars—the same sturdy, extra heavy construction throughout that characterizes ALL Dearborn Truck Units, the same care and attention to detail, material and workmanship forces recognition of their superiority in daily service in nearly every line of business—cheaper to operate than a team and wagon.

\$350 and up **DEARBORN** **\$350** and up
One or Two-Ton
Truck Unit

All Dearborn Truck Units are designed so that 90% of the load is carried on their heavy Dearborn Rear Axles, Heavy Springs and Heavy Pruden artillerytype Rear Wheels, with guaranteed hickory spokes and felloes. Bock Heavy Duty Roller Bearings, Baldwin Roller Chains, Baldwin Steel Sprockets, Jack-Shaft Hangers and Back-Rod Hangers HOT riveted to frame—not merely bolted.

We Want an Exclusive Dealer in Every Locality

Dearborn Truck Units are built in our own factory under our own supervision by expert auto mechanics and are guaranteed. It is the Biggest Seller in the truck field today and our Dealers are making Big Money. Territory is being rapidly taken under our liberal, exclusive agency plan. It will pay you to write TODAY for particulars and territory desired.

Dearborn Truck Co., Manufacturers
1244-1264 So. Campbell Ave.
CHICAGO

A MONEY MAKER FOR ALERT DEALERS.

Please Mention Popular Mechanics

Fair List Prices

Fair Treatment

Cords that are Cords



GOODRICH SILVERTOWN CORD TIRES

BEHOLD the *cord* that has made *cord tires* mean *durability, easy-riding comfort, mileage, and gasoline saving economy* to knowing automobile owners. Behold **CABLE CORD**, the unique cord made especially for the patent-protected two-ply Silvertown Cord Tires, and found **ONLY** in them.

Note the **SIZE** of **CABLE CORD**, its **SUPPLE STRENGTH**, and the **TWO** layers of it **CROSS WRAPPED** into a sinewy tire body.

Wrought of many threads the size of the "cords" of **WEB TIRES**, strong enough to swing the weight of a man, **CABLE CORD** gives Silvertowns a flexible strength which, yielding to the blows of a rough road, comes back without jolt or jar.

Fused with rubber as a cobbler's waxed end is waxed—a perfect weld of cord and rubber **40 PER CENT. RUBBER—CABLE CORD** keeps

Silvertown Tires immune to tire fever (internal friction), the destroyer of many ply tires.

Therefore, Silvertown Cord Tires, the only *two-ply, cable-cord* tires, outlast many ply tires with their multiplied tire fever.

Know them by their **Red-Double-Diamond** trade mark and graceful extra size, the tires you can not afford to deny yourself.

The **B. F. GOODRICH CO., Akron, Ohio**

Goodrich also makes the famous fabric tires — **Black Safety Treads**

"Silvertowns make all cars high-grade"

Please Mention Popular Mechanics



"The Best Thing I Ever Did Was to Send a Coupon Like This!"

"I KNEW that accidents were a greater danger than the old smallpox or yellow fever. I knew that twice as many people are hurt at home as on street cars—that four times as many are hurt at home as on railroad trains—and when I saw that 3 cents a day would save me and my family—I sent that coupon. That's why my mind's at ease, even though that fall down the step-ladder did put me out of business."

3 cents a day saved him. Let it save you from worry and money loss—



AETNA-IZE



If you are in a "Preferred" occupation and under 50 years of age, 3 cents a day brings \$1,250 to \$3,250 in case of death by accident; \$5 to \$10 weekly income for life for disability, plus \$1,000 to \$3,000 for loss of two limbs or eyes, or the income plus \$500 to \$1,500 for loss of one hand, foot or eye; or \$250 for death from any cause. You can make these amounts as much larger as you like by paying more than three cents daily.

Send this coupon now and find out. Don't wait until the accident comes. Don't wait until street car or cellar steps or slippery sidewalk puts you in bed. Remember one man in seven is killed or hurt each year. Send the coupon now and be safe in time.

AETNA LIFE INSURANCE COMPANY

Drawer 1341

HARTFORD, CONN.

The largest company in the world writing Life, Accident, Health and Liability Insurance

Agency opportunities for all Casualty and Bonding lines

An Aetna Agent has a national advertising campaign working for him all the time

Name.....
 Occupation.....
 Bus. Address.....
 AETNA LIFE INSURANCE COMPANY
 Drawer 1341
 I have marked the kinds of insurance I
 wish to know about: Accident
 Health Disability \$250
 Life Certificate My age
 is _____ years. I am
 in good health.

P. M. 7.17

22

Please Mention Popular Mechanics

A Hot Summer Task Made Easy and Cool

The high cost and scarcity of servants make it imperative that you simplify your laundry work. Do it the easy way—the *cool* way—the economical way—with a

Western Electric Washer and Wringer

When you experience the saving in labor and time, and particularly when you realize that the old way rubs the life out of the fabrics, you will find this machine an investment that will soon pay for itself.

In the Western Electric Washer the clothes are gently *rocked* back and forth through hot suds. Since there is no rubbing, the clothes do not wear or tear. And the cost of electricity for one week's wash is only about three cents! The step-saving electric iron will complete the week's work in quick time and with none of the discomforts of ironing the old way.

*If you are an efficient Home Manager,
get all the Facts about this Labor Saver.*

Just write for Booklet No. 102-AW and we will tell you about our No-Cost Trial Plan.

WESTERN ELECTRIC COMPANY
INCORPORATED

195 Broadway
New York, N. Y.

*Houses in all
Principal Cities*

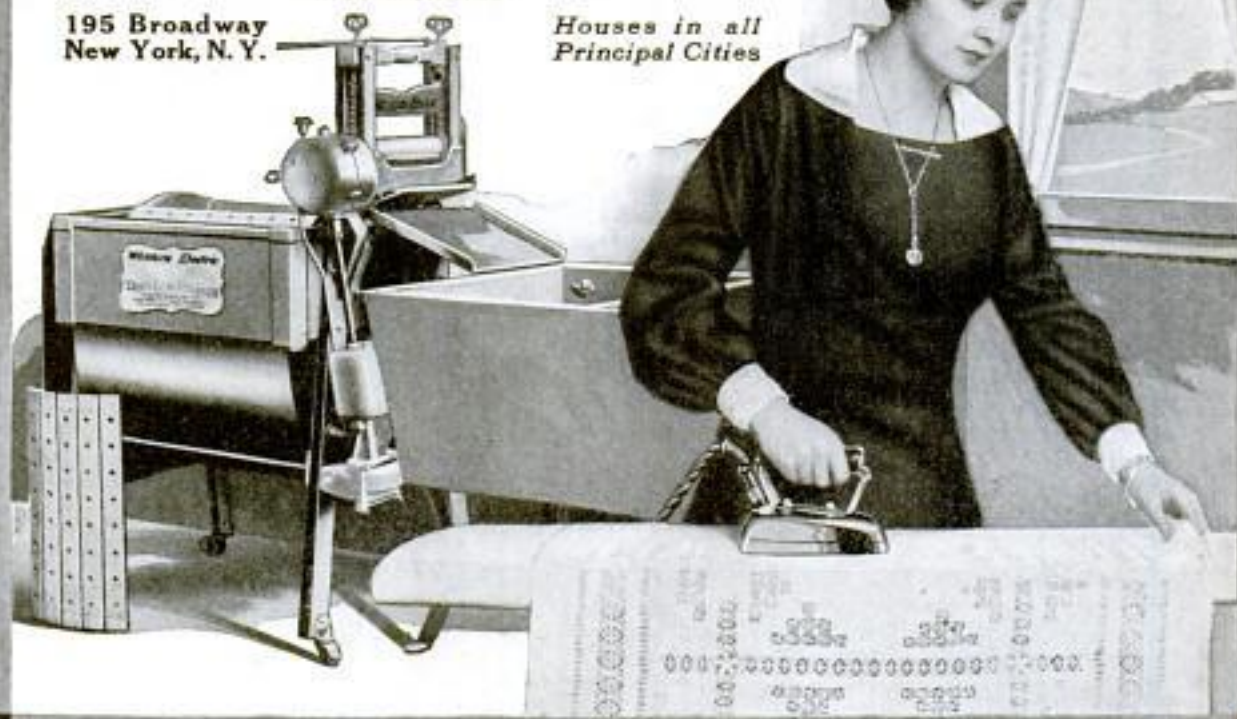

Please Mention Popular Mechanics

Save Money On Any Motion Picture Outfit

"Two Cameras That Cover the Field"

WE ARE EXCLUSIVE DISTRIBUTORS

Regular \$300
UNIVERSAL
Motion Picture Camera
\$260

NEW—Right from the Factory. Aluminum doors and front. Lens—2" B. & L. Tessar F: 3.5 in focusing mount.



Capacity 200 feet. Film register. Trick crank and reverse take-up. Guaranteed the finest motion picture camera that money can buy.

REGULAR \$90

Universal Tripod
NEW—Right from the Factory. Panoramic and tilting head. Quick panoramic release. Truss construction. Extremely light weight. Handle any camera. Absolutely the finest motion picture camera tripod made. Order now and save money.

\$75

Bargains in Slightly Used Motion-Picture Cameras

\$350, 400 ft. capacity U. S. Cinematograph M. P. camera. Regular and trick crank. Forward and Reverse take-up. Film meter, speed indicator. Direct focus tube 50 M. M. Zeiss Tessar F: 3.5 lens in interchangeable tube. Complete with 4 round Metal Magazines. Our price, \$200.

\$500, Pathe - Outside Magazine Professional M. P. Camera, Carl Zeiss F: 3.5 lens, outside diaphragm adjustment. Spot dissolve. Complete with Studio tripod and extra magazine. Our price complete, \$300.

\$160, 200 ft. Ernemann Model "A" Professional. Regular and trick crank. Finest mechanism. Erson F: 3.5 lens in focusing mount. Our price complete, \$125.

\$175, 200 ft. capacity Paragon. Mahogany case, special Claw movement. Outside focusing tube through rear. Tessar F: 3.5 lens in focusing tube. Our price, \$90.

\$350, 400 ft. Williamson Professional, Diaphragm and Spot Dissolve, Prismatic focus device, forward and reverse take-up, trick crank. Our price, \$185.

\$950, 400 ft. U. S. Deluxe, Studio Model—One pair of 2" F: 3.5 Tessar lenses, one pair of 3" F: 3.5 Tessar lenses, 3/4 x 4 1/4 Still Camera attached. Telephotolens. Most complete and finest focus device. Automatic and hand dissolve—with finest tripod made. Our price, \$550.

\$250, 400 ft. Photo Cines, Automatic Dissolve, all movements. Our price, \$155.

\$325, U. S. Automatic Motion Picture Printer—Motor Driven, Automatic light control for twenty different light intensities, rewind, equal to new condition. Price \$150.

Newest Model
DAVSCO

Professional Kino

\$110

NEW—Right from the Factory. Lens—50 M. M. focus B. & L. Tessar series 1 c F: 3.5.

Capacity 200 ft. Film meter.

Mahogany case, covered with genuine leather.

Guaranteed to take absolutely the finest pictures.

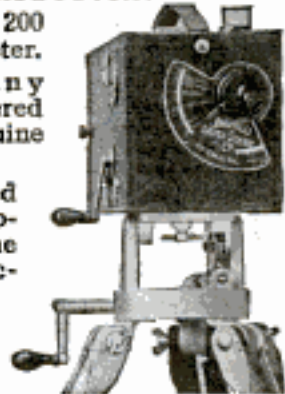

NEWEST MODEL

U. S. TRIPOD

NEW—Right from the Factory. Aluminum head panoramic and tilting top. Made of the best materials to stand the severest uses. Used by professionals everywhere.

\$25

Order Now and Save Money

Save Money On Cameras, Too! Send for SPECIAL Catalog!

Save 10 to 50 per cent on cameras, kodaks, graflex, lenses, photo accessories, etc. 10 days' free trial guarantee. Save money. Send coupon now for catalog.

DAVID STERN COMPANY

"In Business since 1885—Everything is Guaranteed"
711 Davaco Bldg., 1047 Madison St.
CHICAGO, ILL.

Gentlemen: Send me your catalog and prove to me that I can save money on any motion-picture outfit, camera, Kodak, lens, etc., or photographic accessories.

Name _____
Address _____
City _____
State _____



Please Mention Popular Mechanics

Life Insurance Without Agents is a Distinct Public Service

POSTAL LIFE METHOD SANCTIONED BY THE UNITED STATES SUPREME COURT

TIMELY TALK ON A VITAL SUBJECT

(SCENE: Pullman smoking compartment. Judge Kirkland and Lawyer Roberts continuing a conversation begun at dinner).

Judge: "Well, this business of selling direct-by-mail throughout the country is surely very popular with the public."

Lawyer: "Yes, but some of my clients say that in the interests of local merchants, the States ought to find some way to check it."

Judge: "I don't see why they should check it or how they can do it. Selling merchandise is an interstate business. I can sell and you can buy in the best market wherever it is. What can a State do about it?"

Lawyer: "You're probably right, I'll admit. The States can't very well put the 'kibosh' on legitimate interstate business."

Judge: "Certainly not. The States cannot hold up arbitrarily any direct-by-mail transaction, such as paying life-insurance premiums by mail."

Lawyer: "How's that?"

Judge: "Policies are written for people, 'direct,' all over the country, and have been for years. The United States Supreme Court has decided unanimously that life-insurance premiums on such policies are exempt from State taxes. The usual license fees and charges also do not apply. All this helps policyholders."

Lawyer: "Oh, you refer to the Postal Life?"

Judge: "Yes, that Company hasn't any agents and never has had. The applicant deals direct, personally or by letter. The method is good common sense as well as sanctioned by law."

That tells the story. Thoughtful insurers like Judge Kirkland take policies with the Postal Life and not only hold on to them, but are disposed to take new insurance, while those like Lawyer Roberts, who at first write in out of curiosity, at last find they can save money by taking a Postal Policy and they do it.

Find Out What YOU Can Save

You should take advantage of Postal benefits and economies. Call at the Company's office or simply write and say: *Mail insurance particulars as mentioned in POPULAR MECHANICS for July.*

In your letter be sure to give:

1. Your full name.
2. Your occupation.
3. The exact date of your birth.

You will receive full information based on official reports regularly filed with the New York State Insurance Department. Writing places you under no obligation and no agent will be sent to visit you. The resultant commission-savings go to you because you deal *direct*.

POSTAL LIFE INSURANCE COMPANY
WM. R. MALONE, President 511 Fifth Ave., Cor. 43rd St., New York

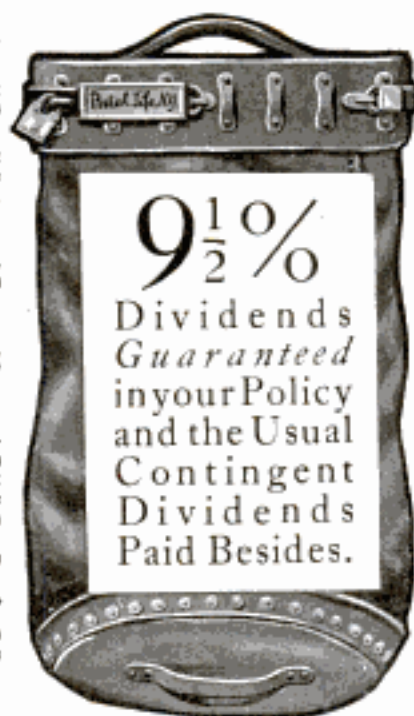

Lawyer (laughing): "Guess you're right. I wrote the Postal once myself just to find out how the Company did business, but never followed it up."

Judge (laughing): "I go you one better; I not only wrote them, but took a policy nine or ten years ago and have carried it ever since."

Lawyer: "How's the cost?"

Judge: "Lower than in other companies for the same kind of insurance—legal reserve—and besides that, they give me a free medical examination each year just so I can keep in trim."

Lawyer: "That's pretty good. You live in Idaho and deal with a New York company by mail. Did you ever look the Company up?"

Judge: "Only to know that it is chartered and licensed by New York State, whose laws are very strict, but I called on them when I was East a while ago. They're now in their new building on Fifth Avenue."

Lawyer: "So I've heard. Believe I'll write them to figure on a policy for me."

Judge: "Don't think you could do better. Life insurance without agents is a distinct public service. The point is made, and I think it is a good one, that the Company is subject to the United States Postal Authorities. The Postal simplifies the business, saves you money, safeguards your health and will treat you right in every way. I'd take another policy myself if I hadn't passed the age limit."



New Postal Life Building

The King of Sports

Invigorating — spontaneous — and interesting to the last degree — is trapshooting. It is the Sport of Kings and the King of Sports — replete with excitement and exhilaration.

Winging the wily clay pigeon has become quite *de rigueur* in smart country places and has proved a welcome boon to both host and hostess in the entertainment of house parties.

Write for the "Sport Alluring"
Booklet No. 386

E. I. du Pont de Nemours & Co.

Wilmington, **DU PONT** Delaware



Oxy-Acetylene Welding and Cutting

**Makes steel barrels stronger, neater—
at lower cost**

THE steel barrel is just one of the thousands of manufactured metal products which are made stronger, neater, better and at less cost by using oxy-acetylene welding in place of rivets, bolts and threaded joints.

In thousands of American factories—in the manufacture of automobiles, farm implements, engines, metal furniture, delicate tools and instruments—this process is used in routine production. To secure its economies and advantages many manufacturers have even made sweeping changes in the design of their products.

If you use bolts, rivets or threaded joints in the construction of any product, let us show you what welding can accomplish. This process is saving millions of dollars for railroads, factories, foundries, machine shops, garages, in quick repairs to broken machinery parts, tools, and defective castings.

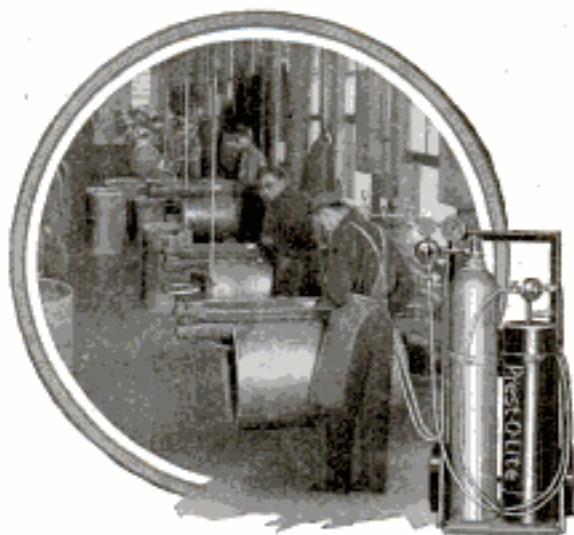

Above illustration shows part of large department devoted to welding seams of steel barrels by the Prest-O-Lite Process.

Prest-O-Lite **PROCESS**

Employs both gases (acetylene and oxygen) in portable cylinders. Prest-O-Lite Dissolved Acetylene (ready-made carbide gas) is backed by Prest-O-Lite Service, which insures prompt exchange of full cylinders for empty ones. Provides dry, purified gas, insuring better welds, quicker work, and lower cost, and also avoids the large initial outlay and heavy depreciation incurred in making crude acetylene in a carbide generator.

Necessary equipment is not expensive. We furnish high-grade welding apparatus for \$75 (Canada \$100); acetylene service at additional cost. Adaptable for oxy-acetylene cutting by the addition of special cutting blow-pipe. Thorough instructions are furnished free to every user of Prest-O-Lite Dissolved Acetylene—any average workman who understands metals can learn the process quickly and easily.

Send today for illustrated literature and data, showing specific instances of savings made by welding—savings that may be made for your shop or factory.

Extra profits for repair shops and garages

Repair shops and service garages everywhere are finding oxy-acetylene welding a ready money-maker. Broken or worn parts are made good as new—easily, quickly and at small cost. This kind of service and the savings made on repairs attract many new customers. At moderate charges *your* profits are too large to overlook. Necessary equipment is not expensive. Write us today for full details.

The Prest-O-Lite Co., Inc. U. S. Main Office & Factory: 816 Speedway, Indianapolis
Canadian General Office, Ingt. U. Toronto, Ontario
59 Branches and Charging Plants in Principal Industrial Centers



World's Largest Makers of Dissolved Acetylene

Ho! for the Open Road!

WHAT is more delightful than spinning along cool, shady country roads away from the heat and grime and dust of the hot city?

Especially if your bike is equipped with *GOOD* tires—tires as soft as cushions and as tough as a rubber ball—tires that defy the road—

United States Bicycle Tires

all twelve and one, at least, to meet all your needs.

Have you written for the pin yet? Fill in the coupon below *NOW*. It costs nothing.

United States Tire Company
1791 Broadway NEW YORK



FILL OUT—TEAR OUT—MAIL TODAY

United States Tire Company, 1791 Broadway, New York

Gentlemen:—

Please tell me how to get one of your beautiful green-gold bicycle bugs free.

Full Name

Address

Name of Nearest Dealer

Address of Nearest Dealer

*M*ANY an order directing the deadly curtain of fire, many a reconnaissance dispatch, is today taking legible, official form on sturdy little Coronas, carried from point to point as the lines of battle change.

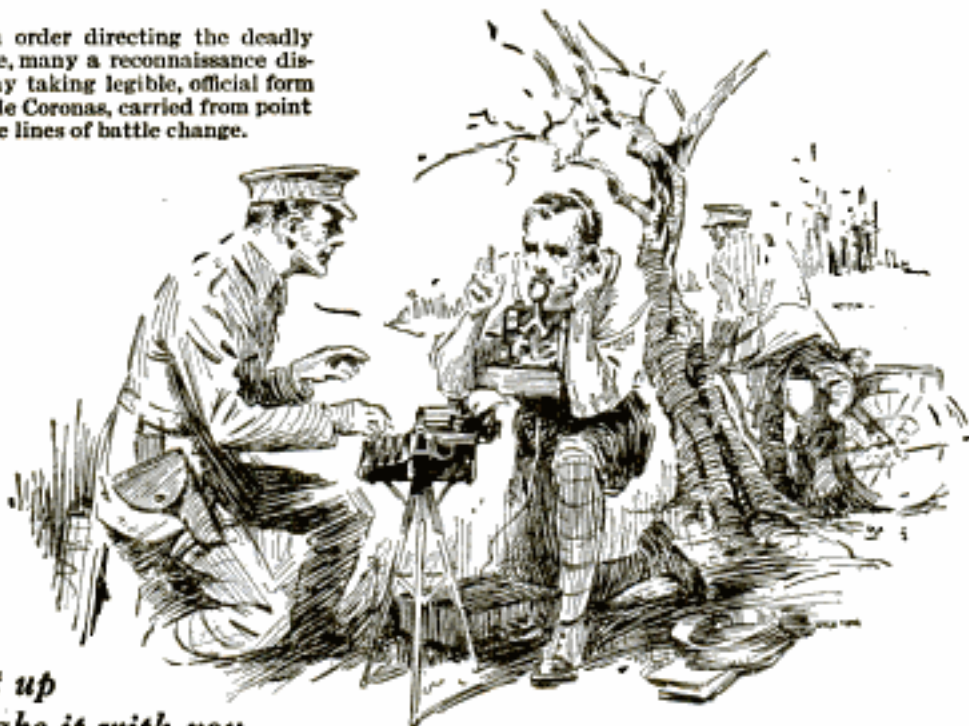

—fold it up

—take it with you

—typewrite anywhere

CORONA

The Personal Writing Machine

Countless Coronas are in daily use in many sectors of the great battle-fields. Their ready portability, made possible by their light weight and compactness, appeals alike to the officer whose orders must be legible and to the war correspondent who today is contributing history.

The same qualities of convenience and dependability which mark Corona for the service of war, establish it securely in the broader development of the arts of peace. Not a mere writing machine, but a machine for your individual use—because you can take it with you anywhere. Corona folds for travel and weighs but six pounds—can be carried in one hand from room to room or from office to home, or used on train or steamer or in the wilderness camp.

Complete with neat black case, Corona costs fifty dollars. Our Booklet No. 13—“The Personal Touch in Typing”—tells about it; and a copy is yours for the asking.

CORONA TYPEWRITER CO., GROTON, N. Y.
NEW YORK CHICAGO SAN FRANCISCO
AGENCIES IN ALL PRINCIPAL CITIES



Please Mention Popular Mechanics

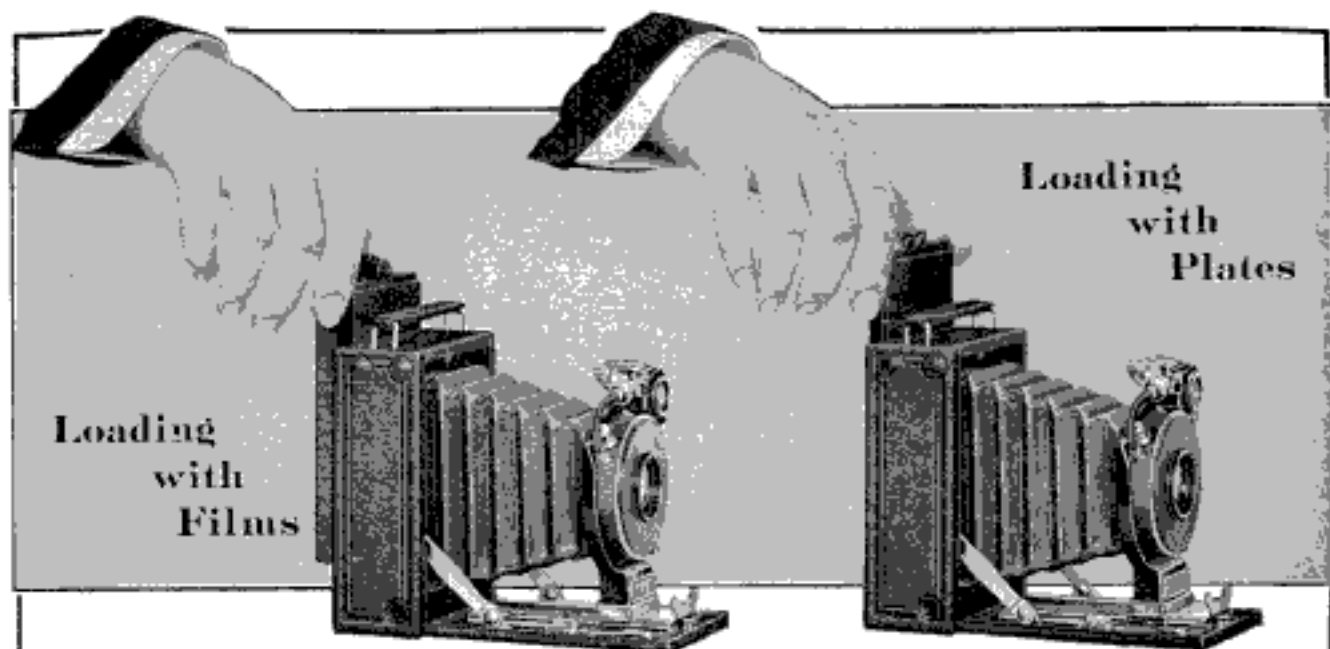

Really two cameras in one

PREMO No. 12

And it is such a small, such a thoroughly capable one, too. It is at once a plate or a daylight loading film camera. One method may be employed as easily as the other. It's just as the user chooses.

Focusing and composing may be done by use of finder and focusing scale, or at any time, for absolute accuracy the ground glass screen is easily used with either film or plates.

The camera makes $2\frac{1}{4} \times 3\frac{1}{4}$ pictures, it measures $1\frac{5}{8} \times 3\frac{1}{4} \times 4\frac{5}{8}$ inches, it weighs but 24 ounces, but it is so cleverly constructed that it will accommodate a three-hundredth of a second shutter, and the best and speediest of anastigmat lenses, including the Kodak Anastigmat $f.6.3$, and the B. & L. Ic Tessar $f.4.5$. With such equipments

and its careful, accurate mechanical construction, the Premo No. 12 offers the very limit of photographic efficiency—it will make good pictures wherever amateur pictures can possibly be made.

The negatives, while of good size for contact prints, are of such quality that enlargements may be made from them to any reasonable size.

For those who do not care for the high speed lenses, the same camera is supplied fitted with Kodak Ball Bearing shutter and either Rapid Rectilinear or Kodak Anastigmat lens, $f.7.7$.

Thin, smooth, richly finished, this will make a faithful, unobtrusive biographer of your personal experiences.

Price, \$15.00 to \$56.00.

Premo catalogue free at your dealer's, or mailed by us on request.

Rochester Optical Department, Eastman Kodak Co., Rochester, N. Y.

Champion Conical
Price \$1.00



Champion

Toledo

Dependable
Spark Plugs



The Giant Force that Makes the Car Go

The Do-ability of Champion Spark Plugs comes from their Dependability.

Pleasure car—fire engine—and motor truck perform exactly as the *impulses* from their engines make them perform—and not one iota better.

The *strength* of these impulses—(explosions of gas mixtures in cylinders)—depends upon the work of the spark plugs that *cause* the explosions.

Gas mixtures vary in quality, weather and fuel differ, but Champion Plugs never fail to set off *all* the power latent in every gas mixture.

Champion Plugs are the *source* of four out of every five cars' power—they start the things happening inside these cars that make them run.

There is an especially designed type of Champion Plug for every type of automobile, tractor, stationary, marine and motorcycle engine.

Ask for, demand and *get* Champion Plugs.

CHAMPION SPARK PLUG COMPANY, 418 Upton Avenue, TOLEDO, OHIO

SAXON ROADSTER

A CAR COMPLETELY EQUIPPED WITH EVERY MODERN FEATURE

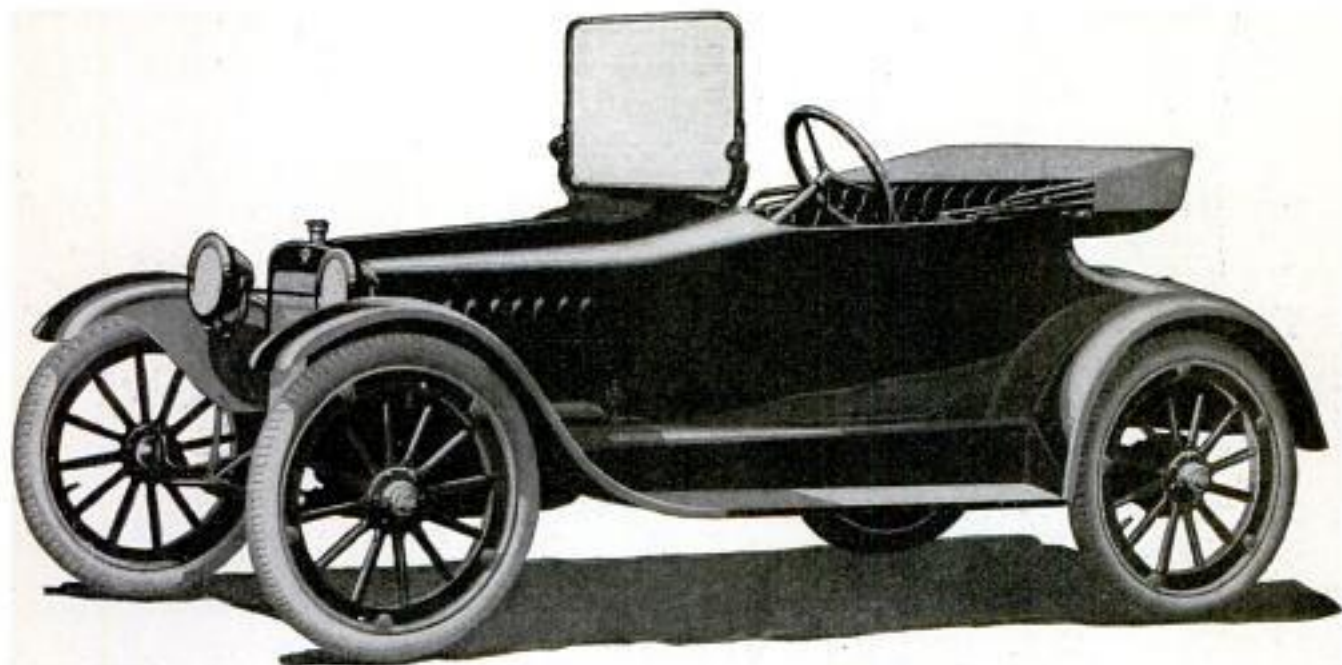

Some More Road Records Sent in by Saxon Roadster Owners

"I wish to congratulate you on the great car you build in Saxon Roadster. After running mine over 5,000 miles, it does not show the least sign of wear, and is mechanically perfect. When it comes to all around service there is no car at anywhere near its price that can match it. My Saxon Roadster is good for 5,000 more miles and then some."—DOUGLAS SHAPE, New York City, N. Y.

Runs Perfectly After 5,200 Miles

"Last Saturday I ran to Youngstown, Ohio, in my Saxon Roadster. It is a 64-mile trip, and half of the distance the roads were extremely rough. My exact running time was 4 hours, which is very good when road conditions are considered. The return trip was made in the same time. I used 5 gallons of gasoline and one quart of lubricating oil, and the car came home like a humming bird. I have driven my Saxon Roadster 5200 miles already, and it runs as sweetly and smoothly as any car could. It is certainly a wonderful car to drive and always rides comfortably. This car has given me less trouble than any car I have ever driven, and I have owned big ones of many kinds for ten years."—W. P. LUCAS, Oil City, Pa.

Averages 35 Miles to Gallon

"For complete service satisfaction my Saxon Roadster sets a standard. Recently I went from Bridgeport to Brockton, Mass., a distance of 175 miles, in 9 hours, averaging 35 miles to the gallon of gasoline. This is really a noteworthy performance when you consider that I carried a passenger and a heavy load in the car. Incidentally, there were a great many hills in this distance, but I experienced no trouble in making them 'on high.'"—S. L. LOUNDS, Boston, Mass.

Salesman Enthusiastic Over Saxon

"Early this spring I purchased a Saxon Roadster with full equipment, including electric starting and lighting system. I wanted to cover the southern and central parts of Minnesota and the eastern part of South Dakota with a line of merchandise, and I wanted to accomplish it as expeditiously and economically as possible. After considering all methods of transportation, and all kinds of cars, I finally came to the conclusion that Saxon Roadster was the best car from the standpoint of motor service, as well as the cheapest car to drive. What I believed then has been proved to me. As you probably know, the roads in this part of the country in the spring time are in a terribly bad condition, but my sturdy Roadster went thru every obstacle, and I kept to schedule time without one delay. My starter has never failed to work, and I have never been towed in. I have absolutely nothing but the highest praise for Saxon Roadster."—GEO. F. COOKE, Minneapolis, Minn.

Saxon Makes Good With U. S. Mail

"When it comes to rural mail service, Saxon Roadster is certainly the ideal car. It has ample room, utmost ease of control and light weight combined with sturdy construction. I missed but three trips all last winter, and then the deep snow made it absolutely impossible for any kind of conveyance. My Saxon Roadster has gone thru mud up to the axles, and over freshly graded roads, and has never yet failed me. My wife drove over the route three weeks, and is just as enthusiastic over the Saxon Roadster as I am."—F. MANBECK, Marion, Md.

Saxon Roadster, \$495 f. o. b. Detroit

(81)

SAXON MOTOR CAR CORPORATION, DETROIT

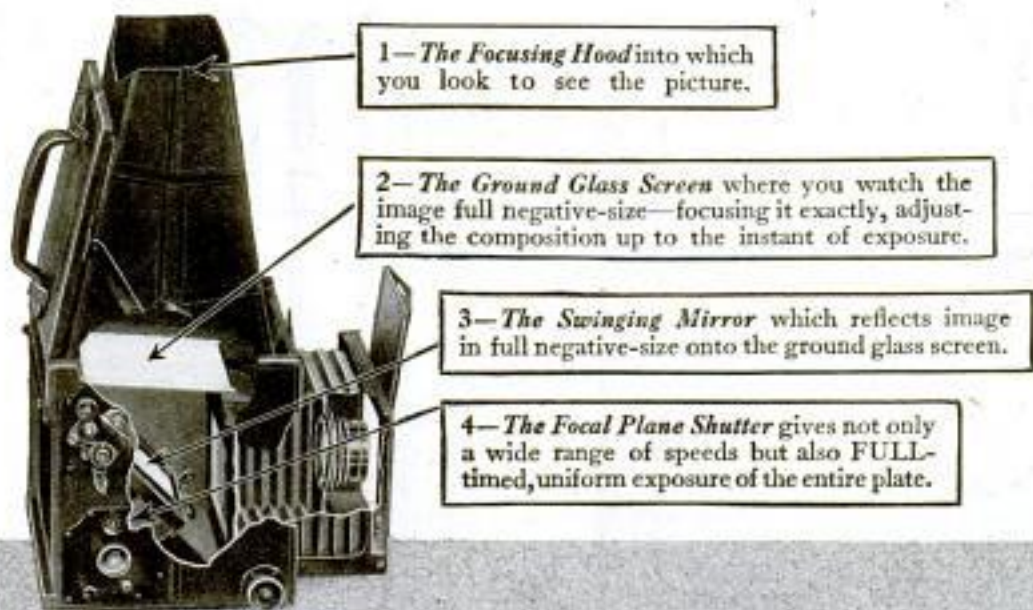

GRAFLEX Camera



WHY with a **GRAFLEX** you are ready, *instantly*, to take that picture which you may never have another chance to get—how *all* of your film or plate is *uniformly* exposed, during the *entire* exposure—and why the **GRAFLEX** takes **GOOD** pictures in sun or shade, indoors or out, is told on pages 3, 4 and 5 of the 64-page **GRAFLEX** Catalog. Get a copy from us or your dealer.

**FOLMER & SCHWING
DEPARTMENT**

Eastman Kodak Company
Rochester, N. Y.



Please Mention *Popular Mechanics*



Aviation

Learn Practical Aeronautics By Mail

FOR the first time in the History of Aviation, a Practical and Efficient Correspondence Course is waiting for you under the direction of Qualified Aviators and Aeroplane Builders, and a **Special Offer of Great Importance** is yours, if you will send the coupon at once.

Aviation is in its infancy. It stands today where the automobile and moving picture business did ten years ago. And the big men, the money kings in these colossal enterprises were ten years ago obscure mechanics with less opportunity than you have today with this wonderful Course in Practical Aeronautics. Now is the time to rise with the tide that means to you both fame and fortune.

Earn \$50 to \$500 a Week!

Today there is a great demand for men in all branches of Aviation. Experts in Aeronautics command tremendous salaries. Government Branches, Aero Societies, Aeroplane Builders, Repair Shops and others are clamoring for trained men.

We prepare you by mail to train for flying—in spare time to fill any of these positions:

Aeroplane Mechanic
Aeroplane Builder **Aeronautical Engineer**
Aeroplane Salesman
Aeroplane Assembler **Aeroplane Repairman**
Aeronautical Contractor
Aeronautical Instructor **Aeroplane Inspector**

No matter what your present business may be, equip yourself NOW to take up the new profession of Practical Aeronautics. Send the Coupon today for full particulars of our Course and the Special Offer we are now making. This is your opportunity.

Highest Endorsement By Aviation Authorities

This wonderful Course is highly endorsed by leaders in Aviation and Flying Organizations. It has their unqualified approval as a quick and reliable basic training for the business of Aviation. Under the personal direction of Mr. Bud Morriss, well known Aviator and Instructor, assisted by a distinguished Staff of Aviators, Aeroplane Manufacturers, and Aeronautical Engineers, you learn all about this fascinating, profitable profession. Every Lesson, every Lecture, every Blue Print and Bulletin self-explanatory, in plain terms, for quick understanding. Your training is thorough and complete. A common school education is all that is necessary to thoroughly understand the Course. Get the facts today. Send the Free Coupon.

Special Limited Offer-- Write Now

Send the coupon at once for full particulars of our remarkable special offer open to you now. Find out all about the marvelous opportunities that are opening in the Aviation game. This offer is the greatest stepping stone to bigger opportunities ever known. Write today for complete literature, all free and prepaid. You are not obligated in any way. Do not waste time in thinking about it. Act! Send the coupon or a letter or a post card will do.

WRITE AT ONCE.

AMERICAN SCHOOL OF AVIATION
 431 So. Dearborn St., Dept. 2627 Chicago, Ill.



EXHIBITION FLYING



AERONAUTICAL ENGINEER



AEROPLANE BUILDER



AEROPLANE REPAIRMAN



AEROPLANE INSPECTOR

American School of Aviation
 431 So. Dearborn St.
 Dept. 2627
 Chicago, Ill.

Gentlemen: Please send me free and without obligation, full particulars of your Course in Practical Aeronautics and Your Special Offer to those who write at once.

Name

Address.....

Please Mention Popular Mechanics

Tougher Than Elephant Hide



It's Play to Pedal With Vitalics On Your Wheel

More fun, more sparkle to bicycling since Vitalics rolled into sight. It's play to pedal to school or work with Vitalics between you and the road.

Thousands of miles of untroubled going in every tire. Every inch

of fabric in Vitalic tires is thoroughly impregnated with finest rubber. Vitalics won't seep air. The most exacting men and boys ride on

VITALIC Bicycle Tires

Three Vitalics to choose from. Each a marvel of toughness, resiliency, resistance and endurance.

Vitalic De Luxe is made of the choice of the world's best rubber throughout its extra-thick tread and tube. Its two-ply motorcycle tire fabric is built of the strongest cotton thread, triply-twisted. Highest quality friction. Distinctive V-shaped suction non-skid tread. All white. \$4.25 each.

Vitalic Cord Racer represents the highest type of racing tire, adapted for

both track and road racing. Purest rubber combined with powerful Sea Island cotton cord fabric. All white. Smooth tread. \$4 each.

Vitalic Brigadier is a rugged, enduring performer. Tough, 4-ply Egyptian fabric. A favorite with riders who demand long service at a moderate price. White, heavy-studded tread. Extra-heavy inner tube. Gray sides. \$3.25 each.

**Vitalic
De Luxe
\$4.25 Each**



Send for Testing Section

FREE Vitalic testing section and booklet, "Tougher Than Elephant Hide." Be sure to give name and address of your bicycle tire dealer.



**Vitalic
Brigadier
\$3.25 Each**

CONTINENTAL RUBBER WORKS, 1964 Liberty Street, Erie, Pa.

Highest Grade UNDERWOOD

With Back Spacer—Two-Color Ribbon and Tabulator

FOR



You Try It
10 Days
Free

Guaranteed
for Five
Years

Think What
You Can Get
Now for \$39.96

A genuine No. 4 Underwood—the standard visible typewriter, with back spacer, two-color ribbon and tabulator—*complete* with waterproof cover, new ribbon and special touch typewriting instruction book—the machine that is

today the leading typewriter of the world! *Guaranteed* to be delivered in perfect condition! Fully guaranteed for five years.

You May
RENT APPLYING RENT ON PURCHASE PRICE
OR
BUY FOR CASH OR ON EASY PAYMENTS

'Way Under 1/2 Manufacturer's Price

Read This Letter And Then Write Us for NEW Offer

Grand Rapids, Mich.,
March 5, 1917

The Underwood No. 4 Typewriter you sent me, was received promptly, and to say I was highly pleased with it is only putting it mildly. I have spent about five years in New York and other Eastern cities as stenographer, and have used nearly every type of modern machines. In view of the fact I think I can lay claim to be a reasonably accurate judge of a typewriter, and I want to say that the machine you sent me is first class in every respect. It has been thoroughly rebuilt and it works and looks like a brand new machine.

Very truly yours,
(Signed) R. H. Pousma

Moreover, you don't have to buy it to try it! We will send one to you on Ten Days' Trial. Write all you please on it for ten days and then if you are not *perfectly* satisfied, send it back at *our* expense. What's more, if you do not care to buy, you may rent it at our low monthly rates. If later you want to own it, we will apply *six months'* rental payments on the low purchase price. Any national bank in Chicago, or any Dun's or Bradstreet's Agency anywhere will tell you that we are responsible. Learn all the facts about this remarkable offer. Write us today—send us your name and address on the attached coupon—or a post card. Ask for Offer No. 52.

Write tonight—send your name and address on the coupon or a post card and learn all about Offer No. 52.

Write for our agency
proposition.

Typewriter Emporium, 34-36 W. Lake St., Chicago
Established for a Quarter of a Century

Send me immediately full facts about your Offer No. 52

Name _____
St. or R.R. No. _____
City _____
State _____

Don't Take a Trip With a Corn



DON'T handicap yourself
in a business way or socially with a painful corn.
There's no need to keep your mind on your corn.

Blue-jay—the easy way—brings instant relief from pain. And your corns are gone in 48 hours. That is, the average corn. Some very stubborn cases require a second or third treatment.

Millions upon millions of corns have been removed the **Blue-jay** way. Millions of families keep a supply on hand, and they never have corns. You, too, can be freed now and forever.

Paring corns brings only temporary relief. And harsh liquids are dangerous. **Blue-jay** is the scientific way.

BAUER & BLACK
Chicago and New York
Makers of
Surgical Dressings, etc.

Blue-jay

Stops Pain—Ends Corns
Instantly Quickly

For sale by
all Druggists
Also **Blue-jay**
Bunion Plasters

DIAMONDS 415 \$25
420 \$50
ON CREDIT
NO MONEY DOWN



MAKE YOUR LOVED ONES HAPPY

What could give more pleasure to your Wife, Sweetheart or Friends than a genuine Diamond? A noble gift that will last a lifetime. Every Diamond is especially selected, blue white, perfect cut, with which a guarantee certificate is furnished attesting its quality and value. Any Diamond purchased from us can be exchanged at a yearly increased value of 7% per cent on a larger purchase.

We will send you any Diamond you choose. **No money in advance.** If not satisfactory, send it back. If you are perfectly satisfied, pay for it on our easy monthly payment plan—20 per cent down, 10 per cent monthly. Only a few cents a day. **No interest charged.**

Let us send you our beautiful new catalog De Luxe No. 6-B. Select an appropriate gift for yourself or loved one, pay for it at convenient intervals.

L. W. SWEET & COMPANY, Inc., Department 6-B, 3-4 Maiden Lane, New York City

Please Mention Popular Mechanics



Swear Off Tobacco

Tobacco Habit Banished In 48 to 72 Hours

Immediate Results

Trying to quit the tobacco habit unaided is a losing fight against heavy odds, and means a serious shock to your nervous system. So don't try it! Make the tobacco habit quit you. It will quit you if you will just take **Tobacco Redeemer** according to directions.

It doesn't make a particle of difference whether you've been a user of tobacco for a single month or 50 years, or how much you use, or in what form you use it. Whether you smoke cigars, cigarettes, pipe, chew plug or fine cut or use snuff—**Tobacco Redeemer** will positively remove all craving for tobacco in any form in from 48 to 72 hours. Your tobacco craving will begin to decrease after the very first dose—there's no long waiting for results.

Tobacco Redeemer contains no habit-forming drugs of any kind and is the most marvelously quick, absolutely scientific and thoroughly reliable remedy for the tobacco habit.

Not a Substitute

Tobacco Redeemer is in no sense a substitute for tobacco, but is a radical, efficient treatment. After finishing the treatment you have absolutely no desire to use tobacco again or to continue the use of the remedy. It quiets the nerves, and will make you feel better in every way. If you really want to quit the tobacco habit—get rid of it so completely that when you see others using it, it will not awaken the slightest desire in you—you should at once begin a course of **Tobacco Redeemer** treatment for the habit.

Results Absolutely Guaranteed

A single trial will convince the most skeptical. Our legal, binding, money-back guarantee goes with each full treatment. If **Tobacco Redeemer** fails to banish the tobacco habit when taken according to the plain and easy directions, your money will be cheerfully refunded upon demand.

Let Us Send You Convincing Proof

If you're a slave of the tobacco habit and want to find a sure, quick way of quitting "for keeps" you owe it to yourself and to your family to mail the coupon below or send your name and address on a postal and receive our free booklet on the deadly effect of tobacco on the human system, and positive proof that **Tobacco Redeemer** will quickly free you from the habit.

Newell Pharmacal Company
Dept. 300 St. Louis, Mo.



Free Book Coupon

NEWELL PHARMACAL CO.,
Dept. 300 St. Louis, Mo.

Please send, without obligating me in any way, your free booklet regarding the tobacco habit and proof that **Tobacco Redeemer** will positively free me from the tobacco habit.

Name.....

Street and No.....

Town..... State.....

Please Mention Popular Mechanics

Amateur Carpenters

**Wood, Iron,
Aluminum Levels**

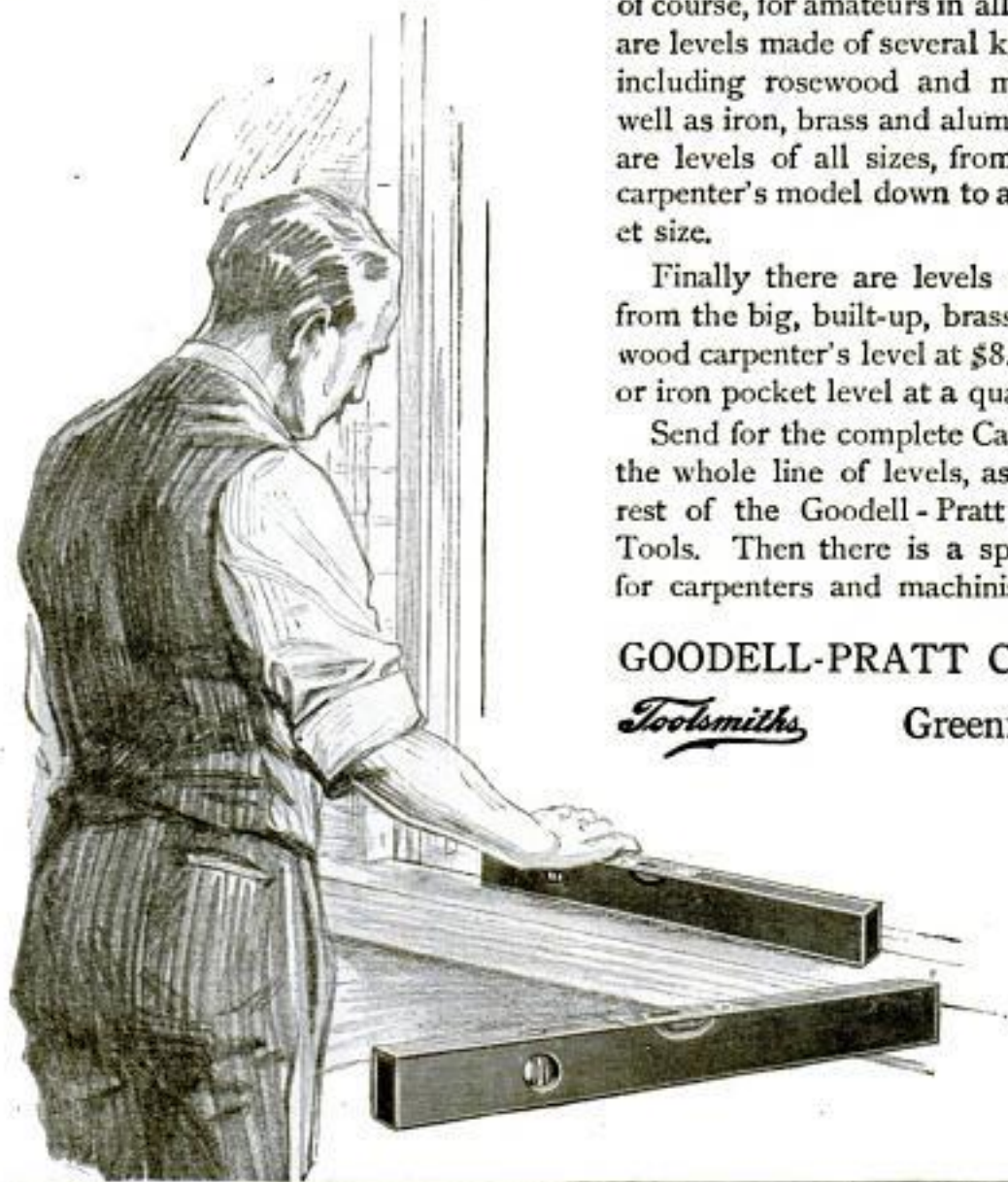

There is a Goodell-Pratt (Stratton) level for every purpose and every pocket; levels for carpenters, masons, plumbers, machinists, engineers, electricians; and, of course, for amateurs in all lines. There are levels made of several kinds of wood, including rosewood and mahogany, as well as iron, brass and aluminum. There are levels of all sizes, from the 30 inch carpenter's model down to a 2 inch pocket size.

Finally there are levels of all prices, from the big, built-up, brass-bound rosewood carpenter's level at \$8.00 to a brass or iron pocket level at a quarter.

Send for the complete Catalog and see the whole line of levels, as well as the rest of the Goodell-Pratt 1500 Good Tools. Then there is a special Catalog for carpenters and machinists.

GOODELL-PRATT COMPANY

Toolsmiths

Greenfield, Mass.

**GOODELL
PRATT**

1500 GOOD TOOLS

And Home Mechanics

Making models, patterns, small motors, etc., for experimental work or purely for fun, this Bench Lathe fills the bill at relatively small expense. It is equally suitable for the home workshop, the laboratory, the repair shop and the trade school. It is well made, of good materials, excellent design, and accuracy sufficient for all ordinary purposes.

This lathe will take work up to 12 inches in length, with a swing of 7 inches. The tail stock has both screw and lever feed; the spindle is hollow, with a No. 1 Morse Taper Socket and a $\frac{3}{8}$ inch hole clear through. It is furnished complete as shown, with a saw arbor and a three-jawed chuck in addition.

With various attachments that we manufacture or which you may make, it is possible to do almost any wood or metal work within the capacity of the machine.

GOODELL-PRATT COMPANY

Toolsmiths

Greenfield, Mass.

Amateur Bench Lathe

No. 125



GOODELL PRATT

1500 GOOD TOOLS

PAIN, VARNISH, KALSOMINE, ETC.

will not adhere fixedly if applied in any way which does not rub them into the pores of the surface covered, so as to permanently bind them. Throwing paint, etc., at a surface is a cheap, make-shift method, gives only a skim coat, which too often brings trouble.

Rub in good Paint, Varnish, Kalsomine, etc., with

WHITING-ADAMS BRUSHES

and they never let go. Crawling, cracking, peeling and other devilties are sinful as well as expensive, and can be avoided. Send for Illustrated Literature. Dept. C

JOHN L. WHITING-J. J. ADAMS CO., Boston, U.S.A.

Brush Manufacturers for Over 100 Years

Whiting-Adams Brushes Awarded Gold Medal and Official Blue Ribbon, the Highest Award at Panama-Pacific Exposition, 1915

CRESCENT WOOD - WORKING MACHINERY

will satisfy those particular buyers who want enduring service in wood-working equipment. Ask today for catalog telling about our line of Band Saws, Jointers, Saw Tables, Planers, Disk Grinders, Planers and Matchers, Swing Cut Off Saws, Shapers, Boreers, Hollow Chisel Mortise, etc. Variety Wood Workers, Universal Wood Workers.

THE CRESCENT MACHINE CO.

93 Columbia St., LEETONIA, OHIO

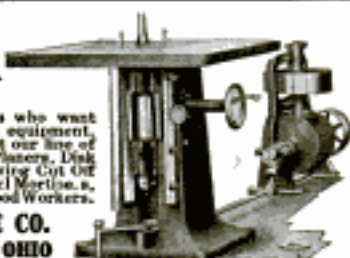

A complete line of appliances for the transmission of Power. Anything from a belt to a complete mill or factory outfit. Send for catalogue. Largest Manufacturers of Pulleys in the country. 6400 W. 12th Street

W.A. Jones Foundry & Machine Co. CHICAGO



SEBASTIAN LATHES

Give service—stand the test of time. The first Sebastian Lathe built over 30 years ago. Send for catalog.

The Sebastian Lathe Co. 107 Culvert Street Cincinnati, O., U.S.A.

CARRY YOUR Claw Pipe Vise

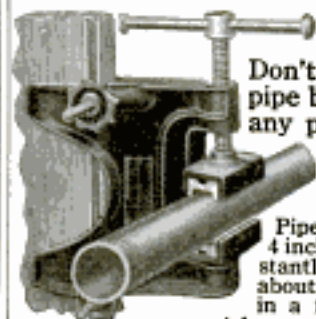

to the job and attach it INSTANTLY.

Don't waste time carrying pipe back to a bench. Fits any post, round or square, iron or wood, door or window casing. Fastens absolutely rigid.

Pipe simply cannot slip in the 4 inch teeth. Reverse jaws instantly for small pipe. Weight about 25 lbs. Pays for itself in a few weeks. Price \$15.75.

Ask your dealer or write us

COMMONWEALTH ENGINEERING CO., BOSTON, MASS.

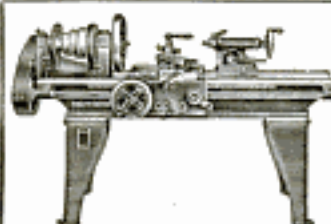

South Bend Lathes

For the Machine and Repair Shop

How to Run a Lathe A 50 cent book for 10 cents. Postpaid, stamps accepted.

Straight or Gap Beds. Send for free catalog giving prices on entire line. **SOUTH BEND LATHE WORKS** 423 Madison St., South Bend, Ind.

Drilling Wells is a Year Round Business



Drilling Water Wells is a profitable, healthful, year-round business. There are wells all around you to be drilled. Don't you want to get into a money-making business for yourself? Write for particulars.

STAR DRILLING MACHINE CO. 664 Washington St. AKRON, OHIO

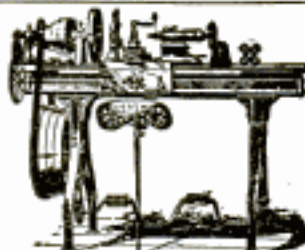

LATHES

9 to 18-inch Swing

List price \$75 and up according to size. When ready to buy send for Lathe Catalog and prices.

W. F. & John Barnes Co. 100 Ruby Street, ROCKFORD, ILL.

Water Pumps Water

with a Rife Ram. Plenty of it for every purpose about your farm and country home—day and night, winter and summer, without fuel, labor, freezing or repairs. The

RIFE RAM

is operated by any small stream having a fall of three feet or more and a supply of three or more gallons per minute. Fills high elevated tanks or operates air pressure system. Easy to install. First cost the only cost. Always on the job; over 11,000 in daily use. Tell us your water supply conditions. Ask for free estimate and catalog. Now is the time to install. Write today.

RIFE ENGINE CO., Dept. 3131, 90 West St., NEW YORK



DISSTON

SAWS AND TOOLS

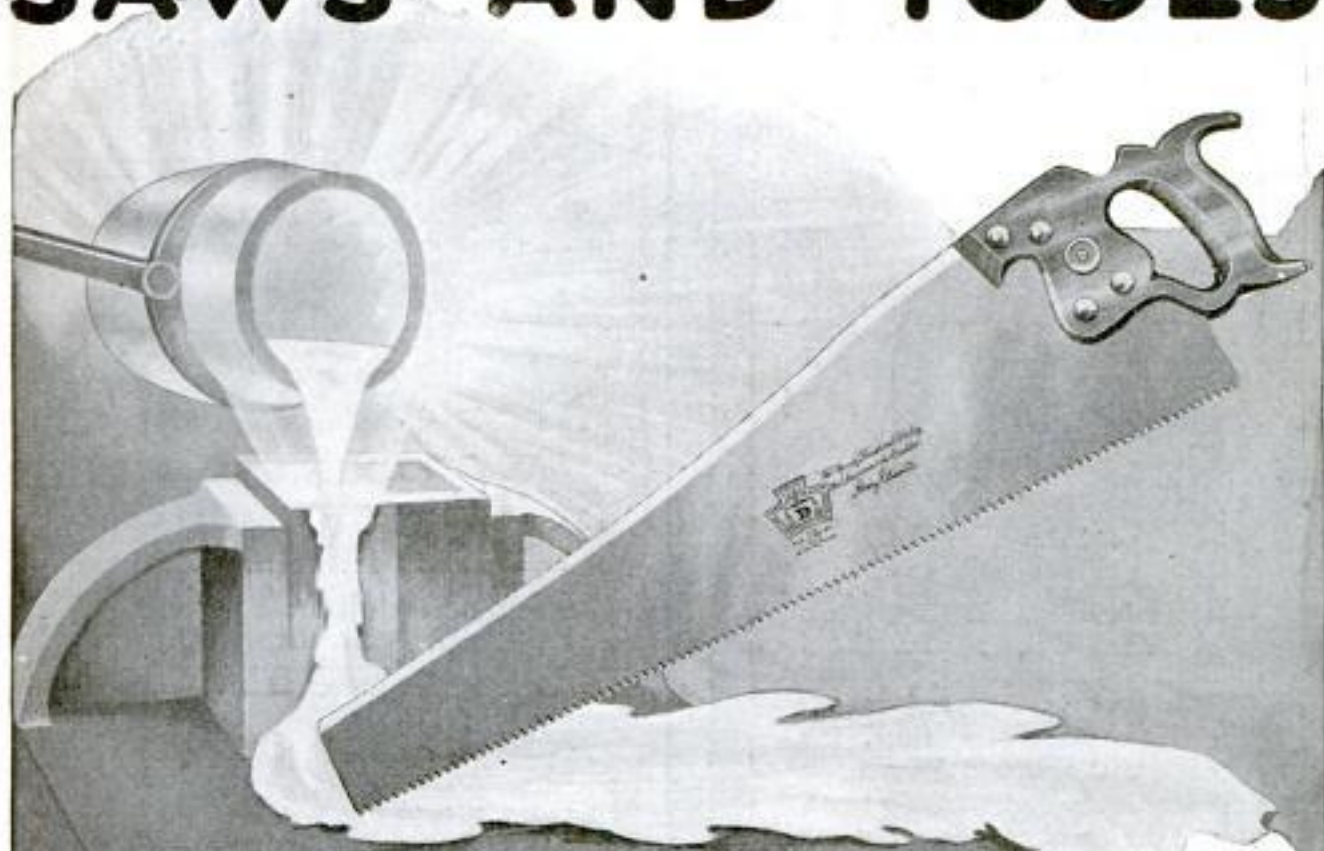

It's the Steel That Makes the Saw

When you buy a saw the first question to consider is, "What kind of steel is it made of?"

Henry Disston built the first crucible saw steel plant in America in 1855. For 62 years, Disston crucible steel has been the standard for high grade tool steel. The crucible process is the most expensive in commercial use—and produces steel of higher quality than is possible by any other process. The methods invented by Henry Disston and the Disston engineers, and controlled exclusively by Disston, have resulted in a steel superior to other crucible steels.

When you buy a saw for use around the house, buy the kind carpenters use. Nearly all carpenters use Disstons.

Disston trowels, files, screw-drivers, squares, levels, gauges and other tools are all of the same Disston quality.

Let us send you, free, a copy of our "Hand-Saw Booklet."

HENRY DISSTON & SONS, Inc., Philadelphia, U. S. A.

Canadian Works: Toronto, Canada



Please Mention Popular Mechanics

ADJUSTED
TWICE IN
24
YEARS



**B
&
S**

Yet in Constant Use

Purchased in 1893 and in use every working day since, the anvil of this B & S Micrometer has needed adjustment only twice, and the owner goes on to say that "what wear there is in the tool is scarcely discernible." This only proves what a good tool can do when properly used and why it is a good investment to buy.

**Brown & Sharpe
MACHINISTS'
TOOLS**

Our interesting instructive Catalog 27 should be in the hands of every machinist and toolmaker in America.

FREE ON REQUEST

Brown & Sharpe Mfg. Co.
Providence, R. I., U. S. A.

Please Mention Popular Mechanics

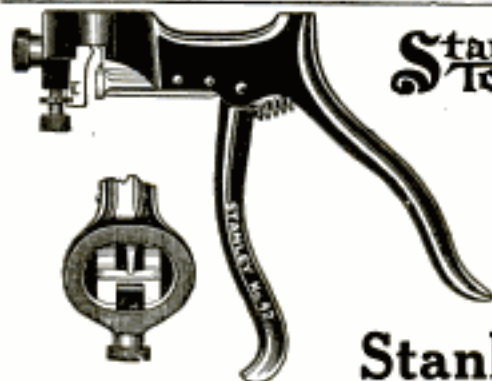

**Stanley
Tools**

Stanley "Pistol Grip" Adjustable Saw Set No. 42

This Saw Set embodies several unique and important features not heretofore seen in tools of this description.

The shape of the Body and Handle enables the user to operate the tool with great ease and with the least possible exertion, and the saw is held firmly against the gauge while the tooth is being set.

It can be readily adjusted by means of the knurled thumb screw to give a greater or less set to the teeth of the saw, according as the saw is to be used for coarse or fine work. As the anvil or part against which the plunger works is graduated, the same adjustment can be easily obtained for duplicate work.

The tool is so designed that the saw teeth are in plain view which enables the user to quickly adjust the tool to the tooth to be set.

The plunger and anvil are made of tool steel—hardened and tempered. All parts are carefully machined and are interchangeable. The tool is given a fine black finish.

ADDRESS

STANLEY RULE & LEVEL CO.
NEW BRITAIN, CONN. U.S.A.



CRANE VALVES

are made in all sizes



Here's the Exact INSIDE Measurement!

Interlox GIVES inside as well as outside measurements, instantly and accurately. The only interlocking rule made. Slides in and out—no awkward folding, or hinges to break. Strong, durable, brass-trimmed.

If not at dealer's send his name and 20c per foot (any length from 2 to 8 feet) and get your rule, sent prepaid.
DAHL MFG. CO., 51D E. 42nd St., New York City
Dealers and Agents: Request Attractive Proposition!



Tool Cases for Toolmakers and Machinists

Keep your tools orderly arranged in a Gerstner Portable Tool Case. There's a place for every tool in one of the felt lined drawers. Every up-to-date mechanic needs one and you'll find our Cases the best built, neatest and most practical on the market. We guarantee to please or refund all money. Write for our free booklet!

Gerstner Sons

Mfrs. of Mechanics' High Grade Tool Cases
808 Columbia St., DAYTON, OHIO

LEPAGE'S
GLUE
HANDY BOTTLES
WHEN A NAIL WON'T DO IT!

When you thread pipe do it the easiest way—

Don't waste your time tinkering with studs and bushings. Use the simplified

Each tool
threads from
four to eight
sizes



OSTER

BULL-DOG DIE STOCKS

The tools with the perfected lever control.

The dies open and close and reset to size at the twist of a lever. The guides, lever operated, center the pipe automatically. There's not a loose part, set-screw, stud or bushing to bother you. Better write today for a catalog of Bull-Dog Tools—ask for List 29.

THE OSTER MANUFACTURING CO.

2100 East 61st Street

CLEVELAND, OHIO

Duplicate Keys

for all Pin Tumbler Locks made in one minute with Harrison M.I.P. Key Filing Machine. No misfits. Thousands in use. \$3.50 net. Special diamond-shaped files for angular cut keys, 40c each; 3 for \$1.00. Harrison C.K. Key Clamp duplicates all common keys without a caliper. Price, \$1.10. Parcel post prepaid. Money returned if not satisfactory.

HARRISON & CO., 81 New St., New York

THE AWL YOU WANT



See That Reel
Is the genuine MYERS \$1.00 "Lock Stitch" Sewing Awl with the exclusive feature. See thread reel in front of handle under the finger tips. Natural tension. Sews heavy or light material, diamond point, full grooved needles used to protect the thread when sewing.
C. A. MYERS COMPANY, 6339 University Ave., Chicago, Illinois

Money Spent for Good Tools Is an Investment, Not an Expense

They will work more faithfully for you under all conditions, stand harder wear and outlast other tools if you will specify

"Red Devil" Tools

A complete line of Files, Glass Cutters, Hack Saws, Snips, Screw Drivers, etc. You will consider their ownership the best investment. To be obtained from all good dealers. Literature free.

SMITH & HEMENWAY CO., Inc.
97 Coit St. Irvington, N. J.

CRESCENT HAMR-HANDL SCREW DRIVER

75c.

GUARANTEED SATISFACTORY OR YOUR MONEY BACK

ASK TO SEE THIS SCREW DRIVER

The Crescent Hamr-Handl Screw Driver is designed for difficult work, impossible with ordinary screw drivers.

The adjustable handle readily forms a hammer to start the screw. Swung back to its regular position, a deeply knurled, balanced grip is afforded. Twist it to the transverse position, and there is leverage enough to easily seat heavy screws in the hardest wood.

The handle holds firmly in both positions. The blade is drop-forged, hardened and oil tempered. The Hamr-Handl screw driver may safely be used as a hammer. It's a Crescent. Made in three sizes to retail from 65c to 75c.

CRESCENT TOOL CO., Jamestown, N. Y.



FINCK'S "DETROIT-SPECIAL" OVERALLS "They Wear Like a Pigs Nose"

PROBABLY we've got more good friends among the readers of Popular Mechanics than among almost any other body of men. It shows that you men appreciate extra wear and extra comfort in your overalls and work-garments—and you give them pretty hard service, too.

If you haven't tried them yet, get a pair from your dealer today. If he hasn't them, we'll forward by prepaid parcels post on receipt of size and price.

Overalls, \$1.50 Jackets, \$1.50 Combination Suits, \$3.00

W. M. FINCK & COMPANY
1154 Gratiot Avenue Detroit, Michigan

SIMONDS

Eighty-five years of saw making have made "Simonds" a synonym for good saws. The only steel good enough for them is "Simonds" steel. That is why they have such sturdy construction and fine cutting qualities.

Simonds Saws should be in every tool chest. Are they in yours? We have saws for every purpose. Send for our interesting booklet and catalog.

Simonds Manufacturing Co.
FITCHBURG, MASS.
5 Factories 11 Branches

*"I Tell You It's
A Great Saw"*

Please Mention Popular Mechanics

Portable Cases

For Tool Makers and Machinists

Twelve styles, felt lined drawers, solid brass trimmings, best of material, beautiful finish, low prices, satisfaction guaranteed. Ask for booklet of cases built for service.

THE PILLIOD LUMBER CO.
SWANTON, OHIO

Sharpens Safety Blades Perfectly

At last, the perfect sharpener—the **Stag Sharpener**. The only sharpener that both hones and stropps all makes of safety blades. Keeps blades in perfect shaving condition. Makes old blades better than new. Surprisingly simple. **Roller** in holder automatically sets blade always at correct honing and stropping angle. Our **New Patented Feature** makes inserting and removing blades easy. Just press rollers together. Heavily nickeled holder, barber's hone and stropp in neat box, complete, postpaid, **\$1.00**. Try it 10 days; money back if not satisfactory.

Dealers Write for Special
Introductory Offer

STAG CO. 329 Plymouth Court
Dept. 5251, Chicago

\$1

ASBESTOS

We are miners and shippers of Crude Asbestos in any quantity. We produce all grades at our world-famous Bell Asbestos Mines, in Canada. We also card fibres, spin yarns, weave cloths, and make all sorts of Asbestos products.

For anything you want in Asbestos, turn to

KEASBEY & MATTISON COMPANY
Dept. 5-3, AMBLER, PENNA., U.S.A.
Owners of the world's largest Asbestos Mines



Meets All Requirements

No matter what kind of a measuring tool or laying-out tool you need, you'll find what you require among the 2100 sizes and styles of

TRADE MARK
Starrett
REG. U.S. PAT. OFF.
Tools

These fine tools are the *standard*; they are the favorites among tool makers and machinists because of superior design and quality of workmanship. The line includes rules, squares, levels, calipers, dividers, micrometers, vernier height and depth gages, etc.

Write for Catalog No. 21AP

The L.S. Starrett Co.
The World's Greatest Toolmakers
 Athol, Mass



Please Mention Popular Mechanics

Take Pictures with—

The EXPO WATCH CAMERA



A camera that closely resembles a watch in size and appearance—takes pictures $\frac{5}{8} \times \frac{3}{4}$ inches as shown on margin. Easy to operate. It's a camera for both amateur and professional.

Surprise Your Friends

Take their picture in the act of doing some funny stunt. Next time you see them produce the print. You will have a lot of fun over their bewilderment and catching people in queer and awkward positions. Carry the EXPO about in your pocket—easily concealed in the palm of the hand—picture can be taken unobserved. Produces clear, sharp negatives, indoors or outdoors equal to any camera on the market.

One Cent a Picture

The EXPO loads in daylight with a 25 exposure film costing 25c. A whole day's outing picture taking can be had for the small sum of 1c a picture. Films are also made in 10 exposures for 15c. Photos may be enlarged to any size. We have Automatic Enlargers specially made for the purpose, that may be had any time.

\$2.50

For EXPO WATCH CAMERA, postage 10c extra. Films 25 Exposures 25c—10 Exposures 15c. Leather Pocket Carrying Case 35c.

JOHNSON SMITH & CO., 7163 N. Clark Street, CHICAGO

Quick as a Flash

The EXPO takes pictures through the stem, where the rapid fire lens is located. Equipped with a time and instantaneous shutter. Weighs but three ounces and is highly nickel-plated. Endorsed and in constant use by the police, newspaper reporters, detectives and general public. Important evidence can be secured with a camera of this kind. Sold under a positive guarantee. Delivered to any address in the world.

Johnson
Smith & Co.
7163 N. Clark St.
Chicago, Ill.

Please send me one EXPO
WATCH CAMERA for which
I enclose \$2.50 and 10c to
cover postage.

Name _____

Street Address _____

City _____



4 Weeks' Trial

Any
Superb

Wings Pinnor Player
Piano, choice of 33
styles, on 4 weeks'
absolutely free trial.
No money down, all
freight prepaid. Return at our expense, or keep
it at the rock-bottom direct price. Easy terms.

Valuable Book FREE

Write today for "The Book of Complete
Information About Pianos." Also free catalog.

Wing & Son, (Est. 1868) 9th Ave. and 13th St., Dept. B119 New York

AGENTS—Make \$100 to \$300



per month easy selling our new Triple
Sauce Pan. Cooking utensil for 3 different
foods on one burner. 400 Specialties—all
Whirlwind sellers. Write quick for ex-
clusive territory and large catalogue.

AMERICAN ALUMINUM MFG. CO.
Div. H-T LEMONT, ILL.

FIBRE LEGS
ARMS

4-LB. FIBRE LEGS—ON EASY TERMS

Orthopedic braces for all deformities. Send for booklet.
MINNEAPOLIS ARTIFICIAL LIMB CO., 636 Dean Bldg., MINNEAPOLIS, MINN.

AN ARMY
OF BOYS

MORE THAN
150,000
STRONG

ARE REGULAR READERS and loyal
boosters for THE BOYS' MAGA-
ZINE, and this army is gaining recruits
every day because every month this
splendidly illustrated magazine

CONTAINS STORIES LONG AND SHORT by the world's best
writers. Special Articles up-to-date and authoritative on every in-
terest of boy life. Depart-
ments edited by experts on
Athletics and Physical
Training, Hunting, Camping
and Fishing, Electricity and Mechan-
ics, Photography and

SEND A QUARTER TODAY (STAMPS IF YOU PREFER), as
this special offer of a 5-months' subscription for 25c is for a limited
time only. If not satisfied, your money will be promptly refunded
on request. Address

THE SCOTT F. REDFIELD CO., 1247 Main St., Smetport, Pa.
TO BOYS' FRIENDS: Invest a quarter and make some boy happy.
(REGULAR PRICE, \$1.00 A YEAR.)

The Boys Magazine



SPECIAL
OFFER
25c
FOR FIVE
MONTHS

Drawing, Stamp and
Coin Collecting, Poultry
and Pets, Boy Societies
and Clubs, Joe Jolly's
Joke Market, Cash
Contests, etc., etc.

Relief to Ruptured People

Any appliance is a
truss. Ruptured people must
wear a support. Our New Sponge
Rubber Pad (pat'd) is velvety, soft to the
skin, pliable, cannot slip, extremely comfort-
able, adapts itself to ruptured parts with
less pressure, is sanitary, long lived. Mas-
sages and strengthens muscles, allows
blood circulation and produces many cures.

Scrotal Pad Needs No Leg Strap

Our New Akron Sponge Rubber Scrotal Pad (pat'd) holds it out of 10 cases
of scrotal hernia perfectly without strap between the legs.

Cures Man of 86

The Akron Truss Co. Gentlemen: I am 86 years old and
have had a rupture for 27 years. I am an active man, tend to a large garden.
I was and split the wood and do the household chores. I bought an Akron
Truss and wore it one year and am as sound as a dollar.
Respectfully yours, S. W. Glaze, Illinois.

Cured Double Hernia

The Akron Truss Co. Gentlemen: I have worn one of your trusses for
some time. All this time have carried two heavy sample cases; notwith-
standing this handling, your truss has cured me of a double hernia.
Yours truly, O. E. Jones, Indiana.

Girl Baby Cured

The Akron Truss Co. Gentlemen: The infant's truss was a perfect suc-
cess. The child wore it about one year, and the rupture healed so that a
person cannot see she was ruptured. Yours truly, J. Hayunga, Illinois.

Free Sample Pad A Sample Akron Sponge Rubber Truss Pad will
be sent absolutely FREE upon request, also book-
let "Relief to Truss Users." It's full of help. Ask your dealer, or write us.
THE AKRON TRUSS CO. 87 TRUSS BLDG. Akron, Ohio

Please Mention Popular Mechanics

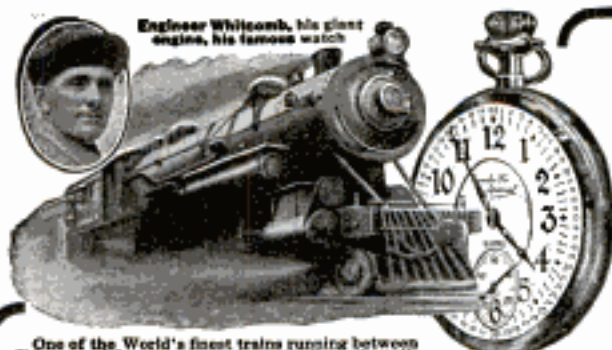

One of the World's finest trains running between Chicago and Los Angeles makes a "mile a minute" trip with a Famous "Santa Fe Special" Watch in the cab. Whitcomb says: "BEST WATCH I EVER CARRIED"

21 JEWEL \$3.50 A MONTH

"Santa Fe Special"

The REAL triumph of watch manufacturing — SEE this watch FIRST. Sent without one Penny down.

Write for FREE Watch Book Today—

shows newest watch case designs in 4 colors. READ the so-called SECRETS of watch making. READ how you can save from ONE-THIRD to ONE-HALF of your money — Buy "Direct," cut out the wholesale jeweler's profit.

Buy the BEST RAILROAD Watch
The Famous "Santa Fe Special"

—the one watch "That's Guaranteed for Life," thin model, all sizes. EASY PAYMENTS TO SUIT YOU — Write today — Your name on a postal brings the FREE watch book.
SANTA FE WATCH CO., Dept. 76, TOPEKA, KANSAS
Send for Diamond Book B The Home of the Great Santa Fe Ry.

EXTRA WATCH OFFER Wear ³⁰ Days FREE

SOME FACTS about the "Santa Fe Special" movement you should consider JEWELS

Either 17 or 21 absolutely flawless sapphire and ruby jewels are used in the Men's "Santa Fe Special." Lever set, double roller escapement. The Ladies' Watch is fitted with 17 of these perfect jewels.

ADJUSTMENTS

"Santa Fe Special" movements are Adjusted to positions, Adjusted to temperature, Adjusted to isochronism, Adjusted to the least fraction of a second. Factory fitted in case you select.

SIZES AND MODELS

The "Santa Fe Special" is made in all sizes. 16 and 12 sizes and ladies' 0-3 thin model. The 12 size watch is fitted with 21 jewel movement. BE SURE TO SEE THE NEW MODEL BRACELET WATCH—the ideal watch for the lady.

AL-COOL FAN \$12.50

The wireless breeze builder—runs without electricity. Driven by a self-contained air motor. Operates anywhere with alcohol or gas. More economical and usable than an electric fan. Absolutely safe. Simple, substantial, 18 inches high. A new — wonderful — necessity. Price, \$12.50. Cash with order.

DEALERS and AGENTS WANTED
THE AL-COOL FAN CO. 10601 Corliss Ave.
CHICAGO, ILL.



MAZDA

Always etched on electric lamps to which MAZDA Service has been applied.



Amazing Profits In Mushrooms

Anybody can add \$10 to \$40 per week to their income, in spare time, entire year growing mushrooms in cellars, sheds, barns, boxes, etc. I tell you where to sell, at highest prices.

Free Illustrated Instruction Booklet
HIRAM BARTON
Desk 2, 329 W. 48th St., New York

Attention Boy Scouts!

THIS FINE U.S.A. MODEL TRUMPET \$3.95

\$3.95 brings you this durable, graceful, loud toned, trumpet. U. S. Army specifications. Key of G with slide to F. Silver plated mouthpiece. Ten days' trial and money returned if not satisfactory. When ordering mention No. 12BL3320. Our Musical Instrument Catalog No. 50754 includes Fifes, Drums and supplies of all kinds. It is free. Send for it.
SEARS, ROEBUCK AND CO., CHICAGO.

Health with the Arnold Vibrator

The joy of glorious health, strength, and power, is yours through vibration with the Arnold Vibrator. Sold on 10 days' trial. 80 page book free, tells all the facts with special low price. Write today.
ARNOLD ELECTRIC CO., 1468 12th St., Racine, Wis.

Hand Forged
Razor Steel
Blades, No. 57



Direct at Factory Prices

This \$2 KNIFE 88c Postpaid
Hand Forged Razor Steel Blades

Handy shaped blade makes this knife best for mechanics, sportsmen and farmers; light but strong; re-sharpened easily. Stag handle. German silver finish; blades file tested.

hand forged from razor steel and warranted.
Sample 88c. 3 for \$2.12 postpaid.
Send for our 100 page List and
"HOW TO USE A RAZOR" FREE

MAHER & GROSH CO., 106 A. St., Toledo, Ohio

STEGER PLAYER-PIANO



☐ Your home will be happier and more cheerful if you select a superb New Steger Piano or Player-Piano. Entertain your family and friends. Give your children a greater love for music. Enjoy the delightful strains of your favorite melodies.

☐ Artists of eminence praise Steger Instruments. The Steger tone is of wonderful richness. It possesses beautiful, clear, mellow, singing qualities.

☐ Steger Instruments are used in many leading conservatories, musical colleges and schools. Their reliability is backed by the liberal guarantee of the largest piano factories in the world, located in the "Piano-city," Steger, Illinois, on the Dixie Highway.

☐ Let us tell you about the reasonable prices and convenient terms on which you may have a New Steger Piano or Player-Piano in your home.

Three years in which to pay, if desired. Liberal allowance for old instruments. Delivered direct from our factories to your home, or through our regular appointed distributors. We invite comparisons. Beautiful illustrated Steger Style Brochure, sent free, on request.

Steger & Sons
PIANO MANUFACTURING COMPANY
Established 1879
Dept. 24 Steger Building
N.W. Cor. Wabash & Jackson, Chicago, Ill.

Let Me Quote You a Special Price On My **Rapid** FIRELESS COOKER



Cook every meal on it. If you are not satisfied and delighted I will refund every cent. Get my

Special Low Factory Price

direct to you. Cooker is aluminum lined throughout. Full set of famous "Wear Ever" aluminum cooking utensils comes with it. Ask for free book of valuable recipes.

WILLIAM CAMPBELL CO.
Dept. 64 DETROIT, MICH.



DO YOU INTEND TO BUILD? 75 PRACTICAL PLANS

California Bungalows and Houses especially suited to any climate. New, attractive designs with valuable building suggestions all in handsome 1917 Art Plan Book. Price \$1.00 postpaid. Send today for your copy. Save time, trouble. Money refunded if not satisfactory. Address

BUILDING DEPARTMENT
AURELIUS SWANSON COMPANY, Inc.
1001 State Nat'l Bank Bldg. Oklahoma City, Okla.

Make Water Pressure Work and Save Your Back

The Divine Red Devil Water Motor built with bucket-wheels like big water wheels—easy to install, has nothing to get out of order and does work at very low cost.

4 in. Motor Complete, \$3. Including Emery, Buffing Wheel and Pulley for household use. With pulley for sewing-machine only \$2.50.

6 in. Motor with Pulley, \$5. For Mechanics, Tradesmen, Doctors and Dentists and the Home. Will run washing machine easy. Guaranteed to give satisfaction or money back. Booklet and Prices Sent Free if you will write today and give us size of faucet, water pipe and water pressure and work to be done. You must furnish information to get booklet.

DIVINE WATER MOTOR CO.
Dept. P., Utica, N. Y.

THIS BUNGALOW \$900 CAN BE BUILT FOR

This and many others in my new book, Building Plans for Modern Homes, will save you hundreds of dollars. One of the most complete and comprehensive books of plans ever published by any architect. Fifth edition just off the press. Two hundred and fifty floor plans and photographs of bungalows, etc., costing from \$200 up; gives sizes and cost to build.



FREDERICK H. GOWING
ARCHITECT
18 Tremont St., BOSTON, MASS.

★ **The Thor**

Send for the big Thor Book which describes the Thor Electric Washing Machine and shows how a good sized washing can be done at a cost of only 2 cents.

HURLEY MACHINE CO., Dept. B119, CHICAGO

Replace Your Heating Plant with a
ROUND OAK
Moistair Heating System

Only Heating System that Automatically Ventilates and HUMIDIFIES.— Keeps air moist, free from disease germs. Durable, dependable, easy to operate, a big fuel-saver. Send for FREE Book explaining all.

Made by Makers of Good Goods Only

The Beckwith Co. Round Oak Folio—Established 1871
100 Front St., DOWAGIAC, MICH.

BUY PLUMBING and HEATING SUPPLIES
at **WHOLESALE** Will Save You 30%

Don't pay retail prices. Full stock on hand for prompt shipment. Send for Free catalog.

B. P. KAROL, 800-802 South Kedzie Ave., CHICAGO

Diamonds Watches

2000 ILLUSTRATIONS

Send Today for Your Catalog

This Handsome 116-Page Catalog contains over 2,000 illustrations of Diamonds, Watches, Jewelry. All the new, popular styles are shown—gorgeously beautiful Diamonds, artistic solid gold and platinum mountings—exquisite things—at prices to suit any purse. Select anything desired, either for personal wear or for a gift, then ask us to send it for your examination, all charges prepaid by us.

You See and Examine the Article Right in Your Own Hands

If you like it, pay one-fifth of price and keep it, balance divided into eight equal amounts, payable monthly. Send for Catalog today.

LOFTIS BROS. & CO., National Credit Jewelers
Dept. B894 100 to 108 N. State St., CHICAGO, ILL.
Established 1888. Stores in CHICAGO, PITTSBURGH, ST. LOUIS, OMAHA

This Is the Ring She Wants

The Loftis "Perfection" Diamond Ring is our great special. Only fine, high-grade Diamonds, perfect in cut and full of fiery brilliancy, are used. Skilfully set in our famous Loftis "Perfection" 14k solid gold six-prong ring mounting. Our large Catalog shows

Wonderful Values at \$25, \$40, \$50, \$75, \$100, \$125

EASY CREDIT TERMS

Our prices on guaranteed Watches are lowest. All the new models are shown in Catalog. Any one you select will be sent for your examination, charges prepaid.

THE BEST GIFT OF ALL



300 Candle Power of Light at a Cost of 1-8c Per Hour

Burns Kerosene or Gasoline

This lamp generates and burns its own gas from ordinary kerosene. "QUICKLIT" gasoline lamps can be lit with an ordinary match like city gas.

Write today for illustrated catalog of our complete line of kerosene and gasoline lamps, lanterns. **Agents Wanted** and lighting systems.

The Nagel-Chase Mfg. Co.
176 East Erie St., Chicago



ACORN UNI-LITE

Turns night into day. 300 candle power. Carry as a lantern; use anywhere as a lamp. Weather proof. For house, barn, garage, camp and around the farm. Write for big, free offer. Special opportunity to farmers, Stockmen and motorists. Agents make big money.

WRITE TONIGHT for new 1914-1917 offer.

ACORN BRASS MFG. CO., 821 Uni-Lite Bldg., Chicago

FREE OFFER



SMALL ENGINES

Perfected Gasoline Engines— $\frac{1}{2}$, 1 and 1 $\frac{1}{2}$ h. p.—for Farm and Shop use. Price \$19.50 and up. Also

WASHING MACHINES

We ship on trial. Send for Booklet and Special Offer.

SIEVERKROPP ENGINE CO., 1224 18th St., RACINE, WIS.

STARTER for FORD CARS

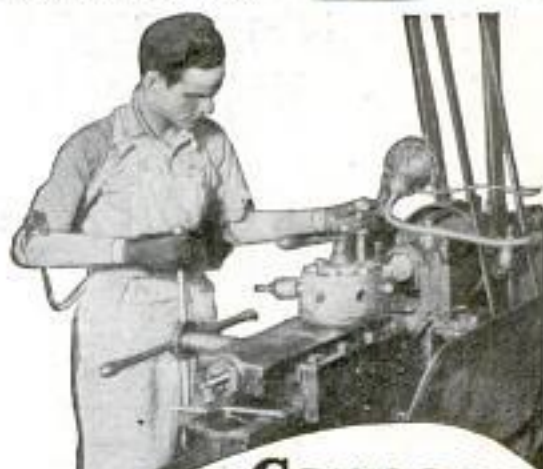
Carnes Artificial Arm

has put Louis Rondeau back on the payroll as a wage-earner. He now is employed in a big Kansas City factory operating a machine. Both of his arms have been amputated and he wears two Carnes Artificial Arms. His salary and efficiency have not been lessened.

Endorsed by surgeons everywhere, the Carnes Arm has been declared to be the best substitute ever invented for a natural arm. Is the only arm with full finger motion, hand turning and bending wrist and bending elbow.

Awarded Gold Medal at San Francisco, San Diego and London.

Write us today for big illustrated Catalog \$1.25 containing pictures and testimonials from wearers of Carnes Arms.

CARNES ARTIFICIAL LIMB CO.
31 Carnes Bldg.,
504 East 12th St. Kansas City, Mo.

Lend Me 3 Feet of Floor Space for 30 Days

I'll Cut Your Ice Bills

ORDER a beautiful White Frost Refrigerator on a month's trial. I'll show you a *real* quality refrigerator—one that holds the temperature without eating its head off in ice. The only round white enamel refrigerator on earth. Revolving shelves save room inside and out, move-easy casters, cork cushion doors, noiseless and air-tight. Steel walls insulated with granulated cork, crystal glass water cooler, easy to fill. **I sell direct to you—no middlemen.** I pay freight—quick shipments. Easy terms—\$5.50 brings a White Frost at once, balance pay as you use. Write today for catalog.

H. L. SMITH, Pres.

WHITE FROST REFRIGERATOR CO.
779 N. Mechanic St., JACKSON, MICHIGAN

White Frost Refrigerator

SANITARY





We Want Agents at \$30 to \$75 a Week

New Invention—Just out. Needed in every home every day. Patented. Nothing else like it. Low priced—**Sells on sight**. Sharpens any kitchen knife, paring knife, carving knife, bread knife, or shears and scissors in **ten seconds**. Mechanical masterpiece. A child can use it. Just put knife in slot—turn crank—sharpens both sides at once automatically. **We want representatives at once**—men and women hustlers. Get this position where **profits start first day**.

No Experience Necessary — 200% Profit

Make as much money next week as these men are making now. J. C. Lewis, of Kansas, says: "I have sold one hundred sharpeners in four days." Robert Kerr, of Md., writes: "The women can hardly wait till they get them." Herbert Cain, of Ky., sold nine after supper. At the end of the first day, J. W. Gordon, of Pa., writes: "I sold two dozen and I sold to every one I saw." Wm. G. Hall, of N. J., says: "I think it is great. I sold six in about one-half hour. The machine is a mighty fine proposition. I am a mechanic and I know what I am talking about." You can make this money. **WRITE TODAY. TERRITORY FREE. GET BUSY AT ONCE.**

QUICKEDGE SHARPENER CO., 686 Sharpener Bldg., CHICAGO, ILL.
215 N. Desplaines St.

Lift Corns out with Fingers

A few drops of Freezone applied directly upon a tender, aching corn stops the soreness at once and soon the entire corn or callus loosens and can be lifted off with the fingers without even a twinge of pain.

Freezone

Removes hard corns, soft corns, also corns between the toes and hardened calluses. Does not irritate or inflame the surrounding skin or tissue. You feel no pain when applying it or afterward.

Women! Keep a small bottle of Freezone on your dresser and never let a corn ache twice.

Small bottles can be had at any drug store in the U.S. or Canada

THE EDWARD WESLEY CO. CINCINNATI, OHIO

STOP USING A TRUSS

Do Away With Steel And Rubber Bands



Inner surface is made adhesive to secure the PLAPAO-PAD firmly to the body, keeping the PLAPAO continually applied and the pad from slipping. No straps, buckles or springs attached. Soft as velvet—easy to apply.

It's the Non-Slip-ping, yet Non-Rigid Pad and What is Within It That Counts

FREE to 5,000 Truss Sufferers

To the extent of 5,000 sufferers who may apply I will send, ABSOLUTELY FREE, a sufficient quantity of the Plapao to positively convince them that this is the only logical, common-sense way of treating rupture. Plapao is a highly astringent medication placed within the Plapao-Pad and being absorbed through the skin, creates a wonderful feeling of relief and at the same time tends to strengthen the weakened muscles and thus permanently close the rupture opening. The process of recovery is natural, so you'll have no use for a truss—you can throw it away forever! Old and young have testified under oath that the Plapao-Pads cured their rupture—many of them long-standing, aggravated cases—without delay from work. Patent allowed in U. S. and foreign countries. Awarded Gold Medal at Rome and Grand Prix at Paris.

Send No Money—sent without charge to enable you to give it a thorough test; you pay nothing for this trial now or ever. Write for it and full information today. Address: Plapao Laboratories, Block 1427 St. Louis, Mo.



\$500 REWARD

We will pay \$500.00 reward to anyone who can permanently dim the brilliancy of the RAJAH Im. diamond without destroying the stone.

RAJAH Im. Diamonds
They stand all diamond tests—fire, acid, file, and glass cutting. Their brilliancy is eternal. Guaranteed for a lifetime. Set in solid gold, and sent to you on a **30 Days' Free Trial**. If you can tell it from a real diamond return it. Send today for our beautiful, FREE illustrated jewelry catalog in colors. Write now. KRAUTH & REED, 159 N. State St., Dept. P2 CHICAGO, ILL.

A YEAR TO PAY



Deafness Is Misery

I know because I was Deaf and had Head Noises for over 30 years. My invisible Anti-septic Ear Drums restored my hearing and stopped Head Noises, and will do it for you. They are Tiny Megaphones. Cannot be seen when worn. Easy to put in, easy to take out. Are "Unseen Comforts." Inexpensive. Write for Booklet and my sworn statement of how I recovered my hearing.

A. O. Leonard, Suite 226, 150 5th Ave., N. Y. City



Actual size of gummed sticker

PATRIOTIC FLAG STICKERS

Show your colors. Flag-seal your letters, packages, menus, circulars, bills, etc. Be for America first, last and always.

1000 Seals, \$1.00; 3000 Seals, \$2.00; 6000 Seals, \$3.60

Actual colors: red, white and blue. Beautiful stay-stuck stickers. Money back if not satisfied. Largest exclusive gummed label plant in the world.

FENTON LABEL COMPANY, Ninth and Thompson Sts., Phila., Pa.

PATENTS

IF YOU HAVE AN INVENTION which you wish to patent you can write fully and freely to Munn & Co. for advice in regard to the best way of obtaining protection. Please send sketches or a model of your invention and a description of the device, explaining its operation.

All communications are strictly confidential. Our vast practice, extending over a period of seventy years, enables us in many cases to advise in regard to patentability without any expense to the client. Our Hand-Book on Patents is sent free on request. This explains our methods, terms, etc., in regard to *Patents, Trade Marks, Foreign Patents, etc.*

All patents secured through us are described without cost to the patentee in the *SCIENTIFIC AMERICAN*.

MUNN & CO.
SOLICITORS OF PATENTS
672 WOOLWORTH BLDG., NEW YORK
and 625 F STREET, WASHINGTON, D. C.

PRINT MY OWN
Cards, circulars, menus, book, paper, etc. Press \$5. Larger \$18. Rotary \$90. Save money. Print for others, big profit. All easy, rules sent. Write factory today for illustrated catalog presses, TYPE, cards, samples. **THE PRESS CO. D-37. MERIDEN, CONNECTICUT.**

JOHNS-MANVILLE
Asbestos
COVERS THE CONTINENT

MONEY IN MUSHROOMS
GROW AND SELL MUSHROOMS
An uncrowded occupation. Exceptional opportunities for live men and women. Raised at home. Only small space needed. Small expenditure will start you in a practical money-making enterprise. Big profits. Booklet telling all free. Write **Nat'l Spawn Co., Dept. 12, Boston, Mass.**

FREE BOOK TELLS HOW TO MAKE \$150 TO \$1000 PER MONTH
Making celebrated **Flavo Nature-Flavored Flour** in rural communities or small towns with **AMERICAN MARVEL Flour Mill** (Self-Contained)
You can quickly become a member of Community Marvel Millers. We start you. Help you. 30 days' free trial. Investment and terms easy to handle. Write for fully illustrated book. **ANGLO-AMERICAN MILL CO., Inc., 135-141 Trust Bldg. Owensboro, Ky.**

BIG CHANCE FOR AGENTS



You can earn BIG MONEY selling the most complete line of guaranteed transparent handle Knives and Razors with Photo, Name and Lodge Emblem—also full line of cutlery. Write today for catalogue and terms. **Golden Rule Cutlery Co., 212 N. Sheldon St., Dept. 335, Chicago, Ill.**



"I Got the Job!"

"I'm to be Manager of my Department starting Monday. The boss said he had been watching all the men. When he found I had been studying at home with the International Correspondence Schools he knew I had the right stuff in me. Now we can move over to that house on Oakland Avenue and you can have a maid and take things easy. I tell you, Nell, taking that course with the I. C. S. was the best thing I ever did."

Spare-time study with the I. C. S. is winning promotions for thousands of men and bringing happiness to thousands of homes all over the world. In offices, shops, stores, mines, mills and on railroads, I. C. S. trained men are stepping up to big jobs, over the heads of older men, past those whose only qualification is long service.

There is a Job Ahead of YOU

Some man is going to be picked for it. The boss can't take chances. He is going to choose a trained man with sound, practical knowledge of the work.

Get busy right now and put yourself in line for that promotion. You can do it in spare time in your own home through the International Correspondence Schools, just as nearly two million men have done in the last twenty-five years, just as more than 100,000 men are doing today.

The first step these men took was to mark and mail this coupon. Make your start the same way—and make it right now.

TEAR OUT HERE INTERNATIONAL CORRESPONDENCE SCHOOLS BOX 5590, SCRANTON, PA.

Explain, without obligating me, how I can qualify for the position, or in the subject, before which I mark X.

- | | |
|---|--|
| <input type="checkbox"/> ELECTRICAL ENGINEER | <input type="checkbox"/> SALESMANSHIP |
| <input type="checkbox"/> Electric Lighting | <input type="checkbox"/> ADVERTISING |
| <input type="checkbox"/> Electric Railways | <input type="checkbox"/> Window Trimmer |
| <input type="checkbox"/> Electric Wiring | <input type="checkbox"/> Show Card Writer |
| <input type="checkbox"/> Telegraph Engineer | <input type="checkbox"/> Sign Painter |
| <input type="checkbox"/> Telephone Work | <input type="checkbox"/> Railroad Trainman |
| <input type="checkbox"/> MECHANICAL ENGINEER | <input type="checkbox"/> ILLUSTRATING |
| <input type="checkbox"/> Mechanical Draftsman | <input type="checkbox"/> Cartooning |
| <input type="checkbox"/> Machine Shop Practice | <input type="checkbox"/> BOOKKEEPER |
| <input type="checkbox"/> Gas Engine Operating | <input type="checkbox"/> Stenographer and Typist |
| <input type="checkbox"/> CIVIL ENGINEER | <input type="checkbox"/> Cert. Public Accountant |
| <input type="checkbox"/> Surveying and Mapping | <input type="checkbox"/> TRAFFIC MANAGER |
| <input type="checkbox"/> NINE FOREMAN OR ENGINEER | <input type="checkbox"/> Railway Accountant |
| <input type="checkbox"/> Metallurgist or Prospector | <input type="checkbox"/> Commercial Law |
| <input type="checkbox"/> STATIONARY ENGINEER | <input type="checkbox"/> GOOD ENGLISH |
| <input type="checkbox"/> Marine Engineer | <input type="checkbox"/> Teacher |
| <input type="checkbox"/> ARCHITECT | <input type="checkbox"/> Common School Subjects |
| <input type="checkbox"/> Contractor and Builder | <input type="checkbox"/> Mathematics |
| <input type="checkbox"/> Architectural Draftsman | <input type="checkbox"/> CIVIL SERVICE |
| <input type="checkbox"/> Concrete Builder | <input type="checkbox"/> Railway Mail Clerk |
| <input type="checkbox"/> Structural Engineer | <input type="checkbox"/> AUTOMOBILE OPERATING |
| <input type="checkbox"/> PLUMBING AND HEATING | <input type="checkbox"/> Auto Repairing |
| <input type="checkbox"/> Sheet Metal Worker | <input type="checkbox"/> Navigation |
| <input type="checkbox"/> Textile Overseer or Supt. | <input type="checkbox"/> AGRICULTURE |
| <input type="checkbox"/> CHEMIST | <input type="checkbox"/> Poultry Raising |
| | <input type="checkbox"/> Spanish |
| | <input type="checkbox"/> German |
| | <input type="checkbox"/> French |
| | <input type="checkbox"/> Italian |

Name _____

Present Occupation _____

Street and No. _____

City _____ State _____

Please Mention Popular Mechanics



Here's the Way to Make Big Money!



Write us today. See how easy for you to start a money-making business of your own with a Bartholomew Pop-corn and Peanut Machine. Use your whole time or spare time. *Wonderful profits!* Set your machine wherever the business is—on a corner, in a theater or hotel lobby, at baseball or picnic grounds, etc.

On Credit!

Write for free catalog! See our famous big line and our easy payment plan. Terms so easy you won't miss the money. Let the machine pay for itself out of your pop-corn and peanut sales. Here's your chance! Write today—a post card will do.

The Bartholomew Company
106 Heights St.
Peoria, Illinois



Bausch and Lomb BALOPTICON

THE PERFECT STEREOPTICON

Bausch & Lomb Optical Co., 576 St. Paul St., Rochester, N. Y.

Compare It With a DIAMOND

Get a genuine Lachnite on ten days' free trial. If you can tell it from a diamond send it back. Put it to every diamond test. Wear it everywhere. The dazzling brilliance of Lachnite is eternal. They are cut by diamond cutters.

3 1/3c a Day

Pay only the rock-bottom price at the rate of a few cents a day. Get only the solid gold. Write for new jewelry book. It's free.
HAROLD LACHMAN COMPANY
12 N. Michigan Av., Dept. 8119 Chicago



Deafness



Perfect hearing is now being restored in every condition of deafness or defective hearing from causes such as

Relaxed or Sunken Drums, Roaring or Hissing Sounds, Perforated, Partially Destroyed Drums, etc.

Wilson Common-Sense Ear Drums

"Little Wireless Phones for the Ears"—require no medicine but effectively replace what is lacking or defective in the natural drums. They are simple devices, which the wearer easily fits into the ears where they are invisible. Soft, safe and comfortable to wear at all times.

Write today for our 168 page FREE book on DEAFNESS, giving you full particulars and plenty of testimonials.

WILSON EAR DRUM CO., Incorporated
889 Inter-Southern Building LOUISVILLE, KY.

"I Would Not Part With It for \$10,000"

So writes an enthusiastic, grateful customer. "Worth its weight in gold," says another. In like manner testify over 100,000 people who have worn it.

The Natural Body Brace

For MEN and WOMEN

Develops erect, graceful figure; overcomes WEAKNESS and AILMENTS of Women & Men.

Brings womanly beauty and manly strength, restful relief, ability to work and enjoy life.

Makes You Feel Good and Look Good

Does away with the strain and pain of standing and walking; replaces and supports misplaced internal organs; reduces enlarged abdomen; straightens and strengthens the back; corrects stooping shoulders; develops lungs, chest and bust; relieves backache, curvatures, nervousness, ruptures. Easy to wear.

Wear It 30 Days Free at Our Expense

Write today for illustrated booklet measurement blank, etc., and read our very liberal proposition.

HOWARD C. RASH, Pres. Natural Body Brace Co.
223 Rash Building SALINA, KANSAS



For Children Also



B-E-T-T-E-R MUSIC

Williams' Sounding Board

Placed under record on any disc phonograph.

SEND \$1.50 TO

O. B. WILLIAMS CO., Seattle, Wash., U. S. A.
Manufacturers Sash and Doors.

The Wellington

THE UNIVERSAL PIPE

I will send my 25 cent BOOK

STRONG ARMS

for 10c in stamps or coin



Illustrated with 20 full-page halftone cuts, showing exercises that will quickly develop, beautify, and gain great strength in your shoulders, arms, and hands, without any apparatus.

PROF. ANTHONY BARKER

646 Barker Bldg., 127 W. 42d Street, NEW YORK

A Baseball Jersey



Be the First in Your Club

School, City or Town, to wear this pure, all wool sweater, double collar and cuffs. Your choice in colors. This jersey was selected by 10,000 of my customers for last season. Your chum will recommend it. Send for my big illustrated catalogue. Write me and learn my offer for your club's order. Popular Prices. Best Grade Sporting Goods—Baseball, Basketball, Tennis, Golf, Football, etc. WRITE ME NOW.

JACK SHANNON CO., Dept. 46, 54 E. Monroe St., Chicago

Hartman Will Trust You

Rock Bottom Prices

Furniture, Carpets, Rugs, Etc.

Easiest Terms Hartman's credit terms easiest, most liberal ever offered. No security—no notes—no mortgage. Free from all objections.

At the end of a month you may 30 Days Approval

return anything unsatisfactory. Hartman refunds your money including freight.

FREE—Big Bargain Book Over 8,000 bargains. Write today for FREE copy.

HARTMAN FURNITURE AND CARPET CO.

3945-47 Wentworth Av., Chicago





I Own and Operate the Largest Exclusive Engine Factory in the World, Selling Direct to the User

I MAKE engines only, and I specialize in the following sizes: 2, 3, 4, 6, 8, 12, 16 and 22 H-P, either Gasoline or Kerosene. A few years ago, any one of my high-grade engines would have cost you approximately double what I can sell you the same engine for today. Nothing has changed, except that my method of **selling** is different. Now I deal direct with the user, making it possible for you to buy at **lowest factory prices**.

Ed. H. Witte

Master Engine
Builder, Farmer,
and Breeder of
Prize Winning
Holstein-Friesian
Cattle

WITTE ENGINES

KEROSENE, GASOLINE, DISTILLATE, GAS

Are Guaranteed for Five Years

Cities, Counties, States, the U. S. Government, and thousands of individuals in every state in the union are using my engines on farm and in shop. My factory capacity is 12,000 perfect engines yearly, and I am able to ship, at once, any size wanted—no delay or waiting. **Select Your Own Terms.**

**BUY
ON YOUR
OWN
TERMS**

If you need an engine for any purpose, pumping, grinding, sawing, or to operate machinery, I can save you \$25 to \$100. The reason is because of my better factory equipment, superior methods, fair dealing and big values. Write for my book, Mailed Free, "How to Judge Engines." If you are interested in dependable, low-cost power, direct from the man who designs his own engines, and has made and sold nothing but engines for over 30 years.—Ed. H. WITTE.

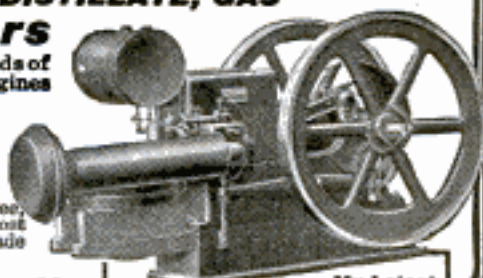

My Latest
Model 6 H-P, Kerosene Engine

**Witte Engine Works, 1740 Oakland Ave., Kansas City, Mo.,
1740 Empire Bldg., Pittsburgh, Pa.**

Engine User-Agents Wanted

Men wanted in every county to **USE, demonstrate and sell "BIG BOSS"**—wonderful new gasoline engine for every work. Big demand. Liberal profits. Free details and introductory offer. C. Benninghofen & Sons, Department 511, Hamilton, Ohio.

50c TRIAL OFFER FOR BEST KODAK FINISHING 10c
Any size roll developed, 10c. Six prints free with first roll. Or, send six negatives, any size, and 10c (stamps) for six prints. 8x10 Enlargements, 30c.
Roanoke Photo Finishing Co. (Formerly Roanoke Cycle Company)
54 Bell Ave., ROANOKE, VA.

TYPEWRITERS SUMMER PRICES

Our entire stock of latest models is offered at special prices for the summer only.

Factory Rebuilt Typewriters
All trademarked, and guaranteed for one year. Buy now and save as much as \$75. Branch stores in leading cities.

Write for Catalog and Summer Price-List
American Writing Machine Co., Inc., 339 Broadway, N. Y.



Red or Black "Vulcan" Ink Pencils

The ONLY perfect, non-leakable ink pencils at moderate prices.
Order today \$1
Two Sizes—
4 1/4 and 5 1/2 inches.
Extra Size—8 inches (black only) \$1.25.
Your name in gold ink 35c.
FREE—liberal supply of ink with retail orders. *Agents Wanted. Big Profits.*
J. C. ULLRICH & CO., 27 Thames St., New York

Over 100,000 in Use

Mostly sold through recommendation. For **PERSONAL DESK** or **GENERAL OFFICE**. It checks mental calculations. Buy through your Stationer. Write for 10-day trial offer.
E. GANCHER, A. A. M. CO.
148 Duane Street, NEW YORK



AGENTS WANTED

Multiplies—Subtracts

OTTAWA THE ENGINE EASY TO RUN

Uses Kerosene, Gasoline, Distillate, Gas and other cheap fuels. Built to last and do hard work. Many sizes; up-to-date design. Good material. Built by painstaking workmen. Sizes 1 1/2 to 22 H. P. Pulls 1/2 to 1 1/2 over rated H. P. **THREE MONTHS' TRIAL. Sold direct. TEN YEAR GUARANTEE.** Engine book free.
OTTAWA MANUFACTURING CO., 531 King St., OTTAWA, KANSAS

1 1/2-24 75
2-26 75
3-47 50
4-61 75
6-88 90
8-114 75

TYPEWRITERS

\$10 and Up. ALL MAKES SAVE \$25 TO \$50

on rebuilt at the factory by the well known "Young Process." Sold for low cash—installment or rented. Rental applies on purchase price. Write for full details and guarantee. Free trial.
YOUNG TYPEWRITER CO., Dept. 247, Chicago



Don't Wear a Truss

Brooks' Appliance, the modern scientific invention, the wonderful new discovery that relieves rupture will be sent on trial. No obnoxious springs or pads.

Brooks' Rupture Appliance

Has automatic Air Cushions. Binds and draws the broken parts together as you would a broken limb. No salves. No lies. Durable, cheap. Sent on trial to prove it. Protected by U. S. patents. Catalogue and measure blanks mailed free. Send name and address today.

C. E. BROOKS, 126 State St., Marshall, Mich.

Please Mention Popular Mechanics

Get 5,000 More Miles

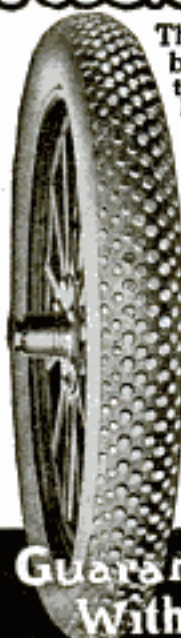

The worn tires that you have been throwing away can be made to give at least 5,000 miles more service. Durable Steel Studded Treads are a perfected product of the World War. Over half the cars in Europe are equipped and more than 50,000 American motorists have already profited by the saving and security which they have made possible.

5,000 Miles without puncture is guaranteed whether your tires are new or old.

We Deliver Free without a cent deposit, and prepay express. You can apply them in a few minutes in your own garage and judge for yourself.

Special Discount offered to motorists in new territory on first shipment direct from factory.

Mail the coupon today. You will hear from us within a week.

Guaranteed 5000 Miles Without Puncture

MAIL TODAY—SAVE THE DISCOUNT,
The Colorado Tire & Leather Co.

744 Trend Bldg., Denver, Colorado, G-44 Transportation Bldg., Chicago, Ill., 720-447 Woolworth Bldg., New York City

Send me without obligation or expense booklet, sample and written guarantee for 5,000 miles more service.

Name _____

Address _____

My Tire Sizes are _____

The Map shows How—but the Compass shows Where
Every Outdoor Man Needs a

LEEDAWL COMPASS

The only Guaranteed Jeweled Compass at \$1.00.
Ask your dealer. If you can't get it, send direct to us.

\$1.00 LEEDAWL COMPASS



Taylor
Instrument Companies
ROCHESTER, N.Y.

Makers of Scientific Instruments of Superiority



DEALERS WANTED to make money selling the famous METZ Car—\$650 completely equipped.

108" wheel-base—4-cylinder 25-h.p. motor—7 forward speeds—electric starting and lighting, etc.
Write To-day for full details of the Money-Making METZ Proposition

METZ COMPANY, WALTHAM, MASS.

GET FACTORY PRICES ON GALVANIZED

ROOFING



EDWARDS

"Reo" Metal Shingles

Absolutely rust-proof—edges as well as sides. Not the space of a pin point exposed to the weather. Also fire and lightning proof. Reduces insurance. Outlasts building. Need no repairs—end all roofing expense. Easy to lay—hammer and nails only tools needed. Lay over old shingles if desired. Patent Interlocking Device makes water tight seams—all nail heads covered—no rust or leaks possible.

Exclusive "Tightcote" Process

actually makes zinc coating a part of the metal sheet. Bend, twist, strike it with a hammer as much as you like—you can't loosen or scale off the galvanizing. No other galvanized roofing can withstand this test.



Corrugated



Patent Side Lock
No nail heads in sight or exposed to the weather



Brick Siding



THE EDWARDS MFG. CO.,
700-750 Pike St., Cincinnati, O.

FREE Roofing Book describing Edwards famous "Tightcote" Roofing, Siding and Ceiling and our lowest prices paid prices. Ask for Roofing Book No. 256.

Garage \$69.50 Up.

Lowest prices on Ready-Made Fire-Proof Steel Garages. Get up any place. Send postal for Garage Book.



FREE
Samples &
Roofing Book

STANWELD Cold Drawn Seamless Steel TUBING

Lightest, smoothest, strongest Steel Tubing made. World's largest manufacturers of bicycles, motorcycles and automobiles use it exclusively. Send for Folder "A."

THE STANDARD WELDING COMPANY
Main Office and Factory CLEVELAND, OHIO

Driver Agents Wanted

Five-Pass., 34.7 H. P. Drive and demonstrate the Bush Car. Pay for 82 x 8 1-2 Tires. If out of your commissions on sales, my agents are making money. Shipments are prompt. Bush Cars guaranteed or money back. Write at once for my 48-page catalog and all particulars. Address J. H. Bush, Pres., Dept. 717, 114-inch Wheelbase Delco Ignition—Elect. Stg. & Ltg. BUSH MOTOR COMPANY, Bush Temple, Chicago, Ill.



Mobiloils

A grade for each type of motor

Used by All Leading Makers As Regular Equipment

Firestone Motorcycle TIRES

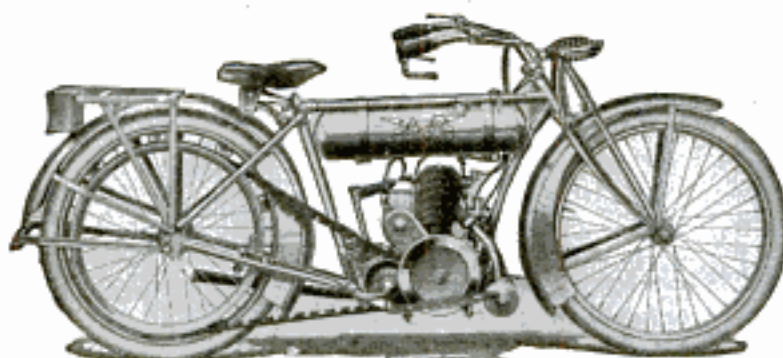

The EXCELSIOR Lightweight PRICE \$140.00

Two Speed, Foot Starter,
Free Motor Clutch, Handle
Bar Control—Maximum
Value at Minimum Cost

Sensible Economy Is in Order

Not the "Frantic Economy" that so many people started to practice the moment war was declared, but a *Sane, Sensible Economy*, which means getting a dollar's worth for every dollar spent, whether for pleasure or utility. The EXCELSIOR Lightweight is a real motorcycle designed and built with one object in view. That object is

EFFICIENT ECONOMY

A means of transportation that will be Rapid, Safe, Clean, Comfortable and Convenient and yet cost less per mile than any other. It is the ideal machine for the business man to use in scooting quickly down to his office, for the workman to reach his place of employment, and for the pleasure seeker to reach his spot of recreation.

Be independent of street cars. Go any place — any time.

If there's not a dealer in your town who can show you all the merits of the EXCELSIOR Lightweight, just drop us a Postal Card and we'll send you our new catalog, fully describing this and our heavier models.

EXCELSIOR MOTOR MFG. & SUPPLY CO., 3702 Cortland Street, CHICAGO, ILL.

IVER JOHNSON

REVOLVERS SHOTGUNS BICYCLES MOTORCYCLES

Send for free books, "A"—Arms,
"B"—Bicycles, "C"—Motorcycles.

Iver Johnson's Arms & Cycle Works
307 River Street FITCHBURG, MASS.

The Boy's Junior Power Drives Automobile 1917 Model

You can build it yourself or buy it complete already assembled. Parts inexpensive. Send 25c for blue print and price list of parts.

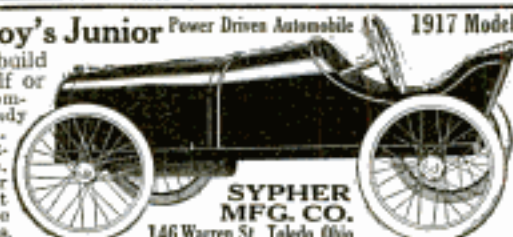

SYMPHER
MFG. CO.
146 Warren St., Toledo, Ohio

The Harley-Davidson "Master 17"



It sets the pace for 1917. Has more power, more speed, greater flexibility, faster getaway. Equipped with hand-operated, auxiliary brake in addition to regular service brake. Finished in beautiful military drab. Write for 1917 catalog.

HARLEY-DAVIDSON MOTOR COMPANY
509-B Street Milwaukee, Wis.
Producers of High-Grade Motorcycles for More Than Fifteen Years

Attractive Catalog Free

Columbia BICYCLES

Westfield Manufacturing Company,
Department 15. Westfield, Mass.

Start a Tire Repair Business of your OWN

Get into the one line where there is more work than men to handle it—where you need but little capital or experience to make big money from the start. Over a hundred million dollars is being spent this year for tire repairs. It's easy for you to get your share with—

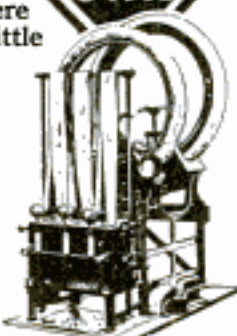

75 of the largest tire manufacturers use this equipment to repair tires in their own factories and branches—sell it to their dealers because they know it is built right and does the best class of work. Car owners don't want to take chances with their tire repairs. That is why you can make the biggest profit from—

Akron-Williams
TIRE REPAIR EQUIPMENT

Send Back This Coupon
Get this free book

It is brim full of just the information you need. Gives you all the details. Tells you how to make money with an Akron-Williams Outfit right from the start. Shows your opportunity in this big field. Write today—Now. Your free copy is ready.

The Williams Foundry & Machine Co.
50 Cherry St., Akron, O.
Gentlemen:—Please send me your free book. This of course with no obligation on my part.

Name.....

Address.....

Please Mention Popular Mechanics

Pulls you out of trouble

Carry this little Pull-U-Out in your tool box and you will be independent of road conditions. With it a boy can, unaided, pull a 5000 lb. car out of ditch or mud. Pays for itself on its first job. Besides pulling autos out of trouble it will do all kinds of lifting and pulling in the factory, garage, on the farm or construction job, etc.

Consists of a winding drum, lever crank, 40 feet of steel cable, two 7 ft. chains and 3 stakes. Weighs only 28 lbs. and goes in space 4x6x14 inches.

A pressure of only 30 lbs. on the handle will lift a ton



Cheaper and better than a chain block. Does jobs no other machine can do.

WRITE FOR BOOKLET - VERY INTERESTING
Tells how and why this marvelous little Pull-U-Out works.

Pull-U-Out Sales Co., 2035 Market Street, St. Louis, Mo.

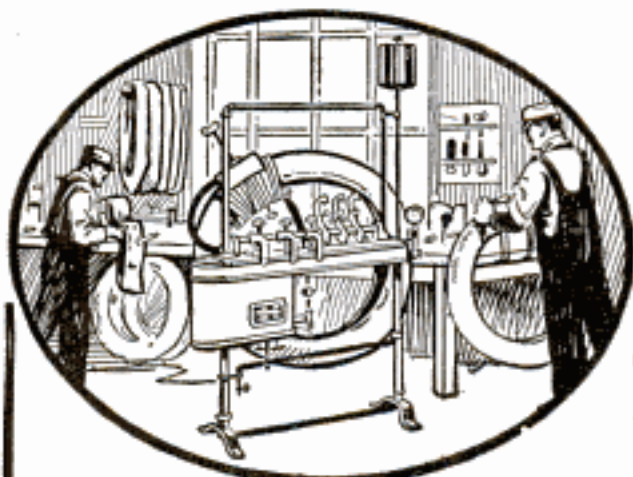

Big money for you

Think of the auto owners in your own locality who are eager to have their tires repaired! Open a repair shop with a Shaler Tire Repair Outfit. Earn \$250.00 per month. No experience necessary. We make it easy for you to start right away. You have your own business.

Free Book Tells How

Write for our wonderful book, "How to Open a Tire Repair Shop." It will open your eyes! Shows you how easy the work is. Shows you the big money that can be made. Write for this book today. A post card will do.

C. A. SHALER COMPANY

2006 Fourth Street

Waupun, Wis.

Veeder COUNTERS

register reciprocating movements or revolutions. Any mechanical engineer will tell you that the word Veeder stands for the best constructed and most accurate counting devices in the world.

There are many kinds of Veeder counters, to suit practically every need. Send for our Free Booklet, which illustrates our counters and gives much interesting information.

Cyclometers, Odometers, Tachometers. All kinds of counters. Fine Die Castings

VEEDER MFG. CO.
4 Sargeant Street, Hartford, Conn.

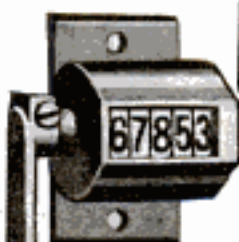

Full Size
\$1.25

MAKE YOUR BIKE A MOTORCYCLE

at a small cost, by using our attachable outfit. Fits any Bicycle. Easily attached. No special tools required.

"Used His Four Years"

Harry A. Hyatt, of Boreas River, New York, writes: "About four years ago I received my motor attachment, and wish to say that I am satisfied with it in every way, for it has certainly given me good service. Anyone wanting a motorcycle or attachment, I would recommend them to the Shaw Manufacturing Co."

FREE BOOK Write today for bargain list and free booklet, fully describing the SHAW Bicycle Motor Attachment. Motorcycles all makes, new and second-hand, \$35.00 up.

SHAW MANUFACTURING CO.
Dept. 6 GALESBURG, KANSAS



UNCONTROLLABLE MACHINE GUN ENDANGERS TOWN—Sometime ago a 500-shot-a-minute machine gun, being tested at the proving ground near an eastern town, escaped control, and showers of bullets damaged, among other structures, a gas tank, about a half mile distant, and a church. Happily no persons were hit.



Convert Your Bicycle into a Motor-Cycle

Motor fits any wheel. BEST, MOST RELIABLE. Best hill climber. More STEFFEY'S in use than all others. Stamp for circulars. STEFFEY MFG. CO., 5007 Brown Street, PHILA., PA.

1917 Indian Motorcycles

With New Power-plus Motor and Cradle Springframe. Write for catalog.

HENDEE MFG. CO., 710 State Street, SPRINGFIELD, MASS.



CHARGING AUTO BATTERIES PAYS BIG

Every 110 Charger can net the average owner \$20.00 to \$60.00 per month. No experience required to operate. Current costs 15c per battery. You get 75c to \$1.50 from the motorist. Charges up to seven batteries at once. This money-maker shipped ready to install for \$15 with order, balance in your monthly payments. Absolutely guaranteed. Can be returned if unsatisfactory. Write for full particulars, enclosing this ad. Hobart Bros. Co., Box 57, Troy, Ohio

FORD THEFT INSURANCE

Protect your Ford against theft with a Safeguard Lock. Does what all others claim to do—positively makes your car impossible to drive. Renders steering wheels helpless. No hammer can smash it. Price \$5.00 includes new pignon post. Money-back guarantee certificate with each lock. Try a Safeguard 30 days at our risk. Write today—tomorrow your car may be gone.

THE RELIANCE CO., 431 W. 36TH STREET, CHICAGO, ILL.

FOR
\$5
DEALERS WANTED

Wanted—Ideas

Inventors! Send for these Remarkable FREE BOOKS, Today

“Inventions Needed”

This book lays before you a description of the active and profitable field of invention. It tells you the inventions the world needs today, the devices manufacturers are seeking for their business, the ideas for which the public will pay big money.

“How to Get Your Patent”

This book is a guide to the inventor. If you have invented something and desire to learn what it will cost you to get your patent and what you must do to find your market, read this book.

“Special Bulletin of Patent Buyers”

This bulletin contains letters from men who are seeking to purchase patents. We act as intermediary without one cent of charge, between the man who invents and the man who invests.

Send Model or Sketch and description of your invention for Free Opinion as to patentability

*Rejected and Difficult
Cases are Our
Specialty*

RANDOLPH & CO.

600 F St., N.W., Washington, D.C.

RANDOLPH & CO.
600 F St., N. W., Washington, D. C.

Gentlemen: Please send me without obligation on my part, the books indicated on margin of this coupon. (Write on margin of coupon, names of books desired.)

NAME.....
STREET.....
CITY.....STATE.....



Inventions Wanted!

Manufacturers constantly writing us for patents. List of inventions actually requested and book "How to Obtain a Patent" sent free. Send rough sketch for free report regarding patentability. Special assistance given our clients in selling patents. Write for details of interest to every inventor.
CHANDLEE & CHANDLEE, Patent Attorneys
Est. 21 Years 1011 F Street, WASHINGTON, D. C.

HIGH-VALUE PATENTS
—the ONLY kind Wanted and BOUGHT by Manufacturers.
Send 5c. postage for new book of Extraordinary Interest to Inventors
R. S. & A. B. LACEY, 51 Barrister Building, Washington, D. C.

PATENTS

C. L. PARKER
Formerly Member Examining
Corps, U. S. Patent Office
PATENT LAWYER
MCGILL BLDG.
WASHINGTON, D. C.

Patents, Trade Marks, Copyrights, Patent Litigation

Handbook for Inventors, "Protecting, Exploiting and Selling Inventions," sent free upon request.

Send for FREE BOOK { WHAT TO INVENT
WHAT NOT TO INVENT
HOW TO SELL YOUR PATENT
Nearest Patents and report in each case to be filed—no charge
H. L. WOODWARD, 9th and G Sts., WASHINGTON, D. C.

PATENTS THAT PROTECT and PAY

Send for FREE BOOKS.

Advice free. Terms reasonable. Highest references. Best results.

Send sketch or model for FREE examination and opinion.

BONDED and recommended Patent Lawyer in the Rand-McNally Directory of Bankers and Attorneys, Published by Rand-McNally & Co., Chicago, Ill. Recommended Patent Attorney in the Bankers Register and special list of selected lawyers published by the Credit Company, Pontiac Building, Chicago, Sharp & Alleman's Directory of Lawyers and Bankers, published at Philadelphia, and Martindale's American Legal Directory of New York City.

ALL BUSINESS GIVEN PROMPT AND PROPER ATTENTION

A large list of strong recommendations furnished free

WATSON E. COLEMAN, Patent Lawyer, 624 F St., Washington, D. C.

PATENTS TRADE-MARKS AND COPYRIGHTS

LARGEST PATENT FIRM
IN THE WORLD

SPECIAL OFFER Free Opinion as to Patentability

Before sending your invention to any attorney or manufacturer or disclosing your invention, write for our free blank form **PROOF OF CONCEPTION** in order to protect your invention and secure your rights. This should be signed and witnessed and returned to us, together with a model or sketch and description of your invention, and we will give a **FREE OPINION** as to the patentability of the invention. If we report the invention patentable we will furnish a Certificate of Patentability.

This Certificate of Patentability, together with our blank form Proof of Conception will protect the inventor and serve as proof of the invention until the case can be filed in the U. S. Patent Office.

Obtaining Assistance for Inventors—Our certificate is of great assistance to inventors who require financial aid to obtain patents.

OUR FIVE BOOKS MAILED FREE

(See Coupon Below)!

to any address. Send for these books—the finest publications ever issued for free distribution.

How to Obtain a Patent

Our illustrated eighty-page Guide Book is a book of reference for inventors and contains 100 mechanical movements, illustrated and described. Tells how to invent for profit.

What to Invent

Contains a valuable list of inventions wanted and suggestions concerning profitable fields of inventions; also information regarding prizes offered for inventions amounting to **One Million Dollars**

Millions in Trade-Marks

Shows the value of Trade-Marks and information regarding unfair competition.

We Advertise Our Clients' Inventions Free in a list of Sunday newspapers, in manufacturers' journals and in *World's Progress*. Sample Copy Free. We save you time and money in securing patents. After the patent is granted we assist you to **sell your patent**.

WANTED NEW IDEAS

Prepare Now to meet the Demands of Industry in All Fields for New Ideas and New Inventions. We are constantly receiving requests from manufacturers who consult us when purchasing patents for inventions in all lines. We invite manufacturers and promoters to address our Sales Department regarding the purchase or leasing of a number of meritorious patents secured by us.

List of Patent Buyers

Contains requests from manufacturers, mail order houses and promoters for patents secured by us and suggestions as to **New Ideas** they wish to purchase. We place our clients in touch with capital free of charge. We have recently received over 300 requests from manufacturers.

Foreign Patents

We have direct agencies in all the principal foreign countries and secure foreign patents in the shortest possible time and at the lowest cost. Write for our illustrated Guide Book on Foreign Patents, sent free to any address.

VICTOR BUILDING



VICTOR J. EVANS



FREE COUPON!

VICTOR J. EVANS & CO.

New York Offices:

1007 Woolworth Bldg.

PATENT ATTORNEYS

Pittsburg Offices: 514 Empire Bldg.

Philadelphia Offices:

1429 Chestnut St.

Main Offices: 765 Ninth St., N. W., WASHINGTON, D. C.

Name..... Address.....

Please Mention Popular Mechanics

PATENTS SECURED OR ALL FEES RETURNED!!

THAT
PAY
"Trade-Mark"

Protect Your Idea!
DONT' DELAY!

We Issue a Contract with Each
Favorable Report to Return
ALL FEES!

Send data at once by registered mail and we will promptly advise how our clients proceed to make fortunes.

Actual Search FREE of the Patent Office Records, and Report as to Patentability Free!

PATENTS SOLD FREE: Proof given in our *Guide Book*, FREE! We help sell only *Our Clients'* Patents FREE.

PATENT BUYERS please write our "Patent Sales Department" Today! Excellent Opportunities!

Patents advertised Free in Popular Mechanics, and further promoted. Write us at once and be one who secures this valuable free service! Read the "Patent Sales Department" of our *Guide Book*, FREE. We write manufacturers for you—we don't wait until they write us.

WE LEAD—WE ARE LIVE WIRES!

"Vrooman" Clients' Patents SELL! Over \$627,212.00 made by our clients, as fully told in our 1917 190-page book.

Best References

*****FREE COUPON*****

E. E. VROOMAN & CO.,
871 F St., Washington, D. C.

Well-Established Firm, and Practitioners Before
Supreme Court of U. S.

Send me full particulars and your patent (book) literature FREE.

Name.....

Address.....

Reliable, prompt service by a Competent Attorney. Inquiries invited.

Norman T. Whitaker

Attorney-at-Law and Mechanical Engineer
Former Examining Official of the U. S. Patent Office
27 Legal Building - - Washington, D. C.

Patents on Easy Payments

Send model or sketch for Free Search and opinion as to patentability. Write today for our free book of Inventions Wanted and How to Obtain Patent on Easy Fee Payments. We furnish our clients with list of patent buyers and assist inventors to sell patents.
C. C. HINES & CO., 591A Loan & Trust Bldg., Wash., D. C.

PATENTS

MASON, FENWICK & LAWRENCE, oldest U. S. firm having main office at Washington, D. C. Also New York and Chicago. Established 1861. Best References. Trade-Marks Registered. BOOKLET and Information FREE.

Protective Patents

Procured Promptly. No fee refund, no guarantee certificate, no so-called prize or free search schemes used in our business. Inventors 104 page Blue Book sent on request.
Robb & Robb, 211-215A Southern Bldg., Washington, D. C.

Models
and
Gears

Experimenters—Inventors

Developing inventions and making working models our specialty. Well equipped shop and staff of experts at your service. Carry complete stock of gears. Shipments same day order received. ESTABLISHED 1892.

UNION MODEL WORKS, 121 S. Clark St., CHICAGO



PATENTS

Send Sketch or Model of Your Invention for
Free Opinion as to Patentability

Our Certificate of Patentability is Evidence

of Conception of your invention and may prove valuable to you. Our Credit System enables you to file your application for Patent and proceed without delay. Every case receives personal attention of one or both members of the firm. Patents we secure advertised at our expense in Popular Mechanics Magazine.

Write today for Free copy of 104-page book,
"How to Obtain a Patent and What to Invent"

Talbert & Parker, Patent Lawyers
4683 Talbert Bldg. WASHINGTON, D. C.



EVERY INVENTOR

should have this book, "Patents and Patent Possibilities." It is chock-full of ideas and practical advice, telling what to invent and where to sell. Write for your copy today. It is FREE. I have requests for patents upon sound inventions of all kinds. Can you help supply the demand? My service is individual, prompt and efficient. (14 years' experience.) Every expedient is employed to secure patents at least possible cost.

H. S. HILL, 802 McLachlen Bldg., WASHINGTON, D. C.

Special Technical Service

Offering confidential aid in correcting faults in mechanical and electrical designs, processes and articles of manufacture, under guarantee of strict secrecy and assignment to you of results attained without reserve. Over twenty years' experience in many special fields of technical research and application enables us to render competent service. If development of the new invention or specific adaptation you now have in hand drags or has stalled, let us help you. Fees in accordance with the character and intricacy of services rendered. References furnished.
CHAS. M. HAYNES, Prudential Building, NEWARK, N. J.

PATENTS SECURED OR FEE RETURNED

Latest and
Most Complete
Patent Book
Ever Published
for Free Dis-
tribution

WRITE FOR IT

Compare My SERVICE and TERMS with Those
of Any First Class Attorney

Send Sketch, Photograph, or Model of your invention for an ACTUAL SEARCH of the Records of the Patent Office and report as to patentability—FREE. I give every detail of every case my closest personal attention and do not entrust your interests to assistants. Impartial advice on your ideas. I help you sell your patent. Terms moderate. My 90-page book (1917 edition) tells what inventors should know before they apply for a patent.

GEORGE P. KIMMEL, Patent Lawyer
200 Barrister Bldg. Washington, D. C.

U.S. PATENTS



REGISTERED ATTORNEYS

LANCASTER & ALLWINE

204 OURAY BLDG. WASHINGTON, D. C.

Don't Lose Your Rights

We publish forms called "Evidence of Conception" by which you can establish your rights before sending the invention to anyone. It is your best protection. We issue up-to-date bulletins of improvements wanted; aid inventors to promote their rights; render reliable opinions free of charge and secure valuable patents and trade marks on reasonable terms. Personal service assured by our **Service Guarantee Contract**. References: 2nd National Bank, Washington; John P. Roth Packing Co., Cincinnati.

SIMPLY MAIL COUPON

LANCASTER & ALLWINE, 204 Ouray Bldg., Washington, D. C.
Send me free book "Inventions—Patenting and Promoting," "Bulletin of Improvements Wanted and blank forms," "Evidence of Conception."

Name.....

Address.....

R. MORGAN ELLIOTT & Co.
PATENT ATTORNEYS
MECHANICAL, ELECTRICAL & CHEMICAL EXPERTS
713-721 WOODWARD BUILDING
WASHINGTON, D. C.

PATENTS PROMPTLY SECURED

I assist you to market your invention. Send sketch or model for my honest advice. Prompt personal service. **BOOKLET FREE.**

J. R. KELLY 743 Woodward Bldg.
WASHINGTON, D. C.



Models and Supplies

We make working models of any description and material, also dies, tools and sheet metal stampings. Send your drawing or sample for estimate. Write for catalog of gears and model supplies.
The Pierce Model Works, 3405 Pierce Ave., Chicago, Ill.

Save \$20 to \$50 on COAL BILL



Save \$20 to \$50 on winter coal bill with a New Scientific Down Draft Jahant Furnace. Lasts a lifetime. Heats every room evenly. Burns oxygen, saves coal. Burns coal to fine ash. Heats quickly in morning.

WE PAY THE FREIGHT

We pay freight anywhere in U. S. or Canada. Price includes entire equipment out to fit. Easily installed.

Sold on Monthly Payments

Buy a Jahant now, a payment down, rest may monthly payments. It will pay for itself in short time. Sold on 300 day Money-back, Least Guarantee Bond. Engineers' advice FREE.

FREE! Complete set of erecting tools Free with each Jahant. Get book, "WHAT USERS SAY," and literature, all free.

JAHANT HEATING CO.

27 Jahant Bldg., AKRON, OHIO, U.S.A.



GEARS ALL KINDS SMALL

The most accurate made and prices reasonable. We carry a complete line of gears in stock for immediate shipment. Can also quote on special gears of all kinds. Send us your inquiries.

WRITE FOR CATALOGUE

CHICAGO STOCK GEAR WORKS
16 S. Fifth Av. CHICAGO



MECHANICAL SUPPLIES AND MATERIAL of all kinds.

EXPERIMENTAL AND LIGHT MACHINE WORK to order.

132 MILK STREET, BOSTON

INDOOR CHEMICAL CLOSET

No smell, no germs, sanitary. Useful any room. Needs no plumbing, sewerage or running water. Chemicals in closet kill germs. Fine for the sick and old folks.

DESTROY OUTDOOR CLOSET

Put in a warm, Indoor Sanitary Closet. Empty twice monthly, only attention necessary. Satisfied users and Boards of Health endorse it. Fully Guaranteed. **30 Days Free Trial.** Write for FREE literature. Agents wanted.
SANITARY CLOSET CO. 27 Colton Bldg., Toledo, O.



Does The Socket Chafe Your Stump?
If so, you are NOT wearing

BUCHSTEIN'S VULCANIZED FIBER LIMB

which is soothing to your stump, cool, neat, light, walls not much thicker than a silver dollar, strong

Sold on easy payments to good people. D. Buchstein
Co., 113 6th St. S., Minneapolis, Minn. **Guaranteed 5 Years!**

NO MORE BALD HEADS



WHEN our VACUUM CAP is used a few minutes daily. We accept no pay until you have tried the Cap 60 days and are satisfied. The Vacuum Cap is an appliance that draws the blood to the Hair Roots and starts a new healthy crop of hair. It stops Dandruff, stops the hair from falling out.

Bought by Doctors and men who know that it is the only reasonable HAIR GROWER known to science. No Drugs Used. Write for application blank, testimonials and booklet on "HAIR," sent sealed in plain envelope, FREE.

THE MODERN VACUUM CAP CO.

R. 559 BARCLAY, DENVER, COLO.

DIAMONDS. WATCHES ON CREDIT

YOU SHOULD HAVE THE JAMES BERGMAN 160 PAGE JEWELRY BOOK IN YOUR HOME. 4,000 Photos, Diamonds, Watches, Jewelry, Toilet Articles, etc. Anything selected sent on approval, all charges prepaid. If satisfactory, Pay 20 per cent Down - 10 per cent Monthly. Write Today for Big Free Catalog No. 5. It tells all about our confidential relations, Banking Guarantee and Liberal Exchange Offer. 10 per cent off for cash. **James Bergman** Ltd., 1896 NEW YORK CITY

WANTED IDEAS



Inquiries from Manufacturers and Other Buyers of Patents
Who Are Looking for Good Ideas

Protected by Owen Patents

Are constantly being received. Hundreds of ideas are wanted—a market exists for them to-day. **YOURS** may be one of them. Send for my free books and see for yourself—read the requests for inventions protected by me. Many are simple. You can help supply this demand.

As soon as my clients' rights are protected I aid in every practicable way, **without charge**, to sell. Their applications are advertised free—their patents are called to the attention of the proper prospective buyers—every necessary thing is done. Get my booklets and see.

THESE ARE FREE

You will incur no obligation by writing me. A simple request will bring them to you—the finest, most reliable and instructive patent books published. A postal will do.

"Successful Patents"—a 72 page guide book, tells how to proceed; describes my advantageous business methods; gives references, testimonials, etc.

"Stepping Stones"—gives hundreds of hints of inventions wanted; articles from interviews of noted authorities; tells the truth about prizes for inventions.

"Patent Promotion"—tells you how to sell; why some inventors fail; discusses the value of your idea; how I aid my clients; manufacturing aids furnished you; recent successful patents, etc.

"Patent Buyers"—Publishes letters, and abstracts of letters, from over 400 of the many manufacturers, and other patent buyers, who wish to buy, or obtain on royalty, **Owen Patents** on innumerable inventions of interest to them.

You will also be sent from time to time, as new inventions are wanted, full information concerning them. Only in this way can you keep up to date.

WRITE FOR THESE TO-DAY—Advice costs nothing. All communications confidential. Your work will receive my personal supervision—but my fees are no higher than others.

Results Speak Loudest — But Here Are Some References

Columbia National Bank, Washington, D.C.	Antholene Mfg. Co., Hutchinson, Kan.
National Locktite Co., Washington, D.C.	National Rack Co., 61 Hanover St., Boston, Mass.
The Carnahan Press, Washington, D.C.	The C. J. Loftus Co., 13 Spring Common, Youngstown, Ohio.
Lightning Gun & Cycle Works, Oklahoma City, Okla.	Whitehead Hosiery Mills, Burlington, N. C.
	Dickinson Mfg. Co., Des Moines, Iowa.

A LARGE NUMBER OF OTHERS IN MY BOOKLETS.

Nuts for You to Crack

Invent something for which a demand exists—for which there is a waiting market. Here are abstracts from a few recent requests—**hundreds** are published in full in my literature. Can you invent any of these? Watch this list each month.

A large middle Western manufacturer states "we are interested in any novelty that has merit and can be manufactured at an attractive profit. We would prefer something selling to the shoe trade; however, will consider any good novelty. We would rather favor the royalty proposition."

An unusual request has just come in, an investor desiring to purchase a patent covering different kinds of Guitar Zithers "such as base and treble attachments."

Can you make even a slight improvement in your suspenders? If so I can refer you to a manufacturer who has just inquired for anything new in this line.

Another unusual request has just come from a man who desires patents "in the line of playthings or dolls made of a new kind of paper-mache composition to be pressed in moulds or cast in same."

SPECIAL FREE REPORT

Send sketch or model of your invention for free report on patentability, practicability, etc.

RICHARD B. OWEN WASHINGTON, D. C.
NEW YORK OFFICE: 22d Floor Woolworth Building

Inventors submitting their inventions to me are protected in a tangible manner until their applications are filed.

Belber

TRAVELING GOODS

Man's Suit Case

No. 682 Black
No. 686 Brown

A sturdy, well made suit case in small crossgrain effect. Has sewed-on, heavy corners, sewed-on loops, heavy strap all around, reinforced by two strong bolts and side hasp lock. Durable linene lining and equipped with BELBER FITALL, to hold your own toilet articles.

24 inch size, \$10.00
26 inch size, 12.00



TRAVEL bags and suit cases that give pride of possession. Handsome, luxurious, wear resisting. Fashioned out of Du Pont Fabrikoid, Craftsman Quality—the best grade of Fabrikoid made—and built with the usual Belber skill. Snappy in style, strong in every detail of construction—and made to give real service. Doubly guaranteed by these two quality trade marks:



Sixteen styles for men and women

\$7.50 to \$12.00

At the better shops and department stores

Write for illustrated booklet

The Belber Trunk and Bag Co.
Turner & Mascher Streets, Philadelphia, Pa.

Acetylene Blow Torch Prest-O-Torch

Quicker and cheaper than a gasoline blow-torch for brazing and soldering

For factories, repair shops, firemen, dentists, jewelers, the Prest-O-Torch saves time and money. Used with Prest-O-Lite Tanks—ready made gas. Intense, concentrated flame instantly lighted. No depreciation, safe and convenient. Style "A", price, 75c (Canada, 85c) will braze up to 3/8 inch round rod. Style "C" for heavier work, \$2.25 (Canada, \$2.75). Special styles for dentists. Write for literature or send order now. Money refunded if not satisfied.

The Prest-O-Lite Co., Inc. 835 Speedway
Indianapolis, Ind.
Canadian General Office, Dept. A4, Toronto, Ont.

A Birthday Present

If you are racking your brains to think of a suitable birthday present—stop. Go to any dealer and ask to see Ingersoll watches. There are eleven kinds from a \$1 to \$3.

5¢ A DAY BUYS A GIBSON

Terms as low as \$1.00 down and \$1.50 per month. Mandolin or Guitar on approval. Get new FREE BOOK. Valuable information for player and teacher. Explains wonderful new violin construction with carved and graduated Top and Back and Stradivarius Arching. Also FREE treatise on "How to Practice."

Make \$1800 to \$5000 a Year Teaching and Selling Gibsons

Become a teacher. Splendid opportunities for Mandolin and Guitar teachers—either sex, in every locality, private and class instruction, and sale of Gibsons. The Gibson has "made" many a teacher professionally and financially.

Do Business on Our Capital

If teacher, become our agent. Territory protected. Instruments furnished. We help sell. We pay advertising. You make profits. Pay for goods when sold; return unsold goods. Try our Skill Hunt. Catalog and Thematic List Free.

Gibson Mandolin Guitar Co., 167 Harrison Carl, Kalamazoo, Mich.

The Book of 100 Houses

Sent free to anyone who intends to build.

This book contains photographic views of over 100 houses of every variety and style of architecture (from the smallest bungalows and camps to the largest residences) that have been built in all parts of the country, under widely varying conditions of climate and surroundings, and stained with the rich, velvety shades of

Cabot's Creosote Stains

and with the soft, cool, brilliant white of Cabot's Old Virginia White.

They are designed by leading architects and the book is full of ideas and suggestions that are of interest and value to those who are planning to build.

SAMUEL CABOT, Inc., Manufacturing Chemists
18 Batterymarch St., Boston, Mass.



Walls finished with Cabot's Old Virginia White.
Roof stained with Cabot's Creosote Stain
Person & Goodrich, Architects, N. Y.

"Every Angler Should Have a Bottle in his Kit"

3
in One

—says Mr. Lody Smith of New York about 3-in-One Oil. Mr. Smith fishes whenever he has a moment to spare; and when he talks about anything relating to fishing he knows whereof he speaks. Read Mr. Smith's letter:

"For use on floating flies, I find that the feathers are not affected by the hackles and wings sticking together. There is an entire absence of paraffin which is present in most of the dry fly solutions. I also use 3-in-One for my reels, lines, etc., and recently discovered that it was a good repellent of black flies, mosquitos and midgits; better to use than heavy greases."

Try 3-in-One Free

Send for a generous sample with full information about its many uses. 3-in-One is sold in all good stores in 50c, 25c and one-ounce (small size) bottles; also in the Handy Oil Can, 25c.

Three-in-One Oil Co.,
165CNF. Broadway, N. Y.

New Automatic Adder \$2.50

Makes adding easy for anyone. It's accurate, quick, durable and easily operated. Capacity 999,999.99. Saves time, brain work and eliminates errors. Thousands of pleased owners. Guaranteed one year. Delivered complete for \$2.50. ORDER YOURS TODAY. AGENTS WANTED.

J. H. BASSETT & CO., Dept. 49, 5921 Indiana Ave., Chicago, Ill.

Be Sure It's **"POROSKNIT"**
GENUINE SUMMER UNDERWEAR
Cool, elastic, comfortable—**GUARANTEED**
Chalmers Knitting Co., 78 Washington St., Amsterdam, N. Y.

PIGEONS PAY

Better than chickens. Young pigeons (squabs) bring 40c to 60c each when 8 to 4 weeks old. Big demand in city markets. Each pair of pigeons easily clear \$1 per year. Always penned up. Free book explains all. MAJESTIC SQUAB CO., Dept. 18, Adel, Iowa.

FREE BOOK

POULTRY PAPER

44-124 PAGE periodical, up-to-date; tells all you want to know about care and management of poultry for pleasure or profit. Four months for 10 cents. POULTRY ADVOCATE, Dept. 98, SYRACUSE, N. Y.

RAISE GUINEA PIGS

We buy all you raise. Splendid money making opportunity. Big demand—thousands needed weekly. Easy to raise—inexpensive to house, feed, keep. Pay better than poultry or squabs. Particulars, contract, booklet how to raise free. CAVIES DISTRIBUTING CO., 740 W. 74th St., KANSAS CITY, MO.



RAISE GUINEA PIGS

Big Demand Thousands needed weekly. Government figures show a profit of \$9.00 each annually. Experience or special knowledge unnecessary. Send for our money making proposition and big free illustrated book which explains all.

Laboratory Supply Co., Dept. B, 2841 Ridge Ave., Phila., Pa.

Fitting Jobs versus Fitting Shoes

You can't fit yourself or any other man into a job like you fit a pair of shoes to your feet. Experience and natural ability make a man particularly well fitted to hold one certain position. He can do the work better. He will make more money in this position than in any other.

The American School of Correspondence makes a study of fitting men into the right positions. Throughout our entire existence, we have fitted men into the lines of work where they belong, judging from their natural ability and experience.

Free Analysis

If you will send the coupon, we will send you free and prepaid our "Personal Examination Blank." Fill out this blank and send it to us. Our experts will go over your answers to the questions very carefully and tell you the position you are best fitted to hold.

Your practical experience is worth dollars to you. It may be worth much more than you are getting for it now. By applying your natural ability just a little bit differently, a new and bigger opportunity may be open for you.

We go into your case thoroughly. Just send the coupon and ask for our "Personal Examination Blank."

Send the Coupon

Put your name and address in the coupon now and find out the kind of work our experts think you should do. Get our new "Personal Examination Blank"—fill it out and mail it to us. Get your abilities analyzed without charge. This service is free and you will be under no obligation. Filling out this blank has meant success to thousands and you have the same opportunity now. Your name and address in the coupon or a letter or post card is enough. The first step is to send the coupon today.

American School of Correspondence, Chicago, U.S.A.

Dept. G9198

American School of Correspondence, Dept. G9198, Chicago, Ill.

Gentlemen: Please send me booklet and tell me how I can fit myself for the position marked "X."

- | | |
|-------------------------------|----------------------------|
|Electrical Engineer |Business Law |
|Elec. Light & Power Supt. |Business Manager |
|Hydroelectric Engineer |Auditor |
|Telephone Engineer |Accountant |
|Architect |Cert'd Public Acct't |
|Architectural Draftsman |Stenographer |
|Building Contractor |Bookkeeper |
|Building Superintendent |Fire Ins. Inspector |
|Structural Engineer |Fire Ins. Adjuster |
|Structural Draftsman |Fire Ins. Expert |
|Mechanical Engineer |Sanitary Engineer |
|Mechanical Draftsman |Master Plumber |
|Civil Engineer |Plumb'g & Heat'g Est. |
|Steam Engineer |Heat'g & Vent. Engin'r |
|Shop Foreman |Reclamation Eng. |
|Shop Superintendent |Automobile Engineer |
|Sheet Metal Draftsman |Automobile Repairer |
|Lawyer |High School Course |

We also prepare for civil service examinations in all engineering subjects

NAME

ADDRESS

Please Mention Popular Mechanics

SAVE 1/3

On Your Outboard Motor

\$20 to \$30 is well worth saving, isn't it? The average row boat motor of the same high grade as the Columbian sells for \$80 to \$90.

\$60 COLUMBIAN \$60 ROW BOAT MOTOR

With high tension magneto built in fly-wheel \$70.

The Columbian has been giving "General Efficiency" service to thousands of owners for over 5 years. We are headquarters for Boats, Canoes, Cruisers and Motor Boat Accessories. Marine Engines up to 300 h. p.

Send for Boat and Engine Books, or visit Chicago's big Motor Boat Show, everything from a canoe to a cruiser, at our show rooms.

CULLEN MOTOR CO.
Dept. I, 112 W. Lake St., Chicago, Ill.



Travel the Water Way

Railroad tickets are honored for transportation on all D & C line steamers without extra charge.

Steamer Schedules

Daily service between Detroit and Buffalo; also between Detroit and Cleveland, and between Toledo and Put-in-Bay. Four trips weekly between Toledo, Detroit, Mackinac Island and Lake Huron way ports.

Send 2c stamp for illustrated pamphlet and Great Lakes Map. Address: L. G. Lewis, 26 Third Street, Detroit, Mich.

DETROIT & CLEVELAND NAVIGATION COMPANY

Philip K. McMillan, Pres.
A. A. Schantz, Vice-Pres. & Gen. Mgr.



WITHOUT AN EQUAL

The World's Greatest Rowboat Motor

Built on different lines. Has two-cylinder principle, which does away with vibration. It does not shake the boat.

THE GREAT KOBAN ROWBOAT MOTOR

High grade and absolutely dependable. Easy to start and easy to manage — light weight and smooth running — reverses by pressing a button. New devices — aeroplane type magneto, tilting device and many others. Has great speed, yet slows down to a trolling pace. Both cylinders firing at the same time is cause of the absence of vibration. Saves the boat. Fully explained in new 24-page catalog sent free upon request. **AGENTS AND DEALERS WANTED.** KOBAN MFG. CO., 291 South Water St., MILWAUKEE, WIS. Ask about the Great Koban Inboard Motor — A Wonderful Engine for Light Launches or Boats.

Built-in Magneto or Battery Ignition



Universal MARINE MOTOR

9-12 H. P. 4 Cycle 4-Cylinder. Speed range 300 to 1800 R.P.M. Adapted to boats from 14 to 30 feet. Write to

Reliable Service



UNIVERSAL MOTOR CO.
OSHKOSH, WIS. Dept. P

For Bulletin No. 25 giving full description

Get this LA Engine Book

— it gives valuable information about motor boat engines. It describes the full line of L-A inboard and outboard motors and tells of the 30 days' free trial plan. Write for your copy today.

LOCKWOOD-ASH MOTOR CO.
1420 Horton Ave. Jackson, Mich. (25)



ROWBOAT MOTOR FERRO

Pay for Yours by Selling Others

Make your rowboat or canoe into a motorboat, and make the motor pay for itself. Get our agency proposition 235. The Ferro Rowboat Motor is a sturdy and dependable power plant, with carburetor and a more mixing valve. Bosch magneto and complete equipment. Runs 4 hours on a gallon of gasoline; 2 to 3 miles an hour; easy to start, easy to run, practically trouble proof. Quiet, efficient, durable; thousands in satisfactory use—some near your home, perhaps. Write up.

\$60 with Bosch high-tension magneto.
\$70 with waterproof batteries.

The Ferro Machine & Foundry Company
742 Hubbard Avenue Cleveland, Ohio

DON'T GO ROWING - GO FERROWING



Order Your "Old Town" Now and Enjoy the Hot Days

Quick, prompt delivery

"Old Town Canoes"

will carry you swiftly and safely everywhere. Note the superb construction. Built to last, light, swift, beautiful and safe. No trouble, easy to paddle and manage. Order now from dealer or factory. \$34 up. Catalog on request.

Old Town Canoe Co.
1667 Middle St., Old Town, Maine, U.S.A.

An unusual photograph of an "Old Town Canoe" hull before canvas is put on, showing long length planks.



FISHERMEN!

You can get to the fishing grounds early and feel fit for fishing when you get there, if you have an

EVINRUDE

DETACHABLE ROWBOAT & CANOE MOTOR

Equipment includes Evinrude Magneto—Built-in Flywheel Type, Automatic Reverse—new refinements for 1917. More speed and power. Catalog and dealer's name on request. Special folder describes rowboats, skiffs, canoes and accessories.

EVINRUDE MOTOR COMPANY
567 Evinrude Blk., Milwaukee, Wis.

Also manufacturers of 3 and 5 H. P. Inboard motors for launches, canoes, dinghies, tenders.
BRANCHES: New York, Boston, Portland, Ore., San Francisco

Over 80,000 Sold—Used by 25 Governments



Evinruding—Is Rowboat Motoring

Racine ^{Wis}

America's Finest Canoe

Speed, lightness and beautiful finish combined to the highest degree. Write for free catalog showing the many distinctive features of the *Racine*.

Racine Boat Company, Dept. O, Racine, Wis.

GET THIS CATALOG

FULL OF VALUABLE INFORMATION TO EVERY BOAT OWNER ON

RACING PROPELLER WHEELS,
REVERSE GEARS AND
MARINE ACCESSORIES

LARGE CATALOG FREE. SEND TODAY
MICHIGAN WHEEL CO.
1133 MONROE AVE. GRAND RAPIDS, MICH.

**The Brooks System
Knocked Down Boats**

ALL parts accurately machined ready for assembling. Everything from Canoes to Cabin Cruisers. V-bottoms—high speed—semi-speed, and work boats. Full size paper patterns and illustrated instructions for amateur builders. The "Brooks System" saves over two-thirds the cost of a boat. Present conditions of freight rates, labor costs, slow deliveries, makes this the only practical method of getting a boat. We are the originators of the pattern system of boat building. *Send now for illustrated catalog.*

BROOKS MANUFACTURING COMPANY
8207 Ship St. Saginaw, Mich.

Largest and oldest concern of its kind in the world.

**The Burlington
Smashes**

Mail the
Coupon
TODAY
for Free
Watch
Book

All Watch
Competition
Look!



21 Ruby and Saphire Jewels—

Adjusted to the second—

Adjusted to temperature—

Adjusted to isochronism—

Adjusted to position—

65 year gold strata case—

Genuine Montgomery Railroad Dial—

New ideas in Thin Cases.

Every fishing vessel in the U. S. Navy has the Burlington Watch aboard. This includes every torpedo boat—every submarine as well as the big Dreadnaughts. Some have over 500 Burlingtons aboard.

\$2.50

Only 2.50 A Month

And all of this for \$2.50—only \$2.50 per month—a great reduction in watch price—direct to you—positively the exact prices the wholesale dealer would have to pay. Think of the high-grade, guaranteed watch we offer here at such a remarkable price. And if you wish, you may pay this price at the rate of only \$2.50 a month. Indeed, the days of exorbitant watch prices have passed

See It First!

You don't pay a cent to anybody until you see the watch. You don't buy a Burlington watch without seeing it. Look at the splendid beauty of the watch itself. Then model, handsomely shaped—aristocratic in every line. Then look at the work! There you will see the masterpiece of watch makers skill. A timepiece adjusted to positions, temperature and isochronism.

Free Watch Book

Get the Burlington Watch Book by sending this coupon now. You will know a lot more about watch buying when you read it. You will be able to "steer clear" of the over-priced watches which are no better. Send the coupon today for the book and our offer.

Burlington Watch Co.

19th St. & Marshall Blvd., Dept. B119
Chicago

Free Watch Book Coupon

Burlington Watch Co.
19th St. and Marshall Blvd.
Dept. B119 Chicago, Ill.

Please send me (without obligations and prepaid) your free book on watches with full explanation of your cash or \$2.50 a month offer on the Burlington Watch.

Name.....

Address.....

Please Mention Popular Mechanics

Please Mention Popular Mechanics

Copyrighted material



For
Fishing
Hunting
Pleasure
Business

Steers
And
Controls
With
Same
Lever

Be a **CAILLE** 5 Speed Motor

OWNER AGENT

Hundreds of Caille Owners have asked to become our agents,—they have seen how easy it is to sell Caille 5 Speed Master Motors. They wanted to represent us in their vicinity because everyone who saw the Caille perform wanted one. We are going to give everyone a chance to be an owner agent and sell the Caille 5 Speed outboard motor. No previous selling experience is necessary. No office or shop is needed. Anyone can easily understand and operate a Caille 5 Speed Outboard Motor. Be first in your neighborhood.

Special Owner Agent Offer

We will give a special "Owner Agents" discount to one in each community. Our best advertisement is the Caille in operation. Owner Agents sell from 1 to 12 Caille Motors a year easily among friends and acquaintances. Buy yours at discount and sell all you can. *We want a Caille Owner Agent in your vicinity.*

2 Speeds Forward — Standstill — 2 Speeds Reverse Without Stopping Motor

The Caille 5 Speed Motor Starter operates with a quick, easy pull,—women and children operate it easily. There are two speeds forward—two reverse or standstill without stopping the motor. This makes the Caille so flexible that anyone can use it for hunting, fishing, pleasure in fresh or salt water. The Caille is simple in construction, made of best materials and is fully Guaranteed.

FREE Catalog, Special Owner Agents Discount, Booklet "Installation-Operation and Care of 2 Cycle Motors and Equipment," all absolutely **FREE**. Here's a chance to earn while you play.

Caille Perfection Motor Co., 27 Caille Bldg., Detroit, Mich., U. S. A.

*We make a complete line of Inboard Marine Engines from 2½ to 30 h. p.
If interested ask for catalog, giving dimensions of boat.*



Motor Perfection

is what you get in Watkins Class "B" all iron motors. Especially fine for canoes and light boats. Constant and efficient.

3 H. P. single cylinder	45 lbs.
6 H. P. double cylinder	85 lbs.
12 H. P. four cylinder	155 lbs.

Are light, at the same time strong, accomplished by using semi-steel castings, high carbon steel shaft, bronze bearings, high class workmanship.

THE WATKINS MOTOR CO.
Cincinnati, Ohio

837-839 W. 6th Street

Mullins Steel Boats Can't Sink

When you think of buying a boat, whether it be a 16-foot Runabout, a big 26-foot Auto Boat, or something in between—remember that Mullins Steel Boats are guaranteed for life. They cannot sink, leak, water-log, dry out or open at the

seams—never require caulking. Designed by America's foremost naval architects—built in the largest boat factory in the world. More than 65,000 in use. Big catalog of steel or wooden motor boats, run-boats or canoes, on request.

THE W. H. MULLINS CO., 52 Franklin Street, SALEM, OHIO

"It Is My Patriotic Duty

to keep myself physically and mentally fit. I owe my country 100% efficiency in order that the burden of war may be borne with the least disturbance to prosperity.

"I am going to take two weeks off in the great outdoors with my kit of 'Bristol' Rods and Meek Reels and rest up and fish, and come back full of the joy of living and the zest of fighting."

16,000 sporting goods dealers handle "Bristol" Rods and Meek Reels. If your dealer cannot supply you, order from us at catalogue prices.

Meek and "Bristol" Catalogues FREE.

THE HORTON MFG. CO.

196 Horton St. BRISTOL, CONN.

Has The Motor Boat Bug Got You?



Health and happiness are assured with one of the new popular priced Gray motors in your boat. Select your boat from our 1917 Boat Builders Catalog showing products of 200 leading boat builders. Select your engine from our new complete Engine Catalog. Both books **FREE**. Send today.

GRAY MOTOR COMPANY
746 Oakland Ave., DETROIT, MICH.

Kennebec Canoes

give more real pleasure at less cost than most anything else in the world. Send for our free 1917 canoe book.

KENNEBEC BOAT & CANOE CO., 49 R. R. Sq., Waterville, Me.

FREE TRIAL



Cut out this ad and mail it to us, with your name and address (no money); and we will send you our **FAMOUS KARNAK RAZOR** by return mail, postpaid. You may use the razor for 30 days **FREE**; then, if you like it, pay us \$1.85. If you don't like it return it. **SEND NO MONEY.**

MORE COMPANY, 355 More Bldg., St. Louis, Mo.



Greenfield Tap and Die Corporation, Greenfield, Mass.

Please Mention Popular Mechanics

JAPANESE ROSE BUSHES**The Wonder of the World**

Japanese Rose Bushes bloom all the year round. Just think of it. Six weeks after planting the seed, the plants will be in full bloom. It may not seem possible, but we positively guarantee it to be so. They will bloom every ten weeks, Summer or Winter, and when three years old the bush will be a mass of roses, bearing from five hundred to a thousand roses on each bush. The flowers are in three shades—white, pink, and crimson. The plants will do well both in and out doors. We guarantee at least three bushes to grow from each packet of seed. Price, 10c packet, 3 pkts. for 25c postpaid.

10
Ct.**Chinese Fragrant Tree Fern**

Just introduced; noted for its rapid growth. An exceptionally pretty ornamental plant. Foliage is rich dark green. Forms grand pyramidal bushes about 3 feet high. Branches very desirable for decorative purposes, wreaths, etc. Seeds 15c pkt., 3 for 40c.

Weather Plant

NATURE'S WEATHER PROPHECY
By mysterious changes that take place, this remarkable plant accurately forecasts the weather many hours in advance. Will grow anywhere all the year around. An interesting house plant. Bears large, fragrant, pink, butterfly shape flowers. Seeds, 15c packet, 3 for 40c, postpaid.

GROUND ALMONDS

Amazingly Prolific—Easily Grown From Seed
The Ground Almond has a flavor that is MOST EXCELLENT, resembling the coconut. The meat is snow white, covered with a shell or skin of brown color. It grows close to the surface and anything from 200 to 300 Almonds may be expected from a single nut. It is so trouble whatever in growing anywhere and in any kind of soil. May be planted any time, and in eight or ten weeks from time of planting you will have an ENORMOUS CROP of the MOST DELICIOUS ALMONDS YOU EVER TASTED. Seeds 15c Pkt.

**Perfume Plant**

Blooms only at night, giving forth the most delightful scented fragrance for quite a distance. Causes much comment. For house or garden. Also valuable because of rare perfume made from it. SEEDS, 10c pkt., 3 for 25c.

SENSITIVE PLANT

Marvel of the Philippines. Leaves curl, fronds droop when touched. Apparently resents interference. A handsome shrub for house or garden; very curious and interesting. Seeds, 15c pkt., 3 for 40c.

Calabash or Pipe Gourds

A luxuriant and rapid growing climber. Produces the ornamental gourds from which the famous African calabash pipes are made. Grow this interesting vine and make your own. Seeds, with instructions, 15c pkt., 3 for 40c.

Japanese Nest Egg Gourd

Very curious. Produces fruit same size, shape and color of nest eggs. Matured fruit does not crack. Will serve/occur as a nest egg, stocking ornament, or ornamental purposes. Seeds 15c pkt., 3 pkts. for 40c.

Seeds 15c pkt., 3 pkts. for 40c.

Mammoth Peanuts

Peanuts can be easily cultivated. Their culture is very simple and exceedingly interesting. Mammoth Peanuts grow to an astonishing size. It is a good producer, very prolific, and the giant nuts have a thick, heavily ribbed protecting shell. The plant is very attractive, the leaves being of odd shape and a handsome green shade, tinted through the center with white. You will derive much pleasure cultivating this interesting species. Seeds 15c pkt., 3 pkts. for 40c.

**Shoo Fly Plant**

A very remarkable botanical curiosity you should have. Though quite odorless, flies will not remain in a room where it is grown.

Bears very pretty blossoms; blooms summer and winter. Grows rapidly from seed.

SEEDS 15c packet, 3 for 40c, postpaid.

Japanese Climbing Cucumber

Unusually strong and vigorous growing vine. Attains twice the size of ordinary varieties. Grows readily on fences, poles, trellises, etc. One hill will keep an entire family supplied all summer. Seeds 15c, 3 pkts. for 40c.

HERE ARE A FEW OTHER SEED NOVELTIES YOU SHOULD CULTIVATE: Price 15c packet

Japanese Kudzu Vine (Jack and Beanstalk)
Chinese Balloon Flower
Purple Feather Grass (Ornamental)
Curious Ferns (grown from seed)
Red of Paradise Flower
Japanese Begonia

Caster Oil Plant
Ornamental Cactus
Job's Tears (Great curiosity)
Cathedral Bells
"Tiger" Flower
Snake Chameleon
Emerald Leaf Kale

Famous Passion Flower Vine
Fuchsias
Ornamental Gourds
Bouquet, or Red Cluster Pepper
Salsify, or Oyster Plant
White Velvet Opera

**NITTO'S PLANT & FLOWER FOOD**

NITTO'S PLANT FOOD is clean, odorless, and highly concentrated. It is used in liquid form on all kinds of plants, shrubs, roses, ferns, bulbs, berries, lawns, fruit, flower and vegetable gardens. It changes ill-nourished plants into LUXURANT BEAUTIES, producing masses of blooms that will equal any. Causes plants to bloom early and ahead of others. Your friends will marvel at your success. Makes no difference how healthy or how delicate your plants may be. Nitto's Plant Food will bring out New Fallage and Flowers, and cause a Marvelous Transformation. 15c, 3 for 40c

ANY WATCH YOU WANT on CREDIT**1917 Models****WALTHAM
HAMILTON****ELGIN, MILLER
Illinois, Howard****Sent on 30 Days Free Trial****No Money Down****Express Prepaid in Advance by Me**

You take no chances with me. I am "Square Deal" Miller and I trust the people. That is why I am doing the greatest Credit Watch, Diamond and Jewelry business in the country. Suppose you want any one of the country's best makes of watches? Name any one. I have it for you. No money down, Express Prepaid. A full month to carry it in your pocket and the easiest of long time payments. That's the test that tells. All these watches **GUARANTEED 25 YEARS**

I Smash the Terms**No References Demanded**

My terms are made to suit you. You get unlimited credit, with no red tape, notes or collectors. All unnecessary detail left out.

An "Open Charge" Account

the same kind of credit you get from your grocer. No matter where you live or what your income is, you can now own the finest watch, a beautiful diamond or any rare jewelry and never miss the money.

Costly Catalog FREE

Send me your name and address so I can mail you, Free and postpaid, the most beautiful catalog of its kind ever printed. I want you to have this book. It's a gem. It illustrates all makes of valuable Watches, Elegant Genuine Diamonds, and a vast assortment of Beautiful Jewelry, all on the easiest and most liberal terms

**Square Deal MILLER
PRES.**

881 Miller Bldg., Detroit, Mich.

**BE THRIFTY
BUY A DIAMOND
PAY MONTHLY**

**MONEY REFUNDED
IF YOU CAN BUY
CHEAPER
FOR CASH.**

**SQUARE DEAL
MILLER
PRES.****Fine Diamonds**

Our diamonds are all perfect but beautiful stones, white in color and lots of fire.

Fine Diamonds

You cannot buy by mail better diamonds at any price than we are selling on credit.

FREE CATALOG COUPON

SQUARE DEAL MILLER, Pres.
881 Miller Bldg., Detroit, Mich.

Please send me your 1917 Catalog and explain fully your 30 Day Trial Plan and Easy Terms

Name.....

Address.....

Johnson Smith & Co., 7163 N. Clark St., Chicago

Please Mention Popular Mechanics



Build a Model of this Curtiss Military Tractor used in the U. S. Army.

Build and Fly Model War Aeroplanes

that are perfect copies of real, war-famous airships; that rise from the ground by their own power and fly 50 to 100 feet in the air. It's easy! With "IDEAL" Accurate Scale Drawings and Building and Flying Instructions any bright boy can construct a 3-foot Model Aeroplane that will fly. Send today for Drawings and Instructions for the one you want to build—

Curtiss Military Tractor	25c	Wright Biplane
Bleriot Monoplane		Curtiss Hydroplane
Nieuport Monoplane	EACH	Curtiss Flying Boat
Taube Monoplane	8 for \$1.75	Cecil Peell Racer

"IDEAL" Aeroplane Construction Outfits, containing all parts and materials needed to build these Aeroplanes, are sold by leading Toy, Sporting Goods and Department Stores. Ask your dealer for "IDEAL" Aeroplane Construction Outfits.

Send 5c for This Aeroplane Catalogue

Tells about Model Aeroplanes and how they are built. About Racing Aeroplanes and Flying Toys. Lists all kinds of parts and supplies to build them with. 48 pages for five cents. Send for it today.

IDEAL AEROPLANE & SUPPLY CO.
82-88 West Broadway NEW YORK



THE "ELECTRO" TELEGRAPH

is not a toy, but a practical, basically built telegraph outfit, which not only sends but works like the big commercial instruments. By studying the code for 30 days you can become a first-class telegraph operator. Such operators are in big demand now. Outfit consists of TWO complete telegraph instruments, each measuring 3 1/2 x 2 1/2 x 2 1/2. All metal parts are highly nickel plated, including key lever. Note hard rubber knob. Telegraph Code Chart, telegraph blanks and connecting wire come with set, but no batteries. Outfit works on two dry cells (one cell for each instrument). The "Electro" is the ONLY outfit that works both ways; each station can call; no switches, no extras. Nothing to get out of order. Guaranteed to please you or money back. Price complete as illustrated.

\$1.00

AT ALL GOOD DEALERS AND DEPARTMENT STORES

If your dealer cannot supply you send us \$1.00 for outfit and add mailing charges for two periods, otherwise we ship express collect. Goods shown here are only a fraction of our wonderful assortment illustrated and described more information than most electrical works. Also contains twenty coupons for free Wireless Course.

TELEGRAPH CODES.



Electro Importing Co., 245 Fulton Street, New York City

\$1



Cyclopedia Sent FREE on receipt of 4c to cover postage. Send for your copy today

RECTIFIERS for garages. All sizes. Charge from alternating current 1 to 8 batteries. \$12.00 upwards. **AMERICAN BATTERY CO., 1137 Fulton St., Chicago. (Estab. 1889)**

ELECTRIC HOME, FARM, PICTURE THEATRE, HOTEL & STORE LIGHT PLANTS, Auto Starter Storage Batteries & Chargers. All Cars. Ask Price. Deacons, Power Motors, Bells, Engines, Railways, Personnel & Traveling Motion Picture Machines. OHIO ELECTRIC WORKS, CLEVELAND, O.

DUCK'S BIG 300-Page No. 11 Electrical and Wireless CATALOG

Mailed on receipt of 8 cents in stamps or coin, which may be deducted on first dollar purchase. Great cost of catalog and low prices prohibit distribution otherwise. Catalog contains 100 pages of wireless apparatus and 140 pages of electrical supplies. No bigger or better values are obtainable elsewhere. **THE WILLIAM B. DUCK CO., 223-227 Superior Street, TOLEDO, OHIO**

ERECTOR THE TOY LIKE STRUCTURAL STEEL

BOYS: Write for facts about the Big Prize Contest and get Erector Tips, the boys' magazine, FREE. **THE A. C. GILBERT COMPANY, 104 Fox St., New Haven, Conn.**

GACHOO! Make the whole family "just sneeze their heads off" without knowing why, with Gachoo, the new long distance harmless snuff. Sent anywhere for 10c. 3 for 25c, 1 doz. and special premium for 90c. **AMERICAN NOVELTY CO., St. Paul, Minn.**



BOYS! HAVE DAD GET STRUCTO

Structo—Mechanics in miniature—will turn the trick. With it you can build that bridge or derrick, and a hundred other models that really work. Write for Free Illustrated book. **STRUCTO MFG. CO., Dept. 118, FREEPORT, ILL.**

Lost—A valuable key. Dropped it in the dark. Burned my fingers several times with lighted matches. Could have found it instantly with an Eveready DAYLO—the light that says, "There it is!"

The Electrical Experimenter



BOYS!

Here is **THE** electrical magazine for you. For the Dabbler and the "How-to-make-it" fiend. Chuck full of experiments and the latest electrical doings. Non-technical—in plain English. One of the foremost authorities on **WIRELESS** in U. S. 200 Illustrations, 90 big pages, over 100 articles.

One copy will convince you
At All News Stands, 15c
\$1.50 a year (Foreign \$2.00).
Send 25c for 3 numbers.

THE ELECTRICAL EXPERIMENTER
234 Fulton St., New York

Ask Your Dealer



Red Seal Dry Batteries Are Guaranteed

to give absolute satisfaction for Automobiles, Motor Boats, Gas or Gasoline Engine Ignition, Medical Batteries, Telephone, Door Bells, Annunciators, Wireless Apparatus or any other open circuit work.

Our New Edition Pocket Catalog P28

Ready About July 1st.

It will be pocket size, 8x4 1/2, and will contain 248 pages with over 1,000 illustrations, describing in plain, clear language all about Bells, Push Buttons, Batteries, Telephone and Telegraph Material, Electric Toys, Burglar and Fire Alarm Contrivances, Electric Call Bells, Electric Alarm Clocks, Medical Batteries, Motor Boat Horns, Electrically Heated Apparatus, Battery Connectors, Switches, Battery Gangs, etc.

There exist a thousand and one ways where electrical devices may be used, and to know what is best for your purpose you will need this catalog. It will be in fact a pocket encyclopedia of the most popular and up-to-date electrical appliances in general use, and will cost you nothing.



Send for a Copy Now

MANHATTAN ELECTRICAL SUPPLY COMPANY, Inc.

NEW YORK, 17 Park Place

CHICAGO, 114 So. 5th Ave.

ST. LOUIS, 1106 Pine St.

San Francisco, 604 Mission St.

A Scientific Solution of the Sanitary Drinking Water Question

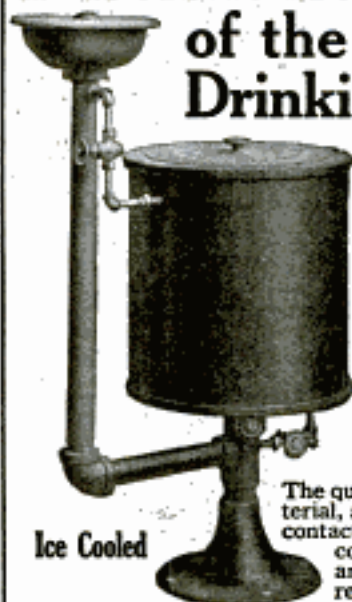

Holds 75 lbs. of Ice.
Supplies 150 Men.

Fifteen and one-half circulating coils of pipe in the cork-jacketed ice tank insure an ice-cooled sanitary drink to every employee.

The quality of the ice is immaterial, as it does not come into contact with the water. This construction reduces the amount of ice and water required to a minimum.

Ice Cooled

Send for Our Complete Catalogue

showing our line of Wash Bowls, Metal Lockers, All Steel Stools and Chairs with Inset Wood Seats, Stock and Storage Racks, Metal Shelving, Metal Vault Fixtures, Improved Soda Kettles, 40 and 60 gallons, Water Heaters and Instantaneous Mixers, Bubbling Drinking Fountains, Work Benches and Bench Legs, Drawing Stands, full line of Plumbing Fixtures, etc.

Manufacturing Equipment and Engineering Co.
136 Federal Street Boston, Mass., U. S. A.
Works and Mail Address, Framingham, Mass.

AGENTS—ONLY ONE IN THE WORLD KEROSENE (COAL OIL) BURNER

JUST OUT

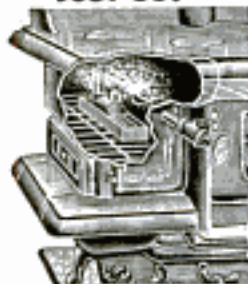

Fits in any cook-stove. Makes its own gas from kerosene (coal oil). Gives every home a gas stove. Absolutely safe. Cheapest fuel known.

BURNS 5 HOURS FOR 1 CENT

Agents just coining money. Women wild about it. No more overheated kitchens. No more danger from gasoline.

SAFE, CLEAN, ODORLESS, CHEAP

Every home a prospect. Low price makes quick sales. Easy to carry and demonstrate. Big profits. Your territory is open. Write today.

THOMAS BURNER CO., 2448 Gay St., Dayton, Ohio

SAVE 25% to 60%

On GRAFLEX—KODAKS—ANSCO,
REXO AND PREMO CAMERAS

10-DAY FREE TRIAL GUARANTEE

If unsatisfactory, money will be refunded in full.
Complete Line of Motion Picture Cameras.

Write at Once for Our Free

BARGAIN BOOK and CATALOG

listing hundreds of slightly used and new cameras, also supplies of every description. No matter what camera you want, we can save you money. Compare our prices with others on slightly used and new cameras and we know you will be another one of our satisfied customers. Our prompt and fair dealing will please you. Established in the Photographic Business over 16 years. (5)

Central Camera Co., 124 S. Wabash Ave.
Dept. 130X, CHICAGO, ILL.



For a World of Uses

Here's a most wonderful little gasoline engine—a perfect marvel of $\frac{1}{2}$ and 1 horsepower for a hundred and one uses. This remarkable little

*Maytag
Multi-Motor*

solves the problem of low-cost power for the small power user. No other engine of its size offers such wonderful combination of simplicity, efficiency and economy. The same little engine that amazed the power washer world by its marvelous service on the famous Maytag Multi-Motor Washers.

One-half h. p. \$30.00—One h. p. \$37.50

For the small power user, nothing has yet been conceived that offers a wider range of usefulness than the Multi-Motor. No matter what your problem is, if a $\frac{1}{2}$ or 1 h. p. engine will do it, a Maytag will not disappoint you.

You can't question its reliability—you can't beat its economy—you can't find its equal in any engine of the same rated horsepower. The name Maytag assures you of that.

Don't be content with anything less. Lightest weight, $\frac{1}{2}$ h. p., 35 pounds; 1 h. p., 65 pounds. Easy to carry and quickly connected for use. Smallest number of parts—no gears, cams or valves to cause trouble. If your dealer can't supply you, we will ship direct. Buy now and avoid possible advance in prices.

THE MAYTAG COMPANY 75
Dept. 225 NEWTON, IOWA

World's Foremost Builders of Working Machines

JOBBER AND DEALERS: Write for Multi-Motor Proposition. It pays.

Please Mention Popular Mechanics

Prest-O-Lite

For
Motorcycles



Ride With Safety On Any Road

No matter how good the motorcycle or how careful the rider, safety demands that the lighting system be perfect.

Every rider needs good, dependable light just as much as he needs fuel.

Prest-O-Lite gives the rider maximum lighting efficiency at minimum cost—makes night riding safe and enjoyable.

It furnishes brilliant, steady light—penetrates dust, fog or smoke—never goes out suddenly or fails you at a critical moment.

Its operation is perfectly simple—what little attention is needed the rider can easily give.

The first cost of Prest-O-Lite is small—its upkeep expense is trifling.

Insist on Prest-O-Lite for Your Motorcycle

It's your guarantee of safety, economy and efficiency in motorcycle lighting. No matter what make machine you have or intend to buy, your dealer can fit you out with Prest-O-Lite. Ask him about this combination, "A Prest-O-Lite, a good lamp and mechanical horn." He'll probably quote you an attractive price on this special equipment combination.

It will save you money on its first cost and give perfect service and satisfaction.

Information of value to every motorcycle rider is contained in our special folder. Write for your copy today.

The Prest-O-Lite Co., Inc.

U. S. Main Office & Factory, 265 Speedway, Indianapolis
Canadian General Office, Dept. N8, Toronto, Ont.

Prest-O-Lite Exchange Agencies Everywhere
The World's Largest Makers of Dissolved Acetylene

Please Mention Popular Mechanics

FEDERAL BICYCLE TIRES

**Follow
The Leader!**

Alone or a wheel, it is great fun. And with your bike, "Follow the Leader" is one of the most enjoyable and healthful of outdoor sports.

With Federal Tires—Rugged or Traffic tread—you can follow your leader anywhere—uphill, downhill—over any kind of roads—with greatest comfort, safety and satisfaction. They are built to give the best of service.

Write for the illustrated booklet.

THE FEDERAL RUBBER COMPANY
OF ILLINOIS
Factories: Cudahy, Wisconsin

FOLDING TRUCK BODY

STEEL BUTLER PRODUCTS

CLOSED **OPEN**

Open, it's a strong, serviceable, practical, economical, light truck. Closed, it's an attractive roadster. No tools needed to change. Nicely finished in black enamel. Lettering does not show when folded. Easily attached. Low in price. For Ford or Chevrolet. Write for free circular giving full description. Also shows other style bodies.

BUTLER MANUFACTURING CO.
804 Butler Bldg., Kansas City, Mo.
899 Sixth Ave. S. E., Minneapolis, Minn.

60 SECONDS MAKES THIS CHANGE—

I Never Stop for Punctures since I treated my tires with

NEVERLEAK TIRE FLUID

No more delays—no more stopping by the wayside to "fix a leak." Saves repair costs of punctures—saves porous tires from the junk pile—preserves new tires and doubles their life.

25c Treatment Gives \$2.50 Extra Tire Mileage

Neverleak automatically heals punctures on the run. Get a tube or two today and save your tires. Sold by Repairmen & Bicycle Dealers.

BUFFALO SPECIALTY COMPANY
BUFFALO, N. Y.

30 Days Trial

Choose from **44 styles, colors, and sizes** in the famous "RANGER" line of bicycles. All are pictured in natural colors in our big new catalog. There are many other models also—in fact the most complete line of bicycles in the world, all at **FACTORY PRICES**, from \$16.75, \$17.75 up. There is a Mead bicycle to suit the taste of every rider—electric lighted Motorbike models, Racers, Juniors for children; Ladies' models too—all at prices made possible only by our **Factory-direct-to-Rider** selling policy.

Delivered to You Free We send the "RANGER" bicycle, **FREIGHT CHARGES FULLY PREPAID TO YOUR TOWN**, for **30 days free trial**—actual riding test. We pay return charges if you decide not to keep it, and make no charge for wear and tear during trial. We make no effort to influence your decision. The trial is all at our expense.

Factory-to-Rider Back of your "RANGER"—if you decide to keep it—is the oldest and most successful bicycle concern in the world, with a Service department that cares for the parts and repair needs of more than a million riders. With every "RANGER" we ship, goes a **Certificate of Guarantee for Five Years**.

Parts & Repairs Lamps, Horns, ready-to-use front and rear wheels, Inner Tubes, Tool Kits, etc., etc. Repair parts for all bicycles and coaster-brakes, all accurately pictured and described in the sundry pages of the big new **Ranger Catalog**. All the latest imported and American novelties in equipment and attachments at prices so low they will astonish you.

Rider Agents wanted everywhere to ride and exhibit "RANGER" bicycles. Select the model you prefer and, while you ride and enjoy it, make money by taking the orders of your neighbors who want a bicycle like yours.

Send No Money but write today for this big new catalog, also full particulars of the great new offer to send, all charges prepaid, the "RANGER" bicycle you select for **30 Days Free Trial**. You cannot afford to buy a bicycle, tires or sundries without first learning what we offer.

MEAD CYCLE COMPANY

Dept. D108, CHICAGO, U.S.A.



The Electric Lighted Ranger "Motor-Bike"

More Miles From Gasoline—Guaranteed!

The Wilmo Manifold gives your car a flying start at the first few turns of the motor—increases gasoline mileage from 42 to 54 per cent by actual official A. A. A. tests—keeps the engine free from carbon—makes a smoother running motor at all speeds. Quickly and easily applied with a monkey-wrench. No holes to bore. Absolutely guaranteed. Made for various cars. Price \$7.50 up. Ask your dealer or garage man, or write.

THE WHITTIER CO., 807 First National Bank Building, CHICAGO



How's This for a Coaster?

Here's a Coaster that has real roller-bearings, dust-proof hub caps, steel axles and tires—and a body built for speed and endurance.

Auto-Wheel Coaster

It's the Coaster that wins the races—the Coaster that goes down hill faster—and pulls up hill easier. IT'S THE COASTER FOR YOU.

A Catalog and Pennant Sent FREE!

All we ask you to do is send us names of three coaster-dealers, telling which ones handle the Auto-Wheel. The Catalog tells all about this speed wagon—imitated, but not equalled. Make sure you buy the Auto-Wheel.

BUFFALO SLED CO.

137 Schenk St., N. TONAWANDA, N. Y.
In Canada, Preston, Ont.

TWIN FIRE

The Only Plug That Fires

Two Distinct Sparks

Laughs at soot and oil. If one points fouls, the other continues firing; the hot explosions soon clean the clogged point. The laws of electricity make it impossible for any other than Twin Fire Spark Plug to fire two distinct sparks at the same instant—it fires two series sparks.

Price Only \$1.00

Saves gasoline, adds energy to each explosion (double intense sparks) and reduces carbon. Test one in your motor—put it in that oil-shooting cylinder and watch it. If your dealer cannot supply you, send direct. Give size required. You'll find this the most satisfactory plug you ever used.



Twin Fire Spark Plug Co.
660 Woodward Ave.
DETROIT, MICH.

Dealers: There's a big demand for Twin Fire Plugs—write for dealer's proposition



Ordinary plug dead when even one point clogs.



Twin Fire always fires—one point cleans the other.

Please Mention Popular Mechanics

LET THE GAS MAN LOAF



Make fuel stops few and far between. Stretch mileage and shorten gas costs with the

New Stromberg Carburetor FOR FORDS

It "does it." We show you in figures on your speedometer—with 10 Day Free Trial.

The Economy Record That Made the Motoring World Marvel

37 4/10 miles on a gallon of gasoline—was made by a Stromberg-equipped Model T 1915 Ford—carrying three passengers and weighing 2170 lbs.—in an official test. A wonderful record—made more wonderful by the fact that the same Ford was accelerated from standing start to 25 miles an hour in 11.4 seconds—then speeded up to 43 miles an hour without touching the carburetor. Get the same remarkable results from your Ford—immense savings—gigantic power and speed increase—easier starting. No risk. The purchase price—\$18—will be returned if not satisfied with 10 Day Trial. Order now. Or send for Free Literature.

Stromberg Motor Devices Co., Dept. 714, 64 E. 25th St., Chicago, Ill.

New STROMBERG Does it! CARBURETOR

\$100 a week pays for the
Black-Beauty-Bicycle



JUST THINK OF IT—here's the classiest bicycle ever built—and yours at the unusual terms of \$1 a week. What's more, we ship freight prepaid. DIRECT FROM FACTORY—ON APPROVAL. You take no risk, for if you don't like the Black Beauty, send it back at our expense—you're not out a penny.

5-YEAR GUARANTEE

All sizes, all styles, and a tool kit free. Get color catalog now.

WRITE US TODAY

HAVERFORD CYCLE CO.

Est. 1896. Dept. F, Philadelphia, Pa.



THE PLEASING AND POSITIVE SIGNAL

The Buell Explosion Whistle is sweet toned. It cuts the air—"carries" great distances—still doesn't "grate on the ear." Announces your approach—but doesn't annoy. New style whistle. Vastly superior. Screws in place of peining cup. Blown by direct explosion. No upkeep cost. Positive in operation. Now standard equipment on many cars. Write for interesting FREE circular.

THE BUELL CO., 1610 Michigan Ave. CHICAGO

FORD OWNERS

The Van Sicken Headlight DIMMER & INTENSIFIER

Makes night driving safe. A mere flip of the control switch instantly provides the kind of light you need at any speed. Easily installed. Unfailing in results. Write for free booklet, "Headlight Control." Address The Van Sicken Company, Elgin, Illinois



Price \$4 Complete

No More Creaky Wheels

Last summer thousands of motorists stopped the creaking of their heat-shrunk wheels with Spoktite. And they prevented the rattling and possible collapse that might have followed. Be on the safe side yourself this year—at least be without creaky, squeaky wheels.

Use SPOKTITE

It penetrates the pores and prevents shrinkage. \$1 saves 4 wheels. Auto supply dealers—or postpaid on receipt of dealer's name and \$1.

LIQUID WHEEL TIGHTENER CO.

Dept. 1, Modesto, California
Sales Offices: Boston-New York



For Auto, Buggy Or Wagon Wheels

Violet Ray Treatment

Restores, Beautifies, Benefits, Relieves

Anyone can now enjoy this wonderful, invigorating, electrical treatment. Electrical energy transmitted without shock or pain, to any part of the body in the privacy of their home, with our



Vi-Ray-O

The true Violet Ray generator. Endorsed by leading physicians and satisfied users everywhere.

Write for our 68-page illustrated Free book—Vi-Ray-O. It tells of the soothing, delightful, nerve-toning and health-giving Violet Ray and all details about our wonderful Vi-Ray-O instruments.

With it comes our special 10 day offer. — Order today.
Western Coil & Electrical Co., Box 21, Racine, Wis.



Please Mention Popular Mechanics

SARGENT

REG. U. S. PAT. OFF.

Automatic-Set Bench Planes

For working against the grain on cross-grained hard wood.



Mechanics who have used these Planes say they are the BEST. They have superior features and do work that no other Planes will do.

The automatic set is a great time saver; the rigidity insures good work; and the ease of adjustment is a great advantage.

These features are fully explained and the six sizes of these Planes described in the Sargent Plane Catalogue, a copy of which will be sent free on request.

SARGENT & COMPANY
49 Water St., New Haven, Conn.

AGENTS \$60 WEEKLY

Robinson Folding Bath Tub, Big-seller. Costs little, no plumbing, little water. Weight 15 pounds, folds into oval roll. Full length baths, far better than hot tubs. Guaranteed 10 years. \$10 a day easily made. Write for free offer.

ROBINSON CABINET MFG. CO., 4713 Factory Bldg., Toledo, Ohio



"Bow Legs and Knock-Knees"
Unsightly Send for booklet showing photos of men with and without

The PERFECT LEG FORMS

Perfect Sales Co., 140 N. Mayfield Ave., Dept. 5
Austin Station, CHICAGO, ILL.

Erickson Artificial Limb Co., 38 Wash. Av. N., Minneapolis, Minn.



We are
Under
Govt.
Bond

A Yearly Income for You

Would you invest a moderate amount in small monthly or semi-annual installments, if you felt assured it would earn for you an income from \$1000.00 to \$5000.00 annually, according to your investment? A Dixie Estate near Tampa, Florida, planted to grapefruit, oranges and avocados, should do this for you. The proof is what you want. We have it and will gladly send it to you free. Write us today for details of this money making opportunity.

The Thomas Nurseries, Inc., Tower Bldg., Chicago

KEROSENE Gas Lamps

BURNS KEROSENE or GASOLINE

one just as well as the other; or the two mixed. Make their own gas. 300 to 600 C. P. at 1/2c an hour. Family or Business use.

WRITE FOR COMPLETE ILLUSTRATIONS
BRILLIANT GAS LAMP CO.
1009X So. Wabash Ave., CHICAGO, ILL.



**Driving
Screws
as Easy**

**As Winding
Your Watch**

Because the same principle of ratchet mechanism that is found in the stem-winding watch is used in this

**"YANKEE"
Ratchet**

Screw Driver No. 10

only on a larger and stronger scale. Easy and smooth working—practically frictionless.

Once the blade of the screw driver is inserted in the slot of the screw, you just twist your wrist back and forth, without that tiresome grip-and-let-go movement of the fingers. You never shift your first good grip until the screw is driven home. Thus you can drive more screws and drive 'em faster, without tiring. A push of the ratchet shifter gives right or left ratchet movement or rigid adjustment. Made of selected materials, special care and accuracy given to every detail of construction. Handle of polished hardwood, all steel parts nickel plated.

Eight Lengths of Blades:

2-in. Blade, 45c 6-in. Blade, 80c
3-in. Blade, 55c 8-in. Blade, 90c
4-in. Blade, 65c 10-in. Blade, \$1.05
5-in. Blade, 70c 12-in. Blade, 1.15

The "Yankee" Ratchet Screw Driver No. 11 is just the same as No. 10, but has the ratchet shifter working across the tool.

Your dealer can supply you

Write for "Yankee" Tool Book"—
free for mechanics and householders

NORTH BROS. MFG. CO., Philadelphia

**"YANKEE"
TOOLS**

Make Better Mechanics

Please Mention Popular Mechanics

NEW BOOK ON ROPE SPLICING

Useful Knots, Hitches, Splices, etc.

How Different Knots Are Made and What They Are Used For INDISPENSABLE TO EVERY MECHANIC AND RIGGER

PRICE 20c



A most practical handbook giving complete and simple direction for making all the most useful knots, hitches, rigging, splices, etc. Over 100 illustrations. All about wire rope attachments, lashing, blocks, tackles, etc. 37 Heraldic Knots illustrated. Of great value to mechanics, riggers, campers, boatmen. Price 20 cents postpaid.



LUMINOUS PAINT

Make Your Watches, Clocks, Etc., Visible by Night

The very latest discovery in the scientific world. Herberts, succeeded in producing this remarkable LUMINOUS PAINT, which, applied to the surface of any article, emits rays of white light, rendering it perfectly visible in the dark. THE DARKER THE NIGHT, THE MORE BRILLIANT IT SHINES. Quite simple to use. Anyone—you can do it. A little applied to the dial of your watch or clock will enable you to tell the time by night. You can coat the push buttons or switch plates of your electric lights, match boxes, and innumerable other articles; make your own Luminous Candles, Luminous Rosaries, etc. Bottle contains sufficient to coat several small articles. Price 25c. Larger sizes 50c and \$1.00 postpaid.



INVISIBLE INK VANISHING INK

The most confidential message can be written with this ink for the writing MAKES NO MARK. Cannot be seen unless you know the secret. Invaluable for many reasons. Keep your passwords and other private memorandums away from prying eyes. Great fun for playing practical jokes. Only 15c Bottle



Writing written with this remarkable ink vanishes entirely in a few weeks/sooner if desired, leaving the paper QUITE BLANK. 15c p.p.d. LUMINOUS INK writing can be READ ONLY IN A DARK ROOM: writing appears like fire. Quite invisible at daytime. Very remarkable. 15c

All the Latest Surprising and Joke Novelties

- Pharo's Serpents Eggs, box . . . 10c
- Miniature Water Pistol . . . 10c
- Cleopatra's Snake (very lifelike) . . . 10c
- False Mustache (feed your friends) . . . 10c
- The Roll Stage Money . . . 10c
- Ford Auto Puzzle (Latest) . . . 15c
- Magic Plate (anyone can play it) . . . 15c
- Rubber Earrings . . . 10c
- Rubber Dagger (sensational) . . . 20c
- Window Smashers (great joke) . . . 25c
- Pocket Detective (see behind you) . . . 15c
- Ghost Mind Reading Mystery Cds. . . 10c
- Thorton's Mystery Trick Cds. . . 10c
- Fighting Howlers, pair . . . 10c
- Cover the Spot Trick, a scene, nov. . . 10c

- X Ray Novelty . . . 10c
- Trick Pencil . . . 10c
- Rubber Tacks (a good joke) . . . 10c
- Measurized Penny (defies the law of gravitation) . . . 20c
- Catches 1 Sweeping Powder . . . 10c
- Mysterious Tumbler and Vanishing Coin Trick . . . 25c
- Enchanted Bottle (won't lay down) . . . 20c
- Magic Plate Lifter . . . 25c
- Imitation Gold Teeth . . . 3 for 10c
- Great Eclipse Puzzle . . . 10c
- Wire Puzzles, 10c. 22 different, \$1.95

SILK FLAG PINS 4 for 10c



Wear the colors and show your patriotism. The flags are made in bow shape of silk ribbon, with pin for sticking into coat or dress. 4 for 10c, 12 for 25c

AMERICAN FLAG GUM STICKERS

These flags are about same size as a postage stamp. Gummed on the reverse side ready for use. Use them on your envelopes, stationery, etc., and let every one know you are an American. Put up in sheets, each containing 100 flags. Four sheet pkg. at 10c. 12 sheet pkg. at 25c. PRICE 10c per sheet, 3 sheets for 25c.



JOHNSON SMITH & COMPANY, 7163 North Clark Street, CHICAGO

(2 in 1) HIKEMETER (Price \$2.00)

Hikemeter Dial in Front, Compass in Back

Measures the distance you walk. Adjustable to any step. Registers 100 miles or any fraction. No winding. Accurate, interesting and fully guaranteed. Just the thing for Golfers, soldiers, sailors, tourists, hunters, hikers, boy scouts and all sportsmen. Sold by all dealers or sent by mail. SEND FOR FOLDER.

Front Reduced Back Reduced

SCOUTS COMPASS WATCH CO. 235 Jewelers Bldg. MINNEAPOLIS, MINN.

Enormous Profits

START GROWING MUSHROOMS

Learn the latest authoritative way to make still bigger profits than you ever thought possible or ever made growing mushrooms. Add \$10 to \$75 a week to your income. Anyone, men, women and children can do it in spare time in city or country. Grow in basements, cellars, sheds, boxes, etc. Start now. Demand bigger than supply. Send for big free book of expert authority. The Truth About Mushrooms. Write to:

BUREAU OF MUSHROOM INDUSTRY Dept. 392 1342 N. Clark St. Chicago

Automatic Repeating Rifle

Fires 20 Shots in One Loading



This is a regular size automatic revolver. Shoots B. B. shots obtainable anywhere, same as other rifles and guns. Repeats 20 times with one loading. Handsomely finished in gun metal. No caps or load necessary, as it works with a spring and shoots with rapidity and accuracy. Simply load with 20 B. B. shot, then press the trigger. Nothing to explode—absolutely harmless and safe. Remember, it is not a mere toy, but the same size and shape as a REGULAR AUTOMATIC. Sent complete with a round of shot for ONLY 25c postpaid. Extra shot, 10c a package.

Only 25c Postpd

GREATEST TOY SENSATION OF THE DAY!

FIGHTING DREADNAUGHT

SENSATIONALLY REALISTIC!!!

Exact Model of a Modern Warship

The Fighting Dreadnaught is an exact model of Uncle Sam's latest fighting monster. It carries eight big guns, each of which flashes, at correct intervals, from twelve to twenty times. Extra ammunition always obtainable. Absolutely harmless. Can be operated indoors or out. Now, boys! Here's your chance to see a battleship in action, and the best of it is you can OWN the ship and command the firing yourself! By having two or more Battleships, you can arrange EXCITING NAVAL BATTLES in your own home. Price of Warship and Ammunition, 15c, three for 40c, or a fleet of 12 ships for \$1.50 postpaid. Extra Ammunition, 5 cents per pkg.



New Vamping Card

PIANO PLAYING MADE EASY

NO TEACHER NEEDED—SURPRISINGLY SIMPLE SYSTEM

Persons having neglected their Musical Education need not despair, for with the aid of our new VAMPING CARD (placing the card upright over the piano keys), you can at once Vamp away to thousands of Songs, Ballads, Waltzes, Rag Time, etc., etc., equal to a Professional Musician. No knowledge of music is required. After using it a few times, you will be able to dispense with the aid of the Vamping Card entirely. The price of this very clever invention is only 15 cts. postpaid.

Comfort Indoor Closet

Odorless, Sanitary, Germ-proof. Can be placed anywhere in home. A guarantee of healthy, sanitary conditions. 30 days' Free Trial.

SWAT FLY BREEDING CLOSET

Have city conveniences. Germs killed instantly by chemicals. Emptied once a month. Needs no other attention. Boards of Health endorse. Write for literature.

Agents wanted—exclusive territory

COMFORT CHEMICAL CLOSET CO. 387 Factoria Bldg. TOLEDO, OHIO

Diamonds on Credit

20% Down; 10% a Month

Every customer is protected by our written guarantee to refund his money if his dealer can duplicate our diamond at our price.

Write for Illustrated Catalog No. 3.

J. M. LYON & CO. 1 Maiden Lane, New York City

Double The Value Of Your Phonograph

No matter what make of machine you have, how fine or how expensive—its reproducing qualities—its real musical value can be *doubled* by attaching the

Perfect-Tone Reproducer

—a wonderful little device that eliminates the harsh, metallic noises and brings out the superb, natural tones of the human voice or any instrument. The effect is positively amazing. The scratch, twang and rasping disappears—only mellow, silvery, "natural" harmonies are heard. Fits any machine using disc records. Fully guaranteed. Costs little—positively doubles enjoyment of any photograph. Write for circular and low factory price, **ELLIS-BUTLER CO., 415 Jefferson St., Milwaukee, Wis.**



Write for Band Book

WRITE today for our new 194-page band book—it is free. Over two thousand instruments described. Read the startling offer made direct to you from the manufacturer. All instruments at Rock-Bottom prices.

WURLITZER Cornet for 10c a Day

10c buys this superb triple silver plated Lyric Cornet. Free carrying case. This is only one of the bargains.

Write Today for 194 page Book of all instruments. No obligations. It is free. Write today.

THE RUDOLPH WURLITZER CO., Dept. B364
E. 4th St., Cincinnati, O.—S. Wabash Ave., Chicago, Ill.



10c A Day for Electric Washer

Save a day a week by washing by electricity. Costs 5c a week to run. Send for special offer now.

Laskin Co. Desk 717 BUFFALO, N. Y.

DIXON'S ELDERADO

"the master drawing pencil"

THE \$15 MICROPHO DEAF-PHONE

is a super-sensitive instrument which has been developed to meet the demand for a practical and efficient hearing device at an extremely low price. This instrument of marvelous sensitivity is a great benefit to all those who are afflicted with impaired hearing, as it has perfect clarity of tone and articulation. The outfit consists of: One Super-Sensitive Transmitter with cord connector; One Super-Sensitive Ear-Piece with small black cord; One Black Single Headband; Black Case and Two Small Batteries. The Transmitter is 2 3/8 inches in diameter, 5/8 of an inch thick, and weighs less than three ounces.

Price Complete, \$15. Write today for free booklet.

MICROPHO-DETECTOR CO., Inc.

Gaston Boissonneault, President
25 Day Street Tel. Cortlandt 7290 NEW YORK



AVIATION Practical Aeronautics BY MAIL

under personal guidance of the well-known aviator, Bud Morris, Chief Instructor. Salaries of \$50.00 to \$500.00 a week now waiting for trained men. Now is the time and this is your opportunity to step into fame and fortune. Write today for complete literature, all FREE. Special offer open to you now. Write at once. **AMERICAN SCHOOL OF AVIATION**
431 So. Dearborn St., Dept. 5147, CHICAGO, ILL.



No Money In Advance

This Marvelous CAMERA On FREE Trial!

Only 10,000 of these marvelous, instantaneous picture-taking and making cameras to be sent out absolutely on approval without a penny in advance just to prove that it is the most wonderful invention—the camera sensation of the age. So you

must send for it quick! Just think of it—the new Mandel-ette



TAKES AND MAKES Finished Pictures Instantly!

You press the button, drop card in developer and in one minute take out a perfect, finished post card photo, 2 1/4 x 3 1/2 inches in size. Camera, itself, is about 4 1/2 x 3 x 7 inches. Loads in daylight 16 to 50 post cards at one time.

No Films—No Plates—No Dark Room

Not a bit of the fuss and bother of the ordinary kodak or camera. It is instantaneous photography. Universal focus lens produces sharp pictures at all distances. Pictures develop and print automatically. Can't overdevelop; results simply amazing.

We Trust You

No difference who you are, where you live or what your age, we will send you the complete "Mandel-ette" outfit absolutely on approval and give you 10 days to test it. If not satisfactory return it. But when you see what elegant pictures it takes—so quick, so easy, with no trouble at all—if you wish to keep it you simply send us \$1.00 per month until our special price of only \$5.00 is paid.

EASY PAYMENTS—NO REFERENCES

No red tape of any kind. Monthly payments so small you'll not notice them. Lots of fun and big profits.

NO EXPERIENCE REQUIRED

Plain instructions and everything complete with outfit so you can begin taking pictures the moment it arrives. We guarantee that even a child can operate it. Mail coupon right now. No risk or obligation to keep camera.

The Chicago Ferrotpe Co.,

Desk 516 Ferrotpe Bldg., Chicago, Ill.

Send me at once one complete model Mandel-ette Camera outfit including supply of post cards and instructions. I agree to examine and test it thoroughly and if satisfied keep it and pay you \$1 a month until your special price of \$5 is paid. Otherwise I will return it at the end of 10 days.

Name

St. and No.

Town.....State.....



ATTENTION!

Every soldier, every individual in a Home Defense League, every member of a semi-military organization, and in fact every citizen of the United States will need one or more of the following books at once:

UNITED STATES ARMY Infantry Drill Regulations

With War Department Text Corrections to February 12, 1917

Gives the officially prescribed army drill regulations for soldier, squad, company, battalion, regiment, and brigade as well as the rules for combat, marches and camps, ceremonies and inspections; includes the following Manuals: Color, Band, Saber, Tent-Pitching, Bugle (with bugle calls and signals), Arms and The Bayonet.
Pocket Size Latest Edition 246 Pages Cloth Binding Illustrated Price 58 Cents, Postpaid

Cavalry Drill Regulations

UNITED STATES ARMY
Pocket Size Latest Edition Cloth

Small Arms Firing Manual

With Text Corrections to February 21, 1917
Pocket Size Latest Edition Cloth



Field Service Regulations

UNITED STATES ARMY
Pocket Size Latest Edition Cloth
Price Each 80 Cents, Postpaid

Send for our carefully selected list of standard books covering every branch of military and naval service and including all the army and navy drill regulations and manuals.

These Books for Sale by

Popular Mechanics Book Dept.
 6 N. Michigan Ave., Chicago

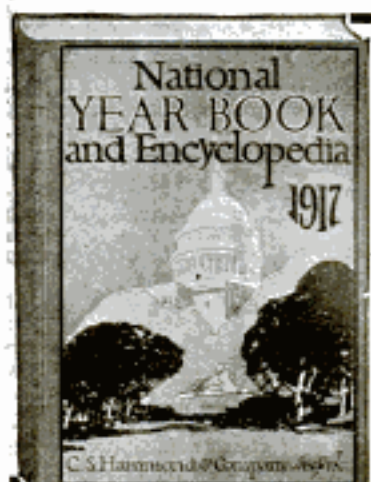

America's First Really NATIONAL YEAR BOOK 1917 Edition Now Ready A Book You Need To-Day

No expense has been spared in the production of the 1917 edition of the **National**

Year Book and Encyclopedia. It is very much enlarged and far superior to any previous issue. Its success in the past has prodded the ambition of the publishers to give its readers the most complete and compact volume of the World's Statistics and Facts ever published, and in this issue they feel that their fond hopes have been fully realized.

More Than a Thousand Facts

Space will not permit elaborate digest of all the good things to be found within its covers, but here are just a few:

The Eight Hour Labor Law, The Naval Appropriation Law, Pure Food Law, Interstate Commerce Law, Income Tax, Tariff Law, and other important Federal Laws, in which all are vitally interested.

Compilations of Election Returns, Sporting Records, Population Figures, Distances, Areas, Marine Resources, Rivers of the World, etc.

Statistics on Manufacturing, Agriculture, Mining, Commerce, Legislation, Religious Denominations, Progress of the United States, Etc.

Descriptive articles on each of the States of the Union, treating of physical features, industries, government, education, climate, and history.

Articles and statistics on such timely subjects as the U. S. Board of Medicine and Certification, Political Platforms, Panama Canal, South America, American Hall of Fame, U. S. Army and Navy, League for National Defense, Commission on Industrial Relations, Boy Scouts of America, and Woman Suffrage.

Important Events of 1916—Chronology of the Great War; Chronology of the Mexican Revolution; Important Dates in American History; Great Events in the World's History. Price Cloth Binding Postpaid, 60c.

POPULAR MECHANICS BOOK DEPT. 6 NORTH MICHIGAN AVE. CHICAGO

The Book For the Man With His First Car How to Run an Automobile

By VICTOR W. PAGE

Price \$1.00 Postpaid 178 Pages 72 Engravings



This treatise gives concise instructions for starting and running all makes of gasoline automobiles, how to care for them, and gives distinctive features of control. Shows the control groups of all popular makes of automobiles and describes every step for shifting gears, controlling engine, etc.

Makes Automobile Driving Easy
 Convenient—Up-To-Date—Inexpensive

Everything Explained in Simple Language

Send for complete description and synopsis of contents.

Popular Mechanics Book Dept. 6 N. Michigan Avenue CHICAGO

Mathematics Made Easy by ROPP'S CALCULATOR AND SHORT-CUT ARITHMETIC

Shows the Answer as Quickly as a Watch shows the Time to all Problems likely to occur in the Office, Store, Shop, Bank, Farm, or Factory.



Over 2,000,000 Sold

Explains and simplifies every principle in Arithmetic, Mechanics, and Mensuration.

PRICES, POSTPAID

Desk Size.....\$1.25

Leather, Pocket Size.....\$1.00

Leather, Vest Pocket Size.....\$0.50

Pocket Size.....\$0.50

Send for 4-page description of this work

Popular Mechanics Book Dept., 6 North Michigan Avenue, Chicago



Nujol *for Constipation*

Overcoming the difficulties of the nursing mother

If nursing mothers will only realize that practically everything they take for constipation just before and during the nursing period affects the infant, they will realize the tremendous benefit to be derived from taking Nujol.

Nujol is not absorbed into the system. It will therefore not upset the mother's stomach, nor affect the nursing baby's nutrition in any way.

Many nursing mothers have already discovered the wonderful properties of Nujol and have written telling us of their relief and happiness.

Nujol is not habit forming; the longer you take it, the less you need it. Nujol does not gripe, relieves you of straining, does not weaken (even when taken in large quantities), it is not absorbed into the system, does not upset the stomach, is absolutely pure and harmless and is delightful to take. Even the infant will enjoy it, and it will do as much for him as it does for the mother.

The Standard Oil Company (New Jersey) has used its world-wide resources in producing Nujol, and its reputation is behind the product. Nujol is sold only in pint bottles, bearing Nujol trademark—never in bulk.

Nujol is absolutely distinctive and individual. There is no other product on the market like it.

Write today for instructive booklet on Nujol and its uses.

STANDARD OIL COMPANY (New Jersey) Bayonne, New Jersey

Please send me booklet on Nujol and its uses. Write your name and address plainly below. Dept 68.

Name.....
Address.....

Please Mention Popular Mechanics



No Slamming—No Banging

WITH THIS HANGER

The
Perfect
Garage
Door
Hanger
Set

Use This Hanger on the Garage You're
Going to Build This Summer

Allows use of full door opening without risk of damage to car or door, and door cannot swing or blow shut, as it automatically fastens itself open. No extended run-way on either side of building, and no sticking or getting out of order. Can be opened to any width desired, and is weather-tight when closed. No sawing or cutting of holes necessary to attach. Your doors "STAY PUT."

Ask your hardware dealer—Also send today
for descriptive circular, surprisingly low price.

Dealers—Get ready for the big summer garage building season. There's big profit in this device, and there'll be a big demand. Architects—Specify this in your plans and make every client happy. Write for terms.

Safety Door Hanger Co., 107 Topping Bldg., Ashland, Ohio

Mr. Edison's Wonderful Phonograph

Only **\$1.00** After Free Trial



Yes, you may keep this New Edison—Thomas A. Edison's great phonograph with the diamond stylus—and your choice of records, too, for only \$1. Pay the balance at rate of only a few cents a day. Try the New Edison in your own home before you decide to buy. Send no money down. Entertain your friends with your favorite records. Then return it if you wish.

Write Today For Our New Edison Book. Send your name and address for our new book and pictures of the new Edison phonograph. No obligations—write now while this offer lasts.

F. K. BABSON, Edison Phonograph Distributors
8719 Edison Block, Chicago, Illinois

BIGGEST VALUE



Ever Offered in a VIOLET RAY MACHINE
A triumph in mechanical construction! Pronounced most perfect by eminent mechanics. In convenience and efficiency of operation THE VIOLETTA is without a peer. In price—the most economical. The greatest money's worth ever offered. Send quick for Free Descriptive Matter and scores of testimonials from users who have received amazing health and beauty benefits—an astounding cash-saving offer.

BLEADON-DUNN CO., Dept. C8
11 So. Desplaines St. Chicago, Ill.

WE PAY CASH for Scrap
PLATINUM
and Old False Teeth

On rubber or metal plates. Highest cash price paid for old Gold, Silver, contact points, crowns, bridge work, mercury and broken jewelry. Send your package today by parcel post to

The Mutual Smelting and Refining Company
116 North Front Street, Columbus, Ohio

RUNS ON KEROSENE
ALCOHOL, GASOLINE OR GAS
A MOST REMARKABLE INVENTION

No electricity, wires or springs. 1917 Improved patented Model. Runs 8 hours for a cent on kerosene. Quiet—convenient. Brings genuine comfort and satisfaction. Ideal for the sick. A proved success. The Wonder Fan. 2 Models. 3 Sizes.

A { 12-in. \$16.50, Alcohol or Gas only (Gas \$1.50 ex)
 { 16-in. \$18.50, Alcohol or Gas only (Gas \$1.50 ex)
B { 16-in. \$19.50, Any Burner (Gasoline \$2.50 ex)
 { 21-in. \$22.50, Any Burner (Gasoline \$2.50 ex)

F. O. B. Chicago. Cash with order only. KEEP COOL.

LAKE BREEZE MOTOR, 546 W. Monroe St. CHICAGO, ILL.



Russel Internal Gear
Drive Axle



The most serviceable and economical motor truck axle made. Write for convincing reasons why your truck should be equipped with the Russel Axle.

RUSSEL MOTOR AXLE COMPANY, Central Ave., North Detroit

Get about
A.M.C. \$125 Built That Every Man May Ride



The lowest priced complete motor vehicle in the world, including starter and clutch. Light weight and easy to handle. Goes almost 100 miles on a gallon. WRITE FOR BOOKLET.

Schickel Motor Company 69 Garden St. STAMFORD, CONN.

When You Build
please bear in mind that there is still plenty of
WHITE PINE

Send for our free booklet, "WHITE PINE IN HOME-BUILDING"

WHITE PINE BUREAU
1626 Merchants' Bank Bldg. ST. PAUL, MINN.

MIAMI-MADE BICYCLES
Stand at the top of the bicycle world.
RACYCLE, HUDSON, MIAMI, FLYING MERKEL
Write for our catalog.

THE MIAMI CYCLE & MFG. CO., MIDDLETOWN, OHIO

THE CORBIN DUPLEX COASTER BRAKE
is the standard brake equipment assuring absolute control. Equip it now. Send for catalog.

THE CORBIN SCREW CORP. The American Hardware Corporation, Successor
NEW BRITAIN, CONN. BRANCHES: New York, Chicago, Philadelphia

3 YEARS TO PAY
Meister Piano 30 days' free trial in your own home
\$1 A WEEK or \$5 A MONTH Price \$210.00



No cash payment down. No interest—no extras. Piano stool and scarf free.

ROTHSCHILD & COMPANY
Dept. E16 CHICAGO, ILL.

Learn Aviation

Learn at home! The U. S. Government will spend 60 million dollars on aviation. Right now we need thousands of flying men. And there is even greater need for Airplane Designers; Builders; Salesmen; Assemblers; Repairmen; Inspectors; Instructors; Mechanics. This course gives you all the basic training for these positions.

Write Today! Get our Special Offer. Learn how you can get free a flying model and all materials to build your own model. Don't fail to write us today!

National Aero Institute, Dept. B719 Morton Bldg., CHICAGO

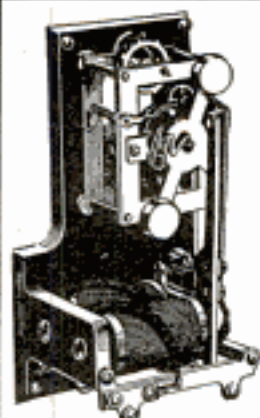

Size 6 x 3 1/2 inches

Build Your Own Clock \$5

ELECTRIC SELF-WINDING

We sell self-winding electric clock movements for \$5.00 that we guarantee for one year. All that is required to run these movements is two dry batteries. Throw away your bothersome key-wound works and replace it with an "American" self-winding movement. Also excellent for time switches and experimental work.

SAVE THE BIG PROFITS

by buying direct from the manufacturers. For a small sum you will have a better clock than your jeweler would charge for one of the old-fashioned key-wound clocks, so why not get an "American" self-winding movement for your clock that you never have to wind. We can also sell you self-winding clocks, complete in mission or mahogany cases, very attractive in design and workmanship, ranging in prices from \$1.50 to \$17.00. *Catalogue sent you free upon request.*

REMEMBER—"YOU NEVER HAVE TO WIND THEM"
AMERICAN SELF-WINDING CLOCK CO. Dept. 5, No. 3121 W. Harrison St. CHICAGO, ILL.



How to Cut Coal Bills 1/2 to 2/3

Free Book "From Overfed to UNDERFEED" tells how—guaranteed. Tells how to burn cheaper grades of coal cleanly and effectively. No clinkers. No partly burned coal. Ashes few, clean and white. No sifting. A boy can tend the Williamson UNDERFEED Furnace or Boiler with expert results. Coal fed from below. Hot, clean fire always on top. Write for free book today. NOW.

THE WILLIAMSON HEATER COMPANY
 65 Fifth Avenue Cincinnati, Ohio

Super-Sensitive Microphone Only \$7.50

This instrument is offered at an extremely low price. It is excellent for building your own amplifier. Can also be used in many experiments where a sensitive microphone is required.



Detectograph, \$15

This detecting instrument of marvelous sensitivity can be used for detecting secret conversations. Outfit consists of Sensitive Transmitter, 25-ft. Black Cord, Receiver, Headband, Case and Battery.



Detectograph, \$15

Send for One Today and Convince Yourself.

MICROPHO-DETECTOR COMPANY

Gaston Boissonnault, President
 25 DEY STREET NEW YORK
Makers of Super-Sensitive Microphone Apparatus



YOUR OWN BOSS

Easiest thing—right in your town. Small investment—sure profit with a Kingery Peanut and Popcorn Machine. Prices \$40 to \$400—easy to buy!

Ask for particulars and Catalog No. 50.

KINGERY MFG. CO. Pearl, East of Broadway, CINCINNATI, OHIO

GREEN AUTOMATIC MACHINE



Let This Machine Grind Out Money for You

THE GREEN AUTOMATIC MACHINE \$10 A DAY AND UP

Sharpens, Honors and Strops all kinds of safety razor blades in one operation, from four to six blades in one minute. For both quality and quantity this machine is in a class by itself. There is nothing like it on the market. Let us send you our free booklet explaining everything, including the "AMERICAN" Key Cutter—cuts square, angular or round slots.

AMERICAN SHARPENING MACHINE CO. (Inc.), 184 W. Washington St., Dept. 524T, CHICAGO



"AMERICAN" Key Cutter

WEBER Throttle-Governed VALVE-IN-HEAD KEROSENE ENGINES

WILL SAVE YOU HALF IN FUEL COST. All 1917 Weber Engines are equipped with that great engine improvement, the "Weberator." Makes kerosene as convenient to use as Gasoline. Saves 1/2 the cost. Write today for full details and 60 day trial offer. Sold direct to user at factory prices.
WEBER ENGINE CO., Dept. 1774 KANSAS CITY, MO.



Dealers Wanted



Guaranteed \$6

Grind Your Own Tools —
 Sharpen Your Own Cutlery —
 Polish Your Own Silver —
 and save money with a

UNIVERSAL MOTOR

Attached to any socket will run electric fan, sewing machine and perform many other household or shop duties. Complete with emery, wheel, buffer, cord and plug for \$6.00. This offer may never be repeated. Write today.
Racine Universal Motor Co., 53 W. Jackson Blvd., Chicago

Makers of Fans, Vacuum Cleaners, Motor Appliances of All Kinds

1900 Motor Washer Electric or Water Power

on Free Trial to Readers of Popular Mechanics
 Reduce household expenses by using this great laundry outfit. Cuts cost of washing to 2 cents per week. Write for Free Book, giving full details, to

1900 WASHER CO., 6337 Court St., Binghamton, N. Y.
 Address Canadian 1900 Washer Co., 355 Yonge St., Toronto if you live in Canada

BUILD THIS CAR OR BUY IT COMPLETE

Lowest Priced Car in the World



Very fast. Economical. Seats 2 full grown persons. Not a toy. **Complete Detailed Drawings, 35c.** Catalog 10c. Cycle Car and Light Car parts at low prices. Discount to Agents.

Tribune Engineering Co., Dept. P, Owego, Tioga Co., N. Y.

DIAMONDS AT LESS THAN CASH RETAIL PRICE WEAR AS YOU PAY WATCHES

50 cents Down and 50 cents a Week. No Interest Charged

Guaranteed perfect cut and brilliant color. Latest 14K Gold Mounting. For Ladies or Gentlemen.
PRICE \$25.00

Sent on First Payment Anywhere in U. S. A. Why Pay Cash? We can Save You Money. Send for Catalog.

LENOX JEWELRY CO. 373 Washington Street Boston, Mass.
 20 Years of Honest Dealing

Illinois Rockland, Elgin, Waltham and Hamilton. Adjusted in 20-year Gold Case.

PRICE \$10.75 to \$28.50



Are You Mechanically Inclined?

If so, this list of Practical, Up-to-Date Electrical and Mechanical BOOKS at

25c each, postpaid

WILL INTEREST YOU

Each one is a complete, dependable treatise and worth the price several times over.

	Pages	Illustrations
Practical Electrics	135	126
Study of Electricity for Beginners	88	54
Dry Batteries, Their Construction	59	30
Modern Primary Batteries	105	55
Electric Gas Igniting Apparatus	101	57
Alternating Currents	90	33
Electrical Circuits and Diagrams—Part I	72	217
Electrical Circuits and Diagrams—Part II	80	78
Magnets and Magnetism	94	49
Small Electrical Measuring Instruments	90	59
Woodwork Joints	101	178
How to Build a Bi-Plane Glider	60	31
Model Vaudeville Theatres	90	34
Windmills and Wind Motors	83	76
A. B. C. of the Steam Engine	30	6
Steam Engine Design	102	34
Inventions, How to Protect, Sell and Buy Them	108	1
Simple Soldering, Both Hard and Soft	82	52
Induction Coils, How to Make and Use Them	75	35
Experimenting With Induction Coils	73	26
Wimshurst Machine, How to Make and Use It	112	30
Simple Experiments in Static Electricity	72	51
Making Wireless Outfits	61	27
Wireless Telephone Construction	74	43
Telegraphy for Beginners	63	19
Small Accumulators, How to Make and Use	80	40
Wiring Houses for Electric Light	93	42
Low Voltage Electric Lighting	92	23
Electric Bells, Annunciators and Alarms	95	70
Magneto Telephone	86	23

A uniform series, size 5x7 inches. Paper cover. You will be surprised at how much good reliable information 25 cents will buy.

Any of the above books sent postpaid to any address upon receipt of price by

Popular Mechanics Book Dept.
6 N. Michigan Ave., CHICAGO

1000 Interesting Things FOR BOYS TO DO



are described in this greatest of all boys' books

The Boy Mechanic

VOL. II

A sequel to, but containing nothing found in Volume I. It gives complete directions for making those things every boy likes to build and experiment with in electricity, mechanics, wood-work-

ing, model work, indoor and outdoor sports, magic, tricks, arts and crafts work, etc., such as

Bobsleds—Snowshoes—Ice Boats—Ice Gliders—Boats—Camps—Fishing Tackle—Houses of Poles—Kites—Aerial Gliders—Motion-Picture Camera—Spot-Light Lantern—Mile-O-View Camera—Photographic Appliances—Games—Cyclemobile—Pushmobile—Flymobile—Roller Coaster—Ferris Wheel—Sunlight Flasher—Reed Furniture—Electrical Devices—Mechanical Contrivances and hundreds of equally interesting things.

480 Pages. 995 Illustrations
Handsomely Bound in Cloth

Price \$2.00 Prepaid to Any Address

Popular Mechanics Book Dept.
6 N. Michigan Ave., CHICAGO



JUST OUT Shop Notes for 1917

This is Volume XIII of the series of Shop Notes books reprinted from Popular Mechanics Magazine and comprises

524 Articles
422 Illus.
224 Pages

Price 50c
POSTPAID

The following partial list of contents gives some idea of the wealth of time and labor-saving kinks for all the trades found in this book:

(Size 6½ x 9½ x ½ in.)

Automobile, Turntable
Band Saw, Care of
Barn Construction, Modern
Camp House
Dynamo Troubles
Electro-Pneumatic Signal
Fence, Metal
Garage, Private
Hammock, Swinging-Chair
Ice House, Hollow-Tile
Lawn Cleaner and Sprinkler
Milk House, Concrete-Block

Motorcycle Trailer and
Camp Outfit
Multiple Window Opener
Oil Gauge
Pressure Gauge
Range Finder
Road Roller
Sandblast, Homemade
Siphon, Automatic
Tent House
Tool Chest Curt
Workshop, Small-Farm

Shop Notes Series of 13 Volumes contain 6795 Articles, 2884 Pages, and 6373 Illustrations.

These books are a perfect gold mine of information for everyone who uses tools for pleasure or as an occupation. They tell easy ways to do hard things.

Price 50 cents per Volume Postpaid

Popular Mechanics Book Department
6 N. Michigan Ave., CHICAGO

MADE IN U.S.A.

DIRECT FROM THE DIAMOND CUTTERS

GENUINE DIAMONDS

\$70

PER CARAT - PURE WHITE

3-16 Carat . . .	\$10.90
1-4 Carat . . .	16.25
3-8 Carat . . .	26.60
1-2 Carat . . .	35.00
5-8 Carat . . .	43.75
3-4 Carat . . .	52.50
7-8 Carat . . .	61.25

Buy diamonds from us—the only diamond cutters in the United States selling to the public direct—and you will save 40 per cent. Money back in full any time within one year. Our 226-page free catalog will be a revelation to you. Write for it today.

BUY THROUGH YOUR BANK

J. PRESS & SONS
IMPORTERS AND CUTTERS OF DIAMONDS
WHOLESALE JEWELERS
331 CHESTNUT ST.
PHILADELPHIA, PA.

AGENTS—NEW INVENTION

Ventilated chemical indoor closet, for country, village and suburban homes; no plumbing, no waterworks, no cesspool; absolutely odorless; 30 days' free trial guarantee; every village and farm home a customer; an order at every house; one agent made \$112 commission in 8 hours. Agent's outfit free. Exclusive territory contract. Write today for full particulars of this biggest winner ever offered to salesmen. Address

SHAFER MFG. CO., 481 Colton Bldg., Toledo, O.

Make Big Money Selling a Fridger a day is making money at the rate of \$25,000 a year. We want more dealers. Investigate our proposition. See our ad, page 58 June issue Popular Mechanics.

FRIDGER THE SILK HAT ICEMAN
WELLS STREET BRIDGE BUILDING CHICAGO

SAVE American Metal Shoes

save from \$10 to \$30 shoe bills every year. Outwear many all-leather pairs. FREE SHOE BOOK tells all. Write

BILLS Am. Metal Shoe Co., 10-12th St., Racine, Wis.

HAVE YOU A REALLY GOOD IDEA

Or INVENTION or ARTICLE that you feel would be valuable if properly developed? We are in the position to handle this right. Small, conveniently handled article preferred—Bank references.

PETTINGILL & CO., Box 2685, BOSTON, MASS.

INDOOR CLOSET

More Comfortable, Healthful and Convenient than the Out-Door Closet

Eliminates the out-door closet and open vault. They are breeding places for germs. Have a warm, sanitary, odorless toilet right in your house. No going out in cold weather. A boon to invalids. Endorsed by State Boards of Health.

W. M. Davis writes: "Your indoor closet is giving absolute satisfaction. It is certainly the thing for a home without sewerage."

Absolutely Odorless
Put It Anywhere in the House

The germs are killed by a chemical process in water in the container, which you empty once a month. Absolutely no odor. No more trouble to empty than dishwasher. Closet absolutely guaranteed. Write for full description and price.

Agents Wanted — Big Profits Wonderful opportunities in every town, village and in the country. Best season just at hand. Every home is a good prospect. Sell right out of every ten you call on. Ernest Ridwell writes, "Have ten orders." G. A. Diesman says: "Ship at once twenty closets and fifteen washstands. Sold them all in one community." Sells itself. Everybody hates the outdoor closet. Everybody wants a Ro-San Indoor Closet. Write quick for territory and full particulars.

ROWE SANITARY MFG. CO., 705 Sixth St., Detroit, Mich.
Ask about the Ro-San Washstand — Hot and Cold Running Water Without Plumbing

Please Mention Popular Mechanics

\$76 PROFIT

FOR

Every \$24 Invested



Or

OVER 300% PROFIT

That's what this man makes every time he pushes the lever—every time he turns out a batch of these delicious Popcorn Confections. Every nickel he takes in nets him almost 40 profit. Every \$1.00 nets him almost 80c. Five dollars in sales means \$4.00 profit. What does this mean to you? It meant \$1500 in one month to Eakin, \$7,179.12 to Kunkle of Michigan. It meant "Easy Street," as Grady, another Michigan operator, says. To scores of ambitious men it has meant independence—riches beyond their fondest hopes—success unparalleled. That's what over 300% Profit in the Crispette business means. It means that to you.

No Experience Necessary

Start in any town of 500 population, or more. We furnish directions and secret formula FREE. It's easy and simple. Equipment is portable. Operate in show window—in an open stand, in parks, summer resorts, fairs—wherever crowds gather. Everybody wild over these delicious flavored popcorn crispettes. Common popcorn shunned wherever Crispettes are sold. It's a year 'round business. In winter, operate in any spare room or basement of your home. Supply the town, both at wholesale and retail.

Get This FREE Book

Let us send you all details—facts about this sound business opportunity, how you can become the Crispette manufacturer of your town. Let us tell you about our Confidential Selling Plans, Service, Formulas, etc. Let us show you how easy Crispettes are made and sold—how a Crispette Machine earns big money daily. Everything is fully explained in a wonderful book, "The Shortest Way to Big Profits." Send for it today.

W. Z. Long Company
1338 High Street
SPRINGFIELD, OHIO



WEAR

Trade Mark Registered **B.V.D.** U.S. Patent Office and Foreign Countries

UNDERWEAR

WORLD'S BEST SHOE VALUE

200 Shoe Bargains for Men, Women, Boys and Girls
Big, New 1917 Scientific Footwear Catalog shows over 200 styles and how to save 20% to 50% on shoes for the whole family.
FREE ON REQUEST.

Ruthstein Scientific Shoe Co., Dept. 640-A, RACINE, WIS.
America's Greatest Mail Order Shoe Factory

The Cleveland Lightweight

The only light, low priced Motorcycle with straight line worm drive. Weighs 150 pounds. Highest quality throughout. 75 miles to the gallon. 600 sold in one city last year. Price, \$160.00; with Kick Starter, \$170.00. Dealers wanted.

THE CLEVELAND MOTORCYCLE MFG. CO.
7202 Platt Avenue, CLEVELAND, O.

TEMCO

Portable Electric Drill

Drills by Electricity Anywhere — Direct or Alternating Current

Five Sizes — 9 to 19 pounds.
Capacities to $\frac{1}{2}$ " drilling in steel.

Almost a Complete Machine Shop
Great for Garages

Quicker, cheaper and more accurate than hand work. It drills all kinds of wood and metal, taps threads, drives and draws screws, buffs metal, grinds valves, sharpens tools. Take it anywhere — any time. Attach to electric light socket and you're ready. Costs only a cent an hour to run. Easy, instant control by finger switch. A good use for it every hour in the day on dozens of jobs. Saves hours and hours of disassembling to take work to stationary tool. You simply take tool to the job, snap the switch button and you're at work.



TEMCO TOOLS OF Larger Capacity

Besides Temco Portable Drills we can serve you with Grinders, Buffers, Drills, etc., of larger capacity. Put your requirements up to us and we'll fit you out right.

Leading dealers and jobbers Everywhere can furnish Temco Tools.

Write for FREE Catalog

THE TEMCO ELECTRIC MOTOR COMPANY

140 Sugar St., Leipsic, Ohio

Makers, also, of TEMCO-Alta Shock Absorbers, and Temco Shock Absorbers, Master Vibrators and Lock Switches for Fords.

THE TOOL OF MANY USES

BUILD YOUR OWN SPEEDSTER

Disk Wheel Patterns included for \$4



With the remarkably simple, sure-fit, "Red-i-Kut" patterns and a few dollars worth of material from the hardware store you can make your Ford (old

or new) into this Kuempel Speedster with all the class of a \$1500 car. No parts of old body used; no need to lay up your car—body can be built without it. Spacious cock-pit with plenty of room for two. Scientifically designed by our own racing body automobile engineers. Anyone who can drive a nail or saw a board can build this body entirely eliminating the Ford look. Think of it! In a few hours with these simple instructions covering everything from A to Z. Specify for old or new radiator. Your name and address on margin with two two-dollar bills brings life-size, mistake-proof patterns. Send today!

KUEMPEL COMPANY, Design Dept. 25, DUBUQUE, IOWA

Extra money for you now

You need more money this summer—and here's a dignified, easy way to get it. Take orders for the

Wisconsin Detachable Motor Row Boat

Equip your boat with a guaranteed Wisconsin—enjoy yourself while demonstrating and making money. Thousands in use. Everyone interested. Has many exclusive features including self-locking tiller and patented top adjustment, which make the Wisconsin the best row boat or canoe motor to use, and the easiest to sell. Ask for our agents' plan. Ask for catalog Q.

WISCONSIN MACHINERY & MANUFACTURING COMPANY
Minor Street, Milwaukee, Wisconsin

Highest Award Panama-Pacific Exposition.
Purchased by U. S. Government.

This NEW ELGIN ON 30 DAYS FREE TRIAL



Adjusted
17 Jewel Elgin

This New Thin Model 17 Jewel Elgin is absolutely supreme where Reliability is a factor. Double sunk dial—Double Roller Escapement—Double strata 25-year Gold case. It's just the watch you've always wanted.

Send No Money! \$150

—A MONTH
Easy Credit Terms as Low as
Just send your name and address for this New Elgin with our Special \$5 Gold Chain FREE, and our bed-rock confidential price will surprise and delight you.

Sent on Approval You do not risk a cent. We send this Watch and \$5 Chain complete on your own approval—also our 160 page FREE CATALOG, showing all kinds of Watches, Diamonds, etc., all on smilingly easy terms. Send your name and address today.

The House That Sells More Elgin Watches Than Any Other Firm in the World.

HARRIS-GOAR CO., Dept. 125, KANSAS CITY, MO.
WE DO AS WE ADVERTISE!

Increase Your Tire Mileage

Crank Shaft Driven

Taylor Tire Pump



Carried in tool box when not in use, attached in 30 seconds to end of crank shaft (front of radiator). Pumps bone-dry air and pumps fast. Pays for itself in added tire mileage.

If your dealer cannot supply you, write direct.
\$10 Complete with hose and gauge.
TAYLOR MANUFACTURING COMPANY
24 Lahser Ave., Redford, Mich. (Suburb of Detroit)

PHONOGRAPH PARTS

SEND FOR CATALOGUE

ELECTRO MECHANICAL PARTS CO., 57 E. Jackson Blvd., CHICAGO

See our ad on page 183, June issue, Popular Mechanics Magazine.

Mammoth Jubilee Book Free

Picturing 5152 Home Things

Make your own Credit Terms—1 to 3 years' time.

SPIEGEL, MAY, STERN CO., 1409 W. 35th St., Chicago

Now \$250



\$250 down brings brand new Rex—with 10 years' guarantee—built because world's greatest merchandise houses wanted a better machine than any on market. Sent on trial, typewritten copies included. Write today for big free book and starting offer. REX TYPEWRITER CO. — Dept. 8919 — Siegel Building, Chicago, Ill.

YOUR SPINE NEEDS STRETCHING



This University discovery is the most important health invention of the century. It relaxes and rejuvenates the Human Body. It produces normal spines. It frees impinged and irritated nerves, corrects contracted muscles, shortened ligaments, eliminates congestion, improves circulation and firmness of the body. IT WILL INCREASE THE BODY'S LENGTH. THE PANDICULATOR CO., Cleveland, O.



Do You Like to Draw?

Whether your ambition is to become a second Bud Fisher or whether you draw merely for your own amusement—you will find lots of inspiration in

CARTOONS MAGAZINE

It contains each month the cream of caricature, and cartoon art the world over. The foremost American cartoonists are represented, together with the most famous of the Parisian artists and cartoonists of Berlin, London, Petrograd, and Rome.

Either as an art student or a student of current events you will enjoy seeing how cartoonists are portraying world history in the making. "Cartoons" is a monthly review, but doesn't take itself too seriously.

There are pictures by Ethel Plummer, stories by Helena Smith-Dayton, comics by King, Webster, and others, and Parisian sketches by the artists of Fantasio and La Baionnette. It also tells what the big fellows in the cartoon world are doing.

A two-bit piece together with the following blank filled out, will bring you post haste a sample copy.

CARTOONS MAGAZINE,
6 North Michigan Avenue, CHICAGO

Enclosed find 25 cents for which send me a sample copy of your magazine.

Name.....
Street and No.....
City..... State.....

1/2 CARAT Genuine Perfect Cut STEEL BLUE WHITE DIAMONDS

WAS \$100
NOW \$66

Send No Money!

Here is my offer. Send for my big free book—select your choice of diamond and setting. I will ship for your free examination at my expense. You will not be obligated to buy or to pay one cent. I will prove to you as I already have to thousands of my satisfied customers, that my small-profit direct-import price will save you 35%.



Let me send you this extra fine quality Steel Blue White Solitaire, guaranteed weight is over, in 14K, Tiffany style setting. I will ship at my expense to any bank or express. No obligation to buy. My claim is that one for size, color for color you cannot match it anywhere for less than \$100. Now only . . . \$66

I Give the Only BANKABLE Money Back Guarantee

This is the only Diamond guarantee that you can take to any bank in America and cash in your Diamond investment if you wish to do so. It's a legal certificate of carat weight, quality and value. Permits exchange at full value at any time!



3/4 Carat SPECIAL!

Fine quality Extra Blue White Diamond. Retail value \$35.00. 14K solitaire engagement mounting. O U F import price, complete . . . \$24.99

Fine Quality Diamonds

Perfect cut diamonds as low as \$77.50 per carat. Blue White, perfect cut diamonds as low as \$88.00 per carat. We specialize in very fine qualities: extra Blue White, Steel Blue White, Wesselson, and Jagersfontein Violet Blue White, at prices ranging up to \$288 per carat, for diamonds of rare fancy color which are flawless under a strong glass.

My DeLuxe Book of Diamonds FREE!

New 1917 Edition Now Ready

Mail coupon and get free book even if you have not yet made up your mind to order. True facts about Diamond qualities and values, and thousands of beautiful illustrations of 1917 Diamond Jewelry. References: Lake & State Bank,

Chicago; Dun, Bradstreet, your banker, 100,000 satisfied customers all over America.

Mail coupon or postal or letter—do it now!

BARNARD & CO.
Dept. 2988C

N. W. Cor. State & Monroe,
CHICAGO

IGNATIUS BARNARD,
President
BARNARD & CO.
Dept. 2988C

N. W. Cor. State & Monroe, Chicago, Ill.

Without expense or obligation please send me, Free, postage paid, 1917 De Luxe Diamond Book.

Name.....
Address.....

Please Mention Popular Mechanics

Don't Pay "War Prices" for Shirts

Buy Direct From the Makers



Send \$2.90 for Three Guaranteed Shirts

Wrapped neatly in a box

SHIRTS guaranteed for six months' splendid wear—or three new shirts free. If upon receipt you find the shirts unsatisfactory, money will be refunded without dispute. You get the jobbers', wholesalers' and retailers' profits by ordering direct from the manufacturer. You get three good-looking, comfortable-feeling, well-made shirts—each bears

Famous **MENSWEAR** Label
MFG. CO.

Shirts of fine and durable white madras, in neat stripes of different colors. Latest coat style; soft cuffs attached. Sizes 13½ to 17½. State size desired. **ORDER NOW.**

THE MENSWEAR MFG. CO. 649 Broadway, Dept. F
NEW YORK CITY
HIGHEST BANK REFERENCES

Members of the Naval Militia,
Naval Reserve and Motor-Boat
Owners, Yachtsmen, etc., who con-
template entering the service—

The most useful book you can get hold of is

The Elements of Navigation

in a new revised edition by

LIEUT. W. J. HENDERSON
First Naval Battalion of New York

It is the only book published giving the whole science of practical navigation in a nutshell which is non-technical and yet absolutely authoritative. New chapters have been added to cover the motor-boat situation.

It gives a short and complete explanation of the standard methods of finding the position of a ship at sea and the course to be steered. Designed for the instruction of beginners; of especial use to owners of motor-boats and yachts. Recommended by the Navy Department for use by the naval militia.

218 Pages. Illustrated. Cloth Binding. Fits the Pocket.

Price \$1.35 Postpaid

ORDER YOUR COPY TODAY

Popular Mechanics Book Dept.
6 N. Michigan Ave., CHICAGO



OLD CAR →

Effecto
AUTO
FINISHES

A little time, Effecto, and *voilà*, your car looks like new! Made in seven colors, Clear Varnish and Top and Seat Dressing. Sold by paint, hardware and auto accessory dealers. Send for Color Card. Pratt & Lambert, Inc., 153 Tonawanda St., Buffalo, N. Y. In Canada, 99 Courtwright St., Bridgeburg, Ontario.

MADE BY THE MAKERS OF
PRATT & LAMBERT VARNISHES

JUST PUBLISHED

Storage Batteries Simplified

Action — Maintenance — Repair — Use
By **VICTOR W. PAGE**



The greatly increasing application of storage batteries in modern engineering and mechanical work has created a demand for a book that will consider this subject completely and exclusively. This is the most up-to-date book on this subject. Describes fully the Exide, Edison, Gould, Willard, U. S. L. and other storage battery forms in the types best suited for automobile, stationary and marine work. Nothing of importance has been omitted that the reader should know about the practical operation and care of storage batteries. No details have been slighted. The instructions for charging and care have been made as simple as possible, yet are technically correct. Send for complete description and synopsis of contents.

320 Pages. Price \$1.50 Postpaid. Fully Illustrated.
POPULAR MECHANICS BOOK DEPT., 6 N. Michigan Avenue, CHICAGO

YOU WILL NEED

Our New 1917 Handy Reference

Catalog of the Latest and Best Books

on Mechanical, Electrical
and Industrial Subjects

128 Pages. More than 400 good books described.
Free upon request. Write for your copy today.

Popular Mechanics Book Dept.
6 N. Michigan Ave., Chicago



BOAT DRILL AT NAVY TRAINING STATION

YOUR NAVY NEEDS YOU

The **RIGHT** kind of men are needed **RIGHT** now!

The first duty of every American is to his country and his flag. The **NAVY** is the first line of defense and offers the best opportunity to see active service.

Young man, are **YOU** doing your duty by the country which has protected you? If you have not decided what you intend to do in response to the country's appeal, **DECIDE NOW**.

The **UNITED STATES NAVY** will pay you well for the service you render. The **NAVY** holds many attractions to young men. These inducements are fully explained in a handsome illustrated booklet which will be sent **FREE** upon request. It tells all about the instruction at the training stations, the courses at the **NAVY** trade schools, the different rates of pay, the chances for advancement, the daily routine on board ship, the drills and sports—in fact, everything you want to know about the **BEST NAVY ON EARTH**. Send for this booklet, mentioning your age, trade or experience. Men of mechanical ability especially needed.

Address: Recruiting Division

BUREAU OF NAVIGATION

Navy Department

WASHINGTON, D. C.

[NOTE—This page contributed by Popular Mechanics Magazine.—Editor.]

EXCEPTIONAL-MEN WANTED

Tire Repairing Revolutionized!!

Motorists To Save Millions in Tire Expense

A new scientific method of Tire Repairing has been originated—the only Scientific Tire Repair Service known. It strikes a new chord in tire economy. It is done on a standard of efficiency. It saves tires—increases mileage. It lasts. It has required years of experience to develop it. Practical tests have proven it. Its excellence and superiority is acknowledged—accepted by those who know, as a **Triumph**.

30 Million Tires to Repair!

Haywood Stations are to be established at once throughout the country. We want capable, energetic, ambitious men in charge of each—men who are dependable—competent. **You can have this opportunity**—share in the Haywood success—become a link in a mammoth chain of a country-wide, thoroughly efficient Tire Repair Service.

Make \$3,000 a Year or Better!

You Own Your Own Business! Keep Your Own Profits!

Haywood equipment is sold outright. We teach you Haywood Scientific Tire Repairing in our Laboratory especially equipped for this purpose. Here you learn all about tires—the inner mechanism of construction—how to repair **scientifically** every tire injury. This training is thorough—practical and equips you to give Haywood Service of the standard we advertise nationally and are so careful to maintain—the Service that saves motorists millions of dollars in tire up-keep.

A Wonderful Opportunity!

The coupon below—your name and address, brings full particulars. How to start. How to tie up with the Haywood Service. We'll give inside facts and figures about costs and profits. Explain in detail our co-operative plans which mean your Success. Write today without fail. Learn how you can start at once.

Haywood Tire & Equipment Co.

645 N. Capitol Ave.
Indianapolis, Indiana

Mail
This
Coupon
Today

OPPORTUNITY COUPON

Haywood Tire & Equipment Co.
645 N. Capitol Avenue
Indianapolis, Ind.

Gentlemen: Please send full particulars of your Scientific Tire Repair Service and details of your co-operative plans.

Name _____

Address _____



This
Man
Makes

Big Money
Repairing
Tires

Scientifically

Please Mention Popular Mechanics

NOW YOU NEED A GOOD ATLAS

Never before in the World's History has an atlas been so constantly necessary to an intelligent understanding of the World's News.

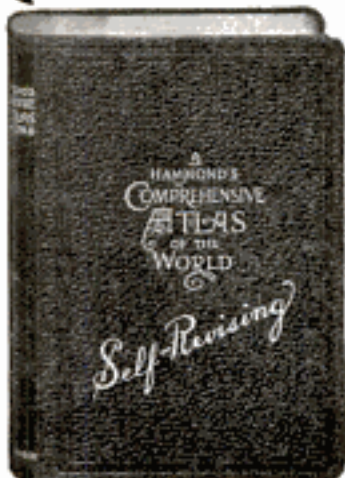

Size 9½ x 6¾ x 1¼ Inches

Special New Maps Show the Several War Zones

Get your atlas now. Use it during the great war when you need it most and rest assured it will be up-to-date after the war is over. Price, Leather \$2.50, Cloth, \$1.65 Postpaid

Return Privilege Any purchaser who is not more than satisfied with this atlas may return same and have his money promptly refunded.

POPULAR MECHANICS BOOK DEPT.
6 N. Michigan Ave., CHICAGO

Here is the IDEAL ATLAS

Hammond's Comprehensive Atlas is a compact octavo volume, bound in flexible leather. It solves the problem of

Large Scale Maps in a Book of Handy Size

Contains 512 pages, 256 pages of large scale maps of all States, Canadian Provinces, Countries of the World, etc., also 256 pages of text, index, compilations, gazetteer, statistics of population, etc.

Self-Revising After the War

Each copy contains a certificate entitling the purchaser to a supplement of maps showing the new boundaries after the war is over, making this atlas self-revising.

YOUNG MAN! LEARN DRAFTING

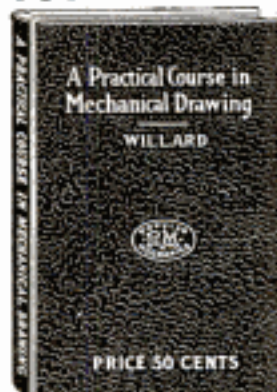

ONE of the most practical subjects of study today; an essential in most lines of engineering; indispensable in many occupations and often the secret of successful advancement; of no less importance to the farmer than the mechanic. There is bound to come a time when you will feel the need of the ability to "lay out" something in accordance with the rules and conventions used in the drafting profession.

Individual Study

may be successfully engaged in with the aid of our new enlarged edition of the book

A Practical Course in Mechanical Drawing

By WM. F. WILLARD

(For several years instructor in Mechanical Drawing at Armour Institute of Technology, Chicago)

160 PAGES — SIZE 5x7 — 157 DRAWINGS — CLOTH COVER

Price 50 Cents, Postpaid

There has been a real need for a book of this kind, as it clinches each problem in the mind of the student by giving the practical application of that problem to every day practice in some phase of the world's work. It meets every modern requirement and is in advance of any other work on the subject. Excellent for use in shop classes, trade or high schools. A complete detailed description of the contents of this book sent free upon request.

Order of your Book Dealer or direct from the publishers

POPULAR MECHANICS BOOK DEPT.
6 N. Michigan Ave., CHICAGO

Home Builder's Guide

By WM. ARTHUR



EVERY one who is interested in building a house, either for a home or commercially, should read this new book, for it aims to give those who are not professional builders or contractors a thorough understanding of the value of good construction. It is written in Mr. Arthur's simple and direct style, so that the veriest

novice may understand the why and wherefore of every operation.

Starting with the site, the author has given pointers from his experience on the proper selection of a plot from the standpoint of health and economy. He then explains the planning of a house so that it will have the best light and be conveniently arranged. All types of construction are then taken up so that the reader may get an unbiased professional opinion of the best for many purposes.

CONTENTS

The "Lay" of the Land; The Planning of the Home; The Big Four; A Firm Foundation; The Framework; Covering and Adorning the Frame; The Bungalow; Brickwork; Cement Stone—and Mere Stone; Lath and Plaster; Sheet Metal Work; The Interior Finish; Plumbing and Gasfitting; Ventilation; Heating and Lighting; Painting; Finish Hardware; An Analysis of an Ideal Plan; Tornado Construction; Wind Bracing.

186 Pages, 5x8 Inches. 40 Figures, Cloth

Price \$1.10 Postpaid

POPULAR MECHANICS BOOK DEPT.
6 North Michigan Ave., CHICAGO

A BOOK OF NEW MISSION FURNITURE DESIGNS



Part 3—Mission Furniture HOW TO MAKE IT

A 128 page collection of 35 excellent new designs that have never before been published and that are entirely different from those in the books Parts One and Two previously issued.

Handsome Cloth Binding

Price 50c Postpaid

This new number has just been published and those already in possession of Parts One and Two will find this an even greater value in variety and excellence of the plans.

A feature of the New Book is a

Complete Set of Dining-Room Furniture

Designed to Harmonize Perfectly

If you are at all handy with tools, you will find that the plainly written directions, dimension drawings and half-tone illustrations will enable you to

Make Your Own Furniture and Save Two-Thirds

The many who use tools for pleasure will find this book a working guide which will furnish many moments of delightful and profitable occupation while several of our readers have been able to devote their entire time to this work by disposing of what they have made at a nice profit. One man made and sold \$400 worth of one piece alone.

Parts One and Two in this series are also 50 cents each postpaid

Ask Your Book Dealer or Address the Publishers

POPULAR MECHANICS BOOK DEPT.
6 N. Michigan Ave. CHICAGO



Service Station
Sign of the Good-
year Dealer in
Blue Streak Black
Tread Motorcycle
Tires and Good-
year Tubes. It will
pay you to know
him.



BLUE STREAKS

TRADE MARK REG. U. S. PAT. OFF.

Tougher, thicker, longer wearing treads. Wider breaker strip. Carcass of extra high grade four-ply skim coated fabric. Thicker side walls. More and higher grade material throughout.

That is the construction of Goodyear's new Black Tread Blue Streak Motorcycle Tires.

Goodyear is proud of these tires — the best motorcycle tires Goodyear ever made.

The Goodyear Dealer is proud of them.

You will be proud of them.

Buy Goodyear Black Tread Blue Streaks of your Goodyear Dealer. And Goodyear Tubes, too.

The Goodyear Tire & Rubber Company, Akron, Ohio

GOODYEAR
AKRON

Please Mention Popular Mechanics

Play On a Brunswick 30 Days In Your Home

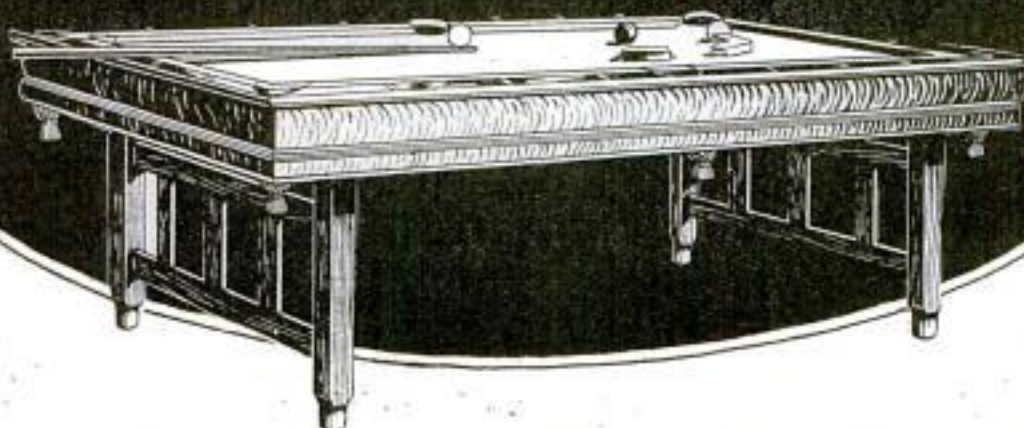

Then Pay for It a Few Cents a Day

With our wonderful easy payment plan every family can afford a Brunswick. Just put up a box near the table and drop a few cents in every game. Before you know it, the table is paid for.

Our 30 day home trial plan lets you test the Brunswick right in your own home. You are the only judge. And if it doesn't come up to our every claim we return every dollar you have paid.

BRUNSWICK HOME BILLIARD TABLES

A Model for You

There is a style and size Brunswick to fit every home. The "Grand," "Baby Grand," "Convertibles," and "Quick Demountables," are in great favor.

Beautiful oak and mahogany, accurate angles, fast ever level beds and quick acting Monarch cushions. Complete high grade playing outfit included free.

The Brunswick-Balke-Collender Company

Dept. 50W, 623-633 S. Wabash Ave., Chicago

Write for Color Catalog

See actual photographs of these tables in homes just like yours. Read what others have to say. Learn all about our home trial offer and easy payment plan.

All contained in our interesting billiard book—"Billiards—The Home Magnet." Write for it today. It's free.

Write for Catalog Today

The Brunswick-Balke-Collender Company
Dept. 50W, 623-633 S. Wabash Ave., Chicago

Without obligation, I should like to receive your color catalog, "Billiards—The Home Magnet," and details of your free trial offer.

Name

Address



INSTALL Your Own PLUMBING

or Heating our New Hardin Easy Way. Save high cost of skilled labor. Save on unnecessary material our new cut-to-fit way. Buy plumbing and heating goods at wholesale direct from us and save $\frac{1}{2}$. Our new big Handy-Man book actually shows and tells you how to properly install any plumbing or heating system, make repairs, etc., with wholesale prices on everything in plumbing and heating supplies **exclusively**. Any handy man with a few ordinary tools can install our goods with the aid of our FREE SERVICE DEPT.

Our New Hardin Easy Way

Every home owner, contractor, farmer, institution and factory needs this big valuable book. It clearly explains our new Hardin Easy Method. Shows you how easily you can install any kind of plumbing outfit or heating plant our new, original, practical cut-to-fit way. This 236-page book shows over 10,000 different kinds of guaranteed plumbing and heating fixtures, supplies, parts and repairs, fitted throughout with our easy installing features, perfected by us through 40 years of scientific and practical experience in this same business.

Send us a rough sketch of what you have in mind. Our Service Dept. will show you the easiest, cheapest and most economical way to install a complete plumbing or cut-to-fit steam, hot water, or air heating system. Write today. To avoid sending this large valuable Handy-Man book broadcast to non-interested parties, we request a temporary deposit of 25c, which will be refunded on first order, or, if you are not satisfied with book, return same and we will gladly refund your money.

New Pipeless Heating System Order from this page and save 10%. Satisfaction Guaranteed.

Our modern all cast furnace heats and ventilates entire home automatically. No cold corners. It supplies pure humidified warm air, free from dust, gas and smoke. Has longest interrupted staggered fire travel; deep fire pot; extra large overhanging combustion circulating chamber. Makes most heat on smallest amount fuel. Easy to operate. Smooth, heavy, tight-fitting castings. Highest Quality with Lasting Durability, Ease of Installation, Convenience, Comfort and Economy built thru and thru.

No.	FIRE POT	SIZE REQ.	CAP. CUB. FT.	PRICE
320	20 in.	22 x 24	13,000	\$ 65.75
322	22 in.	24 x 27	16,000	76.50
324	24 in.	30 x 30	23,000	92.55
326	26 in.	30 x 36	35,000	105.50

Money-Back Guarantee

Our "Money-Back Guarantee Label" is on every fixture. It protects you, and assures you that all Hardin-Lavin fixtures are Highest Quality, Grade A, Guaranteed. Our aim is to furnish plumbing and heating plants with new, original, easy installing features, combining highest quality, lasting durability, and complete satisfaction.

The Hardin-Lavin Co.

40 Years at
4540-50A Cottage Grove Ave.
CHICAGO

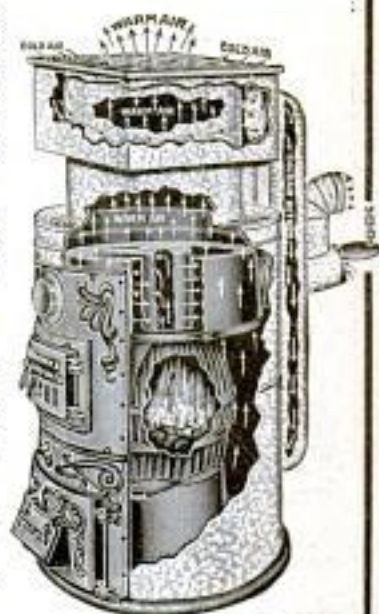

P. M.
JULY '17
"Handy-Man"
BOOK COUPON

The Hardin-Lavin Co.
4540-50A Cottage Grove
Ave., Chicago

Enclosed find 25c, for which send me complete Handy-Man Book. This 25c is to be refunded on my first order, or if I am not satisfied with the book, I will return same and you are to refund my money at once.

Name

Address

SIGN, TEAR OFF AND MAIL

Now You Save the \$51

That It Used to Cost to Sell You a Typewriter

When the Oliver Nine was priced at \$100 over half of it was spent in selling you the machine. That we found out in 22 years of selling. Some of it went to salaries and commissions for 15,000 salesmen and agents—some was necessary to pay the rent of 50 expensive offices. Tradeouts and a dozen other costly and wasteful practices demanded their share.

We could have sold the machine for \$49 then—as we do now—if the old customs had not been so ingrown. People expected salesmen to come and talk. And push through a sale.

But now economic conditions are different. Men know more of efficiency. Short cuts pay. Frills are foolish. Bed-rock prices alone appeal.

To Meet Today's Demands

The Oliver Typewriter Company rebelled from the old way and startled the country. It cut the price in two by doing away with monstrous sales expense.

Now we send an Oliver to you direct from our shipping room at the factory. And you get the \$51.

It wasn't necessary to cheapen the machine nor put out a lighter model. We offer the identical model—brand new—never used—for \$49.

This Oliver Nine is the finest, the costliest, the most successful model we ever built. If any typewriter is worth \$100 it is this handsome machine, the greatest Oliver triumph.

Over 600,000 have been sold. This is the same commercial machine used by the U. S. Steel Corporation, the National City Bank of N. Y., Montgomery Ward & Co., The National Biscuit Co., The Pennsylvania Railroad and a host of others.

The Oliver Typewriter Company
109-A Oliver Typewriter Bldg., Chicago, Ill.

It is not a special model made to sell at a lower price. But it is the same handsome, sturdy Oliver long admired by all.

Free Trial—No Money Down

To make the economy of the Oliver Nine available for everyone, we have arranged a simple plan. Here it is:

We ship an Oliver Nine to you for five days' free trial. Use it in your office or at home. Try it out without anyone to influence you.

If you want to keep it, send us \$3.00 per month until the \$49 is paid.

That is the entire plan. Simple, isn't it? You are the sole judge. At no time during the trial are you under the slightest obligation to buy. We will even refund transportation charges if you decide not to keep it. This is not a cheap machine in any particular—except the price.

Follow This Suggestion

Fill out and mail the coupon now. It will bring a free-trial order blank, our latest catalog and an amazing book. All free.

You may then have an Oliver for trial, if you wish. And own it for 50 per cent less than other standard makes. Surely no economy could be greater. And you would make no sacrifice in quality nor performance.

Don't wait—know all the facts now—all the inside secrets exposed for the first time. Fill out the coupon below—tear it out and put it in the mail. It does not obligate you.



THE OLIVER TYPEWRITER COMPANY
109-A Oliver Typewriter Bldg., Chicago, Ill.
Mail me your book—The High Cost of Typewriters—The Reason and the Remedy, the facts, figures and further information—all free and without obligation to me.
Name _____
Street Address _____
City _____ State _____
Mail Now

Get Your Fan Early

HOT, sultry days are coming! Last year, thousands kept cool, slept better—and did better work because they had "The Breezer" Electric Fan. But, we could not supply the entire demand.

This year, *you* can have "The Breezer" if you order it early.

This remarkable electric fan is built of the finest materials and best workmanship. It can be used either as a desk or wall fan, adjustable to any angle. It is handsomely nickel-plated and makes a beautiful addition to the most elegantly furnished home. This 8-inch fan can be operated at three speeds so you can regulate the cooling breeze to suit yourself.

Yet, the price is only \$8.75.

For the Chicago fan, illustrated below, you need pay but \$7.75. However, this fan has only one speed and is not adjustable. Both fans come complete with 6 feet of cord. Send the coupon today.

Shipped Free!

To get "The Breezer" fan all you need to do is to send the coupon below with your name and address. Don't send a penny. See this handsome "Breezer" fan for yourself before you decide whether you wish to buy or not. See how thoroughly it is made. Connect it with the electric light socket and turn the switch and feel its cooling breeze. Compare it with any other electric fan you have ever seen—even fans much larger—then, if you do not think it is the most remarkable electric fan value ever offered, send it back at our expense. If you decide to keep it, pay only the net transportation charges and the price of \$8.75 to the express agent. Don't miss this big offer. Write today.

Send the Coupon

Get one of these fans for your home—your office or your store. Do not delay. Thousands of people were disappointed last year. They couldn't buy a fan any place at any price. Send the coupon today if you want to get one of these handsome fans at the rock-bottom price. Act immediately. The output is limited. The demand, tremendous. Send the coupon now.

Lindstrom-Smith Co. Dept. B119—Chicago, Ill.

Dealers and Agents Write



Nickel plated, size 12 1/2 inches high, 8 1/2 inches wide. Operates on either direct or alternating current. 2 to 120 volts, any cycle, can be adjusted to any angle. Three speeds—regulated by lever in back of fan. Base provided with rubber feet. Guard made from heavy drawn metal.

Lindstrom-Smith Company
1100-1110 S. Wabash Av.
Dept. B119 Chicago, Ill.

Gentlemen:—Please send me a "Breezer" electric fan, complete with cord and ready to be connected. To be operated on _____ volts, _____ cycle. (State here the voltage and how it is to be operated on.) After I have seen it and examined it, I will either return it to you or pay the express agent the net transportation charges and the price of \$8.75.

Name.....

Address.....

Electrical Dealer's Name.....

If you want Chicago fan merely write "Chicago" in place of "Breezer" change price to \$7.75. Size 11 1/2 inches high, 8 1/2 inches wide.

Copyrighted Material