

POPULAR MECHANICS MAGAZINE

WRITTEN SO YOU CAN UNDERSTAND IT

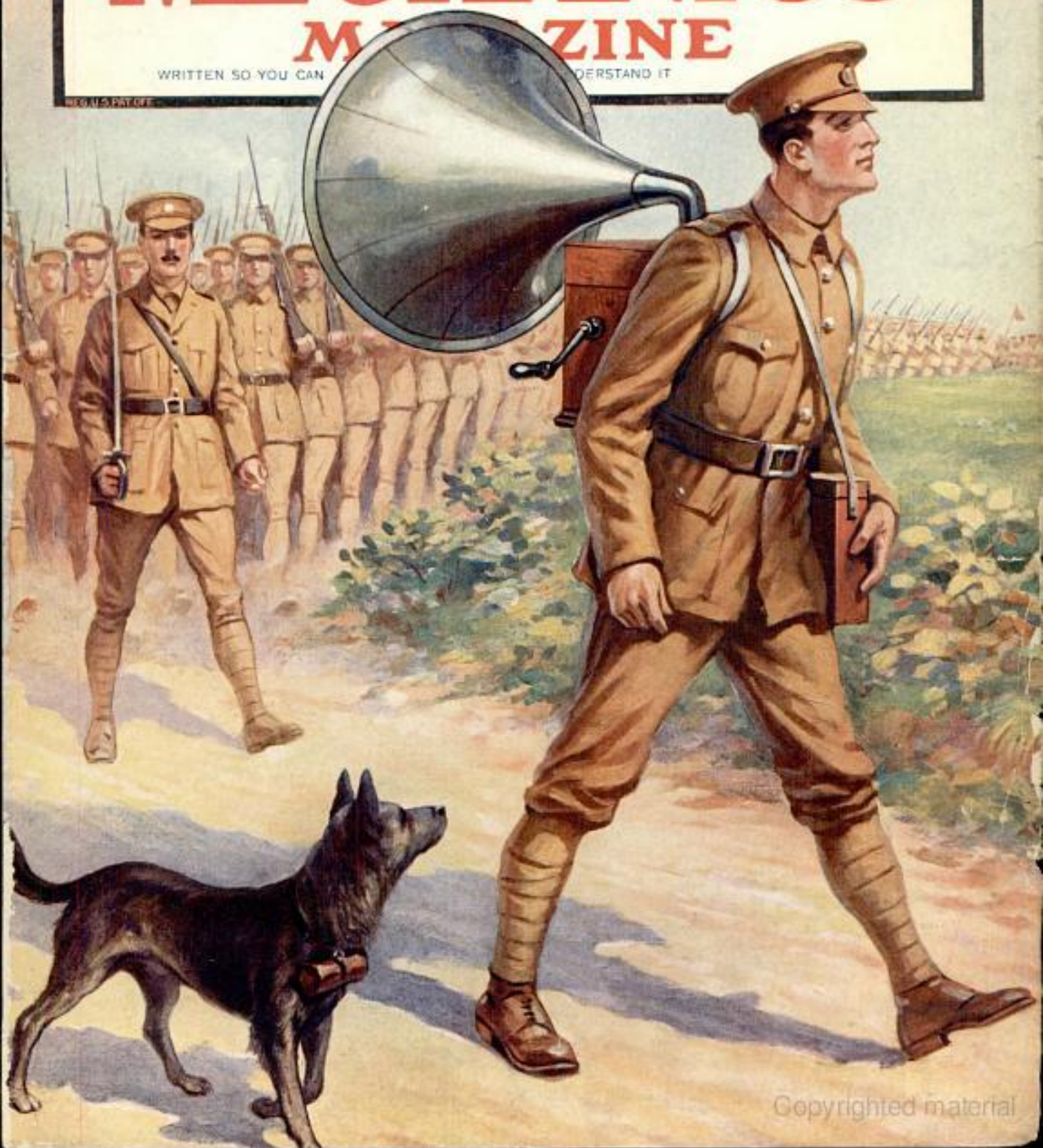



\$641 Buys the Material to Build this Home!

NO MONEY IN ADVANCE!

When you "Build-To-Stay—The Harris Way," you secure the *utmost possible* in Quality, Economy and Service. Why? Simply because you profit directly — *immediately* — by our 24 years' experience. You get the benefit of our practical knowledge as the *originators* of the "Direct-to-You" Home Building Industry. We were the *first* to sell Lumber and Material direct to Home Builders at one small profit. We were the *first* to reduce this vitally important industry to a *perfect system* and extend the benefits uniformly to the people of the nation. *The splendid Harris Home above has 5 rooms, bath, pantry and reception hall in an excellent arrangement. The size is 22 ft. x 26 ft.*



"THE HARRIS WAY"

has exclusive merits—special advantages for the shrewd and careful Home Builder—possessed by no other plan or method. It is the best, safest and most sensible way to build your ideal home *right* without sacrifice of quality—or *the waste of a single penny!* Thousands have built "The HARRIS WAY" with profit and satisfaction.

SEND LUMBER BILLS

Our ten million dollar buying power gives Harris customers an overwhelming price advantage. We can—and do—undersell all others. *The proof?* Easy! Just send us your lumber bills—for any kind of building you may be planning and get *our* prices. Compare them item for item, and let the *test* be the *proof.* Write us today!

BUY YOUR HOME SENSIBLY CUT-TO-FIT—SHIPPED ALL COMPLETE IN ONE CAR

The material used in building all Harris Homes is prepared by us, complete for your use in a way that is instantly—and easily understood. It is sensibly cut-to-fit with *absolute accuracy* and *positive elimination of all waste.* You pay for nothing you do not get—you pay our *bed rock low, one-small-profit bargain price only* for what is needed to do the *work right*—"The HARRIS WAY."

Our mammoth material stations, in the heart of the finest lumber tracts are always filled to overflowing with brand new, quality material. These stations are centrally located for quick and economical deliveries, "DIRECT-TO-YOU," no matter where you live, at the *lowest possible freight charge.*

Free Beautiful New \$10,000 Book of Over 100 Harris Homes

Be sure to mail free coupon for the latest edition of the famous \$10,000 HARRIS HOME PLAN BOOK, now ready. A golden guide to Quality, Service and Economy in Home Building. Explains—fully and freely—everything about building economy. Contains 100 modern Harris Home Designs, with descriptions, material, specifications, prices, etc., and explains how we save you \$50 to \$75 on our Special Free Architect's Plans. Think twice before you pass this opportunity.

Harris Bros. Co.
Dept. FH-7, CHICAGO

Please send me free—without the slightest obligation—the Harris Home Book of Plans, and show me how to save big money in building my home.

Name

Address

Harris Brothers Co. Dept. FH-7 35th & Iron Streets Chicago



To insure Victor quality, always look for the famous trademark, "His Master's Voice." It is on every Victrola and every Victor Record. It is the identifying label on all genuine Victorolas and Victor Records.

Victor Supremacy means—the greatest music by the greatest artists

It is indeed a wonderful thing to have the greatest artists of all the world sing and play for you right in your own home.

The instrument that accomplishes this inevitably stands supreme among musical instruments.

And that instrument is the Victrola.

The greatest artists make records for the Victrola exclusively. They agree that only the Victrola can bring to you their art and personality with unerring truth.

The Victrola is the logical instrument for your home.

There are Victors and Victrolas in great variety of styles from \$10 to \$400, and there are Victor dealers everywhere who will gladly demonstrate them and play any music you wish to hear.

Victor Talking Machine Co. Camden, N. J., U. S. A.

Berliner Gramophone Co., Montreal, Canadian Distributors

Important Notice. All Victor Talking Machines are patented and are only *licensed*, and with right of use with Victor Records only. All Victor Records are patented and are only *licensed*, and with right of use on Victor Talking Machines only. Victor Records and Victor Machines are scientifically coordinated and synchronized by our special processes of manufacture; and their use, except with each other, is not only unauthorized, but damaging and unsatisfactory.

"Victrola" is the Registered Trade-mark of the Victor Talking Machine Company designating the products of this Company only.

Warning: The use of the word **Victrola** upon or in the promotion or sale of any other Talking Machine or Phonograph products is misleading and illegal.

Victrola XVII, \$250
Victrola XVII, electric, \$300
Mahogany or oak



New Victor Records demonstrated at all dealers on the 28th of each month

Please Mention Popular Mechanics

This One



W1L9-JD1-ASZL

WHAT IT IS.

WHY YOU
WANT IT.

"Tide-water" Cypress

"A WORD TO THE 'BUYS' IS SUFFICIENT."

HOW TO GET IT.

Owing to the nation-wide insistence upon Cypress, "The Wood Eternal," for all uses that invite decay, (as well as for artistic uses in interiors), it became necessary to devise safeguards for lumber-consumers who have had no reason to become skilled in identifying different woods or in judging their gradations or adaptabilities.

The one way for you to be sure that the Cypress you get was grown in a region near enough to the coast to possess the MAXIMUM of *decay-resisting quality* is to refuse all but genuine "TIDE-WATER" CYPRESS—and the only way to *know* that you're getting *Tide-water* Cypress is to *insist* (and *keep on insisting*) upon SEEING WITH YOUR OWN EYES the REGISTERED TRADE-MARK of the Southern Cypress Mfrs. Assn., *stamped ineradicably in one or both ends* of EVERY CYPRESS BOARD OR TIMBER, and on EVERY BUNDLE of "small sticks," such as flooring, siding, moulding and shingles. This is the mark to BUY BY—now that every piece of thoroughly reliable

**"TIDE-WATER" CYPRESS
MANUFACTURED BY
ASSOCIATION MILLS
IS IDENTIFIED BY
THIS TRADE-MARK**



TRADE MARK REG. U.S. PAT. OFFICE

Only mills which are qualified by the superior physical character of their product AND the ethical character of their business practice can belong to the Southern Cypress Mfrs. Assn.—and *only member-mills* can ever apply this legally registered trade-mark to ANY Cypress.

Let our ALL-ROUND HELPS DEPARTMENT help YOU MORE.

Our entire resources are at your service with Reliable Counsel.

SOUTHERN CYPRESS MANUFACTURERS' ASSOCIATION
1219 HIBERNIA BANK BLDG., NEW ORLEANS, LA., or 1219 HEARD NAT'L BANK BLDG., JACKSONVILLE, FLA.

INSIST ON TRADE-MARKED CYPRESS AT YOUR LOCAL LUMBER DEALER'S.

IF HE HASN'T IT, LET US KNOW.

TELL HIM TO
REMEMBER"BUY BY THE
CYPRESS ARROW"

"Signed Lumber is Safe Lumber."

Please Mention Popular Mechanics

Popular Mechanics Magazine

6 N. Michigan Avenue, Chicago, U. S. A.

EDITED BY H. H. WINDSOR

England: The International News Co.,
5 Breems Bldg., Chancery Lane, London, E. C.

Australia:
The Australasian News Co.

ISSUED MONTHLY

SUBSCRIPTION:

SINGLE COPY, 15 CENTS

In United States, and its possessions, Cuba and Mexico, per year, postpaid - - - - \$1.50
To Canada - - - - - 1.75
To all other countries in the Postal Union - - - - - 2.50

All subscriptions are discontinued at expiration. Please examine the date printed on your wrapper.

Entered as Second Class Matter Sept. 15, 1933, at the Post Office at Chicago, Illinois, under Act of March 3rd, 1879.

Entered as Second Class Matter at the Post Office Department, Canada.

Published monthly by POPULAR MECHANICS CO.

Copyright, 1917, by H. H. WINDSOR.

Copyright, in France.

Contents for June, 1917

Acetylene Generator Has Automatic Feed.....	820	Coal Pier, Huge, Loads with Belt Conveyors...	818
Aeroplane—Plan Aerial Patrol for Large Sheep Ranch.....	806	Coin Card, New, Savings Deposits Mailed in....	908
Aeroplane Routes, Anglo-Indian, Proposed....	808	Cold Storage, American, for Foreign Trade.....	879
Agricultural Implement—New Farm Tiller to be Attached to Plow.....	832	Comment and Review, by H. H. Windsor:	
Air, Indoor, Rivals Desert in Aridity.....	828	Boys, Raise a Sheep.....	836
Air Vender Is Complete Compression Plant....	854	Can Food at Home.....	835
Airmen Scatter Flowers upon Comrade's Grave, 830		High Standard in Our Navy.....	836
Alfalfa, Baled, "Palace" of Houses Farmers' Fair.....	829	Training a Good Thing.....	833
Apples Baked with Gas in Machine.....	804	Universal Training the Only Way.....	833
Aquarium, New, Ever Changing Colors Light....	822	Why Are Slackers?.....	834
Asbestos Industry, Blue, Expanding.....	851	Concrete Mouth for an Ocean Inlet, by Stanley W. Todd.....	881
Automobile Does Duty as Locomotive.....	876	Corn in Crib, Device for Ventilating.....	912
Automobile Lock, Keyless, Works Like Safe Combination.....	916	Cripple, Holder Enables to Write with Knee.....	856
Automobile, Low Priced, Equipped for Fire Fighting.....	860	Dentist's Case Card Can be Added to as Desired 818	
Automobile, Movie Platform on Front of.....	832	Dining Room, Striking Well Equipped Hotel... 890	
Automobile, Novel, Vacuum Cleaner a Feature of.....	870	Dog—Collie, Big, Is Chauffeur of Master's Motor Car.....	823
Automobile Speed Indicator Locks on Collision, 878		Door Lock, Safety, Works by Lifting Knob... 922	
Automobiles Sent in Caravans during Freight Tie-Up.....	872	Door, Revolving, Collapses in Case of Panic... 919	
Autos, Foot, Used in Postal Delivery Service... 820		Drilling Machines, New, for Deep Holes.....	878
Ballot Box, New, Protects against Fraud.....	908	Electric Decorations for Inauguration Week....	828
Bees Use Telephone Box for Hive.....	852	Electric Heater, Novel, for Laboratory Use....	905
Blackboard, Spherical, Aids in Map Drawing....	916	Electric Lights, Building, Cross of for Good Friday.....	817
Boat, Collapsible, Tested by Forest Service....	878	Electric Player, New, for Use with Movies....	897
Boat—River Steamer Loaded on Its Barge.....	873	Engine, New Type Rotary, for Steam or Gas... 906	
Bottle for Radioactive Fluids, New Form of....	919	Ferry on North Dakota River, Current Propels... 830	
Boxes, Collapsible, for Ship Freight.....	898	Fire Escapes, Ornamental, for New Building... 877	
Bridle, Breaking, Governs by Nerve Pressure... 917		Fire Extinguisher for Threshing Machines....	904
Building—City Hall, San Francisco Completes... 859		Flag, Big American, Unfurled in Boston.....	824
Building—Fire Insurance Company's Own Home Is Fireproof.....	884	Flag, State, for Centennial Year.....	808
Building—Museum, New Mexico, Built Like Indian Missions.....	888	Flags on Cars, Autoists Show with Searchlights. 802	
Building—Octagonal Summer Home Encircled by Redwoods.....	849	Float, Auto, Resembles Battleship in Action... 851	
Buttons, Honor, Presented to Rejected Volunteers.....	837	Flotation Process Gains Widespread Favor....	913
Cabinetmaker's Clamp Carrier Saves Time....	907	Food Control, System of Needing No Tickets... 824	
Cables and Rods, Steel, Handy Cutter for....	902	Food Drying Process Has Many Advantages... 829	
Carnival, Winter, Held in Mid-Pacific.....	899	Fuel Resources, Great Britain Makes Move to Save.....	830
Children, Variety of New Toys for.....	920	Furniture, Reed, New Designs in.....	892
Clogs Coming into Use in London.....	902	Glass, American, Leading in Chinese Trade... 820	
Clothing—Germany Limits Wardrobes of Subjects.....	908	Glass Plate, Protecting from Subway Blasts... 823	
Clubhouses and Golf Courses, America's Attractive.....	910	Golf Links, Concerning Public, by Searle Hendee 867	
		Grate, Fire Box, can be Repaired during Use... 895	
		Grates, Hollow Gas Stove, Replace Hot Water Coil.....	917
		Guns, Machine, Portable Folding Tripod for... 870	
		Heating Plant, Central, for City Buildings... 821	
		Hook, Convenient, with Looped Handle.....	903
		Horse, Old, Teaches Other Horses to Dive....	830
		House, Hillside, for Small Family.....	960
		Ice on Great Salt Lake Causes Perplexity....	896

[Continued on Page 6]

Popular Mechanics offers no premiums; does not join in "clubbing offers," and employs no solicitors to secure subscriptions. It is for sale by nearly every newsdealer in the United States and Canada.

[Contents—Continued]

Irrigation Lines, Relief Pipes for.....	880
Jacks, Twin Auto, Mounted on Wheels.....	905
Keys, Duplicate, Quickly Made by Machine....	894
Ladder Cart, Extension, for Tree Trimming....	896
Lake, Artificial, and Dams Built by Students....	894
Lamp, Warning, on Street Light Standard.....	909
Lands, Texas Overflow, Move to Reclaim.....	894
Lantern, Gas, Lighting with Match.....	878
Life Preserver and Cushion, Combination.....	886
Litter Which One Man can Operate.....	853
Llamas Rivalled by Motor Trucks High Up in Andes.....	854
Locomotives, Electric, Shipped in Boxes.....	900
Lookout Station on Mt. St. Helens, Building a, by R. H. Chapler.....	874
Lumber Carrier, Electric, Cuts Handling Cost..	903
Lumber, Philippine, Wins Chinese Trade.....	856
Lunch Box, Convenient, for Motorist.....	805
Magnesium, New Uses for in Industries.....	852
Mail Carrier, Saving Miles for.....	852
Medals, Bronze, Presented to Iowa Guardsmen..	805
Medicine Case, Fiber, for Labrador Missionary..	809
Metals and Alloys, Government Desires Data on.	880
Meter Device Indicates Mileage of Tires.....	879
Micrometer, Limit Arms Attachable to.....	856
Moldings for Wall Board Which Allow Expan- sion.....	922
Monument, National, to Popular Scout.....	869
Motor, Rowboat, Carried at Rear of Car.....	908
Motor Truck, Aeroplane Engine Tested with....	822
Motor Truck, Army, Soldiers Use to Saw Wood..	894
Motor Truck Made into Portable Grocery.....	894
Motor Truck—Office on Wheels for Military Use	908
Motor Truck, Road Repair, Breaks through Pavement.....	912
Motor Truck Used as Traveling Notion Store...	883
Motor Truck Used as Traveling Vaudeville Stage.....	885
Motor Trucks Move House across Country....	823
Motorboat, Disappearing Propeller in.....	861
Moving Picture Films, Paper, and Motor Driven Camera.....	866
Moving Pictures Depict Whaling Scenes.....	904
Music, New System of Notation for Writing....	918
Novelties for the Home and Its Members.....	914
Paper, Wrapping, Unrolled Easily with New Rack.....	820
Paving Repair, Economical Method of.....	876
Philippines, New Port in, Shortens Voyage....	806
Phonograph, Device Stops without Setting....	834
Phonograph Replaces Band and Drills "Tom- mies".....	847
Pier, Municipal, Fishing Facilities on.....	860
Pipes, Hot Water, Tests Show How Freezing Hursts.....	888
Playground, Down Town, for Newsboys.....	885
Plow Burrows Drain Holes Underground.....	887
Pocket, Novel Watch, Made for Man's Waist- coat.....	922
Press Prints Ad Matter on Pencils at Low Cost..	852
Rats, White, by Scur for Biology Class.....	877
Real Estate Deals, Need of Engineers in.....	849
Reel, Folding, Devised for Forestry Service....	896
Road Building in Panama Canal Zone.....	825
Safety First Ad, Effective, in Comic Section...	870
Salt Spread on Streets to Lessen Dust Evil....	855
Sash, Fireproof Steel, is Formally Tested.....	871
School Equipment, China's Educational Census Shows.....	850
Schoolhouse on Wheels Follows Its Pupils.....	862
Sea Wall Provides Seats for Beach Habitues....	888
Searchlight, Rear, Turned on by Reverse Shift..	919
Seats for Board Walk Have Counterweights....	849
Sheep, More, Raising of to Improve Land.....	890
Ship of New Type, Speed and Safety Sought in.	817
Ship—Warship, Unsinkable, Inventor's Model of	871
Ship's Color a Factor in Its Safety at Sea.....	864
Ships, Whirling Disks to Guard from Torpedoes.	802
Shoe Shining Stand, Self-Help, Pulpit Is.....	861
Shotgun Has Barrels Set One above Other....	900
Silos, New Disk Thrower Device for Filling....	865
Silos, Pit, Help Farmers of the West.....	873
Slingshot Crotch, Metal, Holds Elastics Fast...	917
Spark Plug Cleaner, New, Works Quickly.....	922
Spotlight Bracket, Improved.....	873
Staircase, Movie, Built in Seven Minutes.....	871
Starch, Common Fern Stems as Source of.....	886
Statue, Lincoln, Unveiled in Cincinnati.....	828
Stone, Big Spherical, May Be Meteorite.....	866
Stone Breaker, Huge, Built for Michigan Com- pany.....	807
Street Car Tickets, Metal, That Register Auto- matically.....	857
Styles and Pads Engendered by the War.....	849
Submarine, Wrecked, How Recovered.....	808
Sugar Mill, Primitive, in Mexico.....	900
Table, Chocolate Coating, with Electric Heat...	818
Tattooing Shuttle's Bobbin Winds Like Reel...	916
Telephone Cable, World's Biggest, Laid under Hudson.....	857
Telephone Device, Patent, "Holds the Wire"....	804
Tent, Big, Enlarged to Shelter Tractor Show...	850
Theater, Little, Prospers in Mid-West Town....	804
Tires, Rubber, German Substitutes for.....	808
Tower and Smoke Room for Firemen's Drill...	886
Tower, Steel Signal, Motor Car Supports.....	801
Tree, Big Oak, Moved Like House.....	891
Trees and Shrubs, Harvard's Museum Garden of	860
Trolley Poles on Bridge, Clamps Support.....	900
Trophies, Efficiency, for Kansas Guardsmen....	897
Trucks, Labor Saving, Supplant Wheelbarrows..	889
Turntable, Steel, Moved by Wrecking Crane...	889
Uniforms, Time Saving Methods in Making....	804
Ventilation, Prospectors Use Stove for.....	908
War:	
Alps, Blowing Up the, by Lewis R. Freeman...	809
British and French Missions in United States..	839
Coast Defenders, Our, Interesting Views of...	838
Food Preparedness New Phase of World War...	841
France's Gallant Heroes, Glimpses of.....	842
Our Fighting Spirit, by Searle Hendee.....	845
Russia—Birth of World's Newest Republic....	840
Zeppelin and Its Inventor, Finis of.....	844
Watch, Five Handed, Tells Time of Four Zones.	839
Water Power in Ireland, Plan to Develop.....	807
Water Wheel, Homemade, Elevates Water to Truck Garden.....	862
Weather Records, Private, Aids in Settling Claims.....	819
Windshield, Device Keeps Clear Despite Rain...	899
X-Ray Dental Films, Cabinet for Developing....	804

SHOP NOTES

Air in Polishing Rooms, Testing.....	926
Automobile, Detachable Hauling Brackets on..	929
Automobile Fender, Loose, Angle Strengthens..	931
Automobile Oiling System, Unreliable, Remedy for.....	926
Automobile, Padded Compartments in for Small Equipment.....	940
Automobile Springs, Proper Care of.....	933
Automobile Starters and Generators, Locating Trouble in.....	924
Ball Bearings Overcome Thrust in Gear Shaft..	931
Bridge, Collapsing, for the Movies.....	923
Caliper with Locking Scale.....	920
Cnamosis Skin Wash Leather, Care of.....	940
Comb Used as Ruling Pen.....	937
Concrete Blocks, Lead Form Varies Face of....	939
Drafting Board, Extension for.....	933
Drill, Compressed Air Motor, Operates Wind- lass.....	942
Electric Stove, Nonwarping Frying Plate for...	939
Electric Switch Controlled by Hinged Stair Tread.....	940
Erasing Shield Adjustable to Various Lines....	938
Eye Magnet, Making of.....	941
Floors, Concrete, Keeping Down Dust on.....	935
Flue Cleaner, Steam Operated.....	935
Fumigating Plants with Tobacco Smoke.....	932
Gas Fixture, Long Droplight, Bracing.....	939
Goggles, Rack and Case for Sterilizing.....	937
Grease Gun, Large, for Garage or Shop.....	940
Hay Carrier Rigged to Handle Excavation Dirt..	929
Hay Shed, Adjustable.....	932
Heater Coils, Leaky Copper, Repairing.....	934
Hydroplane Catamaran Built for Speed.....	927
Lathing, Quickly Made Stand for.....	924
Leather Covering for Auto Magneto Coupling...	933
Limestone, Floor, Sawdust Foundation Levels...	942
Mica Washers, Tray for Storing without Damage	938
Painting Cold Water Pipes.....	923

[Contents Continued on Page 8]

Dealers Are Making Big Money!

Converting *Fords* ^{New or Old} into
Dearborn One-Ton Trucks

Dearborn One-Ton Truck Unit

\$350

F.O.B. Chicago



90% of the Load is Carried on the Dearborn Rear Axle, Heavy Springs and Truck Wheels

Ford-Dearborn One-Ton Truck
A Combination of FORD Chassis and
DEARBORN One-Ton Truck Attachment

THE DEARBORN TRUCK ATTACHMENT for converting Ford Cars into one-ton trucks is proving a tremendous money-maker for wide-awake dealers. It enables business men and farmers to secure a one-ton truck with **Ford Efficiency**, **Ford Simplicity** and **Ford Economy**, at less than **one-half the cost** of the average one-ton truck. It is the most economical one-ton truck on the market today.

Attaching the Dearborn unit to the Ford chassis is a very simple matter and any auto mechanic can do it in a few hours' time. Full instructions are sent every dealer. The Dearborn frame surrounds and reinforces the Ford frame to which it is bolted at the front, sides and rear. The rear axle assembly on the Ford becomes a jackshaft, and is rigidly held in place by our specially designed hangers. The Ford rear wheels are removed and sprockets attached to the Ford hubs in their place. The tread of rear wheels is standard width, 56 inches, the same as front wheels of Ford. Our frame and various parts differ from other makes and are far superior in material and construction.

Important Features

Carrying Capacity—Guaranteed One Ton.

Frame—14 ft. long, 4-inch channel steel, braced with I-beam over rear axle, to which cross spring is bolted.

Rear Axle—2 1/4 x 1 1/4 inches, drop forged and heat-treated; 3000 lbs. capacity.

Drive—Double side chains, Baldwin roller chains and steel sprockets.

Gear Ratio—27 teeth on jackshaft sprocket and 54 on rear sprocket; about 7 1/2 to 1.

Loading Space—8 ft. 10 in. back of Ford gas tank.

Wheelbase—When attached to Ford chassis, 125 inches.

Tread—Standard, 56 inches.

Weight—Dearborn attachment, 1000 lbs.; attached to Ford chassis, complete, 1850 lbs.

Bearings—Heavy Duty Bock Roller Bearings.

Springs—Heavy Truck, 2 x 44 in., 10 leaves, bronze bushings.

Wheels—Artillery, 32 x 3 1/2 in., twelve 2-in. spokes; guaranteed hickory.

Tires—Solid rubber, 32 x 3 1/2 in.

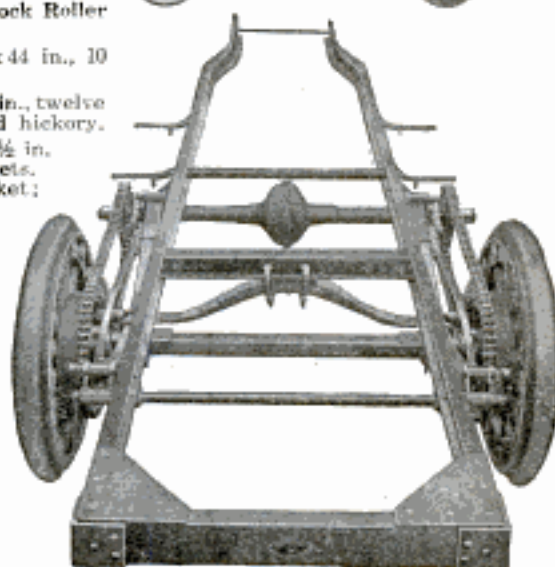

Rear View Dearborn Unit Completely Assembled

Big Opportunity for Wide-Awake Dealers

The Dearborn Truck Unit is built in our own factory, under our own supervision by expert auto mechanics and is guaranteed for one year. It is the **Biggest Seller** in the truck field today. We want a live dealer in every town, and offer a liberal exclusive agency proposition to the right man. Territory is being taken quick. Write for full particulars and territory desired. **IMMEDIATE DELIVERIES.**

DEARBORN TRUCK CO. 1244-1264 So. Campbell Ave., Chicago, Ill.

OFFICE AND FACTORY:

The Automobile Business is Growing

More help needed and big pay. No other business offers such opportunities. It's easy to learn. An Auto Repairman is not a machinist—his work consists of adjustments and re-fitting worn parts, "knowing the principle," that's the thing. One of our students writes: "Before I started with your course I was a clerk at \$50 per month. After finishing I followed your instructions, started a repair shop and cleared \$122 the first month—pretty good for the first month." Let us show you this and many other letters.

LEARN THE Automobile Business during your spare time

WE CAN HELP YOU—in 3 ways:

- 1st We can teach you quickly and thoroughly.
- 2nd After we teach you, we have a plan to assist you in getting started in the actual practical line of work and assist you in getting actual driving experience.
- 3rd While we are teaching you we show you how to make money right on the start.

THE DYKE WORKING MODEL METHOD

of teaching by mail is a new invention—a new idea—we use real 4 and 6 cylinder engine models—11x11½ inches—on which you can actually see all parts moving—it is the only system of its kind in the world.

This is one of the 7 real models used, in addition to 50 simplified instructions with hundreds of illustrations, charts and manikin.

This is the valve side of the four cylinder model. The other side is the crank and piston side. Turn the crank and all of the real metal parts actually operate. The six cylinder engine model is similar.

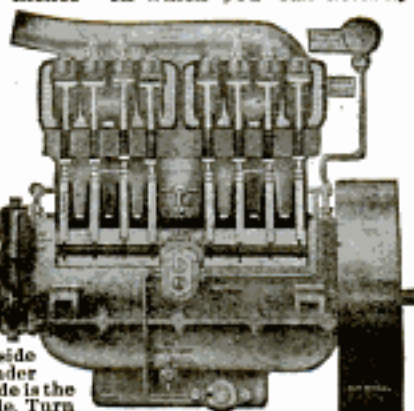

This system is endorsed by Barney Oldfield, Elwood Haynes, Chas. Duryea and other motor authorities.

Mr. Dyke has been identified as a pioneer inventor, supply man, etc., with the auto industry since its beginning. He originated the first auto supply Co. and manufactured and marketed the first float type carburetor in America. No other man with such experience is today teaching others.

If we prove to you that we have started hundreds of others into the repair business and as chauffeurs—who had no previous experience and who knew no more about an auto than you do right now—you must admit we can do the same for you. Write me TODAY—NOW—and LET ME PROVE IT.

Write for DYKE'S FREE BOOKLET

It is interesting and instructive in itself. Fully illustrated. Learn how you can get all this training for only \$15. Fill out below or write a postal—but do it NOW.

Send me your free 32-page booklet about your New Idea Working Model Course and testimonials and proofs. It is understood I am under no obligations in sending for this.

Name.....

Address.....



Deal with the originators. Beware of imitators. This school is a department of the firm of A. L. Dyke, Pub. and Importer, Box 188, Roe Bldg., St. Louis, Mo.

(Contents—Continued from Page 6)

Paper Drinking Cups as Containers for Wood Finishing Material.....	922
Paper Weights, Padded and Flexible.....	922
Poultry Feeder, Automatic, with Clock Control.....	931
Printing Machine, List, for Use with Rubber Type.....	934
Pulley and Hanger Support at Anvil, Traveling.....	925
Roadway, Strike Board for Tamping and Crowning.....	942
Saw, Circular, Molding Head for.....	936
Saw, Hand, Depth Gauge on.....	935
Scissors Used as Envelope Sealer.....	935
Shafting, Exposed, Safety Guard for.....	934
Sign Painted on Machine Saves Cleaning.....	939
Speaking Tube, Orchestra Pit Rail Used as.....	925
Tapping Small Machine Parts, Device for.....	930
Tire Tube Punctures, Small, Repairing.....	931
Tool Holder for High Speed Steel.....	929
Triangle Holder Aids in Inking Drawings.....	925
Trucks, Handle Forms Coupler for Train of.....	932
Ventilator Hood, Double, Draws Fumes Away Quickly.....	942
Washers, Hard Sheet Rubber, Punching by Hand.....	928
Water Level Indicator, High and Low.....	930
Wooden Arch, Light, Reinforcing.....	938
Workbench for Use Singly or in Multiple.....	926

AMATEUR MECHANICS

Bell, Call, Curious Support for.....	950
Bicycle Carried on Automobile as Tender.....	944
Brush, Metal Band Stiffens.....	957
Canoe or Boat Stored in Pulley Slings.....	949
Card or Ticket Holder, Revolving.....	959
Chair, Door Bumpers Raise Height of.....	946
Chest, Camp, Guarding against Theft.....	950
Cigar and Pipe Lighter, Non Blow Out.....	953
Coop for Sitting Hens.....	948
Electric Chimes, Set of.....	958
Electric Counting Glass for Thread Fabric.....	953
Envelopes, Unsealed, Safeguarding Contents of.....	951
Exerciser, Pulley and Weight, Homemade, in Orient.....	955
Fruit Picking Pole with Gravity Delivery Chute.....	957
Game, Finger Tug of War, Device for.....	945
Gas Hose Bracket for Ironing or Shop Use.....	956
Hammock Support, Spring, Made of Boughs.....	959
Lamp, Homemade Trouble.....	955
Lamp, Smoking of Overcome by Increasing Draft.....	949
Litmus Paper, Testing Direct Current Polarity with.....	959
Memorandum List for Camping and Outing Trips.....	955
Music Sheet, Tabs for Turning Quickly.....	958
Newspaper Stand, Penny in the Slot.....	954
Oars Flattened to Make Rowing Easier.....	945
Pen, Ordinary, Converted into Fountain Pen.....	950
Pencil Sharpener Made of Wafer Razor Blade.....	949
Phonograph Needles, Fiber, Device for Sharpening.....	942
Photo and Paper Trimmer, Homemade Guide.....	956
Photography—Heater Keeps Developer at Proper Temperature.....	944
Photography, Putty Deadens Glossy Surfaces in.....	948
Photography—Window Frame and Table for Dark Room.....	952
Rake, Clod, Protects Corn in Cultivating.....	950
Scoop on Painter's Knife Catches Scrapings.....	955
Screwdriver Made from Button Hook.....	950
Seat, Folding Ground, with Back Rest.....	944
Suitcase Extension, Homemade.....	948
Swing, Child's, Built of Pipes in Narrow Space.....	946
Swing, Porch, Headrest for.....	957
Table, Revolving Outdoor Lunch.....	951
Telephone Cord, Rubber Band Prevents Tangling of.....	957
Tennis Court Backstop, Knock Down.....	943
Tent, Portable, Made from Umbrella and Paper Muslin.....	954
Thermometer, Joining Broken Liquid Column in.....	956
Toy Horse That Walks.....	951
Trick—One Piece Bracelet Cut from Card.....	945
Trousers Hanger, Improvised, in Train Berth.....	957
Typewriter Space and Shift Keys, Pedals for Increases Speed.....	954
Ukulele, Homemade Hawaiian.....	946
Umbrella Used as Clothes Drier.....	956
Watch Crystal, Timing Pointer on.....	954

Learn Piano Twice Faster By Scientific "Short Cut"

Wonderful Invention now saves you months of time and effort—
Leaves nothing out, but gets you there sooner—Cuts cost in half, too.

You learn more *thoroughly*—play more artistically, more individually—hundreds who have tried it say so. Old-fashioned, round-about methods *must yield to scientific, direct methods*. It's the Law of Life.

A Momentous Discovery — Send for Free Book

After twenty-five years of research, Dr. Quinn discovered the great Law of Nature that the "vibration waves" of twelve tones in music (Key of E) **exactly coincide** with the "vibration waves" of twelve tones in color. This simple Law of Nature, opened out whole worlds of **practical benefits**—and led to Dr. Quinn's inventing the COLOROTONE.

Easy to Understand—For Beginners or Experts—Nothing Else Like It

The COLOROTONE, like all great inventions, is simplicity itself. Children master it as easily as grown people. It brings the same amazing results to experts that it does to beginners. Investigate without cost, by writing today for 64-page free book explaining all about it and how to join Dr. Quinn's own Instruction Class.

Sweeps Away Century-Old Stumbling Blocks—No Special Music Necessary

The important musical subject of Transposition—usually a "nightmare" to students—becomes easy and fascinating by the use of the COLOROTONE. The COLOROTONE enables you to master, from the very beginning of your study, the great Liszt System, by which you play every piece in every key with **exactly the same fingering**. Formerly this great time-saver could be taught only to advanced students. By using the scientific COLOROTONE you start the Liszt System in your **third lesson—a tremendous advantage**. And the COLOROTONE has scores of other equally important advantages. Write for free book. There is nothing else like the COLOROTONE. It stands on the keyboard before you and instantaneously solves, by correct scientific methods, all kinds of troublesome playing problems. After three months you discontinue using the COLOROTONE. Its purpose has been accomplished. You thereafter play and study without using it. No special music is necessary. You play by note from **any music**.

Surprising Results of Learning By a Scientific System

It's remarkable to see how quickly you gain skill at either the piano or organ, and how feelingly you play. Men and women who have failed by all other methods have quickly and easily attained success when using Dr. Quinn's COLOROTONE, and his famous WRITTEN METHOD. Dr. Quinn's WRITTEN METHOD is a **complete COURSE IN PIANO OR ORGAN** for home study. It gives you a musical knowledge and playing skill fully equal to that which you could obtain in three years by the old-fashioned system of instruction. It accomplishes this in considerably less than half the time, even if you can devote only spare moments to your study. These remarkably rapid results are obtained entirely by the use of the COLOROTONE and other scientific systems, and not by omitting anything.

The Course consists of the COLOROTONE and 142 lessons, with complete instructions for studying them in your own home. The lessons are fully illustrated with diagrams and photographs showing every position and movement of the fingers, hands and arms. Thus you rely not on your memory of verbal instructions, which can not always be correct, but on detailed illustrations and explanations always before you. Cost of lessons is small. You obtain the personal instruction and coaching of Dr. Quinn himself at all times without extra charge. All necessary music is included **FREE**. A diploma of internationally-recognized value is granted. You practice in spare time at your own convenience, in the privacy of your own home. Nothing is nor can be forgotten. Progress as rapidly or as slowly as you wish. Earn money by professional playing or by giving lessons to others, if you desire, even before you complete the Course.

Endorsed by Distinguished Musicians

Among our graduates are thousands of accomplished amateur players, as well as prominent professional players, successful music teachers and leading composers. The COURSE is endorsed by many distinguished musicians and educators in whose opinion you have the **utmost confidence**. We have five times more students since the invention of the COLOROTONE, and new applications to study with us are being received so rapidly that we may soon be forced to turn away students.

Investigate Without Cost—Special Offer

Write today, using post card, letter or Free Book Coupon, for our new 64-page book, "How to Study Music." It is the most complete catalogue ever published by a Conservatory. It describes the remarkable COLOROTONE, tells just what the lessons contain, and gives much other valuable information. Our Tuition Fee is greatly reduced this month on account of our Twenty-Fifth Anniversary Offer. Investigate without cost or obligation NOW.

Marcus Lucius Quinn Conservatory of Music

Studio KS, Social Union Building, BOSTON, MASS.

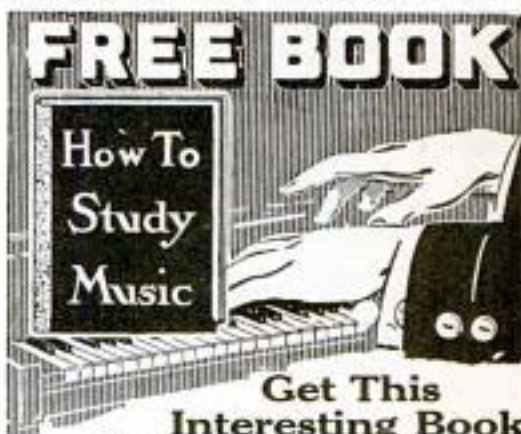

It explains how we teach you piano or organ in your own home by scientific methods which cut the time and the cost in half.

FREE Book Coupon

QUINN CONSERVATORY.
Studio KS, Social Union Bldg., Boston, Mass.

You may send me without obligation or expense your 64-page Free Book, "How To Study Music," which describes Dr. Quinn's COLOROTONE and his WRITTEN METHOD of teaching piano or organ at home in 142 lessons. Also tell me how much the lessons cost at the reduced Tuition Fee allowed this month as a Twenty-Fifth Anniversary offer.

NAME

ADDRESS

These books will help you to greater

Electr

PARTIAL CONTENTS OF THE 10 GUIDES

No. 1. Contains 240 pages, 246 illustrations. Electrical signs and symbols—static and current electricity—primary cells—conductors and insulators—resistance and conductivity—magnetism—induction coils—dynamo principles—classes of dynamo, etc.

No. 2. Contains 218 pages, 256 illustrations. Armatures—windings—commutation—brushes—motor principles—armature reaction—motor starting—calculations—brake horsepower—selection and installation of dynamos and motors, etc.

No. 3. Contains 276 pages, 280 illustrations. Galvanometers—standard cells—current measurement—resistance measurement—voltmeters—wattmeters—watt hour meters—operation of dynamos—operation of motors, etc.

No. 4. Contains 308 pages, 423 illustrations. Distribution systems—wires and wire calculations—inside, outside, and underground wiring—sign flashers—lightning protection—rectifiers—storage battery systems, etc.

No. 5. Contains 278 pages, 379 illustrations. Alternating current principles—alternating current diagrams—the power factor—alternator principles—alternator construction—windings, etc.

No. 6. Contains 272 pages, 538 illustrations. A. C. motors—synchronous and induction motor principles—A. C. commutator motors—induction motors—transformers—losses, construction, connections, tests—converters—rectifiers, etc.

No. 7. Contains 320 pages, 460 illustrations. Alternating current systems—switching devices—circuit breakers—relays—lightning protector apparatus—regulating devices—synchronous condensers—indicating devices—meters—power factor indicators.

No. 8. Contains 288 pages, 330 illustrations. Wave form measurement—switch boards—alternating current wiring—power stations—turbines—management, selection, location, erection, testing, running, care and repair.

No. 9. Contains 576 pages, 849 illustrations. Telephones—telegraph—wireless—electric bells—electric lighting—photometry—electric railways—electric locomotives—car lighting—trolley car operation, etc.

No. 10. Contains 704 pages, 730 illustrations. Miscellaneous applications—motion pictures—gas engine ignition—automobile self-starters and lighting systems—electric vehicles—elevators—cranes—pumps—air compressors—electric heating—electric welding—soldering and brazing—industrial electrolysis—electro-plating—electro-therapeutics—X-rays, etc.

Also a complete ready reference index of the complete library.

The work of the world today is done by electricity. Electricity runs our machines; transports our goods; lights our homes, shops and factories; heats our buildings—is indispensable in hundreds of ways. Opportunities in electricity are greater than ever before. Exact electrical knowledge means more money and greater success for you.

HAWKINS ELECTRICAL GUIDES

give you ALL the electrical information you want, in the shortest, most concise form—namely, by means of questions and answers and unlimited illustrations. No matter how great or how little your previous knowledge of the subject at hand, you "get the point" at once in Hawkins Guides. They are absolutely complete—brought right up-to-date—the last volumes are just off the press.

FLEXIBLE POCKET-SIZE TEXTS Arranged for Home Study and Reference

They are the handiest books to read and to use, ever produced. In flexible, black covers, leather binding—just the right size—5x6½ inches—to fit in your pocket, so that you can carry each single volume about with you until you have mastered its contents. The whole set fits easily in the hollow of your arm, and still there are actually 3,500 pages and 4,700 illustrations.

10 Practical Volumes. 3500 Pages. 4700 Illustrations
\$1 Per Volume—Payable \$1 Per Month

Please Mention Popular Mechanics

success through electricity

WHAT USERS SAY

"Every Electrician, Operating Engineer or Student who wants to advance himself in the Electrical field should have a set of these books."
JOHN KELLEY, 116 Union St., Newark, Ohio.

"For the man not getting a college training, and even in that case, I can sincerely say I do not believe there is a better set of books on the market today."
LLOYD D. HUFFMAN, Dayton, Ohio.

"We consider Hawkins Electrical Guides the most compact and complete set of electrical references in the market."
NOGGLE ELECTRIC WORKS, Monterey, Cal.

"Hawkins surely knows the art of condensing information."
ELDRIDGE F. BALL, Buckland, Conn.

"I think they should be in the hands of everyone who has anything to do with Electricity."
T. E. MURPHY, Orange, Va.

"For the practical electrician, they are the best books published—worth many times their price."
L. C. WAGNER, Wyoming, Ill.

"I have gained valuable information from them which has helped me directly in my line of work."
HERMAN NODENBERG, Hoboken, N. J.

"They are wonderful value. Everything is so clear and concise. Even one who had no knowledge of Electricity would have no difficulty in grasping the facts."
F. L. TAYLOR, Amesbury, Mass.

"It is the best work an apprentice can study if he wants to get ahead in his trade. As a reference for the experienced worker HAWKINS ELECTRICAL GUIDES are unexcelled."
I. McCLELLAN, Chillum, Mo.



THE ENTIRE SET of 10 VOLUMES SHIPPED TO YOU FREE

Send no money. Examine the books first. Use them for seven days in connection with your work, and decide for yourself that they are the most complete, the most helpful and the clearest written electrical books ever published. This unusual offer is a sign of our confidence in the Guides.

EASY PAYMENTS Accept the offer now—mail the coupon today. If you decide to keep the books you can make settlement at only \$1 per month until paid for.

THEO. AUDEL & CO.
72 Fifth Avenue
NEW YORK N.Y.

THEO. AUDEL & CO.,
72 Fifth Avenue, N. Y.

Please submit me for examination Hawkins Electrical Guides (Price \$1 each). Ship at once, prepaid, the 10 numbers. If satisfactory I agree to send you \$1 within seven days and to further mail you \$1 each month until paid.

Signature.....

Occupation.....

Business Address.....

Residence.....

Since we have not yet had the pleasure of business relations with you, we shall appreciate your giving us name of reference on line below

Reference.....

P. M. June 17

Please Mention Popular Mechanics



33,000 sq.ft. of
Additional
Floor
Space

Come to Detroit The Automobile Center and

DETROIT

trained men get preference and get jobs quickly. No other city can give what Detroit offers. Think what it means to learn in the Michigan State Auto

School. Factories endorse our school, glad to employ our graduates or offer them territory in which to sell cars and start garages. Unlimited opportunities. 71% of Automobiles are made in Detroit. You're right in the Heart of the Auto Industry. Men are needed everywhere as testers, repairmen, chauffeurs, garage men, and salesmen. Hundreds of our graduates start in business for themselves.

Earn \$75 to \$300 a Month

We teach you to handle any auto proposition. You graduate in from ten to twelve weeks. Our equipment is new, up-to-the-minute, and complete. No old, obsolete motors, chassis or electrical equipment used. Students actually build cars from start to finish, getting factory training in assembling, block-testing, road-testing, everything. Special complete course in Oxy-Acetylene brazing, welding and cutting, separate from regular course. Learn to time motors, rebore cylinders, adjust carburetors, magnetos, valves and bearings quickly and accurately. Six-cylinder Lozier, Chalmers "6," Detroit "6," Overland, and 8-cylinder King

are used for road instruction. We have the following completely equipped chassis:

Chalmers "6-30" 1917 chassis	Detroit Electric 1917 chassis
Detroit "6-45" 1917 chassis	G. M. C. Truck
Buick light "6" 1917 chassis	Saxon "6" 1917 chassis
Willys-Knight 1917 chassis	Maxwell 1917 chassis
Studebaker "6" 1917 chassis	Oldsmobile "8" 1917 chassis
Hudson Super-Six 1917 chassis	Winston "6" chassis
Cole "8" 1917 chassis	Packard Twin "6" 1917 chassis

All completely equipped for students to work on. We have more than 20 motors in our block test department—2 cyl., 4 cyl., 6 cyl., 8 cyl., and 12 cyl. Our electrical department is complete, having every standard starting, lighting, and ignition system, including Delco System as used in Buick, Hudson, and Packard Twin "6."

Detroit Is the Place to Learn—Start Any Time

There are 44 auto factories in Detroit and vicinity and 140 accessories and parts factories. Our students have the privilege of going through any or all of them. We operate Starting, Lighting, Ignition Service Station. This has added thousands of dollars' worth of equipment and makes our electrical department unequalled. Students get actual experience in handling all kinds of electrical auto equipment and taking care of trouble. We have just installed a Sprague Electric Dynamometer for block-testing purposes for students' use. Cars is the only Auto

school having this equipment. Auto factories need Dynamometer men constantly. Factories and garages are paying big salaries to men who know how to handle electrical equipment quickly and properly. Detroit is the automobile center. You get practical instruction. School open all the year. Enter classes any time, any day. Three classes daily: morning, afternoon, evening. All instructors are members of the Society of Automobile Engineers (S.A.E.) There is a great demand for Michigan State Auto School students. Auto factories write and phone for men constantly.

Follow the Crowd to the Michigan State Auto School. Come to Detroit

MONEY-BACK GUARANTEE

We guarantee to qualify you in a short time for a position as chauffeur, repair man, tester, demonstrator, auto electrician, garage man, or automobile dealer, paying from \$75 to \$300 monthly or refund your money. We have constantly more requests for Detroit trained men at GOOD salaries than we can supply.



THIS IS ONE OF THE FEBRUARY 1917 CLASSES



Additional Building and Equipment Factory Co-Operation

Thousands of dollars' worth of new equipment, plenty of room for students to work, at 687-89-91 Woodward Ave., in addition to our building at 11-19 Selden Ave. Our school has grown by leaps and bounds, students come from all over the world. We are constantly adding new equipment. Our electrical department is thorough and complete.

We have completed arrangements with the Auto factories to put them in touch with men who intend going into business for themselves. Men who know the auto business from A to Z are in biggest demand. Remember, the price of course is based on giving full value. Graduates in the complete auto course are competent to handle farm tractors.

Auto Factories Endorse Our School

The Leading Automobile factories in Detroit, as well as in other cities, endorse our school. They have been watching our school and graduates for years and are satisfied. They are putting their latest model, complete chassis in our school for students to work on. They are employing our graduates in their factories and service stations and assisting them in opening garages and salesrooms. They allow our students to go through their factories. They need trained, competent men and are asking for more of our graduates constantly. The Michigan State Auto School in Detroit, the heart of the Auto Industry, is endorsed by the Leading Auto Factories, is receiving their hearty co-operation. What better endorsement could you ask?

Act Quickly—NOW! Fill in the coupon; get full particulars, "Auto School News" and New 128-Page Illustrated Catalog. All absolutely free. Or better still, jump on the train, as hundreds have done, and come to the "Heart of the Automobile Industry," and learn right. We have no branches. Write or come direct to this school.

Michigan State Auto School

The Old Reliable School
308 Auto Building
687-89-91 Woodward Ave.

A. G. ZELLER, Pres.
DETROIT, MICHIGAN, U.S.A.

SEND THIS COUPON TODAY

MICHIGAN STATE AUTO SCHOOL
308 Auto Bldg., 687-89-91 Woodward Ave.
DETROIT, MICHIGAN, U. S. A.

Gentlemen: Send me absolutely FREE "Auto School News" and New Catalog, or better still, you can expect

me about.....

Name.....

Street.....

Town..... City.....

Our Country needs competent trained
Auto Mechanics in the
Quartermaster's
Dept. and Signal
Corps



A Packard Truck
Used By The
U.S. Government

The United States needs thousands of truck, transport, aeroplane and motorcycle drivers. Trained competent men are needed, men who can take care of the machines, men who know how to keep them in service. Any piece of motor driven machinery the government owns or will own must be in service. Preference will be given to trained men. No matter what service the Army is doing it must be fed. If it is on the firing line it will need thousands of rounds of ammunition. The importance of trained men is very evident. Food and ammunition must be delivered regularly. Then too, the army must often be transported.

Quartermaster Department and Signal Corps Needs Trained Men

The Michigan State Auto School trains men thoroughly.

Every student learns pleasure cars, trucks, motorcycles and gasoline motors of every kind from A to Z. Graduates of the Michigan State Auto School are in big demand by the leading Automobile plants in Detroit. These factories know from actual experience that our men are thoroughly, completely and practically trained. No matter what happens to a truck or pleasure car, a Michigan State Auto School graduate is competent to repair it. Cars in the care of a graduate give highest efficiency.

This is the kind of men Our Government wants and is daily enlisting. Trained men who will be efficient themselves and keep every bit of motor driven equipment in the most serviceable condition.

This branch of the Army Service pays good salaries. There are wonderful opportunities for clean, clear headed, trained men to advance in the service and certainly now is the time to train.



Aerial View of Motor Truck Group at Ft. Sam Houston, Texas. Major F. H. Pope, Cavalry, Commanding

This view gives an idea of the large number of transport trucks that will be used in our Army. Thousands of trained men are needed and will be needed to care for these machines and keep them operating up to their highest efficiency. Trained men will be given preference and men who graduate from the Michigan State Auto School are now and have been holding big, responsible jobs in Detroit and over the country and will be able to serve their country in the most efficient way.

You Can Serve Your Country Best as a Trained Man

TRAINED Auto and Motor Mechanics are always in big demand. Men who have learned motor mechanics from beginning to end at the Michigan State Auto School can take care of every type of motor, motorcycle, automobile, truck, motor boat, aeroplane and stationary engines, and are capable of filling any of the positions in the Army where competent men are needed.

You can serve your country better as a trained man and draw more money. You can complete your course in from 10 to 12 weeks and there will be a place waiting for you. Trained men are needed most and will be paid highest salary. You can serve both your country and yourself best

and certainly in these times of preparation, you should do your part. Men who can drive and keep up motor transport trucks are needed by the Quartermaster Department.

Motorcycle and Auto Mechanics and drivers will be needed by the Signal Corps and in every branch of the service as chauffeurs for officers' cars and as messengers. Motor Mechanics will be needed for Aeroplane work — this branch of the service is very important.

Motor Mechanics will be needed on the "Mosquito Fleet" of "U boat chasers." "Tanks," tractors and trench digging machines will need Trained Motor Mechanics.

Train NOW to do your part right.

Learn a Business That You Can Use When Peace Comes

By training to serve Your Country best you are preparing yourself in one of the best paying businesses of today. You can readily see your country's need. After Peace comes you will find plenty of jobs — and hundreds of good locations to go into business for yourself. There will always be Automobiles in abundance — trucks of every size are being used more and more each year, the newspapers are full of

advertisements asking for men who know their business.

The men get from \$75.00 to \$300 a month and many foremen and superintendents get more. Good pay is the rule but the best pay always goes to the trained man.

The work is interesting as well as profitable — new things are coming on the market continually; there are hundreds of new, interesting problems coming up in the work.

TRAIN NOW AND SERVE YOUR COUNTRY BEST

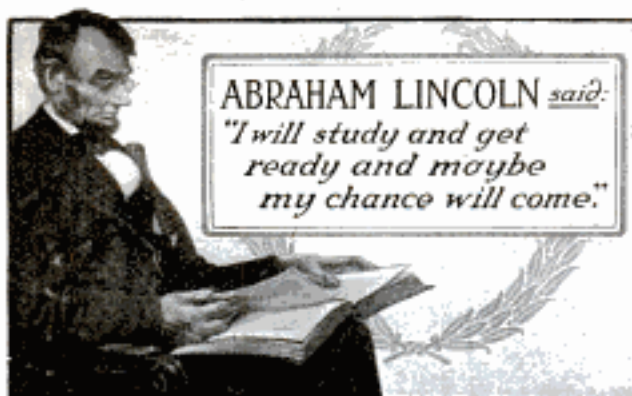

ABRAHAM LINCOLN *said*:
*"I will study and get
 ready and maybe
 my chance will come."*

YOUR Chance Will Come

Born in a log cabin, Abraham Lincoln had little chance to acquire an education. But he was determined to succeed. "Some day," he said, "my chance *will* come." So he studied and got ready. And his chance *DID* come.

Your chance will come. Some day you'll be considered for promotion or for a good job in some other line of work. If you are ready, you'll go up.

And you *CAN* get ready. No matter if your schooling was limited—if you do have to work long hours. If you really want a better job, the International Correspondence Schools can train you for it at home during your spare time.

Every month more than 400 I. C. S. Students voluntarily report promotions or salary increases due to I. C. S. help. What the I. C. S. have done for these men they can do for *YOU*. Mark and mail the coupon NOW.

INTERNATIONAL CORRESPONDENCE SCHOOLS, Box 5581, Scranton, Pa.

INTERNATIONAL CORRESPONDENCE SCHOOLS BOX 5581, SCRANTON, PA.

Explain, without obligating me, how I can qualify for the position, or in the subject, before which I mark X.

- | | |
|--|---|
| <input type="checkbox"/> ADVERTISING MAN | <input type="checkbox"/> ELECTRICAL ENGINEER |
| <input type="checkbox"/> Salesmanship | <input type="checkbox"/> Electric Lighting |
| <input type="checkbox"/> Commercial Law | <input type="checkbox"/> Electric Car Running |
| <input type="checkbox"/> BUSINESS (Complete) | <input type="checkbox"/> Electric Wiring |
| <input type="checkbox"/> Certified Public Accountant | <input type="checkbox"/> Telegraph Expert |
| <input type="checkbox"/> Higher Accounting | <input type="checkbox"/> Practical Telephony |
| <input type="checkbox"/> Bookkeeper | <input type="checkbox"/> Railroader |
| <input type="checkbox"/> Stenographer and Typist | <input type="checkbox"/> Mine Foreman or Engineer |
| <input type="checkbox"/> Railway Accountant | <input type="checkbox"/> Metallurgist or Prospector |
| <input type="checkbox"/> WINDOW TRIMMER | <input type="checkbox"/> ARCHITECT |
| <input type="checkbox"/> Show Card Writer | <input type="checkbox"/> Contractor and Builder |
| <input type="checkbox"/> Outdoor Sign Painter | <input type="checkbox"/> Architectural Draftsman |
| <input type="checkbox"/> Common School Subjects | <input type="checkbox"/> Concrete Builder |
| <input type="checkbox"/> Good English | <input type="checkbox"/> Structural Engineer |
| <input type="checkbox"/> Teacher | <input type="checkbox"/> Plumbing and Heating |
| <input type="checkbox"/> Civil Service | <input type="checkbox"/> Sheet Metal Worker |
| <input type="checkbox"/> Railway Mail Clerk | <input type="checkbox"/> CHEMICAL ENGINEER |
| <input type="checkbox"/> CIVIL ENGINEER | <input type="checkbox"/> Illustrator |
| <input type="checkbox"/> Surveying and Mapping | <input type="checkbox"/> Designer |
| <input type="checkbox"/> MECHANICAL ENGINEER | <input type="checkbox"/> Textile Overseer or Supt. |
| <input type="checkbox"/> Mechanical Draftsman | <input type="checkbox"/> AGRICULTURE |
| <input type="checkbox"/> Machine Shop Practice | <input type="checkbox"/> Navigator |
| <input type="checkbox"/> Stationary Engineer | <input type="checkbox"/> Poultry Raising |
| <input type="checkbox"/> Gas Engineer | <input type="checkbox"/> AUTOMOBILES |
| | <input type="checkbox"/> Spanish |
| | <input type="checkbox"/> German |
| | <input type="checkbox"/> French |
| | <input type="checkbox"/> Italian |

Name _____
 Present Occupation _____
 Street and No. _____
 City _____ State _____

If name of Course you want is not in this list, write it below.

Please Mention Popular Mechanics



Learn a Paying Profession

that assures you a good income and position for life. For twenty-two years we have successfully taught

PHOTOGRAPHY

Photo-Engraving and Three-Color Work

Our graduates earn \$20 to \$50 a week. We assist them to secure these positions. Learn how you can become successful. Terms easy—living inexpensive. Write for catalogue—NOW!
 ILLINOIS COLLEGE OF PHOTOGRAPHY, 999 Wabash Avenue, Effingham, Ill.

ENGINEERING MECHANICAL ELECTRICAL

One Year Practical Courses. Day and Evening classes. Splendid equipment and instruction. Low tuition. For particulars address

DETROIT TECHNICAL INSTITUTE
 Box 308, Y. M. C. A. Building, DETROIT, MICH.

COPY THIS SKETCH

and let me see what you can do with it. Illustrations and cartoons earn from \$20 to \$120 a week or more. My practical system of personal individual lessons by mail will develop your talent. Fifteen years' successful work for newspapers and magazines qualifies me to teach you. Send me your sketch of President Wilson with 4c in stamps and I will send you a test lesson plus, also collection of drawings showing possibilities for you.

The Landon School of Illustrating and Cartooning
 1438 Schofield Building, CLEVELAND, O.



FINLAY Engineering College KANSAS CITY, MISSOURI

ONLY SCHOOL OF THE KIND IN THE WEST

Specialties: Electricity, Steam, Gas. Six weeks, three months, year, and two year courses. Auto-Tractor, Armature Winding, Conduit Work, Latho Work, Oxy-Acetylene Welding, Corliss Valve Setting, Operation of Steam, Gas Electric Machinery. Anything you want, any time you want it, night or day, from a week to two years. Write for Catalog T.



SEND 2 CENTS

in United States stamps to pay postage and we will send you FREE a SAMPLE COLLAR of our New Style "Copley." State size wanted.
 REVERSIBLE COLLAR CO., Dept. U, BOSTON, MASS.



WANTED—Railway Mail Clerks

Commence \$75 Month
 Increase to \$150

Franklin Institute
 Dept. C105, Rochester, N.Y.

Common Education Sufficient

Sure Pay. Life Job. Pull Un-necessary.

Send me, without charge, sample Railway Mail Clerk Examination questions; schedule showing dates and places of examinations; list of other government jobs now easily obtainable and free book describing them.

NAME _____

ADDRESS _____

\$25 to \$50 Per Week

is easily earned if you possess the knowledge contained in the

Machine Shop Library

Never before in the world's history has there been such activity in machine shop work as there is today. And glancing into the future we see a never-ending increase in this unheard-of activity.

Unlike any other line Unlike those engaged in the average line of work, the services of the efficient machine shop worker are constantly sought. No one familiar with the machine shop field will deny this. The trained man wastes no time in looking for a position. Weigh this in your mind and then decide which trade to learn.

Knowledge, not strength, counts Now more than ever a man's earning power is gauged by his knowledge, rather than by his strength and deftness. More and more is the Machine Shop Library looked upon as a positive and unfailing medium for acquiring easily the knowledge which takes a man to the highest positions in the machine industry of today.

THE STANDARD IN AMERICA

The Machine Shop Library being formed by eight authors, all practical men, who were assisted in this great work by over two hundred other experts from different shops in different parts of the country, is now accepted as the standard in America.

Direct to your home without deposit. Ten days for examination

We not only agree to pay the forwarding expense on the books to you, but to send you return charges if you are not satisfied that the nine volumes will tell you everything you want to know about machine shop practice. Return them for any reason whatsoever. We will not argue. The books speak for themselves. It is nearly impossible for anyone in the machine profession, or anyone who expects to take up the work, to convince himself that he can get along without these books after seeing them. Upon first glance it can be readily observed that they furnish the essentials of success in machine shop work.

Small Monthly Payments After thoroughly satisfying yourself that you need the books send us small monthly payments which you will not miss.

McGraw-Hill Book Co., Inc.

Publishers of Books for Machinists Since 1876
239 W. 39th Street, NEW YORK



**Machine Shop
Practice
Complete**
Not One Cent in Advance

SMALL MONTHLY PAYMENTS

Easily understood The Machine Shop Library contains the plain facts about machine shop practice—facts that you want to know and must know to achieve success. The books are written so clearly, and so carefully illustrated that the very beginner can understand them—and so accurately that thousands of the highest paid machine shop workers in the country are using them as a daily guide.

You can thoroughly master each subject One by one the subjects in machine shop practice are taken up and covered entirely, so that you can master each subject completely. The reader is able to conquer the most difficult problems in machine shop work, because each item of information is carefully and explicitly worked out by men who have actually done the work themselves.

3000 Pages—3000 Illustrations

The Machine Shop Library contains nine volumes, 6x9 inches. They are beautifully bound in a stout, morocco-grained dark red cloth, having the appearance of leather, and of equal strength. With average care they will last a lifetime.

**Just a few minutes of
your time each day**

Every day you delay sending the coupon below means something to you. You can earn \$25 to \$50 per week just as easy as you can earn a few dollars a week, if you will give up a little of your time each day to the Machine Shop Library. Let us prove this absolutely at our expense. Return this coupon now. You do not risk one cent.

McGraw-Hill Book Company, Inc.
239 W. 39th St.,
NEW YORK

Gentlemen:—I am interested in your Machine Shop Library. You may send me the nine volumes, charges paid, for my inspection. If satisfactory I will send \$2 in ten days and \$2 per month until I have paid the price of the books, \$16. If the books are not what I want, I will write you for shipping instructions.

COUPON—NOTHING TO PAY IN ADVANCE

Signature.....
Your Address.....
City and State.....
Name of Employer.....
His Address.....
Your Position.....

P. M. June '17

LEARN AUTOS

WHERE AUTOS ARE MADE



Enlarged
Facilities

Freely Endorsed by
Automobile Manufacturers



Detroit is the training camp for men who make good in the automobile and allied lines. Never has the call for men skilled as mechanics, testers, inspectors, repair-men, bearing scrapers, welders, chauffeurs and salesmen been as great as it is today — and the demand is growing.

The Y.M.C.A. Auto School

is organized to train men. A Course in this School will quickly fit the beginner to do well-paid work, and get in line for advancement in the rapidly growing automobile industry. Tuition fees go to procure the highest class of instructors and best of equipment.

Growth Brings Added Facilities

The Y. M. C. A. Auto School is now in its New Building. Among the manufacturers who have contributed liberally toward our equipment are: Studebaker, Buick, Hupp, Chalmers, Ford, Packard, Hudson, Gray & Davis, Delco, Cutler-Hammer, Zenith, and many others. Can you ask stronger proof of the school's standing than the fact that men who know give freely of their time and money to co-operate with us.

Tuition includes membership in the "Y" and free service of **Employment Bureau for one year.** Our big Club House, adjoining our New Building, is at your disposal. Reading rooms, lounging rooms, gymnasium, swimming pool, billiard and pool tables, bowling alleys, with five floors of dormitories and restaurant at low rates. You are assured of not only thorough and competent instruction, but good companionship and clean living conditions with the comforts of home and club life combined.

Don't Visit Detroit Without Seeing Us. You want to consider everything carefully before you enroll for any course of instruction. Come and look us over, whatever purpose brings you to Detroit. Get all the particulars of this school, get the records of our instructors, hear what auto factories and automobile men have to say about us, see for yourself our comfortable quarters and big equipment. We will be glad to see you and show you around whether you enroll or not. Day and night classes. Start at any time.

Write today for full particulars. Address

EDUCATIONAL DIRECTOR

Box 305, Y. M. C. A., DETROIT, MICH.



NEW HOME OF Y.M.C.A. AUTO SCHOOL

Please Mention Popular Mechanics

Stop Forgetting!



Prof. Henry Dickson
America's foremost Authority on Memory Training, Public Speaking, Self Expression, Lecturer and Principal of the Dickson Memory School, Hearst Building, Chicago.

The Executive



Mr. William H. Weeks, District Attorney of Putnam County, N. Y., writes:

"After a thorough trial of your method of mental and memory training, I find it to be not only first class—simply wonderful. I can truthfully say that I would not be again without the benefits I have received from your study for \$10,000."

The Salesman



O. G. Wehmeler, of the American Miner's Accident Association, Indianapolis, Ind., writes:

"I can honestly and truthfully say I am a new person. I have more friends than I really expected I could have. Everyone who has known me says that a wonderful change has come over me in the last six months. It is all due to the Dickson School of Memory."

Perfect Your Memory and You Can Command What Salary You Will

Your salary—what it is today—what it will be tomorrow—depends very much on your memory. Tricky memories—wandering minds—unable to grasp detail—have thwarted thousands in their battle for success—have held them down to bare living wages—working long hours with slight prospect of advancement—subordinates for life.

The Ability to Concentrate, to Think and Express Yourself Clearly Means Everything to Your Success

America's men of power—in business, social or public life—are uniformly men of **trained memories**. Train your memory properly and you will find yourself able to concentrate absolutely on matters at hand—to think and speak connectedly—to develop self control, to overcome self consciousness—to make your **PERSONALITY DOMINATE**. Think what this means—a better position—bigger pay—social and business success—the **EFFICIENT LIFE**.

Give Me 10 Minutes a Day and I Will Give You a "Steel Trap" Memory

That is all I ask—just ten minutes a day for a few weeks and I will train your memory just as I have trained the memories of 50,000 others. I will make your mind an infallible classified index from which you can instantly select facts, figures, faces, arguments. No matter what your age—your education—your vocation—your place of residence—I can make you "forget proof"—can train your memory for **SUCCESS**.

Special Offer!

"How to Speak in Public"—**FREE!**

For a limited period I am offering "How to Speak in Public," a de luxe edition, handsomely bound book—regularly priced at \$2.00—**FREE** to every student enrolling in my course. Full particulars of this unusual offer—together with a copy of my famous Memory Test and my remarkable book "How to Remember" will be sent **FREE**—simply for the mailing of the coupon or a postal. This is **YOUR** opportunity—mail it **NOW**.

The Key to Success

Stop Forgetting

**Prof. Henry Dickson, Prin. Dickson School of Memory
1705 Hearst Bldg., Chicago, Ill.**

Please send me free of charge and without obligation your booklet, "How to Remember"; also your remarkable copyrighted "Memory Test." Give me facts on your special offer of a free copy of "How to Speak in Public."

Name

Street and No.

City State

The Public Speaker



Carl F. Schader, one of California's biggest men, writes:

"I have been improved physically and mentally beyond my own expectations by the continued study of your course. Every business man, especially those called upon to talk at Chambers of Commerce, unity boards, advertising clubs and other meetings should take your course. I unhesitatingly recommend it to my many friends."

In Social Life



Roland Miller, of New York City, writes:

"What I have gotten from your method has advanced me both socially and financially and I feel it my duty to tell you of these excellent results."





Train at Home For This Big Job

Over half a million large shippers need **TRAINED Traffic Men**—men who know Interstate Commerce Laws and how to route shipments, obtain shortest mileage, secure quickest deliveries, classify goods—and secure lowest rates. The demand is greater than the supply. Big positions are waiting for competent men to fill them. Let us tell you how our training by mail will qualify you for an important traffic position.

More than 125,000 men of all ranks and positions, from office clerks to corporation officials, have benefited from LaSalle training and service. Over 20,000 new students annually now avail themselves of the home-study courses offered in the various departments of the University.

Traffic Managers Earn \$35.00 to \$100.00 Weekly

Our course is endorsed and recommended by railroad executives and big concerns throughout the country. Prepared by some of the greatest traffic and transportation experts in America. Covers thoroughly everything you should know to be a high grade traffic manager or traffic expert—trains you so that you can qualify for an important high-salaried railroad or industrial traffic position while holding your present job. Send coupon for students' letters and full details concerning LaSalle University Home Study Course in Traffic Management; particulars regarding our convenient monthly payment plan.

A Remarkable Book Free

"Ten Years' Promotion in One." Hundreds of men who have read this book say it does more to inspire the ambitious man for big things, than any other book they have ever read. A prominent Chicago business man recently said, "It would pay every ambitious person to get this book even if it cost him \$5.00 for a copy." Let us send it to you **FREE**, with literature explaining how you can train for a Big Traffic Job without interference with your present duties. Send in coupon **TODAY—NOW**.

LaSalle Extension University, Dept. 664-C Chicago
"The World's Greatest Extension University"

FREE Book Coupon

LaSalle Extension University, Dept. 664-C Chicago
"The World's Greatest Extension University"

Send Free Proof about opportunities now open to **TRAFFIC EXPERTS** with LaSalle University training—also valuable book "Ten Years' Promotion in One." It is understood that I am not obligating myself in any way.

Name

Address

Please Mention Popular Mechanics

LEARN TO DRUM

Easiest instrument to play. Most demanded instrument today. Earn \$15.00 or \$20.00 weekly as a side line nights, or double that much as an occupation. Demand far exceeds the supply. We can place dozens of pupils in fine positions. Motion picture theatres, vaudeville, musical comedy, bands, dance orchestras, cabarets, summer and winter resorts must have drummers, and pay fine salary. The great growth of motion picture theatres makes an enormous demand for drummers everywhere. Opportunity knocks but once. Listen! Now is your chance. Write today.



No Instruments to Buy

You don't have to invest any money in instruments until you have learned to play. We teach you by mail in a few lessons at surprising low terms. Double your income, on the most popular instrument known.

Send for our free booklet. Write Now—Today.

MICHIGAN SCHOOL OF DRUMMING
LANSING, MICHIGAN

Public Speaking

Taught at Home Write for our special offer. Become a powerful speaker in spare time by mail. Overcome "stage fright", enlarge your vocabulary, train your memory, gain self-confidence. Learn how and when to use gestures; how to suit the speech to the occasion. Increase your earning power—become more popular. We have trained hundreds of successful speakers by mail at home.

Write Now for Special Offer Send quick for details of our special limited offer. No obligation. Write while this offer lasts.

Public Speaking Dept. American Correspondence School of Law,
1196 Manhattan Building, Chicago, Ill.



ART

STUDIES OF ANIMALS and BIRDS

For Artists, Cartoonists and Art Students. A series of 40 9x12 technique plates. Just what you have been wanting—and the entire set, over 400 drawings, for \$3. The Students Art Magazine publishes cash art assignments, lessons and articles on practical art and one animal plate each issue. 10 cents a copy, \$1 a year. 40 animal plates and magazine for a year. \$3.50—SEND NOW to the editor,

G. H. LOCKWOOD
Dept. 245
KALAMAZOO, MICH.



From Newsboy to Electrical Meter Engineer!

Some jump, but this is the record of Chas. King. A few years ago he was a newsboy. Now he is superintendent of instruments and meters at a large Electric Plant at a big salary. He gives full credit to our home study course for his rapid rise.

Write Today for Mr. King's own story of his success. Learn about the big jobs that are open now in this profession. You can qualify. No experience needed. Learn at home. Interesting, fascinating, profitable employment the year round. Just your name and address on a letter or postal will bring you full information. **FREE**. No obligations. Write today.

Fort Wayne Correspondence School
Dept. A119 Fort Wayne, Indiana



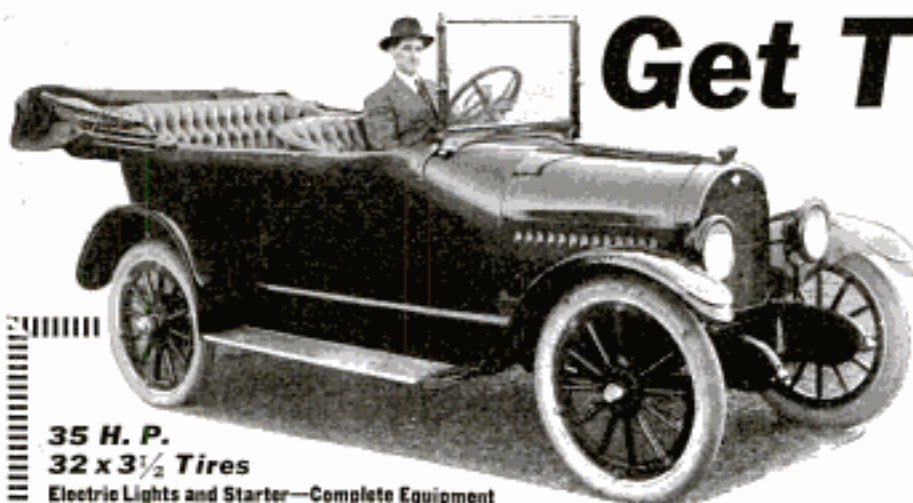

35 H. P.
32 x 3 1/2 Tires

Electric Lights and Starter—Complete Equipment

Write now for full specifications of

BIRCH SUPER-FOUR

Find out how you can get one of these superb cars for yourself and make money selling them to others. A big opportunity is open to ambitious men who are willing to train themselves and then get out and hustle. Hundreds of cars will be sold this year in every county in the United States. Millions of dollars will be paid to automobile agents. We pay big commissions for selling Birch Cars. Send the coupon now for full information.

Here Are a Few of Our Agents—

John Slingerland . . . Danforth, Ill.
W. C. Yeunt . . . Pine Bluff, Ark.
Louis H. Totterdale . . . Warren, Ohio
Edwin Gaertner . . . Dundee, Mich.
Lafe Burleson . . . Prescott, Ariz.
Neil Bland . . . Statesboro, Ga.
J. C. Linn . . . Electra, Texas
H. M. Maloy . . . Mangum, Okla.
W. R. Harmon . . . Kinsley, Kan.
Mitchell & Mitchell, Hillsboro, Texas
Ernest Birch . . . St. Anthony, Idaho
R. B. Shealy . . . Leesville, S. C.
R. G. Moore . . . Mt. Vernon, Oregon
Warren A. Jones . . . Winchester, Ill.
Ben Doyle . . . Carlisle, Ky.

Ask
Them



What New Mexico Agent Says:

"I received my car all O. K. It's the finest looking car in the county and suits me better than any car I ever saw. Lots of men have looked at the car and they said it had the finest motor they ever saw on a car. Some have asked me if the car didn't cost \$1,000 or \$1,200.

R. R. REAGAN, Boaz, N. M."

and The Agency for Your Territory

Drive a new 1918 Model Birch Super-Four. Pay for it out of your commissions on sales and make good money selling Birch Cars to your friends and neighbors. Probably you know right now anywhere from six to ten people who are going to buy automobiles in the near future. Make some of these sales yourself. Get our proposition quick. Mail the coupon.

Birch Agents Are Making Money

One of our Texas Agents sold two carloads of Birch cars within 60 days after he received his first demonstrating car. His territory is no better than others. There is no reason why you cannot do as well. Every sale means a good big commission for you and the Birch is such a wonderful car for the money that it practically sells itself to men who know automobile values.

Whether you own a car or not, get the full details of our great offer. We have a proposition worthy of the careful consideration of every man who wants to make more money. Let you hear from you as soon as possible. Mail the coupon in the lower right hand corner right now for big free booklet and full information.

Be The BIRCH AGENT in Your Locality

Cash in on the demand for a strictly high-grade, light-weight, fully-equipped motor car, that exists right now in your vicinity. You have the customers. We have the cars. Let's get together. Hurry in the coupon so we can send you all the facts about this great opportunity.

PREVIOUS EXPERIENCE NOT NECESSARY

We want men of character and ability and high standing in their communities to represent us. Previous experience in the automobile business is unnecessary. We require all our agents to take a brief but thorough course of training in Automobile Driving, Repairing, and Selling which will fit them to represent us in a manner creditable to us and profitable to them. We have trained hundreds of others for success in this way, and we believe this is one of the reasons for the splendid success which Birch Agents are enjoying. But of course the BIG REASON is the cars themselves and the remarkable records they are making in the hands of satisfied owners all over the United States. Eighty per cent of all Birch cars are in use by farmers and in small towns, and get the hardest kind of service. Mud, sand, rocks, hills and rough going have not terrors for these sturdy cars.

Send COUPON for Big FREE BOOK and Full Information

Get all the details at once. We have agents in every state in the Union now, but we want an agent in every county. You will be astonished at the liberality of our offer. Let us put all the facts before you at once. It costs you nothing to investigate, so tear off the coupon right now. Sign it and mail it to us today. RALPH BIRCHARD, Pres.

BIRCH MOTOR CARS Dept. 619, 81 E. Madison St.
CHICAGO, ILLINOIS

MEMBER CHICAGO ASSOCIATION OF COMMERCE

Sign and
Mail This
Coupon

MAIL THIS FREE COUPON NOW!

Name.....

Street No. or R. F. D.

P. O. State.....

Please Write Plainly

FREE
COUPON

Ralph Birchard, Pres.
Birch Motor Cars
81 E. Madison St., Chicago
Dept. 619

Please send me your big free booklet and full particulars as to how I can get a Birch Super-Four and the agency.



"I propose
to fight it out
on this line if it
takes all summer"

— Gen. U.S. Grant

Resolve to Win!

Determination made Grant one of the great generals in history. The world knows his story. It knows, too, the stories of thousands of other determined men, who succeeded because they had a purpose and stuck to it.

Do you want to succeed? Do you want that better job? Do you want that increase in pay?

If you *do* want to get out of the rut—if you *are* determined to make something of yourself, send the International Correspondence Schools the attached coupon. Tell them what kind of position you want and they will show you how you can fit yourself to get it.

More than 100,000 determined men and women are getting ready for better positions right now through I. C. S. training. They are securing this training in their own homes, at small cost and without losing an hour from their everyday work.

**Determine to mark and
mail the coupon to-day**

INTERNATIONAL CORRESPONDENCE SCHOOLS BOX 5583, SCRANTON, PA.

Explain, without obligating me, how I can qualify for the position, or in the subject, before which I mark X.

- | | |
|---|--|
| <input type="checkbox"/> ELECTRICAL ENGINEER | <input type="checkbox"/> SALESMANSHIP |
| <input type="checkbox"/> Electric Lighting | <input type="checkbox"/> ADVERTISING |
| <input type="checkbox"/> Electric Railways | <input type="checkbox"/> Window Trimmer |
| <input type="checkbox"/> Electric Wiring | <input type="checkbox"/> Show Card Writer |
| <input type="checkbox"/> Telegraph Engineer | <input type="checkbox"/> Sign Painter |
| <input type="checkbox"/> Telephone Work | <input type="checkbox"/> Railroad Trainman |
| <input type="checkbox"/> MECHANICAL ENGINEER | <input type="checkbox"/> ILLUSTRATING |
| <input type="checkbox"/> Mechanical Draftsman | <input type="checkbox"/> Cartooning |
| <input type="checkbox"/> Machine Shop Practice | <input type="checkbox"/> BOOKKEEPER |
| <input type="checkbox"/> Gas Engine Operating | <input type="checkbox"/> Stenographer and Typist |
| <input type="checkbox"/> CIVIL ENGINEER | <input type="checkbox"/> Cert. Public Accountant |
| <input type="checkbox"/> Surveying and Mapping | <input type="checkbox"/> TRAFFIC MANAGER |
| <input type="checkbox"/> NINE FOREMAN OIL ENGINEER | <input type="checkbox"/> Railway Accountant |
| <input type="checkbox"/> Metallurgist or Prospector | <input type="checkbox"/> Commercial Law |
| <input type="checkbox"/> STATIONARY ENGINEER | <input type="checkbox"/> GOOD ENGLISH |
| <input type="checkbox"/> Marine Engineer | <input type="checkbox"/> Teacher |
| <input type="checkbox"/> ARCHITECT | <input type="checkbox"/> Common School Subjects |
| <input type="checkbox"/> Contractor and Builder | <input type="checkbox"/> Mathematics |
| <input type="checkbox"/> Architectural Draftsman | <input type="checkbox"/> CIVIL SERVICE |
| <input type="checkbox"/> Concrete Builder | <input type="checkbox"/> Railway Mail Clerk |
| <input type="checkbox"/> Structural Engineer | <input type="checkbox"/> AUTOMOBILE OPERATING |
| <input type="checkbox"/> PLUMBING AND HEATING | <input type="checkbox"/> Auto Repairing |
| <input type="checkbox"/> Sheet Metal Worker | <input type="checkbox"/> Navigation <input type="checkbox"/> Spanish |
| <input type="checkbox"/> Textile Overseer or Supt. | <input type="checkbox"/> AGRICULTURE <input type="checkbox"/> German |
| <input type="checkbox"/> CHEMIST | <input type="checkbox"/> Poultry Raising <input type="checkbox"/> French |
| | <input type="checkbox"/> Italian |

Name _____
Present Occupation _____
Street and No. _____
City _____ State _____

Please Mention Popular Mechanics

Wonderful Watch Bargains



High grade Elgin or Waltham watches shipped for one full week's examination and approval. You wear the watch and test it out for one full week and pay only if you choose to keep it. Satisfaction guaranteed.

Wholesale Prices

We ship direct from factory to consumer, eliminating all middlemen's profits. The watch must serve as its own salesman. Our prices are so low and our terms of payment so easy that no one may be deprived of the pleasure of carrying a splendid time piece.

Write Today for Free Catalogue Sheets

We will mail our attractive and latest catalogue sheets free to all who ask for them. Write at once. A postal card will do. These catalogue sheets show the newest designs in cases and include a beautiful line of ladies' wrist watches, also the latest gentleman's military wrist watch, and a splendid line of beautiful chains. These catalogue sheets are free. Write today.

H. E. Sever & Co., 140 So. Dearborn St., Chicago

Become a MOTION PICTURE Photographer

War has doubled the demand for trained Camera Men. Learn in a few weeks. Salaries \$40 to \$150 weekly. Light, easy, fascinating employment. Travel everywhere. Day or evening classes. Actual practice in up-to-date studios under expert instructors. Call or write for booklet, free. Easy terms. Special offer to those enrolling now. Send at once.

Note: If interested in studio photography, ask for special booklet on camera portraiture.

N. Y. INSTITUTE OF PHOTOGRAPHY

2406-141 West 36th Street, NEW YORK



Do You Like to Draw? Cartoonists Are Well Paid

We will not give you any grand prize if you answer this ad. Nor will we claim to make you rich in a week. But if you are anxious to develop your talent with a successful cartoonist, so you can make money, send a copy of this picture, with \$2 in stamps for portfolio of cartoons and sample lesson plate, and let us explain.

The W. L. Evans School of Cartooning
821 Leader Bldg., Cleveland, O.

Wrestling Book FREE

Learn to be an expert wrestler. Know scientific wrestling, self-defense, and jiu-jitsu. Develop a splendid physique, and have perfect health. Join this popular school and learn by mail. The famous world's champion—the marvelous Frank Gotch and Farmer Burns offer you a wonderful opportunity. Wrestling is easily and quickly learned at home by mail. Men and boys write now for splendid free book. Learn all the science and tricks. Be able to handle big men with ease. Accept this wonderful offer NOW. Send for free book today, stating your age.

Farmer Burns School of Wrestling, 1119 Range Bldg., Omaha, Neb.

If You Want to Succeed in Life

—you should read the latest book by Orison Swett Marden, who has helped more men succeed than any other writer, living or dead. He can help you, just as he helped J. C. Penney rise from a \$12.00 a week clerkship to the presidency of a \$12,000,000 a year business. The new book will be sent you for 5 days on approval. Send no money. If you don't want to keep it, return it at my expense. Otherwise mail \$3.00

Frank E. Morrison, Publisher, Dept. 25, 1133 Broadway, New York, N. Y.

Learn Watchwork, Jewelrywork and Engraving.

A fine trade commanding a good salary, and your services are always in demand. Address HOROLOGICAL, Dept. P, Bradley Institute, Peoria, Ill., for our latest catalog.

60 BOOKS Bound in Leather \$1.00 AFTER TRIAL

Balance in small payments each month. Not a penny in advance. The masterpieces of Kipling, De Maupassant, Stevenson, G. Bernard Shaw, Victor Hugo and dozens of others. Each book bound in genuine limp leather, pocket size. Write postal now for offer.

LITTLE LEATHER LIBRARY, 150 Hercules Bldg., 23rd St., New York

Be an Artist

Comics, Cartoons, Commercial-
Newspaper and Magazine Illustrating. Pencil and Crayon Portraits. Earn \$25 to \$200 a week. By our simple method your talent is quickly developed without interfering with present work. By Mail or Local Classes. Small sums you now fritter away pay your

tuition. Write for terms, list of successful pupils and instruction method FREE. ASSOCIATED ART STUDIOS, 2203 Flatiron Building, New York

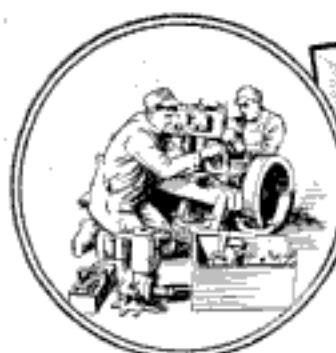

MOTOR WORK



WELDING DEPT

TIRE VULCANIZING
WORK

MACHINE SHOP WORK



TRACTOR WORK

Are You Mechanically Inclined? Get in the Automobile and Tractor Business and Grow with It!



The Automobile and Tractor Business

holds more possibilities for men that are mechanically inclined, than any business in the world. It is growing faster, and it is the only business where the demand for men is greater than the supply.

Pick up any newspaper and read what the country thinks about the *scarcity of automobile and tractor mechanics*. Today men who can operate and repair tractors are in such demand that they can *command their own price*, and the usual pay is from \$5 to \$15 per day. Compare the amount you can earn in this business with that possible in any other.

The Sweeney System of teaching this business means giving you the **actual experience**, and these *two words* tell the story. I don't work any miracles for any one, or promise things that I cannot do, but if you will come here and apply yourself, it will be very easy for me to give you the training that will make you an expert automobile or tractor mechanic and in a position to demand the wages paid for expert service.

Experience, backed by *common sense*, is the only teacher, and it is what I use in my school. It has proven to be the right method, for my graduates are successful. We use no books, and while education is a fine thing, don't think you can't learn the automobile and tractor business without it, because you can. Ambition and determination are the things that count. I've trained thousands of men to become automobile and tractor experts by my *common sense methods*, and I can do the same for you.

Get in the BIG PAY and BIGGER OPPORTUNITIES BUSINESS and grow with it. Success is easy to obtain if you make up your mind to work for it.

Write for my big, FREE catalogue that tells the story of Success in the automobile and tractor business, and how to obtain it. Do it today, it means a new lease on life for you.

Take advantage of present conditions.

EMORY J. SWEENEY, President

Sweeney Automobile School

Latest and Best Equipment Throughout

1164 E. 15th St., Kansas City, Mo.

Sweeney Automobile School
1164 E. 15th Street, Kansas City, Mo.
Mail me your big, FREE catalogue.

Name.....

Address.....

Please Mention Popular Mechanics

YOU CAN DO THIS



AFTER HOME STUDY

\$36⁰⁰ TO \$100⁰⁰ A WEEK

You can earn \$36 to \$100 a week and more as an Expert Electrician. If you have a common school education I can train you in a few months at home. Big lighting and power companies, municipalities, and manufacturers are always seeking trained men to handle their Electrical problems.

I Guarantee Satisfaction

Every student receives our Sealed Guarantee Bond, which guarantees to return every penny of his money if he is not entirely satisfied. No other school has made this wonderful offer, but I know the success I have brought to hundreds of my students, and I know what I can do for any ambitious young man who will give me a little of his spare time each day.

FREE ELECTRICAL OUTFIT

For the next 30 days I am giving each student an Outfit of Electrical Testing Instruments, Tools, Electrical materials, and Motor absolutely Free. My instruction is by practical methods and this outfit is used in working out the lessons. Practical training with the theory makes perfect. I am Chief Engineer of the Chicago Engineering Works, and I can give you the training that will land the big jobs and hold them.

If you are in real earnest I want to send you my new Book—"How to Become an Electrical Expert." It's free. No matter how many other schools you write to I want you to have my book—It's different because it's practical—Write today.

CHIEF ENGINEER COOKE
CHICAGO ENGINEERING WORKS
 422 Cass Street, CHICAGO, ILL.

CHIEF ENGINEER
 Chicago Engineering Works
 422 Cass St.
 Chicago, Illinois

Without obligation on my part kindly send at once, fully prepaid, particulars of your complete Practical Home Study Course in Electricity.

Name

Address

Town..... State.....

USE THIS FREE "OUTFIT" COUPON

CLASSIFIED ADVERTISEMENTS

WORLD'S BEST WANT AD MEDIUM

We have records to prove that a classified ad in these columns will find a buyer for almost anything which can be sold. Doubtless you have some article of value to some one else which you no longer need. Why not turn it into money?

Advertisements in this section, 18 cents per word, each insertion, minimum 10 words, payable in advance. To insure ads being inserted under proper classified head in the July issue, copy must reach this office not later than May 31st.

Popular Mechanics Magazine, Chicago, Illinois.

Gentlemen: I have received orders from almost every country on the globe, besides from every state in the United States, all from the little want ad in Popular Mechanics Magazine. You sure do cover the earth. I have now received about \$5.00 worth of orders for each penny the ad cost me. That's sure going some.

GEO. E. TUFFLEY,

W. Pullman, Chicago.

AUTOMOBILES

THE Big Opportunity! We will place a few agencies for our new car, the "Greyhound," a two-passenger roadster, racy model, selling for \$250.00. Also a light delivery model, same price. 40 to 50 miles per gallon gasoline or kerosene. Catalog upon request. We want capable, successful men. Auto experience immaterial. Better wire. Bank references. American Motor Vehicle Co., Lafayette, Ind.

PAINT your own car for \$5. With Autonomel you can do the work as perfectly as a skilled workman with common paint. Autonomel is not a paint—it is a new chemical discovery. It lays a smooth and lustrous with one coat as a shop-painted car with several coats. \$5 outfit paints car. Send for Booklet "B" and color card showing black and eight colors. Autonomel Company, Rochester, N. Y.

GET into the Automobile business, as salesman, chauffeur, garage manager, mechanic. Automobile instruction in four weeks' residence course. Send for booklet P. M., West Side Y. M. C. A. Auto School, 318 West 57th St., New York.

MAGNETOS \$15 up or exchanged any make like new; guar. 1 yr.; a.s.o. coils, generators, starters, half price. Repairing. Ben Wade, 4105-07 Cottage Gr., Chicago.

INVENT Something; Your Ideas may bring wealth. Free book tells what to invent and how to obtain a patent, through our credit system. Talbert & Parker, 4637 Talbert Bldg., Washington, D. C.

CYLINDERS reground, new pistons and rings fitted. Restores lost power. Write for prices, giving make and model. The Evars Machine Co., Hartford, Conn.

PATENTS for Automobile Improvements are in great demand. We have special Automobile Department in charge of experts who are in touch with demands of trade. Write for "What To Invent and List of Patent Buyers," sent free. Victor J. Evans & Co., 153 Ninth, Washington, D. C.

AUTOMOBILE SUPPLIES

TIRES—Double Tread Guaranteed for good service. Absolutely Puncture-Proof. Big—Strong—Extra heavy, 30x3 tire, \$5.90; 32x3½, \$6.00; 32x4, \$9.00; 34x4, \$9.25; 36x4½, \$12.00; 37x5, \$13.00. Big saving on other sizes and tubes also. Trade in your old tires. Discount to dealers, 10% deposit required on C. O. D. orders. Send for list now! State size and brand of tire. Max Liben & Co., 205B West 48th Street, New York.

GET into biggest money-making end automobile business—replacing necessary equipment. Live, ambitious men wanted as special factory representatives, exclusive territory, taking orders for tops, top coverings, seat covers, "Stik-Tite" Windows. No experience necessary. No capital required. No competition. Copyrighted system protects you. Free catalog, samples, full details. Cincinnati Auto Specialty Company, Dept. MA-07, Cincinnati, Ohio.

BANKRUPT Stock less than half of cost. 2 Three-Ton Radiators, \$25.00 each; 2 Air-Cooling Engines, \$25.00 each; 5 Ross Steering Gears, \$15.00 each; 5 18" Mah. Steering Wheels, 65c each; 13 Gas Tanks, 16½" x 19" x 23", \$2.50 each; 2 Rear Axles, \$3.50 each; 11 24" Break Bands, \$1.00 each; Roller-Bearing Pins; Steel Washer Rings; Shifting Connections and Pins, P. O. B. Milwaukee; all goods are new; made mainly for one-ton Trucks, J. E. Billing & Company, Milwaukee, Wis.

AUTOMOBILE Parts for most all makes of cars: Buicks, 19, 17, 19, 27, 29 and 25; Maxwells, E. M. F., Flanders, Paige 25 and 30; Overlands, 37, 38, 42 and 50; Cadillacs, '09 to 1912, Parry, Regals '09 to 1913; Oakland, Jeffery, Mitchells, 1907 to 1913; Empire, Elmore, Chalmers, '09 to 1913; Auburn, Jackson 35; Interstate 30, Hudson 20 and 33, Hupp 20, Ohio, Staver, Marlon, Halladay, Velle, Reo, Peerless, Empire 25, Abbott, Lexington and many others. Pistons, connecting rods, Cam Shafts, Crank Shafts, Cylinders, Axles, Bearings and gears for most any make of car. Write us your needs. Satisfaction guaranteed. The Auto Parts Co., 4116-18 Olive St., St. Louis, Mo.

INSIDE Tyres, inner armor for Automobile tires, double mileage and prevent punctures and blowouts. Quickly applied. Cost little. Demand tremendous. Profits unlimited. Details free. American Automobile Accessories Co., Dept. P2, Cincinnati, O.

CELLULOID Goggles, for automobile owners. 25c. Alport, 161 E. 2nd St., New York.

AUTOMOBILE Repairing Made Easy—The most needed and useful book on automobiles ever written. Only book of its kind—just out. Covers every phase of automobile repairing practice. 1,056 pages (5½x8 in.), 1,000 engravings. Cloth. Price \$3.00 postpaid. Send for complete description of this and other reliable automobile books. Popular Mechanics Book Dept., 6 N. Michigan Ave., Chicago.

JUST Out—Modern Starting, Lighting and Ignition Systems—A new book on automobile electricity without an equal. Nearly 400 Pages. 250 Engravings. Cloth. Price \$1.50 postpaid. Complete description sent on request. Popular Mechanics Book Dept., 6 N. Michigan Ave., Chicago.

UNUSUAL Bargains in Automobile Repair Parts, Axles, Bearings, Carburetors, Complete Engines, Cylinders, Differentials, Magnets, Pistons, Radiators, Springs, Valves, Wheels and other parts for Buick, Cadillac, Chalmers, Interstate, Maxwell, Mitchell, Moon, Overland, Packard, Peerless, Regal, Studebaker, Thomas and other cars, at a discount of 50% to 75% off manufacturer's list price. Maxwell Bros., 3931 Olive St., St. Louis, Mo.

BATTERY chargers earn big profits. Engine or city current operates. Electrical knowledge unnecessary. \$15 places money-maker in your Garage, balance easy terms. Hobart, Box JC, Troy, Ohio.

ONE Oil Company purchased 100 gross "Gids"; there's a reason. "Gids" eliminates carbon, takes the hump out of hills, and knock out of engines. One Dollar Can convinces. Only one Dealer Wanted each locality, free advertising proposition, net you \$12. "Gids," Galsburg, Illinois.

SAVE 50% to 70% on your next tire purchase. Our tires are practically blow-out and puncture-proof. Guaranteed for 5,500 miles. Send for illustrated catalog No. 4 and Price List. Tuxedo Auto Tire Exchange, 206 W. 54th St., New York City.

REAL Vulcanizer and s's Patches sent postpaid for \$1.25. Worth \$2.00. Elert Rubber Company, 1307 Sutter, San Francisco.

MANUFACTURER desires state, local and Canadian agents. Fast selling auto necessity. Schulz Mfg Co., 1105 Fort Dearborn Bldg., Chicago.

AUTO Engines; 4-cylinder-water-cooled \$35. Buick 19-17 and 24. Metz, Continental, Buda-Mitchell, Cadillac, all sizes—low prices. Johnston, West End, Pittsburgh, Pa.

CASH paid for job lots of any of the following: want nothing but standard article; if you have a quantity of any other standard accessory to close out for cash, send out and detail particulars: Air Pumps, Spark Plugs, Cantilever Shock Absorbers, Hand Actuated Horns, Tungsten Globes (Ford), Globe Carriers to hold two Globes, Spot Lights, Truck Bodies for Ford chassis. The Jenkins Co., Thomasville, Ga.

33% PROFIT selling Jubilee Spark Intensifiers to automobile owners, garages. Sure cure for Spark Plug troubles. Sells like wildfire. Brand new. Exclusive territory. Write today. Jubilee Mfg. Co., Dept. N-4, Omaha, Nebraska.

"GAS-SOL" gives you 15 to 40% more mileage and eliminates carbon. Money back Guarantee. 120 tablets treats one hundred gallons gasoline. Price One Dollar. Live Agents wanted. Gas-Sol, Dept. A, Wakefield, Mass.

SPARK Plug or Tire Troubles? Pronto Spark Gaps, either separate or Plug and Gap as one construction, eliminate all missing, new design. Pronto Inner-tube Patches repair any puncture or blow-out instantly. Big profit and sellers. Real Salesmen write quick. Pronto Manufacturing Co., Omaha, Neb.

AUTO Top Roof Covers Save you two-thirds price of new top; tailored to fit any car; easy to apply; \$6 to \$15, parcel post paid; seat covers \$5 and up; catalog and samples free. S. & H. Top Co., 430 Hunt St., Cincinnati, O.

MAGNETOS—Bosch K4, \$10. D4, \$15. DU4, \$20. Remy, \$3.50. Splidoef, \$5.00. Coils \$3.00, all makes and sizes. Presto tanks \$5.00. Head lamps, steering wheels, windshields. Other parts—low price. Johnston, West End, Pittsburgh, Pa.

GEARS for all purposes; transmission gears, bevel-drive gears, sprockets, axles. Special machine work. Must have old parts or drawing. Turley Gear Plant, 1505 N. 10th St., St. Louis, Mo.

POWER increased; carbon eliminated; results guaranteed. Write for folder. Automobile Accessories Co., (G.) Baltimore, Md.

AUTO Owners! Agents! New Gasoline and Oil Pump—Screws into Barrel Bungs—Fores through hose. Write Gasump Co., Johnston, Ohio.

VULCANIZER for shop. Bargain. Vandernool's, Springfield, Ohio.

AUTOMOBILE owners, and Garage men. Send \$1.00 for 12 Blue Prints of wiring of starting and lighting systems. All Popular Cars. Electrical troubles made easy. Martin Electric Co., 835 Acoma St., Denver, Colo.

EXPLOSION Whistle—Fits priming cap. First whistle adopted as standard equipment on any automobile. See display ad. Page 172. Baell Co., 1610 Michigan Ave., Chicago.

MODEL 39 Buick Eng. \$125. Studebaker 25 885. Ford Motor \$75. Continental 39 \$75. Parts for 190 old model autos. No catalogue. Auto Salvage Co., 1436 Wabash Ave., Chicago, Ill.

FORD ACCESSORIES

NEW 200-page book on the Ford car for every Ford owner, dealer and repairman. Deals fully with construction, operation and repair. 100 engravings. Best and most complete Ford book published. Price, \$1.50 postpaid. Also Ford Engine Chart, 25x38 in. Location of engine troubles made easy. Price, 25 cents postpaid. Popular Mechanics Book Dept., 6 N. Michigan Ave., Chicago.

TO FORD OWNERS

EVERY Ford needs an attachment on steering mechanism to hold the front wheels from wobbling, absorb road shocks and relieve tension on arms while steering. A guaranteed \$4.50 Ford Steering Device for \$3.99 this month only. Satisfaction guaranteed. A. W. Moeller, 1910 West Ninth St., Des Moines, Iowa.

FORD Driver Agents wanted. 1,000,000 owners need this specialty. Sample on car is silent salesman and gets orders. Send for "How to get yours free," make money easy. Auto Specialty Co., Winthrop, Mass.

SLEEP in your car. Auto-Sleeper only \$1.50! Auto-Sleeper Co., 917-L, Sacramento, Cal.

STEADY lights for Fords. Make your own regulator. Complete instructions, 25 cts. Superior Repair Co., Terrell, Texas.

GET full value out of present low grade gasoline. Drive your car on hot air with a foot control. Eliminate carbon and cut your fuel cost practically in half. By injecting hot air into your intake manifold above carburetor the Foot Air-Accelerator will enable you to do all this. Only six dollars, postpaid. Some good agency territory still open. Write Foot Air-Accelerator Co., Cincinnati, Ohio.

BE our agent. Buy a Safety Ford Starter for \$5.00. Retail for \$15.00. Try one, write for particulars. Safety Ford Starter Corporation, Columbia Theatre Bldg., New York.

"STEER Relief" corrects faulty steering in Fords. Gives safety and better service. Sample \$3.50. Pays agents. Chas. B. Post, New London, Ohio.

FORD Top Roof Cover \$6 and up. Easy to apply. You save two-thirds price of new top. Seat covers \$5 and up. Samples and catalog free. S. & H. Top Co., 429 Hunt St., Cincinnati, O.

SLEEP in your Ford in McMillin Auto Bed, \$8.50. Other small cars \$10. Free booklet on auto camping. Auto Bed Company, Box O, Bellingham, Wash.

MOTORCYCLES BICYCLES & SUPPLIES

MOTORCYCLES—New 12-H. P. Peerless Twin. Direct chain drive—sensation of the year—1918 Models ready only \$79 with the order—balance easy monthly payments. Send 6 cents stamps for Catalog and special proposition. Peerless Motorcycle Co., Boston, Mass.

LARGE stock of rebuilt motorcycles, new parts for all makes 25% discount; second-hand parts, good as new, 50% discount. Motorcycle Parts Mfg. Co., Chicago.

1917 POPE Twin. Run less than 50 miles. Guaranteed perfect. Bargain \$290. Logan Mendenhall, Magnolia, Ark.

BIG bargains in second-hand motorcycles, \$25 up. Indians, Harleys, Thors, Excelsiors and Mercks. Write for description. Howard A. French & Co., Baltimore, Md.

BIG bargains in good motorcycles we have taken in exchange on new ones. Send for special bargain list. Shaw Mfg. Co., Galesburg, Kansas.

READING Standard, Twin; fine order; cheap. C. R. Vaster, Myrtle Ave., Kansas City, Mo.

BRAND new Dunham Sidocar, \$50. Thomas Dunham Co., Aurora, Ill.

FOR Sale—Motorcycle Garage. Agent for Harley-Davidson and Excelsior Motorcycles and General Supplies. Write at once. Henry Beck, 1993 Franklin St., Michigan City, Ind.

SACRIFICE for \$70, 1914 Indian Twin. Equipment and tires best shape thruout. Address W. W. Whiting, "Personal," 1309 Broadway, Denver, Colo.

MOTORCYCLES from \$25 up—New and second hand—easy terms—large list to choose from—all makes. Send 4 cents stamps for Bulletin "K." Peerless Motorcycle Co., Boston, Mass.

A REAL bargain in second-hand motorcycles. We have an overstock of all makes, such as Indians, Harley-Davidsons, Excelsiors, Pops, Mercks, and 4-cylinder Hendersons. All are in A-1 condition and fully equipped. If interested in buying a motorcycle write for our Bargain Bulletin No. 5 giving description and prices from \$35 up. Gotham Sporting Goods Co., 57 Warren St., New York City.

SEND for our catalog. Hundreds of Used and Rebuilt Motorcycles, \$25 up. Myerow Bros., 149 Berkeley St., Boston, Mass.

FIFTY 1916 Henderson and Harley Police Machines, just like new. Grab these quickly! 1917 Harley Electric Twin \$290.00, 1917 Excelsior \$145.00. Several hundred used Motorcycles \$20.00 up. Write for illustrated Bargain Sheet. Tires and Accessories being sacrificed. Money refunded if unsatisfactory. Three Big Stores, W. E. Wandersee Company, Detroit, Mich., Main Store, 1561-1563 Woodward Ave. Branches: 129 Gratiot Ave., 2906 Woodward Ave.

BIG Bicycle Book Free! Be a Bicycle Repairman—tells how to repair everything from a puncture to the building of a wheel—how to care for the working parts of all makes of bicycles. If you own or intend to own a bicycle, get this valuable book, enclosing 2c stamp. Address Dept. 1F, Pierce Cycle Supply Co., Johnstown, Pa.

1917 POPE Motorcycles, \$50 down, \$3 weekly. Pope Motorcycle Co., 289 Northampton St., Boston, Mass.

MAKE your bicycle up-to-date with a Sturmey-Archer 3-Speed Hub—gives three gears to meet every road condition, just like an automobile. Then you can climb any hill and pedal twice as far with half the effort. Get our special offer for rear wheel with three-speed hub—goes in bicycle same as ordinary wheel. Cycle Mfg. & Supply Co., 183 North Dearborn St., Chicago.

INVENT Something; your ideas may bring wealth. Free book tells what to invent and how to obtain a patent, through our credit system. Talbert & Parker, 4658 Talbert Bldg., Washington, D. C.

1915 INDIAN Twin. Fully Equipped, good as new, \$150. Robert Parkinsson, Saunderstown, R. I.

MAKE your bike a motorcycle by using our motor. Fits any wheel. Good hill climber. Price only \$32. Ashland Motor Works, Dept. B, Ashland, Ohio.

MOTORCYCLE cylinders reground, fitted with new piston and rings, \$5.00, guaranteed. Muncie Piston Co., Muncie, Ind.

FOR Sale—New Miami Motorbicycle, 2 1/2 h. p. Half price. Rev. Rowlands, Linn Grove, Iowa.

DON'T buy a Bicycle Motor Attachment until you get our catalogue and prices. Shaw Mfg. Co. Dept. 27, Galesburg, Kans.

WANTED: We pay cash for used motorcycles or take them in on exchange for new machines. Write with complete description, State condition of tires, frame, motor, make and model. Shaw Manufacturing Co., Dept. 157, Galesburg, Kans.

WANT to sell your motorcycle? I have a method which has sold many. Write me today for free information. F. W. Johnson, Room 900, 78 E. Madison St., Chicago.

BICYCLE expert repairing. Tandems for sale. McDougald, 300 N. 5th Ave., Chicago.

BARGAIN—Indian with side car, equipped \$115. L. Darby, Belvidere, Ill.

WANTED—Motorcycle engines, 2 and 4 cylinder Henderson preferred. Johnston, West End, Pittsburgh, Pa.

FOR Sale Cheap, 3 Speed Indian Motorcycle, Electric equipped, with or without 8 do-car. A. F. Landergerst, 830 Marshall St., Milwaukee, Wis.

TWO Twin Indians; two twin Harleys; late models; big reductions. Satisfaction sure. Maurice Schwartz, Windsor, Detroit, Mich.

WELDING

LEARN to solder aluminum to any metal with ordinary solder, brass steel and iron. Write immediately for special offer. Modern School of Soldering, 471 Fabre, Montreal, Canada.

WELDING Plants for All Purposes. Small Cash Payment. Balance to Suit. Bertschy Mfg. & Engineering Co., Omaha, Neb.

DAY'S Welding Solder, for soldering cylinders and all metals, apply with soldering-iron. Sample bar 50c or \$1.50 per pound. Day's Solder Co., Bellingham, Wash.

MANUFACTURING

INVENTIONS manufactured under contract. Write Adam Fisher Mfg. Co., 2061F Railway Exchange, St. Louis, Mo.

WIRE Goods, all kinds, made to order. Cooley Mfg. Co., 553 W. Monroe St., Chicago.

HARD rubber and brass specialties developed and manufactured. Rubber, glass or metal models quickly and cheaply made. International Rubber & Brass Works, 1514 Foster Ave., Chicago.

AERONAUTICS

THE National Aero Institute offers you the opportunity to learn the principles and mechanics of Aviation in your spare time at home. Hundreds—yes, thousands—of men are wanted in this new field at once. Opportunity is ripe. Fame and financial independence await you. Write for free particulars of the training we offer. You can save time and money—you can put yourself ahead of the men who must go through apprenticeship on aviation fields—by equipping yourself as an Aviation expert in short time at home. Very limited introductory offer now in force. Write for details while it lasts. National Aero Institute, Dept. A119, Morton Bldg., Chicago, Ill.

FOR Sale. Finished material for constructing small biplane. Complete. Cheap. Catalog free. Box 382, Texarkana, Texas.

AVIATION. Send for free and prepaid literature on Aviation. Courses in Practical Aeronautics and Flying. Learn how you may prepare yourself for this fascinating and big paying profession at home. Special Limited Offer to all who write immediately. American School of Aviation, Dept. 7916, 431 South Dearborn St., Chicago.

DICTIONARY of Aviation. Paper \$1, cloth \$1.50. Languages, 143 West 47th St., New York.

CHICAGO Aero Works, 324 River. Plans half price. Limited time.

FOR Sale or Trade—Hydro-Aeroplane, 55 horse-power, 34-foot wings. R. P. Campbell, Waterloo, Iowa.

INVENT Something; your ideas may bring wealth. Free book tells what to invent and how to obtain a patent, through our credit system. Talbert & Parker, 4658 Talbert Bldg., Washington, D. C.

THE American School of Aviation offers new and complete Courses in Aviation. Exceptional opportunities open for men who write today for our Special reduced price offer. American School of Aviation, Dept. 7926, 431 South Dearborn St., Chicago.

HEATH Aerial Products and Supplies. Why are they the best and cheapest? It's the old story—quantity production, Aeronautical supply catalogue, 6 red stamps; propeller catalogue, 3 red stamps. Heath Aeroplane Co., formerly Heath Aerial Vehicle Co., Chicago.

AVIATION Motors, all makes, up to 150 H.P., \$250 up. Complete aeroplanes, all types, \$500 up. State your needs. Aero Exchange, 38 Park Row, N. Y. C.

SPECIAL Light Weight gasoline engine, 1/2 H.P., 2 1/2 pounds. Send stamp for catalog. Weiss Mfg. Co., Torrington, Conn.

PATENTS Wanted in Aeronautics—U. S. Government spending millions in this class for Army and Navy. Our Aeronautic Department will give full information on this subject upon inquiry. Write for "What to Invent," sent Free. Victor J. Evans & Co., 189 Ninth, Washington, D. C.

MODEL Aeroplanes—materials, supplies. Motor-driven Scout Monoplane. Submarine diving boat. Send 5c for catalogue. Wadding River Mfg. Co., 559 Marcon St., Brooklyn, N. Y.

GLIDERS, building materials and instruction. Particulars. Paul Mason, Parker, Idaho.

BOOKS AND PERIODICALS

TRUTH about alcohol. A deceptive drug leading to the scrap pile. Dr. Kellogg, Satisfaction guaranteed, 10c. John E. Miller Company, 142 Irving Ave., Brooklyn, New York.

"VOICE of Senam." Hindoo mystic. Nothing like it ever published. Weird messages from the great somewhere 25c. Sovereign Pub. Co., 169 Sycamore, Buffalo, N. Y.

THE Smallest Bible on Earth. Size of postage stamp. 200 pages illustrated. 15c each. 1) for \$1.00. F. & S., 1318 Spraight, Madison, Wis.

ROPE splicing, knots, hitches, 130 illustrations 20c. M. Brady, 744 Jackson, Chicago.

WORLD-ROMIC System. Masterkey to All Languages. Three books, 38c. Languages, 143 West 47th St., New York.

MAGAZINES at rock bottom prices. Send today for our free catalog "P." S. C. Hanson Magazine Agency, 4928 Kinzie, Chicago.

UNDERGROUND Treasures. How and where to find them. Morton Bldg., Chicago, Ill.

FIND Out for Yourself what to invent and how to procure and sell a patent for the same. My book, "Inventor's Universal Educator," covers the matter from A to Z—140 pages, elegantly bound. Also contains 640 mechanical movements and 50 perpetual motions. Price \$1.00, postage free. F. G. Dietersch, 451 Oarway Bldg., Washington, D. C.

USED Books, Bargains, Catalog. Higen's, A-2441 Post, San Francisco. (Books Bought.)

ENGINEERS' questions and answers for license by Hobson, for twenty-five cents, postpaid. Send stamps, Reilly's Book Store, Philadelphia, Pa.

CARTOONS

CHALK Talk Series—Turnover, trick, applause-getting caricatures. Complete program with "talk" \$1.50. Copy "Drawing Made Easy" (fifty sets trick drawings) free with order. Chalk Talk Magazine, Elmcreek, Nebraska.

EDUCATIONAL AND INSTRUCTION

GOOD Cartoonists earn enormous incomes. Demand cannot be supplied. Our highly developed course of instruction will fit you, at a minimum expenditure of time and money. We guarantee to refund your money if you are not satisfied in every way. Write today for particulars. Denison School of Cartooning, Box 14, Harrison, N. Y.

LEARN the Landscape Engineering Profession. Dignified—Fascinating—Profitable. Complete information free. Gross School of Landscape Engineering, West Second St., Beardstown, Illinois.

FREE Tuition by Mail: Normal, Grammar School, High School, Bookkeeping, Shorthand, Typewriting, Civil Service, Agricultural, Drawing, Domestic Science, Engineering, Automobile, Salesmanship, Law, and Real Estate Courses thoroughly taught by mail. Membership Fee, \$15.00; tuition free to first applicants. For "Free Tuition Plan," address, Carnegie College, Rogers, Ohio.

BE a Finger Print Expert—\$25 to \$50 a week in this new and fascinating profession. Write—find out how you can learn at home to supply the big demand for finger print experts in banks, big factories, detective agencies, etc. Special limited offer—write while it lasts. Evans University, Finger Print Dept., Room A-119, 1810 Wilson Ave., Chicago, Ill.

STAMMERING Cured. Educational methods. Private lessons. J. P. King, Constantine, Michigan.

SHORTHAND. Learn at home. Thousands of stenographers have risen to prominence, so may you. We stay by you until you learn a dependable system. Write for booklet, Fairfield School of Shorthand, Davis Bldg., Fairton, New Jersey.

ARTIFICIAL Marble, sanitary flooring, complete instructions, \$1. Ornamental casting, concrete, plaster, papiermache, decorations, garden furniture, statuary, rubber moulds, electrometallurgy. Particulars, 203 Illustrations free. Mahler, D-721 Woodland Ave., Woodhaven, L. I., New York.

ARTISTS make big money. Fascinating profession quickly learned at home by New Easy method. Artist's Outfit Free to new students. Write today for handsome book—free. Washington School of Art, 1630 H. St., N. W., Washington, D. C.

ELECTRICITY—Learn it at America's largest and best equipped trade and Engineering School. Here you are taught by practical work on finest equipment. No books, no classes, no useless subjects to waste your time. 18 years of success. Write for our big free book of trades. Coyne Trade & Engineering Schools, Dept. 719X, Chicago, Ill.

SHORTHAND by correspondence. Cheapest; easiest; best. G. T. Churchill, Chicago Heights, Ill.

SINGLE Subject Series. No. 1: How to Enlarge Your Stock of Words, Practical, helpful, interesting. Silver dime. Helme Publishing Co., 178 Avery, Detroit.

SHORTHAND 25c first lesson. Improved Pitman. R. Howe, 132 St. Felix St., Brooklyn.

MOULD making for ornamental casting, particulars, 203 Illustrations, free. Mahler, Woodhaven, N. Y.

SPANISH Alphabet, Masterkey to Spanish, 37c. Languages, 143 West 47th St., New York.

MARR'S "D. E. Bookkeeping in 2 lessons." 25c; practical, easy self-study. B285, Nashville, Tenn.

SHORTHAND—The New Way. Boyd System. The Wonder of the Age. Learned in 30 Days in Spare Time. 100 to 150 words a minute. Writers hold World's Record. Send today for Special Offer, Catalog and Sample Lesson, Chicago Home Study Schools, 551 Reaper Block, Chicago, Illinois.

BOPP'S Calculator and Short-Cut Arithmetic—Shows the answer as quickly as a watch shows the time to all problems likely to occur in office, store, shop, bank, farm or factory. Over two million sold. Price, vest pocket size, 50 cents; leather, pocket size, \$1.00; large, desk size, \$1.25 postpaid. Complete description sent upon request. Popular Mechanics Book Dept., 6 N. Michigan Ave., Chicago.

WANTED—New Ideas. Write for list of Patent Buyers and Inventors Wanted. \$1,000,000 in prizes offered for inventions. Our Four Books sent free upon request. Victor J. Evans & Co., 167 Ninth, Washington, D. C.

LEARN Drafting—One of the most practical subjects, and indispensable in many occupations. Individual study at home without an instructor may be successfully carried out with the aid of our book, "A Practical Course in Mechanical Drawing," 160 pages, 157 drawings, cloth. Price 50 cents postpaid. Popular Mechanics Book Dept., 6 N. Michigan Ave., Chicago.

IDEAL Atlas—Just Published—Contains large scale maps, yet is a book of handy size. Has special maps of all war zones in addition to all regular maps found in a good atlas. Is self-revising, that is, contains a certificate entitling the purchaser to a supplement of new maps after the war is over. Genuine flexible leather binding. 512 pages, 256 pages of maps, 256 pages of text. Price \$1.65 postpaid. Popular Mechanics Book Dept., 6 N. Michigan Ave., Chicago.

READ blue prints correctly. Make big money. 33 large instruction blue prints make it easy, adopted by Midvale Steel Co., for apprentices. Price \$7.50, complete. Mechanics Improvement Association, P. O. Box 625, Philadelphia, Pa.

AUS Nah und Fern. For students of German. Fascinating quarterly. 8th volume, 2 years, \$1.90. "Nahfern," Parker School, Clark and Webster, Chicago.

TRADE SCHOOLS

ELECTRICITY, Plumbing, Bricklaying, Mechanical, Architectural and other Drafting Courses. Motion Picture Operating taught by practical work. Largest, best equipped practical trade school in America. Short time to learn. Small cost, easy payments. Write for big illustrated book: It's free. Coyne National Trade Schools, Dept. 819X, Chicago, Ill.

HELES' Watchmaking and Engraving School, the largest and best equipped school in the West. 717 Market Street, San Francisco, Cal.

LEARN Decorating, Paperhanging, Graining, Sign Painting, Showcard Writing by Practical Training. Catalog Free. Chicago Painting School, 131 North Fifth Avenue, Chicago.

TELEGRAPHY

TELEGRAPHY—Morse and Wireless—taught at home in half usual time and at trifling cost. Omnigraph Automatic Transmitter will send, on Sounder or Buzzer, unlimited messages, any speed, just as expert operator would. Adopted by U. S. Govt. and used by leading Universities, Colleges, Technical and Telegraph Schools throughout U. S. Catalog free. Omnigraph Mfg. Co., 41-G Cortlandt St., New York.

TELEGRAPHY for Beginners—Best textbook for students of telegraphy. The standard method. 64 pages, 19 illustrations. 25c postpaid. Popular Mechanics Book Dept., 6 N. Michigan Ave., Chicago.

TELEGRAPHY—Morse and Wireless—also Station Agency taught. Graduates assisted. Cheap expense—easily learned. Largest school—established 42 years. Correspondence courses also. Catalog Free. Dodge's Institute, 15th St., Valparaiso, Ind.

WIRELESS

WIRELESS Telegraph—Two instruments and Morse alphabets, for beginners; instructive, amusement. Postpaid 10c. "Lever" Co., Elizabeth, N. J.

PICTURES, POSTCARDS & PENNANTS

BIGGER than ever, more names, stories, etc. 1,000 names to select each issue. Enrollment, 6,000; rapidly growing. Trial 10c. Elite Postcard Exchange, R-47, 3684 Milwaukee Ave., Chicago, Ill.

BARGAIN! Post-cards. 24 Views, 10c. Castle Co., N. Locust, Hagerstown, Md.

EXCHANGE Postcards, Best Club, 10c. Jolly Card Exchange, Decatur, Indiana.

WATERBURY. Views of the Brass City of the East. Twelve, 25c. Feature Card Co., Box 811-E, Waterbury, Conn.

MEMBERSHIP and 25 poster stamps, 10c. Sagebrush Exchange, Goldfield, Nevada.

FREE particulars. Largest postcard club, Membership 10c silver. Capital League, Box 1539-P, Washington, D. C.

203 ILLUSTRATIONS free, beautiful art statuary. Mahler, Woodhaven, L. I., New York.

JOIN our dainty card exchange. A trial will surely convince you. Send just a dime. Rose Postcard Society, Portland, Ore.

PRETTY view cards from everywhere. Membership and 6 pretty cards, 10c. Riverside Club, Knoxville, Md.

IF you really want to exchange postcards, try our splendid club. Lists circulate in many countries. Membership, 10c. Halcyon Club, Box 133, Erie, Pa.

OPTICAL GOODS

MICROSCOPE, magnifies 3,600 times. Every microscope guaranteed to give clear and perfect definition of object, 25c. Catalog for stamp. Specialty Mfg. Co., 30, Box 164, Milton, Pa.

CAMERAS AND PHOTO SUPPLIES

FREE trial of ten days on Kodaks. Cameras or Lenses. Write now for our latest free Bargain Book and Catalogue listing hundreds of slightly used and new bargains at extraordinary saving prices. \$20 3A Eastman Folding Pocket Kodak \$10.75; \$18.50 No. 2 Anso Vest Pocket f7.7. Anastigmat Lens \$14.75, new. Everything guaranteed. Money back if unsatisfactory. If you desire to exchange or sell your outfit, or are in doubt making proper selection for your special need, consult us. Central Camera Co., 124 South Wabash Ave., Dept. E-1, Chicago, Illinois.

FREE Camera Catalog saves you money. Eastman Kodaks, Anso and Rexo cameras, Graflex, Motion-Picture outfits and Lenses—everything in cameras from a box Brownie, at lowest prices. 10 Days' Free Trial—Money-back Guarantee. Developing and printing accessories. Eastman, Anso Speedee and Rexo Speed film—Cyko and Rexo paper at cut prices. Free Camera Catalog shows everything for photography at money-saving prices. Send for your copy now. See our display advertisement on page 162. David Stern Company, "In Business Since 1885," 618 Davaco Bldg., 1047 Madison St., Chicago, Ill.

"ECONOMIZE." Attach a film Economizer to your camera; use all of film for exposure and get seven pictures on six-exposure film. Pays for self many times over. Price One Dollar. State name of camera, film used and size. Satisfaction guaranteed. Voigt Mfg. Co., Sheboygan, Wis.

FREE. Send negative for sample print. Films developed 5c per roll. Print 2½x3¼ 5c each; 3½x4¼ 4c each. 8x10 enlargement 25c each, for your own negative. Send for price list. M. A. Leese, 611 9th St., Washington, D. C.

FILMS developed Free—Prints 4x5 or less 3c. Beautiful work—8x10 25c. Postals \$2 hundred—\$15 thousand—photos colored. Deyographic Art Company, Jamaica, N. Y. City.

FILMS developed, 10c roll. Packs 20c. Prints, Brownies, 2c; 1a, 3x4, 3x5 and Post Cards, 3c. Returned next day. Prepaid. Kodak Film Finishing Co., 112 Merchants Station, St. Louis.

FILMS Developed, any size 5c. Any size prints 3c. 8x10 enlargements 25c. Work returned same day received. Address Camera Shop, Box 69, Ann Arbor, Michigan.

FILMS Developed Free, perfect prints, modern up to the minute methods. We do the best work in this the Photo City. Films developed absolutely free when we make the prints. No matter where you live send us your films. We return all work promptly by parcels post. Bryans Drug House, Rochester, N. Y.

EASTMAN Vest Pocket Kodak, anastigmat lens F7.7, \$8; elsewhere \$10. Just the camera if you are going away. J. L. Lewis, 522 6th Av., N. Y. Dept. A.

If you appreciate quality, send us your Developing and Printing. Trial Roll finished at your own price. Sample Enlargement 20c. Myland, 2125 N. Front, Philadelphia.

MUST Sacrifice—Filmplate Premo Special with Graflex view finder auxiliary lenses, leather case, etc. John R. Black, 908 South Osteopathy Ave., Kirksville, Mo.

SENSATIONAL discovery—Autol develops and fixes films or plates in one operation. Automatic and sure; develops until just right, then fixes. Make it, use it, and supply your county. Formula \$1.00. Be the first. Chromaloscope Company, Norwalk, Conn.

FILMS developed by experts, 5c. Prints any size, 40c doz. Kodak supplies. Jamestown Ferrotyping Co., 1119 S. Halsted, Chicago, Ill.

FILM Service Shop, 3415 Ogden Ave., Chicago. Professional finishing for amateurs. Capacity, 1,000 rolls daily. Any roll film developed and 6 prints 25c. Prints 6 for 20c. Cash with order.

INVENTIONS Wanted in Motion Pictures and Photography. Special department for these classes of invention. Advice, What to Invent and List of Patent Buyers Sent Free. Victor J. Evans & Co., 159 Ninth, Washington, D. C.

No. 2 **HARVEY** Exposure Meter for Kodaks, Graflex and other cameras. New Exposures and Films, Plates, Interiors, Portraits and Night Photography. \$1.25. Ask your dealer or G. Harvey, 105 S. Dearborn, Chicago.

FOR Sale: No. 1 Autographic Kodak Special, 3A Autographic Kodak Special, 1A Ansco Speedex, Vest Pocket Kodak Special, Ica Atom and outfit, 5x7 Long Focus and outfit, 4x5 Burke & James Enlarging Lantern. Brand new condition. Write at once. V. G. Schwartz, Edwardsville, Ill.

EXPERT Photo Finishing. Send us a trial roll. Our expert handling brings out all there is on your film. Developing 10c. Prints 3 to 5c. Better pictures will result from our service. Send negative for sample. G. R. Hoke, 1517P East 63rd St., Chicago.

FREE. "Flashlights Made Easy." Never-Fall Instructions for indoor and outdoor groups and portraits. Outfits loaned, 25c. Ashton Photo Works, Ashton, Illinois.

PRINTS made, 2c each—any size. Rolls developed 5c each. Ideal Photograph Co., Winston-Salem, N. C.

EQUIP your camera or Kodak with a Wollensak lens and shutter and obtain the best possible results. Beautiful descriptive catalogue "B" sent on request gratis. Wollensak Optical Co., Rochester, N. Y.

FILMS developed, 10c; prints, 2c to 5c. A reputable incorporated company conducting largest existing plant. Price list and special offer. Enlargements our specialty. Chicago Photo Finishing Co., 54 W. Lake St., Dept. A, Chicago.

FILMS Developed, 10c all sizes. Prints 2x3 1/4, 3c; 3x4 1/4, 4c. We give Profit Sharing Coupons. 24 hour service; work guaranteed. Send negatives for samples. Girard's Com'l Photo Shop, Mills Alderman Bldg., 316 High St., Holyoke, Mass.

AMATEUR Photographers—Send for our catalog on photo supplies. We retail to you at wholesale prices. Fahrwald Bros. & Co., Kildare & Cortland, Chicago, Ill.

MAKE Beautiful transparent photos on watch dials, cases, etc. Complete process and working instructions 25c. C. Johnson, 4319 N. Whipple St., Chicago.

FILMS developed 5c, any size. Prints 2c each, all sizes. Free enlargement with first \$1.00 order. Johnson's Studio, Oswego, N. Y. 3 months' instruction in Photography \$10.00 at studio.

BIG Money Saved on Photographic Lenses and Apparatus—goods exchanged; repairing done. Ralph J. Golsen, 5123 Kenmore Ave., Chicago, Department P.

FOR Sale—Film-Plate Premo Camera, with R.R. lens, Automatic shutter. Post-card size. Takes excellent pictures. Will include leather carrying case, tripod (fits nicely in case), 3 plate holders. All condition. \$16 takes the outfit. F. W. Johnson, Room 925 Tower Bldg., Chicago.

FILMS developed 5c roll. Velox prints finished by Professional Photographers, 2 to 3c. Beautiful Hand colored enlargement from your negative free with dollar order. Prints returned 24 hours, prepaid. Taylor Camera Shop, Box 574, St. Louis, Mo.

FILMS Developed Free. Prints any size 4c. Expert workmanship. Louis H. Levan, 234 East 121st Street, New York.

INGENIO camera, 2 1/4 x 3 1/4, Voigtlander Radiar Anastigmat lens, F:6.8. Compound shutter. \$27 cash. Fox, 45 W. 91st, New York.

MOTION PICTURES

JUST Out—Concise book of facts. Teaches you to plan, write and market Movie Plays, including sample scenario. 25c in coin. Remcott Booklet Co., 8 Spring Lane, Boston, Mass.

WRITE for Free Copy "Hints on Writing and Selling Photoplays, Short Stories, Poems." Atlas Publishing Co., 271, Cincinnati.

INCREASE your patronage, useful office and household specially cheaper than any other advertising. Last a lifetime. Stamp for particulars. ("Gidz"2), Galesburg, Illinois.

WRITE photoplays in spare time and earn money; big prices paid; constant demand. Details free. Glisse Co., 315 Whiteman St., Cincinnati, Ohio.

MAKE Big Money in moving-picture business. We start you and furnish guaranteed outfit on easy payment plan. Easy to accomplish. Catalog free. Monarch Film Service, 228 Union Ave., Dept. P, Memphis, Tenn.

CAMERAMEN earn big money. If you are ambitious, you can earn as you learn under our plan. U. S. Cinematograph Institute, 28-30 Orleans St., Newark, N. J.

MOTION picture machines bought and sold; bargain lists free. National Equipment Company, Duluth, Minn.

MAKE a complete Motion Picture Camera and Projector from instructions given in our book Amateur Mechanics No. 4. Full details given. Not hard to construct. Worlds of enjoyment taking and exhibiting subjects dear to the heart. Price of book only 25c, postpaid. Popular Mechanics Book Dept., 6 N. Michigan Ave., Chicago.

ARE You a Movie Type? Many of the greatest stars were discovered by accident. You want to know if you have the natural qualifications that bring \$50,000 salaries. The book Motion Picture Acting tells you this, also 191 screen favorites show you how they register 499 human emotions. Use of cosmetics, costume requirements and color schemes also treated. Price cloth 75 cents postpaid. Popular Mechanics Book Dept., 6 N. Michigan Ave., Chicago.

MAKE money writing Photo-plays; details free to beginners. No correspondence course. Producers League, 239 Wainwright, St. Louis.

BIG Profit Nightly—Moving Picture Business—small capital starts you, easily accomplished. Teach you—furnish everything. Ralph J. Golsen, 5123 Kenmore Ave., Chicago, Dept. M.

BUSINESS OPPORTUNITIES

SHINES in the dark. Our Luminous Paint, coated on any article, makes them visible at night. Watches, clocks, electric switch plates, crucifixes, match boxes, etc., can be coated with splendid results. (Everlasting.) Only 25c bottle. Luminous Paint Co., Douglas Park Station, B-14, Chicago, Ill.

OUR Latest Discovery, Borendry Glaze, absolutely greaseless, for polishing, cleaning and renewing auto bodies, tops, cushions, windshields, furniture, pianos, floors, mirrors, windows, brass and iron beds, leather and metal finishes. Agents, dealers and garage owners act quick. Large sample bottle 25c. Elloit's Auto & Furniture Finishing Co., 336-338 Farrington Ave., St. Paul, Minn.

SILVERING Mirrors—My exclusive French Tartaric Method opens enormously profitable business. Booklet Free. H. Barstow, 514 23rd St., Oakland, Calif.

DOLLARS yearly in your backyard. No ginseng, mushrooms dope. New ideas. Investigate. Particulars free. C. Metz, 313 East 89, New York.

PATENTS and Inventions for sale or on royalty. My clients have valuable inventions for market. No better investment for manufacturers or individuals. Full information without charge. Mention line of invention interesting you and data will be sent. Richard B. Owen, Patent Lawyer, Owen Building, Washington, D. C.

LEARN the Real Estate business; Great money-making opportunities open; easily acquired. Send for detailed plans. It's free. Dept. 49, MacMichael Realty Company, Victor, N. Y.

CONSULT Dugdale on all advertising and sales questions. His forceful ads, booklets, follow-up and sales plans increased one advertiser's business fifteen hundred per cent in eighteen months. Submit your literature or proposed plan for personal advice. H. K. Dugdale, 115 Warder Building, Washington, D. C.

MAKE Big Money Repairing Safes and Setting Combinations. Wayne Strong, Box 1426, Los Angeles, Cal.

INVENT Something; your ideas may bring wealth. Free book tells what to invent and how to obtain a patent, through our credit system. Talbert & Parker, 4671 Talbert Bldg., Washington, D. C.

YOU can erect a chain of our six-foot Giant Advertising Thermometers in public places, and become independent. Sell the 14 advertising spaces for \$184. Erecting one Giant a week nets you \$125 immediately, plus \$170 yearly on renewals. This is a dignified proposition enabling you to make money and preserve your self-respect. Write for book. Winslow Cabot Company, 31 Congress Bldg., Boston, Mass.

500 FORMULAS, including Resilvering Mirrors—Renewing Dry Batteries, Luminous Paint, Luminous Ink, 25c. Ideal Book Shop, 3315-C8, Bellerlaine Ave., Chicago.

IF you want to start a sideline business with a reliable product, see what we offer for \$750. Box 26, Providence, R. I.

WOULD a paying, independent business of your own (not a mail order or agency scheme), appeal to you? If so, ask for proposition of Fourpoint Co., Sturgis, Mich.

PLASTOGRAPHY: Make beautiful imitation marble Medallions yourself. Instructions \$2.50. Mould or model of President Wilson or Lincoln sent free with your order. P. B. Spahr, York, Penna.

DISTRIBUTOR and Dealer Agents Wanted Everywhere for cleverest line electrical specialties ever erected. Sterling Corporation, 1275 West Third St., Cleveland, O.

VALUABLE Old English Formula for sale. Especially adapted to cleaning paints, woodwork, etc., enamelware, washes clothes without rubbing. Can't be beaten around engine rooms, factories, shops and homes. \$5 to \$29 easily made daily. Repeat article. Very cheaply put up. Price, only one dollar. B. G. Rogers, Analyst, Summerside, P. E. I., Canada.

PATENTABLE Ideas Wanted—Send for 4 free books. R. B. Owen, 30 Owen Bldg., Washington, D. C.

MAKE Music Rolls for profit and pleasure, with simple perforator. Splendid opportunity. Particulars free. The Leabarian Mfg. Co., Hamilton, Ohio.

MAIL Order Dealers. Let the 4 in 1 coupon plan increase your profits. Sell valuable instruction systems by cut price coupon under money back guarantee. Big margin. Small selling expense. Complete plan, sample coupons and bargain bulletin sent on request. Mail Dealers' Coupon System, 519 So. Dearborn St., Chicago.

MANUFACTURERS, Promoters and Patent Buyers are invited to write us stating the line of invention in which they are interested, as we can supply their wants in any class of patents. Victor J. Evans & Co., 162 Ninth St., Washington, D. C.

BIG money in promoting inventions. Write Adam Fisher Mfg. Co., 2061D Railway Exchange, St. Louis, Mo.

GOOD monthly income easy in spare time manufacturing letters for signs. Free particulars. J. P. McPherson, 677 Brown Avenue, Butler, Pa.

ENTER a new business. Earn \$3,000 to \$6,000 yearly in professional fees making and fitting a foot specialty, openings everywhere, with all the trade you can attend to; easily learned by anyone at home in a few weeks, at small expense; no further capital required, no goods to buy, job hunting, soliciting or agency. Address Stephen-Laboratory, 11 Back Bay, Boston, Mass.

WE start you in business furnishing everything; men and women make handsome income weekly operating our "New System Specialty Candy Factories" home or small room anywhere; no canvassing. Opportunity lifetime; booklet free. W. Ragsdale Co., East Orange, N. J.

INVENTORS: We develop and perfect inventions, make models, dies, tools. Metal stamping and special manufacturing. Gerding Bros., Lion Bldg., Cincinnati, O.

ADVERTISERS, Mail Dealers. Our New Rate Book lists 2,000 Principal Publications, rates, circulation. Includes 30 Mail-Order Plans. Free. Dearborn Advertising Agency, 210 Franklin Bldg., Chicago.

LEARN to collect money. Good income; quick results. Send for free booklet, "Skillful Collecting," Collectors' Association, Long Street, Newark, Ohio.

LEARN the real estate business; our enlarged instruction book teaches listing, appraising, management, salesmanship, insurance, brokerage, advertising, renting, agency, estates, titles, rights, forms, etc.; revised edition; 240 indexed subjects; excellent \$25 correspondence course; buckeye cover, \$1; silk cloth, \$1.25, postpaid. Realty Book Co., Dept. No. 29, Cleveland, Ohio.

INDEPENDENCE and fortune quickly attained in the Manufacturing Mail Order business. I furnish Formulas, Manufacturing Processes and Trade Secrets in all lines. Sold under positive guarantee; 18 years' practical experience. Revision and improvement of Formulas and Processes—reduction of manufacturing cost—utilization of waste materials, etc., a specialty. Booklet, Formula List, and Valuable Information Free. W. L. Cummings, Ph. D., 127 Standard St., Syracuse, N. Y.

RESILVERING Mirrors—Recharging Dry Batteries—Gas Tonic—Orange-ade Powder—Straw Hat Cleaner—Luminous Paint. This valuable collection of formulas 25c. C. Johnson, 4319 N. Whipple St., Chicago.

OPERATE Paying Business. Startling book Plans, Opportunities, Formulas, Ideas. Free circular. S. W. Sivel, 5460 Spruce, Philadelphia.

MONTHLY Income Paid those writing lists of names for us at home, spare time. No supplies to purchase, no investment, expense or other work required. No false scheme but legitimate business of national scope. Write for particulars, National Exchange, Box 1401, New York.

TO MANUFACTURERS

ARTICLE wanted for Mail Order business. L. C., 45 Grant Ave., Medford, Mass.

MAIL-ORDER SUPPLIES

INCREASE your sales. Place your proposition before the readers of "Cartoons Magazine," 20,000 copies guaranteed every month. Classified rate 5c per word. Mail in a trial ad today. Cartoons Classified Dept., 78 E. Madison St., Chicago.

FOR ADVERTISERS

YOUR Thirty-Word Ad. in our big post-card magazine, 25c. Inch display. 50c. Elite Exchange, 3694 Milwaukee Ave., Chicago.

BOOST Your Business. 25 Model Grocery Advertisements prepaid only \$1.00. 12 Clothing Ads. 50c. Written by experts. Other series for other lines. Write Ira Crawford, Business Builder, Box 128, Duluth, Minn.

20-WORD Advertisement in 120 monthlies \$1.50. Continent Exchange, Hollywood, California.

ADVERTISERS—Here's your opportunity. Your proposition placed before the readers of "Cartoons Magazine" for only 5c per word. Circulation 20,000 copies guaranteed. Send a trial ad for our next issue. Cartoons Classified Dept., 6 N. Michigan Ave., Chicago, Ill.

ART AND ADVERTISING SERVICE

ADVERTISING Expert prepares pulling, profit-producing sales letters, folders, prospectuses; mail-order campaigns. Efficient, economical business-builders. Counsel free. Harry A. Stern, 1060 Gaylord, Denver.

ADVERTISING Pencils. Stamp brings samples. Graybill & Co., Lancaster, Pa.

BUSINESS SERVICE

INCORPORATE. Our lawyers do the work, saving you time, annoyance and money in incorporating under the most liberal laws of Arizona. Laws and forms free. Southwestern Securities & Investment Co., Box D488, Phoenix, Ariz.

COLLECTIONS

DEBTS Collected Anywhere, Quickly! Established 25 years. William H. Dodd, 87 Nassau Street, New York.

AGENTS WANTED

AGENTS: Biggest moneymaker ever put on the market, "Eggette," the original egg substitute. Takes place of eggs in baking and cooking at less than ten cents per dozen. Sells rapidly to homes, stores, bakers, etc. A Guaranteed pure food product. Good opportunity to build permanent business with big income. No competition. Regular size package 10c, equivalent to 12 eggs. Attractive moneymaking proposition free. Write quick. Bestever Products Co., B-1, Douglas Park Station, Chicago.

MARVELOUS Expanding Cuff Buttons. Presto, slip your cuffs up on forearms without unbuttoning same. Cuffs positively stay where placed. Lowered they close automatically. Great Laundry saver. Indispensable for all latest styles of shirts. A guaranteed necessity that appeals to all. Worn and approved by over 50,000 satisfied users. Sensational seller. Large profit and fine mail-order article; also 50 other high-class agent's specialties. Fixco Mfg. Corporation, Sheboygan, Wisconsin.

AGENTS—Wanted to handle Bonanza Sales Boards. Can be used for any purpose desired. Latest Sensation in Specialties for Sales Boards. Write for particulars. Gordon Specialty Agency, Dept. B, 52 West Chippewa, Buffalo, N. Y.

WORLD'S Fastest selling auto accessory. County distributors wanted. Good profits. Write today. G. L. W. Spring Oiler Co., San Diego, Calif.

SELLS like hot cakes. Brand new ironing wax. Perfumes clothes with lasting violet perfume. Working outfit, 5c. Perfume Gloss, 13 Water Street, New York.

\$61.50 WEEKLY. Introducing and selling a new gas light burner for kerosene lamps. Beautiful light. No chimney. No mantle. Samples free. Luther Manufacturing Co., Dept. 316, Cincinnati, Ohio.

"WASHWHITE" makes easy sales. Big profit. Sure repeat business. Genuine Rogers Silverware free to your customers, and valuable Premiums for you. Free printed matter and Sales Course. Free samples with every order. Cleans clothes without rubbing, and without injury to the finest fabric. 7 big washings for 15 cents. Sales Guaranteed. Write for Our Offer. The Naema Co., Dept. K-7, 29 W. Lake St., Chicago.

GENERAL Agents—Crew Managers—Capable of earning \$75 or more weekly. Sell new guaranteed home specialty backed by \$200,000 corporation. Big profit. Quick sales. Exclusive Territory. Sales Manager, Dept. K-8, 29 W. Lake St., Chicago, Ill.

AGENTS—Telephone appliance. The only instrument not an attachment. Approved by telephone companies. Big seller. Sensation of last business exposition. Write now for selling right! Westphone, Inc., 1 Madison Avenue, New York City.

\$99 PER week. Abbott makes it. You can too, selling our guaranteed Auto Shock Absorber. New principle. Better and cheaper than others. Write for territory. Act quick. Kux Rebound Check Co., Chicago.

SENSATIONAL Seller. Most remarkable discovery of science, Sanitary bed-bug climinator. Keeps bugs away while you sleep. Sample 25c. Agents wanted. Dewilde Chemical Co., Sheboygan, Wis.

MEN or women for small quick selling article, 2 to 4 to a customer. Send 15c for sample. A customer in most every house. T. E. Gahan, 36 Western Ave., Toledo, O.

"1916's SENSATION!" Eleven piece toilet article set selling like blazes at \$1.00 with \$1.00 carrying set Free! Enormous profits! Tremendous hit! Engle made \$51.00 first week. Write quick! Pierce Co., Dept. P, 998 Lake St., Chicago.

AGENTS financially responsible who understand heating plants to sell Blasko Fuel Saving Devices on monthly payment plan. Every heating plant a prospect. Guaranteed to save 25%. Evaporation tests at two universities averaged 25% saving. Wolff Fuel Saver Company, 14 East Jackson, Chicago.

AGENTS: New invention prevents loss of hat pins. Whirlwind seller. Untouched field. Enormous profits. Goods sent prepaid. Loss Preventing Device Co., Div. A, Gardena, Calif.

SOFT Drinks in Powder. Just add water—delicious, refreshing, healthful. Everyone buys—big profits. Enough for 10 glasses Orangeade and particulars 10c postpaid. Chas. S. Morrissey Co., 4417 Madison St., Chicago, Ill.

AGENTS: Make real money this year; not "paper money." Just think! Our Eradium (luminous) Articles Shine in the Dark. We manufacture a complete line so that every call can be turned into a sale. Everyone amazed at the wonderful possibilities of these goods. Our Eradium Bulb is easily attached to any light and "Locates Your Light in a Jiffy" in the darkest room. Our Eradium Crucifix showing the Christ figure in startling outline throughout the night sells to every Catholic. Our Eradium House Numbers (just out) are selling like Ford automobiles. Our Eradium Clock tells the time in the dark. Our Eradium Match Box sells like hot cakes everywhere. Garages, homes, etc. Our Eradium Switch Plate for hotels is a big seller. Write today for best proposition you ever heard of. Sole manufacturers. The Pioneer Corporation, 1239 West 63rd, Chicago.

TAILORING Agents Wanted—Big complete sample outfit and case, nearly 250 large cloth samples, 2 piece lists and everything needed for canvassing or use in store, free to live agents. \$25.00 to \$50.00 a week; may make more. Write us today for free elegant outfit to begin, cloth samples, wholesale prices, special offer on a suit for yourself and full information—see our wonderful values, beautiful fabrics and styles. Established 28 years. Every garment made to measure—everything guaranteed and express prepaid. Just send a postal. American Woolen Mills Co., Dept. 614, Chicago.

AGENTS: Big profits selling our New \$2.50 Automatic adding machine. Quick sales. Ten a day easy. No competition. Anyone having adding to do is positive customer. You'll be glad you wrote us. Bassett Company, 5921 Indiana Ave., Chicago.

INSYDE Tyres, inner armor for Automobile tires, double mileage and prevent punctures and blowouts. Quickly applied. Cost little. Demand tremendous. Profits unlimited. Details free. American Automobile Accessories Co., Dept. P, Cincinnati, O.

BIG Profits for You! Manufacture Barley Crisp. New Confection, 5c package costs you 1c. Machine instructions complete \$7.50 prepaid. Send 10c for samples. Barley Crisp Co., 1295 Broadway, San Francisco.

GET Davis' Latest Proposition. \$15.00 daily a cinch. No matter how many times you have answered my ads in last 20 years, write again. E. M. Davis, Dept. 549, 993 Lake, Chicago.

AGENTS—Line up for big profits this year. Hot string of brand-new, exclusive sellers with the big "punch" just being brought out. Grab your territory now. You'll regret it if you delay. Adam Fisher Mfg. Co., Agency Dept. 2061 Railway Exchange, St. Louis, U. S. A.

MEDALLIONS—300% profits. Make up your own goods and be independent. Catalogue free. Resag Co., 1235 Randolph St., Chicago.

AGENTS—Our gold window letter proposition beats 'em all. Stahlrite Co., Dept. P, 1115 Second Ave., N. Y. Established 1895.

AGENTS—Establish yourself in a permanent well-paying business. Automobile owners everywhere have been looking for this article. Newman's Nu-Mend positively seals punctures automatically as fast as they occur. Guaranteed. Large profits. Write for agency. Newman Mfg. Co. (Estab. 1882), 713 Sycamore Street, Cincinnati, Ohio.

AGENTS: Sell "Motorsep," New Gasoline Saver, 100% profit. Write for particulars. Universal Supply Co., Box 194, Sidney, Ohio.

AGENTS make 500% profit handling Auto Monograms. Patriotic Pictures, Flag Novelties, Window Letters and Changeable Signs. Catalogue free. Hinton Co., 6142 40th Court, Chicago, Ill.

AGENTS. General Agents, District Managers: Economic gas burner saves 1/2 gas on gas ranges. Entirely new, just out. 133% profit. Exclusive territory. Apply immediately. Sample 25c. Phillip Mills, 212 Drake Bldg., Omaha, N. Y.

YOUR Name brings a copy of Money-Making Ideas. The great 32-page agent's and mail dealer's magazine. A Kraus, Kraus Bldg., Milwaukee, Wis.

NEW Knife Sharpener puts razor edge on any knife instantly without grinding. Demonstration creates sensation. 30 sales a day easy. Carry right in pocket. 100 per cent profit. Write for free sample offer now. American Products Co., 8639 Central Ave., Cincinnati, O.

AGENTS: Big Hit: Our 5-Piece Aluminum Set is all the rage. Cheaper than Enamel Ware. Sells like wildfire. Guaranteed 20 years. Retail value \$7.00. You sell to housewives for only \$1.98. Biggest seller of the age, 9 sure sales out of every 10 shown. Others cleaning up \$10.00 to \$20.00 a day. Answer this quick to secure your territory. Div. G-5, American Aluminum Mfg. Co., Lemont, Ill.

SEND dime for fifty square inches of America's best agent's product. Money back guarantee. The American Mfg. & Sale Co., 210 Sufferin Bldg., Decatur, Ill.

AGENTS: Sell Dryola—Chemically Dry Cleans all Fabrics without water. Non-injurious. Big seller. Big profits. Particulars and sample free. Send postal today. Archart Drug Co., Rosholt, So. Dak.

AGENTS wanted to sell automobile accessory. Can earn five dollars or more a day according to their ability. Write for particulars. Hand Manufacturing Co., Inc., Haverhill, Mass., Dept. A.

OUR Representatives—either sex—easily earn \$200 monthly introducing new marvelous vacuum Butter Maker. Guaranteed. Retail \$1.50. Sample free. United Sales Co., Springfield, Ohio.

AGENTS Wanted—Tolliver Puncture-Proof Inner Tubes sell easily—our Agents make \$5.00 to \$50.00 a day net profit—no competition. If you wish to establish a business of your own with unlimited possibilities for profit, write us for complete details. Tolliver Tube & Tire Co., 523-C Foster Bldg., Denver, Colo.

A WONDERFUL new invention; sure sales; big profits everywhere. Safety Specialty Co., Detroit, Mich.

AGENTS. I want 100 men to act as my agents and take orders for "Kantleak" Raincoats. I paid Ed Bridge \$88.95 for one week's spare time. Cooper \$314 last month. Wonderful values. A dandy coat for \$3.98. No money required. No delivering or collecting. Sample coat and complete outfit all free. Big season just starting. There's a thousand dollars in this for you if you grab it quick. Write now. Corner Mfg. Co., 129 Palze St., Dayton, Ohio.

AGENTS make 500 per cent profit selling our Auto Monograms and Initials. Window Sign Letters, Changeable Signs, and Show Cards. 1,000 Varieties. Enormous Demand. Sullivan Co., 1123 Van Buren St., Chicago, Ill.

AGENTS—Men and women. Make \$30 to \$50 weekly selling the New Improved Monitor Self-Heating Iron—the "World's Best." Over 850,000 in use. Positively the easiest, fastest selling, lowest priced, best known iron made. Binding guarantee. Big profits for all or part time. Evans, N. Car., sold two dozen on Saturday. Mrs. Nixon, Va., sold eight first half day. Liberal terms. Exclusive territory. Sample outfit free to workers. Write today. The Monitor Sd Iron Co., 836 Wayne St., Big Prairie, Ohio.

AGENTS—Send for sample "Fretnot"—the wash day wonder. Be convinced you can do a whirlwind business. You can clear at least \$20 to \$100 weekly, according to spare or whole time. You don't have to talk; if she doesn't buy at sight, leave sample; she will be looking for you long before you are able to make the rounds again. Samples furnished free. Premiums for your customers. Exclusive territory granted to agents who can produce. Credit given. Don't call. P. M. Motter & Sons, 8213 Warren Ave., Chicago.

OVEN Fish Ball. Harmless, lawful, effective for all species of fish. 20 years on market. Great summer seller for Agents. Sample 25c. Hayes Mfg. Co., 326 River, Chicago.

AGENTS—Transparent Flags, attached like postal stamps, two sizes; for window panes, automobile headlights. Fast seller. Send 20c for set of samples. J. C. Tutt, Manufacturer, Sibbey Building, 1214 Filbert, Philadelphia, Pa.

SELL guaranteed made to measure raincoats. Agent's price \$2.50 delivered. Material, workmanship incomparable. Outfit free. Standard Raincoat Co., 395 Broadway, New York.

INVENT something; your ideas may bring wealth. Free book tells what to invent and how to obtain a patent, through our credit system. Talbert & Parker, 4663 Talbert Bldg., Washington, D. C.

AGENTS—We ship on consignment. Pay us when you collect. Great selling plan. Evans Solvent Carbon Remover is such a whirlwind seller people quitting jobs in factories, offices, etc., to sell it. Sold under money-back guarantee. Write today. Evans Mfg. Co., 622 E. 43rd St., Chicago.

AGENTS: You can make big money taking orders for our fine made-to-measure clothes, so write quick for 60 beautiful cloth samples, 32 smart styles in rich colors, wholesale and retail price lists, lowest prices and best offer to agents, \$5.00 to \$15.00 a day easy. Big outfit, over 250 samples free to live wires. No experience needed—no capital. We furnish everything free—pay postage or express charges—back you, boost you, show you how and clearly explain everything. Costs nothing to try. Let us make you a stylish suit to measure to prove our fine quality and style. Send postal or letter today. Paragon Tailoring Co., Dept. 614, Chicago.

SAY! If You Only Knew How Easy It Is to Make the Big Selling Specialties you sell by Miller's Guaranteed Formulas.—You'd Get Busy—Make Wizard Washing Tablets—No Wax, Potash or Lye—costs 5c pound, bring sixty. Egg-o-lene, only real egg substitute—represent eggs nine cents dozen. Putnam's Dry Cleaner, Non-Alcoholic Tube Flavors—Dessert Powders—Zerocool—preserves eggs indefinitely. Carbocide Guaranteed Gasoline Intensifier—Decarbonizer—Fibro-Vac Automatic Fibrous Puncture Plugger. Send Stamp Today for Latest Lists and Money-making Propositions. Miller, Analytical Chemist, Tampa, Florida.

RELIABLE! People Wanted to Place Our Orangeade Powder in stores and appoint agents. Makes the most delicious drink you ever tasted by just adding cold water and sugar. Enough for 10 glasses and particulars 10c postpaid. Chas. A. Merrissey Co., 4117 Madison St., Chicago, Ill.

THE Peoria Starter for Ford Cars. Practical, durable and guaranteed. The best mechanical Starter on the market. Some territory still open. Money maker for hustlers. Write for particulars and territory. The United Co., Peoria, Illinois.

SHOW public how to cut high cost of living; send 25c for samples and particulars; make money. Eyer Sales Co., 9643 Ave. M., Chicago, Ill.

GOOD income refinishing chandeliers, brass beds, automobiles by new method, producing amazing results; no capital or experience necessary; particulars free. Gunmetal Co., Ave. H, Decatur, Ill.

PHOTO Pillow Tops, Portraits, Frames, Sheet Pictures, Photo Plates, Pennants. Rejects credited. Prompt shipments; samples and catalogues free to agents; 30-days' credit. Jas. C. Bailey Co., M-1, Chicago.

RUSH postal for Free Sample "Spik & Span." Wonderful new washing tablet. Washes clothes spotless, without rubbing. Tremendous seller. 200% profit. Free Samples to boost sales. Newberry Co., 212 Peoria, Chicago, Ill.

"RUST-GO"—Selling like wildfire—\$8-\$15 daily. Something new. Every house buying. Removes Rust, Ink and Stains. Astounding proposition. Lawrence Co., Bowling Green, Ohio.

AGENTS—Self-threading needles; sell at sight; package and terms 10c. Clarence Maugans, Anderson, Ind.

AGENTS: Neverfall Iron Rust and Stain Remover. Big summer leader. Huge profits. Big line. Credit; sample. Sanford-Beal Co., Inc., Newark, New York, Dept. C.

\$100 PER month easily made during spare time selling one of the oldest fully guaranteed automobile tires. Prices low enough to permit selling to dealers and garages. Write at once if you want to represent us in your district. Economy Auto Supply House, 4353 Cottage Grove, Chicago.

SNYDER'S Toilet Preparations and Household necessities are big values; big profit makers; sell themselves; start making money immediately. T. H. Snyder & Co., Dept. M., Cincinnati, O.

RELIABLE People Wanted—Place Engine in stores and appoint agents. Takes place of eggs in baking and cooking at 3c doz. Large package and particulars 10c postpaid. Morrissey Company, 4403-5 Madison, Chicago.

WHO wants to make more money selling brushes that every household needs? Special method of getting entrance to demonstrate. Fuller Sanitary Brushes are nationally advertised—largest output—best terms and prices—western distributing stations. Your territory is valuable. Write. Fuller Brush Company, Hartford, Conn.; Rock Island, Ill.

253% PROFIT—\$2.80 on each set sold. Newly invented Jubilee Spark Intensifier. Banishes spark-plug trouble forever. Sells on sight. Huge profits. Exclusive territory. Hurry! Jubilee Mfg. Co., Dept. M-7, Omaha, Neb.

STOP Here—Just Out—Eisen Regulator for Ford Headlights. Selling like wildfire everywhere. Gives splendid driving light at low speed—keeps bulbs from burning out—works entirely automatically. Needed on every Ford. Big profits quick. Listen; Hopkins, Tenn., cleared \$16.25 first day. McFarland, Nebr., made \$3,492 in 17 weeks. Siler, Okla., sells 12 a day—profit \$20. No experience or capital needed. We show you how. Sales guaranteed. Hurry, don't delay; write now for special information how you can make money. Address Eisen Instrument Co., 645 Valentine Bldg., Toledo, Ohio.

LARGE Manufacturer wants agents to sell guaranteed custom-made raincoats. We deliver to customer. Enormous profits. Defy competition. 1917 Outfit Free. "Aerco," 175 East Broadway, Desk P, New York.

GET into biggest money-making and automobile business—replacing necessary equipment. Live, ambitious men wanted as special factory representatives, exclusive territory, taking orders for tops, top coverings, seat covers, "Stik-Tite" windows. No experience necessary. No capital required. No competition. Copyrighted system protects you. Free catalog, samples, full details. Cincinnati Auto Specialty Company, Dept. MC-67, Cincinnati, Ohio.

THEY sell themselves; big profits. Wire Products Co., Scranton, Pa.

MEN and women make \$3.00 to \$8.00 a day. Easy work, product light and compact. Needed in every home. Money-back guarantee. Send 25c for outfit worth 50 cents. Make sales from it. Write today for your territory and details. Radio Companion, P. O. Box 721, Waterbury, Conn.

AGENTS: \$8 to \$12 for six hours' work. Big money in automobile transfer initials and flags—applied in ten minutes. \$1.35 profit on \$1.50 order. Get this quick. Write today. Auto Accessories Co., 28 Advertisers Bldg., Dayton, O.

AGENTS Wanted—To advertise our goods by distributing free samples to consumer. 90 cents an hour. Write for full particulars. Thomas Mfg. Co., 562 North St., Dayton, O.

AGENTS grab this 25c household specialty. Lightning seller. One agent sold 100 one day. 140% profit. Write today. G. L. Erwin & Co., Manufacturers, 2113E, Harrison St., Chicago.

AGENTS: \$30 to \$100 a week. Free samples. Gold sign letters for Stores and Office Windows. Anyone can do it. Liberal offer to general agents. Metallic Letter Co., 401 N. Clark, Chicago.

EXCEPTIONAL opportunity selling Sanitary Brushes. Large profits, no permanent capital required. Every home a customer. Special selling help for agents. Proposition free. Sample ten cents. Puritan Sales Company, Dept. M, 1966 Broadway, N. Y.

AGENTS: Automatic Automobile Signal just patented; enormous seller; big profits. Territory reserved. Write: Jordan, 1920 9th St., Washington, D. C.

AGENTS Wanted—500% profit. Our sign letters get the money. Easily applied. Sample free. Anderson Stores Co., 2444 Chicago Ave., Chicago.

400% PROFIT for Hustling Agents. Our Magnetic Razor Stick sharpens any style razor or safety blade. Simply apply to strip. E-dressed everywhere. Sensational seller. Guaranteed. Sample 15 cents. Keenedge Company, Sheboygan, Wisconsin.

AGENTS—Wake up: We've got it, greatest invention for Automobiles; out seven weeks; Owners and garages buying at sight a necessity; Sawyer's profits \$271 first week, McDonalds \$146 three days; protected territory; money-back guarantee. Homestead Engineering Laboratories Co., Homestead, Pa.

DISCOVERED! Extraordinary New Proposition. Supreme Opportunity. \$200 per week Easy, demonstrating marvelous Adding Machine. Retail \$7.50. Work equals \$309 machine. Subtracts, Multiplies, Divides, automatically. Whirlwind in speed. Guaranteed Five Years. Used by U. S. Government. Sells everywhere. Amazing profits. Write quick for exclusive territory. Calculator Corp., Dept. PM, Grand Rapids, Mich.

FLAG Emblems for Window Panes, Automobile Wind Shields and Headlights. Selling like wildfire—Something new—Retail price and samples to agents 25c. 12 for \$2.00. Quantity discounts. Translucent Medallion Co., Fisher Bldg., Chicago.

SELL everywhere unique metal preparedness novelty. Patented. Constructive. Big profits, sample quarter. Refund guarantee. Helme Manufacturing Co., 178 Avery, Detroit.

\$50 WEEKLY and up selling Mexican Diamonds. Exactly resemble genuine; Same Rainbow Fire; Stand tests; sell at sight; Repeat orders. Write quick for Sample Case offer free. Mexican Diamond Importing Co., S. W. Las Cruces, New Mexico.

EARN \$50 to \$100 monthly distributing Parker Hosiery to repeat customers at mill prices. All or spare time. Protected territory. Credit. D. Parker Mills, 2733 No. 12th St., Philadelphia, Pa.

AGENTS, Make Big Money; fast office seller; particulars and samples free. One Dip Pen Co., Dept. 2, Baltimore, Md.

SIGN Letter Agents and Painters; 500% Profit Gold and Silver Sign Letters for Stores and Office Windows. Anyone can put on. Big demand. Free samples. Metallic Letter Co., 404 N. Clark St., Chicago.

PORTRAIT Agents, new and old, write us. We know what you want and need. Established 17 years. Pioneer, 1244 W. 67th St., Chicago.

LUMINOUS Paint! Shines in the dark. Big seller to hotels, garages, etc. Any article can be coated with splendid results, watches, clocks, electric switch plates, crucifixes, match boxes, etc. (Everlasting.) Only 25c a bottle. Particulars free. Luminous Paint Co., B-10 Douglas Park Station, Chicago, Ill.

AGENTS—100% Profit. Three-In-One Shoe Brush, Polish, Dauber and Shiner—all in one. Costs only 1/6 of a cent a shine. Write quick for territory and free pocket sample. Fountain Shoe Brush Co., 1402 North St., Dayton, O.

EXCLUSIVE selling rights given for our Wonderful Triplex Folding handbag and other sellers. None sold in Stores. Write for terms and catalogue. Diamond Bros., 35 West 21st Street, New York.

CALIFORNIA Flower Bead Necklaces beat anything for quick sales and profits. Absolutely new. Write for agent's proposition. Mission, 2819 P.M. West Pico, Los Angeles, Calif.

AGENTS—Salary or commission. Greatest seller yet. Every user pen and ink buys on sight. 250 to 500 per cent profit. One agent's sales \$620 in six days; another \$32 in two hours. Monroe Mfg. Co., N.6, La Crosse, Wis.

"GOLDINE" Sign Letters—1,000% profit. Particulars free. Johnston Co., Quincy, Ill.

MARRIED Salesmen and Agents—Wives to demonstrate in dept. stores, on salary. Easy sales to jobbers, dealers, consumers. All or part time, or side line. Appoint sub-agents. Silver, the Silver-plating polish—needed in every home, hotel, restaurant, and garage. Guaranteed to Deposition Pure Silver. Write for proposition and sample. Exclusive territories open. Silver, 157 Cedar St., N. Y.

AGENTS—Ho-Ro-Co Skin Soap and Toilet Goods plan beats everything for agents' profits. "Ho-Ro-Co," 412 Locust St., St. Louis, Mo.

AGENTS—"Exclusive features" are what make easy sales—I can gain attention, close the sale and collect the money on six customers with the exclusive features of my non-alcoholic flavoring extracts, while you are struggling with one customer on the old commonplace line of talk. So can you! Prove it! Write today—big summer sellers—extra summer profits. J. M. Pitkin Co., 626 R. St., Newark, New York.

LARGE Manufacturer wants representatives to sell shirts, underwear, hosiery, dresses, waists, skirts, direct to homes. Write for free samples. Madison Mills, 536 Broadway, New York City.

WANTED—New Ideas. Write for list of Patent Buyers and Inventions Wanted. \$1,000,000 in prizes offered for inventions. Our Four Books sent free upon request. Victor J. Evans & Co., 162 Ninth, Washington, D. C.

AGENTS Wanted: Sell Polishing Cloths, Best Remover, Food Flavors, etc. 130 household necessities, guaranteed line, big profits, quick repeater, permanent business. Stuart & Co., 18 Main St., Newark, N. Y.

TAKE orders for men's custom tailoring, part time or all time. We furnish samples and everything needed to make a success without experience. Low prices; fit guaranteed or money refunded. You make good money on every order. You can wear swell clothes for almost nothing. Write quick for samples and all information if you live in a town smaller than 5,000 or on R. F. D. Knickerbocker Tailoring Co., Dept. 613, Chicago.

AGENTS Wanted for best-selling household specialties on earth; goods sell themselves; write at once. The Addison Co., 224 Franklin Av., Scranton, Pa.

AGENTS make \$100 monthly selling our 500 handy household articles. Catalogue free. Scheff Company, DesPlaines, Ill.

MAKE and Sell Your Own Goods. Formulas by Expert Chemists. Manufacturing Processes and Trade Secrets. Formula Catalog for Stamp, Blake Mystic Company, Washington, D. C.

\$1,000 PER Man per county. Strange invention starts world—agents amazed. Ten inexperienced men divide \$40,000. Korstad, a farmer, did \$2,200 in 14 days. Schleicher, a minister, \$195 in first 12 hours. \$1,200 cold cash made, paid, banked by Stoneman in 30 days; \$15,000 to date. A hot or cold running water bath equipment for any home at only \$6.50. Self-heating. No plumbing or waterworks required. Investigate. Exclusive sale. Credit given. Send no money. Write letter or postal today. Allen Mfg. Co., 311 Allen Bldg., Toledo, Ohio.

EASY, pleasant work for Mechanics, Shop Men, Clerks, during spare hours, will add many dollars to their salaries. Also want persons who can give full time. Big wages assured. Novelty Cutlery Co., 67 Bar St., Canton, Ohio.

AGENTS, 500% Profit. Sign-Letters for office and store fronts. Samples and particulars free. Inter-States Letter, 2424 N. Halsted St., Chicago.

A NEW, Novel, and Clever Invention; wonderfully attractive; a market in every home; good profits; big demand; particulars free. Shomescop Mfg. Co., 523 W. 13th St., Kansas City, Mo.

PORTRAIT Agents: Deal with artist direct. Good work at reasonable prices. Chas. A. Sweet, Artist, 526 New Era Bldg., Chicago, Ill.

AGENTS—Just out, New Dollar Winner. One-Hand Speed Wrench. Machinists, autoists, farmers, everybody buys at sight. 100% profit. Make \$30 to \$50 weekly. Toledo Speed Wrench Co., Toledo, Ohio.

AGENTS—Make a dollar an hour. Sell Mendets, a patent patch for instantly mending leaks in all utensils. Sample package free. Collette Mfg. Co., Dept. 404-B, Amsterdam, N. Y.

AGENTS sell Reliable Custom-Made Raincoats and Gabardines. Big commission. Complete sample line free. Temple Raincoat Company, Templeton, Mass.

FREE sample with particulars. No splashing water strainers. Easy seller. Returns big. Experience unnecessary. Union Filters Co., New York.

ONE good man wanted in each small town to take orders for tailoring in spare time or as a regular business. Good profits. Get your own clothes at special inside wholesale prices. Perfect fit and satisfaction guaranteed or no pay. Wonderful opportunity, experience not needed. Beautiful sample book and fashion plates free. Banner Tailoring Co., Dept. 562, Chicago.

DECALCOMANIA Transfer Initials and Monograms: You apply them on automobile while they wait; cost 2c each; profit \$1.38 on \$1.50 job; free particulars. Auto Monogram Supply Co., Dept. 1, Niagara Bldg., Newark, N. J.

A FEW reliable men or women to handle my 1916 "Business Guide." Sells everywhere. Beginners clear \$7 per day. 60% commission. Outfit free. Prof. Nichols, Box P. M., Naperville, Ill.

HUGE profits selling Nibco Sanitary Brushes, Auto Washers, Brown Beauty Adjustable Floor Mops, Dustless Dusters, and other specialties. Big line. Fast sellers. Write today. Silver-Chamberlin Company, Department M, Clayton, New Jersey.

FREE! Sample Creaso. Keeps trousers in shape 30 days. Astounding profits. Ava, 2616 Greenview, Chicago.

AGENTS—Stamping names on Pocket Key Protectors; sample Check with your name and address, 12c. Stamping Outfits, Emblem Checks, Check Fobs, Name Plates. Hart Mfg. Co., Desk 2, 393 Degraw St., Brooklyn, N. Y.

YOU can be your own boss with our Key Check outfit. Good for \$5 a day stamping names on pocket key checks, fobs, etc. Sample check with your name and address, 15 cents. Pease Die Works, Dept. M., Winchester, N. H.

PORTRAIT Agents: Our goods will make you big profits. Delivery guaranteed. Refunds credited. Prompt shipments. Send for latest catalogue and prices. Adam J. Kroll & Co., 602 Blue Island Ave., Chicago, Ill.

GENTLEMEN: Mason sold 18 Sprayers and Auto Washers one Saturday. Profits \$2.00 each—Square Deal. Write Rusler Company, Johnstown, Ohio.

MAN or Woman to travel for old-established firm. No canvassing; \$1,170 first year, payable weekly, pursuant to Contract. Expenses advanced. G. E. Nichols, Philadelphia, Pa., Pepper Bldg.

AGENTS—Sell rich-looking imported 36x58 rugs, \$1 each. Carter, Tenn., sold 115 in 4 days. Profit, \$57. You can do same. Write for sample offer selling plan; exclusive territory. Sample rug by parcel post prepaid, 25c. E. H. Condon, Importer, Stonington, Maine.

\$3.50 PER day Salary Paid One Person in each town to distribute Free circulars, and take orders for White Ribbon Concentrated Flavoring. Non-alcoholic—Big demand, steadily increasing. J. S. Ziegler Co., 77 E. Harrison St., Chicago.

WE Want High Grade Owner-Agents to sell and install a new Ford specialty of proven worth. Exceptional chance for men who can earn \$150.00 to \$300.00 or more per month. Only device of its kind. For full particulars address Field Manufacturing Company, Dept. M, Owosso, Michigan.

\$25.00 TO \$200.00 Weekly! "GoodDrink"—New, Pleasingly Delicious soft-drink; staggering profits; also "KwikKleen," 10c Washing Tablets. Rodolph, Northwestern Building, Chicago.

"AMERICA First!" Beautiful shield hanger, patriotic decoration, with Wilson's portrait, 25c. Unprecedented seller, \$15.00 hundred, cash. Ernest Benninghofen, Anderson, Indiana.

AGENTS, Salesmen, brand new made to measure raincoat proposition. Big demand, big commissions, biggest line of all, we deliver and collect, samples free. Write today. Rainproof Coat Co., 433 St. Clair St., Toledo, Ohio.

NEWEST Home Invention now ready for agents, side-line men, demonstrators. Automatic Sash Lock. Prevents burglary; permits ventilation; stops rattling. Locks either sash any position. Homes and offices buy two to ten each. Enormous demand everywhere. To prove it's greatest agent's article we'll postpay 25c sample for 10c. Try it; then you'll order a gr-ss. Write now for sample and "No-talking" Sales Plan. Stonaker Mfg. Co., 410 Standard Theatre Bldg., Cleveland, Ohio.

MERCHANTS Buy at Sight. New changeable letter sign for window advertising. Large metal sign with 270 letters. Sells \$150. 300% profit. Greatest seller ever invented. Write for proposition. Changeable Sign Co., E. 102, Cleveland.

AGENCIES WANTED

WANTED—Good articles for agents and mail-order. Address: Manager, P. O. Box 9, Chatham, Ontario, Canada.

SALESMEN WANTED

SALESMEN—Handle our Gas Saver as sideline. On any automobile increases mileage two to ten miles per gallon, kills carbon. Tremendous field. Big margin for you. Some exclusive territory still open. Full-time high-grade agents also wanted. Write today. S & H Mfg. Co., Dept. 4, 466 Palace Bldg., Minneapolis, Minn.

WANTED—Native salesmen in Hawaii, Cuba, Philippines and South America, to handle America's greatest specialty proposition. Sells to housewives, auto-owners, garages, hotels, cafes, etc.; light, easily carried. Big commissions. Particulars and sample for stamped addressed envelope. The American Mfg. & Sales Co., 210 Sufferin Bldg., Decatur, Illinois.

SALESMEN, local in every city and country, to manage agents and canvassers; \$300 capital necessary; every one who owns a phonograph, of any make, will buy it on demonstration; a clean, legitimate money making proposition for any man who can qualify. Wilson-Laird Phonograph Co., Inc., Department P., 136 Liberty St., New York City.

TRAVELING salesman for side line to establish agencies for fuel saving devices. University tests show 25% saving. Wolff Fuel Saver Co., Lytton Bldg., Chicago.

WANTED—Salesmen everywhere, 3,500 mile factory guaranteed tire. Large commission for exclusive territory. Opportunity. References, W. & G. Tire Co., Flatiron Building, New York.

SALESMEN—Sell beautiful 28x58 Artz-kraft felt rugs for \$13.50 per doz. Your profit \$2.50 per doz. Kelso, Battle Creek, Mich., sold 30 doz. last week, his profit \$75. Sample Rug prepaid \$1.50. E. H. Condon, Mgr., 12 Pearl St., Boston, Mass.

YOUNG men everywhere as Cigar Salesmen. Start \$20 weekly. Neway Sales Co., Hartford, Conn.

WANTED—Representatives everywhere. Exclusive territory. Gold sign letters for stores and office windows. Any one can put on. Write today for free sample. Metallic Letter Co., 403 N. Clark St., Chicago.

SALESMEN—Acquainted with grocery trade. Large demand; liberal commission; pocket sample. Wirth Salesbook Co., Dept. P., Chicago.

EARN \$3,000 to \$20,000 yearly. New business necessity. Retail \$5 to \$200. 100-200% profit. Purchaser satisfied or money refunded. No competition. Exclusive territory. Free samples. Sayers, 408 Wainwright, St. Louis.

SALESMEN—Wanted everywhere to sell Ajax Chemical Fire Engines. Liberal commission on every Engine sold. An average of one or two machines a week would earn you \$2,000 to \$4,000 a year. Factories, Stores, Industrial Plants, Private Estates, etc., all use Ajax Engines. No capital required. Goods well advertised. Ajax Fire Engine Works, 95 W. Liberty St., New York.

SALESMEN—Get our plan for Monogramming Automobiles and motorcycles by transfer methods. Very large profits. Motorists' Accessories Co., Mansfield, O.

HELP WANTED

MECHANICS Wanted. Minot Auto Company of Minot, North Dakota, Overland distributors. Largest shop in Northwest. Only A-1 mechanics wanted. Fifty cents an hour for good men. Year around employment.

THE way to get a Gov't Job is through the Washington Civil Service School. We prepare you and you get a position or we guarantee to refund your money. Write to Earl Hopkins, President, Washington, D. C. for Book FK-29, telling about 292,928 Gov't Positions with lifetime employment, short hours, sure pay, regular vacations.

CHAUFFEURS get \$25 week. Learn while earning. Sample lessons free. Franklin Institute, Dept. C-501, Rochester, N. Y.

GET a sure job with big pay, steady work, short hours, regular vacations, rapid advance. Thousands of positions open with Uncle Sam. I will prepare you in a few weeks at small cost. Write immediately for big Free Book DU-29 with special offer. Earl Hopkins, Washington, D. C.

RAILROADS want men for traffic inspectors. Big pay; Eight-hour law creates big demand. Promotion; Free Transportation; Experience not necessary. Ask for free booklet A-13, Frontier Prep. School, Buffalo, N. Y.

GOVERNMENT Positions are easy to get. My free booklet BY-29 tells how. Write today—now. Earl Hopkins, Washington, D. C.

RAILWAY Mail clerks wanted. \$75.30 month. Examinations soon. Also Salesmen wanted. Civil Service and Salesmanship Courses by mail. For "Free Tuition Plan," address Carnegie College, Rogers, Ohio.

TECHNICAL Men are wanted for Federal Civil Service. We coach by correspondence for many of these examinations. Write for free booklet QF-29, Washington Civil Service School, Washington, D. C.

WANTED—Responsible plumber every town. Addressed stamped envelope for reply. The John A. Williams Co., Aurora, Mo.

GOVERNMENT pays \$930 to \$1,800 yearly. Prepare for coming "exams" under former Civil Service Examiner. New Book Free. Write Patterson Civil Service School, Box 3029, Rochester, N. Y.

A POSITION is open for you in the Government service after we have helped you qualify. My money back offer guarantees it. Write quick for big free book DA-29. Earl Hopkins, Washington, D. C.

CASH paid for butterflies, insects. Some \$1 to \$7 each. Easy work. Even two boys earned good money with mother's help and my pictures, descriptions, price list, and simple instructions on painless killing, etc. Send 2c stamp at once for prospectus. Sinclair, Box 244, D 5, Los Angeles, Cal.

WANTED. Men and women to qualify for Government positions. Several thousand appointments to be made next few months. Full information about openings, how to prepare, etc., free. Write immediately for booklet CG-29. Earl Hopkins, Washington, D. C.

WEEDS Wanted. Many common ones worth 2c to 75c pound. Dept. F, National Drug Co., North Yakima, Wash.

CIVIL Service Examinations Open the Way to good Government positions. I can coach you by mail at small cost. Full particulars free to American citizens of eighteen or over. Write for Booklet CE-29. Earl Hopkins, Washington, D. C.

FOREMEN, Shapemen, and Office-men Wanted to work spare time as special representative of large well-known mail-order house, selling Watches, Diamonds and Jewelry on Credit. Liberal commissions and exclusive sales rights granted. No investment or deposit required for outfit or samples. Write at once for details. Address S. D. Miller, Dept. 14, Agency Division, Miller Bldg., Detroit, Mich.

UNCLE Sam has thousands of jobs open this year. I will help you get one. Write for my big Free book, DX29. Earl Hopkins, Washington, D. C.

GOOD income refashioning chandeliers, brass beds, automobiles by new method, producing amazing results; no capital or experience necessary; particulars free. Gunmetal Co., Ave. G, Decatur, Ill.

DO you want a position for life, with big pay, short hours and sure advancement? Then work for Uncle Sam. My free illustrated book DK-29 tells how to get an appointment. Earl Hopkins, Washington, D. C.

SALESMAN—\$6,500 Accidental Death, \$20.30 Weekly Accident Benefit, \$25.00 Weekly Sick Benefit, \$10.50 yearly, half amount \$5.50, \$250,000 deposited Insurance Department. Become independent. Experience unnecessary. Guaranteed steady income from renewals. Registration, Dept. B, Newark, N. J.

WORK for Uncle Sam. He is the best employer. Big pay, sure work, easy hours, long vacations, rapid advance. Thousands of jobs open this year. I will help you get one. Write for my big Free book, DW-29, today. Earl Hopkins, Washington, D. C.

NO Strike—8 Hour Day. Men Everywhere. Firemen, Brakemen, Baggage-men, \$120. Colored Porters, Experience unnecessary. 810 Railway Bureau, E. St. Louis, Ill.

GOVERNMENT Civil Service positions highly desirable; Men—Women over 18 eligible; splendid salaries; thousands appointed annually; our \$5.00 thorough correspondence instruction unexcelled; request particulars concerning any desired position. Federal Civil Service School, Kellogg Building, Washington, D. C.

WORK for Uncle Sam. He is the best employer. Big pay, sure work, easy hours, long vacations, rapid advance. Thousands of jobs open this year. I will help you get one. Write for my big Free book, DY29, today. Earl Hopkins, Washington, D. C.

INVENT Something; Your Ideas may bring wealth. Free book tells what to invent and how to obtain a patent, through our credit system. Talbert & Parker, 4132 Talbert Bldg., Washington, D. C.

FIREMEN, Brakemen, railroads everywhere; beginners paid \$125-\$150 monthly; wages recently increased one-fourth; positions guaranteed. Railway Association, Dept. 254, Brooklyn, N. Y.

FREE Illustrated Book tells of about 300,000 protected positions in U. S. service. Thousands of vacancies every year. There is a big chance here for you, sure and generous pay, lifetime employment. Just ask for booklet CS-29. No obligation. Earl Hopkins, Washington, D. C.

BE a Mirror Expert. Good income; spare time home at first; no capital; we train, start you making and silvering mirrors; French method. Free prospectus. W. F. Herr, Pres., 579 Decatur, Brooklyn, N. Y.

WANTED—Draftsmen and Designers. Cleveland Engineering Agency, Rose Building, Cleveland.

MAKE money writing Photo-plays; details free to beginners. No correspondence course. Producers' League, 250 Wainwright, St. Louis.

WANTED—An Idea! Who can think of some simple thing to patent? Protect your ideas; they may bring you wealth. Write for "Needed Inventions" and "How to Get Your Patent and Your Money." Randolph & Co., Patent Attorneys, Dept. 144, Washington, D. C.

GOVERNMENT Examinations. Most thorough preparation, \$5; returned if not appointed; particulars free. American Civil Service School, Washington, D. C.

MECHANIC or inventor capable of making certain improvements. Big money for right party. B-7 care Patent News, Washington, D. C.

WANTED

WILL Buy—Small article to manufacture and sell to automobile trade. Crum Manufacturing Co., Ottawa, Kansas.

PICTURES, colored and lithographed, miscellaneous sizes, not to exceed 13"x20", assorted and unmounted. Box 172, Cleveland, O.

SLOT machines of all kinds—new or used. Give description, condition and spot cash price. Box 172, Cleveland, Ohio.

FOR SALE

STANLEY 10-hp. Runabout, 10-hp. and 20-hp. engine. 20 and 13 foot speed boats. Coffee grinder, Slicing machine. Owner, Box 695, South Norwalk, Conn.

UNIVERSAL Knitting Machines. Many styles, hand or power. For Catalogue, address Daniel Becker, Peabody, Mass.

POWERFUL Marine day and night glasses with case, 25 mile adjustment, \$9.50. Satisfaction or money returned. Wells Curiosity Shop, 29 South Second Street, Philadelphia, Penna.

SALE OR EXCHANGE

OLD Violin to Exchange for any Standard make shotgun or rifle. M. L. Richards, Lawrence, Mass.

IF you want to sell, buy, or trade anything, write Home Specialty Co., Exchange Dept., Box 223, Cleveland, Ohio.

GUNS, SPORTING GOODS, ETC.

BARGAINS, With trade, buy or sell Guns, Rifles, Revolvers. Send Stamp for Bargain List. Oldest, most reliable Dealer in Country. Wm. R. Burkhard, 145 East Fourth Street, St. Paul, Minnesota.

BUY, sell, exchange all sorts old-time and modern Firearms. Stephen Van Remselaar, Antiques, 895 Madison Ave., New York.

FLOUR & FEED MILLING MACHINERY

SPECIAL bargains in second hand Attrition mills, burr mills, crushers, corn shellers, bran dusters, dust collectors, purifiers, reels, double, single, 2 and 3-pair high roller mills, sieve bolters, receiving separators, scourers, etc. Write for description and prices. Sprout, Waldron & Co., P. O. Box 429, Muncy, Pa.

MACHINERY, TOOLS AND SUPPLIES

"RED-DEVIL" Glass Cutter, improved type; cuts any thickness. Saves labor, time, glass. Sample, 10c. Booklet free. Smith & Hemenway Company, 97B Chambers Street, New York.

FIFTY Light Dynamo, Switchboard, Battery \$165. Guaranteed. Engine \$32. Magneto \$5. Wobos, Fullerton Building, St. Louis.

INDICATOR—Trell "Triumph" steam engine indicator \$50.00. C. H. Norton, 12 W. 3rd St., Cincinnati, O.

PULLEYS, Gears, Sprockets, Shafting, Hangers. See page 147. W. A. Jones Foundry & Machine Co., Chicago.

GRINDING machines, sharpeners, cutlery, etc., without touching tools with hands. Mustin Mfg. Co., Newport, Kentucky.

38-INCH lathe with 10-ft. bed, 4 side wood moulder. W. H. Pence Machine Co., Fairfield, Ia.

PRINTING outfit with power press at low price. Stewart Typewriter Exchange, Mattoon, Ill.

TOOLS—for shop, factory, garage and home—many high-class tools attractively priced in our "Odds and Ends" pamphlet—which is mailed free on request by Montgomery & Co., Inc., 195 Fulton St., New York City.

WIRE—all sizes— $\frac{3}{8}$ to No. 16. Coppered, tinned, galvanized and plain steel wire for sale. Cooley Mfg. Co., 553 W. Monroe St., Chicago, Ill.

SMALL Bench lathe for \$3. See our ad page 177.

FOR MECHANICS

TOOL Cases. For Carpenters and Machinists. Write for catalog. Keystone Case Co., 215 Keystone Ave., Chicago.

ENGINES, MOTORS AND DYNAMOS

ENGINE User Agents Wanted to use, demonstrate and sell "Big Ben," wonderful new 2½ H. P. gasoline engine. Free introductory offer and free details. C. Benninghofen & Sons, Dept. F, Hamilton, Ohio.

ELECTRIC vehicle motor generator charging set with rheostat complete; little used, excellent condition. A. C. motor, 2-h. p., 220-volt, single-phase 60-cycle, speed 1800 R. P. M., direct connected to an 80-volt 20-7-10 amp. generator. Lincoln electric make. Call, Alms & Doepke Garage, Elliott St., near Broadway, Cincinnati. Original cost \$275.00.

MOTORS. Exceptional values, alternating and direct current motors. Reliable makes only. Tell us your needs. Illustrated catalog, supplies and motors. Hyre Electric Co., 613-BM South Dearborn St., Chicago.

CHARGING Dynamoes—Several hundred small machines from bankruptcy stock. Also lighting dynamo and several moving picture arc generators. One and three phase motors up to 5 H. P. in stock for immediate shipment. ¾ H. P. A. C. motors \$15. All sizes—low prices. Write for list. Johnston, West End, Pittsburgh, Pa.

TEN stationary steam engines, 15 to 160 H. P. each. Send for description of size wanted. Lucas & Son, Bridgeport, Conn.

WANTED—Electric portable drills, all sizes, both A. C. and D. C. Johnston, West End, Pittsburgh, Pa.

REBUILT Engines—We have rebuilt "Buffalo" Engines, guaranteed, at greatly reduced prices. Write for bargain list. Buffalo Gasoline Motor Co., 1293-1365 Niagara Street, Buffalo, N. Y.

BLACKSMITHS

BLACKSMITHS. Listen! The Blacksmiths come first of all trades. He must make the tools for all, from the Surgeon to the Safe Blower. With Toy's Modern Methods doing hard jobs easy. Forging and making solid welds, hardening and tempering to a standard, with colored tempering charts. All for one dollar. Samples Free. W. M. Toy, Sidney, Ohio.

ELECTRICAL

RHUMKORFF coil twelve inch spark \$60. Wm. Strock, Dyersville, Iowa.

DRY Batteries and Their Construction for All Purposes. A practical handbook of 60 pages with 30 illustrations dealing with batteries for automobiles, gas engines, medical and coil work, electric bells, alarms, telephones, experiments, etc. Price, 25 cents postpaid. Popular Mechanics Book Dept., 6 N. Michigan Ave., Chicago.

PRACTICAL Electrics—Universal handy book on every-day electrical matters, alarms, batteries, bells, carbons, connections, coils, dynamos, wires, lamps, motors, telephones, etc. 135 pages, 126 illustrations, 25c postpaid. Popular Mechanics Book Dept., 6 N. Michigan Ave., Chicago.

ELECTRICIANS—The "Connectogram," latest patented device, shows at a glance diagrams of windings and connections Three-phase motors. Price 50c postpaid. O. C. Sutherland, 1829 N. Main Ave., Richmond, Calif.

ELECTRICAL. Illustrated wholesale bargain catalog describing motors and supplies including rosettes, wire, tape, plugs, sockets, lamps, switches, loom, fuses, cutouts. Send for free copy today. Hyre Electric Co., 613-HX South Dearborn St., Chicago.

ELECTRICIANS: Diagrams, blueprints, information on anything electrical. Send 25c. Explain your problem. Electricians' Service Bureau, Box 3, Brockton, Mass.

MUSIC

FAVORITE Old Home Songs—No home in the land should be without this book of 280 of the familiar old songs everybody loves. Words and music complete in a substantial volume 9½x7 inches in size. Price 50 cents postpaid. Popular Mechanics Book Dept., 6 N. Michigan Ave., Chicago.

GREATEST patriotic hit. Get it. "Go, My Son, God Bless You," 15c. Mother to her son wanting to fight for freedom and liberty. Sovereign Pub. Co., 160 Sycamore, Buffalo, N. Y.

STAMP COLLECTING

STAMPS—500 fine foreign incl. Mex. War, Salvador, incl. officials, Guatemala, China, etc., only 10c. Best App. Sheets 60 to 80% dis. We give valuable extra Presents free! Big 120 pg. catal. free. We buy stamps. Hussman Stamp Co., St. Louis, Mo.

FREE—60 different stamps, including Newfoundland, China, Japan, Mexico, etc., to applicants for our high-grade approvals. Send 2c stamp for return postage. The Edgewood Stamp Company, Dept. H, Milford, Conn.

PACKET of 23 stamps; no two countries alike, 500 hinges. Set of \$1 and \$2 U. S. Rev., all for 5c. Mention paper. Miami Stamp Co., Toledo, Ohio.

FREE—201 different world-wide stamps or 101 United States. Remit 25c six months' subscription McKee's Stamp Weekly, Beverly, Mass.

500 MIXED U. S., Old and New, 12c. Weatherly, Medina, Ohio.

CANADA Packet Free—Early Issues, Maple Leaves, War Stamps, send 2c coin. Midland Stamp Company, Midland, Ontario.

300 STAMPS from 40 different countries 15c. Lufbery, Wallingford, Conn.

STAMPS—12 different from warring nations, 10c; 10 different foreign coins, 15c; 20 Belgian stamps, 10c. Lots free. Toledo Stamp Co., Toledo, Ohio.

THE way to build your Stamp Collection. Send 50 cents for one of my approval Books. Select the stamps you want, to the value of Fifty Cents, and return me the Book. F. J. Pope, Charlotte, Vermont.

FREE! 25 Different British Colonials to applicants for approvals. Postage 2c. Nickles, 122 Florida Avenue, Washington, D. C.

STAMPS sent on approval at 70% discount. Reference required. Emory Renoll, Hanover, Pa.

24 VARIETIES Cuban stamps, 10 cents. List of 6,000 low-priced stamps free. Chambers Stamp Co., 111 P. Nassau St., New York City.

STAMPS, 75, all different, free. Postage, 2c. Mention paper. Quaker Stamp Co., Toledo, Ohio.

105 CHINA, etc., stamp dictionary, list, 2c. Album (500 illustrations) 3c. Bullard, Sta. A., Boston.

20 UNUSED stamps free. All different. Postage, 2c. Fish Stamps, Toledo, Ohio.

PACKET "A" 100 varieties foreign stamps, 20c. F. J. Pope, Charlotte, Vermont.

RARE COINS

WILL pay \$7.00 for 1853 Quarter; \$100.00 for 1853 Half without arrows. \$2.00 for 1904 Dollar proof. We buy all rare coins to 1912, cents, nickels, dimes, etc., to dollars, old bills and stamps. Cash premiums paid. Send us 4c. Get our Large Coin Circular, Numismatic Bank, Dept. H, Fort Worth, Texas.

FIVE Villa Coins and Bills, 35c. Villa Silver Dollar, \$1.50. Moore Coin Company, Commerce, Texas.

OLD Coins Wanted. 24-page catalog quoting prices paid, 5 cts. A. Kraus, Kraus Bldg., Milwaukee, Wis.

TEN old curious coins; catalogue, package of stamps, mail for two dimes. Vance Supply House, 2125 W. Van Buren St., Chicago, Illinois.

CALIFORNIA gold, quarter size, 27c. ¾ size, 53c. \$1.50 size, \$1.10. Large cent before 1821, Columbian Nickel Coins and Price List 10c. Norman Shultz, King City, Mo.

OLD Coins. Large Spring Coin Catalogue of Coins for Sale, free. Catalogue quoting prices paid for coins, ten cents. William Hesselin, 101 Tremont St., Boston, Mass.

1917 COIN stamp and relic catalog sent on request. Coin Exchange, New Rochelle, New York.

\$1.25 EACH Paid for U. S. Flying Eagle Cents dated 1856. We pay cash premiums on hundreds of Old Coins. Send ten cents a' once for New Illustrated Coin Value Book 4x7. It may mean your fortune. Clarke & Co., Coin Dealers, Box 15, Le Roy, N. Y.

VILLA money; big package postpaid for 25c. M. Grossman, Roswell, New Mexico.

GAMES AND ENTERTAINMENTS

MAGIC—Tricks, Books and Supplies. For Amateurs as well as the Great Professionals. Any one can learn through our instructions. Feature Acts in Mind Reading, Spiritualism, Rope Ties, etc. Large Illustrated Professional Catalogue, 10c. Chicago Magic Co., Dept. B, 72 West Adams St., Chicago, Illinois.

FUN! Just out! Shooting fountain pen, looks like real pen, makes report like pistol, 25c. Two hundred other tricks and puzzles. Send 2c for illustrated catalogues. Grandfeld, 1238 Theist Avenue, Bronx, New York.

INK erasing blotters fool every one—formula 10c. Hobson, P. O. Box 1543, St. Louis, Mo.

GROW Chemical Plants while you watch. Chemicals, 25c coin. Zenith Chemical Laboratories, Duluth, Minn.

SHOW them what a wad you carry. Big bunch greenbacks 10c. 4. 25c. Howes, 3684 Milwaukee Ave., Chicago.

TRICKS and Stage Money. Catalog No. 33 ready, 52 pages. 775-Magic Bargains, 2c. Finest Stage Money, 100, 35c; 20, 15c. Blanks for advertising. Gilbert Magic Co., 11135 Irving, Chicago.

TRICKS, Puzzles, Jokes, Magical Apparatus, Plays, Stage Supplies, Mind-reading Acts, Sensational Escapes and Illusions. Free large illustrated 1917 catalog. Oaks Magical Co., Dept. 407, Oshkosh, Wis.

SEND 10c for latest puzzle out, M. Franklin, 519 State St., Schenectady, N. Y.

FOR BOYS

EARN Vacation Money by selling permanent glass house numbers in your neighborhood. You can earn 50c each hour after school. Free outfit to any boy or girl who means business. Pittsburgh Art Glass Co., Pittsburgh, Pa.

JUST Issued—Amateur Mechanics No. 8. How to make 132 different interesting things such as electric fountains, bird houses, model monoplanes, porch swing, kites of various kinds, fishing rods, camp outfits, scarecrow, shoeing machine, etc., 128 pages, 234 illus. Price 25 cents, postpaid. Also all preceding numbers in the series at same price. Popular Mechanics Book Dept., 6 N. Michigan Ave., Chicago.

BIG New Book for Boys—The Boy Mechanic, Vol. II—Just Out—A sequel to, but containing nothing found in Vol. I. Tells all about 1,600 interesting things to make and do, 480 pages; 995 illus. Cloth. Price, \$2.00, postpaid. Send for descriptive circular. Popular Mechanics Book Dept., 6 N. Michigan Ave., Chicago.

FOR MEN

SHAVE without water, brush or soap. Lewis' Shave-Eeze Creme gives a delightful shave and a soothing, comfortable feeling to the most tender skin. Absolutely no water used. Protects skin from sun and wind. 8 oz. pkg. prepaid, 35c. Local and territorial agents wanted. The Kream-Eeze Co., Roseville, Cal.

SOLDIERS, Sailors, every man, Shaver's Turkish towel straps over head, steams face before shaving. Three for fifty cents. Shaver's Co., 3142 21st St., San Francisco, Calif.

FREE to every man who shaves—a Shaving Brush, if you introduce it to one of your friends. Something new. Gives shaving sanitation-satisfaction. Charles W. Sauer, Jr., Mgr., 209 Fifth Ave., New York City.

\$1 BUYS beautiful calfskin belt. Hand-made. Guaranteed. Send waist measure. Modern Novelty Co., Gardiner, Me.

RAZORS AND BLADES SHARPENED

SAFETY Blades Resharpened. Double 3c; Single 2c. Meentzen, Beaumont, Texas.

SAFETY razors sharpened; two cents each. Guaranteed. Blade box free. Electro Strapping Co., 134 Shelby St., Detroit, Mich.

PIANOS AND MUSICAL INSTRUMENTS

YOU can tune and keep your own piano or player piano in perfect condition. Van Atta's book on The Piano and Player Piano not only tells you but shows you every movement in their care, repair and tuning. 156 Pages. 51 Illustrations. Cloth. Price, \$1.50 postpaid. Popular Mechanics Book Dept. 6 N. Michigan Ave., Chicago.

FOR THE HOME

"EGGETTE" (the original egg substitute) takes the place of eggs in all kinds of baking and cooking. Simple to use—always fresh. Guaranteed pure food product. Makes delicious cakes, cookies, puddings, etc. 13c package equals 12 eggs. Send 10c for a package today. (Agents Wanted.) Best-ever Products Co., (Dept. P. M.) Douglas Park Sta., Chicago.

PATENTED Novelty, 100 samples, 10c. (Worth 50c.) Satisfaction or 15c back. DeLoof, 247 Harmon, Detroit.

MISSION Furniture—Make your own at little expense. Complete instructions, working drawings and stock lists for 96 different pieces. Price \$1.50 postpaid for set of three books. Send for complete descriptive matter. Popular Mechanics Book Dept., 6 N. Michigan Ave., Chicago.

DIAMONDS, WATCHES AND JEWELRY

LOOK! 17 jewels adjusted Elgin, 18 size, 20 year case, \$14.88. Bargain list free. Faulkner's, Russellville, Ark.

LOOK Here! Genuine diamond-set scarf pin, 45c coin. Huggard Co., A7, Goldfield, Nevada.

PHONOGRAPHS AND RECORDS

PHONOGRAPH, Real Value \$7.50. Illustrated circular free. George Talbot, Norwood, Mass.

BUILD Your Own Phonograph. Any type, Big saving. Patents expired. Profits making and selling them. We furnish parts you can't make. Full instructions, dimension drawings, illustrations, parts—price-list only 25c. Circular Free. Associated Phonograph Co., Dept. P, Cincinnati, O.

VICTOR, Columbia, Edison Disk and Cylinder Records bought and sold. Victor and Columbia 15 cents up. Edison Standard 9 cents, Blue Amberol 25 cents. Well Attachment with Jewel Needle to play Edison disk records on Victrola and Graphonolas \$9.00. Send for record list. Wells Curiosity Shop, 20 South Second Street, Philadelphia, Penna.

FORMULAS AND TRADE SECRETS

1,000 FORMULAS, 25c. 75 Manufacturing Secrets, 10c. Resilvering Mirrors—Renewing Dry Batteries—Gas Tonic—Mechanics Soap—Luminous Paint—20c each. Entire Collection, 50c. Satisfaction guaranteed. Big Catalog, 2c. Ideal Book Shop, 3215-F8 Bellegaine Ave., Chicago.

SEE Rogers' valuable ad under "Business Opportunities."

GUARANTEED Formulas for polishing automobiles and furniture, postpaid, \$1.00 each. Herbert Kamiah, 81 Cloud, Minn.

MECHANICS' Soap paste formula 10c. Stanley's, 8430 Escanaba Ave., Chicago, Ill.

500 GREAT Advertising Secrets, 100 Business Opportunities, 3 formulas for renewing dry batteries, 6 big money-making formulas and book of manufacturing secrets, all for 20c, stamps or coin. Western Laboratories, Bay Point, California.

LUMINOUS Paint—10 formulas—different colors, 25c. "Puncture Plugger"—automatically seals punctures on the run, complete formula 25c. "Carbon Remover," carbons worst enemy, 25c. All sent for 50c. C. Johnson, 4319 N. Whipple St., Chicago.

MUST sell; rigidly tested Psoriasis formula. Make offer. Doctor, 3835 Vincennes, Chicago.

BUY formula, "Comfortable Shaving," twenty-five cents. Box Seven-Thirty, Cedar-town, Ga.

FORMULA Wanted—Will buy tested formula of product to sell to automobile trade. Crum Manufacturing Co., Ottawa, Kansas.

MASSAGE Cream made at fifth retail price. Formula 50c. M. Smith, 730 Shirley St., Nashville, Tenn.

20,000 FORMULAS, \$1. Postpaid. Complete list to stamps. Edna Bromley, Watervliet, N. Y.

MAILING LISTS

TRY our mailing for results. 6x9 or smaller, 20c per 100. Huggard Mailing Service, Goldfield, Nevada.

1,000 PROSPEROUS Buyers or Agents' names postpaid \$1.50. Liebau, Drawer 585, Erie, Pa.

TYPEWRITERS AND SUPPLIES

STARTLING Values in Typewriters. \$10 to \$15 up. Factory rebuilt. All makes. Shipped on trial. Write for our special offer No. 126F, Whitehead Typewriter Co., 188 N. La Salle St., Chicago.

TYPEWRITERS—Prices wrecked. All Makes. Nearly New and Rebuilt, \$5.00 up. Coronas and other portable machines, \$10.00 up. Write for catalog 503. Beran Typewriter Co., 58 W. Washington St., Chicago.

LARGEST Stock of Typewriters in America. Underwoods, one-fourth to one-half manufacturer's prices; rented anywhere, applying rent on purchase price. Free trial. Installment payments if desired. Write for catalogue 70. Typewriter Emporium, estab. 1892, 34-36 W. Lake St., Chicago, Illinois.

GUARANTEED Typewriter Ribbons 3 for \$1.00, any color, any machine. Non-Smear Carbon Paper, any size, any color. Featherweight or Standard, \$1.00 per box. Acme Co., 440 S. Dearborn, Chicago.

FRESH typewriters 1/2 manufacturer's prices! Investigate Free Trials (name typewriter you prefer). Co-Operative Union, Covington, Ky.

DUPLICATORS AND DEVICES

"MODERN" Duplicator—a Business Get-ter. \$1 up, 50 to 75 copies from pen, pencil, typewriter; no glue or gelatine. 35,000 firms use it. 31 days' trial. You need one. Booklet Free. J. E. Durkin & Reeves Company, Pittsburgh, Pa.

\$300 MULTIGRAPH like new for \$100. Guaranteed. Russell Baum, Philadelphia Bourse, Philadelphia.

PRINTING, ENGRAVING AND MULTI-GRAPHING

PREPAID: Name and address 50 elegant cards, 15c. Commercial printers, samples free. Makette Printing Co., 3044 Leeward Ave., Los Angeles, Cal.

PRINTING everything cheap, write us; tell what you want. S. C. Printers, 1295 2d Av., Milwaukee, Wis.

FINE printing cuts \$1. Joe Bek, 118 Gazette Ave., Lexington, Kentucky.

PERFECTION Letter Company, Muncie, Indiana, Multigraphs 500 purple letters with black letter heads, \$2.15. Samples for stamp.

CIRCULARS—1,000, 3x8, 90c; 4 1/2x6, \$1.15; 6x9, \$1.75. Chas. Walter, Lancaster, Ohio.

PRINTING of every description. Large, modern plant. Get our prices. A Kraus, Kraus Building, Milwaukee, Wis.

GUMMED labels! Any size! Catalog free. Edward Harrison, Baltimore, Maryland.

AUTOMATIC Card Printer, complete with motor; cost \$135.00 new, our price \$65.00. David Stern Company, 1047 Madison, Chicago.

500 HIGH-GRADE Business Cards sent postpaid for \$1.00; 75, 25c. Work guaranteed. U. S. A. Co., Central Station, P. O. Box 217, Toledo, Ohio.

1,000 BOND Letterheads, Billheads, Envelopes or Statements, \$2.50, prepaid. Samples, Leo Mountain, Chavies, Alabama.

BEST Printing—Lowest Prices. Price list Free. Write today. Hunt's Printery, Lambertville, N. J.

ACME combination; 250 Bond letterheads, 250 Envelopes, 250 Bill heads, 250 Statements, 250 Business Cards, \$5.75, post paid. Acme Co., 440 S. Dearborn St., Chicago.

250 LETTERHEADS or envelopes \$1.00. Meyer Supply House, Milton, Pa.

500 SWELL Linen-Finish Letterheads printed two colors, \$2.50. Bond \$2. Price list, Samples 2c. Starb Printing Co., Hamilton, Ohio.

GUMMED Labels, 1x2 inches, 3,000 \$1. Circular free. Helmers Co., Hoboken, N. J.

QUALITY Printing Prepaid. 500 either envelopes, noteheads, cards, statements, \$1.35; 1,000, \$2.25; 1,000 envelope slips, \$1.25; 1,000 6x9 circulars, \$1.85; 500 linen-finish letterheads or envelopes, \$2.25; 1,000 \$2.50. Prepaid. Typewriter letters. Stamp brings samples. Model Company, Manchester, Iowa.

PRINTING Outfits—Presses, type, supplies, type novelties. Send stamp for catalogue. Model Press, York, Penna.

AT Last! Beautiful Lithography for small users. 1,000 Letterheads, 1,000 Billheads and 1,000 Statements, \$9.90. Engraving Free. Kaydee Lithographing Co., 764 Teutonia, Milwaukee.

PRE-USED Printing presses, Type, Supplies, cheap. List for stamp. Popular Bargains, Richland, Pa.

CATALOG 102 free illustrating gummed Labels and advertising stickers, 3,000 75 cents upward—direct from manufacturer, Royal Label Co., 408 Cherry, Philadelphia.

GOOD Printing at low prices. 1,000 good letterheads, envelopes, cards, billheads, labels, circulars, \$2.50. Samples free. Catalogues, booklets and circulars our specialty. Ernest L. Fantus Co., 523 S. Dearborn St., Chicago.

LABEL Catalog "A" free. Irvin Wolf, 3126 Jasper Street, Philadelphia.

AMERICAN Colored Flag Stickers our specialty. 1,000—40c; 10,000—\$2.70; pre-paid, 100 samples assorted designs with wholesale prices, 25c. Stephens-Wetzel (Manufacturer), Box 101-A, Madison Square, New York City.

1,000 NICELY Printed Business Cards \$1.35; 2,000, \$2.00; 1,000 Bond letterheads, envelopes or statements, \$2.50. All kinds of extra good printing cheap. We make rubber stamps at low cost for business men. Price List Free. Bee Publishing Company, Rothville, Mo.

QUALITY Printing. Economy prices. Leonard Nathan, 1011 Chestnut Street, Philadelphia.

PATENT ATTORNEYS

PATENTS—Herbert Jenner, patent attorney and mechanical expert, 604 F St., Washington, D. C. I report free of charge if a patent can be had and its exact cost. Send for circular.

PATENTS that protect and pay. Advice and books free. Rates reasonable—highest references; best results. Watson E. Coleman, Patent Lawyer, 634 F St., N. W., Washington, D. C.

PATENTS: Send model, sketch or drawing. Advice, 100 Mechanical Movements and 50 Perpetual Motions, Free. Fred G. Dieterich & Co., 61 Ouray Bldg., Washington, D. C.

H. L. WOODWARD—Safe methods. Paying patents. Write today. 902 G. St., Washington, D. C.

INVENTORS. Let us sell your patent. Send for our liberal proposition. Atlantic Supply Co., Long Branch, N. J.

PATENT Your Ideas—\$9,000 offered for certain inventions. Books, "How to Obtain a Patent," and "What to Invent," sent free. Send rough sketch for free report as to patentability. Manufacturers constantly writing us for patents we have obtained. We advertise your patent for sale at our expense. Established 20 years. Address Chandler & Chandler, patent attorneys, 1090 F. St., Washington, D. C.

DON'T lose your rights to patent protection. Before proceeding further send for our blank form "Evidence of Conception" to be signed and witnessed. Book, suggestions and advice free. Lancaster & Allwine, 221 Ouray Bldg., Washington, D. C.

PATENTS. R. Morgan Elliott & Co., Patent Attorneys, Mechanical, Electrical and Chemical Experts, 713-721 Woodward Bldg., Washington, D. C.

HIGH-VALUE Patents. See R. S. & A. B. Lacy's advertisement on page 156.

PATENTS—Send Sketch, Free Opinion and Certificate of Patentability. Free Book, "How to Obtain a Patent and What to Invent." Patents secured through Credit System. Talbert & Parker, Patent Lawyers, 422 Talbert Bldg., Washington, D. C.

PATENTS secured or all fees returned. Do not miss the generous offers in E. E. Vrooman & Company's display ad on page 157.

PATENTS Wanted. Write for list of Patent Buyers who wish to purchase patents and What to Invent with List of Inventions Wanted. \$1,000,000 in prizes offered for inventions. Send Sketch for free opinion as to patentability. Write for our four Guide books sent free upon request. Patents advertised Free. We assist inventors to sell their inventions. Victor J. Evans & Co., 160 Ninth, Washington, D. C.

"PATENTS and Patent Possibilities," a 72-page treatise which tells all about patents, what to invent and where to sell it. It gives honest advice to inventors and tells about the successes of some of my clients, also explaining what are frequent causes of failure. Manufacturers are constantly writing for protective patents upon all kinds of sound inventions. Can you help supply their wants? The book is free. Write for it today. H. S. Hill, 905 McLachlen Bldg., Washington, D. C.

PRACTICAL Patent Service such as comes only with the mature judgment and years of experience of an old established firm, you can secure from Fetherstonhaugh & Co., 480 Victor Building, Washington, D. C. 35 years in U. S. and Canada. Free Booklet.

KEEP Up with Progress. Promote Your Patent. Send \$1.00 for Year's Subscription to Best Inventor's Magazine, "Invention and Manufacturing," United States Patent Corporation, Washington, D. C.

THE Patentome is free. An education in obtaining patents. Established 1865. Anderson & Son, Attorneys, 707-7th St., Washington, D. C.

PATENTS obtained through D. Swift being promptly sold to manufacturers. Write to-day for free books of "Inventions Needed" and surprising references. D. Swift, 317 7th St., Washington, D. C.

PATENT applications filed on partial payment plan. We help sell the patent. Trade-marks, copyrights, etc. Milo B. Stevens & Co., 685 F. St., Washington; 353 Monadnock Bldg., Chicago. Estab. 1864.

PATENTABLE Ideas Wanted—Send for 4 free books. R. B. Owen, 30 Owen Bldg., Washington, D. C.

PATENTS on Easy Payments. Send model or sketch for Free Search and Certified Registration of Your Invention for Your Protection. Free Book Tells What to Invent and How to Obtain a Patent on Easy Payments. C. C. Hines & Co., 591A Loan & Trust Bldg., Washington, D. C.

PATENTS—Send sketch for free search and report. Books on patents and book of reference letters sent free. John S. Duffie & Co., 610 F St., Washington, D. C.

INVENTORS—Write our Patent Dept. Adam Fisher Mfg. Co., 2061 C Railway Exchange, St. Louis, Mo.

PATENTS Secured or Fee Returned. Actual search free. Send sketch or model. 1917 Edition, 90-page patent book free. My patent sales service gets full value for my clients. It should never require more than two days to report upon the patentability of your invention; not longer than ten days to prepare your application for filing. Longer delay amounts to gross neglect and the jeopardizing of your rights. For prompt personal service write, George P. Kimmel, 212 Barrister Building, Washington, D. C.

PATENT what you invent. It may be valuable. Write me. No attorney's fee until patent is allowed. Estab. 1882. "Inventor's Guide" Free. Franklin H. Hough, 522 Loan & Trust Bldg., Washington, D. C.

PATENTS Bring Riches; Protect Your Invention. Attorney's fee payable when patent allowed. Plain advice and "Patent Facts" free. Trade-marks registered. Jaynes & Jaynes, 653 Kellogg, Washington, D. C.

PROTECTIVE patents procured promptly. 104-page blue book on patents sent on request. Trade-marks registered. Robb & Robb, 211-215 Southern Bldg., Washington, D. C.

PATENTS without advance attorney's fees. Send sketch for free report. Books free. Frank Fuller, Washington, D. C.

PROTECT your invention; Send sketch or model for advice; I assist you market it; Personal service. Booklet Free. J. R. Kelly, 740A Woodward Bldg., Wash., D. C.

FOR INVENTORS

HAVE You An Idea? If so, you should protect it by a patent. Send us a model or sketch for free opinion as to patentability. Write for our Four Books sent free to any address. Victor J. Evans & Co., 157 Ninth St., Washington, D. C.

PLANS and drawings made from notes or rough sketches, patent office work a specialty. J. P., Box 547, Gary, Ind.

INVENTIONS—How to protect, sell and buy them. If you are inventive, read this book. 108 pages, 25c, postpaid. Popular Mechanics Book Dept., 6 N. Michigan Ave., Chicago.

INVENTORS—We specialize in manufacturing new patented articles—make models—do experimental work. Leo J. Gerding Mfg. Co., Dept. D, Opera Place, Cincinnati, O.

WISH to communicate with inventor having good patent for sale. Burns, 1227 Walnut, Cincinnati, Ohio.

INVENTIONS—Patenting and Promoting. A book containing practical advice and directions for inventors and manufacturers. Book, suggestions and advice free. Lancaster & Allwine, 221 Ouray Bldg., Washington, D. C.

PUT your invention on the market. Start mail-order business with your own article as foundation. Wonderful profits, only small capital, the world your field. Your opportunity to "cash in." Send 25c fee full information telling how. None free. Brenner, Mail Order Expert, 16 years experience, 304 Walnut, Philadelphia. Make your remittance \$1 and receive also selected mail order handbooks, appropriate for inventors.

PATENTS secured or all fees returned. Do not miss the generous offers in E. E. Vrooman & Company's display ad on page 157.

INVENT Something: your ideas may bring wealth. Free book tells what to invent and how to obtain a patent, through our credit system. Talbot & Parker, 4280 Talbot Bldg., Washington, D. C.

HIGH-VALUE Patents. See R. S. & A. B. Lacey's advertisement on page 156.

WANTED, to buy inventions. State price and full particulars. Howard Smith Company, Inc., Washington, Penna.

INVENTIONS commercialized on cash and royalty basis. Patents secured. Models, experimental work and contract manufacturing. Inventors should write at once. Adam Fisher Mfg. Co., 2061A Railway Exchange, St. Louis, Mo.

PATENTS, Trade-Marks and Copyrights. Our handbook on patents will be sent free on request. All patents secured through us are described without cost to the patentee in the Scientific American. Munn & Co., Patent Attorneys, 623 Woolworth Bldg., N. Y. Washington, D. C., office, 625 F. St.

PATENTABLE Ideas Wanted—Send for 4 free books. R. B. Owen, 30 Owen Bldg., Washington, D. C.

PATENTS on easy payments. Send model or sketch for Free Search and Certified Registration of Your Invention for Your Protection. Free Book Tells What to Invent and How to Obtain a Patent on Easy Payments. C. C. Hines & Co., 591A Loan & Trust Bldg., Washington, D. C.

INSURE Success. Skilled designing, automatic and special machines. Practical working drawings. Tipnam, Box 4708, Philadelphia, Pa.

INVENTORS: Invent for profit. Write for list of needed inventions. Sanders, 7 Webster Bldg., Chicago.

NO Attorney fees until patent allowed. Send sketch for free report. Books free. Frank Fuller, Washington, D. C.

HAVE you a Patent to sell? You'll be interested in my proposition. Write now for free particulars. Don't call. F. W. Johnson, 8 N. Michigan Ave., Chicago.

WANTED—An Ideal! Who can think of some simple thing to patent? Protect your ideas; they may bring you wealth. Write for "Needed Inventions" and "How to Get Your Patent and Your Money." Randolph & Co., Patent Attorneys, 623 F. St., Washington, D. C.

PATENTS FOR SALE

VALUABLE Invention—For gasoline and electric vehicles, aeroplanes, etc. Funnel indicating when receptacle is full; stops overflow instantly, retains remaining liquids in funnel; invaluable for gasoline, oils, wine, acids, etc. Simple construction—will demonstrate by appointment at 1556 Kinshark Avenue, Chicago. Phone Midway 9463. George Heingartner, Inventor.

JUST Out, Wonderful Machine for Washing Diapers, Inexpensive to Manufacture. Great Demand. For further information write, Albert Troy, Kellogg, Idaho.

U. S. PATENT, lock nut and nut lock in one. Particular nuts for particular work when wanted at an accurate position on a bolt or a threaded rod, or wherever an ordinary nut works loose and for locking common nuts; it's a sticker. For particulars write T. Goserud, Sturgeon Bay, Wis. Sole owner and patentee. Patent disposable.

IMPROVEMENT on lathe tool-post, patented U. S. and Canada. Reasonable price, outright or royalty. F. C. Kehr, Box 404, Hartford, Wis.

FOR Sale—Patent No. 1,664,125, R. R. joint. This joint is to do away with all the joints, low and spreading rails at the joints. For further information write, Geo. S. Beemer, Meeker, Colorado.

FOR Sale. Safety first device for buildings. Meets approval of insurance men. Patented. Bargain. Joe Haribut, Macatawa, Mich.

CLOSURE. Keeps pockets closed. Nothing will fall out. Will sell outright. Write for sample. Cheaply manufactured. Lago, 340 B St., San Francisco, Calif.

PUNCTURE proof auto tire patent for sale. E. L. Thompson, Glenns Ferry, Ida.

PATENT Buyers are invited to address our sales department for information on any class of Patents they wish to purchase or lease on a royalty. We have secured a number of valuable patents in all lines of invention. Mail Order, Department Store and Household Novelties a specialty. Victor J. Evans & Co., 160 Ninth St., Washington, D. C.

FOR Sale—U. S. and Canadian patent on new and improved umbrellas. Will fill long-felt want. Good thing for the right party. A. L. Truitt, Owner, Box 69, Lewes, Delaware.

WILL sell "Patented Attachment"—turns "Headlights" on Automobiles automatically—light follows path car is moving. D. Forniraseo (Owner), Klamath Falls, Ore.

AUTOMATIC Hotel Call System. Cheaply manufactured. Forrest Conrath, Alturas, Modoc Co., California.

PATENT on only really improved garden rake ever invented. Kiser Company, Pittsfield, Ill.

ELECTRIC Steering for autos and trucks. Patents owned by Frank W. Austin, Cabool, Mo.

NEW Inventions for sale. Emma Craven, 606 E. 33 Street, North, Portland, Oregon.

"ON Royalty," Folding Chair; cap be readily attached and removed from seat boards in shows. If interested, address Frank E. Knapp, Attorney at Law, Coldwater, Michigan.

PATENT Magnetic Ore Locator. 13 E. 7th, Portland, Ore.

PATENTED Antiskid Tire-Chain Adjuster for sale. Something new. John C. Seitz, 411 E. Park St., Butte, Mont.

LIVE Bait Bucket improved float bait cage. Minnows fully protected and readily removed when needed. Every sportsman will welcome this efficient device. Submit offer. C. W. Patterson, 512 W. Main St., Waukesha, Wis.

FOR Sale—U. S. patent Mixer for kitchen use, mixing drinks, laboratory uses, also mixes paints and oils. Mixer is strong, durable and efficient. John Frame, Searsport, Maine.

SAP Bucket Cover. Patented. Best yet. Information free. Make offer. W. Cotton, Cambridge, N. Y.

FOR Sale or Royalty, patents on "Ship Scale" and "Indicator." Scale accurately weighs ship and cargo. Weighs in any position of vessel afloat. Also indicates draft. Indicator gives draft forward and aft and prevents hogging or buckling. John Frame, Searsport, Maine.

WANT to sell patent. Convertible supports for Book. Read lying down. Write inventor. Ida, Guthrie, Carthage, Ill.

FOR Sale—Agricultural tool, rake and fork. Ingenious device. Convertible, one blade. B. A. Arnold, Box No. 2, Trough, S. C.

LOCKING single or double auto tire carrier. Cash or royalty. Keith Bower, Shelburne, N. S.

PICKET, a metal novelty, on the market three years. Price reduced for quick sale. Donald B. Stone, Springville, Iowa.

PATENT for Sale—Fountain brush for stencilizing, shading and lettering. Charlie Eick'ner, 1383 E. 88 St., Cleveland, O.

TEN Cent Dry Chemical Fire Extinguisher. Container Cheaply Manufactured from paper. Outright or Royalty. Write, A. R., Room 528, 78 E. Madison St., Chicago.

FOR Sale—Patent on Toy. Easily manufactured. Constructed mostly of wood. First check for \$1,500 secured patent rights. A good investment. Write for description of same. Irvine R. Dean, 1664 Lamar, Memphis, Tenn.

PRACTICAL Clamp. Needed by every wood-worker. Cheaply manufactured. Sell outright. Lock Box 248, Geneva, N. Y.

SECTIONAL Oar for small boat; occupies minimum space when not in use. Patent pending. A. Sanborn, Leesee Island, Ct.

MY combined dresser and refrigerator patent for sale on Royalty basis. H. C. Pratt, Norristown, Pa.

WE have some money-making inventions for placing on royalty; outright sale or trade. Write Adam Fisher Mfg. Co., 2061B Railway Exchange, St. Louis, Mo.

VALUABLE patents for sale or lease. Cash or royalty. Our No. 10415, Game; 10416, Railroad Rail Attachment; 10463, Safety Poison-Boiler; 10162, Combined Wheel-Barrow and Step-Ladder; 10244, Match-Box. Write us regarding these and other late patents, mentioning number and name of invention. If you desire to patent an invention send us a sketch, model or photograph for free opinion as to patentability and valuable book "How to Obtain a Patent and What to Invent." We advertise patents for sale in this magazine. Talbert & Parker, Patent Lawyers, 4687 Talbert Bldg., Washington, D. C.

OFFER Cash or Royalty; U. S. Patent No. 1,189,206. Improved, Profitable kite. Big field for this. Further particulars furnished on request. J. M. Moreira, 57 Hancock St., Lowell, Mass.

"SECTIONAL" Boiler—generates full steam in three to five minutes. Reduces fuel cost 75%. Manufacturing cost lower than others. Occupies much less space. Investigate. Carl Motter, Chehalis, Washington.

PATENTED: improved "Article-Carrier." Cash or royalty basis. Reasonable terms. U. S. Patent No. 1,177,692. Canadian Patent No. 175,789. For full particulars address Joseph Fallis, Gunn, Wyoming.

FLOAT-CONTROLLED Circuit breaker. Automatically indicates necessity of replenishing water supply, preventing burning out of engine. Simple—inexpensive and effective. A. Mosegard, Morgan Hill, Calif.

FOR Sale, Patent 1,198,415 motor wheels. For streams, tides or air currents. Cheapest power on earth. Best offer takes it. G. Bjornson, 2149, 15th St., San Francisco, Cal.

THIMBLE with Thread Cutter, made as cheap as ordinary thimble, therefore will take its place. Millions will be sold; worth \$75,000. Cash or Royalty Inventor George J. Baker, 424 Fourth Ave., Office 221, Pittsburgh, Pa.

VACUUM Cleaner, does the work of Electric, without electricity. A. J. Faucher, 402 So. Vine, Wichita, Kansas

MODELS AND MODEL SUPPLIES

INVENTORS. We make models, all sizes, of any device or patent. Inventions advertised and exploited. Send for estimates. Atlantic Supply Co., Long Branch, N. J.

MODELS, Punches and Dies, Patents Perfected. The Sachs-Lawler Co., Inc., Established 1881, 1543 Larimer St., Denver, Colo.

WANTED—An Expert Model Builder. Write to The Johns Machine & Stamping Works Company, Cleveland, Ohio.

WANTED—New Ideas. Write for list of Patent Buyers and Inventions Wanted. \$1,000,000 in prizes offered for inventions. Our Four Books sent free upon request. Victor J. Evans & Co., 165 Ninth, Washington, D. C.

WE make working models for inventors; also dies and stamping of specialties, and carry a complete stock of brass gears and model supplies. Send for catalogue. The Pierce Model Works, 3405 Pierce Ave., Chicago, Ill.

PRODUCERS of Results: Inventions developed. Models, Experimental work, anything special in metal to order, novelties, spinning, forging, castings in any material, electrical devices, patterns of all kinds, plating, general manufacturing, designing, special tools, punches and dies, stampings. Send drawing or sample. Expert information free. The John's Machine & Stamping Works Company, Dept. C, Cleveland, Ohio.

PERFECT models sell inventions. We make them. Write Adam Fisher Mfg. Co., 2061E Railway Exchange, St. Louis, Mo.

INVENTIONS developed, experimental work. Our experts will solve your intricate mechanical and electrical problems. Make any metal novelty. Send drawings or sample. Wm. Gent Machine Company, Box 172, Cleveland, Ohio.

CONSULTING ENGINEERS

AUTOMOBILE Consulting Engineer. Designs and devices criticised, motors a specialty. Opinions as to practicability of use and manufacture of accessories of all kinds given. Fee \$5.00 per answer. Save money by getting decision of practical man. C. F. Halladay, Merritt Bldg., Jackson, Mich.

ANTIQUES AND RELICS

POMO Indian Star Baskets. Prices free. Gilham, Highland Springs, Cal.

REAL ESTATE AND FARM LANDS

VIRGINIA, N. C., W. Va. and Ohio Farms at \$15.00 per acre and up offer big value for the price. Best climate, markets, schools and transportation. Good land and neighbors. Write F. H. LaBaume, Agri. Agt., N. & W. Ry., 259 Arcade, Roanoke, Va.

SELL your property quickly for cash, no matter where located. Don't pay big commissions. Particulars free. Real Estate Salesman Co., Desk B, Lincoln, Neb.

FOR Sale, 84 acres improved. Five thousand. Terms. Possession. Bargain. Route 2, Box 11, Beeville, Texas.

15,000 ACRES rich corn land in South-east Missouri drainage district. Terms. Boyden, Neelyville, Missouri.

FOR Sale—40-acre ranch, irrigated, near Bend, Oregon. Bargain. Write G. B. Young, Daytona Beach, Fla.

BEAUTIFUL Seashore Homesites only \$20. Special sale lots at Alamo Beach, Texas, famous Bayshore resort. First 100 lots \$20. Terms \$1 cash, \$1 monthly. Lots 50x140 feet. Splendid investment. Write for free literature and views. Alamo Beach Company, 422 First National Bank, Houston, Texas.

CALIFORNIA little farms near Los Angeles for sale, easy payments. Write E. R. Waite, Shawnee, Oklahoma.

A FEW Farms for sale or rent in a beautiful part of West Florida. Northern neighbors. Cooler here in Summer than in the North. Expenses light. Prices for produce good. Most desirable terms offered desirable people. Describe yourself fully. Two million dollars sent North last year from this county for food-stuffs easily raised here. Chas. A. Dexter, Dextland, Gonzalez, Florida.

\$5.00 DOWN, \$5.00 monthly; seven acres fruit, poultry, fur farm; river frontage; Ozarks; \$108.00; hunting, fishing, trapping. Harvey Hubbard, 1973 North Fifth, Kansas City, Kansas.

BARGAIN—Highly Improved 80-Acre Farm. Mile from city 11,000. No Incumbrance. Owner. A. Rylington, Route 2, Stevens Point, Wis.

BEAUTIFUL Seashore Homesites Only \$20. Special sale lots at Alamo Beach, Texas, famous Bayshore resort. First 100 lots \$20. Terms \$1 cash, \$1 monthly. Lots 50x140 feet. Splendid investment. Write for free literature and views. Alamo Beach Company, 422 First National Bank, Houston, Texas.

WANTED—Live agents to sell our Northern Minnesota lands. Liberal commission. Northern Realty Company, Duluth, Minn.

A SMALL farm in California will make you more money with less work. You will live longer and better. Delightful climate, Rich soil. Hospitable neighbors. Good roads, schools and churches. Write for our San Joaquin Valley illustrated folders free. C. L. Seagraves, Industrial Commissioner, AT&SF Ry., 1933 Ry. Exch., Chicago.

MONEY-MAKING Farms, 15 states, \$10 an acre up; stock, tools, and crops often included to settle quickly. Write for Big Illustrated Catalogue, Strout Farm Agency, Dept. 3043, New York.

OWN your own Orange or Grapefruit grove in beautiful Fruitland Park. Let me tell you how melons, peaches, hay, your first crops, should pay for your land and grove. J. Q. Lloyd, Desk 83, Fruitland Park, Florida.

EYE Opener—Thousands of acres fine land offered in Cass county. Easy terms. Write Ole Larson, Walker, Minn.

200 ACRES for sale. Good buildings, three-fourths mile from railroad station. Estate to settle. James Lover's Sons, La Porte, Ind.

CALIFORNIA land \$1 per acre cash. Balance purchase 90c month per acre. Immediate possession given. No taxes. No interest. Level San Joaquin Valley. Only four hours from San Francisco, 5 acres up. Clear; ready to plow; open ditch irrigation \$1 acre per annum. Particulars, maps, photographs, free. Steinson Colony, Desk D, 785 Market St., San Francisco.

FARMS, Buy now, 15 acres to 400, 100 miles from Chicago, \$1,200 upward. Easy terms. If you want income producing farm, don't delay. K. R. Fisher, Lock Box 3039, Aurora, Ill.

DOGS, BIRDS, POULTRY, PETS

FOR Sale—Coon, fox, wolfhounds, pointers, trained dogs. Guaranteed. Enclose stamps for reply. Norman Crawford, Downing, Mo.

RAISE Guinea Pigs for us. We buy all you raise. Pay better than poultry. Contract, particulars, booklet how to raise free. Cavies Distributing Co., 707 W. 74th St., Kansas City, Mo.

RAISE skunks in city or country. Odorless method. Illustrated circular P free. Skunk Development Bureau, Chicago.

SQUABS are raised in one month, they sell for fancy prices. Write at once for big free book telling how to make money breeding squabs. Plymouth Rock Squab Co., 634 Howard St., Melrose Highlands, Massachusetts.

RAISE Belgian Hares for Us. Big profits. We furnish stock and pay you \$2.00 each. Also Cavies, mink, skunk, fox, squabs, frogs, etc. Two booklets and contract for dime. None free. Address the Belgian Hare, 31 Main Street, Holmes Park, Mo.

FOR Sale: Beautiful white Collies, Registered. Satisfaction guaranteed. Shomont Kennels, Monticello, Iowa.

FLYING Squirrels—for pets or show; odd, beautiful, intelligent, hardy; mated pair, \$2.50. Safe delivery guaranteed. Wildwoods Fur Farms, Colmesneil, Texas.

PERSONAL

STAMMERING can be treated successfully in the privacy of your own home. Just as surely as you speak with ease at stated times, just so surely can you speak with the same ease at all times. Practical, common sense method prepared especially for Home Training. Kills Fear, increases Vocabulary and develops personal magnetism. Information on request (plain envelope). Stammerer's Co-Operative Ass'n (Spring-garden Branch), P. O. Box 2665, Philadelphia, Pa.

FREE—Stop using tobacco. We will give free information how to conquer habit easily and permanently. Results Guaranteed. Anti-Tobacco League, Box 379, Omaha, Neb.

BROTHER—Discovered root cures tobacco habit. Gladly send particulars. F. Stokes, McHawk, Florida.

TOBACCO Habit cured by harmless recipe. Sent free. Superba Co., BS, Baltimore, Md.

MISCELLANEOUS

HEATING System which saves you hundreds of dollars. Adapted to any furnace for heating Libraries, Schools, Churches, Hotels or wherever heat or steam is required. Easily installed. Patented. Burner and Steam-generator \$50. We employ no salesmen. Root Crude Oil System, 2945 C Street, Eureka, Calif.

CASH paid for butterflies, insects. Some \$1 to \$7 each. Easy work. Even two boys earned good money with mother's help and my pictures, descriptions, price list, and simple instructions on painlessly killing, etc. Send 2c stamp at once for prospectus. Sinclair, Box 244, D6, Los Angeles, Cal.

SHRAPNEL Shell Paper Weight. Be up to date and secure one for 25c. Specialty Mfg. Co., 30, Box 164, Milton, Pa.

NEW \$2.50 Automatic Adding Machine. Circular free. Bassett, 5921-J, Indiana Ave., Chicago.

SHINES in the dark. Our Luminous Paint, coated on any article, makes them visible at night. Watches, clocks, electric switch plates, crucifixes, match boxes, etc., can be coated with splendid results. (Everlasting.) Only 25c bottle. Luminous Paint Co., Douglas Park Station, B-13, Chicago, Ill.

CUTS anybody can make. Simple, cheap process. Specimens, particulars for stamp. M. Day, Windfall, Ind.

BANANAETTES—A simple little machine that inserts a slender shaft of ice cream, lengthwise, through the center of a banana; the combination is great. People like it. Send for circular. Bananaette Machine Co., Ephrata, Pa.

LOCKSMITHS. How to unlock cylinder and all locks. 106 tricks of the trade \$1.00; money back if dissatisfied. Routson, 576 42nd St., Oakland, Cal.

PEARLS, baroque, slugs, bought and sold. Designing, mounting, repairing jewelry done. "Pearls and Pearling"—best book published \$1.00. Laverne Mapes, Indiana Harbor, Ind.

GRANDFATHER'S Clocks. Build your own Grandfather's Clock with our free blue prints. Works. Dial, etc., \$5 and up. Others with chimes at all prices. Write for free offer. Clock Co., 1671 Ruffner St., Philadelphia, Pa.

We Want to Train More Men!



\$2500 to \$10,000 a Year

Grasp the opportunity offered by Chicago "Tech" training. Study any branch of engineering, learn architecture or become an expert draftsman and designer under men who are actually doing big things. The men who will teach you here are not mere theorists—they are actually engaged in the profession they will teach you. They are bridge builders, they are designers and constructors of skyscrapers, they are contractors for large engineering projects. They know exactly what you need to know to hold a big paying position or go into business for yourself. Their graduates are always in demand because they are known to have just the training that fits them to do practical work.

This college was organized to provide a better class of men in these lines. The men at the head of Chicago "Tech" need highly trained men in their own businesses—and they constantly have calls from other employers who demand better than the average ability. Why don't you get a training here? Why not fit yourself for a big salary? At least find out about all this. Tell us just what branch especially interests you. Send the coupon today.

Architecture, Engineering, Drafting

The fees for these courses are so small and the terms are so liberal that even the man of small income can get Chicago "Tech" training. Every man who wants to rise should send for full information now.

Home Study Courses

If you now have a position, no need to give it up. You can get Chicago "Tech" training in your spare hours. We will teach you by mail. Lessons sent direct to your home, examination papers criticised and returned. No preliminary technical education required. Our courses can be mastered by any man even of limited education. Write for book telling you all about our special home study training and our easy terms of payment.

Free Drawing Outfit

Complete set of imported drawing instruments sent free on enrollment to correspondence students. You are ready to begin at once. First lesson goes the day you are registered as our student.

Free Test Lesson

Before you enroll anywhere, get this free test lesson—sent to show you how simple and practical our courses are. Your request on coupon brings it with the other information.



C. W. MOREY

President Chicago "Tech" says: "I want every ambitious man to write and find out just what we offer here. I promise that none will be disappointed."

Resident Courses

Those who have the time and would prefer to take class study here under direct personal supervision may attend the day or evening classes at Chicago "Tech." Direct daily contact with big engineering work. Special opportunities for employment for self-support while studying and for securing paying positions afterwards. We have resident students from all parts of the country—not only beginners, but graduate engineers taking advanced work.

Our book on this course shows pictures of college building and class rooms. Also describes course of study. Ask for it if you are interested in the resident instruction.

BUILDERS' COURSE

Men who are now in business as practical builders and contractors or employed by firms in those lines can be more successful by taking our Special Builders' Course, which teaches Plan Reading, Excavating, Contracting, Estimating, etc. Send for information.

Send Coupon

Don't delay. Chicago "Tech" experts are ready to train you to be a bigger man, a bigger money-maker. Put X in the coupon. Mark the course that interests you and get the coupon into the mail right now.

CHICAGO TECHNICAL COLLEGE

630 Chicago "Tech" Building
2721 South Michigan Ave., CHICAGO, ILL.

CHICAGO TECHNICAL COLLEGE

630 Chicago "Tech" Bldg., CHICAGO

Tell me about your expert training in course marked below.

- | | |
|--|---|
| <input type="checkbox"/> Drafting | <input type="checkbox"/> Electrical Engineering |
| <input type="checkbox"/> Architecture | <input type="checkbox"/> Mechanical Engineering |
| <input type="checkbox"/> Civil Engineering | <input type="checkbox"/> Builders' Course |

Name.....

Address.....

Resident or Home Study Course?.....

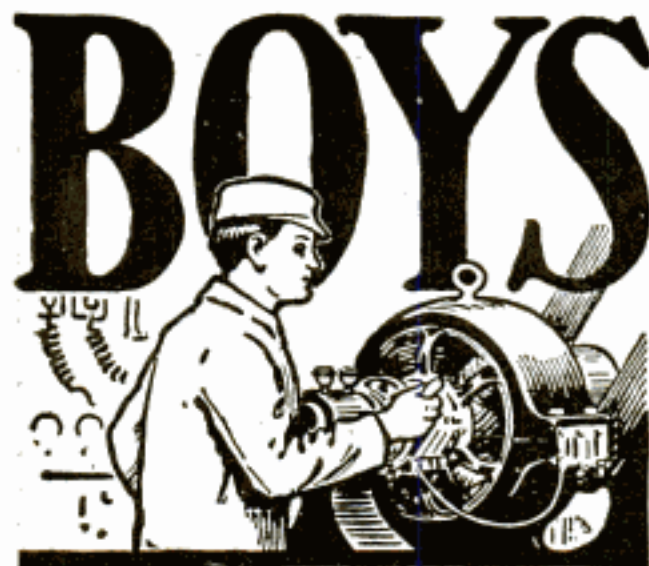

Big Money in Electricity

The Electrical industries offer wonderful opportunities to boys with a liking for Electricity. The salaries paid to trained men are large, promotion comes rapidly and, best of all, the work is fascinating.

The discovery and development of new lines (such as wireless telegraphy and telephony), from time to time, promise attractive and paying fields to those who wish to specialize. The *will to do* and *Special Training* will bring success to you.

The International Correspondence Schools can help you to become an expert in electrical work, no matter what branch you like best. Thousands of young men have already won success through I. C. S. help. You can do as well as anybody, *if you try*. Everything is made so clear that you can learn in your spare time, regardless of where you live or what your work. No books to buy.

There's big money in Electricity. Get after it by marking and mailing the Coupon today. *Finding out costs you nothing.*

INTERNATIONAL CORRESPONDENCE SCHOOLS

Box 5578, SCRANTON, PA.

Explain, without obligating me, how I can train for the position before which I mark X.

- ELECTRICAL ENGINEER
- Electrician
- Electric Wiring
- Electric Lighting
- Electric Car Running
- Electric Machine Designer
- Telegraph Engineer
- MECHANICAL ENGINEER
- Mechanical Draftsman
- STEAM ENGINEER
- GAS ENGINEER
- CIVIL ENGINEER
- Structural Engineer
- CHEMICAL ENGINEER

- ARCHITECT
- Architectural Draftsman
- Mine Foreman or Supt.
- Business (Complete)
- Bookkeeper
- Stenographer
- Advertising Man
- Salesmanship
- Window Trimmer
- Civil Service
- AGRICULTURE
- Poultry Raising
- AUTOMOBILES
- Auto Repairing

Name _____

Present Occupation and Employer _____

Street and No. _____

City _____ State _____

If name of Course you want is not in this list, write it below.

Please Mention Popular Mechanics

**\$80 to \$250
and
more per Month**

— is being made by our graduates as Expert Auto Engineers, Chauffeurs, Race Drivers, Shop Foremen, Testers, etc.; others make \$12,000 to \$20,000 yearly in salary and profits—because our training is thorough and practical.

Opportunities now are **better than ever**; we have constant calls for more and more men. To get the best positions you must have the right training and the place to get it is the

CLEVELAND AUTOMOBILE SCHOOL

14 Years of Success—Over 4000 Graduates

Our school has the latest equipment including Knight type and 12 and 8 cylinder motors; latest starting and lighting equipment; Akron-Williams tire repair equipment, etc., etc.

JOIN US NOW

Up-to-date training in 4 weeks, tuition reasonable, board \$5 to \$6 a week. New classes forming. Come now.

Cleveland Automobile School
2338 Euclid Ave., Dept. 5, Cleveland, O.



High School Course in Two Years

LEARN in your own home. Here is a thorough and simplified high school course that you can complete in 2 years. Meets college entrance requirements. Prepared by leading members of faculties of universities and academies.

Study in Your Own Home

This course was prepared especially for home training. What if you did not get a high school education? You can make up for lost time now. Idle evenings can be spent in pleasant reading that will give you a thorough high school training.

Write For Our Booklet! Send your name and address today for our booklet and full particulars. No obligations. Write NOW!
Dept. P1134
American School of Correspondence, Chicago, U. S. A.

LEARN WATCHMAKING AND ENGRAVING



Earn while learning. Most practical watch school. Individual instructions. Graduates in great demand. Book free. Chicago School of Watchmaking, 63 E. Van Buren St., Chicago

A GOOD POSITION

with **UNCLE SAM** is most desirable. Life positions, pleasant surroundings, good pay, steady work, short hours, promotions on merit. Both sexes. No political pull. Thousands of appointments yearly. Most thorough preparation \$5. Returned if not appointed. Full information and questions used by the Civil Service Commission free.

AMERICAN CIVIL SERVICE SCHOOL WASHINGTON, D. C.

Learn to **PAINT SIGNS and SHOW CARDS**

I teach you personally, by mail, in a short time. Oldest and largest School. Big field, work interesting. You can **EARN \$18 TO \$45 A WEEK**

Wittmer, Minn., wrote: "Did job after first lesson, got \$10, profit \$7.00." Crawford, J. C., says: "Earned \$300.00 while taking course." Get literature, samples, guarantee—all FREE.

DETROIT SCHOOL OF LETTERING
Established 1899. 206 E. S. of L. Bldg. DETROIT, MICHIGAN

Learn Electricity! Drafting—Plumbing

Earn \$125 to \$300 a Month

That's what many of our graduates earn right from the start. That's what **YOU** can earn if you become a **COYNE** trained man. All of these trades offer exceptional opportunities. Thousands of high-salaried positions are open. We are constantly receiving calls for our graduates. On small capital you can start a business of your own and become entirely independent.

Any man between the ages of 16 and 50 who is ambitious, can learn one of these big paying trades thoroughly in a short time in our \$93,000.00, perfectly equipped shops, at small expense. No previous education or training necessary.



18 YEARS OF SUCCESS

COYNE

Trade and Engineering Schools
Largest and Best Equipped in America

We teach all these big paying trades under actual working conditions. No classes; no books; no correspondence teaching.

April 10, 1917.

Mr. R. W. Cooke, Director.
DEAR SIR:—I want to thank you for the interest shown me while at your school. Sorry I could not quite finish my course in plumbing as I have enlisted in the Army as a plumber. Am getting along fine and expect to be made Sergeant Plumber in a short time.
Yours Sincerely,

J. J. VENTURA, Jefferson Barracks, Mo.

U. S. Needs Trained Men

Uncle Sam will need thousands of trained men in these trades at good pay. Learn one of these trades **NOW** and be a real help to your country.

FINISH IN 3 MONTHS

Drafting, Estimating and Plan Reading included in ALL courses. We charge a small tuition fee which can be made in easy payments if desired. All equipment and material furnished by the school **FREE**. Our institution is open all year round. You can enter any time. Day and Evening classes. Many of our students earn a part or all of their expenses while attending. Our employment bureau is always ready to assist a man to earn expenses, without charge.

Motion Picture Operating Bricklaying Builders' Course

These new big paying trades are demanding more and more trained men everywhere and our graduates are sought after by theatre managers, contractors, and Engineering firms throughout the country. Free Book of Trades explains all.

Send for FREE Book of Trades



MAIN BUILDING

Fill in this coupon and mail today. Tells all about our courses, terms, etc. Points out wonderful opportunities for ambitious young men. Help us meet the demand for men trained the Coyne way.

ADDRESS

BENNETT WELLINGTON COOKE, Director
**COYNE TRADE AND
ENGINEERING SCHOOLS**
DEPT. 119X
39-51 E. Illinois St., CHICAGO



SEND THIS COUPON

Bennett Wellington Cooke, Director
Coyne Trade and Engineering Schools
Dept. 119X, 39-51 E. Illinois St., Chicago
Without obligation to me please send at once your wonderful Manual of Trades. I am particularly interested in

- | | |
|---|---|
| <input type="checkbox"/> Electricity | <input type="checkbox"/> Plumbing |
| <input type="checkbox"/> Bricklaying | <input type="checkbox"/> Drafting |
| <input type="checkbox"/> Motion Picture Operating | <input type="checkbox"/> Builders' Course |

(Check course that interests you.)

Name.....

Address.....

Please Mention Popular Mechanics

A Big Job For a Little



Take Ten Lessons— then decide

TAKE your pencil now—and make an X in the coupon before the position in life that you want to fill. You will be under no obligation. This little X is an easy thing to make but it will bring to you a vital, inspiring message that will tell just exactly how you can qualify yourself, right in your own home, to fill the position that you are dreaming about.

We'll tell you, too, how you can start this training and get ten complete lessons. And, then, if you don't think the course is going to put you into the position you want, *we'll refund every cent you have paid.*

Nowadays, the thing that puts a man in a high position is training! There isn't one man in a thousand who can get this training without help.

This advertisement brings to you the chance to get the help that has put thousands on the road to success. And you can prove it to yourself. You can take ten lessons and, if you are not satisfied, we'll refund your money.

Send the Coupon

Make an "X" in this coupon now before the position you want to fill. Find out for yourself what the American School has to offer to you. Find out how the hard places have been made easy and how thousands and thousands of men all over the world are now making their marks in the business world—because they have training. You will be under no obligation by sending the coupon. Send it now.

American School
of Correspondence, Chicago, U.S.A.
Dept. G119A

American School of Correspondence, Dept. G 119A Chicago, U. S. A.

Gentlemen: Please send me booklet and tell me how I can fit myself for the position marked X.

- | | |
|--------------------------------|-------------------------------|
|Electrical Engineer |Business Law |
|Elec. Light & Power Supt. |Business Manager |
|Hydro-electric Engineer |Auditor |
|Telephone Engineer |Accountant |
|Architect |Cert'f'd Public Acc't |
|Architectural Draftsman |Stenographer |
|Building Contractor |Bookkeeper |
|Building Superintendent |Fire Ins. Inspector |
|Structural Engineer |Fire Ins. Adjuster |
|Structural Draftsman |Fire Ins. Expert |
|Mechanical Engineer |Sanitary Engineer |
|Mechanical Draftsman |Master Plumber |
|Civil Engineer |Plumbing & Heating Est. |
|Steam Engineer |Heating & Vent. Engineer |
|Shop Foreman |Reclamation Engineer |
|Shop Superintendent |Automobile Engineer |
|Sheet Metal Draftsman |Automobile Repairer |
|Lawyer |High School Course |

We also prepare for civil service examinations in all engineering subjects

Name.....

Address.....

Garages Earn \$3,000 to \$10,000 Yearly Auto Mechanics \$80 to \$200 Monthly



I will make you a competent Auto Mechanic, Chauffeur, Tractor Operator, Farm Implement expert, Salesman or Garage Owner in a short time, the I. M. I. way, in spare time at home.

Harry L. Wells, Pres.

Get into Auto Business where success is sure. Competent Auto Mechanics needed constantly. Factories and garages advertising for competent men. Garages and Sales companies paying big salaries to men who know autos thoroughly. Farmers need Tractor Operators. The demand is for trained men. 1,250,000 cars will go into use in six months. 3,500,000 now in use. Think of men in Auto Business making fortunes. More cars mean more garages, more auto mechanics. Knowledge means money. Opportunities all about you. I. M. I. Course easy to understand, has complete detailed diagrams of everything. No previous education or auto experience needed. Earn while you learn. Start doing work in spare time, after first few lessons. Extra money will more than pay tuition. Pay for course in small monthly payments.

Learn Electrical Equipments

We teach how to handle every electrical equipment. You learn to locate trouble quickly. Starting, lighting and ignition troubles can't stump you. 80% of auto troubles are electrical. Electrical Auto Men get big pay, have steady jobs. Garages giving best electrical service get business easily and hold it. You learn how to adjust carburetors, time valves, care for electrical troubles. Complete course as quickly as you like. No matter what business you are in, you can succeed if you take I. M. I. Course.

CAR OWNERS—AUTO MECHANICS—GARAGES

One I. M. I. graduate saved price of course in three months fixing his own car. Hundreds of car owners taking I. M. I. Course so they can save repair bills. I. M. I. graduates in demand everywhere because *they make good*. More garages needed everywhere. I. M. I. graduates are competent to open them. We teach men how to build, rebuild, repair and operate every make of auto including Packard Twin-6, Cadillac-8, Hudson Super-6, Owen Magnetic.

25 LESSONS ABSOLUTELY FREE

This remarkable offer is made to 1000 men—One man in each community. I will meet them half way, by giving half the course (25 lessons) free. I want men of quick decision and foresight. Send for special enrollment blank, free offer, testimonials, literature, all free. A post card will do.

Iron Clad Money-Back Guarantee

I guarantee to return to any student all his money if he writes me within 10 days after completing last lesson that he is not satisfied.

Harry L. Wells, Pres.

International Motor Institute

26 Kessler Bldg.
CHICAGO, ILL.

STUDY LAW 30 Days FREE

Let us prove to your entire satisfaction, at our expense, that the Hamilton College of Law is the only recognized resident law school in U. S., Conferring Degree of Bachelor of Laws—LL. B.—by correspondence. Only law school in U. S. conducting standard resident school and giving same instruction, by mail. Over 500 class-room lectures. Faculty of over 30 prominent lawyers. Guarantee to prepare graduates to pass bar examination. Only law school giving Complete Course in Oratory and Public Speaking. School highly endorsed and recommended by Gov. Officials, Business Men, Noted Lawyers and Students. Send today for Large Handsomely Illustrated Prospectus and Special 30-Day Free Trial.

HAMILTON COLLEGE OF LAW, 1256 Advertising Bldg., Chicago, Ill.



IF YOU STAMMER

attend no stammering school till you get my large FREE book and special rate. Largest and best school in the world curing by natural method. Write today.

Lee Wells Millard, Pres., North-Western School, Inc.
2317 Grand Avenue Milwaukee, Wis.

7 DAYS

In your own home, during the evenings of just one week, you can learn the famous

LIGHTENAG PARAGON SHORTHAND

Then Practice Brings the Speed

Used in Government service; also in Court Reporting. Adopted by cities for High Schools. Wonderfully easy to read. Speed capacity practically unlimited. Positive proof before you enroll. Send for #10007.

PARAGON INSTITUTE, 372 COLISEUM PLACE, NEW ORLEANS, LA.

LEARN WATCH REPAIRING



You can learn by our modern and original system of instruction every part of the Watch Repairing Trade at home as good or better than at a shop. You can earn money while learning and secure a well paying position or start in business after completing our course of instruction. Good watch repairers are always in demand and earn from \$20 to \$35 per week. For particulars apply to the Wisconsin School of Watchmaking, Strub Bldg., Milwaukee, Wis.

Please Mention Popular Mechanics



“Look at Him Today!”

“Six years ago he started in here just as you are doing. Now he's General Manager and makes more in a day than he used to make in a week. I'll tell you how he did it. The first week he was here he began to train for the job ahead by studying in spare time with the International Correspondence Schools. Inside of six months he got his first promotion. But he kept right on with the I. C. S. I tell you a man like that is bound to get ahead. Some day he'll be President of the Company. You've got the same chance he had, young man, and if I were you I'd follow his example. Take up some I. C. S. course and do it right away. Use your spare time. Study. What *you* are six years from now is entirely up to you.”

This is the story of thousands of successful men. They did their work well, and in spare time, with I. C. S. help, trained themselves for advancement. That's the thing for *you* to do. Whatever your chosen work may be, there is an I. C. S. Course that will prepare you right at home for a better position with bigger pay.

More than 100,000 men are getting ready for promotion right now in the I. C. S. way. Let us tell you what we are doing for them and what we can do for you. The way to find out is easy. Just mark and mail this coupon. It won't cost you a cent or obligate you in the least, but it may be the first step toward a bigger, happier future. Don't lose a minute. Mark this coupon and get it into the mail right now.

INTERNATIONAL CORRESPONDENCE SCHOOLS BOX 5577, SCRANTON, PA.

Explain, without obligating me, how I can qualify for the position, or in the subject, before which I mark X.

- | | |
|---|--|
| <input type="checkbox"/> ELECTRICAL ENGINEER | <input type="checkbox"/> SALESMANSHIP |
| <input type="checkbox"/> Electric Lighting | <input type="checkbox"/> ADVERTISING |
| <input type="checkbox"/> Electric Railways | <input type="checkbox"/> Window Trimmer |
| <input type="checkbox"/> Electric Wiring | <input type="checkbox"/> Show Card Writer |
| <input type="checkbox"/> Telegraph Engineer | <input type="checkbox"/> Sign Painter |
| <input type="checkbox"/> Telephone Work | <input type="checkbox"/> Railroad Trainman |
| <input type="checkbox"/> MECHANICAL ENGINEER | <input type="checkbox"/> ILLUSTRATING |
| <input type="checkbox"/> Mechanical Draftsman | <input type="checkbox"/> Cartooning |
| <input type="checkbox"/> Machine Shop Practice | <input type="checkbox"/> BOOKKEEPER |
| <input type="checkbox"/> Gas Engine Operating | <input type="checkbox"/> Stenographer and Typist |
| <input type="checkbox"/> CIVIL ENGINEER | <input type="checkbox"/> Cert. Public Accountant |
| <input type="checkbox"/> Surveying and Mapping | <input type="checkbox"/> TRAFFIC MANAGER |
| <input type="checkbox"/> WINE FOREMAN OR ENGINEER | <input type="checkbox"/> Railway Accountant |
| <input type="checkbox"/> Metallurgist or Prospector | <input type="checkbox"/> Commercial Law |
| <input type="checkbox"/> STATIONARY ENGINEER | <input type="checkbox"/> GOOD ENGLISH |
| <input type="checkbox"/> Marine Engineer | <input type="checkbox"/> Teacher |
| <input type="checkbox"/> ARCHITECT | <input type="checkbox"/> Common School Subjects |
| <input type="checkbox"/> Contractor and Builder | <input type="checkbox"/> Mathematics |
| <input type="checkbox"/> Architectural Draftsman | <input type="checkbox"/> CIVIL SERVICE |
| <input type="checkbox"/> Concrete Builder | <input type="checkbox"/> Railway Mail Clerk |
| <input type="checkbox"/> Structural Engineer | <input type="checkbox"/> AUTOMOBILE OPERATING |
| <input type="checkbox"/> PLUMBING AND HEATING | <input type="checkbox"/> Auto Repairing |
| <input type="checkbox"/> Sheet Metal Worker | <input type="checkbox"/> Navigation |
| <input type="checkbox"/> Textile Overseer or Supt. | <input type="checkbox"/> AGRICULTURE |
| <input type="checkbox"/> CHEMIST | <input type="checkbox"/> Poultry Raising |
| | <input type="checkbox"/> Spanish |
| | <input type="checkbox"/> German |
| | <input type="checkbox"/> French |
| | <input type="checkbox"/> Italian |

Name _____
 Present Occupation _____
 Street and No. _____
 City _____ State _____

Please Mention Popular Mechanics

Come to Akron, Ohio
The Tire Center
and

LEARN THE TIRE REPAIR BUSINESS



MONEY-BACK GUARANTEE

We guarantee to qualify our students to go into business for themselves or to hold positions paying \$18.00 to \$40.00 weekly or return their money. The demand for trained repairmen is greater than the supply.

Make big money in this big field. No other field offers such opportunities. Autos run the year around. Tires need constant repairing. Profits are large and work comes easily. Every job is easily and quickly done. There are locations everywhere, right in your home town. We show you how to find best locations. Help you to get jobs paying from \$3.00 to \$6.00 a day if you don't want to open a repair shop. Tire repair shops are as necessary as gasoline stations. Over a Million New Autos put in use this year. Get into this big profit business and become independent.

EARN \$100 TO \$500 MONTHLY

There is no limit to what a man can make. Men are becoming rich in this business. You can start business with small capital. Our graduates are qualified to handle all makes of Cord Tires and get factories O. K. School open all the year. Enter classes any day. Graduate in 4 to 6 weeks.

Tire Factories Now Employ Both Students and Graduates

We have made a deal with the large Tire Factories so that we can get jobs for our students while they are taking the Tire Repair Course or after they have graduated. The factories will employ the students and when they graduate will tell them where the best locations are for tire repair shops, or will get them a good high salaried position in a service station or Tire Repair Shop.

Factories pay \$15 to \$35 and up a week and will give our students jobs on one of the "shifts" so that they can earn while they learn. We have gotten men positions in the factories with salaries enough to pay for our course and all living expenses. We will help every worthy earnest man who will live up to the factory rules and regulations. We can now get you a good job in the factories to pay your expense, put you in touch with best locations or get you good Tire Service Station or Tire Repair Shop Jobs.

FREE Write for School Literature outline of course, letters from Satisfied Students all absolutely Free. Or better still, jump on the train and come to Akron. We will give you every possible help. Get started in this money making business NOW.

THE AKRON TIRE REPAIR SCHOOL The Largest and Best Equipped, Exclusive Tire Repair School
A. G. ZELLER, President, 66 Tire Bldg., 46-48 Main St., AKRON, OHIO

AKRON, OHIO
THE HEART OF THE TIRE INDUSTRY



MORE THAN 800,000 TIRES ANNUALLY

Stronger, Clearer Voice for You!



Weakness, huskiness and harshness banished. Your voice given a wonderful strength, a wider range, an amazing clearness. This done by the Feuchtinger Method, endorsed by leading European musicians, actors and speakers. Use it in your own home. Simple, silent exercises taken a few minutes daily impart vigor to the vocal organs and give a surpassing quality to the tones. Send for the facts and proofs.

Do You Stammer?

If you have any voice impediment this method will help you. You need not stammer or lip—if you will follow our instructions.

WRITE

Send the coupon and get our free book and literature. We will tell you just what this method is, how it is used and what it will do for you. No matter how hopeless your case may seem the Feuchtinger method will improve your voice 300 per cent. No obligation on you if you ask for this information. We gladly send it free, postage prepaid. Just mail the coupon.

Perfect Voice Institute
1810 Wilson Av.
Studio A119
CHICAGO

Name _____
Address _____

Please Mention Popular Mechanics

FREE This Complete Set of Drawing Instruments



\$15.00 Draftsman's Complete Working outfit free to students. They do not cost you a penny on this offer. Write today for particulars. Do it NOW!
\$150 to \$300 a Month
My graduates are earning from \$150.00 to \$300.00 a month and more. WRITE TODAY. Send for my free book on drafting. No obligations. Write now. Chief Draftsman Dobe, Dir. A119 Engineer's Equipment Co., Chicago

STAMMERERS

Our course of private lessons will correct your impediments.
BOSTON STAMMERERS' INSTITUTE
Founded 1867, Samuel D. Robbins, Principal
246 Huntington Ave. BOSTON, MASS.

LEARN WATCHMAKING

and become independent. Good-paying positions secured. Easy to learn. Send for FREE CATALOG.

ST. LOUIS WATCHMAKING SCHOOL, Dept. 5, ST. LOUIS, MO.

Advertising Manager—\$5000 a Year

YOU CAN BE ONE

If our Vocational Director will accept you, then you can succeed in advertising. Ten practical business men will teach you. Write for booklet, "Poverty to \$10,000 a Year" and "Free Personal Analysis/Plan."

BRYANT & STRATTON COLLEGE, 1823 Bryant & Stratton Bldg., CHICAGO, ILL.

Encyclopaedia Britannica

"HANDY VOLUME" ISSUE
Printed on India Paper



Men Wanted To Learn Automobile Business

EARN BIG MONEY—\$75 to \$300 Per Month

Only a few weeks required to train you. In six weeks I teach you to run and repair properly any automobile made. Learn to be repairman, demonstrator, garage manager and salesman. I teach thoroughly, practically and personally on real automobiles in everyday use. No books used. Tools furnished free. Actual practice on big, powerful cars brought here for inspection and repairs.

SEND FOR BOOKLET, "Making You Master of the Auto," Free upon request.

WM. H. ARHELGER Milwaukee Motor School, 217-21 Seventh St., Milwaukee, Wis.



Learn HIGHER ACCOUNTING!

The Profession That Pays Big Incomes

Do you know that accountancy has developed into a big, dignified and well paid profession? There are many certified public accountants whose incomes are \$10,000 to \$25,000 a year. The United States Steel Corporation paid one accounting firm \$250,000 for installing its cost and accounting systems.

Never before have there been so many splendid opportunities for trained accountants—men whose training combines a knowledge of Auditing, Cost Accounting, Business Law, Organization, Management and Finance. Few professions offer better opportunities to young men of ambition and intelligence. The tremendous business growth of this country has created a rich field for the expert. There are only 2,000 Certified Public Accountants to do the work of the half million concerns needing their services. The expert accountant is also needed today in every big executive organization.

Knowledge of Bookkeeping Unnecessary To Begin

We will give you whatever training, instruction or review on the subject of bookkeeping you may personally need—and without any extra expense to you. Our big, free book on the accountancy profession fully explains how we train you from the ground up, according to your individual needs, from the simplest bookkeeping principles to the most advanced accounting problems. All text material supplied in the course has been especially prepared in clear, easy-to-understand language, so you can readily master the principles by home-study.

Small Cost—Easy Terms

Write today and learn how our easy-payment plan places this splendid course of training within the reach of every ambitious person who possesses a real desire for personal advancement and the kind of organized "brain power" that commands big rewards in business everywhere. Mail the coupon now and get our free book which fully describes our expert training course and tells all about our Money-Back Guarantee, C. P. A. examinations, state regulations, salaries, and incomes and how you can qualify for a high-grade accounting position without interference with your present job. If you want to enter an uncrowded field that offers trained men a real opportunity for worth while advancement, send in the coupon and find out what we have done for others and can do for you.

LaSalle Extension University,
"The World's Greatest
Extension University"
Dept. 664-H
Chicago, Ill.

Take
Your First
Step to Success
—Send This Coupon

Name.....
Address.....
City..... State.....

Train By Mail

Under the Direction of These
Prominent Accountants

FACULTY

William Arthur Chase,
LL. M., C. P. A.

Consulting Accountant and Auditor; Former Secretary, Illinois State Board of Examiners in Accountancy; Sometime Lecturer on Accountancy in the University of Illinois; Member of Illinois Bar.

Andrew J. Quigley, C. P. A.

Ex-Chairman of Washington State Board of Accountancy, Specialist in the accounting methods of gas, electric light, street railway and other public service corporations.

E. E. Jones, C. P. A.

Ex-President of the National Business Teachers' Association; Ex-Secretary of National Commercial Teachers' Federation.

LECTURE WRITERS

(Partial List)

DeWitt C. Eggleston, C. P. A.
Department of Finance, New York.

Frank C. Webner, C. P. A.

Specialist in Cost Accounting; former manager, J. Lee Nicholson & Co., Industrial Traffic Engineers, Chicago, New York and Milwaukee.

Walter C. Wright, C. P. A.

President, Audit Company, of Los Angeles, Inc.

The complete LaSalle organization consists of more than 300 business experts, professional men, text writers, instructors and assistants, including recognized authorities in all departments.

Mail Coupon Today

LaSALLE EXTENSION UNIVERSITY,
"The World's Greatest Extension University"
Dept. 664-H Chicago, Ill.

Without cost or obligation on my part, please send me your book of "Accountancy Facts" and particulars regarding your Home-Study Course of Training in Higher Accountancy. Also a copy of your valuable book for the ambitious, "Ten Years' Promotion In One."

Please Mention Popular Mechanics

SIGNAL ENGINEERING

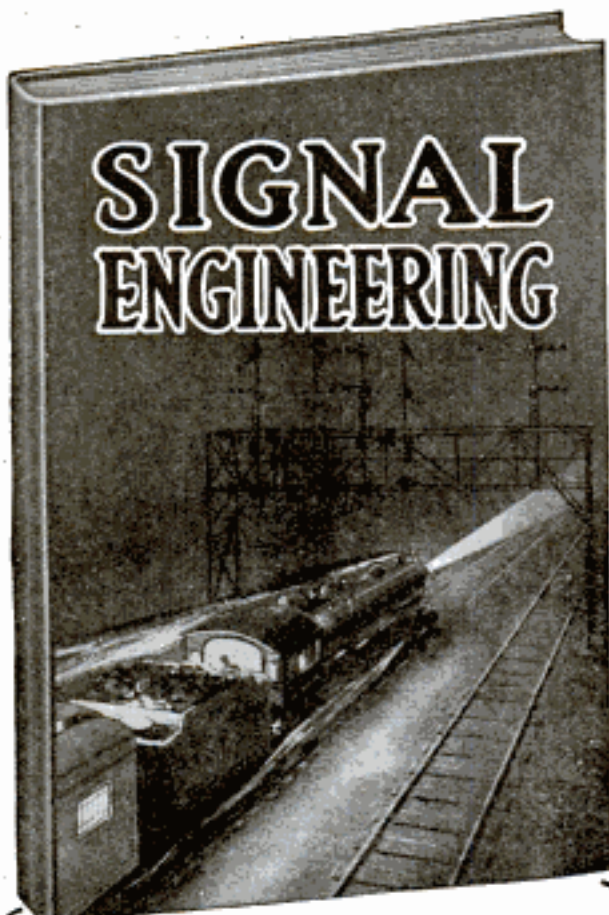

Free Book On Signal Engineering

THERE are thousands of miles of railroad that must be equipped with block signal systems. To superintend these installations and to maintain the systems now in use thousands of men are necessary. Golden opportunities are offered. Every ambitious man in America should write for the free book on Signal Engineering. It will be sent to you prepaid—without obligation.

Men Are Needed to Accept High Salaried Positions

When you stop to consider that, at the present time, less than one-fourth of the passenger lines in this country are equipped with automatic block signal systems—and when you read that the day is fast coming when the law will compel railroads to install them, you will realize what remarkable opportunities are offered to ambitious men in the profession of Signal Engineering. The work is big—broad—high salaries are paid. \$250.00 a month is an ordinary salary for a Signal Engineer.

Department of Signaling

Dept. A119, 1810 Wilson Ave.
Ravenswood Station Chicago

GENTLEMEN:—Please send me absolutely free and prepaid your big new book on Signal Engineering. Also full particulars about your great special free outfit offer. It is distinctly understood that I assume no obligations of any kind.

Name.....

Address.....

Age..... Occupation.....

Send the Coupon

Put your name and address in the coupon, or a letter or post card. Now and get the free book about Signal Engineering. Too, we will tell you how you can get the training that you need in order to become a Signal Engineer. You will be under no obligation by writing for this free book. Do it Now.

Department
of Signaling
Dept. A119
1810 Wilson Ave.
Ravenswood Sta.
Chicago

Are You Interested In Automobiles Motoring Driving Repairing



and the hundreds of things which are of interest to automobilists? "THE AMERICAN CHAUFFEUR," a monthly magazine devoted to automobiles, is of vital interest to Owners who drive, Garagemen, Repairmen and Chauffeurs. Technical features appear in each issue, written by men who have made life studies in their special departments. Every article that appears in this magazine is thoroughly practical—chuck full of sound, solid, meaty, common sense, and in each issue there appear discussions of proper lubrication, fuels, tires, engines, carburetors, axles, lighting and cooling systems, adjustments, repairs, good roads and all the valuable information you should know about. They come down to facts and tell you just what's what. They help and urge you in every way to know more about automobiles.

SPECIAL OFFER Get This Attractive FOB ABSOLUTELY Free

Send us 25c in stamps or coin for a three months' trial subscription to the American Chauffeur, we will send you this beautiful original designed, real rose, gold plated Automobile Watch FOB, with Seal Grain Leather Strap like illustration, **ABSOLUTELY FREE**. Your money back if not satisfied.

AMERICAN CHAUFFEUR
86 Butler Bldg., Cincinnati, Ohio

LAW High-Grade Instruction by CORRESPONDENCE Prepares You for the Bar—Est. 1892

Four Courses: College, Post-Graduate, Business Law and Bar Ex. Review. Classes begin each month. Approved by Bench and Bar. University Methods, Unabridged Text-Books, Cases, Course in Oratory, Public Speaking and Moot Court FREE with regular course. Graduates now practicing in every State. Write today for Catalog and Rules for Admission to the Bar. CHICAGO CORRESPONDENCE SCHOOL OF LAW, 529 Resper Block, CHICAGO



LEARN WATCH REPAIRING

Be a watchmaker—you can learn this profitable trade by correspondence in a few weeks in your own home by the DeSelms Chat System. After you complete the course you will know a watch from A to Z. You will know just what the matter is and how to repair one. When you graduate you will be a practical watchmaker and repairer and competent to fill any position. Positions for our graduates.

Ask for our Free Book. It explains our system and terms.

THE DeSELMS WATCH SCHOOL
23 Perry Street ATTICA, INDIANA



STAMMERING MECHANICALLY STOPPED

Invention fits mouth—simple as false teeth. Controls muscles of articulation. Stammering impossible minute controller is fitted. Soon talk correctly without controller. Write for our scientific explanation of Stammering. PEATE AND BEATTIE, BOX 93, SPENCERPORT, N. Y.

AT HOME Learn TO SING

Send 2-cent Stamp for Helpful Booklet, "The Voice Made Beautiful."

HARVEY SUTHERLAND, 1832P 49th St., BROOKLYN, N. Y.



LEARNED BY ALMOST ANYONE AT HOME VENTRILOQUISM SMALL COST

Send today 2c stamp for particulars and proof.
O. A. SMITH, Room D 151, 823 Bigelow St., PEORIA, ILL.

Aviation

PRACTICAL AERONAUTICS BY MAIL

EARN \$50 to \$500 a Week!



BUD MORRISS, Chief Instructor American School of Aviation

HERE is the one inexhaustible gold mine of opportunity and here is the man

who will lead you to it. It is the most extraordinary condition ever presented, owing to the sudden worldwide demand for aeroplanes. High class positions by the thousand calling for trained men—fame and fortune actually thrust at them. Salaries of from \$50 to \$500 a week are awaiting men who can fill these positions. And now, for the first time in history, a practical, home-study course in practical aeronautics is open to every man at a trifling expense. No matter what your occupation, you can prepare for a better position with big pay. Now is your opportunity.

Enter a practically untrodden field—a new profession. Seize the opportunity that has burst upon the country with tremendous force. Hustle ahead with the rapid development of the aeroplane industry which is outrivalling that of automobile and motion picture, as the quick and sure road to financial independence.

Prepare NOW
for these positions

Aeronautical Engineer
Aeronautical Instructor
Aeronautical Contractor
Aeroplane Repairman
Aeroplane Mechanic
Aeroplane Inspector
Aeroplane Salesman
Aeroplane Assembler
Aeroplane Builder

Conducted by Famous Aviators and Aeroplane Builders

The Course has been prepared by men of international reputation. Mr. Bud Morriss, the well-known aviator, is Chief Instructor and personally guides the progress of each student. He is assisted by a distinguished staff of Aviators, Aeroplane manufacturers and Aeronautical Engineers. Every Lesson, Lecture, Blue Print and Bulletin is self-explanatory, in plain terms for quick understanding. The Course is absolutely up-to-the-minute with every known fact concerning Aeronautics. You get practical, working knowledge of the very highest merit. Now is the time and this is your opportunity to step right into fame and fortune. You are needed. Where there's a will here's the way.

What Our Students Say:

Mr. Stanfield Fries

Fort Bliss, Tex.

My estimation of the new course is excellent; it could positively not be any better.

Mr. Z. Purdy

Shreveport, La.

It is hard to believe that lessons on such a subject could be gotten up in such an interesting manner.

Mr. Lloyd Royer

Haigler, Neb.

I can hardly thank you enough for the way you have personally taken up my enrollment.

Mr. Mayne Eble

Manistee, Mich.

I believe I learn more from my lessons than an aviator who takes his first lesson with an airman in a aeroplane.

Write Now for Our Great Offer

Send the coupon for full particulars of our remarkable special offer open to you now. Find out all about the marvelous opportunities that are opening in the Aviation game. This offer is the greatest stepping stone to bigger opportunities ever known. Write today for complete literature, all free and prepaid. You are not obligated in any way. Do not waste time in thinking about it. Act! Send the coupon or a letter or a post card will do. Write at once.

American School of Aviation

431 So. Dearborn Street, Dept. 1196, CHICAGO, ILL.

American School
of Aviation
431 So. Dearborn St.
Dept. 1196
Chicago, Ill.

Gentlemen: Please send me free and without obligation, full particulars of your Course in Practical Aeronautics and your Special Offer to those who write at once.

Name.....

Address.....

Please Mention Popular Mechanics

Ambition

-take a Lesson
from Life



You men of ambition—you who have considered taking up law either as a profession or as a means of attaining success in business—you do not need to be reminded that law always has been, and is today, the foremost profession; that law has raised more men to positions of power than any other calling; that lawyers' incomes range from \$3,000 to \$10,000 a year. You know these things from daily observation. And you feel that you, too, could make your influence felt in the legal profession, in business, in politics, if you had the necessary legal education. And so you could.

LAW

Is Your Opportunity!

Right now you may be thinking where you can best learn law. Let us help you answer that question. Let us tell you just how easily law can be mastered right in your own home, during spare time; how we have taken the hard work out of the study of law and made it as fascinating as a work of fiction.

There are many things about this really remarkable home study law course which you should know. For instance

Do You Realize—

That the LaSalle Home Study Text and Course are prepared by some of the ablest law professors, jurists and legal experts in the country?

That it is the only home study law course in existence that gives you the same kind of legal instruction and training—individual lessons, class talks, quizzes and examinations—that you would receive at the most famous resident law schools?

That under the laws of the State of Illinois, we are authorized to confer the degree of LL. B. on our graduates?

That LaSalle graduates take bar examinations in States where the requirements are most rigid, and are among those who pass with highest honors?

That if a student fails to pass bar examination in any State, we guarantee to coach and give him additional instruction free of charge until he does pass?

That we guarantee to refund the entire amount of tuition paid, if the student is dissatisfied after completion of course.

That immediately upon enrolling, we furnish a magnificent law library consisting of 14 massive volumes bound in sheep—the preparation of which cost us over \$50,000?

Do you grasp the full significance of what it means to you to be able to obtain this thorough, practical course of university grade on terms so easy that you would scarcely miss the money?

You Owe it to Yourself—to Your Future—to Get All the Facts

Mail the coupon. It imposes not the slightest obligation upon you and we will send you full information, also letters from hundreds of successful graduates which will give you a clearer insight of the work of this great institution. Take your first step toward success TODAY. Mail coupon NOW.

FREE Complete Course in Public Speaking

Every lawyer—every successful man—should be a forceful speaker. Mail coupon for particulars of how, by acting promptly, we will give you, absolutely free, a complete course in public speaking that will quickly train you in the fine art of persuasive speech. Course prepared by F. B. Robinson, A.B., A.M., Ph.D., Prof. Public Speaking at College of City of N. Y.

LaSALLE EXTENSION UNIVERSITY
(The World's Greatest Extension University)
Dept. 664-F Chicago, Ill.

Without obligation on my part, send me by return mail, information concerning your course in law together with the free books: "Evidence" and Valuable Law Guide—also your offer of FREE Course in Public Speaking.

Name

Address

Please Mention Popular Mechanics

FREE 1917 Catalogue of HOME STUDY MECHANICAL BOOKS



Subjects: Automobiles, Starting and Lighting, Electricity (Motors, Meters, Wiring, Armature Winding, Telephones, Wireless, Telegraph), Gas and Oil Engines, Steam Engineering, Machine Shop Practice, Mechanical Drawing, Railroad, Carpentry, Welding, Plumbing, Sign and Scene Painting, Card Writing, Building, Architectural Drawing—
—one hundred titles.

JUST PUBLISHED

Farm Buildings with Plans and Descriptions

By H. A. Shearer. A complete description of all kinds of new farm buildings with plans and views. Practical suggestions for farm homes, use of concrete, etc. 12 mo. 256 pages, fully illustrated. Price, postpaid . . . \$1.00

Send for free descriptive catalogue today

FREDERICK J. DRAKE & CO., 1008 Michigan Ave., Chicago

MUSIC TAUGHT FREE

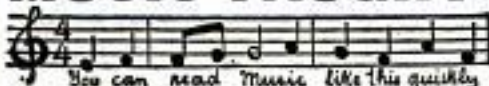

You can read music like this quickly

IN YOUR
OWN
HOME

Piano, Organ, Violin, Mandolin, Guitar, Banjo, etc. Beginners or advanced players. One lesson weekly. Illustrations make everything plain. Only expense about 2c per day to cover cost of postage and music used. Write for FREE booklet which explains everything in full.

AMERICAN SCHOOL OF MUSIC, 51 Lakeside Building, CHICAGO

CIVIL SERVICE

positions are in all parts of the country. Good pay, steady work, life positions, congenial surroundings, promotions on merit, short hours, annual vacation and sick leave with pay. Many thousands appointed yearly. Both sexes. No political pull. Nearly 300,000 classified positions. Common school education sufficient. Full information and questions used by the Civil Service Commission free.

COLUMBIAN CORRESP. COLLEGE, WASHINGTON, D.C.

BE AN ARTIST

We can teach you **DRAWING** in your own home during spare time.

Our 18 years of successful teaching prove our ability. 10 Courses in Commercial and Illustrative Drawing.

Endorsed by high art authorities.

Students trained by members of our Faculty are filling high-salaried positions. Artist's Outfit FREE to Enrolled Students. Fully equipped Residence School. Write today for Art Year Book.

OUR HANDSOME ART YEAR BOOK IS FREE TO YOU

SCHOOL OF APPLIED ART
ANNEX BLDG. No. 2 BATTLE CREEK MICH.

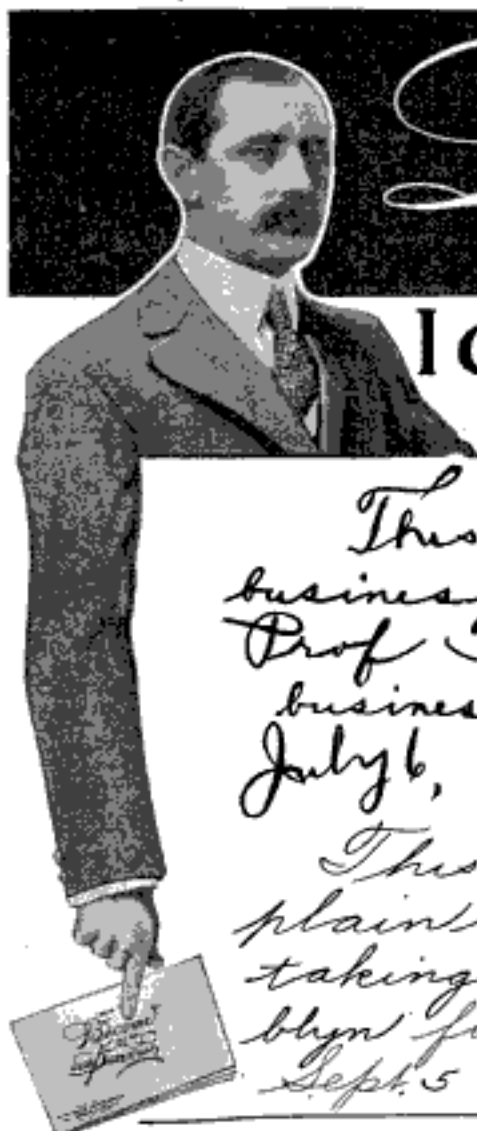

Learn to Write

I CAN TEACH YOU AT HOME
During Spare time

This is a specimen of my business writing before taking Prof Tamblin's course in business writing
July 6, Clarence P. Weber.

This is a specimen of my plain business writing after taking lessons from F. W. Tamblin for 2 months
Sept. 5 Clarence P. Weber.

FREE BOOK

My 32-Page book "How to Become a Good Penman" is FREE to anyone who wants to write better. Contains copies and information that will help you, and beautiful specimens that will make your eyes twinkle with delight.

WRITE FOR IT—use the coupon below—or a postal will do—but

Send at Once!

If you enclose a stamp, I will write your name on a card with white ink, making one of the prettiest specimens of penmanship you ever saw

"A Wonderful Bargain" "It is now about two months since I began your course, and while I am not quite half through with Business Writing, I am delighted with my improvement, which is quite marked as you will see by comparing my present writing with the specimen written when I began. My parents objected to my taking it up, but now see I'm getting a wonderful bargain."

—CLARENCE P. WEBER, Middletown, Del.

Good Writing Is the Very Foundation of Business Success

I can make a good penman of you at your own home, in your spare time, no matter where you live or how poorly you now write. Ever fail to secure a good position because of poor penmanship? Ever know of better positions you could have stepped into if you only wrote a good hand? If not, you're an exception. The advantage of good penmanship is seen all around us.

I have been teaching penmanship by mail over 20 years. I know that any ambitious person can master penmanship just as quickly and thoroughly by my system at home as if in a schoolroom under the personal instruction of the teacher.

BEGIN NOW to learn good handwriting and be ready for the next better position that comes your way. Learn right at home—in your own room, outside of working hours. Your spare time is all I ask.

I teach *Spelling and Letter Writing* also.

F. W. TAMBLYN

418 Ridge Bldg., KANSAS CITY, MO., U.S.A.

Mr. Weber's wonderful improvement shown in the specimens above was made in 2 months. Hundreds and hundreds of others in all parts of the country are doing the same.

YOU CAN DO AS WELL

This Brings FREE BOOK

F. W. TAMBLYN, 418 Ridge Bldg., KANSAS CITY, MO.

I am interested in improving my penmanship. Send me your Free Book, "How to Become a Good Penman," postpaid.

Name.....

Address.....

Take a Pencil and make an "X"

A LITTLE X, like the one shown here, has marked the starting point for a good many big successes. It's an easy thing to make. Your pencil will make it in a jiffy BUT it may mark the turning point in your life.

These days the thing that puts a man above his fellows is TRAINING.

And this little "X" when marked on the coupon below will bring you a handsome free book that will tell just exactly how YOU can get the training that has put THOUSANDS of men into high positions. It won't be necessary for you to leave your home to get this training. For twenty years the American School has been giving ambitious men practical training that started them on the road to success

Send the Coupon

Take a pencil now and mark an X before the position for which you want to qualify yourself. Let us tell you how we have given other men the training that enabled them to hold these positions. Let us tell you how you can get THIS VERY TRAINING right in your own home during your idle hours. You will be under no obligations by sending the coupon.

Find out for yourself what the American School will do for you. Make your mark in the coupon now for the sake of your ambition and the man you want to be. Opportunity is calling. Your ambition is saying, send the coupon. Do it now.

American School
of Correspondence, Chicago, U.S.A.

Dept. G919A, Chicago, U. S. A.

American School of Correspondence, Dept. G919A Chicago, U.S.A.
Gentlemen: Without obligation please send me booklet and tell me how I can qualify for position marked X.

- | | |
|--------------------------------|-----------------------------|
|Electrical Engineer |Business Law |
|Elec. Light & Power Supt. |Business Manager |
|Hydroelectric Engineer |Auditor |
|Telephone Engineer |Accountant |
|Architect |Cert'f'd Public Acc't |
|Architectural Draftsman |Stenographer |
|Building Contractor |Bookkeeper |
|Building Superintendent |Fire Ins. Inspector |
|Structural Engineer |Fire Ins. Adjuster |
|Structural Draftsman |Fire Ins. Expert |
|Mechanical Engineer |Sanitary Engineer |
|Mechanical Draftsman |Master Plumber |
|Civil Engineer |Heat and Vent. Eng. |
|Steam Engineer |Plumb. and Heat. Est. |
|Shop Foreman |Refrigeration Engineer |
|Shop Superintendent |Automobile Engineer |
|Sheet Metal Draftsman |Automobile Repairer |
|Lawyer |High School Course |

We also prepare for civil service examinations in all engineering subjects.

Name.....

Address.....

16 Easy Lessons

that teach you everything about automobiles. The book that tells it ALL.
The Automobile Instructor

By Clyde H. Pratt, B. Sc., M. E., Member Nat'l Society of Auto Engineers. 256 pages, 210 illustrations, cloth bound. Shipping wt., 25 oz.

Now 1917 edition just out. The standard work for home-study, class-room and reference, for amateur and expert. A complete course for all who desire to master this profitable profession.

LEARN AT HOME HOW TO DRIVE AND REPAIR ALL CARS

Invaluable pointers for every car owner, driver, garage man and repair man. Adopted by Cleveland and other Auto Schools and by Boards of Education as their standard text-book. The author will answer your auto inquiries FREE. This book is guaranteed to be just what you want at your money back. (Auto schools, write for quantity prices.)

Price, postpaid \$1.50

Shrewsbury Publishing Co., 5525 South Boulevard, CHICAGO, U. S. A.

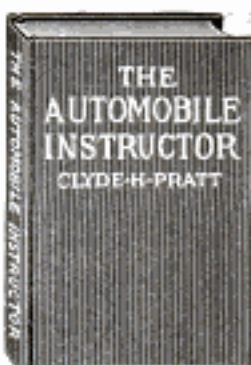

Motor Craft Encyclopedia illustrated. Tells how to build and operate Motor Boats. Best book on boats. Price, \$1.00.

Be an Electrical Engineer

Earn While You Learn — $\frac{1}{2}$ day employment in manufacturing concerns and power plants at good wages — $\frac{1}{2}$ day instruction. Learn by the thorough, approved, practical and original teaching methods — you will begin at once to perform experiments and tests in our completely equipped laboratories, under the guidance of engineers who have been successfully engaged in business. Positions paying \$1500 are waiting for graduates. We offer the following courses: One Year Complete Electrician D. C. & A. C. Two Year Commercial Engineering. Three Year Electrical Engineering.

REGULAR TERM BEGINS JULY 2nd.
Write for free illustrated catalog just off the press. Mention age, education and course interested in.

SCHOOL OF ENGINEERING OF MILWAUKEE, 318 Stroh Bldg., MILWAUKEE, WIS.

EARN TELEGRAPH

Morse and Wireless—R. R. Accounting (Station Agency) taught. Splendid opportunities. Positions secured. Maroon Co. contracts to employ graduates. We own and exclusively occupy two large modern buildings equipped with R. R. and Western Union wires and complete 2 K. W. Maroon Wireless Station. Largest school—established 43 years. Investment \$25,000. Conducted by Railroad, Maroon and Western Union Officials. Expert practical teachers. Low living expenses; easily earned if desired. Tuition low. Easy payments. Correspondence courses also. Catalogs Free.

Dodge's Telegraph, Ry. & Wireless Institute
8th Street, Valparaiso, Ind.

The University of Chicago

HOME STUDY in addition to resident work, offers also instruction by correspondence. For detailed information address

25th Year U. of C. (Div. V) Chicago, Ill. 

Learn to FLY

Build Your Own Bi-Plane Glider NOW Many of the famous birdmen first learned to fly with a GLIDER. It is the initial step in aviation—and the small cost of material to construct such a machine—and the ease with which it can be built, places it within the reach of everyone.

Send to-day for copy of book "How to Build a 20-ft. Bi-Plane Glider" and get full particulars, with detailed drawings—Postpaid **60c**

SPON & CHAMBERLAIN
120 P. M. Liberty St., NEW YORK



READER ASKS ABOUT ELECTRICAL BUSINESS

**His Letter Interests Prominent Electrical Engineer
Who Will Give Series of Lessons Free to Beginners.**

I am told that the electrical industry offers splendid opportunities for young men and I write to ask for advice. Is it possible to gain a thorough, practical training in electricity by correspondence instruction? Thanking you for the favor, I remain,

Cordially yours,

R. E. BURNHAM.

New York City.

NOTE: The foregoing letter was referred to Prof. Albert Wood Wicks, Bachelor of Science and Electrical Engineer, Chicago, who replies as follows:

"I have many friends in the electrical business. Not merely one, but all of them are successful and prosperous.

"I do not know of any other business that offers so many attractions to young men. If Mr. Burnham or any other reader of Popular Mechanics has thought that he could not get into business for himself without capital, or has believed that long years of study and experience are necessary to become a trained electrician, I can quickly show him his mistake.

"As to the demand for men in the electrical field, it was never greater than at present. The tremendous expansion and growth of this wonderful industry is known to all readers. Everywhere in great manufacturing plants steam power for driving machinery is being discarded and replaced with electric power service from big central stations, and firemen and engineers are giving up their places to electrical experts skilled in all the special knowledge required for the maintenance and operation of motors, dynamos, meters and other electrical equipment.

"Almost every month a new small army of trained electricians is required to man the electric lighting and power plants that are being built in cities and towns everywhere. And at this moment thousands of electricians are being drawn from industry for service in our army and on our fighting ships. As a result, instead of men competing for jobs, employers are competing for men with offers of big salaries.

"Meantime in thousands of small towns everywhere more men are needed to wire houses for electric light, to make and repair electric signs, to install doorbells, burglar alarms, annunciators, electric motors for driving machines in all kinds of manufacturing industries, lamps and household electrical conveniences, not to mention repair work of every kind. There are few towns in which the trained electrician cannot earn \$2500 to \$4000 or \$5000 a year as his own boss.

"Let any expert electrician, with a contract in his pocket for a job of house-wiring, for example, ask a dealer in electricians' supplies and he will usually be given credit for the materials he needs to do the work. Without any capital, he can start into business for himself as soon as he has finished his training, unless he prefers to accept a salaried position, which pays \$2400 to \$4000 a year and even more.

"Mr. Burnham asks whether he can learn electricity by correspondence. That must depend upon the teacher he selects. My answer is that if he really wants to learn, I will myself guarantee to teach him successfully.

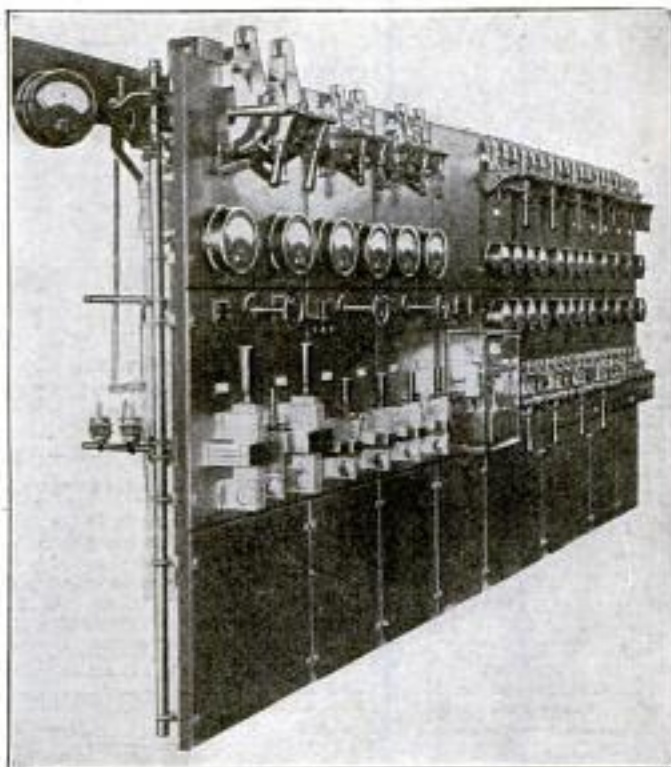

"As president of the Wicks Electrical Institute, of Chicago, I am at the present time training several hundred young men in all parts of the country in Expert Electricity. By a new system of teaching, entirely different from the methods used by ordinary correspondence schools, my students master every branch of the work without the aid of text-books, as I prefer to teach practice rather than theory. That my methods are successful as well as practical is attested by the letters I receive from hundreds of my graduates.

"So simple and easy to learn is this new course that anyone can complete the entire series of lessons in a few short months by giving up only a little of his spare time at home.

"I have read Mr. Burnham's letter with much interest and I have decided to make this rather startling offer to any reader of Popular Mechanics. To anyone who writes me at once I will arrange to give twenty lessons of our course entirely free. These twenty lessons will enable any student to judge for himself how easily the entire course can be learned under my wonderful new system of teaching. No obligations are assumed in writing me for full particulars.

"Just address Albert Wood Wicks, E. E., President Wicks Electrical Institute, Dept. 496, 81 W. Randolph St., Chicago. A postal will do, or write your name and address plainly on the margin below and mail this coupon.

Wicks Electrical Institute,

Dept. 496, 81 W. Randolph St., Chicago, Ill.

Please send me particulars of your course in Electricity and your special offer of free lessons as told about in Popular Mechanics article.

Please Mention Popular Mechanics

For a Bigger Salary Tomorrow —Choose Well Today



A job inside dealing with things and machines

Which Will It Be?



A profit producing position outside dealing with people

FROM SHOP WORK TO SALES WORK

"I have charge of the largest Sales Branch of my firm and the fact that I have made good and have received so many advances in my salary show what your Course did for me. I recommend your school to all."—J. A. Christian, P. O. Bldg., Boston, Mass.

A MECHANIC MAKES GOOD

Had been a mechanic for 25 years. Wanted to earn more money. Took your Course and secured a position. Am now a successful Salesman selling oils, cutting compounds, etc.
W. E. WILLIAMS
7243 St. Lawrence Ave., Chicago, Ill.

Salesmen Earn \$2,000—\$5,000—\$10,000 a Year

Inside workers are a part of a non-business producing machine—their earning capacity is limited. Men who can sell—who have the power to persuade people to purchase their products, always command big incomes. They are the direct producers of profits—the life blood of any concern. It is the trained Salesmen who brings in the orders—whose services, thousands of concerns today are seeking—and to whom they are willing to pay large commissions and salaries.

Be a Salesman—Earn While You Learn

Our Home Study Course in Scientific Salesmanship gives you the necessary training. It tells you how to prepare a "Selling Talk"—how to approach the prospect—how to manage the interview—how and when to close. It is the one system of practical training that links ability to opportunity and fits you to earn while you learn. Employers everywhere recognize the value of N. S. T. A. training. Our Employment Bureau has constantly on file more requests for salesmen than we can possibly fill.

64 Page Book

Write today for Free book "A Knight of the Grip" and list of hundreds of good openings offering opportunities to earn Big Pay while you learn. Address nearest office. Dept. 6076. **FREE**

NATIONAL SALESMEN'S TRAINING ASSOCIATION
Chicago New York San Francisco



Check the Job You Want!

..... Railway Mail Clerk \$900 to \$1800 Customs Positions \$ 600 to \$1500
..... Postoffice Clerk \$800 to \$1200 Internal Revenue \$ 700 to \$1800
..... Postoffice Carrier \$800 to \$1200 Stenographer \$1000 to \$1500
..... Rural Mail Carrier \$600 to \$1200 Panama Canal Ck \$1200 to \$1800

Name

Address

Sign your name and address and send us this coupon immediately. We will immediately send you (1) a full description of the position checked (2) a list of many U. S. Gov't Jobs now easily obtainable and directions telling how to get free coaching for the position checked.

Franklin Institute, Dept. C97, Rochester, N. Y.

NATIONAL TRADE



DENTAL SCHOOL

506 S. Wabash Ave., CHICAGO, ILL.

LEARN MECHANICAL DENTISTRY—DEMAND UNLIMITED

Earn \$1250 to \$4000 yearly in mechanical dentistry. A big and growing demand everywhere for mechanical dentists—like a gold mine, unexplored. Attend this school any time of the day or evening; be taught individually and learn by actual practice, without book study. Our System, the most complete in the world, is used exclusively in this school. We are constantly called upon to fill high-salaried positions. Why not qualify for one? Be fair to yourself; find out more about exceptional opportunity we offer. Visit the school or write for booklet.

JEWELRY ENGRAVING

We teach you, by our new and original method of instruction, this clean, fascinating and profitable business right at your home, and furnish you all tools needed absolutely free. Write for free book to the

WISCONSIN SCHOOL OF ENGRAVING, 2nd Bldg., MILWAUKEE, WIS.

LEARN TO WRITE EARN \$25 to \$100 A WEEK

How to increase your salary. BOOK MAILED FREE. We can positively show you by mail. PAGE-DAVIS CO., 112 Page Building Chicago, Ill., or 150 Nassau St., New York

Be a Finger Print Expert!

Send the coupon. All over the country, the Finger Print System of Identification is springing into wide use. Big demand now for trained experts. Large salaries are offered. Pleasant, fascinating profession. You can be a finger print expert. Send the coupon and find out how you can master this new and fascinating profession in your spare time at home. Don't miss this wonderful opportunity. Send the coupon today and get our free book.

EVANS UNIVERSITY
Finger Print Dept., Desk A919
1810 Wilson Ave., CHICAGO

Please send me absolutely free and prepaid your new book on finger prints. Also particulars of your special limited offer. I assume no obligations whatever.

Urgent Need for Men!

Not only in the police departments, but in government institutions, banks, railroads, insurance companies and other large industries, finger print systems are being installed under the guidance of finger print experts. You can earn from \$25 to \$50 a week. Right now there is an urgent, unfulfilled demand for experts.



Name

Address

Age..... Occupation.....

Free Book on Finger Prints

Send the coupon now for our valuable book telling all about finger prints and their uses; and about the big opportunities in the profession. It tells how you can learn in a short time at home. Special limited offer now. Get this free book and full particulars while it lasts. Evans University, Finger Print Dept., Desk A919, 1810 Wilson Ave., Chicago, Ill.

414 PAGES 145 ILLUSTRATIONS

I.C.S.
ELECTRICAL ENGINEER'S
HANDBOOK

50¢

ELECTRICITY!

HERE'S just the book on Electricity that you need to answer your many questions—to solve your knotty problems, to teach you new kinks, to be your memory for tables, rules, formulas and other Electrical and Mechanical facts that some people try to carry in their heads—and fail.

With this "Little Giant" I. C. S. Electrical Engineer's Handbook in your pocket, tool chest, on your work bench, drawing table or desk, an hour or a day need not be lost "digging up" some forgotten rule, some unfamiliar fact; you'll just turn to the very complete index and get

it "in a jiffy." Just a few of the subjects treated are:

Electricity and Magnetism; Electrical Symbols; Batteries; Circuits; Magnets; Direct and Alternating Currents; Dynamos and Motors; Belts; Shafting; Electroplating; Electrical Measurements; Meters; Arc and Incandescent Lamps; Mercury Arc Rectifiers; Transformers; Insulation; Electric Cars; Single and Multiple-Unit Control; Transmission; Rail Welding; Tables of Wires—Sizes, Capacities, etc.—Mathematical Rules, Formulas, Symbols; Tables of Constants, Equivalents, Roots, Powers, Reciprocals, Areas, Weights and Measures; Chemistry; Properties of Metals; Principles of Mechanics; First Aid, etc.

The Electrical Engineer's Handbook is one of 22 I. C. S. Handbooks covering 22 Technical, Scientific and Commercial subjects, all crowded with value. They have the contents of a full-size book condensed into pocket-size ready to go with you anywhere and be at your instant command. They are substantially bound in cloth, red edges, goldleaf stamping, printed from new, clear, readable type on good quality book paper. There is an illustration at every point where a picture will help. Hundreds of thousands have been sold on a money-back guarantee of satisfaction.

The regular price is \$1.25, but for a LIMITED TIME you can buy the ones you want, postpaid, delivery guaranteed, for only 50 cents each.

You Run No Risk! Money Back if Desired!

International Correspondence Schools

Box 5580, Scranton, Pa.

INTERNATIONAL CORRESPONDENCE SCHOOLS

Box 5580, SCRANTON, PA.

I enclose \$_____ for which send me postpaid the Handbooks marked X, at 50c. each. I may return any or all and get my money back within ten days from receipt:

- | | |
|--|---|
| <input type="checkbox"/> Electrical Engineer's | <input type="checkbox"/> Advertiser's |
| <input type="checkbox"/> Teleph. and Teleg. Engineer's | <input type="checkbox"/> Business Man's |
| <input type="checkbox"/> Mechanic's | <input type="checkbox"/> Bookkeeper's |
| <input type="checkbox"/> Steam Engineer's | <input type="checkbox"/> Steno. and Correspondent's |
| <input type="checkbox"/> Westinghouse Air Brake | <input type="checkbox"/> Salesman's |
| <input type="checkbox"/> Civil Engineer's | <input type="checkbox"/> Window Trimmer's |
| <input type="checkbox"/> Coal Miner's | <input type="checkbox"/> Cotton Textile Worker's |
| <input type="checkbox"/> Concrete Engineer's | <input type="checkbox"/> Farmer's |
| <input type="checkbox"/> Building Trades | <input type="checkbox"/> Poultryman's |
| <input type="checkbox"/> Plumber's and Fitter's | <input type="checkbox"/> Mariner's |
| <input type="checkbox"/> Chemist's | <input type="checkbox"/> Automobile |

Name _____

Street and No. _____

City _____ State _____

Please Mention Popular Mechanics



The Boss Is Sizing You Up

Whether you know it or not, he's on the lookout all the time for men he can promote. He's ready and anxious to give YOU bigger work with bigger pay once you prove you can handle it.

If you want to get ahead, if you want to be somebody, to climb into a position of responsibility and good money—

Get Ready—Your Chance Will Surely Come

Choose the position you want in the work you like best—then train for it. You can do it in spare time in your own home through the International Correspondence Schools.

More than 130,000 men right now are putting themselves in line for promotion through the study of I. C. S. Courses. This way to success is always open. All the I. C. S. ask is the chance to tell you about it. No cost to find out. Just mark and mail this coupon now.

TEAR OUT HERE
INTERNATIONAL CORRESPONDENCE SCHOOLS
BOX 5579, SCRANTON, PA.

Explain, without obligating me, how I can qualify for the position, or in the subject, before which I mark X.

- | | |
|--|---|
| <input type="checkbox"/> ADVERTISING MAN | <input type="checkbox"/> ELECTRICAL ENGINEER |
| <input type="checkbox"/> Salesmanship | <input type="checkbox"/> Electric Lighting |
| <input type="checkbox"/> Commercial Law | <input type="checkbox"/> Electric Car Running |
| <input type="checkbox"/> BUSINESS (Complete) | <input type="checkbox"/> Electric Wiring |
| <input type="checkbox"/> Certified Public Accountant | <input type="checkbox"/> Telegraph Expert |
| <input type="checkbox"/> Higher Accounting | <input type="checkbox"/> Practical Telephony |
| <input type="checkbox"/> Bookkeeper | <input type="checkbox"/> Railroad |
| <input type="checkbox"/> Stenographer and Typist | <input type="checkbox"/> Wire Foreman or Engineer |
| <input type="checkbox"/> Railway Accountant | <input type="checkbox"/> Metallurgist or Prospector |
| <input type="checkbox"/> WINDOW TRIMMER | <input type="checkbox"/> ARCHITECT |
| <input type="checkbox"/> Show Card Writer | <input type="checkbox"/> Contractor and Builder |
| <input type="checkbox"/> Outdoor Sign Painter | <input type="checkbox"/> Architectural Draftsman |
| <input type="checkbox"/> Common School Subjects | <input type="checkbox"/> Concrete Builder |
| <input type="checkbox"/> Good English | <input type="checkbox"/> Structural Engineer |
| <input type="checkbox"/> Teacher | <input type="checkbox"/> Plumbing and Heating |
| <input type="checkbox"/> Civil Service | <input type="checkbox"/> Sheet Metal Worker |
| <input type="checkbox"/> Railway Mail Clerk | <input type="checkbox"/> CHEMICAL ENGINEER |
| <input type="checkbox"/> CIVIL ENGINEER | <input type="checkbox"/> Illustrator |
| <input type="checkbox"/> Surveying and Mapping | <input type="checkbox"/> Designer |
| <input type="checkbox"/> MECHANICAL ENGINEER | <input type="checkbox"/> Textile Overseer or Dept. |
| <input type="checkbox"/> Mechanical Draftsman | <input type="checkbox"/> AGRICULTURE |
| <input type="checkbox"/> Machine Shop Practice | <input type="checkbox"/> Navigator |
| <input type="checkbox"/> Stationary Engineer | <input type="checkbox"/> Poultry Raising |
| <input type="checkbox"/> Gas Engineer | <input type="checkbox"/> AUTOMOBILES |

Name _____

Present Occupation _____

Street and No. _____

City _____ State _____

If name of Course you want is not in this list, write it below



Music Lessons

Book Sent FREE Wonderful home-study music lessons under great American and European teachers given by the University Extension Method. The lessons are a marvel of simplicity and completeness, endorsed by Paderewski and other great authorities. You, too, can now quickly and easily satisfy your musical ambitions.

Any Instrument or Voice

Write, telling us the course you are interested in, age, how long you have taken lessons if at all, etc., and we will send you our Free Book containing text and illustrations covering Lessons in PIANO (students' or teachers' courses) by the great Wm. H. Sherwood, HARMONY by Dr. Protheroe and Rosenbecker, VOICE COURSE (with aid of Phonograph) by Crampton, PUBLIC SCHOOL MUSIC by Frances E. Clark, VIOLIN, CORNET, MANDOLIN, GUITAR, BANJO, REED ORGAN, CHORAL CONDUCTING, by equally eminent teachers.

Send NOW for Free Book and learn how easily you can become a fine singer, or a skillful player. See how quickly you can become successful. Our Free Book tells you how. Write for it today. A few Special Introductory Scholarships now being awarded by our faculty. Full particulars sent with Free Book. Investigate without cost or obligation. Write today.

University Extension Conservatory

Proprietor Siegel-Myers School of Music

2886 Siegel-Myers Building Chicago, Ill.

Mr. A. R. Patterson, whose advertisement appears below, was for eight years a Civil Service Secretary-Examiner, and is well qualified to help YOU secure a Government Position.

FREE BOOK OF GOV'T POSITIONS

Earn \$75 to \$150 a Month

WRITE TODAY

Be a Railway Mail Clerk, Post Office Clerk or Carrier, Rural Mail Carrier, Internal Revenue Officer, Clerk at Washington, D. C., or Panama Canal, or accept any other good Civil Service position with Uncle Sam, world's greatest and best employer.

Good Pay, Easy Work, Vacations, Position for Life

Earn \$75 to \$150 a month from the start. Rapid advancement. Work 8 hours or less a day. 15 to 30 days vacation with full pay. No strikes, no "lay-offs," no "straw bosses." No politics, no "pull" needed. Ordinary education sufficient. American citizens 18 or over **WANTED**.

PATTERSON PREPARES YOU
Only school offering help of former Civil Service Sec'y-Examiner. Quick appointment certain. Save position or no pay. Send coupon or postal NOW for book free.

FREE! Tells what positions are open. How to prepare easily and quickly for job you like best. Don't be satisfied with a small pay, uncertain job. Write for book of Uncle Sam's positions and get on a easy street. Mail coupon or postal NOW. Address.....

COUPON
Send me Free Book of Government Positions.
Name.....
Address.....

PATTERSON CIVIL SERVICE SCHOOL
86 News Bldg., Rochester, New York

Please Mention Popular Mechanics

WANTED MEN!



\$75 TO \$300 A MONTH!

Demand for capable automobile and tractor men far exceeds the supply. Our graduates secure good paying positions as Salesmen, Demonstrators, Factory Testers, Garage Managers, Drivers and Tractor Experts.

\$50 Course FREE

Only six weeks required to train you in this great school. Most complete instruction. Instructors all experts. Enroll now and receive \$50 Course in Tractor and Lighting Engineering Free. Write today for our big Free Book and \$50 Free Scholarship Certificate.

RAHE'S AUTOMOBILE TRAINING SCHOOL

World's Greatest Auto Training School

1028 Locust St., Kansas City, Mo.



TRAVEL at no expense

—see the country while earning big pay in short hours as a **TRAFFIC INSPECTOR**

We train you in 3 to 4 months to fill this desirable position. Learn railroading from the inside—get the experience of travel—meet influential men—get in line for sure promotion. Every U. S. railroad and steamship line is on the watch for capable traffic men—on the watch for men able to rise to big positions. It's up to you to seize the chance. Today, write for booklet G.R. giving full information. Learn how our Employment Bureau helps graduates to good positions.



FRONTIER PREP. SCHOOL, Buffalo, N. Y.

This House and many others "Building Plans for Modern Homes"

will save you hundreds of dollars. One of the most complete and comprehensive books of plans ever published by any Architect. Fifth edition just off the press. One hundred and fifty floor plans and photographs of Colonial Houses, Bungalows, etc., costing from \$250.00 up; gives sizes and cost to build.



Frederick H. Gowling ARCHITECT
18 Tremont St., Boston, Mass.

Your Nearest Neighbor is Nature

She has a lot to say to you. Send for 16 page booklet that will tell you how to understand all outdoors. Eight full pages in color, beautiful enough to frame—all sent FREE. Send a post card at once. Doubleday, Page & Co., Dept. 306, Garden City, N. Y.

SHORTHAND IN 30 DAYS

We absolutely guarantee to teach shorthand complete in only thirty days. You can learn in spare time in your own home, no matter where you live. No need to spend months as with old systems. Boyd's Syllabic System is easy to learn—easy to write—easy to read. Simple. Practical. Speedy. Sure. No ruled lines—no positions—no shading as in other systems. No long lists of word signs to confuse. Only nine characters to learn and you have the entire English language at your absolute command. The best system for stenographers, private secretaries, newspaper reporters and railroad men. Lawyers, ministers, teachers, physicians, literary folk and business men and women may now learn shorthand for their own use. Does not take continual daily practice as with other systems. Our graduates hold high grade positions everywhere. Send today for booklets, testimonials, etc.

Chicago Correspondence Schools
969 Unity Bldg., CHICAGO, ILL.



The Student Illustrator

a practical art magazine, publishes lessons and articles on every phase of cartooning, designing, lettering, newspaper, magazine and commercial illustrating. It is an art education in itself. The latest and most up-to-date methods in the big paying field of commercial art thoroughly explained by experts. Amateur work published and criticized. Satisfaction Guaranteed or money refunded. \$1.00 per year. Three months' trial 25 cents. Dept. B, Schwartz Bldg., Washington, D. C.

Stop Eating Poison! Wrong food combinations are poisonous and destroy health—right combinations build health. Eugene Christian's 24 lessons in Correct Eating tell how to eat for health, strength and efficiency. Send for Free Trial No Money in Advance offer. Write today. **Corrective Eating Co., Dept. 50, 456 Fourth Ave., New York City**

STATEMENT OF THE OWNERSHIP, MANAGEMENT, CIRCULATION, ETC., REQUIRED BY THE ACT OF CONGRESS OF AUGUST 24, 1912, of Popular Mechanics Magazine, published monthly at Chicago, Ill., for April 1st, 1917.

State of Illinois, County of Cook. ss.

Before me, a notary public in and for the state and county aforesaid, personally appeared H. H. Windsor, who, having been duly sworn according to law, deposes, and says that he is the editor and business manager of the Popular Mechanics Magazine and that the following is, to the best of his knowledge and belief, a true statement of the ownership, management, etc., of the aforesaid publication for the date shown in the above caption, required by the Act of August 24, 1912, embodied in section 443, Postal Laws and Regulations, printed on the reverse of this form, to wit: 1. That the names and addresses of the publisher, editor, managing editor, and business manager are: Publisher, Popular Mechanics Co., 6 No. Michigan Ave. Editor, H. H. Windsor, 6 No. Michigan Ave. Managing Editor, J. L. Peabody, 6 No. Michigan Ave. Business Manager, H. H. Windsor, 6 No. Michigan Ave. 2. That the owners are (Give names and addresses of individual owners, or, if a corporation, give its name and the names and addresses of stockholders owning or holding 1 per cent or more of the total amount of stock): H. H. Windsor, 6 No. Michigan Ave. 3. That the known bondholders, mortgagees, and other security holders owning or holding 1 per cent or more of total amount of bonds, mortgages, or other securities are (If there are none, so state): None. 4. That the two paragraphs next above, giving the names of the owners, stockholders, and security holders, if any, contain not only the list of stockholders and security holders as they appear upon the books of the company, but also, in cases where the stockholder or security holder appears upon the books of the company as trustee or in any other fiduciary relation, the name of the person or corporation for whom such trustee is acting, is given; also that the said two paragraphs contain statements embracing affiant's full knowledge and belief as to the circumstances and conditions under which stockholders and security holders who do not appear upon the books of the company as trustees, hold stock and securities in a capacity other than that of a bona fide owner; and this affiant has no reason to believe that any other person, association, or corporation has any interest direct or indirect in the said stock, bond, or other securities than as so stated by him.

H. H. WINDSOR,

Sworn to and subscribed before me this 27th day of March, 1917.

J. GRAHAM,

Notary Public.

(My commission expires June 17, 1920.)

An unusual method of conquering Germany is suggested by C. L. Delbridge of St. Louis, who evidently, does not rate Prussian patriotism very highly. He distributes a small poster reading as follows:

"Buy Europe! \$1,000 Reward! If aviators will drop in Germany, circulars announcing that the U. S. would pay \$1,000 to every German soldier who deserts; also pay him 100 cents on the dollar for all supplies, munitions, aeroplanes, submarines, battleships, etc., he can contrive to bring, also pay \$100 to every German emigrant, young or old, sick or well, who came to the U. S. and would be transported free from the German frontier. It would create a stampede that would end the war in a month. Hohenzollern soldiers would refuse to check the stampede and would themselves desert. German submarines would refuse to torpedo westward bound steamships, loaded with their own Countrymen. It would save the lives of millions of our boys and of our allies and would cost us one cent to win the war in that way, where it will cost us ten dollars to win it in any other way."

The Burlington Smashes

Mail the Coupon TODAY for Free Watch Book

All Watch Competition Look!



\$1 Ruby and Sapphire Jewels—Adjusted to the second—Adjusted to temperature—Adjusted to isochronism—Adjusted to position—55 year gold strata case—Genuine Montgomery Railroad Dial—New ideas in Thin Cases.

Every fighting vessel in the U. S. Navy has the Burlington Watch aboard. This includes every torpedo boat—every submarine as well as the big Dreadnaughts. Some have over 500 Burlingtons aboard.

\$2.50
A Month

And all of this for \$2.50—only \$2.50 per month—a great reduction in watch price—direct to you—positively the exact prices the wholesale dealer would have to pay. Think of the high-grade, guaranteed watch we offer here at such a remarkable price. And if you wish, you may pay this price at the rate of only \$2.50 a month. Indeed, the days of exorbitant watch prices have passed.

See It First!

You don't pay a cent to anybody until you see the watch. You don't buy a Burlington watch without seeing it. Look at the splendid beauty of the watch itself. Thin model, handsomely shaped—aristocratic in every line. Then look at the work! There you will see the masterpiece of watch makers skill. A timepiece adjusted to positions, temperature and isochronism.

Free Watch Book

Get the Burlington Watch Book by sending this coupon now. You will know a lot more about watch buying when you read it. You will be able to "steer clear" of the over-priced watches which are no better. Send the coupon today for the book and our offer.

Free Watch Book Coupon

Burlington Watch Co.
19th St. and Marshall Blvd.
Dept. A119 Chicago, Ill.

Please send me (without obligations and prepaid) your free book on watches with full explanation of your cash or \$2.50 a month offer on the Burlington Watch.

Burlington Watch Co.
19th St. & Marshall Blvd., Dept. A119
Chicago

Name.....

Address.....

Please Mention Popular Mechanics

Auto Books

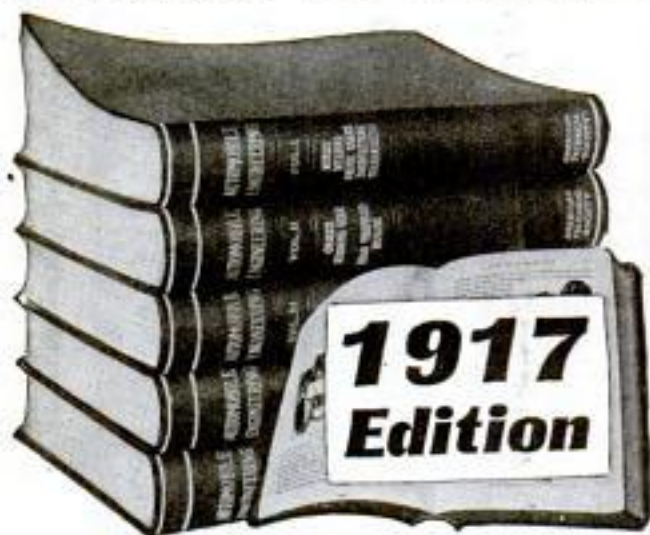

50c a Week

Only 50c a week buys this brand-new automobile library. It is called **Automobile Engineering**, and in it you will find everything about modern automobiles. Almost two entire volumes are devoted to the new systems of ignition, starting and lighting, welding, vulcanizing, and public garage equipment and operation are thoroughly covered. Five thick volumes, 5½x8 inches, flexibly bound in genuine morocco leather, gold stamped, 2,400 pages; 2,000 illustrations, tables and diagrams. Written in simple, easily-understood English, and carefully cross-indexed for quick reference.

Shipped Free

Don't send a penny. Just put your name and address in the coupon and we'll send all five volumes to you, express prepaid. Read them—study them—examine them carefully before you decide to buy. If you don't like them after 7 days—write us and we'll take them back at our expense. If you keep them, send only \$2.00 within 7 days, and then \$1.00 a month—50c a week—until the introductory price of \$16.80 has been paid. The regular price of this set will be \$25.00.

Consulting Service FREE

In addition to the books you get free of all charge a \$12.00 Consulting Membership. If any question puzzles you—write us. Our corps of auto experts will solve any auto problem. Ask all the questions you want for a whole year. This service is absolutely free.

Partial List of Subjects

Motors, Welding, Motor Construction and Repair, Carburetors, Valves, Cooling, Lubrication, Fly-Wheels, Clutch, Transmission, Final Drive, Steering, Tires, Vulcanizing, Ignition, Starting and Lighting Systems, Wiring Diagrams, Shop Kinks, Commercial Garage Equipment, Electricity, Storage Batteries, Motorcycles, Commercial Trucks, Glossary.

American Technical Society,
Dept. A119A, Chicago, U.S.A.

Please send me a set of Automobile Engineering for 7 days' free examination. If I decide to buy, will send \$2 in 7 days and balance \$2 a month until \$16.80 has been paid, when books and Consulting Membership will be mine. Otherwise will notify you and hold books subject to your order. Title not to pass until fully paid.

NAME

ADDRESS

MAIL

This Coupon

See these books before you decide to buy. Remember—don't send us a penny. Just fill in and mail the coupon. This offer is open to any person living within the boundaries of the U. S. and Canada.

AMERICAN TECHNICAL SOCIETY
Dept. A119A
CHICAGO, U.S.A.

Please Mention Popular Mechanics

ENGINEERING



AND
Mechanical Trade Schools
of Highland Park College, Des Moines, Iowa
SCHOOL YEAR OPENS SEPT. 11, 1917

Civil, Electrical, and Mechanical Engineering

Standard four-year courses completed in three years of forty-eight weeks each, and one-year courses in Civil, Electrical, and Mechanical Engineering. Graduates holding some of the best engineering positions in the country.

Machinist and Auto-Machinist Courses

One-year Machinist and Auto-Machinist courses. Elaborately equipped machine shops and skilled mechanics for teachers. Graduates secure positions as journeymen mechanics.

Garage and Traction Courses

Twelve weeks' courses in automobile repairing and Traction engine shop work. Everything taught pertaining to the automobile and Traction engine,—gas or steam.

Mechanical Drafting

One-year course, which fits students for any sort of drafting work. One of the largest and best equipped engineering and mechanical Trade schools in the country. Expenses most reasonable. Write for catalog. State course in which you are interested. Address

DR. GEO. P. MAGILL, President

Highland Park College 121 Euclid Ave., DES MOINES, IOWA



BE THE FIRST MOVING PICTURE REPORTER

in your town. Learn to take motion pictures. Become our local reporter.

BIG MONEY made taking news pictures.

Write for Free Book.

MOTOGRAF SYNDICATE, Clark & Halsted Sts., Chicago



Learn NOW

Write quick for our remarkable free offer to new students. Learn Commercial Art, Cartooning, Illustrating, Designing.

Handsome Free Book explains all about our New

Easy Course. Send for it today. Postcard will do.

WASHINGTON SCHOOL OF ART
1029 H St. N. W., Washington, D. C.



Learn to Concentrate

Prof. Theron Q. Dumont's famous 20 Lesson Course in Concentration, now sent in handy book form, for 5 days' FREE examination. Gives every principle and method. Also practice exercises. Tells you just how to concentrate. Get it now—while offer lasts. Send no money. Read it 5 days. Then, if satisfied, send only \$2. Otherwise return to us. Write for it today on this FREE offer. ADVANCED THOUGHT PUB. CO., Dept. 639 168 N. Michigan Ave., Chicago

SPEAK A FOREIGN LANGUAGE !!!

The War has created unlimited opportunities for those who know Spanish, French, German or Italian. Better your position or increase your business. You can learn quickly and easily, at home, during spare moments, by the

LANGUAGE-PHONE METHOD
And Rosenthal's Practical Linguistry

(Highest Award Panama-Pacific Exposition, 1915)

You listen to the living voice of a native professor pronounce the foreign language, over and over, until you know it. Our records on all talking machines. Write for Booklet, particulars of Free Trial.

The Language-Phone Method, 931 Putnam Bldg., 2 W. 45th St., N.Y.





From an actual photograph of Walter J. Brock, Chief of our Advisory Board, just after winning the famous London to Paris International Race.

Learn
at
Home

Birdmen

of the future are the young men who today know nothing about Aviation—nothing about Aeroplane Engineering.

Fortunes await those who attain leadership in this new profession. Rear Admiral Peary has declared that right at this very moment the United States Government actually needs "thousands and thousands" of aviators. A half a million men are now engaged in England's air service. The whole world at this moment has need of men with a knowledge of aviation and its principles. These men are needed in time of war—but

they are needed in time of peace also. The cry is for trained men. Men are needed for the air routes of the future. They are needed for the passenger carrying routes and express routes of the future. Exhibition companies have set up a cry for these men.

While we cannot teach you to fly we can tell you right at home, while you hold your present position, all about the science of aviation.

Science of Aviation Now Taught by Mail

You do not need to leave the position which you now have until you finish your course. But when you have properly finished this course, you will have all the basic knowledge needed to fit you for such positions as:

{	Designer	Assembler	Inspector
	Builder	Repairman	Instructor
	Salesman	Contractor	Mechanic

Think of what an opportunity this offers to you—to the young men of America. Do not fail to write. Get full information—now.

Mail this Coupon

Mail the coupon today—at once. Let us tell you all about our offer. This very minute is the time for you to write. Be one of the first to start. Get your knowledge while others think about it.

National Aero Institute Dept. A919 Morton Bldg., Chicago

**National
Aero Institute**
Dept. A919
Morton Bldg., Chicago

Gentlemen: Please send me absolutely free and prepaid, full particulars of your course in aviation and details of your special limited offer.

Name.....

Address.....



\$100⁰⁰ EARNED BY YOUNG ARTIST IN TWO DAYS

Conscientious, careful training by members of our Faculty made this possible. You, too, should succeed — *with the right training.*

Earn \$25, \$35, \$50, \$75 a Week and More

Become a Commercial Designer. The business world pays big prices for good designs and illustrations. Learn to draw during your spare time by the "Federal" home-study method — a course endorsed by high authorities.

Easy to Learn, Easy to Apply Write today for "Your Future," a book every young man and woman should read before deciding on their life work. Free for the asking.

Federal School of Commercial Designing, Inc.
620 Warner Building Minneapolis, Minn.



PAY \$75 to \$150 MONTH

U. S. GOVERNMENT WANTS

Railway Mail Clerks — City Mail Carriers — Postoffice — Customs — Internal Revenue Clerks.

Common education sufficient. Send coupon immediately. We are coaching candidates free.

SEND COUPON BELOW

FRANKLIN INSTITUTE

Dept. C 103, ROCHESTER, N. Y.

This coupon, filled out as directed, entitles the sender to (1) free sample examination questions; (2) a free copy of our book, "Government Positions and How to Get Them"; (3) free list of positions now easily obtainable; and (4) to consideration for Free Coaching for the examination here checked.

COUPON

.. Railway Mail Clerk (\$900 to \$1800)	.. Customs Positions (\$ 800 to \$1500)
.. Postoffice Clerk (\$800 to \$1200)	.. Internal Revenue (\$ 700 to \$1800)
.. Postoffice Carrier (\$800 to \$1200)	.. Stenographer (\$1000 to \$1500)
.. Rural Mail Carrier (\$500 to \$1200)	.. Clerk in the Departments at Washington (\$ 800 to \$1500)
.. Bookkeeper (\$900 to \$1800)	

Name.....

Address..... C-103

Use this before you lose it.

Write plainly.

Why live AN INFERIOR LIFE?

I can prove to you that you are only half as alive as you must be to realize the joys and benefits of living in full. I can show you how, without drugs or medicines or dieting, without excessive exercise, without giving up any of the pleasures of life, you can revitalize, re-energize, restore every cell, tissue and organ of the body and become a giant in health and mind. The secret of wealth, health and happiness is fully explained in Swoboda's new book, "Conscious Evolution." In it, hundreds of pupils tell what this great discovery has meant to them in increased earnings, increased ability to live the well-rounded, wholly successful life. This great book will be sent free to all who are interested in greater health and mental power. Write today — now — before you forget. ALONIS P. SWOBODA, 2045 Aeolian Hall, New York City



Be Sure It's "POROSKNIT" GENUINE SUMMER UNDERWEAR Cool, elastic, comfortable — GUARANTEED Chalmers Knitting Co., 78 Washington St., Amsterdam, N. Y.

Are You Earning Less Than \$3000 Yearly?

If you are, — you're on the wrong job. You're in a rut. Why waste a lifetime working for animal wages, — when it's so easy to get into a Man's Job and earn a Man's Salary?

Be a Traffic Manager

Get into a new — clean — fascinating — high salaried — dignified profession that assures you a place on Easy Street. Traffic Managers needed everywhere. Field can't be crowded for years to come. A POSTAL BRINGS FULL INFORMATION.

INTERSTATE TRAFFIC SCHOOL, 26 TRAFFIC BLDG. FT. WAYNE, IND.

ELECTRICAL

Electricity, THE BLISS ELECTRICAL SCHOOL, with its well-equipped shops and laboratories, is peculiarly well qualified to give a condensed course in Electrical

ENGINEERING

including Mathematics, Steam and Gas Engines, Mechanical Drawing, Shop Work, and Theoretical and Practical Electricity, in all branches. Students actually construct dynamos, install wiring and test efficiency of electrical machinery. Course, with diploma, complete

IN ONE YEAR

For practical young men with limited time. 25th year opens Sept. 26th. Catalogue on request. 304 Takoma Ave., Washington, D. C.



"I Can Succeed!"



What other men have accomplished through I. C. S. help, I can. If the I. C. S. have raised the salaries of other men, they can raise mine. To me, I. C. S. means 'I CAN SUCCEED.'

Get the "I Can Succeed" spirit, for the International Correspondence Schools can raise your salary—whether you're a dollar-a-day man or a dollar-an-hour man. No matter where you live, what you now do, or how little time or money you may have, the I. C. S. have a plan and a

Course of Training to fit your needs. Hundreds of thousands of ambitious men have been prepared for and have achieved success through I. C. S. help in the past 25 years—over 130,000 are now studying, getting ready for the big job ahead. Join them and make your life something to be proud of—you can do it. Just mark and mail the coupon TODAY and find out how; it won't obligate you in the least.

TEAR OUT HERE

INTERNATIONAL CORRESPONDENCE SCHOOLS, Box 5584, Scranton, Pa.

Explain fully about your Course in the subject marked X:

- | | | |
|---|---|---------------------------------------|
| <input type="checkbox"/> Electrical Engineering | <input type="checkbox"/> ADVERTISING | <input type="checkbox"/> CHEMISTRY |
| <input type="checkbox"/> Mechanical Engineering | <input type="checkbox"/> Salesmanship | <input type="checkbox"/> Illustrating |
| <input type="checkbox"/> Mechanical Drafting | <input type="checkbox"/> Commercial Law | <input type="checkbox"/> Farming |
| <input type="checkbox"/> Civil Engineering | <input type="checkbox"/> Bookkeeping | <input type="checkbox"/> Poultry |
| <input type="checkbox"/> Stationary Engineering | <input type="checkbox"/> Stenography | <input type="checkbox"/> French |
| <input type="checkbox"/> Mining Engineering | <input type="checkbox"/> Civil Service | <input type="checkbox"/> German |
| <input type="checkbox"/> Architecture | <input type="checkbox"/> Ry. Mail Service | <input type="checkbox"/> Italian |
| <input type="checkbox"/> Architectural Drafting | <input type="checkbox"/> AUTOMOBILES | <input type="checkbox"/> SPANISH |

Name _____

Address _____

DRAWING

Learn by Mail in YOUR OWN HOME

Newspaper, Magazine and Commercial Illustrating, Cartooning, Water Color and Oil Painting. Learn drawing or painting for profit and pleasure. We can develop your talent. This school has taught thousands. Free Scholarship Award—special limited offer. Your name and address brings you full explanation and our handsome illustrated Art Annual by return mail. Don't delay, write to-day. Fine Arts Institute, Studio 56X, Omaha, Neb.



The only way to learn ELECTRICITY

Electrical knowledge is now at a premium. The War has given a tremendous boost to all electrical trades. Electrical experts are in demand at high pay everywhere. But you cannot become an expert in any field by simply reading a book. You must "learn by doing." That's the way electricity is taught at the New York Electrical School. Our concentrated work

with actual apparatus under actual conditions will put you ahead of men with from 5 to 10 years' experience in the electrical field. 4,500 of our students have gone forth into electrical success.

NOW IS THE TIME

Learn by Doing This method makes you an expert, able to command a high salary. All instruction is individual. You go ahead as fast as you can learn. Good students complete the course in seven months. Send today for FREE 64-page book. Tear out this advertisement and mail it with your name and address.

NEW YORK ELECTRICAL SCHOOL
44 West 17th Street NEW YORK, N. Y.

30 DAY COURSE FREE IN TIRE REPAIRING

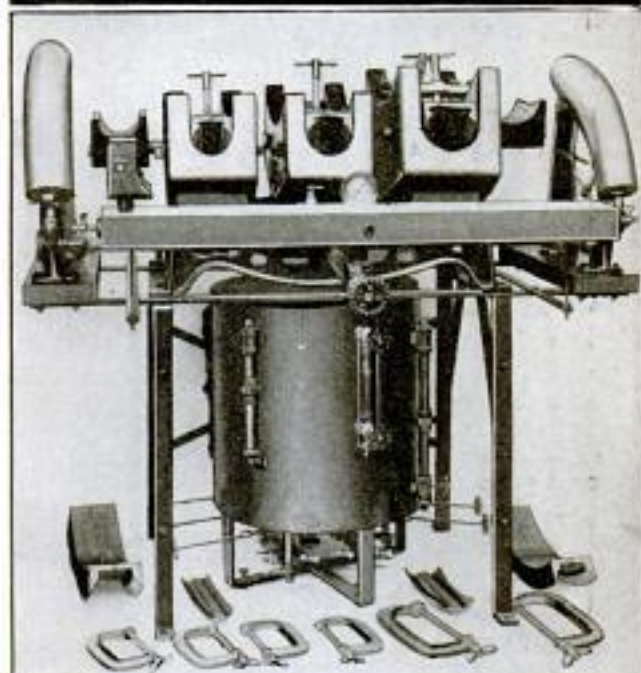

Write Today for remarkably low price and particulars about our free course in tire repairing. Let us show you how to make \$3,000 to \$8,000 a year.

RELIABLE TIRE REPAIR SCHOOL 106 Reliable Bldg. DETROIT, MICH.

AGENTS—NEW INVENTION

Ventilated chemical indoor closet, for country, village and suburban homes; no plumbing, no waterworks, no cesspool; absolutely odorless; 30 days' free trial guarantee; every village and farm home a customer; an order at every house; one agent made \$112 commission in 8 hours. Agent's outfit free. Exclusive territory contract. Write today for full particulars of this biggest winner ever offered to salesmen. Address

SHAFER MFG. CO., 479 Colton Bldg., Toledo, O.

Hartman Will Trust You

Rock Bottom Prices

Furniture, Carpets, Rugs, Etc.

Easiest Terms Hartman's credit terms easiest, most liberal ever offered. No security—no notes—no mortgage. Free from all objections. At the end of a month you may return anything unsatisfactory.

30 Days Approval Hartman refunds your money including freight.

FREE—Big Bargain Book Over 5,000 bargains. Write today for FREE copy.

HARTMAN FURNITURE AND CARPET CO.

3945-47 Wentworth Av., Chicago



40 hours

—be an Expert Book keeper—

Average bookkeeping courses are too elementary and theoretical, too involved, too impractical — to fit you as a successful bookkeeper.

Guaranteed Simplified Method

Our course is so simple that you can easily master its lessons, so practical that you can solve the most intricate bookkeeping problems 40 hours after you begin to study. And you can learn at less than one-third the cost of other courses.

Endorsed by Treasurer of Pennsylvania The State Treasurer of Pennsylvania, business men, bankers, and successful students everywhere have endorsed this practical course.

Write at once for free literature, learn how quickly and cheaply you can better your life-career.

HOFFMAN CORRESPONDENCE SCHOOL OF BOOKKEEPING
506 Dispatch Bldg. 5th Ave. Pittsburgh, Pa.

Here—Take This and Ring the Bell

You can't ring the bell on a striking machine by tapping with a little hammer. You may have the muscle, but the hammer is too light—but with one blow of a heavy maul you can send the ball gliding clear to the top.

—and just so, **Lack of Special Training** is like a little hammer when you try to strike a top-notch salary. You can strike with all your ability, but you can't get a "raise" much higher than \$15 a week. Drop the hammer. Take up **Special Training** and strike up \$50 or \$100 or \$200 a week. Ring the Bell.

We Will Train You to Be A TRAFFIC MANAGER

During your spare time at home we can train you—our "Experience Method" makes this practical. This method was devised by prominent traffic managers of the big railroads and industrial concerns. They will give you just what information a traffic man should know and show you how to fit yourself to earn a good salary. There is nothing difficult. Every thing will be fully explained to you. Ordinary ability is all you need. Remember that this is not a "correspondence course" to be learned from books—but is a system of **Traffic Training** by practical traffic men.

Join This Association—Its Members Will Aid You

Join the American Commerce Association. This will put you in touch with the traffic managers of railroad and steamship lines and thousands of men holding traffic positions with the big manufacturing and shipping concerns of the U. S. You can profit by their experience. They will advise and aid you. You will be admitted to the nearest **Traffic Efficiency Club**. The Association is the largest of its kind in the world. It is substantial and responsible.

Positions Open—The shipping departments of thousands of factories—railroads, warehouses, wharves—are congested with vast quantities of goods. Shippers are crying for help. Men are wanted—but **trained men only**—men who know how to **save freight money**—who know how to get **quick action** on shipments and deliveries.

Salary The salary of trained traffic managers ranges from \$2,500 to \$10,000 a year.

Don't Delay—Apply NOW

Never before in the history of America has there been so much shipping—and so much **trouble** in shipping. Shipments are tied up for want of men to handle them. Hundreds of thousands of dollars are wasted. There are **not half enough** trained men to fill positions. **Now is your time.** Write us now. We will tell you **what to do** and **how to do it.** Send the coupon by return mail.

American Commerce Association
Dept. 50, 206 So. Wabash Ave., Chicago, Ill.

You
Can
Do
It

AMERICAN COMMERCE ASSOCIATION
Dept. 50, 206 So. Wabash Ave., Chicago, Ill.

Send me **FREE**—and without obligation—complete information concerning the Association and tell me how I can train as a traffic man.

NAME.....

OCCUPATION.....

ADDRESS.....

CITY..... STATE.....

Please Mention Popular Mechanics



Big Business for Business Men

The most wasteful thing in American life today is the ice delivery system. It costs the ice manufacturer in excess of five times as much to deliver a ton of ice to the family ice boxes as the entire cost of manufacture of the same ton at the plant. The most insidious and provoking service in your home is the iceman and his sloppy, daily "hunk" of much handled, expensive ice.

Your cleanest and most satisfactory service is the electric wire, and every home has this electric service.

If you do not appreciate the possibilities of introducing in American homes an electric refrigerating service as simple and dependable as electric light, and so far ahead of delivered ice in coldness and cleanliness as a tungsten lamp is superior to the kerosene lamp, this announcement is not for you.

Here Is FRIDGER

placed in the cellar or any other convenient out of the way place. A sturdy apparatus as beautifully built as the best automobile. All parts strictly interchangeable. Its very simplicity is the basis of our patent protection.

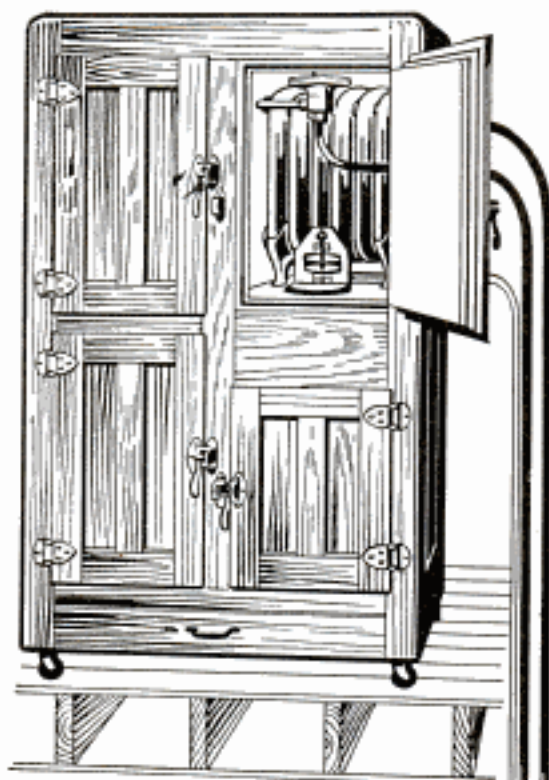

Cools any 100 to 200 lb.
Refrigerator

\$275⁰⁰

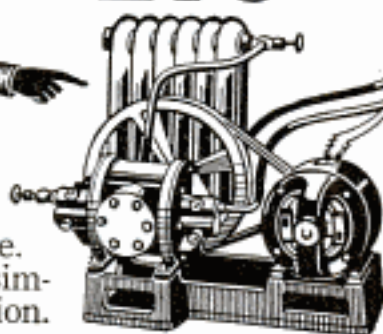

Mechanical and refrigerating engineers who have examined it agree with us that it is the final word in artificial refrigeration.

Manufactured by financially responsible people who have no stock to sell and who have invested a fortune and years of time in solving the domestic refrigeration problem.

FRIDGER Wells Street
327 Wells Street Bridge Bldg.
CHICAGO, ILL.

WE WANT Local Dealers

We want men of force and capital; successful men who see that electric ice in the home will quickly become this country's fastest growing and most profitable business. For such men we have a proposition bigger than any agency contract in any line has ever offered.

The initial investment need not be large, BUT we must have men who can swing big business fast and hard as they see it opening before them in their territories. Today territory is open and tomorrow your territory may be taken.

Popular Mechanics Magazine

REGISTERED IN U. S. PATENT OFFICE
WRITTEN SO YOU CAN UNDERSTAND IT

Vol. 27

JUNE,

1917

No. 6

Motor Car

Signal

Supports Steel Tower

FOR the use of the signal corps in the field, a folding steel observation tower installed upon an armored motor car has been built by two eastern inventors and given a preliminary try-out by military men. It provides a vantage point for a signal officer or observer, and may be used also to carry radio aerials. A small platform, with room for one soldier and a machine gun, is fixed at the top of the mast, which is about 25 feet in height when erected. As constituted at pres-

ent, no shield is provided to protect the observer from snipers, but such a device could easily be added if use were made of the equipment near enemy lines. One of the outstanding features of the arrangement is that the tower can be transported

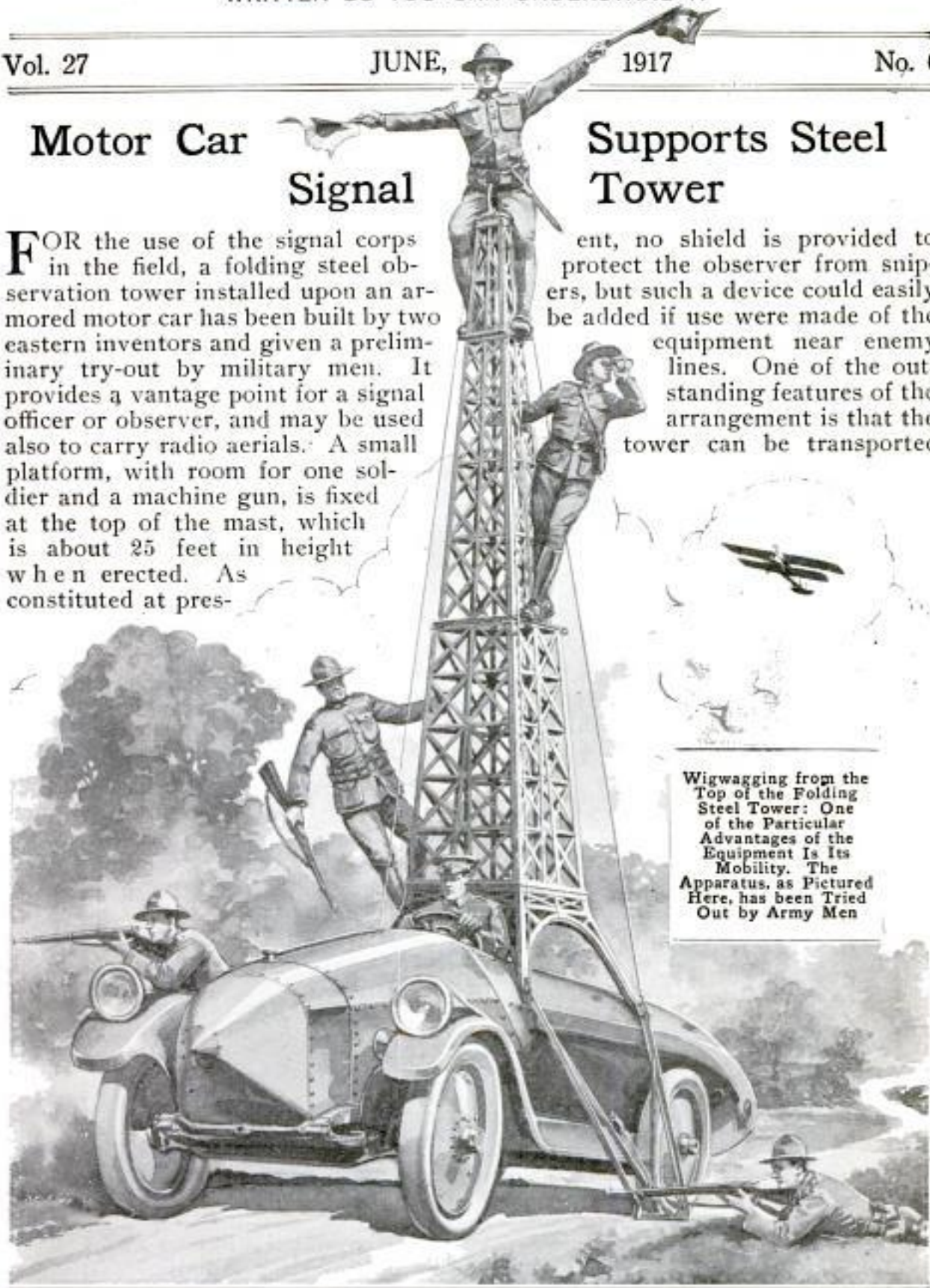

Wigwagging from the Top of the Folding Steel Tower: One of the Particular Advantages of the Equipment Is Its Mobility. The Apparatus, as Pictured Here, has been Tried Out by Army Men

REDRAWN FROM PHOTO COPYRIGHTED BY THE AMERICAN PRESS ASSOCIATION

Newsdealers will have the July issue of Popular Mechanics Magazine on sale June 20th.

from one point to another quickly. When it is to be moved, only a moment is required to fold the mast back so that its height is reduced nearly one-half. The tower is of stanch construction, designed to withstand hard usage. When erected, the middle sec-

tion is locked firmly by a large pin. Two guy wires, and steel braces that may be folded down to the ground on either side of the car, also hold it against movement when observations are being made or signals wigwagged from the elevated platform.

AUTOISTS SHOW ^(Automobile) FLAGS ON CARS WITH SEARCHLIGHTS

An exceedingly striking method of displaying the United States flag has been adopted by many Los Angeles motorists, each of whom mounts the national emblem on the front of his car and brilliantly illuminates it by means of the automobile searchlight attached to the windshield. As a car

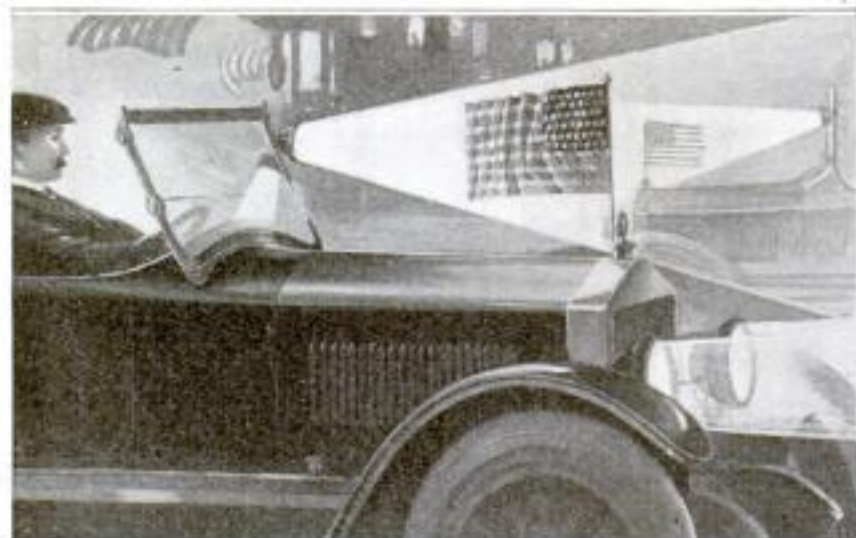

How Motorists Show Their Patriotism at Night: The Flag, Flying in the Stiff Breeze Created by the Movement of the Car, Stands Out Vividly in the Darkness Because of the Searchlight Which is Turned on It

so decorated speeds along at night and the flag stiffens in the breeze, all its beautiful details are brought out in sharp contrast to the surrounding darkness. When occasion demands the light can be turned in another direction.

ⒸIn making tests recently with a model of the collier "Neptune," it was found that if that vessel were steaming against a 30-mile wind at 16 miles an hour it would require 770 effective horsepower to overcome the wind resistance, or about 20 per cent of the power necessary to drive the ship through the water.

WHIRLING DISKS TO GUARD SHIPS FROM TORPEDOES

Believing that wire nets and pontoon-supported steel walls are impractical means of defense against torpedoes for moving vessels, an electrical designer in the Norfolk Navy Yard has invented an equipment with which a curtain of slowly sinking steel disks can be discharged in the path of a torpedo. These disks are 24 in. in diameter and constructed with wide rims and air chambers so that they sink slowly. A special type of gun is provided with an electrically operated driving pulley which sets each disk revolving rapidly and then discharges it edgewise into the water, close by the ship, by means of compressed air. A battery of several of these guns, firing as many as 40 of these shields in

rapid succession, would construct a slowly sinking wall, or curtain of shields, each of which would remain vertical because of its gyroscopic motion. It is claimed that a trained observer can detect the wake of a torpedo 1,000 ft. or more distant and determine with considerable accuracy where the missile will strike. If, after calculations had been made, several volleys of these shields were properly discharged, an oncoming projectile would collide with one of them and explode without injuring the boat. If the projectile were set to explode at a later time it would tend to push aside the

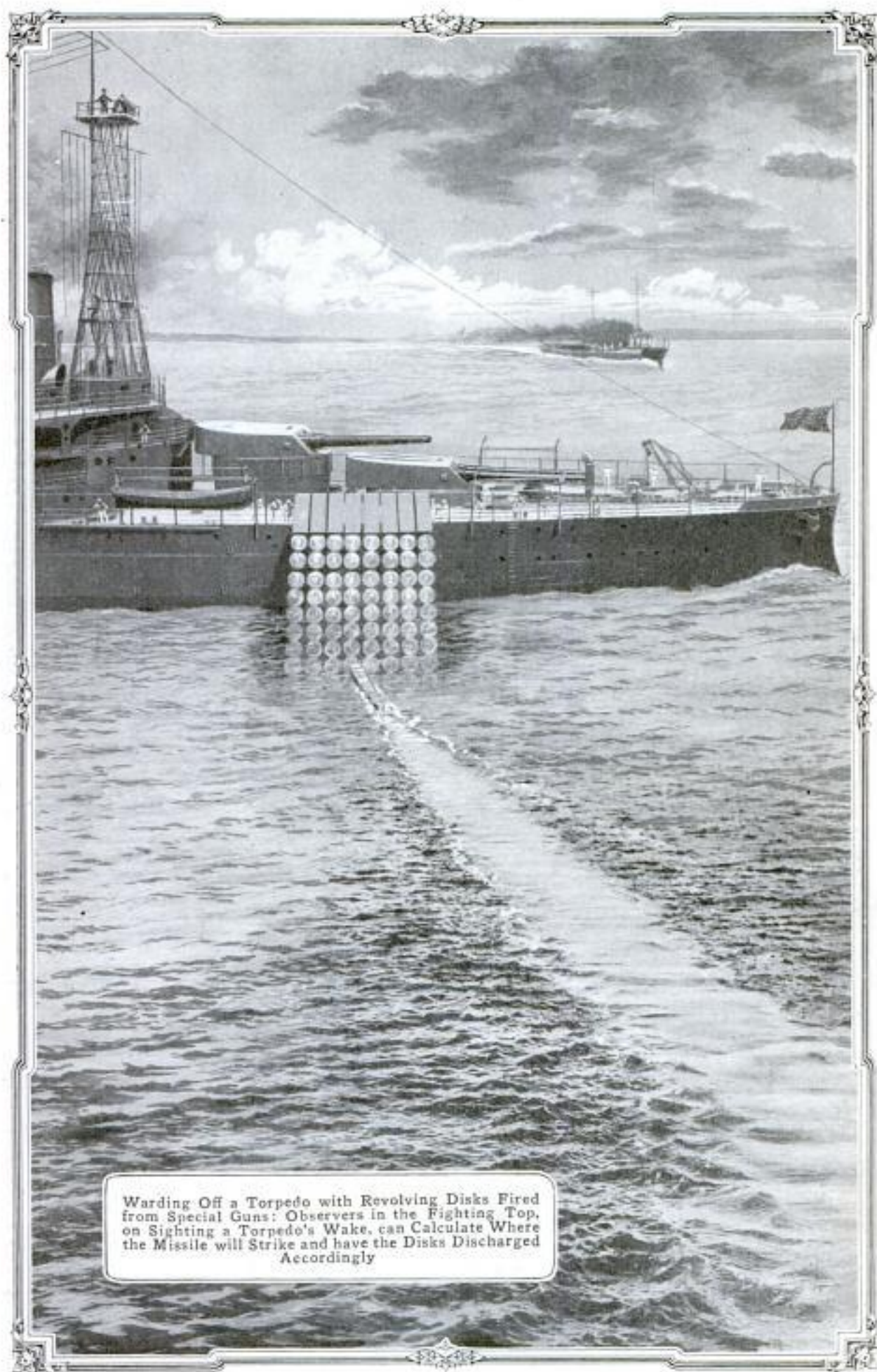

Warding Off a Torpedo with Revolving Disks Fired from Special Guns: Observers in the Fighting Top, on Sighting a Torpedo's Wake, can Calculate Where the Missile will Strike and have the Disks Discharged Accordingly

disk that it struck and its nose would catch in the rim of the shield. This would direct the torpedo in a circular path, and it would do no harm.

PATENT-PHONE DEVICE "HOLDS THE WIRE"

An easily adjusted attachment for desk telephones, lately placed on the market by a Virginia inventor, enables



Telephone Attachment
Which Holds the Wire
Open with the Receiver
on the Hook

the user to return the telephone receiver to the hook and still "hold the wire." This does away with the necessity of laying the receiver aside on a desk or show case, should the wrong person answer a call, or when data must be looked up before giving a reply. It also enables the phone to be passed from one person to another with one hand, instead of requiring two. The device is used by pushing a button, which slides a spring bolt under the hook, so that the receiver can be hung up without giving any disconnecting signal to "central."

LITTLE THEATER PROSPERS IN MID-WEST TOWN

Those concerned with the advancement of art in the drama will be interested in knowing that Galesburg, an Illinois college town, is supporting its "little theater" in a noteworthy manner. The institution is owned, managed, and directed by local men and women, and in two years has built a substantial foundation for further de-

velopment. It is fittingly known as the Prairie Playhouse and has become a democratic community enterprise that is backed by the good will of hundreds of citizens. When properties are needed for its stage, they can be obtained from practically any home in the town. Box-office receipts during the theater's first season paid expenses. The past winter, it is inferred, was even more encouraging. The aim of those actively connected with the venture is interesting. The hope is eventually to organize a strong group of players and bring about the dramatization of unwritten stories of life in the upper Mississippi Valley. The plains, fields, mines, and river settlements of the district offer a great wealth of virgin material.

CABINET FOR DEVELOPING X-RAY DENTAL FILMS

A very serviceable developing outfit has been placed on the market by an Indianapolis manufacturer of electrotherapeutic apparatus, which is designed for developing X-ray dental films, or any other small films or plates. It consists of a small wooden case with doors at either end and other necessary openings. The doors give access to black-cloth sleeves through which the photographer inserts his hands to manipulate the films while they are in the acid baths. Combined with the cabinet is a film-illumination and display



Daylight Developing Cabinet and Equipment with Which Dental X-Ray Films or Other Small Films can be Developed with a Minimum of Inconvenience

device by means of which a large number of negatives can be exhibited. The necessary trays, flasks, etc., form a part of the outfit.



Roadside Luncheon with a Convenient Lunch Box on the Running Board of the Family Car: One Side of the Box Lets Down to Form a Table



This Auto Lunch Box Contains Three Patent Hinged Drawers, Two Swinging Drawers, and a Zinc-Lined Ice Box, and is Carried like a Suitcase

CONVENIENT LUNCH BOX FOR THE MOTORIST

An automobile lunch box, designed and manufactured in Portland, Ore., is intended to be carried on the running board of a car, to which it may be attached by means of two small thumb-screws while traveling. It is shaped like a suitcase. One side lets down to form a picnic table, and the box contains a series of hinged and swinging drawers for food and bottles, also a metal-lined ice box with water drain, and a plate and linen compartment. The materials used in construction of the box are fir wood and veneer, the outside being black-enameled and the interior natural finish. Various sizes are made, suitable for from three to eight persons. The largest size is 34 in. long, 19 in. high, and 9 in. deep, the lid making a 15 by 33 in. table.

BRONZE MEDALS PRESENTED TO IOWA GUARDSMEN

Upon their return home from Mexican border duty recently, the Sioux City members of the 2nd Iowa Infantry were presented with bronze medals commemorating their service. The presentation, arranged by leading



Obverse and Reverse of Bronze Medal Presented to Sioux City Soldiers Returned from Border Duty

citizens, took place after a monster parade and home-coming celebration in which 75,000 persons participated.



PLAN AERIAL PATROL FOR LARGE SHEEP RANCH

FLYING shepherds may add a picturesque touch to life on our western sheep ranges if the plans of a wealthy Montana herdsman prove to be as practicable as they are original. Last season 2,000 of the rancher's sheep wandered into the hills and perished. Therefore he has purchased a biplane and has been receiving instruction at Los Angeles in its operation. He expects to patrol the ranch with the air craft and locate missing flocks. By dropping smoke bombs their positions will be marked. The machine is to be equipped with radio apparatus so as to be in communication with the pack train. If the scheme works out successfully, the rancher contemplates maintaining a flotilla of five or six machines, and it is possible that others of the vicinity will do likewise.

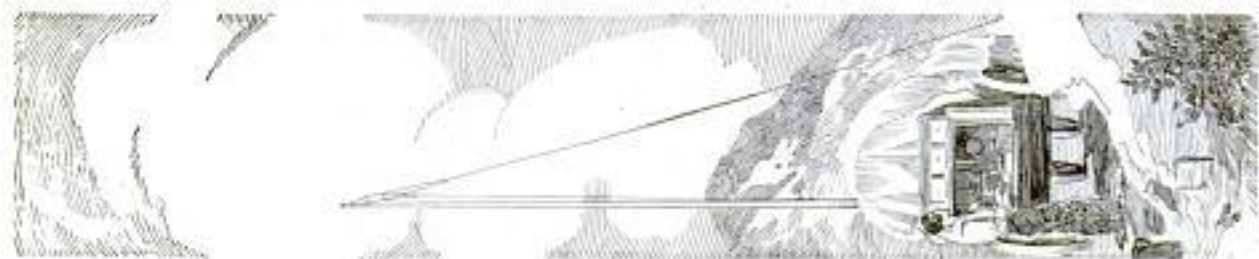

Kennedy - Van ...

HUGE STONE BREAKER BUILT FOR MICHIGAN COMPANY

Of late a stone crusher of remarkable size and capacity has been installed at a limestone and chemical plant on Lake Huron, near Rogers City, Mich. The machine will hold 65 tons of material at one time and handle approximately 1,250 tons in an hour. It is 34 ft. in height, is operated by a 300-hp. electric motor, and crushes 60-in. stone to 8 in. and finer. The driving is accomplished through eighteen 1 1/4-in. ropes that pass over a grooved cast-steel sheave. This style of transmission is employed because of the importance of continuous operation. Should as many as half of the ropes fail at any time through wear, the other nine would suffice to keep the machine running. As the stone is broken it is delivered to a belt conveyor and carried to revolving screens. The material rejected by the latter is fed to small crushers which turn out the finer sizes of stone. The big machine is said to be the largest crusher in existence, and is attracting considerable technical attention.

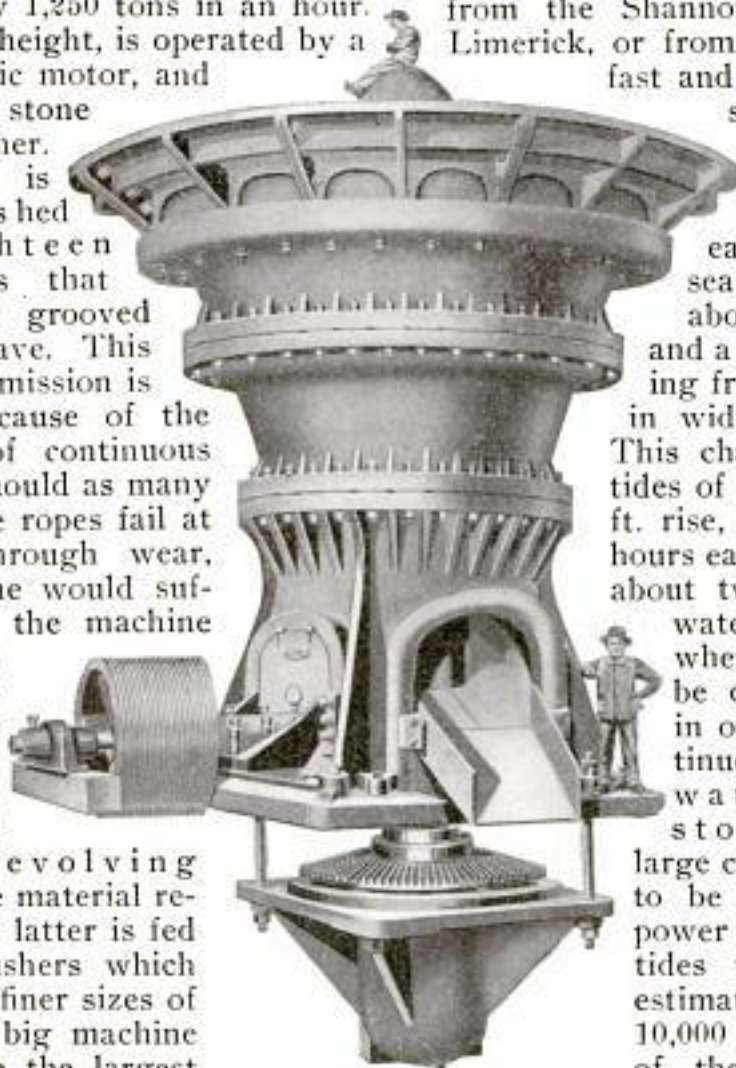

This Giant Machine, Which is Installed at a Michigan Limestone Quarry, is Reported to Be Capable of Crushing 25,000 Tons of Stone in a 20-Hour Day

PLAN TO DEVELOP WATER POWER IN IRELAND

War prices of coal in Ireland, which imports most of its supply, have caused manufacturers and municipalities seriously to consider schemes for obtaining a cheaper electrical supply by developing the water powers of the country. Two principal schemes have

been proposed, one to utilize the flow of the rivers Shannon and Erne, while the other would harness the tidal movements of Strangford Lough. The rivers would each, it is believed, furnish 50,000 hp. for eight months of the year and 20,000 to 40,000 hp. for four months, and it would be a simple engineering matter to transmit the power from the Shannon to Dublin and Limerick, or from the Erne to Belfast and Derry. The tidal

scheme for Strangford Lough is a different matter.

The lough is an east-coast arm of the sea with an area of about 20 square miles and a narrow inlet, varying from 1/4 to 1/2 mile in width for four miles. This channel is swept by tides of from 11 1/2 to 14 1/2-ft. rise, running about six hours each way. There are about two hours of slack water between tides when no power could be developed. Hence, in order to obtain continuous power, storage water reservoirs or storage batteries of large capacity would have to be constructed. The power developed by the tides would vary, it is estimated, from 60,000 to 10,000 hp., or with either of the storage systems suggested, be about 32,000 hp. all the year round. Locks would have to be provided in the inlet

channel of the lough, but it is calculated that the scheme could be carried out for an expenditure of about five to six million dollars.

What appears to be one of the largest high-grade salt deposits in the United States was found recently by two men near Lafayette, La., while drilling for oil.

James ... 1/23/17

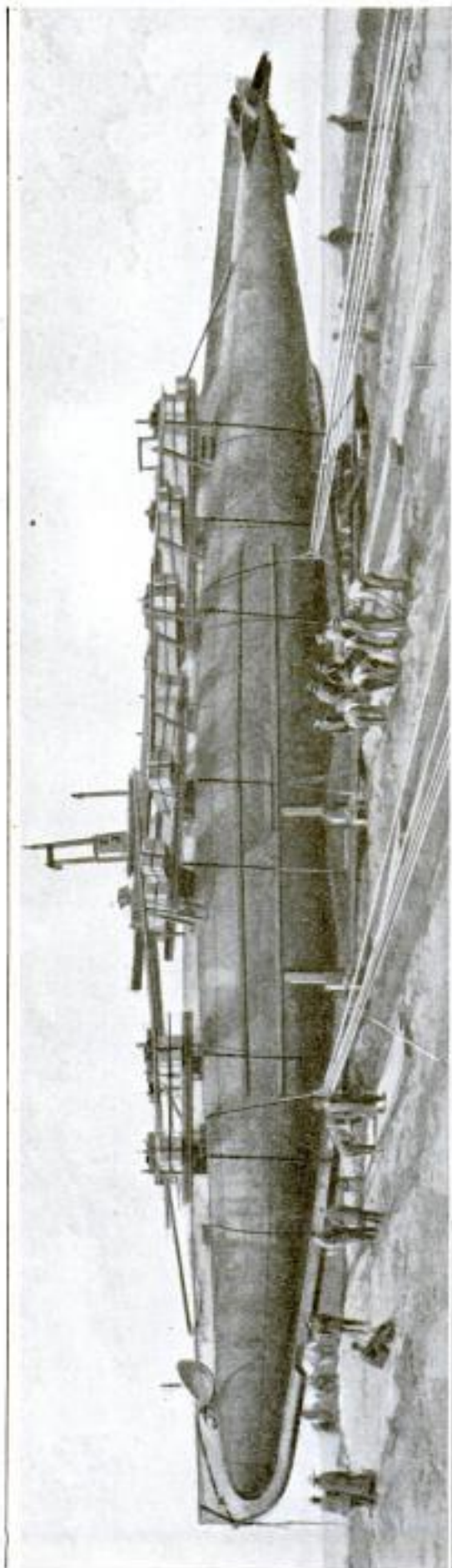

A Most Unusual Moving Job—and a Big One: Salvaging Submarine "H-3," Which Grounded near Eureka, California. Here can be seen the Cables Which were Placed beneath the Cigar-Shaped Body and Fastened to Beams Laid across the Deck. By Means of Jacks Blocked Up under These Beams the Heavy Craft was Lifted from Its Bed of Sand, and Skids were Placed beneath It. With Block and Tackle the Movers Were Then Able to Draw the Ship Sidewise on Land

HOW WRECKED SUBMARINE WAS RECOVERED

One of the big problems that arose in the salvaging of the submarine "H-3" which grounded near Eureka, Calif., last winter, was how to move the heavy craft. By means of powerful jets of water, channels were bored in the sand under the vessel and cables placed beneath it and fastened to heavy beams laid across the deck. Hydraulic jacks, blocked up so that the cross-beams rested on them, were then employed to raise the submarine out of its cradle of sand. When this had been done skids were placed beneath it and it was slowly hauled away.

ANGLO-INDIAN AEROPLANE ROUTES PROPOSED

Aeroplane service for passengers and mail between England and India was proposed in a public address at Delhi recently, by a titled Englishman who declared his belief that it will be established within the next few years. From Bombay to London by the long sea route is 6,000 miles; by way of Brindisi and Marseille it is 5,000 miles; but the shortest aeroplane route, by way of Russia, would be only 3,600 miles. At the present speed of aeroplanes, mail could be transported to London by this route in less than 36 hours. For passenger traffic, traveling only 10 hours a day at 120 miles an hour and starting from Peshawar, India, it would be entirely practicable to reach London on the third day out. An all-British route of 5,220 miles could also be followed, to be covered in five days. It was estimated that 1,000 passengers could be carried in a week, starting 10 aeroplanes a day, each with 14 passengers and two pilots.

ⓄThe American steamship "Minnesota," which passed through the Panama Canal last February, was the largest vessel to make the transit up to that time. The ship is 622 ft. long and has a 73-ft. 5-in. beam.

BLOWING UP THE ALPS

By LEWIS R. FREEMAN

IN January of this year, at a time when Alpine travel was exceedingly dangerous because of threatening avalanches, Lewis R. Freeman visited the scene of the most Titanic operations of the great war, carried out by engineers of the Italian forces in the Dolomite Mountains. He tells, in the following article, how it came to pass that, after repeated disappointments, and after days spent poring over reports that told of stupendous feats, a sudden change of weather permitted his visit to the point where the Italian troops were thwarting the Austrians by blowing off the tops of mountains. The story appalls imagination.—Editor.

IT was about the middle of last July that the laconic Italian bulletin recorded, in effect, that the blowing of the top off a certain mountain in the Dolomite region had been accomplished, and that a considerable extension of line had followed. That was about all there was to it, I believe; and yet the wonder engendered by the superb audacity of the thing had haunted me from the first. There was no suggestion of a hint of how it was done, or even why it was done. All that was left to the imagination. The result—in my own case at least—was the awakening of a burning interest in the ways of the warriors who were wont to throw mountain peaks and fragments of glacier at one another as the everyday plains-bred soldier throws hand grenades. My interest finally impelled me to attempt a visit to the Austro-Italian Alpine front at a time of year when the weather conditions threatened to be prohibitive.

"With 25 degrees of frost at sea level in France," observed a French officer at Amiens, "what do you expect to find at 10,000 feet on the Tyrol?"

"A number of things which they don't do at sea level in France or anywhere else," I replied; "but especially why they blow the tops off mountain peaks, and how they blow the tops off mountain peaks."

Even in Rome and Milan (though there were some who claimed social acquaintance with the Titans who had been conforming Alpine scenery to tactical exigency), they still spoke vaguely of the thing as *fantastico* and *incredibile*, as men might refer to operations in the mountains of the moon.

But once in the *Zona di Guerra*, with every rift in the lowering cloud blanket that so loves to muffle the verdant plain of Venetia in its moist folds revealing evidence that the mountain-top part of the story had at least some foundation of fact, whether the blowing-off part did or not, things took on a different aspect. On my very first day at general headquarters I met officers who claimed to have seen with their own eyes a mountain whose top had been blown off; indeed, they even mentioned the names of the *montagne mutilati*, showed me where



Lewis R. Freeman in the Alpine War Zone: The Tall Figure Is Mr. Freeman. The View was Taken near the Front Line on the "Tofana"

they were on the map, pointed out the strategical advantages which had already accrued from taking them, and of those which might be expected to accrue later. They were still there, I was assured, even if their tops had been blown off. They were still held by the Alpini. Two of the most important of them were not so far away; indeed, both would be in plain sight from where we were—if other and nearer mountains did not stand be-

tween, and, of course, if the accursed storm clouds would only lift. And so, at last, the names of the "Castelletto" and "Col di Lano" took sharpened shape as something more than symbols.

"But can I not go and see them?" I asked. "You have told me *why* you blew them up, but not *how*; yet that is the very thing that I came to find out about at first hand."

They shook their heads dubiously. "Not while this weather lasts," one of them said. "It has snowed in the Alps every day for over a month. The *valange* (avalanches) are coming down everywhere, and, even if you were willing to risk being buried under one of them, the roads in places will not be open for weeks. You might wait here a month or two, and even then be disappointed so far as getting about on the Alpine front is concerned. Best see what you can of the Isonzo front now and come back for the Alps in the spring."

That seemed to settle it so far as seeing the "Castelletto" and "Col di Lano" were concerned. Regarding the way in which they were mined, however, one of the officers at the *Ufficio Stampa* said that he would endeavor to arrange to have the "Castelletto"—much the greater operation of the two—report put at my disposal, as well as a set of photographs.

"Since you came to Italy on purpose to learn about the mountain whose top was blown off," he said, "the *Comando Supremo* may be moved to make a special dispensation in your favor."

Exclusive permission to make use of both report and photographs was granted me in due time, and since the

former makes clear both the why and the how of the unprecedented "Castelletto" operation, it will perhaps be best to summarize it first as a sort of drab background for the more vivid and intimate personal details which a lucky turn of the fitful weather vane made it possible for me to obtain later.

The first part of the report, by the colonel commanding the Alpini group, makes plain why the mining of the "Castelletto" became a *sine qua non* to further progress in this important sector:

In the month of October, 1915, I was charged with

carrying out an attack with two battalions of Alpini against the positions of "Castelletto" and "Forcella Bois." This was the fourth time, if I am not mistaken, that an attempt on these positions had been made. In spite of the fact that the artillery preparation of the opening day had been excellently performed, I discovered, on the evening of October 17, when I moved with my troops to the attack, that its work had been absolutely of no avail. Having received orders at midnight to proceed to Vervei, where the two battalions above mentioned were to take part in another operation, I was forced to abandon the attack. I am convinced, however, that I would not have succeeded in capturing the "Castelletto" position.

As known, the "Castelletto" is a sort of a spur of the "Tofana" (about 12,000 ft. high), with a balcony shaped like a horseshoe, and with a periphery consisting of numerous jagged peaks. In the rear of the balcony, and within this rocky spur, the enemy had excavated numerous caverns in which machine guns and light artillery pieces, handled by isolated but able gun crews, furnished an invisible and almost impregnable position of defense, giving extraordinary confidence and encouragement to the small forces occupying them. Costeana Valley was accordingly at the mercy of the enemy's offense, and actually cut in two. From

Vervei on, all movements of troops had to be carried on only at night and with great difficulty. The conquest of the "Castelletto" was rendered necessary not only for tactical but for moral reasons as well, since our troops came to regard it as absolutely imperative that such an obstacle should be overcome. After completing my observations and researches regarding the "Castelletto" position, I reached the conclusion that the only means of dislodging the enemy therefrom was to blow it up.

On November 10 I formally presented my plan to headquarters, and about the middle of December I was authorized to attempt it. The unusual enterprise was a most difficult one, not only on account of its magnitude, but also on account of the particularly unfavorable conditions of the winter season. Having prepared the necessary material for construction and excavation work, I began, on Jan. 3, 1916, fortifying

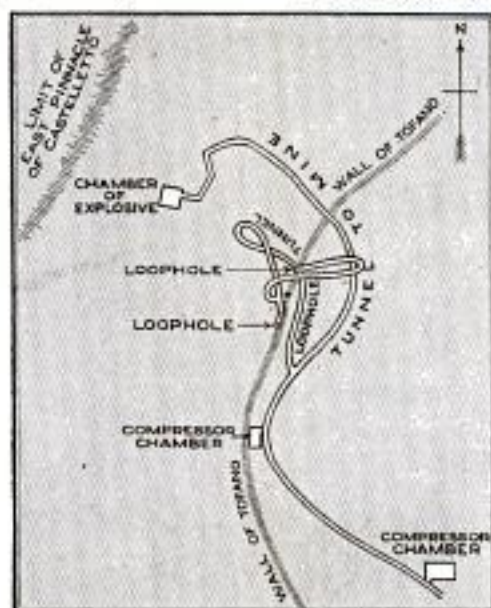

LIEUTENANT MALVEZZI'S MAP

Scale 1 : 1,000

(Owing to military exigencies the complete outline of the "Castelletto" cannot be indicated)

The winding tunnel to the left (marked "Loophole Tunnel") was constructed for a passage through which men could advance to occupy the crater formed by the explosion. Its serpentine character was largely due to the fact that it had to keep continually avoiding fissures in the rock through which its location would have been revealed to the enemy. The tunnel to the right is that to the chamber of the mine, and through it all the explosive for the latter was carried.



The "Castelletto" after the Explosion: The White Dotted Line Shows the Approximate Sky Line of the Peak Blown Off. When One Realizes That This Was a Peak of the Dolomite Alps the Stupendous Nature of the Feat Becomes Apparent

the position (entirely unprotected at the time) from which we would have to work, and completing the construction of the necessary buildings.

Second Lieutenant Malvezzi, in his report on the subject, describes concisely and unostentatiously the development of the work. The accomplishment of the enterprise, considered by many as chimerical, is due not only to the technical ability of Lieutenant Malvezzi, and Lieutenant Tissi, his assistant, but to their special military qualifications as well; also to the courage and good will of the Alpini who, in a very short time, became a personnel of able miners and clever mechanics.

The vicissitudes during more than six months' work, at a distance of only a few meters from the enemy, and under an incessant artillery fire and shelling by *bombarda*, could well form the subject for a book devoted to the study of character. Although fully aware of the attendant dangers, including those of falling rocks due to the countermining of the enemy, the Alpini of the "Castelletto," during the period of more than six months, gave proofs of brilliant valor and unflinching perseverance. They were calm at all times, and moved only by the spirit of duty.

Lieutenant Malvezzi's appended report launched at once into

the *how* of the Titanic task which was set for him.



Ladders and Stairs Leading to the Mouth of the Tunnel

On January 3, 1916, work was begun on the approach to "Castelletto," on the "Tofana di Rothes" slope, leveling the soil and enabling the construction of lodging quarters for officers and troops. This work required the cutting of about 600 cu. yd. of rock. Next the construction of quarters, and the concealing of them, was quickly accomplished. Finally, there was garrisoned at this post the "Castelletto Detachment," commonly called the "T. K.," consisting of the necessary personnel for labor and the defense of the position.

Our first work was to examine and disclose the enemy lines of communication about the "Castelletto" and "Tofana" sides, and to gain full knowledge of their position in detail. In order to accomplish this, observation points were established which allowed us to carry out such investigation and to make topographical sketches of the zone. Being, as we were, always in the proximity of the enemy, this was a long and fatiguing work. After a month, however, we succeeded in constructing a series of positions at short distances from those of the enemy (from 50 to 150 yards). These were provided with cables and rope ladders to enable us the more rapidly

and easily to study (from all possible points of vantage) the enemy's positions and the development of his works.

From the middle of February to the end of March the tools used for piercing consisted only of mallets and chisels. Our progress was necessarily slow, yet it was sufficient in this time to give us, besides 14 yards of tunnel, room for installing the perforating machinery. At the end of March, notwithstanding heavy snowstorms, the machinery—some pieces of it weighed as much as 1,100 and 1,300 lb.—for beginning work was installed. This was all brought up by hand, and without incident.

The mechanical work was begun on the 2nd of April. We utilized two plants as follows:

1. A complete group of benzo-compressors, consisting of a 30 to 40-hp. kerosene motor adjusted to a compressor by means of a belt. This machinery was installed, on a solid base of cement, at the beginning of the tunnel, in a 16 by 28-ft. space dug out in the side of the mountain for that purpose.

2. Another compressor mounted on a four-wheel truck.

Both machines were of American manufacture, and gave complete satisfaction at all times. Each compressed the air to a density of about seven atmospheres, injecting it into an air chamber, whence, by means of a rigid tube, ending in one of flexible rubber, it was conveyed to the respective drills.

Four squads worked at a time, each one consisting of a foreman and from 25 to 30 miners. Each squad worked six hours without interruption. This rate, apparently light, was found, on the contrary, to be very heavy, owing principally to the development of nitric gases which poisoned the air, and to the dust caused by the drills.

The "motorists" (mechanicians in charge of the engines) were divided into two groups, one for each compressor. Each group was directly under a chief engineer. A motorist would alternate with an assistant, each working eight hours. Adjacent to each engine was posted a table containing regulations in detail as to the work to be performed, the upkeep of the machinery, and the responsibility of the personnel.

At first the only explosive used was military gelatin; later, dynamite-gelatin. The system of overcharging the holes was always adopted, in order to reduce the debris to minute particles, easier to be transported and unloaded. The work was carried on in sections, varying from about six by six feet to one-half foot or more larger. The flat stretches of the tunnel were laid with rails. All material was carried out in cars and dumped into a hopper discharging into a large pipe. (The dump was accumulated at a point beyond the observation of the Austrians.) The average rate of progress was about 17 feet per day.

(It may be well to explain here that it was not possible to begin tunneling on the same level at which the mine was to be exploded, but considerable more than 150 feet below that level. The tunnel had, therefore, to be driven on a steep gradient. Another point which the report does not make clear should be borne in mind, viz., that the tunnel divided in the heart of the "Castelletto," the main bore being driven on to where the mine was to be exploded, while a smaller branch—referred to below as the "Loop-hole Tunnel"—was run up to a point where favorable exit could be obtained for charging into and occupying the crater of the exploded mine. In all

1,063 ft. of tunnel had to be driven, involving the excavation of 2,200 cu. yd. of rock.)

It was originally intended to divide the explosive charge between two chambers, each having a mining line of resistance of about 66 feet with a 16-ton explosive charge of 92-per-cent gelatin. However, owing to the countermining work carried on by the enemy—we were only a few yards from one of his positions during the charging of the mine chamber—we were obliged to confine the entire charge to a single chamber.

The enemy, meanwhile, with a view to avoiding the effects of our mine beneath the peaks of the "Castelletto," had transferred most of his shelters to the side of the "Tofana" and the "Scletta." This necessitated a considerable alteration in the location of the mine as originally planned, in order that it should act against the enemy shelters on both the "Castelletto" and "Tofana" flanks.

The charge was computed on a basis of minimum resistance of about 66 feet, taking into consideration the nature of the rock (which was fissured) and the existence of numerous splits and caverns. The coefficient of overcharge was, therefore, rather high. In order to obtain the maximum effect under these conditions, only 92-per-cent explosive nitroglycerin was used. The total charge was 35 tons.

The method of priming adopted was suggested by Lieutenant Colonel Tatoli, of the Engineers' Corps. This consisted of five priming groups, each of three friction tubes. One of the groups ran along the central axis of the chamber, while the other four, parallel with the first, were disposed symmetrically facing the four corners of the chamber. Each tube (1 1/4 in. in inside diameter, by about 15 feet in length) was alternately charged with gelatin and guncotton and pierced by picric acid detonating fuse, ending in a guncotton cartridge with electric percussion cap.



One of the Air Compressors in a Chamber of the Tunnel: The Two Italian Engineers Are of the Enduring Type That Made the Feat Possible

In the very center of the charge there were inserted two cases of guncotton, with electric percussion cap and detonating fuse, with a view to securing a second springing of the mine to follow the first.

We thus had in all 17 electric circuits divided into three groups, each formed by the circuits of five tubes, connected with the five groups of friction tubes. Two of these electric groups were composed of six circuits each, by adding the two circuits of the above-mentioned cases containing the guncotton. Each of these electric groups ended with an exploder, placed at a distance of about 15 feet from the mine chamber.

The tamping was effected with cement and with sandbags, with heavy wooden beams between the latter. It was made more effective by dividing into sections at right angles to each other. The theoretical length of the tamping was about 80 feet.

The charging of the mine chamber began July 3, 1916, at 5 p. m., and was completed at 3 p. m. of July 9, this work including tamping, priming, and laying of electric circuits. The final connections between the latter and the exploders, by means of wires suspended in the air, were made on July 10. The mine was sprung on the 11th of July, at 3:30 p. m., and responded fully to our calculations and expectations.

(Signed) ING. L. MALVEZZI.

2nd Lieut. 7th Regiment Alpini.



Left: Portion of Stairway inside the Tunnel. Much of the Tunnel was Driven on a Gradient of Over 45 Degrees. All of the Explosive and Much Material had to be Carried up This Stairway on the Backs of Men. Right: Natural Fissure in the "Castelletto" Encountered by the Tunnel of the Mine. Fumes Rising through a Similar Fissure Gave the Italians Warning of the Direction of an Austrian Countermine

A week of unspeakable weather went by—an interval the days of which I spent among the "cavemen" of the Carso, and the nights of which were largely devoted to puzzling through the mysteries of the "Castelletto" report with the aid of my Italian dictionary—and then the unexpected happened. Rain and snow ceased, the sky cleared, and a spell of sparkling days succeeded the interminable months of storm and lowering clouds. From the high Alps came word that the grip of the frost had paralyzed the avalanches for the moment, and that rapid progress was being made in opening up the roads for traffic.

"Now is your chance to see the 'Castelletto,'" they told me at headquarters. "If you start at once you ought to be able to get through without much trouble; and, if the weather holds good, you may even be able to get back without long delay, though you'll have to take your chances."

And so it chanced that on a diamond-bright morning in early January I found myself, after a couple of days of strenuous motoring, speeding in a military car past the old customhouse and up into the heart of that most weirdly grand of all Alpine regions, the Dolomites. Already we were well over into what had once been Austrian territory, and the splintered pinnacles which notched the sky line ahead of us were, as my escorting officer explained, held in part by both the Italians and the enemy. As we coasted down into "Cortina di Ampezzo" Captain X—pointed to where a clean-lined wall of snow-capped yellow rock reared itself against the deep purple of the western sky.

"That high mountain ridge is the Tofana *massif*," he said, "and that partly isolated mass of lighter-colored rock (crowned with towers like a medieval stronghold), at its farther end, is what is left of the famous 'Cas-

telletto.' It is twenty kilometers (about 12 miles) or more away, but you can see even from here how it dominated the valley and road, the latter the much-pictured Dolomite road, which is also a route of great military importance. Now look at the end of the 'Castelletto' toward the wall of the 'Tofana.' Do you see where it seems to have been sliced off smoothly at an angle of about forty-five degrees? Well, that is the part they blew off last July. Up to then that end, like the other, was crowned with a lofty spire. That spire, the base from which it sprung, the Austrian barracks and munition depots, together with the men stationed there—all were blown up and destroyed in the explosion. Take a good look at it while you have a chance, for the sky-line view is better from a distance than from close at hand, where we shall go this afternoon if the way is open. To see the effect of the explosion at its best," he added, "one should look at it from the Austrian lines, as it was the blowing out of the other side of the mountain which undermined and let down the top."

Viewed even from a distance of a dozen miles or more, the alteration wrought in the sky line by the explosion was not difficult to imagine. It was indeed literally true—what I had never been fully able to make myself believe until that moment—that a mountain peak had been blown off—hundreds of feet of it, and thousands of tons.

It was not until, after ten miles of precarious climbing and clawing up the ice-paved snow-walled road, our car brought up in the midst of a neat little group of Alpine buildings, nestling in the protection of the last of the timber, that Captain X— revealed the surprise that had been prepared for me there.

"Our host here," he said, "will be Colonel Y—, who conceived and directed the 'Castelletto' project, and at dinner tonight you will meet, and can talk as long as you like with, Lieutenant Malvezzi, who did the work. He is still quartered here, and will be glad

to tell you all that he can about Alpine military engineering. We have already sent him word that you came to Italy expressly to see him."

After a hasty lunch Captain X—and I, accompanied by an officer of Alpini from the camp, started for the "Castelletto." Our powerful military car which, in spite of the fact that it had nonskid tires, had been giving a good deal of trouble on the ice, was left behind, and a smaller but heavily engined machine, with sharp spikes clamped over the rims to grip the glassy surface of the road, was taken for the few miles of the latter which were still open. Abandoning this in a snow bank at a little advanced camp well up under the towering wall of the 'Tofana,' we took our alpenstocks and started on the 2,000-ft. climb up to the base of the "Castelletto." The hard-packed snow on the thirty to forty-degree slope must have averaged from ten to twenty feet deep all the way, while, for a half mile or so midway, it was humped up in crumpled folds where, a fortnight before, one of the largest and most terrible slides ever known in the Alps had plunged down on its sinister mission to the bottom of the valley. The full story of that avalanche will hardly be told until after the war.

Slightly softened by the brilliant sun, the snow gave good footing; but even so it was a stiff pull to the little ice and rock-begirt barracks at the base of the cliff, and I gained some idea of the Titanic labor involved in getting guns, munitions, machinery, food, and 35 tons of high explosive up there, all by hand, in every sort of weather, and much of it (to avoid enemy observation and fire) at night.

Midwinter was not, of course, the time to see anything of the real effects of the great explosion, for the huge crater torn by the latter was drifted full of snow, and snow was also responsible for the complete obliteration of the countless thousands of tons of débris that had been precipitated down the mountain side. A dizzy climb up the ladderlike stairway, and a crawling



Portion of the "Castelletto" Crater Formed by the Mine Which the Italian Engineers Exploded from Their Tunnel Far Below

clamber through a hundred yards of the winding tunnel from the rock chambers which had housed the compressors, revealed about all that was visible at the time of the preparations and consequences of the mighty work; but a peep from the observation port of a certain cunningly concealed gun cavern discovered a panorama which gave illuminative point to the concluding words of the artillery officer who, pointing with the shod handle of an ice pick, explained the situation to me.

"So you see," he finished, "that the 'Castelletto' in the enemy's hands was a stone wall which effectually barred our further progress; while in our hands it becomes a lever which—whenever we really need to take them—will pry open for us positions of vital importance. We simply *had* to have it; and so we took it in the one way it could be taken."

Save for his Alpini uniform, Lieutenant Malvezzi, when I met him at dinner that evening, might well have passed for the typical musician of

drama or romance. His skin and hair and eyes were dark, and his long nervous fingers flitted over the paper on which he sketched various phases of the "Castelletto" work very much as those of a pianist flit above his ivory keys. The dreamy far-away look in his eyes was also suggestive of the musician, but that I had long come to recognize as equally characteristic of all great engineers, the men whose tangible achievements are only the fruition of days and nights of dreaming.

"Where shall I begin the story?" he had asked as the diners in the regimental mess began to resolve into little knots of threes and fours over coffee and cigars; and I had suggested that he take it up where his report left off. "That stopped just as things began to happen," I said. "Now tell what *did* happen."

The *tenente* laughed a laugh suggestive of rueful reminiscence, and a smile ran round among those of the officers who had heard and understood

my words. "So far as I am concerned," he replied, "that covers about five minutes of activity; five minutes for which we had been preparing for six months. You understand that we had constructed a branch tunnel through which our men were to rush and occupy the crater as soon after the explosion as possible. *Ecco!* The men were all massed ready on and under the terrace, and nothing remained but the making of the connection firing the mine. I took one long look around and then threw over the electric switch closing the circuit. Every one seemed to be holding his breath as he waited. One, two, three seconds passed, in a silence so intense that I heard the sharp 'ping' of the water dripping from the roof of the chamber and striking the pool it had formed below. Then, before any other sound was audible, the whole mountain gave a quick convulsive jerk, strong enough to throw some of the men off their feet. A heavy grinding rumble in the earth came with a shivering that followed the jerk, but the real roar of the explosion (from the outside) was not audible for a second or two later. Only those watching from a distance of several kilometers saw the right-hand pinnacle of the 'Castelletto' give a sudden heave, and then sink out of sight in a cloud of dust and smoke.

"In addition to the honor of firing the mine, that of leading my men into the crater had also been reserved for me, and as soon as I heard the roar of the explosion I gave the order for them to follow me up into the tunnel. Well—" he paused and ran his laughing eyes around the grinning circle of his fellow officers—"that is about as far as my evidence is good for anything. As I went clambering up the slippery steps of the tunnel, an almost solid wall of choking fumes struck me in the face, and I—and all of my men except those near or outside of the portal—dropped coughing in my tracks."

"Had the mine blown back through the tamping?" I asked.

"Not exactly," he replied, his rueful

smile becoming almost sheepish, as of one who had allowed himself to become the victim of a prank. "The Austrians had a big store of asphyxiating bombs on hand to use against us, and these, exploded by our mine, vented their spite on friend and foe alike. We were not able to occupy the crater for twenty-four hours. I am glad to say that I spent what would otherwise have been an intolerably anxious interval unconscious in the hospital. By the time I had been revived a friendly breeze had thinned the gas sufficiently to allow our Alpini to move into the crater and reap—in spite of the delay—every advantage we had at any time counted upon from the operation. Our most cherished capture was the 'perforator'—practically intact—with which the Austrians were driving an almost completed counter-mine directly under us."

"The nervous tension must have been rather strong toward the end, wasn't it?" I asked. "Especially when you knew the enemy had at last got your work definitely located and was rushing his counter-mine?"

The smile of whimsical ruefulness died out of the dark sensitive face, leaving behind it lines I had not noticed before, lines that only come on young faces after weeks or months of incessant anxiety. The backward-cast shadows of a time of terrible memory were lurking behind his eyes as he replied:

"For seven days and nights before the mine was sprung neither I nor the officers working with me slept or even rested from work."

That was all he said; but I saw the eyes—brimming with ready sympathy—of his fellow officers turn to where he sat, and knew the time for light questionings was past. Not until that moment did a full appreciation of the travail involved in the blowing up of the "Castelletto" sink home to me, and I nodded fervent assent to the words of the English-educated captain of Alpini next me when he observed that "Malvezzi's little Order of Savoy was jolly well earned, eh?"

SPEED AND SAFETY SOUGHT IN SHIP OF NEW TYPE

There was recently exhibited in Portland, Ore., an electrically driven 7-ft. model of an original type of boat which is designed to be very speedy and practically unsinkable. The inventor estimates that craft of this type could travel 50 miles an hour, thus making them especially suited for submarine chasing, life-saving, etc. This boat rides on two parallel air-tight cylinders laid some distance apart and divided by bulkheads into sections, which in the case of large ships would be used for storage. Lining the bottom of the hull proper, which rests on these cylinders, are hollow metal pontoons, normally just above the water, while on either side of the ship above the principal floats are other pontoons. These supplementary floats aid in righting the ship when it rolls and prevent it from sinking in case the others give out. The propellers are driven by a shaft that lies between the two large cylinders and therefore operate in water undisturbed by the progress of the vessel—an arrangement de-

signed to give them additional effectiveness. The front ends of the two big floats are cone-shaped and are provided with flanges. The function of these cones, which revolve, is to eliminate the head resistance, thus making greater speed possible.

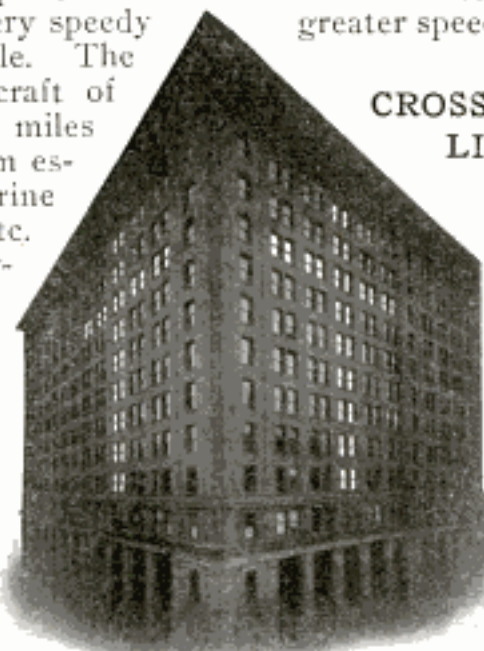

Window Lights Arranged to Show Cross on Either Side of an Office Building on Good Friday Night

CROSS OF BUILDING LIGHTS FOR GOOD FRIDAY

As an appropriate observance of Good Friday, the window lighting of the Northern Pacific general-office building at St. Paul, Minn., was so arranged as to form an illuminated cross on each of the two fronts. This was done by turning on the electric lights in certain rooms of the building and lowering the shades of all other windows to make the cross lights stand out. The result was a cross visible at night for a considerable distance. The complete set of electric switches installed in the building aided greatly in securing the unusual effect, which required lights on nine of the floors.

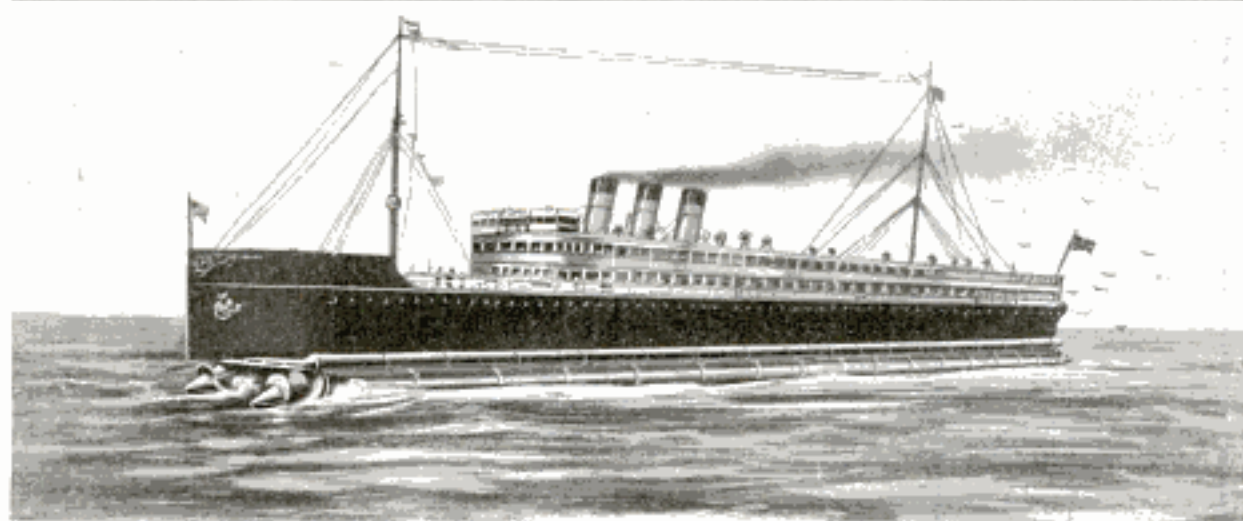

New Type of Speedy Vessel Designed by an Oregon Inventor: The Craft Rests on Two Large Air-Tight Cylinders Having Revolving Heads That Supplement Propellers Located between the Two Pontoons

CHOCOLATE-COATING TABLE WITH ELECTRIC HEAT

The chocolates displayed in tempting array by the confectioner in store

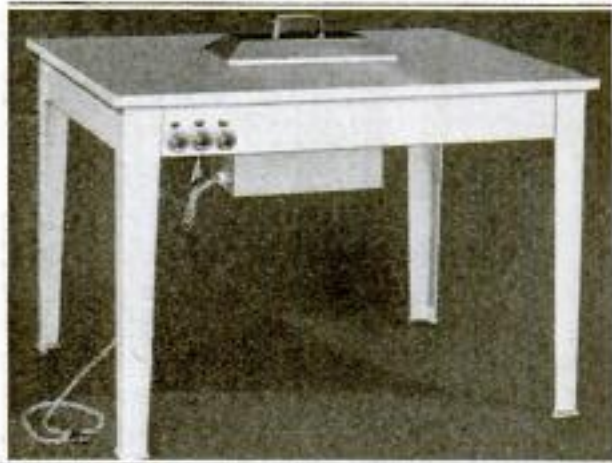

Electric Table Used by Candy Makers for Coating Chocolates: There Are Three Heating Units beneath the Container

window or show case are usually coated by hand, and an up-to-date chocolate coater's working table is an interesting piece of industrial furniture. In its latest form it is an electric table, with marble top mounted on a white-enameled steel frame, easy to clean. In the center of the top is a gal-

vanized-iron container with a capacity of about 30 pounds of chocolate. Under this are three electric heaters, controlled by separate switches, by which the chocolate is melted and kept at the proper temperature for working.

HUGE COAL PIER LOADS WITH BELT CONVEYORS

A \$2,500,000 coal pier that can load 7,000 tons of coal an hour has been opened by the Baltimore and Ohio Railroad at Curtis Bay, near Baltimore. The structure is of unusual interest because of its capacity, which is claimed to be the largest of any coal pier yet constructed, and because it handles coal by belt conveyors instead of by gravity. This arrangement greatly reduces the breakage by making 3 ft. the maximum fall for coal from the time it leaves the car until it reaches the ship. At the land end of the pier, which is of concrete and steel, are two car dumpers and next to them are balancing bins into which certain of the belt conveyors empty. On the pier are four traveling loading towers that can serve as many ships, all at one time. They are



New Coal Pier near Baltimore Which Has a Capacity of 7,000 Tons per Hour: With the Four Loading Towers Vessels with Bunker and

supplied with coal by 60-in. belts having a maximum speed of 500 ft. per minute. Supplementing these are two towers that trim the ships' loads. The functions of the entire plant are interlocked and controlled electrically by push buttons.

PRIVATE WEATHER RECORDS AID IN SETTLING CLAIMS

Authentic data regarding the weather are so important a factor in determining the justness of certain kinds of claims for damages that some large corporations maintain stations on their own property which supply them with records regarding the weather throughout the year. An example of an establishment of this sort is the station belonging to a smelting company near Salt Lake City, equipped to record automatically the velocity and direction of the wind, the temperature, rainfall, and humidity. These facts are valuable in settling claims for damage to crops and live stock, alleged to have been caused by smelter fumes that spread over near-by land. Many railroads keep weather records which help



Weather Station Maintained by a Western Smelting Company: Here Records are Kept Which Often Aid in Determining the Justness of Claims Based on Alleged Damage to Near-By Property

them check up on claims for damage to freight caused by cold or rain.

ⒸThe French government is contemplating the placing of an order in this country for 20,000 and possibly 40,000 railway cars.

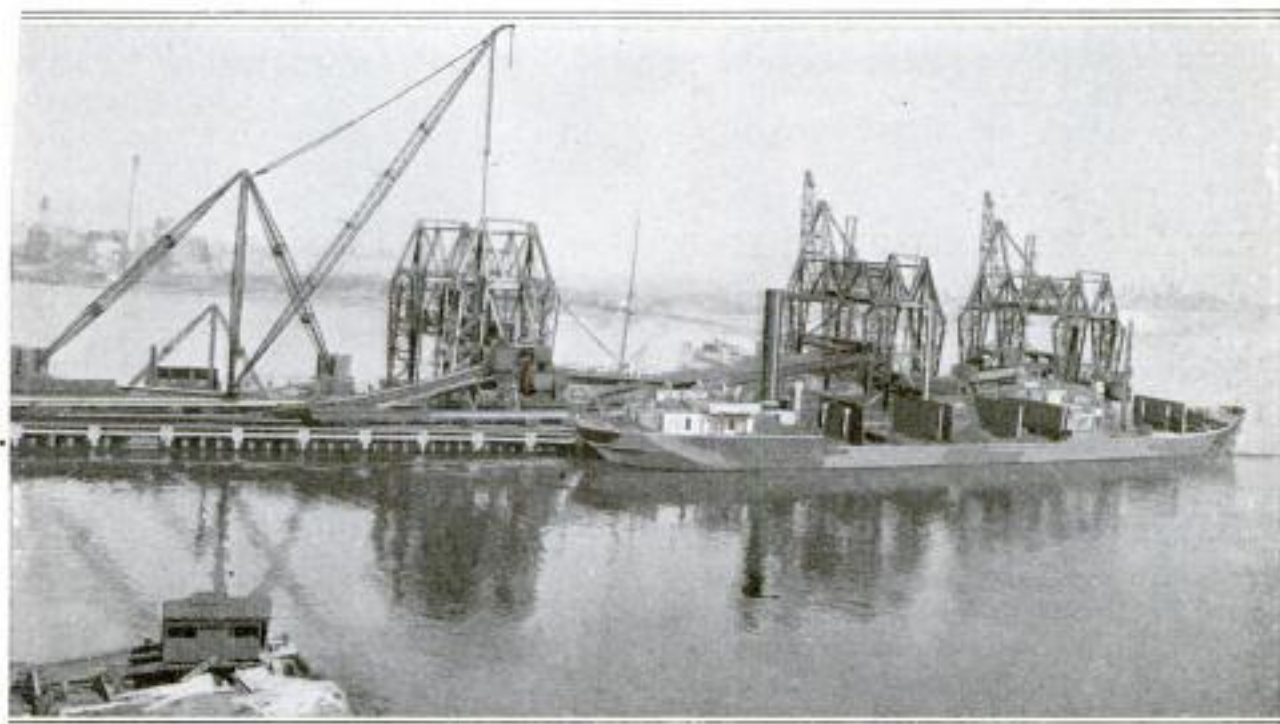

Shown Here, and Two Trimming Towers, That do Not Appear in This Picture, It Is Possible to Load Four Cargo Coal Simultaneously

FOOT AUTOS USED IN POSTAL DELIVERY SERVICE

Experiments made recently by the postmaster of Washington, D. C., have

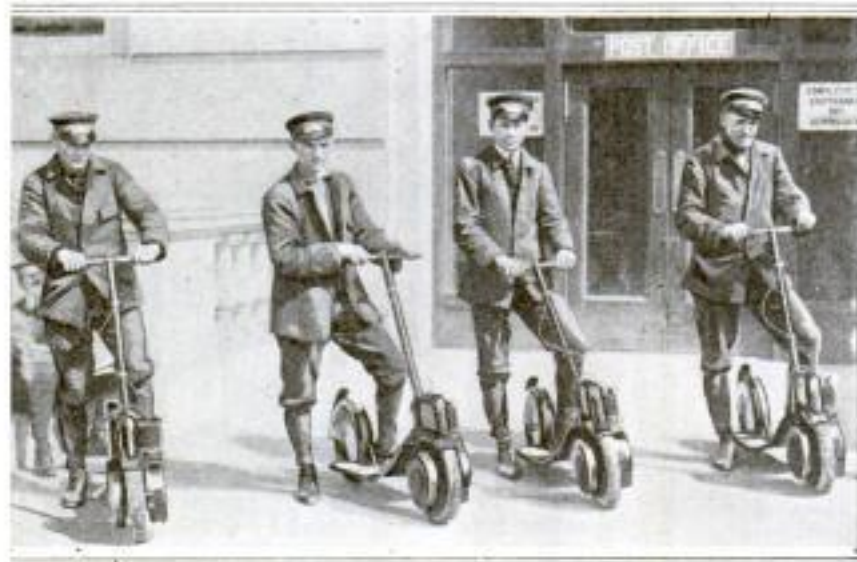

Special-Delivery Messengers of the Washington Post Office, Equipped with Foot Autos Which Did Good Service in a Recent Test

shown that small wheeled motors with a low platform on which the rider stands, can be successfully used in the special-delivery service. Five out of a force of 50 messengers were equipped with these machines, and the experience of the first three weeks of their use tended to prove their efficiency. The little motors cost less than \$100 apiece, and are reported to have given good service at the capital during the storms of the late winter.

ACETYLENE GENERATOR HAS AUTOMATIC FEED

An acetylene generator of recent English design is furnished with two generating chambers, one of which acts as a reserve. Only one is in operation at a time, and as it becomes exhausted the other is automatically switched into service, leaving the first free to be recharged and set so as to be automatically brought into action in its turn. Thus a continuous supply of gas is provided, there being no need of interruption when the carbide in either chamber has to be replenished. Carbide in any size can be used.

AMERICAN GLASS LEADING IN CHINESE TRADE

Most of the window glass imported into China at present is of American manufacture, instead of being the product of Belgian glassworks, as before the war. The United States also supplies the larger part of the plate-glass imports, and would supply practically all of both grades of glass, according to our consul general at Hongkong, if freight rates from this country were adjusted to meet those from Great Britain. Large stocks of Belgian and British window glass were on hand in Hongkong warehouses when

the war came, and it took a year or more to deplete these stocks and open the market for American glass, which was sent to China in large quantities in 1916.

WRAPPING PAPER UNROLLED EASILY WITH NEW RACK

An improved rack has been patented by means of which wrapping paper can be unrolled with one hand, while by

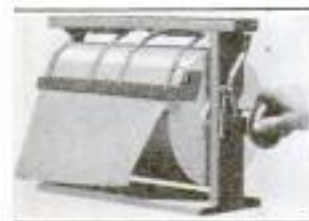

the same operation the torn edge of the paper is drawn away from the roll to which it tends to cling, so that the other hand can grasp it easily. The paper is unrolled by turning a knob on the end of the shaft on which the roll is mounted. By sliding this knob inward on the shaft a set of levers is operated which throws an arm between the roll and the torn edge of the paper, so that the latter can be taken hold of conveniently without rubbing the hand on the roll or crumpling the end.

CENTRAL HEATING PLANT FOR CITY BUILDINGS

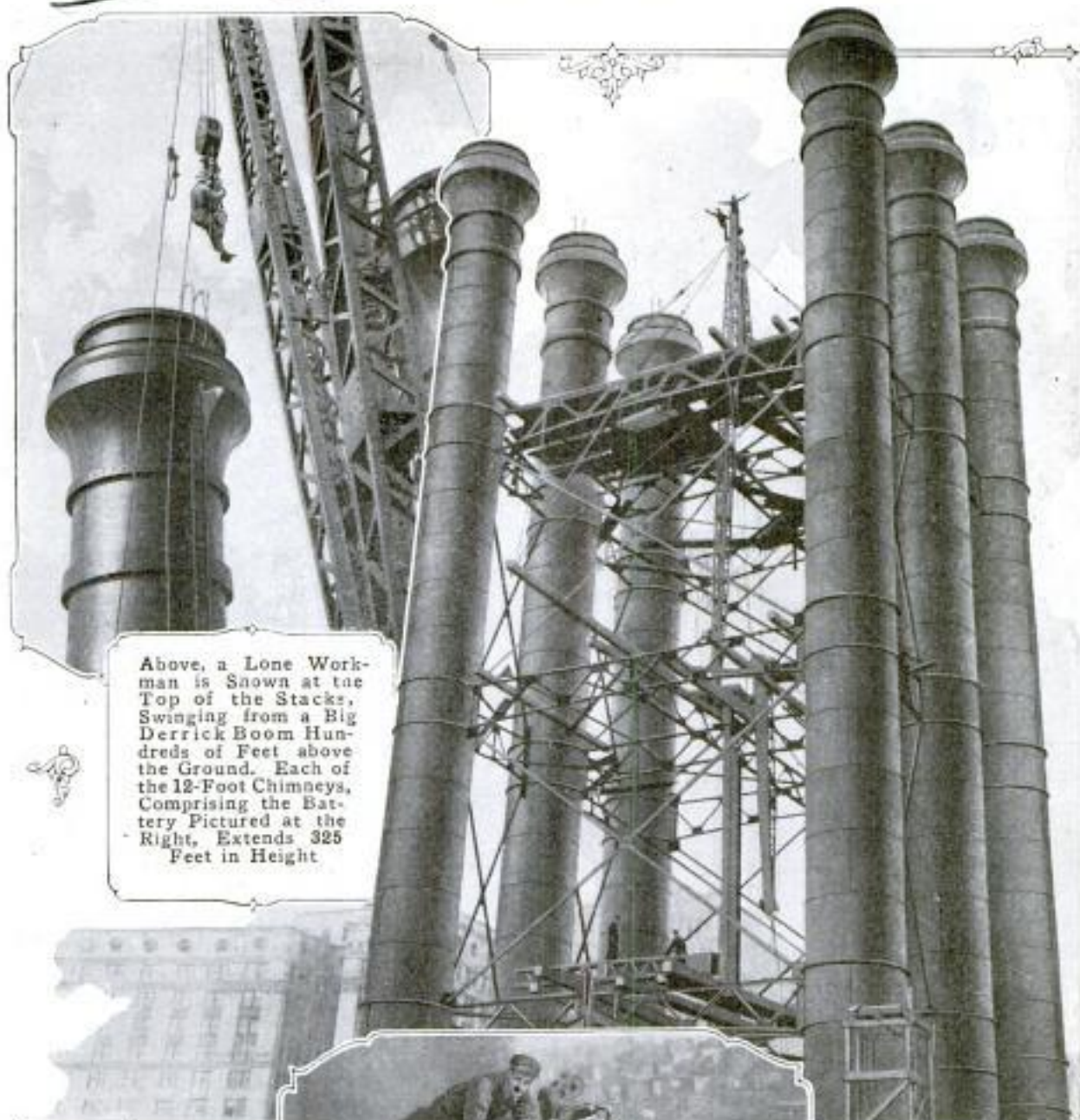

Above, a Lone Workman is Shown at the Top of the Stacks, Swinging from a Big Derrick Boom Hundreds of Feet above the Ground. Each of the 12-Foot Chimneys, Comprising the Battery Pictured at the Right, Extends 325 Feet in Height

Several of the Big Office Buildings in the Financial District of New York are to be Heated and Supplied with Power from a Central Station That is Now in the Course of Completion. The Plant Occupies a Four-Story Structure That is 150 Feet in Height, and Contains Rows of Large Boilers Which will Require a Daily Consumption of About 900 Tons of Coal. It Represents an Investment of Approximately \$1,500,000



The Firing Line is but One Place Where Cool Heads and Abundance of Nerve are Needed. Hundreds of American Structural Workers Demonstrate Capability and Fearlessness Daily While about Their Work, Which More Often than Not is Hazardous. The Picture at the Left, for Instance, Shows Two Men, More than 300 Feet above the Earth, Who are Completely at Ease Where Most Folks would Be as Limp as Rags with "Seasickness"

EVER-CHANGING COLORS LIGHT NEW AQUARIUM

A new type of aquarium is provided with concealed electric lights which beautifully illuminate it with constant-



Colored Electric Lights are Concealed in the Base of This Aquarium. Each is Controlled by a Separate Thermo-Switch and Flashes Intermittently, Suffusing the Water with a Constantly Changing Variety of Colors

ly changing combinations of color, making it a most attractive article for the home. The bowl, which is of clear glass and is hand-decorated, rests on a woven-reed base in which are installed

electric bulbs, each of a different color. Each light is controlled by a separate thermo-switch so that it flashes intermittently. By this means the aquarium is suffused with hues that are constantly changing, the variety being increased by the fact that no two switches operate in unison.

AEROPLANE ENGINE TESTED WITH A MOTOR TRUCK

In testing an aeroplane engine of 200 hp., a Detroit company recently mounted it upon a heavy motor truck and the aerial propeller sent the truck flying along a boulevard at the rate of over 40 miles an hour. This was a speed that the truck could not begin to develop under its own motor power, and the method furnished a better practical test of the 12-cyl. aeroplane engine than was possible in the testing laboratory, or in any stationary trial on blocks. As an additional test, the rear wheels of the two-ton truck were locked, so that they could not revolve, and in this condition it was driven across a ball park by the aeroplane engine and propeller, through heavy drifts of snow and over ice. The motor weighs 800 lb. and develops power sufficient to drive a 12-passenger aeroplane at 40 miles an hour.

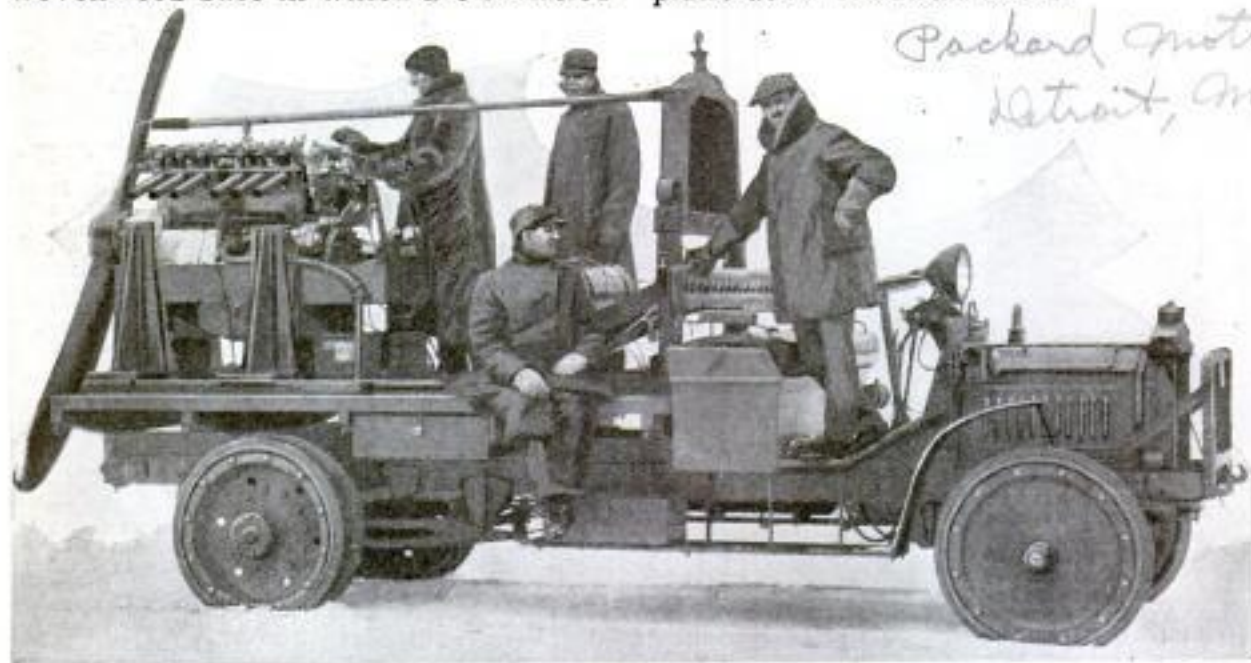

Aeroplane Engine and Propeller Mounted for a Test on a Motor Truck: The 12-Cylinder Engine Developed 200 Horsepower and Drove the Heavy Truck at a Speed of Over 40 Miles an Hour

Four Wheel Motor Trucks
Clinton

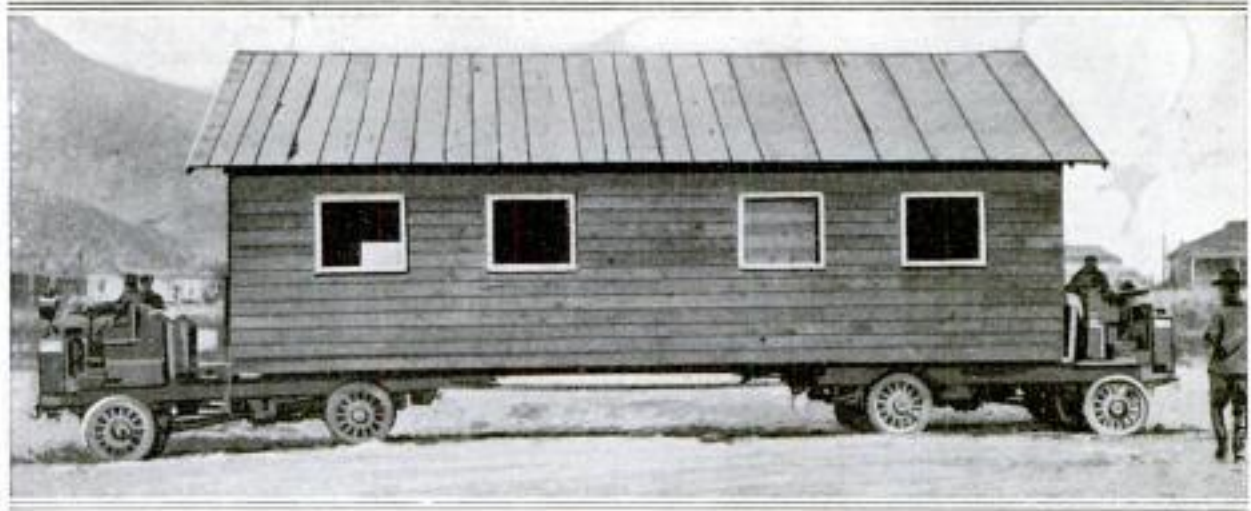

Company House being Moved from Camp Stewart to El Paso, Texas, on Motor Trucks: One was Placed under Each Corner, and the Rear Trucks Ran Backward the Distance of Nearly Eight Miles

MOTOR TRUCKS MOVE HOUSE ACROSS COUNTRY

With the departure of the National Guard from the Mexican border this spring, it became necessary to move one of the company houses from Camp Stewart to the motor-truck park at El Paso, Tex., a distance of 7½ miles. The building was 46 ft. long by 20 ft. wide, and ordinary methods of house moving could not be used, as it was not feasible to transport the building over the roads, because of trees, wires, and other obstructions. The difficulties vanished when four motor trucks were employed, one under each corner of the house. Then with the two rear trucks driving backward, on reverse gear, the trip was made across country, through gullies and ditches, in less than two hours.

BIG COLLIE IS CHAUFFEUR OF MASTER'S MOTOR CAR

Gear-shifting, of course, is outside the limits of possibility for him, but except for this operation a big collie, owned by a Poughkeepsie, N. Y., automobile dealer, is able to drive a motor car. Everybody along "auto row" in New York City was completely dumfounded not long ago when the dog acted as chauffeur for his master. While weaving in and out through Broadway's traffic, however, the owner

had an auxiliary control at hand to help the animal out of tight places and avoid the danger of a mishap. But on ordinary occasions when congested streets do not have to be negotiated, the collie drives along like a man, turning corners and avoiding other vehicles with surprising facility. On such rides his master sits beside him, or in the tonneau behind. On a track, where the chance of accident is eliminated, the dog drives alone with nobody in the



New Yorkers Stood Aghast Not Long Ago When This Dog Drove His Master down Broadway

car to help him. No special device is fixed to the steering wheel to assist him.

¶The progressiveness of the Japanese is well illustrated by the fact that at Port Arthur, Manchuria, they maintain an engineering college having six laboratories, one of which is electrical and well equipped.

Clinton
Poughkeepsie

87

BIG AMERICAN FLAG UNFURLED IN BOSTON

An unusually large American flag was unfurled on the day the war congress assembled, by a department store



Flag Unfurled in Boston as Congress Convened in Washington to Declare War

of Boston, Mass. It measured 100 by 50 ft. and when hung over the store front covered four floors of the building. Half a dozen buglers blew "To the Colors" as the huge flag was unfurled at noon, while all within sight sang "The Star-Spangled Banner."

MOVE TO RECLAIM TEXAS OVERFLOW LANDS

Areas of land in Texas estimated at not less than 6,000,000 acres, now of comparatively little value because subject to overflows or undrained, may be reclaimed if the people pass an amendment to the constitution, to be voted on this summer. This amendment provides for the establishment of suitable

reclamation and conservation districts without regard to county lines, and for the issue of bonds to cover the cost of the necessary projects, with the approval of the property owners of the districts affected. There are some 2,000,000 acres of overflow lands alone, lying along the principal rivers, and nearly all can be reclaimed by the construction of levees. Such lands have a present value of from \$15 to \$25 an acre, but in other cases, as soon as protected from periodical overflow, the value has jumped to between \$100 and \$150 an acre. A state conservation and reclamation association has been organized to work for the passage of the constitutional amendment, which is required to remove certain limitations of public effort.

SYSTEM OF FOOD CONTROL NEEDING NO TICKETS

Under a system of food control proposed in England to secure the same results as issuing tickets permitting the holder to purchase bread, meat, butter, and other supplies (the German system), every householder would be compelled to keep an official "housekeeper's book." All purchases of food would be entered in this book by the shopkeepers, and after a fixed date no food would be sold unless an official passbook was presented. The book would sell for two cents and upward, according to size. It would show the number of adults in each household, also the number and ages of children. Separate columns would be provided for entering different kinds of food, so that the quantities bought could be seen at a glance. No new book would be issued until the old one was returned for official inspection.

It is reported that there has been found in Texas a large deposit of bituminous rock filled with fossil fish very similar to those in the Austrian Tyrol whence America heretofore has obtained its ichthyol oil, a liquid much used for medicinal purposes.

4308
 Aug. 20, 1917
 Texas State Conservation and Reclamation
 Austin, Tex.

ROAD BUILDING IN THE PANAMA CANAL ZONE

AMONG recent improvements and innovations made by American engineers in the Panama Canal Zone may be reckoned many miles of surfaced and asphalt-concrete roads. Some of these roads rank with the best in the world, and make automobiling amid the tropical scenery delightful all the year round.

There is no road, however, across the isthmus, and as the completion of the canal has cut off highway communication between the two sides of the canal,

there are now three separate areas in which automobiles may operate. The

first of these is at the Pacific end of the canal, embracing the city of Panama and the Canal Zone as far to the northwest as the Chagres River; also the roads leading into rural sections of the adjoining Republic of Panama, known as the Sabanas district, in the direction of the ruins of Old Panama and the Juan Diaz River.

The roads in this area consist of 21 miles of city streets in Panama, 17.5 miles in the

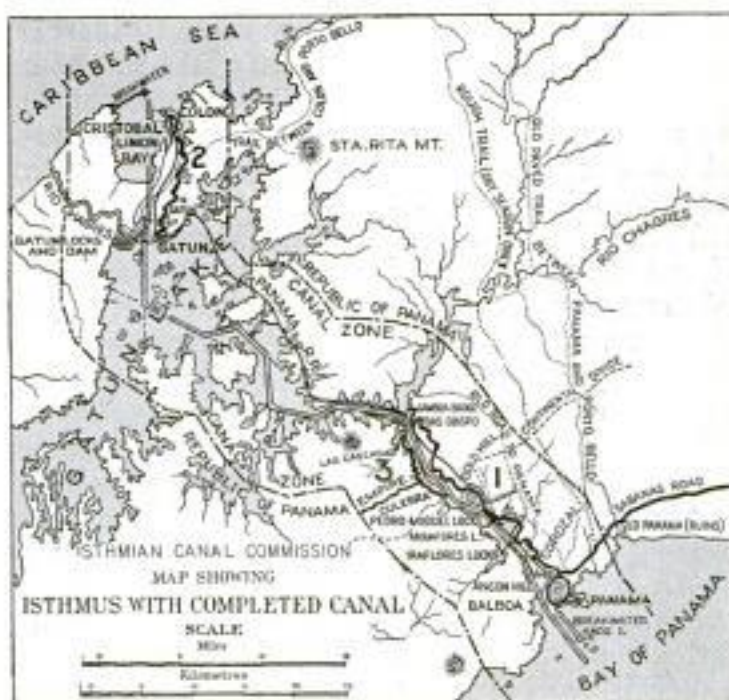

Where the Good Roads of the Panama Canal Zone are Situated: The Large Figures, 1, 2, 3, Indicate the Three Separate Areas Where Automobiling is Now an All-the-Year-Round Delight. The Asphalt-Concrete Roads, Indicated by the Heavy Black Lines, Are among the Best in the World

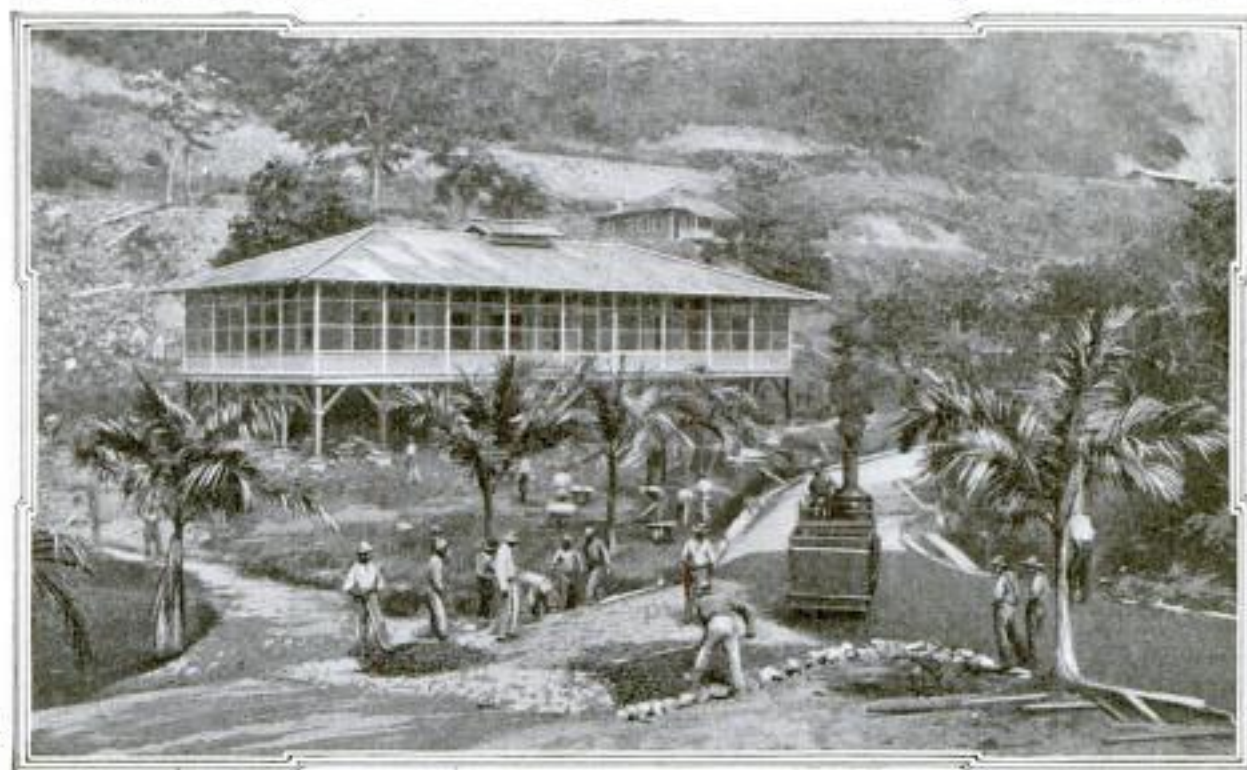

Laying the Asphalt Surface on One of the New Roads at Balboa: These Roads are Finished Like City Streets, and New Mileage is Added Every Year

Sabanas, and 48 miles in the zone. The total length of connecting highways is 85.3 miles.

The second important area of good roads is at the Atlantic or northern end of the canal. This includes the city of Colon with the adjoining town of Cristobal, having eight miles of streets together, and a road leading to Gatun, a distance of nine miles, making a total of 17 miles of road for this area.

The third area is on the west side of the canal and embraces the three villages of Culebra, Empire, and Las Cascadas, and a road running from Empire to the Canal Zone boundary—a total length of 18 miles of auto roads.

Improvement and extension of the roads in the zone and contiguous territory of Panama are going on all the time. The asphalt-concrete roads built at the south end of the canal—over 15 miles—are founded on a broken and rolled-stone base, on which is placed a layer of macadam, and finished like city pavements, with a surface layer of asphaltic concrete. These roads are proving durable, both against traffic and the wearing rains of the tropics.

There are about 600 automobiles licensed in the Republic of Panama and the Canal Zone, most of them operating under reciprocal licenses which allow them to travel in either territory. License fees in the zone were recently greatly reduced by executive order and are now as follows: for pleasure automobiles, \$5 a year; motor vehicles carrying passengers for hire, \$20 to \$30 according to power; auto trucks, \$20 to \$40 according to capacity; motorcycles, \$2. The speed limit is 25 miles an hour on straight roads and 12 miles in city or village streets, or when approaching another vehicle or traversing curves, forks, or crossroads.

Chauffeurs licensed to drive in the Canal Zone are required to carry an official card of identification, under a recent regulation designed to do away with abuses of licenses in the illegal transfer of badges and license cards to others than the authorized holders. This card states the age, color, sex, height, weight, color of hair and eyes, and nationality of the holder, and bears a photograph made by the official photographer at Balboa Heights.



Highway Scene in the Panama Canal Zone, Where the Highest Products of Modern Engineering Skill and Scientific Road Building are Faced by the Structures of a Primitive People



Two of the Motor Busses Operated by the Panama Railroad Company in the Canal Zone are Shown in the Photograph Above, Running on a Smooth-Paved Highway Typical of the Good Roads Which American Engineers have Recently Built



A Charming Bit of Scenery on One of the New Panama Roads: With Tropical Vegetation, Feathery Palms in Profusion, and Smooth Dustless Highways, the Lot of the Motorist in the Canal Zone is a Happy One



One of the Recently Finished Asphalt Streets at Balboa: With a Base of Broken Stone, Layer of Macadam, and Surface of Asphaltic Concrete, They Stand the Tropical Rains Well



All the Roads in the Zone Are Good, in the Sense of being Easily Traveled Over. The Road Shown Here Is Capable of Improvement, but Its Delightful Surroundings Make It a Popular Drive for the Panama Motorist

LINCOLN STATUE UNVEILED IN CINCINNATI

One of the most notable products of American sculpture in late years was



Scene at the Dedication of the Lincoln Statue of Heroic Size, Recently Presented to the City of Cincinnati by a Newspaper Editor and His Wife

unveiled before a great throng of citizens in Cincinnati on March 31, when a fine statue of Abraham Lincoln appeared to public view. The statue is of heroic size and towered above the heads of the crowd that filled the public square selected as the site, to listen to the presentation speeches.

INDOOR AIR RIVALS DESERT IN ARIDITY

That the air in certain well-ventilated, steam-heated offices is drier in

winter than the air of a desert, was shown by tests of indoor and outdoor humidity made by an observer of the United States Weather Bureau at Topeka, Kans. Observations were made three times daily for 40 days in the office in question, which was kept at a temperature of 72°. For the period the average indoor relative humidity was found to be 23, which approxi-

mates that of Death Valley, Calif., in the summer. The outdoor humidity in Topeka, during the period in which the test was made, averaged 82. The average relative humidity during the driest month of the year is about 35 in Yuma, Ariz., and 29 in Santa Fe, New Mexico.

J. Im...

ELECTRIC DECORATIONS FOR INAUGURATION WEEK

Among the many decorations that gave Washington a gala appearance

during inauguration week, the electric display on the government printing



Government Printing Office in Washington as It Appeared at Night during Inauguration Week: The Lights Which Outlined the Building Were Red, White, and Blue. The Rest Were White

office attracted special attention. Red, white, and blue lights showed the outline of the building at night, while white bulbs were used in making a large map of the United States on the side of the structure. In the center of the map was a profile of the president and on either side of it were the words "Our Country" and "Our President." A large five-pointed star was placed just above the map.



Unusual Structure Made from 600 Tons of Baled Alfalfa, in Which Washington Farmers Held Their Country Fair. The Walls Were 25 Feet High and the Building was Electrically Lighted

"PALACE" OF BALED ALFALFA HOUSES FARMERS' FAIR

Farmers in the vicinity of Sunnyside, Yakima County, Wash., did a distinctive thing when they erected a "palace of hay" in which to hold their annual country fair. Some 600 tons of alfalfa were used in building the structure, whose walls were 25 ft. high. It not only housed all the exhibits, but a rest room, information bureau, and a grand stand in front of which a vaudeville program was given daily. The hay was loaned by the farmers and at the end of the fair was auctioned off at a very good price.

NEW FOOD-DRYING PROCESS HAS MANY ADVANTAGES

A process of drying fruits and vegetables is now being employed in this country by which it is claimed the weight of a truck load of mixed vegetables can be reduced to 100 lb. Treated in this way the food retains its flavor and fresh taste because its cellular structure has not been injured by the desiccation, it is said, and on being soaked in water it regains much of its former fresh appearance. A pound of dried soup vegetables will make soup for 60 persons. Special interest attaches to the process at this time because of the advantages it offers in provisioning troops. The new method involves the use of air heated to a more

moderate temperature than is usually employed abroad in such work, and in insuring a thorough circulation of the air, so that it reaches every particle of the fruits or vegetables being treated. From two and one-half to five hours is required to complete the process.

— *Universal* — FIVE-HANDED WATCH TELLS TIME OF FOUR ZONES

The four hour hands with which the novel watch, shown in the accompanying illustration, is provided are so arranged that they indicate the time of day in the four time zones into which the country is divided. One hand is silver and is set according to eastern time. The one next to it is blue and indicates central time. The third hand is red and shows mountain time, while the fourth is green and is set the same as the watches and clocks on the Pacific coast. A timepiece of this sort is serviceable to men in transportation service and also for persons in such cities as Detroit, where the railways follow a different time system from that obtaining in the municipality.



OLD HORSE TEACHES OTHER HORSES TO DIVE

The task of the diving horse shown in the accompanying illustration is not merely to give exhibitions for its mas-



Horse Diving from a Platform 30 Feet High, in an Oakland, California, Park: This Animal is Said to Have been Diving 23 Years and Serves as a "Teacher" for Other Horses

ters in a California amusement park, but also to teach scores of other horses to dive. The animals that are in training are allowed to watch their "teacher" make several plunges from the second platform, which is 30 ft. high. They are then made to leap from the first platform, which is 15 ft. high, and after a few trials they seem to lose their fear. The more experienced animal has been diving for 23 years, it is said. One of its tricks is to make the plunge with a woman on its back and then swim to shore with its burden.

GREAT BRITAIN MAKES MOVE TO SAVE FUEL RESOURCES

Fuel conservation is one of the vital problems that has been faced in Great Britain since the government assumed control of the coal fields. A special board has been appointed to carry out a broad program of scientific inquiry. The importance of the step will be appreciated when it is remembered that the water-power resources of the British Isles amount to comparatively little, and that the kingdom's industrial progress depends almost entirely upon its fuel supply. The board is charged with the task of investigating the character, preparation, and use of all kinds of fuel available. Recommendations made by it, and approved by the advisory council and the privy council's committee of scientific and industrial research, will be carried into effect. In this way it is hoped to uncover new sources of fuel and save millions of tons now wasted.

AIRMEN SCATTER FLOWERS UPON COMRADE'S GRAVE

When Peter Carl Millman, the airman, was buried a few weeks ago, flowers were dropped upon his grave from a dozen aeroplanes that circled above the little churchyard in the East where the funeral service was conducted. It was in this way that a group of the airman's comrades paid to his memory a picturesque and fitting tribute that impressed itself upon the minds of all those present. The custom is one which has been observed many times, especially among the gallant fellows at the front. While the deceased, who was popularly known as "Tex" Millman, was not killed in action, the final rites were no less filled with meaning. The flier, a mere youth, was an instructor of the First Aero Corps. He was known in many parts of the country for the spectacular feats he once performed in exhibition flights. In his five years of aerial experience, he never met with accident. His death was due to pneumonia.

*John Miller
 1917
 Cal. and Cal. Museum*

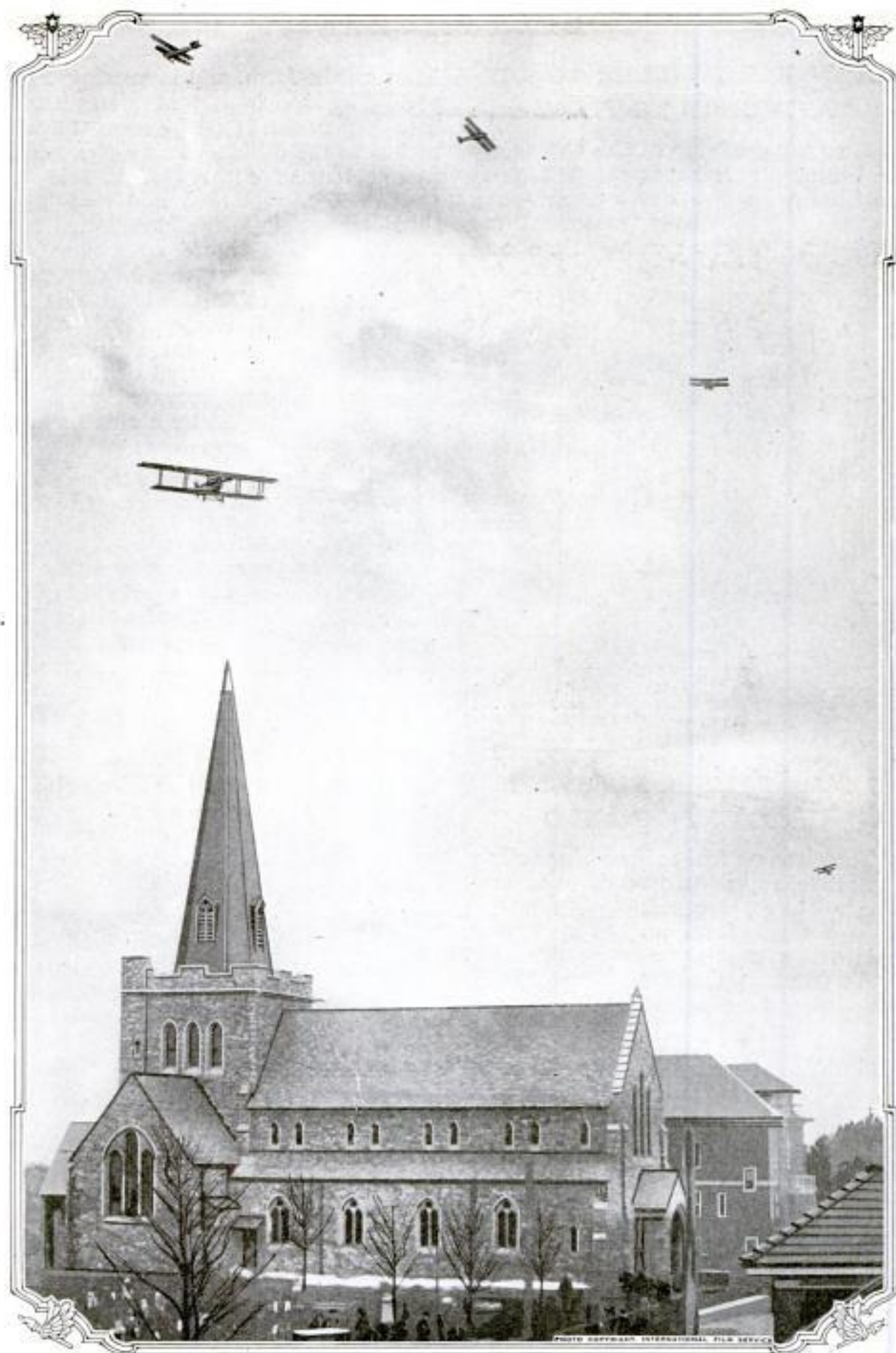

Scattering Flowers upon the Grave of "Tex" Millman: Five of the Twelve Aeroplanes That Cirled Aloft during the Airman's Burial in the Little Churchyard

NEW FARM TILLER TO BE ATTACHED TO PLOW

A young graduate of the University of Minnesota Agricultural College is credited with the development of a new implement for saving time and

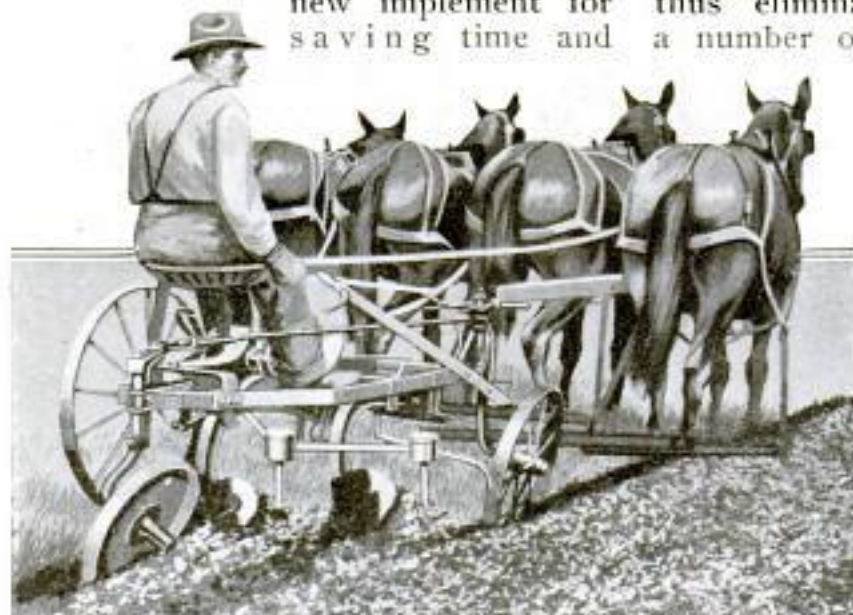

Plowing with a New Tilling Attachment Which Makes a Good Seed Bed at One Trip of the Implement: The Rotor Seen to the Right of Each of the Plowshares is Provided with Steel Teeth Which Pulverize the Soil

labor on the farm, and increasing crop yields by an important percentage. The implement is designed to be attached to the ordinary sulky plow, and in one trip over the field is said to prepare a perfect seed and root bed, thus eliminating the necessity for a number of separate operations of harrowing, disking, and rolling. It consists of a steel-toothed rotor, set to the right of the moldboard of the plow and operated at high speed by a small gasoline motor, which is mounted on the frame of the plow. The revolving teeth pulverize and mix the soil as it is turned up, and throw it out evenly at the rear. Seeding may be done at the same time if desired. A larger size of the tiller is made for use with a tractor.

MOVIE-CAMERA PLATFORM ON FRONT OF AUTO

The close-up front views of speeding motorists, reproduced so often in motion pictures, are not always taken from an automobile immediately in front of the car containing the actors but frequently are obtained from a platform projecting in front of the machine photographed. Film directors have found that the latter arrangement insures accurate focus of the camera and, of course, dispenses with the use of a second automobile. The platform is supported by strong beams that project under the car and rest on the bumper,

thus relieving the camera of considerable jar. The support is large enough to hold two men and the camera, the latter being securely fastened in place by means of a rod and wire.



Motion-Picture Photographer Obtaining a Close-Up View of Speeding Motorists: The Camera is Securely Anchored to the Platform

COMMENT AND REVIEW

WOULD you trust an important message to a telegraph operator who first touched his finger to a key only the week before? Would you choose to operate on your limb or body a medical student in his freshman year? Would you want to ride on a railroad train behind an engineer who had previously been only a chauffeur? Or do your banking with a popcorn wagon? Not one of these possibilities is a bit more illogical or absurd than to expect raw, untrained troops, in whatever numbers, either to safeguard us against threatened invasion or defend us when one is made.

*Universal
Training the
Only Way*

These very words will be read by more than one man who at some time was a victim on stagecoach or passenger train where a single bandit, armed only with a mask and revolver, held up and robbed the entire party, and simply because they were unprepared.

It is not surprising that our people hesitated when universal military training was proposed. It seemed to savor too much of Prussianism to the Simon-pure American; and to the son born here of foreign parents it appeared as one of the chief reasons why his parents left their fatherland and crossed an ocean to find liberty. However, an unpleasant duty has rarely been fully met by volunteers—suppose only volunteers paid taxes, for instance! To rely on volunteers puts a penalty on patriotism and rewards the unpatriotic; there is nothing fair or just in it. We are not a warlike people; we have no desire to add to our territory unless by friendly purchase; and it is hardly believable that any congress would declare war with an overwhelming majority of the people set against the undertaking. The training of our future armies should begin in the high school and continue until we have at all times at least 2,000,000 men ready for active service.

I have no patience with the weaklings who cry "disgrace to be drafted." Is there any disgrace, or only honor, when the family threatened by a madman, the father calls all his sons who are fit to come to his assistance in its defense? When Uncle Sam calls, all the boys should respond.



FROM all the angles of improved self-respect, physical development, recognition of authority, and a better rounded-out young manhood, the military training has everything to commend it. There

*Training
a Good
Thing*

is a great difference between the three consecutive years required in some European countries and what is contemplated here. Nor is there any probability that the American spirit would ever lead our officers to assume or tolerate that arrogance and personal abuse of their inferiors in rank which has existed for years in the army life of Germany. This is illustrated in a story told me a few days ago by a private in the national guard of a southern state, which had just returned from several months on the border. When they first reached Texas not a few of the members were fresh volunteers, with considerable to learn. Their commander, a regular-army man who had been many years in the serv-

ice, when making an inspection at two o'clock in the morning, found one of the new men, who was on sentry duty, asleep. Next morning the offender was called before the officer, who read him the regulations and the punishment prescribed in such cases. He did so in a firm but not unkindly manner. Then he said to the boy: "Do you realize that when on sentry duty you occupied not only a place of utmost responsibility, but the highest position in the country?"

Inasmuch as the camp was many miles from the border, with thousands of troops between himself and Mexico, the private admitted it had not occurred to him. "But you did," continued the officer, "for as sentinel you had authority to stop and challenge the President of the United States." The young man accepted the light punishment imposed with a grateful heart and became one of the best soldiers in his company. The incident, however, not only illustrates the need of proper training, but of that spirit of personal interest on the part of the officer in a well-meaning but very raw recruit, which marks the difference between Americanism and Prussianism.

While the military training will do great things for the young man of good family and sterling principle, it will do vastly more for thousands of young men who have drifted into a more or less purposeless mode of life, a class from which the great army of young criminals are enlisted. It will make men of these. A Chicago judge, who sat for years on the bench of both the city and county criminal courts, says: "If every idle young man in Chicago between 17 and 25 were put into a military-training camp today, the criminal cases would decrease 80 per cent tomorrow. And when they finish their training, thousands would have been transformed into real men with respect for themselves, who now respect neither themselves nor anything else."



THE report in this issue on conditions found at the recruiting stations, by a member of our staff, may be disappointing but is by no means disheartening, for Chicago and Illinois then led the country in enlistments. On the very day when these slackers were hiding behind a marriage license, 3,200 Chicago high-school boys, from 14 to 17 years of age, with a few 18 years old, were parading the loop in Chicago, carrying real muskets, and displaying a military bearing and drill of high order. Old soldiers who viewed the parade almost wept for joy at what the boys had accomplished with only three weeks' drill, and that in addition to their regular high-school work.

*Why
Are
Slackers?*

Let us not delude ourselves, however, with the hope that we can make a seasoned army in a few weeks. We flatter ourselves we can deliver a well-drilled soldier in as few months as any other nation, and quicker than some; but as in many other processes, a certain minimum is inexorable and cannot be reduced.

Why are not the young men thronging to the colors instead of to the license bureau? While scorning the slacker, let us be fair, and not

include scores of those youthful grooms who married because they enlisted the following day.

And why are the young men not enlisting by the ten-thousands?

For the same reason these same young men—and the majority of older ones—do not make their will. The reason for enlisting and the reason for making a will appear as a vanishing point on a far-distant horizon. Today only a few people, comparatively, actually realize we are at war. Our cities are not being bombarded; hostile troops are not sweeping across the land with the devastation of a cyclone; enemy ships have thus far not possessed our ports of entry nor burned our coast cities. For nearly three years we have been saturated with war news, but of a war which seems almost as far away as if on another planet. And we have thought and read and talked of this far-away war so long, our eyes have become adjusted to long-distance lenses, and we do not instantly change their focus to here and now.

Then, too, the stories of months of inactivity, so far as any offensive or defensive is concerned, brought back by the thousands of state militia who were camped in Texas, have given the impression of an apparently purposeless mobilization. It was by no means purposeless, although one company of cavalry of which I knew was five months in camp near El Paso, and during that time was allowed to fire only 10 shots per man in target practice. These conditions have doubtless caused a certain reaction, for if there is any one trait which stands out strong in the American, it is an overwhelming aversion to what he considers inactivity. If there were to be real fighting tonight or tomorrow millions of the untrained would impulsively grab a gun and go out to the combat with the same promptness and zeal as the farmers at Lexington and Concord, and with nothing like their preparedness. But they would go; and what a wicked, needless penalty to pay! The experience of the English, as stated by the visiting commission now at Washington, should forever settle this question, which admits of no argument.

We will awake to the situation, but it may take us some time to do so. Even in England enlisting was no tidal wave until a few Zeppelins had cast their deadly shadows and the noise of falling bombs awoke the sleeping thousands.



VAST amounts of edible corn, tomatoes, pickles, string beans, pumpkins, apples, peaches, grapes, and other fruits and vegetables, are allowed to rot on the ground each year in this country.

*Can Food
at
Home*

The average family with a garden is supplied so bountifully during the season that long before the first killing frost comes waste begins. In the country and country towns especially, there is little or no profitable market for the overproduction. This year not a pound of vegetable food capable of being saved, by drying or canning or preserving, should be allowed to spoil.

The boys can render splendid service by care of the garden and gathering the produce, and the girls can do their part in preparing and canning. The process of cooking for canning is not difficult to learn,

nor too exhausting to perform, and this year we should put upon our shelves for next winter's consumption millions upon millions of quarts of canned food. This will release an equal amount, which otherwise would be taken from the output of the big canneries, and which can go to feed our own Army and Navy or be shipped abroad to starving Europe. No boy or girl need wait until he or she is older in order to do some great thing. If only 5,000,000 families can an extra 100 jars each, the result will be 500,000,000 jars more than last year, and that is anything but a small accomplishment. Don't let a pound of food go to waste this year. Those of us who are not already thrifty must learn to become so, and once the habit is formed, the results are so surprising and satisfying it becomes a pleasure.



WE are very short on sheep. Our 50,000,000 sheep at their best can only grow enough wool to make each one of us a suit of clothes once in four years. The foreign wool which under normal conditions came to us is now largely diverted to war purposes. Thousands of boys and girls can each raise one or two sheep and find sufficient pasture on their own lawn, thus turning into food and clothes the grass which has previously been thrown away. More poultry can be kept, and be fed on the present waste from kitchen and table. We must all learn thrift,

*Boys,
Raise
a Sheep*

and break away from our thoughtless, heedless disregard of waste. Waste is little short of a crime at any time, and fully that in these days when millions are sadly underfed and thousands are actually starving.



IT has always been the policy of this magazine never to reprint an article which had once appeared in its pages. For the first time in its history I will break the rule with the following from an editorial in our October, 1912, issue:

*High
Standard
in Our Navy*

The transformation from the sail-propelled man-o'-war to the complicated mass of machinery known as the modern battleship is not one bit more pronounced than the improvement which has taken place in the personnel of the men who compose the human working parts of these great machines. Time was when the Navy was looked upon by many as a sort of reform school, a last resort to which young men could be sent who were not quite bad enough to be put in jail and not good enough to roam at large. Such conditions have fortunately passed away and the American Navy today is composed of brains and muscle of the highest order and a personnel of which the country can well be proud. I was specially impressed with this fact when during the past season I spent some days in a well-known New England port which is seldom without one or more naval vessels during the summer. At this particular time there were four battleships and eight smaller fighting craft, with a total of over four thousand men on board. On two of the battleships

the men had not set foot on land for six months — an unusually long time — and naturally were anxious to get ashore. When I saw the ships' steam launches towing the long lines of boats filled with a thousand men with 24 hours' shore leave, "a hot time in the old town tonight" seemed to me inevitable. And there's where I guessed wrong. The young men were allowed the fullest liberty; they had plenty of money and were very live wires; and the saloons and places of amusement were making special efforts and working overtime to attract visitors.

When the 24 hours expired and the launches came puffing into dock again, I watched the boys load into their respective ships' boats, and out of the thousand, two, just two boys, required assistance from their comrades. And the chief of police told me his men had not had occasion to arrest a single man. To me the high standard of conduct, the respect for the uniform, and respect for one's self, which is taught these young men, was a most impressive thing. Can you imagine 1,000 young men of equal age, landsmen, including clerks in banks, offices and stores, and skilled young men in all the various mechanical trades, going out on their first holiday in six months, with plenty of money to spend, and all restraint removed, and coming back at the end of 24 hours with only two men "disabled"?

The conduct of the boys of the Navy, ashore in their own land, with less necessity for constraint than in a foreign port, deserves the highest commendation, and better words of praise and congratulation than these few lines express.

April 25th.

H. H. WINDSOR

SEE FRONT
NEW YORK
115 EAST 23RD STREET
RECRUITING STATION
NEW YORK OFFICE
TELEPHONE
115 EAST 23RD STREET
NEW YORK

UNITED STATES NAVY
RECRUITING STATION
24 EAST 23RD STREET
NEW YORK, N. Y.
TELEPHONE 448-8400 (4 LINES)
TELEPHONE CABLE 1281

SEE FRONT
RECRUITING STATION
115 EAST 23RD STREET
NEW YORK OFFICE
TELEPHONE
115 EAST 23RD STREET
NEW YORK

J. J. Dowling

Dear Sir:

I am sorry that the rigid physical requirements make it impossible for you to serve your country in the Navy in time of war. There is good reason for such rigid requirements, so you should not worry about not passing.

I feel that since you have been patriotic enough to volunteer, you should have something to show for it, so that no one will have the right to call you a "Slacker." Therefore, with this letter is a button for your coat. Wear it. It is an honor to have the right to.

If, as a result of wearing this button, and showing this letter, you influence some other man to come forward, you may, in that way, help your country, possibly as much as if you had actually "done your bit" in the Navy.

Now, just a word of caution. It would be highly dishonorable for you to permit any one else to wear this button. It would give him a chance to pretend to do what you have actually done. If you do not care to wear it, and treasure it, put it in an envelope and mail it to my Navy Recruiting Officer. But the right thing to do is to wear it and be proud of it. And if any one ever questions your patriotism, show him this letter. It shows that you have honestly tried to do your duty by your country.

Respectfully, *J. H. Taylor*

U.S. Navy,
Recruiting Officer.

HONOR BUTTONS PRESENTED TO REJECTED VOLUNTEERS

Upon our entrance into the world conflict, prompt steps were taken by navy recruiting stations at New York to protect men of patriotic motives from being confused with spineless slackers because of their civilian attire. Buttons bearing the inscription: "I have volunteered for the navy—have you?" were issued for persons who applied for enlistment but, because of physical imperfections, could not be accepted. When presented, the badge is accompanied by a letter which establishes the holder's right to wear it in full view on the lapel of his coat.



If a New Yorker,
and Not in Uniform,
This Button
will Show Your
Spirit

INTERESTING VIEWS OF OUR COAST DEFENDERS

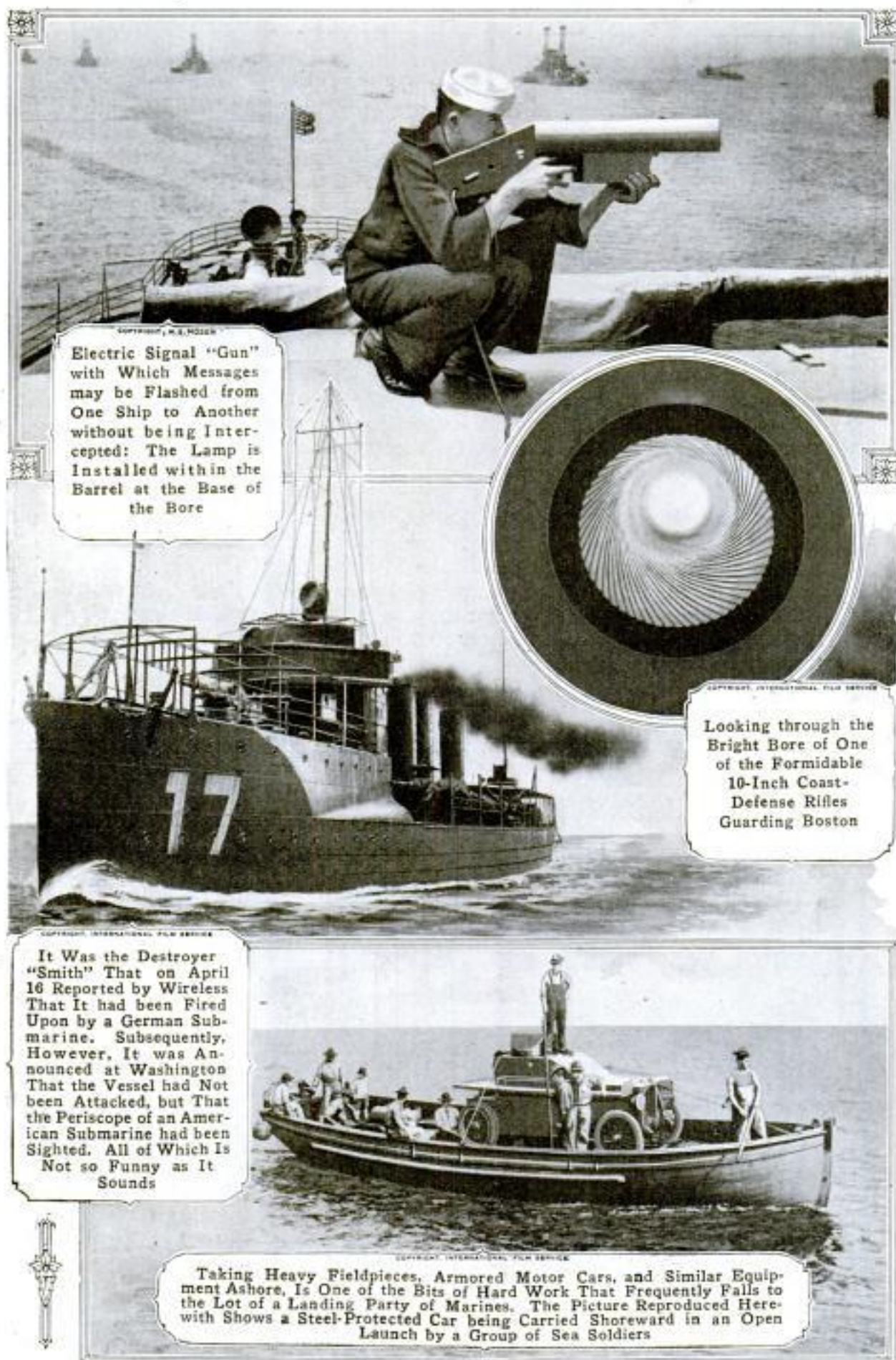

COPYRIGHT, M. S. HOLLER

Electric Signal "Gun" with Which Messages may be Flashed from One Ship to Another without being Intercepted: The Lamp is Installed within the Barrel at the Base of the Bore

COPYRIGHT, INTERNATIONAL FILM SERVICE

Looking through the Bright Bore of One of the Formidable 10-Inch Coast-Defense Rifles Guarding Boston

COPYRIGHT, INTERNATIONAL FILM SERVICE

It Was the Destroyer "Smith" That on April 16 Reported by Wireless That It had been Fired Upon by a German Submarine. Subsequently, However, It was Announced at Washington That the Vessel had Not been Attacked, but That the Periscope of an American Submarine had been Sighted. All of Which Is Not so Funny as It Sounds

COPYRIGHT, INTERNATIONAL FILM SERVICE

Taking Heavy Fieldpieces, Armored Motor Cars, and Similar Equipment Ashore, is One of the Bits of Hard Work that Frequently Falls to the Lot of a Landing Party of Marines. The Picture Reproduced Here-with Shows a Steel-Protected Car being Carried Shoreward in an Open Launch by a Group of Sea Soldiers

BRITISH AND FRENCH COMMISSIONS IN AMERICA



The French Commission, Headed by René Viviani, Former Premier, Entering the Gates before the Henry White Residence at Washington. Where the Members were Entertained during Their Visit at the Capital. They were Escorted through Cheering Throngs by the Mounted Guard that is to be Seen Drawn Up along the Curb



Approaching the State Department Building to Call upon Secretary Lansing, the British Foreign Minister, Arthur James Balfour, Middle, Chief of the British War Mission, and, Left, Sir Cecil Spring-Rice, British Ambassador

Arrival of France's Official Representatives to the War Conference: The "Mayflower," the Presidential Yacht, Which Carried the Visitors to the Navy Yard, Is Visible in the Background. In the Foreground, Left to Right, Are: Secretary Lansing, Marshal Joseph Joffre, and Former Premier René Viviani

The Breckenridge-Long Residence Was the Headquarters of the British Mission. The Picture Shows the Crowd That Formed before the Grounds When the Party, Headed by the Right Honorable Arthur James Balfour, was Received. Both the French and British Delegations were Welcomed Tumultuously by the Populace



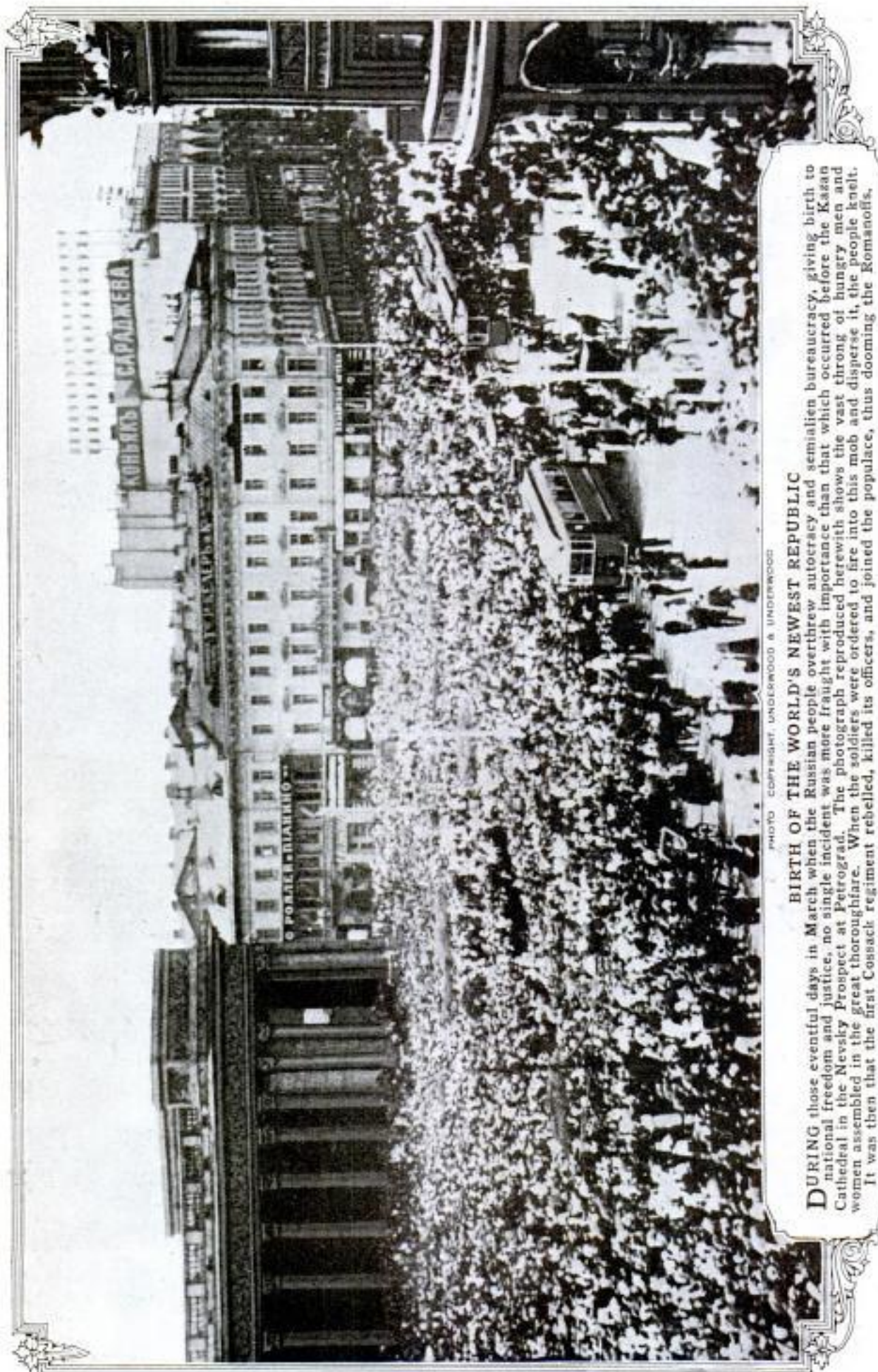
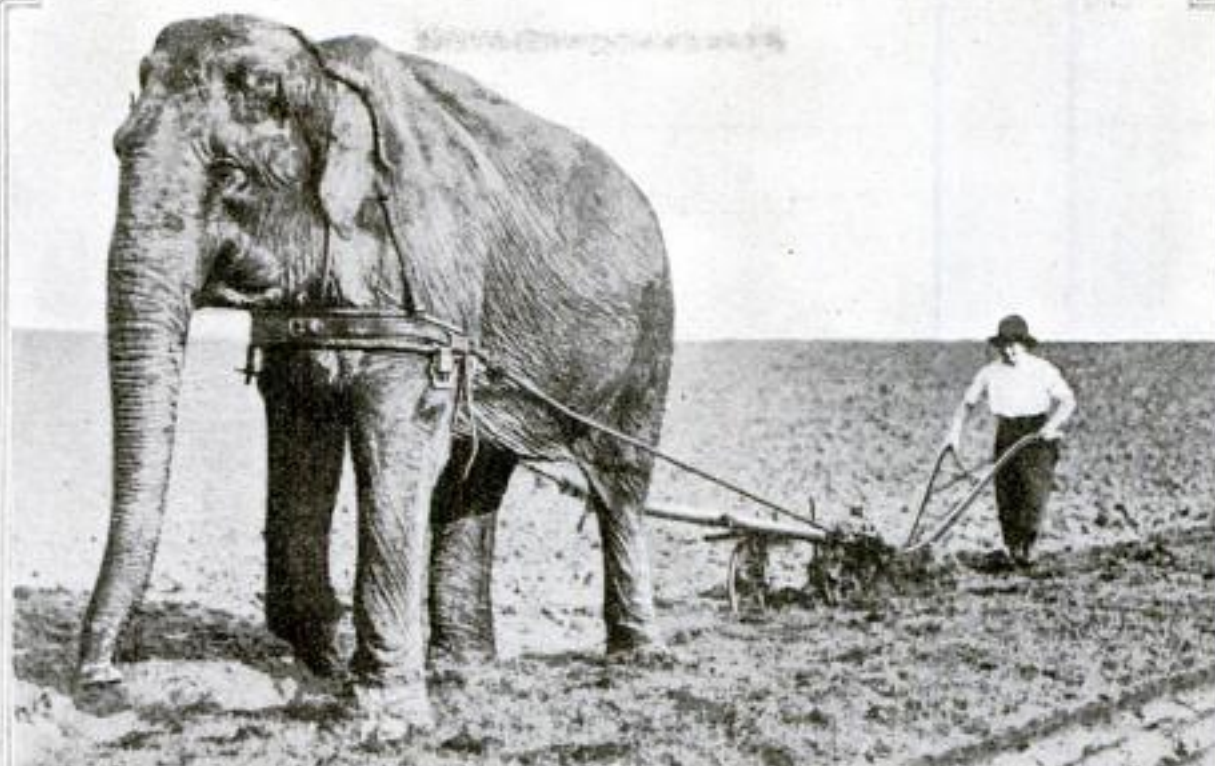

PHOTO COPYRIGHT, UNDERWOOD & UNDERWOOD

BIRTH OF THE WORLD'S NEWEST REPUBLIC

DURING those eventful days in March when the Russian people overthrew autocracy and semiautocratic bureaucracy, giving birth to national freedom and justice, no single incident was more fraught with importance than that which occurred before the Kazan Cathedral in the Nevsky Prospect at Petrograd. The photograph reproduced herewith shows the vast throng of hungry men and women assembled in the great thoroughfare. When the soldiers were ordered to fire into this mob and disperse it, the people knelt. It was then that the first Cossack regiment rebelled, killed its officers, and joined the populace, thus dooming the Romanoffs.

FOOD PREPAREDNESS NEW PHASE OF WORLD WAR



Vital Counsel for America is Given by the Two Photographs Presented on This Page: Each Shows at a Glance the Extremities to Which England is Going in Its Struggle for Food. The Picture Above was Not Inspired by a Circus Press Agent, for in Great Britain Men and Horses Are at the Front, While Women—and Even Elephants—are Plowing the Ground and Making Every Fertile Acre Produce



Plowing at Night, Not While Others Sleep, but While Men Fight: The Conservation of Time is as Important as the Utilization of All Available Energy, and Thus Acetylene Lamps are Lighted and Work Continued When Darkness Shrouds Rural England. The Cry for Food is Not the Cry of Alarmists; It is the Famished Wail of Starving Multitudes. America Has No Alternative: It must Till Its Soil or Go Hungry

GLIMPSES OF FRANCE'S GALLANT HEROES

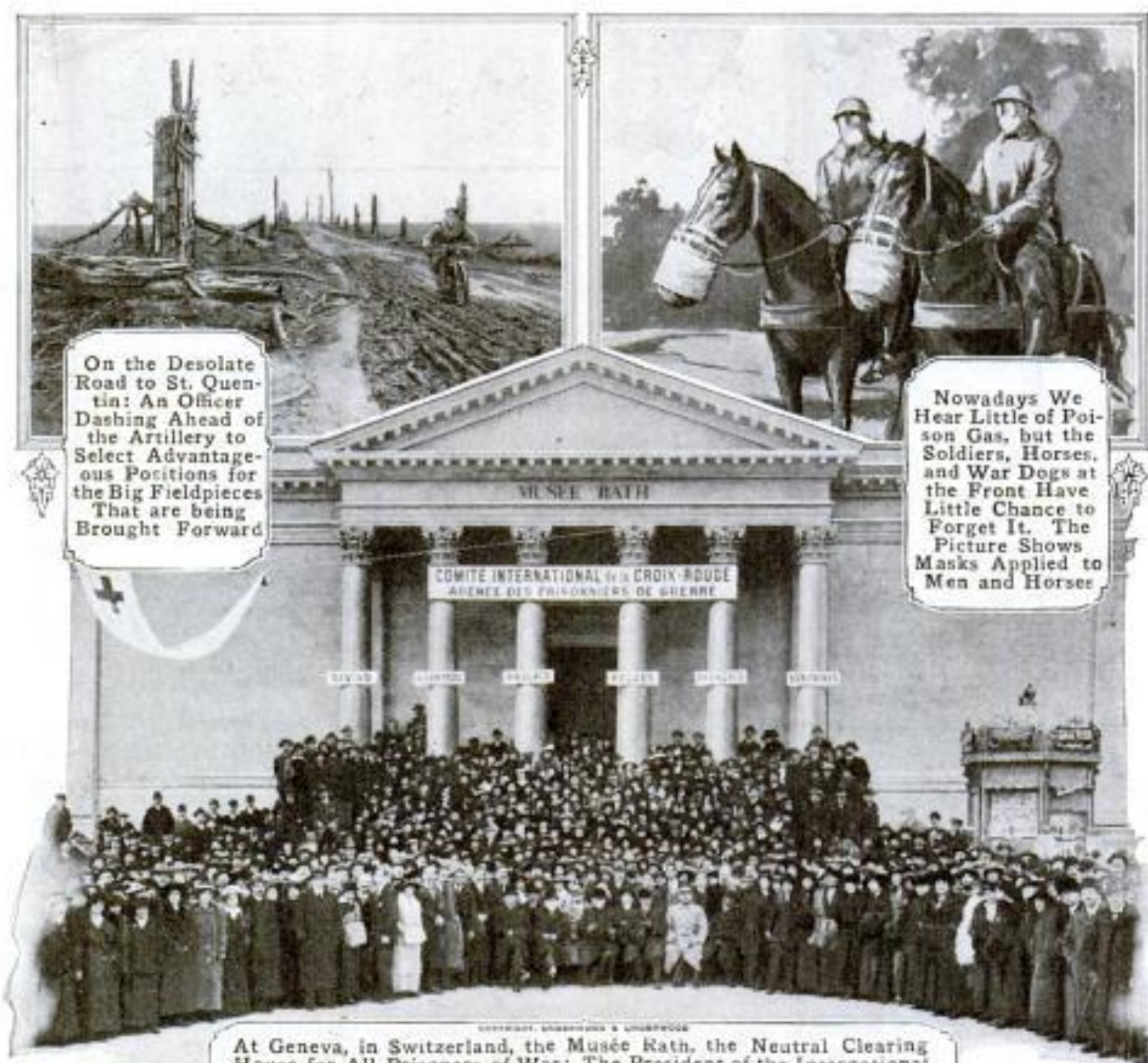

On the Desolate Road to St. Quentin: An Officer Dashing Ahead of the Artillery to Select Advantageous Positions for the Big Fieldpieces That are being Brought Forward

Nowadays We Hear Little of Poison Gas, but the Soldiers, Horses, and War Dogs at the Front Have Little Chance to Forget It. The Picture Shows Masks Applied to Men and Horses

At Geneva, in Switzerland, the Musée Rath, the Neutral Clearing House for All Prisoners of War: The President of the International Red Cross with One Stenographer Founded the Institution a Fortnight after the Outbreak of Hostilities. Some 1,200 Volunteer Workers are Now Employed Forwarding Mail to, and Answering Inquiries Concerning, War Prisoners Everywhere in Europe



One of the Far-Seeing Eyes of the French Navy: A Tricolor Flying Boat and Its Crew. Although They have Had Little Chance to Distinguish Themselves Spectacularly, Craft of This Type Areas Vital to the Sea Forces as Aeroplanes Are to the Land Fighters

AT WORK IN THE SORRY BUSINESS OF WAR



A Digging Machine at Work behind a Screen of Greenery on the French Front: The Picture Illustrates How Machinery has Put Thousands of Men on the Firing Line Who Otherwise would have been Needed for Manual Labor



Listening to the Enemy's Underground Operations: An Officer, Equipped with a Delicate Microphone Apparatus, on Duty in a French Mine Gallery. This Is Not the Least Nerve-Wearing of War's Occupations—There Is Always a Chance of being Blown to Atoms



Deliverance of Noyon from the Hands of the Teutons: French Troops Passing through the Ruined City Hot upon the Heels of the Retreating Enemy. The Day Was One of Great Rejoicing throughout France, for the Place Is only 60 Miles from Paris and the Presence of the Germans had Been a Cause of Constant Concern

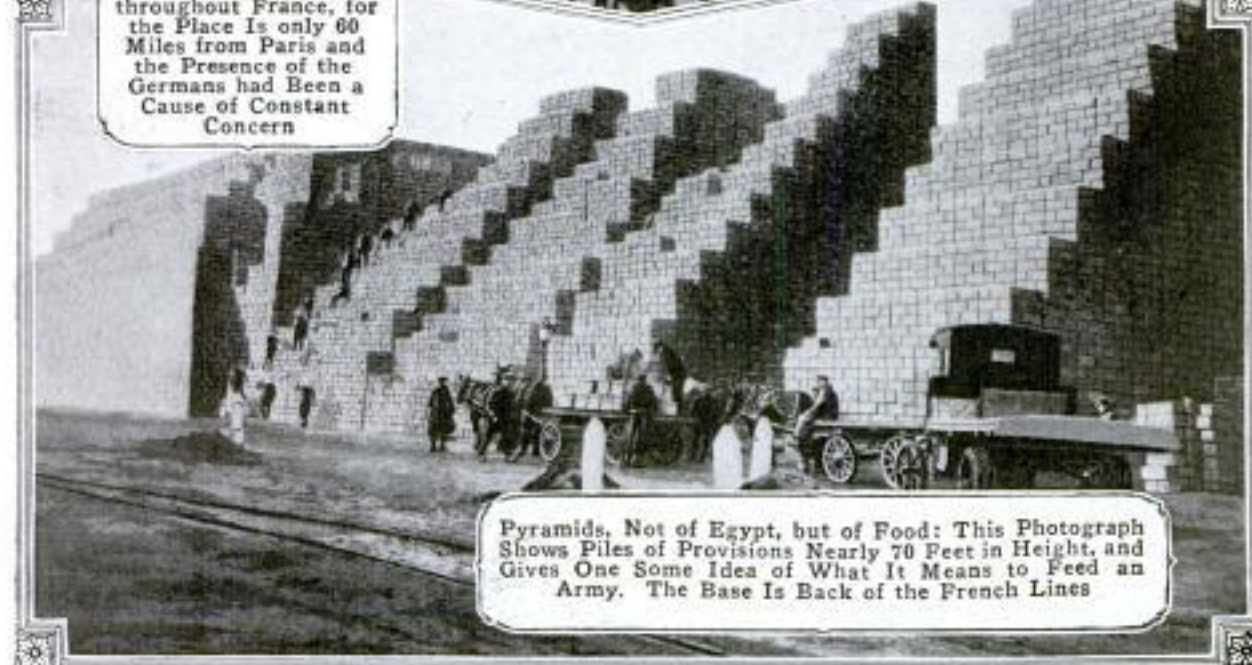

Pyramids, Not of Egypt, but of Food: This Photograph Shows Piles of Provisions Nearly 70 Feet in Height, and Gives One Some Idea of What It Means to Feed an Army. The Base Is Back of the French Lines

FINIS OF GREAT ZEPPELIN AND ITS INVENTOR



Twisted Metal and Blazing Débris: Remains of a Mighty Zeppelin That Ventured Too Far from Home. The Photograph was Taken near Paris Recently After the French Gunners had Accomplished Their Task. Obviously, None of the Crew Survived. This Is the Fate That Now Usually Concludes the Voyages of These Bulky Aerial Dreadnaughts When They Brave French Defenses or Attempt to Reach London



Military Funeral of Count Zeppelin, Who Devoted Years of His Life to the Development of the Rigid Dirigible, Which, for Military Purposes, has Been a Staggering Disappointment to the German War Lords. The Failure of the Zeppelin to Give the Teutons Dominion of the Air, However, does Not Lessen the Scientific Value of the Inventor's Work. The Picture Shows Uhlans Bearing the Casket of the Late Count

OUR FIGHTING SPIRIT

BY SEARLE HENDEE

WHEN the test came, the soap-box predictions of certain pacifists and little-army politicians failed. A million men did not spring to arms before sundown, April 6. Thousands, however, formed weak-kneed lines in front of marriage-license wickets.

Conditions that prevailed at Chicago the first two weeks of the war were fairly representative of those encountered throughout the nation. An attempt was made to measure the city's war spirit. Several interesting, and a few somewhat surprising, observations resulted.

Nowhere did the application for khaki uniforms exceed the limited supply on hand. Although accepting nearly twice as many volunteers as other offices in the United States, the recruiting places were far from filled. Street crowds did not appreciably differ from those in weeks past.

The day was chilly and mist filled the air. Yet 20,000 men and women packed the Cubs' ball park to see the Pirates defeated. Soldiers on recruiting duty there worked hard, but failed to find one man in the whole howling mob, willing then and there to shoulder a rifle. In the loop district a taxicab scraped a large limousine, bending a fender slightly. Some 200 men and boys swarmed about the machine in a moment's time. Across the street two soldiers walked unmolested, back and forth, in front of a recruiting station, inside of which was one civilian, and he a tottering Civil War veteran. During noontime more than 1,500 persons watched a guardsman drill a handful of office workers in Grant Park. Recruiting tents pitched near by barely attracted notice.

At the county building about 800 men and women jammed the corridors on the second floor, where marriage licenses are issued. Many, but not all of them, were of foreign extraction. Slackers and cowards they were called by jeering spectators, but none showed signs of resentment. A dozen fellows

in khaki worked among them trying to find fighters. It was a record day; fifteen men agreed to enlist. The rest of the license seekers shook their heads or turned away. Man after man freely admitted the significance of his purpose and grinned anæmically when a yellow ribbon was pinned to his coat. The sight was astounding. In the course of the day, 591 licenses were granted. On the other hand, 550 men applied for enlistment at army-recruiting places, and of the number about a third were accepted.

A well-groomed youth stepped from a squatty roadster. "Why don't you enlist?" he was asked.

"What's it to you?" he shot back, and then added: "Wait until there is something doing."

A Clark Street "panhandler" whined that he was hungry. "Why don't you enlist?" it was suggested.

"You're all right, kid," he confided, "but slip me a dime."

To the query, a commercial artist parried: "Do you remember the Mexican fiasco? They made goats of the fellows at the border."

A waiter in a loop restaurant was approached. "Why don't I enlist?" he returned. "I would if the country was invaded. But why go to Europe and be shot to ribbons?"

When an unmarried young lawyer was questioned, he explained: "I am fit, but untrained. I would have to go as a private. Who wants to do that? Besides, I would lose my practice."

On an "L" train a companion strap-hanger was interrogated.

"When I am needed," he assured, "I will go. But first, why don't they rope in those West Madison Street I. W. W.'s and Grant Park bums?"

Then a well-known cavalry colonel was interviewed. "Is the American youth patriotic? Is he willing to fight, or does he want 'George to do it'?" the soldier was asked.

"Our young men," he responded, "are divided into two distinct classes.

Some are red-blooded patriots. Some are cowards. There is no middle group. A boy is either patriotic or unpatriotic.

"My regiment is getting young fellows of an exceptional type. They are eager for battle and will scrap like demons when trained. It may surprise you, however, that the majority of them are the sons of foreign-born parents. Old American stock is not particularly in evidence.

"The American boy, when it comes to enlisting, is hindered by several things. He hates like blazes to be inconvenienced. He thinks of the business chances he will lose while in khaki. He counts the financial cost of patriotism. He wants to be sure of service before joining the army. If he knows there is to be shooting, he may come in. But he wants to fight on the day he enlists. He wishes to avoid months of training. His reasoning is inconceivable, for when stirred he aches to grab a flag in one hand, a rifle in the other, and chase the enemy. He doesn't realize that marksmanship counts for more than mere enthusiasm; that the soldier who wins is the one who sticks, who has strength plus, who can keep his head, who can hit when he fires.

"Many American youngsters have had advantages denied others. Therefore they do not want to be privates. They want to be officers. They want to learn soldiering out of a book and get into the Officers' Reserve Corps. One can't make soldiers by giving boys books to read. Neither can soldiers be built by drilling fellows around the floor of an armory. Go to any good musical comedy and you will see chorus girls drilled better than any company of soldiers ever found on a parade ground. But can they fight?"

Down on South State Street, where cheap movies and maudlin vaudeville shows thrive, many recruiters were in evidence. "What is the spirit in the streets?" one was asked.

"They don't insult us any more when we spike them to enlist," he replied. "Those who come in have enthusiasm.

Some reply: 'I'll be with you soon,' and others, 'Wait until things start.' We get smiles where we once got insolence and curses. The temper in the streets is endurable."

An officer in charge of a recruiting station was visited and was asked to give his opinion of the slackers' line at the county building.

"What do I think of any pack of yellow-striped cowards?" he flared. "How many of these cads would make soldiers if we had them? Few could even be used as powder monkeys. If the rush keeps up, it may become damaging. That is not expected, however. We are much pleased with the class of men who are joining, but not satisfied with their number. When the bars are let down, and the term of service limited to the duration of the war, enlistments will increase materially. Many men do not want three years of active service and four years in the reserve unless they are needed."

That same afternoon Washington announced volunteers would be received in the manner described. True to prophecy, enlistments swelled, but by no means to the degree anticipated.

"What is the war spirit of the women?" The question was asked at the Red Cross headquarters. The answer was:

"Oh, gracious! we are simply swamped. Two thousand women have offered their services in two weeks. We have 5,000 enrolled here now. Half of them are trained in special lines. The others are capable and willing to do whatever is asked. They are of all ages and of splendid type. Never fear! There will be women enough with patriotism and enthusiasm galore."

Thus America's fighting spirit, as reflected at Chicago, had not reached its traditional temperature a fortnight after congress announced the existence of war. The world crisis was viewed with amazing calmness and indifference. The feeling prevailed that the silver dollar could defeat the greatest professional army on earth; that we had only to pay the price of admission and view Armageddon from reserved

seats. And this in spite of announcements that France had plainly told our government it was in dire need of men. No ripple of excitement, or burst of enthusiasm, greeted Washington dis-

patches proclaiming it evident that we might shortly be compelled to send troops to Europe's trenches.

The mass of America's youth still waits for "something to happen."

Unusual Use

PHONOGRAPH REPLACES MILITARY BAND AND DRILLS "TOMMIES"

Several striking uses have been made of the phonograph in England during the course of the present war. Before the British resorted to conscription, the talking machine was frequently employed in different ways to attract recruits. Owing, doubtless, to the lack of officers at that time, and also for the purpose of attracting curiosity seekers, recruits drilling in public squares and thoroughfares were occasionally given their commands by phonographs. The novelty of seeing a squad of soldiers responding to orders called out by a cabinet gramophone that had been carried into the street

never failed to draw the attention of passers-by, and that was what was wanted. More recently, the dearth of musicians has now and then made necessary the substitution of phonographs for military bands at home. The County of London motor volunteers, for instance, march behind a "Tommy" who carries a talking machine strapped to his back. The instrument grinds out tuneful martial airs needed to put ginger and spirit into a body of soldiers on parade. It seems a queer makeshift, but apparently the loquacious squeaking of a portable talking machine is more desirable than silence.



British "Tommys." Officer'd by a Phonograph. Drilling in London before Street Crowds: This Is One of the Several Unusual Uses to Which Talking Machines have been Put by the British during the War

STYLES AND FADS ENGENDERED BY WAR



Flag Sticker Worn on Collar: A Fad among Some Youths

The Stars and Stripes Used as a "Beauty Spot" Pasted on the Cheek



For the Military Woman Chauffeur, the Apparel Illustrated Above and at the Sides Seems to Embody Practical Features of Comfort, Freedom, Warmth, Durability, and Attractiveness. From Cap to Puttees, the Same Material is Used

Illustrating the Suit Formed by Wearing the Cape as a Skirt

The Coat Is Heavy and Loose, Giving Warmth and Freedom. Its Lines Are Dignified and Becoming to the True-Blooded American Girl



Old Glory Ornamenting Silk Hose

The National Colors Decorating White Kid Gloves

The War as Reflected in Summer Millinery: A White Milan Straw Decorated with the Red, White, and Blue. The Stripes Are of Grosgrain Silk and Extend around the Crown. The Stars are Embroidered on a Blue Field

PHOTO COPYRIGHT, UNDERWOOD & UNDERWOOD

NEED OF ENGINEERS IN REAL-ESTATE DEALS

That engineers as well as lawyers should be consulted when real estate is to be purchased, is the contention of an engineer who recently read a paper dealing with this question before the Iowa Engineering Society. The speaker cited instances in which purchasers had suffered loss because they had not called in a technical man as well as one to look into the legal phases of the deal. Not only should a real-estate buyer be sure that the lines of the property correspond to the lines indicated in the deed and that buildings do not overlap these lines, but in many cases he should have an engineer report on the sewage, gas, water, and electric service.

OCTAGONAL SUMMER HOME ENCIRCLED BY REDWOODS

A San Francisco business man has done an unusual and picturesque thing by building a summer home at the base of Mt. Tamalpais in the midst of a graceful cluster of redwoods that form a circle about 15 feet in diameter. The structure is of wood, two stories high and octagonal in shape. Outside stairs lead from the yard, which is somewhat below



the street level, to the second or main floor.

CURRENT PROPELS FERRY ON NORTH DAKOTA RIVER

About 20 miles south of Watford, N. D., the Little Missouri River

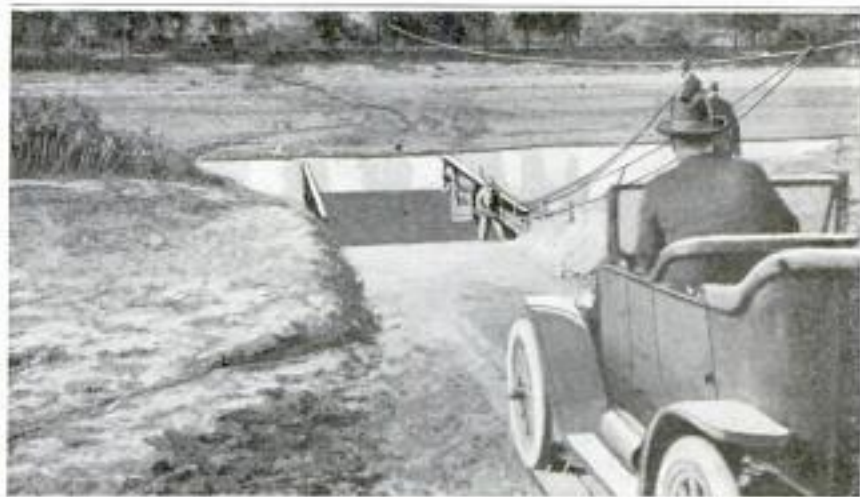

Ferry Which is Attached to Overhead Cable by Means of Ropes and Pulleys: By Pointing the Scow Upstream When Pushing Off from Shore, the Current Carries It to the Opposite Side

changes its course so often that the sparse population of the region have decided that it is unprofitable to span it with a bridge and instead have installed a ferry that operates very easily indeed. Between the two high-water banks a cable has been suspended many feet above the stream. A flat-bottom scow, large enough to hold two automobiles, is attached to this cable by means of ropes terminating at their upper ends in pulleys. When the ferryman pushes off from shore he points his craft a little upstream and the current soon carries it to the opposite side.

SEATS FOR BOARD WALK HAVE COUNTERWEIGHTS

Seats that automatically tilt upward when unoccupied have been installed along the railing of the board walk at Atlantic City, N. J., thereby providing rests that occupy less space than chairs or benches. Each seat bottom is supported by an arm that is pivoted to the lower pipe of the iron railing and is counterbalanced by a weight at the opposite end of the arm. When the rest is not in use the weight drops down,

causing the seat to swing up into a vertical position, out of the way of passers-by. A second arm, fastened securely at right angles to the one already men-



Counterbalanced Seats Fastened to the Railing along the Board Walk at Atlantic City: When Not in Use Each Seat Automatically Tilts Up, Out of the Way of Passers-By, as Shown at the Right

tioned, is so placed that it strikes against the outside of the rail when the seat is swung downward and so holds it in a horizontal position for the occupant.

BIG TENT ENLARGED TO SHELTER TRACTOR SHOW.

An unexpectedly large number of entries for a tractor show, held recently in Kansas City, Mo., made it necessary to twice enlarge the tent of paraffined khaki canvas provided for the exhibi-

tion. After the extra sections of canvas had been inserted between the ends the shelter covered 42,000 sq. ft. of ground, thus making it one of the largest tents in use, for displays of this sort. The inclosure was heated with charcoal burners and floored with planks resting on 8 by 8-in. beams.

EDUCATIONAL CENSUS SHOWS CHINA'S SCHOOL EQUIPMENT

Of late years, with the introduction of Occidental ideas and influences, China's educational facilities have been materially increased. In proportion to its vast population, however, the country has but few schools and extremely few institutions of higher learning. Recent statistics show that only 19 colleges are open to those who want general courses. Added to these are eight engineering, four medical, 59 law, and 91 industrial and technical schools. Of primary and secondary schools there are 53,204, aside from 527 primary and middle schools maintained by some of the more advanced institutions. Ninety-three public seminaries, 507 normal schools, and 357 schools for girls are supported in addition to 1,582 half-day schools.

A permanent flood-lighting system has been installed by which the entire exterior of the capitol building at Washington is illuminated at night. The idea was an outgrowth of the lighting provided during the inauguration period.



Big Tent of Paraffined Khaki Canvas, Covering More than 42,000 Square Feet, Used to House a Tractor Show in Kansas City, Missouri



Float, 44 Feet Long, Mounted on a Single Automobile Chassis: Real Smoke Poured from the Funnel, and the Turrets with Their Wooden Guns Revolved at the Will of the "Crew"

AUTO FLOAT REPRESENTS BATTLESHIP IN ACTION

One of the most striking floats in a street parade held recently in Dallas, Tex., was a 44-ft. model of a fighting ship made of canvas and wood and mounted on a single automobile chassis. Realistic wooden guns pointed from revolving turrets, and smoke, produced by burning crude oil with the aid of a blowtorch, poured from the funnel. More than 700 electric lights, supplied with current from storage batteries, decorated the ship and studded a United States flag and a union jack. Festoons of bulbs hung from the 16-ft. fighting masts to the bow and stern. Later the float "sailed" overland under its own power to Fort Worth, 33 miles distant.

BLUE-ASBESTOS INDUSTRY EXPANDING

According to official reports from British South Africa the blue-asbestos industry, which has been established in that country for a number of years, is growing steadily despite the strong competition which it has had from rival interests and the necessity that the producers faced of doing their own manufacturing and selling. The industry is largely controlled by one concern

which now has factories in England and Italy. Among the claims made for blue asbestos are that it is lighter than the white, that its fibers are longer and finer, that it is superior as an insulating material, as regards heat, and that it is unaffected by moisture, ordinary acids, or sea water. Even if inferior in heat-resisting qualities to the white product, it is regarded as satisfactory in this respect for most industrial purposes.

PULPIT IS A SELF-HELP SHOE-SHINING STAND

What appears to be an old pulpit, standing by the roadside in Manitou, Colo., serves as a case in which shoe polish and brushes are kept for the convenience of passers-by. A sign above it reads, "Brush One Cent, Polish Two Cents. If you have no change, you are welcome to use these free." Since there is much dust in and about Manitou in the summer and the streets are thronged with tourists, the materials made available in this unique way are frequently in demand.



Shoe-shining stand
3/14/19

BEES USE TELEPHONE BOX FOR A HIVE

Trouble on the telephone lines centering at Port Byron, N. Y., was found recently to be caused by a swarm of

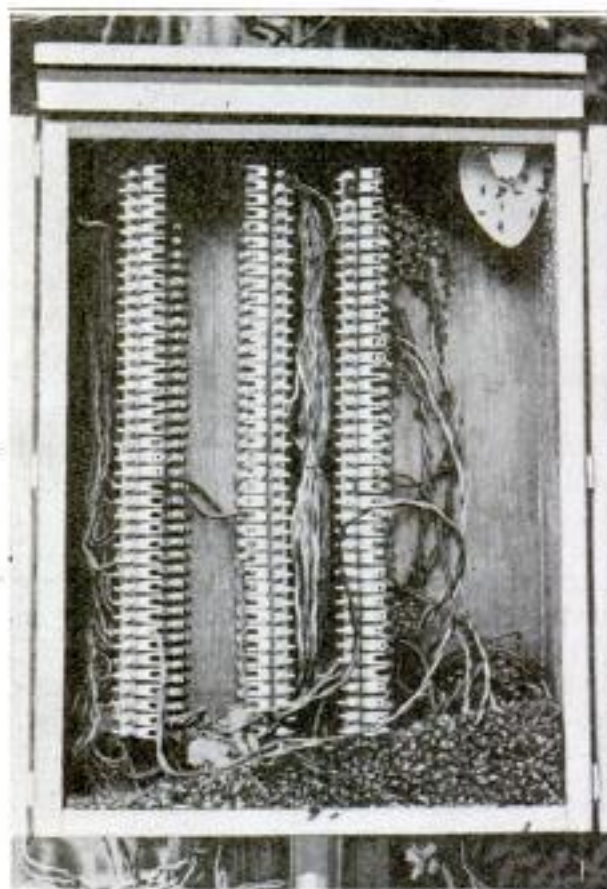

Telephone Terminal Box Used by Bees as a Hive: Comb Making had Begun in the Upper Corner When the Bees were Suffocated and Fell in a Heap Below

bees that had taken possession of the terminal box and were using it as a hive. When the seat of the trouble was discovered, the bees had already started the making of comb in a corner of their new home. The problem of ousting the undesirable tenants from the telephone box was solved by stuffing the cracks with cotton saturated with carbon disulphide, which suffocated the bees.

What is known as an aerological survey of the United States is being urged by those interested in aviation. Such a scientific study of the atmosphere over this continent and adjacent waters as is proposed would furnish valuable data for airmen's charts.

NEW USES FOR MAGNESIUM IN THE INDUSTRIES

New methods of extracting the useful metal magnesium from its ore are being sought by metallurgists. The ore is found in abundance, and magnesium oxide is produced cheaply, costing only a few cents a pound, but the metal itself has hitherto been scarce and expensive because of the difficulty of production. Direct extraction from the oxide by electrolysis is now aimed at by the scientists, and if their efforts are successful, new and interesting uses will be found for cheaper magnesium. In lightness and strength it competes with aluminum, and its alloys may largely displace aluminum alloys in the manufacture of automobile, aeroplane, and dirigible parts. For deoxidizing other metals, magnesium is a much stronger agent than aluminum, and it is also likely to be used therefore as a deoxidizer in industries employing brass, bronze, nickel, and their alloys.

SAVING MILES FOR THE MAIL CARRIER

Many people, unwittingly perhaps, are responsible for making mail carriers walk unnecessary miles every day in delivering mail. Every step added by residents means a total of many in a day, and a big number of miles at the end of a year.

So grave a problem has this matter become in some cities that the postal authorities have taken it up with a view to reducing, or altogether abolishing, the evil. If you put your mail box on your door instead of in a protected place on your gatepost you cause the postman to take a dozen or more extra steps—usually more—every day. If you make him climb a big flight of stairs to hand you your daily mail, you add extra distance to his journey and take unnecessary toll of his pedal extremities.

In hilly towns the mail carrier is oftentimes up against a hard hiking task. San Francisco affords a fair sample of

unlimited abuse of mail carriers by postal patrons in the residence districts. To reach some residence doors mail men must climb not one, but often as many as four and five, and sometimes six flights of stairs. At some homes the stairs number as many as 100 and 125 steps from sidewalk to veranda.

The postmaster of San Francisco has started a crusade against this evil. He is trying to persuade residents to place their mail boxes at the foot of stairways, and if there are no stairs, then as close to the street as possible. There are 75,000 flights of outdoor stairs in San Francisco, a record perhaps unequalled by any other city. The postmaster estimates that if these exterior staircases were placed end to end, they would reach 103 miles up into the sky.

The postal rules require the mail man not to disconnect himself from his bag when filled. But there is no inspector, or other supervising official in the San Francisco service, who has the heart to reprimand

the carriers for setting their bags on the sidewalk while running up a "Pike's Peak staircase" to hand in a cloak-and-suit catalog or a picture post card from milady's country cousin. The carrier who attempts to carry his bag up all the stairs he faces is likely never to return for a second delivery.



This Is a Very Modest Example of the Steps a San Francisco Mail Carrier has to Climb on His Daily Route

LITTER WHICH ONE MAN CAN OPERATE

Two large wire wheels, connected by an inverted-U axle and provided with suitable handles, constitute the recently invented equipment with which one man can pick up and carry a loaded stretcher. To lift up a litter of the type used with this outfit, the running gear is wheeled into position over it and the handles raised

high in the air. This places the "U" of the axle in a horizontal position and allows two iron hooks, which depend from it, to swing close to the ground so that they can be inserted into eyelets in the side of the stretcher frame. The carrier can then be lifted up easily by bringing the han-



Stretcher Requiring the Services of But One Man Instead of Two: The Axle and Handles Serve as a Lever by Which the Laden Litter can be Lifted from the Ground. Because the Wheels Are Large, the Outfit can be Drawn over Rough Ground or up and down Stairs



Motor Truck Carrying Tin Ore in the Andes Mountains along One of the Highest

dles back into a horizontal position. They are then clasped to the stretcher frame to keep it from tilting.

AIR VENDER IS COMPLETE COMPRESSION PLANT

For installation at the curb line in front of public garages, gasoline stations, and accessory shops, a free-air dispenser has been introduced which contains an electrically operated compressing unit. Because of

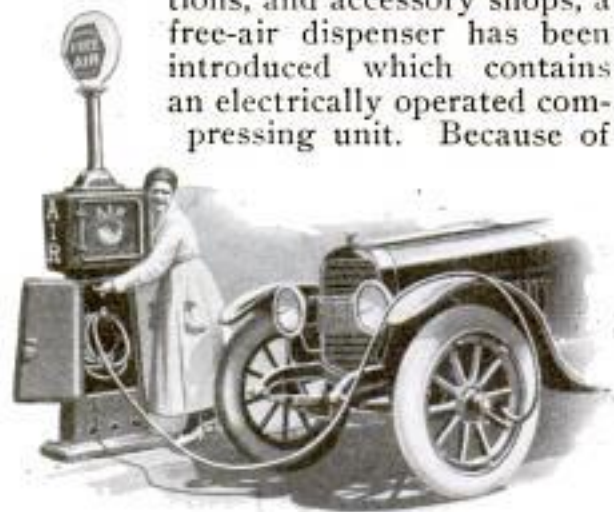

No Piping is Required When This Tire-Inflating Apparatus is Installed, and No Attention Demanded When It Is in Service

this feature, there is no necessity for making pipe connections between the fixture and a pumping plant within the building adjacent to it. All the working parts are locked in a compartment that is separate from that in which are

housed the hose and starting switch used by motorists. The standard is of heavy design and surmounted by a large opalescent globe bearing a green hexagon on which appear the words, "Free Air." A gauge with a large dial is conveniently located in the front of the fixture and illuminated at night so that readings can be made easily. The arrangement of the valve connector permits the pressure in a tire to be registered on the dial before inflation is commenced.

LLAMAS RIVALED BY MOTOR TRUCKS HIGH UP IN ANDES

High up in the Andes Mountains of Bolivia motor trucks have become the rivals of the llamas, which are so much used as beasts of burden in South America. Special interest attaches to this case of motor-truck service because the vehicles, of which there are four, are employed at an altitude varying from two to three miles and more. These machines were supplied by a California concern to a mining company in Bolivia to carry tin ore to the railway station at Oruro, Bolivia. This city is 12,000 ft. above sea level, and the road which the cars traverse rises to 17,300 ft. This is undoubtedly one of the highest gasoline-truck routes in the world. The engines were adjusted

The above is a description of the
1635 Standard 12 ft. 1
machine is, however,

motor truck 10
Copyrighted material



Truck Routes in the World: The Machine is Passing a Herd of Llamas, also Laden with Ore

to operate in the high altitude by making the compression chambers very small, so that if operated at sea level the pressure would be about double the normal pressure. This alteration compensated for the rarefied condition of the atmosphere. The carburetor which is used required no adjustment. Although gasoline in this region costs \$1.25 per gallon, it is claimed that the trucks show greater economy than the llamas, many of which are still used to carry ore. Each beast's burden is about 100 lb., which is carried only a few miles per day.

SPREAD SALT ON STREETS TO LESSEN DUST EVIL

Common coarse salt, when properly applied to dirt roads, quite successfully allays dust during the dry months of summer. The scheme has been tried in many places, and among them the little village of Belleville, Pa., where it obviates the need of street sprinkling. At this particular town the salt is scattered over the road surface with the aid of a lime spreader. The natural affinity of calcium chloride, which is present in salt, for moisture keeps the

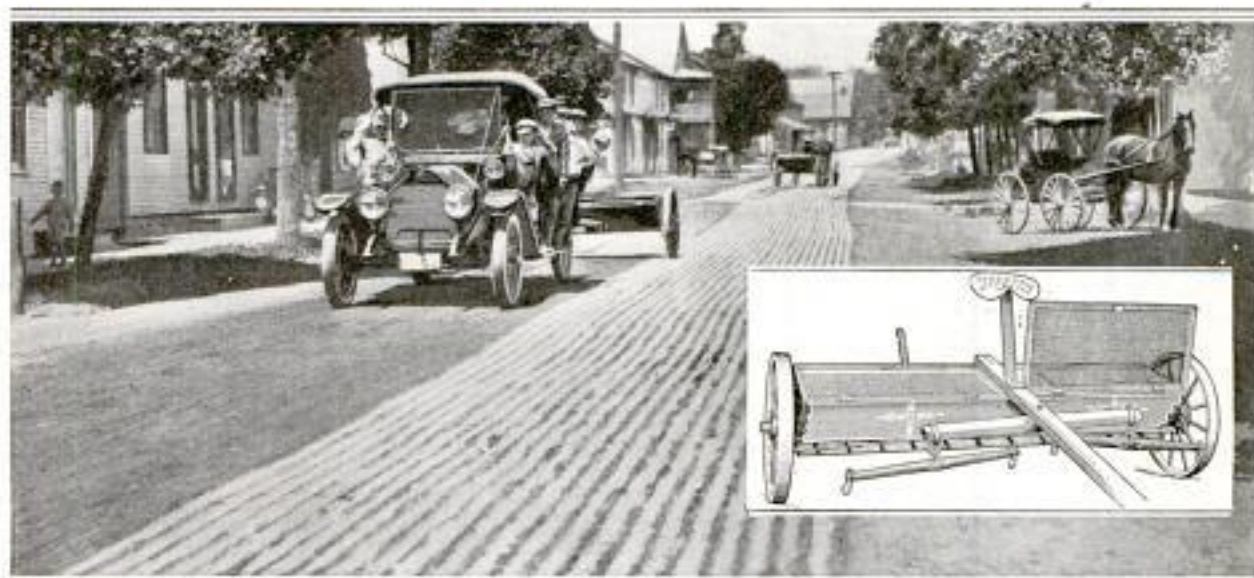

Applying Salt with Aid of Lime Spreader to Dirt Road at Belleville, Pennsylvania. Insert Shows the Lime Spreader Used to Apply the Salt

village thoroughfares fairly free from dust even during very dry periods. The material is applied at intervals of about six weeks at a comparatively low cost. To obtain good results, however, it is necessary that the salt should have an opportunity to become thoroughly mixed with the dirt before encountering a heavy rain. Two or three days, with ordinary traffic, usually suffice to accomplish this.

HOLDER ENABLES CRIPPLE TO WRITE WITH KNEE

The invention of a Portland, Ore., doctor, by means of which one can write with the knee, offers large possi-



Writing with the Knee: By Means of a Simple Pen or Pencil Holder One Deprived of the Use of His Hands can Learn to Write in the Manner Shown

bilities for the person deprived of the use of both hands, for the device affords a much more convenient method of writing than by holding a pencil with the toes or teeth. The apparatus consists of a broad strip of leather that is fastened over the bent knee by means of spring clasps. It is provided with two pencil clips into which a pencil is inserted so that it projects beyond the knee. A low rack, made like a music rack, holds the writing paper firmly in a convenient position. Ample range of motion for the pen is obtained by resting the foot on the ball, with the heel upraised.

PHILIPPINE LUMBER WINS CHINESE TRADE

Certain grades of lumber from the Philippine Islands have largely supplanted American lumber in the Hong-kong market lately, owing to the high rates of freight for the trans-Pacific voyage. Imports of what is known in the Chinese trade as Oregon pine (Douglas fir), which formerly averaged about 10,000,000 board feet annually from the United States, fell in 1916 to about 2,000,000 ft. Cheaper woods from the Philippines are now freely used, although inferior in quality to the American product. Philippine hard woods and log timber are also finding a good demand in China under present conditions.

LIMIT ARMS ATTACHABLE TO A MICROMETER

A set of limit arms for use on micrometer calipers has been devised by a British government inspector and possesses obvious advantages as an attachment to that useful gauging instrument. The set consists of a long and a short arm of hardened steel that can be clamped on the thimble of any standard make of micrometer and convert it at once into a limit gauge which can be set for any tolerance between .0001 in. and .022 in. When fitted, it checks the work between the highest and lowest limits permitted, with a great

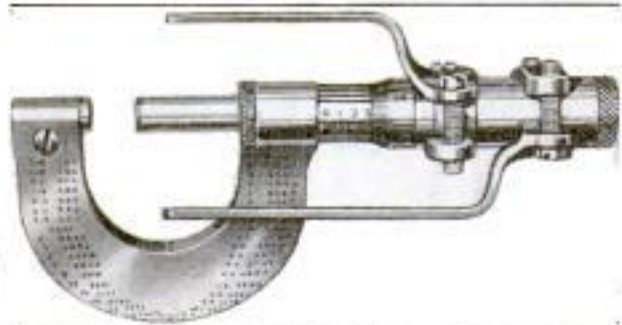

Limit Gauge Arms. Invented by a British Government Inspector, Attached to a Standard Micrometer

saving in time. The attachment is easily removed when it is desired to use the micrometer in the ordinary way.

Dr. J. D. ...
4411 Woodstock ...
Portland, Ore.

...
W. Washington ...
City. Copyrighted material

Chas. F. ...
Western Elec. ...

WORLD'S BIGGEST TELEPHONE CABLE LAID UNDER THE HUDSON

ONE step nearer a world telephone service, in the opinion of engineers engaged on the work, was taken recently, when the largest submarine cable in the history of the telephone was laid under the Hudson River, between the little cities of Nyack and Tarrytown, N. Y. It was designed to make an important connection between the existing systems on each side of the river, but the installation involved so much experimental work and study on the part of the telephone operatives, to say nothing of numerous physical difficulties, that its success was regarded as significant of what may be accomplished in extending telephone cables under sea in the future.

Besides the fact that 14,670 ft. of this heaviest cable ever made was required to span the bottom of the river, the remarkable features of the installation included the use of two loading coils, incased in loading pots 16 ft. long and weighing over four tons each.

The laying of the cable was accomplished by the use of a cable tug-boat, a sand scow, and a light-draft tug, and took eight days to complete. Each step in the work had been carefully planned in advance by technical experts and involved many different operations, from the arrival of the specially made cable by freight to the final splicing of the wires, the strategic laying of the line, and the anchoring of it on the river bottom by means of chains.

The cable used was what engineers call a "74-pair side and phantom," or in other words one containing 74 pairs of loaded wire, of the particular kind necessary to make possible

proper transmission and tests. The cables were thoroughly tested as to water penetration, while the loading pots also were subjected to tests as to their being absolutely water-tight. The cable weighed in the vicinity of 90 tons. After arriving on reels on flat cars, run along a dock accessible to the cable boat, the process of placing the cable on the reel on the tug occupied two days. The scow, on the other hand, was loaded with cable put on in figure "8" form, while the coils and loading pots were also installed on the scow in position, permitting the splicing of the coils and the attaching of the pots. When everything was ready for the cable laying, the cable boat and sand scow went up the river to Tarrytown and Nyack, between which the connection was to be made.

Immediately on arrival at the former city, the land end of the cable was taken ashore and chained. The cable boat then proceeded to the Nyack side



Getting the Nyack-Tarrytown Telephone Cable Ready for Laying beneath the Waters of the Hudson River: Most of the Cable Lies on a Scow, with the Loading Pots in the Foreground

with a piece of cable on its reel for that shore end. Two targets, 10 by 5 ft., painted with red and yellow hori-

zontal stripes and 100 ft. apart, had been erected as guides on each shore, opposite each other. When the land

the shoal water. This started the laying of the cable. The two tugs then hitched up to the scow and towed it



Splicing Ends of the Big Cable While the Scow Lay in the River

end of the cable had been chained ashore at Nyack, the cable boat laid the cable on its reel out from Nyack on the line of the two targets on that side. When the end of the cable was reached, a barrel buoy was attached and thrown overboard. Keeping in line with the targets, the cable boat

got as close to the Tarrytown shore as it could, a light-draft tug bringing out a line from the scow which the cable boat wound on its reel, pulling the scow over

distance from the cable, if it should ever be necessary to take it up.

The second loading pot was also successfully placed. The barrel buoy holding the Nyack piece of the submarine cable was picked up later and the connection made in a satisfactory manner. In order to control the speed with which the cable was laid, an emergency cable brake was erected on the scow, which was simply two light planks held as levers against the cable by two of the crew. Part of the work was done at night, but the principal laying operations were conducted during the daytime.



Method of Controlling the Movement of the Cable as It Dropped to the River Bed



San Francisco's New Edifice Housing the City and County Offices, Which with Its Site Cost Nearly \$5,000,000; The Building Measures 420 by 285 Feet and the Dome Is 306 Feet High. The Exterior is Finished in White Granite, While Bedford Stone and Marble have been Used Extensively on the Interior

SAN FRANCISCO COMPLETES MAGNIFICENT CITY HALL

The city hall in San Francisco, which has recently been completed, is pronounced one of the handsomest and most stately municipal buildings in America. It was erected at a cost of \$3,500,000 on a site for which \$1,411,000 was paid. Its completion adds a most impressive architectural unit to what is known as San Francisco's civic center. The structure measures 420 by 285 ft. and from its center rises a dome 88 ft. in diameter and 306 ft. high. The outer walls, covering the steel framework, are composed of California white granite, while the corridors and rotunda are finished with Bedford stone and Colorado and Italian marble. The balustrades, portions of the dome, the entrances, etc., are decorated in blue and gold.

CA seagoing suction dredge has been purchased from the War Department by a ship broker and converted into a schooner. This is thought to be the first time that a vessel of this character has been changed to a merchant ship to work under canvas.

PRESS PRINTS AD MATTER ON PENCILS AT LOW COST

A hand press now on the market is designed especially for printing advertising, or other lettering, on lead pencils, in gold leaf or white ink. One advantage of this machine is that with it even small lots of pencils can be given special imprints at a low rate of cost. The press is provided with a sliding rack that holds 32 pencils. These are covered with a sheet of gold leaf, if that is the material to be used, and then fed into the machine by operating a hand lever. The type is heated electrically, current being obtained from any light socket. A small rheostat governs the temperature and when the type presses the gold into the enamel of the pencil, the varnish acts as a sizing which makes the imprint permanent without further lacquering.



Dunning Bros.,
71 W 23rd St. N. Y. C.

FISHING-FACILITIES ON A MUNICIPAL PIER

Special facilities for fishermen have been provided in building the new



Fishing Seat and Foot Rest along the Edge of a
Pleasure Pier at a California Resort

municipal pier at Redondo Beach, Calif., the concrete edge being so constructed as to form a convenient seat, with a foot rest below, which serves to brace the feet when the fisherman is hauling in big fish. The brace is necessary, as fish weighing 290 lb. have been caught from the pier.

HARVARD'S MUSEUM-GARDEN OF TREES AND SHRUBS

Forty-five years ago, with a bequest of \$100,000 for "the advancement of agriculture and horticulture," Harvard University started an arboretum, or tree garden, devoted to the task of growing every tree and shrub in the world that can withstand the climate of New England. Today the Arnold

Arboretum, situated in a suburb of Boston, extends over 220 acres and contains the world's greatest collection of trees and woody plants. Headed by a botanist of world-wide reputation, its travelers and explorers have ransacked the earth for specimens of tree growth capable of flourishing in the United States, and have added immeasurably to the world's knowledge of its trees and plants, besides developing in Jamaica Plain a tree museum that is a Mecca for students, residents of Boston, and visitors to New England. One of the first lists of trees and plants brought to the arboretum from all parts of the world has just been published, and the last volume has been completed of a tree bibliography which it took the staff 17 years to compile. The scope of the work done is illustrated by the fact that 650 varieties of the hawthorn tree have been discovered to date by the arboretum staff, while only 18 species were known to exist in New England in 1890. There were only four known species of lilacs when the work started; today visitors to the arboretum are made acquainted with 22 species and 200 varieties of lilacs.

LOW-PRICED CAR EQUIPPED FOR FIRE FIGHTING

Efficient fire-fighting apparatus has been placed within the reach of many small communities by an Indiana concern which transforms a well-known low-priced automobile into a fire engine by adding a water-pumping engine just back of the driver's seat, and also by equipping the car with chemical apparatus, hand extinguishers, a gong, a ladder, firemen's tools, a lantern, etc. The outfit can take water from an open source and pump three streams 80 to 100 ft. high, so that in the absence of water mains, cisterns and wells can be utilized effectively. Where the town's hydrant pressure is weak it will add 80 lb. or more to it. As a chemical engine it is very efficient. It derives its pressure from the motor and pump,

Christ. Sci. Monitor
3/12/17

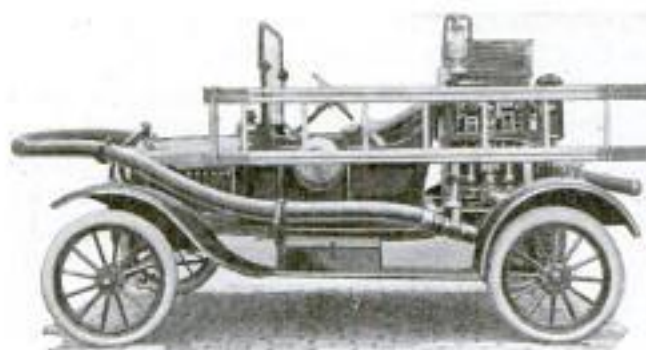

Left: Small-Sized Fire Engine Made by Equipping the Chassis of a Low-Priced Car with the Apparatus Shown. Hose for This Engine is Carried in a Trailer. Right: Low-Priced Car Equipped as a Fire Engine; the Outfit is Here Shown Throwing Three Streams 100 Feet High

which arrangement makes it possible to open the tank at any time and add water or chemicals. One model is made to draw the hose in a trailer, while another is provided with a hose body back of the engine.

DISAPPEARING PROPELLER IN MOTOR ROWBOAT

Equipped with a propeller and shaft that can be made to disappear at will, a new type of motorboat, designed and built by a Canadian concern, is transformable immediately into a rowboat capable of making a landing anywhere. It will also ride without damage over any obstruction, such as submerged logs, driftwood, rocks, or sand bars, being furnished with a skeg which automatically raises the propeller and shaft into a housing above the keel, on striking an obstruction. The skeg,

when raised, forms a continuation of the keelson and at the same time throttles the engine from racing. The boat is fitted with an inboard engine on a stationary bed, located so that the weight falls amidships and keeps the craft on an even keel. A handy lever in the flooring gives complete control over the speed of the boat without touching the engine, and also enables the propeller to be raised into its housing when desired. The change from motorboat to rowboat can be made without leaving one's seat.

☞ Mine timbers of white spruce, Sitka spruce, white birch, and western hemlock, grown in Alaska, were found in recent tests to be fully as good as Douglas fir from the Rocky Mountain region and superior to other Rocky Mountain species for use as mine timbers.

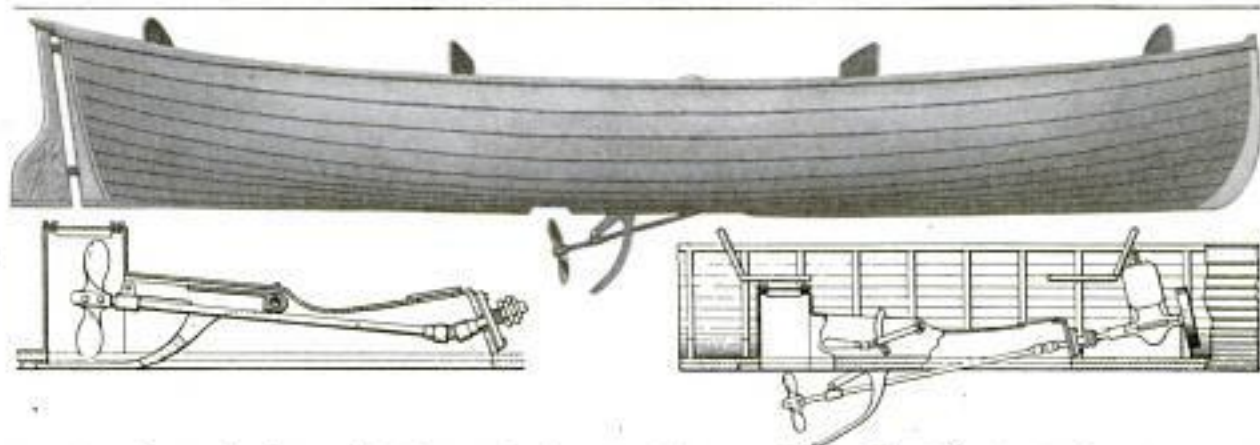

Motorboat Instantly Convertible into a Rowboat by Lifting a Lever: The Propeller Shaft and Skeg are Fitted Amidships and Rise into a Housing above the Keel, as Shown in the Drawing

Disappearing Propeller Boat

33 M. J. ...

SCHOOLHOUSE ON WHEELS —FOLLOWS ITS PUPILS

The directors of an Oregon school district recently built a schoolhouse on wheels to follow the movements of

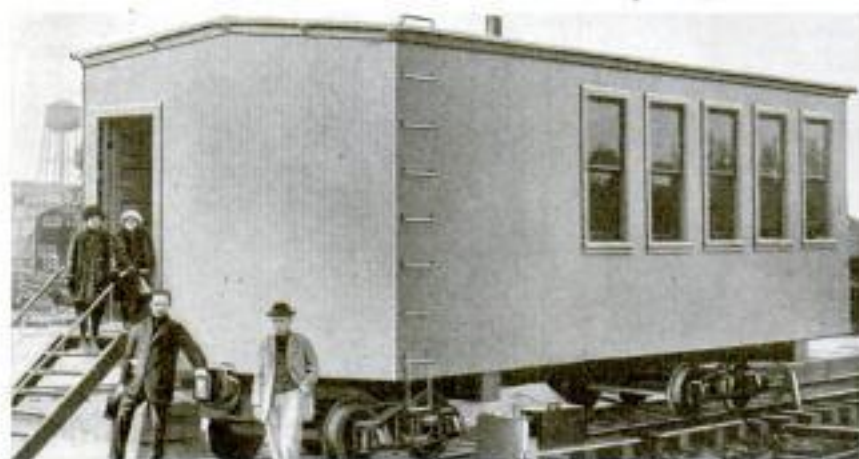

Loggers' Schoolhouse on Wheels: This Itinerant Building may Look Like a Box Car, but was Specially Designed for School Purposes, to Follow a Logging Camp When It Moves

a colony of loggers whose camp is moved from time to time, making it difficult for the children of the colony to attend a stationary school. Now, when the camp moves, the school goes with it. It is not a transformed box car, though it bears some resemblance to one, but was specially designed for school purposes. It accommodates 30 pupils, and is used evenings and Sundays as a community center for social and religious meetings. As the logging colony is growing, a larger building of the same type is planned, with a room for the teacher. The schoolhouse is hitched to a logging train for removal.

HOMEMADE WHEEL ELEVATES WATER TO TRUCK GARDEN

An odd water wheel and a screw have been combined in an original manner by a truck gardener near Salt Lake City in the construction of a lifting device with which a small acreage is supplied with water from the Jordan River. The wheel, which roughly resembles a windmill wheel, is mounted

at the end of a long, hollow shaft containing a screw and is set facing upstream. The shaft is pivoted at its center to an upright framework standing in the water. By means of a cable that winds around a drum, the wheel can be lowered into the current, which sets the wheel and screw to turning. As the water is raised in the shaft it is discharged from the upper end into a flume that leads to the garden.



By Means of a Cable and the Drum, Shown at the Left of the Framework, This Novel Water Wheel is Lowered into the Current. As It Turns, a Screw in the Hollow Shaft Elevates the Water to a Trough That Leads to the Near-By Garden



Labor-Saving Trucks, All of Which, Save One, Have Tongues and Front Wheels Detached: As the Material in the Trucks is Needed the Detachable Unit, Which is Clearly Shown in the Insert, is Hooked onto One of the Loads and It is Drawn Away

NEW LABOR-SAVING TRUCKS SUPPLANT WHEELBARROWS

An especially serviceable labor-saving device which has been introduced into manufacturing plants in recent months is a three-wheeled truck that is now being employed in a number of places in preference to wheelbarrows, elevating trucks, and the like. The front wheel and the tongue of this carrier constitute a unit which can be detached by raising the tongue into an upright position. This lets the front end of the truck down onto a short leg, which then serves as a third support. In the meantime the tongue and wheel can be coupled onto some other truck that is ready for service. This type of carrier lightens the work for a laborer and enables him to move heavier loads than with a wheelbarrow.

PROTECTING PLATE GLASS FROM SUBWAY BLASTS

Storekeepers along Broadway have been compelled to devise means of protecting their plate-glass windows from the effects of the frequent dynamite blasts that occur in the course of

New York subway excavation. The most satisfactory method has been found to be the installation of large

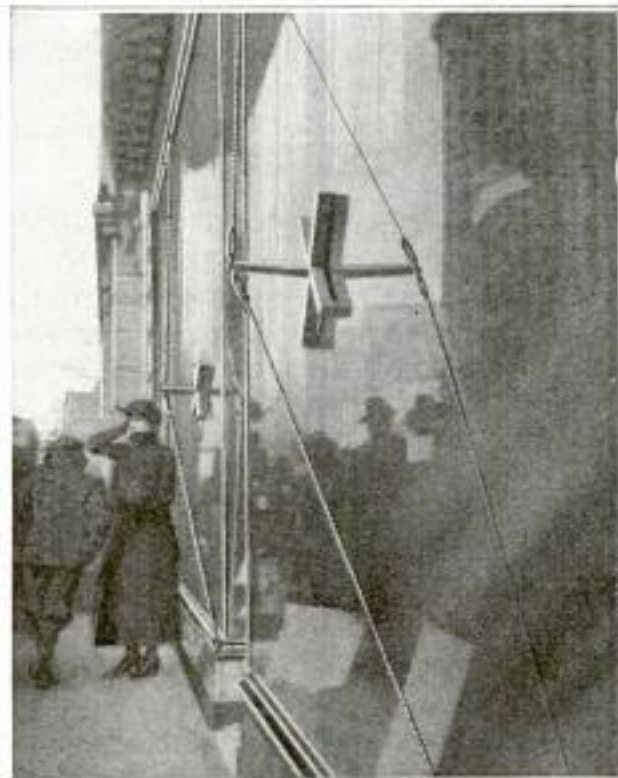

How Broadway Protects Its Plate-Glass Fronts against the Effects of Subway Blasts

wooden crosses, one on each side of the pane of glass in corresponding po-

*How's Chaitin Co.
D. J. S. G. G. C. H. M. I. C. H.*

sitions; each cross having a center arm at right angles to the window, securely braced by wires running to the four corners of the store front. This device relieves the center of the glass pane from much of the shock when a blast occurs near by.

APPLES BAKED WITH GAS IN A MACHINE

The sight of apples being baked by gas on a revolving plate covered with a heavy glass bell, attracted much at-

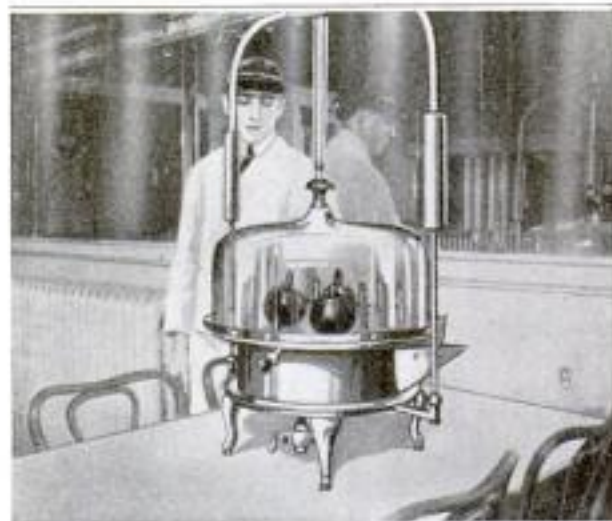

Apple-Baking Machine in a Cincinnati Restaurant:
The Pegs Which Pierce the Apples Are
Gas Burners

attention in a Cincinnati restaurant window recently. The apples are first cored by hand and then placed over metal uprights or pegs, set at convenient intervals on the metal plate. Each peg protrudes through its apple, and is in fact a gas burner. When covered with the glass top, the apples are cooked by the heat of these burners.

TIME-SAVING METHODS IN MAKING UNIFORMS

To make hundreds of thousands of uniforms a week, which is the rate at which a New Jersey manufacturer operating four plants has been turning out orders for the allies, requires methods that effect great economy of time and labor. In the cutting, for example, the cloth is laid on a table in 20-ft.

lengths, usually 60 folds thick. An expert then marks it out as required by the pattern, after which a man with a circular knife, operated by electricity, follows the chalk line, cutting all 60 layers at once. Band saws are used for cutting the shorter lengths and since the saws are stationary, the operators have to move the cloth about to make it follow the markings.

SHIP'S COLOR A FACTOR IN ITS SAFETY AT SEA

The submarine campaign has brought to the attention of ship owners with renewed force the importance of painting vessels in a manner which will secure a minimum of visibility. Many a captain has learned to his sorrow that his craft has been a conspicuous mark on the high seas because the lower part of the hull and the funnels were painted black, while between these two extremes was a sharply contrasting strip of white or gray. The practice is being urged of painting the funnels a neutral tone and shading the bow and stern off into light gray.

DUPLICATE KEYS QUICKLY MADE BY MACHINE

In our February number we published under this heading an account of an ingenious machine for duplicating cylinder-lock keys. Owing to the fact that such a large proportion of the cylinder-lock keys in use are Yale keys, that is, made by the Yale & Towne Manufacturing Company, we inadvertently referred to the machine as specially adapted to cutting keys of the "Yale-lock type." This was an incorrect expression, as the machine is equally adapted to cut cylinder-lock keys of any make, whether Yale or others. Properly speaking there is no such thing as a "Yale-lock type" of key. Yale keys are made to fit every known type of lock; and the word "Yale" in connection with a key or lock signifies nothing as to type, but merely that it is made by the firm mentioned.



Ten Horses Drawing a Strange Stone Weighing Four Tons to a Playground in Martinez, California: Geologists will be Asked to Determine If the Stone, Which has Long Been an Object of Curiosity, Is a Meteorite

BIG SPHERICAL STONE MAY BE METEORITE

What is believed to be a meteorite was dug up recently near Martinez, Calif., and removed to the public playground of the town, where it will remain. The strange stone was found to be an almost perfect sphere and measures $4\frac{1}{2}$ ft. in diameter, while its estimated weight is four tons. Five teams of horses were required to draw it on a stone boat to the new location. From the days of the earliest white settlers in this region the stone, which lay partly exposed to view, has been an object of much curiosity, and now geologists at the University of California will be asked to determine if it is a meteorite.

and joined to it by a series of fans which, while serving to keep the cut silage in motion, also bind the whole strongly together. The momentum given to the cut material by the knives is accelerated by the motion of the

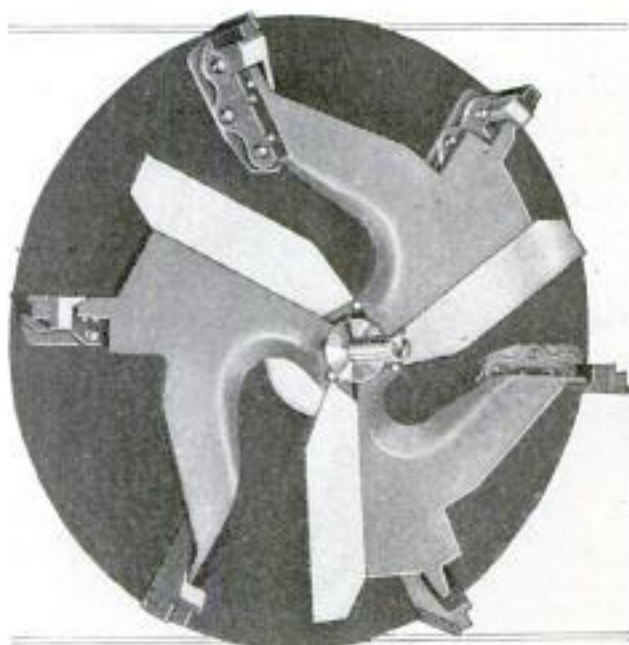

Disk Thrower Wheel of a New Silo Filler: The Cutting Knives, Fans, and Steel Disk All Revolve Together

NEW DISK THROWER DEVICE FOR FILLING SILOS

A new feature of silo-filling machinery is a disk thrower wheel devised by an Ann Arbor, Mich., concern. It consists of the combination of a solid-steel spider, carrying the knives to cut the silage, and a steel-plate disk opposite this knife wheel

steel disk in the same direction, helping the silage in its travel to the chute for delivery into the silo.

PAPER MOVIE FILMS AND MOTOR-DRIVEN CAMERA

Paper films are among the latest inventions in the motion-picture industry.



They are really not films at all, but are composed of tiny photographs taken with a motion-picture camera and printed on a tough photographic paper the width of the regular celluloid film, with the usual perforations along the edges. These paper substitutes are especially adapted for use in the home or school,

both because they are nonexplosive and because their cost is so much less than that of transparent films. A special projector is employed in displaying them. It is so constructed that the tiny pictures are run past an aperture on which are focused the rays of several powerful incandescent lights contained in a circular metal case. The



Right: Special Machine Used in Projecting Paper Motion-Picture Films. Left: Motion-Picture Camera Which Needs No Tripod

image of the picture is cast on the screen, 15 ft. distant, by reflection, and measures 3 by 4 ft. The machine can

be halted, if desired, to permit careful examination of any single exposure. This is a feature of importance in cases where the films are used in the classroom. The same inventor has also brought out a motion-picture camera for amateurs, which can be used without a tripod. It is equipped with a small motor that winds the films while the photographer employs both hands to focus the camera. Power for the motor is derived from batteries carried in the pocket. The machine has a capacity of 100 ft. of film.

NEW PORT IN PHILIPPINES SHORTENS VOYAGE

A new seaport recently built by the government on the east side of the island of Luzon will shorten the voyage to the Philippines from American ports by three to five days. Manila, the destination heretofore of all army transports and most of the commerce of the islands, lies on the west coast of Luzon, and while convenient for Spanish trade sailing eastward, it involves an unnecessary trip around the coast for American ships. The new port is located at a place called Hondagua, meaning "deep water," which is also the terminus of a new railroad from Manila. The improvements made by United States engineers have laid the foundations for a great modern port, from which passengers can reach Manila in a few hours by the new railroad, and the improved means of transportation will open up to commerce 200 or 300 miles of coast hitherto practically isolated and thousands of acres of rich agricultural lands, producing hemp and coconuts in profusion. The harbor at Hondagua is deep, extensive, and almost landlocked by a large island lying across its mouth.

Estimates based on accurate records covering a large part of the United States, show that during a recent year approximately 9,000 persons living in this country lost their lives as a result of conflagrations and burns.

Hart's...
N.Y.S.

Concerning Public Golf Links

by Searle Hendee



ON one chilly Saturday afternoon last fall, a day not particularly inviting to such an excursion, I reached the golf links in Lincoln Park, Chicago, shortly after one o'clock. It was my first visit to that course, or any public one. Therefore the surprise. On the benches back of the starting tee, and in little groups around the



"I recognized my milkman" . . .

I recognized two men: one, my milkman; the other, one of Chicago's foremost corporation lawyers.

The course, which is a nine-hole one, occupies several acres of filled land in a beautiful spot on the shore of Lake Michigan. The fairways are almost flat, the putting greens humpy, and there are no bunkers or ravines. The hazards consist of clumps of shrubbery, that occasionally catch a sliced ball; in one place a few trees, and in another a stretch of rocks bordering the water's edge. To play, one must present himself clubs in hand, register, receive a numbered check, and wait his turn.

On this particular Saturday all of the tickets had been distributed before the afternoon had fairly begun. That meant that as many persons as the links could safely accommodate before

sundown, had placed their names on the record sheet. Those too late to draw a number, however, were privileged to put their bags in line. Then, should enough golfers drop out so that time remained after the last ticket holder teed off, those in the second group might play in foursomes, the positions of their bags determining their sequence. After placing my golf bag at the end of the line, started 15 minutes before, I counted those ahead of it. There were ninety-two.

As the afternoon spent itself, the crowd maintained its original magnitude. Many of those who had drawn tickets had gone elsewhere while waiting their turns. So after utilizing some three and a half hours making new acquaintances, I found that approximately 150 players were still ahead of me. An old Scotchman, who bore all of the external evidences of a real sportsman, explained that the course was always crowded on Saturdays and Sundays. He advised an early arrival on the following day.

At six o'clock the next morning there was as large a crowd at the links as I had encountered the afternoon before. After six and a half hours of waiting, I teed off. On the following Sunday, at three o'clock in the morning, 14 men and three women had lined their bags near the starting tee. During the next half hour 34 men and



"and one of Chicago's foremost corporation lawyers."

women approached through the darkness with golf trappings. At four o'clock, more than a hundred were on the grounds. When it grew light, the usual crowd was in evidence. All of this was late in the fall. In midsummer many who wish to get in a game without wasting the entire day plan to reach the links about two o'clock.



"There were youngsters from Halsted Street."

These three visits to the Lincoln Park golf course were illuminating. A crowd composed of men and women willing to arise in the middle of the night, ride several miles in "L" trains or street cars, and then wait two or more hours in the cold and dark; willing to do all that in order to spend an hour and a half on a flat golf course—such a crowd is an interesting one. Likewise a crowd that will sit for six or seven hours in the teeth of a damp wind, or in the full glare of a blighting sun, to do the same thing, is worth studying.

The impressive thing was that not more than one in a dozen of those who teed off were even mediocre players. The crowd therefore was not composed of fanatic golfers. Instead it comprised a group of city flat dwellers who craved a chance to feel green grass beneath their feet, clean air in their lungs, and sunlight on their faces. They wanted to lose the confinement of the office and apartment, limber their joints, and play.

Usually a crowd grows impa-

tient and grumbly with hours of watchful waiting. Not so, however, with this one. Everybody was either laughing, chatting, or just sitting. No one complained because the price he paid for a short game was the greater part of his one day of rest. There were ill-clad youngsters from Halsted Street with decrepit brassies and rusty irons, there were smartly togged young women from the North Shore, there were office boys and clerks with five-dollar outfits, and there were prosperous men and women with motors in the driveway and crack clubs that were as needless as alpine staffs. And in all this mixed gathering, there was nothing but good humor.

In four of Chicago's parks there are public golf courses. The system at these differs, but the conditions are much the same. All of the links are overcrowded. The Lincoln Park course accommodated about 50,000 players last season. At Jackson Park more than 300,000 persons used the two courses that are maintained. At Garfield Park it is estimated that 125,000 persons played around the nine holes.

The 50 golf clubs surrounding Chicago have approximately 15,000 members. Initiation fees, ranging from \$100 to \$1,500, coupled with proportionate dues and high transportation rates, force the average salaried person to the public courses—or a Sunday afternoon walk; and what is true in Chicago is true in many other cities.



"An old Scotchman . . . explained that the course was always crowded on Saturdays."





Statue and Site Proposed for a Monument to "Buffalo Bill" on Lookout Mountain, near Denver: Parts of Four States in Which Colonel Cody Performed His Exploits Are Visible from This Point. The Town of Golden, Colorado, Is in the Foreground

NATIONAL MONUMENT TO A POPULAR SCOUT

Plans for a national monument to the memory of Col. William F. Cody, known the world over as "Buffalo Bill," have been facilitated by official action of the city of Denver, which has dedicated a most appropriate site for the last resting place and monument of the popular plainsman and army scout. The site selected is on Lookout Mountain, near Denver and 2,000 ft. higher than that city, from which the proposed equestrian statue will be visible. Territory lying in four states—Colorado, Wyoming, Nebraska, and Kansas—which were the arena of the great scout's famous exploits, may be seen from Lookout Mountain, and a painting which depicts Colonel Cody leaning forward in the saddle in typical western scouting attitude has been chosen as a model for the monument. The site is reached by what is known as the Lariat Trail, one of the most spectacular mountain highways in America.

FIBER MEDICINE CASE FOR LABRADOR MISSIONARY

In his long dog-sled journeys across Labrador on errands of mercy, the famous medical missionary, Dr. Wilfred T. Grenfell, has need of a large special case in which to carry medicine for his

widely scattered patients. The last case sent to the mission was equipped with aluminum containers, but the atmospheric conditions of the region produced what is called "aluminum disease," the surface of the metal becoming scaly and marked with eruptions. For this reason the case proved unsatisfactory and a new one has been provided which is made largely of fiber and has small containers with fiber coverings. The outfit is inclosed in a case of heavy canvas. It is believed that it will better withstand the rigors of the bleak country.

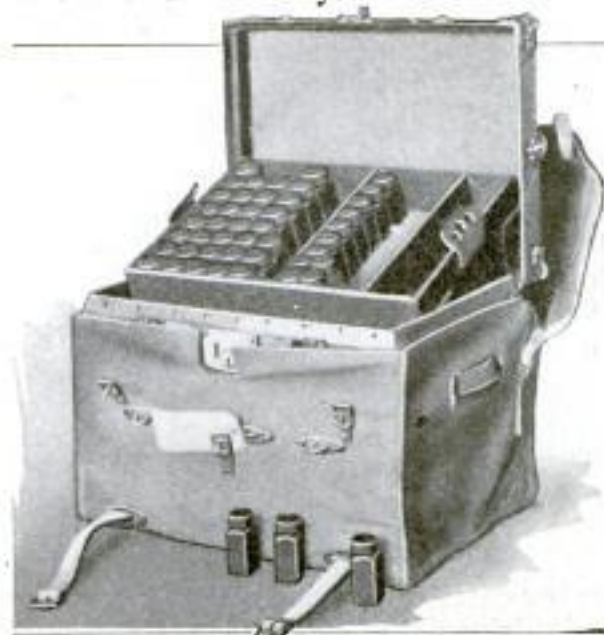

Medicine Case for Dr. Wilfred T. Grenfell of Labrador, Which is Made Largely of Fiber: It will Take the Place of a Case Having Aluminum Containers That Developed "Aluminum Disease" Because of the Climatic Conditions. Note the Fiber-Covered Bottles

Cypher Trust Corp. Co. 1200
Buffalo, N.Y.

PORTABLE FOLDING TRIPOD FOR MACHINE GUNS

A machine-gun carrier of recent construction is equipped with a folding tripod which can be quickly removed from



Machine Gun with Folding Tripod by Which It may be Carried on a Man's Back: The Man in the Photograph is Carrying the Tripod Alone

its place beneath the platform of the carrier, and set up on the ground to hold the gun and its saddle when they are detached from the main mount or pedestal. The tripod has a seat for

Write Small

VACUUM CLEANER A FEATURE OF NOVEL MOTOR VEHICLE

Embodying several rather distinctive characteristics, a three-wheeled

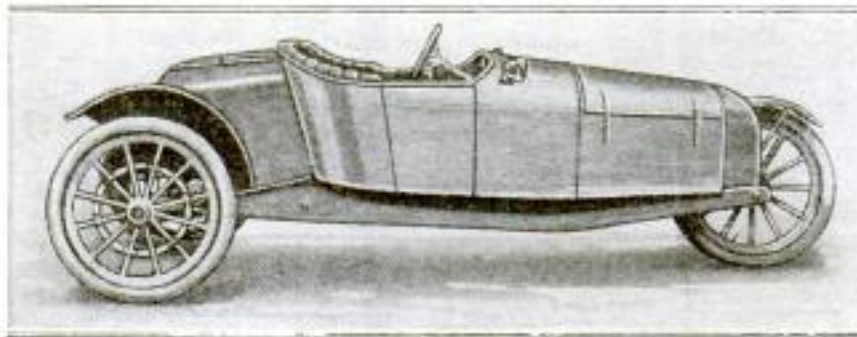

All of the Space beneath the Hood Is Available as a Storage Compartment for One's Luggage

motor carette has made its appearance. It is driven by a twin-cylinder engine of the motorcycle type, which gives it an approximate maximum speed of 45 miles an hour on good roads. The

the operator and is constructed so that it may be swung upon a man's shoulders for transportation; or the machine gun mounted may be carried on his back, leather padding being provided for the protection of the shoulders. The feet of the tripod have claws, to catch in the ground and hold it firm when the gun is in action.

EFFECTIVE SAFETY-FIRST AD IN COMIC SECTION

The colored comic section of the Sunday paper, which is so popular with children and some of their elders, was utilized very effectively in a recent safety-first campaign in Kansas City, conducted by the local traction company. The lower half of the back page of this juvenile section of a Kansas City journal was occupied by eight colored pictures showing eight ways in which a child is apt to be careless around street cars. Anyone familiar with the habit which little children have of asking that the pictures in the comic supplement be fully explained to them, will readily see how effective these advertisements must have been.

wheelbase is 100 in., the weight 500 lb., the body streamline, and the price low. Roomy storage space for luggage is provided beneath the hood and seat. Roller-drive transmission is employed, which means that the customary differential, clutch, and gears are eliminated. Steel driving rollers on the crankshaft extensions grip V-shaped rings fastened to the rims of the rear wheels, the engine being mounted behind the seat. There are three forward, and one reverse, speeds. To prevent the entrance of dust and grit into the carburetor, the air taken in by the latter is filtered. By attaching a hose with a suitable nozzle, a vacuum cleaner is provided. This is not merely

Durham Motor Co. 1200

strong enough to clean the upholstering of the car, but may be employed for general purposes, even commercially if desired.

INVENTOR'S MODEL OF AN UNSINKABLE WARSHIP

A young inventor of Lancaster, Pa., has constructed a model of what he believes to be an unsinkable warship, able to defy submarines and turn torpedoes from the strict path of duty. His working model shows a sort of semisubmerged fort, the great bulk of the ship's hull being under water at all times. The design of the hull shows extraordinary depth, and the inventor's theory is that this construction, with numerous air chambers, would keep the ship afloat even if struck by one or more torpedoes at or near the water line. A belt of air chambers, resembling a huge flange, surrounds the hull near the normal water line, and is designed to assist in maintaining buoyancy after the lower hull has been pierced and partly water-filled by torpedo attack or shell fire.

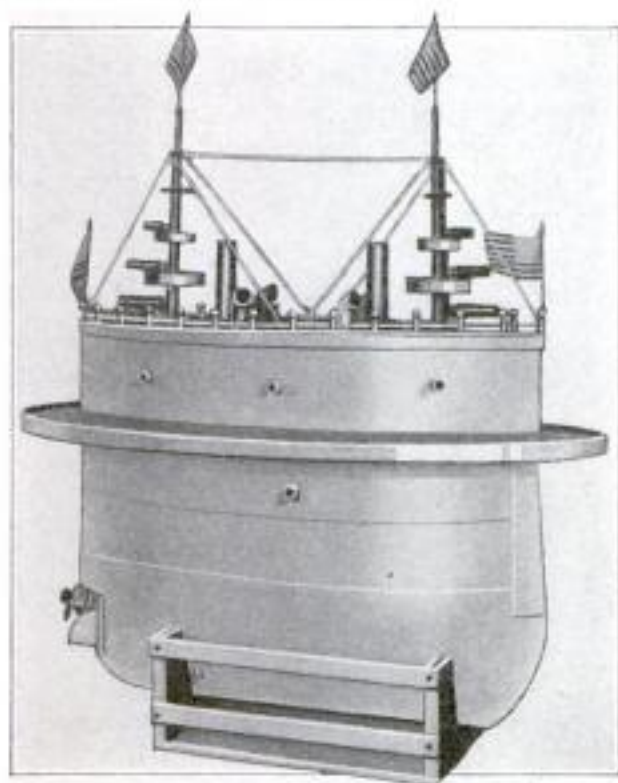

Model of Warship Hull Designed by a Young Inventor to Remain Afloat, Supported by Its Air Chambers, after Torpedo Attack

MOVIE STAIRCASE BUILT IN SEVEN MINUTES

Rapid construction of scenery and "props" is often necessary in a motion-picture studio, but four stage hands in



This Demountable Staircase, Used for Various Purposes in a Motion-Picture Studio, was Set Up in Seven Minutes

a Los Angeles studio claimed a speed record when in seven minutes recently they set up a ballroom staircase capable of sustaining a weight of over two tons. In further proof of their ability as lightning-change artists, they then took down the staircase in six minutes, and in seven minutes more transformed the structure into a tenement staircase for another picture. The demountable staircase was invented by one of the studio staff and can be rapidly changed into a dozen different structures, including a banquet table and other large pieces of furniture used in making film pictures.

FIREPROOF STEEL SASH IS FORMALLY TESTED

An interesting test of fire-resisting steel sash was made recently at the underwriters' laboratories in Chicago, during an official visit of the Illinois chapter, American Institute of Architects. A large section of the fire sash, containing 48 lights, was submitted to the test. It was of counterbalanced

type, three sash high, the upper and lower sash being balanced over a pair of pulleys, so that the upper sash descends as the lower sash is raised.

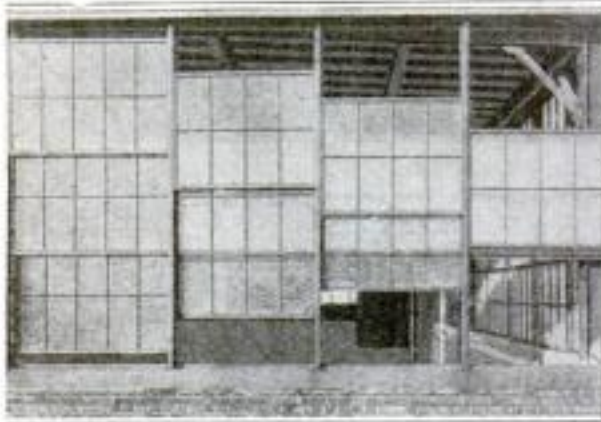

Type of Three-Sash Windows of Counterbalanced Steel Sash Which Withstood Continuous Blazing Heat for an Hour in a Test before Illinois Architects

This type is designed to give a great ventilating area in industrial and other buildings, without interfering with the use of shades, screens, or machinery placed close to the windows. The sash is made of steel specially rolled in solid one-piece sections, each of shape and weight to give maximum strength and stiffness, with joints that resist corrosion and are welded by the oxy-acetylene process. Wire glass is commonly used for glazing. In the formal test before the architects the conditions were similar to those of a fierce factory fire, and the sash stood the test for the prescribed period of one hour.

AUTOS SENT IN CARAVANS DURING FREIGHT TIE-UP

Caravans of a new and modern sort were a familiar sight in various parts of this country while the congestion of freight traffic made it impossible for the railways to handle goods with certainty as to delivery. These processions consisted of long lines of new automobiles sent overland under their own power to agencies in large cities and, in some cases, direct to purchasers. The drivers of the cars were sometimes organized into companies, each of which was commanded by a "captain." It is said that for several weeks an average of 200 cars per day followed the route from Detroit to Chicago.

RIVER STEAMER LOADED ON ITS BARGE

On the completion of a flat-bottomed river steambot and a large barge, built at Lake Charles, La., recently for the Mexican trade, the problem of transporting them to Mexican waters was solved by loading the stern-wheeled boat on the barge, which was then towed to Tampico. The steamer, fully equipped, was supported on a cradle of timbers built above the hold of the barge.

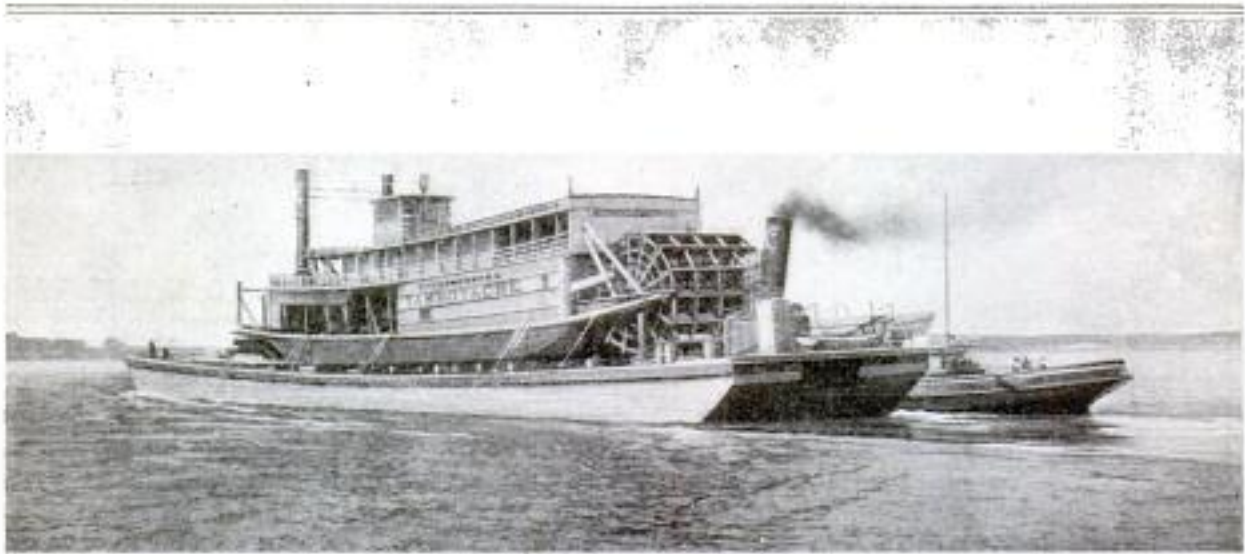

This Shows How a Stern-Wheel River Steamer, Built at a Louisiana Port, was Loaded on Its Barge to be Towed to Tampico, Mexico, Where It will be Placed in Freight Service

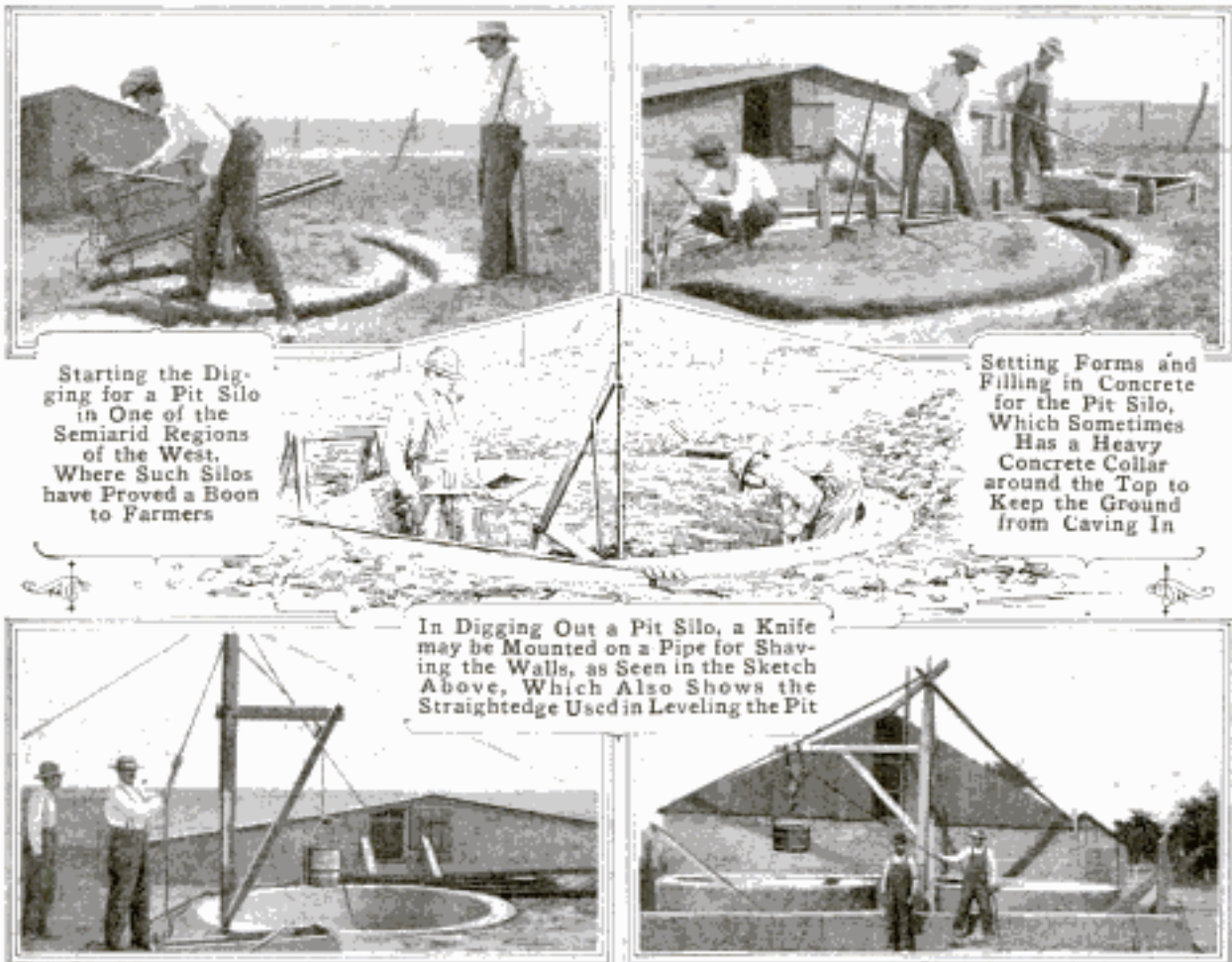

Starting the Digging for a Pit Silo in One of the Semiarid Regions of the West. Where Such Silos have Proved a Boon to Farmers

Setting Forms and Filling in Concrete for the Pit Silo, Which Sometimes Has a Heavy Concrete Collar around the Top to Keep the Ground from Caving In

In Digging Out a Pit Silo, a Knife may be Mounted on a Pipe for Shaving the Walls, as Seen in the Sketch Above, Which Also Shows the Straightedge Used in Leveling the Pit

Left: A Completed Pit Silo, with Derrick Rigged for Drawing Out Earth, Lowering Cement Plaster, and Hoisting Silage. Right: Twin Pit Silos near Cheyenne Wells, Colorado

PIT SILOS HELP FARMERS OF THE WEST

Farmers in the semiarid regions of the West have recently found a valuable aid in the pit silo. This form of silo may be cheaply constructed by the farmer himself and enables him to provide satisfactory feed for his stock in winter, even after a season of drought and crop failure. The pit silo is simply a hole in the ground, lined with cement, and may be made of any size or shape. Sometimes a heavy concrete collar is constructed around the top, to keep the ground from caving in and keep the moisture out; sometimes there are concrete extensions above the ground level.

A wooden top is provided, with an opening and some sort of derrick for the removal of the ensilage. The cost of a pit silo may range from \$5 for a crude small one to \$150 for large ones.

The average cost of hundreds already built in the West is said to have been between \$15 and \$20.

IMPROVED SPOTLIGHT BRACKET

An improved bracket is now being used to attach a spotlight to an automobile windshield, which is of special advantage because it permits the lamp to be turned in practically any direction, either forward, to the right, to the left, or to the rear. This is made possible by means of a T-swivel which turns 270° in a sleeve that is attached to the lamp and through a complete circle in a sleeve attached to the windshield. The cord passes through the swivel, which is hollow.



Cont. ... of Trucks ... Chi.

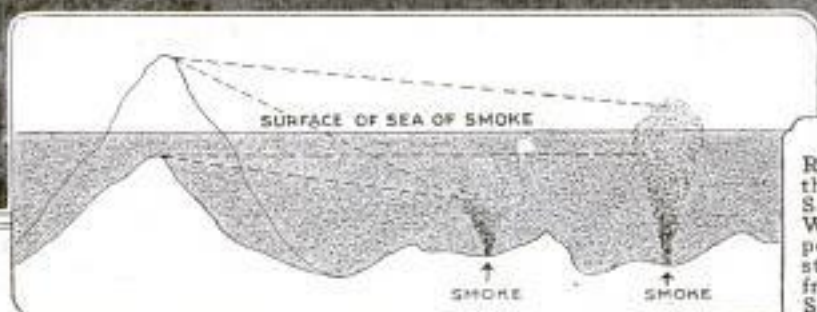
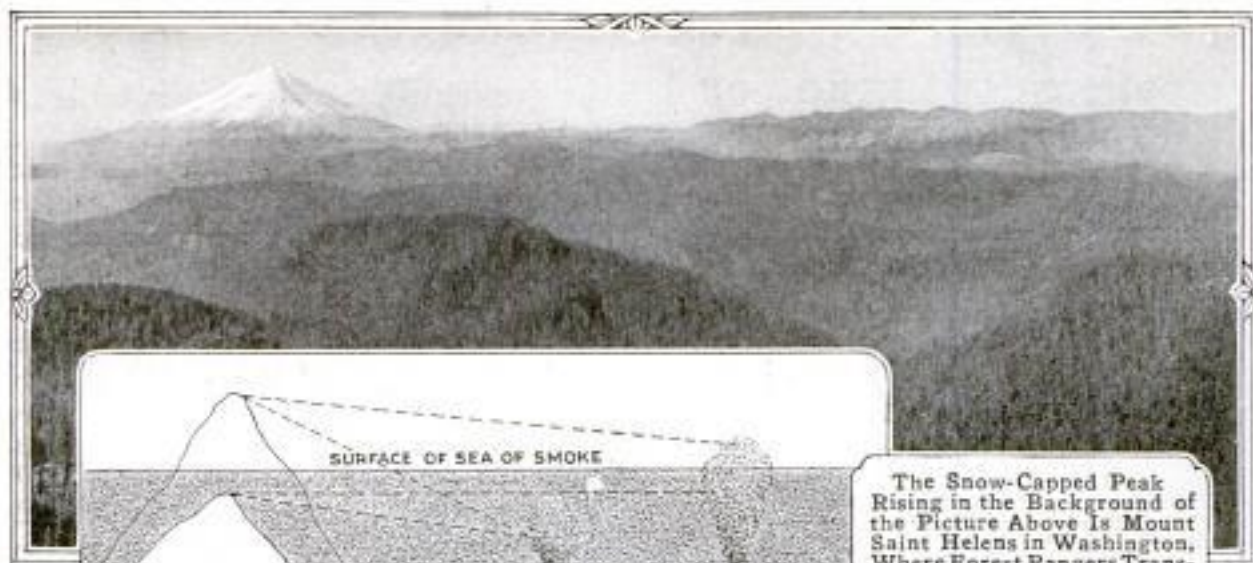

The Snow-Capped Peak Rising in the Background of the Picture Above Is Mount Saint Helens in Washington. Where Forest Rangers Transported Material for the Construction of a Lookout Station from Which an Observer Now Scans the Surrounding Country in a Constant Vigil for Fires. The Diagram Illustrates the Advantage Derived by Having Lookouts on the Highest Mountains. The Valleys are Often Shrouded by a Smudge above Which Jets of Smoke from Fires Rise. The Latter can be Seen from High Elevations

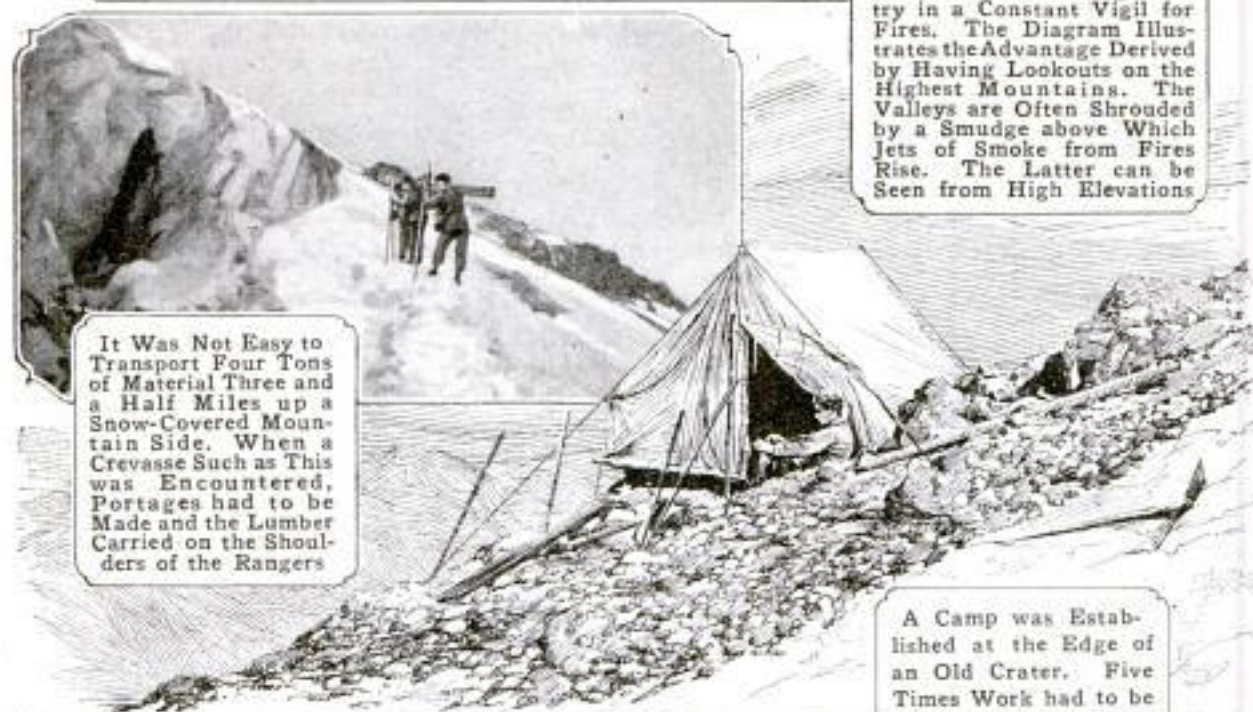

It Was Not Easy to Transport Four Tons of Material Three and a Half Miles up a Snow-Covered Mountain Side. When a Crevasse Such as This was Encountered, Portages had to be Made and the Lumber Carried on the Shoulders of the Rangers

A Camp was Established at the Edge of an Old Crater. Five Times Work had to be Abandoned on Account of Severe Storms, and on One Occasion the Wind Tore the Tents into Shreds. Oil Stoves were Used for Cooking

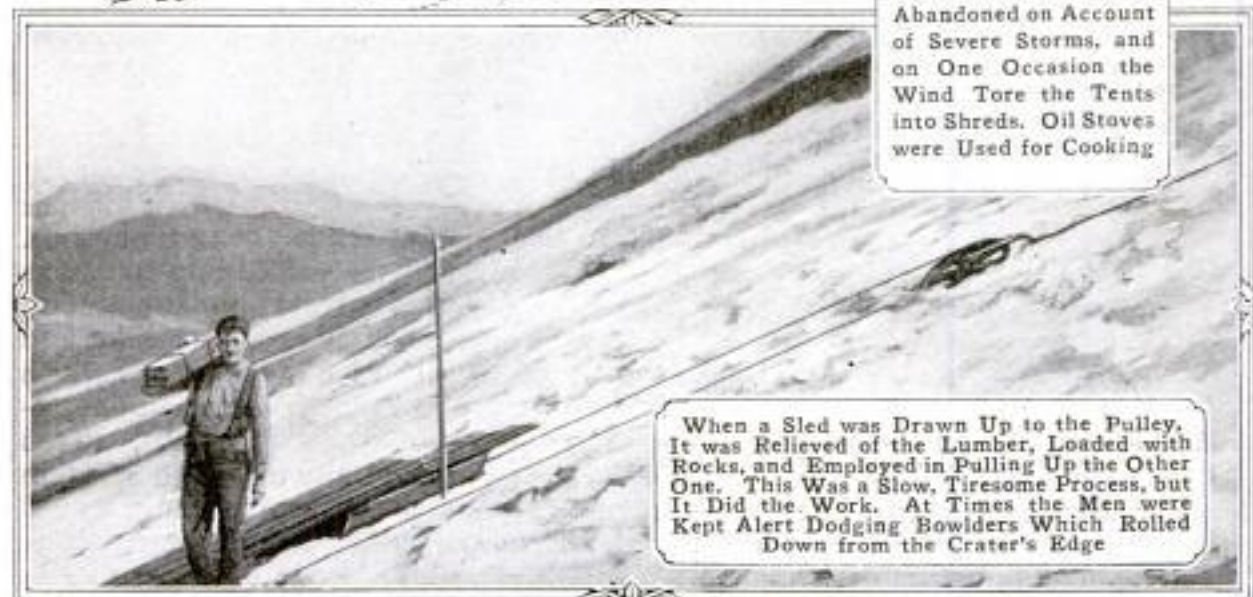

When a Sled was Drawn Up to the Pulley, It was Relieved of the Lumber, Loaded with Rocks, and Employed in Pulling Up the Other One. This Was a Slow, Tiresome Process, but It Did the Work. At Times the Men were Kept Alert Dodging Boulders Which Rolled Down from the Crater's Edge

S. F. Drayser
1876 E.

**ECONOMICAL METHOD OF
PAVING REPAIR**

A paving contractor of Cleveland, Ohio, has reduced his repair gang to two men and a foreman for such work

city is said to have a larger mileage of brick than any like area in the world, and economical methods of repair are therefore important. This contractor first has all the old paving removed with pick and sledge, except along the



Cleaning Out the Old Mortar to Patch Brick Pavement in Cleveland: A Pneumatic Chisel is Used, with Power Furnished by the Air Compressor alongside the Patch, and One Man can Do the Work of Three with Hatchets

as is shown in the illustration, where a brick pavement is to be patched. The

edge of the patch. There the old bricks are loosened for removal, with a pneumatic chisel. This cuts out the old mortar and leaves a clean sound "key" for the new pavement to meet as it is laid. The sound bricks taken up are also cleaned by the pneumatic tool and relaid, which is another economy. Power for the tools is furnished by a portable outfit consisting of a gasoline engine and an air compressor mounted as a unit upon a truck that can be moved along the pavement by hand.

Railroad

**AUTOMOBILE DOES DUTY AS
A LOCOMOTIVE**

In building a mining railroad up a steep cañon in Utah recently, the con-

struction engineer found it slow and expensive to haul ties and rails by team up the cañon grade. He therefore se-

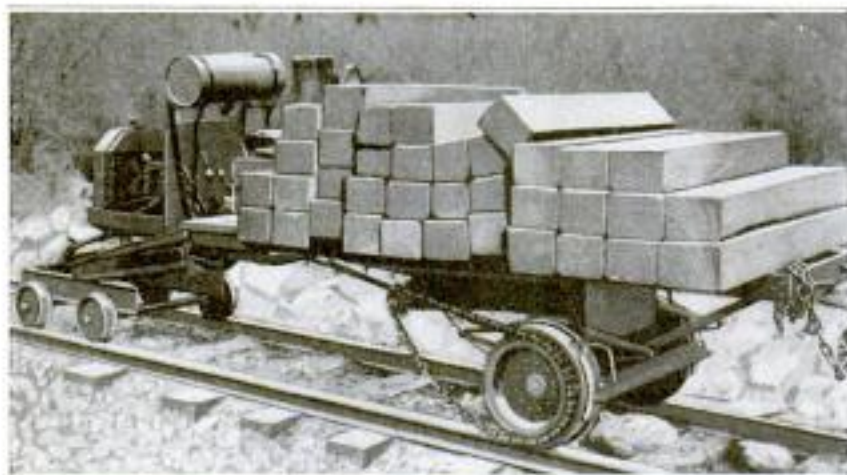

Automobile Engine and Chassis Transformed for Use as a Locomotive and Freight Train in Railroad-Construction Work

one day as a four-horse team could haul up the cañon in ten days. The gasoline tank is carried above the dash.

cured a small automobile, removed the wheels, and placed small railroad trucks under the chassis, with large sprockets on the rear wheels, to which power was transmitted from the regular automobile rear axle by a chain. The transformed machine worked like a charm when used as a locomotive on the new-laid tracks of the railroad, taking a grade of 11 per cent, with a load, at about 12 miles an hour. A load of two tons was carried up the cañon easily on high gear, and the engineer asserts that his newfangled locomotive will haul as many ties and rails in

W. K. Yorston, Engin. Wash. - Hills ...
Little Locomotive Sunny, ...

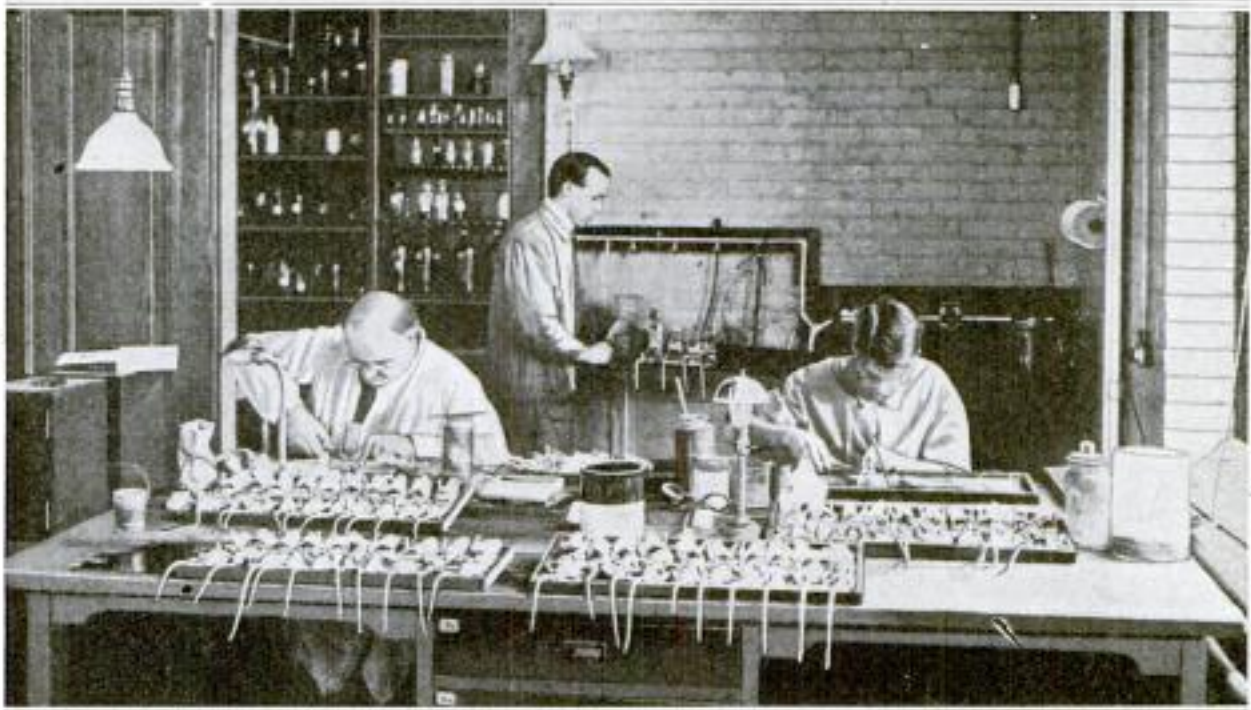

View in Tufts College Laboratory, Showing Professor and Assistants Preparing Scores of Bodies of White Rats for Biology Students

WHITE RATS BY THE SCORE FOR BIOLOGY CLASS

With almost the precision of a window dresser making ready trays of goods for display, a professor in Tufts College, Massachusetts, arranges the bodies of white rats in large shallow pans, this being one of his tasks in preparing work for his biology class. The little white carcasses, arrayed in this unusual manner, are used by the students in their study of veins and arteries and their location. The accompanying photograph shows the professor and an assistant injecting colored fluids into the rats, so that the blood passages and their connections with the various organs can be studied to the best advantage. The man in the background is giving the specimens a final cleansing.

ORNAMENTAL FIRE ESCAPES FOR NEW BUILDING

Fire escapes, even on very handsome structures, are often an ugly feature, but in the case of a new insurance building in Los Angeles they have been so designed as to be truly orna-

mental. The landings of these emergency stairs at each floor are handsomely embellished balconies, finished in the same color and material as the rest of the building. Extending from



Two Views of the Fire Escape on a New Building in Los Angeles, so Designed as to Be Truly Ornamental

one balcony to the next are railed flights of iron steps, painted a light color to match the rest of the exterior.

*Designed by the Fire Escape Co.
Los Angeles, Calif.*

NEW DRILLING MACHINE FOR DEEP HOLES

A machine lately placed on the market is designed to furnish a ready means for drilling the long or deep holes required in lathe spindles and similar work. The drill is set in a vertical position and feeds up into the work. This arrangement prevents the drill from becoming clogged with chips, and a small force pump, included in the equipment, keeps it cool and free from obstruction. Holes of any size up to 4-in. diameter and 48 in. long can be drilled rapidly, the drilling being done from both ends when the hole to be made exceeds 24 in. in length. The feeding mechanism is adjustable by means of removable gears furnished with the machine.

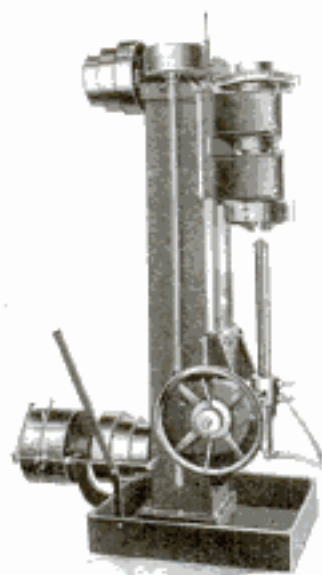

AUTO SPEED INDICATOR LOCKS ON COLLISION

Should an automobile collide with another car or any other object head-on, the speed at which it is traveling at the moment of collision may be registered by a device recently patented by a Seattle inventor. The means employed include a speed indicator with the usual dial and a pointer which is locked by electricity in any position it occupies when a switch mechanism is closed by pressure on a collision bar



carried on the front end of the automobile. The pointer is engaged and locked by a plate supported above it normally by a bar, the latter being withdrawn electrically when a collision occurs, so that the pointer cannot move from the position it occupies at that moment, but remains fixed as evidence of the rate of travel, which often decides the responsibility for accidents.

LIGHTING A GAS LANTERN WITH A MATCH

A recent improvement enables a gasoline lantern to be lighted with a match, outdoors and in any kind of weather. It eliminates the necessity of carrying around a torch and alcohol to start the generation of inflammable gas. A small coil located near the gas mantles and conveniently reached by the flame of a match inserted through a small door in the reflector, is the special feature of the improvement. The heat of the match applied to this coil is sufficient to generate gas and light the lantern in about 15 seconds. As the gasoline lantern is claimed to give more light than 20 kerosene lanterns, and can now be lighted with a match in the wind or rain, its use among farmers, watchmen, campers, and automobilists is likely to be greatly extended.



COLLAPSIBLE BOAT TESTED BY FOREST SERVICE

One of the Pacific coast divisions of the Forest Service has been equipped recently with a new style of collapsible canvas boat, which is being tested in the vicinity of Olallie Butte, Ore., where the national foresters are co-

Any of these
Seattle, Wash.

Any of these
Copyrighted material



Canvas Boat Supplied to Members of Game Fish in Oregon Waters:

operating with the State Game and Fish Commission in planting game fish in navigable streams. When in use, the boat is 12 ft. long, with a 3½-ft. beam, folding seats, and two-piece oars. It folds into small compass for insertion into a canvas bag of convenient form for transportation either by hand or on horseback. The total weight when folded and packed is 50 pounds.

AMERICAN COLD STORAGE FOR FOREIGN TRADE

Representatives of a New York refrigerating firm are reported to have been in Petrograd recently, consulting with government officials regarding the construction of ten large cold-storage warehouses on the Siberian and south-eastern railways of Russia. Since imports from Germany ceased with the war, a great need for refrigerating plants and machinery has developed in Russia, and American manufacturers have been invited officially to bend all their efforts to the satisfaction of the empire's wants, with promises of a reduction of import duty on refrigera-

This Shows How Easily the Folding Canvas Boat, with Its Oars, can be Carried by a Man

the Forest Service Engaged in Planting When Not in Use the Boat Folds Up

tion machinery and prospects of a largely increased market in Russia for American food products. The need for cold-storage and refrigerator cars on Russian lines of transportation is realized by American packers, who are also turning their eyes to India and planning the erection of cold-storage plants for American products there.

METER DEVICE INDICATES MILEAGE OF TIRES

The amount of mileage obtained from each tire used on an automobile, and from spare tires when these are in service, is recorded by an instrument just placed on the market by a Pennsylvania manufacturer. It also performs the usual functions of recording devices, indicating the car speed, trip mileage, and season mileage, besides showing the total gasoline consumption and oil consumption, and giving warning of adjustments, repairs, or cleaning usually found necessary at the end of every 500 and every 1,000 miles of car travel. It thus gives 13 separate readings regarding the service

of the car. With the exception of the car speed, which can always be read on the dial of the instrument, the other readings are obtained by turning a

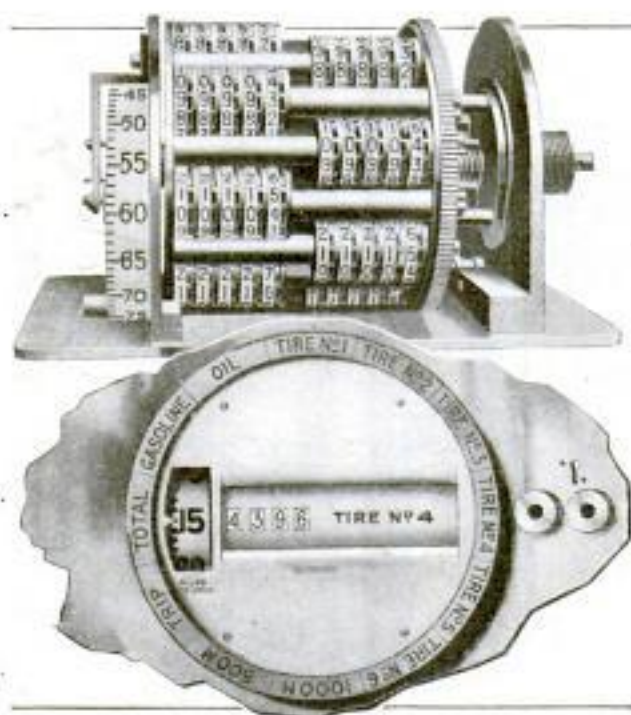

Dial and Mechanism of Auto Recording Device Which Tells the Mileage Obtained from Individual Tires and Keeps Track of Gas and Oil Consumption

movable dial ring, marked in various spaces with names or catchwords for the different records. When one of these names is brought opposite an adjustment thumbscrew on the face of the instrument, and the screw is turned, the appropriate record appears on the dial.

GOVERNMENT DESIRES DATA ON METALS AND ALLOYS

For the purpose of making the information generally available, the Bureau of Standards is compiling data concerning the numerical values expressing properties of metals and alloys, as used by engineers and others. Representative and fair figures for technical use of the material under consideration rather than extreme values, such as the maximum tensile strengths of metals, are desired. In carrying out the work engineers and engineering firms, scientists and scientific institutions, as well as those in allied fields, are being

called upon to cooperate. To facilitate this, form sheets and instructions are being distributed. Some of the alloys for which information is desired are aluminum and its light alloys with zinc, copper, and other metals, of stated percentages; nickel and copper-nickel alloys; aluminum, manganese, and phosphorus bronzes; naval brass and marine bronze; the red and other brasses, and white metals. The list of properties of which average values are sought include the density, shrinkage, tensile strength, yielding point, elastic limit, reduction of area, hardness, behavior in compression, melting range, expansion, conductivity, and hydraulic and optical properties of special metals and alloys.

RELIEF PIPES FOR IRRIGATION LINES

In developing certain arid parts of the West it has been found most practical to carry water used for irrigation

purposes through underground pipes instead of ditches. One of the accidents which has to be guarded against in such irrigating systems is the bursting of pipes by forcing water into them under high pressure when the outlet valves have accidentally been



left closed. To prevent such damage a common practice is to erect what are called relief pipes at certain intervals along the pipe lines. These rise to such a height in the air that when the outlets are open no water flows out of them, but in case a line has been closed through oversight, the vertical extension serves as an outlet, thereby preventing damaging pressure in the pipes underground.

Wash. D.C.

Copyrighted material
1/2 STEPHENSON ST.
LCS

Shark River, New Jersey, 1918

A CONCRETE MOUTH FOR AN OCEAN INLET

By STANLEY W. TODD

CERTAIN small rivers along the north Atlantic coast, emptying into the ocean, have a habit of closing their inlets whenever northeast storms and flood tides shift the sand bars. Invariably, stagnation of the river water follows, producing insanitary conditions in the territory touched by the stream and killing river oyster beds and the fish as well. The closing of the inlet, therefore, presents quite a serious problem to the river communities.

The ocean front between the summer-resort towns of Belmar and Avon-by-the-Sea, N. J., for instance, is divided by the inlet to the Shark River, which opens into an expansive bay in the country behind. The continual shifting of the inlet has made it impossible to bridge the gap, thus cutting off a coast-line highway to the towns lying north. In former years, the inlet closed frequently and produced such insanitary conditions that the county made an attempt to remove the trouble. As a

result, the plan of a Pennsylvania professor, devised to meet the situation, was adopted. This consisted of an elaborate system of wooden jetties on both sides of the river mouth, backed up by sand. The jetties were put in after a good deal of difficulty and expense, and served for several years, until the sea got in its work. It pounded out the sand backing and loosened the piling, putting the inlet again at the mercy of wind and waves.

Then the state of New Jersey took a hand in the matter. A New York engineer conceived the idea of installing a concrete mouth for the river, following the natural course of the water instead of running straight out, as the wooden jetties did. The state appropriated a sum of money and the work was undertaken two years ago. A plant for making reinforced-concrete piles was set up near the inlet, also pumping jets used in piles in station for water making way for the the bed of the river.



Remains of Wooden Jetties Built to Protect the Inlet to the Shark River on the New Jersey Coast. Showing What the Sea has Done to Them: The State is Now Building a Concrete Inlet Mouth



North Wall of the New Concrete Inlet to Shark River. Showing the Trestle Used in Placing Reinforced-Concrete Piles Made at a Special Plant Set Up on the Neighboring Shore

But the original contractors failed and the task of carrying out the improvement fell upon the state, whose Department of Conservation and Development directed the operations through a receiver. The work is now nearing completion.

When the project is finished, the Shark River inlet will have a concrete "mouth" about 100 feet wide. On each side, there will be a reinforced-concrete wall, formed by 24 and 28-ft. piles, of the tongue-and-groove type, with the base sunk several feet in the clay underneath the sand. Besides, the contour of the walls follows the natural flow of the water, keeping the inlet at a standard depth.

The ties which make up the inlet walls are in some cases solid concrete, and in others hollow. They are capped with 2-ft. beams and reinforced with brace bars, 10 ft. 8 in. long.

It was soon discovered that ordinary pressure on the water jets would not be sufficient to remove the thick clay encountered under the sand, and 100-lb. pressure was secured. The north wall had to be strengthened, particularly where it reaches out into the ocean. A solid reinforced-concrete wall, at least 6 ft. wide, has been built out into the sea for about 150 feet. This bulkhead has the effect of protecting the south side of the inlet by holding back the sand that used to close it up periodically. The sand bar shifts outside of it, instead of blocking the river, and the channel is thus maintained.

All the engineering equipment was

erected by the contractors on the Belmar side of the inlet and so trestles had to be constructed to bring the necessary power to the Avon shore. These trestles had to be strong enough to hold a 60-ton locomotive crane. They are built in a sort of semicircle, and then run parallel with the concrete work.

The crane, moving about on the track, greatly facilitated the task of

bringing over the heavy concrete piles from the other shore and doing other heavy work. Another trestle was found to be necessary, to carry the pipes conveying water under 100-lb. pressure from the engine room on the Belmar side to the water jets operating on the other side of the inlet. A 5,500-lb. steam hammer was also used in these operations.

It is proposed to construct a bridge over this concrete mouth, allowing the con-

tinuance of the shore road to the next town. Other contemplated improvements include the development of vast sand wastes for dwelling purposes, similar to a very remarkable draining and filling-in work consummated farther up the river. In the latter case, former mud bars and swamps were filled in and leveled, and are now the center of a summer-home section, made attractive by a system of lagoons.

Upon the successful termination of the Shark River inlet experiment depends the fate of several rivers along the New Jersey coast and the Long Island ocean beaches affected by similar conditions. Never before has concrete been applied to river inlets in

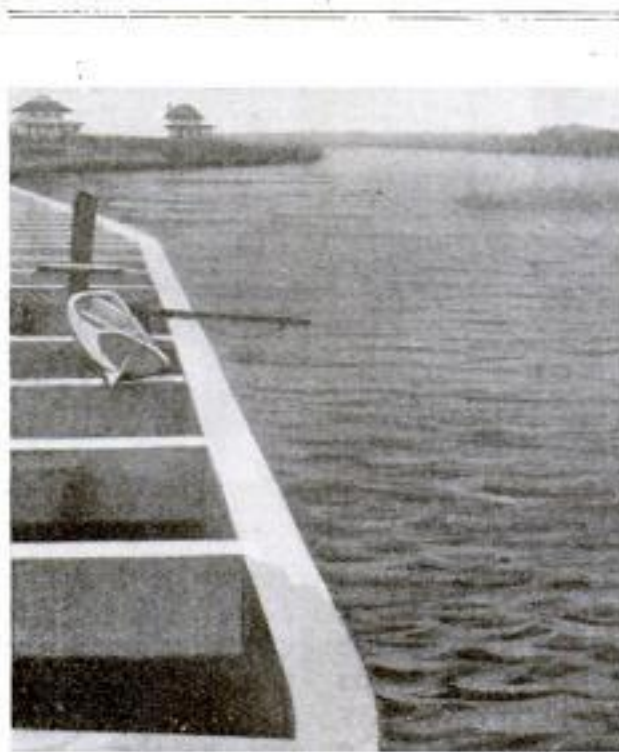

Concrete Inlet for the Shark River at Belmar, New Jersey: The Contour of the Walls Follows the Natural Course of the Water and is Designed for Protection against Shifting Sands

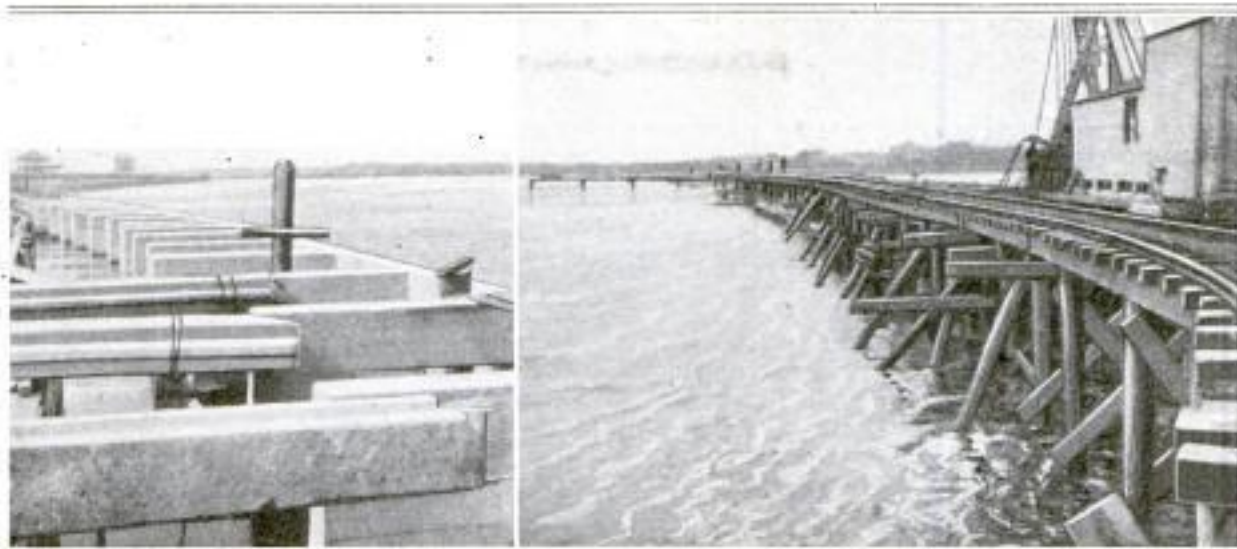

Details of Concrete Inlet Wall at Belmar, New Jersey, at the Left. The Photo at the Right Shows the Swift Current of the Rushing Tides, Which Made the New Structure Necessary

this way, and if the undertaking is considered a success by engineers, it is probable that similar improvements will be made in other streams hampered by shifting and uncontrollable inlets.

TRUCK USED AS TRAVELING NOTION STORE

With a view to making deliveries of goods as soon as an order has been received, a wholesale-notion company in Pasadena, Calif., has purchased a truck equipped with more than 100 compartments, ingeniously arranged to utilize all available space. The car can be en-

tered from the rear by opening the door which allows folding steps to drop into place. Through its center runs an aisle, on each side of which are 48 commodious compartments, while at the front end of the passage are 12 more drawers. At the back side of the driver's spacious compartment, in which there are seats for five persons, are six drawers, and overhead are five more, one of which is attached to the windshield. A sliding glass panel gives the driver a view of the car's interior. Four storage spaces, fastened to the under side of the car floor, are accessible from the outside. A ventilator is provided above the rear door.

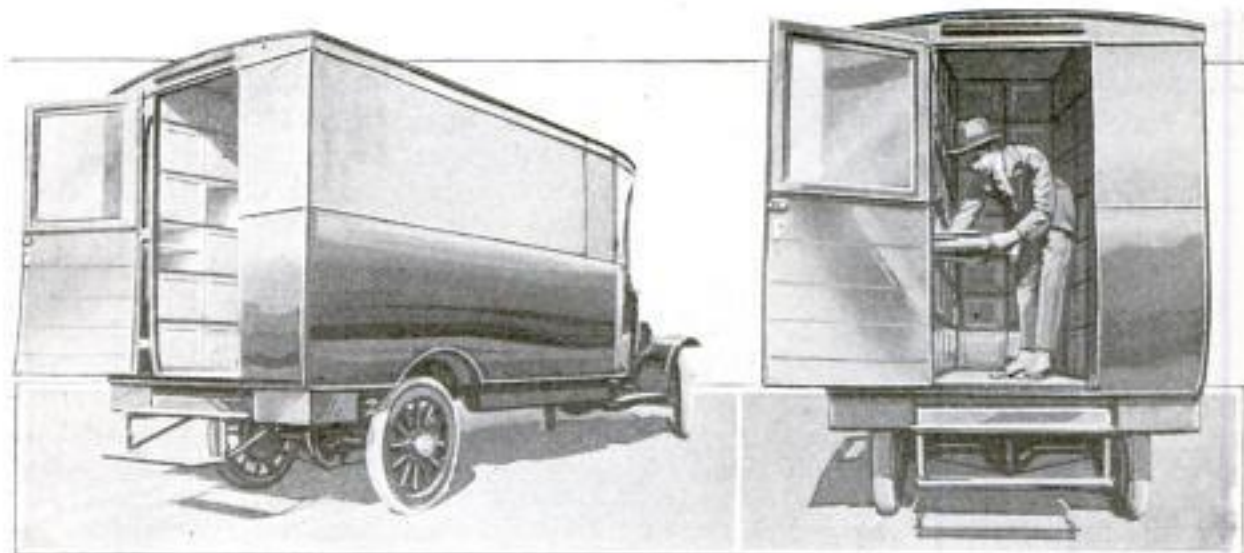

Two Views of a Truck Having More than 100 Storage Compartments: With It a Drummer for a Wholesale-Notion Company Is Able to Deliver Goods at the Time He Makes His Calls

W.F. Duffett & Son,
Pasadena, Calif.

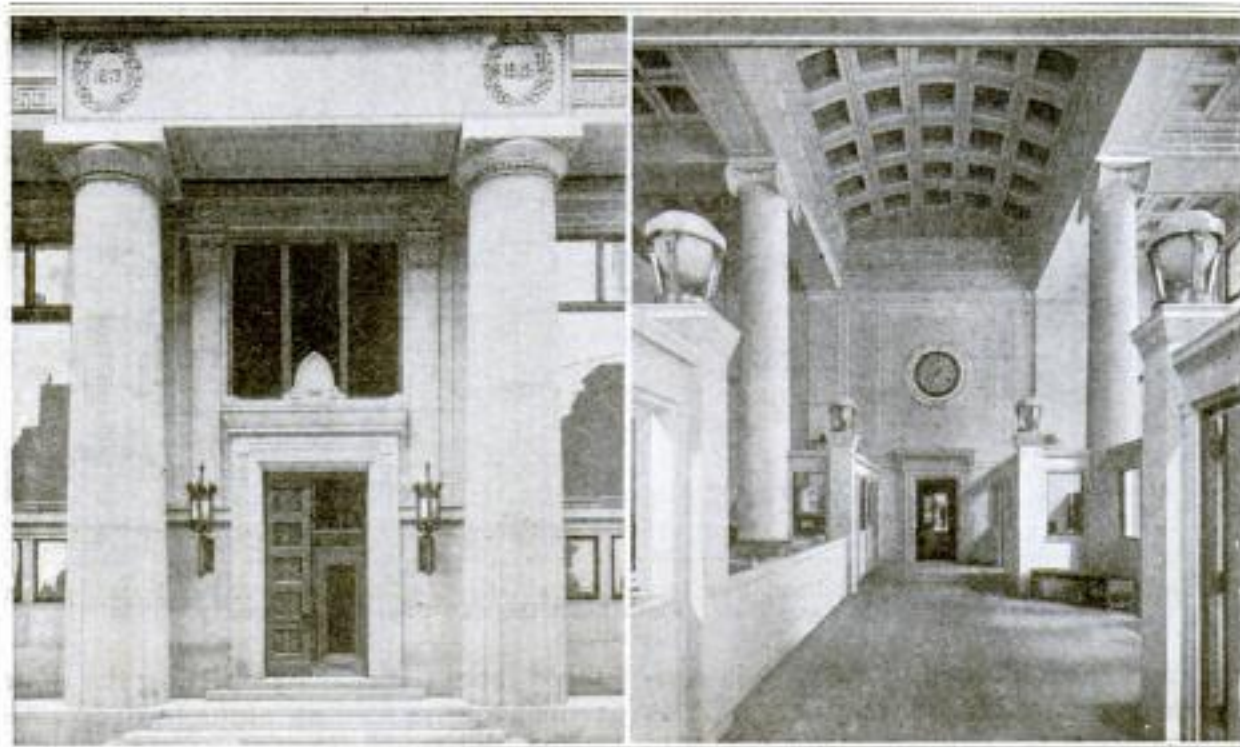

Exterior and Interior Views of the Home of a Philadelphia Fire-Insurance Concern Which has Practiced What It Preaches by Making the Structure Thoroughly Fireproof

DEVICE STOPS PHONOGRAPH WITHOUT SETTING

A mechanical device newly patented automatically starts and stops a talking machine without any special setting or adjustment. It can be applied to any phonograph, old or new, and replaces the regular brake without altering the instrument. Its construction and operation are simple, there being only two working parts, located under the turntable. When the tone arm is swung into position for playing a rec-



Automatic Start and Stop for Phonographs. Replacing the Regular Brake and Requiring No Setting

ord, the movement of the device starts the motor; when the record is finished, the motor is automatically stopped.

FIRE-INSURANCE CONCERN'S OWN HOME IS FIREPROOF

Acting on the principle that a fire-insurance company's own home should be an embodiment of the very latest ideas in fireproof construction, an insurance association in Philadelphia has constructed, and is now located in, an office building that fulfills the rigid requirements of the fireproofing engineer and at the same time possesses much architectural beauty. The tessellated floors, polished columns, walls, and paneled ceilings are all of material that would resist flames. Yet in providing for building materials which were strictly fireproof, the architect has avoided all suggestion of harshness. Instead, the design possesses beauty and strength that are most attractive.

A commercial organization in central Europe is said to have drawn up plans for a tunnel under the Bosphorus. If such an improvement were actually constructed it would be a tremendous stimulus to land commerce with the near East.

Conyon Houston
47 N. 4th St. N.Y.

Arch. E. F. Smith
of No. 1000 Market St.
Phila., Pa.

Com. Club,
K.S., Mo.

TRUCK USED AS TRAVELING VAUDEVILLE STAGE

An automobile truck which was fitted up not long ago as a traveling vaudeville stage illustrates perhaps the latest of the many novel uses to which self-propelled trucks have been put. The idea originated with a group in a Kansas City, Mo., commercial club which planned a "get-together" tour through several neighboring towns and wished to supplement its program of outdoor speeches with vaudeville features to attract the people. To meet these special requirements a one and one-half ton truck was secured and a platform built upon it to serve as a stage. A knockdown framework was also constructed, which was carried on the platform, and when the little company of speakers and entertainers arrived in a town this was quickly set up and the platform surrounded with canvas

walls. Across the front of the stage hung a draw curtain, while the back-



Automobile Truck Fitted Up as a Vaudeville Stage and Part of the Company of Entertainers That Accompanied It: The Upright Framework is so Made That It can be Quickly Taken Down or Set Up

ground consisted of an animated western scene painted in colors. A few pieces of furniture completed the setting.

DOWN-TOWN PLAYGROUND FOR NEWSBOYS

In the heart of Los Angeles, opposite Central Park, a church has equipped a

playground for newsboys, and others who have few recreation facilities. The patrons range from 8 to 18 years of age, and many of them are of foreign birth. The area, which is inclosed



Playground in the Down-Town District of Los Angeles. Equipped and Maintained by a Church for the Benefit of the Newsboys

with wire netting, is open evenings and during the day on Saturdays, when athletic games are played under the supervision of a director or volunteers representing the church. The playground has been established with a view to providing a wholesome substitute for the undesirable pastimes that occupy the attention of many boys in down-town districts.

SMOKE ROOM AND TOWER FOR FIREMEN'S DRILL

At the base of a large frame tower in Pueblo, Colo., on which the firemen hold frequent drills, is the "smoke



Firemen's Practice Tower in Pueblo, Colorado, with a Room That is Occasionally Filled with Smoke so That the Men can Practice Rescue Work

room," which is practically air-tight and in which at stated times old papers, rags, etc., partly saturated with formaldehyde, are placed and set on fire. When the room is filled with fumes and smoke the firemen, wearing their gas helmets, rush in to make their "rescues." By this means the men have developed great skill in this sort of work.

COMMON FERN STEMS AS A SOURCE OF STARCH

An English scientist has suggested that the underground stems of the common fern may be used economically as a source of starch. These stems are simply packed with starch, according to this authority, and others agree with him that the bracken fern, or brake, which grows abundantly in

many climates, might be made to furnish starch for industrial use if the roots or rhizomes containing the starchy element could be collected at small cost. It is said that a coarse kind of bread has been made heretofore from the roots of the brake fern in certain northern climates, and that in the East Indies and Polynesia the rhizomes of several fern species are eaten as a starchy food, or have the starch extracted from them. Experiments will probably be made in England to determine the economic value of the fern in this respect.

COMBINATION CUSHION AND LIFE PRESERVER

A silky vegetable fiber that weighs much less than cork is used as a filling for a type of life preserver which is so made that it serves as a cushion also. The article is especially suited for motorboats and other small craft. The life preserver is made up of two sections hinged together and provided with suitable straps. For use as a cushion it is inclosed in a slip-on khaki-duck cover, equipped with snap fasteners. It weighs but 2 lb., and the



Life Preserver Weighing But Two Pounds, Filled with Silky Vegetable Fiber Which is Much Lighter Than Cork: In the Rear the Preserver is Shown with a Slip-On Cover Which Makes It Serviceable as a Cushion for a Yacht or Motorboat

makers assert it has ample buoyancy to keep any person afloat. The cushion, if submerged, will retain its buoyancy over 48 hours.

Prof. F. E. Shirley - Eng.
2/24/19

Robinson-Peters Co., Newark, N.J.
Copyrighted material



Plow Drawn by Three Tractors: The Arm has been Lowered Four Feet into the Earth



Side of Ditch, Showing Condition of Ground after being Broken Up by Burrowing Plow



Plow Backed Up over Ditch into Which Drainage Holes Empty: Lowered Arm is Ready to Cut Deep Slit through Dirt

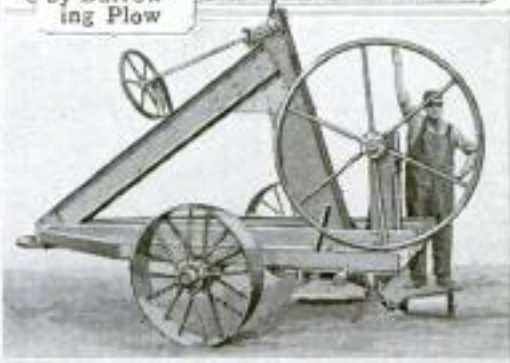

Burrowing Plow with Two-Wheel Running Gear: Note Steel Cone Attached to Lower End of Adjustable Vertical Arm

PLOW BURROWS DRAIN HOLES UNDERGROUND

A method of cultivation and drainage combined, which has been introduced on large farms in the West, requires the use of a plow that makes a horizontal hole under the surface of the ground at a depth of several feet, its action somewhat resembling the burrowing of a mole. The implement has a vertical blade that penetrates the earth the desired distance, and attached to its lower end is a steel cone, 8 in. in diameter, which is drawn through the soil by the arm, making a hole with hard-packed walls as it goes. In its progress through the ground the blade loosens the earth either side of it for some distance, and at the same time makes a narrow incision through which water may seep into the hole. It is said that some of these drains will last for years. The burrowing apparatus is mounted on a low running gear and the depth at which it works is regulated by a hand wheel. As many as three tractors have been required to pull one of these plows when the share was at full depth.

Street Fare
METAL CAR TICKETS THAT REGISTER AUTOMATICALLY

Metal street-car tickets have supplanted paper tickets in Mobile, Ala., where the traction company has inaugurated a new system of registering fares. The new ticket for adults consists of a suitably inscribed flat metal ring, encircling a letter "M," which stands for Mobile. Employees are provided with a metal piece bearing the letter "E." Officials and others holding passes are required, on entering a car, to give up a metal ticket marked with a cross. These disks, as well as



New Street-Car Tickets Recently Adopted in Mobile, Alabama: The Center One Sells at the Rate of 22 for \$1. The One at the Right Is for Employees and That at the Left for Pass Holders

cents, nickels, and dimes, are deposited in a special fare box which automatically registers them according to their value.

Miller
22,07

Mobile Light & Traction Co.
" *AL* Copyrighted material

**SEA WALL PROVIDES SEATS
FOR BEACH HABITUES**

One long section of the reinforced-concrete sea wall skirting a magnificent stretch of beach at San Francisco

**TESTS SHOW HOW FREEZING
BURSTS HOT-WATER PIPES**

Doubtless many persons other than plumbers have reached the conclusion that pipes carrying hot water burst more frequently as a result of freezing than do those that supply cold water. To determine the truth of this opinion and explain the matter, a system of test tubes was arranged to parallel as nearly as possible conditions presented in the average water-supply installation. The tubes were closed at one end. Some of them were filled with cold water and others with water that had been boiled. In the course of several experiments 44 of the tubes holding boiled water burst, while only



Bird's-Eye View of Completed Section of San Francisco's Sea Wall, Which Protects a Splendid Stretch of Beach

and separating it from a broad esplanade which is to be established, has been completed. A rather striking view of the structure, which on its curved, seaward side is provided with a series of deep steps that are used as "bleacher" seats by the surf gazers, is afforded by the accompanying photograph, which indicates clearly the position of the wall in relation to the future boulevard.

four of the others broke. The explanation was found in the fact that while tap water freezes more easily than boiled water, it does not freeze so solidly or exert so great a force in expanding. Unboiled water in freezing produces ice that is filled with air bubbles and is slushy near the middle of the tube. The bubbles and slush tend to react against expansion.

**NEW MEXICO MUSEUM BUILT
LIKE INDIAN MISSIONS**

The new museum building in Santa Fe, N. M., which is being constructed under the auspices of the School of American Archæology at a cost of \$100,000, is a fine example of the results of a movement in the Southwest to preserve, as far as possible in new buildings, the distinctive features of the Indian architecture of the region. The new structure is an enlarged replica, in reinforced concrete, of the

brick and stucco New Mexico state building at the San Diego fair. It combines the picturesque characteristics of several famous missions, reproducing the balustraded recess of one, the façade of another, and so on. It bears special resemblance to the ancient Spanish mission church at the pueblo of Acoma, N. M.—a massive building of stone, timber, and stucco, having walls 10 ft. thick in some places. The museum will serve as a state civic center as well as an appropriate shelter for rare archæological collections.

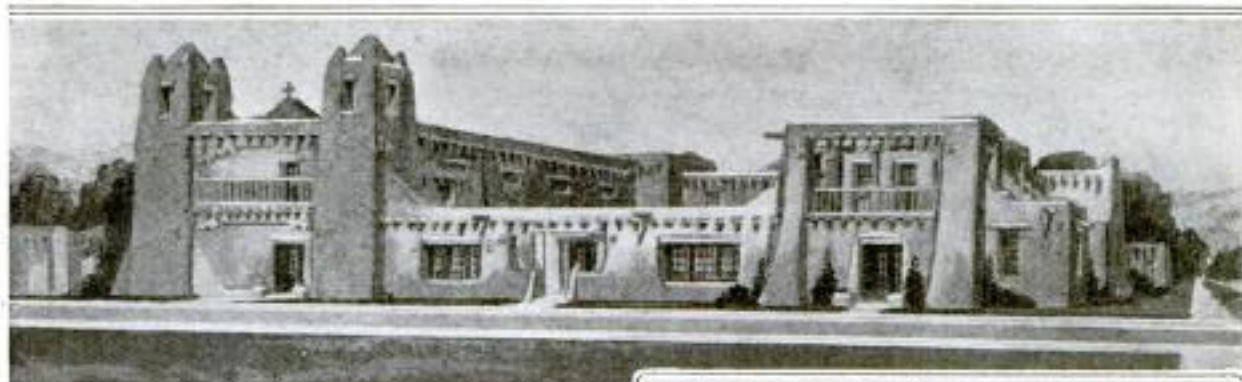

Reinforced-Concrete Building in Indian-Mission Style, That will Serve Both as an Archæological Museum and a Civic Center in Santa Fe

An auditorium with seats for 1,000 is provided, also tea rooms, sitting rooms, a kitchen, etc. It is connected by an overhead passageway with the historic government building known as the Palace of the Governors. The formal dedication of the museum will take place in August.



Old Indian Mission Church at Acoma, New Mexico, Which was Copied in Many Particulars in Designing the New Museum Shown Above

STEEL TURNTABLE MOVED BY WRECKING CRANE

Using a 70-ton wrecking crane to pick up and move a 55-ton steel turntable, an operation recently carried out by a railroad in Chicago, was an unusual proceeding because of the small difference in weight between the crane and its load. In preparation for the work a track supported on cribbing was built out to the center of both the old and the new turntable pit. Supported on the track and clamped to it to prevent overturning, the crane lifted the turntable from its old location by means of heavy chains. With the turntable raised and swung close, so that the boom stood nearly vertical, the crane was backed off the cribbing to a point where the turntable could be swung upon a steel flat car for transportation to the new site.

At the new site the reverse of this proceeding was carried out, except for a variation due to unexpected trouble. As the crane carried the turntable forward, the track sank under the weight,

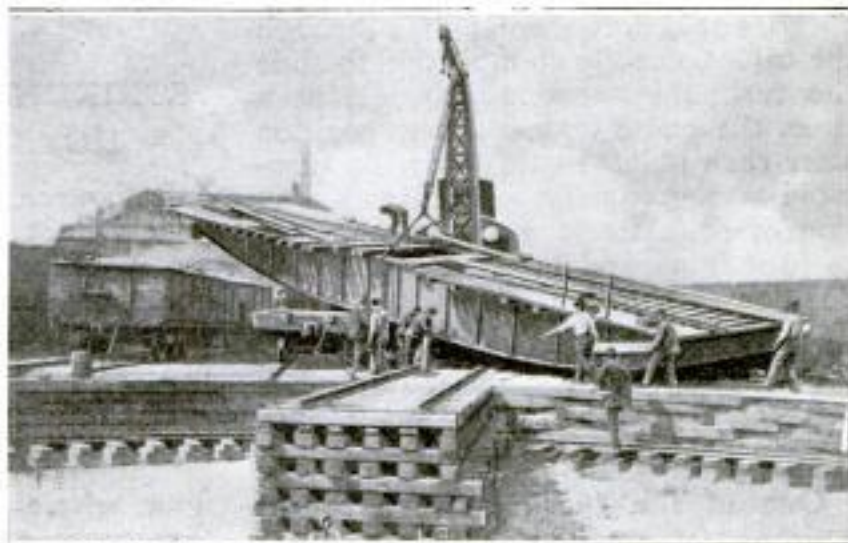

Moving a 55-Ton Steel Turntable with a 70-Ton Crane: The Track Gave Way and the Turntable Fell 20 Feet, but the Operation was Completed Successfully. In the Foreground Is the New Pit with Temporary Track and Cribbing

and a disastrous upset was prevented by the crane operator, who on the instant released all clutches and let the turntable fall. One end of it fell on a steel flat car, which in spite of the

*Experiments in
S.B. & G. Co.
Chi.*



The Mezzanine Balcony Borders the Restaurant on Two Sides and Offers Tables for Some

severe impact was not seriously damaged. After the track had been repaired the turntable was lifted clear of the car and lowered to the track. With the crane in position close behind and the boom reaching horizontally ahead, power was then applied through the cables, exactly as in lifting, to slide the turntable ahead a few feet at a time, the crane taking a new position after each pull. In this way the turntable was gradually worked to a section of solid track where it was safe to pick it up and move it to its final position in the new pit.

RAISING OF MORE SHEEP TO IMPROVE LAND

One of the speakers at a recent gathering of retail clothing merchants made a strong plea for the raising of more sheep in this country, declaring that in spite of our growing population there are several million less sheep in the United States today than in 1900. One of the arguments used in urging that this condition be remedied was that sheep are most valuable as

fertilizers. It was pointed out that in parts of England in which the soil did not possess great natural fertility, the raising of sheep had supplied the desired properties and the value of the land had increased proportionately.

STRIKING, WELL-EQUIPPED HOTEL DINING ROOM

Italian renaissance decorations, large panels hung with English tapestries, an artistic fountain, and a fully equipped stage are some of the outstanding features of a restaurant that has lately been opened in a new hotel at Cleveland. The room is 90 ft. in length, 40 ft. wide, two stories in height, and overlooked by a mezzanine floor where tables are provided for diners who prefer more privacy than is afforded below. The stage occupies a central position and can be seen from practically all parts of the main floor. Although of small size, it is supplied with footlights, a spotlight, and a projector, so that musical skits, one-act sketches, and moving pictures can be presented creditably for the entertain-

Deviser: B. G. Holt
 2nd

Deviser: B. G. Holt
 Hotel

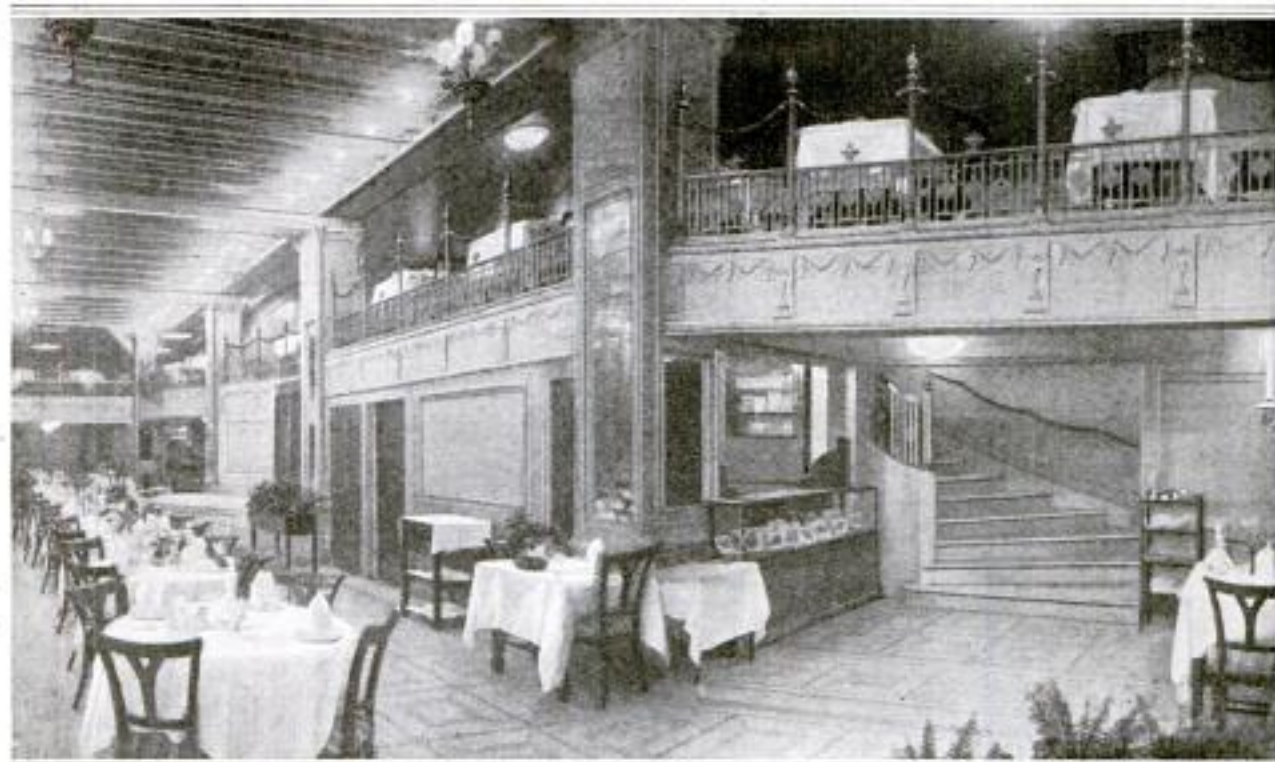

75 Persons. The Columns and Pilasters are Fitted with Mirrors and Finished in Tile

ment of guests. Dressing compartments, and a comfortable room where the performers may rest between numbers, are provided. The dining room is rather a surprising one for a hotel of 300 rooms, and has attracted much comment. The beamed ceiling is ornamented in bright colors, while the chairs are hand-decorated and finished in ivory and blue.

BIG OAK TREE MOVED LIKE A HOUSE

In regions where the winters are cold, it is the common custom, when a large tree is to be moved, to do the transplanting when the earth is frozen about the roots. But California's balmy winters do not admit of such a plan, and so, when the park commissioners of Oakland decided to replace the old oak in City Hall Park, that had died, with a big living oak, they resorted to the means shown in the illustration. The "new" oak's roots and surrounding earth were inclosed in a sort of huge tub, constructed on the spot, and then the task of transporting

the tree to its new location was intrusted to a house mover, who used his regular equipment for the job.



Oak Tree, Set in Big Improved Tub, being Moved Like a House to City Hall Park, Oakland, California, to Replace an Old Oak Which had Died

NEW DESIGNS IN REED FURNISHINGS



Porch Swing with Magazine Pockets at Ends. Cushions of Cretonne or Awning Stripe



Not a Bird Cage but a Novel Cretonne-Lined Shade with Bracket, for Side Lamp



Right: Library Table of Distinctive Pattern, with Convenient Shelf and Pockets



Aquarium Stand, 27 Inches High, Suited for Summer Home or Year-Around Use



Happy Combination of Reed Bird Cage and Flower Holder. Height About Seven Feet



Large Reed-Encased Fountain of Waterproof Cement for Living Room or Sun Porch. Sprays Adjustable as to Height



Day Bed with Box Springs: A Particularly Pleasing Piece of Reed Furniture. Cushions and Mattress Covered with Awning Stripe

ESPECIALLY SUITED FOR SUMMER USE

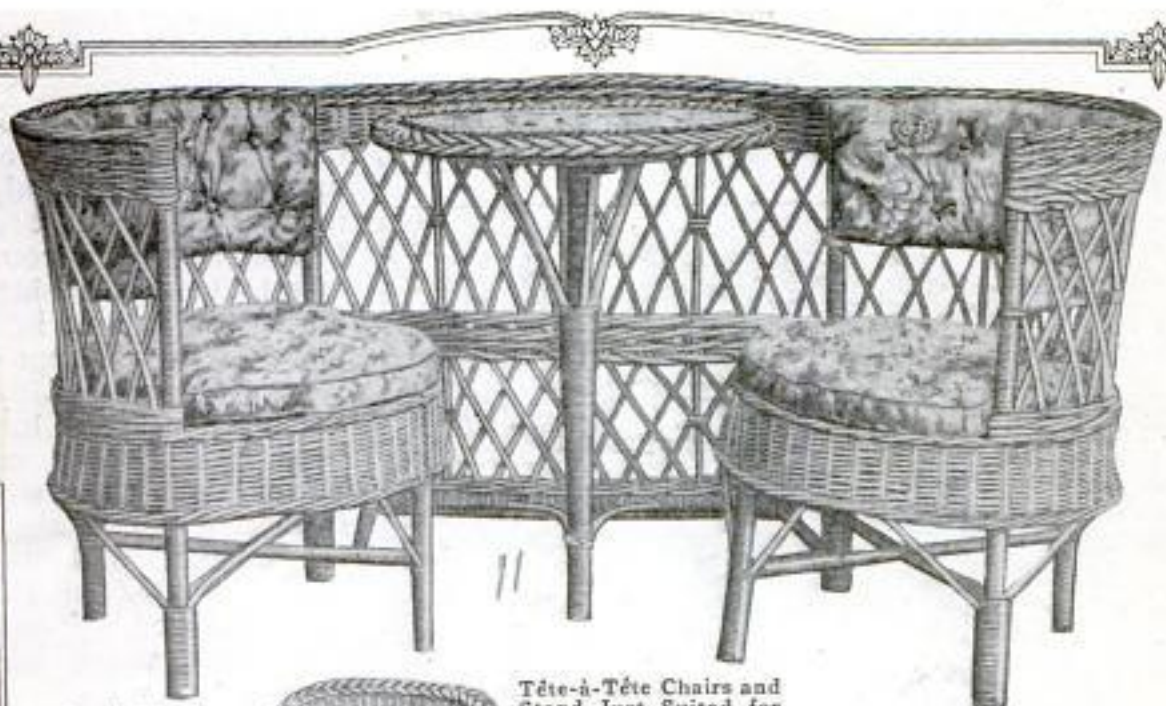

Tête-à-Tête Chairs and Stand Just Suited for Games or Serving Tea. Cushions of Cretonne

Small-Size Chaise Longue That Is Light and Substantial, Made Especially for Children



Unusually Roomy Tea Wagon with Two Trays, a Shelf, Two Pockets, and a Compartment under Top Tray



Artistic Hanging Basket and Bracket for Sun Parlor or Living Room

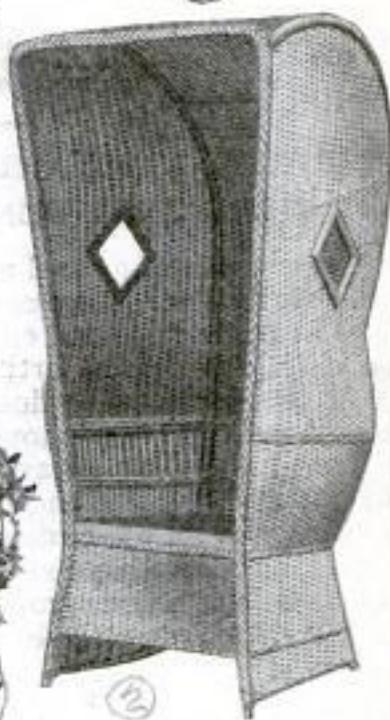

Beach Chair with Windowed Sides: Its Loose Weave Permits Air to Circulate, but Protects from Wind and Sun

Waterproof Kneeling Cushion for Garden Digging, with Places for Tools or Seed Packages



SOLDIERS USE ARMY TRUCK TO SAW WOOD

Certain United States soldiers on the Mexican border found that the

sawing of wood for camp use was a rather arduous task, until one of their number worked out a plan to make an army truck do most of the work. A circular saw, with its shafting, was mounted on a roughly made framework, and thereafter, when wood was to be cut, an idle truck was backed into place beside the improvised equipment. After the rear wheels had been raised up on jacks, one of them was connected with a shaft by a belt and the engine started at the desired speed. Except when the wood was very tough no special attention was given to the motor after it was once set running.



Sawing Wood with an Army Truck: Labor-Saving Arrangement Devised by One of the Soldiers on the Front Which Utilizes One of the Big Cars When It would Otherwise Be Idle

ARTIFICIAL LAKE AND DAMS BUILT BY STUDENTS

At the expense of a loyal alumnus of Iowa State College, the beauty of the campus at Ames has been enhanced by the construction of an artificial lake, most of the work being done by students. A small creek, known as College Creek, was first excavated and a dam built at the lower end of the lake area. Recently an upper dam was constructed and a settling basin provided to keep the lake proper from filling up with the debris carried down by the

stream. The lake has been named in honor of the donor, who has made many other gifts to the college.

AUTO TRUCK MADE INTO PORTABLE GROCERY

The term "vending de luxe" might be used to describe the grocery business which an Arkansas merchant has built up by employing an especially designed auto truck that daily carries a \$750 grocery and meat stock on a five-mile route, stopping at about 100 houses. The body of this two-ton



Students of Iowa State College Excavating for an Artificial Lake on the Campus: In the Foreground at the Left Is the Upper Dam; at the Right, a View of the Lower Dam

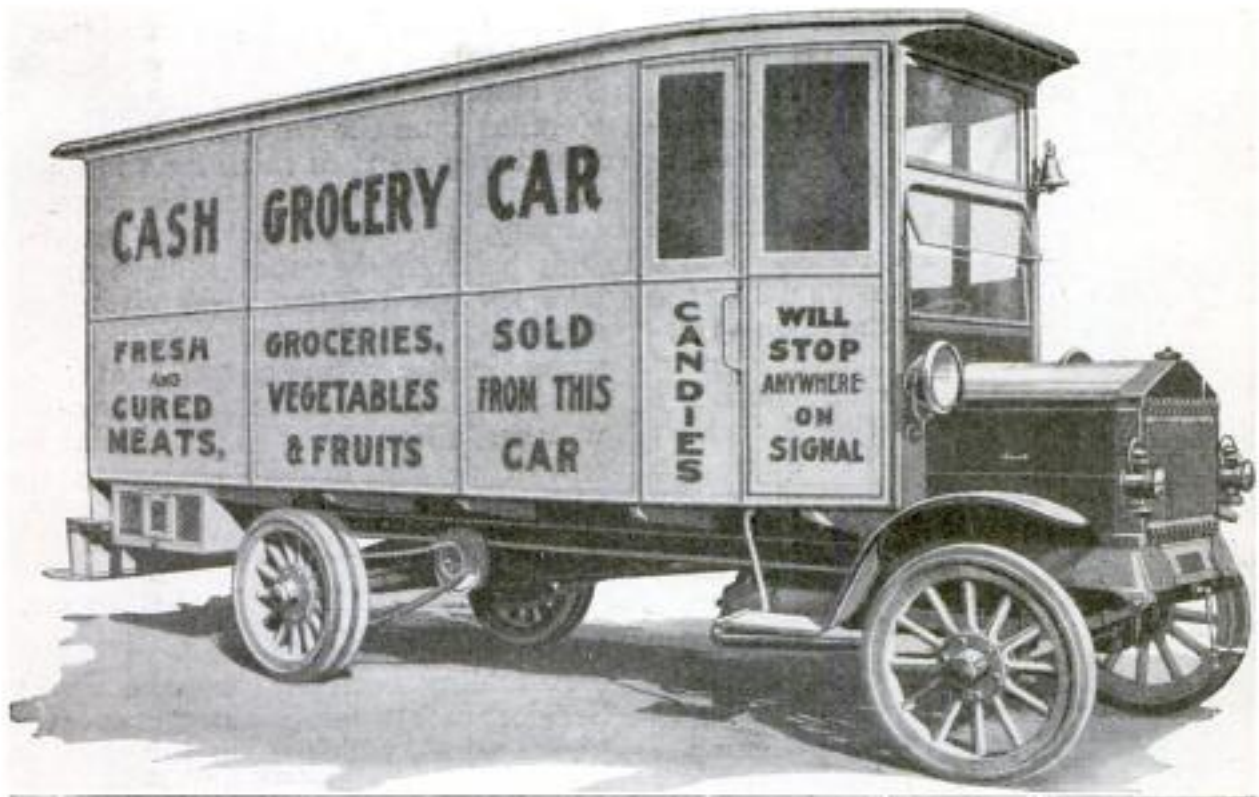

Two-Ton Truck, Loaded with a \$750 Grocery Stock, Which Stops at About 100 Houses on a Five-Mile Route Each Day: The Electric Gong on the Front Warns the Housewives of the Itinerant Grocer's Approach

truck is 16 ft. long and 6 ft. wide. The interior is electrically lighted, and at the rear is a vestibule, with standing room for six persons, which contains a counter and an ice box. Drawers, shelving, and a candy case line the walls, and wire netting, or rods, hold the goods in place. The driver's compartment is shut off from the rest of the little store by a windowed partition. Most of the stock is done up in convenient packages ready for buyers, though scales are provided for use if needed. Underneath the body are two crates for live poultry, and tanks for kerosene and oil.

FIRE-BOX GRATE CAN BE REPAIRED DURING USE

A grate now being introduced for use in stationary boilers and locomotives where hand dumping is practiced, is so built that if a portion of it burns out the burned parts can be replaced without drawing the fire, and at small cost. This fuel bed permits a large volume of air to pass through it and the tendency is to prevent the for-

mation of clinkers. It is provided with crossbars that are rocked by side bars having double instead of single bearings, as a safeguard in case some of the bearings burn out. Fitted onto the crossbars are triangular units called fingers, on which the fuel rests. If one of these burns out, it can be easily removed with pincers and replaced by a new one, without drawing the fire or disturbing the rest of the grate. The upper edge of each finger is grooved to catch fine ashes and so form a coating which prevents clinkers becoming attached to the grate. The crossbars and fingers are so made that air circulates among the parts freely, tending to keep them cool.

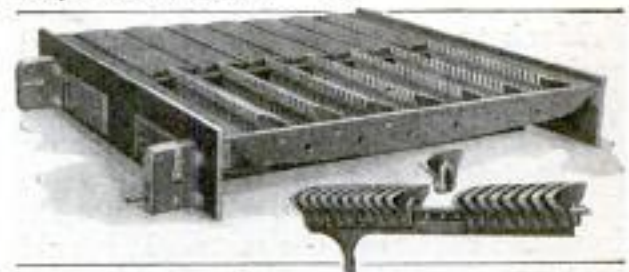

Grate so Designed That It can be Repaired without Drawing the Fire. Below: One of the Crossbars, Showing the Manner in Which the Removable Fingers are Fitted in Place

Hand-drawn Grate: 1911
 K. J. ...
 1911

EXTENSION-LADDER CART FOR TREE TRIMMING

Trimming large trees is made comparatively easy by a portable extension

ladder constructed by a resident of Pasadena, Calif. The ladder is mounted on a two-wheeled base of the pushcart type, by which it can be moved easily from tree to tree by hand



Trimming Trees with the Aid of an Extension Ladder, Wheeled About on Its Cart

when extended, or can be towed behind an automobile for transportation to a distance. In the fully extended position the ladder is 30 ft. high. A tree trimmer can reach an additional 15 ft. from the top with his long snips, wearing a safety belt fastened to the ladder to leave both hands free for work.

ICE ON GREAT SALT LAKE CAUSES PERPLEXITY

Much to the perplexity of many old residents of Utah, acres of ice capable of supporting a man's weight were discovered at one time last winter on Great Salt Lake in the vicinity of Saltair Beach pavilion, which is not far from the capital of the state. It is said that not since the coming of white settlers to this region has such extensive ice been known to remain on this body

of salt water. Investigators made their way through the ice in a motorboat to the mouth of the Jordan River, about 20 miles from the pavilion. Here they found fragments of thick ice and much new thin ice in the wide-spreading estuary into which the river empties. It is believed that the stillness of the lake for several hours permitted the accumulation of considerable fresh water in the estuary, and that after this had frozen because of the very cold weather, a light wind dislodged the ice and it slowly drifted across to the vicinity of the pavilion.

FOLDING REEL DEvised FOR FORESTRY SERVICE

A folding reel used by the Forest Service in stringing emergency telephone wires, which is the invention of an officer in the service, dispenses with the cumbersome reels formerly employed. Folded, it measures only about 6 by 10 inches. The base of the device is a galvanized-iron tray to which shoulder straps are attached to hold it horizontally in front of the worker. To mount a spool of wire on it a rod with a crank handle is inserted

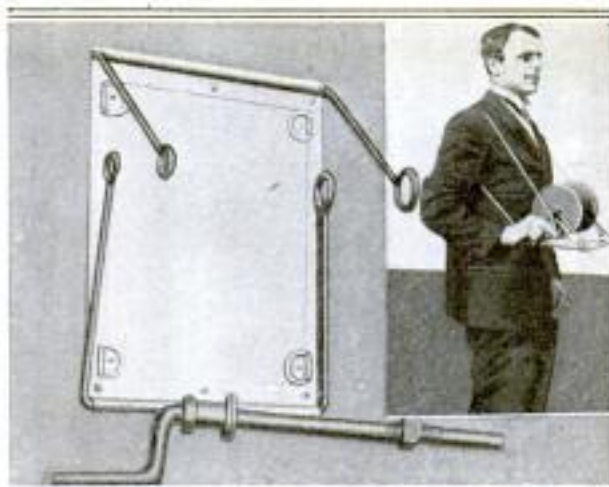

Reel Partly Folded Up, Showing the Rod with Crank Handle and the Hinged Standards Attached to the Four Corners of the Tray. Insert Shows How the Reel is Supported in a Convenient Position in Front of the Wearer by Straps That Extend over the Shoulders

through the spool, the crank rod being mounted in the four braces that are hinged to the corners of the tray and hold it firmly in position.

W. J. Trimm
Pasadena, Calif.

U.S. Forest Service
Pasadena, O.
Copyrighted material

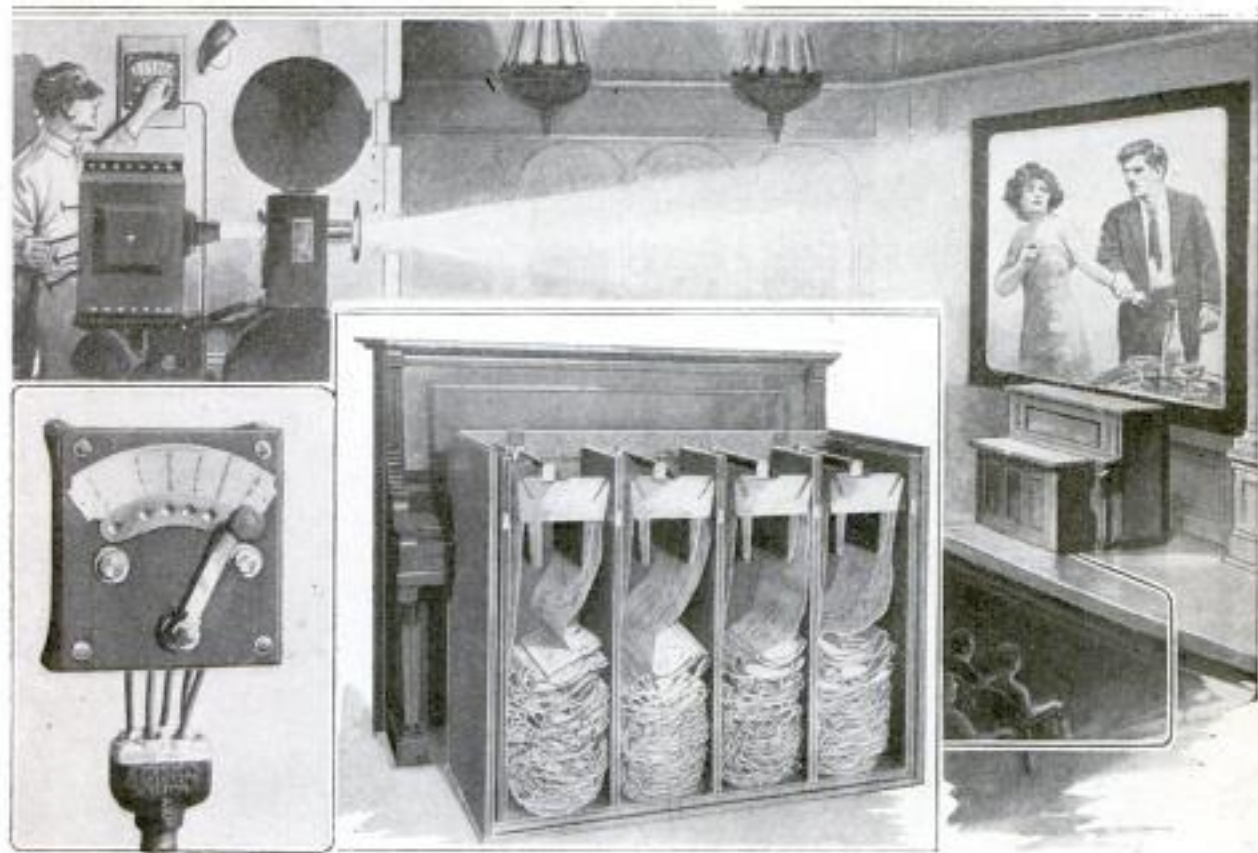

New Piano Player for the Movies, Which is Controlled Electrically by the Operator in His Booth: In the Center Is an Interior View of the Player; at the Left, the Control Switch

NEW ELECTRIC PLAYER FOR USE WITH MOVIES

An entirely electrical piano player, controlled from the operator's booth, is one of the latest adjuncts of motion-picture theaters. It was devised by a Columbus, Ohio, man to furnish instantaneous changes in the music played, to harmonize with the action of each picture shown on the screen. The player occupies an ornamental case, set before the piano, and has four compartments, each containing 10 or 12 complete musical compositions in the form of perforated rolls. In the first compartment are the very fast selections; next, music in moderate time; then, very slow music for pathetic scenes, and last, odd selections for special pictures. Each piano key is played by a mechanical finger, controlled by an electromagnet, the electrical contact being made through the holes of the music roll by metallic brushes normally held above the paper by springs. The music is controlled

by the operator in his distant booth, by means of a switch and dial, which is set for fast, medium, slow, or special music as desired.

EFFICIENCY TROPHIES FOR KANSAS GUARDSMEN

A silver trophy is to be presented annually to the most efficient company of each of the two regiments of the Kansas National Guard. It will be awarded at the annual encampment. Each shield is about 16 inches high, mounted on a wood base, with a flag, a soldier standing at "port arms," and the seal of Kansas in gold relief, and an engraved camp scene in the background.



STATE FLAG FOR ILLINOIS CENTENNIAL YEAR

The State of Illinois was admitted to the Union in 1818 and fitting centennial celebrations are planned for next year by the centennial commission, which has adopted a distinctive state



Official Flag of the Illinois Centennial, to be Flown during the State-Wide Celebration Next Year

flag to be flown during the year below the stars and stripes on public buildings. It was designed by a Chicago poet, and shows a broad blue horizontal bar, typifying union, between two white ones, which symbolize peace and justice. Ten blue stars above and ten below the central bar represent the ten northern and ten southern states admitted before Illinois, which was the 21st state, and is represented by a large white star on the blue bar. This blue bar of union is symbolic of the work of Lincoln, the greatest of all Illinoisans.

GERMAN SUBSTITUTES FOR RUBBER TIRES

Rubber being scarce in Germany nowadays, a number of bicycle tires made of substitutes for rubber are reported to have appeared on the German market. First came a tire made

of steel wire about $\frac{3}{16}$ in. thick, closely coiled, with ends welded together. This was high-priced, damaged pavements, and rattled in use. Then came three different types of wooden tires, the cheapest being made of a single piece of wood, while others are made of wooden sections. Another type of wood tire has the outer surface covered with a leather strip. Steel springs are used with all the wooden tires, either in the forks or between tire and rim, which adds considerably to their cost. Tires covered with leather or with canvas, instead of rubber, are also on the market. But the best substitute for the rubber tire has an outer tube of prepared canvas and a cloth-wound inner tube filled with a solid preparation resembling rubber, that is said to be quite elastic.

COLLAPSIBLE BOXES FOR SHIP FREIGHT

Strong wooden or metal structures of box shape, for the shipment of horses and cattle by sea, or general freight purposes, are made collapsible by a Scottish invention of recent date, and can be put together or taken down in a few minutes. The sides, top, and bottom form separate sections, which are combined by bolt hinges. When the removable rods are withdrawn from the hinges the sections can be packed flat in one-quarter of the space required for the assembled box. Thus the empty boxes can be returned to the place of shipment for further use, at very low charges for freight. Shipping cases for automobiles, pianos, and machinery can be made on this plan.

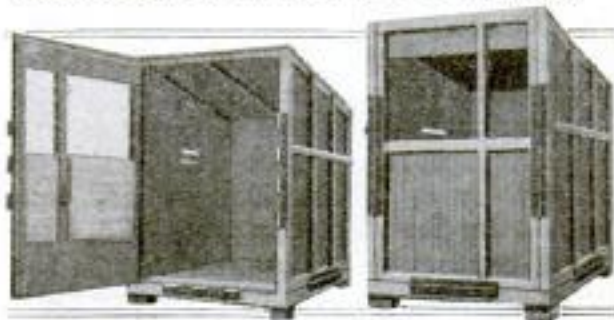

Padded Shipping Box for a Horse: The Box can be Taken Apart by Withdrawing Bolts from the Hinged Sides and Tops

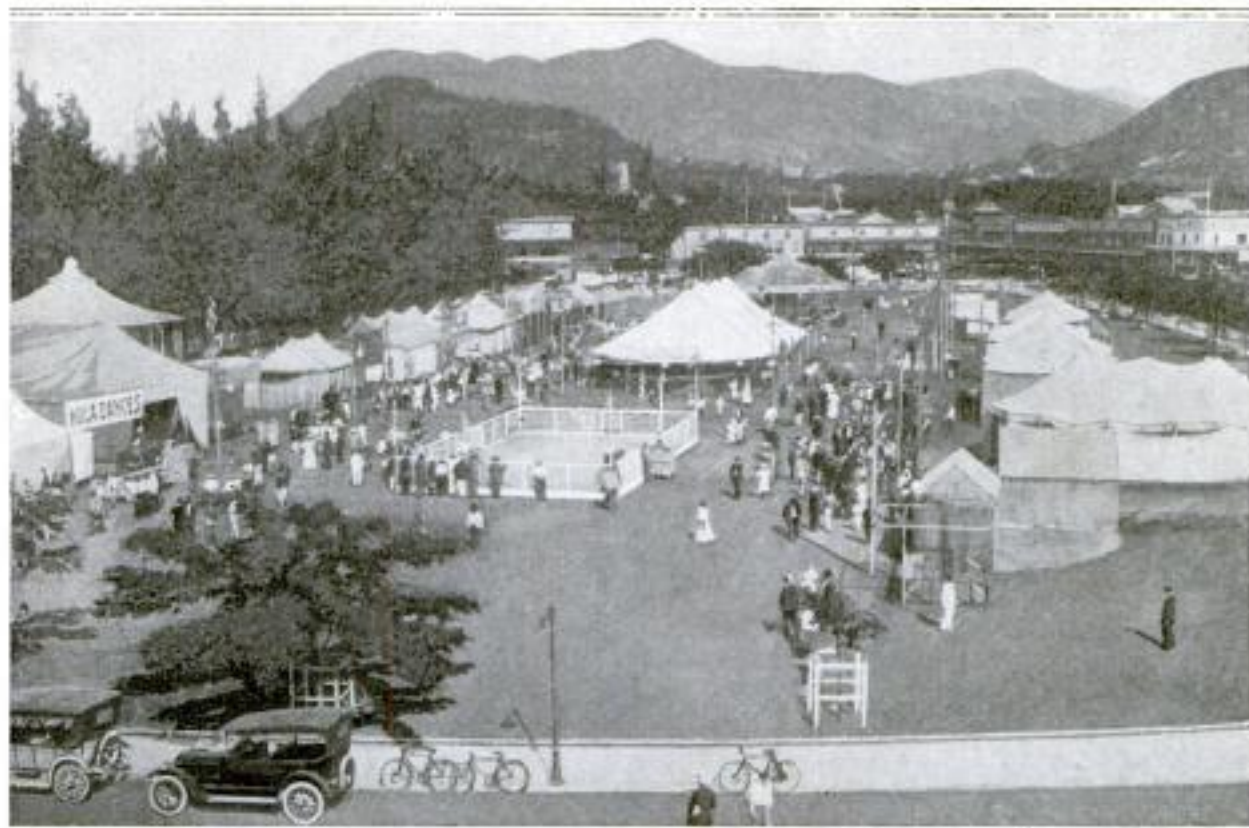

WINTER CARNIVAL HELD IN MID-PACIFIC

ONE of the features of the winter season in Honolulu was a carnival which, though held in mid-Pacific, had many of the elements of similar events in colder climes. At Aala Park, where the carnival was held, typical American circus stunts and sideshows entertained the natives, while many visitors found equal pleasure in watching the hula dances expertly performed within the carnival grounds, with their picturesque background of towering Hawaiian mountains.

DEVICE KEEPS WINDSHIELD CLEAR DESPITE RAIN

An attachment that assures the motorist a clear outlook through the windshield in spite of rain or snow, is the invention of a Chinese resident of Portland, Ore. An important part of the device is an endless sheet of transparent celluloid that fits around the windshield, covering it front and back, and passing about rollers at the right and left of the glass guard. Each roller is inclosed in a housing that is clamped to the windshield frame so that the attachment can be easily removed. One roller is connected by means of a flexible shaft and gearing with a sprocket wheel on the inner side of one front wheel. When the car is in motion the sprocket wheel turns the roller by means of the shafting, causing the celluloid sheet to travel round and round. Teeth near the ends of the

rollers engage perforations at the edge of the sheet and prevent it from slipping. As the celluloid passes through the housings, a rubber or felt wiper brushes off the accumulated rain or snow, so that the driver always has a clean shield in front of him.

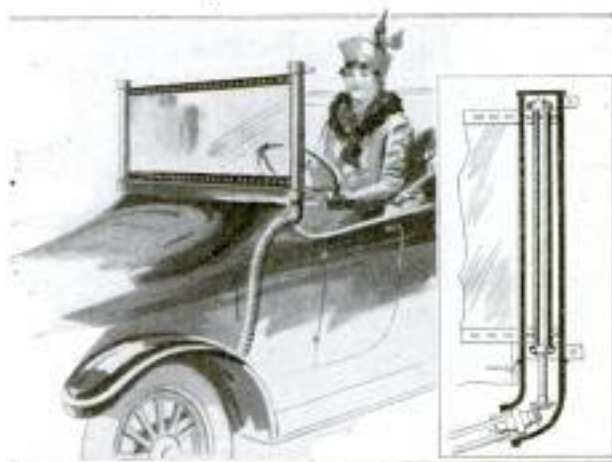

Attachment Which Keeps Windshield Clear: The Revolving Celluloid Band in Passing through the Housings at Either Side is Wiped Clean of Snow or Rain, Giving the Driver an Unobstructed View

✓ Sent G. Back
308 1st St.
Portland, Ore.

CLAMPS SUPPORT TROLLEY POLES ON BRIDGE

Special clamps have been employed by a California electric railway to support trolley poles on the top of the



girders of a bridge over which the line passes, thereby making it unnecessary to fasten the poles to the floor. These fastenings are of cast metal and are used in groups of three. The center one of each group is provided with a socket in which the pole is set, while iron braces

are attached to the other two and give the pole support at opposite sides. The clamps make it possible to erect a pole at any point on a bridge with a minimum of labor and in a position where it takes up no roadway or walk space.

SHOTGUN HAS BARRELS SET ONE ABOVE THE OTHER

A prominent gun manufacturer in England has recently produced a double-barrel shotgun having one barrel above the other, instead of the two being side by side. This arrangement, it is claimed, offers considerable advantage in aiming, for the hunter is



A Shotgun of English Make, Having One Barrel Placed above the Other for the Purpose of Giving an Advantage in Aiming. It is Equipped with a Special Lock Also

not confused by a barrel either side the line of aim. The breadth of the double barrel is reduced by more than one-half, thus permitting the game to be

seen up to the moment of firing. The fore end of the stock is so fashioned that it fills the left hand and allows a firm grip to be obtained, while the arrangement of the barrels brings that hand well below the line of vision when aiming. The gun is equipped with a single trigger and a special lock which make possible a light pull-off, if desired. A system of compound levers in the lock gives 50 per cent more pressure than in the ordinary lock, on the parts which release the hammer, so that a light pull discharges the first barrel without any risk that the jar of the explosion may again release the hammer and set off the second, which danger is present in other double-barrel guns of the single-trigger type.

ELECTRIC LOCOMOTIVES SHIPPED IN BOXES

Three large electric locomotives, weighing 120 tons each, were shipped recently from Erie, Pa., to Chile, South America, in knock-down form, being boxed for convenience of shipment. They are intended for use in transporting iron ore from the mines of an American steel company at Tofo, Chile, 2,200 ft. above the sea level, to Cruz Grande, the nearest shipping port. For a while the problem of getting the engines to Chile baffled the traffic men, as they were too big and too heavy to be taken aboard ship intact. The only alternative was to take them apart for shipment. When this was done and the parts were boxed it was found that each of the locomotives occupied eight freight cars and weighed 290,000 lb. There were 62 separate boxes, ranging in size from over 50 ft. to only a few inches in length, the largest weighing more than a ton before being packed. Everything was boxed but the underframe, wheels, and axles of each car. Each part or section was carefully numbered as it was packed, and full directions for reassembling the locomotives accompanied the shipment, so that the engineers in the South American republic would have little difficulty in putting the parts together as before.

W. Richardson & Co. Ltd.
Bournebrook, Birmingham,
Eng.

Copyrighted material
Science, Inc., N.Y.



One of Three 120-Ton Electric Locomotives Recently "Knocked Down" at Erie, Pennsylvania, and Packed in Boxes for Export to Chile, Where They will be Used in Transporting Iron Ore from the Mines, 2,200 Feet above Sea Level, to the Shipping Port of Cruz Grande



Lowering the Underframe of One of the Electric Giants into the Hold of a Freighter in New York for the 40-Day Voyage to the Chilean Port



Each Locomotive When Taken Apart was Made Up into 62 Separate Packages Which Completely Filled Eight Box and Flat Cars, as Shown. The Largest and Heaviest Parcel Weighed 23 Tons and Measured More than 45 Feet Long; the Smallest could be Lifted by One Man

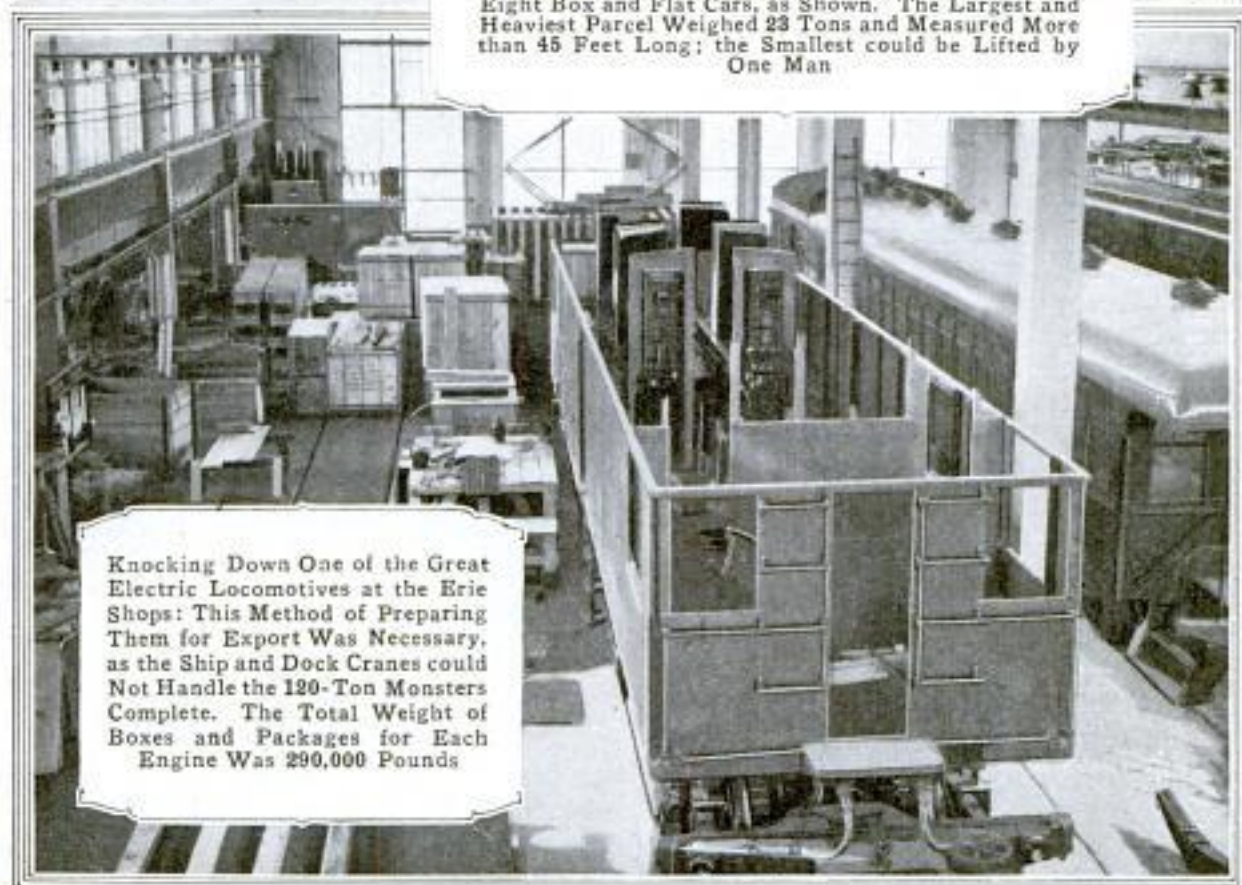

Knocking Down One of the Great Electric Locomotives at the Erie Shops: This Method of Preparing Them for Export Was Necessary, as the Ship and Dock Cranes could Not Handle the 120-Ton Monsters Complete. The Total Weight of Boxes and Packages for Each Engine Was 290,000 Pounds

PROSPECTORS USE A STOVE FOR VENTILATION

A novel method has been adopted by some ingenious prospectors in Montana for ventilating their prospect



Ventilating a Prospect Hole by Means of a Stove: The Shaft beneath the Windlass in This Photo Is 60 Feet Deep

holes. When they have dug to such a depth that fresh air no longer circulates freely to the bottom of the hole, they set up an air-tight stove at the edge of the shaft, putting up three or four lengths of stovepipe for a chimney and running another pipe from the bottom of the hole to the air intake at the front of the stove. The latter pipe is held in place by fastening it to the shaft timbering. When a fire is built in the stove, air is drawn from the bottom of the shaft and fresh air circulates downward to replace it. Ventilation can be secured in this way to a considerable depth.

CLOGS COMING INTO USE IN LONDON

Clogs are coming into use in London on account of the shortage of sole leather. This form of footwear, which consists of a leather upper with a

wooden sole, has long been worn by the textile workers in northern England, and now that leather is so scarce, the London County Council, through the school-teachers, are providing the poor children with clogs which cost about 73 cents per pair. These are paid for in weekly installments of six cents each. It is said that a really fine pair of clogs can be obtained for one-quarter the price of shoes, and it has been urged that business men wear them to work. Already the demand is so great for this economical form of footwear that one British manufacturer has declined an order from Belgium for 100,000 pairs of wooden shoes, because he is busy making clogs.

HANDY CUTTER FOR STEEL CABLES AND RODS

A portable machine for cutting heavy cables and iron and steel rods, invented in Portland, Ore., is built on the plan of a giant wire cutter. It operates by hand, the power of a hand lever being developed through a series of pulleys and 1/4-in. steel cables to give a pressure of 90 tons on the cutting jaws. The machine is designed to cut 1 1/2-in. cable and 1 1/4-in. rod, and is intended for use in the woods or by wreckers. Its action being positive and practically instantaneous, it is said to eliminate all danger of a cable flying when cut. Two sizes will be made, weighing 50 and 100 lb. respectively.

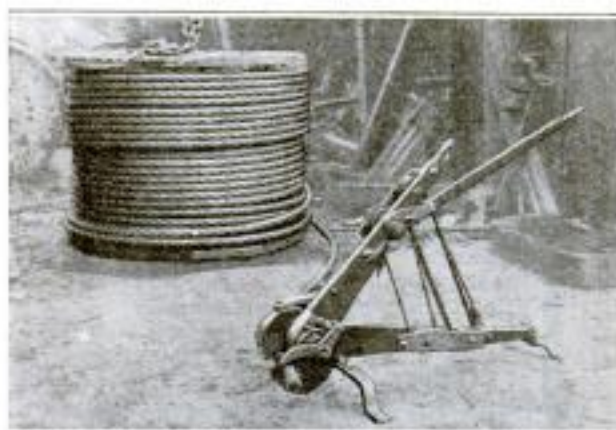

New Machine Ready to Cut the Cable Inserted between Its Powerful Jaws: Its Hand Power is Multiplied by Pulleys

Solomon...
721

John Velt...
Portland Copyrighted material

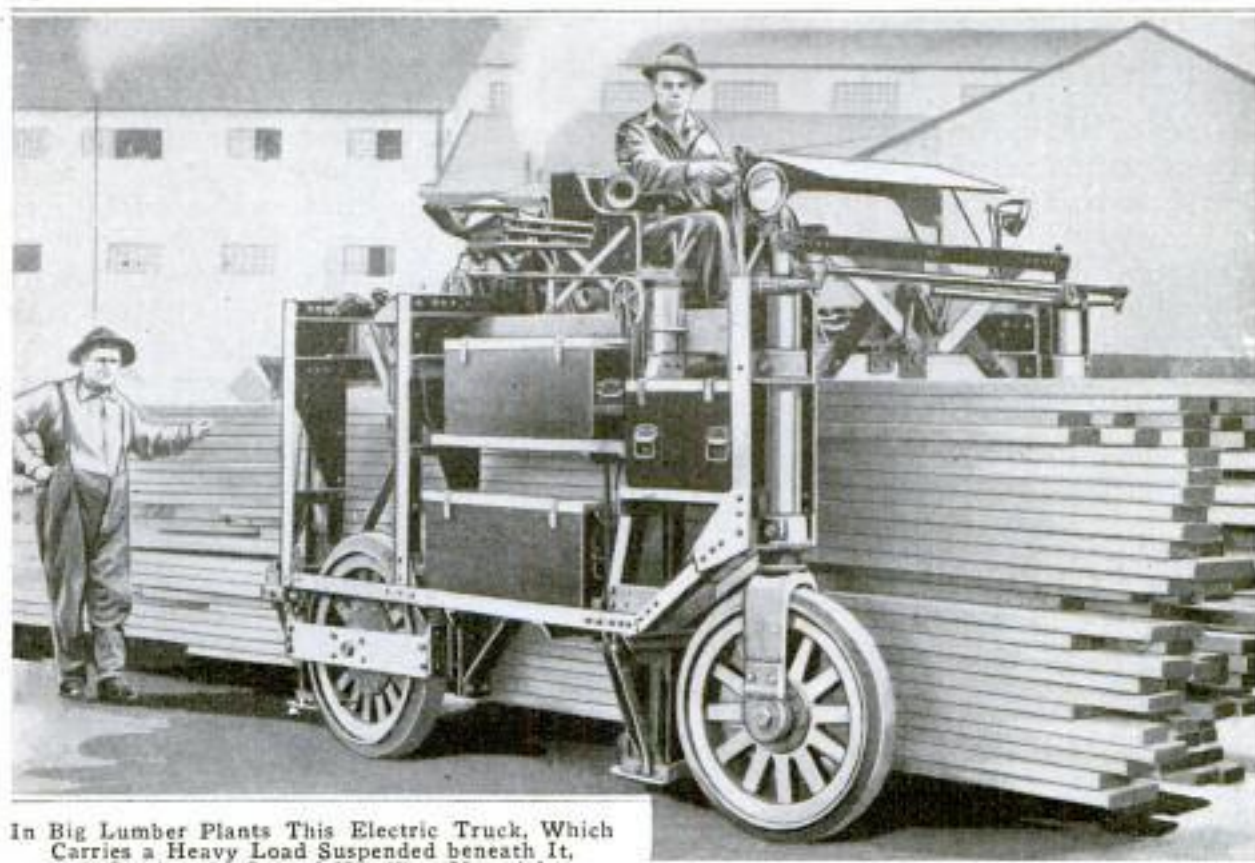

In Big Lumber Plants This Electric Truck, Which Carries a Heavy Load Suspended beneath It, is Cutting the Cost of Handling Material

ELECTRIC LUMBER CARRIER CUTS HANDLING COST

Increasing use is being made of an electrically driven lumber truck that lessens the cost of handling material. In transporting lumber between mills, kilns, yards, and cars, it accomplishes the work of several men and a half dozen or more horses. The outstanding feature of the apparatus is that it carries its load suspended beneath the chassis and is arranged to pick up a pile containing as high as 3,000 board feet in approximately 10 seconds, without requiring the operator to leave his seat. Loads of different size and character are negotiated with equal facility, a 70-ft. timber being accommodated as readily as a railroad tie. Two sets of storage batteries, good for five hours' continuous use, supply the current. The machine will take short six-percent grades and normally travels at a speed of from 7 to 10 miles an hour. One of the trucks is credited with having handled 200,000 ft. of lumber in a day. Forks support the body of the vehicle high above the wheels

and an equalizer automatically adjusts the load when some obstruction or a rut is encountered. Lumber is stacked on two blocks that raise it a couple of inches above the ground, and while the machine straddles it, hooked arms reach under the pile and lift it to the carrying position. That completes the loading operation. The material is released as simply.

CONVENIENT HOOK WITH LOOPED HANDLE

The ordinary latch hook, whether it be for a cupboard, barn door, chest, or the like, frequently causes much annoyance because it is inclined to stick and is difficult to grasp. A recently patented hook provides against such inconvenience by means of a looped handle projecting from its shank, which makes the catch easy to operate. The cost of manufacture is low, for a single strip of wire can be twisted by machinery to form the loop and the hook.



Cover? Mr. Son.
Benton Harbor, Mich.

J. S. Stewart, Jr.
Copyrighted material

MOVIES DEPICT WHALING SCENES DRAMATICALLY

One of the most dramatic sets of educational films that have been produced showing various industries of this country is that illustrating the life of American whalers which was exhibited not long ago in Boston. These views take the spectators aboard a vessel, captained by a veteran whaler, which goes out into the stormy Atlantic in search of its prey. At times the

big waves roll over the decks of the ship, setting everything awash, and the onlooker feels that the very room in which he is sitting is rocking to and fro. At length a spouting whale is sighted in the distance. A little later the audience witnesses the fight with the whale and his capture. The body is dragged to the vessel and cut into pieces, while during part of the performance a school of sharks, attracted by the prospect of much good food, swim near by.

FIRE EXTINGUISHER FOR THRESHING MACHINES

A bureau of the Department of Agriculture has recently developed a fire extinguisher to be attached to threshing machines for the purpose of automatically putting out any fire caused by an explosion in the latter. Explosions are often produced by the ignition of dust from smutty grain which permeates the chambers of the thresher and in many cases have resulted in the total destruction of the newly harvested crop, the threshing outfit, and near-by barns. The protective device consists of a cylindrical tank mounted beside the thresher and connected

with it by pipes. The tank is filled with water containing certain chemicals in solution and also a sealed flask of acid. It is so connected with the machine that an explosion releases a hammer in the tank which breaks the flask. The resulting mingling of the two liquids instantly creates a gas, while the pressure produced by the gas forces the fluid through the pipes, so that the threshing machine is thoroughly sprayed before the fire gains headway. The extinguisher will be patented by the department for the benefit of the public.

Up to the first of March, this year, the minister of munitions had placed 4,770 industrial plants in England and Ireland under government control.

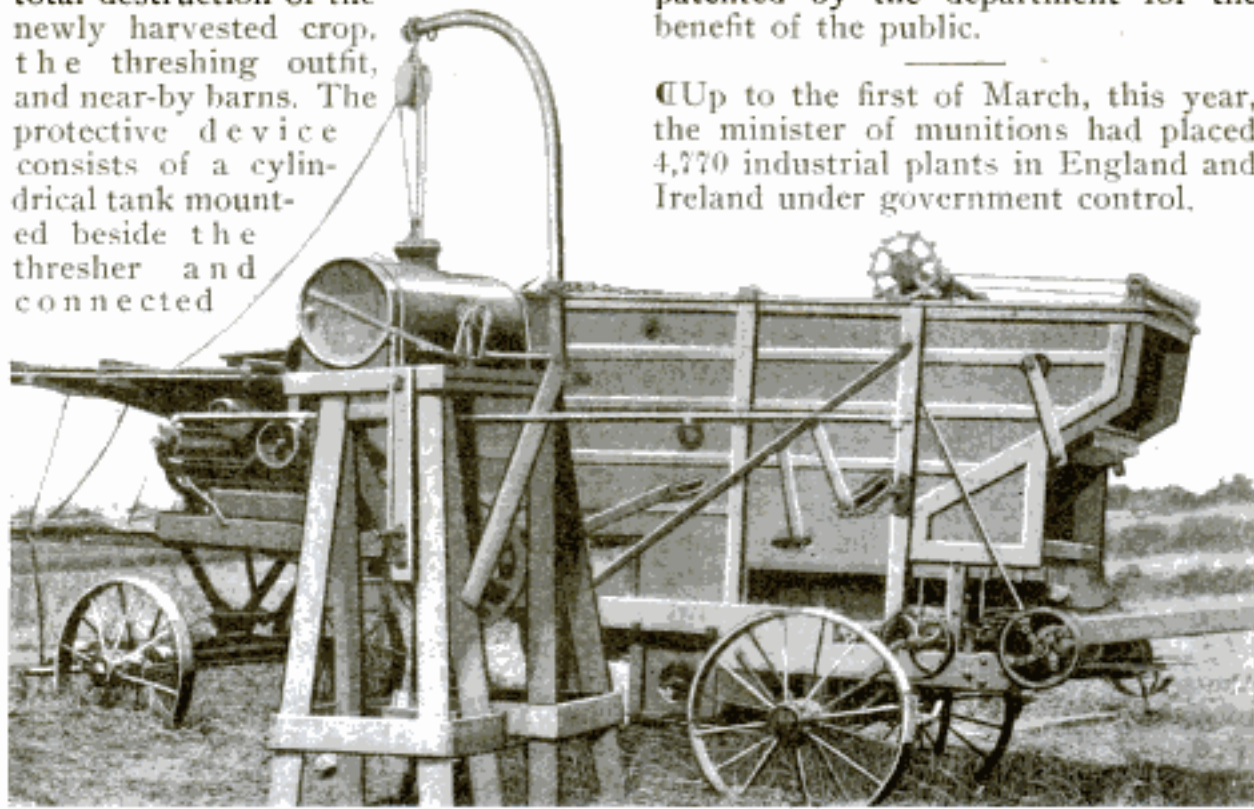

Mounted beside This Threshing Machine Is One of the Government's New Fire Extinguishers, Which Automatically Put Out Any Blaze Caused by a Dust Explosion

*Bureau of Agriculture,
Washington*

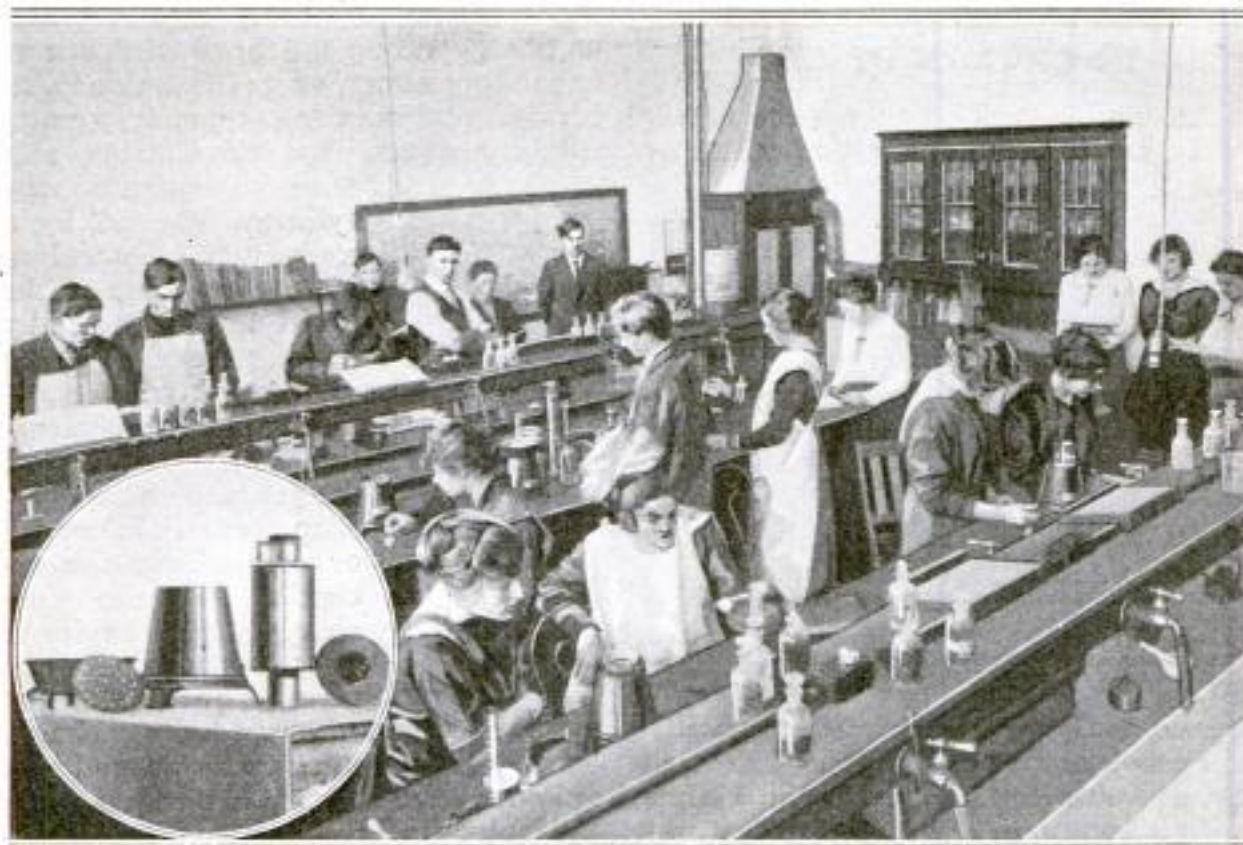

New Electric Heaters in Use in the Chemical Laboratory of an Idaho High School: Each Apparatus is Used by Two Students, with Current from the Light Circuit. Insert Shows the Heater Details.

NOVEL ELECTRIC HEATER FOR LABORATORY USE

An electric heater to take the place of a Bunsen burner was invented recently by an instructor in a new technical high school at Rupert, Ida., and is now used in the science laboratories in all experiments that require heat. Being of convenient conical form, the heater supports the article to be heated, without the aid of a tripod. It is attached to the ordinary light circuit of 110 volts and uses from 275 to 550 watts, according to the amount of heat required for the experiment in hand. Practically all forms of glass and porcelain vessels used in the electric and chemical laboratories can be heated, including test tubes, beakers, flasks, evaporating dishes, crucibles, or sand and water baths. There are simple and inexpensive attachments for these various purposes, while a water heater and steamer attachment is provided for experiments in physics. Each heater serves two students.

TWIN AUTO JACK MOUNTED ON WHEELS

An improved automobile jack for garage use is of the twin type, both of the front or the rear wheels of a car being raised simultaneously by turning the handle of a crank geared to two upright posts on which the axle rests. The whole device is mounted on a triangular steel frame, with a caster wheel at each angle, so that when the twin jack is in use and the wheels of



Twin Automobile Jack Which Raises Two Wheels at Once by Simply Turning the Crank

an auto are raised by it, the car can be freely moved about without releasing the jacks.

H. W. R. S. K. B. 11/10
H. W. R. S. K. B. 11/10

W. W. H. Auto Jack Co. 301
Springfield, Ill.

NEW-TYPE ROTARY ENGINE FOR STEAM OR GAS

An engine which delivers the power of an expanding force, either steam or

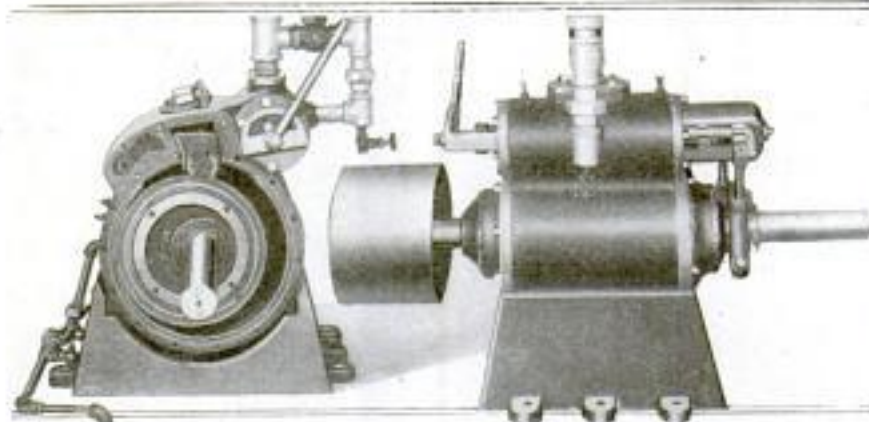

Rotary Engine of a New Type, Having a Reciprocating Feature and Adapted for Either Steam or Gas: Full-Face View at the Right, End View at the Left with Cylinder Head Removed

gas, directly to a rotating shaft, without crank or flywheel, has been devised by a Kentucky inventor, who claims that it combines the desirable features

of both reciprocating and rotating engines. While the head pressure of expanding steam or gas is retained, as in the reciprocating type, a greater rotating effect is secured from side pressure within the cylinder, exerted by a wedge of expanding fuel on the face of the rotor, and directly turning the shaft which passes through the cylinder. By the construction and operation of the engine a wedge-shaped cavity is opened or created for the reception of the fuel charge. This cavity is formed between the pivoted rotor and the cylinder walls, the expanding charge being driven point first around the cylinder from inlet to exhaust, forcing the rotor to turn with it.

SAVINGS DEPOSITS EASILY MAILED IN NEW COIN CARD

Depositors of small sums, especially children, frequently find it inconvenient

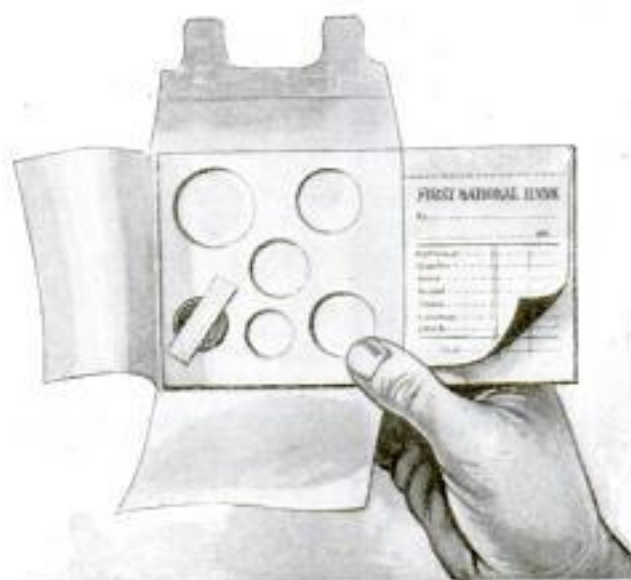

Coin Card, with Deposit Slip Attached, with Which Small Savings Deposits can be Mailed Conveniently: The Bank Using These Cards Starts the Prospective Patron with One Cent Inserted in One Recess

to build up a savings account by mail because they have no satisfactory

means of sending their coins to the bank, but this difficulty seems to have been overcome by the invention of a coin card of which a Brookings, S. D., banker is the originator. In one end of the card are recesses for coins of five sizes, that can be held in place by three gummed flaps. Between these flaps paper money or checks can be placed, if desired. Attached to the other half of the card is a small deposit slip, carbonized on its under side, on which the depositor enters his amounts, making a duplicate of his entries on the card. The slip is retained, while the card and money are sent in a sealed envelope to the bank.

OFFICE ON WHEELS FOR MILITARY USE

An automobile truck, fitted up as a headquarters office for use on the march or in the field, was designed recently for the staff of the New York National Guard. It is mounted on a 1½-ton chassis and while light enough to travel rapidly when required, will

G. W. Coble,
1st National Bank,
Brooklyn, N. Y.

White Truck
N. Y. Nat'l Guards N. Y. S.
Copyrighted material



A National-Guard Headquarters on Wheels: This Motor Truck was Designed for the Use of Staff Officers of New York Troops Serving on the Mexican Border, and Makes a Wonderfully Compact Office. Interior View at the Left

also stand the rough usage of active service. It furnishes office accommodation for eight persons at a time, there being seats for six along the sides, facing a large table in the center of the car, on which maps can be spread out and examined. At one end is a built-in desk with seats for two and plenty of filing cabinets for correspondence, reports, orders, and maps. A telephone is provided for connection when the office car is halted, and electric lights in the roof furnish illumination for night work. Outside the car is a long shelf folding flat to the side, used when open as a desk for writing reports without entering the car. Side and rear curtains are provided for protection against the weather.

¶Fifteen thousand incinerations are made annually at the 62 crematories now operated in North America.

CLAMP CARRIER SAVES CABINETMAKER'S TIME

The advantages claimed for a clamp carrier, designed for cabinetmakers, etc., are that it saves valuable shop space and also the user's time. The essential feature of the apparatus is an endless conveyor about six or seven feet wide provided at intervals of a few inches with transverse rods. The conveyor moves easily in angle-steel runways supported about five feet from the floor by a steel framework. The adjustable steel clamps, of which there are 160 in the model shown, are attached in groups of four to the transverse rods. A movable support is provided to hold the outer ends of the four clamps that happen to be projecting horizontally at the end of the rack, so that the workman can fill them with the parts to be glued together.

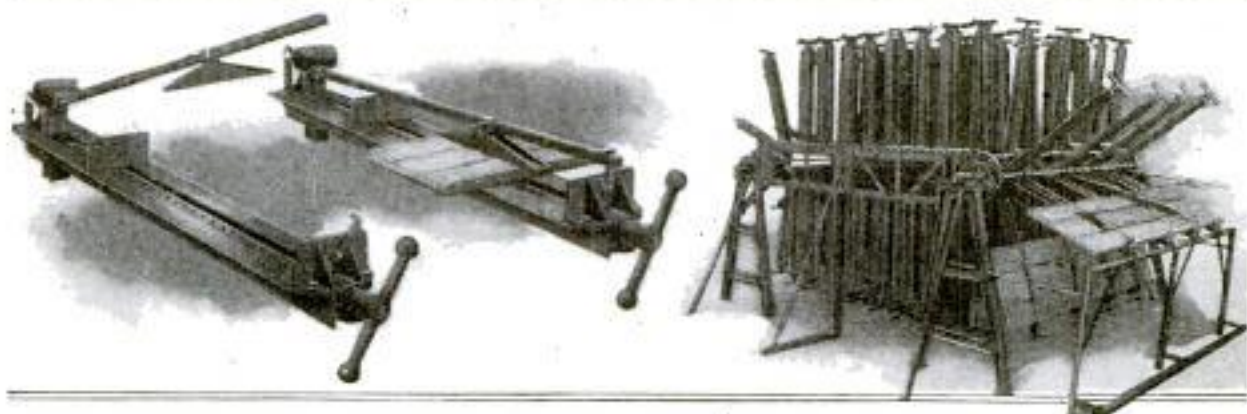

Carrier Equipped with 160 Steel Clamps in Which Freshly Glued Woodwork is Fastened: Arranged as Shown Here the Clamps Occupy a Minimum of Space and Are Always Ready for Use

J. T. Taylor Mfg. Co.
Pau. K. 1913

Geo. P. Hobbie,
Horseshoe Mills, N.Y.

908

POPULAR MECHANICS

ROWBOAT MOTOR CARRIED AT REAR OF A CAR

A motorist in New York state found a way to carry a rowboat motor on



How a New York State Motorist Carried His Rowboat Motor to a Lake: The Rack Also Serves to Carry Baggage

trips to a lake, without taking up any of the passenger space, by bracing a rack with a vertical board at the rear of his car. The portable motor was then hung over the board as at the stern of a boat, leaving about 10-in. clearance with the rudder slipped off. Thus the motor traveled right side up in safety, and it was unnecessary to drain the gas tank.

GERMANY LIMITS WARDROBES OF ALL SUBJECTS

Probably the most significant of Germany's many conservation measures is the radical ruling now in effect which definitely prescribes what articles of clothing and how many of them a man or woman may possess. An imperial clothing bureau has been established, and before any subject can purchase apparel, a permit must be obtained. This is done by supplying the authorities with an inventory of garments on hand and showing that the individual wardrobe is lacking in attire officially allowed. Boys and men are permitted to have two suits, an overcoat, a pair of working jackets and trousers, two waistcoats and business shirts, one pair of gloves, four pairs of hose, a half dozen handkerchiefs, three

suits of underwear, two night robes, three pairs of shoes, and one pair of slippers. Women are allowed three dresses, a skirt, two blouses, a coat, one shawl, a wrapper, four suits of underwear and the same number of pairs of hose, a pair of gloves, three pairs of shoes, four house skirts, a half dozen handkerchiefs, and three night dresses. Such things as bedding and towels are also limited.

NEW BALLOT BOX PROTECTS AGAINST FRAUD

A new type of ballot box has been patented which guards against election frauds by stamping each ballot as it is deposited, by counting the votes, and by remaining closed except when operated by a special key. Many election irregularities are due to stealing or altering the ballots or to willful neglect in the matter of properly initialing them. This box is provided with a small crank that is connected with the stamping and recording apparatus. It is so made that when the locking device is released, the turning of the crank admits the ballot to the container, records the vote by adding one to the number in the open-face register, and stamps the sheets with any desired legend in such a way that two ballots cannot be cast at once and both be marked properly.

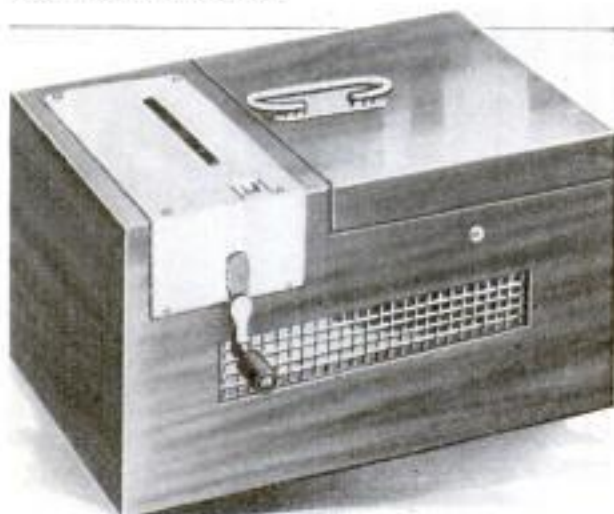

Patented Ballot Box Which Counts the Ballots, Stamps Each One, and Remains Closed Except When Operated by the Official to Whom is Intrusted a Special Key for Releasing the Mechanism

Chi-Tribune 4/2/17

International Ballot Register Co.

Chi.

Copyrighted material

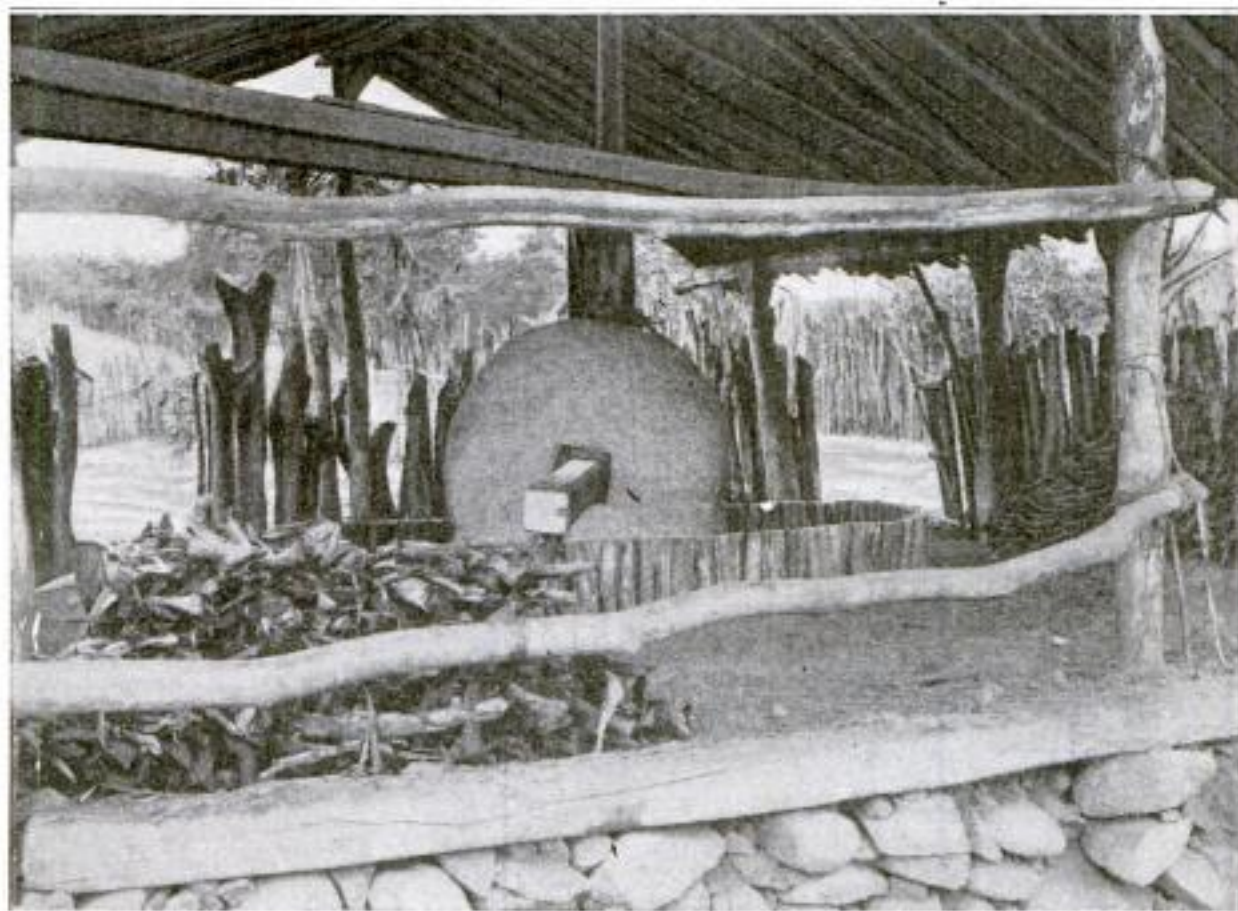

Sugar Mill in Mexico, Showing the Primitive Method of Extracting the Juice from the Sugar Cane: It is Operated by Mule Power and the Cane to be Crushed is Thrown into the Central Inclosed Area, Where It is Crushed by the Big Stone

PRIMITIVE SUGAR MILL IN MEXICO

Primitive simplicity characterizes the Mexican sugar mill shown in the accompanying illustration. Under the central portion of the rough shelter a concrete floor has been laid and surrounded with a low circular wall within which the natives deposit the sugar cane cut into short lengths. Within this area, also, is the big grinding stone, 7 ft. in diameter, 18 in. thick, and weighing a ton. Extending through the stone is a heavy beam, at one end of which is a wheel. To this end a mule is hitched and driven around the inclosed area while the stone crushes out the juice, which runs along grooves in the cement into troughs.

ⒸAn under-water coaling station, with capacity for 100,000 tons, is being constructed in the Ohio River near Pittsburgh.

WARNING LAMP ON STREET- LIGHT STANDARD

An electric-light ^{post} standard in the center of a busy street in Minneapolis has a small red light mounted near its base to indicate to motorists approaching in the dark that it is a substantial support for the lights above, and that the latter are not merely a hanging cluster beneath which they can drive in safety. The overhead lamps include four white lights mounted on arms at right angles to each other, surmounted by a large red light indicating that automobiles must keep to the right in passing.



Street Light Post
Minneapolis

AMERICA'S ATTRACTIVE COUNTRY CLUBHOUSES



Imposing Quarters of the Shaker Heights Country Club, Where Many Cleveland Players Hold Forth: The Broad Low Structure, Which Is the Largest Clubhouse in the Vicinity, is Constructed of Rough Gray Brick and Has Abundant Room and Wide, Inviting Verandas. It Affords a View of Much of the Undulating 18-Hole Course and Is Adjacent to the Tees for the First and Tenth Holes

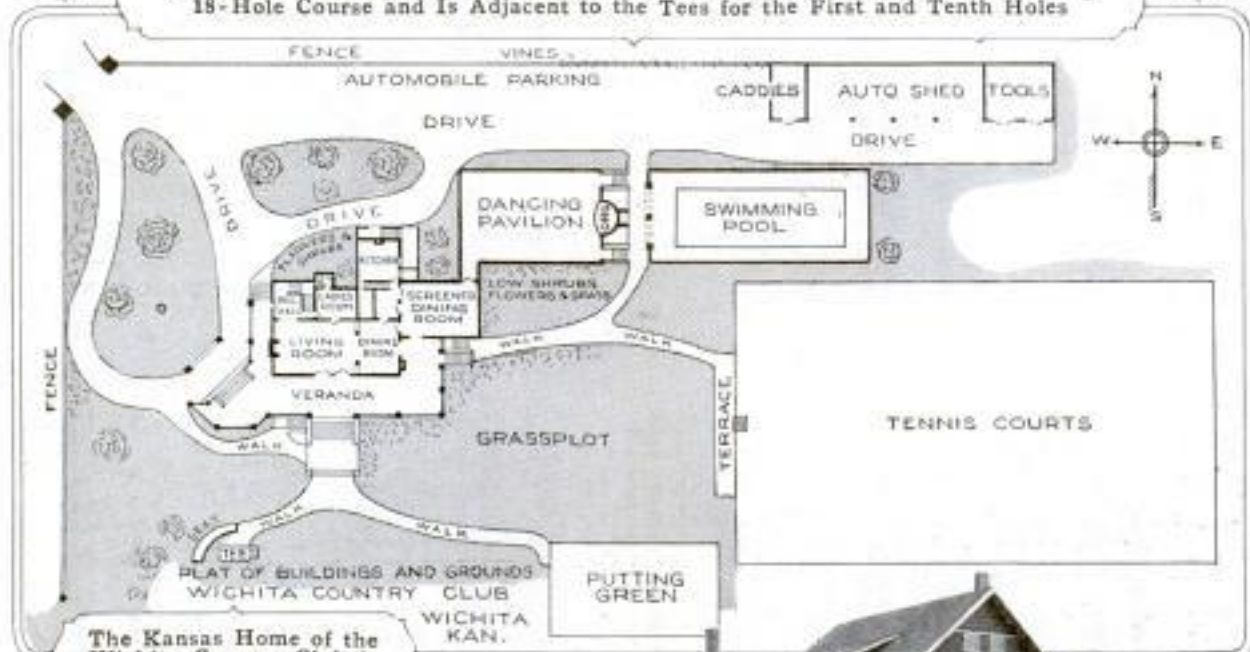

The Kansas Home of the Wichita Country Club is Situated on Top of a Hill Overlooking the City. As is Indicated by the Plat Above, the Grounds are Artistically Landscaped. Splendid Tennis Courts, a Large Bathing Pool, and a Roomy Dancing Pavilion Connected with a Screened Dining Room, are at the Disposal of Members. The Clubhouse, Which is Pictured at the Right, is New and Pleasing, While the 18-Hole Golf Course Adjoining is Well Planned



Three Hundred of Cincinnati's Golf Devotees Support the Western Hills Country Club. As is Disclosed by the Picture Above, the Clubhouse Has a Pronouncedly Homelike Appearance and on Two Sides Offers Broad, Restful Verandas for Foot-Tired Players on Warm Summer Afternoons. It Has 10 Bedchambers and a Number of Outside Sleeping Porches for Its Guests

AND SOME OF ITS BEST-KNOWN GOLF COURSES



The Restful Seat of the Mayfield Country Club at Cleveland and Two Interesting Spots on Its 18-Hole Golf Course are Shown in the Accompanying Illustrations. The Club Building, Which is Constructed of Limestone and Cement, is Attractively Situated at the Edge of a Slope That Overlooks Part of the Links. The Fifth Hole, Viewed from Near the Tee, is Pictured at the Right, and the Thirteenth is Shown Below. Both Keep Players Awake and Call for Careful Strokes



One of the Most Exasperating Natural Hazards Encountered on Cincinnati Golf Courses is This Ravine, Situated on the Hyde Park Country Club's Links. It Guards the Twelfth Hole, Which is Only 110 Yards from Its Tee Situated on the Left Bank. Par is Three, but Many an Enthusiastic Player Approaches the Green from the Bottom of the Gully and Fails to Hole-Out in Three Times Three

Fuller's ...
Sioux City, Iowa.

DEVICE FOR VENTILATING CORN IN THE CRIB

With a view to avoiding the loss caused by ear corn becoming heated

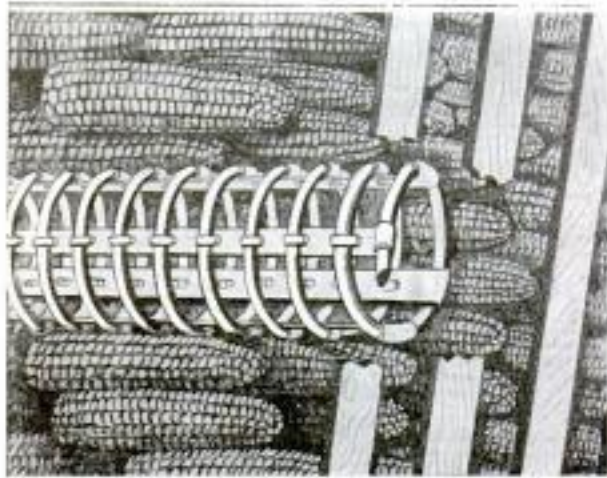

Rigid Coils of Wire, Made in the Form of Tiles, Which are Laid through Piles of Corn or Hay to Allow Circulation of Air and Prevent Overheating

in the crib, or hay becoming heated in the mow, a firm in Sioux City, Iowa, has invented what is called a wire tile,

which can be laid in the midst of the corn or hay, with both ends exposed to the air, and so enable air to circulate freely through the crop. This device for preventing damage to harvested produce is made simply of coils of wire, 7 in. in diameter and 2 ft. long. Each coil is made rigid with metal stays that extend through it lengthwise and hold the ribs of the tile 1 1/4 in. apart. One good way to use these tiles is to lay them horizontally through a crib full of corn and to cross this ventilator with another set of tiles strung on a wire and hung perpendicularly. Though one unit weighs but 3 lb. it is capable of sustaining a weight of 750 lb., and, since it is so durable, can be used for many years.

Investigation carried on in Iceland last year revealed the presence of vast coal fields, which a recently organized Danish-Icelandic company now proposes to develop on a large scale, if conditions warrant.

ROAD-REPAIR TRUCK BREAKS THROUGH A PAVEMENT

An unusual accident occurred recently near Inglewood, Calif., when a 12-ton motor truck, loaded with oil,



Twelve-Ton Oil-Laden Truck with Wheel Sunk through a Paved California Roadway

broke through the pavement on the Los Angeles-Redondo road. One of the rear wheels sank into the hole, the

rear axle was sprung, and the entire chassis was twisted out of line. The truck was one owned by Los Angeles County and used in road-repair work. It was backing up to the edge of the road when the wheel crashed through.

To get it out, it was necessary to unload the oil in buckets, then dig around the sunken wheel, build scaffolding in the hole, and lift the truck with jacks. The accident cost several hundred dollars.



The Load of Oil Had to be Transferred to the Buckets Shown Before the Truck could be Moved

Cont. J. F. Harg
218 S. Hidalgo St. Phoenix, Ariz.

are

FLOTATION PROCESS GAINS WIDESPREAD FAVOR

By far the most radical development that has occurred in the field of metallurgy of late years has been the recent widespread adoption of the flotation process of mineral concentration. This system, which recognized authorities contend is still in an embryonic stage, is considered from a technical viewpoint to mark the beginning of another epoch in the milling industry. Strictly speaking, the method is not altogether a new one, but during the last few years the obstacles that previously interfered with its commercial use have been removed, with the result that there are now 200 or more plants in the United States employing it.

Flotation is a means by which certain minerals in finely ground ore are made to separate themselves from the gangue, consisting of quartz, feldspar, and similar materials, by rising to the top of water in which specific oils are present. Film and froth-flotation methods are distinct. By the former process the mineral particles float on the liquid's surface film. In the other case they are carried to the top by artificially generated air or gas bubbles which form a froth that overflows into troughs.

At the outset the ore is ground with water and a small amount of oil. There are several kinds of oil suited for the work. Not more than two pounds of oil to a ton of ore is used, and at many plants a much smaller proportion is favored. A volume of water about four times as heavy as the ore is introduced and the mixture turned into wooden tanks, which are known as flotation cells. Air is then either beaten into the water with powerful paddles, or it is blown through a thickness of canvas forming the bottom of the container. The particles of mineral, practically free from gangue, are held in the froth that forms in great quantities. The concentrate obtained from the foam is ready for the smelter.

The physics involved is interesting, although in some points obscure and

debated. Essentially, however, what happens, is that the oil causes a selective action which permits the air bubbles to attach themselves to the par-

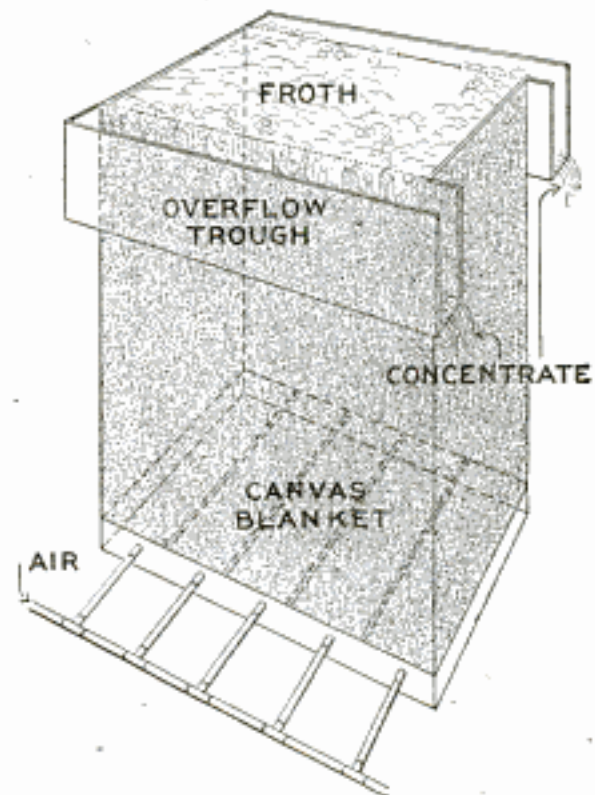

The Diagram Shows How Air is Forced through the Canvas Bottom of the Flotation Cell, Causing Bubbles to Form. The Latter Carry the Valuable Mineral Particles to the Surface, Where the Foam Overflows into Troughs

ticles of mineral, but not to the gangue. Specific gravity does not influence the process, for that of the mineral which is floated is higher than that of the material remaining at the bottom. The efficiency of mineral flotation is of course the important phase of the process. It offers so much greater percentage of recovery than has been obtained in the past by other methods that many old dumps can now be reworked profitably. Within the last year or so equipment for the flotation process has been installed at the reduction works of one of Nevada's most famous copper mines. An extraction of 78 per cent had formerly been obtained, but it is understood that the improvements have raised this ratio to 91, or a little more.

“No more oatmeal for dogs” is the edict that has gone forth in England, and now blooded hounds must accept simpler fare.

SOME NOVEL AND LITTLE-KNOWN ACCESSORIES

① Waterproof Wood-Veneer Covering in Green for Flower Boxes. Ten Feet. 20 Cents

② Rubber Buttons near Ends of Hanger Prevent Light Garments from Falling Off

③ Sanitary Bottle Cover with Disk That Separates Milk from Cream. Has Adjustable Handle, and Spur for Removing Caps. Price 35 Cents

④ Device Punches Two Holes in Condensed-Milk Can and, When Left in Place, Seals Openings

⑤ Cream Whipper and Egg Beater That Fits Any Screw-Top Fruit Jar. Price 50 Cents

⑥ Finger Support for Pen or Pencil: It Steadies Instrument and Lessens Muscular Fatigue

⑦ "Beauty" Kit, Containing Comb, File, Powder, Rouge, Cream, and Pocket for Cloth: It is Worn on Limb, as Pictured. Price \$2

⑧ Attractively Designed Hand-Decorated Desk Set Made of Metal. Price \$17.50

⑨ Loose, Comfortable, and Slightly Overall Suit for Woman Who Does Own Housework or Cares for Motor Car. Price \$28.50

⑩ Pocket Locket for Soldier: A Flag is Emblazoned on One Side, While the Other Identifies the Owner. Price 65 Cents

⑪ Convenient and Compact Stropping Device for Safety-Razor Blades. Illustrations Explain Operation. Price \$3.50

⑫ Clamps of the Sort Shown Above Are Particularly Serviceable in Holding a Cloth in Place on a Picnic Table in the Open. Price Four Cents Each

⑬ When This Clock is Properly Set, the Words, "Will Ring," Appear at the Point Indicated in the Photograph and Show That the Alarm will Sound at Desired Time

INTENDED FOR THE HOME AND ITS MEMBERS



14
Chain Fitted with Identification Disk Which Separates the Most Frequently Used Key from the Others



15
Convenient Needle Threader That may be Folded Like a Pocketknife. Price 10 Cents



16
Novel and Decorative Whisk-Broom Holder in Black and Orange Colors. The Broom Forms Skirt of Hawaiian Hula Dancer. The Price Is \$2



17
When Not Needed on the Telephone, This Watch may be Detached and Worn at the Wrist. The Price Is \$10



18
Sectional Kitchen Cabinet with Deep Table, Roll Front, and Convenient Seat. Compartment at Top may be Removed When Not Needed, or If in the Way. It Costs About \$35



19
Clear, Crisp-Toned Table Bell of Novel Design for Those Who Care for Things Unusual. It Is Gold-Lined and Enameled in Colors. Price \$2.50



20
The Tea Ball is Filled from the Canister, as Shown Above, and Then Placed in a Cup into Which Hot Water is Poured. Price 50 Cents



21
For Cleaning Knives, Forks, and Other Pieces of Table Silver, a Cork Polisher That may be Held Easily. Price 10 Cents



22
Hanger for Screens and Storm Windows That Enables These to be Interchanged Quickly and without Any Trouble

23
Electric Table Stove That Boils, Broils, Toasts, Fries, Poaches, and Steams. Three Different Dishes may be Prepared Simultaneously. Price \$7



D. & D. Lock Co.,
800-21 E. Jackson Blvd.,
Chi.

KEYLESS AUTO LOCK WORKS LIKE SAFE COMBINATION

A new ignition lock for automobiles has the advantage of being compact and keyless. It is installed on the instrument board in place of the key-operated lock, and the visible portion consists simply of three small knurled metal disks, each of which revolves independently and controls a corresponding hard-rubber disk on the opposite side of the board. Penetrating through each rubber disk, near its edge, is a small brass inset. The person that knows the combination turns the knurled rings until these brass insets are all in line and touch the brass contacts that form a part of the car's ignition circuit. Only by properly setting the lock can the circuit be closed. The one way a thief can "beat" the lock is to wire around it, which of course is something that would rarely be attempted.

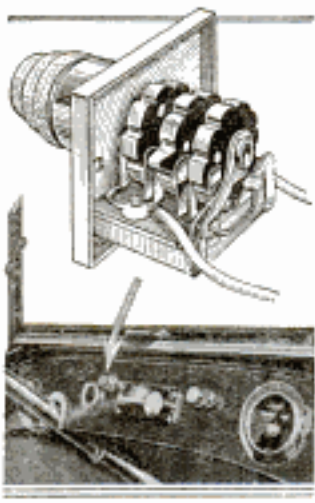

longitudinal lines, while by holding the chalk stationary at any desired point and revolving the globe, zone lines and parallels of latitude may be drawn with accuracy. The outer surface of the globe consists of a shell divided into two hemispheres, which can be removed and preserved, together with the maps on them, or the maps may be erased and the shell used again and again, if so desired.

longitudinal lines, while by holding the chalk stationary at any desired point and revolving the globe, zone lines and parallels of latitude may be drawn with accuracy. The outer surface of the globe consists of a shell divided into two hemispheres, which can be removed and preserved, together with the maps on them, or the maps may be erased and the shell used again and again, if so desired.

TATTING SHUTTLE'S BOBBIN WINDS LIKE A REEL

A new tating shuttle has several novel features. The frame is made of resilient metal and holds a bobbin which is turned by means of a small crank when thread is to be wound on it. Near one end on the inside of the frame is a channeled guideway which receives the crank when it is not in use. Since it is somewhat wider than the normal space between the shuttle's two leaves, the crank tends to spread the latter apart slightly, so that the bobbin is allowed to rotate freely. Instead of the ends of the frame being held together by spring action they are entirely closed. At one end, however, there is a small hole through which the thread passes from the spool. This arrangement makes it unnecessary to turn the shuttle continually in order to unwind the thread.

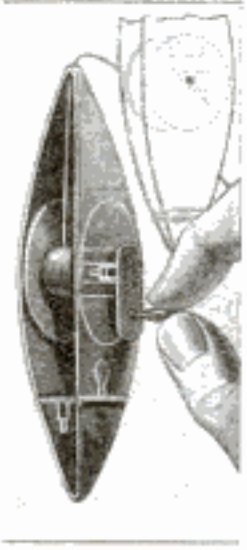

that the bobbin is allowed to rotate freely. Instead of the ends of the frame being held together by spring action they are entirely closed. At one end, however, there is a small hole through which the thread passes from the spool. This arrangement makes it unnecessary to turn the shuttle continually in order to unwind the thread.

SPHERICAL BLACKBOARD AIDS IN MAP DRAWING

A spherical blackboard, for which a patent has recently been issued, is a schoolroom device that can be of great service in teaching pupils to draw accurately such geographic divisions as continents and hemispheres. Hinged to the base supporting this globe is a curved telescoping arm, at the end of which is attached a piece of chalk. This arm serves as a guide in drawing neat



which is attached a piece of chalk. This arm serves as a guide in drawing neat

For the purpose of calling attention to a special section in certain of its issues, a prominent trade journal marks the position of this department with a thumb index, which is made visible in the usual way, that is, by cutting away a portion of the leaves in front of it, as is done on thumb-indexed books.

T.G. Craighuel,
Seattle, Wash.

F. J. Burnsett,
1105 Grove St., Spent 58K, ...
 L. J. Burnsett
 ...
 ...
 ...

BREAKING BRIDLE GOVERNS BY NERVE PRESSURE

A new breaking bridle is so designed that it gives remarkable control over an unmanageable horse, because pressure can be exerted on certain of the animal's spinal-cord nerves. This simple head harness has a rope bit which will not injure the horse's mouth, no matter how tender it may be. At each end is a large circular guard. A strap attached to the bit extends up the right side of the head and then just back of the ears, and terminates in a pulley on the left side. Fastened to the end of the bit at the left side is a small rope which passes upward through the pulley and then back through a metal loop projecting from the end of the

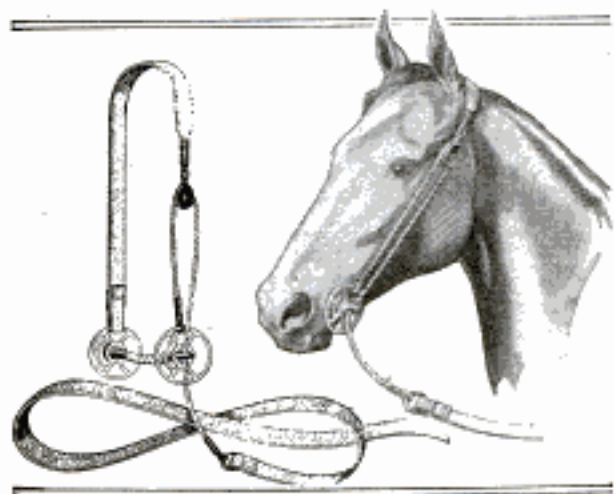

New Breaking Bridle Which will Not Injure a Horse's Mouth but Affords the Trainer Complete Control of the Animal by Exerting Pressure on Nerve Centers

mouthpiece. An extension of this rope serves as the leading rein. A pull on this rein causes the strap behind the ears to press down on a spot in the spine which is so sensitive that the horse is soon brought into subjection.

HOLLOW GAS-STOVE GRATES REPLACE HOT-WATER COIL

Marked reduction in the cost of heating water by gas is made possible by a Minneapolis invention which utilizes the heat that commonly goes to waste around and above the gas burners of a kitchen range. The im-

provement consists of a set of hollow grates that take the place of those ordinarily used. They are connected by water pipes with a hot-water tank.

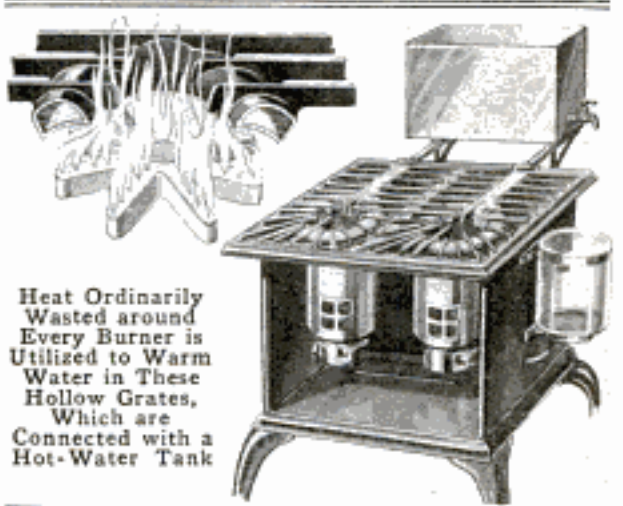

Heat Ordinarily Wasted around Every Burner is Utilized to Warm Water in These Hollow Grates, Which are Connected with a Hot-Water Tank

Whenever the burners are lighted for cooking, the water in them becomes heated and rises into the tank, without the consumption of any additional gas. When the stove is used but little for cooking, water may be warmed by placing metal plates over the grates and lighting the burners. The makers claim that four of these burners will warm water more rapidly than a copper-coil tank heater consuming the same amount of gas. These grates are also made for gasoline and oil stoves.

METAL SLINGSHOT CROTCH HOLDS ELASTICS FAST

A metal slingshot crotch has been patented, which is not only more accurately shaped than the kind that boys cut from forking branches, but also provides a special means for holding the ends of the elastics. Each branch of this crotch is made of two identical parts, between which the rubbers are inserted and held securely by turning a screw which draws the halves of the branch close together. This means of fastening the elastics is less apt to tear them than the old method in which strings were used.



Minneapolis Hot Water Grates Co.
Minneapolis

W. W. ... (Signature)

DENTIST'S CASE CARD CAN BE ADDED TO AS DESIRED

The feature of a dentist's case card, which has been patented, is that a



Extensible Case Card for Dentists: The Original Card Is About the Size of a Postal, and When Full, an Extension can be Attached as Shown in Insert

ruled extension can be conveniently attached to it when the space for memoranda on the original has been filled. This card resembles the ones commonly used by dentists in keeping track of each patient's dental work, in that it bears a diagram of all the teeth, so that the exact location of every filling, crown, etc., can be noted. When all the ruled lines on this card have been filled it is not necessary to make out a new one and copy all the notations made on the diagram. Instead an extension slip with a gummed edge is pasted to it. Cut in the original card are two semicircular slits which form lips that can be used to hold the folded extension so that it will not interfere with the handling of other cards in the file.

¶The New Haven Railroad has been asked by one of the towns through which it passes to lay a drain beneath its tracks at certain crossings so that, in case of near-by fires, hose can be laid in the culvert across the right of way and rail traffic will not be interrupted.

NEW SYSTEM OF NOTATION FOR WRITING MUSIC

In a new system of musical notation, suggested by a Kansas City man for general adoption, the staff used is so arranged that its lines represent the

black keys on the piano keyboard, and its spaces represent the white keys. Instead of being equidistant from each other, as at present, the lines of the

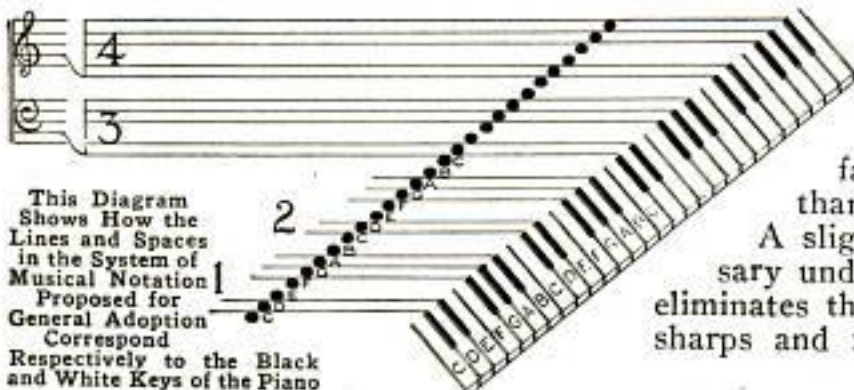

This Diagram Shows How the Lines and Spaces in the System of Musical Notation Proposed for General Adoption Correspond Respectively to the Black and White Keys of the Piano

new staff are grouped in twos and threes, like the black keys, and it is claimed that music written on this staff is far easier to learn and read than the old style of notation.

A slightly wider staff is necessary under the new system, but it eliminates the use of all the signs for sharps and flats, which often puzzle



Here the Old and New Systems of Writing Music are Set Side by Side for Comparison. All Notes Played with Black Keys Are on the Lines in the New Notation

R. B. Borden
1315 Madison Ave, N.Y.C.

and confuse young students of music. Three lines above and two below a double space constitute the new fundamental five-line staff, others being added above and below, similarly spaced in groups, for writing the higher and lower notes.

REVOLVING DOOR COLLAPSES IN CASE OF PANIC

A recent improvement in revolving doors is intended to lessen the danger of their being blocked in case of panic. The new construction provides for the outward collapse of the rotating wings of the door whenever unusual pressure is exerted upon them, as by the efforts of an excited crowd to leave a building. There are as usual four wings, these being extended at right angles to each other when in the normal operating position. Each wing is fastened independently on a central vertical shaft by means of drum and gear castings which



Diagram of Improved Revolving Doors, Showing How They Collapse Outward under Pressure

act as hinges. A cable brace holds each wing in the extended position, and when the pressure on the wing becomes greater than is required to rotate it, one end of this cable slips, releases its hold, and the wing collapses toward the exit.

Auto Access Spot

REAR SEARCHLIGHT TURNED ON BY REVERSE SHIFT

A strong white light may be turned on automatically at the rear of an automobile whenever the gear-shifting lever is put into reverse position, by means of a newly patented device, invented by an Oregon man. This furnishes convenient light for backing out of a garage, turning around on dark

or narrow roads, or parking at night, and tends to secure safety in reversing.



Backing a Car with the Aid of a Rear Searchlight Device, Operated Automatically by the Gear Shift in Reverse

As it is connected with the lighting system the device operates only at night, or when the tail lamp is lighted.

NEW FORM OF BOTTLE FOR RADIOACTIVE FLUIDS

A Swedish inventor has lately patented a new form of bottle for the safekeeping of radioactive fluids, which are apt to lose their properties in ordinary containers, through the escape of gases. The bottle has a fluid-inlet tube, reaching nearly to the bottom, and an air-outlet tube above which is a ledge in the neck of the bottle on which a loose-fitting disk of metal or glass may rest. When the bottle is filled until the fluid reaches above the ledge, and the disk is inserted, under a bell-shaped cover of which it forms a part, a seal is formed which prevents the escape of gas from the inner part of the bottle.

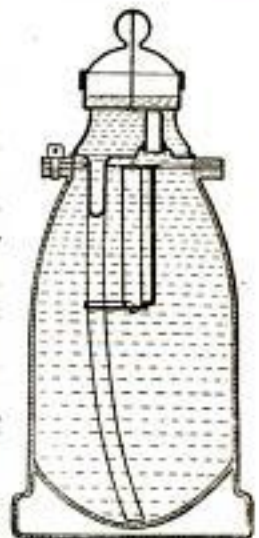

Industriidningens Norden Stockholm 9-10-16

S. V. Van Heford, inventor

Very simple design
 United States Metal Products Co, Los Angeles,

G. G. Stewart, Jr.
 Roseburg, Oregon.

A VARIETY OF NEW TOYS FOR BOYS AND GIRLS



Here is a New Idea in Hand-Power Carts. The Body at the Rear, When Loaded, can be Dumped by Tilting It Backward, Just Like the Big Trucks That Carry Coal



Quaint Bird House with a Roof of Thatch: Houses Like This are Made with Six, Eight, 10, and 14 Rooms. They Cost \$8 to \$15, According to Size

Outfit of Chemicals for Boys and Girls: With It One can Make 85 Fascinating Experiments in Chemistry and Chemical Magic, and Acquire an Interest in Science Besides

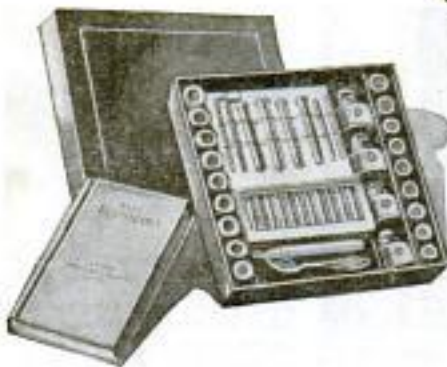

When Closed This Tall Slim Chest Looks Like a Carpenter Waiting for Orders. Upon Opening It, One Finds Just the Tools Wanted, and Also Wrapping Paper and Twine. The Price is \$18, Complete



This Handsome Hobbyhorse does Not Simply Rock Back and Forth but He Really Gallops—If Some One will Take Hold of the Handle at the Back and Push Him

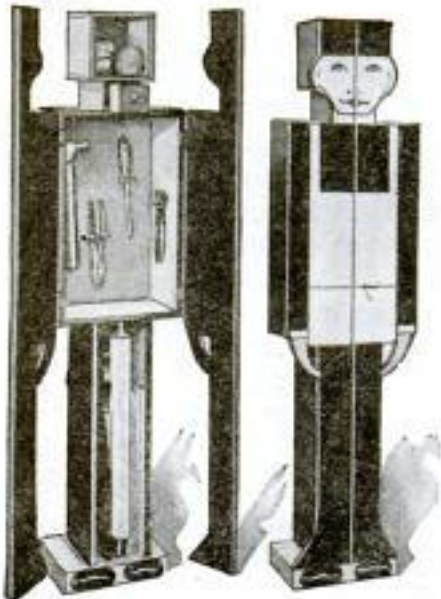

A "Pussycat" Chair, Painted in Colors, That Is a Delight to Very Little Folks, and a Wee Table to Match, with a Kitten Painted on Top. The Table Costs \$14 and the Chair \$12



Bleary Shop of Gifts
1 E. E. ...
D. ...

1 May fair
5th x 5 1/2 ...
N.Y.C.

Archibald ...

AND USEFUL ARTICLES OF INTEREST TO THEM

1871
1872
1873
1874
1875
1876
1877
1878
1879
1880
1881
1882
1883
1884
1885
1886
1887
1888
1889
1890
1891
1892
1893
1894
1895
1896
1897
1898
1899
1900
1901
1902
1903
1904
1905
1906
1907
1908
1909
1910
1911
1912
1913
1914
1915
1916
1917
1918
1919
1920
1921
1922
1923
1924
1925
1926
1927
1928
1929
1930
1931
1932
1933
1934
1935
1936
1937
1938
1939
1940
1941
1942
1943
1944
1945
1946
1947
1948
1949
1950
1951
1952
1953
1954
1955
1956
1957
1958
1959
1960
1961
1962
1963
1964
1965
1966
1967
1968
1969
1970
1971
1972
1973
1974
1975
1976
1977
1978
1979
1980
1981
1982
1983
1984
1985
1986
1987
1988
1989
1990
1991
1992
1993
1994
1995
1996
1997
1998
1999
2000
2001
2002
2003
2004
2005
2006
2007
2008
2009
2010
2011
2012
2013
2014
2015
2016
2017
2018
2019
2020
2021
2022
2023
2024
2025



A Swinging Chair That Children will Delight In Because It can be Stretched Out Flat Like a Couch, Which can be Swung Back and Forth as Before. It is Shipped Prepaid for \$2.50

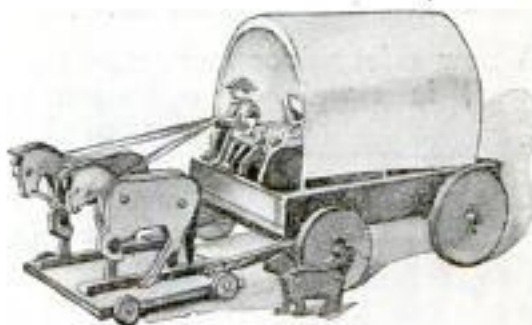

A Truly Picturesque Prairie Schooner Built for Hard Knocks: The Pioneer's Family Are All Inside, While the Dog Keeps Watch Without. The Outfit Sells for \$5.25



Imogens Holloway



Mandel Boston

This Pretty Dish for the Dog will Not Break or Upset Easily. The Figure Stands 10 Inches High. Similar Ones can be Had for Cats. Price \$5 Each



Two Baby Chairs in One: Fold Up the Legs, as Shown Below, and the High Chair Becomes a Low Seat on Wheels, with a Big Tray in Front for Playthings. Finished in Oak, It Costs \$22.50

For Over 100 Years Little Girls have Loved This Doll. It was Brought Long Ago from Poland and Finally Given to the Present Proud Owner, Who Lives in Topeka, Kansas



A Cardboard Advertising Novelty for Children: The Parts of the Puzzle Picture, as Shown at the Left, are Designed to be Cut Out and Assembled in a Frame, as in the Circle Above

*Fallis Toy Shop
637 Franklin St., Denver, Col.*

*J.H. Nevius,
217 S. 38th St., N.K.S.*

N.Y.S.

SAFETY DOOR LOCK WORKS BY LIFTING THE KNOB

A new safety door lock, recently invented, is simple in operation and seems to be a desirable means of fastening the doors of bedrooms, bathrooms, offices, and hotel rooms. Closing the door and lifting the knob operates the lock in one

direction, while the reverse movement of the knob unlocks the door. One advantage is that the occupant of a room can always be sure whether the door is locked or not, because he can tell this from the position of the knob as soon as he looks at it. It affords a ready and certain method of opening a locked door from the inside in case of fire, there being no key to fumble with or to mislay.



W.R. Schrage,
1420 Alcatraz Ave.,
Berkeley, Cal.

MOLDINGS FOR WALL BOARD WHICH ALLOW EXPANSION

A feature of wall board which builders frequently have had difficulty in overcoming, namely that it tends to contract and expand, has been provided for by a molding manufactured in Memphis, Tenn. There are three principal forms of this molding and three kinds of stops that are combined with it in various ways

to furnish grooves into which the wall board may be fitted and by which it is held in place without being nailed. This allows the fiber sheets to expand and contract without unsightly warping. In making panels with these wooden strips, the position of the studing can be disregarded so long as the

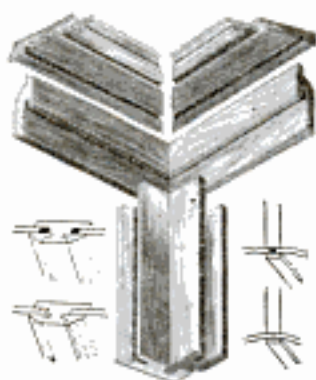

W.R. Friedel Co.
718 S. Dudley St.
Memphis, Tenn.

molding is well secured at either end, for it is strong, and so grooved that it holds the wall board without backing.

NOVEL WATCH POCKET MADE FOR MAN'S WAISTCOAT

When carried in a waistcoat pocket of a new design lately patented, one's watch may be consulted without being removed. The pocket is of conventional type except that it has a circular opening, covered by a transparent shield, through which the dial of an open-face watch, held within it by a glove fastener, is visible. An outer flap covers the pocket and is secured at the bottom by a clasp. If the latter is not desired, it may be slipped within the pocket, thus leaving the face of the watch exposed.



376 So. 3rd St.
Solomon, C.

secured at the bottom by a clasp. If the latter is not desired, it may be slipped within the pocket, thus leaving the face of the watch exposed.

NEW SPARK-PLUG CLEANER WORKS QUICKLY

Spark plugs may be rapidly freed from carbon and oil by a new cleaning device which does not require the plugs to be taken apart for its operation. It consists of a small tube with a bushing at one end to receive the plug, and a number of loose needles contained within. When the tube is half filled with gasoline and the plug to be cleaned is screwed into the bushing, it is only necessary to shake the tube, when the needles inside pick any carbon off the porcelain, while the gasoline dissolves any oil on the plug. A set of plugs can be thus cleaned in a few minutes, without soiling the hands.



Champion Spark Plug Co.
101 Water St.



A Collapsing Bridge for the Movies

By RALPH CUMMINS

A MOVING-PICTURE bridge has one span so constructed that it can be broken away, precipitating an automobile, a carriage, or a horseman into the stream. Many movie fans are curious to know by what mechanical means this thriller is effected. Boys and others interested in making models, for play or diversion, will find a miniature bridge of this kind a novelty. A sure means of tripping the section is necessary, for the fall must be timed just right, so as not to spoil the picture and make necessary an expensive "retake." The tripping apparatus, shown in the sketch, is one that I have used successfully on bridges, towers, and walls. The principle is simple: Two hinges are placed on opposite sides of the trip post—a 4 by 4-in. piece upon which one end of the span rests. A piano wire stretched

from the upper hinge to a point opposite the break-away section, forms the means of tripping. When an automobile is used, a wire can be run through pulleys in such a manner that the machine trips the break-away span at the proper instant.

Painting Cold-Water Pipes

It is very difficult to obtain a satisfactory painted surface on cold-water pipes, because of the condensed moisture which collects on them. The water should be run out of the pipes and a thin coat of shellac applied after the surface has been dried thoroughly. Bronze aluminum, dusted over a preliminary coat of copal varnish, or over the shellac, which dries quickly, produces a neat finish.—A. Ashmun Kelly, Malvern, Pa.

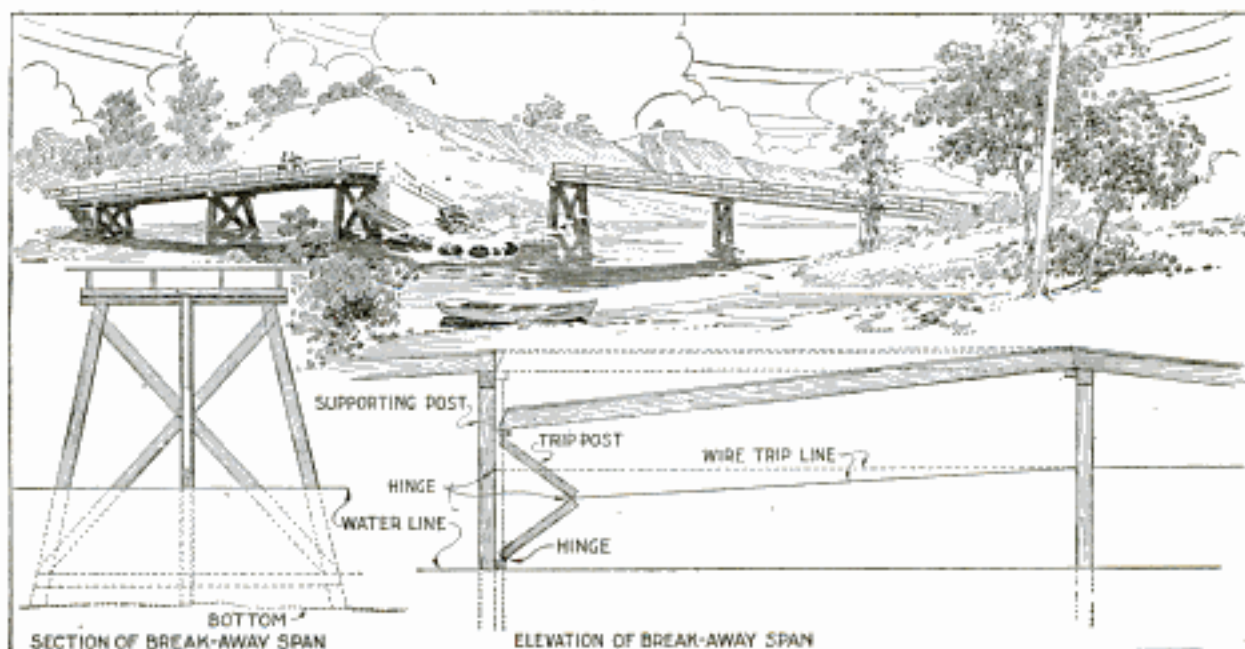

The Car Automatically Trips the Break-Away Span, Precipitating Itself into the Stream

Quickly Made Stand for Lathing

In lathing I found a stand built up on a horse and braced, as shown, to be quite convenient. The laths were placed in a barrel supported near the end of the platform, and could be easily taken without stoop-



The Rapid Work of the Lather is Made Even More Speedy by the Use of This Stand

ing. The platform is light and easily moved. It is so cheaply made that after a job is finished it can be knocked down and only the horse taken to another job, if desired. The barrel used was a nail keg, like those obtainable at most buildings in construction.—John S. La Fleur, Haverhill, Mass.

Safety Guard for Exposed Shafting

Suitable coverings for exposed shafting should be provided as a safety measure. If the shafting is already in operation and cannot be taken down

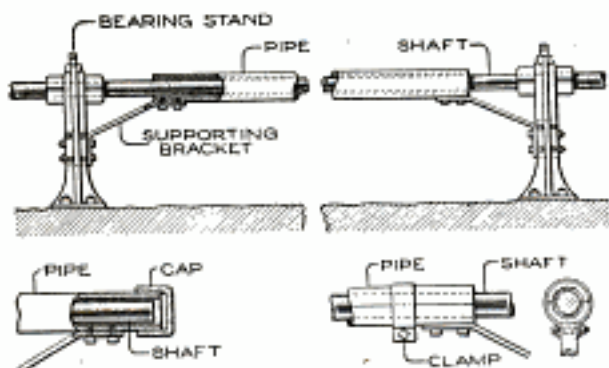

The Workmen are Protected from Exposed Shafting by Pipe Coverings

handily, a pipe may be cut into halves longitudinally in a keyseating machine

and the parts clamped together with straps of sheet iron, when in position. A typical installation is that between bearing stands, to which the pipe is braced with brackets, as shown. Exposed ends of shafting are protected with a pipe and cap, as detailed.

Locating Trouble in Automobile Starters and Generators

After a season's use, the automobile starter and generator should be carefully examined to make certain that its efficiency is up to standard. The starter may lack the necessary turn-over torque, especially when the engine is cold and spinning is difficult. The generator may heat up rapidly or fail to charge the battery properly. Before taking the motor or generator apart, go over every external connection to see that there are no grounds, breaks, or shorts. Examine the starter foot switch to make sure that the electrical contacts are in good condition. Note, also, the condition of the battery, whether it needs water or acid and that its voltage is sufficient. As for the generator, pay special attention to the relay to see that cutting-in occurs at the proper engine speed. This speed should average eight or ten miles an hour, for most generators. If trouble is experienced with the sticking of relay contact points, a small flat file should be used to smooth the contacts, care being taken to see that they meet evenly. An ordinary finger-nail file will serve the purpose. Still failing to locate the trouble, inspect the machine internally. As a rule, very little difficulty may be traced to the field coils, but a close examination of the armature and commutator is suggested.

Bad sparking at the brushes is generally a sign of high mica. A ground in the armature winding is caused by contact of the winding with the armature core. A careful examination should show the weak point in the insulation.

The last test to be made is for broken lead wires. Substitute a small piece of sheet metal for one of the

brushes, so that only one commutator bar at a time is touched. A single dry cell should then be connected, through an ammeter, to the metal brush and to the next carbon brush. Turn the armature very slowly by hand, so that the metal brush may make sure contact with each commutator bar in succession. Unless the design is very special, there will be two lead wires soldered to each bar. A reduced deflection will indicate a break in one lead, and no deflection, a break in both, when the metal brush passes over the bar to which the faulty leads belong.—K. M. Coggeshall, Webster Groves, Mo.

Triangle Holder Aids in Inking Drawings

It is often desirable, for rapid work in tracing, to draw ink lines with a triangle over lines that are wet. It is hard to do this without making blots. I made a protector, as shown, with which it is easy to move the triangle over wet lines, at the same time keeping it at right angles to the T-square. The device is made of metal,

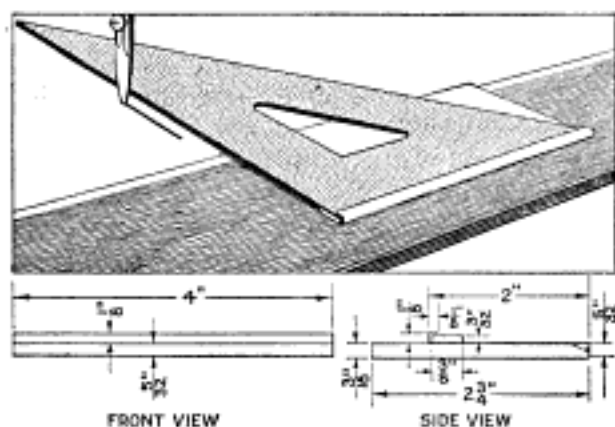

The Device with the Triangle in It is Moved in the Usual Manner

sheet aluminum being preferable. The size may be varied, that indicated being suitable for smaller triangles.—Howard Scott, Jersey City, N. J.

CA smooth, well-tinned soldering iron transmits more heat than a rough or dirty one.

Traveling Pulley-and-Hanger Support at Anvil

In the small forge shop where long pieces must be handled occasionally, as well as in the shop where drills and

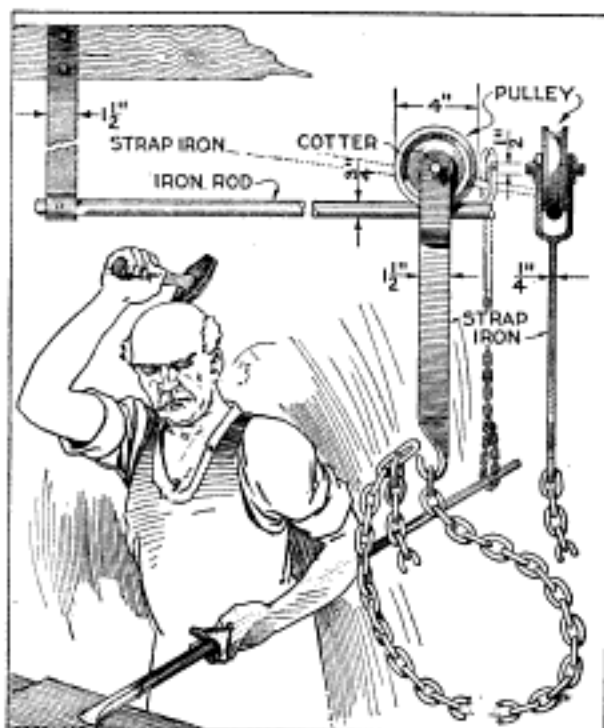

This Support was Made for Handling Long Rock Drills, and Has Many Other Uses

similar tools are sharpened, the pulley-and-hanger arrangement shown in the illustration is convenient. The rod on which the pulley travels is supported from the joists. A forged hanger supports a chain sling which is adjustable to various sizes and shapes of work.—John E. Cahill, Jr., New York, N. Y.

Orchestra-Pit Rail Used as Speaking Tube

Musicians and the leader in an orchestra often wish to communicate with each other, which in a large orchestra is inconvenient. By cutting 1-in. openings in the pit rail at each player's chair in a local theater, and connecting the rail to a tube at the leader's station, means of communication was provided. At more expense, speaking tubes may be installed along the rail, but the plain openings proved a success.—Jack Wolmer, Marion, Ind.

Remedy for Unreliable Auto-Oiling System

Many small automobiles are equipped with a constant-level splash system of engine lubrication in which a shaft-

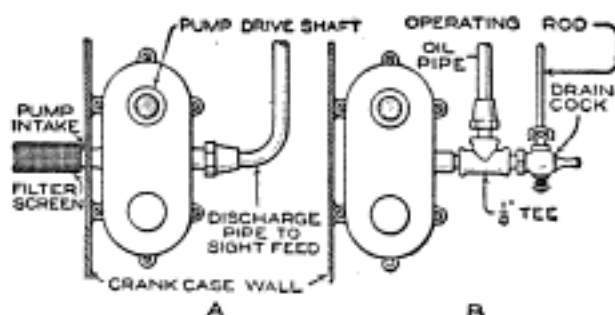

Frequent Stoppage of the Oiling System was Overcome by the Installation of a Drain Cock

driven gear pump draws oil from a chamber cast in one piece with the lower part of the crank case. This pump discharges the oil through a copper tube to a sight-feed fitting on the dash, from which it goes to the crank case by gravity. In one such case frequent stoppages of the oil flow were experienced, and when the parts were cleaned, little dirt was found, and the system worked temporarily on re-assembly. An air lock was found to be responsible, and the change shown in the diagram was made to overcome the difficulty, the old arrangement at A, and the new at B.

A change in the piping was made, as shown, the other fittings being undisturbed. The regular discharge fitting was attached with a tee. A petcock was placed opposite the discharge and an operating rod for it was run up

small quantity of oil to be pumped out. When this is then closed, the oil flows through the discharge pipe, whether the stoppage was due to an air lock or to dirt.—Victor W. Pagé, Bristol, Connecticut.

Testing the Atmosphere in Polishing Rooms

A test for detecting metallic dust in the atmosphere of a polishing room may be made by placing a lighted Bunsen gas burner in the middle of the room, about 4 ft. from the floor. When steel and iron particles float in the atmosphere, the dust comes into contact with the flame, as indicated by the sparkling of the flame. The presence of brass dust is indicated by an intense greenish color. This simple device is valuable for the inspection of blower systems, intended to clear the air.

A Workbench for Use Singly or in Multiple

This heavy workbench was designed for use in engine houses and small railroad shops where room is at a premium, and can be adapted for the use of machinists, carpenters, pipe fitters, boilermakers, and other mechanics who need a substantial bench. It accommodates four men, but can be arranged to be used in two sections. Two drawers are provided for each workman, and also a large cupboard with a screened door. The construction is such that the bench can be made quickly by machine or hand process,

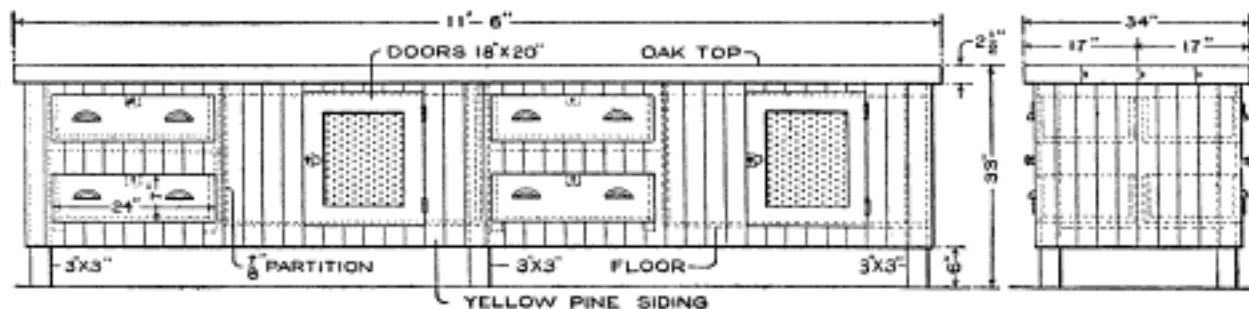

A Substantial Workbench of This Type may be Used in Single or Double Units for Heavy Shop Work

to the top of the engine. As soon as the oil feed stops, it is but a minute's work to open the petcock, and allow a

and there are no out-of-the-way corners to catch dirt.—Joseph A. Long, Sunbury, Pa.

A Hydroplane Catamaran Built for Speed

By L. B. ROBBINS

THE building of this 16-ft. power boat of the catamaran type, involves no special skill in boat construction, and it is designed to be made without the bending of planks, ribs, etc., by mechanics having only a fair knowledge of handwork with tools. The craft is for use on fairly smooth water, and with a 4-hp. motor, develops a speed of 15 miles an hour. For greater speed with a more powerful motor, the size of the catamaran must be correspondingly increased. The bottoms of the hulls have steps, turning them into simple hydroplanes, and increasing their speed quality. The open structure simplifies the mounting of the power plant and its driving connections, as compared with conditions met in ordinary motorboats. The perspective sketch in the headpiece of this article, and the plan and elevations, Figs. 1, 2, and 3, show the general arrangement of the parts.

Cut the sideboards from $\frac{3}{4}$ -in. pine. They fit between the top and bottom, and over the ends. Begin the construction with the hulls, detailed in Fig. 4. All of the wood used should be first-quality stock. Plane the edges square, and fasten the 1-in. battens into place with screws, applying white lead under them, on the inside of each sideboard, except at A, Fig. 4, where a bulkhead supports the structure. Coat the inside of the sides with marine paint.

The bow piece B is of oak, 2 in. sq. and 1 ft. $1\frac{1}{2}$ in. long, and the stern piece C is of 1-in. pine. Fit the pine bulkhead A water-tight, the rear surface of it flush with the step. Fasten the end and bow pieces, and the deck board, painting the inner surfaces. Use 2-in. brass screws, countersinking

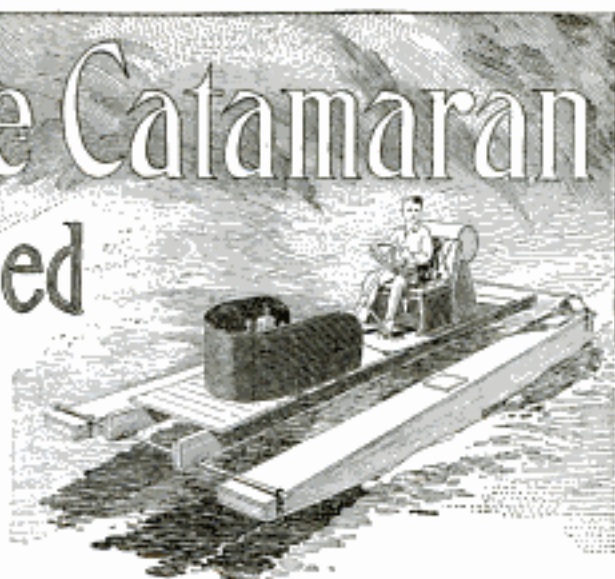

the heads, and place a strip of muslin soaked in white lead between all joints. Cut the holes D, and fit them with plugs. These holes are for filling in or pumping out ballast to distribute the weight properly. Scrape off the excess white lead, sandpaper the surfaces, and fill the screw holes with white-lead putty, and apply two coats of marine paint to the hulls. Next construct the deck of matched boards mounted on two 2 by 6-in. spruce timbers, 16 ft. long. These must be of fairly straight grain, and of very good quality. Set the timbers on edge and taper them to 5 in. at the ends, into a truss effect. Place the timbers, as indicated, 2 ft. apart, arched edges uppermost, and nail on the $\frac{3}{4}$ -in. matched pine deck boards 3 ft. long. Leave 1 ft. of the timbers uncovered at the ends. Leave two openings forward, the size and position of them depending on the motor used. The center of the engine bed is 4 ft. 6 in. from the bow and heavy boards are laid for its support. Notch the timbers, 6 in. from the ends, and fit them with iron straps, bolted on, as detailed, to accommodate the supporting end shafts.

An old automobile seat and round gasoline tank is mounted on the frame, as shown, making certain that the bottom of the tank is higher than the carburetor of the motor. The seat and tank are set about 10 ft. 6 in. from the bow, to obtain an even distribution of weight. An auto steering wheel and column, fitted with a wooden drum,

keyed in place, is used. A bracket near its base supports the post.

The deck is next fitted to the hulls.

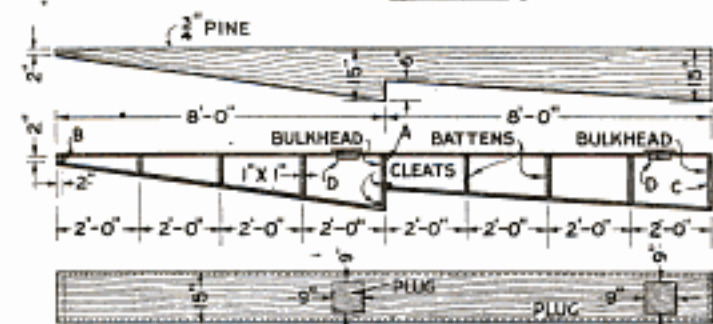
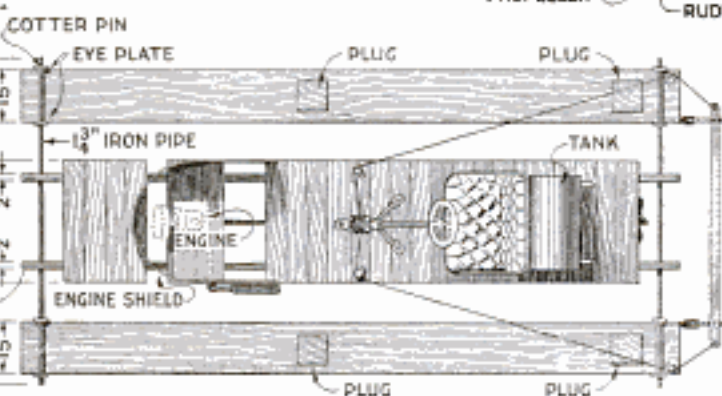
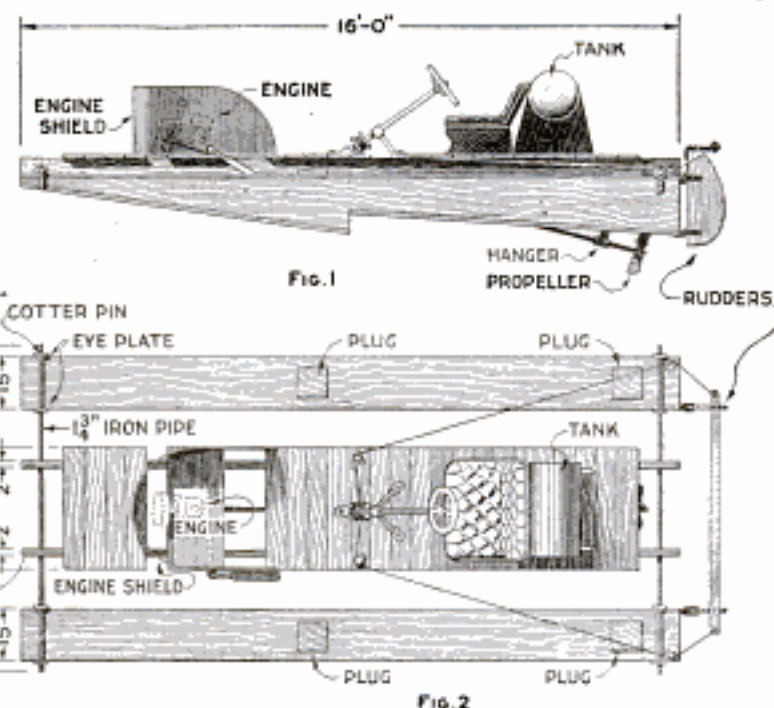
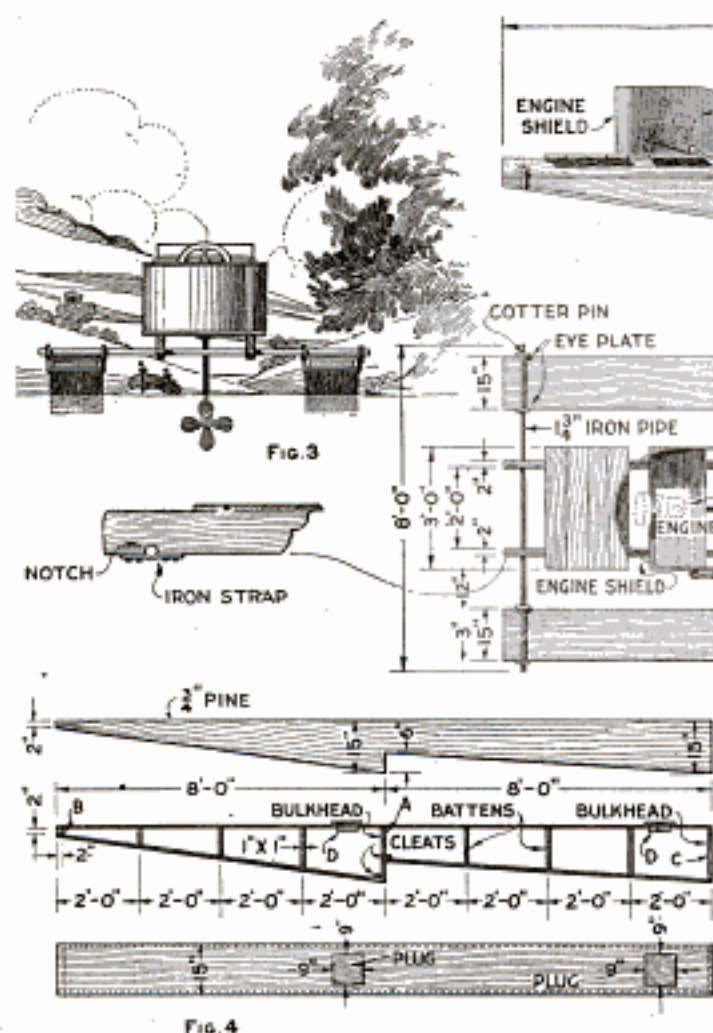

Eye plates, as shown, hold the end rods carrying the long timbers. The plates are secured with screws, 6 in. from the ends of each hull. An 8-ft. length of 1 3/4-in. galvanized-iron piping is slipped through the sets of eyes, and through the notches of the deck timbers; cotter pins hold the piping in place. The straps at the ends of the timbers keep the deck frame in position on the piping.

Two rudders of thin oak or of sheet metal, as shown in Figs. 1 and 2, are hinged to the inner edge of each hull. An angle of strap iron at the upper edge of each rudder is bolted loosely to a bar of iron or wood, so that the rudders operate together. The steering rope is rigged through pulleys, as shown, and wound around the drum on the steering column.

The installation of the motor will depend upon its style and size. The usual connections of the gasoline sup-

Fig. 2
The Hydroplane Catamaran Is an Interesting Craft, the Making of the Supporting Structure Being Quite Simple as Compared with the Building of Ordinary Motorboat Hulls

ply and electrical equipment are, of course, provided. The batteries and coil are placed under the seat, and the wire connections carried in rubber hose. Heavy oak or ash engine timbers are bolted to the flooring for the engine bed, arranging the pitch so that the propeller will rest about 6 in. under water. Bolt the hanger for the propeller shaft to the floor boards, as shown in Fig. 1. A spray hood, of canvas over an iron frame, or of sheet metal, protects the motor.

Punching Hard Sheet-Rubber Washers by Hand

Vulcanized, or hard, sheet rubber may be worked with shears or ordinary leather punches, using stock 1/8 in. in thickness, by gently heating the part to be cut, and sometimes heating the tool also. To cut a hard-rubber washer from a piece of flat stock, use two leather punches, a large one to cut out the blank, and a smaller one to punch out the center hole. Lay the

stock on a flat piece of lead, or other fairly soft metal, heated just sufficiently to cause the rubber to become pliable, so as not to crack when the punch strikes it. The washer will cool flat if laid on a flat surface. Hard-metal tubing is suitable for cutting the stock, if properly sharpened, and other shapes may also be cut.—F. L. Whitaker, Olney, Ill.

Padded and Flexible Paper Weights

For weighting large maps and drawings, standard square 2 or 2½-in. nuts, with a layer of cotton waste or cloth padding, about ¾ in. thick, evenly wrapped about them and covered with strong paper or cloth, are excellent and inexpensive. A smooth leather bag, 3 in. square, filled with small lead shot or dry sand and securely sewed, makes a good paper weight that is very flexible, and if accidentally dropped on a drawing, does it no injury.

Tool Holder for High-Speed Steel

By the use of this tool holder, high-speed steel need not be broken into

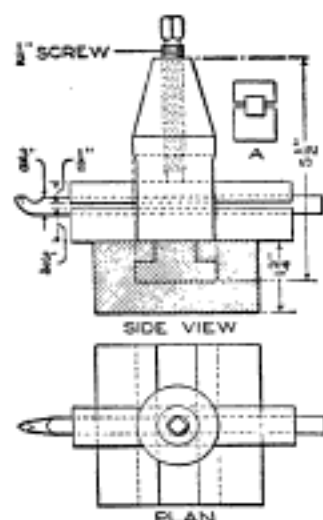

short lengths, but may be fed forward as required. The holder was designed for a medium-sized lathe tool post, and the device may be made strong enough for use on a shaper or planer, and to withstand heavy cuts. It consists of two sliding members of machine steel, grooved to fit the tool steel, as indicated at A, and is clamped in the tool post in the usual manner.—C. A. Gilson, Niles, Mich.

Undue forcing in photo development is indicated by a tendency of the fixed prints to sink in the wash water.

Detachable Hauling Brackets on Passenger Auto

Two simple methods of adapting an automobile quickly for business pur-

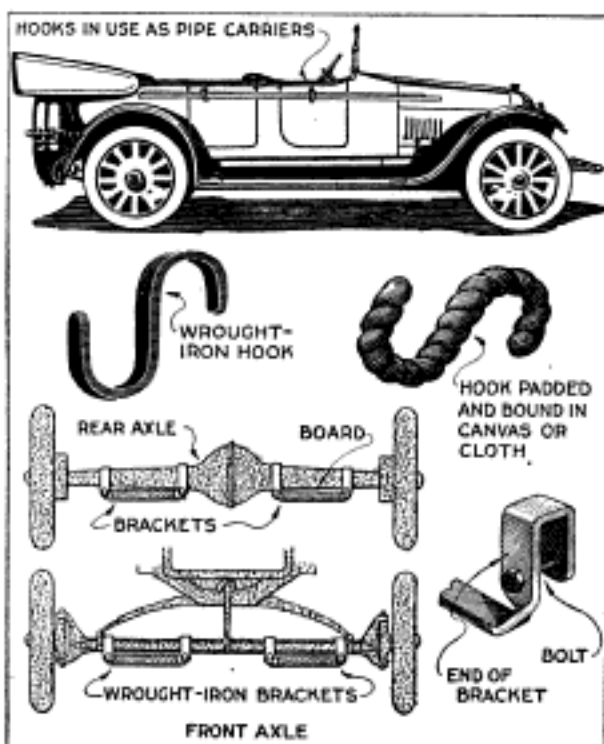

These Devices Are Useful in Carrying Pipes, Ladders, Fish Poles, and Similar Articles

poses are shown in the sketch. The S-shaped wrought-iron hooks, padded in cloth or canvas, are used by a plumber to convey long sections of pipe handily. The brackets are used by a paper hanger in transporting scaffolding. They are made of wrought iron, as shown, to conform to the axles of the car.—G. A. Luers, Washington, District of Columbia.

Hay Carrier Rigged to Handle Excavation Dirt

In digging a cellar under my house, how to remove the dirt was a problem. I made a track for my hay-carrier tripping pulleys and hanger of 1 by 4-in. boards. I then made a strong box, 1 by 2½ by 3 ft. in size, and attached it to the carrier in such a way that by loosening a hook it would dump easily. With this arrangement one man took out an average of 7 cu. yd. a day.—J. H. Knight, Cumberland, Ohio.

High and Low Water-Level Indicator

This easily made water-level indicator is in daily use and was worked out by me. Where the supply tank is located so that it is not visible from the pump house, such a device is reliable and convenient. Branch wires from an ordinary lighting circuit are run to the tank and to the pump house, office, etc., as desired.

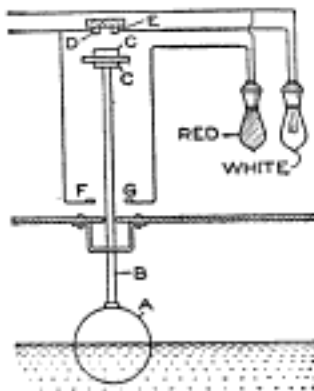

The copper float, at A, is fastened to a rod, B, to which are attached the plates C, with an insulating strip between them. The clamp and the hole in the tank act as guides to hold the rod in a vertical position. When the tank is full the lighting circuit is closed by bridging the space at the contacts D and E, lighting the white globe. When low water is indicated, the space at F and G is bridged, and the red globe is lighted.—James E. Noble, Toronto, Can.

Device for Tapping Small Machine Parts

A machine which was found useful in tapping quantities of small parts is made as follows:

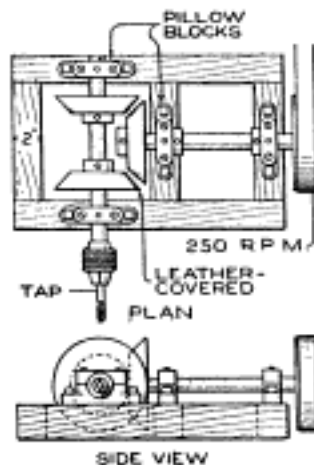

Turn off one side of each of three 5-in. grooved pulleys, at an angle of 45°, making cone-shaped wheels. Remove the chuck from a breast drill, and thread one end of a 3/4 by 12-in. shaft to fit it. Upon this shaft mount two of the pulleys, 4 in. apart, facing each other, and equally distant from the center. A

second shaft, at right angles to the first, takes the third bevel pulley at one end, the pulleys being faced with leather. The leather is drawn tightly over the shellacked face of each pulley, bound down at the back with wire, and later trimmed off. A wooden frame of 2 by 4-in. stock forms the support of the two shafts, which run in pillow blocks. The shaft carrying the friction wheel is belted to the source of power and runs continuously, while the chuck shaft runs ahead when pushed in, and reverses when pulled in the opposite direction. The speed should be about 200 to 250 revolutions per minute.—Dexter W. Allis, Whitman, Mass.

A Caliper with Locking Scale

Mechanics who have had experience with calipers will readily perceive the advantages of the indicating feature of this homemade caliper.

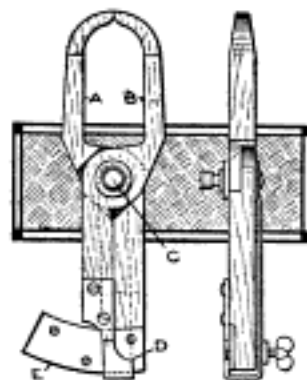

I made this instrument of wood for gauging the top and back of a violin in course of construction, and it has many other uses. The legs A and B are fitted together at the lap joint C with a washer, and secured with a screw and knurled nut. The movable arm D is made of sheet metal, and is swung from the bolt that secures the legs, the thumbscrew locking the arm of the scale E. The latter is a piece of sheet metal fastened to the leg A, and its extension, with screws. A pointer is also fastened to leg B. When the caliper is completed, the pointer D is locked against arm A, and the indicating marks scribed deeply on the pointers. A scale may also be marked on the part E. Ordinarily, the arm D is clamped on E, as desired, the opening gauged by the pointers.—William A. Robinson, Waynesboro, Pennsylvania.

Repairing Small Tire-Tube Punctures

Many automobile-tire repairmen, in repairing a pinhole puncture, use a patch several times as large as the injury. This requires very heavy pressure to obtain a smooth surface. A better way is to trim the hole just enough to remove all ragged edges. Clean it thoroughly and apply cement. When the cement has dried, force a small thread of gum through the hole with an awl, trimming it flush on the outside. In curing, use just enough pressure to hold the tube firmly on the tube plate; tracing cloth laid on the plate insures a smooth surface.

Automatic Poultry Feeder with Clock Control

Uniform quantities of feed may be fed to poultry with a minimum of attention by the person caring for them, if the simple arrangement shown in the illustration is installed in the poultry house or yard. The grain or other feed is placed in the metal hopper, the device being supported on the rafters or other suitable support. The hinged door at the bottom of the hopper is controlled by a trigger, connected to the clock alarm winder by a cord. When the alarm is released, the cord is wound on a spool fixed on the alarm winder, and the trigger is freed. The feed falls to the conical spreader, and is scattered to the ground.

The hopper may be made in various sizes, and several may be rigged with the same clock control. It is mounted on a $\frac{7}{8}$ by 9 by 18-in. board, on one end of which the clock is fastened, by a strap of iron. The spreader is supported from the board by metal rods. The hole in the bottom of the hopper is 2 in. in diameter, and the spreader is 12 in. wide.

A spool is secured to the alarm winder of the clock and the cord controlling the trigger is wound on it. The clock is wound up, and the alarm set for the desired time. When the alarm is freed, the spool turns with the alarm winder, winding up the cord,

and releasing the trigger, and feed. The fowls soon become accustomed to

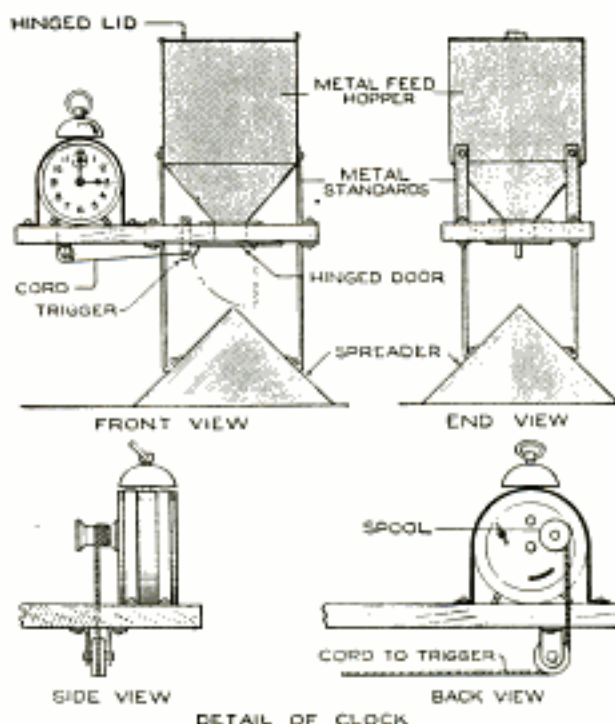

The Poultry Feed is Scattered on the Ground from the Suspended Hopper and Spreader, When the Alarm Mechanism Releases the Trigger

the ringing of the alarm, and respond to it quickly.—C. C. Holmes, Detroit, Michigan.

Ball Bearings Overcome Thrust in Gear Shaft

The countershaft in the gear box of a motorboat power plant was subjected to a great end thrust when the gears were engaged. This caused considerable wear on the gear box, as indicated. Hardened steel balls were placed at each end of the countershaft, slightly countersunk holes being pro-

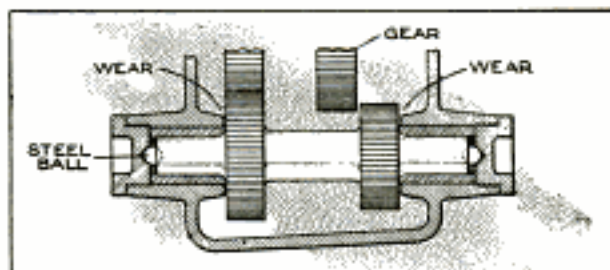

Steel Balls Set in Conical Bearings Take Up the End Thrust

vided in both the shaft and the housing. They took up the thrust in both directions, eliminating the wear.

Handle Forms Coupler for Train of Trucks

By arranging the tongues of shop trucks so that they may be set in



sockets on the rear of similar trucks, forming a train, one man can handle a number of them when empty. The end of the tongue and the socket are protected by metal fittings.—J. J. O'Brien, Buffalo, N. Y.

An Adjustable Hay Shed

As a protection for hay stacked in the field, the hay shed shown in the illustration proved effective. It was built by setting four heavy cedar poles

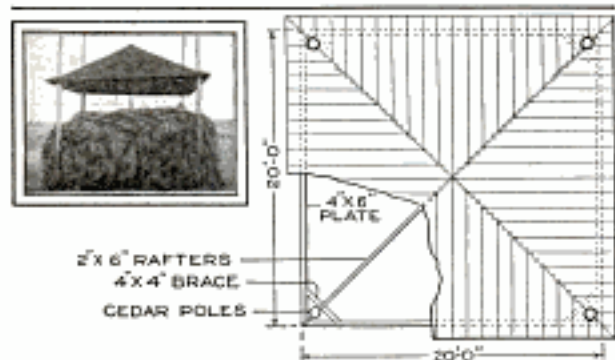

The Roof is Raised and Lowered by Sliding It on the Poles, in Which Heavy Supporting Bolts are Inserted

in concrete at the four corners of the stack and then constructing a roof to

slide up and down on the poles. A desirable location for the haystack from year to year was determined upon, and the shelter built at that place. Holes were bored 2 ft. apart in the supporting poles, and the roof is set at various heights by means of bolts placed in the holes. The roof is of comparatively light construction so that it is not difficult to raise or lower it. The tops of the poles are guyed together by means of wire braces.—W. E. Frudden, Charles City, Iowa.

Fumigating Plants with Tobacco Smoke

The accumulation of insects or scale on plants should be held in check by fumigating them, at intervals. An efficient means of overcoming the pests is by the smoke of tobacco. A suitable arrangement whereby this can be done



either in the house or outside, is shown in the sketch. Bore 1-in. holes in the top of the box, and cut an opening in the end to admit a saucer. Make a cloth bag to be slipped over the box and tied closely, inclosing the plants, which are set on the box, above the holes. Light the tobacco on a saucer, and put the latter through the opening, so that the smoke may rise around the inclosed plants. The bag is carefully taken out of doors to remove the smoke remaining in it. A light fumigating performed twice is better than fumigating heavily, with possible injury to the plants.—F. H. Sweet, Waynesboro, Va.

Paper Drinking Cups as Containers for Wood-Finishing Materials

In a shop where many kinds of stains, paints, etc., are used, considerable time and material are wasted in cleaning bottles, cups, or other containers. A satisfactory solution of this

problem is the use of paper drinking cups. They cost less than one-half cent each, and may be thrown away after being used once, or used several times for the same kind of stain.—P. Gaffney, Chicago, Ill.

Leather Covering for Auto Magneto Coupling

In an automobile, a small leather covering over the coupling connecting the magneto to the engine is desirable. The dirt and grit will in this manner be prevented from working into the parts of the coupling. The boot is made of thin flexible leather, formed in the shape of a tube, and clamped to the two shafts by means of soft-iron wire.

Extension for Drafting Board

A drawing board of considerable size was found too small for drawings which were to be made from time to time, and an extension was built, which could be removed quickly. The wood used was the same as that in the board, and the ends were fitted with cleats, to prevent warping, and to provide a good edge for the T-square. Metal straps hold the sliding pieces under the board. The extension is held rigid by two deep dowels, set in the joined edges. Hooks hold it firmly

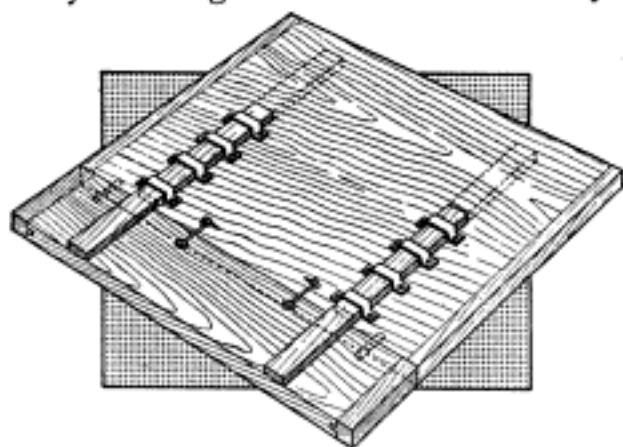

The Sliding Strips are Fastened on the Lower Side of the Board, and the Hooks Hold the Extension in Place

against the edge of the board. When not in use, the sliding strips are kept under the board.—Ralph W. Sherman, Burlington, N. J.

Proper Care of Automobile Springs

A practical illustration of the care of automobile leaf springs is that frequently employed on racing cars, the

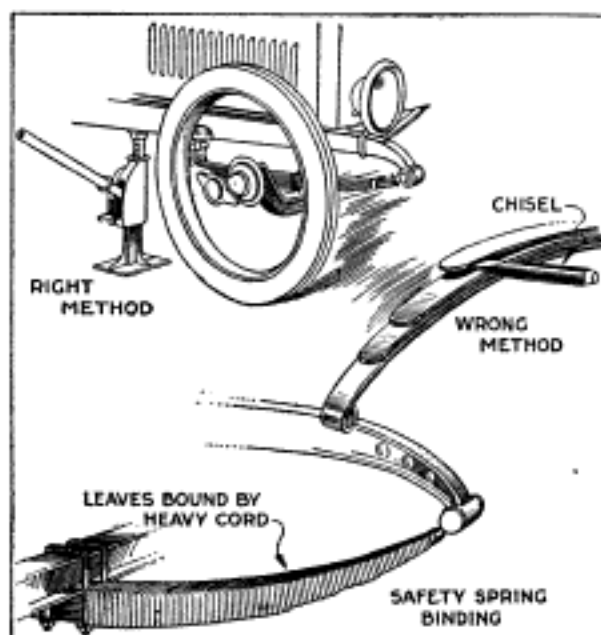

The Leaves should be Properly Released, and Not Pried Apart with a Cold Chisel

springs being wrapped with heavy cords to crowd the faces of the leaves firmly together, increasing the frictional contact, as shown in the sketch. Mechanics, with a hammer and cold chisel or crowbar, sometimes pry apart the leaves of the springs to lubricate them. This method often produces permanent sets or bends. The correct method of separating the leaves is by releasing the clips and staybolts, and placing a jack between the frame and floor to raise the load. Beeswax, or this and powdered resin, heated, is suitable for the springs, if applied as suggested. The unsightly sagging rear of many cars is often caused by failure to maintain proper contact between the leaves, and in some instances by abuse through methods of lubrication. To insert a lubricant, such as oil, between them, may cause distortion and frequently broken springs.

CA strip of canvas glued in several layers to the flanged driving pulley of a motorcycle overcomes the slipping of the belt.

List-Printing Machine for Use with Rubber Type

It was found difficult to print a long list of names by the use of the flat type

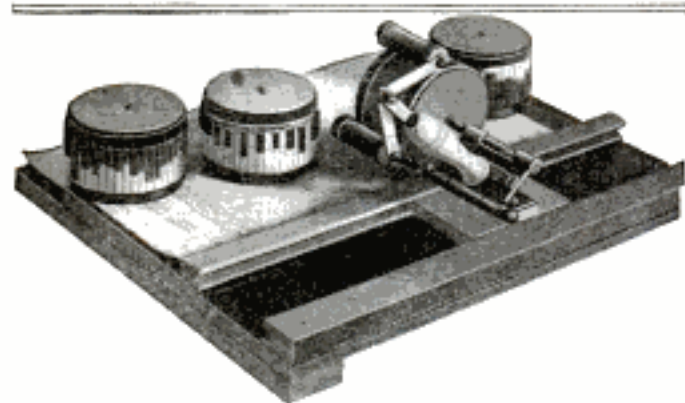

This Printing Device was Made for Duplicating Lists of Names, and Has Other Uses

board ordinarily used with rubber type, and, since many copies were to be made, the machine shown was devised. It requires a comparatively small ink pad, and the rollers for the type can be used for many forms of this kind of printing. The rollers were spaced on their circumferences so that the lines of type registered properly in the forms to be printed, which were ruled. Ordinarily it will be necessary to space the type lines at standard spacings, or at spacings determined upon for special reasons. The type may be glued directly to the rollers, or to paper strips, which are then mounted on the rollers. The type rollers are inked by felt-covered ink rollers mounted in a hinged metal angle. The printing device is carried on a sliding block, fitted into a groove on the baseboard.

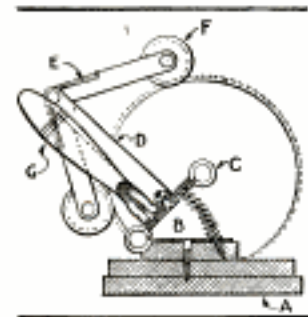

which engages the grooves of the baseboard. One butt hinge, B, and half of another, are fastened with screws. The half hinge carries the shaft C, which is the pin of the hinge. A strip, D,

holds the angle E, carrying the ink rollers F. They are held at proper pressure on the type by the spring at E, and are kept from dropping between the rows of type by small flanges at their ends, bearing on the wooden edge of the type rollers.

The printing roller is set firmly on the shaft. The first printing line is indicated on the side of the roller, as a guide in starting the impression, the roller being "spotted" by the fingers of the right hand, which holds the handle. The handle G is pushed forward, and the additional sheets are fed against the guide strip with the left hand. The coil spring holds the printing roller off the paper on the return stroke, and tends also to make the impressions more nearly uniform on the forward stroke.—T. T. Sturgeon, Los Angeles, Calif.

Repairing Leaky Copper Heater Coils

Leaky or burned-out copper water-heating coils, such as are used in most

water tanks, can be repaired either by brazing a small hole, or, in case of large leaks, a new piece can be inserted. The burned-out part

is sawed off, as at A, the shading indicating the burned-out section. Discarded coils from which good parts may still be cut, are used in repairing. One of the ends to be joined is spread with the round head of a machinist's hammer, as at B. The other end C is set into the funnel-shaped part, and, backed with asbestos sheeting, is put under the blowtorch flame. At white heat, using plenty of borax, the spelter is introduced about the joint, fluxing with the copper. At the same instant, the flame must be shut off, to avoid melting the copper coil. Heater coils repaired in this manner are nearly as good as new.—Ralph W. Tillotson, Erie, Pa.

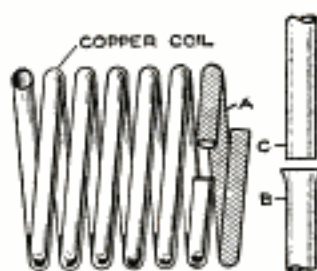

Keeping Down Dust on Concrete Floors

Mopping of some types of concrete floors is objectionable because the water is retained for a considerable time, causing dampness. In other instances the floor wears off, producing a disagreeable dust. By cleaning the floor thoroughly, and painting it with several coats of boiled linseed oil, allowing plenty of time for them to dry, the surface becomes filled. It wears to a smooth polish and the floor may be kept clear of dust easily, by mopping it.

Steam-Operated Flue Cleaner

A handy labor-saving device was rigged up by a fireman in a local boiler room, the details of which are given in the sketch. The boiler it is used on is 16 ft. long, with 56 flues $3\frac{1}{2}$ in. in diameter, and it is quite a job to scrape the flues twice a week with the usual scraper. To make this steam-operated flue scraper, he used 2-in. seamless steel tubing, cut 17 ft. long. On each end he fitted a cap, and a packing nut on the forward end. Next he molded a piston of babbitt metal, 3 in. long, cutting grooves for two rings taken from a small motorcycle engine. A hole was then tapped at each end of the 17-ft. tubing for the steam pipes. A piece of $\frac{1}{2}$ -in. pipe was attached at the back end, with a suitable fixture to fasten to a steam hose. Two three-way lever cocks were attached as shown, and $\frac{1}{4}$ -in. pipe run from the lever cocks to the forward end. A $\frac{1}{2}$ -in. pipe was used as a piston rod, to which the scraper was fixed.

In use, a rope is fastened to the end bearing the scraper, as shown, and run through a small pulley fastened to the ceiling. The scraper is started in the tube, and then the operator simply holds against the cylinder and opens the end cock, permitting the steam to drive the scraper through the flue. Then he opens the same cock to the exhaust position, and at the same time turns steam into the cylinder through

the other cock, which forces the scraper back. By means of the rope and pulley, all flues are quickly

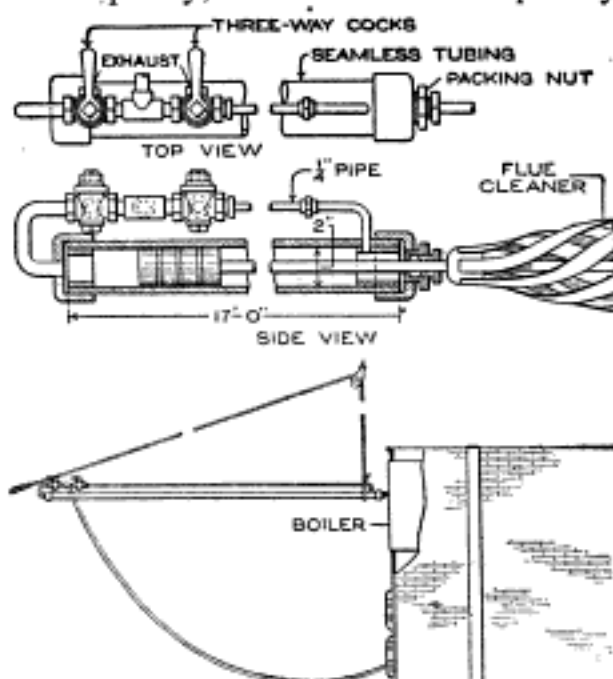

Anyone Who has Pushed a Tight Scraper through Boiler Flues will Appreciate the Labor Saved by This Device

reached. The device is used at from 40 to 90-lb. pressure, as the firemen find convenient.—R. S. Matzen, Fort Collins, Colo.

Depth Gauge on a Hand Saw

In making the saw cuts for joints in timber, much time can be saved, and the job made more nearly uniform, by using a depth gauge on the hand saw. A simple contrivance for this purpose is made by clamping a steel square on the side of the saw, as shown. By adjusting the square properly, cuts may be made which are deeper on one side than on the other. When this kink was used by a carpenter recently, his fellow workmen immediately fol-

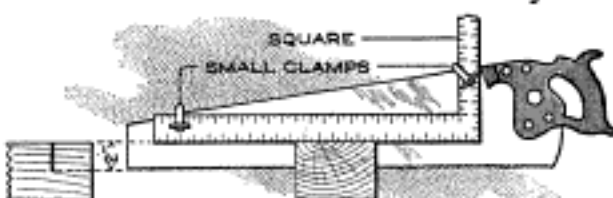

The Depth of Saw Cuts is Gauged Accurately by the Use of This Simple Device

lowed suit by rigging up devices in imitation of it.—J. V. Romig, Allentown, Pa.

A Molding Head for the Circular Saw

By CHARLES A. KING

THE modern circular-saw table, with its tilting top, its ripping, cutting-off, and mitering devices, and its movable throat, is an almost indispensable tool, but its possibilities either

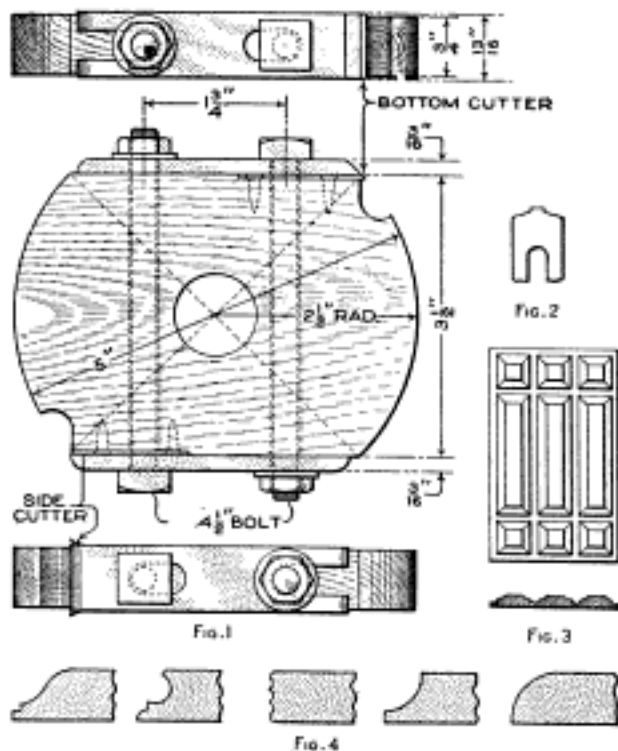

The Molding Head Is a Useful Addition to the Circular Saw Table, Especially in the Small Shop

are not realized or are ignored in many smaller woodworking shops. A variety of jigs and attachments for the circular-saw table may be made which will greatly broaden its range of usefulness. The head herein described, if accurately made, with knives properly shaped, tempered, and balanced, will be found efficient for many purposes.

The low cost of making a head of this sort, compared with the cost of the patented heads upon the market, will permit several of them to be made and kept on hand for special work; they are especially valuable in small shops, where there are no machines but a circular-saw table.

In making the head, select a well seasoned piece of maple, or other very hard wood, a little less in thickness than the width of the knife it is expected to carry, and cut it to a circle a little

larger than the desired dimensions, about 5 in. Bore a hole in the center of this circle, to fit the spindle of the saw arbor. The roughly shaped head may then be placed upon the spindle and the collars set tightly up against its side. A rest for a turning tool should be devised, and, after starting the machine, the edge may be turned until the head is of the desired size.

Remove the head from the spindle and draw diagonals, as shown in Fig. 1, at angles of 45° with the direction of the grain, and indicate the portions to be cut off at the upper and lower edges. Cut away the segments, and straighten the edges until they are parallel with each other and square with the sides of the head.

Locate upon each side of the center, and $1\frac{3}{4}$ in. apart, the centers for two $\frac{3}{8}$ -in. holes, which pass through the head at right angles with the direction of the grain of the wood. These must be placed at exactly the same distance from the center, and bored carefully from each side until the holes meet. Cut out places for chip clearance, as shown, making the cut at right angles with the straight surfaces.

Fit a $\frac{5}{16}$ -in. bolt of proper length into each hole, and place a washer and nut on it. The head should now be put in place and the machine started up to see if the head runs smoothly. Usually there will be no trouble, but if the head jumps it should be balanced by boring small holes in the wood upon the heavy side until it runs with little or no vibration. If the bare head runs as it should, but vibrates when the cutters are in place, it will be known that the trouble is with them.

The cutters may be ground, or forged, from regular sizes of tool-steel blanks, as indicated in the sketch, but if such are not available, heavy worn-out files may be used. The knives should be slotted to permit endwise adjustment.

If it is desired to make a grooving head, the straight cutter should be $\frac{1}{16}$

in. narrower than the width of the desired groove; the other, being the lip, or scratcher knife, should project slightly beyond the edge of the straight knife, to perform the same function as the lips of an auger bit, which enter the wood ahead of the cutters, to prevent the latter from tearing the grain of the wood.

The points of the lips may be swaged so that only their ends will come in contact with the wood, as friction of the wood against the back of their edges may injure the temper. The form of the bottom cutter may be varied within a wide range of designs, suited to other work than cutting grooves. For instance, one shaped like Fig. 2, used with a lip cutter, will make a good design for a checkered panel, like Fig. 3; or the panel may be carried diagonally over the knives, making diamond-shaped checks, and by using different-shaped knives, the head may be adapted to a number of decorative and constructive uses. If a groove narrower than the thickness of the head is to be cut, the knives will have to be made long enough to cut the depth of the groove before the head reaches the surface of the wood.

Knives may be made in pairs, for molding the edges of shelves, for panel moldings, surface moldings, quarter-rounds, and scotias, as indicated in Fig. 4. One essential in the fitting of each pair is that they balance perfectly, as otherwise it will be impossible to make even fairly smooth work.

The head described is $\frac{3}{4}$ in. thick, but it may be made as thick as the distance between the collars upon the spindle will permit, and in some cases, the knives may project beyond the sides of the head.

A head of this type, 5 in. wide, if fitted with slotted adjustable knives, will make a satisfactory jointer or molding head, which can be used in many ways. An arrangement of springs, or pressure bars, may be devised which will hold the wood firmly against the knives and reduce the vibration of the wood to a minimum, besides giving added safety to the operator.

Rack and Case for Sterilizing Shop Goggles

In a shop where the workmen were required to wear safety goggles at

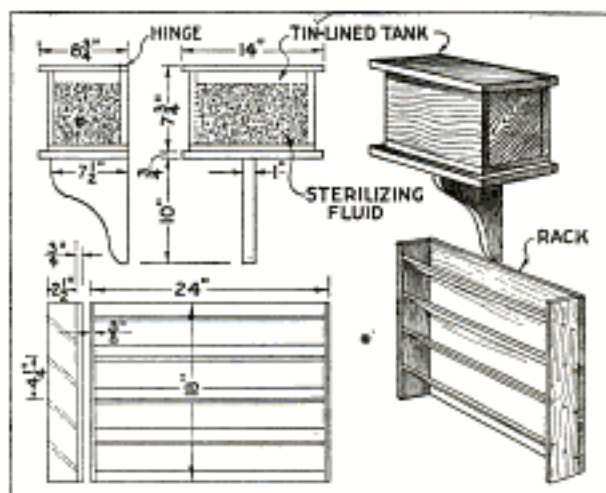

This Sterilizing Tank and Rack were Provided for the Care of Shop Goggles for General Use

various times, a number of pairs were provided for general use. For hygienic reasons these were sterilized before being used again. A tin-lined tank, mounted on a bracket support, contained the sterilizing fluid, and the goggles, after being removed from the fluid, were placed on a rack, made of $\frac{3}{8}$ -in. wood, as shown.—B. A. Donley, Renovo, Pa.

Comb Used as Ruling Pen

In an emergency a fine-toothed comb will serve as a ruling pen for drawing

two or more parallel lines at one operation. Five-lined music scores, cross-section and profile papers, borders for drawings, and various

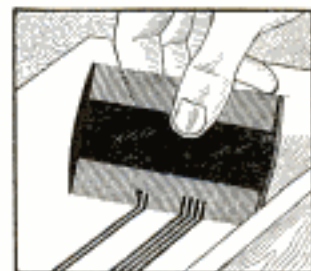

classes of decorative designs can be made with this device. Bevel slightly the edges of the teeth in contact with the paper, to give straighter edges to the lines. The teeth on one side of the comb, cut down to half length, afford a multiple stylus for making carbon copies.—H. L. Wiley, Portland, Ore.

Pair of Scissors Used as Envelope Sealer

A useful envelope sealer was made in an emergency, when a large number of envelopes were to be sealed. In an old pair of scissors a small piece of wood was inserted between the blades, as indicated, and the blades bound with electric tape. A string was wound around the top of one of the handles A. The string was moistened and inserted under the right end of the flap, and drawn along, the handle B pressing down the flap and sealing it.—Wilfred Reeves, Toronto, Can.



Tray for Storing Mica Washers without Damage

Mica washers become ruined quickly if kept loosely in a box, or other container, and the tray shown in the sketch was made to care for an assortment of them. The box is 5 by 8 by 10 in. in inside measurements. The washers are placed on dowel rods, mounted in a $\frac{7}{8}$ -in. board that is fitted loosely into the box. A long screw hook was fastened at the center of this board so that the assortment may be removed quickly, using the screw eye as a handle.—L. M. Drake, Daytona, Fla.



Water made slightly acid with muriatic acid will clean and restore the brightness of gold-leaf gilding; this method is used by sign painters.

Reinforcing a Light Wooden Triple Arch

I had occasion recently to make a wooden arch for the purpose of decorating with miniature incandescent bulbs. The arch, shaped as shown, was 7 ft. from B to C, with curves of $1\frac{1}{4}$ by 2-in. material. The standards were of white pine, but the arch itself was of yellow pine, a wood that is somewhat brittle. I secured a lot of thin wood from orange crates, and glued it on the curves with its grain across the yellow pine. Brads were used to hold the strips. To facilitate handling in transportation I divided the arch at A, B, and C. The parts were joined with pieces of maple, secured with screws. This method of strengthening the arch was so effective that I carried it, in a bundle of four sections, a distance of 17 miles on the trolley car and erected it without a split developing.—James M. Kane, Doylestown, Pa.

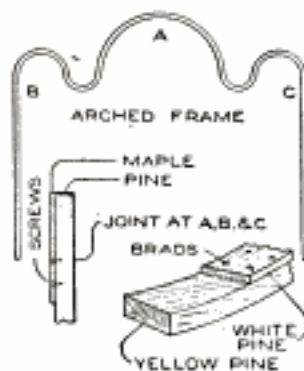

Erasing Shield Adjustable to Various Lines

The advantage of this erasing shield, which I made for my own use in the drafting room, is that it is adjustable to many shapes of lines, even in intricate drawings. It may be made of thin sheet metal, preferably aluminum, or of celluloid. The central piece is slipped through openings cut in the main portion and is prevented from falling out by a small knob, pressed into the surface at the end.—W. K. Creson, Newcastle, Ind.

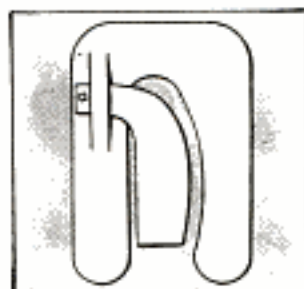

Bracing a Long Droplight Gas Fixture

On a long gas pipe, extending vertically from the ceiling, a brace was found necessary. It was provided by building up a right angle of lighter pipe and fitting it to the main pipe, so that the brace joined it about 4 ft. from the ceiling and extended vertically about 1 ft. from the main pipe. It was fastened to the ceiling with a pipe flange.—M. K. James, Chicago, Ill.

Lead Form Varies Face of Concrete Blocks

In a homemade wooden form for making concrete blocks of the hollow type, used on porch and column foundations, the faces of the blocks were varied by making the corresponding side of the form a frame with a lead panel. The form was built up in the usual way, of $\frac{7}{8}$ -in. wood. The core A was braced with angles, and the outer form B was hinged at two of the corners. The corner at which it opens was provided with catches. The lead face was made of a sheet of lead, $\frac{1}{8}$ in. thick. It was hammered into various forms, each block, or group of several blocks, being made slightly different.

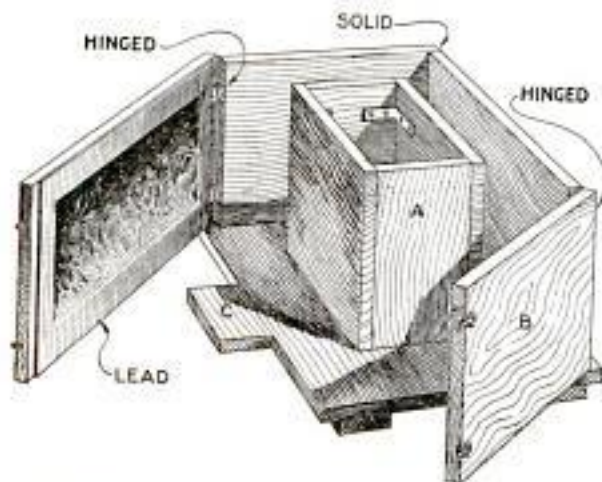

The Lead Panel is Shaped so as to Produce Various Faces on the Concrete Blocks

The cast block is set aside to dry on the base C. A block 8 by 10 by 12 in., with walls $2\frac{1}{2}$ in. thick, is suitable for porch columns.—Fred Quantmeyer, River Vale, N. J.

Nonwarping Frying Plate for Electric Stove

An electric stove was provided, when purchased, with an aluminum pan, as shown at A. The first time it was used



The Cast-Iron Hearth of a Stove Proved to Be Better than an Aluminum Pan and a Sheet-Iron Plate for Making Hot Cakes

for hot cakes it warped diagonally across the middle, as at B. This made cooking with it very slow, and to straighten it so it would not warp seemed impossible.

A piece of No. 20 gauge sheet iron was cut a little larger than the stove, and used as a plate. However, it warped, as at C. The hearth of a discarded wood cookstove was then used. The sides, as shown at D, were sawed off, leaving a cast-iron plate, $\frac{1}{8}$ in. thick. The edges were filed straight and smooth and the top smoothed as much as possible. This plate did not warp and has given satisfaction, as indicated at E.—C. F. J. Charliss, Houston, Tex.

Directions Painted on Machine Save Cleaning

The floor around the spot where a lever shear was located in a sheet-metal shop, was frequently littered with cuttings. A box was provided for them, but little used. A sign "Put Cuttings in Box," painted in white letters on the lever of the machine, furnished the necessary constant reminder. Thereafter the floor was clean, and the expense of gathering up the scrap was eliminated.

Padded Compartments in Auto for Small Equipment

Tool compartments, under the seats, in automobiles are usually of rough



A Lining in the Tool Compartment Protects the Contents and Overcomes the Annoyance of Rattling

wood or sheet-iron construction, which exposes their contents, such as curtains, top cover, inner tubes, spark plugs, electric bulbs, tools, and other equipment, to the damaging effect of jostling over the roadways. If a lining of felt, canvas, or carpet is provided, it eliminates this to some extent, and overcomes the annoying rattle of the loose parts. It is a good plan to provide separate compartments in one side for storing inner tubes and electric bulbs.

For those who carry an emergency can of gasoline or oil, a similar covering will protect the container. A convenient foot rest is provided where the emergency can is padded, and then strongly covered.

Electric Switch Controlled by Hinged Stair Tread

Electric lights in the cellar, or attic, are often left burning by accident, but

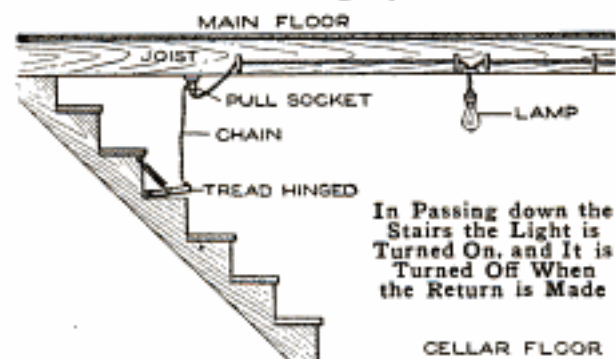

by arranging the light to be turned out automatically when a person leaves the

place, no special attention need be given to the light. In the use of such a scheme for a cellar, as shown, a pull socket was fixed to the joist above the stairway. The socket chain was adjusted carefully and fastened to the edge of a hinged tread, kept slightly raised by a spring. Pressure on the tread controls the light socket.—Albert Bourget, Lauzon, Que., Canada.

Large Grease Gun for Garage or Shop

In a shop or garage the ordinary grease gun is often inefficient, because

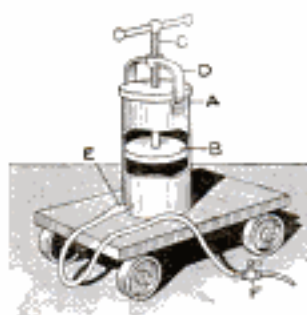

of its small capacity. A portable machine that I made holds 15 lb., sufficient for a large number of cars. The work is also done very quickly with the device, which is mounted on a truck. It was made as follows: An old engine cylinder, A, and piston, B, were fitted with a $\frac{3}{4}$ -in. rod, 14 in. long, C, threaded as shown. A handle was fixed to it, and the yoke D, threaded to engage the rod, was bolted to the cylinder. An outlet was fitted with $\frac{1}{2}$ -in. hose, E, and a valve, F, with a nozzle. The nozzle should be long enough to reach the machine parts to be greased, and is made of $\frac{1}{8}$ -in. pipe. To use the gun, fill the cylinder, screw the piston down tightly and open the valve to the feed desired.—M. R. Landin, Denver, Colo.

Care of Chamois-Skin Wash Leather

So-called chamois skin, or wash leather, should be wrung out at once after using it in water. Spread the leather out carefully, and hang it up to dry. Hot water makes it harsh. Wash the leather in soapsuds, using a good white soap, and permit some of the suds to remain in it. If properly cared for, a wash leather, used considerably, is better than a new one.

The Making of an Eye Magnet

By JOHN D. ADAMS

When one considers the number of accidents to the eye that occur in machine shops and factories from flying chips of iron and steel, it is remarkable that the eye-magnet method of extracting is not more commonly used. It is the purpose of this article, therefore, to describe the construction of a strong eye magnet that may be connected up directly, without any additional resistance, to the ordinary 110-volt alternating-current supply. The device may be made at a cost of about \$1.50 for materials.

The sketch shows the essential dimensions. A stiff paper tube is first formed by wrapping a strip of strong paper, about 18 in. long, on a round smooth rod, about $\frac{5}{8}$ in. in diameter.

The core is composed of soft-iron wires, neatly packed together and temporarily wrapped with wire near each end to hold them together. Dip the ends in soldering fluid and then in a small pot of melted solder, in which they should be held until the solder works well in among the wires. Before unwrapping, file off the ends, one to a dull point and the other quite sharp.

The temporary core upon which the tube was formed is then mounted on the bench in a pair of blocks, so that it may be turned readily with an improvised crank fastened on the end. The tube is then forced on tightly, after which the winding is begun. This preliminary work will save time, as it is impractical to wind wire by hand, and winding in a lathe is often unavailable for amateurs. Secure the end of the wire to the mandrel; about $1\frac{1}{2}$ lb. of No. 20 wire will be necessary. Wind on the first layer tightly and shellac it. In beginning the second layer pull the wire tightly, and then wind it in the hollows of the first layer. By continuing this method the ends of the coil will build up at an angle of 60 degrees.

To mount the coil, a wooden yoke should be prepared and fitted to match the curve of the coil. In the center of

this, a wooden handle, having a central hole large enough for the usual flexible cord, is fitted and glued into place. A

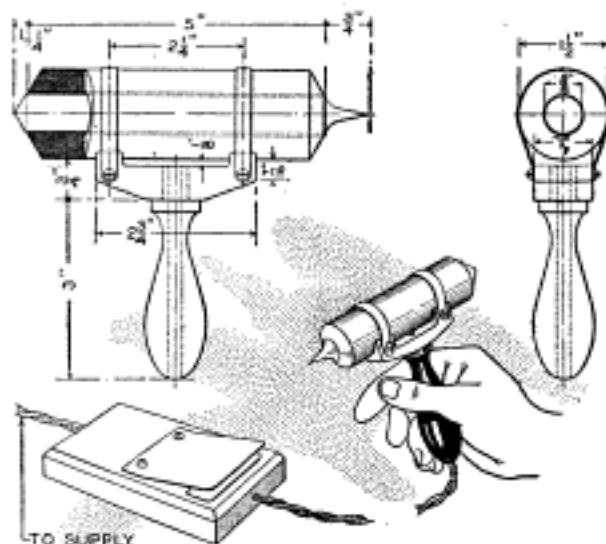

A Powerful Eye Magnet may be Made at a Cost of \$1.50 for Materials, and Is Useful in Shops Where There Is Danger from Flying Chips

pair of brass or copper bands are fitted and drilled at each end. Run the flexible cord up through the handle and connect it to the coil, soldering the two joints, after which place the bands in position and tighten the screws.

The floor switch is a block of hardwood, 1 by 3 by 4 in., hollowed out underneath. The spring is made of a wide strip of brass or heavy tin, which is screwed down at one end while the other stands about $\frac{1}{8}$ in. above the block. The lower contact is a strip of the same metal, about $\frac{1}{2}$ in. wide and screwed down directly below.

Angle Strengthens Loose Auto Fender

The connection between the fender and running board on an automobile became loose, and caused considerable racket, and in addition the fender became badly distorted. An angle of $\frac{1}{8}$ -in. sheet steel was riveted below the break. It served as a rigid connection, and was scarcely visible, also making possible the continued use of the old fender.

Compressed-Air Motor Drill Operates Windlass

In repairing a 500-ft. well, a portion of the casing was dropped to the bottom. Two men were required to turn

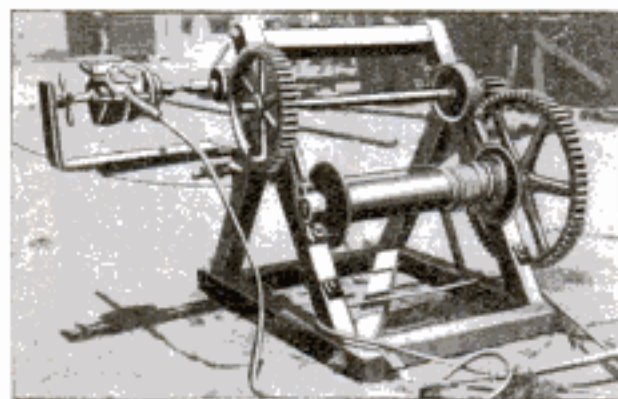

A Socket Wrench was Gripped in the Air-Motor Drill and Set on the Windlass Shaft

the crank of a windlass alternately while "fishing" operations for recovery of the section were in progress. The use of the air motor of a drill, as shown, greatly reduced the cost of labor and the time required. The air-motor drill was clamped to the windlass with U-clamps and angle irons. A socket wrench was tapered and slipped into the drill holder. The wrench was put in place over the square end of the windlass crank, operating the windlass at a moderate speed. The air motor may be used similarly for other winding or shaft-driving operations.—C. E. Eurit, Indianapolis, Ind.

Strike Board for Tamping and Crowning Roadway

A combined template and tamper, used in the laying of a one-course concrete pavement, is shown in the illustration. The street being only 37 ft. from curb to curb, the concrete was placed across the entire width as each



The Concrete was Tamped and the Pavement Crowned in One Operation by the Use of This Strike Board

batch came from the mixer. The template conformed to the 8-in. crown, and was constructed of 2 by 12-in. planks, joined to make the implement the required length. Two such sections were bolted together, and the bottom shod with $\frac{1}{8}$ by 4-in. steel. A system of trussing supports the template, and a set of plow handles is fitted at each end. This device was handled by two men throughout the entire job of 102,800 square feet.—A. C. Francis, San Diego, Calif.

Double Ventilator Hood Draws Fumes Away Quickly

If a ventilator over a stove, furnace, or for similar uses, is made with a double hood, the fumes are drawn away more quickly because of the increased draft. The hood is formed like an inverted funnel having a smaller cone of sheet metal fitted inside of it, the lower edges of both being on a level. The inner cone has a small opening at the top, and a space of about 6 in. is allowed between the outer and inner hoods. The draft through this outer ring is considerably increased.—B. J. Ryan, Buffalo, N. Y.

Sawdust Foundation Levels Floor Linoleum

Occasionally it is desired to lay linoleum on floors, that, by the warping of the boards, have acquired ridges which would be hard on the linoleum. Instead of ruining a plane, and perhaps ruffling one's temper, by attempting to plane down a painted or hardwood surface, it is better to put about $\frac{1}{2}$ in. of fine sawdust on the floor, leveling it off with a straightedge and laying the linoleum over it. The sawdust makes the floor level and adds to the resiliency of the linoleum.



A Knock-Down Tennis-Court Backstop

By EDWARD R. SMITH

SEVERE weather soon damages a tennis-court backstop that is built on posts set in the ground, and permitted to remain in place during the winter. The backstop shown in the illustration was designed to overcome this objection, and proved efficient on this score, as well as economical to build and maintain. Instead of setting the supports in the ground, they are set on the ground, and guyed by a system of wire braces. The wire netting is also held taut by wire braces, and the entire rigging is quickly taken down for storage, and easily set up when needed again. The lower edge of the wire is held down by hooks pinned to the ground with tent stakes, making it convenient to unhook the netting when the grass is to be cut around the backstop. The towers are 50 ft. apart, about 14 ft. high, and built up of 4 by 4-in. and 2 by 4-in. pieces of sound yellow-pine timber.

Foundations of brick, anchored into the ground, were made for the towers. End braces of heavy wire, fastened to the top, and guyed to the sunken

anchors at the ground, support the towers against the weight of the netting and wire rigging. This is convenient in setting up the arrangement, as a ladder can be leaned against the end of the tower, guyed securely. To withstand side motion at the top edge of the netting, the supporting wires are carried on crossarms of 1 by 1-in. pieces of wood, 2 ft. long. This rigging is suspended between the

towers and wired to the netting. When this is drawn up tightly, the netting is fairly taut. Additional supporting wires, with vertical leaders to the netting, are used to draw up the entire length of the netting tautly, as desired.

The netting extends under the towers, and is supported there by wires. As the netting extends nearly to the end guy wires, players cannot be harmed easily by running into the wires, particularly if a white flag is attached to the guy wires, about 6 ft. from the ground. Number 20 gauge wire was used for the supporting cables, and No. 9 for the end braces extending to the anchored fastenings.

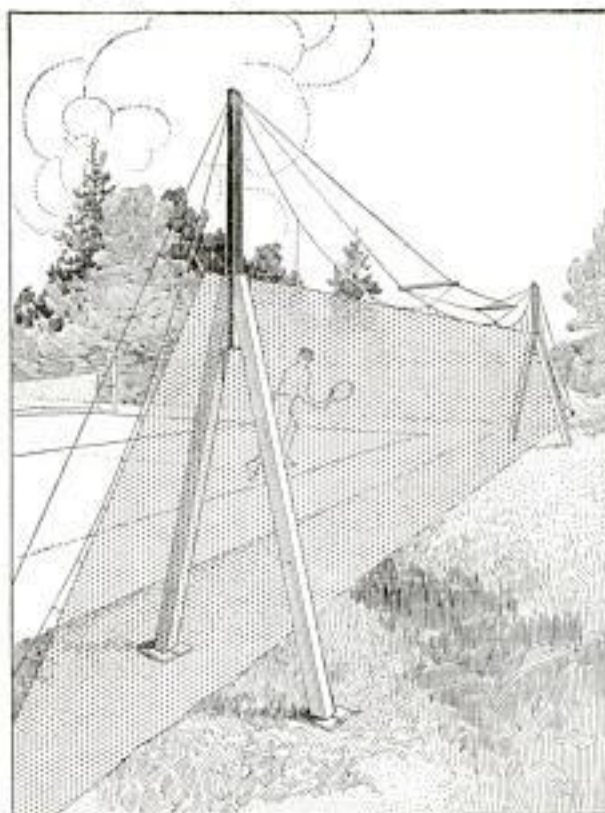

The Backstop is Taken Down between Seasons, and can be Raised Quickly by Means of the Supporting Cables

A Folding Ground Seat with Back Rest

Those who enjoy sitting or lying upon the grass while reading will find the device shown in the illustration

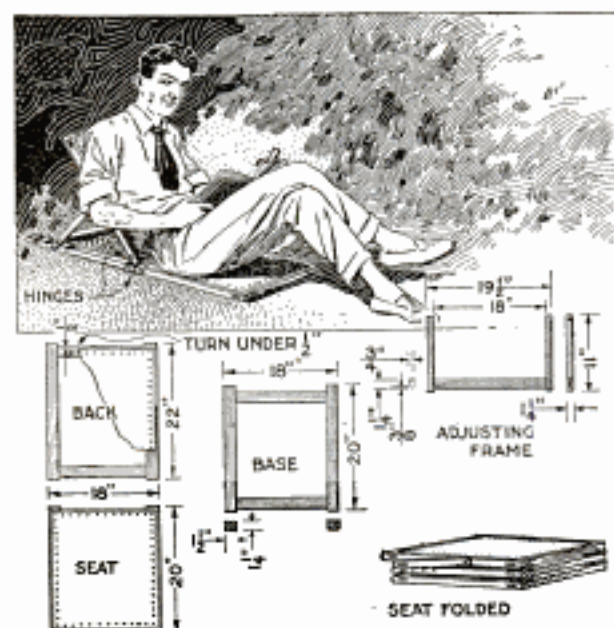

This Seat Is Useful Out of Doors and Also for Special Purposes Indoors

convenient and comfortable. With this, one may enjoy the coolness of the ground without harm to the person or clothing. The adjustable back rest supports the body in various positions. The device is light, compact, and readily transported. It is useful also in the home and elsewhere. By placing it across the bed, or on a trunk, a good substitute for an extra chair is provided. The seat proper may be folded under and the back rest used as a prop for reading in bed.

Oak is a suitable wood, and other common woods may be used. First construct, according to the dimensions given, three rectangular frames, with mortise-and-tenon joints. Cover the seat and back frames with heavy duck, turning it in $\frac{1}{2}$ in. at the edges. The base is an open frame, provided with adjusting notches, spaced 2 in. apart. Next make the adjusting frame, as detailed. Hinge the back and the seat to the base, and fasten the adjusting frame to the back with screws, permitting it to fold, as shown.—T. H. Linthicum, Annapolis, Md.

Bicycle Carried on Automobile as Tender

Steam yachts often carry a motorboat tender, and an automobile may carry a bicycle for emergencies. An autoist whose duties require him to travel through rural districts, had numerous unhappy experiences with a stalled car until he hit upon this scheme. The bicycle is strapped on the running board of the car, its handlebars turned flat against the side, and its wheels in tire sockets in the running board. A tank in the bicycle frame holds several gallons, and if the owner runs out of gasoline, he uses the tender to get a supply, filling the auto tank by siphoning the gasoline through a flexible tube.—John Miller Bonbright, Philadelphia, Pa.

Heater Keeps Developer at Proper Temperature

Having had trouble with developer cooling down and failing to work properly, while developing in the dark room, I

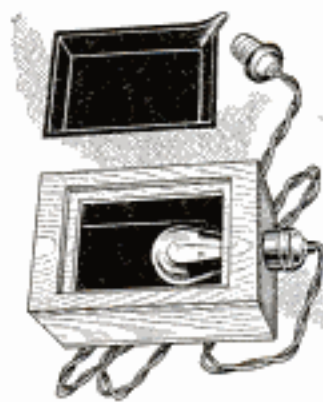

constructed the apparatus shown. A small light-tight box was made slightly larger than the tray, with a removable top having an opening to hold the tray. An electric-light socket was fastened inside at one end of the box and a lamp fitted to it. A wire was attached across the middle of the lower side of the box, so that the latter and the tray could be rocked. The box was lined with black paper and varnished black. The edges of the opening in the top were fringed with felt to guard against light leakage. A thermometer is used to determine the temperature. When the developer cools, turn on the light until it reaches the required temperature.—John Hoeck, Alameda, California.

Oars Flattened to Make Rowing Easier

When rowing a small boat, we were bothered by the turning of the oars in the locks, so that the blade of the oar was not in proper position to take the water. We overcame this by planing off slightly one side of the oar, so that when this surface was against the lock, the blade was in the correct position to catch the water. It is unnecessary to grip these oars tightly, as they fall naturally into place and save the novice a great deal of trouble. In locks where this method is undesirable, the handgrips may be cut as a guide.—H. D. Burnside, Madison, Wis.

A One-Piece Bracelet Cut from a Calling Card

A trick that will amuse and interest persons both old and young can be performed with a calling card, cigarette paper, or other similar material, cut with a scissors or knife, as indicated in the diagram. The card is shown, and the performer announces that he will pass his hand through the card, making a bracelet of it. He will, of course, be challenged, and proceeds as follows: He folds the card lengthwise and cuts through two thicknesses from 1 to 2, 3 to 4, etc.; then opens the card, and cuts from 1 to 13. By stretching the paper, as shown in the

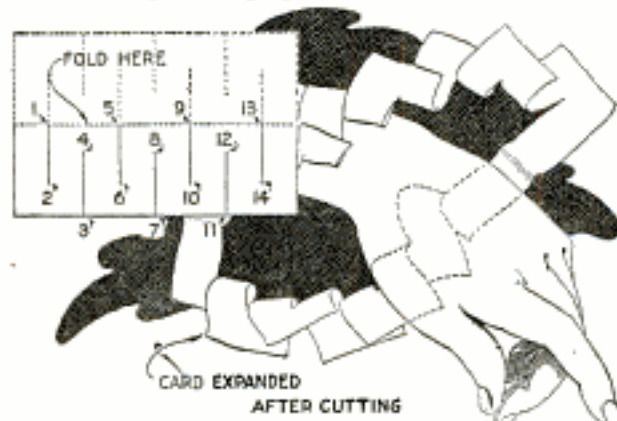

It Is Hard to Imitate a Quick and Skillful Performance of This Simple Trick

sketch, the hand may be passed through the card readily. The spectators are soon trying to duplicate the trick.—R. E. Jones, Velasco, Texas.

Device for a Finger Tug-of-War Game

Considerable pleasure and pastime was afforded by the tug-of-war game which I made. Two contestants, one

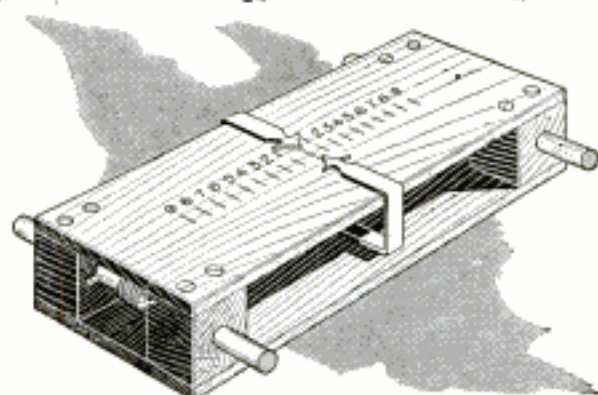
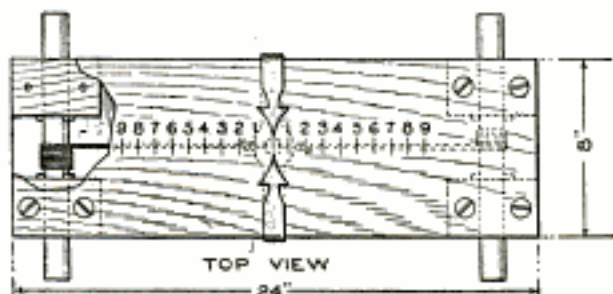

The Contestants Grasp the Rollers, One at Each End, and Attempt to Draw the Pointer Over in Their Favor

at each end, take hold of the rollers with their forefingers and thumbs and endeavor to move the pointer to their respective ends. The game interests persons of various ages, and they all want to try it.

The device should be made strongly to stand the wear on it. The top and bottom are boards, $\frac{1}{2}$ by 8 by 24 in., and four blocks, 3 in. high and $2\frac{1}{2}$ in. square, are fastened between them at the corners with screws. The rollers are set in the blocks, and held by small nails passing through them and set against the inner faces of the blocks. The pointer is made of a strip of brass, bent to the shape shown. Cords extend from the pointer inside of the box and are tied to the rollers.—James E. Noble, Kingston, Ontario, Can.

¶ In applying a white paint over a dark, or mottled, surface, tint the first coat with a little black, making it gray; then the next coat will show solid white.

Child's Swing Built of Pipes in Narrow Space

A narrow space between two city houses was used to erect a swing, as detailed in the illustration. A piece of

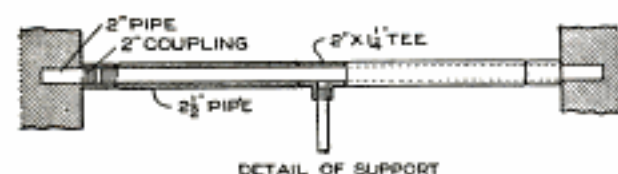
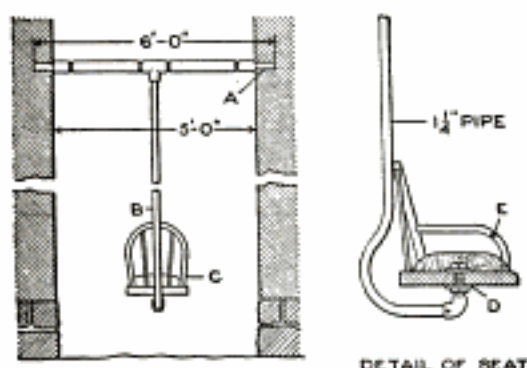

This Substantial Swing Guards the Youngsters from Injury by Brushing against the Brick Walls

2-in. iron pipe, A, was cut 1 ft. longer than the space between the walls. Two pieces of 2½-in. pipe and a 2½

by 2½ by 1¼-in. tee, as shown in the detail, was slipped over the 2-in. pipe, which was built into the walls. A 1¼-in. pipe, B, 20 ft. long, bent as shown, was joined to the tee, and a seat, C, was attached. The construction of the seat is shown in detail, being fixed to the wooden part with washers, nuts, and a threaded nipple, D. A cushion and a removable safety bar, E, were also features. This swing is safer than one of rope, and will stand much greater wear.—James N. Reed, San Francisco, Calif.

Door Bumpers Raise Height of Chair

Four wooden door bumpers, of the rubber-tipped knob type, fastened to the lower ends of the legs of one of the kitchen chairs, make an almost indispensable high chair, which will bring the table work to a more comfortable height than the ordinary chair does. The young child also will appreciate such a chair at the dining table. When it is no longer needed, the knobs can be unscrewed quickly.—J. E. McCoy, Philadelphia, Pa.

A Homemade Hawaiian Ukulele

By S. H. SAMUELS

THE one-string banjo, the cigar-box guitar, and similar vaudeville favorites are giving way to the tantalizing ukulele, and the home mechanic, to be up to date in his musical craftsmanship, must fall in line. The size of this instrument makes it especially suited to the cigar-box type of body construction, as detailed in the several



This Cigar-Box Ukulele Cost the Maker 30 Cents, and Affords Him the Pleasures of a More Expensive One

sketches and shown in the photograph reproduced. This neat ukulele was

made at a cost of 30 cents, by careful selection of materials from the shop scrap stock.

A cigar box of good-quality Spanish cedar, about 2½ by 6 by 9 in., as shown in Fig. 1, is used for the body. Remove the paper carefully, so as not to mar the surface, soaking it if necessary. Take it apart, and if the nail holes are too numerous, or broken out, trim off the edges. Fit the parts of the body together, as shown in Fig. 2, the top and bottom pieces resting against the side and end pieces, and the latter between the sides. Cut the 2½-in. hole in the top piece, as shown, 3¾ in. from the neck end. To reinforce the body make strips A, ¼ in. square, and fit them to be glued into the corners at the top and bottom. Make strips B,

$\frac{1}{4}$ by $\frac{5}{8}$ by $4\frac{1}{2}$ in., and glue them under the top and on the bottom as indicated in Fig. 2. The final assembling and gluing of these parts, using

by $\frac{3}{16}$ in. and cut grooves $\frac{1}{8}$ in. deep for them. The spacing of the frets is determined as follows, a standard practice: The distance from the metal

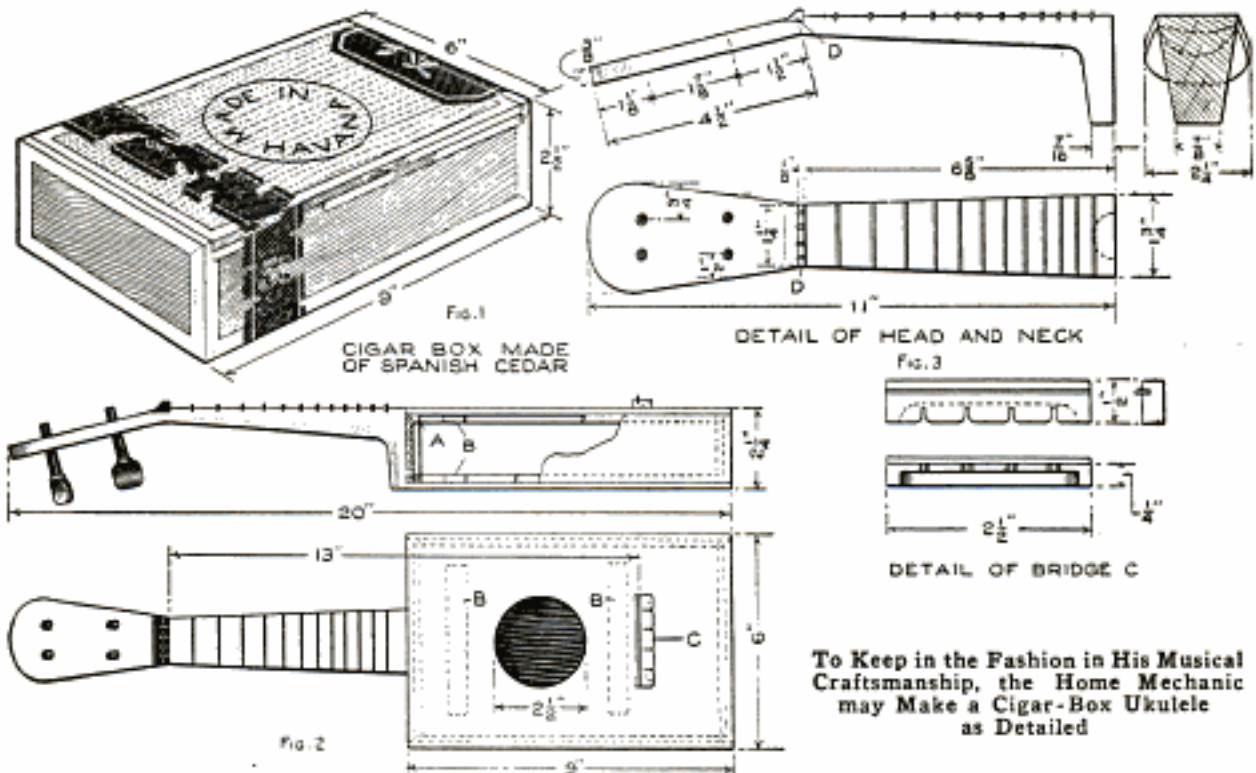

animal glue, should be done after the bridge C is in place, and the other parts are made. The bridge is of hard wood hollowed underneath the notched edge, as detailed, and is fitted with a metal string contact.

Spanish cedar or mahogany is suitable for the neck, detailed in Fig. 3. A single piece is best, but the extension for the pegs and the wider end at the body may be joined and glued to the main portion of the neck. Dowels should then be used to reinforce the joints. The outline of the parts of the neck are shown in detail in Fig. 3. In the sectional view at the right, the shape of the neck at the thinnest and thickest parts is shown by the two upper curved, dotted lines. The nut D is made of mahogany, walnut, or other hard wood, the grain extending lengthwise, and the notches for the strings spaced as shown.

The making and spacing of the frets must be done very carefully. They are of aluminum, brass and other metals being suitable also. Make the frets $\frac{1}{16}$

string-contact on the bridge to the nut should be measured carefully. The first fret, near the head, is $\frac{1}{18}$ of this distance from the nut, the total length being in this instance, 13 in. The second fret is set $\frac{1}{18}$ the distance from the first fret to the bridge; the third, $\frac{1}{18}$ from the second fret to the bridge, etc. The frets must fit tightly in the grooves, requiring no special fastening. The tuning pegs may be bought or made.

In assembling the parts, fasten the end of the body to the neck, with glue, reinforced by screws. Set its upper edge parallel with the fingerboard, and so that the latter is flush with the top of the body, when fitted to it. Assemble the body, without the top, gluing it to the end, fixed to the neck. When this portion is thoroughly dried, fit the top into place finally, and glue it. The whole construction is then cleaned, sandpapered, stained, and shellacked or varnished. The stringing of the instrument is simple, and the strings may be purchased in sets.

Homemade Suitcase Extension

A handy addition to the traveler's equipment is a suitcase extension that may be removed when not in use, and

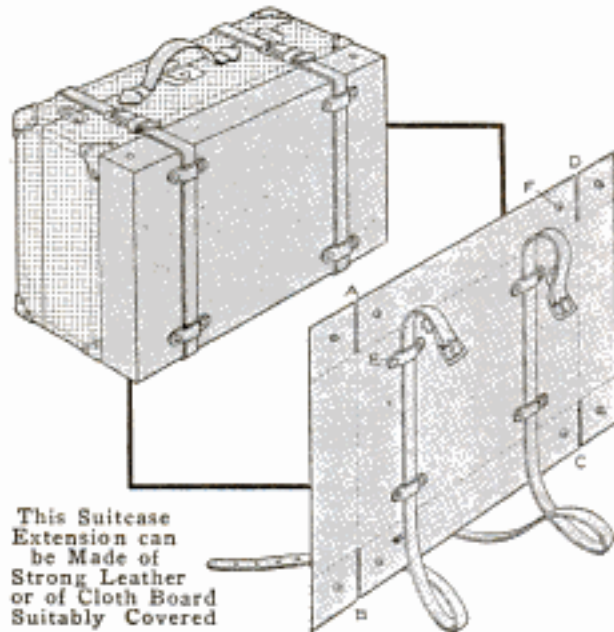

This Suitcase Extension can be Made of Strong Leather or of Cloth Board Suitably Covered

folded compactly, inside of the suitcase if desired. This latter feature is provided for by arranging the extension to be folded vertically at the middle. Heavy leather, cloth board covered with strong linen, or canvas of a suitable color may be used. If cloth board is used it should be cut the size of the side of the suitcase, and smaller sections hinged to it at the folds. The leather need not be reinforced if it is fairly strong. Cut the leather at A, B, C, and D, and arrange it to be folded on the dotted lines. Rivet guides for the straps, as at E. Fit the corners with buttons or snaps F, which are locked in position when the extension is in use. The device slides over the suitcase and may be drawn tightly against it when empty.—R. S. Matzen, Fort Collins, Colo.

Putty Deadens Glossy Surfaces in Photography

Attempts to make "close-up" photographs of machinery, or highly polished objects, often fail because the reflection of light upon the bright surfaces causes a blur in the photograph.

Some photographers use putty to deaden the gloss. A lump of putty is rubbed over the surface gently where a brilliant reflection is visible, or the entire surface is rubbed so that it presents an even, dead finish on the ground glass of the camera, when focusing.—Ralph W. Tillotson, Erie, Pennsylvania.

Coop for Sitting Hens

When several hens are to hatch out settings at the same time, considerable space can be saved and much convenience afforded by making a coop as shown in the illustration. It consists of an outer frame of boards, 1 ft. wide and 6 ft. long, or as long as desired for the runway. The frame is divided into compartments by boards extending from end to end, each compartment being for one hen. The frame is placed on level ground and staked in place. At opposite ends of each compartment is a hinged cover. The intervening space is covered with wire netting, with shelter boards placed loosely over it. Under one of the hinged covers the nest should be placed on the ground, and at the opposite end food and water are provided. Each hen has plenty of space to exer-

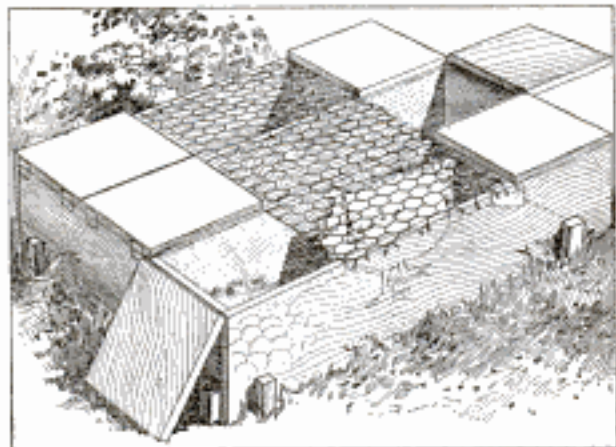

Each Hen Has a Compartment, with Plenty of Space for Exercising

cise in, and must at least get up for food and water. The individual covers permit separate examination of the eggs, or feeding of the hens.—F. W. Buerstatte, Pullman, Wash.

Smoking of Lamp Overcome by Increasing Draft

While sitting in a room around a lamp, a group of workmen discussed the probable causes for the smoking of an oil lamp. By way of experiment, holes were punched in the perforated part of the burner, increasing the draft through the glass chimney. It was then possible to turn the light up much higher, without the usual deposit of smoke. As a result of this, several other troublesome lamps were soon remedied.—J. E. McCormack, Haliburton, Ontario, Can.

place a needle in the groove so that a very small portion of the playing end

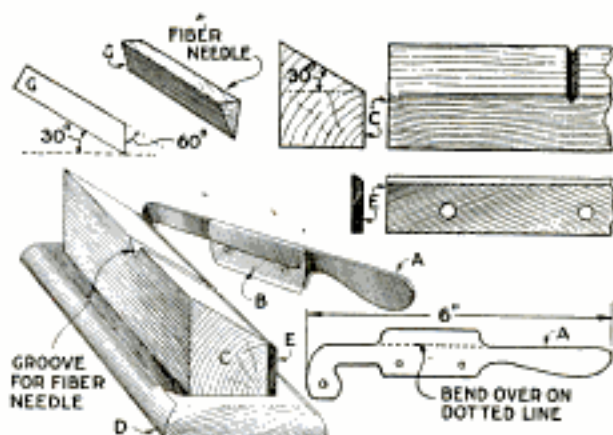

By Using This Needle-Sharpening Device the Life of Records is Prolonged

extends past the face of E, and shear off the end.—C. M. Hall, St. Louis, Missouri.

Canoe or Boat Stored in Pulley Slings

A canoe, or small boat, which is taken from the water when not in use, suffers damage if it is left unprotected in the open. A practical method of storing it so that it can be taken out quickly is to suspend it from the roof structure of a small shed, or a garage, by means of slings. The latter are made of double thicknesses of strong canvas, and are provided with rings where they join to the lower pulleys of the hoisting rope and tackle. The

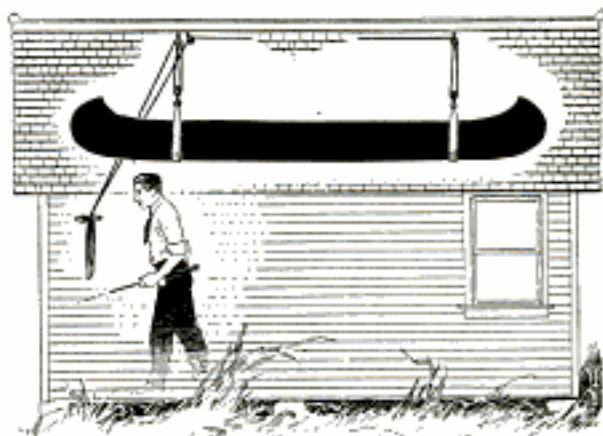

The Canoe is Stored in the Garage, and Conveniently Hoisted into the Gable

cushions, paddles, etc., may be left in the canoe.—Robert W. Jamison, Mitchell, S. D.

Device for Sharpening Fiber Phonograph Needles

A practical sharpener for fiber phonograph needles may be made as follows: A lever handle, A, is cut from heavy sheet metal. A safety-razor blade, B, is bolted to it, and the metal flap bent over as indicated. A block, C, cut so that the upper face makes an angle of 30° with the base, is faced with a metal strip, E. A triangular groove is cut or filed for the needle G. The lever is hinged, as shown, by means of a screw. A base, D, may be added. To operate the sharpener,

Clod Rake Protects Corn in Cultivating

Small corn is often injured by lumps of dirt being thrown on it when cultivating. If these are not removed the corn may grow to one side, or may lie flat on the ground. In order that I need not get off the cultivator to remove such lumps, I made a rake out of an old fork. The tines were heated and bent, as shown. An iron rod may be used for the handle, but the wooden one is light and easy to hold.



Curious Support for Call Bell

Two highly polished horns fitted into a polished wooden base and banded with silver form the support for a call bell shown in the illustration. A tapper, which rests beside the stand, was made of a deer hoof.—James M. Kane, Doylestown, Pa.



Ordinary Pen Converted into Fountain Pen

An ordinary penholder and pen point may be easily converted into a fountain pen, with the aid of a brass paper clip of the kind shown. The cap is pried off and the prongs straightened. One of the prongs is cut to suitable length, and the end bent as indicated. It is then inserted in the penholder, and adjusted to $\frac{1}{8}$ in. from the end of the pen point. The ink is

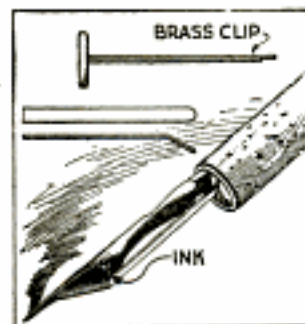

placed between the bent clip and pen point, from where it feeds evenly as needed. This kink is helpful when using the heavier drawing inks, as well as with writing inks.—R. L. Templin, Champaign, Ill.

Screwdriver Made from Buttonhook

Losing a sewing-machine screwdriver, I easily made another by cutting off the hook end of a buttonhook with a chisel. The cut end was placed upon a piece of

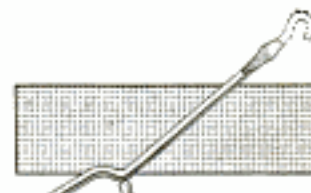

set into the ground with crosspieces, D, a secure fastening is provided. Cleats, C, with holes for lag screws, are fitted into the bottom of the chest, making it easy to remove the fastening when desired. The cleats are kept in the bottom of the chest when not in use.—K. A. Thompson, Lexington, Va.

By carefully piercing the small end of an eggshell with a large needle, a funnel for filling very small bottles is provided.

A Toy Horse That Walks

This toy, amusing for the youngsters, and their elders as well, will repay one for the making of it. Use a cigar box for the carriage, making it about 10 in. high, and shape it in the design shown. Nail a piece of wood, $\frac{1}{8}$ by 2 by 4 in. wide, on each side of the carriage, and drill $\frac{1}{8}$ -in. holes in them for the axle. For the horse, take a piece of wood, $\frac{1}{2}$ by 4 by 6 in. long, and draw an outline of the head, neck, and body. Cut this out and drill $\frac{1}{8}$ -in. holes where the legs are attached.

Cut the legs as shown, about $3\frac{1}{2}$ in. long. Attach them with small bolts, or rivets, allowing space to move freely. The wheels are made of pine, $\frac{1}{2}$ in. thick and 3 in. in diameter. The axle is made of $\frac{3}{16}$ -in. wire bent to the shape indicated, $\frac{1}{2}$ in. at each offset. Fit the wheels on the axle tightly, so as not to turn on it, the axle turning in the pieces nailed to the sides of the carriage. The horse is attached to the top of the carriage by a strip of wood. A 3-ft. wooden handle is attached to the back of carriage to guide it. Wires

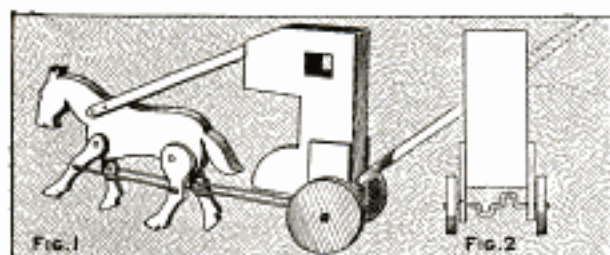

The Toy is Pushed by Means of the Handle, Causing the Horse to Walk

are attached to the legs, connecting with the offsets in the axle.—Charles Claude Wagner, Los Angeles, Calif.

Safeguarding Contents of Unsealed Envelopes

The gummed flaps on envelopes for first-class mail are generally short, and for sending photographs or second-class matter these short flaps do not stay tucked in. The solution is to lengthen the flap, by pasting on a sheet of paper, using the gum thereon.—G. N. Neary, New York, N. Y.

Revolving Outdoor Lunch Table

Picnic parties on one of the Maine lakes make much use of a large table, having a revolving top, so that the

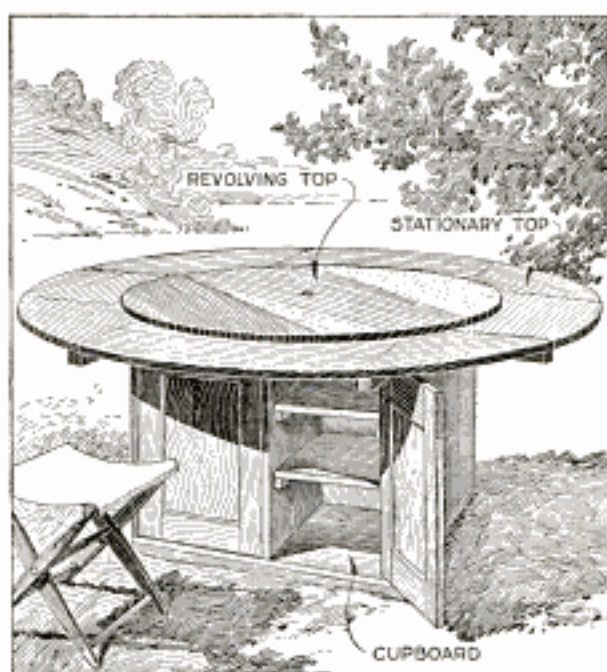

The Persons Seated around the Table Help Themselves to the Food Conveniently by Turning the Central Top

lunch may be placed on the center portion and the persons seated around the board may help themselves handily. The stationary top is supported on several cross braces of 2 by 4 in. stuff, and the revolving top, pivoted at the center, is carried on wooden roller bearings, fixed near its circumference. The lower portion of the table is in the form of cupboards which are padlocked, providing storage space for equipment left for the use of picnickers. The table is set under a pergola, which provides shade. Benches, curved to fit the table, may be used conveniently with it. A small table of this type is practical as a children's play table, providing convenient storage space for toys and other articles.—E. E. Dickson, Holyoke, Mass.

When, in papering a bathroom with the same tiled paper on sides and ceiling, the paper does not match in the ceiling corners, place a strip of quarter-round there, and color it to suit the paper.

Window Frame and Table for Dark Room

By JOSEPH LIMBRUNNER

THE amateur photographer often has a poor dark room, sometimes made worse by the use of an evil-smelling lamp. If he wishes to use a room that has daylight, he finds it difficult to convert the room quickly for his purposes, especially if he desires to make use of the daylight for his work. Under these conditions, the arrangement described in this article was devised, and proved so satisfactory that I pass it on to the host of amateurs who find satisfaction in making part of their equipment. The table and window frame in place are shown in Fig. 1. The table is removed by withdrawing the rod, and bending up the hinged legs. The frame and window covering are removed by releasing the four small hooks. Ruby, yellow, or ground glass may be inserted in the sliding frame, as required, nearly all of the light being shut out, or light admitted without a glass, by sliding the frame.

The general arrangement of the parts is shown in Fig. 2. The dimensions are suggestive only, being suited to a small window in a bathroom,

where the equipment was installed. The table is merely a board top supported by hinged legs, which are braced by a removable round wooden rod. A frame, C, as detailed in the section at A-B, Fig. 3, is fitted closely in the window casing. It is covered with heavy cardboard, tacked on. The ways J, in which the frame for the glass slides, are fixed to the lower rail of the frame C, and to a crossbar at its middle. A 5 by 7-in. opening is cut in the cardboard to admit the light, as shown in Fig. 2. Holes D are bored in the ways to receive pins which hold the frame at various positions, as indicated by the stop holes E, Fig. 4.

The sliding frame is detailed in Fig. 4. It consists of a back frame of $\frac{1}{2}$ -in. wood, sliding in the grooves of the ways J, and a frame of 1-in. stuff, mounted on the front of it. The openings may be made to suit the size of plate to be used, 5 by 7-in. openings being indicated. The openings are provided with rabbeted edges, as indicated by the width G, and the height H, in which frames of light weight, for the 5 by 7-in. glass plates, are

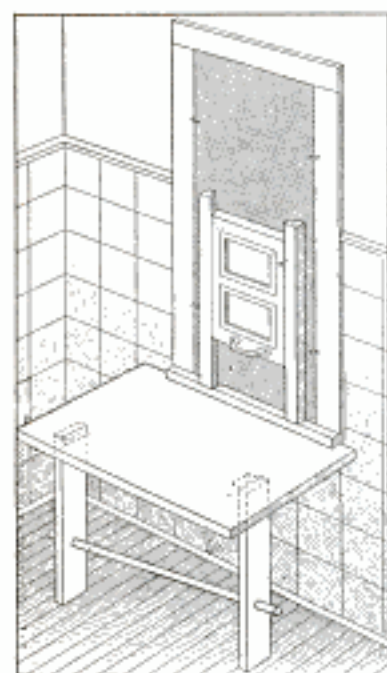

Fig. 1

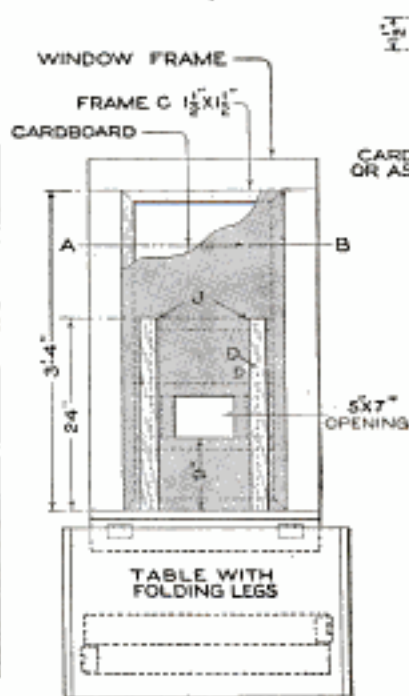

Fig. 2

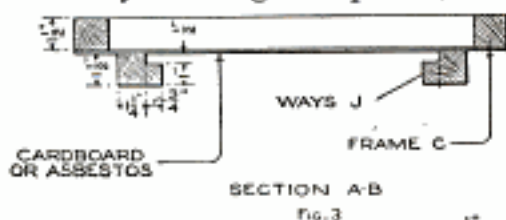
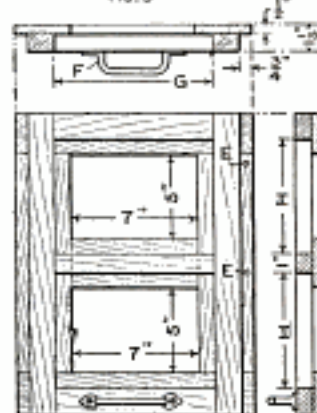

Fig. 3

DETAIL OF SLIDING FRAME
Fig. 4

With This Sliding Frame and Folding Table, the Work of the Photographic Dark Room can be Done by Daylight in the Home Bathroom

fitted. The frames may be made, or plain, cheap picture frames may be used. The sliding frame is raised and lowered by means of the handle F. The cardboard covering the larger frame should be painted a dull black, and the wooden parts may be shel-lacked in the natural color.

When developing films or plates, the frames with the red and yellow glasses should be inserted in the sliding frame, and held in place by turn buttons. The red glass will ordinarily be satisfactory for developing, but on very bright days, with the sun shining directly on the glass, a layer or two of "post-office" paper is placed over it. The yellow glass may be used when fixing, and other work requiring a subdued light, but not when developing is done. For printing, put in the yellow and the ground glasses, the latter admitting sufficient light for the purpose. To use the dark room occasionally in the evening, I set a lamp on a well-protected shelf outside of the opening in the cardboard, and proceed as in the use of daylight.

Non-Blow-Out Cigar and Pipe Lighter

"It is a poor Irishman that cannot light his pipe when the wind is blowing," but the sketch shows a device that will make a "Paddy" out of anyone, with a great saving of matches. It is made from a small piece of brass tubing, or drawn shell, $\frac{1}{2}$ in. in diameter, and about $1\frac{1}{2}$ in. long. The open end is placed in the bowl of the pipe or over the end of the cigar, a match inserted through the slot, and a quick stroke on the threaded portion ignites the match. The small holes provide air. The top is soldered in place.—James H. Rodgers, Montreal, Canada.

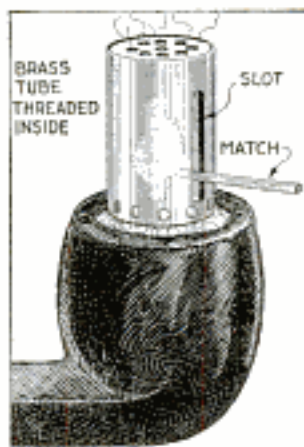

Electric Counting Glass for Thread Fabric

The intelligent housewife and shopper, as well as persons professionally interested in the structure and quality

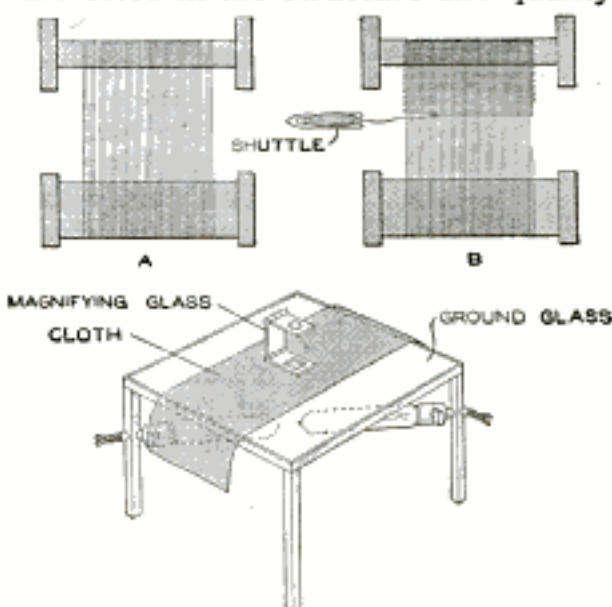

Woven Fabrics are Examined under the Magnifying Glass and the Number of Threads to the Square Inch Counted

of woven fabrics of various kinds, can make good use of a counting glass for close examination of such material. In its simplest form the device consists of a cigar box with a ground-glass top and a small electric light inside. Where larger pieces of goods are to be examined a small table with wooden legs and wooden frame for the glass may be made.

The diagrams at A and B represent the threads making up the cloth as stretched on the rollers of a loom. The lengthwise threads, or warp, are shown at A, and the cross threads, or weft, at B. By magnifying the material with a glass exposing an area of $\frac{1}{2}$ or 1 in. square, the threads may be counted or closely examined and the quality determined. This also enables one to identify goods as being the same.—F. Ball Pinkus, La Crescenta, California.

☞An inexperienced workman broke eight curved window panes on a lake steamer by attempting to cut them on the inside, instead of on the outside of the curve, in fitting the glass.

A Penny-in-the-Slot Newspaper Stand

A silent, yet very successful "newsboy" is shown in the photograph reproduced. Each rack holds one of the daily newspapers. The passer-by puts a penny in the slot and selects his paper. The penny falls down a chute, striking a bell, as evidence that the customer has paid. Hundreds of papers are sold from this rack each day without the aid of the newsboy's shouts. The slanting shelves make it unnecessary to provide weights for the papers.—M. F. Hall, St. Louis, Mo.



Pedals for Typewriter Space and Shift Keys Increase Speed

By attaching pedals to the space key and shift key I increased my typewriting speed about 20 words a minute. I made two pedals fast to the typewriter desk, as shown, then ran stiff steel wires up to the keys, connecting the latter to the wire with rubber bands. The pedals are adjusted so that a light tap operates them. If a light typewriter is used, it should be fixed to the desk. The wires can be unhooked quickly from the typewriter, and suspended on hooks under the edge of the desk.—W. J. M., Manila, P. I.

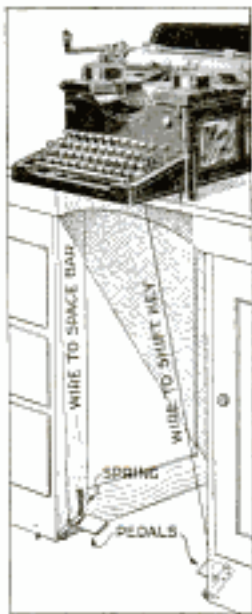

Timing Pointer on Watch Crystal

Working in a photo-print finishing plant where often several jobs need attention and accurate timing, all at the same time, I find a pointer on my watch crystal a great help. The crystal was loose enough to permit turning it. I glued a three-cornered piece of black paper to the under side of the crystal at the edge. When a batch of prints is placed in a bath, the pointer is set 15 minutes ahead of the minute hand. When the latter reaches the pointer, it reminds me to remove the prints. After placing a batch of films in the developing tank, I set the pointer ahead of the minute hand the required time for developing, placing the watch in view, to see readily when the time is up.—A. J. Viken, Waterloo, Iowa.

Portable Tent Made from an Umbrella and Paper Muslin

Picnickers desiring to go in bathing are often handicapped by the lack of a convenient place to change clothes. An umbrella and some paper muslin provides a light portable tent, that is practical and inexpensive for such uses. Cut the dark paper muslin into as many 9-ft. lengths as there are sections of the umbrella. Sew these strips together. At each seam tie a string about a yard long and a stout cord 15 ft. long to the handle to hold up the tent. For use, open the umbrella, invert it, and to each rib tie one of the strings. Then tie one end of the cord to the handle of the umbrella and suspend it from a tree or other support, as shown, weighting or tying down the other end.—Mabel Hubbard Birch, Cincinnati, Ohio.



Memorandum List for Camping and Outing Trips

Persons who occasionally take an outing or go camping will find a written list of articles needed on the trip a great saving of time and mental energy. This list should be made while making preparations, and again read shortly before the departure. It may be kept from year to year, and items added or withdrawn, as experience teaches. Classification is desirable, under heads such as camping gear, cooking utensils, tableware, foods, supplies, etc. Each member of a party can agree to furnish certain articles, avoiding duplication. Anyone who has gone on outings and left behind some much-needed article, will readily realize the help such a list can be, and by its use the amateur may profit from the experience of others.

A Homemade Trouble Lamp

By attaching a handle for carrying, and making suitable connections, a portable trouble light was made of a dry battery. A strip of iron was bent to the shape shown, for the handle, and fixed to the binding post on the carbon. A bell from an alarm clock was drilled and tapped to fit a small light bulb, and fastened at the zinc post. The upper edge of the bell was bolted to the extension of the handle, as shown, leather washers insulating it. A small switch, riveted loosely to the iron strip, controls the light.—Carl A. Haberlein, McPherson, Kan.

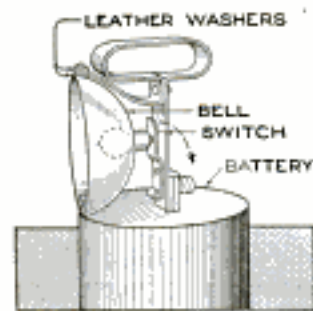

Books to be stacked or carried should be arranged with the backs on alternate sides.

Pulley and Weight Exerciser Homemade in the Orient

Finding it difficult to obtain materials for the making of a gymnastic

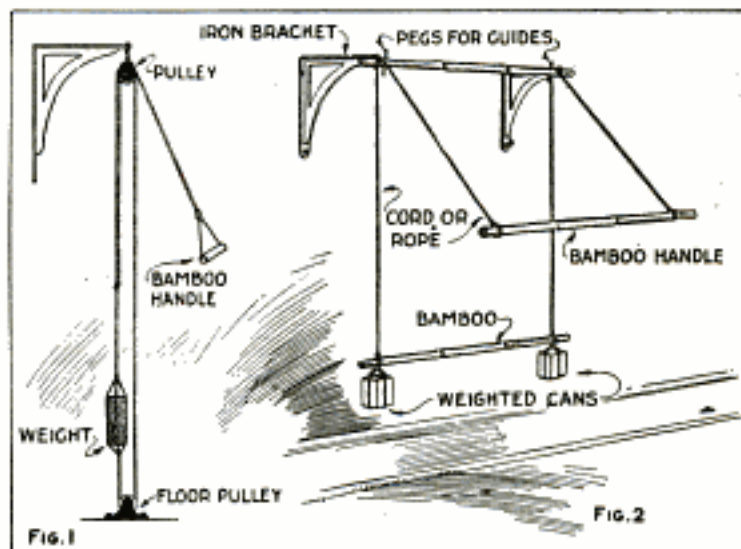

When the Necessary Hardware Was Not at Hand, a Satisfactory Rigging was Made for Exercising, by the Use of Novel Substitute Materials

exerciser, I made one with makeshift parts, typical of this locality. Later I was able to get the necessary hardware and made an exerciser, as shown in Fig. 1, quite similar to those manufactured commercially. The original arrangement is shown in Fig. 2. I mounted a bamboo rod on two iron brackets fastened to the wall. Small pegs provided guides for the ropes, and the smooth surface of the bamboo caused little wear. Other bamboo rods were used for the handle and to support the weights. These were made by filling cans with sand, and tying them with cords. This arrangement was quite practical, but did not give the desired freedom of movement.—M. A. Laner, Hongkong, China.

Scoop on Painter's Knife Catches Scrapings

By fitting a sheet-metal scoop to a painter's putty knife or wall scraper, much of the dirt and refuse resulting is caught in the receptacle instead of falling to the floor and being tracked into other rooms. The scoop is a rectangular can, and is fastened into place by small bolts fitted through the scraper.

Gas-Hose Bracket for Ironing or Shop Use

In a home where it was customary to use an overhead gas fixture for the

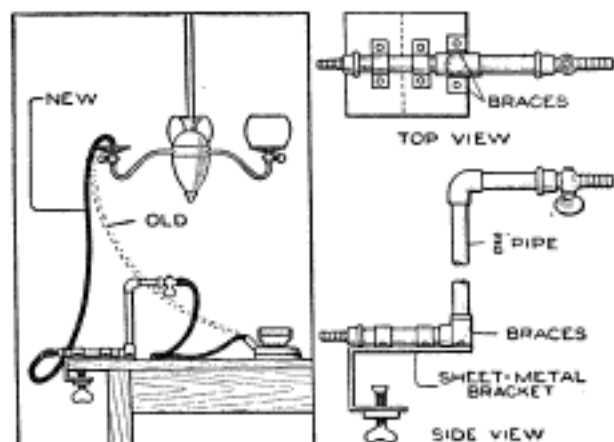

The Bracket Gives Greater Freedom in the Use of the Gas Iron

attachment of the gas iron for ironing clothes, it was found that mantles were frequently broken by the resulting jar. By making a bracket for the gas hose, which is fastened to the end of the ironing board or to the edge of the table, this trouble was remedied. The new arrangement gave much greater freedom in the use of the iron. The bracket can be removed quickly and fitted to a bench for use in the shop.—M. J. F. Schramm, Ridgewood, N. Y.

Homemade Guide for Photo and Paper Trimmer

Having an old but still serviceable photograph trimmer, with which it

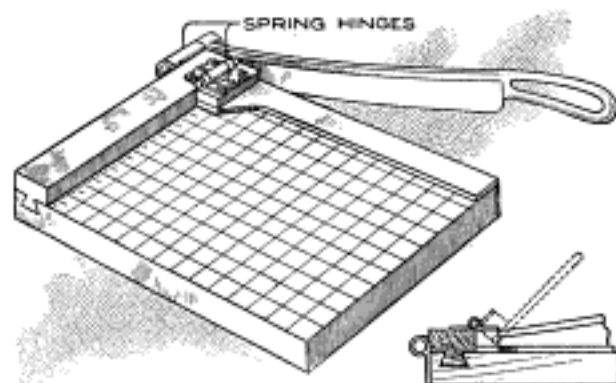

The Spring Hinge Presses the Guide Down on the Print being Cut

was difficult to trim prints uniformly and quickly, I made a guide for this purpose and fitted it to the board, as

shown. The guide is a strip of wood, $\frac{1}{4}$ in. thick, and is fastened to the cleat with a spring hinge, mounted on a block. Although it is not transparent, like the best commercial devices of this kind, it gives good service.—R. B. Manck, Nazareth, Pa.

Joining Broken Liquid Column in Thermometer

To reunite the particles of mercury or other liquid, which have become separated in a thermometer, raise it to the level of the extended arm, the bulb outward, and jolt the tube with a quick downward stroke. Repeat this, not too vigorously, until the liquid returns to its proper position.

Umbrella Used as a Clothes Drier

A clothes drier that can be carried in a purse or a vest pocket will appeal to travelers, and persons living in small quarters. An umbrella, four yards of strong wrapping twine, and several small brass rings are required. Knot the rings into the twine at intervals, measuring the distance between the rib points of the umbrella, and hook the twine to the points by the rings, as shown, providing considerable drying space for small articles. Hook the umbrella handle over a suitable support, or tie it carefully to the supporting pipe of a light fixture in the middle of the room, ready for the articles to be dried. The twine may also be wrapped around the points, but it is better to carry a line with rings attached.

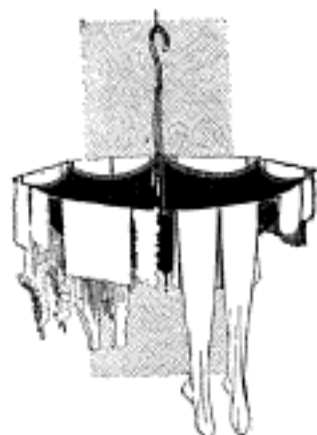

By reversing the handle on a dust brush which has been worn near the point, additional wear may be obtained.

Metal Band Stiffens Brush

In painting, and other work where a brush is used, it is often desirable to stiffen the bristles. This may be done readily by fixing a band of sheet metal over the brush, to slide tightly. By adjusting it, the length and stiffness of the part of the bristles used may be controlled.

Rubber Band Prevents Tangling of Telephone Cord

It is exasperating to pick up the telephone receiver to answer a call and find the cord twisted or wound around the telephone standard. A long receiver cord will not tangle if a rubber band is used to support it, as shown in the sketch. The elastic permits considerable play, and if the fullest extension of the cord is desired, it may be supported on several linked rubber bands, on the left of the standard.—K. M. Coggeshall, Webster Groves, Mo.



Improvised Trousers Hanger in Train Berth

The berth of a sleeping car is usually provided with a coat hanger, but if there is a rod on it for trousers, there is nothing to keep them from slipping off. By removing two of the curtain hooks, hanging the trousers over the curtain pole, and replacing the hooks over the trousers, a satisfactory hanger is obtained, which will not permit them to slip down no matter how rough the road.

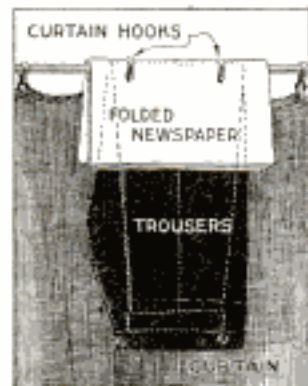

Headrest for Porch Swing

Here is a "peach" of a homemade porch swing—a shock-absorbing species. The top board is attached with

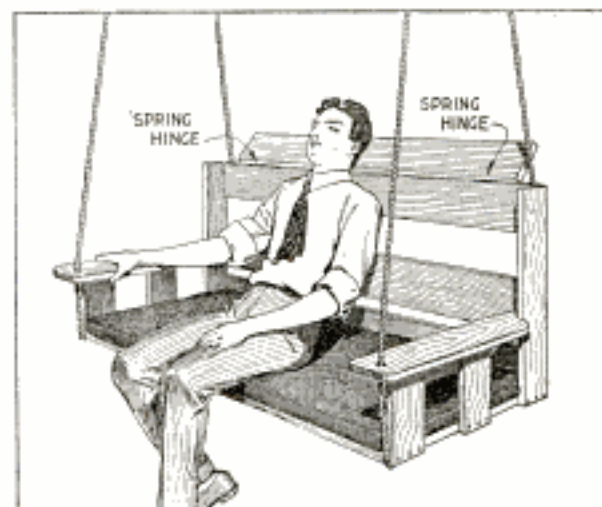

The Hinged Board Provides a Comfortable Headrest, and Is a Safety Feature

springy hinges, and affords an ideal headrest. It also tends to prevent children from climbing over the back.—H. W. Hart, St. Paul, Minn.

Fruit-Picking Pole with Gravity Delivery Chute

For picking fruit without bruising it, in the home garden, or for exhibition purposes, the fruit-picking pole shown in the sketch is useful. A wire ring is fixed to the top of the pole, and the bag, suspended from it, is fastened to the pole at intervals. The fruit is removed by means of the ring and drops to the bottom of the chute, which is held closed by the hand. For picking large quantities of fruit a receptacle is carried by the picker.—Mrs. Ella L. Lamb, Mason, Michigan.



A Set of Electric Chimes

A set of electric dinner chimes is a welcome and useful addition to many households, and may be made at a

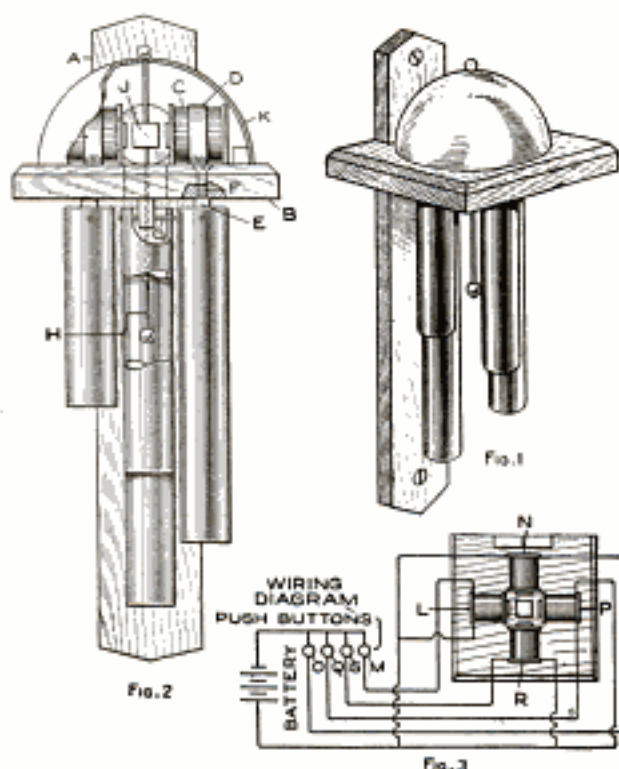

When the Buttons are Pressed, Tones are Given Forth by the Electrically Operated Gongs

trifling cost by the average person handy with tools. The completed article is shown in Fig. 1, the details in Fig. 2, and the wiring diagram in Fig. 3. The woodwork is of $\frac{1}{2}$ -in. stock. The back A, Fig. 2, is $1\frac{1}{2}$ in., by $9\frac{3}{4}$ in. long. The ends may be shaped to suit the builder's fancy. The shelf B is 4 in. square, and is fastened to the back piece $2\frac{1}{4}$ in. from the upper end. It supports the magnets C, which are made on cores, $\frac{3}{8}$ in. in diameter and $\frac{3}{4}$ in. long, with ends $\frac{1}{16}$ in. by 1 in. in diameter. The spools are wound full of No. 28 silk-covered copper magnet wire. These coils are mounted on the shelf by means of brass straps D. Four magnets are used, the forward one being omitted in Fig. 2.

The supports E, for the tubes, consist of $\frac{1}{2}$ -in. lengths of $\frac{1}{4}$ -in. square brass rod. One end of the rod is drilled and tapped for an 8-32 screw which holds the support in place.

Drill a small hole, $\frac{1}{4}$ in. from the end, for the pin G, made of steel wire. The taper H is made from a $4\frac{1}{2}$ -in. length of stiff iron wire; $1\frac{1}{4}$ in. from one end a $\frac{3}{8}$ -in. cube of iron, J, is soldered, the wire passing through it. The ends of the wire are fitted with balls as shown. A nicked gong, K, covers the four magnets. The end of the taper is passed through the hole in the gong, and the ball riveted into place.

Four $\frac{3}{4}$ -in. diameter tubes are used, respectively 3, 4, 5, and 6 in. long. When the apparatus is assembled as shown, and one of the magnets is energized, the latter will draw the iron cube J toward it, and the taper will strike one of the tubes.

To control the current supplying the magnets, four small push buttons mounted on a wooden base are used. They are wired up with the battery and coils, as shown in Fig. 3. A wire from each of the coils runs directly to one terminal of the battery, the other wire from each coil being connected to a separate push button. The other sides of the push buttons are connected to the battery. By this means any of the magnets may be energized at will, the coils and corresponding push buttons being marked L and M, etc., alphabetically.

Tabs for Turning Sheet Music Quickly

Musicians sometimes have trouble in turning over sheet music quickly.



Here is a simple way to turn the leaves quickly and easily: Paste a tab on the edge of each sheet, as shown. The first sheet is tagged at the top, the second in the middle, and the last sheet at the bottom,

like a letter file. Where there are many sheets, it is easy to grasp the upper tab, on each successive sheet.—M. W. Meier, Chicago, Ill.

A Springy Hammock Support Made of Boughs

In many camping places, balsam branches, or moss, are available for

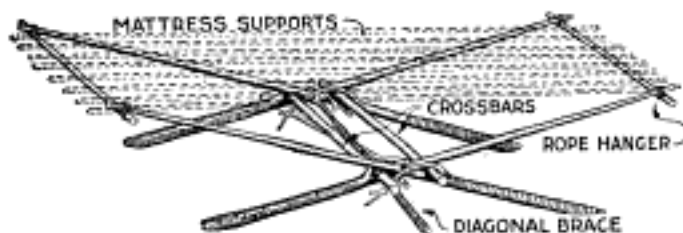

The Camp Bed can be "Knocked Down," or Transported Considerable Distances as It Stands

improvising mattresses. Used in connection with a hammock, or a bed made on the spot, such a mattress substitute provides a comfort that adds to the joys of camping. A camp hammock, or bed of this kind, is shown.

To make it, cut four 6-ft. poles, of nearly the same weight and 1 in. in diameter at the small end. These saplings should have a fork about $2\frac{1}{2}$ ft. from the lower ends, as resting places for the crossbars, as shown. Then cut two poles, 2 in. in diameter and $3\frac{1}{2}$ ft. long, and two smaller poles, 3 ft. long. Also cut two forked poles, $4\frac{1}{2}$ ft. long, for the diagonal braces. Place two of the long poles crossing

each other, as shown, 1 ft. from the ground. Set up the second pair similarly. Fix the crossbars into place, in the crotches, the ends of the crotch branches being fastened under the op-

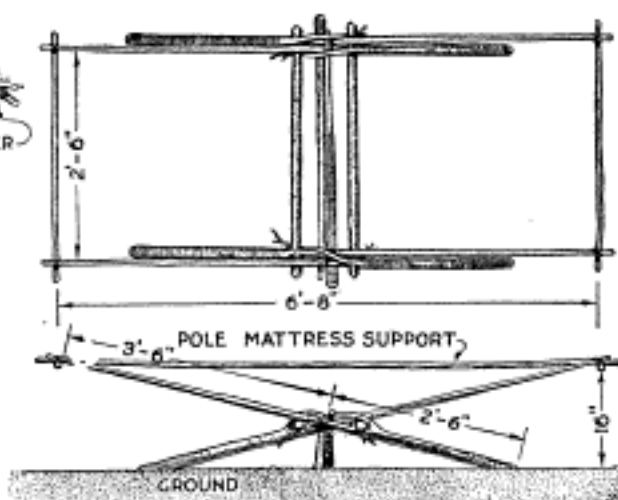

The Poles are Selected Carefully and Set Up with Stout Cross Braces at the Middle and Lighter Ones for the Mattress Support

posite crossbar. The end bars are fixed to the crossed poles by means of short rope loops. The mattress is placed on springy poles, 7 ft. long and 2 in. apart, alternating thick and thin ends. The moss is laid over the poles, and the balsam branches spread on thickly. Blankets may be used as a cover.—J. S. Zerbe, Coytesville, N. J.

A Revolving Card, or Ticket, Holder

A holder which may be ornamented and trimmed with leather or other materials,

was made of several disks of wood, joined at the center by a thumbscrew, and provided a neat place for calling cards, post cards,

etc. The block A, which fits against the wall, is $\frac{3}{8}$ in. thick and 2 in. in diameter. The disk C is $\frac{1}{4}$ by 7 in., the disk D, 6 in., and the metal disk E, 5 in. in diameter. The edge of the metal disk, which may be of ornamented or etched brass, or copper, is curled forward as shown. The thumb-

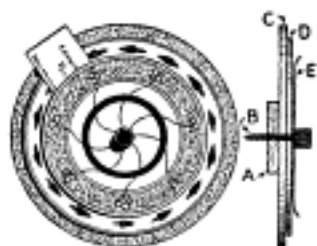

screw B holds the disks together and fastens them to the wall.—James E. Noble, Portsmouth, Ontario, Can.

Testing Direct Current Polarity with Litmus Paper

Litmus paper laid on glass, and moistened with a weak solution of sodium sulphate can be used to test the polarity of a direct current. If the two conductors are touched on the moistened paper, the latter will turn red at the positive, and blue at the negative conductor.

CA berry stemmer made of a small pair of tweezers is useful for removing superfluous buds from garden flowering plants.

Arch. P. A. Needham, 809 Investment Bldg. " " "

CHARMING HILLSIDE HOUSE FOR SMALL FAMILY

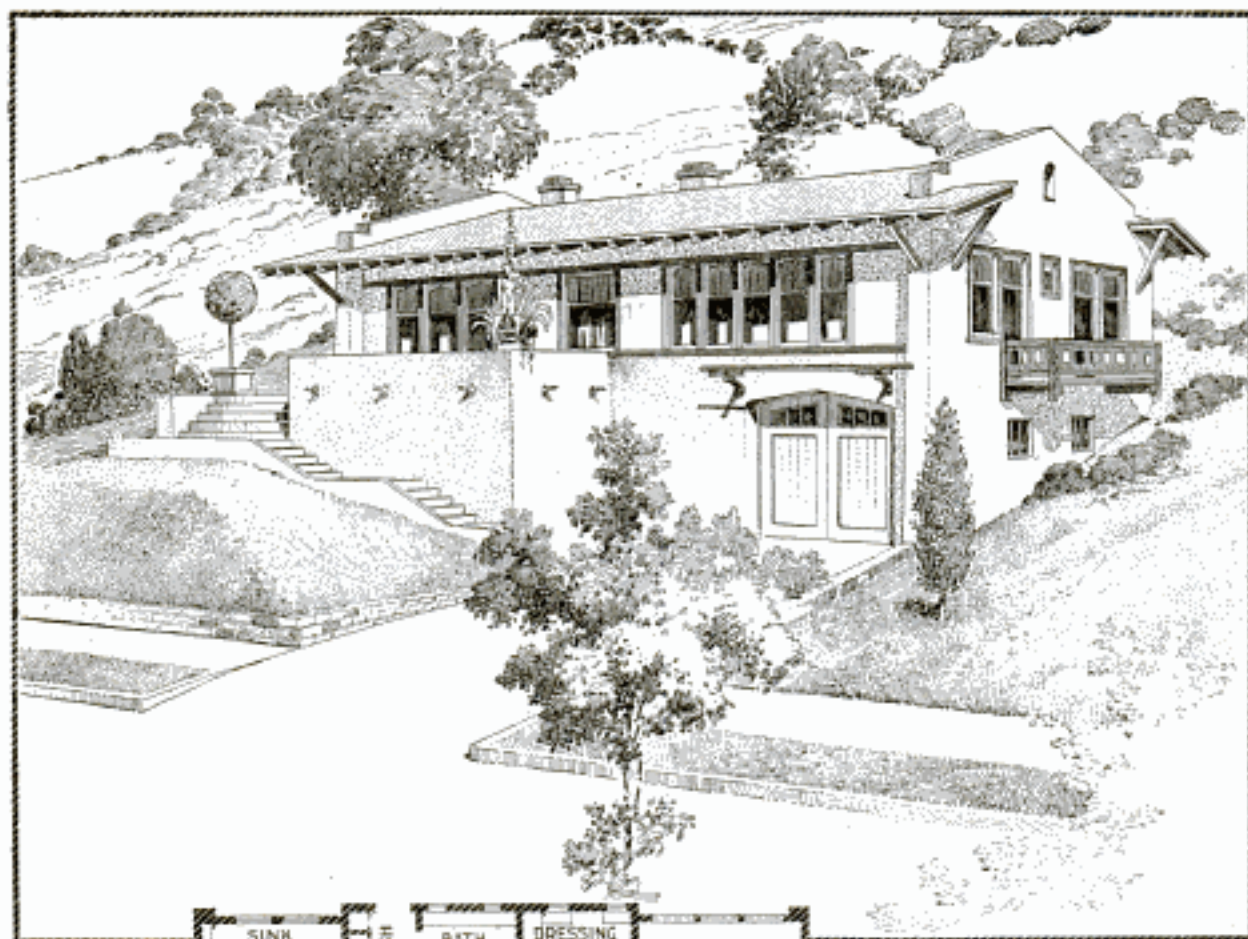

P. A. NEEDHAM, ARCHITECT

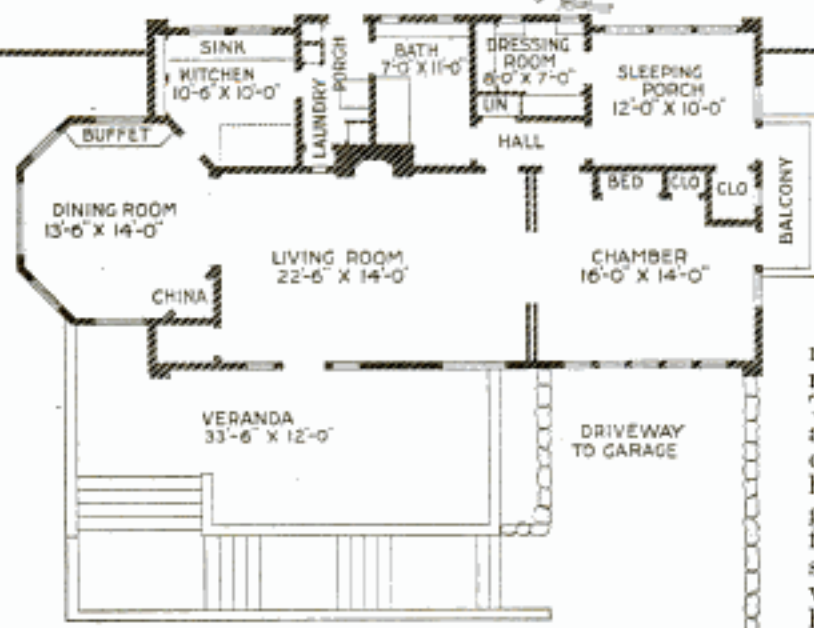

IN one of the suburbs of Los Angeles there is a little residence that will undoubtedly appeal strongly to the prospective builder who has the right kind of a site for a structure of its type. It is situated on a hillside, is of distinctive, restful architecture, and is most conveniently arranged. The house was built for \$3,500, an amount which included the cost of wiring, plumbing, and heating. The slope of the ground places the apartment floor high above the street level so that privacy is afforded without curtaining the windows heavily. One part of the basement is reserved for garage

purposes, the entrance facing the pavement and the driveway giving access to a series of steps that extend to the broad veranda above. The exterior of the dwelling is finished in cream-colored stucco and trimmed with wood stained a rich brown. There is one large bedroom, and back of it a sleeping porch with a dressing compartment of liberal size adjacent. The toilet is easily accessible from either of these rooms. The living room is of pleasing proportions and opens onto the veranda. An octagonal form is given to the dining room.

IN accordance with the editorial policy of this magazine never to accept compensation in any form for what appears in our reading pages, and also to avoid all appearance of doing so, we are obliged to omit the name of the maker or the seller of any article described. This information, however, is kept on file and will be furnished free, by addressing Bureau of Information, Popular Mechanics Magazine, Chicago. [Editor.]

Eliminate Waste in Home Building

Aladdin System Conserves Home Builders' Money

THE present rapidly increasing costs of building materials have caused prospective home builders to pause. Yet, a knowledge of the remarkable cost lowering features of the Aladdin System of Construction removes all fear of present high costs.

The Aladdin Read-Cut System reduces labor costs by about forty percent and reduces the usual eighteen percent waste in lumber to two percent. The result is a conservation of the home builders' money, a saving of time in the building of the home, and the removal of the many annoyances usually expected in the building project.

Modern power driven machines can do better work and at lower cost than hand labor. The experience of thousands of home builders in building Aladdin Read-Cut Homes during the past twelve years has proved this thoroughly.

All of the lumber in an Aladdin House is cut to exact size and shape and guaranteed to fit perfectly when erected. This work is done almost automatically by power machines in the Aladdin Mills.

Reduces Lumber Waste from 18% Down to 2%

THE material for a complete home is furnished from a single source and at a single fixed price—eliminating extras. All of the lumber, framing, sheathing, building paper, shingles, siding, porch work, outside finish, flooring, windows, doors, stairways, interior woodwork, nails, glass, paints, varnish, stains, and lath and plaster are included in one price and shipped together at one time. Delays usually experienced waiting for deliveries of material are thus done away with.

Aladdin lumber, millwork and interior finish are all of the very highest grades and highest quality to be found in the forests. All exposed lumber inside and outside is clear and free from knots.

The Aladdin Book of Homes illustrates and describes over one hundred modern homes, priced from \$100 to \$8000—bungalows, two-story dwellings of stucco, siding and shingle exteriors, summer cottages, barns, and garages. If you expect to do any building, you should certainly have a copy. Send stamps for Aladdin Book of Homes No. 180.



The Aladdin Co. 1462 Aladdin Ave.
Bay City, Michigan
Canadian Branch: Canadian Aladdin Co., Ltd., C. P. R. Building, Toronto, Ontario

How I Raised My Earnings from \$30 to \$1000 a week

*The Story of a Young Man's
Remarkable Rise, as Told by Himself*

THREE years ago I was earning \$30 per week. With a wife and two children to support it was a constant struggle to make both ends meet. We saved very little, and that only by sacrificing things we really needed. To-day my earnings average a thousand dollars weekly. I own two automobiles. My children go to private schools. I have just purchased, for cash, a \$25,000 home. I go hunting, fishing, motoring, traveling, whenever I care to, and I do less work than ever before.

What I have done, anyone can do—for I am only an average man. I have never gone to college, my education is limited, and I am not "brilliant" by any means. I personally know at least a hundred men who are better business men than I, who are better educated, who are better informed on hundreds of subjects, and who have much better ideas than I ever had. Yet not one of them approaches my earnings. I mention this merely to show that earning capacity is not governed by the extent of a man's education and to convince my readers that there is only *one* reason for my success—a reason I will give herein.

One day, a few years ago, I began to "take stock" of myself. I found that, like most other men, I had energy, ambition, determination. Yet in spite of these assets, for some reason or other I drifted along without getting anywhere. My lack of education bothered me, and I had thought seriously of making further sacrifices in order to better equip myself to earn more. Then I read somewhere that but *few millionaires* ever went to college. Edison, Rockefeller, Hill, Schwab, Carnegie—not one of them had any more schooling than I had.

One day something happened that woke me up to what was wrong with me. It was necessary for me to make a decision on a matter which was of no great consequence. I knew in my heart what was the right thing to do, but something held me back. I said one thing, then another, I decided

one way, then another. I couldn't for the life of me make the decision I knew was right.

I lay awake most of that night thinking about the matter—not because it was of any great importance in itself, but because I was beginning to discover myself. Along towards dawn I resolved to try an experiment. I decided to cultivate my will power, believing that if I did this I would not hesitate about making decisions—that when I had an idea I would have sufficient confidence in myself to put it "over"—that I would not be "afraid" of myself or of things or of others. I felt that if I could smash my ideas across I would soon make my presence felt. I knew that heretofore I had always begged for success—had always stood, hat in hand, depending on others to "give" me the things I desired. In short, I was controlled by the will of others. Henceforth, I determined to have a strong will of my own—to *demand and command what I wanted*.

But how shall I begin? What shall I do first? It was easy enough for me to determine to do things—I had "determined" many times before. But this was a question of will power, and I made up my mind that the first step was to muster up enough of my own will power to stick to and carry out my determination.

With this new purpose in mind I applied myself to finding out something more about will power. I was sure that other men must have studied the subject, and the result of their experience would doubtless be of great value to me in understanding the workings of my own will. So, with a directness of purpose that I had scarcely known before, I began my search.

The results at first were discouraging. While a good deal had been written about the memory and other faculties of the brain, I could find nothing that offered any help to me in acquiring the new power that I had hoped might be possible.

But a little later in my investigation I encountered the works of Prof. Frank Channing

Please Mention Popular Mechanics

Haddock. To my amazement and delight I discovered that this eminent scientist whose name ranks with James, Bergson and Royce, had just completed the most thorough and constructive study of will power ever made. I was astonished to read his statement, "The will is just as susceptible of development as the muscles of the body"! My question was answered! Eagerly I read further—how Dr. Haddock had devoted twenty years to this study—how he had so completely mastered it that he was actually able to set down the very exercises by which anyone could develop the will, making it a bigger, stronger force each day, simply through an easy, progressive course of Training.

It is almost needless to say that I at once began to practice the exercises formulated by Dr. Haddock. And I need not recount the extraordinary results that I obtained almost from the first day. I have already indicated the success that my developed power of will has made for me.

But it may be thought that my case is exceptional. Let me again assure you that I am but an average man, with no super-developed powers, save that of my will. And to further prove my contention, let me cite one or two instances I have since come across, which seem to show conclusively that an indomitable will can be developed by anyone.

One case that comes to my mind is that of a young man who worked in a big factory. He was bright and willing, but seemed to get nowhere. Finally he took up the study of will training, at the suggestion of Mr. W. M. Taylor, the noted efficiency expert and in less than a year his salary was increased 800%. Then there is the case of C. D. Van Vechten, General Agent of the Northwestern Life Insurance Company, Cedar Rapids, Iowa. Just a short time after receiving the methods in will development suggested by Prof. Haddock, he felt that they would be worth from \$3,000 to \$30,000 to him.

Another man, Mr. H. D. Ferguson, residing in Hot Springs, Ark., increased his earnings from \$40 a week to \$90 a week in a remarkably short space of time after he began the study of will training. These are but a few—there are many other equally amazing examples which I personally know about. And aside from the financial gain, this training has enabled thousands to overcome drink and other vices almost overnight—

has helped overcome sickness and nervousness, has transformed unhappy, envious, discontented people into dominating personalities filled with the joy of living.

Prof. Haddock's lessons, rules and exercises in will training have recently been compiled and published in book form by the Pelton Publishing Co., of Meriden, Conn. Mr. Pelton has authorized me to say that any reader who cares to examine the book may do so without sending any money in advance. In other words, if after a week's reading you do not feel that this book is worth \$3, the sum asked, return it and you will owe nothing. When you receive your copy for examination I suggest that you first read the articles on: the law of great thinking; how to develop analytical power; how to perfectly concentrate on any subject; how to guard against errors in thought; how to drive from the mind unwelcome thoughts; how to develop fearlessness; how to use the mind in sickness; how to acquire a dominating personality.

Some few doubters will scoff at the idea of will power being the fountainhead of wealth, position and everything we are striving for, and some may say that no mere book can teach the development of the will. But the great mass of intelligent men and women will at least investigate for themselves by sending for the book at the publisher's risk. I am sure that any book that has done for me—and for thousands of others—what "Power of Will" has done—is well worth investigating. It is interesting to note that among the 150,000 owners who have read, used and praised "Power of Will," are such prominent men as Supreme Court Justice Parker; Wu Ting Fang, Ex-U. S. Chinese Ambassador; Lieut.-Gov. McKelvie, of Nebraska; Assistant Postmaster-General Britt; General Manager Christeson, of Wells-Fargo Express Co.; E. St. Elmo Lewis; Governor Arthur Capper, of Kansas, and thousands of others.

As a first step in will training, I would suggest immediate action in this matter before you. It is not even necessary to write a letter. Use the form below, if you prefer, addressing it to the Pelton Publishing Company, 13-K Wilcox Block, Meriden, Conn., and the book will come by return mail. This one act may mean the turning point of your life, as it has meant to me and to so many others.

PFLTON PUBLISHING COMPANY

13-K Wilcox Block, Meriden, Conn.

I will examine a copy of "Power of Will" at your risk. I agree to remit \$3 or return the book in 5 days.

Name..... Address.....

City..... State.....

Please Mention Popular Mechanics

BLUE

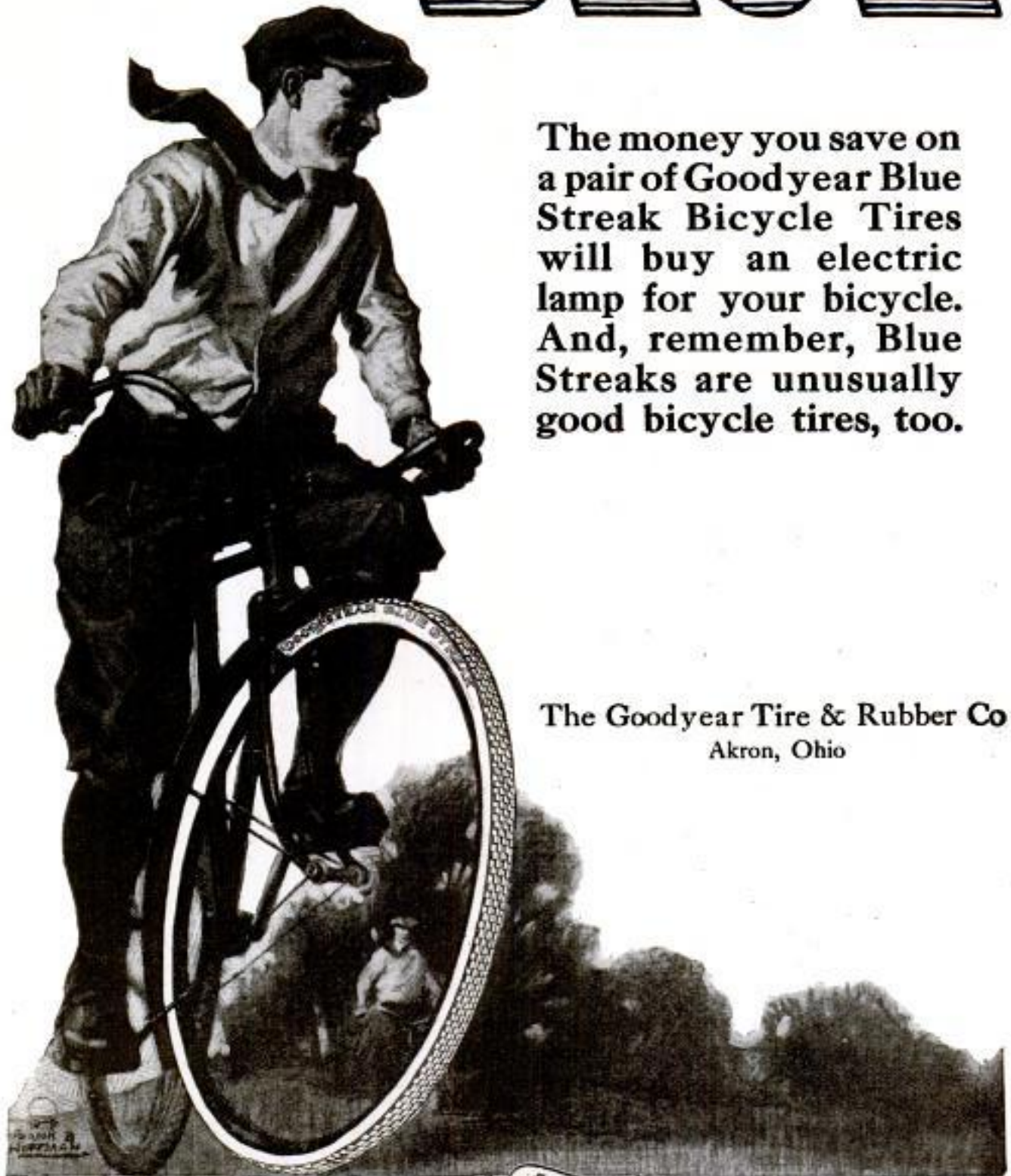

The money you save on a pair of Goodyear Blue Streak Bicycle Tires will buy an electric lamp for your bicycle. And, remember, Blue Streaks are unusually good bicycle tires, too.

The Goodyear Tire & Rubber Co
Akron, Ohio

GOODYEAR
AKRON

Please Mention Popular Mechanics

STREAKS

TRADE MARK REG. U. S. PAT. OFF.

WHY PAY MORE?

Many good bicycle tires sell for as high as \$5.00 each. But Goodyear Blue Streaks cost you only \$3.25 each, even in these days of high material costs.

So you may save as much as \$3.50 per pair by buying Goodyear Blue Streaks. And remember, in Blue Streaks you are getting wonderful tire quality and value. That's what Goodyear's square deal bicycle tire policy means to the bicycle rider.

HOW THEY DO IT

Goodyear is able to make these big savings for you, *first*, by cutting out the extra profits which you pay on other tires. Goodyear sells *direct* to the dealer in your town and eliminates needless profits between the factory and you.

Second, Goodyear makes only one bicycle tire—the Blue Streak. By making only one tire we cut down factory costs. That's doing one thing at a time and doing it well. These savings come to you in a tire just that much better.

YOU'LL BE PROUD OF BLUE STREAKS

Goodyear Blue Streak Bicycle Tires are tires you will be proud to have on your wheel. They are handsome, durable, rugged, strong, skid-proof and easy-riding.

Goodyear Blue Streaks have tough, rugged treads with two reinforcing strips of fine fabric under the tread. This makes them long-wearing and trouble-free. The stout, two-ply tire body is laid in lively rubber, which makes the tire quick and elastic and, therefore, easy to pedal.

Blue Streaks have superior non-skid advantages. The tread is made of blocks of rugged rubber which come together and bite the ground to prevent side-slipping.

MAKE THESE SAVINGS YOURSELF

Ride around to the Goodyear dealer in your town. If you can't find him, write to us. You have a right to make these savings yourself. The money will come in very handy when prices of everything are so high. And it will please Dad. You can prove to him you're a good business man.

So look for the Blue Streaks on the tire. Be sure you get Goodyears. Then see how much better your bicycle will look. And how much easier riding it will be.



GOODYEAR
AKRON

Please Mention Popular Mechanics

These Men
Are
Making
Big
Money

So Can You!

Haywood Tire & Equipment Co.,
Indianapolis, Ind.

Gentlemen: Our vulcanizing business is becoming better and better all the time. Keep four men going. Saturday is our big day, but Friday I cleared between \$50 and \$75. The Vulcanizing game is a good one for a fellow to follow at the beginning of his business career.
Yours truly, SHEELY TIRE COMPANY,
Marshalltown, Ia.

Haywood Tire & Equipment Co.,
Indianapolis, Ind.

Gentlemen: The Plant arrived here the 18th of May. On the 22nd had it in operation. Work is piling in daily. Have one man employed: expect to put on another this week. **The Haywood system is the only kind for car owners out here now.** Every job has an unconditional guarantee. The possibilities here are great.
Yours truly, THOS. E. SCHOENFELDER,
Stratfield, Mass.

Haywood Tire & Equipment Co.,
Indianapolis, Ind.

Gentlemen: I am piled up with work and just can't begin to handle it, although I am working night and day to keep up.
Yours truly, MR. R. A. OLBRIAM,
Centralia, Ill.



Tire Repairing Revolutionized

Motorists to Save Millions in Tire Expense

A new scientific method of Tire Repairing has been originated—the only Scientific Tire Repair Service known. It strikes a new chord in tire economy. It is done on a standard of efficiency. It saves tires—increases mileage. It lasts. It has required years of experience to develop it. Practical tests have proven it. Its excellence and superiority is acknowledged—accepted by those who know, as a **Triumph**.



Mail
This
Coupon
Today

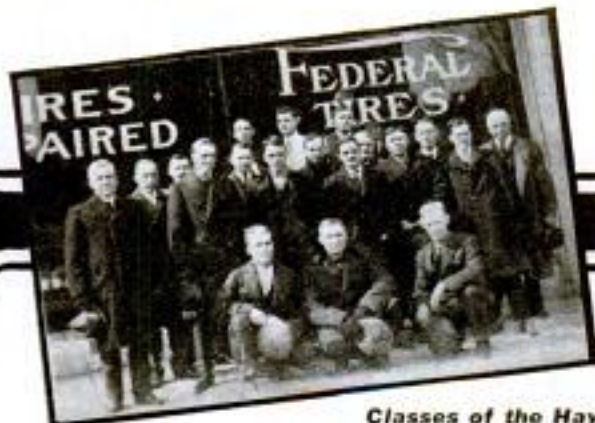

Classes of the Haywood

Please Mention Popular Mechanics

Copyrighted material

EXCEPTIONAL MEN! WANTED

30,000,000
Tires
to Repair!

Haywood Stations are to be established at once throughout the country. We want capable, energetic, ambitious men in charge of each—men who are dependable—competent. You can have this opportunity—share in the Haywood success—become a link in a mammoth chain of a country-wide, thoroughly efficient Tire Repair Service.

Make \$3,000 a Year or Better You Own Your Own Business—Keep Your Own Profits

Haywood equipment is sold outright. We teach you Haywood Scientific Tire Repairing in our Laboratory especially equipped for this purpose. Here you learn all about tires—the inner mechanism of construction—how to repair scientifically every

tire injury. This training is thorough—practical, and equips you to give Haywood Service of the standard we advertise nationally and are so careful to maintain—the Service that saves motorists millions of dollars in tire up-keep.

A Wonderful Opportunity! The coupon below—your name and address, brings full particulars. How to start, How to tie up with the Haywood Service. We'll give inside facts and figures about costs and profits. Explain in detail our co-operative plans which mean your Success. Write today without fail. Learn how you can start at once.

Haywood Tire & Equipment Co., 1160 N. Capitol Ave., Indianapolis, Ind.



Tire Repairing Laboratories

Opportunity Coupon

Haywood Tire & Equipment Co.
1160 N. Capitol Ave., Indianapolis, Ind.

GENTLEMEN: Please send full particulars of your Scientific Tire Repair Service and details of your co-operative plans.

Name

Address

Please Mention Popular Mechanics

Give Your Feet a Vacation This Summer

Every day is vacation day for feet incased in stylish, comfortable Keds. They are durable and modish for office wear, smart and dressy for vacation and week-end trips and easy and comfortable for after-hours recreation. Women and children love to wear them around the home, in the park, everywhere.

Keds

mean pleasing comfort for all the family. The new styles are many and varied, but in all there are the same smart, attractive features—tops of soft, flexible canvas, springy rubber soles, high or low rubber heels. Give every member of your family

a pair of Keds. They'll wear longer than any shoe at anything like the price. The reputation of the largest rubber manufacturer in the world is back of every pair of Keds. Ask to see the three leading grades at your dealer's.

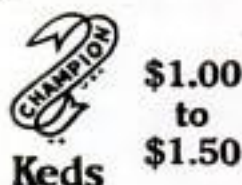
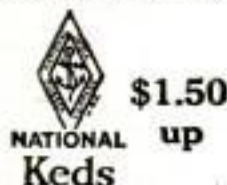

United States Rubber Company

New York

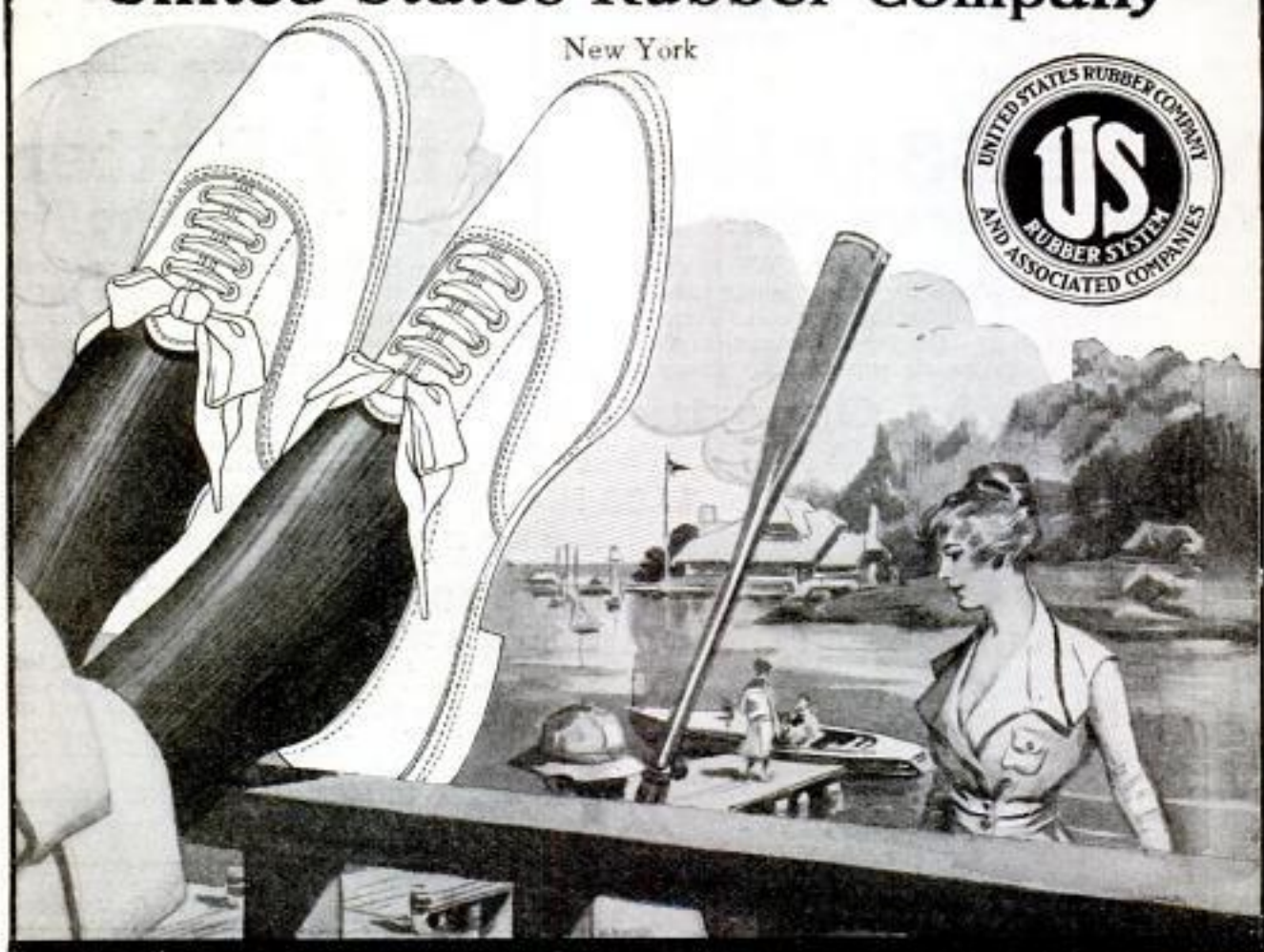

Please Mention Popular Mechanics

Copyrighted material

*Bridge across the Hillsboro
River—Tampa, Florida*

What Goodyears Are Built to Do

The best thing an automobile tire can do for its user is to deliver him extreme mileage and exempt him from ordinary troubles.

That is precisely the service to which Goodyear Tires are built.

The various Goodyear features—the On-Air cure, the No-Hook bead, the Rubber-Rivet construction, the Braided Piano-Wire base, the All-Weather tread and the like—are pointed directly to this end.

The effort of Goodyear workmen, the goodness of Goodyear materials, the methods of Goodyear manufacture are focused in the same direction.

How well these factors combine to the results desired, may be seen in the service being delivered by Goodyear Tires everywhere, every day.

How far this service surpasses that ordinarily given, may be seen in the fact that more Goodyear Tires are sold in America than any other brand.

Goodyear Tires, Heavy Tourist Tubes and "Tire Saver" Accessories are easy to get from Goodyear Service Station Dealers everywhere.

The Goodyear Tire & Rubber Co., Akron, O.



GOODYEAR
AKRON

Please Mention Popular Mechanics

Gillette



The Armies of the World Use the Gillette Safety Razor

WAR is the great test of any article of utility. The soldier's kit is reduced to actual necessities.

You can't imagine a soldier carrying 'round a strop and hone.

The official Army Regulations of all Countries now call for a clean shave.

And beyond all question the Gillette is the Razor of the Great War—of all the Armies, on all Fronts.

Gillette Razors and Blades have gone abroad in a continuous stream of shipments from this Country by thousands, by hundreds of thousands and by millions!

If You Live in Canada—write the Gillette Safety Razor Company of Canada, Ltd., 73 St. Alexander St., Montreal, for Canadian Catalogue and Prices.

Milady Décolleté is the dainty little Gillette used by the well-groomed woman to keep the underarm white and smooth.

One recent shipment was 80,000 Razors and 600,000 dozen Blades.

They've gone by Atlantic Passenger Steamers—by Freight—by International Parcels Post. By first-class registered mail and they've gone as personal baggage with passengers.

They've gone by Pacific Steamers to Japan and through Manchuria, then via the Trans-Siberian Railway to Russia.

Isn't there a lesson in this for every man in America who has not yet adopted the Gillette?

There are thousands of young men just coming to shaving age. The Gillette will help them to form good habits—the saving of small sums that count up to big ones—the habit of getting started on time—of doing a thing perfectly in the quickest way with the fewest motions.



Write for the New Gillette Catalogue. See the thirty styles of Gillette Safety Razors, \$5 to \$50. *Gillette dealers everywhere.*

GILLETTE SAFETY RAZOR COMPANY
BOSTON, U. S. A.

NO STROPPING

NO HONING



Copyright U.S.A. 1917 by
The B.V.D. Company

*American Institutions
—Baseball and B.V.D.*

JUST as Baseball is the great American Game, so B.V.D. is the great American Underwear. It is made to fit the American climate, the American figure and the American idea of personal efficiency through cool comfort.

In our own modernly equipped cotton mills at Lexington, N.C., the fabric from which these Loose-Fitting B.V.D. undergarments are made, is produced in a scientific manner from selected cotton to insure durability in wash and wear.

In our own B.V.D. Factories the garments are skilfully cut, strongly stitched, accurately finished —to fit and be cool and comfortable all day long.

*If it hasn't
this Red
Woven Label*

MADE FOR THE

B.V.D.

BEST RETAIL TRADE

(Trade Mark Reg. U. S. Pat. Off. and Design Copyright)

*It isn't
B.V.D.
Underwear*

B.V.D. Coat Cut Undershirts
and Knee Length Drawers,
50c. the Garment. B.V.D.
Closed Crotch Union Suits
(Pat. U.S.A.) \$1.00 the Suit.

Copyright U.S.A. 1917 by
The B.V.D. Company

Copyright U.S.A. 1917 by
The B.V.D. Company

THE B.V.D. COMPANY, N.Y.

Please Mention Popular Mechanics

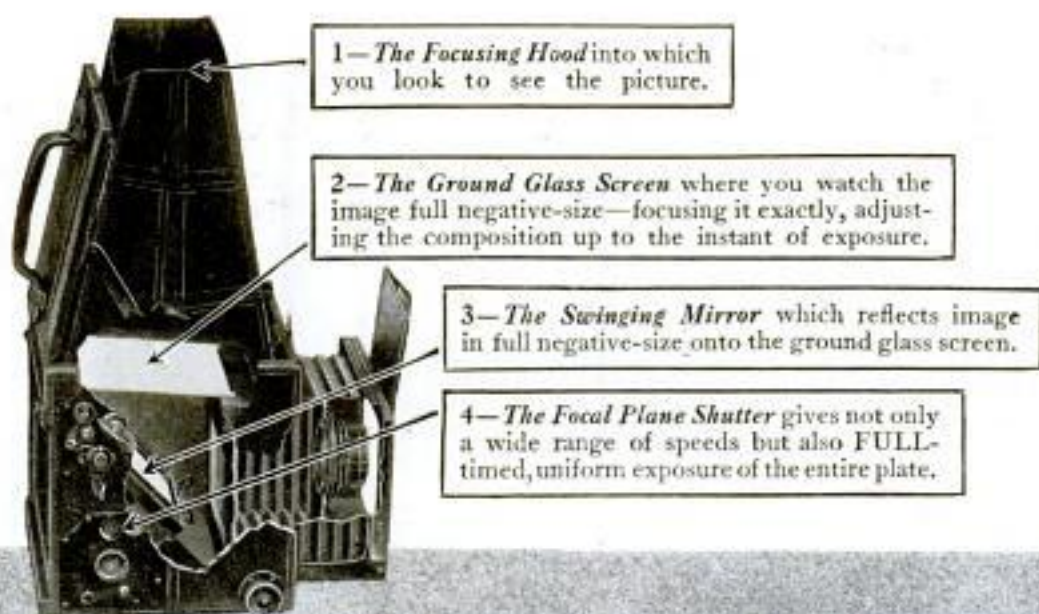

GRAFLEX Camera



HOW your lens is enabled to work at its highest speed and efficiency—how your film or plate is *uniformly* exposed, and receives the greatest volume of light during the *entire* exposure—and how the GRAFLEX makes you sure of GOOD pictures even on dull and cloudy days, is explained on pages 3 to 6 of the 64-page GRAFLEX Catalog. Ask us, or your dealer, for a Free copy.

**FOLMER & SCHWING
DEPARTMENT**

Eastman Kodak Company
Rochester, N. Y.



Please Mention Popular Mechanics

Williams'

PAT. EN. TED

Holder Top Shaving Stick



Three other forms of Williams' Shaving Soap

When you multiply the daily shave by 365 you realize what the rich, moist, abundant, soothing lather of Williams' Shaving Soap means to you in a year's time. Add to this wonderful Williams' lather the convenience of the Holder Top and you increase the importance of getting Williams'. Anything below the standard of Williams', though it be but a *shade* below, might matter little if used once or twice, but the shave is the daily duty of a lifetime. Ask for it by its full name—Williams' Holder Top Shaving Stick.

Williams' Shaving Soap comes in several convenient forms

Stick, Powder, Cream, Liquid
and in round Cakes

Send 12c in stamps for a trial size of the four forms shown here. Then decide which you prefer or send 4c in stamps for any one.

The J. B. Williams Co.
Dept. A, Glastonbury, Conn.

Add the finishing touch to your shave with Williams' luxurious Talc Powder



Liquid

Powder

Cream



Williams'
Holder
Top
Shaving
Stick

Please Mention Popular Mechanics

Oxy-Acetylene Welding and Cutting

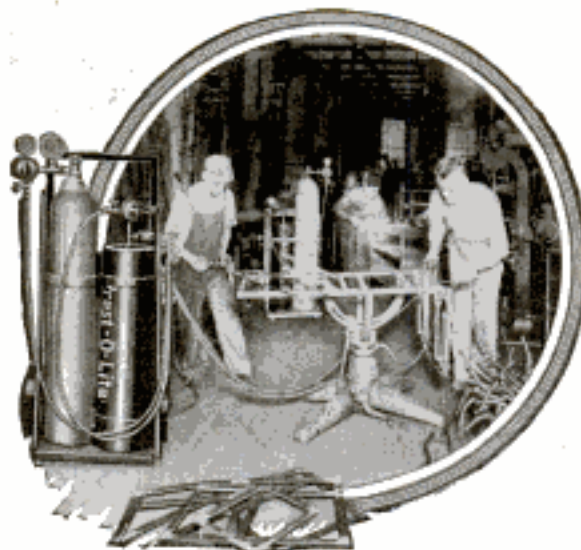

Prest-O-Lite Oxy-acetylene Process is used in the manufacture of hospital furniture by the Max Wocher Co., of Cincinnati.

Makes better, neater metal furniture at lower cost

TODAY the leading makers of all kinds of metal furniture—for offices, hospitals, homes and laboratories—employ oxy-acetylene welding instead of bolts and rivets.

By this welding process the finished product is made better, neater and stronger. Production is simplified, and other striking economies are obtained.

Oxy-acetylene welding is used as a production process by thousands of American industries—wherever two pieces of metal are to be joined it offers decided advantages.

Many factories have even made radical changes in the design of their products to reap the economies of oxy-acetylene welding and increase efficiency in manufacturing methods. In the manufacture of metal products of any kind, no matter what process you now employ, oxy-acetylene welding merits your careful investigation.

Prest-O-Lite **PROCESS**

Employs both gases (acetylene and oxygen) in portable cylinders. Prest-O-Lite Dissolved Acetylene (ready-made carbide gas) is backed by Prest-O-Lite Service, which insures prompt exchange of full cylinders for empty ones. Provides dry, purified gas, insuring better welds, quicker work, and lower cost, and also avoids the large initial outlay and heavy depreciation incurred in making crude acetylene in a carbide generator.

Necessary equipment is not expensive. We furnish high-grade welding apparatus for \$75 (Canada \$100); acetylene service at additional cost. Adaptable for oxy-acetylene cutting by the addition of special cutting blow-pipe. Thorough instructions are furnished free to every user of Prest-O-Lite Dissolved Acetylene—any average workman who understands metals can learn the process quickly and easily.

Our illustrated literature fully describes the oxy-acetylene welding and cutting process and shows hundreds of profitable applications. Write for it today.

Big profits for repair shops in job welding

Repair shops and service garages are making big profits and saving money for their customers by using oxy-acetylene welding to make broken or worn metal parts good as new. These profits you can realize. The cost of necessary equipment is low. The big growing demand for job welding insures continuous profits. Write today and get full details.

The Prest-O-Lite Co., Inc. U. S. Main Office Factory, 816 Speedway, Indianapolis
Canadian General Office, Dept. U. Toronto, Ontario

55 Branches and Charging Plants in Principal Industrial Centers



World's Largest Makers of Dissolved Acetylene

FAIR LIST PRICES

FAIR TREATMENT

GOODRICH SILVERTOWN

Cord TIRES

**Patrician in Look
Yeoman in Service**

THOUGH you make sure of
Silvertown Cord Tires
by their Red-Double-Diamond
trade mark, you can always
pick them by their *Patrician*
look—their generous
yet symmetrical
extra-size



Ten Silvertown Cord X-cels

1. Increased engine power.
2. Smoother riding.
3. Fuel saving.
4. Speedier.
5. Coast farther.
6. Start quicker.
7. Easier to guide.
8. Give greater mileage.
9. More resistive against puncture.
10. Repaired easily and permanently.

You *can not afford* to be without their *smarter appearance, smoother riding COMFORT and ultimate ECONOMY.*

Where You See This Sign
Goodrich Tires are Stocked



Ask Your Dealer for Them

The B.F. Goodrich Rubber Company,
Akron, Ohio.

*Also Maker of the Famous Fabric Tire
Goodrich Black Safety Tread*

SILVERTOWNS MAKE ALL CARS HIGH GRADE

Please Mention Popular Mechanics

Boys! Here's the Bug! Get It!

LAST month we asked you if you wanted a beautiful green-gold scarf-pin free. We also told you to watch for the answer here this month, 'member? Well, the answer is: Send in your full name and address, and the name and address of a bicycle dealer near you, to us and we will give you full instructions where to go to get this lovely stick-pin free. No boy who loves bicycling will want to be without one.

WRITE TODAY

United States Tire Company
1791 Broadway NEW YORK

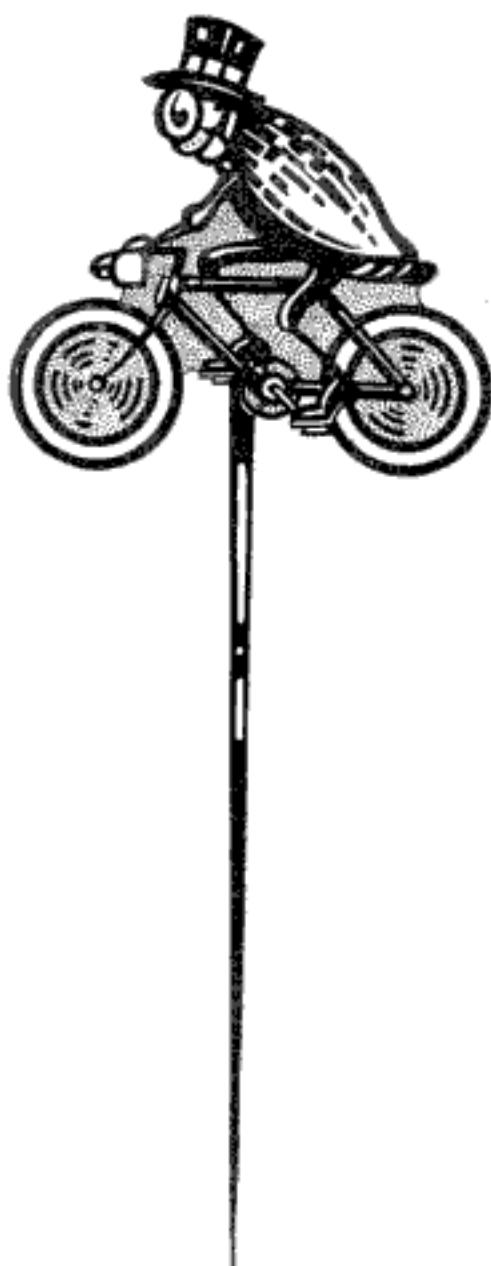

MAZDA

"Not the name of a thing, but the mark of a service"

As the turbines draw from Niagara the energy that sets the motors whirling—so MAZDA Service draws from the flood of new thoughts in lighting, the ideas that help the lamp-makers make better lamps.

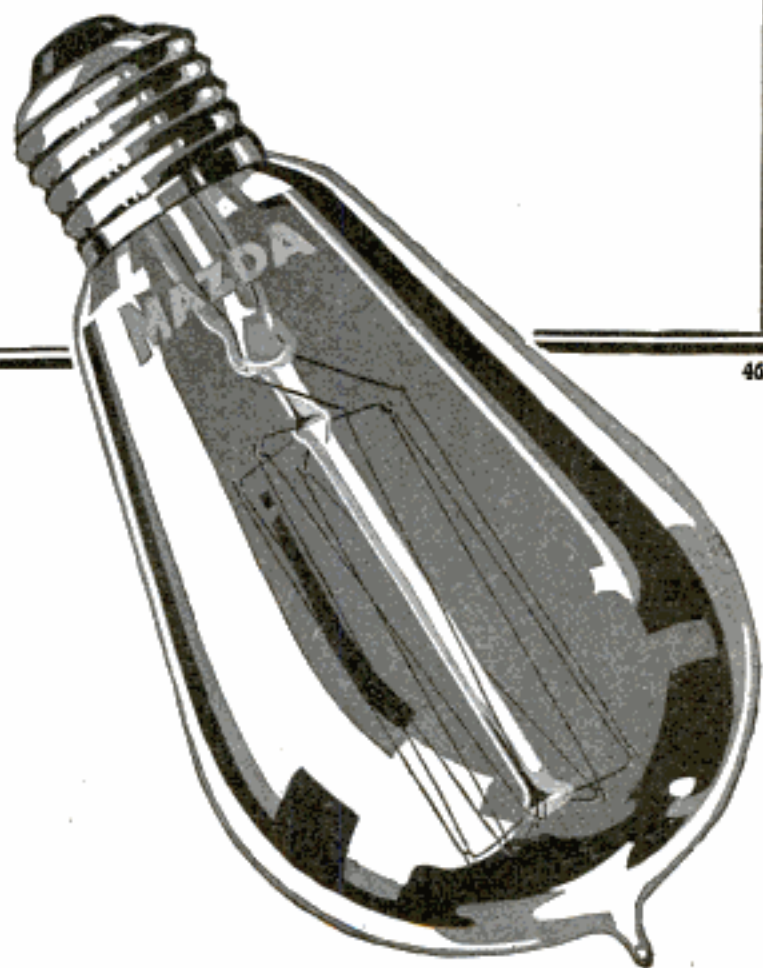

4637

—The Meaning of MAZDA—

MAZDA is the trademark of a world-wide service to certain lamp manufacturers. Its purpose is to collect and select scientific and practical information concerning progress and developments in the art of incandescent lamp manufacturing and to distribute this information to the companies entitled to receive this Service. MAZDA Service is centered in the Research Laboratories of the General Electric Company at Schenectady, New York. The mark MAZDA can appear only on lamps which meet the standards of MAZDA Service. It is thus an assurance of quality. This trademark is the property of the General Electric Company.



RESEARCH LABORATORIES OF
THE GENERAL ELECTRIC COMPANY

Please Mention Popular Mechanics



DODGE BROTHERS CLOSED CAR

The varied uses to which the convertible sedan may be put make an especial appeal to women

For shopping, for touring, for social functions — it is always ready the whole year 'round

Touring Car or Roadster, \$835. In Canada, \$1185
Winter Touring Car or Roadster, \$1000. In Canada, \$1420
Sedan or Coupe, \$1265. In Canada, \$1800
All prices f. o. b. Detroit

DODGE BROTHERS, DETROIT

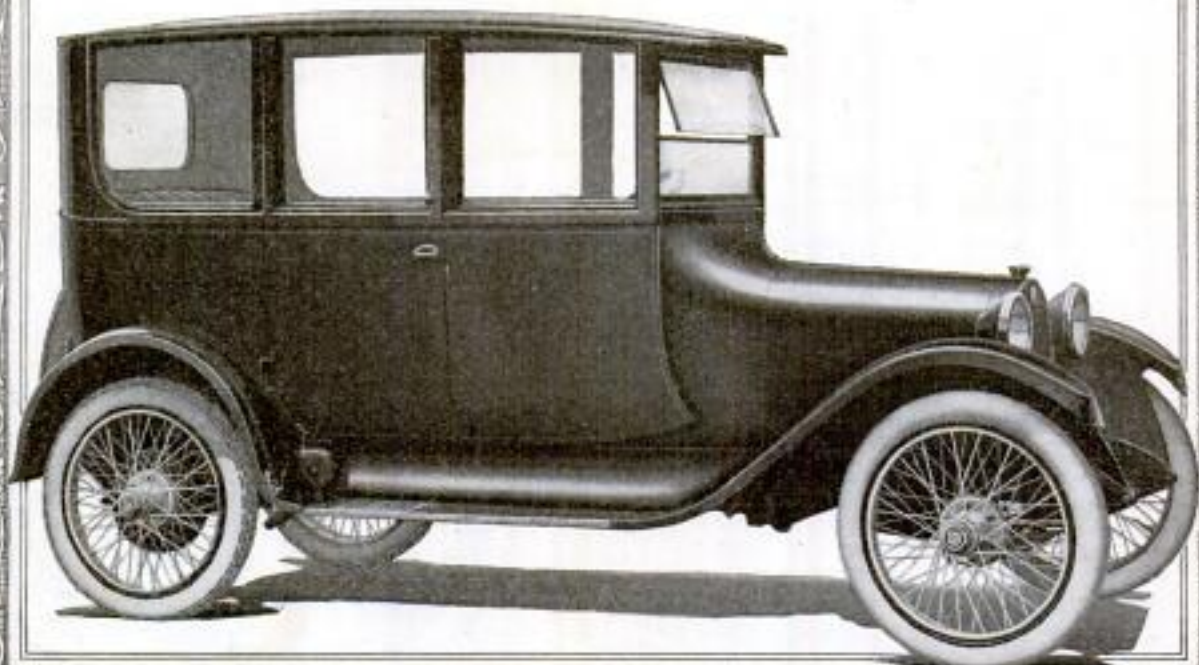

Please Mention Popular Mechanics

South Bend

*The Watch with the
Purple Ribbon*

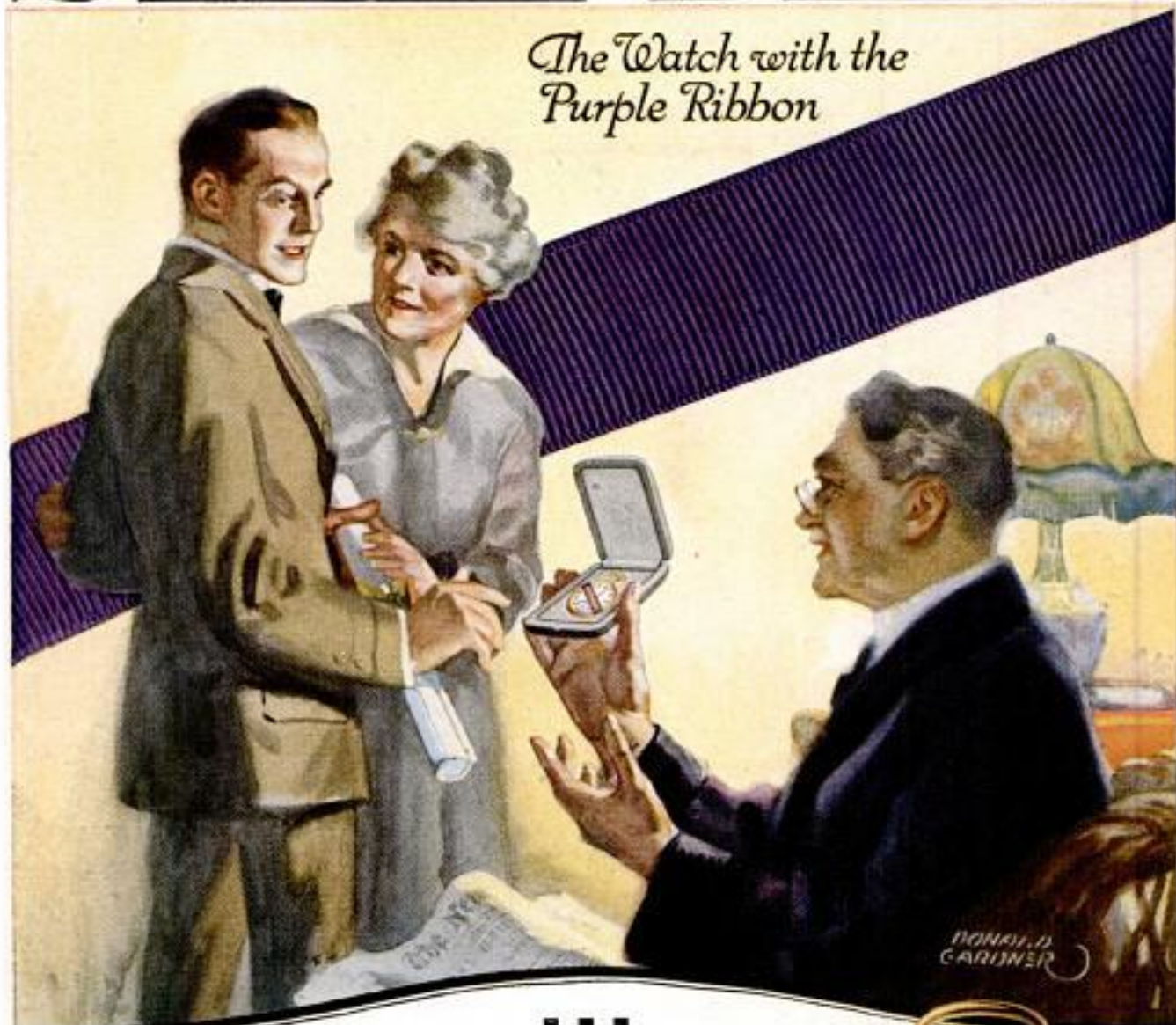

At Graduation Time

Surprise and delight him with a South Bend Watch. He will prize it instantly for its trim, stylish beauty, and will always treasure its unfailing accuracy.

Throughout his lifetime it will serve him faithfully and be a constant reminder of the taste and regard of the giver.

Made in many stylish models for men and women, at from \$16 to \$125. The new 19-jewel watch at \$28.75 gives you

SOUTH BEND WATCH COMPANY, 26 Studebaker St., South Bend, Ind.

value you cannot duplicate in other makes without paying a higher price.

At your jeweler's; distinguished by the South Bend Purple Ribbon of Quality. Send for our interesting booklet.

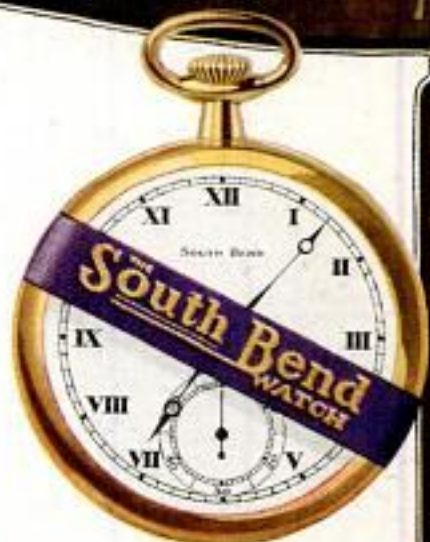

Please Mention Popular Mechanics



Where a slip means ruin!

Big hoists that lift a hundred-ton load with ease and precision are controlled by brakes that must not slip, crush or burn. The motorist, too, knows that a safe brake band is the best protection to his life and his car. And both the giant hoist and the motor-car have brakes lined with

JOHNS-MANVILLE

Asbestos

Resistant to heat,

water, wear and weather



To many fields, in many forms, this wonderful substance brings safety—roofings that resist fire and time, and wrappings for electric wires—theatre curtains and flame-proof clothing. Fashioned from natural

COVERS
THE CONTINENT

rock, J-M Asbestos today serves man in countless homes and industries. The list of J-M Products below is but an outline, but it tells the story. Asbestos in useful form—this is Johns-Manville's achievement.

H. W. JOHNS-MANVILLE COMPANY

New York City

Branches in 54 Large Cities

Asbestos Fabrics, Packings, Roofings, Shingles, Brake Linings, Building Materials, Electrical Devices, Heat Insulations, Refractory Cements, Waterproofing.

The Motor Car



The Farm



The Home



Industry



Power Plants



Transportation



Roofings



**When you think of Asbestos you think of
Johns-Manville**

Please Mention Popular Mechanics

SAXON ROADSTER

A CAR COMPLETELY EQUIPPED WITH EVERY MODERN FEATURE

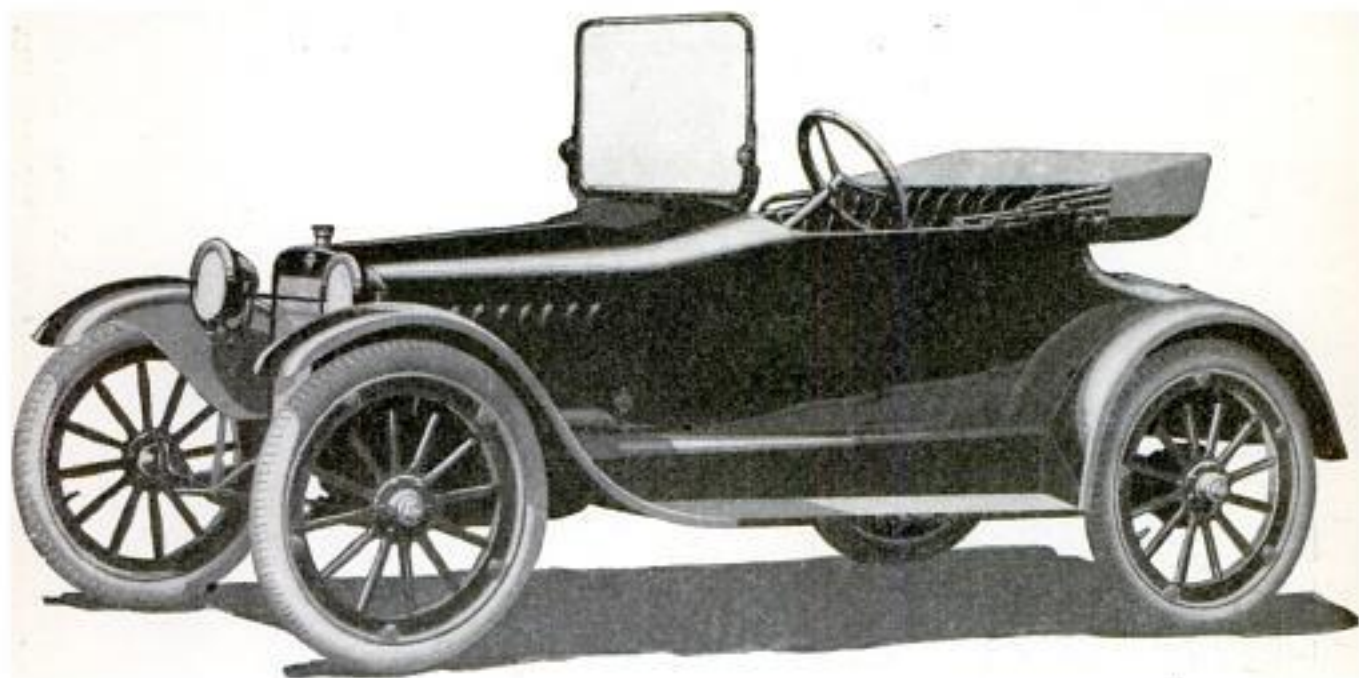

Read these reports from owners as to the service this car gives

"As for my Saxon Roadster—show me a car that can beat it. I can out-run and out-climb anything from a (*higher priced car*) down the line. Recently I persuaded (*another low priced car*) to race me by giving him a half mile handicap. The result was to put the (*other car*) in the ditch and my Saxon Roadster a half-mile in the lead. I can throttle down to 2 miles per hour on high or speed up to over 50, and can prove it any day. I average 32½ miles to the gallon of gasoline and 125 miles to the quart of oil. This new series Saxon Roadster is certainly a 'bear.' For power, speed and endurance it cannot be beat."—F. P. PORT, Owosso, Okla.

200 miles for \$1.32

"I have owned and driven my Saxon Roadster for two years. Repair bills have been practically negligible, it has never failed to give me thoroughly fine service. I have found it an absolutely dependable car. One trip I made this spring of 200 miles, over bad, winter-roughened roads, on 6 gallons of gasoline. Paid 22c per gallon—so the total cost of that trip was \$1.32, or considerably less than a cent per mile. Another trip I made recently was for 165 miles—over slightly better roads. I used but 4¾ gallons of gasoline, by actual measurement. Your Saxon Roadster is not only a wonderful performer, but it is a wonderfully economical car."—RAY LESSIG (Address on request.)

Resists hardest road abuse

"My Saxon car has always been faithful and dependable. I have driven it every day this winter, over roads that were

deeply rutted and frozen as hard as iron, and the way it has stood up under all kinds of abuse is truly wonderful. One would naturally think any car would begin to squeak and rattle after such treatment, but my Saxon Roadster runs just as smoothly and silently as when I first got behind the wheel. In my judgment it has made a wonderful record, and you can be sure that my name will continue to be on the list of Saxon owners."—G. W. HUGHES, Armstrong, Ill.

Costs less than \$1 a week

"I wish to put myself on record as to the advantages of using a Saxon Roadster. I have made so many successful trips in this car, at such low cost, that I feel that I cannot too highly recommend this car for the use of other ministers. I drive my car every day—looking after a large pastorate—besides attending weddings, etc., and my actual running expense is less than \$1.00 a week. For a minister, or for any man who wants lots of service with rare trouble and little expense, I know of no car better than a Saxon Roadster."—REV. F. Z. BURKETTER, Greensburg, Ind.

The Saxon Roadster is \$495; Saxon "Six" Touring Car, \$935; Six Sedan, \$1250, f. o. b. Detroit. Canadian Prices—Six Cylinder Touring Car, \$1260; Touring Sedan, \$1725; Four-Cylinder Roadster, \$665. Price of special export models, "Six," \$950; Four, \$515; f. o. b. Detroit.

(10)

SAXON MOTOR CAR CORPORATION, DETROIT



Champion Toledo

Dependable
Spark Plugs



“**H**AND me that plug please
—I want to see if it says
‘Champion’ on the porcelain.

“Hereafter when you buy plugs,
make sure that they always have
‘Champion’ on the *porcelain* as
well as on the box.”

An inferior plug can completely handicap
the performance of a costly machine—
while Champion spark plugs make *any*
priced car perform better.

There is no excuse for not getting
maximum service from your motor, not if
the plugs you buy say “Champion” on
the porcelain.

The *number* of cylinders is not as
important as the *results* obtained from
them. “Champion” spark plugs insure
the desired results.

There is a Champion Spark Plug especially
designed for every type of motor car,
motorcycle, marine and stationary engine.

Champion Spark Plug Co.
417 Upton Ave. TOLEDO, OHIO



Please Mention Popular Mechanics



It Does the Work the Easy Way

There are no intricacies—it is a matter of seconds to make pictures with a Premo Film Pack camera, even without previous experience.

The illustration shows how easily and quickly the camera may be loaded or unloaded. Just open the back in any light and drop in the unexposed pack or lift out the exposed one. To make the exposures, locate the subject in finder, snap the shutter, and pull out from top of pack a black tab. That's all there is to it. This operation is simply repeated until the entire pack is exposed.

Film pack film is from the same stock as the Eastman N. C. films—an assurance of highest quality. It offers you the advantage of tank development and the unique feature of removing one or more films for development at any time, without waiting until the complete pack is exposed. Its thin, flat form and its simple principle have made possible the manufacture of unusually light, compact and inexpensive cameras, one of which is the

PREMOETTE JR.



Just a trifle larger than the pictures it makes, yet capable of as good results as those obtainable with the largest cameras.

Made of aluminum, covered with genuine leather, and fitted with Kodak Ball Bearing shutter and a choice of selected lenses, tested in the thorough Eastman way. Prices \$5.00 to \$14.00. Pictures $2\frac{1}{4} \times 3\frac{1}{4}$ and $2\frac{1}{2} \times 4\frac{1}{4}$.

The new Premo Catalogue describes in detail a complete line of film pack, plate and cartridge film Premos and accessories. It's free at your dealer's, or will be sent by us postpaid on request.

Rochester Optical Department, *Eastman Kodak Company*, Rochester, N. Y.

**Road
Construction
and
Maintenance**



Published by
E. I. du Pont de Nemours Powder Co.
Wilmington, Delaware

Save Road Building Labor and Time

GOOD roads are imperative—vital. They deal with your personal welfare and the progress—the stability—the safety of the Nation. Road construction requires labor. Labor is scarce. Something must be done. This book tells how. It covers in a

complete and practical way all of the latest road building methods. It explains the use of all up-to-date road building machinery. It tells how to speed up road work, economize in time, and cut down manual labor. It covers every phase of road building from choice of location down to the finished road.

It is written in a plainly understandable style, is profusely illustrated and is now being used as a text book in many colleges and universities.

Get this Big Book Free

Send today for your copy of

Good Roads Book No. 248

E. I. du Pont de Nemours & Company

Wilmington, Delaware

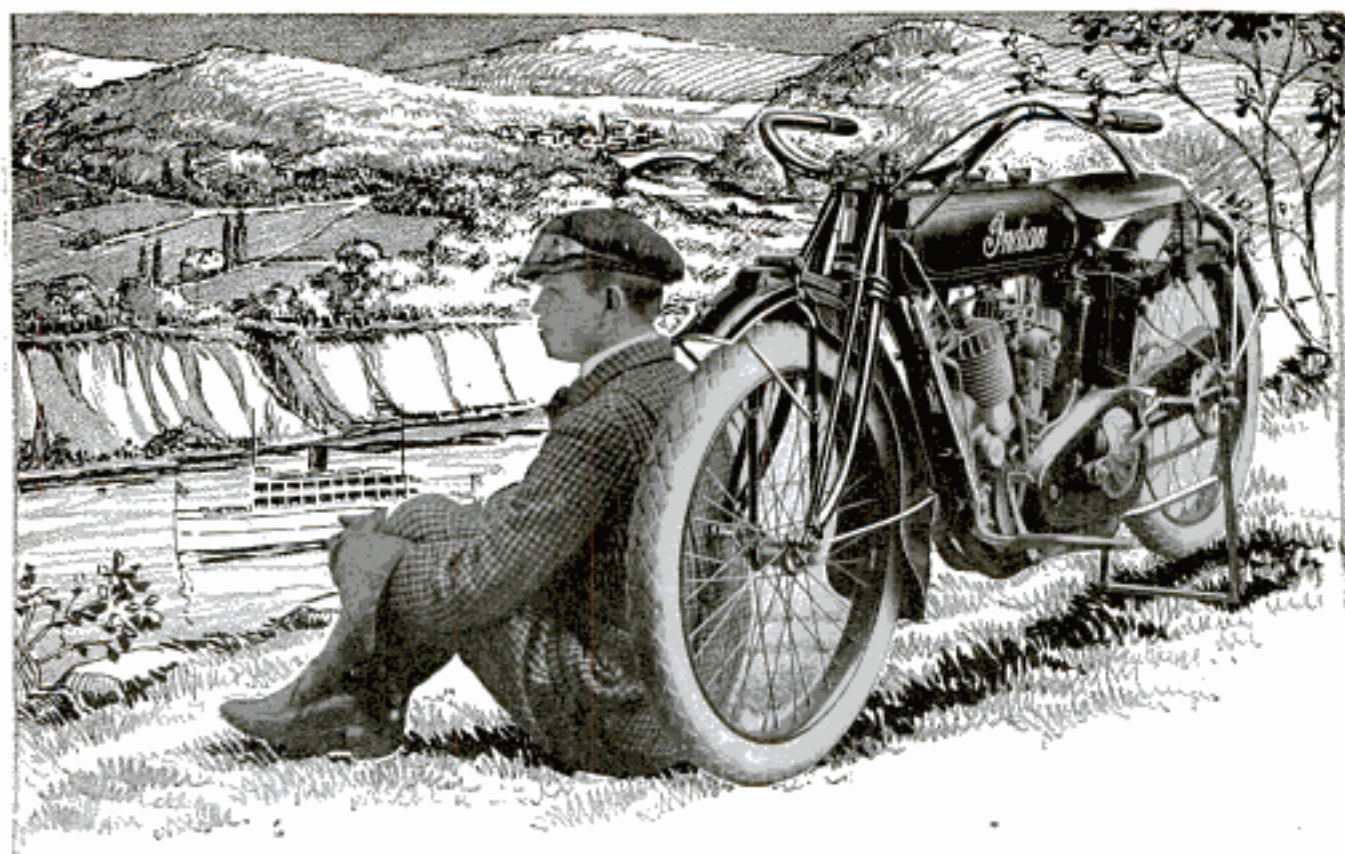

Here It Is, Almost June!

The motorcycle riding season is in full swing. The arteries of the nation are thickly dotted with Indians. Every road's an Indian road. Your veins are filled with wanderlust. You're asking yourself *why* you've delayed buying your 1917

Indian Motorcycle With Powerplus Motor

Will another holiday or Sunday go by without an Indian? That red blood in your system, that love of the open which is every man's heritage, tells you *decidedly no*.

Way over a hundred thousand Indian riders have had *your* experience. They, too, found *Indian-ing* couldn't long be resisted.

Let us send you the standard Motorcycle Text Book—the 1917 Indian Catalog.

Makers also of the 1917 Indian Light Twin Motorcycle, Side Car, Electrically Equipped Bicycle and ten other model Bicycles.

HENDEE MANUFACTURING CO., 710 State Street, Springfield, Mass.
(Largest Motorcycle Manufacturers in the World)

Please Mention Popular Mechanics



IVER JOHNSON

Safety
Automatic **REVOLVER**

"I'll take this
one—

I'm going to give my family
real protection. No trifling
with burglars in my home."

FOR years I have carried insurance on my life and home and jollied myself into thinking that this was all the protection any husband and father *could* throw around his family.

"Last night a burglar broke into my neighbor's house. IF Reynolds had only had a revolver he—

"That was enough for me! No temporizing with burglars in my home. I'm for *real* protection. I'll take this revolver I have in my hand, Mr. Clerk."

Are you ready—when the time comes—to do *your* duty by your burglar? Will you master him or will he master you? Will you give your family protection that is one jot short of *real, full, complete* protection?

When you buy a revolver buy a *good* one. The Iver Johnson is the safest small firearm made. It is proof against accidental discharge. You can "Hammer the Hammer."

Hammer model with Regular grip \$6.75. Hammerless model with Regular grip \$7.50. Both models also made with "Perfect" Rubber or "Western" Walnut grip. Send for Free Arms Book—"A."

Iver Johnson Bicycles can't be beat for speed, easy riding, strength and long wearing qualities. Racing, Cushion Frame, Truss Frame Roadsters and Mobicycle models. \$35 to \$55. Juveniles, \$20 to \$25. Send for

THREE BOOKS FREE

Indicate which books you want: A—"Arms," B—"Bicycles," C—"Motorcycles."



IVER JOHNSON'S
ARMS & CYCLE WORKS

307 River Street Fitchburg, Mass.

99 Chambers Street, New York
717 Market Street, San Francisco

\$40.



Please Mention Popular Mechanics

A Watch that the People Want

Waterbury
\$3



Illustrations
 $\frac{1 1}{2}$ actual size



Waterbury
Radiolite
\$4

The New *Ingersoll* Waterbury

IN the first place it's the size that is so much wanted today—especially in the cities—the smaller "12-size".

Stylish in Appearance

Then the whole "get-up" of the watch is smart, stylish, up-to-the-minute in all the little features found in the high-priced watches. Notice the gracefully shaped bow and crown, and the distinctive figures on the dial. An attraction that doesn't show in the illustration is the enamel dial.

Accurate and Sturdy

But a watch is to keep time and meet practical requirements. Here is three dollars' worth of watch by the best Ingersoll standards. It's jeweled with four jewels at points of greatest friction. It is accurate; yet it is sturdy too. It isn't put out of business by a little rough handling that most watches won't stand.

The Waterbury "Radiolite"

As an added attraction you have the Waterbury "Radiolite". Since the stem wind was invented there has been no greater innovation in watches than the "Radiolite" feature. The hands and figures are made of a new self-luminous substance containing genuine radium.

The power of radium is practically permanent, and the other twelve minerals of the substance on which it acts will respond in a brilliant glow for years and years—we'll say ten years to be conservative.

Let the Dealer Show You

The dealer has both these Waterbury models, which he'll be glad to show you. You can nearly always tell an Ingersoll store by the display of Ingersolls in the window. If the dealer hasn't the model you want, it will be sent on receipt of price by any of the offices named below.

ROBT. H. INGERSOLL & BRO. New York Chicago San Francisco

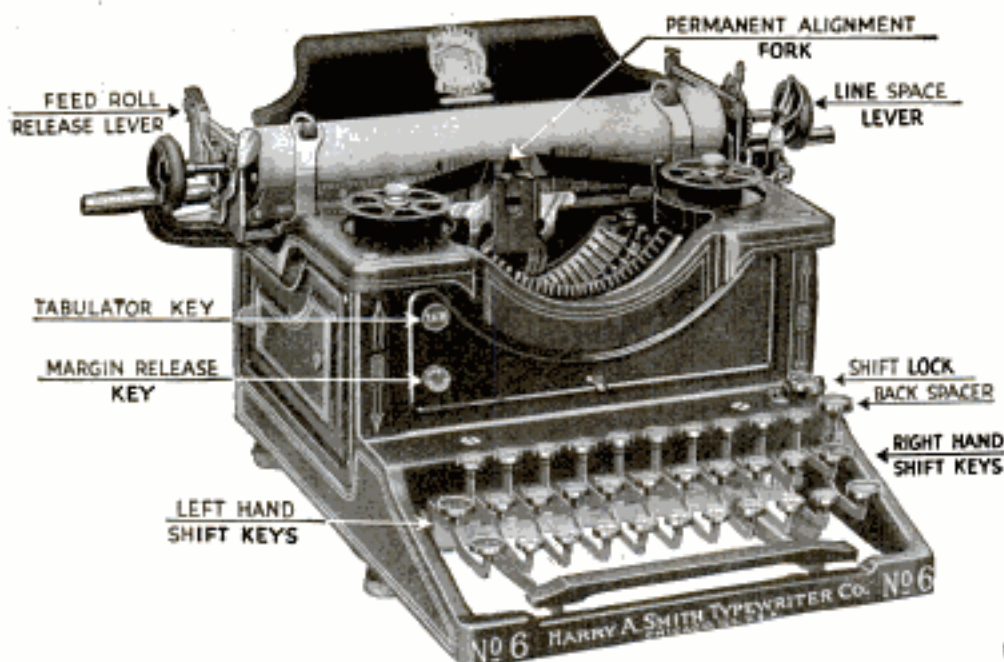

I want, through this advertisement, to establish as friendly business relations with you as I possibly can. I want you to realize also that it is my earnest effort and intention to give you full honest value for every dollar that you spend with me. This is the only way I can succeed. My advertisement has appeared in this magazine continuously for more than four years.

I am building up my business on the foundation of good value and square dealings. I am saving thousands of satisfied customers thousands of dollars, by supplying perfect—late style—visible writing—typewriters, at remarkably low prices.

All my transactions are handled throughout by personal correspondence. I assure you every courtesy and consideration in your dealings with me. Your order will have my prompt, careful, personal attention. I will be glad to do business with you.

Harry A. Smith

TYPEWRITER SENSATION

Free TRIAL—Use As You Pay

Send me only \$2.00 a month until the low total price of \$34.15 is paid, and the machine is yours

This is absolutely the most generous typewriter offer ever made. Do not rent a machine when you can pay \$2.00 a month and own one. Think of it—Buying a \$100.00 model for \$34.15. Cash price, \$32.30. Never before has anything like this been attempted.

Standard Visible MODEL No. 6

Perfect machines, Standard Size, Keyboard of Standard Universal arrangement, writing 84 characters—universally used in teaching the touch system. The entire line of writing completely visible at all times, has the tabulator, the back spacer; in fact, every late style feature and modern operating convenience. Comes to you with everything complete, tools, cover, operating book and instructions, ribbon, practice paper—nothing extra to buy. You cannot imagine the perfection of this beautiful reconstructed typewriter until you have seen it. I have a thousand of these perfect latest style Model No. 6 typewriters at this bargain price, and each purchaser fortunate enough to secure one of these beautiful machines must try it out in home or office for five days before deciding to buy. I will send it to you F. O. B. Chicago for five days' free trial. It will sell itself, but if you are not satisfied that this is the greatest typewriter bargain you ever saw, you can return it at my expense. You won't want to return it after you try it—you cannot equal this wonderful value anywhere.

H. A. SMITH
Room 510-231 N. Fifth Ave.
CHICAGO, ILL.

Ship me a No. 6 Smith F. O. B. Chicago, as described in this advertisement. I will pay you the \$28.00 balance of the SPECIAL \$34.15 purchase price, at the rate of \$2.00 per month. The title to remain in you until fully paid for. It is understood that I have five days in which to examine and try the typewriter. If I choose not to keep it I will carefully repack it and return it to the express agent. It is understood that you give the standard guarantee for one year.

You Take No Risk—Put In Your Order Now

When the typewriter arrives deposit with the express agent \$6.15 and take the machine for five days' trial. If you are convinced that it is the best typewriter you ever saw, keep it and send me \$2.00 a month until my bargain price of \$34.15 is paid. If you don't want it, return it to the express agent, receive your \$6.15 and return the machine to me. I will pay the return express charges. This machine is guaranteed just as if you paid \$100.00 for it. It is standard. Thousands and thousands of people own and use these typewriters and find them the best ever manufactured.

The supply at this price is very limited, the price will probably be raised when my next advertisement appears, so don't delay. Fill in the coupon today—mail to me—the typewriter will be shipped promptly. There is no red tape. I employ no solicitors—no collectors—no chattel mortgage. It is simply understood that I retain title to the machine until the full \$34.15 is paid. You cannot lose. It is the greatest typewriter opportunity you will ever have. Do not send me one cent. Get the coupon in the mails today—sure.

HARRY A. SMITH, 510-231 N. Fifth Ave., Chicago

Name

Address

Pop. Mech. June

LOWEST PRICES IN THE WORLD FOR HIGHEST GRADE AMERICAN WATCHES

Why pay retail prices for watches when you can buy the world's standard makes at practically the *wholesale* cost and save, in many instances, approximately 40%? For example, a 16 Size Hamilton No. 974—17 Jewel Adjusted Watch complete in 25 year gold filled case, sells at retail for \$21.00 to \$25.00—this very same watch can be bought direct from us at the *wholesale* cash price of only \$14.50! Think of that! Get our beautiful 226-page catalog just off the press, and you will be utterly amazed at the way we undersell all others in the United States. In this great book you will see all the world's most famous watches illustrated and described—Elgin, Waltham, Hamilton, Illinois, etc., etc. Page after page opens before you with such positively sensational values that there will be no question in your mind of our being the lowest-priced distributors in the country.

FREE Examination See It Before You Pay For It!

So as to absolutely convince you that you are getting exactly what you order, and that the big value you get is true in every respect, we will gladly send you a selection at our expense, to any bank or express, and let you see it before you pay a penny. Write today for our 226-page catalog. It is the greatest authority on watches ever published. And it is free for the asking.

Big Catalog Free

Hamilton Watches at lowest prices in the world

- 18-Size No. 924—17 Jewel **\$8.98**
Solid Nickel
- 16-Size, No. 974—17 Jewel **\$14.50**
25 Year Gold Filled
- 16-Size, No. 992—21 Jewel **\$26.80**
25 Year Gold Filled

Extra Special

14 KARAT SOLID GOLD

23 Jewel **\$11.75** \$20 Value

17 Jewel **\$9.75** \$18 Value

7 Jewel **\$7.75** \$14 Value

10 KARAT GOLD FILLED

21 Jewel **\$4.75** \$8 Value

15 Jewel **\$3.98** \$7 Value

7 Jewel **\$2.75** Value \$5

15 Jewel **\$10.50**
17 Jewel **\$12.35**
21 Jewel **\$15.00**

Elgin or Waltham Ladies' Watch Bracelets, 20 Year Gold Filled.

7 Jewel **\$8.98**
15 Jewel **\$11.65**
17 Jewel **\$16.98**

10 Year Free Repair Guarantee Bond Given With Every Watch.

I. PRESS & SONS
IMPORTERS AND CUTTERS OF DIAMONDS
WHOLESALE JEWELERS
262 CHESTNUT ST.
PHILADELPHIA, PA.



Engraving
Free

7 JEWEL ELGIN OR
WALTHAM
20 Year Gold Filled
Watches All Sizes
\$6.66 \$10 Value

15 Jewel
Octagon
\$10.50

Guaranteed Gold Filled \$4.62
7 Jewel Solid Gold \$11.95
15 Jewel Gold Filled \$6.95

Gentlemen's Octagon New Style 25 Year Gold Filled 12 Size Watches

15 Jewel \$10.50
17 Jewel \$12.35
21 Jewel \$15.00

Elgin or Waltham Ladies' Watch Bracelets, 20 Year Gold Filled.

7 Jewel \$8.98
15 Jewel \$11.65
17 Jewel \$16.98

10 Year Free Repair Guarantee Bond Given With Every Watch.

7 JEWEL ELGIN OR
WALTHAM
20 Year Gold Filled
Watches All Sizes
\$6.66 \$10 Value

15 Jewel
Octagon
\$10.50

Guaranteed Gold Filled \$4.62
7 Jewel Solid Gold \$11.95
15 Jewel Gold Filled \$6.95

Gentlemen's Octagon New Style 25 Year Gold Filled 12 Size Watches

15 Jewel \$10.50
17 Jewel \$12.35
21 Jewel \$15.00

Elgin or Waltham Ladies' Watch Bracelets, 20 Year Gold Filled.

7 Jewel \$8.98
15 Jewel \$11.65
17 Jewel \$16.98

10 Year Free Repair Guarantee Bond Given With Every Watch.

7 JEWEL ELGIN OR
WALTHAM
20 Year Gold Filled
Watches All Sizes
\$6.66 \$10 Value

15 Jewel
Octagon
\$10.50

Guaranteed Gold Filled \$4.62
7 Jewel Solid Gold \$11.95
15 Jewel Gold Filled \$6.95

Gentlemen's Octagon New Style 25 Year Gold Filled 12 Size Watches

15 Jewel \$10.50
17 Jewel \$12.35
21 Jewel \$15.00

Elgin or Waltham Ladies' Watch Bracelets, 20 Year Gold Filled.

7 Jewel \$8.98
15 Jewel \$11.65
17 Jewel \$16.98

10 Year Free Repair Guarantee Bond Given With Every Watch.

7 JEWEL ELGIN OR
WALTHAM
20 Year Gold Filled
Watches All Sizes
\$6.66 \$10 Value

15 Jewel
Octagon
\$10.50

Guaranteed Gold Filled \$4.62
7 Jewel Solid Gold \$11.95
15 Jewel Gold Filled \$6.95

Gentlemen's Octagon New Style 25 Year Gold Filled 12 Size Watches

15 Jewel \$10.50
17 Jewel \$12.35
21 Jewel \$15.00

Elgin or Waltham Ladies' Watch Bracelets, 20 Year Gold Filled.

7 Jewel \$8.98
15 Jewel \$11.65
17 Jewel \$16.98

10 Year Free Repair Guarantee Bond Given With Every Watch.

7 JEWEL ELGIN OR
WALTHAM
20 Year Gold Filled
Watches All Sizes
\$6.66 \$10 Value

15 Jewel
Octagon
\$10.50

Guaranteed Gold Filled \$4.62
7 Jewel Solid Gold \$11.95
15 Jewel Gold Filled \$6.95

Gentlemen's Octagon New Style 25 Year Gold Filled 12 Size Watches

15 Jewel \$10.50
17 Jewel \$12.35
21 Jewel \$15.00

Elgin or Waltham Ladies' Watch Bracelets, 20 Year Gold Filled.

7 Jewel \$8.98
15 Jewel \$11.65
17 Jewel \$16.98

10 Year Free Repair Guarantee Bond Given With Every Watch.

7 JEWEL ELGIN OR
WALTHAM
20 Year Gold Filled
Watches All Sizes
\$6.66 \$10 Value

15 Jewel
Octagon
\$10.50

Guaranteed Gold Filled \$4.62
7 Jewel Solid Gold \$11.95
15 Jewel Gold Filled \$6.95

Gentlemen's Octagon New Style 25 Year Gold Filled 12 Size Watches

15 Jewel \$10.50
17 Jewel \$12.35
21 Jewel \$15.00

Elgin or Waltham Ladies' Watch Bracelets, 20 Year Gold Filled.

7 Jewel \$8.98
15 Jewel \$11.65
17 Jewel \$16.98

10 Year Free Repair Guarantee Bond Given With Every Watch.

7 JEWEL ELGIN OR
WALTHAM
20 Year Gold Filled
Watches All Sizes
\$6.66 \$10 Value

15 Jewel
Octagon
\$10.50

Guaranteed Gold Filled \$4.62
7 Jewel Solid Gold \$11.95
15 Jewel Gold Filled \$6.95

Gentlemen's Octagon New Style 25 Year Gold Filled 12 Size Watches

15 Jewel \$10.50
17 Jewel \$12.35
21 Jewel \$15.00

Elgin or Waltham Ladies' Watch Bracelets, 20 Year Gold Filled.

7 Jewel \$8.98
15 Jewel \$11.65
17 Jewel \$16.98

10 Year Free Repair Guarantee Bond Given With Every Watch.

7 JEWEL ELGIN OR
WALTHAM
20 Year Gold Filled
Watches All Sizes
\$6.66 \$10 Value

15 Jewel
Octagon
\$10.50

Guaranteed Gold Filled \$4.62
7 Jewel Solid Gold \$11.95
15 Jewel Gold Filled \$6.95

Gentlemen's Octagon New Style 25 Year Gold Filled 12 Size Watches

15 Jewel \$10.50
17 Jewel \$12.35
21 Jewel \$15.00

Elgin or Waltham Ladies' Watch Bracelets, 20 Year Gold Filled.

7 Jewel \$8.98
15 Jewel \$11.65
17 Jewel \$16.98

10 Year Free Repair Guarantee Bond Given With Every Watch.

7 JEWEL ELGIN OR
WALTHAM
20 Year Gold Filled
Watches All Sizes
\$6.66 \$10 Value

15 Jewel
Octagon
\$10.50

Guaranteed Gold Filled \$4.62
7 Jewel Solid Gold \$11.95
15 Jewel Gold Filled \$6.95

Gentlemen's Octagon New Style 25 Year Gold Filled 12 Size Watches

15 Jewel \$10.50
17 Jewel \$12.35
21 Jewel \$15.00

Elgin or Waltham Ladies' Watch Bracelets, 20 Year Gold Filled.

7 Jewel \$8.98
15 Jewel \$11.65
17 Jewel \$16.98

10 Year Free Repair Guarantee Bond Given With Every Watch.

7 JEWEL ELGIN OR
WALTHAM
20 Year Gold Filled
Watches All Sizes
\$6.66 \$10 Value

15 Jewel
Octagon
\$10.50

Guaranteed Gold Filled \$4.62
7 Jewel Solid Gold \$11.95
15 Jewel Gold Filled \$6.95

Gentlemen's Octagon New Style 25 Year Gold Filled 12 Size Watches

15 Jewel \$10.50
17 Jewel \$12.35
21 Jewel \$15.00

Elgin or Waltham Ladies' Watch Bracelets, 20 Year Gold Filled.

7 Jewel \$8.98
15 Jewel \$11.65
17 Jewel \$16.98

10 Year Free Repair Guarantee Bond Given With Every Watch.

7 JEWEL ELGIN OR
WALTHAM
20 Year Gold Filled
Watches All Sizes
\$6.66 \$10 Value

15 Jewel
Octagon
\$10.50

Guaranteed Gold Filled \$4.62
7 Jewel Solid Gold \$11.95
15 Jewel Gold Filled \$6.95

Gentlemen's Octagon New Style 25 Year Gold Filled 12 Size Watches

15 Jewel \$10.50
17 Jewel \$12.35
21 Jewel \$15.00

Elgin or Waltham Ladies' Watch Bracelets, 20 Year Gold Filled.

7 Jewel \$8.98
15 Jewel \$11.65
17 Jewel \$16.98

10 Year Free Repair Guarantee Bond Given With Every Watch.

7 JEWEL ELGIN OR
WALTHAM
20 Year Gold Filled
Watches All Sizes
\$6.66 \$10 Value

15 Jewel
Octagon
\$10.50

Guaranteed Gold Filled \$4.62
7 Jewel Solid Gold \$11.95
15 Jewel Gold Filled \$6.95

Gentlemen's Octagon New Style 25 Year Gold Filled 12 Size Watches

15 Jewel \$10.50
17 Jewel \$12.35
21 Jewel \$15.00

Elgin or Waltham Ladies' Watch Bracelets, 20 Year Gold Filled.

7 Jewel \$8.98
15 Jewel \$11.65
17 Jewel \$16.98

10 Year Free Repair Guarantee Bond Given With Every Watch.

7 JEWEL ELGIN OR
WALTHAM
20 Year Gold Filled
Watches All Sizes
\$6.66 \$10 Value

15 Jewel
Octagon
\$10.50

Guaranteed Gold Filled \$4.62
7 Jewel Solid Gold \$11.95
15 Jewel Gold Filled \$6.95

Gentlemen's Octagon New Style 25 Year Gold Filled 12 Size Watches

15 Jewel \$10.50
17 Jewel \$12.35
21 Jewel \$15.00

Elgin or Waltham Ladies' Watch Bracelets, 20 Year Gold Filled.

7 Jewel \$8.98
15 Jewel \$11.65
17 Jewel \$16.98

10 Year Free Repair Guarantee Bond Given With Every Watch.

7 JEWEL ELGIN OR
WALTHAM
20 Year Gold Filled
Watches All Sizes
\$6.66 \$10 Value

15 Jewel
Octagon
\$10.50

Guaranteed Gold Filled \$4.62
7 Jewel Solid Gold \$11.95
15 Jewel Gold Filled \$6.95

Gentlemen's Octagon New Style 25 Year Gold Filled 12 Size Watches

15 Jewel \$10.50
17 Jewel \$12.35
21 Jewel \$15.00

Elgin or Waltham Ladies' Watch Bracelets, 20 Year Gold Filled.

7 Jewel \$8.98
15 Jewel \$11.65
17 Jewel \$16.98

10 Year Free Repair Guarantee Bond Given With Every Watch.

7 JEWEL ELGIN OR
WALTHAM
20 Year Gold Filled
Watches All Sizes
\$6.66 \$10 Value

15 Jewel
Octagon
\$10.50

Guaranteed Gold Filled \$4.62
7 Jewel Solid Gold \$11.95
15 Jewel Gold Filled \$6.95

Gentlemen's Octagon New Style 25 Year Gold Filled 12 Size Watches

15 Jewel \$10.50
17 Jewel \$12.35
21 Jewel \$15.00

Elgin or Waltham Ladies' Watch Bracelets, 20 Year Gold Filled.

7 Jewel \$8.98
15 Jewel \$11.65
17 Jewel \$16.98

10 Year Free Repair Guarantee Bond Given With Every Watch.

7 JEWEL ELGIN OR
WALTHAM
20 Year Gold Filled
Watches All Sizes
\$6.66 \$10 Value

15 Jewel
Octagon
\$10.50

Guaranteed Gold Filled \$4.62
7 Jewel Solid Gold \$11.95
15 Jewel Gold Filled \$6.95

Gentlemen's Octagon New Style 25 Year Gold Filled 12 Size Watches

15 Jewel \$10.50
17 Jewel \$12.35
21 Jewel \$15.00

Elgin or Waltham Ladies' Watch Bracelets, 20 Year Gold Filled.

7 Jewel \$8.98
15 Jewel \$11.65
17 Jewel \$16.98

10 Year Free Repair Guarantee Bond Given With Every Watch.

7 JEWEL ELGIN OR
WALTHAM
20 Year Gold Filled
Watches All Sizes
\$6.66 \$10 Value

15 Jewel
Octagon
\$10.50

Guaranteed Gold Filled \$4.62
7 Jewel Solid Gold \$11.95
15 Jewel Gold Filled \$6.95

Gentlemen's Octagon New Style 25 Year Gold Filled 12 Size Watches

15 Jewel \$10.50
17 Jewel \$12.35
21 Jewel \$15.00

Elgin or Waltham Ladies' Watch Bracelets, 20 Year Gold Filled.

7 Jewel \$8.98
15 Jewel \$11.65
17 Jewel \$16.98

10 Year Free Repair Guarantee Bond Given With Every Watch.

7 JEWEL ELGIN OR
WALTHAM
20 Year Gold Filled
Watches All Sizes
\$6.66 \$10 Value

15 Jewel
Octagon
\$10.50

Guaranteed Gold Filled \$4.62
7 Jewel Solid Gold \$11.95
15 Jewel Gold Filled \$6.95

Gentlemen's Octagon New Style 25 Year Gold Filled 12 Size Watches

15 Jewel \$10.50
17 Jewel \$12.35
21 Jewel \$15.00

Elgin or Waltham Ladies' Watch Bracelets, 20 Year Gold Filled.

7 Jewel \$8.98
15 Jewel \$11.65
17 Jewel \$16.98

10 Year Free Repair Guarantee Bond Given With Every Watch.

7 JEWEL ELGIN OR
WALTHAM
20 Year Gold Filled
Watches All Sizes
\$6.66 \$10 Value

15 Jewel
Octagon
\$10.50

Guaranteed Gold Filled \$4.62
7 Jewel Solid Gold \$11.95
15 Jewel Gold Filled \$6.95

Gentlemen's Octagon New Style 25 Year Gold Filled 12 Size Watches

15 Jewel \$10.50
17 Jewel \$12.35
21 Jewel \$15.00

Elgin or Waltham Ladies' Watch Bracelets, 20 Year Gold Filled.

7 Jewel \$8.98
15 Jewel \$11.65
17 Jewel \$16.98

10 Year Free Repair Guarantee Bond Given With Every Watch.

7 JEWEL ELGIN OR
WALTHAM
20 Year Gold Filled
Watches All Sizes
\$6.66 \$10 Value

15 Jewel
Octagon
\$10.50

Guaranteed Gold Filled \$4.62
7 Jewel Solid Gold \$11.95
15 Jewel Gold Filled \$6.95

Gentlemen's Octagon New Style 25 Year Gold Filled 12 Size Watches

15 Jewel \$10.50
17 Jewel \$12.35
21 Jewel \$15.00

Elgin or Waltham Ladies' Watch Bracelets, 20 Year Gold Filled.

7 Jewel \$8.98
15 Jewel \$11.65
17 Jewel \$16.98

10 Year Free Repair Guarantee Bond Given With Every Watch.

7 JEWEL ELGIN OR
WALTHAM
20 Year Gold Filled
Watches All Sizes
\$6.66 \$10 Value

15 Jewel
Octagon
\$10.50

Guaranteed Gold Filled \$4.62
7 Jewel Solid Gold \$11.95
15 Jewel Gold Filled \$6.95

Gentlemen's Octagon New Style 25 Year Gold Filled 12 Size Watches

15 Jewel \$10.50
17 Jewel \$12.35
21 Jewel \$15.00

Elgin or Waltham Ladies' Watch Bracelets, 20 Year Gold Filled.

7 Jewel \$8.98
15 Jewel \$11.65
17 Jewel \$16.98

10 Year Free Repair Guarantee Bond Given With Every Watch.

WHITE HOUSE

BRAND

COFFEE

And TEAS



In our campaign for a "Better Cup of Coffee" we need the assistance of the intelligent housewife to the end that the *splendid material* furnished by us under the name of "White House" be not spoiled in the brewing.

The WHITE HOUSE COFFEE is sold in the bean, ground or pulverized, and *never* in any package but the *one, two, or three-pound ALL-TIN cans*. White House TEA, quarter and half-pound *ALL-TIN cans*, all *varieties*, just as good as White House Coffee.

DWINELL-WRIGHT CO.

Principal Coffee Roasters

BOSTON-CHICAGO

Save \$20 to \$50 on COAL BILL

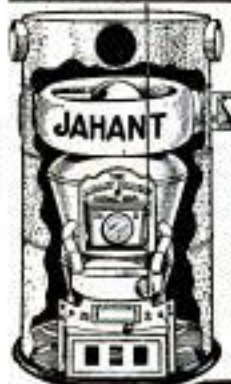

Save \$20 to \$50 on winter coal bill with a New Scientific Down Draft Jahant Furnace. Lasts a lifetime. Heats every room evenly. Burns oxygen, saves coal. Burns coal to fine ash. Heats quickly in morning.

WE PAY THE FREIGHT

We pay freight anywhere in U. S. or Canada. Price includes entire equipment cut to fit. Easily installed.

Sold on Monthly Payments

Buy a Jahant now, a payment down, rest easy monthly payments. It will pay for itself in short time. Sold on 30 day Money-back, Legal Guaranty Bond. Engineers' advice FREE.

FREE! Complete set of erecting tools Free with each Jahant. Get book, "WHAT USES HAY," and literature, all free.

JAHANT HEATING CO.
26 Jahant Bldg., AKRON, OHIO, U.S.A.

See October and December Popular Mechanics for advertising of

The Pullman Company

Let Me Quote You a Special Price
On My *Rapid* FIRELESS COOKER



Cook every meal on it. If you are not satisfied and delighted I will refund every cent. Get my

Special Low Factory Price

direct to you. Cooker is aluminum lined throughout. Full set of famous "Wear Ever" aluminum cooking utensils comes with it. Ask for free book of reliable recipes.

WILLIAM CAMPBELL CO.
Dept. 61 DETROIT, MICH.



Let Me Keep Your Ice for 30 Days

I'll Save You 1/2 of It

Let me put a White Frost Refrigerator in your home on 30 days' trial.

I'll pay the freight. Write and get my catalog. I sell the only round, white enameled refrigerator on earth. Made of zinc coated steel, soldered air-tight. Lasts a lifetime. Insulated with granulated cork. Noiseless doors and covers. Revolving shelves—nickel trimmings. Move-easy casters. Improved crystal glass water cooler with removable top. Write for catalog and factory-to-you price. Cash or easy payments. Yours truly, H. L. SMITH, Pres.

White Frost Refrigerator Co., 679 N. Mechanic St., Jackson, Mich.

White Frost
SANITARY
Refrigerator



Highest Grade UNDERWOOD

With Back Spacer—Two-Color Ribbon and Tabulator

FOR



You Try It
10 Days
Free

Guaranteed
for Five
Years

Think What
You Can Get
Now for \$39.96

A genuine No. 4 Underwood—the standard visible typewriter, with back spacer, two-color ribbon and tabulator—*complete* with waterproof cover, new ribbon and special touch typewriting instruction book—the machine that is

today the leading typewriter of the world! *Guaranteed* to be delivered in perfect condition! Fully guaranteed for five years.

You May
RENT APPLYING RENT ON PURCHASE PRICE
OR
BUY FOR CASH OR ON EASY PAYMENTS

'Way Under 1/2 Manufacturer's Price

Read This Letter And Then Write Us for NEW Offer

Grand Rapids, Mich.,
March 5, 1917

The Underwood No. 4 Typewriter you sent me, was received promptly, and to say I was highly pleased with it is only putting it mildly. I have spent about five years in New York and other Eastern cities as stenographer, and have used nearly every type of modern machines. In view of the fact I think I can lay claim to be a reasonably accurate judge of a typewriter, and I want to say that the machine you sent me is first class in every respect. It has been thoroughly rebuilt and it works and looks like a brand new machine.

Very truly yours,
(Signed) R. H. Pousma

Moreover, you don't have to buy it to try it! We will send one to you on Ten Days' Trial. Write all you please on it for ten days and then if you are not *perfectly* satisfied, send it back at *our* expense. What's more, if you do not care to buy, you may rent it at our low monthly rates. If later you want to own it, we will apply *six months'* rental payments on the low purchase price. Any national bank in Chicago, or any Dun's or Bradstreet's Agency anywhere will tell you that we are responsible. Learn *all* the facts about this remarkable offer. Write us today—send us your name and address on the attached coupon—or a post card. Ask for Offer No. 52.

Write tonight—send your name and address on the coupon or a post card and learn all about Offer No. 52.

Write for our agency
proposition.

Typewriter Emporium, 34-36 W. Lake St., Chicago
Established for a Quarter of a Century

Typewriter Emporium, 34-36 W. Lake Street, Chicago, Illinois
Send me immediately full facts about your Offer No. 52.

Name _____
St. or R.R. No. _____
City _____
State _____

Please Mention Popular Mechanics



The Truth About Corns

You have read much fiction about corns. Were that not so there would be no corns. All people would use Blue-jay.

Here is the truth, as stated by a chemist who spent 25 years on this corn problem. And as proved already on almost a billion corns.

"This invention—Blue-jay—makes corn troubles needless. It stops the pain instantly, and stops it forever. In 48 hours the whole corn disappears, save in rare cases which take a little longer."

That is the truth, and millions of people know it. Every month it is being proved on nearly two million corns. So long as you doubt it you'll suffer. The day that you prove it will see your last corn-ache.

It costs so little—is so easy and quick and painless—that you owe yourself this proof. Try Blue-jay tonight.

BAUER & BLACK
Chicago and New York
Makers of
Surgical Dressings, etc.

Blue=jay

Stops Pain—Ends Corns

15c and 25c at Druggists

Also Blue-jay Bunion
Plasters

50c TRIAL OFFER FOR BEST KODAK FINISHING **10c**
Any size roll developed, 10c. Six prints free with first roll. Or, send six negatives, any size, and 10c (stamps) for six prints. 8x10 Enlargements, 30c.
Roanoke Photo Finishing Co. (Formerly Roanoke Cycle Company)
84 Bell Ave., ROANOKE, VA.

SAVE SHOE BILLS **American Metal Shoes**
save from \$10 to \$30 shoe bills every year. Outwear many all-leather pairs. **FREE SHOE BOOK** tells all. Write **Am. Metal Shoe Co., 10-12th St., Racine, Wis.**

The Santa Fe SHATTERS WATCH PRICES

SEE THIS WATCH FIRST

Don't Send a Penny Examine Watch Free

21 JEWEL \$3.50 A MONTH
"Santa Fe Special"

—the one standard railroad watch "That's Guaranteed for Life," thin model, all sizes, **adjusted** to positions, **adjusted** to isochronism, **adjusted** to temperature, **adjusted** to the second.

Write for FREE Watch Book Today — shows newest watch case designs in 4-colors. READ the so-called SECRETS of watch making. READ how you can save from **ONE-THIRD** to **ONE-HALF** of your money — Buy "Direct," cut out the wholesale jeweler's profit.

EASY PAYMENTS TO SUIT YOU — Write today — your name on a postal brings the **FREE** watch book.

SANTA FE WATCH CO., Dept. 66, TOPEKA, KAN. Home of the Great Santa Fe Ry.

Swear Off Tobacco

Tobacco Habit Banished In 48 to 72 Hours

Immediate Results

Trying to quit the tobacco habit unaided is a losing fight against heavy odds, and means a serious shock to your nervous system. So don't try it! Make the tobacco habit quit you. It will quit you if you will just take **Tobacco Redeemer** according to directions.

It doesn't make a particle of difference whether you've been a user of tobacco for a single month or 50 years, or how much you use, or in what form you use it. Whether you smoke cigars, cigarettes, pipe, chew plug or fine cut or use snuff—**Tobacco Redeemer** will positively remove all craving for tobacco in any form in from 48 to 72 hours. Your tobacco craving will begin to decrease after the very first dose—there's no long waiting for results.

Tobacco Redeemer contains no habit-forming drugs of any kind and is the most marvelously quick, absolutely scientific and thoroughly reliable remedy for the tobacco habit.

Not a Substitute

Tobacco Redeemer is in no sense a substitute for tobacco, but is a radical, efficient treatment. After finishing the treatment you have absolutely no desire to use tobacco again or to continue the use of the remedy. It quiets the nerves, and will make you feel better in every way. If you really want to quit the tobacco habit—get rid of it so completely that when you see others using it, it will not awaken the slightest desire in you—you should at once begin a course of **Tobacco Redeemer** treatment for the habit.

Results Absolutely Guaranteed

A single trial will convince the most skeptical. Our legal, binding, money-back guarantee goes with each full treatment. If **Tobacco Redeemer** fails to banish the tobacco habit when taken according to the plain and easy directions, your money will be cheerfully refunded upon demand.

Let Us Send You Convincing Proof

If you're a slave of the tobacco habit and want to find a sure, quick way of quitting "for keeps" you owe it to yourself and to your family to mail the coupon below or send your name and address on a postal and receive our free booklet on the deadly effect of tobacco on the human system, and positive proof that **Tobacco Redeemer** will quickly free you from the habit.

Newell Pharmacal Company
Dept. 300 St. Louis, Mo.

Free Book Coupon

NEWELL PHARMACAL CO.,

Dept. 300

St. Louis, Mo.

Please send, without obligating me in any way, your free booklet regarding the tobacco habit and proof that **Tobacco Redeemer** will positively free me from the tobacco habit.

Name.....

Street and No.....

Town..... State.....



Tobacco Tells on
Nervous System



Tobacco Ruins
Digestion



Tobacco Stunts
Boy's Growth



Tobacco Robs
Man of Virility



Tobacco Steals
from You the
Pleasures, Com-
forts, Luxuries
of Life

Please Mention Popular Mechanics

Your Summer Bungalow

should be planned now. Make it artistic and appropriate so that it will melt into its surroundings and be a restful thing to look at.

Cabot's Creosote Stains

will color it in restful tones—soft greens, browns and grays that harmonize with the foliage, the bark and the rocks. The colors are not "painty" but rich and velvety. They cost only half as much as paint, wear as well and the creosote preserves the wood.

You can get Cabot's Stains all over the country. Send for stained wood samples and name of nearest agent.

SAMUEL CABOT, Inc., Manfg. Chemists, 18 Batterymarch St., Boston, Mass.
 24 West Kinzie Street, CHICAGO 523 Market Street, SAN FRANCISCO
Cabot's Stucco Stains—for cement houses



*Stained with Cabot's Creosote Stains
 W. P. Seaver, Architect, New York*



DO YOU INTEND TO BUILD? 75 PRACTICAL PLANS

California Bungalows and Houses especially suited to any climate. New, attractive designs with valuable building suggestions all in handsome 1917 Art Plan Book. Price \$1.00 postpaid. Send today for your copy. Save time, trouble. Money refunded if not satisfactory. Address

**BUILDING DEPARTMENT
 AURELIUS SWANSON COMPANY, Inc.
 1001 State Nat'l Bank Bldg. Oklahoma City, Okla.**

THIS BUNGALOW \$900 CAN BE BUILT FOR

This and many others in my new book, Building Plans for Modern Homes, will save you hundreds of dollars. One of the most complete and comprehensive books of plans ever published by any architect. Fifth edition just off the press. Two hundred and fifty floor plans and photographs of bungalows, etc., costing from \$500 up; gives sizes and cost to build. Sent postpaid for \$1.00



**FREDERICK H. GOWING
 ARCHITECT
 18 Tremont St., BOSTON, MASS.**



300 Candle Power of Light at a Cost of 1-8c Per Hour Burns Kerosene or Gasoline

This lamp generates and burns its own gas from ordinary kerosene. "QUICKLIT" gasoline lamps can be lit with an ordinary match like city gas.

Write today for illustrated catalog of our complete line of kerosene and gasoline lamps, lanterns, Agents Wanted and lighting systems.

**The Nagel-Chase Mfg. Co.
 176 East Erie St., Chicago**



ACORN UNI-LITE

**FREE
 OFFER**

Turns night into day. 300 candle power. Carry as a lantern; use anywhere as a lamp. Weather proof. For house, barn, garage, camp and around the farm. Write for big, free offer. Special opportunity to farmers, Stockmen and motorists. Agents make big money.

**WRITE TONIGHT for new 1916-1917 offer.
 ACORN BRASS MFG. CO., 620 Uni-Lite Bldg., Chicago**



Replace Your Heating Plant with a ROUND OAK Moistair Heating System

Only Heating System that Automatically Ventilates and HUMIDIFIES.—Keeps air moist, free from disease germs. Durable, dependable, easy to operate, a big fuel-saver. Send for FREE Book explaining all.

Made by Makers of Good Goods Only

**The Beckwith Co., Round Oak Folks—Established 1871
 100 Front St., DOWAGIAC, MICH.**



SMALL ENGINES

Perfected Gasoline Engines— $\frac{1}{2}$, 1 and 1 $\frac{1}{2}$ h. p.—for Farm and Shop use. Price \$15.00 and up. Also

WASHING MACHINES

We ship on trial. Send for Booklet and Special Offer.
**SILVERKROPP ENGINE CO., RACINE, WIS.
 1224 18th St.**

STARTER for FORD CARS

BUY PLUMBING and HEATING SUPPLIES



at WHOLESALE Will Save You 30%

Don't pay retail prices. Full stock on hand for prompt shipment. Send for free catalog.

B. P. KAROL, 800-802 South Kedzie Ave., CHICAGO

How to Cut Coal Bills $\frac{1}{2}$ to $\frac{2}{3}$

Free Book "From Overfed to UNDERFEED" tells how—guaranteed. Tells how to burn cheaper grades of coal cleanly and effectively. No clinkers. No partly burned coal. Ashes few, clean and white. No sifting. A boy can tend the Williamson UNDERFEED Furnace or Boiler with expert results. Coal fed from below. Hot, clean fire always on top. Write for free book today. NOW.

**THE WILLIAMSON HEATER COMPANY
 65 Fifth Avenue Cincinnati, Ohio**

DIAMONDS

ON CREDIT

20% DOWN 10% A MONTH

The most beautiful Diamonds are the Blue-white, especially if absolutely perfect. **LYON DIAMONDS**

are 1st Quality, Blue-white. A certificate furnished with every Diamond guaranteeing its value and providing for exchange at full purchase price. Goods sent prepaid for examination and approval. Write for Catalog No. 3. **10 per cent DISCOUNT FOR CASH.**

J. M. LYON & CO. (Est'd 1843) 1 Maiden Lane, NEW YORK, U.S.A. Northeast cor. Broadway





Hamasilk Everready Safety Cushion

Here is the newest idea in boating equipment—a cushion with a life-preserver inside. It saves the space of separate life-preservers, insures greater safety and provides a handy, comfortable and easily cleaned cushion. The Life-Preserver is the only type that supports the wearer's head clear of water and is stamped to comply with motor-boat laws. It is filled with the remarkably soft and buoyant "Hamasilk," the only fiber approved by the U. S. Steamboat Inspection Service for life saving equipment for all vessels. With slip-on, snap-button cover of 8 oz. Khaki duck, \$5.00 each postpaid. Write for booklet showing other Hamasilk Boating and Camping Equipment.

UNIVERSAL SAFETY MATTRESS CO., INC.
Dept. 12 31 Nassau Street New York

AGENTS 500% PROFIT

Gold and Silver Sign Letters



For store fronts, office windows and glass signs of all kinds. No experience necessary. Anyone can put them on and make money right from the start.

\$30.00 to \$100.00 A WEEK!
You can sell to nearby trade or travel all over the country. There is a big demand for window lettering in every town. Send for **FREE** Samples and full particulars.

Metallic Letter Co., 406 No. Clark St., Chicago

KEROSENE

**\$30 a Week
EASY**

Men and Women Wanted to Sell

PERFECTO Kerosene Irons

No experience necessary. Big profits selling this wonderful self-heating satisfaction guaranteed iron. Easy to operate and demonstrate. Sells itself. Use Kerosene (Coal Oil) or Gasoline with same satisfactory results. Absolutely safe, no smoke or odor. Get facts in detail and let us tell you how to obtain **Free Sample** and start you in a big paying business. Sample case **FREE** to Agents.

PERFECTO SADDLE IRON FACTORY
Dept. P, 129 So. Clinton St., CHICAGO, ILL.

BIG CHANCE FOR AGENTS



You can earn BIG MONEY

selling the most complete line of guaranteed transparent handle Knives and Razors with Photo, Name and Lodge Emblem—also full line of cutlery. Write today for catalogue and terms. Golden Rule Cutlery Co., 212 N. Sheldon St., Dept. 353, Chicago, Ill.

Mammoth Jubilee Book Free

Picturing 5152 Home Things

Make your own Credit Terms—1 to 3 years' time.

SPiegel, MAY, STERN CO., 1409 W. 35th St., Chicago

Our Automatic Card Printing Press

will put you in business for yourself.

Big Profit—Easy Work
Only \$150.00 required.
Get Free Booklet No. 11

S. B. Feuerstein & Co.
542 W. Jackson Blvd., Chicago



Why
Work
for
Wages?

FREE 20 Lessons in Electricity

Yes, absolutely free. Did you ever hear of such an offer? Here, at last, is your opportunity to become a Trained Electrician and qualify for big salary or go into business as an Electrical Contractor. All students personally taught by Albert W. Wicks, Electrical and Mechanical Engineer and Bachelor of Science.



NEW Wonderful, Easy SYSTEM

A. W. Wicks, E. E.
Formerly with the General Electric Co.; former General Manager of company manufacturing Jenney Electric Motors; also formerly with Fairbanks, Morse & Co.; now Consulting Engineer and Director of the Wicks Electrical Institute.

Amazingly simple and easy to learn. Far ahead of old fashioned teaching methods. No text books used. Complete, thorough training in practical electricity in your spare time at home. Write for new free book, "Opportunities in the Electrical Field." Send the coupon. Get our amazing offer.

Learn at Home Earn \$2400 to \$4000 a Year—20 Lessons Free

to a limited number of new students to advertise the wonderful Wicks New System and to prove to you how easily and quickly Prof. Wicks can make you a Trained Electrician. Nothing to pay for the entire course if you are not perfectly satisfied.

READ what students say

"I have secured a fine position with the Smith Electric Company of this city and have been busy for the past three weeks. I have found your lessons a big help."—A. H. KELLEY, Carthage, Tenn.

"Any man wishing to make more money by learning electricity should take your course."—JULIUS SOVIAUX, Lovington, Ill.

"I have been well satisfied with your Electrical Course and the way you conduct your pupils through it and think that every man wishing to take up Electrical work should take a course in the Wicks Electrical Institute."—EDWARD COPE, Cleveland, Ohio.

A. W. WICKS, E. E., Director,
WICKS ELECTRICAL INSTITUTE
81 W. Randolph St., Dept. 486
CHICAGO, ILL.

Send the Coupon NOW Do Not Delay

This offer may be withdrawn without notice. Seize this extraordinary opportunity before it is too late.

Send this coupon or a postal.

NAME

ADDRESS

A. W. Wicks, E. E.,
Director, Wicks
Electrical Institute,
81 W. Randolph St.,
Dept. 486,
Chicago, Ill.

Without any obligation on my part, please send me full particulars of your 20 Free Lessons Offer and all other information about your wonderful new system for teaching Electricity at home.

Please Mention Popular Mechanics

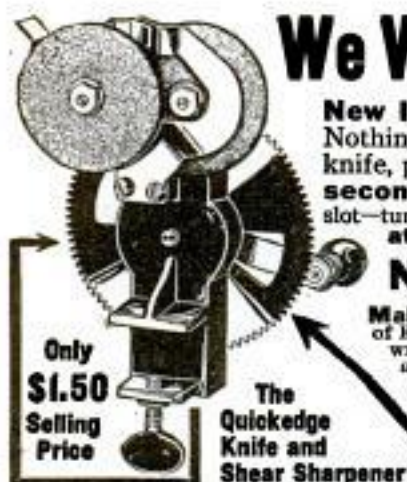

Only
\$1.50
Selling
Price

The
Quickedge
Knife and
Shear Sharpener

We Want Agents at \$30 to \$75 a Week

New Invention—Just out. Needed in every home every day. Patented. Nothing else like it. Low priced—**Sells on sight**. Sharpens any kitchen knife, paring knife, carving knife, bread knife, or shears and scissors in **ten seconds**. Mechanical masterpiece. A child can use it. Just put knife in slot—turn crank—sharpens both sides at once automatically. **We want representatives at once**—men and women hustlers. Get this position where **profits start first day**.

No Experience Necessary — 200% Profit

Make as much money next week as these men are making now. J. C. Lewis, of Kansas, says: "I have sold one hundred sharpeners in four days." Hobart Kerr, of Md., writes: "The women can hardly wait till they get them." Herbert Cain, of Ky., sold nine after supper. At the end of the first day, J. W. Gordon, of Pa., writes: "I sold two dozen and I sold to every one I saw." Wm. G. Hall, of N. J., says: "I think it is great. I sold six in about one-half hour. The machine is a mighty fine proposition. I am a mechanic and I know what I am talking about." You can make this money. **WRITE TODAY. TERRITORY FREE. GET BUSY AT ONCE.**

QUICKEDGE SHARPENER CO., 684 Sharpener Bldg., 215 N. Desplaines St. CHICAGO, ILL.



Carnes Artificial Arm

has put Louis Rondeau back on the payroll as a wage-earner. He now is employed in a big Kansas City factory operating a machine. Both of his arms have been amputated and he wears two Carnes Artificial Arms. His salary and efficiency have not been lessened.

Endorsed by surgeons everywhere, the Carnes Arm has been declared to be the best substitute ever invented for a natural arm. Is the only arm with full finger motion, hand turning and bending wrist and bending elbow.

Awarded Gold Medal at San Francisco, San Diego and London.

Write in today for big illustrated Catalog B.25 containing pictures and testimonials from wearers of Carnes Arms.

CARNES ARTIFICIAL LIMB CO.

31 Carnes Bldg.,
804 East 12th St. Kansas City, Mo.

"I Would Not Part With It for \$10,000"

So writes an enthusiastic, grateful customer. "Worth its weight in gold," says another. In like manner testify over 100,000 people who have worn it.

The Natural Body Brace

For MEN and WOMEN

Develops erect, graceful figure; overcomes **WEAKNESS and AILMENTS of Women & Men.**

Brings womanly beauty and manly strength, restful relief, ability to work and enjoy life.

Makes You Feel Good and Look Good

Does away with the strain and pain of standing and walking; replaces and supports misplaced internal organs; reduces enlarged abdomen; straightens and strengthens the back; corrects stooping shoulders; develops lungs, chest and bust; relieves backache, curvatures, nervousness, ruptures. Easy to wear.

Wear It 30 Days Free at Our Expense

Write today for illustrated booklet measurement blank, etc., and read our very liberal proposition.

HOWARD C. RASH, Pres. Natural Body Brace Co.
223 Rash Building SALINA, KANSAS



For
Children
Also

Compare It With a DIAMOND

Get a genuine Lachnite on ten days' free trial. If you can tell it from a diamond send it back. Put it to every diamond test. Wear it everywhere. The dazzling brilliance of Lachnites is eternal. They are cut by diamond cutters.

3 1/3c a Day

Pay only the rock-bottom price at the rate of a few cents a day. See only in real gold. Write for new jewelry book. It's free.

HAROLD LACHMAN COMPANY
12 N. Michigan Av., Dept. A119 Chicago



AGENTS \$60 WEEKLY

Robinson Folding Bath Tub, Big seller. Costs little, no plumbing, little water. Weight 15 pounds, folds into small roll. Full length baths, far better than tubs. Guaranteed 10 years. \$10 a day easily made. Write for free tub offer.

ROBINSON CABINET MFG. CO. 4612 Factory Bldg., Toledo, Ohio



Hand Forged
Razor Steel
Blades, No. 57

A Genuine \$2 Knife for **88c**

Direct at Factory Prices

This \$2 KNIFE 88c Postpaid
Hand Forged Razor Steel Blades

Handy shaped blade makes this knife best for mechanics, sportsmen and farmers; light but strong; re-sharpened easily. Stag handle, German silver finish, blades file tested.

Hand forged from razor steel and warranted.
Sample 88c. 3 for \$2.12 postpaid.

Send for our 100 page List and "HOW TO USE A RAZOR" **FREE**

MAHER & GROSH CO., 106 A. St., Toledo, Ohio

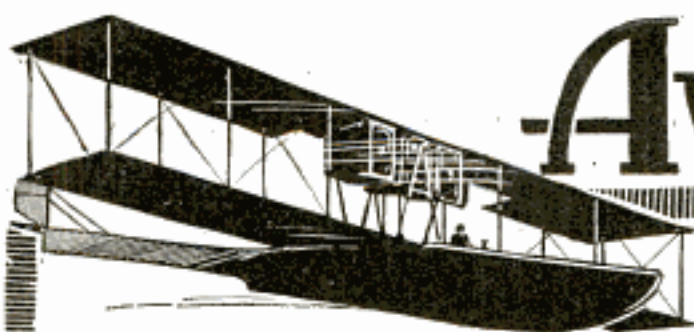

Aviation

Learn Practical Aeronautics By Mail

FOR the first time in the History of Aviation, a Practical and Efficient Correspondence Course is waiting for you under the direction of Qualified Aviators and Aeroplane Builders, and a **Special Offer of Great Importance** is yours, if you will send the coupon at once.

Aviation is in its infancy. It stands today where the automobile and moving picture business did ten years ago. And the big men, the money kings in these colossal enterprises were ten years ago obscure mechanics with less opportunity than you have today with this wonderful Course in Practical Aeronautics. Now is the time to rise with the tide that means to you both fame and fortune.

Earn \$50 to \$500 a Week!

Today there is a great demand for men in all branches of Aviation. Experts in Aeronautics command tremendous salaries. Government Branches, Aero Societies, Aeroplane Builders, Repair Shops and others are clamoring for trained men.

We prepare you by mail to train for flying—in spare time to fill any of these positions:

Aeroplane Mechanic
Aeroplane Builder **Aeronautical Engineer**
Aeroplane Salesman
Aeroplane Assembler **Aeroplane Repairman**
Aeronautical Contractor
Aeronautical Instructor **Aeroplane Inspector**

No matter what your present business may be, equip yourself NOW to take up the new profession of Practical Aeronautics. Send the Coupon today for full particulars of our Course and the Special Offer we are now making. This is your opportunity.

Highest Endorsement By Aviation Authorities

This wonderful Course is highly endorsed by leaders in Aviation and Flying Organizations. It has their unqualified approval as a quick and reliable basic training for the business of Aviation. Under the personal direction of Mr. Bud Morriss, well known Aviator and Instructor, assisted by a distinguished Staff of Aviators, Aeroplane Manufacturers, and Aeronautical Engineers, you learn all about this fascinating, profitable profession. Every Lesson, every Lecture, every Blue Print and Bulletin self-explanatory, in plain terms, for quick understanding. Your training is thorough and complete. A common school education is all that is necessary to thoroughly understand the Course. Get the facts today. Send the Free Coupon.

Special Limited Offer-- Write Now

Send the coupon at once for full particulars of our remarkable special offer open to you now. Find out all about the marvelous opportunities that are opening in the Aviation game. This offer is the greatest stepping stone to bigger opportunities ever known. Write today for complete literature, all free and prepaid. You are not obligated in any way. Do not waste time in thinking about it. Act! Send the coupon or a letter or a post card will do.

WRITE AT ONCE.
AMERICAN SCHOOL OF AVIATION
 431 So. Dearborn St., Dept. 2626 Chicago, Ill.



AEROPLANE BUILDER



AEROPLANE REPAIRMAN



AEROPLANE INSPECTOR



EXHIBITION FLYING



AERONAUTICAL ENGINEER

American School of Aviation
 431 So. Dearborn St.
 Dept. 2626
 Chicago, Ill.

Gentlemen: Please send me free and without obligation, full particulars of your Course in Practical Aeronautics and Your Special Offer to those who write at once.

Name

Address.....

Please Mention Popular Mechanics



With mirth and laughter let old wrinkles come.

The key to a keen and cheerful old age is vigor.

ANHEUSER-BUSCH'S
Malt-Nutrine
REG. U.S. PAT. OFF. TRADE MARK
Liquid-Food-Tonic

is a strengthening food-tonic. It does just those things that are of particular benefit to the old and weak—aids digestion and nourishes without over-burdening the system. Is there a birthday in your home whose celebration crowds the cake with candles? Malt-Nutrine should be taken at each meal and before retiring.



← The key to the situation

All Druggists
Most Grocers

Malt-Nutrine declared by U. S. Internal Revenue Department to be a pure malt product—no alcoholic beverage. Contains 14.59 per cent malt solids—1.9 per cent alcohol.

Interesting booklet on request.

Anheuser-Busch
St. Louis,
U. S. A.



Please Mention Popular Mechanics

Become a Game Farmer
Write for these two books which tell all about this interesting and profitable work. "Game Farming for Profit and Pleasure" is sent free on request. It treats of the subject as a whole; describes the many game birds, tells of their food and habits, etc. "American Pheasant Breeding and Shooting" is sent on receipt of 10c in stamps. It is a complete manual on the subject.

HERCULES POWDER CO.
1025 Market Street
Wilmington Delaware

ETNA-IZE Protect yourself and your family in case of sickness or accident. \$50 a week, and as high as \$15,000 for death. Write for particulars.
ETNA LIFE INSURANCE COMPANY
Drawer 1341 Dept. PM. 6-17 Hartford, Conn.

5¢ A DAY BUYS A GIBSON

Terms as low as \$1.00 down and \$1.50 per month. Mandolin or Guitar on approval. Get new FREE BOOK. Valuable information for player and teacher. Explains wonderful new violin construction with carved and graduated Top and Back and Stradivarius Arching. Also FREE treatise on "How to Practice."

Make \$1800 to \$5000 a Year Teaching and Selling Gibsons
Become a teacher. Splendid opportunities for Mandolin and Guitar teachers—either sex, in every locality, private and class instruction, and sale of Gibsons. The Gibson has "made" many a teacher professionally and financially.

Do Business on Our Capital
If teacher, become our agent. Territory protected. Instruments furnished. We help sell. We pay advertising. You make profits. Pay for goods when sold; return unsold goods. Try our "Still Hunt." Catalog and Thematic List Free.
Gibson Mandolin Guitar Co., 166 Harrison Court, Kalamazoo, Mich.

Here's Health and Power, Vim and Vigor



Do you want them? Strength that is more than mere muscular strength. The strength, health, power and vigor of youth is now within your reach through the White Cross Electric Vibrator. Its strength—be healthy—enjoy things the way you used to. Write—learn what vibration may do for you.

The White Cross Electric Vibrator

With this machine in your home you can give yourself the treatments for which specialists receive \$3.00 to \$5.00. Can be connected up as easily as an electric lamp. Or, if your home is not wired for electricity, it will run on its own batteries. See it—try it.

Write Today For Our Big FREE BOOK!

Just your name and address on a letter or post card is enough. We will send you, absolutely free and prepaid, our new book, "Health and Beauty." It tells you about vibration and about our special offer. Write today.

Lindstrom-Smith Co., Dept. A119, 1100 So. Wabash Ave., Chicago

Diamonds Watches

ON CREDIT

2000 ILLUSTRATIONS

Send Today for Your Catalog

This Handsome 116-Page Catalog contains over 2,000 illustrations of Diamonds, Watches, Jewelry. All the new, popular styles are shown—gorgeously beautiful Diamonds, artistic solid gold and platinum mountings—exquisite things—at prices to suit any purse. Select anything desired, either for personal wear or for a gift, then ask us to send it for your examination, all charges prepaid by us.

You See and Examine the Article Right in Your Own Hands

If you like it, pay one-fifth of price and keep it, balance divided into eight equal amounts, payable monthly. Send for Catalog today.

LOFTIS BROS. & CO., National Credit Jewelers
Dept. A 894 100 to 108 N. State St., CHICAGO, ILL.
(Established 1883) Stores in: CHICAGO: PITTSBURGH: ST. LOUIS: OMAHA

This Is the Ring She Wants

The Loftis "Perfection" Diamond Ring is our great special. Only fine, high-grade Diamonds, perfect in cut and full of fiery brilliancy, are used. Skillfully set in our famous Loftis "Perfection" 14k solid gold six-prong ring mounting. Our large Catalog shows

Wonderful Values at \$25, \$40, \$50, \$75, \$100, \$125

EASY CREDIT TERMS

Our prices on guaranteed Watches are lowest. All the new models are shown in Catalog. Any one you select will be sent for your examination, charges prepaid.

THE BEST GIFT OF ALL



TYPEWRITERS

FACTORY REBUILT

Buy Right From Our Own Factories And Save \$25 to \$75

Up-to-date Machines of Standard Makes thoroughly rebuilt, trade-marked and guaranteed the same as new. Efficient service through Branch Stores in leading cities. Send for latest booklet.

American Writing Machine Co., Inc., 345 Broadway, N. Y.



Red or Black "Vulcan" Ink Pencils

The ONLY perfect, non-leakable ink pencils at moderate prices.

Two Sizes—
4 1/4 and 5 1/4 inches.
Extra Size—8 inches (black only) \$1.25.
Your name in gold inlay 35c.
FREE—liberal supply of ink with retail orders. Agents Wanted. Big Profits.

J. G. ULLRICH & CO., 27 Thames St., New York

Order today \$1



Over 100,000 in Use

Mostly sold through recommendation. For PERSONAL DESK or GENERAL OFFICE. It checks mental calculations. Buy through your Stationer. Write for 10-day trial offer.

E. GANCHER, A. A. M. CO.
148 Duane Street, NEW YORK

AGENTS WANTED

Golden Gem
PORTABLE Adding Machine \$10

Multiples—Subtracts



TYPEWRITERS

\$10 and Up. ALL MAKES SAVE \$25 TO \$50

on rebuilt at the factory by the well known "Young Process." Sold for low cash—installment or rented. Rental applies on purchase price. Write for full details and guarantee. Free trial.

YOUNG TYPEWRITER CO., Dept. 246, Chicago



Everybody Takes Orders from the "Blue Print"

And back of every blue print there is a neat penciled drawing. Many hands touch it. It must be cleaned often. Working drawings demand the best pencil. For this work, and for all other exacting pencil work, use

DIXON'S ELDORADO

"the master drawing pencil"

True to quality all the way through, it holds a fine point and does not need frequent sharpening. Send 14c in stamps for samples worth double the money.

Joseph Dixon Crucible Co., Dept. 10-J, Jersey City, N. J.

DIXON'S BEST WHITE N° 352
writes white on blueprints



Pay for a Conn Instrument in Small Monthly Amounts

Now you can pay for a Conn instrument in small monthly amounts. The "New Wonder" Conn Cornet is the newest triumph in Cornet making—the easiest blowing—the most perfect in tone. And we will send it to you for a free trial right in your own home. See it for yourself. Play on it—and then you will know why it is used by all the great soloists. Anyone can learn to play all the popular music on a Conn Saxophone in a few days. Conn Saxophones are extremely rich in tone. They are used and endorsed by the greatest Saxophone artists.

Write Today for Catalog

Send us your name and address for our new catalog and special offer. Absolutely no obligations. All Conn instruments sent for free trial. Send for this valuable book now. **IT IS FREE.**

C. G. CONN, Ltd. Dept. A119 Elkhart, Indiana



STEGER PLAYER-PIANO



☐ Your home will be happier and more cheerful if you select a superb New Steger Piano or Player-Piano. Entertain your family and friends. Give your children a greater love for music. Enjoy the delightful strains of your favorite melodies.

☐ Artists of eminence praise Steger Instruments. The Steger tone is of wonderful richness. It possesses beautiful, clear, mellow, singing qualities.

☐ Steger Instruments are used in many leading conservatories, musical colleges and schools. Their reliability is backed by the liberal guarantee of the largest piano factories in the world, located in the "Piano-city," Steger, Illinois, on the Dixie Highway.

☐ Let us tell you about the reasonable prices and convenient terms on which you may have a New Steger Piano or Player-Piano in your home.

Three years in which to pay, if desired.

Liberal allowance for old instruments. Delivered direct from our factories to your home, or through our regular appointed distributors. We invite comparisons. Beautiful illustrated Steger Style Brochure, sent free, on request.

Steger & Sons
PIANO MANUFACTURING COMPANY
Established 1879
Dept. 24 Steger Building
N.W. Cor. Wabash & Jackson, Chicago, Ill.



New Automatic Adder \$2.50

Makes adding easy for anyone. It's accurate, quick, durable and easily operated. Capacity 999,999.99. Saves time, brain work and eliminates errors. Thousands of pleased owners. Guaranteed one year. Delivered complete for \$2.50. ORDER YOURS TODAY. AGENTS WANTED.

J. H. BASSETT & CO., Dept. 45, 5921 Indiana Ave., Chicago, Ill.

Roofing Book FREE

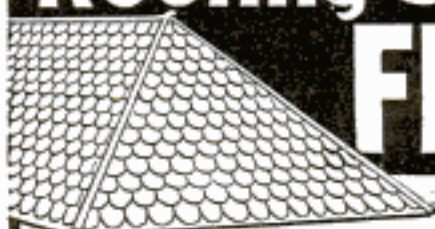

Get Our Freight Paid Roofing Prices

Don't buy Roofing of any kind until you get our big Free Roofing Book, describing full line of Edwards Famous "Tightcote" Galvanized Roofings, Sittings and Ceilings, and our lowest freight-paid prices. Then see for yourself how much we save you by selling direct and saving you all in-between dealers' profits.

EDWARDS "REO" Metal Shingles

Absolutely rust proof. By our patented "Tightcote" process, edges as well as sides of metal sheets are heavily coated with zinc—not a space the size of a pin point exposed to weather. Fire and lightning proof. Outlasts three ordinary roofs. Forever wind and weather proof. Need no repairs—end all roofing expense. Patent INTERLOCKING DEVICE makes water tight seams—all nail heads covered—no chance for rust or leaks.



EDWARDS Galvanizing Test

Edwards "Tightcote" Galvanized Roofing can be bent, twisted or struck by lightning, and the galvanizing will not crack or flake. Bend it or hammer it—you can't loosen or scale the galvanizing. No other galvanized roofing can withstand this test.

Garage \$89.50 Wide variety of styles, all

sizes of Portable Fireproof, Metal Garages, \$69.00 and up.

Lowest prices ever made. Postal brings Big Garage

Catalog free.

Write Today for free samples and proof that we

can save you a lot of money on any

kind of roofing siding or ceiling you may need. Ask

for Roofing Book No. 100.

THE EDWARDS MFG. CO.,

600-650 Pike St., Cincinnati, O.

FREE
Samples &
Roofing Book



Amazing Profits In Mushrooms

Anybody can add \$10 to \$40 per week to their income. In spare time, entire year growing mushrooms in cellars, sheds, barns, boxes, etc. I tell you where to sell, at highest prices.

Free Illustrated Instruction Booklet

HIRAM BARTON

Desk 2, 329 W. 48th St., New York

Bausch and Lomb BALOPTICON

THE PERFECT STEREOPTICON

Bausch & Lomb Optical Co., 576 St. Paul St., Rochester, N. Y.

Now \$200



Only \$2 down brings brand new Rex (10 years' Guarantee) built because world's greatest merchandise house wanted a better machine.

FREE CATALOGUE

Don't consider purchasing a possible unreliable typewriter when you can have a brand new Rex at an astounding low price. Sent on trial. Write today for "Typewriter Secrets." Will be a revelation!

Rex Typewriter Company Dept. A119, Steger Bldg. CHICAGO, ILL.

The
Prophy-lactic
Tooth Brush

Earned its reputation by
"mouth to mouth" advertising

PATENTS

IF YOU HAVE AN INVENTION which you wish to patent you can write fully and freely to Munn & Co. for advice in regard to the best way of obtaining protection. Please send sketches or a model of your invention and a description of the device, explaining its operation.

All communications are strictly confidential. Our vast practice, extending over a period of seventy years, enables us in many cases to advise in regard to patentability without any expense to the client. Our Hand-Book on Patents is sent free on request. This explains our methods, terms, etc., in regard to *Patents, Trade Marks, Foreign Patents, etc.*

All patents secured through us are described without cost to the patentee in the SCIENTIFIC AMERICAN.

MUNN & CO.
SOLICITORS OF PATENTS
672 WOOLWORTH BLDG., NEW YORK
and 625 F STREET, WASHINGTON, D. C.



\$500 REWARD

We will pay \$500.00 reward to anyone who can permanently dim the brilliancy of the RAJAH In. diamond without destroying the stone.

RAJAH In. Diamonds

They stand all diamond tests—fire, acid, file, and glass cutting. Their brilliancy is eternal. Guaranteed for a lifetime. Set in solid gold, and sent to you on 30 Days' Free Trial. If you can tell it from a real diamond return it. Send today for our beautiful, FREE illustrated jewelry catalog in colors. Write now, KRAUTH & REED, 159 N. State St., Dept. P2 CHICAGO, ILL.

Comfort Indoor Closet

Odorless, Sanitary, Germ-proof. Can be placed anywhere in home. A guarantee of healthy, sanitary conditions.

SWAT FLY BREEDING CLOSET

Have city conveniences. Germ-life killed instantly by chemicals. Emptied once a month. Needs no other attention. Boards of Health endorse. Write for literature.

Agents wanted—exclusive territory
COMFORT CHEMICAL CLOSET CO. 386 Factory Bldg. TOLEDO, OHIO



UNCLE SAM WANTS YOU



Get a U. S. Government Job \$75 to \$150 a Month

Rapid advancement to higher Government Positions. No "Layoffs" because of STRIKES, WARS, FINANCIAL FLURRIES or THE WHIMS OF SOME PETTY BOSS. THE POSITION IS YOURS FOR LIFE.

Country residents and city residents stand the same chance for immediate appointment.

Common sense education sufficient.

We Will Coach 25 Candidates Free of Charge

Write immediately for full list of many positions now easily obtainable. Don't delay. Every day you lose means the loss of just so much chance of early appointment.

FREE COACHING COUPON

FRANKLIN INSTITUTE, Dept. C 96, Rochester, N. Y.

This coupon, properly filled out, entitles the holder to (1) full list of positions now obtainable, (2) a free copy of our valuable copyrighted book, "GOVERNMENT POSITIONS AND HOW TO GET THEM," (3) free sample examination questions; and (4) to consideration for FREE COACHING for the Civil Service position here checked.

... Railway Mail Clerk (\$800 to \$1800)	... Customs Positions (\$800 to \$1500)
... Postoffice Clerk (\$450 to \$1200)	... Internal Revenue (\$700 to \$1800)
... Postoffice Carrier (\$550 to \$1300)	... Stenographer (\$1000 to \$1500)
... Rural Mail Carrier (\$600 to \$1200)	... Clerk at Wash., D.C. (\$800 to \$1500)

Name.....

Address.....

Use this before you lose it. Write plainly.

Play This Saxophone While You Pay



Get this Saxophone on six days' free trial. Then, if you decide to buy, pay only a few dollars a month.

WURLITZER

THE HOUSE OF WURLITZER

The House of Wurlitzer is now making a direct money saving offer to you. All kinds of instruments. We supply the U. S. Government. New 194 page catalog free.

This Saxophone is a special value, and sent you on a remarkable offer. Generous allowance on old instruments.

One Week Free Trial

Try this instrument six days free. Learn how easy it is to play a Saxophone. Get our special offer.

Write Today Send today for the special booklet. No obligations. Write today. We will send our 194 page catalog too, if you wish it. First send us your name and address.

The Rudolph Wurlitzer Company

Dept. A422—E. 4th St., Cincinnati, Ohio—S. Wash. Ave., Chicago, Ill.

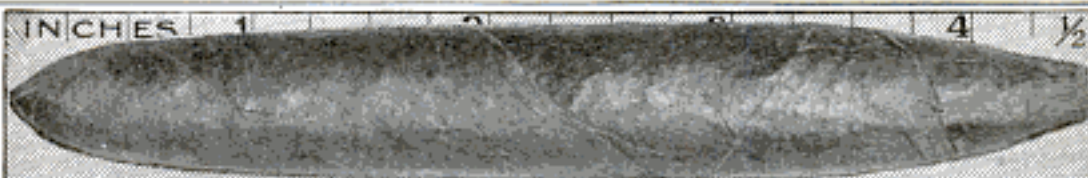

100 GENUINE Havana Seconds \$2.15

From Factory Direct To YOU By Ex. or Parcel Post Prepaid

Made of Imported Havana Picadura, from our own plantations in Cuba—leaves that are too short to roll into our 15c cigars. They're not pretty, no bands or decorations, but you don't smoke looks. Customers call them "Diamonds in the Rough." All 4½ inches long. Only 100 at this "Get Acquainted" price. Money refunded if you don't receive at least double value. When ordering specify mild, medium or strong. Your Check accepted. Our references, Dun or Bradstreet's or any Bank. To each purchaser of 100 Edwin's GENUINE HAVANA SECONDS, we will extend the privilege of ordering, for 40c additional, one of Edwin's "SAMPLE CASES" containing one sample cigar each of our 12 Best Sellers—all Bargain Values—priced up to \$12.00 per 100. Include this in your order—it's the biggest sample value ever offered.

Largest Mail Order Cigar House in The World
EDWIN CIGAR CO. Dept. No. 16 Get Acquainted 2338 2342 THIRD AVE. NEW YORK
When in New York SAVE MONEY by Patronizing any of the 100 EDWIN Retail Stores



\$100 TO \$150 SAVED ON MEISTER PIANOS

Let us send this beautiful instrument to you on

30 Days' Free Trial Freight Prepaid

Eight beautiful styles to choose from. If it proves highly desirable to you, we will sell it to you on

Small monthly payments. No cash deposit down.

No interest or extras. Stool and scarf FREE.

THREE YEARS TO PAY!

A binding guarantee of high-class material and workmanship. Write today for our beautiful 100-page illustrated catalog. IT'S FREE.

Rothschild & Company Dept. D-16 Chicago, Ill.

COIN RINGS, 50 CENTS POST-PAID

Made of new dimes, embossed. Big hit! Agents, big discount. Send 50 cents for sample. Money refunded if not satisfied.

WM. COMERFORD, 44 Seneca Street, BUFFALO, NEW YORK



B-E-T-T-E-R MUSIC

Williams' Sounding Board

Placed under record on any disc phonograph.

SEND \$1.50 TO

O. B. WILLIAMS CO., Seattle, Wash. U. S. A.
Manufacturers Sash and Doors.

Mr. Edison's Wonderful Phonograph

Only **\$1.00** After
Free Trial



Yes, you may keep this New Edison—Thomas A. Edison's great phonograph with the diamond scriber—and your choice of records, too, for only \$1. Pay the balance at rate of only a few cents a day. Try the New Edison in your own home before you decide to buy. Send no money down. Retain your friends with your favorite records. Then return it if you wish.

Write Today For Our New Edison Book. Send your name and address for our new book and pictures of the new Edison phonograph. No obligations—write now while this offer lasts.

F. K. BABSON, Edison Phonograph Distributors
4119 Edison Block, Chicago, Illinois

Please Mention Popular Mechanics

INVESTIGATE BEFORE YOU INVEST IN A VIOLET RAY MACHINE



Be Sure You'll Be Satisfied

— you who have made up your mind that a Violet Ray instrument is essential to development of greatest beauty and health—and all who are familiar with the beauty and body building value of this most scientific, quickest, most pleasing and surest means of restoring health and personal attractiveness—have made a decision to purchase a Violet Ray appliance of some sort.

Don't jump at a buying decision. Don't think that all Violet Ray machines are alike in make or results. They're not.

The VIOLETTA

High Frequency Generator. Generates ozone. Enriches blood. Produces soothing, invigorating, curative Violet Rays. The most advanced type—most reliable. Productive of best results. And you want the best. You'll probably buy but one appliance of the kind in a lifetime. Make certain you're not cheating yourself. The VIOLETTA machine is employed by leading physicians—scientists—physical culturists who use only the most perfect instrument to be had. And whose selections are founded on most critical—most exhaustive tests. More VIOLETTA instruments are used by these discriminating buyers than any other make. We ship the VIOLETTA on approval—C. O. D. subject to inspection. You know you'll be satisfied. No risk.

Send for Free Descriptive Matter

Read the scores of testimonials from eminent physicians. Write at once. Just say on a post card, "Send me free literature"—sign your name—address to us. We'll send you convincing evidence of superior excellence. Will show you many wonderful improvements and astounding savings in cost. Send now.

Bledson-Dunn Co.
Dept. C7, 258 N. 5th Ave.
CHICAGO, ILL.



See
It
Before
Spending
a Cent

A Baseball Jersey



Be the First in Your Club

School, City or Town, to wear this pure, all wool sweater, double collar and cuffs. Your choice in colors. This jersey was selected by 10,000 of my customers for last season. Your club will recommend it. Send for my big illustrated catalogue. Write me and learn my offer for your club's order. Popular Prices. Best Grade Sporting Goods—Baseball, Basketball, Tennis, Golf, Football, etc.

WRITE ME NOW.

JACK SHANNON CO., Dept. 46, 54 E. Monroe St., Chicago

FREE

BOOK TELLS HOW TO MAKE \$150 TO \$1000 PER MONTH

Making celebrated Flavo Nature-Flavored Flour in rural communities or small towns with

AMERICAN MARVEL FLOUR MILL

(Self-Contained)

You can quickly become a member of Community Marvel Millers. We start you. Help you. 30 days' free trial. Investment and terms easy to handle. Write for fully illustrated book.

ANGLO-AMERICAN MILL CO., Inc.
135-141 Trust Bldg. Owensboro, Ky.



Don't Wear a Truss

Brooks' Appliance, the modern scientific invention, the wonderful new discovery that relieves rupture will be sent on trial. No obnoxious springs or pads.

Brooks' Rupture Appliance

Has automatic Air Cushions. Binds and draws the broken parts together as you would a broken limb. No salves. No lies. Durable, cheap. Sent on trial to prove it. Protected by U. S. patents. Catalogue and measure blanks mailed free. Send name and address today.

C. E. BROOKS, 126 State St., Marshall, Mich.



Sportsmen, Here's Your Canoe!

For that early fall sporting trip or to get out where it's cool now, there's nothing as fine as an

"Old Town Canoe"

"Old Towns" last indefinitely—they're always safe, swift and easy to paddle. The universal choice of sportsmen everywhere because they're the best. Write for catalog. Order from dealer or factory—\$34 up. Quick delivery.

OLD TOWN CANOE COMPANY
1666 Middle St., Old Town, Maine, U.S.A.

Universal MARINE MOTOR

9-12 H. P. 4 Cycle 4-Cylinder. Speed range 300 to 1800 R.P.M. Adapted to boats from 14 to 30 feet. Write to

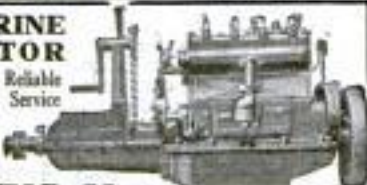

Reliable Service

UNIVERSAL MOTOR CO.
OSHKOSH, WIS. Dept. P

For Bulletin No. 25 giving full description

Get this LA Engine Book



—it gives valuable information about engines. It also describes the full line of L-A motors and tells of the 30 days' free trial plan. Write for your copy today.
LOCKWOOD-ASH MOTOR CO.
1430 Horton Ave., Jackson, Mich.

Extra money for you now

You need more money this summer—and here's a dignified, easy way to get it. Take orders for the

Wisconsin Detachable Motor

Equip your boat with a guaranteed Wisconsin—enjoy yourself while demonstrating and making money. Thousands in use. Everyone interested. Has many exclusive features including self-locking tiller and patented top adjustment, which make the Wisconsin the best row boat or canoe motor to use, and the easiest to sell. Ask for our agents' plan. Ask for catalog Q.

WISCONSIN MACHINERY & MANUFACTURING COMPANY
Misor Street, Milwaukee, Wisconsin

Highest Award Panama-Pacific Exposition. Purchased by U. S. Government, after competitive tests.



Boat in Comfort

Jump into your rowboat, start your Caille 5-speed rowboat motor, and you can go any place without the slightest effort. Skip over to the farthest fishing grounds or skim around the lake and breathe in the vigorous fresh air. You'll find this motor always dependable, runs 7 to 10 miles an hour and 4 hours on 1 gallon of gasoline.

CAILLE 5 Speed Motor

HAS FIVE SPEEDS

Fast speed, trolling speed, neutral, slow and fast speed reverse accomplished without altering speed of motor. When set in neutral, the boat stands still while motor remains running. Trappers find this motor a great time and labor saver.

TRAIN YOUR BOY

Teach him how to handle small boats—develop his self-reliance. This is the ideal motor for him and perfectly safe. Splendid for yacht tenders, too.

DEALERS WANTED

We also build the famous Caille Perfection inboard motors up to 30 H.P., 2 and 4 cycle, 1 to 4 cylinders. When writing be sure to give dimensions, style and purpose of boat to be powered.

Caille Perfection Motor Co.
1523 Caille St. Detroit, Mich.



Please Mention Popular Mechanics

THERE'S NO OTHER SPORT LIKE BOATING

CAN any other sensation equal that of skimming over the water, fast or slow at will, in a speedy motor boat? Is there anything more soothing than the scent of wild places; more thrilling than the gentle throb of the motor as it reaches your fingers at the steering wheel? There is no other sport like boating. Your preference will probably be a Mullins boat because

MULLINS STEEL BOATS CAN'T SINK

also, because they are beautiful in design, seaworthy and built in the world's largest boat factory.

Mullins boats are trouble-proof. They cannot leak, water log, dry out, warp or open at the seams and never require calking. Powered with 2 and 4-cycle motors of the most approved type, properly installed, equipped with airtight chambers fore and aft and Silent Underwater Exhaust. With a Mullins boat you can enjoy boating at its best. Forty models now ready for delivery.

Write for our big catalog of steel and wooden motor boats, rowboats and canoes—free.

THE W. H. MULLINS COMPANY
52 FRANKLIN STREET SALEM, OHIO

World's Largest Manufacturers of Steel and Wooden Pleasure Boats and Builders of the Celebrated Mullins Outboard Special 14-ft. Steel Boat





Only
\$60

"In the Good
Old Summer Time"

THOSE cruising days are coming. Are you ready? Our announcement of the old price of \$60 on the Columbian (a clear saving of \$20 to \$30 over any other rowboat motor of equal quality) has resulted in a flood of early orders.

We have greater manufacturing and shipping facilities this year than ever before, but don't want to disappoint you. *Order now* and be sure of getting your Columbian on time. Send for illustrated folder describing Columbian Motors.

Fine showing of Boats, Canoes, Cruisers, Marine Engines, Motor Boat accessories. We'll save you money—literature free on request.



CULLEN MOTOR COMPANY
Dept. I 112 W. Lake St., CHICAGO, ILL.

NO MORE MIRRORS IN PASSENGER ELEVATORS—Mirrors are to be removed from passenger elevators, in some parts of the United States, says the Christian Science Monitor. The reason given is that most of these cars now go up and down at a rate of speed sometimes 600 ft. a minute. This makes it impossible for young women to get half through looking at themselves before it is time to get out.

Has The Motor Boat Bug Got You?



Health and happiness are assured with one of the new popular priced Gray motors in your boat. Select your boat from our 1917 Boat Builders Catalog showing products of 200 leading boat builders. Select your engine from our new complete Engine Catalog. Both books FREE. Send today.

GRAY MOTOR COMPANY
646 Oakland Ave., DETROIT, MICH.

ROWBOAT MOTOR

FERRO

Make Your Rowboat a Motorboat

For fishing—the Ferro gets you there quickly without tiring with oars. Runs quietly and slowly for trolling. For camping—takes you anywhere in a jiffy. For racing—has lots of speed. For general use—easy to carry, easy to run. 6 hours on a gallon of gasoline. 2 to 9 miles an hour. Bosch magneto, float-feed carburetor, rubber, wood-proof propeller, noiseless muffler. Price includes everything. Agents wanted. You only need buy a motor for demonstration. Ask for agency proposition 215.

\$90 with Bosch high-tension magneto.
\$70 with waterproof batteries.

The Ferro Machine & Foundry Company
648 Hubbard Avenue Cleveland, Ohio



DON'T GO ROWING - GO FERROWING

Please Mention Popular Mechanics

Roberts Motors for Boats

4 h. p.—\$68.00 8 h. p.—\$120.00 16 h. p.—\$240.00



You will find that Roberts Motors will give your boat more speed, more dependability than you thought possible. Buy a Motor Boat Roberts equip and you make a good investment on your pleasure's behalf and on your health's behalf.

Immediate Shipments Can Be Made on Roberts Motors

Despite a big increase in sales we have a full stock of all sizes on hand and can make immediate shipment. Write for full details today.

ROBERTS MOTORS, 2000 Roberts Bldg., Sandusky, Ohio

GET THIS CATALOG
FULL OF VALUABLE INFORMATION TO EVERY
BOAT OWNER ON
**RACING PROPELLER WHEELS,
REVERSE GEARS AND
MARINE ACCESSORIES**
LARGE CATALOG FREE. SEND TODAY
MICHIGAN WHEEL CO.
1179 MONROE AVE., GRAND RAPIDS, MICH.

Racine Wis

America's Finest Canoe
Speed, lightness and beautiful finish combined to the highest degree. Write for free catalog showing the many distinctive features of the Racine Wis.
Racine Boat Company, Dept. O, Racine, Wis.

THE REEL WITHOUT A RIVAL

The **CASTER'S IDEAL**

A reel that is really reliable. Faultless in construction. Steady in strength. The **GUY-RA-TORY** Reel is *entirely* new. Power parts. Greater simplicity. Spool action distributes line without thumbing. Eliminates cutting in. *Dries it on spot.* Prevents back lashes and snarls. Taken apart in jiffy. Other exclusive improvements fully described in attractive catalog. Write at once for copy. It's free.
Guy-Ra-Tory Reel Co.
317 Fifth St.
Racine, Wis.

SPEEDIER THAN THE AVERAGE LAUNCH



A big claim? Yes. Exaggeration? Not a particle. That the famous 2-cylinder Koban is speedier than the average launch is borne out by the experience of thousands of Koban users in all parts of the world.

The Great 2-CYLINDER KOBAN ROWBOAT MOTOR

A Koban owner at Madison, Wis., writes: "We can easily pass a good number of the larger launches on the lakes." Another user says: "There was not another outboard motor on the lake that could keep up with us." Develops a full 3 H. P. Makes 10 to 12 miles an hour on a good-sized boat. Insures wonderful fuel economy. Starts, reverses, "picks up" and throttles down with perfect ease. **The 2 opposed cylinders fire simultaneously, neutralizing all vibrations.**

Send for Catalog showing 1917 Models.
Agents wanted at every watering point.

KOBAN MANUFACTURING CO., 291 South Water Street
MILWAUKEE - WIS.
Write for Descriptive Circular on our 2-cylinder 3 H. P. VIBRATIONLESS Inboard
Marine Engine for small launches, canoes, etc.

Please Mention Popular Mechanics



YOUR OUTDOOR DAYS

You'll enjoy them more with an

EVINRUDE

DETACHABLE ROWBOAT & CANOE MOTOR

Easily portable—quickly attached to any rowboat or canoe. Equipment includes Evinrude Magneto—Built-in Flywheel Type, entirely enclosed—Automatic Reverse—new refinements for 1917. More speed and power. Catalog and dealer's name on request. Special folder describes rowboats, canoes, skiffs and accessories.

Evinrude Motor Co., 566 Evinrude Bldg., Milwaukee, Wis.

Over 80,000 Sold—Used by 25 Governments.

Also manufacturers of 2 and 3 H. P., 2 cycle inboard motors for launches, canoes, dinghies, tenders.

Branches: New York Boston Portland, Ore. San Francisco



Motor Perfection

is what you get in Watkins Class "B" all iron motors. Especially fine for canoes and light boats. Constant and efficient.

3 H. P. single cylinder 45 lbs.

6 H. P. double cylinder 85 lbs.

12 H. P. four cylinder 155 lbs.

Are light at the same time strong, accomplished by using semi-steel castings, high carbon steel shaft, bronze bearings, high class workmanship.

THE WATKINS MOTOR CO.

837-839 W. 6th Street

Cincinnati, Ohio



PRINT MY OWN

Cards, circulars, menus, book, paper, etc. Press \$1. Larger \$18. Rotary \$61. Save money. Print for others, big profit. All easy, rules sent. Write factory today for illustrated catalog presses, TYPE, cards, samples.

THE PRESS CO. D-37, MERIDEN, CONNECTICUT.

KENNEBEC CANOES

Enjoy a back-to-nature vacation with a canoe. Exciting and healthful. Kennebec Canoes are light, strong and safe.

Send for free illustrated catalogue. Many styles and prices.

Kennebec Boat & Canoe Co.,
459 Railroad Sq.,
Waterville, Maine



In the field, on the stream, or in the home

HOMOL

TRADE MARK

is a necessity. Five ounces of good oil that lubricates and prevents rust. For guns, tackle, bicycles, automobiles, phonographs, typewriters, etc. Put up in the can with the patented spout; can't leak or break; always ready.

If your dealer has not yet received his supply of HOMOL, send us his name and a quarter, and we will put a can in your hands promptly, carriage prepaid.



WM. PETERMAN, Inc.

200 Fifth Avenue
New York City



Enormous Profits



START GROWING MUSHROOMS

Learn the latest authoritative way to make still bigger profits than you ever thought possible or ever made growing mushrooms. Add \$10 to \$75 a week to your income. Anyone, man, woman and children can do it in spare time in city or country. Grow in basements, cellars, sheds, boxes, etc. Start now. Demand bigger than supply. Send for big free book of expert authority. "The Truth About Mushrooms." Write to

BUREAU OF MUSHROOM INDUSTRY
Dept. 387 1342 N. Clark St. Chicago

BARODA DIAMONDS

FLASH LIKE THE GENUINE—AT 1-50 THE COST

SOLID GOLD MOUNTINGS Stand acid test and expert examination. See them first, then pay. Catalog FREE. Patent Ring Gauge included for 5 two-cent stamps.

The Baroda Co., Dept. F3, 1456 Island Ave., Chicago



Relief to Ruptured People

Any appliance is a truss. Ruptured people must wear a support. Our New Sponge Rubber Pad (pat'd) is velvety, soft to the skin, pliable, most elastic, extremely comfortable, adapts itself to ruptured parts with less pressure, is sanitary, long lived. Massages and strengthens muscles, allows blood circulation and produces many cures.

Scrotal Pad Needs No Leg Strap

Our New Akron Sponge Rubber Scrotal Pad (pat'd) holds 8 out of 10 cases of scrotal hernia perfectly without strap between the legs.

Cures Man of 86

The Akron Truss Co. Gentlemen: I am 86 years and 6 months old and have had a rupture for 27 years. I am an active man, tend to a large garden, saw and split the wood and do the household chores. I bought an Akron Truss and wore it one year and am as sound as a dollar.

Respectfully yours, H. W. Glaze, Illinois.

Cured Double Hernia

The Akron Truss Co. Gentlemen: I have worn one of your trusses for some time. All this time have carried two heavy sample cases; notwithstanding this handicap, your truss has cured me of a double hernia.

Yours truly, O. E. Jones, Indiana.

Girl Baby Cured

The Akron Truss Co. Gentlemen: The infant's truss was a perfect success. The child wore it about one year, and the rupture healed so that a person cannot see she was ruptured. Yours truly, J. Hayunga, Illinois.

Free Sample Pad & Sample Akron Sponge Rubber Truss Pad will be sent absolutely FREE upon request, also booklet "Relief to Truss Users." It's full of help. Ask your dealer, or write us.

THE AKRON TRUSS CO. 64 TRUSS BLDG. Akron, Ohio

Please Mention Popular Mechanics

OSTER PIPE-THREADING EQUIPMENT

Combination machines for threading straight and bent pipe, nipples and bolts.

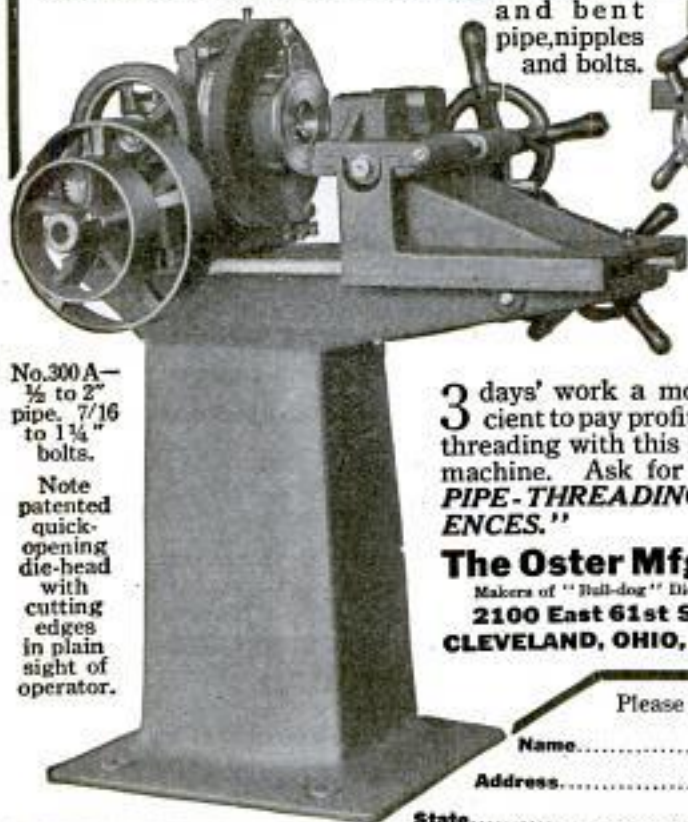

No. 300 A—
1/2 to 2"
pipe, 7/16
to 1 1/4"
bolts.

Note patented quick-opening die-head with cutting edges in plain sight of operator.

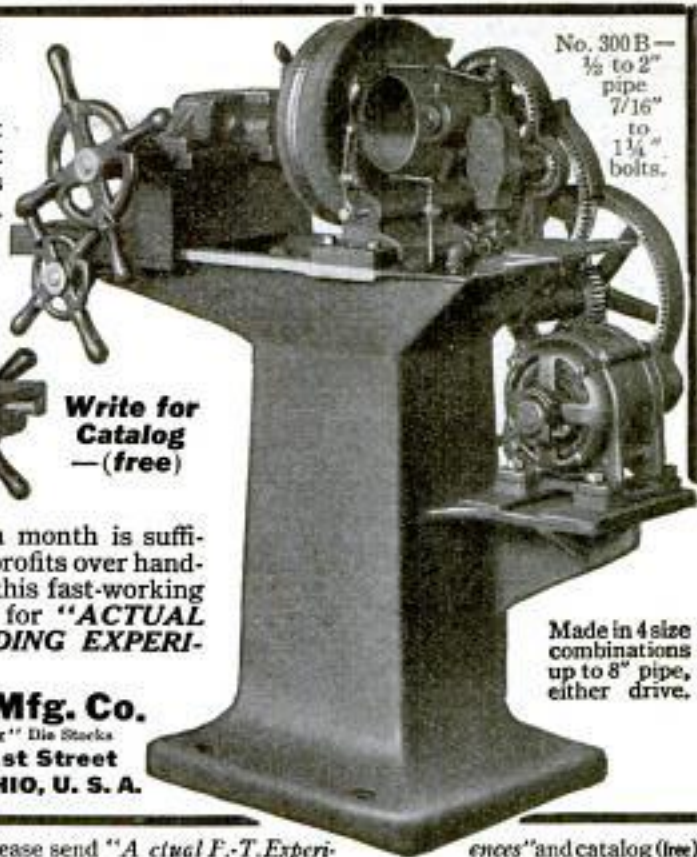

No. 300 B—
1/2 to 2"
pipe
7/16"
to
1 1/4"
bolts.

Write for Catalog—(free)

3 days' work a month is sufficient to pay profits over hand-threading with this fast-working machine. Ask for "ACTUAL PIPE-THREADING EXPERIENCES."

The Oster Mfg. Co.

Makers of "Bull-dog" Die Stocks
2100 East 61st Street
CLEVELAND, OHIO, U. S. A.

Made in 4 size combinations up to 8" pipe, either drive.

Please send "Actual F.T. Experiences" and catalog (free)

Name.....
Address..... City.....
State..... Occupation..... (2100)

HERRINGS AS BAROMETERS—New experiments have brought investigators to the conclusion that certain fishes are guided in their migrations by highly developed senses of smell and touch. The fishes, Popular Science Siftings says, recognize the presence of slight traces of acids and alkalis, and herrings prove sensitive to changes of a fraction of a degree in temperature. It is also concluded that salmon find their way from far at sea to their chosen rivers by some chemical peculiarity of the water.



CRESCENT WOOD WORKING MACHINERY

satisfies experienced users of wood working equipment because they are competent to choose the best and to know it when they see it. Ask today for catalog of hand saws, jointers, saw tables, planers, disk grinders, planers and matchers, variety wood workers, universal wood workers, hollow chisel mortisers, swing cut off saws, shapers.

THE CRESCENT MACHINE CO., 93 Co'umbia St., Leetonia, OHIO



A Constant Water Supply For Your Farm Home

Don't depend on a windmill or the back-breaking hand pump to fill your water tank. It's more reliable and economical to install a

RIFE RAM

and be sure of a constant supply of fresh water, without fuel or attention. The Rife Ram operates by the flow of any stream having a fall of 3 feet or more and a supply of 3 gallons or more per minute. Will maintain air pressure system. Simple to install. Over 11,000 in use. Satisfaction guaranteed.

Write today for catalog and free estimate

RIFE ENGINE CO.
3131 Trinity Building NEW YORK



Do you know that there are more "Sebastian" Lathes used in Garage and General Repair Shops than any other make?

The Sebastian Lathe Co. 107 Calvert Street Cincinnati, Ohio, U. S. A.



A complete line of appliances for the transmission of Power. Anything from a bolt to a complete mill or factory outfit. Send for catalogue. Largest Manufacturers of Pulleys in the country. **W.A. Jones Foundry & Machine Co.** 1400 W. North Ave. CHICAGO

Please Mention Popular Mechanics

Every Builder and Contractor Needs this Level

10 Days' Free Trial

We have been making levels of transits and levels since 1883 and our instruments are the standard of the world. Prove the superior quality of the Aloe Convertible Level by giving it a 10 days free trial. Use it on your every-day work laying out buildings, leveling up foundations, walls and floors, aligning, shafting walls, piers, etc., for getting angles or levels anywhere.

Easy Monthly Payments

If you decide to keep it, the instrument will earn its way while you make monthly payments so small that you hardly feel them. Costs no more than to pay all cash. No red tape about it, no embarrassing questions, everything confidential.

Aloe Convertible Level

is the finest instrument ever offered at anywhere near its price. Permits taking of sights both above and below the horizontal. For taking vertical sights it is provided with a special convertible bracket rigidly and permanently attached to the cross bar. The telescope is fitted with permanent axis which rests in bracket bearings and is held by clasps easily and quickly released.

Aside from being a level, it is a modified transit that permits a much wider range of work than is possible with the ordinary architect's level. With it the man without technical training can obtain the same absolutely accurate results as the expert. Write today for descriptive circular.

A. S. ALOE CO.,
620 OLIVE ST., ST. LOUIS, MO.



Money Spent for Good Tools Is an Investment, Not an Expense
They will work more faithfully for you under all conditions, stand harder wear and outlast other tools if you will specify

"RED DEVIL" Tools
A complete line of Pliers, Screwdrivers, Snips, Glass Cutters, Hack Saws, etc. You will consider their ownership the best investment.
To be obtained from good dealers.
Send for tool literature, free.

SMITH & HEMENWAY CO., Inc.
97 Chambers Street, NEW YORK CITY

CARRY YOUR Claw Pipe Vise

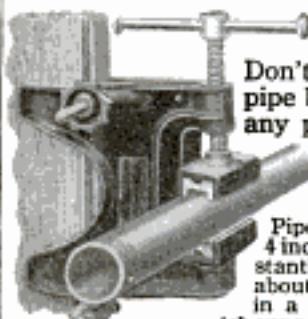

to the job and attach it INSTANTLY.

Don't waste time carrying pipe back to a bench. Fits any post, round or square, iron or wood, door or window casing. Fastens absolutely rigid.

Pipe simply cannot slip in the 4 inch teeth. Reverse jaws instantly for small pipe. Weight about 25 lbs. Pays for itself in a few weeks. Price \$15.75.

Ask your dealer or write us

COMMONWEALTH ENGINEERING CO., BOSTON, MASS.

Sixty-one years of development with the ablest mechanical minds have placed

CRANE VALVES AND FITTINGS

on a vantage-ground of excellence that has not been equalled by competition.

FOUNDED BY R. T. CRANE, 1868

CRANE CO.
836 S. MICHIGAN AVE.
CHICAGO

Branches in 52 leading cities

NAVY DEPARTMENT NEEDS DRAFTSMEN—While millions of dollars are available for new naval construction and the speeding of construction already begun, the work is retarded by lack of draftsmen, and the need of additional help is likely to continue for a considerable time, the Navy Department has announced. Applications are accepted at any time by the United States Civil Service Commission, where also application forms (No. 1312) and other information may be had. Besides, the secretaries of the United States Civil

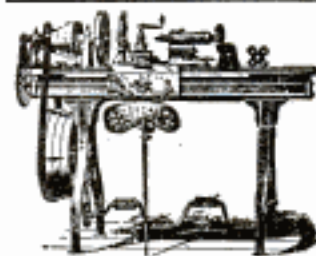

LATHES

9 to 18-inch Swing

List price \$75 and up according to size. When ready to buy send for Lathe Catalog and prices.

W. F. & John Barnes Co.
100 Ruby Street, ROCKFORD, ILL.

Use Water Power \$250 UP for Hard Work

The Divine Red Devil Water Motor

will operate washing machines, sewing machines, small lathes, small dynamos, do grinding and polishing. No muss—no fuss—nothing to get out of order.

A Simple, Durable, Economical Motor

that costs little or nothing to operate. Improved bucket-wheel construction exactly like big turbines. Power for small shops, mechanics, grocers, doctors and dentists. Money back if not entirely satisfied. Booklet and Prices Sent Free if you will write today and give us size of faucet, water pipe and water pressure and work to be done. You must furnish information to get booklet.

Divine Water Motor Co., Dept. P, Utica, N. Y.



Agents Wanted

"YANKEE" TOOLS *Make Better Mechanics*

The Automatic Feed Saves Drills

Every mechanic—whether machinist, plumber, metal worker or garage man—needs this No. 1500 "Yankee" Chain Drill, with Automatic Friction-and-Ratchet Feed. Friction feed tightens chain and quickly brings drill point to the work, or as speedily draws drill from hole after job is finished. Shift the lever and the Automatic Ratchet feed maintains a uniform pressure as the drill bites through the work. The workman pays no attention thereafter to the feeding as it is automatically, uniformly and exactly adjusted for all drills from smallest up to $\frac{3}{8}$ inch in diameter. You save drill points with this chain drill; and work speedily and accurately.

Your Dealer Can Supply You

Write for "Yankee" Tool Book, illustrating and describing the various styles of "Yankee" metal- and wood-boring, and screw-driving tools.

North Bros. Mfg. Co., Philadelphia, U. S. A.

"YANKEE" Chain Drill No. 1500

The "Yankee" Chain Drill comes in two styles:

No. 500—2-jaw chuck

Length, 10 $\frac{3}{4}$ in.

Weight, 3 $\frac{1}{2}$ lbs.

Holds square shank drills up to $\frac{3}{8}$ in. diameter.

No. 1500—3-jaw chuck

Length, 9 $\frac{3}{4}$ in.

Weight, 3 $\frac{1}{2}$ lbs.

Price \$3.90

Chuck holds round shank drills up to $\frac{1}{2}$ in. diameter, has tool steel jaws specially hardened. Square thread, steel feed screw.

Service Board at the following cities can furnish application forms: Boston, Mass.; Philadelphia, Pa.; Atlanta, Ga.; Cincinnati, Ohio; Chicago, Ill.; St. Paul, Minn.; Seattle, Wash.; San Francisco, Calif.; New York, N. Y.; New Orleans, La.; Honolulu, H. I.; St. Louis, Mo.; Balboa Heights, C. Z.; and also the chairman of the Porto Rican Civil Service Commission, San Juan, P. R.

STOP THAT SQUEAK

with 3-in-One Oil. It will make door hinges work noiselessly. For longer wear and easier work use 3-in-One on your:

Sewing machine, typewriter, talking machine, ice cream freezer, bicycle, skates, music box, lawn mower, cream separators, clocks, locks, hinges, bolts, catches, pulleys, scales, scissors, and everything else *around your home* that ever needs oiling.

3-in-One is a clear, light oil preparation that cuts out all dirt and never gums or cakes. It lubricates perfectly every action part and prevents wear. No grease; no acid.

3-in-One also cleans and polishes all wood and metal surfaces—absolutely prevents rust and tarnish, indoors and out.

FREE Write for generous *free* sample of 3-in-One, today. Give it a good hard test. Sold everywhere in 3 size bottles: 10c (1 oz.), 25c (3 oz.), 50c (8 oz., $\frac{1}{2}$ pint). Also in new Handy Oil Can containing 3 ozs. of oil, 25c.

3-IN-ONE OIL CO.

165 CNM. Broadway, New York City



South Bend Lathes

For the Machine and Repair Shop

How to Run a Lathe
A 50 cent book for 10 cents.
Postpaid, stamps accepted.

Straight or Gap Beds. Send for free catalog giving prices on entire line.
SOUTH BEND LATHE WORKS
423 Madison St., South Bend, Ind.



TOOL CASES

For Up-to-Date TOOLMAKERS and MACHINISTS

We carry the finest and most complete line of mechanics' toolcases and tools in the country. We guarantee to please you or refund money. Write for free catalogue.

J. M. WATERSTON

75 Woodward Ave., DETROIT, MICH.

GOODELL PRATT

1500 GOOD TOOLS

Please Mention Popular Mechanics



SIMONDS

A College Education

in saw-making science would enable you to pick out the best saw no easier than any man or boy can by just looking for the trade-mark etched on the side of every

Simonds Saw



No saw ever leaves our factory until it is good enough to bear that trade-mark.

Always insist upon getting a Simonds Saw, and you will be sure of complete satisfaction. Our guarantee is your protection.

Send for your copy of "How To File A Hand Saw." Free!

Simonds Manufg. Co.
"The Saw Makers"
 Established 1872
FITCHBURG, MASS.
 Five Factories, Eleven Branches

"I Tell You It's A Great Saw"

Please Mention Popular Mechanics



One Crescent Replaces This Kit

The Crescent wrench is adjustable to any size, while sacrificing none of the advantages of the solid wrench.

The thin, flat head, set at the scientific angle, makes usually difficult places accessible. Correct design permits adjustment with the hand holding the wrench.

Crescent material insures durability.

The Crescent Tool Co.
JAMESTOWN, N. Y.



PULLING TEETH OF WHALES AT SEA—In the museum of the Dartmouth Historical Society, at New Bedford, Mass., there is a collection of ivory carvings made mostly from whale teeth on board old whaling ships on long voyages, says the Marine Journal. Capt. George L. Howland, who served 19 years in the old whale ship "Canton," told recently of pulling teeth at sea.

"First," he said, "the jawbone was cut from the whale and lifted on deck by a tackle. It was then lashed firmly to a ringbolt in the deck. The gum was cut from the teeth on both sides of the jaw with a whale spade. A seaman then took a crowbar and drove it in hard under the first tooth at the end of the jaw. A line was



Duplicate Keys

for all Pin Tumbler Locks made in one minute with Harrison M.L.P. Key Filing Machine. No misfits. Thousands in use. \$3.50 net. Special diamond-shaped files for angular cut keys, 40c each; 3 for \$1.00. Harrison C. K. Key Clamp duplicates all common keys without a caliper. Price, \$1.10. Parcel post prepaid.

Money returned if not satisfactory.

HARRISON & CO., 81 New St., New York



Tool Cases for Toolmakers and Machinists

Keep your tools orderly arranged in a Gerstner Portable Tool Case. There's a place for every tool in one of the felt lined drawers. Every up-to-date mechanic needs one and you'll find our Cases the best built, neatest and most practical on the market. We guarantee to please or refund all money. Write for our free booklet!

Gerstner & Sons

Mfrs. of Mechanics' High Grade Tool Cases,
808 Columbia St., DAYTON, OHIO

LE PAGE'S
CHINA
CEMENT
 STANDS HOT AND COLD WATER 10¢

The slightest cut, received while working with tools, may become infected.

LISTERINE

The Safe Antiseptic

Manufactured only by Lambert Pharmaceutical Company, St. Louis, Mo. U.S.A.

should always be at hand, so it may be applied promptly to cuts and small wounds to prevent infection.



strapped around the first two or three teeth thus loosened and three men then hauled on the other end of the tackle, loosening the whole row. The big ivories were then cleaned and usually distributed among the men who wanted to make carvings. In a fully developed whale there are 46 teeth, varying in size from three to seven inches."

Many ornamental things were made by the whalers from these teeth, but the majority of the carvings in the collection are very fancy pie cutters.

Here is one of the best

The ONLY interlocking, sliding rule made

Interlox

MASTER SLIDE RULE

Here is the Exact INSIDE Measurement

Best, quickest, most accurate rule for outside measurements, too.

If not at dealer's, send his name and 20c per foot (any length, 2 to 8 ft.), and we'll send rule prepaid.

DAHL MFG. CO., 51C E. 42nd St., N. Y.

Liberal Proposition for Dealers and Agents

Here is the Other

DON'T SCRAP ALUMINUM PARTS

SO-LUMINUM

repairs cracks, breaks or defects in aluminum in $\frac{1}{2}$ the time and cost of acetylene welding. Parts so mended are stronger at welded joint than elsewhere. Gasoline torch only thing necessary. No flux needed.

Send 50 cents for trial bar. \$3.00 pound. Money refunded if not satisfactory. Booklet on request.

SO-LUMINUM MFG. & ENG. CO., Inc.

Room 12, 1790 Broadway, NEW YORK CITY

THE AWL YOU WANT

See That Reel



Is the genuine MYERS \$1.00 "Lock Stitch" Sewing Awl with the exclusive feature. See thread reel in front of handle under the finger tips. Natural tension. Sews heavy or light material, diamond point, full grooved needles used to protect the thread when sewing.

C. A. MYERS COMPANY, 6339 University Ave., Chicago, Illinois

Insure Your Work Against the Scrap Heap

The careful use of dependable precision tools and your skill as a mechanic is all the protection you need.

Use B & S Tools **B.S.**



For over fifty years toolmakers, machinists, and manufacturers have found protection against the scrap pile in the accuracy of

Brown & Sharpe Machinists' Tools



Our Catalog 27 besides listing our complete line of tools, contains much of interest and instructive value. Get a copy for your kit.

FREE ON REQUEST

Brown & Sharpe Mfg. Co.
Providence, R. I.

**Stanley
Tools**



Shoot Board and Plane

A tool for **Pattern Makers—Carpenters—Cabinet Makers**—in fact, for any workers in wood who have nice fitting to do.

PRINTERS and ELECTROTYPERS use it for squaring up and sizing electrotypes

The plane moves in a run-way, insuring absolutely the same position of cutter for every stroke. Can be adjusted to plane at any angle between zero and ninety degrees. Cutter can be set to give any draft desired to a pattern. Special circular containing full description upon request. Base 22 in. long—plane 15 in. long—cutter 2 1/4 in. wide—weight 17 1/2 lbs.

If you cannot procure this tool from your Hardware Dealer, write us direct.

STANLEY RULE & LEVEL CO.
NEW BRITAIN, CONN. U.S.A.

Acetylene Blow Torch Prest-O-Torch



Quicker and cheaper than a gasoline blow-torch for brazing and soldering

For factories, repair shops, linemen, dentists, jewelers, the Prest-O-Torch saves time and money. Used with Prest-O-Lite Tanks—ready-made gas. Intense, concentrated flame instantly lighted. No depreciation, safe and convenient. Style "A", price, 75c (Canada, 85c) will braze up to 3/8 inch round rod. Style "C" for heavier work, \$2.25 (Canada, \$2.75). Special styles for dentists. Write for literature or send order now. Money refunded if not satisfied.

The Prest-O-Lite Co., Inc. 816 Speedway
Indianapolis, Ind.
Canadian General Office, Dept. U, Toronto, Ont.



**\$100
Oxy-Acetylene
Welding Outfit**
Complete as shown

\$37⁵⁰

Anybody can operate it; printed instructions furnished. Enormous output makes low price possible. Highest quality. No agents, strictly cash with order, one price to all. Every user can afford this outfit. Worth fully \$100. **ORDER TODAY.**

WELDIT ACETYLENE CO.
506 Kresge Bldg. DETROIT, MICHIGAN

Please Mention Popular Mechanics

SARGENT
REG. U. S. PAT. OFF.

Automatic-Set Bench Planes

For working against the grain on cross-grained hard wood.



Mechanics who have used these Planes say they are the BEST. They have superior features and do work that no other Planes will do.

The automatic set is a great time saver; the rigidity insures good work; and the ease of adjustment is a great advantage.

These features are fully explained and the six sizes of these Planes described in the Sargent Plane Catalogue, a copy of which will be sent free on request.

SARGENT & COMPANY
49 Water St., New Haven, Conn.

Portable Cases

For Tool Makers and Machinists



Twelve styles, felt lined drawers, solid brass trimmings, best of material, beautiful finish, low prices, satisfaction guaranteed. Ask for booklet of cases built for service.

THE PILLIOD LUMBER CO.
SWANTON, OHIO

DISSTON SAWS AND TOOLS

Deafness Is Misery



I know because I was Deaf and had Head Noises for over 30 years. My invisible Anti-septic Ear Drums restored my hearing and stopped Head Noises, and will do it for you. They are Tiny Megaphones. Cannot be seen when worn. Easy to put in, easy to take out. Are "Unseen Comforts." Inexpensive. Write for Booklet and my sworn statement of how I recovered my hearing.

A. O. Leonard, Suite 226, 150 5th Ave., N. Y. City

INDOOR CHEMICAL CLOSET



No smell, no germs, sanitary. Use in any room. Needs no plumbing, sewerage or running water. Chemicals in closet kill germs. Fine for the sick and old folks.

DESTROY OUTDOOR CLOSET

Put in a warm, Indoor Sanitary Closet. Empty twice monthly, only attention necessary. Satisfied users and Boards of Health endorse it. Fully Guaranteed. **30 Days' Free Trial.** Write for FREE Literature. Agents wanted.

SANITARY CLOSET CO. 26 Colton Bldg., Toledo, O.

\$10

TRADE MARK
Starrett
 REG. U.S. PAT. OFF.



Tools

Reduce Mistakes to a Minimum

One slight error in laying out a job or measuring the progress on it may ruin the stock and render futile the labor spent upon it.

Good men using Starrett Tools reduce mistakes to a minimum. These tools are the standard for accuracy all over the world.

The line of these fine measuring instruments includes: rules, squares, levels, calipers, dividers, micrometers, vernier height gages, depth gages, test indicators, etc., and hack saws.

Write for FREE CATALOG No. 21AP describing the whole 2100 styles and sizes of these tools.

THE L. S. STARRETT CO.

The World's Greatest Toolmakers
 ATHOL, MASS.

42-671



Please Mention Popular Mechanics

PATENTS TRADE-MARKS AND COPYRIGHTS

LARGEST PATENT FIRM
IN THE WORLD

SPECIAL OFFER Free Opinion as to Patentability

Before sending your invention to any attorney or manufacturer or disclosing your invention, write for our free blank form **PROOF OF CONCEPTION** in order to protect your invention and secure your rights. This should be signed and witnessed and returned to us, together with a model or sketch and description of your invention, and we will give a **FREE OPINION** as to the patentability of the invention. If we report the invention patentable we will furnish a Certificate of Patentability.

This Certificate of Patentability, together with our blank form Proof of Conception will protect the inventor and serve as proof of the invention until the case can be filed in the U. S. Patent Office.

Obtaining Assistance for Inventors—Our certificate is of great assistance to inventors who require financial aid to obtain patents.

OUR FIVE BOOKS MAILED FREE

(See Coupon Below)

to any address. Send for these books—the finest publications ever issued for free distribution.

How to Obtain a Patent

Our illustrated eighty-page Guide Book is a book of reference for inventors and contains 100 mechanical movements, illustrated and described. Tells how to invent for profit.

What to Invent

Contains a valuable list of inventions wanted and suggestions concerning profitable fields of inventions; also information regarding prizes offered for inventions amounting to **One Million Dollars**

Millions in Trade-Marks

Shows the value of Trade-Marks and information regarding unfair competition.

We Advertise Our Clients' Inventions Free in a list of Sunday newspapers, in manufacturers' journals and in World's Progress. Sample Copy Free. We save you time and money in securing patents. After the patent is granted we assist you to **sell your patent**.

WANTED NEW IDEAS

Prepare Now to meet the Demands of Industry in All Fields for New Ideas and New Inventions. We are constantly receiving requests from manufacturers who consult us when purchasing patents for inventions in all lines. We invite manufacturers and promoters to address our Sales Department regarding the purchase or leasing of a number of meritorious patents secured by us.

List of Patent Buyers

Contains requests from manufacturers, mail order houses and promoters for patents secured by us and suggestions as to **New Ideas** they wish to purchase. We place our clients in touch with capital free of charge. We have recently received over 300 requests from manufacturers.

Foreign Patents

We have direct agencies in all the principal foreign countries and secure foreign patents in the shortest possible time and at the **lowest cost**. Write for our illustrated Guide Book on Foreign Patents, sent free to any address.

VICTOR BUILDING



FREE COUPON!

VICTOR J. EVANS & CO.

New York Offices: 1007 Woolworth Bldg. **PATENT ATTORNEYS** Philadelphia Offices: 1429 Chestnut St.
Pittsburg Offices: 514 Empire Bldg. **Main Offices: 765 Ninth St., N. W., WASHINGTON, D. C.**

Name..... Address.....

Please Mention Popular Mechanics

Wanted—Ideas

Inventors! Send for these Remarkable FREE BOOKS, Today

“Inventions Needed”

This book lays before you a description of the active and profitable field of invention. It tells you the inventions the world needs today, the devices manufacturers are seeking for their business, the ideas for which the public will pay big money.

“How to Get Your Patent”

This book is a guide to the inventor. If you have invented something and desire to learn what it will cost you to get your patent and what you must do to find your market, read this book.

“Special Bulletin of Patent Buyers”

This bulletin contains letters from men who are seeking to purchase patents. We act as intermediary without one cent of charge; between the man who invents and the man who invests.

Send Model or Sketch and description of your invention for Free Opinion as to patentability

Rejected and Difficult Cases are Our Specialty

RANDOLPH & CO.

600 F St., N.W., Washington, D.C.

RANDOLPH & CO.
600 F St., N. W., Washington, D. C.

Gentlemen: Please send me without obligation on my part, the books indicated on margin of this coupon. (Write on margin of coupon, names of books desired.)

NAME.....
STREET.....
CITY.....STATE.....



PATENTS

C. L. PARKER
Formerly Member Examining
Corps, U. S. Patent Office
PATENT LAWYER
MCGILL BLDG.
WASHINGTON, D. C.

Patents, Trade Marks, Copyrights, Patent Litigation

Handbook for Inventors, "Protecting, Exploiting and Selling Inventions," sent free upon request.

SAFE METHODS

No catches resulting in useless patents. Large lists of manufacturers and inquirers. Nearest patents and report in each case to be filed; no extra charge.

EASY PAYMENT PLAN

Send for FREE BOOK { WHAT TO INVENT
WHAT NOT TO INVENT
HOW TO SELL YOUR PATENT
H. L. WOODWARD, Att'y, 9th and G, Washington



PATENTS

Send Sketch or Model of Your Invention for Free Opinion as to Patentability

Our Certificate of Patentability is Evidence

of Conception of your invention and may prove valuable to you. Our Credit System enables you to file your application for Patent and proceed without delay. Every case receives personal attention of one or both members of the firm. Patents we secure advertised at our expense in Popular Mechanics Magazine.

Write today for Free copy of 104-page book, "How to Obtain a Patent and What to Invent"

Talbert & Parker, Patent Lawyers
4683 Talbert Bldg. WASHINGTON, D. C.



PATENTS SECURED OR FEE RETURNED

Compare My SERVICE and TERMS with Those of Any First Class Attorney

Send Sketch, Photograph, or Model of your invention for an ACTUAL SEARCH of the Records of the Patent Office and report as to patentability — FREE. I give every detail of every case my closest personal attention and do not entrust your interests to assistants. Impartial advice on your ideas. I help you sell your patent. Terms moderate. My 90-page book (1917 edition) tells what inventors should know before they apply for a patent.

GEORGE P. KIMMEL, Patent Lawyer, 200 Barrister Bldg. Washington, D. C.

Latest and Most Complete Patent Book Ever Published for Free Distribution

WRITE FOR IT

DIAMONDS \$2 A MONTH



OWN A DIAMOND NOW! OUR CATALOG TELLS HOW

21 Jewel ELGIN Only \$2.50 a Month

Sent on Approval with lowest price ever made on a genuine 21 Jewel Elgin. See Special Offer with our Free Catalog.

Why Pay Cash? Our New Easy Payment Plan Helps Thousands and Will Help You—

Our New Catalog teems with Watch Bargains. It shows the very watch you have always wanted at the low price and Easy Terms you can afford to pay. A Guaranteed \$10 Elgin as low as \$7; \$25 Thin Models at \$17.50; and on Railroad Watches, we save you a third.

Free Catalog Write for it Today. Postal will do. This New Book will post you. It tells you just what you want to know about Watches, Diamonds and Jewelry.

HARRIS-GOAR CO., Dept. 89, Kansas City, Mo.
The House that sells more Elgin Watches than any other Firm in the World.

Inventions Wanted!



Manufacturers constantly writing us for patents. List of inventions actually requested and book "How to Obtain a Patent" sent free. Send rough sketch for free report regarding patentability. Special assistance given our clients in selling patents. Write for details of interest to every inventor.

CHANDLEE & CHANDLEE, Patent Attorneys
Est. 21 Years 1011 F Street, WASHINGTON, D. C.

GEARS ALL KINDS SMALL



The most accurate made and prices reasonable. We carry a complete line of gears in stock for immediate shipment. Can also quote on special gears of all kinds. Send us your inquiries.

WRITE FOR CATALOGUE

CHICAGO STOCK GEAR WORKS
16 S. Fifth Av. CHICAGO

Deafness



Perfect hearing is now being restored in every condition of deafness or defective hearing from causes such as

Relaxed or Sunken Drums, Roaring or Hissing Sounds, Perforated, Partially Destroyed Drums, etc.

Wilson Common-Sense Ear Drums

"Little Wireless Phones for the Ears"—

require no medicine but effectively replace what is lacking or defective in the natural drums. They are simple devices, which the wearer easily fits into the ears where they are invisible. Soft, safe and comfortable to wear at all times.

Write today for our 168 page FREE book on DEAFNESS, giving you full particulars and plenty of testimonials.

WILSON EAR DRUM CO., Incorporated
859 Inter-Southern Building LOUISVILLE, KY.

Please Mention Popular Mechanics

High-Value PATENTS

Get These Books now—read them—and if in your honest judgment they are not more interesting and worth more to you than all other patent books combined, we will refund the price in full.



- Talks by a Successful Inventor;
- How High Value Patents are Obtained;
- Facts about Prizes, Rewards and Offers for Certain Inventions; and
- The Patents Really Wanted by Manufacturers;
- Answers to All Questions of Greatest Interest to Inventors and Manufacturers concerning Patents and Trade-Marks; and
- Inside Information (contained in these books alone) of Utmost importance to Inexperienced Inventors—

That is a very general outline of what is contained in the 256 pages of these extraordinary books. Both will be mailed on receipt of 20 cents, coin or stamps, which is the regular price of the P. T. & S. Book alone. For Patent-Sense alone send 8 cents stamps.

R. S. & A. B. LACEY

32 Barrister Building, Washington, D. C.

SETS OF CASTINGS OF MODEL ENGINES



MECHANICAL SUPPLIES AND MATERIAL of all kinds. EXPERIMENTAL AND LIGHT MACHINE WORK to order.

132 MILK STREET, BOSTON

The American coal industry is barely over a century old. Its modest beginning is revealed by an old record which shows that in 1810 the United States produced only 20 tons of coal, while in 1914—the latest complete year for which statistics are available—the output was close to 490,000,000 tons.

The thoroughness of the sanitation of the Panama Canal Zone is exemplified by the report that since 1905 not one case of yellow fever has been contracted there.

Protective Patents

Procured Promptly. No fee refund, no guarantee certificate, no so-called prize or free search schemes used in our business. Inventors 104 page Blue Book sent on request.

Robb & Robb, 211-215A Southern Bldg., Washington, D. C.

NO MORE BALD HEADS



WHEN our VACUUM CAP is used a few minutes daily. We accept no pay until you have tried the Cap 30 days and are satisfied. The Vacuum Cap is an appliance that draws the blood to the Hair Roots and starts a new healthy crop of hair. It stops dandruff, stops the hair from falling out.

Bought by Doctors and men who know that it is the only reasonable HAIR GROWER known to science. No Drugs Used. Write for application blank, testimonials, and booklet on "HAIR," sent sealed in plain envelope, FREE.

THE MODERN VACUUM CAP CO.

Q. 559 BARCLAY, DENVER, COLO.

PATENTS SECURED OR ALL FEES RETURNED!!

PATENTS THAT PAY **Protect Your Idea!** **Don't Delay!**

Send data at once by registered mail and we will promptly advise how our clients proceed to make fortunes.

We Issue a Contract with Each Favorable Report to Return ALL FEES!

Actual Search FREE of the Patent Office Records, and Report as to Patentability Free!

INVENTORS READ \$500.00 IN AWARDS

For Best Testimonials about OUR "ALL FEES RETURNED" and "PATENTS SOLD FREE" Services

For Particulars Write Us

PATENTS SOLD FREE: Write Today For Our FREE "Patent Sales Department" Bulletin! Proof Given.

WATCH THIS SPACE NEXT MONTH:

\$1,200.00 SALE BY OUR CLIENT

"This is to inform you that W. S. Gorsche, Champion, Alta., Canada, has bought a one-fourth interest in "St. Louis Sheaf Loader," consideration \$1,200.00. Please make out whatever papers are necessary to that effect."

Yours truly,
(Sig.) GEORGE ST. LOUIS,
Champion, Alta., Canada
April 12, 1917

We Help Sell Only Our Clients' Patents FREE!

PATENT BUYERS please write Our "Patent Sales Department" Today! Excellent Opportunities!

Patents advertised Free in Popular Mechanics, and further promoted if applied for thru us in 1917; write us at once and be one who secures this valuable free service!

We write manufacturers for you—We don't wait until they write us!

WE LEAD — WE ARE LIVE WIRES!

"Vrooman" Clients' Patents SELL! Over \$626,012.00 made by our clients.

Foreign Patents Guaranteed

Branch Offices all over the world. Write for prices under guarantee.

Best References: The Lincoln National Bank, Washington, D. C.; The Griffin Mfg. Co., New York, N. Y.; The Dancy-Davis Press, New York, N. Y.; Twin-City Cord-Tire Co., Minneapolis, Minn.; The Davenport Mfg. Co., Davenport, Ia.; New Era Mfg. Co., Fairfield, Ia.; Garl Electric Co., Akron, Ohio; Lambert Machine Co., Marshall, Mich.; Blodgett Mfg. Co., Alameda, Calif.; and a THOUSAND others listed in our GUIDE book (BOOK FREE)



Our Offices Across Street from Patent Office

FREE COUPON " \$500.00 IN AWARDS "

E. E. VROOMAN & CO., 871 F St., WASHINGTON, D. C.

(Old-Established Firm, and Practitioners Before Supreme Court of U. S.)

Send me full particulars and your patent (book) literature FREE.

Name

Address

Models and Gears

Experimenters—Inventors

Developing inventions and making working models our specialty. Well equipped shop and staff of experts at your service. Carry complete stock of gears. Shipments same day order received. ESTABLISHED 1882.

UNION MODEL WORKS, 121 S. Clark St., CHICAGO

PATENTS

MASON, FENWICK & LAWRENCE, oldest U. S. firm having main office at Washington, D. C. Also New York and Chicago. Established 1861. Best References. Trade-Marks Registered. BOOKLET and Information FREE.

PATENTS THAT PROTECT and PAY

Send for FREE BOOKS.

Advice free. Terms reasonable. Highest references. Best results.

Send sketch or model for FREE examination and opinion.

BONDED and recommended Patent Lawyer in the Rand-McNally Directory of Bankers and Attorneys, Published by Rand-McNally & Co., Chicago, Ill. Recommended Patent Attorney in the Bankers Register and special list of selected lawyers published by the Credit Company, Pontiac Building, Chicago, Sharp & Alleman's Directory of Lawyers and Bankers, published at Philadelphia, and Martindale's American Legal Directory of New York City.

ALL BUSINESS GIVEN PROMPT AND PROPER ATTENTION

A large list of strong recommendations furnished free

WATSON E. COLEMAN, Patent Lawyer, 624 F St., Washington, D. C.

Please Mention Popular Mechanics

THE EXPO WATCH CAMERA

The most wonderful and ingenious Camera made

It is but little larger than a watch, which it closely resembles. You can carry the Expo about in your pocket and take pictures without any one being the wiser.

One Cent a Picture

The Expo loads in daylight with 10 or 25 Exposure Films, costing 15c and 25c respectively, and thus the picture taking part of a whole day's outing may be had for a very nominal sum — One cent a picture.

Easy to Manipulate

It is simplicity itself to operate. Takes pictures through the stem, where the Rapid Fire Lens is located. The photos 6/8x7/8 may be enlarged to any size.

QUICK AS A FLASH Time and instantaneous shutters; weighs but 3 ounces; rickety plated; Endorsed by amateurs and professionals the world over. Thoroughly practical; printing and developing of films just the same as ordinary cameras—in daily use by the police, newspaper reporters, detectives, and the general public. Important hints have been secured with the Watch Camera by enterprising reporters. Produces clear, sharp negatives indoors or outdoors equal to any camera on the market, size or price notwithstanding.

Sold Under a Positive Guarantee

Expo Watch Camera **\$2.50** FILMS, 10 Exposures 15c, 25 Exposures, 25c postage 10c
 Leather Pouch Carrying Case, 35c
 Adjustable View Finder for Watch Camera, 50c
MAILED TO ANY ADDRESS IN THE WORLD

JOHNSON SMITH & CO., 7161 North Clark Street, CHICAGO



Price \$2.50

New Vamping Card



PIANO PLAYING MADE EASY

NO TEACHER NEEDED—SURPRISINGLY SIMPLE SYSTEM

Persons having neglected their Musical Education need not despair, for with the aid of our new **VAMPING CARD** (placing the card upright on the piano keyboard, you can at once Vamp away to thousands of Songs, Ballads, Waltzes, Rag Time, etc., etc., equal to a Professional Musician. No knowledge of music is required. After using it a few times, you will be able to dispense with the aid of the Vamping Card entirely. The price of this very clever invention is only 15c, postpaid.

NEW BOOK ON ROPE SPLICING

Useful Knots, Hitches, Splices, etc.

How Different Knots Are Made and What They Are Used For
INDISPENSABLE TO EVERY MECHANIC AND RIGGER

PRICE 20c

A most practical handbook giving complete and simple direction for making all the most useful knots, hitches, rigging, splices, etc. Over 100 illustrations. All about wire rope attachments, lashing, blocks, tackles, etc. 37 Heraldic Knots illustrated. Of great value to mechanics, riggers, campers, boatmen. **Price 20 cents postpaid.**

Cheap and Interesting Popular Books

<p>Chemical Wonders, Secrets & Mysteries 10c</p> <p>Money-Making Secrets 10c</p> <p>Amateur Electrician 10c</p> <p>100 Dramatic & Comic Recitations No. 1 10c</p> <p>100 Dramatic & Comic Recitations No. 2 10c</p> <p>Book Fun, Magic & Mystery 10c</p> <p>Ventriloquism 10c</p> <p>Humorous Dialogues 10c</p> <p>Humorous Recitations 10c</p> <p>Complete Letter Writer 10c</p> <p>How to Dance 10c</p> <p>Southwick's Monologues 10c</p> <p>Vest Pocket Dictionary (Indexed) 10c</p> <p>100 Parodies on Latest Songs 10c</p> <p>Vandeville Joke Book 10c</p> <p>Popular Recitations 10c</p> <p>Clap Dancing Made Easy 10c</p> <p>Lightning Calculator & Short-Cut Arithmetic 50c</p> <p>Hunters' and Trappers' Guide 50c</p> <p>Song and Joke Book 10c</p> <p>How to Become American Citizen 10c</p> <p>Irish Song & Joke Book 10c</p> <p>How to Play Piano 25c</p> <p>.. .. . Violin 25c</p> <p>.. .. . Mandolin 25c</p> <p>.. .. . Guitar 25c</p>	<p>Tricks with Coins 25c</p> <p>250 Parlor Tricks, Games, etc. 25c</p> <p>Painters' & Decorators' Guide Bk. 25c</p> <p>Boyle's Card Games 25c</p> <p>50 New Card Tricks 25c</p> <p>Fortune Telling by Cards 25c</p> <p>Old Secrets and New Discoveries 25c</p> <p>Old Dr. Brown's Great Book of Secrets, Writings, Formulas, etc. \$1.00</p> <p>(Contains over 200 pages) 75c</p> <p>Collection of Famous Songs 25c</p> <p>Ready Made Speeches and Toasts 25c</p> <p>Rare Coin Guide 10c</p> <p>Rhazes; How to Breed 10c</p> <p>New Guide to Beauty 25c</p> <p>How to Play Checkers, Chess and Dominoes 25c</p> <p>Prof. Gaskell's Course on Penmanship 25c</p> <p>3000 Priceless Recipes, Formulas, and Trade Secrets 60c</p> <p>Moore's Universal Assistant & Complete Mechanic cover a million industrial processes, facts, calculations, receipts, trade secrets, etc. (616 pages) \$2.00</p> <p>Encyclopaedia Industrial Cyclopaedia (How to make thousands of useful articles for everybody) \$1.50</p>
--	---

JOHNSON SMITH & COMPANY, 7161 N. Clark St., CHICAGO
 Only Concern of its Kind in America

JAPANESE ROSE BUSHES

The Wonder of the World

Japanese Rose Bushes bloom all the year round. Just think of it. Six weeks after planting the seed, the plants will be in full bloom. It may not seem possible, but we positively guarantee it to be so. They will bloom every ten weeks, Summer or Winter, and when three years old the bush will be a mass of roses, bearing from five hundred to a thousand roses on each bush. The flowers are in three shades—white, pink, and crimson. The plants will do well both in and out doors. We guarantee at least three bushes to grow from each packet of seed. **Price, 10c** packet, 3 pkts. for 25c postpaid.



Chinese Fragrant Tree Fern

Just introduced; noted for its rapid growth. An exceptionally pretty ornamental plant. Possesses rich dark green. Forms grand pyramidal bushes about 5 feet high. Branches very desirable for decorative purposes, wreaths, etc. **Seeds 15c** pkt., 3 for 40c.



Weather Plant

NATURE'S WEATHER PROPHECY
 By mysterious changes that take place, this remarkable plant accurately forecasts the weather many hours in advance. Will grow anywhere all the year around. An interesting house plant. Bears large, fragrant, pink, butterfly shape flowers. **Seeds, 15c** packet, 3 for 40c, postpaid.



GROUND ALMONDS

Amazingly Prolific—Easily Grown From Seed

The Ground Almond has a flavor that is MOST EXCELLENT, resembling the coconut. The meat is snow white, covered with a shell or skin of brown color. It grows close to the surface and anything from 200 to 300 Almonds may be expected from a single nut. There is no trouble whatever in growing any where and in any kind of soil. May be planted any time, and in eight or ten weeks from time of planting you will have an ENORMOUS CROP of the MOST DELICIOUS ALMONDS YOU EVER TASTED. **Seeds 15c** Pkt.

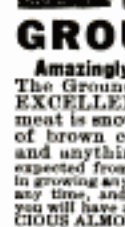

Perfume Plant

Blooms only at night, giving forth the most delightful scented fragrance for quite a distance. Grows in house or garden. Also valuable because of rare perfume made from it. **SEEDS, 10c** pkt., 3 for 25c.



SENSITIVE PLANT

Marvel of the Philippines. Leaves curl, droop when touched. Apparently resists interference. A handsome shrub for house or garden; very curious and interesting. **Seeds, 15c** pkt., 3 for 40c.



Calabash or Pipe Gourds

A luxuriant and rapid growing climber; thrives anywhere. Produces the ornamental gourds for use in which the famous African calabash pipes are made. Grow this interesting vine and make your own. **Seeds, with instructions, 15c** pkt., 3 for 40c.



Japanese Nest Egg Gourd

Very curious. Produces fruit same size, shape and color of a set of eggs. Matured fruit does not crack. Will serve for years as a nest, etc., for collecting birds, ornamental purposes, etc. **Seeds 15c** pkt., 3 pkts. for 40c.



Mammoth Peanuts

Peanuts can be easily cultivated. Their culture is very simple and exceedingly interesting. Mammoth Peanuts grow to an astonishing size. It is a good producer, very prolific, and the giant nuts have a thick, heavily ribbed protecting shell. The plant is very attractive, the leaves being of odd shape and a handsome green shade, tinted through the center with white. You will derive much pleasure cultivating this interesting species. **Seeds 15c** pkt., 3 pkts. for 40c.

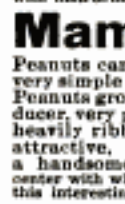

"Wong Bok" Chinese Cabbage

NEW. Can be eaten raw as a salad, or cooked same as other cabbage. Much nicer flavor and tenderer than ordinary cabbages. Grows 15 to 18 inches high. Creates quite a sensation wherever grown. **Seeds 15c.** 3 pkts. for 40c.



Japanese Climbing Cucumber

Unusually strong and vigorous growing vine. Attains twice the size of ordinary varieties. Grows readily on fences, poles, trellises, etc. One will keep an entire family supplied all summer. **Seeds 15c** 3 pkts. for 40c.



Here Are a Few Other Seed Novelties You Should Cultivate:

Japanese Kudzu Vine (Jack and Bonnet) 15c	Ornamental Cotton 15c
Chinese Ballon Flower 15c	Job's Tears (Great curiosity) 15c
Purple Feather Grass (Ornamental) 15c	Cathedral Bells 15c
Curious Ferns (grown from seed) 15c	Tiger Flower 15c
Birds of Paradise Flower 15c	Snake Cucumbers 15c
Japanese Hop Vine 15c	Emerald Isle Kale 15c
Castor Oil Plant 15c	Famous Passion Flower Vine 15c
	Puzzles 15c
	Ornamental Gourds 15c

NITTO'S PLANT & FLOWER FOOD

NITTO'S PLANT FOOD is clean, odorless, and highly concentrated. It is used in liquid form on all kinds of plants, shrubs, roses, ferns, bulbs, berries, lawns, fruit, flowers and vegetable gardens. It changes ill-sourish plants into LUXURIANT BEAUTIES, producing masses of blooms that will equal any. Causes plants to bloom early and ahead of others. Your friends will marvel at your success. Makes no difference how healthy or how delicate your plants may be, Nitto's Plant Food will bring out new foliage and flowers, and cause a marvelous transformation. **15c.** 3 for 40c



Johnson Smith & Co., 7161 N. Clark St., Chicago
 Read the next page, too

GREATEST TOY SENSATION OF THE DAY! FIGHTING DREADNAUGHT

SENSATIONALLY REALISTIC!!!

Exact Model of a
Modern Warship

The Fighting Dreadnaught is an exact model of Uncle Sam's latest fighting monster. It carries eight big guns, each of which flashes, at correct intervals, from twelve to twenty times. Extra ammunition always obtainable. Absolutely harmless. Can be operated indoors or out. Now, boys! Here's your chance to see a battleship in action, and the best of it is you can OWN the ship and command the firing yourself! By having two or more Battleships, you can arrange EXCITING NAVAL BATTLES in your own home. Price of Warship and Ammunition, 15c, three for 40c, or a fleet of 12 ships for \$1.50 postpaid. Extra Ammunition, 5 cents per pkg.



LUMINOUS PAINT

Make Your Watches, Clocks, Etc., Visible by Night

The very latest discovery in the scientific world. Hitherto, practically unobtainable except at an exorbitant price, we have at last succeeded in producing this remarkable LUMINOUS PAINT, which, applied to the surface of any article, emits rays of white light, rendering it perfectly visible in the dark. THE DARKER THE NIGHT, THE MORE BRILLIANT IT SHINES. Quite simple to use. Anyone—you can do it. A little applied to the dial of your watch or clock will enable you to tell the time by night. You can coat the push buttons or switch plates of your electric lights, match boxes, and innumerable other articles; make your own Luminous Crucifixes, Luminous Rosaries, etc. Bottle contains sufficient to coat several small articles. Price 25c. Larger sizes 50c and \$1.00 postpaid.

INVISIBLE INK

The most confidential message can be written with this ink. For the writing MAKES NO MARK. Cannot be seen unless you know the secret. Invaluable for many reasons. Keep your postals and other private memoranda away from prying eyes. Great fun for playing practical jokes. Only 15c Bottle.

VANISHING INK

Writing written with this remarkable ink vanishes entirely in a few weeks (sooner if desired), leaving the paper QUITE BLANK. 15c per bottle. LUMINOUS INK writing can be READ ONLY IN A DARK ROOM; writing shines like fire. Quite invisible at daytimes. Very remarkable. 15c

DISSOLVING INK A new kind of invisible and vanishing ink combined. Writing is quite invisible, but can be made to appear or disappear at will in a very simple yet mysterious manner. Same PRICE, 15c postpaid.

Thumb Brander

NEW & NOVEL JOKE to play on your friends. Fits on your thumb, and "brands" your victims as you very easily, either. Any of these choice epithets: Owl, fool, liar, grouch, baby, chicken, hot air, bull, Safety First. Complete with pad and ink, 17c.

INKLESS PEN

WRITES WITH WATER 400 words you dip. Makes its own ink every time you dip. Makes its own ink. Writes fashionable violet color. Better and cheaper than fountain pens. Writes a long letter with one dip in plain water. No trouble—no bother—no mess. A pleasure to use. With Nickel Plated Reversible Holder 10 CENTS, 3 for 35c

The Handy Duplicator

A really efficient apparatus at a very low price

With this outfit, you can, in a few moments, duplicate from 75 to 100 or more letters (hand or typewritten), drawings, circulars, postal cards, etc. Just as well as with the most costly apparatus sold. No trouble at all to use, and no mess. Remarkably clear, legible copies obtained, either in one or any combination of colors. Can be used over and over again. ALWAYS READY FOR USE. It is quick, efficient, and clean. Each outfit consists of 1 Duplicator, 1 Bottle of Duplicator Ink, 1 Duplicating Pan, 1 Stamp, and 4 Holder Clips in three sizes. POSTAL SIZE, 4x5 1/2 in., Price 75c. CAP SIZE, 5x7 1/2 in., Price \$1.10. Extra Ink (choice of black, purple, green or red) 15c bottle. All postpaid, with full instructions.



Potmend Stops a leak in a minute

The finest repairer for ironware, Agateware, Enamelware, etc. Good for kettles, pots, pans, boilers, and every kind of ironware, also for tin, copper, aluminum, ice boxes, iron pipes, cracks in stoves, broken china, porcelain, brick-a-brac, bisque, crockery, woodwork, marble, etc. Will not chip, fry, burn, bake or boil out. THE MEND IS THE STRONGEST SPOT IN THE POT. Could not be simpler; just mix the powder with water. HARDENS LIKE IRON. Fire-proof, Water-proof. You can fill a big hole or a small crack. Mended places stronger than new. Replaces chipped enamel. Anyone can do it. FAILURE IS IMPOSSIBLE. Better and easier than solder. Three sizes, 15c, 25c, and 50c.

Ink Erasing Fluid Magic Transfer

Better and more effective than Rubber Erasers. Simply dip reverse end of penholder in fluid and apply to the blot or error. The fluid absorbs the ink, then dry off with blotting paper, and the thing is done, leaving no trace of the blot. Of special value for this paper. Price, 15c bottle, 3 for 40c postpaid.

A process for transferring pictures, engravings, etc., in their original colors, from news papers, books, etc., to album or elsewhere. Several copies may be made. Butterflies and moth wings can also be reproduced, and an instructive collection preserved in a scrap book. Process is very simple and highly interesting. 10c, 3 for 25c, postpaid.

Johnson Smith & Co., 7161 N. Clark St., Chicago

Automatic Repeating Rifle

Fires 20 Shots in One Loading

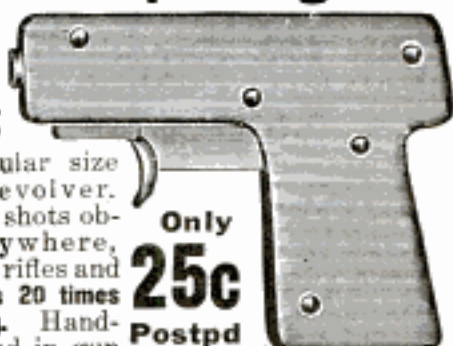

This is a regular size automatic revolver. Shoots B. B. shots obtainable anywhere, same as other rifles and guns. Repeats 20 times with one loading. Handsomely finished in gun metal. No caps or load necessary, as it works with a spring and shoots with rapidity and accuracy. Simply load with 20 B. B. shot, then press the trigger. Nothing to explode—absolutely harmless and safe. Remember, it is not a mere toy, but the same size and shape as a REGULAR AUTOMATIC. Sent complete with a round of shot for ONLY 25c postpaid. Extra shot, 10c a package.

Only
25c
Postpd

SILK FLAG PINS

3 for 5c



Wear the colors and show your patriotism. The flags are made in bow shape of silk ribbon, with pin for sticking into coat or dress. 3 for 5c, 12 for 20c

AMERICAN FLAG GUM STICKERS



These flags are about same size as a postage stamp. Guaranteed on the reverse side ready for use. Use them on your envelopes, stationery, etc., and let every one know you are an American. Put up in sheets each containing 50 flags. Tear them apart like stamps. PRICE 10c per sheet, 3 sheets for 25c.



New Flag Holder

The Very Thing for DECORATING PURPOSES. This Flag Holder solves the problem of displaying flags in home, office, porch, show window, auto, etc. Contains receptacles for three flags that effectively hold them in proper position, making a very beautiful and patriotic display. Size 3 1/2 x 1 in. Readily attached anywhere in a moment. Also handy for various decorative purposes, such as displaying keys, keys with aprons, automatic leaves, etc. PRICE complete with brass headed tacks, 15c, 3 for 40c

15c



Calendar Pen and Pencil Clip

An excellent clip for Fountain Pen or Pencil, preventing it falling out of the pocket, with Calendar combined. Months easily altered. Well made, nickel plated, novel, useful, attractive, and cheap. 12 cents, 3 for 30c, postpaid.

ELECTRIC SCARF PINS

A SENSATIONAL NOVELTY

Flashing Gems, Sparkling Jewels: Weird, Mystical, Startling Effects



When wearing one of these you become "the observed of all observers," the "synonym of wondering eyes," the admiration of ladies and the envy of the men. As shown in the illustration, the pin is connected by a double insulated wire with the flashlight, that you carry in your pocket. By merely pressing the button the Scarf Pin bursts into dazzling effulgence that attracts instant attention. The effect is both startling and beautiful. The darker the night the more brilliant the illumination appears. The Pins and Flowers may be worn without being illuminated, and they are very attractive. Assorted designs, including Skull, Horse Shoe, Pearl, Colored Stone Cluster, Flower, Auto Lamp, etc. Price, not including flashlight, 75 cents each. Flashlights, for using with above, 75 cents.

All the Latest Surprising and Joke Novelties

Pharo's Serpents Eggs, box	10c	X Ray Novelty	10c
Mimicry Snake (very lifelike)	10c	Trick Fan	10c
Pharo's Snake (very lifelike)	15c	Rubber Tacks (a good joke)	10c
Pharo's Snake (cool your friends)	6c	Mentorized Prizes (dodges the law of gravitation)	25c
The Roll Stage Money	10c	Casho! Sneezing Powder	10c
Pharo's Auto Puzzle (Latest)	10c	Mysterious Tumbler and Vanishing Coin Trick	25c
Magic Flute (anyone can play it)	15c	Enchanted Battle (won't lay down)	6c
Roller Race (very formidable)	15c	Magic Plate Lifter	20c
Roller Dagger (sensational)	20c	Imitation Gold Teeth	3 for 10c
Window Smashers (great joke)	25c	Great Eclipse Puzzle	10c
Packet Detective (see behind you)	15c	Wire Puzzles, 10c, 25 different, \$1.50	
Great Mind Reading Mystery Cds.	10c		
Pharo's Mysterious Trick Cds.	10c		
Fighting Bombers, pair	10c		
Cover the Spot Trick, a splash, nov.	10c		

Johnson Smith & Co., 7161 N. Clark St., Chicago

Large 232-page catalog of unique, novel and useful articles (unobtainable elsewhere) free with all orders, or mailed on receipt of stamp.

Runs on Kerosene, Alcohol, Gasoline, Gas



Model B
The Whirlwind

without electricity, springs, wires, batteries or trouble. Operates on kerosene

8 hours for a cent

A most wonderful invention: cooling, convenient, invigorating. An article of genuine merit.

A proved comfort

bringer. Brings restful slumber in the hottest nights; a blessing to the sick. Sustains efficiency. This is your chance to escape the heat. Order immediately.



Model A
The Wonder Fan

KEEP COOL

2 Models, 3 Sizes

- A { 12-in.—\$16.50—Alcohol or Gas only (Gas \$1.50 extra)
16-in.—\$18.50—Alcohol or Gas only (Gas \$1.50 extra)
B { 16-in.—\$19.50—Any Burner (Gasoline \$2.50 extra)
21-in.—\$22.50—Any Burner (Gasoline \$2.50 extra)

F. O. B. Chicago. Cash with order only.

LAKE BREEZE MOTOR
546 W. Monroe St., CHICAGO, ILL., U. S. A.

POCKET BOOK OF ELECTRICITY

SPECIAL WAR EDITION FREE



Distributed as a supplement to our big Handy Book during temporary government suspension of wireless. Lots new things to experiment with. Also motors, flashlights, telegraph apparatus, puzzles, magic circuits, books, athletic goods, chemical sets, fishing tackle, novelties. Handy, interesting. For every boy in America. For or report

THE ELECTRICITY CO., 245 Fulton St., New York City
THE NEWSBURY COMPANY, Dept. P-13 Cleveland, Ohio



Big League Book

BRISTLING WITH LIVE DOPE

of all the Prominent Players, their Playing Records and Biographies. "Clash at the Bat," Schedules for 1917, Hints on How to Score, etc., etc. All for five cents, the cost of mailing. Just to introduce **The Sporting News**, the only baseball weekly published. A big jitney's worth for a few cents.

Send your nickel today, sure.
CHARLES C. SPINK & SON, ST. LOUIS, MO

 2 Volt 40 Amp. Storage Battery, Glass Jar \$2.00	 Real Telephone Receiver, Talks loud, wt. 1 lb., With 2 phones and no battery you can talk 1000 feet. 50c	 6 Volt 60 Amp. Storage Battery, guaranteed 3 yrs. \$8.00
 Handy Light Generator, Handy and 3 wire (no bat.) wt. 1 lb. \$1.15	 Lighting Dynamo, 12 Volts 5 Amp. High Voltage \$17.50	 "Ball Dog" 1/2 in. Spark Coil, Full Spark \$2.50
 Rheostat Regulator, Precise in Heavy weight 1 lb. 60c	When ordering the above articles include postage, also goods go by express collect. Where no weight is given, mail shipments not advised. Goodshaw's are only a fraction of our wonderful assortment illustrated and described in our great 228 page Electrical Cyclopaedia contains more information than most electrical works. Also contains twenty coupons for free Wireless Course. Cyclopaedia sent free on receipt of 4c to cover postage. Send for your copy today	
		 Galvanometer (Voltmeter) very accurate; wt. 1 lb. 40c

Electro Importing Co., 245 Fulton Street, New York City

DUCK'S BIG 300-Page No. 11 Electrical and Wireless CATALOG

Mailed on receipt of 8 cents in stamps or coin, which may be deducted on first dollar purchase. Great cost of catalog and low prices prohibit distribution otherwise. Catalog contains 160 pages of wireless apparatus and 140 pages of electrical supplies. No bigger or better values are obtainable elsewhere. **THE WILLIAM B. DUCK CO., 223-227 Superior Street, TOLEDO, OHIO**

BOYS! HAVE DAD GET STRUCTO

Structo—Mechanics in miniature—will turn the trick. With it you can build that bridge or derrick, and a hundred other models that really work. Write for Free Illustrated book. **STRUCTO MFG. CO., Dept. 118, FREEPORT, ILL.**

GACHOO! Make the whole family and all your friends "just sneeze their heads off" without knowing why. With **Gachoo**, the new long distance harmless snuff. Sent anywhere for 10c. 34c for 25c, 1 doz. and special premium for 90c. **AMERICAN SUPPLY CO., St. Paul, Minn.**



RECTIFIERS for garages. All sizes. Charge from alternating current 1 to 8 batteries. **\$12.00 upwards.** **AMERICAN BATTERY CO., 1137 Fulton St., Chicago. (Estab. 1889)**

ELECTRIC HOME, FARM, PICTURE THEATRE, HOTEL & STORE LIGHT PLANTS. Auto Starter Storage Batteries & Chargers. All Cars. Ask Price. Dynamos, Power Motors, Belts, Engines, Railways, Permanent & Traveling Motion Picture Machines. **OHIO ELECTRIC WORKS, CLEVELAND, O.**

Send 10c for Copy of Our New Wireless Manual P. 9

YOU GET YOUR MONEY BACK ON AN ORDER OF \$1.00



It contains 180 pages and tells how to erect and maintain wireless telegraph stations. Shows a number of diagrams. Has the Morse and Continental Telegraph Codes. Illustrates the best instruments to use; tells what they are for and how to use them. Has many new diagrams and other valuable information not contained in any other book. Do not wait. Send your request now. Get the best 10c value you will ever buy.

Send for Our Pocket Catalog P28

It contains 248 pages, with over 1,000 illustrations, and describes in plain, clear language all about Bells, Push Buttons, Batteries, Telephone and Telegraph Material, Electric Toys, Burglar and Fire Alarm Contrivances, Electric Call Bells, Electric Alarm Clocks, Medical Batteries, Motor Boat Horns, Electrically Heated Apparatus, Battery Connectors, Switches, Battery Gauges, Wireless Telegraph Instruments, Ignition Supplies, Etc.

MANHATTAN ELECTRICAL SUPPLY COMPANY, Inc.

NEW YORK, 17 Park Place

CHICAGO, 114 So. 5th Ave.

ST. LOUIS, 1106 Pine St.

San Francisco, 604 Mission St.

DEPENDABLE
KNAPP
ELECTRIC SPECIALTIES

LEADER

The Big Power **\$3.00**
Motor for Boys

A compact, highly efficient, reversible motor, perfect in every detail. The reducing gear, easily adjusted, transforms the high speed to more power at slower speed. This motor is guaranteed by us to be exactly as represented.

Insist on your dealer showing you the Knapp line—Knapp goods are best. If your dealer cannot supply you, order direct from us.

Send for FREE illustrated catalogue showing a complete line of Electrical Motors and Novelties ranging in price from 10 cents up.

KNAPP ELECTRIC & NOVELTY CO.
519 W. 51st St., NEW YORK CITY



The Electrical Experimenter



BOYS!

Here is **THE** electrical magazine for you. For the Dabbler and the "How-to-make-it" fiend. Chuck full of experiments and the latest electrical doings. Non-technical—in plain English. One of the foremost authorities on **WIRELESS** in U. S.

200 Illustrations, 50 big pages, over 100 articles.

One copy will convince you
At All News Stands, 15c
\$1.50 a year (Foreign \$2.00).
Send 25c for 3 numbers.

THE ELECTRICAL EXPERIMENTER
234 Fulton St., New York

FIBRE LEGS ARMS

4-LB. FIBRE LEGS—ON EASY TERMS

Orthopedic braces for all deformities. Send for booklet.
MINNEAPOLIS ARTIFICIAL LIMB CO., 836 Deas Bldg., MINNEAPOLIS, MINN.



"Bow Legs and Knock-Knees"

Unsightly Send for booklet showing photos of men with and without

The PERFECT LEG FORMS

Perfect Sales Co., 140 N. Mayfield Ave., Dept. 5
Austin Station, CHICAGO, ILL.



Free to Wear 10 Days

Wonderful, genuine Tifnite in solid gold 6 prong Becher mounting. Gem nearly a carat large. Looks like genuine diamond. Stands all diamond tests. Just ask us to send this superb ring. Send string fitting 2nd joint of finger. If you find it a superb value, send \$3 on arrival and \$3 monthly until only \$12.25 is paid. Otherwise return in 10 days and any payment made will be refunded. No risk to you. Only 10,000 on these terms. Send now while offer is on.

THE TIFNITE GEM CO., Dept. 202, Rand McNally Bldg., Chicago



I will send my **25c book**

Improve Your Eyes

For 10c stamps or coin

A high-grade exercise and massage method that quickly strengthens and beautifies the eyes.

Also a most beneficial system of exercises that will improve the muscles of the temples and sides of face, thereby facilitating mastication and vocal pronunciation. Completely illustrated. Entirely without apparatus.

MUSCLE BUILDER

A steel spring exerciser and chest expander, with a complete course of twenty-four selected exercises for developing all the muscles of the body. It is equal to any \$3.00 exerciser. My price for a short time only, \$1.00.

PROF. ANTHONY BARKER
4643 Barker Bldg., 127 W. 42d St., New York



Never Mind How STRONG You are— What d'ye Know?



Today it's a battle of wits—and brains win. Muscle and brawn don't count so much as they used to.

The great question now is "What do you Know?" It draws the line between failure and success.

What do you know? Have you special ability in any one line? Could you "make good" in a big job right now?

For 25 years the International Correspondence Schools have been helping men to get ready for better work and bigger salaries. They can do the same for YOU. No matter where you live, what hours you work, or how little your education—the I. C. S. can train you for a more important and better-paying position.

Mark and mail the attached coupon—it won't oblige you in the least—it won't cost you anything to find out how you can get this salary-raising ability right in your own home, during your spare time.

MARK THE COUPON NOW

INTERNATIONAL CORRESPONDENCE SCHOOLS

Box 5582, SCRANTON, PA.

Explain, without obligating me, how I can qualify for the position, or in the subject, before which I mark X.

- | | |
|---|--|
| <input type="checkbox"/> ELECTRICAL ENGINEER | <input type="checkbox"/> SALESMANSHIP |
| <input type="checkbox"/> Electric Lighting | <input type="checkbox"/> ADVERTISING MAN |
| <input type="checkbox"/> Electric Car Running | <input type="checkbox"/> Window Trimmer |
| <input type="checkbox"/> Electric Wiring | <input type="checkbox"/> Show Card Writer |
| <input type="checkbox"/> Telegraph Expert | <input type="checkbox"/> Outdoor Sign Painter |
| <input type="checkbox"/> Practical Telephony | <input type="checkbox"/> RAILROADER |
| <input type="checkbox"/> MECHANICAL ENGINEER | <input type="checkbox"/> ILLUSTRATOR |
| <input type="checkbox"/> Mechanical Draftsman | <input type="checkbox"/> DESIGNER |
| <input type="checkbox"/> Machine Shop Practice | <input type="checkbox"/> BOOKKEEPER |
| <input type="checkbox"/> Gas Engineer | <input type="checkbox"/> Stenographer and Typist |
| <input type="checkbox"/> CIVIL ENGINEER | <input type="checkbox"/> Cert. Public Accountant |
| <input type="checkbox"/> Surveying and Mapping | <input type="checkbox"/> Railway Accountant |
| <input type="checkbox"/> MINE FOREMAN OR ENGINEER | <input type="checkbox"/> Commercial Law |
| <input type="checkbox"/> Metallurgist or Prospector | <input type="checkbox"/> GOOD ENGLISH |
| <input type="checkbox"/> STATIONARY ENGINEER | <input type="checkbox"/> Teacher |
| <input type="checkbox"/> Marine Engineer | <input type="checkbox"/> Common School Subjects |
| <input type="checkbox"/> ARCHITECT | <input type="checkbox"/> CIVIL SERVICE |
| <input type="checkbox"/> Contractor and Builder | <input type="checkbox"/> Railway Mail Clerk |
| <input type="checkbox"/> Architectural Draftsman | <input type="checkbox"/> AGRICULTURE |
| <input type="checkbox"/> Concrete Builder | <input type="checkbox"/> Textile Overseer or Supt. |
| <input type="checkbox"/> Structural Engineer | <input type="checkbox"/> Navigator |
| <input type="checkbox"/> PLUMBING AND HEATING | <input type="checkbox"/> Poultry Raising |
| <input type="checkbox"/> Sheet Metal Worker | <input type="checkbox"/> AUTOMOBILES |
| <input type="checkbox"/> CHEMICAL ENGINEER | <input type="checkbox"/> auto Repairing |
| | <input type="checkbox"/> Swedish |
| | <input type="checkbox"/> German |
| | <input type="checkbox"/> French |
| | <input type="checkbox"/> Italian |

Name _____

Occupation & Employer _____

Street and No. _____

City _____ State _____

If name of Course you want is not in this list, write it below.

Please Mention Popular Mechanics



Men Who Exercise require the Boston Garter
Wrist Grip

It allows the utmost freedom of action—stands great strain—gives perfect comfort and long wear.
Sold Everywhere
25c. 35c. 50c.
Geo. Frost Co., Makers, Boston

Send for This Book Now



Save 10% to 50% On Any Camera, Kodak, Lens etc.

See where you can save big money. Every item backed by **10 Days' Free Trial Money Back Guarantee** Eastman, Ansco and Rexo films—Cyko and Rexo paper at cut prices. Write us NOW.
DAVID STERN COMPANY
"In Business Since 1885"
610 Davis Bldg., 1047 Madison St. CHICAGO, ILLINOIS



RAISE GUINEA PIGS

Big Demand Thousands needed weekly. Government figures show a profit of \$9.00 each annually. Experience or special knowledge unnecessary. Send for our money-making proposition and big free illustrated book which explains all.

Laboratory Supply Co., Dept. B, 2841 Ridge Ave., Phila., Pa.

RABBITS



Tells all you want to know about Rabbits. Our book: "The Rabbit; How to Select, Breed, and Manage the Rabbit and Belgian Hare for Pleasure or Profit," by breeders of long experience with rabbits. Sixth edition, nicely illustrated, enlarged and much improved. Price 25 cents with sample copy of the *American Poultry Advocate* containing Belgian Hare Department.

POULTRY ADVOCATE, Dept. 257, Syracuse, N. Y.

The Brooks System Knocked Down Boats

ALL parts accurately machined ready for assembling. Everything from Canoes to Cabin Cruisers. V-bottoms—high speed—semi-speed, and work boats. Full size paper patterns and illustrated instructions for amateur builders. The "Brooks System" saves over two-thirds the cost of a boat. Present conditions of freight rates, labor costs, slow deliveries, makes this the only practical method of getting a boat. We are the originators of the pattern system of boat building. *Send now for illustrated catalog.*

BROOKS MANUFACTURING COMPANY
8206 Ship St. Saginaw, Mich.
Largest and oldest concern of its kind in the world.

PIGEONS PAY

Better Than Chickens
Young pigeons (squabs) bring 40 to 60c each when 3 to 4 weeks old. Big demand in city markets. Each pair of pigeons easily clear \$4 per year. Always panned up. Very little space and money needed to start. Free Book explains all. **MAJESTIC BIRDS CO., Dept. 55, ADRIAN, IOWA.**



RAISE GUINEA PIGS

We buy all you raise. Splendid money-making opportunity. Big demand—thousands needed weekly. Easy to raise— inexpensive to house, feed, keep. Pay better than poultry or squabs. Particulars, contract, booklet how to raise free.

CAVIES DISTRIBUTING CO., 740 W. 74th St., KANSAS CITY, MO.

ERECTOR THE TOY LIKE STRUCTURAL STEEL

BOYS: Write for facts about the Big Prize Contest and get Erector Tips, the boys' magazine, FREE.
THE A. C. GILBERT COMPANY, 104 Fox St., New Haven, Conn.

DIAMONDS ON CREDIT

BEAUTIFUL DIAMONDS SENT ON APPROVAL

NO MONEY DOWN. Order any diamond from our catalogue; we will send it, all charges paid. After you have made a thorough examination and are satisfied as to the quality and value, pay 20 per cent of the price and only 10 per cent per month thereafter. If not satisfactory, return it at our expense. Don't pay a cent until you are satisfied. Certificate furnished guaranteeing the quality of every diamond. Your diamond purchased from us can be exchanged at a yearly increased value of 7 1/2 per cent on a larger purchase. Own a genuine Diamond. Send for our Catalogue De Luxe No. 6A. It's free.

L. W. SWEET & CO., Inc., 2 and 4 Maiden Lane, New York City





Nujol the Internal Cleanser

MCARTHY

The Athlete's First Principle Is To Keep His System Clean

He doesn't allow food to ferment in his intestines. He doesn't give his body a chance to absorb poisons.

He knows—and your doctor will tell you—that anything from a headache to the most serious illness may result from such absorption.

Nujol removes poisons from the system, and gives the tissues of the body a chance to build up and resist disease.

Nujol is not habit-forming, does not gripe, relieves straining, does not weaken nor upset the stomach, is absolutely pure and harmless, and is delightful to take.

It is especially fine for young mothers, as it is not absorbed into the system, and therefore in no way affects the child.

Nujol is sold only in pint bottles, bearing Nujol trade-mark, never in bulk.

The Standard Oil Company (New Jersey) has used its world-wide resources in producing Nujol, and its reputation is behind the product.

Nujol is absolutely distinctive and individual. There is no other product on the market like it.

STANDARD OIL COMPANY

Bayonne ^(New Jersey) Dept. 63 New Jersey

Please send me booklet on the treatment of constipation
Write your name and address plainly below

Name..... Address..... City..... State.....

Please Mention Popular Mechanics



ED.
H.
WITTE,
Pres.

My Special Model KEROSENE ENGINE

**CUTS
FUEL
COST
65 PER
CENT**

Not an experiment! Thousands in use! Better and more powerful than ever! Starts as easily as a gasoline engine! Will use any fuel that can be used in a kerosene engine! You get three times as much power for the money, at present fuel prices! Latest improvements! Your Own Terms! Cash, Deposit, Payments, or No Money Down! If you are in the market, write me today! I CAN MAKE YOU THE BEST PRICE—Sells You A BETTER Engine. Any style, 2 to 22 H-P.—Save you \$25 to \$100.

**Immediate
Shipment**

WITTE HIGH GRADE ENGINES

are made in the largest exclusive engine factory in the world, selling direct. You can see quality in every line and curve. Look at the long solid base affording absolutely solid footing. See how cleanly-built—no cumbersome overweight of cast iron—no cylinder hanging out behind—no interior packing—vertical valves—auto ignition—no cranking—and many other special features that make WITTE Engines high-grade, better and more desirable. **90 Days' Trial** will fully prove superior quality.

Write for latest Engine prices and Free Book. Or, wire your order—I will handle it—save you time and money. Ed. H. Witte,

WITTE ENGINE WORKS
1748 Oakland Ave., Kansas City, Mo.
1748 Empire Bldg.,
Pittsburgh, Pa.

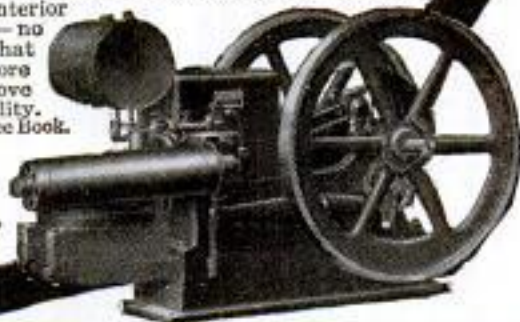

REAL BARGAINS IN Kodaks—Graflex

and Cameras of every description.
WE CAN SAVE YOU 25% TO 60%

on any slightly used equipment
which is fully as good as new.

10-DAY FREE TRIAL GUARANTEE

If unsatisfactory, money will be refunded in full.

Write at Once for Our Free **BARGAIN BOOK** and **CATALOG** listing hundreds of slightly used and new cameras, also supplies of every description. No matter what camera you want, we can save you money. Compare our prices with others on slightly used and new cameras and we know you will be another one of our satisfied customers. Our prompt and fair dealing will please you. Established in the Photographic Business over 16 years.

Central Camera Co., 124 S. Wabash Ave.
Dept. 4, CHICAGO, ILL.



OTTAWA THE ENGINE EASY TO RUN

Uses Kerosene, Gasoline, Distillate, Gas and other cheap fuels. Built to last and do hard work. Many sizes, up-to-date design. Good material. Built by painstaking workmen. Sizes 1 1/2 to 22 H. P. Pulls 1/4 to 1/2 over rated H. P. **THREE MONTHS' TRIAL.** Sold direct. **TEN YEAR GUARANTEE.** Engine book free.

OTTAWA MANUFACTURING CO., 531 King St., OTTAWA, KANSAS

1 1/2	24 75
2	26 75
3	47 50
4	61 75
6	88 90
8	114 75



Engine User-Agents Wanted

Men wanted in every county to sell, demonstrate and sell "OTTAWA" wonderful new gasoline engine for every work. See demand. Liberal profits. Free design and introductory offer. C. Beuninghofen & Sons, Department 511, Hamilton, Ohio.

Erickson Artificial Limb Co., 38 Wash. Av. N., Minneapolis, Minn.



We are
Under
Govt.
Bond

"Bristol" Steel Fishing Rods

Fly, Bait,
Casting,
Silk Wound,
Telescopic,
Trolling,
Etc.

Whatever the fishing, we have the rod for it. 38 different models, each one guaranteed 3 years. "Bristol" Rods will stand more wear and tear than any other rods. Works of art in finish, hang and balance.

\$3.50 to \$25.00 of your dealer

TWO CATALOGUES FREE
of "Bristol" Rods and Meek and Blue Grass Reels.

THE HORTON MFG. CO. 196 Horton Street,
BRISTOL, CONN.
Also manufacturers of Meek and Blue Grass Reels

Attention Boy Scouts!

**THIS FINE
U.S.A. MODEL TRUMPET \$3.95**

\$3.95 brings you this durable, graceful, loud toned, trumpet. U. S. Army specifications. Key of G with slide to F. Silver plated mouthpiece. Ten days' trial and money returned if not satisfactory. When ordering mention No. 12BL320 1/2. Our Musical Instrument Catalog No. 50P54 includes Pipes, Drums and supplies of all kinds. It is free. Send for it.

SEARS, ROEBUCK AND CO., CHICAGO.

STOP USING A TRUSS

Do Away With Steel And Rubber Bands

FREE TRIAL



PATD
APRIL 6
1909

Inner surface is made adhesive to secure the PLAPAO-PAD firmly to the body, keeping the PLAPAO continuously applied and the pad from slipping. No straps, buckles or springs attached. Soft as velvet—easy to apply.

It's the Non-Slip- ping, yet Non-Rigid Pad and What is Within It That Counts

FREE to 5,000 Truss Sufferers

To the extent of 5,000 sufferers who may apply I will send, ABSOLUTELY FREE, a sufficient quantity of the Plapao to positively convince them that this is the only logical, common-sense way of treating rupture. Plapao is a highly astringent medication placed within the Plapao-Pad and being absorbed through the skin, creates a wonderful feeling of relief and at the same time tends to strengthen the weakened muscles and thus permanently close the rupture opening. The process of recovery is natural, so you'll have no use for a truss—you can throw it away forever! Old and young have testified under oath that the Plapao-Pads cured their rupture—many of them long-standing, aggravated cases—without delay from work. Patent allowed in U. S. and foreign countries. Awarded Gold Medal at Rome and Grand Prix at Paris.

Send No Money—for a sufficient quantity of the Plapao is sent without charge to enable you to give it a thorough test; you pay nothing for this trial now or ever. Write for it and full information today. Address: Plapao Laboratories, Block 1427 St. Louis, Mo.



* The Thor

Send for the big Thor Book which describes the Thor Electric Washing Machine and shows how a good sized washing can be done at a cost of only 2 cents.

HURLEY MACHINE CO., Dept. A119, CHICAGO

AGENTS—Make \$100 to \$300



per month easy selling our new Triplicate Sauce Pan. Cooking utensil for 3 different foods on one burner. 400 Specialties—all whirlwind sellers. Write quick for exclusive territory and large catalogue.

AMERICAN ALUMINUM MFG. CO.
Div. H-T LEMONT, ILL.

Ten-Pinnet

The New Bowling Sensation!



GET into business of your own with this great new automatic bowling game. Has taken the country by storm. Great chance! Big money, quick profit! Cash rolls in every day. No operating expense. Find out quick about this great opportunity. Send for our big FREE book.

\$25.00 to \$75.00 a Week

That's what you can earn with Ten-Pinnet. Get the big money. You can! Write today for free book and special offer. Learn how to start with little money—pay for alleys out of profits.

TEN-PINNET CO., Dept. A119 Indianapolis, Ind.



A Real Man's Wrist Watch

THE day of the wrist watch is here! A wrist watch is part of every officer's equipment in the European armies. Practically every officer in the U. S. army wears one. *It has been proven the most convenient watch in the world.*

And here is the Aviator's model. This New Burlington was built for aviators and is adjusted to keep time to the second anywhere. 17 jewels—finest nickel movement. Square design. Clear, distinct, military dial. Extra heavy hands. Buckles with sturdy pig skin strap that can not slip. Send coupon today for beautifully illustrated catalog.

The Burlington \$250 a Month

Yes,—all of this for \$2.50—only \$2.50 a month for this masterpiece of watch manufacture. Now sold direct to you at positively the exact price that the wholesale dealer would have to pay.

See It First! You don't pay a cent to anybody until you see the watch. Strap it on your wrist and then realize the satisfaction and convenience of a man's wrist watch.

Send the Coupon for Watch Book

Get the Burlington Watch Book by sending this coupon now. You will know a lot more about watch buying when you read it. You will know why a man who has become accustomed to the convenience of a wrist watch would never go without one again. Send the coupon today for book and our special offer. Mail it now.

Burlington Watch Company
Dept. A919
19th and Marshall
Boulevard,
Chicago, Illinois

Burlington Watch
Company

19th and Marshall Blvd.
Dept. A919 Chicago, Illinois

Please send me (without obligations and prepaid) your free book on watches with full explanation of your cash or \$2.50 a month offer on the Burlington Watch.

Name.....

Address.....

WANTED IDEAS



Inquiries from Manufacturers and Other Buyers of Patents
Who Are Looking for Good Ideas

Protected by Owen Patents

Are constantly being received. Hundreds of ideas are wanted—a market exists for them to-day. **YOURS** may be one of them. Send for my free books and see for yourself—read the requests for inventions protected by me. Many are simple. You can help supply this demand.

As soon as my clients' rights are protected I aid in every practicable way, **without charge**, to sell. Their **applications** are advertised free—their patents are called to the attention of the proper prospective buyers—every necessary thing is done. Get my booklets and see.

THESE ARE FREE

You will incur no obligation by writing me. A simple request will bring them to you—the finest, most reliable and instructive patent books published. A postal will do.

"Successful Patents"—a 72 page guide book, tells how to proceed; describes my advantageous business methods; gives references, testimonials, etc.

"Stepping Stones"—gives hundreds of hints of inventions wanted; articles from interviews of noted authorities; tells the truth about prizes for inventions.

"Patent Promotion"—tells you how to sell; why some inventors fail; discusses the value of your idea; how I aid my clients; manufacturing aids furnished you; recent successful patents, etc.

"Patent Buyers"—Publishes letters, and abstracts of letters, from over 400 of the many manufacturers, and other patent buyers, who wish to buy, or obtain on royalty, **Owen Patents** on innumerable inventions of interest to them.

You will also be sent from time to time, as new inventions are wanted, full information concerning them. Only in this way can you keep up to date.

WRITE FOR THESE TO-DAY—Advice costs nothing. All communications confidential. Your work will receive my personal supervision—but my fees are no higher than others.

Results Speak Loudest—But Here Are Some References

Columbia National Bank,
Washington, D. C.
National Locktite Co.,
Washington, D. C.
The Carnahan Press,
Washington, D. C.
Lightning Gun & Cycle Works,
Oklahoma City, Okla.

Antholene Mfg. Co., Hutchinson, Kan.
National Rack Co.,
61 Hanover St., Boston, Mass.
The C. J. Loftus Co.,
13 Spring Common, Youngstown, Ohio.
Whitehead Hosiery Mills,
Burlington, N. C.
Dickinson Mfg. Co., Des Moines, Iowa.

A LARGE NUMBER OF OTHERS IN MY BOOKLETS.

RICHARD B. OWEN 9-303 OWEN BLDG.
WASHINGTON, D. C.
NEW YORK OFFICE: 22nd Floor Woolworth Building

Inventors submitting their inventions to me are protected in a tangible manner until their applications are filed.

Nuts for You to Crack

Invent something for which a demand exists—for which there is a waiting market. Here are abstracts from a few recent requests—hundreds are published in full in my literature. Can you invent any of these? Watch this list each month.

A large middle Western manufacturer states "we are interested in any novelty that has merit and can be manufactured at an attractive profit. We would prefer something selling to the shoe trade; however, will consider any good novelty. We would rather favor the royalty proposition."

An unusual request has just come in, an investor desiring to purchase a patent covering different kinds of Guitar Zithers "such as base and treble attachments."

Can you make even a slight improvement in your suspenders? If so I can refer you to a manufacturer who has just inquired for anything new in this line.

Another unusual request has just come from a man who desires patents "in the line of playthings or dolls made of a new kind of papier-mache composition to be pressed in moulds or cast in same."

SPECIAL FREE REPORT

Send sketch or model of your invention for free report on patentability, practicability, etc.

PATENTS

References:
 American Security &
 Trust Co.,
 Washington, D. C.
 Munsey Trust Co.,
 Washington, D. C.
 The Auto-Ordinance
 Corp.,
 New York City
 The Ramberg Remedy
 Co.,
 Elkins, W. Va.

Promptly secured. The demand for good patents is increasing and I will assist you to sell your invention as soon as protected. Prompt Personal service. Send sketch or model for my honest advice. Booklet, "The Truth About Patents," sent upon request.

J. R. KELLY 743 Woodward Bldg.
 WASHINGTON, D. C.

R. MORGAN ELLIOTT & Co.

PATENT ATTORNEYS

MECHANICAL, ELECTRICAL & CHEMICAL EXPERTS
 713-721 WOODWARD BUILDING
 WASHINGTON, D. C.



EVERY INVENTOR

should have this book, "Patents and Patent Possibilities." It is chock-full of ideas and practical advice, telling what to invent and where to sell. Write for your copy today. It is FREE. I have requests for patents upon sound inventions of all kinds. Can you help supply the demand? My service is individual, prompt and efficient. (14 years' experience). Every expedient is employed to secure patents at least possible cost.

H. S. HILL, 802 McLachlen Bldg., WASHINGTON, D. C.

Patents Secured by a Former Examining Official of the U. S. Patent Office

Norman T. Whitaker

Attorney-at-Law and Mechanical Engineer

Inquiries Invited

27 Legal Building - - Washington, D. C.

Abdominal MASSAGE

with the wonderful new **KOLON MOTOR** brings health, strength and energy. Banishes chronic constipation. Write for interesting booklet—"Colon Cleanliness"—mailed free. Send a postal. **MARTIN'S METHOD, Inc.**, Dept. 80, 50 E. 31st St., NEW YORK

AGENTS—BIG SUMMER SELLER

Filter for Country or City Homes

100% efficient. Takes out all bacteria. Renders water pure and safe. Prevents deadly typhoid and other diseases. Wonderfully simple to use.

EVERY HOME NEEDS IT

Low price puts it in reach of all. Splendid profits for agents. Betz made \$5 first day. Kramer averaging \$40 a week. Noerr making big money in his spare time. Makes a convincing demonstration—makes muddy water clear as crystal. Write quick for territory and demonstrating sample.

HOME FILTER CO., 848 Gay St., Dayton, Ohio



Come! Get Rich in the Candy Business



Yes, You—no matter who you are or where you live. You can start small—with nothing. You will grow fast and make money— heaps of it— every day. Everybody buys candy—and the profits are tremendous. We teach you all the secrets, furnish you all the equipment—we help you, guide you—make you succeed. You can make \$2,000 to \$10,000 a year easily. Hundreds are doing it. Send for testimonials from folks just like you, in the same kind of a town, who are succeeding. You can quit working for wages! You can make money! You can have what you want, travel and enjoy independence. You can become the biggest success of your town. Equal opportunity for women and men, young or old.

BUT YOU MUST HURRY! Now is the best time of the year. Don't wait. Write for full particulars. Use a post card—or the coupon. Do it before you turn the page—NOW!

Otter-Swain Corporation
 Room J 4759 Broadway, Chicago

Use This Coupon

OTTER-SWAIN CORPORATION,
 Room J, 4759 Broadway, Chicago
 Send full particulars to

Name

Address

City.....State.....

U.S. PATENTS



FREE →
BOOK-BULLETINS & ADVICE

REGISTERED ATTORNEYS

LANCASTER & ALLWINE

204 OURAY BLDG. WASHINGTON, D. C.

Don't Lose Your Rights

We publish forms called "Evidence of Conception" by which you can establish your rights before sending the invention to anyone. It is your best protection. We issue up-to-date bulletins of improvements wanted; aid inventors to promote their rights; render reliable opinions free of charge and secure valuable patents and trade marks on reasonable terms. Personal service assured by our **Service Guarantee Contract**. References: 2nd National Bank, Washington; John P. Roth Packing Co., Cincinnati.

SIMPLY MAIL COUPON

LANCASTER & ALLWINE, 204 Ouray Bldg., Washington, D. C.
 Send me free book "Inventions—Patenting and Promoting." Bulletins of Improvements Wanted and blank form, "Evidence of Conception."

Name

Address

20 Years!

KOKOMO Bicycle Tires are built to give the longest possible service at the lowest possible price. Every KOKOMO—from the \$5 tires to the \$2.25—is built to this standard.

Every KOKOMO Tire is the very best tire we know how to build at its price—and we have been building bicycle tires for more than twenty years!

There are seven different tires in the KOKOMO line. You can get almost anything you want in treads, colors or prices. When buying a bicycle, see that it has KOKOMO Tires. When buying tires—get KOKOMOS, and know how good a bicycle tire really can be!

The dealer who has the KOKOMO Agency in your community is a dealer who believes in superior merchandise. That is why he sells KOKOMO Tires. Such a dealer is well worth finding.

LONG-LIFE
Kokomo
BICYCLE TIRES

They'll take You Fishing!



2
of
the
7

CHOOSE:

EVERLASTER	each \$5.00
KOKOMO KORD	each 5.00
NO. 13 SPECIAL	each 4.25
STICK TIGHT . . .	each 3.75
DEFENDER	each 3.25
OXFORD	each 2.50
PIONEER	each 2.25

KOKOMO RUBBER CO., Kokomo, Ind.

A leader for more than twenty years

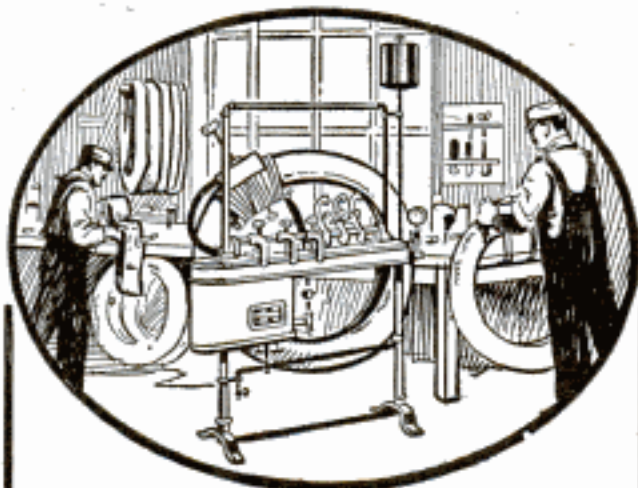

Big money for you

Think of the auto owners in your own locality who are eager to have their tires repaired! Open a repair shop with a Shaler Tire Repair Outfit. Earn \$250.00 per month. No experience necessary. We make it easy for you to start right away. You have your own business.

Free Book Tells How

Write for our wonderful book, "How to Open a Tire Repair Shop." It will open your eyes! Shows you how easy the work is. Shows you the big money that can be made. Write for this book today. A post card will do.

C. A. SHALER COMPANY

2005 Fourth Street

Waupun, Wis.

BUILD THIS CAR OR BUY IT COMPLETE

Lowest Priced Car in the World



Very fast. Economical. Seats 2 full grown persons. Not a toy. Complete Detailed Drawings, 35c. Catalog 10c. Cycle Car and Light Car parts at low prices. Discount to Agents.

Tribune Engineering Co., Dept. P, Owego, Tioga Co., N. Y.

MAKE YOUR BIKE A MOTORCYCLE

at a small cost, by using our attachable outfit. Fits any Bicycle. Easily attached. No special tools required.

"Used His Four Years"

Harry A. Hyatt, of Boreas River, New York, writes: "About four years ago I received my motor attachment, and wish to say that I am satisfied with it in every way, for it has certainly given me good service. Anyone wanting a motorcycle or attachment, I would recommend them to the Shaw Manufacturing Co."

FREE BOOK Write today for bargain list and free booklet, fully describing the SHAW Bicycle Motor Attachment. Motorcycles all makes, new and second-hand, \$35.00 up.

SHAW MANUFACTURING CO.
Dept. 6 GALESBURG, KANSAS



Please Mention Popular Mechanics

The Excelsior Family Is Now COMPLETE

No matter what your requirements, there is an "X" to meet them.

For all heavy duty service the Big X Twin has again and again proved its supremacy.

Not only winning hill-climbing contests of national importance, but again and again going entirely over hills always considered absolutely beyond the capacity of any motor driven vehicle until they succumbed to the stupendous power of the X.

Our new Series 18 Sidecar, furnished in both passenger and commercial types, is EXCELSIOR quality thruout, with many new and exclusive features found in no other sidecar.

For the rider desiring a comfortable, economical and convenient means of personal transportation, the EXCELSIOR LIGHTWEIGHT meets every possible requirement at minimum cost in purchase and maintenance.

If you have not seen our new Series 18 catalog, describing the new EXCELSIOR KUSHION Sprocket, write for it today.

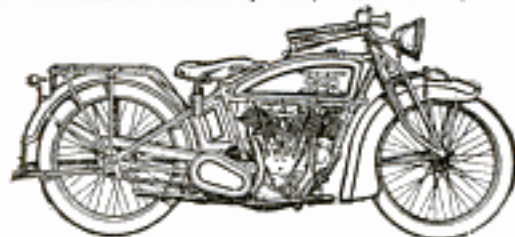

The Ultra Power Big Twin X

The most powerful, reliable and efficient heavy duty Motorcycle ever built with

*Three Speed Automobile Type Transmission
Enclosed Clutch Mechanism
Heavy Double Brake
Foot Motor Starter, with Automatic Compression Control
Nickel Steel Frame, with Removable Center Bar
And other exclusive features*

Price electrically equipped **\$310** With standard equipment **\$275**

EXCELSIOR Series 18 Sidecar

THE LAST WORD IN SIDECAR LUXURY

A Sidecar of EXCELSIOR quality throughout, with such superior features as

*Semi-Flexible Spring Center Brace
Self-Alining Pivot Frame Connections
The Most Graceful and Comfortable Sidecar Body ever made
Folding Foot Rest, and Rubber Covered Step*

Price, with all connections **\$80**

EXCELSIOR Series 18 Lightweight

THE TRIUMPH OF LIGHTWEIGHT CONSTRUCTION

A real Motorcycle, with

*Powerful, Single Cylinder Two-Stroke Motor
Foot Operated Motor Starter
Two Speed Automobile Type Transmission
Powerful Shoe Brake, casting on the Belt Rim
Long Folding Foot Boards, and Cushioned Seat*

Price **\$140**

EXCELSIOR MOTOR MFG. & SUPPLY CO., 3702 Cortland St., Chicago

Auto Lighting for Bicycles



Get a Delta complete electric lighting system. Great for night riding. Throws searchlight 300 ft. Turns any direction. Uses common dry batteries. Strongly made, finely finished. See your dealer today.

DELTA ELECTRIC CO.
Dept. 21 MARION, IND.
Canadian Branches: Winnipeg and Toronto.

\$175 up

The Harley-Davidson "Master 17"



It sets the pace for 1917. Has more power, more speed, greater flexibility, faster getaway. Equipped with hand-operated, auxiliary brake in addition to regular service brake. Finished in beautiful military drab. Write for 1917 catalog.

HARLEY-DAVIDSON MOTOR COMPANY
509-B Street Milwaukee, Wis.
Producers of High-Grade Motorcycles for More Than Fifteen Years

Get 5,000 More Miles



The worn tires that you have been throwing away can be made to give at least 5,000 miles more service. Durable Steel Studded Treads are a perfected product of the World War. Over half the cars in Europe are equipped and more than 50,000 American motorists have already profited by the saving and security which they have made possible.

5,000 Miles without puncture is guaranteed whether your tires are new or old.

We Deliver Free without a cent deposit, and prepay express. You can apply them in a few minutes in your own garage and judge for yourself.

Special Discount offered to motorists in new territory on first shipment direct from factory.

Mail the coupon today. You will hear from us within a week.

Guaranteed 5000 Miles Without Puncture

MAIL TODAY—SAVE THE DISCOUNT,
The Colorado Tire & Leather Co.

644 Tread Bldg., Denver, Colorado, F-44 Transportation Bldg., Chicago, Ill., 720-446 Woolworth Bldg., New York City

Send me without obligation or expense booklet, sample and written guarantee for 5,000 miles more service.

Name

Address

My Tire Sizes are

Please Mention Popular Mechanics

MAP OF THE ROADS OF THE WORLD

The Guiding Hand

LEEDAWL DOLLAR COMPASS



You need more than your eyes to read a map—the best ever drawn is useless, unless you know direction. You need a **LEEDAWL** Jeweled Compass at **\$1**

Ask your dealer. If he does not have them, or will not order for you, send direct to us. Ask for free folder or send 10c for book, "The Compass, The Sign Post of the World."

Taylor Instrument Companies, Rochester, N.Y.
Makers of Scientific Instruments of Superiority

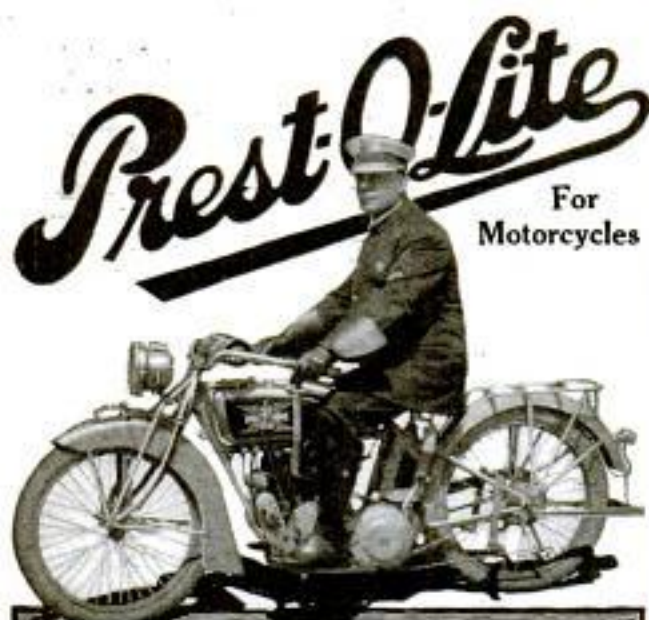

Every rider needs this brilliant, sturdy light

Police departments of practically every large city in the country have chosen Prest-O-Lite for their motorcycle squads. These men need a lighting system that stands all sorts of hard usage—one that enables officers to ride with safety and confidence on all roads.

Prest-O-Lite gives the motorcycle rider ideal light—throws a brilliant, steady ray far into the darkness ahead—shows up the road clear as day—penetrates dust, smoke and fog.

It gives you the utmost in convenience, economy and reliability, yet costs less to buy and use than any other system of brilliant light.

Use Prest-O-Lite on your motorcycle

Go to your dealer today and let him equip your machine with Prest-O-Lite. Nearly all dealers now offer, at an attractive price, a popular equipment combination including "a Prest-O-Lite, and a good lamp and mechanical horn." This will save you money and give you maximum service.

Write for literature of great interest to every motorcycle rider. Sent on request.

The Prest-O-Lite Co., Inc.

U. S. Main Office & Factory, 265 Speedway, Indianapolis
Canadian General Office, Dept. U, Toronto, Ont.

Prest-O-Lite Exchange Agencies Everywhere

World's Largest Makers of Dissolved Acetylene

FEDERAL BICYCLE TIRES



Treat Your Bike Right

Give your bike a square deal. Fit it out with tires that look well, wear well and don't fall down.

These two Federals are dandies—the "lugged" with heavy blue studded tread; the "Trafik" with staunch black patterned tread—both fast, sturdy and strong. Give your bike a set.

For sale by leading dealers everywhere. Send for catalogue and handsome felt pennant FREE.

THE FEDERAL RUBBER COMPANY
Factories, Ontario, Wisconsin



Convert Your Bicycle into a Motor-Cycle

Motor fits any wheel. BEST, MOST RELIABLE. Best hill climber. More STEFFEYS in use than all others. Stamp for circulars. STEFFEY MFG. CO., 5007 Brown Street, PHILA., PA.



Mobiloils

A grade for each type of motor

Bush Car Delivered Free



Five-Pass., 34.7 H. P. Drive and demonstrate the Bush Car. Pay for it out of your commissions on sales, my agents are making money. Shipments are prompt. Bush Cars guaranteed or money back. Write at once for my 48-page catalog and all particulars. Address J. H. Bush, Pres. Dept. 617

114-inch Wheelbase Delco Ignition-Elect. Sigs. & Ltg. BUSH MOTOR COMPANY, Bush Temple, Chicago, Ill.

The Boy's Junior Power Driven Automobile

You can build it yourself or buy it complete already assembled. 1917 Model

Parts inexpensive.

Send 20c for blue print and price list of parts.



SYMPHER MFG. CO.

146 Warren St., Toledo, Ohio

Pull-U-Out

The little thing with the big pull

Consists of a winding drum, lever crank, 40 ft. of steel cable, two 7 ft. chains and three stakes. Weighs only 28 lbs. and goes in space 4x8x14 in.



Pull-U-Out Portable Crane

We also make a wonderful portable crane. Weighs only 300 lbs.; lifts 1000 lbs.; 9 ft. 6 in. Easily moved wherever needed. Slip-jointed; can be put together in a few minutes with an 8 wrench. Has longer reach; weighs about 1/2 as much as other cranes of same capacity costing twice as much. Pull-U-Out easily detached and used for other pulling and hoisting.

Guaranteed and shipped on a strictly make good basis!



The motorist who has this wonderful and powerful little device in his tool box never fears road conditions. He knows that the moment his car gets stuck in the mud, skids into a ditch or overturns, he has efficient and immediate help at hand. No motorist can foresee these accidents. They come unexpectedly and without warning and are likely to happen to even the most experienced motorists. You may be miles from the nearest house when an accident happens, or you may skid from a perfectly good road into a ditch.

It is at such time that you will bless the day you bought powerful little Pull-U-Out. If your car gets stuck in hub-deep mud, Pull-U-Out will have you out and on your way rejoicing inside 10 minutes, without delay, trouble, damage to car or clothes, or expense. Unaided, a boy with a Pull-U-Out can pull a 5,000 lb. auto out of hub-deep mud easily. Pull-U-Out combines a rescuing device and a tow line—two things every auto should have. WRITE FOR FREE ILLUSTRATED BOOK.

Does wonders in factory, garage, repair shop!

It's an efficiency device of the first order. Does the work of a number of chain blocks, because it can be easily moved about by one man and used wherever needed. Pulls as well as lifts; is lighter than a chain block, has longer reach, will work in any position, costs less than half and will do lifting and pulling jobs that now require several men. Lifts 2,000 lbs.; pulls 100,000 lbs. on wheels (larger sizes have greater capacities).

Pull-U-Out Sales Co., 2035 Market St., St. Louis, Mo.

Bicycle Book FREE

A book to delight boys' and girls' hearts. Save money! 137 new guaranteed bicycles—\$19.95 and up. Write nearest house, Dept. G 133 New York, Chicago, Kansas City, Ft. Worth, Portland, Ore.

Auto Heel Rest for Fords

MADE OF FROSTED ALUMINUM. A neat, useful foot rest, sold by all dealers at 80¢ each, or will be sent postpaid on receipt of price.

Dealers—Send for circular and trade discount. Made only by J. L. LUCAS & SON, 10 Fox Street, Bridgeport, Conn.

FORD AUTO GIVEN TO AGENTS

HERE'S an opportunity to earn big money—\$6 to \$12 a day, with easy work, all your time or spare time and obtain a Ford Automobile besides. A straight out from the shoulder business proposition. No voting or guessing contest. We want wide-awake men and women to introduce into every home our famous ZANOL Pure Food Products, Non-Alcoholic Food Flavors in tubes, Toilet Preparations, Perfumes and Soaps; 250 other light weight household necessities.

Make \$50 a Week Easy

No experience necessary—we teach you how, give you the right start and help you make a success. Absolutely no limit to your earning power. We can use only a certain number of General Agents, so get in touch with us at once. We furnish our representatives with an automobile. Just send postal for particulars and money making offer.

AMERICAN PRODUCTS CO. 8239 Third St., Cincinnati, O.



Start a Tire Repair Business of your own

Get into the one line where there is more work than men to handle it—where you need but little capital or experience to make big money from the start. Over a hundred million dollars is being spent this year for tire repairs. It's easy for you to get your share with—

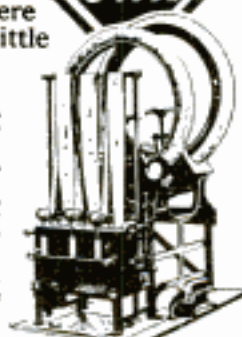

60 of the largest tire manufacturers use this equipment to repair tires in their own factories and branches—sell it to their dealers because they know it is built right and does the best class of work. Car owners don't want to take chances with their tire repairs. That is why you can make the biggest profit from—

Akron-Williams TIRE REPAIR EQUIPMENT

Send Back This Coupon Get this free book

It is brim full of just the information you need. Gives you all the details. Tells you how to make money with an Akron-Williams Outfit right from the start. Shows your opportunity in this big field. Write today—New. Your free copy is ready.

The Williams Foundry & Machine Co. 50 Cherry St., Akron, O. Gentlemen—Please send me your free book. This of course with no obligation on my part.

Name.....
Address.....

Please Mention Popular Mechanics

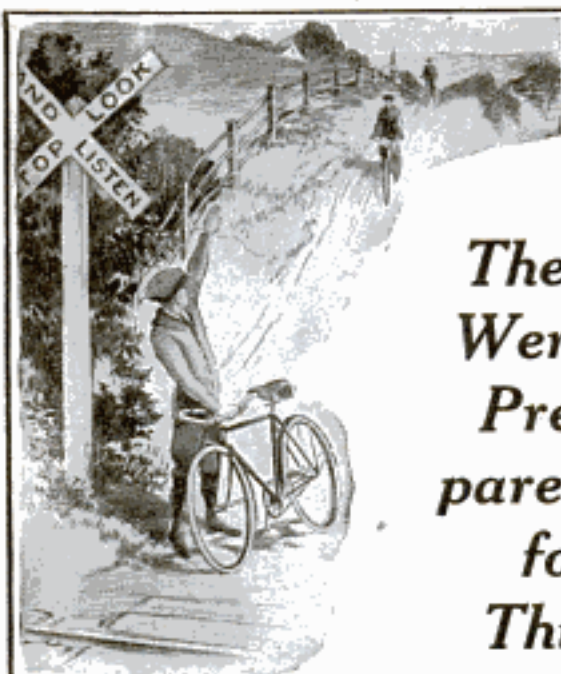

*They
Were
Pre-
pared
for
This*

BEFORE they started to coast this hill they knew from past experience that they were taking no chances—they knew that they could rely absolutely upon the powerful grip of the famous



DUPLEX COASTER BRAKE

There can be no improvement on this brake. It is powerful, it is durable, it is simple, it is reliable.

With a Corbin Duplex on your hub you are in a position to handle quickly and conveniently any situation that might arise on road or street. Elbow turns, dizzy hills and traffic-laden thoroughfares present not the slightest difficulty. It gives you complete mastery over your bicycle, a freedom and control that doubles the pleasures and possibilities of riding. It has no equal.

"Corbin Control Means Safety Assured"

Specify it. Sold and equipped by all dealers. Catalog on request.

The Corbin Screw Corporation

The American Hardware Corp., Successor
200 High Street New Britain, Conn.
Branches New York Chicago Philadelphia
Makers of Corbin-Brown Speedometers

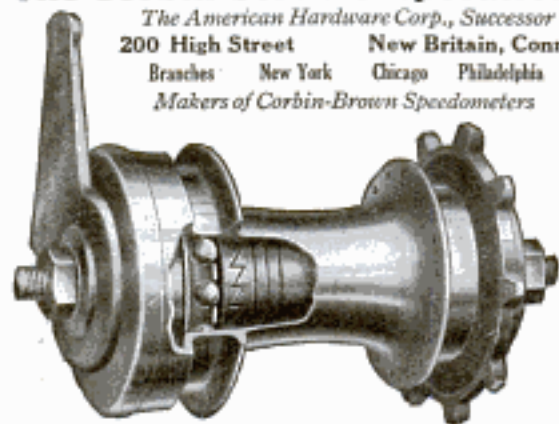

Please Mention Popular Mechanics



**CLEAR
THE
TRACK**

Here comes a real Coaster Wagon
— with real speed and real "pep"

Auto-Wheel Coaster

Other wagons have to get out of the way when it's gliding down the hill. Its record for making time gives it the right-of-way.

Free Pennant

and descriptive literature for names of three local coaster-wagon dealers. Mention those who handle the Auto-Wheel

The roller-bearings, protected by dust-proof hub-caps, insure speed AT ALL TIMES.

Built for Service—Not a Toy

The Auto-Wheel is solidly constructed. Stands wear and tear of long use, but always rides fast and smooth — like an automobile.



In Canada:
Preston, Ont.

**BUFFALO
SLED CO.**
137 Schenk St., N. Tonawanda, N. Y.



THE "SURE" SIGNAL

Sure in operation—sure to receive a "hearing" and instant obedience. New, superior style whistle warning. Not an exhaust signal. Different. Better. Screws in place of priming cup. Blown by direct explosion. Penetrating. Positive. No operative—repair—or upkeep cost. Standard equipment on numerous cars. Send for free literature. Get acquainted with the **sure** sale—**sure** whistle signal.

THE BUELL CO.

1610 Michigan Avenue CHICAGO

More Miles From Gasoline—Guaranteed!

The Wilmo Manifold gives your car a flying start at the first few turns of the motor—increases gasoline mileage from 42 to 54 per cent by actual official A. A. A. tests—keeps the engine free from carbon—makes a smoother running motor at all speeds. Quickly and easily applied with a monkey-wrench. No holes to bore. Absolutely guaranteed. Made for various cars. Price \$7.50 up. Ask your dealer or garage man, or write.

THE WHITTIER CO., First National Bank Building, CHICAGO

Start a Big-Paying Business of your own with a BADGER TIRE REPAIR OUTFIT

The man who's equipped to supply the stupendous demand for auto-tire repairs can make an assured income of \$100 to \$300 or more per month. The famous Badger Solid Pad System with its strong array of improved features



insures your customers quick, economical, high-grade repair jobs, the kind that build up steady trade. We teach you free and help you start the business. Write for copy of Catalog and details of complete money-making Free Aid Service.

TIRE REPAIR EQUIPMENT CO.

601 Johnson Street
APPLETON, WIS.

Delivered TO YOU FREE

No other concern will offer you such values or such terms. Make your choice from



Electric Lighted RANGER Motorbike

We Want a Rider Agent in Every Neighborhood

Send No Money but write today for this big free catalog, also full particulars of new 30-day free trial offer. Do not buy until you receive it. Write Now.

MEAD CYCLE COMPANY
Dept. C-108, Chicago

44 Styles

colors and sizes in the famous "Ranger" line of bicycles, freight prepaid to your town. Sent on approval for **30 DAYS' FREE TRIAL**. From our new big catalog select the particular style of **RANGER** bicycle you desire. We pay return charges if you decide not to keep it. You get one month riding test at our expense. **LOW FACTORY PRICES** direct from one of the largest, oldest and most successful bicycle concerns in the country.

TIRES

Lamps, Horns and parts for all bicycles at half usual prices.



PUT A CRIMP IN FUEL COSTS

YOU have no part in the establishment of gasoline prices. You must bow to the current per gallon "cost sign"—a high one, too. But you can, however, through employment of the

New Stromberg Carburetor

reduce the cost of car operation by reducing the amount of fuel consumed—by getting more miles per gallon.

The unapproached records of gasoline economy created by the New Stromberg Carburetor would appear miraculous indeed could they not be explained by proper principles of operation, and would bear the stamp of achievement attained under most favorable conditions were they not solidly backed by day after day performances of pronounced reduction in fuel consumption on all styles of cars.

Installation of the New Stromberg Carburetor on any car not only means instant and decided reduction in fuel consumption, but also increased speed, easier starting and more perfect acceleration.

Write for full particulars, giving name, model and year of your car.

STROMBERG MOTOR DEVICES CO.
Dept. 614
64 East 25th St., Chicago, Ill.

New **STROMBERG** Does It!
CARBURETOR

STANWELD Cold Drawn Seamless Steel TUBING

Lightest, smoothest, strongest Steel Tubing made. World's largest manufacturers of bicycles, motorcycles and automobiles use it exclusively. Send for Folder "A."

THE STANDARD WELDING COMPANY
Main Office and Factory CLEVELAND, OHIO

FORD OWNERS

The Van Sicken Headlight DIMMER & INTENSIFIER

Makes night driving safe. A mere flip of the control switch instantly provides the kind of light you need at any speed. Easily installed. Unfailing in results. Write for free booklet, "Headlight Control." Address The Van Sicken Company, Elgin, Illinois

Price \$4 Complete



DEALERS WANTED to make money selling the famous METZ Car—\$650 completely equipped.

108" wheel-base—4-cylinder 25-h.p. motor—7 forward speeds—electric starting and lighting, etc. Write To-day for full details of the Money-Making METZ Proposition
METZ COMPANY, WALTHAM, MASS.

Please Mention Popular Mechanics

Copyrighted material



"There
She Goes!"

Why Didn't I Use
NEVERLEAK
TIRE FLUID

Boys! why take chances? Why waste time fixing punctures? Why pump, pump, pump, trying to keep up a porous tire. Get all the fun out of your bicycle, and save money on your tires.

**A 25c Tube of
Neverleak Tire Fluid**

—heals punctures instantly — keeps porous tires up to pressure — increases the mileage of your tires — doubles the life of new tires.

Your bicycle dealer knows the value of Neverleak. For 25 years it has been the "Old Reliable" with tire manufacturers, repairmen, and hundreds of thousands of riders.

Get a tube or two today from your nearest bicycle store, and find out what it means to get rid of all tire troubles.

BUFFALO SPECIALTY COMPANY
BUFFALO, N. Y.



No More Creaky Wheels

Last summer thousands of motorists stopped the creaking of their heat-shrunk wheels with Spoktite. And they prevented the rattling and possible collapse that might have followed. Be on the safe side yourself this year—at least be without creaky, squeaky wheels.

Use SPOKTITE

It penetrates the pores and prevents shrinkage. It saves 4 wheels. Auto supply dealers—or postpaid on receipt of dealer's name and \$1.

LIQUID WHEEL TIGHTENER CO.

Dept. F, Modesto, California
Sales Offices: Boston-New York



For Auto, Buggy Or Wagon Wheels

Please Mention Popular Mechanics



**A New
Butler Tank
Was Born
May 12**

Its Name Is **Rus-Pruf Jr.**

At last you can buy a steel tank made along scientific lines, and backed by long actual experience. We know this new tank is right. It's the greatest value on the market.

War time shortage of steel made it necessary to bring out something new in steel tanks or raise the price away up. Rus-Pruf Jr. is the result. It's your patriotic duty as well as an economical necessity to read our booklet before buying a steel tank.



GET
THIS
FREE
MONEY
SAVING
BOOK
NOW.

Get this free book today. It's interesting and instructive. Write our nearest factory.

BUTLER MFG. CO.

204 Butler Bldg., Kansas City, Mo.
699 Gibbs S.E. Minneapolis, Minn.

Truck Bodies, Gasoline
Systems, Garages, etc.



CHARGING AUTO BATTERIES PAYS BIG

Every HB Charger can net the garage owner \$20.00 to \$90.00 per month. No experience required to operate. Current costs 10c per battery. You get 25c to \$1.50 from the motorist. Charges up to seven batteries at once. This money-maker shipped ready to install for \$15 with order, balance in easy monthly payments. Absolutely guaranteed. Can be returned if unsatisfactory. Write for full particulars, enclosing this ad. **Hobart Bros. Co., Box 56, Troy, Ohio**

Vitalic Bicycle Tires Deluxe

\$8 a pair, Brigadier \$6 a pair—made for endurance
Continental Rubber Works, 1964 Liberty St., Erie, Pa.

**The Cleveland
Lightweight**

The only light, low priced Motorcycle with straight line worm drive. Weighs 150 pounds. Highest quality throughout. 75 miles to the gallon. 600 sold in one city last year. Price, \$160.00; with Kick Starter, \$170.00. Dealers wanted.

THE CLEVELAND MOTORCYCLE MFG. CO.
7202 Platt Avenue, CLEVELAND, O.

**Russel Internal Gear
Drive Axle**



The most serviceable and economical motor truck axle made. Write for convincing reasons why your truck should be equipped with the Russel Axle.

RUSSEL MOTOR AXLE COMPANY, Central Ave., North Detroit

Attractive Catalog Free

Columbia BICYCLES

Westfield Manufacturing Company,
Department 15. Westfield, Mass.

TWIN FIRE

The only spark plug of its kind on the market

The Twin Fire Spark Plug laughs at soot and oil, for if one point clogs the other continues to fire—the hot explosions soon clean the fouled point. Add a world of energy to each combustion, too. Each spark fires independently of the other but at the same instant; gives double intensity. The laws of electricity make it physically impossible for any other than Twin Fire plug to fire two separate and distinct sparks simultaneously.

The first efficient spark plug



Ordinary plug dead when even one point is clogged.



Twin Fire always fires—one point cleans the other.

Price Only \$1.00

See your dealer today—he will prove Twin Fire superiority. If he cannot supply you order direct.

Twin Fire Spark Plug Company

660 Woodward Ave., Detroit, Mich.

Dealers: Big demand for Twin Fire plugs—write for dealers' plan.

REDUCE FUEL COSTS ONE-HALF

FOR FORDS AND ALL OTHER CARS

START EASY IN COLDEST WEATHER! MORE POWER and ONE-HALF MORE MILEAGE! Air Friction Carburetors use cheapest grade gasoline or even half gasoline and half coal oil with excellent results. Over 250,000 enthusiastic users! Start your car instantly and move off at once, while motor is cold (even zero weather), with no "spitting," "popping" or "missing." In other words, end your carburetor troubles.

AIR-FRICTION CARBURETORS

Newly Perfected Model for 1917

If your dealer cannot supply you, write or wire us at once, sending his name and the name and model of your car. 30% off list price where no representative is already appointed. Ask us about our 30-DAY TRIAL OFFER.

Dealers, garages and repair shops make greater profits and give more satisfaction supplying AIR-FRICTION CARBURETORS, and spark plugs, than on any other accessory they can handle.

THE AIR-FRICTION CARBURETOR CO.

213 Madison Street, DAYTON, OHIO

Manufacturers of carburetors for pleasure cars, trucks, tractors and motor boats.

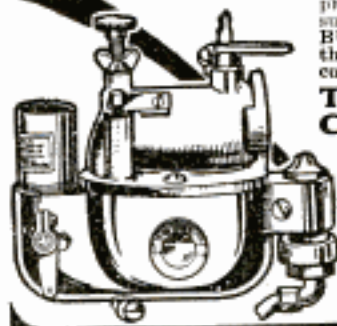

Show this adv. to your dealer or repair shop

MIAMI-MADE BICYCLES

Stand at the top of the bicycle world.

RACYCLE, HUDSON, MIAMI, FLYING MERKEL

Write for our catalog.

THE MIAMI CYCLE & MFG. CO., MIDDLETOWN, OHIO



CORONA The Personal Writing Machine weighs 6 lbs.

Writes all kinds of correspondence.

\$50 with carrying case. Write for booklet No. 32.

Corona Typewriter Co., Inc., Groton, N. Y.

Get about

\$125



Built That Every Man May Ride

The lowest priced complete motor vehicle in the world, including starter and clutch. Light weight and easy to handle. Goes almost 100 miles on a gallon. WRITE FOR BOOKLET.

Schickel Motor Company 69 Garden St. STAMFORD, CONN.

OWN A DIAMOND!

Get One Free!

Our Free Coupon System tells how you too can own a Genuine Diamond. Write today for full particulars. Costs nothing to join our Monthly Diamond Clubs. Thousands do it and are always ahead. You are now given the opportunity to earn a Genuine Diamond Ring Free or pay at \$2 a Month as you prefer.

Free Catalog 160 pages - Diamonds - Watches - Easy Terms - all goods sent on approval. \$29.50 Diamond Engagement Club now being formed. Send your name at once! Answer quick!

HARRIS-GOAR CO.

Dept. 91. Kansas City, Mo.



Test this Yourself

KOR-KER PUNCTURE CURE

Seals punctures instantly—Stops slow leaks. Reduces blowouts to a minimum. Preserves tubes. Increases mileage. Keep tires at normal inflation. Not a filler. 5 years success. Booklet gives details and proof. Write today.

Live managers wanted for local branches

Can make \$40 to \$150 a week

Alcemo Mfg. Co., 7 Bridge St., Newark, N.J.

\$1 a week buys a



Black Beauty Bicycle

You must see and ride a Black Beauty to appreciate how really different it is. Its style, durability and speed defy imitation.



At Factory Prices—On Approval NO MONEY IN ADVANCE

Let us send you (freight prepaid) a Black Beauty on trial. If you don't like it, return at our expense. If you do like it, you pay only \$1 a week.

Guaranteed for 5 Years by the largest exclusive Cycle House in America.

Write Today for Black Beauty Color Catalog showing all sizes, all styles

HAVERFORD CYCLE CO., Est. 1895, Dept. F, Phila., Pa.

GENUINE FRENCH BRIAR

Make your choice from 24 standard shapes of W. D. C. pipes in these four grades

BRIGHTON	50¢ and up
WINDSOR	75¢ and up
STRATFORD	\$1.00 and up
W.D.C. HAND MADE	\$1.50 and up

Each is a brim-full money's worth of pipe satisfaction—made by the makers of

The Wellington
THE UNIVERSAL PIPE

at good dealers'

WM. DEMUTH & CO.
NEW YORK



SOLID RUBBER BITS

Please Mention Popular Mechanics

All that a "linen" collar is
—and more



The end
of laundry bills

CHALLENGE CLEANABLE COLLARS

Best for summer months. Indispensable for motoring. Ever-white, stitched edge effect, dull linen finish—and instantly cleanable, with soap and water.

Positively no-wilt

A \$5 to \$10 annual saving—and real comfort. All accepted styles, half sizes. At your dealers or samples by mail 25¢ each. Style booklet on request.

The Arlington Company
725 Broadway, New York

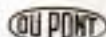

ARE you reading the double-page Westinghouse more-than-advertisements in The Saturday Evening Post, Literary Digest, Collier's, Leslie's, National Geographic, Popular Mechanics and other publications?



4 Weeks' Trial

Any
Superb



Pianoor Player
Piano, choice of 38
styles, on 4 weeks'
absolutely free trial.

No money down, all
freight prepaid. Return at our expense, or keep
it at the rock-bottom direct price. Easy terms.

Valuable Book FREE

Write today for "The Book of Complete
Information About Pianos." Also free catalog.

Wing & Son, (Est. 1865) 9th Ave. and 13th St., Dept. A119 New York



Makes
Popcorn
Crispettes

One Man and This Machine WILL EARN \$50 to \$100 DAILY PROFIT

Eakins' profits \$1500 in one month
making Crispettes in a store
window. Palmer sold \$680
worth on Labor Day; Kunkle's
sales over \$7000 in less than
year. One machine—a small
investment starts you. You learn in
a day. Turn out batch after batch.
Sell at 5¢ a package and clear about 4¢ profit.

SEND FOR THIS FREE BOOK NOW!

It tells the whole story—how to succeed,
gives experience of others, etc. It's
worth reading. If you're looking for a
money-making business write today.
Send post card or letter.

W. Z. LONG CO.
1336 High St. Springfield, Ohio



Build Model War Aeroplanes That Fly Like Real Ones!

Learn how Aeroplanes are built; how they fly. Build a model of any of the war-famous Aeroplanes and learn the principles of Aeronautics. It's easy; we furnish complete Construction Outfits containing all parts and full instructions. You assemble the parts and build your own 3-ft. Model Aeroplane that looks exactly like a real one; that has rubber-tire disk wheels, adjustable planes and rudder, hand-carved propeller, and other necessary fittings; all of which are perfect copies of the man-carrying aeroplane's parts. These Model Aeroplanes will rise from the ground by their own power and fly 50 to 100 feet in the air. It's the most fascinating and instructive sport you ever had. Find out all about it now. Send for

Scale Drawings With Building and Flying Instructions

which tell you how to build your own Aeroplane.

Curtiss Military Tractor—**25c** Wright Biplane—
Bleriot Monoplane—**EACH** Curtiss Hydroaeroplane—
Nieuport Monoplane—**81c** Curtiss Flying Boat—
Taube Monoplane—**\$1.75** Cecil Peoli Racer—

"IDEAL" Model AEROPLANES and Supplies are Sold by
Leading Toy, Sporting Goods and Department Stores.
Ask your Dealer for "IDEAL" Construction Outfits.

SEND 5c FOR THIS AEROPLANE CATALOGUE

Tells about Model Aeroplanes and how they are built. About Racing Aeroplanes and Flying Toys. Also lists all kinds of parts and Supplies for Model Aeroplanes. 48 pages; see picture below.

IDEAL AEROPLANE & SUPPLY CO.

82-84 West Broadway
New York City



This is the Bleriot—
Build a model of it!



Cash with order buys this small
\$3 BENCH LATHE
Spring 3 in. 8 in. C. to C. Shipping Wt. 10 lbs.
PETER AUSTIN, 910 W. First St., MUNCIE, IND.

\$3 Brings This Electric Washer
Balance small monthly payments. Do a big family washing at cost of only 5c for power. Complete with wringer ready to run. Write today for special offer.
Larkin Co. Desk 617 BUFFALO, N. Y.

"Health and Success"

To be a success you need health and a vast reserve of vitality. A clogged system brings sickness and failure. A recent invention, a Turkish bath in your bed, guides you to sparkling health and vitality. Physicians and patients laud the wonderful effects of this bath. Cost within reach of everybody. Our booklet on "Health" will tell you more.
WRITE FOR A FREE COPY TODAY TO

RATHER-TURKISH-BATH, Rosebank, S. I., New York

Violet Ray Treatment

Restores, Beautifies, Benefits, Relieves

Anyone can now enjoy this wonderful, invigorating, electrical treatment. Electrical energy transmitted without shock or pain, to any part of the body in the privacy of their home, with our



Vi-Ray-O

The true Violet Ray generator, endorsed by leading physicians and satisfied users everywhere.



Write for our 68-page illustrated Free book—Vi-Ray-O. It tells of the soothing, delightful, nerve-toning and health-giving Violet Ray and all details about our wonderful Vi-Ray-O instruments.

With it comes our special 10 day offer. — Order today.

Western Coil & Electrical Co., Box 15, Racine, Wis.

Quick and Easy Ironing

2c
TO
4c
an
Ironing



Every housewife can avoid the hard labor of hand ironing, which is always tiring and many times positively injurious to health, by using the

SIMPLEX IRONER

"THE BEST IRONER"

Irons easily and quickly at trifling expense and with better results. Gas, Gasoline or Electricity for heat. Hand, Engine or Motor for power.

**Just What Every Housewife Needs
Every User Is Enthusiastic**

**American Ironing Machine Company
505-168 No. Michigan Avenue, Chicago, Ill.**

Steel Blue White
Perfect Cut Genuine
DIAMONDS
Were \$50. NOW \$33.



TOTAL WEIGHT
 $\frac{3}{8}$
Carat



14K Engagement
Solitaire Mounting **\$2.50**

Price complete with
1-3 Carat Diamond, \$4.00, \$9.33, \$11.00,
1-4 Carat Diamond, \$17.25, \$23.00, \$29.00,
2-3 Carat Diamond, \$29.00, \$42.00, \$67.50,
1-2 Carat Diamond, \$42.75, \$68.00, \$78.00.
Choice of 3 qualities.

I import Diamonds direct from cutters in vast quantities. I sell direct to the people who wear Diamonds and by so doing I wipe out the profits of many middlemen. Therein lies the secret of my remarkably low Diamond prices which are less than established jewelers must pay wholesale. I actually save you 35%. I personally grade every Diamond in our vast stock. This is your assurance that you get exactly what we promise, exactly what you expect in fine quality and money's worth.

Send No Money I Ship for Free Examination

any Diamond you select by any express or to any bank to prove that I sell the same Diamond for 35% less money or a bigger Diamond for the same money.

Give the Only Bankable Money Back Guarantee

The only Diamond Guarantee that you can take to any bank and cash in your Diamond investment if you wish to. It's a legal certificate of carat weight, quality and value. Permits exchange at full value at any time.

1917 DeLuxe Book of Diamonds

FREE Mail coupon and get this handsome free book. Contains true facts about Diamond qualities and values, and thousands of beautiful illustrations of 1917 Diamond Jewelry. References: Lake and State Bank, Chicago; Dan, Broadway, your banker, 100,000 satisfied customers all over America.

Barnard & Co., Chicago

**BARNARD & CO.,
Dept. 2888C-
N.W. Cor. State & Monroe
Chicago, Ill.**

Without expense or obligation please send me, Free postage paid, your 1917 DeLuxe Diamond Book.

Name.....

Address.....

Please Mention Popular Mechanics

The
ILLINOIS
Rockland
SPECIAL
50¢
a week
20 Year Case
19 Jewels



THE LATEST CREATION
19 Jewel
Illinois **ROCKLAND** Special
Known the world over as accurate
Railroad Timekeeper
Made by Illinois Watch Co.

Sold with this guarantee. Money refunded if any jeweler in the United States can duplicate this watch for less money for Spot Cash.

19 JEWELS, adjusted to positions, heat, cold, isochronism with Double Roller. Guaranteed 20 year case. **\$28.50**
Cash or Payments

SEND FOR CATALOG

LENOX JEWELRY COMPANY
20 YEARS OF HONEST DEALING
373 WASHINGTON STREET, BOSTON.

Drilling Wells is a Year Round Business



Drilling Water Wells is a profitable, healthful, year-round business. There are wells all around you to be drilled. Don't you want to get into a money-making business for yourself? Write for particulars.

STAR DRILLING MACHINE CO.
664 Washington St. AKRON, OHIO

BIG SPORTING GUIDE AND CATALOG



FREE! Some Sample Bargains

Beverly Tennis Racket, \$1.65. Ash frame, walnut throat, strung with oriental gut.

Fielder's Glove, \$1.05. Professional model. Weltd seams, perspiration proof lining.

Wedge Tent, \$3.10. 5x5 feet. Best duck, complete with poles.

Brunswick Jr. Bicycle, \$25.65. High grade. Fully guaranteed. Complete with coaster brake, tools, etc.

Fishing Outfit, \$2.85. Complete with tackle box, steel or bamboo rod, 60-yard reel, line, sinkers, hooks, etc.

Send for complete catalog today. Free.

THE BRUNSWICK-BALKE-COLLENDER CO.

Dept. 85, 623-633 S. Wabash Ave., CHICAGO

Every lover of outdoors and outdoor sports should have this Guide and Catalog. It is chock full of information. It lists and pictures everything needed in Sporting and Athletic Goods. Many new articles—all quality goods—all bargains.

Making and buying in tremendous quantities and selling direct to you is the secret of the low prices.

Send for this Big Sporting Goods Book now.

Electric Light for Your Home

Uni-Lectric lighting plant generates standard 110-volt direct current; operates from one to 50 lights, electric motor, electric iron, vacuum cleaner, electric toaster, force pump, churn, washing machine, etc.

No Batteries — No Switch-Board and a better machine for less money. High speed gasoline motor, generator and automatic governor, all complete in one small, compact unit. Uses standard lamps and fixtures. Simple, easily installed, dependable, economical. Costs less than other systems to buy and to operate.

WATERMAN MOTOR COMPANY
182 Mt. Elliott Ave. DETROIT, MICH.

Write today for full description and low price.

Uni-Lectric
GASOLINE-ELECTRIC UNIT
LIGHTING SYSTEM



MONEY IN MUSHROOMS

GROW AND SELL MUSHROOMS

An uncrowded occupation. Exceptional opportunities for live men and women. Raised at home. Only small space needed. Small expenditure will start you in a practical money-making enterprise. Big profits. Booklet telling all free. Write

Nat'l Spawn Co., Dept. 12, Boston, Mass.

ASBESTOS

We are miners and shippers of Crude Asbestos in any quantity. We produce all grades at our world-famous Bell Asbestos Mines, in Canada. We also card fibres, spin yarns, weave cloths, and make all sorts of Asbestos products.

For anything you want in Asbestos, turn to
KEASBEY & MATTISON COMPANY
Dept. S-3, AMBLER, PENNA., U.S.A.
Owners of the world's largest Asbestos Mines



MARBLE'S Woodcraft Hunting Knife

The biggest value ever offered in a hunting knife. Costs you only \$1.50, yet has the shape, weight, quality and desirable features of \$2.50 and \$3.00 knives. Adapted for sticking, cleaning, skinning, slicing, chopping bone, etc. High-grade steel—bevel blade thick at back, tapering to a fine point. Handle of laminated leather. Absolutely guaranteed. Price \$1.50 at your dealer's or direct by mail postpaid upon receipt of price. Write for catalog Marble's 60 Outing Specialties. Sample Marble's Nitro-Solvent Oil free if dealer's name is mentioned.

MARBLE ARMS & MFG. CO.
578 Delta Ave., Gladstone, Mich., U.S.A.

Please Mention Popular Mechanics

A Scientific Solution of the Sanitary Drinking Water Question



Ice Cooled

Holds 75 lbs. of Ice.
Supplies 150 Men.

Fifteen and one-half circulating coils of pipe in the cork-jacketed ice tank insure an ice-cooled sanitary drink to every employee.

The quality of the ice is immaterial, as it does not come into contact with the water. This construction reduces the amount of ice and water required to a minimum.

Send for Our Complete Catalogue

showing our line of Wash Bowls, Metal Lockers, All Steel Stools and Chairs with Inset Wood Seats, Stock and Storage Racks, Metal Shelving, Metal Vault Fixtures, Improved Soda Kettles, 40 and 60 gallons, Water Heaters and Instantaneous Mixers, Bubbling Drinking Fountains, Work Benches and Bench Legs, Drawing Stands, full line of Plumbing Fixtures, etc.

Manufacturing Equipment and Engineering Co.
136 Federal Street Boston, Mass., U.S.A.
Works and Mail Address, Framingham, Mass.

Write for FREE Book on Vibratory Massage

Explains this new scientific way of gaining health and strength with the Arnold Vibrator. Gives the low price with special 10 day trial offer. Write today for this valuable book.

ARNOLD ELECTRIC CO., 1467 12th St., Racine, Wis.



No. 2



No. 1

Free to Wear 10 Days

Send no money. Just ask us to send you either of these wonderful, dazzling, genuine Tifnite gem rings to wear for ten days. See how beautiful it is. See how it stands all diamond tests. Write now while this offer lasts. Say which one you want.

No. 2—Ladies' guaranteed genuine Tifnite gem ring in beautiful six-prong solid gold mounting. Almost a carat Tifnite gem. Sparkles like a genuine diamond. An amazing Gem. Send no money.

No. 1—Gentlemen's guaranteed genuine Tifnite gem ring in solid gold eight-prong Hecher mounting. Almost a carat large. Tifnite Gems contain no glass. will scratch glass, won't file.

In ordering send strip of paper fitting around second joint of finger. Yes, send for either of these beautiful rings. If satisfied upon arrival send \$3—then \$3 monthly until the price, \$12.55, is paid for ladies' ring or \$12.75 for gent's ring. Otherwise return the ring within ten days and we will refund any payment made. This offer is limited. Send while it holds good. Send no money. Address

The Tifnite Gem Co., Dept. 203 Rand McNally Bldg., Chicago

No Money In Advance

This Marvelous CAMERA On FREE Trial!

Only 10,000 of these marvelous, instantaneous picture-taking and making cameras to be sent out absolutely on approval without a penny in advance just to prove that it is the most wonderful invention—the camera sensation of the age. So you must send for it quick! Just think of it—the new Mandel-ette



TAKES AND MAKES Finished Pictures Instantly!

You press the button, drop card in developer and in one minute take out a perfect, finished post card photo, 2 3/4 x 3 3/4 inches in size. Camera, itself, is about 4 1/2 x 5 x 7 inches. Loads in daylight 16 to 50 post cards at one time.

No Films—No Plates—No Dark Room

Not a bit of the fuss and bother of the ordinary kodak or camera. It is instantaneous photography. Universal focus lens produces sharp pictures at all distances. Pictures develop and print automatically. Can't overdevelop; results simply amazing.

We Trust You

No difference who you are, where you live or what your age, we will send you the complete "Mandel-ette" outfit absolutely on approval and give you 10 days to test it. If not satisfactory return it. But when you see what elegant pictures it takes—so quick, so easy, with no trouble at all—if you wish to keep it you simply send us \$1.00 per month until our special price of only \$5.00 is paid.

EASY PAYMENTS—NO REFERENCES

No red tape of any kind. Monthly payments so small you'll not notice them. Lots of fun and big profits.

NO EXPERIENCE REQUIRED

Plain instructions and everything complete with outfit so you can begin taking pictures the moment it arrives. We guarantee that even a child can operate it. Mail coupon right now. No risk or obligation to keep camera.

The Chicago Ferrottype Co.,
Desk 516 Ferrottype Bldg., Chicago, Ill.

Send me at once one complete model Mandel-ette Camera outfit including supply of post cards and instructions. I agree to examine and test it thoroughly and if satisfied keep it and pay you \$1 a month until your special price of \$5 is paid. Otherwise I will return it at the end of 10 days.

Name

St. and No.

Town.....State.....

Please Mention Popular Mechanics



Your Garage Doors "STAY PUT" WITH THIS HANGER

The
Perfect
Garage
Door
Hanger
Set

Use This Hanger on the Garage You're
Going to Build This Spring

Allows use of full door opening without risk of damage to car or door, and door cannot swing or blow shut, as it automatically fastens itself open. No extended run-way on either side of building, and no sticking or getting out of order. Can be opened to any width desired, and is weather-tight when closed. No sawing or cutting of holes necessary to attach. Your doors "STAY PUT."

Ask your hardware dealer—Also send today
for descriptive circular, surprisingly low price.

Dealers—Get ready for the big spring garage building season. There's big profit in this device, and there'll be a big demand. Architects—Specify this in your plans and make every client happy. Write for terms.

Safety Door Hanger Co., 106 Topping Bldg., Ashland, Ohio

\$960
and accrued interest
will buy a **\$1000**
Standard Gas & Electric
Company
6% Gold Note

which will put \$60.00 in your pocket annually—\$5 for every month in the year.

Standard 6% Gold Notes combine the chief features of a desirable investment—safety of principal and interest—and better than ordinary yield. Notes may be purchased in denominations as low as \$50.

Write today for earnings circular P.M.
H. M. Byllesby & Company
Incorporated

New York CHICAGO Tacoma
1248 Trinity Bldg. 1933-208 So. La Salle St. Gas Bldg.

WEBER THROTTLE-GOVERNED VALVE-IN-HEAD KEROSENE ENGINES

All 1917 Weber Engines are equipped with that great engine improvement, the "Weberator." Makes kerosene as convenient to use as gasoline. Kerosene has more units of energy per gallon than gasoline. Saves you one half fuel cost. Write today for full details and 60-day trial offer. Now sold direct to user at factory prices.

WEBER ENGINE CO.
Dept. 177 C
Kansas City, Mo.

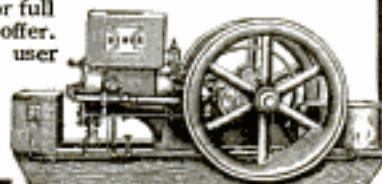

\$10c a Day Now Buys This Superb Farny Violin

An exquisite instrument. Made by the great Violin Maker, Henri Paris. Pay for it at the rate of 10 cents a day. One week free trial. Rare Old Violin Circular Free on request. We supply the U. S. Govt. Thousands of superb instruments to choose from. You get the benefit of our month facilities by buying in large quantities.

Write Today for Special Circular. No obligations. See handsome illustrations of the superb instruments that you have to choose from. Read our direct money saving offer. Write to the
RUDOLPH WURLITZER COMPANY Dept. A-386
E. 4th St., Cincinnati, Ohio So. Wabash Ave., Chicago, Ill.

GAS LAMPS and **LANTERNS** for Kerosene or Gasoline
One to 600 candle power for homes, stores and all lighting purposes. The most satisfactory and reliable gas lamps made. Big profits to agents and dealers. Write for catalog.
BRILLIANT GAS LAMP CO., 1009C South Wabash, CHICAGO

WORLD'S BEST SHOE VALUE

200 Other Shoe Bargains for Men, Women, Boys and Girls
Big, New 1917 Scientific Footwear Catalog shows over 200 styles and how to save 20% to 50% on shoes for the whole family.
FREE ON REQUEST.

Ruthstein Scientific Shoe Co., Dept. 640, Racine, Wis.
America's Greatest Mail Order Shoe Factory

DIAMONDS, WATCHES ON CREDIT

YOU SHOULD HAVE THE JAMES BERGMAN 160 PAGE JEWELRY BOOK IN YOUR HOME. 4,000 Photos, Illustrations, Watches, Jewelry, Toilet Articles, etc. Anything selected sent on approval, all charges prepaid. If satisfactory, Pay 20 per cent Down—10 per cent Monthly. Write Today for Big Free Catalog No. 5. It tells all about our confidential relations. Binding Guarantee and Liberal Exchange Offers. 10 per cent off for cash. **James Bergman** Estd. 1896 NEW YORK CITY



YOUR OWN BOSS

Easiest thing—right in your town. Small investment—sure profit with a Kingery Peanut and Popcorn Machine. Prices \$40 to \$400—easy to buy!

Ask for particulars and Catalog No. 50.

KINGERY MFG. CO. Pearl, East of Broadway, CINCINNATI, OHIO



**Greenfield
Tap and Die
Corporation**

Gages-Taps-Dies

Threading Machines, Reamers, etc.

Greenfield, Massachusetts

CANADIAN FACTORY: Wells Brothers Company of Canada, Ltd., Galt, Ontario

GREEN AUTOMATIC MACHINE



Let This Machine Grind Out Money for You

THE GREEN AUTOMATIC MACHINE \$10 A DAY AND UP

Sharpens, Honors and Strops all kinds of safety razor blades in one operation, from four to six blades in one minute. For both quality and quantity this machine is in a class by itself. There is nothing like it on the market. Let us send you our free booklet explaining everything, including the "AMERICAN" Key Cutter—cuts square, angular or round slots.

AMERICAN SHARPENING MACHINE CO. (Inc.), 184 W. Washington St., Dept. 524S, CHICAGO



SMALL SET BACK Veeder Counters

(Ratchet or Revolution)
RESET TO ZERO BY A SINGLE TURN

These counters are just as high grade as our large counters, but are lower in price. Price \$5.

There are Veeder counters for practically every purpose. Our booklet describes these uses in detail and shows various instruments. It is interesting and free. Send for it.

The word Veeder stands for the best constructed and most accurate counting devices.

Cyclometers, Odometers, Tachometers. All kinds of counters. Fine Die Castings.

VEEDER MFG. CO.
4 Sargeant St., Hartford, Conn.



Half Size



Sharpens Safety Blades Perfectly

At last, the perfect sharpener—the **Stag Sharpener**. The only sharpener that both hones and stropps all makes of safety blades. Keeps blades in perfect shaving condition. Makes old blades better than new. Surprisingly simple. Roller in holder automatically sets blade always at correct honing and stropping angle. Our **New Patented Feature** makes inserting and removing blades easy. Just press rollers together. Heavily nickeled holder, barber's hone and stropp in neat box, complete, postpaid, \$1.00. Try it 10 days; money back if not satisfactory.

Dealers Write for Special Introductory Offer
24 So. State Street
Dept. 5230, Chicago

STAG CO.



\$1

Motorize Your Home with Universal Motors

Ask for Catalogue



Money back if not completely satisfied. Order today.

Attach to any electric light socket and this Universal Motor will clean and polish your Silverware, sharpen your Carving Knives and Cutlery; drive your Sewing Machine, revolving top of foot pedal drillpress; grind your small tools, such as Scissors, Chisels, Screw Drivers, etc.; serve you as an Electric Fan with Fan Blade Attachment; operate efficiently as a Power Motor for Driving Green and Egg Beaters, etc., and will perform many other household duties. Costs only \$6.00 complete with Buffer, Emery Wheel, Cord and Plug. Fan attach. extra. Racine Universal Motor Co., 53 W. Jackson Blvd., Chicago

Makers of Racine Fans, Vacuum Cleaners, Vibrators, Motor Appliances of All Kinds

YOUR SPINE NEEDS STRETCHING



This University discovery is the most important health invention of the century. It relaxes and rejuvenates the Human Body. It produces normal spines. It frees impinged and irritated nerves, corrects contracted muscles, shortens ligaments, eliminates congestion, improves circulation and drainage of the body. IT WILL INCREASE THE BODY'S LENGTH. THE PANDICULATOR CO., Cleveland, O.

INDOOR CLOSET

More Comfortable, Healthful and Convenient than the Out-Door Closet

Eliminates the out-door closet and open vault. They are breeding places for germs. Have a warm, sanitary, odorless toilet right in your house. No going out in cold weather. A boon to invalids. Endorsed by State Boards of Health.

W. M. Davis writes: "Your indoor closet is giving absolute satisfaction. It is certainly the thing for a home without sewerage."

Absolutely Odorless Put It Anywhere in the House

The germs are killed by a chemical process in water in the container, which you empty once a month. Absolutely no odor. No more trouble to empty than dishwater. Closet absolutely guaranteed. Write for full description and price.

Agents Wanted — Big Profits Wonderful opportunities in every town, village and in the country. Best season just at hand. Every home is a good prospect. Sell eight out of every ten you call on. Ernest Rindell writes: "Have ten orders." G. A. Dismann says: "Ship at once twenty closets and fifteen washstands. Sold them all in one community." Sell it. Everybody hates the outdoor closet. Everybody wants a Ro-San Indoor Closet. Write quick for territory and full particulars.

ROWE SANITARY MFG. CO., 605 Sixth St., Detroit, Mich.
Ask about the Ro-San Washstand — Hot and Cold Running Water Without Plumbing

ANY WATCH YOU WANT on CREDIT



1917 Models

**WALTHAM
HAMILTON
ELGIN, MILLER
Illinois, Howard**

Sent on 30 Days Free Trial

No Money Down

Express Prepaid in Advance by Me

You take no chances with me. I am "Square Deal" Miller and I trust the people. That is why I am doing the greatest Credit Watch, Diamond and Jewelry business in the country. Suppose you want any one of the country's best makes of watches? Name any one, I have it for you. No money Down, Express Prepaid. A full month to carry it in your pocket and the easiest of Long Time Payments. That's the test that tells. All these watches **GUARANTEED 25 YEARS**

I Smash the Terms

No References Demanded

My terms are made to suit you. You get unlimited credit, with no red tape, notes or collectors. All unnecessary detail left out.

An "Open Charge" Account

the same kind of credit you get from your grocer. No matter where you live or what your income is, you can now own the finest watch, a beautiful diamond or any rare jewelry and never miss the money.

Costly Catalog FREE

Send me your name and address so I can mail you, Free and postpaid, the most beautiful catalog of its kind ever printed. I want you to have this book. It's a gem. It illustrates all makes of valuable Watches, Elegant Genuine Diamonds, and a vast assortment of Beautiful Jewelry, all on the easiest and most liberal terms

Square Deal MILLER
PRES.

867 Miller Bldg., Detroit, Mich.



BE THRIFTY
BUY A DIAMOND
PAY MONTHLY

MONEY REFUNDED
IF YOU CAN BUY
CHEAPER FOR CASH.



Fine Diamonds

Our diamonds are all perfect cut beautiful stones, white in color and lots of size.

SQUARE DEAL MILLER
PRES.

Fine Diamonds

You cannot buy by mail better diamonds at any price than we are selling on credit.

FREE CATALOG COUPON

SQUARE DEAL MILLER, Pres.
867 Miller Bldg., Detroit, Mich.

Please send me your 1917 Catalog and explain fully your 30 Day Trial Plan and Easy Terms

Name.....
Address.....

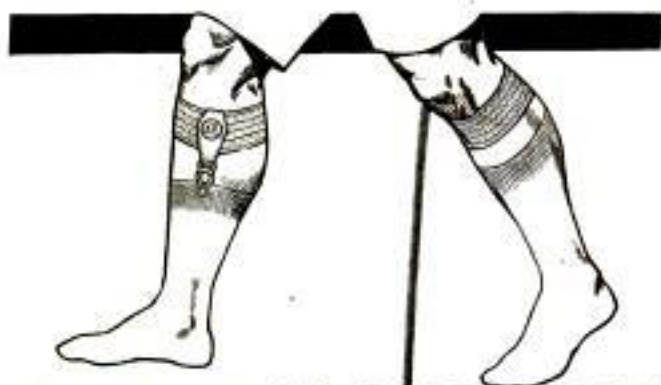

ON THE MARCH

Whether with the army afield, or in peaceful pursuits, the walker's muscles and veins must not be confined. You will like the

E.Z. GARTER

"THE ONE THAT WON'T BIND"

Made WIDE for Comfort and Free Circulation

No straps, buckles or adjustments.
Quickest on and off. Cool in summer.

25c for lisle, 50c for silk. If not at dealer's, send his name and price to

THE THOS. P. TAYLOR CO., Dept. P, BRIDGEPORT, CONN.

Dealers: Ask your jobber, or order sample dozens from us without obligation.



GIVE YOUR CAR A NEW FINISH—DO IT YOURSELF WITH ONE OR TWO COATS

OF
Effecto
AUTO
FINISHES

MAKES your car look like new, at small expense. Not a wax or polish. A durable, quick drying, high luster auto finish. Made in seven colors, also Clear Varnish and Top and Seat Dressing. Keep a can of Effecto handy for touching up rusty spots. Sold by paint, hardware and auto accessory dealers. Send for Color Card. Pratt & Lambert, Inc., 133 Tonawanda St., Buffalo, N. Y. In Canada, 99 Coonwright St., Bridgeburg, Ontario.

MADE BY THE MAKER OF
PRATT & LAMBERT VARNISHES

TEMCO



Connects to ordinary electric lamp socket—wound for any voltage from 50 to 250 A. C. or D. C.

This
Electric Tool
pays big returns

to shops, factories and maintenance depts. all over the country

The grocer doesn't send a dray to deliver a can of baking powder. Nor should shops and factories set big stationary machine tools for hurry-up or odd jobs, but rather use the Temco Portable Electric Tool, ready in an instant to drill metal or wood, tap threads, drive or draw screws, and with attachments to sharpen tools, grind valves, etc.

Take this portable tool anywhere

and connect to lamp socket. Faster and more accurate than hand tools. Weighs but 9 to 19 pounds according to size. One and two speed types with instant reverse. Capacities to 3/4 inch bore in steel. Staunch, durable. Temco motor costs but one cent an hour to run.

Write or see your jobber for literature and proof of the utility of this remarkable tool.

The Temco Electric Motor Company
139 Sugar Street LEIPSIK, OHIO

THE TOOL OF MANY USES

When You Build

please bear in mind that there is still plenty of

WHITE PINE

Send for our free booklet, "WHITE PINE IN HOME-BUILDING"

WHITE PINE BUREAU

1626 Merchants' Bank Bldg. ST. PAUL, MINN.

12
SIZE **FREE!**



Rich Advertising Offer to those who Answer Now!

A Special 12-Size Thin Model 25 Year Gold Case—fine 15 Jewel genuine Ducler-Hampden, now offered for the first time direct to you

Net \$2-A-
Cost 2 Mo.

Finely finished—regulated to the second—fully guaranteed—just the watch you have always wanted. See it Now! A thousand being sent out on approval this month. Our price is so low we cannot give it here, as retailers must be protected against our publicly giving wholesale prices, except to those interested enough to write now for our \$5 Free Chain Offer. Your name and address on postal will do. This small ad means much to you if you answer at once! An amazing Watch Offer direct to you!

IMPORT MERCANTILE CO.

Dept. 122

KANSAS CITY, MO.

\$100⁰⁰ Phonograph

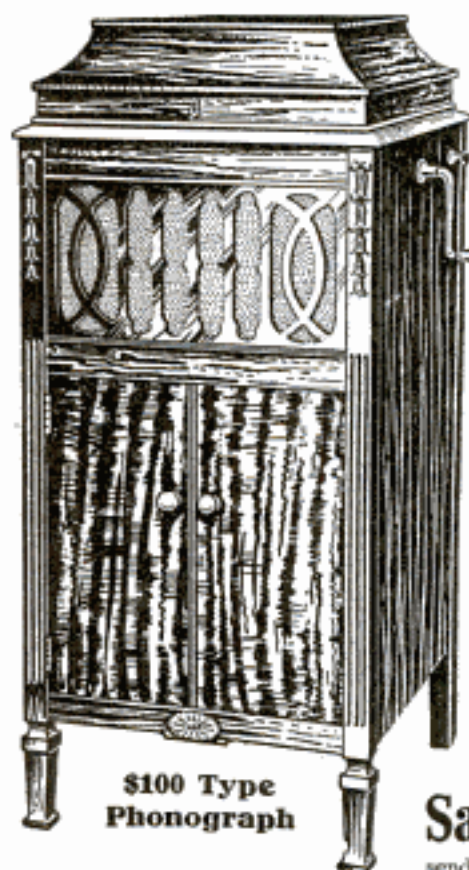

\$100 Type
Phonograph

**In Fine Tonal Quality
and Rich Music Value
with Your Own Cabinet**

New, amazing, money-saving offer on a fine phonograph. Now is your opportunity. Basic Patents have expired. You can now get the finest phonograph for the bare cost of the parts. You will be surprised how simple and easy it is when you have the parts. You will then have the finest machine with all the many big profits in your own pocket. The saving is positively astonishing. You can get all the metal and moving parts for only \$7.85.

\$7⁸⁵

Build a Talking Machine

We tell you all the secrets of phonograph design and construction. All the secrets of fine tone and sweet music. We show you how simple and easy it is to assemble the finest phonograph. We furnish complete detailed blue prints of the fine cabinet shown in this ad, furnished to you for only 50c. Blue prints and all details of this fine cabinet sent free to you if you purchase the complete outfit of parts for \$7.85. If you don't need the parts and want to assemble a magnificent cabinet, send us only 50c for the blue prints, plans and details for making the phonograph cabinet.

50c

Save the Big Profits

sending to us for the parts. You get the parts alone would cost you from \$7.00 to \$15.00 from dealers. All metal exposed parts are nickel-plated. Send today and get all these parts for only \$7.85.

You can save the enormous profits on phonograph construction and assembling by all complete, all metal and moving parts for only \$7.85. The reproducer of this quality

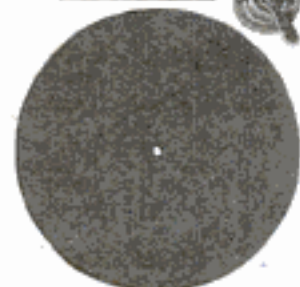
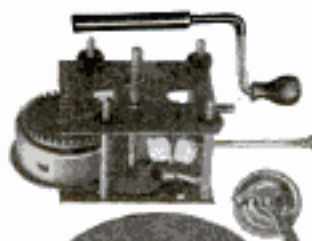

Plays All Records Your phonograph made by assembling these parts will play all Disc records. Plays Victor, Little Wonder, Columbia, Emerson, Edison and Pathe, and all Disc records up to 12 in. Motor full force with spring regulator.

Here Are All the Working Parts of \$100.00 Type Phonograph

In addition to the parts illustrated we send you all necessary screws, needle cups, etc. When you get the parts you will be delighted to see how easy it is to assemble them and have your own magnificent phonograph. If you don't want to make your own cabinet use a table or any other suitable piece of furniture. You save the profits of *manufacturers, distributors, jobbers, dealers and agents.* Act quick and get the full benefit of this special offer.

Send Coupon

Send the coupon or copy it on a piece of paper. Enclose only \$7.85 for all parts all complete, including the blue print, for making the fine cabinet, only \$7.85. Blue print and plans for cabinet alone only 50c, free with parts. All parts guaranteed. Send today.

One of Many Unsolicited Testimonials

SINGER SEWING MACHINE CO.
SPRINGFIELD, MASS.

Electro-Mechanical Parts Co.,
Chicago

I am very pleased with the motor and tonearm, and now have a grand good cabinet, which makes as fine a phonograph as any on the market at \$100.00. The tone of vocal and all music and voice is as real and free from fault as in any high priced phonograph.
C. E. TYRUS.

Special Coupon

Electro-Mechanical Parts Co.
57 E. Jackson Blvd., Dept. 524R
Chicago

GENTLEMEN: I wish to take advantage of your special limited offer on complete set of working and moving parts for \$100 quality phonograph, and blue print of plans free. I enclose \$7.85 for parts as advertised with your guarantee attached.

We Sell Everything to Make Phonographs

All styles and types of motors, electric and spring wound. Reproducers of all styles. Descriptive circulars and all particulars free. *Send today.*

Electro-Mechanical Parts Co.

57 E. Jackson Blvd., Dept. 524R, Chicago, Ill.

Name.....

Address.....

Have a Speedster Body

There is wonderful sport driving a speedster. Make a **Kuempel Speedster Body** for your Ford Chassis, with the wonderfully simple, **Red-I-Kut Patterns**, designed by our engineers,—you can build the body yourself in a very few hours for only a few dollars with a few simple tools. Your car will look like **\$1500**,—with beautiful distinctive lines. Bodies are built low, making riding many times easier, increasing engine power and pick up, making cars keep the road better especially at turns, saving tires, gas and oil, giving greater riding comfort. **Red-I-Kut Patterns** are life size, mistake proof,—just follow the simple instructions,—your car is ready in two days.

It's all the rage now. Build a **Kuempel Speedster** and look like a "real owner." Let us send you illustrations of our various models. **Model "55"** shown here is the favorite,—patterns sent at once on receipt of only **\$4.00**. Specify if for old or new Ford radiator. Get ready for the coming season now.



Design Dept. 21 THE KUEMPEL CO. DUBUQUE, IA.

1900 Motor Washer Electric or Water Power

Reduce household expenses by using this great laundry outfit. Cuts cost of washing to 2 cents per week. Write for Free Book, giving full details, to

1900 WASHER CO., 6336 Court St., Binghamton, N. Y.
Address Canadian 1900 Washer Co., 355 Yonge St., Toronto
if you live in Canada

Increase Your Tire Mileage

Crank Shaft Driven

Taylor Tire Pump

Carried in tool box when not in use, attached in 10 seconds to end of crank shaft (front of radiator). Pumps bone-dry air and pumps fast. Pays for itself in added tire mileage.

\$10 Complete with hose and gauge.
TAYLOR MANUFACTURING COMPANY
24 Lahser Ave., Bedford, Mich. (Suburb of Detroit)



Diamond Banking

Why Pay Full Prices for Diamonds

WE lend money, taking diamonds

as security. When loans are not paid, diamonds are sold. For over 60 years we have offered diamonds 40 to 51 per cent lower than market price. Free examination, 3/4-3/16, 1/64 kt. blue-white genuine perfect cut diamond of high degree of perfection, wonderful fire and brilliancy.

Platinum and gold engagement ring. Try to match at \$225. Guaranteed Cash Loan \$100. Unpaid Loan Price \$116.80

Write Now for New Bulletin

Send name and address to us—TODAY!
Jos. DeRoy & Sons, 1927 DeRoy Bldg., Pittsburgh, Pa.
Reference: *Harper's National Bank*



New Typewriters at Half Price

Famous Oliver Nines—brand new—latest model—standard visible—now \$49—formerly \$100. Our amazing book, "The High Cost of Typewriters—The Reason and the Remedy," exposes old methods. Oliver has rebelled. So now you save \$51. Low terms—free trial—no C. O. D. Write for book.



THE OLIVER TYPEWRITER COMPANY
1096 Oliver Typewriter Bldg., CHICAGO

WE PAY CASH for Scrap and Old False Teeth PLATINUM

On rubber or metal plates. Highest cash price paid for old Gold, Silver, contact points, crowns, bridge work, mercury and broken jewelry. Send your package today by parcel post to

The Mutual Smelting and Refining Company
116 North Front Street, Columbus, Ohio



ATTENTION!

Every soldier, every individual in a Home Defense League, every member of a semi-military organization, and in fact every citizen of the United States will need one or more of the following books at once:

UNITED STATES ARMY

Infantry Drill Regulations

With War Department Text Corrections to February 12, 1917



Gives the officially prescribed army drill regulations for soldier, squad, company, battalion, regiment, and brigade as well as the rules for combat, marches and camps, ceremonies and inspections; includes the following Manual: Color, Band, Saber, Tent-Pitching, Bugle (with bugle calls and signals), Arms and The Bayonet. **Pocket Size Latest Edition 246 Pages Cloth Binding Illustrated Price 58 Cents, Postpaid**

Cavalry Drill Regulations

UNITED STATES ARMY
Pocket Size Latest Edition Cloth

Small Arms Firing Manual

With Text Corrections to February 21, 1917
Pocket Size Latest Edition Cloth

Field Service Regulations

UNITED STATES ARMY
Pocket Size Latest Edition Cloth
Price Each 80 Cents, Postpaid

Boys! Form your own drill squads. By following the official drill manuals you can make your training count.

These Books for Sale by
Popular Mechanics Book Dept.
6 N. Michigan Ave., Chicago



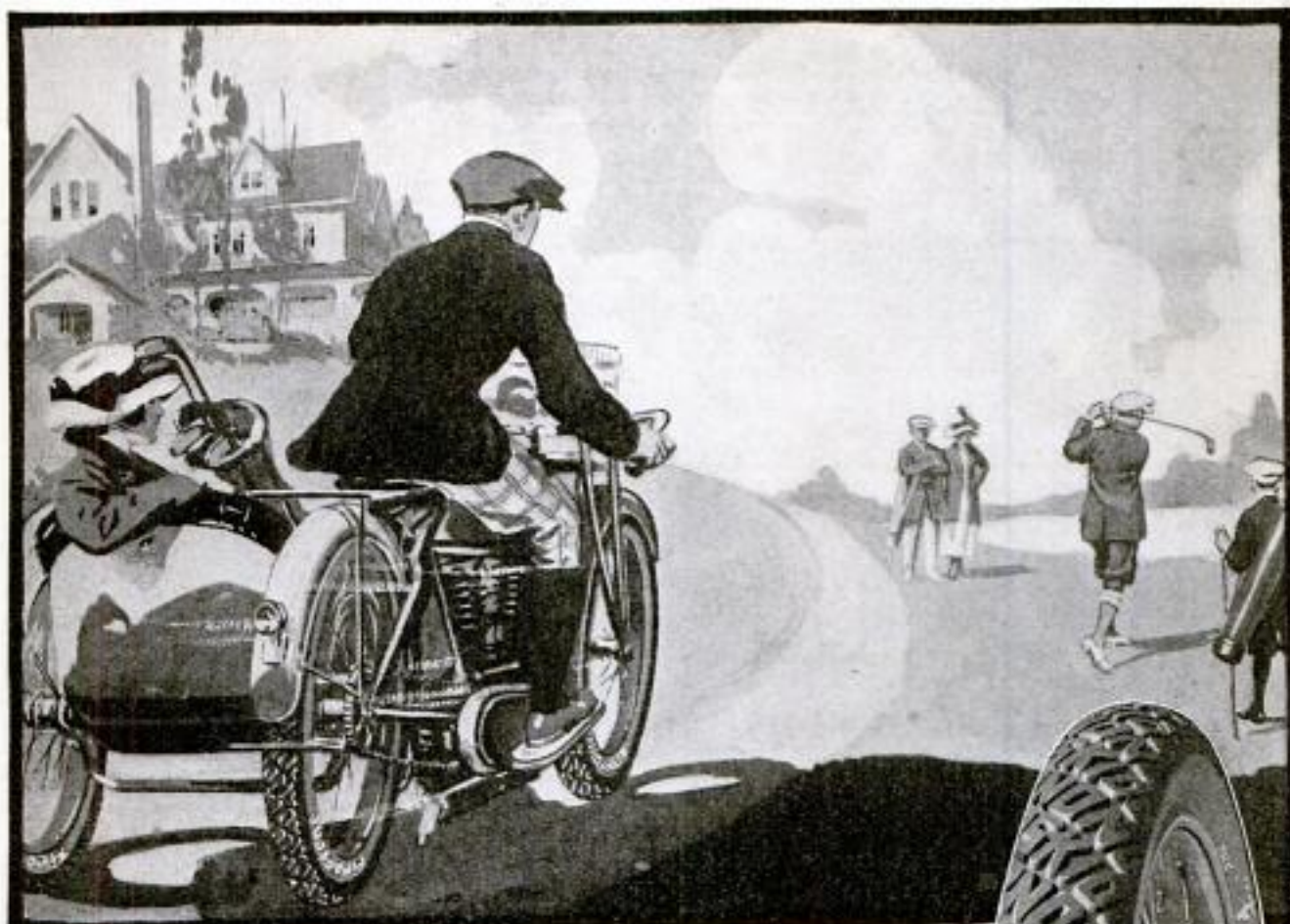

A Quick Trip To The Links

TO arrive "on time," ride on Firestone Tires. These extra thick-tread, extra tough-fibred, wear-like-wire tires give most comfort in riding and "Most Miles per Dollar" in tire endurance. And 30 per cent greater angle against skid renders them the safest equipment for your mount on any road at any speed.

Furthermore, you can enjoy the extra value of Firestone Motorcycle Tire equipment at no extra cost, if you buy a Cleveland, Dayton, Emblem, Excelsior, Harley-Davidson, Henderson, Indian, Reading Standard, Schickel, Thor, Smith Motor Wheel.

FIRESTONE TIRE AND RUBBER COMPANY
Akron, Ohio Branches and Dealers Everywhere

Firestone

Motorcycle Tires



Please Mention Popular Mechanics

Copyrighted material.

EVEREADY DAYLO



The light that says
"There it is!"

There are nooks and corners in every home that even daylight cannot reach—

where matches, candles or lamps are positively dangerous. That's why you need an *Eveready* DAYLO* about the house, for both convenience and safety.

Nearly all good electrical, hardware, drug, sporting goods and stationery dealers display and carry *Eveready* DAYLO'S* in 77 different styles at prices from 75 cents up. And your satisfaction is always assured by the *Eveready* TUNGSTEN battery, the only battery that is long-lived, dependable and really economical. Always specify this make when your battery must be renewed.

*DAYLO is not merely the new name for our product, but a mark by which the public will hereafter distinguish between the ordinary "flasher" or "flashlight" and the highest development of the portable electric light.

AMERICAN EVER READY WORKS

of National Carbon Co. Long Island City, N. Y.
Canadian National Carbon Co., Limited, Toronto

when a leak in the water or gas pipe must be fixed quickly.

when you lose a key, a coin or a ring in the dark.

when the watch dog barks his alarm.

when all the lights in the house go out

when the wrong medicine bottle may mean a tragedy.

when you awake in the night and wonder what time it is.

whenever you need light—indoors or out—that cannot cause fire or blow out—you need an *Eveready* DAYLO*.

Don't ask for a flashlight—
get an *Eveready* DAYLO

Ames-bilt

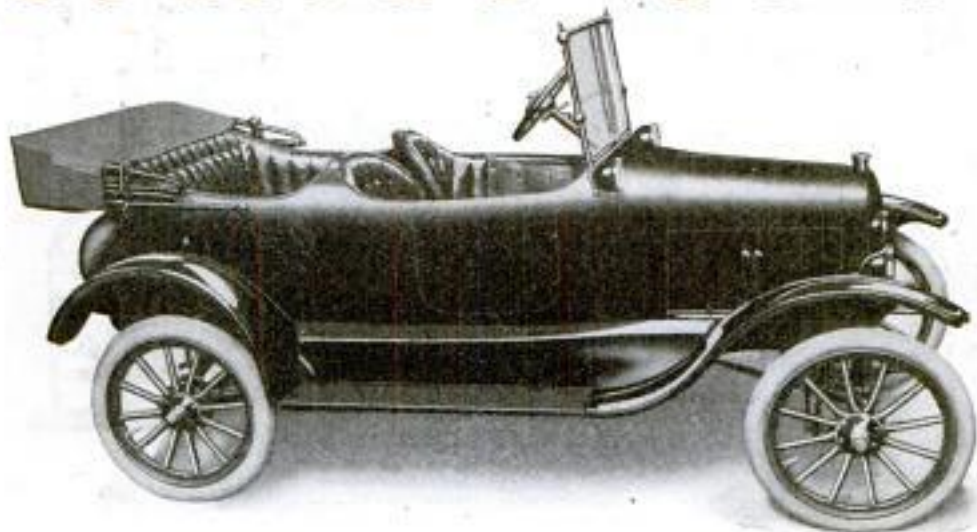

You'd Never Believe It Was Your Ford

Any Ford—new or old—can now be put in the luxury car class. It can be given the grace, beauty, comfort and luxury of the high priced cars and still retain the economy, the dependability, the sturdiness and the low upkeep cost of the Ford. Look at the picture above (the side view) and then the one below (the aeroplane view). Such a class car is possible with any Ford chassis and an Ames-bilt Body. Beauty, strength, class, power, economy and luxury combined.

Everything Is Included

The transformation is easy, quickly and economically made. Anyone can do it. No skill required. Everything is furnished. Note the specifications below for the Four-passenger Clover-leaf as pictured. Every provision for comfort and luxury is made. All the class, style and snap required to put your Ford in the "envied" class.

In a few moments you can change your Ford from a car that looks its \$375 to a car with the appearance, luxury and comforts of one costing many times as much. But it is still a Ford with Ford economy and low upkeep cost.

Write us today about these wonderful bodies. Price \$215 F. O. B. Factory.

Note These Brief Specifications

- FRAME:** Selected hardwood. All joints mortised, glued and screwed, solidly reinforced and ironed by hand.
- DOORS:** Concealed hinges. Entrance from both sides, front only. Best quality 20-gauge automobile sheet steel throughout.
- UPHOLSTERING:** Best quality genuine M. S. leather, stuffed with real curled hair. Deep, luxurious cushions.
- BODY** comes complete with one man top, clear vision windshield, hood, radiator shell, running boards, fenders and skirts, ready to attach.



The F. A. Ames Company
1306 Third Street OWENSBORO, KY.

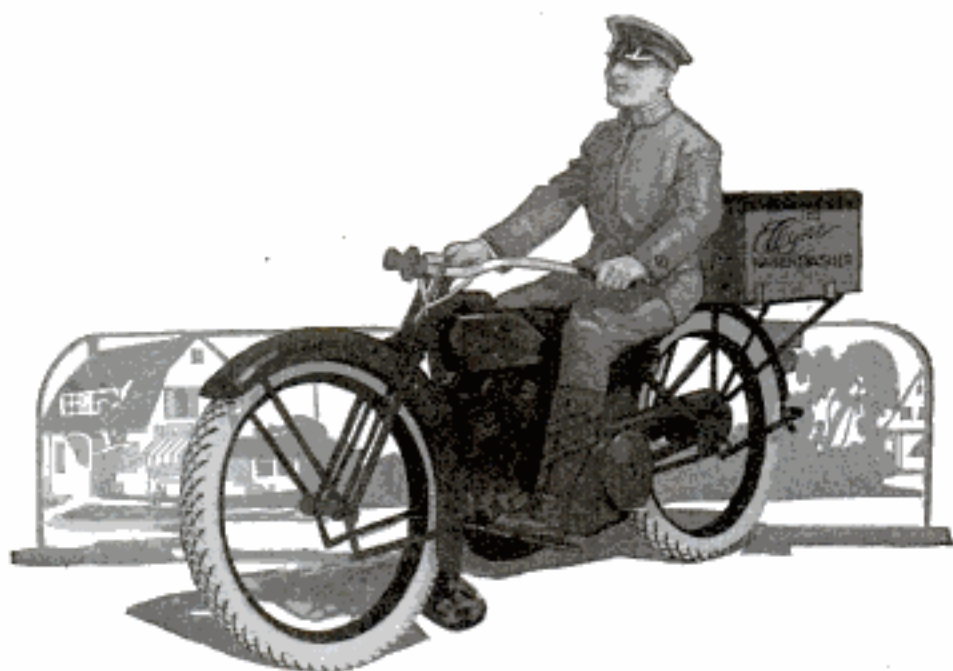

BLUE STREAKS

Your clothier or haberdasher—does he apologize for his deliveries? Or does his service win your admiration? Many such merchants today have advanced to the use of the motorcycle. And the shrewdest of these employ Goodyear Blue Streak Motorcycle Tires so that

deliveries may be unfailing and prompt. Blue Streak reliability is a well known factor in business, pleasure, racing and military service. Somewhere in these fields, Goodyear will serve you, too.

Blue Streaks Deliver: Economy, Mileage, Speed, Service. Everywhere—one standard, one quality, one guaranty.

The Goodyear Tire & Rubber Co.
Akron, Ohio

GOODYEAR
AKRON

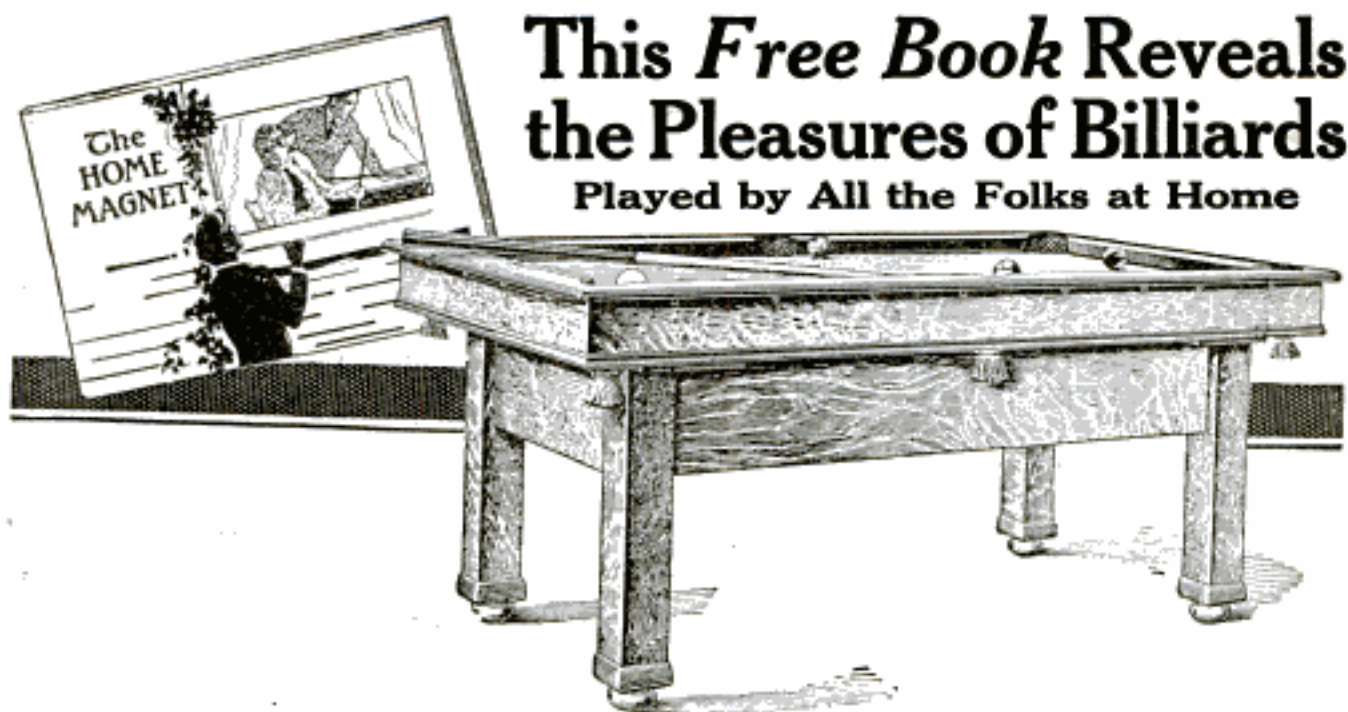

This *Free Book* Reveals the Pleasures of Billiards

Played by All the Folks at Home

This book is crammed full of things about billiards that will interest you. Shows these tables in photographs of homes just like yours. Also letters telling about the rollicking good times others have had from their Brunswick.

What Doctors say about Billiards. Shows how to play 33 different games, all on a Brunswick. Explains about Brunswick low prices and our offer of "pay while you play." It's a regular storehouse of interesting information.

BRUNSWICK

HOME BILLIARD TABLES

Pay While You Play—10c a Day

A Model for You

Our "Quick Demountable" Brunswick is an ideal table for you. Folded up it can be put in a closet or any spare space, out of the way. In a jiffy it can be set up in the center of the room, chairs shoved aside and the big game is on.

Other models are the "Grand," "Baby Grand," "Convertible." There is a size and a style to fit in any home.

Balls, Cues, Etc., Free

With every table you get a complete high grade playing outfit—Balls, Cues, Racks, Markers, Tips, Cue Clamps, Chalk, Brush, Expert Book of 33 games, etc. No heavy after costs. Once you have paid for the table, all expense is ended.

Don't fail to send for our free catalog today.

THE BRUNSWICK-BALKE-COLLENDER CO.
Dept. 50T, 623-633 S. Wabash Ave., Chicago

Send free, postpaid, a copy of your billiard book and color catalog—"Billiards—The Home Magnet"—and tell about your home trial offer.

Name.....

Address.....

SEND TODAY FOR YOUR COPY

**The Brunswick-Balke-Collender
Company**

Dept. 50T, 623-633 S. Wabash Ave., CHICAGO



INSTALL ^{Your Own} PLUMBING

Our new *Hardin Easy Way* enables anyone to easily install a complete plumbing or heating system. Our method is perfect, simple, and easy. Reduce the high cost. Install your own plumbing and save time, labor and material. Our 40 years selling plumbing and heating goods *exclusively* direct has qualified us to turn out all material equipped with patented easy adjustable connections that any handy man can do the work himself and SAVE $\frac{1}{2}$.

Our Service Helps You Plan and Install

Send a sketch or plan of any plumbing or heating job. This department will show you the easiest and cheapest way. They will draw simple, clear and easily understood installing plans free. If necessary, we will loan you the tools. Our *Cut-to-Fit* steam, hot water and air heating plants save the high cost of labor, unused material, costly delays, time and price. Buy *direct* from the producer.

Send for Valuable "Handy-Man" Book

This book tells you in advance what your plumbing and heating will cost. Gives you suggestions on what fixtures to select and how to install them. Every contractor, home owner, institution, etc., needs this valuable book. It explains the new *Hardin Easy Way*. Tells you how to save on material, time and labor by putting in plumbing this new, original, exclusive, practical, and economical way. It contains a complete line of latest improvements and new designs in guaranteed plumbing and heating outfits, water supply systems, sinks, roughing-in goods, pipe, fittings, valves, etc., and all parts and repairs at *wholesale prices*. It also contains practical and exclusive information of value to every builder. **Note:**—To avoid sending this 236-page *Handy-Man Book* broadcast to non-interested parties, we request 25c as a temporary deposit, which will be refunded on first order.

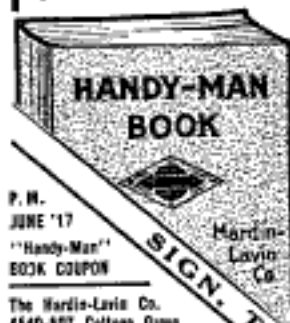

P. H.
JUNE '17
"Handy-Man"
BOOK COUPON

The Hardin-Lavin Co.
4540-50T Cottage Grove
Ave., Chicago

Enclosed please find 25c
(to be refunded on my first
order) for which send me your
"Handy-Man" Book showing
everything in plumbing and heat-
ing supplies at lowest wholesale
prices.

Name

Address

Money-Back Guarantee

Our "Money-Back Guarantee Label" is on every fixture. It protects you, and assures you that all *Hardin-Lavin* fixtures are Highest Quality, Grade A, Guaranteed. Our aim is to furnish plumbing and heating plants with new, original, easy installing features, combining highest quality, lasting durability, and complete satisfaction.

Immediate Delivery This is as much a part of our special service as our guaranteed quality or wholesale prices. 40 Years in Business at the same address is a record to be proud of. It speaks volumes for our wholesale price policy and money-back guarantee. Send for "Handy-Man" Book and full particulars. \$500,000 plants behind our guarantee.

The Hardin-Lavin Co.

40 Years at
4540-50T Cottage Grove Ave.
CHICAGO

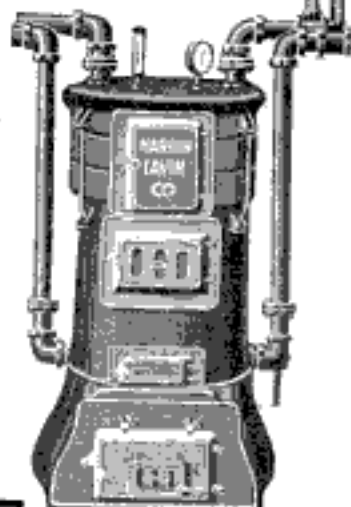



"I won't be ready to give you this for two years. It's for VELVET."

We Won't Say VELVET is the Best Pipe Tobacco—

We couldn't until we had tried every tobacco made, but—we know that most American pipe smokers agree that Kentucky Burley is the world's choicest pipe tobacco.

Too many cooks spoil the broth. When Time and Nature are makin' VELVET, no use anybody else stirrin' in.

Velvet Joe

We know that this tobacco can only be at its best *after* two years' natural ageing, and we take the time and pay the price to age VELVET in Nature's sure, patient way.

Liggett & Myers Tobacco Co.



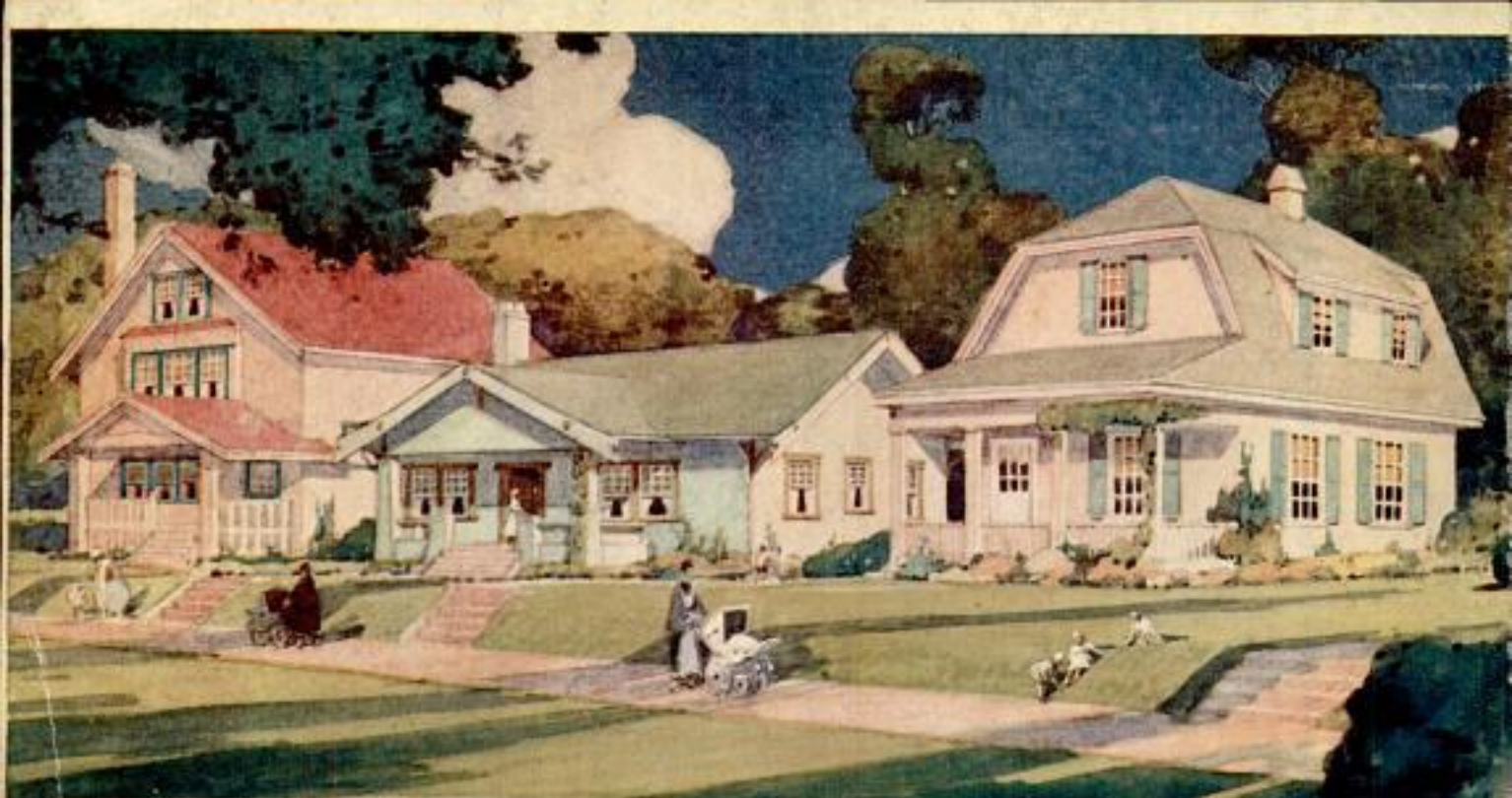

Benton — \$1,457.68 Net
 Price..... \$1,535.50
 Less 5% Cash Discount..... 77.72
 Net Price..... \$1,457.68

Verona — \$878.18 Net
 Price..... \$925.50
 Less 5% Cash Discount..... 47.32
 Net Price..... \$878.18

Wolverine — \$915.13 Net
 Price..... \$963.30
 Less 5% Cash Discount..... 48.17
 Net Price..... \$915.13

3 New Beautiful Homes

(Note the Low Prices)

HERE are three handsome new houses. We're proud of them. You should be proud to own one of them. They have just been made ready for this spring's building. The architects were told to design three artistic homes, beautiful, roomy and airy to be offered at a very low price.

Look at the homes the architects gave us. Look at the low prices. Write for complete description and floor plans of these and many other homes. Find out how you may now have an artistic home of the genuine Sterling System Quality at the price of an ordinary house. Find out how you can buy direct from the mill. Hundreds have done it. So can you. Find out about this wonderful Sterling System of Home Building today by sending the coupon. Learn *why* this is the *accepted way* to purchase and erect a home. Two years to pay if you wish. Write today for this Sterling book.

Sterling System Homes

The three homes in this illustration were built on the Sterling System. All the waste and costly mistakes, all unused lumber, all the extras eliminated. You pay only for what materials are used. Quality and satisfaction guaranteed. A big saving on labor and time of erection. Get the facts about Sterling System. Then decide!

Send the Coupon for "The Sterling Book"

The first step toward securing a home for yourself and your family is to send the coupon for full information. This book tells how to build at least expense. Shows a hundred wonderful Sterling System designs for all sizes

and all styles of homes. Interior views. Floor plans. A real guide to home building. Enclose 10 cents to pay postage and wrapping. Don't miss this great opportunity. Mail the coupon today.

International Mill & Timber Company, Dept. A119, Bay City, Michigan

International Mill & Timber Company,
 Dept. A119 Bay City, Michigan

I am interested in Sterling System Homes. Please send me your book, "The Sterling System of Home Building." I enclose 10 cents for postage and wrapping.

Name.....

Address.....

Copyrighted material