

May

See Page 646

15 Cents

POPULAR MECHANICS MAGAZINE

WRITTEN SO YOU CAN UNDERSTAND IT

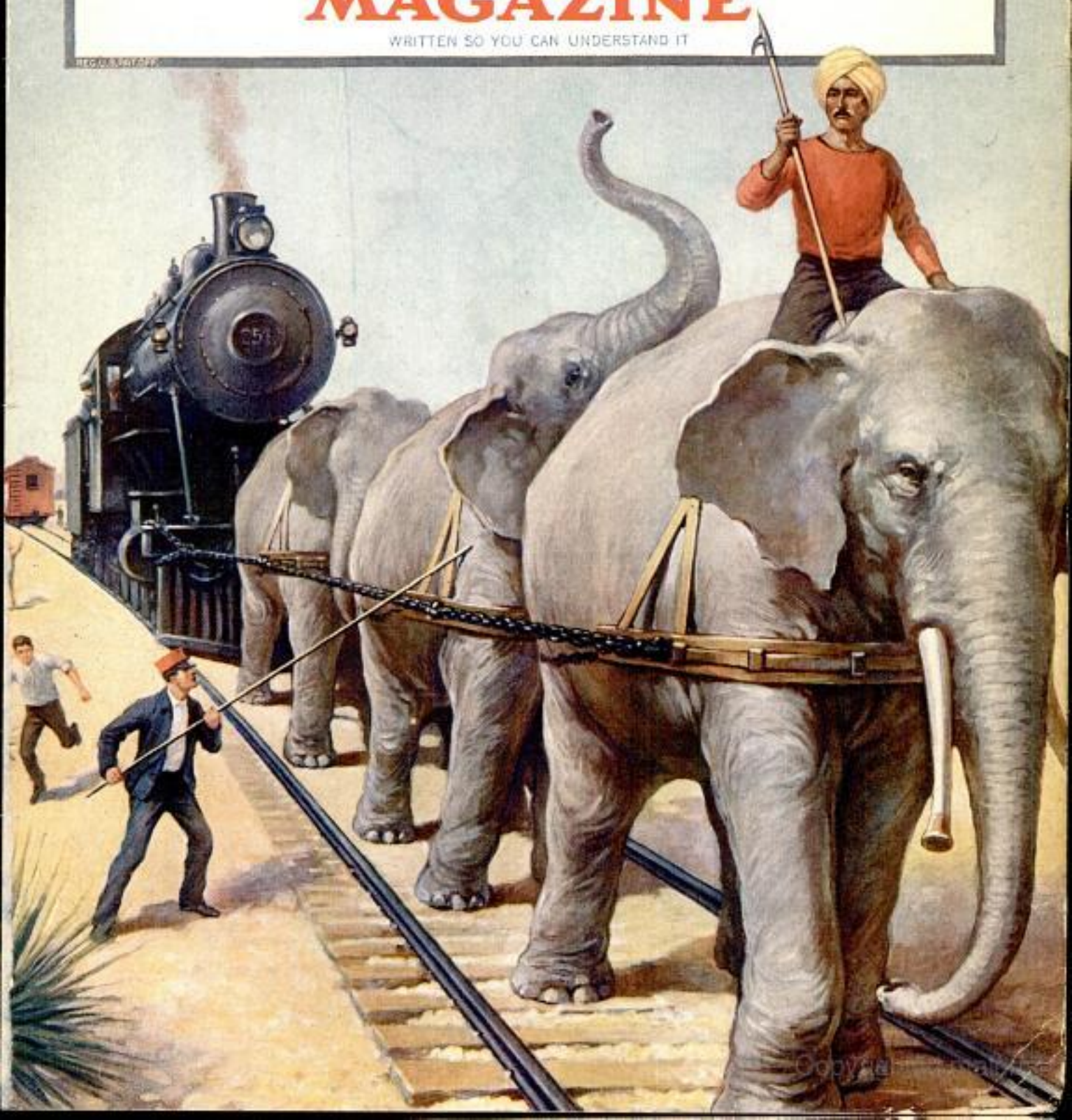



\$641 Buys the Material to Build this Home!

NO MONEY IN ADVANCE!

When you "Build-To-Stay—The Harris Way," you secure the *utmost possible* in Quality, Economy and Service. Why? Simply because you profit directly—*immediately*—by our 24 years' experience. You get the benefit of our practical knowledge as the *originators* of the "Direct-to-You" Home Building Industry. We were the *first* to sell Lumber and Material direct to Home Builders at one small profit. We were the *first* to reduce this vitally important industry to a *perfect system* and extend the benefits uniformly to the people of the nation. *The splendid Harris Home above has 5 rooms, bath, pantry and reception hall in an excellent arrangement. The size is 22 ft. x 26 ft.*



"THE HARRIS WAY"

has exclusive merits—special advantages for the shrewd and careful Home Builder—possessed by no other plan or method. It is the best, safest and most sensible way to build your ideal home *right* without sacrifice of quality—*or the waste of a single penny!* Thousands have built "The HARRIS WAY" with profit and satisfaction.

SEND LUMBER BILLS

Our ten million dollar buying power gives Harris customers an overwhelming price advantage. We can—and do—undersell all others. The *proof?* Easy! Just send us your lumber bills—for any kind of building you may be planning and get *our* prices. Compare them item for item, and let the *test* be the *proof.* Write us today!

BUY YOUR HOME SENSIBLY CUT-TO-FIT—SHIPPED ALL COMPLETE IN ONE CAR

The material used in building all Harris Homes is prepared by us, complete for your use in a way that is instantly—and easily understood. It is sensibly cut-to-fit with *absolute accuracy* and *positive elimination of all waste.* You pay for nothing you do not get—you pay our *bed rock low, one-small-profit bargain price only* for what is needed to do the work *right*—"The HARRIS WAY."

Our mammoth material stations, in the heart of the finest lumber tracts are always filled to overflowing with brand new, quality material. These stations are centrally located for quick and economical deliveries, "DIRECT-TO-YOU," no matter where you live, at the *lowest possible freight charge.*

Free Beautiful New \$10,000 Book of Over 100 Harris Homes

Be sure to mail free coupon for the latest edition of the famous \$10,000 HARRIS HOME PLAN BOOK, now ready. A golden guide to Quality, Service and Economy in Home Building. Explains—fully and freely—everything about building economy. Contains 100 modern Harris Home Designs, with descriptions, material, specifications, prices, etc., and explains how we save you \$50 to \$75 on our Special Free Architect's Plans. Think twice before you pass this opportunity.

Harris Bros. Co.
Dept. FH-7, CHICAGO

Please send me free—without the slightest obligation—the Harris Home Book of Plans, and show me how to save big money in building my home.

Name

Address

Harris Brothers Co. Dept. FH-7 35th & Iron Streets Chicago



To insure Victor quality, always look for the famous trademark, "His Master's Voice." It is on every Victrola and every Victor Record. It is the identifying label on all genuine Victrolas and Victor Records.

Every kind of music for everybody

Your kind of music for you! The kind of music you like best! Do you prefer to hear magnificent operatic arias, portrayed by Caruso or Farrar or Melba? Or are your favorites the charming old songs of yesteryear—the ballads so sweetly sung by Gluck and McCormack?

Or it may be that your tastes run to instrumental solos—the exquisite renditions of Elman or Kreisler or Paderewski. Then again, perhaps, you would rather hear Sousa's Band play some of his own stirring marches, or enjoy Harry Lauder's inimitable witticisms.

No matter—you can hear them all on the Victrola. It is supreme in all fields of musical endeavor. It is *the* instrument for every home.

Hear your favorite music today at any Victor dealer's. He will gladly play any music you wish to hear, and demonstrate the various styles of the Victor and Victrola—\$10 to \$400.

Victor Talking Machine Co.
Camden, N. J., U. S. A.

Berliner Gramophone Co., Montreal, Canadian Distributors

Important Notice. All Victor Talking Machines are patented and are only licensed, and with right of use with Victor Records only. All Victor Records are patented and are only licensed, and with right of use on Victor Talking Machines only. Victor Records and Victor Machines are scientifically coordinated and synchronized by our special processes of manufacture; and their use, except with each other, is not only unauthorized, but damaging and unsatisfactory.

"Victrola" is the Registered Trade-mark of the Victor Talking Machine Company designating the products of this Company only. **Warning:** The use of the word *Victrola* upon or in the promotion or sale of any other Talking Machine or Phonograph products is misleading and illegal.



Victrola XVII, \$250
Victrola XVII, electric, \$300
Mahogany or oak

Victrola

New Victor Records demonstrated at all dealers on the 28th of each month

"Signed Lumber is Safe Lumber."

It's a pretty good idea (now that the lumber mills in the Southern Cypress Mfrs. Assn. are IDENTIFYING EVERY CYPRESS BOARD THEY SAW) to MENTION TO YOUR LUMBER DEALER, CONTRACTOR OR CARPENTER—and to ASK YOUR ARCHITECT to SPECIFY—that YOUR CYPRESS MUST BE

**"TIDEWATER" CYPRESS
IDENTIFIED BY
THIS TRADE-MARK
Stamped in the End of Every Piece
or APPLIED TO EVERY BUNDLE**



When a manufacturer places his imprint indelibly upon his product it evidences to the consumer two factors of value which, together, are the sum total of all any buyer wants; these factors are integrity of purpose and complete responsibility on the part of the maker of the desired commodity.

The above legally registered "Tidewater Cypress" trade-mark is now *YOUR INSURANCE POLICY of LUMBER QUALITY.*

It appears stamped mechanically into the end of EVERY board and timber of

CYPRESS "THE WOOD ETERNAL."

Thoroughly dependable Cypress Flooring, Siding, Moulding and Shingles, etc., which come in bundles, bear the same mark on EVERY BUNDLE.

The legal right to apply this epoch-making symbol of STRICT RESPONSIBILITY IN LUMBER MAKING AND SELLING is restricted to those Cypress mills which, by their membership in the Southern Cypress Manufacturers' Association, attest their devotion to its Principles of SERVICE to the CONSUMER. Only mills cutting "Tidewater" Cypress are eligible for membership. (Cypress which grows too far inland is not equally noted for the "Eternal" or decay-resisting, quality.) Only mills which subscribe to the Association's standard of scrupulous care in Methods of MANUFACTURE, INTEGRITY OF GRADING and ACCURACY OF COUNT can belong to the Association. These responsible mills the Association now licenses to CERTIFY THEIR CYPRESS by applying the registered trade-mark with their identifying number inserted.



TRADE MARK REG. U.S. PAT. OFFICE

BY THIS MARK YOU KNOW THAT IT'S CYPRESS. "THE WOOD ETERNAL" AND WORTHY OF YOUR FAITH. IT IS WELL TO INSIST ON SEEING THIS TRADE-MARK ON EVERY BOARD OFFERED AS "CYPRESS."



TRADE MARK REG. U.S. PAT. OFFICE

Let our ALL-ROUND HELPS DEPARTMENT help YOU MORE. Our entire resources are at your service with Reliable Counsel.

Southern Cypress Manufacturers' Association

1219 HIBERNIA BANK BLDG., NEW ORLEANS, LA., or 1219 HEARD NATIONAL BANK BLDG., JACKSONVILLE, FLA.

INSIST ON TRADE-MARKED CYPRESS AT YOUR LOCAL LUMBER DEALER'S. IF HE HASN'T IT, LET US KNOW.

Please Mention Popular Mechanics

Popular Mechanics Magazine

6 N. Michigan Avenue, Chicago, U. S. A.

EDITED BY H. H. WINDSOR

England: The International News Co.,
5 Breems Bldg., Chancery Lane, London, E. C.

Australia:
The Australasian News Co.

ISSUED MONTHLY

SUBSCRIPTION:

SINGLE COPY 15 CENTS

In United States, and its possessions, Cuba and Mexico, per year, postpaid \$1.50
To Canada 1.75
To all other countries in the Postal Union 2.50

All subscriptions are discontinued at expiration. Please examine the date printed on your wrapper.

Entered as Second Class Matter Sept. 15, 1913, at the Post Office at Chicago, Illinois, under Act of March 3rd, 1879.
Entered as Second Class Matter at the Post Office Department, Canada.

Published monthly by POPULAR MECHANICS CO.

Copyright, 1917, by H. H. WINDSOR.
Copyright, in France.

Contents for May, 1917

Accident—Boiler Blown Two Blocks Away by Explosion	716	Casket, Odd Shaped, for Body of Cripple	681
Accident—Farmhouse Wrecked by Gas Explosion	724	Chair, Folding, Equipped with Awning	757
Aeroplane Microphone Tested Here	650	Children at Work and Play and Scenes That Interest Them	761
Aeroplanes, Coast Guard Stations to Use	642	Church, Attractive Little, Costs Modest Sum	800
Air Craft, Our New, by Searle Hendee	651	Coins, Municipal, Used Repeatedly in Mexico	720
Automobile Bus for Oregon Railway	664	Concrete Culvert, Cheap, Is Removable	698
Automobile Differential without Gears	738	Concrete Farm Building of Arched Roof Type	729
Automobile, Novices Learn to Drive in Stationary Car	702	Cork and Cloth, Waterproof Fabric Made of	650
Automobile—Racing Car, New American, Holds Much Promise	662	Curves, Many, New Drafting Device Draws	689
Automobile, Two Interchangeable Bodies for	747	Dictaphone—Machine Takes Dictation for Cutting Movie Films	714
Automobile—Vaultlike Car to Carry Funds of Paris Banks	689	Dining Outfit, Compact, for Camp or Auto	688
Automobiles, Powerful Electric Brake for	697	Dinner Served at Bottom of Skyscraper Caisson	734
Automobiles Present Fantastic Appearance after Fire	706	Dredger, Sunken, Floated by Similar Craft	704
Aviation—Lost by Map and Compass	711	Dry-Docking Ships on Rails to Meet Congestion	700
Bait, Muskellunge, with Folding Hooks	650	Dutch Copy Equipment of Fighting Nations	745
Ball Has Thrilling Trip around World	740	Editorial	673
Barrel Loading Machine Does Work of Many Men	659	Egg Candler That Needs No Darkened Room	671
Birds, Singing, Supply of Cut Off by War	642	Egg Cup, Double Walled, Keeps Contents Warm	740
Boat, Patrol, of New Type Added to Navy	609	Eggs Shipped Safely in Paper "Hammocks"	730
Boats, Atlantic, Crusted with Ice in Cold Snap	680	Electric Bulbs, Hidden, Illuminate Sidewalk Steps at Night	728
Boats Instead of Wagons Used by Farmers	747	Electric Drier for Shoe-Shining Parlors	670
Bookkeeping, Mechanical Device Does	738	Electric Light Chains, Insulator and Links for	750
Box, Siberian Jewel, of Fossil Ivory	681	Electric Light Fixtures, Suspension Fitting for	698
Breakwaters, Glacier, on Land in Alaska	660	Electric Lights—Flood-Light Skyscraper from across Street	716
Bridge, Hotel Builds to Divert Farm Traffic	644	Electric Shock Victims Revived in Odd Way	762
Bridge, Long, Has Trestle in Center	662	Electric Sign, Novel, Made for Eastern Theater	736
Bridge, Primitive Timber, in Northern India	727	Elephants Compelled to Haul Circus Train	646
Bridge, Single Track Dual Gauge Railway	756	Elevator That Climbs Stairway	753
Brooder, Easily Operated, for Little Pigs	735	Embroidery, Scallop Cutting Machine for	728
Building, Alpine, Ohio Factory Duplicates	750	Fence, Dam, and Gutter, Combination	689
Building, Curved Library, Has Unusual Features	737	Fire Alarm Apparatus Explained to Public	671
Building Material, Labor Saving Plan for Unloading	729	Fireproof Case Contains Whole Accounting Outfit	702
Building, Six Ton, Border Troops Carry	753	Fish Hatchery, Handsome, High in Western Range	714
Buildings, Unit Steel, for Factories	740	Flag, Official, Adopted by State of Illinois	603
Calves, Dairy, Recording Growth of in Food Tests	645	Fleas, Prisoners Dress to Sell as Souvenirs	750
Camera, "Gun Type" Scout, Used by Our Airmen	648	Floor Washer Does Work of Several Men	745
Camping Frolic, Mountain Folk Make Plans for	727	Food Preparedness the Nation's Need	674
Canal, Plan to Connect Milan and Venice	750	Forest Survey, National, Made with Camera	708
Canvas Treads Prevent Tires Slipping in Mud	698	Fuels, New, Used in Spain to Replace Coal	733
Carpenter Shop, Portable, Saves Builder's Time	725	Furnace, Draft Attachment for, Saves Fuel	703
Cart for Cornstalks can Load Itself	713	Furnace, Smokeless, Burns Coal and By-Products	747
		Furniture, Woven Reed, in New Designs	742
		Fuse Puller, Wooden, for Household Use	756
		Garage Doors, Electric Device Operates	650
		Garage, Large, in Business District of City	658
		Garage, Round Concrete, Silo Forms used for	730

[Continued on Page 6]

Popular Mechanics offers no premiums; does not join in "clubbing offers," and employs no solicitors to secure subscriptions. It is for sale by nearly every newsdealer in the United States and Canada.

This One



P9CF-C57-RQZO

Copyrighted material

[Contents—Continued]

Garages, All, Face on One Artistic Driveway...	709
Gardens Surrounding Beautiful Western Homes...	706
Golf Score Chart Shows Season's Record...	753
Golfers in Canada and Northwest, With...	657
Guns, Machine, Adaptable Navy Pedestal for...	642
Handcuffs Used to Lock Motorcycles...	752
Hay Stackers, Old Time, Seen in Montana...	715
House with Double Roof to Resist Heat...	713
Ice Blocks Frozen Together, Apparatus Separates...	668
Inaugurating a President as War Threatens...	667
Incline, Any, Device Measures Pitch of...	762
Knives and Forks, Sanitary Holder for...	759
Lamps and Screens, Interlaboratory Tests of...	680
Language Classes, Conduct in Department Store...	710
Lift Heavy Weights, Right and Wrong Way to...	753
Locomotive, Interesting, Built for Western Road...	641
Mail—Note Accompanies Package When Put in Holder...	646
Masks, Gas, for Hazardous Occupations...	659
Money Chute, Sidewalk, for Relief Funds...	644
Money, French Paper, Laden with Germs...	690
Motorcycle Used to Run Lawn Mower...	659
Motorcycles, Agent for Carries Sample in Car...	713
Mountains, Why Remain High in Air...	746
Moving Picture Studio, Realistic Subway Built in...	660
Moving Pictures, Clay Figures Used for...	709
Net, Minnow, Frees Itself if Snagged...	725
Nets, Fish, Glass Globes as Floats for...	690
Novel Accessories for the Home and Its Members...	754
Oil Burner, New Fuel, for Steam Plants...	649
Oil Wells, Data about Shown in "Peg Model"...	704
Paper, Fireproof Writing, Given Severe Tests...	747
Periscope, Germans' Giant, French Capture...	710
Phonograph Records, Mechanical Cabinet for...	694
Photographs in Motion, Individual, New Style of...	643
Piano Wires, Vibration of Sustained Electrically...	672
Picture, Inlaid, Many Rare Woods Compose...	636
Pine, Galvanized, Special Joint Employed on...	759
Platform, High, Two Piers Support in Forest...	740
Platform, Portable, from Which Movies are Taken...	751
Playground, Public, in the Hills, by Albert Marple...	721
Porash, Big Increase in Output of...	720
"Pump, Dry," Takes Place of Grocery Scoop...	746
Rabbits, Raising for Fur Declared Unprofitable...	682
Railroad, Kansas, Sold at Public Auction...	683
Railroad Trap Box Cars Terribly Tramped...	744
Reconstruction in France, Beginnings of, by Lewis R. Freeman...	691
Reservoir, Movements of Earth under...	736
Rifle, Army, Adapted for French Warfare...	681
Rifle Sighting Device for Target Practice...	756
Rock—White Quartzite Mass in Red Sandstone Arroyo...	717
Roller Skates Geared to Increase Wearer's Speed...	756
Rubber Shoes Prevent Slipping of Tripod...	737
Rubber, Sponge, Many Special Uses for...	712
Salt Supplies, Large, Made Usable...	741
Sand Blast Nozzle of Suction Type...	741
Shears, Motor Driven, New Tool for Tailors...	757
Sheep, Mountain, Famine Takes Flocks of...	661
Ship—Whaler, Old, Big Model of Built for Museum...	752
Shipping, Merchant, War Loss of in 1916...	670
Shipwreck—Krammed Schooner Sinks in New York Harbor...	669
Sign, Electric, Used for Patriotic Purpose...	678
Signs, Checkered Danger, in Columbus Streets...	708
Silage, Machine Packs so That Little Spoils...	698
Smiths' Shop, Primitive, Has Crude Bellows...	719
Smoke "Gun" Saves Ship from Submarines...	658
Smoking Stand Made of War Shells...	739
Sprinkler, Hand, Operates by Compressed Air...	703
Sprinklers, Lawn, Automatic Valves Govern Set of...	697
S-Rays, New, of Value in Cure of Wounds...	665
Statuary, Exposition, in Desolate Surroundings...	645
Steel, Rustless, American Cutlery to be Made of...	678
Stenladder, Improved, for Fruit Pickers...	748
Stone, Lithographic, from Domestic Quarries...	690
Stove and Kitchen Kit, Portable Camp...	738
Street Cleaners Taught to Clean, by C. L. Edholm...	731
Switch, Crank Operated, Prevents Accidents...	718
Table, Magnetized, for One-Armed Draftsmen...	681
Tanks, Graph, Battery of Resists Great Heat...	717
Telephone Exchange, Great Branch, for Hotel...	665

Telescope, Most Powerful, South of Equator...	726
Theater Aisles Lighted from Recesses in Floor...	648
Theater, Dual, Convenient for Its Patrons...	735
Tires, Making and Curing by New Process...	726
Tractor, Small, Used by Truck Farmer...	686
Trapshooting Grounds Electrically Lighted...	705
Tuning Device Decides Orchestral Pitch...	751
Tunnel, Pipe Line, Temporary Track Laid on...	669
Tunnel to Divert Flood Waters, Nuremberg Plans "United Regions of America" Planned...	744
Vacuum Cleaner, Sanitary, of New Type...	672
Valve, Stop, Which Aids in Repairing Faucets...	702
Vise, Machinist's, Foot Lever Operates...	708
Wall Insulation, Tie Wire Injures Effect of...	714
War, America Prepares for:	
Battle Cruisers for Land and Air, Our...	676
Preparedness, Eleventh Hour, Sweeps Country...	677
War Pictures of Interest, Timely American...	675
War, European:	
Devices, Some Late, Used in Warring Europe...	683
Dogs, War, Housing in War Zone...	682
European Army Views from Here and There...	684
War Phases, Striking, Pictorially Treated...	685
Water, Drummer Heats with Light Bulb...	739
Water Power, Russian, Development of Planned...	663
Water Tanks, Method of Fighting Frost in...	748
Window, Revolving Pantry, Handy Serving Device...	744
Women as Skilled Workers in Auto Factory...	749
Women, Foreign Born, Making Americans Out of...	752
Wreck—Bridge Collapses beneath Weight of Train...	678
Wreck—Passengers Escape Death When Engine Hits Car...	673
Zeppelin, New Ray Destroys, by Frank O'Callaghan...	679

SHOP NOTES

Anvil and Hammer, Saw Setting...	765
Automobile Engine, Frame for Assembling or Examining...	770
Automobile Fenders, Preventing Rapid Rusting of...	772
Brush, Chip Supports in Pail...	775
Bushing, Loose, Tightening...	783
Cableway for Handling Shipbuilding Material...	764
Cement Grouting, Dirt Collecting Corner Filled with...	778
Clock, Shop Timekeeping, Decimal Dial on...	775
Concrete Mixer, Cushion for Charging Pan of...	782
Cultivating Small Corn, Kink in...	762
Drill, Hand, Used as Lathe...	779
Electric Pad Warms Auto Radiator in Garage...	774
Engine or Machinery, Device Locates Pounding in...	774
Feed Mixer, Revolving...	771
Fence Wire, Device for Tightening...	781
Filter, Barrel Water...	770
Garage Roof as Playhouse...	766
Garbage Can Housing of Reinforced Concrete...	764
Gas Lighter, Electric...	778
Gear Box, Preventing Oil Leaking in...	779
Graining Woodwork, Garden Hose Rollers for...	772
Harrow, Soaked Roller Garden...	763
Horse Stalls of Concrete...	776
Hose, Water, Device for Repairing...	766
Jig for Drilling Holes at Ends of Shafting...	775
Jig for Slotting Bushings on Milling Machine...	772
Lathe Chucks, Center and Turret Lathe, Auxiliary Jaws for...	782
Leather Pattern Fillets Set in Shellac...	769
Nut, Machine, Soldering to Sheet Metal...	778
Oil, Testing for Lubricating Qualities...	773
Painting Iron to Withstand Wear...	770
Pliers, Cutting, for Tool Room...	772
Reflector for Flood Lighting Construction Work...	774
Refrigerator, Homemade, at Small Cost...	769
Rigging, Improved, for Lifting Heavy Machine...	767
Sawhorse Tool Kit...	775
Scale Pit, Keeping Dirt Out of...	775
Shelving, Steel, Test of for Deflection...	780
Shovels, Two, Used as Post Hole Auger...	705
Sign, Danger, for Unsafe Grinding Wheel...	775
Signs, Quick Drying Cloth, Painting...	781
Sprayer, Garden, of Varied Uses...	780

[Contents Continued on Page 8]

A Lightning Edge on Safety Blades



A keener edge than you ever felt. An edge that will flash through the stiffest, wiriest hair. Only a few strokes works marvels on any safety blade. You can't fail to get a lightning edge. You can't misuse a Stag Sharpener. A child can sharpen blades on a Stag as well as an expert. Makes old blades better than new. Makes new blades better.

Complete \$1 postpaid to you on this special offer

Stag Sharpener

with barber's hone and strop complete, on our money back guarantee

\$1

Protect Yourself

A dull razor is dangerous to health and life itself. The Stag Sharpener is a health protection as well as a positive luxury in shaving. The truest, simplest, quickest, easiest safety blade sharpener on earth.

Sharpen Any Blade

New Blades - Old Blades

Positively gives new blades a better shaving edge. Puts the oldest, dullest blades in lightning edge condition. Gives new blades a better edge than when they come from the factory. You can never know the delights of shaving with a positively perfect razor edge, until you sharpen your own blades with the Stag Sharpener. The quickest way. The truest way. The surest way. The safest way. The easiest way. The wheels of the sharpener guide the angle. Nothing to adjust. Nothing to get out of order. Practically lasts a lifetime. Our new patented feature makes the Stag more desirable than ever. Stag Sharpeners are used around the world. The new patented simplified sharpener is more popular than ever. Complete outfit includes heavily nicked sharpener, barber's hone and strop, in neat box, suitable for traveler's kit. Complete, postpaid to you only \$1. Send now.

Sent on FREE TRIAL

Try a Stag Sharpener at our risk and at our expense. Use it ten days free. Use it at our risk and at our expense. Then if you are not delighted, send it back and get your money back in full. We gladly assume the risk and welcome your order on this liberal, free trial, money back guarantee. Send only \$1 today.

Hone and Strop Free With every Stag Sharpener we send a barber's hone and strop free. It is a part of the Stag outfit. The new patented, simplified improvements in the perfected Stag Sharpener and a new broad-width barber's hone and strop in attractive kit-box, all complete only \$1. Two minutes after you open the box, you can enjoy the first soft, smooth, silent shave with a lightning Stag edge. You will wonder how you ever got along without a Stag. It is the most suitable and welcome gift for any man for birthdays, weddings, or any occasion. **SEND \$1 TODAY.**

Special \$1 Coupon
Hone and Strop Free
THE STAG COMPANY
38 So. State St., Dept. 5249, Chicago

Send Today Enclose only \$1.00, money order, draft, dollar bill, or check. Send today and make a comfortable shave for yourself. You need a Stag Sharpener. Clip coupon, put in \$1 and get it by return mail.

GENTLEMEN: Wishing to take advantage of your 10 days' free trial and money-back guarantee, you may send a Stag Sharpener, hone and strop complete. I am sending herewith \$1.

The Stag Company Name.....
Dept. 5249
38 So. State St., Chicago Address.....

Please Mention Popular Mechanics



STAG sharpens all safety blades without a Stag. It is the man for birthdays, weddings, or any occasion.

Dealers

Write to us for special terms to dealers. The Stag is the quickest and best seller on earth. Get the benefit of this advertising and our Dealer Service.

The Automobile Business is Growing

More help needed and big pay. No other business offers such opportunities. It's easy to learn. An Auto Repairman is not a machinist—his work consists of adjustments and re-fitting worn parts, "knowing the principle," that's the thing. One of our students writes: "Before I started with your course I was a clerk at \$50 per month. After finishing I followed your instructions, started a repair shop and cleared \$122 the first month—pretty good for the first month." Let us show you this and many other letters.

LEARN THE Automobile Business during your spare time

WE CAN HELP YOU IN 3 WAYS:

- 1st We can teach you quickly and thoroughly.
- 2nd After we teach you, we have a plan to assist you in getting started in the actual practical line of work and assist you in getting actual driving experience.
- 3rd While we are teaching you we show you how to make money right on the start.

THE DYKE WORKING MODEL METHOD

of teaching by mail is a new invention—a new idea—we use real 4 and 6 cylinder engine models—11x11½ inches—on which you can actually see all parts moving—it is the only system of its kind in the world.

This is one of the 7 real models used, in addition to 50 simplified instructions with hundreds of illustrations, charts and manikin.

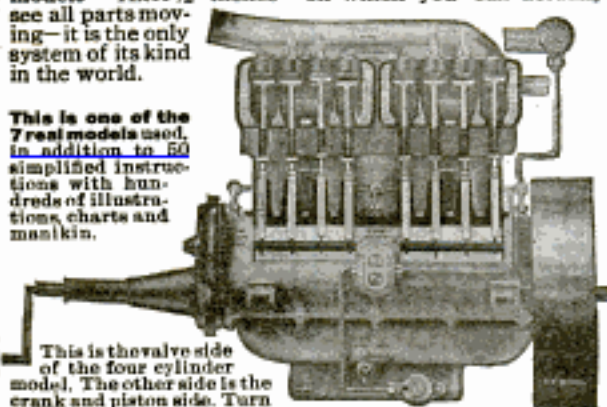

This is the valve side of the four cylinder model. The other side is the crank and piston side. Turn the crank and all of the real metal parts actually operate. The six cylinder engine model is similar.

This system is endorsed by Barney Oldfield, Elwood Haynes, Chas. Duryea and other motor authorities.

Mr. Dyke has been identified as a pioneer inventor, supply man, etc., with the auto industry since its beginning. He originated the first auto supply Co. and manufactured and marketed the first float type carburetor in America. No other man with such experience is today teaching others.

If we prove to you that we have started hundreds of others into the repair business and as chauffeurs—who had no previous experience and who knew no more about an auto than you do right now—you must admit we can do the same for you. Write me TODAY—NOW—and LET ME PROVE IT.

Write for DYKE'S FREE BOOKLET

It is interesting and instructive in itself. Fully illustrated. Learn how you can get all this training for only \$15. Fill out below or write a postal—but do it NOW.

Dyke's Correspondence School of Motoring
Box 188, Roe Bldg.
St. Louis, Mo.

Send me your free 32-page booklet about your New Idea Working Model Course and testimonials and proofs. It is understood I am under no obligations in sending for this.



OPPORTUNITIES OF THE AUTO BUSINESS
HOW TO GET INTO THE AUTOMOBILE BUSINESS

Name.....

Address.....

Deal with the originators. Beware of imitators. This school is a department of the firm of A. L. Dyke, Pub. and Importer, Box 188, Roe Bldg., St. Louis, Mo.

(Contents—Continued from Page 6)

Spruce, Japanese Finish for.....	779
Steps, Collapsible, for Boarding Boat.....	781
Table for Mounting Drawings on Muslin or Backing.....	776
Vegetables, Rack for Washing.....	785
Vise Pads for Polished Tubing or Rods.....	778
Vise, Support for Long Work in.....	781
Washers, Compressed Air Punch for Cutting.....	779
Wax Patterns for Making Plaster Molds.....	783
Wheel, Boat's, Made from Bicycle Sprocket.....	772
Wire Cutter, Foot Lever, Made of Plier.....	786
Wood Finish, Polished Black.....	782
Wrench, Flexible Socket.....	778

AMATEUR MECHANICS

Aluminum Cooking Utensils, Mending.....	785
Bicycle Fitted Up to Resemble Motorcycle.....	793
Birdhouse—California Bungalow for Canaries.....	785
Blind, Homemade Device Aids in Writing.....	788
Bookcase, Trunk, for Convenient Shipment.....	791
Bookmark, Leather and Silk.....	792
Bottle Carrier Made of Pipe Straps.....	791
Box, Small, Army in.....	789
Brushes, Polish or Stencil, Wire Compacts Brushes in.....	787
Cardboard Tubes for Electrical Coils, Making.....	786
Chair, Cushioned, Made of Barrel.....	789
Flatiron, Sheet Metal Stand for.....	784
Flue Stopper, Safety, Made of Tin Pail.....	798
Frying Pan Made of Tin Cover.....	796
Game of Skill, Marble under Bridge.....	796
Gas Stoves, Safety Cover for Valves on.....	796
Laundry Tub and Dishwashing Sink, Combination.....	792
Locker, Boys' Athletic Equipment.....	787
Masks, Novel, for Printing Pictures.....	794
Music Stand, Book Rest for.....	798
Oillock, Emergency, of Rope.....	792
Paraffin Covers, Removable, for Jars.....	796
Phonograph Records, Disk, Played Eccentrically.....	798
Phonograph, Split Needle Causes Echo on.....	791
Photographic Print Washing Machine.....	797
Photographic Prints, Lettering without Marking Negative.....	799
Photography—Developing or Etching Tray Rocker.....	792
Pile Driver, Small Working.....	789
Planing Thin Sticks Held in Flooring Groove.....	792
Radiator Cover, Summer, Serves as Cupboard in Winter.....	795
Roadster, Homemade, with Motorcycle Engine.....	785
Rope Pad Prevents Slamming of Door.....	799
Spark Plugs, Extra, Box to Protect.....	799
Strap, Carrying, and Lock for Hand Cases.....	798
Swings, Porch, Safety Spring for.....	795
Switch, Cylinder Reversing.....	795
Table, Old, Used as Wall Workbench.....	799
Tent, Homemade, Shoulder Pack.....	783
Toy—Come Back Rolling Can.....	796
Toy Submarine Made of Shade Roller.....	793
Tray, Liquid Filled, Carried Safely.....	787
Trinket Case, Secret, for Bookshelf.....	794
Typewriter, Feeding Cards into.....	785
Umbrella Handle, Making Detachable.....	787
Wagon Seat, Homemade Spring.....	799
Washstand for Baby.....	798
Weighting Metal Base.....	791
Well, Rustic, for Bazaar or Fair Booth.....	784

ALL departments of Popular Mechanics Magazine purchase manuscripts and pictures—either photographs or drawings. Material is passed upon promptly and payment is made upon acceptance. For the general reading section contributions should relate to new developments in the fields of science, mechanics, invention, and discovery. Photographs may be of any size, providing they are sharp and accompanied by accurate descriptive data.

The Shop Notes and Amateur Mechanics departments use new ideas and kinks for workmen of all crafts and amateurs of all ages, respectively. Pencil sketches are acceptable; descriptions should be brief and in simple language. Address Managing Editor, 6 N. Michigan Ave., Chicago.

Please Mention Popular Mechanics

FREE BOOK

How To Learn Piano

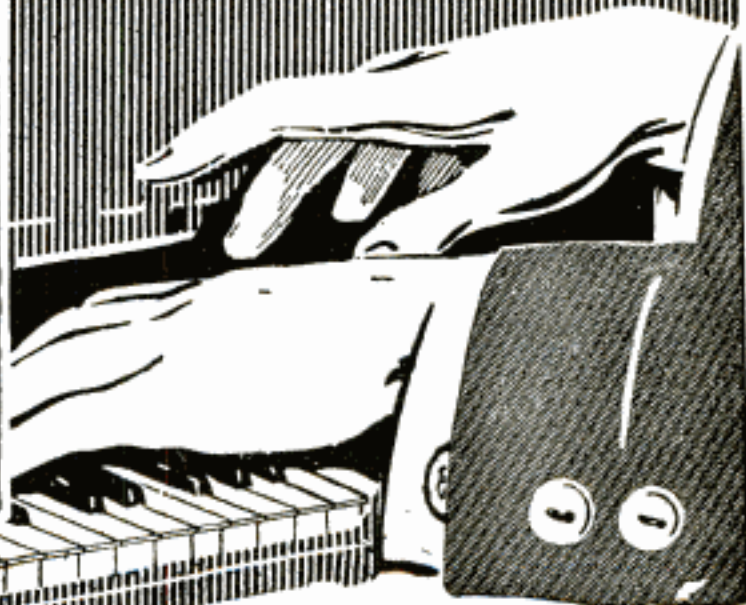

This Interesting Book

shows how you can learn to play the piano or organ in your own home, in one-quarter the usual time and at *one-quarter the usual cost*. It explains the profound pleasures and well-known social advantages of musical training, and contains much information which will be

Dr. Quinn's Famous WRITTEN METHOD for Piano or Organ

has revolutionized the study of music. By the use of Dr. Quinn's remarkable device, the COLOROTONE (patented), you save three-quarters of the time, effort and money usually required for learning piano or organ. You play chords immediately and a complete piece, *in every key, within four lessons*. Investigate without cost by sending for free book.

Endorsed by Distinguished Musicians

Dr. Quinn's WRITTEN METHOD has been proving its merit by RESULTS for 25 years. Among our graduates are thousands of accomplished amateur players, as well as leading composers, distinguished virtuosos and heads of conservatories. The method is endorsed by prominent musicians and educators who can *speak with authority*. It is scientific and systematic, yet practical and easy to understand. It is fully illustrated. It is equally effective for beginners or experienced players, children or adults. All necessary music is included FREE. You practice in spare time at your own convenience. Progress as rapidly or slowly as you wish. Diploma of recognized value is granted.

Investigate Without Cost

Write today, using postcard, letter or free book coupon, for our 64-page book, explaining everything you want to know about "How To Learn Piano Or Organ," and giving full particulars of our COURSE. Special reduced terms this month on account of our Twenty-Fifth Anniversary Offer. Investigate without cost or obligation NOW.

Marcus Lucius Quinn Conservatory
Studio K. R., Social Union Bldg., BOSTON, MASS.

extremely interesting to you whether you are already an accomplished player or do not know a single note. Send letter, postcard or coupon below for *your* copy of this valuable 64-page book. It is free.

Music As A Career

Our free book tells you of the concert career which may be open to you. It explains the great and increasing demand for professional players and tells how you can earn \$25 to \$100 weekly through your own playing skill or by giving musical instruction to others in spare time.

It fully describes a method of home study which brings you all the advantages of the best foreign conservatories at *less than 43 cents a lesson*. Send for this free book at once.

**FREE
BOOK
COUPON**

M. L. Quinn Conservatory
Studio K. R., Social Union Bldg.
BOSTON, MASS.

Please send me without cost or obligation, your 64-page FREE Book, "How to Learn Piano or Organ," and full particulars regarding Dr. Quinn's Course in Piano or Organ by the Written Method, and special Twenty-Fifth Anniversary Offer now open.



Write
Today

Name

Address

Win Your War for Super-Health of Mind and Body!

Within Yourself You Have Millions of Enemies, Destroying, Tearing Down, Defeating Your Health Power, Mind Power, Earning Power, Pleasure Power and Resisting Power. How to Win Your War by Overpowering Your Enemies

By W. W. WASHBURN

When you think of war, you think of units of men fighting to destroy each other. You think of the appalling destruction of life and property and you are amazed that civilization countenances such waste.

Yet if you but stop to realize, even greater warfare exists every day within your own throbbing human system, and the waste proportionately is as great as that caused by international warfare.

In your own personal war more than five billion units are constantly fighting. Upon the result of this war your life, your health, your success and your very happiness depends.

Man is made up of billions of cells. These cells are the sole governing factors in your health. Millions of germs are constantly endeavoring to invade the system and destroy these cells. When you are sick or ailing—when you lack energy and vitality—when you are troubled with indigestion, constipation, heart weakness, sick kidneys, morbid livers, it is plain that the invading army of

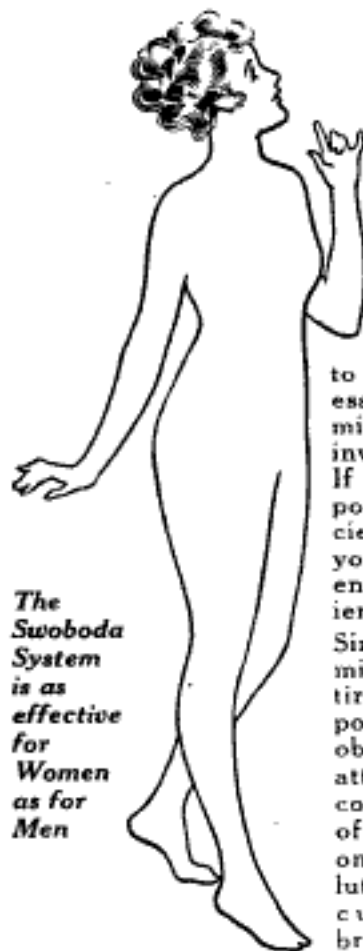

The Swoboda System is as effective for Women as for Men

germs has secured the upper hand and has succeeded in weakening or actually killing hundreds of thousands of the tiny cells in your body. In other words, your health and vitality, your physical and mental efficiency depend entirely on the ability of your cells to destroy, by the process of digestion, the millions of germs as they invade your organism. If the germ-destroying power of the cells is sufficient, the invasion of your organism by the enemy is of no inconvenience or consequence.

Since your health and mind power depend entirely on the resisting power of your cells, it is obvious that if you are to attain and maintain a condition of super-health of mind and body it is not only advisable but absolutely essential that you cultivate these cells, bringing them to the

point of perfection which makes the invasion of cell-destroying factors null and void. If your cells are prepared against invasion, if they are highly organized to repel the hordes of germs which we all acquire in our daily work and play—if your cells are vitalized, energized and evolutionized, your whole system is possessed with a germ-destroying power which will permit nothing to interfere with the proper functioning of every organ of your body, including the brain. The way to cell perfection is through cell cultivation. The way to cell cultivation is through conscious application of the principles of evolution and energy, in short, through Conscious Evolution.

Conscious Evolution is a simple, scientific, practical, convenient and easy method of compelling nature to give you energy and vitality to spare, digestive power to spare, self-reliance to spare, youth to spare, mind power to spare, living power to spare and working power to spare.

By applying the Swoboda System of Conscious Evolution you can become a better human being physically, mentally and in every way, without drugs, apparatus or devices of any character. The Swoboda System tells you how to apply the positive evolutionary principles of your cells and forces, creating a resistance against reaction, supplying a higher germ-destroying power, and higher powers of health-preservation. Conscious Evolution, therefore, amplifies and develops every characteristic of personality, not only to win internal warfare but also to win warfare against poverty.

Conscious Evolution enables you to win the struggle against adverse conditions of environment. It enables you to overcome the billions of germs that attack you, by so fortifying every cell, that it becomes easy for it to overwhelm adverse conditions.

Conscious Evolution not only removes the germs of destruction by increasing the life power and vitality of every tissue and organ, but produces a condition of health which lives upon itself, multiplying and increasing, so that you become infinitely superior in health and mind to average men. The man who, through Conscious Evolution, has won an overwhelming victory against sickness and disease soon becomes overwhelmingly superior to average people by continuing the development of the cells. What you are and what you are capable of accomplishing depends entirely and absolutely on the degree of development of your cells. They are the sole controlling factors in you. You are only as young, you are only as great, and you are only as powerful as your cells are. You can become as powerful physically and mentally as you desire. You can

live as completely as you like. You can enjoy life to any extent that you please. You can work or play as long as you care to without suffering from fatigue or any other consequence, by developing cell perfection.

Conscious Evolution is no experiment. There is nothing else in the world that is anything like it. It does not compel you or even ask you to give up any of the things you like to do; instead it enables you to do what you like without suffering afterwards. Swoboda is giving Conscious Evolution successfully to pupils all over the world. He has among his pupils hundreds of Doctors, Judges, Senators, Members of Cabinet, Ambassadors, Governors, thousands of Business and Professional Men, Farmers, Mechanics and Laborers, and almost an equal number of women—more than 262,000 people have already profited through Swoboda's System of consciously energizing the cells.

If you are at all interested in acquiring health above the average, resisting power above the average, mental power above the average—if you are at all interested in fortifying every vital organ in the system, not only against disease, but against wear and tear incident to a fully and completely satisfactory life—a well-rounded life—you will be interested in reading a remarkable book published by Swoboda, in which he explains the secret of Conscious Evolution. The book is free. Write for this book, not because Swoboda's followers include such prominent people as are listed here, but because it means so much to you in multiplied living power, earning power, health power and mind power.

A Few of Swoboda's Pupils

F. W. Vanderbilt, W. G. Rockefeller, Jr., William Barnes, Jr., Gen. W. A. Kobbe, Gen. J. F. Bell, Franklin Murphy, Woodrow Wilson, Howard Gould, W. R. Hearst, John B. Stanchfield, John C. Spooner, Alfred I. du Pont, Percy A. Rockefeller, Charles F. Swift, E. A. Cudahy, Oscar Straus, Chas. E. Hughes, Simon Guggenheim, A. Lewishohn, Mrs. C. P. Huntington, Mrs. Archer M. Huntington, Countess de Loquezenille, Mrs. Herman Oelribs, Maxine Elliott, Anna Held, Mr. H. C. Chatfield Taylor, Clarence Buckingham, W. P. Clyde, Nat C. Goodwin, Jacob A. Cantor, Oscar Hammerstein, Francis Wilson, F. L. Perley, H. M. Flagler, Frank A. Vanderbilt, Pliny Fisk, Edward Lauterbach, J. R. Roosevelt, Samuel W. McCall, Otto H. Kahn, W. Lyman Biddle, F. N. Doubleday, Boies Penrose, Edward Thaw, G. Schwab, Elihu Root, Jr., James H. Post, Marshall Clyde, W. H. Havemeyer, Caldwell K. Biddle, Stanley Washburn, W. M. K. Olcott, Judge Staake, George A. Post, Adolf Pavstedt, Rev. Dr. Robert J. Achetter, the Earl of Meath, Burton Holmes, etc., etc.

Swoboda's book will startle, educate and enlighten you. In this book Swoboda has given a maximum of information in a minimum of words. It tells in a highly interesting and simple manner just what you have always wanted to know about yourself. Regardless of how well you may feel, of how efficient you may think you are—regardless of how active, energetic and alert you may consider yourself—regardless of how happy you may pride yourself on being—regardless of how healthy, wealthy or successful you may be, you cannot afford, in justice to yourself, to miss the facts about your body and mind which this book contains. A mere reading of this book will give you a clear understanding of the unlimited possibilities for you through Conscious Evolution of your cells. You will be so filled with enthusiasm and ambition after reading "Conscious Evolution" that you will not rest until you have yourself acquired the Swoboda kind of health and energy. Tear out the coupon on this page. Write your name and address on it or write a letter or postal card and mail it today. Even if you gain but one suggestion out of the 60 pages of this book you will have been repaid a thousandfold while you read it. Do not delay—do not lose a single moment in taking the step to secure Swoboda's free book.

Send now while the matter is on your mind. Remember, the book is absolutely free for you to keep. There is no charge or obligation now or later—simply address Alois P. Swoboda, 2044 Aeolian Hall, New York City, and the book will come by return mail. Beware of individuals pretending to be my agents or representatives. All such are imposters and frauds.—SWOBODA.

CREATOR OF CONSCIOUS EVOLUTION



Swoboda

A Remarkable Personality

Swoboda, himself, is a wonderful example of what Conscious Evolution can accomplish. As Swoboda gains in years, he grows younger in enthusiasm, younger in vitality, younger in health; he is becoming stronger, more energetic, more confident, more dominant and more alive by capitalizing his creative powers through Conscious Evolution. What Swoboda is accomplishing for himself you too can accomplish—every individual can accomplish, for every individual is governed by the same laws and principles, and every individual has it within himself to make use of these laws and principles. Swoboda's mind and body are so alert and so active that in his presence one feels completely overpowered. His personality dominates everything with which it comes in contact; yet Swoboda is real—there is absolutely nothing mysterious about him. He knows not what fatigue is—he is a tireless worker. He delights in making sick people well and weak people strong. He loves his work because he feels he is of benefit to humanity—making a better, more vital, more potent race of men and women.

What Others Have to Say

"Worth more than a thousand dollars to me in increased mental and physical capacity."

"Effect was almost beyond belief."

"I have been enabled by your System to do work of mental character previously impossible for me."

"My reserve force makes me feel that nothing is impossible; my capacity both physically and mentally is increasing daily."

"I am greatly pleased with the results, and feel that any person not using Conscious Evolution is doing himself a great injustice."

"Last week I had a reading of my blood pressure, and was gratified to learn that it was fully ten points below the previous reading. This was a surprise to me as well as to my physician, who did not believe that my blood pressure could be reduced because of my advanced age."

"I was very skeptical, now am pleased with results; have gained 17 pounds."

"The very first lessons began to work magic. In my gratitude I am telling my croaking and complaining friends, 'Try Swoboda.'"

"All your promises have been fulfilled."

Please send me your free copyrighted book, "Conscious Evolution."

Name

Address

City

State

Mail to ALOIS P. SWOBODA, 2044 Aeolian Building, New York City

These books will help you to greater

Electr

PARTIAL CONTENTS OF THE 10 GUIDES

No. 1. Contains 240 pages, 246 illustrations. Electrical signs and symbols—static and current electricity—primary cells—conductors and insulators—resistance and conductivity—magnetism—induction coils—dynamo principles—classes of dynamo, etc.

No. 2. Contains 218 pages, 256 illustrations. Armatures—windings—commutation—brushes—motor principles—armature reaction—motor starting—calculations—brake horsepower—selection and installation of dynamos and motors, etc.

No. 3. Contains 276 pages, 280 illustrations. Galvanometers—standard cells—current measurement—resistance measurement—voltmeters—wattmeters—watt hour meters—operation of dynamos—operation of motors, etc.

No. 4. Contains 308 pages, 423 illustrations. Distribution systems—wires and wire calculations—inside, outside, and underground wiring—sign flashers—lightning protection—rectifiers—storage battery systems, etc.

No. 5. Contains 278 pages, 379 illustrations. Alternating current principles—alternating current diagrams—the power factor—alternator principles—alternator construction—windings, etc.

No. 6. Contains 272 pages, 538 illustrations. A. C. motors—synchronous and induction motor principles—A. C. commutator motors—induction motors—transformers—losses, construction, connections, tests—converters—rectifiers, etc.

No. 7. Contains 320 pages, 460 illustrations. Alternating current systems—switching devices—circuit breakers—relays—lightning protector apparatus—regulating devices—synchronous condensers—indicating devices—meters—power factor indicators.

No. 8. Contains 288 pages, 330 illustrations. Wave form measurement—switch boards—alternating current wiring—power stations—turbines—management, selection, location, erection, testing, running, care and repair.

No. 9. Contains 576 pages, 849 illustrations. Telephones—telegraph—wireless—electric bells—electric lighting—photometry—electric railways—electric locomotives—car lighting—trolley car operation, etc.

No. 10. Contains 704 pages, 730 illustrations. Miscellaneous applications—motion pictures—gas engine ignition—automobile self-starters and lighting systems—electric vehicles—elevators—cranes—pumps—air compressors—electric heating—electric welding—soldering and brazing—industrial electrolysis—electro-plating—electro-therapeutics—X-rays, etc.

Also a complete ready reference index of the complete library.

The work of the world today is done by electricity. Electricity runs our machines; transports our goods; lights our homes, shops and factories; heats our buildings—is indispensable in hundreds of ways. Opportunities in electricity are greater than ever before. Exact electrical knowledge means more money and greater success for you.

HAWKINS ELECTRICAL GUIDES

give you ALL the electrical information you want, in the shortest, most concise form—namely, by means of questions and answers and unlimited illustrations. No matter how great or how little your previous knowledge of the subject at hand, you "get the point" at once in Hawkins Guides. They are absolutely complete—brought right up-to-date—the last volumes are just off the press.

FLEXIBLE POCKET-SIZE TEXTS Arranged for Home Study and Reference

They are the handiest books to read and to use, ever produced. In flexible, black covers, leather binding—just the right size—5x6½ inches—to fit in your pocket, so that you can carry each single volume about with you until you have mastered its contents. The whole set fits easily in the hollow of your arm, and still there are actually 3,500 pages and 4,700 illustrations.

10 Practical Volumes. 3500 Pages. 4700 Illustrations
\$1 Per Volume—Payable \$1 Per Month

success through

Electricity

WHAT USERS SAY

"Every Electrician, Operating Engineer or Student who wants to advance himself in the Electrical field should have a set of these books."

JOHN KELLEY, 116 Union St., Newark, Ohio.

"For the man not getting a college training, and even in that case, I can sincerely say I do not believe there is a better set of books on the market today."

LLOYD D. HUFFMAN, Dayton, Ohio.

"We consider Hawkins Electrical Guides the most compact and complete set of electrical references in the market."

NOGGLS ELECTRIC WORKS, Monterey, Cal.

"Hawkins surely knows the art of condensing information."

ELDRIDGE F. BALL, Buckland, Conn.

"I think they should be in the hands of everyone who has anything to do with Electricity."

T. E. MURPHY, Orange, Va.

"For the practical electrician, they are the best books published—worth many times their price."

L. C. WAGNER, Wyoming, Ill.

"I have gained valuable information from them which has helped me directly in my line of work."

HERMAN NODENBERG, Hoboken, N. J.

"They are wonderful value. Everything is so clear and concise. Even one who had no knowledge of Electricity would have no difficulty in grasping the facts."

F. L. TAYLOR, Amesbury, Mass.

"It is the best work an apprentice can study if he wants to get ahead in his trade. As a reference for the experienced worker HAWKINS ELECTRICAL GUIDES are unexcelled."

I. MCCLELLAN, Chillicothe, Mo.



**THE ENTIRE SET of
10 VOLUMES**

SHIPPED TO YOU FREE

Send no money. Examine the books first. Use them for seven days in connection with your work, and decide for yourself that they are the most complete, the most helpful and the clearest written electrical books ever published. This unusual offer is a sign of our confidence in the Guides.

EASY PAYMENTS Accept the offer now—mail the coupon today. If you decide to keep the books you can make settlement at only \$1 per month until paid for.

THEO. AUDEL & CO.
72 Fifth Avenue
NEW YORK N.Y.

**THEO.
AUDEL & CO.,**
72 Fifth Avenue, N. Y.

Please submit me for examination Hawkins Electrical Guides (Price \$1 each). Ship at once, prepaid, the 10 numbers. If satisfactory I agree to send you \$1 within seven days and to further mail you \$1 each month until paid.

Signature.....

Occupation.....

Business Address.....

Residence.....

Since we have not yet had the pleasure of business relations with you, we shall appreciate your giving us name of reference on line below

Reference.....

P. M. May 17

Please Mention Popular Mechanics

Copyrighted material.

Send For This Book Today

Free To All Ambitious Men



Ten Years'
Promotion
In One

There are hundreds of thousands of men with clear brains, good health and plenty of ambition who ought to succeed, but who are regularly "fired", "kicked out" or "held down". WHY? Read the answer in this book "Ten Years' Promotion In One"—a book that will open your eyes to some plain, common-sense success facts.

If a man feels that the chances are all against him; that it requires "pull" or "luck" or a combination of both to land the job higher up or to increase his income, this helpful, inspiring book will convince him otherwise. A prominent Chicago business man

recently said, "It would pay every ambitious person to read this book, even if he had to pay \$5 to get a copy." Let us send it to you FREE, with literature explaining how thousands of men have found the short cut to promotion through the training offered by

La Salle Extension University

"The World's Greatest Extension University"

More than 125,000 men of all ranks and positions, from office clerks to corporation officials, have benefited from LaSalle training and service. Over 20,000 new students annually now avail themselves of the home-study courses offered in the various departments of the University.

The complete La Salle organization and its associations consist of more than 800 people. It is backed by capital of \$1,000,000, with assets in excess of \$2,000,000. It has a staff of more than 350 prominent business experts, professional men, text and special lecture writers, contributors, instructors and assistants, including recognized authorities in all departments. Its students and graduates can be found throughout the entire English-speaking world.

Within the past two years the buying power of the American dollar has shrunk from 30 to 50 per cent. If your income is not more today than it was a year or two ago, your earning power too, has shrunk in proportion.

Today, big incomes are virtually begging for men to come and earn them. A recent editorial in the Saturday Evening Post on "Help Wanted at \$5000 a Year" referred to a business man who complained that "At \$10 a week he had three applications for every job; at \$100 a week, two jobs for every applicant." A want ad for a \$15 a week job in Chicago brought 171 written applicants. A \$5000 a year position advertised by the same concern at the same time in the same paper did not bring a single applicant—NOT ONE.

Big business is in need of capable executives, auditors, comptrollers, business and office managers, traffic managers, legally-trained men, bank officials, certified public accountants, cost accountants, sales managers, etc. Any one of these positions is within the reach of the wide-awake man who has intelligence and common-sense and will apply himself. No man need be content to do under-paid, disagreeable work, with the abundant opportunities trained men now have to pick positions with worth-while incomes.

Indicate in coupon the position for which you wish to qualify. We will send you a complete descriptive catalog, explaining fully how our training places the position of your choice within your grasp. Our plan enables you to use your spare time. You can carry on the work in your home or office, by mail, without interference with your present duties and you can pay for the course a little each month if you wish.

Your chance to get ahead is here before you—right now. Mark with an X the course in which you are interested. Send for your copy of "Ten Years' Promotion In One" today. You will never part with it except to loan it to a friend.

FREE BOOK COUPON—MAIL IT TODAY—

LASALLE EXTENSION UNIVERSITY, Dept. 564R, Chicago

Send me free copy of book "Ten Years' Promotion In One"; also catalog and particulars regarding the training course and service in department marked with X.



- Business Administration:**
Official, managerial and executive positions.
- Higher Accountancy:**
Auditors, Comptrollers, Certified Public Accountants, Cost Accountants, etc.
- Business English:**
Business Correspondents, Writers of Advertisements and Sales Literature.

- Interstate Commerce and Railway Traffic:**
Railway and Industrial Traffic Managers, Traffic Experts, etc.
- Banking and Finance:**
Officials, Tellers, Cashiers, Trust Officers, Financial Managers, etc.
- Law: Degree of L.L.B.**
Executive-Business Positions Requiring Legally-Trained Men.

- Commercial Spanish:**
Foreign Correspondent with Latin American Countries.
- Effective Public Speaking:**
Training in the Art of Forceful, Effective Speech.
- Elements of Accounting:**
Training for Expert Bookkeeping Positions.

Name.....

Address.....

Please Mention Popular Mechanics

You Men Who Want to Find Success Through ELECTRICITY

Three minutes spent in reading this article will be well repaid



Dr. Charles P. Steinmetz, A.M., Ph.D.
Chairman Advisory Board
New York Electrical School

"There is an enormous field for the electrical worker"—says Dr. Charles P. Steinmetz, the foremost Electrical Engineer in the world, whose salary with the General Electrical Company is reputed to be over \$100,000.00 a year.

It is indeed an enormous field—a field of unlimited opportunity—a field which has hardly as yet begun to grow. With all the modern applications of electricity to railroads, transportation, power drive, automobiles, telephones, telegraphy, signalling, lighting, heating, household conveniences, and thousands of other applications, new uses are still being rapidly developed.

There are, in fact, more big money-making opportunities in this field today than there are men trained to fill them. Men ask us about the opportunities for success in the electrical field. We have seen hundreds of men with little or no electrical experience and other men, who for years had been plodding along in an electrical rut, go out into the world after a few months of proper training, and start to make things hum. We have hundreds of letters from just such men. Here is what some of them say:

Letters from Successful Men

"I have done well since leaving school and am now Superintendent of the light, telephone and steam heat company here."

"Ten months after I left you I was given charge of this station. I saved at least 3 years by taking your course instead of working up as an apprentice."

"I have been in the contracting business here in Avon since Jan. 1st, 1914, and am doing fine."

"I have sole charge of all motors, lights, electrical devices and appliances, and in being able to hold this position I give all credit to the New York Electrical School and your personal interest in me, which until lately I did not realize would be so wonderfully beneficial to me."

"We had no electrical experience before taking your course and just one year since leaving school are working side by side with men of from five to ten years' experience."

"I am thanking you for the service you did for me while attending school as I accepted a position as Sales Engineer for the New England Appliance Co., of Boston, Mass. My position takes in all of New England territory."

"Since graduating from your school, I have been able to handle successfully any problem that has come before me in my line of electrical work and I wish to express my feelings for the school and its methods of training."



The New York Electrical School

What is this school which gave these men and four thousand five hundred others such a splendid start in the electrical field? It is the NEW YORK ELECTRICAL SCHOOL. It is like no other school or college in the country. It is a school which cuts out long years of apprenticeship or long years of study by its unique method of instruction—the "learn by doing" method.

Learn by Doing To learn Electricity you must handle the actual apparatus with the help of a practical man who knows. You must do the real work which you will be paid for later on. In other words you must learn by doing. That is the method of the New York Electrical School—a method proved successful by our graduates.



In the New York Electrical School you learn in a few months—seven months is the usual time required—what would take you years to learn plodding along in an electrical apprenticeship. You waste no time doing over and over again the same old task. You go ahead all the time. Here at the New York Electrical School you are doing something different every minute, and you do everything thoroughly.

You do the actual work. If you are learning to wire a house you have actual floors, walls and ceilings in an actual ten-room apartment to work with. If you are learning how to run compound generators in parallel, you have the same type of machine and the same type of load as used in power houses. The work you do is actual work, and you learn to do it right. All the time a competent instructor stands behind you to see that you miss no point of importance.

Don't you think that with this kind of training you are assured of success in the electrical field?

Our course begins with primary cells, magnetism and electrical measuring instruments. Then you pass on to the installation and operation of every possible system of bells and annunciators, together with the practical operation of telegraph and telephone systems, wireless telegraphy and wireless telephony. Electrical drafting gets its share of attention, and you continue with interior light and power wiring, electrical illumination and testing, electrical signs and flashers.

A most important part of the course is estimating and contracting, including business methods in contracting, estimating cost of material and labor, how to submit estimates for work and methods employed in getting work, with lessons on how to compile information on work done to assist in estimating on future work.



As the course progresses you learn to erect switchboards and to operate motors and generators of every type. You learn the methods of their installation and maintenance. You take up storage batteries—the manufacture of modern types, different rates of charging and discharging efficiency, rules governing output, care of accumulators. Direct and alternating current practice are covered in full detail.

And last of all you make a thorough review of the work, with practice of armature winding and experience in general repair and machine shop work. In this way the knowledge that you gain stays with you.

Our equipment for all this work is complete and up-to-date. The seven floors of our building make up one complete and tremendous workshop, with every facility for thorough and accurate electrical work.

You Start Higher Up

When you graduate from the New York Electrical School you are ready to step right into a position of responsibility. You are an expert, not a dabbler in electricity. Yet the course is so simple that anyone with a common school education can take it. We have no requirements for entrance.

The length of the course we have mentioned is seven months. But that depends on you. You can start any time and work as fast or as slow as you like. You do not have to keep up with anybody else. No one holds you back. Your work is entirely individual all the way through and you can stay till you feel you have learned it all. Whether you devote seven months or more than a year to the course, the cost is the same.

We have both day and night sessions, but most of our men take the day sessions because it naturally enables them to complete the course quicker.

New York the Center

We are located in the heart of New York City and you can see the advantage of that. New York is the heart of everything electrical—there are big plants nearby, electrical expositions, libraries and facilities for good, quick work in an atmosphere of industry.

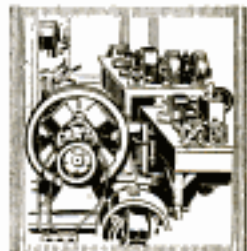

A large number of our students come from other cities, from all over the United States. They realize the advantage of coming to New York to learn electricity. About 4500 in all have gone out from our school into success. You can do the same. We believe that with us you can learn more thoroughly and more quickly than anywhere else because we give you practice. We teach you only what you use.

And Now

If you have an ambition to make a name for yourself in the electrical field you will want to join the New York Electrical School. It will be an advantage to you to start with our May sessions. Then you should hurry to send for our 64-page book which tells you all about the school, with pictures of our equipment and students at work, and a full description of the course. You need not hesitate to send for this book. It is FREE to everyone interested in electricity. It will not obligate you to send for it. Send the coupon or write us a letter. But write us now while you are thinking about the subject of electricity. Address—NEW YORK ELECTRICAL SCHOOL, 39 West 17th St., New York, N.Y.

Mail this coupon today for free book

NEW YORK ELECTRICAL SCHOOL, 39 W. 17th St., New York
Please send FREE and without obligation to me your 64-page book.

NAME.....
ADDRESS.....

Please Mention Popular Mechanics



Civil Engineers Earn \$1500⁰⁰ to \$5000⁰⁰ a Year!

DON'T take our word for it that these books will fit you to earn \$1500 to \$5000 a year as a Civil Engineer. Get them into your home—free of all charges—and determine their value for yourself. Send the coupon now for your free-for-examination set of the brand-new Cyclopaedia of Civil Engineering. The demand for Civil Engineers was never greater than today. The enormous development of reinforced concrete construction insures steady employment at big pay.

50c a Week This trivial sum will soon pay the low introductory price of the Cyclopaedia of Civil Engineering. But you must act now! This liberal offer can't be continued indefinitely. Mail the coupon today—now.

Use Them 7 Days

The entire nine volumes will be sent to you by prepaid express for seven days' free examination. Don't send a penny. The books are bound in half red morocco leather, gold stamped, and contain 3600 (7x10 inches) pages and 3000 illustrations, plates, maps, diagrams, etc.

Free Consulting SERVICE

With each set of this New Cyclopaedia we give without charge a year's Consulting Membership in the American Technical Society. Such a membership regularly costs \$12.00, but in connection with this special offer you do not pay a cent for it.

These volumes contain everything you need to know to become a successful Civil Engineer. They cover surveying, highway construction, railway engineering, earthwork, specifications, estimating, contracts, bridge engineering, masonry, reinforced concrete, water supply, sewers and drains, water power equipment, river and harbor improvements, irrigation engineering, etc., etc. Every line is written in plain English.

Don't Send a Penny! Just the Coupon

American Technical Society
Dept. C1195, Chicago, U.S.A.

Please send me the nine-volume set of Cyclopaedia of Civil Engineering for 7 days' free examination. If I decide to buy, I will send \$2.00 within 7 days and the balance at \$2.00 a month until \$29.80 has been paid. Then you send me a receipt showing that the \$45.00 set of books and the \$12.00 consulting membership are mine and fully paid for. If I think that I can get along without the books after the 7 days' trial, I will return them at your expense.

Fill in and mail the coupon. Then the entire nine-volume set will come to you by prepaid express for a full week's examination. If you keep it, send only \$2.00 within seven days, and then \$2.00 a month—50c a week—until the introductory price of \$29.80 has been paid. This is \$15.20 less than the regular price of \$45.00. If you do not want the books, send them back at our expense.

This is a remarkable opportunity to prepare yourself—in your spare time—for the fascinating, highly-paid work of a Civil Engineer. If you live within the boundaries of the United States or Canada, fill in and mail the coupon today—now.

American Technical Society
Dept. C1195
Chicago, U.S.A.

Name.....

Address.....

Reference.....

FREE 1917 Catalogue of HOME STUDY MECHANICAL BOOKS



Subjects: Automobiles, Starting and Lighting, Electricity (Motors, Meters, Wiring, Armature Winding, Telephones, Wireless, Telegraph), Gas and Oil Engines, Steam Engineering, Machine Shop Practice, Mechanical Drawing, Rail-roading, Carpentry, Welding, Plumbing, Sign and Scene Painting, Card Writing, Building, Architectural Drawing—**one hundred titles.**

JUST PUBLISHED

Farm Buildings with Plans and Descriptions

By H. A. Shearer. A complete description of all kinds of new farm buildings with plans and views. Practical suggestions for farm homes, use of concrete, etc. 12 mo., 256 pages, fully illustrated. Price, postpaid . . . **\$1.00**

Send for free descriptive catalogue today

FREDERICK J. DRAKE & CO., 1008 Michigan Ave., Chicago

LEARN WATCHMAKING

and become independent. Good-paying positions secured.

Easy to learn. Send for FREE CATALOG.

ST. LOUIS WATCHMAKING SCHOOL, Dept. 5, ST. LOUIS, MO.

PERPETUAL MOTION

A new book tells all about it. History.

Explanation, Prophecy. Most interesting mechanical book in existence. 350 pages, 110 cuts. Postpaid, **\$2.00.**

ENLIGHTENMENT SPECIALTY CO., 411 Olive St., St. Louis, Mo.



SEND 2 CENTS

in United States stamps to pay postage and we will send you FREE a SAMPLE COLLAR of our New Style "Copley." State size wanted.

REVERSIBLE COLLAR CO., Dept. U, BOSTON, MASS.

SENT This Wonderful Key FREE to Health & Success



YOU will find this remarkable book of startling interest. It will fascinate, educate and enlighten you.

Written by Robert Duncan, whose system of nerve building is pronounced by scientific authorities to be the most important discovery in human development within recent times. The principles of this remarkable course are fully described in this book.

Send for a copy and learn how thousands of men and women have found the Robert Duncan System a blessing in better health and greater success.

Just send your name, and without cost the book will be sent you promptly.

**ROBERT DUNCAN DEPT., Boreen Publishing Corporation
Room 447, U. S. Express Bldg., New York City**

Aviation

PRACTICAL AERONAUTICS BY MAIL

EARN \$50 to \$500 a Week!

HERE is the one inexhaustible gold mine of opportunity and here is the man

who will lead you to it. It is the most extraordinary condition ever presented, owing to the sudden world-wide demand for aeroplanes. High class positions by the thousand calling for trained men—fame and fortune actually thrust at them. Salaries of from \$50 to \$500 a week are awaiting men who can fill these positions. And now, for the first time in history, a practical, home-study course in practical aeronautics is open to every man at a trifling expense. No matter what your occupation, you can prepare for a better position with big pay. Now is your opportunity.

Enter a practically untrodden field—a new profession. Seize the opportunity that has burst upon the country with tremendous force. Hustle ahead with the rapid development of the aeroplane industry which is outrivaling that of automobile and motion picture, as the quick and sure road to financial independence.

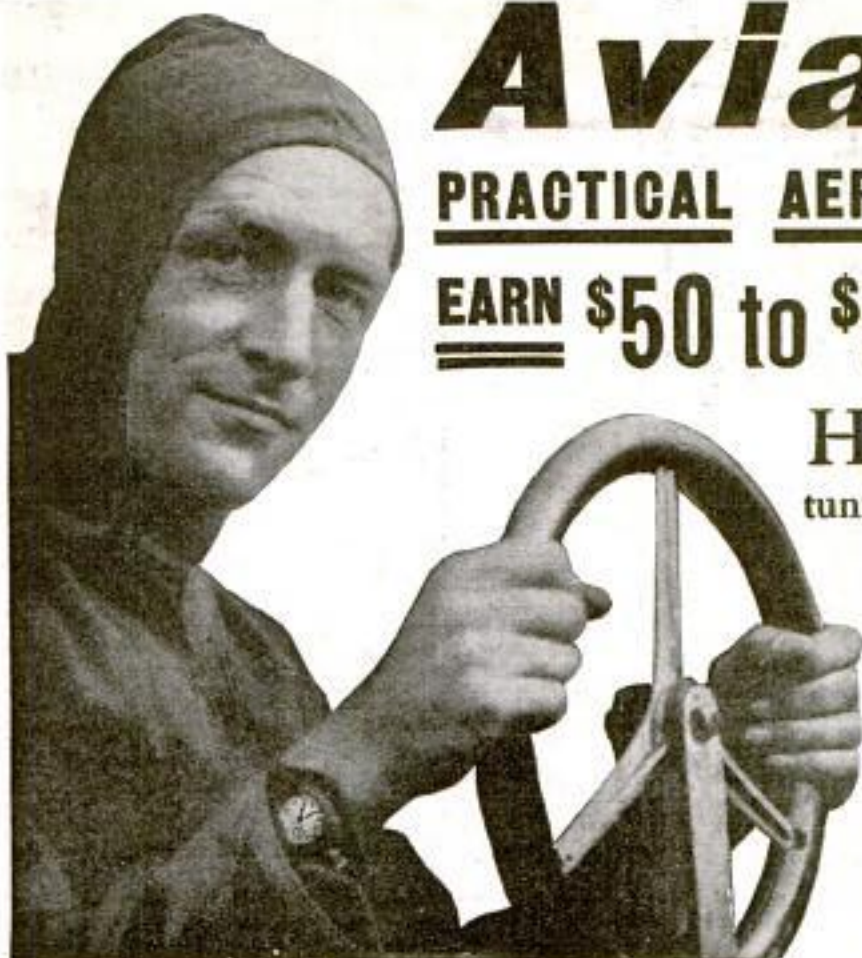

BUD MORRIS, Chief Instructor American School of Aviation

Prepare NOW
for these positions

Aeronautical Engineer
Aeronautical Instructor
Aeronautical Contractor
Aeroplane Repairman
Aeroplane Mechanic
Aeroplane Inspector
Aeroplane Salesman
Aeroplane Assembler
Aeroplane Builder

Conducted by Famous Aviators and Aeroplane Builders

The Course has been prepared by men of international reputation. Mr. Bud Morris, the well-known aviator, is Chief Instructor and personally guides the progress of each student. He is assisted by a distinguished staff of Aviators, Aeroplane manufacturers and Aeronautical Engineers. Every Lesson, Lecture, Blue Print and Bulletin is self-explanatory, in plain terms for quick understanding. The Course is absolutely up-to-the-minute with every known fact concerning Aeronautics. You get practical, working knowledge of the very highest merit. Now is the time and this is your opportunity to step right into fame and fortune. You are needed. Where there's a will here's the way.

What Our Students Say:

Mr. Stanfield Fries

Fort Bliss, Tex.
My estimation of the new course is excellent; it could positively not be any better.

Mr. Z. Purdy

Shreveport, La.
It is hard to believe that lessons on such a subject could be gotten up in such an interesting manner.

Mr. Lloyd Royer

Haizler, Neb.
I can hardly thank you enough for the way you have personally taken up my enrollment.

Mr. Mayne Eble

Manistee, Mich.
I believe I learn more from my lessons than an aviator who takes his first lesson with an airman in a aeroplane.

Write Now for Our Great Offer

Send the coupon for full particulars of our remarkable special offer open to you now. Find out all about the marvelous opportunities that are opening in the Aviation game. This offer is the greatest stepping stone to bigger opportunities ever known. Write today for complete literature, all free and prepaid. You are not obligated in any way. Do not waste time in thinking about it. Act! Send the coupon or a letter or a post card will do. Write at once.

American School of Aviation
431 So. Dearborn Street, Dept. 1195, CHICAGO, ILL.

American School
of Aviation
431 So. Dearborn St.
Dept. 1195
Chicago, Ill.

Gentlemen: Please send me free and without obligation, full particulars of your Course in Practical Aeronautics and your Special Offer to those who write at once.

Name.....

Address.....

Please Mention Popular Mechanics

Finish This Story For Yourself —

The girl got \$6 a week and was lonely. "Piggy"—you can imagine his kind—was waiting downstairs. He knew where champagne and music could be had. But that night she didn't go. That was Lord Kitchener's doing. But another night?

O. Henry

(12 Volumes)

tells about it in this story, with that full knowledge of women, with that frank facing of sex, and that clean mind that has endeared him to the men and women of the land.

Great Story Writer

From the few who snapped up the first edition at \$125 a set before it was off the press, to the 120,000 who have eagerly sought the beautiful volumes offered you here—from the professional man who sits among his books to the man on the street and to the woman in every walk of life—the whole nation bows to O. Henry—and hails him with love and pride as our greatest writer of stories.

To Those Who Are Quick

Kipling

6 vols. Given Away

Never was there an offer like this. Not only do you get your 274 O. Henry stories in 12 volumes at less than others paid for one volume of the first edition, but you get Kipling's best 179 short stories and poems and his long novel—without paying a cent. You get 18 volumes, packed with love and hate and laughter—a big shelf full of handsome books.

SHIPPED ON APPROVAL

We will ship the complete sets so that you can look them over in your home and then decide whether or not you wish to buy. If you are not delighted with O. Henry and the free Kipling notify us and we will take the sets back as cheerfully as we sent them. How could any proposition be more fair?

INSPECTION COUPON

THE RIVERSIDE PUBLISHING CO. (5-17)
543 Marquette Bldg., Chicago, Ill.

Please ship me on approval the Works of O. Henry, 12 volumes, half leather binding, gold tops. Also the 6 volumes set of Kipling bound in silk cloth. If I keep the books I will pay you \$1.00 as first payment within 15 days after books are received and \$2.00 per month until your special price of \$25.00 for the O. Henry set only is paid, and it is agreed I am to retain the Kipling set without charge. If not satisfactory I will notify you within 10 days and return both sets to you as soon as you give me shipping instructions as offered readers of Popular Mechanics Magazine.

Name.....
Address.....

Garages Earn \$3,000 to \$10,000 Yearly Auto Mechanics \$80 to \$200 Monthly



I will make you a competent Auto Mechanic, Chauffeur, Tractor Operator, Farm Lighting expert, Salesman or Garage Owner in a short time, the I. M. I. way, in spare time at home.
Harry L. Wells, Pres.

Get into Auto Business where success is sure. Competent Auto Mechanics needed constantly. Factories and garages advertising for competent men. Garages and Sales companies paying big salaries to men who know autos thoroughly. Farmers need Tractor Operators. The demand is for trained men. 1,250,000 cars will go into use in six months. 3,500,000 now in use. Think of men in Auto Business making fortunes. More cars mean more garages, more auto mechanics. Knowledge means money. Opportunities all about you. I. M. I. Course easy to understand, has complete detailed diagrams of everything. No previous education or auto experience needed. Earn while you learn. Start doing work in spare time, after first few lessons. Extra money will more than pay tuition. Pay for course in small monthly payments.

Learn Electrical Equipments

We teach how to handle every electrical equipment. You learn to locate trouble quickly. Starting, lighting and ignition troubles can't stump you. 80% of auto troubles are electrical. Electrical Auto Men get big pay, have steady jobs. Garages giving best electrical service get business easily and hold it. You learn how to adjust carburetors, time valves, care for electrical troubles. Complete course as quickly as you like. No matter what business you are in, you can succeed if you take I. M. I. Course.

CAR OWNERS—AUTO MECHANICS—GARAGES

One I. M. I. graduate saved price of course in three months fixing his own car. Hundreds of car owners taking I. M. I. Course so they can save repair bills. I. M. I. graduates in demand everywhere because they make good. More garages needed everywhere. I. M. I. graduates are competent to open them. We teach men how to build, rebuild, repair and operate every make of auto including Packard Twiz-6, Cadillac-8, Hudson Super-6, Owen Magnetic.

25 LESSONS ABSOLUTELY FREE

This remarkable offer is made to 1000 men—One man in each community. I will meet them half way, by giving half the course (25 lessons) free. I want men of quick decision and foresight. Send for special enrollment blank, free offer, testimonials, literature, all free. A post card will do.

Free Glad Money-Back Guarantee

I guarantee to return to any student all his money if he writes me within 30 days after completing last lesson that he is not satisfied.
Harry L. Wells, Pres.

International Motor Institute

25 Keener Bldg.
CHICAGO, ILL.

STUDENTS

ART MAGAZINE

Publishes cash art assignments, lessons and articles on Cartooning, Designing, Illustrating, Lettering, and Chalk-Talking. Critiques amateurs' work. Full of interesting and helpful information for artists and art students. Satisfactory or money refunded. 10 cents a copy, \$1 a year.

Send \$1 NOW, stamps or bill.

STUDENTS ART MAGAZINE, Dept. 243, Kalamazoo, Mich.

7 DAYS

LIGHTENAG PARAGON SHORTHAND

Then Practice Brings the Speed

In your own home, during the evenings of just one week, you can learn the famous

Used in Government service; also in Court Reporting. Adopted by cities for High Schools. Wonderfully easy to read. Speed capacity practically unlimited. Positive proof before you enroll. Send for it TODAY.

PARAGON INSTITUTE, 355 COLISEUM PLACE, NEW ORLEANS, LA.

Learn to FLY

Build Your Own Bi-Plane Glider

—NOW Many of the famous birdmen first learned to fly with a GLIDER. It is the initial step in aviation—and the small cost of material to construct such a machine—and the ease with which it can be built, places it within the reach of everyone.

Send to-day for copy of book "How to Build a 20-ft. Bi-Plane Glider" and get full particulars, with detailed drawings—Postpaid

60c

SPON & CHAMBERLAIN

123 P. M. Liberty St., NEW YORK

Also see three
following
pages

Final!

The End
of the sale of the new
Encyclopaedia Britannica in
the popular "Handy Volume"
form — printed on
genuine India paper **Is Here**

Over 50,000 persons have written us, in April, for information about this work. The stock remaining is so limited we can fill only a very small portion of this number.

THEREFORE, we have arranged with merchants in 305 cities to show The Encyclopaedia Britannica in each style of binding, so that every one who wants to make sure of getting a set can **make sure** the Britannica is useful and helpful before ordering.

We want no one to order a set unless he is positive he will find it useful.

We could sell ten sets of The Encyclopaedia Britannica, "Handy Volume" issue, printed on genuine India paper, for each one we can deliver.

BUT—two essential raw materials for making this wonderful paper, flax from Belgium, Germany or Ireland, and hemp from Russia, are **unobtainable**.

On the next two pages is a list of the stores. To be sure of getting one of the remaining sets, go to the store in your city and place your **order TO-DAY.**

For those who cannot go to one of these stores we print a "Reserve" Order Form on page 4 of this insert

THERE is no time to write for information. To make sure that the Britannica will be useful to you, go **TO-DAY** to the store in

Alabama
Birmingham—Book Dept. of Loverman, Joseph & Loeb
Mobile—L. Hammel Dry Goods Co., 7-15 S. Royal St.
Montgomery—J. Montgomery Fair

Arizona
Phoenix—Adams Pharmacy, In the Adams Hotel Bldg.
Arkansas
Fort Smith—Arthur H. Morrow, 715 Garrison Ave.
Little Rock—Allsopp & Chapple, 307-309 Main St.

California
Oakland—Kahn's, Broad—16th—San Pablo
Los Angeles—A. Hamburger & Sons, Inc., Broadway, 8th & Hill Sts.
Pasadena—Pasadena Grocery & Dept. Store, 141-5 E. Colorado St.

San Diego—Holzwasser, Inc., Broadway at Sixth
San Francisco—The Whitehouse, Sutter, Grant Ave. & Post Sts.
San José—Winch & Marshall, 80 So. First St.
Santa Barbara—J. A. Walton Co., 819 State St.
Stockton—Tredway Bros., 516 E. Main St.

Colorado
Colorado Springs—Hardy's
Pueblo—Pueblo Store Co.
Connecticut
Bridgeport—Chamberlin & Shropshire
Hartford—Sage, Allen & Co., Inc., 890 Main St.
New Britain—Dickinson Book Store, 169-171 Main St.

New Haven—The Henry A. Beebe Co., 193 Church St.
Norwich—The Porteous & Mitchell Co.
Waterbury—Davis & Nye, 114 Bank Street

Delaware
Wilmington—E. S. R. Butler & Son, 421 Market St.
District of Columbia
Washington—S. Kann Sons & Co., 8th St. & Penn'a Ave.

Florida
Jacksonville—The H. & W. B. Drew Co.
Georgia
Atlanta—Cole Book Co., 85 Whitehall St.
Augusta—J. B. White & Co.
Macon—Wood-Peavy Furniture Co.
Savannah—Leopold Adler, Dept. Store

Idaho
Boise—Golden Rule Store
Illinois
Aurora—M. C. Sawyer, Fox & Water Sts.
Bloomington—W. B. Read & Co.
Chicago—The Fair, State, Adams & Dearborn Sts.
Danville—Woodbury Book Co., 125-7 N. Vermilion St.

Indiana
Anderson—The Fair Department Store
Evansville—The Party Shop, 311 N. Second St.
Gary—"Tribe of K," Inc., 676 Broadway
Hammond—Summers Pharmacy, Hohman St., near State
Indianapolis—The Kautz Stationery Co., 116 N. Pennsylvania St.
Muncie—W. A. McNaughton Co.
Richmond—Nicholson Bros., Book Shop, 729 Main St.
South Bend—The Herr & Herr Co., 111 W. Washington Ave.
Terre Haute—A. Herz

Iowa
Burlington—John Boesch Co.
Clinton—John D. Van Allen & Son, Inc., 5th Ave. & 2nd St.
Council Bluffs—Joe Smith & Co.
Davenport—E. M. White, 405 Brady St.
Des Moines—Yunker Bros., Inc.
Marshalltown—McBride & Will Drug Co., Corner Main & Center Sts.
Ottumwa—Parks Drug Store, Corner Main & Court Sts.
Waterloo—Warwick's Book Store, 208 East 4th St.

Kentucky
Covington—The John R. Coppin Co., Madison & 7th Avenues
Louisville—W. K. Stewart Co., Inc., 425 S. 4th St.
Paducah—Wilson's Book Store, 306 Broadway

Louisiana
New Orleans—M a l i s o n Blanche Co., Canal & Dauphine Sts.

Decatur—Linn & Scruggs Dry Goods & Carpet Co.
Elgin—Kennell Bros., 160 Chicago St.

Evanston—Rosenberg's
Galesburg—Temple & Carroll, 136 E. Main St.
Jacksonville—Lane's Book Store, West State St.
Joliet—Joliet Book & Stationery Co., 206 N. Chicago St.

Kankakee—Kankakee Book Store
Moline—Carlson Brothers, 417 15th St.
Peoria—Jacquin & Co., 321 Main Street
Quincy—Halbach-Schroeder Co.

Rockford—Ashton Dry Goods Co.
Rock Island—The Stationery Shop, 118 Eighteenth St.
Springfield—Coe Brothers Book Store, 5th & Monroe St.

Indiana
Anderson—The Fair Department Store
Evansville—The Party Shop, 311 N. Second St.
Gary—"Tribe of K," Inc., 676 Broadway
Hammond—Summers Pharmacy, Hohman St., near State
Indianapolis—The Kautz Stationery Co., 116 N. Pennsylvania St.
Muncie—W. A. McNaughton Co.

Richmond—Nicholson Bros., Book Shop, 729 Main St.
South Bend—The Herr & Herr Co., 111 W. Washington Ave.
Terre Haute—A. Herz

Iowa
Burlington—John Boesch Co.
Clinton—John D. Van Allen & Son, Inc., 5th Ave. & 2nd St.
Council Bluffs—Joe Smith & Co.
Davenport—E. M. White, 405 Brady St.
Des Moines—Yunker Bros., Inc.
Marshalltown—McBride & Will Drug Co., Corner Main & Center Sts.
Ottumwa—Parks Drug Store, Corner Main & Court Sts.
Waterloo—Warwick's Book Store, 208 East 4th St.

Kentucky
Covington—The John R. Coppin Co., Madison & 7th Avenues
Louisville—W. K. Stewart Co., Inc., 425 S. 4th St.
Paducah—Wilson's Book Store, 306 Broadway

Louisiana
New Orleans—M a l i s o n Blanche Co., Canal & Dauphine Sts.

Maine
Augusta—J. Frank Pierce Store
Bangor, F. C. Cunningham, 126 Main St.
Lewiston—B. Peck Co.
Portland—Loring, Short & Harmon, 474 Congress St.

Maryland
Baltimore—The Norman, Remington Co., 308 N. Charles St.
Cumberland—White & Ankeney, 16 No. Centre St.

Massachusetts
Attleboro—Allen's Book & Stationery Store, 65 Park St.
Boston—W. B. Clarke Co., 26-28 Tremont St.
Brookton—James Edgar Co.
Fall River—R. A. McWhirr Co., 165-193 S. Main St.
Fitchburg—The Morris Store, 15 Blossom St.
Haverhill—S i m o n s & Adams, 42-54 Merrimack St.

Holyoke—The Fitzgerald Book & Art Co., 196 High St.
Lowell—G. C. Prince & Son, Inc., 106-8 Merrimack St.
Lynn—The R. S. Bauer Co., 33 & 35 Central Square
New Bedford—The Star Store
Newburyport—The Boston Marché, Pleasant St.
North Adams—The Boston Store
Northampton—A. McCallum & Co.
Pittsfield—T. Cooney, Jr., Miller Bldg.
Somerville—Gordon's Department Store, Union Sq.
Springfield—Meekins, Packard & Wheat, Inc.
Taunton—Peck-Leach Furniture Co., 37 Main St.
Westfield—Joseph F. Geehern, Main St.
Worcester—Denholm & McKay Co.

Michigan
Adrian—Swift's Book Shop, 24 Maumee St., East
Alpena—C. R. Hawley
Bay City—Wilton & Mack, 208 Center Ave.
Battle Creek—E. C. Fisher & Co., 12-14 Main St., West
Detroit—John V. Sheehan & Co., 260-262 Woodward Ave.
Flint—M. E. Carlton & Co., 510 So. Saginaw St.
Grand Rapids—E. Higgins Co., 138 Monroe Ave.
Jackson—Hyndman & Way, Main & Mechanic Sts.
Lansing—Dancer-Brogan's
Muskegon—Brundage Drug Co., 34 W. Western Ave.
Port Huron—The David MacTaggart Co., 935 Military St.
Saginaw—J. E. Anderson, 119 S. Jefferson Ave.

Minnesota
Duluth—Boyce Drug Store, 331 W. Superior St.
Minneapolis—Edwin R. Williams Stationery Co., 415 Hennepin Ave.
St. Paul—St. Paul Book Exchange, 9 E. Sixth St.

Missouri
St. Louis—Buxton & Skinner Ptg. & Stat'y Co., 306-8 N. 4th St.

Montana
Billings—McDowell Co., 112 North Broadway
Butte—Post Office News Stand, 25 W. Park St.
Helena—The New York Store
Missoula—The Office Supply Co.

Nebraska
Lincoln—Miller & Paine
Omaha—J. L. Brandeis

Nevada
Reno—Mott Stationery Co., 133 Virginia St.

New Hampshire
Manchester—Goodman's Book Store, 25 Hanover St.

New Jersey
Atlantic City—R. T. Chapman, 1404-1406 Atlantic Ave.
Bayonne—Berkowitz Bros., Broadway & 20th St.
Camden—Bleakly Bros., 532-4 Federal Street
Elizabeth—Goerke - Kirch Co., Broad & West Jersey Sts.
Hoboken—The Lining Store, 412-414 Washington St.
Jersey City—Perlmutter, 175 Newark Ave.
Newark—P. F. Mulligan, Inc., 927 Broad St.
New Brunswick—W. R. Reed, 380 George St.
Passaic—Stemmerman Co. Main and Jefferson
Paterson—Quackenbush & Co.
Perth Amboy—Albert Leon, Corner Smith & State Sts.
Trenton—Clayton L. Traver, 108 S. Broad St.

New York
Albany—John Skinner's Book Store, 44 N. Pearl St.
Amsterdam—Seely Conover Co.
Auburn—Irving S. Colwell, 99 Genesee St.
Binghamton—Hills, McLean & Haskins, Court & Chango Sts.
Buffalo—The Wm. Hengerer Co., 457-471 Main St.
Corning—L. T. Goodridge, 18 E. Market St.
Elmira—MacGreevy-Sleight-DeGraff Co., 315 E. Water St.
Ithaca—The Corner Book Stores, Taylor & Co.
Jamestown—Frank Marvin Clark
Lockport—A. J. Laux Co., 45 Pine St.
Middletown—The Book Shop, 55 North Street

For those who cannot go to one of these stores

your city, listed below, and examine a set. Then when you **KNOW** that the Britannica will be useful to you **ORDER AT ONCE.**

Newburgh—George W. Green, 65-67 Water St.
New York—Gimbel Brothers, 22nd St., Broadway, 33rd St.
Charles Scribner's Sons, 597 Fifth Avenue
Henry Malkan, 42 Broadway

Niagara Falls—Niagara Dry Goods Co., Inc., 114-120 Falls St.

Ogdensburg—Nathan Frank's Sons Dept. Store
Olean—The Cramer Lynch Co.

Plattsburgh—A. Sharron, 98-102 Margaret St.

Poughkeepsie—Lucky, Platt & Co.

Rochester—Scrantom, Wetmore & Co., 21-23 State St.

Saratoga Springs—Robson & Adee
Schenectady—The Wallace Company

Troy—G. V. S. Quackenbush & Co.

Utica—Grant's Book Shop, 127-9 Genesee St.

Watertown—Sterling's Book Shop, 111-113 Washington St.

Yonkers—Biber Bros., Inc., 46 Warburton Ave.

North Carolina

Charlotte—Brockman & Co., 224 So. Tryon St.

Raleigh—James E. Thiem, 125 Fayetteville St.

Wilmington—C. W. Yates Co.

Ohio

Alliance—Valentine's Book & Wall Paper Store, 420 E. Main St.

Ashtabula—Cook's Drug & Book Store

Cambridge—The Potter-Davis Co.

Canton—The News Exchange, 223 Tuscarawas St., West

Cincinnati—Stewart & Kidd Co., 121 E. Fifth St.

Cleveland—Book and Art Exchange, Taylor Arcade

Columbus—Green - Joyce, Corner Chestnut & High Sts.

Dayton—Rike-Kumler Co., N. W. corner Main & Second Sts.

East Liverpool—The Sloan-Buchan Co., 519-23 Washington St.

Elyria—Central Book Store
Hamilton—The Forbes & Todd Co., 217 High St.
Lima—The Deisel Co.
Lorain—Eldred & Co., 534 Broadway
Middletown—Johnson Drug Co., 109 Third St.
Newark—The A. L. Norton Co., 26 Arcade
Portsmouth—The Anderson Bros. Co.

Sandusky—The Herb & Myers Co.

Steubenville—The Hub
Toledo—Newcomer's Drug Store, 319 Summit

Oklahoma

Enid—E. H. Naylor
Guthrie—Rucker-Burton Dry Goods Co.

McAlester—McAlester Book & Stationery Co., 110 E. Choctaw Ave.

Tulsa—Vandever Dry Goods Co., 109-111 S. Main St.

Oregon

Portland—The J. K. Gill Co., Third & Alder Sta.

Salem—H. W. & M. L. Meyers

Pennsylvania

Allentown—H. Leh & Co.
Altoona—Bartle's Stationery Store, 1327 11th Ave.

Bradford—Barney Garbarsky
Butler—Eyth's Book Store, 103 So. Main St.

Chester—Spencer Stationery Co., 523 Market St.

Connellsville—Penn Office Supply Co., 113 W. Crawford Ave.

Erie—Trask, Prescott & Richardson Co., State at 9th St.

Greensburg—A. E. Troutman Co.

Harrisburg—Dives, Pomesoy & Stewart

Lancaster—The Donovan Company
McKeesport—J. D. O'Neil Co.

New Castle—New Castle Dry Goods Co.

Norristown—Warner's Dept. Store

Oil City—W. K. George, 224 Seneca Street

Philadelphia—Gimbel Brothers, 9th & Market Sts.

Pittsburgh—Joseph Horne Co., Penn & 5th Ave.

Pottstown—Chas. J. Custer, 206 High St.

Scranton—Hagen & Wagner Co., 205-7 Washington Ave.

Shamokin—Bee Hive Dept. Store

West Chester—Fath's, 22 No. High St.

Williamsport—Horace Y. Otto, Market Square Book Store

York—Barnhart's Book Store, 35 W. Market St.

Rhode Island

Newport—Carr's, Daily News Bldg.

Pawtucket—A. A. Lupien, 24 Broad St.

Providence—The Boston Store, 239 Westminster St.

Woonsocket—Harris & Mowry's

South Carolina

Charleston—Louis Cohen & Co.

Columbia—The State Book Store, State Bldg.

South Dakota

Aberdeen—The Salisbury Book Store, Cor. Main St. & 3rd Ave.

Sioux Falls—The Cataract Book & Stationery Co.

Tennessee

Memphis—Bry-Block Mercantile Co., Main St. & Jefferson Ave.

Nashville—Presbyterian Book Store, 415 Church St.

Texas

Austin—Jno. E. Keller, 716 Congress Ave.

Beaumont—E. Szafr & Son Co.

Dallas—Hargreaves Printing Co., 1012 Elm St.

El Paso—Popular Dry Goods Co., Inc.

Fort Worth—The Fair
Galveston—Ohlendorf's Book Store, 2015 Market St.

Houston—Teolin Pilot Co., 409 Main St.

Waco—Goldstein-Migel Co.

Utah

Ogden—Bramwell Book & Stationery Store, 2362 Washington Ave.

Salt Lake City—Sunday School Union Book Store, 44 East on South Temple

Vermont

Burlington—The W. G. Reynolds Co.

Rutland—The Tuttle Co., 11 & 13 Center St.

Virginia

Lynchburg—J. P. Bell Co., Inc., 816 Main St.

Norfolk—William Freeman, 304 Main St.

Petersburg—T. S. Beckwith & Co.

Washington

Aberdeen—Benson Office Supply Co., Wishkah & H Street

Bellingham—E. T. Mathes Book Co., 110 W. Holly St.

Everett—The Grand Leader Dry Goods Co.

Seattle—Lowman & Hanford Co., First Ave. & Cherry St.

Spokane—Kemp & Hebert
Tacoma—Cole-Martin Co., 926 Pacific Ave.

Walla Walla—The Book Nook

West Virginia

Charleston—The S. Spencer Moore Co., 118 Capital St.

Huntington—Zenner - Bradshaw Co.

Wheeling—Stone & Thomas

Wisconsin

Beloit—Cleveland's, On the Bridge

Eau Claire—Eau Claire Book & Stationery Co.

Fond du Lac—J. W. Burnton Book Store

Green Bay—Eckhart Bros., 223 N. Washington St.

Janerville—Jas. Sutherland & Sons, 12 S. Main St.

Kenosha—C. H. Ernst & Co., 271 Main St.

Madison—University Co-operative Co., 504-508 State St.

Marinette—Krueger's Drug Store, 1904 Hall Ave.

Milwaukee—Gimbel Brothers, Grand Ave., S. E. corner W. Water St.

Oshkosh—Hurn's Book Store, 147 Main Street

Racine—S. H. White, 504 Monument Square

Wausau—Winkelman's Dept. Store



Canada

Brantford, Ont.—E. B. Crompton & Co., Ltd.

Calgary, Alta.—Young & Kennedy, Ltd., 715 First St., West

Edmonton, Alta.—A. H. Esch & Co., Ltd., Jasper Ave. at 104th St.

Fort William, Ont.—Walker's 417-419 Victoria Ave.

Halifax, N. S.—Nova Scotia Furnishing Co., Ltd., 72-76 Barrington St.

Hamilton, Ont.—Robert Duncan & Co., James St. & Market Square

Kingston, Ont.—The College Book Store, 160-162 Princess St.

Lethbridge, Alta.—The Red Cross Drug & Book Co., Ltd.

London, Ont.—Hay's Stationery Store, 173 Dundas St.

Montreal, Que.—Goodwin's, Ltd.

Moose Jaw, Sask.—Robinson, McBean, Ltd.

New Westminster, B. C.—New Westminster & Fraser Valley Dept. Store

Ottawa, Ont.—James Hope & Sons, Ltd., 61-63 Sparks St.

Peterboro, Ont.—Trebilcock Bros., 417 George St.

Quebec, Que.—John E. Walsh, Reg'd, 11 St. John St.

St. Catharines, Ont.—McLaren & Co., Ltd.

Saskatoon, Sask.—J. F. Cairns

Sherbrooke, Que.—Ansell's Drug Store

Sydney, N. S.—Crowell's, Ltd.

Toronto—McAlinsh & Co., Ltd., 4 to 12 College St.

Vancouver, B. C.—O. B. Allan, Corner Granville & Pender Sts.

we print a "Reserve" Order Form on next page.

Also see three
preceding
pages

Final!

This
Announces
The END
of the sale of the
Encyclopaedia Britannica
printed on genuine India paper

If the publishers could get any more India paper, we could sell two or three hundred thousand more sets. **BUT** no more genuine India paper can be had because two important raw materials, flax from Belgium, Germany or Ireland, and hemp from Russia are unobtainable. Our stock of "Handy Volume" sets of the Britannica is so nearly exhausted, and we have received so many thousands of requests for full information about this work, that if you are considering ordering you must decide at once.

We want you to make sure before ordering that you will find the Britannica useful to you. Therefore, go to the store in your town listed on the two preceding pages, and decide **TO-DAY**.

*Those who cannot go to one of these stores may use this
"Reserve" Order Form*

Sears, Roebuck and Co.
Chicago, Ill.

Please reserve me a set of the "Handy Volume" Encyclopaedia Britannica, printed on genuine India paper. I enclose \$1.00 as first payment. Send me an order form which I agree to sign and return immediately.

Name _____ BH-18

Street and Number _____

City _____

P. O. Address _____

CLASSIFIED ADVERTISEMENTS

WORLD'S BEST WANT AD MEDIUM

We have records to prove that a classified ad in these columns will find a buyer for almost anything which can be sold. Doubtless you have some article of value to some one else which you no longer need. Why not turn it into money?

Advertisements in this section, 18 cents per word, each insertion, minimum 10 words, payable in advance. To insure ads being inserted under proper classified head in the June issue, copy must reach this office not later than April 30th.

Popular Mechanics Magazine, Chicago, Illinois.

Gentlemen: I am very much pleased to inform you that I have sold my motorcycle by means of a ten-word "ad" inserted in November number. I would also say that I received the asking price. Would also state that I received an inquiry yesterday from a prospective buyer five months after inserting the ad. I shall be pleased to recommend your columns to my friends.

ARTHUR J. LYONS,

Brookline, Mass.

AUTOMOBILES

USED Cars—All Makes are costly at any price when you can own a 1917 Buick Touring Car without a cent of cost by spending an hour each day for a few weeks, representing us among your friends, neighbors and acquaintances. No Experience or Bond Required. Anyone can do the little work required. Obeera Pettit, 11-year-old, of Iowa, earned an auto under our plan. E. C. Gullett, 17-year-old farmer boy, of Mississippi, earned touring car in 16 days. We can give you names and addresses of dozens of others who have done likewise. Write for free information. Auto Tom, 547 South 17th St., Omaha, Neb.

WANTED—Chassis less motor. Prefer wire wheels, fullfloating axles. P. O. Box 348, Anderson, Ind.

GARAGE business taught by mail. A fascinating and profitable business for energetic young men. Garage men invariably become accessory and automobile dealers. Send \$5.00 for personal letter course. E. Ray Kraitz, Detroit, Mich.

PAINT Your Own Car with Automamel; you can do the work as perfectly as a skilled workman with common paint. Automamel is not a paint. It is a new chemical discovery. It lays a smooth and lustrous with one coat as a shop-painted car with several coats. \$3 outfit paints car. Booklet "B" explains all. Write for it. Automamel Company, Rochester, N. Y.

AUTOMOBILE Questions and Answers—A self-educator on automobiles without an equal. Covers over 2900 questions and their answers relating to the modern automobile. 650 pages, 350 illustrations. Cloth, \$1.50 postpaid. Complete description on request. Popular Mechanics Book Dept., 6 N. Michigan Ave., Chicago.

CYLINDERS reground, new pistons and rings fitted. Restores lost power. Write for prices, giving make and model. The Everts Machine Co., Hartford, Conn.

PATENTS for Automobile Improvements are in great demand. We have special Automobile Department in charge of experts who are in touch with demands of trade. Write for "What To Invent and List of Patent Buyers," sent free. Victor J. Evans & Co., 155 Ninth, Washington, D. C.

AUTOMOBILE Repairs—Automobile owners, Garages, and Repairmen should subscribe for the Automobile Dealer and Repairer; 150-page illustrated monthly devoted exclusively to the care and repair of the car. The only magazine in the world devoted to the practical side of motoring. The "Trouble Department" contains five pages of numbered questions each month from car owners and repairmen which are answered by experts on gasoline engine repairs. \$1 per year; 15c per copy. Canadian subscription, \$1.50. Postals not answered. Charles D. Sherman, 59 Windsor Road, Hartford, Conn.

THE Modern Gasoline Automobile—Most complete and up to the minute automobile book published. Recognized as the standard book on construction, operation, maintenance and repair, showing every recent improvement. Over 700 pages, 300 illustrations. Cloth. Price \$2.50 postpaid. Send for complete description of this and other reliable automobile books. Popular Mechanics Book Dept., 6 N. Michigan Ave., Chicago.

AUTO SUPPLIES

CAR Owners—Use "Renewal" liquid wax. Removes dirt, stains, dullness and small scratches, sheds rain; greaseless, no dust collector. Cheaper and easier to apply than bulk wax. Shipped prepaid within 1,000 miles of Chicago. Trial bottle (15c coin). Koertge Mfg. Co., Belvidere, Ill.

AUTOMOBILE Parts for Maxwells, Buick, Overland, Oakland, Chalmers, Cadillac, Everett, Emf, Interstate, Reh, Franklin, Reo, Mitchell, Jackson, Peerless, Thomas, Stevens, St. Daxton, Great Smith, Locomobile, Premier, Velle, Hupmobile, Parry, Brush. Kent Auto-Parts, Denver, Colo.

500 SALESMEN Wanted. Sell Magic Motor Gas. \$10 per day. One quart, price \$2, equals 50 gallons gasoline in mileage. Write today for territory. Auto Remedy Co., 4 Evans St., Cincinnati.

WANTED—Ford engine not later than 1912. Cheap for cash. Adams, 2823 Ave. D, Brooklyn, New York.

BATTERY Chargers earn big profits. Engine or city current operates. \$10.00 places moneymaker in your garage, balance easy terms. Hobarts, Box MC, Troy, Ohio.

DOUBLE Service Tires. Guaranteed 3,500 miles. Sizes 30x3 \$5.00, 30x3½ \$6.00, 33x4 \$8.00, 34x4 \$9.00, 36x4 \$9.00, 36x4½ \$10.00, 36x5 \$11.00, 37x5 \$11.00. Non-skid \$1.00 extra. 10% required on C. O. D. orders. State if Q. D. straight bead or clincher type. Special discount to dealers. J. Jaffess, 1319 H. Fifth Ave., Branch, 241 W. 54th St., New York.

AUTO Top Roof Covers Save you two-thirds price of new top; tailored to fit any car; easy to apply; \$6 to \$15, parcel post paid; seat covers \$5 and up; catalog and samples free. N. & H. Top Co., 430 Hunt St., Cincinnati, O.

TIRES—Double Tread Guaranteed for good service. Absolutely Puncture-Proof. Big—Strong—Extra heavy 30x3 tire, \$5.00; 30x3½, \$6.00; 33x4, \$9.00; 34x4, \$9.25; 36x4½, \$12.00; 37x5, \$13.00. Big saving on other sizes and tubes also. Trade in your old tires. Discount to dealers. 10% deposit required on C. O. D. orders. Send for list now! State size and bead of tire. Max Liben & Co., 295B West 48th Street, New York.

SAVE 50% to 70% on your next tire purchase. Our tires are practically blow-out and puncture-proof. Guaranteed for 3,500 miles. Send for illustrated catalog No. 4 and Price List. Tuxedo Auto Tire Exchange, 306 W. 54th St., New York City.

MODEL 39 Buick Eng. \$125. Studebaker 25 \$85. Ford Motor \$90. Continental 30 \$75. R. C. H. \$75. Parts for 100 old model autos. No catalogue. Auto Salvage Co., 1436 Wabash Ave., Chicago, Ill.

GET into biggest money-making end automobile business—replacing necessary equipment. Live, hustling, ambitious men wanted as special factory representatives, exclusive territory, taking orders for tops, top coverings, seat covers, patent "Silk-Tite" Windows. No experience necessary. No capital required. No competition. Copyrighted system protects you. Free catalogue, samples, full details. Cincinnati Auto Specialty Co., Dept. MAS-47, Cincinnati, Ohio.

FEW Cans Gaso-tonic. Removes carbon. Makes Gasoline last. Cheap. Cornelius Campbell, 4201 Carnegie Ave., Cleveland, Ohio.

AUTO Engines: 4-cylinder-water-cooled \$25. Buick 10-17 and 21. Meta, Continental. Buda-Mitchell, Cadillac, all sizes—low prices. Johnston, West End, Pittsburgh, Pa.

MAGNETOS—Bosch K4, \$10; D4, \$15. D4, \$20. Remo, \$3.50. Splittdorf, \$5.00. Coils \$3.00, all makes and sizes. Presto tanks \$5.00. Head lamps, steering wheels, windshields. Other parts—low price. Johnston, West End, Pittsburgh, Pa.

MODEL 39 Buick Eng. \$125. Studebaker 25 \$85. Flanders 20 \$60. Adams 30 \$75. R. C. H. \$75. Parts for 100 old model autos. No catalogue. Auto Salvage Co., 1436 Wabash Ave., Chicago, Ill.

AUTOMATIC Gear Cutting. We cut steel ring gears, for fly-wheel starters, for Maxwells, Chevrolet, Overland, Oldsmobile, Ford, Regal, Auburn, Mitchell, Paige, Interstate, Monroe, also transmission and axle gears. Kent Auto Parts, Denver, Colo.

MANUFACTURER desires state and local agents. Fast selling auto necessity. Schulz Mfg. Co., 1195 Fort Dearborn Bldg., Chicago.

EXPLOSION Whistle—Fits priming cup. First whistle adopted as standard equipment on any automobile. See display ad, Page 161. Busli Co., 1610 Michigan Ave., Chicago.

GASOLINE 16 cents a gallon. Reduce your fuel cost to this figure by using Moto-Pep, the guaranteed motor-fuel intensifier and carbon remover. It makes a high-grade fuel out of low-grade gasoline, and you get from three to five miles on every gallon you use. More power. Makes new engines out of old. Money back if not satisfied. Enough for 125 gallons of gasoline \$1, or special 50-gallon trial size, 25 cents. silver. The Moto-Pep Mfg. Co., Dept. G, Youngstown, O.

MAGNETOS, High and Low Tension, Bosch, Connecticut, Remo, Splittdorf, etc., \$5.00 and up. Jump Spark Coils \$1.50 and up. E. Q. Williams, 537 So. Clinton St., Syracuse, N. Y.

AUTOMOBILE Parts for most all makes of cars: Buicks, 10, 17, 19, 27, 29, and 35; Maxwells, E.M.F., Flanders, Paige 25 and 30; Overlands, 37, 38, 42 and 59; Cadillacs '09 to 1912. Parry, Regals, '09 to 1913; Oakland, Jeffery, Mitchells, 1907 to 1913; Empire, Elmore, Chalmers, '09 to 1913; Auburn, Jackson 35, Interstate 30, Hudson 20 and 33, Hup 20, Ohio, Staver, Marlon, Halladay, Velle and many others. Pistons, connecting rods, Cam shafts, Crank Shafts, Cylinders, Axles, Bearings and gears for most any make of car. Write us your needs. Satisfaction guaranteed. Auto Parts Company, 4118-18 Olive St., St. Louis, Mo.

GEARS for all purposes; transmission gears, bevel-drive gears, sprockets, axles. Special machine work. Must have old parts or drawing. Turley Gear Plant, 1505 N. 10th St., St. Louis, Mo.

POWER increased; carbon eliminated; results guaranteed. Write for folder. Automobile Accessories Co., (G.) Baltimore, Md.

INSYDE Tires, inner armor for Automobile tires, double mileage and prevent punctures and blowouts. Quickly applied. Cost little. Demand tremendous. Profits unlimited. Details free. American Automobile Accessories Co., Dept. P2, Cincinnati, O.

23% PROFIT selling Jubilee Spark Intensifiers to automobile owners, garages. Sure cure for Spark Plug troubles. Sells like wildfire. Brand new. Exclusive territory. Write today. Jubilee Mfg. Co., Dept. N-3, Omaha, Nebraska.

YOU CAN DO THIS



AFTER HOME STUDY

\$36⁰⁰ TO \$100⁰⁰ A WEEK

You can earn \$36 to \$100 a week and more as an Expert Electrician. If you have a common school education I can train you in a few months at home. Big lighting and power companies, municipalities, and manufacturers are always seeking trained men to handle their Electrical problems.

I Guarantee Satisfaction

Every student receives our Sealed Guarantee Bond, which guarantees to return every penny of his money if he is not entirely satisfied. No other school has made this wonderful offer, but I know the success I have brought to hundreds of my students, and I know what I can do for any ambitious young man who will give me a little of his spare time each day.

FREE ELECTRICAL OUTFIT

For the next 30 days I am giving each student an Outfit of Electrical Testing Instruments, Tools, Electrical materials, and Motor absolutely Free. My instruction is by practical methods and this outfit is used in working out the lessons. Practical training with the theory makes perfect. I am Chief Engineer of the Chicago Engineering Works, and I can give you the training that will land the big jobs and hold them.

If you are in real earnest I want to send you my new Book—"How to Become an Electrical Expert." It's free. No matter how many other schools you write to I want you to have my book—It's different because it's practical—Write today.

CHIEF ENGINEER COOKE
CHICAGO ENGINEERING WORKS
 Dept. 22, 439 Cass Street, CHICAGO, ILL.

Dept.
22
**CHIEF
 ENGINEER**
 Chicago Engineering Works
 439 Cass St.
 Chicago, Illinois

Without obligation on my part kindly send at once, fully prepaid, particulars of your complete Practical Home Study Course in Electricity.

USE THIS FREE "OUTFIT" COUPON

Name

Address

Town State

VULCANIZE your own tires; save money; full particulars free. Superior Vulcanizer Co., 16B Fulton Ave., Rochester, N. Y.

"GIDZ," a fuel for increasing the efficiency of Gasoline Engines. Registered. United States Patent Office, April, 1915. Endorsed by owners of automobiles, aeroplanes, motorcycles, tractors, lighting systems. One Dollar Can convinces. Dealers wanted. Quick repeat. "Gidz," Galesburg, Illinois.

WISE Motorists Specify Davoline trouble-proof bushings for repairing bearings; outlast bronze. Order any size direct. Davoren Mfg. Co., Denver, Colo.

AUTO OWNERS! Agents! New Gasoline and Oil Pump—Screws into Barrel Bung—Forces through hose. Write Gaspump Co., Johnstown, Ohio.

STOP! Does your motor sputter or knock? Mail dollar bill to Motor Trouble Finders, Incorporated, Haverhill, Mass., for an instrument that will tell you why and how to stop it, warranted to do the business of money back.

UNUSUAL Bargains in Automobile Repair Parts. Axles, Bearings, Carburetors, Complete Engines, Cylinders, Differentials, Magnets, Pistons, Radiators, Springs, Valves, Wheels and other parts for Buick, Cadillac, Chalmers, Interstate, Maxwell, Mitchell, Moon, Overland, Packard, Peerless, Regal, Studebaker, Thomas and other cars at a fraction of factory cost. Maxwell Bros., 3931 Olive Street, St. Louis, Mo.

VULCANIZER for shop. Bargain. Vanderpool's, Springfield, Ohio.

REPAINT your car at home with a Presto Auto Paint Kit. Details free. American Accessories Co., Dept. P-3, Cincinnati.

BUCKET seats for racing cars. Prices low. American Accessories Co., Dept. P-4, Cincinnati.

STORAGE Batteries Simplified—A complete new treatise on action—maintenance—repair—use. Describes fully the Exide, Edison, Gould, Willard, U. S. L. and other forms. Only complete and up-to-date book on subject. 320 pages, fully illustrated. \$1.50 postpaid. Complete description sent upon request. Popular Mechanics Book Dept., 6 N. Michigan Ave., Chicago.

TO FORD OWNERS

DON'T over feed your motor! The Aero-gram will reduce gasoline consumption and increase its efficiency. Only costs a dollar, and it's guaranteed. If your dealer can't supply you, send a dollar by mail and we will send you one immediately. Aero-gram Company, 105 Mass. Ave., Boston, Mass.

"STEER Belief" corrects faulty steering in Fords. Gives safety and better service. Sample \$3.50. Pays agents, Chas. B. Post, New London, Ohio.

CLASSIEST, staggered seating, speedster body, \$40.00. Drawings fifteen cents. Skelton, Auburn, Mich.

FORD Top Roof Cover \$6 and up. Easy to apply. You save two-thirds price of new top. Seat covers \$5 and up. Samples and catalog free. S. & H. Top Co., 429 Hunt St., Cincinnati, O.

RECTIFIER. Make it yourself. Charge batteries with Ford magneto. Money-making Secret yours for \$1.00. L. B. 179, Belmont, S. D.

SLEEP in your Ford in McMillin Auto Bed, \$8.50. Other small cars \$10. Free booklet on auto camping. Auto Bed Company, Box O, Bellingham, Wash.

\$1.50 LITTLE Wonder Ford gas saver. Approximately 30 miles on gallon; applied one minute. Vanderpool's, 1044 South Main, Los Angeles, Calif.

SLEEP in your car in McMillin Auto Bed, \$8.50. Free booklet on auto camping. Auto Bed Company, Bellingham, Wash., Box O.

PEUGEOT Type Ford speedster, blue prints, instruction. Patterns \$2.00. Send 10c for photograph. Will Wand, Onarga, Ill.

\$29 FORD Starters. Standard makes guaranteed by manufacturers. Write at once for particulars. Geo. M. Studebaker, Jr., South Bend, Ind.

BE our agent. Buy a Safety Ford Starter for \$5.00. Retail for \$15.00. Try one, write for particulars. Safety Ford Starter Corporation, Columbia Theatre Bldg., New York.

YOU can get the best Starter ever made for a Ford car, regardless of price, for \$5.00, from Symons Brothers Co., 2611 E. Railroad Ave., Evanston, Ill.

FORD ACCESSORIES

DON'T Crank—Don't Pull. The "Peoria Mechanical Ford Starter" is practical, guaranteed to turn motor with every push of foot lever. Back-fire absolutely harmless. Write for particulars and territory. The United Co., Peoria, Illinois.

FOR Sale: Ford Model N. R. S. used parts, cheap. Will Wand, Onarga, Ill.

MOTORCYCLES, BICYCLES & SUPPLIES

FOR Sale—1 1913 Flying Merkel Motorcycle, run less than 1,200 miles, as good as new. \$100. 1 1915 Flying Merkel, run less than 500 miles, bargain, \$135. Will ship on a \$25 deposit, balance C.O.D. C. O. Barron, Lebanon, N. H.

TWO Speed Yale, 1914. Fully equipped. Three speed Indian, 1915, equipped, and side car like new. Price \$185 each. Wm. Wright, 211 Charlott Street, Lynchburg, Virginia.

DON'T buy a Bicycle Motor Attachment until you get our catalogue and prices. Shaw Mfg. Co. Dept. 27, Galesburg, Kans.

1914 **TWIN** Merkel. Just overhauled. Guaranteed, \$75. 1492 W. Cumberland, Philadelphia, Pa.

100 MOTORCYCLES, \$35-250. Automobiles \$150-450. Knights, 3323 Locust, St. Louis, Mo.

FOR Sale—Indian twin, two speed, all equipment, nearly new. Cheap if sold quick. Walter Johnson, Las Cruces, N. M.

A REAL bargain in second-hand motorcycles. He has an overstock of all makes, such as Indians, Harley-Davidsons, Excelsors, Pejos, Merckles, and 4-cylinder Hendersons. All are in A-1 condition and fully equipped. If interested in buying a motorcycle write for our Bargain Bulletin No. 5 giving description and prices from \$35 up. Gotham Sporting Goods Co., 57 Warren St., New York City.

I SAVE you half on parts and accessories for all makes. Jones, "The Parts Man," Box 691, Brockton, Mass.

FOR Sale—Giant 1915 Twin Thor, equipped. Condition guaranteed excellent. New tires. Big value—\$150. Brady, 4746 Princeton Ave., Chicago, Ill.

HARLEY-DAVIDSON, 1916; snappy; perfect running; big bargain; \$140. Maurice Schwartz, Winder, Detroit, Mich.

100 USED motorcycles at your own price. Indians, \$65. Excelsors, \$30. Harley-Davidsons, \$35, and other makes. Send for list. Motors all makes, \$15, \$25, \$50. We lead them all for motorcycle parts. We have anything and everything for new and old machines. "The Price Wrecker," 1-day service on parts. A. Weitzman Cycle Co., 175 Gratiot Ave., Detroit, Mich.

1917 EAGLE Motorcycle now ready. Get Circular M3, and agency proposition. Eagle Motorcycle Company, Brockton, Mass.

MOTORCYCLE Bargains! Prices 25% lower than any house quotes. Lake Excelsior twin, magneto, \$69; Dandy Indian, 4 hp., \$45; Big valve Excelsior twin, \$145; 2-speed Thor twin, \$120; Harley twin, \$85. Big list free. All guaranteed. Write today. Western Supplies Company, 156 Harutin Bldg., Denver, Colo.

MOTORCYCLES! New 1917 Eight Horsepower Twin, \$125.00. Yale Four Horsepower, \$10.00. Flying Merkel Twin, \$45.00. Indian Twin, \$45.00. Excelsior Demonstrator, like new, \$55.00. Motorcycle Casings \$5.50, tubes \$1.50. Write for Bargain Sheet with cuts. Money refunded if unsatisfactory. Three Big Stores, W. E. Wandersee Co., 129 Gratiot Ave., Detroit, Mich. Branches: 1561-1563 and 2996 Woodward Avenue, Detroit, Mich.

WANTED—Motorcycle engines, 2 and 4 cylinder Henderson preferred, Johnston, West End, Pittsburgh, Pa.

BARGAIN—Brand New Dayton Motor Bicycle with clutch. Never Used, \$25 cash. Also Remington pump gun and typewriter cheap. E. R. Frost, East Chicago, Indiana.

1915 THREE-SPEED Harley \$110. 1914 two-speed Harley \$85. Box 1089, Atlanta, Ga.

TWIN Indian Motorcycle \$75.00; another motorcycle \$40.00. Good order, real bargains. Photographs furnished. Robert Rubel, Mobile, Alabama.

BARGAIN—1916 Henderson with Sidecar; Electric Equipped, Speedometer; Tandem. Write for Particulars and Price. P. S. Gilbertson, Pierre, S. D.

EASY Terms on new and rebuilt motorcycles, side cars, tandems and lighting outfit. Motorcycles Investment Company, 805 Centre St., Brockton, Mass.

MOTORCYCLES—\$25. If you want a high grade New or Used Motorcycle and have \$25 Cash, write quick for Bulletin "K"; lowest prices, easiest terms. Peerless Motorcycle Co., Boston, Mass.

BIG bargains in good motorcycles we have taken in exchange on new ones. Send for special bargain list. Shaw Mfg. Co., Galesburg, Kansas.

MOTORCYCLES and small cars on easy payments. List and terms, Geo. Stroganoff & Company, Schenectady, N. Y.

LARGE stock of rebuilt motorcycles, new parts for all makes 25% discount; second-hand parts, good as new, 50% discount. Motorcycle Parts Mfg. Co., Chicago.

BIG bargains in second-hand motorcycles, \$25 up, Indians, Harleys, Thors, Excelsors and Merckles. Write for description. Howard A. French & Co., Baltimore, Md.

SEND for big list of slightly used motorcycles; from \$25 up. Buy on easy terms. Howard Cycle Co., Trenton, N. J.

WANTED: We pay cash for used motorcycles or take them in on exchange for new machines. Write with complete description. State condition of tires, frame, motor, make and model. Shaw Manufacturing Co., Dept. 157, Galesburg, Kans.

BARGAINS in used motorcycles—all machines guaranteed and in A-1 condition ready for use. Write for terms and new bulletin. Photos free. Harley-Davidson Sales Company, Birmingham, Alabama.

WRITE for list of bargains on used motorcycles. Little Falls Motorcycle Co., Little Falls, N. Y.

WANT to sell your motorcycle? I have a method which has sold many. Write me today for free information, F. W. Johnson, Room 300, 78 E. Madison St., Chicago.

INDIAN—Big twin two speed and side car, \$105. E. S. Emerson, Webster, Mass.

1912 MERKEL 8 Clutch \$40. 1913 Indian Twin \$50, 1912 Single 4 1/2 \$15. Big Bargain. Wm. Fleming, Corsica, Penna.

MOTORCYCLE (Merckle)—Good condition; bargain. Globe Storage Co., 1712 Main St., Kansas City, Mo.

Will sacrifice entire stock of used and rebuilt motorcycles, all makes. Write for list. Will accept any reasonable offer. Seeber & Hofheins, Buffalo, N. Y.

REBUILT used motorcycles for little money. Motor Supply Co., Decorah, Iowa.

WELDING

GUARANTEED Formula of Finest Aluminum Solder Made. Gasoline blowtorch solders aluminum and welds castings. Complete instructions, fifty cents. C. W. Snell, Chemist, 527 West Main, Battle Creek, Mich.

WELDING outfits \$60. To Canada \$70. Cutting torch and hose \$50. Extra rods and wire of all metals and fluxes of all mixtures at reasonable prices. Wm. Crowell Co., Jersey City, N. J.

WELDING Plants for All Purposes. Small Cash Payment. Balance to Suit. Bertschy Mfg. & Engineering Co., Omaha, Neb.

DAY'S Welding Solder, for scored cylinders and all metals, apply with soldering-iron, sample bar 50c or \$1.50 per pound. Bellingham Solder Co., Bellingham, Wash.

WELDING—Automobile Welding with the Oxy-Acetylene Flame—Just Out—147 pages, fully illustrated. Price \$1.00 postpaid. Explains the actual welding of all automobile parts in a manner understandable by every one. Popular Mechanics Book Dept., 6 N. Michigan Ave., Chicago.

OXY-ACETYLENE Welding and Cutting, Electric and Thermit Welding. Brand new book of practical instruction in this process. The workman will find all necessary information for handling any kind of welding. 215 pages, fully illus. Cloth, \$1.00; Leather, \$1.50 postpaid. Popular Mechanics Book Dept., 6 N. Michigan Ave., Chicago.

SIMPLE Soldering, both hard and soft—52-page book telling how to join metals. Do your own repairing. 52 illustrations, 25c postpaid. Popular Mechanics Book Dept., 6 N. Michigan Ave., Chicago.

AERONAUTICS

HEATH Aerial Products and Supplies. Why are they the best and cheapest? It's the old story—quantity production. Aeronautical supply catalogue, 6 red stamps; propeller catalogue, 3 red stamps. Heath Aeroplane Co., formerly Heath Aerial Vehicle Co., Chicago.

THE American School of Aviation announces a new correspondence course in aero-construction and design. A thorough training in aeronautical engineering. American School of Aviation, Dept. 9185, 431 South Dearborn Street, Chicago.

AVIATION is calling thousands of men Right Now. The government wants experts quick. Big opportunities—fame—fortune await you if you get in at once. Write—find out how you can learn the principles and mechanics of Aviation in your spare time at home. You must know these things before you can learn to fly. Our course gives you this training in a short time. Puts you ahead of other men who must learn by long practical experience. Endorsed by leading aviation authorities. Write for full particulars at once—no obligation. Special offer now in force. Write while it lasts. National Aero Institute, Dept. 1195, Morton Bldg., Chicago, Ill.

WORKING Drawings of small Tractor-biplane latest model, 10 to 25 H. P.; complete in every detail; You can build your own Aeroplane easily at a very low cost. Write for particulars, Northern Aircraft Co., 311 Center Ave., Bay City, Mich.

SHINES in the dark. Luminous Paint coated on any article makes them visible at night. Watches, clocks, compasses, altimeters, etc. Only 25c bottle. Luminous Paint Co., B17, Douglas Park Station, Chicago, Ill.

PROPELLERS, for air Propulsion. Write for information and prices. The Crawford Motor and Aeroplane Manufactory, Pittsburgh, Pa.

HEADLESS Biplane, 50 hp., \$300. Kingan, New Market, Virginia.

CHICAGO Aero Works, 324 River Street. Latest Ideas for Stamp.

GET into the aviation game and get into it right. We can and will help you. American School of Aviation, Dept. 9195, 431 South Dearborn Street, Chicago.

GLIDERS—Biplane-building instructions \$2.00. Frame timber \$2.50. Hardware \$8.00. Tools needed \$2.50. Paul Mason, Rexburg, Idaho.

JUNIOR Tractors—Plans—Motors—Engineering. Interrogate, Chicago Aero Works, Chicago.

TANDEM Monoplane Glider, full size, how to make—Our book "Amateur Mechanics No. 6" contains a complete detailed description of how to make one and also over a hundred other interesting articles. Price 25c postpaid. Popular Mechanics Book Dept., 6 N. Michigan Ave., Chicago.

BI-PLANE Glider, full size, how to make—Our book "Amateur Mechanics No. 2" contains a complete detailed description of how to make one and also over a hundred other interesting articles. Price 25c postpaid. Popular Mechanics Book Dept., 6 N. Michigan Ave., Chicago.

AVIATION Motors, all makes, up to 150 H.P., \$250 up. Complete aeroplanes, all types, \$500 up. State your needs. Aero Exchange, 38 Park Row, N. Y. C.

SPECIAL Light Weight gasoline engine, 1/2 H.P., 2 1/2 pounds. Send stamp for catalog. Weiss Mfg. Co., Torrington, Conn.

PATENTS Wanted in Aeronautics—U. S. Government spending millions in this class for Army and Navy. Our Aeronautic Department will give full information on this subject upon inquiry. Write for "What to Invent," sent free. Victor J. Evans & Co., 169 Ninth, Washington, D. C.

BUILDING and Flying an Aeroplane—100-page handbook covering the building of small models and full-sized gliders and machines. In both biplane and monoplane models the well-known Curtiss and Bleriot types are followed. Fully illustrated with detail drawings. Price \$1 postpaid. Popular Mechanics Book Dept., 6 N. Michigan Ave., Chicago.

MODEL Aeroplanes—materials, supplies. Motor-driven Scout Monoplane. Submarine diving boat. Send 5c for catalogue. Wadling River Mfg. Co., 350 Macon St., Brooklyn, N. Y.

GET our latest Aeroplane Book containing full information about "Ideal" Model Aeroplanes, parts, plans, etc. 5c postpaid. Ideal Aeroplane Co., 82 1/2 West Broadway, N. Y.

PUSHER biplane, double surfaced type, with crates and 30 H. P. Maxmotor. Flown but little. \$390 takes all. John J. Woods, 120 Nachure Ave., Plainfield, N. J.

YOUR future may be marked with great success. "Join" Ecker School of Flying, Syracuse, N. Y.

BOOKS AND PERIODICALS

100,000 **SECOND-HAND** books for sale, 25c each; costly leather, velvet and cloth bindings; some cost \$10.00 new; Scientific, Technical, Educational, Medicine, Law, History, Fiction, Encyclopaedias, Home Study Text Books, Mathematics, Chemistry, Physics, Engineering; Illustrated Catalogues 6c stamps. McCarthy, 1236 Arthur Ave., Chicago, Ill.

SOMETHING New—"Comparative Cancellation Calculator." Solves all mathematical problems in one simple, figure-saving operation. 145 pages, \$1.00 postpaid. Circulars free. Herrick & Horton, Publishers, Princeton, Ill.

DEVELOP your Mental Powers for greater efficiency and success by reading "Your Mind and How to Use It," by William Walker Atkinson. 224 pages. One dollar postpaid. Inland Book Co., Ft. Wayne, Ind.

ESTIMATING the price of second-hand automobiles, repairs, cost, etc. Book 35c. Industrial Facts Publishing Co., Milwaukee, Wis.

HOW to operate and repair Automobiles. Book 19c. Derrin, M409 W. Division St., Chicago.

AMATEUR Electrician—Illustrations for making motors, wireless, telephone current reverser, electric engine. With catalogue 10c. "Lever" Company, Elizabeth, N. J.

MAGAZINES at rock bottom prices. Send today for our free catalog "P." S. C. Hanson Magazine Agency, 4926 Kinzie, Chicago.

WORLD-ROMIC System, Masterkey to all languages. Two sample books, 26c stamps. Languages Company, 143 West 47th St., New York.

NEW 1917 Catalog of Latest and Best Books on Mechanical, Electrical and Industrial Subjects, comprising 128 pages and adequately describing more than 400 works. Sent free upon request by Popular Mechanics Book Dept., 6 N. Michigan Ave., Chicago.

WORLD Romie System. Master-key to all languages. Three sample books, 36c. Languages Company, 143 West 47th St., New York.

UNDERGROUND Treasures. How and where to find them. Morton Bldg., Chicago, Ill.

"RAILROADING As a Vocation." Start right and reap promotions. Fifty cents, postpaid. Chas. Elliott, Fayetteville, N. C.

REFSE Publishing House, Mt. Pleasant, Pa., can supply any book published. Catalogs free.

FIND Out for Yourself what to Invent and how to procure and sell a patent for the same. My book, "Inventor's Universal Educator," covers the matter from A to Z. 140 pages, elegantly bound. Also contains 600 mechanical movements and 50 perpetual motions. Price \$1.00, postage free. F. G. Dietzsch, 651 Ouray Bldg., Washington, D. C.

USED Books, Bargains. Catalog Higgins's, A-2441 Post, San Francisco. (Books Bought.)

ENGINEERS' questions and answers for license by Hobson, for twenty-five cents, postpaid. Send stamps, Reilly's Book Store, Philadelphia, Pa.

MOTORCYCLES, Side Cars and Cyclecars. Their Construction, Management and Repair—The only complete work published on this subject. The dealer, mechanic and rider will find this an excellent treatise. 350 pages, cloth, 35c illus. Price \$1.50 postpaid. Complete description sent upon request. Popular Mechanics Book Dept., 6 N. Michigan Ave., Chicago.

BINDER for Popular Mechanics magazines. Best adjustable magazine binder on the market made especially to hold any number from one to six copies of this magazine with name "Popular Mechanics" in gold letters on front cover. No laces or cutting or perforating of pages necessary. Simple, unique adjustment; handsome, durable and neat. We buy in quantities and can offer our readers this regular \$1.50 binder for \$1.25, all shipping charges prepaid. Address Popular Mechanics Book Dept., 6 N. Michigan Avenue, Chicago.

EDUCATIONAL AND INSTRUCTION

LEARN Ad Writing from practical ad writer; no school; profitable profession. Write John Allen, 25 Parthurst Street, Newark, New Jersey.

SPANISH Alphabet, World-Romic masterkey to the Spanish language. 37c stamps. Languages Company, 143 West 47th St., New York.

MAIR'S "D. E. Bookkeeping in 2 lessons." 25c; practical, easy self-study. B285, Nashville, Tenn.

ARTIFICIAL Marble, sanitary flooring, complete instructions, \$1. Ornamental casting, concrete, plaster, papiermache, decorations, garden furniture, statuary, rubber moulds, electrometallurgy. Particulars, 200 illustrations free. Mahler, D-721 Woodland Ave., Woodhaven, L. I., New York.

BE a Finger Print Expert—\$25 to \$50 a week in this new and fascinating profession. Write—find out how you can learn at home to supply the big demand for finger print experts in banks, big factories, detective agencies, etc. Special limited offer—write while it lasts. Evans University, Finger Print Dept., Room 1195, 1810 Wilson Ave., Chicago, Ill.

SHORTHAND—Home study. Particulars free. Takigraphy, 257 W. 64th St., Chicago.

ARTISTS in big demand. \$50 paid for one drawing. Learn quickly at home, in spare time. Commercial Art, Cartooning, Illustrating, Designing. Artist's Output Free! Handsome book free explains. Write now. Washington School of Art, 1024 H St., N. W. Washington, D. C.

WOULD you like to study law in your spare moments? I have a splendid opportunity to offer you. Send me your name and address right now. P. H. Harler, 1195 Manhattan Bldg., Chicago.

READ Blue Prints correctly and make real money. 26 Copyrighted Instructions. Blue Prints that make it easy to master. Write. Mechanics Improvement Association, P. O. Box 625, Philadelphia, Pa.

SHORTHAND—The New Way. Boyd System. The Wonder of the Age. Learned in 29 Days in Spare Time. 100 to 150 words a minute. Writers hold World's Record. Send today for Special Offer, Catalog and Sample Lesson. Chicago Home Study Schools, 551 Reaper Block, Chicago, Illinois.

PERSONAL Instruction—Cartooning, Comic Art, Lettering. Write Freeburn, Hicksville, Ohio.

MOULDS, 200 illustrations free, beautiful art casts, concrete, artificial marble, plaster. Complete instructions thoroughly pictured, (copyright). Beautiful homes, garden ornaments, garages, statuary taken from life, quick sale novelties. Make them yourself. (mail address today). Mahler, Woodhaven, N. Y.

MOULDS; Simplified and inexpensive methods of reproducing works of art. Ornamental casting, Novelties, Statuary, Garden Fixtures, Italian Marble, etc. Illustrations and Instructions—Fifty (50) cents. Beaux-Art-Moulds Co., 436 Broadway, Brooklyn, N. Y.

ROFF'S Calculator and Short-Cut Arithmetic—Shows the answer as quickly as a watch shows the time to all problems likely to occur in office, store, shop, bank, farm or factory. Over two million sold. Price, vest pocket size, 50 cents; leather, pocket size, \$1.00; large, desk size, \$1.25 postpaid. Complete description sent upon request. Popular Mechanics Book Dept., 6 N. Michigan Ave., Chicago.

FINGER Print Instructor—A text book for the guidance of finger print experts and an instructor for persons interested in the study of finger prints. Book based on the Henry System and prepared by an expert. Cloth, 150 pages, illustrated, Price, \$2.00 postpaid. Popular Mechanics Book Dept., 6 N. Michigan Ave., Chicago.

WAR Atlas—Large 20-page (11x15 in.) Atlas of the War in Europe, containing large colored scale maps of the Battle-ground, showing Europe, Austria, Serbia, Germany, England, Belgium, France, Russia, Italy, Greece, the World, etc. Special data showing comparison of armies and navies involved, pictures of rulers, etc. Price 50 cents postpaid. Popular Mechanics Book Dept., 6 N. Michigan Ave., Chicago.

WANTED—New Ideas. Write for list of Patent Buyers and Inventions Wanted. \$1,000,000 in prizes offered for inventions. Our Four Books sent free upon request. Victor J. Evans & Co., 167 Ninth, Washington, D. C.

LEARN Drafting—One of the most practical subjects, and indispensable in many occupations. Individual study at home without an instructor may be successfully carried on with the aid of our book, "A Practical Course in Mechanical Drawing," 160 pages, 157 drawings. Cloth. Price 50 cents postpaid. Popular Mechanics Book Dept., 6 N. Michigan Ave., Chicago.

IDEAL Atlas—Just Published—Contains large scale maps, yet is a book of handy size. Has special maps of all war zones in addition to all regular maps found in a good atlas. Is self-revising, that is, contains a certificate entitling the purchaser to a supplement of new maps after the war is over. Genuine flexible leather binding. 512 pages, 256 pages of maps, 256 pages of text. Price \$1.65 postpaid. Popular Mechanics Book Dept., 6 N. Michigan Ave., Chicago.

TRADE SCHOOLS

GOOD Pay for Trained Men—Our courses include practical training in Gas and Electrical Engineering, Mechanical Drafting, Automobile and Tractor Repairing and Operating. Write for special summer rates and illustrated catalogue. Seattle Engineering School, Seattle, Washington.

ELECTRICITY, Plumbing, Bricklaying, Mechanical, Architectural and other Drafting Courses. Motion Picture Operating taught by practical work. Largest, best equipped practical trade school in America. Short time to learn. Small cost, easy payments. Write for big illustrated book; it's free. Coyne National Trade Schools, Dept. 8196, Chicago, Ill.

LEARN these Big-Paying Trades: Sign Painting, Showcard Writing, Paperhanging, Graining, Decorating. Catalog Free. Chicago Painting School, 131 North Fifth Ave., Chicago.

HILES' Watchmaking and Engraving School, the largest and best equipped school in the West. 717 Market Street, San Francisco, Cal.

TELEGRAPHY

TELEGRAPHY—Morse and Wireless—taught at home in half usual time and at trifling cost. Omnicograph Automatic Transmitter will send, on Sounder or Buzz, unlimited messages; any speed, just as expert operator would. Adopted by U. S. Govt. and used by leading Universities, Colleges, Technical and Telegraph Schools throughout U. S. Catalog free. Omnicograph Mfg. Co., 41-G Cortlandt St., New York.

TELEGRAPHY for Beginners—Best textbook for students of telegraphy. The standard method. 64 pages, 19 illustrations. 25c postpaid. Popular Mechanics Book Dept., 6 N. Michigan Ave., Chicago.

TELEGRAPHY—Morse and Wireless—also Station Agency taught. Graduates assisted. Cheap expense—easily learned. Largest school—established 42 years. Correspondence courses also. Catalog Free. Dodge's Institute, 15th St., Valparaiso, Ind.

WIRELESS

WIRELESS Set. How to Make—36-page book telling how to construct at small cost an outfit suitable for transmitting four or five miles. Price, 50 cents, postpaid. Popular Mechanics Book Dept., 6 N. Michigan Ave., Chicago.

MAKING Wireless Outfits—Become a wireless constructor. This book tells how. 61 pages, 27 illustrations. 25c postpaid. Popular Mechanics Book Dept., 6 N. Michigan Ave., Chicago.

PICTURES, POSTCARDS, PENNANTS

BIGGER than ever, more names, stories, etc. 1,600 names to select each issue. Enrollment 6,000; rapidly growing. Trial 10c. Elite Postcard Exchange, R-46, 3684 Milwaukee Ave., Chicago, Ill.

SEND two silver dimes—you get twenty good post cards—name, address, in Post Card Directory one month free. Sam Burg, Commercial Hotel, Gary, Indiana.

JOIN an interesting postcard club. Trial 10c. "Monarch," Box 149, Station C, Cleveland, Ohio.

PRETTY view cards from everywhere. Membership and 6 pretty cards, 10c. Riverside Club, Knoxville, Md.

MAKE friends exchanging postcards. Membership 10c. Universal Exchange, 454 Palisade Ave., Jersey City, N. J.

POSTCARD Collectors! Join now! 10c. Rose Postcard Society, Portland, Oregon.

RECEIVE pretty postcards from everywhere. Join best card club. Membership 10c. Jolly Card Exchange, Decatur, Indiana.

100 FINE Post Cards 35 cents prepaid. Townes Novelty Co., Richmond, Va.

240 ILLUSTRATIONS free, beautiful art statuary. Mahler, Woodhaven, L. I., New York.

IF you really want to exchange postcards, try our splendid club. Lists circulate in many countries. Membership, 10c. Halyon Club, Box 133, Erie, Pa.

FREE, 25 poster stamps; membership 10c. Sagebrush Postcard Exchange, Goldfield, Nevada.

EXCHANGE postcards; large club. Membership 10c silver. Capital League, Box 1539-P, Washington, D. C.

CROSS-SECTIONAL view of ocean liner "Britannic," showing interior arrangement of ship in colors, size, 14x20 inches, on heavy plate paper for framing or hanging. Very interesting. Reproduced from front cover design of July, 1914. Popular Mechanics. Will be sent postpaid to any address in the world on receipt of 4 cents in stamps to cover packing and mailing. Popular Mechanics Magazine, 6 N. Michigan Ave., Chicago.

OPTICAL SUPPLIES

MICROSCOPE, magnifies 3,600 times. Every microscope guaranteed to give a clear and perfect definition of object. Price 25c for complete outfit. Circular of other models and supplies sent for stamp. Specialty Mfg. Co., 8, Box 164, Milton, Pa.

GLASSES fitted by mail. Low prices. Request Particulars. Dollar Optical Co., Shoreport, La.

CAMERAS AND PHOTO SUPPLIES

SPRINGTIME is Camera time. \$20 3A Kodak, our price \$11. Brownies. Motion Picture Cameras and everything photographic, at remarkable money-saving prices. Ten days' trial, money-back guarantee backs every item we sell. Our new catalog just off the press. Send for your copy today. See our display advertisement on page 169. David Stern Company. Everything in Cameras. In business since 1885. 518 Davisco Bldg., 1047 Madison Street, Chicago, Ill.

BUY Now—Graflex and Kodaks—save 25 to 60%. Write at once for our latest Bargain Book and catalogue listing hundreds of slightly used bargains in Cameras and Lenses. Great reductions on Films, Papers, Chemicals and Apparatus of every description. Everything guaranteed. Money back if unsatisfactory after ten days' free trial. We buy and exchange Kodaks-Cameras-Lenses. Central Camera Co., 124 S. Wabash Ave., Dept. E, Chicago, Illinois.

ENLARGEMENTS, Developing, Printing, Copying, Lantern Slides, etc. Quality guaranteed. Send Negative and 20c for finished and mounted sample Enlargement. Myland, 2125 N. Front, Philadelphia, Pa.

SPECIAL—One roll developed and 6 prints 20c. Enlargement free. Emil Sprauer, Hamilton, Ohio.

PRINTS made, 2c each—any size. Rolls developed 5c each. Ideal Photograph Co., Winston-Salem, N. C.

HASTMAN Kodaks, equal to new; tell us what you want; get our price; no list! Cash for cameras or lenses. Minneapolis Camera Exchange, 621 Oliver No., Minneapolis, Minn.

FILMS Developed Free, perfect prints, modern up to the minute methods. We do the best work in this the Photo City. Films developed absolutely free when we make the prints. No matter where you live send us your films. We return all work promptly by parcel post. Bryans Drug House, Rochester, N. Y.

EQUIP your camera or Kodak with a Wollensak lens and shutter and obtain the best possible results. Beautiful descriptive catalogue "B" sent on request gratis. Wollensak Optical Co., Rochester, N. Y.

\$95.00 No. 1A GRAFLEX Camera, \$69.00, \$83.00 Auto Graflex, 3 1/2 x 4 1/4, \$55.00. 100 other bargains in our Special Price List. J. L. Lewis, 522 Sixth Avenue, New York, Dept. A.

FILMS developed, 10c; prints, 3c to 5c. A reputable Incorporated Company conducting largest existing plant. Price list and special offer. Enlargements our specialty. Chicago Photo Finishing Co., 54 W. Lake St., Dept. A, Chicago.

FILMS Developed, any size 5c. Any size prints 3c. 8x10 enlargements 35c. Work returned same day received. Address Camera Shop, Box 69, Ann Arbor, Michigan.

FILMS Developed, 10c all sizes. Prints 2 1/2 x 3 1/4, 3c; 3 1/2 x 4 1/4, 4c. We give Profit Sharing Coupons. 24 hour service; work guaranteed. Send negatives for samples. Girard's Com'l Photo Shop, Mills Alderman Bldg., 316 High St., Holyoke, Mass.

AMATEUR Photographers—Send for our catalog on photo supplies. We retail to you at wholesale prices. Fahrenwald Bros. & Co., Kishore & Cortland, Chicago, Ill.

HIGH Quality kodak work. Expert service to each order. Money refunded if not satisfactory. Developing roll 25 cents, prints 5 cents each. Educational Laboratories Co., Independence, Iowa.

OUR Introductory Offer expiring June 1, 1917. We will develop any size roll film (one to a customer) and furnish 3 prints for 10c with order. Future orders at our established list prices. 25 years' reputation as Specialists. Dun, Bradstreet, or local bank. T. V. Moore Co., Inc., Minneapolis, Minn.

MAKE Beautiful transparent photos on watch dials, cases, etc. Complete process and working instructions 25c. C. Johnson, 4219 N. Whipple St., Chicago.

AUTOMATIC Card Printer, complete with motor; cost \$135.00 new, our price \$85.00. David Stern Company, 1047 Madison, Chicago.

THEO. MOHLER, Fremont, Neb., Expert Kodak finishing. Samples on request.

FILMS developed 5c, any size. Prints 5c each, all sizes. Free enlargement with first \$1.00 order. Johnson's Studio, Oswego, N. Y. 3 months' instruction in Photography \$10.00 at studio.

FILMS Developed 10c. Prints Post-card size and less 3c. Enlargements. Price List. Established sixteen years. Deusing Studio, West Allis, Wis.

HARVEY Exposure Meter gives correct Exposures for all kinds of Cameras. Extentiors, Interiors, Night work or Color Plates. Ask your dealer, or write G. L. Harvey, 105 S. Dearborn St., Chicago. Price \$1.00.

KODAK films developed, 7 cents each, any size. Prints, three cents each, all sizes, 8 by 10 enlargements 25 cents. C. C. Smith, Tarrytown, N. Y.

FILM developed, 10c roll. Packs 20c; Prints, Brownies, 2c; 1a, 3x4, 3x5 and Post Cards, 3c. Returned next day. Prepaid. Kodak Film Finishing Co., 112 Merchants Station, St. Louis.

BIG Money Saved on Photographic Lenses and Apparatus—goods exchanged; repairing done. Ralph J. Goben, 5125 Kenmore Ave., Chicago, Department P.

MOTION PICTURES

MOTION Picture Camera Men Earn Big Money. Have You the Ambition To Get Ahead? Details Free. U. S. Cinematograph Institute, 28-30 Orleans St., Newark, N. J.

REBUILT Moving-Picture Machines, also films \$2.50 and \$5.00 a reel; big list. Lyric Film Supply Company, Terre Haute, Ind.

MAKE Money writing photoplays; big demand. Good income for writers; experience unnecessary. Valuable \$2 instruction book 50c, tells how. Nat'l Film Service, 39A Sheridan St., Orange, N. J.

SPECIAL Arc Generator makes current for half. Engine or motor operates. Easy payments. Hobart, Box 31, C., Troy, Ohio.

TRAVEL exhibiting Movies. Small capital required. Box 1155, Tampa, Florida.

MAKE money writing Photo-plays; details free to beginners. No correspondence course. Producers League, 230 Wainwright, St. Louis.

WRITE for free copy "Hints to Writers of Photoplays, Short Stories, Poems." Also catalog of best books for writers. Atlas Publishing Co., 71, Cincinnati.

ARE You a Movie Type? Many of the greatest stars were discovered by accident. You want to know if you have the natural qualifications that bring \$50,000 salaries. The book Motion Picture Acting tells you this, also 101 screen favorites show you how they register 499 human emotions. Use of cosmetics, costume requirements and color schemes also treated. Price leather \$1.10, cloth 75 cents postpaid. Popular Mechanics Book Dept., 6 N. Michigan Ave., Chicago.

MAKE Big Money in moving-picture business. We start you and furnish guaranteed outfit on easy payment plan. Easy to accomplish. Catalog free. Monarch Film Service, 228 Union Ave., Dept. P, Memphis, Tenn.

BIG Profit Nightly—Moving Picture Business—small capital starts you, easily accomplished. Teach you—furnish everything. Ralph J. Golsen, 5123 Kenmore Ave., Chicago, Dept. M.

MOTION Picture Operation. Stage Electric and Illusions—The only practical handbook and guide published for motion picture operators, theater electricians and managers. A thoroughly practical and useful book, covering the subject comprehensively. Pocket size, leather, 393 pages, fully illustrated. Price \$2.00 postpaid. Popular Mechanics Book Dept., 6 N. Michigan Ave., Chicago.

BUSINESS OPPORTUNITIES

OUR Latest Discovery. Bonedry Glaze, absolutely greaseless, for polishing, cleaning and veneering auto bodies, tops, cushions, windshields, furniture, pianos, floors, mirrors, windows, brass and iron beds, leather and metal finishes. Agents, dealers and garage owners act quick. Large sample bottle 25c. Elliott's Auto & Furniture Finishing Co., 336-338 Farrington Ave., St. Paul, Minn.

GOOD Income. Cleaning, Dyeing, Pressing Business. Complete instructions, \$1. Particulars Free. Chester Zoll, Springfield, Ohio.

YOU can earn big money yearly. Learn candy making. Qualify for traveling candy salesman; good position guaranteed. Own a candy store, or factory. We start you, help you succeed. Write for free booklet. We built a big candy business—give you our own experience. Oster-Swain Corp., Suite 118, 4759 Broadway, Chicago.

\$129 IN 3 days is Big Profit but Jennings did it in 3 hours. How? Selling our wonderful, brand new, repeat advertising proposition to retail merchants, stores, etc., everywhere. Work when you like—make what you want. Experience unnecessary. Our book tells all—write quick. Salesmanager, Winslow Cabot Co., 39 Congress Bldg., Boston, Mass.

MAIL Order Business is your opportunity. Start us side line, the Breniser way, gradually earn good income. Business like dealings, common sense, honest help, exclusive plan to every client; proved successes. Send 25c for information worth a dollar; no free circulars. Breniser, 302 A, Walnut, Philadelphia. Send \$1 and receive all the above, also a big collection of other mail order books.

MANUFACTURE "Gas-luc." Saves one-third of the gasoline. Every motorist your customer; big profits; easy work; formula and instructions \$1. Particulars, stamp. Hile Company, Carey, Ohio.

MAIL Order Plans, formulas and trade secrets. Send for free booklet, F. S. Parkin, 260 Fifth Ave., New York City.

PATENTS—Send Sketch, Free Opinion and Certificate of Patentability. Free Book, "How to Obtain a Patent and What to Invent." Patents secured through Credit System. Talbert & Parker, Patent Lawyers, 4071 Talbert Bldg., Washington, D. C.

FORTUNES in Food Products: Product now selling in 35 States; \$25 Invested now may yield big returns. Particulars free. Home Securities, First National Building, Oakland, Cal.

DISTRIBUTOR and Dealer Agents Wanted Everywhere for cleverest line electrical specialties ever created. Sterling Corporation, 1278 West Third St., Cleveland, O.

WE Will start you in the cleaning and dyeing business, little capital needed, big profits. Write for booklet, Ben-Voude System, Dept. C, Charlotte, N. C.

EARN good income writing advertisements. "How to write convincing advertisements," prepaid \$1.00, Wilson L. Glover, 17 Brandley St., Bridgeport, Conn.

GOOD profit with our proposition. Write at once, Hingston, White-Jojo, N. Y.

PATENTABLE Ideas Wanted—Send for 4 free books. R. B. Owen, 29 Owen Bldg., Washington, D. C.

TATTOOING Outfits, \$1 up. Electric and hand. Roberts Company, 635 West Ave., Buffalo, N. Y.

LEARN the Real Estate Business. Be independent. No other business offers such great money-making opportunities for you. Easily acquired, without capital. Full particulars free. MacMichael Realty Co., Dept. 49, Victor, N. Y.

LEARN Sewing Machine Repairing, start a business. 160-page book, \$1.00; particulars free. R. Brown, 921 Caroline St., Baltimore, Md.

VALUABLE Trade-Secrets: Resilvering Mirrors—Recharging Dry Batteries—Gas Tonic—Orange-skin Powder—Straw Hat Cleaner—Luminous Paint. This valuable collection 25c. C. Johnson, 4319 N. Whipple St., Chicago.

BUILD a profitable business of your own. Let us start you in the collection business. No capital needed; big field. We teach secrets of collecting money; refer business to you. Write today for Free Pointers and new plan, American Collection Service, 101 State Street, Detroit, Mich.

To manufacturers of Hardware, I offer my idea on an adjustable window screen. Write for particulars, Joseph Cuomo, 2137 Prospect Ave., Bronx, New York.

PROFITABLE formulas, Trade Secrets and money-making Plans. Three Volumes for \$1.00. Three "B" Supply Co., Perth Amboy, N. J.

MAKE Money Painting Signs with our patterns. No experience. Sample for stamp. Lightning Signs, Box 186, St. Paul, Minn.

START For Sale and Exchange Agency. Particulars free. Advance, Rolling Prairie, Ind.

125 WORDS printed on 3,000 circulars and mailed to good list, \$4.50. Miller, 1926 Germantown Ave., Philadelphia. (Mechanical Digest says: "Have had better results from your circulars than any others.")

500 FORMULAS, including Resilvering Mirrors—Renewing Dry Batteries, Luminous Paint, Luminous Ink, 25c. Ideal Book Shop, 3315-47, Belleplaine Ave., Chicago.

START Original Mail Order Business. Honest, legitimate, highly profitable, exclusive. Write Clement Moore, Box 98, New Egypt, N. J.

MAKE Music Rolls for profit and pleasure, with simple perforator. Splendid opportunity. Particulars free. The Leabarian Mfg. Co., Hamilton, Ohio.

MAIL Order Dealers. Let the 4 in 1 coupon plan increase your profits. Sell valuable instruction systems by cut price coupon under money back guarantee. Big margin. Small selling expense. Complete plan, sample coupons and bargain bulletin sent on request. Mail Dealers' Coupon System, 319 So. Dearborn St., Chicago.

MANUFACTURERS, Promoters and Patent Buyers are invited to write us stating the line of invention in which they are interested, as we can supply their wants in any class of patents. Victor J. Evans & Co., 162 Ninth St., Washington, D. C.

BIG money in promoting inventions. Write Adam Fisher Mfg. Co., 2601D Railway Exchange, St. Louis, Mo.

GOOD monthly income easy in spare time manufacturing letters for signs. Free particulars, J. F. McPherson, 677 Brown Avenue, Butler, Pa.

ENTER a new business. Earn \$3,000 to \$6,000 yearly in professional fees making and fitting a feet specialty, openings everywhere, with all the trade you can attend to; easily learned by anyone at home in a few weeks, at small expense; no further capital required, no goods to buy, job hunting, soliciting or agency. Address Stephenson Laboratory, 11 Bark Bay, Boston, Mass.

WE start you in business furnishing everything; men and women make handsome income weekly operating our "New System Specialty Candy Factories" home or small room anywhere; no canvassing. Opportunity lifetime; booklet free. W. Ragsdale Co., East Orange, N. J.

INVENTORS: We develop and perfect inventions, make models, dies, tools. Metal stamping and special manufacturing. Gerding Bros., Lion Bldg., Cincinnati, O.

ADVERTISERS, Mail Dealers. Our New Rate Book lists 2,000 Principal Publications, rates, circulation. Includes 50 Mail-Order Plans. Free. Dearborn Advertising Agency, 210 Franklin Bldg., Chicago.

PLASTOGRAPHY: Nothing so engaging and profitable: "Plastography" instructions \$2. A model or mould of President Wilson or Lincoln sent free with your order. P. B. Spahr, York, Pa.

LEARN to collect money. Good income; quick results. Send for free booklet, "Skillful Collecting," Collectors' Association, Long Street, Newark, Ohio.

25-WORD Advertisements in 100 monthly magazines, 3 months, \$1. Quadri Co., 426 E. 144th St., N. Y.

LEARN the real estate business; our 64, large instruction book teaches listing, appraising, management, salesmanship, insurance, brokerage, advertising, renting, agency, estates, titles, rights, forms, etc.; revised edition; 240 indexed subjects; excels \$25 correspondence course; buckeye cover, \$1; silk cloth, \$1.25, postpaid. Realty Book Co., Dept. No. 29, Cleveland, Ohio.

SILVERING Mirrors—My exclusive French Tartaric Method opens enormously profitable business. Booklet Free. H. Barstow, 511 23rd St., Oakland, Calif.

COMPETENT Chemical Advice Reduces Costs, improves products, bridges difficulties. Analyses are inexpensive. Let us study your requirements. Formulas developed. Chemist N. Industrial Laboratories, New Orleans.

INDEPENDENCE and fortune quickly attained in the Manufacturing Mail Order business. I furnish Formulas, Manufacturing Processes and Trade Secrets in all lines. Sold under positive guarantee; 18 years' practical experience. Revision and improvement of Formulas and Processes—reduction of manufacturing cost—utilization of waste materials, etc., a specialty. Booklet, Formula List, and Valuable Information Free. W. L. Cummings, Ph. D., 127 Standard St., Syracuse, N. Y.

GOOD money easily earned at home, sparetime, silvering mirrors; No capital. Free instructive book tells how. Patterson & Co., Brooksville, Ky.

LARGE concern having a profitable small power motor department desires to dispose of same on account of limited factory capacity for other lines. Good proposition for live young man. Investment small. Business established. R. D. Room 910, 78 E. Madison St., Chicago.

WOULD a paying, independent business of your own (not a mail order or agency scheme), appeal to you? If so, ask for proposition of Fourpoint Co., Sturgis, Mich.

BUSINESS FOR SALE

FLOUR Mill—30-barrel capacity, with corn mill, saw mill, and small farm. Bargain. G. C. Stone, Hurt, Va.

TO MANUFACTURERS

PATENTS—Send Sketch, Free Opinion and Certificate of Patentability. Free Book, "How to Obtain a Patent and What to Invent." Patents secured through Credit System. Talbert & Parker, Patent Lawyers, 4071 Talbert Bldg., Washington, D. C.

MAIL-ORDER SUPPLIES

INCREASE your sales. Place your proposition before the readers of "Cartoons Magazine," 20,000 copies guaranteed every month. Classified rate 5c per word. Mail in a trial ad today. Cartoons Classified Dept., 78 E. Madison St., Chicago.

FOR ADVERTISERS

INCREASE Your Business.—Make your Advertising and Circularizing pull More Orders and Cash. Consult Dugdale Now. His forceful Ads, Letters, Booklets, Circulars and Sales Plans increased one advertiser's business 1,500%. Submit your present literature and plan for personal advice. H. K. Dugdale, 112 Warder Building, Washington, D. C.

BOOST Your Business. 25 Model Grocery Advertisements prepaid only \$1.00, 12 Clothing Ads, 50c. Written by experts. Other series for other lines. Write Ira Crawford, Business Builder, Box 128, Duluth, Minn.

29-WORD Advertisement in 120 monthlies \$1.00. Continent Exchange, Hollywood, California.

YOUR ten-word ad, in our 9x12 magazine, reaching 50,000 boys, for 50c. Extra words 5c. Country Boy Magazine, 2075 Mallers Bldg., Chicago.

ADVERTISERS—Here's your opportunity. Your proposition placed before the readers of "Cartoons Magazine" for only 5c per word. Circulation 20,000 copies guaranteed. Send a trial ad for our next issue. Cartoons Classified Dept., 6 N. Michigan Ave., Chicago, Ill.

YOUR Thirty-Word Ad in our big post-card magazine, 25c. Inch display, 50c. Elite Exchange, 3694 Milwaukee Ave., Chicago.

ART AND ADVERTISING SERVICE

HIGH-POWER Sales Letters, Folders, Booklets, Prospectuses, Mail-Order Campaigns. What Are Your Needs? Satisfaction Guaranteed. Harry A. Stern, 1099 Gaylord, Denver. (Twelfth Year.)

ADVERTISING counsel free; twenty years' experience. R. M. Angle, St. Cloud, Minn.

BUSINESS SERVICE

INCORPORATE your company under the common law. No organization, franchise, registration or corporation taxes to pay. No reports to make. I finance meritorious enterprises. W. G. Lowery, 312 Plymouth Bldg., Minneapolis, Minn.

KIMLEY'S Business Service, Indianapolis, Ind. Collections, Adjustments and Information Everywhere. Personal calls. Correspondence solicited.

INCORPORATE. Our lawyers do the work, saving you time, annoyance and money in incorporating under the most liberal laws of Arizona. Laws and forms free. Southwestern Securities & Investment Co., Box D188, Phoenix, Ariz.

COLLECTIONS

DEBTS Collected Anywhere, Quickly! Established 25 years. William H. Dodd, 87 Nassau Street, New York.

AGENTS WANTED

SELL the Delbon Oil Burners, good money; quick sales. 3031 Main St., Kansas City, Mo.

TIP—Shake no more. Something new. Unlimited sales. Unusual profits. Agents—secure your territory before others do. Particulars free. Write now. Franklin Co., Dept. 5, Three Rivers, Mich.

AGENTS: We have a good proposition for you. Write for particulars and samples. Chicago Agency Co., 838 Altgeld St., Chicago.

AGENTS: 50 Calling Cards 10c. F. Shepard, Rome, N. Y.

\$50 WEEKLY and up selling Mexican Diamonds. Exactly resemble genuine; Same Rainbow Fire; Stand tests; sell at sight; Repeat orders. Write quick for Sample Case offer free. Mexican Diamond Importing Co., S. W. Las Cruces, New Mexico.

MARVELOUS Discovery—Jiffy Home, sanitary razor sharpener, gets keen shaving edge any razor or safety blade in few seconds. Guaranteed, 25 cents, 150% profit. Endorsed by barbers. Agents, mail order men cutting money. Here's something new. President, 111 Victor Bldg., Canton, Ohio.

AGENTS: If you are earning less than \$280 a month our Sentinel Burglar Alarm proposition will interest you. Many agents earn \$15 daily. New invention. Exclusive territory. No competition. Sells on sight to homes, offices. Instantly attached any door knob. Impossible turn knob without ringing bell. No batteries, screws, nails. Handsomely nickel-plated. Provides cheap burglar insurance. It is a big money maker. Write today for liberal terms to agents. Marshall Dobbins & Co., Manufacturers, 1422 Marquette Building, Chicago.

AGENTS: Biggest moneymaker. Trouser support. New invention. Sample 15c; give exact waist measure. Money refunded if not satisfactory. Big discount to agents. M. & M. Mfg. Co., Greenville, Ohio.

AGENTS—Big Hit, 6 Piece Aluminum cutlery set; new specialty delights housewives; good profits; 2 premiums clinch sales. Aluminum Cutlery Co., Div. 25, Sag Harbor, N. Y.

A SPLENDID proposition; make \$27 a week; \$168 a month; article guaranteed; good references required. We refer to Central Savings Bank, 20th and Madison Ave., Covington, Ky. Trade Supply Co., 1556 Madison Ave., Covington, Ky.

AGENTS make 500% profit handling Auto Monograms and Initials, Changeable Signs, Novelty Signs, and Window Letters. Catalog Free. Hinton Co., 6142 40th Court, Chicago, Ill.

A NEW, wonderful discovery—Instantly Silver Polish—restores silver to its original brightness and finish as it left the factory. No rubbing, works instantly. Greatest repeat article on the market. Regular 25c size and valuable premium certificate, special to agent, 10c. Gordon Specialty Agency, Dept. A-52, West Chippewa, Buffalo, N. Y.

ONE Agent earned \$72,653.21 profit in five years. Starting with but a small amount of capital you can make Big Money selling the World Famous Frantz Premier Electric Cleaner. Think of it. You make from 40% to 60% profit on this fast selling, nationally advertised, factory guaranteed product. Backed by a \$100,000 National Advertising Campaign. See Saturday Evening Post or Good Housekeeping Magazine. Manufactured and absolutely guaranteed by world's largest makers of Electric Cleaners. Every housewife needs one—every home with electricity your prospect. A few exclusive territories still available. If you are a live wire with a small amount of capital—enough to start you off, in a modest way—write immediately for our agent's money-making proposition. Address Dept. "A," The Frantz Premier Company, Cleveland, Ohio.

TAILORING Agents Wanted—Big complete sample outfit and case, nearly 300 large cloth samples, 3 piece lists and everything needed for canvassing or use in store, free to five agents, \$25.00 to \$30.00 a week; may make more. Write us today for free elegant outfit to begin, cloth samples, wholesale prices, special offer on a suit for yourself and full information—see our wonderful values, beautiful fabrics and styles. Established 28 years. Every garment made to measure—everything guaranteed and express prepaid. Just send a postal. American Woolen Mills Co., Dept. 514, Chicago.

AGENTS: Biggest moneymaker ever put on the market, "Eggette," the original egg substitute. Takes place of eggs in baking and cooking at less than ten cents per dozen. Sells rapidly to homes, stores, bakers, etc. A Guaranteed pure food product. Good opportunity to build permanent business with big income. No competition. Sample package and attractive offer 10c. Write quick. Bestovall Products Co., Douglas Park Station, Chicago.

FREE! Sample Crease. Keeps trousers in shape 30 days. Astounding profits. Ava, 2656 Greenwood, Chicago.

"WASHWHITE" makes easy sales. Big profit. Sure repeat business. Genuine Rogers Silverware free to your customers, and valuable Premiums for you. Free printed matter and Sales Course. Free samples with every order. Cleans clothes without rubbing, and without injury to the finest fabric. 7 big washings for 15 cents. Sales Guaranteed. Write for Our Offer. The Nacma Co., Dept. J-7, 20 W. Lake St., Chicago.

EARN \$50 to \$100 monthly distributing Parker Hosiery to repeat customers at mill prices. All or spare time. Protected territory. Credit. D. Parker Mills, 2723 No. 12th St., Philadelphia, Pa.

AGENTS—200 Per Cent Profit. Wonderful little article. Something new; sells like wildfire. Carry right in pocket. Write at once for free sample. E. M. Feltman, Sales Mgr., 9539 3rd St., Cincinnati, O.

AGENTS. Make Big Money; fast office seller; particulars and samples free. One Dip Pen Co., Dept. 2, Baltimore, Md.

SIGN Letter Agents and Painters; 500% Profit Gold and Silver Sign Letters for Stores and Office Windows. Anyone can put on. Big demand. Free samples. Metallic Letter Co., 401 N. Clark St., Chicago.

PORTRAIT Agents, new and old, write us. We know what you want and need. Established 17 years, Pioneer, 1244 W. 63rd St., Chicago.

AGENTS make 500 per cent profit selling our Auto Monograms and Initials, Window Sign Letters, Changeable Signs, and Show Cards. 1,900 Varieties. Enormous Demand. Sullivan Co., 1123 Van Buren St., Chicago, Ill.

RELIABLE People Wanted to Place Our Orangeade Powder in stores and appoint agents. Makes the most delicious drink you ever tasted by just adding cold water and sugar. Enough for 10 glasses and particulars 10c postpaid. Chas. A. Morrissey Co., 4417 Madison St., Chicago, Ill.

\$61.50 WEEKLY introducing and selling a new gas light burner for kerosene lamps. Beautiful light. No chimney. No mantle. Samples free. Luther Manufacturing Co., Dept. 308, Cincinnati, Ohio.

LUMINOUS Paint! Shines in the dark. Big seller to hotels, garages, etc. Any article can be coated with splendid results, watches, clocks, electric switch plates, crucifixes, match boxes, etc. (Everlasting.) Only 25c a bottle. Particulars free. Luminous Paint Co., B-10 Douglas Park Station, Chicago, Ill.

AGENTS—\$3 daily selling our Handy Tool, 12 articles in one. Lightning seller. Sample free. Thomas Mfg. Company, 762 North St., Dayton, Ohio.

AGENTS—Men and women. Make \$30 to \$50 weekly selling the New Improved Monitor Self-Heating Iron—the "World's Best." Over 850,000 in use. Positively the easiest, fastest selling, lowest priced, best known iron made. Binding guarantee. Big profit for all or part time. Evans, N. Car., sold two dozen on Saturday. Mrs. Nixon, Vt., sold eight first half day. Liberal terms. Exclusive territory. Sample outfit free to workers. Write today. The Monitor Sash Iron Co., 836 Wayne St., Big Prairie, Ohio.

AGENTS—100% Profit. Three-In-One Shoe Brush, Polish, Dauber and Shiner—all in one. Costs only 1/6 of a cent a shine. Write quick for territory and free pocket sample. Fountain Shoe Brush Co., 1462 North St., Dayton, O.

EXCLUSIVE selling rights given for our Wonderful Triplex Folding handbag and other sellers. None sold in Stores. Write for terms and catalogue. Diamond Bros., 25 West 21st Street, New York.

HOW Men and Women can earn more money. Start now with the newest line. Establish a permanent and profitable agency business selling the Yanoco Complexion brush. French Ivory combs, mirrors, brushes and other household articles. Big assortment, repeat sales, liberal commission. Write now for money-making plan and territory. Yanoco Ivory Company, Avenue P., Leominster, Mass.

RAPID Fire Repeat Order necessity—startling profits—motor-back guarantee—factory prices—protected territory. Free particulars. H. E. Delbare, President, 728 So. Dearborn St., Chicago.

AGENTS—One cent invested in a postal card brings you our \$7.50 per day double money Ford Accessory proposition. Pocket samples. Pfau Manufacturing Co., 101 Meuter, Cincinnati, Ohio.

TAILORING Agents—Sell Cool Cloth, Beach Cloth-Mohair Suits, made to measure. Any styles wanted. Prices lower than Ready-Mades. Sample Outfit ready. Can make big money on this line. Leeds Woolen Mills, Dept. B, Chicago, Ill.

FOR newly invented article, novel, useful. In demand among all classes, everywhere. Sells on sight, many customers buy dozens. No competition, exclusive territory. Good profit. Dandy mail-order proposition. Sample postpaid 35 cents. Geo. W. Clark Co., 259 Fifth Ave., New York.

MAKE a break into this cold coaxing game. Why waste these Spring months on some dead proposition or at inside work when \$10 a day stares you in the face this moment. Wow! how they fall for our 11.00 piece toilet article combinations at \$1.60 each up with \$1.00 Carling Set Free. Get out and sell 15 to 25 a day and you will think you are in paradise with the streets paved with gold. Eagle made \$51 first week. Randall sold 30 sets in one day. Postcard gets full inside information with convincing proofs. Act! You owe it to yourself to get next this great opportunity, then decide. Face towards prosperity by writing us quick. T. Pierce Co., 906 Lake St., Chicago.

AGENTS: Big profits selling our New \$2.50 Automatic adding machine. Quick sales. Ten a day easy. No competition. Anyone having adding to do is positive customer. You'll be glad you wrote us. Bassett Company, 5921 Indiana Ave., Chicago.

AGENTS, \$50 a week. Will show you how. Genuine Gold Leaf Window Letters. Chicago Agency Co., 842 Altgeld St., Chicago.

AGENTS Wanted—Tolliver Puncture-Proof Inner Tubes sell easily—our agents make \$3.00 to \$50.00 a day net profit—no competition. If you wish to establish a business of your own with unlimited possibilities for profit, write us for complete details. Tolliver Tube and Tire Co., 523-E Foster Bldg., Denver, Colorado.

AGENTS—Make \$40 weekly selling Good-year raincoat. Sample coat free. Write for agency. Goodyear Mfg. Co., 400 Lillis Bldg., Kansas City, Mo.

GET into biggest money-making and automobile business—replacing necessary equipment. Live, hustling, ambitious men wanted as special factory representatives, exclusive territory, taking orders for tops, top coverings, seat covers, patent "Stik-Tite" Windows. No experience necessary. No capital required. No competition. Copyrighted system protects you. Free catalogue, samples, full details. Cincinnati Auto Specialty Co., Dept. MC-47, Cincinnati, Ohio.

AGENTS Wanted—500% profit. Our sign letters get the money. Easily applied. Sample free. Anderson Co., 2444 Chicago Ave., Chicago.

CALIFORNIA Flower Bead Necklaces beat anything for quick sales and profits. Absolutely new. Write for agent's proposition. Mission, 2819 P.M., West Pico, Los Angeles, Calif.

AGENTS, stop looking for free automobiles. Make \$75 to \$100 weekly selling our guaranteed custom-made raincoats. We deliver and collect. 1917 outfit free. "Aerco," Desk P, 175 E. B'way, New York.

BUILD UP a profitable Manufacturing Business of your own making Marvello-Wizard Laundry Tablets—No Paraffin, Iro or Potash—unequaled Washing Wonder. Zeero-Salz—New Egg Preserver—powdered form—beats cold storage. Fibro-Vac—Automatic Puncture plugger tire treatment—Carbo-Clide, the only satisfactory gasoline intensifier, decarbonizer. I supply guaranteed Formulas for making these and latest advertised specialties in all lines. Particulars, latest lists, Stamp, Miller, Analytical Chemist, Tampa, Florida.

AGENTS—Don't miss this unusual opportunity. Valuable premiums make quick sales. Particulars free, Sound Supply Co., Seattle, Washington.

RUSH postal for Free Sample "Spik & Span." Wonderful new washing tablet. Washes clothes spotless without rubbing. Tremendous seller, 200% profit. Free Samples to boost sales. Newberry Co., 212 Peoria, Chicago, Ill.

PHOTO Pillow Tops, Portraits, Frames, Sheet Pictures, Photo Plates, Pennants, Reflects credited. Prompt shipments; samples and catalogues free to agents; 30-days' credit. Jas. C. Bailey Co., K-1, Chicago.

AGENTS—Send for sample "Fretnot"—the wash day wonder. He convinced you can do a whirlwind business. You can clear at least \$20 to \$100 weekly, according to spare or whole time. You don't have to talk; if she doesn't buy at sight, leave sample; she will be looking for you long before you are able to make the rounds again. Samples furnished free. Premiums for your customers. Exclusive territory granted to agents who can produce. Credit given. Don't call. P. M. Motter & Sons, 3213 Warren Ave., Chicago.

"BE a Winner." Arnold made \$112 last week without investing a cent. Sell for large manufacturers finest to-order "Rex" raincoats and bathrobes. Sensational demand. We deliver and collect. American Mercantile Co., 969H Stimpson St., New York.

NEW "4 in 1" changeable letter sign. Agent's profit 100%. New England Co., New Haven, Conn.

AGENTS—Salary or commission. Greatest seller yet. Every user pen and ink buys on sight. 200 to 500 per cent profit. One agent's sales \$620 in six days; another \$32 in two hours. Monroe Mfg. Co., X6, La Crosse, Wis.

SELL guaranteed made-to-measure raincoats. Agent's price \$2.50 delivered. Material, workmanship, incomparable. Outfit free. Standard Raincoat Co., 395 B'way, New York.

"GOLDINE" Sign Letters—1,000% profit. Particulars free. Johnston Co., Quincy, Ill.

OFFICE Specialty—Sure sales getter. An up-to-the-minute necessity. Something different. Portland Sales Co., P. O. Box 422, Springdale, Me.

SEVEN out of ten automobile owners buy on sight. Campbell's Self-Vulcanizing Fabric Patch Tire and Tube Repair Outfits. 100% profit. Send 50c for sample \$1.60 outfit. Blowouts repaired in three minutes without heat. One Illinois agent averaged \$20.00 day profit last week. Campbell Tire Company, Kansas City, Mo.

OUR Simplex (kerosene) gas burners do away with wood and coal. Hundreds of pleased customers. Agents earning money. Write today for exclusive territory. Simplex Gas Plants Company, 154 Whiting Street, Chicago.

GENERAL Agents—Crew Managers—Capable of earning \$75 or more weekly. Sell new Guaranteed home specialty backed by \$200,000 corporation. Big profit. Quick sales. Exclusive Territory. Sales Manager, Dept. J-8, 20 W. Lake St., Chicago, Ill.

\$10 DAILY refinishing chandeliers, brass beds, automobiles by new method, producing amazing results; no capital or experience necessary; particulars free. Gunmetal Co., Ave. H, Decatur, Ill.

SOFT Drinks in Powder. Just add water—delicious, refreshing, healthful. Everyone buys—big profits. Enough for 16 glasses Orangeade and particulars 10c postal. Chas. S. Morrissey Co., 4417 Madison St., Chicago, Ill.

WANTED. General Agent to represent us in your locality. Exclusive territory. Big inducements. Chicago Agency Co., 840 Alameda St., Chicago.

AGENTS, grab this 25c household specialty. Lightning seller. One agent sold 160 one day. 140% profit. Write today. G. L. Erwin & Co., Manufacturers, 2113B Harrison St., Chicago.

AGENTS Wanted to handle Bonanza Sales Boards. Can be used for any purpose desired. Latest sensation in watch specialties that attract instant attention. Write for particulars. Gordon Specialty Agency, Dept. B-52, West Chippewa, Buffalo, N. Y.

\$25.00 TO \$200.00 Weekly. "GoodDrink"—new soft-drink flavors, \$500,000,000 spent last year for soft beverages. Exclusive territory if you act now! Merford Company, Incorporated, Department 250, Chicago.

AGENTS financially responsible who understand heating plants, to sell Blasko Fuel-Saving Devices on monthly payment plan. Every heating plant a prospect. Guaranteed to save 20%. Evaporation tests at two universities averaged 25% saving. Wolff Fuel Saver Company, 14 East Jackson Boulevard, Chicago.

MARRIED Salesmen and Agents—Wives to demonstrate in dept. stores, on salary. Easy sales to jobbers, dealers, consumers. All or part time, or side line. Appoint sub-agents. Silveron, the Silver-plating polish—needed in every home, hotel, restaurant, and garage. Guaranteed to Deposit Pure Silver. Write for proposition and sample. Exclusive territories open. Silveron, 157 Cedar St., N. Y.

REVIVO Rug Massage cleans Rugs, restores colors, 50c package, postpaid. Agents wanted. F. Shannon, Wellston, Ohio.

DON'T worry about the high cost of living! If you need more money, write us today. We have helped hundreds of inexperienced men and women into business for themselves with our gigantic household necessity lines, and can help you. No capital required. Outfit free! Write immediately! Costello Mfg. Co., 306 Ewing St., St. Louis, Mo.

AGENTS stung with slow-selling goods mail data immediately to Agents Protective Agency, 2408 P. St., Sacramento, Cal. Protect other Agents. No charge.

ONE agent in each town to handle our new system of heating; quick sales, good profits; easy to install. 3031 Main St., Kansas City, Mo.

AGENTS—Ho-Ro-Co Skin Soap and Toilet Goods plan beats everything for agents' profits. "Ho-Ro-Co," 112 Locust St., St. Louis, Mo.

LARGE Manufacturer wants agents to earn good pay selling high-grade custom-made raincoats. Goods sell themselves. No experience nor capital necessary. Deliver to customer. Prices defy competition. Guaranteed every sale. 1917 outfit free. Amer-Europ, Raincoat Co., 175 E. Broadway, N. Y., Desk P.

AGENTS—"Exclusive features" are what make easy sales—I can gain attention, close the sale and collect the money on six customers with the exclusive features of my non-alcoholic flavoring extracts, while you are struggling with one customer on the old commonplace line of talk. So can you! Prove it! Write today—big summer sellers—extra summer profits. J. M. Pitkin Co., 626 B. St., Newark, New York.

LARGE Manufacturer wants representatives to sell shirts, underwear, hosiery, dresses, waists, skirts, direct to homes. Write for free samples. Madison Mills, 586 Broadway, New York City.

WANTED—New Ideas. Write for list of Patent Buyers and Inventions Wanted. \$1,000,000 in prizes offered for inventions. Our Four Books sent free upon request. Victor J. Evans & Co., 163 Ninth, Washington, D. C.

SELL fiber brooms. Big profits. Best house to house proposition on the market. Outdoors four corn brooms. Write today. Robert Small, 443 W. 67th St., Chicago, Ill.

AGENTS Wanted; Sell Polishing Cloths, Rust Remover, Food Flavors, etc. 150 household necessities, guaranteed line, big profits, quick repeater, permanent business. Stuart & Co., 10 Main St., Newark, N. Y.

AGENTS—Big Hit: Our 5-Piece Aluminum Set is all the rage. Cheaper than Enamel Ware. Sells like wildfire. Guaranteed 20 years. Retail value \$5.00. You sell to housewives for only \$1.28. Biggest seller of the age. 0 sure sales out of every 10 shown. Others cleaning up \$10.00 to \$20.00 a day. Answer this quick to secure your territory. Div. G. G. 5, American Aluminum Mfg. Co., Lomont, Ill.

AGENTS: You can make big money taking orders for our fine made-to-measure clothes, so write quick for 60 beautiful cloth samples, 32 smart styles in rich colors, wholesale and retail price lists, lowest prices and best offer to agents, \$5.00 to \$10.00 a day easy. Big outfit, over 250 samples free to live wires. No experience needed—no capital. We furnish everything free—pay postage or express charges—back you, boost you, show you how and clearly explain everything. Costs nothing to try. Let us make you a stylish suit to measure to prove our fine quality and style. Send postal or letter today. Paragon Tailoring Co., Dept. 514, Chicago.

23% PROFIT selling Jubilee Spark Intensifiers to automobile owners, garages. Sure cure for Spark Plug troubles. Sells like wildfire. Brand new. Exclusive territory. Write today. Jubilee Mfg. Co., Dept. M-6, Omaha, Nebraska.

AGENTS, I want 100 men to act as my agents and take orders for "Kantleak" Raincoats. I paid \$21 Bridge \$88.95 for one week's spare time. Cooper \$314 last month. Wonderful values. A dandy coat for \$3.98. No money required. No delivering or collecting. Sample coat and complete outfit all Free. Big season just starting. There's a thousand dollars in this for you if you grab it quick. Write now. Comer Mfg. Co., 128 Paige St., Dayton, Ohio.

SELL Vulkless auto inner-tube repair material and Kurlite rubber dough for tire casings. Good profits. American Accessories Co., Dept. P-6, Cincinnati.

TAKE orders for men's custom tailoring, part time or all time. We furnish samples and everything needed to make a success without experience. Low prices; fit guaranteed or money refunded. You make good money on every order. You can wear swell clothes for almost nothing. Write quick for samples and all information if you live in a town smaller than 5,000 or on R. F. D. Knickerbocker Tailoring Co., Dept. 613, Chicago.

LIVE agents wanted for Superior Vulcanizers; large profits; every auto owner a prospect. Superior Vulcanizer Co., 16D Fulton Ave., Rochester, N. Y.

AGENTS: 100% profit selling Gas-Tonak. Reduces fuel cost, increases power and eliminates carbon. Every Auto owner a possible customer. Write for details. The Leslie Supply Co., 64 Union St., Newark, New York.

500 FORMULAS, including Resilvering Mirrors—Renewing Dry Batteries, Luminous Paint, 25c. Ideal Book Shop, 3315-A5, Belleplaine Ave., Chicago.

AGENTS make \$100 monthly selling our 500 handy household articles. Catalogue free. Scherf Company, Desplaines, Ill.

HERE'S your opportunity to get into a permanent, profitable business, "Evello," the great washing compound, fills a real want, repeat orders sure. We guarantee your sales, furnish samples and advertising free. Protected territory. If you mean business ask for sample and proposition. Do it now. Creston Mfg. Co., Creston, Iowa.

RAINPROOF Cap Goggles sewed in, 50c. Agents Wanted. Waterproof Novelty Co., 128 W. 23rd St., New York.

AGENTS: Sell our automobile necessity, enforced by law; heavily advertised. Every car a sale. Big quick profits; money-back guarantee. A. Alletannac, P. O. Box 46, Station B, Brooklyn, N. Y.

AUTOISTS who carry Klesling's Magic Vulcanizer laugh at punctures, and agents who sell it are cleaning up from \$35 to \$60 weekly. What motorist won't buy a device to patch tires that works without gasoline, alcohol or electricity? Anywhere, anytime and independent of mechanics. Five million prospects waiting for you to sell them. Investigate this. Klesling & Co., 333 Real Estate Trust Bldg., Phila., Pa.

AGENTS Wanted for best-selling household specialties on earth; goods sell themselves; write at once. The Addison Co., 224 Franklin Av., Scranton, Pa.

LUMINOUS Crucifix—Heatless Trouser Press; Toledo sold 60 Crucifixes in 10 days. Old Paduke, Paducah, Ky.

AGENTS. \$5-\$10 daily selling Iron Rust Soap, Removes Ink and Stains. Big demand. Every house. Exclusive territory. Other Past Sellers, Lawrence Co., E. Wooster St., Bowling Green, Ohio.

AGENTS: Sell "Motorpen." New Gasoline Saver, 100% profit. Write for particulars. Universal Supply Co., Box 394, Sidney, Ohio.

AGENTS: Motorists eagerly buy our automatic puncture cure, profitable. Chandler Co., Rocky Ford, Colo.

500% PROFIT putting initials on automobiles, new transfer method, particulars free. Auto Monogram, 2025 East Monmouth St., Philadelphia, Penna.

MAKE and Sell Your Own Goods. Formulas by Expert Chemists. Manufacturing Processes and Trade Secrets. Formula Catalog for Stamp. Blake Mystic Company, Washington, D. C.

GENERAL Agents, District Managers: Asbestos gas burner saves one-third gas, on gas ranges. Entirely new. Just out. 133% profit. Exclusive territory. Apply immediately. Sample 25c. Phillip Sills, 212 Drake Building, Oneida, N. Y.

AGENTS for all locations, as we find competent persons to handle our new system of oil heating. Quick sales, good profits. 3021 Main St., Kansas City, Mo.

OUR New Pocket Check Protector does work of \$25 machine. Sells for 50c. Big profits. All writers of checks ready customers. 50c brings sample and full particulars. Gray Mfg. Co., 304 1/2 Main, Fort Worth, Texas.

YOUR Name brings a copy of Money-Making Ideas. The great 32 page agent's and mail dealer's magazine. A. Kraus, 300 Kraus Bldg., Milwaukee, Wis.

\$1,000 PER Man per county. Strange invention startles world—agents amazed. Ten inexperienced men divide \$40,000. Kerstad, a farmer, did \$2,200 in 14 days. Schleicher, a minister, \$195 in first 12 hours. \$1,200 cold cash made, paid, banked by Stoneman in 30 days; \$15,000 to date. A hot or cold running water bath equipment for any home at only \$6.50. Self-heating. No plumbing or waterworks required. Investigate. Exclusive sale. Credit given. Send no money. Write letter or postal today. Allen Mfg. Co., 311 Allen Bldg., Toledo, Ohio.

AGENTS—Steady Income. Large manufacturer of Handkerchiefs and Dress Goods, etc. wishes representative in each locality. Factory to consumer. Big profits, honest goods. Whole or spare time. Credit given. Send for particulars. Freeport Mfg. Co., 59 Main St., Brooklyn, N. Y.

AGENTS Wanted Everywhere—To sell our attractive theatre Brass Poster Frames, Changeable Signs, Building Directories, Brass Signs, Brass Railings, Bank Fixtures, Adjustable Electric Light Brackets. Big demand; easy sales. Established 1882. Newman Manufacturing Company, Cincinnati, Ohio.

EASY, pleasant work for Mechanics, Shop Men, Clerks, during spare hours, will add many dollars to their salaries. Also want persons who can give full time. Big wages assured. Novelty Cutlery Co., 67 Bar St., Canton, Ohio.

\$5 TO \$15 profit a day selling most complete line Sanitary Household Brushes for every purpose. Our own make. Your territory awaits you. Write for attractive proposition. Puritan Sales Co., Dept. M, 1966 Broadway, New York.

AGENTS, 500% Profit, Sign-Letters for office and store fronts. Samples and particulars free. Inter-States Letter, 2424 N. Halsted St., Chicago.

BIG Money Selling Flower Seeds, List Free. John Weaver, Kinzers, Pa.

A NEW, Novel, and Clever Invention; wonderfully attractive; a market in every home; good profits; big demand; particulars free. Rhinoscope Mfg. Co., 323 W. 13th St., Kansas City, Mo.

PORTRAIT Agents: Deal with artist direct. Good work at reasonable prices. Chas. A. Sweet, Artist, 529 New Era Bldg., Chicago, Ill.

SNYDER'S Toilet Preparations and household necessities are big values; big profit makers; sell themselves; start making money immediately. T. H. Snyder Co., Cincinnati, Ohio.

BE your own employer. 100% profit. Manufacturer, 264 Spring, New York.

AGENTS—Just out, New Dollar Winner. One-Hand Speed Wrench. Machinists, autoists, farmers, everybody buys at sight. 100% profit. Make \$30 to \$50 weekly. Toledo Speed Wrench Co., Toledo, Ohio.

AGENTS—Make a dollar an hour. Sell Mendets, a patent patch for instantly mending leaks in all utensils. Sample package free. Collette Mfg. Co., Dept. 404-B, Amsterdam, N. Y.

AGENTS sell Reliable Custom-Made Raincoats and Gabardines. Big commission. Complete sample line free. Temple Raincoat Company, Templeton, Mass.

FREE sample with particulars. No splashing water strainers. Easy seller. Returns big. Experience unnecessary. Union Filters Co., New York.

INSYDE Tyres, inner armor for Automobile tires, double mileage and prevent punctures and blowouts. Quickly applied. Cost little. Demand tremendous. Profits unlimited. Details free. American Automobile Accessories Co., Dept. P, Cincinnati, O.

ONE good man wanted in each small town to take orders for tailoring in spare time or as a regular business. Good profits. Get your own clothes at special inside wholesale prices. Perfect fit and satisfaction guaranteed or no pay. Wonderful opportunity, experience not needed. Beautiful sample book and fashion plates free. Banner Tailoring Co., Dept. 562, Chicago.

DECALCOMANIA Transfer Initials and Monograms: You apply them on automobile while they wait; cost 2c each; profit \$1.38 on \$1.50 job; free particulars. Auto Monogram Supply Co., Dept. 1, Niagara Bldg., Newark, N. J.

A FEW reliable men or women to handle my 1916 "Business Guide." Sells everywhere. Beginners clear \$7 per day. 60% commission. Outfit free. Prof. Nichols, Box P. M., Naperville, Ill.

SELL Presto Auto Paint Kits for repainting Fords, etc. Good profits. American Accessories Co., Dept. P-5, Cincinnati.

BEST paying offer: 75c Water Filter for 25c; 25c for 18c; 25c for 13c; 15c for 6c, etc. Sample, 5c. Catalogue free. Surtis, 696 East 161st St., New York.

SIGN Letter Agents and Painters: 500% Profit Gold and Silver Sign Letters for Stores and Office Windows. Anyone can put on. Big demand. Free samples. Metallic Letter Co., 444 N. Clark St., Chicago.

HUGE profits selling Nibco Sanitary Brushes, Auto Washers, Brown Beauty Adjustable Floor Mops, Dustless Dusters, and other specialties. Big line. Fast sellers. Write today. Silver-Chamberlain Company, Department M, Claxton, New Jersey.

WHO wants to make more money selling brushes that every household needs? Special method of getting entrance to demonstrate. Fuller Sanitary Brushes are nationally advertised—largest output—best terms and prices—western distributing stations. Your territory is valuable. Write. Fuller Brush Company, Hartford, Conn.; Rock Island, Ill.

AGENTS—Stamping names on Pocket Key Protectors; sample Check with your name and address, 12c. Stamping Outfits, Emblem Checks, Check Fobs, Name Plates. Hart Mfg. Co., Desk 2, 393 Degraw St., Brooklyn, N. Y.

AGENTS: Make real money this year; not "paper money." Just think! Our Eradium (luminous) Articles Shine in the Dark. We manufacture a complete line so that every call can be turned into a sale. Everyone amazed at the wonderful possibilities of these goods. Our Eradium Bulb is easily attached to any light and "Locates Your Light in a Jiffy" in the darkest room. Our Eradium Crucifix showing the Christ figure in startling outline throughout the night sells to every Catholic. Our Eradium House Numbers (just out) are selling like Ford automobiles. Our Eradium Clock tells the time in the dark. Our Eradium Match Box sells like hot cakes everywhere. Garages, homes, etc. Our Eradium Switch Plate for hotels is a big seller. Write today for best proposition you ever heard of. Sole manufacturers. The Pioneer Corporation, 1259 West 63rd, Chicago.

BIG Profits for You! Manufacture Barley Crisp, New Confection, 5c package costs you 1c. Machine instructions complete \$7.50 prepaid. Send 10c for samples. Barley Crisp Co., 1263 Broadway, San Francisco.

YOU can be your own boss with our Key Check outfit. Good for \$5 a day stamping names on pocket key checks, fobs, etc. Sample check with your name and address, 15 cents. Pease Die Works, Dept. M, Winchester, N. H.

PORTRAIT Agents: Our goods will make you big profits. Delivery guaranteed. Refunds credited. Prompt shipments. Send for latest catalogue and prices. Adam J. Kroll & Co., 692 Blue Island Ave., Chicago, Ill.

BUILD your own phonograph or manufacture them to sell. Instructions, drawings, illustrations, parts-price-list 25c. Circular free. Associated Phonograph Co., Dept. P2, Cincinnati, O.

MAN or Woman to travel for old-established firm. No canvassing: \$1,170 first year, payable weekly, pursuant to Contract. Expenses advanced. G. E. Nichols, Philadelphia, Pa., Pepper Bldg.

AMAZING, new invention. Marvelous adding machine. Details \$7.50. Addis, Subtracts, Multiplies. Does work of \$200 machine. Five-Year Guarantee. Offices, stores, factories buy from one to dozen. Enormous demand. Every demonstration sells. Write quick for trial offer and protected territory. Dept. PM, Calculator Corporation, Grand Rapids, Mich.

GET Davis' Latest Proposition, \$15.00 daily a cinch. No matter how many times you have answered my ads in last 20 years, write again. E. M. Davis, Dept. 506, 900 Lake, Chicago.

AGENTS—Sell rich-looking imported 36x58 rugs, \$1 each. Carter, Tenn., sold 115 in 4 days. Profit, \$57. You can do same. Write for sample offer selling plan; exclusive territory. Sample rug by parcel post prepaid, 8c. E. H. Condon, Importer, Stonington, Maine.

AGENTS wanted for "Air-Cure" self-rejuvenating tire patch. Wild Mfg. Co., 1307 Nicollet, Minneapolis, Minn.

AGENTS—Line up for big profits this year. Hot string of brand-new exclusive sellers with the big "punch" just being brought out. Grab your territory now. You'll regret it if you delay. Adam Fisher Mfg. Co., Agency Dept., 2061 Railway Exchange, St. Louis, U. S. A.

MEDALLIONS—300% profits. Make up your own goods and be independent. Catalogue free. Besag Co., 1265 Randolph St., Chicago.

AGENTS—Our gold window letter proposition beats 'em all. Stalibrite Co., Dept. P, 1115 Second Ave., N. Y. Established 1905.

AGENTS, sideline men, sell Security Bash Locks, newest home invention. Locks windows any position; prevents burglary; permits ventilation; stops rattling. Homes and offices buy two to ten each. Enormous demand everywhere. Big repeater. To prove it's greatest agent's article on the market will postpay 25c sample for 10c. Try it, then you'll order a gross. Write today for sample and "no-talking" sales plan. Stonaker Mfg. Co., 1410 Standard Theatre Bldg., Cleveland, Ohio.

GREATEST of all clotheswashing compounds. No Rubbing, No Boiling, No Injury. Our agents cobbling money under our plan. Proof of success and particulars on request. Sample 10c. Utility Specialty Co., Chippewa Falls, Wis.

\$2.50 PER day Salary Paid One Person in each town to distribute Free circulars, and take orders for White Ribbon Concentrated Flavoring. Non-alcoholic—Big demand, steadily increasing. J. S. Ziegler Co., 7P E. Harrison St., Chicago.

STOP Here—Just Out—Eisen Regulator for Ford Headlights. Selling like wildfire everywhere. Gives splendid driving light at low speed—keeps bulbs from burning out—works entirely automatically. Needed on every Ford. Big profits quick. Listen: Hopkins, Tenn., cleared \$16.30 first day; McFarland, Neb., made \$3,492 in 17 weeks; Siler, Okla., sells 12 a day—profit \$20. No experience or capital needed. We show you how; sales guaranteed. Hurry—don't delay. Write now for special information. Address Eisen Instrument Co., 625 Valentine Bldg., Toledo, Ohio.

MERCHANTS wild over them. Kellner of Chicago sold first twelve "in no time." He says the Ever-Ready Changeable Letter Sign is "the greatest seller ever invented." Profits 95c on every \$1.50 sale. \$2.00 profit every hour guaranteed. Changeable Sign Co., 581-1024, Cleveland.

\$100.00 MONTHLY leaving "Easywash" free with Grocers everywhere. Particulars 2c. Michael Hertz, Cutler St., Newark, N. J.

AGENTS. Exclusive territory men and women to sell line of merchandise in demand the year around. Used in every home. Large profits. Valuable book free. Nassau Laboratories, Flushing, N. Y.

\$1,000 FOR your next 100 days, spot cash. New money-making invention for agents, general agents, managers. Recently invented, 1,000,000 already sold; 200 more salesmen wanted at once. Amazing automatic Compressed Air Washing Machine. Washes tub of clothes in six minutes. No cranks to turn or levers to push—no rubbing. Works like magic. Price only \$1.50—make sale at every house; 200% profit. L. Palmer, Glen Allen, Ala., put out on trial 108 machines, sold 197. Profit \$107. Write today. Wendell Co., 1183 Oaks St., Leipsic, O.

GENTLEMEN: Mason sold 18 Sprayers and Auto Washers one Saturday. Profits \$2.00 each—Square Deal. Write Rusler Company, Johnstown, Ohio.

AGENCIES WANTED

EXPERIENCED salesman wants agency for article of merit, specialty or staple. P. O. Box 333, Roanoke, Va.

SALESMEN WANTED

CAN you sell to business firms? If so, earn big commissions with our Advertising Calendars, Fans, Lead Pencils, other Advertising Novelties. Irresistible line. Plenty vacant territory West, Middle West. Only experienced traveling salesmen 25 to 45 years considered. Give particulars yourself, and references, first letter. Baker Advertising Co., Pueblo, Colo.

WHERE you ever offered a grocery store? Our proposition is better. Let us tell you how you can handle Flour, Canned Goods, Provisions—an entire line of Groceries, as well as Paints, Roofing, Stock Foods, Automobile and Machinery Oils and Greases. No rent to pay, no investments in stock. Larger orders taken from samples. Goods of guaranteed and proven quality. Selling experience not necessary. Very profitable work for "workers." Address R. S. Hill, President, Hitchcock Hill Co., Chicago. Reference: Any bank or express company.

HIGH opportunity for traveling salesmen for side line to establish agencies for a fuel saving device. University tests show saving 25%. Commission basis. Wolff Fuel Saver Co., Lytton Building, Chicago.

YOUNG men everywhere as Cigar Salesmen. Start \$29 weekly. Neway Sales Co., Hartford, Conn.

WANTED—Representatives everywhere. Exclusive territory. Gold sign letters for stores and office windows. Any one can put on. Write today for free sample. Metallic Letter Co., 463 N. Clark St., Chicago.

WANTED—Live Wire Advertising Salesmen—Exclusive line Signs and Novelties. Protected territory. Liberal commission. Funds advanced for traveling expenses. Give age, height, weight, business experience and three late references. Ithaca Sign Works, Ithaca, N. Y.

SALESMEN—Acquainted with grocery trade. Large demand; liberal commission; pocket sample. Wirth Salesbook Co., Dept. P., Chicago.

SALESMAN or Manufacturer's agents wanted on new line of electric fans, signs, etc. Liberal commission—basis. T. C. Smith Co., 1535 Cherry, Philadelphia, Pa.

EXCLUSIVE county rights. Sell Tankik: modern auto fuel. Profitable. Tankik Chemical Co., Cleveland, Ohio.

EARN \$5,000 to \$20,000 yearly. New business necessity. Retails \$5 to \$200. 100-200% profit. Purchaser satisfied or money refunded. No competition. Exclusive territory. Free samples. Sayers, 408 Wainwright, St. Louis.

SALESMEN—Wanted everywhere to sell Ajax Chemical Fire Engines. Liberal commission on every Engine sold. An average of one or two machines a week would earn you \$2,000 to \$4,000 a year. Factories, Stores, Industrial Plants, Private Estates, etc., all use Ajax Engines. No capital required. Goods well advertised. Ajax Fire Engine Works, 95 W. Liberty St., New York.

SALESMEN—Sell beautiful 28x34 Artz-kraft felt rugs for \$13.50 per doz. Your profit \$2.50 per doz. Kelso, Battle Creek, Mich., sold 30 doz. last week, his profit \$75. Sample Rug prepaid \$1.50. E. H. Condon, Mgr., 12 Pearl St., Boston, Mass.

SALESMEN—Get our plan for Monogramming Automobiles and motorcycles by transfer methods. Very large profits. Motorists' Accessories Co., Mansfield, O.

HELP WANTED

SALESMAN—\$6,000 Accidental Death, \$30.00 Weekly Accident Benefit, \$25.00 Weekly Sick Benefit, \$10.50 yearly, half amount \$5.50, \$250,000 deposited Insurance Department. Become independent. Experience unnecessary. Guaranteed steady income from renewals. Registration, Dept. B, Newark, N. J.

BE a Mirror Expert. Good income; spare time home at first; no capital; we train, start you making and silvering mirrors; French method. Free prospectus. W. P. Derr, Pres., 579 Decatur, Brooklyn, N. Y.

SPARKLING Jewels. Wear a beautiful gem. Earn \$50.00 monthly income, spare time, representing large jewelry house. Write today. Am. Jewelers, Box 1942, Riverside, Calif.

WANTED—Men to become chauffeurs, \$25 week. Learn while earning. Franklin Institute, Dep't B-801, Rochester, N. Y.

GOVERNMENT Positions are easy to get. My free booklet BY-29 tells how. Write today—Now. Earl Hopkins, Washington, D. C.

HIGH Pay. Free Travel, for Traffic Inspectors. We fit you in 3 months for influential position. Quick promotions. Big salary—all expenses paid. Ask for Free Booklet A-13. Frontier Prep. School, Buffalo, N. Y.

FREE Illustrated Book tells of about 300,000 protected positions in U. S. service. Thousands of vacancies every year. There is a big chance here for you, sure and generous pay, lifetime employment. Just ask for booklet C8-29. No obligation. Earl Hopkins, Washington, D. C.

U. S. GOVERNMENT wants Clerks, Men—Women, 18 or over. \$75.00 month. Write immediately for free list of positions now obtainable. Franklin Institute, Dep't B-21, Rochester, N. Y.

UNCLE SAM has thousands of jobs open this year. I will help you get one. Write for my big free book, DX-29. Earl Hopkins, Washington, D. C.

WE have an opportunity in California for an ambitious and capable young engineer, electrical and mechanical; technical graduate, with some shop experience to develop into engineering salesman. Give full experience, age and complete references. M. F., Room 928, 78 E. Madison St., Chicago.

WANTED—Men, 18 or over, as Railway Mail Clerks. Sample examination questions free. Franklin Institute, Dep't B-21, Rochester, N. Y.

CIVIL Service Examinations Open the Way to good Government positions. I can coach you by mail at small cost. Full particulars free to American citizens of eighteen or over. Write for Booklet CE-29. Earl Hopkins, Washington, D. C.

CASH paid for butterflies, insects. Some \$1 to \$7 each. Easy work. Even two boys earned good money with mother's help and my pictures, descriptions, price list, and simple instructions on painless killing, etc. Send 2c stamp at once for prospectus. Sinclair, Box 244, D 6, Los Angeles, Cal.

GET a sure job with big pay, steady work, short hours, regular vacations, rapid advance; thousands of positions open with Uncle Sam. I will prepare you in a few weeks at small cost. Write immediately for big free book, DU-29, with special offer. Earl Hopkins, Washington, D. C.

THOUSANDS Government Jobs open to Men—Women. \$75.00 month. Steady work. Short hours. Common education sufficient. Write immediately for free list of positions now obtainable. Franklin Institute, Dep't B-21, Rochester, N. Y.

GOVERNMENT Employees Wanted—Big pay, sure work. I will prepare you in a short time at small cost. Must be American citizen. Write for my free book FC-29, today. Earl Hopkins, Washington, D. C.

GOVERNMENT pays \$900 to \$1,800 yearly. Prepare for coming "exams" under former Civil Service Examiner. New Book Free. Write Patterson Civil Service School, Box 3020, Rochester, N. Y.

DO you want a sure job with big pay, easy hours and rapid advance? Write for my big free book, DW-29, which tells you how you can get a good Government position. Earl Hopkins, Washington, D. C.

TEACHERS, Register now for northwest positions. Inland Empire Teachers' Agency, Box 396, Shelton, Wash.

BRAKEMAN, Fireman, \$90 to \$200 monthly; positions now open for inexperienced men. Application blank sent upon request. Write Superintendent, Box 506, Fresno, Calif.

NO Strike! \$ Hour Day. Men Everywhere. Firemen, Brakemen, Baggage-men, \$120. Colored Porters. Experience unnecessary. Railway Bureau, E. St. Louis, Ill.

DO you want a position for life, with big pay, short hours and sure advancement? Then work for Uncle Sam. My free illustrated book, DK-29, tells how to get an appointment. Earl Hopkins, Washington, D. C.

THOUSANDS Government Jobs open to Men and Women. \$75 month. List positions free. Write immediately. Franklin Institute, Dep't B-21, Rochester, N. Y.

FIREMEN, Brakemen, railroads, everywhere, beginners \$125, positions guaranteed. Railway Association, Dept. 254, Brooklyn, N. Y.

WANTED. Men and women to qualify for Government positions. Several thousand appointments to be made next few months. Full information about openings, how to prepare, etc., free. Write immediately for booklet CG-29. Earl Hopkins, Washington, D. C.

\$10 DAILY refitting chandeliers, brass beds, automobiles by new method, producing amazing results; no capital or experience necessary; particulars free. Gunmetal Co., Ave. G, Decatur, Ill.

PATENTS—Send Sketch. Free Opinion and Certificate of Patentability. Free Book, "How to Obtain a Patent and What to Invent." Patents secured through Credit System. Talbert & Parker, Patent Lawyers, 4102 Talbert Bldg., Washington, D. C.

WORK for Uncle Sam. He is the best employer. Big pay, sure work, easy hours, long vacations, rapid advance. Thousands of jobs open this year. I will help you get one. Write for my big free book, DY-29, today. Earl Hopkins, Washington, D. C.

MEN—Women Wanted. \$75.00 month. List Government Jobs open—Free. Franklin Institute, Dep't B-21, Rochester, N. Y.

A POSITION is open for you in the Government service after we have helped you qualify. My money back offer guarantees it. Write quick for big free book DA-29. Earl Hopkins, Washington, D. C.

WANTED—Draftsmen and Designers. Cleveland Engineering Agency, Rose Building, Cleveland.

MAKE money writing Photo-plays; details free to beginners. No correspondence course. Producers' League, 230 Wainwright, St. Louis.

STOP that daily grind; take nose off grindstone; be no man's slave—punch nobody's time clock. Own your business. I start you silvering mirrors, plating tableware; home. Sure income—plans free. Clarence Sprinkle, Dept. 28, Marion, Ind.

WANTED—An Ideal! Who can think of some simple thing to patent? Protect your ideas; they may bring you wealth. Write for "Needed Inventions" and "How to Get Your Patent and Your Money." Randolph & Co., Patent Attorneys, Dept. 144, Washington, D. C.

GOVERNMENT Examinations. Most thorough preparation, \$5; returned if not appointed; particulars free. American Civil Service School, Washington, D. C.

SPLENDID chance to become drugless physician. Wanted: Strong, healthy young men and women to work in our Institutions on a "New Plan." Three year courses in all branches of natural healing. We give room, board, wages and full tuition in our college in exchange for services. High School Certificate required. Write for particulars. Lindlahr Nature Cure Institutes, Inc., 525 So. Ashland Blvd., Chicago.

WANTED

FOOT-POWER Screw-Cutting Lathes, machine-shop machinery, tools and supplies of all kinds. Send description for liberal cash offer. J. B. Murphy, Lock Box 675, Plainfield, New Jersey.

CASH Registers: Two. State model number, description, lowest cash price. Ronald J. Bailey, 1427 Walnut, Kansas City, Mo.

MANUFACTURERS of office and household specialties, looking for new lines. Empire Sales Agency, 114 E. 28th St., New York City.

CONSULTING ENGINEERS

AUTOMOBILE Consulting Engineer. Designs and devices criticised, motors a specialty. Opinions as to practicability of use and manufacture of accessories of all kinds given. Fee \$3.00 per answer. Save money by getting decision of practical man. C. L. Halladay, Merritt Bldg., Jackson, Mich.

GUNS, SPORTING GOODS, ETC.

BUY, sell, exchange all sorts old-time and modern Firearms. Stephen Van Rensselaer, Antiques, 805 Madison Ave., New York.

FLOUR & FEED MILLING MACHINERY

SPECIAL bargains in second hand Attrition mills, burr mills, crushers, corn shellers, bran dusters, dust collectors, purifiers, reels, double, single, 2 and 3-pair high roller mills, sieve bolters, receiving separators, scourers, etc. Write for description and prices. Sprout, Waldron & Co., P. O. Box 429, Muncy, Pa.

FOR SALE

\$500.00 TOLEDO Auto Vacuum Cleaner. Used one season. Sacrifice, quick sale. Write E. Dixon, 4636 Penn Street, Kansas City, Mo.

POWERFUL marine day and night glasses with case, 25-mile adjustment, \$7.50. Satisfaction or money refunded. Weil's Curiosity Shop, 20 South Second St., Phila., Penna.

UNIVERSAL Knitting Machines. Many styles and sizes. Hand machines and power machines, making seamless stockings, etc., plain or fancy. For catalogue address D. A. Becker, Peabody, Mass.

NEW, Improved Writterpress complete with Type, etc., at half price. Koester, Brunswick, Neb.

BOOKS, single or sets—sacrifice prices. We can save you money. Send your requirements—if we haven't got what you want we can get it. Books wanted, mention condition and spot cash price. Home Specialty Company, Box 172, Cleveland, O.

SALE OR EXCHANGE

WANT to Swap? Send 10 cents for "The Market for Exchange" to Pierre Notley, 141 Milk Street, Boston, Mass. It gives a long list of those who have things to trade or sell. Send list of things you have to trade or sell.

\$380.00 AUTOMATIC Pop-Corn Machine, trade for Job Printing Outfit. Koester, Brunswick, Neb.

MACHINERY, TOOLS & SUPPLIES

"RED Devil" 6½-inch nickel-plated steel combination Plier with screwdriver and prestolite key. Style 1124, sample 65c. Smith & Hennebury Co., 918 Chambers St., New York.

TOOLS—for shop, factory, garage and home—many high-class tools attractively priced in our "Odds and Ends" pamphlet—which is mailed free on request by Montgomery & Co., Inc., 105 Fulton St., New York City.

SMALL Bench Lathe for \$3, see our ad page 131.

PULLEYS, Gears, Sprockets, Shafting, Hangers. See page 133, W. A. Jones, Foundry & Machine Co., Chicago.

WIRE—all sizes—% to No. 16. Coppered, tinned, galvanized and plain steel wire for sale. Cooley Mfg. Co., 553 W. Monroe St., Chicago, Ill.

ENGINES, MOTORS AND DYNAMOS

WESTINGHOUSE, Wagner, Century, Emerson, Crocker-Wheeler, Western, Fort Wayne, General Electric rebuilt motors guaranteed for one year. Alternating and direct current. All sizes from ½ H. P. upwards. Tell us your needs. Satisfaction guaranteed or money refunded. Send for illustrated price list supplies and motors just issued. Hyre Electric Co., 6187 South Dearborn St., Chicago.

CHARGING Dynamos—Several hundred small machines from bankruptcy stock. Also lighting dynamo and several moving picture Arc generators. One and three phase motors up to 5 H. P. in stock for immediate shipment. ¼ H. P. A. C. motors \$15. All sizes—low prices. Write for list. Johnston, West End, Pittsburgh, Pa.

FALLS Motor—4 cyl, 3½x5¼, valve in head, high speed design for Indianapolis Speedway. Block tested O. K. Never used. Genuine bargain at \$235 f. o. b. Detroit. For quick sale. C. A. S. Sales Co., 891 Woodward Ave., Detroit.

TEN stationary steam engines, 15 to 100 H. P. each. Send for description of size wanted. Lucas & Son, Bridgeport, Conn.

WANTED—Electric portable drills, all sizes, both A. C. and D. C. Johnston, West End, Pittsburgh, Pa.

REBUILT Marine and Stationary motors, \$18 up. Particulars, Frazer Bros., Adams, N. Y.

MOTOR Wiring Diagrams—Twenty AC, four DC, four rotary converter blue-prints sent postpaid for \$1.50. Make windings easy. Korach Engineering Co., 536 Menard-st., Chicago.

PATENTS—Send Sketch, Free Opinion and Certificate of Patentability. Free Book, "How to Obtain a Patent and What to Invent." Patents secured through Credit System. Talbert & Parker, Patent Lawyers, 4645 Talbert Bldg., Washington, D. C.

REBUILT Engines—We have rebuilt "Buffalo" Engines, guaranteed, at greatly reduced prices. Write for bargain list. Buffalo Gasoline Motor Co., 1293-1305 Niagara Street, Buffalo, N. Y.

ENGINE User Agents Wanted to use, demonstrate and sell "Big Ben," wonderful new 2½ H. P. gasoline engine. Free introductory offer and free details. C. Benninghofen & Sons, Dept. P, Hamilton, Ohio.

FOR MECHANICS

TOOL Cases, For Carpenters and Machinists. Write for catalog, Keystone Case Co., 215 Kerstone Ave., Chicago.

CLEAN Hands perfectly with Kleen Kwik soap. Removes stains, grease and paint. Send 2c for Formula easily made at home by anyone. Geo. M. Studebaker, Jr., South Bend, Ind.

BOATS, LAUNCHES, ETC.

BUILD your own Steel boat from patterns. Material furnished, also finished boats. Catalogue free. Darrow Boat Co., Albion, Mich.

MOTORCRAFT Encyclopedia—A 150-page book that tells 1001 things every motor boatman should know. How to overcome engine troubles. Price \$1, postpaid. Popular Mechanics Book Dept., 6 N. Michigan Ave., Chicago.

FOR THE SHOP

SHOP Notes for 1917—Just Published—524 Articles, 422 Illustrations, 221 Pages. Easy Ways to do the Hard Things in every trade and calling. Price 50 cents, postpaid. Also all previous numbers in Shop Notes series Volumes 1 to 12 inclusive at 50 cents each, postpaid. Send for description. Popular Mechanics Book Dept., 6 N. Michigan Ave., Chicago.

PATTERN Makers! A book devoted to the principles of pattern and core making and molding. Written by G. H. Willard, a practical pattern maker of years' experience. This book, just published, treats the subject in a much more simple, direct and effective manner than most books along this line. 224 pages, 312 illustrations. Price, \$1, postpaid. Popular Mechanics Book Dept., 6 N. Michigan Ave., Chicago.

BLACKSMITHS

BE a Tempering Wizard. Tools and springs tempered by my formula, indestructible. Secret method never before divulged. You need it. \$1.00. Nontbreakable cold chisel free to every formula buyer. The Cold Chisel King, Stockton, Illinois.

BLACKSMITHS, Listen! The Blacksmiths come first of all trades. He must make the tools for all, from the Surgeon to the Safe Blower. With Top's Modern Methods doing hard jobs easy. Forging and making solid welds, hardening and tempering to a standard, with colored tempering charts. All for one dollar. Samples Free. W. M. Tor, Sidney, Ohio.

ELECTRICAL

WONDERFUL bargains, illustrated price list showing electrical motors and supplies, including sockets, wire, chisels, loom, switches, rosettes, porcelain goods, tape, plugs. Hyre Electric Co., 617PG South Dearborn St., Chicago.

ELECTRICIANS: Diagrams, blueprints, information on anything electrical. Send 25c. Explain your problem. Electricians' Service Bureau, Box 3, Brockton, Mass.

PATENTS—Send Sketch, Free Opinion and Certificate of Patentability. Free Book, "How to Obtain a Patent and What to Invent." Patents secured through Credit System. Talbert & Parker, Patent Lawyers, 4645 Talbert Bldg., Washington, D. C.

STAMP COLLECTING

STAMPS—12 different from warring nations, 10c; 10 different foreign coins, 15c; 20 Belgian stamps, 10c. Lists free. Toledo Stamp Co., Toledo, Ohio.

PRECANCELS, 100 different, fine, 25c. Bargain List Free. Weatherby, Medina, Ohio.

THE way to build your Stamp Collection. Send 50 cents for one of my approval Books. Select the stamps you want, to the value of Fifty Cents, and return me the Book. P. J. Pope, Charlotte, Vermont.

QUAINT Japanese Poster Ad Stamps, 10 different varieties, 12c. Miyako Company, 2218 W. 7th Street, Los Angeles, Cal.

THE Belmont Collector. Just out, with bargain galore. Free. Belmont Stamp Co., 32 South 17th Street, Philadelphia.

500 VARIETIES 75c. Approvals 60% discount. Lang, 1433 59th Ave., Cicero, Ill.

FREE! 25 Different British Colonials to applicants for approvals. Postage 2c. Nickles, 122 Florida Avenue, Washington, D. C.

STAMPS sent on approval at 70% discount. Reference required. Emory Benoit, Hanover, Pa.

FREE—60 different stamps, including Newfoundland, China, Japan, Mexico, etc., to applicants for our high-grade approvals. Send 2c stamp for return postage. The Edgewood Stamp Company, Dept. H, Milford, Conn.

750 STAMPS from 50 different countries, 15c. Luffbery, Wallingford, Conn.

FREE! 5 War Stamps to approval applicants. Riedell, Schenectady, N. Y.

AMERICAN Packet Free—Old Issues, Commemoratives, Galore, Dues, Revenues, sent 2c coin. Midland Stamp Company, Midland, Ontario.

LIBERAL Cash paid for old stamp collections containing good stamps. Write first to Beebe Company, Yonkers, N. Y.

24 VARIETIES Cuban stamps, 10 cents. List of 6,000 low-priced stamps free. Chambers Stamp Co., 111 P. Nassau St., New York City.

STAMPS, 75, all different, free. Postage, 2c. Mention paper, Quaker Stamp Co., Toledo, Ohio.

PACKET of 23 stamps; no two countries alike, 50¢ hinges. Set of \$1 and \$2 U. S. Rev., all for 5c. Mention paper. Miami Stamp Co., Toledo, Ohio.

105 CHINA, etc., stamp dictionary, list, 2c. Album (500 illustrations) 3c. Bullard, Sta. A., Boston.

STAMPS—500 fine foreign incl. Mex. War, Salvador, incl. officials, Guatemala, China, etc., only 15c. Best App. Sheets 60 to 80% dis. We give valuable extra Presents free! Big 120 pg. catal. free. We buy stamps. Hussman Stamp Co., St. Louis, Mo.

20 UNUSED stamps free. All different. Postage, 2c. Fisk Stamps, Toledo, Ohio.

PACKET "A" 100 varieties foreign stamps, 20c. F. J. Pope, Charlotte, Vermont.

121 ALL Different Foreign Stamps, including Guatemala, Honduras, Roumania, Costa Rica, Egypt, Chili, China, Mexico, Peru, Cuba, Russia, Japan, India, Victoria, Portugal, etc., 15c. 200 hinges free. Royal Stamp Co., 48 N. 51st Street, Philadelphia, Pa.

RARE COINS

CALIFORNIA gold, quarter size, 2c. Half dollar size, 5c. Dollar size, \$1.10. Large cent before 1821, Columbian nickel, and catalogue, 10c. Norman Shultz, King City, Mo.

50,000 COINS, notes, guns, pistols, Indian relics, curios. Catalogue 4c. Collectors Exchange, C-1336 Willington, Philadelphia.

RARE Notes for Collectors, A. Atlas Levy, Syracuse, N. Y.

WILL pay \$75.00 for 1884 Trade Dollar, 10 cents for 1912 nickels, 8c. mint. We buy for cash premiums all rare coins, bills and stamps to 1912—all rare cents to dollars. Send now 4c. Get our Large Coin Circular. Numismatic Bank, Dept. H, Fort Worth, Texas.

\$38.50 VILLA or \$16.00 Carranza Currency, choice 35c. Moore Coin Company, Commerce, Texas.

OLD Coins, Large Spring Coin Catalogue of Coins for Sale, free. Catalogue quoting prices paid for coins, ten cents. William Haslell, 101 Tremont St., Boston, Mass.

\$4.25 EACH Paid for U. S. Flying Eagle Cents dated 1856. We pay cash premiums on hundreds of Old Coins. Send ten cents at once for New Illustrated Coin Value Book 4x7. It may mean your fortune. Clarke & Co., Coin Dealers, Box 15, Le Roy, N. Y.

1917 COIN stamp and relic catalog sent on request. Coin Exchange, New Rochelle, New York.

GAMES AND ENTERTAINMENTS

FUN! Just out! Shooting fountain pen, looks like real pen, makes report like pistol. 25c. Two hundred other tricks and puzzles. Send 2c for illustrated catalogue. J. Grandfield, 1238 Theriot Avenue, Bronx, New York.

TRICKS, Puzzles, Jokes, Magical Apparatus, Plays, Stage Supplies, Mind-reading Acts, Sensational Escapes and Illusions. Free large illustrated 1917 catalog. Oaks Magical Co., Dept. 401, Oshkosh, Wis.

SHOW them what a wad you carry. Big bunch greenbacks 10c. 4. 25c. Hewes, 3684 Milwaukee Ave., Chicago.

SEND 10c for two Standard Puzzles. Receive Free. 2 Card, 2 Coin, 2 Joke Tricks; Apparatus and Catalogues. Chicago Puzzle Works, 3510 Herndon St., Chicago.

"HIGH-FLY"—Toy Pistol, Safe—Same. Throws Ball high. Agents wanted. Sample 10c. Novelty Sales Co., Lyons, Iowa.

AGENTS' Outfit (15 Joker's Novelties) 10c. Chambers Company, Plainwell, Mich.

SPECIAL—Greenbacks—Sneezing powder—Stink bombs—Magic Cards. All 25c. Mears, Box 66, Anderson, Ind.

TRICKS and Stage Money. Catalog No. 32 ready, 52 pages, 775 Magic Bargains, 2c. Finest Stage Money, 190, 35c; 29, 15c. Blanks for advertising. Gilbert Magic Co., 11135 Irving, Chicago.

CATALOG with 500 Illusions of 800 Tricks, Illusions, Escapes, 10c. Call or write. Hornmann Magic Manufacturers, 470 8th Ave., New York.

BING-BANG Fountain Pen, 50c. Chung Ling Soo's Linking Ring Trick 25c. Mysterious Tumbler and Vanishing Coin 25c. Trick loaded cigars 10c. Bogus Spikes 10c. Stage money, 15 bills 10c. Hundreds of others. Send 3c for large catalog. D. DeLuca, Dept. A, 880 Charles St., Marietta, R. I.

BE a Handcuff King. Escape from handcuffs, boxes, ropes, etc. Secrets of 20 Sensational Escapes \$1.00. Particulars free. Magcraft Co., Box 251, Detroit, Mich.

NIFTIEST Collection of Novelties and Money-Makers out. Big sample package, 10c. Peerless, 1616 Cleveland Avenue, Chicago, Illinois.

NEW Red Hot Novelty and Catalog for a Dime. Novelty Sales Co., Saginaw, Mich.

PLAYS, Vaudeville Sketches, Monologues, Dialogues, Speakers, Minstrel Material, Jokes, Recitations, Tableaux, Drills, Musical Pieces. Entertainments for all occasions. Make-Up Goods. Large Catalog Free. T. S. Denton & Co., Dept. 11, Chicago.

MAGIC—Tricks, Books and Supplies. For Amateurs as well as the Great Professionals. Any one can learn through our instructions. Feature Acts in Mind Reading, Spiritualism, Rope Ties, etc. Large illustrated Professional Catalogue, 10c. Chicago Magic Co., Dept. B, 72 West Adams St., Chicago, Illinois.

FOR THE HOME

SILKOLINE Pillow Tops, Very Beautiful! Retail 50 cts. Sample 25 cts. 3 for 50c postpaid. J. Walborn, Webster City, Iowa.

DIAMONDS, WATCHES AND JEWELRY

LOOK Here! Genuine diamond-set scarf pin, 45c coin. Huggard Co., Goldfield, Nevada.

PHONOGRAPHS AND RECORDS

VICTOR, Columbia, Edison Disc and Cylinder Records bought and sold. Victor and Columbia 15 cents up, Edison standard 9 cents, blue ambered 25 cents. Well attachment with jewel needle to play Edison disc records on Victorolas and Grapholas \$2.00. Send for record list. Well's Curiosity Shop, 20 S. Second St., Philadelphia, Penna.

BUILD your Phonograph. Highest quality motors, tone arms, reproducers, cabinets, lowest prices. Circulars free. Central Music Exchange, Indianapolis, Indiana.

PHONOGRAPH, Real Value \$7.50. Illustrated circular free. George Talbot, Norwood, Mass.

BUILD Your Own Phonograph. Any type. Big saving. Patents expired. Profits making and selling them. We furnish parts you can't make. Full instructions, dimension drawings, illustrations, parts—price-list only 25c. Circular Free. Associated Phonograph Co., Dept. P, Cincinnati, O.

FOR BOYS

"HOW to Pitch" 10c. Illustrated. Catalogue Free. Corson, 1720 N. Tripp Ave., Chicago.

BOYS: Make vacation money; distribute art goods among your friends and neighbors. We trust you. Gilbert's Arts, 824 Diversey, Chicago, Ill.

"SLIMMY Shlora" Metallic Frame Kite. Big value for a dime. Thayer Mfg. Co., Jackson, Mich.

FOR MEN

DIRECT from factory, one pound smoking tobacco for 50c. Retail 10c oz. 25 fresh mixed Havana cigars, 4 1/2" long, packed in cans, \$1.00. Chalken Tobacco Works, 2107 W. Grand, Chicago.

PATENTED Novelty, 100, 10c. Satisfaction Guaranteed. DeLoaf, 247 Harmon, Detroit.

SELL at half price—\$3.00 automatic razor sharpener, old style or safety blades; two \$2.50 old-style razors; three \$1.00 safety razors. All new, never used. Taylor, 719 Cook, Canton, Ohio.

WAVECURL imparts beautiful wavy curls, however listless your hair. One testimonial says, "My hair soon became a mass of wavy curls." Send 15c for a sample. Wavecurl Co., St. Paul, Minn.

RAZORS AND BLADES SHARPENED

SAFETY razors sharpened; two cents each. Guaranteed. Blade box free. Electro Stropping Co., 134 Shelby St., Detroit, Mich.

THEATRICAL GOODS

ELECTRICAL Stage Effects—Clouds, Ripples, Snow, Rain, Cyclone, Fire, Waterfalls, Waves, etc.; Spotlights, Stereoscopes, Nitrogen projectors. (Stamps for catalogue.) Stagecraft, 305 West 15th St., New York.

FOR WOMEN

OF Interest to Women. Cloth for Ladies' Suitings direct from factory; write for samples. F. A. Packard, Box P, Camden, Me.

MUSIC

"SWEET Luana" and "Honolulu Pakika," popular Hawaiian songs. 25 cents brings both. Money refunded if dissatisfied. Request catalog. Quince Company, Majestic Theater Bldg., Los Angeles, Cal.

BARGAINS—Selling out complete music stock. \$3.99 values \$1.00. Sample 10c. R. Scholz, Majestic Theatre Bldg., Sheboygan, Wis.

FORMULAS AND TRADE SECRETS

1,000 FORMULAS, 25c. 75 Manufacturing Secrets, 10c. Resilvering Mirrors—Renewing Dry Batteries—Gas Tonic—Mechanics Soap—Luminous Paint—20c each. Entire Collection, 50c. Satisfaction guaranteed. Big Catalog, 2c. Ideal Book Shop, 3315-F5 Belleplaine Ave., Chicago.

FORMULA for making aluminum solder, directions how to use, \$2.00. Birmingham Welding Co., Birmingham, Ala.

HIGH-GRADE, guaranteed formulas for everything. Staff of former U. S. Government experts for chemical analyses. No catalogs. Tell us your exact needs. United Chemical Laboratories, 13 H. Street, Washington, D. C.

OUR money-making formulas and receipts, 25c. C. E. Ayer, Flora, Ill.

FOR Sale—A formula to make and cure the highest powered smokeless powder in two hours; no nitro-glycerine. Write J. P. Kinney, Humboldt, Kansas. R. P. D. No. 4.

2,380 FORMULAS, Trade Secrets and money-making plans in "Encyclopedia Business Opportunities," 3 volumes. Worth \$3. Special offer \$1. Ideal Book Shop, 3315-K-5, Belleplaine Ave., Chicago.

1,000-PAGE volume of formulas. Trade search recipes embracing every trade and profession, \$2.00. Ellemu, 667 Ocean Ave., Jersey City, N. J.

GUARANTEED formulas, any kind 50c. M. Blair, Barre, Vermont.

20,000 FORMULAS, \$1, Postpaid. Complete list 4c stamps. Edm Bromley, Watervliet, N. Y.

TYPEWRITERS AND SUPPLIES

LARGEST Stock of Typewriters in America. Underwoods, one-fourth to one-half manufacturer's prices; rented anywhere, applying rent on purchase price. Free trial. Installation payments if desired. Write for catalogue 70. Typewriter Emporium, estab. 1892, 31-33 W. Lake St., Chicago, Illinois.

TYPEWRITERS—Prices wrecked. All Makes. Nearly New and Rebuilt, \$5.00 up. Coronas and other portable machines, \$10.00 up. Write for catalog 50H. Beran Typewriter Co., 58 W. Washington St., Chicago.

STARTLING Values in Typewriters, \$10 to \$15 up. Factory rebuilt. All makes. Shipped on trial. Write for our special offer No. 126-E. Whitehead Typewriter Co., 186 N. La Salle St., Chicago, Ill.

GUARANTEED Typewriter Ribbons 3 for \$1.00, any color, any machine. Non-Smear Carbon Paper, any size, any color. Featherweight or Standard, \$1.00 per box. Acme Co., 140 S. Dearborn, Chicago.

FRESH typewriters—1/2 manufacturer's prices! Big corporations select these bright, unused display models. Investigate Free Trials and name typewriter preferred. Co-operative Union, Covington, Kentucky.

DUPLICATORS AND DEVICES

\$300 MULTIGRAPH like new for \$100. Guaranteed. Russell Baum, Philadelphia Bourse, Philadelphia.

"MODERN" Duplicator—A Business Getter. Saves money, time, trouble. No glue or gelatin. Always ready. Easy to operate, 25,000 firms use it. 50 to 75 copies from pen, pencil, typewriter. Letter size complete, \$4.50. Satisfaction or money back. You need one. Write for free booklet now! J. E. Durkin & Reeves Company, Pittsburgh, Pa.

OFFICE EQUIPMENT

THE Ray Adding Machine, complete for \$15, handsome desk stand free. Adds with speed and accuracy of highest priced machines—also actually subtracts. Saves time, money, labor. Convenient to have on desk or to carry wherever needed. Used by Hershey Chocolate Co., Barrett Manufacturing Co., etc. Send no money, but write for 20 days' free trial. Ray Company, 1401 Power Bldg., Richmond, Va.

MAILING LISTS

AUTO owners, any state in Union, \$1 per thousand. Ford owners \$1.50. Guaranteed latest registration. A. S. Davis Co., Durham, N. C.

1,000 ILLINOIS Farmers' names \$1.50. 98% correct. Miss Lawrence, 245, Lincoln, Ill.

1,000 MAIL-ORDER Aspirants, dealers, formula users, late 1916 and 1917 \$2.00. All lists compiled from original letters. Service Company, 11521 Tuscora Ave., Cleveland.

GUARANTEED names of mechanics or other classifications \$1.00 per 500. J. L. Barbera, 3443 St. James Place (Oakland), Pittsburgh, Pa.

5,000 GUARANTEED Farmers. Also other lists. Sample hundred, 50c. P. O. Box 237, Youngsville, Penna.

GUARANTEED Mailing Lists of every description. Write us your wants. Western List and Letter Co., St. Paul, Minn.

1,000 PROSPEROUS Buyers or Agents' names postpaid \$1.50. Liebaw, Drawer 585, Erie, Pa.

PRINTING, ENGRAVING AND MULTIGRAPHING

1,000 3x6 CIRCULARS \$1.00; 5,000 for \$4.00; printed both sides 1,000 for \$1.50; 5,000 for \$6.50. Prepaid. 500 white bond letterheads \$1.50, prepaid. Burton Brothers, Louisville, Ky.

500 SWELL, Linen-Finish Letterheads printed two colors, \$2.50. Bond \$2. Price list. Samples 2c. Starb Printing Co., Hamilton, Ohio.

1,000 NICELY Printed Business Cards \$1.25; 2,000, \$2.00; 1,000 Bond letterheads, envelopes or statements, \$2.50. All kinds of extra good printing cheap. We make rubber stamps at low cost for business men. Price List Free. Bee Publishing Company, Rothville, Mo.

GUMMED Labels, 1x2 inches, 3,000 \$1. Circular free. Holmera Co., Hoboken, N. J.

250 LETTERHEADS and envelopes \$1.55 postpaid. Samples for stamp. Rose Company, Culberson, N. C.

STANDARD Sticker Co., 212 West 101, New York City, makes printed Gummed Labels, every purpose. Catalogue.

1,000 6x9 CIRCULARS \$1.35; 1,000 Bond Letterheads \$2.40. Both prepaid. Other printing in proportion. Samples free. Lee Mountain, Chavies, Ala.

1,000 LETTERHEADS, envelopes, billheads, statements, noteheads, \$2.25. Samples free. Weaver's Print Shop, Michigan City, Ind.

250 LETTERHEADS or envelopes \$1.60. Moyer Supply House, Milton, Pa.

QUALITY Printing Prepaid. 500 either envelopes, noteheads, cards, statements, \$1.35; 1,000, \$2.25; 1,000 envelope slips, \$1.25; 1,000 6x9 circulars, \$1.85; 500 linen-finish letterheads or envelopes, \$2.25; 1,000 \$3.50. Prepaid. Typewriter letters. Stamp brings samples. Model Company, Manchester, Iowa.

PRINTING Outfits—Presses, type, supplies, type novelties. Send stamp for catalogue. Model Press, York, Penna.

AT Last! Beautiful Lithography for small users. 1,000 Letterheads, 1,000 Billheads and 1,000 Statements, \$9.99. Engraving Free. Kaydee Lithographing Co., 764 Teutonia, Milwaukee.

SOMETHING New: Patented business and calling cards in book-form; tear off smooth; 100 cards and elegant seal grain case 50c; agents wanted. Sample case 15c. Anderson Co., 8112 South Green St., Chicago.

PRE-USED Printing presses, Type, Supplies, cheap. List for stamp. Popular Bargains, Richland, Pa.

CARDS, envelopes, bond noteheads, letterheads, statements, billheads, \$2.50 per thousand. Samples free. Gale Printing Co., Galton, Pa.

CATALOG 102 free illustrating gummed Labels and advertising stickers. 3,000 75 cents upward—direct from manufacturer. Royal Label Co., 468 Cherry, Philadelphia.

GOOD Printing at low prices. 1,000 good letterheads, envelopes, cards, billheads, labels, circulars, \$2.50. Samples free. Catalogues, booklets and circulars our specialty. Ernest L. Fautus Co., 323 S. Dearborn St., Chicago.

PERFECTION Letter Company, Muncie, Indiana, Multigraphs 500 purple letters with black letter heads, \$2.15. Samples for stamp.

LABEL Catalog "A" free. Irvin Wolf, 3186 Jasper Street, Philadelphia.

GOOD Printing, low prices, 1,000 good Letterheads, Envelopes, Cards, Bill Heads, Statements, \$2.60 per 1000. Imitation Typewritten Letters \$2.60 per 1000. Acme Co., 440 S. Dearborn, Chicago.

200 WHITE Bond Letterheads, printed \$1.00. W. Kinneer, Box 246, Brooklyn.

50 CLASSY Calling Cards and patented card case, 25c. Extra grade. Linen, 35c. Samples. Better, 304 Fourth, Tipppecanoe City, Ohio.

TYPEWRITTEN form letters, \$2.00 thousand. Get Samples and price-list. E. C. Marty, Canton, Ohio.

PATENT ATTORNEYS

PATENTS Wanted. Write for list of Patent Buyers who wish to purchase patents and What to Invent with List of Inventions Wanted. \$1,000,000 in prizes offered for inventions. Send Sketch for free opinion as to patentability. Write for our four Guide books sent free upon request. Patents advertised Free. We assist inventors to sell their inventions. Victor J. Evans & Co., 169 Ninth, Washington, D. C.

PATENTS and Patent Possibilities. A 72-page treatise which tells all about patents, what to invent and where to sell it. It gives honest advice to inventors and tells about the successes of some of my clients, also explaining what are frequent causes of failure. Manufacturers are constantly writing for protective patents upon all kinds of sound inventions. Can you help supply their wants? The book is free. Write for it today. H. S. Hill, 985 McLaughlin Bldg., Washington, D. C.

PRACTICAL Patent Service such as comes only with the mature judgment and years of experience of an old established firm, you can secure from Fetherstonhaugh & Co., 480 Victor Building, Washington, D. C. 85 years in U. S. and Canada. Free Booklet.

HIGH-VALUE Patents. See R. S. & A. B. Lacey's advertisement on page 154.

PATENTS—Send Sketch. Free Opinion and Certificate of Patentability. Free Book, "How to Obtain a Patent and What to Invent." Patents secured through Credit System. Talbert & Parker, Patent Lawyers, 4622 Talbert Bldg., Washington, D. C.

KEEP Up with Progress. Promote Your Patent. Send \$1.00 for Year's Subscription to Best Inventor's Magazine, "Invention and Manufacturing." United States Patent Corporation, Washington, D. C.

PROTECT your invention. Honest advice free. Personal service. Write for "The Truth About Patents." J. R. Kelly, 740A Woodward Bldg., Washington, D. C.

THE Patentome is free. An education in obtaining patents. Established 1865. Anderson & Son, Attorneys, 747-7th St., Washington, D. C.

PATENTS obtained through D. Swift being promptly sold to manufacturers. Write to-day for free books of "Inventions Needed" and surpassing references. D. Swift, 317 7th St., Washington, D. C.

PATENTS. R. Morgan Elliott & Co., Patent Attorneys, Mechanical, Electrical and Chemical experts, 713-721 Woodward Bldg., Washington, D. C.

PATENT applications filed on partial payment plan. We help sell the patent. Trade-marks, copyrights, etc. Milo H. Stevens & Co., 685 F. St., Washington; 253 Monmouth Bldg., Chicago, Estab. 1861.

PATENTABLE Ideas Wanted—Send for 4 free books. R. B. Owen, 30 Owen Bldg., Washington, D. C.

PATENTS on Easy Payments. Send model or sketch for Free Search and Certified Registration of Your Invention for Your Protection. Free Book Tells What to Invent and How to Obtain a Patent on Easy Payments. C. C. Hines & Co., 591A Loan & Trust Bldg., Washington, D. C.

PATENTS secured or all fees returned. Do not miss the generous offers in E. E. Vrooman & Company's display ad on page 151.

PATENT Your Ideas—\$9,990 offered for certain inventions. Books, "How to Obtain a Patent," and "What to Invent," sent free. Send rough sketch for free report as to patentability. Manufacturers constantly writing us for patents we have obtained. We advertise your patent for sale at our expense. Established 26 years. Address Chandee & Chandee, patent attorneys, 1099 F. St., Washington, D. C.

INVENTORS Attention—Get particulars of my system before applying for patent through others. It saves you money, and keeps you in touch with, and in control of, your case at all times. W. N. Roach, Jr., 350 McGill Bldg., Washington, D. C.

PATENTS—Send sketch for free search and report. Books on patents and book of reference letters sent free. John S. Duffie & Co., 619 F St., Washington, D. C.

INVENTORS: Write our Patent Dept. Adam Fisher Mfg. Co., 2661 C Railway Exchange, St. Louis, Mo.

PATENTS Secured or Fee Returned. Actual search free. Send sketch or model. 1917 Edition, 90-page patent book free. My patent sales service gets full value for my clients. It should never require more than two days to report upon the patentability of your invention; nor longer than ten days to prepare your application for filing. Longer delay amounts to gross neglect and the jeopardizing of your rights. For prompt personal service write. George P. Kimmel, 212 Barrister Building, Washington, D. C.

PATENT what you invent. It may be valuable. Write me. No attorney's fee until patent is allowed. Estab. 1882. "Inventor's Guide" Free. Franklin H. Hough, 522 Loan & Trust Bldg., Washington, D. C.

DON'T lose your rights to patent protection. Before proceeding further send for our blank form Evidence of Conception to be signed and witnessed. Book, suggestions and advice free. Lancaster & Allwine, 221 Ouray Bldg., Washington, D. C.

PATENTS Bring Riches; Protect Your Invention. Attorney's fee payable when patent allowed. Plain advice and "Patent Facts" free. Trade-marks registered. Jaynes & Jaynes, 653 Kellogg, Washington, D. C.

PATENTS: Send model, sketch or drawing. Advice, 100 Mechanical Movements and 50 Perpetual Motions, Free. Fred G. Dieterich & Co., 61 Ouray Bldg., Washington, D. C.

PROTECTIVE patents procured promptly. 104-page blue book on patents sent on request. Trade-marks registered. Robb & Robb, 211-215 Southern Bldg., Washington, D. C.

H. I. WOODWARD—Safe methods. Paying patents. Write today. 992 G St., Washington, D. C.

PATENTS that protect and pay. Advice and books free. Rates reasonable—highest references; best results. Watson E. Coleman, Patent Lawyer, 624 F St., N. W., Washington, D. C.

PATENTS—Herbert Jenner, patent attorney and mechanical expert, 606 F St., Washington, D. C. I report free of charge if a patent can be had and its exact cost. Send for circular.

PATENTS without advance attorney's fees. Send sketch for free report. Books free. Frank Fuller, Washington, D. C.

ATTENTION—Patents. You will like my easy Plan. Write for free booklet. C. L. Drew, 8 Victor Bldg., Wash., D. C.

FOR INVENTORS

INVENTIONS commercialized on cash and royalty basis. Patents secured. Models, experimental work and contract manufacturing. Inventors should write at once. Adam Fisher Mfg. Co., 2061A Railway Exchange, St. Louis, Mo.

Will manufacture on Royalty Household or other Specialties, which are Patented or Patent Applied For. Home Craft Shop, Toledo, Ohio.

INVENTORS of metal toys, novelties and specialties offered attractive proposition; inventions developed and marketed. Wonder Specialty Manufacturing Co., P. O. Box 497, Pittsburgh, Pa.

PATENTS—Send Sketch. Free Opinion and Certificate of Patentability. Free Book, "How to Obtain a Patent and What to Invent." Patents secured through Credit System. Talbert & Parker, Patent Lawyers, 4280 Talbert Bldg., Washington, D. C.

PATENTS, Trade-Marks and Copyrights. Our handbook on patents will be sent free on request. All patents secured through us are described without cost to the patentee in the Scientific American. Munn & Co., Patent Attorneys, 623 Woolworth Bldg., N. Y. Washington, D. C., office, 625 F. St.

PATENTABLE Ideas Wanted—Send for 4 free books. R. B. Owen, 30 Owen Bldg., Washington, D. C.

HIGH-VALUE Patents. See R. S. & A. B. Lacey's advertisement on page 154.

PATENTS on easy payments. Send model or sketch for Free Search and Certified Registration of Your Invention for Your Protection. Free Book Tells What to Invent and How to Obtain a Patent on Easy Payments. C. C. Hines & Co., 591A Loan & Trust Bldg., Washington, D. C.

INSURE Success. Skilled designing, automatic and special machines. Practical working drawings. Tipoons, Box 4708, Philadelphia, Pa.

PATENTS secured or all fees returned. Do not miss the generous offers in E. E. Vrooman & Company's display ad on page 151.

INVENTORS: My patent made a fortune. Let me sell yours. Send description. Eugene Pearl, 23 Union Square, New York.

INVENTORS: Invent for profit. Write for list of needed inventions. Sanders, 7 Webster Bldg., Chicago.

NO Attorney fees until patent allowed. Send sketch for free report. Books free. Frank Fuller, Washington, D. C.

INVENTORS—We specialize in manufacturing new patented articles—make models—dies—and do experimental work. Leo J. Geeding Mfg. Co., Dept. D, Opera Place, Cincinnati, O.

HAVE You An Idea? If so, you should protect it by a patent. Send us a model or sketch for free opinion as to patentability. Write for our Four Books sent free to any address. Victor J. Evans & Co., 157 Ninth St., Washington, D. C.

HAVE you a Patent to sell? You'll be interested in my proposition. Write now for free particulars. Don't call. F. W. Johnson, 8 N. Michigan Ave., Chicago.

WANTED—An Ideal! Who can think of some simple thing to patent? Protect your ideas; they may bring you wealth. Write for "Needed Inventions" and "How to Get Your Patent and Your Money." Randolph & Co., Patent Attorneys, 629 F. St., Washington, D. C.

INVENTIONS—Patenting and Promoting. A book containing practical advice and directions for inventors and manufacturers. Book, suggestions and advice free. Lancaster & Allwine, 221 Ouray Bldg., Washington, D. C.

PATENTS FOR SALE

WANT to Sell Patent Convertible Supports for Books. Write inventor. Ida Guthrie, Carthage, Illinois.

FOR Sale—Several inventions. Motion-picture projecting machine lens. L. Parrish, 67 Griffith St., Rochester, N. Y.

PATENTED Electrical devices. Outright royalty. John Mignone, Spring Valley, Ill.

OFFER Cash or Royalty; U. S. Patent No. 1,189,206. Improved, Profitable kite. Big field for this. Further particulars furnished on request. J. M. Moreira, 57 Hanover St., Lowell, Mass.

BIG monthly income for anyone operating Premium vending machines. Circulars free. Premium Vending Co., 3470 Scranton Rd., Cleveland, Ohio.

WANTED—A Canadian manufacturer to manufacture Pihlaja's Improved Lamp Extinguisher and Self-Wick cleaners for royalty. Has a big demand. Investigate, Pihlaja, Patentec, Box 417, Youngstown, Alta., Canada.

COMBINATION square, seven tools in one. Practical for mechanics, engineers. H. P. Farrington, 1347 Pacific St., Brooklyn, N. Y.

HOISTING Apparatus for use in automobile shop, etc. Light, durable and movable. Joseph Quinn, 3634 N. 3rd St., Philadelphia, Pa.

FOR Sale—U. S. and Canadian patents for automatic protection for telephones, cable pairs, and block switch systems. Don't write unless you mean business. J. E. Fullmer, Kilbourn "Dells," Wisconsin.

SANITARY Garbage Receptacle. Patented. Endorsed by physicians. Outright or royalty. Stanley, 136 Alder St., Waltham, Mass.

FOR Sale: Recent patent on a combined hair comb and brush. Very practical and novel device. Exclusive rights to the patent may be obtained on cash or royalty basis on suitable terms. Address Tadeusz Zdrodowski, 29 Orchard St., Plinston, Pa.

FOR Sale. Patents for piano attachment. Great help to beginners. Useful on all pianos. Write now for particulars. Geo. M. Studebaker, Jr., South Bend, Ind.

PATENT for Sale. For cash or royalty. An automatic gas cut-off valve. Can be used on natural or artificial gas. A safety first device and a sure money maker. For particulars address, Coley & Absalom, Montgomery, W. Va.

TRAY, no heating, serves hot food. Hotels, Hospitals, etc., pronounce necessity. E. L. Stine, 736 Brush, Detroit, Mich.

FOR Sale cheap. My patent on safety neckyoke device, for wagon or buggy pole. Cheaply made from pressed steel. Those interested, make offer. P. E. Guenther, Dagmar, Mont.

TATTING Machine, cash or royalty. Universal demand and enormous profits. Splendid mail-order or agents' article. C. Luther Brown, Chandler, Oklahoma.

CHEERRY Clipper, practical, sanitary and time-saving device, also attachment for stationary Electric Fan. Patent pending. Throws breeze several directions simultaneously. Adjustable, simple; substitutes oscillating fan, saving dollars to user. Manufactured cheaply. Best offers accepted. Edward Hanstey, 963 E. Main St., Stockton, Calif.

WINDOW Shade Bracket, adjustable; does not mar workwood. Easy and cheap to manufacture. F. Bett, 1325 West 104 Street, Cleveland, Ohio.

U. S. AND Canadian Patents on Lock Robe Rail for Automobiles for sale reasonable. A money maker for right party. Will sell a long felt want. D. C. Russell, 507 Laughlin St., The Dalles, Ore.

FOR Sale—Canadian patent on time-saving device. A light stamping proposition. Saves time, saves time. C. D. C., 409 Caesar Mich Bldg., Providence, R. I.

FOR Sale, patent 1,267,473, on corn planter harrow. Simple and cheap to make. F. O. Beckman, Grundy Center, Iowa.

CASH or Royalty. Patent No. 1,216,287. High chair substitute and Theater Chair attachment. E. Corbin 2324 N. Kenneth Ave., Chicago.

OUTRIGHT or royalty, funnel with automatic check valve, for sale. Just patented. Paul J. Reitzel, Silver City, N. C.

FOR Sale—Malted Milk Dispenser, patents pending. Hall, 2630 Pomeroy Street, Los Angeles, California.

SALE or Royalty. Horseshoes anyone can apply; rasp hoof level all that is necessary. No horseshoeing experience needed. Patent applied for, not yet issued. J. H. Howard, Taylor, Ariz.

STATE rights for wonderful invention as soon as patent issues. Lee Collins, 18th and Maple, Louisville, Ky.

ATTENTION, Disinfecting Pencil Rack, for use in Schools, Preventing Spread of Infectious and Contagious diseases. Patent Rights for Canada, England, France, Belgium and Germany. E. S. Mathis, Haddonfield, New Jersey.

MODEL Yacht Patent For Sale—License for exploitation of patent 1,134,476 April 20, 1915, covering a simple device. No clockwork; for operating model sailing yachts. Enables you to start boat from shore and have it return when desired. Prefer to sell this simple device on a royalty basis. For further particulars, address Dr. Mace, Grasse, France.

FASTENER for Shoes, Gloves, Automobile Curtains, Pocketbooks, etc. Most reliable ever invented. Millions will be used. Just patented, Outright or royalty. Investigate immediately. Hugh McIntyre, 784 Worthington Street, Springfield, Mass.

DO you want to buy a good money maker? Best Water Filter "patented" on the market. Michael Petritz, 82 Harmonia St., Buffalo, N. Y.

INVENTION—Windmill, simple, durable, inexpensive and develops wonderful power. Excellent proposition. C. A. Colvin, 608 Spruce St., Little Rock, Ark.

"DIRIGIBLE Auto Lights." A great boon to automobile owners. Assures safe night driving. R. O. Frost, Minden, Ontario.

PORCH Hammock Head or Back Rest. Patent pending; outright or royalty, adjusted under mattress. A. B. Wilcox, 546 Brandywine Ave., Schenectady, N. Y.

FOR Sale or Royalty. Gravity Hook for Extension Ladders. Best out, good seller. J. Austin Johnson, Hampton, N. H.

"SECTIONAL Boiler"—generates full steam in three to five minutes. Reduces fuel cost 75%. Manufacturing cost lower than others. Occupies much less space. Investigate. Carl Motter, Chelalis, Washington.

FOR Sale—\$5,000.00, and small royalty takes patent No. 1,118,749 on reinforced steel back, Main rod brass, for locomotives. Successfully used over three years. F. A. Eichorn, 33 Mitchell Ave., Chattanooga, Tenn.

PATENT for Sale: Much-needed Sanitary hair-cut bib or neck protector. Cash or royalty. S. DeVingo, Franklin Ave. and 6th St., Mt. Vernon, N. Y.

"PIPE Fitter's Rule." Necessary, simple, accurate. Cheaply manufactured. Large demand. Mail order or hardware. Patents pending. Blueprints on request. John Houston, 5901 N. Crawford Ave., Chicago, Ill.

WONDERFUL, new, simple, sanitary, extremely effective mouse-trap. United States and Canada patent for sale outright or royalty. Humbert Pierini, Sunny Side, Arkansas.

FOR Sale—Patent 1,179,023, automobile spring wheel. Practical, durable, simple, inexpensive, use standard wheels. E. W. Miller, Hazelton, Penn.

FOR Sale—Patent No. 1,066,130, projectile automatic. Can be made for 2 in. to 14 in. guns, 9 distinct explosives in one. Perfectly safe to handle in any way. Address J. A. Marker, Lamar, Mo.

PATENT No. 1,214,522, outright or royalty; simple, new novelty—Automatic Pan Cake Turner. F. Eckert, 2322 Park Ave., Chicago.

AUTOMATIC Sprinkling system for Gardens. Saves hose, time and trouble. Sell outright or royalty. Francis Nemeo, 1333 Ballou St., Chicago.

ADVERTISING Novelty Label on a match. Harvey Seaman, Charlottesville, Va.

PATENTS and Inventions for sale or on royalty. My clients have valuable inventions for market. No better investment for manufacturers or individuals. Full information without charge. Mention line of invention interesting you and data will be sent. Richard B. Owen, Patent Lawyer, Owen Building, Washington, D. C.

FOR Sale or Royalty—Safety Window Jack for Window Cleaner. A. P. Acuin, 824 Vallejo St., San Francisco, Calif.

MILITARY Game, cash or royalty. Rudolph W. Doan, LaCrosse, Washington.

FOR Sale: Valuable patent on household necessity. Can sell for \$1 or less, affording big profit. Will accept best offer. Marvin A. Smith, Cottonwood, Alabama.

NO. 1,217,288, Safety Razor. Best Sharp and double edge. Bargain. P. O. Box 112, Butte, Mont.

VALUABLE patents for sale or lease, cash or royalty. No. 10,355 Friction Speed Controller; 10,517 Folding Box; 10,143 Sanitary Paper Bread Board and Rolling Pin; 10,656 Self-Soaping Wash-Board; 10,554 Latch. Write us for price and terms regarding these and other late patents. Mention number and name of invention. If you desire to secure a patent send us a sketch, model, or photograph for free opinion as to patentability and copy of valuable book, "How to Obtain a Patent and What to Invent." Talbert & Parker, Patent Lawyers, 4687 Talbert Building, Washington, D. C.

PATENT outright or royalty. Surveyor's self-reading leveling rod. Wm. J. Barnecut, Painesdale, Houghton Co., Mich.

FOR Sale or Royalty, twin cylinder force pump, beats anything yet for open or driven wells. Guy Smyth, Shawneetown, Ill.

UNPATENTED inventions for sale. Henry Graff, 15 Victoria Ave., Jamestown, New York.

REMOVABLE, metal window ventilator, air controlled, filtered, humidified, sterilized or perfumed. Manufactured cheaply. Oscar Barth, Ft. Madison, Iowa.

PACKAGE-TIE—Substantial and effective. Tie for packages. Especially designed for trunk. Cheaply manufactured. A. J. Kershner, R. R. 19, Mount Vernon, Ill.

FOR Sale, Box and Barrel Warehouse truck patent. A. Wollbrandt, 3530 Brookdale Ave., Oakland, Calif.

KEY Looking Device for sale outright. Can be used inside of door as an excellent night lock, and outside of door with the padlock. Simple to manufacture. If properly advertised will sell with good success. Magnus Petersen, 222 Minor Avenue, North, Seattle, Wash.

PATENTED improved "Article-Carrier." Cash or royalty basis. Reasonable terms. U. S. Patent No. 1,177,692, Canadian Patent No. 175,789. For full particulars address Joseph Falls, Gunn, Wyoming.

PATENT wagon Jack for sale. Saleable article. C. S. Lehman, Lawn, Pa.

PATENT Buyers are invited to address our sales department for information on any class of Patents they wish to purchase or lease on a royalty. We have secured a number of valuable patents in all lines of invention. Mail Order, Department Store and Household Novelties a specialty. Victor J. Evans & Co., 160 Ninth St., Washington, D. C.

FOR Sale—U. S. and Canadian Patents on My Solid Tire Spring Base Auto Wheel. Will sell outright. For further information, address Philipp Wehner, 2922 Rear Market St., New Albany, Ind.

WE have some money-making inventions for placing on royalty; outright sale or trade. Write Adam Fisher Mfg. Co., 2061B Railway Exchange, St. Louis, Mo.

FLOAT-CONTROLLED Circuit breaker. Automatically indicates necessity of replenishing water supply, preventing burning out of engine. Simple—inexpensive and effective. A. Mosegard, Morgan Hill, Calif.

MODELS AND MODEL SUPPLIES

CONTRACT manufacturing models of anything in metal. Good work and a square deal. Barth Stamping and Machine Works, 3963 Reservoir Ave., Cleveland, O.

PATENTS—Send Sketch, Free Opinion and Certificate of Patentability. Free Book, "How to Obtain a Patent and What to Invent." Patents secured through Credit System. Talbert & Parker, Patent Lawyers, 4687 Talbert Bldg., Washington, D. C.

WANTED—New Ideas. Write for list of Patent Buyers and Inventions Wanted. \$1,000,000 in prizes offered for inventions. Our Four Books sent free upon request. Victor J. Evans & Co., 165 Ninth, Washington, D. C.

WE make working models for inventors; also dies and stamping of specialties, and carry a complete stock of brass gears and model supplies. Send for catalogue. The Pierce Model Works, 3405 Pierce Ave., Chicago, Ill.

PRODUCERS of Results: Inventions developed, Models, Experimental work, anything special in metal to order, novelties, spinning, forging, castings in any material, electrical devices, patterns of all kinds, plating general manufacturing, designing, special tools, punches and dies, stampings. Send drawing or sample. Expert information free. The John's Machine & Stamping Works Company, Dept. C, Cleveland, Ohio.

PERFECT models sell inventions. We make them. Write Adam Fisher Mfg. Co., 2061B Railway Exchange, St. Louis, Mo.

MANUFACTURING

AUTOMOBILE Accessories, Metal Specialties, electrical and mechanical devices; will manufacture on contract or royalty accurate die, tool, screw machine, brass finishing, drill and punch press, model and experimental work. Send models, drawings or blue prints for estimate. Berkmann Mfg. Co., 623 Jackson Blvd., Chicago.

PATENTED Articles, Models, Brass Work, Machine Construction; Dies Made. Baum's Metal Specialties, Kansas City, Mo.

INVENTIONS manufactured under contract. Write Adam Fisher Mfg. Co., 2061F Railway Exchange, St. Louis, Mo.

WIRE Goods, all kinds, made to order. Cooley Mfg. Co., 553 W. Monroe St., Chicago.

REAL ESTATE AND FARM LANDS

A **SMALL** farm in California will make you more money with less work. You will live longer and better. Delightful climate. Rich soil. Hospitable neighbors. Good roads, schools and churches. Write for our San Joaquin Valley illustrated folders free. C. L. Seagraves, Industrial Commissioner, AT&SF Ry., 1833 Ry. Exch., Chicago.

WANTED—Live agents to sell our Northern Minnesota lands. Liberal commission. Northern Realty Company, Duluth, Minn.

320 ACRES, close in, 200 in wheat, \$5,000, terms. A. A. Kendall, Owner, Colby, Kansas.

FOR Sale—Summer Resort. Modern hotel. Cottages. Completely furnished; electricity. Natural gas; motor-boat; row-boats. John Scheef, Lake View, Ohio.

VIRGINIA Farms—Large and small. Improved and unimproved. Reasonable. State your wants. G. C. Stone, Hurt, Va.

BEAUTIFUL Seashore Homesites only \$20. Special sale lots at Alamo Beach, Texas, famous Bayshore resort. Lots low as \$20. Terms \$1 cash, \$1 monthly. Lots 50x140 feet. Splendid investment. Write for free literature and views. Alamo Beach Company, 422 First National Bank, Houston, Texas.

TREGO County—You want a Grain or Stock Farm in the Great Wheat Belt? Hotel or Town Lots in the County-Seat? Pure water, fine climate, happiness and prosperity. Tell your wants to S. M. Hutzler, Wa-Keeney, Kansas.

FREE Government Lands—Our official 112 page book "Vacant Government Lands" lists and describes every acre in every county in U. S. Tells location, place to apply, how to secure free, 1917 Diagrams and Tables, new laws, lists, etc. Price 25 cents postpaid. Webb Publishing Co., (Dept. 71), St. Paul, Minn.

BARGAIN—Highly improved 80-Acre Farm. Mile from City, \$11,000. No Incumbrance. Owner, A. Byington, Route 2, Stevens Point, Wis.

CALIFORNIA farms for sale. Write for list. E. R. Waite, Shawnee, Oklahoma.

BARGAINS! Your pick of ten to eighty acres choice land near Plant City. Improvements required. Edward Miller, Crystal Springs, Fla.

MONEY-MAKING Farms, 15 states, \$10 an acre up; stock, tools, and crops often included to settle quickly. Write for Big Illustrated Catalogue. Strout Farm Agency, Dept. 3943, New York.

OWN your own Orange or Grapefruit grove in beautiful Fruitland Park. Let me tell you how melons, peaches, hay, your first crops, should pay for your land and grove. J. O. Lloyd, Desk 33, Fruitland Park, Florida.

EYE Opener—Thousands of acres fine land offered in Cass county. Easy terms. Write Ole Larson, Walker, Minn.

200 ACRES for sale. Good buildings, three-fourths mile from railroad station. Estate to settle. James Lower's Sons, La Porte, Ind.

TEXAS School Lands for sale by the state at \$2 per acre; 5c per acre cash and no more for 40 years, but 3 percent interest; send 6c postage for further information. Investor Pub. Co., Dept. 4, San Antonio, Texas.

CALIFORNIA land \$1 per acre cash. Balance purchase 90c month per acre. Immediate possession given. No taxes. No interest. Level San Joaquin Valley. Only four hours from San Francisco. 5 acres up. Clear; ready to plow; open ditch irrigation \$1 acre per annum. Particulars, maps, photographs, free. Stevinson Colony, Desk D, 785 Market St., San Francisco.

A **LITTLE** Farm Complete for \$330. With comfortable little bungalow, live stock, flock of chickens, poultry house and set of implements. Ready to move into and go to work. Only ten of these ready-made little farms available on Little Planters Colony at Richland Heights in the Shenandoah Valley of Virginia. Write quick for full description and easy terms of payment. F. H. LaBaume, A. & I. Agt., N. & W. Ry., 250 Arcade Bldg., Roanoke, Va.

NO interest. No taxes. No interest charged. Taxes paid by seller. First payment for ten acres only \$10. Subsequent payments only \$9 month. Five acres one-half this. Land cost \$45 to \$115 acre. Four hours rail from San Francisco. Level San Joaquin Valley. Clear. Ready to plow. Photographs, maps, particulars, free. Howard H. Hogan, Desk J, 785 Market Street, San Francisco.

SELL your property quickly for cash, no matter where located. Don't pay big commissions. Particulars free. Real Estate Salesman Co., Desk B, Lincoln, Nebr.

I HAVE a successful way of selling farms and farm lands. Write me for free particulars. No obligation whatever. Don't call. E. J. Zimmer, 925 Tower Bldg., Chicago.

NOT One Cent of Purchase Money Required to secure truck or chicken farm site, driving distance from Jacksonville, Fla., good fertile soil and title guaranteed; possession whenever you like and pay for land whenever you like, 25 years or more if desired; not more than 40 or less than 10 acres allotted to one person; any bank, city official, chamber of Commerce or commercial agency our references; write for particulars. Jacksonville Heights Improvement Company, Box 243, Jacksonville, Fla.

GINSENG

ROOTS and Herbs; how to gather, where to sell, and market prices. Books postpaid only 20c. Medical Plant Co., W. Milan, N. H.

DOGS, BIRDS, POULTRY AND PETS

SQUABS are raised in one month, they sell for fancy prices. Write at once for big free book telling how to make money breeding squabs. Plymouth Rock Squab Co., 634 Howard St., Melrose Highlands, Massachusetts.

RAISE Belgian Bares for us. Big profits. We furnish stock and pay you \$2.00 each. Also Cavies, mink, skunk, fox, squabs, frogs, etc. Two booklets and contract for dime. None free. Address the Belgian Hare, 31 Main Street, Holmes Park, Mo.

WHITE Collie Puppies, Registered Stock. Krouch Kollie Kennels, Tullahoma, Tenn.

DOGS, terriers, all breeds, workers and show, pedigree, Allstone Kennels, Bound Brook, N. J.

BIG Money in Pigeons and Squabs. Free book tells you all about it. Write today. Start profitable business of your own. Demand unlimited. Investment is small. Write today for Free Book. Indiana Squab Co., Dept. 1195, Terre Haute, Ind.

FOR Sale: Beautiful white Collies, Registered. Satisfaction guaranteed. Shomont Kennels, Monticello, Iowa.

WHITE curly Poodle pups for sale; also male dog. Wm. Stewart, Elkton, Minn.

FLYING Squirrels—for pets or show; odd, beautiful, intelligent, hardy; mated pair, \$2.50. Safe delivery guaranteed. Wildwoods Fur Farms, Colmesneil, Texas.

BREED Canaries. Profitable Pastime. Particulars Free. Bird Farm, Woodside, N. Y.

RAISE Guinea Pigs for us. We buy all you raise. Pay better than poultry. Contract, particulars, booklet how to raise free. Cavies Distributing Co., 707 W. 74th St., Kansas City, Mo.

RAISE skunks in city or country. Odorless method. Illustrated circular P free. Skunk Development Bureau, Chicago.

ANTIQUES AND RELICS

INDIAN Relics—Invaluable book for the collector of Ancient Indian Relics, describing 850 specimens, 150 illustrations. Postpaid 75c. James Ruby, Middletown, Pa.

POMO Indian Star Baskets. Prices free. Gilham, Highland Springs, Cal.

PERSONAL

FREE—Stop using tobacco. We will give free information how to conquer habit easily and permanently. Results Guaranteed. Anti-Tobacco League, Box 370, Omaha, Nebr.

BROTHER—Discovered root cures tobacco habit. Gladly send particulars. F. Stokes, McHawk, Florida.

FULL information about Divorce Laws of any state \$1.00. Legal Bureau, Athens, Penna.

MISCELLANEOUS

SHINES in the dark. Our Luminous Paint, coated on any article, makes them visible at night. Watches, clocks, electric switch plates, crucifixes, match boxes, etc., can be coated with splendid results. (Everlasting.) Only 25c bottle. Luminous Paint Co., Douglas Park Station (B-11), Chicago, Ill.

MAKE your own Printing Cuts. Complete process and working instructions 20c. Ideal Book Shop, 3315-P3 Belleplaine Ave., Chicago.

PLATES repaired like new \$1.00. Freshman Laboratory, 1773 Union Street, Brooklyn, N. Y.

PEARLS, baroque, slugs, bought and sold. Designing, mounting, repairing jewelry done. "Pearls and Pearlina"—best book published \$1.00. Laverne Mapes, Indiana Harbor, Ind.

TATTOOING Machines and Supplies. Our new 20-page Illustrated Catalogue is now off the press; it's free; get it at once. "Nuff Sed." Dogs, P., Werner Mfg. Co., 1321 Bremen St., Cincinnati, O.

ESCAPE King's trick set of Three Keys will open most ordinary doors. 25c complete set. Padlock Trick Opener, 10c. Chicago Novelty Works, 3310 Herndon St., Chicago.

SHOW Your Colors! Tiny American Flag, screw-back lapel button. Beautifully made of gold, and red, white and blue enamel 12c postpaid. Clarence C. Dry, 327 E. Spruce, Sault Saint Marie, Mich.

WORKING drawing of sun dial. Your own latitude. \$1.00. D. T. Marshall, Hollis, N. Y.

SPECIAL Offer—10% off. \$6.50 Hot or Cold running water. Bath outfits for \$5.85. No plumbing necessary. Thousands pleased. Order today. De Maagd Bros., 742 Atwood St., Grand Rapids, Mich.

CASH paid for butterflies, insects. Some \$1 to \$7 each. Easy work. Even two boys earned good money with mother's help and my pictures, descriptions, price list, and simple instructions on painless killing, etc. Send 2c stamp at once for prospectus. Sinclair, Box 214, D6, Los Angeles, Cal.

AMERICAN Flag—6 feet long—sewed handling—guaranteed fast color. Prepaid for \$2.00. C. Jensen, 342 W. 42nd, New York.

SHRAPNEL Shell Paper Weight. Be up-to-date and secure one for 25c. Representatives wanted. Specialty Mfg. Co., 10, Box 164, Milton, Pa.

NEW \$2.50 Automatic Adding Machine. Circular free. Bassett, 5921-J, Indiana Ave., Chicago.

LOCKSMITHS. How to unlock cylinder and all locks, 100 tricks of the trade \$1.00; money back if dissatisfied. Boutson, 305 Brook St., Oakland, Cal.

CUTS anybody can make. Simple, cheap process. Specimens, particulars for stamp. M. Day, Windfall, Ind.

C. S. A. MONEY. I guarantee what I handle are not Reprints of Confederate Money. Write for price list. Frank Shilling, Navarre, Ohio.

GRANDFATHER'S Clocks. Build your own Grandfather's Clock with our free blue prints. Works, Dial, etc., \$5 and up. Others with chimes at all prices. Write for free offer. Clock Co., 1671 Ruffner St., Philadelphia, Pa.

10,000 SELECTED scientific, chemical, technological, and practical recipes and processes, including hundreds of so-called trade secrets for every business, alphabetically arranged in one large volume of 800 pages. Price \$3 prepaid. Large descriptive circular sent upon request. Popular Mechanics Book Dept., 6 N. Michigan Ave., Chicago.

LEARN AUTOS

WHERE AUTOS ARE MADE

Enlarged
Facilities



Freely Endorsed by
Automobile Manufacturers

Detroit is the training camp for men who make good in the automobile and allied lines. Never has the call for men skilled as mechanics, testers, inspectors, repair-men, bearing scrapers, welders, chauffeurs and salesmen been as great as it is today — and the demand is growing.

The Y.M.C.A. Auto School

is organized to train men. A Course in this School will quickly fit the beginner to do well-paid work, and get in line for advancement in the rapidly growing automobile industry. Tuition fees go to procure the highest class of instructors and best of equipment.

Growth Brings Added Facilities

The Y. M. C. A. Auto School is now in its New Building. Among the manufacturers who have contributed liberally toward our equipment are: Studebaker, Buick, Hupp, Chalmers, Ford, Packard, Hudson, Gray & Davis, Delco, Cutler-Hammer, Zenith, and many others. Can you ask stronger proof of the school's standing than the fact that men who know give freely of their time and money to co-operate with us.

Tuition includes membership in the "Y" and free service of Employment Bureau for one year. Our big Club House, adjoining our New Building, is at your disposal. Reading rooms, lounging rooms, gymnasium, swimming pool, billiard and pool tables, bowling alleys, with five floors of dormitories and restaurant at low rates. You are assured of not only thorough and competent instruction, but good companionship and clean living conditions with the comforts of home and club life combined.

Don't Visit Detroit Without Seeing Us. You want to consider everything carefully before you enroll for any course of instruction. Come and look us over, whatever purpose brings you to Detroit. Get all the particulars of this school, get the records of our instructors, hear what auto factories and automobile men have to say about us, see for yourself our comfortable quarters and big equipment. We will be glad to see you and show you around whether you enroll or not. Day and night classes. Start at any time.

Write today for full particulars. Address

EDUCATIONAL DIRECTOR

Box 305, Y. M. C. A., DETROIT, MICH.



NEW HOME OF Y.M.C.A. AUTO SCHOOL

Please Mention Popular Mechanics

We Want to Train More Men!



\$2500 to \$10,000 a Year

Grasp the opportunity offered by Chicago "Tech" training. Study any branch of engineering, learn architecture or become an expert draftsman and designer under men who are actually doing big things. The men who will teach you here are not mere theorists—they are actually engaged in the profession they will teach you. They are bridge builders, they are designers and constructors of skyscrapers, they are contractors for large engineering projects. They know exactly what you need to know to hold a big paying position or go into business for yourself. Their graduates are always in demand because they are known to have just the training that fits them to do practical work.

This college was organized to provide a better class of men in these lines. The men at the head of Chicago "Tech" need highly trained men in their own businesses—and they constantly have calls from other employers who demand better than the average ability. Why don't you get a training here? Why not fit yourself for a big salary? At least find out about all this. Tell us just what branch especially interests you. Send the coupon today.

Architecture, Engineering, Drafting

The fees for these courses are so small and the terms are so liberal that even the man of small income can get Chicago "Tech" training. Every man who wants to rise should send for full information now.

Home Study Courses

If you now have a position, no need to give it up. You can get Chicago "Tech" training in your spare hours. We will teach you by mail. Lessons sent direct to your home, examination papers criticized and returned. No preliminary technical education required. Our courses can be mastered by any man even of limited education. Write for book telling you all about our special home study training and our easy terms of payment.

Free Drawing Outfit

Complete set of imported drawing instruments sent free on enrollment to correspondence students. You are ready to begin at once. First lesson goes the day you are registered as our student.

Free Test Lesson

Before you enroll anywhere, get this free test lesson—sent to show you how simple and practical our courses are. Your request on coupon brings it with the other information.



C. W. MOREY
President Chicago "Tech" says: "I want every ambitious man to write and find out just what we offer here. I promise that none will be disappointed."

Resident Courses

Those who have the time and would prefer to take class study here under direct personal supervision may attend the day or evening classes at Chicago "Tech." Direct daily contact with big engineering work. Special opportunities for employment for self-support while studying and for securing paying positions afterwards. We have resident students from all parts of the country—not only beginners, but graduate engineers taking advanced work.

Our book on this course shows pictures of college building and class rooms. Also describes course of study. Ask for it if you are interested in the resident instruction.

BUILDERS' COURSE

Men who are now in business as practical builders and contractors or employed by firms in those lines can be more successful by taking our Special Builders' Course, which teaches Plan Reading, Excavating, Contracting, Estimating, etc. Send for information.

Send Coupon

Don't delay. Chicago "Tech" experts are ready to train you to be a bigger man, a bigger money-maker. Put X in the coupon. Mark the course that interests you and get the coupon into the mail right now.

CHICAGO TECHNICAL COLLEGE

530 Chicago "Tech" Building
2721 South Michigan Ave., CHICAGO, ILL.

CHICAGO TECHNICAL COLLEGE
530 Chicago "Tech" Bldg., CHICAGO

Tell me about your expert training in course marked below.

- | | |
|--|---|
| <input type="checkbox"/> Drafting | <input type="checkbox"/> Electrical Engineering |
| <input type="checkbox"/> Architecture | <input type="checkbox"/> Mechanical Engineering |
| <input type="checkbox"/> Civil Engineering | <input type="checkbox"/> Builders' Course |

Name.....

Address.....

Resident or Home Study Course?.....



ALL ABOUT CARPENTRY

Here, in ten volumes, is explained in simple, easily-understood English, everything in carpentry and building from the first rough sketch of the architect to the acceptance of the finished structure. Includes wood, stone, steel and reinforced concrete construction, estimating and contracting, interior finishing and decorating, modern house lighting and sanitation. No one interested in the building profession can afford to be without these books—they increase incomes. Valuable alike to the handyman, the experienced carpenter, and the contractor and builder. And—we will send you the entire set of books without a penny down, so you can see them for yourself.

Mr. Fletcher Cunningham, Shreveport, La., writes:

"After receiving the books I decided that with their help I could go into the contracting business for myself. I have just closed a contract on which I expect to clear about \$112.00 for two weeks' work."

Partial Table of Contents

Mechanical, Fresh and Perspective and Architectural Drawing, Lettering, Pen and Ink Rendering, The Orders, Superintendence, Strength of Materials, Masonry, Reinforced Concrete, Carpentry, Steel Square, Stair-Building, Hardware, Steel Construction, Roof Trusses, Practical Problems, Estimating, Contracts, Specifications, Building Law, Sanitation, Sheet Metal Work, Electric Wiring and Lighting.

Shipped Free

We send the entire ten volumes, prepaid, right to your own home. This offer is open to every person living within the boundaries of the U. S. and Canada. Read them—examine them—put them to every test for seven full days. Then decide whether or not you can afford to get along without them. If you do not want to keep them, send them back at our expense. If you decide to buy, pay only—

50c a Week

Yes, send only \$2.00 after the seven days' trial, and then \$2.00 a month (50c a week) until the total price of \$24.50 has been paid. The regular price of these books is \$50.00, but you get them at the special price of \$24.50, a saving of more than one-half. The set consists of ten volumes, bound in half black morocco, stamped in gold, 4,790 pages (7x10 inches); 4,000 illustrations, full-page plates, building plans, diagrams, etc. See it for yourself before you decide to buy.

American Technical Society
Dept. R 1195 Chicago, U. S. A.

Please send me a complete set of the ten-volume Cyclopedia of Architecture, Carpentry and Building for seven days' examination. I will send \$2.00 after seven days and \$2.00 a month thereafter until I have paid \$24.50, or notify you and hold books subject to your order. Title not to pass until fully paid.

NAME

ADDRESS

REFERENCE

MAIL This Coupon

Don't send us a single penny. Just put your name and address in the coupon and mail it to us. Then we will send you the books for seven days' free trial. You don't have to come to a decision until you have examined them carefully for seven full days. Send the coupon now.

AMERICAN TECHNICAL SOCIETY
Dept. R 1195
CHICAGO, U. S. A.

Please Mention Popular Mechanics

A 'Steel Trap' Memory

One that takes a tight grip on facts, figures, names, details of every kind and hangs onto them through life—that's the kind of memory you ought to have and the kind you can have if you will give me ten minutes of your spare time daily for a few weeks. I will make your mind an infallible classified index of the things it is to your advantage to remember—give you power to concentrate, overcome self-consciousness, enable you to think on your feet, and address an audience intelligently without hesitancy and without notes.



The Key to Success



Henry Dickson, Principal, Dickson School of Memory

During the past 28 years I have trained thousands of people to STOP FORGETTING—aided them to greater business and social success—I know positively that the person with a strong, tenacious memory, though he be far behind at the beginning of the race for success, advances and soon out-distances his forgetful rival. The demands of commercial and professional life are so exacting in their details of facts and figures to be remembered, that to succeed or even hold your own you simply must possess a good memory.

Get My Remarkable Memory Test Free

I've had this test—most ingenious and most exclusive memory test ever devised—copyrighted. I'll send it to you, free, also a copy of my book "How to Remember" and tell you how to obtain a copy of my De Luxe edition, "How to Speak in Public," a handsomely illustrated \$2 book, absolutely free.

HENRY DICKSON, Principal,
Dickson School of Memory, 1105 Hearst Bldg., Chicago

LAW High-Grade Instruction by CORRESPONDENCE

Prepares You for the Bar—Est. 1892

Four Courses: College, Post-Graduate, Business Law and Bar Ex. Review. Classes begin each month. Approved by Bench and Bar. University Methods, Unabridged Text-Books, Cases. Course in Oratory, Public Speaking and Moot Court FREE with regular course. Graduates now practicing in every State. Write today for Catalog and Rules for Admission to the Bar. CHICAGO CORRESPONDENCE SCHOOL OF LAW, 520 Raper Bldg., CHICAGO



DRAWING

Learn by Mail in YOUR OWN HOME

Newspaper, Magazine and Commercial Illustrating, Cartooning, Water Color and Oil Painting. Learn drawing or painting for profit and pleasure. We can develop your talent. This school has taught thousands. Free Scholarship Award—special limited offer. Your name and address brings you full explanation and our handsome illustrated Art Annual by return mail. Don't delay, write to-day. Fine Arts Institute, Studio 565, Omaha, Neb.



LEARN TO WRITE ADVERTISEMENTS EARN \$25 to \$100 A WEEK

We can positively show you by mail How to increase your salary. BOOK MAILED FREE. PAGE-DAVIS CO., 112 Page Building Chicago, Ill., or 150 Nassau St., New York

STAMMERER

Attend no school until you read my book "How to Stop Stammering." A practical, modern Method that kills the fear of stammering. The Hatfield Institute, 109 North Dearborn St., Chicago, Ill.



LEARN WATCH REPAIRING



You can learn by our modern and original system of instruction every part of the Watch Repairing Trade at home as good or better than at a shop. You can earn money while learning and secure a well paying position or start in business after completing our course of instruction. Good watch repairers are always in demand and earn from \$20 to \$25 per week. For particulars apply to the Wisconsin School of Watchmaking, 518th Bldg., Milwaukee, Wis.



Learn Electricity

in the Great Shops of

COYNE!

Practical training is the golden road to quick success. No mere books or theory can fit you to hold the big paying jobs. Here in our great shops you learn Electricity from the bottom up — under actual working conditions — as every great electrical expert must learn to completely master it. Here you handle actual equipment! Here you actually do the work that pays

\$125 to \$300 a Month

Think of the difference! No correspondence! No books and papers! No long hours of tedious grind. The work at Coyne is vibrating with life — charged with electricity. Experts show you everything. They work with you — show you how. You imitate these masters! You learn by doing. It's amazing how quickly you progress. From the simplest door bell to the mighty motors — dynamos — electrical locomotives — everything is mastered with remarkable ease. Hundreds of successful graduates prove this fact. Many finish in 4 to 5 months.

Day or Evening Courses

LOW COST — EASY TERMS

Come to the great Shops of Coyne. Enter day or evening courses! Nothing bars you! Our tuition is so low it will astound you. You don't have to pay cash! We arrange acceptable easy payments if necessary. All tools and equipment are furnished free. Think of it! Your opportunity to thoroughly learn **Electricity, Drafting, Plumbing, Motion Picture Operating, Bricklaying** is right before you.

FREE Employment Bureau!

Don't let *anything* stop you! We maintain a Free employment bureau. We help worthy — serious young men get work while studying. We also help place graduates in big jobs.

BENNETT WELLINGTON COOKE, Director
COYNE TRADE AND ENGINEERING SCHOOLS

Dept. 1195, 39-51 E. Illinois St., CHICAGO

Drafting

Mechanical,
Architectural,
Builders' Course

Most thorough and complete Practical Courses in America. No correspondence. No mere copy work. Experts show you every move in our big shops. Check coupon for FREE Book.

MAIL COUPON FOR FREE BOOK

Get this book of Opportunity! From cover to cover it tingles with interest. Tells about our great shops! Covers many jobs open for Coyne trained men! Tells of great successes of Coyne graduates. Get this book by all means! It's free. Merely fill in the coupon, stating which trade you are interested in, and mail it **now — at once!**

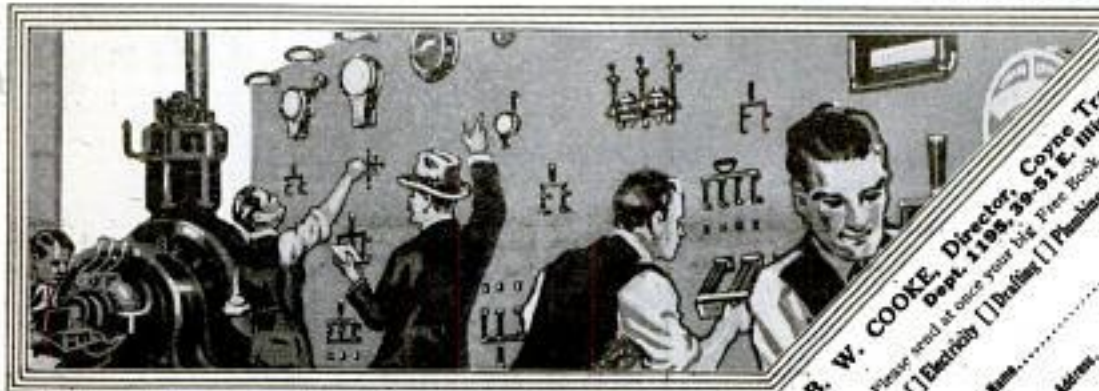

B. W. COOKE, Director, Coyne Trade and Engineering Schools
 Dept. 1195, 39-51 E. Illinois St., CHICAGO

Please send at once your big Free Book of Opportunity. I am interested in —

Electricity Drafting Plumbing Bricklaying Motion Picture Operating

Name.....
 Address.....
 Town.....
 State.....

YOUR LANGUAGE TELLS WHAT YOU ARE

Grenville Kleiser (Famous Speech Specialist) is giving a wider scope in life to hundreds of earnest men and women through his "wholly different" Mail Course in Practical English and Mental Efficiency.

ENLARGE YOUR STOCK OF WORDS.

Learn to use the right word in the right place. A limited vocabulary means limited thought, limited power and authority. Grenville Kleiser will give you a supreme command of words.

WRITE LETTERS, ADVERTISEMENTS AND STORIES THAT MOVE MEN TO "DO THINGS."

The Kleiser Course will give you the fundamentals that lead to success in any style of literature. It teaches the kind of English expression that awakens attention and compels action.

INCREASE YOUR INCOME OR BUSINESS.

There is scarcely any stronger impetus towards promotion and individual progress in business than the ability to express yourself in concise, grammatical English. The Kleiser Course will make you a bigger, more successful man by giving you this power.

BE A MAN OF CULTURE AND POWER.

Good English is the "hall-mark" of a gentleman. It enables you to enter good society and to feel at ease in the company of cultured people. The Kleiser Course in Practical English will awaken latent powers and ambitions. Not only will it give you a command of language, but it will develop personal magnetism, powers of concentration, will power, and build up a personality which will command recognition and advancement. It requires spare time only, and is free from involved rules.

Write to-day on a post-card for full information and free Booklet "How to Become a Master of English."

FUNK & WAGNALLS COMPANY, Dept. 978, New York

Mr. A. R. Patterson, whose advertisement appears below, was for eight years a Civil Service Secretary-Examiner, and is well qualified to help YOU secure a Government Position.

FREE BOOK OF GOV'T POSITIONS

Earn \$75 to \$150 a Month



WRITE TODAY

Be a Railway Mail Clerk, Post Office Clerk or Carrier, Rural Mail Carrier, Internal Revenue Officer, Clerk at Washington, D. C., or Panama Canal, or accept any other good Civil Service position with Uncle Sam, world's greatest and best employer.

Good Pay, Easy Work, Vacations, Position for Life

Earn \$75 to \$150 a month from the start. Rapid advancement. Work 8 hours or less a day. 15 to 30 days vacation with full pay. No strikes, no "lay-offs," no "glass ceilings." No politics, no "pull" needed. Ordinary education sufficient. American citizens 18 or over WANTED.

PATTERSON PREPARES YOU

Only school offering help of former Civil Service Sec'y-Examiner. Quick appointment certain. Bare position or no pay. Send coupon or postal NOW for book free.

FREE! Tells what positions are open. How to prepare easily and quickly for job you like best. Don't be satisfied with small pay, uncertain job. Write for book of Uncle Sam's positions and get on easy street. Mail coupon or postal NOW. Address

PATTERSON CIVIL SERVICE SCHOOL
88 News Bldg., Rochester, New York

Please Mention Popular Mechanics



*****COUPON*****
Send me Free Book of Government Positions.
Name.....
Address.....

Learn to PAINT SIGNS and SHOW CARDS

Get into this interesting, profitable and fascinating business where the field is not crowded. Thousands of cards used weekly.

Department stores, clothiers, movie shows, etc., pay big prices—work done quickly and easily—profits large—hundreds of jobs all around you. My students can more than pay for course doing jobs in spare time while studying. Increase your salary, get a better job or go into business for yourself.

Earn \$18.00 to \$45.00 a Week—Easily

I will train you to fill a big salaried job. I personally correct every lesson. 17 years' successful teaching. Thousands of successful graduates all over the world. No town too small, no job too big for my graduates. Get my training—start now.

Big Money in Card, Sign and Bulletin Business

No other profession pays such profits—work comes to you in abundance—no job will stump you—my students learn all. All the newest, sweetest designs, how to run the business, how to hire men, how to keep records, in fact gives you a complete training. You can finish my course in a short time. Read my guarantee—don't be out of a job or work at low wages any longer—

FREE Outfit
Write now for special literature and prices on 5 courses—terms, testimonials, sample lesson and Free Outfit offer. All Free—Don't delay, act quickly.

Get Started Now.

Guarantee
I guarantee to place competent graduates at \$85.00 to \$175.00 monthly. The demand for trained competent men is far greater than the supply.

Detroit School of Lettering, Dept. 205, Detroit, Mich.

A High School Course In Two Years

Learn in your own home. Here is a thorough, complete, and simplified high school course that you can finish in two years. Meets all college entrance requirements. Prepared by leading members of the faculties of universities and academies.

Write for booklet. Send your name and address for our booklet and full particulars. No obligations whatever. Write today—now. American School of Correspondence, Dept. P1195, Chicago, U. S. A.



IF YOU STAMMER

attend no stammering school till you get my large FREE book and special rate. Largest and best school in the world curing by natural method. Write today. Lee Wells Millard, Pres., North-Western School, Inc. 2317 Grand Avenue, Milwaukee, Wis.



BE A BANKER

Prepare by mail for this high profession, in which there are great opportunities. Six months' term. Diploma awarded. Send for free book, "How to Become a Banker." EDGAR G. ALDERSON, Pres. AMERICAN SCHOOL OF BANKING, 419 East State Street, COLUMBUS, OHIO

AT HOME Learn TO SING

Send 2-cent Stamp for Helpful Booklet, "The Voice Made Beautiful."

HARVEY SUTHERLAND, 1832P 49th St., BROOKLYN, N. Y.

SHORTHAND IN 30 DAYS

We absolutely guarantee to teach shorthand complete in only thirty days. You can learn in spare time in your own home, no matter where you live. No need to spend months as with old systems. Boyd's Syllabic System is easy to learn—easy to write—easy to read. Simple. Practical. Speedy. Sure. No ruled lines—no positions—no shading as in other systems. No long lists of word signs to confuse. Only nine characters to learn and you have the entire English language at your absolute command. The best system for stenographers, private secretaries, newspaper reporters and railroad men. Lawyers, ministers, teachers, physicians, literary folk and business men and women may now learn shorthand for their own use. Does not take continual daily practice as with other systems. Our graduates hold high grade positions everywhere. Send today for booklets, testimonials, etc.

Chicago Correspondence Schools
969 Unity Bldg., CHICAGO, ILL.



Train for a Job Like This

Don't be content to stay in a job that almost any man can fill. Prepare yourself for a position in a new profession—for a position that needs you—wants you.

There are 500,000 Firms that need the services of Expert Accountants. There are only 2,000 certified public accountants in America. The field is unlimited; the demand many times greater than the supply; the salary far in excess of that earned in other fields.

**We
Train
You By
Mail**

**Be An Expert
ACCOUNTANT**
At \$3,000 to \$10,000 a Year

**Your Instruction
Will Be Under
Direct
Supervision of
William
Arthur Chase,
C. P. A.**

—in spare time at home to qualify for one of these positions. You can advance as quickly as your time permits.

The expert accountant is the big man in the office—one of the most important factors in the conduct of any business. His knowledge of the innermost secrets of a business makes him indispensable to the boss. He is one of the first men to be consulted in all matters of management and finance and is confidential adviser in important executive affairs. His salary is anywhere from \$3,000 to \$10,000 a year.

Our training is made personal and individual. It takes into consideration your present knowledge or lack of knowledge and is fitted to serve your exact requirements. We prepare you from the ground up; provide complete and comprehensive training according to your individual needs from the simplest bookkeeping principles to the most advanced accounting problems. We will give you whatever training, instruction or review on the subject of bookkeeping you may personally need—and without any extra expense to you.

Small Cost—Easy Terms

In this course all needless text-book theory has been eliminated. It is practical, directly to the point, giving you such instruction as you need in the shortest possible time. The cost is surprisingly small, and the terms so easy that you will scarcely miss the money. You owe it to yourself to learn all the facts about this course and the truly remarkable opportunities it opens up in the business world today. We have published a book which tells the whole story. Explains state examinations, state regulations, salaries paid expert accountants, etc.—also gives complete information regarding the course. We will be glad to mail you a copy free, without the slightest obligation to you. Write your name and address in the coupon, mail it and learn how quickly you can, if you will, say good bye forever to hard grinding work, long hours, low wages with little or no chance for advancement and enter a field where there is plenty of room, where you can give orders instead of take them, and draw a real man's salary. Take the first step now. Mail the coupon today.

LaSalle Extension University, Dept. 564 H Chicago
"The World's Greatest Extension University"

Ex-Secretary of the Illinois State Board of Examiners in Accountancy, and other experts who rank among the highest. No expense has been spared to make this the easiest-to-understand, simplest-to-master, and most complete Home Study Accountancy Course ever prepared. It covers thoroughly every phase of Practical Accounting, Theory of Accounts, Auditing, Cost Accounting, Business Organization, Business Management, Business Laws, etc.

Hundreds of accountants, bookkeepers, clerks, cashiers, correspondents and office men in subordinate positions have developed into executives of rare ability and today are commanding handsome salaries—all because of LaSalle training. What we have done for others we can do for you.

The LaSalle Guarantee

We give you a written agreement signed by our Treasurer that upon your satisfactory completion of the course, should you fail to pass the certified Public Accountant's examination held in any state, we will give you special instruction and help—without additional charge—until you do pass. We further agree to refund entire amount of tuition, according to our Guarantee Bond, if dissatisfied with the course.

MAIL COUPON TODAY

LaSalle Extension University,
Dept. 564-H Chicago, Ill.

Send at once without cost or obligation to me, your valuable book of accounting facts and full details of your course in Higher Accountancy; also advise me about Special Reduced Rate and Convenient-Payment Plan.

Name.....

Street and No.....

City.....State.....

Please Mention Popular Mechanics



"I have watched the progress of the International Correspondence Schools almost from the very beginning, and while their rapid growth might be marvelled at by some, to me it is easily understood because I realize the practical value that is back of it, and know something, too, of the success attained by many ambitious men who have taken I. C. S. courses."

Thomas Edison

Edison Knows!

He knows the worth of spare time study. He knows what stuff men are made of who use their spare hours to train themselves for the bigger jobs ahead. And he knows what the International Correspondence Schools will do for the man with the grit to say, "I will."

All big men who have made their mark in the world had the ambition—the determination—to improve their spare time, to train themselves for big work. Edison did. You, too, can possess power, money and happiness if you'll only make the effort.

Put it up to us without paying or promising. Let us send you the details of others' success through the I. C. S. Mark and mail this coupon now.

INTERNATIONAL CORRESPONDENCE SCHOOLS

Box 5574, SCRANTON, PA.

Explain, without obligating me, how I can qualify for the position, or in the subject, before which I mark X.

- | | |
|---|--|
| <input type="checkbox"/> ELECTRICAL ENGINEER | <input type="checkbox"/> SALESMANSHIP |
| <input type="checkbox"/> Electric Lighting | <input type="checkbox"/> ADVERTISING MAN |
| <input type="checkbox"/> Electric Car Running | <input type="checkbox"/> Window Trimmer |
| <input type="checkbox"/> Electric Wiring | <input type="checkbox"/> Show Card Writer |
| <input type="checkbox"/> Telegraph Expert | <input type="checkbox"/> Outdoor Sign Painter |
| <input type="checkbox"/> Practical Telephony | <input type="checkbox"/> RAILROADER |
| <input type="checkbox"/> MECHANICAL ENGINEER | <input type="checkbox"/> ILLUSTRATOR |
| <input type="checkbox"/> Mechanical Draftsman | <input type="checkbox"/> DESIGNER |
| <input type="checkbox"/> Machine Shop Practice | <input type="checkbox"/> BOOKKEEPER |
| <input type="checkbox"/> Gas Engineer | <input type="checkbox"/> Stenographer and Typist |
| <input type="checkbox"/> CIVIL ENGINEER | <input type="checkbox"/> Cert. Public Accountant |
| <input type="checkbox"/> Surveying and Mapping | <input type="checkbox"/> Railway Accountant |
| <input type="checkbox"/> WIRE FOREMAN OR ENGINEER | <input type="checkbox"/> Commercial Law |
| <input type="checkbox"/> Metallurgist or Prospector | <input type="checkbox"/> Traffic Management |
| <input type="checkbox"/> STATIONARY ENGINEER | <input type="checkbox"/> GOOD ENGLISH |
| <input type="checkbox"/> Marine Engineer | <input type="checkbox"/> Teacher |
| <input type="checkbox"/> ARCHITECT | <input type="checkbox"/> Common School Subjects |
| <input type="checkbox"/> Contractor and Builder | <input type="checkbox"/> CIVIL SERVICE |
| <input type="checkbox"/> Architectural Draftsman | <input type="checkbox"/> Railway Mail Clerk |
| <input type="checkbox"/> Concrete Builder | <input type="checkbox"/> Textile Overseer or Supt. |
| <input type="checkbox"/> Structural Engineer | <input type="checkbox"/> Navigator |
| <input type="checkbox"/> PLUMBING AND HEATING | <input type="checkbox"/> AGRICULTURE |
| <input type="checkbox"/> Sheet Metal Worker | <input type="checkbox"/> Poultry Raising |
| <input type="checkbox"/> CHEMICAL ENGINEER | <input type="checkbox"/> AUTOMOBILES |
| | <input type="checkbox"/> Spanish |
| | <input type="checkbox"/> German |
| | <input type="checkbox"/> French |
| | <input type="checkbox"/> Italian |

Name _____

Occupation
& Employer _____

Street
and No. _____

City _____

State _____

If name of Course you want is not in this list, write it below.

Please Mention Popular Mechanics



MEN WANTED

FOR THIS HIGH CLASS TRADE

\$25 TO \$75 A WEEK

Any One Can Learn
in THREE TO SIX MONTHS

This strong statement is proved by the success of our graduates. Our Big Catalog tells How You Can Double and Treble Your Earning Capacity at moderate cost on easy terms.

ADDRESS DEPT. P.-102
Bodee Dental Trade School
Estab. 1892, 15-17 W. 44 St., New York
Under Supervision of N. Y. State Board of Regents

WRITE FOR IT RIGHT NOW



Learn a Paying Profession

that assures you a good income and position for life. For twenty-two years we have successfully taught

PHOTOGRAPHY

Photo-Engraving and Three-Color Work

Our graduates earn \$20 to \$30 a week. We assist them to secure these positions. Learn how you can become successful. Terms easy—living inexpensive. Write for catalogue—NOW!

ILLINOIS COLLEGE OF PHOTOGRAPHY, 999 Wabash Avenue, Effingham, Ill.

STUDY LAW 30 Days FREE

Let us prove to your entire satisfaction, at our expense, that the Hamilton College of Law is the only recognized resident law school in U. S., conferring Degree of Bachelor of Laws—LL. B.—by correspondence. Only law school in U. S. conducting standard resident school and giving same instruction, by mail. Over 500 class-room lectures. Faculty of over 30 prominent lawyers. Guarantee to prepare graduates to pass bar examination. Only law school giving Complete Course in Oratory and Public Speaking. School highly endorsed and recommended by Gov. Officials, Business Men, Noted Lawyers and Students. Send today for Large Handsomely Illustrated Prospectus and Special 30-Day Free Trial.

HAMILTON COLLEGE OF LAW, 1255 Advertising Bldg., Chicago, Ill.

The University of Chicago

HOME STUDY in addition to resident work, offers also instruction by correspondence.

For detailed information address

25th Year U. of C. (Dir. V) Chicago, Ill.



Learn Watchwork, Jewelrywork and Engraving.

A fine trade commanding a good salary, and your services are always in demand. Address HOROLOGICAL, Dept. P, Bradley Institute, Peoria, Ill., for our latest catalog.

MUSIC TAUGHT FREE

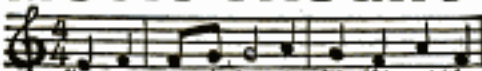

You can read Music like this quickly

IN YOUR OWN HOME

Piano, Organ, Violin, Mandolin, Guitar, Banjo, etc. Beginners or advanced players. One lesson weekly. Illustrations make everything plain. Only expense about 2c per day to cover cost of postage and music used. Write for FREE booklet which explains everything in full.

AMERICAN SCHOOL OF MUSIC, 51 Lakeside Building, CHICAGO

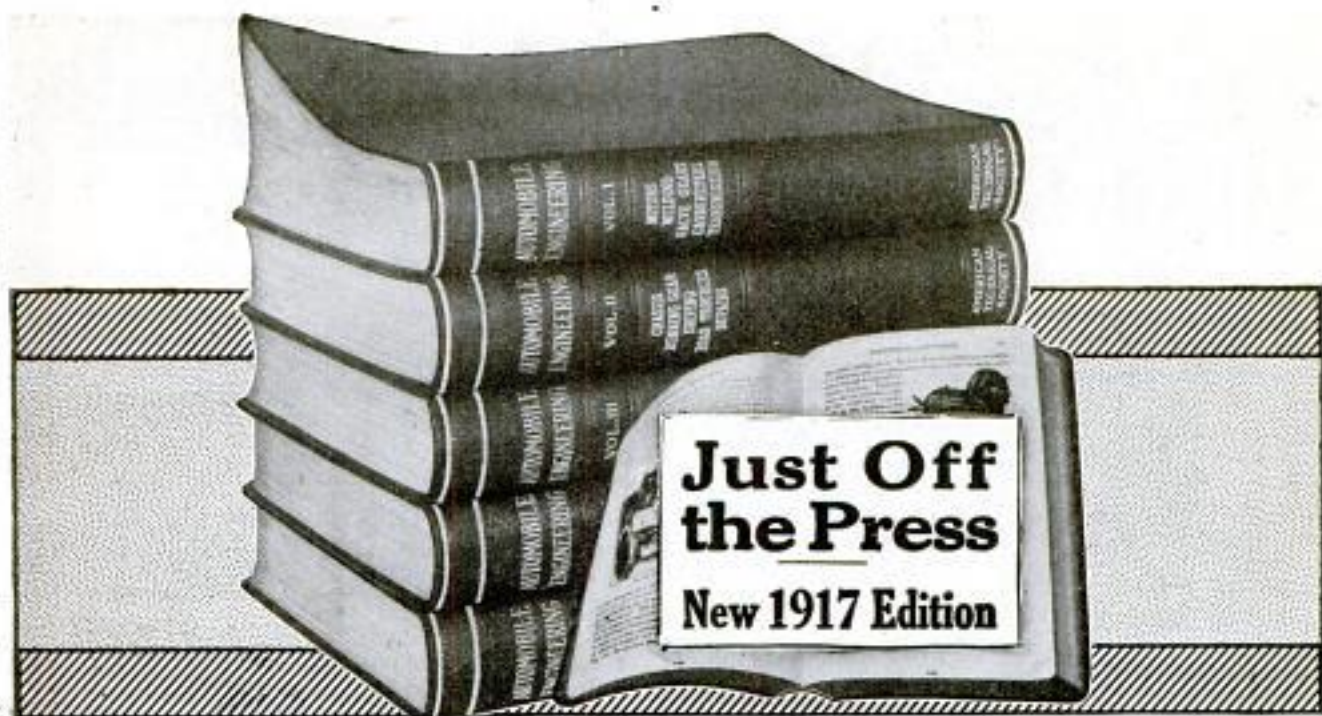

Automobile Engineering

— 50c a Week —

YES, you may get this newly-written automobile library for only 50c a week (\$3 a month.) The five thick volumes—which have just been printed—contain 2200 pages (5½x9¾ in.) and 2000 illustrations, diagrams and charts. Flexibly bound in genuine leather, gold stamped. Hundreds of pages explain all the up-to-date systems of ignition, starting and lighting. Welding; vulcanizing, and commercial garage equipment and operation is thoroughly covered. Carefully cross-indexed, so that the information you want can be referred to instantly. Handsomely bound in flexible morocco leather, gold stamped, these five volumes should be owned by every man interested in automobiles. They contain the combined knowledge of the greatest experts in the business. 2,200 pages (5½x9¾ in.) and 2,000 illustrations, tables and explanatory diagrams.

And for a limited time we are making an astounding offer. The regular price is \$25.00 but on a limited number of sets, we are making the very special price of \$15.84—and you can pay this rock-bottom price in easy monthly payments.

Shipped Free

On 7 Days' Trial

We'll send you the entire set, prepaid, for seven days' examination. Use the books just as if they were your own. See what it will mean to you to have this set always at your elbow. Then, if you decide you can do without it, send it back at our expense. However, if you decide to buy, send us \$2.00 after seven days and the balance \$2.00 a month.

Partial List of Subjects:
Explosion Motors, Welding, Motor Construction and Repair, Carburetors and Settings, Valves, Cooling, Lubrication, Fly-Wheels, Clutch, Transmission, Final Drive, Steering, Frames, Tires, Vulcanizing, Ignition, Starting and Lighting Systems, Wiring Diagrams, Shop Kits, Commercial Garage Design and Equipment, Electric Storage Batteries, Cars and Repair, Motorcycles, Commercial Trucks, Glossary.

FREE Consulting Service!

With each set we give you, absolutely free, a year's consulting membership in the American Technical Society. The regular price is \$12.00, but you get it free with this set. Put your perplexing problems up to a staff of experts. Ask them any motor question you wish. The solution of one problem might easily be worth more than you pay for the books. Ask as many questions as you wish during the year.

Send the Coupon!

Your name and address on the coupon brings the five books to you, express prepaid, for seven days' free trial. This offer is open to every resident in the United States and Canada. Act quick—while the offer lasts! Send the coupon today—NOW!

American Technical Society Dept. A-1195
Chicago, U.S.A.

American Technical Society
Dept. A-1195 Chicago, U.S.A.

Please send me the 5 volume Automobile Engineering for 7 days' free examination. If I decide to buy, I will send \$2.00 within 7 days and the balance at \$2.00 a month until \$15.84 has been paid. Then you send me a receipt showing that the \$15 set of books and the \$12.00 consulting membership are mine and fully paid for. If I think that I can get along without the books after the seven days' trial I will return them at your expense.

Name.....

Address.....

Reference.....

SIGNAL ENGINEERING



Free Book On Signal Engineering

THERE are thousands of miles of railroad that must be equipped with block signal systems. To superintend these installations and to maintain the systems now in use thousands of men are necessary. Golden opportunities are offered. Every ambitious man in America should write for the free book on Signal Engineering. It will be sent to you prepaid—without obligation.

Men Are Needed to Accept High Salaried Positions

When you stop to consider that, at the present time, less than one-fourth of the passenger lines in this country are equipped with automatic block signal systems—and when you read that the day is fast coming when the law will compel railroads to install them, you will realize what remarkable opportunities are offered to ambitious men in the profession of Signal Engineering. The work is big—broad—high salaries are paid. \$320.00 a month is an ordinary salary for a Signal Engineer.

Department of Signaling

Dept. 1195, 1810 Wilson Ave.
Ravenswood Station Chicago

GENTLEMEN:—Please send me absolutely free and prepaid your big new book on Signal Engineering. Also full particulars about your great special free outfit offer. It is distinctly understood that I assume no obligations of any kind.

Name.....

Address.....

Age..... Occupation.....

Please Mention Popular Mechanics

Send the Coupon

Put your name and address in the coupon, or a letter or post card. Now and get the free book about Signal Engineering. Too, we will tell you how you can get the training that you need in order to become a Signal Engineer. You will be under no obligation by writing for this free book. Do it Now.

Department of Signaling

Dept. 1195
1810 Wilson Ave.
Ravenswood Sta.
Chicago



**\$80 to \$250
and
more per Month**

—is being made by our graduates as Expert Auto Engineers, Chauffeurs, Race Drivers, Shop Foremen, Testers, etc.; others make \$12,000 to \$20,000 yearly in salary and profits—because our training is thorough and practical.

Opportunities now are better than ever; we have constant calls for more and more men. To get the best positions you must have the right training and the place to get it is the

CLEVELAND AUTOMOBILE SCHOOL

14 Years of Success—Over 4000 Graduates

Our school has the latest equipment including Knight type and 12 and 8 cylinder motors; latest starting and lighting equipment; Akron-Williams tire repair equipment, etc., etc.

JOIN US NOW!

Up-to-date training in 4 weeks, tuition reasonable, board \$5 to \$6 a week. New classes forming. Come now.

Cleveland Automobile School
2338 Euclid Ave., Dept. 5, Cleveland, O.



A Legal Training In Two Years

Study at home—during your spare time and get a thorough legal training. Successful graduates everywhere. Write for New Book. Send your name and address today for our new free book. Read about the possibilities open to law trained men and how you can fit yourself in two years. Write today.

American School of Correspondence, Dept. L 1195, Chicago, U. S. A.

A GOOD POSITION

with UNCLE SAM is most desirable. Life positions, pleasant surroundings, good pay, steady work, short hours, promotions on merit. Both sexes. No political pull. Thousands of appointments yearly. Most thorough preparation \$5. Returned if not appointed. Full information and questions used by the Civil Service Commission free.

AMERICAN CIVIL SERVICE SCHOOL WASHINGTON, D. C.

LEARN WATCHMAKING AND ENGRAVING

Earn while learning. Most practical watch school. Individual instructions. Graduates in great demand. Book free. Chicago School of Watchmaking, 63 E. Van Buren St., Chicago

STAMMERERS

Our course of private lessons will correct your impediments.
BOSTON STAMMERERS' INSTITUTE
Founded 1867. Samuel D. Robbins, Principal.
246 Huntington Ave. BOSTON, MASS.

LEARN LANGUAGES BY LISTENING ON YOUR OWN PHONOGRAPH

at home with Disc Cortinaphone Language Records. Write to us for FREE booklet today; easy payment plan. Endorsed by leading universities
CORTINA ACADEMY OF LANGUAGES
Suite 2307, 12 East 46th St., New York

Spanish-French-English-Italian-German

414 PAGES 145 ILLUSTRATIONS

I. C. S.
ELECTRICAL ENGINEER'S
HANDBOOK

50¢

ELECTRICITY!

HERE'S just the book on Electricity that you need to answer your many questions—to solve your knotty problems, to teach you new kinks, to be your memory for tables, rules, formulas and other Electrical and Mechanical facts that some people try to carry in their heads—and fail.

With this "Little Giant" I. C. S. Electrical Engineer's Handbook in your pocket, tool chest, on your work bench, drawing table or desk, an hour or a day need not be lost "digging up" some forgotten rule, some unfamiliar fact; you'll just turn to the very complete index and get it "in a jiffy." Just a few of the subjects treated are:

Electricity and Magnetism; Electrical Symbols; Batteries; Circuits; Magnets; Direct and Alternating Currents; Dynamos and Motors; Belts; Shafting; Electroplating; Electrical Measurements; Meters; Arc and Incandescent Lamps; Mercury-Arc Rectifiers; Transformers; Insulation; Electric Cars; Single and Multiple-Unit Control; Transmission; Rail Welding; Tables of Wires—Sizes, Capacities, etc.—Mathematical Rules, Formulas, Symbols; Tables of Constants, Equivalents, Roots, Powers, Reciprocals, Areas, Weights and Measures; Chemistry; Properties of Metals; Principles of Mechanics; First Aid, etc.

The Electrical Engineer's Handbook is one of 22 I. C. S. Handbooks covering 23 Technical, Scientific and Commercial subjects, all crowded with value. They have the contents of a full-size book condensed into pocket-size ready to go with you anywhere and be at your instant command. They are substantially bound in cloth, red edges, goldleaf stamping, printed from new, clear, readable type on good quality book paper. There is an illustration at every point where a picture will help. Hundreds of thousands have been sold on a money-back guarantee of satisfaction.

The regular price is \$1.25, but for a LIMITED TIME you can buy the ones you want, postpaid, delivery guaranteed, for only 50 cents each.

You Run No Risk! Money Back if Desired!
International Correspondence Schools
Box 5571, Scranton, Pa.

INTERNATIONAL CORRESPONDENCE SCHOOLS
Box 5571, SCRANTON, PA.

I enclose \$_____ for which send me postpaid the Handbooks marked X, at 50c. each. I may return any or all and get my money back within ten days from receipt:

- | | |
|--|---|
| <input type="checkbox"/> Electrical Engineer's | <input type="checkbox"/> Advertiser's |
| <input type="checkbox"/> Teleph. and Teleg. Engineer's | <input type="checkbox"/> Business Man's |
| <input type="checkbox"/> Mechanic's | <input type="checkbox"/> Bookkeeper's |
| <input type="checkbox"/> Steam Engineer's | <input type="checkbox"/> Steno. and Correspondent's |
| <input type="checkbox"/> Westinghouse Air Brake | <input type="checkbox"/> Salesman's |
| <input type="checkbox"/> Civil Engineer's | <input type="checkbox"/> Window Trimmer's |
| <input type="checkbox"/> Coal Miner's | <input type="checkbox"/> Cotton Textile Worker's |
| <input type="checkbox"/> Concrete Engineer's | <input type="checkbox"/> Farmer's |
| <input type="checkbox"/> Building Trades | <input type="checkbox"/> Poultryman's |
| <input type="checkbox"/> Plumber's and Filter's | <input type="checkbox"/> Mariner's |
| <input type="checkbox"/> Chemist's | <input type="checkbox"/> Automobile |

Name _____

Street and No. _____

City _____ State _____



"What y' Doin' Now, Bill?"

You don't have to ask that question of a *trained* man, because you *know* his position is a permanent one—that he is not at the mercy of conditions that affect the *untrained* man.

You can always be sure of a good position and a good salary if you have the *special training* that puts and keeps you in demand. The International Correspondence Schools will bring *special training* to you, no matter where you live, or how little spare time or spare cash you have.

To learn *how* the I. C. S. can help you, and how you can easily qualify for success in your *chosen occupation*, mark and mail the attached coupon today. Doing so costs you only the postage. You assume no obligation. If you *think* you're ambitious, marking the coupon will *prove* it. Do it NOW.

I. C. S., Box 5572, Scranton, Pa.

INTERNATIONAL CORRESPONDENCE SCHOOLS
Box 5572, SCRANTON, PA.

Explain, without obligating me, how I can qualify for the position, or in the subject, before which I mark X.

- | | |
|---|--|
| <input type="checkbox"/> ELECTRICAL ENGINEER | <input type="checkbox"/> SALESMANSHIP |
| <input type="checkbox"/> Electric Lighting | <input type="checkbox"/> ADVERTISING MAN |
| <input type="checkbox"/> Electric Car Running | <input type="checkbox"/> Window Trimmer |
| <input type="checkbox"/> Electric Wiring | <input type="checkbox"/> Show Card Writer |
| <input type="checkbox"/> Telegraph Expert | <input type="checkbox"/> RAILROADER |
| <input type="checkbox"/> MECHANICAL ENGINEER | <input type="checkbox"/> ILLUSTRATOR |
| <input type="checkbox"/> Mechanical Draftsman | <input type="checkbox"/> DESIGNER |
| <input type="checkbox"/> Machine Shop Practice | <input type="checkbox"/> BOOKKEEPER |
| <input type="checkbox"/> Gas Engineer | <input type="checkbox"/> Stenographer and Typist |
| <input type="checkbox"/> CIVIL ENGINEER | <input type="checkbox"/> Cert. Public Accountant |
| <input type="checkbox"/> Surveying and Mapping | <input type="checkbox"/> Railway Accountant |
| <input type="checkbox"/> MINE FOREMAN OR ENGINEER | <input type="checkbox"/> Commercial Law |
| <input type="checkbox"/> Metallurgist or Prospector | <input type="checkbox"/> GOOD ENGLISH |
| <input type="checkbox"/> STATIONARY ENGINEER | <input type="checkbox"/> Teacher |
| <input type="checkbox"/> Marine Engineer | <input type="checkbox"/> Common School Subjects |
| <input type="checkbox"/> ARCHITECT | <input type="checkbox"/> CIVIL SERVICE |
| <input type="checkbox"/> Contractor and Builder | <input type="checkbox"/> Railway Mail Clerk |
| <input type="checkbox"/> Architectural Draftsman | <input type="checkbox"/> AGRICULTURE |
| <input type="checkbox"/> Concrete Builder | <input type="checkbox"/> Textile Overseer or Supt. |
| <input type="checkbox"/> Structural Engineer | <input type="checkbox"/> Navigator |
| <input type="checkbox"/> PLUMBING AND HEATING | <input type="checkbox"/> Poultry Raising |
| <input type="checkbox"/> Sheet Metal Worker | <input type="checkbox"/> AUTOMOBILES |
| <input type="checkbox"/> CHEMICAL ENGINEER | <input type="checkbox"/> Auto Repairing |

Name _____

Occupation & Employer _____

Street and No. _____

City _____ State _____

Please Mention Popular Mechanics

For a Bigger Salary Tomorrow —Choose Well Today



A job inside dealing with things
and machines

Which Will It Be?



A profit producing position out-
side dealing with people

FROM SHOP WORK TO SALES WORK

"I have charge of the Boston Sales Branch of my firm and the fact that I have made good and have received so many advances in my salary show what your Course did for me. I recommend your school to all."—J. A. Christian, P. O. St. Bldg., Boston, Mass.

A MECHANIC MAKES GOOD

Had been a mechanic for 20 years. Wanted to earn more money. Took your C. O. R. S.—secured a position. Am now a successful Salesman selling oils, cutting compounds, etc.
W. E. WILLIAMS
7243 St. Lawrence Ave., Chicago, Ill.

Salesmen Earn \$2,000—\$5,000—\$10,000 a Year

Inside workers are a part of a non-business producing machine—their earning capacity is limited. Men who can sell—who have the power to persuade people to purchase their products, always command big incomes. They are the direct producers of profits—the life blood of any concern. It is the trained Salesmen who brings in the orders—whose services, thousands of concerns today are seeking—and to whom they are willing to pay large commissions and salaries.

Be a Salesman—Earn While You Learn

Our Home Study Course in Scientific Salesmanship gives you the necessary training. It tells you how to prepare a "Selling Talk"—how to approach the prospect—how to manage the interview—how and when to close. It is the one system of practical training that links ability to opportunity and fits you to **earn while you learn**. Employers everywhere recognize the value of N. S. T. A. training. Our Employment Bureau has constantly on file more requests for salesmen than we can possibly fill.

64 Page Book

Write today for Free book "A Knight of the Grip" and list of hundreds of good openings offering opportunities to earn Big Pay while you learn. Address nearest office. Dept. 6075. **FREE**

NATIONAL SALESMEN'S TRAINING ASSOCIATION

Chicago

New York

San Francisco



COPY THIS SKETCH

and let me see what you can do with it. Illustrators and cartoonists earn from \$20 to \$125 a week or more. My practical system of personal individual lessons by mail will develop your talent. Fifteen years' successful work for newspapers and magazines qualifies me to teach you. Send me your sketch of President Wilson with \$c in stamps and I will send you a test lesson plate, also collection of drawings showing possibilities for YOU.

The Landon School of Illustrating and Cartooning
1438 Schofield Building, CLEVELAND, O.



FREE BOOK ON BANKING



Tells of the great opportunities in this wonderful profession, and how you can learn by mail. Six months' term. Diploma awarded. EDGAR G. ALGORN Pres., **AMERICAN SCHOOL OF BANKING**
490 East State St., Columbus, Ohio

JEWELRY ENGRAVING

We teach you, by our new and original method of instruction, this clean, fascinating and profitable business **right at your home**, and furnish you all tools needed absolutely **free**. Write for free book to the **WISCONSIN SCHOOL OF ENGRAVING, 20th Bldg., MILWAUKEE, WIS.**



VENTRILOQUISM AT HOME

LEARNED BY **ALMOST ANYONE** SMALL COST
Send today 2c stamp for particulars and proof.
O. A. SMITH, Room D 150, 823 Bigelow St., PEORIA, ILL.



Do You Like to Draw? Cartoonists Are Well Paid

We will not give you any grand prize if you answer this ad. Nor will we claim to make you rich in a week. But if you are anxious to develop your talent with a successful cartoonist, so you can make money, send a copy of this picture, with \$c in stamps for portfolio of cartoons and sample lesson plate, and let us explain.

The W. L. Evans School of Cartooning
821 Leader Bldg., Cleveland, O.

WANTED—RAILWAY MAIL CLERKS

\$75 to \$150 a Month for Life

Every second week off with full pay—no "lay-offs" because of strikes, war, panics, etc.—sure pay—rapid advancement to higher positions. City and country residents stand same chance. Common sense education sufficient—no political influence. Examinations everywhere soon.

CANDIDATES PREPARED FREE

Write for free schedule of places. Every day's delay means so much less coaching—so write at once.

FRANKLIN INSTITUTE, Dept. B97, Rochester, N. Y.

Mail This Coupon

Write Plainly
Use It Before You Lose It

COUPON

FRANKLIN INSTITUTE, Dept. B97, Rochester, N. Y.

Kindly send me, without any obligation whatever on my part and entirely free of charge, (1) a full description of the position checked below; (2) Sample examination questions; (3) Free copy of copyrighted book "Government Positions and How to Get Them"; (4) A list of U. S. Government Jobs now easily obtainable; (5) Directions telling me how to get free coaching for the position checked; (6) Schedule showing dates and places of examinations.

<input type="checkbox"/> Railway Mail Clerk (\$800 to \$1800)	<input type="checkbox"/> Customs Positions (\$800 to \$1500)
<input type="checkbox"/> Postoffice Clerk (\$800 to \$1200)	<input type="checkbox"/> Internal Revenue (\$700 to \$1800)
<input type="checkbox"/> Postoffice Carrier (\$800 to \$1200)	<input type="checkbox"/> Stenographer (\$800 to \$1500)
<input type="checkbox"/> Rural Mail Carrier (\$500 to \$1200)	<input type="checkbox"/> Clerk in the Departments of Washington (\$800 to \$1500)
<input type="checkbox"/> Bookkeeper (\$800 to \$1500)	

Name.....
Address.....



Learn Electricity

Earn \$2500 to \$4000 a Year

Your CHANCE has come! Your chance for big money. Your chance to do the kind of work you'll be proud of. Your chance to go into business for yourself. Think of it! You can now qualify AT HOME for that most wonderful of all fields open to the ambitious man—the great field of ELECTRICITY! Yes, no matter who you are, where you live or what you do, I will take you in hand and make you a TRAINED ELECTRICIAN so that you should easily earn \$2,500 to \$4,000 a year and more. And I'll do it so quickly and with so little effort on your part that you'll wonder how it was possible.

LEARN AT HOME

What if you don't know a thing about electricity! What if you've never had a bit of electrical experience. All I ask is that you give me a little of your spare time. I will instruct you personally and make the whole matter so simple for you that you can't help but learn. You don't have to buy a lot of books or equipment. You can master MY personal instructions easily right at home. I've solved this question of teaching electricity. I'll show you I have by giving you 20 personal lessons ABSOLUTELY FREE. Almost from the very first instructions you will have the knowledge and skill to do practical, electrical work—work that you can demand good money for doing. You can earn as you learn—more than pay for your instruction as you go along.

Be An Electrician

Think! When you have finished my instructions you are a TRAINED ELECTRICIAN! You are right then and there ready to take a big paying job or start in for yourself. I will train you until you consider yourself competent regardless of the time it takes. I not only show you how to do expert electrical work but show you how to estimate on jobs so you can take contracts at big profits. That's what it means to be personally trained by a man of my practical experience in every phase of electricity. Decide today to take advantage of my big free 20 personal lessons offer. Don't let the question of money bother you. I make the cost so small and the payments so easy that you won't miss the money.

MEN WANTED Wherever you go there's always urgent demand for Expert Electricians and at big pay. That's because the watchword of the age is, "DO IT ELECTRICALLY." Electricity advances so fast that there's a big shortage of competent electricians. And the demand is constantly increasing every day.

20 Complete Lessons FREE!

That's the sensational offer I am making now to a few more ambitious men. I make it for two reasons. 1st. To show you how easy my personal instructions are to master. 2nd. To secure quick action on the part of a few more prospective students. This offer means that you get 20 complete personal lessons ABSOLUTELY FREE! But you must act quick. The offer closes in 23 days. Send coupon or postcard at once. I'll send full particulars immediately. Mail coupon today—sure!

**A. W. WICKS, E. E., Director Wicks Electrical Institute,
81 West Randolph St., Dept. 293, Chicago, Ill.**

Send this
Coupon

**A. W. WICKS,
E. E., Director,
WICKS ELEC. INSTITUTE,
81 West Randolph St.,
Dept. 293, Chicago, Ill.**

Without any obligation on me whatever, please send me full description of your personal instructions in Electricity and particulars of your special offer of 20 of your lessons free.

Name.....

Street and No.....

City.....State.....

Please Mention Popular Mechanics

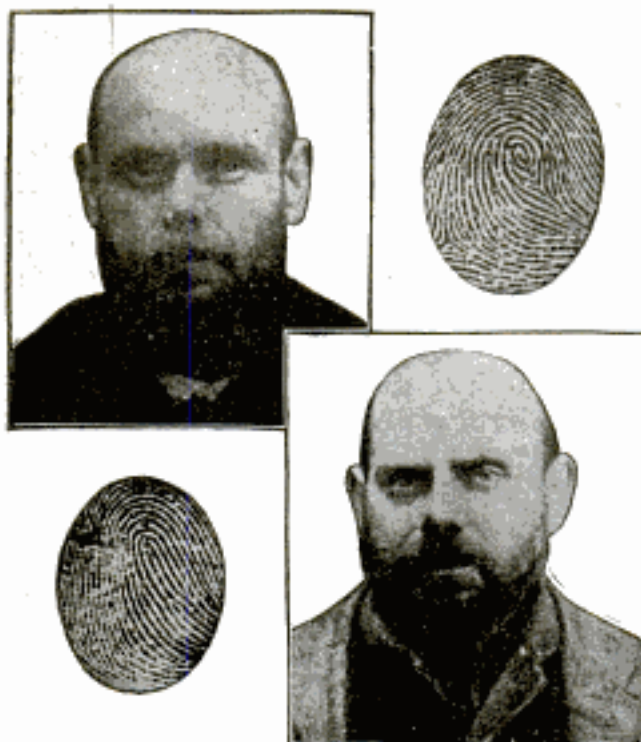

One Man -or Two?

Finger-prints Tell

If you learn to be a *Finger-Print Expert* you can tell instantly. Send the coupon below. Find out about this new and fascinating profession. Learn about the opportunity and fame which it holds out to you.

Wherever it is necessary to establish people's identity, finger-print systems are being installed. Large industries, railroads, banks, government institutions—all businesses where a large number of people are employed—are installing finger-print systems under the guidance of finger-print experts.

Be a Finger-print Expert

You can earn from \$25 to \$50 a week in this fascinating profession. With the development of the science of finger-prints and its increasing use all over the country, the demand for trained men is growing by leaps and bounds. You can train yourself for this lucrative and virgin field in your spare time at home. Find out about this attractive profession.

Free Book on Finger-prints

Send the coupon now for our valuable, absorbing book telling all about the uses of finger-prints in business and for purposes of identification. Find out how you can become a finger-print expert in a very short time at home. Special limited offer now in force. Write for this free book now, while this offer lasts. No obligations.

EVANS UNIVERSITY
Finger-print Department
Desk 9195
1810 Wilson Ave., Chicago

Gentlemen: Please send me, absolutely FREE and PREPAID, your new book on finger-prints. Also particulars of your special offer. I assume no obligations whatever.

Name.....

Address.....

EVANS UNIVERSITY
Finger-print Department
Desk 9195
1810 Wilson
Avenue
CHICAGO

The 1917 Book

ABOUT MOTOR CARS

This very latest authoritative book gives ALL the information in 16 easy lessons.

The Automobile Instructor

By Clyde H. Pratt, B. Sc., M. E., Member Nat'l Society of Auto Engineers. 286 pages, 219 illustrations, cloth bound. Shipping wt., 22 oz.

New 1917 edition out Jan. 3. The standard work for home-study, class-room and reference, for amateur and expert. A complete course for all who desire to master this profitable profession.

LEARN AT HOME HOW TO DRIVE AND REPAIR ALL CARS

Invaluable pointers for every car owner, driver, garage man and repair man. Adopted by Cleveland and other Auto Schools and by Boards of Education as their standard text-book. The author will answer your auto inquiries FREE. This book is guaranteed to be just what you want or your money back. (Auto schools, write for quantity prices.)

Price, postpaid - - - - - \$1.50

Shrewsbury Publishing Co. 5525 South Boulevard
CHICAGO, U. S. A.

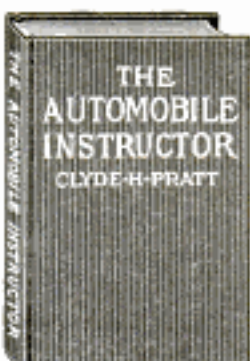

Motor Craft Encyclopedia
Illustrated. Tells how to build and operate Motor Boats. Best book on boats. Price, \$1.00.

Be an Electrical Engineer

ELECTRICIAN OR COMMERCIAL ENGINEER

Earn While You Learn—Part time positions furnished to students. Learn by the thorough, approved, practical and original teaching methods—you will begin at once to perform experiments and tests in our completely equipped laboratories, under the guidance of engineers who have been successfully engaged in actual engineering and commercial business. Positions paying \$1500 are waiting for graduates. **Enter at any time.**

REGULAR TERM BEGINS JULY 2nd.

Write for free illustrated catalog. Mention age, education and course interested in.

SCHOOL OF ENGINEERING OF MILWAUKEE, 316 Stroh Bldg., MILWAUKEE, WIS.

BE AN ARTIST

We can teach you **DRAWING** in your own home during spare time.

Our 18 years of successful teaching prove our ability. 10 Courses in Commercial and Illustrative Drawing.

Endorsed by high art authorities.

Students trained by members of our Faculty are filling high-salaried positions. Artist's Outfit FREE to Enrolled Students. Fully equipped Residence School. Write today for Art Year Book.

OUR HANDSOME ART YEAR BOOK IS FREE TO YOU

SCHOOL OF APPLIED ART
APPLIED ART BLDG. No. 2 BATTLE CREEK MICH.

LEARN MUSIC AT HOME!

SPECIAL OFFER—EASY LESSONS FREE—Piano, Organ, Violin, Banjo, Mandolin, Guitar, Cornet, Harp, Cello, Clarinet, Piccolo, Trombone, Flute, or to sing. You pay only for music and postage—which is small. No extras. Beginners or advanced pupils. Plain, simple, systematic, 16 years' success. Start at once. Send your name and get Free Booklet by return mail. Address U. S. School of Music, Box 132-E, 225 5th Ave., N. Y. City

HIGH SCHOOL-BY MAIL

Make up High School Credits—prepare for college or the professions—twice as fast—by mail—at home—during part of your spare time. Each student receives personal instruction—equivalent to that given in the best resident schools. Strong faculty—all college graduates. Accredited relations with leading Universities and Colleges. Courses prepared by eminent high school educators. Text books furnished free. Eighteen years of successful service and thousands of graduates—our sponsors. Tuition extremely low—terms easy. Complete information sent free. **WRITE TODAY.**
NORTH AMERICAN INSTITUTE including
Interstate School of Correspondence 1195 Manhattan Bldg., Chicago, Ill.

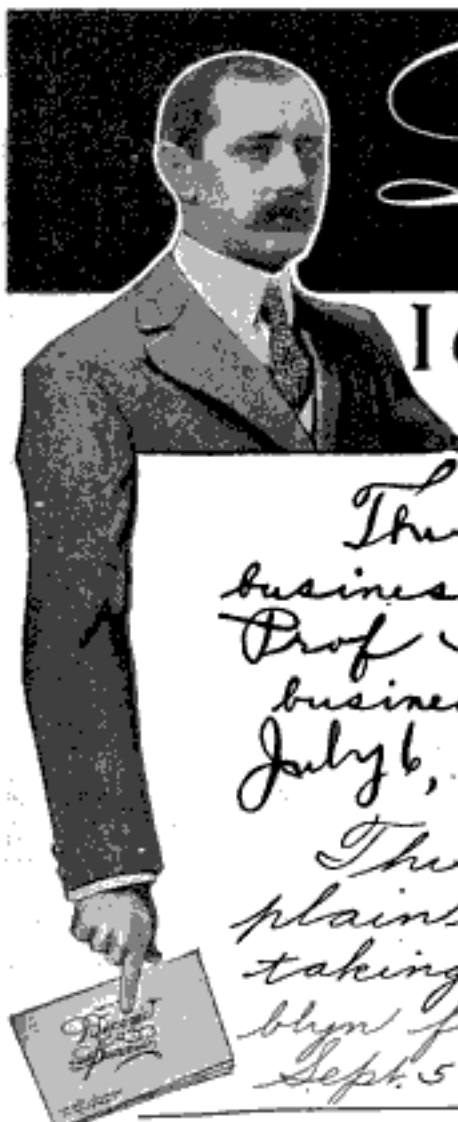

Learn ^{TO} *Write*

I CAN TEACH YOU AT HOME
During Spare time

This is a specimen of my business writing before taking Prof Tamblin's course in business writing.
July 6, *Clarence P. Weber.*

This is a specimen of my plain business writing after taking lessons from F. W. Tamblin for 2 months.
Sept. 5 *Clarence P. Weber.*

FREE BOOK

My 32-Page book "How to Become a Good Penman" is FREE to anyone who wants to write better. Contains copies and information that will help you, and beautiful specimens that will make your eyes twinkle with delight.

WRITE FOR IT—use the coupon below—or a postal will do—but

Send at Once!

If you enclose a stamp, I will write your name on a card with white ink, making one of the prettiest specimens of penmanship you ever saw

F. W. TAMBLYN

418 Ridge Bldg., KANSAS CITY, MO., U.S.A.

"A Wonderful Bargain" "It is now about two months since I began your course, and while I am not quite half through with Business Writing, I am delighted with my improvement, which is quite marked as you will see by comparing my present writing with the specimen written when I began. My parents objected to my taking it up, but now see I'm getting a wonderful bargain."

—CLARENCE P. WEBER, Middletown, Del.

Good Writing Is the Very Foundation of Business Success

I can make a good penman of you at your own home, in your spare time, no matter where you live or how poorly you now write. Ever fail to secure a good position because of poor penmanship? Ever know of better positions you could have stepped into if you only wrote a good hand? If not, you're an exception. The advantage of good penmanship is seen all around us.

I have been teaching penmanship by mail over 20 years. I know that any ambitious person can master penmanship just as quickly and thoroughly by my system at home as if in a schoolroom under the personal instruction of the teacher.

BEGIN NOW to learn good handwriting and be ready for the next better position that comes your way. Learn right at home—in your own room, outside of working hours. Your spare time is all I ask.

I teach *Spelling and Letter Writing* also.

Mr. Weber's wonderful improvement shown in the specimens above was made in 2 months. Hundreds and hundreds of others in all parts of the country are doing the same.

YOU CAN DO AS WELL

This Brings FREE BOOK

F. W. TAMBLYN, 418 Ridge Bldg., KANSAS CITY, MO.

I am interested in improving my penmanship. Send me your Free Book, "How to Become a Good Penman," postpaid.

Name

Address



Everything the Boss Knows

Here, in these new books you have all the knowledge that gave the boss his job. All the problems he had to work out by actual experience are classified and indexed so that you can refer to them instantly. The books are called Modern Shop Practice and every man interested in shop work will find them money makers and money savers.

Just think what it would mean if you knew all shop methods. Think what it would mean to have all the latest machinery described and explained. That is what you have in these six handsome volumes.

Modern Shop Practice

In these six volumes you have all the information you need to make you an authority on modern shop methods. You can be the man who gives the money saving—time saving methods—and tells how to operate the most complex machinery. They are bound in genuine Bagdad leather, limp covers, 5 1/2 x 8 1/2 inches, 2300 pages, 2500 illustrations, full page plates, tables and diagrams, all cross-indexed for quick reference. The regular price of the set is \$30.00 but for a limited time we are offering a few sets at \$17.80, about half price. And you can pay this low price at the rate of \$2.00 a month. This offer is made to every man within the boundaries of the United States and Canada.

Important Subjects Covered
Machine Shop Work—Modern Manufacturing—Machine Shop Management—Metalurgy—Welding—Die Making—Tool Making—Tool Design—Foundry Work (Molding, Casting and Forging)—Pattern Making—Mechanical Drawing—Auto Shop Work. Nearly two thousand subjects indexed.

Use Them Seven Days

Upon your simple request we will ship you the entire set, express prepaid, for free examination. Use them seven days—just as if they were your own. Don't send us a penny. Just send the coupon and we'll send the books. Use them seven days—and see for yourself what they are going to mean to you. If you think you aren't throwing away a golden opportunity send them back.

50c a Week

American Technical Society
Dept. M 1195, Chicago, U. S. A.
Please send me the set of Modern Shop Practice for seven days' free examination. If I decide to keep them I will send \$2.00 after seven days and \$2.00 a month until the special price of \$17.80 has been paid. Then you will send me a receipt showing the \$30.00 set of books and the \$12.00 consulting membership are mine and fully paid for. Otherwise, I will return them at your expense.

But if you decide to keep them send us \$2.00 after the trial and then \$2.00 a month until you have paid \$17.80. And too, if you order now we will also include free a year's consulting service. This entitles you to the advice of a corps of experts for an entire year. Ask as many questions as you wish.

Send the Coupon

Just mail us the coupon. Don't send a penny. We will send you the entire set, express prepaid, for your examination. Act quick—before the offer is withdrawn.

American
Technical Society
Dept. M 1195
CHICAGO, U. S. A.

NAME.....
ADDRESS.....
REFERENCE.....

WANTED! MEN FOR NEW JOBS!

Short hours. Easy work. No strikes, no hard times, no layoffs. No petty bosses. No politics—no pull. Ordinary education sufficient. 15 and 30 day vacations each year with full pay. Sick leave with full pay. Positions for life with

Bigger Pay—Lifetime Positions

Steady income, rapid advancement. Earn \$75 to \$150 a month to start. Earn up to \$2000, \$3000 or more later. These are but a few of the many attractive features of working for the U. S. Government in the Railway Mail Service, Post Office Service, Custom House Service, Internal Revenue Service, Panama Canal Service, R. F. D. Service and other divisions.

Write Now! If you are an American Citizen 18 or over, send in your name for all facts about Government Positions and how to get one. Send no money—this book is free. Tells how A. R. Patterson has successfully prepared thousands for government service, how you can prepare for coming examinations at home in spare time. Mr. Patterson was U. S. Civil Service Secretary-Examiner for 8 years and has students and graduates in practically every State in the Union in all branches of Government Service. Not one cent if you do not secure a position. Don't be satisfied with uncertain job and small pay when you can so easily secure a permanent position with Uncle Sam. Mail Postal **NOW** for Free Book and special 20-Day Offer! Address Patterson Civil Service School, 375 News Building, Rochester, N. Y.

EARN TELEGRAPH

Morse and Wireless—R. R. Accounting (Station Agency) taught. Splendid opportunities. Positions secured. Marconi Co. contracts to employ graduates. We own and exclusively occupy two large modern buildings equipped with R. R. and Western Union wires and complete 2 K. W. Marconi Wireless Station. Largest school—established 42 years. Investment \$50.00. Endorsed by Railroad, Marconi and Western Union Officials. Expert practical teachers. Low living expenses; easily earned if desired. Tuition low. Easy payments. Correspondence courses also. Catalogs Free.

Dodge's Telegraph, Ry. & Wireless Institute
8th Street, Valparaiso, Ind.



Men Wanted To Learn Automobile Business

EARN BIG MONEY — \$75 to \$300 Per Month

Only a few weeks required to train you. In six weeks I teach you to run and repair properly any automobile made. Learn to be repairman, demonstrator, garage manager and salesman. I teach thoroughly, practically and personally on real automobiles in everyday use. No books used. Tools furnished free. Actual practice on big, powerful cars brought here for inspection and repairs. **SEND FOR BOOKLET, "Making You Master of the Auto."** Free upon request.

WM. H. ARHOLDEN, Milwaukee Motor School, 217-21 Seventh St., Milwaukee, Wis.

A CLEAR TRACK TO

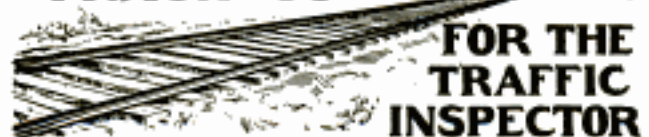

SUCCESS
FOR THE
TRAFFIC
INSPECTOR

Learn this new profession in 3 to 4 months with our complete course. Prepare for big pay—promotion—success. Railroads everywhere are watching for good traffic inspectors. The training obtained in this work leads to sure opportunities for advancement.

Get Ready for the Success that Awaits You

Earn big pay with short hours. Travel at no expense. Our Employment Bureau helps successful graduates obtain positions. Write now for Booklet G2, giving full information. **FRONTIER PREP. SCHOOL, BUFFALO, N. Y.**



All Are Law-Trained Men

The first is a trusted adviser of corporations. He knows how to make business moves that are legally sound.

The second is a successful manager of a large banking institution, chosen because his legal knowledge equips him to direct and control affairs more successfully than ordinary men.

The third is a successful Attorney-at-Law. He is skilled in legal argument; can present facts forcefully.

The fourth is prominent in Public Life; picked for leadership because his legal training gives him a keener grasp of government affairs.

Any ambitious man who is willing to make use of some of his spare time can acquire the legal education and training necessary to qualify for one of these big positions. That training and legal knowledge we are prepared to give you—at home—during your spare moments—at a very slight cost—and on convenient terms.

Now is the time for you to begin. The great prosperity of the country, the wonderful growth of our industries, the extension of our foreign trade, the addition of new departments of government, have created thousands of important positions which demand Law-Trained Men.

Look into this unusual opportunity. A LaSalle training will help you to succeed as a practicing lawyer, to become a leader in business or in public life. A legal training puts men into the class who earn

Big Incomes

The LaSalle Home Study Law Course is written in plain language by America's foremost legal authorities and professors of law in big resident colleges. Recognized as the foremost home study course and gives you all advantages including degree of LL.B., which we are authorized to confer under the Laws of the State of Illinois.

We Train You By Mail

So that you get an education in law without giving up your present position. You need no longer wish and wait for such an opportunity. No longer need you try to adapt yourself to uncongenial work. Here is the complete, successful LaSalle Course in Law ready to help you to rise to a position of respectability and worth-while income.

Begin Now

Don't lose another day. Don't let this week slip by without entering upon this fascinating study which has made so many men respected, honored and wealthy. The LaSalle Extension University is the largest and best equipped institution of its kind. Our graduates are found in every state—occupying positions of honor, trust and power. Their successes show what any man of intelligence and common sense can do. Send and get free information. Write today.

LaSALLE EXTENSION UNIVERSITY
"The World's Greatest Extension University"
Dept. 564-F Chicago, Ill.

Any man of intelligence can rise through law

The coupon brings information free

Law Library FREE



14 massive law volumes—"AMERICAN LAW AND PROCEDURE"—standard size—8½x11½ inches—bound in $\frac{1}{2}$ sheep. All branches of law are fully covered. This work cost us over \$50,000.00 but is FURNISHED YOU AT ONCE on your enrollment WITHOUT ADDITIONAL COST.

FREE COMPLETE COURSE IN PUBLIC SPEAKING

Every lawyer—every successful man should be a forceful speaker. Our Course is highly endorsed as most complete and authoritative—prepared by Frederick B. Robinson, A.B., A.M., Ph.D., Professor Public Speaking at College of City of New York, formerly Editor of Public Speaking Review. Send coupon and learn how you can NOW secure this valuable course free. Learn about this offer while it lasts.

Free Book Coupon

LaSalle Extension University, Dept. 564-F Chicago, Ill.
"The World's Greatest Extension University"

Without obligation on my part, send me by return mail information concerning your Course in Law with the free books "Evidence" and "Valuable Law Guide"—also your offer of FREE Course in Public Speaking to students enrolling now.

Name.....

Address.....

City.....State.....

Please Mention Popular Mechanics

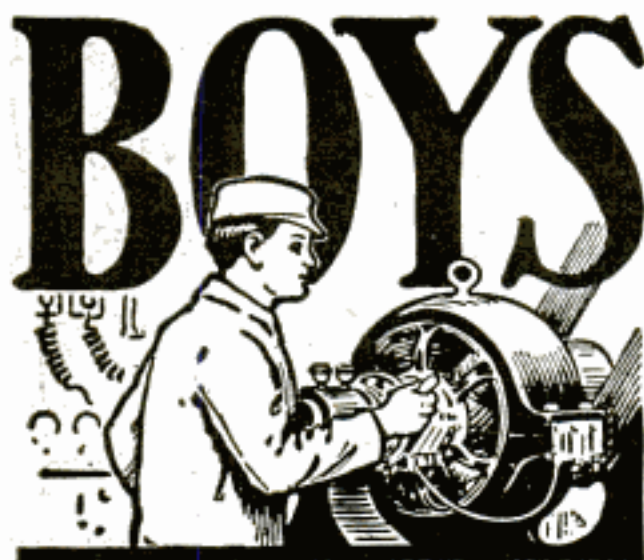

Big Money in Electricity

The Electrical industries offer wonderful opportunities to boys with a liking for Electricity. The salaries paid to trained men are large, promotion comes rapidly and, best of all, the work is fascinating.

The discovery and development of new lines (such as wireless telegraphy and telephony), from time to time, promise attractive and paying fields to those who wish to specialize. The *will to do* and *Special Training* will bring success to you.

The International Correspondence Schools can help you to become an expert in electrical work, no matter what branch you like best. Thousands of young men have already won success through I. C. S. help. You can do as well as anybody, *if you try*. Everything is made so clear that you can learn in your spare time, regardless of where you live or what your work. No books to buy.

There's big money in Electricity. Get after it by marking and mailing the Coupon today. *Finding out costs you nothing.*

INTERNATIONAL CORRESPONDENCE SCHOOLS

Box 5570, SCRANTON, PA.

Explain, without obligating me, how I can train for the position before which I mark X.

- | | |
|--|--|
| <input type="checkbox"/> ELECTRICAL ENGINEER | <input type="checkbox"/> ARCHITECT |
| <input type="checkbox"/> Electrician | <input type="checkbox"/> Architectural Draftsman |
| <input type="checkbox"/> Electric Wiring | <input type="checkbox"/> Mine Foreman or Supt. |
| <input type="checkbox"/> Electric Lighting | <input type="checkbox"/> Business (Complete) |
| <input type="checkbox"/> Electric Car Running | <input type="checkbox"/> Bookkeeper |
| <input type="checkbox"/> Electric Machine Designer | <input type="checkbox"/> Stenographer |
| <input type="checkbox"/> Telegraph Engineer | <input type="checkbox"/> Advertising Man |
| <input type="checkbox"/> MECHANICAL ENGINEER | <input type="checkbox"/> Salesmanship |
| <input type="checkbox"/> Mechanical Draftsman | <input type="checkbox"/> Window Trimmer |
| <input type="checkbox"/> STEAM ENGINEER | <input type="checkbox"/> Civil Service |
| <input type="checkbox"/> GAS ENGINEER | <input type="checkbox"/> AGRICULTURE |
| <input type="checkbox"/> CIVIL ENGINEER | <input type="checkbox"/> Poultry Raising |
| <input type="checkbox"/> Structural Engineer | <input type="checkbox"/> AUTOMOBILES |
| <input type="checkbox"/> CHEMICAL ENGINEER | <input type="checkbox"/> Auto Repairing |

Name _____

Present Occupation and Employer _____

Street and No. _____

City _____ State _____

If name of Course you want is not in this list, write it below.

Please Mention Popular Mechanics

This Man



Has the Most Wonderful Memory Ever Known

HE can give the population of any place in America of over 5,000—

HE can give every important date in world-history—
HE has 300,000 Facts and Figures stored away in his brain.

William Berol is this man's name, and a few years ago his memory was distressingly poor. His amazing efficiency was developed through his own simple practical method.

His system is being taught with great success to large classes at educational institutions in New York City. Thousands of men and women are learning it easily, quickly, *by mail*.

The Berol Method Will Strengthen YOUR Memory Amazingly

It will assist you in recalling Names, Faces, Dates, Telephone Numbers; his simple system will correct mind-wandering and teach concentration; you will remember the facts in what you read; you can recall episodes and experiences; you can become a clearer thinker, and in public speaking seldom be at a loss for a word. Give this method a few spare minutes daily, at home, and you will be astonished.

Write to-day for full free particulars of this man's wonderful memory and our offer to YOU.

FUNK & WAGNALLS COMPANY, Dept. 979 NEW YORK

LEARN WATCH REPAIRING

Be a watchmaker—you can learn this profitable trade by correspondence in a few weeks in your own home by the DeSelms Chart System. After you complete the course you will know a watch from A to Z. You will know just what the matter is and how to repair one. When you graduate you will be a practical watchmaker and repairer and competent to fill any position. Positions for our graduates.

Ask for our Free Book. It explains our system and terms.

THE DeSELMS WATCH SCHOOL
23 Perry Street ATTICA, INDIANA



CIVIL SERVICE

positions are in all parts of the country. Good pay, steady work, life positions, congenial surroundings, promotions on merit, short hours, annual vacation and sick leave with pay. Many thousands appointed yearly. Both sexes. No political pull. Nearly 300,000 classified positions. Common school education sufficient. Full information and questions used by the Civil Service Commission free.

COLUMBIAN CORRESP. COLLEGE, WASHINGTON, D.C.

Learn Bookkeeping in 40 Hours

Right Now there are thousands of positions open to the competent bookkeeper paying from \$80 to \$250 per month. Can you afford to pass up big opportunities like these when we can prepare you in 40 hours to handle them successfully?

We are so sure we can teach you and qualify you for one of these positions that we offer you our guarantee. Will any other school do this?

We Positively Guarantee to Teach You Bookkeeping in Your Own Home in 40 Hours

Don't waste your time and money studying bookkeeping elsewhere when we can offer you our Guaranteed course at 1/3 of the cost charged by other schools.

Our work is endorsed by bankers, business men, hundreds of our students, and the treasurer of the State of Pennsylvania.

If you are seeking success and more salary write for free literature E. No obligation.

THE HOFFMAN CORRESPONDENCE SCHOOL OF BOOKKEEPING
1331-35 Fifth Ave., PITTSBURGH, PA.

Make \$25 to \$50 Per Week



Titles: Practical Mathematics, by Palmer. Drawing and Design, by Marshall. Composition and Heat Treatment of Steel, by Lake. American Machinist Gear Book, by Logue. Accurate Tool Work, by Goodrich and Stanley. American Machinist Grinding Book, by Colvin and Stanley. Jigs and Fixtures, by Colvin and Haas. Automatic Screw Machines, by Goodrich and Stanley. Practical Die Making, by Colvin.

This is the famous Machine Shop Library NOT ONE CENT IN ADVANCE

When we say that you can earn \$25 to \$50 per week in the machine shop, we mean that this is the average salary, not something beyond your reach. And when we say to you that it is not unusual for the expert to earn \$100 per week and over, we mean that it is perfectly within reason for you to earn that much—if you are properly trained.

Small Monthly Payments

The Way to Start What must you do—how must you proceed in order to earn a large salary in the machine industry? First, you must make a study of the subject. To reach any worthwhile position today you must study. But in machine shop practice especially you must have the right books, otherwise your time is wasted, and you get nowhere. You must have books written by practical men, and written in accordance with actual machine shop work, then you are sure. Nothing can hold you back. The position is ready for you even before you start. There never have been enough properly trained men in the machine industry, and there probably never will be.

Eight authors and over 200 experts

The Machine Shop Library is the result of years of study and practical work by eight authors with a nation-wide reputation, and over two hundred experts from different shops in different sections of the country.

Be a technically trained man

Everything is explained by word and illustration so that you can master the entire work. You can grasp the most difficult operations in the machine shop. The education that you now

have, no matter how limited, will enable you to understand these clearly written books. After you have mastered them you are a technically trained man. You are no longer a man without a trade. All this knowledge you will have acquired easily during your spare time, and at very little expense.

Everything you need to know

Everything you need to know and want to know about machine shop practice is contained in these nine handsomely and strongly bound volumes. Nothing is omitted and nothing is left to guess-work.

Nine beautifully and strongly bound volumes—weight 16 pounds—3000 pages—3000 illustrations—all will be sent to you upon receipt of coupon below. We pay all charges.

You have the full use of the library for 10 days. Return charges are borne by us.

Examination costs you nothing, and you run no risk whatever. Merely return the coupon to us. We trust you.

You can pay small monthly installments if you are satisfied the books will tell you all you want to know about Machine Shop Practice.

Gentlemen:—I am interested in your Machine Shop Library. You may send me the nine volumes, charges paid, for my inspection. If satisfactory I will send \$2 in ten days and \$2 per month until I have paid the price of the books, \$16. If the books are not what I want, I will write you for shipping instructions.

Signature.....

Your Address.....

City and State.....

Name of Employer.....

His Address.....

Your Position.....

P. M. May '17

McGraw-Hill Book Co., Inc.

Publishers of Books for Machinists Since 1876
239 W. 39th Street, NEW YORK

COUPON—NOTHING TO PAY IN ADVANCE

Make Your Own Future



14 Hours' Hard Work



Long Hours, No Future



Automobiles
Ruin His Business



Dangerous Work

The Success of a Man

does not depend on how hard he can work, but what he can do. If hard work paid, the laboring man would be a millionaire. The only difference between success and failure is training. Look around you, who are the men who are making good?—THE TRAINED MEN.

The Automobile and Tractor Business

holds more possibilities for men that are mechanically inclined and have the necessary ambition and backbone to learn it, than any business in the world.

THE SWEENEY SYSTEM of Teaching this Business by Actual Experience

has proven to be the successful method. It is based on the idea that no man is sure of what he can do until he has done it. We use no books, and it isn't a question of how much education you have, but how much application. There is nothing mysterious about learning this business by the Sweeney System. It means you do the actual work with an expert instructor right with you to see that you do it right. Your experience here covers all branches of the business, from forging, vulcanizing and welding, machine shop work, valve timing, piston ring fitting, babbitting, special training in storage batteries, magnetos, self-starters, and all electrical equipment, and a thorough course in tractor work, both in my factory, where I manufacture the Sweeney Iron Horse, and in the field, where I have nine of the most popular makes of tractors. Your education is finished in my garage, which is one of the biggest in the West. If you do the work here, you can say that you are an automobile man.

Write for My Big Catalog that will tell you how I have trained hundreds of men to be successes, and you can be the same if you will come here and apply yourself.

Wake up! Be honest with yourself. Don't be a drifter.

E. J. SWEENEY, Pres.

**SWEENEY AUTO-
MOBILE SCHOOL**

1163 E. 15th St., Kansas City, Mo.

*Largest and Best
Equipped in the World*



*Training Made This Man
a Success.*

He Has Money in the Bank

SWEENEY AUTO SCHOOL 1163 E. 15th Street
KANSAS CITY, MO.

Send free and without obligation your catalog and tractor scholarship certificate.

Name

Address

Please Mention Popular Mechanics

<input type="checkbox"/> Electrical Engineer \$2000—\$5000 A Year	<input type="checkbox"/> Structural Draftsman \$1800—\$2500 A Year	<input type="checkbox"/> Steam Engineer \$1500—\$2000 A Year	<input type="checkbox"/> Civil Engineer \$2000—\$5000 A Year	<input type="checkbox"/> Contractor and Builder \$2000—\$5000 A Year
<input type="checkbox"/> Telephone Expert \$1800—\$4000 A Year	<h1>Which One?</h1> <p><i>Not one of these jobs is beyond your reach. Which one do you want?</i></p> <p>THE kind of a fellow who gets ahead today—and holds one of these high positions is the fellow with <i>training</i>. Nowadays employers can find men with training very easily—because colleges are graduating them pretty fast—so the fellow who had to leave school early is handicapped unless he gets training during his idle hours.</p> <p>Today you can get it in your own home, every man can, regardless of how much time he spent in school. And you can make every hour of your practical experience pay big dividends as well. American School training was made for you and has brought success to thousands.</p> <h2>Why Don't You Try It?</h2> <p>Why don't you see what an American School course will do for you.</p> <p>You may start the training with the distinct understanding that if you do not believe the training will raise your pay and put you in a high position, after you have completed ten lessons merely by returning the text books, you will be relieved of all obligation. No charge will be made for these ten lessons.</p> <h2>Mail This Page Today</h2> <p>Send us your name and address on the coupon. Just check the job that you want to hold and mail this page to us. We'll tell you how you can get just the training you need right in your own home. You'll be under no obligation—and the information you will get may do you a great deal of good. Let us help you. We are at your service—and all you need to do is to send this page with your name and address. Do it now—for your own sake and the man you want to be.</p> <p>American School of Correspondence, Chicago, U.S.A.</p> <p>Dept. G 1195</p>			<input type="checkbox"/> Hydro-Electrical Engineer \$2000—\$5000 A Year
<input type="checkbox"/> Certified Public Accountant \$2000—\$10,000 A Year				<input type="checkbox"/> Automobile Engineer and Designer \$2000—\$4000 A Year
<input type="checkbox"/> Machine Draftsman and Designer \$1500—\$2500 A Year				<input type="checkbox"/> Mechanical Engineer \$2000—\$5000 A Year
<input type="checkbox"/> Architectural Designer \$1800—\$2500 A Year				<input type="checkbox"/> Lawyer \$2000—\$10,000 A Year
<input type="checkbox"/> Architect \$2000—\$7000 A Year				<input type="checkbox"/> Heating and Ventilating Engineer \$1800—\$2500 A Year
<input type="checkbox"/> High School Course in Two Years				<input type="checkbox"/> Fire Prevention Expert \$1500—\$3000 A Year

Please tell me now I can qualify for the position marked X.

Name

Address

TRAFFIC MEN earn \$3,500 to \$10,000 Yearly



TRAFFIC MANAGER



R. R. TRAFFIC MEN

No other field or profession offers such advantages as are open to trained Traffic Men, Railroads, Factories, Jobbers, Commerce Clubs are taking all the trained men they can find. They are paying from \$3,500 to \$10,000 and more yearly for competent men. There are now more than 95,000 Traffic positions open in all parts of the country. We are training men in a short time to fill these positions. Only spare time is needed. The work is easy to understand; you begin to earn more after your first few lessons. The course is thoroughly practical. Anyone who understands common every day language will succeed. Positions are permanent.

Learn from Practical Traffic Men

Our instructors are practical, experienced, successful traffic men. Been in the work for years, and are teaching men successful methods. Students get personal attention of our faculty. One man wrote: "I saved my firm \$4,000 from August 1st to December 1st." It was his first traffic position and he made good. Instructors help graduates for two years after graduation. We have over 100,000 tariffs on file. Rates, routing and classifications can be quoted from any two points in the U. S., Canada and Mexico. This immense tariff file, together with our practical instructors, gives an advantage found in no other school.

Post Graduate Course Free Our Students and Graduates have the privilege of coming to our School for Post Graduate Work. They may stay as long as they like. They get actual experience in rates, routing, classification and packing. This work is absolutely free. It is not essential, but is very helpful. This privilege is not found in any other school.



TRAFFIC BUREAU



COMMERCE CLUB TRAFFIC SEC'Y

Why Traffic Men Are Needed

Factories, Auto Manufacturers and Wholesale Houses are extending territory. Every extension means new rates, routing, classification or changed packing methods. The Interstate Commerce Commission and the Railroads are constantly changing rates and classifications. It takes a trained Traffic man to handle problems like these. Only men who have been in the Traffic business for years, men who have grown up in this big high-salaried business, are competent to train men. There will always be a demand for trained, Competent Traffic Men.

FREE Our Booklet "TRAFFIC," catalog and full information, all **ABSOLUTELY FREE**. Make up your mind Now to get started. Get our literature at once.

Traffic Managers

Salaries range from \$3,000 to \$25,000 yearly.

Traffic Bureaus

Bureaus make \$2,000 to \$10,000 yearly.

R. R. Traffic Men

Salaries vary from \$1,800 to \$12,000 yearly.

Commerce Club Traffic Secretaries

\$2,800, \$3,000, \$4,000, \$5,000, \$10,000 and up.

MEN WITH VISIONS

James J. Hill was a man with a vision. He saw the possibilities of a railroad through the north west; he accomplished his vision.

Cecil Rhodes envisioned an immense railroad in South Africa. He lived to see his vision come through.

Thomas Jefferson saw a vision of the U. S. reaching from ocean to ocean. He accomplished this.

Abraham Lincoln saw great visions in the law practice and by hard knocks reached his goal.

The vision of these great men made it possible for them to stand the hard knocks and surmount every obstacle. They were pioneers and it took a lifetime for them to win out. No one guided them or told them how.

Think of the possibilities for you in the traffic field. Think how quickly you can reach the big salary. Make up your mind to be a traffic man. Get started and don't let anything change your vision.

Let our experienced practical traffic instructors train you for a big traffic position. It's a vision worth while. Graduates of the Interstate Traffic School are competent to handle any traffic position.

INTERSTATE TRAFFIC SCHOOL, 25 Traffic Building, FORT WAYNE, IND., U. S. A.



"I WANT YOU"
-Uncle Sam

PAY \$75 to \$150 MONTH

U. S. GOVERNMENT WANTS

Railway Mail Clerks — City Mail Carriers — Postoffice — Customs — Internal Revenue Clerks.

Common education sufficient. Send coupon immediately. We are coaching candidates free.

SEND COUPON BELOW

FRANKLIN INSTITUTE

Dept. B-96, ROCHESTER, N. Y.

This coupon, filled out as directed, entitles the sender to (1) free sample examination questions; (2) a free copy of our book, "Government Positions and How to Get Them;" (3)

free list of positions now easily obtainable; and (4) to consideration for Free Coaching for the examination here checked.

COUPON

.. Railway Mail Clerk [\$900 to \$1800]	.. Customs Positions [\$800 to \$1500]
.. Postoffice Clerk [\$800 to \$1200]	.. Internal Revenue [\$700 to \$1800]
.. Postoffice Carrier [\$800 to \$1200]	.. Stenographer [\$800 to \$1500]
.. Rural Mail Carrier [\$500 to \$1200]	.. Clerk in the Department at Washington [\$900 to \$1500]
.. Bookkeeper [\$900 to \$1800]	

Name.....

Address..... B-96

Use this before you lose it.

Write plainly.

Electrical Meter Engineering

"The Profession With a Future"

Now learned at home. Big demand for competent men. Pleasant, interesting, fascinating employment all the year 'round, with exceptional opportunities for advancement. Success guaranteed. High salaries offered. No experience necessary.

Special Offer! In order to get more men to train for good positions, we are making a great special offer to a limited number. Write today for full particulars—FREE. No obligations. Be a Meter Engineer, the man who fixes, not the one who is fixed. Be boss. Write today. Fort Wayne Correspondence School Dept. 1195 Fort Wayne, Indiana

WANTED MEN!

\$75 TO \$300 A MONTH!

Demand for capable automobile and tractor men far exceeds the supply. Our graduates secure good paying positions as Salesmen, Demonstrators, Factory Testers, Garage Managers, Drivers and Tractor Experts.

\$50 Course FREE

Only six weeks required to train you in this great school. Most complete instruction. Instructors all experts. Enroll now and receive \$50 Course in Tractor and Lighting Engineering Free. Write today for our big Free Book and \$50 Free Scholarship Certificate.

RAHE'S AUTOMOBILE TRAINING SCHOOL
Largest Auto Training School
In the World
1028 Locust St., Kansas City, Mo.



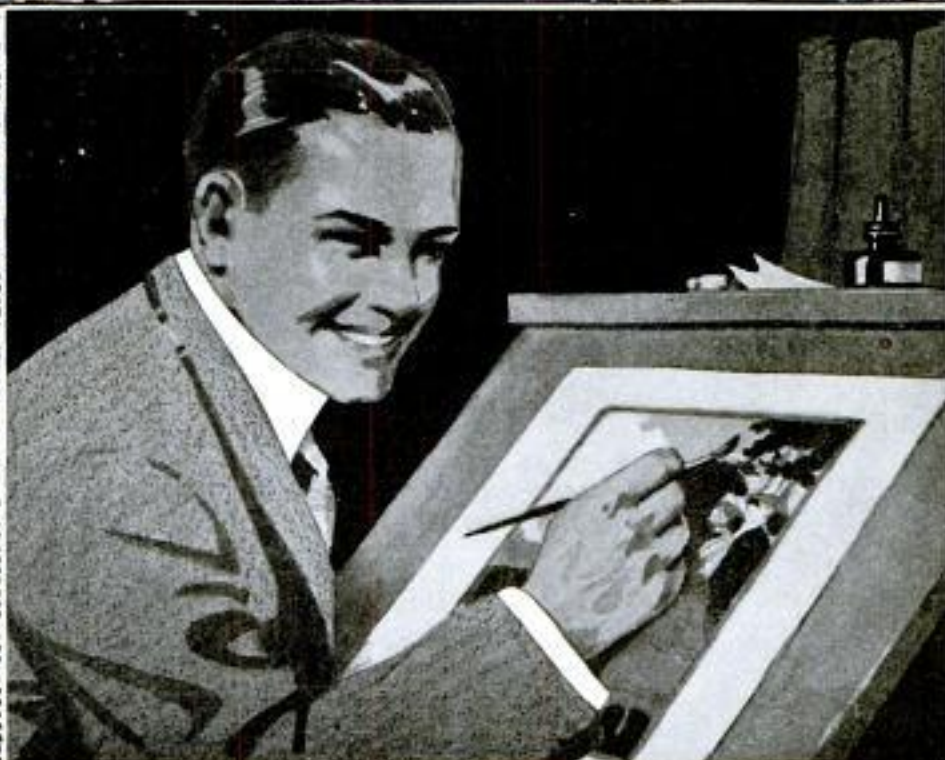

\$100.00 EARNED BY YOUNG ARTIST IN TWO DAYS

Conscientious, careful training by members of our Faculty made this possible.

Earn \$25, \$35, \$50, \$75 a Week and More

A well-executed drawing in a magazine or catalog often sells thousands of dollars' worth of merchandise. That's why the business and publishing world pays big prices for good designs and forceful illustrations. Artists with trained ability such as Franklin Booth, Coles Phillips, Charles E. Chambers, Leyendecker, Jessie Willcox Smith, and others earn extraordinary incomes. **Federal Course a Complete, Practical Training.** Our copyrighted method of home instruction is a proven result-getter. The work is fascinating, easy to learn and to apply. On the **Federal Advisory Council** are nationally known American illustrators and designers. That they have heartily endorsed the Federal Course is splendid evidence of its practical worth.

Write Today for "Your Future" FREE

This beautiful 56-page book, handsomely printed in colors, shows striking examples of work done by Federal Students. It will open your eyes. It explains the wonderful opportunities those with training can grasp; shows how easily you can devote spare time you may now be wasting, to develop a high-salaried ability. **Every young man and woman should read it before deciding on their life work.** Parents should read it with the future of their children in mind. **Are you living toward a future—or just living?** Take the first step today toward a more successful life. Send for this book—the coupon will get it quick.

Federal School of Commercial Designing
619 Warner Building, MINNEAPOLIS, MINN.

P.M.
Free Book Coupon

Federal School of
Commercial Designing
619 Warner Bldg.,
Minneapolis, Minn.

Please send me free book
"Your Future," also your
portfolio of Commercial Illustrations.

NAME.....
(Write your address in margin)



Here is Your BIG Opportunity

OXY-ACETYLENE WELDERS

are in demand in almost every line of industrial work—machine, boiler, railroad shops, building construction, garages, auto factories, wrecking work, foundries, etc.

A knowledge of this interesting process takes you out of the hum drum of ordinary shop work—promotes you above your fellow workman into an independent, high paid position where brains count. The stubbornness of iron and steel become as wax in your hands. In slack times when men are laid off, your services can not be dispensed with. Often a few hours of your work will save your company hundreds of dollars in avoiding delays from a breakdown, which you can quickly repair.

WELDERS
Get BIG Pay
Are Always in Demand

IN YOUR OWN BUSINESS

If you own a repair shop, garage, machine shop or similar plant you will find it a great asset to know Oxy-Acetylene Welding and Cutting or to have one of your men trained in this art, for thousands of dollars of profitable custom work, which could not otherwise be attempted, may be taken in, and which, if successfully accomplished, means the best kind of advertising for your business.

LEARN BY DOING

The Chicago Welding Institute is a practical school for earnest, ambitious men. Theory has not been slighted, being covered by a course of thoroughly prepared lectures supplemented by text book studies, but every principle thus brought out is immediately put into practice by the student himself, in a regularly organized, completely equipped commercial shop. In this shop custom work is taken in and pushed through each day, under practical shop conditions, the work being done by the student, under the personal supervision of expert instructors.

YOUR FUTURE ASSURED

Make up your mind to qualify yourself for a permanent position with big pay by enrolling for our course. The time required is exceedingly short and the cost of the course to you is remarkably low. No crowding—we limit the number of students so that each one can receive all the individual attention and personal instruction he requires. Do not pass up this opportunity—write now for full particulars.

CHICAGO WELDING INSTITUTE

506 South Racine Avenue, CHICAGO, ILL.



Stronger, Clearer Voice for You!



Weakness, huskiness and harshness banished. Your voice given a wonderful strength, a wider range, an amazing clearness. This done by the Feuchtinger Method, endorsed by leading European musicians, actors and speakers. Use it in your own home. Simple, silent exercises taken a few minutes daily impart vigor to the vocal organs and give a surpassing quality to the tones. Send for the facts and proofs.

Do You Stammer?

If you have any voice impediment this method will help you. You need not stammer or lisp—if you will follow our instructions.

WRITE

Send the coupon and get our free book and literature. We will tell you just what this method is, how it is used and what it will do for you. No matter how hopeless your case may seem the Feuchtinger method will improve your voice 800 per cent. No obligation on you if you ask for this information. We gladly send it free, postage prepaid. Just mail the coupon.

Perfect Voice Institute
1810 Wilson Av.
Studio 1195
CHICAGO

Name

Address

Perfect Voice Institute
Studio 1195 - 1810
Wilson Av., Chicago

Send me the book and facts about the Feuchtinger Method. Have put X opposite subject that interests me most.

Singing Speaking
 Stammering Lisper

"THE LAW-TRAINED MAN"

is a remarkable book, showing how Big Business picks law-trained men for its leaders. It also shows how men unable to leave home or business can, for the first time, secure a Course including the comprehensive features of the best Resident Law Schools. 80 eminent legal authorities prepared the Modern American Law Course and Service of BLACKSTONE INSTITUTE. This 105-page book is inspiring, practical and FREE. Write for your copy today.



BLACKSTONE INSTITUTE

20 W. Jackson Blvd., Dept. 1359, CHICAGO, ILL.

ARTIST'S OUTFIT FREE

Write quick for our remarkable offer. Learn NOW at home, in spare time, by our new instruction method, Commercial Art, Cartooning, Illustrating, Designing. Delightful fascinating work in big demand. \$50.00 paid for one drawing. Handsome free book explains everything. Send for it today. Postcard will do.

WASHINGTON SCHOOL OF ART
1016 H Street N.W. WASHINGTON, D. C.



THIS JOB PAYS \$25-\$50 Weekly

Thousands of Spring Vacancies

Learn evenings at your own home while earning. We will help you get a good position. ONE MILLION AUTOMOBILES will be built this year. The demand for trained help next spring will be tremendous. **Sample Lessons Free—Write for Them Today** Franklin Auto Institute, Dept. B802, Rochester, N. Y.

Please Mention Popular Mechanics



Our January 1917 Class—These Men are now Making Big Money as Auto Mechanics

\$70.00 STARTS YOU

IN THE AUTOMOBILE BUSINESS

\$100 Course with all tools, material used, parts, breakages, etc. The biggest bargain ever offered by an up-to-date, thorough, automobile training school.

**For Four Months Only—May—June—July—August
September First Price Will Be Raised**

You save a cool \$30 by enrolling in the I. M. S. *now*. Now is the time to get into the biggest and best business in the country, a fascinating business—a money-making business. In eight weeks you're ready for a business of your own or a good job with big pay.

Can We Deliver the Goods? Read On!

Nowhere will you find a better organized school—nowhere a better system of teaching—nowhere a better or more extensive equipment. Our students are all delighted.

Over Forty-Five Different Motors From One-Lungers to Twelve Cylinders

Now GET THIS—you work on all of them. They are not to look at and "study" at lectures, etc., but you actually work on them and you learn motors from A to Z. Same thing with transmissions, axles, brakes, carburetors, driving gears, magnetos, and all electrical equipment. We've got a corking electrical department—the boys are crazy about it. There is a good man right with you all the time to show, explain and teach everything. Right straight down through the course—from first day to last—you are learning under experts and *actually working on automobiles*. Our class room is a place to get together and talk things over—for you to ask questions and get the right answer. No dry lectures—no theory—no book stuff. Just the actual get-down-to-business experience. Don't go where you must spend hours listening to lectures. Come to Indianapolis—jump into a suit of overalls and get the real stuff.

Pay After You Learn You don't have to pay us before you enroll. You have a chance to see whether we do as we say in our ads. You pay just enough down to show you mean business. You pay the rest only when you are satisfied we deliver the goods.

Now Is the Best Time The best season in the year for automobile men is just beginning. Act at once and get in on this big money-making line of work. We have call after call from employers, that we can't fill. You can have a job—a good big job, the minute you're through, so the sooner you start the sooner you'll fatten your pay envelope. W. H. Rogers, of Paris City, Kentucky, has advanced from \$1.25 per day to \$125.00 a month in twelve weeks with our help. P. O. Smith of Indianapolis has doubled his salary in thirty days—you can do the same.

Indianapolis Is a Great City—You'll Like It Lots of our graduates stay here. If you decide to do the same we will gladly help you to secure a good paying job right here. There is a bunch of big automobile factories here, and hundreds of garages, sales agencies and service stations. It's a good town—just the right size. Plenty of work—good pay—and moderate living expenses. If you think this ad rings true—hit the next train for Indianapolis and start right in. If you want to look into it further—send for our catalog, and we will give you the names of some of our graduates to write to. Remember—you want a better job—a better chance in life—and there is nothing that offers you the wonderful opportunities that are in the automobile business.

Indianapolis Motor School 105 Southeastern Ave.
INDIANAPOLIS, IND.



Showing students in electrical department wiring up a two unit autolite grounded system.



Students in storage battery department making hydrometer test.



This is a picture of W. H. Rogers taken while he was in the block test department of school.

Come to Akron, Ohio The Tire Center and



MONEY-BACK GUARANTEE

We guarantee to qualify our students to go into business for themselves or to hold positions paying \$18.00 to \$40.00 weekly or return their money. The demand for trained repairmen is greater than the supply.

THE TIRE REPAIR BUSINESS

Make big money in this big field. No other field offers such opportunities. Autos run the year around. Tires need constant repairing. Profits are large and work comes easily. Every job is easily and quickly done.

There are locations everywhere, right in your home town. We show you how to find best locations. Help you to get jobs paying from \$3.00 to \$5.00 a day if you don't want to open a repair shop. Tire repair shops are as necessary as gasoline stations. Over a Million New Autos put in use this year. Get into this big profit business and become independent.

EARN \$100 TO \$500 MONTHLY

There is no limit to what a man can make. Men are becoming rich in this business. You can start business with small capital. Our graduates are qualified to handle all makes of Cord Tires and get factories O. K. School open all the year. Enter classes any day. Graduate in 4 to 6 weeks.

Tire Factories Now Employ Both Students and Graduates

We have made a deal with the large Tire Factories so that we can get jobs for our students while they are taking the Tire Repair Course or after they have graduated. The factories will employ the students and when they graduate will tell them where the best locations are for tire repair shops, or will get them a good high salaried position in a service station or Tire Repair Shop.

Factories pay \$15 to \$35 and up a week and will give our students jobs on one of the "shifts" so that they can earn while they learn. We have gotten men positions in the factories with salaries enough to pay for our course and all living expenses. We will help every worthy earnest man who will live up to the factory rules and regulations. We can now get you a good job in the factories to pay your expense, put you in touch with best locations or get you good Tire Service Station or Tire Repair Shop Jobs.

FREE Write for School Literature outline of course, letters from Satisfied Students all absolutely Free. Or better still, jump on the train and come to Akron. We will give you every possible help. Get started in this money making business NOW.

THE AKRON TIRE REPAIR SCHOOL The Largest and Best Equipped, Exclusive Tire Repair School
A. G. ZELLER, President, 65 Tire Bldg., 46-48 Main St., AKRON, OHIO

AKRON, OHIO THE HEART OF THE TIRE INDUSTRY



MORE THAN 800,000 TIRES ANNUALLY

Drums FREE



We teach you by mail and give you a professional orchestra drum absolutely Free. You pay weekly for lessons as taken. Drum comes with first lesson. Noise pictures analyze the beat. We teach and supply all brass band instruments. Write

INTERNATIONAL CORNET SCHOOL, 715 Federal St., Boston, Mass.

The Student Illustrator



a practical art magazine publishes lessons and articles on every phase of cartooning, designing, lettering, newspaper, magazine and commercial illustrating. It is an art education in itself. The latest and most up-to-date methods in the big paying field of commercial art thoroughly explained by experts. Amateur work published and criticized. Satisfaction Guaranteed or money refunded. \$1.00 per year. Three months' trial 25 cents. Dept. B, Schwartz Bldg., Washington, D. C.

Be an Artist

Comics, Cartoons, Commercial Newspaper and Magazine Illustrating, Pastel and Crayon Portraits. Earn \$25 to \$200 a week. By our simple method your talent is quickly developed without interfering with present work. By Mail or Local Classes. Small sums you now fritter away pay your tuition. Write for terms, list of successful pupils and instruction method FREE.

ASSOCIATED ART STUDIOS, 2203 Flatiron Building, New York

DON'T TAKE A COURSE IN MACHINE DRAFTING

till you've read my proposition. Practical, experienced Draftsman, regularly employed in large modern works, will teach a few men by mail. Best way to become a well-paid Draftsman. Special courses in Mathematics also. Instruments furnished. States very reasonable. Pay a part after in position. Draftsman, 252 S. Corona St., Denver, Colo.

Baker's Show Card Book \$3.00
EARN \$20 TO \$40 A WEEK
LEARN TO MAKE SHOW CARDS. Salary or business of your own. My book teaches all the tricks of the trade. No simple anyone can learn. Elaborately illustrated. Have while learning. Send today. Money refunded if not satisfied.
WM. J. BAKER, HENRY BUILDING, PORTLAND, ORE.

60 BOOKS Bound in \$1.00 After The world's Trial greatest literature now shipped to you FREE on approval, not a penny in advance. The masterpieces of Kipling, De Maupassant, Stevenson, G. Bernard Shaw, Victor Hugo and dozens of others. Each book bound in genuine limp leather, pocket size. Write postal now for offer.
LITTLE LEATHER LIBRARY, 131 Marcella Bldg., 23rd St., New York

Advertising Manager—\$5000 a Year YOU CAN BE ONE

If our Vocational Director will accept you, then you can succeed in advertising. Ten practical business men will teach you. Write for booklet, "Poverty to \$10,000 a Year" and "Free Personal Analysis blank."
BRYANT & STRATTON COLLEGE, 1623 Bryant & Stratton Bldg., CHICAGO, ILL.

John Wanamaker says that he would have gone without a meal a day if necessary to save the money to buy one of Dr. Orison Swett Gardner's books. Would YOU? Send today for Gardner's latest and greatest book, "Everybody Ahead," or "Getting the Most out of Life," and learn how to better your position in life—Send no money. Just write for the book. Send it 5 days. Then remit \$3.00 if you want to keep it—otherwise return it. Address
Frank E. Morrison, Publisher, Dept. 20, 1133 Broadway, New York

STAMMERING Invention fits mouth—simple as false teeth. Controls muscles of articulation. Stammering mechanically possible minute controller in fitted. Soon talk correctly without controller. **STOPPED** Write for our scientific explanation of Stammering. PEATE AND SCENTIE, BOX 93, SPENCERPORT, N. Y.

STENOGRAPHERS BE PRIVATE SECRETARY

Don't be satisfied with small pay. Typewrite the New Way, write 80 to 100 words a minute, get better position, bigger pay. Thousands of New Way typists now earn

\$25 to \$40 per Week

Learn in 10 lessons, at home, in spare time. No interference with regular work. Entire course on trial.

Typewrite the NEW Way

Totally new system based on Gymnastic Finger Training, practiced away from machine. First day shows results. Send postal for 32-page BOOK FREE. Explains why New Way must bring you amazing speed, perfect accuracy, increased salary. Write NOW.

The Tulloss School
125 College Hill, Springfield, O.



10 Easy Lessons

Here—Take This and Ring the Bell

You can't ring the bell on a striking machine by tapping with a little hammer. You may have the muscle, but the hammer is too light—but with one blow of a heavy maul you can send the ball gliding clear to the top.

—and just so, **Lack of Special Training** is like a little hammer when you try to strike a top-notch salary. You can strike with all your ability, but you can't get a "raise" much higher than \$15 a week. Drop the hammer. Take up **Special Training** and strike up \$50 or \$100 or \$200 a week. Ring the Bell.

We Will Train You to Be A TRAFFIC MANAGER

During your spare time at home we can train you—our "Experience Method" makes this practical. This method was devised by prominent traffic managers of the big railroads and industrial concerns. They will give you just what information a traffic man should know and show you how to fit yourself to earn a good salary. There is nothing difficult. Everything will be fully explained to you. Ordinary ability is all you need. Remember that this is not a "correspondence course" to be learned from books—but is a system of **Traffic Training** by practical traffic men.

Join This Association—Its Members Will Aid You

Join the American Commerce Association. This will put you in touch with the traffic managers of railroad and steamship lines and thousands of men holding traffic positions with the big manufacturing and shipping concerns of the U. S. You can profit by their experience. They will advise and aid you. You will be admitted to the nearest Traffic Efficiency Club. The Association is the largest of its kind in the world. It is substantial and responsible.

Positions Open—The shipping departments of thousands of factories—railroads, warehouses, wharves—are congested with vast quantities of goods. Shippers are crying for help. Men are wanted—but **trained men only**—men who know how to save freight money—who know how to get quick action on shipments and deliveries.

Salary The salary of trained traffic managers ranges from \$2,500 to \$10,000 a year.

Don't Delay—Apply NOW

Never before in the history of America has there been so much shipping—and so much trouble in shipping. Shipments are tied up for want of men to handle them. Hundreds of thousands of dollars are wasted. There are not half enough trained men to fill positions. Now is your time. Write us now. We will tell you what to do and how to do it. Send the coupon by return mail.

American Commerce Association
Dept. 49, 206 So. Wabash Ave., Chicago, Ill.

You
Can
Do
It

AMERICAN COMMERCE ASSOCIATION
Dept. 49, 206 So. Wabash Ave., Chicago, Ill.
Send me FREE—and without obligation—complete information concerning the Association and tell me how I can train as a traffic man.

NAME.....

OCCUPATION.....

ADDRESS.....

CITY..... STATE.....

Please Mention Popular Mechanics



30 DAY COURSE IN TIRE REPAIRING **FREE**

Complete Tire Repair Outfit
Less Than \$250.00

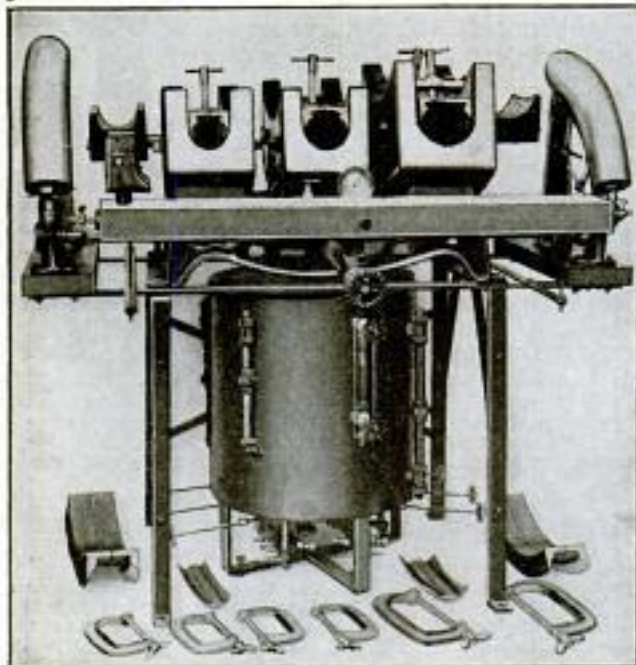

With this outfit and our course of free instruction, you can start up a good business.

Learn to Repair Tires

Bigger opportunities than in any other branch of the Auto business. A broad claim, but easy to prove. Only stop and think!—you know it's true. Listen! Not one single Auto factory can build cars fast enough. Everybody is car crazy, and the craze is growing. 2,000,000 autos now in use. Four tires to each car. That means 8,000,000 tires to repair. Just think of it—8,000,000 tires! Each car wears out its cost in tires alone. Punctures and blowouts are common. Vulcanizing, patching, retreading, etc., must be done. Retreading alone—the new and better process—brings big money.

Earn \$3000 to \$8000 a Year

Begin now. In almost every city, town, village, and cross corners, there is a fine chance to start. We know the places and put you next. Just a little money starts you in a business of your own. We guarantee to make an expert of you in 30 days free of charge. Write today for free catalog, or why not take a run over to Detroit and investigate personally? Don't let the chance slip by. Investigate now.

Reliable Tire Repair School

105 Reliable Bldg., DETROIT, MICH.

FATHERS! This is a great opportunity for that boy of yours. Start him in the Tire Repair business. You'll always be glad. When in Detroit, look us up. We'll be glad to show you through.

COUPON

RELIABLE TIRE REPAIR SCHOOL

Send me your free catalog and full particulars about the tire repair business.

Signed.....

Address.....

P. M.

Please Mention Popular Mechanics

Are You Interested In Automobiles Motoring Driving Repairing



and the hundreds of things which are of interest to automobilists? "THE AMERICAN CHAUFFEUR," a monthly magazine devoted to automobiles, is of vital interest to Owners who drive, Garagemen, Repairmen and Chauffeurs. Technical features appear in each issue, written by men who have made life studies in their special departments. Every article that appears in this magazine is thoroughly practical—chuck full of sound, solid, meaty, common sense, and in each issue there appear discussions of proper lubrication, fuels, tires, engines, carburetors, axles, lighting and cooling systems, adjustments, repairs, good roads and all the valuable information you should know about. They come down to facts and tell you just what's what. They help and urge you in every way to know more about automobiles.

SPECIAL OFFER

Get This Attractive **Free**
FOR ABSOLUTELY

Send us 25c in stamps or coin for a three month trial subscription to the American Chauffeur, we will send you this beautiful original designed, real rose, gold plated Automobilst Watch Fob, with Seal Grain Leather Strap-like illustration, absolutely FREE. Your money back if not satisfied.

AMERICAN CHAUFFEUR
85 Beller Bldg., Cincinnati, Ohio

LAW UNIVERSITY EXTENSION LAW SCHOOL

ESTABLISHED 1897

Our Simple Experience Method of Home Training in Law prepares you for the Bar or Business Law. A complete Standard Law Library Free to every student. Low tuition costs. Free consultation privilege. Law prepares you for bar examination in any state. Our business course will qualify you to act as legal adviser for corporations and firms. Pay in monthly installments. Money refunded if dissatisfied. Write today for catalogue

UNIVERSITY EXTENSION LAW SCHOOL

Dept. A-1, 206 S. Wabash Ave.

CHICAGO, ILL.

ENGINEERING MECHANICAL ELECTRICAL

One Year Practical Courses. Day and Evening classes. Splendid equipment and instruction. Low tuition. For particulars address

DETROIT TECHNICAL INSTITUTE
Box 308, Y. M. C. A. Building, DETROIT, MICH.

LEARN PIANO TUNING



Making Trials of True Tone by Tune-a-Phone

Capitalize YOUR Ability

THE WORLD PAYS FOR SKILL

We teach piano tuning and its allied branches by correspondence. Our patented teaching device, the Tune-a-Phone and other mechanical aids, make it easy and sure.

Write today for FREE illustrated booklet describing the school and its methods.

NILES BRYANT SCHOOL OF PIANO TUNING
28 Fine Arts Inst., BATTLE CREEK, MICH.



Music Lessons

Book Sent FREE Wonderful home-study music lessons under great American and European teachers given by the University Extension Method. The lessons are a marvel of simplicity and completeness, endorsed by Paderewski and other great authorities. You, too, can now quickly and easily satisfy your musical ambitions.

Any Instrument or Voice

Write, telling us the course you are interested in, age, how long you have taken lessons if at all, etc., and we will send you our Free Book containing text and illustrations covering Lessons in PIANO (students' or teachers' courses) by the great Wm. H. Sherwood, HARMONY by Dr. Frotheroe and Rosenbecker, VOICE COURSE (with aid of Phonograph) by Crampton, PUBLIC SCHOOL MUSIC by Frances E. Clark, VIOLIN, CORNET, MANDOLIN, GUITAR, BANJO, BANJO, REED ORGAN, CHORAL CONDUCTING, by equally eminent teachers.

Send NOW for Free Book and learn how easily you can become a fine singer, or a skillful player. See how quickly you can become successful. Our Free Book tells you how. Write for it today. A few Special Introductory Scholarships now being awarded by our faculty. Full particulars sent with Free Book. Investigate without cost or obligation. Write today.

University Extension Conservatory

Proprietor Siegel-Myers School of Music

2881 Siegel-Myers Building Chicago, Ill.

20 Lessons in Concentration Free for 5 Days

Prof. Theron Q. Dumont's famous 20 Lesson Course in Concentration, now sent in handy book form, for 5 days' FREE examination. Gives every principle and method. Also practice exercises. Tells you just how to concentrate. Get it now—while offer lasts. Send no money. Read it 5 days. Then, if satisfied, send only \$2. Otherwise return to us. Write for it today on this FREE offer.

ADVANCED THOUGHT PUB. CO.,
168 N. Michigan Ave., Dept. 539 Chicago, Ill.

Get This CAR And the AGENCY For Your Territory



Drive a new 1917 Model Birch Motor Car. Pay for it out of your commissions and make big money on sales. Special offer now. Write quick for Big Free Book and full information. Address

Ralph Birchard, Pres.
Birch Motor Cars, Dept. 519, 81 E. Madison St., Chicago

FINLAY Engineering College KANSAS CITY, MISSOURI ONLY SCHOOL OF THE KIND IN THE WEST

Specialties: Electricity, Steam, Gas. Six weeks, three months, year, and two-year courses. Auto-Tractor, Armature Winding, Conduit Work, Lathe Work, Oxy-Acetylene Welding, Corliss Valve Setting, Operation of Steam, Gas, Electric Machinery. Anything you want, any time you want it, night or day, from a week to two years. Write for Catalog W.

Public Speaking Taught at Home

Write for our special offer. Become a powerful speaker in spare time by mail. Overcome "stage fright", enlarge your vocabulary, train your memory, gain self-confidence. Learn how and when to use gestures; how to suit the speech to the occasion. Increase your earning power—become more popular. We have trained hundreds of successful speakers by mail at home. Write Now for Special Offer Send quick for details of our special limited offer. No obligation. Write while this offer lasts.

Public Speaking Dept. American Correspondence School of Law,
1125 Manhattan Building, Chicago, Ill.

Wanted—

FROM THE
CHICAGO TRIBUNE
MARCH 23, 1917.



the nation's aerial speed-up con-
Dr. Charles D. ... dness, ...
of the executive committee and secretary
of the Smithsonian institution, presided.
Outlining the needs of the government,
Mr. Walcott estimated that 4,000 aero-
planes and 2,400 aviators would be re-
quired by 1919. For an army of 1,000,
event of hostilities, he estimated that
1,000 planes and 1,000 aviators would be
required. In addition to this, according
to plans worked out with government
experts, the navy would require 500
planes and operators, and for harbor
and seaport defenses and for trading
pilots there should be on hand 2,000
planes and at least 400 aviators.

Aviation Experts

READ the clipping above. It shows you the urgent demand for experts in Aviation. Thousands of men are needed not only in government but in private enterprises. 500,000 men are now employed in the British and Naval flying corps of England. Think of the possibilities in the United States! Send the coupon at once. Learn about the big opportunities for aviation experts.

A Partial List of subjects in our course:

Elementary Principles;
History; Nomenclature;
Motor Development;
Stream Line Shapes;
Aerodol Curves; Controls
Types and Operation;
Dynamics of the Air; Bal-
ance; Inherent and Auto-
matic Stability; Propeller
and Wing Design; Perform-
ance Calculations; Prin-
ciples of Construction;
Stresses; Materials.

Learn at Home

Yes, you can learn the principles and mechanics of Aviation in your spare time at home. You must know these principles before you can learn to fly. Our course puts you ahead of the men who must get this knowledge by practical experience upon the field. Endorsed by aviation authorities. Under direction of Glenn H. Curtiss, promoter of the New York-Chicago Aerial Mail Route and co-inventor of the first rotary aviation motor.

Send Coupon— Free Information

Find out, now, about this great course. Learn the opportunities that are opening every day for scientifically trained men. Get particulars of this course which revolutionizes the training of aviation experts. We are making a special introductory offer now. Write for free information while this offer lasts.

National
Aero Institute
Dept. 9195
Morton Bldg.
Chicago, Ill.

National Aero Institute

Dept. 9195 Morton
Bldg., Chicago, Ill.

Gentlemen: Please send me absolutely free and prepaid, full particulars of your course in aviation and details of your special limited offer.

Name.....

Address.....



HELP WANTED

FRANKLIN INSTITUTE
Dept. B103, ROCHESTER, N. Y.

Kindly send me, without any obligation whatever on my part, and entirely free of charge, (1) a full description of the position checked below; (2) Sample examination questions; (3) Free copy of copyrighted book, "Government Positions and How to Get Them;" (4) A list of U. S. Government Jobs now easily obtainable; (5) Directions telling me how to get free coaching for the position checked; (6) Schedules showing dates and places of the Spring examinations in my locality.

-Railway Mail Clerk . . . (\$900 to \$1800)
-Postoffice Clerk . . . (\$800 to \$1200)
-Postoffice Carrier . . . (\$800 to \$1200)
-Rural Mail Carrier . . . (\$500 to \$1200)
-Bookkeeper . . . (\$800 to \$1800)
-Customs Positions . . . (\$800 to \$1500)
-Internal Revenue . . . (\$700 to \$1800)
-Stenographer . . . (\$800 to \$1500)
-Clerk in the Departments at Washington, D. C., or at Panama Canal . . . (\$800 to \$1800)

Name.....

Address.....

USE THIS COUPON BEFORE YOU MISLAY IT—WRITE PLAINLY

B103

\$65 to \$150 Month—LIFE JOBS

The United States Government wants thousands of Railway Mail Clerks, City Carriers, Postoffice Clerks, Customs, Internal Revenue Clerks, Clerks at Panama Canal and Washington, D.C.

Railway Mail Clerks Have Pleasant Work — Travelling Continually Government positions have yearly vacations with full pay. The position is not affected by strikes, wars or the whims of some petty boss. Country residents and city residents stand the same chance for immediate appointment — common education is sufficient — Pull is not required. Write us today for schedules showing dates and places of coming examinations in your locality.

Don't Delay Every day you delay lessens your chance of immediate appointment.

We Coach Candidates FREE

VALUABLE COUPON



Detroit Wants You

We can teach you the Automobile Business in Detroit and, if you so desire it, our Self-Help Department can obtain work for you to cover your expenses while here. You can be fitted for all automobile work, including driver, demonstrator, repairman, tester, inspector, foreman, etc.

Our Full Regular Course \$50

Our graduates are working in a number of Detroit factories and earning big money, what we have done for them we can do for you. Write us TODAY for full information and FREE illustrated booklet entitled, "Detroit, The World's Automobile Capital."

National Automobile School
734 Woodward Ave. Detroit, Mich.

NATIONAL TRADE DENTAL SCHOOL

506 S. Wabash Ave., CHICAGO, ILL.

LEARN MECHANICAL DENTISTRY—DEMAND UNLIMITED

Earn \$1200 to \$4000 yearly in mechanical dentistry. A big and growing demand everywhere for mechanical dentists—like a gold mine, unexplored. Attend this school any time of the day or evening; be taught individually and learn by actual practice, without book study. Our System, the most complete in the world, is used exclusively in this school. We are constantly called upon to fill high-salaried positions. Why not qualify for one? Be fair to yourself! Find out more about exceptional opportunity we offer. Visit the school or write for booklet.

ELECTRICAL ENGINEERING men with training are always in demand. Having trained over 2000 young men in the past 23 years in the fundamentals of Applied Electricity, The **Silas Electrical School**, with its well-equipped shops and laboratories, is peculiarly well qualified to give a condensed course in Electrical



including Mathematics, Steam and Gas Engines, Mechanical Drawing, Shop Work, and Theoretical and Practical Electricity, in all branches. Students actually construct dynamos, install wiring and test efficiency of electrical machinery. Course, with diploma, complete

IN ONE YEAR

For practical young men with limited time. 25th year opens Sept. 25th. Catalogue on request. 154 Takoma Ave., Washington, D. C.

Camera Men Wanted for MOTION PICTURES



Salaries \$40 to \$150 weekly. Light, easy, fascinating work. Travel everywhere. Demand for trained men exceeds supply. Our full course requires only few weeks. Day or evening classes. No book study; actual practice in up-to-date studio under expert instructors. No schooling required. Easy terms. Special offer to those enrolling now. Call or write for free booklet. **DON'T DELAY. SEND AT ONCE.**

NEW YORK INSTITUTE OF PHOTOGRAPHY
2405, 141 West 36th St. NEW YORK

Let This Man Train You For A Big Traffic Position



NORMAN D. CHAPIN

Faculty

N. D. Chapin
Formerly Chief of Tariff Bureau
of the New York Central Railroad
and West Shore Railroad.

R. E. Riley
Formerly Instructor in Railway
Transportation at Y. M. C. A.,
New York City; formerly with
the I. C. R. R., N. Y. C. Lines, C.
N. O. & T. P. Ry., C. H. & D.
Ry., and H. & O. E. W. R. R., and
S. P. Co.—Atlantic Steamship
Lines.

G. F. Falley, A. B.
Formerly General Freight and
Passenger Agent of the
E. & N. W. Railway.

John P. Curran, I. L. B.
Central Freight Association; formerly
with Southwestern Tariff
Committee, St. Louis.

F. R. Garrison
Chief Clerk, Central Freight Association; formerly with L. E. &
W. H. R., C. H. & D. Ry., and
G. R. & I. Ry.

J. W. Harnach
Formerly with C. M. St. P. Ry.,
and Chicago Great Western R. R.

L. E. O'Brien, Ph. B.
Formerly Industrial Traffic Mgr.

Text Writers

(Partial List)

E. R. Dewanup, A. B. A. M.
Professor of Railway Administration,
The University of Illinois;
Author of Freight Classification.

A. R. Smith
Vice-Pres., Louisville & Nashville
Railroad; Author of Freight
Rates in Southern Territory.

W. H. Chandler
Manager Transportation Bureau,
Boston Chamber of Commerce;
Author of The Express Service
and Rates.

B. Olney Hough
Editor, American Exporter; Author
of Ocean Traffic and Trade.

C. C. McCain
Chairman, Trunk Line Association;
Joint Author of Freight
Rates—Official Classification
Territory.

C. S. Sikes
General Auditor, Pere Marquette
Railroad; Author of Railway
Accounting.

J. F. Morton
Asst. Traffic Director, Chicago
Association of Commerce; Author
of Routing Freight Shipments.

C. L. Lingo
Traffic Manager, Inland Steel Co.

The complete LaSalle organization consists of more than 300 business experts, professional men, text writers, instructors and assistants, including recognized authorities in all departments.

Over 25,000

ambitious men in all lines of railroad and industrial traffic work, throughout the United States, have benefited through membership in our Department of Interstate Commerce and Railway Traffic. More than

\$150,000

has been expended by our institution in organizing and perfecting the training and service rendered members of this department, which is now under the direct, personal supervision of

MR. N. D. CHAPIN

Formerly Chief of Tariff Bureau, New York Central Lines

Mr. Chapin has been engaged to devote his entire time to this work, and is assisted by a selected corps of railroad and industrial traffic experts, together with an organization of more than 300 people.

LaSalle Training Fully Recognized

The LaSalle Course in Interstate Commerce and Railway Traffic is now fully recognized by the country's greatest traffic authorities as the highest type of traffic training now available. It has been adopted as representing the highest standard of technical training, information and practice, in the matter of interstate commerce, railway and industrial management, in important traffic centers and is approved by many trunk railroads, such as the following:

**Baltimore & Ohio R. R., Louisville & Nashville R. R.,
Cumberland Valley R. R., Erie R. R.,
Pennsylvania Lines West**

The course is a complete, up-to-date, and thoroughly practical system of training, covering all phases of modern traffic operations. It is a "100 man power" course, conducted by thoroughly qualified traffic experts who have risen from the ranks. No other course compares with it. Should not be confused with so-called traffic clubs or traffic associations. Hundreds of men are now holding big positions and drawing greatly increased salaries as a direct result of LaSalle training and service.

A few of the many LaSalle Students Now Industrial Traffic Managers: W. S. Epsky, Traffic Manager, Hammermill Paper Co., Erie, Pa.; T. J. Bennett, Traffic Manager, American Steel Foundries, Chicago; P. D. Eivers, Traffic Mgr., The Garland Corp., Pittsburg; R. P. Moller, Traffic Mgr., U. S. Light and Heating Co., Niagara Falls, N. Y.; J. D. Quinn, Traffic Mgr., Franklin Steel Works, Franklin, Pa.; Thos. S. Barry, Traffic Mgr. for the Pawtucket Board of Trade, Pawtucket, R. I.; Seth Tate, Traffic Mgr., Higginbotham, Bailey-Logan Co., Dallas, Texas; K. L. Crickman, Traffic Mgr., Great Western Smelting & Refining Co., St. Louis; Alex. Denholm, Traffic Mgr., The Lakewood Engineering Co., Cleveland; E. H. Culbertson, Traffic Mgr., Seattle Construction & Dry Dock Co., Seattle, Wash.

Send Coupon For FREE Traffic Book

Send now for big illustrated traffic book giving full particulars regarding our course of instruction by mail, opportunities open, salaries paid, etc. There is no obligation on your part. Book and all information sent free. Act promptly. Special reduced rate scholarships and small monthly payment plan open to those enrolling now. Write today.

LaSALLE EXTENSION UNIVERSITY

"The World's Greatest Extension University"

Dept. 564-C

Chicago, Ill.

Read This Letter From A Well Known Traffic Official

"If the information in the enclosed clipping (referring to Mr. Chapin's appointment as head of the department of Interstate Commerce and Railway Traffic) from 'The Pittsburgh Dispatch' today is correct, I wish to extend sincere congratulations to yourself and the University in the selection of Mr. N. D. Chapin for the position mentioned. I consider Mr. Chapin not only one of the best-informed rate and tariff men in the country, but also possessed of all the necessary personal qualifications to engage successfully in the good work of your University.

F. S. DAVIS,
Gen'l Western Freight and
Passenger Agent,
N. Y., N. H. & H. R. R.

Other Prominent Railroad Men Endorse LaSalle Training

"Your enterprise has my entire approval."

E. P. RIPLEY, Pres.,
Santa Fe Ry.

"I unhesitatingly recommend your course to anyone."

H. J. STEEPLE, Gen'l Agt.,
Erie Railroad.

"I have no hesitancy in saying that any student taking the course and diligently and studiously applying himself to the task of absorbing the information, cannot help being benefited and his efficiency will be increased."

W. H. PAXTON, Gen'l Frt. Agt.,
Southern Ry., Atlanta, Ga.

Among others who endorse our course are: E. T. Campbell, Gen'l Traffic Mgr., Erie Railroad; James Webster, Asst. Freight Traffic Manager, N. Y. C. Lines; R. H. Drake, Division Freight Agent, American Can Co.; etc., etc.

Mail Coupon NOW

LaSalle Extension University,
Dept. 564-C Chicago, Ill.

Please send FREE proof about opportunities now open to TRAFFIC EXPERTS with LaSalle training.

Name.....

Occupation.....

Address.....

City..... State.....

Please Mention Popular Mechanics



Come to Detroit The Automobile Center and

33,000 sq. ft. of
Additional
Floor
Space

LEARN THE AUTOMOBILE BUSINESS

We teach you to handle any auto proposition. You graduate in from ten to twelve weeks. Our equipment is new, up-to-the-minute, and complete. No old, obsolete motors, chassis or electrical equipment used. Students actually build cars from start to finish, getting factory training in assembling, block-testing, road-testing, everything. Special complete course in Oxy-Acetylene brazing, welding and cutting, separate from regular course. Learn to time motors, rebore cylinders, adjust carburetors, magnetos, valves and bearings quickly and accurately. Six-cylinder Lozier,

Get Better Job—or—Go in Business

Chalmers "6," Detroit "6," Overland, and 8-cylinder King are used for road instruction. We have a new Chalmers "6-30" chassis with 3400-r. p. m. motor, the latest thing out, Willys-Knight 1917 chassis, Studebaker "6" 1917 chassis, Hudson Super-Six 1917 chassis, Cole "8" 1917 chassis, Detroit Electric 1917 chassis, G. M. C. Truck, Packard Twin "6" 1917 chassis, and many others.

All completely equipped for students to work on. We have more than 20 motors in our block test department—2 cyl., 4 cyl., 6 cyl., 8 cyl., and 12 cyl. Our electrical department is complete, having every standard starting, lighting, and ignition system, including Delco System as used in Buick, Hudson, and Packard Twin "6."

Detroit Is the Place to Learn—Start Any Time

There are 44 auto factories in Detroit and vicinity and 140 accessories and parts factories. Our students have the privilege of going through any or all of them. We operate Starting, Lighting, Ignition Service Station. This has added thousands of dollars' worth of equipment and makes our electrical department unequalled. Students get actual experience in handling all kinds of electrical auto equipment and taking care of trouble. We have just installed a Sprague Electric Dynamometer for block-testing purposes for students' use. Ours is the only Auto

school having this equipment. Auto factories need Dynamometer men constantly. Factories and garages are paying big salaries to men who know how to handle electrical equipment quickly and properly. Detroit is the automobile center. You get practical instruction. School open all the year. Enter classes any time, any day. Three classes daily: morning, afternoon, evening. All instructors are members of the Society of Automobile Engineers (S.A.E.) There is a great demand for Michigan State Auto School students. Auto factories write and phone for men constantly.

Follow the Crowd to the Michigan State Auto School. Come to Detroit

MONEY-BACK GUARANTEE

We guarantee to qualify you in a short time for a position as chauffeur, repair man, tester, demonstrator, auto electrician, garage man, or automobile dealer, paying from \$75 to \$300 monthly or refund your money. We have constantly more requests for Detroit trained men at GOOD salaries than we can supply.



THIS IS ONE OF THE FEBRUARY 1917 CLASSES



Additional Building and Equipment Factory Co-Operation

Thousands of dollars' worth of new equipment, plenty of room for students to work, at 687-89-91 Woodward Ave., in addition to our building at 11-19 Selden Ave. Our school has grown by leaps and bounds, students come from all over the world. We are constantly adding new equipment. Our electrical department is thorough and complete.

We have completed arrangements with the Auto factories with the Auto factories to put them in touch with men who intend going into business for themselves. Men who know the auto business from A to Z are in biggest demand. Remember, the price of course is based on giving full value. Graduates in the complete auto course are competent to handle farm tractors.

SEND THIS COUPON TODAY

MICHIGAN STATE AUTO SCHOOL
305 Auto Bldg., 687-89-91 Woodward Ave.
DETROIT, MICHIGAN, U. S. A.

Gentlemen: Send me absolutely FREE "Auto School News" and New Catalog, or better still, you can expect

me about.....

Name.....

Street.....

Town..... State.....

Auto Factories Endorse Our School

The Leading Automobile factories in Detroit, as well as in other cities, endorse our school. They have been watching our school and graduates for years and are satisfied. They are putting their latest model, complete chassis in our school for students to work on. They are employing our graduates in their factories and service stations and assisting them in opening garages and salesrooms. They allow our students to go through their factories. They need trained, competent men and are asking for more of our graduates constantly. The Michigan State Auto School in Detroit, the heart of the Auto Industry, is endorsed by the Leading Auto Factories, is receiving their hearty co-operation. What better endorsement could you ask?

Act Quickly—NOW! Fill in the coupon; get full particulars. "Auto School News" and New 128-Page Illustrated Catalog. All absolutely free. Or better still, jump on the train, as hundreds have done, and come to the "Heart of the Automobile Industry," and learn right. We have no branches. Write or come direct to this school.

Michigan State Auto School

The Old Reliable School
305 Auto Building
687-89-91 Woodward Ave.

A. G. ZELLER, Pres.

DETROIT, MICHIGAN, U. S. A.

EARN \$75. TO \$300. A MONTH

With the New Building and Thousands of Dollars Worth of New Equipment, Our's is the Largest Exclusive Auto School in the Country



We teach the newest and best way to re-bore cylinders as a part of the complete Auto Course. No need to have big, heavy, expensive machines. This is very important instruction.



These men are getting final instructions after they have taken down and rebuilt a new up-to-date 6 cyl. motor.



This is a partial view of our Chassis room showing eight up-to-date chassis for students' use.



A new 12 cyl. motor connected to our Sprague Electric Dynamometer in Block Test Dept. for students' use.



DECEMBER 1916 CLASS IN MECHANICAL LECTURE ROOM

This is the first work a student receives. A 6 cyl. 1917 Saxon "Cut-open" chassis is used to make perfectly clear and practical the first instructions. There were 350 men set for this picture. The Electrical Lecture room is the same size. The classes are divided so that more intense work can be done on each subject. Every man is given personal help and his progress through the school is watched carefully.



This is a section of the Brazing, Welding and Cutting Department. Each man handles the torches and works with an individual outfit.



View showing about 18 motors in the Block Test Department. Sprague Electric Dynamometer shown in center background.

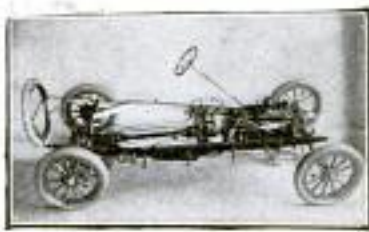

A close view of Saxon "Cut-open" chassis used in Mechanical Lecture room. Hidden parts are cut open and electric lighted.



Students getting personal instructions on Willys-Knight 1917 chassis.



Students making final test on Maxwell 1917 unit power plant motor.



Complete working Deleco System as used in Buick, Hudson, and Packard Twin "6."



Battery charging room, showing lighted switchboard and distilled water rack.

These cuts were all made from actual photographs taken in our school.

Use the Coupon on left-hand page **—DO IT NOW** **Don't Even Hesitate**



“John, Every Ironing, I Have a Headache
—a severe backache. It just wears me all out. I could save myself hours of hard, tedious labor and money, besides, if I, like our neighbors, had a—

SIMPLEX IRONER

“THE BEST IRONER”

Thirty Days' Free Trial—Easy Terms

An average family ironing costs about 3c and is done in one hour. The SIMPLEX irons beautifully most everything but shirtwaists and skirts.

A size for every home. \$30 up. Lasts a lifetime. Write for handsomely illustrated Free Book TODAY.

American Ironing Machine Co.
505—168 N. Michigan Ave., CHICAGO

We also make Ironing Machines and Equipment for the Small or Hand Laundry, Hotel, Institution, etc. WRITE FOR CATALOG



Please Mention Popular Mechanics

American Locomotives
30 Church St. N.Y.C.
Built at Brooks Works, Dickinson, N.Y.

Popular Mechanics Magazine

REGISTERED IN U. S. PATENT OFFICE

WRITTEN SO YOU CAN UNDERSTAND IT

Vol. 27

MAY, 1917

No. 5

4131 *Or. W. R.* Interesting Engine Built for Western Road

MOST striking is the appearance of a powerful locomotive that has lately been constructed for the Denver & Rio Grande Railway. Although it is one of the largest engines of the single-expansion, nonarticulated class, its chief interest to the layman doubtless lies in the peculiarities of its design. The boiler is of such height that it was necessary to dwarf all of the upper protuberances in order to permit operation beneath low bridges and through certain tunnels. In building it, the sand

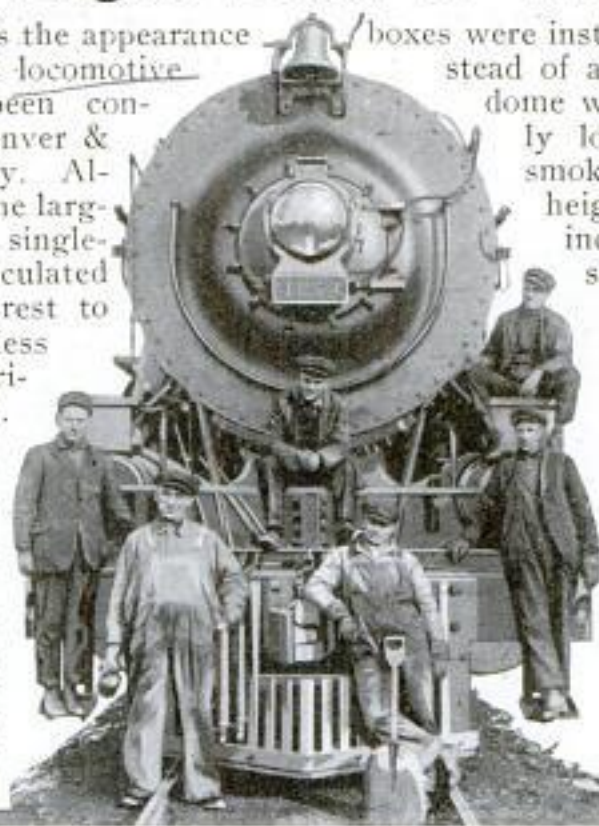

boxes were installed at the sides, instead of at the top, the steam dome was built exceptionally low and broad, the smokestack was given a height of only a few inches, and the bracket supporting the bell was attached to the front of the smoke box above the headlight. The engine, which is one of several of a type being placed in service, is thoroughly equipped with devices designed to facilitate operation and lighten the work of the engine-men. A mechanical stoker, actuated

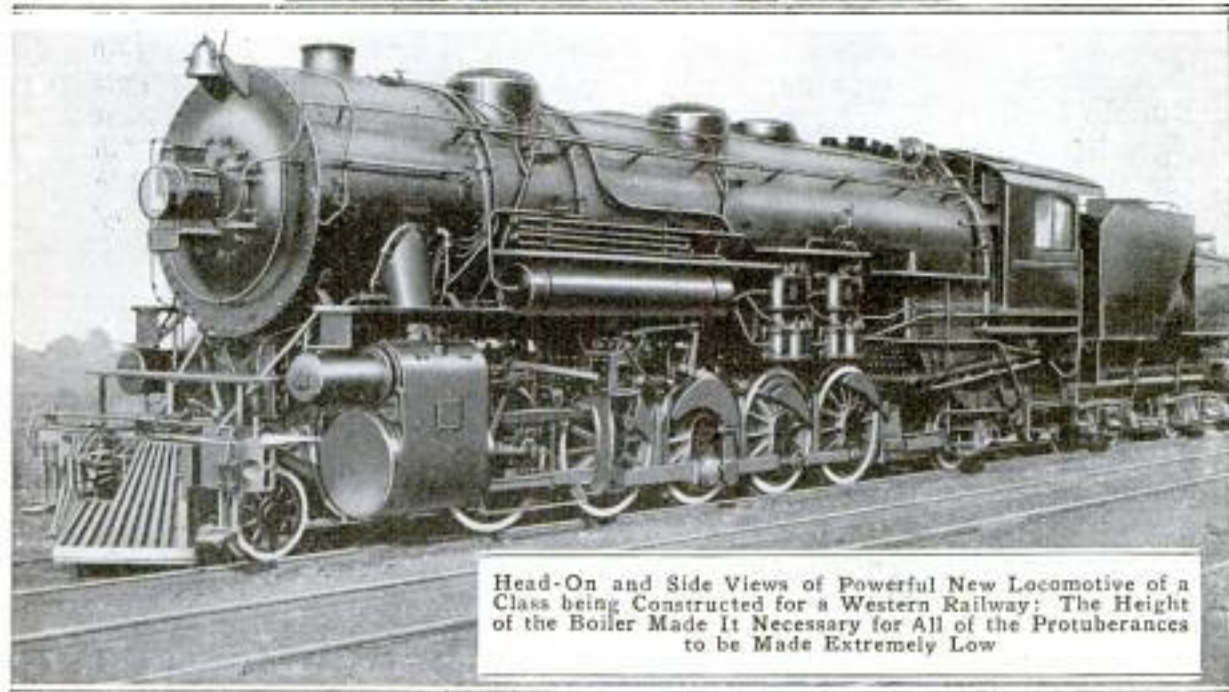

Head-On and Side Views of Powerful New Locomotive of a Class being Constructed for a Western Railway: The Height of the Boiler Made It Necessary for All of the Protuberances to be Made Extremely Low

Newsdealers will have the June issue of Popular Mechanics Magazine on sale May 20th.

both by steam and compressed air, feeds pulverized coal to the fire. In cases requiring hand stoking, the door of the fire box is opened and closed by power. There are no large, heavy

levers for the pilot to manipulate, for compressed air again is brought into play. Alone, the locomotive weighs 428,500 lb., and with the tender, 624,900 pounds.

4065

ADAPTABLE NAVY PEDESTAL FOR MACHINE GUNS

The nation wide discussion of measures for increasing our defenses on sea gives added interest to a machine-gun

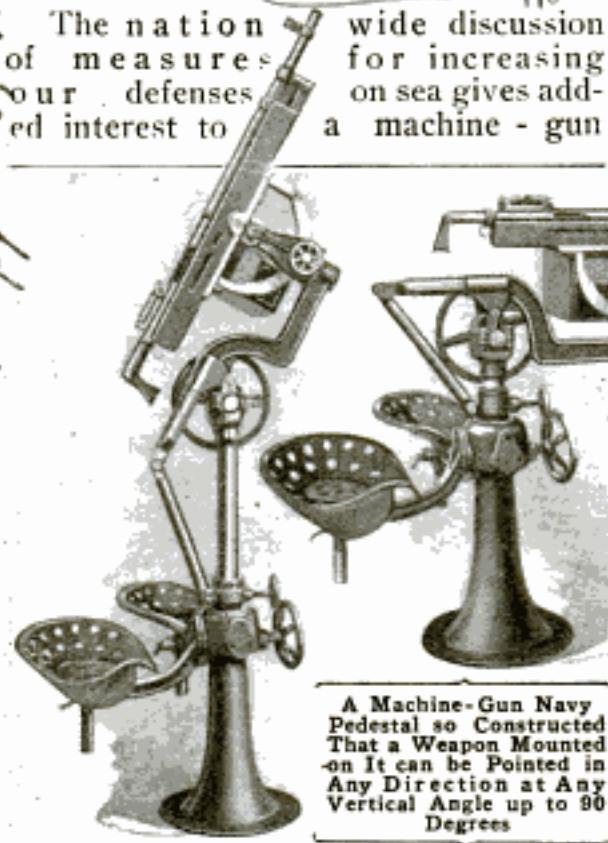

A Machine-Gun Navy Pedestal so Constructed That a Weapon Mounted on It can be Pointed in Any Direction at Any Vertical Angle up to 90 Degrees

pedestal for the navy, manufactured by a Buffalo concern. This mounting is designed to be fastened to the deck of a coast cutter, or harbor-patrol boat, etc. It consists of a base with gun mounting, and is so constructed that a complete circle can be described in the operation of the gun regardless of the angle at which it is placed. The firing piece can be elevated to practically 90° or pointed lower than horizontal. If desired, two seats can be attached to the base.

¶ An electric steel furnace, which has been operating in Duquesne, Pa., since last November, produces 30 tons of steel in each heat, and is said to be the largest electric steel furnace in the world.

4093

SUPPLY OF SINGING BIRDS CUT OFF BY WAR

One of the sidelights of the great war is furnished by the disappearance from the market of singing canary birds, of which many thousands were formerly imported annually from Germany, where their breeding and training occupied many of the peasants of the Hartz Mountains and neighboring districts. War conditions, it is said, have caused the birds practically to disappear in the Hartz. The services of the inhabitants have been otherwise required and the birds have lacked their customary supplies of food, so that the region will have to be restocked after the war before a fresh supply of the familiar songsters is available for export. As a consequence, the price of canaries, which before the war was about \$3 or \$4 in Chicago bird stores, has jumped to \$12 or \$15, and there are few to be had at any price.

3659

COAST-GUARD STATIONS TO USE AEROPLANES

Aeroplanes will be added to the equipment of the United States Coast Guard stations to aid in rescue work, if recent proposals are adopted. Many a vessel has been wrecked on the rocks at a point too far from shore to be reached by the line-throwing gun, and while the sea was running so high that the imperiled crew and passengers could not be rescued with lifeboats. In such a case a flying boat would be called on to carry a life line out to the distressed vessel. Another task which the air craft may be employed in is locating derelicts so that they can be removed as quickly as possible from navigation routes.

Cygnus Rear Car Co.
1200 Niagara St.
Buffalo, N. Y.

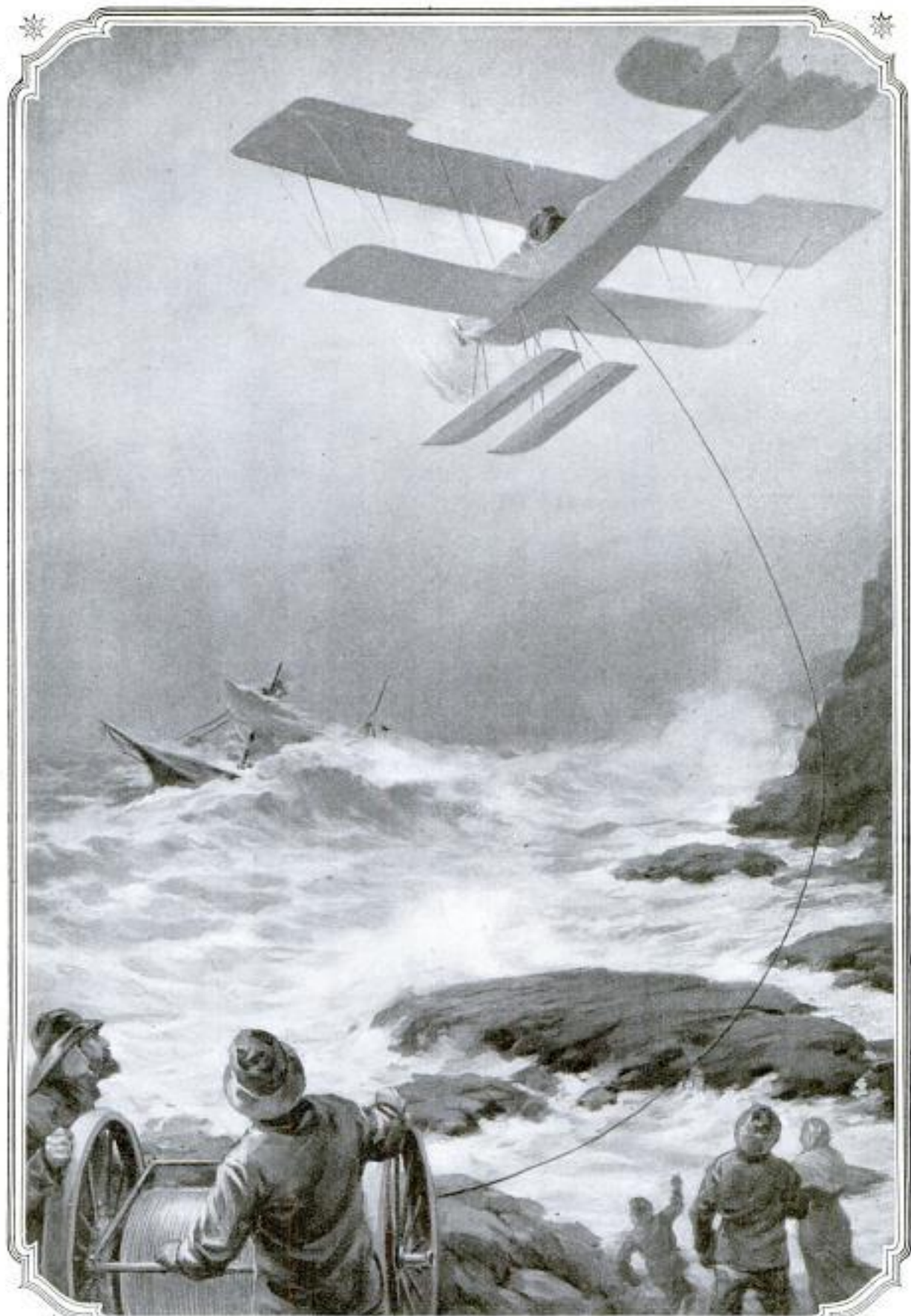

The Fury of a Stormy Sea, Lashing Hidden Reefs off the Shore, has Baffled Shipwrecked Sailors and Life-Savers Countless Numbers of Times, but Now It is Proposed to Lend Aid to Those in Distress, despite the Storms and Reefs, by Means of Air Craft as Graphically Portrayed Herewith. Ships are Often Grounded Out of Reach of Line-Throwing Guns and Lifeboats, and to Overcome This Fatal Handicap, the Equipment of Our Coast-Guard Stations with Flying Boats is Contemplated

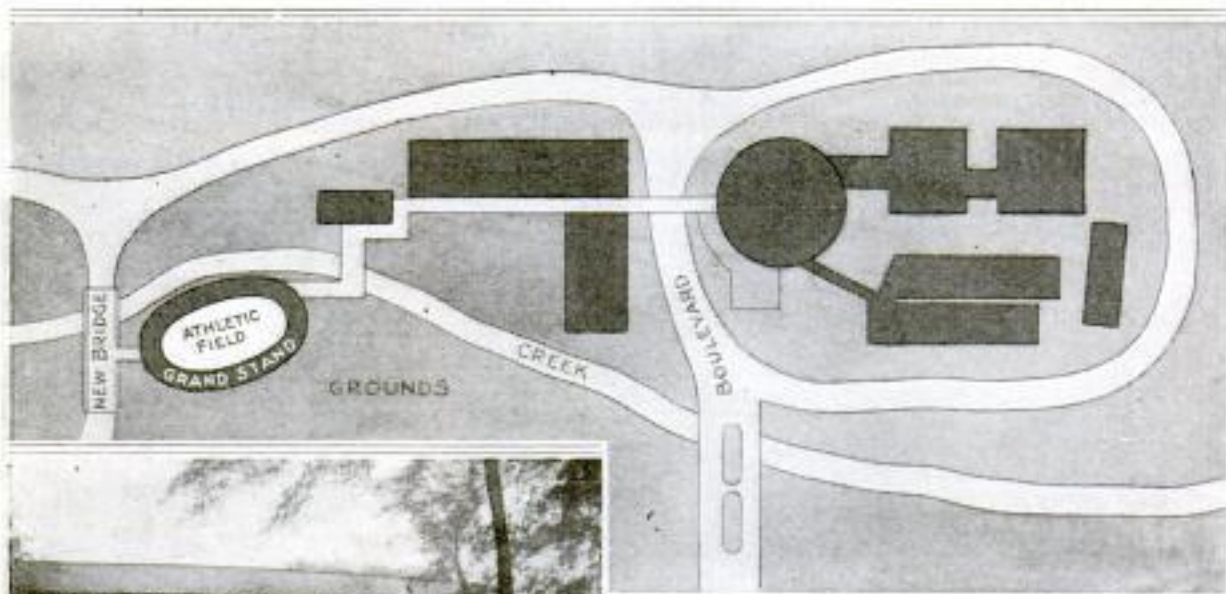

New Concrete Bridge Built to Divert Farmers from the Grounds of an Indiana Resort: Baseball Grand Stand in Background

Ground Plan of the West Baden Resort. Showing in the Center the Old Road, Now Boulevarded, Which Brought Farm-Wagon Traffic Too Close to the Hotel Verandas: The New Road Is at the Left

HOTEL BUILDS BRIDGE TO DIVERT FARM TRAFFIC

In order to divert farm traffic from a county road running in front of a hotel at West Baden, Ind., the proprietors of the resort recently spanned a neighboring creek with an attractive concrete bridge connecting new sections of road which shorten local travel for the farmers and obviate the necessity of rural traffic passing through the hotel grounds. The new road and bridge were turned over to the county, while the old thoroughfare was boulevarded, paved with brick, planted with grass along the center, and illuminated with street lamps for the convenience of motorists and guests of the pleasure resort. The new bridge on the public road is 300 ft. long, with a wagon road 14½ ft. wide, and a 7½-ft. walk. Midway of its length is an exit to the walk from the grand stand of a ball park. The bridge is constructed of steel beams and concrete, finished in stucco.

SIDEWALK MONEY CHUTE

2791 FOR RELIEF FUNDS

Small cash contributions to the Belgian relief fund were solicited and collected in a novel way by the installation of a money chute, with appropriate signs, outside the relief headquarters in Boston. A 4-in. iron tube, passing through a hole in the sidewalk to a strong box in the basement, was topped with a large funnel at a convenient height to receive the cash offerings of pedestrians as they passed. Both pipe and funnel were painted with the Belgian colors—black, yellow, and red—and a conspicuous sign read: "Money Dropped Here Goes Direct to Belgium."



Small cash contributions to the Belgian relief fund were solicited and collected in a novel way by the installation of a money chute, with appropriate signs, outside the relief headquarters in Boston. A 4-in. iron tube, passing through a hole in the sidewalk to a strong box in the basement, was topped with a large funnel at a convenient height to receive the cash offerings of pedestrians as they passed. Both pipe and funnel were painted with the Belgian colors—black, yellow, and red—and a conspicuous sign read: "Money Dropped Here Goes Direct to Belgium."

☐ The cost of seed potatoes for home gardens may be practically eliminated, it is said, by planting potato peelings which are cut a little deeper than ordinarily under the eyes.

*Belgian Relief Headquarters
Boston*

O. F. Humziker

Purdue University
Lafayette, Ind.

4057

NEW METHOD OF TESTING DAIRY-CALF FOODS

An interesting series of experiments was conducted recently at Purdue University to determine the nutritive value of skim milk and milk substitutes in feeding dairy calves. Instead of relying solely upon tabular records, individual photographs were taken of each of the trial animals, showing their general appearance and development at regular 30-day intervals during the tests. Thirty calves of three different breeds were used in the experiments, these being divided into three lots and fed three distinct rations for a period of 180 days. At the end of each 30 days the calves were photographed under the same conditions. The camera was placed on a stationary support, at the same height and distance for each exposure, the calves standing upon a convenient platform, with a background screen, divided into 6-in. squares. The background was black or white according to the general color of each calf. In this way the development of each animal was clearly shown by the photographs and the merits of the respective rations could be judged. Incidentally it was found that the average monthly growth of dairy calves is from 1½ to 2 in. in height under proper care and feeding.

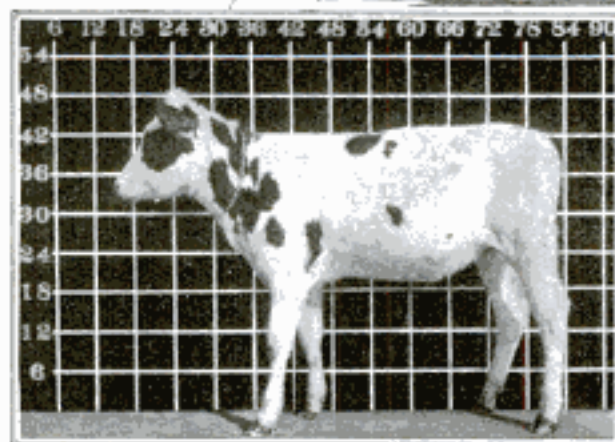

Using the Camera to Record Growth of Dairy Calves in Nutrition Tests at Purdue University: At the Left is a Holstein Calf before a Black Screen with Six-Inch Squares Which Show Development of the Animal in Successive Pictures, Like Those of a Jersey Calf, at the Right, Which were Taken at Intervals of 60 Days

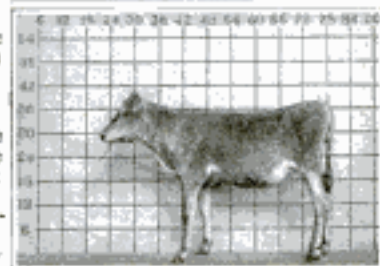
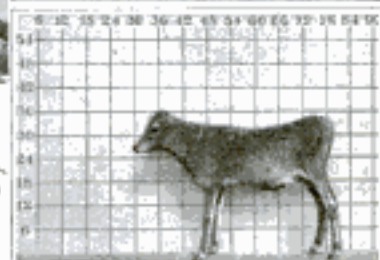
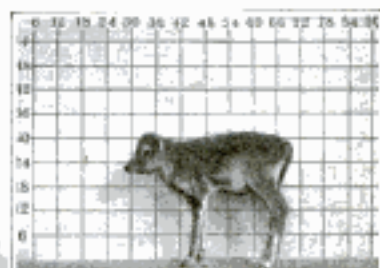

EXPOSITION STATUARY IN DESOLATE SURROUNDINGS

Much of the statuary that adorned the buildings of the Panama-Pacific Exposition has lost all its impressive-



Two Views of the Panama-Pacific Exposition Water Front, Showing the Accumulated Statuary That is being Defaced by Weather and Souvenir Hunters. "The End of the Trail" so Far has been Injured But Little

ness by being assembled, indiscriminately, near the water front of the exposition grounds. The weather and souvenir hunters have shared in defacing these abandoned works of art. However a few have so far escaped unmolested. One such is "The End of the Trail." This statue of an exhausted horse and rider seems strangely in accord with its surroundings.

NOTE ACCOMPANIES PACKAGE WHEN PUT IN HOLDER

Quite an ingenious envelope holder is being gotten out which enables a catalog or parcel to be accompanied by

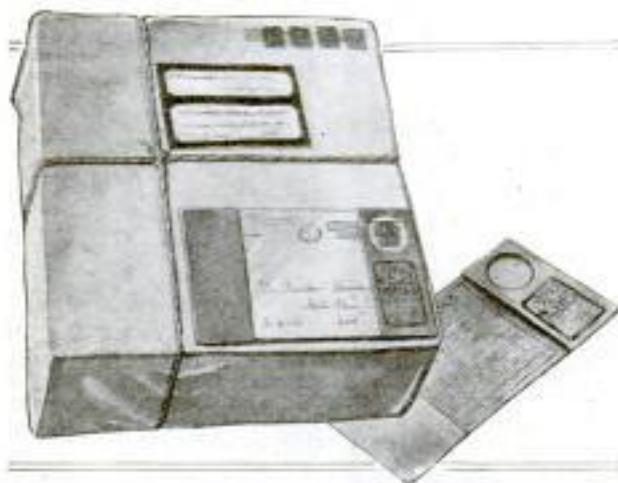

When the Holder is Attached to a Package and an Envelope Inserted in It, Both Pieces of Mail will Reach Their Destination Simultaneously

a letter so that the two pieces of mail, although of separate classes, will reach their destination simultaneously. Frequently in forwarding a parcel-post package to an individual, a business house will direct a communication to the person, advising him that such and

such has been dispatched "under separate cover." The letter is most often delivered several days before the other piece of mail, and therefore loses whatever effect it might otherwise have had. The envelope holder, which may be attached to the outside of a package, overcomes this condition. It consists of a piece of paper gummed on one side and having, at opposite ends on the other surface, flaps into which an envelope can easily be inserted. A circular opening at the top of one flap exposes the stamp. Both package and letter must be individually addressed and provided with the proper postage.

3394 ELEPHANTS COMPELLED TO HAUL A CIRCUS TRAIN

When a circus train on the Southern Pacific came to an involuntary stop near Galveston not long ago, investigation by the engineer revealed the cause, it is reported, in a carload of elephants right behind the water tank of the engine tender. Being athirst and dusty, the intelligent animals had reached with their trunks through the end window of the car into the tank,

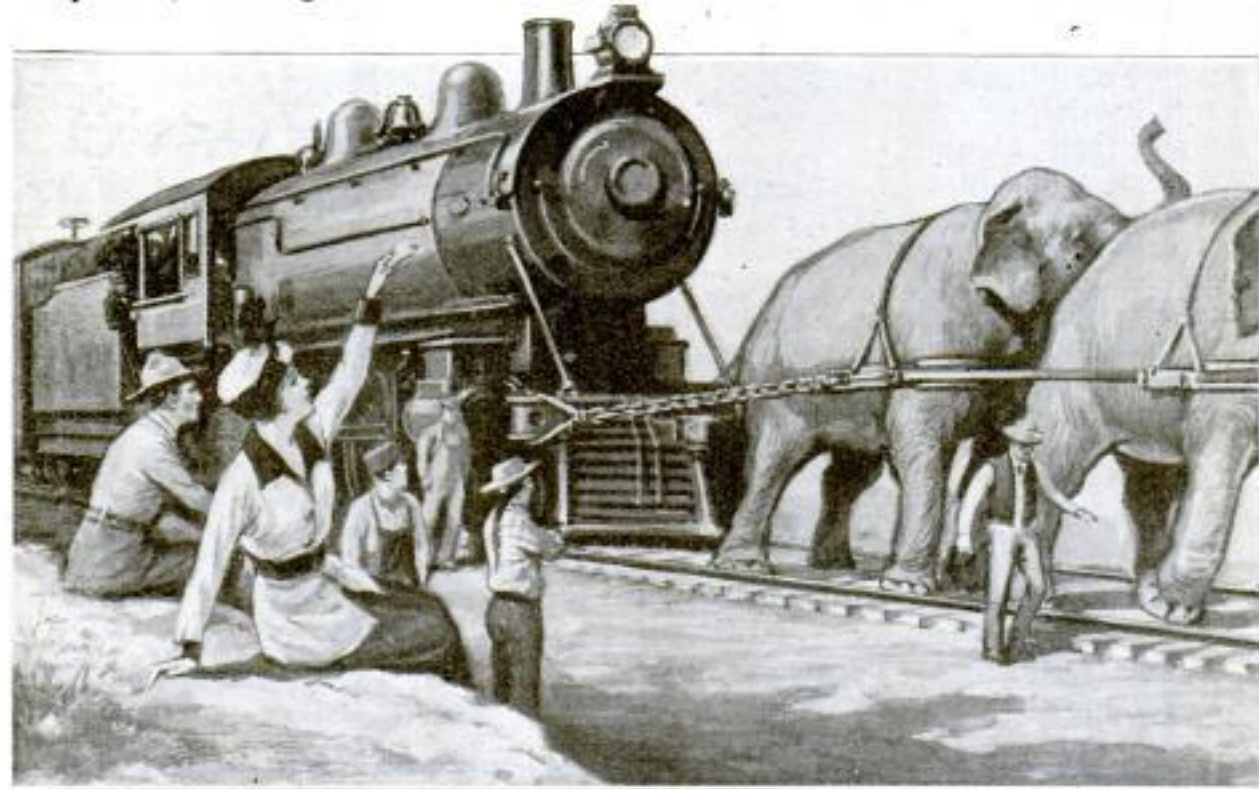

When Their Train Came to a Standstill Because They had Stolen the Engine's Water Supply, These Four Water Supply. This Remarkable Scene is Reported to have

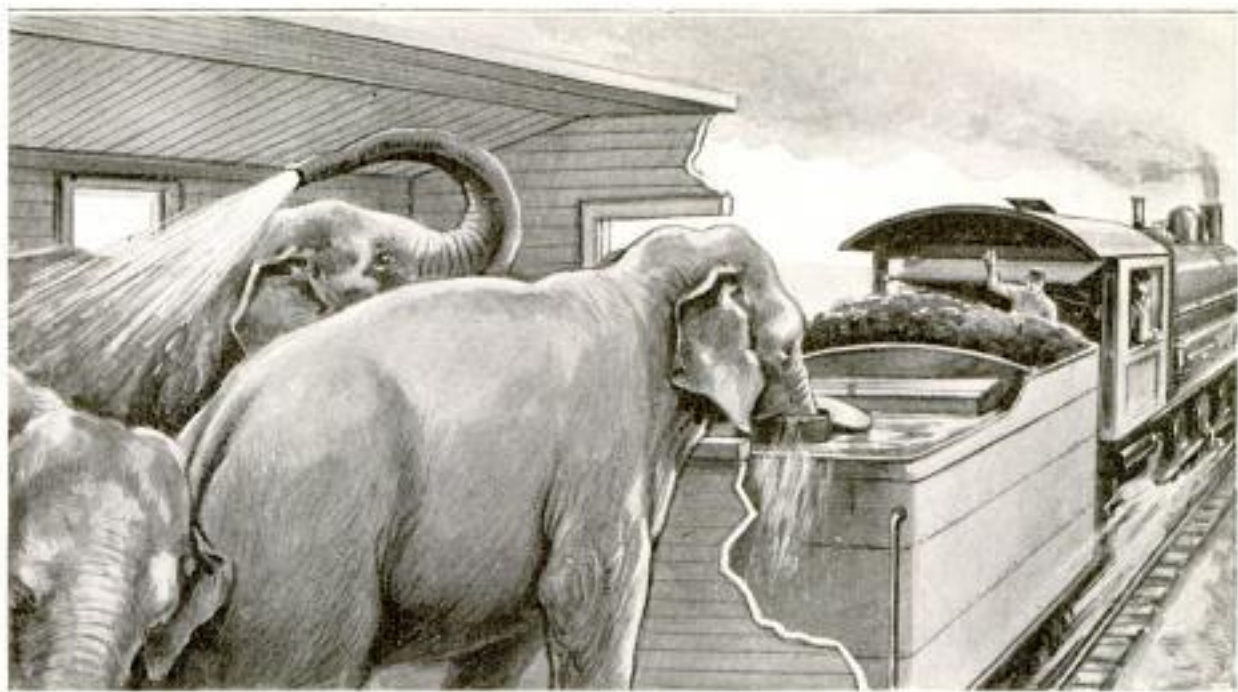

Elephants Emptying the Water Tank of a Locomotive Drawing a Circus Train: The Sketch Shows How the Big Animals Reached through the End Window of Their Box Car into the Tank.
Lack of Water Stopped the Train

and every drop of the water had gone to assuage elephantine thirst and spray vast areas of dusty hide. The elephant trainer was called from the caboose to a consultation and solved the problem of moving the stalled train by unloading the four offending ele-

phants, who were then hitched in tandem in front of the locomotive and compelled to pull the engine for a distance of three miles along the track to the tender supply, where the tender was replenished.

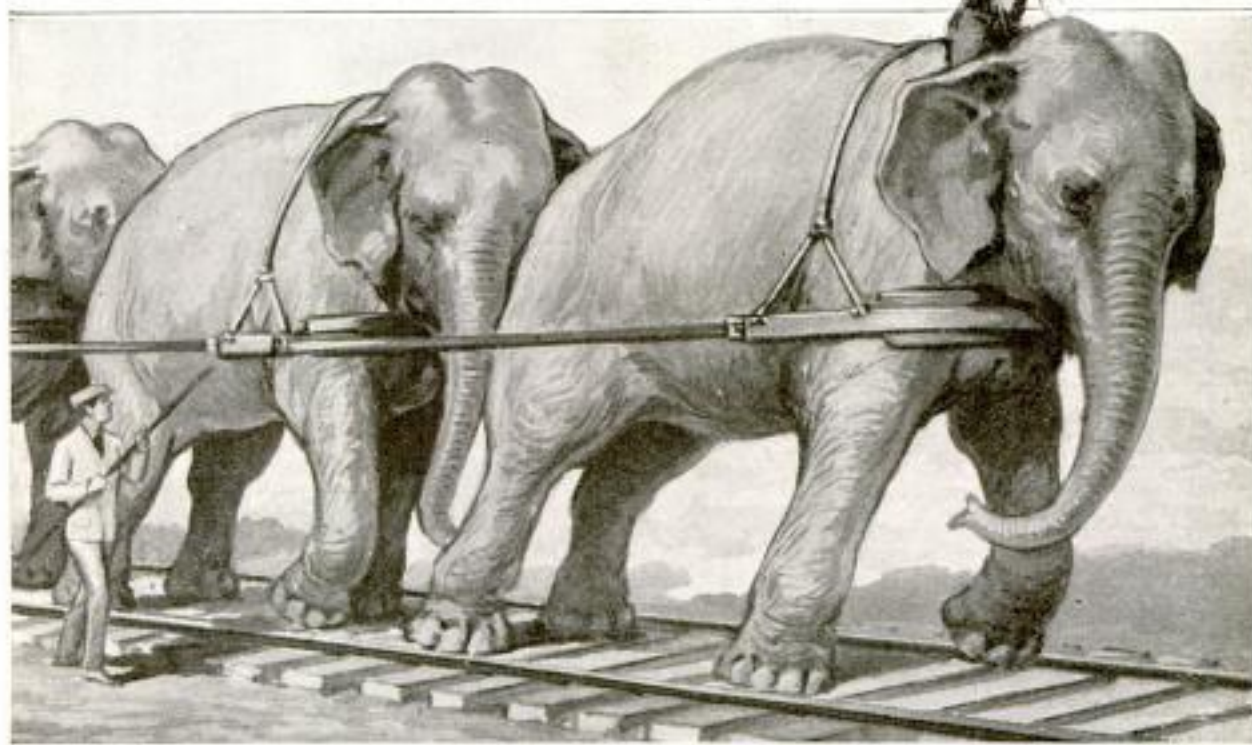

Elephants were Hitched in Front of the Locomotive and Compelled to Pull the Engine Three Miles to the Nearest Occurred on the Southern Pacific Railroad, Near Galveston, Texas

Invr. E. Oppenheimer
2304 Mich. av. Chicago

NEW STYLE OF INDIVIDUAL PHOTOS IN MOTION

With a motion-picture camera recently invented by a New York man,

tached to a similar camera in the home or by means of a booklet arrangement of the finished photographs, to be flipped over rapidly by hand. Such a booklet, containing, say, 36 consecutive pictures of the subject in motion, can be retailed for 25 cents or 50 cents, while the camera itself, with the projecting attachment, is designed to be sold at a moderate price, so that motion pictures can be both taken and reproduced at home. For taking the pictures a daylight-loading film or plate holder is provided with both a vertical and a lateral movement, so that 36 small impressions of an object in motion may be quickly made in six rows on the film or plate. When developed, enlarged prints are quickly prepared from



Booklet of Individual Photographs Which, When Snapped Over between the Thumb and Finger, Give the Impression of a Moving Picture

individuals or groups can now have a series of photographs taken while they wait, at very small expense, for reproduction either by a projector at-

the small impressions, placed in a pack in successive order, and bound to form a booklet. Snapping over the leaves gives the effect of moving pictures.

3841

THEATER AISLES LIGHTED FROM RECESSES IN FLOOR

A system of lighting theater aisles from recesses in the floor has been patented in England, the advantage of which is that it does not interfere with

the presentation of motion pictures or illuminate a darkened stage. Under this arrangement pockets containing electric bulbs are located at the ends of the rows of seats and are covered with transparent or translucent glass. If desired, advertising can be inserted under the glass in the form of transparencies. The lamps can be made to light automatically when anyone steps on the covers.

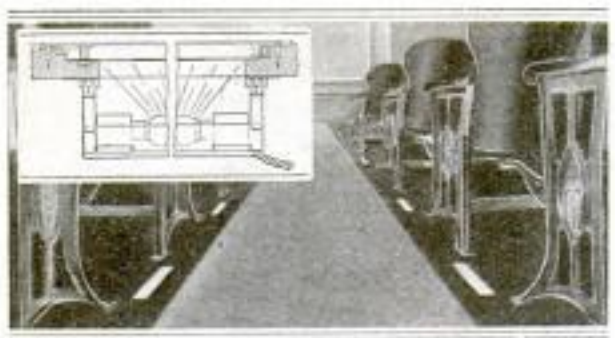

Lighting System for Theater Aisles in Which the Electric Lamps are Installed in Recesses in the Floor at the End of the Seat Rows

4052

"GUN-TYPE" SCOUT CAMERA USED BY OUR AIRMEN

Europe's war has demonstrated the importance of aerial photography and moreover has brought it quickly to a high stage of development. Although military aviation has been seriously

Invr: J.T. Taylor 8 Springfield St., Wigan, England
M. H. Herd 34 Main St., So. 52
Copyrighted material

U + U

C. N. O. S.

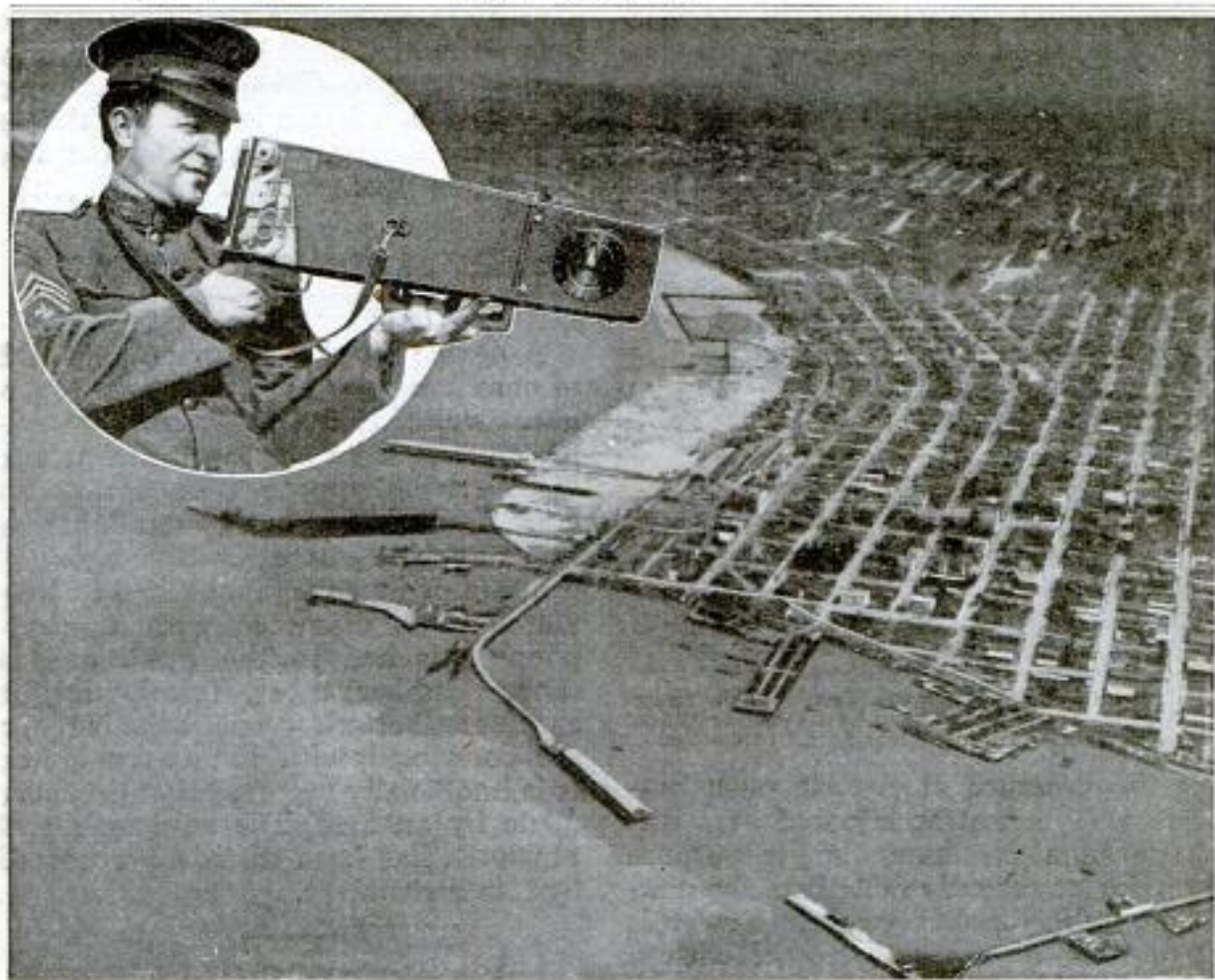

San Diego's Water Front, Business District, and Environs as Seen by New Aerial Scout Camera. Insert Shows the Camera Held in the Position in Which It is Used by an Aerial Photographer

neglected in this country, this particular phase of it, contrary to what is doubtless the popular impression, has not been entirely overlooked. Of late a new and apparently promising camera of the "gun type" has been developed and placed in the hands of official photographers of the flying corps. It has a telescopic lens of a 24-in. focal length, is supplied with sights, and is light in weight, although somewhat elongated. The shutter is controlled by a trigger like that of a gun. Detailed photographs have been made with the instrument from great heights. It is considered likely by certain authorities that American scouting cameras of the future will follow the lines of this machine.

CA jewelry firm is making over defective cartridge shells, bought from a munitions firm, into flower vases.

NEW FUEL-OIL BURNER FOR STEAM PLANTS

In industrial plants where oil is used as fuel, the problem of firing is simplified by a new oil burner designed and patented by a Florida engineer. This burner, it is claimed, produces a clean, clear flame, free from unburned oil, uses a minimum amount of steam for atomizing, and can be used for months without requiring cleaning or repairs. It consists essentially of a metal body containing a coil in which the fuel oil is heated by steam, then ejected to be vaporized with the steam and passed into the furnace through a length of piping with special tip. There are no complicated parts.



3721
G. C. Long, Tallahassee, Fla.

Tate, Jones & Co., Inc.

Pittsburgh, Pa.

Copyrighted material

ELECTRIC DEVICE OPERATES GARAGE DOORS

Opening and closing the folding doors of garages, and other buildings,

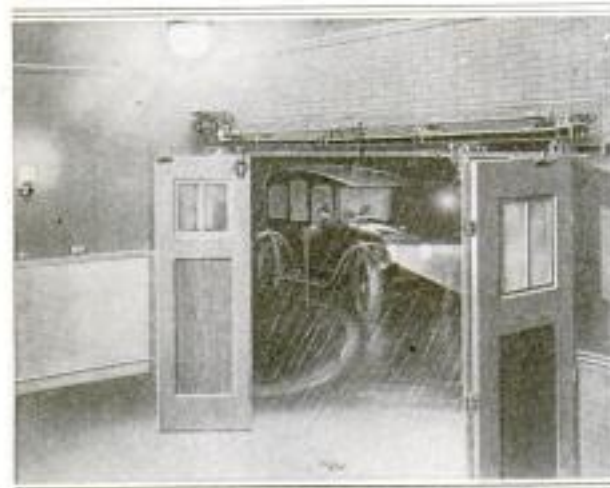

With the Overhead Apparatus Seen in This Photograph, the Garage Doors may be Opened or Closed by Pressing a Button While Seated in the Car.

by the pressure of electric push buttons which may be situated at a distance from the doors, is the purpose of a device recently placed on the market by an Illinois concern. Power is furnished by a small motor, with a worm-wheel connection to an overhead shaft bearing two pairs of bevel gears, which work in connection with the doors. The push-button controls may be located at as many stations as desired, each station having three buttons, one for opening, one for closing, and one for stopping the doors at any position desired. A safety attachment prevents injury to any person or thing standing in the way when the doors are operated.

4119 —

WATERPROOF FABRIC MADE OF CORK AND CLOTH

Sc. Am. Supp. 3-3-17

A new waterproof fabric has recently been produced in France which is made partly of cork, and in addition to being impervious to moisture, is said to be very durable and a nonconductor of heat. The cork is cut up into very thin slices and then placed in chemical baths to remove certain resinous substances that tend to give it brittleness. As finally prepared, the thin

sheets are so pliable that they can be bent double without being injured. By gluing them to cloth with a suitable preparation, a fabric is obtained that is light and strong, and affords complete protection against rain.

Aero Acoust 4060
AEROPLANE MICROPHONE

TESTED HERE

N. Y. Times 2-24-17

A device for detecting the approach of aeroplanes is being tested at Governors Island, New York, which resembles instruments employed in Paris to discover the approach of enemy air craft, as described in Popular Mechanics Magazine some months ago. It consists of four megaphones, 6 ft. long and 3 ft. in diameter, with a microphone attached to the small end of each. Rubber tubes, terminating in earpieces that are worn by the listener, are connected with the microphones. It is unofficially reported that the noise made by an aeroplane at a height of 11,000 ft. has been distinctly recorded by this instrument.

— 4011

MUSKELLUNGE BAIT WITH FOLDING HOOKS

A new lure for muskellunge, and other large game fish, invented by a Chicago man, resembles in size and



form the open mouth of a slim fish and is furnished with a pair of hooks that are normally folded on one another with the barbs inside. When a big fish bites at the bait, the jaws of the lure close and the hooks open outward in such a way as to hold

the victim securely. The size for muskellunge is 4 in. long and 1 1/4 in. in diameter, painted light blue and silvery white, with jaws of red. It is also made with a finish of luminous paint.

Inv: D. B. Fischer
1949 Cleveland Av.,
Chicago.
Copyrighted material

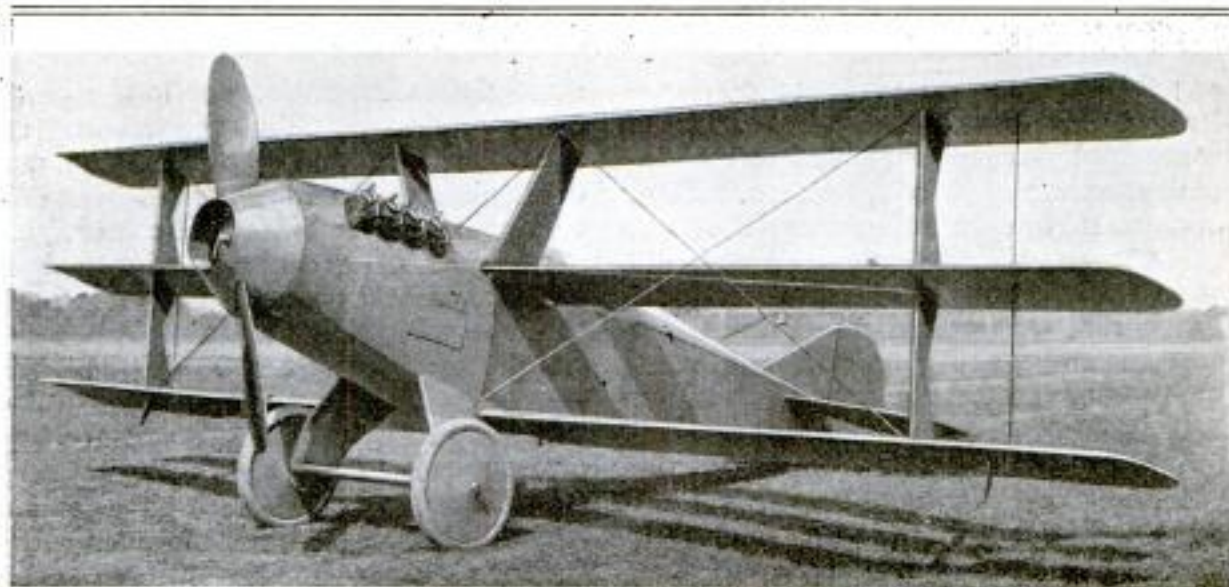

This Fleet Little Curtiss Triplane, Designed as a Pursuit Machine for Military Purposes, has Shown a Speed of 120 Miles an Hour and Climbed at the Rate of 1,000 Feet a Minute

OUR NEW AIR CRAFT

By SEARLE HENDEE

IN even remote European villages the passage of air craft is so commonplace that it fails to attract the attention of children at play. Traffic falters and pedestrians twist their necks heavenward, however, on those rare occasions when an aeroplane darts across the skyline of an American metropolis.

In spite of this contrast, American progress in aeronautics is gathering momentum. Our plants are building aerial cars and boats that compare favorably with the best foreign machines. Furthermore, they are developing some of the most prodigious craft that have ever taken to the air.

Significant, in view of the popular conception of flying as extreme dare-deviltry, is the record of the United States Army aviation service from Jan. 1 to Dec. 26, 1916. During that period 7,087 flights were made by military pilots. In all, 3,357 hours were spent in the air; which means that

more than nine hours each day of the year some soldier-airman was aloft. The distance traveled amounted to approximately 251,775 miles, or slightly more than ten times the circumference of the earth. There was no fatality. Evidently these figures cannot be fairly compared with current railroad and motor-car statistics. Contrasts are not needed, however, to accent their import. Sane flying is not yet



The Novel Mounting of the Propeller Makes the New Gallaudet Seaplane Especially Interesting. The Arrangement Permits the Use of a Streamline Fuselage and Affords Pilot and Observer Unobstructed Vision

accident-proof, and possibly never will be, but neither is it extremely foolhardy.

Europe's war has done more than

any other thing to promote aeronautics in this country. It has aroused some popular interest in aerial vehicles, stimulated congress to action, and given our manufacturers the first real support they have had. The fruits of this awakening have begun to ripen. Formerly we looked to France for motors and gave domestic engineers little encouragement. The situation has changed and we have a dozen different types of power plants, in the class between 125 and 300 hp., that are good. We are building planes that make 125 miles and more an hour. We are producing craft designed to lift from 10 to 15 tons. Furthermore, what is considered the largest aeronautic research and testing laboratory is a part of an eastern aeroplane factory.

What then of the American machines for 1917? The trend is chiefly toward military craft, with tractors strongly predominating. This is true of both aeroplanes and flying boats. There is a particular need for small, swift scouting machines of great climbing power. In providing the latter quality we are improving slowly. Builders are devoting chief attention to fast reconnaissance tractors. These are almost entirely biplanes. The demand for stanch, large battleplanes capable of mounting several guns is an important one, and this eventually will doubtless affect the development of commercial vehicles. Several sporting models have been announced. Those in touch with the situation feel that the general adoption of pleasure craft will precede any marked use of commercial carriers just as the touring car came before the truck in the automobile world. It remains for the future to determine the accuracy of this reasoning. Already there is a serious movement toward the establishment of aerial postal service, a thing which unquestionably would exert profound influence in favor of commercial aerial transportation.

While the biplane is holding the field, the triplane is once more making its appearance. This is particularly interesting in view of the opposition to

multiplanes expressed not long ago by many engineers. The general impression has been that a third plane was of little value and lessened the efficiency of a machine. The need for aeroplanes of great size and weight has drawn attention of designers back to three-wing construction. When the weight of a vehicle is multiplied, the area of its supporting surface must also be enlarged proportionately, since any pronounced increase in the landing speed is impracticable. In biplane construction a wing spread of much more than 100 ft. presents difficulties, structurally and otherwise. Recent investigation has proved that when given the needed power, a triplane, although not quite so efficient as a biplane, will carry almost the same load as the latter. All of which means that the wing spread of a dual-plane craft can be reduced 25 per cent or more by adding a third supporting surface. Hence the introduction of the 1917 triplane.

Triplanes are displayed more in Curtiss products than in others. One astonishing little craft of this type is the new Curtiss pursuit machine which has a wing spread of only 25 ft. and an over-all length of 18 ft. It has attained a speed of 120 miles an hour and climbed 1,000 ft. a minute. The engineers expect to improve the speed at least five miles an hour. It is an exceedingly trim tractor, weighing not much more than 1,100 lb., and is driven by an eight-cylinder, 100-hp. motor. Several of the speedsters have been built for the War Department.

More spectacular than this is the Curtiss autoplane, which proved to be one of the principal attractions at the recent aeronautic exposition. It is virtually a "family touring" plane and in appearance is not unlike a streamline limousine to which wings have been attached. The upper two planes are of 40½ ft. spread, but the lower one has a reach of only 23⅓ ft. The speed range is from 45 to 65 miles an hour, while the lifting capacity permits a useful load of 710 lb. to be carried. The interior of the car affords upholstered seats for two passengers and a pilot.



COPYRIGHT, UNDERWOOD & UNDERWOOD

One of the Season's Most Radical Models Is the Curtiss Autoplane, an Aerial Limousine for Private Touring. Seats are Provided for a Pilot and Two Passengers. The Speed Range Is from 45 to 65 Miles an Hour

The motor, of 100 hp., is situated beneath the hood at the front and drives a pusher propeller of four blades. Although ultradistinctive in this country, the craft is not the first of the sort ever built. Before the war a machine of similar characteristics was constructed for M. Henry Deutsch de la Meurthe, president of the Aero Club of France.

Of all the new machines that have been produced, a Curtiss seaplane,

shipped a few months ago to the British Admiralty, is probably the most astonishing. Little information concerning its structural features has become known, for secrecy shrouded its development. It is a triplane mounting four motors that generate 1,090 hp. Its wings spread 135 ft., while its possible speed is about 100 miles an hour. Eight men, several guns, and 600 gal. of fuel are carried by it. The machine was shipped abroad without being

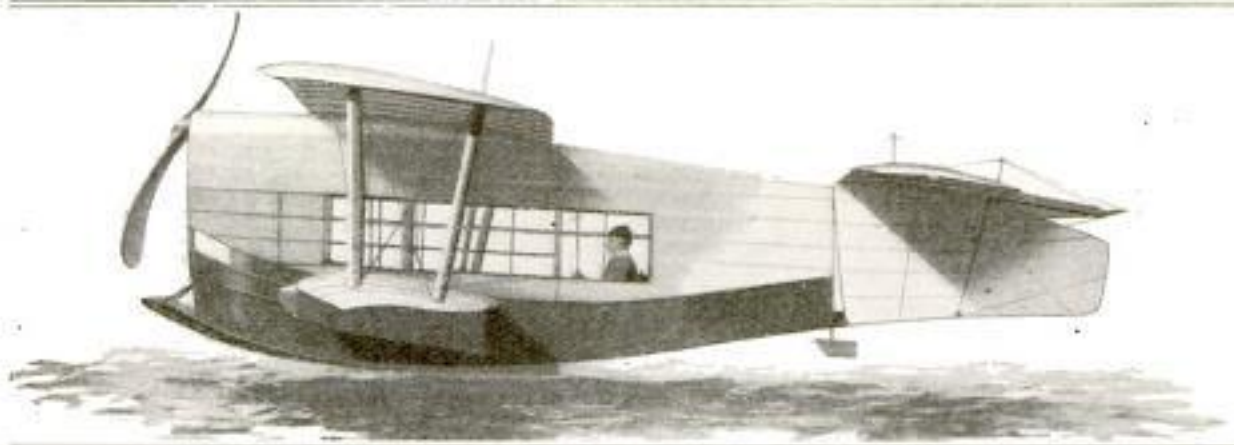

Inherent Stability, Simplicity of Control, and Slow Landing Speed Are Three of the Things That Make the Lawrence Airplane, a Combination Land and Water Machine, Especially Attractive for the Sportsman



Inherent Stability and Wide Speed Range, the Latter Permitting Slow Landing, Suit the New Burgess-Dunne Seaplane for Both Training and Sporting Purposes. The Pilot and Passenger Sit Side by Side in the Cockpit That Extends Forward over the Single Pontoon, and are Afforded an Unobstructed Vision. The Machine is of Light, Stanch Construction

COPYRIGHT, INT. FILM SERVICE

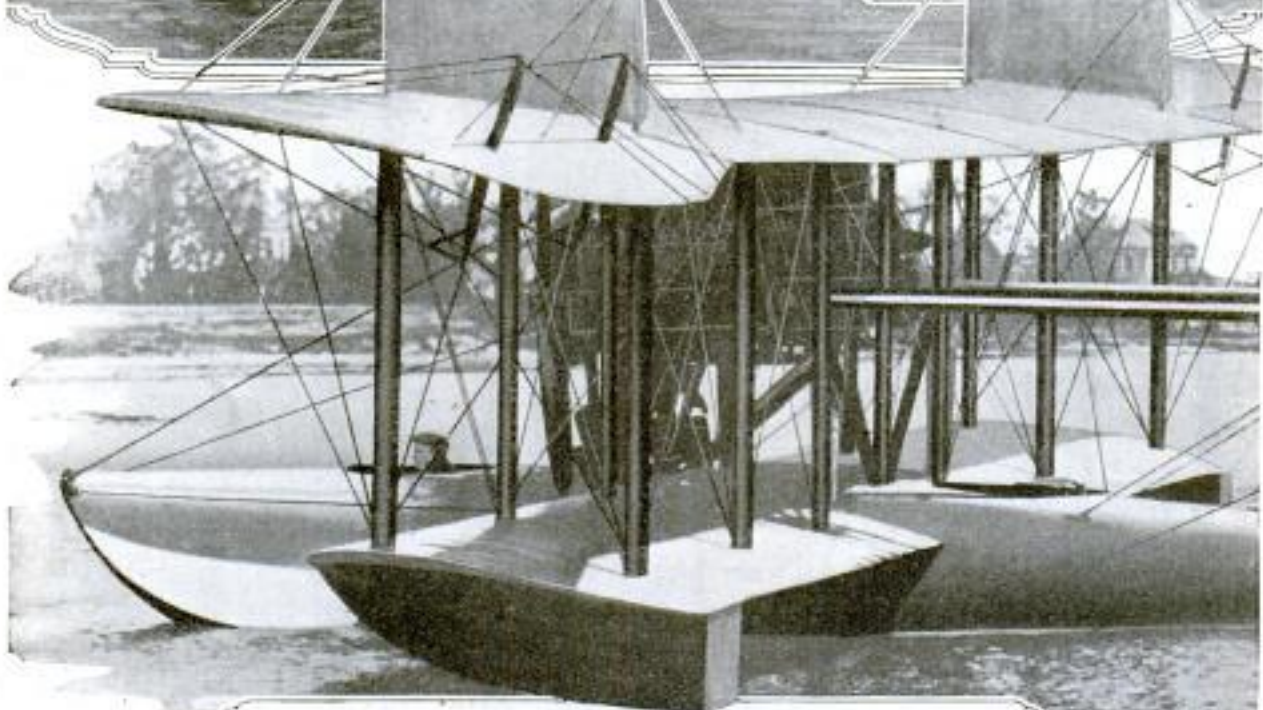

Here is One of the Big Twin-Motored "Super-America" Flying Boats, Many of Which are in Use by the British Navy. The Machine has Excellent Lifting Capacity and in its Class has Exceedingly Few Rivals. Some Authorities Contend that the Vessel with a Crew of Four Men can Take the Place of Three Cruisers for General Duty



The New Sturtevant Steel Seaplane, One of the Season's Interesting Craft Suited for Naval as Well as Sporting Purposes: It Rides on Two Floats and Holds Its Own on Fairly Rough Water. The Speed Range is from 40 to 75 Miles an Hour. It Carries Two Passengers, Has a 140-Horsepower Motor, and a Wing Spread of Practically 50 Feet

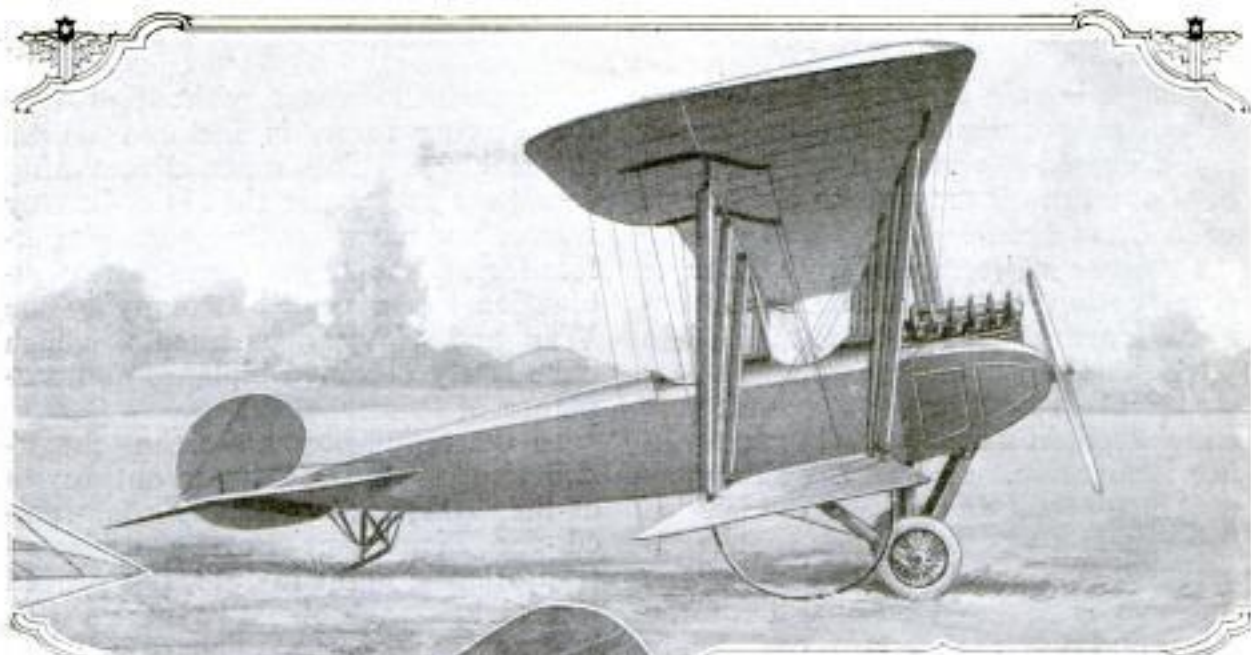

The Picture Above Shows One of the Latest Wright-Martin Reconnaissance Tractors. Another Recent Wright-Martin Model is Designed for Long-Range Work and is an Exceedingly Trim, Capable-Looking Tractor. The Wings are Slightly Staggered and Dihedral. One of the Distinctive Features of This Machine is That the Forward Section Holding the Motor is Detachable. The Landing Gear, Which is Patterned to Reduce Head Resistance, Has a Wide Tread and is Supplied with Shock Absorbers. Large Ailerons are Fixed to the Trailing Edge of the Wings

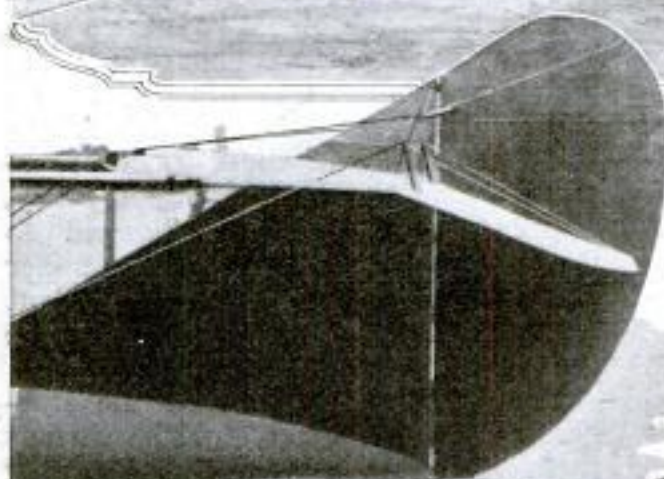

Testing the Wing Panels of One of Our "Fragile Flying Boats." Sixty Persons are Shown on the Planes, Which a Few Minutes Before were Subjected to a Load of Sand Bags Weighing 20,000 Pounds. In View of This Graphic Illustration of Strength, the Popular Expression, "Fragile Air Craft," Seems Quite Out of Place

tried out in this country. Flying vessels of supposedly similar construction and designed to transport a useful load of about 10 tons are now in the course of construction.

In other ways, aside from triplane construction, radical tendencies in designing are evident in some of the late models. The Lawrence airplane, a new combination land and water craft just announced, in many respects is a striking innovation. In flight, a side view of it is not unlike a thick-bodied winged fish. It is a tractor biplane that is inherently stable and noncapsizable. The fuselage is inclosed so that both the pilot and passengers are completely protected and do not need to wear goggles. As soon as the vehicle takes to the air from the ground, the landing chassis is drawn into the body, thus removing a source of drag. Safety and simplicity of control have been the major considerations of the designers, and these with other attributes, such as the ability to ascend or descend at slow speed, adapt the craft remarkably for private cruising. Two models are being produced, one with three seats and the other with facilities for seven persons. Stop-watch tests have demonstrated that the machine can leave the water from a standing start in five seconds. An experimental craft with a 45-hp. motor has attained a speed of 75 miles an hour. Both of these records are significant, since 150-hp. engines are being installed as standard equipment. While particularly attractive as sporting craft, the Lawrence machines are expected to compete also for military honors.

Standard practice has been discarded and increased propulsive efficiency gained in producing the new Gallaudet machines, which combine the inherent advantages of both the pusher and tractor. Twin motors producing 300 hp. are mounted near the middle of the streamline fuselage, back of the places provided for the pilot and observer. Four propeller blades extend through a ring that separates the fore and aft portions of the body. The middle part of the propeller, which nor-

mally absorbs power without producing driving force, is inclosed within the fuselage. This unusual mounting conserves the power that is ordinarily wasted and advances the propulsive effect from 10 to 20 per cent. The combination has appealed strongly to the War and Navy departments, which have lately obtained biplanes and seaplanes of this type.

In the flying-boat class the "Super-America" type, which is an outgrowth of the "America" originally constructed for Lieutenant Porte's projected transatlantic flight in 1914, has proved a remarkable vessel. It has flown with as many as 16 persons aboard, and not long ago made an hour's flight with eight passengers. The British Admiralty has many of these machines in service, and the United States Navy, at present, one, which was "loaned" to it as a gift. From tip to tip the upper plane measures 80 ft. The power plant consists of two 160-hp. motors that give the craft a speed of 90 miles an hour.

The inherent stability of the Burgess-Dunne machines, which prevent them from stalling, side-slipping, or diving, has always given them particular favor in navy aeronautic circles. Therefore much interest has been shown in the new reconnaissance seaplane, which was completed in time for the Pan-American Aeronautic Exposition. The body, which extends ahead of the planes, is designed so that the pilot and observer sit side by side. The wings are of the same span, 46½ ft., are staggered 2 ft. 8 in., and are fitted with ailerons of equal area. The purpose of this model is to meet the demand for vessels capable of ascending and descending at slow speed while carrying a large load. The motor develops 140 hp. and drives a pusher propeller.

Steel enters largely into the construction of the new Sturtevant seaplane, a tractor biplane of trim, stanch appearance. The body, control surfaces, struts, and wing spars are metal. The speed range is from 40 to 73 miles an hour. Steel also is used in the body of the new Benoist cross-country plane,

which seems well adapted for sportsmen. It is equipped with a 100-hp. motor that gives a speed range of from 40 to 60 miles with pilot, passenger, four hours' fuel, and 100 lb. of luggage.

In military circles considerable interest has been manifested in late announcements of new models in Wright-Martin and Thomas reconnaissance biplanes. Both are tractors of fleet design intended for the army aviation service. The former is especially built for long-range work. Its planes have a spread of about 40 ft., with large ailerons attached to the trailing edges. They are set at a slight angle and staggered. With pilot, passenger, luggage, and six hours' fuel, the craft weighs about 2,630 lb. In the new Thomas, which has a 135-hp. motor, the exhaust passes to the top of the plane instead of over the side of the body.

Of battleplanes there are several that command attention, and among them two or three Curtiss machines. Of the latter the "Canada," a giant twin-motored tractor built in a special plant erected at Toronto, shows a significant trend in designing. It is capable of making 100 miles an hour while carrying three men and three guns. Its engines develop 320 hp. and are mounted on either side of the fuse-

lage and well above it, as in the case of the Curtiss twin battleplane. The body extends far in front, so that the airmen have the same advantage of unobstructed vision that a pusher craft offers. The great size and weight of the machine makes necessary a four-wheel landing chassis. Large ailerons fit the trailing edge at either end of the upper plane, which in both machines is considerably greater in span than the lower one. In California a battleplane of 72-ft. spread, propelled by two 120-hp. motors, and fitted with biplane ailerons, has been constructed.

Although there are several foreign machines that outdistance all American craft in speed and climbing ability, our aeronautic progress during the past year has been nothing short of astonishing. That the near future holds surprises, and big ones too, is self-evident. These, however, are to be expected as a result of thorough adherence to engineering principles rather than the application of radical ideas.

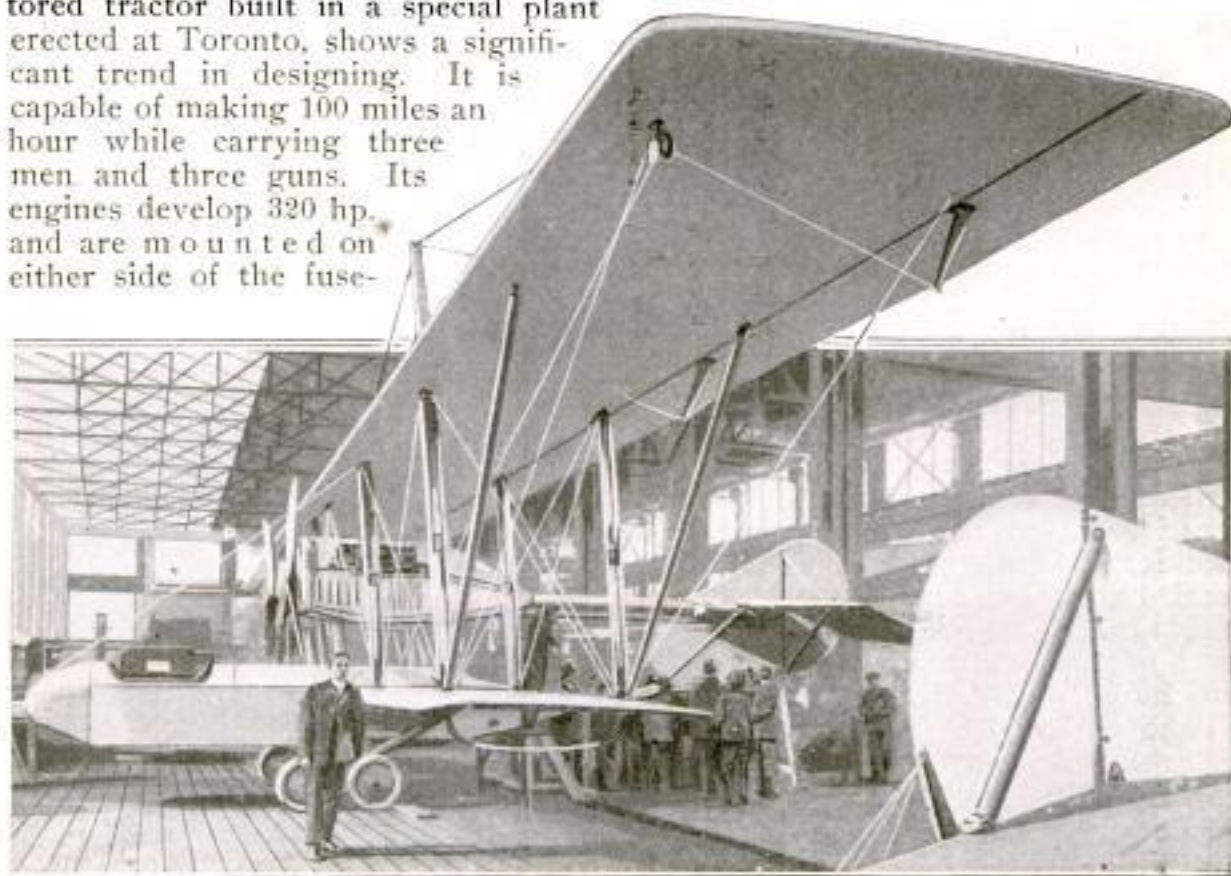

COURTESY OF FLYING

One of the **Prodigious "Canada" Battleplanes** Designed to Fly with Three Men and Three Guns at a Speed of 100 or More Miles an Hour: It is Equipped with Two 160-Horsepower Motors and a Four-Wheel Landing Chassis

LARGE GARAGE IN BUSINESS DISTRICT OF CITY

Increasing traffic congestion in most large cities is making necessary the enforcement of strict regulations governing the parking of motor cars in business thoroughfares. This in turn is presenting a problem to the man who drives an automobile to and

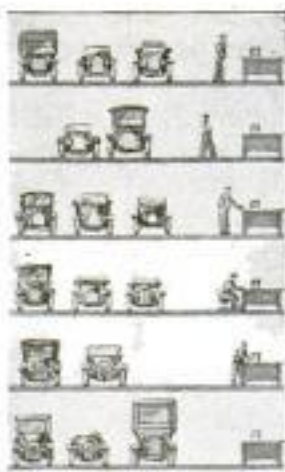

By Means of Telautographic Connections, Orders are Transmitted to the Various Floors without Delay. Only a Moment or So is Consumed in Delivering a Car After Its Owner Presents a Claim Check



from his office daily. In Chicago, where street congestion is especially troublesome, this two-phase riddle has lately brought about the establishment in the loop district of a large garage within easy access of office buildings, hotels, theaters, and the shopping zone. It offers daytime parking space for several hundred pleasure cars, storage room for commercial vehicles at night, and garage facilities at all times for machines owned by permanent and temporary residents of down-town hotels. The basement and six floors of a fair-sized building are used. The arrangement is such that a patron has merely to drive his automobile into the garage through one of the front entrances, receive a claim check, and depart. Attendants take care of the

machine, washing it, filling the gas and oil tanks, or making repairs, if so ordered. The car is delivered by elevator to one of the rear exits a minute or so after the owner calls for it in the evening. Telautographic connections between the cashier's office and the various floors permit the speedy transmission of orders. The facilities provide for the delivery of two cars a minute to the ground floor.

SMOKE "GUN" SAVES SHIP FROM SUBMARINE

Equipped with a new device invented by British chemists and engineers for concealing ships by a cloud of heavy black smoke, the big Glasgow freighter "Lakonia" arrived at Baltimore recently with a tale of thrilling escape from a German submarine by the successful operation of the smoke "gun," as the captain called it. All that appeared above deck was a funnel structure resembling a ship's ventilator, the rest of the apparatus being described as a large copper vat below decks, into which certain smoke-producing chemicals are slowly run and mixed, and a fan which blows the resulting smoke out horizontally through the funnel on deck. The heavy smoke screen thus produced rises very slowly from the surface of the sea, effectually hides the vessel from sight of an enemy, and enables it to change its course unobserved. A small quantity of the chemicals is said to make a tremendous amount of smoke, but tanks containing over 1,000 gal. were carried by the "Lakonia." The members of the crew were equipped with smoke helmets in case of need. The

smoke machine is used on several other vessels, including the White Star liner "Baltic" and the Cunarder "Carmania."

3668 —

BARREL-LOADING MACHINE DOES WORK OF MANY MEN

A portable machine that can load 500-lb. barrels into a railroad car at the rate of 180 per hour, is one of the latest devices for handling freight economically. Its steel framework is set at an inclined position and supports an endless conveyor, driven by a 2-hp. motor. One man is employed in rolling barrels up to the elevator and a second guides the barrels into the car as they are discharged onto a platform level with the car door. Being mounted on

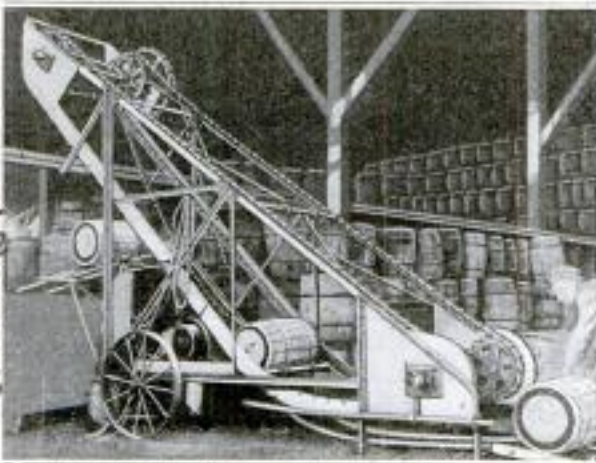

Portable Machine Equipped with a Two-Horsepower Motor, Which will Elevate 500-Pound Barrels to a Car Door at the Rate of 180 per Hour. Two Men are Required to Operate It

wheels and provided with suitable handles, the machine can be easily moved about on a shipping platform or in a warehouse.

MOTORCYCLE USED TO RUN LAWN-MOWER

That new uses for motorcycles are still being discovered is shown by the fact that a Californian with a big lawn to care for, drives his mower with the aid of his powered cycle. After several unsuccessful attempts he devised satisfactory means of attaching the grass cutter to the front forks of his machine and now he asserts that he can trim the lawn in about one-tenth the time formerly required. The only

consideration that limits his speed, apparently, is the fact that the mower



Californian Driving His Lawn Mower with a Motorcycle: By This Means He Is Able to Cut the Grass in a Fraction of the Time Formerly Required

must be oiled frequently. The front motorcycle wheel is so made that it can be detached very quickly and the substitution of the cutter is the work of only a minute or two. The trimming of the edges of the lawn has to be done by hand in the usual way.

4010

GAS MASK FOR HAZARDOUS OCCUPATIONS

An air-tight face mask, provided with suitable valves and connected with a long air-tight tubing reinforced with wire, constitutes the outfit now being furnished by gas companies and other corporations to employes whose tasks place them in danger of asphyxiation. The mask can be inflated at its edge, so that it fits snugly against the face. An inlet valve permits the wearer to draw pure air from the pipe into his mouth or nostrils, while an outlet valve provides for expelling the breath directly into the room. The protector weighs only seven ounces and can be put on or off as easily as a baseball mask. The tubing may be had in various lengths.



The protector weighs only seven ounces and can be put on or off as easily as a baseball mask. The tubing may be had in various lengths.

Gasco Protector Co.
1103 North Av.

Edwin Edgerton,
Alhambra, Calif.

War. Copyrighted Material

Stanley W. Lord
527 Ms. Dorough St.
Brooklyn, N.Y.

REALISTIC "SUBWAY" BUILT IN MOVIE STUDIO

The ingenuity of the stage carpenters and scenery artists employed



A Movie Scene—Not an Accident at All: What Appears to Be a Subway Station Is the Clever Work of Stage Carpenters and Artists in a Motion-Picture Studio. A Cloud of Smoke Conceals What is Supposed to Be the Mouth of the Tunnel

by an eastern motion-picture concern was well illustrated recently in their reproduction of a New York subway station. One of the scenes of a play being produced included the sequel of a subway collision, and since a real underground railway could not be used for the setting, a station with its tiled walls and a section of the track were built in the studio. The crushed stone on the roadbed, the posters on the walls, and an automatic weighing scale, all helped to make the scene appear remarkably real. From what was supposed to be the mouth of the tunnel issued a cloud of smoke. Several days were required to build the "subway," though it occupied but a very small part of the play.

4035 GLACIER BREAKWATERS ON LAND IN ALASKA

To prevent damage to agricultural lands in Alaska from floods caused by the melting of glacier ice in warm weather, it is sometimes necessary to build breakwaters on land. Though they serve the purpose, these are usually crude affairs, built of brush, poles, earth, and stone, boulders being piled along the base to give the structure weight, so that it will not be carried away by the glacier waters and seepings from the ice packs. The form of construction is similar to that of marine breakwaters, broad at the base and

narrowing toward the top. The land thus protected is usually very rich, with great possibilities for farming purposes. Its fertility is often a welcome surprise to new settlers.



An Alaskan Inland Breakwater, for the Protection of Farming Lands from a Deluge of Glacier Waters: Such Breakwaters are Constructed by the Government for the Benefit of Settlers



Wild Mountain Sheep Tamed by Famine: Excessive Snows Covered Up Their Food and Forced Them Down into Inhabited Regions. Humane Citizens of Ouray, Colorado, Provided This Flock with Hay

FAMINE TAMES FLOCKS OF MOUNTAIN SHEEP

Impending famine during the past winter temporarily overcame the wild nature of flocks of mountain sheep to be found in sparsely settled regions of Colorado, and brought them down close to human habitations. Their distress was caused by the excessive snows which covered up all the vegetation on which they browsed. The Colorado law forbids at all times the killing of mountain sheep, but in spite of this protection they are seldom seen at close range. A few months ago people in the mining town of Ouray, Colo., discovered that the flocks were near starvation and raised money to feed them. Hay was purchased and scattered within a few rods of the railway station, and the famished animals came and ate it, apparently without fear, as the unusual photograph shown herewith indicates.

4068

SIBERIAN JEWEL BOX OF FOSSIL IVORY

A curious specimen of primitive art work has been on exhibition in the Museum of Natural History, New York, in the form of a large jewel box of fossil ivory which was made by na-

tives of Siberia. The sides and top are composed of flat pieces of ivory, elaborately carved and carefully fitted together, the corners being dovetailed. Incorporated in the geometric open-work patterns are scenes suggestive of the northland, that on the front representing two hunters returning home, one riding a reindeer. The material from which the box is made is obtained from the tusks of mammoths that have been buried for ages beneath the ice



Carved Jewel Box Made by Natives of Siberia from the Tusks of Mammoths Which They Exhume in the Frozen North

of Siberia. Natives frequently go on long expeditions in search of these huge tusks, some of which weigh 200 or 300 lb. each.

LONG BRIDGE HAS TRESTLE IN CENTER

A bridge has recently been completed by the Burlington Railroad across the Platte River at Yutan, Neb., which has girders at either end, while the center is trestlework. At Yutan the stream often overflows, becoming over half a mile wide, and in winter destructive ice jams have formed on it. With a view to providing a bridge strong enough to resist the ice and yet not excessive in cost, the width of the Platte was decreased at this point from 2,000 ft. to about 1,380 ft. by building an embankment on one side. This intensified the two currents that flowed near the two banks and automatically deepened their channels, so that the ice was more easily carried off in spring. The two current beds were spanned by girders placed on piers, set 75 ft. apart, while be-

tween these was built a trestle 700 ft. long. This rather unusual handling of the problem made it possible to construct the bridge, which is 1,383 ft. long, for \$125,000. It was found impracticable in building the caissons for the piers to keep them open at the top, so they were capped and the work carried on under compressed air. Concrete was supplied from a train that ran out on a temporary bridge, which also served as a base from which the girders were handled.

NEW AMERICAN RACING CAR HOLDS MUCH PROMISE

During the coming season a surprising American racing car will be entered in the foremost speed events and piloted by Barney Oldfield. So far as practical considerations have permitted, all efforts have been made, in designing the body, to reduce air resistance. The result closely approaches the ideal in streamline and makes the racer distinctive in appearance. Exposed parts, such as the front axle, tie rod, and starting-crank support, are individually streamlined. Back of the motor, the entire chassis, frame, springs, and all, is covered. Entrance to the body, which is completely inclosed, is gained through large doors provided on either side. Practically unobstructed vision in every direction is afforded the driver and mechanic by narrow, elongated openings screened and so placed as not to per-

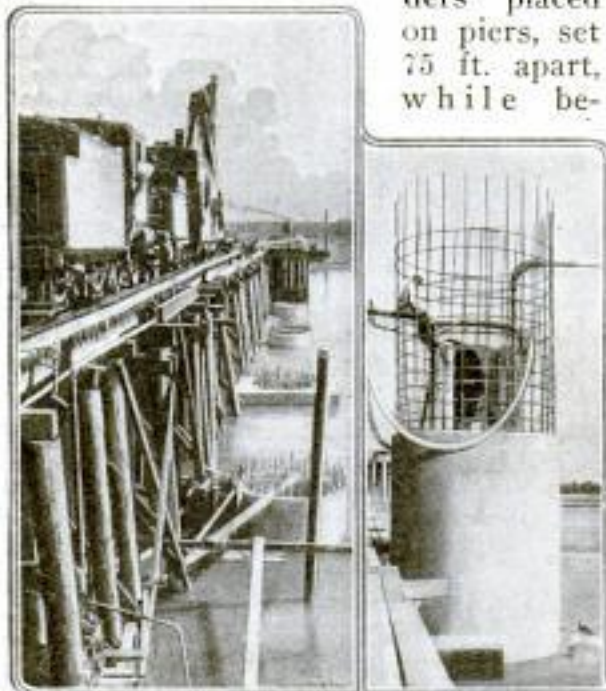

General View of Bridge across Platte River at Yutan, Nebraska, Showing Girder Spans at Either End and 700 Feet of Trestle in the Center. Above, Left, Temporary Bridge from Which Material was Supplied for the Construction of Concrete Piers; Right, Pneumatic Caisson in Operation, Showing the Pipe through Which Sand and Dirt is Forced Up from Below

mit an objectionable draft to sweep through the interior. The compartment is heavily upholstered with tufted

OFFICIAL FLAG ADOPTED BY STATE OF ILLINOIS

When the Illinois legislature met in January, a new state flag of authorized

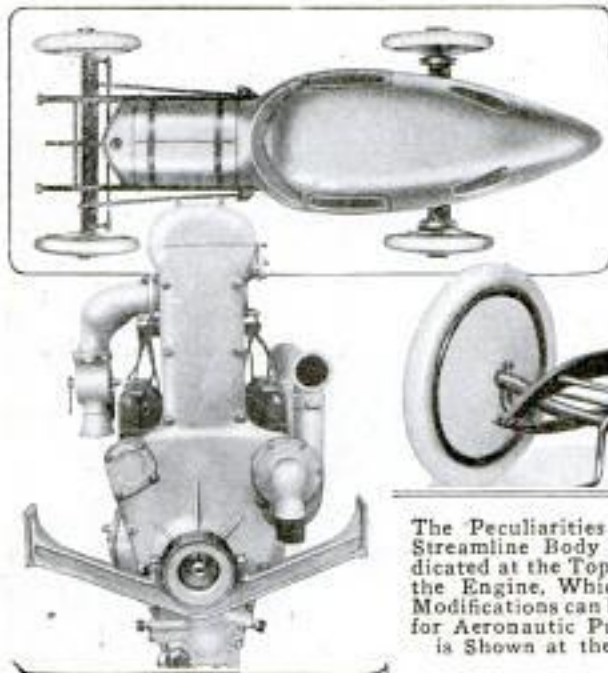

The Peculiarities of the Streamline Body are Indicated at the Top, While the Engine, Which with Modifications can be Used for Aeronautic Purposes, is Shown at the Left

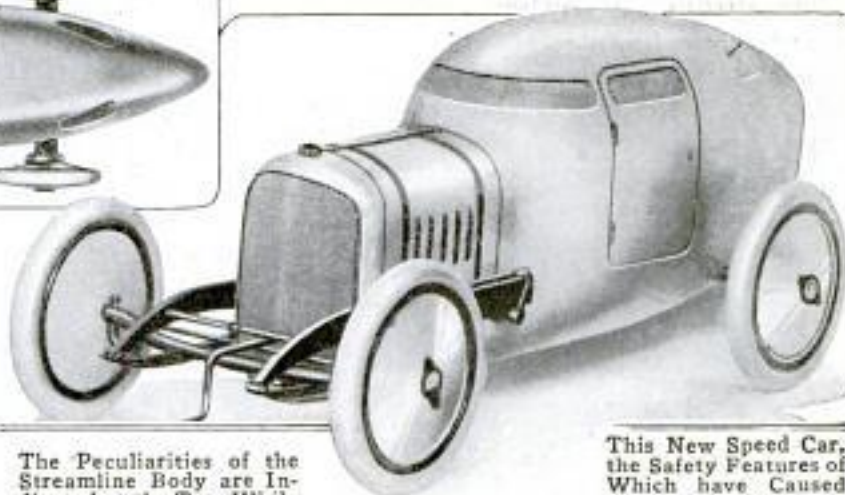

This New Speed Car, the Safety Features of Which have Caused Barney Oldfield Again to Enter the Racing Game, is Expected to Be Capable of Making Approximately Three Miles a Minute. There is Some Question, However, Whether the Car, Because of Its Lightness, will Get Sufficient Traction

hair and leather to protect the occupants in case of a spill. Consistent lightness was aimed at throughout, and the car, although powered with a 139-hp. motor, weighs under 1,800 pounds. A speed of three miles a minute is hoped for.

design was exhibited for the first time. The flag was inspired by the action of a Galesburg woman, state regent of the Daughters of the Revolution, who began an agitation for the adoption of a state banner five years ago and

DEVELOPMENT OF RUSSIAN WATER POWER PLANNED

ENGINEERING 2/16/17

One of the evidences of Russia's increased interest in her natural resources is the proposal that the government take over many of the empire's wonderful waterfalls and develop them for power purposes. In fact, the state has already expropriated the Little Imatra Falls in Finland, and for some time fairly detailed plans have been prepared for the transmission of power from the Great Imatra Falls to Petrograd. It is estimated that these two cataracts, in connection with the neighboring rapids, could be made to produce so much power that sufficient current could be transmitted to the Russian capital to effect an annual saving of 3,000,000 tons of coal. The cost of the current, it is estimated, would be quite low.



The First Illinois State Flag: Five Feet by Three in Size and Made of White Taffeta with Gold Fringe; the State Coat of Arms in the Center

finally secured an act of the legislature authorizing the flag. The design selected was one of 35 submitted to a committee headed by the secretary of state, and consists mainly of the Illinois coat of arms on a white ground, bordered with gold fringe.

Mrs. Ben, Lawrence, Galesburg, Ill.

MECHANICAL CABINET FOR PHONOGRAPH RECORDS

In a cabinet for phonograph records of the disk type, a young Chicago inventor has provided a turntable device

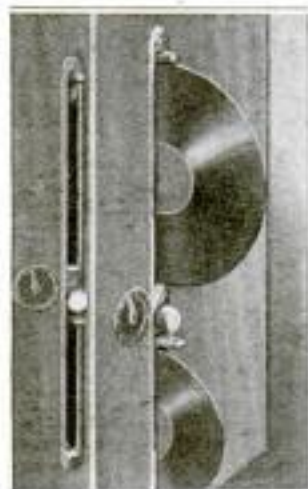

with separate pockets for the records, which are delivered to the hand mechanically, as required. All the records being first numbered and listed, any particular one may be withdrawn from the cabinet for use by setting an indicator at the

number it bears on the list and then pushing a spring. This causes the inclosed turntable to revolve, and the record wanted slides out through a narrow felt-lined opening into one's hand, dusted and ready for use. The

cabinet is made with either a single or a double container, one compartment being set over the other in the latter case, to increase the capacity for holding records. The delivering device is said to operate equally well in either form.

AUTOMOBILE BUS FOR OREGON RAILWAY

A 30-passenger automobile bus, that runs on standard railway tracks through power derived from gasoline or distillate, has been added to the equipment of the Mt. Hood Railway, a short line running from Hood River, Ore., to Parkdale, a small town near the base of Mt. Hood. An uncommon feature of the bus is that the front end is supported by a truck having four small wheels. The flanged tires of all the wheels are demountable. The entrance to the car is at the side, near the front. In the place of windows are curtains that roll up and are provided with oval openings covered with transparent material. The car will be employed largely in carrying passengers to the foot of Mt. Hood, which each year attracts an increasing number of tourists.

4030 motor

White's Auto. Co.
Stevensburg, Va.



Thirty-Passenger Auto Bus, with Four-Wheel Truck in Front, Built to Run on a Standard Railway Track in the Hood River Region in Oregon

NEW RAYS OF GREAT VALUE IN CURE OF WOUNDS

Sphere 1-6-17

New York Herald Tribune

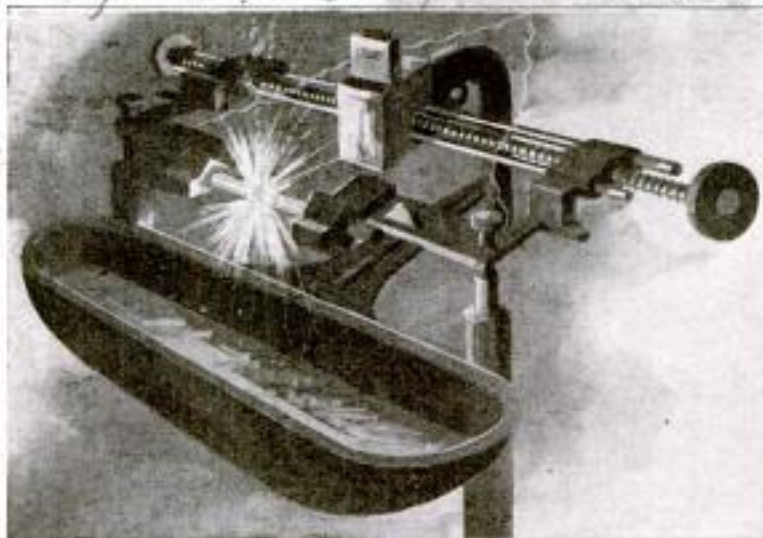

Apparatus Used to Produce the Simpson Rays, Showing the Tray Which Catches Particles Thrown Off by the Lamp

Applying the S-Rays to a War Patient, Who at the Same Time Inhales the Beneficial Fumes Arising from the Light

Many hospital cases arising from the great war, including shrapnel wounds and deeply seated chronic affections, have been successfully treated in recent months by what is known as the Simpson light, or "S-rays," so called after the discoverer, an English engineer. Their efficacy in the cure of wounds was discovered while he was experimenting on the affinity of rare metals for one another. Finding that the light produced in electric treatment of certain ores had curative effects upon the



FROM THE SPHERE, LONDON
COPYRIGHT IN THE UNITED STATES BY THE NEW YORK HERALD CO.
Lamp and Reflector to Focus S-Rays upon a Wound or Diseased Area to be Treated: Many Bad Cases of War Wounds have been Treated Successfully with This New Light, Discovered by an English Engineer

hands, he made electrodes of wolframite, the chief ore of tungsten, which produce the S-rays when placed in an arc lamp with a current of 40 to 50 volts and 5 to 8 amperes. Tested in the worst cases of wounds, it has been found that they improve at once when subjected to the rays with special apparatus for the purpose. The exposure required is unusually short and there seems to be a wide field for the use of the light for medical purposes. Many European hospitals now use S-rays.

system in advance, as the service to be rendered is greater than that in the whole kingdom of Greece, with its mainland and island territory, and equal to the requirements of a progressive American city with 20,000 population. The main switchboard will be equipped to serve 2,400 extension stations, and is to be erected in a penthouse on the roof of the hotel. Four other switchboards will be needed.

4121

GREAT BRANCH TELEPHONE EXCHANGE FOR HOTEL

A contract was recently signed for the installation of the largest private-exchange telephone system in the world. This will be located in a new hotel which is to occupy an entire block in New York City and will take rank as the world's largest hostelry. It was necessary to plan the telephone

system in advance, as the service to be rendered is greater than that in the whole kingdom of Greece, with its mainland and island territory, and equal to the requirements of a progressive American city with 20,000 population. The main switchboard will be equipped to serve 2,400 extension stations, and is to be erected in a penthouse on the roof of the hotel. Four other switchboards will be needed.

*Hotel Cassimone
New York*



THE remarkable scene depicted in the above photograph was presented outside the Capitol in Washington at noon on March 5, 1917, when President Wilson was publicly sworn in for his second term. It was a solemn and memorable occasion because of the impending peril of war with Germany. The president devoted his inaugural address to our international relations, and his words echoed around the world. Above, at the left, is a photograph of women completing the new president's flag, unfurled for the first time at the inauguration. At the right is one of the completed flags; the ground is blue, with a white star in each corner.

INAUGURATING A PRESIDENT AS WAR THREATENS



PHOTO COPYRIGHT INTERNATIONAL FILM SERVICE



COPYRIGHT CINEPOST FROM UNDERWOOD & UNDERWOOD

President Wilson on His Way to Take the Oath of Office for Four Years More: He was More Strongly Guarded for the Trip from the White House to the Capitol and Back than Any Former President has Ever Been. Around His Carriage are Seen Some of the 32 Secret-Service Men Who, with Mounted Troops, Formed His Escort. At the Left is an Army Auto with a Machine Gun Which was Demounted in Front of the Inauguration Platform during the Ceremonies—an Unusual Sight Which Deeply Impressed Spectators

H. L. F. Trebert Engine Works,
495 St Paul St.
Rochester, N. Y.

668

3794

POPULAR MECHANICS

APPARATUS SEPARATES ICE BLOCKS FROZEN TOGETHER

To facilitate the separation of ice cakes that have become frozen together

during a long period of storage, an eastern inventor has developed a cutting machine that is reported to accomplish the work of eight men, in addition to eliminating much waste.



The Motor-Driven Cutter is Held in a Vertical Position so That It Is Possible to Cut along the Irregular Seams between Cakes of Ice That are Frozen Together

A motor driving a spiral saw-tooth 'milling' cutter at the rate of 1,850 revolutions a minute is secured to an adjustable base mounted on a pair of runners, to the opposite ends of which plow handles are attached. When ready to start working, the motor and cutter are in a horizontal position. A lever swings them to the vertical, so that the cutter digs its way into the ice. By then pushing the apparatus, a seam may be followed readily. The cutting member may be raised or lowered so as to cut to a specified depth.

3098

MACHINE PACKS SILAGE SO THAT LITTLE SPOILS

Ziller
A machine for packing silage in a silo has been invented and tried out by an Iowa farmer. This mechanical

much more satisfactorily, for the machine weighs a ton and is able to pack the silage close to the wall as thoroughly as in the center. The looseness of the material around the edges, which often results when silage is packed by tramping, is a source of considerable loss because the air gets into the fodder and causes it to spoil. This machine is equipped with a heavy cone-shaped roller whose length is about equal to half the diameter of a silo. It is driven in a circular course by a gasoline engine mounted on a supporting frame. The packer can be quickly knocked down into parts, few of which weigh more than 100 lb., so that they can be lowered down the silo chute.

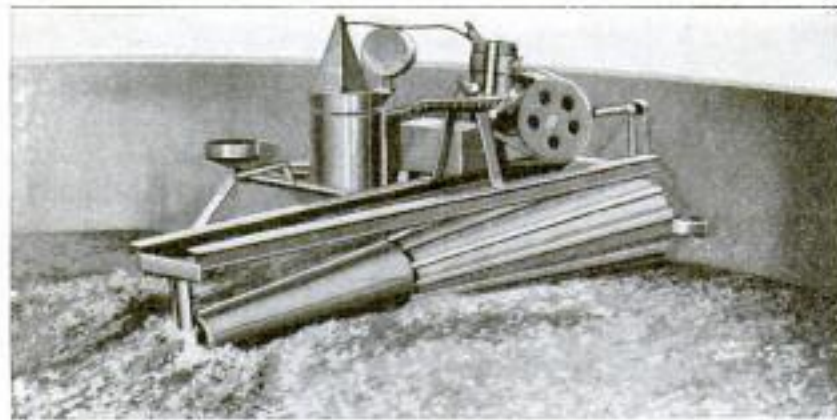

Silage Packer Which is Driven by a Gasoline Engine and Packs Fodder so Thoroughly That There Is Little Loss from Spoiling

packer does away with the disagreeable task of tramping the feed down with the feet. It also does the work

F. O. Griffin, Oscoda, Ia.

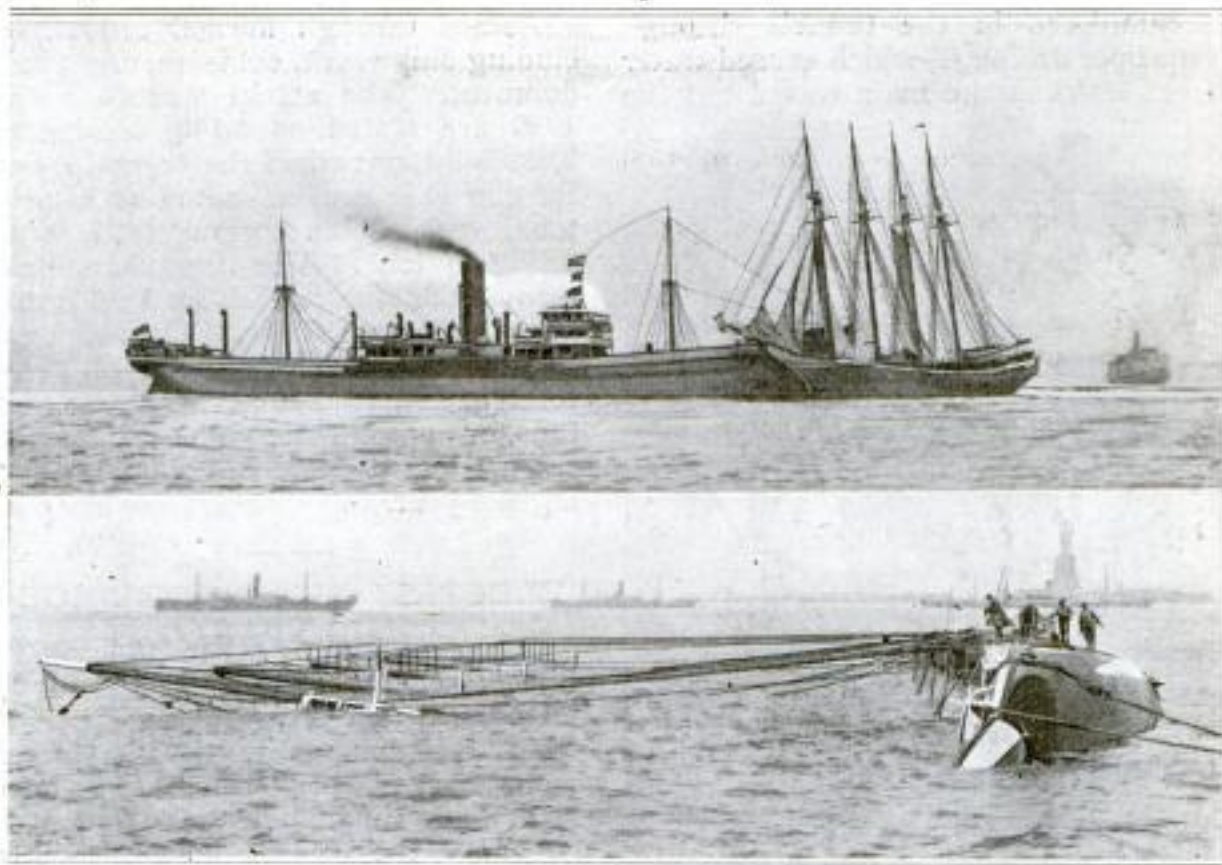

PHOTO COPYRIGHT, INTERNATIONAL FILM SERVICE

Top, Schooner Rammed by Freighter in New York Harbor: The "Valeria" Crashing into the Side of the "Dustin G. Cressy," Which Sank as a Consequence of the Collision. Below, Salvaging the "Cressy," Which Went Down While the Crew was Trying to Beach It after the Accident. The Statue of Liberty Appears Faintly in the Distance at the Right

4092

RAMMED SCHOONER SINKS IN NEW YORK HARBOR

Sudden disaster overtook the four-masted schooner "Dustin G. Cressy" a few weeks ago while making its way up the channel in New York Bay. The accident seems to have been caused by the sailing vessel suddenly veering from its course. A moment later there was a loud crash when the outbound freighter "Valeria" struck it a fatal blow on its right side. The injured schooner began to take water rapidly, but the captain hoped to be able to beach it and so save its valuable cargo, consisting of mahogany and other tropical woods. However, after drifting for some time the "Cressy" suddenly capsized and went down. The skipper and the crew of 12, who had plunged into the water, were all rescued by a tug. The sailing vessel sank in 60 ft. of water, and the work of salvaging it began shortly after.

It was valued at between \$150,000 and \$200,000. Being uninjured by the collision, the "Valeria" continued on its way, having stopped only long enough to put out and then recall its lifeboats. It was laden chiefly with munitions.

— 3530

TEMPORARY TRACK LAID ON A TUNNEL PIPE LINE

An ingenious method of clearing out accumulated debris from a series of tunnels through which runs a 36-in. water main was adopted recently at San Diego, Calif. As the pipe line occupies practically all the ground space in the tunnel, and there was a great deal of matter to be removed, the men in charge of the work laid a temporary track on the top of the pipe line and operated a small dump car over it. In this way a total length of 6,733 ft. of tunnel was cleaned out and made ready for necessary repairs and pipe renewals. The dirt and debris had

Owned by Percy & Small,
Bath, Me.

accumulated in the tunnels through improper drainage, which caused water from leaks in the main to rot out the



More than a Mile of Tunnels was Cleaned Out by the Aid of a Small Dump Car Run on This Track with Its Pipe-Line Roadbed

timbering and allow the earth from the sides of the tunnels to fall around the pipe.

4118

WAR LOSS OF MERCHANT SHIPPING IN 1916

The net loss to the merchant shipping of the world in 1916, from all causes, including the war, was approximately one per cent of the whole, or about 500,000 tons, according to figures compiled by the Bureau of Navigation of the Department of Commerce. This reduction left the total of the world's merchant marine close to 48,200,000 tons on Feb. 1, 1917, when unrestricted submarine warfare was begun by Germany. In arriving at these conclusions, the tonnage of new ships built by the nations during the year was deducted from the combined totals of tonnage sunk or destroyed through war causes and losses

sustained through normal causes, including shipwreck, collision, and abandonment. The actual war losses in 1916 are stated as 1,149 vessels, of 2,082,683 tons; while the normal losses for the year are estimated at 300,000 tons, making an aggregate loss of 2,382,683 tons. The new ships built throughout the world in 1916 numbered 2,505, of 1,899,943 gross tons. Deducting this new tonnage from the total losses, as above, leaves 482,740 tons, or approximately one per cent, as the net loss of merchant shipping during the year.

— 4033

ELECTRIC DRIER FOR SHOE-SHINING PARLORS

An electric shoe drier is now being introduced in shoe-shining parlors, which is a timesaver, and therefore a money-maker, for it can be employed to dry one shoe while the attendant is polishing the other. It is provided with a small motor-driven fan that forces a strong blast of air through a tubelike mouth directly onto the shoe. The drier is held in place by an iron arm that can be quickly attached to the foot rest. Current is obtained through a cord from any light socket. The little machine weighs only two pounds.



Drier Driven by Small Motor Which can be Utilized to Dry One Shoe While the Other is being Polished

Hamilton-Beach Mfg Co. Racine Wis



Grading Eggs with a New Candling Device That can be Used in a Lighted Room or Out of Doors, Doing Away with the Insanitary and Sight-Destroying Dark Room in Produce Houses: An Inclosed Electric Light Illuminates the Eggs

4051

3925

EGG CANDLER THAT NEEDS NO DARKENED ROOM

The old-fashioned dark room of the egg candler, familiar to packers and commission men for more than a generation, has been eliminated in many produce establishments in favor of a new type of egg candler, invented and marketed by an Indiana concern. With this device eggs are candled in the daylight, either indoors or outside, and the insanitary conditions that often prevailed in the dark room need no longer be endured. It is practically a miniature dark room in itself, consisting of a standard, a dark chamber with an aperture for the insertion of the eggs in a man's hand, an inclosed electric light, and a slanting eyepiece set at a convenient height for use when the operator is standing before it. The light may be furnished from a lighting circuit or from a battery attachment and the candler is made with either a single or a double eyepiece. A small size is made for country merchants, farmers, and hucksters.

FIRE-ALARM APPARATUS EXPLAINED TO PUBLIC

Doubtless a very large proportion of city dwellers know how to turn in a fire alarm, but probably only a very small number understand all that happens when one pulls the little lever that brings the fire company hurrying



Exhibition Booth in Cincinnati in Which Firemen Explained All the Workings of a Fire-Alarm Box and the Complicated Apparatus Connected with It

to the scene. Because Cincinnati officials believed that it was properly a part of a safety-first movement to give its citizens a better understanding of the workings of the fire department, a special exhibition booth was fitted up with a fire-alarm box and related apparatus. Firemen in the booth gave demonstrations to thousands of visitors, showing them the full operation of the fire-alarm system, and how the fire companies responded.

3798

SANITARY VACUUM CLEANER OF A NEW TYPE

Among the new features of a sanitary vacuum cleaner of the stationary type, recently placed on the market, is



Stationary Vacuum Cleaner Which Washes the Dust from the Air as It Passes through the Rotary Separator Seen Above at the Left

a separator which disposes of the dirt automatically. As the dust-laden air, gathered by the floor tools, reaches the separator, it is washed by a spray of water. The dirt and water are then separated from the air by centrifugal force, exerted by means of the shape and construction of a small rotor, and are discharged directly into the sewer through a valve which opens just wide enough for this purpose. The machine is especially adapted, it is claimed, to

complete the work of scrubbing rugs, carpets, and bare floors, thereby saving much of the usual labor on the knees, as it quickly removes the superfluous water.

4051

VIBRATION OF PIANO WIRES SUSTAINED ELECTRICALLY

Many attempts have been made during the past 25 or 30 years to increase the sonorousness of the piano by devising means of prolonging the vibration of its strings. As is most evident, such a scheme has never been worked out to a commercially practicable point. Not many months ago, however, a new plan of sustaining piano notes was unfolded to the French Society of Civil Engineers and an instrument, equipped with a lately developed apparatus, demonstrated. Except for the fact that the invention gained the interest of scientific men at Paris, there is no immediate way of accurately estimating its actual importance.

In brief, each wire is controlled by two electromagnets connected in the same circuit. The major of these operates the string, while the other—which is an auxiliary exciter—governs the arm of a contact member which, with the piano wire, forms an interrupter. A spring tends at all times to throw the contact member against the wire, while the auxiliary magnet works in the opposite direction. The current travels from the main magnet to the secondary one, through the movable arm and contact piece to the piano string, and thence to its source. Thus, when the circuit is formed, the main magnet attracts the wire while the other one draws back the contact arm and interrupts the current. The piano string then vibrates while the auxiliary magnet releases the arm which, by the action of the spring, again forms a contact. This routine continues so long as current is applied, and a sustained note results. Means have been provided for neutralizing the possible vibrations of the contact arm, so as to avoid interference with the regularity of the circuit interruptions.

United Vacuum Appliances Co.,
Covington, La. Copyrighted material

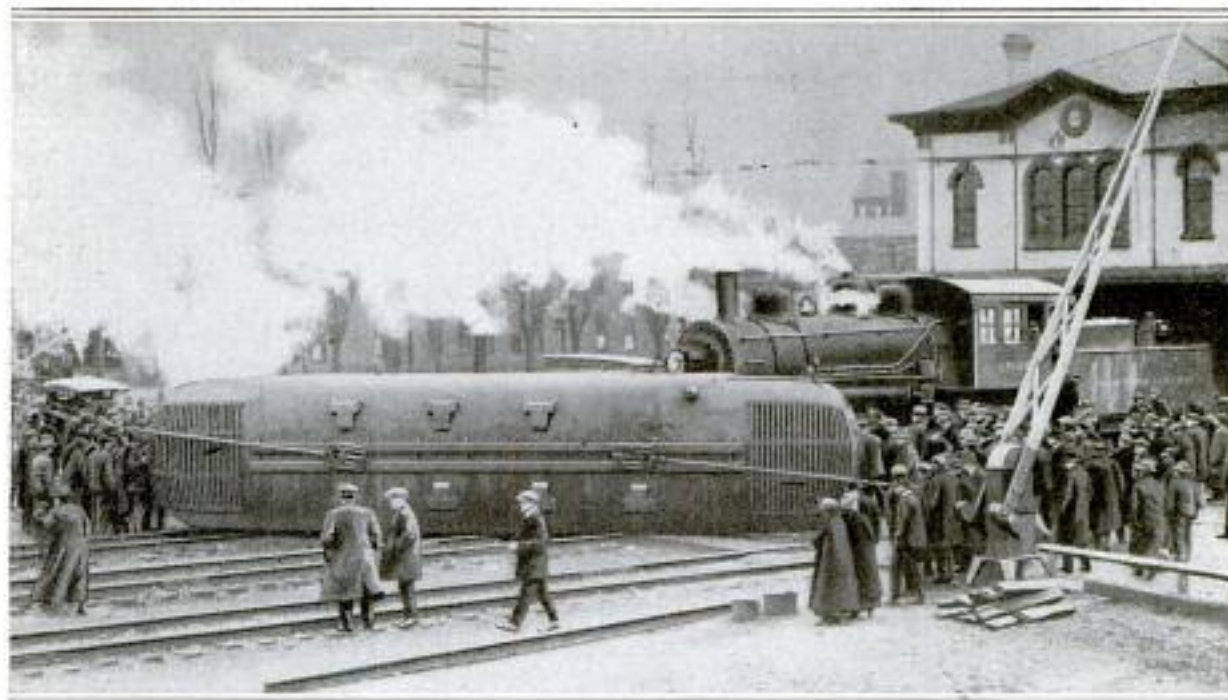

PASSENGERS ESCAPE DEATH WHEN ENGINE HITS CAR

ANOTHER demonstration of the superiority of steel cars over wooden ones, from the standpoint of safety, occurred in a spectacular way at Erie, Pa., a short time ago. The trolley of a local street car left the conductor wire at a railroad crossing, causing the carrier to stall in the path of an oncoming locomotive. Many persons were aboard the car when the engine, which was traveling 20 miles an hour, crashed into it. The traction car was overturned and pushed ahead a number of yards. Incredible as it seems, only one person was injured, and he but slightly. To assist the passengers in extricating themselves, a hole was cut in the car with an oxyacetylene torch.

AS these words are written the President has called Congress to meet in extraordinary session. Before this page can reach our readers war with Germany will doubtless have been declared. Not a war of our choosing—not a war to enlarge our territory—but a war in defense of honor, justice, and the rights of humanity. Because as a nation we have not been given to a pyrotechnic display of patriotism some have blindly thought we had none. The spirit of Paul Revere is again abroad in the land and the response from every city, county, and farm is uniting in a stupendous potentiality. We undertake this mission with sadness but with that intensity of purpose that has made America what it is, in the hope that permanent peace for all the world may be our reward.

H. H. WINDSOR.

✓ Cloche Co., 131 Hudson St., N.Y.C.
 Chas H. Hodges (Iny.)
 50, E 21st St., N.Y.C.

FOOD PREPAREDNESS, THE NATION'S NEED

4204

IT is becoming seriously apparent that Americans must marshal their energies and utilize their resources toward the production of food. With the civilized world at war, waste must be curtailed and supply increased. This means that unused ground must be worked. People in the cities are feeling the pressure of unprecedented prices. To combat actual want, it is imperative that they modify their system of living and become producers. Back yards, vacant lots, and unoccupied tracts of land in outlying districts are available for cultivation. National security demands that they be developed.

For two months the newspapers of the United States as well as certain local and national organizations have urged city garden plots. The campaign has not been for amusement or entertainment. Actual need has prompted it, the Department of Agriculture has encouraged it, and far-sighted persons have heeded it. In France, Germany, and England public parks are being plowed, forest land cleared, and vacant areas planted. And yet there is hunger. America with its vast territory can have plenty, but farming, both in the country and city, must be promoted in dead earnest.

In the cities the gardening movement cannot be left for the poor alone to carry out. Those who are in meager financial circumstances will be benefited most, of course, but the problem is food—quantities of it—and not

solely what market prices will be. In the present emergency, food for the allies is as important as food for ourselves. It must be produced, and every back yard and every fertile lot made to thrive.

At Brooklyn, Philadelphia, Pittsburgh, Chicago, Minneapolis, Denver, Spokane, Los Angeles, Atlanta, Washington, and dozens of other metropoli-

tan centers, gardening campaigns are being conducted. In these places hundreds of acres of ground heretofore abandoned to weeds and rubbish are being converted into gardens which, during the coming months, will add fresh, green touches to many neighborhoods and supply food for their cultivators. The importance of the city-farming agitation cannot be overestimated. Gardening this year is not a fad; it means family and national preparedness.

A concrete illustration of what can be done is furnished by what has been done at Chicago in past years through the endeavors of the City Gardens Association, a philanthropic organization. The body controls four tracts of ground in different parts of the city and divides them into plots an eighth of an acre in size. The little gardens are allotted to needy men and women who are enterprising. The soil is plowed, seed is supplied, the advice of scientific supervisors offered, for a charge of only \$1.50. The rest of the expense is met by popular subscription.

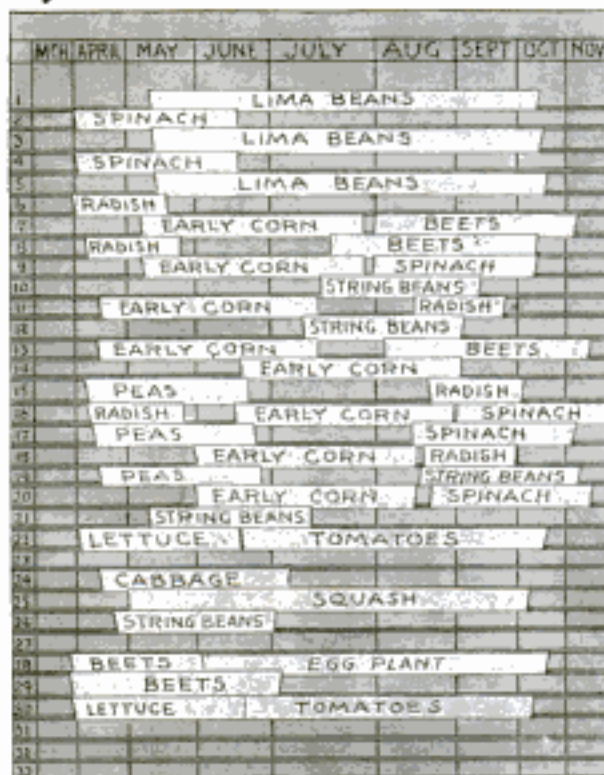

This Chart is Designed to Enable the Amateur to Plan His Vegetable Garden so as to Get the Maximum Yield. Cardboard Strips Fit into Slots Representing Garden Rows, and by Their Lengths Show at a Glance How Long Each Product will Occupy the Space Devoted to It

TIMELY AMERICAN WAR PICTURES OF INTEREST

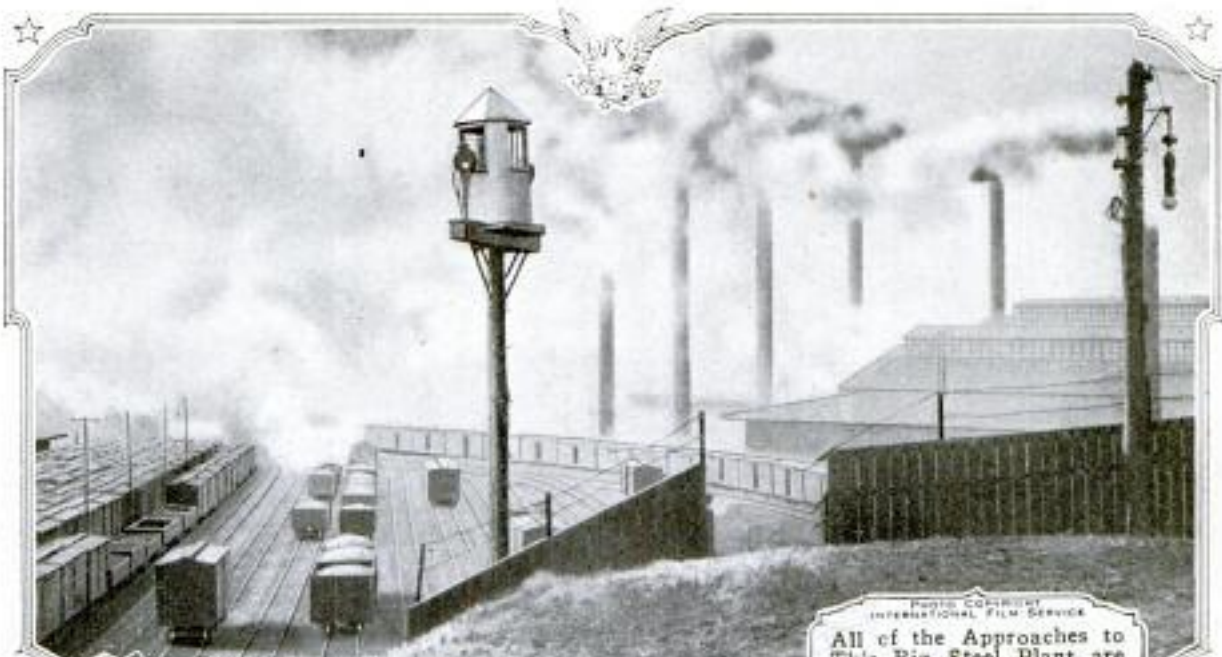

PHOTO COPYRIGHT INTERNATIONAL FILM SERVICE

All of the Approaches to This Big Steel Plant are Illuminated at Night by Batteries of Searchlights Installed at Different Points. In the Foreground of the Picture will be Noticed an Observation Tower Equipped with a High-Power Projector. In This Way a Constant Look-out for Spies and Incendiaries is kept by Watchmen Who are on Duty at All Times, Guarding the Bridges and Gates, and Patrolling Fences



PHOTO COPYRIGHT UNDERWOOD & UNDERWOOD

A Seven-Foot Barbed-Wire Fence Carrying a High-Voltage Current Surrounds the Big Federal Radio Station at San Diego. Sentries are on Guard Night and Day, and Unless on Official Business and Properly Vouched For, No One is Permitted to Enter the Grounds

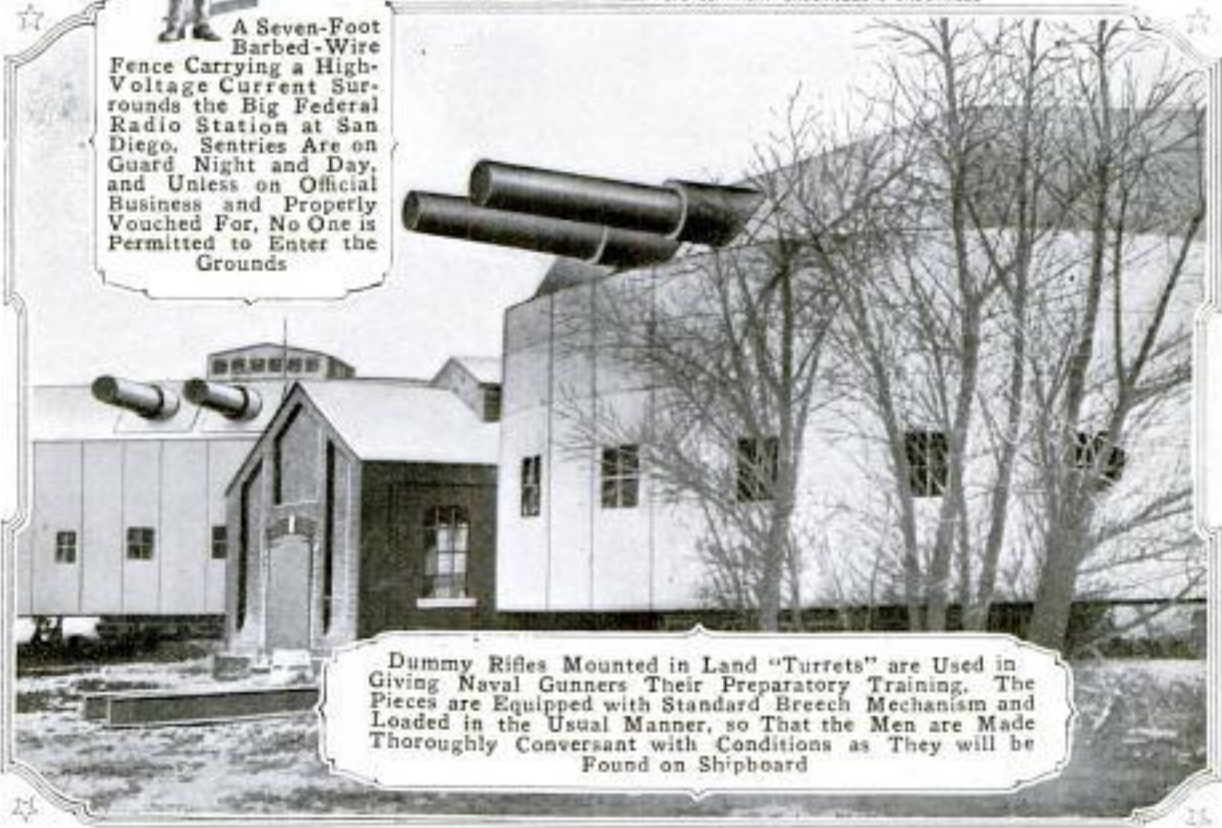

Dummy Rifles Mounted in Land "Turrets" are Used in Giving Naval Gunners Their Preparatory Training. The Pieces are Equipped with Standard Breech Mechanism and Loaded in the Usual Manner, so That the Men are Made Thoroughly Conversant with Conditions as They will be Found on Shipboard

OUR NEW BATTLE CRUISERS FOR LAND AND AIR



PHOTO COPYRIGHT INTERNATIONAL FILM SERVICE.
The Photograph Above was Taken near Los Angeles Lately during a Demonstration of an American-Built "Tank" Car, Similar to Those Used by the British on the Western Battle Front. The Machine was Put through a Series of Severe Tests before Officers of the United States Army. As It was Climbing Out of a River and Ascending a Steep Embankment, the Soft Earth Gave Way and Caused the Heavy Machine to Turn Turtle

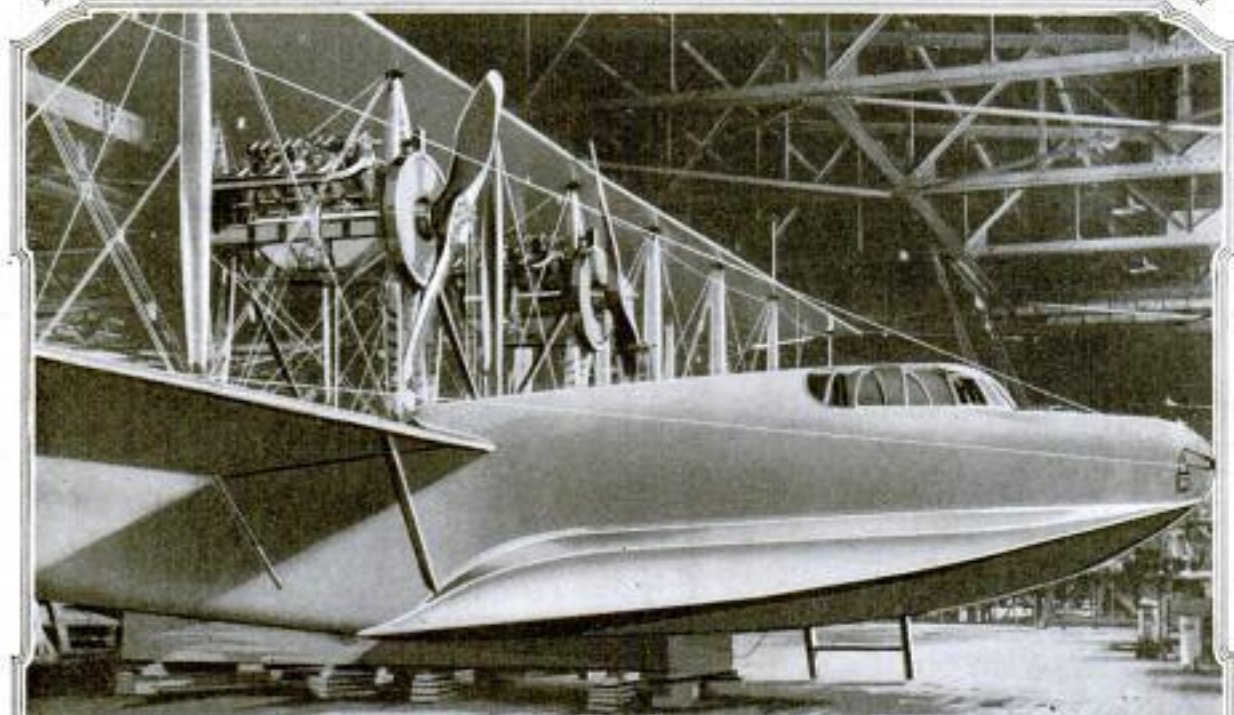

Herewith is Pictured One of the Latest Additions to the United States Navy's Squadron of Flying Boats at Pensacola. The Vessel, One of the Biggest in Our Service, Mounts Two Motors That Together Develop 400 Horsepower and Drive the Craft at a Speed of About 85 Miles an Hour. The Design of the Hull is an Interesting Feature of the New Boat. It will be Observed, Also, That a Transparent Windshield Protects the Occupants

ELEVENTH-HOUR PREPAREDNESS SWEEPS COUNTRY



PHOTO COURTESY INTERNATIONAL FILM SERVICE
 Interned German Sailors of the Raiders "Prinz Eitel Friedrich" and "Kronprinz Wilhelm" have been Transported to Georgia for Safe-Keeping. Above, Their Luggage is Shown on Flat Cars



PHOTO COURTESY INTERNATIONAL FILM SERVICE
 The First Girl to Enlist in the Navy under the Recent Ruling Which Admits Women for Special Duties. As Chief Yeoman, This Girl has been Assigned to a Recruiting Station

The Girl Sailor is No Longer Confined to the Comic-Opera Stage: A Philadelphia Young Woman Taking the Oath of Allegiance to the Country and Flag, and Entering the Navy

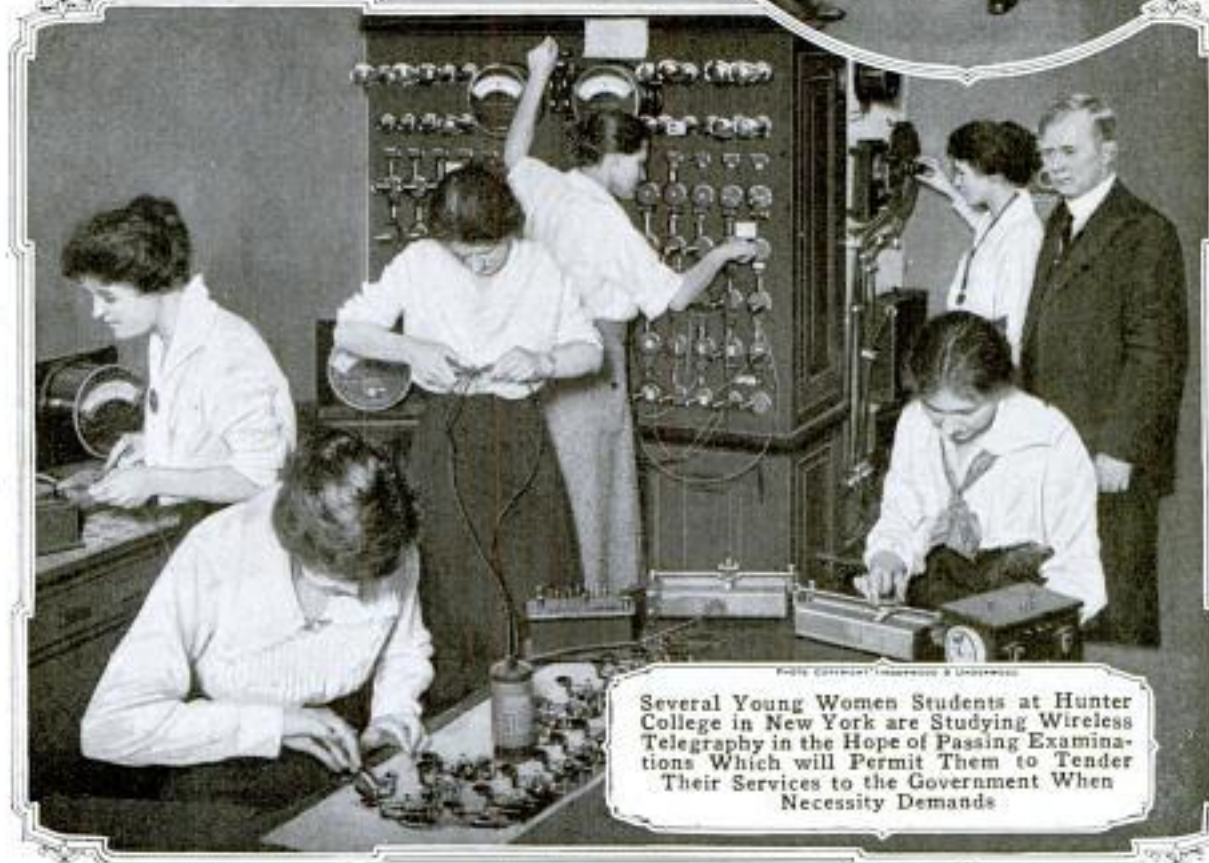
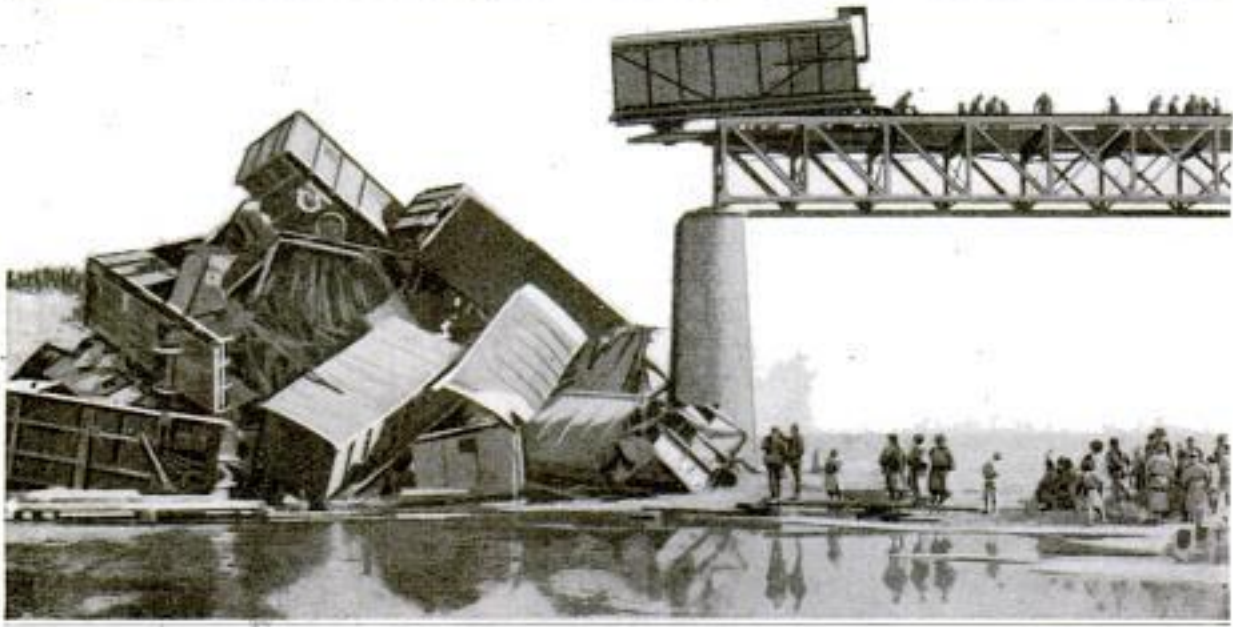

PHOTO COURTESY INTERNATIONAL FILM SERVICE
 Several Young Women Students at Hunter College in New York are Studying Wireless Telegraphy in the Hope of Passing Examinations Which will Permit Them to Tender Their Services to the Government When Necessity Demands



COPYRIGHT, INTERNATIONAL FILM SERVICE

BRIDGE COLLAPSES BENEATH WEIGHT OF TRAIN

TWENTY or more persons, the majority of them soldiers, were killed some time ago in a spectacular wreck that occurred on the Hankow-Peking Railway in China. A long steel bridge spanning one of the streams along the route gave way beneath the strain of a military train that was loaded with provisions. All but one of the cars were hurled into the river, which at the time was shallow. The rolling stock was demolished, but much of the foodstuff was recovered by coolies and carried ashore.

4074

**ELECTRIC SIGN USED FOR
A PATRIOTIC PURPOSE**

During the international crisis a few weeks ago, when patriotic men and



This Sign on Pennsylvania Avenue, Washington, Was a Patriotic Contribution by a Power Company during the Recent Crisis

women were rallying to the support of the president, regardless of party, an electric-power company in Washington, D. C., devoted a large electric sign, usually used for advertising its own service, to the patriotic purpose of writing across the darkness in letters of light the timely message, "Stand by the President!"

4127
**AMERICAN CUTLERY TO BE
MADE OF RUSTLESS STEEL**

Steel made by a rather recently discovered English process, which is said to render it rustless and nontarnishing, is to be used in the manufacture of American table cutlery, according to reports. Plated steel knives are more widely used in this country than in many parts of Europe because Americans object to the tarnishing of ordinary steel blades. It is thought that there will be a large demand for the new tableware because it will not have this undesirable feature and it will be capable of taking a sharp edge.

Potomac Electric Light Co.,
Wash., D.C.

NEW RAY DESTROYS ZEPPELINS

By FRANK O'CALLAGHAN, M. Sc.

IN December of last year, Popular Mechanics Magazine published an article by Lewis R. Freeman describing the destruction of Zeppelins attempting raids on England. The article was badly mutilated by the British censor and one paragraph was deleted at the most interesting point, where probably Mr. Freeman told how the big airships were brought down. Prizes were offered for the two best paragraphs replacing the censored one. The contest excited widespread interest. The winning paragraphs were published in the March, 1917, magazine. It is this contest to which Mr. O'Callaghan here refers. Mr. Freeman is still abroad, on the Italian front at present, and not at liberty to reveal what he had said in the deleted paragraph. In view of the revelations made by Mr. O'Callaghan in the accompanying article, written early in March, Mr. Freeman's statements will be awaited with intensified interest.—Editor.

TEN days ago I arrived in New York City from Liverpool (my first visit to America) and, reading through the March number of Popular Mechanics Magazine, was immediately interested in the article entitled "What Did the Censor Cut?"

The theories therein advanced by the prize winners in explanation of the failure of the raid over London struck me as ingenious but nevertheless erroneous in the light of information which is in the possession of a few people, including myself, concerning the researches of a young Belfastman, Alexander Corr.

About a year ago a sensation was produced in Ireland by an announcement in the press that a young student of the Hardinge Street Christian Brothers School, Belfast, Alexander Corr, had, whilst experimenting in his own home, discovered a new aniline dye, and for this reason, and other services, had been awarded by the British government an annual payment of £3,000 (\$15,000 approximately) and a permanent scientific post of importance in London where he could continue his researches.

Owing to a series of defective systems of education, Ireland does not produce many research students of the first class, and the general astonishment produced by the announcement was augmented by the fact that this important discovery in a difficult field of organic chemistry was made by one so young.

Whilst in Belfast, I had taught, at Skerry's College, several students of the Hardinge Street School and knew that it differed from other Irish schools in ignoring the intermediate examinations and aiming at giving a sound

training in technical work, particularly engineering. It has well-equipped laboratories and a wireless installation, the latter, of course, now dismantled by order of the government. From schoolfellows of Corr I elicited the following information:

The boy was not a brilliant, but rather a hard-working, student. His discoveries were communicated to the British government by his sister, with no result. The Christian Brothers then interested themselves in the matter and accompanied Corr to London, where his demonstrations were approved as satisfactory by the War Office and Committee on Scientific Research.

The most remarkable part of the story is to come.

Corr was credited with having discovered a new ray by means of which Zeppelins could be destroyed. (Experts on science and aviation had maintained that this represented the only possible way of dealing effectively with Zeppelin raids over the coast defenses or the inland towns of England where ordinarily the odds were all in favor of the raiders.) Wishing to test his discovery at home he pasted a sheet of paper on a window at the back of the house and standing with his apparatus at a distance of 10 feet from the window, directed the new radiation toward the sheet of paper. He expected to transmit sufficient energy to ignite the paper. Actually, the window was blown out and a wall at the end of the garden demolished.

I confess that on hearing about the discovery I was inclined to take it with a grain of salt. However, all who heard the statement awaited future Zeppelin

raids over England with interest, as we were assured that the new apparatus was certain to be supplied to all aeroplanes and antiaircraft guns of the Royal Garrison Artillery. As is well known, in the two next attacks by airships the Germans lost one over London and two in a raid over the English midland counties, themselves admitting in their communiqués that the British antiaircraft defenses were "extraordinarily effective." Since then no

air raid has taken place, and latest information from Germany indicates that the Zeppelins have lost the confidence of the experts as weapons of war.

From English officers in the Royal Garrison Artillery on visits to Dublin I have heard that it is current gossip in London military circles that the discovery of a young Irishman (presumably Corr) was responsible for the destruction of the Zeppelins.

4170
**ATLANTIC BOATS CRUSTED
 WITH ICE IN COLD SNAP**

When the unusually bitter weather of last winter reached the north Atlantic coast it caught many vessels on



Ice-Encased Deck House of a Steam Trawler Arriving in Boston Harbor from the Fishing Grounds during the Coldest Weather That has been Known in the North Atlantic in Many Years

the high seas in its grip and by the time they had made their way to port all their exposed surfaces were laden with a massive and picturesque armor of ice. Masts, rigging, hoisting machinery, lifeboats, decks, and deck rails all were covered with the frozen coating, and the steam trawlers arriving from the fishing grounds suffered especially from the cold snap which made navigation unusually difficult.

3155
**INTERLABORATORY TESTS
 OF LAMPS AND SCREENS**

An interesting photometric comparison of blue-glass screens and of tungsten lamps was completed recently by a number of laboratories which had been invited by the

United States Bureau of Standards to participate in the tests. One of the participating institutions was an electrical testing laboratory and another the physical laboratory of a gas-improvement company. The object was to see how closely these different agencies agreed in their estimates of the values of the screens and lamps submitted to them. Each laboratory was permitted to follow its own method. In spite of the differences in procedure the agree-

ment between them was remarkably close. However, in commenting on the tests, the government bureau points out that while the differences were small they are not negligible in precision photometry, and therefore it maintains that measurements to establish standards involving color differences should be left as much as possible to the standardizing laboratory.

J. W. Stratton, Director

Wash. D.C.

Inventor - { L. L. Richards
S. A. Guiberson, Jr. } Los Angeles

4145



COPYRIGHT, INTERNATIONAL FILM SERVICE
Using a New Periscope Rifle, Designed for Trench Warfare: The Man Firing with the Improved Device is Completely Concealed, While the One at the Left Exposes His Head to Shoot. The Rifle Folds into Customary Shape, as Shown at the Right

ARMY RIFLE ADAPTED FOR TRENCH WARFARE

The Springfield army rifle may be made especially useful in trench warfare by the invention of two residents of Los Angeles, which consists of a periscope device adapted to the rifle so that it may be aimed accurately by a marksman entirely concealed in a trench. The device was demonstrated recently at the government rifle range, Beverly Hills, Calif., being tested with success at ranges of 200, 300, and 400 yd. At these distances, targets the size of a man's head were hit, while the marksman's head was a foot below the top of the trench from which he fired. A small framework of steel is built into the stock of the army rifle, with hinges that permit the breech and barrel to be raised and lowered at an angle to the stock, and means for locking the weapon rigidly in its new alignment. Behind the breech and in line with the regular sights, when the framework is open, there is a small periscope which gives a clear view to the marksman of the point at which the sights aim.

4085

MAGNETIZED TABLE FOR ONE-ARMED DRAFTSMEN

In order that any draftsman or architect who has lost an arm in the war may not be forced out of his regular employment because of his misfortune, a drawing table has been introduced in Europe which is equipped with electromagnets that hold the T-square, trian-

gles, and other materials securely in position, while lines are being drawn. The small amount of current for the magnets is derived from batteries or from an ordinary light socket, and is controlled entirely by a foot lever.

4106

ODD-SHAPED CASKET FOR BODY OF A CRIPPLE

At the dying request of a man who had been a cripple from rheumatism for 49 years, and had neither lain down nor straightened up during that entire pe-



Casket Made to Receive Remains of a Cripple Who Desired to be Buried in a Sitting Position

riod, he was buried in the sitting posture in which his friends were accustomed to see him. A special casket was constructed by an Evansville, Ind., undertaker, one end being raised considerably above the level of the lid, with a sloping cover section, to receive the body in the position desired.

The city of Cleveland now has a law which requires that when a resident moves he or she must file a report of the change of address with the police.

see photo

C. S. F. ...
B...

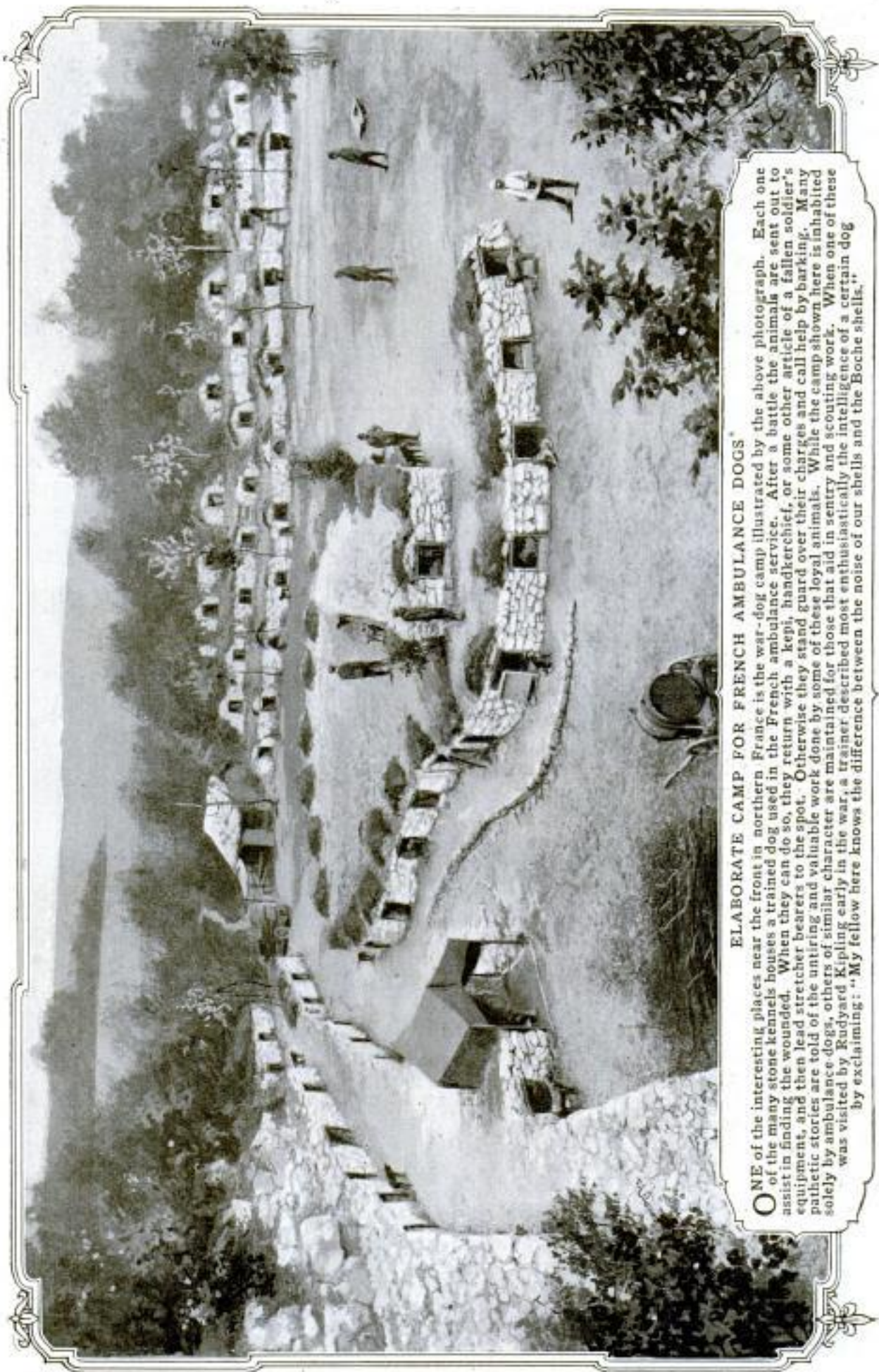

ELABORATE CAMP FOR FRENCH AMBULANCE DOGS

ONE of the interesting places near the front in northern France is the war-dog camp illustrated by the above photograph. Each one of the many stone kennels houses a trained dog used in the French ambulance service. After a battle the animals are sent out to assist in finding the wounded. When they can do so, they return with a kepi, handkerchief, or some other article of a fallen soldier's equipment, and then lead stretcher bearers to the spot. Otherwise they stand guard over their charges and call help by barking. Many pathetic stories are told of the untiring and valuable work done by some of these loyal animals. While the camp shown here is inhabited solely by ambulance dogs, others of similar character are maintained for those that aid in sentry and scouting work. When one of these was visited by Rudyard Kipling early in the war, a trainer described most enthusiastically the intelligence of a certain dog by exclaiming: "My fellow here knows the difference between the noise of our shells and the Boche shells."

SOME LATE DEVICES USED IN WARRING EUROPE



Straddling an Abandoned Trench Somewhere on the Western Battle Front. One of the British Army's Spectacular "Tank" Cars, Crippled: Like Achilles' Heel, the Most Vulnerable Parts of These Machines Are the Treads, Which are Easily Disabled by Well-Directed Shell Fire. When One of the Belts is Broken, as Shown in the Picture Above, the Engine Becomes Helpless



Designed Primarily for Campers and Overland Tourists, This Motor-Car Trailer is Successfully Used by the American Ambulance in France. It is Standard Equipment Manufactured in This Country and Folds Compactly When Not in Use. Opened, as Shown Above, Its Beds Accommodate Four Persons



One of the Effective Weapons Used in Trench Warfare by the French is the Bomb Thrower Pictured in Use Herewith. The Instrument is Light, Easily Portable, and Electrically Operated. For Short-Range Work It is Very Valuable



In Some of the British Military Hospitals Double-Decked Wheeled Stretchers of the Type Illustrated are being Commonly Used. They are of Distinct Advantage, Since One Attendant can Propel Them without Assistance and Move Two Patients at a Time

EUROPEAN ARMY VIEWS FROM HERE AND THERE



Irish-Canadian Troops were Recently Given a Rousing Reception When They Visited the Principal Cities of the Emerald Isle. This Photograph Shows a Detachment of Them Marching in the Streets of Dublin. It is Reported That the Patriotism Stirred by These Well-Drilled Men Caused Many to Volunteer



Practically Every Regiment Has a Mascot of Some Sort, but It is Not Understood That Wild Boars are Usually Chosen. Here is One, However, Captured When Young by Some French Soldiers. That is Nearly as Tame as a Dog



With the United States Flag Aloft, the Woodrow Wilson Soldiers' Rest in Switzerland: The Camp has been Established and Presented to the Government for the Use of Soldiers, by Members of the American Colony. The Picture Shows Infantrymen Enjoying a Meal in the Open Air

STRIKING WAR PHASES PICTORIALY TREATED



Natives Enlisted in the British Naval Expedition to Lake Tanganyika in Africa, Which was Undertaken in 1916 to Crush Germany's Power on That Body of Water, Proceeding across the Swamps of Lake Bangweolo. It will be Recalled That Two Small, Armed Motor Launches were Taken Overland through the Kongo to Battle German Gunboats on the Lake, and That the Latter were Sunk



Some of the Dark-Skinned Natives with a Captive Leopard Progressing toward the Expedition's Destination in One of Their Log Canoes: Twenty-Seven English Officers and Men Engineered the Undertaking, Which Involved Tremendous Obstacles and Hardships



It is an Old Joke That Green Troops Duck Their Heads to Dodge the Bullets When First Introduced to the Firing Line. The Picture Above was Snapped Just as a German Shell Exploded near a Farm Building on the Western Front, and Shows a Group of Soldiers Dropping to the Ground in Order to Escape the Flying Splinters. This Practice, However, is Not in the Same Category as the Other One, for It is a Highly Advisable Thing to Do

Grainden

SMALL TRACTOR USED BY A TRUCK FARMER

A Kansas truck farmer recently suggested to a Topeka foundryman the design of a small light-weight tractor to take the place of a single

horse in the cultivation of his strawberry fields, and the result was the construction of a practical and useful machine. Taking three light binder wheels, the foundryman made an iron frame for them, on which he mounted a single-cylinder gasoline engine of the heavy-duty type, with a sprocket-wheel attachment to the rear wheels, a fuel tank, and the necessary electrical equipment for ignition. A reserve fuel supply is carried on the front end of the frame and the tractor is steered and controlled from a saddle seat at the rear. It works satisfactorily, doing several times as much in a day as a horse could accomplish in the field.

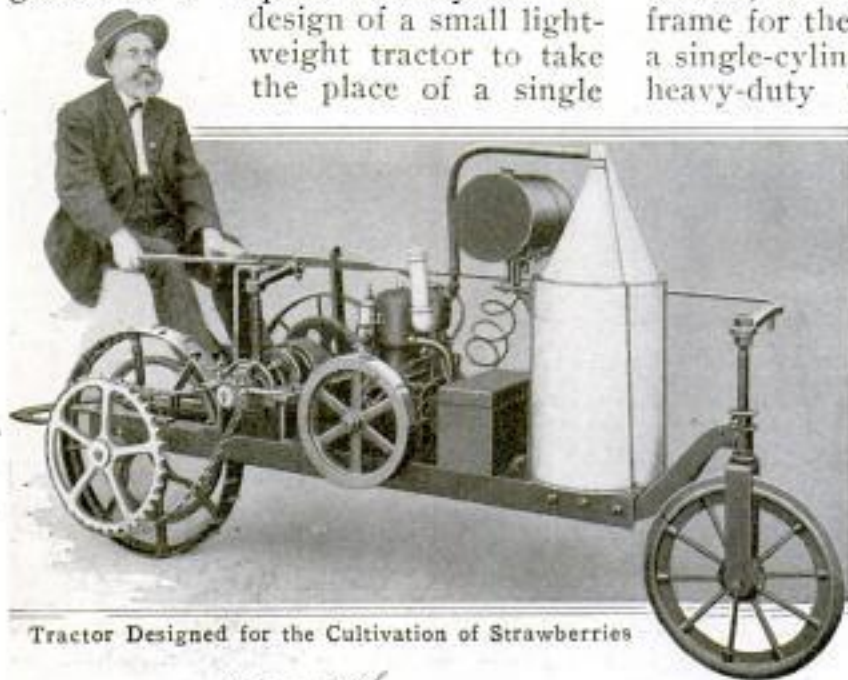

Tractor Designed for the Cultivation of Strawberries

4084

MANY RARE WOODS COMPOSE INLAID PICTURE

An Ohio architect has produced a picture, 16 by 22 in. including the of pieces of natural wood. The artist for years has been collecting specimens of rare and beautiful woods. Spanish mahogany, red cedar, and black walnut were combined in making the picture, which shows a residence interior and stairway. The library table shown is particularly beautiful, because of its harmonious and contrasting colors. The lowest newel post is composed of ebony, butternut, burl, English holly, and Honduras mahogany. There are nearly 300 pieces of wood in the fireplace, which is so made that it can be lighted from behind by an electric lamp. The picture reproduces a scene in an old Virginia home.

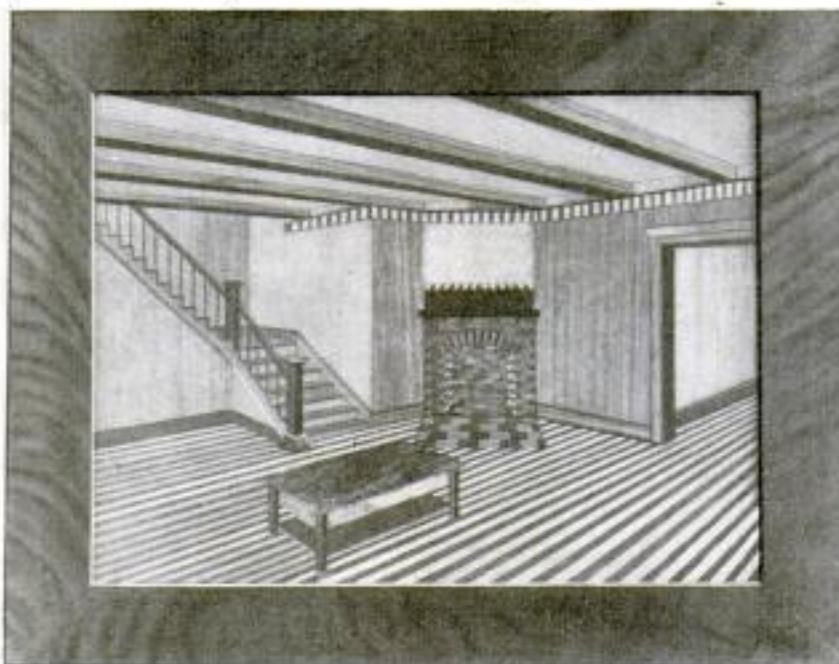

Framed Piece of Inlay Work Composed of Hundreds of Pieces of Rare and Beautiful Woods in Their Natural Colors, Reproducing a Scene in a Virginia Colonial Home

frame, which is quite a remarkable work of art, in that it is made entirely

12000 Green 714 So. Detroit St., Bellefontaine
See data

4146

WITH GOLFERS IN CANADA AND THE NORTHWEST



One of the Beautiful Clubhouses of the North Pacific Coast, the New \$80,000 Home of the Waverley Club at Portland, Oregon. At the Left is Shown the Sixteenth Hole, Known to Waverley Players as the "Punch Bowl." Bunkers Guard the Approach and the Willamette River is Just beyond the Green. A Hook Carries the Ball into Trees and a Slice Sends It Out of Bounds. The Spot is the Waterloo of Many Promising Scores

Delightful, Unconventional, and Hospitable is the Rustic Lodge of the Tualatin Country Club, near Portland, Oregon, Where Fellowship and Golf Hold Sway. The Bungalow Fits Harmoniously into Its Setting and is a Favorite Retreat for Many Lovers of the Outdoors. It Offers Inviting Accommodations for Hungry Sportsmen and Porches for Tired Ones



The Fifth Green on the Calgary Municipal Golf Links, a Course Situated on a Magnificent Promontory Overlooking the Canadian City and Bow River. An Annual Fee of \$5 for Men and \$3 for Women Pays the Running Expenses. The Land was Donated by the Government, and a Small Clubhouse was Erected Last Year Which will be Added To as Necessity Demands



Above is the Picturesque Home of the Beaconsfield Golf Club, a Popular Rendezvous of Montreal Players. Its Early French-Canadian Architecture Gives It Atmosphere and Appeal, While Its Spaciousness Allows It to Give Hospitality to Many Guests. It is One of the Largest Country Clubhouses in the Dominion. An Annex Reserved for Women is Connected to the Main Building by a Portico

KANSAS RAILROAD SOLD AT PUBLIC AUCTION

All the property of the Missouri Pacific in the state of Kansas, known



Scene at the Missouri Pacific Depot in Topeka, Kansas, When the Property of the Railroad in That State was Formally Sold to New York Financiers

separately as the Kansas, Colorado & Pacific Railroad, was sold at public auction recently, under a plan of reorganization arranged by New York

financiers. The sale itself was a mere formality, the property being bid in by representatives of the fiscal agents and trustees of the road at \$9,800,000, the minimum price fixed by the Federal court which ordered the sale. The formal proceedings occurred outside the Missouri Pacific depot at Topeka, in zero weather, before a small crowd of spectators, some of whom did not realize that the sale marked the passing of the Gould family influence from the affairs of the railroad system it had dominated for many years. The reorganization plan provides for the consolidation of the Missouri Pacific and Iron Mountain rail-

roads as one company, with a total capitalization of \$383,824,000, under the presidency of one of the foremost railway men in America.

COMPACT DINING OUTFIT FOR CAMP OR AUTO

A convenient outfit for motorists and campers who take their meals in the open has been designed by a resident of Portland, Ore. It comprises a



This Outdoor Dining Outfit Packs into the Suitcase Form Seen at the Right

folding table and two folding double seats, with interior compartments in the table for food and drink, dishes, towels, napery, and silverware. A checkerboard is inserted in the square covering of the food compartments. The whole outfit, including utensils, weighs less than 30 lb., much of the wood being veneer. When folded it takes the shape of a suitcase, 32 by 17 by 9 in., fitting on the running board of any auto. When unfolded the outside of the suitcase forms the camp seats, with legs kept rigidly upright by a single hook. The table fits inside the case and when similarly unfolded and fastened stands 30 in. high. Its top, unfolded, measures 32 by 46 inches.

Two French inventors have devised a photographic color-printing process which is to be used in printing on silk. It has been adopted at the French government's Gobelins works.

RAISING RABBITS FOR FUR DECLARED UNPROFITABLE

That a widespread misconception concerning the value of rabbits as fur

producers exists at present, is indicated by numerous inquiries received by the Department of Agriculture.

Replies to these questions have stated that there is sufficient demand for rabbit fur to make it worth while to save pelts of domestic rabbits killed for food, but that the raising of rabbits for fur alone would be unprofitable with any known breed. Before the war Great Britain imported as many as 90,000,000 skins annually. The United States also uses large quantities of rabbit fur, making it into

felt and cheap fur garments often sold under such names as "Baltic black fox," "inland seal," "electric seal," etc. The bulk of this fur is sold in bales bringing from 10 to 50 cents per pound. The better skins sell by the dozen, generally bringing less than 10 cents each. Statements to the effect that certain breeds produce pelts of high market value are entirely unwarranted, according to a statement issued by the department, which points out further that certain rabbits have been widely proclaimed as being imported from Siberia, in one case, and Mongolia, in another, while as a matter of fact no wild rabbits occur in either country. The few species of hares found there are small gray creatures. Animals now offered as being from Siberia are pronounced by the government's representative as a strain of Flemish giant rabbits. It should be stated that owing to their great size their skins probably will sell for more than those of other breeds. The skins of common wild rabbits seldom bring over one or two cents each.

VAULTLIKE CAR TO CARRY FUNDS OF PARIS BANKS

Bank messengers and custodians of bank funds in Paris are said to have



A Veritable Vault on Wheels Which Paris Bankers have Procured to Insure the Safe Transportation of Their Funds from Place to Place

been robbed so many times in recent months that the bankers have procured a veritable safe on wheels in which to transport large sums of money from place to place. The body of this high-powered automobile resembles a vault. All the sides are inclosed, and even the driver's seat is protected by a low-hanging metal canopy and high sides of metal. With this heavily guarded car properly manned, it is believed that funds can be taken through the thoroughfares in absolute safety.

COMBINATION FENCE, DAM AND GUTTER

An odd type of barrier has been erected at the side of a lemon orchard in southern California, which serves as a fence, a dam, and a culvert. The fruit trees in question are located near an arroyo which occasionally overflows and formerly flooded the orchard and did much damage. To hold back these floods a wall of wood, stucco, and brick was built in place of an ordinary fence.

at Whittier, Calif.

The heavy posts, which are of brick and set about 12 feet apart, anchor it securely. That the wall might not be



Barrier Erected at the Side of a California Lemon Orchard Which Serves as a Fence and Gutter, and as a Dam That Holds Back Occasional Flood Waters

undermined by water from the road, or arroyo, a cement gutter was laid along its base so as to drain off through a culvert under the highway on which the property abuts.

— 3650

GLASS GLOBES AS FLOATS FOR FISH NETS

Cod and hake fishermen on the coast of Maine have adopted large hollow glass balls as floats for their ground nets, instead of the usual cork or wood floats, because the glass floats last longer and their sheen attracts the fish. The balls are the size of a large grapefruit, are covered with netting, and at-



Cod Nets, Equipped with Hollow Glass-Ball Floats, Drying on Reels on the Beach near Biddeford Pool, Maine; The Rings Seen Are of Iron and Used as Sinkers

Biddeford Pool,

Maine,

June 1917

tached to the nets by short ropes at intervals of 6 or 8 ft. along the top. The net hangs from them straight down like a wall to the bottom, iron rings about nine inches in diameter serving as sinkers. Glass balls of this kind are cheap and last for many months if made sufficiently thick to withstand the buffeting of the sea and occasional contact with each other.

3974 —

LITHOGRAPHIC STONE FROM DOMESTIC QUARRIES

During the past year, for the first time, lithographic stone from American quarries was marketed to a considerable extent. Bavaria has been the chief source of supply hitherto, but war-made conditions are now favorable to domestic quarrying of this peculiar stone, for which lithographers paid in 1916 from 2½ to 27 cents a pound, according to quality. Before the war the Bavarian stone was obtainable at from 5 to 6 cents a pound for 10 by 12-in. slabs of the better grades, and 1½ cents a pound for the poorer grades. About 40,000 lb. of finished stone was sold last year from quarries at Brandenburg, Ky., which contain three distinct beds from which lithographic stone may be obtained after the removal of limestone of other varieties. An effort will be made to market the Kentucky stone after the war, in competition with the Bavarian product.

— 4114

FRENCH PAPER MONEY LADEN WITH GERMS

A recent test made for the municipal authorities of Rouen, France, showed that the bank notes for the sums of two francs and less, which have been issued during the war by French chambers of commerce, are in a remarkably filthy condition. Notes in circulation but eight or ten days were found to have collected a covering of dirt weighing one-fifth as much as the paper itself. Analysis showed that this greasy coating of filth contained many virulent disease germs.



Beginnings of Reconstruction in France

by Lewis R. Freeman

287 E. California St., Pasadena Calif.

IN the number of visits I have made during the last six months to the western battle front and the regions immediately behind it, no question has been oftener in my mind—save, of course, the constantly obsessing one of how and when the war will end—than that of the way in which the ruined cities and towns and villages are to be rebuilt and rendered fit to receive their former inhabitants. The destruction in the constantly broadening belt over which the 500-mile-long dragon of the battle front has twisted and floundered can be characterized as nothing less than absolute obliteration. Yesterday afternoon—scarcely 16 hours ago—I stood upon the rounded heap of débris which marks the site of the Chateau de —, in a portion of the Somme sector recently wrested by the French from the Germans, and the colonel who made his home in one of the wine vaults of the historic building had the greatest difficulty in indicating to me, even with the aid of



The First Attempt at Permanent Reconstruction: The American Girl Shown in the View, Miss Daisy Polk, of Group of San Franciscans Who Remember the Experiences of the

his powerful glasses, the exact locations of what had once been three fair-sized villages, the farthest of which was not over 2,000 yards away. Only darker blurs of color upon the shell-pitted desert and the occasional twisted fragment of an iron grill showed where walls and buildings once had stood, and in passing directly through several such one-time villages on the way up to the first-line trenches, all there was to indicate "what once had been" were fragments of metal—usually farming machinery—and bits of masonry.

Besides these villages and towns that have been literally trampled out of existence by the feet of the war dragon, there are those upon which he has only trod in passing or scorched with his breath from afar. These include the places that were evacuated by the Germans after but brief occupation, as well as those which have been, for greater or lesser lengths of time, near enough to the firing line to suffer intermittent bombardment from the guns or air craft of the enemy. Partial only though the destruction is in such places, the aggregate of it is enormous and must form a very considerable portion of the total established by the final reckoning. The cathedral and Hôtel de Ville in Arras, and several of the great buildings of

Ypres, are in a far completer state of ruin than the temples at Luxor or Karnak or Baalbec, all of which were subjected to the ravagings of the conquerors of 30 centuries. The mere task of removing the débris of Arras cathedral will be an undertaking apt to give pause to authorities whose hands will be full for many years with more imperatively demanded restoration.

How and when are the war-ruined cities and villages of Europe to be rebuilt? I began asking the question nine months ago, and it is only within the last few weeks that I have been able to get a definite answer, and this only so far as the destruction in northern France is concerned. For the most of this time I was able to follow only the flutterings of straws which served merely to indicate the direction of the rising wind. I read in the London papers, for instance, how a once wealthy merchant of Antwerp, dying a refugee in the south of England, bequeathed all that could ultimately be realized after the war from the sale of his very considerable holdings in various parts of Belgium to a fund to be exclusively used for the rebuilding of the dwelling houses in a certain street in Louvain in which the testator had at one time resided, and which had been completely destroyed when the



San Francisco, is Supervising the Rebuilding of Vitrimont, a Village near Nancy. The Work is Financed by a Great Earthquake and Fire in 1806, and the Period Following

Germans occupied that city. Dutch papers have called attention to the fact that several dozen similar wills have been filed in Holland, many of them after being smuggled through from Belgium, and it is also recorded that a number of wealthy Frenchmen, dying since the outbreak of the war, have left their fortunes to be devoted to reconstruction work in northern France and—provisionally—Alsace-Lorraine.

Later I learned of what were probably the first systematic attempts at actual rebuilding. These were initiated by the English Quakers, who, unwilling to fight on principle, were still anxious to give the most practical aid possible to alleviate the suffering caused by fighting. This, they decided, could not be done more effectively than by endeavoring to render habitable some of the villages in northern France



The Remains of a Village on the Somme: This Is One of the Extreme Instances Mentioned by Mr. Freeman. The Very Bricks and Stones are Pulverized, and It Is Not Probable That Any of the Old Material can be used in Rebuilding

destroyed in the first rush of the Germans, but finally left well to the rear of the established front. As their aim—very sensibly—was to provide shelter as quickly as possible for all those who desired to return to their homes, the work of these kindly and practical people was, and still very largely is, of the most temporary character, in many instances consisting only of waterproof roofs thrown over basements and wine cellars. All of this in time, of course, must give way to permanent reconstruction.

The first—and, so far, practically the only—permanent reconstruction work undertaken in France is that financed and directed by a California society, mostly made up of San Franciscans who learned at first hand what destruction and restoration meant as a sequel to their great earthquake and fire of 1906. The work is under the direction of Miss Daisy Polk of San Francisco, who, with the hearty cooperation of the French authorities, is having rebuilt as fast as funds, material, and labor are available, the dwelling houses in a small village near Nancy. The wishes of the surviving owners of the property are being most carefully consulted in all restoration work attempted, and such buildings as have been completed up to this time follow fairly closely the plan of the originals, and no important departures have been made in either construction methods or in the materials employed. This is, indeed, inevitable under any scheme of comparatively sporadic reconstruction of this character. Modern methods and modern materials can only be adopted when an organized plan of rebuilding is undertaken on a great scale, which cannot possibly be before the end of the war.

So much for the "straws"; now for the rising wind of national effort. From the days of the battle of the Marne, when clear-seeing Frenchmen first began to realize that it was only a matter of time until the enemy would be forced to relinquish all he had taken, France commenced to ponder the rebuilding problem. For con-

siderably over a year, with every ounce of effort mobilized to the task of holding the enemy where he was, it was impossible to do more than ponder and plan; but with the stemming of the initial German onslaughts at Verdun in the early spring of 1916 the time was deemed ripe for taking the first tentative steps in a comprehensive scheme of reconstruction that will eventually restore to those brave and beautiful provinces of northern France everything that the war has cost them, save only the blood of their sons and a number of historic buildings and monuments.

In the same cool, methodical, and painstaking way in which she has paved the way for her victory in war France began paving the way for her victory of peace. The first thing to do—indeed, almost the only thing that can be done until the war is over—was, so far as possible, to take stock of the damage done. A commission for this purpose was formed last spring, its principal objects being designated as follows:

To determine as regards all ruined towns, villages, farms, factories, etc.:

1. The number of houses existing before the war.
2. The number of houses completely or partially destroyed.
3. The destruction to public property, such as mairies (town halls), churches, schools, police stations, museums, monuments, etc., with data as to whether or not reparable.
4. The destruction to factories and other industrial establishments, with data as to the approximate number of persons employed by them.
5. The number of detached farming establishments (*bâtiments d'exploitation rursals*), wholly or partially destroyed.

The departments in which destruction had taken place were the following: Nord, Pas-de-Calais, Somme, Oise, Seine-et-Marne, Aube, Meuse, Meurthe-et-Moselle, and Vosges. At the very outset it was evident that no statistics could be collected concerning the communes still occupied by the

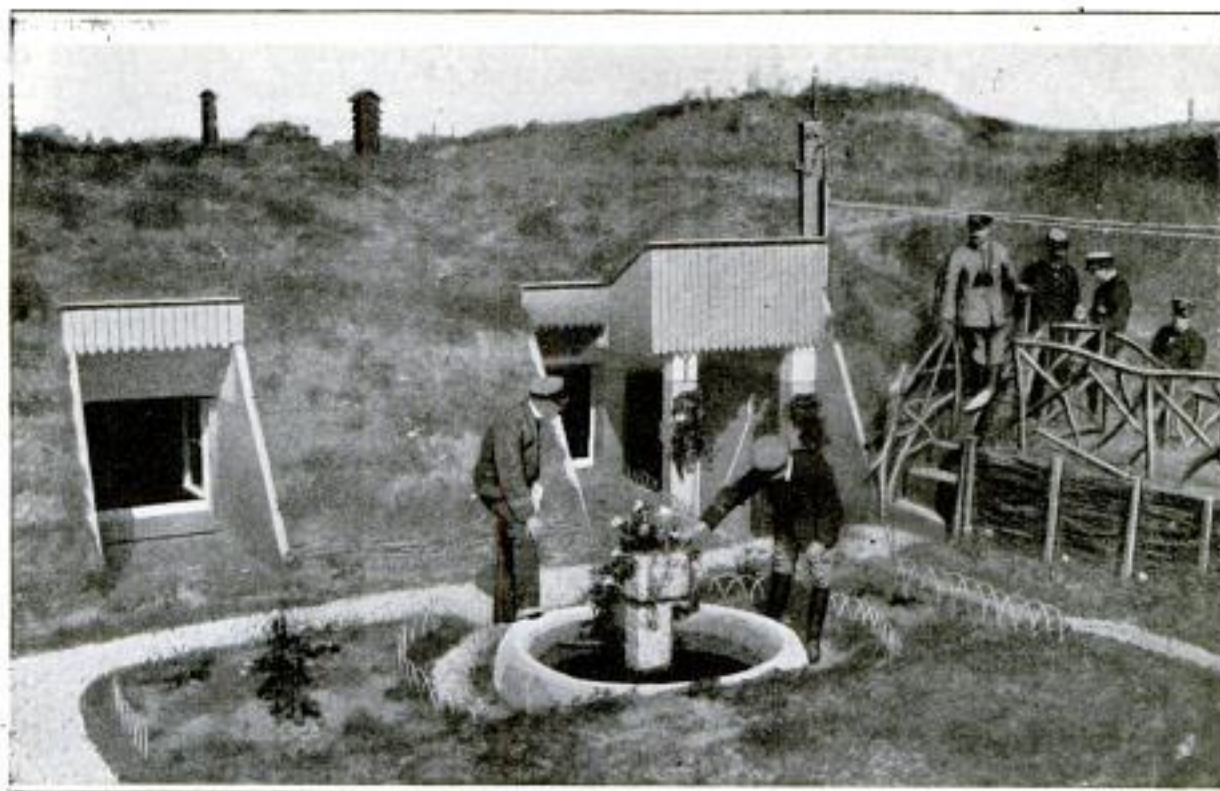

The Germans Think Some of the Inhabitants of Northern France will Welcome These Cave Shelters after the War. The Germans Build Well and the Underground Houses are Not to be Despised. They are Built into the Hills of Northern France

enemy and those which, though on the French side of the front, were still so exposed to fire that they had been evacuated by the inhabitants and no civil administration was in force in them. The communes still occupied by the Germans (December, 1916) are calculated to number 2,554, out of a total of 36,247 in the whole of France. The greater part of these are in the departments of Nord (545), Aisne (569), and Ardennes (503). The number of communes evacuated by the civil population because of their proximity to the zone of fire is 247, of which 21 are in Pas-de-Calais, 27 in the Somme, 25 in the Aisne, 34 in the Marne, 88 in the Meuse, and 39 in Meurthe-et-Moselle. The number of communes in which destruction had taken place, but which were still in the hands of the French, and in which civil administration had been restored, numbered 753, distributed as follows: Nord, 23; Pas-de-Calais, 71; Somme, 34; Oise, 59; Seine-et-Marne, 35; Aisne, 51; Marne, 258; Aube, 2; Meuse, 59; Meurthe-et-Moselle, 109; and Vosges, 53.

It is evident, therefore, that out of

a total of 3,554 French communes more or less completely destroyed, only a little over one-fifth were so situated as to make any estimate of that destruction practicable. It should also be borne in mind that the average of destruction in the 2,554 communes still in German hands is probably much higher than in those in which the civil administration has been restored on the French side of the lines; and again, that the destruction in most of the villages evacuated because of their proximity to the firing line is complete, and that this number is being constantly augmented as the allies, trench by trench, blast the Germans out of their positions and push them backward. All further figures quoted, which I now have permission from the French government to publish for the first time, relate only to the 753 communes in which the civil administration is again in operation. Rough approximations of the destruction in the 2,554 communes still in German hands have been made from information supplied from various sources, but any accurate estimates of such destruction must

await their reoccupation by the French, either by military conquest or following their evacuation by the enemy at the end of the war.

In 299—or about 40 per cent—of the 753 communes under consideration, over half of the buildings have been destroyed, the greater number of these being in the Marne and Meurthe-et-Moselle, in each of which departments there are 87 communes where the destruction is over 50 per cent. In the whole 753 communes the total number of buildings damaged by acts of war is 46,263, of which 16,669 are completely destroyed and 25,594 only partly.

A careful estimate of the value of the property destroyed in the 753 communes under consideration has been prepared, but it is not deemed desirable to publish it at this time. It undoubtedly runs into many hundreds of millions—and possibly thousands of millions—of francs; while for the 2,554 communes still in German hands, and the 247 evacuated by the civil populations because of their proximity to the firing line, the destruction must total anywhere from five to ten times that of those which have been studied.

No sooner had the figures compiled regarding the destruction in the region open to observation been digested, than they were submitted to the chamber of deputies, and that body promptly voted in favor of a resolution committing the government in principle to the full indemnification of all losses suffered by its citizens through the invasion of the country by the enemy. This is much the most important step that has so far been taken toward the rebuilding of any of the war-devastated regions of Europe, and constitutes practically an absolute guaranty that this restoration will be carried out not only in the most expeditious but also the most economical way. The term "full indemnification" is, of course, an elastic one, and its exact interpretation has not yet been determined upon. The exact building cost of a house erected from one to five hundred years ago can hardly be determined at this time, nor will it be possible or desir-

able always to reproduce such a house identically, especially on the score of materials. "Full indemnification" will, therefore, probably be interpreted to mean the cost of reproducing a fairly modern house of approximately the same size and design as the one destroyed. There will, of course, be instances in which an owner may desire to rebuild a larger or a smaller house than the one destroyed, and in the former case this will doubtless be provided for by allowing him to supplement the indemnity from the state from other sources, and, in the latter, by allowing him to make use of the surplus in some other manner. It is certain, however, that an owner will not be permitted merely to bank or invest his indemnity; at least a very considerable part of it will have to be expended in actual reconstruction.

The next great step to be taken in the matter of restoration is that of finance. France, of course, hopes and confidently expects to be able to exact full reparation from Germany for all damage wrought. The payment of such an indemnity, even in the event it shall be exacted, must, at best, be a matter of the somewhat remote future; the need of the money is practically an immediate one. While the actual steps for raising the necessary funds to begin rebuilding have not been taken, the plans are ready. This will be accomplished by the sale of long-time bonds issued by France's leading financial institution, the *Crédit Foncier*. These bonds will be offered both in allied and neutral countries, and while the most of them will probably be subscribed for in France, it is expected that the demand for them in Great Britain and America will be very heavy.

It has been proposed that certain Pacific coast hotels install wireless-telephone apparatus by which guests could communicate with vessels at sea or with other hotels, to make reservations, etc. The manager of an Oakland hotel is taking the initiative in the matter.

Geo. Zint 105 Silver St. West
Wapakoneta, O.
(Inv.) 3274

AUTOMATIC VALVES GOVERN SET OF LAWN SPRINKLERS

An automatic lawn-sprinkling system has been patented which will spray several parts of a lawn or garden in turn, without supervision, so that, if desired, it can be operated at night—a very favorable time for watering plants or grass. It consists of a set of valves, each of which controls a separate sprinkler. The spraying devices can be distributed over the lawn as desired. Each valve is operated by a pair of buckets attached to its handle, which projects horizontally. They are so positioned that when one is upright the other is upside down. The valve is turned by filling the upright bucket with water until its weight is sufficient to tip it over, spilling its contents on the ground or into a tank, and likewise reversing the position of the two buckets. A half turn of this sort opens the valve, while the next half turn closes it. The buckets are each filled automatically by

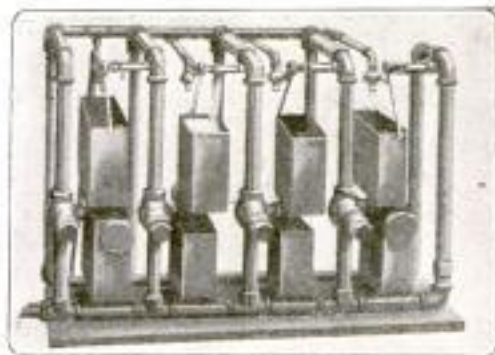

Tumbling Water Buckets That Automatically Operate the Valves in Turn

very small cocks which operate in pairs. One cock fills the bucket whose function is to close a valve, while at the same time the other fills a bucket whose function is to open the next

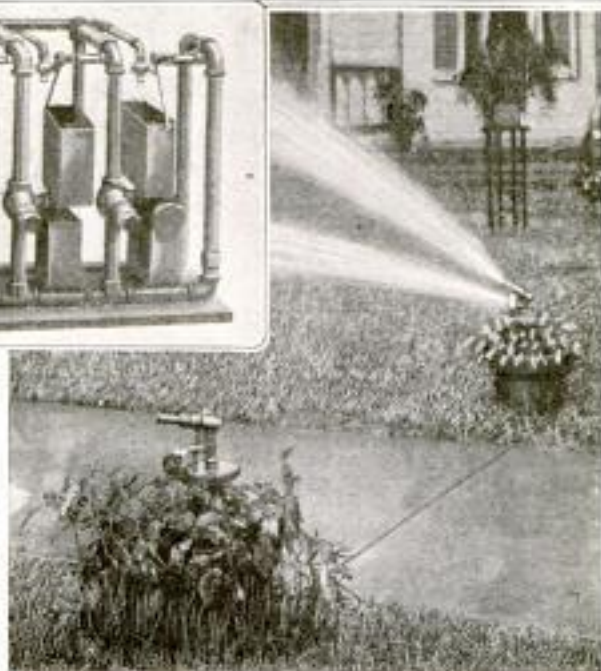

One of Two Automatic Sprinklers at Work: Each is Controlled by a Valve of the Type Shown Above and is Also Provided with Special Apparatus That Causes It to Revolve Slowly, Throwing Water in a Wide Circle

valve of the series. As these buckets tip over, one after another at intervals the sprinklers are supplied with water

3295

POWERFUL ELECTRIC BRAKE FOR AUTOMOBILES

An interesting safety device for motorists is an electric brake devised



By Simply Moving His Finger the Driver Operates a Powerful Electric Brake Which Stops a Rapidly Moving Car Quickly without Skidding

by an inventor while seeking a substitute for the air brake in universal use by railroads. It consists of a light but powerful motor which, through suitable gearing, winds on a drum a steel cable attached to the ordinary brake equipment of an automobile, and a controller attached to the steering column, capable of being operated by the driver with one finger. By this simple operation the driver, through the motor, exerts a pull of from 1,000 to 2,500 pounds on the brake rods, and it is claimed that a car moving at 50 miles an hour can be brought to a dead stop within 45 ft. A radical departure with this brake consists in keeping the brake bands and drums oiled.

Edward V. Hartford, Inc.
143 Morgan St., Sec. 2 Copyrighted Material



Right: Putting the Container, with Partly Unfolded Cloth Tread, in Position, Preparatory to Getting the Car Out of the Mud. Left: The Canvas Tread with Its Rope Grips in Place

SUSPENSION FITTING FOR LIGHT FIXTURES

3796

An electric-light fixture can be hung absolutely vertically from an outlet box, even if the latter is set on a slant in the ceiling, by using a special fitting manufactured in Chicago. It consists of a cast-iron covering that can be screwed over any standard 4-in. outlet case and is provided with



a ball-and-socket joint, to the lower end of which the stem of the light fixture is attached. This joint allows a chandelier to swing in any direction, through an angle of 25°, but will not permit twisting. In concrete buildings, for example, where the outlet boxes are often set imperfectly, this fixture is of special service.

Central Electric Co. Chicago

a box, containing a tread, into a holder attached to the under side of the running board and, partly withdrawing the canvas, ties one end of it to a spoke of the hind wheel. The other rear wheel can be similarly provided for, if desired. Then, by attempting to "spin" the wheels in the mud, the canvas will be wrapped about them without further trouble, and, because of the grips, they will suddenly acquire a traction that even chains do not give. The canvas also prevents the tires from being overheated by slipping.

3730

CHEAP CONCRETE CULVERT IS REMOVABLE

A removable concrete culvert, or crosswalk, for street intersections, has been invented by Denver's street commissioner, the cost of which is said to be only a trifle more than first-class wooden culverts.



The units are made indoors and are 3 ft. 10 in. wide and 17 in. high. The covers, which are reinforced and measure 3 ft. in length, will sustain a weight of from 15 to 20 tons. In case the passageway beneath is clogged, the covers can be lifted to remove the obstruction. Should storm sewers be installed in the streets where these culverts are located, the latter can be taken up and used elsewhere.

CANVAS TREADS PREVENT TIRES SLIPPING IN MUD

3961

Canvas treads have been patented recently which enable one to get a car out of the mud or mire with a minimum of inconvenience. Each of these coverings consists of a long strip of strong canvas, provided with numerous grips in the shape of short pieces of rope attached to it transversely. When a car is mired the driver inserts

Inv: Edward Green

Denver Highway Comm. Copyrighted material

**PATROL BOAT OF NEW TYPE
ADDED TO THE NAVY**

Among recent additions to the navy is the 60-ft. patrol boat "Chingachgook," officially known as "No. 10," which was exhibited at the last annual motorboat show in New York, as a sample of the type approved by the Navy Department for coast defense. It was hoisted from the water by a floating derrick and transported on a special truck to the show. Its beam is 10 ft., draft 3 ft., and steel bulkheads divide the hull into six compartments. Its armament consists of a three-pounder rapid-fire gun aft, and a .30-caliber Colt automatic forward. The gasoline tanks have a capacity of 810 gal. and two 8-cyl. motors give it a maximum speed of about 26 miles an hour. At that speed its radius of action is 600 miles, but at a cruising speed of 12 miles it can cover a distance of approximately 1,200 miles without refilling its tanks. Berths are provided for a crew of eight. The vessel was purchased for the navy after the show, and is now in active service.

**NEW DRAFTING DEVICE
DRAWS MANY CURVES**

The name cyclo-harmonograph has been given to a new machine that draws so-called harmonic curves automatically. It

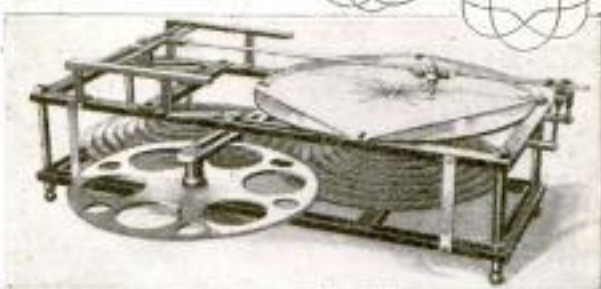

By Setting This Machine Properly 252 Distinct Types of Curves may be Drawn Automatically

is the invention of a professor of mathematics at the University of Washington. By its aid many kinds of curves, among them many used in decorations of buildings, books, and textiles, may be correctly drawn that are now plotted laboriously by hand by designers and draftsmen. In construction it is a rectangular metal framework, bearing a double series of stepped wheels in gear with a large adjustable wheel, the whole capable of being set for no

*Prof. Edward Moritz
Univ. of Washington, Seattle*

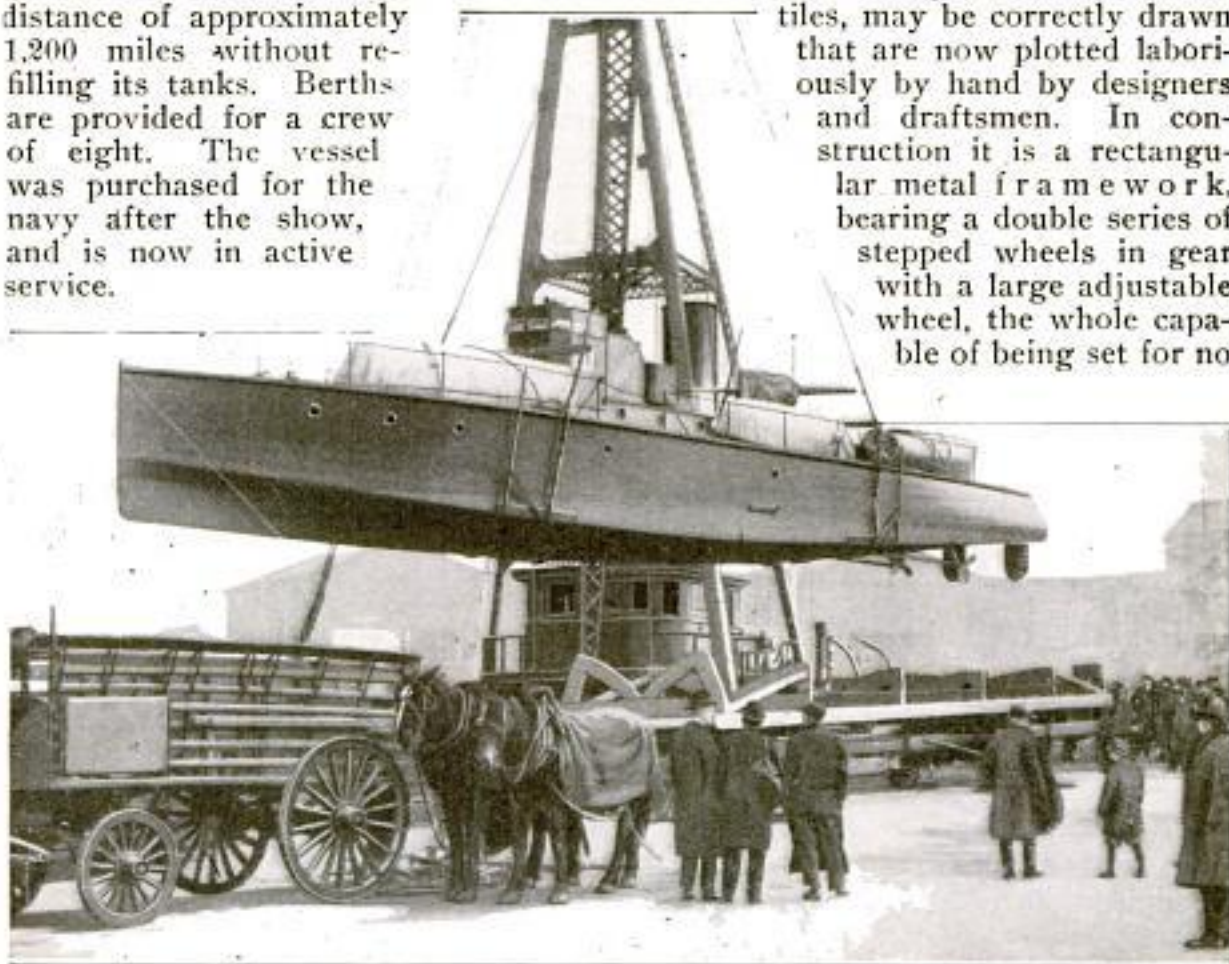

Hoisting a New-Type Patrol Boat from the Water to a Waiting Truck for Exhibition at the New York Motorboat Show: Many Private Owners are Building Boats of This and a Smaller Size. Approved by the Navy for Coast Defense

less than 252 distinct types of curves. The surface to be drawn upon is carried on a circular revolving table, over which the pencil is held by a mechanical arm. The machine is operated by hand. Though it was not designed for commercial use, it has aroused much interest among architects.

3991—

DRY-DOCKING SHIPS ON RAILS TO MEET CONGESTION

With the increasing demand for ships, due to the present-day shipping situation, American vessels are being used to their full capacity. For the purposes of safety, frequent overhauling becomes necessary, which because of the crowded condition of American shipyards, requires dry-docking. Limited facilities for this purpose have led American shipowners to put into use what is known as a "railway dry dock" more extensively than heretofore. Economy of time and expenditure are controlling factors in this dry-docking system, which is capable of handling even the largest of ships.

The purpose of dry-docking a vessel is to give it a berth out of water so that all parts of its bottom are readily accessible for the making of repairs. In all dry docks, the vessel is first "grounded" firmly on keel blocks and bilge supports applied; then the water

is removed. In the basin and floating docks, this is done by pumping machinery; in hydraulic docks it is done by lifts, taking the weight of both vessel and dock.

The "railway dock," on the other hand, is built on a track, resting on firm foundations and constructed on an incline. When the vessel has been placed in position, being held by keel blocks and bilge supports, the operation of dry-docking it is accomplished by powerful hoists, which haul the dock up the inclined track. The largest of the railway docks can accommodate a ship of 4,000 tons, and docking a vessel is a matter of not more than an hour, while it sometimes takes five hours in the ordinary basin dock to lift a ship out of water.

On the smaller docks of this type, the operation may take not more than from one to two minutes after the grounding of the vessel. The best record was established when a 1,600-ton ship was taken out of water by a dock and returned in 25 minutes. In some cases, from ordinary appearances, it looks as though the ship had been brought up on dry land. These docks are being resorted to both in the United States and in Europe, particularly in ports where the congestion is the greatest and every effort is being made to complete repairs quickly.

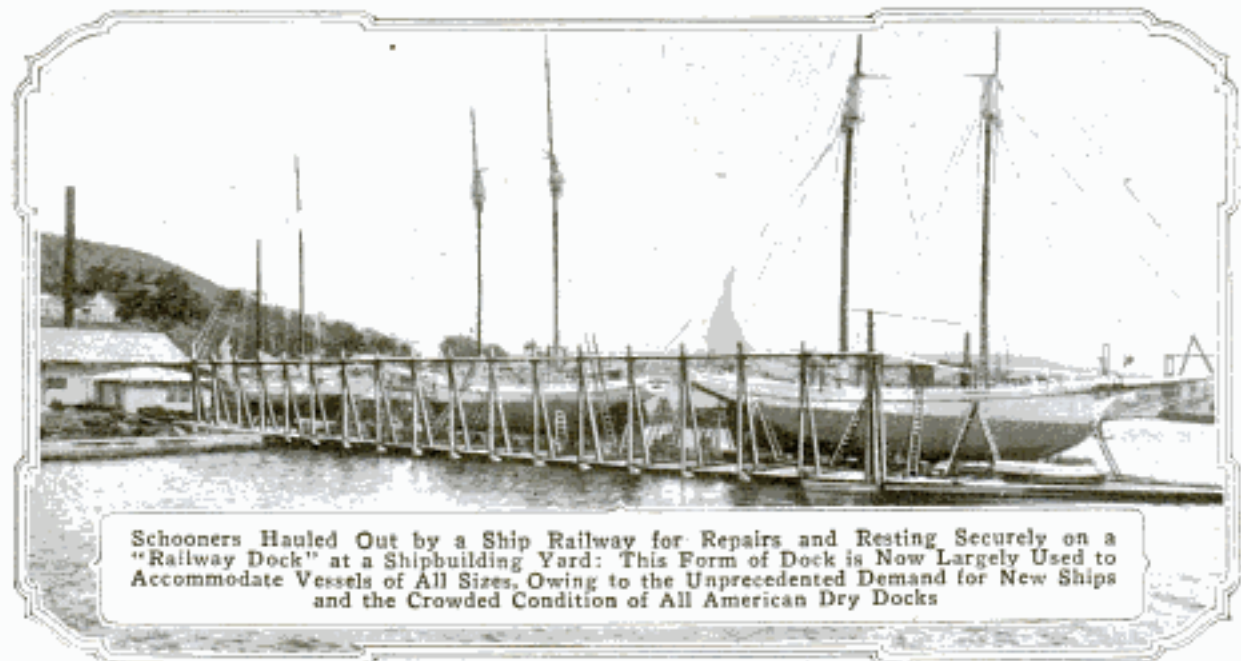

Schooners Hauled Out by a Ship Railway for Repairs and Resting Securely on a "Railway Dock" at a Shipbuilding Yard: This Form of Dock is Now Largely Used to Accommodate Vessels of All Sizes. Owing to the Unprecedented Demand for New Ships and the Crowded Condition of All American Dry Docks

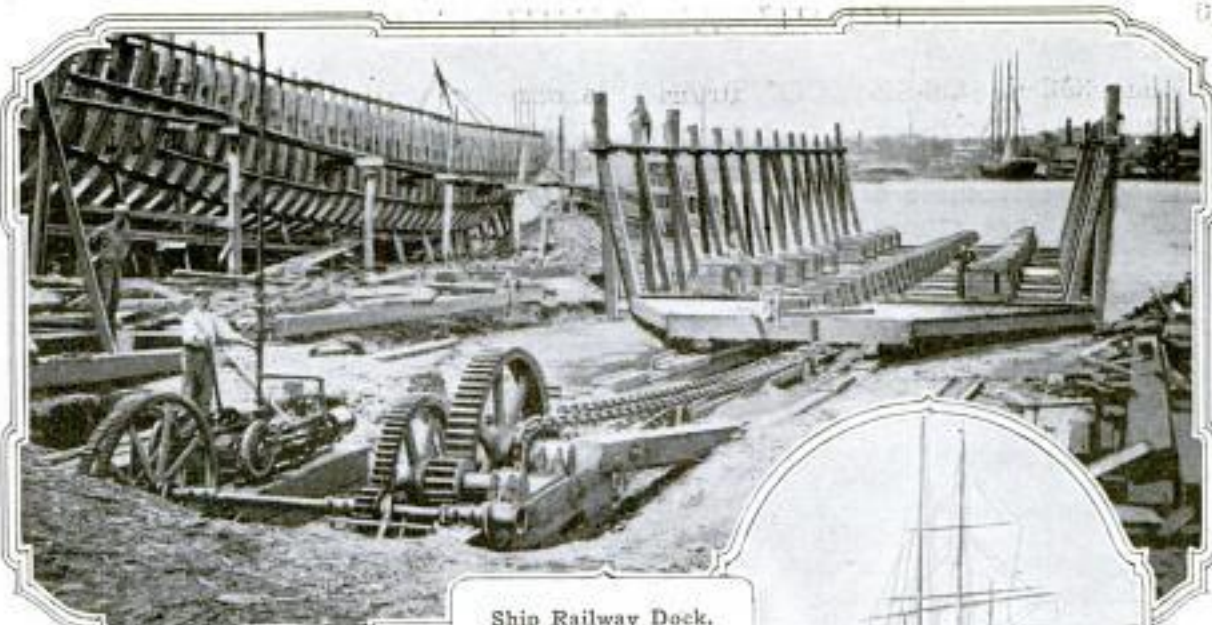

Ship Railway Dock, Showing the Cradle Which is Lowered down an Inclined Track into the Water to Receive a Vessel for Repairs: When the Ship is Firmly "Grounded" on the Keel Blocks and Braced Upright, the Cradle is Hauled Out by the Hoisting Gear in the Foreground



Vessel Entering the Cradle of a Railway Dock: After Settling on the Keel Blocks it will be Braced with Bilge Supports and Then Drawn Out, Cradle and All, by Means of the Inclined - Railway Apparatus



Full-Rigged Clipper Ship Safely Ashore in a Railway Dock, having been Hauled Out in the Cradle in Which it Rests: Vessels up to 4,000 Tons' Burden have been Handled Recently in This Way

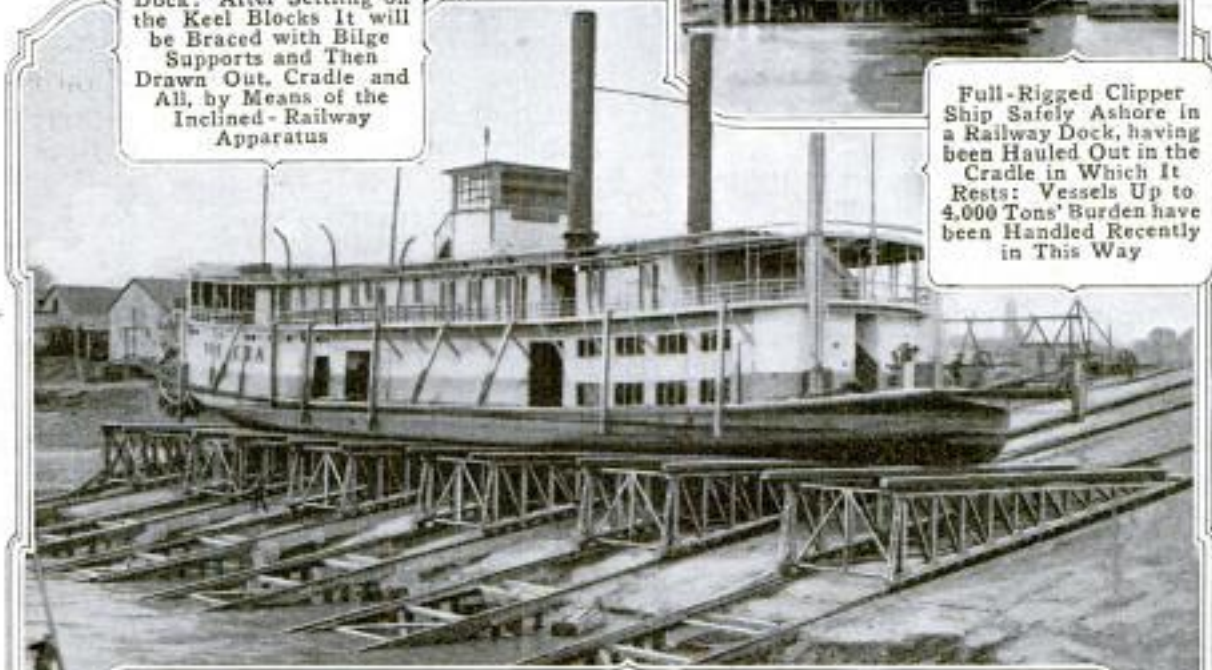

Large Stern-Wheeler Docked for Repairs, on Parallel Tracks of a Ship Railway: The Cradles are Mounted on Wheels and Pulled Simultaneously up the Inclined Tracks from the Water. Flat-Bottomed Vessels Like This are Handled More Easily than Others and Require No Bilge Supports

FIREPROOF CASE CONTAINS WHOLE ACCOUNTING OUTFIT

In one serviceable article, designed for use in offices, stores, etc., have been combined means for keeping accounts

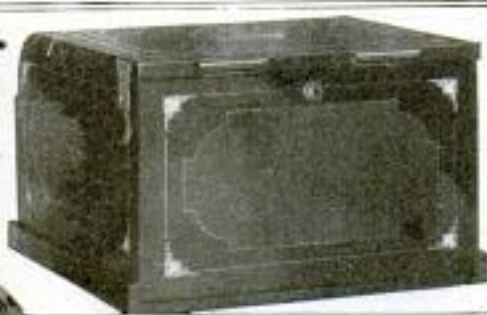

A Fireproof Case Which Is Convertible into a Desk and Contains Complete Equipment for Keeping Accounts

and recording cash transactions, a convenient writing desk, and a fireproof safe. The case in which this equipment is incorporated is made with

three-ply walls of cold-rolled steel. Between the outer and the central ply of these walls is an inch of corrugated air-cell asbestos. Inside the central ply is a 3/4-in. dead-air space, while against the inner ply is a thickness of solid asbestos. The top is hinged to the back in such a manner that on raising it, the rear drops down a few inches, permitting the cover to stand vertically and hold in full view the index which attaches to the under side of the top. In the

grooves where the hinged parts come in contact with the sides is flexible asbestos packing. The front side of the chest can be lowered to a horizontal position and used as a writing desk, or pushed back under a cash drawer and a recording device which occupy the lower part of the case. Above the drawer are numbered racks, so placed as to be accessible at all times, which are used in keeping individual accounts.

3959

NOVICES LEARN TO DRIVE AUTO IN STATIONARY CAR

An eastern automobile agency has devised a mounting for cars by means of which a novice at driving can experience most of the sensations of running his auto up and down hill, over muddy roads, etc.,—all while sitting in a motionless machine. This framework holds the wheels off the ground. In place of the rear tires are hollow iron castings about which powerful band brakes are fitted. They are controlled by a lever placed within reach of the instructor who stands beside the car. By means of cords he throws various signs into

view, one after the other. These read "Danger," "Steep Hill," "Down Hill," etc., and the teacher adjusts the brake load to correspond to the sign shown, so that the driver has to regulate his motor accordingly. Beginners learn

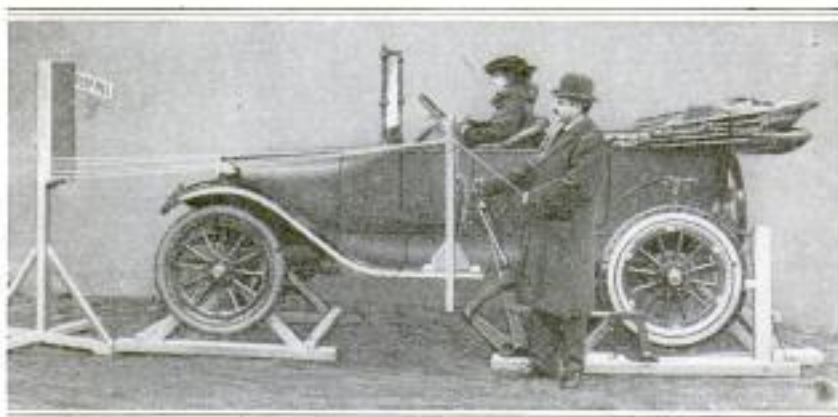

Mounting for an Automobile with Brakes about Back Wheel and Signals in Front: With This Equipment the Pupil Learns to Operate the Car without Endangering Himself or Others

very rapidly by this means, without risk to themselves or others.

Bishop, Mc Cormick & Bishop, Inc.
15 Halsey St., Brooklyn, N.Y.

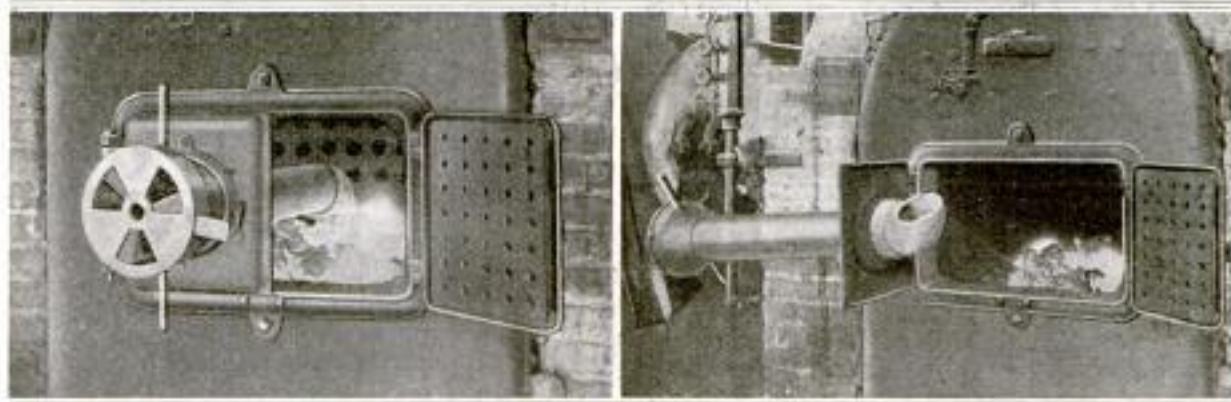

Left: In This Position the Pipe Forces Preheated Air Down into the Fuel, Greatly Increasing Combustion. Right: The Attachment Withdrawn, Showing the Simplicity of Its Construction

3988

DRAFT ATTACHMENT FOR FURNACE SAVES FUEL

More perfect combustion and a large saving in fuel, it is claimed, result from the use of a patent draft for furnaces, boilers, and stoves, which is made in Gary, Ind. The attachment is inserted through an opening in the furnace door and consists of a large pipe terminating at the inner end in a right-angle curve, while at the outer end is a shutter. The tube can be introduced any desired distance into the fire pot and can be set with the curved end pointing up or down. When in the latter position and when the shutter is open, hot air is forced down into the burning fuel. The preheated oxygen supplied in this way tends to increase combustion and force the heat toward the sides of the furnace. By pointing the tube upward the draft through the fuel is lessened, making it possible to bank the fire very effectively.

3413

Street
HAND SPRINKLER OPERATES BY COMPRESSED AIR

A new type of pressure sprinkler recently placed on the market is wheeled about by hand. It is designed to lay the dust on street pavements and to prevent the usual dust nuisance associated with hand-broom sweeping. It includes a 45-gal. water tank mounted between two large wheels, with a small horizontal compressed-air tank which furnishes sufficient pressure to throw the water 35 ft. laterally from a needle-

shower device in front of the apparatus, about eight inches above the ground. The needle shower is controlled by a lever within reach of the operator as he trundles the sprinkler along. It is claimed that there is no waste and no splash with this sprinkler, and that it is adapted for



This Hand Sprinkler Carries a Small Tank of Compressed Air behind the Water Tank and Throws a Spray Clear across a Wide Pavement

sprinkling tennis courts, lawns, public halls, and train sheds as well as pavements. A pressure gauge is mounted on the tank, and also a valve for use with the refilling hose.

Buffalo Municipal Equip. Co.,
503 Mutual Bldg. Bldg.
Buff. N. Y.

F R Shepherd,
Fellows, Calif.

704 3949 POPULAR MECHANICS

DATA ABOUT OIL WELLS SHOWN IN "PEG MODEL"

Data regarding 650 oil wells on the Pacific coast, in a region covering sev-



Map of Oil Fields with the Location of Each Well Indicated by a Tall Peg Marked with Colored Rings to Show the Depth of Various Strata. The Strings Show the Slope of the Strata

eral square miles, are made instantly available by means of a "peg model" of the oil fields, which measures 6 ft. 5 in. by 20½ ft. Various property divisions are marked on the maplike representation, and the location of wells is indicated by holes in which tall wooden pegs are inserted. The pegs are painted with rings of red, green, and black, and represent the different strata of sand, water, oil, etc., encountered in boring, and enable one to ascertain at a glance various facts about the wells. Black rings show the sea level. Connected with the pegs are numerous

strings indicating the position and slope of different strata. For example, at the west side, oil sand was found at a depth of about 250 feet, while three and a half miles to the east it was encountered at a depth of 3,250 feet.

3803 —

SUNKEN DREDGER FLOATED BY SIMILAR CRAFT

The upper waters of Oakland Harbor, Calif., were the scene of a peculiar wreck and rescue recently, when a large dredger of the clamshell type sank by the bow at its pier and was raised by means of another dredging vessel. The latter was a steam schooner which did notable work in preparing the San Francisco fair grounds, having been refitted with rotary pumps and suction apparatus. The big clamshell dredger was caught by the falling tide on three forgotten piles, which held up the starboard side of its stern while the bow sank in 20 or 30 ft. of water. Divers with difficulty sawed off the three piles under water, boarded over the holes made in the sunken hull, and covered up all other vents, ports, and hatchways; after which the refitted steam dredge was moored alongside the wreck and with a 12-in. suction pipe pumped out the submerged hold. This being done at low tide, the rising water then floated the great hull, and it was towed to a marine railway for repairs.



Left: View of Sunken Dredger, Which was Pumped Out by Another Dredging Craft, Showing the Elevated Stern under Which Divers Sawed Off Piling. Right: This Shows the Rescuing Vessel at the Scene; Also the Large Suction Pipe Running to the Wreck, and Diving Operations at the Stern

Standard dredging Co.,
Oakland, Calif.

Copyrighted material



Ice-Festooned Scene in Detroit Automobile Factory After the Firemen had Extinguished the Blaze That Partly Destroyed the Plant

4028
CARS PRESENT FANTASTIC APPEARANCE AFTER FIRE

One of the most fantastic-appearing collections of automobiles ever assembled was to be found not long ago in a Detroit factory, after the firemen had extinguished the flames that partly destroyed the building. Many cars were burned in this conflagration, but others, in various stages of completion, were thickly crusted over with the ice which formed because of the intensely cold weather. From the frames and wheels hung glistening rows of icicles that anchored the machines to the floor, while all about them hung huge festoons of ice, formed by the freezing of tons of water that flowed down from the floors above.

3745

TRAPSHOOTING GROUNDS ELECTRICALLY LIGHTED

Trapshooting at night as well as by day is enjoyed by members of a gun club in a Boston suburb which has installed a special lighting system that brilliantly illuminates the club grounds.

About 75 feet back of the traps, a narrow platform, 15 ft. high, has been erected on which are mounted eight 250-watt stereopticon lamps with powerful reflectors. The shooters find that in some instances the targets can be seen more quickly under these bright lights than in the daytime, when there are more visible objects to distract the attention.

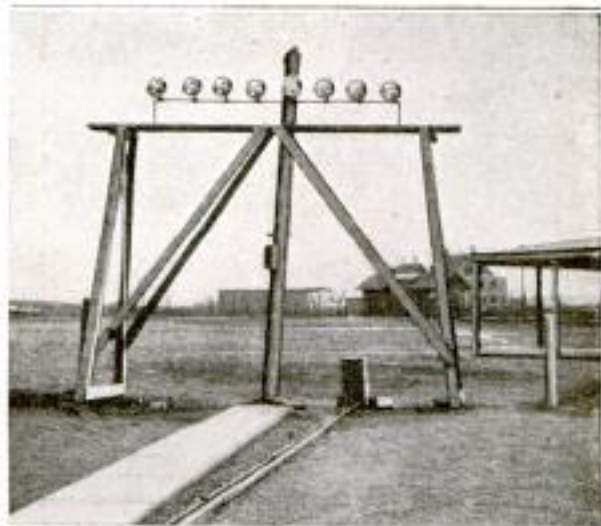

Battery of Eight Powerful Electric Lights on Grounds of a Trapshooting Club near Boston, Which Permits the Members to Enjoy Clay-Pigeon Shooting at Night as Well as in the Daytime

Malden Electric Co.
Boston, Mass.

ARTISTIC POOLS AND VISTAS IN GROUNDS



Six Short Flights of Steps Separated by Pergola-Covered Landings Lead up the Terraces and Reach the Pasadena Mansion Pictured at the Left. Near the Bottom is a Large Platform, and beneath the Rose-Entwined Crossbeams Are Semicircular Benches Where One may Rest



A Most Unusual and Effective Vista: Narrow, Sunken Pools Divide the Stepped Walk That Passes through an Avenue of Cedars to the Walled Flight of Stairs Mounting the Elevation Ahead. At the Top is an Imposing Pergola and Beyond, the Mansion

Goldfish Lend a Brilliant Note to This Small Pool in Its Tropical Setting. At Night Fish can be Removed from a Garden Pool Easily by Employing a Flash Light and a Small Net. The Light Attracts the Fish within Easy Reach



Glimpse of the Approach through a Formal Garden to a California Mansion: The Conventional Suggestion Given by the Arrangement of the Steps Extending to the Semicircular Peristyle Adds a Certain Refinement to This Charming Place. Palms, Beautiful Trees, and Well-Kept Shrubs Contribute the Finishing Touches

SURROUNDING BEAUTIFUL WESTERN HOMES

Through Heavy Gates at the Bottom of the Terrace, Broad Steps Lead to the Entrance of This Picturesque Japanese Home Set in a Sunny Spot amid Palms and Shrubbery. It is Situated in California and Never Fails to Draw Forth Pleased Expressions of Surprise from Those Who Happen upon It for the First Time



When Interest is Taken, Back Yards Become as Delightful and Inviting as Front Ones. This Shows an Illuminated Fountain at the Rear of a Western Residence, Where It is Visible Day and Night to Motorists Passing along a Near-By Highway



When One Strolls along a Path That Winds beneath Spreading Oaks and Crosses a Picturesque Bridge Arching a Babbling Brook, He is Refreshed. Visitors are Repaid in This Way for Their Walk to the Hospitable Doors of the Home Above



In a Magnificent Garden at Beverly Hills, California, One may Find This Poetic Spot. The Pool, Which is Nearly 200 Feet in Length, is Beautified with Lilies. A Concrete Wall, Two Feet High, Confines the Water, the Surface of Which is About a Foot and a Half above the Surrounding Lawn



CHECKERED DANGER SIGNS IN COLUMBUS STREETS

Checkerboard signs are being erected in Columbus, Ohio, as danger signals. Certain street intersections and



the narrow parkways in the center of wide thoroughfares have been the scenes of numerous motor accidents, and these boards, composed of black and white squares arranged alternately, have been set up as

warnings at these places. They bear no inscription except a statement that they were installed by the Columbus Automobile Club. It is believed that the checkered pattern will attract the eye readily and soon will come to be recognized by all as an emblem of danger. The city has promised to equip them with red lights. The signs measure three by six feet.

3120

NATIONAL FOREST SURVEY MADE WITH A CAMERA

Unusual methods were adopted in making a survey recently of the Columbia National Forest in the state of Washington, which comprises an area of over 1,000 square miles, mostly rough, hilly, and heavily timbered land, difficult and expensive to survey in the ordinary manner. With the aid of a photographic outfit, however, a satisfactory survey was made by one member of the Forest Service, who covered 93 square miles a month on an average during the progress of the field work. This has occupied several open seasons, the winters being spent in working up the field notes into accurate maps showing the contours and all streams in the forest. The surveyor was accompanied by one assistant and packer, and traveled on horseback, with two pack animals. Observations and photographs were made from

definite "stations" when the weather permitted, about 15 such stations being occupied each month. Four exposures were usually made with the camera at each station, each plate developed taking in the view within an angle of 65°. Each photograph was marked on its margin with a horizon line by which elevations and depressions were subsequently measured for map making, and it was found that the contours drawn by this method were surprisingly correct, usually coming within 50 feet or so of actual elevations. About 50 square miles were mapped each month when field work was impossible, the scale used being 1 in. to the mile. The total cost for field and office work was approximately \$4.60 a square mile, which is regarded as low, compared with the cost of ordinary surveys.

FOOT LEVER OPERATES MACHINIST'S VISE 3217

A new type of vise, which is operated entirely with foot power, can be employed to advantage in machine



shops, and elsewhere, because it allows the mechanic the free use of both hands, and can be locked or unlocked quickly. Extending downward to the floor from the bench to which the vise is attached is a shaft, from near the lower end of which project two pedals, one

to the right and the other to the left. The upper end of the shaft terminates in a cam. When the left pedal is pressed with the left foot this cam revolves and causes the movable jaw of the vise to be drawn up tightly and locked. Pressure with the right foot on the right pedal instantly releases the jaw.

Fisher & Norris

Trenton, N. J.

Coast & Geodetic Survey,
Mr. G. S. ... Wash. D. C.

CLAY FIGURES USED FOR MOVING PICTURES



Motion Photographs of Sculptress Modeling Her "Clayfolk"

In a new style of moving pictures little clay models of human figures are used to represent the actors. The result, when seen on the screen, is both startling and amusing, the tiny clay figures seeming to walk, jump, and go through all the motions of talking and singing as if actually alive. Such pictures are called animated sculpture. They owe their origin to a woman sculptor of New York, whose clayfolk, as she calls them, are photographed in a succession of slightly different poses, each specially modeled to carry out the action of a regular scenario or film story. The process of molding the figures is slow and laborious, as 16 different poses are required to make a foot of film. Thus if the action of the story calls for four actors in the picture, a film of ordinary length, say 200 ft., requires the careful molding by the sculptor's hands of at least 12,800 different poses for the clay figures. In some scenes, however, only slight changes are needed to give the necessary animation, these being quickly made by the deft touch of the sculptor while the camera man waits to photograph them.



Strip of Film Showing Clay Figures Acting for the Movies

3924 Division

ALL GARAGES FACE ON ONE ARTISTIC DRIVEWAY

For the purpose of selling quickly property in a certain block in a new subdivision near Portland, Ore., a real-

estate agency offered to give a low-priced automobile to each purchaser of one of these homes. For this reason every house is provided with a garage, and in planning approaches to these outbuildings special care was taken



All Houses in This Block Have Garages Facing on a Common Artistic Driveway, Thus Avoiding the Necessity of Private Entrances. Right: Paved Driveway on Which All Garages in the Block Face

to have no driveways passing through the front yards. The houses are arranged in two rows, standing back to back, with the garages abutting on a common paved thoroughfare that runs down through the center of the block. Each of the structures is designed along individual and artistic lines, and about midway between the ends of the square is an oval flower bed. By these means the real-estate firm succeeded unusually well in avoiding all suggestion of an ordinary alley. The plans also include formal gardens facing on the drive.

3829 _____
**CONDUCT LANGUAGE CLASSES
 IN DEPARTMENT STORE**

*Mangled
 in wa.*

Courses of instruction in several foreign languages are being given in one of Chicago's large department stores. No tuition is charged, the classes are conducted by experienced instructors, and some 400 pupils are enrolled. The undertaking, an ingenious, unusual sales scheme, is being tried out for the first time. It is promoted by an eastern concern that exploits a phonograph system of language study. Instruction in French, German, Spanish, or Italian is offered to any person who is sufficiently interested to matriculate and attend the classes, each of which is limited to 30 members and meets once a week in a lecture room provided in the department store. A course of instruction consists of 20 lessons and is

carried out by the conversational method. By attending the classes a pupil does not obligate himself to purchase the phonograph records, but obviously the purpose of the plan is to interest him so thoroughly that he will want to acquire them for further home study.

3687 _____

**FRENCH CAPTURE GERMANS'
 GIANT PERISCOPE**

One of the most interesting of the devices which have been produced during the war to amplify the range of human vision, is the giant periscope shown here, which the French captured from the Germans. With this equipment an observer need not seek out some tall tree or high tower from which to spy on the enemy, for this collapsible steel mast can be reared at any desired point in a very few minutes. At its upper end are a conical tube and lenses by which horizontal light rays are deflected downward to the observer stationed below. The apparatus is strongly built and the carriage is so made as to form a wide-spreading base. Supported by the carriage alone the mast can be raised to a height of 50 ft. When it is extended to its full length, which is 80 ft., guy ropes are required to steady it. For detailed observation of distant points, particularly in a rolling or mountainous region, such an instrument is of great value.



A Powerful Land Periscope, Captured by the French from the Germans, Which can be Reared to a Height of 80 Feet. It is Shown Extended at the Right, and at the Left Collapsed, in Which Position It Closely Resembles an Ordinary Field Gun

*London Electric Cycle Agency, Ltd.,
 10, St. Brice's Av., Fleet St., London.*

Territorial
Military

3992
Capt. G. W. Russell, 1st Aero Squad.

LOST BY MAP AND COMPASS

Columbus
N. M.

THE following article, written by a man actively engaged in aviation, casts an interesting side-light on the perils of the airman's calling. It will be recalled that the two men referred to in the introduction are Lieut. Col. Harry G. Bishop and Lieut. W. A. Robertson, U. S. A. These airmen made a flight from San Diego on January 10th, broke a propeller, and alighted to find themselves lost in Mexico. Robertson was discovered by a civilian searching party on January 18th and directed the rescuers to Bishop, who, unable to travel, was 30 miles farther inland. Both men suffered from lack of food and from exposure. Two oranges and two sandwiches each, and water from the radiator of the machine, had been all the food and drink they had had since the date of their flight.—Editor.

A SHORT time ago two army airmen left the aviation school at San Diego to make a cross-country flight into the Imperial Valley. An automobile map of the country was the best that could be obtained. The aeroplane was equipped with a compass which later proved to be faulty. They lost their bearings and finally landed on the east shore of the Gulf of California, which they had mistaken for the Salton Sea. The machine was damaged in landing and the airmen undertook to walk to a town near the Mexican border which they thought to be about 25 miles distant. They walked for more than a week, and were exhausted from lack of food and water when they were at last rescued.

No doubt a great many people are wondering how it is possible to become lost so easily in an aeroplane equipped with map and compass. A statement of some of the difficulties encountered in flying cross country, especially over mountainous and desert country, will, perhaps, clear up the matter a bit.

First to be considered in flying over strange country is the accuracy of the map. The maps of the mountainous and desert regions of southwestern United States and northern Mexico are sadly inaccurate. The landmarks are not at all shown in their true relations to each other, a lake is not mapped in its true shape, cañons and rivers are not shown taking their true directions. Any one of these discrepancies is suffi-



"The landmarks are not at all shown in their true relations to each other, a lake is not mapped in its true shape, cañons and rivers are not shown taking their true directions. Any one of these discrepancies is sufficient to lead the pilot astray."

cient to lead the pilot astray. Now, in addition to an inaccurate map, suppose the weather is cloudy, and the flier catches only glimpses of the landscape; it is then practically impossible for the pilot to find his way over strange country. Not enough of the earth can be seen to enable him to use his map intelligently, even though it should be an accurate one. It is under this condition that the pilot has to rely on his compass.

The compass in an aeroplane is very often a treacherous instrument and not to be trusted too far. In mounting a compass in an aeroplane a great many conditions are met with which are not found on board a ship, and it is next to impossible to mount a compass in an aeroplane so that it will give the true directions. Many corrections have to be applied. The close proximity of the motor has to be considered, for the various directions in which the machine may be pointed each has a correction, and a variance of from 30 to 40° may be noted when the motor is running and when it is not. After a compass is once installed in a machine any small change in the metal parts of it will affect the reading of the compass, and scarcely a day passes but there is some such change being made. And again any magnetic substance that the pilot may carry in his pocket will cause the needle to deviate. In short, the reading of a compass mounted in an aeroplane is never accurate, and to what extent it is inaccurate is unknown to the pilot. However, the compass

will give a general direction and serves as a check on the map. To follow the compass blindly is a hazardous undertaking, for it may be several degrees off and there is no knowing how fast a cross wind may be drifting the machine. The airman can tell in a general way the direction in which he is being carried by a cross wind, but he has no way of knowing how fast. A 30-mile cross wind—moderate for the upper atmosphere—will carry the machine many miles off the course in a short time. As an example, an army aviator, flying from Los Angeles to San Diego over the clouds, had to fly by compass, and, consulting his map, laid a proper course and followed it by compass. A strong cross wind blew him off his course and many miles out to sea. A rift in the clouds disclosed to him his plight, and what he had taken for mountain tops was, in reality, the Santa Barbara Islands. He reached the mainland only a few minutes before his supply of gasoline was exhausted.

The two airmen who were lost in Mexico are both experts in the use of maps—it is a part of their profession—the pilot is an experienced flier, but an inaccurate map, a faulty compass, clouds, and a strong wind, each was a sufficient reason for causing them to lose their way.

Thus it is seen that a cross-country flight over strange and inaccurately mapped country is a hazardous undertaking, fraught with many dangers, and comparable with putting to sea without charts or compass.

4045

MANY SPECIAL USES FOR SPONGE RUBBER

India Rubber World 3/1/17
A product which is now attracting the attention of many manufacturers, because of the special uses to which it can be put, is sponge rubber. On account of its cellular structure it is very light and at the same time is water-tight and nearly gas-tight. These properties tend to make it an ideal substance for life preservers, for it will not waterlog and it can easily

be made to conform to any shape. Of course punctures do not affect it, and for this reason it has been seriously proposed as a filler for automobile tires. Almost endless experimenting has shown that, after all, air serves as the best cushion for tires. Sponge rubber supplies the air cushion, and at the same time is said to "stand up" under long usage. Having great insulating properties it can be used also in sound-proofing, in clothing for airmen, and so on.

Cyril Massing,
Marlboro, N.J.

Paul Serkum

look up

3452

3786

**CART FOR CORNSTALKS CAN
LOAD ITSELF**

**AGENT FOR MOTORCYCLES
CARRIES SAMPLE IN CAR**

By the invention of a New Jersey farmer the problem of removing bunches of cornstalks from the field to the barn has been made comparatively easy. A new two-wheeled cart with special mechanical features does the trick, so that one man with a team can cart in an average field of fodder in one day. The cart consists of a low frame with a small winch attached to its under side. It works by backing the team up to a bunch of stalks, where the frame is tilted back against the bunch by means of the tongue, which is hinged; then wrapping a rope, or small chain, around the stalks, and tightening it with the winch. The team is then started and the frame with the bunch of stalks falls forward into the normal position of a cart for the trip to the barn, locking automatically when horizontal. In unloading, the stalks are placed upright, as in

It seems a little strange to find a sales manager for a motorcycle concern visiting his agencies in a big touring



A Sales Manager for a Motorcycle Concern and the Touring Car Which He Uses to Carry His Sample Machine from Place to Place

car and carrying one of the machines that he sells on the running board, but a certain Pacific coast sales manager has learned that this is by far the most satisfactory arrangement. For long journeys motoring is more comfortable than motorcycling and permits one to carry more luggage, and a companion if desired. The manager finds that he becomes less travel-stained and so is ready to talk business on short notice. His motorcycle can be detached from the running board in an instant when he wants to make a demonstration. The arrangement also enables him to keep his sample machine looking as good as new.



New Cart That Loads Itself with Cornstalks in the Field, as Shown Here, and Unloads Them Upright in the Barn

the field, by unlocking the frame and backing the team as before, after which the rope is removed and the cart returns for another bunch.



Removing a Big Bunch of Stalks from the Field by Means of the Self-Loading Cart

Arthur James, Director Publicity,
Metro Picture Corp'n, 1476 Broadway
N.Y.C.

714 3895 POPULAR MECHANICS

MACHINE TAKES DICTATION FOR CUTTING MOVIE FILMS

A visitor to the studio of a well-known motion-picture concern, if he



Motion-Picture Director Viewing a New Film and Dictating into a Dictaphone Instructions as to How It should be Cut or Altered

calls at the proper time, will find the director talking into a dictaphone while he critically views new pictures that are being projected on the screen for the first time. This innovation has been introduced to save time and avoid errors in cutting films. As is well



Cutting and Assembling Room, Showing the Film Cutter Following the Director's Orders, Which are being Reproduced from a Dictaphone Record

known, after a picture has been taken it is often necessary to cut out certain parts of the film. Proper captions must be inserted also. In the studio in question, instructions relating to these matters formerly were given to a "cutter" who sat beside the director and wrote them down while the film was being shown. This arrangement often resulted in error and in a waste of the cutter's time. Now the phonographic record, bearing full instructions, is sent to the cutting and assembling room with the film. With the dictaphone receivers to his ears the cutter is able to spend practically all his time following instructions and wastes none taking dictation.

TIE WIRES INJURE EFFECT OF WALL INSULATION

While attempting to insulate thoroughly the concrete walls of a cold-storage warehouse that was being erected in a western city, the high conductivity of steel was lost sight of, to the subsequent detriment of the building. A thickness of cork was inserted in the walls, but unfortunately short lengths of steel wire were passed through it and imbedded in the concrete on either side. This mistake in a certain degree defeated the purpose of the insulation, for the innocent-looking tying wires now serve most excellently to conduct heat and cold through the barrier of cork. As a result moisture spots the inner surface of the walls around the scores of places where the wires are anchored.

HANDSOME FISH HATCHERY HIGH IN WESTERN RANGE

High up on the eastern slope of the Sierra Nevada Mountains, near Independence, Calif., and the home of the golden trout, the State of California has erected the first unit of what will be one of the largest fish hatcheries in the world. It stands at an elevation of 4,300 ft. in the shadow of peaks two and one-half miles high. The structure

Mr. ...
Chicago
...
...
...

cost \$75,000, and is of special interest because of the completeness of its equipment and the taste displayed in its design. It is 200 ft. long, and at one end is a square tower which rises 85 ft. The style of architecture is suggestive of the Scandinavian. The walls, in some places 3 ft. thick, are of rubble work, reinforced with steel, and contain approximately 3,500 tons of bowlders, all picked up within a quarter of a mile of the site. Not a single stone in the outer surface of the walls, including arches and steps, has been cut or even broken, but each presents the finish given it by nature.

The hatchery proper is a room 45 by 155 ft., with snow-white walls, and is equipped with the most modern scientific apparatus. The superintendent's office and suite, and a handsome guest room, occupy part of the tower, while at the opposite end of the building are living and dining rooms, bedrooms, laundry, kitchen, etc., for the employes. For domestic use and fire protection water is supplied from a higher elevation, while the water for the hatchery is taken from a near-by stream and enters the building through a 12-in. pipe. The institution has been named the Mt. Whitney Hatchery, as that great peak is not many miles distant. Because of its location, it will be able to obtain and propagate some of the finest mountain fish. Its supply of rainbow-trout eggs will be brought on pack horses from lakes 20 miles back in the mountains. It will help stock all the lakes and streams in California, south of the Yosemite National Park.

**OLD-TIME HAY STACKERS
SEEN IN MONTANA**

One of the interesting sights that meet the eye of the traveler in Montana is illustrated by the photograph of an old-fashioned hay stacker, taken west of Billings, where many of these antiquated aids to the prairie farmer are still to be found. The picture plainly shows the simplicity of the old method, which was efficient enough in its day, but strikes the observer as odd in the light of modern inventions and agricultural progress. It consists of a wooden framework with a high revolving pulley for hoisting.



The Dam in a Near-By Stream Which Supplies Water for the Main Hatchery



The Main Entrance, Showing How Even the Arches and Steps were Built of Bowlders

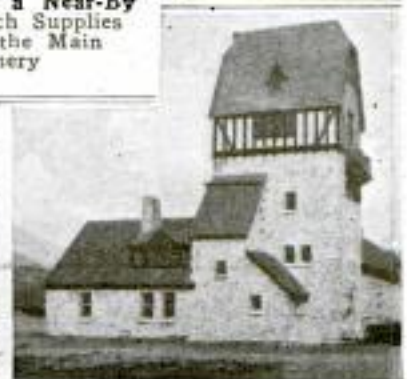

New Fish Hatchery near Independence, California, Which Cost \$75,000. Right: The Handsome Square Tower, 85 Feet High, Which Is Suggestive of Scandinavian Architecture

FLOOD-LIGHT SKYSCRAPER FROM ACROSS STREET

A variation of the ordinary flood-lighting methods, used in many cities to illuminate the outside of tall buildings, is to be found in Baltimore, where an electric-light company has stationed batteries of lamps across the street from the structure illuminated. The skyscraper made conspicuous by this means is 20 stories high, and is the new home of the lighting concern. When the city authorities recently placed a heavy tax on electric signs because they extend over public thoroughfares and shut out daylight, the corporation adopted this alternative means of advertising its business. Powerful batteries of lamps are stationed on the roofs of low buildings opposite the edifice, and it can now be seen at night a long distance.



Twenty-Story Building in Baltimore Flood-Lighted by Batteries of Lamps Located on the Roofs of Buildings across the Street. Insert Shows Batteries of Electric Lamps and Reflectors Installed on the Roof of a Low Building on the Opposite Side of the Street from the Skyscraper

BOILER BLOWN TWO BLOCKS AWAY BY EXPLOSION

When the 48-in. boiler in an old mill building in Davenport, Iowa, exploded early one morning recently, the entire boiler was blown through the roof of the building to a great height, and brought up against the porch of a residence two blocks away. After describing an aerial arc, estimated at half a mile in length, it first landed on a concrete sidewalk,

leaving a 4-in. depression with the imprint of its flues, and then bounced across the street to the yard in which it was found. The boiler weighed about 3,000 pounds. Pieces of iron, brick, stone, and wood littered the neighborhood after the explosion, but no one was killed or injured. The engineer and fireman noticed signs of danger and so were able to escape in time.

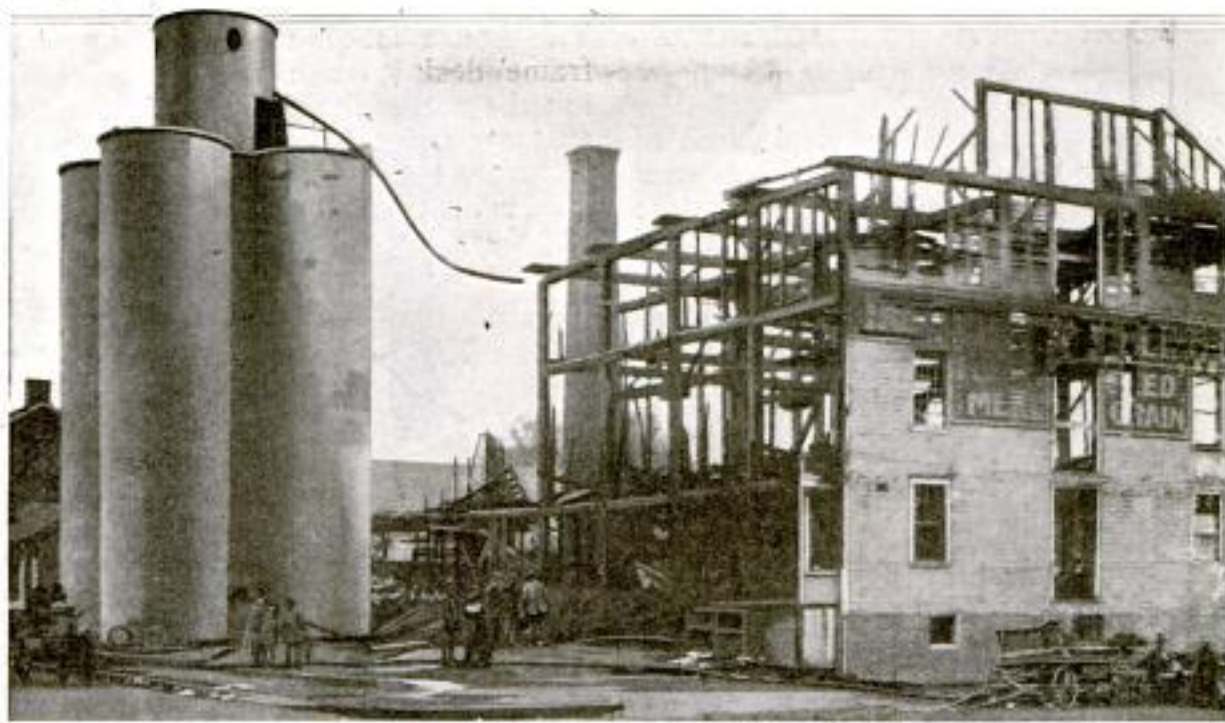

When the Old Frame Mill Burned, the Concrete Tanks were Enveloped in Flames for More than an Hour. Wheat Stored in Them, However, was Not Injured

BATTERY OF GRAIN TANKS RESISTS GREAT HEAT

In a really striking way, the destruction of a frame building at Coshocton, Ohio, recently demonstrated the fire and heat-resisting qualities of heavy concrete construction. A nest of five grain-storage tanks was erected a couple of years ago against one side of a flour mill. When the latter structure was demolished by fire not long ago, the concrete bins were enveloped in flames for more than an hour. The tank closest to the building was subjected to the most intense heat. It passed through the ordeal uninjured, however, and the wheat contained within it was found to be in good condition when removed the following day.

— 1539

WHITE QUARTZITE MASS IN RED-SANDSTONE ARROYO

In an arroyo in northeastern New Mexico is a huge mass of quartzite which is of interest both because it contrasts strikingly with the red sandstone which surrounds it on all sides and because of its unusual shape. The

natural monument, if such it can be called, rises almost to the level of the arroyo's rim. The white mass is irregularly hollow and scattered through it here and there appears a very dark mineral, chalcocite, slightly oxidized. It is supposed that volcanic activity produced the quartzite from near-by sandstone in ages past, before the arroyo had been formed, and then the softer rock was worn away, while this white, crystalline formation was left standing.



Unusual White Quartzite Formation Standing in the Midst of a Red-Sandstone Arroyo in Northeastern New Mexico

Day Esmerion Valley
N.M.

J. Q. Adams
818 Marquette Bldg.
Chicago

718 3847 POPULAR MECHANICS

**HOUSE WITH DOUBLE ROOF
TO RESIST HEAT**

By adopting some tropical ideas of house building, a Florida landowner has constructed on the banks of the



A Javanese Style of Architecture Introduced in Florida: Note the Double Roof and Large Screened Porches on Three Sides

Miami River a dwelling that promises the maximum of comfort in summer.

The house is of a simple two-story frame design, with low-pitched roof, but the roof is double, with a considerable air space between, which serves to protect the upper story from the direct heat of the sun. There are also wide two-story screened porches around the house on three sides, so as to get all the benefit of the northeast trade wind which prevails during the summer. The porches are all under the double roof, which has overhanging eaves. This style of construction is common in Java and Ceylon, and is also found in the Panama Canal Zone, but the house on the Miami is believed to be the first of its kind in the United States, as well as the first in Florida.

2937

**CRANK-OPERATED SWITCH
PREVENTS ACCIDENTS**

The special advantages of an inclosed switch, put on the market not long since by an electrical-equipment manufacturer, are that it promotes safety and affords protection against theft of current. This switch is operated by a crank handle that projects through the side of the metal box and connects with the crossbar that unites the various contact blades. An outward bulge in the door provides ample room for the swing up or down of the movable parts when the crank handle is turned. If deemed desirable the door can be locked and, while the switch can be turned on or

off at any time, the danger of receiving a shock is eliminated and at the same time the dishonest practice, sometimes followed, of wiring around an adjoining meter, is effectually guarded

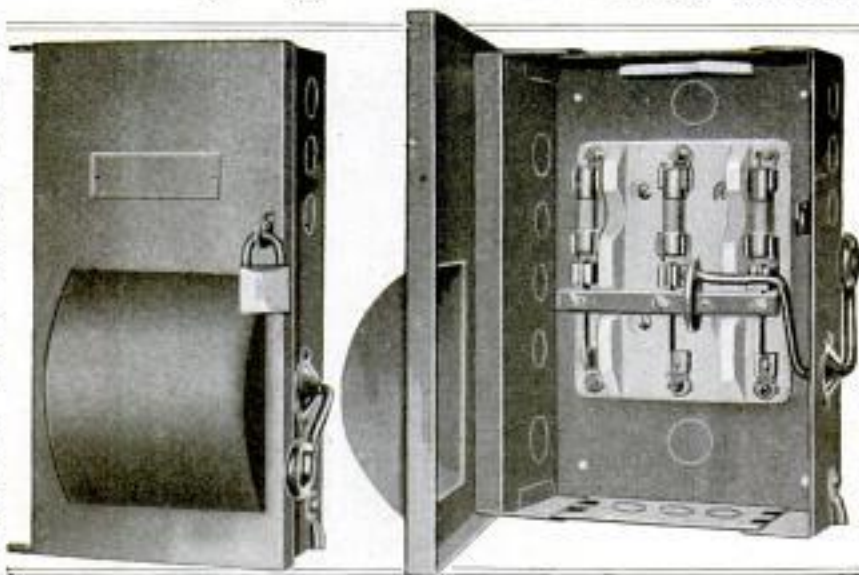

New Type of Electrical Switch Provided with a Crank Handle by Which Connection can be Made or Broken When Door is Locked, Thus Avoiding a Cause of Frequent Accident and Preventing Tampering with the Wires

against. This type of switch is made in a number of sizes.

Western Electric Co.

Herbert C. Wither
 323 N Curtis Av.
 Alhambra, Calif.
 3861 POPULAR MECHANICS

PRIMITIVE SMITHS' SHOP HAS CRUDE BELLOWS



African Smiths and Their "Workshop": The Two Men at the Rear are Holding the Slender Handles of the Crude Bellows. Stones are Used for Anvils

The American village blacksmith has his counterpart not only in all parts of the civilized world but even among primitive peoples, as the accompanying illustration taken in Angola, in central west Africa, indicates. This crude shop is merely a spot out in the open at which is assembled a collection of the simplest tools. The most intricate device employed is the bellows, the air pipe for which is made of burnt

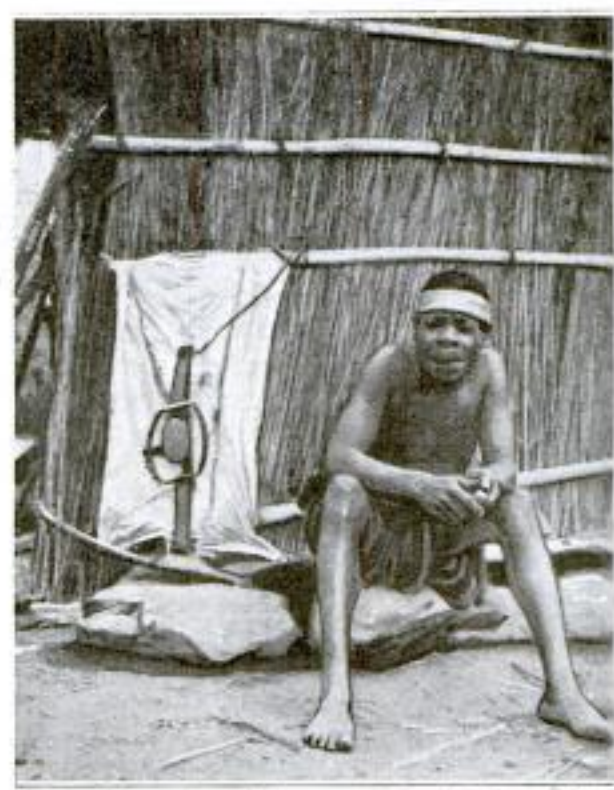

Smith in Angola, Africa, and Animal Trap Which He Copied from an American-Made Article. Using Machetes in Making the Springs

clay and terminates close to the fireplace. A stone holds it in place and at its opposite end are four small air chambers covered with deer or goat skins. Each skin is provided with a slender handle which a blower moves up and down rapidly, producing a rather weak but steady draft, for a comparatively large amount of work. That these smiths often do surprisingly good work is shown by implements they make, such as

hoes, hatchets, knives, etc. Occasionally the men get ideas from the outfits of Europeans and Americans in the region. One primitive metal worker copied an American-made animal trap with success, making the pan from an old hoe and the springs from machetes. With his prized device he has caught considerable game.

1722

MUNICIPAL COFFINS USED REPEATEDLY IN MEXICO

In Mexico many of the poor rent, instead of buy, coffins, and for those who are not even able to pay rental, the municipal authorities supply a cas-



Mexican Peon Carrying a Body to a Cemetery in a Municipal Coffin, Which is Used Repeatedly for Such Services

ket which is used again and again for such purposes. These publicly owned coffins are merely roughly made boxes with handles at either end. The primitive manner in which one is carried to the cemetery, with its freighting of mortal remains, presents a sharp contrast to the hearse and conveyances that make up a funeral procession in this country. A common practice is for a sturdy, and generally very ragged, peon to carry the burden strapped to his back. On arriving at the burial ground the body is rolled in straw and deposited in a grave, whereupon the wooden box is carried back to the city and held in readiness for the next occasion.

4041

BIG INCREASE IN POTASH OUTPUT

The value of the production of potash salts and potash products in this country in 1916 was 10 times that of the reported production in 1915, according to the United States Geological Survey. Last year the output represented about 10,000 tons of potash, with a net value at the shipping point of at least \$3,500,000, figured at prevailing prices. It is predicted that the production for the present year will far exceed the mark already set, for many of the firms reporting in 1916 were only in operation during the closing months of that year. The potash obtained from organic sources is about half that from mineral sources. It is interesting to note that 1,110 tons were produced from kelp, which in recent years has been the subject of much investigation because of the considerable amount of potash that can be obtained from it. The largest output has come from the Nebraska alkali lakes. One of these Nebraska plants was described in Popular Mechanics Magazine a few months ago.

With the aid of motor trucks the picturesque circus caravan is to be revived. A circus has announced that this summer it will tour the country in motor cars.

2653

A PUBLIC PLAYGROUND IN THE HILLS

By ALBERT MARPLE

322 Boynton St., Tropic, Calif.

PUBLIC playgrounds are common—every enterprising city of any importance has them—but the playground camp, located far away in the hills where the clang of the street car and the nerve-racking hustle of business are not known, is new, at least so far as its general use is concerned. Such a camp is now being conducted by the city of Los Angeles. It is strictly a municipal affair, being conducted for the people by the people, the aim being to make it possible for residents of that city, who would otherwise

be kept at home, to secure a short stay in the hills at a moderate cost. Although this municipal camp has been in progress for more than five years—this being the sixth summer—it is the only one of its kind in the world, so far as is known. It has passed the experimental stage and is now a regular department of the city's "work."

Shortly before this camp was started, one of the boosters of the Angel City conceived the idea of a "city-conducted



One of the Big Motor Stages, Loading Up at San Bernardino with Residents of Los Angeles Bound for the Vacation Camp Maintained by Their City at Seeley's Flats in the Mountains

home in the hills." He took the proposition to the city council and they thought the idea a good one; so good, in fact, that they gave a small handful of money for a sort of try-out. This experiment was in the form of a camp at Balboa Beach, about 40 miles from the city, and so well was that camp patronized that it was decided to con-



The "Bread Line" at Camp Los Angeles: Campers at the City's Public Playground in the Hills Lining Up at Mealtime with Appetites Sharpened by the Mountain Air and the Invigorating Life of a Real Holiday Enjoyed at Small Cost

tinue the experiment over another year. One thing was learned at the first encampment, however, and that was that the great cry was for the hills rather than the seashore, so the following year, San Gabriel, 40 miles from the city, in the mountains, was selected, and for two years camp was conducted at this point. This, however, was not "the" place, so the following year, after an extensive hunt, a 23-acre piece of government land in the heart of the San Bernardino Mountains, known as Seeley's Flats, was chosen, the government giving the city a 99-year lease for \$10 per year. No more attractive spot could have been chosen for the purpose. The trees and the foliage are soul-thrilling, not to mention the wonderful trout stream which cuts the valley in two.

For three years Seeley's Flats has been the scene of Camp Los Angeles, and so well is it liked that a permanent outing place is being established. The tents which were used the first year have been replaced by modern mountain cabins and every feature which might be considered temporary is rapidly being discarded.

The outing at the camp is remarkable in itself, but the most astonishing thing about these trips is their price to the citizens. For a two-weeks' stay at camp a charge of \$7.50 is made, while for the single week \$5.50 is charged, these prices including "feed," transportation, baggage—everything. The camp is located about 85 miles

from the city. Sixty-five miles of this distance is made by electric car, this being from Los Angeles along the foot of the most beautiful of foothills to San Bernardino, at which place a change is made from the electric cars to immense motor stages. Then the climb up the mountain side is begun. For mile after mile the stages creep along the mountains, ascending to an

altitude of something like 6,000 feet in a distance of 20 miles, with the scenery unsurpassed and the mountain air healthful and bracing. At the camp the campers get "three squares" every day, served in cafeteria style in the immense dining room overlooking the beautiful stream and covered by immense pines. One thing is required of the camper every day and that is one hour's work, this being spent in helping to keep the camp clean, or in the kitchen. A trip of this kind to the

average camp—and everything at this camp is up to the standard—would cost between \$30 and \$35 for the two-weeks' outing.

Each of the camp cabins is equipped with sanitary beds, table, chairs, etc. They are grouped a satisfactory distance apart around the main lodge, which is a large rustic affair. This contains a large living room with mammoth fireplace, where the "residents" assemble in the evening for good times; the library, the office, etc. Close at hand, and completely surrounded by trees, is the 50 by 100-ft. new concrete-



A Pool below Heart Rock, in "the Wonderful Trout Stream That Cuts the Valley in Two," near Camp Los Angeles, Where a Permanent Vacation Playground is being Established amid Healthful and Beautiful Surroundings



Finished Cabins of the Genuine Mountain Type, Built by the City of Los Angeles at Its Hill Playground, 85 Miles Away, for the Benefit and Enjoyment of Citizens of Moderate Means. Everything Furnished Is of the Best, but It Costs Only \$7.50 for a Two-Weeks' Vacation Here



Approach to Camp Los Angeles Is over a Mountain Trail from San Bernardino, and Usually Made by Motor Stage, but Campers Have Plenty of Riding Exercise on the Burros Here Seen in a Corner of the Camp Corral



Scene on the Mountain Road to the Camp: Bordered with Pines, the Road Climbs up the Mountain Side for 20 Miles to an Altitude of 6,000 Feet, with Scenery of Surpassing Grandeur



Swimming Tank at Camp Los Angeles, Where the Water Is Always Cool and Refreshing: Far above Sea Level and Many Miles Away from "the Clang of the Street Car and the Nerve-Racking Hustle of Business," the Pool Is Always Popular, Especially When the Girls Are in Camp, as in This Picture, Making Every Minute of the Brief Vacation Count in Building Them Up for the Year's Work

lined swimming pool, the baseball diamond, the croquet and tennis courts, the exercising ground, etc. In order that the handling of the crowds might be facilitated, the campers are taken up in groups. For instance, there are two camping groups of boys, two groups of girls, and four family groups, the stay of each of these parties being of two weeks' duration. Each camper furnishes his own bedding and towels, the laundry being done at the camp. During the past year the camp has been provided with many conveniences, including new sanitary wash basins, flush toilets, porcelain bathtubs, shower baths, stationary washtubs, and so forth.

The question which is generally asked in connection with these trips is "How can the city give so much for the money?" The answer is, that the money that each camper pays goes to defray the actual cost of taking him to and from the camp and for the food he eats. The city, out of its public playground fund, which is appropriated

yearly for this purpose, has leased the ground and established the camp, this including the buildings and attractions and the construction of the same. This expense comes out of the general income of the city, and is therefore paid for by the entire city. Something like \$7,500 has already been spent on this camp. The cost of the paid help in camp is also met by the playground fund, as is the cartage of necessities to camp, etc. So it will be seen that each camper simply pays for what he actually gets, and nothing more.

Nothing that has ever been started by the city of Los Angeles has grown so rapidly as has this playground-camp undertaking. From a mere handful of campers six years ago, the number has grown to a thousand, with prospects of three or four times that number in a year or two. It has been found that the "entrance fee" to camp, although ridiculously small, has been sufficient to keep the camp free from undesirables, who would doubtless have flocked there, were the excursions free.

look up
3791 FARMHOUSE WRECKED BY GAS EXPLOSION

As the household and guests of a farmer living near Elkhorn, Ia., were

basement, where an acetylene lighting plant was unfortunately situated.



This Farmhouse Wreck was Caused by an Explosion of Leaking Gas from an Acetylene Plant in the Basement, Three Persons being Killed

seated at table recently, celebrating a family reunion, the house was completely wrecked by an explosion in the

Three persons were killed and ten injured. A leakage of gas had been observed and a repair man had been summoned from a neighboring town to inspect the gas generator. The explosion occurred as this man opened the basement door, his dead body being found near by. It was believed that the accumulation of leaking gas was ignited from the kitchen fire, when the open door permitted its escape.

The explosion furnished an additional argument for the location of such plants outside residence buildings.

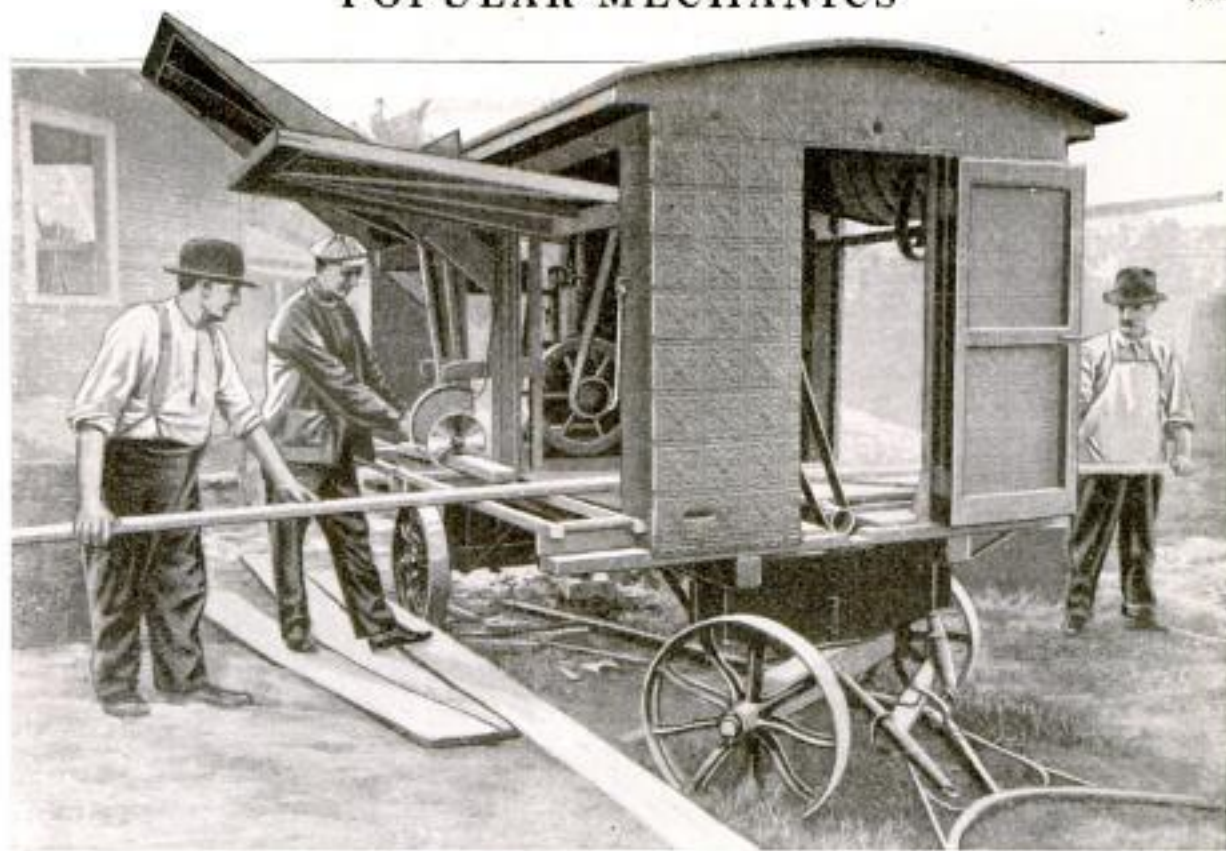

Workshop Mounted on Wheels and Containing a Two-Horsepower Engine, Rip saw, Sandpaper Drum, Planer, and Other Equipment Usually Found in a Carpenter Shop

PORTABLE CARPENTER SHOP SAVES BUILDER'S TIME

A carpenter shop on wheels, constructed by a Brookfield, Mo., contractor, enables its owner to save much time, because it can be used right at the scene of his building operations. The structure is mounted on a low running gear and is provided with a 2-hp. gasoline engine, a rip saw, an 18-in. sandpaper drum, a planer, groover, etc. Sections of the sides are hinged so that they can be drawn out and upward and made to serve as awnings. The shelter can be securely locked and furnishes ample protection against the weather.

MINNOW NET FREES ITSELF IF SNAGGED

Fishermen who use minnows as bait can now obtain a minnow net with several new features, among which is a device to free the net easily in case of snagging. It is a folding drop net of the basket type, with a frame made of six spring-steel rods. When the

net is snagged, or under extraordinary strain, the rods bend inward and downward until all but one of the rings by which the net is attached slip out of open hooks at the rod ends, the frame collapses, and the net is freed. A pocket for bait to attract the minnows is at the bottom of the net, and the little fish when netted can be removed without handling.



This New Minnow Net Is Strong, as This Picture Shows, and Collapses When Snagged, So That It can be Readily Freed from the Obstruction

J. F. Brown,
Brookfield, Mo.

Henry J. Dougherty, Box 274, Providence
R.I. U.S.A.

726

3277

POPULAR MECHANICS

**MAKING AND CURING TIRES
BY A NEW PROCESS**

Automobile tire casings are made in one continuous mechanical process by

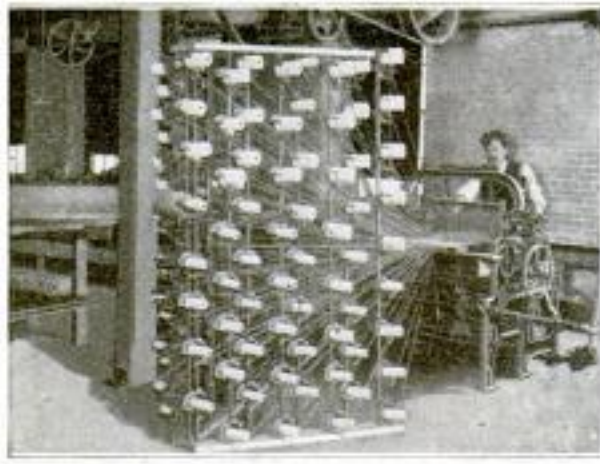

This Loom Weaves the Fabric for a Tire Casing, Making It the Exact Shape and Width Required

a method of recent invention, which includes the weaving of the fabric that forms the base of the tire, impregnating it with rubber in a special friction calender, forming it to the required shape, and vulcanizing. This method, employed in a Rhode Island factory, is said to be the only one that makes the loom and the calender parts of a continuous process. The first operation is to weave the fabric in strips, the desired width and shape for the casing. The strip is next passed through the calender and impregnated with rubber; the wires, or rubberized cords, to form the beads are laid in

place, and the edges of the strips are folded up over the beading of each ply separately, giving each layer of fabric its own individual lock. This operation of frictioning and making the carcass of the tire takes only five minutes for a six-ply casing. The cushion, breaker, and outside rubber-tread stock being then put on, the casing is ready for vulcanizing in a hot mold, which takes from 10 to 15 minutes, according to size. The time required for the whole process is about 30 minutes.

3976

**MOST POWERFUL TELESCOPE
SOUTH OF THE EQUATOR**

Commercial Reports 2/20/17/69

The most powerful telescope in the southern hemisphere, ranking as the third most powerful in the world, will soon be completed at the national astronomical observatory, Cordoba, Argentina. It is of the reflector type, with an aperture of 61 in., and will be mounted in a steel dome, 59 ft. in diameter, situated 3,937 ft. above sea level in the Sierra Chica. A special road has been built to the site. The great mirror and its auxiliaries are being ground in optical shops attached to Cordoba Observatory for the purpose, the disks of glass required having been imported from France just before the war. The large disk was 10 in. thick before grinding and weighed 2,315 lb. The telescope will be used mainly for photographic observations.

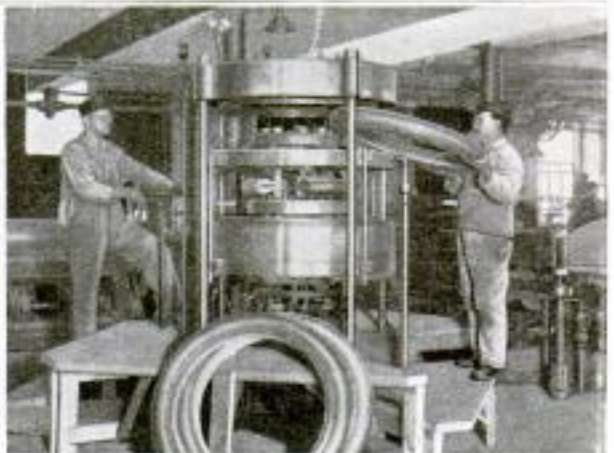
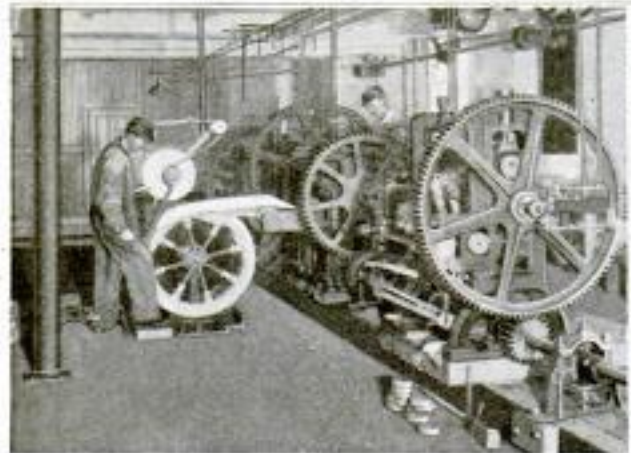

Making Tires by a Continuous Process: At the Left, Building Up the Carcass with Fabric as It Comes from the Calender. Right, the Tire Press Mold, Where the Tire is Vulcanized over an Electrically Heated Core

MOUNTAIN FOLK MAKE PLANS FOR PICTURESQUE FROLIC

If plans now being made by the year-around residents of the Estes Park region in Colorado are actually carried out, the first of a series of annual autumnal festivals in some grassy vale of the Rockies will be inaugurated next fall.

The district has a permanent population of 400 or 500 persons, and these — men, women, and children—will go in a body to a group of big, rambling log buildings which are to be erected in one of the animating spots far up in the bosom of the continental divide. There, within easy reach of perpetual snow, skiing, tobogganing, and other rejuvenating sports will be enjoyed. For three weeks the whole colony will devote itself to outdoor play throughout the daylight hours, and to the good-fellowship of roaring fireplaces, the companionship of music, and the merriment of dancing, during the long, crisp evenings. A number of years ago the pioneers of the region banded together and went into the mountains late in September for a big, jolly camping expedition. Of late, however, this custom has not been observed, for the increasing popularity of Estes Park as a summer resort has kept the residents busy each fall enlarging their facilities to meet the demands of the next season's tourists. There is no longer need for this, and so the townsmen plan to have a real neighborly frolic in the autumn after the crowds of tourists have departed to their homes in different states.

PRIMITIVE TIMBER BRIDGE IN NORTHERN INDIA

An example, both curious and instructive, of primitive bridge building is to be found in the Vale of Cashmere, high up in the Himalaya Mountains of northern India. This large

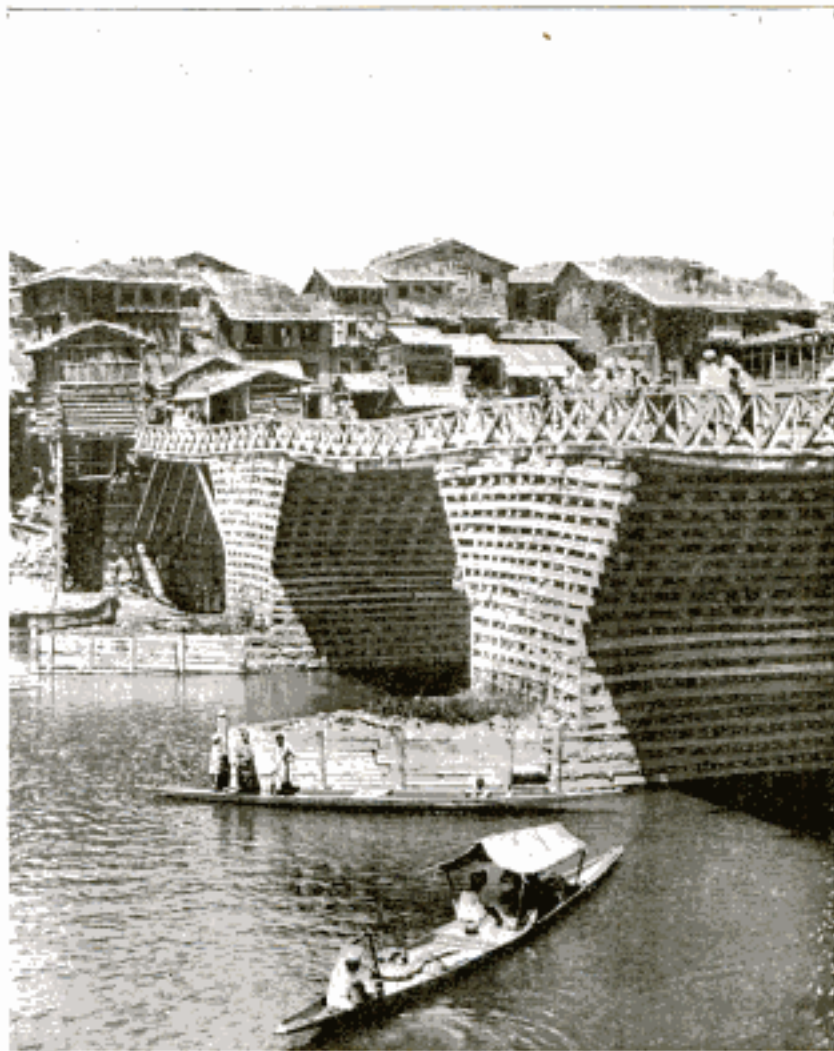

COPYRIGHT, UNDERWOOD & UNDERWOOD.
Picturesque Primitive Structure in Cashmere, India, Which Offers Suggestions in Bridge Building for Remote Regions in America

structure is constructed almost entirely of roughly hewn timbers and is supported by large piers made of cribbing, filled with stone or riprap at least to the point where the corbeling of the supports begins. This slanting of the sides serves to narrow the gaps between the piers so that single timbers are long enough to extend from one to the other and thus support the floor of the structure. Each pier is provided on its upstream face with a cut-

water, or sharpened point, filled with stone, thus materially adding to the stability of the supports in case of flood.

3704

SCALLOP-CUTTING MACHINE FOR EMBROIDERY

Strips of embroidery are now cut with the familiar scalloped edge from the embroidered fabric by a machine of

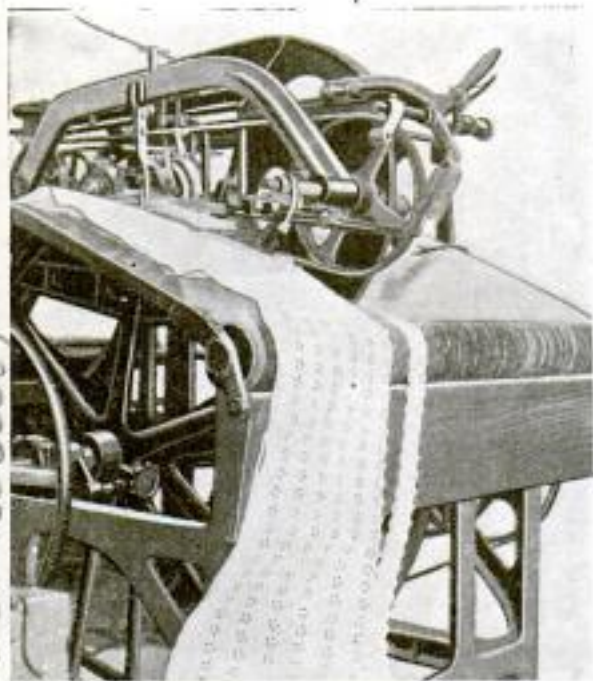

Cutting Embroidery Strips by Machine: This Swiss Invention Does the Work of 50 Persons Operating by Hand

Swiss invention. This was formerly done by hand and each machine will do the work of 50 persons, its capacity being about 12,000 yards a day. The fabric to be cut is drawn under a knife, 36 in. long and $\frac{1}{2}$ in. wide, by a wide belt run over two pulleys, the under side being in contact with a large wheel which gives proper tension to the cloth. The machine is operated by a small electric motor, and the knife is removable for resharpening. As the strips of embroidery are cut off they are wound upon cartons ready for sale.

¶The Cuban government has been engaged in constructing a canal 32 miles long in the province of Matanzas which will reclaim a large and very fertile area.

NEW FUELS USED IN SPAIN TO REPLACE COAL

Shortage of coal in Spain has led to experiments with various substitutes, including the husks of rice and inferior qualities of lignite. In the provinces that raise rice, the husks have lately been mixed with tar and formed into briquettes under hydraulic pressure. In their natural form rice husks make an expensive fuel, burning with little heat, but the briquettes are said to ignite readily, give off little smoke, and can be used to some extent as a substitute for coal. Another kind of fuel briquette, giving similar service, is made from cheap qualities of lignite, including lignite dust and waste formerly regarded as worthless, from which the volatile matter is first expelled and a binding material then added to form the briquette under pressure.

3866

HIDDEN BULBS ILLUMINATE SIDEWALK STEPS AT NIGHT

In front of the public library of Alhambra, Calif., is a flight of three steps at the juncture of the street and library sidewalk, which is ingeniously illuminated by concealed lights so that the difference in walk levels may not be the cause of accident to pedestrians. The electric bulbs are recessed in the low stone abutments at each end of the steps and are covered with frosted glass. Strong reflectors aid in making the flight particularly prominent in the dark.



Three Steps in Front of the Alhambra, California, Public Library Which are Well Illuminated at Night by Lights Recessed in Stone Abutments Either Side of the Walk



Platform on Second-Story Level from Which Trucks Dumped Their Contents into a Bin Below, Thereby Saving Much Labor in the Handling of Building Materials for a \$500,000 Concrete Structure

LABOR-SAVING PLAN FOR UNLOADING MATERIAL

An elevated platform, approached by inclines of a 10-per-cent grade, served as one of the simple but effective labor-saving arrangements used by contractors in erecting a new \$500,000 concrete building in Cleveland, Ohio. Instead of dumping gravel, and the like, on the ground, each loaded truck was driven onto this platform, and its contents dumped into a bin below. From this container, which served as a hopper, it was an easy matter to transfer the material to mixers, or handle it for other purposes, with a minimum of labor.

3850

CONCRETE FARM BUILDING OF ARCHED-ROOF TYPE

In using concrete as a building material for sheds, one-story barns, etc., it has been found that an arched-roof type of structure is desirable. A good example of a building of this character is to be found on a large farm near Eddyville, Ia. It is 72 ft. long, and

its side walls and roof form a continuous arched wall of concrete. The ends are of tile. In building this structure the form was made chiefly of 1-in. native lumber, the material being bent while green. The concrete poured over this form was reinforced with fence wire. The wooden lining has not been removed but serves to strengthen the arched roof, which has been partly covered with earth. A portion of the building is used as a garage in winter, but most of it is used for handling fruit and for storage purposes.



Farm Building, 72 Feet Long, with Barrel-Arch Roof of Reinforced Concrete. The Wooden Form for the Curved Portion has been Retained to Give It Added Strength

W. H. Gray, Eddyville, Ia.

EGGS SHIPPED SAFELY IN PAPER "HAMMOCKS"

By suspending each egg in a sort of paper hammock, a Syracuse, N. Y., firm has hit upon an inexpensive and appar-

ently safe means for shipping eggs by mail, or otherwise. In preparing the product for transportation, a wide paper ribbon is laid out on a special rack having a dozen divisions, in each of which an egg is placed. The paper is

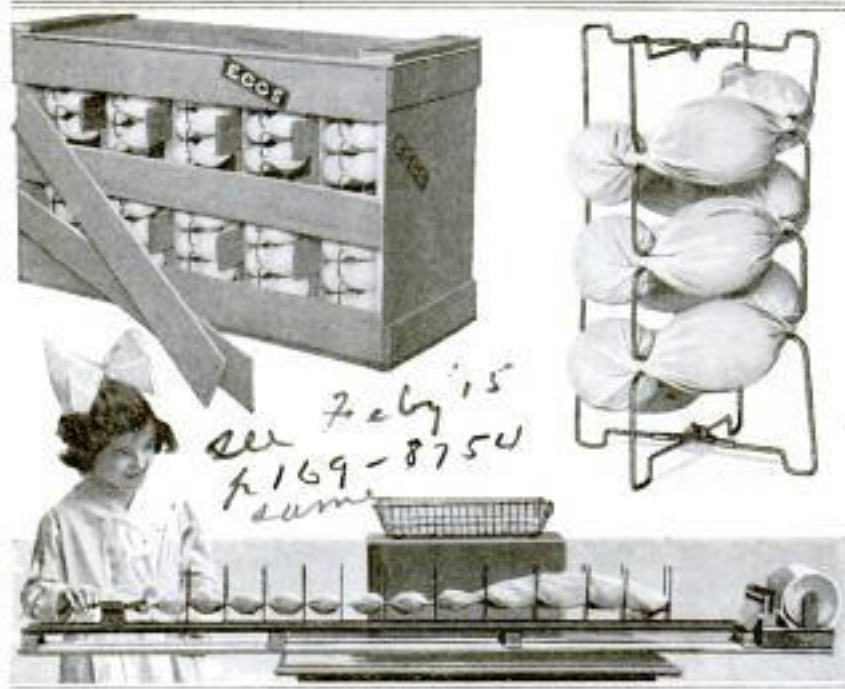

then twisted by means of a crank and clasp attached to the end of the strip. The wrapper is dampened before being twisted and so binds closely about the eggs, making a sausagelike string which is wound around a four-cornered wire reel. The reel holds the eggs in such a way that no two touch. As the wrapper dries it shrinks and holds its contents firmly in place and also serves to keep the eggs fresh by protecting them from the air. One or several reels can be shipped in a suitable case.

Above: Crate Filled with Eggs in Paper "Hammocks" and a Single Reel with a Dozen Eggs. Below: View Showing How Eggs are Wrapped

*see Feb 15
#169-8750
same*

*W. J. Wood
Private*

2309

SILO FORMS USED FOR ROUND CONCRETE GARAGE

A circular concrete garage has recently been built in Republic, Mo., in the construction of which 16-ft. steel silo forms were used. The concrete walls are 4 in. thick and the roof 3 in. thick; the whole structure forms one solid piece of concrete. Special reinforcing was used. The roof has a rise of 3 in. to the foot and is painted with black concrete paint, while the inside of the structure was washed with a brush coat of cement. Under the 4-in. eaves is fastened the curved track on which are hung the two doors which themselves are curved to conform to the walls. The structure is fireproof except for the wooden doors and window frames. The entire cost of the garage was

about \$150, including a concrete floor. The circular form affords convenient work room either side of the car, and three windows furnish plenty of light.

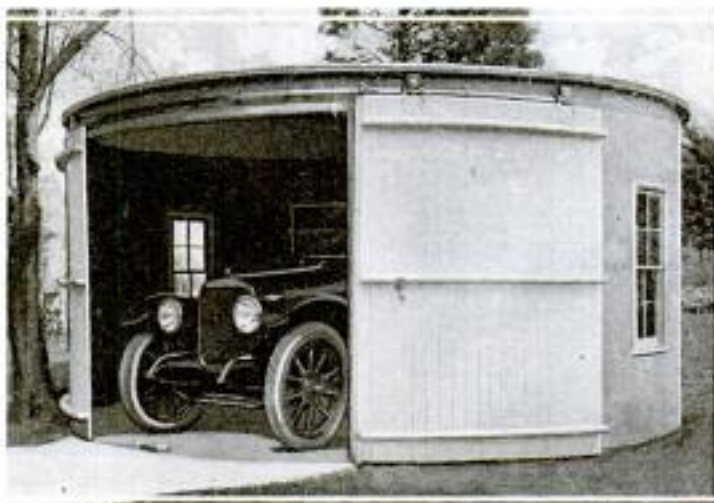

A Circular Garage Made of Concrete with the Aid of Steel Silo Forms: Built as an Experiment, the Cost was Found to Be Small and the Effect Pleasing

*J. S. McMillan
Concrete Construction Co.
Republic, Mo.*

STREET CLEANERS TAUGHT TO CLEAN

295-3

By C. L. EDHOLM

DON'T imagine that anybody can start out with broom and bucket to sweep the streets and do it right. For many years the city of New York thought that willingness to work was all that was needed to make a good street cleaner, but now it knows better, and therefore a school has been established to teach the "white wings," the drivers, the flushers, and the chauffeurs of the garbage tractors the how and why of their business.

This school was established only a few months ago in the dumping-dock building at the foot of East Nineteenth Street, where a hall, about 40 feet long and half as wide, was devoted to that purpose.

The equipment of this classroom consists of the articles used in cleaning streets, including a regulation ash wagon with a full-size model of "Teddy," the prize horse of the department, hitched to it. Teddy carries a set of standard harness and blanket, and one of the features of the course of instruction for drivers is thorough drill in "hooking up." The need of such teaching is apparent when it is understood that men who have never handled horses may be required to act as drivers for the carts that contain the city's waste. So "rookies"—men who have been taken on after passing the preliminary examination—are required to put the harness on the dummy and take it off, time after time, until every movement is done with the precision of military drill. The reason for every move is explained to the new men, so that they will not think that the carefully considered regulations are mere arbitrary orders.

As a matter of fact, each detail is important, as it may have far-reaching

results if ignored. For instance, in laying aside the harness the pad that lies between the animal's withers and the saddle is not to be thrown on the ground but tucked under the arm as the driver removes it. The rookies are told the why of this: a bit of gravel might lodge in the pad if it were thrown on the stable floor, and then, when it came in contact with the horse's back, could wear a raw spot in a single day, and the animal would be laid off until healed. Special instructions for fitting the collar, bridle, and other parts, are given, so that the horse may work without undue strain. Even the business of hanging up the harness on the stable hook is taught, so that the man who oils and cleans the leather can handle it without confusion.

The course includes a bit of veterinary instruction. The common ailments of the horse are described, and the driver must know by the symptoms when his equine helper is suffering from colic or overheating; and he is taught first aid in relieving the animal when it becomes sick in the streets, or when it falls. Also, the men are shown how to avoid such mishaps.



New York Street-Cleaning Recruit Learning How to Harness a Horse Properly, in the Training School for "White Wings," Which is Equipped with a Dummy Horse and a Standard Ash Wagon

How and what to feed the horse, when to give it water, and similar details, are not left to guesswork, but are taught in the lectures. As the welfare

of the horses is vital to the street-cleaning department, the men are carefully warned against allowing their horses to drink from public troughs, where they might acquire glanders and spread the contagion to a thousand others in short order. One of the common errors—that of allowing the horses to nibble at the green garbage at the dumps—has received attention. The drivers are cautioned that this apparently good-natured act, in allowing the creature to eat an apple or some vegetable tops from the garbage, might cause colic or even poisoning, as disinfectants are often sprinkled in the cans.

The details were formerly learned by experience, and the result was loss of stock, delay, and confusion. Now, in addition to his book of instructions, the driver receives lessons in class, and has to answer correctly the questions about his work, and demonstrate that he understands, by going through the drill.

The officers of the department gather in the hall once a week for lectures on the best methods of doing the work, and at the same time, while a squad of officers occupy the rear benches, a class of new men occupy the front rows and watch the instructor put one of their number through a demonstration exercise.

The advantage of this method is that the rookies get the benefit of the theoretical training, and realize the magnitude of the work in which each plays his small part. This gives the intelligent manual workers a chance to study the intricate problem of keeping a city

clean, and enables the best men to work up to responsible places as officers.

Another advantage is that the superiors, who have learned by experience only, may keep up with the times and follow more scientific methods. Many a gray-headed officer is allowing his men to waste time and energy by doing the work as the veteran did it when he was at the business end of the broom. Now there is a wrong



Instructor in the Street Cleaners' School Correcting a Common Error: The Street Flusher must Not Bend the Hose in Turning Down the Nozzle, as It Tends to Break the Rubber

way and a right way to perform such a simple task as sweeping a street, and some of the men in charge of a district are learning the best method at this late day through the demonstrations in class. It might cause friction and hard feeling were the instructor to take one of these veterans aside and tell him that his practice was wrong; the effective method is to take a group of officers and show them the approved method.

The demonstration floor is painted in gray and black, to represent a section of a city street. A street-car track with cable slot is shown, a street intersection, with the courses of paving block laid at angles, also manholes and sewer openings.

On this realistic bit of pavement the new man is placed with his broom and scraper, and as he does the work of sweeping it, he tells what he is doing and why. For instance, he states that he sweeps away from the cable slot, in order to avoid filling it with dirt, and that he never pushes a pile of sweepings across it. The length and direction of the stroke, and the posi-

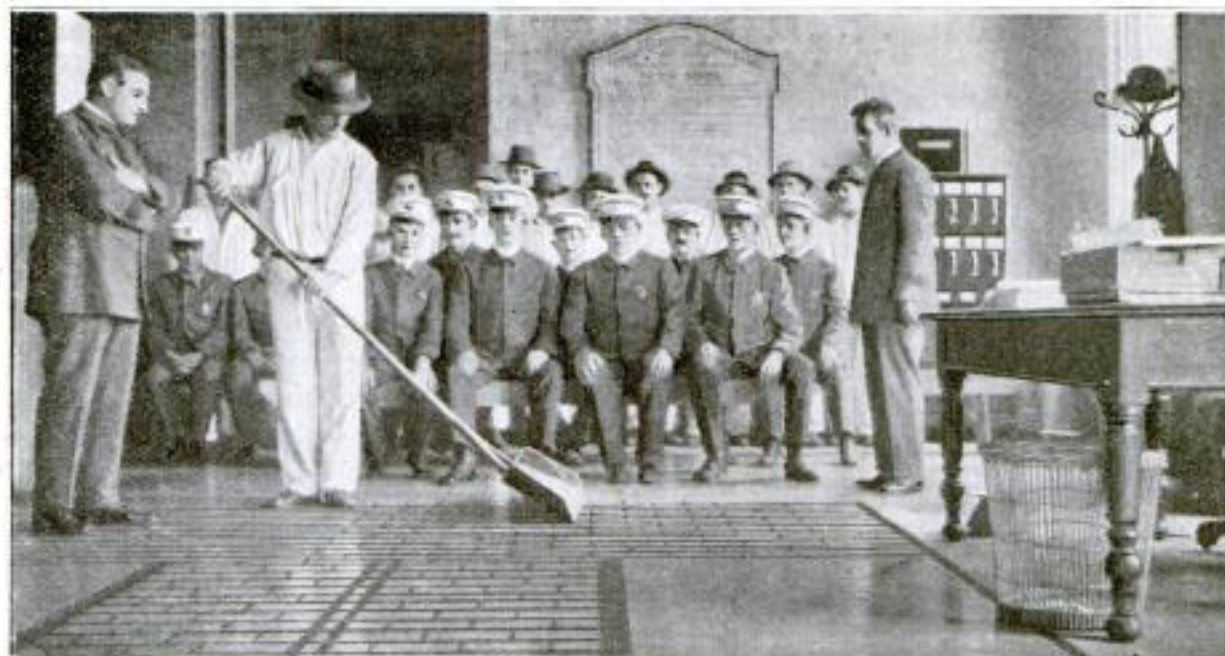

New York Street Cleaners' School in Session: The Floor is Painted to Represent a Street Pavement, with Car Tracks, Cable Slot, and Gutters. A Demonstrator is Showing the Class How to Use the Scraper Properly

tion while sweeping, are all taught, and the rules are enforced.

Most of the rules are intended to secure greatest efficiency; some to prevent annoyance to the public, and others to safeguard the men. Among the latter is the regulation always to work facing the traffic, so that there may be no danger of being struck from behind by a vehicle. This is a simple precaution, but one that few green men would think of. Another safety rule is that the scraper, while being pushed along the gutter, must be held to one side of the body, never against the abdomen. The reason is that if the scraper should hit an obstruction, the body would receive a shock from the end of the scraper handle that might cause rupture. Here again is a detail that a beginner would not think of until he had been jolted once or twice.

Among the other equipment of the hall is a hydrant and flushing outfit, hose, nozzle, and reel. The instruction gives in detail the correct method of preparing to flush the street, of extending and reeling up the hose. The cost of the apparatus is emphasized, and as a couple of men are in charge of equipment worth nearly a hundred dollars, it is a point worth making. The hose costs 54 cents a foot, and the

flushers are shown how to avoid undue wear and breakage. The portable reel on its wheeled carriage is set at a convenient point near the hydrant and in a position where a passing truck cannot smash it. The demonstrator was asked, "Why do you lay the nozzle on the street when you are through? Why don't you drop it?" And he replied that brass nozzles cost a lot of money, and it was part of his job to handle them carefully.

Even the correct position of the nozzle, while flushing a street, is insisted on. Too great elevation weakens the force of the flow, and it descends as spray on the pavement, while too great depression causes the stream to hit the street with force that is destructive to the pavement and is not effective in cleaning the surface. Even such a detail as turning the stream away from vehicles is not overlooked. The instruction is to divert the stream when the approaching vehicle is about 20 feet away, turning the hose toward the gutter and putting a finger over the nozzle to throw down a fan-shaped spray. Uninstructed flushers had the bad habit of holding the stream across the street until the last moment, and then bending the hose sharply to cut off the flow, causing breakage of the hose.

The men who apply for positions as sweepers, flushers, and drivers have, as a rule, little education and many of them are foreigners. Most of them would muddle through the day's work in some fashion, but under the present system the recruits are as well fitted for their duties as the experienced workers.

In addition to the simple equipment of cart, brooms, and scrapers, the classroom contains a complete motor of the type used in the garbage tractors. In a certain section of Manhattan, known as the model district, 12 of these huge machines are in operation, and as they cost \$7,500 each, it is essential that the drivers should be experts. Therefore,

the course in this school gives the thorough instruction in motor mechanism that a first-class automobile school gives its paying pupils. Not only the present drivers are taught, but applicants as well receive the course. Thus a large waiting list is kept, from which new drivers may be appointed when required.

It should be added that the training given by the street cleaners' school is not confined to the classroom. The men are taken out on the streets and given practice work under the supervision of officers before they graduate, and the result is that the new men do not have to be broken in when they are assigned to regular work.

3295
**DINNER SERVED AT BOTTOM
 OF SKYSCRAPER CAISSON**

A dinner at the bottom of a 110-ft. caisson was the unusual feature which marked an early stage in the construction of the second half of a new Chicago hotel. The shaft was 10 ft. 2 in. in diameter and extended down

through various strata of earth to solid rock. The dinner at the bottom of this vertical tube was given by the president of the hotel company, who invited as his guests the mayor of the city, the chief of police, and 10 other prominent persons. A special cage was built to carry the diners to and from the richly laden tables, which rested on bedrock. Two pipes were used to keep the air in the well pure. Immediately following the meal the host deposited a tube in the bottom of the shaft, containing



Guests of Hotel
 President About to
 Descend to the
 Bottom of a 110-Foot
 Caisson, Where a
 Dinner was Served

View Looking Down into
 the Caisson, Showing
 the Dining Tables
 and Guests Standing
 on Bedrock

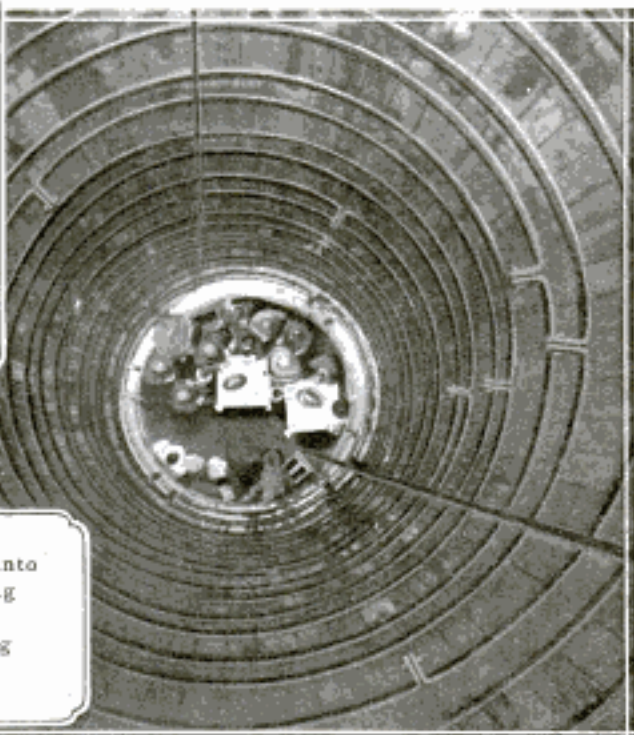

*Hotel Morrison
 Harry C. Blair, Manager
 Chicago*

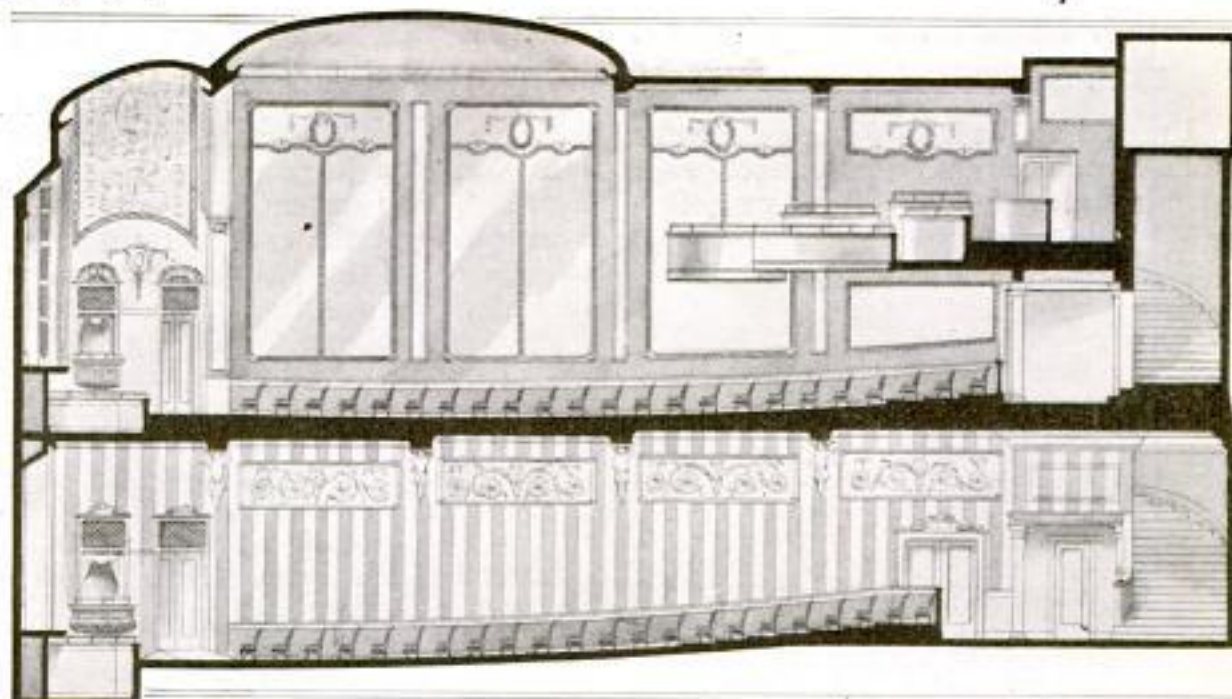

RICHARDSON & YOST, ARCHITECTS

Sectional Plan of New Dual Theater Building, Cleveland, Built with Entrances from Streets of Different Levels: The Same Moving Pictures are Shown in Both Houses, Beginning at Different Times for the Convenience of Patrons

data regarding the hotel and the dinner, together with appropriate photographs. When this formality was over, the shaft was filled with concrete. There are 12 of these supports under the new section of the hotel, which will be 21 stories high.

3881

DUAL THEATER CONVENIENT FOR ITS PATRONS

In Cleveland, Ohio, there is a dual theater building, designed with a complete motion-picture theater on each of its two stories, and believed to be the only playhouse of its kind in the country. It is situated on property that lies between two buildings fronting on streets—one of them Euclid Avenue—that have 11 ft. difference in their levels. A passageway, treated as a theater entrance and lobby, was therefore provided by the architects on the lower street level, leading to the lower theater, which seats 600, with a stairway to the second-story auditorium, which has a balcony and seating capacity for 750. The upper house also has an entrance from Euclid Avenue, the higher street, making it possible to enter either theater from either street. The same program is given in both

houses, a film picture being started in one from half to three-quarters of an hour before it begins in the other.

EASILY OPERATED BROODER 3878 FOR LITTLE PIGS

An inexpensive brooder for little pigs, consisting of a substantial wooden case having a door in the top and another in one side, has recently been patented by a Wisconsin farmer. The box is divided into an upper and a lower compartment by a perforated sheet of metal which serves as a floor for the upper chamber. The latter is heated by placing a lighted lamp or lantern in the lower half. Young pigs requiring special care are wrapped up and placed in the top compartment, and in this way chills, which sometimes prove fatal, are avoided. Handles are provided for moving the brooder about.



Paulie DeGan
Grant Co.
 2/12
See Pat. 207000
 Copyrighted material

NOVEL ELECTRIC SIGN MADE FOR EASTERN THEATER

Erected on the front of a new theater in an eastern city is an illuminated sign that has a distinctive, if not new, fea-

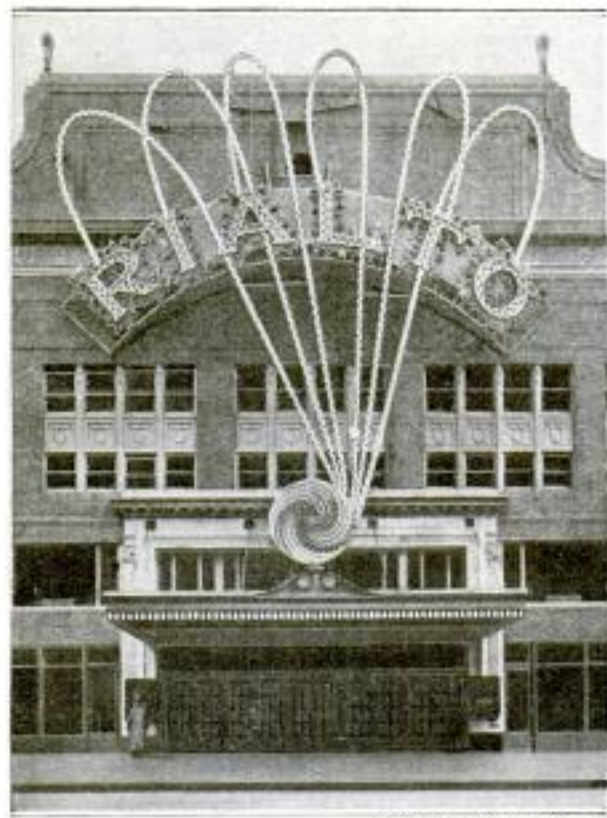

COURTESY AMERICAN EXPORTER

A Pyrotechnic Effect Accompanied by a Loud Hissing Sound, like That of an Ascending Skyrocket, is Produced When This Electric Sign Is in Operation

ture. The name of the theater appears in large letters arranged in the form of an arc. Below, a wheel studded with varicolored lamps revolves rapidly and apparently shoots out streamers that "burst" rocketlike over each of the several letters, which immediately thereafter are illuminated. The unusual phase is that a loud hissing noise, like that of an ascending skyrocket, is to be heard as each streamer flashes up from the spinning wheel. This is produced by a special contrivance that allows compressed air to escape.

¶ The Pacific coast delegates to the national advertising convention, to be held in St. Louis this summer, plan to make the trip from the West in automobiles, following the Lincoln Highway as far as Omaha.

MOVEMENTS IN THE EARTH UNDER A RESERVOIR

Sci. Am. 7-113-17
Scientists took advantage of the construction of a huge reservoir in New South Wales recently to study the movements of the earth's crust under the weight of the 30,000,000,000 cu. ft. of water which is its storage capacity. Special pendulums were hung in deep shafts dug in the hills which inclose the reservoir, the latter having a height of 236 ft., and the instruments connected therewith have already recorded earthquake movements and dislocations, also earth tides and other phenomena due apparently to the great water load.

PORTABLE CAMP STOVE AND KITCHEN KIT

When one goes camping, the question of a cooking outfit is all-important. A Chicago lover of outdoor life has decided the question for himself by the invention of a camp stove that may be packed with all the dishes and utensils necessary for a party of 12 persons, and weighs complete about 90 pounds. The stove is 24 by 26 in. on top, with four 8-in. holes, burns wood, and has a hearth that lets down. Seven feet of tapering stovepipe are stowed in the fireplace, with four stove legs, poker, and lid lifter; while in the oven over 100 articles of table and stove ware may be nested.

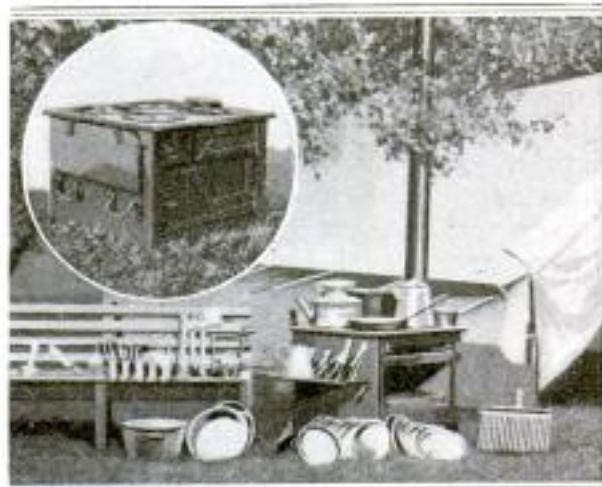

Portable Stove and Kitchen Outfit for a Camping Party: In the Insert the Stove is Seen Packed

Inv. & Comp.
Henry B. Roney
1021 LeCandor St. N.Y.

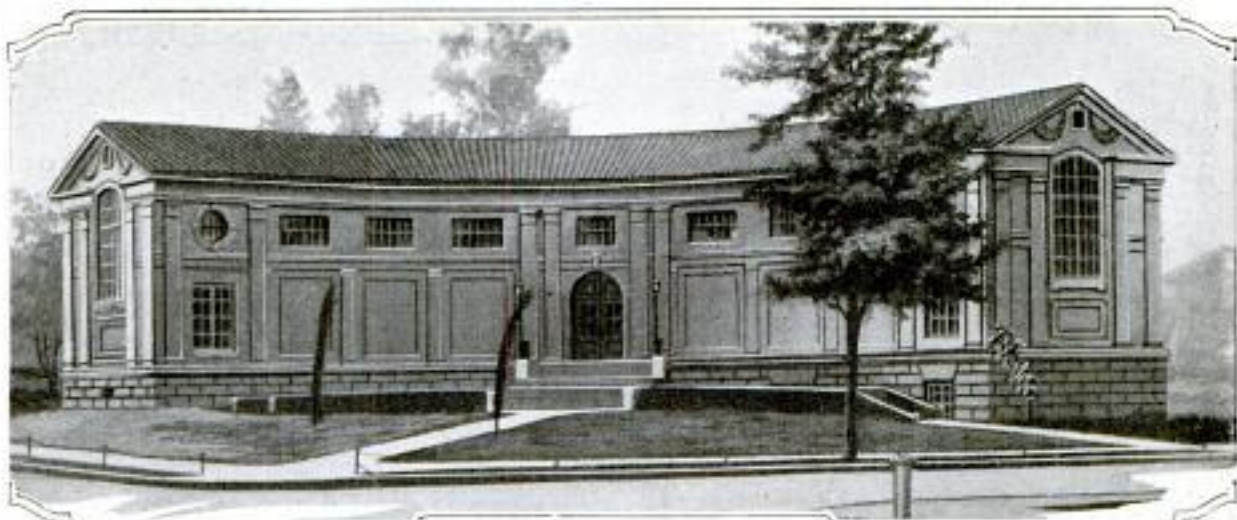

View of a Branch-Library Building in Los Angeles, Showing Its Concave Front

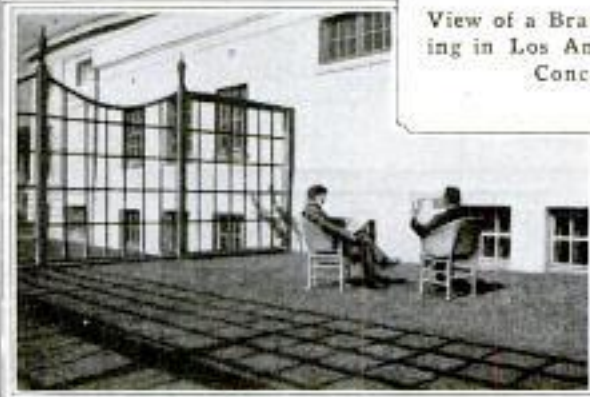

Left: The Outdoor Reading Room, Photographed Before the Trellis was Covered with Vines.
Right: View of Interior of Main Reading Room

CURVED LIBRARY BUILDING HAS UNUSUAL FEATURES

A beautiful branch-library building, recently opened in Los Angeles, is of unusual interest because it is built in the form of a curve which describes an arc of 90° , with the concave side facing the intersection of two streets. This odd shape is especially suited to the location and permits the equipment to be arranged in a way that makes the best use of the floor space. The front wall is 105 ft. long, while the corresponding rear curve is 147 ft. long. This curved portion is 27 ft. wide and 22 ft. high, inside. At the rear is a rectangular extension containing several rooms, including a rest room for the staff which is furnished with an electric cookstove and a sanitary food cabinet. Adjoining this extension is a vine-shaded arbor, or outdoor reading room, which is a most attractive feature. In the basement are

a good-sized auditorium, a heating plant, and store rooms. The building cost \$34,000, and is furnished largely in old English oak. At present it houses 15,000 volumes. *3126 Pamela*

RUBBER SHOES PREVENT SLIPPING OF TRIPOD

Rubber tripod shoes, now being manufactured by an English concern, are intended to be used when a camera is set up on a smooth floor, or other slippery surface. It is a not uncommon experience of a photographer to find that a slight jar has thrown his camera out of focus because the tripod slipped about easily. These rubber shoes, which can be stretched over the end of a tripod leg of any shape, are intended to prevent just such accidents. When not needed they can be removed.



*Atkinson Rubber Co.,
60 Stamford New York
Atkinson, Eng.*

MECHANICAL DEVICE FOR KEEPING BOOKS

A bookkeeping machine now on the market might almost be said to do bookkeeping mechanically, for it pro-

will illustrate, in a general way, what the invention does. The device is operated like a typewriter and is mounted

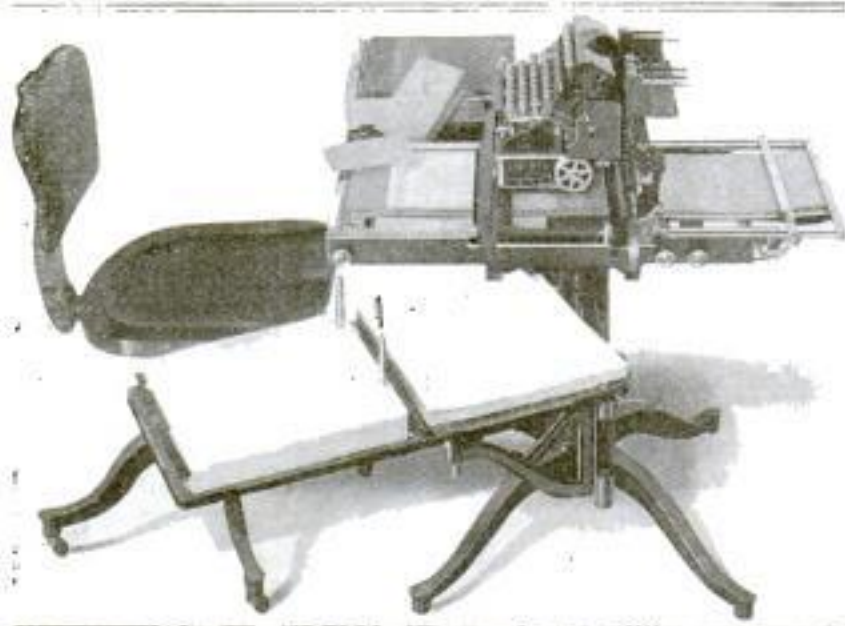

on a suitable standard over a flat platen, on which is placed the sheet containing the account to be posted. The operator first writes the last balance in the old-balance column and then the debit and credit items are recorded in their proper places. While the sums are being written they are also being added to the totals on registers corresponding to the various columns, so that the operator can see at a glance what the totals are. Simultaneously with these operations

A Machine with Which All Bookkeeping Entries are Made, Which Not Only Adds Several Columns of Figures at Once but Also Strikes Balances as Fast as Items are Entered, Thus Keeping the Books Perpetually in Balance

duces work which is wholly free from mistakes in addition and subtraction, and saves a great amount of time by performing several mathematical operations at once. It is a combination of an adding machine and typewriter and has special features in addition. A description of one style of this machine and how it is used in posting a ledger

a special device, called the cross-footing register, adds the debits to the old balance and subtracts the credits, so that as soon as the entries have been made the balance is calculated automatically and all that remains is to record it. When this is done the cross-footing register is cleared, thereby proving the work.

MOTOR-CAR DIFFERENTIAL

3616 WITHOUT GEARS

A mechanical principle of novel application governs the construction of

a differential recently devised for motor cars and trucks. The ordinary differential includes an arrangement of gear wheels connecting the shafts of the rear, or driving, wheels in such a way as to permit one shaft to revolve faster than the other when required, as in turning a corner. This is accomplished by the new differential without the use of gears, and at the same time it prevents idle spinning and slippage of the car wheel which has the lesser traction. The device consists essentially of four units, including a central driving plate and two grooved blocks of chrome steel, with a set of eight steel balls through which the power is transmitted. There

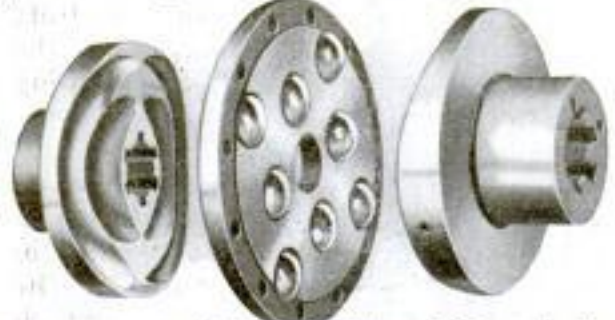

This Differential for Automobiles and Motor Trucks is Constructed without Gears and will Enable Any Car to Pull Out of a Hole with Traction on Either Wheel

Miller Transmission Co. Harrisburg, Pa.
People's Sav. Bldg., Harrisburg, Pa.

740 3962 POPULAR MECHANICS

TWO FIRS SUPPORT HIGH PLATFORM IN FOREST

Two giant firs, standing side by side at an elevation of 4,000 ft., on Larch



Mountain, 40 miles east of Portland, Ore., now serve as supports for an unusual observation station built by the Forest Service, in cooperation with Portland business men. The trees were cut off 100 ft. from the ground and a zigzag stairway constructed between the trunks to the top, where there is a railed

platform and a glassed-in shelter. The tower is open to the public, and in it is sometimes stationed a lookout who watches for forest fires.

3470

DOUBLE-WALLED EGG CUP KEEPS CONTENTS WARM

There is now being introduced in many clubs and restaurants an egg cup



so constructed that it will keep boiled eggs, broken into it, warm for 15 minutes or more. It consists of two parts, a standard to which an outer bowl is attached and an inner bowl, or cup, which fits in the outer one. Before the inner cup is put into

place for use, a tablespoonful of hot water is poured into the outer bowl, which has a small recess in the bottom. When the parts are fitted to-

gether, the water is forced up around the sides of the cup between the two walls and serves to keep the eggs warm for some time. The article stands 5 1/2 in. high. The inner bowl is made of crystal glass and the standard of nickel or German silver.

3818 Look up

BALL HAS THRILLING TRIP AROUND THE WORLD

A round-the-world journey which

fo:
ex
co
ba
sh
w:
w:
it
lin

3470



Constructed on the Vacuum Principle



Keeps Eggs Hot for 15 Minutes Longer Than Any Other Cup

Patented August 23, 1910

Most Practical, and Useful Lasting Gift

CAN BE HAD IN NICKEL OR GERMAN SILVER
ASK FOR THEM

For Sale by All Leading Hotel-Supply Houses

W. S. ENSIGN CORPORATION

MANUFACTURERS

141-147 FIFTH AVENUE NEW YORK CITY

fin
Sy
Sa
Yc
wa
du
Y.
wa
for
U
3
de
pr
ar
ne
ha



Interior of Factory Building of Steel Sections Rapidly Put Together: Note the Plan of Roof Construction and Method of Lighting by Window Panels.

with split bolts, form the connections that lock the sections to each other to make a solid, substantial structure. In construction detail, the unit factory building is formed of various steel and steel-and-glass panels, standard in size and interchangeable. Steel roof trusses are placed on 8-ft. centers and roofed over with steel plates resembling fine roofing tile. The size of an average factory unit is 28 by 100 ft., but the sectional construction is well adapted for smaller buildings.

10216
LARGE SALT SUPPLIES

MADE USABLE

Sc. Am. 2/17/1917 p. 185

Among the states which possess vast salt resources in one form or another are Michigan, New York, Ohio, Utah, and West Virginia, the first-named claiming that it has enough salt to supply the whole world several hundred years. But most salt in its natural state is impure and some brines contain barium chloride which makes it poisonous. The Bureau of Chemistry at Washington, after careful research, has found that such salt can be deprived of its poisonous properties by adding a solution of sulphate of soda, and so large salt supplies of this character, which have had a limited use, are now made available for general commercial purposes.

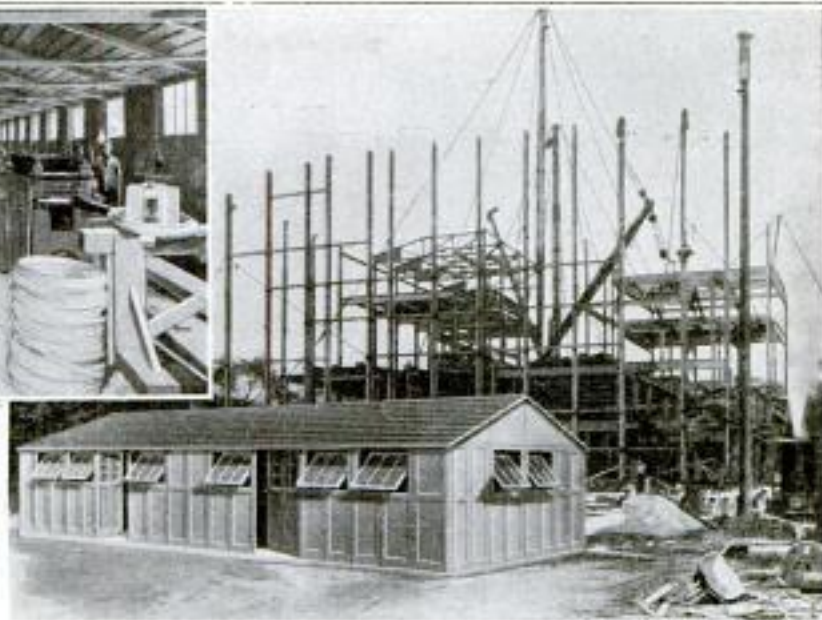

Steel Building of Unit Factory Type Used as a Contractor's Office: This Method of Construction is Adapted for Garages and Small Buildings Like This, as Well as for Rapid Extension of Factories

SAND-BLAST NOZZLE OF
 3218 **SUCTION TYPE**

IRON AGE 8-22-1916

Special advantages claimed for a recently patented sand-blast nozzle are that it lessens the wear on the sand pipe, is easy to operate, and eliminates the necessity of using an ordinary cumbersome sand tank. The compressed-air supply pipe, which is connected with any desired source of compressed air, and the sand pipe unite at this nozzle. The free end of the sand tube is placed in a pile or pail of sand. The passages in the nozzle merge in such a way that the passing of the air swiftly across the mouth of the sand tube draws the sand up through the latter by suction and then forces it out in a violent blast. The particles are not driven through the sand tube with as much force as in ordinary machines and so less wear results.

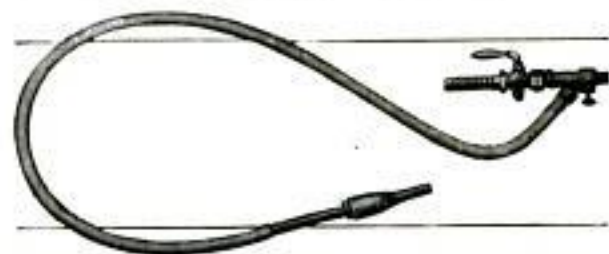

Sand-Blast Nozzle Which Draws Sand from a Pile or Pail by Means of Suction and Subjects the Sand Pipe to Less Wear Than in Ordinary Outfits

M. F. Stordale,
 O. C. Vol. 747-218 Copyrighted material
 Syracuse N. Y.

WOVEN-REED FURNITURE IN NEW DESIGNS



1
That Serviceable Furniture for the Bedroom can Now be Obtained in Reed is Shown by This Plain but Artistic Three-Piece Set Composed of a Bedstead, Chiffonier, and a Dressing Table



2
2
Open Bookcase with Reed Back and Sides, and Shelves of Quarter-Sawn Oak, Suitable for Year-Round Use



3
This Screen is Something New in Reed Ware and is Exceedingly Attractive. The Same is True of the Needlework Stand, Lined with Cretonne. The Sewing Chair at the Right Matches Both These Pieces



Van Rannel Revolving Pantry
250 W. 54th St., New York
U. S. Metal Products Co., Los Angeles.

744

POPULAR MECHANICS

REVOLVING PANTRY WINDOW

3707 A HANDY SERVING DEVICE

A revolving pantry window is a labor-saving convenience suitable for either a dwelling or a restaurant, with



A Revolving Window through Which Food can be Passed into the Dining Room, at the Same Time Shutting Out the Noises and Odors of the Kitchen

which food can be passed from the kitchen to the dining room without disturbing those at their meals with the noise and odors incident to preparing the food. The device is cylindrical in shape and is inserted in the wall between the two rooms to be connected. Being pivoted at the top and bottom it revolves easily. A shelf divides the window into two compartments. In one side of each compartment is a glass panel and opposite it is an opening. Preferably the openings are so arranged that when one is turned toward the kitchen the other is accessible from the dining room.

3937

NUREMBERG PLANS TUNNEL TO DIVERT FLOOD WATERS

Commercial Reports 1-25-1917
After the war the Pegnitz River, which time and time again has overflowed and wrought havoc in the picturesque old town of Nuremberg, Germany, is to be controlled by means of a tunnel nearly two miles in length, into which the flood waters will be

diverted. Over \$285,000 had been spent on the project when war was declared and it is anticipated that, when peace comes, work will be resumed. The total expenditure will be about \$2,300,000. The control of the Pegnitz has long been the subject of study, but no satisfactory method has been found heretofore because of the peculiar conditions to be met. One plan was abandoned on account of uncertainty as to its efficiency and the disfiguring of the landscape that would necessarily result. The building of a few large reservoirs, or several small ones, was pronounced impracticable, partly because of the character of the ground, on the one hand, and the difficulty of properly controlling the barriers, on the other. The present plan includes the construction of a dam above the inlet to the proposed tunnel. The excess water will be made to run over a weir into the underground passageway. At its lower end the tunnel will empty into a canal which will parallel the river for some distance. The subterranean channel will be about 12 feet below the earth's surface and will be able to carry off 12,340 cu. ft. of water per second. This, it is believed, will be sufficient to take care of the greatest inundations. In the past 600 years Nuremberg has had no less than 138 floods, 11 of which have been great catastrophes. The government of Bavaria will assist the city in its big effort to prevent further devastation.

3900 TRAP BOX CARS TERRIFY TRAMPS IN SOUTHWEST

In the Southwest it is no longer safe for care-free "hobos" to climb into an empty box car and lie down to rest, for the innocent-looking car may be one of the "tramp traps" which the Southern Pacific has made a part of its freight trains. Before the unsuspecting vagrants have ridden many miles in one of these especially equipped cars the doors are closed suddenly by unseen hands and locked with automatic locks. In due time they are opened by

Van Kannel Revolving Door
250 W. 54th St., New York
U. S. Metal Products Co., Los Angeles.

3707 **REVOLVING PANTRY WINDOW**
A HANDY SERVING DEVICE

A revolving pantry window is a labor-saving convenience suitable for either a dwelling or a restaurant, with



A Revolving Window through Which Food can be Passed into the Dining Room, at the Same Time Shutting Out the Noises and Odors of the Kitchen

which food can be passed from the kitchen to the dining room without disturbing those at their meals with the noise and odors incident to preparing the food. The device is cylindrical in shape and is inserted in the wall between the two rooms to be connected. Being pivoted at the top and bottom it revolves easily. A shelf divides the window into two compartments. In one side of each compartment is a glass panel and opposite it is an opening. Preferably the openings are so arranged that when one is turned toward the kitchen the other is accessible from the dining room.

3937 **NUREMBERG PLANS TUNNEL**
TO DIVERT FLOOD WATERS

Commerce Reports 1-25-1917
After the war the Pegnitz River, which time and time again has overflowed and wrought havoc in the picturesque old town of Nuremberg, Germany, is to be controlled by means of a tunnel nearly two miles in length, into which the flood waters will be

diverted. Over \$285,000 had been spent on the project when war was declared and it is anticipated that, when peace comes, work will be resumed. The total expenditure will be about \$2,300,000. The control of the Pegnitz has long been the subject of study, but no satisfactory method has been found heretofore because of the peculiar conditions to be met. One plan was abandoned on account of uncertainty as to its efficiency and the disfiguring of the landscape that would necessarily result. The building of a few large reservoirs, or several small ones, was pronounced impracticable, partly because of the character of the ground, on the one hand, and the difficulty of properly controlling the barriers, on the other. The present plan includes the construction of a dam above the inlet to the proposed tunnel. The excess water will be made to run over a weir into the underground passageway. At its lower end the tunnel will empty into a canal which will parallel the river for some distance. The subterranean channel will be about 12 feet below the earth's surface and will be able to carry off 12,340 cu. ft. of water per second. This, it is believed, will be sufficient to take care of the greatest inundations. In the past 600 years Nuremberg has had no less than 138 floods, 11 of which have been great catastrophes. The government of Bavaria will assist the city in its big effort to prevent further devastation.

3900 **TRAP BOX CARS TERRIFY**
TRAMPS IN SOUTHWEST

In the Southwest it is no longer safe for care-free "hobos" to climb into an empty box car and lie down to rest, for the innocent-looking car may be one of the "tramp traps" which the Southern Pacific has made a part of its freight trains. Before the unsuspecting vagrants have ridden many miles in one of these especially equipped cars the doors are closed suddenly by unseen hands and locked with automatic locks. In due time they are opened by



Trap Car being Entered by Tramps, Who do Not Suspect That It Is Anything More than an Ordinary "Empty"

Brakeman Operating the Lever on the Roof Which Closes the Car Doors and Locks in Any Tramps Stealing a Ride

a sheriff or railroad policeman, and the imprisoned trespassers placed under arrest. On the roof of these trap cars is a lever connected by concealed cables with the sliding doors which are provided with counterweights, also concealed. When one of these cars is made a part of a train the doors are left open invitingly and the floor is covered with straw which conceals a burglar mat. The moment this mat is stepped on it lights a bulb, on the roof of the car, which is supplied



Photograph of an Actual Arrest of Tramps Caught in a Trap Car: It will be noted that the Railroad Police are Well Armed

with current from a small storage battery. The light burns until some member of the train crew, walking along the tops of the cars, discovers it and turns it off, and at the same time closes

the doors by means of the lever. The use of these traps has spread so much terror among tramps that the number of vagrants, which formerly was very large, has been greatly reduced, and between Los Angeles and Yuma they are said to have almost entirely disappeared.

3783

DUTCH COPY EQUIPMENT OF FIGHTING NATIONS

21. - 21. 417 5th Av. NYC.
A militant neutrality is maintained by the Dutch army in keeping the soldiers at war from encroaching on



neutral territory, and while constantly on guard the Hollanders have been quick to adopt the best inventions which they see employed by the belligerents. The gas mask and the steel helmet of the Dutch border sentinels illustrate the way in which Holland has copied the equipment of the soldiers beyond its borders.

3911

FLOOR WASHER DOES WORK OF SEVERAL MEN

In one operation a new electrically driven floor-cleaning machine wets, sweeps, scrubs, and dries a surface while it is pushed slowly across it. The machine weighs 100 lb., is 28 in. long, and is connected to an ordinary lighting circuit by a flexible cable. An eight-



A Dutch Border Sentinel Wearing a Gas Mask and Steel Helmet Similar to the Equipment of the Belligerents, by Whom His Little Country is Surrounded

*3911 machinery
Sells - Gray Corp'n, 111 E. 15th St. NYC.*

gallon tank holds soapy water that is delivered to the floor through pipes, the valves of which are constantly under



the operator's control. A cylindrical brush that is revolved 600 times a minute does the work and removes the dirty water from the floor by sweeping it into a special receptacle. An automatic

This Machine Sweeps and Scrubs a Floor in a Single Operation and Does Its Work Rapidly

reel holds 75 ft. of conductor cable and keeps the line, which is held up out of the way, fairly taut while work is being done. When pushed at normal speed, the machine cleans about 5,000 square feet of floor space in an hour.

WHY MOUNTAINS REMAIN HIGH IN THE AIR

In answer to the question, "What holds the mountains up in the air?" the Coast and Geodetic Survey has issued a report which seems to prove conclusively that the mountains, in this country at least, are not held up above the surface of the sea by the rigidity or strength of the earth's materials but are held in place by materials underneath them that are lighter than normal. The higher the mountain or plateau, the lighter the material under it. The comparison is made with an

iceberg, the visible portion of which is held above the water by the ice below, which has a specific gravity lower than water. The light material under the mountains, corresponding to the submerged part of an iceberg, extends down to a depth of about 60 miles. Likewise the bottom of the ocean is depressed, the report shows, because the material under it is heavier than normal. The normal condition may be considered as that obtaining in the large river valleys and under coastal plains.

"DRY PUMP" TAKES PLACE OF GROCERY SCOOP

A sanitary substitute for the familiar grocery scoop has been invented, with which beans, coffee, sugar, rice, etc., can be removed from their containers merely by turning a crank. The new machine is attached permanently to the top of a bin, or barrel, while its lower end, consisting of a conveying screw, inclosed in a 5-in. tube, is immersed in the food product. The crank is connected, by gearing, with this screw, and as the latter is revolved, it elevates the rice, sugar, or whatever it may be, to the top and discharges it through a spout. By using this invention barrels and bins can be kept covered at all times. The device, which might be designated as a "dry pump," also saves times and prevents waste.

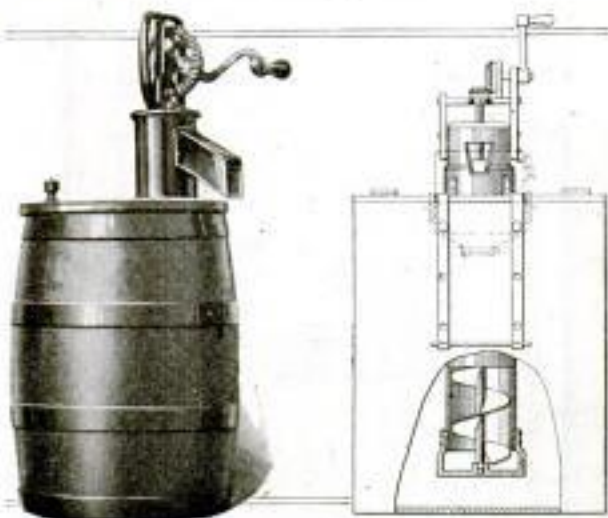

Sanitary Machine Designed to Remove Food Products, Such as Beans, Rice, Sugar, and the Like, from Their Containers without the Use of a Scoop

H. L. Branstetter
3825 Texas

land, as well as that under cultivation, borders the tidewater sloughs down which the lumbermen raft timber to the mills. It is much more convenient to rely upon water transportation than to make long treks over the few country roads that are available. Therefore nearly every rancher owns a power boat and employs it whenever there is any trip to be made. Marshfield is the marketing center for the dairymen of the vicinity, so milk and other products are carried to its wharfs daily by launches. It is not an unusual sight even to see a calf or cow occupying the stern portion of the deck on one of the little craft, riding across the water with apparently no more concern than if it were going to market in a farm wagon.

IMPROVED STEPLADDER FOR FRUIT PICKERS

An improved type of stepladder, especially serviceable for fruit pickers, is



Stepladder Especially Suited for Use in an Orchard Because of the Two Supplementary Legs Which Serve as Braces at Either Side

provided with two extra legs, one of which is hinged to each side of the top. They are equipped with steel points so that they will not slip when employed

*Inv. B. B. Keith,
Marshfield, O.*

as braces. The ladder is well suited for use on soft or sloping ground and even if mounted to the top step will not tip over. In cases where the side braces are not required they need not be spread out.

"THE UNITED REGIONS OF AMERICA" PLANNED

Phila. Public Ledger 12/24-16

Under a plan advocated by the business men and interests represented in the Philadelphia Bourse, a new grouping of the territorial United States should be made, for economic reasons, by erasing present state lines and creating "The United Regions of America." This plan would divide the country into six great regions according to "community interests," with special regard to the importance of railroad coöperation and the character of the industries and general conditions of each. The regions proposed, with their suggested regional capitals, are as follows: Eastern Region, New York City; Southern, Atlanta, Ga.; Lake, Fort Wayne, Ind.; Central, Omaha, Neb.; Southwestern, Dallas, Tex.; and Western, Salt Lake City, Utah. It is insisted by advocates of the plan that the country has outgrown the artificial divisions of state lines, and that it should be redivided according to natural resources and economic conditions which the Interstate Commerce Commission has already recognized by designating definite zones for railroad regulation. The plan calls for the creation of an economic government for the "United Regions," under which the present Interstate Commerce Commission would be completely reorganized. It is the intention of the Philadelphia Bourse to submit the plan to congress at a convenient opportunity.

☐ The very high price of cork caused by the war has resulted in the production, in Sweden, of more or less satisfactory substitutes, one of which is made of cork waste mixed with paste. Wood is also used as a substitute in making bottle stoppers.

WOMEN AS SKILLED WORKERS IN AUTO FACTORY



Inspecting Automobile-Engine Pistons with the Aid of the Micrometer: Women are Said to Develop Great Skill in the Use of This Instrument for Detecting Defective Work

Women at Work in the Top Department of a Detroit Automobile Plant, Cutting and Sewing Materials for Auto Tops and Side Curtains: From This Department the Use of Female Help has Spread to Half a Dozen Other Departments of the Factory Requiring Skilled Labor Hitherto Furnished by Men



Above is a Woman Operating a Machine in the Auto Factory. The Result of Setting Women at New Tasks in This Plant has Been Uniformly the Same: Increased Efficiency and Greater Output in Every Department Where They are Employed

The Girl Above is Assembling Small Parts for Auto Engines. Among the Tasks to Which Women are Now Set in This Factory are the Assembly of Primer Systems, Switches, and All Wiring for Automobiles, besides Inspection and Drill-Press Work



Women Workers in This Factory, Who are Now Engaged, as Seen in the Above Photograph, in the Inspection and Assembly of Auto Parts, and Heavier Work of a Mechanical Nature, are Paid Men's Wages, Have Rest Rooms for Their Use, and Find the Work More Congenial than the Usual Occupations of Women

D. Green & Sons.

Chamber of Commerce
Milan, Italy.

750

3835

Cincinnati O.
POPULAR MECHANICS

3933

**OHIO FACTORY DUPLICATES
AN ALPINE BUILDING**

**PLAN CANAL TO CONNECT
MILAN AND VENICE**

Planned from photographs of a watch factory in the Alps of Switzer-

5c Am. 1-6-17
After the war the city of Milan, Italy, is to be connected with the Adriatic



This Beautiful New Building Is a Cincinnati Watch Factory, and an Exact Copy of the Company's Plant in the Swiss Alps

land, the building and grounds of a new watchmaking plant in Cincinnati are an exact duplicate of the picturesque original, to the last detail of construction and landscape gardening. The building is in effect a large Swiss chalet transplanted in America. Over 2,000 native Alpine plants were imported to add realism to the scene.

Sea by a system of artificial waterways, if plans which engineers have perfected and which Milan authorities have approved are carried out. It is proposed to build a canal 45 miles long, connecting the city with the Po River. The Adda River, already partly canalized, would be utilized in making this connection. The Po would be used for a distance of 160 miles and connected with the lagoon of Venice by a canal 30 miles in length.

In the latter sector artificial waterways already constructed would be used. It is proposed to provide Milan with a port which would include three basins 200 ft. wide and 2,500 ft. long. The water traffic, which according to estimates would be 1,500,000 tons a year, probably would consist chiefly of coal and ores.

3877

**PRISONERS DRESS FLEAS
TO SELL AS SOUVENIRS**

From the pest-ridden prisons of Mexico comes one of the strangest types of mementos that men in involuntary confinement have ever produced—dressed fleas. By methods not wholly known to outsiders the inmates of Mexi-



co's penitentiaries dry, dress, and mount fleas which they catch in their cells. The bottom of a bottle is sometimes used as a magnifying glass and

tiny pincers are also employed in this work. The pair shown herewith represent a bride and groom. The former is about an eighth of an inch high and is dressed in fine white material with a flowing train. The groom wears the usual black. The illustration shows the fleas magnified many times.

3891

**PORTABLE PLATFORM FROM
WHICH MOVIES ARE TAKEN**

The thrilling chase which every "movie" enthusiast has witnessed on the screen so often, and frequently at close range, is photographed by mounting the motion-picture camera on some sort of vehicle that is driven or drawn behind those that are pursued. One of



Efficient Type of Camera Truck Attached to the Rear of a Vehicle Used in a Comic "Movie" Scene, Showing How Continuous Close-Up Views are Obtained of a Moving Conveyance

the most practical of these camera trucks, as they are often called, has been built in Santa Barbara, Calif., and consists of two pairs of automobile wheels from the axles of which is hung a platform measuring 4 by 6 ft. The rubber-tired wheels minimize the jar to which the camera is subjected. The platform is large enough to hold the camera and tripod and three men. The outfit is often tied to the rear of the vehicle being photographed, as shown in the accompanying illustration. This truck can be used to advantage in a studio also.

3243 —

TUNING DEVICE DECIDES ORCHESTRAL PITCH

✓ A musical director of Los Angeles, Calif., has invented what he calls a tonameter, which does for the instruments in an orchestra the same thing that a tuning fork does for the voice—that is, it establishes the pitch, and tells whether the instrument is in tune or not. In form, however, it differs widely from the ordinary tuning fork, being a large wooden box in which are fixed six bars of metal so perfectly tuned and adjusted that there is a difference of only one vibration a second

between any two bars, the first having 435 vibrations—international pitch; and the last 440—orchestral pitch. A pendulum attached to the box and, making a complete swing in exactly one second, assures the correct measure-



Testing the Pitch of Instruments in an Orchestra with a New Tuning Device: By Striking the Metal Bars Differences from Standard Pitch are Detected

ment of the variations in tone which follow the striking of one of the bars. The inventor claims that the instrument makes it easy for a leader to detect any tendency to play the least bit out of tune.

✓ Prof. Adolph Tardieu
Symphony Orchestra

HANDCUFFS USED TO LOCK MOTORCYCLES

An instance in which handcuffs have been employed to prevent theft, instead of to manacle criminals, is to be found in Los Angeles where members of the police force use these shackles to lock their motorcycles. This arrangement has effectively checked the thieves who have stolen several police machines and also relieved the officers of the inconvenience of carrying special locks.



of the National Americanization Committee of New York City was invited to Detroit to suggest the best methods of work, and most of the women's organizations in the "City of the Straits" are now coöperating effectively in the patriotic movement to Americanize their foreign sisters.

3512

BIG MODEL OF OLD WHALER IS BUILT FOR MUSEUM

At New Bedford, Mass., once the seat of the industry, a museum devoted exclusively to whaling relics has lately been established. Among other things it contains a half-size replica of the "Lagoda," an old whaler accredited with 12 voyages during a 44-year period of service in which it netted the owners about \$650,000. The model, which is fully rigged and equipped, was constructed at a cost of \$25,000 and occupies most of the floor space in the new museum, a building designed after the old Salem custom-house where Hawthorne was once employed. The lofty spars of the "Lagoda" extend to within a few feet of the high, arched ceiling, stalwartly commemorating the once romantic and flourishing industry of the east coast. The building is 118 ft. in length and 57 ft. wide, while the model ship measures 89 ft. from flying jib to spanker boom.

N. C. Goh, Secy.

4015 Naturalization
MAKING AMERICANS OUT OF FOREIGN-BORN WOMEN

Strong efforts to Americanize the foreign-born women of Detroit's new population are being made by club-women of that city, with the support of the Detroit Board of Commerce, which has had a committee at work for some time on the Americanization of foreign-born men. When the women's campaign was started, a representative



Left: Fully Rigged and Equipped, This Interesting Big Model of a Once Famous Whaling Vessel is Sheltered in a Museum at New Bedford, Massachusetts. Right: Deck View of the Ship That Commemorates a Once Flourishing and Romantic Industry of New England

Jonathan Bourne Whaling Museum

C. L. Wilhelm 41 Wilton Heights, St. E., Baltimore, Md.



Two Hundred and Fifty North Dakota Troopers at Mercedes, Texas, Carrying the Christian Association Building, Weighing Six Tons, to a New Site

3941

3884

BORDER TROOPS CARRY SIX-TON BUILDING

Carrying a six-ton building without the aid of machinery, or other equipment, was one of the unusual tasks performed by 250 North Dakota soldiers when they were on the Mexican border. The frame structure that was moved housed the army Y. M. C. A. at Mercedes, Tex., and measured 72 by 24 ft. Because the site was undesirable, it was proposed to hire a contractor to move the structure to a new location, but the army engineers devised a plan by which the men themselves could perform the task and so save money. They estimated that with 250 soldiers helping, each would have to carry less than 50 lb. Accordingly the building was well braced and its walls provided with runners. Since there was no floor the men were stationed along all four walls, inside as well as out, each soldier standing next to a beam inserted beneath. At the word of command they lifted the building from the ground and marched away with it, to a site 200 yd. distant.

☞ Fishermen on the Pacific coast, from San Francisco to San Diego, have brought in so few fish in recent months that the situation is becoming serious. The cause of the shortage is not known.

ELEVATOR THAT CLIMBS A STAIRWAY

An elevator for carrying loads up an ordinary stairway is in use at a New Jersey factory. Its platform is normally level with the floor at the bottom of the stairs, which can then be used in the ordinary way. When a load is placed on the platform, and an electric button is pressed, a 1/4-hp. motor raises the elevator, which runs on four small wheels on tracks resting on the risers of the stairway. The shaft driven by the motor is at the top of the stairs and connected to the ele-



Stair-Climbing Elevator. Just After It has Left the Lower Floor Level, Where It Normally Rests Out of the Way

vator platform by small chains on either side. When the load is removed at the top, the elevator returns automatically to the lower level.

G. Howlett Jarvis (Inv.)

SOME NOVEL AND LITTLE-KNOWN ACCESSORIES



Convenient for the Woman Who Does Her Own Sewing: A Simple Skirt Marker That Lessens the Work of Turning a Hem. Price, 25 Cents



For the Lawn, a Weed Exterminator: The Hollow Handle Contains Kerosene or a Saline Solution Which is Injected into the Roots of Dandelions or Burdock Plants. Price, \$1



Open-End Pans in Which Bread may be Baked in a Variety of Shapes. Available for 25 and 40 Cents



Fuel-Saving, Glass-Door Oven for Gas Stove: It Is Especially Serviceable for Small Baking in the Summer Time When the Use of an Ordinary Oven Overheats a Kitchen. Price, \$6.20



Combination Magazine Rack and Smoker's Stand, Finished in Cream Color and Ornamented with Bright-Hued Parrot. Price, \$12



This Aluminum Pot Prepares Coffee in One Minute. Grounds and Boiling Water are Placed in Upper Section, Which is Separated from Bottom by Muslin Strip. Price, Six-Cup Size, \$5

Dough Gun, with Assortment of Dies, That Enables a Housewife to Make Cookies in Attractive and Original Shapes. Price, \$1.25



Wire Vessel in Which Doughnuts, Fritters, Sea Foods, and Vegetables may be Retained White being Cooked. Price, 50c.



When Orange Rinds are to be Used as Sherbet Cups, the Tool Shown Above Is Valuable. Price, 25 Cents



Folding Ironing Board That Occupies Little Space When Not in Use: It may Easily be Carried in a Trunk. The Price Is \$3



Fruit Jars can be Removed from Boiling Water, in Which Their Content has been Cooked, by Means of the Device Illustrated Above. Pictures Explain Its Operation

Motor-Driven Washing Machine with Adjustable Legs: The Swinging Wringer Operates in Any Position. Extra Pulley Permits Motor to Run Household Appliances. Price, \$60



- 1 SUPERIOR SKIRT MARKER, Superior Mfg. Co., 603 Pacific Bld., San Francisco
- 2 "DANDY-LION" WEED KILLER, Rochester Spray Pump Co., 179 Broadway, Rochester, N.Y.
304 Hewes St.
- 3 OPEN BREAD PANS, Silver & Co., Brooklyn, N. Y.
- 4 BOLO OVEN, Grisweld Mfg. Co., Erie, Pa.
- 5 DOUGH GUN, Tate Mfg. Co., 40 Hanover St., Boston, Mass.
- 6 "KIN-HEE" COFFEE POT, National Aluminum Works, Elmira, N. Y.
- 7 FREEBORN PERFECT COOKER, Freeborn Specialty Co., 244 Plymouth Ave., Buffalo
- 8 MAGAZINE & SMOKING STAND, Ovington's *Brooklyn, N.Y.C.* *314 21st St. N.Y.C.*
- 9 SELL'S PORTABLE FOLDING IRONING BOARD, A. J. Vernier, 602 Straus Bld., Chicago
- 10 "SAFETY-FIRST" FRUIT JAR LIFTER, Invt. W. F. Guidetti, 745 W. San Fernando St., San Jose, Calif. *5+*
- 11 MAYTAG WASHER, The Maytag Company, Newton, Iowa
- 12 STARR ORANGE DERINDER, JOHNSON & STARR CO., 220 Bushnell Bld., Springfield, O.
- 13 ELEPHANT TEAPOT, A. A. Vantine & Co., 5th. Ave., and 39th. St., N. Y.
- 14 DEODORIZER, E. E. Woods, 517 Fairbanks Bld., 56 E. Randolph St., Chicago
- 15 ANCHOR PICTURE HOOKS, Buffalo-Dehn Co., Buffalo, N. Y.
- 16 FOLDING KIT-BAG, Mark Cross, 404 5th. Ave., New York
- 17 SILVER KNIFE, Shoelbred's, Tottenham Court Road, London
- 18 HYGEIA LUNCH FORK, Hygeia Antiseptic Tooth Pick Co., N. Y. *160 E. 14th St. N.Y.C.*
- 19 SIX-INCH FAN, Western Electric Co.
- 20 J.H.B. ADJUSTABLE CURTAIN RODS, James H. Boye, Mfg. Co., 351 W. Austin Ave., Chicago
- 21 CRETONNE CLOSET, Jean L. Benson, 36 S. State St., Chicago
- 22 BROOKLYN KNIFE & FORK CLEANER, Silver & Co., Brooklyn, N. Y.
- 23 BUDDINGTON HUMIDIFIER, Reid-Geisler Mfg. Co., 326 W. Madison St., Chicago
- 24 DE-LIGHT JEWELRY DRING BOX, Heekin Can Co., Cincinnati, O.

March 8-1917

INTENDED FOR THE HOME AND ITS MEMBERS



For Those Whose Tastes Run to Unusual Designs, There Is This Odd Oriental Teapot Made of a Very Thin Japanese Earthenware. The Price, Prepaid, Is 75 Cents



This Ornamental Plaque Has a Concealed Chamber That Holds a Deodorizer for Sick Room



Picture Hooks That Eliminate Use of Wire, Do Little Injury to Wall, and Prevent Picture from Getting Out of Line. Box of 20, Ten Cents



Folding Pigskin Bag with Attractive Linen Lining and

Strong Locks. Twenty-Inch Size, \$28



The Blades of This Silver Knife are Opened by Turning the Rings Provided at Either End. Price, \$1.35



Light-Weight, Practical Electric Fan with Six-Inch Blades. It is Particularly Suited for the Small Office. The Price Is \$5.95



For Picnickers, Motorists, and Others, Sanitary Lunch Forks Like This One are Provided in Sealed Individual Envelopes



For the Woman Traveler, a Collapsible, Hanging Depository for Hats and Delicate Apparel Requiring Protection from Dust: It is Made of Cretonne and Folds to Size Shown. Price, \$8.75



Double Curtain Rod Especially Desirable for Bay Windows: Knuckle Joints Permit Proper Adjustment without Bending Rod or Brackets. Price, \$1.60



A Convenient Household Device That Lessens Work of Cleaning and Polishing Knives and Forks: Consists of Adjustable Spring over Which Chamois is Laid. Price 40 Cents

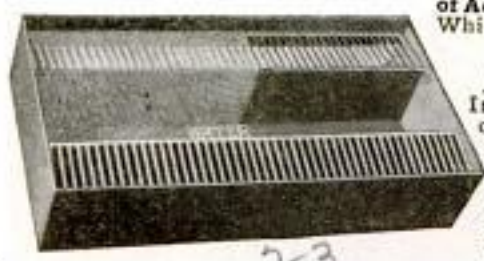

At Left is Shown Interior Construction of a New Humidifier That, on a Hot Radiator, will Evaporate a Gallon of Water in 12 Hours. The Perforated Wings Hold Wicks; the Central Part, Water. Price \$3



Jewelry-Drying Can Supplied with Hardwood Sawdust: After Proper Cleaning, Stones are Given Brilliant Luster

Ina. J. Muller,
 1423 Park Pl.,
 Brooklyn, N.Y.
 756 2910 POPULAR MECHANICS

**WOODEN FUSE PULLER
 FOR HOUSEHOLD USE**

A serviceable article for use in an electrically lighted home is a fuse puller designed by a Brooklyn inventor.



It consists of two wooden arms about eight inches long, each of which is fashioned at one end into a handle, while the opposite ends are suitably notched. The arms are held side by side by two long bolts. Around the bolt nearest the handles, and between the two members, is a coil spring that

serves to spread the arms apart, while on the other bolt are two coil springs, outside of the arms, which tend to press the ends of the arms together. By merely pressing the handles together while holding the tool in one hand, the notched ends may be opened to grasp a fuse, without in any way exposing the user to an electric shock.

3572 —

**ROLLER SKATES GEARED TO
 INCREASE WEARER'S SPEED**

Roller skates equipped with gearing intended to increase the wearer's speed automatically, are among recently patented inventions.

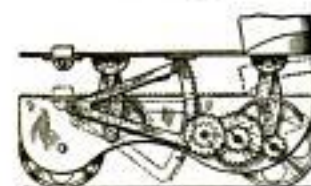

Power is transmitted to the rear roller of this skate by means of a set of gears, a ratchet, etc., concealed beneath the footplate. When the foot is raised off the floor that part of the skate below the footplate drops down an inch or more. Then, when the weight is thrown on the footplate

Joe. Lehardt,
 Chicago,

again, it presses it down to its normal position, at the same time causing the rear roller to revolve by means of a suitably connected ratchet. With each new stroke the ratchet is drawn up and then pressed down, as described, thus giving driving force to the rear roller.

3267 —

**RIFLE-SIGHTING DEVICE
 FOR TARGET PRACTICE**

A sighting device for use in rifle-target practice, recently patented, includes an adjustable iris diaphragm which operates in a manner resembling the accommodation of the human eye, by which the pupil is expanded or contracted automatically. In this gun sight a similar adjustment is obtained by manual operation of a lever attached to the diaphragm at the front of the rifle. This enables the marksman to adjust the opening so as to shut out all undesirable rays of light while allowing the eye to view the bull's-eye and a small clear space



Sighting Device for Firearms, in Which the Front Sight Is an Adjustable Iris Diaphragm Operated by a Lever to Suit the Marksman

around it. A peep sight is arranged at the rear of the rifle and with the iris-diaphragm adjustment the shooter can choose the most suitable aperture for the front sight, according to his individual requirements.

3983 —

**SINGLE-TRACK DUAL-GAUGE
 RAILWAY BRIDGE**

So as to accommodate the rolling stock of both Russian and Swedish railways, which are of different gauge, two sets of rails are to be laid on a single-track bridge that will span the Torneå River between Torneå and Haparanda, at the upper end of the Gulf of Bothnia. This structure will be a part of the connecting line which

Brion S. Bullish,
 148 Hamilton Ave.,
 Paterson, N.J.

Commerce Reports 2/17/17

is to link the Finnish and Swedish transportation systems. The engineering plans for the project have been completed and it is expected that the work will be finished some time in the fall of next year.

2781 —
FOLDING CHAIR EQUIPPED WITH AWNING

A beach or garden chair has been patented which is especially convenient for outdoor use because it can be folded into small space and is equipped with an adjustable shade to shield the occupant from the sun. The frame of the chair is of wood and is built like an easel, the front half serving both as a support and as the back of the chair. Hinged to it at the proper height is a seat which can be raised to a horizontal position and held in place by braces. The back of the chair is made high enough to extend above the head of the occupant. Fastened to the upper end of the back, by brackets, is a canvas curtain mounted on a spring roller. Attached on either side of the brackets is a U-shaped wire frame which can be held out in a horizontal position by



Beach or Garden Chair Which can be Folded into Small Space and is Equipped with an Adjustable Canvas Awning

adjustable supports. The canvas can be stretched out over this frame and so made to serve as an awning.

3827
MOTOR-DRIVEN SHEARS NEW TOOL FOR TAILORS

For the benefit of cutters in the tailoring industry and also of those engaged in similar branches of associated

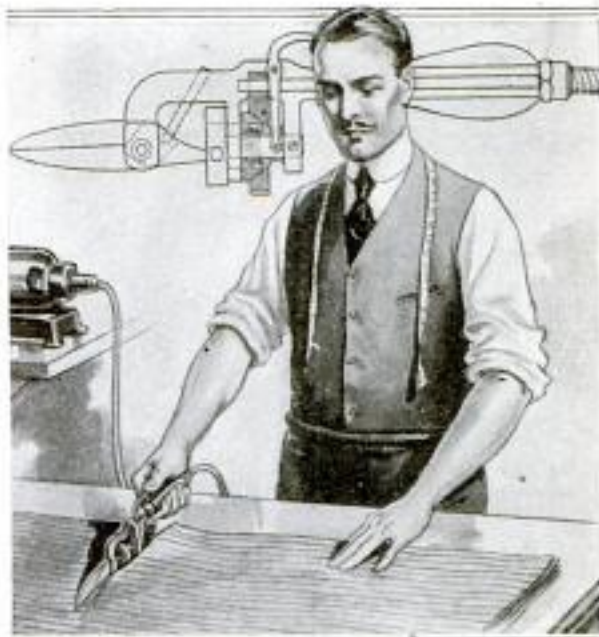

Electrically Operated Shears Intended for Cutters in Garment Making and Similar Industries

occupations, power-driven shears have been developed by a Chicago inventor. Although materially increasing a tradesman's capacity, a more important advantage of the instrument lies in the fact that it obviates manual work of a character which frequently disables the person constantly employed at it. Driven by a small motor installed above a workbench, a flexible shaft connects with a rigid one extending through the handle of the tool and supplies the power that operates the upper blade. The lower cutting member remains stationary. One hundred cuts a minute is the normal working speed of the tool. A thumb lever stops and starts the shears, but otherwise the instrument is controlled in the feeding. The weight is about the same as that of ordinary tailor shears.

CA Pittsburgh scientist has invented a bayonet that carries near its end a capsule containing antiseptics, etc., designed to render painless and cleanse the wound inflicted.

Inv: Eugene A. How
 4609 Sheridan Rd.
 Chicago

RIGHT AND WRONG WAYS TO LIFT HEAVY WEIGHTS

A well-known metallurgical company has recently issued instructions show-



Left: A Lifting Posture Which Subjects the Small of the Back to Undue Strain and may Result in a Rupture. Right: With This Position the Strain is Thrown on the Thighs and Shoulders

ing the right and the wrong ways to lift heavy objects, such as ingots or

2769

GOLF-SCORE CHART SHOWS SEASON'S RECORD

A graphic portrayal of a golfer's scores for an entire season, or any desired period, together with the scores

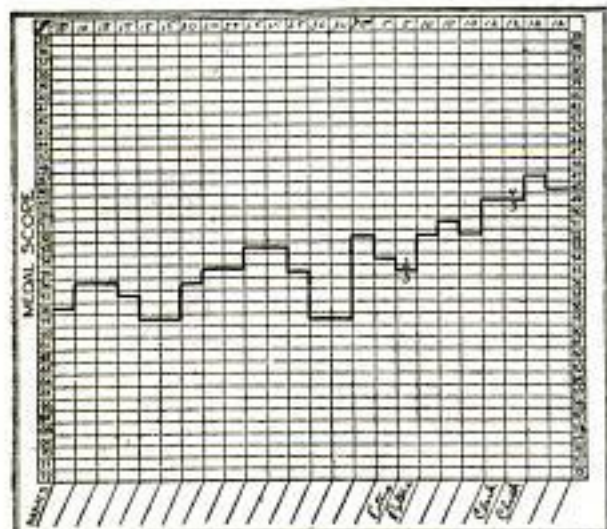

A Golfer's Score Board Which Shows at a Glance One's Scores for an Entire Season, Together with Those of One's Opponents

of his opponents, can be prepared by using a golf-score chart which has been patented by a frequenter of a Kansas

M. W. Peck,
200. Graphic Arts Bldg.,
Kansas City, Mo.

castings. The way which is condemned, and which many workmen thoughtlessly follow, consists in grasping the load with both hands while stooping over and scarcely bending the legs at all. Lifting in this posture throws most of the weight on the lower part of the back, where the muscles are weakest, and may produce a severe strain, or rupture. The proper way is to grasp the load after squatting down close to it so that the knees are drawn well up against the body. Lifting in this manner throws the weight on the thighs and shoulders, which are strong and best

suited to the severe stress that comes in raising the body to an erect posture.

City course. The chart consists of a piece of cardboard ruled off with uniformly spaced vertical and horizontal lines. In the tops of the columns are written the dates of the games. At the right and left-hand sides are figures set down in numerical order from 35 to 72, for example, to represent the range of possible scores. The medal score for each nine holes played by the owner is recorded merely by drawing horizontal lines, under the proper dates and through the squares opposite the respective scores. When match games are played, the opponent's name is written at the bottom of the column, the score of the chart's owner is written above the line in the square, and his opponent's is entered below the line.

— 3975

METHOD OF FIGHTING FROST IN WATER TANKS

Electrical World 1/13-17
Dairy farmers and stockmen in the vicinity of Goshen, Ind., have found an inexpensive way of using electricity to prevent their water tanks from freezing in cold weather, without re-

sorting to the aid of electric heaters. Where the pumps are equipped with electric motors, they operate the motor so as to pump just fast enough to raise the warmer water of the well to the tank in sufficient quantities to keep the water temperature in the tank just above freezing. It is necessary to let enough cold water run off from the bottom of the tank to make room for the water added, but the value of this wasted water is regarded lightly in view of the saving effected by keeping the tank in service when the weather is severe.

2594

SPECIAL JOINT EMPLOYED ON GALVANIZED PIPE

It requires only a few seconds to make a water-tight connection between two lengths of galvanized steel pipe



This Joint Facilitates the Laying of Pipe, for It Enables a Water-Tight Connection to be Made Quickly

fitted with a patented joint lately introduced in Australia. Locking members, whose inner edges are corrugated, are supplied on the inside at one end of a section of pipe and on the outside of the other end. Thus by inserting the small end of one length into the large end of the other and twisting them, the locking members are engaged. A rubber washer makes the joint water-tight. Lugs on the circumference of both sections enable a wrench to grip firmly.

bottom and an open back, in which two deep trays are placed side by side. One half of the top is covered by a hinged glass door which affords access to the

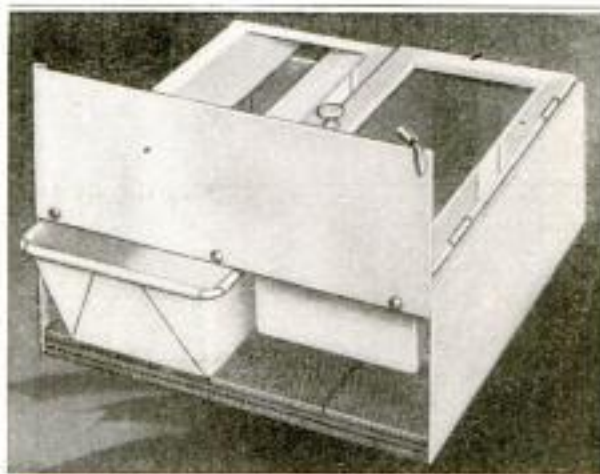

A Sanitary Holder for Knives, Forks, and Spoons, in Which Are Two Trays, One for Clean Utensils and the Other for Used Utensils. This Rear View Shows How the Tray for the Latter may be Removed

tray containing clean utensils only. The other half is entirely covered except for a narrow slot extending lengthwise in a slight depression. Through this opening used utensils are deposited in the second tray. A sign explains the purposes of the compartments. The trays can be easily removed and others put in their places as occasion demands.

3654

INSULATOR AND LINKS FOR ELECTRIC-LIGHT CHAINS

Elect. World 12/9/16
A new type of a splicing link for electric-light chains consists of an S-shaped hook slotted at each end,



so that two chains can be united by fitting their ends into these slots. By using two links and inserting between them a special insulating unit, having suitable knobs at the ends to which the hooks can be attached, a light chain can be thoroughly insulated from the electric current—an arrangement most desirable in a bathroom where short-circuiting may prove fatal to a bather, particularly if he operates a switch while in the water.

333 **SANITARY HOLDER FOR KNIVES AND FORKS**

A sanitary holder for knives, forks, or spoons has been designed for use in eating places in which the patrons wait on themselves and, when the meal is over, return their dishes and utensils to a counter. The device consists of a white-enamel case, having a wooden

John Danks & Son, 110 St. George, Melbourne, Australia.

Designed by M. H. Harris, Thomas Woodstock, Ill.

The World Traders, 516 Harvester Bldg., Chicago, Ill.

YOUNG FOLKS AT WORK AND PLAY,

A Boy Scout Who Is in Two States at Once—Kansas and Nebraska. He is Saluting from the Top of an Old Iron Post That Marks the Boundary between the Two

Left: Only Six Years Old and a Wonderful Swimmer and Diver! This Los Angeles Boy Learned to Swim at Three, and at Four Was More at Home in the Water than the Average Grown-Up. He has Won Many Honors, as His Medals and Loving Cup Show, and Is a Licensed Swimming Instructor!

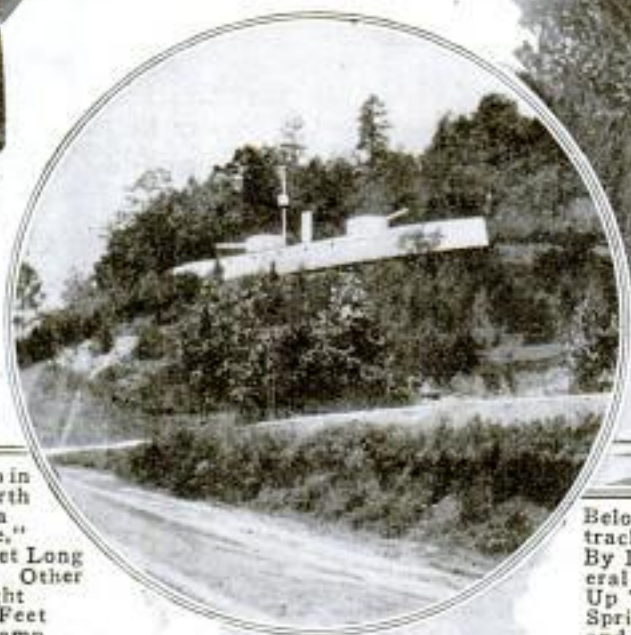

Center: A Summer Camp in the Mountains of North Carolina, Built Like a Battleship: The "Maine," as It is Called, Is 92 Feet Long and Contains, among Other Accommodations, Eight "Cabins," Each Seven Feet Square. Boy Scouts Camp Here in Summer

Below: A Boy-Made Race-track for Young Bicyclists. By Dint of Hard Work Several California Lads Threw Up These Adobe Banks and Sprinkled Them with Water and Then with Crude Oil Until They Had a Hard Track



AND SCENES THAT INTEREST THEM



A Little Alaska Miss, All Bundled Up as if for a Dog-Team Ride: This Picture was Taken in New York Where She Went Recently to See the "Sights"

PHOTO COURTESY INTERNATIONAL FILM SERVICE

Every Day after School This Lad Rides 22 Miles Carrying Papers to Folks Outside of Salt Lake City — and Rain, Cold, or Desolate Country do Not Stop Him. His Last Delivery Place is Shown at the Left. It is a Mine Prospector's Hole in the Side of a Mountain Two Miles up a Rocky Cañon

Just to Show That It Isn't Afraid, This Yellowstone Park Deer is Taking Food from the Man's Mouth. It Is the Government's Protection That Makes the Park Animals so Friendly

PHOTO COURTESY INTERNATIONAL FILM SERVICE

Charles H. G. Ford
40 H. W. Sargent & Co.,
521 Chamber of Commerce,

762

3301

POPULAR MECHANICS

Rochester, N. Y.

DEVICE MEASURES PITCH
OF ANY INCLINE

An instrument has been patented which simplifies such problems as that arising in calculating the length of

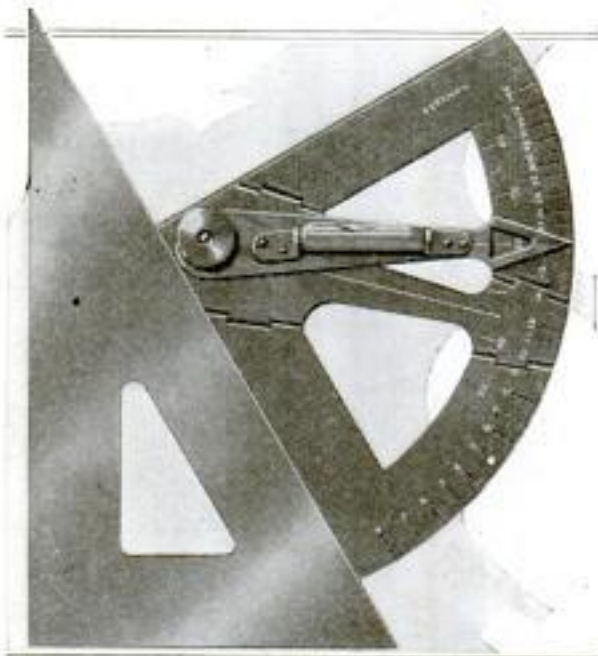

A Device with Which One can Quickly Ascertain the Angle of Any Incline and Its Rate of Fall per Foot

rafters required for a roof of a certain pitch. It consists of a flat quadrant-shaped framework to which is pivoted an arrow at the right-angle corner. The inner edge of the curved side is marked by graduations representing degrees, and on the outer edge are figures to show, in inches, the fall per foot which marks the various angles indicated by the graduations. By placing the edge of the instrument marked "level" on a roof and then swinging the arrow, to which is fastened a spirit level, into a horizontal position, the arrow will indicate both the angle of the roof's pitch and the fall per foot which the roof makes. With these data it is easy to calculate the length of rafters required. The framework is made in three parts so hinged together that it can be folded into small space.

Deposits of long-fiber asbestos, discovered in Arizona, may somewhat relieve a shortage caused by the war, which has lessened the supply of this material coming from Canada.

ELECTRIC-SHOCK VICTIMS 3971

REVIVED IN ODD WAY

Sc. Am. Sup. 12-30-16

Quite a peculiar but apparently effective method of reviving persons who have received serious electric shocks is practiced by the employes of a New York light and power company. A victim is seized by the ankles, lifted until the weight of his body is imposed upon his neck, and then allowed to fall. Without removing the shoes, some one vigorously hammers the soles of the man's feet, just as a policeman commonly does to rouse men from drunken slumber. Usually when a heavy current passes through a person's body, the tongue is swallowed. Thus it is expedient that the mouth be opened and the tongue pulled forward. These three things constitute this particular plan of first-aid treatment. Not long ago a line foreman received 2,300 volts and fell from a pole. Although to all appearances he was dead, his fellow workers resuscitated him by following the outlined rules, and the man recovered completely.

— 1881

STOP VALVE WHICH AIDS
IN REPAIRING FAUCETS

A stop valve has been devised for use in connection with faucets of a certain type, so that it is unnecessary to turn off the water in all the pipes of a home, or apartment, when a single faucet is in need of repair. This new valve is situated close behind the regular tap and is covered with a cap that screws into place. When it is necessary to keep the water back so that the faucet can be repaired, the plumber removes this cap and with his wrench turns the valve, thus shutting off the water. In this way the household is put to little inconvenience, and the plumber is able to do his work in the least possible time.



Glauco Brass Mfg. Co.,
Cleveland

Copyrighted material



Wax Patterns for Making Plaster Molds

In experimental work, as well as in the making of patterns for ornamental or shaped pieces, the use of wax patterns is economical and practical. Pour the melted beeswax into a rough mold, or box, approximately the size of the pattern. Cool it, and carve it to the desired form, using a knife, or other sharp tool, slightly warm. If a plaster mold is desired for the casting of the pattern in metal, immerse the beeswax pattern in plaster of Paris, pouring it into a suitable container, which may be used when the resulting mold is poured in metal. Provision for the entrance of the metal should be made by cutting gates in the plaster mold, or by making suitable additions to the wax pattern before pouring the plaster around it. The wax is removed from the mold by heating it gradually and then pouring the molten metal, solder or lead, into the mold. The latter is sawed open carefully and can then be used again. The soft metal may be shaped further to form a pattern for molding in sand, if desired.

Spiked-Roller Garden Harrow

Proper cultivation of perennials in the home garden, beds of which cannot be spaded handily without injury to the plants, was provided by the use of a homemade roller harrow. In the spring, when the asparagus, for example, comes up, the bed is harrowed

thoroughly, stirring up the soil, and pulverizing it, without cutting the roots. The piercing of the plants by the spikes does no serious harm. The frame supporting the harrow may be fitted to a plain roller when desired.

The roller harrow was made as follows: A large can was fitted with 6-in. spikes, spaced as shown in the detail sketch. A pipe was set in the center of the can, which was then filled with

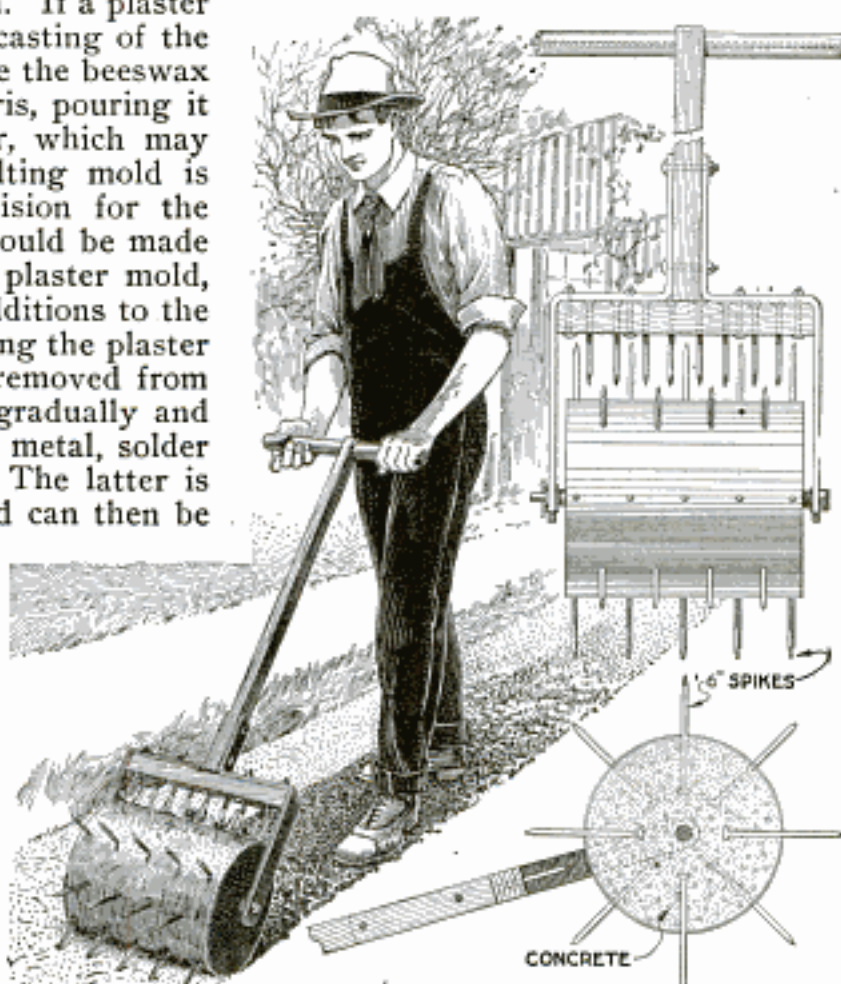

The Roller is Run over Beds of Perennials, Cultivating Them with Only Slight Injury to the Roots, Which does Not Hinder Growth

concrete. A rakelike cleaning bar, made of 2 by 2-in. stock, and fitted with spikes, spaced to mesh with those

on the roller, was fixed to the handle and the strap-iron braces. The latter were set on a long bolt, inserted in the center pipe, and provided with a cotter for easy removal.—E. B. Smith, Chicago, Ill.

Garbage-Can Housing of Reinforced Concrete

The unsightliness, and most of the common insanitary features, of the home garbage can were overcome by

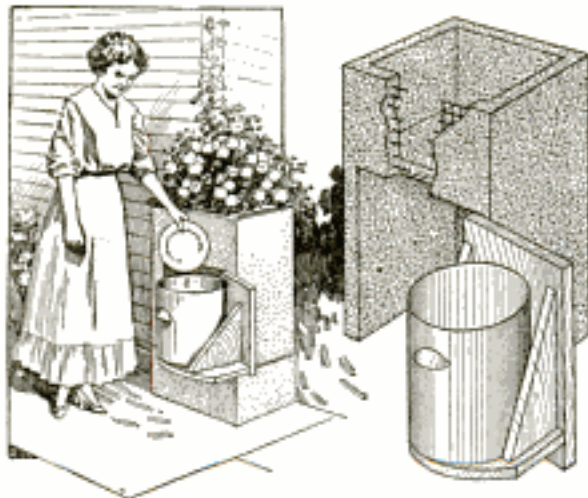

The Garbage Can is Concealed in a Container Which Serves Also as a Flower Box

providing a concrete receptacle for it. The upper part was arranged as a flower box. A large lard can was used as the garbage container, its comparatively small size making it necessary to empty it frequently. The can is set on a shelf, bracketed to the door, which is hinged on a wooden strip, set into the concrete. A metal latch holds the door shut.

The size of the housing is suited to the can. That shown is 36 in. high. The hollow base is cast separately, without reinforcement. The form for the base consists of one box within another, the intervening space being filled with concrete, the concrete for the top of the base being placed over the top of the inner box, and leveled off on the upper edges of the outer form.

The main section of the housing is built up around a wire-mesh frame. The mesh is cut to form reinforcement for the three longer vertical sides, and

bent into shape. The smaller piece for the front is wired into place. The mesh for the bottom of the flower box is also wired securely. The concrete is applied to the sides of the mesh, a roughing coat being first applied. The surface of this is left rough to afford a good hold for the finishing coat. For the roughing coat a mixture of 1 part Portland cement and 2 parts of clean, fairly fine sand is used; and for the finishing coat, 1 part cement and 1 part fine sand. The surfaces are troweled smooth.—M. Veldman, Grand Rapids, Mich.

Cableway for Handling Shipbuilding Material

Rigging for the handling of material for the building of ships that offers suggestion for application to other types of large construction was devised for a plant in Seattle, as indicated in the diagram. At each end of the slip, in which the craft lies, are two posts, 110 ft. high, well guyed and anchored. A steel cable, 1½ in. in diameter, extends between the posts and carries a trolley operated by power winches, of the double-drum type. One drum on each winch raises

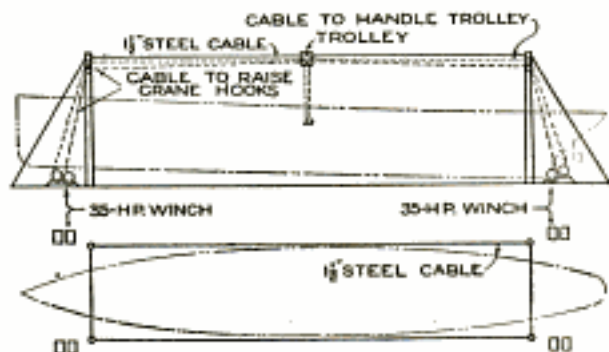

The Cable Suspended from the 110-Foot Posts Carries a Trolley for Handling Material

and lowers the crane hook on the trolley and the other pulls the trolley back and forth.—B. W. Brintnall, Seattle, Washington.

CA coat of raw linseed oil brightens and preserves old outside paint. Do not permit it to gather in drops on the lower edges of clapboards and similar edges.

Two Shovels Used as Post-Hole Auger

When only a few holes for posts are to be made, and no auger is at hand, a good substitute may be devised by using two spades, or shovels. A strong rope is tied around the handles of the shovels to form a loop, about 8 in. long when extended. Grasp the shovels by the handles, extend them within the rope, and drive them into the ground. The earth is cut loose, and then removed from the hole by spreading the handles, and drawing it up between the shovels.

Saw-Setting Anvil and Hammer

A set of tools such as are often used by saw setters may be made readily by mechanics. A hammer and anvil with gauges are shown in the sketch. The hammer is tempered and provided with a hickory handle. The anvil is mounted in an oak, or maple, block, or post, to be set on a bench, or on the floor. The latter is preferable, as it makes a more solid base. The anvil is fitted into the block deeply, and pins are driven through the side holes. The anvil, not receiving the blow of the hammer directly, may be left hard. Mild-steel pieces are fixed on each end

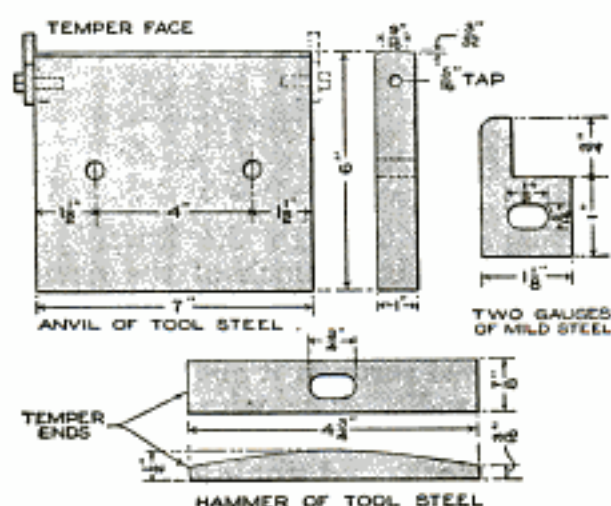

This Outfit Is Practical for Individual Use, or for Saw Setting as a Business

of the anvil, and adjusted for various sizes of saw teeth, which are set over the beveled edge of the anvil.—Donald A. Hampson, Middletown, N. Y.

A Rack for Washing Vegetables

A simple device for washing vegetables, and by the use of which a truck farmer was able to get better prices for

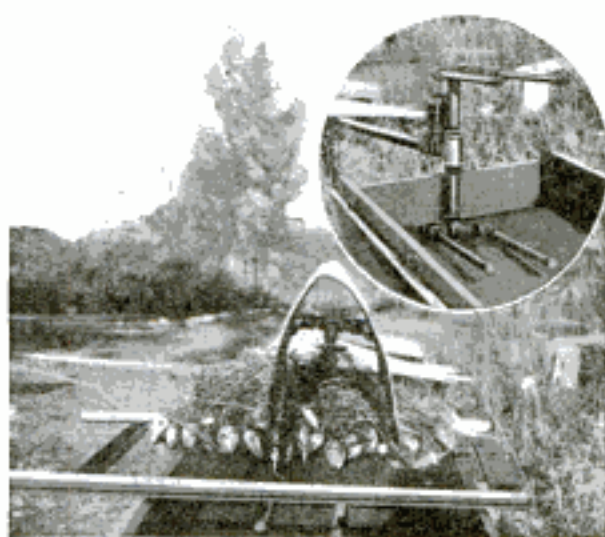

Better Prices were Procured for Vegetables Washed by the Use of This Arrangement

his product, is shown in the illustration. It is made of gas pipe and connected to the irrigating system of the farm. A 2-in. pipe is connected to a smaller one and a cut-off is placed between them. A 1-in. pipe is connected to the cut-off and reduced to smaller connecting pipes on each branch. The water finally reaches four short lengths of pipe. On the upper side of the lower pipes and on the lower side of the two upper ones, small holes are drilled in a line. The small streams make two vertical sheets of water. The vegetables are placed on a screen, which is set on top of the trough. A cover of sheet iron is fitted over the pipes and the tray. It prevents the water from sprinkling on the person washing the vegetables.—M. Glen Kirkpatrick, Des Moines, Ia.

Local reductions of density in photographic negatives may be effected by rubbing with a bit of old handkerchief dampened with alcohol. The cloth "bites" best when nearly dry, and two folds should be used over the end of a match for working in small areas.

Garage Roof as a Playhouse

In building a garage in a small city lot, the roof was utilized to make up for the space taken from the play area



The Roof of the Garage was Fitted Out as a Useful Play Area and Recreation Spot

of the children, by building a pergola on it, as shown in the photograph reproduced. A high coping was built around the edge of the wall and an outside stairway provided. The space is very popular as an open-air room for the whole family, a safe play place for the children, and a cool recreational spot for informal little parties. Porch furniture was fitted to the playhouse and increased its usefulness.—Lee McCrea, Claremont, Calif.

Device for Repairing Water Hose

If breaks in rubber or fabric hose are repaired promptly, the life of the hose can be extended considerably. By

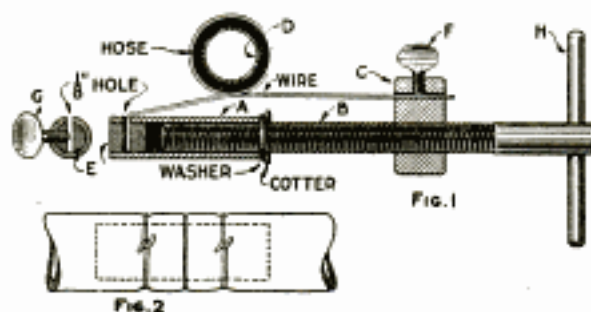

the use of the device shown in the sketch, repairs of this kind may be made quickly and substantially. A short nipple is placed in the ends of

the hose, as shown in Fig. 2, and binding wires fixed around them, by the method shown in Fig. 1. The wire tightener is made as follows: A short piece of $\frac{1}{2}$ -in. iron pipe, A, is fitted with a threaded bolt, B, which slides in it. A cotter is set through the bolt, and engages a washer at the end of the pipe A. A metal block, C, is tapped to fit the bolt B, and a hole is drilled in it for the wire, which is clamped by means of the thumbscrew F. The end of the pipe A is plugged, as shown at E, and a $\frac{1}{8}$ -in. hole drilled for the wire, clamped by the screw G. When the wire is in position around the hose D, the handle H is turned, and the wire drawn up tightly. The device is then twisted so that the wire is held securely around the hose and the nipple.—W. Drynan, Kansas City, Mo.

Foot-Lever Wire Cutter Made of a Plier

In cutting a large quantity of wire in short lengths, when only a hand cutting plier was available, con-

siderable time was saved by rigging the plier with a foot lever and a gauge, as shown. The plier was mounted on a slotted block by means of two straps of sheet iron, and a

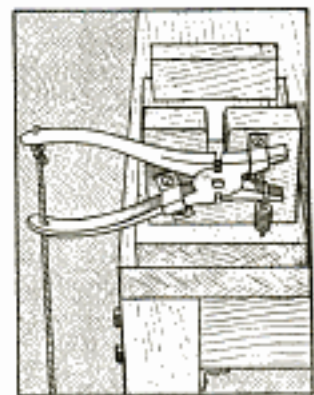

spring was fixed to the lower jaw, and to the base block of the device. A hole was drilled into the lower handle and a cord from the foot lever was passed through it and fixed to the upper handle. The wire was passed through the slot, its end against the gauge block, and cut off by a light stroke on the foot lever.—James P. Lewis, Golden, Colo.

CA large leather or rubber washer on the handle of a brush, used overhead, prevents the liquid being applied from dripping on the hand.

A Homemade Refrigerator

At Small Cost

by Charles A. King



AIR-PROOF walls, free circulation of cool, dry air, the purity of the ice, and the cleanliness of the ice chamber, are essential factors in the efficiency of a refrigerator. That described in this article, and detailed in the illustrations, was designed with these factors considered, and makes ample provision for the needs of a large family. It was built at a cost of \$17.50. If it is kept well iced, the circulation of the air, which is fundamental, will be maintained by the rising of the warmer, and the falling of the colder, air. The interior is of spruce—white-wood or poplar are good—having no odor to affect milk or butter.

The stock bill, lumber listed in lineal feet unless otherwise specified, is as follows:

- 95 board ft. matched spruce; insides; $\frac{3}{8}$ in., 10 and 16 ft. lengths.
- 85 board ft. matched pine; outsides; $\frac{3}{8}$ in., 10 and 16 ft. lengths.
- 100 ft. strapping; furrings; $\frac{3}{8}$ by 2 in.
- 18 ft. spruce; linings and furrings, corners of front; $\frac{3}{8}$ by 2 in.
- 14 ft. spruce; linings and furrings, header and base of front; $\frac{3}{8}$ by 4 in.
- 4 ft. spruce; linings and furrings under ice door of front; $\frac{3}{8}$ by 5 in.
- 9 ft. spruce; linings and furrings for mullion; $\frac{3}{8}$ by 2 $\frac{1}{2}$ in.
- 9 ft. pine; corners of front; $\frac{3}{8}$ by 3 in.
- 4 ft. pine; mullion; $\frac{3}{8}$ by 2 $\frac{1}{2}$ in.
- 7 ft. pine; header and base; $\frac{3}{8}$ by 4 in.
- 4 ft. pine; under ice door; $\frac{3}{8}$ by 5 in.
- 3 ft. pine; legs; 1 $\frac{3}{4}$ by 5 $\frac{3}{4}$ in.
- 3 ft. pine; legs; 1 $\frac{3}{4}$ by 3 $\frac{3}{4}$ in.
- 12 ft. pine; cap; $\frac{1}{2}$ by 3 in.
- 12 ft. pine; base; $\frac{1}{2}$ by 4 in.
- 30 ft. spruce; door jambs, milled; 1 $\frac{1}{4}$ by 2 $\frac{1}{2}$ in.
- 30 ft. spruce; door frames, milled; 1 $\frac{1}{4}$ by 2 $\frac{1}{2}$ in.
- 50 ft. whitewood; shelves; $\frac{1}{2}$ by 1 $\frac{1}{2}$ in.
- 140 sq. ft. building paper.
- 1 sheet galvanized iron, No. 26 gauge; 28 by 96 in.
- 1 sheet galvanized iron, No. 26 gauge; 21 by 40 in.
- 1 lb. solder.
- 1 piece lead pipe, light weight; for waste pipe.
- 2 lb. sixpenny common nails.
- 1 lb. 2-in. tinned clinch nails.
- 2 lb. eightpenny common nails.
- 1 lb. sixpenny finish nails.
- 1 lb. eightpenny finish nails.
- 3 pair galvanized-iron hinges, 4 in.
- 3 lever door fasteners; galvanized, 4 in.
- 8 screws; 3 $\frac{1}{2}$ in., No. 15; to fasten legs.
- 1 pt. shellac.
- 1 qt. paint.

First make horizontal frames C and D for the top and bottom, of 2-in. strapping, as shown in Figs. 1 and 3. Square them carefully to give a good

support for the structure. Tack building paper for insulation on the inner side, and nail spruce lining boards over it. From the stock for the outside, cut pieces for the outer sides of the top and bottom, to project about 3 in. around the edges of the frames, as indicated at E, Fig. 3. Tack building paper upon the open side of each frame, and nail on a part of the boarding, leaving an opening for packing in the filling. The latter may be dry shavings, sawdust, mineral wool, paper, or other nonconducting material. When the

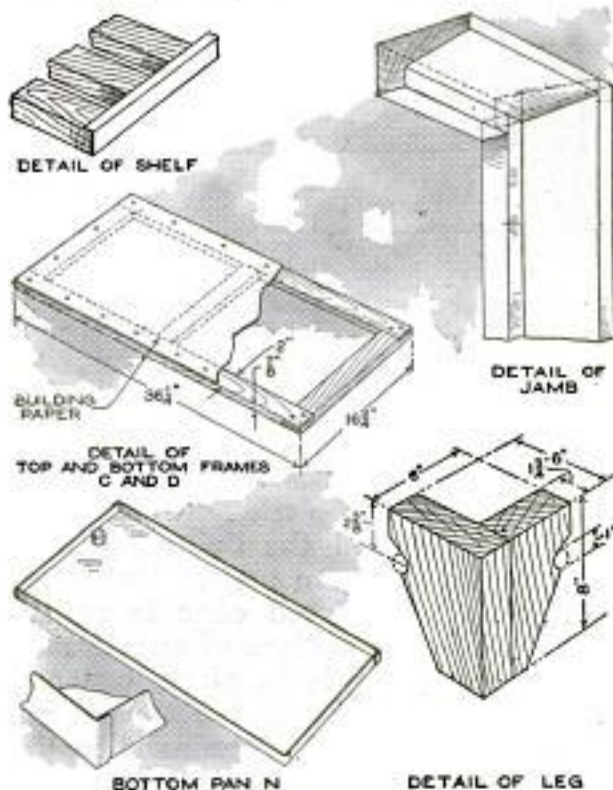

Fig. 1
Details of Several Constructional Features and Fittings

filling is in place, nail on the rest of the boards. Bore a hole for the waste pipe F, centered 1 $\frac{1}{2}$ in. from the end

and $4\frac{1}{4}$ in. from the back edges of the lower frame.

Cut spruce lining, 4 ft. $4\frac{1}{4}$ in. long, to make a width of 6 ft., to cover the

ments, as detailed in Fig. 3. Care must be taken that the door openings are square.

Cover the furrings of the ends with

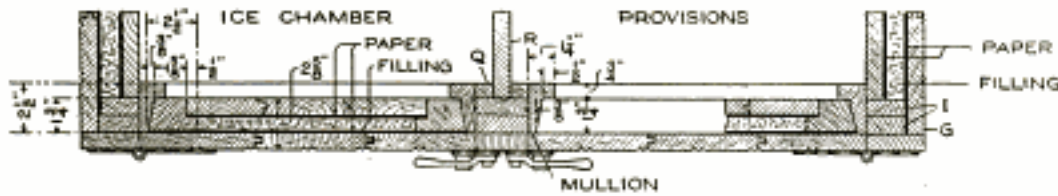
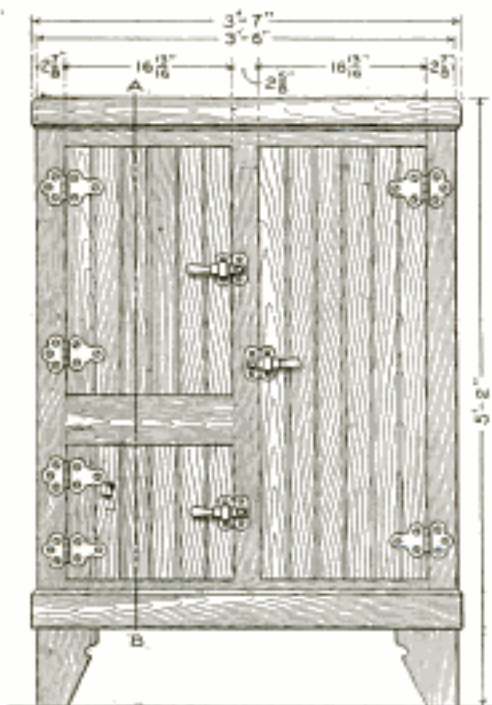
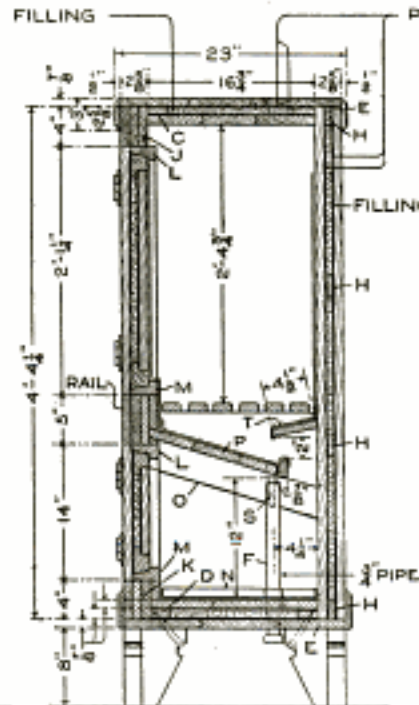
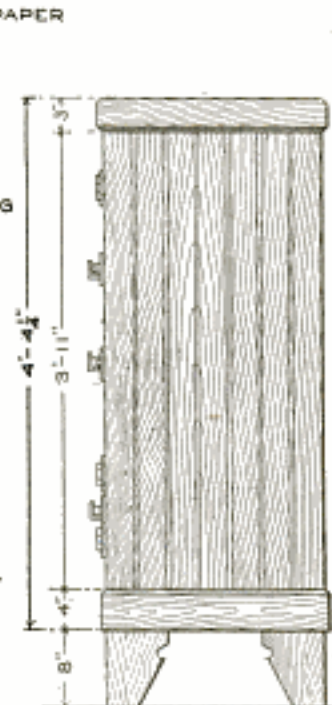

Fig. 5

FRONT VIEW
Fig. 2SECTION A-B
Fig. 3END VIEW
Fig. 4

The Working Out of the Parts and Their Assembling Involve Processes Which Are Comparatively Simple, If the Work is Done Systematically as Described

two ends and the back. Remove the grooved edge of one piece and joint it straight; nail it as the first piece of the lining at the front right corner G, Fig. 5. Set the top and bottom frames on end, and nail the lining on with eightpenny common nails. Make certain that the jointed edge is square with the inside surface of each frame. After the lining is in place, cover it with sheathing paper. Nail on the furrings H, clinching the nails in the middle ones on the outside.

Make the corner strips I, Fig. 5, the width shown. The linings J, above, and K, below the doors, are fitted as shown in Fig. 3. The mullion is built up, as detailed in Fig. 5, and the rail between the upper and lower compart-

ments, as detailed in Fig. 3. Care must be taken that the door openings are square. Cover the furrings of the ends with sheathing paper, and pack the spaces with insulation. Fit and nail the headers L, and thresholds M, of the door jambs, matching the corners as detailed in Fig. 1. The bottom pan N, as shown in Fig. 1, should be $\frac{3}{8}$ in. narrower and shorter than the bottom of the inside of the refrigerator. Nail the pan around the top edge with tinned nails. Set the waste pipe F through the bushing of the pan and the hole in the bottom, in nailing the edges of the pan.

The interior of the refrigerator is fitted next. Nail in cleats O, Fig. 3, supporting the ice floor P, of spruce, and cleats similar to those at Q, Fig. 5, on the back, to receive the fence R. The latter is of spruce, fitted horizon-

tally, and extends 6 in. from the top of the interior. A $\frac{3}{4}$ -in. hole is bored in the ice floor to receive the thimble S, fitted into the top of the waste pipe.

The measurements of the metal protection for the ice chamber are next taken. Every part that comes in contact with the ice should be covered. The iron lining on the inside of the door fits between the jambs when the door is closed. After the ice pan, on the floor P, is fitted, the hood T is nailed in, and its iron covering fitted. A trap is fitted on the lower end of the waste pipe F, to prevent the escape of cold air. The making of the metal interior should be left to a tinsmith, unless one is experienced in this work.

The trim on the front is built up in one piece, and fitted into place after the interior is complete. The door frames are fitted to allow for swelling, $\frac{1}{16}$ in. on all sides. The doors should be fitted tightly against the rabbet of the jamb, and should not bind on the sides. The fronts of the doors are put on with screws from the back of the rabbets of the door frames. Line and fill the doors as shown in Fig. 5. The cap and the base moldings are mitered and nailed on. The legs, detailed in Fig. 1, are fastened with screws. The trimmings may be of galvanized iron, brass, or bronze. The shelves, detailed in Fig. 1, are made of slats and are bound with iron. Parts of the lining not covered with iron are shellacked two coats, and the outside is suitably finished.

Leather Pattern Fillets Set in Shellac

Thick orange shellac should be used in setting leather fillets in patterns, in preference to glue, as the moisture from the wet sand tends to loosen the leather. Both the fillet and the corner are shellacked with several coats before applying the fillet, which is rubbed in with a round stick of suitable size.

☞ In painting or finishing wooden rods, small patterns, etc., it is convenient to hold them by brads driven in the ends.

Improved Rigging for Lifting Heavy Machine

In an engine room where there was no crane it was found necessary to remove the armature of a 75-kw. alter-



This Support for Differential Tackle was Devised in an Emergency for Taking Down a Generator

nator and the upper part of its frame. The roof timbers could not be depended upon, and a tripod derrick would lift but not swing aside the armature.

An improvised crane was erected by using two 4 by 8-in. timbers, rigged as shown. One end of the joined timbers was inserted into an adjacent wall, and fastened with a slanting brace. The other end was supported on a strongly braced horse. Two 10-in. diameter pulleys were mounted on a steel bar, the outer ends of which were secured by cotters. A chain was run over the bar to form a short loop, to which the differential block was hooked. The frame was unbolted and the upper part raised 1 ft., and rolled beyond the base, where it was set down. The armature was next lifted and shifted to a truck.—H. S. Rich, Poughkeepsie, N. Y.

A Barrel Water Filter

A filter, which was constructed for use in a summer camp, and which can be used in various sizes for other situations, is shown in the illustration in a vertical sectional view. A cask of

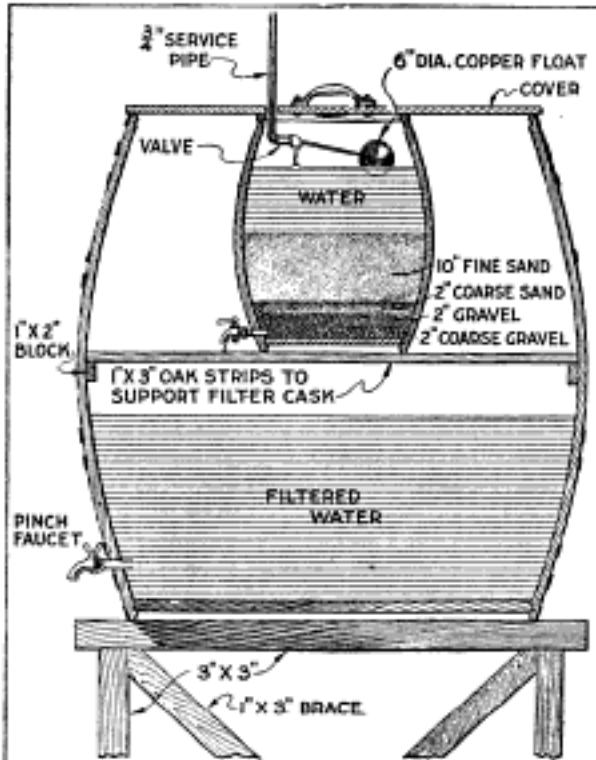

The Water is Filtered through the Layers of Sand and Gravel, and Stored in the Reservoir

about 15-gal. capacity was used as the filter tank, and partly filled with gravel and sand, as indicated. The service pipe was fitted with a check valve operated by a copper float and lever arm. The cask is supported in the larger barrel or reservoir by two oak strips, the water from the filter flowing down into the reservoir, and being drawn from it at the pinch faucet.

The cover of the reservoir is made in two parts, so that it may be removed from around the service pipe. Where water is not available through a pipe line, it can be poured into the filter from pails. The supporting frame is of oak, strongly braced. The reservoir should be painted inside with tar, such as is used in damp-proofing. The sand, particularly the upper portion, should be replaced from time to time.—John E. Cahill, Jr., New York, N. Y.

Painting Iron to Withstand Wear

Iron should be painted immediately after being cast or fabricated, if the best results in protection by the paint are desired. The paint should be applied in a dry wind or the warm sun, rather than on a damp day or at times of the day when the air is damp. The surfaces to be painted should be free from rust. A first coat of red lead and linseed oil is applied and permitted to dry hard. Two or three additional coats of red or white lead are then applied. If the iron is old, the paint should be burned off, rust and scales removed, and a coating of turpentine applied. Then the process is the same as with new iron.

Frame for Assembling or Examining Automobile Engine

An automobile engine is hard to handle when being assembled, repaired, or tested, unless a device is provided by which it can be reached at any part. The frame shown in the illustration is useful for the garage or shop, and is made of heavy wood, braced with iron rods and protected at the points of wear with angle iron. The engine is mounted on the frame, which is pivoted at its ends. A locking pin at each end steadies the frame. When it is desired to get at another part of the engine the frame may be turned and locked at the

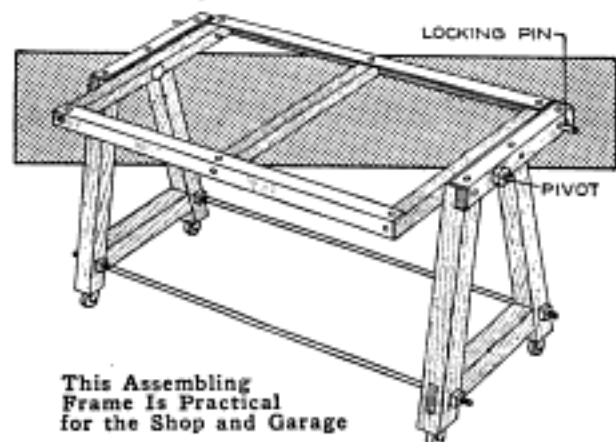

This Assembling Frame Is Practical for the Shop and Garage

desired position. Casters make it convenient to move the frame from place to place.—R. L. Hervey, Washington, District of Columbia.

A Revolving Feed Mixer

The mixing of feed for poultry, stock, and other animals can be done quickly and thoroughly by means of the

sketches. The iron strips at A and B are formed into a pin at one end, and this is bent and set in the shaft, holding the chamber in place. The door catch is a bolt hinged between two

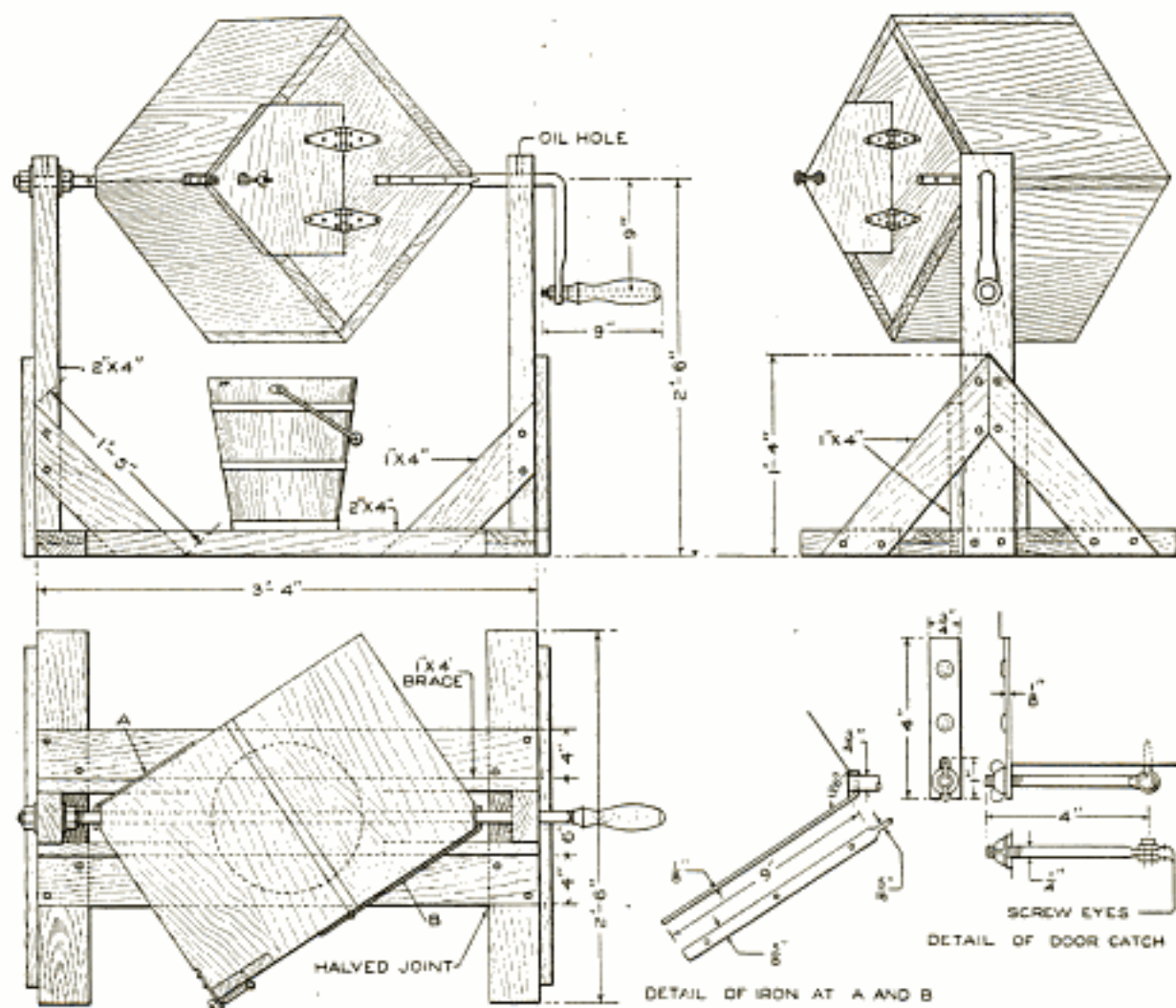

The Front and Side Elevations, Above, and the Plan, Below, Show the General Structure; the Metal Fixtures are Detailed in the Smaller Sketches

homemade mixer shown in the detailed drawings. It consists essentially of a box of $\frac{7}{8}$ -in. lumber, inclosing a chamber in the form of an 18-in. cube, mounted diagonally on a shaft, and supported by a wooden stand. The detail dimensions may be varied, but the main sizes indicated are such that the device can be handled conveniently. The feed is inserted at the hinged door, and the shaft is turned by means of the crank. The supporting stand is of 2 by 4-in. stuff, strongly braced, and bored to carry the shaft. Metal fittings are provided for the chamber, as shown in the detail

drawings. The iron strips at A and B are formed into a pin at one end, and this is bent and set in the shaft, holding the chamber in place. The door catch is a bolt hinged between two screw eyes, and provided with a wing nut, by means of which the door is clamped at the notched strip of iron at the corner. In any case, the device should be set high enough so that a bucket or feed box may be set under the mixing chamber.—Gus Hansen, Peachland, Canada.

Drain tile and similar products are awkward to carry, and a convenient method of handling them with slight breakage is by the use of an iron bar, bent U-shape to form a handle. One end of the bar is inserted in the tile and the other serves as a grip.

Boat's Wheel Made from Bicycle Sprocket

By mounting an old bicycle sprocket wheel on a wooden ring, cut from a board glued up of several layers, as shown in the sketch, I made a steering wheel for a motor-driven canoe which gave complete satisfaction. The veneered stock was obtained from an old tea-shipping

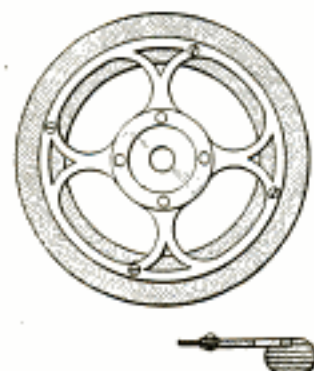

case and was built up to a thickness of 1 in. The wheel is 9 in. in diameter, and the wooden part was varnished, rubbed down with steel wool, and given a high polish. A piece of $\frac{3}{4}$ -in. pipe was used as the shaft, and the wheel was locked to it with locknuts. —B. E. Dobrée, Battleford, Canada.

Jig for Slotting Bushings on Milling Machine

The slotting of three bushings, A, at once, on the milling machine is accomplished by the use of this jig. Part B is bolted to the milling-machine table; part C is also bolted down, at the holes D, but must be loosened and moved back when the work is changed. The bushings are held on the pins E, which are a trifle shorter than the bushings. The bushings should fit snugly on these pins. The adjusting screws F are used to tighten the bushings and take up any slight variation in length. The stop should be set to prevent the saw from going through member C.—C. Anderson, Worcester, Mass.

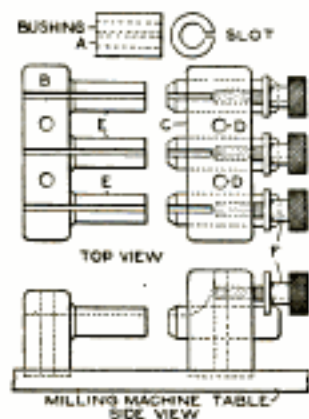

Garden-Hose Rollers for Graining Woodwork

Short sections of rubber-surface garden hose can be made into satisfactory rollers for use in graining woodwork by cutting rings around the hose carefully, in imitation of the grain of the wood. The hose may be mounted on a wooden roller and fitted with a handle. Used in this way, it is best to make the wood grain fairly straight. The hose may also be cut to give several strips on the surface, extending its length, each strip being notched to produce a grain effect in varying sizes, when drawn over the woodwork.

Cutting Pliers for Tool Room

A powerful cutter for cutting screws to length without injuring the thread was made in a tool room, as shown in the sketch. The side plates are of wrought iron and the handles and cutters are of tool steel, tempered. Machine screws may be used instead of rivets, and the cutters removed easily for sharpening. The outside cutting edge is not essential but gives the tool a wider range of use.

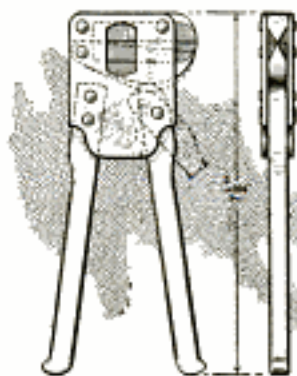

Preventing Rapid Rusting of Auto Fenders

It is not uncommon to observe automobile fenders through which holes have rusted and which are loose at the fastenings. To prevent this and to give the fenders longer life, wash the mud and dirt from under them frequently. A rust preventive, or any suitable oil, will aid as a preservative, but the most important precaution is to prevent the accumulation of mud, under which the rust soon forms.—C. H. Thomas, Kennett Square, Pa.

Testing Oils for Lubricating Qualities

The user of lubricating oils should have a knowledge of their merits and this can be gained readily by a series of simple tests, shown in the illustrations. One of the chief characteristics of lubricating oil is its tendency of gumming into a resin by oxidation, rendering it unfit for lubrication purposes.

A simple test can be made by elevating a sheet of glass, 2 by 4 ft., 6 in. at one end, thus forming an inclined plane. A drop of oil from each sample under test is put at the top of the plane. The drops should be placed several inches apart so that they will not spread into each other. A notation is made of the progress of the oil as it flows down the plane, several days being necessary to complete the experiment. It is desirable to make a record of the flow every six hours. The oil flowing the farthest has the best body. The oil under test should be kept free from dust, under cover if possible.

To test the fluidity of oil, heat a piece of $\frac{5}{8}$ -in. glass tubing to a red heat, draw out one end to a diameter of $\frac{1}{16}$ in., and cut it to a length of 4 in. Fill it with the oil and note the time required for all of it to drip out at the small end. Repeat this with each sample to learn the relative viscosity.

Oils for gas or oil engines should be selected for their ability to pass suc-

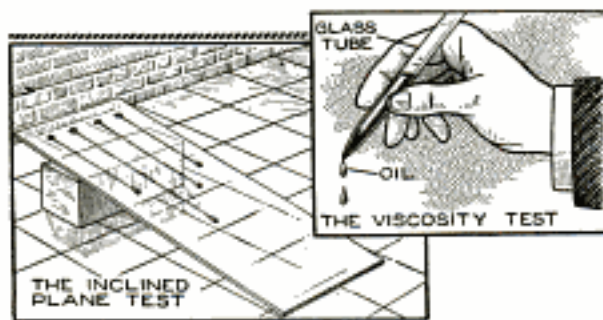

Ease of Flow Is an Important Factor in Determining the Lubricating Value of Oil

cessfully the "fire test." A metal cup of $\frac{1}{2}$ -pt. capacity is filled with oil and heated to a high temperature. A thermometer is held continuously in the

oil so that the temperature at the "flash point" can be determined. As the temperature approaches a high value, pass a lighted taper back and forth across

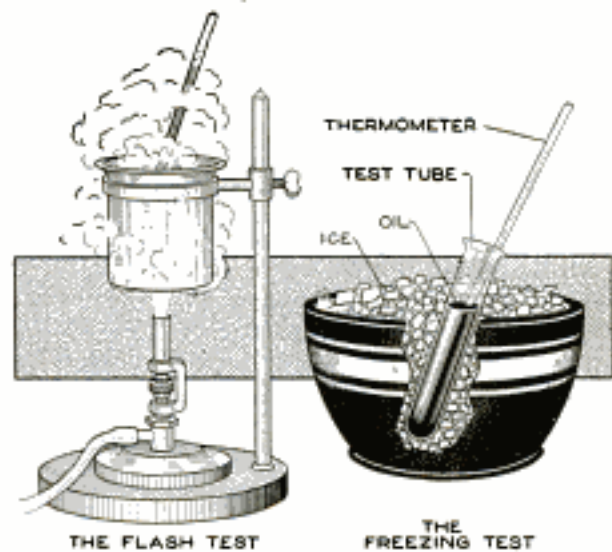

The Flash and the Freezing Tests Are Both Important in Grading Oils for Lubrication

the top of the cup, $\frac{1}{2}$ in. above the smoking oil. The moment the rising gas "flashes," then goes out, and "flashes" again, note the temperature immediately. This is called the "flash point." Continue to heat the oil until it bursts into flame, and continues in this state. Read the temperature again. This value is known as the "fire point." These two tests are especially valuable in selecting oil for high-speed tool work where the temperature is often high. These tests should be made only in a suitable shop, or a laboratory, and proper precautions against fire taken.

To ascertain the freezing point of an oil, fill a test tube and place it in a vessel of crushed ice. If the oil, which should be continually stirred with a thermometer, does not solidify at this temperature, salt should be mixed with the crushed ice. The moment the oil solidifies, read the temperature, for the "freezing point."—K. M. Coggeshall, Webster Groves, Mo.

Wax applied to the bottom of cleats, supporting temporary walks over newly finished floors, will prevent the cleats from sticking.

Reflector for Flood Lighting Construction Work

On a large construction job much of the work was done at night. The problem of providing good illumination

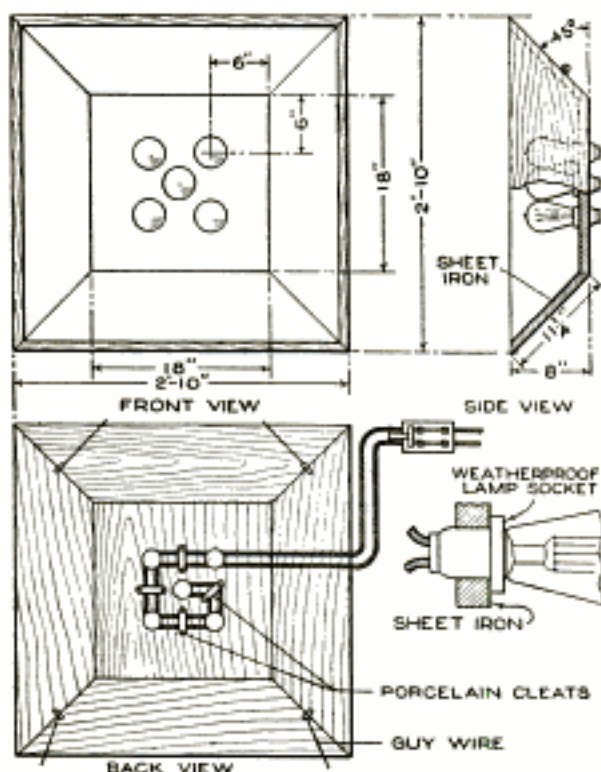

This Cheaply Constructed Reflector Proved Useful in Illuminating a Large Construction Job

was finally met by the use of the flood-lighting reflector shown, because of the considerable cost of metal fixtures with glass, or porcelain, reflectors. The inside of the reflector was covered with thin sheet iron, and weather-proof lamp sockets were set in place, as shown. The wiring was done on the back. The inside surface was painted with two coats of white enamel and the outside with red lead. The reflectors were fitted with 100-watt nitrogen-filled lamps and suspended on wires, to project the light as desired, and guyed to prevent swinging. Before blasting, it was only necessary to unhook the suspension wires, placing the reflectors flat, planks protecting them from heavy fragments of rock. One of the reflectors was mounted on the boom of each derrick, making the skip, or bucket, plainly visible.—T. S. Burns, Elmira, N. Y.

Electric Pad Warms Auto Radiator in Garage

In order to prevent the freezing of the water in the radiator of an automobile, stored in an unheated garage, an electric heating pad was used. The pad was flexible, 12 by 15 in. in size, and was connected to the light socket. With the current turned on to "low," ample heat was provided to prevent freezing, at a cost of about six cents a day.—C. E. Drayer, Cleveland, Ohio.

Device Locates Pounding in Engine or Machinery

Better satisfaction is given by the homemade device shown in the sketch in locating "knocks" in engines and machinery than anything I have yet found. It was made as follows: Two small funnels of metal were fitted into the ends of a 3-ft. length of $\frac{1}{4}$ -in. pipe, and a coupling was placed over the joints. Tin disks were soldered into the funnels, as shown, and a cord was drawn tightly through the pipe and tied at the centers of the disks. A ring of rubber packing, with a $1\frac{1}{2}$ -in. circular opening in the center, was cemented to the upper edge of each funnel. By placing the packing ring on the engine, or machine, under inspection, a slight pounding in it will be heard distinctly at the other end of the device. Care

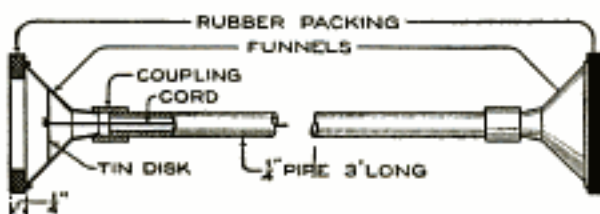

Pounding in Machinery may be Heard Distinctly by the Use of This Telephonelike Device

must be taken that the cord is taut, and does not touch the pipe.—R. S. Matzen, Fort Collins, Colo.

Ⓞ A small V-shaped notch cut in one jaw of a vise, $\frac{1}{8}$ in. deep, will be in no way objectionable for other work, and has many uses. It gives a three-point bearing on work held vertical.

Clip Supports Brush in Pail

Paint brushes are injured by being permitted to stand in the paint pail when temporarily not in use. By fastening a small metal clip to the side of the brush on the wooden part above the bristles, the brush may be hung on the edge of the can or on a wire stretched across it, the bristles hanging straight instead of being curled against the bottom of the pail.

Danger Sign for Unsafe Grinding Wheel

A workman cannot readily observe whether a grinding wheel is damaged or unsafe, particularly when the wheel is properly hooded. A safety measure used in a large shop is that suggested in the sketch. When a grinding wheel is found to be unsafe, a red danger sign, usually kept on the side of the machine, is fastened to the front of the grinder.—J. R. Minter, Washington, Indiana.



Jig for Drilling Holes at Ends of Shafting

Holes like A and B, as shown in the sketch, near the ends of sections of shafting, and at right angles to each other, were drilled by the use of the jig shown. The body C is of steel with a hole for the shaft D, and drill bushings E and F. The set-screw G keeps the shaft in place while the first hole is being drilled. After one hole has been drilled, a pin is inserted, counteracting the tendency to twist the work on the second hole.—L. J. Hansen, Chicago.

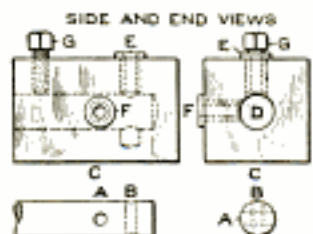

A Sawhorse Tool Kit

For mechanics, carpenters, or for use in odd jobs around the home or shop, the sawhorse tool kit will be found useful. It serves the double purpose of a convenient container and carrying case, and a lightweight horse. The trestle is of the common form and the tool kit is built into it by paneling the ends and one side, around a lower shelf.—J. B. Butler, Morganfield, Ky.



Decimal Dial on Shop Timekeeping Clock

A large structural steel and bridge company has adopted the dial shown, for timekeeping clocks. Zero is at 7 a. m., the start of the day's work; 5 at 12 a. m. and 1 p. m., the lunch hour; and 10 at 6 p. m., the end of the day's work. A single hand is used, and the hours are divided decimally, simplifying timekeeping on the various jobs.—Peter W. Seiter, Kansas City, Mo.



Keeping Dirt Out of Scale Pit

Discarded rubber belting was fastened to the frame around a scale pit, and lapped over the platform, as shown, to prevent gravel, dirt, and other small particles, from working down into the scale pit. The rubber belting does not interfere with the scale in weighing.

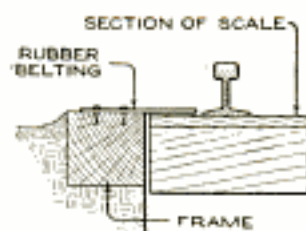
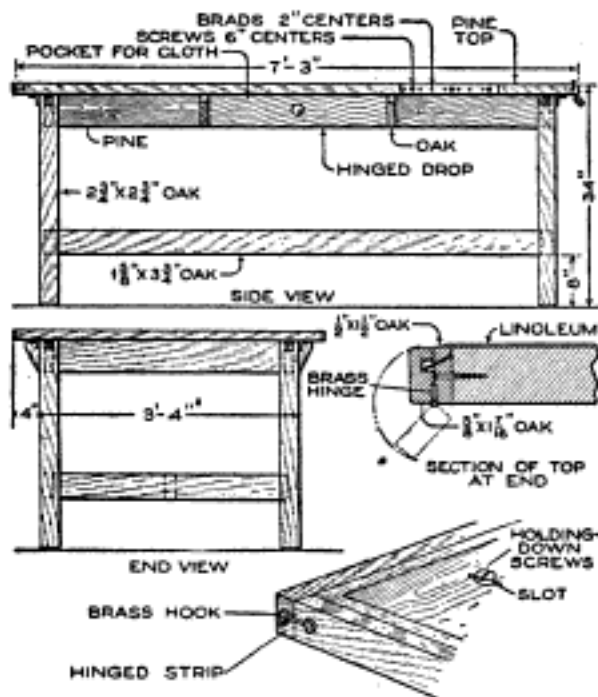

Table for Mounting Drawings on Muslin or Backing

A good method of mounting muslin backing on a drawing, or blueprint, is



This Large Table, Designed for Mounting Drawings Quickly, Is Also of General Use

as follows: Stretch the muslin on a board, or table, as shown, and tack it

around the edges. The stretching should be uniform and should not distort the fabric. Dip the drawing to be mounted in water for about a minute and remove the surplus water between blotters. Place it, face down, on the table and evenly coat the back with paste. Turn it over, put the muslin on, and roll it down flat, working from the center outward. A mounting table, large enough to hold eight or a dozen drawings, is of great assistance, and can be used for other purposes as well. The table, shown in the drawing, is covered with linoleum, an excellent top. When it is desired to mount drawings, a hook at each corner is unfastened, permitting an oak strip on each side to drop down, exposing a row of sharp points, as shown in the detail. The muslin is stretched over these points, which are hidden when the table is used for general purposes.—John D. Adams, Phoenix, Ariz.

CA piece of corrugated cardboard is a convenient drier for photographic prints, the ends of the prints being arched in the corrugations, giving a current of air easy access.

Horse Stalls of Concrete

By W. E. FRUDDEN

Serviceability and sanitary considerations make concrete desirable for the building of horse stalls. The illustration shows stalls of this type that may be built into a new structure in various units, or fitted in an old one. The floor, drain trough, feed box, manger, and partitions are built as a unit, and wooden partitions are set above the concrete sections. A removable plank floor in the stalls gives the horses foot comfort, not possible upon even a heavily bedded concrete floor. The concrete partitions and the mangers are reinforced with wire mesh and steel pipes. The front edge of the manger is also guarded with a pipe, so as to prevent undue wear on the harness. The edges and corners of the exposed

concrete should be rounded off so as to prevent injury to the horses from accidental contact in entering and leaving the stall. A stall in use and another in section are shown to the left in the sketch; a plan view is shown at the right, together with a detailed sectional view of the construction of the partitions and manger.

The floor is laid down first, and of the same material used for the other concrete portions, a 1 to 2 to 4 mixture. A weaker mixture may be used for the floors if there is a considerable area to be laid. The drain trough, 6 by 6 in. in section, is cast with the floor, a box of 7/8-in. stock being fitted into the floor as a mold. The shallow drain grooves may be tooled into the

surface, and the offsets at the top of the trough are provided by strips fixed

heavy wear on the harness. Bolts to support the upper portions of the par-

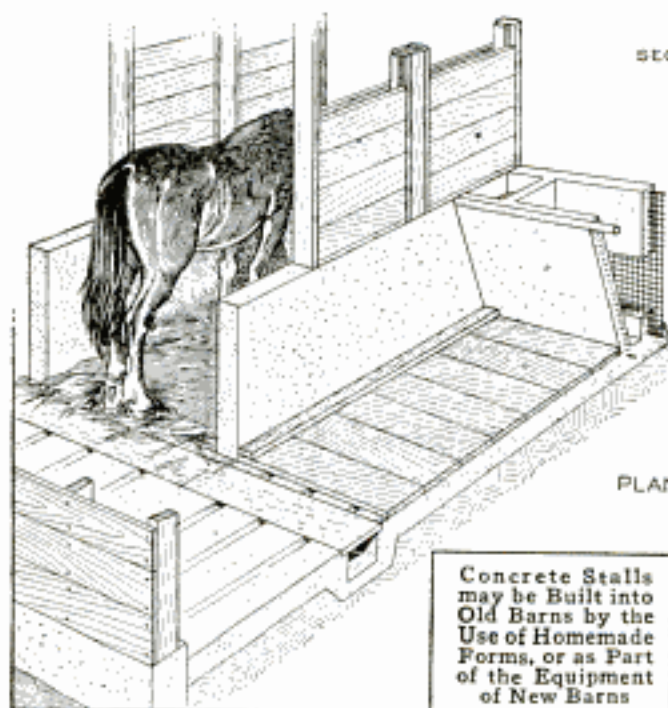

Concrete Stalls may be Built into Old Barns by the Use of Homemade Forms, or as Part of the Equipment of New Barns

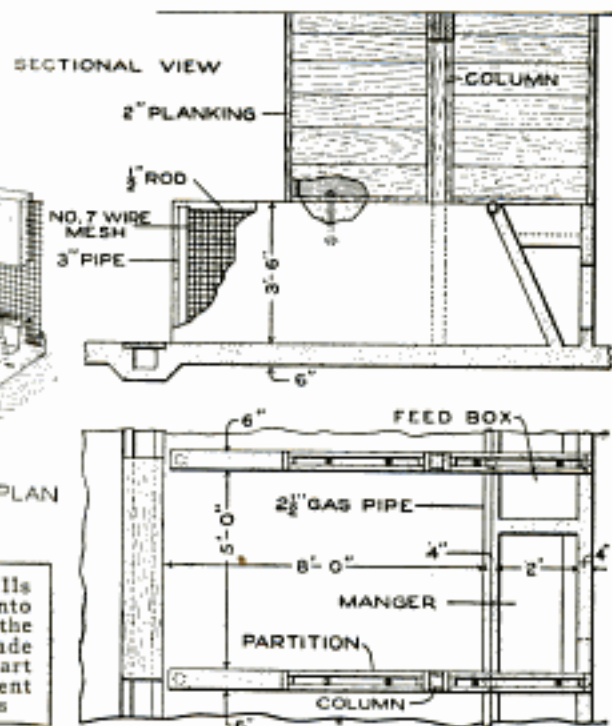

to the trough mold. The 3-in. pipe, reinforcing the partitions at their rear ends, is set into the floor when the latter is laid, and it is desirable, also, to set the lower edges of the wire-mesh reinforcement into the floor.

Wooden forms are provided for the partitions and the manger. These should be built to be taken apart readily so that they may be used repeatedly. The form for the partition is a box in which the wire mesh is supported, taut and carefully centered, the mixture being poured into it and leveled at the upper surface. The forms for the manger and feed box should be set into place and fixed to the partition forms before any of the forms are filled. The inside of the manger is formed by a tapered box resting upon the floor. The feed box is poured around a similar but smaller form, and the portion below it is cast hollow by inserting a form, which remains in place after the concrete is poured into the molds. A 2½-in. pipe is set into the front edge of the manger, its ends being imbedded in the partitions, to protect the horses from the edge of the manger and to prevent

titions are set into the concrete, as indicated in the sectional view.

The mixture must be freshly mixed and thoroughly wet when being poured, in order that the molds may be filled properly. If necessary, the aggregate may be tamped into the molds slightly. The forms should be left in place three days, and then removed carefully, so as not to damage the concrete. Sprinkling the work occasionally, several days after the forms are removed, is also desirable as an aid in uniform drying. The surfaces should be smoothed by removing imperfections in the molds, and a mixture of cement and water should be brushed over them to produce a satisfactory finish, when the molds are removed. The work may be surfaced and troweled smooth if desired, but this is not essential.

The floor planking is laid crosswise and spiked to 2 by 4-in. pieces set at the sides of the stall. This arrangement makes it convenient to replace pieces of the planking where the greatest wear occurs, and the planking may be removed readily for flushing of the stall.

Dirt-Collecting Corners Filled with Cement Grouting

Column footings and similar corners in a factory were filled with cement grouting, as shown, overcoming the unsightly dirt accumulations. The floor may be washed with water from a hose, in many instances, and the fire risk from inflammable materials collecting in corners is reduced, and sanitation promoted.—Roy H. Poston, Flat River, Mo.

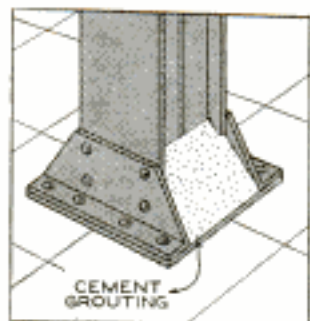

Vise Pads for Polished Tubing or Rods

If a length of highly polished pipe, or rod, is placed in a metal vise, it is usually marred or dented. The pads shown eliminate this. The holes are bored in a suitable board, about $1\frac{1}{2}$ by 6 by 18 in., which is then sawed in two, as indicated, and hinges and a hook and eye are attached. It may also be given a coat of shellac.—Arthur W. Dahl, Superior, Wis.

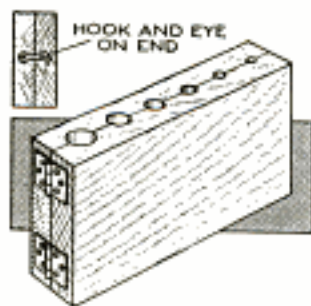

An Electric Gas Lighter

For lighting gas burners used intermittently, the lighter shown in the sketch was found satisfactory. A piece of wood, $\frac{3}{8}$ by $\frac{3}{4}$ by 3 in., was provided with two pieces of metal, and the two conductors were connected through a central hole to them. The other ends of the cord were connected to a 110-volt lighting circuit, in series with a small choke

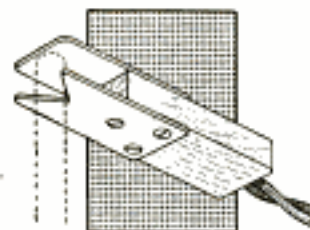

coil. When it is desired to light the gas, it is only necessary to turn it on and then place the lighter over the tip of the burner, moving it slightly to produce sparks. A coil of 10 or 15 ohms, having an iron core, will produce a sufficiently hot spark without endangering the usual 10-ampere fuse. The two metal contact pieces should be taped except on the ends projecting from the wooden handle.

Soldering a Machine Nut to Sheet Metal

In fitting a can to receive a tap it was necessary to solder a nut securely to it and the method described was used. It has numerous other applications. The nut was placed on the metal and a line drawn around it, as shown. The center hole was cut and the six portions of the hexagon were cut and bent down. The nut was supported by them and soldered into place. A very strong fitting resulted.—J. H. S. Cronk, Woodstock, Canada.

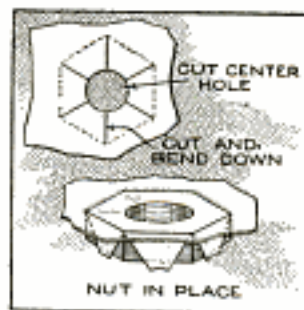

A Flexible Socket Wrench

For use in places where an ordinary wrench cannot be applied, a flexible socket wrench is useful. It is a home-made device, the socket portion being formed from a short piece of iron pipe and the other sections from steel pipe. It may be made in various sizes and provided with several sizes and shapes of sockets, which can be fixed into place as desired, by means of the pin.—Charles C. Brabant, Detroit, Mich.

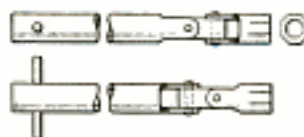

Putty for glazing should contain 10 per cent of white lead to withstand the weather.

Japanese Finish for Spruce

A finish used on spruce by Japanese craftsmen is produced by the application of dilute sulphuric acid, after which the surface is charred slightly. The acid is permitted to dry and the wood is then held over a hot stove, until the surface is well blackened. The charcoal surface is brushed off thoroughly, and the surface oiled with linseed oil and beeswax. The harder grain appears black and the rest has a rich brown tone.

Preventing Oil Leakage in Gear Box

Occasionally trouble is experienced from leakage of grease or oil out of the ball bearings of an automobile gear box, as shown in the sketch at the left. This is usually due to the failure of the felt ring within the ball-bearing nut to press closely around the shaft. Such a condition was overcome by turning out one side of the nut that holds the felt packing, and threading it to receive

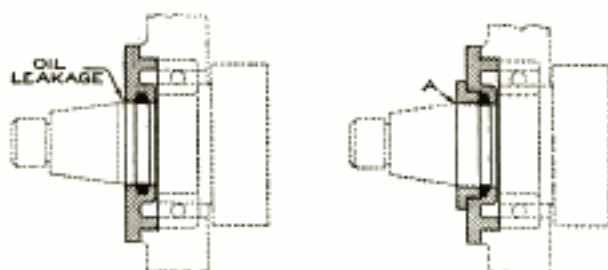

Leakage of Oil from an Automobile Gear Box was Prevented by Fitting a Pressure Nut against the Packing

another nut, A. The latter, when drawn up properly, forces the packing ring against the shaft, preventing leakage at this point.

Compressed-Air Punch for Cutting Washers

A punch for making washers, and the automobile tires from which the latter were cut, are shown in the illustration. The punch is operated by compressed air. The cylinder is 6 in. in diameter and the piston has a stroke of 3 in. A heavy coil spring in the cylinder, directly under the piston, lifts

the punch after it has cut a washer. The lower spring strips the washers from the punch. The lever on the two-way cock controls the air, and when

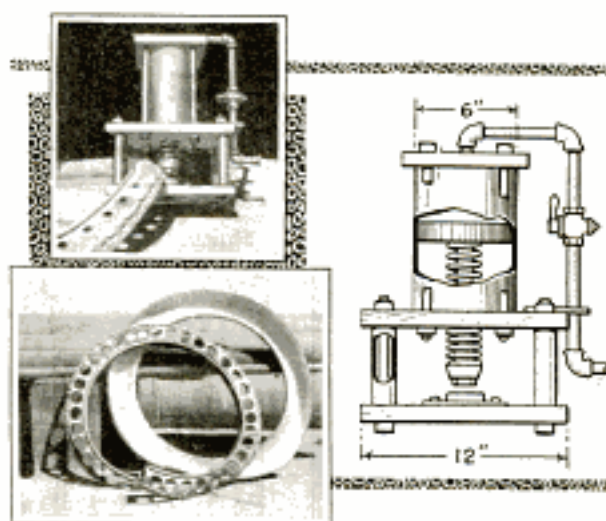

Old Automobile Tires were Cut into Washers with This Device

pulled down, permits the air to force the piston down for the cutting stroke. When the lever is raised, the air escapes as the spring lifts the piston. Tire casings were used with this device to make packing washers for oil-well pumps, and washers for other uses can be made similarly.—F. R. Shepherd, Fellows, Calif.

Hand Drill Used as Lathe

An ordinary hand drill was used effectively as a small lathe in turning a number of brass pulleys, by rigging it as shown. Two wooden bearings with metal strips, A and B, hold the drill firmly on the baseboard. An arbor is held in the drill chuck, and supported on two metal angles, D. The pulley

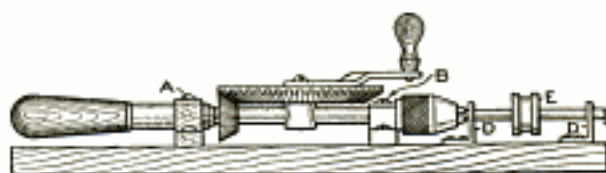

Small Brass Pulleys were Turned by Means of This Makeshift Lathe

E was drilled and forced on the arbor, and a suitable support for hand-turning tools was provided.—R. C. Fulton, Scarsdale, N. Y.

A Garden Sprayer of Varied Uses

Primarily for use in spraying plants in a garden, the sprayer shown in the sketch, Fig. 1, and made at small cost

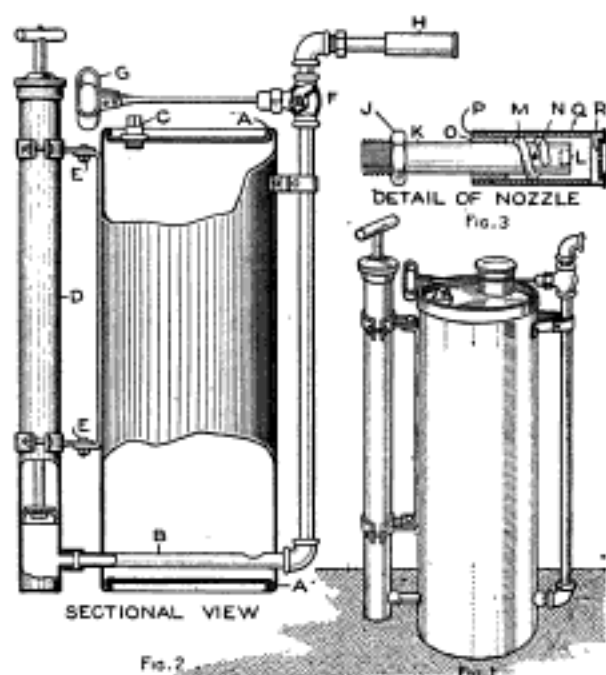

Fig. 2
A Revolver Cartridge Shell was Used in Making the Nozzle of This Handy Garden Sprayer

in the home workshop, is useful also in the garage, on the farm, and for other purposes. The tank A, Fig. 2, is 5 by 14 in., and operates satisfactorily at a pressure of about 15 lb., when used with ordinary liquids for plants. It is made of No. 26 gauge galvanized iron, the ends being riveted into place. It is filled at the pipe plug C. The pressure pipe B extends through the tank, and is connected to the pump D, a ball valve, originally in the connecting tube when the pump was used as a foot bicycle-tire pump, being at the junction, and controlling the back pressure. Straps E support the pump.

The liquid passes through the tube B to the valve F, controlled by the handle G, convenient to the pump, by which the sprayer is carried. When the valve is opened, the liquid is driven into the nozzle H, which is shown in detail in Fig. 3. The threaded $\frac{1}{8}$ -in. nipple J fits into the elbow, and is soldered to the $\frac{3}{16}$ -in. copper pipe K, which is plugged at the end L. A $\frac{1}{16}$ -

in. hole, N, is bored in the tube, and two turns of brass wire, M, soldered into place, produce a spiral course for the spray. The brass tube O, soldered to the tube P, is set on the tube K, with a tight fit. The cap Q is a .38-caliber, long cartridge shell, sliding tightly on tube P. The end of the shell is drilled out, and the disk R, having a $\frac{1}{16}$ -in. hole, is soldered into place. In filling the tank, sufficient air must be left in it to afford the proper possibility for compression. The parts, especially of the nozzle, should be cleaned after use.—T. T. Sturgeon, Los Angeles, Calif.

Test of Steel Shelving for Deflection

A manufacturer of metal shelving desired to test it as to deflection under various loads. No special apparatus was available, and the arrangement shown in the sketch was devised for the purpose. The shelving, which was of various types, was supported on a wooden frame bolted to a bench. A scale was set into place below it, and a simple jack made by setting a bolt into a washer in the top of the tubing, as

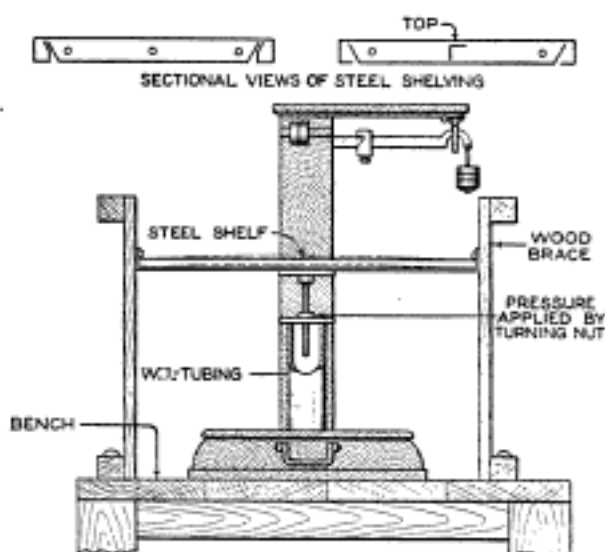

Shelving was Tested for Deflection under Load by Means of This Simple Rigging

shown. The pressure was applied by means of the screw and nut, and the shelves were deflected under a load specified for each size.—K. George Selander, Jamestown, N. Y.

Painting Quick-Drying Cloth Signs

Where cloth, or muslin, signs are wanted for temporary use, exposed to the weather, letter them with a paint made without oil. Use dry colors of fine quality and grind them with varnish or japan to a thick paste; then thin out with benzine when ready for the work. If too thin, the paint will spread. Use a sign writer's one-stroke brush, and if especially good wearing qualities are desired in the paint, add a small quantity of boiled oil to the letter color.—A. A. Kelly, Malvern, Pa.

Device for Tightening Fence Wire

A large length of loose fence wire was tightened by the use of the device

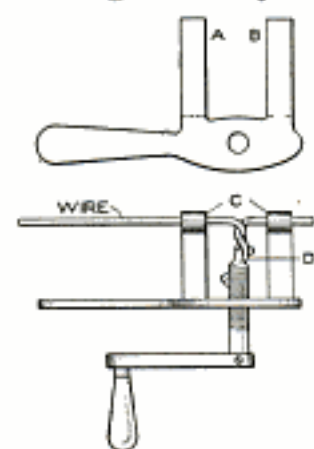

shown in the sketch, made for the purpose. A piece of $\frac{1}{4}$ -in. iron was shaped to form a handle, and the two ends A and B were bent at right angles to it to form the upright parts. These may also

be made by riveting pieces to the handle portion. Their upper ends, at C, were formed into eyes, left slightly open. A hole for the threaded crank was made in the handle section, and the pointed end of the screw bent into a hook, at D. The wire is tightened by looping it over the hook and turning the crank.—R. S. Matzen, Fort Collins, Colo.

Collapsible Steps for Boarding a Boat

Boarding steps for launches and small yachts are often bulky to stow away on the craft. The type shown in the sketch packs flat, takes up little space, and is safe and substantial. The sidepieces, of $\frac{7}{8}$ -in. hard wood, are curved to fit the sides of the boat. Two iron hooks, the proper shape to fit over the gunwale, support the steps.

The treads are 18 by 10 by $\frac{7}{8}$ in., placed 12 in. apart. They are set horizontally by hanging the sidepieces in

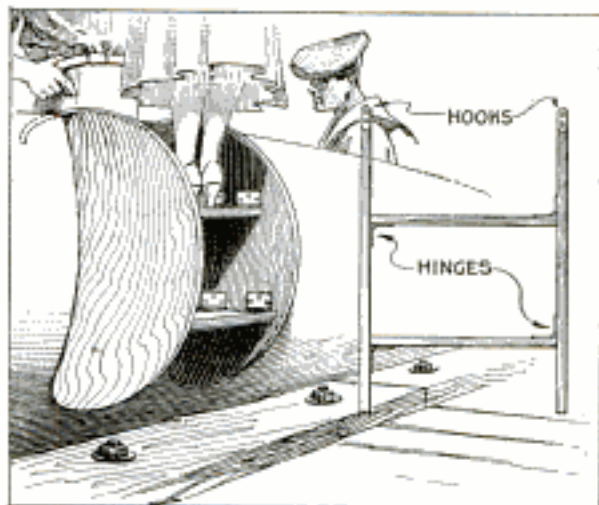

The Steps Fold Flat for Convenient Storage on Board the Craft

place, and marking the proper position. Strap hinges are fixed as indicated, and rubber treads provided.—L. B. Robbins, Attleboro, Mass.

Support for Long Work in Vise

Blocking-up, or other makeshift, methods of supporting long work in a vise were discarded in a shop, in favor of the simple arm fitted to the sliding member, as shown in the illustration. The device is especially useful on a pivoted vise, since it revolves with the

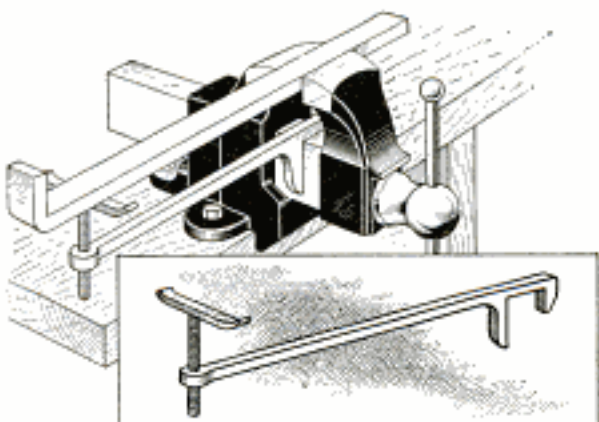

This Simple Support Makes Unnecessary the Blocking Up of Long Work in a Vise

latter. The extreme end is provided with an adjustable screw to fit irregular work.—S. L. Wade, Montgomery, Alabama.

Cushion for Charging Pan of Concrete Mixer

Cable breakages on the lifting rigging and damage to the charging pan of a concrete mixer were avoided by

the use of a spring cushion made of two wagon springs, mounted as shown in the illustration.

Sections of rubber hose were

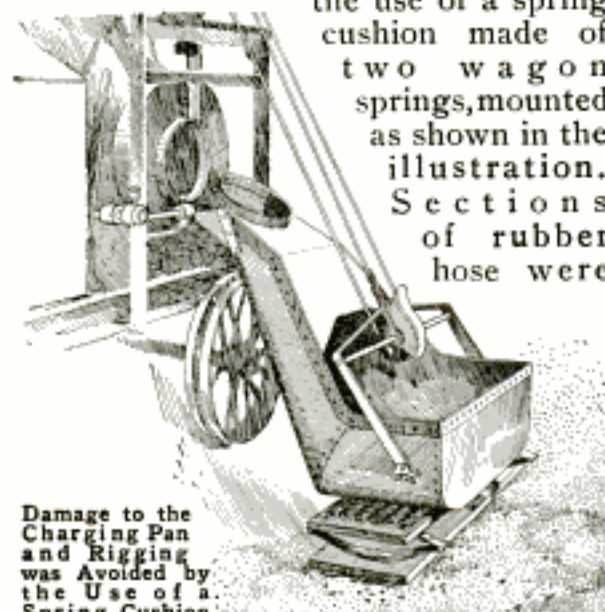

Damage to the Charging Pan and Rigging was Avoided by the Use of a Spring Cushion

nailed on the top of the upper board of the cushion as a further protection to the charging pan.—J. J. O'Brien, Buffalo, N. Y.

Auxiliary Jaws for Center and Turret-Lathe Chucks

In turning a number of castings which were too large for the ordinary-size lathe chuck, it was found desirable

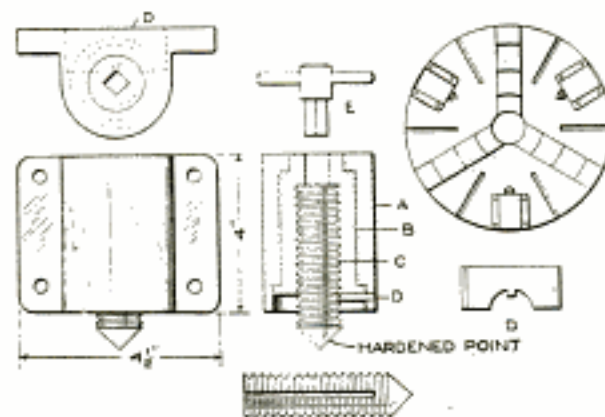

This Auxiliary Fitting for a Chuck Made Possible the Handling of Large Castings in a Lathe

to make a set of auxiliary jaws, which were fastened to the face of the chuck, as shown in the sketch. The casing A

is made of soft steel, the sleeve B, of steel, tempered at the upper end, which is provided with a socket for the wrench E. The screw C is of tool steel, tempered at the point, and has a keyway, as shown, which extends longitudinally at the back of the casing. This keyway engages the key D, which is set in a slot at the back of the casing and has its back edge flush against the face of the chuck. The screw is adjusted by means of the wrench E, which causes the sleeve B to revolve.—G. T. E., Pittsburgh, Pa.

Tightening a Loose Bushing

Sometimes, after pressing bushings into their places, they are loose and turn when an attempt is made to ream them out. In this case, remove the bushing, and run a coat of solder around the outside of it. Force the bushing back into place and the excess solder will be scraped off and a tight fit will result, with no turning of the bushing in reaming it.—J. W. Reynolds, Mason, Ill.

Kink in Cultivating Small Corn

When corn is small, it is difficult to do a good job of cultivating it, because of the tendency to cover it with earth. By wrapping the shovels of the cultivator next to the row with binder twine, the dirt is not pitched on the small corn, and it is possible to work close to the plant, the binding aiding in breaking up the lumps of soil.—Irl R. Hicks, Moberly, Mo.

A Polished-Black Wood Finish

A finish for woodwork in a high-polished black is produced as follows: Prime the work with linseed oil, turpentine, and white lead; apply two coats of black mixed with turpentine and copal varnish. Rub this down with pumice stone and water, and apply another coat of varnish. Rub again and polish to the gloss desired with rottenstone and oil.



Homemade Shoulder-Pack Tent

By J. D. BOYLAN

AFTER sleeping under various kinds of canvas coverings and not finding any of them entirely to my liking, I made the tent shown in the illustration, which proved quite satisfactory. It is of light weight, easily set up or taken down, and when buttoned closely is practically rain, wind, and bug-proof. The cost of materials necessary for making it is comparatively slight. I use it not only as a sleeping tent but also as a carry-all in packing camping equipment. The canvas is supported by frames made of pliable branches cut in the woods.

The layout for the canvas is shown in the detailed drawings. The sections for the ends are made of three pieces, one for the ground and two, divided vertically, for the end covering. The ground section of the main portion of the tent and the covering are made in one piece, 6 ft. wide, joined at the middle, as shown. The adjoining

edges B, which are set at the ridge of the tent, are sewed, after the other pieces are joined. Brass grommets are fitted in the canvas, as indicated, and the points of the supporting frames pass through them in driving the supports into the ground. The shoulder

straps C are placed so that they are in position when the tent is folded, and rolled into a pack. Other equipment may be placed inside of it. The tent supports D are pointed at the ends E, and are twisted together at the top. The ridge pole F steadies them and holds the canvas at the middle.

To set up the tent, lay the canvas flat on the ground and place the supports, twisted together, through the grommets. Spring them into the ends of the canvas, and insert the ridge pole by springing it between the supports. The canvas is 8-oz.

duck, and the fastenings used are snap buttons; buttonholes, buckles, or harness snaps may also be used.

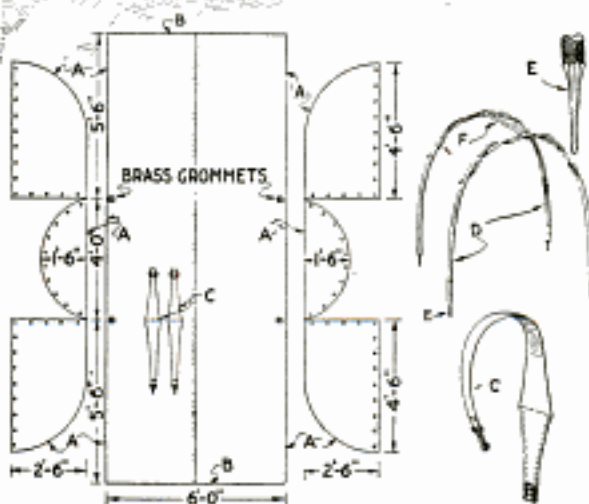

Stakes, Rope Braces, and Supporting Poles are Not Required for This Shoulder-Pack Tent, the Supports being Cut at the Camp

Rustic Well for a Bazaar or Fair Booth

A feature of a bazaar which attracted much attention was a rustic well from which a pretty girl dipped cool drinks



A Pretty Country Maid, Delicious Lemonade, a Peep into the Well, and Music from a Phonograph Were Attractions at This Booth

with the aid of an "old oaken bucket." The arrangement may also be used at an outdoor fair or lawn party.

A corner of the room was marked off by a rail fence and turnstile. The floor was covered with green cloth and green excelsior, for grass. The well was constructed as shown in the detail sketch. Half of a barrel, B, with the head removed, was inverted, and a mirror, C, was set in a shallow pan of water on the floor. The pan was surrounded with pebbles, D, and a framework, E, built over the barrel. The supply of lemonade was kept cool in the tub G, behind the partition. When the bucket A was lowered into the well, by means of the sweep, it was filled by pouring the beverage in the trough F. The bucket was then raised and the drinks served from it, a cocoa-nut-shell dipper being used.

So many persons became curious to

learn how the well was constructed, that an admission fee was charged to pass the turnstile, and the reward was a peep at the reflection in the mirror at the bottom of the well.—Susan E. W. Jocelyn, New Haven, Conn.

Novel Masks for Printing Pictures

In printing pictures, I have made use of various masks, and those suited to the particular picture, for some special reason, have proved especially popular. For instance, in making a picture for a contractor and mason, a mask in the shape of a trowel was used; for a policeman, a star; an automobile for the motorist. Sometimes the special interests of persons in a picture, or the background, will suggest good outlines for masks.—Russell Waldo, Indianapolis, Ind.

Sheet-Metal Stand for Flatiron

Considerable energy is consumed in lifting a heavy flatiron to the stand which protects the ironing board. The device shown in the illustration was made to overcome this objection to most flatiron stands and proved efficient, as well as easy to make. The iron is shoved onto the stand at one end, provided with an incline. The layout for the sheet metal is shown in detail. The piece A is cut $4\frac{1}{2}$ by 9 in., and the stop B, the incline C, and the leg D, are cut as shown, and bent to shape. The stand is fastened near the end of the ironing board by means of screws.—Ernest Ward, Detroit, Mich.

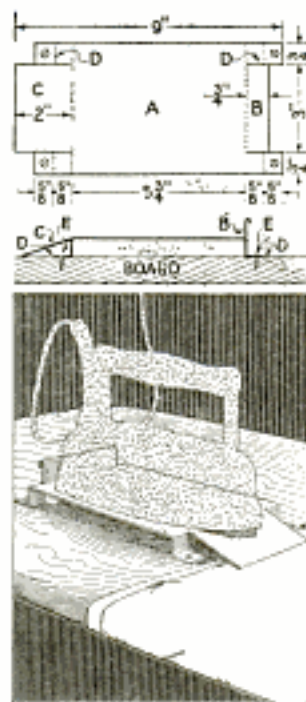

Homemade Roadster with Motorcycle Engine

By mounting a 5-hp. motorcycle engine on a frame built of 2 by 4-in. stuff, and rigging the outfit on running gear made of gas-pipe axles, old buggy springs, and motorcycle wheels, I made the light roadster shown in the photograph, at small cost. It develops 30 miles an hour easily, carrying only the driver, and has carried five persons. The frame is suspended from the springs, with an underslung effect, on the front axle. The power is transmitted by a friction drive, consisting of a fiber contact pulley, obtained from an old commercial car, and a disk used as a cutter on a plow.

The front axle is of 1-in. gas pipe, fitted with suitable-size solid nipples,

and washers, at the bearings. The steering knuckle was made of steel shafting turned down to fit a pipe tee, set in the axle. The drive shaft is $\frac{7}{8}$ in. in diameter, and has a ball thrust bearing on the end. Sprocket gearing



This Friction-Drive Cyclecar was Built in Spare Time by a Mechanic, Using Largely Makeshift Material

gives a ratio of 6 to 1, on high speed.—E. L. Munsen, La Conner, Wash.

Mending Aluminum Cooking Utensils

Holes in aluminum ware may be mended by plugging them with rivets as follows: Make a rivet of lead or solder, and enlarge the hole to fit the rivet tightly. Insert the rivet from the inside and back it with a piece of hard wood, or metal. Rivet the other end to fill the hole and lap over it slightly. Suitable rivets may be made by cutting a lead wire, about $\frac{3}{4}$ in. long, and of the desired diameter, on which a head is formed by riveting down the end. The wire is set in a hole in a block during this operation.—L. C. Burke, Madison, Wis.

Feeding Cards into Typewriter

Trouble is sometimes experienced in feeding cards into a typewriter, and this may be overcome by providing a paper sheet as a leader. Run the sheet of paper into the machine and feed the card in after it, lapping their adjoining edges. This prevents the edge of the card from catching on the rolls.

A California Bungalow for Canaries

An outdoor birdhouse, which has proved popular in various sizes, especially for canaries, is that with a bungalow roof, and sides of wire netting, as shown in the photograph reproduced. While a number of these houses were made in a workshop to order, the construction is so simple that boys will find considerable fun in making them, especially in framing the roof. The house shown is 18 by 28 in., and $14\frac{1}{2}$ in. high to the eaves strip. The body of the house is made in two side and two end frames, fastened at the corners with screws. The wire is put on the frames before



assembling them. A small, sliding door, of wood and wire, is provided, or one end may be made in two frames, one of which is hinged for a door. The eaves should extend at least $2\frac{1}{2}$ inches.—H. L. Coolidge, Pasadena, Cal.

Homemade Device Aids Blind Person in Writing

To assist my father in writing, notwithstanding his blindness, I made the machine shown in the illustration. It

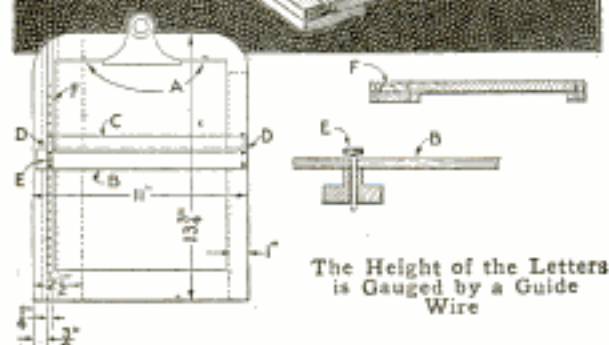

has been in use two years, and proved thoroughly practical. It consists of a board, $\frac{1}{2}$ by 11 by $13\frac{3}{4}$ in., on which the paper is held by a clip. Two stops, A, insure a good alinement of the sheet. A T-square, B, slides in a groove at the left side; the upper edge is beveled. At a distance of $\frac{3}{4}$ in. from this edge is stretched a brass guide wire, C, by means of which the height of the script is gauged. The wire is supported on brass strips, D. When the line is written, a pin, E, set in one of a row of holes in the groove F, is raised, the T-square moved, and the pin inserted in the next hole below, giving the correct spacing. As the wire does not touch the paper, either ink or pencil can be used. The board consists of four pieces, glued, and fastened with screws, as detailed.—Arthur E. Tremaine, Brookline, Mass.

Making Cardboard Tubes for Electrical Coils

It is often difficult to obtain cardboard tubes as foundations for coils of special sizes, and the following is a practical method for making them as desired: Cut a strip of cardboard somewhat wider than the length of the tube desired and about 2 ft. long. Soak the cardboard in water until it is quite pliable. Wrap it tightly around a wooden rod of suitable size, gluing or shellacking each successive layer. When the desired thickness has been obtained, bind the tube with string, and place the whole in a moderately warm oven to dry. The tube may then be cut to length.—Alexander V. Bollerer, New Britain, Conn.

An Army in a Small Box

A play device that will afford much amusement and which is interesting for boys to make is that shown in the sketch. To make the peephole cabinet, obtain a box of suitable size; fasten a piece of looking-glass inside, at each end. Make a peephole at one end of the box, and rub the silvering from the back of the looking-glass at the hole. Place a few metal soldiers, horses, etc., along the sides of the box 1 or 2 in. apart, one being set to hide the reflection of the hole. By looking through the hole an endless army may be seen. Light is provided

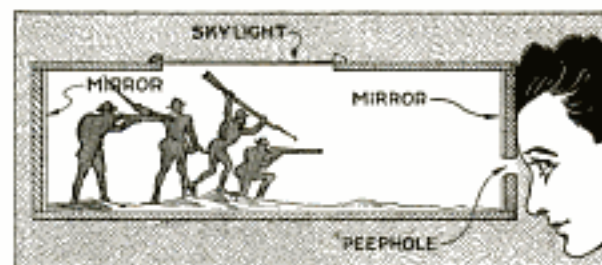

By Reason of the Mirrors, a Few Soldiers Appear as an Army

through the skylight at the top, which is fitted with ground glass or tissue paper. This device perplexes most persons who are not familiar with its construction.—James E. Noble, Portsmouth, Canada.

Liquid-Filled Tray Carried Safely

In photographic work, and in the shop or laboratory, chemicals carried in shallow trays are easily spilled. In photographic work, especially, this endangers materials used, as the spilled liquid dries and dust affected by it may spoil chemicals with which it comes into contact. The tray should be carried in a larger pan or basin partly filled with water, thus keeping the tray level.

Making an Umbrella Handle Detachable

A parasol or umbrella with a detachable handle is a great convenience in

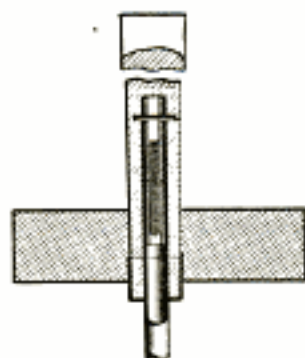

packing when traveling, and a handle may be made detachable as follows: Remove the handle by using a block of wood and a hammer. Clean out the hole, and polish the steel stem with emery, as far as it goes into the handle. Cut off 1 in. from the end, and then solder a section of brass tubing into this piece, and another section into the end of the stem. The abutting ends are then tapped to fit an 8-32 screw, which is then soldered into the shorter piece, as shown. The latter is pushed into the handle, and a hole, $\frac{1}{16}$ in. in diameter, is drilled almost through the handle. A piece of wire nail is driven into this hole. By making the screw fast in the handle rather than in the stem, the threads are protected, and the length when taken apart is correspondingly reduced.—John D. Adams, Phoenix, Ariz.

¶To renew a typewriter ribbon, roll it on a spool and apply a very small drop of glycerin at intervals of several inches, with a fountain-pen filler, and permit the glycerin to soak in thoroughly.

Boys' Athletic-Equipment Locker

The boy should have a place in the home for his sports togs and equip-



The Boy Who Takes Pride in His Athletic Equipment will Find Much Pleasure in Making This Cupboard for It

ment, and a cupboard like that shown can be made easily for the purpose. Its size will depend on the quantity of articles to be stored. A good size is 12 by 30 in., by 5 ft. high. Plain boards are used, and for the door they are fastened together with cleats and screws. The drawer is convenient but not essential.—J. D. Hough, Toledo, Ohio.

Wire Compacts Bristles in Polish or Stencil Brushes

The bristles of brushes used for applying shoe polish and for painting through stencils often curl so much that the brush becomes almost useless. In order to overcome this I bound the bristles with several turns of wire and soldered them into place as shown. When desirable, part of the wire may be removed by cutting it at the solder.—Hugo Kretschmar, West Nyack, N. Y.



A Small Working Pile Driver

By EDWARD A. KRUEGER

[These directions will enable boys of varying skill with tools to make a pile driver, as a toy or model. Several simple methods of making the parts in the home workshop, with materials easily obtainable, are suggested.—Editor.]

THE construction of small docks, wharves, piers, and foundations for bridges, buildings, and other structures, by the driving of piling is interesting out-of-door play, in which boys will find much fun. A pile driver for this work is shown in the page plate, Fig. 1. The hammer is raised by means of a winch, and is dropped automatically when it reaches the cap of the derrick, as indicated in Fig. 3. The drum is then released, and the weighted double-hook nipper drops down, picking up the hammer on the next upstroke. A single-hook nipper, that can be made easily of wire, is also shown in the detail sketch, Fig. 6. The small boy who cannot make the nippers or the winch, may tie the rope directly to the hammer, drawing it up by hand, and dropping it as desired. The hammer need not be fitted to the guides, but merely arranged to drop between them, and the derrick can be made of only a few main pieces. The larger parts of the hammer and nipper weight are best made of lead, babbitt, or white metal, as these may be cut or melted readily. Iron, brass, or copper, solid or in plates, may be used, if means for shaping them are at hand.

The making of the derrick may be undertaken first. Make two pieces for the bed A, $\frac{7}{8}$ by $\frac{7}{8}$ by 17 in.; two hammer guides B, $\frac{7}{8}$ by $\frac{7}{8}$ by $33\frac{1}{8}$ in.; one bed piece, C, $\frac{3}{8}$ by $\frac{7}{8}$ by 20 in.; two bed pieces, D, $\frac{3}{8}$ by $\frac{7}{8}$ by $5\frac{1}{4}$ in.; two posts, E, $\frac{1}{2}$ by $\frac{1}{2}$ by $34\frac{1}{2}$ in.; two braces, F, $\frac{3}{8}$ by $\frac{3}{4}$ by $26\frac{1}{2}$ in. Cut these pieces slightly over their finished lengths as given, allowing for trimming and fitting. Make strips, $\frac{1}{4}$ by $\frac{1}{2}$ in., for the bracing on the sides of the derrick and the ladder bracing on the back.

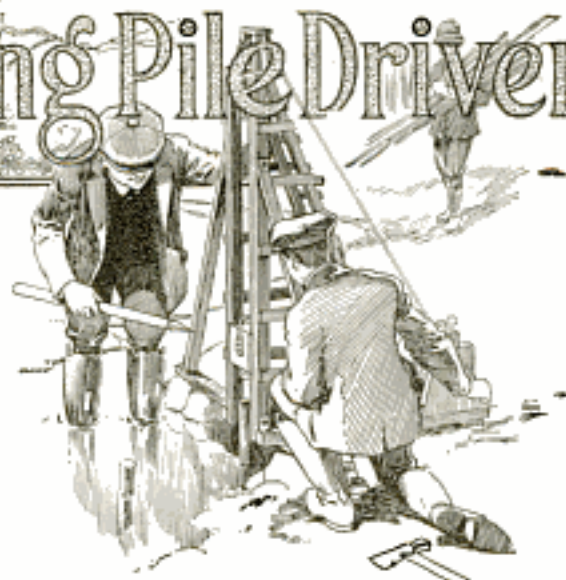

Notch the lower ends of guides B; $\frac{1}{8}$ by $\frac{7}{8}$, and the lower ends of posts E, on an angle, $\frac{1}{8}$ in. deep, to fit pieces A. Join the parts of the bed, as shown in the page plate, pieces A being set $3\frac{1}{2}$ in. apart, fastening them with bolts or screws. Make braces G, of sheet metal, and bolt them in place. Fit the posts E into place, and fasten them at the bed and the top. Put on several ladder braces temporarily, to steady the frame. Fit the braces F carefully, and bolt them in place. Remove the piece C and the braces F, and nail the horizontal bracing to the sides of the frame. Then fit and nail the diagonal braces. The bolted construction is convenient in "knocking down" the derrick for storing it. Reassemble the parts, and make the cap for the headblock.

The headblock and cap are shown in detail in Figs. 2 and 3. Make two pieces, H, $\frac{1}{4}$ by $1\frac{5}{16}$ by $1\frac{3}{4}$ in.; one piece, J, $\frac{1}{4}$ by 1 by $1\frac{3}{16}$ in.; two braces, K, $\frac{1}{4}$ by $1\frac{13}{32}$ by $1\frac{3}{4}$ in. Make the two beveled pieces of the cap $\frac{7}{8}$ by $1\frac{3}{4}$ by $11\frac{1}{2}$ in., and provide a wooden strip or metal plate for the front and rear edges, as shown. Fasten strips of sheet metal to the bevel of the notch, to protect it from wear by the striking of the nipper hooks. Make the sheave $1\frac{1}{2}$ in. in diameter and $\frac{3}{8}$ in. thick, with a groove for the rope. Assemble the parts, as shown.

The details of the winch are shown in Figs. 4 and 5, and the method of assembling the parts, in Fig. 1. The

drum may also be driven without gears by fixing the crank directly to the shaft. Gears may be obtained

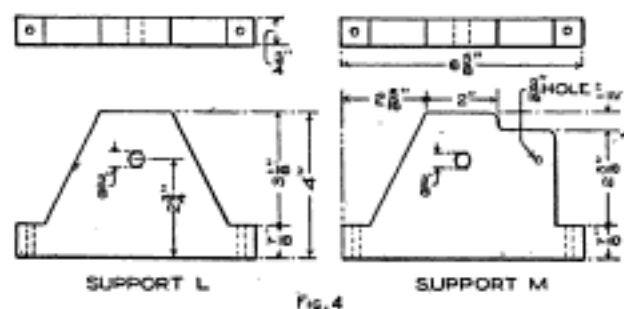

The Supports of the Winch are Made of $\frac{3}{4}$ -Inch Wood, Bolted to the Bed

from old machines, or purchased from dealers in model supplies. Make the supports L and M, Fig. 4, $\frac{3}{4}$ by 4 by $6\frac{5}{8}$ in., cutting patterns of paper, if desired.

The gear, Fig. 5, is $3\frac{1}{2}$ and the pinion $\frac{3}{4}$ in. in diameter. The drum is of wood, 2 in. in diameter and $3\frac{5}{16}$ in. long. Its ends are $3\frac{1}{2}$ -in. metal disks, fastened with screws. The shaft is a $\frac{3}{8}$ -in. bolt, $5\frac{3}{8}$ in. long, and bears in holes bored in the supports, as shown in the details of these parts. The crank N, Fig. 5, is made of a $\frac{3}{16}$ -in. rod, bent as shown, and fitted with a washer to fit next to the pinion. The gear is set by means of the pawl O, which is bent from a strip of $\frac{1}{16}$ -in. sheet metal. The brace P is bent from a $\frac{1}{16}$ by $\frac{3}{4}$ by $1\frac{5}{8}$ -in. strip of sheet metal, and riveted to the pawl. Assemble the parts, fastening the gear to

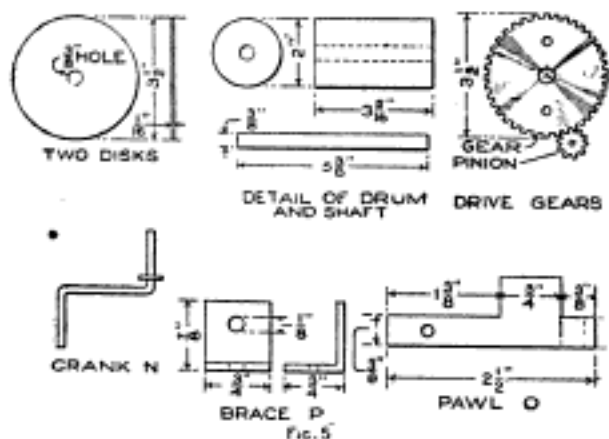

Details of the Drum, Its Driving Mechanism, and Fittings

the drum end, and bolt the supports into place. Put the pinion into mesh

with the gear at its proper place, and carefully mark the hole for the crank. Square the end of the crank and the hole in the pinion, and fit them to a driving fit. Fix the rope to the drum, and reeve it through the head block. The derrick is then ready for the hammer and the weighted nipper.

The hammer, shown in Fig. 6, may be made easily from a solid block of lead, $1\frac{1}{4}$ by $2\frac{5}{8}$ by $2\frac{5}{8}$ in. Cut $\frac{3}{16}$ by $\frac{7}{8}$ -in. grooves in the vertical edges to fit the guides. Make the circular $\frac{3}{16}$ by $1\frac{5}{8}$ -in. hammer plate Q of iron or brass, and fasten it with screws.

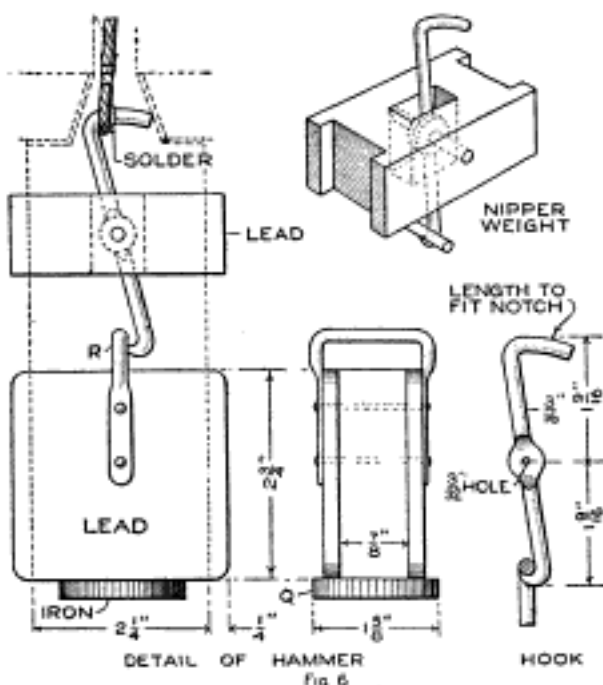

A Simple Method of Making the Tripping Device, and Details of the Hammer

Rivet the wire lifting strap R, as shown.

The single-hook nipper, shown in Fig. 6, is made as follows: Flatten a piece of $\frac{3}{16}$ -in. wire at the middle, and drill a $\frac{3}{32}$ -in. hole for the bolt. Shape the lower end into a pointed hook, and bend the upper end to form the trip arm. This strikes the notch in the cap of the derrick, releasing the hammer. The rope is wired to the hook as shown. The nipper weight is made of a solid piece of lead, $1\frac{1}{4}$ by $2\frac{5}{8}$ in., by 1 in. high, grooved at the ends to fit the guides. Cut a slot through it, for the hook, as shown in Fig. 6, and bolt the latter into place. The double-

hook nipper is better mechanically, and may be made of two pieces of wire, or cut from sheet metal.

Test the action of the nippers, and bend or file the hooks to operate properly. The pile driver may then be painted, and work on "jobs" begun. If it is used at the water, fix metal guards at the lower ends of the guides, to prevent the hammer from falling into the water.

Split Needle Causes Echo on Talking Machine

An amusing stunt is to split the end of a fiber talking-machine needle carefully about $\frac{1}{4}$ in., so as to make two points, slightly separated. The needle is then placed on the machine, preferably on an old record, so that the points play the record successively, producing an echo. If the work is carefully done, and the points are separated slightly, both reproductions will be fairly clear.—Frank Murphy, Fari-bault, Minn.

Weighting a Metal Base

Having to weight a shallow metal base to support a 4-ft. brass tube, I found that the easiest way was to fasten four screws on the base with nuts, as shown in the illustration, and pour

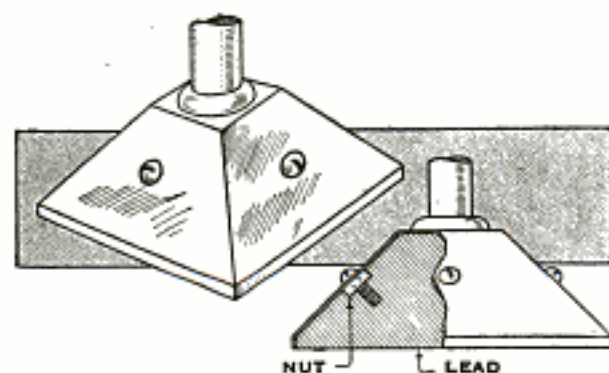

Molten Lead was Poured In around Screws Fastened to the Base

in lead. The screws were taken out in polishing the base.—James M. Kane, Doylestown, Pa.

☞ In toasting bread over a camp fire, it is best to cover the fire with a tin pan.

Trunk Bookcase for Convenient Shipment

Mechanics, engineers, and other persons are sometimes engaged in work

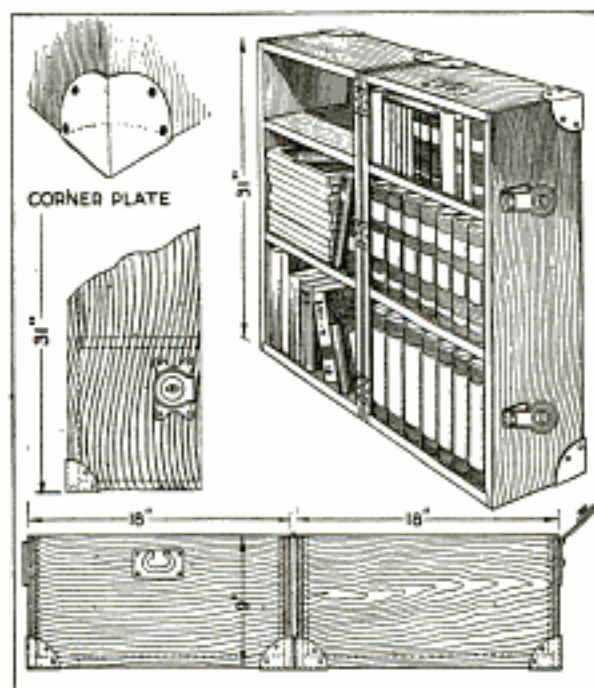

A Small Library may be Shipped Handily in This Bookcase

which keeps them at the same locality only a few months. Those who desire to carry with them a small library will find the trunk bookcase, as shown, convenient. It may be shipped as a trunk, and used as a bookcase in one's hotel or dwelling. Other articles than books may be packed in it. The outside dimensions when closed are 31 by 18 by 18 in., providing for three shelves. It may be made of $\frac{3}{4}$ -in. pine or whitewood, and stained, or covered with impregnated canvas. The outer corners are reinforced with metal corner plates, and suitable hardware is provided.—Lloyd C. Eddy, Jr., Buffalo, N. Y.

Bottle Carrier Made of Pipe Straps

Two metal pipe straps, fitted around the neck of a bottle and bolted together, form a convenient method of attaching a carrying handle to a large bottle. The handle proper is made by fixing a grip in a bail of wire similar to that on a bucket.

A Developing or Etching-Tray Rocker

An appliance that saves time for the worker in a photographic dark room is

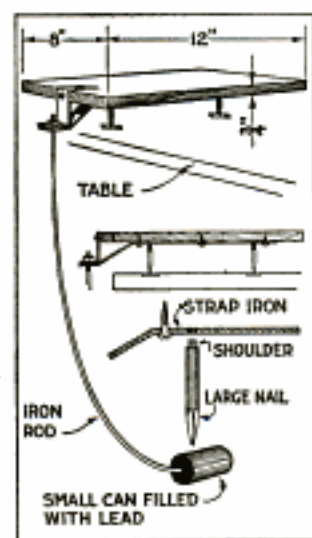

a tray rocker, made as follows: Fasten a bracket of strap iron, into which are riveted the pointed ends of two spikes, to the under side of a board, as shown in the detail sketch. Support this further with a double angle fastened at the end of the board. Fix a

small can, weighted with lead, on the end of an iron rod, adjusted to a suitable curve, and fasten the rod to the bracket. The weighted end should extend under the edge of the table, as shown, and be balanced so that it will rock the board and tray without tipping the latter toward the bracket. The nails pivot on metal pieces, to protect the table top.—L. L. Llewellyn, Piedmont, Calif.

Combination Laundry Tub and Dishwashing Sink

A saving of space and time was effected in a home kitchen by the use

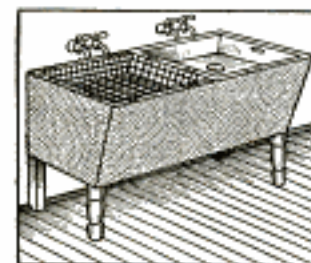

of a sink developed in a large kitchen. Two ordinary laundry tubs were installed with the faucets raised above the tubs, as shown.

A sink of sheet zinc was fitted in the upper part of one tub; it has handles, and a strainer set in the bottom. The strainer is closed by a rubber stopper, and the sink becomes a dishpan. The sink is easily lifted out for cleaning, or for washing clothes. Another use for the sink, between meals, is for

washing and preparing vegetables and fruits. The second tub has a wire dish-draining rack, in which the china is rinsed and sterilized by hot water from the faucet.—Mrs. Avis Gordon Vestal, Chicago, Ill.

A Leather and Silk Bookmark

An artistic and useful bookmark was made from a silk ribbon passed through a buckle of leather, tooled with an inscription and a conventional design. Ribbon of various sizes may



be used, and the leather left plain if desired. The ends of the ribbon are fringed, as shown. Monograms make interesting and individual decorations for the leather portion.—Will Chapel, Manchester, Ia.

Emergency Oarlock of Rope

An oarlock that will give considerable service may be made by fixing a

loop of rope to the gunwale of a boat at the proper position. This kink is useful in an emergency, such as when an oarlock is dropped overboard.

Planing Thin Sticks Held in Flooring Groove

Boys who make thin sticks for arrows, kites, etc., as well as the mechanic, can make good use of the following suggestion: The difficulty of handling thin strips while planing them may be overcome by setting the strip in the groove of a piece of flooring, clamped in a vise. A peg or nail is driven into the groove and acts as a stop for the end of the strip.

Bicycle Fitted Up to Resemble Motorcycle

The boy who cannot own a motorcycle but who has a bicycle, may remodel it to resemble a power-driven machine by fitting it up with equipment, much of which can be made in the home workshop. The illustration shows how an ordinary bicycle was improved by several practical fittings. The lower end of the mud-guard of the rear wheel was extended to form a clip, for the homemade stand A. Brackets were made of strap iron to support the bundle carrier B, the basket of which was made of wood. The tank C, 3 by 3 by 21 in., with two compartments and doors, contains batteries and tools. It is fastened to the frame by means of two bolted straps. The bracket D was made of strap iron, to support the electric headlight E. The handlebars were ex-

tended, as shown at F, and the horn G was provided. The seat post was lengthened by welding a piece to it, and reversed, as at H. A tail light, J, and a pump, K, held by straps, were provided, and the front mudguard was

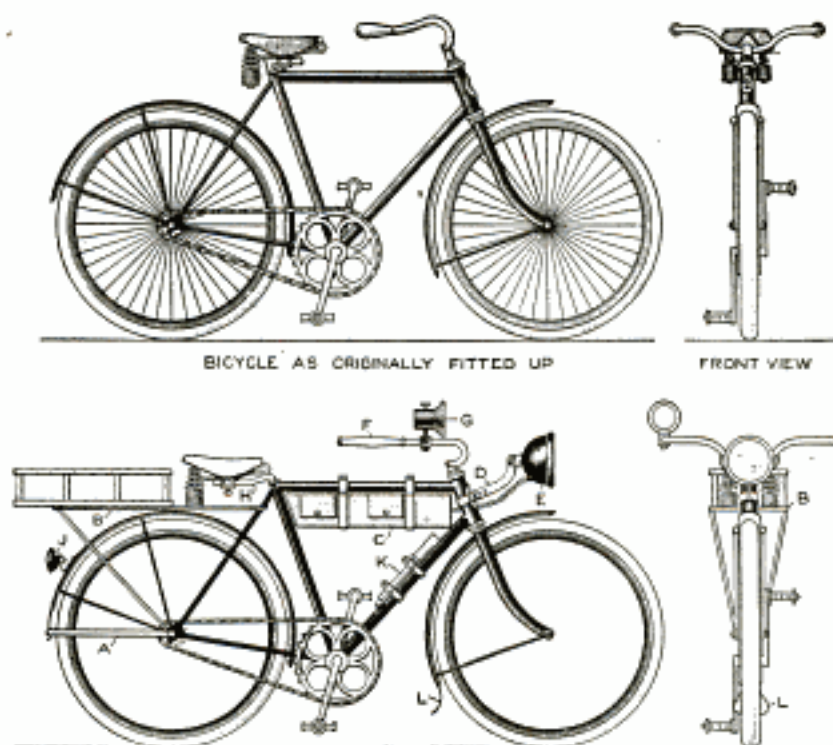

BICYCLE AS ORIGINALLY FITTED UP

FRONT VIEW

Comparison of the "Before and After" Illustrations Shows Strikingly the Resemblance to a Motorcycle

fitted with a leather piece, L, shaped as shown in the front view.—P. P. Avery, Garfield, N. J.

Toy Submarine Made of Shade Roller

The submarine shown really goes, and was made of a bit of tin, some lead, a few brads, and an old window-shade roller, with a good spring. The spring is the submarine engine. Saw off the roller 3 in. beyond the inner end of the spring, and shape it like the bow of a submarine. Flatten a piece of lead, and fasten it to the bottom of the boat for a keel. Experiment until the keel is of the right weight, and in the proper place, permitting the boat to move evenly, just below the surface of the water. For the propeller, cut a 2-in. tin disk as shown, and bend the blades into shape. In the center make a hole to admit the

end of the spring, to which it is then soldered. Wind up the "engine" by turning the propeller. The shade-

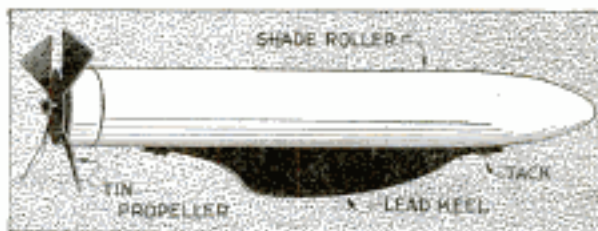

This Submarine's "Engine" is Wound by Means of the Propeller

roller spring can also be used for other toy craft.—E. P. Sullivan, Arlington, Massachusetts.

☞ Rub powdered graphite on rubber and asbestos gaskets so that they may be removed easily when desired.

A Secret Trinket Case for the Bookshelf

By T. H. LINTHICUM

PRACTICAL use as well as the novelty of its construction makes the trinket case shown in the illustration well worth the time and effort necessary to make it. Various kinds of wood—preferably of the better cabinet varieties—are suited to the design shown, which was made of $\frac{3}{16}$ -in. stock, like that used in cigar boxes. The size shown is that of a bound volume of a magazine like Popular Mechanics, and may be adapted to special needs. The back and the cover slide in grooves, which are not visible when the "book" is closed, making it difficult and interesting for one to discover how the case is opened. The back may be marked and lettered to resemble a bound volume closely, and

Make the pieces for the frame of the box first. If possible, make one strip of the proper width—2 in., in this case—and long enough for the two ends and the front. Make another strip $1\frac{3}{4}$ in. wide and long enough for the partition and false back of the tray. Cut these to the lengths indicated in the detailed sketches of the parts. Mark out the grooves in the end pieces carefully and cut them with a saw that cuts a groove $\frac{3}{32}$ in. wide. The grooves may be cut by clamping a straight strip of wood on the surface of the ends the proper distance from the top, and sawing cautiously along the strip to the proper depth. The grooves across the grain may be cut similarly, or in a miter box.

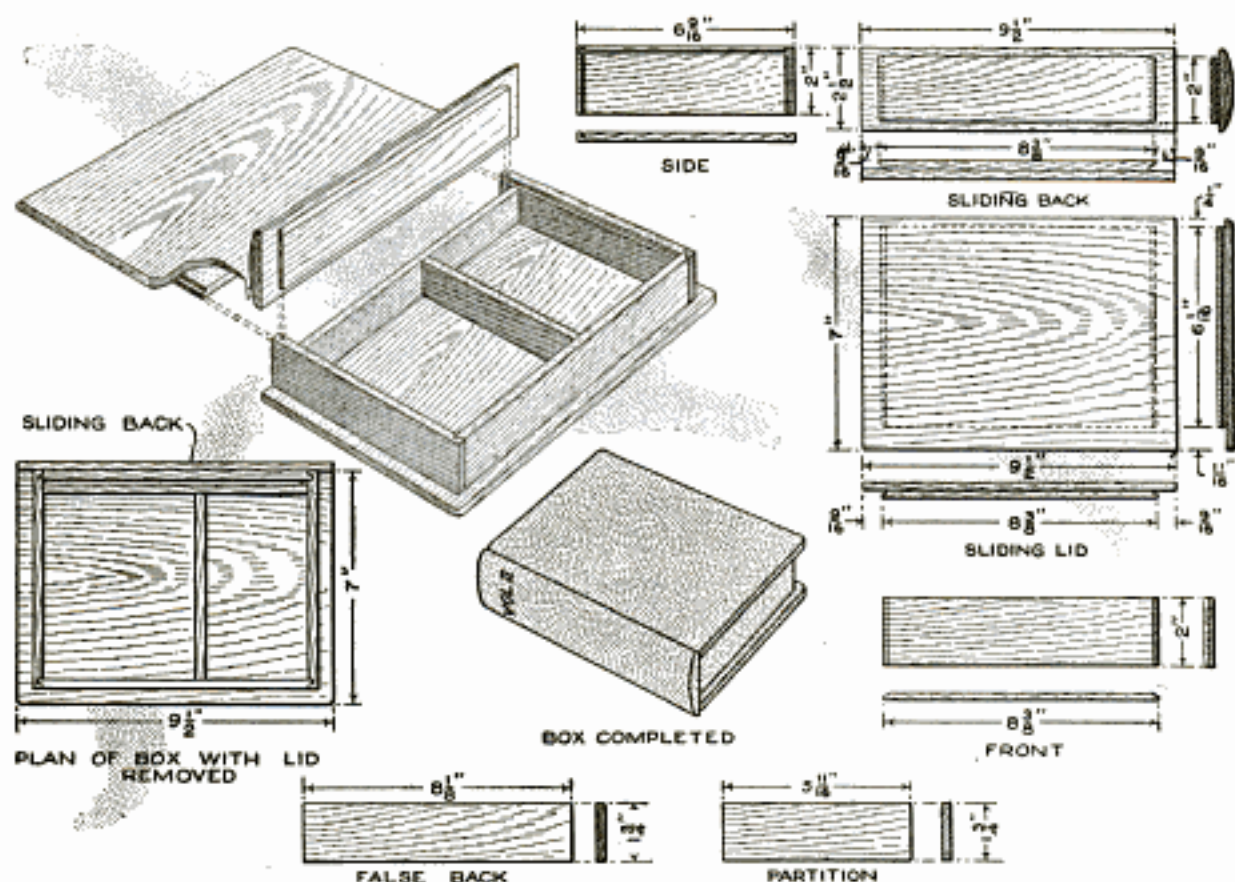

This Trinket Case Is a Practical Novelty That may be Used as a Secret Container to be Set on the Bookshelf with Similar Bound Volumes

if special secrecy is desired, it may even be covered with leather, in exact duplication of those on a bound set of magazines kept in the bookcase with it.

Glue the pieces of the frame together, taking care that the corners are square. If necessary, place blocks inside to insure that the clamping will

not disturb the right angles of the box. Shape the bottom and cover pieces nearly to the final size before gluing them; then, if small nicks are made in the edge, they may be removed by a cut of the plane, when the case is complete. Glue the sliding pieces to the cover and to the back. This must be done carefully, and it is convenient to drive small brads part way into the second piece, from the inner side, to prevent the pieces from slipping while being glued. If proper care is taken, only a small amount of glue will be forced out, and this can be removed with a chisel when dry. The edges may be trimmed off to their exact size, and the entire construction given a final light sandpapering. It is then ready for the stain and shellac, or other finish. The parts that slide in grooves should not be shellacked or varnished, because this is apt to cause them to stick.

A Cylinder Reversing Switch

A cylinder reversing switch for small battery motors may be constructed cheaply, from a 3-in. length of broom handle and $\frac{1}{2}$ -in. boards, as shown. The four brushes are strips of copper. The contacts on the moving cylinder are eight brass tacks, connected as indicated in the diagram. The wires are insulated with paper where they cross. The handle is of heavy wire, and two tacks limit its motion, as shown. The method of connecting the switch is as follows, for either a series or shunt motor: Remove the two wires from the motor brushes, and connect the two middle brushes of the switch to the motor brushes. Connect the wires removed from the motor brushes to the outer brushes of the switch.—Claude Schuder, Sumner, Ill.

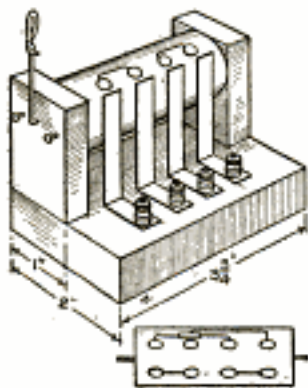

Summer Radiator Cover Serves as Cupboard in Winter

Because of the accumulation of dust on a kitchen radiator in the summer,

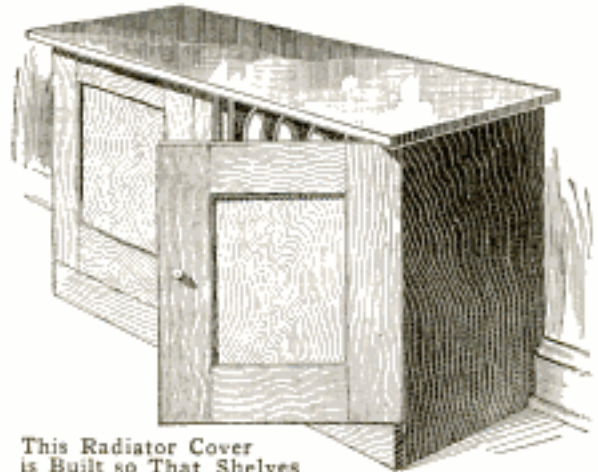

This Radiator Cover is Built so That Shelves may be Inserted Quickly for Use as a Cabinet

a cupboard was built over it, and used at other seasons of the year for the storage of various articles, by fitting it with shelves. While in use as a radiator cover, the top of the cupboard provided a convenient seat. If properly made, cabinets of this type can be used in other parts of the home to advantage.

A Safety Spring for Porch Swings

It is often necessary to hang swinging porch seats fairly close to surrounding woodwork, which is marred by their swinging too far. To overcome this, procure a coil screen-door spring and cut it in two. Bend a hook on each cut end, and fasten one of the springs to the center of each end of the swing, and to the floor. This permits only gentle swinging.—F. C. Hayes, Niagara Falls, Canada.



Ⓒ Proper ventilation of cellars makes it desirable to provide a screen door on the cellar entrance.

Frying Pan Made of Tin Cover

If you want an egg done to perfection try the frying pan made of a tin cover. It was intended for emergency use only, but proved so satisfactory that I kept it as a regular fixture. The wire handle was fitted to the rim through two holes, as shown, and hooks under the bottom of the pan, the twisting of the wires giving the required strength.

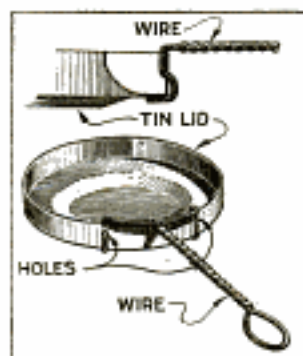

Safety Cover for Valves on Gas Stove

In order to safeguard the valves of a kitchen gas stove with which children might occasionally meddle, I fitted a sheet-metal cover over the valves, as shown in the sketch. The cover is wired to the feed pipe and is swung forward, as indicated by the dotted outline, when not in use. Small catches may be fixed at each end of the cover, if desired.—Leroy Schenck, Mount Vernon, N. Y.

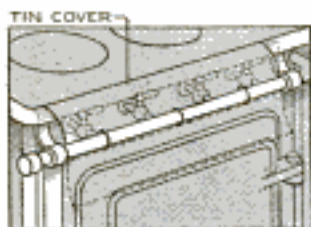

A Come-Back Rolling Can

An interesting toy may be made by fitting a rubber band into a tin can and weighting it as shown. When the can is rolled on the floor it will return to its original place by reason of the weight which is supported on a string at the middle of the rubber band. The latter is passed through two holes

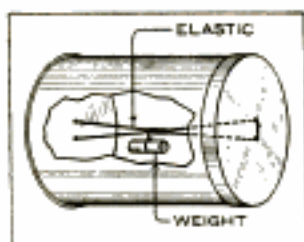

at each end of the can, and when the can is rolled along the floor the elastic is wound at the middle. The weight reverses the direction of rolling.—Albert French, Hamilton, Ontario, Can.

Removable Paraffin Covers for Jars

To remove paraffin from the tops of glasses or jars of preserves, without getting bits of the covering into the contents, is difficult. When pouring the melted paraffin over the top, put a small cork in the center and let the paraffin harden around it, as shown. To remove the covering, dip the top of the glass in hot water. This sealing can be used again by placing it on the top of hot jelly, the paraffin melting and adhering to the glass.—J. E. McCoy, Philadelphia, Pennsylvania.



A Marble-under-Bridge Game of Skill

The object of this game is to pass a marble from one end to the other of the "roadway," under the "bridges," and over the "inclines," without dropping it. A stop must be made at each hole. The device is made as follows: Cut two pieces of wood, $\frac{1}{4}$ by $1\frac{3}{4}$ by 12 in., and join them to form a right angle. Cut pieces of cardboard, 4 each, $1\frac{3}{4}$ by $2\frac{1}{2}$ in. wide, with a $\frac{3}{4}$ -in. hole in the center, for inclines B, and $1\frac{3}{4}$ by 3 in., for bridges A; also two pieces $1\frac{3}{4}$ in. square for stops C. Fasten them with tacks as shown. The marble should be large enough so that it will rest in the holes at B.

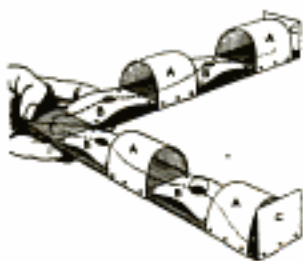

Photographic-Print Washing Machine

By HARRY MARCELLE

MANY amateur photographers have occasion to make a considerable number of prints and find the washing of them tedious, by the ordinary methods. In order to overcome this difficulty the print-washing machine shown in the sketch was made. It is simple in construction and performs the work quite satisfactorily at a saving of not a little time. Since the water in which the prints are washed must be agitated, a pivoted tray is provided. A unique feature is the water wheel through which the water supply passes, at the same time developing power to operate the rocker arm, by means of which the tray is agitated.

The frame for the large trough, which contains the tray and other apparatus, is made of 2 by 4-in. uprights, braced with 2 by 2-in. pieces. The trough is made of $\frac{7}{8}$ -in. stock, joined at the ends with a water-tight grooved, or dado, joint. The top is fitted to form a cover and may be hinged or arranged as a lid, supported and held in place by cleats, fixed on its under side with screws. The trough and its fittings may be made of a size suited to individual requirements. The device illustrated is 4 ft. long, and has a trough 18 in. wide and 13 in. high. The interior of the trough is given a coat of tar to make it waterproof, and the exterior may be painted thoroughly to preserve the wood.

The rocking tray, in which the prints are placed, is made of $\frac{5}{8}$ -in. stock. It is 5 in. high, 15 in. wide, and 28 in. long. Splash boards are fixed at its ends, as shown, and the bottom is made of muslin, reinforced with wooden strips, $\frac{1}{2}$ in. wide. The tray is sup-

ported on a rod or pipe at its center, the ends of the support being set into the sides of the trough. A crank arm

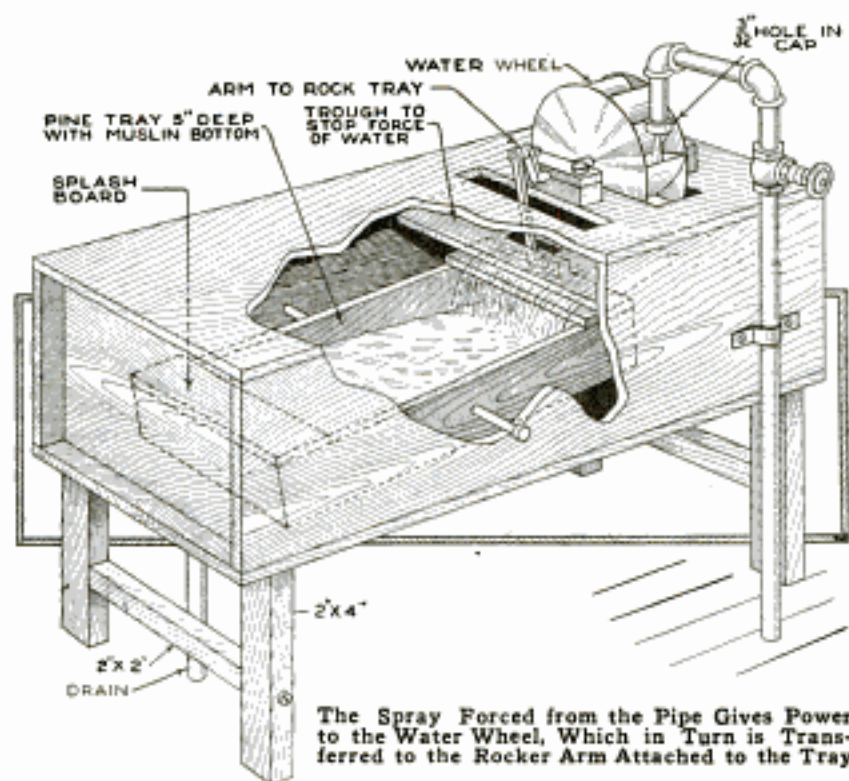

The Spray Forced from the Pipe Gives Power to the Water Wheel, Which in Turn is Transferred to the Rocker Arm Attached to the Tray

of wood or metal is attached to the center of one end of the tray, and operates through an opening in the top of the trough. The crank arm engages a crank fixed to the shaft of the water wheel, as shown in the sketch. The crank must be made not longer than 2 in., or the resulting action on the tray will pour out too much water, the prints being thus in danger of damage.

The water wheel is made of two round disks of sheet metal, 9 in. in diameter. Strips of wood are fitted between them so that the wheel is 3 in. wide on the face. Wooden blocks, grooved to fit the shaft of the water wheel, are used as bearings. They are fixed to the top with bolts. The water supply is provided through a pipe at one end. A cap is fitted over the end of the extension on the pipe and a small hole drilled through it. This forces the water against the blades of the water wheel rather than permitting it to drop under normal pressure. The flow of water is regulated by the valve on the

supply pipe, and the excess water is drained off at the opposite end of the trough. The force of the water, as it leaves the water wheel, is lessened, and the water carried gently to the tray, by means of a board set between the top and the tray, at the wheel end of the trough.

A Washstand for the Baby

To make this washstand, I mounted a cheese box on a frame 20 in. from the floor, and fitted a shelf between the legs 9 in. from the floor. In the center of this shelf a hole was cut, with a compass saw, to hold a wash basin. Rods between the legs are handy for towels, wash cloths, etc.

Within the circular box are kept baby's toilet and bath articles. The inside of the box is padded with cotton and lined with nainsook, the latter being used, also, for the cover. When the cover is on the box, the stand is used as a small table. White enamel gives the stand a neat finish.—F. E. Brimmer, Dalton, New York.



Carrying Strap and Lock for Hand Cases

The illustration shows how to make a locking device for hand cases or satchels, and providing, also, a strap for carrying. Cut two pieces of $\frac{5}{8}$ by 2-in. strap iron, and two pieces, $2\frac{1}{2}$ in. long. Bend them, and fasten them with screws or rivets, as shown. When the case is carried, the strap holds the crosspieces firmly.



Disk Talking-Machine Records Played Eccentrically

A hole was bored about an inch from the center of a disk talking-machine record and the latter was placed on the machine with the new hole over the center pin of the table. When the record was played, the result was a reproduction extremely amusing and hardly recognizable as compared with the original one.

Safety Flue Stopper Made of Tin Pail

The usual method of covering stove-pipe holes in chimneys with a tin disk is not as safe as it should be, especially adjoining nonfireproof material. A safer method is to fit a tin can, or a tin pail, into the chimney hole, as shown. Cut it off the right length, with a pair of tin shears, leaving projections as stops, and replace the disk stopper.—J. A. Raught, Janesville, Wisconsin.

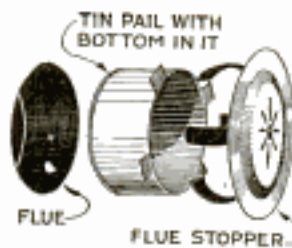

Book Rest for Music Stand

The music-stand attachment shown in the illustration aids in the handling of music books, and is easily made. Some stands are provided with a supporting edge about 1 in. wide and will not properly carry larger music books, and the device is attached to this edge. The device is of wood, $\frac{3}{16}$ by $3\frac{1}{4}$ in., and the length of the stand. On the bottom, two wood strips are fastened. They are beveled as shown in the sectional view, to wedge on the music rest.—L. R. W. Allison, Newark, N. J.

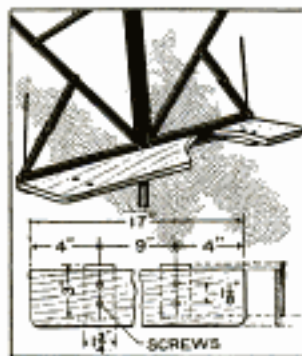

Old Table Used as Wall Workbench

Good use was made of an old table, one leg of which was broken, by removing two of the legs at one side and fitting the table against a wall. A wide board was set on the back edge of the table, against the wall, and provided a rack for tools. A drawer was fitted into the front of the table, and a small iron vise was clamped at one end. The arrangement provided a convenient bench for home shop work.

Lettering Photo Prints without Marking Negative

Instead of scratching titles on photographic negatives, which often produces a poor result, a good method is to write the title on the sensitive paper with black ink before printing. Care must be taken not to scratch the paper. The toning and fixing baths wash away the ink, leaving the script or lettering white. The negative is thus unmarred.

Rope Pad Prevents Slamming of Door

An antislam pad, made of a piece of rope and fixed to the knobs of doors, is in general use in a large hospital. The device is made by forming loops on the end of a short section of rope, as shown, and fitting them over the door knob. This also prevents the closing of the door so that a patient may be heard in calling an attendant.—C. M. Hall, St. Louis, Missouri.



ⒸCurtain rollers should be arranged so that the direction of pull on the tacked edge of the curtain is away from the end.

Box to Protect Extra Spark Plugs

Damage often results to spark plugs which are thrown in the tool box of an

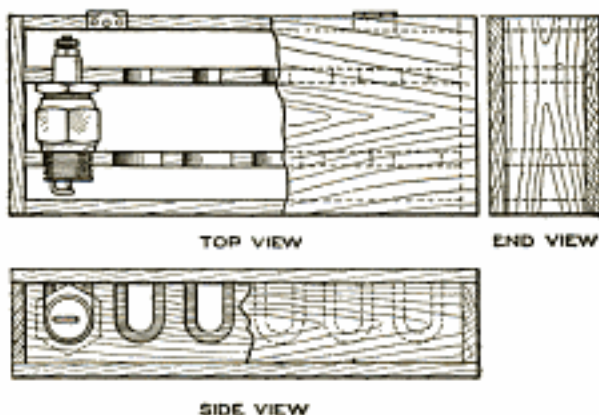

The Spark Plugs are Fitted Compactly in the Case and are Protected from Damage

automobile, and the use of a small case for the extra spark plugs is desirable. Partitions may be fitted into an old box of suitable size, or a case may be specially made. That shown was designed to provide for six spark plugs in a minimum of space. It was made of $\frac{1}{4}$ -in. wood, and of a length so that the spark plugs could be slipped in the recesses only by turning the faces of adjoining plugs together. A hinged cover keeps them firmly in place.—E. R. Mason, Danville, Ill.

Homemade Spring Wagon Seat

Two $\frac{7}{8}$ -in. boards, 12 in. wide, between which two 12-in. pieces of 2 by 4-in. wood are bolted, provide a strong spring seat for a wagon. The boards are cut to a suitable length, and the 2 by 4-in. pieces are set near the middle, and about 8 in. apart. This gives a spring seat at each end of the device.

Cushioned Chair Made of a Barrel

A strong barrel may be made into a comfortable chair by cutting it halfway through at the middle and shaping the remaining upper portion into an arm and back rest. Holes are bored at the seat level and at the back, and wires woven through them to form a backing for excelsior-stuffed cushions.

35.90 Rev. Eleanor E. Gordon,
Orlando, Fla.

ATTRACTIVE LITTLE CHURCH COSTS MODEST SUM

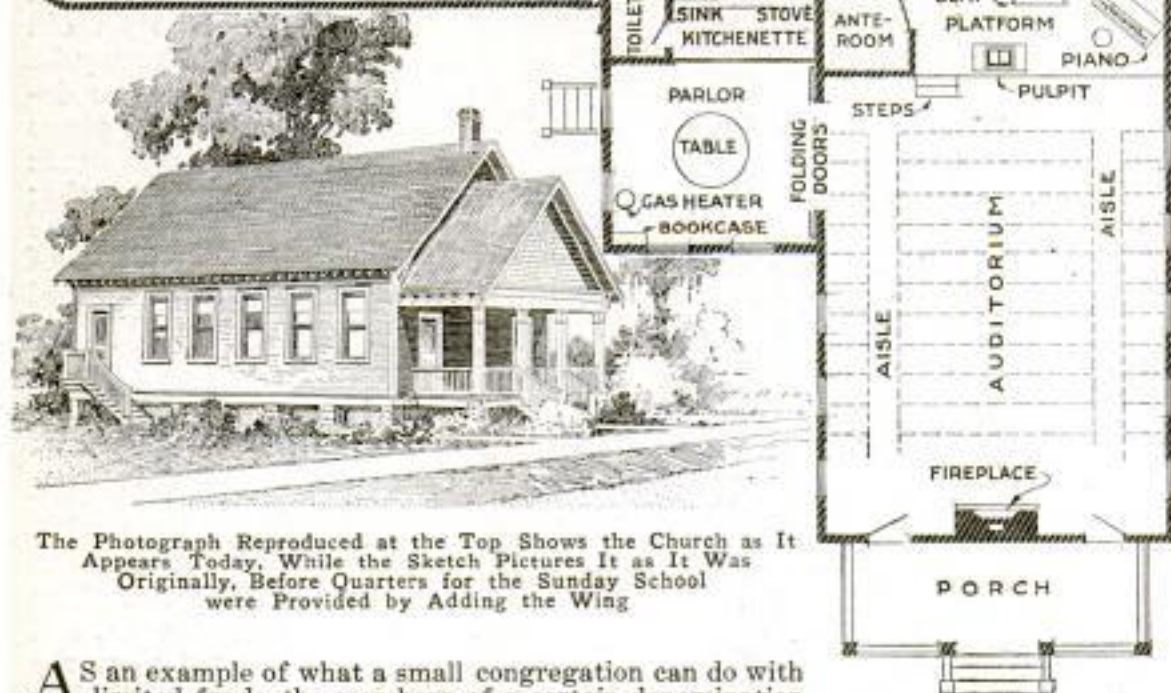

The Photograph Reproduced at the Top Shows the Church as It Appears Today, While the Sketch Pictures It as It Was Originally, Before Quarters for the Sunday School were Provided by Adding the Wing

As an example of what a small congregation can do with limited funds, the members of a certain denomination at Orlando, Fla., some time ago erected an unpretentious but inviting frame chapel on a bank of one of the many small lakes of that vicinity. The structure, as then constituted, offered a single room 25 by 41 ft. in size, and cost, exclusive of painting, \$1,545. This provided sufficient floor space for 100 chairs. More recently a wing has been added to the building and a pleasant room that serves both for parlor and Sunday-school purposes, outfitted at an expense of \$646. This amount included the cost of painting the whole building, equipping a toilet and kitchenette, and installing four gas heating stoves. In most respects the edifice has the exterior appearance of a cottage, and thus is homelike and attractive. For approximately \$600 the furnishings, consisting of chairs, screens, china, bookcases, and a piano, were obtained.

IN accordance with the editorial policy of this magazine never to accept compensation in any form for what appears in our reading pages, and also to avoid all appearance of doing so, we are obliged to omit the name of the maker or the seller of any article described. This information, however, is kept on file and will be furnished free, by addressing Bureau of Information, Popular Mechanics Magazine, Chicago. [Editor.]

ALADDIN HOUSES ^{READI-CUT}

Cut High Building Costs

\$ 989 for this

**7-ROOM
ALADDIN
HOME**

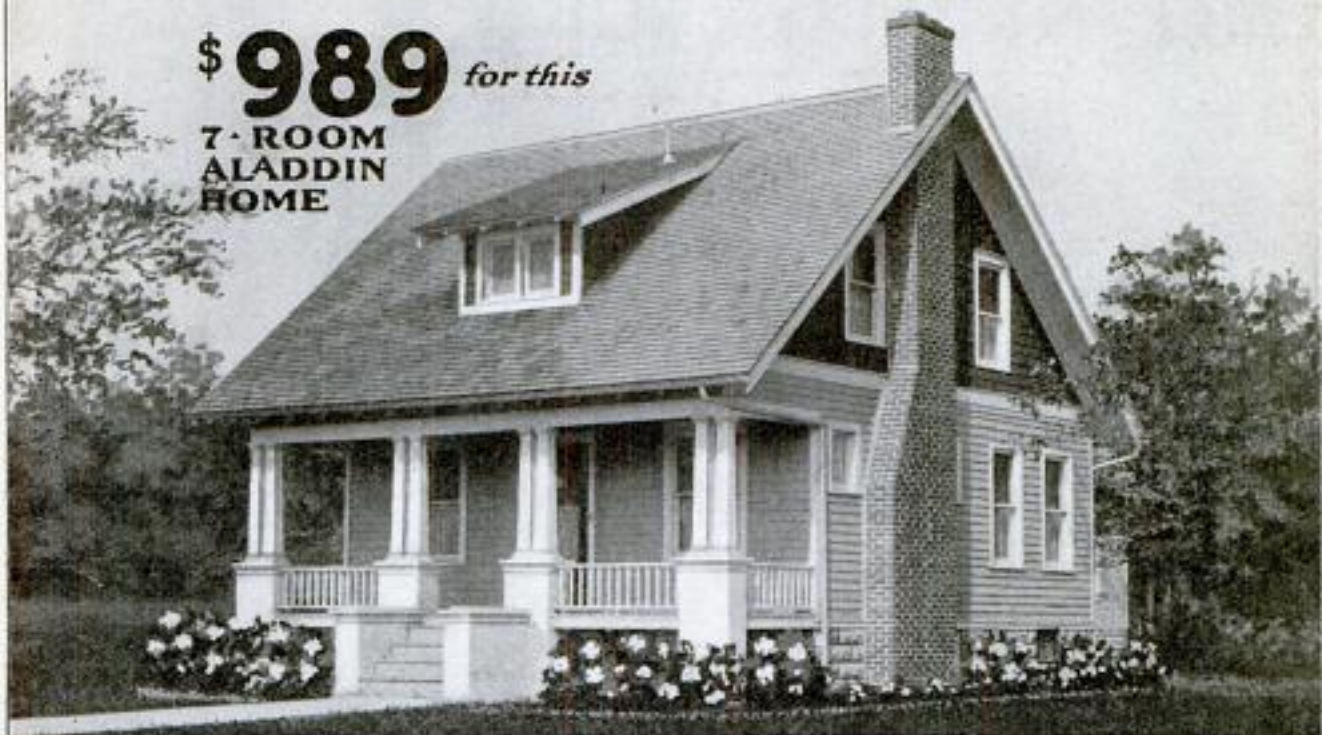

BUILD THIS YEAR—AVOID HIGH PRICES

Don't delay your building plans. Decide to start building now. Building prices are going up. Labor prices will advance. The Aladdin Read-Cut System enables you to build your new home, garage, barn or farm building at a substantial saving in cost. Thousands of Aladdin customers—some near you—will tell you how much they have saved building the Aladdin way. The big book "Aladdin Homes" will show you plans and pictures of over 100 homes. It will also demonstrate the saving you can make by building NOW. Send stamps for your copy today.

Save Waste of Lumber

Ordinary building methods waste on an average of 18 per cent of the lumber you pay for. Think of it! \$18 out of every \$100 goes to the waste pile and is burned up for kindling wood. Of course, the lumber that is wasted costs just as much as the lumber that is used. Are you willing to pay \$18 on every \$100 worth of lumber for waste? This is an important item to consider, especially when lumber prices are advancing. The Aladdin system saves you this unnecessary expense—puts the \$18 from every \$100 into your pocket. Aladdin Read-Cut Homes are cut-to-fit in our mills. You pay for the material used in your house—to more.

Aladdin Price Includes All Material

Aladdin price includes all lumber, millwork, flooring, outside and inside finish, doors, windows, shingles, lath and plaster, hardware, locks, nails, paint, varnish, etc. Your home is shipped in a special box car, complete, Read-Cut, ready to erect. Safe arrival of the complete material in perfect condition is guaranteed. Floor plan arrangement and complete description of the house shown above will be found in the Aladdin Book of Homes. Send stamps today for the book "Aladdin Homes" No. 180.

Save Waste of Labor

When you receive the material for an Aladdin Home it is all cut-to-fit, marked and numbered. You will make a substantial saving in the erection, as it is not necessary for your carpenter to spend their time sawing and measuring. All they do is put the material in place and drive the nails. It is also unnecessary for you to employ skilled labor to erect your Aladdin. Complete instructions and illustrations for erection are sent to you. You can erect it yourself in spare time.

120 Page Book "ALADDIN HOMES"

The big book "Aladdin Homes" shows over a hundred attractive bungalows and dwellings from \$341 for a 4-room home to homes valued at \$8,000 complete. Many attractive low cost garages—from the single car garage at \$54 to the largest size built for three touring cars. Range of different types from \$250 for a complete barn to the largest and most complete type designed. This big book will help you plan your home, help you to save money on your building, help you to build it in less time than usually required. Let us send you a copy of "Aladdin Homes" No. 180. Send stamps today—it will be sent to return mail.

CANADIAN BRANCH:
Canadian Aladdin Co., Ltd., C.P.R. Bldg., Toronto, Ont.

**THE ALADDIN CO. 1461 Aladdin Avenue
BAY CITY, MICH.**

\$735



\$1,096



\$684



\$1,064



Send This
Coupon
Today

The Aladdin Co., 1461 Aladdin Ave., Bay City, Mich.
Enclosed find stamps for a copy of your book "Aladdin Homes" No. 180.

Name _____
Street _____
City _____
State _____

How a Failure at Sixty Won Sudden Success

*From Poverty to \$40,000 a Year—
A Lesson for Old and Young Alike*

By R. D. RAINES

The old-time millionaire "made his pile" by squeezing the pennies, by overwork and self-denial. A much bigger army of men today are piling up millions without denying themselves the comforts and little luxuries of life—by giving up poor jobs for better ones, by preserving their health and strength, and by retaining their manhood and independence all through the struggle. Theirs is a new secret and one well worth learning.

Our story is about one who learned it—an old man who got hold of some of these young ideas. If you could have met him in the summer of 1915 you would have pitied him. For forty years he had been true to the old creed—hard work, long hours, patience, faithfulness, and economy. By dint of scrimping and scraping he would save a few dollars only to have them swept away by a season of illness in his family.

And his reward? It came at sixty, when he was thrown out of employment, onto the scrap-heap.

His old-fashioned rules for winning success had failed to work. "What was wrong with them or with him?"

He reviewed, one by one, the careers of some of his old business associates who had prospered. A suspicion entered his mind. He turned his attention to several young men who were forging rapidly to the front. Suspicion became conviction. In one respect all those men were identically alike. The climbing youngsters and the prosperous oldsters were strong-willed fellows of determined purpose. It was almost amusing, the way he and others of his kind scurried to get out of the way of

these men whenever they set out to accomplish any purpose.

Slowly the full truth came to him. Success was not a matter of age. It was not luck. It was not even a matter of opportunity. It was simply a question of dominating will power—determination that brooks no interference, commands respect, and easily leaps all obstacles.

Somewhere, lying dormant within him like an unused muscle, he too possessed a will. He knew it. He would uncover it. He would exercise and train it and put it to work.

For a long time he had believed he could make a success in a certain line of manufacturing. He had some new ideas about it. But he had never been bold enough to even mention his thoughts to others. Now he sought out some business friends. Instead of begging a small loan with which to pay his rent, he presented and explained his plans for launching a business of his own. His friends' first response was to smile. But as they listened they were struck by a new note in the old man's voice, a new self-confident poise in his bearing; his tone was magnetic, compelling; his argument sound and convincing. This gentleman was not to be denied.

In two days he raised \$600 capital for his plant. Three days later his little factory was in operation. In three months he repaid every penny of the loan and at the end of one year his books showed profits of \$20,000, and his second year's operations promise \$35,000 to \$40,000 more.

A better understanding of the tremendous power of the human will as a force in business and in fortune building may be

Please Mention Popular Mechanics

had by studying the successes of any of our big money makers.

Interesting and inspiring are several cases that have come to my personal attention, because the same methods are open to us all no matter how young or how old we may be.

One is that of a man who was \$6,000 in debt three years ago. Since then he has accumulated \$200,000 without speculating and today is earning \$1,000 a week. He is only one of many who frankly credit their good fortune to Prof. Frank Channing Haddock and his very remarkable book, "Power of Will." Another is a young man who worked in a big factory. One day he met Mr. W. M. Taylor, the noted efficiency expert, who advised him to read "Power of Will." He did so, applied himself to the training of his will, and in less than one year his salary was increased to more than eight times what he had been earning.

Then there is the case of C. D. Van Vechten, General Agent of the Northwestern Life Insurance Company. After his first examination of Prof. Haddock's methods and lessons in will power development, as published in "Power of Will," he told the author that they would be worth \$3,000 to \$30,000 to him.

Another man, Mr. H. D. Ferguson, residing in Hot Springs, Ark., increased his earnings from \$40 a week to \$90 a week in a remarkably short space of time after he began the study of will training. Will power training by Haddock's system has enabled thousands to conquer drink and other vices almost overnight—has helped overcome sickness and nervousness—has transformed unhappy, envious, discon-

tented people into dominating personalities filled with the joy of living.

In this new book Prof. Haddock, whose name ranks with Bergson, James, and Royce in the scientific world, has given to the world for the first time a practical, simple system of rules and exercise for will power training that has completely revolutionized the lives of thousands of people. For the will is just as susceptible to exercise and training as any muscle of the body.

"Power of Will" is being distributed by the Pelton Publishing Co. of Meriden, Conn. Any reader who cares to examine the book may do so without sending any money. If, after five days, you do not feel that this book is worth the \$3 asked for it, return it and you will owe nothing.

Some few doubters will scoff at the idea of will power being the key to wealth and achievement. But intelligent men and women will investigate for themselves by sending for the book at the publisher's risk. Among the 150,000 owners who have read, used, and praised "Power of Will," are such prominent men as Supreme Court Justice Parker; Wu Ting Fang, ex-U. S. Chinese Ambassador; Lieut.-Gov. McKelvie of Nebraska; Assistant Postmaster-General Britt; General Manager Christenson, of Wells-Fargo Express Co.; E. St. Elmo Lewis; Governor Arthur Capper of Kansas, and thousands of others equally prominent.

As a first step in will training, act on your present impulse to write a letter or address this coupon to the Pelton Publishing Company, 13-J Wilcox Block, Meriden, Conn., and the book will come by return mail. This one act may mean the turning point of your life. Do not hesitate.

**PELTON PUBLISHING COMPANY,
13-J Wilcox Block, Meriden, Conn.**

I will examine a copy of "Power of Will" at your risk. I will remain the book in 5 days or send you \$3 in payment for it.

Name

Address

Please Mention Popular Mechanics

The Dangers of Stomach Acidity and Fermentation

By ARTHUR TRUE BUSWELL, M. D.



Eugene Christian

If I were asked to sound a health warning that would be of the greatest possible benefit to mankind, I should say emphatically—"Beware of acid stomach." For acid stomach is the cause of fermentation which, bad enough in itself, is the forerunner of a hundred

ills that sap the energy and vitality of its victims. I venture to say that ninety per cent of all sickness starts with acid stomach.

Nature provides hydrochloric acid as one of the digestive fluids, but too much of this acid causes fermentation, hurries the food out of the stomach and carries the acid all through the body. As a consequence, poisons (toxins) are formed which are absorbed into the blood causing auto-intoxication, nervousness, mental depression and countless ills of which this is but the beginning.

Every one of the vital organs in time becomes affected—the heart, the liver, the kidneys, the intestines, the nerves and the brain all decline, for the stomach is the Power Plant of the body. Even the teeth are affected by acid stomach, for the gums recede and pyorrhœa will be the result.

Stomach remedies only neutralize the acid because they are stronger than the acid. This ultimately ruins the lining of the stomach. The acid being neutralized is absorbed into the blood only to come back to the stomach in greater quantities at the next meal.

How much more sensible would it be to attack this disorder at its source. Instead of attempting to neutralize the acid after it has

formed, why not prevent it from forming in the first place?

Superacidity is caused by wrong eating and the remedy must be found in the field of the cause—in eating correctly.

The individual sufferer from indigestion, acidity, fermentation, gas and such disorders has not carried his experiments with food very far. If he had he could easily cure himself as Eugene Christian, the famous food scientist, has proved beyond all doubt.

The reason which led Eugene Christian to take up the study of food in the first place was because he himself, as a young man, was a great sufferer from stomach and intestinal trouble.

So acute was his affliction that the best specialists of the day, after everything within their power had failed, gave him up to die. Educated for a doctor himself, Christian could get no help from his brother physicians.

Believing that wrong eating was the cause and that right eating was the only cure, he took up the study of foods and their relation to the human system. What he learned not only restored his own health in a remarkably short space of time, but has been the means of relieving some 25,000 other men and women for whom he has prescribed with almost invariable success, even though most of them went to him as a last resort.

Christian says that all stomach and intestinal disorders with their countless sympathetic ills—are caused by wrong selections and wrong combinations of food and that right combinations of food will positively remove every stomach and intestinal disorder by removing its causes.

Please Mention Popular Mechanics

No one would think of putting salt into an open wound, and yet we do worse than that when we keep putting irritating acid-creating food combinations into our stomachs already surcharged with acid.

The word diet is one which has an unpleasant sound—it makes us think of giving up all the things we like for those we have no taste for. But Eugene Christian's method is entirely different—instead of asking his patients to give up the things they enjoy, he prescribes menus which are twice as enjoyable as those to which the patient is accustomed.

Christian believes in good foods deliciously cooked—the kind all of us like best and which may be obtained at any home store, hotel or restaurant. He says that most of the things we eat are all right—but that we don't know how to combine or balance them.

Often, one food good in itself, when combined with another equally good food, produces an acid reaction in the stomach; whereas either of the foods alone or eaten in combination with some other food would have been easily and perfectly digested.

Unfortunately, each food we eat at a meal is not digested separately. Instead, all of the foods we combine at the same meal are mixed and digested together. Consequently, if we eat two or more articles at the same meal which don't go well together, there is sure to be acidity, fermentation, gas and all kinds of digestive trouble.

At Eugene Christian's New York office there is a constant stream of men and women who go to him for treatment after having tried everything else, and rarely are they disappointed in the outcome. Some of the results he has attained read like fairy tales. I know

of a number of instances where his rich patrons have been so grateful for their restoration of health and energy that they have sent him checks for \$500 or \$1,000 in addition to the amount of the bill when paying it.

There have been so many inquiries from all parts of the United States from people seeking the benefit of Eugene Christian's advice and whose cases he is unable to handle personally that he has written a course of little lessons which tell you exactly what to eat in order to overcome the ailment which is troubling you.

These lessons, there are 24 of them, contain actual menus for breakfast, luncheon and dinner, curative as well as corrective, covering all conditions of health and sickness, including stomach acidity, constipation and all intestinal disorders from infancy to old age and all occupations, climates and seasons. They also tell you how to reduce and how to gain.

With these lessons at hand it is just as though you were in personal contact with the great food specialist, because every possible point is so thoroughly covered and clearly explained that you can scarcely think of a question which isn't answered. You can start eating the very things that will remove the causes of your disorder the day you receive the lessons and you will find that you secure results with the first meal.

If you would like to examine these 24 Little Lessons in Corrective Eating simply write The Corrective Eating Society, Inc., Dept. 55, 450 Fourth Avenue, New York City. It is not necessary to enclose any money with your request. Merely ask them to send the lessons on five days' trial with the understanding that you will either return them within that time or remit \$3, the small fee asked.

Please clip out and mail the following form instead of writing a letter, as this is a copy of the official blank adopted by the society and will be honored at once.

CORRECTIVE EATING SOCIETY, Inc., Dept. 55, 450 Fourth Ave., NEW YORK CITY

You may send me prepaid a copy of Corrective Eating in 24 Lessons. I will either remail them to you within five days after receipt or send you \$3.

Name..... Address.....

City..... State.....

Please Mention Popular Mechanics

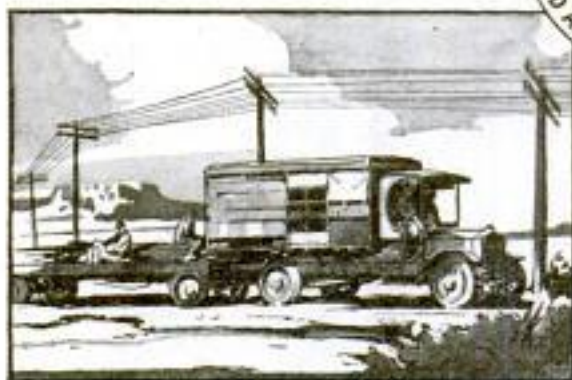
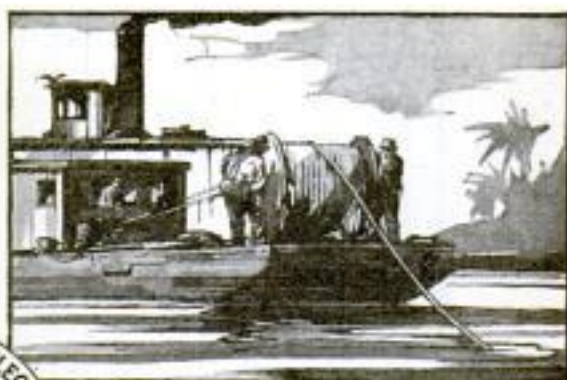

Meeting the Universal Need

In the high passes of the mountains, accessible only to the daring pioneer and the sure-footed burro, there are telephone linemen stringing wires.

Across bays or rivers a flat-bottomed boat is used to unreel the message-bearing cables and lay them beneath the water.

Over the sand-blown, treeless desert a truck train plows its way with telephone material and supplies.

Through dense forests linemen are felling trees and cutting a swath for lines of wire-laden poles.

Vast telephone extensions are progressing simultaneously in the waste places as well as in the thickly populated communities.

These betterments are ceaseless and they are voluntary, requiring the expenditure of almost superhuman imagination, energy and large capital.

In the Bell organization, besides the army of manual toilers, there is an army of experts, including almost the entire gamut of human labors. These men, scientific and practical, are constantly inventing means for supplying the numberless new demands of the telephone using public.

**AMERICAN TELEPHONE AND TELEGRAPH COMPANY
AND ASSOCIATED COMPANIES**

One Policy

One System

Universal Service

Please Mention Popular Mechanics

Shore Road—Monterey,
California

You Can Expect Better Value

There is nothing new, or untried, or indeterminate, in the method or make-up of Goodyear Tires.

They are built to a fixed standard of excellence, the highest we know—under a process allowing no variation or irregularity.

The Goodyear Tire you buy from your dealer—no matter where, or in what season—may be depended upon to return full and unstinted service for your investment.

That this service will exceed that commonly given by other tires is evidenced by the position Goodyears hold as the preferred tire of this hemisphere.

You can expect in all Goodyear Tires you buy, that *better value* which has made them the largest selling brand in America.

You can expect that *consistent superiority* of service which keeps the margin of Goodyear leadership steadily widening.

Goodyear Tires, Heavy Tourist Tubes and "Tire Saver" Accessories are easy to get from Goodyear Service Station Dealers everywhere.

The Goodyear Tire & Rubber Co.
Akron, Ohio



GOODYEAR

AKRON

Please Mention Popular Mechanics



Her Smiling Face Means Toilet Comfort

If you see a smiling nurse-face on a packet of San-Tox blue—purchase it. It is the symbol of purity. Try the particular preparation that lies beneath. It is pure.

Try San-Tox Tooth Paste for its refreshing, antiseptic quality which searches out the fine, destroying particles and healthies up the corners in which they hide.

Try San-Tox Shaving Lotion—that tonic, cool refreshment to the newly shaven face.

Try San-Tox After-Shave Talc

—whose skin-protecting comfort completes the shave.

Try, in fact, any San-Tox preparational purity, in whose efficiency San-Tox druggists so well believe that they offer to return your money on any purchase which does not even our every claim.

There are 125 San-Tox preparational purities—all sold under the sign of the San-Tox Nurse, which is the sign of a San-Tox druggist carefully selected. There is one, only one, in each locality.

SAN-TOX FOR PURITY
De Pree Chicago



Please Mention Popular Mechanics



Put Your Family in

Keds

**Canvas Rubber-soled Footwear
for Men, Women and Children**

KEDS is the name to guide you to grace, beauty and solid comfort in footwear. Keds is the new name of an old-established family of ultra-stylish, serviceable and comfortable rubber-soled shoes with uppers of a specially woven, fine grade of canvas.

If you glory in a light, springy step, full of noiseless grace, ask your dealer for Keds. There are many styles and shapes. You can find your particular Keds, whether for the fashionable boulevard or afternoon tea on your own porch.

Keds are vogue—they are worn by particular dressers at all the smart places—they add a refreshing grace to the dainty feet of society women—they give substantial wear with good looks and solid comfort to business men—for children they are next to going "barefoot."

There are three grades of Keds. Choose the kind you want. You are sure of wear in every pair. Each grade carries with it the reputation of the largest rubber manufacturer in the world.



**\$1.50
up**



**\$1.25
to
\$2.00**



**\$1.00
to
\$1.50**

There is style in Keds. They are built on popular lasts and approved by fashion authorities.

There is comfort in Keds. The tops offer full, elastic support; the soles are durable, flexible and buoyant.

There is economy in Keds. Cost considered, Keds outwear any other footwear yet devised.

Ask your dealer to show you Keds and shoe the family in style and comfort.

United States Rubber Company

New York

Please Mention Popular Mechanics

HERCULES

Smokeless Shotgun

POWDERS



At this end of the shell is the name of the powder. Ask for and look for

INFALLIBLE
or "E. C."

Know Your Shotgun Shells

YOU can't know too much about the shells you shoot. The information you should have is easy to obtain for it is told on the shell itself. The two ends give the story.

On the base you will of course find the name of the maker and the loader of the shell, and the gauge. At the other end, on the top wad, are printed the size and quantity of shot, the quantity of powder and, last but not least—the name of the powder.

Hercules Smokeless Shotgun Powders, Infallible and "E. C.," may be obtained in any standard make of shell. Undoubtedly the name of the maker of your favorite shell is given in the column to the right.

The next time you order shotgun shells it will pay you to see that they are loaded with Infallible or "E. C." Powder. By so doing you will obtain a powder of the highest quality and of uniform quality—a powder that gives unusually light recoil, high velocity, and even patterns. You will find the name of the powder stenciled on the outside of the box, as well as on the top wad.

For a booklet on ammunition, of interest to any sportsman, address

HERCULES POWDER CO.

1025 Market Street

Wilmington



Delaware

On this end is the name of the maker. Hercules Smokeless Shotgun Powders may be obtained in shells made by the following:

PETERS
REMINGTON
SELBY
U. S.
WESTERN
WINCHESTER



*Each Hour's Recreation Is
60 Minutes Comfort In B.V.D.*

FEELING hot is a state of body first, and a state of mind afterward. When you put on B. V. D. in the morning, its cool, clean touch helps take your mind off the heat, as well as the heat off your body. You're at your best physically and mentally.

In our own modernly equipped cotton mills at Lexington, N.C., the fabric from which these Loose-Fitting B.V. D. undergarments are made, is produced in a scientific manner from selected cotton to insure durability in wash and wear.

In our own B. V. D. Factories the garments are skilfully cut, strongly stitched, accurately finished—to fit and be cool and comfortable all day long.

*If it hasn't
this Rod
Woven Label*

MADE FOR THE

B.V.D.

BEST RETAIL TRADE

(Trade Mark Reg. U. S. Pat. Off. and Foreign Countries)

*It isn't
B.V.D.
Underwear*

B. V. D. Coat Cut Undershirts
and Knee Length Drawers,
50c. the Garment. B. V. D.
Closed Crotch Union Suits
(Pat. U. S. A.) \$1.00 the Suit.

Copyright © 1917 by
The B.V.D. Company

Copyright © 1917 by
The B.V.D. Company

THE B.V.D. COMPANY, N.Y.



Rinex Soles

YOU are going to like your Rinex Soles from the first day you have them on—they're so comfortable from the start, so soft and pliable, so sure-footed.

And the big return they give on your small investment in the form of long wear is going to make you a friend of Rinex for life.

Rinex Soles are not rubber, not leather, but a scientific, synthetic product of the world's largest rubber manufacturer, infinitely better for shoe-soles than either rubber or leather.

Rinex Soles wear down slowly, evenly—not in short-lived layers like leather soles of nowadays. They are the shoe-tread of *successful* men and women everywhere. Modern sons and daughters are being brought up on Rinex Soles.

Buy your first pair—either on new shoes or re-soling for old ones—you won't need urging after that. Many thousand first-class stores have new shoes with Rinex Soles in stock. Thousands of repair shops have Rinex Soles for re-soling. The genuine have "Rinex Sole" stamped in the shank. Look for this name.

In black, white and tan at first-class shoe stores and repair-shops.

United States Rubber Company

Sole and Heel Dept., 1790 Broadway, New York
60 High Street, Boston

Please Mention Popular Mechanics



CHALMERS UNDERWEAR



ALL STYLES

*"Lets the
Body Breathe"*

UNION SUITS

For Men \$1.25
For Boys 75c

SHIRTS AND
DRAWERS

Per
Garment
For Men 75c
For Boys 90c

CHALMERS
TRADE MARK
Porosknit
DESIGN PAT. DEC. 17, 1908
FABRIC PAT. DEC. 17, 1908
REG. U. S. PAT. OFF.
UNDERWEAR

This Label on Every Garment

Chalmers "Porosknit" Lets You Perspire Comfortably

Chalmers "Porosknit" Underwear absorbs perspiration so quickly that you scarcely know you are perspiring.

But you *do* know you are cool.

The little openings let out the heat of your body and let the dry, cooling fresh air get to your skin.

Put Chalmers "Porosknit" to the severest kind of a test. Wear it to business on a warm, sticky day or when you are "playing your game."

If you don't find this underwear most

satisfactory in every respect, we will gladly refund your money.

You will be delighted with the way "Porosknit" is made. The best materials, seams reinforced, buttons tightly sewed on. Fits comfortably without bagginess or tightness. Elastic and responsive to your movements as your own skin. Easy to wash thoroughly.

Chalmers "Porosknit" Union Suits are made with a special elastic closed crotch that prevents binding and cutting.

Ask your dealer to show you genuine "Porosknit"

Chalmers Knitting Co.

Also Makers of Chalmers Spring Needled
Ribbed Underwear

Amsterdam, New York

Please Mention Popular Mechanics

Copyrighted material

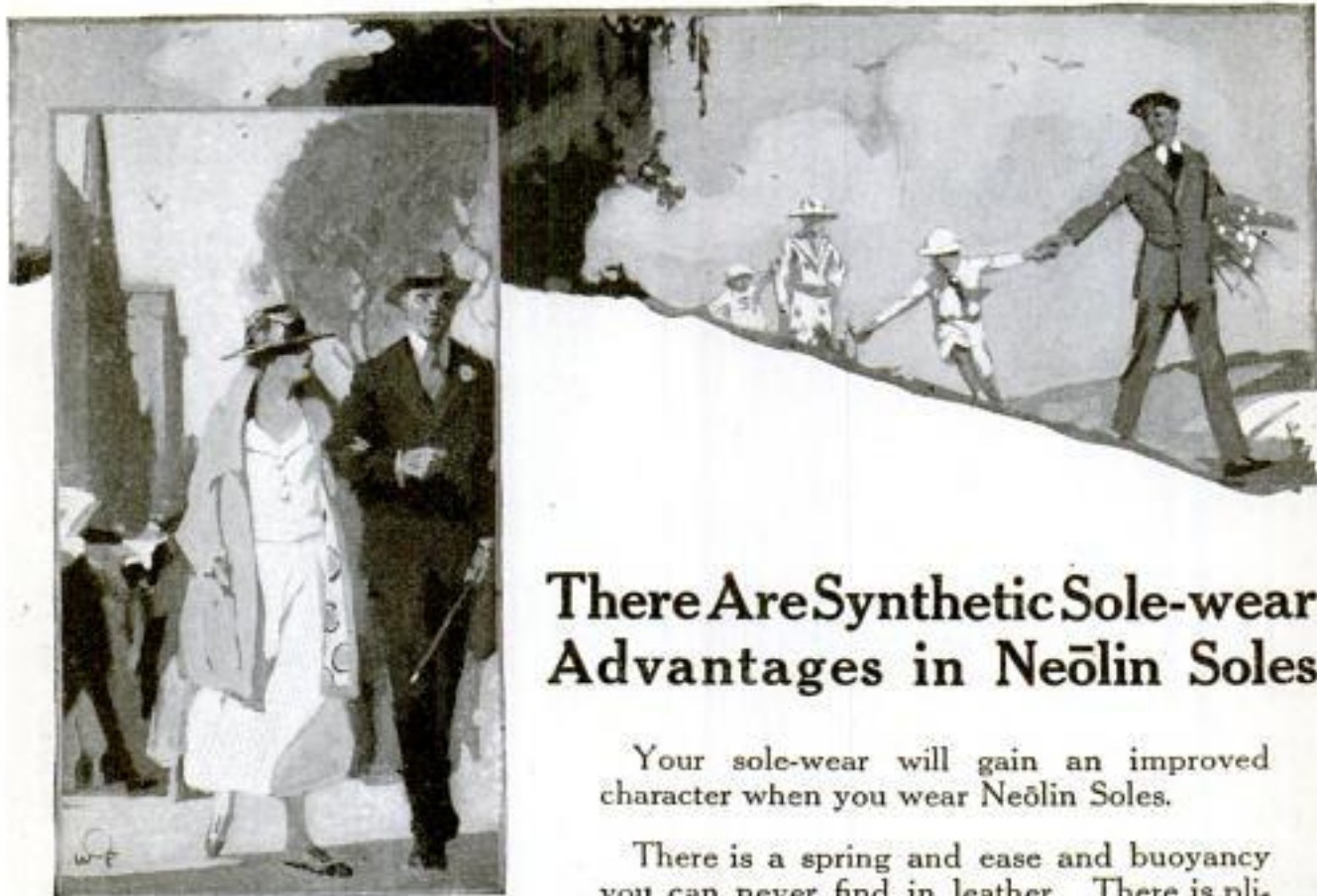

There Are Synthetic Sole-wear Advantages in Neolin Soles

Your sole-wear will gain an improved character when you wear Neolin Soles.

There is a spring and ease and buoyancy you can never find in leather. There is pliancy and foot-comfort in Neolin Soles — which need no breaking in.

There is consistent, lasting quality in Neolin Soles—trustworthy and unflinching. You prove it by lessened shoe-bills.

There is certainty of waterproof quality in Neolin Soles, which keep the foot sole unvaryingly dry. They hold the sole in shape, and the shoe-shape, too.

There is a definite improvement in tread-sureness with Neolin Soles. Neolin is better than leather, partly because it is *safer* than leather.

Neolin Soles are, in fact, a scientifically improved tread; and seven million modern people are today recognizing this by wearing them. The same in quality on any price of shoe. Won't scratch floors or furniture.

Avoid imitations and *mark* that mark; stamp it on your memory: Neolin—

the trade symbol for a never-changing quality product of

Neolin

Trade Mark Reg. U. S. Pat. Off.

Better than Leather The Goodyear Tire & Rubber Company, Akron, Ohio

Please Mention Popular Mechanics

Copyrighted material

The King of Sports

Invigorating — spontaneous — and interesting to the last degree — is trapshooting. It is the Sport of Kings and the King of Sports — replete with excitement and exhilaration.

Winging the wily clay pigeon has become quite *de rigueur* in smart country places and has proved a welcome boon to both host and hostess in the entertainment of house parties.

Write for the "Sport Alluring"
Booklet No. 386

E. I. du Pont de Nemours & Co.

Wilmington, **DU PONT** Delaware





The Patch That "Pulls You Through" On Time

The tire mishap that would mean disastrous delay becomes merely a brief halt if the kit is packed with

Firestone

Accessories

Firestone Cementless Tube Patches render "first aid" that lasts. They are easiest to apply and they stay put. Note the tab on protecting muslin for quick, convenient removal.

Firestone Accessories also include: Hook-On Boots for Clincher or Straight Side Tires, Lace-On Boots, Blow-Out Patches, Pure Gum and Red Wrapped Tube Patches, Cure-Cut, Cement, Air Pressure Gauges, Tire Tape, Tire Mica, etc., all of that quality which has made the name "Firestone" mean confidence. Firestone Cementless Tube Patch Free. To prove the success of Firestone patches, we will send you one free. Ask also for Book, "Mileage Talks."

FIRESTONE TIRE & RUBBER COMPANY
AKRON, OHIO Branches and Dealers Everywhere



Please Mention Popular Mechanics



FOR their sake, so that no matter what happens to you, their little faces will smile and their little bodies will grow strong and they will have all that they need, all that you want to give them.

Now they're safe. Now you can give them everything. But suppose one day pneumonia or appendicitis, or some accident should strike you—what would happen to them then?

It is your wife who tells you all this. She knows that **one man in seven is hurt or killed in an accident each year** and that sickness comes to even the most careful. For your sake, for your wife's sake, for the children's sake—



AETNA-IZE



For an annual premium of \$60 on the Accumulative Disability Policy, if you are in a "Preferred" occupation, and under 51 years of age, we will pay you \$50 a week for as long as you are totally disabled by a railway, steamship or burning building accident, or \$25 a week if you are disabled by an ordinary accident. And we will pay you \$25 a week up to 52 weeks, if you are totally disabled by sickness. We will pay hospital charges or for a surgical operation.

If you are killed by accident, we will pay your estate from \$5,000 to \$15,000, depending on the character of the accident and on the number of years you have carried the insurance. If you lose two limbs, or both eyes by accident, we will pay you the same amounts. One-half of these amounts will be paid if you lose one hand, one foot or one eye by accident. In addition to weekly payments while you are disabled between date of accident and time of death or any one of the other losses named.

It takes so small a thing to put you in bed and stop your income.

Tear off this coupon and mail it today. It will be the best thing you ever did.

AETNA LIFE INSURANCE COMPANY

Drawer 1341

HARTFORD, CONN.

The largest company in the world writing Life, Accident, Health and Liability Insurance

Agency opportunities for all Casualty and Bonding lines
An Aetna Agent has a national advertising campaign working for him all the time

Name

Occupation

Bus. Address

.....
AETNA LIFE INSURANCE COMPANY
Drawer 1341
HARTFORD, CONN.

I have marked the kind of insurance I wish to know about: Accident Health Disability Life Life Certificate My age is _____ years. I am in good health.

.....
F.M. 5-17

Please Mention Popular Mechanics

The simplest of cameras

PREMO FILM PACK CAMERAS

Every process from loading to unloading can be performed more quickly and easily than with cameras of any other type.

To load, open back of camera, drop in twelve-exposure Premo Film Pack, and close back.

To change films for successive exposures, merely pull out from the top successive film pack tabs. A film may be so changed in less than a second.

To remove exposed pack, just open back of camera and take it out. After the last exposure, the pack is automatically rendered light-tight.

At any time one or more films may be removed for development without injury to the remaining unexposed films—a unique feature in film photography.

This simple operation not only eliminates all complications, but makes it possible to supply exceptionally light and compact cameras for the most popular sizes of amateur pictures.

As for quality, these cameras are fitted with Kodak Ball Bearing shutters and tested lenses, they are all rigidly inspected, and the film is from the same stock as the Eastman N. C.

Get the new Premo catalogue from your dealer, or write us for it. Every one interested in photography should have a copy of this interesting book.

ROCHESTER OPTICAL DIVISION, EASTMAN KODAK CO., ROCHESTER, N.Y.

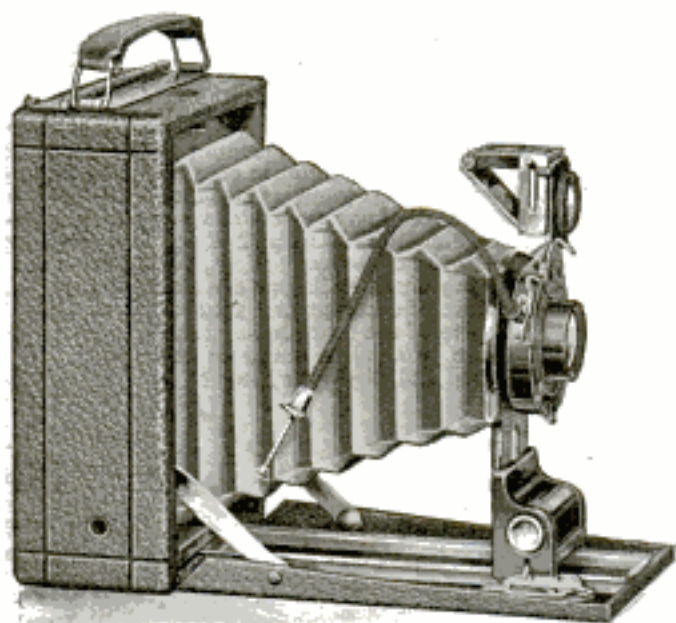

An illustration of the PREMOETTE SR.

The Shutter is the Kodak Ball Bearing with Kodak Anastigmat lens *f*.7.7. With this equipment prices are:

2½ x 4¼,	•	\$15.00
3¼ x 4¼,	•	\$15.00
3¼ x 5½,	•	\$17.50

PERFECT
FITTING

MUNSING
WEAR

UNION
SUITS

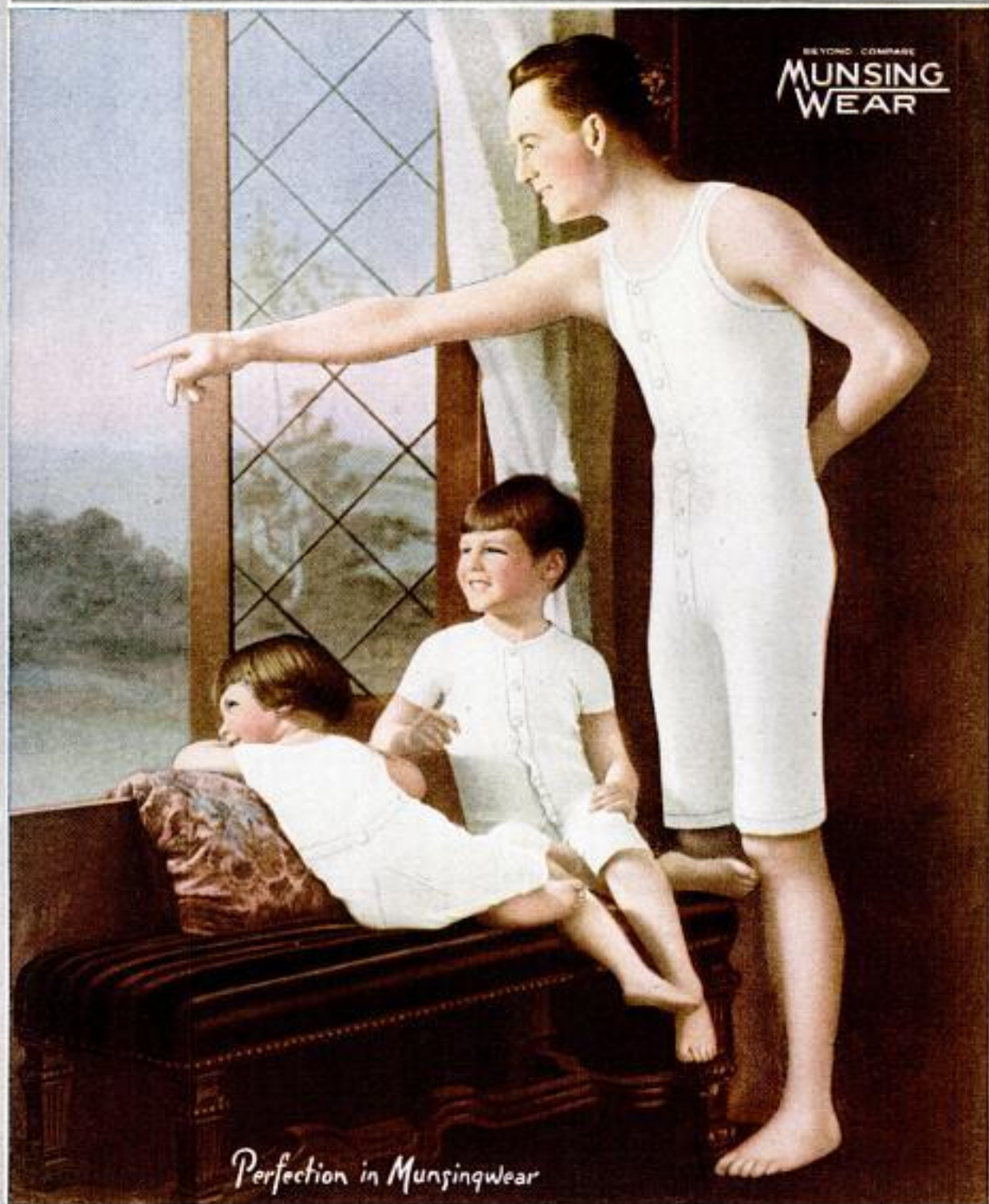

Perfection in Munsingwear

Munsing Union Suits In Summer Styles That Weigh Only A Few Ounces.
 Fine in Quality, Non-Irritating, Long Wearing, Always Perfect Fitting. The fit won't wash out. The most in demand because the most satisfactory. Offered in either knitted or woven fabrics. Remember
DON'T SAY UNDERWEAR—ALWAYS SAY MUNSINGWEAR.

Please Mention Popular Mechanics

Copyrighted material



Make your home beautiful, artistic and distinctive. This color page gives you but a mere hint of the possibilities of Alabastine.

The beautiful tones and delicate shades and tints that can be secured with Alabastine are almost limitless. With Alabastine you can put your own individuality into every room in your house,

Easy to prepare and apply

FREE—Color Scheme Demonstrator—This is absolutely a new and unique way of showing complete color scheme effects. Write today for your copy before the supply has been exhausted. Be sure the Red Cross in the circle is on every package you accept. This is your protection.

MIX IN ONE MINUTE
WITH COLD WATER.



Our art department will furnish complete color scheme suggestions for any home or building you wish to decorate with Alabastine. Ask about our special stencil offer.

Alabastine is for sale at all leading drug, paint and hardware stores

The Alabastine Company
112 Grandville Road, Grand Rapids, Mich.

THE ONLY TOOL
NEEDED TO APPLY



making the color scheme harmonize with draperies, rugs and furnishings.

Quite as important as the beauty of your home are the health conditions. Unsanitary walls are not only dangerous but criminal. Alabastine is not only strictly sanitary but is an actual disinfectant when applied to any wall.

To each five-pound package add two quarts of either cold or hot water, stir one minute. A flat wall brush does the work.

Have You Seen This New Electric Sewing Machine?



You can use it on the porch

You can carry it in one hand.

It can be put away on the closet shelf when not in use.

Motor and machine are one unit.

Costs Only \$35

(\$37 West of the Rockies)

Western Electric Portable Sewing Machine

Think of it! A machine that you can carry upstairs, downstairs, out on the porch—and use wherever there is an electric light socket.

A light pressure of the foot on the control pedal starts the motor, stops it, or gives you just the speed you need. The cost of current is less than one-half cent an hour. Complete machine is guaranteed for ten years.

If your lighting company or electrical dealer cannot show you this wonderful machine, send coupon to nearest office.

**WESTERN ELECTRIC
COMPANY, Inc.**

New York Chicago Kansas City San Francisco
Houses in all Principal Cities

**WESTERN
ELECTRIC
COMPANY
Inc.**

Gentlemen:
Please send me Booklet
No. 506-AW, describing your portable
electric sewing machine.

Name _____

Address _____

Please Mention Popular Mechanics

Even She Had Corns



Until a little while ago she thought them unavoidable. If you have corns don't blame yourself too much. Many an old person has had them fifty years.

YET they have done what you do—pared them and used old-time, useless treatments.

But what folly it is when nowadays about half the world keeps free.

The chemist who invented Blue-jay made corns forever needless.

Last year some 17 million corns were ended in this simple, easy way.

Just try one corn.

Apply a Blue-jay plaster in a jiffy. Then forget it. It will never pain again.

In two days take the plaster off. The corn will disappear. Only one corn in ten needs another application.

You will laugh at the old ways when you try Blue-jay. You will wonder why people ever let corns hurt. Please start tonight. You have suffered long enough.

BAUER & BLACK
Chicago and New York
Makers of Surgical Dressings, etc.

Blue=jay

Stops Pain — Ends Corns

15c and 25c at Druggists

Also Blue-jay Bunion
Plasters



New Automatic Adder \$2.50

Makes adding easy for anyone. It's accurate, quick, durable and easily operated. Capacity 999,999.99. Saves time, brain work and eliminates errors. Thousands of pleased owners. Guaranteed one year. Delivered complete for \$2.50. ORDER YOURS TODAY. AGENTS WANTED.

J. H. BASSETT & CO., Dept. 38, 5921 Indiana Ave., Chicago, Ill.



GROW AND SELL MUSHROOMS

An uncrowded occupation. Exceptional opportunities for live men and women. Raised at home. Only small space needed. Small expenditure will start you in a practical money-making enterprise. Big profits. Booklet telling all free. Write

Nat'l Spawm Co., Dept. 12, Boston, Mass.

Hand Forged
Razor Steel
Blades. No. 57

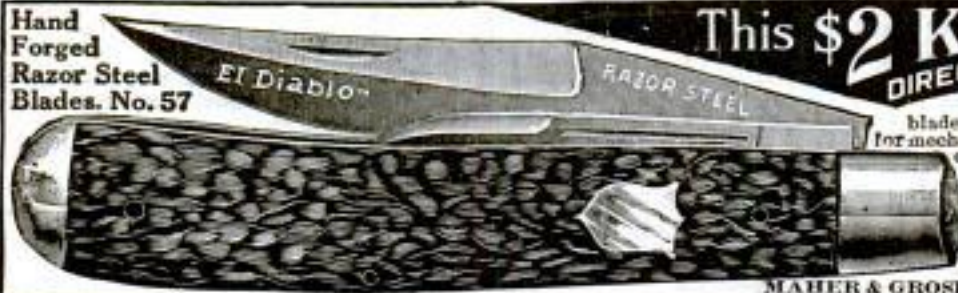

This \$2 KNIFE 83¢
DIRECT AT FACTORY PRICE

Handy shaped blade makes this knife best for mechanics, sportsmen and farmers; light but strong; resharpened easily. Stag handle, German silver finish; blades file tested, hand forged from razor steel and warranted. Sample 83c, 3 for \$2 postpaid. Choicest pearl \$2 each. Send for our 80 Page List and "How to use a Razor" **FREE**

MAHER & GROSH CO., 106 A. St., Toledo, Ohio.

Please Mention Popular Mechanics

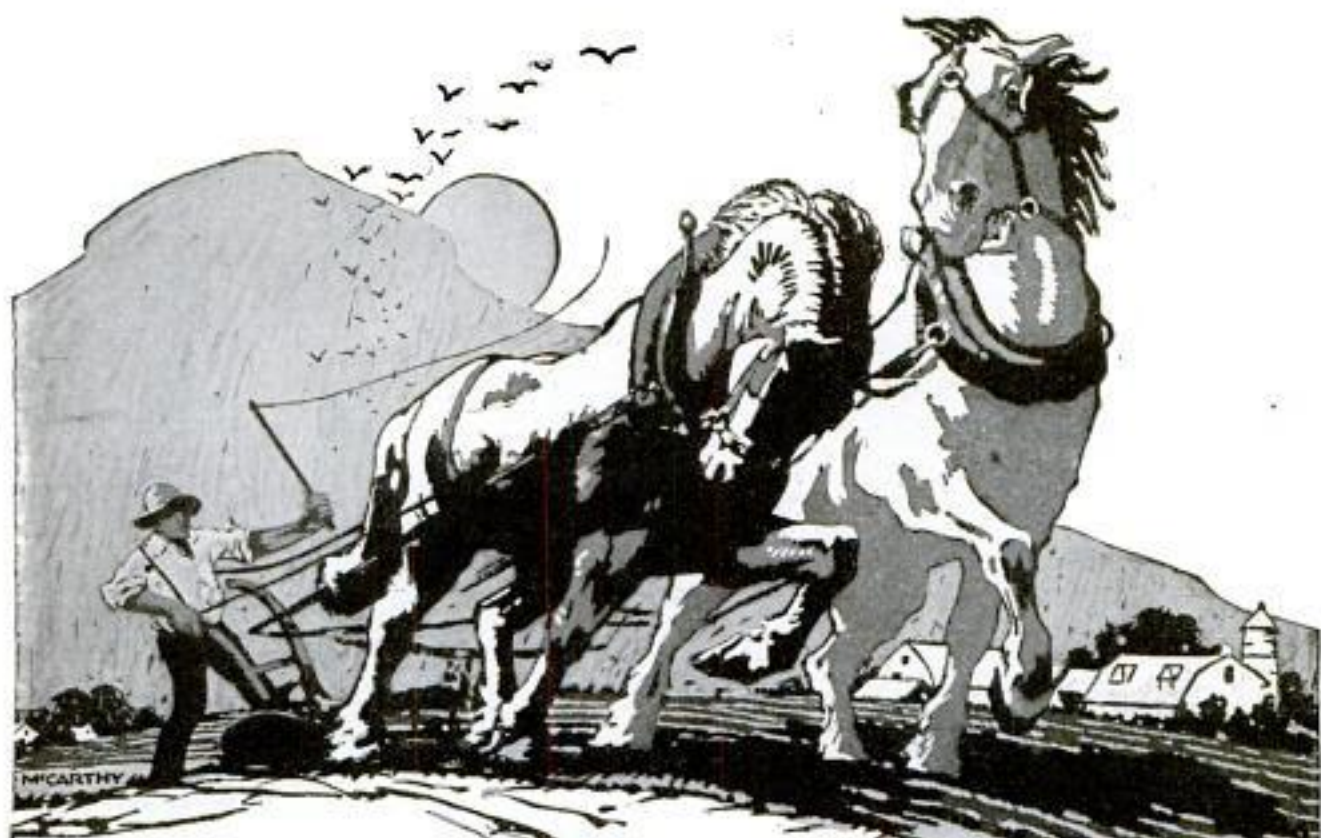

Nujol for Constipation

How Do You Expect to "Work Like a Horse"

—yet treat yourself as an intelligent farmer would scorn to treat his plow-horse? Your body demands careful attention, like any other finely adjusted piece of machinery. It responds just as readily to good treatment and suffers just as acutely from neglect.

Neglect of the bowel function and the habitual use of laxative pills and waters frequently result in chronic constipation. Drug "remedies" for constipation whip the bowels into action until eventually the system comes to demand the spur of a cathartic before it will work at all. For this reason physicians everywhere are recommending Nujol—the internal lubricant. Nujol, unlike physics or drugs, acts mechanically by keeping the intestinal contents soft and so facilitating normal movements.

Nujol being a lubricant, does not gripe or upset the system. It is tasteless, and easy to take.

The Standard Oil Company (New Jersey) has used its world-wide resources in producing Nujol and its reputation is behind the product.

Nujol is the only remedy for constipation we manufacture. The genuine sold only in pint bottles bearing Nujol trade-mark. All bottles filled at our Nujol plant, absolutely modern and sanitary.

STANDARD OIL COMPANY

(New Jersey)

Bayonne Dept. 68 New Jersey

Please send me booklet on the treatment of constipation
Write your name and address plainly below

Name _____ Address _____ City _____ State _____

Please Mention Popular Mechanics

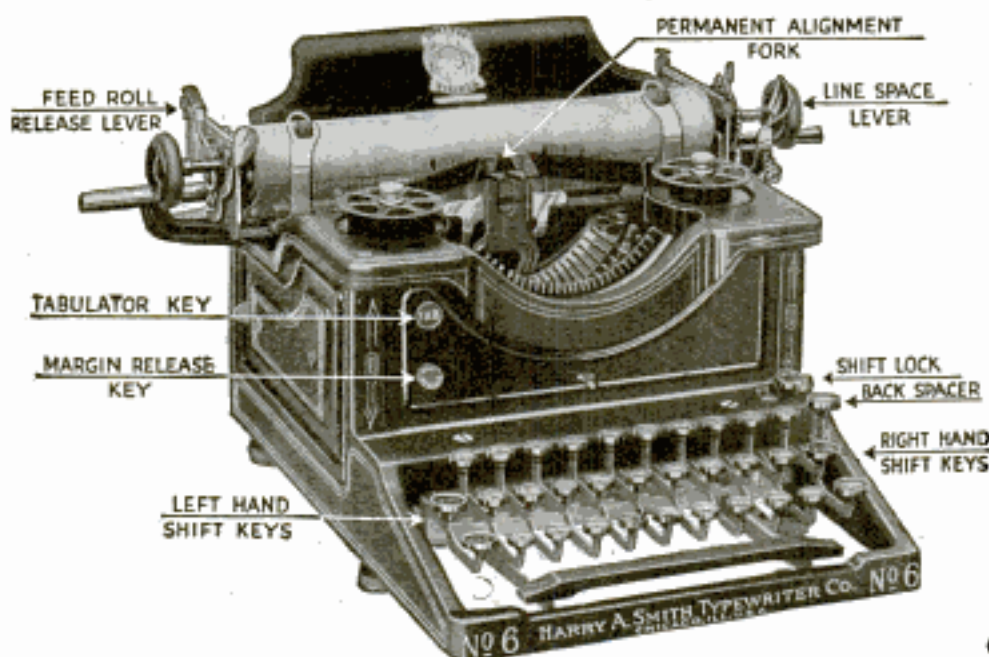

I want, through this advertisement, to establish as friendly business relations with you as I possibly can. I want you to realize also that it is my earnest effort and intention to give you full honest value for every dollar that you spend with me. This is the only way I can succeed. My advertisement has appeared in this magazine continuously for more than four years.

I am building up my business on the foundation of good value and square dealings. I am saving thousands of satisfied customers thousands of dollars, by supplying perfect—late style—visible writing—typewriters, at remarkably low prices.

All my transactions are handled throughout by personal correspondence. I assure you every courtesy and consideration in your dealings with me. Your order will have my prompt, careful, personal attention. I will be glad to do business with you.

Harry A. Smith

TYPEWRITER SENSATION

Free TRIAL—Use As You Pay

Send me only \$2.00 a month until the low total price of \$34.15 is paid, and the machine is yours

This is absolutely the most generous typewriter offer ever made. Do not rent a machine when you can pay \$2.00 a month and own one. Think of it—Buying a \$100.00 model for \$34.15. Cash price, \$32.30. Never before has anything like this been attempted.

Standard Visible SMITH Model No. 6

Perfect machines, Standard Size, Keyboard of Standard Universal arrangement, writing 84 characters—universally used in teaching the touch system. The entire line of writing completely visible at all times, has the tabulator, the back spacer; in fact, every late style feature and modern operating convenience. Comes to you with everything complete, tools, cover, operating book and instructions, ribbon, practice paper—nothing extra to buy. You cannot imagine the perfection of this beautiful typewriter until you have seen it. I have a thousand of these perfect latest style Model No. 6 typewriters at this bargain price, and each purchaser fortunate enough to secure one of these beautiful machines must try it out in home or office for five days before deciding to buy. I will send it to you F. O. B. Chicago for five days' free trial. It will sell itself, but if you are not satisfied that this is the greatest typewriter bargain you ever saw, you can return it at my expense. You won't want to return it after you try it—you cannot equal this wonderful value anywhere.

H. A. SMITH
Room 510-231 N. Fifth Ave.
CHICAGO, ILL.

Ship me a No. 6 Smith F. O. B. Chicago, as described in this advertisement. I will pay you the \$28.00 balance of the SPECIAL \$34.15 purchase price, at the rate of \$2.00 per month. The title to remain in you until fully paid for. It is understood that I have five days in which to examine and try the typewriter. If I choose not to keep it I will carefully repack it and return it to the express agent. It is understood that you give the standard guarantee for one year.

You Take No Risk—Put In Your Order Now

When the typewriter arrives deposit with the express agent \$6.15 and take the machine for five days' trial. If you are convinced that it is the best typewriter you ever saw, keep it and send me \$2.00 a month until my bargain price of \$34.15 is paid. If you don't want it, return it to the express agent, receive your \$6.15 and return the machine to me. I will pay the return express charges. This machine is guaranteed just as if you paid \$100.00 for it. It is standard. Thousands and thousands of people own and use these typewriters and find them the best ever manufactured.

The supply at this price is very limited, the price will probably be raised when my next advertisement appears, so don't delay. Fill in the coupon today—mail to me—the typewriter will be shipped promptly. There is no red tape. I employ no solicitors—no collectors—no chattel mortgage. It is simply understood that I retain title to the machine until the full \$34.15 is paid. You cannot lose. It is the greatest typewriter opportunity you will ever have. Do not send me one cent. Get the coupon in the mails today—sure.

HARRY A. SMITH, 510-231 N. Fifth Ave., Chicago

Name

Address

Pop. Mech. May

Please Mention Popular Mechanics

Our 21 Jewel SMASHES PRICES



Look!

- ☞ 21 Ruby and Sapphire Jewels—
- ☞ Adjusted to the second—
- ☞ Adjusted to temperature—
- ☞ Adjusted to isochronism—
- ☞ Adjusted to positions—
- ☞ 25-year gold strata case—
- ☞ Genuine Montgomery Railroad Dial—
- ☞ New Ideas in Thin Cases.

Only \$2.50 A Month

And all of this for \$2.50—only \$2.50 per month—a great reduction in watch prices—direct to you—positively the exact prices the wholesale dealer would have to pay. Think of the high-grade, guaranteed watch we offer here at such a remarkable price. And, if you wish, you may pay this price at the rate of \$2.50 a month. Indeed, the days of exorbitant watch prices have passed.

See It First

You don't pay a cent to anybody until you see the watch. You don't buy a Burlington Watch without seeing it. Look at the splendid beauty of the watch itself. Thin model, handsomely shaped—aristocratic in every line. Then look at the work! There you will see the masterpiece of the watch makers' skill. A perfect timepiece adjusted to positions, temperature and isochronism.

Every fighting vessel in the U. S. Navy has the Burlington Watch aboard. Many have over 100 Burlingtons—a few over 500. This includes every torpedo boat—every submarine as well as the big Dreadnaughts.

Send Your Name on This Free Coupon

Get the Burlington Watch Book by sending this coupon now. You will know a lot more about watch buying when you read it. You will be able to "steer clear" of the over-priced watches which are no better. Send the coupon today for the watch book and our offer.

Burlington Watch Co.

19th St. & Marshall Blvd., Dept. 1195 Chicago, Ill.

Burlington Watch Co.

19th Street and Marshall Blvd.
Dept. 1195 Chicago, Ill.

Please send me (without obligation and prepaid) your free book on watches with full explanation of your cash or \$2.50 a month offer on the Burlington Watch.

Name.....

Address.....

Please Mention Popular Mechanics

Copyrighted material



Stands for Manufacturing Integrity

The Bissell Company has devoted over 40 years to making the best carpet cleaning devices that invention could develop; the name stands for manufacturing integrity in the mind of every purchaser; is the unwritten guarantee of mechanical superiority, general efficiency and extra-convenience. Thus

BISSELL'S Carpet Sweeper

has been the standby of American housewives for three generations.

Now it has an equally efficient companion in *Bissell's Vacuum Sweeper*, a machine that if used regularly keeps rugs and carpets always clean; that has special features of design that make it the most convenient of all Vacuum Machines to operate.

"Cyco" Ball-Bearing Carpet Sweepers are \$3.00 to \$5.50; Vacuum Sweepers, \$7.50 and \$9.00. A trifle more in the far West, South and Canada. Sold by dealers everywhere. Booklet on request.

BISSELL CARPET SWEEPER CO.
Largest and Oldest Exclusive Manufacturers
of Carpet Sweeping Devices in the World
Dept. 385, Grand Rapids, Mich.
Made in Canada, too (281)

**300 Candle Power of Light
at a Cost of 1-8c Per Hour**
Burns Kerosene or Gasoline

This lamp generates and burns its own gas from ordinary kerosene. "QUICKLIT" gasoline lamps can be lit with an ordinary match like city gas.

Write today for illustrated catalog of our complete line of kerosene and gasoline lamps, lanterns **Agents Wanted** and lighting systems.

The Nagel-Chase Mfg. Co.
176 East Erie St., Chicago

ACORN UNI-LITE
FREE OFFER

Turns night into day. 800 candle power. Carry as a lantern; use anywhere as a lamp. Weather proof. For house, barn, garage, camp and around the farm. Write for big, free offer. *Special opportunity to farmers, stockmen and motorists. Agents make big money.*

WRITE TONIGHT for new 1916-1917 offer.
ACORN BRASS MFG. CO., 619 Uni-Lite Bldg., Chicago

AGENTS WANTED

for independent hollow-wire lighting systems for homes, stores, etc.; also complete line of lanterns and portable and street lamps. Use common gasoline.

AKRON GAS LAMPS

are most improved, simplest and safest of all. Best and cheapest illumination known. Shed a clear, soft, bright, white light of high candle power. Fully Guaranteed. Handy demonstration outfit. Our Agency Proposition cannot be beat. Exclusive territory.

Write quick for Catalog and Terms
Akron Gas Lamp Co., 622 So. High St., Akron, O.

The "BEST" LIGHT

Positively the cheapest and strongest light on earth. Used in every country on the globe. Makes and burns its own gas. Casts no shadows. Clean and odorless. Absolutely safe. Over 200 styles. 100 to 2000 Candle Power. Fully Guaranteed. Write for catalog. **AGENTS WANTED EVERYWHERE.**

THE BEST LIGHT CO., 324 E. 5th St., CANTON, O.

BUY PLUMBING and HEATING SUPPLIES
at WHOLESALE Will Save You 30%
Don't pay retail prices. Full stock on hand for prompt shipment. Send for free catalog.

B. P. KAROL, 800-802 South Kedzie Ave., CHICAGO

4 Weeks' Trial

Any **Wings** Superb Piano, choice of 88 styles, on 4 weeks' absolutely free trial. No money down, all freight prepaid. Return of our expense, or keep it at the rock-bottom direct price. Easy terms.

Valuable Book FREE

Write today for "The Book of Complete Information About Pianos." Also free catalog.

Wing & Son, (Est. 1868) 9th Ave. and 13th St., Dept. 1195 New York

**KEROSENE
Gas Lamps**

**BURNS KEROSENE
or GASOLINE**

one just as well as the other; or the two mixed. Make their own gas. 300 to 600 C. P. at 1/2c an hour. Family or Business use.

WRITE FOR COMPLETE ILLUSTRATIONS
BRILLIANT GAS LAMP CO.
1000X So. Wabash Ave., CHICAGO, ILL.

DIAMONDS - WATCHES ON CREDIT

EXAMINE OUR GOODS THOROUGHLY BEFORE DECIDING TO PURCHASE. WE PAY ALL SHIPPING CHARGES IF SATISFACTORY IN EVERY WAY. PAY 20% DOWN, 10% MONTHLY. SEND FOR FREE CATALOG NO. 9. 7-DAY, 150 PAGES, 4000 PHOTOS. DIAMONDS, WATCHES, JEWELRY, ETC. IT TELLS ABOUT OUR LOW PRICES, CONFIDENTIAL RELATIONS AND BINDING GUARANTEE. 10% OFF FOR CASH.

JAMES BERGMAN ESTD 1896 37-39 MAIDEN LANE NEW YORK CITY

1506 \$37.25
3237 \$100
7070 \$25
7073 \$45
9738 \$85
9734 \$50

\$100 Model UNDERWOOD

WITH BACK SPACER—TWO
COLOR RIBBON AND TABULATOR

FOR



**You Try It
10 Days
Free**

Guaranteed
for Five
Years

**Think What
You Can Get
Now for \$39.96**

A genuine No. 4 Underwood—the standard visible typewriter, with back spacer, two-color ribbon and tabulator—*complete* with waterproof cover, new ribbon and special touch typewriting instruction book—the machine that is

today the leading typewriter of the world! *Guaranteed* to be delivered in perfect condition!

Fully guaranteed for five years.

You May
RENT APPLYING RENT
ON
PURCHASE PRICE
OR
BUY FOR CASH OR
ON EASY
PAYMENTS

'Way Under 1/2 Manufacturer's Price

Moreover, you don't have to buy it to try it! We will send one to you on Ten Days' Free Trial. Write all you please on it for ten days and then if you are not *perfectly* satisfied, send it back at *our expense*. What's more, if you do not care to buy, you may rent it at our low monthly rates. If later you want to own it, we will apply *six months'* rental payments on the low purchase price. Any national bank in Chicago, or any Dun's or Bradstreet's Agency anywhere will tell you that we are responsible. Learn *all* the facts about this remarkable offer. Write us today—send us your name and address on the attached coupon—or a post card. Ask for Offer No. 52

Our Other Plan Brings You This Underwood

This is a new plan—Our Agency Plan. You are not asked to do any canvassing—no soliciting of orders. You simply co-operate with us. Become one of our nation-wide organization. You can easily get your Underwood *free* by this new plan. Write tonight—send your name and address on the coupon or a post card and learn all about Offer No. 52

FREE

Typewriter Emporium, 34-36 W. Lake St., Chicago
Established for a Quarter of a Century

Send me immediately full facts about your Offer No. 52

Name _____
St. or R.R. No. _____
City _____
State _____

A Pointer from West Point



LIFETIME VALET SERVICE

LESS THAN 1c A MONTH

TAKE a tip from West Point Cadets, the best turned out men in the world—press your trousers by a **Heatless method**, as they do. Don't let the tailor scorch your trousers with a hot iron while the wet steam rots the cloth. Get the famous West Point trouser press, knife-like from belt to boot—by automatic heatless pressing. It's only \$1.00 for

Leahey's HEATLESS Trouser Press

(Protected by U. S. letters patent No. 1,112,922)

No operating cost for this wonderful money-saver. First cost the last cost. No worry, no inconvenience, no loss of time, no skill required.

New Trousers for Old

every day of your life. Be spick and span—be envied for your appearance. Good appearance pays banker or clerk.

Less than a Penny a Month

makes you the best-groomed man in your set for the rest of your life. It's a Creaser, a Presser, a Stretcher, and a Hanger, all combined in one.

Fold the HEATLESS press with trousers in it, in suitcase, closet—over back of chair—ANYWHERE! Your trousers last 50% longer.

Cut Out Tailor's Bills

Takes one minute to put trousers in Heatless Press. Automatically ready in the morning. This press pays for itself the first month in tailor's bills saved.

Try It—At Our Risk

At your dealer's—or mail the coupon. One dealer sells 35,000. Dealers, write at once.

MONEY BACK COUPON GUARANTEE

Auto Vacuum Freezer Co., (Truss Press Dept.) 30 5 W. 57th St., N. Y. CITY
Enclosed find \$1. for which please send me postpaid one Leahey's HEATLESS Trouser Press. If at the end of 10 days I do not wish to keep it, I will return it to you and you will return my dollar.

Name.....

Address.....

State whether slim or medium.

AGENTS Get Next to This!



A
WORLD
BEATER

AMERICAN PRODUCTS CO., 7739 3rd St., CINCINNATI, O.

A Big Money Maker

The biggest, fastest, snappiest sellers in the world. A big box of the finest

Toilet Soaps, and give a pair of Patented Tension Shears free with each sale. Hundreds of other

Big Snaps. Makes selling easy. Beginners cleaning up \$5 to \$6 a day. Start while new. Outfit furnished free. Write today.

AGENTS 500% PROFIT Gold and Silver Sign Letters

N For store fronts, office windows and glass signs of all kinds. No experience necessary. Anyone can put them on and make money right from the start.

\$30.00 to \$100.00 A WEEK!
You can sell to nearby trade or travel all over the country. There is a big demand for window lettering in every town. Send for **FREE** Samples and full particulars.

Metallic Letter Co., 406 No. Clark St., Chicago

Please Mention Popular Mechanics

STOP USING A TRUSS

Do Away With Steel And Rubber Bands



Inner surface is made adhesive to secure the PLAPAO-PAD firmly to the body, keeping the PLAPAO continually applied and the pad from slipping. No straps, buckles or springs attached. Soft as velvet—easy to apply.

It's the Non-Slipping, yet Non-Rigid Pad and What is Within It That Counts

FREE to 5,000 Truss Sufferers

To the extent of 5,000 sufferers who may apply I will send, ABSOLUTELY FREE, a sufficient quantity of the Plapao to positively convince them that this is the only logical, common-sense way of treating rupture. Plapao is a highly anstringent medication placed within the Plapao-Pad and being absorbed through the skin, creates a wonderful feeling of relief and at the same time tends to strengthen the weakened muscles and thus permanently close the rupture opening. The process of recovery is natural, so you'll have no use for a truss—you can throw it away forever! Old and young have testified under oath that the Plapao-Pads cured their rupture—many of them long-standing, aggravated cases—without delay from work. Patent allowed in U. S. and foreign countries. Awarded Gold Medal at Rome and Grand Prix at Paris.

Send No Money—for a sufficient quantity of the Plapao is sent without charge to enable you to give it a thorough test; you pay nothing for this trial now or ever. Write for it and full information today. Address: Plapao Laboratories, Block 1427 St. Louis, Mo.



I PRINT MY OWN

Cards, circulars, menus, book, paper, etc. Press \$5. Larger \$18. Rotary \$50. Save money. Print for others, big profit. All easy, sales sent. Write factory today for illustrated catalogues, TYPE, cards, samples. THE PRESS CO., D-37, MERIDEN, CONNECTICUT.

BIG CHANCE FOR AGENTS

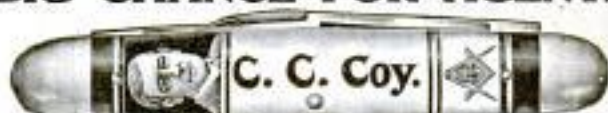

You can earn BIG MONEY

selling the most complete line of guaranteed transparent handle Knives and Razors with Photo, Name and Lodge Emblem—also full line of cutlery. Write today for catalogue and terms. Golden Rule Cutlery Co., 212 N. Sheldon St., Dept. 357, Chicago, Ill.

There is **Big Money** for you in **Automatic Card Printing**

Everybody—everywhere—wants cards—for Business, Social, Professional, and thousands of other uses. Our wonderful press feeds and prints automatically any card from smallest to post-card size—100 a minute—Almost All Profit. Investigate this clean All-Year-Round, good-paying business. Get our free booklet No. 11.

S. B. FEUERSTEIN & CO.
Patentees and Manufacturers
542 W. Jackson Boulevard CHICAGO

KEROSENE

\$30 a Week EASY Men and Women Wanted to Sell **PERFECTO Kerosene Irons**

No experience necessary. Big profits selling this wonderful self-heating satisfaction guaranteed iron. Easy to operate and demonstrate. Sells itself. Use Kerosene (Coal Oil) or Gasoline with same satisfactory results. Absolutely safe, no smoke or odor. Get facts in detail and let us tell you how to obtain **Free Sample** and start you in a big paying business. Sample case **FREE** to Agents.

PERFECTO IRON FACTORY
Dept. P, 126 So. Clinton St., CHICAGO, ILL.

One of the World's Greatest Inventions

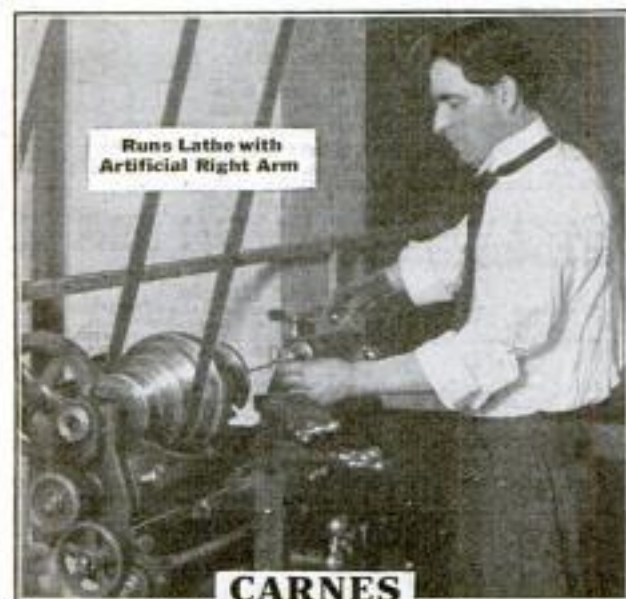

Runs Lathe with
Artificial Right Arm

CARNES

Artificial Arm

The only artificial arm and hand that you can really do so many things with and without assistance of natural hand. The only artificial arm with full finger motion hand, turning and bending wrist and bending elbow. Comfortable to wear. Easy to operate. Perfect fit guaranteed. Recommended by wearers the world over. Endorsed by surgeons. Awarded Gold Medal, San Francisco, San Diego, London, Eng. Write for illustrated catalog B. 25 of this wonderful invention.

CARNES ARTIFICIAL LIMB CO.

31 Carnes Bldg., 904-906 E. 12th St., Kansas City, Mo.



Amazing Profits In Mushrooms

Anybody can add \$10 to \$40 per week to their income, in spare time, entire year growing mushrooms in cellars, sheds, barns, boxes, etc. I tell you where to sell, at highest prices.

Free Illustrated Instruction Booklet

HIRAM BARTON
Desk 2, 329 W. 48th St., New York

"I Would Not Part With It for \$10,000"

So writes an enthusiastic, grateful customer. "Worth its weight in gold," says another. In like manner testify over 100,000 people who have worn it.

The Natural Body Brace For MEN and WOMEN

Develops erect, graceful figure; overcomes **WEAKNESS** and **AILMENTS** of Women & Men.

Brings womanly beauty and manly strength, restful relief, ability to work and enjoy life.

Makes You Feel Good and Look Good

Does away with the strain and pain of standing and walking; replaces and supports misplaced internal organs; reduces enlarged abdomen; straightens and strengthens the back; corrects stooping shoulders; develops lungs, chest and bust; relieves backache, curvatures, nervousness, ruptures. Easy to wear.

Wear It 30 Days Free at Our Expense

Write today for illustrated booklet, measurement blank, etc., and read our very liberal proposition.

HOWARD C. RASH, Pres. Natural Body Brace Co.
223 Rash Building SALINA, KANSAS



For
Children
Also



Ignatius Bernard
Pres.



1/2 Carat

Save

35%

on

Genuine
DIAMONDS
1/2 Carat \$
Extra Blue White **66**
Engagement Ring
Guaranteed \$100 Retail Value!



1/4 Carat
SPECIAL!

Fine quality Extra Blue White Diamond. Retail value \$85.00. 14K solitaire engagement mounting. Our import price, complete. . . \$24.88



3/8 Carat
SPECIAL!

3-8 Carat Steel Blue White, very fine quality diamond, in 14K solid gold engagement solitaire mounting. Value \$75.00. Our import price, complete. \$49.88



1/2 Carat
SPECIAL!

1/2 Carat Extra Blue White, perfect cut diamond in 14K Ideal Tooth solitaire mounting. Retail value \$150.00. Our import price, complete. . . \$100.00



1 1/2 - 3/8 Ct.
SPECIAL!

N-3-8 Carat Wessolton Blue White, fine quality diamond in 14K Tiffany style solitaire mounting. Value \$30.00. Our bargain price. . . \$19.00

Let me send you this elegant Steel Blue White 1/2 carat Diamond Ring just to prove to you that size for size - color for color - you cannot duplicate it at any local jeweler's for less than \$100. See for yourself the big money-saving I give you!

Direct Importing— Smaller Profits

There's the secret of my low prices! I import diamonds direct from the cutters in vast quantities. I, myself, personally grade every diamond in our vast stock. This is your assurance that you get exactly what we promise, exactly what you expect in fine quality and money's worth! By selling diamonds direct to people who wear them, I have wiped out the profits of many middlemen. I actually save you 35%. Our diamond prices are less than established jewelers must pay wholesale!

Fine Quality Diamonds

Perfect cut diamonds as low as \$77.50 per carat. Blue White, perfect cut diamonds as low as \$88.00 per carat. We specialize in very fine qualities: extra Blue White, Steel Blue White, Wessolton, and Jagersfontein Violet Blue White, at prices ranging up to \$284 per carat, for diamonds of rare fancy color which are flawless under a strong glass.

NO MONEY | Ship for FREE EXAMINATION

any diamond you select by any express or to any bank to prove that I sell the same Diamond for 35% less money or a bigger Diamond for the same money.

I Give the Only BANKABLE Money-Back Guarantee

This is the only Diamond guarantee that you can take to any bank in America and cash in your Diamond investment if you wish to do so. It's a legal certificate of carat weight, quality and value. Permits exchange at full value at any time!

De Luxe Book of Diamonds FREE! A Costly Bound Book 1917 Edition Now Ready

Mail coupon and get free book even if you have not yet made up your mind to order. True facts about Diamond qualities and values, and thousands of beautiful illustrations of 1917 Diamond Jewelry. References: Lake & State Bank, Chicago; Dup, Bradstreet, your banker, 100,000 satisfied customers all over America.

Mail coupon or postal or letter
— do it now!

**BARNARD
& CO.** Dept.
N. W. Cor. State &
Monroe, CHICAGO

Use This Coupon
FOR FREE BOOK

IGNATIUS BARNARD, President

BARNARD & CO.

Dept. 2788C, N.W. Cor. State
and Monroe, CHICAGO, ILL.

Without expense or obligation please
send me, Free, postage paid, 1917 De
Luxe Diamond Book.

Name

Address

Please Mention Popular Mechanics



\$100 TO \$150 SAVED ON MEISTER PIANOS

Let us send this beautiful instrument to you on

30 Days' Free Trial Freight Prepaid

Eight beautiful styles to choose from. If it proves highly desirable to you, we will sell it to you on

Small monthly payments. No cash deposit down. No interest or extras. Stool and scarf FREE.

THREE YEARS TO PAY!

A binding guarantee of high-class material and workmanship. Write today for our beautiful 100-page illustrated catalog. IT'S FREE.

Rothschild & Company Dept. C-16 Chicago, Ill.



HERE YOU ARE, BOYS A medallion pin of Foxy Grandpa. Everyone will notice it on the lapel of your coat and try to get a closer look at it. All you have to do is press the bulb.—Foxy Grandpa will finish the job by squirting a fine stream of water over the inquisitive one. Will squirt 20 feet. Greatest joke out. Order one today and fool your friends. Price 15c. Foxy Grandpa and Hooligan both for 25c. 5 for 50c or 1 doz. for \$1.00. A beautiful fountain pen free with every \$1.00 order.

AMERICAN SUPPLY CO., ST. PAUL, MINN.

A Baseball Jersey



Be the First in Your Club

School, City or Town, to wear this pure, all wool sweater, double collar and cuffs. Your choice in colors. This jersey was selected by 10,000 of my customers for last season. Your club will recommend it. Send for my big illustrated catalogue. Write me and learn my offer for your club's order. Popular Prices. Best Grade Sporting Goods—Baseball, Basketball, Tennis, Golf, Football, etc.

WRITE ME NOW.

JACK SHANNON CO., Dept. 46, 54 E. Hersee St., Chicago

Now \$200

Only \$2 down brings brand new Rex (10 years' Guarantee) built because world's greatest merchandise house wanted a better machine.

Typewriter Prices Smashed

Don't consider purchasing a possible unreliable typewriter when you can have a brand new Rex at an astounding low price. Sent on trial. Write today for "Typewriter Secrets." Will be a revolution!

Rex Typewriter Company Dept. 1195, Steger Bldg. CHICAGO, ILL.



Please Mention Popular Mechanics

Relief to Ruptured People

Any appliance is a truss. Ruptured people must wear a support. Our New Sponge Rubber Pad (pat'd) is velvety, soft to the skin, pliable, ~~most~~ ^{most} ~~slip~~, extremely comfortable, adapts itself to ruptured parts with less pressure, is sanitary, long lived. Massages and strengthens muscles, allows blood circulation and produces many cures.

Scrotal Pad Needs No Leg Strap

Our New Akron Sponge Rubber Scrotal Pad (pat'd) holds 8 out of 10 cases of scrotal hernia perfectly without strap between the legs.

Cures Man of 86

The Akron Truss Co. Gentlemen: I am 86 years and 6 months old and have had a rupture for 27 years. I am an active man, tend to a large garden, saw and split the wood and do the household chores. I bought an Akron Truss and wore it one year and am as sound as a dollar.

Respectfully yours, S. W. Glaze, Illinois.

Cured Double Hernia

The Akron Truss Co. Gentlemen: I have worn one of your trusses for some time. All this time have carried two heavy sump cases; notwithstanding this handicap, your truss has cured me of a double hernia.

Yours truly, O. E. Jones, Indiana.

Girl Baby Cured

The Akron Truss Co. Gentlemen: The infant's truss was a perfect success. The child wore it about one year, and the rupture healed so that a person cannot see she was ruptured. Yours truly, J. Haystack, Illinois.

Free Sample Pad A Sample Akron Sponge Rubber Truss Pad will be sent absolutely FREE upon request, also booklet "Relief to Truss Users." It's full of help. Ask your dealer, or write us.

THE AKRON TRUSS CO. 65 TRUSS BLDG. Akron, Ohio

TYPEWRITERS FACTORY REBUILT

Buy Right From Our Own Factories And Save \$25 to \$75

Up-to-date Machines of Standard Makes thoroughly rebuilt, trade-marked and guaranteed the same as new. Efficient service through Branch Stores in leading cities. Send for latest booklet.

American Writing Machine Co., Inc., 345 Broadway, N. Y.



RAISE GUINEA PIGS

Big Demand Thousands needed weekly. Government figures show a profit of \$9.00 each annually. Experience or special knowledge unnecessary. Send for our money making proposition and big free illustrated book which explains all.

Laboratory Supply Co., Dept. B, 2841 Ridge Ave., Phila., Pa.

PIGEONS PAY

Better Than Chickens Young pigeons (squabs) bring \$5 to \$6 each when 2 to 4 weeks old. Big demand in city markets. Each pair of pigeons easily clear \$4 per year. Always in demand. Very little space and money needed to start. Free Book explains all.

MAZETEC SQUAB CO., Dept. 65, Anson, Iowa.

FREE BOOK

POULTRY PAPER

44-124 PAGE periodical, up-to-date; tells all you want to know about care and management of poultry for pleasure or profit. Four months for 10 cents.

POULTRY ADVOCATE, Dept. 98, SYRACUSE, N. Y.

A High School Course In Two Years

Learn in your own home. Here is a thorough, complete, and simplified high school course that you can finish in two years. Meets all college entrance requirements. Prepared by leading members of the faculties of universities and academies.

Write for booklet. Send your name and address for our booklet and full particulars. No obligations whatever. Write today—now.

American School of Correspondence, Dept. F9195, Chicago, U. S. A.

SUPERIOR SINCE 1900

Over 100,000 in Use

Mostly sold through recommendation. For PERSONAL DESK or GENERAL OFFICE. It checks mental calculations. Buy through your Stationer. Write for 10-day trial offer.

E. GANCHER, A. A. M. CO. 148 Duane Street, NEW YORK

AGENTS WANTED

Golden Gem PORTABLE Adding Machine \$10

Multiplicates—Subtracts

The Santa Fe
SHATTERS
WATCH PRICES

SEE THIS WATCH FIRST



Don't Send a Penny
Examine Watch Free

21 JEWEL \$3.50
"Santa Fe Special" A MONTH

—the one standard railroad watch "That's Guaranteed for Life," thin model, all sizes, adjusted to positions, adjusted to isochronism, adjusted to temperature, adjusted to the second.

Write for FREE Watch Book Today — EASY PAYMENTS

Our "direct to you," easy payment plan is explained fully in the Santa Fe Special catalog. Payments are so small you will not miss the money, only \$1.50 a month and you wear the watch right from the start.

NEW CASE DESIGNS
The new watch book shows all the very latest designs of the world's most talented engravers, each case illustrated in beautiful color combinations, showing three color inlay monograms, engraved monograms, fraternity emblems, French art and special designs.

A postal brings the new watch book
Address Dept. 56
SANTA FE WATCH CO.
Topeka, Kan.



Here's Health

—vim, vigor, vitality! The keen, vivid relish of youth for work and pleasure! Snap, ginger, punch in every thought and action! The joy of glorious health, strength, power, life—yours through vibration.

Wake up that sluggish circulation! Send the rich, red blood leaping along through every vein and artery! Tune up those jangled nerves! Stir up those sluggish organs! Flood your whole body with health! Don't be satisfied with mere existence! **Begin to live!**

Arnold Vibrator

Try this wonderful machine yourself. Test it on your own body. Notice the difference after the very first treatment. See how pleasant and easy it is to use—how marvelous the results. And don't forget that these results are permanent because vibration gets right at the cause of things—goes to the very root of the trouble. Aches and pains vanish like magic. You don't need to take anybody's word for these things—you can find out for yourself.

10 Days' Trial Free

Get the facts about our generous free trial offer. Learn how you may get these things yourself at our risk, and if you are familiar with the prices asked for ordinary vibrators you will be amazed to find how much less it costs to own the genuine guaranteed Arnold Vibrator. When there is so much at stake why risk buying an imitation unknown machine? Insist on the Arnold. Ask for it by name.



80-Page Book Free

Your name and address on the coupon or a postal or letter brings you valuable 80-page book on Vibration free and full particulars of our special offer.

ARNOLD ELECTRIC CO., 1466 W. 12th St., Racine, Wis.

Mail Coupon For FREE Book

ARNOLD ELECTRIC CO., 1466 W. 12th St., Racine, Wis.
Please send me your big illustrated Book and 10 days' TRIAL REDUCED PRICE OFFER, all free.

Name

Street

City.....State.....

Bausch and Lomb BALOPTICON

THE PERFECT STEREOPTICON

Bausch & Lomb Optical Co., 576 St. Paul St., Rochester, N. Y.

JENKINS BAND
AND ORCHESTRA INSTRUMENTS

are world famous. Own a Cornet, Trombone, Clarinet, Drum, Saxophone, Violin, Guitar—any Band or Stringed Instrument. **PLAY WHILE YOU PAY** a little a day on the Jenkins Plan. **SAVE BIG MONEY. FREE Lesson Certificate** with each instrument.

FREE Complete Cornet and Violin parts from Jenkins' Beginners' Band Book and Instructor and Jenkins' Beginners' Orchestra Book and Instructor. All instructions to start and make a new band or orchestra. A big success. Easy to play pieces for a starter. Band instrument parts, each 25c; orchestra, 50c; piano, \$1.00. Jenkins' instruments and music stock the largest and best in the country.

CATALOG Write for big Catalog of instruments and latest music lists. A test will prove us best. Address **JENKINS MUSIC CO., 90 JENKINS BLDG., KANSAS CITY, MO.**



Don't Wear a Truss

Brooks' Appliance, the modern scientific invention, the wonderful new discovery that relieves rupture will be sent on trial. No obnoxious springs or pads.

Brooks' Rupture Appliance
Has automatic Air Cushions. Binds and draws the broken parts together as you would a broken limb. No salves. No lies. Durable, cheap. Sent on trial to prove it. Protected by U. S. patents. Catalogue and measure blanks mailed free. Send name and address today.

C. E. BROOKS, 126 State St., Marshall, Mich.





Lend Me 3 Feet of Floor Space for 30 Days



I'll Cut Your Ice Bills

ORDER a beautiful White Frost Refrigerator on a month's trial. I'll show you a real quality refrigerator—one that holds the temperature without eating its head off in ice. The only round white enamel refrigerator on earth. Revolving shelves save room inside and out, move-easy casters, cork cushion doors, noiseless and air-tight. Steel walls insulated with granulated cork, crystal glass water cooler, easy to fill. I sell direct to you—no middlemen. I pay freight—quick shipments. Easy terms—\$6.50 brings a White Frost at once, balance pay as you use. Write today for catalog.

H. L. SMITH, Pres.
WHITE FROST REFRIGERATOR CO.
 579 N. Mechanic St., JACKSON, MICHIGAN

White Frost
 SANITARY
Refrigerator



Seventeen
 Degrees

The Pencil as a Thought Conductor

A sketch illustrates thought more powerfully than words. The more perfect the pencil the more efficiently is the thought conducted.

DIXON'S ELDORADO

"the master drawing pencil"

is preferred for every class of pencil work in the field or in the drafting room. The leads are strong and long-wearing, responsive and even in tone. Send 14c in stamps for samples worth double the money.

JOSEPH DIXON CRUCIBLE CO.
 Dept. 10-J, Jersey City, N. J.

DIXON'S BEST WHITE No 352
writes white on blueprints

Why Pay Full Prices for Diamonds

Diamond Banking

WE lend money, taking diamonds as security. When loans are not paid, diamonds are sold. Over 20 years we have offered them 4% to 5% per cent lower than market prices. Free examination, 3/4-3/16, 1/64 ct. blue-white gemma perfect cut diamond of high degree of perfection, wonderful fire and brilliance. Platinum and gold engagement ring. Try to reach at \$225. Guaranteed Cash Loan \$116.80 \$100. Unpaid Loan Price.

Write Today Send your name and address for New Bulletin.
 Jos. DeRoy & Sons, Pittsburgh
 (Only Opposite Post Office)
 1926 DeRoy Bldg.

Let Me Quote You a Special Price On My *Rapid* FIRELESS COOKER



Cook every meal on it. If you are not satisfied and delighted I will refund every cent. Get my

Special Low Factory Price

direct to you. Cooker is aluminum lined throughout. Full set of famous "Wear Ever" aluminum cooking utensils comes with it. Ask for list book of suitable recipes.

WILLIAM CAMPBELL CO.
 Dept. 64 DETROIT, MICH.

THIS BUNGALOW \$900 CAN BE BUILT FOR

This and many others in the new book, Building Plans for Modern Homes, will save you hundreds of dollars. One of the most complete and comprehensive books of plans ever published by any architect. Fifth edition just off the press. Two hundred and fifty four plans and photographs of bungalows, etc., costing from \$200 up; gives sizes and cost to build. Sent postpaid for \$1.00



FREDERICK H. GOWING
 ARCHITECT
 18 Tremont St., BOSTON, MASS.

ELECTRIC HOME, FARM, PICTURE THEATRE, HOTEL & STORE LIGHT PLANTS. Auto Starter Storage Batteries & Chargers, All Cars. Ask Price. Dynamos, Power Motors, Belts, Engines, Railways, Permanent & Traveling Motion Picture Machines. OHIO ELECTRIC WORKS, CLEVELAND, O.



Made by Makers of Good Goods Only

Replace Your Heating Plant with a ROUND OAK Moistair Heating System

Only Heating System that Automatically Ventilates and HUMIDIFIES.—Keeps air moist, free from disease germs. Durable, dependable, easy to operate, a big fuel-saver. Send for FREE Book explaining all.

The Beckwith Co. Round Oak Folks—Established 1871
 100 Front St., GOWAGIAC, MICH.

1900 Motor Washer Electric or Water Power

on Free Trial to Readers of Popular Mechanics Reduce household expenses by using this great laundry outfit. Cuts cost of washing to 2 cents per week. Write for Free Book, giving full details, to

1900 WASHER CO., 6335 Court St., Binghamton, N. Y.
 Address Canadian 1900 Washer Co., 355 Yonge St., Toronto if you live in Canada



SMALL ENGINES

Perfected Gasoline Engines—15, 1 and 1 1/2 h. p.—for Farm and Shop use. Price \$19.00 and up. Also

WASHING MACHINES

We ship on trial. Send for Booklet and Special Offer. SIEVERKROPP ENGINE CO.
 1224 18th St. RACINE, WIS.

STARTER for FORD CARS



Gathering scraps of wisdom

There are SEVERAL MILLION PERSONS in the United States who are continually using

WHITING-ADAMS BRUSHES

THE BRUSHES OF CIVILIZATION

The most extensive and best line of Brushes in the world

Send for illustrated literature

Manufactured only by **JOHN L. WHITING-J. J. ADAMS CO.**
BOSTON, U. S. A.

Brush Manufacturers for Over One Hundred Years

Whiting-Adams Brushes awarded Gold Medal and Official Blue Ribbon, the highest award at Panama-Pacific Exposition, 1915



A complete line of appliances for the transmission of Power. Anything from a bolt to a complete mill or factory outfit. Send for catalogue. Largest Manufacturers of Pulleys in the country.

W. A. Jones Foundry & Machine Co. 1400 W. North Ave. CHICAGO



Do you know that there are more "Sebastian" Lathes used in Garage and General Repair Shops than any other make?

The Sebastian Lathe Co. 107 Culbert Street Cincinnati, Ohio, U. S. A.

HEN BEATS HER WAY SOUTH, HOBO-FASHION—A car inspector at Atlanta, Ga., it is reported, recently found a fat Minorca hen perched on the rods of a box car in a fast freight train that was just pulling in from the North. How far she had ridden and why she left her home barnyard, could not be ascertained. Owing to the high cost of eggs, however, she was permitted to live and pay her fare in the only way she could.



South Bend Lathes
For the Machine and Repair Shop

How to Run a Lathe
A 50 cent book for 10 cents. Postpaid, stamps accepted.

Straight or Gap Beds. Send for free catalog giving prices on entire line.

SOUTH BEND LATHE WORKS
423 Madison St., South Bend, Ind.



LATHES

9 to 18-inch Swing

List price \$75 and up according to size. When ready to buy send for Lathe Catalog and prices.

W. F. & John Barnes Co.
100 Ruby Street, ROCKFORD, ILL.



CRESCENT

Wood Working Machinery will satisfy these particular users of wood working machinery who are honestly hard to please because they know the features most desired in substantial wood working equipment. Send today for catalog of hand saws, jointers, saw tables, planers, disk graders, planers and matchers, swing cut off saws, shapers, hollow chisel mortisers, variety wood workers, universal wood workers.

THE CRESCENT MACHINE CO.
53 Columbia St. LEETONIA, O.

New Profits from Waste

EVERY scrap of paper that goes into your waste basket is worth money. Common mixed paper sells as high as \$16 a ton when baled—and this cash is added to your net profits if you own a Woodall Baler. Big companies all over the country are making their waste paper pay big dividends.

Baling Press

Not only paper, but rags, excelsior, scraps and other marketable waste is readily sold when baled. Use the Woodall Baler as a depository for this waste. When you have the press full, merely pull the lever, hook the wires and the bale is ready. Send the coupon now for details.

30 Days' Free Trial!

We'll send you a Woodall Baler on 30 days' trial. Find out what it is going to mean in your business before you decide to buy.

Send for **FREE** Catalog —

Send the coupon, a letter or a post card for our new circular—it is free—but will show you how to make money from your waste paper, rags, etc. Write today. Don't wait another minute.

Woodall Mfg. Co.
Dept. 1195
Davenport, Iowa

Woodall Mfg. Co.
Dept. 1195 — Davenport, Iowa
You may send me your free circular which tells about profits in waste paper.

Name.....

Address.....

American Toolmakers Lead the World

For over 60 years, in fact, they have maintained this leadership. That the spirit of the pioneer toolmaker is not dead is shown by the development of the Gun Tap illustrated below.

In one step forward a complete change in the tap business has been effected. The Gun Tap is new, correct in principle, and proves its value in practice. Whereas formerly about 90% of all taps broke, *this one wears out before breaking.*

The Gun Tap is the first type to cut with a shearing action—the only true cutting. It is therefore the easiest cutting tap on the market. It shoots the chips ahead in a long curl (whence the name "Gun" Tap) instead of jamming them into the flutes until the tap breaks. It cuts more accurate threads, and holds its size longer, than any other tap made.

For more information as to these details, and the time and money saving possible with the Gun Tap, send for Bulletin.

Greenfield Tap and Die Corporation Gages-Taps-Dies

Threading Machines, Reamers, etc.
Greenfield, Massachusetts

Canadian Factory, Wells Brothers Company of Canada, Ltd.
Galt, Ontario



Showing how chips are shot forward.

AMERICA FIRST

"IDEAL" Lawn Mower Grinder

Big Money-Maker

Many of our customers make \$300 in one season. **YOU CAN DO AS WELL.**

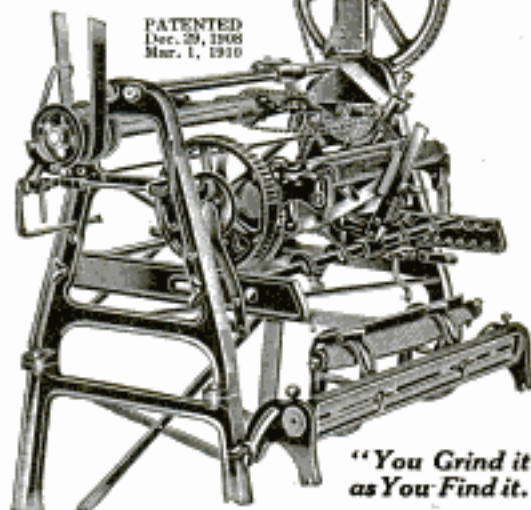

PATENTED
Dec. 29, 1908
Mar. 1, 1910

"You Grind it as You Find it."

Grinds all makes of Mowers perfectly in 15 minutes without removing wheels, ratchets or reel knife, **BETTER, QUICKER and EASIER** than it can be done by hand. Has perfect Skate Sharpener Attachment. Run by hand or power. Nearly 10,000 in use. Price, only \$50. Sold on easy-payment terms. Also makers of the "Peerless" Horse Mower Grinder.

WRITE TODAY for catalog and full information

THE ROOT-HEATH MFG. CO., Plymouth, Ohio

THE DIPLOMATIC RAINBOW—A French publication has inquired into the beginnings of the varicolored books used by European governments for the publication, mainly, of diplomatic correspondence with foreign powers. Thus the "Blue Books" of Great Britain date back to the



ORDER TODAY
DON'T DELAY

Cash with order buys this small
\$3 BENCH LATHE

Swing 3 in. 8 in. C. to C. Shipping Wt. 10 lbs.
PETER AUSTIN, 910 N. First St., MUNCIE, IND.

Drilling Wells is a Year Round Business



Drilling Water Wells is a profitable, healthful, year-round business. There are wells all around you to be drilled. Don't you want to get into a money-making business for yourself? Write for particulars.

STAR DRILLING MACHINE CO.
664 Washington St. AKRON, OHIO

DIVINE Red Devil Water Motor

4 inch size
6 inch size

A perfect small motor—made like the big turbines—wonderful power.

No muss—no fuss—no mechanical complications. Attach in cellar or at any faucet.

4-inch size for Polishing 6-inch size for Power

Only Motor to do This Work

For Mechanics, Tradesmen, Doctors, Dentists, Shop and Home

Anyone can install. We also supply pulley, emery and buffing wheel.

Booklet and Prices Sent Free if you will write today and give us size of faucet, water pipe and water pressure and work to be done. You must furnish information to get booklet.

Divine Water Motor Co., Dept. P, Utica, N. Y.





OSTER BULL DOG DIE-STOCKS

"The tools with 5 big features"

WHEN you thread pipe, do it with the least labor, bother and complication possible. **BULL-DOG DIE-STOCKS** give you the 5 big features: (1) Self-locking, adjustable dies; (2) Self-centering guides, lever-operated; (3) Dies open up after cut (to lift off pipe without backing up) and reset automatically to size; (4) No loose bushings to lose or mislay; (5) No small, breakable parts.

Send for **List 28 B** A complete catalog of 47 hand tools and machines for pipe threading free.

The Oster Mfg. Co.
2100 East 61st St., CLEVELAND, OHIO

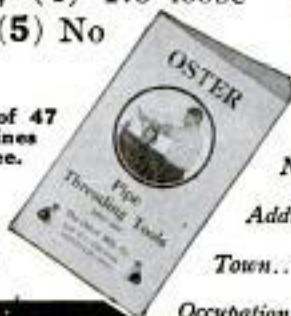

Bull-Dog Die-Stocks include eleven tools, plain and ratchet types. Each tool threads from 4 to 8 sizes of pipe.



Please send free copy of List 28 B to

Name

Address

Town State

Occupation (21005)

seventeenth century. The first French "Yellow Book" was sent to the legislative chamber by Napoleon III in 1861, and not long afterward the Italian government began issuing "Green Books," this color being chosen because it also appears in the Italian flag. The first "Red Book" of Austria-Hungary was fathered by Mr. Beust, minister of foreign affairs in 1893. Russia issues "Orange Books," Germany "White Books," and Belgium "Blue Books."

**DON'T
SCRAP
ALUMINUM
PARTS**

SO-LUMINUM

repairs cracks, breaks or defects in aluminum in $\frac{1}{2}$ the time and cost of acetylene welding. Parts so mended are stronger at welded joint than elsewhere. Gasoline torch only thing necessary. No flux needed.

Send 50 cents for trial bar. Money refunded if not satisfactory. Booklet on request.

SO-LUMINUM MFG. & ENG. CO., Inc.
Room 12, 1790 Broadway, NEW YORK CITY



FOR EVERY WALL DECORATION
You will find pleasure in hanging Pictures, Draperies, etc. in every room, when you use

Moore Push-Pins

with glass heads and needle points, for smaller articles, and Moore Push-less Hangers for heavy Pictures, Clocks, Hall-racks, etc. Will not mar finest walls. Samples free.

Moore Push-Pins. Made in 2 sizes **10c pkts.**

Moore Push-less Hangers. 4 sizes **2 Pkts. for 25c.**

At Stationery, Hardware, Photo, Dept. Stores, or by mail.
MOORE PUSH-PIN CO., Dept. 86 Philadelphia, Pa.



Save Money, Time and Worry

GET A

UNION TOOL CHEST

Style A

Save money—keep tools clean, safe, free from rust.

Save time—keep tools in place.

Save worry—you know immediately if one is borrowed or misplaced.

Built of selected plain or quartered oak, or mahogany. Some leatherette covered. Perfectly fitted drawers—19 styles and sizes. **ONE FOR YOU!**

Write for our catalog and prices. Chest guaranteed to give entire satisfaction or money refunded.

Union Tool Chest Works
22 Railroad St., Rochester, N. Y.



Water Pumps Water

with a Rife Ram. Plenty of it for every purpose about your farm and country home—day and night, winter and summer, without fuel, labor, freezing or repairs. The

RIFE RAM

is operated by any small stream having a fall of three feet or more and a supply of three or more gallons per minute. Fills high elevated tanks or operates air pressure system. Easy to install. First cost the only cost. Always on the job; over 11,000 in daily use. Tell us your water supply conditions. Ask for free estimate and catalog. Now is the time to install. Write today.

RIFE ENGINE CO., 3131 Trinity Building, NEW YORK



True in any position

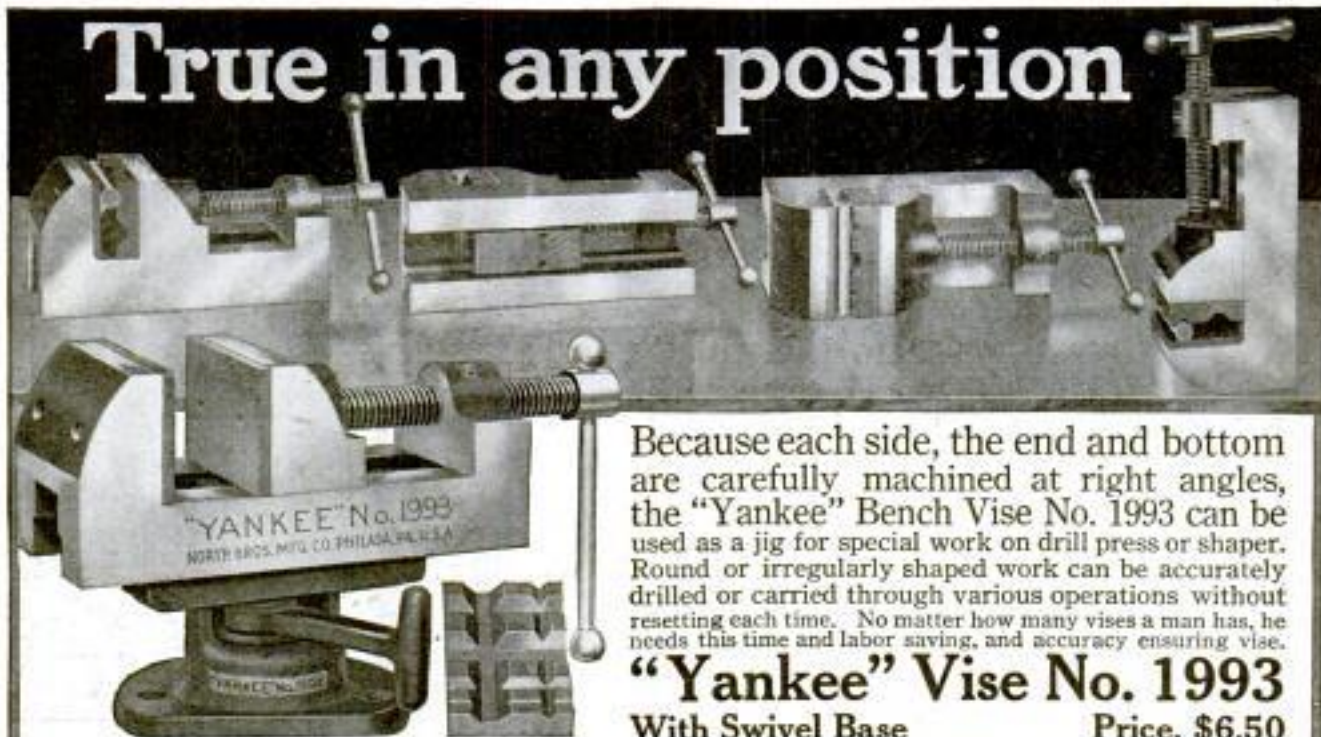

Height with base, 5 1/4 in., length of body 7 1/4 in. Base 4 1/2 in. diameter. Jaws 2 1/4 in. wide, 1 3/4 in. deep; open 3 1/4 in. Jaws have hardened steel faces. The hardened Steel Block with V-shaped grooves of various sizes is used for holding round or irregularly shaped work at any angle. Steel screw. Weight, 13 lbs., 6 oz.

Because each side, the end and bottom are carefully machined at right angles, the "Yankee" Bench Vise No. 1993 can be used as a jig for special work on drill press or shaper. Round or irregularly shaped work can be accurately drilled or carried through various operations without resetting each time. No matter how many vises a man has, he needs this time and labor saving, and accuracy ensuring vise.

"Yankee" Vise No. 1993

With Swivel Base Price, \$6.50

Securely locked to its Swivel Base by turning set screw. Camthrow Lever locks Vise firmly in any position.

Your dealer can supply you.

Write for "Yankee" Tool Book" showing all "Yankee" wood- and metal-boring and screw-driving tools. Free.

NORTH BROS. MFG. CO., Philadelphia, U. S. A.

"YANKEE" TOOLS Make Better Mechanics

Handy Oil Can
THREE IN ONE OIL

This is the Handy Oil Can

Good old reliable 3-in-One, which you've been buying in bottles for 20 years, is now also put up in the Handy Oil Can, containing 3 1/2 ounces, price 25c.

3-in-One is The *Universal Oil*. Lubricates, cleans, polishes and prevents rust. Right for everything that needs a good pure oil. Buy 3-in-One in the new Handy Oil Can. Convenient. Slips into the pocket, the auto repair kit, the tool box, the sewing machine drawer.

Of course you can still buy 3-in-One in 10c, 25c and 50c bottles the same as ever. At all stores.

FREE—Liberal sample of 3-in-One Oil and Dictionary of Uses—both sent free for the asking.

3-in-One Oil Co., 42 CNG. Broadway, N. Y.

SHARKS ARE NOT AS DANGEROUS AS BELIEVED—No less an authority than Dr. Frederick A. Lucas, director of the American Museum of Natural



Tool Cases for Toolmakers and Machinists

Keep your tools orderly arranged in a Gerstler Portable Tool Case. There's a place for every tool in one of the felt lined drawers. Every up-to-date mechanic needs one and you'll find our Cases the best built, neatest and most practical on the market. We guarantee to please or refund all money. Write for our free booklet.

Gerstler Sons

Mfrs. of Mechanics' High Grade Tool Cases
808 Columbia St., DAYTON, OHIO



OUR famous *Lakeside* Hollow Handle Tool Set. Has 7 1/2 inch handle of polished cocobolo, 10 real quality tempered steel tools. Strong, nickel plated chuck. Handy around home or shop. Worth \$1.50. Order direct from this ad by No. 85Z1334. Shipping weight 1 1/4 pounds. Satisfaction Guaranteed—or Money Back.

1,000 TOOL BARGAINS

in our New Tool Book. Write for it. Address nearest house.

Montgomery Ward & Co. Dept. A.M. 133
Established 1858—Organized as Montgomery Ward & Co. in 1902

NEW YORK FT. WORTH CHICAGO PORTLAND, ORE. KANSAS CITY



Please Mention Popular Mechanics

Stanley Tools



Stanley Combination Hafts Nos. 305

Very handy little tools, as they are well made, strong, and fit easily in the pocket. The illustration shows same about two-fifths actual size.

With each Haft, 12 tools are furnished as follows: 1 each Chisel, Reamer, Scratch Awl, Screw Driver, Tack Puller, Belt Awl, and 6 Brad Awls assorted. All are hardened and tempered and the tips are polished. They are approximately 1 3/8 inches long.

Price .75 Each Sent Postage Prepaid
Upon Receipt of Price

STANLEY RULE & LEVEL CO.
NEW BRITAIN, CONN. U.S.A.

History, makes the statement that the stories told about the great white shark and the blue shark are greatly exaggerated. One of the commonest statements that "the shark bit off the man's leg as though it were a carrot" cannot be accepted. Notwithstanding popular opinion to the contrary, a shark is not particularly strong in the jaws. Sharks 12 ft. long have difficulty in tearing meat from the carcass of a whale. But a truly large white shark, 30 ft. long, with teeth over an inch long, is a formidable creature, and a blow of its tail may be as fatal as its bite.

THE AWL YOU WANT



Is the genuine MYERS \$1.00 "Lock Stitch" Sewing Awl with the exclusive feature. See thread reel in front of handle under the finger tip. Natural tension. Sews heavy or light material, diamond point, full grooved needles used to protect the thread when sewing. C. A. MYERS COMPANY, 6339 University Ave., Chicago, Illinois

"RED DEVIL"

—That's All You Need to Know About Mechanics' Tools

You can accept that trade-mark with the utmost confidence of your skill that they will work more faithfully for you, stand harder wear and outlast other tools. Made by master mechanics with over 20 years' experience.

To be obtained from dealers, or if not, write us for tool literature.

SMITH & HEMENWAY CO., Inc.
97 Chambers Street NEW YORK CITY

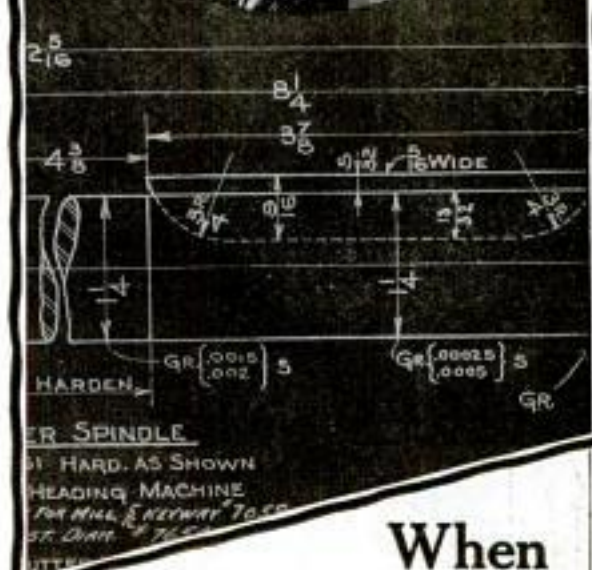

When Limits Are Close

When the blueprint calls for a variation of not over .0005" does it mean worry and suspense until your work goes to the inspector, or do you go ahead with the next lot with the absolute confidence that owners of

A Kit of Brown & Sharpe Tools

always have in the reliability of measurements taken with these tools?

*Our interesting, instructive
Catalog 27 free on request*

Brown & Sharpe Mfg. Co.
Providence, R. I., U. S. A.



SIMONDS

The Amateur Mechanic

will appreciate the fine temper, shape and hang of a

SIMONDS SAW

because it always makes good workmanship easier. If he counts in a Simonds Saw when making up his tool chest, he will later take pleasure in showing it to his friends.

When you need a Circular Saw, a Hack Saw, or a Coping Saw, just specify the brand made by SIMONDS "The Saw Makers."

Let us send you a copy of our booklet "The Professor and the Saw." It's good reading. Free!

Simonds
Manufacturing Co.
"The Saw Makers"
Established 1832
FITCHBURG, MASS.

Five
Factories
Eleven
Branches

"I Tell You It's
A Great Saw"



Every Builder and Contractor Needs this Level

10 Days' Free Trial

We have been makers of transits and levels since 1863 and our instruments are the standard of the world. Prove the superior quality of the Aloe Convertible Level by giving it a 10 days free trial. Use it on your every-day work laying out buildings, leveling up foundations, walls and floors, aligning, shafting walls, piers, etc.; for getting angles or levels anywhere.

Easy Monthly Payments

If you decide to keep it, the instrument will earn its way while you make monthly payments so small that you hardly feel them. Costs no more than to pay all cash. No red tape about it, no embarrassing questions, everything confidential.

Aloe Convertible Level

is the finest instrument ever offered at anywhere near its price. Permits taking of sights both above and below the horizontal. For taking vertical sights it is provided with a special convertible bracket rigidly and permanently attached to the cross bar. The telescope is fitted with permanent axis which rests in bracket bearings and is held by clasps easily and quickly released.

Aside from being a level, it is a modified transit that permits a much wider range of work than is possible with the ordinary architect's level. With it the man without technical training can obtain the same absolutely accurate results as the expert. Write today for descriptive circular.

A. S. ALOE CO.,
620 OLIVE ST., ST. LOUIS, MO.



WAR MULES MADE MUTE BEFORE GOING TO FRONT—Brayless mules have been developed by the exigencies of war, according to a Paris dispatch. Their habit of braying at inconvenient moments counteracted their usefulness, and so veterinarians, after a little experimenting, discovered that a slight operation on the nostril deprived them of their "voice." All the mules sent to the front are now made mute.

Portable Cases

For Tool Makers and Machinists



Twelve styles, felt lined drawers, solid brass trimmings, best of material, beautiful finish, low prices, satisfaction guaranteed. Ask for booklet of cases built for service.

THE PILLIOD LUMBER CO.
SWANTON, OHIO

The RIGHT Rule "Interlox" for YOU!

Don't waste time with a folding rule that can't give you accurate inside measurements—use this up-to-date Interlocking Rule that SLIDES in and out. No other rule like it. Gives quick and correct inside and outside measurements. If not at hardware dealer's, send his name and \$20 per foot (any length from 2 to 8 ft.) and we'll send one prepaid.

Dealers and Agents!
Write for Liberal Proposition

DAHL MFG. CO., 513 E. 43d Street, NEW YORK

Duplicate Keys

for all Pin Tumbler Locks made in one minute with Harrison M.I.P. Key Filing Machine. No misfits. Thousands in use. \$3.50 net. Special diamond-shaped files for angular cut keys, 40c each; 3 for \$1.00. Harrison C.K. Key Clamp duplicates all common keys without a calliper. Price, \$1.00. Parcel post prepaid.

Money returned if not satisfactory.

HARRISON & CO., 81 New St., New York

Please Mention Popular Mechanics

SARGENT

REG. U. S. PAT. OFF.

Automatic-Set Bench Planes

A new and superior type said to be the best by mechanics who have used them



Intended for both heavy and very fine cuts and especially adapted for working against the grain on cross-grained hard wood.

The features are the automatic set, a great time saver; the rigidity, which insures good work; and the ease of adjustment.

These features are fully explained and the six sizes of these Planes described in the Sargent Plane Catalogue, a copy of which will be sent free on request.

SARGENT & COMPANY
49 Water St., New Haven, Conn.

The Crescent Wrench Defies Difficulties

The thin head, set at an angle of $22\frac{1}{2}$ degrees with the handle, insures maximum clearance and powerful leverage. It can be adjusted by the hand holding the wrench.

The Crescent replaces inefficient "monkey wrenches" and abolishes the expense and bother of whole sets of solid wrenches. Crescent materials mean durability. The name means satisfaction.

Crescent Tool Co.
Jamestown, N.Y.

EVEREADY
SAFETY LIGHTS

American Ever Ready Works
of National Carbon Co.
Long Island City, New York

**TOOL CASES**

For Up-to-Date TOOLMAKERS and MACHINISTS

We carry the finest and most complete line of mechanics' toolcases and tools in the country. We guarantee to please you or refund money. Write for free catalogue.

J. M. WATERSTON

75 Woodward Ave., DETROIT, MICH.

AGENTS—A Big Seller
SCREEN DOOR CHECK



Low Priced Splendid summer seller. Stops the bang and saves the door. Easy sales. Big profits. Big demand. A sale in every home. Dozen can be carried in pocket. Demonstration sample free to workers.
THOMAS CHECK CO., 4448 East St., DAYTON, O.

INDOOR CHEMICAL CLOSET

No smell, no germs, sanitary. Use in any room. Needs no plumbing, sewerage or running water. Chemicals in closet kill germs. Fine for the sick and old folk.

DESTROY OUTDOOR CLOSET

Put in a warm, Indoor Sanitary Closet. Empty twice monthly, only attention necessary. Satisfied users and Boards of Health endorse it. Fully Guaranteed. 30 Days Free Trial. Write for Fitch's Literature. Agents wanted.
SANITARY CLOSET CO. 25 Calton Bldg., Toledo, O.



JOHNS-MANVILLE
Asbestos

**HERE'S WHAT YOU NEED**

The American
Combined Level
and Grade Finder
With Compass



Side View



Top View

For Contractors, Masons,
Carpenters, Bricklayers,
Surveyors, etc.

It is simple, accurate, easily understood. Shows its true slant on any line or grade in degrees, inches, and percentages. Write at once for Agency, has over 300 testimonials, booklet, and introducing prices.

EDWARD HELB, P. O. Box 75, RAILROAD, PA.

\$100
Oxy-Acetylene
Welding Outfit
Complete as shown
\$37⁵⁰

Anybody can operate it; printed instructions furnished. Enormous output makes low price possible. Highest quality. No agents, strictly cash with order, one price to all. Every user can afford this outfit. Worth fully \$100. **ORDER TODAY.**

WELDIT ACETYLENE CO.
506 Kresge Bldg. DETROIT, MICHIGAN

Please Mention Popular Mechanics

No Motor
No Wear
No Oiling
No Care

HEALTH-BEAUTY-VIGOR

Health, Beauty and Vigor are the most desirable things to this big human family. Health brings Beauty and Vigor. Health puts the warm, rich color on the cheeks and the blood fairly tingles with vigor and vitality. Doctors have been recommending vibrators for years, but the price was too high. Nu-System Vibrator is patented, it is a brand new invention, a new principle of vibration that has been thoroughly tested, it has only one working part. We make but one design—of best materials, by best electricians, everything first grade. It is electrically operated without a motor, attaches to electric light fixture. Vibration works Nature's way by producing activity, not by drugging the body to heat it. Vibration is condensed exercise, it does in a few minutes daily what it takes hours of exercise to accomplish. Nu-System Vibrator can be used in home, office or factory.

\$15 Nu-System Electric Vibrator Introductory Price **\$9⁸⁵**

Nu-System Vibrator is a high grade instrument, it must be for we make but one model and make it the best. It has been used for a long time and is absolutely Guaranteed and is sold on a 30 day money-back Free Trial plan. It has been used in Beauty Parlors, Barber Shops, Hospitals, Sanitariums, Doctors' Offices and Residences, and we have never had one returned. What it has done for others, it will do for you. Any one can use it. It is lightweight and needs no oiling or care. Does not get garments soiled or oily. Nu-System Vibrators have been used successfully to treat the Blood, Nerves, Stomach, Bowels, Liver, Kidneys, Skin, Complexion, Lungs, Hair, Scalp, Neck, Checks, Chin, Shoulders, and for Headache, Backache, Tired, Aching Feet and Brain Fog. Nu-System Vibrators are a preventative as well as a curative agency.

Special Offer

For a limited time we will sell Nu-System Vibrators complete with 2 applicators and packed in a beautiful Leatherette Case, prepaid at \$9.85. Write NOW for literature, testimonials, order blank, etc.—All Absolutely FREE.

NU-SYSTEM ELECTRIC VIBRATOR CO.

25 Lighter Bldg. DETROIT, MICH.



Absolutely Guaranteed

We guarantee Nu-System Vibrators for one year—it will last a life-time.

30-Day Money-Back Free Trial

If after 30 days' trial Nu-System Vibrator does not do as we claim your money will be refunded.

DEALERS:
Write for
Co-Operative Plan



CACHOO! Make the whole family and all your friends "just sneeze their heads off" without knowing why, with fakes, the new long distance harmless snuff. Sent anywhere for 10c. 3 for 25c. 1 doz. and special premium for 90c. **AMERICAN SUPPLY CO., St. Paul, Minn.**



Warner's
"Infallible
Automatic"

"The PISTOL that SHOOTs and HITS THE MARK"



Before buying ask your dealer about \$10.00 Warner Infallible. Get the best and save at least \$5. Booklet describing this marvelous pistol sent on receipt of stamp. Warner Arms Co., 38 Chambers St. Department P. M., New York City



15
Quick
Shots

32
Cal.

Makers of Davis Guns & Warner Pistols

TYPEWRITERS

\$10 and Up. ALL MAKES
SAVE \$25 TO \$50



on rebuilt at the factory by the well known "Young Process." Sold for low cash—installment or rental. Rental applies on purchase price. Write for full details and guarantee. Free trial. **YOUNG TYPEWRITER CO., Dept. 245, Chicago**

Red or Black "Vulcan" Ink Pencils

The ONLY perfect, non-inkable ink pencils at moderate prices.



Two Sizes—
4 1/4 and 5 1/4 inches.
Extra Size—8 inches (black only) \$1.25.
Your name in gold inlay 35c.
FREE—liberal supply of ink with retail orders. Agents Wanted. Big Profits.

J. C. ULLRICH & CO., 27 Thames St., New York

Order today \$1

DIAMONDS 415 \$25
420
ON CREDIT
\$50 NO MONEY DOWN
425 \$75



MAKE YOUR LOVED ONES HAPPY

What could give more pleasure to your Wife, Sweetheart or Friends than a genuine Diamond? A noble gift that will last a lifetime. Every Diamond is especially selected, blue white, perfect cut, with which a guarantee certificate is furnished attesting its quality and value. Any Diamond purchased from us can be exchanged at a yearly increased value of 7% per cent on a larger purchase.

We will send you any Diamond you choose. No money in advance. If not satisfactory, send it back. If you are perfectly satisfied, pay for it on our easy monthly payment plan—20 per cent down, 10 per cent monthly. Only a few cents a day. No interest charged.

Let us send you our beautiful new catalog De Luxe No. 6. Select an appropriate gift for yourself or loved one, pay for it at convenient intervals.

L. W. SWEET & CO., Inc. Dept. 6 2-4 Maiden Lane, New York City



Your Gun

deserves good care. Its mechanism resents neglect.

You can't score hits if the action lags—keep it oiled with

HOMOL

The Real Sportsmen's Oil

in the improved can—keeps locks "snappy" and prevents rust. Also a splendid lubricant for reels and traps, for tools, typewriters, phonographs and other home uses.

If your dealer is not ready to supply you, send us his name and a quarter and we will send you a 5-ounce can, carriage prepaid.

William Peterman, Inc.
200 Fifth Avenue
New York City



"Expanding Cuff Buttons"

Permit cuffs to be raised in a jiffy without unbuttoning. They spread two inches. Cuffs positively stay where you place them upon forearm. Lower cuffs, they close automatically. Neat—Durable and Guaranteed. Great shirt and laundry saver. Endorsed by 100,000 enthusiastic wearers. A real necessity that appeals to all. We want Live District Representatives and Sideline Salesmen everywhere.

Price 50c, \$1, \$1.50 per pair. Satisfaction Guaranteed.
FLEXO CUFF LINKS MFG. CO., Dept. P.M., Sheboygan, Wisconsin.

Enormous Profits

START GROWING MUSHROOMS

Learn the latest authoritative way to make still bigger profits than you ever thought possible or ever made growing mushrooms. Add \$10 to \$75 a week to your income. Anyone, men, women and children can do it in spare time in city or country. Grow in basements, cellars, sheds, boxes, etc. Start now. Demand larger than supply. Send for big free book of expert authority. "The Truth About Mushrooms." Write to

BUREAU OF MUSHROOM INDUSTRY
Dept. 382 1342 N. Clark St. Chicago



BUILD YOUR OWN GRANDFATHER'S CLOCK WITH OUR HELP

We furnish blue prints, finishing material and instructions. Buy the works, dial, weights and pendulum from us at surprisingly low prices. You make a fine profit building artistic clocks for your friends.

Complete Works \$5.00. Others with Chimes at all prices. Ask for our attractive Free Offer
CLOCK CO., 1673 Ruffner St., Philadelphia, Pa.



LEPAGE'S

GLUE

HANDY TUBES
WILL MEND IT 10¢

FREE BOOK

Tells All About Metal

ROOFING

Siding—Ceiling—Wall Board—
Paints—Garages

Write at once for our Big Roofing Book illustrating and describing every kind of Sheet Metal Roofing and Building Material at Rock-Bottom Factory Prices.

We are the largest manufacturers of Iron and Steel Roofing in the world. We sell direct to you—save you all middlemen's profits—and PAY the FREIGHT to your station. Get our low factory-to-consumer freight paid prices NOW.

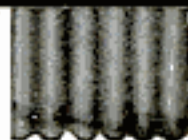

Corrugated



Brick Siding

EDWARDS "REO" Metal Shingles

cost less, yet outwear three ordinary roofs. Absolutely proof against the elements. The Edwards Patented Interlocking Device makes all joints and seams absolutely and permanently watertight and weatherproof. All nail heads—the points where rust first attacks other metal roofs—are covered by upper layer. (See Interlocking Device.) No chance for water to get at nail heads and start rust. No warping, breaking or buckling.

Edwards Exclusive Tightcote Process

Covers each separate sheet of metal—edges as well as sides—with a thick, heavy zinc coating; not a pin point space of steel exposed to weather. Galvanizing can't scale off no matter how much you bend or hammer the sheet. No other galvanized steel can withstand this test. Edwards Galvanized Roofing is lightning proof.



"Reo" Cluster Metal Shingles



Patent Side Lock
No nail heads in sight or exposed to weather



Metal Spanish Tile



Garage
\$69.50
and Up

Wide variety of styles, all sizes of Portable Fireproof, Metal Garages, \$69.50 and up. Lowest prices ever made. Postal brings Big Garage Catalog FREE.

Mail Coupon TODAY

for Free Samples and Book quoting lowest factory prices on Roofing, Siding, Ceiling, Wall Board, etc. Send coupon for Book No. 550

THE EDWARDS
MANUFACTURING
COMPANY
500-550 Pike Street
CINCINNATI,
OHIO

FREE
Samples &
Roofing Book

THE EDWARDS
MANUFACTURING CO.
500-550 Pike Street
CINCINNATI, OHIO

Please Send FREE samples
Freight-Paid Prices and World's
Greatest Roofing Book No. 550.

Name

Address

Please Mention Popular Mechanics

BAYER-TABLETS

Pocket Boxes of 12
Bottles of 24
and
Bottles of 100

BAYER-CAPSULES

Sealed Boxes of
12 and 24



Bayer-Tablets of Aspirin

When you buy Aspirin you want **genuine Aspirin**—nothing else. As additional protection against substitutes, every package and every tablet bears

"The Bayer Cross—  Your Guarantee of Purity"

The trade-mark "Aspirin" (Reg. U. S. Pat. Office) is a guarantee that the monoaceticacid ester of salicylic acid in these tablets and capsules is of the reliable Bayer manufacture.

"Best" Hand Lantern



A powerful portable lamp, giving a 300 candle power pure white light. Just what the farmer, dairyman, stockman, etc., needs. Safe—Reliable—Economical—Absolutely Rain, Storm and Bug proof. Burns either gasoline or kerosene. Light in weight. Agents wanted. Big Profits. Write for Catalog.

The Best Light Co., 324 E. 5th St., Canton, O.

Deafness



Perfect hearing is now being restored in every condition of deafness or defective hearing from causes such as

Relaxed or Sunken Drums, Roaring or Hissing Sounds, Perforated, Partially Destroyed Drums, etc.

Wilson Common-Sense Ear Drums

"Little Wireless Phones for the Ears"—require no medicine but effectively replace what is lacking or defective in the natural drums. They are simple devices, which the wearer easily fits into the ears where they are invisible. Soft, safe and comfortable to wear at all times.

Write today for our 168 page FREE book on DEAFNESS, giving you full particulars and plenty of testimonials.

WILSON EAR DRUM CO., Incorporated
795 Inter-Southern Building LOUISVILLE, KY.



I will send my 25 cent BOOK

STRONG ARMS

for 10c in stamps or coin

Illustrated with 20 full-page halftone cuts, showing exercises that will quickly develop, beautify, and gain great strength in your shoulders, arms, and hands, without any apparatus.

PROF. ANTHONY BARKER

645 Barker Bldg., 110 W. 42d Street, NEW YORK

AGENTS—Make \$100 to \$300



per month easy selling our new Triplicate Sauce Pan. Cooking utensil for 3 different foods on one burner. 400 Specialties—all whirlwind sellers. Write quick for exclusive territory and large catalogue.

AMERICAN ALUMINUM MFG. CO.

Div. H-T LEMONT, ILL.



"Bow Legs and Knock-Knees"

Unsightly Send for booklet showing photos of men with and without

The PERFECT LEG FORMS

Perfect Sales Co., 143 N. Mayfield Ave., Dept. 3
North Station, CHICAGO, ILL.

FIBRE LEGS ARMS

4-LB. FIBRE LEGS—ON EASY TERMS

Orthopedic braces for all deformities. Send for booklet.
MINNEAPOLIS ARTIFICIAL LIMB CO., 636 Deane Bldg., MINNEAPOLIS, MINN.



GREEN AUTOMATIC MACHINE



ADD TO YOUR INCOME

WITH LITTLE EFFORT
\$5 to \$10 A DAY MADE
EASY WITH

The GREEN AUTOMATIC MACHINE

Sharpens, Honors, and Strops all kinds of safety razor blades, in one operation, from four to six blades per minute. For both Quality and Quantity this machine is in a class by itself. There is nothing like it on the market. Let us send you our free booklet explaining everything, including the "AMERICAN" Key Cutter—cuts square, angular or round slots.

AMERICAN SHARPENING MACHINE CO. (Inc.), Dept. 5, 184 W. Washington St., CHICAGO



"AMERICAN" Key Cutter



ROBERTS MOTORS FOR BOATS



16 H. P. Bore 3 1/2
inch Stroke 4-inch
Net Price \$240.00



8 H. P. Bore 3 1/2
inch Stroke 4-inch
Net Price \$120.00



4 H. P. Bore 3 1/2
inch Stroke 4-inch
Net Price \$60.00

MORE power, more speed sums up the Roberts Motors for 1917. Three new engines have been brought out, characteristically Roberts in design, appearance and construction, with Roberts Dependability built right into them.

Get Your Boatbuilder's Advice Before Getting That New Engine

Your Boatbuilder is the man that knows by experience just what a Roberts Motor will do for you, furthermore, his expert knowledge will enable him to advise you as to which size is best adapted to your boat and the necessary equipment required. He can tell you why Roberts Motors are so free from breakdowns, so absolutely dependable, yet full of power which means speed for your boat.

We have prepared a concise, clear description of the new Roberts Motors, write for this description today.

ROBERTS MOTORS

1704 ROBERTS BLDG.

SANDUSKY, OHIO



Catch Fish, Beels, Mink and Muskrats, in large numbers, with the New, Folding, Galvanized, Steel Wire Trap. It catches them like a fly-trap catches flies. Strong and durable. Made in all sizes. Write for descriptive price list, and Free Booklet on best bait ever discovered for attracting all kinds of fish. **J. F. GREGORY, K-257 St. Louis, Mo**

Universal MARINE MOTOR

9-12 H.P. 4 Cycle 4-Cyl. Reliable Service
inder. Speed range 300 to 1800 R.P.M. Adapted to boats from 14 to 30 feet. Write to

UNIVERSAL MOTOR CO.
OSHKOSH, WIS. Dept. P



For Bulletin No. 25 giving full description



Same \$90
Old Price

In spite of the high cost of materials and labor, we will continue to sell this wonderful Rowboat motor at \$60 (\$70 with high tension magneto built in flywheel). Fifth year of successful performance. Send for Boat and Engine books.

CULLEN MOTOR COMPANY Dept. I, 112 W. Lake St.
CHICAGO, ILL.

Motor Boat Headquarters



Write for New LA Engine Book

Your Engine Makes or Mars Your Motoring Pleasure

So don't decide definitely on the engine for your boat until you have read the new L-A Engine Book—new—just off the press.

It fairly bristles with valuable suggestions and interesting engine information. This new L-A Engine Book describes and depicts in detail the complete line of L-A inboard and outboard motors for launches, row-boats, work-boats, etc. It provides you with complete particulars covering our

30 DAYS' TRIAL PLAN

which allows you the privilege of proving the performance of L-A motors before making your final decision. Write for your copy to-day.

LOCKWOOD-ASH MOTOR COMPANY, 1431 Morton Avenue, Jackson, Mich.

(4)



AN LA ENGINE FOR EVERY
PURSE AND PURPOSE

The Little Giant of Rowboat Motors

Facts—not words—clinch the claim of superiority of the Koban. With the revolutionary features of the Koban design and construction, no vibration, greater power and greater speed are inevitable.

The Great 2-CYLINDER KOBAN ROWBOAT MOTOR.

DOES NOT SHAKE THE BOAT

The Koban is a wonder for speed and unequalled for riding comfort. Both cylinders fire simultaneously, neutralizing all vibration.

Starts easily—reverses by simply pressing a button—special tilting device for shallow water and beaching the boat.

A Koban owner at Grand Rapids, Michigan, writes: "My Koban towed a 26-foot launch, loaded down with 12 passengers and a trailer holding 4 more, against the stiff current of Grand River."

Catalog of 1917 Models on request. Dealers or agents wanted near every water point.

KOBAN MANUFACTURING CO., 291 South Water St., MILWAUKEE, WIS.
Write for Circular No. 80 describing our 2-cylinder, 3 H. P. vibrationless inboard Marine Engine for small launches, canoes, etc.



ROWBOAT MOTOR FERRO

Pay for Yours by Selling Others

Make your rowboat or canoe into a motorboat, and make the motor pay for itself. Get our agency proposition first. The Ferro Rowboat Motor is a sturdy and dependable power plant, with carburetor (not a mere mixing valve), Bosch magneto and complete equipment. Runs 4 hours on a gallon of gasoline; 2 to 3 miles an hour; easy to start, easy to run, practically trouble proof. Quiet, efficient, durable; thousands in satisfactory use—some near your home, perhaps. Write us.

\$90 with Bosch high-tension magneto.
\$70 with waterproof batteries.

The Ferro Machine & Foundry Company
548 Hubbard Avenue Cleveland, Ohio



DON'T GO ROWING - GO FERROWING

Extra money for you now

You need more money this summer—and here's a dignified, easy way to get it. Take orders for the

Wisconsin Detachable Motor Row Boat

Equip your boat with a guaranteed Wisconsin—enjoy yourself while demonstrating and making money. Thousands in use. Everyone interested. Has many exclusive features including self-locking tiller and patented top adjustment, which make the Wisconsin the best row boat or canoe motor to use, and the easiest to sell. Ask for our agents' plan. Ask for catalog G.

WISCONSIN MACHINERY & MANUFACTURING COMPANY
Minor Street, Milwaukee, Wisconsin

Highest Award Panama-Pacific Exposition. Purchased by U. S. Government, after competitive tests.



Yours for the Asking

HERE'S a book that every one interested in outdoor sports should read—many have said it to be worth a permanent place in the library. Anyway, it is a most interesting and helpful book on the sport of angling—a story that will make any red-blooded individual's heart beat livelier. It contains, also, many practical hints on bait casting as well as valuable information which will be appreciated by any reader.

We have a copy waiting your name and address. **South Bend Bait Co.**
3565 Colfax Ave., South Bend, Indiana

A Postal Card Will Bring You a Copy



HEN MOTHERS WOODPECKERS—Eleven chicks and two woodpeckers were hatched and are being mothered by a hen belonging to a farmer near Federalsburg.

Kennebec Canoe Book FREE



Properly made a canoe gives many years of enjoyment and pays big dividends in health and strength. Our new illustrated booklet gives information every prospective canoeist needs. Write for it today. Our canoes and boats are world's best. All models. Prompt shipments.
Kennebec Boat & Canoe Co.
49 R.R. Sq., Waterville, Me.

KENNEBEC

Happy, Joyous Days for Everybody

Young folks and grown-ups—everybody enjoys

"Old Town Canoe"

a pleasure trip in an "Old Town Canoe." Out there next to Nature, with the cool wind blowing, your "Old Town" rides as lightly as a feather. Safe, swift, easy to paddle and to manage. You can't turn an "Old Town Sponson Canoe" over. Lasts indefinitely.

"Old Town Canoe"

Write for catalog. Order from dealer or factory. Speedy delivery. \$34 up.



OLD TOWN CANOE CO., 1665 Middle St., Old Town, Maine, U. S. A.



LOOK NO FURTHER FOR THAT BOAT

HERE it is—a Mullins! The boat in the picture is a 26-foot Auto Boat and like all Mullins boats it means the most for the money in looks, speed, service and safety. Whether you want to pole, row or motor, in deep, shallow, fresh or salt water, there is a Mullins boat exactly suited to your purpose.

MULLINS STEEL BOATS CANT SINK

65,000 owners of Mullins power boats, rowboats and canoes, endorse them enthusiastically. Designed by America's leading naval architects and built in the world's largest boat factory, Mullins boats cannot leak, water log, dry out, warp or open at the seams—need no boat house and never require calking.

Motor boats are powered with 2 and 4-cycle motors of the most approved type, correctly installed and equipped with Silent Under-water Exhaust. Mullins boats assure boating at its best. Forty models now ready for delivery.

Write for big catalog of steel and wooden motor boats, rowboats and canoes—FREE

THE W. H. MULLINS COMPANY
52 Franklin St. Salem, Ohio
World's Largest Manufacturers of Steel and Wooden Pleasure Boats and Builders of the Celebrated Mullins Outboard Special 14-ft. Steel Boat.



Calif. The hen "stole out" her nest, and when found was mothering both the chicks and woodpeckers. It was later learned that mischievous boys had placed the woodpecker eggs in the hen's nest "just to see what would happen." The hen seems to be quite as fond of the woodpeckers as of her own offspring, and the little birds have no objection to having the hen feed them, with her own brood, on grain, worms and insects.

Has The Motor Boat Bug Got You?



Health and happiness are assured with one of the new popular priced Gray motors in your boat. Select your boat from our 1917 Boat Builders Catalog showing products of 200 leading boat builders. Select your engine from our new complete Engine Catalog. Both books FREE. Send today.

GRAY MOTOR COMPANY
546 Oakland Ave., DETROIT, MICH.

THE REEL THAT RISES TO ALL CASTING EMERGENCIES

New idea. Greatest advancement ever made in reel construction. The

Guy-Ra-Tory Reel

eliminates back lashes. Automatically distributes line over spool. No thumbing. Large open spool. More easily controlled. Greater accuracy. Positive automatic lock. Wind line crisp-true. Lets it on reel. Toolless. Fewest parts. Less care. Longest wear. Many wonderful improvements. Write now for catalog. It's Free.

Guy-Ra-Tory Reel Co.
217 Fifth Street
Racine, Wis.



A Likely Spot

Easy to pull anchor and find a likely spot if your rowboat is equipped with an

EVINRUDE

DETACHABLE ROWBOAT & CANOE MOTOR

Used by sportsmen the world over for hunting, fishing and camping. Equipment includes Evinrude Magneto - Built In Flywheel Type - Automatic Reverse - new refinements for 1917. More speed and power. Catalog and dealer's name on request. Special folder describes rowboats, canoes, skiffs and accessories.

EVINRUDE MOTOR CO.,
565 Evinrude Bldg. Milwaukee, Wis.
Over 80,000 sold - Used by 25 Gov'ts. Also manufacturers of 2 and 5 H. P. 2 cycle inboard motors for launches, canoes, dinghies, tenders.

Distributors,
New York, Portland,
Boston, San Francisco



Evinruding - is Rowboat Motoring

Prepare Your Boy for Auxiliary Naval Work

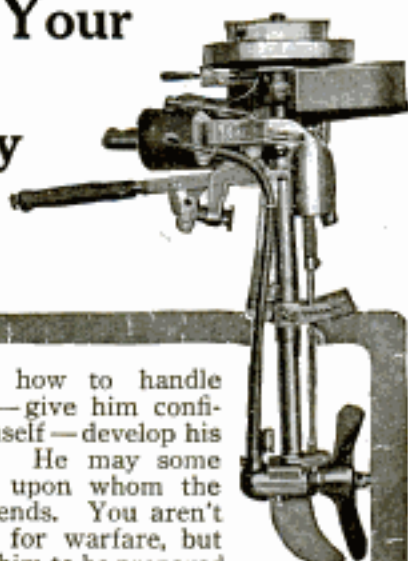

Teach him how to handle small boats—give him confidence in himself—develop his self-reliance. He may some day be one upon whom the country depends. You aren't raising him for warfare, but you do want him to be prepared if his country should ever need him—it's his patriotic duty.



Every boy should know something about the water and boats. Get him a small row-boat and equip it with a Caille 5-speed outboard motor. He will thoroughly enjoy it and he will benefit greatly.

The Ideal Motor for Him

The Caille 5-speed is just the motor for him. It's a splendid piece of machinery; well built, speedy and highly refined. The many Caille exclusive features make it ever-dependable, speedy and economical to run. Runs 4 hours on one gallon of gasoline. Has 5 speeds—two ahead, neutral and two reverse, without stopping motor. Can be equipped with the famous Caille Starter—a wonderful improvement. Many other Caille advantages.

Ask for "Caille 5-Speed Catalog."

CAILLE PERFECTION MOTOR COMPANY
1523 Caille Street, DETROIT, MICHIGAN

DEALERS WANTED

We also build a complete line of inboard motors up to 20 h. p., known and used the world over. When writing, state style and size inboard motor you're most interested in.



Please Mention Popular Mechanics

MEEK REELS

now made at Bristol, Conn., by
The Horton Mfg. Co., makers of the famous

"Bristol" Steel Fishing Rods

The name "Meek" on a reel has come to mean the same as "Tiffany" on a ring, "New Departure" on Coaster Brakes or "Bristol" on a Steel Fishing Rod. Every MEEK Reel has decided superiority of material, design and workmanship. The No. 33 Meek Blue Grass is the best \$7.00 reel ever produced. See catalogue for full description.

The No. 8 "Bristol" Steel Fishing Rod is one of the best sellers; 10 ft. Fly Rod, 9 1/2 oz. 3 joints—38 inches long, \$4.50 to \$6.25. See catalogue for full description.

Both for sale at all dealers or by mail direct from us.

BOTH CATALOGUES FREE
describing Meek Reels and "Bristol" Rods.

THE HORTON MFG. CO. 196 Horton St.
BRISTOL, CONN.

The Brooks System Knocked Down Boats

ALL parts accurately machined ready for assembling. Everything from Canoes to Cabin Cruisers. V-bottoms—high speed—semi-speed, and work boats. Full size paper patterns and illustrated instructions for amateur builders. The "Brooks System" saves over two-thirds the cost of a boat. Present conditions of freight rates, labor costs, slow deliveries, makes this the only practical method of getting a boat. We are the originators of the pattern system of boat building. Send now for illustrated catalog.

BROOKS MANUFACTURING COMPANY
8205 Ship St. Saginaw, Mich.

Largest and oldest concern of its kind in the world.

GET THIS CATALOG
FULL OF VALUABLE INFORMATION TO EVERY
BOAT OWNER ON
**RACING PROPELLER WHEELS,
REVERSE GEARS AND
MARINE ACCESSORIES**
LARGE CATALOG FREE. SEND TODAY
MICHIGAN WHEEL CO.
1139 MONROE AVE., GRAND RAPIDS, MICH.

Motor Perfection
is what you get in Watkins Class "B" all iron motors. Especially fine for canoes and light boats. Constant and efficient.
3 H. P. single cylinder . . . 45 lbs.
6 H. P. double cylinder . . . 85 lbs.
12 H. P. four cylinder . . . 155 lbs.
Are light, at the same time strong, accomplished by using semi-steel castings, high carbon steel shaft, bronze bearings, high class workmanship.
THE WATKINS MOTOR CO.
837-839 W. 6th Street Cincinnati, Ohio

Racine Wis
America's Finest Canoe
Speed, lightness and beautiful finish combined to the highest degree. Write for free catalog showing the many distinctive features of the Racine Wis.
Racine Boat Company, Dept. O, Racine, Wis.

Free to Wear 10 Days
Wonderful, genuine Tifnite in Solid gold 6 prong Helcher mounting. Gem nearly a carat large. Looks like genuine diamond. Stands all diamond tests. Just ask us to send this superb ring. Send string fitting 2nd joint of finger. If you find it a superb value, send \$3 on arrival and \$25 monthly until only \$25.25 is paid. Otherwise return in 10 days and any payment made will be refunded. No risk to you. Only 10,000 on these terms. Send now while offer is on.
THE TIFNITE GEM CO., Dept. 156 Rand McNally Bldg., Chicago



Tobacco Habit BANISHED

in 48 to 72 Hours



Immediate Results

Trying to quit the tobacco habit unaided is a losing fight against heavy odds, and means a serious shock to your nervous system. So don't try it! Make the tobacco habit quit you. It will quit you if you will just take Tobacco Redeemer according to directions.

It doesn't make a particle of difference whether you've been a user of tobacco for a single month or for 50 years, or how much you use, or in what form you use it. Whether you smoke cigars, cigarettes, pipe, chew plug or fine cut or use snuff Tobacco Redeemer will positively remove all craving for tobacco in any form in from 48 to 72 hours. Your tobacco craving will begin to decrease after the very first dose—there's no long waiting for results.

Tobacco Redeemer contains no habit-forming drugs of any kind and is the most marvelously quick, absolutely scientific and thoroughly reliable remedy for the tobacco habit.

Not a Substitute

Tobacco Redeemer is in no sense a substitute for tobacco, but is a radical, efficient treatment. After finishing the treatment you have absolutely no desire to use tobacco again or to continue the use of the remedy. It quiets the nerves, and will make you feel better in every way. If you really want to quit the tobacco habit—get rid of it so completely that when you see others using it, it will not awaken the slightest desire in you—you should at once begin a course of Tobacco Redeemer treatment for the habit.

Results Absolutely Guaranteed

A single trial will convince the most skeptical. Our legal, binding, money-back guarantee goes with each full treatment. If Tobacco Redeemer fails to banish the tobacco habit when taken according to the plain and easy directions, your money will be cheerfully refunded upon demand.

Let Us Send You Convincing Proof

If you're a slave of the tobacco habit and want to find a sure, quick way of quitting "for keeps" you owe it to yourself and to your family to mail the coupon below or send your name and address on a postal and receive our free booklet on the deadly effect of tobacco on the human system, and positive proof that Tobacco Redeemer will quickly free you from the habit.

Newell Pharmacal Company
Dept. 300, St. Louis, Mo.



Mail Coupon NOW for FREE Booklet

NEWELL PHARMACAL CO.,
Dept. 300, St. Louis, Mo.

Please send, without obligating me in any way, your free booklet regarding the tobacco habit and proof that Tobacco Redeemer will positively free me from the tobacco habit.

Name

Street and No.

Town..... State.....

Please Mention Popular Mechanics

Manufacturers Calling for Over Two Hundred Inventions

Money Is Waiting to Back the Good Idea

(By a Washington Patent Attorney)

Never was there so good an opportunity for the inventor of something — *anything* — of merit as right now.

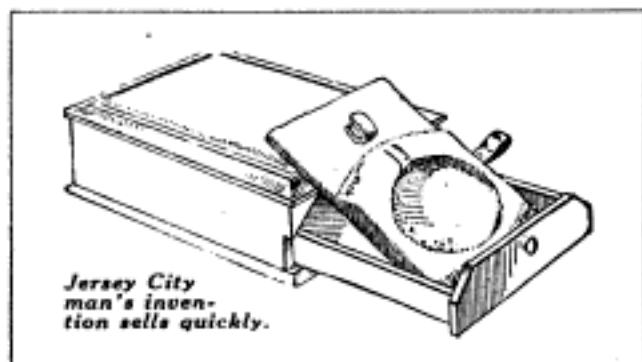

Jersey City man's invention sells quickly.

Manufacturers with money and facilities are asking for ideas — *calling* for them. The supply is not nearly equal to demand. Over 200 inventions are asked for in a list just given in a little book "What to Invent." The demand is not for anything extraordinary — just the common everyday things that make work easier or life more pleasant in the household, the shop or the field.

You might think the possibilities of the window screen had been exhausted, but I know of 28 concerns that are looking for a new screen, duly covered by patent, which they can manufacture. I know of 46 manufacturers and others who are ready to manufacture any good, patented household article such as can openers, baking pans, coffee pots, washing machines, carpet sweepers and other devices.

Within the last few weeks I have received forty special requests for a dishwasher and drainer; seventeen others request an improvement in scissors. Manufacturers know that everyone must have a pair of scissors in the house, and they realize that a novelty in them would always sell in place of the old kind, and hence the demand. Among my letters are sixteen requests for a

device to turn sheet music on a music stand or piano, and seventeen people are interested in the purchase of a patent on a device for holding an electric light in any position. Besides these there are hundreds of manufacturers who do not specify any particular device but state that they would be interested in anything of merit.



Coupling hook adopted by Pennsylvania R. R.

A Chicago man says: "I want something that can be sold to farmers by mail. There is practically no limit to the investment my associates would make in a good proposition." A man in Woodhaven, N. Y., says he is in the market for a small household article, light in weight, which can be sold somewhere around ten cents.

A prominent manufacturing company is interested in something to sell to hardware stores, but would also be interested in other things promising to be money-makers.

A man in Revere, Mass., says: "I am looking for something that can be manufactured, plant equipped, etc., and marketed for an outlay of not over twenty-five thousand dollars."

A big textile machinery company says they are interested in newly patented devices that can be either bought outright or manufactured on royalty. They do not require machinery inventions alone, but anything of merit.

A company in Belvidere, Illinois, wants patents on small tools or metal novelties.

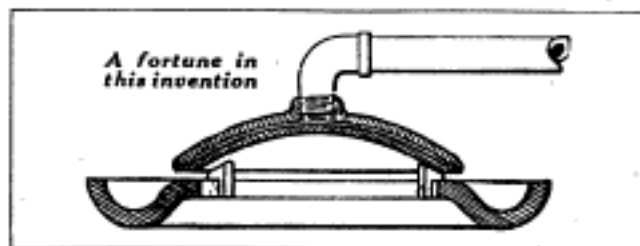

A fortune in this invention

A Dayton, Ohio, concern writes for some machine or device that would have a general sale throughout the land.

The names and addresses of these prospective purchasers are supplied absolutely without charge by Messrs. Chandlee & Chandlee to those who obtain patents through their firm. This firm has been in practice before the Patent Office for over twenty years, and its members are, consequently, familiar with every detail of patent work. They also issue a booklet entitled "How to Obtain a Patent," which tells in simple words just how to go about protecting an invention. The two books, "What to Invent" and "How to Obtain a Patent," are both free. Why don't you write for them and learn what manufacturers are looking for and how to protect your ideas? If you have an invention, send a sketch or model and description of it to Chandlee & Chandlee, 1011 F Street, Washington, D. C. They will give you a free opinion as to whether or not it can be patented.

PATENTS TRADE-MARKS AND COPYRIGHTS

LARGEST PATENT FIRM
IN THE WORLD

SPECIAL OFFER

Free Opinion as to Patentability

Before sending your invention to any attorney or manufacturer or disclosing your invention, write for our free blank form **PROOF OF CONCEPTION** in order to protect your invention and secure your rights. This should be signed and witnessed and returned to us, together with a model or sketch and description of your invention, and we will give a **FREE OPINION** as to the patentability of the invention. If we report the invention patentable we will furnish a Certificate of Patentability.

VICTOR J. EVANS

This Certificate of Patentability, together with our blank form Proof of Conception will protect the inventor and serve as proof of the invention until the case can be filed in the U. S. Patent Office.

Obtaining Assistance for Inventors—Our certificate is of great assistance to inventors who require financial aid to obtain patents.

OUR FIVE BOOKS MAILED FREE

(See Coupon Below)

to any address. Send for these books—the finest publications ever issued for free distribution.

How to Obtain a Patent

Our illustrated eighty-page Guide Book is a book of reference for inventors and contains 100 mechanical movements, illustrated and described. Tells how to invent for profit.

What to Invent

Contains a valuable list of inventions wanted and suggestions concerning profitable fields of inventions; also information regarding prizes offered for inventions amounting to **One Million Dollars**.

Millions in Trade-Marks

Shows the value of Trade-Marks and information regarding unfair competition.

List of Patent Buyers

Contains requests from manufacturers, mail order houses and promoters for patents secured by us and suggestions as to **New Ideas** they wish to purchase. We place our clients in touch with capital free of charge. We have recently received over 300 requests from manufacturers.

Foreign Patents

We have direct agencies in all the principal foreign countries and secure foreign patents in the shortest possible time and at the lowest cost. Write for our illustrated Guide Book on Foreign Patents, sent free to any address.

We Advertise Our Clients' Inventions Free in a list of Sunday newspapers, in manufacturers' journals and in *World's Progress*. Sample Copy Free. We save you time and money in securing patents. After the patent is granted we assist you to **sell your patent**.

WANTED NEW IDEAS

Prepare Now to meet the Demands of Industry in All Fields for New Ideas and New Inventions. We are constantly receiving requests from manufacturers who consult us when purchasing patents for inventions in all lines. We invite manufacturers and promoters to address our Sales Department regarding the purchase or leasing of a number of meritorious patents secured by us.

VICTOR BUILDING



FREE COUPON!

VICTOR J. EVANS & CO.

New York Offices: 189-191 Broadway
 PATENT ATTORNEYS
 Pittsburgh Offices: 514 Empire Bldg.
 Philadelphia Offices: 1429 Chestnut St.
 Main Offices: 765 Ninth St., N. W., WASHINGTON, D. C.

Name..... Address.....

Please Mention Popular Mechanics

PATENTS THAT PROTECT and PAY

Send for FREE BOOKS.

WATSON E. COLEMAN, Patent Lawyer, 624 F St., Washington, D. C.

Read the following testimonials. This is the way they are coming right along from inventors all over the United States

Aurora, Ill., Nov. 27, 1916
I wish to thank you for the way you handled my application for patent, and the fair way in which you treated me. I will be glad to refer any one to you. O. E. PARIS, 258 S. Ave.

THE MARICOPA CREAMERY CO.
Phoenix, Arizona, Oct. 24, 1916

We are certainly pleased to know that our trade-mark has been passed by the Patent Office, and we wish again to take occasion to remark upon the reasonable charge for your services in this connection and to assure you of our appreciation of your services. We trust you will feel at liberty to call on us if we can ever be of service to you in these parts by recommending your excellent work. MARICOPA CREAMERY CO., by Dudley B. Webster, Treasurer.

THE KEWANEE SURE-THING OILER CO.

Manufacturers of
THE SURE-THING STOCK OILER

Kewanee, Ill., June 18, 1916
We thank you for the work you have performed in obtaining the patent. The patent papers are good and strong and will stand the test. LLOYD E. GAMBLE, Pres.

Mason City, Ill., June 16, 1916

I received my patent papers for car wheel clamp yesterday, which was just four months from the date of my letter to you for the application. This is sooner than I expected to get it when I applied. J. T. FIELDS, Owner and Manufacturer Carwheel Rail Clamp.

COUNTY COURT, MOFFAT COUNTY

Craig, Colo., July 13, 1916
I received the notice that the patent had been allowed and want to thank you for your courteous treatment in handling the work for me. I am more than pleased with the prompt and able manner in which you handled the matter at all times. FRED BOWER.

GRIFFIN MOTOR CO.

Sheldon, Iowa, July 8, 1916
I received the Official Notice of allowance of my patent on Farm Tractor and wish to thank you for the prompt and efficient manner in which you have handled all of my business. J. B. O'DONNELL.

Warren, Ohio, March 8, 1917

Have just received notice of my patent being allowed. I wish to thank you for your prompt attention and good results. Will recommend you to any one wanting a good patent attorney. ADDISON E. GRAY, 424 Hunter Street.

Phillips, Miss., March 5, 1917

I received my patent and am well pleased because it describes my invention so correctly and so broadly protects it. I can HIGHLY recommend you to any one who has work to be done at the Patent Office. W. W. FRAZIER.

Springfield, Ohio, Feb. 4, 1917

I wish to thank you heartily for your rapid method of work which has shown more than ordinary skill and experience. I shall recommend you at all opportunities. WILLIAM KASTENS, 1181 Lagonda Ave.

Detroit, Texas, Feb. 26, 1917

I received my patent and am thankful to you for your promptness in handling the business. JOHN L. PRATT, Farmer and Breeder, Route 3.

Fruitland, Idaho, Feb. 5, 1917

Yours at hand with the Official Notice of allowance of my application for patent. I want to thank you for the promptness and the manner in which you handled the business. I did not expect to hear from the application so soon, and I am well pleased with your work. I can certainly recommend you to any one having patent work to do. B. F. TUSING, Prop., Ideal Apple Orchard.

Chicago, Ill., Feb. 26, 1917

On my arrival this morning I found your letter awaiting me. I was surprised to receive the Official Notice that my application had been allowed. This is what I call big time, and I cannot find words to express to you my thanks for your promptness of action in putting it through so quickly. J. S. SMARY, 3826 Dearborn St.

THE SANITARY MAUSOLEUM COMPANY, Incorporated
Mortuary Architects and Engineers

Reading, Penna., March 8, 1917

I want to thank you for the very good services you have shown in patenting my invention. You have given me the best service I have ever had in work of this kind. U. J. SMITH, 306 Berks County Trust Bldg.

Savannah, Georgia, Feb. 16, 1917

Permit me to thank you for the able, courteous and legal manner in which you have handled our invention. I can assure you that whenever I have the opportunity to speak a good word for you I will do so. JOHN M. MIDDLETON, 237 East Gordon Street.

Henning, Minn., Feb. 20, 1917

I am very well pleased with the way you handled my patent work and will recommend you to any one who wishes to employ an expert attorney. DEAN GREVEN.

Council, Idaho, Jan. 8, 1917

Your letter of recent date at hand and I am more than pleased with the promptness and courtesy which has marked the management of my application for patent. R. T. WHITEMAN, M. D.

Harvard, Nebraska, Jan. 8, 1917

Received my letters patent on MOTOR TRACTOR, January 5. I am ever so much obliged to you for quick and efficient service. ALFRED NOWKA, Builder of Auto Tractors.

Lukemont, Pa., June 29, 1914

I am in receipt of your favor of recent date containing official notice of allowance of patent on Window Shade Protecting Caps. I wish to thank you for prompt and efficient service in this matter. I consider it quick work—46 days from date of application to date of allowance. WM. A. FRY.

Swords Creek, Va., June 20, 1914

Please accept my thanks for your kindness and honesty in sending me back twenty dollars. It was five dollars more than I was expecting. I will gladly recommend you to any of my friends as being an honest lawyer and one they need not be afraid to risk their money with, as you have acted so prompt with me. W. M. OSBORNE.

Stinesville, Ind., March 19, 1914

With sincerest gratitude I acknowledge receipt of the return check of \$20 paid you on patent. You have been very fair with me, and will always speak a word wherever possible for you to my friends and those interested in patents. EDWIN G. WHITTED, Pastor, M. E. Church.

Medford, Wisconsin, April 19, 1916

I thank you for your prompt service in getting my patent, and you certainly shall have all my business. DR. C. E. NYSTRUM.

(His application was filed March 25, 1915, and allowed April 10, 1916—sixteen days.)

Henry, Tennessee, March 14, 1914

I am well pleased with your excellent work and promptness, as I have received notice that my application was allowed. If I have any more inventions I shall take out the patents through your office. WM. P. HASTINGS, R. F. D. No. 2.

(His application was filed Jan. 10, 1914, and allowed February 21, 1914.)

PATENTS THAT PROTECT and PAY

Send for FREE BOOKS.

WATSON E. COLEMAN, Patent Lawyer, 624 F St., Washington, D. C.

PATENTS SECURED OR ALL FEES RETURNED!!

PATENTS SECURED OR ALL FEES RETURNED!!
THAT PAY
 "Trade-Mark"
Protect Your Idea!
DON'T DELAY!

Send data at once by registered mail and we will promptly advise how our clients proceed to make fortunes.

We Issue a Contract with Each Favorable Report to Return ALL FEES!

Actual Search FREE of the Patent Office Records, and Report as to Patentability Free!

INVENTORS READ \$500.00 IN AWARDS

For Best Testimonials about OUR "ALL FEES RETURNED" and "PATENTS SOLD FREE" Services

For Particulars Write Us

PATENTS SOLD FREE: Write Today For Our FREE "Patent Sales Department" Bulletin! Proof Given.

WATCH THIS SPACE NEXT MONTH:

\$600.00 SALE MADE BY US!

Washington, D. C.

I know how to sell patents. I sold U. S. Patent No. 909,833 for SIX HUNDRED (\$600.00) DOLLARS.

WITNESSED, this twenty-third day of January, 1917.

(Sig.) E. E. VROOMAN.

Witnesses:

I. L. McCathran
H. B. Vrooman

We Help Sell Only Our Clients' Patents FREE!

PATENT BUYERS please write Our "Patent Sales Department" Today! Excellent Opportunities!

Patents advertised Free in Popular Mechanics, and further promoted if applied for thru us in 1917; write us at once and be one who secures this valuable free service!

We write manufacturers for you - We don't wait until they write us!

WE LEAD - WE ARE LIVE WIRES!

"Vrooman" Clients' Patents SELL! Over \$626,012.00 made by our clients.

Foreign Patents Guaranteed

Branch Offices all over the world. Write for prices under guarantee.

Best References: The Lincoln National Bank, Washington, D. C.; The Griffin Mfg. Co., New York, N. Y.; The Klebold Press, New York, N. Y.; Twin-City Cord-Tire Co., Minneapolis, Minn.; The Davenport Mfg. Co., Davenport, Ia.; New Era Mfg. Co., Fairfield, Ia.; Garl Electric Co., Akron, Ohio; Lambert Machine Co., Marshall, Mich.; Blodgett Mfg. Co., Alameda, Calif.; and a THOUSAND others listed in our GUIDE book (BOOK FREE)



Our Offices Across Street from Patent Office

FREE COUPON

"\$500.00 IN AWARDS"

E. E. VROOMAN & CO., 871 F St., WASHINGTON, D. C.
 (Old-Established Firm, and Practitioners Before Supreme Court of U. S.)
 Send me full particulars and your patent (2 books) literature FREE.

Name.....

Address.....

It is predicted that the umbrella—first used in London about 1780—will soon give way before the increasing use of waterproof clothing.



Models and Supplies

We make working models of any description and material, also dies, tools and sheet metal stampings. Send your drawing or sample for estimate. Write for catalog of gears and metal supplies.

The Pierce Model Works, 3405 Pierce Ave., Chicago, Ill.

Protective Patents

Procured Promptly. No fee refund, no guarantee certificate, no so-called prize or free search schemes used in our business. Inventors 104 page Blue Book sent on request.

Robb & Robb, 211-215A Southern Bldg., Washington, D. C.

PATENTS SECURED OR FEE RETURNED

Compare My SERVICE and TERMS with Those of Any First Class Attorney

Send Sketch, Photograph, or Model of your invention for an ACTUAL SEARCH of the Records of the Patent Office and report as to patentability - FREE. I give every detail of every case my closest personal attention and do not entrust your interests to assistants. Impartial advice on your ideas. I help you sell your patent. Terms moderate. My 90-page book (1917 edition) tells what inventors should know before they apply for a patent.

GEORGE P. KIMMEL, Patent Lawyer, 200 Barrister Bldg. Washington, D. C.

Latest and Most Complete Patent Book Ever Published for Free Distribution

WRITE FOR IT

WANTED IDEAS

Inquiries from Manufacturers and Other Buyers of Patents
Who Are Looking for Good Ideas

Protected by Owen Patents

Are constantly being received. Hundreds of ideas are wanted—a market exists for them to-day. YOURS may be one of them. Send for my free books and see for yourself—read the requests for inventions protected by me. Many are simple. You can help supply this demand.

As soon as my clients' rights are protected I aid in every practicable way, without charge, to sell. Their applications are advertised free—their patents are called to the attention of the proper prospective buyers—every necessary thing is done. Get my booklets and see.

THESE ARE FREE

You will incur no obligation by writing me. A simple request will bring them to you—the finest, most reliable and instructive patent books published. A postal will do.

"Successful Patents"—a 72 page guide book, tells how to proceed; describes my advantageous business methods; gives references, testimonials, etc.

"Stepping Stones"—gives hundreds of hints of inventions wanted; articles from interviews of noted authorities; tells the truth about prizes for inventions.

"Patent Promotion"—tells you how to sell; why some inventors fail; discusses the value of your idea; how I aid my clients; manufacturing aids furnished you; recent successful patents, etc.

You will also be sent from time to time, as new inventions are wanted, full information concerning them. Only in this way can you keep up to date.

WRITE FOR THESE TO-DAY—Advice costs nothing. All communications confidential. Your work will receive my personal supervision—but my fees are no higher than others.

Results Speak Loudest—But Here Are Some References

Columbia National Bank,
Washington, D. C.
National Locktite Co.,
Washington, D. C.
The Carnahan Press,
Washington, D. C.
Lightning Gun & Cycle Works,
Oklahoma City, Okla.

Antholene Mfg. Co., Hutchinson, Kan.
National Rack Co.,
61 Hanover St., Boston, Mass.
The C. J. Loftus Co.,
13 Spring Common, Youngstown, Ohio.
Whitehead Hosiery Mills,
Burlington, N. C.
Dickinson Mfg. Co., Des Moines, Iowa.

A LARGE NUMBER OF OTHERS IN MY BOOKLETS.

RICHARD B. OWEN 9-303 OWEN BLDG.
WASHINGTON, D. C.
NEW YORK OFFICE: 22nd Floor Woolworth Building

Inventors submitting their inventions to me are protected in a tangible manner until their applications are filed.

Nuts for You to Crack

Invent something for which a demand exists—for which there is a waiting market. Here are abstracts from a few recent requests—hundreds are published in full in my literature. Can you invent any of these? Watch this list each month.

A manufacturers' agent writes "do you know of any invention or patent on a new or novel cigarette box? I refer to the original paper box package, in which the cigarettes are sold. I have been asked by two of my customers to discover something new in the way of a cigarette box, so if you can assist me I shall appreciate it."

All kinds of metal ware, metal specialties, etc., are in great demand. A large Eastern manufacturer has just written "we are looking for patented inventions in the household utensil specialty line that can be retailed at prices from 10c to \$2.50. If you have any list of inventions for sale that might fit our requirements we would be glad if you would send it to us."

One of the largest cotton seed oil refineries has inquired of me for a patent upon a machine for separating the fibre from cotton seed hulls by means of a friction process.

Can you invent such simple things as new office specialties? If so there is a big market. I having recently received many requests in this line.

SPECIAL FREE REPORT

Send sketch or model of your invention for free report on patentability, practicability, etc.

U.S. PATENTS FREE → BOOK & FORM EVERY INVENTOR SHOULD USE :-

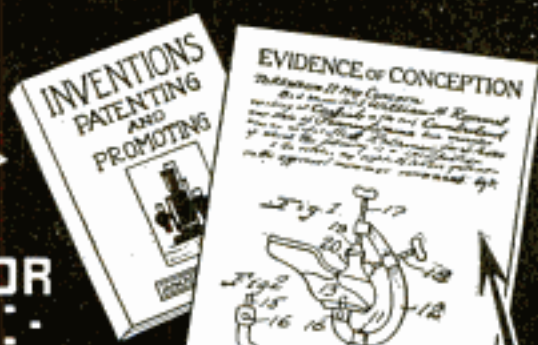

OUR CO-OPERATION

With an inventor is, **First**, to help him establish his rights before sending a sketch, drawing or model to any attorney; **Second**, to give a frank opinion whether it will pay to patent his idea, based upon our extensive knowledge of the patent laws, manufacturers' wants and facilities; **Third**, to obtain for him on reasonable terms, a patent that absolutely protects; and, **Fourth**, advise and assist him in making the invention a source of profit by outright sale, territorial grants, obtaining royalty, or the independent manufacture of the invention.

Before disclosing the invention to anyone, sign, witness and deposit in our fireproof safe, the form "Evidence of Conception" and establish your rights. A completed sample form in our book shows you clearly how to protect your invention. All are free. Just ask for them on a postcard or simply mail coupon below.

**DON'T
LOSE
YOUR
RIGHTS**

Without charge or obligation, we will give you our frank opinion on any questions you may put to us touching on patent, trade mark and copyright matters. You may ask, "Should I protect myself by a patent, or register under the trade mark or copyright laws? What kind of a patent should I obtain? What will it cost? Will it sell?" and many other questions that may occur to you. These are vital points to consider, and questions will be cheerfully answered. If you want suggestions on what to invent, in our **Bulletins of Improvements Wanted**, which are sent free to all on our mailing list, you will find the wants of progressive manufacturers and valuable information. All matters are held strictly confidential, and personal services are assured by our **Service Guarantee Contract**. **References:** 2nd National Bank, Washington, D. C.; John F. Roth Packing Co., Cincinnati, Ohio; Daskil Mop Co., Paducah, Kentucky; North Capitol Savings Bank, Washington, D. C. Listed in the Bankers' and Brokers' Directory.

LANCASTER & ALLWINE
245 Ouray Building Washington, D. C.

COUPON

LANCASTER & ALLWINE, 245 Ouray Bldg., Washington, D. C.
Send me free book "Inventions—Patenting and Promoting," *Bulletins of Improvements Wanted* and blank form "Evidence of Conception."

Name.....
Address.....

Wanted—Ideas

Inventors! Send for these Remarkable FREE BOOKS, Today

"Inventions Needed"

This book lays before you a description of the active and profitable field of invention. It tells you the inventions the world needs today, the devices manufacturers are seeking for their business, the ideas for which the public will pay big money.

"How to Get Your Patent"

This book is a guide to the inventor. If you have invented something and desire to learn what it will cost you to get your patent and what you must do to find your market, read this book.

"Special Bulletin of Patent Buyers"

This bulletin contains letters from men who are seeking to purchase patents. We act as intermediary without one cent of charge, between the man who invents and the man who invests.

Send Model or Sketch and description of your invention
for Free Opinion as to patentability

Rejected and Difficult
Cases are Our
Specialty

RANDOLPH & CO.

600 F St., N.W., Washington, D.C.

RANDOLPH & CO.
600 F St., N. W., Washington, D. C.

Gentlemen: Please send me without obligation on my part, the books indicated on margin of this coupon. (Write on margin of coupon, names of books desired.)

NAME.....
STREET.....
CITY.....STATE.....

Please Mention Popular Mechanics



FREE BOOKS

PRACTICAL SUGGESTIONS

PATENTS AND PATENT POSSIBILITIES

INVENTORS' RECORD FILE

SOME ACTUAL SUCCESSSES

Four New Booklets for Inventors

Chock full of ideas and practical advice. Tell what to invent and where to sell it. "Patents and Patent Possibilities," and "Practical Suggestions for Inventors" are bristling with facts that every inventor should have. They explain how many of my clients have made money from patents procured by me. What I have done for them I can do for you, if you have **inventive genius** and the **will power** to use it. The "Inventors Loose Leaf Record File" will enable you systematically to preserve evidence to prove priority of invention on your part in the event of a controversy. These booklets are unlike anything ever issued for inventors, they were prepared with the idea of **Service**. If you are interested in inventions send for these books; they are free while they last. My service is individual, prompt, efficient and satisfactory. (16 years' experience). I am frank in my opinion on the value and patentability of inventions. Every expedient is employed to secure patents at the least possible cost.



M. S. HILL;
802 McLaughlin Bldg., WASHINGTON, D. C.

Send all four of your booklets to

Name.....

Address.....

"The Truth About PATENTS"

This booklet tells you the plain truth about patents and how to successfully procure and market them. Every inventor should read it before proceeding. Write to-day. It will be sent promptly upon request.

I personally report upon and prepare and prosecute every case submitted to me. Prompt service. Highest references. **Honest advice free.**

My clients receive my personal assistance in marketing their inventions. They receive real co-operation.

J. R. KELLY, 743 Woodward Bldg., Washington, D. C.



PATENTS

Send Sketch or Model of Your Invention for **Free Opinion as to Patentability**

Our Certificate of Patentability is Evidence of Conception of your invention and may prove valuable to you. Our Credit System enables you to file your application for Patent and proceed without delay. Every case receives personal attention of one or both members of the firm.

Patents we secure advertised at our expense in Popular Mechanics Magazine.

Write today for Free copy of 104-page book, "How to Obtain a Patent and What to Invent"

Talbert & Parker, Patent Lawyers
4683 Talbert Bldg. WASHINGTON, D. C.



Please Mention Popular Mechanics

High-Value PATENTS

Get These Books now—read them—and if in your honest judgment they are not more interesting and worth more to you than all other patent books combined, we will refund the price in full.



- Talks by a Successful Inventor;
- How High Value Patents are Obtained;
- Facts about Prizes, Rewards and Offers for Certain Inventions; and
- The Patents Really Wanted by Manufacturers;
- Answers to All Questions of Greatest Interest to Inventors and Manufacturers concerning Patents and Trade-Marks; and
- Inside Information (contained in these books alone) of Utmost importance to Inexperienced Inventors—

That is a very general outline of what is contained in the 256 pages of these extraordinary books. Both will be mailed on receipt of 20 cents, coin or stamps, which is the regular price of the P. T. & S. Book alone. For Patent-Sense alone send 8 cents stamps.

R. S. & A. B. LACEY
32 Barrister Building, Washington, D. C.

Patents Secured by a Former Examining Official of the U. S. Patent Office

Norman T. Whitaker

Attorney-at-Law and Mechanical Engineer

Inquiries Invited

27 Legal Building - - Washington, D. C.

PATENTS

C. L. PARKER

Formerly Member Examining Corps, U. S. Patent Office

PATENT LAWYER

MCGILL BLDG.

WASHINGTON, D. C.

Patents, Trade Marks, Copyrights, Patent Litigation

Handbook for Inventors, "Protecting, Exploiting and Selling Inventions," sent free upon request.

SAFE METHODS

No catches resulting in useless patents. Large lists of manufacturers and inquirers. Nearest patents and report in each case to be filed; no extra charge.

EASY PAYMENT PLAN

Send for **FREE BOOK** { **WHAT TO INVENT**
WHAT NOT TO INVENT
HOW TO SELL YOUR PATENT

H. L. WOODWARD, Att'y, 9th and G, Washington



GEARS ALL KINDS SMALL

The most accurate made and prices reasonable. We carry a complete line of gears in stock for immediate shipment. Can also quote on special gears of all kinds. Send us your inquiries.

WRITE FOR CATALOGUE

CHICAGO STOCK GEAR WORKS
16 S. Fifth Av. CHICAGO

A Scientific Solution of the Sanitary Drinking Water Question



Ice Cooled

Holds 75 lbs. of Ice.
Supplies 150 Men.

Fifteen and one-half circulating coils of pipe in the cork-jacketed ice tank insure an ice-cooled sanitary drink to every employee.

The quality of the ice is immaterial, as it does not come into contact with the water. This construction reduces the amount of ice and water required to a minimum.

Send for Our Complete Catalogue

showing our line of Wash Bowls, Metal Lockers, All Steel Stools and Chairs with Inset Wood Seats, Stock and Storage Racks, Metal Shelving, Metal Vault Fixtures, Improved Soda Kettles, 40 and 60 gallons, Water Heaters and Instantaneous Mixers, Bubbling Drinking Fountains, Work Benches and Bench Legs, Drawing Stands, full line of Plumbing Fixtures, etc.

Manufacturing Equipment and Engineering Co.
136 Federal Street Boston, Mass., U. S. A.
Works and Mail Address, Framingham, Mass.



\$500 REWARD

We will pay \$500.00 reward to anyone who can permanently dim the brilliancy of the RAJAH Im. Diamond without destroying the stone.

RAJAH Im. Diamonds

They stand all diamond tests—fire, acid, file, and glass cutting. Their brilliancy is eternal. Guaranteed for a lifetime. Set in solid gold, and sent to you on **30 Days Free Trial** if you can dull it from us. Send today for our beautiful, FREE illustrated jewelry catalog in colors. Write now. KRAUTH & REED, 159 N. State St., Dept. P2 CHICAGO, ILL.

**A YEAR
TO PAY**

**Models
and
Gears**

Experimenters—Inventors

Developing inventions and making working models our specialty. Well equipped shop and staff of experts at your service. Carry complete stock of gears. Shipments same day order received. ESTABLISHED 1882.

UNION MODEL WORKS, 121 S. Clark St., CHICAGO



**MECHANICAL
SUPPLIES AND MATERIAL**
of all kinds.

**EXPERIMENTAL AND
LIGHT MACHINE WORK**
to order.

132 MILK STREET, BOSTON

R. MORGAN ELLIOTT & Co.
PATENT ATTORNEYS

MECHANICAL, ELECTRICAL & CHEMICAL EXPERTS

713-721 WOODWARD BUILDING
WASHINGTON, D. C.

Aviation



Learn Practical Aeronautics

BY MAIL

YES, right in your own home, in your spare time, you can learn all the principles, the theory and the mechanics of Aviation. You can prepare yourself for flying, if you wish. Or you can gain all the practical knowledge to equip you to enter the big paying and fascinating business of aeroplane construction and as aero-mechanical engineer. Send the coupon at once! Find out how our wonderful course in Aviation will give you the knowledge necessary to enter this field. Everybody planning to enter the Aviation field needs the knowledge which this course offers. This is the first time that anyone has had the opportunity to gain this instruction at home—and without great sacrifice of time and expense. Waste no time in sending coupon.

Big Opportunities NOW!

Now is the time for every man who has considered Aviation to get into the field. Each day presents new opportunities. The pioneers are going to reap the rich rewards. Automobile history, railroad history, motion picture history will repeat itself in Aviation. The men who get in early are the men who will amass the fortunes. Right now there are opportunities for men who are experts in the mechanics of Aviation that pay anywhere from \$50 to \$200 a week. In aeroplane factories, government branches, aero societies, repair shops. Only trained men will do. Heretofore this was obtainable only at a great sacrifice of time and expense by field training. Now you may secure this same training at home—in much shorter time, a mere fraction of the expense, and without interfering with your regular work.

Endorsed by Aviation Authorities

Leading aviators and flying organizations have endorsed this course as a quick and reliable means of training for the business and practice of Aviation.

Special Offer

Send the Coupon

Those who write at once will still be able to take advantage of the special limited offer which is now in force by which they may secure a large tuition reduction. Write now while this offer lasts for full particulars. Send coupon—no obligation.

AMERICAN SCHOOL OF AVIATION

431 So. Dearborn Street
Dept. 1185
CHICAGO, ILLINOIS

Name.....
Address.....

**American
School
of
Aviation**

431 So. Dearborn St.
Dept. 1185 CHICAGO

Gentlemen—Please send me, free and without obligation, full particulars of your course in Aeronautical Engineering and details of your special limited offer.

Please Mention Popular Mechanics



THE EXPO WATCH CAMERA

The most wonderful and ingenious Camera made

It is but little larger than a watch, which it closely resembles. You can carry the Expo about in your pocket and take pictures without any one being the wiser.

One Cent a Picture

The Expo loads in daylight with 10 or 25 Exposure Films, costing 15c and 25c respectively, and thus the picture taking part of a whole day's outing may be had for a very nominal sum — One cent a picture.

Easy to Manipulate

It is simplicity itself to operate. Takes pictures through the stem, where the Rapid Fire Lens is located. The photos (6/8 x 1/8) may be enlarged to any size.

QUICK AS A FLASH Time and instantaneous shutters; Endorsed by amateurs and professionals the world over. Thoroughly practical—printing and developing of films just the same as ordinary cameras—in daily use by the police, newspaper reporters, detectives, and the general public. Important hints have been secured with the Watch Camera by enterprising reporters. Produces clear, sharp negatives indoors or outdoors equal to any camera on the market, size or price notwithstanding. **Sold Under a Positive Guarantee.**

Expo Watch Camera \$2.50 FILMS, 10 Exposures 15c, 25 Exposures, 25c postage 10c

MAILED TO ANY ADDRESS IN THE WORLD

JOHNSON SMITH & CO., 7159 North Clark Street, CHICAGO

JAPANESE ROSE BUSHES

The Wonder of the World

Japanese Rose Bushes bloom all the year round. Just think of it. Six weeks after planting the seed, the plants will be in full bloom. It may not seem possible, but we positively guarantee it to be so. They will bloom every ten weeks, Summer or Winter, and when three years old the bush will be a mass of roses, bearing from five hundred to a thousand roses on each bush. The flowers are in three shades—white, pink, and crimson. The plants will do well both in and out doors. We guarantee at least three bushes to grow from each packet of seed. **Price, 10c packet, 3 pkts. for 25c postpaid.**

Shoo Fly Plant

A very remarkable botanical curiosity you should have. Though quite odorless, flies will not remain in a room where it is grown. Bears very pretty blossoms; blossoms summer and winter. Grows rapidly from seed.

SEEDS 15c packet, 3 for 40c, postpaid.

Weather Plant

NATURE'S WEATHER PROPHECY By mysterious changes that take place, this remarkable plant accurately forecasts the weather many hours in advance. Will grow anywhere all the year around. An interesting house plant. Bears large, fragrant, pink, butterfly shape flowers.

SEEDS, 15c packet, 3 for 40c, postpaid

GROUND ALMONDS

Amazingly Prolific—Easily Grown From Seed The Ground Almond has a flavor that is MOST EXCELLENT, resembling the coconut. The meat is snow white, covered with a shell or skin of brown color. It grows close to the surface and anything from 200 to 300 Almonds may be expected from a single nut. There is no trouble whatever in growing anywhere and in any kind of soil. May be planted any time, and in eight or ten weeks from time of planting you will have an ENORMOUS CROP of the MOST DELICIOUS ALMONDS YOU EVER TASTED. **SEEDS 15c Pkt.**



Perfume Plant

Blooms only at night, giving forth the most delightful scented fragrance for quite a distance. Causes much comment. For house or garden. Also valuable because of rare perfume made from it. **SEEDS, 10c pkt., 3 for 25c.**

Musk Plant

Another charming floral novelty of the sweet scented variety. Equally suitable as house plant or garden. Makes the most delightful perfume. **SEEDS, 10c pkt., 3 for 25c.**

The Wonderful Sensitive Plant

The Marvel of the Philippine Islands. Almost human in its nervous susceptibility. Leaves curl, and fronds droop when touched. Apparently resents interference; it dislikes strong odors, and is painfully affected by artificial heat and electricity. Has graceful foliage and dainty pink flowers. It is a handsome shrub for house or garden and very curious and interesting; blooms all the year round. **SEEDS 15c pkt., 3 pkts. for 40c postpaid**



NITTO'S PLANT & FLOWER FOOD

NITTO'S PLANT FOOD is clean, odorless, and highly concentrated. It is used in liquid form on all kinds of plants, shrubs, roses, ferns, bulbs, berries, lawns, fruit, flower and vegetable gardens. It changes ill-nourished plants into LUXURIANT BEAUTIES, producing masses of blooms that will equal any. Causes plants to bloom early and ahead of others. Your friends will marvel at your success. Makes no difference how healthy or how delicate your plants may be, Nitto's Plant Food will bring out new foliage and flowers, and cause a marvelous transformation. **15c, 3 for 40c**

Johnson Smith & Co., 7159 N. Clark St., Chicago
Only Concern of its Kind in America

Automatic Repeating Rifle

Fires 20 Shots in One Loading



This is a regular size automatic revolver. Shoots B. B. shots obtainable anywhere, same as other rifles and guns. Repeats 20 times with one loading. Hand-somely finished in gun metal. No caps or load necessary, as it works with a spring and shoots with rapidity and accuracy. Simply load with 20 B. B. shot, then press the trigger. Nothing to explode—absolutely harmless and safe. Remember, it is not a mere toy, but the same size and shape as a REGULAR AUTOMATIC. Sent complete with a round of shot for ONLY 25c postpaid. Extra shot, 10c a package.

Only 25c Postpd

It is simplicity itself to operate. Takes pictures through the stem, where the Rapid Fire Lens is located. The photos (6/8 x 1/8) may be enlarged to any size.

THE FIGHTING DREADNAUGHT

Sensationally Realistic! Exact Model of Modern Warship

The greatest toy sensation of the day. The Fighting Dreadnaught is an exact model of Uncle Sam's latest fighting monster. It carries eight big guns, each of which flashes, at correct intervals, from twelve to twenty times. Extra ammunition always obtainable. Absolutely harmless. Can be operated indoors or out. Now, boys! Here's your chance to see a battleship in action, and the best of it is you can OWN the ship and command the firing yourself! By having two or more Battleships, you can arrange EXCITING NAVAL BATTLES in your own home. **Price of Warship and Ammunition, 15c, three for 40c, or a fleet of 12 ships for \$1.50 postpaid. Extra Ammunition, 5 cents per pkg.**



Nu-Face Masks

12 COMPLETE DISGUISES FOR 95 CENTS. Slip on and off in an instant. No end of fun. Possess your friends. ABSOLUTELY UNRECOGNIZABLE. They change the shape of your face beyond belief. Cool and comfortable. For Parties and Masquerades, Fairs, Car Rides, Mask Balls, Amateur Theatricals, they are simply immense. There are SIX MASKS FOR UPPER HALF OF FACE, AND SIX FOR LOWER, as follows: 101, Clown; 102, Sherlock Holmes; 103, Foxey Grandpa; 104, The Colonel; 105, The Firt; 106, The Smiler; 201, Ze Count; 202, The Doctor; 203, The Sport; 204, The Robe; 205, Weary Willie; 206, Mr. Dooley. **Price, 10c each, or the complete set of 12 Masks for only 95c postpaid.**



New Vamping Card

Persons having neglected their Musical Education need not despair, for with the aid of our new VAMPING CARD (placing the card upright over the piano keys), you can at once Vamp away to thousands of Songs, Ballads, Waltzes, Rag Time, etc., equal to a Professional Musician. No knowledge of music is required. After using it a few times, you will be able to dispense with the aid of the Vamping Card entirely. The price of this very clever invention is only 15 cents postpaid.

All the Latest Surprising and Joke Novelties

- Pharo's Serpents Eggs, box . . . 10c
- Miniature Water Pistol . . . 10c
- Cleopatra's Snake (very lifelike) . . . 10c
- False Mustache (fool your friends) . . . 5c
- Big Roll Stage Money . . . 10c
- Fast Auto Puzzle (Latest) . . . 10c
- Magic Flute (anyone can play it) . . . 10c
- Rubber Razor (very formidable) . . . 20c
- Rubber Dagger (amazing!) . . . 20c
- Window Sunburns (great joke) . . . 25c
- Pocket Detective (see behind you) . . . 15c
- Great Mind Reading Mystery Cds. . . 10c
- Thurston's Mysterious Trick Cds. . . 10c
- Fighting Roosters, pair . . . 15c
- Cover the Spot Trick, a scene, nov. . . 10c
- X Ray Novelty . . . 10c
- Trick Pencil . . . 10c
- Rubber Tacks (a good joke) . . . 10c
- Memorized Penny (defies the law of gravitation) . . . 20c
- Cachoo! Sneezing Powder . . . 10c
- Mysterious Tumbler and Vanishing Coin Trick . . . 25c
- Enchanted Bottle (won't lay down) . . . 15c
- Magic Plate Lifter . . . 20c
- Imitation Gold Teeth . . . 3 for 10c
- Great Eclipse Puzzle . . . 10c
- Wire Puzzles, 10c, 25 different, \$1.95

Large catalog of unique, novel and useful articles (unobtainable elsewhere) free for wholesale prices. Catalogs and circulars furnished at cost. Send 10 cents (credited) for samples of each and particulars of our proposition.

Johnson Smith & Co., 7159 N. Clark St., Chicago
Read the next page, too

LUMINOUS PAINT

Make Your Watches, Clocks, Etc., Visible by Night

The very latest discovery in the scientific world. Hitherto practically unobtainable except at an exorbitant price, we have at last succeeded in producing this remarkable LUMINOUS PAINT, which, applied to the surface of any article, emits rays of white light, rendering it perfectly visible in the dark. **THE DARKER THE NIGHT, THE MORE BRILLIANT IT SHINES.** Quite simple to use. Anyone—you can do it. A little applied to the dial of your watch or clock will enable you to tell the time by night. You can coat the push buttons or switch plates of your electric lights, match boxes, house numbers and innumerable other articles; make your own Luminous Crucifixes, Luminous Rosaries, etc. All ready for use. Requires no preparation; contains no phosphorus. Luminous effect is positively permanent. Bottle containing sufficient to coat several small articles, **Price 25c.** Larger sizes **50c and \$1.00 Postpaid.**

Manufactured by
JOHNSON SMITH & COMPANY, 7159 North Clark Street, CHICAGO

INVISIBLE INK

The most confidential messages can be written with this ink. For the writing **MAKES NO MARK.** Cannot be seen unless you know the secret. Invaluable for many reasons. Keep your position and other private communications away from prying eyes. Great fun for playing practical jokes. **Only 15c Bottle**



VANISHING INK

Writing written with this remarkable ink vanishes entirely in a few weeks (sooner if desired), leaving the paper **QUITE BLANK.** **15c p.p.d.**

LUMINOUS INK

Writing can be **READ ONLY IN A DARK ROOM!** Writing glows like fire. Quite invisible by day time. **Very remarkable. 15c**



DISSOLVING INK

Writing is quite invisible, but can be made to appear or disappear at will in a very simple yet mysterious manner. Same **PRICE, 15c postpd.**

A new kind of invisible and vanishing ink combined. Writing is quite invisible, but can be made to appear or disappear at will in a very simple yet mysterious manner. Same **PRICE, 15c postpd.**

PRICE
20c

Book on ROPE SPLICING

Useful Knots, Hitches, etc.



A most practical handbook giving complete and simple directions for making all the most useful knots, hitches, splices, rigging, etc. Over 100 illustrations. All about wire rope attachments, lashing, blocks, tackle, etc. 27 Heraldic knots illustrated. Of great value to mechanics, riggers, campers, boatmen. **Price 20c postpd.**



Ink Erasing Fluid

Better and more effective than Rubber Erasers. Simply dip reverse end of penholder in fluid and apply to the blot or error. The fluid absorbs the ink, then dry off with blotting paper, and the thing is done, leaving no trace of the blot. Of special value for this paper. **Price, 15c bottle, 3 for 40c postpaid.**



Magic Transfer

A process for transferring pictures, engravings, etc., in their original colors, from newspapers, books, etc., to album or easel here. Several copies may be made. Rubber-ty and moth wings can also be reproduced, and an instructive collection preserved in a scrap book. Process is very simple and highly interesting. **10c, 3 for 25c, postpaid.**



Vest Pocket SECRETARY

MARVELOUS COMBINATION. Not a toy, but a really useful article you need every day. 22 Articles in one—Pen, Pencil, Paper Knife, Ink Eraser, 4-inch Ruler (divided into sixteenths), Compass can be set for any size circle, Knife, Opener, Mechanical Marking Point, Pencil Sharpener, etc. Made entirely of steel, nickel plated. Fold up—no small space occupied. Nothing so more room than an ordinary pencil in the pocket. **Price 15c, 3 for 50c postpaid.**



Thumb Brander

NEW & NOVEL JOKE to play on your friends. Put on your thumb, and "brand" your victims as you shake hands. Great fun. Won't wash off very easily, either. Any of these choices available: Owl, Foot, Hat, Grasshopper, Baby, Chicken, Hot Air, Bull, Safety First. Complete with pad and ink, 17c.



INKLESS PEN

WRITES with WATER 600 words every time you dip. Makes its own ink. Writes fashionable violet color. Better and cheaper than fountain pens. Writes a long letter with one dip in plain water. No trouble—no bother—no mess. A pleasure to use. With Nickel Plated Resilient Holder **10c, 3 for 50c**



The Handy Duplicator

A really efficient apparatus at a very low price. With this outfit, you can, in a few moments, duplicate from 75 to 100 or more letters (hand or typewritten), drawings, circulars, postal cards, etc., just as well as with the most costly apparatus sold. No trouble at all to use, and no mess. Remarkably clear, legible copies obtained, either in one or any combination of colors. Can be used over and over again. **ALWAYS READY FOR USE.** It is quick, efficient, and clean. Each outfit consists of 1 Duplicator, 1 Bottle of Duplicator Ink, 1 Duplicating Pen, 1 Eraser, and 4 Holders. Made in three sizes: **POSTAL SIZE, 4x6 1/2 in., Price 50c.** **NOTE SIZE, 6x9 1/2 in., Price 75c.** **CAT. SIZE, 8x10 1/2 in., Price \$1.50.** Extra ink (bottle of black, purple, green or red) 50c bottle. All postpaid, with full instructions.



JOHNSON SMITH & COMPANY, 7159 N. Clark St., CHICAGO

EUREKA SILVER-PLATING SOLUTION

A WONDERFUL PREPARATION
Plates Brass, Copper, Nickel, Bronze or Electro-Plate
Simply Rub it on, Brilliant and Durable.



The Eureka Silver-Plating Solution is a preparation that has been long sought in vain. It is a cheap, non-poisonous liquid by which table ware and other metal articles could be durably plated. Many compounds have been offered for the purpose, but all have failed in some way; some required too much skill, others were too slow, the effect rapidly passing away, while the most effective were violently poisonous. At last, "Eureka!" the real thing was found. In less than one minute, with very little rubbing, a plating of PURE SILVER is deposited upon spoons, forks, cruet and plated ware of all kinds, metal and carriage fittings, lamp chimneys, brass instruments, tools, etc. The effect is brilliant and lasting, equal in every respect to ordinary silverplating. **But it will wash and keep free from tarnish equal to any silver-plated ware.** The Eureka Solution is far better than any polishing material, because it adds to the silver coating, not wears it away; that the article is improved by repeated polishing, not injured, as when abrasives are used. The operation is so simple that any child can use the Eureka Solution satisfactorily, and so it contains no poisonous ingredients, there is no need to be afraid. It especially washes the articles to overcome risk from the same and prevents ordinary rinsing and wiping make them fit for use. **PRICE, 25c. 30c Glass Bottle, containing sufficient to plate several articles. Postpaid, 30c. 3 for \$1.00 postpaid.** JOHNSON SMITH & CO., 7159 North Clark Street, Chicago

TOOTH-ACHE STOP

Easy to Use
Stops the Pain; Stops the Tooth
Squeeze a little in hollow of tooth; the Ache Stops Instantly; the paste hardens, forming an antiseptic filling. Absolutely harmless. Have it ready for the next bad attack. **25c postpaid.**



"SAFETY 1st" PINS

A clever novelty. The National "Safety First" Movement has made them very popular. Also handy for wearing at amateur theatricals and the like. Two sizes, 5/8 in. (gold plated) and 1 1/4 in. (nickel-plated) **6c each, two for 10c p. pd.**



Potmend

Stops a leak in a minute
The finest repairer for Ironware, Enamelware, etc. Good for kettles, pots, pans, boilers, and every kind of ironware, also for tin, copper, aluminum, ice boxes, iron pipes, cracks in stoves, broken china, porcelain, brick-ware, blazes, crockery, woodwork, marble, etc. Will not chip, fry, burn, bake or boil out. **THE MEND IS THE STRONGEST SOWT IN THE POT.** Could not be simpler: just mix the powder with water. **HARDENS LIKE IRON.** Fire-proof, Water-proof. You can fill a big hole or a small crack. Mended places stronger than new. Replaces chipped enamel. Anyone can do it. **FAILURE IS IMPOSSIBLE.** Better and easier than solder. Three sizes, **15c, 25c, and 50c.**



Cheap and Interesting Popular Books

- | | | | |
|---------------------------------------|-----|--|------|
| Chemical Wonders, Secrets & Mysteries | 10c | Tricks with Coins | 25c |
| Money-Making Secrets | 10c | 250 Parlor Tricks, Games, etc. | 25c |
| Amateur Electrician | 10c | Painters' & Decorators' Guide Bk. | 25c |
| 100 Dramatic & Comic Recitations | 10c | Boy's Card Games | 25c |
| No. 1 | 10c | 50 New Card Tricks | 25c |
| 100 Dramatic & Comic Recitations | 10c | Fortune Telling by Cards | 25c |
| No. 2 | 10c | Old Secrets and New Discoveries | 25c |
| Book Fun, Magic & Mystery | 10c | Old Dr. Brown's Great Book of Secrets, Winkles, Formulas, etc. | 1.00 |
| Ventriloquism | 10c | (Contains over 400 pages) | |
| Humorous Dialogues | 10c | Collection of Famous Speeches | 10c |
| Humorous Recitations | 10c | Ready Made Speeches and Toasts | 25c |
| Complete Letter Writer | 25c | Rare Coin Guide | 10c |
| How to Succeed | 25c | Rabbits: How to Breed | 10c |
| Southwick's Monologues | 25c | New Guide to Beauty, Chins and | 25c |
| Vest Pocket Dictionary (Indexed) | 25c | How to Play Checkers, Chess and | 25c |
| 100 Parodies on Latest Songs | 10c | Dromaeus | 25c |
| Vanderbilt Joke Book | 10c | Prof. Gaskell's Course on Penmanship | 75c |
| Popular Recitations | 25c | 3600 Priceless Recipes, Formulas, and Trade Secrets | 50c |
| Cheer-Dancing Made Easy | 25c | Moore's Universal Assistant & Complete Mechanic (over a million industrial processes, facts, calculations, receipts, trade secrets, etc. 1016 pages) | 2.00 |
| Lightning Calculator & Short-Cut | 15c | Blakely's Industrial Cyclopedia (how to make thousands of useful articles for everybody) | 1.50 |
| Arithmetic | 50c | | |
| Hunters' and Trappers' Guide | 25c | | |
| Song and Joke Book | 10c | | |
| How to Become American Citizen | 10c | | |
| Irish Song & Joke Book | 10c | | |
| How to Play Piano | 25c | | |
| " " Violin | 25c | | |
| " " Mandolin | 25c | | |
| " " Guitar | 25c | | |

JOHNSON SMITH & COMPANY, 7159 N. Clark St., CHICAGO

All goods on these two pages sent postpaid to any address in the world on receipt of amount. No extra postage on Foreign Orders

Please Mention Popular Mechanics

Send 10c for Copy of Our New Wireless Manual P. 9

YOU GET YOUR MONEY BACK ON AN ORDER OF \$1.00



It contains 180 pages and tells how to erect and maintain wireless telegraph stations. Shows a number of diagrams. Has the Morse and Continental Telegraph Codes. Illustrates the best instruments to use; tells what they are for and how to use them. Has many new diagrams and other valuable information not contained in any other book. Do not wait. Send your request now. Get the best 10c value you will ever buy.

Send for Our Pocket Catalog P28

It contains 248 pages, with over 1,000 illustrations, and describes in plain, clear language all about Bells, Push Buttons, Batteries, Telephone and Telegraph Material, Electric Toys, Burglar and Fire Alarm Contrivances, Electric Call Bells, Electric Alarm Clocks, Medical Batteries, Motor Boat Horns, Electrically Heated Apparatus, Battery Connectors, Switches, Battery Gauges, Wireless Telegraph Instruments, Ignition Supplies, Etc.

MANHATTAN ELECTRICAL SUPPLY COMPANY, Inc.

NEW YORK, 17 Park Place

CHICAGO, 114 So. 5th Ave.

ST. LOUIS, 1106 Pine St.

San Francisco, 604 Mission St.

Type \$6 AK A motor of universal application

UNIVERSAL ELECTRIC MOTORS

Operating on A.C. or D.C.—110 to 130 volts

THIS MOTOR \$6

1/20 H.P.—6000 R.P.M.

Being used successfully for grinding, polishing, driving small machinery, machines, fans, spark gaps, sewing machines, check indicators, portable projectors, humidifiers, electric hair clippers, valve grinders and numerous other appliances.

Complete with Pulley Emery Wheel Buffer "Clacks" Cord & Plug

Racine Electric Sales Co.
53 W. Jackson Blvd. Chicago, Ill.

If your dealer cannot supply you, order from us direct.
1/40 hp/1/8 HP Catalogue Free

Charge Storage Batteries

from alternating current with

The Blitzen Rectifier

Safe, Clean, Economical

\$2.50 and up

Bulletin for 2c stamps.
2 catalogs of wireless telegraph and electrical apparatus sent for 6c stamps to cover postage.

CLAPP-EASTHAM CO.

147 Main Street Cambridge, Mass.



BOYS! Learn Wireless FREE

Talk to your friends all over the country by wireless. Hear Uncle Sam's weather reports twice daily. Get lots of news before it reaches any one else. Form a wireless club among your friends and become its President. We will teach you Wireless Telegraphy from start to finish absolutely free, just as we have hundreds of other boys.

20-Lesson Course

Yes, 20 complete lessons without costing you a penny! That's just what we offer and after you have finished you'll know more about this fascinating science than any boy in your town. The course is absolutely complete in every particular. All you have to do is to get your wireless supplies from us at wholesale prices and pay for the lessons with free coupons we give you.

400 PICTURES in THIS GREAT BOOK

Our big 228-page book of wireless supplies is the most complete catalogue ever published. It lists over 1,500 articles and contains the Morse Code and Navy codes besides a complete description of wireless telegraphy by an expert. Lists complete line of electric novelties, flash-light, lighting plants, motors, experimental appliances, etc., all at wholesale prices. No other book contains so much valuable information on how to install and operate a wireless outfit. Also explains how you can get the free 20-lesson course and become a Wireless Telegraph expert.

Mail Coupon Now

Now is the time to send for this big book—the quicker you get the 20-lesson course, the sooner will you know all the ins and outs of Wireless Telegraphy and be the authority in your town. The big book will be sent for 5 cents to cover mailing charges. Send today and begin having lots of fun as a Wireless Expert.

Electro Importing Co.
245 Fulton St., New York, N. Y.

ELECTRO IMPORTING CO.,
245 Fulton St.,
New York, N. Y.

Please send me your 228-page book and free 20-lesson offer in Wireless Telegraphy for which I enclose 5 cents in stamps to cover mailing charges.

Name.....

Address.....

City..... State.....

Please Mention Popular Mechanics

BOYS! HAVE DAD GET STRUCTO

Structo—Mechanics in miniature—will turn the trick. With it you can build that bridge or derrick, and a hundred other models that really work. Write for Free illustrated book.

STRUCTO MFG. CO., Dept. 118, FREEPORT, ILL.

ELECTRICAL HANDY BOOK AND CATALOGUE FREE



WORTH 25 CENTS TO ANYBODY

The BIG BOOK you need and want. Describing positively the finest and most complete line of wireless, novelty, and experimental goods ever listed in any catalogue and containing besides, innumerable tables, hook-ups and treatises of inestimable value to the experimenter. Absolutely Free. Send No Postage.

THE ELECTRO-SET COMPANY
Leader Bldg., Dept. P-12 Cleveland, Ohio

Try for Better Wireless Results WE'LL TAKE ALL RISK

Get a set of Brandes Matched Tone Receivers and go after those weak, far-away signals that have been eluding you. If Brandes don't show up better than any receivers you compare them with, we'll return your money any time within 10 days. Send 4c to-day for Catalog P, which tells about Matched Tone.

C. Brandes, Inc., Room 817, 32 Union Square, New York

BRANDES WIRELESS HEAD SETS

The Receivers with MATCHED TONE

THORDARSON Wireless Transformer

Making new records for distance and distinctness. Perfected by C. H. Thordarson, whose high-tension transformers won the Gold Medal at the St. Louis and Panama-Pacific Expositions. Exclusive Variable Shunt and Amperes Scale. Comes completely assembled; no chance for mistakes or burnouts. Five sizes, 5 to 25 K. W.; 10,000-20,000 volts; any cycle desired.

WRITE FOR SPECIAL BULLETIN AND PRICES

Thordarson Electric Mfg. Co.
518 So. Jefferson St., Chicago, Ill.



The Electrical Experimenter



BOYS!

Here is **THE** electrical magazine for you. For the Dabbler and the "How-to-make-it" fiend. Chuck full of experiments and the latest electrical doings. Non-technical—in plain English. One of the foremost authorities on **WIRELESS** in U. S. 200 Illustrations, 90 big pages, over 100 articles.

One copy will convince you
At All News Stands, 15c
\$1.50 a year (Foreign \$2.00).
Send 25c for 3 numbers.

THE ELECTRICAL EXPERIMENTER
234 Fulton St., New York

SAVE 25 to 60%



On **GRAFLEX—KODAKS**
CAMERAS—LENSES
of all makes. Write us for
Free Bargain Book

listing hundreds of slightly used excellent values. Money back if unsatisfactory after ten days' trial. Everything in supplies at saving prices.

CENTRAL CAMERA CO.
124 S. Wabash Ave., Dept. 2, Chicago, Ill.

ERECTOR THE TOY LIKE STRUCTURAL STEEL

BOYS: Write for facts about the Big Prize Contest and get Erector Tips, the boys' magazine, **FREE**.
THE A. C. GILBERT COMPANY, 104 Fox St., New Haven, Conn.

The production of shoe leather from various fish skins is increasing. Lately shoes made of the tanned skin from the beluga, or white whale, have made their appearance in the East.

RECTIFIERS for garages. All sizes. Charge from alternating current 1 to 8 batteries. \$12.00 upwards.
AMERICAN BATTERY CO., 1137 Fulton St., Chicago. (Estab. 1889)



B-E-T-T-E-R MUSIC

Williams' Sounding Board

Placed under record on any disc phonograph.

SEND \$1.50 TO

O. B. WILLIAMS CO., Seattle, Wash.
U. S. A.
Manufacturers Sash and Doors.

WATCHES

21 JEWEL Watches, 16 Size, \$2.50
that will pass Railroad inspection
CREDIT TERMS
AS LOW AS → **1/2 Month**



Watch Prices "Down to Bed Rock"

Our prices on high-grade, standard Watches are always the lowest, while values are top-notch. Send for Watch and Diamond Catalog and get posted about Watches before you purchase. Our Catalog illustrates and describes all the new models—Egin, Waltham, Illinois, Hampden, and others—10, 17, 19, 21, 23 Jewels, adjusted to temperature, isochronism and positions. You do not have to take any one special make when you buy of us, for we have all the best for you to select from, and you judge for yourself after you see and examine the watch. Our watches are guaranteed by the factory and further guaranteed by us. We make any necessary repairs, barring accident, free of charge, for a period of three years from date of purchase.



Diamonds On Credit

Diamonds Win Hearts

SEND FOR CATALOG and see the splendid Diamond Rings we are selling on credit terms as low as \$2.50 a month; Diamond La Vallieres as low as \$1 a month; Diamond Ear Screws, Studs, Scarf Pins, at \$2 a month; all mountings solid gold or platinum. Wrist watches at \$1.50 a month. Anything you select will be sent prepaid by us. You examine the article right in your own hands. If satisfactory, pay one-fifth of the purchase price and keep it, balance divided into eight equal amounts, payable monthly. If not what you wish, return at our expense. You are under no obligation. Send for Catalog today.

LOFTIS BROS. & CO., The National Credit Jewelers
Dept. N894, 100 to 108 N. State Street, Chicago, Illinois
(Established 1852) Stores in: Chicago; Pittsburg; St. Louis; Omaha

Wireless Receivers?

Get a **Murdock 2000-ohm** \$4 complete double set for \$4 and prove to your own satisfaction that there are no better 'phones obtainable at **DOUBLE** the prices. Fourteen days' trial allowed and money back without question if you are not sufficiently convinced of the remarkable value to keep them.

Our catalog is free. Ask for a copy.

WM. J. MURDOCK CO., 10 CARTER ST. Chelsea, Mass.

We Want Agents at \$30 to \$75 a Week

New Invention—Just out. Needed in every home every day. Patented. Nothing else like it. Low priced—**Sells on sight**. Sharpens any kitchen knife, paring knife, carving knife, bread knife, or shears and scissors in **ten seconds**. Mechanical masterpiece. A child can use it. Just put knife in slot—turn crank—sharpens both sides at once automatically. **We want representatives at once**—men and women hustlers. Get this position where **profits start first day**.

No Experience Necessary — 200% Profit

Make as much money next week as these men are making now. J. C. Lewis, of Kansas, says: "I have sold one hundred sharpeners in four days." Hobart Kerr, of Md., writes: "The women can hardly wait till they get them." Herbert Cain, of Ky., sold nine after supper. At the end of the first day, J. W. Gordon, of Pa., writes: "I sold two dozen and I sold to every one I saw." Wm. G. Hall, of N. J., says: "I think it is great. I sold six in about one-half hour. The machine is a mighty fine proposition. I am a mechanic and I know what I am talking about." You can make this money. **WRITE TODAY. TERRITORY FREE. GET HUST AT ONCE.**

QUICKEDGE SHARPENER CO., 681 Sharpener Bldg., CHICAGO, ILL.
215 N. Desplaines St.

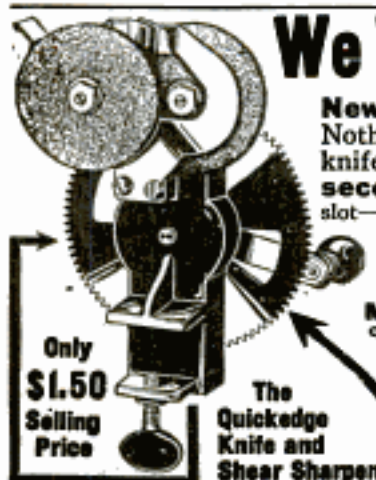

18 Months— and Then Some

A 220-pound man rode *one pair of Kokomo Bicycle Tires day after day*—for 18 months—and then reported that he was "still going." *A year and a half of solid service!*

Your pair of Kokomo Tires may, or may not, be "still going" after a year and a half of continuous service. It depends somewhat on the care you give them. But, all Kokomo Tires *do* have the habit of lasting *long enough*—and then some!

There are seven different tires in the Kokomo line. They offer you a wide range of choice in treads, colors, and prices. When buying a bicycle, see that it has Kokomo Tires. When buying tires, ask for Kokomo.

The dealer who has the Kokomo Agency in your community is a dealer who believes in superior merchandise. That is why he sells Kokomo Tires. Such a dealer is well worth finding.

LONG-LIFE
Kokomo
BICYCLE TIRES

"When the Day is done"



2
of
the
7

CHOOSE:

EVERLASTER	each \$5.00
KOKOMO KORD	each 5.00
NO. 13 SPECIAL	each 4.25
STICK TIGHT . . .	each 3.75
DEFENDER	each 3.25
OXFORD	each 2.50
PIONEER	each 2.25

KOKOMO RUBBER CO., Kokomo, Ind.

A leader for more than twenty years

Please Mention Popular Mechanics

Good News for You

You Don't Have to Wear
Overalls Any More

Pat.
June 8,
1915

The
Modern
Work
Garment



They
Belong to
The Past
BUY A
"Sensible"



Patented button-down shirt showing a neat jacket effect.

Just the garment that appeals to railroad men.

Union Made
Convenient,
Safe,
Comfortable

Order from your dealer or direct from us. Retail for about the price of an overall and jacket.

But Is Lots Better
Money back if not delighted. Write for descriptive circular.

JOHNSTON & LARIMER
MFG. COMPANY,
Dept. PM Wichita, Kan.



Shirt up showing suspenders which are attached to back of jacket.



Showing the convenient drop seat arrangement.

SENSIBLE

COMBINATION WORK SUIT

STANWELD Cold Drawn Seamless Steel TUBING

Lightest, smoothest, strongest Steel Tubing made. World's largest manufacturers of bicycles, motorcycles and automobiles use it exclusively. Send for Folder "A."

THE STANDARD WELDING COMPANY
Main Office and Factory CLEVELAND, OHIO

NEVERLEAK TIRE FLUID

The great tire healer and preserver. 25c worth means \$2.50 extra tire service—because it

Heals Punctures Instantly

Cures porous tires—lengthens tire life. Simply inject a tube of Neverleak Tire Fluid in each tire—no more tire troubles—no more stopping by the wayside to fix a "leak."

Get a tube today
Sold by Repairmen and Bicycle Dealers.

Buffalo Specialty Co.
Buffalo, N. Y., U.S.A.
Bridgeburg, Ont., Canada

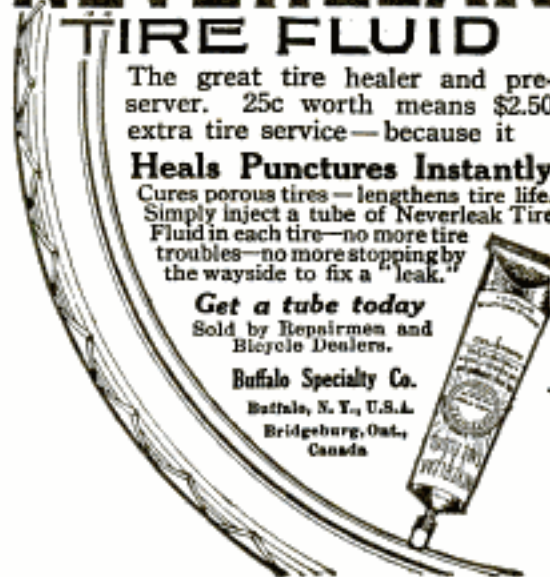

Pull-U-Out

The little thing with the big pull

—pulls you out of trouble



Consists of a winding drum, lever crank, 40 ft. of steel cable, two 7 ft. chains and three stakes. Weighs only 28 lbs. and goes in space 4x8x14 in.

Here is the most wonderful little device ever invented for pulling autos out of hub deep mud and ditches, or righting over-turned cars. Small enough to go into your tool box; powerful enough to pull a 5,000 lb. auto out of mud in ten minutes. Simply drive the three little stakes in the ground, hitch on, turn the crank and out you come without delay, damage, trouble or expense. Combines a rescuing device and tow line—two things every auto should carry.

For Garages, Factories, Farms, Construction Jobs

Cheaper and better than a chain block. Pulls and lifts. Does jobs no other machine can do. Light, portable, strong, inexpensive. Works in any position. Can be rigged up to do jobs that now require several men.

Pull-U-Out Portable Crane

We also make a wonderful portable crane. It weighs only 300 lbs.; lifts 1000 lbs. 9 ft. 6 in. Easily moved about. Slip jointed. Put together in few minutes with S wrench. Has longer reach; weighs about a third as much as other cranes of same capacity at twice the cost. Pull-U-Out can be detached and used for pulling and hoisting.

Interesting Book FREE

Pull-U-Out Sales Co., 2035 Market St., St. Louis, Mo., U.S.A.



The old way — everybody help.



Ever have to do this?



The new way — Let Pull-U-Out do it.

GUARANTEED

Money refunded if it fails to deliver. If your dealer hasn't it, write us.

BUILD THIS CAR OR BUY IT COMPLETE
Lowest Priced Car in the World



Very fast. Economical. Seats 2 full grown persons. Not a toy. Complete Detailed Drawings, 35c. Catalog 10c. Cycle Car and Light Car parts at low prices. Discount to Agents.

Tribune Engineering Co., Dept. P, Owego, Tioga Co., N. Y.



Powerful and Positive

This whistle is not an exhaust signal. It screws in place of the priming cup and is blown by the explosion direct. Standard equipment on the following cars: "Little Giant," Sandow, Doss, Lamson, Hendrickson, Fargo, Palmer, Nelson, and LeMoon. Could you wish further proof of the merits of the Buell? Write for interesting circular.

THE BUELL CO.

1610 Michigan Avenue CHICAGO

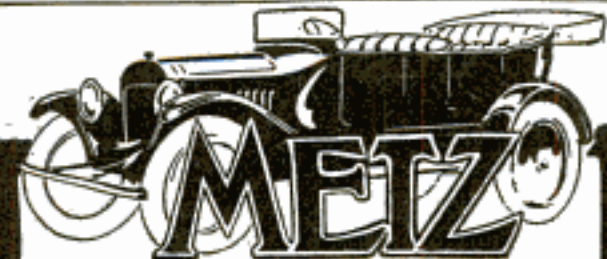

DEALERS WANTED to make money selling the famous METZ Car—\$600 completely equipped.

108" wheel-base—4-cylinder 25-h.p. motor—7 forward speeds—electric starting and lighting, etc. Write To-day for full details of the Money-Making METZ Proposition METZ COMPANY, WALTHAM, MASS.

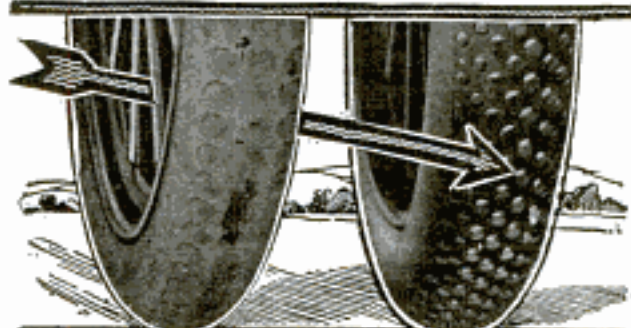

Save Your Old Tires

Get 5,000 Miles More Service by putting on Steel Studded Treads the same as European Motorists have been doing for over three years. 40,000 American Motorists have done this in the last 8 months and are saving \$50.00 to \$200.00 a year in tire expense.

5,000 Miles Without Puncture is the signed guarantee you get with every Durable Steel Studded Tread.

We Deliver Free without a cent deposit, prepay express and allow you to judge. Special Discount offered to motorists in new territory on first shipment direct from the factory. Mail the coupon below for details. Be sure and put in your tire sizes.

MAIL TODAY—SAVE THE DISCOUNT

The Colorado Tire & Leather Co. 544 Tread Bldg., Denver, Colorado, E-44 Transportation Bldg., Chicago, Ill. 720-445 Woolworth Bldg., New York City

Without obligation send me free catalog, copy of guarantee, sample and booklet "10,000 Miles on One Set of Tires."

Name

Address

My Tire Sizes are

Please Mention Popular Mechanics

Rider Agents Wanted

We want a Rider Agent in every neighborhood to ride and exhibit the new "RANGER." You can select the particular style suited to your own needs. Boys and young men in all parts of the country are riding "Rangers" and taking orders from their friends. Our great output, perfected methods and machinery enable us to sell "quality" Bicycles at prices below all competitors.

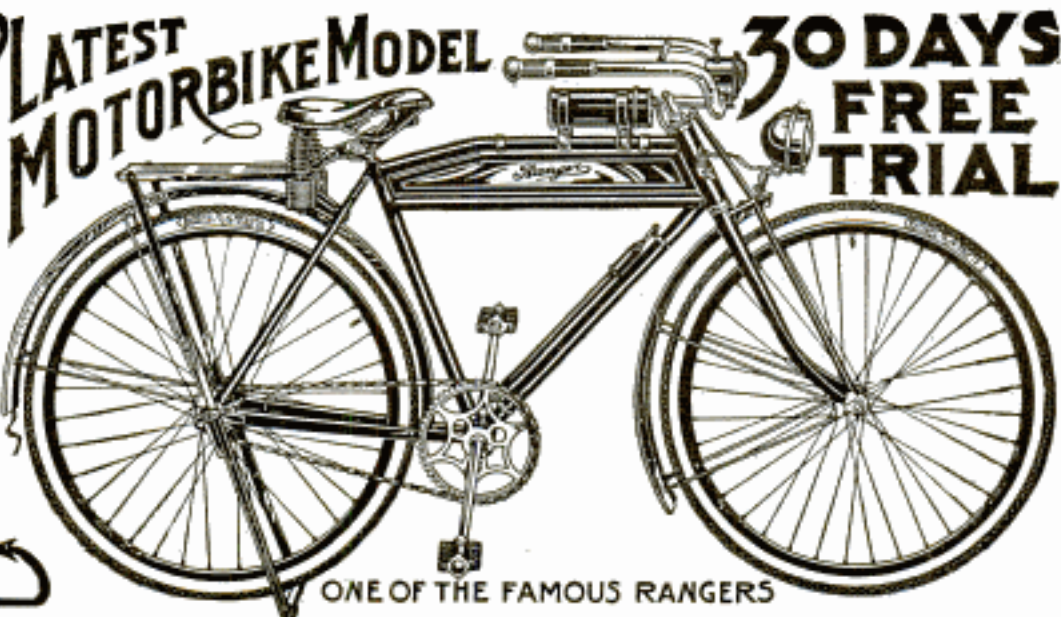

Your Choice of Forty-Four (44) Styles, Colors and Sizes in the famous line of "RANGER" Bicycles, shown in full color in our big new 1917 Catalogue just off the press. There are eighty-three (83) others, also, at prices ranging from \$14.75, \$15.75, \$17.75, up. There is a MEAD Bicycle for every rider, at prices made possible only by our FACTORY-DIRECT-TO-RIDER sales plan.

SEND NO MONEY but write TODAY for the new 1917 Catalogue of "Ranger" Bicycles, Tires and Sundries at prices so low they will astonish you. Also, full particulars of our great new offer to deliver to you all charges prepaid your choice of any of the 44 kinds of "RANGER" Bicycles you may select, for **ONE MONTH'S FREE TRIAL**. This wonderful offer is absolutely genuine.

TIRES, LAMPS, Built-up Wheels with Coaster-Brakes, Inner Tubes, Electric Lighting Outfits, all the newest ideas in Bicycle equipment and Sundries, as well as the Repair Parts and Combination Offers for refitting your old Bicycle—all shown fully illustrated, at **HALF USUAL PRICES**. Our new Catalogue is the largest ever issued by any Bicycle concern. Even if you do not need a new Bicycle now, or Repair Parts, Tires, etc., for your old Bicycle, you need this Catalogue to tell you the prices you should pay when you do buy.

MEAD CYCLE COMPANY, Dept. B108

CHICAGO, ILLINOIS

IVER JOHNSON

REVOLVERS SHOTGUNS BICYCLES MOTORCYCLES

Send for free books, "A"—Arms,
"B"—Bicycles, "C"—Motorcycles.

Iver Johnson's Arms & Cycle Works
307 River Street FITCHBURG, MASS.

58 seconds

to slumberland

The ANY-CAR Auto Kot will fit any 5 or 7 passenger car and be placed in position for sound and comfortable sleeping in less than a minute. Two Kots can be placed in any car made. Lie perfectly level.

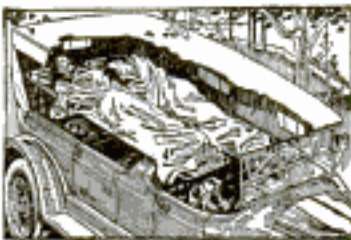

When not in use they fold up and fit in front of tonneau. Made of iron tubing and covered with heavy canvas, laced underneath. Weighs less than 15 lbs. Every tourist, hunter, fisherman and camper needs these kots.

Price complete—\$10.00
Two for 18.00



detail view

Peoria Auto-Kot Co., Peoria, Illinois

FREE details

Write for complete description, uses, advantages, etc. They save their cost in four days.

Dept. 18



Convert Your Bicycle into a Motor-Cycle

Motor fits any wheel. BEST, MOST RELIABLE. Best hill climber. More STEFFEYS in use than all others. Stamp for circulars STEFFEY MFG. CO., 5007 Brown Street, PHILA., PA.

\$19.95 and up

New Service Bicycle

Speedy—easy running. Sturdily built of seamless steel tubing—triple truss forks. With motorcycle type, anti-skid, puncture-resisting tires. Beautifully enameled and striped. Satisfaction guaranteed or money back. \$19.95 from Chicago. Write for our Bicycle Book, bicycles shown in colors! FREE! Address house nearest you.

Montgomery Ward & Co. Dept. G133
New York Chicago Kansas City
Ft. Worth Portland, Ore.



Edwards Steel Buildings

Everything from Garages to Factories

Erected easily and quickly. Taken down just as readily and moved to any desired new location. Weather-proof, fireproof, timeproof. Wonderfully durable. Whatever the need—garage, booth, bathhouse, office, storehouse, school, cottage, barn, hospital, or factory, there's an Edwards Steel Building for the purpose. Write today for descriptive literature and prices.

THE EDWARDS MANUFACTURING COMPANY
Metal Roofing, Metal Lockers, Rolling Doors, etc.
1320-1370 Eggleston Avenue Cincinnati, Ohio

Price \$140.00

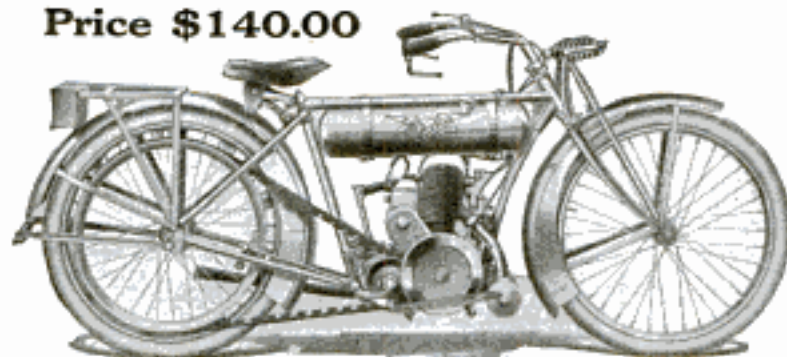

LIGHTWEIGHT
Sensible Safe
Economical
Efficient

The Man on the Job Is the Man Who Gets Ahead

While the strap-hanger is wondering why the car is delayed, the man with his own means of transportation is already on the job, and, whether owner or employee, his time is bringing him direct financial results.

With an EXCELSIOR Model L 18 the cost of travel is less than carfare; you have no tiresome waiting or strap-hanging and are on the job, fresh, full of pep and ready for business.

Then, when the day's work is done, you have the same rapid, comfortable and pleasant means of transportation to take you where rest and enjoyment await.

The tired worker is assured a comfortable seat and the brain-weary official finds bodily rest and mental recuperation in the homeward flight in the open air.

If you have not examined the EXCELSIOR LIGHTWEIGHT, do it now or write for our new catalog of Heavy Duty and Lightweight Motorcycles and Sidecars.

Excelsior Motor Manufacturing & Supply Co.
3702 Cortland Street, CHICAGO

Auto Lighting for Bicycles



Get a Delta complete electric lighting system. Great for night riding. Throws searchlight 300 ft. Turns any direction. Uses common dry batteries. Strongly made—finely finished. See your dealer today.

DELTA ELECTRIC CO.
Dept. 20 MARION, IND.

Canadian Branches:
Winnipeg and Toronto.



More Miles From Gasoline—Guaranteed!

The Wilmo Manifold gives your car a flying start at the first few turns of the motor—increases gasoline mileage from 42 to 54 per cent by actual official A. A. tests—keeps the engine free from carbon—makes a smoother running motor at all speeds. Quickly and easily applied with a monkey-wrench. No holes to bore. Absolutely guaranteed. Made for various cars. Price \$7.50 up. Ask your dealer or garage man, or write.

THE WHITTIER CO., First National Bank Building, CHICAGO



**MAKE A
MOTORCYCLE
OUT OF YOUR
BIKE**

FITS EITHER
SINGLE OR
DOUBLE BAR
BICYCLES

**WITH OUR ATTACHMENT
1917 MODEL NOW READY**

No special tools required. Fits right in the frame of any single or double bar bicycle. Weighs only 15 pounds (including magneto). Runs 80 to 100 miles per gallon gasoline. Write now for FREE CATALOGUE and special offer for introducing first machine in your locality.

CYCLEMOTOR CORPORATION ROCHESTER NEW YORK

THE ONLY 2-STROKE HIGH-SPEED BIKE MOTOR

Start a Tire Repair Business of your OWN

Get into the one line where there is more work than men to handle it—where you need but little capital or experience to make big money from the start. Over a hundred million dollars is being spent this year for tire repairs. It's easy for you to get your share with—

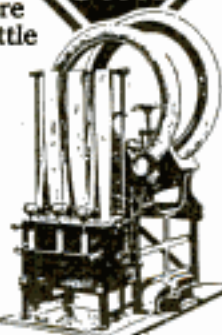

60 of the largest tire manufacturers use this equipment to repair tires in their own factories and branches—sell it to their dealers because they know it is built right and does the best class of work. Car owners don't want to take chances with their tire repairs. That is why you can make the biggest profit from—

Akron-Williams
TIRE REPAIR EQUIPMENT

**Send Back This Coupon
Get this free book**

It is brim full of just the information you need. Gives you all the details. Tells you how to make money with an Akron-Williams Outfit right from the start. Shows your opportunity in this big field. Write today—Now. Your free copy is ready.

The Williams Foundry & Machine Co.
50 Cherry St., Akron, O.

Gentlemen:—Please send me your free book. This of course with no obligation on my part.

Name.....

Address.....

Please Mention Popular Mechanics



Prest-O-Lite

for
Motorcycles

Chosen by Riders Everywhere

Prest-O-Lite meets perfectly the demand of experienced riders for brilliant, reliable, low-cost light.

It gives a rich flood of penetrating light—is independent of road conditions—bumps and jolts do not affect its brilliancy. You can absolutely rely on Prest-O-Lite at all times and under all conditions. It is simple, sturdy and practical in operation—never needs expert attention to keep it in first class order. What little care it requires you yourself can give, easily and at trifling cost.

Yet with all its advantages Prest-O-Lite costs less to buy and less to use than any other brilliant lighting system.

You Get Real Service from Prest-O-Lite

You can use Prest-O-Lite with maximum satisfaction on *any* make of motorcycle.

See your dealer about it. He can supply you an equipment combination including a Prest-O-Lite, a lamp and good horn—at a reasonable price. This gives you the greatest value for the least money.

Know all about Prest-O-Lite for motorcycle lighting before you buy any lighting system. Send for interesting literature today.

The Prest-O-Lite Co., Inc.

World's Largest Makers of Dissolved Acetylene
U. S. Main Office and Factory 265 Speedway, Indianapolis
Canadian Main Office and Factory, Toronto, Ontario
Prest-O-Lite-Exchange Agencies Everywhere

Goes Like Sixty!



There's no slipping—a positive drive prevents that—full steam ahead every time.

The Atherton Coaster Brake

Coasting with the Atherton is real gliding, because there is no friction—just "pep" and lots of it.

You can sprint away from the bunch or jam on brakes and come to a sudden stop—it beats them all at every point with its bull-dog grip.

2 Driving Contacts 3 Braking Surfaces 6 Working Parts in All

Ask your dealer to show you the Atherton **FREE Pencil Clip**—just send us names of 3 bicycle dealers in your town. A dandy Pencil Clip will be sent by return mail. Also interesting bicycling literature.

Buffalo Metal Goods Company
221 Winchester Road
Buffalo, N. Y.

The
atherton
It always works!

FOLDING TRUCK BODY

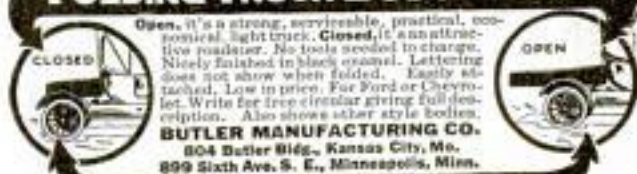

Open, it's a strong, scrappable, practical, economical light truck. Closed, it's an attractive roadster. No tools needed to change. Nicely finished in black enamel. Lettering does not show when folded. Easily attached. Low in price. For Ford or Chevrolet. Write for free circular giving full description. Also shows other style bodies.
BUTLER MANUFACTURING CO.
804 Butler Bldg., Kansas City, Mo.
809 Sixth Ave. S. E., Minneapolis, Minn.

60 SECONDS MAKES THIS CHANGE—

MAKE YOUR BIKE A MOTORCYCLE

at a small cost, by using our attachable outfit. Fits any Bicycle. Easily attached. No special tools required.

"Used His Four Years"

Harry A. Hyatt, of Boreas River, New York, writes: "About four years ago I received my motor attachment, and wish to say that I am satisfied with it in every way, for it has certainly given me good service. Anyone wanting a motorcycle or attachment, I would recommend them to the Shaw Manufacturing Co."

FREE BOOK Write today for bargain list and free booklet, fully describing the SHAW Bicycle Motor Attachment. Motorcycles all makes, new and second-hand, \$35.00 up.

SHAW MANUFACTURING CO.
Dept. 6 GALESBURG, KANSAS

Please Mention Popular Mechanics





Happy Days!

First in the hearts of American Boys who know—are the world-famous

Red Wing Wheels

They're real men's models, not "juvenile" wheels. With special frames and interchangeable hangers—to make and keep them right for growing boys. If you want a wheel to be proud of—Red Wing is the wheel you ought to ride.

Write for free illustrated catalog in colors, and the nearby Red Wing agent's name.

New England Bicycle Co.
68 High Street
WORCESTER, MASS.



The Cleveland Lightweight

The only light, low priced Motorcycle with straight line worm drive. Weighs 150 pounds. Highest quality throughout.

75 miles to the gallon. 600 sold in one city last year. Price, \$160.00; with Kick Starter, \$170.00. Dealers wanted.
THE CLEVELAND MOTORCYCLE MFG. CO.
7202 Platt Avenue, CLEVELAND, O.

Start a Big-Paying Business of your own with a BADGER TIRE REPAIR OUTFIT

The man who's equipped to supply the stupendous demand for auto tire repairs can make an assured income of \$100 to \$300 or more per month. The famous Badger Solid Pad System with its strong array of improved features



insures your customers quick, economical, high-grade repair jobs, the kind that build up steady trade. We teach you free and help you start the business. Write for copy of Catalog and details of complete money-making Free Aid Service.
TIRE REPAIR EQUIPMENT CO.
501 Johnson Street
APPLETON, WIS.

TIRE REPAIR EQUIPMENT CO.

Do Some Gas Cost "Juggling" of Your Own

28
19 30

The new Stromberg Carburetor for Fords puts the lowering of fuel costs in your hands. It cuts costs by lessening consumption. It has been exhaustively tested on thousands of Fords. In every instance it has made good.

37 4/10 MILES ON A GALLON OF GASOLINE

The world's official Ford record was made by a Stromberg-equipped Model T 1915 Ford—carrying three passengers—total weight 2170 lbs. Just a sample of amazing economy—a forecast of the mileage you can really get with The New

STROMBERG CARBURETOR FOR FORDS

Because that record was made under the same conditions which your Ford is ordinarily operated! The same Ford was accelerated from a standing start to 25 miles an hour in 11.4 seconds—then speeded up to

43 MILES PER HOUR

without adjustment. Flexibility—speed—you're not getting—can't get without it. Besides this you obtain easy, quick, sure starting in any kind of weather. All you want from your Ford—any time you want it.

10 DAY TRIAL

No risk. Test it. If you are not satisfied, return the Carburetor and back comes your money—without question. The price is only \$18. But you pay really nothing. For your money is returned time and time again in fuel savings—with extra power—speed—and easy starting thrown in. Order now. Descriptive matter and economy records free upon request.

STROMBERG MOTOR DEVICE CO.

Dept. 514, 64 E. 25th Street
Chicago, Ill.

New STROMBERG Does it!
CARBURETOR

Please Mention Popular Mechanics

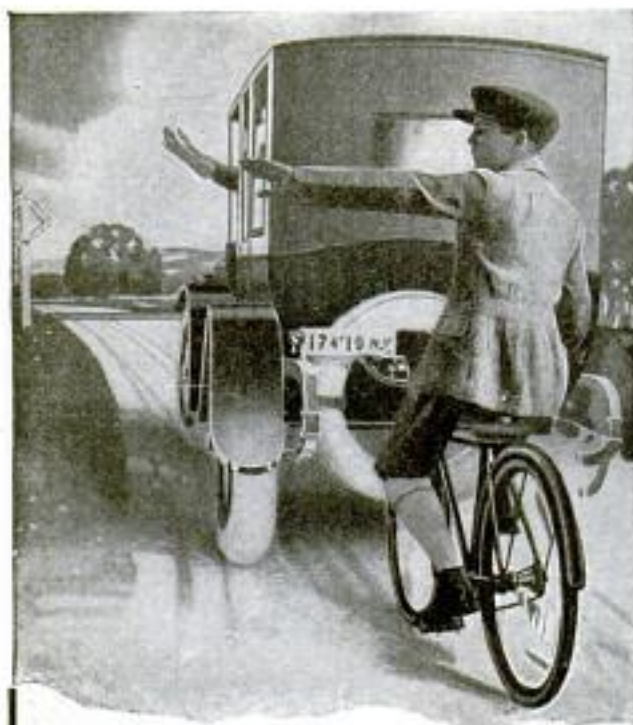

Complete Control In Your Pedals

FOR quick or gradual action — the Corbin Duplex! At any time, in any place — the Corbin Duplex! On street and road, hill and dale, wherever and whenever control is required, put your trust in the dead sure grip of the famous



DUPLEX COASTER BRAKE

There is no qualification to this statement. The Corbin Duplex has built up its enviable reputation and universal popularity on the strength of its day-in-day-out dependable service.

You do not want any brake other than the best brake on that bicycle of yours and there is no need to experiment. The Corbin Duplex has shown what it can do and what it has shown has been sufficient to convince the majority of bicyclists that it is the most satisfactory brake on the market.

"Corbin Control Means Safety Assured"

Catalog on Request

The Corbin Screw Corporation

The American Hardware Corp., Successor
200 High Street New Britain, Conn.
Branches: New York Chicago Philadelphia
Makers of Corbin-Brown Speedometers

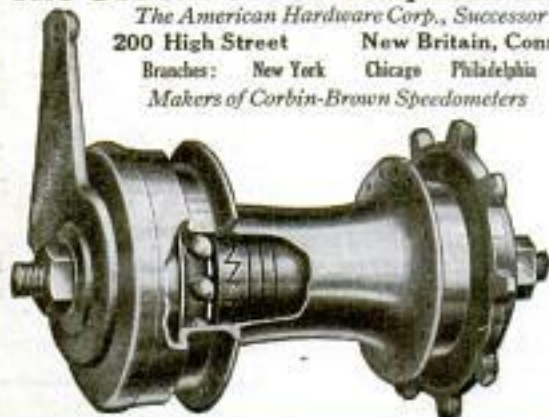

FEDERAL BICYCLE TIRES

Your Bicycle Tires should be just as good as your bike. They must be dependable always. When you want speed they must be fast. For your long hikes they must be sturdy and strong. That's why **Federal Tires** are best for your bicycle.

Write for booklet that tells you all about them

THE FEDERAL RUBBER COMPANY
OF MILWAUKEE
Factories: Curtabay, Wisconsin

Bush Car Delivered Free

Five-Pass., 34.7 H. P.,
32 x 3 1/2 Tires

Ride in a Bush Car. Pay for it out of your commissions on sales, my agents are making money. Shipments are prompt. Bush Cars guaranteed or money back. Write at once for my 48-page catalog and all particulars. Address J. H. Bush, Pres. Dept. 117.

114-inch Wheelbase
Decco Ignition—Elect. Sec. & Ltg.

BUSH MOTOR COMPANY, Bush Temple, Chicago, Ill.



Overland GIVEN

Send me your name at once if you live in the country or town under 10,000 for my new easy plan for winning this New 1917 OVERLAND Touring Car, or \$850 in cash. It will surely appeal to you. No money needed. I have already given away 40 autos. If you want one write today for full particulars.

C. F. ALDRICH, Dept. A, St. Paul, Minn.

LEEDAWL COMPASS

the only
Guaranteed
Jewelled
Compass
for \$1.00

*If not at Dealer's
Remit Direct*



Taylor Instrument Companies
ROCHESTER N.Y.
Makers of Scientific Instruments of Superiority

This Is The Way It Runs



— smooth and silent
— and fast as an automobile. It's the

Auto-Wheel Coaster

Riding in an Auto-Wheel is like driving a racing car. And it's always the first to reach the bottom of the hill, because it's especially built for speed. It will stand up under wear, too, for it's built of ash and maple, with steel axles and tires.

The Big Features

are the Real Roller Bearings. There's speed in every one, and the speed endures, because they are protected by Best-Frost Hub Caps.

FREE Beautiful Pennant—also Booklet. Just send names of three local Coaster-Wagon Dealers, mentioning those who handle the Auto-Wheel.

BUFFALO SLED CO.

137 Schenck St., No. Tonawanda, N. Y.

In Canada: Preston, Ont.

- and here's
the reason



Charging Motor Car Batteries PAYS BIG
Every 111 charging set nets the garage owner \$20.00 to \$60.00 per month. No experience required to operate. Current costs 15c per battery. You get 10c to \$1.50 from the motorist. This money-making HB Charger shipped ready to install for \$10.00 down—balance in 10 monthly payments of \$1.00 each. Absolutely guaranteed. Can be returned if unsatisfactory. Write for full particulars, enclosing this ad. **HOBART BROS. CO., Box 55, Troy, Ohio**

Throw Away Your Crank—
Start from the seat with a
SANDBO 2-Compression STARTER
One pull on the handle turns the crank a complete revolution past two compression and two ignition points, spins the motor faster than you can do it by hand. Over 100,000 in use. Sold on 30 days' trial. Fully guaranteed. Positive release in case of back fire. **ONLY \$14**
SANDBO STARTER CO., 86 Sande Bldg., Rock Island, Ill.

TWIN FIRE

The only spark plug of its kind on the market

The Twin Fire Spark Plug laughs at soot and oil, for if one point clogs the other continues to fire—the hot explosions soon clean the fouled point. Add a world of energy to each combustion, too. Each spark fires independently of the other but at the same instant; gives double intensity. The laws of electricity make it physically impossible for any other than Twin Fire plug to fire two separate and distinct sparks simultaneously.

Ordinary plug dead when even one point is clogged.

The first efficient spark plug

Twin Fire always fires—one point cleans the other.

Price Only \$1.00
See your dealer today—he will prove Twin Fire superiority. If he cannot supply you order direct.

Twin Fire Spark Plug Company
660 Woodward Ave., Detroit, Mich.
Dealers: Big demand for Twin Fire plugs—write for dealers' plan.

Keep Your Wheels Solid

The summer heat will sap the moisture out of your wheels and shrink the wood. That means loose, creaky, rattly spokes and a general dangerous weakening of the wheels. A sudden twisting jolt may cause collapse—certain damage and possible personal injury.

SPOKTITE PREVENTS LOOSENING
Keeps wood from shrinking. Easily applied. Your auto supply dealer sells it. If not, send his name and \$1 for enough to treat 4 wheels. Address **LIQUID WHEEL TIGHTENER CO., Dept. C, Modesto, California**
Sales Offices: Boston—New York

Temco Comfort Coils for Fords

New—different—wonderful in action. Backs all shock absorbing devices off the boards. Strong statement, but true. The double helical steel springs do the business. They're longer—stronger—more flexible. Bumps and holes are eaten alive. The roughest road becomes almost a boulevard. One man writes: "They're life-savers on rough roads."

SAVE YOUR VITALITY Conserve your strength. Be kind to your back and nerves. Jolts and bumps produce fatigue, nervousness, weak spines, headache, trouble with vital organs, etc. Put on a set of comfort coils and avoid all this.

GET YOUR SET NOW Once on, you wouldn't take them off for love or money. Words cannot picture the ease and comfort they give. It's wonderful. Nothing like them anywhere. Temco Comfort Coils are supreme. Listen to this: "Have used six different shock absorbers in the past six years, but none satisfied except Temco. Comfort Coils is the right name."

30 DAY TRIAL But don't take our word. Send now for your set. Try them 30 days. Just as long as your Ford. Money cheerfully returned if you can part with them. Substantial. Will write quick for full details, and astonishingly low price, prepaid. **DEALERS AND AGENTS GET BUSY.**

THE TEMCO ELECTRIC COMPANY, 2102 Sugar St., Leipsic, Ohio

LOOK!

A Perfect Patch in 5 Minutes!

Vulcanize a perfect, permanent patch on your inner tube in five minutes, anywhere on the road. Thousands of motorists doing it with the Shaler 5-minute Vulcanizer. Over 100,000 sold in 60 days. No cement, gasoline, acid or flame. A combustible disc furnishes the heat. The disc is in a metal container with the rubber patch on the other side. You clamp the complete unit over the puncture and light the combustible with a match. It creates just the right amount of heat to do the work.

SHALER

5-Minute Vulcanizer

A clamp, 12 patches and 12 heat units all neatly boxed—that's all there is to the outfit. Carry it right in your tool box. Price complete only \$1.50. You can buy additional units as you need them at 75c per doz. Order a Shaler 5-Minute Vulcanizer from your dealer today. If he's not supplied send direct to us. Tire book "Care and Repair of Tires" sent free to motorists. Write today!

\$1.50

Complete with 12 Discs and 12 Patches

C. A. SHALER COMPANY, 2004 Fourth St., WAUPUN, WIS.

AT ALL DEALERS
OR POSTPAID**\$1.50**

"It's-It" VULCANIZER

Save your tubes for \$1.50. Weeks off battery of car. 6 or 12 volts. Anyone can make perfect patch. Specify voltage and style connecting plug when ordering. PREMIER ELECTRIC CO., 4041 Ravenswood Ave., CHICAGO, ILL.

FORD OWNERS

The Van Sicken Headlight DIMMER & INTENSIFIER

Makes night driving safe. A mere flip of the control switch instantly provides the kind of light you need at any speed. Easily installed. Unfailing in results. Write for free booklet, "Headlight Control." Address The Van Sicken Company, Elgin, Illinois

Price
\$4
Complete

\$1
a
week
buys a



Black Beauty Bicycle

You must see and ride a Black Beauty to appreciate how really different it is. Its style, durability and speed defy imitation.

At Factory Prices—On Approval
NO MONEY IN ADVANCE

Let us send you (freight prepaid) a Black Beauty on trial. If you don't like it, return at our expense. If you do like it, you pay only \$1 a week.

Guaranteed for 5 Years by the largest exclusive Cycle House in America.
Write Today for Black Beauty Color Catalog showing all sizes, all styles
HAVERFORD CYCLE CO., Est. 1896, Dept. F, Phila., Pa.

The Boy's Junior Power Driven Automobile

You can build it yourself or buy it complete already assembled. 1917 Model

Parts inex-
pensive.Send 20c
for blue
print and
price list
of parts.**SYPPER
MFG. CO.**

146 Warren St., Toledo, Ohio

Increase Your Tire Mileage

Buy a Taylor Tire Pump on an investment basis—soon pays for itself in added tire mileage. Easy to use; fastened to end of crank shaft in front of radiator in 30 seconds. Carried in tool box when not in use. Ask your dealer. If he can't supply you send \$10 direct, giving name and model of car.

TAYLOR MFG. CO., 24 Lahser Ave., Redford, Mich. (Suburb of Detroit)

MIAMI-MADE BICYCLES

Stand at the top of the bicycle world.

RACYCLE, HUDSON, MIAMI, FLYING MERKEL

Write for our catalog.

THE MIAMI CYCLE & MFG. CO., MIDDLETOWN, OHIO



Diamonds on Credit

20% Down; 10% a Month

Every customer is protected by

our written guarantee to refund

his money if his Dealer can dupli-

cate our diamond at our price.

Write for Illustrated Catalog No. 3.

J. M. LYON & CO. 71-73 Nassau St.

New York City

Build This Speedster Yourself For Only

\$4Model
"55"

WITH the remarkably simple, sure-fit, **Red-I-Kut System of Patterns**, you can make your Ford Car into one of the classiest Speedsters on the road, with all the appearance of a \$1500 car—in a few hours! Any one can do it with Red-I-Kut Patterns, a saw, hammer, screw driver and materials bought at any hardware store. The lines of Red-I-Kut bodies are beautiful beyond comparison.

distinctive, different. The bodies stand low, keep the road, hug the turns at all speeds, weigh less, saving tires, gas and oil, have livelier pick up, greater

riding comfort—designed on aerodynamic speed principles by our engineers. Red-I-Kut Patterns are life size, mistake-proof. Sent with full instructions, from A to Z, on receipt of price. Model 55, only \$4.00. Money back if not satisfactory. Get into the \$1000 class. Make everybody in town sit up and take notice. Specify if patterns are for old or new Ford Radiator.

From actual photo

Right now is the time. Special proposition to Ford Agents.

THE KUEMPEL COMPANY, Design Dept. 16, Dubuque, Iowa



Model K-9—Built low, sides wonderfully easy, bullet-shaped rear, formed by special metal finish, given free. Complete, \$6.00.

SAVE MONEY ON CAMERAS

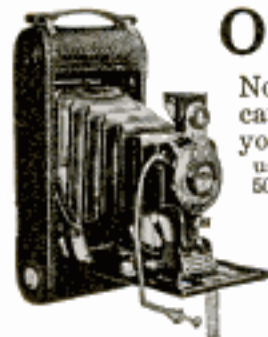

No matter what style or size camera you want, we will save you money on it. The camera users of America are saving 10% to 50% on our low direct-to-you prices.

10 Days' Free Trial

Guaranteed satisfaction backs every purchase. 32 years' success proves our prestige. Camera users the country over back our service and business dealings.

Our Camera Catalog Will Save You Money

Send for it today. Compare our prices with any.

It shows Cameras, any size or style, Kodaks, Graflex Machines, Lenses, Motion-Picture Outfits and Photo Accessories at money-saving prices. And remember our liberal 10 Days' Free Trial—Money-Back Guarantee. Eastman film, Ansco Speedex film and Rexo Speed film; also Cyko and Rexo paper at cut prices. You'll want a camera this summer. Get just the outfit you want and save money.

Send for Your Copy Now

David Stern Company

Everything in Cameras—In Business Since 1865
510 Davisco Bldg., 1047 Madison St., Chicago, Ill.

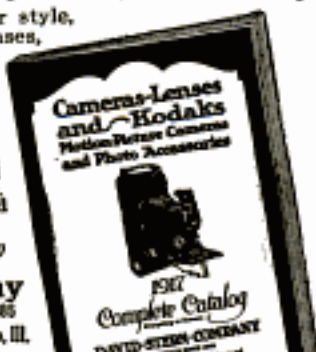

No Hands Can Wash
So Clean as This

Washing Done for 2 Cents

Only two cents for electricity! That's all it costs to do a good sized washing—and your clothes are all ready for the line in an hour. No more of that tiresome rub-rub-rub that makes your back ache and wears out your clothes. Mail coupon today and we will send you our big free book on washing and tell you where you can see the Thor.

Thor

Electric Washing Machine

Makes linens snowy white. Washes anything from heavy blankets to delicate laces. All by the push of a button. Used by more than 130,000 women. They would never go back to the tub and washboard.

Easy Payments

Any Thor dealer will sell you a machine for a small amount down and easy monthly payments. If you live on a farm or in a community which has not electric lights and have a Delco or other private electric light system we will furnish a special motor to run the Thor.

Send the Coupon for FREE Book

This big 48-page book tells all about how to make washday easy. We will also send you the name of the nearest dealer who can show you this wonderful machine. Send coupon today.

Hurley Machine Co.

29 So. Clinton Street
Dept. 1195, Chicago
147 W. 42nd St., New York
418 Yonge St., Toronto

Manufacturers also of
the Thor Electric
Ironing Machines
and Thor Electric
Vacuum Cleaners

HURLEY MACHINE CO.

29 S. Clinton Street
Dept. 1195, Chicago
147 W. 42nd St., New York
418 W. Yonge Street, Toronto

I am interested. Send name of nearest Thor dealer. Also your big 48-page book.

Name

Address

Please send the name of a dealer in your city who sells electrical supplies:

Please Mention Popular Mechanics



Be Your Own Boss

Do as many others have—Operate a Kingery Peanut Roaster and Corn Popper. Over 50 styles. Liberal terms, excellent profits.

No. 50 catalog tells you all about it.

KINGERY MFG. CO., Pearl, East of Broadway, Cincinnati, O.

WE PAY CASH for Scrap and Old False Teeth PLATINUM

On rubber or metal plates. Highest cash price paid for old Gold, Silver, contact points, crowns, bridge work, mercury and broken jewelry. Send your package today by parcel post to

The Mutual Smelting and Refining Company
116 North Front Street, Columbus, Ohio

Here's Health and Power, Vim and Vigor



Do you want them? Strength that is more than mere muscular strength. The strength, health, power and vigor of youth is now within your reach through the White Cross Electric Vibrator. Be strong—be healthy—enjoy things the way you used to. Write—learn what vibrations may do for you.

The White Cross Electric Vibrator

With this machine in your home you can give yourself the treatments for which specialists receive \$3.00 to \$5.00. Can be connected up as easily as an electric lamp. Or, if your home is not wired for electricity, it will run on its own batteries. See it—try it.

Write Today For Our Big FREE BOOK!

Just your name and address on a letter or post card is enough. We will send you, absolutely free and prepaid, our new book, "Health and Beauty." It tells you about vibration and about our special offer. Write today.

Lindstrom-Smith Co., Dept. 1195 1100 So. Wabash Ave., Chicago



Genuine French Briar

PIPE-WISE smokers know the **W. D. C. Trade Mark** means real pipe pleasure and smoke satisfaction. You have choice of 24 popular shapes in each of these four grades:

BRIGHTON	50c and up According to size
WINDSOR	75c and up According to size
STRATFORD	\$1 and up According to size
W.D.C. HAND-MADE,	\$1.50 and up According to size

At Good Dealers

WM. DEMUTH & CO.
New York

**Solid
Vulcanite
Bits**

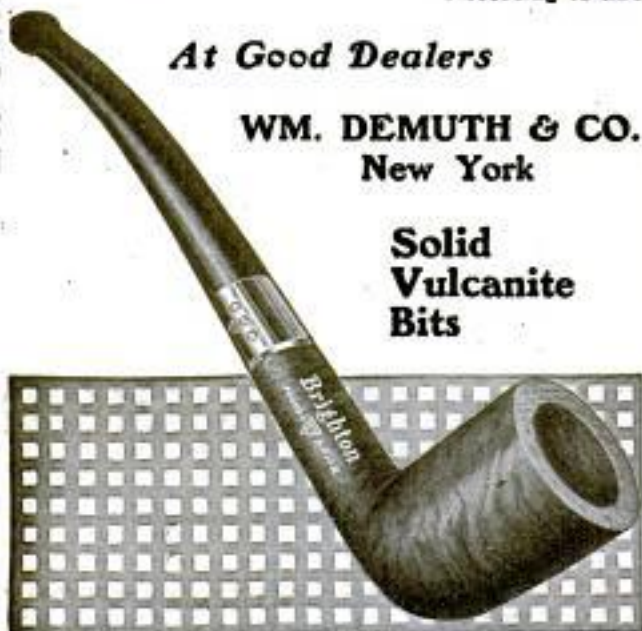

Please Mention Popular Mechanics

No More Laundry Bills

Save
\$5⁰⁰ to \$10⁰⁰
per Year

Challenge Cleanable Collars

A real worthwhile yearly saving. Made with cotton cloth same as your "linen" collar. Similar dull finish. Stitched edge effect. Ever-white. Waterproof stiffening—better than starched. *Cannot wilt.* Instantly cleanable with soap and water. 25 cents each—at your dealers or direct post-paid. State your (half) size and style. Write for new style booklet.

The Arlington Company
725 Broadway, New York

1/2 c diamond	\$8.25	GENUINE PERFECT CUT Diamonds \$97.50 PER CARAT
3/4 c diamond	\$17.50	
1 c diamond	\$31.25	Buy direct from Busch, the importer, and save 35%. Any diamond shipped for free examination. Iron-clad Money-Back Guarantee with every purchase. Handsome 1917 Diamond Book mailed free upon receipt of name and address. Write now to
3/4 c diamond	\$45.00	
1 c diamond	\$67.50	
1 c diamond	\$97.50	

L. BASCH & CO. Dept. K-2470
State & Quincy Sts. CHICAGO, U. S. A.

Phone More

Take Less Time
All the Usual Bother
of Phoning Is Gone

No tangled cords sweeping over your desk—no reaching—no knocking over and breaking the phone—but—your mind always clear for the big, important things. That's why you need a

SPERRY TELEPHONE BRACKET

Complete for \$3.50—not \$5.00

Get this practical bracket. A little push and your phone's out of the way. It must give perfect satisfaction for 5 years—the dealer you buy it from will take it back and return your money if it doesn't.

Write us for the name of the "Sperry" dealer in your town

MODERN APPLIANCE CO.
Dept. B-51, 115 So. Clinton St., CHICAGO, ILL.

Belber

TRAVELING GOODS

Man's Bag No. 670

Extra large pattern in black small cross grain. Sewed corners, strong frame, inside lock, flat catches and durable, waterproof lining. Equipped with Belber Pital which can be adjusted to hold your own toilet articles.

16 & 18" size, \$7.50
20" size, \$8.50



SUPERLATIVE bags and suit cases—natty in design and luxurious in appearance—combining Belber skill with the beauty and service of Du Pont Fabrikoid, Craftsman Quality—the very best Fabrikoid made. Each style designed especially to meet the particular traveler's needs and the hardships of heavy handling—and each doubly guaranteed by the quality trade marks.



Eight fine styles for men and women

\$7.50 to \$12.00

At the better shops and department stores

Write for illustrated booklet

The Belber Trunk and Bag Co.
Turner & Mascher Streets, Philadelphia, Pa.

Mammoth Jubilee Book Free

Picturing 5152 Home Things
Make your own Credit Terms—1 to 3 years' time,
SPIEGEL, MAY, STERN CO., 1409 W. 35th St., Chicago

Free Shoe Book Saves You \$20



More than a million satisfied customers named our shoes "The World's Greatest." Don't think of buying any shoes until you get our 1917 shoe book. It shows the most complete line of lasts, styles and leathers for every purpose no matter what your requirement. Saves your health and money. Free 15-day try-on.

200 SHOE BARGAINS

For Men, Women, Boys and Girls
Also complete line Ruthstein's Famous Steel Shoes. Big New 1917 Scientific Footwear Catalog shows over 200 styles and how to save 20 to 50 per cent on shoes for the whole family—FREE on request.

Ruthstein Scientific Shoe Co.
America's Greatest Mail Order Shoe Factory
Dept. 681 RACINE, WISCONSIN

No Retail
At Less Than
Wholesale Prices

Acetylene Blow Torch Prest-O-Torch



Quicker and cheaper than
a gasoline blow-torch for
brazing and soldering

For factories, repair shops, linemen, dentists, jewelers, the Prest-O-Torch saves time and money. Used with Prest-O-Lite Tanks—ready-made gas. Intense, concentrated flame instantly lighted. No depreciation, safe and convenient. Style "A", price, 75c (Canada, 85c) will braze up to 3/4 inch round rod. Style "C" for heavier work, \$2.25 (Canada, \$2.75). Special styles for dentists. Write for literature or send order now. Money refunded if not satisfied.

The Prest-O-Lite Co., Inc. 816 Speedway
Indianapolis, Ind.
Canadian Main Office and Factory, Toronto, Ont.

Pay for a Conn Instrument in Small Monthly Amounts

Now you can pay for a Conn instrument in small monthly amounts. The "New Wonder" Conn Cornet is the newest triumph in Cornet making—the easiest blowing—the most perfect in tone. And we will send it to you for a free trial right in your own home. See it for yourself. Play on it—and then you will know why it is used by all the great soloists. Anyone can learn to play all the popular music on a Conn Saxophone in a few days. Conn Saxophones are extremely rich in tone. They are used and endorsed by the greatest Saxophone artists.

Write Today for Catalog

Send us your name and address for our new catalog and special offer. Absolutely no obligations. All Conn instruments sent for free trial. Send for this valuable book now. **IT IS FREE.**
C. G. CONN, Ltd. Dept. 1195 Elkhart, Indiana





ED. H. WITTE

BUY ON YOUR OWN TERMS

I Have Now Made it Possible for Every Worthy, Creditable Man in the United States to Buy a High-Grade WITTE Engine.

ONLY a big successful engine factory, making thousands of engines yearly and selling direct to users, could offer you the engine quality and engine terms that I can. If you need an engine, either Kerosene or Gasoline, for any purpose—Pumping, Grinding, Wood-Sawing, Spraying, Cream Separating, Silo Filling, or you have shop machinery to operate—

**Try a WITTE Engine
90 Days**

Do your work—Prove that a WITTE Engine is the biggest engine value on the market, that WITTE prices will save you a lot of money. Your WITTE Engine if taken care of will be just as good ten or twenty years from now as the day you start it. Some are using WITTE Engines built 20, 25 and 30 years ago. I guarantee any WITTE Engine you select for **Five Years from Date of Purchase**, and my Guarantee has a Million Dollar Factory back of it.

**NO
MONEY
DOWN**
Easy Payments
Bank Deposit
or
CASH

THE low prices I am able to quote are possible only because of the large number of engines I am able to produce and sell. The more engines I can sell, the less it costs to manufacture, the more material I can buy at reduced rates. I make nothing but engines—sell them direct from the factory—and when I tell you that I can save half your engine money, I mean just what I say. You take no more chance in buying from me, than you would to draw money from one bank and deposit it in another. I can ship your engine at once—Save you from \$25 to \$100.

FREE, Postpaid. My New 1916 Book, "How to Judge Engines." Tells you how to properly judge engines, and describes the many distinctive and desirable WITTE features that you cannot get in other engines. Write me today for this Free Book.—Ed. H. WITTE,

WITTE ENGINE WORKS, 1749 Oakland Ave., Kansas City, Mo., 1749 Empire Bldg., Pittsburgh, Pa.

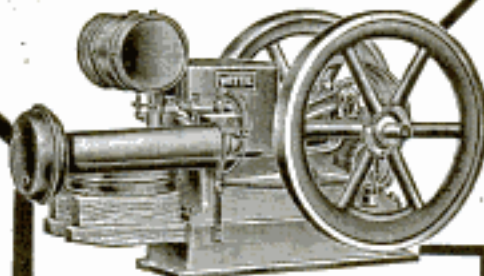

The above shows my latest type Kerosene Engine. Built in Sizes 2, 3, 4, 6, 8, 12, 16 and 22 H.P.

WEBER THROTTLE-GOVERNED VALVE-IN-HEAD KEROSENE ENGINES

All 1917 Weber Engines are equipped with that great engine improvement, the "Weberator." Makes kerosene as convenient to use as gasoline. Kerosene has more units of energy per gallon than gasoline. Saves you one half fuel cost. Write today for full details and 60-day trial offer. Now sold direct to user at factory prices.

WEBER ENGINE CO.
Dept. 177 B
Kansas City, Mo.

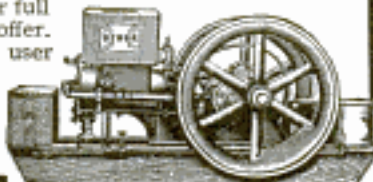

OTTAWA ENGINES Kerosene-Gasoline

With my Kerosene Engine you can get more power from a gallon of 6c Kerosene than you can from a gallon of 20 or 25 cent gasoline in any gasoline engine. No cranking, no batteries, easy to start, easy to operate.

Valuable Free Book Every farmer who owns an engine or expects to buy one should know how to figure exactly what an engine is worth.—Why I use the valve in the head design, the offset cylinder construction and larger valves.



**90 DAYS' TRIAL
10-YEAR GUARANTEE**
Longest sold direct from factory to user. Before you buy any engine get my newest and finest book and money saving offer. Write today. **Geo. E. Long,**
OTTAWA MFG. CO.
836 King St. Ottawa, Kans.

Please Mention Popular Mechanics

COIN RINGS 50 Cents POST PAID

Made of dimes, beautifully embossed. Big hit! Agents, big discount. Send for circular, coin jewelry.

WM. COMERFORD, 44 Seneca St., BUFFALO, N. Y.

Pay as You Wish

We'll send you a genuine Lachnite for you to wear for 10 full days. If you can tell it from a real diamond send it back at our expense. Costs but 1-30th as much. If you decide to keep it pay only a few cents a month. Write for catalog.

Genuine Lachnite Gems keep their dazzling fire forever. Set in solid gold. Cut by world renowned diamond cutters. Will stand fire and acid tests. All kinds of jewelry at astounding low prices. Easy payments. **WRITE TODAY.** H. Lachnite Co., 12 N. Michigan Av., Chicago, Dept 1195



Comfort Indoor Closet

Odorless, Sanitary, Germ-proof. Can be placed anywhere in home. A guarantee of healthy, sanitary conditions.

SWAT FLY BREEDING CLOSET

Have city conveniences. Germ-life killed instantly by chemicals. Emptied once a month. Needs no other attention. Boards of Health endorse. Write for literature.

Agents wanted—exclusive territory
COMFORT CHEMICAL CLOSET CO. 385 Factories Bldg. Toledo, Ohio



DEPENDABLE KNAPP Dynamo \$6.25 Motor

For producing current for inductance coils, re-charging storage batteries, electroplating, and hundreds of other uses.

Well constructed throughout, exceptionally smooth running and highly efficient. A good, strong, durable dynamo.

At all live dealers. If your dealer cannot supply you, order direct from us. Send for **FREE Illustrated Catalog.**
KNAPP ELECTRIC & NOVELTY CO.
519 W. 51 St., N. Y. City



STEGER PLAYER-PIANO



□ Your home will be happier and more cheerful if you select a superb New Steger Piano or Player-Piano. Entertain your family and friends. Give your children a greater love for music. Enjoy the delightful strains of your favorite melodies.

□ Artists of eminence praise Steger Instruments. The Steger tone is of wonderful richness. It possesses beautiful, clear, mellow, singing qualities.

□ Steger Instruments are used in many leading conservatories, musical colleges and schools. Their reliability is backed by the liberal guarantee of the largest piano factories in the world, located in the "Piano-city," Steger, Illinois, on the Dixie Highway.

□ Let us tell you about the reasonable prices and convenient terms on which you may have a New Steger Piano or Player-Piano in your home.

Three years in which to pay, if desired. Liberal allowance for old instruments. Delivered direct from our factories to your home, or through our regular appointed distributors. We invite comparisons. Beautiful illustrated Steger Style Brochure, sent free, on request.

Steger & Sons

PIANO MANUFACTURING COMPANY

Established 1879

Dept. 24 Steger Building
N.W. Cor. Wabash & Jackson, Chicago, Ill.

See October and December Popular Mechanics for advertising of

The Pullman Company

FREE

BOOK TELLS HOW TO MAKE \$150 TO \$1000 PER MONTH

Making celebrated **Flavo Nature-Flavored Flour** in rural communities or small towns with

AMERICAN MARVEL Flour Mill

(Self-Contained)

You can quickly become a member of Community Marvel Millers. We start you. Help you. 30 days' free trial. Investment and terms easy to handle. Write for fully illustrated book.

ANGLO-AMERICAN MILL CO., Inc.
135-141 Trust Bldg. Owensboro, Ky.

Please Mention Popular Mechanics



Thomas
A.
Edison

Mr. Edison's Wonderful New Phonograph

The world's greatest inventor has made the music of the phonograph life-like, at last. Success—after years of labor on his favorite invention! Read our offer on his wonderful new phonograph.



Only
\$1.00 and
after trial

An astounding offer—the New Edison, Mr. Edison's great new phonograph with the new Diamond Stylus reproducer and your choice of all the brand new Diamond Amberol Records will be sent to you on **free trial without a penny down**. The finest, the best that money can buy at very, very much less than the price at which imitations of the genuine Edison are offered—a **rock-bottom offer direct from us**.

Entertain Your Friends

Hear all the latest up-to-date song hits of the big cities. Laugh at the side-splitting minstrel shows. Entertain your family and your friends with everything from Grand Opera to Comic Vaudeville—then if you choose, send the outfit back to us at our expense.

Rock-Bottom Direct Offer

If you wish to keep Mr. Edison's superb new instrument, send us only \$1.00 after the free trial. Pay the balance on the easiest kind of monthly payments.

Think of it—a \$1.00 payment, and a few dollars a month to get this outfit of Mr. Edison's new phonograph with the Diamond Stylus reproducer, the life-like music—the same Diamond Amberol Records—all the musical results of the highest priced outfits—yes, the greatest value for \$1.00 down, balance on **easiest monthly terms**. Convince yourself—a free trial first! No money down, no C. O. D., not one cent to pay us unless you choose to keep the instrument.

Our New Edison Catalog Sent Free

Your name and address on a postal or a letter (or just the coupon) is enough. No obligations in asking for the catalog. Get this offer—while this offer lasts. Fill out coupon today.

F. K. BABSON
Edison Phonograph Distributors
1195 Edison Block
Chicago, Ill.

Canadian Office:
855 Portage Ave.
Winnipeg,
Manitoba.

To
F. K. Babson
Edison
Phonograph Distributors
1195 Edison Bk.
Chicago, Ill.

Gentlemen: Please send me your New Edison Catalog and full particulars of your free trial offer on the new model Edison Phonograph.

Name.....

Address.....



To the well man, every day is a feast day

Business men. The daily grind and the nightly fag—the meagre appetite which makes fasts of feasts and unpleasant duties of what should be enjoyable dinners.

ANHEUSER-BUSCH'S
Malt-Nutrine
REGISTERED TRADE MARK
Liquid-Food-Tonic

helps the appetite, aids digestion, strengthens, builds—a tonic in the best sense of the word. Lightens the burden that over-work, over-play, years or sickness may place on one's shoulders. Take at each meal and before retiring.

All Druggists—
Most Grocers

Malt-Nutrine declared by U. S. Internal Revenue Department to be a pure malt product—not an alcoholic beverage. Contains 14.50 per cent malt solids—1.9 per cent alcohol.

Interesting booklet on request

Anheuser-Busch
St. Louis, U. S. A.

← The key to the situation



The
Rockland
SPECIAL
50¢
a week
20 Year Case
19 Jewels

Before you buy a watch find out about the best watch made in America—a watch of reputation, quality and appearance in a class by itself. Sold at prices that defy competition. We guarantee the Illinois Rockland and our catalog gives facts and figures that cannot be ignored.

Cash or Liberal Payment Plan

SEND TODAY FOR CATALOG

LENOX JEWELRY COMPANY

20 YEARS OF HONEST DEALING

373 WASHINGTON STREET, BOSTON.

Unusual Trial Offer for 10c

Best Kodak Finishing, any size roll developed 10c. Six prints free with first roll. OR, send 6 negatives, any size, and 10c (stamps) for 6 prints. 8 x 10 Enlargements, 25c. **ROANOKE PHOTO FINISHING CO.** (formerly Roanoke Cycle Company), 54 Bell Ave., Roanoke, Va.

Erickson Artificial Limb Co., 38 Wash. Av. N., Minneapolis, Minn.



We are
Under
Govt.
Bond



Deafness Is Misery

I know because I was Deaf and had Head Noises for over 30 years. My invisible Anti-septic Ear Drums restored my hearing and stopped Head Noises, and will do it for you. They are Tiny Megaphones. Cannot be seen when worn. Easy to put in, easy to take out. Are "Unseen Comforts." Inexpensive. Write for Booklet and my sworn statement of how I recovered my hearing.

A. O. Leonard, Suite 226, 150 5th Ave., N. Y. City

NO MORE BALD HEADS



WHEN our VACUUM CAP is used a few minutes daily. We accept no pay until you have tried the Cap 60 days and are satisfied. The Vacuum Cap is an appliance that draws the blood to the Hair Roots and starts a new healthy crop of hair. It stops Dandruff, stops the hair from falling out.

Bought by Doctors and men who know that it is the only reasonable HAIR GROWER known to science. No Drugs Used. Write for application, blank testimonials, and booklet on "HAIR" sent sealed in plain envelope. FREE.

THE MODERN VACUUM CAP CO.

P. 559 BARCLAY, DENVER, COLO.



DEAF?

**Here's
Free Proof
that**

YOU CAN HEAR!

You see the wonderful improved Acousticon has now enabled 275,000 deaf people to hear. We are sure it will do the same for you; are so absolutely certain of it that we are eager to send you the

**1917 Acousticon
On FREE TRIAL**

No Deposit—No Expense

There is nothing you will have to do but ask for your free trial. No money to pay, no red tape, no reservations to this offer. Our confidence in the present Acousticon is so complete that we will gladly take all the risk in proving beyond any doubt that

The Joy of Hearing Can Be Yours Again!

The Acousticon has improvements and patented features which cannot be duplicated, so no matter what you have ever tried, just ask for a free trial of the New Acousticon. You'll get it promptly, and if it doesn't make you hear, return it and you will owe us nothing—not one cent. Address

GENERAL ACOUSTIC CO., 1307 Gander Bldg., New York City
Canadian Address, 621 New Birks Bldg., Montreal



Tear Off That Blindfold!

Your chance to *be somebody*, to hold a position of responsibility, to have an income that will provide every comfort of life, is within your reach.

Just one thing keeps you from finding it, grasping it: you're not *prepared*. Through the door of opportunity big jobs are waiting in every field of work. But only trained men will get them. Don't play blindman's buff with your future! Start today and train yourself to do some one thing better than others.

You can get that training in spare time through the International Correspondence Schools, just as others have done for twenty-five years—just as more than 130,000 ambitious men and boys are doing right now.

Choose your own career. The I. C. S. will train you for the position you want in the work you like best. And you need not lose a day or a dollar in your present occupation.

Tear off that blindfold! Your chance is here. The time to start is now. The way is to ask the I. C. S. to show you what they can do for you. Mark and mail this coupon—it costs nothing, but the evidence it will bring you will open your eyes.

Stop Smoking! Prove at our risk this scientific discovery that destroys all craving for tobacco in any form. Used, praised and endorsed by all who have used it. Not an internal remedy. Write today for free particulars. Positive results.

HUNTSMAN PHARMACAL COMPANY, Bozeman, Mont.

Be a Taxidermy Artist

Marvelous Book Sent FREE

You can now learn Taxidermy, the wonderful art of mounting birds, animals, tanning skins, etc. Learn at home, by mail. The free book tells how. Mount your own trophies. Decorate homes and dens. Hunters, trappers, nature lovers, you need taxidermy. Interesting, fascinating, big profits. Join our school, 5,000 students. Success guaranteed. Get our free book without delay. Send right now—today.

N. W. School of Taxidermy, 1195 Elwood Bldg., Omaha, Neb.



INDOOR CLOSET

More Comfortable, Healthful and Convenient than the Out-Door Closet

Eliminates the out-door closet and open vault. They are breeding places for germs. Have a warm, sanitary, odorless toilet right in your house. No going out in cold weather. A boon to invalids. Endorsed by State Boards of Health.

W. M. Davis writes: "Your indoor closet is giving absolute satisfaction. It is certainly the thing for a home without sewerage."

Absolutely Odorless
Put It Anywhere in the House

The germs are killed by a chemical process in water in the container, which you empty once a month. Absolutely no odor. No more trouble to empty than dishwater. Closet absolutely guaranteed. Write for full description and price.

Agents Wanted—Big Profits Wonderful opportunities in every town, village and in the country. Best season just at hand. Every home is a good prospect. Sell eight out of every ten you call on. Ernest Hildell writes, "Have ten orders." G. A. Deeman says: "Ship at once twenty closets and fifteen washstands. Sold them all in one community." Sells itself. Everybody hates the outdoor closet. Everybody wants a Ro-San Indoor Closet. Write quick for territory and full particulars.

ROWE SANITARY MFG. CO., 505 Sixth St., Detroit, Mich.

Ask about the Ro-San Washstand—Hot and Cold Running Water Without Plumbing

TEAR OUT HERE

INTERNATIONAL CORRESPONDENCE SCHOOLS
Box 5573, SCRANTON, PA.

Explain, without obligating me, how I can qualify for the position, or in the subject, before which I mark X.

<input type="checkbox"/> ELECTRICAL ENGINEER	<input type="checkbox"/> SALESMANSHIP
<input type="checkbox"/> Electric Lighting	<input type="checkbox"/> ADVERTISING MAN
<input type="checkbox"/> Electric Car Running	<input type="checkbox"/> Window Trimmer
<input type="checkbox"/> Electric Wiring	<input type="checkbox"/> Show Card Writer
<input type="checkbox"/> Telegraph Expert	<input type="checkbox"/> Outdoor Sign Painter
<input type="checkbox"/> Practical Telephony	<input type="checkbox"/> RAILROADER
<input type="checkbox"/> MECHANICAL ENGINEER	<input type="checkbox"/> ILLUSTRATOR
<input type="checkbox"/> Mechanical Draftsman	<input type="checkbox"/> DESIGNER
<input type="checkbox"/> Machine Shop Practice	<input type="checkbox"/> BOOKKEEPER
<input type="checkbox"/> Gas Engineer	<input type="checkbox"/> Scenographer and Typist
<input type="checkbox"/> CIVIL ENGINEER	<input type="checkbox"/> Cert. Public Accountant
<input type="checkbox"/> Surveying and Mapping	<input type="checkbox"/> Railway Accountant
<input type="checkbox"/> WIRE FOREMAN OR ENGINEER	<input type="checkbox"/> Commercial Law
<input type="checkbox"/> Metallurgist or Prospector	<input type="checkbox"/> Traffic Management
<input type="checkbox"/> STATIONARY ENGINEER	<input type="checkbox"/> GOOD ENGLISH
<input type="checkbox"/> Marine Engineer	<input type="checkbox"/> Teacher
<input type="checkbox"/> ARCHITECT	<input type="checkbox"/> Common School Subjects
<input type="checkbox"/> Contractor and Builder	<input type="checkbox"/> CIVIL SERVICE
<input type="checkbox"/> Architectural Draftsman	<input type="checkbox"/> Railway Mail Clerk
<input type="checkbox"/> Concrete Builder	<input type="checkbox"/> Textile Overseer or Supt.
<input type="checkbox"/> Structural Engineer	<input type="checkbox"/> Navigator
<input type="checkbox"/> PLUMBING AND HEATING	<input type="checkbox"/> AGRICULTURE
<input type="checkbox"/> Sheet Metal Worker	<input type="checkbox"/> Poultry Raising
<input type="checkbox"/> CHEMICAL ENGINEER	<input type="checkbox"/> AUTOMOBILES

Spanish German French Italian

Name _____

Occupation & Employer _____

Street and No. _____

City _____ State _____

If name of Course you want is not in this list, write it below.

Please Mention Popular Mechanics

PATENTS

IF YOU HAVE AN INVENTION which you wish to patent you can write fully and freely to Munn & Co. for advice in regard to the best way of obtaining protection. Please send sketches or a model of your invention and a description of the device, explaining its operation.

All communications are strictly confidential. Our vast practice, extending over a period of seventy years, enables us in many cases to advise in regard to patentability without any expense to the client. Our Hand-Book on Patents is sent free on request. This explains our methods, terms, etc., in regard to *Patents, Trade Marks, Foreign Patents, etc.*

All patents secured through us are described without cost to the patentee in the **SCIENTIFIC AMERICAN**.

MUNN & CO.
SOLICITORS OF PATENTS
672 WOOLWORTH BLDG., NEW YORK
and 625 F STREET, WASHINGTON, D. C.

5 A DAY BUYS A GIBSON

Terms as low as \$1.00 down and \$1.50 per month. Mandolin or Guitar on approval. Get new **TRICK BOOK**. Valuable information for player and teacher. Explains wonderful new violin construction with curved and graduated top and back and Stradivarius Arching. Also **FREE** treatise on "How to Practice."

Make \$1800 to \$5000 a Year Teaching and Selling Gibsons
Become a teacher. Splendid opportunities for Mandolin and Guitar teachers—either sex, in every locality, private and class instruction, and sale of Gibsons. The Gibson has "made" many a teacher professionally and financially.

Do Business on Our Capital
If teacher, become our agent. Territory protected. Instruments furnished. We help sell. We pay advertising. You make profits. Pay for goods when sold; return unsold goods. Try our "Still Hunt." Catalog and Thematic List Free.
Gibson Mandolin Guitar Co., 185 Harris Court, Kalamazoo, Mich.

Healthy Men Employed

They must be dependable—Must be on the job every hour of the day—And every day. We have no time for physical weaklings or nervous wrecks. At the best they are uncertain quantities—So say the captains of industry everywhere to-day.

Can you meet these rigid requirements of our modern strenuous life? If not you are already foredoomed to failure in the race. The doors of opportunity are closed to you. The relentless hand of unsentimental business necessity is everywhere turned against you. You are the undesirable citizen.

How About You Young Man?

You who have wrecked your future by deplorable habits, not realizing the consequences? Do you know that the **STRONGFORT METHODS** can lift you out of the depths and bring you back to the bloom and vitality of **Real Manhood and Success**. Your half-sickness shows plain in your face and the world loves healthy people. **Be Healthy—Strong—Vital**. That's living. Don't think too long; send 4 cents in stamps to cover mailing of my book, "**Intelligence in Physical and Health Culture**," written by the strongest physical instructor in the world, and learn how to fit yourself to command the best positions. Write a short history of your condition, which I will treat in the strictest confidence, and advise you without charge.

LIONEL STRONGFORT, Physical Culture Expert
111 Park Bldg., NEWARK, N. J.

Abdominal Massage

WILL GIVE YOU

ENERGY

PLUS+

Send
Coupon
Below



Double your powers to resist fatigue and disease. Prove, at our risk, on this special offer, what this new scientific invention will do for you. Try it free. The vim and vigor of perfect health, the tireless energy of youth may be yours with the aid of the

Wonderful New KOLON MOTOR

Used, praised, and endorsed by eminent physicians. By localized massage treatment and exercise of the abdomen and intestines it induces regular and natural action of the colon with none of the injurious effects of physics. Positively conquers constipation and prevents the formation in the colon of thirty-seven poisons that cause auto-intoxication with all its attendant ills—headaches, backaches, colitis, neurasthenia, melancholia, dizziness, dys-

pepsia, skin disease, liver and kidney troubles—in fact, a large majority of all the maladies and disorders that afflict our generation. Attaches to any wall. Instantly adjustable to any height for adults or children.

5 Days' Trial Free

Be your own judge. See what the Kolon Motor will do for you. While this special offer lasts we will ship you one on five days' trial free—your money back if you decide not to keep it. Write now for particulars.

Valuable New Book FREE! "Colon Cleanliness"

Just published—the most interesting, instructive and helpful book ever written on the subject of health and the vital importance of keeping the colon free from accumulations of putrefying, germ-infested, disease-breeding toxins. Fill out and mail the coupon below for free copy and our free trial offer.

MARTIN'S METHOD, Incorporated
Dept. 85, 38 East 31st Street New York, N. Y.

MARTIN'S METHOD, Incorporated
Dept. 85, 38 East 31st Street, New York, N. Y. **FREE COUPON**

Without any obligations on my part, you may send me, free and postpaid, a copy of the book, "Colon Cleanliness," with particulars about the Kolon Motor.

Name.....

Address.....

City..... State.....

"Days of Real Sport" By Claire Briggs



Send for the Briggs Book
— full of cartoons of boys having fun with Kings; containing story of the air rifle and how it is made, and listing the full King line with prices.

Send 2c stamp to Dept. E

The MARKHAM AIR RIFLE CO.
Plymouth, Michigan

SPRING TIME, and out of doors, with a King "thousand shootin'" air rifle— isn't that the high point of happiness for any boy? There's no end of fun he can have at target practice, and if his imagination is good, every fence post will be a hostile Indian, and every old circus poster will furnish the material for an African jungle hunt that even T. R. himself would envy.

A boy with a King not only has a barrel of fun, but he gets a real training in marksmanship at the same time — and that's what every boy wants and should have. Boys and King Air Rifles were just made for each other.



INVESTIGATE BEFORE YOU INVEST IN A VIOLET RAY MACHINE

Be Sure You'll Be Satisfied

— you who have made up your mind that a Violet Ray instrument is essential to development of greatest beauty and health—and all who are familiar with the beauty and body building value of this most scientific, quickest, most pleasing and surest means of restoring health and personal attractiveness— Arrive made a decision to purchase a Violet Ray appliance of some sort.

Don't jump at a buying decision. Don't think that all Violet Ray machines are alike in make or results. They're not.

The VIOLETTA

High Frequency Generator. Generates ozone. Enriches blood. Produces soothing, invigorating, curative Violet Rays. The most advanced type — most reliable. Productive of best results. And you want the best. You'll probably buy but *one* appliance of the kind in a lifetime. Make certain you're not cheating yourself. The VIOLETTA machine is employed by leading physicians — scientists — physical culturists who use *only* the most perfect instrument to be had. And whose selections are founded on most critical — most exhaustive tests. More VIOLETTA instruments are used by these discriminating buyers than any other make. We ship the VIOLETTA on approval — C. O. D. subject to inspection. You know you'll be satisfied. No risk.

Send for Free Descriptive Matter

Read the scores of testimonials from eminent physicians. Write at once. Just say on a post card, "Send me free literature" — sign your name — address to us. We'll send you convincing evidence of super-excellence. Will show you many wonderful improvements and astounding savings in cost. Send now.

Bleedon-Dunn Co.
Dept. C-8, 238 N. 9th Ave.
CHICAGO, ILL.



See It Before Spending a Cent

Please Mention Popular Mechanics

A Birthday Present

If you are racking your brains to think of a suitable birthday present—*stop*. Go to any dealer and ask to see Ingersoll watches. There are eleven kinds from a \$1 to \$3.

Free To Wear 10 Days

This wonderful, dazzling, genuine Tifnite gem. Set in Solid Gold, 8 claw, flat Belcher mounting. Yours to wear for 10 days if you send at once. You should see this superb gem. Looks like a genuine diamond. Has all the sparkle, glow and radiance. Stands all diamond tests. Almost a carat large. Send no money. Just send string or strip of paper fitting around 2nd joint of finger. If you find it an amazing bargain, send \$3 upon arrival and \$3 monthly until only \$12.75 is paid.

If not satisfied, return it in ten days and any payment made will be refunded. Only 10,000 of these remarkable gems to go out on these terms. Send now while the offer lasts.

THE TIFNITE GEM CO., Dept. 155 Rand McNally Bldg., Chicago

Save \$20 to \$50 on COAL BILL



Save \$20 to \$50 on winter coal bill with a New Scientific Down Draft Jahant Furnace. Lasts a lifetime. Heats every room evenly. Burns oxygen, saves coal. Burns coal to fine ash. Heats quickly in morning.

WE PAY THE FREIGHT

We pay freight anywhere in U. S. or Canada. Price includes entire equipment cut to fit. Easily installed.

Sold on Monthly Payments

Buy a Jahant now, a payment down, rest easy monthly payments. It will pay for itself in short time. Sold on 30 day Money-back, Legal Guaranty Basis. Engineers' advice FREE.

FREE! Complete set of erecting tools Free with each Jahant. Get book, "WHAT USERS SAY," and literature, all free.

JAHANT HEATING CO.
25 Jahant Bldg., AKRON, OHIO, U. S. A.

This is the Curtiss Military Tractor used in the U. S. Army. Build a Model of It!

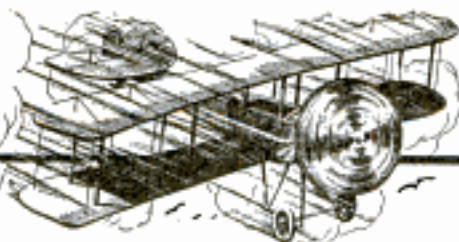

Build and Fly A Model Aeroplane Greatest Sport You Ever Had!

You can build and fly a perfect duplicate of the well-known, man-carrying Aeroplanes now used in the war. It's easy! We furnish everything—all the parts and full plans and instructions. You put the parts together and build your own 3-foot Model Aeroplane that will rise from the ground by its own power and fly 50 to 100 feet in the air—just like a real aeroplane! You can have heaps of fun and learn a whole lot about Aeroplanes and how they fly. Find out all about it; send for the drawings and instructions, or for the catalogue offered below. We will send you

Complete Scale Drawings with Building and Flying Instructions at These Prices

Curtiss Military Tractor	25c	Blériot Monoplane	25c
Curtiss Flying Boat	25c	Nieuport Monoplane	25c
Curtiss Hydroaeroplane	35c	Wright Biplane	25c
Zeppelin Monoplane	25c	Cecil Peck Race	25c

Catalogue Offered Below Included with Each Plan.

Build a Fleet—Plans for All Eight Aeroplanes, \$1.75

Leading Toy, Sporting Goods, and Dept. Stores sell IDEAL Model Aeroplanes and Supplies. Ask your dealer for them.

Send 5 Cents for This Aeroplane Catalogue

Every boy should have this book. 48 pages full of useful information. Tells about Model Aeroplanes and how to build them; How to Assemble and their records; Flying Toys that are fine fun. Also lists all kinds of parts and Supplies for Model Aeroplanes, and contains list of stores where you can buy Ideal Model Aeroplanes and Supplies. Send 5 cents right away and get your copy.

Ideal Aeroplane & Supply Co.
82-88 West Broadway
NEW YORK CITY



BARODA DIAMONDS

FLASH LIKE THE GENUINE—AT 1-50 THE COST
SOLID GOLD MOUNTINGS Stand acid test and expert examination. See them first, then pay. Catalogue FREE. Patent Ring Geared for 10 two-cent stamps.
The Baroda Co., Dept. 15, 1454 Lind Ave., Chicago



Gray Hair

Restored to Original Color

Gray hair positively, quickly restored to original color, no matter what color it was. KOLOR-BAK guaranteed to do this or it costs you nothing! KOLOR-BAK is a pleasing, pure, harmless, grand preparation. Contains no injurious ingredients. Colorless, stainless. Not a dye or stain, but a wonderful scientific preparation. Acts directly on the pigments of the hair. Also banishes dandruff and itching scalp in two applications. Write for free book and positive proof.

KOLOR-BAK PRODUCTS CO., 68 W. Washington St., Dept. 33 Chicago

Veeder COUNTERS

register reciprocating movements or revolutions. Any mechanical engineer will tell you that the word Veeder stands for the best constructed and most accurate counting devices in the world.

There are many kinds of Veeder counters, to suit practically every need. Send for our Free Booklet, which illustrates our counters and gives much interesting information.

Cyclometers, Odometers, Tachometers. All kinds of counters. Fine Die Castings

VEEDER MFG. CO.
4 Sargeant Street, Hartford, Conn.

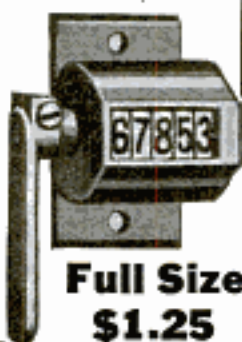

Full Size
\$1.25

Please Mention Popular Mechanics



What D'ye KNOW?"

Today it's a battle of wits—and brains win. Muscle and brawn don't count so much as they used to. The great question now is "What do you Know?" It draws the line between failure and success.

What do you know? Have you special ability? Could you "make good" in a big job right now?

For 25 years the International Correspondence Schools have been training men for better work and bigger salaries. They can train YOU, no matter where you live, what hours you work, or how little your education. Mark and mail the coupon and find out—it won't obligate you in the least.

INTERNATIONAL CORRESPONDENCE SCHOOLS, Box 5575, Scranton, Pa.

Explain fully about your Course in the subject marked X:

- | | | |
|---|---|---------------------------------------|
| <input type="checkbox"/> Electrical Engineering | <input type="checkbox"/> ADVERTISING | <input type="checkbox"/> CHEMISTRY |
| <input type="checkbox"/> Mechanical Engineering | <input type="checkbox"/> Salesmanship | <input type="checkbox"/> Illustrating |
| <input type="checkbox"/> Mechanical Drafting | <input type="checkbox"/> Commercial Law | <input type="checkbox"/> Farming |
| <input type="checkbox"/> Civil Engineering | <input type="checkbox"/> Bookkeeping | <input type="checkbox"/> Poultry |
| <input type="checkbox"/> Stationary Engineering | <input type="checkbox"/> Stenography | <input type="checkbox"/> French |
| <input type="checkbox"/> Mining Engineering | <input type="checkbox"/> Civil Service | <input type="checkbox"/> German |
| <input type="checkbox"/> Architecture | <input type="checkbox"/> Ry. Mail Service | <input type="checkbox"/> Italian |
| <input type="checkbox"/> Architectural Drafting | <input type="checkbox"/> AUTOMOBILES | <input type="checkbox"/> SPANISH |

Name

Address

No Money In Advance

This Marvelous Camera on FREE TRIAL!

Only 10,000 of these marvelous, instantaneous picture-taking and making cameras to be sent out absolutely on approval without a penny in advance just to prove that it is the most wonderful invention—the camera sensation of the age. So you must send for it quick! Just think of it—the new Mandel-ette takes and makes finished pictures

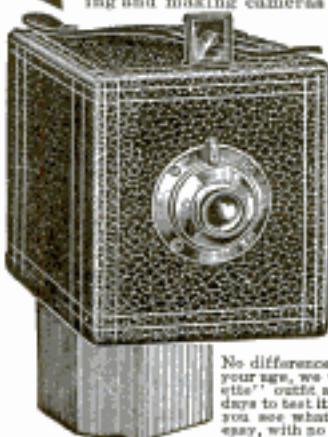

INSTANTLY!

You press the button, drop card in developer and in one minute take out a perfect, finished post card photo, 2 1/4 by 3 1/2 inches in size. Camera, itself, is about 4 1/2 by 7 inches. Loads in daylight 10 to 50 post cards at one time. No Plates—no Plates—no Dark Room. Not a bit of the fuss and bother of the ordinary kodak or camera. It is instantaneous photography. Universal focus lens produces sharp pictures at all distances. Pictures develop and print automatically. Can't overdevelop; results simply amazing.

WE TRUST YOU

No difference who you are, where you live or what your age, we will send you the complete "Mandel-ette" quite absolutely on approval and give you 10 days to test it. If not satisfactory return it. But when you see what elegant pictures it takes—so quick, so easy, with no trouble at all—if you wish to keep it you simply send us \$1.00 per month until our special price of only \$5.00 is paid. Easy Payments—no References. No red tape of any kind. Monthly payments so small you'll not notice them. Lots of fun and big profits. No Experience Required. Plain instructions and everything complete with outfit as you can begin taking pictures the moment it arrives. We guarantee that even a child can operate it. Mail coupon right now. No risk or obligation to keep camera.

Send me at once one complete model Mandel-ette Camera outfit, including supply of post cards and instructions. I agree to examine and test it thoroughly and if satisfied keep it and pay you \$1 a month until your special price of \$5 is paid. Otherwise I will return it at the end of 10 days.

Name

St. and No.

Town

State

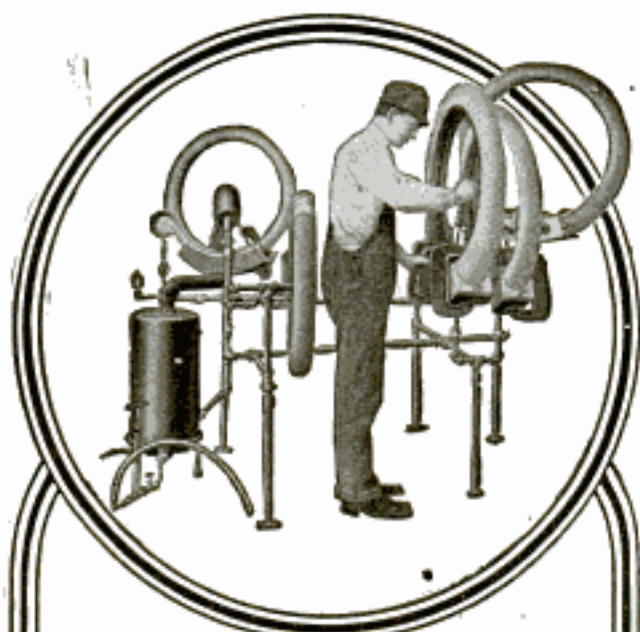

Make This Your Business At \$3,000 Per Year

Repairing and Retreading Automobile Tires. There isn't a business you could get into that offers such sure possibilities of success and fortune. One man and a Haywood Tire Repair Plant can make \$250 a month and more. Scores already have done it and this year there is a greater demand than ever for tire repair work.

15 Million Tires to Repair

That's not a myth nor some man's dream. It's an actual fact. Tire factories everywhere are building new buildings—enlarging their plants for the biggest period of prosperity in the automobile business. 15 million tires will be built and every one will need repairing.

Punctures and Blow Outs Are Common

Why not cash in on this opportunity? Start in the business while it is yet young. A business that's growing, and getting bigger and better. As it grows it will make big money for you.

No Experience Necessary

No previous training, no apprenticeship is required to enter this business—not even the faintest knowledge of tires. If you have a little mechanical turn of mind, you can quickly become an expert. We teach everything. You learn in a week. Handle all kinds of jobs—figure prices at big cash profits. Nothing is easier to master completely.

A Rich Opportunity

Awaits ambitious men everywhere. No city too large—no town too small—everywhere the same opportunity exists. A Moderate investment starts you. Get one machine and build the business from there. Business comes easy. We show how to get it. You grow and grow. You're soon a Real Manufacturer—a Success—a mighty big factor in your community.

Write for the Facts

INVESTIGATE. Send the coupon below, a letter or postal. This brings full information—and a big interesting catalog. Tells all about tires and how to repair them. Shows how to make money—to become independent. Do this today—NOW—before you forget it.

HAYWOOD TIRE & EQUIPMENT COMPANY
539 Capitol Avenue INDIANAPOLIS, IND.

FREE CATALOG COUPON

HAYWOOD TIRE & EQUIPMENT CO., 539 Capitol Ave., Indianapolis, Ind.

Gentlemen:—Please send me your catalog, details and plans for starting ambitious men in the Tire Repair business.

Name.....

Address.....

TEMCO

Quicker and Cheaper than Hand Work

This tool attaches to lamp socket anywhere (A.C. or D.C.) and costs but about 1c an hour to run. It saves time and labor and does clean-cut accurate work.

ELECTRIC DRILLING ANYWHERE

Not only drills to 3/8" bore in steel or wood but also taps threads, grinds auto valves and sharpens small tools. It is the handiest tool in the shop—gets at "odd jobs" in cramped

quarters, saves disassembling costs to take work to fixed machine tool, saves time of setting large machine tools. Finger switch, on tool, for starting, stopping and instant reverse. Its cost is small and its remarkable Temco Motor is built to withstand long, hard service.

Shops, factories and maintenance departments in every industry are using it with profit. Write for full particulars, NOW.

THE TEMCO ELECTRIC MOTOR CO.
138 Sugar Street LEIPSI, OHIO

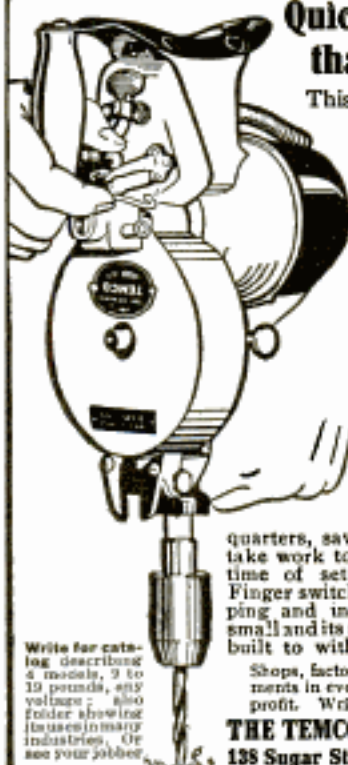

Write for catalog describing 4 models, 9 to 19 pounds, any voltage; also folder showing fixtures in many industries. Or see your jobber.

THE TOOL OF MANY USES

10c And We Send You An Illinois Watch

Send only 10c and get a magnificent Illinois watch, 17 jewel, new thin model, \$22.50. Pay balance only a dime added to a dime a week. Easiest way on earth to buy a guaranteed Illinois watch. Your choice 16, 12, or ladies' size \$16.50 and \$18 or bracelet watch \$18. Send your dime today and get your watch. **WHOLESALE JEWELRY CO., 5707 W. Lake St., Dept. 5249, CHICAGO, ILL.**

House of Brunswick MEANS QUALITY

Every sportsman should have "The House of Brunswick Sporting and Athletic Goods Catalog." It's crammed full of information that will interest you. Everything you want in sporting goods is listed here. Every single article you find listed is a real bargain. Our extremely low prices are made possible only by the tremendous demand that exists for Brunswick Sporting Goods.



Write for Catalog Today

Beverly Tennis Racket, \$1.65. Made of selected ash with walnut throat. Double strung center of oriental gut.
Fielder's Baseball Glove, \$1.05. Made of high-grade wine-colored leather. Professional model. Welled seams, sanitary perspiration-proof lining.
Wedge Tent, 5 x 5 foot, \$3.10. Made of tan and white duck. Complete with poles.
Brunswick Junior Bicycle, \$25.65. Complete with Atherton coaster brake and tool bag. High grade, fully guaranteed.
Fishing Outfit, complete, \$2.85. Consists of tackle box, steel or bamboo rod, 60-yard reel, sinkers, float, fish stringer and gut hooks.
Roller Skates, 63c. Adjustable, sidewalk style, made of high grade steel.
The BRUNSWICK-BALKE-COLLENDER CO.
Dept. 72, 623-633 S. Wabash Ave., CHICAGO



LISTERINE
The Safe Antiseptic

A SUPERIOR antiseptic to be used immediately as a dressing to prevent infection of any cut, small wound or abrasion.



WILLIAMSON CUT
NEW-FEED
UNDERFEED
Furnaces and Boilers $\frac{1}{4}$ - $\frac{3}{8}$

Send today for free book, "From Overfed to Underfed." Explains wonderful coal-saving performance of the Underfeed. Guaranteed to cut fuel bills $\frac{1}{2}$ to $\frac{3}{4}$. Over 35,000 enthusiastic users. Get the facts—write now.

THE WILLIAMSON HEATER COMPANY
65 Fifth Ave. CINCINNATI, OHIO



FREE This Complete Set of Drawing Instruments



\$15.00 Draftsman's Complete Working outfit free to students. They do not cost you a penny on this offer. Write today for particulars. Do it NOW. **\$150 to \$300 a Month** My graduates are earning from \$150.00 to \$300.00 a month and more. **WRITE TODAY.** Send for my free book on drafting. No obligations. Write now. Chief Draftsman Dobe, Div. 1195 Engineer's Equipment Co., Chicago.

Trap Outfit For 20¢ a Day



COMPLETE trap outfit for 20¢ a day. Hear the boat whistle, the hen cackle, the baby cry and the horse gallop. Realistic theatre music for 20¢ a day. Money back if not satisfied.

Send for Catalog

Write for information about trap outfits. Catalogs and circulars—everything free. Write today.

The Rudolph Wurlitzer Company — Dept. 1195
E. 4th Street, Cincinnati, O. — S. Wabash Avenue, Chicago, Ill.

20 Year
Guaranteed Gold
Filled
Cases

Elgin Watches
at
Wholesale!

Were \$18
NOW
\$11.66



Barnard Cuts the Price on 2,000 New Octagon Elgin Watches

Never before sold for less than \$18. This cut price sale your only opportunity to buy guaranteed 7 jewel new octagon Elgin Watches at less than the wholesale price to jewelers. Hampden 7 jewel movement, if you prefer it, 20 year guaranteed gold filled double-strata cases, thin model, jewel winding stem. Guaranteed accurate time keeper.

Monogram Free

In ribbon or any other fashionable style desired. Return watch for free monogram after acceptance, by express, or monogram engraved free at once where watch is paid for at time ordered. Illustration shows one of hundreds of beautiful hand engraved designs we offer.

Never Before Offered at \$11.66!

We have long been known as headquarters for greatest diamond bargains. This less than wholesale price on new Elgin octagon watches will establish our supremacy in the watch business. The secret is, buying for cash in vast quantities and reselling direct to you at the smallest profit.

4 Guarantees with Every Watch

1. Unconditional guarantee of Elgin Watch Co. stands back of the movement.
2. Case manufacturer guarantees to replace free any case in which thick gold wears through within 20 years.
3. Barnard & Co. also guarantee case and movement, doubly protecting you.
4. Barnard & Co. guarantee to ship for free inspection and to refund full price if you are not satisfied.

Order Now for Free Inspection

Let us send you one of these magnificent watches by express or in care of any bank. You will not be obligated to buy. Examine it carefully and judge for yourself. You will say it is the biggest watch bargain you ever saw or heard of. Only 2,000 watches will be sent out on this offer. To make sure of yours, write at once Money-Back Guarantee protects you.

BARNARD & CO. Wholesale Watches
Diamond Importers
Dept. 3788C, N. W. Cor. State & Monroe, Chicago

Without obligation please send me for free inspection new octagonal watch, 7 jewel movement as marked below, in 20 year guaranteed gold filled case as per your less than wholesale price offer in Popular Mechanics.

Ship C.O.D. by..... Express to.....

Name..... Elgin

Address..... Hampden

If you desire to remit with order we protect you with our Money Back Guarantee. Full purchase price will be refunded if watch is returned within 10 days.

Carbon All Gone in the Morning!



REMOVE CARBON OVER NIGHT

Sure! That's not hard and there's no reason why you should tolerate power-eating carbon another single day. You'll remove carbon over-night or while your car runs, just as soon as you realize the unfailing value of

AUTOPOWER

THE REAL CARBON REMOVER

Simply pour a quart of Autopower into the gas tank — every 1200 miles, that's all — and carbon simply *vanishes!* Meanwhile your engine recovers power, develops increased mileage per gallon and rapid acceleration on the start-up.

CRYSTAL OIL & PAINT CO., (Autopower Division)
6506 Detroit Ave. CLEVELAND, OHIO

I enclose \$1.50 for which please send me one quart of Autopower. At the same time you will send me draft for \$1.50 which I may cash at any bank if Autopower is unsatisfactory.

Name.....

Address.....

Now then — with each can of Autopower you get a sight draft on your bank — simply present it if Autopower fails to entirely please you. You *can't* lose, so why not get a quart of AUTOPOWER *today?* Send in the attached coupon and \$1.50 — *now*, why not?

Crystal Oil & Paint Co. 6506 Detroit Ave.
(Autopower Division) CLEVELAND, O.



Here's the Way to Make Big Money!



Write us today. See how easy for you to start a money-making business of your own with a Bartholomew Pop-corn and Peanut Machine. Use your whole time or spare time. *Wonderful profits!* Set your machine wherever the business is — on a corner, in a theater or hotel lobby, at baseball or picnic grounds, etc.

On Credit!

Write for free catalog! See our famous big line and our easy payment plan. Terms so easy you won't miss the money. Let the machine pay for itself out of your pop-corn and peanut sales. Here's your chance! Write today — a post card will do.

The Bartholomew
Company
106 Heights St.
Peoria, Illinois

Free
Catalog

Please Mention Popular Mechanics

\$60 A WEEK AND THIS AUTOMOBILE

EVERY AGENT CAN
GET AN AUTO
NO CONTEST



Tub
Guaranteed
For Ten Years

You—yourself—can positively make \$30 a week and get an Auto. I want men, hustling, energetic, ambitious fellows, anxious to make money, who are willing to work with me. Not for me, but with me. Are you that kind? I want you to advertise, sell, and appoint local agents for the biggest, most sensational seller in 50 years—the ROBINSON FOLDING BATH TUB. Demonstrating Tub Furnished. Here's an absolutely new invention—nothing like it. Makes instant appeal. Sells easily. Gives every home a modern up-to-date bathroom in any part of the house. No plumbing, no water-works needed. Folds in small roll, handy as umbrella. Self-emptying, positively unbreakable. Absolutely guaranteed for 10 years. Remember, fully 70% of homes have no bath rooms.

Sensational Sales Successes

Two sales a day means \$300 a month. Breeze, of Idaho, made \$400 profit in 30 days. Rev. Otto Schulze, Mo., got \$1000 to date. Burkholder, Mont., orders \$1072 in 17 days. Hamlington, of Wyo., made \$90 first two days. Hundreds like that. Pleasant, permanent, fascinating work. Write a postcard. Let me write you a long letter. No experience needed, no capital. Your credit is good if you mean business. But you must be ambitious, you must want to make money. That's all. Write a postcard now. I want to pay you \$60.00 every week.

H. S. ROBINSON, PRES. THE ROBINSON CABINET MFG. CO.
4669 Factories Building TOLEDO, OHIO

Keep Cool



In Peace or In War

The Lake Breeze Fan brings you genuine comfort and satisfaction. Makes a cool breeze on hottest days and nights. Ideal for the sick.

A most remarkable invention — no electrical wires or springs.

1917 improved patented model. Quiet — convenient. The wonder fan.

Runs on Kerosene Alcohol, Gasoline or Gas

Runs eight hours for one cent on kerosene. Cheaper and more satisfactory than electricity. A proved success. 2 models, 3 sizes.

- A { 12-in.—\$16.50—Alcohol or Gas only (Gas \$1.50 extra)
 { 16-in.—\$18.50—Alcohol or Gas only (Gas \$1.50 extra)
 B { 16-in.—\$19.50—Any Burner (Gasoline \$2.50 extra)
 { 21-in.—\$22.50—Any Burner (Gasoline \$2.50 extra)
 F. O. B. Chicago. Cash with order only.

A Lake Breeze in your home or office will enable you to escape the heat this summer

LAKE BREEZE MOTOR
546 West Monroe Street CHICAGO

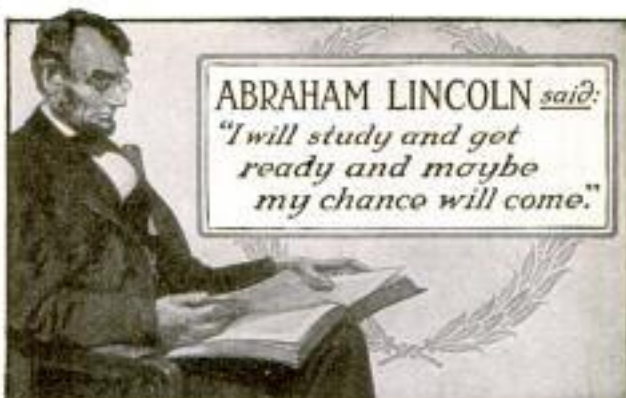

ABRAHAM LINCOLN *said:*

"I will study and get ready and maybe my chance will come."

Born in the woods, in the poverty of a log cabin, Abraham Lincoln had little chance to get an education. But he was so determined to succeed that he brushed obstacles aside; he made the most of what slender advantages he had (he once walked forty miles to borrow a book); he used every spare moment for study; his chance *did* come and he was *ready!*

Some day you'll be considered for a good job ahead. Get ready, and you'll surely go up! You have ten chances for every one that Lincoln had. The International Correspondence Schools will train you, right at home in spare time, for a better job, for more pay, for the big chance when it comes. Make your start now. Mark and mail the coupon and find out how.

TEAR OUT HERE

INTERNATIONAL CORRESPONDENCE SCHOOLS, Box 5576, Scranton, Pa.

Explain fully about your Course in the subject marked X:

- | | | |
|---|---|---------------------------------------|
| <input type="checkbox"/> Civil Engineering | <input type="checkbox"/> ADVERTISING | <input type="checkbox"/> CHEMISTRY |
| <input type="checkbox"/> Electrical " | <input type="checkbox"/> Salesmanship | <input type="checkbox"/> Illustrating |
| <input type="checkbox"/> Steam " | <input type="checkbox"/> Commercial Law | <input type="checkbox"/> Farming |
| <input type="checkbox"/> Mining " | <input type="checkbox"/> Bookkeeping | <input type="checkbox"/> Poultry |
| <input type="checkbox"/> Mechanical " | <input type="checkbox"/> Stenography | <input type="checkbox"/> French |
| <input type="checkbox"/> Mechanical Drafting | <input type="checkbox"/> Civil Service | <input type="checkbox"/> German |
| <input type="checkbox"/> Architectural Drafting | <input type="checkbox"/> Ry. Mail Service | <input type="checkbox"/> Italian |
| <input type="checkbox"/> ARCHITECTURE | <input type="checkbox"/> AUTOMOBILES | <input type="checkbox"/> SPANISH |

Name _____

Address _____



Blanasilk Everready Safety Cushion

Here is the newest idea in boating equipment — a cushion with a life-preserver inside. It saves the space of separate life-preservers, insures greater safety and provides a handy, comfortable and easily cleaned cushion. The Life-Preserver is the only type that supports the wearer's head clear of water and is stamped to comply with motor-boat laws. It is filled with the remarkably soft and buoyant "Blanasilk," the only fiber approved by the U. S. Steamboat Inspection Service for life saving equipment for all vessels. With slip-on, snap-button cover of 8 oz. Khaki duck, \$3.00 each postpaid. Write for booklet showing other Blanasilk Boating and Camping Equipment.

UNIVERSAL SAFETY MATTRESS CO., INC.
Dept. 12 31 Nassau Street New York

CORONA The Personal Writing Machine weighs 6 lbs. Writes all kinds of correspondence. \$50 with carrying case. Write for booklet No. 32. Corona Typewriter Co., Inc., Groton, N. Y.

1/2 PRICE — TO INTRODUCE



ONLY \$2.50

To prove to you that our blue-white MEXICAN DIAMOND

exactly resembles the finest genuine South African Gem, with same dazzling, rainbow-hued brilliancy (GUARANTEED), we will send you this beautiful, high-grade, 12-kt gold-filled Tuff. Ring, set with 1-kt. gem, regular catalog price, \$4.96, **\$2.50 FOR ONE-HALF PRICE.**

Same gem in Gem's Heavy Tooth Belcher Ring, catalog price, \$6.26, for \$3.10. Wonderful, dazzling, rainbow brilliancy. GUARANTEED 20 YEARS. Send \$1.00 and we will ship

C. O. D. for FREE EXAMINATION. Money back if not pleased. Act quick. State size. Offer limited. Only one to a customer. Catalog Free. Agents Wanted. MEXICAN DIAMOND IMPORTING CO., Dept. E. T., LAS CRUCES, NEW MEXICO (Exclusive Controllers of the Genuine Mexican Diamond)



FOLDING FONOGRAF

Ideal talking machine. For motorists, soldiers, campers, travelers and the home. Opens and closes like a book. Fine wooden case. Carries like a handbag. Holds 12 discs, 24 selections. Special limited price offer.

\$5.55

Fine Tone — Extra Loud

Plays all records. Beautiful tone quality. Most compact high-grade talking machine ever invented. Comes knocked down. Everything complete and perfect. Nothing to buy. All you need is a hammer and screwdriver. Everything complete, now special, only \$5.55.

Money Back Send only \$5.55. Price to advance soon. Money-back guarantee. If not delighted return all parts undamaged and get your money back in full. Send today. Also, we sell parts for building all kinds of talking machines.

ELECTRO-MECHANICAL PARTS CO., 57 E. Jackson Blvd., Dept. 5249, Chicago

FREE TRIAL
COUPON

Electro-Mechanical Parts Co.,
57 E. Jackson Blvd., Dept. 5249
CHICAGO

Gentlemen: Send Folding Fonograf, all complete, ready to be assembled. Enclosed is \$5.55. My money back if not satisfied.

Name.....

Address.....



Ames-bilt

Four Passenger Cloverleaf

The biggest car bargain in the world

\$215 and a Ford chassis (old or new) gives you this chummy clubster which is the equal in quality, style, luxury and service to any \$1500 car on the market. The AMESBILT cloverleaf completely covers and disguises the Ford chassis and is so strikingly beautiful it attracts a second look of admiration wherever it is seen. It is being bought by thousands of Ford owners and the AMESBILT equipped Ford has been pronounced the "smartest little car in America."

Specifications:

FRAME—Selected hardwood. All joints mortised, glued and screwed, solidly reinforced and ironed by hand.

CONSTRUCTION—30-gauge cold rolled automobile sheet steel, thoroughly sand blasted to prevent rusting when painted.

DOORS—Nicely hinged, 20" opening. Entrance from both sides front only.

UPHOLSTERY—Extrafine quality M. S. leather, stuffed with natural curled hair.

TOP—One-man top with Jiffy curtains and dust hood.

SEATS—Divided front seats, 7½ inch aisle. Width of front seats 17 inches. Depth of cushion 16 inches. Distance from back of front cushion to dash 44 inches. Rear seat 36 inches wide. Cushion 17 inches deep. Distance from back of rear seat to back of front seat 35 inches. This means 33-inch leg room.

WINDSHIELD—Cool fitting, clear vision, ventilating.

HOOD—Streamline with Bull-Nose Radiator. Heavy, best quality hood steel.

FENDERS—Crown fenders, 20-gauge fender steel. Finished in high glossy enamel, thoroughly baked.

GASOLINE TANK—Filler pipe and cap, also gas-line furnished. Tank is carried in rear.

PAINTING—Rich glossy black standard and carried in stock. Any other color extra. See "Special Color" heading.

EQUIPMENT—All necessary attachments for mounting on Ford chassis.

WEIGHT—Net 280 lbs.; crated about 470 lbs.

PRICE—F. O. B. Factory, \$215.00.

Terms: Deposit of \$50. Balance C. O. D.

Beautiful illustrated catalog on request.

Order from any Ford dealer or send direct to

The F. A. Ames Company, Incorporated

Makers of pleasure vehicles for over 30 years.

3rd and St. Elizabeth Streets, OWENSBORO, KY.



"New-Skin"

—for cuts and scrapes

New-Skin is an antiseptic liquid for use on little hurts. It forms a waterproof covering over the wound and allows it to heal naturally.

In two sizes, at all druggists 10c, 25c.

NEWSKIN CO., NEW YORK

3 Horse Power
2 Cylinders
No Vibration

ONLY 65 POUNDS

KOBAN INBOARD MARINE ENGINE



SUITABLE for light boats, launches and canoes up to 22 feet.
A powerful, smooth-running engine which delivers the horse power and occupies small space. Write for free circular No. 80.

KOBAN MFG. CO., 291 Barclay St., Milwaukee, Wis.



DO YOU INTEND TO BUILD? 75 PRACTICAL PLANS

California Bungalows and Houses especially suited to any climate. New, attractive designs with valuable building suggestions all in handsome 1917 Art Plan Book. Price \$1.00 postpaid. Send today for your copy. Save time, trouble. Money refunded if not satisfactory. Address

BUILDING DEPARTMENT

AURELIUS SWANSON COMPANY, Inc.
1001 State Nat'l Bank Bldg. Oklahoma City, Okla.

Please Mention Popular Mechanics



\$45 Starts You in the Tire Repair Business

Here is your opportunity to get into this big paying, big profit business. A business of your own in which you can be your own boss—a business that runs hand in hand with the automobile business—that grows with it and is fast becoming the biggest paying proposition in the automobile field. You can start now on small capital—only \$45, and cash in this gigantic opportunity. The coupon below will bring you full details—full particulars. Mail it today.

Millions of Tires to Repair—Means \$3,000 a Year for You

It is estimated that more than 30,000,000 tires will be made this year. These, with all the old tires now in use, will need repairing—will demand the expert attention—the expert service that you can give as a **Haywood Tire Repair Man**. You can learn this business in a few days. You can open a shop and make money almost at once. Auto owners will come to you—tell their friends, and if you are a live-wire, your business will soon grow from a one-man shop to a big complete tire repair shop and accessory store.

Complete \$45

HAYWOOD'S Model D.B. VULCANIZING PLANTS

One Machine Will Start You Making Big Money

This machine at its unusual price is practically the last word in efficient, economical tire repairing. It is simple, compact, quick acting, and requires but little room. It will vulcanize and make tire repairs of almost any nature—will do practically everything in the tire repair business except retreading. Just a small investment—\$45—a trifling amount, places you on this road to prosperity—gives you the start in this wonderful business.

The Only Nationally Known Tire Repair Service

Through National advertising, Haywood Tire Repair Service is known to auto owners everywhere. When you open a Haywood Shop you have the advantage of an established business—a business of unlimited profits—a business you don't have to wait for—that comes to you with scarcely an effort. In this, most wonderful year of the automobile business, is the time for you to start. More tires are to be used than ever before. The cost of operating cars is steadily climbing. Punctures and blow-outs are still common, and every man now, regardless of wealth, knows that keeping his tires repaired, prompt attention to the little cuts and bruises of his tires, is true tire economy. Tires are the biggest item in the up-keep expense of an automobile. You know that.

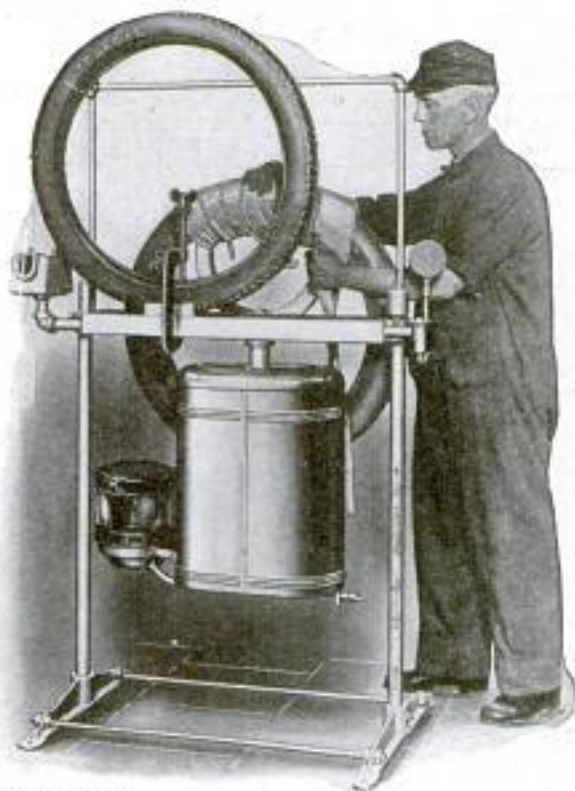

ACT QUICK—MAIL COUPON / FREE BOOK COUPON

I have published a big interesting book—a book all about tires. Tells how they are made—how they are repaired by the Haywood method. Gives complete details of this wonder machine—the new model D-B at its unusual price. Gives inside figures and profits of the tire repair business. Gives proof of success, letters from others who are now operating Haywood shops and making big money. What these men have done you can do. \$2,500 to \$4,000 a year is the ordinary income of live-wire tire repair men. Send no money. Just mail the coupon—a letter or postal will do.

HAYWOOD TIRE & EQUIPMENT CO.
645 N. Capitol Ave., INDIANAPOLIS, IND.

GENTLEMEN: Please send me full details of the tire repair business and complete description of the new Haywood Model D-B Vulcanizing Plant which you are offering at the unusually low price of \$45.

Haywood Tire & Equipment Co.
645 N. Capitol Ave., Indianapolis, Ind.

Name.....

Address.....

JOIN THE ARMY

Of Peaceful, Contented Smokers Of The BREECHLOADER; The FIRST and ONLY DRY, "JUICELESS," "HEELLESS," "CLOGLESS," SWEET, SANITARY, SAFETY SMOKING PIPE Ever Devised. Anticipating Scepticism As To The Credibility of Said Statement, We Hereby GUARANTEE To Substantiate Each and Every Claim; MAKE GOOD, Or REFUND The Purchaser's Money Upon DEMAND. Columns of "Pipe-Talk" Could NOT Strengthen So EQUITABLE A Proposition, Positive Proof Of Which Is At YOUR Command.



THE BREECHLOADER is EXTREMELY SIMPLE, Most Substantial and Practical; Neat and Unique in Design; A Very Desirable Size; 5 1/4 in. long With Graceful Curve; A Little on the "Chubby" order, Quarter Bent; Considerably Lighter, Holding about one fourth more Tobacco than the ordinary pipe of the same size. The Bowl and Breech Plug is made of **FIRST QUALITY, GENUINE FRENCH BRIAR**; Given a Rich, Natural, Friction Finish; Solid Rubber Stem; Sterling Silver Mounted; Price Including Nickel Plated Pipe Companion \$1.00 Postpaid. Or Write for Free Pamphlet.

THE BREECHLOADER PIPE CO., Inc.
Suite Four, 335 Broadway, New York, N. Y.

One Man and This Machine Will Earn

\$50 to \$100

Daily Profit



Not a dream—not a myth—but a reality. If you are honest—earnest, and anxious to go in business for yourself, I will help you. I have helped lots of men to make from \$500.00

to \$1500.00 per month. It's an honorable business—can be started most anywhere, in any town of over 500 population.

A GOOD BUSINESS PROPOSITION

You want a business of your own. Go into the Popcorn Crispette business and make \$2000.00 to \$7000.00 a year. All you need is a machine, a few dollars and a good location. You can learn to make Crispettes in a day. They sell everywhere for a nickel a package. You make almost four cents profit.



SEND FOR FREE BOOK

It tells the whole story—how and where to start, how to succeed, gives experiences of others, etc. It's worth reading, even if you don't start. If you are looking for a good thing and easy money, write today for **FREE BOOK**.

Eakin made \$1500.00 in one month with a Long Crispette Machine in a store window.

You can do equally as well, or even better.

W. Z. LONG CO.
1335 High St., SPRINGFIELD, O.

Without any obligation at all, please send me free, your book, "Dollars and Sense in the Crispette Business."

Name.....

W. Z. LONG CO.

1335 High St.,
SPRINGFIELD, OHIO

Address.....

Electric Light for Your Home

Uni-Lectric lighting plant generates standard 110-volt direct current; operates from one to 50 lights, electric motor, electric iron, vacuum cleaner, electric toaster, force pump, churn, washing machine, etc.

No Batteries — No Switch-Board

and a better machine for less money. High speed gasoline motor, generator and automatic governor, all complete in one small, compact unit. Uses standard lamps and fixtures. Simple, easily installed, dependable, economical. Costs less than other systems to buy and to operate.

WATERMAN MOTOR COMPANY

182 Mt. Elliott Ave.

DETROIT, MICH.

Write today for full description and low price.

Uni-Lectric
GASOLINE-ELECTRIC UNIT
LIGHTING SYSTEM



Your Garage Doors "STAY PUT"

WITH THIS HANGER

The Perfect Garage Door Hanger Set

Use This Hanger on the Garage You're Going to Build This Spring

Allows use of full door opening without risk of damage to car or door, and door cannot swing or blow shut, as it automatically fastens itself open. No extended run-way on either side of building, and no sticking or getting out of order. Can be opened to any width desired, and is weather-tight when closed. No sawing or cutting of holes necessary to attach. Your doors "STAY PUT."

Ask your hardware dealer — Also send today for descriptive circular, surprisingly low price.

Dealers—Get ready for the big spring garage building season. There's big profit in this device, and there'll be a big demand. Architects—Specify this in your plans and make every client happy. Write for terms.

Safety Door Hanger Co., 105 Topping Bldg., Ashland, Ohio





Waltham—Elgin—Howard—Hamilton—Illinois—Rockford ANY, MAKE—ANY SIZE—ANY JEWEL WATCH ON CREDIT—PAY MONTHLY

The Watch or Diamond that persons wear indicates immediately their social and financial standing. Carry a cheap Watch and the world thinks of you as a failure because time and money are one. Pull a cheap Watch from your pocket and no power on earth can keep that Watch from fairly screaming **You are a Cheap Man.** Wear an imitation or fake Diamond and the only person you fool is yourself; your friends may be too kind or polite to tell you that they know it is a fake, but they will sneer behind your back and spread the news among all the neighbors.

Now my friends you cannot afford to wear a cheap Watch or fake Diamond, and in this age and generation there is no excuse for such little self-respect. With my easy monthly payment plan you can wear a Watch or Diamond that is a credit to yourself and does not belittle you in the eyes of the world. Pay a little each month while wearing a good Watch or a fine Diamond and never miss the money.

SEND NO MONEY WITH YOUR ORDER

Send no money with your order. I want you to see the watch or diamond before you pay one cent. See it first is my way of selling watches, because my line of watches is the best made, and I am proud of the fact that I can send out my goods on approval and make sales by this method.

30 DAYS' FREE TRIAL

After receiving and accepting any one of my watches, I want you to wear and test it for 30 days. If you are not delighted, pleased and satisfied at the end of 30 days, send it back at my expense.

MY PAYMENTS ARE SMALLER

Our capital and buying power are such that I can offer you terms that local jewelers could not meet with their limited capital. I can surely please you on terms.

WRITE FOR BIG CATALOG

Use the Free Coupon and write for my big catalog today. It's full of all the best watches, finest diamonds and exquisite jewelry, all sold on credit.

SQUARE DEAL MILLER, Pres.
MILLER-HOEFER CO.

844 Miller
Building
Detroit,
Mich.



Birthday Gifts

Wedding Gifts

If you buy an imitation diamond the only person you Fool is Yourself



We invite Women as well as Men to open up a Charge Account and Pay Monthly. Our Terms are the same for Diamonds as for Watches or any other piece of jewelry.

A Personal Word from Square Deal Miller

Because every account of my books represents a real friendship established on the basis of a "Square Deal," I have become known to my customers from coast to coast as Square Deal Miller. I have taught the public the real meaning of "dignified credit," and I have won the confidence of over a million customers by selling only the highest grades of diamonds, watches and jewelry on a Square Deal basis from start to finish.



FREE CATALOG COUPON

Square Deal Miller, Pres., 844 Miller Bldg., Detroit, Mich.
Dear Mr. Miller— Please send me your large free catalog of Watches, Diamonds, etc., and explain your easy no money with order terms, also tell me all about your 30 day trial plan.

Name.....

Address.....



Open Up a New World

See These Books!

GREATEST guide to Nature ever written. Nine wonderful volumes which tell you all about animals, birds, fish, butterflies, flowers, trees, insects. Richly bound in flexible leather or cloth. Now sent on a very special offer. Read below:

The New Nature Library

Opens your eyes to the marvelous life of all outdoors. Identifies, classifies, tells you all about thousands of Nature's wonderful creatures. Edited by eminent naturalists—men like Dr. David Starr Jordan of Leland Stanford University, Dr. Howard U. S. Dept. of Agriculture, Dr. Evermann of U. S. Fish Commission, Dr. Holland of Carnegie Museum.

Size of volumes, 7¼ in. x 9¼ in. Hundreds of illustrations. Thousands of pages of fascinating text matter. Sent for seven days examination while present editions last.

Splendid Pictures!

A vast collection of wonderful color plates, made direct from Nature. Shows you just how the birds, animals, fish, trees and flowers look in their native haunts.

Special Outdoor Edition Finest set published. Yours on this special offer. You save if you buy now. Future editions will cost more because paper, ink, leather, etc., have advanced in price. Do not postpone sending. See the books on this special offer. Write today—at once. Send coupon below.

Doubleday, Page
& Company

Dept. 978, Garden City, N. Y.

Send me the big 9-vol. Nature Library. (Special Outdoor Edition) for 7 days' examination. If I keep it I will send \$1.50 down and \$3.00 per month until the price, \$34.50, is paid. Otherwise I will return the books. (For limp leather binding, price \$44.50, \$4.00 monthly (same terms) put X here []).

Name.....

Address.....

Send This Coupon

Mail the coupon today and see the wonderful color plates. We will ship the books. Read them for 7 days. If you keep them buy on our easy credit terms (see coupon). Otherwise send them back.

Doubleday, Page
& Company
Dept. 978
Garden City,
N. Y.



"Ship Your Oars— We'll Motor Upstream!"

When you've got to work up power and speed to buck the tide, oars won't help you. Straining your back and your temper to make camp against time is needless when an

ARROW 2-CYLINDER 4 H. P. Detachable

will speed you anywhere as fast as you like. Double your boating pleasure by putting your rowboat in the motor class.

Absorb these features of the new Arrow 2-Cylinder Motor: One gallon of gasoline is enough to run your boat steadily for four hours. Compare this with the operating expense of the average motor boat. The 2-cylinder construction practically eliminates vibration and gives your boat the steadiness of a big yacht.

The new Arrow Tilting Device permits your boat to pass over obstacles and to beach easily. You can steer from any part of the boat. You can dock without stopping your engine.

ARROW MOTOR & MACHINE CO.
30 Church St., NEW YORK Factory: Newark, New Jersey
Foreign Office: 47 Broadway, New York J. E. Satterly, Foreign Sales Manager

MAZDA Always etched on electric lamps to which MAZDA Service has been applied.

The Keys To Success WILL FORCE AND POWER OF PERSONALITY

Marvelous and epoch making utilization of these forces for Health, Wealth and Success is the Secret of the Veritas Mental System. Send for Free Book "The Keys to Success."

Veritas Mental System
1400 Broadway, Suite 631, NEW YORK

THERE'S BIG MONEY IN COIN MACHINES

Do you know that coin operated machines earn millions of dollars every year? We can show you, and prove to you how you can start with a small investment and by re-investing the profits, build up an independent income.

This is not a get-rich-quick scheme, but a good safe investment proposition that will stand the strictest investigation.

Figure up the profits from a machine that cost you \$10.00 and will earn you from \$2.00 to \$5.00 a week. Suppose you are operating fifty of them—that means from \$100 to \$250 a week.

Some of the penny weighing scales that you see in drug stores, waiting rooms, etc., are backed by Million Dollar Corporations that started in a small way and grew, simply by re-investing the profits.

We manufacture 350 different kinds of machines ranging in price from \$5.00 to \$3000—with an earning capacity of from \$1.00 to \$50.00 a week. Look us up in Dun's or Bradstreet's.

Remember your money in the bank is only earning 3%—in coin machines it will earn from 100% to 500%. Ask for proof.

MILLS NOVELTY COMPANY, 223-235 South Green St., CHICAGO
Largest manufacturers of coin operated machines in the world.

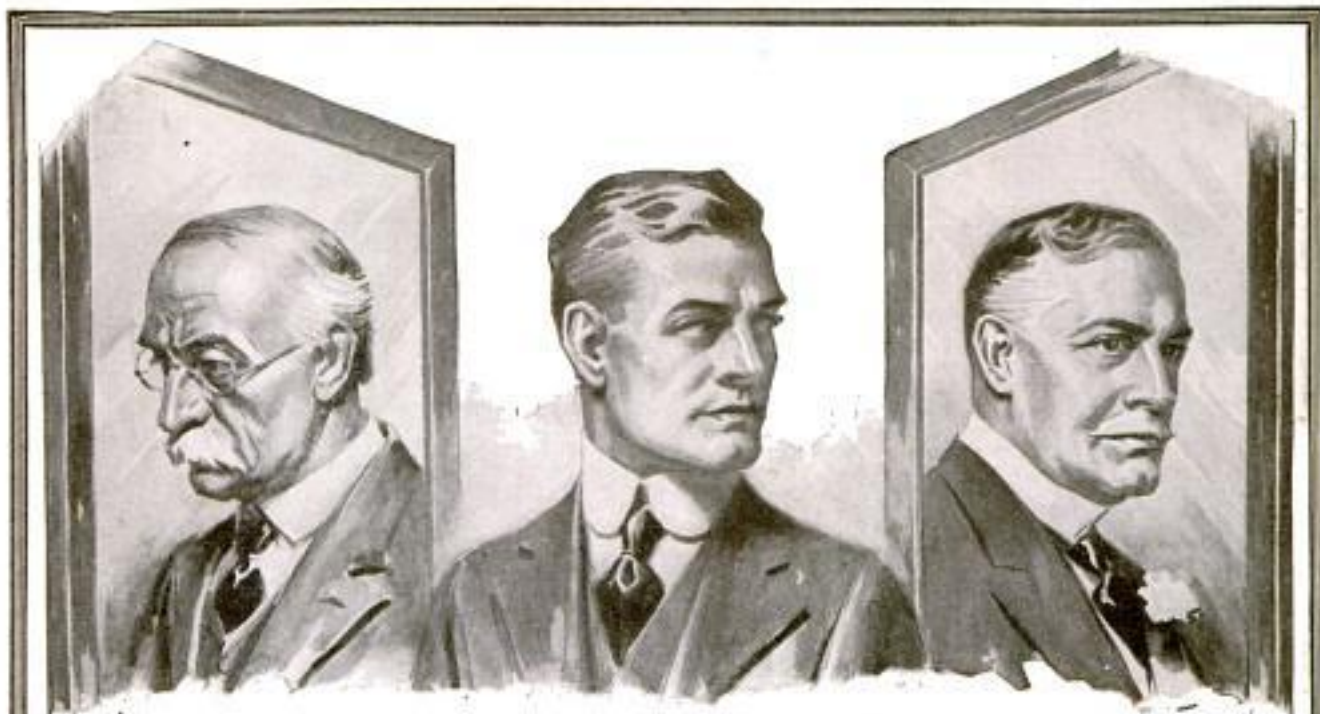

What's Ahead of You?

How many times have you said to yourself, "I wish I could see what's ahead of me"?

You can! You're going to do one of two things—drift along into the ranks of the poorly paid, or rise to a position of power, wealth and influence, commanding the respect of big men and living a life of happiness and satisfaction.

You can make your own success. Just believe in yourself, train yourself, and work. Those are simple rules. But they made Lincoln, Edison, Schwab. They will make you.

And you have a chance that they never had. The International Correspondence Schools will prepare you, right at home, to take the place you want to take in life—to be the man you want to be.

You get I. C. S. training without interfering with your present work. You don't have to sacrifice recreation or pleasure. You train yourself in spare time—time that now goes to waste.

For 25 years the I. C. S. have been helping men to succeed. I. C. S. trained men are constantly going to the top in shops, factories, stores, offices and on engineering jobs, in every line of industry, all over the world.

Your future depends on what you do today. If you want to make it a real success, start right now. Start by *deciding*. Mark and mail this coupon.

INTERNATIONAL CORRESPONDENCE SCHOOLS

Box 5569, SCRANTON, PA.

Explain, without obligating me, how I can qualify for the position, or in the subject, before which I mark X.

- | | |
|---|--|
| <input type="checkbox"/> ELECTRICAL ENGINEER | <input type="checkbox"/> SALESMANSHIP |
| <input type="checkbox"/> Electric Lighting | <input type="checkbox"/> ADVERTISING MAN |
| <input type="checkbox"/> Electric Car Running | <input type="checkbox"/> Window Trimmer |
| <input type="checkbox"/> Electric Wiring | <input type="checkbox"/> Show Card Writer |
| <input type="checkbox"/> Telegraph Expert | <input type="checkbox"/> Outdoor Sign Painter |
| <input type="checkbox"/> Practical Telephony | <input type="checkbox"/> RAILROADER |
| <input type="checkbox"/> MECHANICAL ENGINEER | <input type="checkbox"/> ILLUSTRATOR |
| <input type="checkbox"/> Mechanical Draftsman | <input type="checkbox"/> DESIGNER |
| <input type="checkbox"/> Machine Shop Practice | <input type="checkbox"/> BOOKKEEPER |
| <input type="checkbox"/> Gas Engineer | <input type="checkbox"/> Stenographer and Typist |
| <input type="checkbox"/> CIVIL ENGINEER | <input type="checkbox"/> Cert. Public Accountant |
| <input type="checkbox"/> Surveying and Mapping | <input type="checkbox"/> Railway Accountant |
| <input type="checkbox"/> MINE FOREMAN OR ENGINEER | <input type="checkbox"/> Commercial Law |
| <input type="checkbox"/> Metallurgist or Prospector | <input type="checkbox"/> Traffic Management |
| <input type="checkbox"/> STATIONARY ENGINEER | <input type="checkbox"/> GOOD ENGLISH |
| <input type="checkbox"/> Marine Engineer | <input type="checkbox"/> Teacher |
| <input type="checkbox"/> ARCHITECT | <input type="checkbox"/> Common School Subjects |
| <input type="checkbox"/> Contractor and Builder | <input type="checkbox"/> CIVIL SERVICE |
| <input type="checkbox"/> Architectural Draftsman | <input type="checkbox"/> Railway Mail Clerk |
| <input type="checkbox"/> Concrete Builder | <input type="checkbox"/> Textile Overseer or Supt. |
| <input type="checkbox"/> Structural Engineer | <input type="checkbox"/> Navigator <input type="checkbox"/> Spanish |
| <input type="checkbox"/> PLUMBING AND HEATING | <input type="checkbox"/> AGRICULTURE <input type="checkbox"/> German |
| <input type="checkbox"/> Sheet Metal Worker | <input type="checkbox"/> Poultry Raising <input type="checkbox"/> French |
| <input type="checkbox"/> CHEMICAL ENGINEER | <input type="checkbox"/> AUTOMOBILES <input type="checkbox"/> Italian |

Name _____

Occupation
& Employer _____

Street
and No. _____

City _____ State _____

If name of Course you want is not in this list, write it below.

Please Mention Popular Mechanics



Tour Anywhere Without Hotel Bills

Hitch an Auto-Kamp Trailer to your car. Be at home anywhere, with a completely equipped living and sleeping tent, electric light, two full size beds, cook stove, ice box, complete cooking outfit, dishes, cutlery and dust-proof food compartment that carries an ample supply of food for several people.

The "AUTO-KAMP" TRAILER

saves hotel bills, garage expenses, delays and discomfort. Pays for itself in one season and makes touring or outing trips very inexpensive. Last summer a party of four made a two weeks' trip with an Auto-Kamp at a total expense of only \$24—less than 50 cents a day apiece. It's cheaper than staying at home and lots of fun.

The Auto-Kamp attaches by universal socket joint. Adjustable to any car, and folds compactly like a Pullman berth. It follows your rear wheels around corners or turns, at any speed and over any kind of roads. You can set it up anywhere you choose in seven minutes. Make camp beside the road, under a great oak, near a beautiful river or lake in the forest—anywhere.

Don't Delay—Write for Booklet

Complete specifications and terms. Get full information about the Auto-Kamp Trailer. Read the testimonials of users. But do it now—before you forget, as later we may not be able to accept your order.

THE AUTO-CAMP EQUIPMENT CO., 2107 Sheridan Ave., SAGINAW, MICH.



NEW CAR, JOHN?
NIX, 1915! REFINISHED
HER MYSELF WITH

Effecto
AUTO
FINISHES

YOU can make your little old last year's car look like new in a jiffy and at small cost. Made in seven colors, also Clear Varnish and Top and Seat Dressing. Sold by paint, hardware and auto accessory dealers. Send for Color Card. Pratt & Lambert-Inc. 153 Tonawanda St., Buffalo, N. Y. In Canada, 99 Courtwright St., Bridgeburg, Ontario.

MADE BY THE MAKERS OF
PRATT & LAMBERT VARNISHES

Please Mention Popular Mechanics

A Yearly Income for You

Would you invest a moderate amount in small monthly or semi-annual installments, if you felt assured it would earn for you an income from \$1000.00 to \$5000.00 annually, according to your investment? A Dixie Estate near Tampa, Florida, planted to grapefruit, oranges and avocados, should do this for you. The proof is what you want. We have it and will gladly send it to you free. Write us today for details of this money making opportunity.

The Thomas Nurseries, Inc., Tower Bldg., Chicago

“GENUINE”
**BULL
DURHAM**
TOBACCO

METAL PIPE CASES



Cases are adjustable with extension device to fit various shapes and length of Clay Pipes. No odor or ashes. Each Case is enclosed with imported Pipe Free Clean - Odorless - Sanitary.

Send Money Order or 2¢ stamp for Cir

to The Monarch Service Co 15 Cornhill Boston-Mass.

AGENTS—NEW INVENTION

Ventilated chemical indoor closet, for country, village and suburban homes; no plumbing, no waterworks, no cesspool; absolutely odorless; 30 days' free trial guarantee; every village and farm home a customer; an order at every house; one agent made \$112 commission in 8 hours. Agent's outfit free. Exclusive territory contract. Write today for full particulars of this biggest winner ever offered to salesmen. Address

SHAFER MFG. CO., 478 Colton Bldg., Toledo, O.

BUY DIRECT FROM THE DIAMOND CUTTERS

BY MAIL TO YOU

GENUINE DIAMONDS

Pure White
GENUINE
DIAMONDS

\$ **70**

Per Carat
ALL SIZES
1/4 to 10
Carats

Absolutely
Perfect
GENUINE
DIAMONDS

\$ **125**

Per Carat
ALL SIZES
1/8 to 1 1/4
Carats

Save 40 Per Cent

Genuine Diamonds by Mail to You From the
Only Diamond Cutters in the World Selling

To the Public Direct. Money Back Any Time Within One Year in Full!

For years we have sold Diamonds to Jewelers. There are but ten Diamond cutting concerns in the public direct. The prices at which we sell all grades you. As you turn page after page of our costly catalog

Now we also sell them to the PUBLIC DIRECT—at the same prices. United States—and we are the ONLY Diamond Cutters who sell to the United States—from \$39 a carat to \$275 a carat—will absolutely amaze your astonishment will grow greater and greater. This book will open your eyes. It shows you where and how diamonds are mined and cut; how to distinguish between a perfectly cut gem and one that was not cut correctly; why some diamonds are more intensely brilliant than others; how to recognize the difference between the various grades of diamonds; what to look for in a diamond and what to avoid, etc. It is the greatest authority on Diamonds ever published. And this valuable book is given without a penny's cost to you. It shows you why a jeweler must charge \$140, for example, for a diamond which we sell for \$100. It explains how we save the 10 per cent import duty by purchasing our diamonds in the rough; the 10 per cent wholesaler's profit; the 10 per cent, retailer's profit and the 10 per cent cutter's profit. Write for this intensely interesting book today—it's FREE.



Ladies' or Gentlemen's
Solitaire Diamond
Rings
Pure White

1-8	Carat Rings	\$6.25
3-16	Carat Rings	\$10.90
1-4	Carat Rings	\$16.25
3-8	Carat Rings	\$26.60
1-2	Carat Rings	\$35.00
5-8	Carat Rings	\$43.75
3-4	Carat Rings	\$52.50
1-8	Carat Rings	\$61.25
1	Carat Rings	\$70.00



Ladies' or Gentlemen's
Solitaire Diamond
Rings
Absolutely Perfect

1-8	Carat Rings	\$9.75
3-16	Carat Rings	\$14.00
1-4	Carat Rings	\$21.88
1-3	Carat Rings	\$27.90
3-8	Carat Rings	\$38.50
1-2	Carat Rings	\$58.75
5-8	Carat Rings	\$75.63
3-4	Carat Rings	\$93.75
1	Carat Rings	\$125.00
1-2	Carat Rings	\$187.50

Ladies' or Gentlemen's
Diamond Rings—Seven
Diamonds Set As One

3-16	Carat—has appearance of 3-4 Carat	\$12.75
1-4	Carat—has appearance of 1 Carat	\$15.00
3-8	Carat—has appearance of 1 1/4 Carat	\$18.75



Buy Through Your Bank

See these diamonds first before you pay a single penny. We gladly ship selections at our risk and our expense to your BANK or EXPRESS for free examination. If you are not absolutely convinced that they are the best values you have ever seen, you are not obliged to buy.

Money Back

With every purchase we give our Protective Money Back Guarantee Bond, absolutely assuring you legally of the full return of your money to the penny any time within one year, simply on request.



This catalog is not confined to diamonds—it shows everything in Gold and Platinum Jewelry, Watches, Silverware, etc., at wholesale prices.

Fill Out This Coupon And You Will Get Our Big FREE CATALOG.

Coupon
L. PRESS & SONS
846 Chestnut St.
Philadelphia, Pa.

You may send me free, postpaid, without any obligation, your 226-page catalog.

Name.....

Address.....

L. PRESS & SONS
IMPORTERS AND CUTTERS OF DIAMONDS
WHOLESALE JEWELERS
846 CHESTNUT ST.
PHILADELPHIA, PA.

Please Mention Popular Mechanics

UNITED STATES BICYCLE TIRES



A Sure Winner



in favor this year among your customers will be the United States Heavy Service Traction Tread Tire — the all-white or all-red rubber tire — two ply motorcycle fabric — giving high anti-skid service, more mileage-per-dollar and all-round better wear and pleasure.



One of the twelve — you cannot go wrong if you stock the famous and favorite United States Tires — the GOOD Tire.



United States Tire Company

1790 Broadway, New York



Please Mention Popular Mechanics

The Sportsman's Best Pal

YOU men, who like to hunt and fish, or just loiter along the by-paths—those long, winding paths through the woods where the scents and sounds of spring make your pulses throb—get a

Harley-Davidson

and let it take you, whenever you're ready, to those inaccessible lakes and streams where the fish are hungry for your lure and the game is not cleaned out by those hunters who follow the railway lines.

It's a better machine than ever this year. Its increased speed and elastic power have earned for it the title of "Master 17."

You, who know motorcycles, will appreciate the "Master 17" at a glance—you, who have never tasted the joys of motorcycling will revel in a new sensation with your first ride.

If there is no dealer in your town, write for catalog

Harley-Davidson Motor Co.

508 "B" STREET, MILWAUKEE, WIS.

*Producers of High-Grade Motorcycles For More Than 15 Years
Also Manufacturers of Harley-Davidson Bicycles*

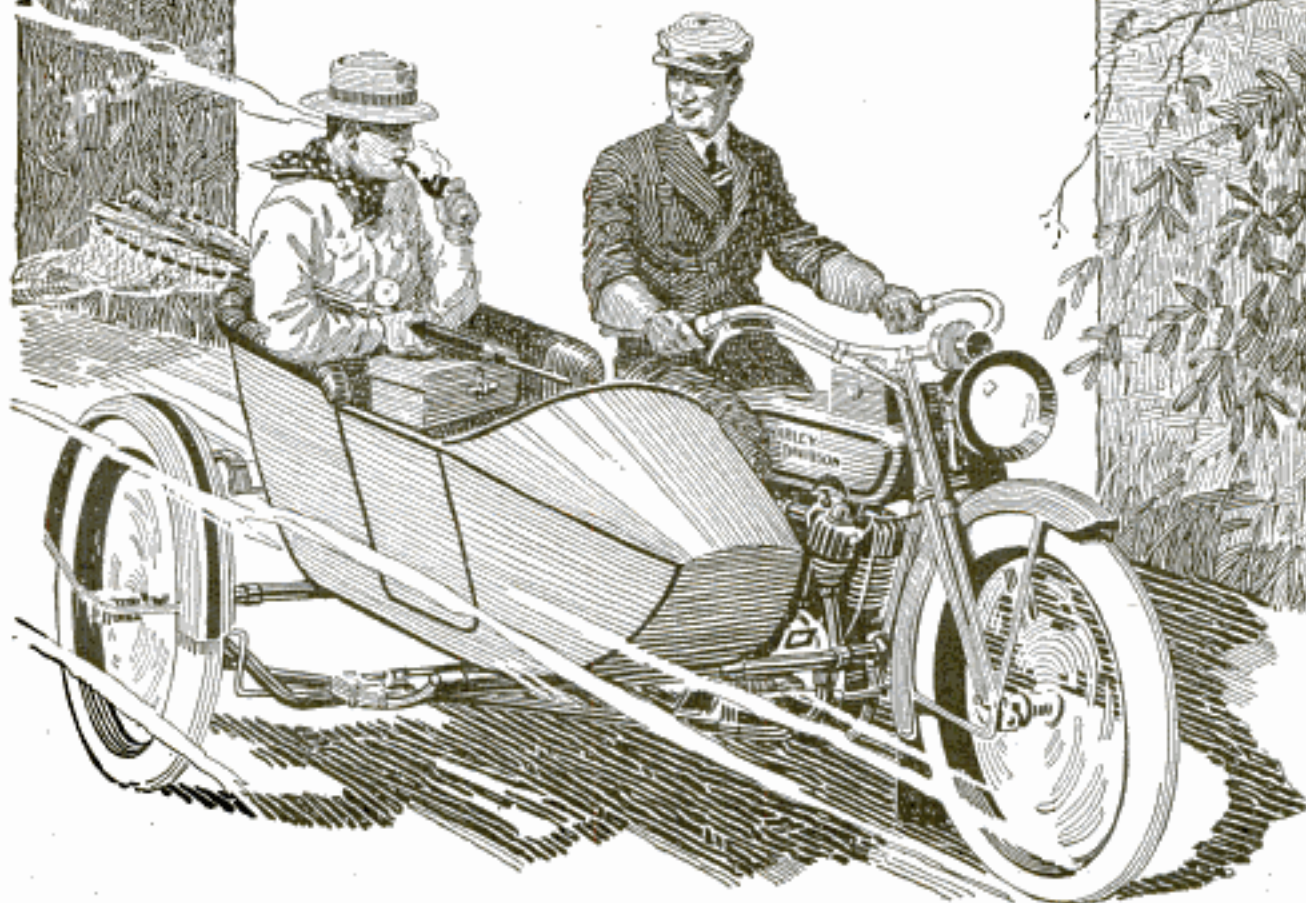

Please Mention Popular Mechanics

Tougher than Elephant Hide



*Ten thousand miles
without a puncture*

The great triumph of Vitalics is due to the great quality built into every tire that bears this name.

Vitalics, from tread to tube, bring to bicyclists a mastery of mileage, safety, stamina, and satisfying service.

Vitalic tires bring you immeasurably better value by virtue of better workmanship and material than any tire can possibly

boast that is built down to a price.

For 25 years, California's veteran amateur bicyclist, Dr. F. S. Cate, has held a bicycle tire "clinic," keeping accurate mileage records of 60 different tires, including the most widely known on the market.

VITALIC Bicycle Tires

ran more than three times the average mileage of the seven next best makes. Vitalics scored more than 11,000 miles, over 2,000 miles better than their nearest rival. Vitalics, front and rear, ran 10,000 miles without a puncture.

Vitalics are powerfully built of pure rubber and extra long, double-thick motorcycle tire fabric for endurance and elasticity.

No bicycle tire exists that equals Vitalics in extra-heavy thickness of both tube and tread—in quality of friction—in resilient resistance.

Three great tires bear the great name Vitalic. **Vitalic De Luxe**, all white, with heavy V-shaped suction non-skid tread. Price, \$4 each. **Vitalic Brigadier** is a stalwart four-ply tire; two layers of rugged Egyptian fabric, two additional plies on tread; extra-heavy inner tubes, gray sides, heavy white studded tread. Price, \$2.50 each. **Vitalic Cord Racer**, all white, is made of the most resilient blend of pure rubber and powerful cotton cord fabric ever produced. Greater resilience means greater speed. Price, \$4 each.

**VITALIC
DE LUXE**
\$4.00
Each



Send today for Free Vitalic Testing Section and booklet "Tougher Than Elephant Hide" giving the name and address of your bicycle tire dealer.

CONTINENTAL RUBBER WORKS

1964 Liberty Street . . . Erie, Pennsylvania

Please Mention Popular Mechanics

**VITALIC
BRIGADIER**
\$2.50 Each



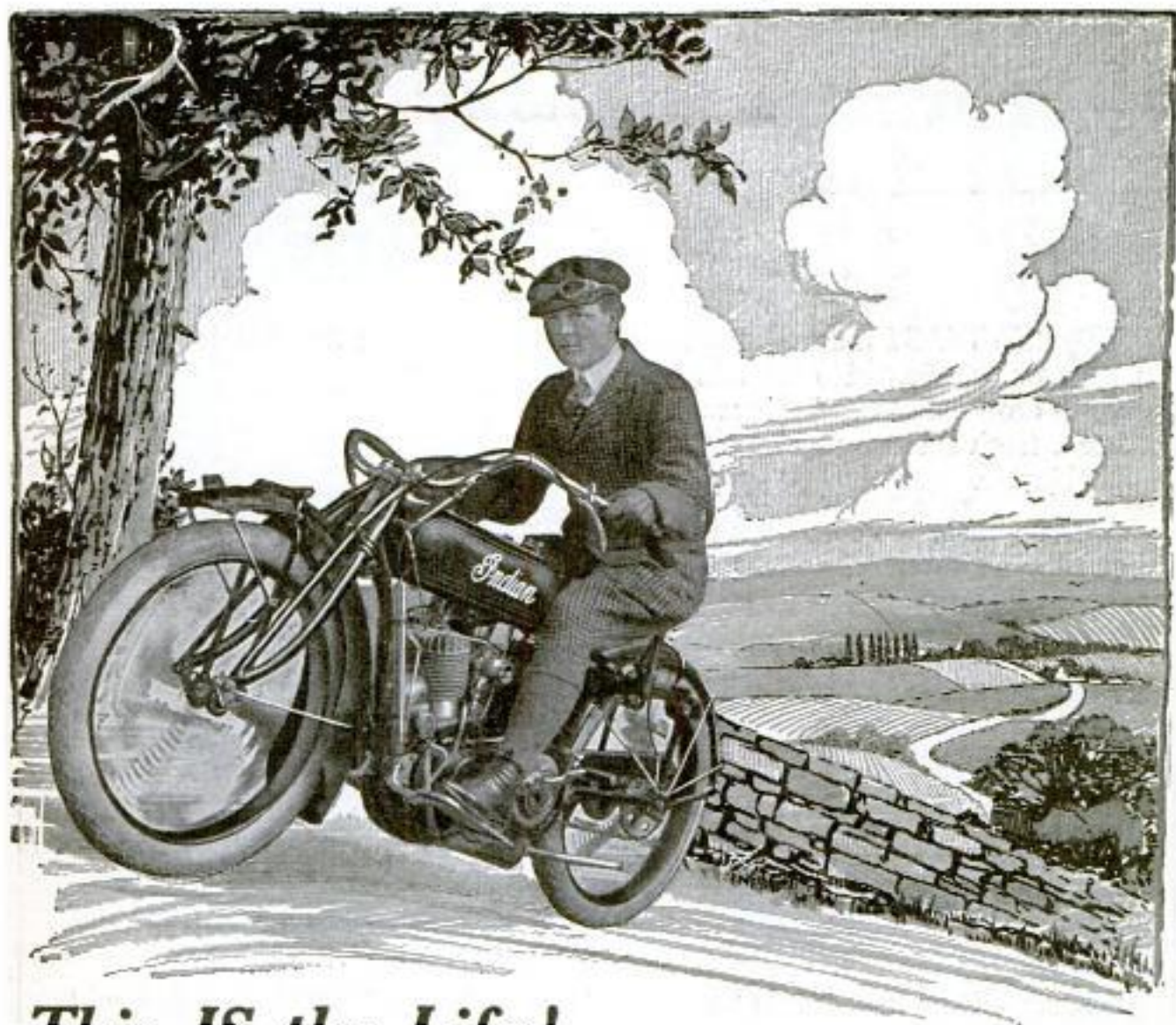

This IS the Life!

Motorcycling is just motorcycling until *you yourself* start the motor, get in the saddle, advance the gas, and gently engage the clutch. An instant—then the supreme thrill of feeling, for the first time, the quick responsiveness to your every touch of the 1917

Indian Motorcycle With Powerplus Motor

Away you go—through cities and towns, up hills, into valleys—wherever you *want* to go—beneath you a motorcycle built for greatest duty and almost human in its faithful, constant *fulfillment* of that duty.

Pictures galore and entertaining description of Indian Powerplus in the 1917 Indian Catalog. Send for it.

Makers also of the 1917 Indian Light Twin Motorcycle, Side Car, Electrically Equipped Bicycle and ten other model Bicycles.

HENDEE MANUFACTURING CO., 710 State Street, Springfield, Mass.
(Largest Motorcycle Manufacturers in the World)

Please Mention Popular Mechanics

Through the Day with a *Columbia* Bicycle

BREAKFAST finished. No hustle or bustle. No running for crowded cars. Off through the keen, fresh morning air on a Columbia bicycle.

Home again at noon — with plenty of time for a restful sprawl on lawn or lounge — then back to work refreshed.

But when the day's toil is done comes the most comfortable time of all — the leisurely ride through streets light-



ed by the setting sun—the spin through the park, or along the country roads—the arrival home with appetite keen and the mind brushed free of the day's cares.

The bicycle today is playing an important part in the life of every man, woman and child in America.



It delivers their mail — runs their errands—helps to fight their battles during time of war.

It is depended upon by thousands

as the means of delightful vacation days — when free as the wind, they can ride through town or country, to beach or lake or mountain camp, as their fancy dictates.



And the Columbia bicycle is the recognized standard of the world. It maintains the same high standard of quality today that Col. Albert A. Pope established thirty-nine years ago when he built the first American bicycle, the Columbia.

Among the 1917 models you will find the exact type of bicycle you are looking for — at the price you wish to pay.



Ask your dealer to show you the Columbia line. Write to-

day for the new illustrated catalog.

**Westfield
Manufacturing Company**

Department 15

WESTFIELD, MASS.

Makers of the Pope Motorcycle



NEW!

Thin Model 17 Jewel Elgin \$3⁰⁰ - A - Month

FULLY ADJUSTED The New Thin Model 17 Jewel Elgin, 12 or 16 Size—The King of all Watchdom—The one Watch that is absolutely Supreme wherever Reliability is a factor. Double sunk dial—Double Roller Escapement—Double Strata Gold Cases—positively the classicst Watch on the American market, NOW OFFERED YOU for the first time on the original Harris-Goar Easy Payment Plan at an astonishingly low, introductory, Money Saving Price.

Our Biggest Offer!

We Sell More Elgin Watches Than any other Firm in the World, and in a "Nutshell," We Know This is the Biggest Offer of Them All—We Know This Thin Model, Fully Adjusted Elgin will be the Happy Surprise of Your Life.

It's just the Watch you have always wanted. It's just the Watch we have long urged the Elgin Factory to produce for you. We knew what you wanted and now we have it for you in this beautifully Adjusted, Thin Model, Light Weight Elgin—"a perfect dream of a Watch"—all fitted in Superba Double Strata 25-year Gold Cases—plain polished—satin finished—monogram—hand engraved—any design to suit your fancy—

Fully Adjusted \$35 Elgin \$24⁸⁵
Now Offered to You for the First Time at the Big Money Saving Price of Only

On Special Terms of Only \$3.85 (After examination) and \$3.00 a Month.

\$5⁰⁰ Gold Chain FREE!

Fine 14k Gold Filled Chain Free if You Send Coupon at Once—A Guaranteed chain of extra quality, made of heavy gold filled stock, all links carefully soldered and burnished—in fact a chain of very superior quality, selected to please you and advertise our business. We have 5000 of them, and while they last we add one Free to the above Watch Offer as Extra Measure but we ask you to send Coupon without delay.

On Approval

You do not risk a cent. You pay nothing until the Watch and Chain have been delivered to you for your own inspection and approval, and then only the small first payment of \$3.85, balance at \$3 a month, and if at any time in 30 days after you have received the Watch and Chain, you are not proud of your Bargain, return them to us, and your small deposit will be promptly returned.

We send this New Elgin and \$5 Free Chain on approval



Free Catalog Watches, Diamonds Jewelry, Silverware.

This Big Special Offer on This New Thin Model Elgin and Our New Catalog will be Mailed You Immediately upon receipt of Coupon. Our New Catalog contains hundreds of illustrations and you can buy any kind of a Watch or Diamond you want on the Easiest and Simplest Payment Plan in the world. No interest—No red tape. Quick Service and More Than 200,000 satisfied customers. But to get our Free \$5 Gold Chain, answer this Ad Now—Today.

COUPON MAIL IT NOW

HARRIS-GOAR CO.,
12th and Walnut Sts.,
Dept. 72 Kansas City, Mo.

Please send me (without obligation and pre-paid) your Special Offer on New 17 Jewel Thin Model Elgin with \$5 Free Chain—Also your New Catalog of Watches—Diamonds, Etc.

Name

Address

To make sure of \$5 Free Chain send us this Coupon at once.

Harris-Goar Co. Department 72
Kansas City, Mo.

The House That Sells More Elgin Watches Than Any Other Firm in the World.

Please Mention Popular Mechanics

Copyrighted material

Russel

Internal Gear Drive Axles

Your Truck Is No Better Than Its Drive Axle

The success of any motor truck is dependent upon the rear axle.

If it is called upon to carry the load and drive the truck at the same time, trouble is bound to occur sooner or later.

That is why the Russel Internal Gear Drive Axle is conceded to be the best motor truck axle built.

The load carrying axle is a one-piece chrome nickel steel round bar—admittedly the best design for carrying purposes.

The drive axle is separate, but rigidly connected to the round bar axle, leaving it free to drive the truck.

Durability, serviceability and economy with efficiency are positively assured with the Russel Axle.

Backed by Russel reputation, no motor truck buyer can afford to place his order for a motor truck without carefully investigating the merits of the Russel Internal Gear Drive Axle.

Russel Motor Axle Company
Central Avenue, North Detroit

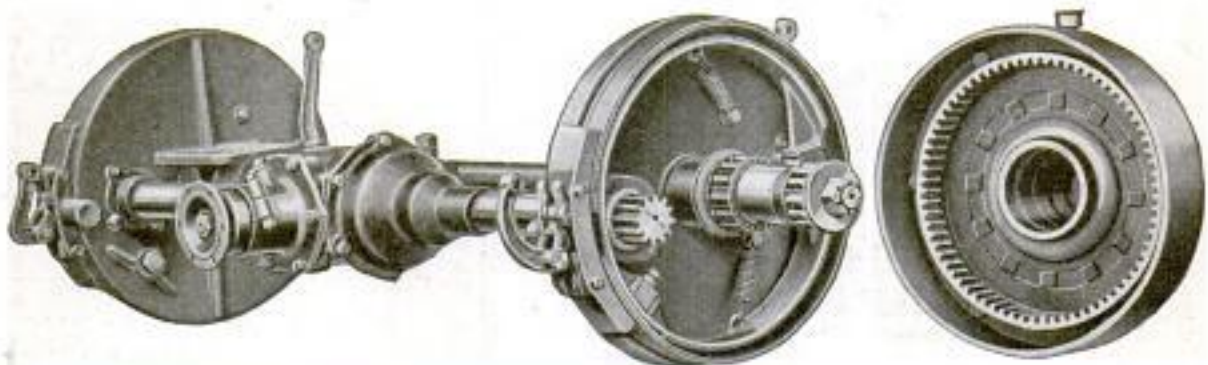



Standard for Accuracy

No matter how skillfully you use tools, your work cannot be accurate unless the measuring tools with which you lay out and check up the work are of the highest practical degree of accuracy. It is easy to measure accurately with

TRADE MARK
Starrett
REG. U. S. PAT. OFF.
Tools

These fine measuring tools are the recognized standard for accuracy among the finest tool-makers and machinists in the country.

There are rules, tapes, squares, levels, calipers, dividers, micrometers, vernier calipers, height and depth gages, wire gages, screw drivers, cabinet scrapers, nail sets, hack saws, etc., described in our free catalog No. 21AP.

Write for Your Copy Today

42-660

The L.S. Starrett Co.

The World's Greatest Toolmakers

Athol, Mass



Please Mention Popular Mechanics

DISSTON

SAWS AND TOOLS

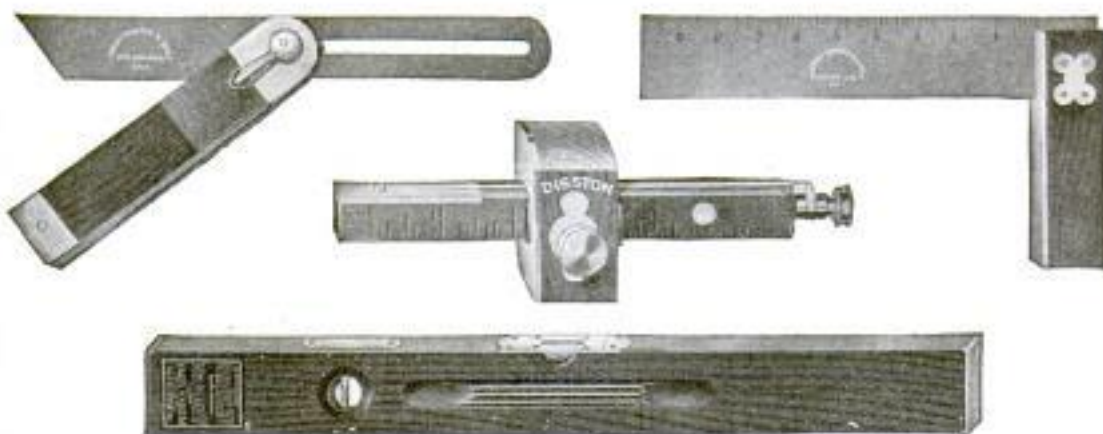

Apply Disston Standards to Your Own Work

A try square, level, gauge or bevel is of value to its user only in proportion to its accuracy. Approximate accuracy is not enough. It must be as nearly perfect as human ingenuity can make it.

A building erected by other than the most accurate methods would be unsafe. A piece of furniture made by other than the most accurate cabinet work would be practically worthless.

The name Disston on a measuring tool, level or bevel, is an assurance of accuracy, as the same name on a saw or trowel or screw-driver or other tool

is an assurance of the highest quality attainable.

Whether you are a mechanic whose livelihood depends on the quality of the work you do, or an amateur tool-user who takes pride in doing a workmanlike job, you owe it to yourself to lay out and test your work by instruments of Disston accuracy.

Free Booklet for Tool-Users

Let us send you, free, our "Hand-Saw Booklet." It tells how to select, use and care for saws and the other Disston tools. Address

HENRY DISSTON & SONS, INC. - PHILADELPHIA, U. S. A.
Canadian Works: Toronto, Canada



Please Mention Popular Mechanics

For the Home Workshop

WHETHER used in the line of business or for amusement, a lathe in your workshop opens up a new world of possibilities — a sort of fourth dimension. It enables you to make models, patterns, small machines, in wood or metal, that were utterly impossible before. The Amateur Bench Lathe fills this need at the least expense consistent with quality. It is well made, of good materials, excellent design, and accuracy sufficient for all ordinary uses. It takes work up to 12 inches in length and has a swing of 7 inches. The lathe proper is furnished complete as shown, with a saw arbor and a three-jawed chuck in addition.

With various attachments that you can get from us or make yourself, it is possible to do almost any wood or metal work within the capacity of the machine.

For more information about the lathe, or about the 1500 other good tools, send for the complete catalog.

GOODELL-PRATT COMPANY

Toolsmiths

GREENFIELD, MASS.

*Partial List of
Goodell-Pratt Tools*

Hacksaws	Screw-drivers
Drills	Micrometers
Levels	Calipers
Grinders	Mitre Boxes
Vises	Bit Braces
Squares	Glass Cutters

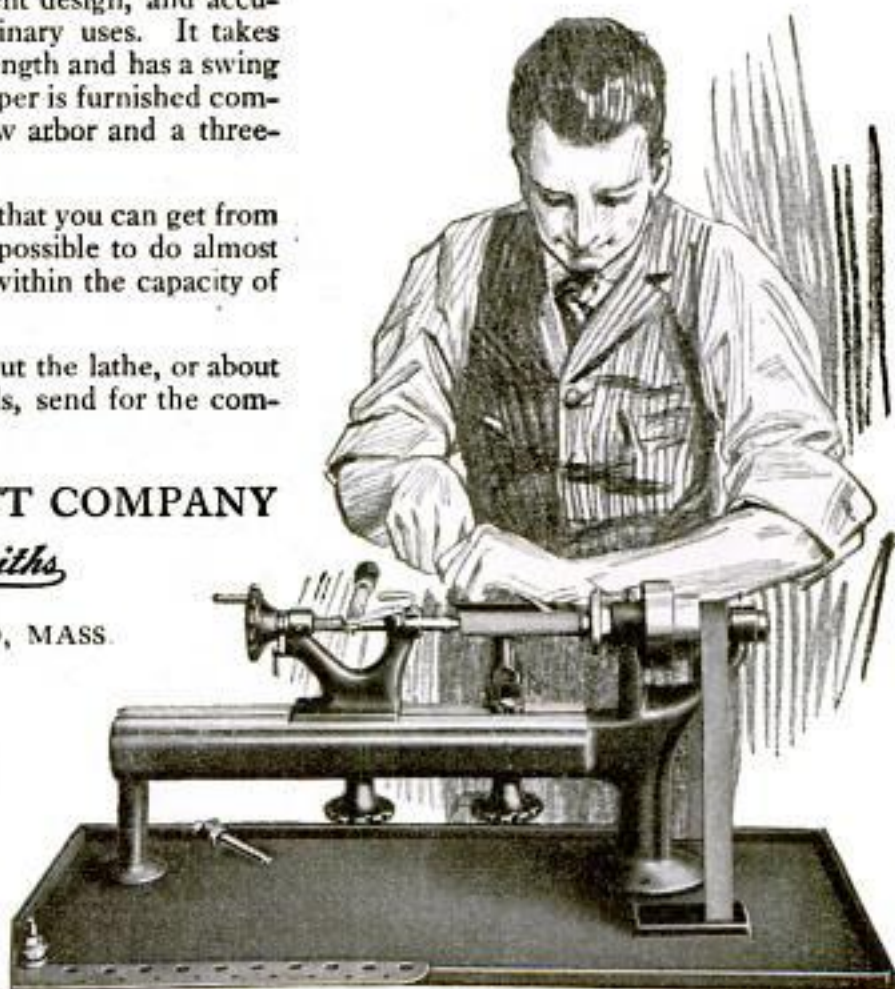

GOODELL PRATT

1500 GOOD TOOLS

Please Mention Popular Mechanics

Copyrighted material

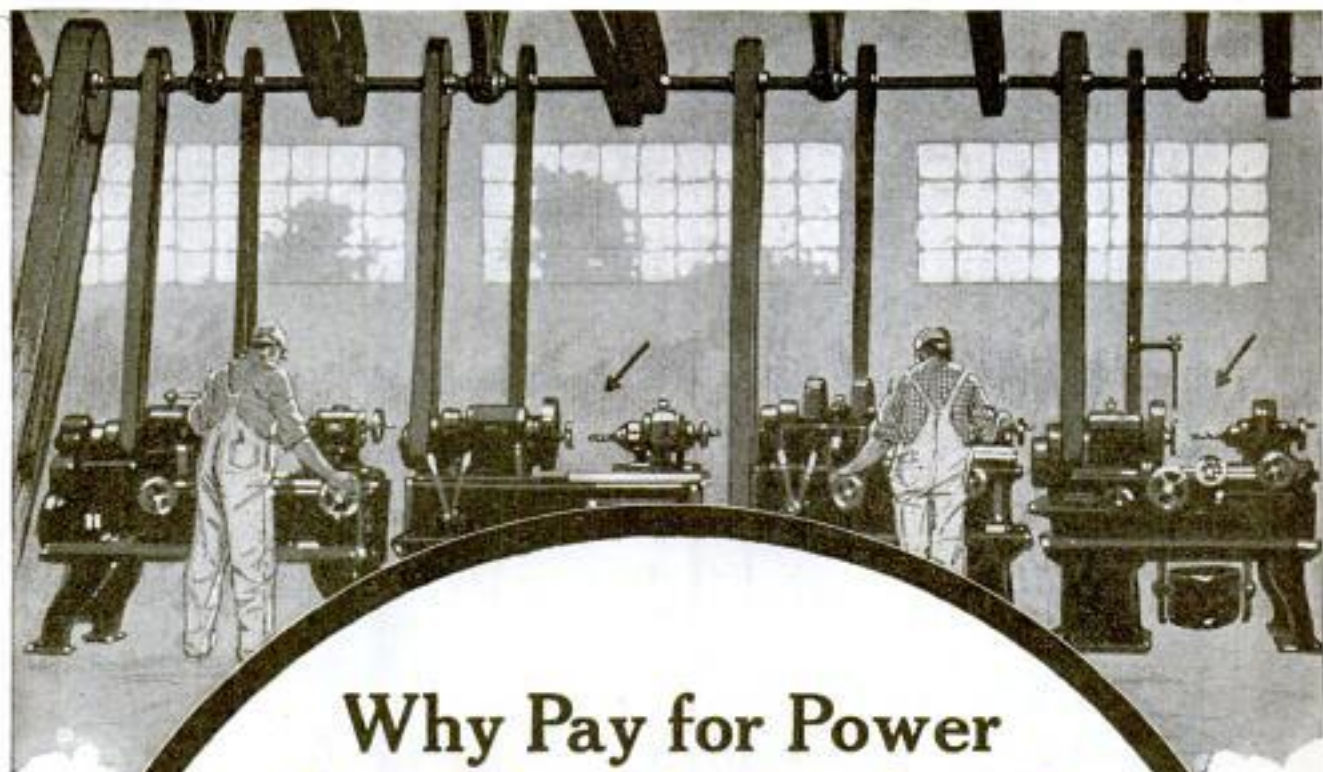

Why Pay for Power that Doesn't Produce?

That's what you're doing when you run your machine by means of a long line-shaft and belts.

For the power that produces is the power that's delivered *right at the machine*, and with line-shafting and belts only part of the power transmitted to the shaft finds its way to the point of production.

It takes power to turn the shafting. It takes power to overcome belt-friction. And lost power means lost dollars.

But great as is the waste with every machine running, it's even greater with idle ones on the line. If but a single machine is operating,

the same long heavy shafting must be turned.

More and more manufacturers are realizing that the use of line-shafts and belts means paying for power that doesn't produce. That's one of the reasons for the great extension of individual electric motor drive.

With a Westinghouse Motor on every machine, you pay for only the power that yields returns. And that's but one of the many advantages of Westinghouse Individual-Drive Motors.

Let Westinghouse engineers study your power problem. They'll soon learn what individual drive will do for you. If they find it isn't so well adapted to your needs as some other kind of drive, they'll tell you so. This service won't cost you a cent, and it may save you thousands of dollars.

WESTINGHOUSE ELECTRIC & MANUFACTURING CO.
East Pittsburgh, Pa.

Westinghouse

MOTORS AND CONTROLLERS



Please Mention Popular Mechanics

Copyrighted material



Here You Pay
for *Only* the Power
that *Produces*

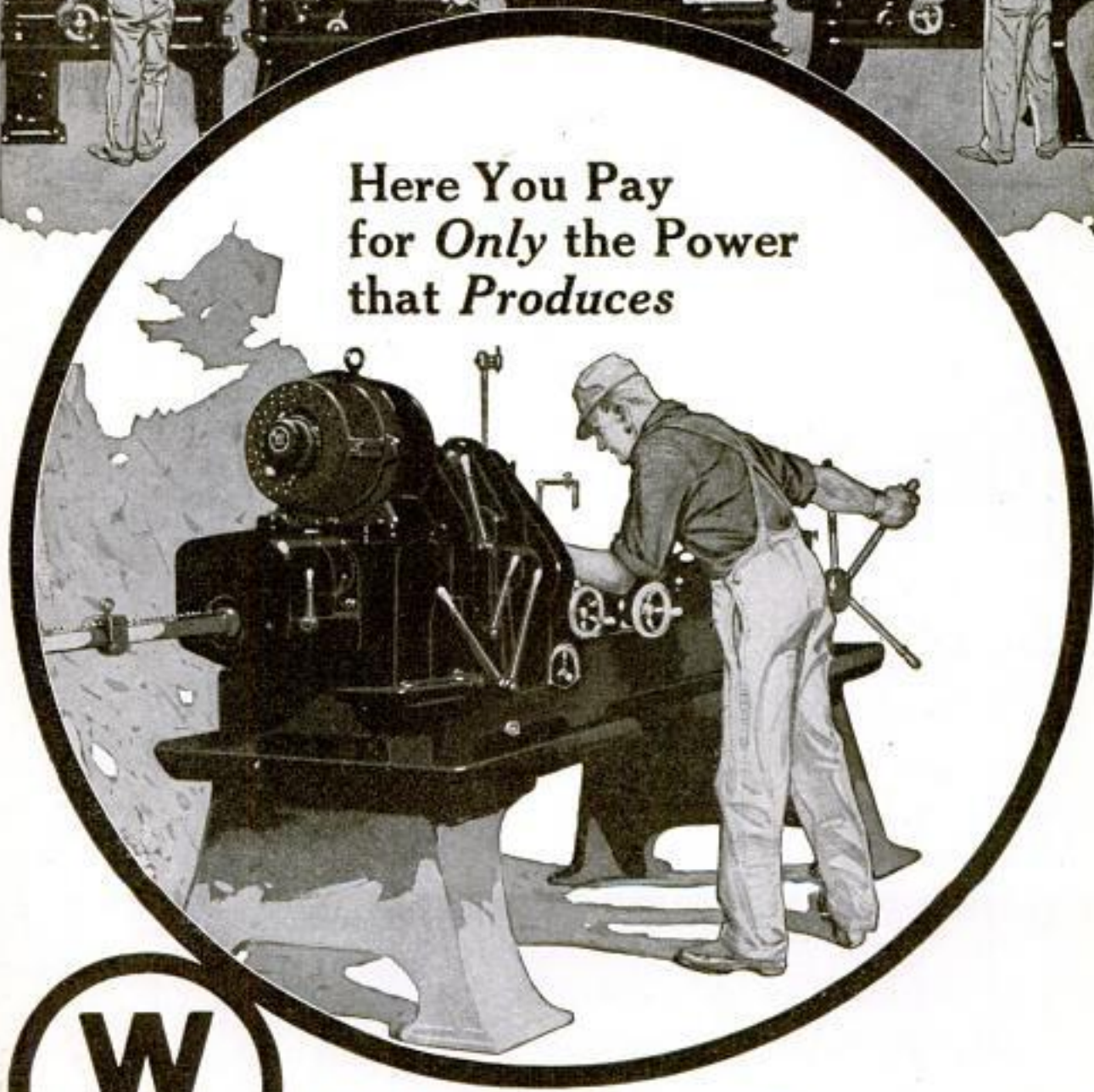

Westinghouse
MOTORS AND CONTROLLERS

Please Mention Popular Mechanics



OIL BANKING

How shrewd motorcyclists save money

WHEN most motorcyclists were novices, strong words made strong impressions.

But today the roads are toured by thousands of veterans. These veterans have learned how to test words. They know how to prove or disprove claims.

If you are a veteran you know this: An oil that burns up rapidly or breaks down quickly cannot be really cheap. Though it may be low-priced by the gallon, it is bound to prove high-priced by the mile.

You know that a wrong-bodied oil raises your gas

consumption. Instead of saving your oil pennies it eats up your gas dollars.

You know that wear-and-tear on the metal parts means, some day, a heavy bill which the low price per-gallon can never wipe out.

In recent years no oils have made such steady progress toward a dominant place in the market as Gargoyle Mobiloils.

Why?

Because now-a-days experienced motorcyclists have learned that gasoline saving depends largely on thorough piston-ring seal—they know that the piston-

ring seal depends solely on the *body and character* of their lubricating oil.

Because the experienced motorcyclist knows that an oil which uses up rapidly is not lubricating properly.

Because the experienced motorcyclist of today knows that the higher price per gallon of Gargoyle Mobiloils means a lower cost per mile in operating expense.

Write for new 56-page booklet containing complete discussion of your lubrication problems and Complete Charts of Recommendations for Automobiles, Motorcycles, Tractors and Marine Engines.



Mobiloils

A grade for each type of motor

In buying Gargoyle Mobiloils from your dealer, it is safest to purchase in original packages. Look for the red Gargoyle on the container. If the dealer has not the grade specified for your motorcycle, kindly write our nearest branch, giving dealer's name and address.

VACUUM OIL COMPANY
Rochester, N. Y., U. S. A.

Specialists in the manufacture of high-grade lubricants for every class of machinery. Obtainable everywhere in the world.

Domestic Branches:

Detroit Boston New York Chicago Philadelphia Indianapolis
Minneapolis Pittsburgh Des Moines Kansas City, Kan.

Correct Motorcycle Lubrication

Explanation: The four grades of Gargoyle Mobiloils for engine lubrication, purified to remove free carbon, are:

Gargoyle Mobiloil "A"
Gargoyle Mobiloil "B"
Gargoyle Mobiloil "E"
Gargoyle Mobiloil "Arctic"

In the Chart below, the letter opposite the motorcycle indicates the grade of Gargoyle Mobiloils that should be used. For example, "A" means "Gargoyle Mobiloil A," "Arc" means "Gargoyle Mobiloil Arctic," etc. For all motorcycle transmissions use Gargoyle Mobiloil "C." The recommendations cover all models of the same make, unless otherwise noted.

MODEL OF MOTORCYCLES	1917		1916		1915		1914		1913	
	Summer	Winter	Summer	Winter	Summer	Winter	Summer	Winter	Summer	Winter
A. M. C.			B	A	B	A	B	A	B	A
American							B	A	B	A
Amer. Peugeot (2 cyl.)							B	A	B	A
" (4 cyl.)									B	A
Arrow									B	A
Autoped	B	B	B	A					B	A
Auto Tri.									B	A
Bailey Flyer							B	A		
Black Hawk									B	A
Cleveland	B	B	B	B						
Crawford							B	A		
Curcio							B	A	B	A
Cyclomotor	B	B	B	B						
Cyclone					B	A	B	A	B	A
Dayton	B	A	B	A	B	A	B	A	B	A
De Luxe (2 cyl.)							B	A	B	A
" (2 cyl.)			B	A	B	A	B	A	B	A
Eagle					B	A	B	A	B	A
Emblem (1 cyl.)			B	A	B	A	B	A	B	A
" (2 cyl.)			B	A	B	A	B	A	B	A
Excelsior	B	A	B	A	B	A	B	A	B	A
" (Lightweight)			B	B						
Fellbach									B	A
Flanders					B	A	B	A	B	A
F. N.									B	A
Gen.									B	A
Greyhound									B	A
Harley-Davidson	B	A	B	A	A	Arc	A	Arc	A	Arc
Henderson	A	A	B	A	B	A	A	A	B	A
Indian (1 cyl.)			B	A	B	A	B	A	B	A
" (2 cyl.)			B	A	B	A	B	A	B	A
Jay Johnson	B	A	B	A	B	A	B	A	B	A
Jefferson							B	A	B	A
Limited							A	Arc		
Majestic									B	A
Marvel									B	A
Maxie Triear							B	A	B	A
Merckel	B	A	B	A	B	A	B	A	B	A
Miami (Power Bicycle)	B	A	B	A	B	A	B	A	B	A
Michelson					B	A	B	A	B	A
Militaire			A	A						
Minneapolis									B	A
M. M.									B	A
Monarch					B	A	B	A	B	A
Motorette					E	E	E	E	E	E
New Era									B	A
New Hudson									B	A
N. S. U. (1 cyl.)									B	A
" (2 cyl.)									B	A
Okay	B	B							B	A
P. E. M.									B	A
Peugeot									B	A
Pierce (1 cyl.)							B	A	B	A
" (4 cyl.)							A	Arc	B	A
Pirate							B	A	B	A
Pope	B	A	B	A	B	A	B	A	B	A
Reading Standard	B	A	B	A	B	A	B	A	B	A
Reliance									B	A
Schickel	B	A	B	A	B	A	B	A	B	A
Scout									B	A
Show			B	A	B	A	B	A	B	A
Smith (Motor Wheel)	A	A	A	A	A	A				
Therion							B	A	B	A
Thor (1 cyl.)	B	A	B	A	B	A	B	A	B	A
" (2 cyl.)	B	A	B	A	B	A	B	A	B	A
Tiger Automobile					B	A	B	A	B	A
Wagner			B	A	B	A	B	A	B	A
Yale (1 cyl.)					B	A	B	A	B	A
" (2 cyl.)					B	A	B	A	B	A

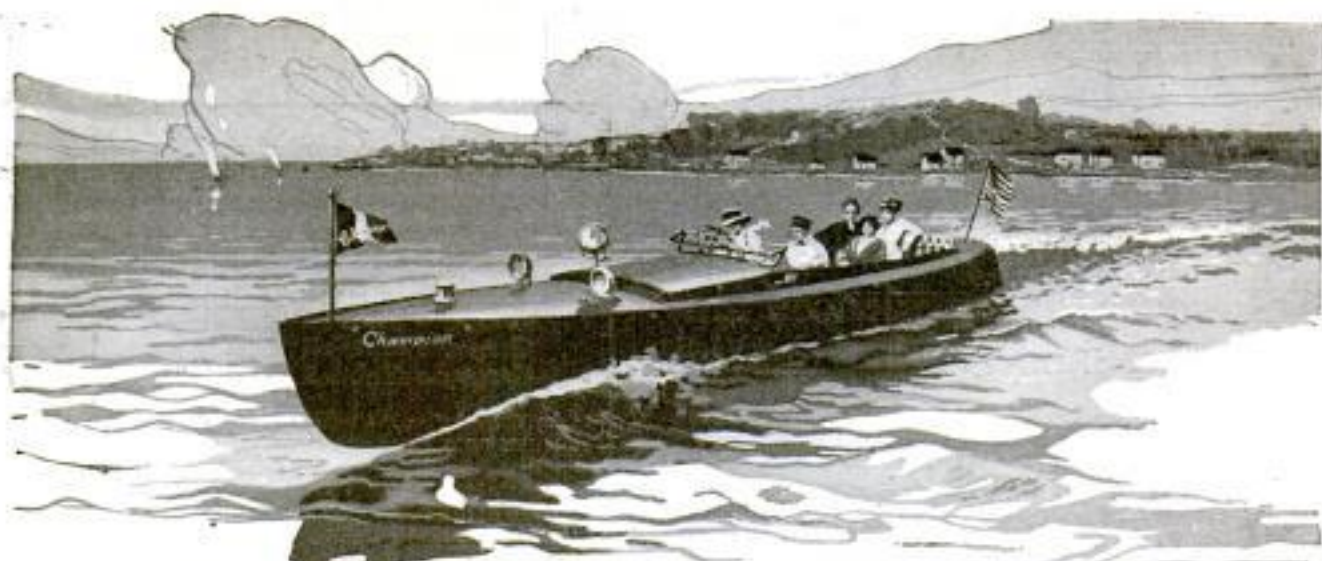

Champion Toledo

Get Off to a Flying Start with Champion Spark Plugs

A little care right now in the selection of your spark plugs may be the means of saving you a lot of time and worry over "engine troubles" later on in the season.

Make your engine give you the best it has in it this summer by equipping it with Champion dependable spark plugs.

Champion plugs perform their duties steadily. They furnish big, fat, hot sparks at all times. They do not miss, crack or weaken under the incessant hammering of the explosions.

There is a Champion Plug especially designed—not only for marine engines, but for every type of motor car, motor-cycle, gas and stationary engine.

*Every dealer carries Champions.
Insist upon them.*

See that the name "Champion" is on the porcelain—not merely on the box.

Champion Spark Plug Co.
416 Upton Avenue
TOLEDO, O.



**CHAMPION
HEAVY STONE
Price, \$1.25**

Please Mention Popular Mechanics

◆ FAIR LIST PRICES ◆

◆ FAIR TREATMENT ◆

The Trade has 400 Tires
The Speedway But **ONE**
GOODRICH
SILVERTOWN
CORD TIRES

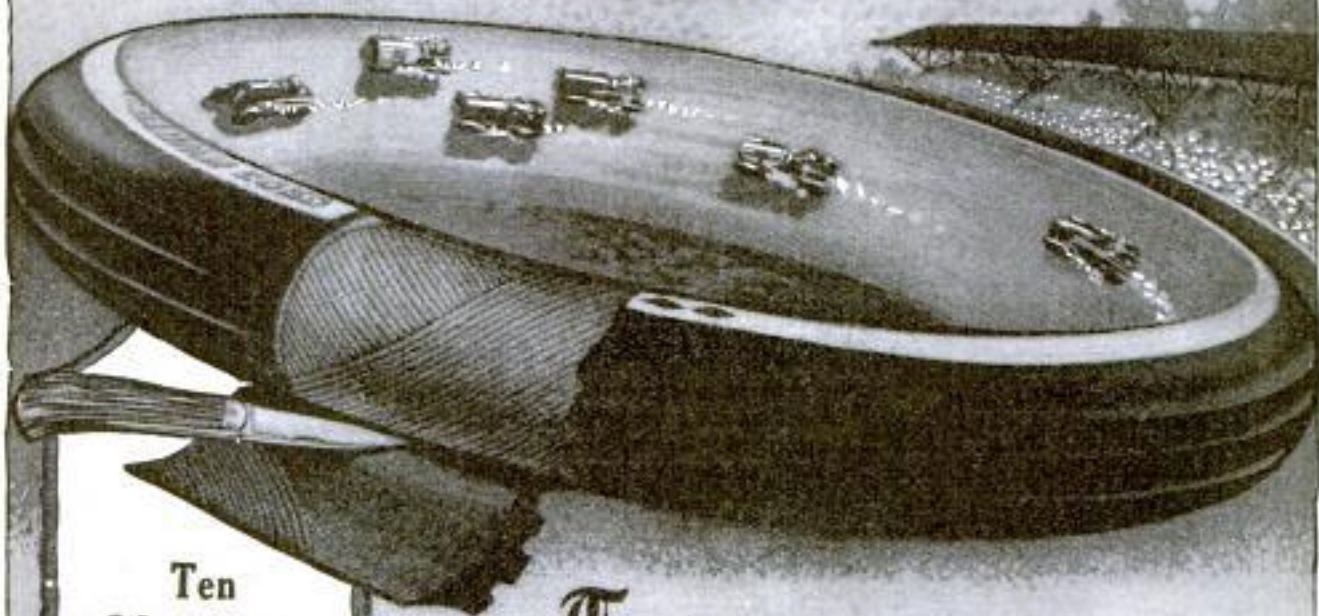

Ten
Silvertown
Cord X-cels

1. Increased engine power.
2. Smoother riding.
3. Fuel saving.
4. Speedier.
5. Coast farther.
6. Start quicker.
7. Easier to guide.
8. Give greater mileage.
9. More resistive against puncture.
10. Repaired easily and permanently.

THOUGH rubber making has given birth to more than 400 brands of automobile tires, the racing season of 1916 demonstrated that there is but one tire with the *resilience* to produce the 100-mile-an-hour pace and the *durability* to stand the stress of that pace—SILVERTOWN—the original and only CABLE CORD tire.

Driving solely on Silvertowns, Dario Resta won the National Racing Championship of the A.A.A., the only championship awarded to an automobile racing driver.

And SILVERTOWN equipped cars scored 15,582 points toward the trophy, to 7,176 by all Silvertown's competitors combined.

Know Silvertown by its Red Double-Diamond trademark—the tire you can not afford to be without.

Where You See This Sign—
Goodrich Tires are Standard



THE B. F. GOODRICH COMPANY, Akron, O.

Also maker of the famous fabric tires—Goodrich Black Safety Treads

◆ ◆ "SILVERTOWNS MAKE ALL CARS HIGH-GRADE" ◆ ◆

Please Mention Popular Mechanics



DODGE BROTHERS CLOSED CAR

The number of those who prefer the Sedan for use throughout the year is steadily increasing

The reason is easily understood when you consider how adaptable it is to the frequent weather changes common to all parts of the country. Almost instantly it can be changed to accommodate itself to heat or cold, rain or shine

Touring Car or Roadster, \$835. In Canada, \$1185
Winter Touring Car or Roadster, \$1000. In Canada, \$1420
Sedan or Coupe, \$1265. In Canada, \$1800
All prices f. o. b. Detroit

DODGE BROTHERS, DETROIT

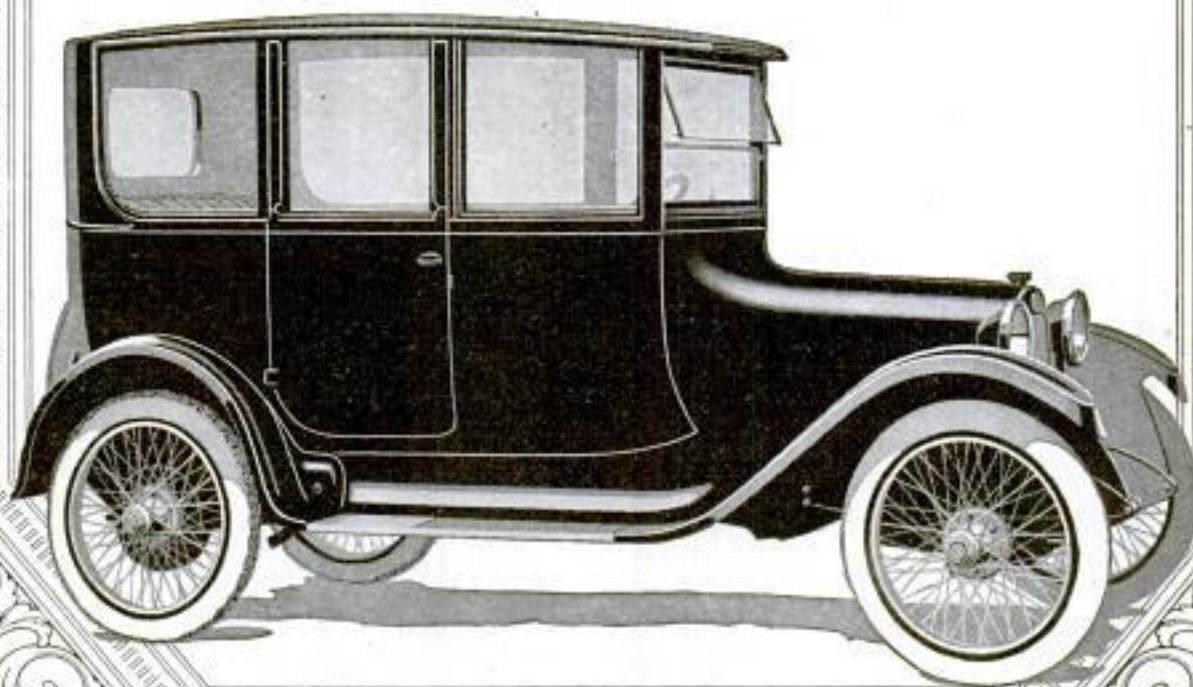

Please Mention Popular Mechanics

Oxy-Acetylene Welding and Cutting

Let This Process Lower Production Costs in Your Shop or Factory

Automobile manufacturers today employ the oxy-acetylene welding process with great profit. Using it as a routine production method, they are increasing output, securing new features in design, greater strength and decreased weight in vital parts, at the same time effecting substantial savings in time, cost of labor and materials.

These savings and advantages are possible for your shop or factory. Where you now use rivets, bolts or threaded points, investigation may show a real need for welding.



Rear axle brace of Packard Chainless - Drive Truck. Operator is welding an "eye" to end of rod. Welding is found superior to drop forging or stamping in that it strengthens a vital part of the rear axle-brace.

Not only is oxy-acetylene welding of great value as a manufacturing process, but it effects big savings in repair work of all kinds—broken or worn metal parts and castings quickly and inexpensively reclaimed for useful service—in factories, large and small, and in thousands of repair shops.

Prest-O-Lite PROCESS

Employs both gases (acetylene and oxygen) in portable cylinders. Prest-O-Lite Dissolved Acetylene (ready-made carbide gas) is backed by Prest-O-Lite Service, which insures prompt exchange of full cylinders for empty ones. Provides dry, purified gas, insuring better welds, quicker work and lower cost, and also avoids the large initial outlay and heavy depreciation incurred in making crude acetylene in a carbide generator.

Necessary equipment is not expensive. We furnish high-grade welding apparatus for \$75 (Canada, \$100); acetylene service at additional cost. Adaptable for oxy-acetylene cutting by the addition of special cutting blow-pipe. Thorough instructions are furnished free to every user of Prest-O-Lite Dissolved Acetylene—any average workman who understands metals can learn the process quickly and easily.

Secure the economies and advantages of oxy-acetylene welding for your shop or factory—NOW. Let us send you valuable data and information. Write today.

Job Welding Pays Good Profits

Every repair shop—every enterprising mechanic—should realize the worthwhile profits easily made by oxy-acetylene welding. There is a large, steadily growing demand for oxy-acetylene welding repairs. The cost of necessary welding equipment is low. Let us give you full details.

The Prest-O-Lite Co., Inc.

Main Office and Factory: 816 Speedway, Indianapolis, Ind.
Canadian Main Office and Factory: Toronto, Ontario

World's Largest Makers of Dissolved Acetylene: 55 Branches and Charging Plants in Principal Cities

IF-



IF the brake had not held, what turned out to be "just a scare," might have been a serious accident. Realize that nothing saved them except their brakes.

An automobile brake is no better than its lining. Send today for our booklet "IF" — which tells you what you ought to know about the brakes on your car.

REG. U.S. PAT. OFF.

TESTBESTOS

Automobile Brake Lining

AMERICAN ASBESTOS COMPANY
 1208 Stambridge Street, Norristown, Pa.
 Manufacturers of Asbestos Yarns, Cloths, Theatre
 Curtains, Tapes, Packings, Gaskets, Multiple
 Disc Clutch Rings, Etc.



If-



Join
 the
**Look-it-over
 Club**
*Ask your
 garage man*

Wherever you see the metal sign "TesTbesTos Tim" and the "Look-it-over Club" emblem, you will find a garage prepared to give you satisfactory service at a reasonable price. If your garage man has not taken up the Look-it-over Club idea, suggest it to him.

Please Mention Popular Mechanics

Copyrighted material

SAXON ROADSTER

A CAR COMPLETELY EQUIPPED WITH EVERY MODERN FEATURE

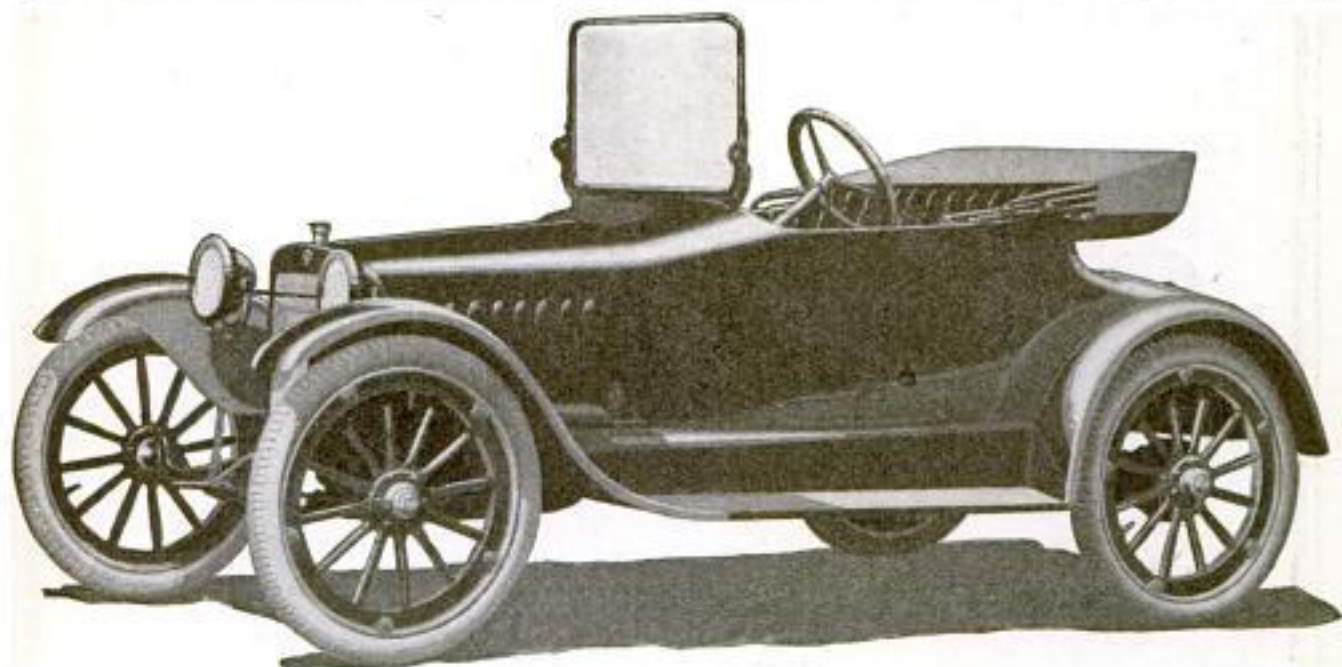

Lowest-Priced Car with These Costly Features

Electric starting and lighting system,
two-unit type, built by Wagner
Demountable rims
30 inch by 3 inch tires
High-speed Saxon Continental Motor
Reichenbach carburetor
3-speed transmission

Dry plate clutch
Hyatt Quiet bearings
Streamline body
Honeycomb radiator
Atwater-Kent ignition
Extra long vanadium steel springs,
cantilever type

This new series Saxon Roadster is completely equipped with every modern motor car feature. It has a 2-unit electric starting and lighting system built by Wagner—the finest that can be purchased. So there's no cranking to be done. Simply press a button convenient for your heel and your motor is running. And you are always certain of full-shining lights.

Next among the added attractions is its new-style body. The design is of the newest mode. The body is larger with greater roominess and added seat space and leg length.

With thought of further comfort for you, demountable rims and 30 inch by 3 inch tires have been made part of the equipment. So in event of some tire mishap a change is readily made.

A new style top with Grecian rear bow enhances the outward attractiveness of Saxon Roadster. And among the further conveniences of equipment is an electric horn; extra tire carrier; speedometer; ventilating windshield; adjustable pedals; storm curtains; one-man rubber top and top cover.

And beyond all this, Saxon Roadster has the added advantage of being the **world's low-cost car** to drive. It gives the most miles of satisfactory service at the least expense.

The Saxon Roadster is \$495; Saxon "Six" Touring Car, \$865; Six Sedan, \$1250, f. o. b. Detroit. Canadian Prices—Six Cylinder Touring Car, \$1175; Touring Sedan, \$1675; Four-Cylinder Roadster, \$665. Price of special export models, "Six," \$965; Four, \$495; f. o. b. Detroit.

(999)

SAXON MOTOR CAR CORPORATION, DETROIT

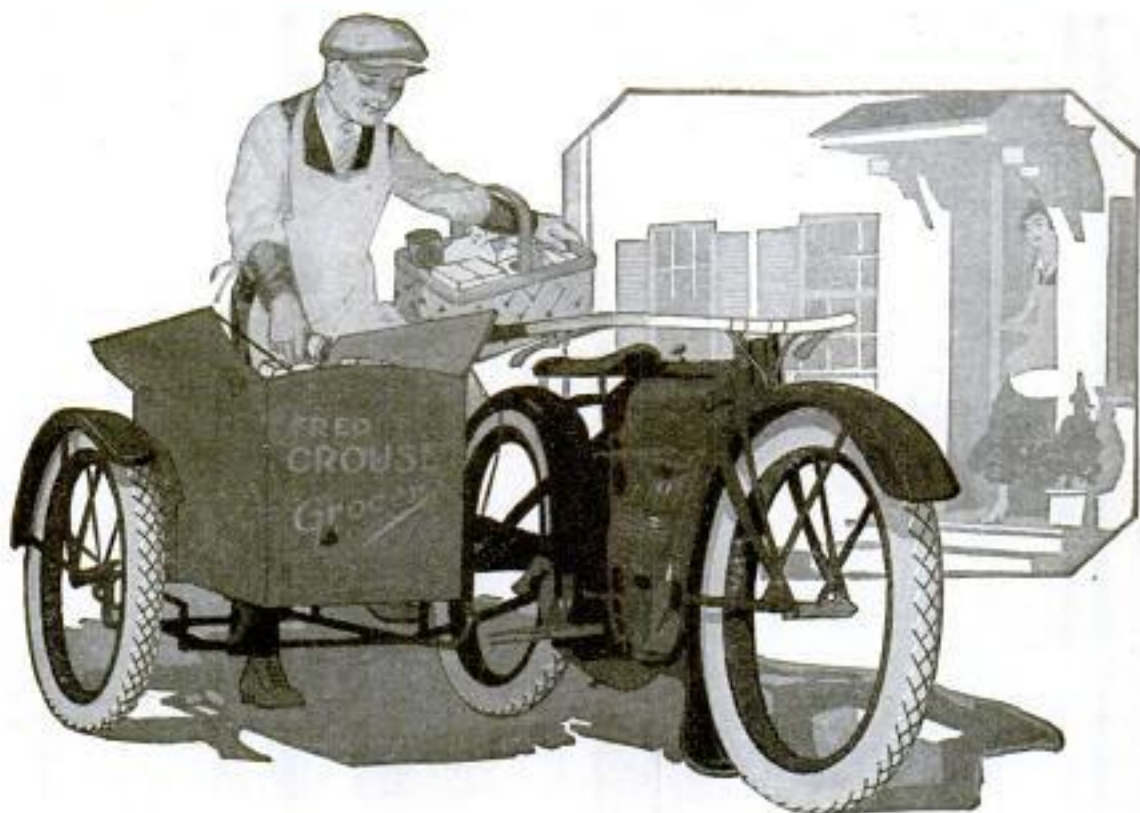

BLUE STREAKS

Unexpected guests for dinner. You telephone the grocer. As a modern merchant, he is prepared to serve you quickly. His motorcycle is as needful as the telephone. And Goodyear Blue Streak Motorcycle Tires play a major part in making his delivery service critic-proof.

They win satisfied patrons. In business, pleasure, racing and military service they are chosen for the un-failing service Goodyear builds into them. That same service is there when you want it.

Blue Streaks Deliver: Economy, Mileage, Speed, Service. Everywhere—one standard, one quality, one guaranty.

The Goodyear Tire & Rubber Co.
Akron, Ohio

GOODYEAR
AKRON

BRUNSWICK

HOME BILLIARD TABLES



"Baby Grand" Brunswick—favorite home table with complete Playing Outfit FREE and patented Interchangeable Cushions for all 33 Carom and Pocket Billiard games.

The Family Playground

Is the Billiard Table

And a Few Cents a Day Will Buy It

Carom and Pocket Billiards are today the reigning sport in American homes. Parents now praise billiards for its magic charm in making home the favorite haunt of boys and girls.

When the day's work is over and the mind craves relaxation, renew the vigor of youth at Carom or Pocket Billiards. In these rollicking contests of wit and skill, meet with your guests and young folks, man to man!

Low Prices— Balls, Cues, Etc., FREE

Pay while you play. This is a plan that any home can afford. There are no heavy after-costs.

Complete high-class Playing Equipment is included FREE—Balls, Cues, Markers, Rack, Cue Clamps, Tips, Chalk, expert book of 33 games.

Beautiful Woods— Scientific Accuracy

Fast Monarch rubber cushions, scientific accuracy, life, speed and action make Brunswick tables the choice of experts.

Beautiful oak and mahogany woods and masterful cabinet work make them an adornment worthy of the finest home.

Accept This Trial Offer

First see these tables in our handsome color-book and catalog, "Billiards—The Home Magnet." It tells how we let you try any Brunswick for 30 days in your home.

Write for this interesting book. It's Free!

The BRUNSWICK-BALKE-COLLENDER CO.
Dept. 50F, 623-633 So. Wabash Ave., CHICAGO

Send Today For Catalog

The Brunswick-Balke-Collender Co.,
Dept. 50F, 623-633 So. Wabash Ave., Chicago

Without obligation, I should like to receive a free copy of your color-catalog, "Billiards—The Home Magnet," and details of your free trial offer.

Name.....

Address.....



INSTALL ^{Your Own} PLUMBING

Our new *Hardin Easy Way* enables anyone to easily install a complete plumbing or heating system. Our method is perfect, simple, and easy. Reduce the high cost. Install your own plumbing and save time, labor and material. Our 40 years selling plumbing and heating goods *exclusively* direct has qualified us to turn out all material equipped with patented easy adjustable connections that any handy man can do the work himself and SAVE $\frac{1}{2}$.

Our Service Helps You Plan and Install

Send a sketch or plan of any plumbing or heating job. This department will show you the easiest and cheapest way. They will draw simple, clear and easily understood installing plans free. If necessary, we will loan you the tools. Our *Cut-to-Fit* steam, hot water and air heating plants save the high cost of labor, unused material, costly delays, time and price. Buy *direct* from the producer.

Send for Valuable "Handy-Man" Book

This book tells you in advance what your plumbing and heating will cost. Gives you suggestions on what fixtures to select and how to install them. Every contractor, home owner, institution, etc., needs this valuable book. It explains the new *Hardin Easy Way*. Tells you how to save on material, time and labor by putting in plumbing this new, original, exclusive, practical, and economical way. It contains a complete line of latest improvements and new designs in guaranteed plumbing and heating outfits, water supply systems, sinks, roughing-in goods, pipe, fittings, valves, etc., and all parts and repairs at *wholesale prices*. It also contains practical and exclusive information of value to every builder.



P. M.
MAY '17
FREE
"Handy-Man"
BOOK COUPON

The Hardin-Lavin Co.
4540-505 Cottage Grove
Ave., Chicago

Please send me your
"Handy-Man" Free Book
showing everything in plumbing
and heating supplies at
lowest wholesale prices.

Name

Address

Money-Back Guarantee

Our "*Money-Back Guarantee Label!*" is on every fixture. It protects you, and assures you that all *Hardin-Lavin* fixtures are Highest Quality, Grade A, Guaranteed. Our aim is to furnish plumbing and heating plants with new, original, easy installing features, combining highest quality, lasting durability, and complete satisfaction.

Immediate Delivery This is as much a part of our special service as our guaranteed quality or wholesale prices. 40 Years in Business at the same address is a record to be proud of. It speaks volumes for our wholesale price policy and money-back guarantee. Send for free "Handy-Man" Book and full particulars. \$500,000 plants behind our guarantee.

The Hardin-Lavin Co.

40 Years at
4540-505 Cottage Grove Ave.
CHICAGO



**FREE
TRIAL
OFFER**

Be Your Own Salesman and Save \$51—

New Oliver Typewriters for \$49

Let us send you a brand new Oliver Nine—the world-famous typewriter—for five days' free trial. Keep it or return it.

That is our plan in a nutshell. Our new plan—besides saving you \$51—makes it easy for every one to convince himself of Oliver superiority. No red-tape—no money down—no C. O. D. No salesman to influence you. No need to ever pay \$100 for a typewriter again.

But here is a warning— all advertisements for *brand new* Oliver Nines at \$49 must be signed by the Oliver Typewriter Company.

Prices Cut in Two— and Why

With greater production and huge financial resources, the Oliver Typewriter Company is the pace setter.

Its officials seek to relieve the public of a useless tax. In the past, it has cost \$51 to sell typewriters through an expensive sales force—high rents for offices in 50 cities—and other frills. All are wasteful from an economic viewpoint. That is why Oliver Nines are shipped direct from the factory to the user—on free trial. This permits us to wholesale machines to you for \$49. You get the saving. No middlemen with their tolls.

This plan, we feel sure, is in keeping with modern demands. All will welcome such a sincere effort to reduce the High Cost of Typewriters.

10 Cents a Day

Easy payments of \$3.00 per month. This in addition to our cutting the price in two. Could any one go further? Yet we offer this free trial without obligation on your part. The plan is daring—but we believe discerning people will respond.

This is the first time in history that a new, never-used \$100 typewriter of the latest model has been offered at the price of cheaper or second-hand machines. It is cheaper to own than rent.

No Money Down

Simply send in the coupon properly filled in. There is no red tape—no salesmen—no collectors—no bother. Keep the Oliver for \$3.00 per month. Or return it. It is up to you.

Mail the coupon today.

The Oliver Typewriter Company
1095 Oliver Typewriter Bldg., Chicago

This Is Our Offer

No Money Down. No C. O. D.

Easy Monthly Payments

Maker and user deal direct. You are your own salesman. You pay yourself the \$51. Own this master typewriter at the rate of \$3.00 per month.

The Oliver Nine itself must convince you. It is the greatest, the most durable, the most successful typewriter ever built. No finer can be bought for any price. It is a twenty year development.

There is no need now to ever pay \$100 again for a new typewriter. The Oliver rebellion gives everyone an opportunity to own an Oliver. And at the lowest time payments.

This is the same machine used by the largest concerns. It has all the latest improvements.

For speed and fine workmanship, it can't be beat.

If after trial of 5 days, you are not satisfied—ship it back at our expense.

MAIL TODAY



Over 600,000 Sold

Do Not Confuse

This \$49 Oliver is *not* a second-hand nor rebuilt machine—but brand new, direct from the factory to you. It is not a special model—but the identical machine that was \$100. Reduced selling expenses saves you \$51.

Some of the big concerns using Oliver's are: U. S. Steel Corp., Standard Oil Co., Nat'l City Bank of N. Y., Montgomery Ward, Pennsylvania R. R. The Oliver is famous the world over. You can now own one for 10c per day.

FREE TRIAL COUPON

THE OLIVER TYPEWRITER CO.

1095 Oliver Typewriter Bldg., Chicago

You may send me a new Oliver Nine on approval. I will keep it five days. Then, if I decide to buy it, I will pay \$49 at the rate of \$3 per month. The title to remain in you until fully paid for.

If I decide to return it, I will turn it over to the express company, properly packed and addressed to you.

Name.....

Address.....

References.....

COLGATE'S

"HANDY GRIP"

The *NEW* SHAVING STICK

Colgate's "Handy Grip" combines economy, convenience, speed and comfort better than any other shaving preparation.

We couldn't improve the soap—so in each detail of economy and convenience we improved the box to make it worthy of its contents.



FACTS —about other shaving soaps

—creams for instance. Soap and Glycerine are the two essentials in shaving cream—the first to make a lather, the second to take up and hold water to keep the lather moist. Both Soap and Glycerine sink in water—and a shaving cream which floats is "fluffed up" with air.

Try the Sinking Test

Drop half an inch of Colgate's Shaving Cream in a glass of water—it sinks. It has its full money's worth of soap and glycerine.

Try the same with any other shaving cream. If it floats—it is "fluffed up" with air.

Besides its full money value, Colgate's gives a most luxurious shave and needs no "rubbing in" with the fingers.

Economy—No Waste

—for the last of the soap *unscrews* from the grip¹ and can be stuck to the top of the next stick.² This gives a fifth to a sixth more usable soap than in other containers. An economy—and a *new* feature.



1
Unscrew the stub



2
Stick it on the new stick



3
The box locks



4
Refill

Greater Security

—no coming apart in your traveling case—one turn of the screw-thread locks the box. This, too, is *new*.³

Less Cost

—for the "Handy Grip" box can be refilled with "filler sticks" at a lower price. This also is *new*.⁴

COLGATE & CO., New York