

March
475,000 COPIES

See Page 354

15 Cents

POPULAR MECHANICS MAGAZINE

WRITTEN SO YOU CAN UNDERSTAND IT





\$641 Buys the Material to Build this Home!

NO MONEY IN ADVANCE!

When you "Build-To-Stay—The Harris Way," you secure the *utmost possible* in Quality, Economy and Service. Why? Simply because you profit directly—*immediately*—by our 24 years' experience. You get the benefit of our practical knowledge as the *originators* of the "Direct-to-You" Home Building Industry. We were the *first* to sell Lumber and Material direct to Home Builders at one small profit. We were the *first* to reduce this vitally important industry to a *perfect system* and extend the benefits uniformly to the people of the nation. *The splendid Harris Home above has 5 rooms, bath, pantry and reception hall in an excellent arrangement. The size is 22 ft. x 26 ft.*



"THE HARRIS WAY"

has exclusive merits—special advantages for the shrewd and careful Home Builder—possessed by no other plan or method. It is the best, safest and most sensible way to build your ideal home *right* without sacrifice of quality—*or the waste of a single penny!* Thousands have built "The HARRIS WAY" with profit and satisfaction.

SEND LUMBER BILLS

Our ten million dollar buying power gives Harris customers an overwhelming price advantage. We can—and do—undersell all others. *The proof? Easy!* Just send us your lumber bills—for any kind of building you may be planning and get *our* prices. Compare them item for item, and let the *test* be the *proof*. Write us today!

BUY YOUR HOME SENSIBLY CUT-TO-FIT—SHIPPED ALL COMPLETE IN ONE CAR

The material used in building all Harris Homes is prepared by us, complete for your use in a way that is instantly—and easily understood. It is sensibly cut-to-fit with *absolute accuracy* and *positive elimination of all waste*. You pay for nothing you do not get—you pay our bed rock low, one-small profit bargain price *only* for what is needed to do the work *right*—"The HARRIS WAY."

Our mammoth material stations, in the heart of the finest lumber tracts are always filled to overflowing with brand new, quality material. These stations are centrally located for quick and economical deliveries, "DIRECT-TO-YOU," no matter where you live, at the *lowest possible freight charge*.

Harris Bros. Co.
Dept. FH-7. CHICAGO

Please send me free—without the slightest obligation—the Harris Home Book of Plans, and show me how to save big money in building my home.

Name

Address

Free Beautiful New \$10,000 Book of Over 100 Harris Homes

Be sure to mail free coupon for the latest edition of the famous \$10,000 HARRIS HOME PLAN BOOK, now ready. A golden guide to Quality, Service and Economy in Home Building. Explains—fully and freely—everything about building economy. Contains 100 modern Harris Home Designs, with descriptions, material, specifications, prices, etc., and explains how we save you \$50 to \$75 on our Special Free Architect's Plans. Think twice before you pass this opportunity.

Harris Brothers Co. Dept. FH-7 35th & Iron Streets Chicago



Caruso
as Rhodanes
in Aida



Masterpieces of opera by the world's greatest artists

The mere mention of opera suggests Caruso, Alda, Braslau, Calvé, Destinn, Farrar, Gadski, Galli-Curci, Garrison, Gluck, Hempel, Homer, Journet, Martinelli, McCormack, Melba, Ruffo, Schumann-Heink, Scotti, Sembrich, Tetrazzini, Whitehill—the commanding personalities who dominate the operatic stage.

These renowned artists in full realization and acknowledgment that the Victor alone reproduces their art with absolute fidelity, make records for the Victor exclusively.

Any Victor dealer will gladly play any music you wish to hear, and give you a copy of the Victor Record catalog—the most complete catalog of music in all the world.

Victor Talking Machine Co.
Camden, N. J., U. S. A.

Beilner Gramophone Co., Montreal, Canadian Distributors

Important Notice. All Victor Talking Machines are patented and are only licensed, and with right of use with Victor Records only. All Victor Records are patented and are only licensed, and with right of use on Victor Talking Machines only. Victor Records and Victor Machines are scientifically coordinated and synchronized by our special processes of manufacture; and their use, except with each other, is not only unauthorized, but damaging and unsatisfactory.

Victor Supremacy

Please Mention Popular Mechanics

This One



L141-AX9-J1FZ

Copyrighted material

IMPORTANT NOTICE to LUMBER USERS:

THE SOUTHERN CYPRESS MANUFACTURERS' ASSOCIATION HEREBY INFORMS YOU THAT ALL CYPRESS NOW AND HEREAFTER SHIPPED BY MILLS WHICH ARE MEMBERS OF THE ASSOCIATION WILL BE

**IDENTIFIED
BY THIS MARK**



TRADE MARK REG. U.S. PAT. OFFICE

This registered trade-mark will be, henceforth,

YOUR INSURANCE POLICY OF QUALITY.

It will appear stamped (mechanically and ineradicably) on one end, or both ends, of EVERY board and timber of

CYPRESS "THE WOOD ETERNAL."

CYPRESS FLOORING, SIDING, MOULDING AND SHINGLES, which come in bundles, will bear the same mark on EVERY BUNDLE.

The legal right to apply this epoch-making symbol of strict RESPONSIBILITY IN LUMBER MAKING AND SELLING

is, of course, restricted to those Cypress mills which, by their membership in the Southern Cypress Manufacturers' Association, attest their devotion to its Principles of SERVICE to the CONSUMER and their foresighted appreciation of its open and progressive educational methods.

Only mills cutting "Tide-water" Cypress (within about 200 miles of the coast) are eligible for membership. Cypress grown elsewhere has less of the "Eternal" quality.

Only mills meeting the Association's ideas of scrupulous care in methods of MANUFACTURE, ACCURACY OF COUNT and INTEGRITY OF GRADING, in accord with the user's welfare, belong to the Association. Such mills the Association licenses to

CERTIFY THEIR CYPRESS by applying the registered trade-mark with their identifying number inserted.



TRADE MARK REG. U.S. PAT. OFFICE

BY THIS MARK YOU KNOW THAT IT'S CYPRESS, "THE WOOD ETERNAL," AND WORTHY OF YOUR FAITH. IT IS WELL TO INSIST ON SEEING THIS TRADE-MARK ON EVERY BOARD OFFERED AS "CYPRESS."



TRADE MARK REG. U.S. PAT. OFFICE

Let our ALL-ROUND HELPS DEPARTMENT help YOU MORE. Our entire resources are at your service with Reliable Counsel.

Southern Cypress Manufacturers' Association

1219 HIBERNIA BANK BLDG., NEW ORLEANS, LA., or 1219 HEARD NATIONAL BANK BLDG., JACKSONVILLE, FLA.

INSIST ON TRADE-MARKED CYPRESS AT YOUR LOCAL LUMBER DEALER'S. IF HE HASN'T IT, LET US KNOW.

Popular Mechanics Magazine

6 N. Michigan Avenue, Chicago, U. S. A.

EDITED BY H. H. WINDSOR

England: The International News Co.,
5 Beams Bldg., Chancery Lane, London, E. C.

Australia:
The Australasian News Co.

ISSUED MONTHLY

SUBSCRIPTION:

SINGLE COPY, 15 CENTS

In United States, and its possessions, Cuba and Mexico, per year, postpaid	\$1.50
To Canada	1.75
To all other countries in the Postal Union	2.50

All subscriptions are discontinued at expiration. Please examine the date printed on your wrapper.

Entered as Second Class Matter Sept. 15, 1903, at the Post Office at Chicago, Illinois, under Act of March 3rd, 1879.
Entered as Second Class Matter at the Post Office Department, Canada.

Published monthly by POPULAR MECHANICS CO.

Copyright, 1917, by H. H. WINDSOR.
Copyright, in France.

Slide rule (filler) Contents for March, 1917

Accident, Bad, Serves as Warning to Kite Fliers	366	Bullet, English, Shape of Affects Aluminum Mar-	330
Accident—Flying Machine and Steam Roller in		ket	330
Collision	392	Canal, Atlantic to Gulf, for Florida Proposed	333
Advertising Characters, Cotillion of	433	Canal, Widened Swedish, Opened to Traffic	349
Aeroplane Propellers, Apparatus for Testing	421	Canals, Idle, May Empty and Use Them for Cars	394
Aeroplanes may Give Warning of Storms, How	412	Cars for Alaskan Roads Shipped from Seattle	398
Air, Compressed, Used to Stir Tannery Vats	371	Cats, Firemen's, Trained to Descend Brass Pole	426
Alligators, Community of at Tourist Resort	347	Cement Mixer Built for End and Side Delivery	361
Amusement Device, New, Whirling "Tango Girl"		Chart, Sportsman's, Shows Game Laws Simplified	437
Is	394	Chicken Coop, Grease Spreading Device for	413
Arithmetic, Teaching by Mechanical Device	410	Chimney Stack, Concrete, with New Features	335
Army, Vocational Training for Men in	442	Chute, Logging, is Built of Steel Rails	352
Arrow, Electric Direction, for Autos	432	Chutes for Fire Escapes, Powder Plant Has	417
Atlas of Country, Topographic, Want Completed	410	Clamshell Bucket, New, Arch Yoke Feature of	382
Automobile, Attempted Theft of Screamed by		Club, Police, Serves as Extension for Pistol	373
Siren	370	Coal Dealer, City Turns Because of Fuel Famine	336
Automobile Hood, Large Round Ventilators in		Coal, New Light on Formation of	334
Sides of	396	Coal, New Golf, Permits Free Arm Movement	439
Automobile Picnic Outfit, Convertible	343	Coins, Chinese Brass, are Melted for Copper	372
Automobile Radiator, Water System Keeps Well		Concrete Block Machine Has Special Face Plate	410
Filled	437	Concrete Mixer, New, Run by Foot Power	425
Automobile Testing Shed, Brick Walled Stalls in	430	Cot, Simple Folding, for Motor Tourists	351
Automobile Trailer, New, Has Only One Wheel	368	Cradles, Sanitary Wire, for Babies' Sanitarium	365
Automobile Wheels Changed for Driving in Snow	366	Crane, Small, for Farm Wagon Saves Labor	376
Automobiles, Rear Signal for, Works Automati-		Crossings, Grade, Carelessness at Shown	348
cally	362	Crossings, Steel Humps at, Regulate Traffic	349
Automobiles, Roaring Mountain Torrent Grave-		Crutch, Adjustable Nonslip Device for	375
yard of	354	Daisies, Fifteen Acres of Unwelcome Flower Bed	399
Aviation—Accident and Then Record Mark Air-		Dam Foundation, Making Water-Tight	369
man's Flight	328	Dam, Large, Mills Built to Insure Water Supply	403
Baby, Swinging Basket in Motor Is Crib for on		Dance Ticket Prevents Errors by Partners	381
Tour	400	Davit, Two Type of Passes Government Tests	414
Band Stand, Green Shingle, in Denver	425	Dental Accessory, Sanitary Chip Blower	351
Bank, New Type of Drives Out Loan Sharks	326	Dies, Wood Cutting, Take Place of Saws	322
Barn, Eight Sided, with Folding Windmill	351	Disinfectors, Portable, for Our Army	344
Baskets, Shell, Armadillo Farm in Texas Source		Ditch Diggers, American, Cut Battle Trenches	389
of	417	Ditches, Concreting to Conserve Fields	368
Bath Spray Attachment for Tub Faucet	355	Diver, Girl, Clears Rocks by Narrow Margin	321
Bird Flies Long Distance with Address	436	Doors, Car, New Pneumatic Engine to Operate	420
Boat, Electric Harbor, for Artillery Armories	329	Dredge Propelled, Eight Miles with Its Dipper	407
Bottles, Nursing, Convenient Holder for	395	Ear Phone Eliminates Foreign Noises	424
Boys and Girls, Varied Activities of	440	Electric Lights, Indirect, Pull Socket Outfit for	432
Breakwater, Crumbling of may be Due to Salt	329	Engines, How Weight of is being Lessened	439
Breakwater, Dynamic Tears Hole through for		Fence Posts, Angle Iron Used for	352
Passage of Sewer	390	Ferry, Sturdy, Navy Builds for Goat Island Trips	398
Bridge, Curious, on Mexican Border	424	Film Rewinder with New Safety Features	426
Bridge, Long Floating Railroad, across Canal	379	Fire Alarm Box Designed to Be Meddler Proof	436
Bridge, Motor Car, Built on New Safety Plan	334	Fire, Garage, Spark from Man's Body Causes	424
Bridges, Large, are Shifted Quickly	331	Fire, Gas Well, Fight behind Screens	407
Bridges, Primitive Log, for Western Railways	346	Fireless Cooker, Simple, Used in Germany	330
Building—Art Gallery Built Like Big Steel		Flag, Metal American, Prefer to Cloth One	412
Bridge	360	Flags, Crossed, Holder for	366

[Continued on Page 6]

Popular Mechanics offers no premiums; does not join in "clubbing offers," and employs no solicitors to secure subscriptions. It is for sale by nearly every newsdealer in the United States and Canada.



BLUE STREAKS

Burst water pipes on a cold morning! A plumber as quickly as possible! Right then it's mighty good to know one who is prepared to give you emergency service. Of course, he has a motorcycle. But a motorcycle is no better than the tires that carry it.

Goodyear Blue Streaks are known for their utter reliability in business, pleasure, racing and military service. Let them serve you on *your* motorcycle.

Blue Streaks Deliver: Economy, Mileage, Speed, Service. Everywhere—one standard, one quality, one guaranty.

The Goodyear Tire & Rubber Co.
Akron, Ohio

GOOD  YEAR
AKRON

The Automobile Business is Growing

More help needed and big pay. No other business offers such opportunities. It's easy to learn. An Auto Repairman is not a machinist—his work consists of adjustments and re-fitting worn parts, "knowing the principle," that's the thing. One of our students writes: "Before I started with your course I was a clerk at \$50 per month. After finishing I followed your instructions, started a repair shop and cleared \$122 the first month—pretty good for the first month." Let us show you this and many other letters.

LEARN THE Automobile Business during your spare time

WE CAN HELP YOU IN 3 WAYS:

- 1st We can teach you quickly and thoroughly.
- 2nd After we teach you, we have a plan to assist you in getting started in the actual practical line of work and assist you in getting actual driving experience.
- 3rd While we are teaching you we show you how to make money right on the start.

THE DYKE WORKING MODEL

of teaching by mail is a new invention—a new idea—we use real 4 and 6 cylinder engine models—11x11 1/2 inches—on which you can actually see all parts moving—it is the only system of its kind in the world.

This is one of the 7 real models used, in addition to 50 simplified instructions with hundreds of illustrations, charts and manikin.

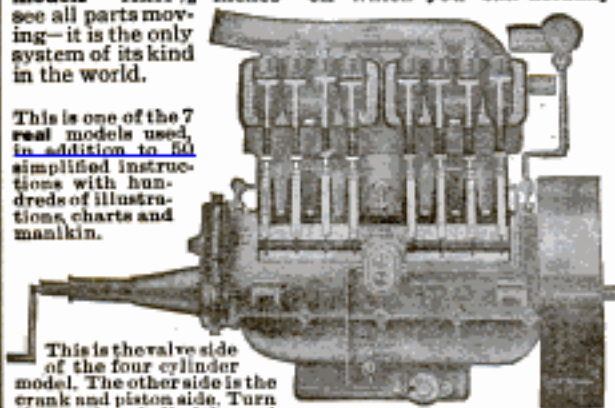

This is the valve side of the four cylinder model. The other side is the crank and piston side. Turn the crank and all of the real metal parts actually operate. The six cylinder engine model is similar.

This system is endorsed by Barney Oldfield, Elwood Haynes, Chas. Duryea and other motor authorities.

Mr. Dyke has been identified as a pioneer inventor, supply man, etc., with the auto industry since its beginning. He originated the first auto supply Co. and manufactured and marketed the first float type carburetor in America. No other man with such experience is today teaching others.

If we prove to you that we have started hundreds of others into the repair business and as chauffeurs—who had no previous experience and who knew no more about an auto than you do right now—you must admit we can do the same for you. Write me TODAY—NOW—and LET ME PROVE IT.

Write for DYKE'S FREE BOOKLET

It is interesting and instructive in itself. Fully illustrated. Learn how you can get all this training for only \$15. Fill out below or write a postal—but do it NOW.

Dyke's Correspondence School of Motoring
Box 188, Roe Bldg.,
St. Louis, Mo.

Send me your free 32-page booklet about your New Idea Working Model Course and testimonials and proofs. It is understood I am under no obligations in sending for this.



Name.....
Address.....

Deal with the originators. Beware of imitators. This school is a department of the firm of A. L. Dyke, Pub. and Importer, Box 188, Roe Bldg., St. Louis, Mo.

(Contents—Continued from Page 6)

Trowel, Plastering, Gauge for.....	458
Truck Arranged for Hauling Long Stock or Ladders.....	462
Vise Jaw, Auxiliary, for Holding Irregular Pieces	450
Water, Distilled, Handy Containers for.....	459
Water System, Gravity, for Summer Cottage or Camp.....	446
Watering Tank, Rooted, of Concrete.....	454
Wire Substitute for Lattice-work.....	452
Wrench, Powerful, Used in Dismantling Large Pipe Line.....	458

AMATEUR MECHANICS

Barrel Staves as Springs for Play Auto.....	467
Benches, Lawn, Made from Old Bedsteads.....	470
Candle, Lighting without Touching Wick.....	476
Condenser, Small Variable.....	476
Eggshells as Flowerpots.....	466
Flash Light Used as Bedroom Night Light.....	478
Gas Heater, Pie Plate.....	478
Ice Pick, Household, Holder for.....	477
Inkwell Base Made from Fuse Socket.....	474
Lifting Device, Emergency, of Rope and Lever.....	476
Mailbox, Bell Ringing.....	478
Match Safe of Miniature Cannon Shell.....	477
Mucilage Brush and Container Made of Test Tube.....	477
Pail, Valve Bottom, for Dipping Water.....	474
Phonograph Cabinet, Homemade.....	466
Photographic Printing Machine.....	475
Flow, Garden, Made of Pick-Up Material.....	463
Polarity Indicator, Simple.....	478
Reel for Use with Seed Planting Guide String.....	478
Refrigerator, Making Use of in Winter.....	474
Repairing Wood-Wind Instruments.....	470
Rubber Band, Making Scale Enlargements with.....	471
Scraper for Tennis Court.....	467
Shoe Polishing Strop.....	474
Signal Telegraph with Green and Red Lights.....	472
Sod Cutter, Horse Drawn.....	465
Sundial Plate, Laying Out.....	473
Swing Made of Hickory Sapling.....	477
Target, Recording Annunciator.....	466
Telescope, Interesting Water.....	464
Trellis, Rustic, to Shade Door or Window.....	471
Umbrellas, Kinks on Care of.....	478
Wastebasket, False Bottom for Emptying.....	474
Wind Motor, Sail Rigged.....	468
Window Display, Revolving.....	465
Wire Mesh Support for Flower Centerpiece.....	474
Writing on Moving Train.....	464

ALL departments of Popular Mechanics' Magazine purchase manuscripts and pictures—either photographs or drawings. Material is passed upon promptly and payment is made upon acceptance. For the general reading section contributions should relate to new developments in the fields of science, mechanics, invention, and discovery. Photographs may be of any size, providing they are sharp and accompanied by accurate descriptive data.

The Shop Notes and Amateur Mechanics departments use new ideas and kinks for workmen of all crafts and amateurs of all ages, respectively. Pencil sketches are acceptable; descriptions should be brief and in simple language. Address Managing Editor, 6 N. Michigan Ave., Chicago.

LEARN PIANO TUNING



Making Trials of True Tone by Tune-a-Phone

Capitalize YOUR Ability

THE WORLD PAYS FOR SKILL

We teach piano tuning and its allied branches by correspondence. Our patented teaching device, the Tune-a-Phone and other mechanical aids, make it easy and sure.

Write today for FREE illustrated booklet describing the school and its methods.

NILES BRYANT SCHOOL OF PIANO TUNING
28 Fine Arts Inst., BATTLE CREEK, MICH.

Learn Piano Twice Faster By Scientific "Short Cut"

Wonderful Invention now saves you months of time and effort—
Leaves nothing out, but gets you there sooner—Cuts cost in half, too.

You learn more *thoroughly*—play more artistically, more individually—thousands who have tried it say so. Old-fashioned, round-about methods *must yield to scientific, direct methods*. It's the Law of Life.

A Momentous Discovery

After twenty-five years of painstaking, technical research, Dr. Quinn discovered the great Law of Nature that the "vibration waves" of twelve tones in music (Key of E) **exactly coincide** with the "vibration waves" of twelve tones in color. This simple Law of Nature, like all such laws, opened out whole worlds of PRACTICAL BENEFITS—and led to Dr. Quinn's inventing the COLOROTONE.

Easy to Understand—For Beginners or Experts

The COLOROTONE, like all great inventions, is simplicity itself. Children master it as easily as grown people. It brings the same amazing results to experts that it does to beginners. Investigate without cost, by writing today for 64-page free book explaining all about it.

Sweeps Away Century-Old Stumbling Blocks

The important musical subject of Transposition—usually a "night-mare" to students—becomes easy and fascinating by the use of the COLOROTONE. The COLOROTONE enables you to master, from the very beginning of your study the great Liszt System, by which you play every piece in **every key with exactly the same fingering**. Formerly this great time-saver could be taught only to **advance students**. By using the scientific COLOROTONE you start the Liszt System in your **third lesson**—a **tremendous advantage**. And the COLOROTONE has scores of other equally important advantages. Write for free book.

Nothing Else Like It—No Special Music Necessary

There is nothing else even remotely like the COLOROTONE. It stands on the keyboard before you and instantaneously solves, by correct, scientific methods, all kinds of troublesome playing problems. After the first dozen lessons you discontinue using the COLOROTONE. Almost miraculously it has taught you; and you thereafter play without using it. No special music is necessary. You play by note from **any** music.

Surprising Results of Learning By a Scientific System

It's amazing to see how quickly you gain skill at either the piano or organ, and how expressively and feelingly you can play. Men and women who have failed by all other methods have quickly and easily attained success when using Dr. Quinn's COLOROTONE, and his famous WRITTEN METHOD. Dr. Quinn's WRITTEN METHOD (now including the COLOROTONE) is a complete COURSE IN PIANO OR ORGAN for home study. Each of the clearly-written lessons leads you logically, correctly, and systematically to playing skill. The COURSE is fully illustrated with diagrams and drawings showing every position and movement of the fingers, hands, and arms. Thus you rely not on your memory of verbal instructions, which must sometimes be incorrect, but on detailed illustrations and explanations **always before you**. Nothing is, nor can be forgotten. You practise in spare time, at your convenience, in the privacy of your own home. Progress as rapidly or slowly as you wish. All necessary music is included **Free**. Diploma of recognized value is granted.

Endorsed by Distinguished Musicians

Among our graduates are thousands of accomplished amateur players, as well as prominent professional players, successful music teachers and leading composers. The COURSE is endorsed by many distinguished musicians and educators in whose opinion you have the **utmost confidence**.

Investigate Without Cost—Special Offer

Write **today**, using post card, letter or free book coupon, for our new 64-page book explaining everything you want to know about how to study music and learn to play piano or organ in less than half the time usually required. The book gives full particulars of our COURSE and wonderful COLOROTONE and is a possession **worth having**. Special reduced terms this month on account of our Twenty-Fifth Anniversary offer. Investigate without cost or obligation **Now**.

Marcus Lucius Quinn Conservatory of Music
Box 650 KO, Chicago, Ill.

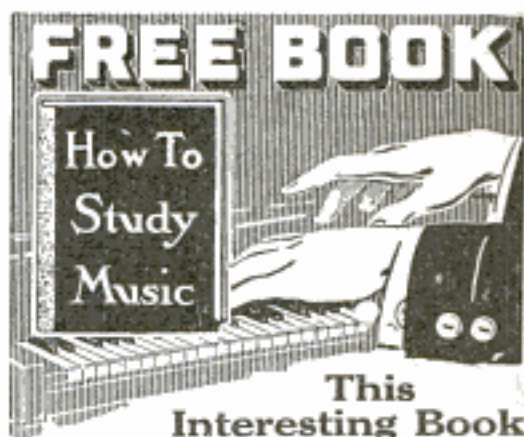

contains 64 pages of vital information about how to study music and learn to play the piano or organ. It explains the great pleasures and social advantages of skill at the piano or organ and tells how you can acquire this skill at half the usual cost and effort by a method of home study which is scientific. It tells how you can become a music teacher and earn \$25 to \$100 weekly. It tells how you can become a professional player at a liberal salary—and how the world's greatest pianists, organists and composers earned their way to Fame, Honor and Wealth. It fully explains everything about Dr. Quinn's wonderful COLOROTONE and his famous WRITTEN METHOD. Send for this remarkable free book at once. No cost or obligation.

**Free
Book
Coupon**

Quinn Conservatory
Box 650 KO, Chicago, Ill.

You may send me without obligation or expense your 64-page Free Book "How To Study Music," explaining Dr. Quinn's COLOROTONE, his WRITTEN METHOD, your Twenty-Fifth Anniversary offer, and other interesting information about how to learn piano or organ.



Write



Now

NAME.....

ADDRESS.....

DRAKE'S HOME-STUDY BOOKS FOR MECHANICS

Increase Your Earning Power By increasing your knowledge and efficiency. These books, written in non-technical language for Electricians, Engineers, Railroad Men, Telephone Men, Machinists, Automobileists, Carpenters, Plumbers, Sign and Scene Painters, are the best and most practical books ever written. They tell you what you want to know about the practical problems you have to solve every day.

12 ELECTRICAL BOOKS ALL UP-TO-DATE, BOUND IN LIMP CLOTH, POCKET SIZE AND POST PAID, EACH . . . \$1.00

Electric Motors, Direct and Alternating
By PROF. MORETON. 250 pages, fully illustrated. Leather, \$1.50.

Motion Picture Operation—Stage Electric and Illusions. By HORSTMANN AND TOUSLEY. 303 pages, 216 illustrations. Leather, \$2.00.

Alternating Current, Theory, Practice, and Diagrams. By HORSTMANN AND TOUSLEY. 300 pages, fully illustrated. Leather, \$2.00.

Electricians' Operating and Testing Manual. By HORSTMANN AND TOUSLEY. 360 pages, 211 illustrations and diagrams. Leather, \$1.50.

Modern Electric Illumination. By HORSTMANN AND TOUSLEY. 274 pages, 40 illus. and diagrams, 21 tables. Leather, \$2.00.

Wiring Diagrams and Descriptions
By HORSTMANN AND TOUSLEY. 300 pages, 230 illustrations and diagrams. Leather, \$1.50.

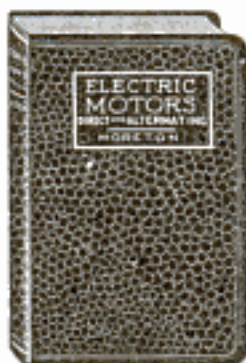

Electrical Measurements and Meter Testing
By PROF. MORETON. All meters carefully described. 328 pages, 191 illustrations and diagrams. Leather, \$1.50.

Modern Electrical Construction
By HORSTMANN AND TOUSLEY. 440 pages, 263 illustrations. Leather, \$1.50.

Drake's Telephone Handbook
By PROF. M. REYON, of Armour Institute. 286 pages, 161 illus. and diagrams. Leather, \$1.50.

Armature and Magnet Winding
By HORSTMANN AND TOUSLEY. 260 pages, 153 diagrams and illustrations. Leather, \$1.50.

Electrical Tables and Engineering Data
By HORSTMANN AND TOUSLEY. 300 pages, 150 diagrams, tables and illus. Leather, \$1.50.

Drake's Electrical Dictionary
By P. E. LOWE. 320 pages of electrical words, terms and phrases, carefully defined and explained. Leather, \$1.50.



AUTOMOBILE BOOKS

Brookes' Automobile Handbook (New Edition)

Over 700 pages, of which 400 pages are devoted to practical information on new equipment, 335 illustrations and diagrams. Special articles on carburetors, ignition starting and lighting and every new device used. Pocket size, leather. Price, postpaid, \$2.00

Automobile Starting and Lighting

By Harold P. Manly. Every starting and lighting device in the market is covered in this work in a practical manner, for the owner, operator and repair man. 302 pages, illustrated. Pocket size. Cloth, Postpaid, \$1.00. Full leather, postpaid, \$1.50

Automobile Catechism and Repair Manual

By C. F. Swingle and H. A. Tarantous. The book is divided into two parts. Part I comprises questions and answers. Part II is devoted entirely to automobile repairs. Pocket size. Leather, 165 pages, illustrated. Price, postpaid, \$1.25



Oxy-Acetylene Welding and Cutting, Electric and Thermit Welding

By H. P. Manly. 215 pages, fully illustrated, cloth, \$1.00. Leather, stamped in gold, red edges, \$1.50. The extensive use of the oxy-acetylene flame in welding and cutting has created an active demand for a practical book explaining this process. It includes electric and thermit welding, also a chapter on hand forging and welding.

Scene Painting and Bulletin Art



By Frank H. Atkinson, author of "Art of Sign Painting," "A Show at Show Cards," etc. Covers Principles, Color, Drawing, Scene Painting and the latest in Bulletin Art. Size 9x12. 256 pages, illustrated. Cover stamped in five colors. Postpaid, \$3.00

Published Feb. 1, 1917

FARM BUILDINGS With Plans and Descriptions

By H. A. Shearer. 12mo, cloth. Fully illustrated. Contains full description of the latest and best farm buildings of all kinds. Price, postpaid, \$1.00

Other New Books and New Editions

Practical Gas and Oil Engine Handbook. By BROOKES. 230 Pages. Cloth, \$1.00.

Swingle's Handbook for Steam Engineers and Electricians. 1500 Pages. Leather, \$3.00.

Traction Farming and Traction Engineering. 330 Pages. Cloth, \$1.50.

Operation of Trains and Station Work. By PRIOR. 618 Pages. Leather, \$2.00.

Hodgson's Estimator and Contractors' Guide. 318 Pages. Cloth, \$1.50.

Hodgson's Hardwood Finisher. 320 Pages. Cloth, \$1.00.

Hodgson's Concrete. 520 Pages. 12mo Cloth, \$1.50.

Practical Up-to-Date Plumbing. By CLOW. 310 Pages. Cloth, \$1.50.

Builders' Architectural Drawing Self-Taught. By HODGSON. 336 Pages. 250 Illustrations. 12mo Cloth, \$2.00.

Guarantee:

We will send postpaid one or all of these books upon receipt of price. If after 5 days' examination you are dissatisfied for any reason, return the book or books and we will refund your money.

Write Today for any book listed above. Remember our Guarantee. Or send for our full catalog—over 150 titles—all practical books. It's

FREE

Frederick J. Drake & Co.
1008 Michigan Ave. CHICAGO

Know Your Car—

It Means Money to You

Audels Automobile Guide—the world's most scientific book on automobiles—will enable you to quickly solve every problem of driving, repairing, locating of trouble. It is recognized as the authority by experts. Its value is unlimited. It tells you everything you should know about your car. Sent to you for free examination.

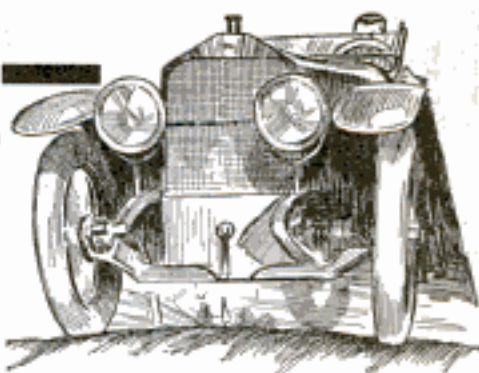

If you are an Owner

You are losing money every time you run with ill-adjusted Carburetor, with faulty ignition, with your engine at the wrong speed, or with a score of other faults. You may be a careful student of your car and take all the precautions you know of. But unless you know the technical details of driving and operation, and know them right, your car is an expense burden instead of a pleasure.

If you are a Chauffeur

We don't need to mention the things you must have at your fingers' ends in order to manage your car at top efficiency. Here are a few of the points you may be in doubt about:—How to care for batteries and keep them operating at maximum voltage. How to wire a car for Electric Starting, Lighting and Ignition according to the most modern systems. How to overhaul the car. How a car is best lubricated, etc.

If you are a Mechanician

Then more than anyone else you will realize the importance of knowing the details of design of every part of your car. New inventions in design and construction are coming up every day, which puzzle the untrained man. Do you know these things?—Methods of cooling—Timing and Balancing—Designing Clutches—Design of ball and roller bearings, etc.

Audels Automobile Guide

Solves every single one of these problems and solves them in a way that you can understand. It's a value you cannot afford to miss. It will save you many times its cost before you have had it a week.

Text Arranged in QUESTIONS AND ANSWERS

The story is told in the best known way,—in the form of questions you would ask and the answers to them—in plain, practical, everyday language, complete, concise, and to the point. The book is complete, concise, and to the point.

handsomely bound in durable full flexible leather. Pocket Size. It is easy to handle and easy to study. There are 30 chapters covering every single phase of Automobile engineering and Automobile operation. Every chapter is modern, concise, and practical.

Written by Practical Men for Practical Men

There is no idle theory in Audels Automobile Guide. Every paragraph is written to help you in the easiest, most practical way. The chapters on carburetors, ignition, gas engine operation, How to run an Automobile, overhauling the car, Battery Troubles, and Starting and Lighting Systems, are alone worth the price asked for the 30 complete chapters. There are 700 information-full pages, with 550 illustrations that show you in picture just what you want to see.

Sent to You FREE

We don't ask you to take our word for the merits of this book. Seeing is believing, so we will send you the book without deposit. You will say at once that as books go it is worth at least twice what we ask for it. Use it seven days in connection with your car. Then if you are not satisfied that Audels Automobile Guide is positively the best book on the subject, send it back to us. But if on the other hand you decide that you need it, that it is the one book for you, remit us only \$1.50.

Mail This Free Coupon TODAY

Do not delay. Put your name and address on the coupon today. The book will be mailed to you at once for FREE examination. Convince yourself of the wonderful assistance this book will be to you. Send for it today—now.

THEO. AUDEL & CO., 72 Fifth Ave., New York

HERE ARE SOME OF THE SUBJECTS

Parts—Operation—Care—Management—Road Driving—Carburetor—Wiring—Timing—Ignition—Motor Trouble—Lubrication—Tires, etc. Chapters on Storage Batteries—Electric Vehicles—Overhauling Car—Special Chapter on Self-Starters and Lighting Systems, etc., etc.

FREE Examination Coupon

Theo. Audel & Co., 72 Fifth Ave., New York

Without obligation please mail for free examination "AUDELS AUTOMOBILE GUIDE" If I find it satisfactory I will remit \$1.50. Otherwise return it to you.

Name

Occupation

Address.....P. M. March

These books will help you to greater

Electr

PARTIAL CONTENTS OF THE 10 GUIDES

No. 1. Contains 240 pages, 246 illustrations. Electrical signs and symbols—static and current electricity—primary cells—conductors and insulators—resistance and conductivity—magnetism—induction coils—dynamo principles—classes of dynamo, etc.

No. 2. Contains 218 pages, 256 illustrations. Armatures—windings—commutation—brushes—motor principles—armature reaction—motor starting—calculations—brake horsepower—selection and installation of dynamos and motors, etc.

No. 3. Contains 276 pages, 280 illustrations. Galvanometers—standard cells—current measurement—resistance measurement—voltmeters—wattmeters—watt hour meters—operation of dynamos—operation of motors, etc.

No. 4. Contains 308 pages, 423 illustrations. Distribution systems—wires and wire calculations—inside, outside, and underground wiring—sign flashers—lightning protection—rectifiers—storage battery systems, etc.

No. 5. Contains 278 pages, 379 illustrations. Alternating current principles—alternating current diagrams—the power factor—alternator principles—alternator construction—windings, etc.

No. 6. Contains 272 pages, 538 illustrations. A. C. motors—synchronous and induction motor principles—A. C. commutator motors—induction motors—transformers—losses, construction, connections, tests—converters—rectifiers, etc.

No. 7. Contains 320 pages, 460 illustrations. Alternating current systems—switching devices—circuit breakers—relays—lightning protector apparatus—regulating devices—synchronous condensers—indicating devices—meters—power factor indicators.

No. 8. Contains 288 pages, 330 illustrations. Waveform measurement—switch boards—alternating current wiring—power stations—turbines—management, selection, location, erection, testing, running, care and repair.

No. 9. Contains 576 pages, 849 illustrations. Telephones—telegraph—wireless—electric bells—electric lighting—photometry—electric railways—electric locomotives—car lighting—trolley car operation, etc.

No. 10. Contains 704 pages, 730 illustrations. Miscellaneous applications—motion pictures—gas engine ignition—automobile self-starters and lighting systems—electric vehicles—elevators—cranes—pumps—air compressors—electric heating—electric welding—soldering and brazing—industrial electrolysis—electro-plating—electro-therapeutics—X-rays, etc.

Also a complete ready reference index of the complete library.

The work of the world today is done by electricity. Electricity runs our machines; transports our goods; lights our homes, shops and factories; heats our buildings—is indispensable in hundreds of ways. Opportunities in electricity are greater than ever before. Exact electrical knowledge means more money and greater success for you.

HAWKINS ELECTRICAL GUIDES

give you ALL the electrical information you want, in the shortest, most concise form—namely, by means of questions and answers and unlimited illustrations. No matter how great or how little your previous knowledge of the subject at hand, you "get the point" at once in Hawkins Guides. They are absolutely complete—brought right up-to-date—the last volumes are just off the press.

FLEXIBLE POCKET-SIZE TEXTS Arranged for Home Study and Reference

They are the handiest books to read and to use, ever produced. In flexible, black covers, leather binding—just the right size—5x6½ inches—to fit in your pocket, so that you can carry each single volume about with you until you have mastered its contents. The whole set fits easily in the hollow of your arm, and still there are actually 3,500 pages and 4,700 illustrations.

10 Practical Volumes. 3500 Pages. 4700 Illustrations

\$1 Per Volume—Payable \$1 Per Month

success through

Electricity

WHAT USERS SAY

"Every Electrician, Operating Engineer or Student who wants to advance himself in the Electrical field should have a set of these books."

JOHN KELLEY, 116 Union St., Newark, Ohio.

"For the man not getting a college training, and even in that case, I can sincerely say I do not believe there is a better set of books on the market today."

LLOYD D. HUFFMAN, Dayton, Ohio.

"We consider Hawkins Electrical Guides the most compact and complete set of electrical references in the market."

NOGGLE ELECTRIC WORKS, Monterey, Cal.

"Hawkins surely knows the art of condensing information."

ELDRIDGE F. BALL, Buckland, Conn.

"I think they should be in the hands of everyone who has anything to do with Electricity."

T. E. MURPHY, Orange, Va.

"For the practical electrician, they are the best books published—worth many times their price."

L. C. WAGNER, Wyoming, Ill.

"I have gained valuable information from them which has helped me directly in my line of work."

HERMAN NOBENBERG, Hoboken, N. J.

"They are wonderful value. Everything is so clear and concise. Even one who had no knowledge of Electricity would have no difficulty in grasping the facts."

F. L. TAYLOR, Amesbury, Mass.

"It is the best work an apprentice can study if he wants to get ahead in his trade. As a reference for the experienced worker HAWKINS ELECTRICAL GUIDES are unexcelled."

I. MCCLELLAN, Chillum, Mo.



**THE ENTIRE SET of
10 VOLUMES
SHIPPED TO YOU FREE**

Send no money. Examine the books first. Use them for seven days in connection with your work, and decide for yourself that they are the most complete, the most helpful and the clearest written electrical books ever published. This unusual offer is a sign of our confidence in the Guides.

EASY PAYMENTS Accept the offer now—mail the coupon today. If you decide to keep the books you can make settlement at only \$1 per month until paid for.

THEO. AUDEL & CO.
72 Fifth Avenue
NEW YORK N.Y.

**THEO.
AUDEL & CO.,**
72 Fifth Avenue, N. Y.

Please submit me for examination Hawkins Electrical Guides (Price \$1 each). Ship at once, prepaid, the 10 numbers. If satisfactory I agree to send you \$1 within seven days and to further mail you \$1 each month until paid.

Signature.....

Occupation.....

Business Address.....

Residence.....

Since we have not yet had the pleasure of business relations with you, we shall appreciate your giving us name of reference on line below

Reference.....

P. M. Mar. 17

Please Mention Popular Mechanics

414 PAGES 145 ILLUSTRATIONS

I.C.S.
ELECTRICAL ENGINEERS
HANDBOOK

50¢

ELECTRICITY!

HERE'S just the book on Electricity that you need to answer your many questions—to solve your knotty problems, to teach you new kinks, to be your memory for tables, rules, formulas and other Electrical and Mechanical facts that some people try to carry in their heads—and fail.

With this "Little Giant" I. C. S. Electrical Engineer's Handbook in your pocket, tool chest, on your work bench, drawing table or desk, an hour or a day need not be lost "digging up" some forgotten rule, some unfamiliar fact; you'll just turn to the very complete index and get it "in a jiffy." Just a few of the subjects treated are:

Electricity and Magnetism; Electrical Symbols; Batteries; Circuits; Magnets; Direct and Alternating Currents; Dynamos and Motors; Belts; Shafting; Electroplating; Electrical Measurements; Meters; Arc and Incandescent Lamps; Mercury Arc Rectifiers; Transformers; Insulation; Electric Cars; Single and Multiple-Unit Control; Transmission; Rail Welding; Tables of Wires—Sizes, Capacities, etc.—Mathematical Rules, Formulas, Symbols; Tables of Constants, Equivalents, Roots, Powers, Reciprocals, Areas, Weights and Measures; Chemistry; Properties of Metals; Principles of Mechanics; First Aid, etc.

The Electrical Engineer's Handbook is one of 22 I. C. S. Handbooks covering 22 Technical, Scientific and Commercial subjects, all crowded with value. They have the contents of a full-size book condensed into pocket-size ready to go with you anywhere and be at your instant command. They are substantially bound in cloth, red edges, goldleaf stamping, printed from new, clear, readable type on good quality book paper. There is an illustration at every point where a picture will help. Hundreds of thousands have been sold on a money-back guarantee of satisfaction.

The regular price is \$1.25, but for a LIMITED TIME you can buy the ones you want, postpaid, delivery guaranteed, for only 50 cents each.

You Run No Risk! Money Back if Desired!
International Correspondence Schools
Box 5557, Scranton, Pa.

INTERNATIONAL CORRESPONDENCE SCHOOLS

Box 5557, SCRANTON, PA.

I enclose \$_____ for which send me postpaid the Handbooks marked X, at 50c. each. I may return any or all and get my money back within ten days from receipt:

- | | |
|--|---|
| <input type="checkbox"/> Electrical Engineer's | <input type="checkbox"/> Advertiser's |
| <input type="checkbox"/> Teleph. and Teleg. Engineer's | <input type="checkbox"/> Business Man's |
| <input type="checkbox"/> Mechanic's | <input type="checkbox"/> Bookkeeper's |
| <input type="checkbox"/> Steam Engineer's | <input type="checkbox"/> Stens. and Correspondent's |
| <input type="checkbox"/> Westinghouse Air Brake | <input type="checkbox"/> Salesman's |
| <input type="checkbox"/> Civil Engineer's | <input type="checkbox"/> Window Trimmer's |
| <input type="checkbox"/> Coal Miner's | <input type="checkbox"/> Cotton Textile Worker's |
| <input type="checkbox"/> Concrete Engineer's | <input type="checkbox"/> Farmer's |
| <input type="checkbox"/> Building Trades | <input type="checkbox"/> "oultryman's |
| <input type="checkbox"/> Plumber's and Fitter's | <input type="checkbox"/> Mariner's |
| <input type="checkbox"/> Chemist's | <input type="checkbox"/> Automobile |

Name _____

Street and No. _____

City _____ State _____

Please Mention Popular Mechanics



Learn to FLY

Build Your Own Bi-Plane Glider

NOW Many of the famous birdmen first learned to fly with a GLIDER. It is the initial step in aviation—and the small cost of material to construct such a machine—and the ease with which it can be built, places it within the reach of everyone.

Send to-day for copy of book "How to Build a 20-ft. Bi-Plane Glider" and get full particulars, with detailed drawings—Postpaid

60c

SPON & CHAMBERLAIN
123 P. M. Liberty St., NEW YORK

BE AN ARTIST

We can teach you **DRAWING** in your own home during your spare time.

Our 18 years of successful teaching prove our ability. 30 Courses in Commercial and Illustrative Drawing. Teachers Normal and Applied Art. Endorsed by high art authorities. Students trained by members of our Faculty are filling high-salaried positions. Artist's Outfit FREE to Enrolled Students. Fully Equipped Residence School. Write today for Art Year Book.

OUR HANDSOME ART YEAR BOOK IS FREE TO YOU

SCHOOL OF APPLIED ART
Applied Art Bldg. No. 59, BATTLE CREEK MICH.

LEARN Show Card Writing and Lettering

Complete, thorough course, size 11x15—32 lesson plates, over 100 illustrations and diagrams; carefully explained by an expert. Mailed postpaid for \$2.

Money refunded if not satisfied.

C. E. CORNELL, 81 E. 125th St., New York

FREE BOOK ON BANKING

Tells of the great opportunities in this wonderful profession, and how you can learn by mail. Six months' term. Diploma awarded. EDGAR G. ALGORN Pres., AMERICAN SCHOOL OF BANKING, 490 East State St., Columbus, Ohio

BOY ELECTRICIAN

with 75 illustrations for making Batteries, Dynamos, Motors, Telegraph Apparatus, Telephone, Lights, Bells, Alarms, Colla. "Wireless" Current Reverser, Electric Engine, etc. By Electrical Experts, so that anyone can understand it. With Cat. All 10c Postpaid. NATIONAL CO., Dept. 34, 3422 Lyndale St., CHICAGO

Stop Eating Poison! Wrong food combinations are poisonous and destroy health—right combinations build health. Eugene Christian's 24 lessons in Correct Eating tell how to eat for health, strength and efficiency. Send for Free Trial No Money in Advance offer. Write today. **Corrective Eating Co.**, Dept. 53, 460 Fourth Ave., New York City

"Linene"

REVERSIBLE TRADE MARK

SEND 2 CENTS in United States stamps to pay postage and we will send you FREE a SAMPLE COLLAR of our New Style "Copley." State size wanted. REVERSIBLE COLLAR CO., Dept. U, BOSTON, MASS.

\$25 to \$50 Per Week

is easily earned if you possess the knowledge contained in the

Machine Shop Library

Never before in the world's history has there been such activity in machine shop work as there is today. And glancing into the future we see a never-ending increase in this unheard-of activity.

Unlike any other line Unlike those engaged in the average line of work, the services of the efficient machine shop worker are constantly sought. No one familiar with the machine shop field will deny this. The trained man wastes no time in looking for a position. Weigh this in your mind and then decide which trade to learn.

Knowledge, not strength, counts Now more than ever a man's earning power is gauged by his knowledge, rather than by his strength and deftness. More and more is the Machine Shop Library looked upon as a positive and unfailing medium for acquiring easily the knowledge which takes a man to the highest positions in the machine industry of today.

THE STANDARD IN AMERICA

The Machine Shop Library being formed by eight authors, all practical men, who were assisted in this great work by over two hundred other experts from different shops in different parts of the country, is now accepted as the standard in America.

Direct to your home without deposit. Ten days for examination

We not only agree to pay the forwarding expense on the books to you, but to send you return charges if you are not satisfied that the nine volumes will tell you everything you want to know about machine shop practice. Return them for any reason whatsoever. We will not argue. The books speak for themselves. It is nearly impossible for anyone in the machine profession, or anyone who expects to take up the work, to convince himself that he can get along without these books after seeing them. Upon first glance it can be readily observed that they furnish the essentials of success in machine shop work.

Small Monthly Payments After thoroughly satisfying yourself that you need the books send us small monthly payments which you will not miss.

McGraw-Hill Book Co., Inc.

Publishers of Books for Machinists Since 1876
239 W. 39th Street, NEW YORK

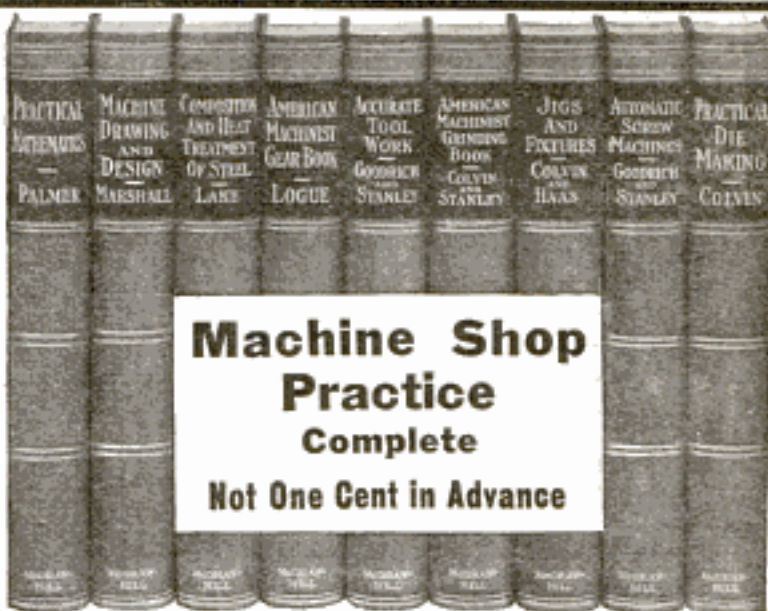

**Machine Shop
Practice
Complete**
Not One Cent in Advance

SMALL MONTHLY PAYMENTS

Easily understood The Machine Shop Library contains the plain facts about machine shop practice — facts that you want to know and must know to achieve success. The books are written so clearly, and so carefully illustrated that the very beginner can understand them — and so accurately that thousands of the highest paid machine shop workers in the country are using them as a daily guide.

You can thoroughly master each subject One by one the subjects in machine shop practice are taken up and covered entirely, so that you can master each subject completely. The reader is able to conquer the most difficult problems in machine shop work, because each item of information is carefully and explicitly worked out by men who have actually done the work themselves.

3000 Pages — 3000 Illustrations

The Machine Shop Library contains nine volumes, 6x9 inches. They are beautifully bound in a stout, morocco-grained dark red cloth, having the appearance of leather, and of equal strength. With average care they will last a lifetime.

Just a few minutes of your time each day

Every day you delay sending the coupon below means something to you. You can earn \$25 to \$50 per week just as easy as you can earn a few dollars a week, if you will give up a little of your time each day to the Machine Shop Library. Let us prove this absolutely, at our expense. Return this coupon now. You do not risk one cent.

Signature.....

Your Address.....

City and State.....

Name of Employer.....

His Address.....

Your Position.....

McGRAW-HILL BOOK COMPANY, Inc.
239 W. 39th St., NEW YORK

Gentlemen: — I am interested in your Machine Shop Library. You may send me the nine volumes, charges paid, for my inspection. If satisfactory I will send \$2 in ten days and \$2 per month until I have paid the price of the books, \$15. If the books are not what I want, I will write you for shipping instructions.

P. M. Mar.

EARN WHILE YOU LEARN



LEARN WHILE YOU EARN

Leading Electrical Concerns Join America's Foremost School In PRACTICAL ELECTRICITY To Develop TRAINED Men

To meet the extraordinary present-day demand for trained electrical men, a number of big Milwaukee Industrial Concerns have just taken a step without precedent or parallel. They have entered into a contract with this school to give our students part time employment at practical electrical work during their entire course of study.

This gives you an opportunity absolutely unique in the history of technical education—the opportunity to secure a sound, through-and-through training in both the “book” and the “dollars-and-cents” sides of

Commercial and Electrical Engineering

You earn your living expenses while pursuing your studies. Mornings—lectures and laboratory work at school—afternoons—actual practice in the work rooms of the industrial companies. What better start in life could you ask than this chance to acquire a complete, job-insuring technical training under actual wage-earning working conditions, giving you confidence in yourself and a feeling of security in holding your job.

A Permanent Job for Every Graduate

Feeling the tremendous need for more men with the sound, technical training afforded by this school, these same concerns have agreed to employ all our duly qualified graduates at good salaries the moment they receive their diplomas.

To meet this demand we offer the following courses to students with credits in algebra and plane geometry:—

Complete Commercial Engineering	2 yrs.
Electrical Engineering	2½ "
Special Course in Practical Electricity	1 "

Students with only a common school education may finish the complete Commercial Engineering Course in 2½ years, Electrical Engineering in 3 years, Special Course in Practical Electricity 1 year.

Established thirteen years ago, the School of Engineering of Milwaukee stands absolutely alone in the field of electrical and commercial engineering. Has the emphatic and unqualified endorsement of all leading engineering industries. Write at once for full particulars. New term opens April 2nd.

School of Engineering of Milwaukee
307 Stroh Building MILWAUKEE, WIS.

Fill out this coupon and return now for full information

SCHOOL OF ENGINEERING, 307 Stroh Building, Milwaukee, Wis. Gentlemen: Please send me complete details regarding your “Earn While You Learn” proposition.

Name.....

Address.....

Age..... Education.....

(Mark X after course you are interested in.)
Commercial Engineering.....
Electrical Engineering.....
Practical Electricity.....

Please Mention Popular Mechanics

SHORTHAND IN 30 DAYS

We absolutely guarantee to teach shorthand complete in only thirty days. You can learn in spare time in your own home, no matter where you live. No need to spend months as with old systems. Boyd's Syllabic System is easy to learn—easy to write—easy to read. Simple. Practical. Speedy. Sure. No ruled lines—no positions—no shading as in other systems. No long lists of word signs to confuse. Only nine characters to learn and you have the entire English language at your absolute command. The best system for stenographers, private secretaries, newspaper reporters and railroad men. Lawyers, ministers, teachers, physicians, literary folk and business men and women may now learn shorthand for their own use. Does not take continual daily practice as with other systems. Our graduates hold high grade positions everywhere. Send today for booklets, testimonials, etc.

Chicago Correspondence Schools
969 Unity Bldg., CHICAGO, ILL.

COPY THIS SKETCH

and let me see what you can do with it. Illustrators and cartoonists earn from \$25 to \$125 a week or more. My practical system of personal individual lessons, by mail will develop your talent. Fifteen years' successful work for newspapers and magazines qualifies me to teach you. Send me your sketch of President Wilson with 6c in stamps and I will send you a best lesson plate, also collection of drawings showing possibilities for you.

The Landon School of Illustrating
and Cartooning
1438 Schofield Building, CLEVELAND, O.



CIVIL SERVICE

positions are in all parts of the country. Good pay, steady work, life positions, congenial surroundings, promotions on merit, short hours, annual vacation and sick leave with pay. Many thousands appointed yearly. Both sexes. No political pull. Nearly 300,000 classified positions. Common school education sufficient. Full information and questions used by the Civil Service Commission free.

COLUMBIAN CORRESP. COLLEGE, WASHINGTON, D. C.

DRAWING

Learn by Mail in YOUR OWN HOME

Newspaper, Magazine and Commercial Illustrating, Cartooning, Water Color and Oil Painting. Learn drawing or painting for profit and pleasure. We can develop your talent. This school has taught thousands. Free Scholarship Award—special limited offer. Your name and address brings you full explanation and our handsome illustrated Art Annual by return mail. Don't delay, write to-day.

Fine Arts Institute, Studio 563, Omaha, Neb.



Debates and Orations

Essays and orations, about 1,000 words; debates on either side of any subject, about 1,500 words: one dollar each. Addresses for all occasions prepared to order. All work done by college graduates. Satisfaction guaranteed or money refunded. Let us know your wants. Questions for debates free.

COLUMBIAN INFORMATION BUREAU, WASHINGTON, D. C.

Cartooning, Comic ZIM Art and Caricature

There is big money in the above for you. I will show you how. Send 6c in stamps today for my prospectus explaining method and terms. Write your name plainly.

ZIM ART SCHOOL, Dept. Q, Horseheads, N. Y.

SPEAK A FOREIGN LANGUAGE !!!

The War has created unlimited opportunities for those who know Spanish, French, German or Italian. Better your position or increase your business. You can learn quickly and easily, at home, during spare moments, by the

LANGUAGE-PHONE METHOD
And Rosenthal's Practical Linguistery
(Highest Award Panama-Pacific Exposition, 1915)

You listen to the living voice of a native professor pronounce the foreign language, over and over, until you know it. Our records fit all talking machines. Write for Booklet, particulars of Free Trial. The Language-Phone Method, c/o Palram Bldg., 2 W. 45th St., N. Y.



CLEOPATRA TESTING THE POISON

The most beautiful, passionate and faithless woman of antiquity, having first infatuated, then ruthlessly destroyed the great Antony; at the moment of her downfall coolly arranges her own death rather than go to Rome in disgrace. Before taking the poison herself, she watches with keen interest its effect upon her own bodyguard. No more characteristic action could be shown. This is one of the thousands of historical incidents of tragic interest in Dr. John Lord's



Beacon Lights of History

The heirs of Dr. John Lord, the Modern Plutarch, author of the most famous historical work of its kind ever written, have agreed to reduce their royalties so that we are here able to offer you a set of Beacon Lights of History at a price so low you can't afford to miss it. The set is complete in 15 beautiful volumes and contains famous lectures on every great character in history—Cyrus the Great, Julius Caesar, Marcus Aurelius, Cleopatra, Alexander, Hannibal, Napoleon, Washington, and all the Hosts of History who constitute the Beacon Lights of the World.

More Than 1,000,000 Volumes Sold

More than one million volumes of Beacon Lights have been sold and every customer is more than satisfied. Never before has a work of similar nature had so great a sale. Dr. Lord epitomizes the history of the entire world, and groups the historical events around the great Beacon Lights of History—the famous men and women of all nations and races. It is complete and graphic, absorbing and interesting, and holds the reader spellbound with the rapt interest of a stirring tale.

Greatest World History Ever Written

Have you ever watched history's procession from its starting point? Have you seen Egypt rearing her pyramids and other world wonders? Have you looked upon Assyria, Babylonia and Persia rising to their zenith, pour forth their radiance and then sink again into oblivion? Have you marked Greece, her chiseled temples crowning a thousand hills, her genius endowing the world? Has Rome risen before you pre-eminent, her laws supreme, her army invincible, her science mature, and then under the fever of luxury sunk into decay? Have you lived through the cruelty of the middle ages? Have you thrilled over the romance of the age of chivalry? Have you watched the ennobling influence of the Renaissance? Have you stood by as France received her baptism of blood? Have you seen that God-guided group of patriots draft the American Constitution? If you have not, then the pages of this work hold much in store for you. If you would quicken your pulse, enlarge your horizon, cultivate your imagination, stimulate your patriotism, then read the world's story—Beacon Lights.

Here is Our Bargain Offer—Send No Money!

Just fill out and mail attached coupon and we will ship you the complete set Beacon Lights of History for 10 days' examination in your own home. We want you to see these beautiful volumes and to read several of the wonderful lectures, and you can then decide whether or not you wish to buy. If you are satisfied then send \$1.00 only as a first payment and pay the balance \$2.00 per month for only 14 months until our special price of \$29.00 for the silk cloth binding is paid. If you prefer the beautiful $\frac{1}{2}$ morocco, which we strongly recommend, send only \$1.00 as a first payment and \$2.00 monthly for 19 months until the sum of \$39.00 is paid. This binding is so attractive and the reading matter so intensely interesting that we strongly recommend the better binding, but you can have your choice.

Satisfaction Guaranteed

If you are not entirely satisfied in every way then notify us within ten days and we will give you shipping instructions for return of the set. We ship direct from factory to consumer and guarantee satisfaction. How could any offer be more fair?

COUPON

Beacon
Lights

History Club
140 So. Dearborn St.
Chicago, Illinois

Ship me for examination and approval, one set Beacon Lights of History, 15 volumes, $\frac{1}{2}$ morocco binding. If satisfactory I will remit you \$1.00 within 10 days and \$2.00 monthly thereafter for 19 months. If not satisfactory I will notify you within 10 days and return books at your expense as offered Popular Mechanics readers. (Mech.)

Name.....

Address.....

If Cloth Binding is preferred change " $\frac{1}{2}$ Morocco" to "Cloth" and "19 months" to "14 months."

FOLD HERE. TEAR OUT, SIGN AND MAIL



Read What My Drafting Students Say:

Am at present employed at a salary of \$1800 a Year.

\$1800 a Year

I have been earning from \$125 to \$160 per month.

\$160 a Month

I have made more than \$300.00 per month.

\$300 a Month

I designed special automatic machinery getting \$150 per month.

\$150 a Month

I am employed at a straight salary of \$3500.00 per year.

\$3500 a Year

The Chief Did It! They All Say

Yes, that's what they all say,
"The Chief Did It."

I have trained the best paid men in expert drafting and designing. Letters like those above come to me right along. I give my students personal, practical, thorough training—and now they are holding high salaried positions.

The same opportunity that was open to them is yours. The pleasant work—the short hours—the big salary—are all yours through my special individual training.



Write To Me—Send Coupon!

**Chief
Draftsman Dobe**
Engineer's Equipment Co.
Div. 1193, Chicago, Ill.

Without any obligations on me whatsoever, please mail your book "Successful Draftsmanship" and full particulars of your liberal "Personal Instruction" offer to a few students. It is understood that I am obligated in no way whatsoever.

Name

Address

I am Chief Draftsman of a large and well-known company. During my spare time I will train a few ambitious men to hold positions as high-grade draftsmen. Men are needed. There is a constant demand for trained draftsmen all over the country. **\$125 to \$200 a month straight salary** is ordinary pay for a good draftsman. And I will give you just the kind of practical training that you need right in your own home. Write to me today for the new book "Successful Draftsmanship" that tells about the opportunities in the profession. The book is free—no obligation. Send coupon at once.

Chief Draftsman Dobe
Engineer's Equipment Co.
Div. 1193 Chicago, Ill.

FREE Instruments

For a limited time, I am giving to my students a complete draftsman's working outfit absolutely free. In the outfit you get a complete set of instruments—just like I use myself—in addition to the drawing board, T square, triangles, paper, erasers, etc.

With this outfit you will get the practical training that will put you in the big money class. Write today.

CLASSIFIED ADVERTISEMENTS

WORLD'S BEST WANT AD MEDIUM

We have records to prove that a classified ad in these columns will find a buyer for almost anything which can be sold. Doubtless you have some article of value to some one else which you no longer need. Why not turn it into money?

Advertisements in this section, 18 cents per word, each insertion, minimum 10 words, payable in advance. To insure ads being inserted under proper classified head in the April issue, copy must reach this office not later than February 28th.

Popular Mechanics Magazine, Chicago.

Gentlemen: We are sure that you will be glad to know that returns received from the classified section of Popular Mechanics Magazine have been phenomenal. We do not believe that there is any medium published at the present day which will bring in one-tenth the number of inquiries as yours. We have much pleasure in letting you know of the excellent returns we have received from Popular Mechanics Magazine.

Yours very truly,

AMERICAN SCHOOL OF AVIATION.

AUTOMOBILES

BUICK Auto given. I have given away more than fifty automobiles in the last three years to people all over the United States. These automobiles have not cost these persons one cent. They were earned under my wonderful new system of prize distributions in which I am soon to give another automobile. This time it's a 5-passenger Buick Touring Car, fully equipped, and self-starting. Full information is free and does not obligate you in any way. Don't send money or stamps, just your name and address on postal card. Auto Tom, 547 So. 17th St., Omaha, Nebr.

AUTOMOBILE Books by Victor Page For Sale at cut prices; Model T Ford Car, construction, operation, repair, 200 pages, 78c. Motorcycles, side cars, cycle cars, construction, operation, repair, 550 pages, 350 illustrations, \$1.19; Automobile repairing made easy, 1,940 pages, 1,000 illustrations, \$1.95; Chart showing sectional view of Gasoline Engine, 25c; Catalogues, etc. McCarthy, 1236 Arthur Ave., Chicago, Ill.

PAINT Your Car Yourself—Save \$25 to \$75 by doing the work at home with the Arsenal system. Our big free booklet "The Car Beautiful" tells how. Send for it today. Arsenal Varnish Co., Dept. P, Rock Island, Ill.

AUBURN 2 Cyl., 5 passenger; good condition, \$150. Lloyd Kelley, Council Grove, Kan., R. R. 2.

READ about cross continent trip of wonderful new car with Rotary Motor that spins around; this month's Motor Mechanics, Cleveland, Ohio. Also covers Farm Tractors, Motorcycles, Gas Engines, Power Machines, Sample copy 10c. Six months' trial 50c.

THE Modern Gasoline Automobile—Most complete and up to the minute automobile book published. Recognized as the standard book on construction, operation, maintenance and repair, showing every recent improvement. Over 700 pages, 500 illustrations. Cloth. Price \$2.50 postpaid. Send for complete description of this and other reliable automobile books. Popular Mechanics Book Dept., 6 N. Michigan Ave., Chicago.

AUTOMOBILE Questions and Answers—A self-educator on automobiles without an equal. Covers over 2000 questions and their answers relating to the modern automobile, 650 pages, 350 illustrations. Cloth, \$1.50 postpaid. Complete description on request. Popular Mechanics Book Dept., 6 N. Michigan Ave., Chicago.

WANTED—Stanley Twenty Engine, Rear Axle, 1914. Geneva Steam Engine, Rear Axle. Box 87, Pueblo, Colorado.

CYLINDERS reground, new pistons and rings fitted. Restores lost power. Write for prices, giving make and model. The Evars Machine Co., Hartford, Conn.

PAINT Your Own Car. Easy to do and very satisfactory by using Autonamel. Complete outfits and directions, \$5 to \$10. Write for booklet and color card. Autonamel Company, Dept. B, Rochester, N. Y.

STANLEY Cars—Piston Rod Packing Tool \$1.50 pair—New Superheating system. Box 87, Pueblo, Colorado.

PATENTS for Automobile Improvements are in great demand. We have special Automobile Department in charge of experts who are in touch with demands of trade. Write for "What To Invent and List of Patent Buyers," sent free. Victor J. Evans & Co., 188 Ninth, Washington, D. C.

AUTOMOBILE Repairs—Automobile owners, Garages and Repairmen should subscribe for the Automobile Dealer and Repairer; 150-page illustrated monthly devoted exclusively to the care and repair of the car. The only magazine in the world devoted to the practical side of motoring. The "Trouble Department" contains five pages of numbered questions each month from car owners and repairmen which are answered by experts on gasoline engine repairs. \$1 per year; 15c per copy. Canadian subscription, \$1.50. Postals not answered. Charles D. Sherman, 50 Windsor Road, Hartford, Conn.

A REAL Automobile: The American Junior; with a real gasoline engine. Two passenger. Eighteen miles per hour, ninety miles on a gallon of gas. Just the thing for Juniors, Salesmen, School Teachers, etc. Price, \$160. Send for Catalogue. Some good territory open for dealers. American Motor & Vehicle Co., La Fayette, Ind.

AUTOMOBILE SUPPLIES

TIRES—Double Tread Guaranteed for 3,500 miles. Absolutely Puncture-Proof. Big—Strong—Extra, heavy 39x3 tire, \$5.00; 39x3 1/2, \$6.00; 33x4, \$5.00; 34x4, \$9.25; 34x4 1/2, \$12.00; 37x5, \$13.00. Big saving on other sizes and tubes also. Trade in your old tires. Discount to dealers. 10% deposit required on C. O. D. orders. Send for list now! State size and bead of tire. Max Liben & Co., 205B West 18th Street, New York.

MAGNETOS—4-cyl. high-tension—Bosch—K. W.—other makes, \$10.00. Simms \$15.00. Dixie \$15.00. Remy & Splittorf \$5.00 each. All makes and sizes. Presto Tanks \$5.00. Head lamps \$2.50. French Ebony steering wheels \$2.50. Cots—Windshields—other parts, low price. Johnston, West End, Pittsburgh, Pa.

PARTS for Maxwells, Buick, Overland, Oakland, Chalmers, Cadillac, Everett, Emf, Interstate, Beh, Franklin, Reo, Mitchell, Jackson, Peerless, Thomas, Stevens, St. Dayton, Great Smith, Locomobile, Premier, Velle, Hugmobile, Parry, Brush. Kent Auto-Parts Co., Denver, Colo.

BUCKET seats for racing cars. Prices low. American Accessories Co., Dept. P-4, Cincinnati.

PEUGEOT Type Cylinder Head for Fords; 16 Overhead Valves, Rocker Arms, Push Rods, Special intake manifold for 13" Carburetor. Complete assembled, \$75.00 f. o. b. Anderson, Indiana, Robert M. Roof, M. E.

MODEL 39 Buick Eng. \$125. Studebaker 25 \$85. Flanders 20 \$60. Adams 30 \$75. R. C. H. \$75. Parts for 100 old model autos. No catalogue. Auto Salvage Co., 1436 Wabash Ave., Chicago, Ill.

EXPLOSION Whistle. Fits priming cup. Most powerful signal made. Rapid seller, owing to real value. See display ad page 166. Buell Manufacturing Co. (Dept. 21), 1610 Michigan Blvd., Chicago.

SPARK Plugs Guaranteed special brand \$1.25 set, postpaid. Schelp-Budke Co., 2942 Locust St., St. Louis, Mo.

GEARS for all purposes; transmission gears, bevel-drive gears, sprockets, axles. Special machine work. Must have old parts or drawing. Turley Gear Plant, 1505 N. 10th St., St. Louis, Mo.

\$40 BUYS 4 Regular Briction Trends, 33x4, practically good as new. F. F. Harris, Sheldon, Ill.

WE wreck cars for parts. Special prices on used motors, carburetors, coils, magnetic, etc. All parts for all cars. Warschawsky & Co., 1921 South State St.,

BATTERY Chargers earn big profit. Engine or City current operates. Ten dollars places money-maker in your Garage, balance easy Terms. Hobart's, Troy, Ohio.

DOUBLE Service Tires. Guaranteed 3,500 miles. Sizes 30x3 \$5.00, 30x3 1/2 \$6.00, 33x4 \$8.00, 34x4 \$9.00, 36x4 \$9.00, 38x4 1/2 \$10.00, 38x5 \$11.00, 37x5 \$11.00. Non-skid \$1.00 extra. 10% required on C. O. D. orders. State if Q. D. straight bead or clincher type. Special discount to dealers. I. Jaffess, 1319 H. Fifth Ave.; Branch, 241 W. 54th St., New York.

INSYDE Tyres, inner armor for Automobile tires, double mileage and prevent punctures and blowouts. Quickly applied. Cost little. Demand tremendous. Profits unlimited. Details free. American Automobile Accessories Co., Dept. P2, Cincinnati, O.

LOCOMOBILE Motor Complete. Rayfield carburetor, magneto, fan, pump, etc. Completely overhauled, A No. 1 condition, \$80.00. Box 275, Burlington, Wis.

AUTOMOBILE Parts for most all makes of cars: Buicks, 10, 17, 19, 27, 29 and 35; Maxwells, E. M. F. Flanders, Paige 25, Overlands, 37, 38, 42, 49 and 59; Cadillacs '09 to 1912, Parry, Regals, '09 to 1913; Oakland 25, Jeffery, Mitchells, 1907 to 1913; Empire, Elmore, Chalmers, '09 to 1913; Auburn, Jackson 35, Interstate 30, Hudson '20, Hupp '20 and many others. Pistons, Connecting Rods, Cam Shafts, Crank Shafts, Cylinders, Axles, Bearings and gears for most any make of car. Write us your needs. Satisfaction guaranteed. Auto Parts Company, 4116-18 Olive St., St. Louis, Mo.

DAYOLINE Bushings Satisfy; outwear habbit and bronze. Experts recommend. Sample bar, quarter. Investigate profitable dealer's proposition. Literature? Davoren Mfg. Co., Denver, Colo.

"GIDZ," the Modern Auto Fuel, takes the bump out of hills. Puts new Vim, Vigor and Velocity into your motor. "Gidz" is scientific, non-injurious, removes carbon, prevents formation. Used by thousands past two years. \$1 can Prepaid will satisfy you. Quick Repeater for Dealers. "Gidz" (Dept. 3P), Galesburg, Illinois.

JUST Out—Modern Starting, Lighting and Ignition Systems—A new book on automobile electricity without an equal. Nearly 400 Pages. 250 Engravings. Cloth. Price \$1.50 postpaid. Complete description sent on request. Popular Mechanics Book Dept., 6 N. Michigan Ave., Chicago.

POWER increased, carbon eliminated, results guaranteed. Write for folder. Automobile Accessories Co., Baltimore, Maryland.

MAXOTIRES, guaranteed blowout proof; 30x3, \$6.40; 34x4, \$11.00. Increase mileage 3,000 miles. Mail orders should have \$2.00 deposit any size. Balance C. O. D. Auto Sales Co., 908-10 Chestnut St., St. Louis, Mo.

PUNCTURES farwell, the only successful Plugger; good territory left; Agents hurry. Every auto owner a prospect. P. P. Mr. Co., 324 Bradley Ave., Peoria, Ill.

AUTO Engines: 4-cylinder water-cooled, \$35.00. Buick 16—Buick 17—Mets—Franklin 4—Pierce. All sizes—low price. Johnston, West End, Pittsburgh, Pa.

REPAINT your car at home with a Presto Auto Paint Kit. Details free. American Accessories Co., Dept. P-3, Cincinnati.

23% PROFIT selling Jubilee Spark Intensifiers to automobile owners, garages. Sure cure for Spark Plug troubles. Sells like wildfire. Brand new. Exclusive territory. Write today. Jubilee Mfg. Co., Dept. N-1, Omaha, Nebraska.

SHOCK Absorbers: Ford \$5, Large Cars \$20. Agents buying 350 worth samples get 40%. Schultz, 1230 St. James St., Philadelphia.

UNUSUAL Bargains in Automobile Repair Parts, Axles, Bearings, Carburetors, Complete Engines, Cylinders, Differentials, Magnets, Pistons, Radiators, Springs, Valves, Wheels and other parts for Buick, Cadillac, Chalmers, Interstate, Maxwell, Mitchell, Moon, Overland, Packard, Peerless, Regal, Studebaker, Thomas and other cars at a fraction of factory cost. Maxwell Bros., 2331 Olive Street, St. Louis, Mo.

AUTO Top Roof and Rack Curtain Roadster, \$6.95; touring, \$8.95. Parcel post paid. Our instructions make it easy to apply. You save \$7. Samples and catalogue free. S. H. Top Co., 430 Hunt, Cincinnati, Ohio.

VULCANIZER for shop, Bargain. Vanderpool's, Springfield, Ohio.

TO FORD OWNERS

"SCANDINAVIA" Transmission Band Set \$1.25 postpaid. Catalog and Fan-belt free. Miller, 101 West 163 Street, New York.

SYMONS Brothers Co., Evanston, Ill., notes, can save you from 20% to 30% on your gasoline bills on Ford cars. It will pay you to make them prove it.

SLEEP in your Ford in McMillin Auto Bed, \$7.50. Free booklet on auto camping. Auto Bed Company, Bellingham, Wash., Box 0.

NEW Fasco Ford body complete with steering gear and vacuum feed; cost \$150. Will take \$100. Reuben A. Riesland, Fowler, Mont.

BE our agent. Buy the Safety Ford Starter for \$4.50. Details for \$15.00. Try one; write for particulars. Safety Ford Starter Corporation, Columbia Theatre Bldg., New York.

WANTED—Ford car owner in every county to demonstrate the \$10 Ajax Ford Starter. \$30 to \$50 weekly. Write for territory to the Ajax Ford Starter Co., Keene, N. H.

GAS Vaporizer, starts cold motors. Attachment \$1.50. Thirty days' trial. Whitmore, Box 313, Stevensville, Montana.

"RED-1-KUT" Speedster, see full description on page 182 this issue.

FORD ACCESSORIES

FTT your car with an Automobile Clock. C. O. D. \$2.00. Auto Clock Co., 1111 Fourth St., Peru, Illinois.

FORDS given double light automatically at low speeds. Salesmen guaranteed \$18.00 per week. North American Instrument Co., 208 Michigan Ave., Grand Rapids, Mich.

CYCLECARS AND MATERIAL

BUILD your own Cyclecar or small Racing Cars. Either tandem or side by side seating. Very fast and economical. We supply all parts fully machined and you assemble them, or we sell fully finished cars. Well known successful cars now in use in every State. 10 h. p. "V" Motor \$27.50. Ball bearing wire wheels \$9.00 per set. Four cylinder motors, frames, axles, etc., at low prices. Guaranteed as represented or money refunded. Special discount to act as agents for the smallest small car in the country. Send two cent stamp for full catalog. Tribune Engineering Company, Oregon, Trego County, N. Y.

WELDING

DAY'S Welding Solder, for scored cylinders and all metals, apply with soldering-iron, sample bar 50c or \$1.50 per pound. Bellingham Solder Co., Bellingham, Wash.

LEARN to solder aluminum, braze steel and cast iron, write for particulars. Modern School of Soldering, 471 Faber, Montreal, Canada.

WELDING Plants for All Purposes. Small Cash Payment. Balance to Suit. Bermo Co., Omaha, Neb.

WELDING—Automobile Welding with the Oxy-Acetylene Flame—Just Out—167 pages, fully illustrated. Price \$1.00 postpaid. Explains the actual welding of all automobile parts in a manner understandable by everyone. Popular Mechanics Book Dept., 6 N. Michigan Ave., Chicago.

OXY-ACETYLENE Welding and Cutting, Electric and Thermit Welding. Brand new book of practical instruction in this process. The workman will find all necessary information for handling any kind of welding. 215 pages, fully illus. Cloth, \$1.00; Leather, \$1.50 postpaid. Popular Mechanics Book Dept., 6 N. Michigan Ave., Chicago.

SIMPLE Soldering, both hard and soft—82-page book telling how to join metals. Do your own repairing. 52 illustrations. 25c postpaid. Popular Mechanics Book Dept., 6 N. Michigan Ave., Chicago.

MOTORCYCLES, BICYCLES & SUPPLIES

A REAL bargain in second-hand motorcycles. We have an overstock of all makes, such as Indians, Harley-Davidsons, Excelsiors, Pops, Merks, and 4-cylinder Hendersons. All are in A-1 condition and fully equipped. If interested in buying a motorcycle write for our Bargain Bulletin No. 5 giving description and prices from \$35 up. Gotham Sporting Goods Co., 57 Warren St., New York City.

FOR Sale—Modern Twin Indian; fully equipped. Excellent condition. Albert Olson, 2318 Live Oak, Dallas, Texas.

HIG bargains in good motorcycles we have taken in exchange on new ones. Send for special bargain list. Shaw Mfg. Co., Galesburg, Kansas.

TWO Speed Twin Merkel Motorcycle. Write for price. Allan Pearson, Morrison, Ill.

1913 EXCELSIOR single, overhauled, renamed; horn, tandem, good condition. \$50. Clayton Williams, Reed, Ky.

BARGAINS, new motorcycles, F. Zimmermann, Jr., Oakland St., Shreveport, La.

FOR Sale—1916 Harley-Davidson, horn, Prest-O-Lite tank, lamp, and F-N tandem, run less than 2,000 miles. Everything in good condition. Price \$230. Chester Lucas, Reynoldsdale, Pa.

SLIGHTLY Used Parts at very low prices. Bosch magnets \$4 to \$10. Cylinders \$3 to \$7. Pistons \$1, etc. Complete engines \$10 to \$30. All makes. Van's Motorcycle Wrecking Shop, 11 West Tenth St., Los Angeles, Cal.

WANTED: We pay cash for used motorcycles or take them in on exchange for new machines. Write with complete description. State condition of tires, frame, motor, make and model. Shaw Manufacturing Co., Dept. 157, Galesburg, Kans.

MOTORCYCLES, Side Cars and Cyclecars. Their Construction, Management and Repair—The only complete work published on this subject. The dealer, mechanic and rider will find this an excellent treatise. 350 pages, cloth, 350 illus. Price \$1.50 postpaid. Complete description sent upon request. Popular Mechanics Book Dept., 6 N. Michigan Ave., Chicago.

I SAVE you half on parts and accessories for all makes. Jones 3d, "The Parts Man," Box 702, Brockton, Mass.

1917 EAGLE Motorcycle now ready. Get Circular M.E. and agency proposition. Eagle Motorcycle Company, Brockton, Mass.

EASY Terms on new and rebuilt motorcycles, side cars, tandems and lighting outfit. Motorcycle Investment Company, 893 Center St., Brockton, Mass.

MOTORCYCLES—Buy now, at right prices; bank references. Crosst Motor Co., 291 River St., Mattapan, Mass.

WRITE for list and terms on used motorcycles. F. A. Shottenheimer, 213 Barr St., McDonald, Pa.

INDIAN Twin, 2-Speed, 1915 Model, fully equipped, in best running order. Price, \$150. Isaac Gossard, R 1, Hagerstown, Md.

DEPENDABLE Used Motorcycles which you can have for \$2 more than they cost us. Satisfaction guaranteed. Write for Bargain Bulletin. Haverford Cycle Co., Philadelphia, Pa.

LOOK Here! 1916 Indian Powerplus twin, brand new, \$225; Lightweight Thor 3-speed twin, \$175; Big Valve Excelsior twin, \$135; Electrically equipped Thor 2-speed twin, \$150; 1914 Indian twin, electrically equipped, \$180; 2-speed Excelsior single, \$75. Other bargains from \$30 up. Free list. Western Supplies Company, 136 Hayutin Bldg., Denver, Colo.

DON'T buy a Bicycle Motor Attachment until you get our catalogue and prices. Shaw Mfg. Co., Dept. 27, Galesburg, Kansas.

WHY Not Save Money? 1916—2 Speed Henderson \$119.00, another \$95.00, 3 speed Harley-Davidson Electric \$125.00, perfect order 1916 Indians—\$129.00. These will go quickly—Grab them—200 of the biggest bargains in the country, write for catalog. Money refunded if not satisfied. 3 Big Stores. Write today. W. E. Wandersee Co., 129 Gratiot Ave., Detroit, Mich.

WANTED: Henderson or other 4-cylinder engines. High-tension magnets, all sizes. Johnston, West End, Pittsburgh, Pa.

BARGAINS in used motorcycles—all machines guaranteed and in A-1 condition ready for use. Write for terms and new bulletin. Photos free. Harley-Davidson Sales Company, Birmingham, Alabama.

YALE 1914 two-cylinder with delivery side car, good running condition, \$95.00. Schelp-Budde Co., 3942 Locust St., St. Louis, Mo.

WILL sacrifice entire stock of used and rebuilt motorcycles, all makes. Write for list. Will accept any reasonable offer. Seeber & Hofheins, Buffalo, N. Y.

WRITE for list of bargains on used Motorcycles. Little Falls Motorcycle Co., Little Falls, N. Y.

JUST Out—Send for our revised list of genuine bargains in used motorcycles of all makes. Victor H. Boos, "The Cycle Man," 2701-03 Leavenworth St., Omaha, Neb.

INDIAN Sidecar—1915-16 model, good condition, tire. Price \$33, \$10 in advance, balance C. O. D. W. W. Newby, Box B, Tulsa, Oklahoma.

MOTORCYCLES overhauled \$35 up. C. C. Williams, Reed, Ky.

MAKE your bike a motorcycle by using our motor. Fits any wheel. Good hill climber. Price only \$32. Ashland Motor Works, Dept. B, Ashland, Ohio.

MOTORCYCLE Bargains, single and Twins, Hendersons, Harleys, Indians, Excelsiors, Kultures, Emblems, Thors, Pops. All makes guaranteed. A-1 Shape, tuned up ready to ride. \$35 to \$100. Motorcycle tires, \$3. Lamps, \$5. Automobile tires, \$3. Bicycles, \$5. Tandems, \$20. Bicycle tires, \$1. Bicycles and motorcycles at Factory Prices. Old motorcycles taken in trade. Highest prices allowed for them. Swap in yours. Designer, the Price Cuts, Rochester, N. Y. Send for Catalog. Free.

OVERSTOCKED—100 Used and rebuilt motorcycles, Harley-Davidsons, Indians, Excelsiors, Thors, etc. Must be sold at once. Write for our latest catalog. Easy terms. Myerow Bros., 149 Berkeley St., Boston, Mass.

MOTORCYCLES—\$25. If you want a high grade New or Used Motorcycle and have \$25 Cash, write quick for Bulletin "K"; lowest prices, easiest terms. Peerless Motorcycle Co., Boston, Mass.

BARGAINS in used motorcycles. Photo. R. H. Sunderlin, Goldfield, Colorado.

LARGE stock of rebuilt motorcycles, new parts for all makes 25% discount; second-hand parts, good as new, 50% discount. Motorcycle Parts Mfg. Co., 2127 Michigan Ave., Chicago.

MOTORCYCLE cylinders reground, fitted with new piston and rings, \$5.00, guaranteed. Muncie Piston Co., Muncie, Ind.

WANT to sell your motorcycle? I have a method which has sold many. Write me today for free information. F. W. Johnson, Room 900, 78 E. Madison St., Chicago.

AERONAUTICS

THE American School of Aviation announces a new correspondence course in aero-construction and design. A thorough training in aeronautical engineering. American School of Aviation, Dept. 9193, 431 South Dearborn Street, Chicago.

GET into the aviation game and get into it right. We can and will help you. American School of Aviation, Dept. 8193, 431 South Dearborn Street, Chicago.

WILL exchange automobile, racing runabout for complete aeroplane or high powered aviation motor. Adams, 2823 Ave. D, Brooklyn, N. Y.

TANDEM Monoplane Glider, full size, how to make—Our book "Amateur Mechanics No. 6" contains a complete detailed description of how to make one and also over a hundred other interesting articles. Price 25c postpaid. Popular Mechanics Book Dept., 6 N. Michigan Ave., Chicago.

FOR Sale—75 H. P. Aero Motor, without magneto. Guaranteed good. Nearly New, \$275. John Brans, 2511 N. Central Ave., Dallas, Texas.

BI-PLANE Glider, full size, how to make—Our book "Amateur Mechanics No. 2" contains a complete detailed description of how to make one and also over a hundred other interesting articles. Price 25c postpaid, Popular Mechanics Book Dept., 6 N. Michigan Ave., Chicago.

AVIATION Motors, all makes, up to 150 H.P., \$250 up. Complete aeroplanes, all types, \$500 up. State your needs. Aero Exchange, 38 Park Row, N. Y. C.

BUILD yourself a Baby White Monoplane this winter. The smallest, simplest and lowest powered practical machine in America. Flies with motorcycle engine. Plans \$5 per set. White Aeroplane Company, 419 Exchange Building, Los Angeles.

DETROIT Aeroplane Motor and Propeller. Complete. Price \$85. Lee Howe, 110 21st St., Oakland, Cal.

GET wise on small tractors, Motors, Plans. Everything aeronautical. Chicago Aero Works, River Street, Chicago.

SPECIAL Light Weight gasoline engine, 1/2 H.P., 2 1/2 pounds. Send stamp for catalog. Weiss Mfg. Co., Torrington, Conn.

GET our latest Aeroplane Book containing full information about "Ideal" Model Aeroplanes, parts, plans, etc. 5c postpaid. Ideal Aeroplane Co., 82 1/2 West Broadway, N. Y.

AEROPLANE accessories, propellers, fittings, etc. Dependable parts at the right price. Illustrated catalog eight cents postpaid. Chicago Aeronautical Supply Co., Chicago.

TRACTOR type biplane, complete, good condition. Cheap if taken at once. T. P. Hindman, 132 West 4th Street, Oklahoma City, Okla.

MODEL Aeroplanes—materials, supplies. Motordriven Scout Monoplane. Submarine diving boat. Send 5c for catalogue. Waring River Mfg. Co., 313 Sumpter St., Brooklyn, N. Y.

1916 ROBERTS Motor, new, 65 H. P., radiator, propeller, \$475. 50 H. P. Roberts, guaranteed, radiator, propeller. Solbrig, Aviator, Davenport, Iowa.

LEARN flying, Aero Club license guaranteed. Flying instruction given students daily and Sunday. Tractor Biplanes and Monoplanes used. United Eastern Aeroplane Corporation, 1251 DeKalb Avenue, Brooklyn, N. Y.

AEROPLANE motor and propeller, 40 H. P. Write Petalick, Horton, Kansas.

HEATH Aerial Products and Supplies. Why are they the best and cheapest? It's the old story—quantity production. Aeronautical supply catalogue, 6 red stamps; propeller catalogue, 3 red stamps. Heath Aeroplane Co., formerly Heath Aerial Vehicle Co., Chicago.

PATENTS Wanted in Aeronautics—U. S. Government spending millions in this class for Army and Navy. Our Aeronautics Department will give full information on this subject upon inquiry. Write for "What to Invent," sent free. Victor J. Evans & Co., 169 Ninth, Washington, D. C.

BUILDING and Flying an Aeroplane—160-page handbook covering the building of small models and full-sized gliders and machines. In both biplane and monoplane models the well-known Curtiss and Bleriot types are followed. Fully illustrated with detail drawings. Price, \$1 postpaid. Popular Mechanics Book Dept., 6 N. Michigan Ave., Chicago.

BOOKS AND PERIODICALS

FOR Sale—Any Technical or Scientific Text or Hand Book published, including International Correspondence School, Drake or American Technical Society at 20 per cent discount from publisher's prices. Enclose price, state book desired. McCarthy, 1236 Arthur Ave., Chicago, Ill.

MAGAZINES at rock bottom prices. Send today for our free catalog. Agents wanted. S. C. Hanson Magazine Agency, 4926 Kinzie St., Chicago.

"THE Straight Way from Earth to Heaven"—written by a Southern darkey in true plantation style; humorous; illustrated; 200 pages, \$1.00, postage prepaid. Minter-Moore Publishing Company, Norfolk, Va.

"STENOGRAPHY and Bookkeeping Simplified Down," 50c. Practical, easy studies. Marr, B 285, Nashville, Tenn.

ESSENTIALS of Chemistry for home study; over 300 pages, 68c. Brazing and Soldering, 25c. Modern Submarine Chart, 200 parts named, 25c. Boiler Room Chart, 25c. How to run and install gasoline engines, 25c. Drafting of cams, 25c. Threads and Thread Cutting, 25c. Catalogues, 4c. McCarthy, 1236 Arthur Ave., Chicago, Ill.

FIND Out for Yourself what to invent and how to procure and sell a patent for the same. My book, "Inventor's Universal Educator," covers the matter from A to Z. 140 pages, elegantly bound. Also contains 600 mechanical movements and 50 perpetual motions. Price \$1.00, postage free. F. G. Dieterich, 651 Ouray Bldg., Washington, D. C.

USED Books, Bargains, Catalog. Higgins's, A-2441 Post, San Francisco. (Books Bought.)

ELECTRICIANS—The repulsion-induction motor is being widely used. Send 20c for trouble chart, written by a factory tester. Schuder, 3881 Delmar Blvd., St. Louis, Mo.

MATHEMATICAL Hit of Century—"Comparative Cancellation Calculator." Solves all Arithmetical and Geometrical problems in one simple operation. 145 pages, \$1 postpaid. Refunded if dissatisfied. Herrick & Horton, Publishers, Princeton, Illinois.

FOR Sale—Second Hand Books, all kinds 25c, some cost new \$10; Catalog 4c; McCarthy, 1236 Arthur Ave., Chicago, Ill.

SOLEERS Self Calculating Scale for stair builders. Thoroughly tested and approved. Sent postpaid for \$1.00. (Good cloth binding.) R. C. Smyers, Mt. Union, Pa.

ENGINEERS' questions and answers for license by Hobson, for twenty-five cents, postpaid. Send stamps. Reilly's Book Store, Philadelphia, Pa.

PERPETUAL Motion. Old, honored mechanical problem. All about it. History, explanation, prophecy. Descriptive literature with beautiful cuts. Free. Enlightenment Specialty Co., 411 Olive St., St. Louis, Mo.

30 DIFFERENT Magazines, value \$3.00. All late issues. Yours for 25c. Eastern Bureau, New Egypt, N. J.

REESE Publishing House, Mt. Pleasant, Pa., can supply any book published. Catalogs free.

BINDER for Popular Mechanics magazines. Best adjustable magazine binder on the market made especially to hold any number from one to six copies of this magazine with name "Popular Mechanics" in gold letters on front cover. No laces or cutting or perforating of pages necessary. Simple, unique adjustment; handsome, durable and neat. We buy in quantities and can offer our readers this regular \$1.50 binder for \$1.25, all shipping charges prepaid. Address Popular Mechanics Book Dept., 6 N. Michigan Avenue, Chicago.

EDUCATIONAL AND INSTRUCTION

SHORTHAND \$1.00—Easiest and quickest. Arranged for self-instruction in seven lessons, \$1.00 complete. Satisfaction or money refunded. Write for introduction, I. V. Shorthand Company, P. O. Box 32, Station W., Brooklyn, N. Y.

MOULDS: Simplified and inexpensive methods of reproducing works of art. Ornamental casting, Novelties, Statuary, Garden Fixtures, Italian Marble, etc. Illustrations and instructions—Fifty (50) cents. Beaux-Art-Moulds Co., 438 Broadway, Brooklyn, N. Y.

LETTERING—Send dollar for authoritative construction charts; classic Roman alphabet, 5 1/2 inches high, every compass center given. Irl Wallace, 1150 Jackson St., Grand Rapids, Mich.

ROPP'S Calculator and Short-Cut Arithmetic—Shows the answer as quickly as a watch shows the time to all problems likely to occur in office, store, shop, bank, farm or factory. Over two million sold. Price, vest pocket size, 50 cents; leather, pocket size, \$1.00; large, desk size, \$1.25 postpaid. Complete description sent upon request. Popular Mechanics Book Dept., 6 N. Michigan Ave., Chicago.

HAVING finished my correspondence course in Show Card Writing and Commercial Designing, I will sell this complete course worth \$60.00 for \$16.00 spot cash. This is a wonderful course and dirt cheap. E. Delaney, Ft. Worth, Texas.

UNDERGROUND Treasures. How and where to find them. Morton Bldg., Chicago, Ill.

ELECTRICITY and Mechanics. A fifteen weeks' correspondence course that is different. Twenty dollars covers everything. For the man who wishes to better himself. Write for particulars. Western School of Correspondence, 600 East 15th St., Kansas City Mo.

WOULD you like to study law in your spare moments? I have a splendid opportunity to offer you. Send me your name and address right now. M. G. Miles, 1195 Manhattan Bldg., Chicago.

MECHANICAL Drawing Course. Booklet free. Foundation Course, Washington, N. J.

FOR a \$2.00 money order, I will give you personal instructions in the use of my new alphabet. Writes any language, mathematics. Originality and Secrecy Guaranteed, number limited. Sample, 20c silver. A. H. Miller, No. 608 Wylie Ave., Pittsburgh, Pa.

STUDY Bookkeeping or Shorthand at home. Special Offer. Pacific School of Commerce, Box 372, Spokane, Washington.

CHALK Talk Series—Turnover, trick, applause-getting caricatures. Complete program with "talk" \$1.00. Copy "Drawing Made Easy" (fifty sets trick drawings) free with order. Chalk Talk Magazine, Elm Creek, Nebraska.

ARCHITECTURAL instructors should have our views on American architecture. Samples 4c. Architectural Post Card Co., Philadelphia.

WRITE 100 words a minute with Briefhand. Uses Longhand letters. Simple. Practical. Home study. Complete manual \$1.00. Sample lesson free. Premier Briefhand School, Washington, D. C.

MECHANICAL Drafting pays big. Jones Brief System prepares you in twelve lessons—not a book, but a wonderful, direct and complete course. Set of tools free. The Jones System, Crilly Bldg., Chicago.

AMERICA'S 300 Years' History, condensed. Two colors. Nearly one thousand pen pictures. Every American should have copy, especially scholars. An exceptional bargain. Postpaid 60c. Description sent upon request. Hugh McIntyre, 784 Worthington Street, Springfield, Mass.

ORNAMENTAL casting, make moulds yourself. Two hundred illustrations free. Mahler, Woodhaven, L. I., New York.

START life right and be happy and successful. 1700 word, copyrighted, advice letter 25c. C. L. Phillips, 5 West Weir St., Taunton, Mass.

PRACTICAL, Thorough Courses in Mechanical Drafting, also Map Drafting and Lettering. Unique method. Big demand; high salaries. Columbia School of Drafting, McLachlin Building, Washington.

ARE you ambitious? You can earn good money in vaudette. Valuable information mailed free. London, 739 Crilly Bldg., Chicago.

PERSONAL Instructions in show-card writing by experienced man, short course, original methods, results guaranteed. C. L. McKie, Dept. M, Ypsilanti, Mich.

BOOKLET "For Better Job and Higher Pay" free. Foundation Drawing Course, Washington, N. J.

HIG Income Writing Advertising. Complete Course 18 lessons only \$1.00. Worth \$10.00. Educational Bureau, New Egypt, N. J.

FINGER Print Instructor—A text book for the guidance of finger print experts and an instructor for persons interested in the study of finger prints. Book based on the Henry System and prepared by an expert. Cloth, 155 pages, illus. rated. Price, \$2.00 postpaid. Popular Mechanics Book Dept., 6 N. Michigan Ave., Chicago.

IDEAL Atlas—Just Published—Contains large scale maps, yet is a book of handy size. Has special maps of all war zones in addition to all regular maps found in a good atlas. Is self-revising, that is, contains a certificate entitling the purchaser to a supplement of new maps after the war is over. Genuine flexible leather binding, 512 pages, 256 pages of maps, 256 pages of text. Price \$1.65 postpaid. Popular Mechanics Book Dept., 6 N. Michigan Ave., Chicago.

WAR Atlas—Large 20-page (11x15 in.) Atlas of the War in Europe, containing large colored scale maps of the Battle-ground, showing Europe, Austria, Serbia, Germany, England, Belgium, France, Russia, Italy, Greece, the World, etc. Special data showing comparison of armies and navies involved, pictures of rulers, etc. Price 30 cents postpaid. Popular Mechanics Book Dept., 6 N. Michigan Ave., Chicago.

WANTED—New Ideas. Write for list of Patent Buyers and Inventions Wanted. \$1,000,000 in prizes offered for inventions. Our Four Books sent free upon request. Victor J. Evans & Co., 167 Ninth, Washington, D. C.

LEARN Drafting—One of the most practical subjects, and indispensable in many occupations. Individual study at home without an instructor may be successfully carried on with the aid of our book, "A Practical Course in Mechanical Drawing," 166 pages, 157 drawings. Cloth. Price 50 cents postpaid. Popular Mechanics Book Dept., 6 N. Michigan Ave., Chicago.

ARTIFICIAL MARBLE, sanitary flooring, complete instructions, \$1. Ornamental casting, concrete, plaster, papiermache, decorations, garden furniture, statuary, rubber moulds, electrometallurgy. Particulars, 290 Illustrations free. Mahler, D-721 Woodland Ave., Woodhaven, L. I., New York.

TRADE SCHOOLS

ANYONE can learn sign painting and card writing by our easy modern method in a short time. The greatest of all home study courses. Earn \$50 to \$75 weekly. Sign Card School, 5th Ave., Chicago.

BECOME Auto and Tractor Expert. Practical work; no books; tools furnished; no special education required; free tractor, farm lighting and electric starter courses to all who enroll for auto course; free catalog. Lincoln Auto School, 3119 "O" St., Lincoln, Neb.

NATIONAL Dental Trade School. Men earn \$1300 to \$4000 a year. Learn mechanical dentistry in 3 months. We guarantee you can earn before completion of the course. Tuition payable in installments. Individual instructor, no study. National School of Mechanical Dentistry, 506 S. Wabash, Chicago.

COME to Seattle, the gateway to Alaska and the Orient. Learn practical electrical and gas engineering; mechanical drawing, machine shop practice, automobile construction. Splendid openings for ambitious students when competent. Seattle Engineering School, Seattle, Washington.

ELECTRICITY, Plumbing, Bricklaying Mechanical, Architectural and other Drafting Courses. Motion Picture Operating taught by practical work. Largest, best equipped practical trade school in America. Short time to learn. Small cost, easy payments. Write for big illustrated book; it's free. Cyne National Trade Schools, Dept. 8192, Chicago, Ill.

HILES' Watchmaking and Engraving School, the largest and best equipped school in the West. 717 Market Street, San Francisco, Cal.

CIVIL Engineering—Practical one-year course. Students received any time. Technical Institute, Greenville, Ohio.

TELEGRAPHY

TELEGRAPHY—Morse and Wireless—taught at home in half usual time and at trifling cost. Omnigraph Automatic Transmitter will send, on Soudner or Buzzer, unlimited messages, any speed, just as expert operator would. Adopted by U. S. Govt. and used by leading Universities, Colleges, Technical and Telegraph Schools throughout U. S. Catalog free. Omnigraph Mfg. Co., 41-G Cortlandt St., New York.

TELEGRAPHY for Beginners—Best textbook for students of telegraphy. The standard method. 64 pages, 19 illustrations. 25c postpaid. Popular Mechanics Book Dept., 6 N. Michigan Ave., Chicago.

PRACTICAL Railroad Telegraph School. Circular free. 1034 Arch St., Philadelphia, Pa.

TELEGRAPHY—Morse and Wireless—also Station Agency taught. Graduates assisted. Cheap expense—easily learned. Largest school—established 42 years. Correspondence courses also. Catalog Free. Dodge's Institute, 15th St., Valparaiso, Ind.

WIRELESS

WIRELESS Set. How to Make—96-page book telling how to construct at small cost an outfit suitable for transmitting four or five miles. Price, 50 cents, postpaid. Popular Mechanics Book Dept., 6 N. Michigan Ave., Chicago.

MAKING Wireless Outfits—Become a wireless constructor. This book tells how. 61 pages, 27 illustrations. 25c postpaid. Popular Mechanics Book Dept., 6 N. Michigan Ave., Chicago.

PICTURES, POSTCARDS, PENNANTS

IF you really want to exchange postcards, try our splendid club. Lists circulated in many countries. Membership, 10c. Halcyon Club, Box 133, Erie, Pa.

JOIN at once! Membership 10c. Rose Postcard Society, 651 East Morrison St., Portland, Oregon.

POSTCARD Showers 15c. Fun starts immediately. Cascade Exchange, Rainier, Wash.

BIGGER than ever, more names, stories, etc. 1,000 names to select each issue. Enrollment 6,000; rapidly growing. Trial 10c. Elite Postcard Exchange, R-44, 3684 Milwaukee Ave., Chicago.

JOIN a new postcard club; trial 10c. Monarch Exchange, 1364 Marquette Road, Cleveland, Ohio.

NAVY Post Cards. Real Photographs. Submarines, etc., 3 for 25c. Lambert and Stumpf, New London, Conn.

PRETTY view cards from many cities, towns and countries. Membership and 6 pretty cards, 10c. Riverside Club, Knoxville, Md.

RECEIVE pretty postcards from everywhere. Join best card club. Membership 10c. Jolly Card Exchange, Decatur, Indiana.

CROSS-SECTIONAL view of ocean liner "Britannic," showing interior arrangement of ship in colors, size, 14x20 inches, on heavy plate paper for framing or hanging. Very interesting. Reproduced from front cover design of July, 1914, Popular Mechanics. Will be sent postpaid to any address in the world on receipt of 4 cents in stamps to cover packing and mailing. Popular Mechanics Magazine, 6 N. Michigan Ave., Chicago.

200 ILLUSTRATIONS free, beautiful art cards. Mahler, K-721 Woodland Ave., Woodhaven, L. I., New York.

CAMERAS AND PHOTO SUPPLIES

FOR Sale—Film-Plate Premo Camera, with R.R. lens, Automatic shutter. Postcard size. Takes excellent pictures. Will include carrying case, tripod, 3 plate holders. All condition. \$17.50 takes the outfit. F. W. Johnson, Room 925 Tower Bldg., Chicago.

EXPERT Kodak Finishing. Roll films developed, 10c. Packs, 20c; Prints, 2 1/2 x 3 1/4, 2c; 2 1/2 x 3 1/4, 3 1/4 x 4 1/4 and Post Cards, 3c each. Work returned next day. Postpaid. Sample Free. Heen Photo & Printing Co., 810 Hickory St., St. Louis.

INVENTIONS wanted in Motion Pictures and Photography. Special department for these classes of invention. Advice. What to Invent and List of Patent Buyers sent Free. Victor J. Evans & Co., 159 Ninth, Washington, D. C.

QUALITY. Cyko prints, 2c, 2 1/2c, 3 1/2c. Roll developed, 5c. May, Owensboro, Ky.

AMATEUR Photographers—buy Arco, a metal substitute, \$1.00 lb., \$1.35 1/4 lb., postpaid. Wright Photo Supplies, Racine, Wis.

DO you take pictures? Write for free sample of our big magazine, showing how to make better pictures and earn money. American Photography, 790 Pope Bldg., Boston, Mass.

KODAKS, Graflex, and Ansco Cameras. Save 20% to 50%. Bargain list on request. Agents wanted. J. L. Lewis, 522 Sixth Avenue, New York.

KODAK Finishing that is different. Write for valuable information and how to get free enlargement. Salsbery Studio, Cherokee, Iowa.

FILMS Developed 10c. Prints Postcard size and less 3c. Enlargements. Price List. Established sixteen years. Deusing Studio, West Allis, Wis.

TRANSFER photographs to China, etc. Sensitized Fabrics, sensitizing solutions. Flinn, 2156 8th Ave., New York City.

FREE Film Development! Prints 3 1/2c. Expert work. G. Olive, Willmar, Minn.

FILMS Developed, 10c roll. Prints and Postcards, 3c. Elmer Johnson, Lake Ave., Winona, Minn.

FILMS improved by being retouched. Sizes up to 5x7, 10c; larger, 25c. Retouching Studio, 10 Hunter St., Dorchester Centre, Mass.

PRINTS 2c—Any size. Rolls developed free. Nice work. Quick service. Try us. Ideal Photograph Co., Winston-Salem, N. C.

VIEW Time is Coming. Order now and be prepared. New improved Seneca View Cameras at Rock Bottom Prices. Size 5x7, Bellows Extension 2 1/2", \$15.75; 6 1/2 x 8 1/2, Bellows Extension 2", \$17.50; 8x10, Bellows Extension 3", \$19.50, including long carrying case and one holder. Fitted with leather bellows. 5x7, \$18.00; 6 1/2 x 8 1/2, \$20.75; 8x10, \$23.00. Extra double plate holders 5x7, 50c each; 6 1/2 x 8 1/2, 70c; 8x10, 88c. Money back if not satisfactory. Our 1917 Complete Catalog free. Send for catalog 81 today. David Stern Company, Everything in Cameras, in business since 1885, 1047 Madison Street, Chicago, Ill.

FILMS Developed Free, perfect prints, modern up to the minute methods. We do the best work in this the Photo City. Films developed absolutely free when we make the prints. No matter where you live send us your films. We return all work promptly by parcel post. Bryans Drug House, Rochester, N. Y.

CAMERA Kinks and Photo Fads—Tells how to make—Transparent photos on watches—Red firelight photos—Photo stationery—Fuzzy enlargements sharp and clear—French Folio photos, and many others; price 10c. Greenhalgh, 2961 Gale, Indianapolis.

TRIAL offer. One roll developed and 6 prints 20c. Enlargement free. Emil Sprauer, Hamilton, Ohio.

CAMERAS, Supplies, Developing and Printing. Lowest prices. Catalog free. Heaney Company, Berlin, Wisconsin.

PHOTOGRAPHIC Enlargements equal to contact prints. To prove quality send Film or Negative and 20c for trial Print, Artistically Mounted. Myland, 2125 N. Front, Philadelphia.

KODAKERS! Best finishing, lowest prices. Any roll developed 5c. Prints 3c each. 24-hour service. National Photo Company, Omaha, Neb.

FILMS Developed, 10c all sizes. Prints 2 1/2 x 3 1/4, 3c; 3 1/4 x 4 1/4, 4c. We give Profit sharing Coupons. 24 hour service, work guaranteed. Send negatives for samples. Girard's Com'l Photo Shop, Holyoke, Mass.

FILMS developed 5c, any size. Prints 3c each, all sizes. Free enlargement with first \$1.00 order. Johnson's Studio, Oswego, N. Y. 3 months' instruction in Photography \$10.00 at studio.

EQUIP your camera or Kodak with a Wollensak lens and shutter and obtain the best possible results. Beautiful descriptive catalogue "B" sent on request gratis. Wollensak Optical Co., Rochester, N. Y.

KODAK films developed, 7 cents each, any size. Prints, three cents each, all sizes. 8 by 10 enlargements 25 cents. C. C. Smith, Tarrytown, N. Y.

FILMS developed, any size, 5c. Any size prints, 3c. Work returned same day. Enlargements, 8x10, 25c. Eastman Kodak and Supplies. Address Camera Shop, Box 69, Ann Arbor, Michigan.

BIG Money Saved on Photographic Lenses and Apparatus—goods exchanged; repairing done. Ralph J. Golsen, 5123 Kenmore Ave., Chicago, Department P.

MOTION PICTURES

WRITE for free copy "Hints to Writers of Photoplays, Short Stories, Poems." Also catalog of best books for writers. Atlas Publishing Co., 71, Cincinnati.

FREE, "How to sell Photoplays direct to Film Producers." Manuscripts attractively typewritten. Small charges. B. Nestle, 180 N. Dearborn, Chicago.

EDISON moving picture machine for sale, \$45. Olinger Brothers, Kittanning, Pa.

WE make Lantern Slides for all purposes. Quality and service guaranteed. United Print Co., 417 S. Irving Ave., Chicago.

MAKE a complete Motion Picture Camera and Projector from instructions given in our book Amateur Mechanics No. 4. Full details given. Not hard to construct. Worlds of enjoyment taking and exhibiting subjects dear to the heart. Price of book only 25c, postpaid. Popular Mechanics Book Dept., 6 N. Michigan Ave., Chicago.

PHOTOPLAY Short Story Writers. Complete instructions by authorities. Books listed at New York Library. Writing to sell—Edwin Wildman 65c. Photoplay Scenarios—List of buyers—50c. Prepaid. Student Directory Bureau, 451 W. 23d St., New York.

\$100 TAKES motion-picture machine. Good as new. L. T. Jolley, Elgin, Ill.

SPECIAL Arc Generator produces current economically. Your engine operates. Easy Terms. Hobarts, Box A, Troy, Ohio.

MOTION Picture Film developed and printed. Film Titles; Cartoon-films; Expert Camera men furnished. Scenarios produced. All work guaranteed. Camera Bargains. Standard Motion Picture Co., Suite 1420, Millers Building, Chicago.

WRITE Moving Picture Plays; constant demand; big prices paid; past experience or literary ability unnecessary; details free. Giese Co., 297 Whiteman St., Cincinnati, Ohio.

MAKE Big Money in moving-picture business. We start you and furnish guaranteed outfit on easy payment plan. Easy to accomplish. Catalog free. Monarch Film Service, 228 Union Ave., Dept. P, Memphis, Tenn.

BIG Profit Nightly—Moving Picture Business—small capital starts you, easily accomplished. Teach you—furnish everything. Ralph J. Golsen, 5123 Kenmore Ave., Chicago, Dept. M.

ARE You a Movie Type? Many of the greatest stars were discovered by accident. You want to know if you have the natural qualifications that bring \$50,000 salaries. The book Motion Picture Acting tells you this, also 194 screen favorites show you how they register 499 human emotions. Use of cosmetics, costume requirements and color schemes also treated. Price leather \$1.10, cloth 75 cents postpaid. Popular Mechanics Book Dept., 6 N. Michigan Ave., Chicago.

MOTION Picture Operation, Stage Electrics and Illusions—The only practical handbook and guide published for motion picture operators, theater electricians and managers. A thoroughly practical and useful book, covering the subject comprehensively. Pocket size, leather, 303 pages, fully illustrated. Price \$2.00 postpaid. Popular Mechanics Book Dept., 6 N. Michigan Ave., Chicago.

MAKE money writing Photo-plays; details free to beginners. No correspondence course. Producers League, 230 Wainwright, St. Louis.

BUSINESS OPPORTUNITIES

\$50 TO \$100 a day can be earned with a Long Crispette Machine in any town. Machine a wonder. Makes Crispettes—a new, delicious popcorn confection. Sells at 5c a package—almost to net profit. Everybody buys at sight—nickels roll in. All you need is one machine and good location. No experience necessary. Investment small, returns large. Write at once for free book "Dollars & Sense"—a valuable guide to wealth and independence—a start to the ownership of a store of your own. Don't wait. Send postal today. Address, W. Z. Long Co., 1317 High St., Springfield, Ohio.

ENTER the Rubber Manufacturing Business. Guaranteed Rubber Formulas, for the manufacturing of Dipped rubber goods, balloons, nipples, gloves, etc. Equipment not expensive. Write to-day. Department E, 31 Central Office Bldg., Akron, O.

ENTER a new business. Earn \$3,000 to \$6,000 yearly in professional fees making and fitting a foot specialty, openings everywhere, with all the trade you can attend to; easily learned by anyone at home in a few weeks, at small expense; no further capital required, no goods to buy, job hunting, soliciting or agency. Address Stephen Laboratory, 11 Back Bay, Boston, Mass.

OUR advertisement under Agents Wanted will interest you. Read it, Marshall Dohbins & Co.

WE start you in business furnishing everything; men and women make handsome income weekly operating our "New System Specialty Candy Factories" home or small room anywhere; no canvassing. Opportunity lifetime; booklet free. W. Ragsdale Co., East Orange, N. J.

INVENTORS: We develop and perfect inventions, make models, dies, tools. Metal stamping and special manufacturing. Gerding Bros., Lion Bldg., Cincinnati, O.

ADVERTISERS, Mail Dealers. Our New Rate Book lists 2,000 Principal Publications, rates, circulation. Includes 50 Mail-Order Plans. Free. Dearborn Advertising Agency, 210 Franklin Bldg., Chicago.

BUILD a profitable business of your own. Let us start you in the collection business. No capital needed; big field. We teach secrets of collecting money; refer business to you. Write today for Free Pointers and new plan. American Collection Service, 101 State Street, Detroit, Mich.

DURING 1916 I made good income in my sparetime evenings, writing articles for trade papers. Good opportunity for anyone. No experience necessary. Particulars and list for 3 red stamps. Box 206, Ft. Collins, Colo.

"HIRE Yourself as Boss." Big corporation will back you in a money-making mail-order business selling Guaranteed quick sale goods. Start spare time at home or office without interfering with your regular work. Handle everything by mail; no stock to carry, as we will ship direct if you wish. Experience unnecessary. Valuable instructions free. Write for Free Instructive Booklet, "Foreword Facts." Wm. J. Dick, Mgr., Dept. G10, 20 W. Lake St., Chicago, Ill.

PLASTOGRAPHY: Nothing so engaging and profitable; "Plastography" instructions \$2. A model or mould of President Wilson or Lincoln sent free with your order. P. B. Squar, York, Pa.

BIG Profits Daily, making sparkling chipped glass name and number plates, big illustrated book sent free. E. E. Palmer, Wooster, O.

LEARN Dry Cleaning—Profitable, fascinating profession. Complete instructions, 25 cts. The Wiener Co., Madisonville, Ky.

TAKE in \$300 to \$1,500 a week traveling with carnivals or fairs, or at a park, with our Automatic Fishpond. Many are doing this. Write for folder P. Automatic Fishpond Co., 131 Michigan St., Toledo, Ohio.

LEARN the real estate business; our enlarged instruction book teaches listing, appraising, management, salesmanship, insurance, brokerage, advertising, renting, agency, estates, titles, rights, forms, etc.; revised edition; 240 indexed subjects; excels \$25 correspondence course; buckeye cover, \$1; silk cloth, \$1.25, postpaid. Realty Book Co., Dept. No. 29, Cleveland, Ohio.

MAKE Good Living in the Real Estate Business. Our Real Estate Educator tells how Real Estate deals are made by successful Real Estate Agents; how to list property; how to sell; advertise; manage property; write insurance; about landlord and tenants; real estate titles; legal forms; hundreds of pointers, tips, etc. 246 pages nicely bound. Only \$1.00 postage prepaid. Your money right back if you are not perfectly satisfied. Realty Educator, Desk 102; Station F, Washington, D. C.

500 FORMULAS, including Bestilvering Mirrors—Renewing Dry Batteries, Luminous Paint, 25c. Ideal Book Shop, 3315-C3, Belleplaine Ave., Chicago.

I FURNISH latest guaranteed address lists of auto owners, motorcycle owners, auto dealers, repair garages, high school principals, sheet metal workers, plumbers, building contractors, or list suitable for your requirements. Frank Suter, Hill Station, Harrisburg, Pa.

SEVEN money-making plans and formulas for 2c. Robert Dreiske, Ravinia, Ill.

WANTED—Financier, pay patent fees on invention. R. Harner, 203 Division St., Elkhart, Indiana.

BIG profits every day. Start most anywhere in the popcorn Crispette business. Have a complete outfit for \$150. Formula and full instructions to start you. J. S. MacElroy, Olney, Philadelphia.

START an original mail-order or parcel-post business. Honest, independent, small capital. New methods. Big money. Clement Moore, Business Specialist, New Egypt, N. J.

LEARN the "Practical" Advertising Business and become independent. I teach you how to establish yourself without capital, and furnish you original plans and methods to work upon; rare opportunities; booklet free. Dawson, Avenue 3, Stockton, California.

LEARN to collect money. Good income; quick results. Send for free booklet, "Skillful Collecting." Collectors' Association, Long Street, Newark, Ohio.

25-WORD Advertisement in 100 monthly magazines, 3 months, \$1. Quadri Co., 426 E. 14th St., N. Y.

YOUNG Men—We build our big organization from ranks. Lifetime business, big income before any live intelligent man in our company. We are establishing branches everywhere. We train you; start you right, \$1,500 to \$5,000 yearly, at home or elsewhere. No capital required, though possession of \$100 to \$500 gives better chance. Rogers, Thurman & Company, 55 East Madison St., Chicago.

HERE'S your opportunity to make money. "Hart's Gold Brand Book of Plans" filled with new, original money-making plans, formulas and trade secrets will help increase your income. Each plan and formula herein easily worth \$1. This wonderful book sent prepaid \$1. H. S. Hart, Box 85, Shreveport, La.

MANUFACTURERS want new inventions. I secure valuable patents and help make your invention a success when patented. Send for booklet "Pointers about Patents." Lester Lyman Sargent, 709 26th St., Wash., D. C.

FORTUNES in Food Products; Product now selling in 35 States; \$25 invested now may yield big returns. Particulars free. Home Securities, First National Building, Oakland, Cal.

SILVERING Mirrors—My exclusive French Tartaric Method opens enormously profitable business. Booklet Free, H. Barstow, 514 23rd St., Oakland, Calif.

LARGE hardware manufacturer desires to manufacture marketable articles, patented preferred. Must be meritorious and profitable. Not necessarily tools, yet must be confined to hardware line. State number and date of patent, cost and selling price, and give model or sketch. H. C. Rosen 990, 78 E. Madison St., Chicago.

FINANCIAL Success, live mail-order monthly. 6 months 25c. Robbins, publisher, 871 First Ave., New York.

MECHANICAL sensation, Drawing and enlarging photos, landscapes, etc., without skill, practice, or expense, rapid work, fascinating business, all profit. Particulars, Utility Products, Cardston, Alberta, Canada.

YOU can earn big money yearly. Learn candy making. Quality for traveling candy salesman; good position guaranteed. Own a candy store, or factory. We start you, help you succeed. Write for free booklet. We built a big candy business—give you our own experience. Otter-Swain Corp., Suite 118, 4759 Broadway, Chicago.

PROFITABLE Formulas, Trade Secrets, and money-making Plans. Particulars free. Write now. Three "B" Supply Co., Perth Amboy, N. J.

BE Independent. Have your own business. Will teach by mail, man or woman, to make high-grade toilet preparations. Full particulars for stamp. School of Cosmetics, Omaha, Nebr.

PATENTS—Send Sketch, Free Search and Certificate of Patentability. Free Book, "How to Obtain a Patent and What to Invent." Patents secured through Credit System. Talbert & Parker, Patent Lawyers, 4280 Warder Bldg., Washington, D. C.

CRAYON Portrait Finishing; easy; profitable home employment. Walton, L-29, Prairie City, Ill.

SPARE Time Money-makers, Unlimited Possibilities, Little Capital Required. Formulas, 10c. Particulars Free. Chester Zoll, Springfield, Ohio.

CONDUCT a profitable Candy Kitchen; very small capital required; booklet free. Kennon School, 509 Wells St., Dept. A, Chicago.

PATENTS on easy payments. See our advertisement under Patent Attorneys. C. C. Hines & Co.

COMPETENT Chemical Advice Reduces Costs, improves products, bridges difficulties. Analyses are inexpensive. Let us study your requirements. Formulas developed. Chemist N, Industrial Laboratories, New Orleans.

MAKE Money Painting Signs with our patterns. No experience. Samples for stamp. Lightning Signs, Box 188, St. Paul, Minn.

STOP that daily grind. Take nose off grindstone; be no man's slave, punch nobody's time clock. Own your business. I start you silvering mirrors, Plating tableware home. Sure income. Plans free. Clarence Sprinkle, Dept. 38, Marion, Ind.

ADVERTISE—Get business everywhere 25 words in 100 monthlies, \$1; 108 weeklies, \$2.50; 40 Sunday papers, \$10. Cops Agency, St. Louis.

WE will start you in the cleaning and dyeing business, little capital needed, big profits. Write for booklet. Ben-Vonds System, Dept. C, Charlotte, N. C.

"MAKING Money in the Mail-Order Mint." Practical money-making book. Booklet P-2 Free. Neuman Co., Box 94, Jersey City, N. J.

LUMINOUS Paint, Shines in the dark. Make and sell your own Luminous articles; watches, clocks, electric switch plates, crucifixes, etc. Latest discovery. Only 25c bottle. (Agents wanted.) Luminous Paint Co., Douglas Park Sta., (B) 3 Chicago.

MANUFACTURERS, Promoters and Patent Buyers are invited to write us stating the line of invention in which they are interested, as we can supply their wants in any class of patents. Victor J. Evans & Co., 162 Ninth St., Washington, D. C.

INDEPENDENCE and fortune quickly attained in the Manufacturing Mail Order business. I furnish Formulas, Manufacturing Processes and Trade Secrets in all lines. Sold under positive guarantee; 18 years' practical experience. Revision and improvement of Formulas and Processes—reduction of manufacturing cost—utilization of waste materials, etc., a specialty. Booklet, Formula List, and Valuable Information Free. W. L. Cummings, Ph. D., 127 Standard St., Syracuse, N. Y.

GOOD monthly income easy in spare time manufacturing letters for signs. Free particulars. J. F. McPherson, 677 Brown Avenue, Butler, Penn.

DOLLARS yearly in your backyard. No ginseng, mushroom dope. New ideas. Investigate. Particulars free. C. Metz, 313 East 89, New York.

PATENTABLE Ideas Wanted—Send for 3 free books. H. B. Owen, 39 Owen Bldg., Washington, D. C.

GOOD money easily earned at home, sparetime, silvering mirrors; No capital. Free instructive book tells how. Patterson & Co., Brooksville, Ky.

HUGE Opportunity to make money, new simple ways. Blue Ribbon Scheme Book, Particulars free. Sheridan Company, 417 E 151st St., New York.

THE New Mail Order Poultry Business earns Big Profits on Little Capital. Write National Poultrymen's League, 2121 Times Bldg., Chicago.

BIG money in promoting inventions. Write Adam Fisher Mfg. Co., 2601D Railway Exchange, St. Louis, Mo.

MAIL Order Dealers. Let the 4 in 1 coupon plan increase your profits. Sell valuable instruction systems by cut price coupon under money back guarantee. Big margin. Small selling expense. Complete plan, sample coupons and bargain bulletin sent on request. Mail Dealers' Coupon System, 519 So. Dearborn St., Chicago.

INCORPORATE—Congress laws for D. C. and all States; cheap, raise money easily, advise free. Collections and legal matters everywhere. All courts and Government Departments. U. S. Legal Corporation, Washington, D. C. Representing \$1,225,000,000.

BUSINESS FOR SALE

GARAGE for sale, complete with stock, tools, and machinery. For particulars address, Friendship Garage, Friendship, Wis.

MAIL-ORDER SUPPLIES

WE sell good mail-order articles. What have you? Medina Merchandising Company, Medina, Ohio.

FOR ADVERTISERS

THIRTY word advertisement 15c. Alexander's Magazine, 408 West 11th, Charlotte, N. C.

DUGDALE Writes Sales Letters, Booklets, and Direct-By-Mail Advertising Matter that Lands the Orders. Sales and Advertising Campaigns Planned and Directed. Send your present literature or details of your plan and write me fully on your letterhead for advice. H. K. Dugdale, Advertising, 105 Warder Bldg., Washington, D. C.

"THE Buyers Bulletin" will reach your customer. Classified ads 5 cents per word. Saranac Lake, N. Y.

ADVERTISE! 20 words in 120 monthlies \$1. Southwestern, 1413-1 Berendo, Los Angeles.

5c PER word in over 100 monthlies, smallest advertisement \$1.00. National Opportunity, Stratford, Wis.

BUILD more business—Advertise! 25 words in 160 monthlies, \$1; in 200 Eastern weeklies, \$3; in 20 Sunday papers, \$1.75. Lists free. Stanford Agency, Canonsburg, Pa.

YOUR Thirty-Word Ad. in our big post-card magazine, 25c. Inch display, 50c. Elite Exchange, 2494 Milwaukee Ave., Chicago.

BUSINESS SERVICE

LET us buy for you and save money. Tell us your needs. R. & G. Austin, Manufacturers' Agents, 3224 Polk St., Chicago, Ill.

INCORPORATE. Our lawyers do the work, saving you time, annoyance and money in incorporating under the most liberal laws of Arizona. Laws and forms free. Southwestern Securities & Investment Co., Box 10488, Phoenix, Ariz.

COLLECTIONS

EIGHT Good Will Collection Letters, 25c. For small and mercantile accounts. If dissatisfied, return immediately and money will be refunded. Lester Service Co., 56 Capitol Ave., Hartford, Conn.

DEBTS Collected Anywhere, Quickly! Established 25 years. William H. Dodd, 57 Nassau Street, New York.

AGENTS WANTED

AGENTS: Money talks—how much are you making? If less than \$200 a month you will positively be delighted with our Sentinel Burglar Alarm proposition. Many agents easily earn \$15.00 daily. Brand new invention. Sells quickly on sight to homes, offices. Patented. No competition. Free exclusive territory. Instantly attached any door knob. Impossible turn knob without ringing bell. No batteries, screws, nails. Handsomely nickel-plated. Retail \$1.00. Provides cheap burglar insurance. It's a big money maker. Let us prove why. Write today for liberal terms to agents. Marshall Dobbins & Co., Manufacturers, 1422 Marquette Bldg., Chicago.

AGENTS: Make real money this year; not "paper money." Just think! Our Eradium (luminous) Articles Shine in the Dark. We manufacture a complete line so that every call can be turned into a sale. Everyone amazed at the wonderful possibilities of these goods. Our Eradium Bulb is easily attached to any light and "Locates Your Light in a Jiffy" in the darkest room. Our Eradium Crucifix showing the Christ figure in startling outline throughout the night sells to every Catholic. Our Eradium House Numbers (just out) are selling like Ford automobiles. Our Eradium Clock tells the time in the dark. Our Eradium Match Box sells like hot cakes everywhere. Garages, homes, etc. Our Eradium Switch Plate for hotels is a big seller. Write today for best proposition you ever heard of. Sole manufacturers, The Pioneer Corporation, 1259 West 63rd, Chicago.

AGENTS Who want to make a tremendous profit introducing the most wonderful and practical article, now ready to be put on the market; useful necessity to all, always and everywhere. Write for free particulars and sample, 10 cents. Excelsior Novelty, 192 Grand St., New York.

\$1,000.00 REWARD if this is not the greatest money-making house-to-house proposition. N. R. G. Laundry Tablet washes clothes in 10 minutes without rubbing. Contains no Lime, Lye, Paraffin Wax or other injurious chemical, and cannot possibly injure the clothes or hands. Nothing like it on the market. Positively the wonder of the age—sells for 15c, enough for 5 family washings. We supply one free sample with every package you buy and guarantee the sale of same. Just leave the free sample with the housewife and when you call again, she is eagerly awaiting to become your steady customer. Secure territorial rights at once, or you will regret it. 1c postal brings sample and full particulars. Farouhar-Moon Mfg. Co., Dept. K-200, 149 W. Van Buren St., Chicago.

LUMINOUS Paint! Shine like fire in the dark. Big seller to Hotels, Garages, etc. Make and sell your own Luminous articles, watches, clocks, electric switch plates, crucifixes, etc. Sample bottle only 25c. Particulars and special price list free. Luminous Paint Co., Douglas Park Station (B1), Chicago, Ill.

AGENTS—Send for sample "Footnot"—the wash day wonder. Be convinced you can do a whirlwind business. You can clear at least \$20 to \$100 weekly, according to spare or whole time. You don't have to talk; if she doesn't buy at sight, leave sample; she will be looking for you long before you are able to make the rounds again. Samples furnished free. Premiums for your customers. Exclusive territory granted to agents who can produce. Credit given. Don't call. P. M. Motter & Sons, 3213 Warren Ave., Chicago.

WE require general representatives and local agents to demonstrate and sell our individual lighting systems, portable lamps and lanterns for use in stores, homes, streets, etc., which are distinctly superior to, and more economical than, any other known method of lighting. If you wish to establish a permanent and very profitable business of your own, tell us in confidence, your business experience, age and other qualifications. Pitzer Gasoline Lighting Company, 8 East Kinzie St., Chicago.

AGENTS. Make War-Time Profits, build permanent business with our Big line Perfumes, Creams, Extracts, Spices, Medicines. Catalogue free. Western Laboratories, 1969A Van Buren St., Chicago.

SIGN Letter Agents and Painters; 500% Profit Gold and Silver Sign Letters for Stores and Office Windows. Anyone can put on. Big demand. Free samples. Metallic Letter Co., 404 N. Clark St., Chicago.

HUGE profits selling Nibco Sanitary Brushes, Auto Washers, Brown Beauty Adjustable Floor Mops, Dustless Dusters, and other specialties. Big line. Fast sellers. Write today. Silver-Chamberlain Company, Department M. Clayton, New Jersey.

WHO wants to make more money selling brushes that every household needs? Special method of getting entrance to demonstrate. Fuller Sanitary Brushes are nationally advertised—largest output—best terms and prices—western distributing stations. Your territory is valuable. Write. Fuller Brush Company, Hartford, Conn.; Rock Island, Ill.

AGENTS—Stamping names on Pocket Key Protectors; sample Check with your name and address, 12c. Stamping Outfits, Emblem Checks, Check Fobs, Name Plates. Hart Mfg. Co., Desk 2, 303 Degraw St., Brooklyn, N. Y.

BIG Profits for You! Manufacture Barley Crisp. New Confection, 5c package costs you 1c. Machine instructions complete \$7.50 prepaid. Send 10c for samples. Barley Crisp Co., 1205 Broadway, San Francisco.

SELL lettered window valances to merchants. Samples free. Grovic, 1329 St. Clair, Cleveland, Ohio.

NEW household necessity; not sold in stores; quick seller; big repeater. Write Eberhart Co., 6330M, Eberhart Avenue, Chicago.

STOP Here—just out—Eisen Regular for Ford Headlights. Selling like wildfire everywhere. Gives splendid driving light at low speed—keeps bulbs from burning out—works entirely automatically. Needed on every Ford. Big profits quick. Listen! Hopkins, Tenn., cleared \$16.20 first day; White, Michigan, \$131.00 one week. No experience or capital needed. We show you how; sales guaranteed. Hurry—don't delay. Write now for special information. Address Eisen Instrument Co., 309 Valentine Bldg., Toledo, Ohio.

EARN \$50 to \$100 monthly distributing Parker Hosiery to repeat customers at mill prices. All or spare time. Protected territory. Credit. D. Parker Mills, 2733 No. 12th St. Philadelphia, Pa.

AGENTS: You can make big money taking orders for our fine made-to-measure clothes, so write quick for 60 beautiful cloth samples, 32 smart styles in rich colors, wholesale and retail price lists, lowest prices and best offer to agents, \$5.00 to \$10.00 a day easy. Big outfit, over 250 samples free to live wires. No experience needed—no capital. We furnish everything free—pay postage or express charges—back you, boost you, show you how and clearly explain everything. Costs nothing to try. Let us make you a stylish suit to measure to prove our fine quality and style. Send postal or letter today. Paragon Tailoring Co., Dept. 314, Chicago.

AGENTS Coin money handling our new household specialty. Profits enormous. Particulars free. S. P. Weaver Co., Dept. J-4, Westerville, Ohio.

LUMINOUS Crucifix—Heatless Trouser Press; Toledano sold 60 Crucifixes in 10 days. Old Paducah, Paducah, Ky.

AGENTS—Here is the big opportunity you are looking for; Big seller and repeater. Localdo-Co., 3308 Detonty St., St. Louis, Mo.

CHINESE Cook Book in English explains how to cook Chop Suey, etc., the genuine way. Sells for \$1.00. Sample copy 25c. Stamps. Vernon Galster, Box 20, Morris, Illinois.

FASTEST dollar seller on the automobile market. Fine side line for salesmen. Every Motorist a prospect. Write quick. Consumers Manufacturing & Supply Co., Minneapolis, Minn.

YOU can be your own boss with our Key Check outfit. Good for \$5 a day stamping names on pocket key checks, fobs, etc. Sample check with your name and address, 15 cents. Pease Die Works, Dept. M., Winchester N. H.

AGENTS—Automobile and Electrical Specialties are the surest money-makers. We have a practical novelty which sells on sight. Nothing else like it on the market. Apply at once. Bedford Manufacturing Co., Mt. Vernon, N. Y.

PORTRAIT Agents: Our goods will make you big profits. Delivery guaranteed. Refunds credited. Prompt shipments. Send for latest catalogue and prices. Adam J. Kroll & Co., 692 Blue Island Ave., Chicago, Ill.

"BOSTON Pie Juice Saver." Prevents juice from running into oven. Great seller. Splendid profit. Protected territory. Sample 10c. Aluminum Products Co., 164 Federal St., Boston, Mass.

AGENTS—Mail Dealers. Write for my plans. Clarence A. Ritchie, Excelsior, Wis.

AGENTS—500% profit. Sign letters for office and store fronts. Samples and particulars free. Inter State Letter, 2424 N. Halsted St., Chicago.

AGENTS, \$60 a week to travel by automobile and introduce our 300 candle power coal-oil lantern. Write for particulars of our auto offer. Thomas Co., 862 North St., Dayton, Ohio.

SELL our Stamp, Gum, Match Vending Machines, etc. Liberal commissions. Catalogue free. Northwestern Novelty Co., Box 943, Morris, Illinois.

OUR Remedial Soap, Toilet Preparations, Extracts and Food Products beat everything for agent's profits. T. H. Snyder & Co., Dept. M., Cincinnati, Ohio.

WOULD \$150 monthly and opportunity to earn Auto to travel in, as General Agent, handling remarkable sellers, Lightning Patch Vulcanizer, Shock Absorber, and Anti-Theft Combination Auto-Switch Lock, thief proof, interest you? Then address Dept. I-8, U. S. Manufacturing Co., Waukegan, Indiana.

A FEW reliable men or women to handle my 1916 "Business Guide." Sells everywhere. Beginners clear \$7 per day. 60% commission. Outfit free. Prof. Nichols, Box P. M., Naperville, Ill.

AGENTS, make \$5.00 to \$8.00 a day selling never fail Iron Rust and Stain Remover, and 125 other fast sellers. Exclusive territory. Credit given. Sample free. Sanford-Heal Co., Inc., Newark, New York. Dept. C.

LESGASS Device, every automobile owner will buy. Retail \$2. Guaranteed five to eight additional miles per gallon gasoline. Entirely new principle; good commission; exclusive territory. Sample \$1. Particulars free. Hurry. Lesgass Company, 486 Ridge Bldg., Kansas City, Mo.

AGENTS—With selling experience to sell direct to consumer made-to-measure suits. \$12.50 and \$16.50; if you want independent business with big money, answer at once before territory is taken; outfits furnished free. Midland Tailoring Co., Dept. F-9, 19 S. 5th Ave., Chicago.

AGENTS: Enormous Profits. Over 90 Fast Selling Household Necessities. Big repeaters. Outfit free. Permanent business. All or spare time. Write quick. Duo Factories, Dept. E. 58, North Java, N. Y.

BIG Money Easy Selling Uni-Lites. Agents can make \$50 to \$100 weekly in spare time. Equals 20 ordinary lamps or lanterns—300 candlepower. Used in house and outdoors. Get new free Uni-Lite offer. Acorn Brass Mfg. Co., 1156 Uni-Lite Building, Chicago.

AGENTS, sell Feather Flowers, the All-Purpose Home Flower. Sample 15 cents. De Witt Sisters, Route 10, Battle Creek, Mich.

SYN-VAN-CO is Selling! Get aboard and reap your harvest. The only real concentrated Vanilla flavor for Bakers, Confectioners and Household. One-half pint makes a gallon. Send 50c for enough to make a pint, with Agent's confidential price. Particulars free. Chester P. Henshaw, Sole Manufacturer, Dept. A, Wakefield, Mass.

SELL Real Estate on easiest payment system ever devised. \$25.00 to \$200 for lots in New Orleans, the "City of Success." Fine commissions easily earned by men and women working part or full time. Mail one cent for first payment on a \$25.00 lot and get details. Joseph A. Blythe, owner, 844 Gravier St., New Orleans, La.

LOOK for our ad under this heading. It will pay you to read it. Marshall Dobbins & Co.

MINIATURE Japanese sword, made of bamboo, for paper-knife and penholder. Sells dozens at sight. Two samples for dime, 24 for \$1. Miyako Company, Akasaka, Tokyo, Japan. Foreign postage letters 5c.

NEW Knife Sharpener puts razor edge on any knife instantly without grinding. Demonstration creates sensation. 30 sales a day easy. Carry right in pocket. 100 per cent profit. Write for free sample offer now. American Products Co., 8629 Central Ave., Cincinnati, O.

AUTO Owners—We want a few live motorists who drive their own cars to introduce International Half-Sole Tires in their territory. Greatest Tire Cost reducer ever offered to the motoring public. Practically sells on sight. Our sales jumped 400% in ninety days. For details write the International Rubber Company, 31 W. Tennessee, Denver, Colo.

BUILD your own phonograph or manufacture them to sell. Instructions, drawings, illustrations, parts-price-list 25c. Circular free. Associated Photograph Co., Dept. P2, Cincinnati, O.

THEY sell themselves Agents. Wire Products, 1120 North Main, Scranton, Pa.

DAVOLINE Bushings sell themselves; garages, machine-shops, factories, electricians require. Big representatives' profits guaranteed. Sample, quarter. Investigate. Davoren Mfg. Co., Denver, Colo.

AGENTS: 50 calling cards 10c. F. Shepard, Rome, N. Y.

AGENTS—Sell our brand new \$1.50 article to cigar dealers, hotels, restaurants, grocers, general stores, etc., pays 200% profit; sample prepaid 65c. The Eugene Mfg. Co., Drawer P, Canton, Ohio.

NEW "4 in 1" Interchangeable letter sign \$2.00. New England Co., 290 State, New Haven, Conn.

LOOK—Send us your address and we will mail you a surprising sample. Write today. American Mfg. Co., 201 Sufferin Ridge, Decatur, Ill.

AGENTS stung with slow-selling goods. Mail data immediately. No charge. Agents Protective Agency, 2408 P St., Sacramento, Cal., protect other agents.

AGENTS Wanted for best-selling household specialties on earth; goods sell themselves; write at once. The Addison Co., 224 Franklin Av., Scranton, Pa.

AGENTS, Grasp this winner. Just out, Guaranteed, Low Price, Enormous Profits. Write Quick. Hever, Box 76, Laird, Colo.

SELL copyrighted advertising novelties. 15 samples, 10c. Chambers Works, Plainwell, Mich.

AGENTS—Make \$40 weekly selling Good-year Raincoats. Sample coat free. Write for agency. Goodyear Manufacturing Company, 400 Lillis Bldg., Kansas City, Mo.

AGENTS, Send for Circular of best line of Luminous goods, Photo Pillow Tops, and Pennants. Photo Pillow Top Co., 417 S. Irving Ave., Chicago.

SALESMEN (regular or side line) selling our white base line vending machines direct to the merchant. Write Sterling Novelty Co., 863 Oak St., Columbus, Ohio.

23% PROFIT selling Jubilee Spark Intestifiers to automobile owners, garages. Sure cure for Spark Plug troubles. Sells like wildfire. Brand new. Exclusive territory. Write today. Jubilee Mfg. Co., Dept. M-4, Omaha, Nebraska.

TAILORING Agents Wanted—Big complete sample outfit and case, nearly 300 large cloth samples, 3 piece lists and everything needed for canvassing or use in store, free to live agents. \$25.00 to \$50.00 a week; may make more. Write us today for free elegant outfit to begin, cloth samples, wholesale prices, special offer on a suit for yourself and full information—see our wonderful values, beautiful fabrics and styles. Established 28 years. Every garment made to measure—everything guaranteed and express prepaid. Just send a postal. American Woolen Mills Co., Dept. 314, Chicago.

AGENTS—\$3 daily selling our Handy Tool. 12 articles in one. Lightning seller. Sample free. Thomas Mfg. Company, 762 North St., Dayton, Ohio.

LOOK for our ad under this heading. It will pay you to read it. Marshall Dobbins & Co.

MANUFACTURE your own goods. Our highgrade formulas and manufacturing secrets tell how. 109 Genuine money-makers 10c. Catalog for stamp. Best-oval Formula Service, 3315-M-3, Belleplaine Ave., Chicago.

POURTRAIT Agents—Our new Convexes are money getters; your own prices on quantity orders; three-day shipments guaranteed. Write for particulars today. The Favorite Portrait Studio, 2114 West Huron Street, Chicago.

\$5 GILLETTE Safety Razor Set \$3.50, with 12 blades; leather or triple silver plated Case. Gem or Ever-Ready Complete Sets 75c. \$10 Promo No. 1 Eastman Camera \$7. Other Standard Merchandise at Cut Prices. Terms to Agents. Catalog. Standard Merchandise House, Dept. PM, Chicago, Ill.

MARVELOUS Expanding Cuff Buttons, Presto, slip your cuffs over elbows without unbuttoning or touching cuffs. Lower, they close automatically. Cuff positively stays where placed upon forearm. A real convenience, neat, durable, guaranteed. Indispensable for all styles shirts. Great laundry and shirt saver. Fred DeWilde, Sheboygan, sold 1,000 pairs in 15 days; his profits \$500.00. Wanted—High-grade sales agents everywhere. Flexo Corporation, Sheboygan, Wisconsin.

GOOD Openings for men or women—young or old. Particulars free. A. Stephens, Box 101, Madison Square, New York City.

A SPLENDID proposition; make \$27 a week; \$108 a month; article guaranteed; good references required. We refer to Central Savings Bank, 26th and Madison Ave., Covington, Ky. Trade Supply Co., 1356 Madison Ave., Covington, Ky.

RELIABLE People Wanted to Place Our Orangeade Powder in stores and appoint agents. Makes the most delicious drink you ever tasted by just adding cold water and sugar. Enough for 17 glasses and particulars 10c postpaid. Chas. A. Morrissey Co., 4417 Madison St., Chicago, Ill.

AGENTS, Sell One Dip Pens, Clothes Line Reel, Other Specialties. L. Brown, 921 N. Caroline St., Baltimore, Md.

HANSON Making \$380 Monthly Selling Buckeye raincoats. Largest 1917 samples ready. Free. Write at once. Become sole agent. Big season. Buckeye Manufacturing Company, 81 Union Square, N. Y.

AGENTS, Salesmen, large Raincoat Manufacturer desires representatives in every town and county to take orders for made to measure rain and auto coats. We deliver and collect, new proposition. Big profits. Rainproof Coat Co., 120 Long Street, Fintilly, Ohio.

GET INTO the biggest money-making end of the Automobile business—replacing necessary equipment. Live, hustling ambitious men wanted as special factory representatives in exclusive territory to take orders and attach tops, top coverings, seat covers, patent Silk-life windows. No experience necessary. No capital required. No competition on our copyrighted system. Write for free catalog, samples and full details. Cincinnati Auto Specialty Company, Dept. MC 37, Cincinnati, Ohio.

SELL Presto Auto Paint Kits for repainting Fords, etc. Good profits. American Accessories Co., Dept. P-5, Cincinnati.

AGENTS Wanted—Tolliver Puncture-Proof Inner Tubes sell easily. Our agents make \$5.00 to \$50.00 a day net profit—no competition. If you wish to establish a business of your own with unlimited possibilities for profit, write us for complete details. Tolliver Puncture-Proof Tube Co., 325-C Foster Bldg., Denver, Colorado.

TAKE orders for men's custom tailoring, part time or all time. We furnish samples and everything needed to make a success without experience. Low prices; fit guaranteed or money refunded. You make good money on every order. You can wear swell clothes for almost nothing. Write quick for samples and all information if you live in a town smaller than 5,000 or on R. F. D. Knickerbocker Tailoring Co., Dept. 549, Chicago.

AMAZING, new invention. Marvelous adding machine. Retail \$7.50. Adds, Subtracts, Multiplies. Does work of \$200 machine. Five-Year Guarantee. Offices, stores, factories buy from one to dozen. Enormous demand. Every demonstration sells. Write quick for trial offer and protected territory. Dept. PM, Calculator Corporation, Grand Rapids, Mich.

MAN or Woman to travel for old-established firm. No canvassing; \$1.70 first year, payable weekly, pursuant to Contract. Expenses advanced. G. E. Nichols, Philadelphia, Pa., Pepper Bldg.

AGENTS make 500 per cent profit selling our Auto Monograms and Initials. Window Sign Letters, Changeable Signs, and Show Cards. 1,000 Varieties, Enormous Demand. Sullivan Co., 1123 Van Buren St., Chicago, Ill.

PHOTO Pillow Tops, Portraits, Frames, Sheet Pictures, Photo Plates, Pennants. Refunds credited. Prompt shipments; samples and catalogues free to agents; 30-days' credit. Jas. C. Bailey Co., Desk C4, Chicago.

JOIN The Big Christy Organization. Sell Household Necessities. Unlimited Demand. Big Specialties. Enormous Profits. Apply Immediately. Arthur N. Christy & Co., Dept. 31, Newark, New York State.

AGENTS: Big profits selling our New \$2.50 Automatic adding machine. Quick sales. Ten a day easy. No competition. Anyone having adding to do is positive customer. You'll be glad you wrote us. Bassett Company, 5921 Indiana Ave., Chicago.

\$61.50 WEEKLY. Introducing and selling a new gas light burner for kerosene lamps. Beautiful light. No chimney. No mantle. Samples free. Luther Manufacturing Co., Dept. 294, Cincinnati, Ohio.

MANUFACTURE Latest Advertised, Quick-Selling, Agents' Specialties in all lines, yourself, from my Guaranteed Correct High-Class Formulas. Information regarding Wizard Washing Tablets, No Wax; unequalled washing wonder, Zeeroseal—beats cold storage. Latest Automobile Specialties—Klenso-Mist, Automobile Dry-Wash, Carbo-Cide—sure Gasoline Intensifier. Fibro-Vac—Automatic Puncture Plugger—unlimited possibilities—reliable bona-fide information. No Fakes or Trash. Latest Formula Lists—Stamp. Muller, Analytical Chemist, Tampa, Fla.

WOULD \$150 Monthly as General Agent for \$150,000 corporation and opportunity to earn a Ford auto selling Stock and Poultry remedies, Dips, Disinfectants and Sanitary Products interest you? Then address Royoleum Co-Operative Mfg. Co., Dept. 124, Monticello, Ind.

\$10 DAILY refinishing chandeliers, brass beds, automobiles by new method, producing amazing results; no capital or experience necessary; particulars free. Gunmetal Co., Ave. H, Decatur, Ill.

CAR Owner Agents Wanted. Write for details about the Funnel-Vac Gas Saver and Carbon Eliminator. Get going before the Spring rush season. Big repeater. The Funnel-Vac Mfg. Co., Box 651, Denver, Colorado.

AGENTS: Screen door check. Demonstrate and sale is made. Stops the bang and saves the door. Wonderful summer seller. Demonstrating sample free. Thomas Mfg. Co., 1362 North St., Dayton, Ohio.

GET Davis' Latest Proposition. \$15.00 daily a cinch. No matter how many times you have answered my ads in last 20 years, write again. E. M. Davis, Dept. 506, 990 Lake, Chicago.

"CLIMAX" medium, letters all surfaces. Samples free. Wadhams, 80 Broadway, Brooklyn.

HIGHGRADE Pocket Tool. Sells rapidly on demonstration. Big profits. Write immediately. John H. Walker & Co. (Not Inc.), Box 202, Lexington, Ky.

AGENTS who understand heating plants to sell a fuel saving device guaranteed to save 20%. Pays you 100% profit. We aid you in every way. No capital required but must be financially responsible. Wolff Fuel Saver Co., Lytton Bldg., Chicago.

MAKE and sell your own goods. Formulas by Expert Chemists. Manufacturing Processes and Trade Secrets. Formula Catalog for Stamp. Blake Mystic Company, Washington, D. C.

AGENTS—Sell rich-looking imported 3x68 rugs, \$1 each. Carter, Tenn., sold 115 in 4 days. Profit, \$57. You can do same. Write for sample offer selling plan; exclusive territory. Sample rug by parcel post prepaid, 98c. E. H. Condon, Importer, Stonington, Maine.

"WASHWHITE" makes easy sales. Big profit. Sure repeat business. Genuine Rogers Silverware free to your customers, and valuable Premiums for you. Free printed matter and Sales Course. Free samples with every order. Cleans clothes without rubbing, and without injury to the finest fabric. 7 big washings for 15 cents. Sales Guaranteed. Write for Our Offer. The Naema Co., Dept. G-7, 20 W. Lake St., Chicago.

AGENTS—Men and women. Make \$35 to \$50 weekly selling the New Improved Monitor Self-Heating Iron—the "World's Best." Over 850,000 in use. Positively the easiest, fastest selling, lowest priced, best known iron made. Blinding guarantee. Big profit for all or part time. Evans, N. Car., sold two dozen on Saturday. Mrs. Nixon, Va., sold eight first half day. Liberal terms. Exclusive territory. Sample outfit free to workers. Write today. The Monitor Self Iron Co., 836 Wayne St., Big Prairie, Ohio.

A GOLD mine for hustlers, nine months of the year. Food product of highest quality which saves one-half the cost to householder. Sales made by sampling. Very little talk required. Men wanted to handle counties. Small capital needed. Write for particulars. Steuben Manufacturing Company, A. Bath, N. Y.

AGENTS wanted for "Air-Cure" self-vulcanizing tire patch. Wild Mfg. Co., 1307 Nicollet, Minneapolis, Minn.

GREAT Opportunity for live agents to handle our household specialty; sell on sight; big profits; particulars free. Sigler-Stephens Co., Dept. 21, Berlin Heights, O.

SELL guaranteed made-to-measure raincoats. Agent's price \$2.50 delivered. Material, workmanship incomparable. Outfit free. Standard Raincoat Co., 395 Broadway, New York.

SEND 20 cents for Safety Razor Catalogue and Demonstration Razor. Agents wanted. Particulars free. Cornelius, Box 419, Amarillo, Texas.

JIFFY Curtain Stringer—Brand new—25c seller; needed every home; nothing like it. Sells on sight with demonstration; outfit supplied free. Hustlers make \$25 weekly. Sample, details, 15c in coin. Re first, B. M. Gibson Mfg. Co., Dept. 2, 1702 N. La Salle St., Chicago.

\$50 WEEKLY selling our Sign Painting outfits. Particulars Free. Butts Advertising Co., Gumbel Bldg., Kansas City, Mo.

AGENTS—Handy articles; labor saver; fast seller. Howard Rice, Jenkintown, Pa.

INSURANCE Agent in every town. Sickness and Accident, easy selling, popular, successful, commission or salary. Superintendent Mullaney, 421 Westover Building, Kansas City, Mo.

MEN Wanted—To solicit orders for fruit and ornamental trees, roses, bulbs and shrubs. Highest commissions. Free outfit. Knight & Bostwick, Newark, New York.

AGENTS Wanted—New article, 100% profit. Sample 10c. Particulars free. L. Maine, Fort Dodge, Iowa.

AGENTS—Line up for big profits this year. Hot string of brand-new exclusive sellers with the big "punch" just being brought out. Grab your territory now. You'll regret it if you delay. Adam Fisher Mfg. Co., Agency Dept., 2061 Railway Exchange, St. Louis, U. S. A.

\$25 TO \$200 is all you need to rapidly establish a business of your own with big profits. Ask us for details of the fastest selling accessory ever offered to motorists. Consolidated Rubber Manufacturing Company, 62 Consolidated Building, Denver, Colorado.

SOFT Drinks in Powder. Just add water—delicious, refreshing, healthful. Everyone buys—big profits. Enough for 17 glasses Orangeade and particulars 10c postpaid. Chas. S. Morrissey Co., 4417 Madison St., Chicago, Ill.

EXCLUSIVE selling rights given for our Wonderful Triplex Folding handbag and other sellers. None sold in Stores. Write for terms and catalogue. Diamond Bros., 35 West 21st Street, New York.

AGENTS—Sell California Floral Beach; best sellers; big profit. Particulars free. Universal Supply House, Inc., Box 1743-1, Los Angeles, Calif.

ONE good man wanted in each small town to take orders for tailoring in spare time or as a regular business. Good profits. Get your own clothes at special inside wholesale prices. Perfect fit and satisfaction guaranteed or no pay. Wonderful opportunity, experience not needed. Beautiful sample book and fashion plates free. Banner Tailoring Co., Dept. 459, Chicago.

SELL Vulklasa auto insert tube repair material and Kullite rubber dough for tire castings. Good profits. American Accessories Co., Dept. P-6, Cincinnati.

ESTABLISH and Own Exclusive Business in Your home town. Sell Combusto, the real 10 to 20% fuel saver, that appeals to everyone. Over 12,000 now in use, including 40 U. S. Battleships. Liberal contract, full protection for all men. Write today. Combusto Corp., 254 W. 54th St., N. Y.

WANTED! Responsible representatives for new specialty every stenographer needs. Quickly demonstrated, absolutely convincing, liberal proposition in return for ability. Sales Department, Box 468, Asheville, North Carolina.

SELL—An agent in each town; a business of your own; steady weekly income; easy work; immense repeater; big profits; anyone can do it; package and plan 10c. Suda Co., 125 E. 129th St., New York, Dept. M.

SELL something new. Every merchant buys Ever-Ready Changeable signs. Make 9.50 on every \$1.50 sale. If you make less than \$2.00 an hour, write for proposition. Changeable Sign Co., 585 E. 102nd, Cleveland.

\$1,000 FOR your next 100 days, spot cash. New money-making invention for agents, general agents, managers. Recently invented, 1,000,000 already sold; 200 more salesmen wanted at once. Amazing automatic Compressed Air Washing Machine. Washes tub of clothes in six minutes. No cranks to turn or levers to push—no rubbing. Works like magic. Price only \$1.50—make sale at every house; 200% profit. L. Palmer, Glen Allen, Ala., put out on trial 108 machines, sold 107. Profit \$107. Write today. Wendell Co., 1183 Oaks St., Leipsic, O.

AGENTS. We have a good proposition for you. Write for particulars and samples. Chicago Agency Co., 838 Altgeld St., Chicago.

NEW invention. \$10.00 per day to agents. Quickedge Knife and Shear sharpener for household use. Sharpens any kitchen, paring, carving knife or shears in ten seconds. A child can use it. Grinds both sides of blade at once, automatically. Guaranteed. A sale at every house. 200% profit gross lets. No charge for territory. Business furnishes capital, profits, start first day. Low priced. No experience necessary. Ray Carter of Massachusetts sold 36 in four hours—profit \$36.00. J. H. Stemple of West Virginia sold 45 first day. New proposition—just out. Complete particulars free. Write today giving name of your county. Address Quickedge Sharpener Co., 607 Sharpener Bldg., 215 N. Desplains St., Chicago, Ill.

AGENTS. \$50 a week. Will show you how. Genuine Gold Leaf Window Letters. Chicago Agency Co., 842 Altgeld St., Chicago.

WANTED. General Agent to represent us in your locality. Exclusive territory. Big inducements. Chicago Agency Co., 840 Altgeld St., Chicago.

INSYDE Tyres. inner armor for Automobile tires, double mileage and prevent punctures and blowouts. Quickly applied. Cost little. Demand tremendous. Profits unlimited. Details free. American Automobile Accessories Co., Dept. P, Cincinnati, O.

MEDALLIONS—300% profits. Make up your own goods and be independent. Catalogue free. Resag Co., 1205 Randolph St., Chicago.

AGENTS—Our gold window letter proposition beats 'em all. Stalbrit Co., Dept. P, 1115 Second Ave., N. Y. Established 1905.

AGENTS Wanted: Sell Polishing Cloths, Rust Remover, Food Flavors, etc. 150 household necessities, guaranteed line, big profits, quick repeater, permanent business. Stuart & Co., 16 Main St., Newark, N. Y.

AGENTS make \$100 monthly selling our 500 handy household articles. Catalogue free. Scheff Company, Desplains, Ill.

AGENTS, sell reliable custom-made raincoats. Big commission. Complete sample line free. Temple Raincoat Co., Box 62, Templeton, Mass.

"1916's SENSATION!" Eleven piece toilet article set selling like blazes at \$1.00 with \$1.50 carving set. Free! Enormous profits! Tremendous hit! Engle made \$51.90 first week. Write quick! Pierce Co., Dept. P, 906 Lake St., Chicago.

WANTED—New Ideas. Write for list of Patent Buyers and Inventions Wanted. \$1,000,000 in prizes offered for inventions. Our Four Books sent free upon request. Victor J. Evans & Co., 163 Ninth, Washington, D. C.

LARGE Manufacturer wants representatives to sell shirts, underwear, hosiery, dresses, waists, skirts, direct to homes. Write for free samples. Madison Mills, 386 Broadway, New York City.

AGENTS, Either Sex, the greatest 35c proposition on earth. Send six two-cent stamps for sample, particulars. Ideal Specialty Co., Duluth, Minn.

AGENTS—"Exclusive features" are what make easy sales—I can gain attention, close the sale and collect the money on six customers with the exclusive features of my non-alcoholic flavoring extracts, while you are struggling with one customer on the old commonplace line of talk. So can you! Prove it! Write today—big summer sellers—extra summer profit's. J. M. Pitkin Co., 426 E. St., Newark, New York.

LARGE Manufacturer wants agents to earn good pay selling high-grade custom-made raincoats. Goods sell themselves. No experience nor capital necessary. Deliver to customer. Prices defy competition. Guarantee every sale. 1917 Outfit free. Amer-Europ. Raincoat Co., 175 E. Broadway, N. Y., Desk P.

WE Pay \$80 Monthly Salary to those who qualify and furnish rig and expenses to introduce guaranteed poultry and stock powders. Bigler Company, X368, Springfield, Ill.

BIG Textile Mills want ambitious men and women everywhere to show latest dress fabrics, neckwear, hosiery, underwear, and sweaters. 490 styles. Easy sales. Values beat stores. Many making over \$30 weekly. All or spare time. Complete sample outfit starts you. Steadfast Mills, 30 Remsen St., Cobles, N. Y.

A MARVELOUS Selling Article! Used in every home. Silver, the polish that actually rubs on Sterling Silver. Big profits. New selling plan. A good article to handle. Send 25c for sample outfit. F. Silver, 157 Cedar, New York.

AGENTS make 500% profit handling Auto Monograms and Initials. Changeable Signs, Novelty Signs, and Window Letters. Catalog Free. Hinton Co., 6142 40th Court, Chicago, Ill.

DEMONSTRATE Demaco Gas Savers to auto owners. Big seller. Big profits. Results guaranteed. Refund to agents for price of Demonstrator. Write quick. Decatur Mfg. Co., Box 335, Decatur, Ill.

SELL California Rosebuds. Sewell line. Large profits. Send for catalog today. Mission Road Co., 2819PM, West Pico, Los Angeles, Calif.

\$150.00 SALARY for 60 days' work paid woman or man in each town to distribute free circulars, and take orders for White Ribbon Concentrated Flavoring. J. S. Ziegler Co., 7-P E. Harrison St., Chicago.

AGENTS write for particulars fastest selling household necessity. Good profits; assured sales. Pock Specialty Co., Dept. 3, North Haven, Conn.

\$50 WEEKLY and up selling Mexican Diamonds. Exactly resemble genuine; Same Rainbow Fire; stand tests; sell at sight; repeat orders. Write quick for Sample Case offer Free. Mexican Diamond Importing Co., S. W. Las Cruces, New Mexico.

AGENTS—\$30 a week and expenses; free samples; gold and silver letters for store fronts, office windows and glass signs; anyone can put them on; big demand everywhere; liberal offer to general agents. Metallic Letter Co., 407 N. Clark St., Chicago.

AGENTS to sell Handy Dish Washer. Write for particulars. Charles Purcell, 179 Broad St., Newark, New Jersey.

AGENTS—Ho-Ro-Co Skin Soap and Toilet Goods plan beats everything for agents' profits. "Ho-Ro-Co." 112 Locust St., St. Louis, Mo.

DECALCOMANIA Transfer Initials and Monograms: You apply them on automobile while they wait; cost 2c each; profit \$1.38 on \$1.50 job; free particulars. Auto Monogram Supply Co., Dept. 1, Niagara Bldg., Newark, N. J.

AGENTS—Steady income. Large manufacturer of Handkerchiefs and Dress Goods, etc., wishes representative in each locality. Factory to consumer. Big profits, honest goods. Whole or spare time. Credit given. Send for particulars. Freepart Mfg. Co., 59 Main St., Brooklyn, N. Y.

AGENTS Wanted Everywhere—To sell our attractive theatre Brass Poster Frames, Changeable Signs, Building Directories, Brass Signs, Brass Railings, Bank Fixtures, Adjustable Electric Light Brackets. Big demand; easy sales. Established 1882. Newman Manufacturing Company, Cincinnati, Ohio.

EASY, pleasant work for Mechanics, Shop Men, Clerks, during spare hours, will add many dollars to their salaries. Also want persons who can give full time. Big wages assured. Novelty Cutlery Co., 67 Bar St., Canton, Ohio.

\$5 TO \$15 profit a day selling most complete line Sanitary Household Brushes for every purpose. Our own make. Your territory awaits you. Write for attractive proposition. Puritan Sales Co., Dept. M, 1968 Broadway, New York.

\$1,000 PER Man per county. Strange invention startles world—agents amazed. Ten inexperienced men divide \$40,000. Korstad, a farmer, did \$2,200 in 14 days. Schleber, a minister, \$195 in first 12 hours. \$1,200 cold cash made, paid, banked by Stoneham in 30 days; \$15,000 to date. A hot or cold running water bath equipment for any home at only \$6.50. Self-heating. No plumbing or waterworks required. Investigate. Exclusive sale. Credit given. Send no money. Write letter or postal today. Allen Mfg. Co., 311 Allen Bldg., Toledo, Ohio.

\$15.00 MADE first day by 13-year-old boy with Shomescope. Woman made \$8.00 first hour. Particulars free. Shomescope Mfg. Co., 523 W. 15th St., Kansas City, Mo.

GARRETT sold Twenty-Nine Spray Pump Auto Washers in Three days. Profits, two dollars each. A Square Deal. Rusler Co., Johnston, O.

AGENTS: Get an easy seller, Sanitary All-Metal Bread and Pastry Board and Boiling Pin is making big hit. Make \$25 to \$40 every week. Smith, Ohio, sold 38 one day. Profit \$19.00. Sells at sight. No talking necessary. Free Sample to Agents. Write quick for appointment and territory. Union Mfg. Co., 183 Main St., Cambridge, Ohio.

AGENTS. Make Big Money; fast office seller; particulars and samples free. One Dip Pen Co., Dept. 2, Baltimore, Md.

"GOLDINE" Sign Letters—1,000% profit. Particulars free. Johnston Co., Quincy, Ill.

OUR line of sanitary brushes, mops and dusters is a winner. So is our proposition. High territory waiting. Agents wanted now. Sanford Brush Co., 544 W. Lake St., Chicago.

SALESMEN WANTED

WERE you ever offered a grocery store? Our proposition is better. Let us tell you how you can handle Flour, Canned Goods, Provisions—an entire line of Groceries, as well as Palmis, Roofing, Stock Foods, Automobile and Machinery Oils and Greases. No rent to pay, no investments in stock. Large orders taken from samples. Goods of guaranteed and proven quality. Selling experience not necessary. Very profitable work for "workers." Address R. S. Hill, President, Hitchcock Hill Co., Chicago. Reference: Any bank or express company.

SALESMEN—Wanted everywhere to sell Ajax Chemical Fire Engines. Liberal commission on every engine sold. An average of one or two machines a week would earn you \$2,000 to \$4,000 a year. Factories, Stores, Industrial Plants, Private Estates, etc., all use Ajax Engines. No capital required. Goods well advertised. Ajax Fire Engine Works, 85 W. Liberty St., New York.

WANTED—Men financially able to handle sales of portable steam heaters for buildings heated with stoves. Exclusive territory. Bigger money-maker than automobiles. Write for particulars. Whitman Heater Co., 3235 Cottage Grove Ave., Chicago.

SALESMEN to Sell Manufactured Goods. Reference Required. Manhattan, 264 Spring, New York.

NEW "4 in 1" Interchangeable letter Sign \$2.90. New England Co., 260 State, New Haven, Conn.

TRAVELING salesmen calling on hardware and heating trade to sell a high-class specialty for side line. Address W-1524 Lorton Bldg., Chicago.

SALESMEN—Sell beautiful 28x58 Artz-kraft felt rugs for \$13.50 per doz. Your profit \$2.50 per doz. Kelso, Battle Creek, Mich., sold 30 doz. Last week, his profit \$75. Sample rug prepaid \$1.50. E. H. Condon, Mfr., 12 Pearl St., Boston, Mass.

SIDELINE salesmen selling to the trade to introduce our Marvelous Expanding Cuff Buttons. See our advertisement under agents wanted. President Flexo Corporation, Sheboygan, Wisconsin.

NEW Ford Runabout for \$100 and your spare time, distributing Stewart's "Off-On-On" Tire Tools. It's easy. Particulars free. Stewart, 130 Cass Ave., Detroit, Mich.

SALESMEN for Auto Supply, Garage, Hardware, Drug, Grocery and Dept. Store trade on fast selling line of polishing compounds. Liberal commissions. Send ten cents to cover postage for samples of complete line and full particulars. Borg Mfg. Company, Dept. A, 178 21st Street, Milwaukee, Wis.

OUR advertisement under Agents Wanted will interest you. Read it. Marshall Dobbins & Co.

WANTED—Representatives everywhere. Exclusive territory. Gold sign letters for stores and office windows. Any one can put on. Write today for free sample. Metallic Letter Co., 403 N. Clark St., Chicago.

CIGAR Salesmen wanted in every county. All or spare time. \$20-\$40 weekly; no experience required. We show you. Neway Sales Co., Holyoke, Mass.

MB, Live Wire Specialty Salesman. We have a proposition worth \$20.00 a day. Heare Sales Co., Cambridge Bldg., Chicago.

SELL concrete mixers to lumbermen, contractors, and farmers. Rapid sellers, good profits, no capital required. Superior Mfg. Co., 161 Concrete Avenue, Waterloo, Iowa.

SIDE-LINE Salesmen: Cleverest line out. Easy to sell. Pocket samples. Liberal commissions. Write for samples and particulars. Fantus Bros., 529 So. Dearborn St., Chicago.

SALESMEN wanted by reliable firm to call on farmers. Salary and commission paid. Experience not necessary. Prefer those having own rig. Address Dept. A, P. O. Box 1017, Springfield, Mass.

SALESMEN—Acquainted with grocery trade. Large demand; liberal commission; pocket sample. Wirth Salesbook Co., Dept. P, Chicago.

SALESMEN—Get our plan for Monogramming Automobiles and motorcycles by transfer methods. Very large profits. Motorists' Accessories Co., Mansfield, O.

EARN \$5,000 to \$20,000 yearly. New business necessity. Retail \$5 to \$200. 100-200% profit. Purchaser satisfied or money refunded. No competition. Exclusive territory. Free samples. Sayers, 498 Walnut, St. Louis.

HELP WANTED

FROM \$12 a week to \$5,000 a year shows possibilities of life insurance. You can be trained for this business. Will send you free our correspondence course of salesmanship and life insurance. This is not advertising matter but a course of instruction such as you would pay \$50 for. It is yours for asking. It is free. Write today. William King, Agency Supervisor, Dept. "D," Missouri State Life Insurance Company, 86, Louis, Mo. The fastest growing life insurance company in America. Insurance in force over \$120,000,000.

A POSITION is open for you in the Government service after we have helped you qualify. My money back offer guarantees it. Write quick for big free book DA-39. Earl Hopkins, Washington, D. C.

BE a Mirror Expert. Good income; spare time home at first; no capital; we train, start you making and silvering mirrors; French method. Free prospectus. W. P. Dorr, Pres., 87 Saratoga Ave., Brooklyn, N. Y.

THOUSANDS Government Jobs open to Men—Women, \$75.00 month. Steady work. Short hours. Common education sufficient. Write immediately for free list of positions now obtainable. Franklin Institute, Dept 1 W-21, Rochester, N. Y.

WANTED—An Idea! Who can think of some simple thing to patent? Protect your ideas; they may bring you wealth. Write for "Needed Inventions" and "How to Get Your Patent and Your Money." Randolph & Co., Patent Attorneys, Dept. 144, Washington, D. C.

YOUNG Men and Women Wanted to prepare for government positions. Good pay, short hours, permanent. Must be citizens and over 17. Write today for free book FB-29. Earl Hopkins, Washington, D. C.

PATENTS on easy payments. See our advertisement under Patent Attorneys. C. C. Hines & Co.

EARN \$30 to \$60 Weekly Extra while learning to be expert salesman. Our complete course in book form enables you to start selling at once. Only \$5. Positions waiting. Union Sales Co., 643 E. 33rd St., Chicago.

GOVERNMENT pays \$900 to \$1,800 yearly. Prepare for coming "exams" under former Civil Service Examiner. New Book Free. Write Patterson Civil Service School, Box 3020, Rochester, N. Y.

GOVERNMENT Employees Wanted—Big pay, sure work. I will prepare you in a short time at small cost. Must be American citizen. Write for my free book FC-29 today. Earl Hopkins, Washington, D. C.

\$10 DAILY refinishing chandeliers, brass beds, automobiles by new method, producing amazing results; no capital or experience necessary; particulars free. Gunmetal Co., Ave. G, Decatur, Ill.

CASH paid for butterflies, insects. Some \$1 to \$7 each. Easy work. Even two boys earned good money with mother's help and my pictures, descriptions, price list, and simple instructions on painless killing, etc. Send 2c stamp at once for prospectus. Sinclair, Box 244, D. 6, Los Angeles, Cal.

GOVERNMENT wants Clerks. \$75 month. Spring examinations everywhere. Sample questions free. Franklin Institute, Dept 1 W-21, Rochester, N. Y.

MEN—Women, 18 or over, wanted. Government Clerks, \$75 month. Spring examinations everywhere. Education unnecessary. Sample questions free. Write immediately. Franklin Institute, Dep't W-21, Rochester, N. Y.

RAILWAY machinists—Several openings for experienced roundhouse machinists. The best of wages, steady employment, by a railway noted for its kind treatment of its men. Opportunity for promotion. Address E. F. Houghton, Superintendent Shops, Buffalo, Rochester & Pittsburgh Railway, East Salamanca, N. Y.

GET a Sure Job with big pay, steady work, short hours, regular vacations, rapid advance. Thousands of positions open with Uncle Sam. I will prepare you in a few weeks at small cost. Write immediately for big Free Book DU-29 with special offer. Earl Hopkins, Washington, D. C.

CHANCE for Fame! Celebrated magazine will be named after you, rich or poor, printed with your name and called your magazine if you are right person. See current number, fifteen cents postpaid. Address New Magazine, 11-15 West Union Square, New York.

NEW occupation. Turn spare hours into dollars. Want men everywhere. Start your Branch Factory at home. Everything furnished. No selling. "Fakers" not wanted. American Mirror Company, Johnstown, Penna.

FIREMEN, Brakemen, railroads everywhere, beginners \$125-\$150 monthly; positions guaranteed. Railway Association, Dept. 254, Brooklyn, N. Y.

INVENT Something. It may bring wealth. Free book tells what to invent and how to obtain a patent through our Credit System. Waters & Co., Succeeded by Talbot & Parker, 4102 Warder Bldg., Washington, D. C.

UNCLE Sam has thousands of jobs open this year. I will help you get one. Write for my big free book, DX-29, Earl Hopkins, Washington, D. C.

NO Strike: 8 Hour Day. Men Everywhere. Firemen, Brakemen, Baggage-men, \$120. Colored Porters, Experience unnecessary. 819 Railway Bureau, E. St. Louis, Ill.

THOUSANDS Men—Women—Wanted as Government Clerks. \$75 month. Spring examinations everywhere. Sample questions free. Franklin Institute, Dep't W-21, Rochester, N. Y.

WORK for Uncle Sam. He is the best employer. Big pay, sure work, easy hours, long vacations, rapid advance. Thousands of jobs open this year. I will help you get one. Write for my big free book, DY-29, today. Earl Hopkins, Washington, D. C.

WANTED—First-class machine and tool-shop foreman for Japan. Must be familiar with operating screw and milling machines and automatic gear-cutters and have general toolshop experience, including knowledge of hardening and tempering steel. Boozers, fighters and soldiers of fortune will not be tolerated. Reply, stating experience, previous wages; send reference copies, photograph to J. A. Rabbit, 76-C, Yokohama, Japan.

THE way to get a Gov't Job is through the Washington Civil Service School. We prepare you and you get a position or we guarantee to refund your money. Write to Earl Hopkins, President, Washington, D. C., for Book FK-29, telling about 292,928 Gov't Positions with lifetime employment, short hours, sure pay, regular vacations.

WANTED—Ambitious men to become chauffeurs, Automobile experts and salesmen. \$25 to \$50 week. Pleasant, interesting work. Learn while earning. Sample lessons free. Write immediately. Franklin Institute, Dept. W 802, Rochester, N. Y.

OUR advertisement under Agents Wanted will interest you. Read it. Marshall Dobson & Co.

GOVERNMENT Positions are easy to get. My free booklet BY-29 tells how. Write today—now. Earl Hopkins, Washington, D. C.

WANTED—Cartoonists—\$25.00 to \$100.00 per week. Success guaranteed. Free particulars. Dept. A. Denison School of Cartooning, Harrison, New York.

WANTED—Men—Women—as Government Clerks. \$75 month. Spring Examinations everywhere. Sample questions free. Franklin Institute, Dep't W-21, Rochester, N. Y.

LEARN organizing. Make big money. Clean, neat, sober, honest men can learn in three months. \$100 covers full tuition. We guarantee employment. The Owl, South Bend, Ind.

CIVIL Service Examinations open the way to good Government positions. I can coach you by mail at small cost. Full particulars free to any American citizen of eighteen or over. Write today for Booklet CE-29. Earl Hopkins, Washington, D. C.

SALESMAN—\$6,000 Accidental Death, \$30.00 Weekly Accident Benefit, \$25.00 Weekly Sick Benefit, \$10.50 yearly, half amount \$5.50, \$250,000 deposited Insurance Department. Become independent. Experience unnecessary. Guaranteed steady income from renewals. Registration. Dept. B. Newark, N. J.

RAILROAD Firemen make big salaries. Our correspondence course qualifies for position in few days taken in your home. Particulars free. Write at once. Monarch Firemen's Free Co., 1200 W. Franklin Ave., Minneapolis, Minn.

WANTED. Men and women to qualify for Government positions. Several thousand appointments to be made next few months. Full information about openings, how to prepare, etc., free. Write immediately for booklet CG-29. Earl Hopkins, Washington, D. C.

GOVERNMENT Examinations. Most thorough preparation, \$5; returned if not appointed; particulars free. American Civil Service School, Washington, D. C.

NEW occupation for steady workers at home. Whole or part time. No selling. J. Lord Company, Baltimore, Md.

MAKE money writing Photo-plays; details free to beginners. No correspondence course. Producers' League, 230 Wainwright, St. Louis.

WANTED

WANTED—Premium articles to offer with magazine subscriptions. Scout, Taylorsville, North Carolina.

FOR SALE

MODERN Vacuum Cap. makes hair grow; cost \$25.00, for \$12.50. A. H. Trotter, Milwaukee, Wis.

HELPER Concrete Mixers. Write for prices. Superior Mfg. Co., 162 Concrete Ave., Waterloo, Iowa.

MICROSCOPE; Three Cameras; Typewriter. Write C. Herrmann, 944 East 47th St., Chicago.

POWERFUL marine day and night glasses with case, 25-mile adjustment, \$7.50. Satisfaction or money returned. Wells Curiosity Shop, 20 South Second St., Phila., Penna.

SLIGHTLY used Drafting and Surveyors' Instruments, bought and sold. J. B. Poore, Washington, N. J.

TYPE and Printing Material at bargain prices. Now is the time to buy. All sizes rebuilt Job Presses very cheap. Catalogue free. Philadelphia Printers' Supply Co., 14 So. Fifth St., Philadelphia.

AUTOMATIC Card-Press, 16 fonts of type with cases. Used 3 months. D. B. McPherson, Mitchell, S. D.

REINFORCED Concrete Engineering Vol-umes, auditing and accounting volumes, Bennett Typewriter, Golden Gem Adder, W. Schwietzman, Osgood, O.

BARGAIN—One volt meter. One Wheatstone bridge—one lamp wattmeter. Box 283, Greensboro, N. C.

SALE OR EXCHANGE

WANT to Swap? Send 10 cents for "The Market for Exchange," to Pierre Notley, 141 Milk Street, Boston, Mass. It gives a long list of those who have things to trade or sell. Send list of things you have to trade or sell.

IF there is anything you want to buy, sell or exchange, send for free copy of "The Buyers Bulletin," Saranac Lake, N. Y.

GUNS, SPORTING GOODS, ETC.

BUY, sell, exchange all sorts old-time and modern Firearms, Stephen Van Rensselaer, Antiques, 805 Madison Ave., New York.

FLOUR & FEED MILLING MACHINERY

SPECIAL bargains in second hand Attrition mills, burr mills, crushers, corn shellers, bran dusters, dust collectors, purifiers, rebs, double, single, 2 and 3-pair high roller mills, sieve bolters, receiving separators, scourers, etc. Write for description and prices. Sprout, Waldron & Co., P. O. Box 429, Muncy, Pa.

MACHINERY, TOOLS & SUPPLIES

TOOLS—for shop, factory, garage and home—many high-class tools attractively priced in our "Odds and Ends" pamphlet—which is mailed free on request by Montgomery & Co., Inc., 105 Fulton St., New York City.

"RED Devil" Mechanic's plier (drop forged steel). Most efficient, 5" size, 60c. Style 50. Tool booklet free. Smith & Hemenway Co., 97B Chambers Street, New York City.

PULLEYS, Gears, Sprockets, Shafting, Hangers. See page 134, W. A. Jones, Foundry & Machine Co., Chicago.

TO buy or sell a machine, write Interstate Machinery Co., Troy, N. Y.

HELPER Concrete Mixers make cement work easy. Write for prices. Superior Mfg. Company, 162 Concrete Ave., Waterloo, Iowa.

SMALL bench lathe for \$3. Peter Austin, Muncie, Ind.

WIRE—all sizes— $\frac{1}{8}$ to No. 16, Coppered, tinned, galvanized and plain steel wire for sale. Cooley Mfg. Co., 553 W. Monroe St., Chicago, Ill.

ENGINES, MOTORS AND DYNAMOS

NEW $\frac{1}{4}$ -H.P. A. C. Motors \$15. A few $\frac{1}{4}$ -H.P. A. C. \$12, D. C. \$11. Price on other sizes in proportion. Headquarters for motors and generators. Electric Sales & Service Co., 719-21 Liberty Ave., Pittsburgh, Penna.

GASOLINE Kerosene Engines Built to do work. Saves half your fuel expense. No shoddy goods. Price right. Free trial. Address Engine Works, Marcelina, Mich.

GUARANTEED rebuilt alternating and direct current motors. Bargain prices. Reliable makes only. Westinghouse, Wagner, Century, Emerson, Fort Wayne, General Electric. Sizes from 1/30 H.P. upwards. Satisfaction guaranteed or money refunded. Write for illustrated list supplies and motors. Hyre Electric Co., 613 XY South Dearborn St., Chicago.

CHARGING Dynamos—Several hundred small machines from Bankruptcy Stock. All voltages and sizes—guaranteed new, less than factory cost. $\frac{1}{4}$ H. P. A. C. Motors \$15.00 each. Write for illustrated list. Johnston, West End, Pittsburgh, Pa.

HALF kilowatt hundred ten direct generator. Good order \$15. Geo. L. Giles, Shabbona, Ill.

BATTERY charging, lighting, and special Arc Generators sold on easy payments. Hobart, Box E, Troy, Ohio.

$\frac{1}{4}$ HP. Gasoline engine, \$30, A-1 condition. $\frac{1}{4}$ HP. 2-cycle Vm engine, new, \$15. W. B. Meeks, Martelle, Ia.

SIXTY hp. Gas Engine, complete, fine order. Horton Company, Painesville, Ohio.

REBUILT Engines—We have rebuilt "Buffalo" Engines, guaranteed, at greatly reduced prices. Write for bargain list. Buffalo Gasoline Motor Co., 1293-1305 Niagara Street, Buffalo, N. Y.

FOR Sale: A few new 5, 8 and 12 H. P. horizontal, water-cooled engines at cost. Northwestern Steel & Iron Works, Eau Claire, Wisconsin.

FOR MECHANICS

CARPENTERS, machinists, and tool-makers. When buying a tool case get a Keystone Portable Tool Case. Send for catalog. Keystone Case Co., 215 N. Keystone Ave., Chicago, Ill.

WATERLESS Washer Soap. Removes grease instantly with or without water. The wonderful mechanics' or time saving soap. For \$1.00 we send you enough material to make 16 pounds, prepaid, with instructions. Your money back if not satisfactory. Waterless Washer Laboratories, 1428 Michigan Ave., Chicago, Ill.

BOATS, LAUNCHES, ETC.

BUILD your own Steel boat from patterns. Material furnished, also finished boats. Catalogue free. Darrow Boat Co., Albion, Mich.

MOTORCRAFT Encyclopedia—A 150-page book that tells 1001 things every motor boatman should know. How to overcome engine troubles. Price \$1, postpaid. Popular Mechanics Book Dept., 6 N. Michigan Ave., Chicago.

FOR THE SHOP

SHOP Notes for 1917—Just Published—524 Articles, 422 Illustrations, 224 Pages. Easy Ways to do the Hard Things in every trade and calling. Price 50 cents, postpaid. Also all previous numbers in Shop Notes series Volumes 1 to 12 inclusive at 50 cents each, postpaid. Send for description. Popular Mechanics Book Dept., 6 N. Michigan Ave., Chicago.

PATTERN Makers! A book devoted to the principles of pattern and core making and molding. Written by G. H. Willard, a practical pattern maker of years' experience. This book, just published, treats the subject in a much more simple, direct and effective manner than most books along this line. 224 pages, 312 illustrations. Price, \$1, postpaid. Popular Mechanics Book Dept., 6 N. Michigan Ave., Chicago.

BLACKSMITHS

BLACKSMITHS, Listen! The Blacksmiths come first of all trades. He must make the tools for all, from the Surgeon to the Safe Blower. With Toy's Modern Methods doing hard jobs easy. Forging and making solid welds, hardening and tempering to a standard, with colored tempering charts. All for one dollar. Samples Free. W. M. Toy, Sidney, Ohio.

BE a Tempering Wizard. Tools and springs tempered by my formula, indestructible. Secret method never before divulged. You need it \$1.00. Nonbreakable cold chisel free to every formula buyer. The Cold Chisel King, Stockton, Illinois.

ELECTRICAL

ILLUSTRATED wholesale pricelist supplies and motors, including switches, sockets, wire, porcelain goods, loom, Hyre Electric Co., 613 DF South Dearborn St., Chicago.

STORAGE Batteries Simplified—A complete new treatise on action—maintenance—repair—use. Describes fully the Exide, Edison, Gould, Willard, U. S. L. and other forms. Only complete and up-to-date book on subject. 320 pages, fully illustrated. \$1.50 postpaid. Complete description sent upon request. Popular Mechanics Book Dept., 6 N. Michigan Ave., Chicago.

DRY Batteries and Their Construction for All Purposes. A practical handbook of 60 pages with 30 illustrations dealing with batteries for automobiles, gas engines, medical and coil work, electric bells, alarms, telephones, experiments, etc. Price 25 cents postpaid. Popular Mechanics Book Dept., 6 N. Michigan Ave., Chicago.

STAMP COLLECTING

STAMPS—500 fine foreign incl. Mex. War, Salvador, incl. officials, Guatemala, China, etc., only 10c. Best App. Sheets 60 to 80¢ dia. We give valuable extra Presents free! Big 120 pg. catal. free. We buy stamps. Hussman Stamp Co., St. Louis, Mo.

PHILIPPINE approval sheet catalogues \$1, postpaid 24c. George O. Detrich, Pasadena, Calif.

SIX different Newfoundland free to approval applicants. Colman, 634 Keefer Place, Washington, D. C.

FREE—Stamp collections. Choose One. 200 different international, 50 Asiatic, 100 United States, 60 Japanese, or 50 African. Remit 25c six months' subscription. McKee's Stamp Weekly, Beverly, Mass.

150 DIFFERENT stamps from countries at war, etc. 15c. Want lists filled. Borsch and Potter, 460 Widener Building, Philadelphia.

20 UNUSED stamps free. All different. Postage, 2c. Fish Stamps, Toledo, Ohio.

PACKET "A" 100 varieties foreign stamps. 29c. F. J. Pope, Charlotte, Vermont.

121 ALL Different Foreign Stamps, including Guatemala, Honduras, Roumania, Costa Rica, Egypt, Chili, China, Mexico, Peru, Cuba, Russia, Japan, India, Victoria, Portugal, etc., 15c. 200 hinges free. Royal Stamp Co., 48 N. 51st Street, Philadelphia, Pa.

STAMPS—58 all different, Straits Settlements, Bolivia, Malay States, (tiger), New Zealand, China (junk ship), Mexico, etc., and Album; also Perforation Gauge. All for 5c. Interesting List Free. Payn Stamp Co., 138 North Wellington St., Los Angeles, Calif.

STAMPS—195 China, etc., stamp dictionary, list, 2c. Album (500 illustrations) 3c. Bullard, Sta. A., Boston.

1, 2, 3c NET and British Colonials approvals for advanced collectors. Premium, Mint Set New Hebrides, Riedell, Schenckly, N. Y.

FREE! 25 Different British Colonials to applicants for approvals. Postage 2c. 202 different foreign, 17c. Nickles, 122 Florida Avenue, Washington, D. C.

CANADA Packet Free—Early Issues, Maple Leaves, War stamps, etc., postage 2c. Midland Stamp Company, Midland, Ontario.

32 DIFFERENT foreign Free. Write for approvals. Reference Star Stamp Company, Sandusky, Ohio.

12 FINE Poster Stamps, with Album, Tie-pin of U. S. Cent. Handy Dictionary or other interesting book, all for 25c. Frank Mueller, Novelities, Alliance, Ohio.

STAMPS on approval, 60% discount. Lang, 1433E, 59th Ave., Cicero, Ill.

POSTER Stamps are all the rage. Save them. 25 assorted 10c. Album holding 480—30c. Chicago Poster Stamp Co., 6725 East End Ave., Chicago.

FREE—60 different stamps, including Newfoundland, China, Japan, Mexico, etc., to applicants for our high-grade approvals. Send 2c stamp for return postage. The Edgewood Stamp Company, Dept. H, Milford, Conn.

FREE—Packet from Argentine and Salvador, Nicaragua, etc., with request for "Royal Approvals," with reference. Big bargain list free. Belmont Stamp Co., 32 South 17th St., Philadelphia.

FINE Collection of 250 different stamps 25c. Joseph, Roxbury Crossing, Boston, Mass.

STAMPS—12 different from warring nations, 10c; 10 different foreign coins, 15c; 20 Belgian stamps, 10c. Lists free. Toledo Stamp Co., Toledo, Ohio.

STAMPS sent on approval at 70% discount. Reference required. Emory Renoll, Hanover, Pa.

24 VARIETIES Cuban stamps, 10 cents. List of 5,000 low-priced stamps free. Chambers Stamp Co., 111 P. Nassau St., New York City.

STAMPS, 75, all different, free. Postage 2c. Mention paper. Quaker Stamp Co., Toledo, Ohio.

PACKET of 23 stamps; no two countries alike, 500 hinges. Set of \$1 and \$2 U. S. Rev., all for 5c. Mention paper. Miami Stamp Co., Toledo, Ohio.

RARE COINS

OLD Coins. Large Spring Coin Catalogue of Coins for Sale, free. Catalogue quoting prices paid for coins, ten cents. William Hesselein, 101 Tremont St., Boston, Mass.

OLD Coins and Stamps of all kinds. From \$1.00 to \$1,000.00 cash paid for some to 1912. Keep all old money and stamps. Send 4c. Get Large Illustrated Coin and Stamp Circular. You have nothing to lose. Send now. Numismatic Bank, Dept. H, Fort Worth, Texas.

88 PAID for 1853 Quarters, \$100 for rare 1853 half dollars. From \$2 to \$600 paid for hundreds of old coins. Send 10 cts. for our coin Guide Book. Model Co., Morton Bldg., Chicago.

OUR 1917 coin, stamp and relic list sent absolutely free on request. Coin Exchange, New Rochelle, N. Y.

15 COINS, 30 cents per package. Sample coin trays, 25 cents each. Order now. C. Johnson, 100 Maiden Lane, N. Y.

1917 OLD Coin Premium Book, 10c (silver). \$2 to \$1,500 paid for certain dates. Get posted, many in circulation. E. H. Harr, Nora Springs, Iowa.

FIVE Villa Coins and Bills, 35c. Villa silver Dollar, \$1.35. Moore Coin Company, Commerce, Texas.

CALIFORNIA Gold, quarter size, 27c. \$4 size, 55c. Large cent before 1821, Columbian nickel and price list, 10c. Norman Schultz, King City, Mo.

\$4.25 EACH Paid for U. S. Flying Eagle Cents dated 1856. We pay cash premiums on hundreds of Old Coins. Send ten cents at once for New Illustrated Coin Value Book 457. It may mean your fortune. Clarke & Co., Coin Dealers, Box 15, Le Roy, N. Y.

GAMES AND ENTERTAINMENTS

MAGIC—Tricks, Books and Supplies. For Amateurs as well as the Great Professionals. Any one can learn through our instructions. Feature Acts in Mind Reading, Spiritualism, Rope Ties, etc. Large illustrated Professional Catalogue, 10c. Chicago Magic Co., Dept. B, 72 West Adams St., Chicago, Illinois.

"SLEIGHTS." New fifty-cent Magic Book, 45 Photos, Ten Cents. Moose, Crosskill, N. J.

JOKES, Tricks and Novelities, 1917 Illustrated Catalogue sent upon request. W. J. Corson, 1720 N. Tripp Ave., Chicago.

MAGIC—Tricks—Novelties, 144-page Illustrated Catalogue free. Homer A. Howry Co., Los Angeles, Cal.

GAME of Base Ball for children, Outs and Scores made, Outright or Royalty, U. S. and Canadian Patent. W. H. Wallace, Pittsburg, Kansas.

TRICKS. Stage Money, 750 Magic bargains in new catalog No. 34 just out. 2c. Twenty Buffalo Greenbacks, 10c. 100-35c; 1,000-\$1.50. Gilbert Magic Co., 11135 Irving, Chicago.

67 TRICKS, 250 jokes, riddles, 73 toasts, 8 Fortune Telling secrets, 52 moneymaking secrets, 22 funny readings and big catalog 10c. Ideal Novelty Shop, 3315-N-3, Belleplaine Ave., Chicago.

MAGICIAN'S Wonderful Self-Forcing Deck, 35c; Handkerchief Color Change, 25c; String Tricks, 25c; Cigarette Tricks, 25c; Blindfold Mind Reading, 15c; Paper Stack Escape, 15c; Sealed Letter Reading, 15c; New Spirit Reading, 15c; Spirit Slate Writing, 15c; Diminishing Cards, 10c; Book of Sleights, 10c; America's Best Magic Magazine, 10c. New Catalogue Free. C. Penz, 295 Seventh St., Minneapolis, Minn.

MAGIC Tricks for pocket, parlor and stage. Large assortment in the world. Thurston's Book of Pocket Tricks 25c. Book of Card Tricks 25c, postpaid. Send 2c stamp for catalogue. (216 page professional catalogue 10c.) A. Felsman, 115 So. State, Chicago.

1917 CATALOG of Escapes, Illusions. Parlor and Stage Tricks, 6c. Hornman Magic Manufacturer, 470 8th Ave., New York.

MAGIC. Mind-reading, Amusements, Sensational Escapes, Card Tricks, Tricks, Large stock, prompt shipments. Catalog free. Magic Company, Berlin, Wisconsin.

WONDERFUL telephone mind-reading trick, only 10c. "Lonegan," 117 1/2 South 6th, Minneapolis, Minn.

TRICKS, Puzzles, Jokes, Magical Apparatus, Plays, Stage Supplies, Mind-reading Acts, Sensational Escapes, and Illusions. Free large illustrated 1917 catalog. Oaks Magical Co., Dept. 384, Oshkosh, Wis.

SEND 10c for 100 Standard Puzzles. Receive Free, 2 Card, 2 Coin, 2 Joke Tricks; Apparatus and Catalogues. Chicago Puzzle Works, 3310 Herndon St., Room 144 Chicago.

SHOW them what a wad you carry. Big bunch greenbacks 10c, 4, 25c. Hewes, 3684 Milwaukee Ave., Chicago.

GREENBACKS—(nearest imitation allowed), flashy roll, 10c. Sneezing powder, itching powder, 10c each. Trick cards and catalogues sent for 1c. Empire Company, Olneyville, Rhode Island.

SCHOOL of Magic. Join now—no trash to sell—learn magic as performed on the stage. Sample lesson, 3 tricks 10c. Kolliston School of Magic, P. O. Box 138, Cleveland, Ohio.

FUN, fun for everybody, just out, the Panama lock puzzle and cigar cutter. Cleverest novelty ever put on the market only 25c by mail. Trick jewel box, shooting matches, cigars, cigarettes, bombs, sneeze powder, itch, 200 others. Send 2c for illustrated catalogue. J. Grandefeld, 1238 Theat Ave., Bronx, New York.

ARE you ambitious? You can earn good money in vaudeville. Valuable information mailed free. London, 734 Crilly Bldg., Chicago.

PLAYS, Vaudeville Sketches, Monologues, Dialogues, Speakers, Minstrel Material, Jokes, Recitations, Tableaux, Drills, Musical Pieces, Entertainments for all occasions. Make-Up Goods. Large Catalog Free. T. S. Denison & Co., Dept. 11, Chicago.

FOR BOYS

BOYS to distribute circulars. Nothing to sell. John W. Burt, Cothoston, O.

BIG Book for Boys—The Boy Mechanic, Vol. 2—A sequel to, but containing nothing found in Vol. 1. Describes 1000 interesting things boys like to make and do. 480 pages, 95¢ illus. Cloth. \$2.00 postpaid. Send for complete description of same and also of Vol. 1 in same series. Popular Mechanics Book Dept., 6 N. Michigan Ave., Chicago.

"SLIMMY SLIVERS" Metallic Frame Kite. Big value for a dime. Thayer Mfg. Co., Dept. B, Jackson, Mich.

JUST ISSUED—Amateur Mechanics No. 8. How to make 132 different interesting things such as electric fountains, bird houses, model monoplanes, porch swing, kites of various kinds, fishing rods, camp outfit, sewerer, shocking machine, etc., 128 pages, 234 illus. Price 25 cents, postpaid. Also all preceding numbers in the series at same price. Popular Mechanics Book Dept., 6 N. Michigan Ave., Chicago.

FOR MEN

WAVECURE Hair-curling Fluid makes hair beautifully curly. Sample 15c. Send now. Wavecurl Co., St. Paul, Minn.

RAZORS AND BLADES SHARPENED

MARQUIS Razor Strop Dressing restores worn strops. Sharpens dull razors. 25 cents postpaid. Agents wanted. Marquis, 5290 North Keystone, Indianapolis.

RESHARPENED by our "New Process" 2c each. Guaranteed better than new. Each blade honed, hair-tested, sterilized, wrapped individually. Jones Keenedge, Dept. A, Jamaica Plain, Mass.

SAFETY Blades sharpened 2c each. Razors ground, honed and set 40c. Work guaranteed. Ten years in cutlery business. Maspath Grinding Co., 25 Linden St., Maspath, N. Y.

SAFETY razors sharpened; two cents each. Guaranteed. Blade box free. Electro Stropping Co., 134 Shelby St., Detroit, Mich.

FOR WOMEN

LADIES: The problem is solved! Make your own Hair-Tonics and Toilet-Waters with "Tonico Tablets," the sensational invention. Send 15c for sample package to make one pint, which otherwise costs you at least 50c. Money returned if not satisfied. Dept. M, McRoberts & Co., Urbana, Ohio.

FOR THE HOME

MOTTON Safety Window Lock, Double lock, 35c; single lock, 15c. Motton Lock Co., 591 Caesar Misch Bldg., Providence, R. I.

FURNACE Regulators open drafts at any hour. Turn on electric lights. \$5.00. Will Haynes, 2429 Independence Ave., Kansas City, Missouri.

MISSION Furniture—Make your own at little expense. Complete instructions, working drawings and stock lists for 36 different pieces. Price \$1.50 postpaid for set of three books. Send for complete descriptive matter. Popular Mechanics Book Dept., 6 N. Michigan Ave., Chicago.

HONEY

WHITE Clover Honey, 36 pound can, \$3.50; 60 pounds, \$6.60; 120 pounds, \$12.63. Satisfaction guaranteed. E. B. Rosa, 20 10th Street, Monroe, Wis.

FINEST Quality White Clover Honey, crop of 1916, thirty lb. can \$3.60, two or more cans \$3.45 each. Sample 10c. Satisfaction guaranteed. Price list free. M. V. Pacey, Preston, Minn.

PHONOGRAPHS AND RECORDS

VICTOR, Columbia, Edison Disc and Cylinder Records bought and sold. Victor and Columbia 15 cents up, Edison standard 9 cents, blue amberol 25 cents. Well attachment with jewel needle to play Edison disc records on Victorolas and Graphonola \$2.00. Send for record list. Well's Curiosity Shop, 20 S. Second St., Philadelphia, Penna.

MAKE Your Own Phonograph; I furnish all mechanical parts and instructions for \$7.85. Stewart Typewriter Exchange, Mattoon, Illinois.

COLUMBIA hornless disc talking machine and six Columbia double face ten-inch records \$12. Tone equal to any \$50 machine. Sent C. O. D. anywhere, subject to examination. Well's Curiosity Shop, 20 S. Second St., Phila., Penna.

BUILD Your Own Phonograph. Any type. Big saving. Patents expired. Profits making and selling them. We furnish parts you can't make. Full instructions, dimension drawings, illustrations, parts—price-list only 25c. Circular Free. Associated Phonograph Co., Dept. P, Cincinnati, O.

DIAMONDS, WATCHES AND JEWELRY

12-KARAT—Gold Filled—Signet Ring Free. Your Size. Your Initial. Send 10c to help pay advertising. Auction Co., Dept. 44, Attleboro, Mass.

MONTANA Sapphires in the rough direct from the Miner. Specimens 25c. Gems \$1 each. Richard Single, Phillipsburg, Montana.

PIANO AND MUSICAL INSTRUMENTS

FORTY-FOUR note automatic electric piano for sale or exchange. M. C. Elliott, Harborton, Ohio.

YOU can tune and keep your own piano or player piano in perfect condition. Van Atta's book on The Piano and Player Piano not only tells you but shows you every movement in their care, repair and tuning. 134 Pages. 51 Illustrations. Cloth. Price \$1.50 postpaid. Popular Mechanics Book Dept., 6 N. Michigan Ave., Chicago.

MUSIC

DON'T fail to get a copy of these songs: "That Little Ford of Mine" and "Meet Me When the Lights Are Gleaming Low," 10c Each. Allanson Publishing Co., 1409 Auditorium Bldg., Chicago.

"LOVELY Hawaiian Moon" song, 15c. Discontinued, return in 5 days; money refunded. F. Rempe, 2827 Myrtle St., Oakland, Calif.

WE buy worthy musical compositions. Send dime for beautiful sample song and full particulars. Popular Music Publishers, Ft. Worth, Tex.

FAVORITE Old Home Songs—No home in the land should be without this book of 200 of the familiar old songs everybody loves. Words and music complete in a substantial volume 9 1/2 x 7 inches in size. Price 50 cents postpaid. Popular Mechanics Book Dept., 6 N. Michigan Ave., Chicago.

FORMULAS AND TRADE SECRETS

1,000 FORMULAS, 25c. 75 Manufacturing Secrets, 10c. Resilvering Mirrors—Renewing Dry Batteries—Sneezing Powder—Itch Powder—20c each. Entire Collection, 50c. Satisfaction guaranteed. Big Catalog, 2c. Ideal Book Shop, 3315-P3, Belleplaine Ave., Chicago.

GUARANTEED formulas for everything. Highgrade only. Make and sell your own goods. Staff of former U. S. Government experts for analyses and consultation. United Chemical Laboratories, 13 H Street, Washington, D. C.

FORMULAS—Transparent cement and dandruff remover, 25c each. M. Blair, Barre, Vermont.

FORMULAS for two of the best face creams and hand lotions on the market. 25c each. Box 634, La Grande, Ore.

"GAS-TONIC" saves 40% gasoline. Eliminates carbon. Increases speed. Cheaply prepared. Big money-maker. Guaranteed formula, 50c. C. A. Johnson, 4319 N. Whipple St., Chicago.

500 SUCCESSFUL Money-making Formulas and Trade Secrets. Postpaid 25c. Charles Dynes, Winchester, Ind.

GAS Tonic. Valuable formula just perfected. Price \$1.00, with exclusive territory. Other money-making formulas, analyses. Usher Smith, Analytical and Consulting Chemist, St. Paul, Minn.

20,000 FORMULAS, \$1. Postpaid. Complete list 4c stamps. Edna Bromley, Water-vliet, N. Y.

3,380 FORMULAS, Trade Secrets and money-making plans in "Encyclopedia Business Opportunities," 3 volumes. Worth \$3. Special offer \$1. Ideal Book Shop, 3315-K-3, Belleplaine Ave., Chicago.

ONE thousand page book of formulas and trade-secrets of nearly every known trade, farming included. \$1. Ed Egan, 467 Ocean Ave., Jersey City, N. J.

GUARANTEED Rubber Formulas. We have compounds for any line of Rubber. Auto Tires, Tubes, Repair Stocks, Cements, Toy Balloons, Gloves, Etc. Write for our list. Rubber Compound Bureau, 31 Central Office Bldg., Akron, O.

GUNPOWDER—Made and sold by anyone. Big pay. Simple and reliable recipe. 50 cts. Cash only. Register all money. Raymond Bowman, R. P. D. 28, Box No. 23, Chesterfield, Illinois.

10,000 SELECTED scientific, chemical, technological, and practical recipes and processes, including hundreds of so-called trade secrets for every business, alphabetically arranged in one large volume of 800 pages. Price \$3 prepaid. Large descriptive circular sent upon request. Popular Mechanics Book Dept., 6 N. Michigan Ave., Chicago.

POLISHING Cloths, Rust Remover, Silver Polish, Washing Compound, Perfumes, Tube Flavors, full line of Toilet Products, etc., under your own label cheaper than you could manufacture. Pitt Laboratories, 790 Newark, New York.

EXPERIMENTERS: Many interesting and valuable experiments with Laminos. Shines in the dark; hundred uses. Formula and full instructions, 25c. Byron Long, Salem, Iowa.

A-1 FORMULA for polishing automobiles, postpaid for \$1. J. R. DeNoyelles, No. 61 Willis East, Detroit, Mich.

TYPEWRITERS AND SUPPLIES

TYPEWRITERS—Prices wrecked. All Makes. Nearly New and Rebuilt, \$5.00 up. Coronas and other portable machines, \$10.00 up. Write for catalogue. Heran Typewriter Co., 507 W. Washington St., Chicago.

STARTLING values in Typewriters. \$10 to \$15 up. Factory rebuilt. All makes. Shipped on trial. Write for our Special Offer No. 87-G. Whitehead Typewriter Co., 185 N. LaSalle St., Chicago.

TYPEWRITERS, all makes factory rebuilt by famous "Young Process." As good as new, look like new, wear like new, guaranteed like new. Our big business permits lowest cash prices. \$10 and up. Also, machines rented—or sold on time. No matter what your needs are we can best serve you. See our display advertisement on page 153. Write and see now. Young Typewriter Co., Dept. 75, Chicago.

SEND for list of Typewriter Bargains, new and rebuilt; cash, time or rent. 10 days' Free trial. American Typewriter Exchange, 14 N. Dearborn St., No. 4, Chicago.

TYPEWRITER Ribbons Re-linked, made new, 20 cts. each, \$1.50 per dozen. Messon Reinkers, 746 Monon Bldg., Chicago.

GUARANTEED Typewriter Ribbons \$1 for \$1.00, any color, any machine. Non-Smear Carbon Paper, any size, any color. Featherweight or Standard. \$1.00 per box. Arme Co., 448 S. Dearborn, Chicago.

TYPEWRITERS \$10 up. Guaranteed. Write for cash price list. E. Bassett Typewriter Co., Chicago.

LARGEST Stock of Typewriters in America. Underwoods, one-fourth to one-half manufacturer's price; rented anywhere, applying rent on purchase price. Free trial. Installment payments if desired. Write for catalogue 70. Typewriter Emporium, estab. 1892, 34-36 W. Lake St., Chicago, Illinois.

DUPLICATORS AND DEVICES

"MODERN" Duplicator—A Business Getter. Saves money, time, trouble. No glue or retatin. Always ready. Easy to operate. 25,000 firms use it. 50 to 75 copies from pen, pencil, typewriter. Letter size complete. \$4.50. Satisfaction or money back. You need one. Write for free booklet now! J. E. Durkin & Reeves Company, Pittsburgh, Pa.

MAILING LISTS

MAILING List Dealers, Attention. What's the use of getting up mailing lists if you can't sell them? I've got a list of 1,000 prospective buyers, all classifications. Write for special price. Box 52-E, Mansfield, Ohio.

1,000 LIVE Agents \$2.50. Also other lists, any classification. Modern Name Supply, Milwaukee, Wis.

TRY our mailing for results. Huggard Mailing Service, Goldfield, Nevada.

1,000 PROSPEROUS Buyers or Agents' names postpaid \$1.50. Liebau, Drawer 585, Erie, Pa.

FOR Sale, list of 700 Automobile owners of Calhoun County, Alabama, with correct addresses. Price \$2.50. P. O. Box 508, Anniston, Ala.

NAMES and addresses of 200,000 Iowa Farmers. Write for prices. I. C. Scott, Bloomfield, Iowa.

LISTS—Auto Owners, Farmers, Housewives, Addressing. Circular Letters. Address 1733 Davenport, Iowa.

NAMES, 1,000 Mail Order Beginners \$1.00, 500 Agents \$1.00, Farmers 50c 1,000. Other Classifications. Miller, 1952b Germantown Ave., Philadelphia.

SELL. Big Buyers First. Get our up-to-date lists, any classification. State your wants. Get our price. Efficient Sales Letter Campaigns Written, List Dept., Box 593, Atlanta, Ga.

PRINTING, ENGRAVING AND MULTIGRAPHING

QUALITY Printing Prepaid, 500 either envelopes, noteheads, cards, statements, \$1.35; 1,000, \$2.25; 1,000 envelope slips, \$1.25; 1,000 6x9 circulars, \$1.85; 500 linen-finish letterheads or envelopes, \$2.25; 1,000, \$3.50. Prepaid. Typewriter letters, Stamp brings samples. Model Company, Manchester, Iowa.

QUALITY Printing Prepaid, 500 either envelopes, noteheads, cards, billheads or statements, \$1.35; 1,000, \$2.25; 100, 50c. Prompt service. Fine Stock. Samples Free. Henn Photo & Printing Co., 810 Hickory St., St. Louis.

PRINTING Press and outfit for sale; cost \$75; cheap, or will exchange. Make offers. Tompkins, Mt. Sterling, Illinois.

GOOD Printing at low prices. 1,000 good letterheads, envelopes, cards, billheads, labels, circulars, \$2.50. Samples free. Catalogues, booklets and circulars our specialty. Ernest L. Fantus Co., 525 S. Dearborn St., Chicago.

PERFECTION Letter Company, Muncie, Indiana, Multigraphs 500 purple letters with black letter heads, \$2.15. Samples for stamp.

1,000 6x9 CIRCULARS, good white paper, \$1.15; 1,000 fine colored slips, 90c; both shipped prepaid; other printing in proportion. Samples free. Lee Mountain, Chavies, Ala.

LABEL Catalog "A" free. Irvin Wolf, 3126 Jasper Street, Philadelphia.

250 TWO-COLOR Letterheads \$1. Samples and Price-List for Stamp. Rizzo, 344 Michigan, Detroit, Mich.

250 ENVELOPES or Letterheads \$1.25. Moyer Supply House, Milton, Pa.

GOOD Printing, low prices, 1000 good letterheads, envelopes, cards, bill heads, statements, \$2.00 per 1000. Imitation Typewritten Letters \$2.00 per 1000. Acme Co., 440 S. Dearborn, Chicago.

PRINTED Gummed Labels our specialty. S. Wetzell, Box 161-A, Madison Square, New York City.

CATALOG 192 free, illustrating Labels and Advertising Stickers. Three thousand 75c upwards, direct from manufacturer. Royal Label Company, 408 Cherry Street, Philadelphia, Pa.

50 CLASSY Calling Cards and patented card case, 25c. Extra grade, Linen, 35c. Samples, Better, 304 Fourth, Tippencanoe City, Ohio.

200 WHITE Bond Letterheads, printed \$1.00. W. Kinnear, Box 236, Brooklyn.

500 LINEN Finish Letterheads \$1.75; printed 2 colors, \$2.50 prepaid. Samples, Sharp Printing Co., Hamilton, Ohio.

POSTPAID—500 Chessmakers' statements \$1.65. National Opportunity, Stratford, Wis.

1,000 16-PAGE 3 1/2x6 colored booklets printed, \$15.00. Miller, 1952b Germantown Ave., Philadelphia.

ACT Quick! 1,000 Cards and Card Case, \$1.40 prepaid! Agents! Big com. Howard Trimmell, Newfield, N. J.

PRE-USED Printing Presses, Type, Supplies; good material, lowest prices. List for stamp. Popular Bargains, Richland, Pa.

"THE House of Quality" will print your envelopes for \$2.35 per 1,000. House of Quality, Bancroft, Iowa.

GUMMED Labels. Get our new special circular, free. Catalog 2c. Business Courtesy Seals, 50 samples for 10 cents. Helmers Company, Hoboken, N. J.

LITHOGRAPH letter heads 1,000 \$4.50. State your business and let us submit samples. We make rubber stamps to order. Nesco, Zion City, Ill.

1,000 3x6 CIRCULARS \$1.00; 5,000 for \$4.00; printed both sides 1,000 for \$1.50; 5,000 for \$6.50. Prepaid. 500 white bond letterheads \$1.50, prepaid. Burton Brothers, Louisville, Ky.

GUMMED Labels, 3000 6x9, 50pp, catalogue, 2cts. MacTaggart, 13th Arch, Philadelphia, Pennsylvania.

3000 GUMMED stickers \$1.00. 100 letterheads and 100 envelopes, \$1.00, Walden Press, Boston, Mass.

100 ENVELOPES printed, 50c postpaid. Samples. Lincoln Novelty Co., Rochester, N. Y.

CIRCULARS—1,000, 3x6, 90c; 4 1/2x6, \$1.15; 6x9, \$1.75. Chas. Walter, Lancaster, Ohio.

PRINTING Outfits—Presses, type, supplies, type novelties. Send stamp for catalogue. Model Press, York, Penna.

PATENT ATTORNEYS

DON'T lose your rights to patent protection. Before proceeding further send for our blank form Evidence of Conception to be signed and witnessed. Book, suggestions and advice free. Lancaster & Alwine, 221 Ouray Bldg., Washington, D. C.

PATENTS obtained through D. Swift being promptly sold to manufacturers. Write today for free books of "Inventions Needed" and surpassing references. D. Swift, 317 Seventh St., Washington, D. C.

PATENTS Bring Riches; Protect Your Invention. Attorney's fee payable when patent allowed. Plain advice and "Patent Facts" free. Trade-marks registered. Jaynes & Jaynes, 653 Kellogg, Washington, D. C.

ATTENTION—Patents. You will like my easy Plan. Write for free booklet. C. L. Drew, 4 Victor Bldg., Wash., D. C.

PROTECT your invention. Honest advice. Personal service. Write for "The Truth About Patents." J. H. Kelly, 740A Woodward Bldg., Washington, D. C.

PATENTS procured on square deal fee plan with real service. We help sell the patent. Free booklet and advice. Milo B. Stevens & Co., 685 F St., Washington; 353 Monadnock Bldg., Chicago. Est. 1861.

PATENTS on Easy Payments. Send sketch for free opinion as to patentability. Write to-day for our new book on what to invent and how to protect your invention under our new easy payment plan. C. C. Hines & Co., 501-A, W. L. & T. Bldg., Washington, D. C.

PATENTS—Send Sketch. Free Search and Certificate of Patentability. Free Book, "How to Obtain a Patent and What to Invent." Patents secured through Credit System. Talbert & Parker, Patent Lawyers, 4623 Warder Bldg., Washington, D. C.

PATENTS secured or all fees returned. Do not miss the generous offers in E. E. Vrooman & Company's display ad on page 147.

PATENTS secured and sold. Our office being in the largest manufacturing district enables us to deal directly with purchasers. Free book. Williamson & Williamson, 1325 Arch St., Phila., Pa.

HIGH-VALUE Patents. See R. S. & A. B. Lacey's advertisement on page 152.

PATENTS: Send model, sketch or drawing. Advice, 100 Mechanical Movements and 50 Perpetual Motions, Free. Fred G. Dieterich & Co., 61 Ouray Bldg., Washington, D. C.

C. L. PARKER, Ex-member Examining Corps, Patent Office, Patent Attorney, McGill Bldg., Washington, D. C. Inventor's handbook, "Protecting, Exploiting and Selling Inventions," sent free upon request.

H. L. WOODWARD—Safe methods. Paying patents. Write today. 502 G St., Washington, D. C.

PROTECTIVE patents procured promptly, 104-page blue book on patents sent on request. Trade-marks registered. Robb & Robb, 211-215 Southern Bldg., Washington, D. C.

PATENTS that protect and pay. Advice and books free. Rates reasonable—highest references; best results. Watson E. Coleman, Patent Lawyer, 624 F St., N. W., Washington, D. C.

PATENTS—Herbert Jenner, patent attorney and mechanical expert, 606 F St., Washington, D. C. I report free of charge if a patent can be had and its exact cost. Send for circular.

PATENTABLE Ideas Wanted—Send for 3 free books. R. B. Owen, 30 Owen Bldg., Wash., D. C.

THE Patentome is free. An education in obtaining patents. Established 1865, Anderson & Son, Attorneys, 707 7th St., Washington, D. C.

PATENTS Wanted. Write for list of Patent Buyers who wish to purchase patents and what to invent with List of Inventions Wanted. \$1,000,000 in prizes offered for inventions. Send Sketch for free opinion as to patentability. Write for our four Guide books sent free upon request. Patents advertised Free. We assist inventors to sell their inventions. Victor J. Evans & Co., 166 Ninth, Washington, D. C.

"PATENTS and Patent Possibilities" is a 72-page treatise which tells all about patents, what to invent and where to sell it. It gives honest advice to inventors and tells about the successes of some of my clients, also explaining what are frequent causes of failure. Manufacturers are constantly writing for protective patents upon all kinds of sound inventions. Can you help supply their wants? The book is free. Write for it today. H. S. Hill, 905 McLachlen Building, Washington, D. C.

PATENTS without advance attorney's fees. Send sketch for free report. Books free. Frank Fuller, Washington, D. C.

KEEP up with progress. Promote your patent. Send \$1.00 for year's subscription to best inventor's magazine, "Invention and Manufacturing." United States Patent Corporation, Washington, D. C.

PATENTS Secured or Fee Returned. Actual search free. Send sketch or model. 1917 Edition, 99-page patent book free. My patent sales service gets full value for my clients. It should never require more than two days to report upon the patentability of your invention; nor longer than ten days to prepare your application for filing. Longer delay amounts to gross neglect and the jeopardizing of your rights. For prompt personal service write: George P. Kimmel, 212 Barrister Building, Washington, D. C.

PATENTS—Send sketch for free search and report. Books on patents and book of reference letters sent free. John S. Duffie & Co., 610 F St., Washington, D. C.

PATENT Your Ideas—\$9,000 offered for certain inventions. Books, "How to Obtain a Patent," and "What to Invent," sent free. Send rough sketch for free report as to patentability. Manufacturers constantly writing us for patents we have obtained. We advertise your patent for sale at our expense. Established 20 years. Address Chandler & Chandler, patent attorneys, 1690 F. St., Washington, D. C.

INVENTORS: Write our Patent Dept. Adam Fisher Mfg. Co., 2961C Railway Exchange, St. Louis, Mo.

INVENTIONS developed; see ad under classification "Models and Model Supplies." The Wm. Gent Machine Co.

INVENTORS Attention—Get particulars of my system before applying for patent through others. It saves you money, and keeps you in touch with, and in control of, your case at all times. W. N. Roach, Jr., 950 McGill Bldg., Washington, D. C.

PATENT what you invent. It may be valuable. Write me. No attorney's fee until patent is allowed. Estab. 1882. "Inventor's Guide" Free. Franklin H. Hough, 522 Loan & Trust Bldg., Washington, D. C.

FOR INVENTORS

INVENTIONS developed. Models, Tools, Dies, Special Machinery. Send sketch. I do work promptly. Carl C. Gerlach, 3906 Woodbine, Cleveland, O.

PATENTS—Wanted to manufacture on royalty simple automobile accessories—Ford specialties preferred. Address P. O. Box 548, Phila., Pa.

INVENTORS—We specialize in manufacturing new patented articles—make models—dies—and do experimental work. Leo J. Gerding Mfg. Co., Dept. D, Opera Place, Cincinnati, O.

INVENTIONS developed; see ad under classification "Models and Model Supplies." The Wm. Gent Machine Co.

HAVE You An Idea? If so, you should protect it by a patent. Send us a model or sketch for free opinion as to patentability. Write for our Four Books sent free to any address. Victor J. Evans & Co., 157 Ninth St., Washington, D. C.

INVENTIONS—How to protect, sell and buy them. If you are inventive, read this book, 108 pages, 25c, postpaid. Popular Mechanics Book Dept., 6 N. Michigan Ave., Chicago.

HIGH-VALUE Patents. See R. S. & A. B. Lacey's advertisement on page 152.

INVENTIONS Developed—Real co-operation given you in handling all experimental work. Any mechanical device—no matter how intricate—developed and finished. Complete models built. Write us about your needs. Spies Special Machine Works, 692 Goodland Building, Chicago.

WANTED—An Idea! Who can think of some simple thing to patent? Protect your ideas; they may bring you wealth. Write for "Needled Inventions" and "How to Get Your Patent and Your Money." Randolph & Co., Patent Attorneys, 425 F. St., Washington, D. C.

MODEL and Experimental Work of every description. Tools, patterns and special or automatic machinery designed and built. Intricate mechanical and electrical devices perfected, simplified and manufactured. Expert advice. Commercial models our specialty. Acme Apparatus Co., 102 N. Fifth Ave., Chicago, Ill.

INVENTIONS—Patenting and Promoting. A book containing practical advice and directions for inventors and manufacturers. Book, suggestions and advice free. Lancaster & Alwine, 221 Quay Bldg., Washington, D. C.

Will trade Canadian patent ("Post Hole Diggers") for U. S. patent. Re-fused \$2,400 before war. What have you? Hugh McIntyre, 784 Worthington Street, Springfield, Mass.

PATENTS Wanted. Inventors write for Free Booklet. Tells how to get the cash value of your invention. F. E. Wooten, Sta. F., Philadelphia, Pa.

PATENTS secured or all fees returned. Do not miss the generous offers in E. E. Vrooman & Company's display ad on page 147.

PATENTS on easy payments. Send sketch for free opinion as to patentability. Write to-day for our new book on what to invent and how to protect your invention under our new easy payment plan. C. C. Hines & Co., 391-A, W. L. & T. Bldg., Washington, D. C.

INVENTIONS commercialized on cash and royalty basis. Patents secured. Models, experimental work and contract manufacturing. Inventors should write at once. Adam Fisher Mfg. Co., 2061A Railway Exchange, St. Louis, Mo.

CASH for ideas. List of needed inventions and book on Patents free. Sanders, 7 Webster Bldg., Chicago.

PATENTABLE Ideas Wanted—Send for 5 free books. H. B. Owen, 39 Owen Bldg., Washington, D. C.

PATENTS, Trade-Marks and Copyrights. Our handbook on patents will be sent free on request. All patents secured through us are described without cost to the patentee in the Scientific American. Mann & Co., Patent Attorneys, 672 Woolworth Bldg., N. Y. Washington, D. C., office, 425 F. St.

NO Attorney fees until patent allowed. Send sketch for free report. Books free. Frank Fuller, Washington, D. C.

HAVE you a Patent to sell? You'll be interested in my proposition. Write now for free particulars. Don't call. F. W. Johnson, 6 N. Michigan Ave., Chicago.

PATENTS FOR SALE

SELL or Exchange, household article. Costs 5c, sell for 50c. Big money-maker for anyone who will market same. H. Paulson, 302 8th Ave., La Grange, Ill.

WANTED: by owner of patent on new practical device needed in every kitchen, small financial aid in order to manufacture and market same. Partner considered. Field unlimited. Profits big. If you mean business write for particulars to Box A73, Porter, Minn.

WANTED: A backer, help finance big proposition. Already sold six hundred dollars worth gates. Orders for more. Proof given. Can sell State rights. F. Bacho, Alexandria, La.

FOR Sale or royalty. Much needed Lawn Trimmer. Patent 1169802. Fred J. Butler, Enid, Okla.

CURTAIN and Shade Lifter. Needed household device of merit. Laura Myers, Pen Mar, Pa.

FOR Sale. Patent #38583. Engine. 8 cylinder Vertical or 16 cylinder V on 4 Throw Crankshaft, 12 or 24 Cylinders on 6 Throw. Borden, Clifton St., El Paso.

AUTOMATIC shears, just patented, great money-maker, used all over the world. J. Schütz, 421 S. Homan Ave., Chicago, Ill.

WANTED—Partner for good inventions. Write, Orson Kirkpatrick, North English, Ia.

WE have some money-making inventions for placing on royalty; outright sale or trade. Write Adam Fisher Mfg. Co., 2061B Railway Exchange, St. Louis, Mo.

PATENT pending. Folding Faucet. Prevents breakage and obstruction. Supply of water cut off instantly. Joseph A. Noll, 222 M St., Sacramento, Cal.

FOR Sale, 4 Valuable Patents. "Cord Tire," just allowed. "Automatic Machine" for making same. "Rubber Heel and Sole." "Mechanical Process" for reclaiming rubber. Rubber Compound Bureau, 34 Central Office Bldg., Akron, Ohio.

FOR Sale—outright or royalty—Carrot crumbs, breakfast cereal. Mrs. Louise Compagno, 1719 Oak, San Francisco, Calif.

FOR Sale—Several inventions; not yet patented. Smith, Belle Valley, Ohio.

MECHANICAL Toy—Advertising Novelty. A. L. Teeters, Wynne, Ark.

PATENTED invention, absolutely new; nothing like it on the market. Will be used daily by everybody, everywhere. Fills a long-felt want. 10-cent article. Address Owner, S. P., Room 929, 78 E. Madison St., Chicago.

U. S. PATENT for sale—Conical Fruit Stand, made of wire. Holds about 1½ box oranges, etc. \$3.00 each. E. L. Behring, Wykoff, Minn.

NUTLESS Cycle Spindle for vehicles; absolutely dust proof. Oil unable to escape; for sale or royalty preferred. Lorena Felber, 2700 Chartres St., New Orleans, La.

SPLENDID patented Mail Order novelty for sale with over \$100 worth Tools, Dies, etc. Great Opportunity. Smith, 112 Smith Street, Millville, N. J.

PATENT No. 1,172,935 picks potato bugs while you cultivate crop. Cash or royalty. 3214 Mishawaka Avenue, South Bend, Ind.

AUTOMATIC Stock Watering device. Operates by weight of animal on platform, prevents freezing. H. C. Milten, 3029 Ezekiel, Zion City, Ill.

NOVEL device for roof repairs. Simple swinging crane ladder attachment, whereby shingles, roofing felt, or staging, can be hoisted to the roof. Fits any ladder. U. S. Pat. 1,966,892, 1,115,420. J. Farnham, Rockland, Me.

SIMPLE device whereby suitcase is carried with ease. Cash or Royalty. Eula Dunn, 61 Jefferson Ave., Brooklyn, N. Y.

FOR Sale. Patent 1,206,020. Shock-Absorbing leg for Ambulance and army stretchers. Dr. Charles Moses, 815 S. 5th St., Phila.

FOR Sale, good Canadian and U. S. patents on new and novel extension table. Write, L. M. Dunn, R. R. 1, Box 88, Camas, Washington.

AUTO driver's constant heel rest, all positions of clutch pedal, no gears or springs. Will sell. Slatter, 1638 Prairie Ave., Chicago.

FOR Sale—Design Patent No. 49,496, has a Horseshoe forming as Frame around the national colors, with Eagle in center; this is especially designed for making up Jewelry. Send for drawing and see to appreciate its value. Best offer received before May 1, 1917, buys it. Address Andrew C. Moholt, 363 North St., Kenosha, Wis.

U. S. & Canadian Patents on Loe & Robe Rail for Automobiles for sale reasonable. A money maker for right party. Will fill a long felt want. D. C. Russell, 207 Laughlin St., The Dalles, Ore.

RED Cross Sanitary Vacuum Cleaner Sweeper, cheap \$400. Foot power. Sold on royalty. Lahanas, Fort Adams, R. I.

PATENTS and inventions for sale or on royalty. My clients have valuable inventions for market. No better investment for manufacturers or individuals. Full information without charge. Mention line of invention interesting you and data will be sent. Richard B. Owen, Patent Lawyer, Owen Building, Washington, D. C.

USEFUL Metal Novelty. Big possibilities. H. Ritterbusch, Hudson St., Baltimore, Md.

PATENTS for Sale. Adjustable Screen Fastener. Splendid hardware novelty. Good article for Mail Order or Agents. Patent No. 1,206,616. Address Talbert & Parker, Patent Lawyers, 12061 Warder Bldg., Washington, D. C.

FOR Sale. Patent on airbrake and self-starter combined, for automobiles, just allowed. Paul S. Graham, P. O. Box 112, Winters, Tex.

DOOR Holder Patent of merit, 953,662. Outright. Best offer takes it. A. G. Hanson, R1, B71, Willmar, Minn.

THERE has long been needed a good hemmer for sewing machine; here is one patented July 11, 1916. Miss O. M. Cartwright, 255 W. 13th Street, New York, N. Y.

FOR sale on Royalty. Tumbler washer for Soda fountains, Buffets, restaurants, hotels. G. H. B., 762 W. Walnut St., Hastings, Mich.

FOR Sale—U. S. Patent on internal combustion engine. Combines advantages of the 4-stroke cycle motor with those of the two-stroke cycle. Would trade for interest in machine shop. Address E. J. Wagner, 102 N. Alcaniz St., Pensacola, Fla.

SIMPLY constructed, three tools in one Wrench, effective in operation. 35 Purnell Place, South Manchester, Connecticut.

PATENTS on Easy Payments. See our advertisement under Patent Attorneys. C. C. Hines & Co.

FOR Sale—Cotton Pickers' Knee Pad. G. F. Eschenfelder, Sandusky, Ohio.

DETACHABLE radiator footrest, costs 15 cents. Waudlich, 944 Oakland, Detroit, Mich.

TYPEWRITER. Illustrated page 216, February issue. Omer Highley, Converse, Ind.

PATENT Rights for Sale—A machine has been devised and recently patented to cut and stone peaches and apricots, removes husks from almonds, prepares pears for drying, etc. Address Karl G. Mollitzner, Anderson, Cal., or Thos. A. Marlowe, Blufford, Ill.

SELF-WRINGING Mop; practical, inexpensively manufactured. Outright or royalty. J. L. Williams, Lock Box 64, DuPont, Wash.

FOR Sale—Cash or Royalty—U. S. Patent No. 1,207,486 for perfected wire clothes pin. Splendid mail order or Agent's novelty. Talbert & Parker, 13113 Warder Building, Washington, D. C.

NEW patent for sale; Medicine cabinet for sick rooms and hospitals. Joseph Amato, Ossining, N. Y.

PATENT Rights Folding Fruit Stand (Patent pending). Good manufacturing proposition. Herschel L. Yost, 518½ 5th Ave., McKeesport, Pa.

STRAW Dispenser for Soda Fountains. Patent No. 1,102,297. Absolutely sanitary, neat, easy to operate. Delivers just one straw at a time; positively prevents waste. Good advertising device. H. M. Reid, Box 563, Colorado Springs, Colorado.

IMPROVED Trolley pole and Trolley guard. Positively will not come off wire. Full particulars free. Thomas Santore, Box 53, Mt. Braddock, Pa.

2 AWNING patents with materials. Nugent, 435 West 20th St., New York City.

PATENT Buyers are invited to address our sales department for information on any class of Patents they wish to purchase or lease on a royalty. We have secured a number of valuable patents in all lines of invention. Mail Order, Department Store and Household Novelties a specialty. Victor J. Evans & Co., 160 Ninth St., Washington, D. C.

MODELS AND MODEL SUPPLIES

PRODUCERS of Results: Inventions developed, Models, Experimental work, anything special in metal to order, novelties, spinning, forging, castings in any material, electrical devices, patterns of all kinds, plating, general manufacturing, designing, special tools, punches and dies, stampings. Send drawing or sample. Expert information free. The John's Machine & Stamping Works Company, Dept. C, Cleveland, Ohio.

SEE my advertisement under "Manufacturing." Don't fail to write me. It will pay you. R. G. Clyne, Columbia Bldg., St. Louis, Mo.

HARD rubber articles developed and manufactured. Rubber, glass or metal models quickly and cheaply made. Swanberg, 1459 Melrose St., Chicago.

PERFECT models sell inventions. We make them. Write Adam Fisher Mfg. Co., 2061E Railway Exchange, St. Louis, Mo.

NEW Lithographic Model of a Monster Mallet Compound Locomotive. All parts shown and numbered. Size, 9x15 in, in colors. Other models in series are, Atlantic Type Locomotive—Steamship—Gas Engine—Steam Engine—Steam Turbine—Dynamo—Wireless Telegraph. Price, 50c each or set of 8 for \$3.50, postpaid. Popular Mechanics Book Dept., 6 N. Michigan Ave., Chicago.

INVENTIONS developed. The specialists who develop Auto accessories, gasoline engines, electrical appliances, electric signs, repeating rifles, automatic cigarette-making machines, weighing, vending, photograph, moving picture and lead pencil printing machines; turbines, air, electric and steam motors and other intricate devices are at your service. They'll handle your development, drawings, experimental work, patterns, models, special tools, dies stampings, castings, plating, forging and spinning in our big plant—covers two acres. Make any metal novelty. Complete organization for developing and manufacturing. Advice backed by 30 years' experience free. Send drawings or samples. The Wm. Gent Machine Co., Cleveland, Ohio.

WANTED—New Ideas. Write for list of Patent Buyers and Inventions Wanted. \$1,000,000 in prizes offered for inventions. Our Four Books sent free upon request. Victor J. Evans & Co., 165 Ninth, Washington, D. C.

WE make working models for inventors; also dies and stamping of specialties, and carry a complete stock of brass gears and model supplies. Send for catalogue. The Pierce Model Works, 3405 Pierce Ave., Chicago, Ill.

MANUFACTURING

AUTOMOBILE Accessories. Metal Specialties, electrical and mechanical devices. Will manufacture on contract or royalty; accurate die, tool, screw machine, brass finishing, drill and punch press work. Berkmann Mfg. Co., 625 W. Jackson Blvd., Chicago.

LET us build your machine. Send model or drawing and let us quote you price. Hemdill Iron Works Co., Inc., Hemdill, Minn.

INVENTORS and Manufacturers: I design and build special machinery, tools, models, patterns, make drawings, tracings and blue prints. Efficient Engineering Laboratory—Modern Shop—Expert Workmen. No job too large or too small. R. G. Cline, Columbia Bldg., St. Louis, Mo.

WE Manufacture Specialties. Send us your blue prints or models. We can redesign your ideas—make them commercial. Produce a profit by low cost production. Page Engineering Co., Baltimore, Md.

INVENTIONS manufactured under contract. Write Adam Fisher Mfg. Co., 2061F Railway Exchange, St. Louis, Mo.

INVENTIONS developed; see ad under classification "Models and Model Supplies." The Wm. Gent Machine Co.

WIRE Goods, all kinds, made to order. Cooley Mfg. Co., 553 W. Monroe St., Chicago.

REAL ESTATE AND FARM LANDS

CALIFORNIA land \$1 per acre cash. Balance purchase 90c month per acre. Immediate possession given. No taxes. No interest. Level San Joaquin Valley. Only four hours from San Francisco, 5 acres up. Clear; ready to plow; open ditch irrigation \$1 acre per annum. Particulars, maps, photographs, free. Stevenson Colony, Desk D, 785 Market St., San Francisco.

IT'S Different—New Port Richey (Pasco county) surpasses anything in Florida: on Gulf Coast and navigable river; unexcelled boating, fishing and hunting; tropical scenery; ideal climatic and health conditions; high rolling pine and hammock lands; ideal for citrus fruits, vegetables, general farming; good roads, schools, local market; on Dixie Highway, within two hours' ride of Tampa and St. Petersburg; fastest growing town in State—and prices have not yet gone sky high. Send for booklet. Board of Trade, Box 101, New Port Richey, Florida.

SELL your property quickly for cash, no matter where located. Don't pay big commissions. Particulars free. Real Estate Salesman Co., Desk B, Lincoln, Neb.

FOR cheap farms or land for investment, in Michigan, write Fell, 414 Warren Ave., Big Rapids, Mich.

FORTY Acres, clay loam farm, will grow any Mich. crop. Cabin house, barn, well, 3 acres cleared. Double your money in three years; \$1,600, terms. I have other farms. Grant Reynolds, Gladwin, Mich.

PROFITABLE Little Farms in Valley of Virginia, 5 and 10 acre tracts \$250 and up. Good fruit and farming country. Send for literature now. F. H. LaBaume, Agr. Agt. N. & W. Ry., 250 Arcade Bldg., Roanoke, Va.

SILVER Lake Estates, the most beautiful spot in all Florida, offers carefully restricted lake frontage residences, citrus groves, golf links, bathing, fishing and hunting. Two trunk line railroads, Dixie Highway and fine local roads. A high class, exclusive Florida home at moderate cost, combined with exceptionally profitable investment. Box 1011, Leesburg, Florida.

FOR Sale—10, 20 and 40-acre farms at Los Indios in the Isle of Pines, just off Florida Coast. Two crops a year. Soil and climate specially suited for growing big-profit fruits, such as grapefruit, avocados, etc. Delightful outdoor climate all the year around. 99% of land owned by Americans. Shipping rates low, market quickly reached, only deep water harbor at Los Indios accommodates ocean liners. Attractive terms, titles guaranteed. For further information address E. G. Allen, Room 73, 117 Wisconsin St., Milwaukee, Wis.

FOR Sale, 2,640 acres hill land near Hattiesburg, Miss., at \$3.25 per acre. J. A. Hodge, Jackson, Miss.

A SMALL farm in California will make you more money with less work. You will live longer and better. Delightful climate, rich soil, hospitable neighbors. Good roads, schools and churches. Write for our San Joaquin Valley illustrated folders free. C. L. Seagraves, Industrial Commissioner, AT&SF Bldg., 1833 Ry. Exch., Chicago.

160 ACRES for sale or exchange. Rent for \$300. Well improved stock and grain farm. Owner, John Deer, Neodesha, Kan.

SUBURBAN five acres for sale. Improved. A. J. Dunning, 1101 Jay St., Fresno, California.

NO Farms for Sale. We give personal advice on farms in Wisconsin, Minnesota, Iowa, Montana and the Dakotas. Write Wisconsin Real Estate, Whitewater, Wis.

167 ACRES, 6-room house, large barn and other new improvements. Near high school, state road, unlimited bunch-grass range. Finest soil, climate and big crops of clover, alfalfa, grains and vegetables without irrigation, in Summit Valley. Sacrifice price \$1,800. Box 48-b, Route 2, Adley, Washington.

REAL Estate Educator—Containing inside information not generally known. "Don't's" in Real Estate. "Pointers," Legal Forms, etc. It gives in condensed form the essential knowledge of the Real Estate Business. New revised edition covers Workmen's Compensation Act, Income Tax Law, Employers' Liability Act, Statute of Frauds, How to Sell Real Estate, etc. What you need to know, sought to know and want to know. 256 pages, cloth, \$1 postpaid. Popular Mechanics Book Dept., 6 N. Michigan Ave., Chicago.

ELEPHANT Butte Dam, Rio Grande Valley. World's greatest irrigation enterprise. Watering Dona-Ana farms. Now ready for settlers. Practical, real co-operation protecting homeseekers. Write for circular Number 7. Dona-Ana Farms Alliance, El Paso, Texas.

BEAUTIFUL Seashore Homesites only \$20. Special sale lots at Alamo Beach, Texas, famous Bayshore resort. First 100 lots \$20. Terms \$1 cash, \$1 monthly. Lots 50x110 feet. Splendid investment. Write for free literature and views. Alamo Beach Company, 422 First National Bank, Houston, Texas.

MICHIGAN Lots \$10; Huron and inland lake; high and dry; finest summer region; deed, perfect title, abstract. Charles Engelhard, 232-78 Washington Avenue, Detroit.

ENLARGED Homesteads. Valuable information. Booklet dime. Joseph Clark, Sacramento, California.

BUY your cottage site now on Gull Lake, heart of Minnesota scenic resort region. \$79,000 to be spent 1917. Send for booklet and plat of Gull Lake Park and Grand View Lodge. Baker-Sexton Co., Minneapolis, Minn.

ARE you weary of the north?—Then come to Fruitland Park, Florida, a vicinity ideal for a home and for grapefruit and orange growing with big profits, where you can develop a grove with practically no expense and where the first crop you raise should pay for your land. For book of actual photographs and conservative data write today. Lake Co. Land Owners' Association, No. 10 Mack St., Fruitland Park, Florida.

MONEY-MAKING Farms, 15 states, \$10 to \$50 an acre; stock, tools and crops often included to settle quickly. Write for Big Illustrated Catalogue. E. A. Strout Farm Agency, Dept. 3043, New York.

LANDODOLOGY, a magazine giving the facts in regard to the land situation. Three months' subscription, free. If for a home or as an investment you are thinking of buying good farm lands, simply write me a letter and say, "Mail me Landology and all particulars free." Address Editor, Landology, Skidmore Land Co., 40 Skidmore Bldg., Marinette, Wis.

LANDS—Northern Realty Company, Duluth, Minnesota, dealers in Northern Minnesota lands, timber; also iron lands.

FREE Government Lands—Our official 112 page book "Vacant Government Lands" lists and describes every acre in every county in U. S. Tells location, place to apply, how secured free. 1916 diagrams and tables, new laws, lists, etc. Price 25 cents postpaid. Webb Publishing Co., Dept. 71, St. Paul, Minn.

CALIFORNIA little farms near Los Angeles for sale, easy payments. Write E. H. Waite, Shawnee, Oklahoma.

I HAVE a successful way of selling farms and farm lands. Write me for free particulars. No obligation whatever. Don't call. E. J. Zimmer, 925 Tower Bldg., Chicago.

GINSENG

OUR Book describes 200 valuable roots and herbs used in medicine. How to gather, prepare and sell. Address of buyers and War prices. Prepaid for only 25c. Herb Company, West Milan, N. H.

DOGS, BIRDS, POULTRY AND PETS

EGG-O-HATCH applied to eggs during incubation strengthens the chick and weakens the shell. It supplies free oxygen, absorbs the carbon dioxide and rots the shell. Makes better hatches of stronger chicks. Booklet free. Sample, treats 100 eggs, 10 cents. Package, treats 600 eggs, 50 cents, postpaid. Geo. H. Lee Co., 506 Lee Bldg., Omaha, Neb.

FOR Sale—Blue-blooded registered Airedales. All ages. W. Bebee, 4290 6th Ave., Des Moines, Ia.

AUSTRALIAN Leghorn—Real world's champions. 1,675 eggs; average 279. Direct importation. White Ranch, South Haven, Mich.

THOROUGHBRED English Bull Terrier Pups, 4 months old, at \$10.00 to \$35.00 each. Pere Bunker, North Manchester, Ind.

RAISE Guinea Pigs for us. We buy all you raise. Pay better than poultry. Contract, particulars, booklet how to raise free. Carver Distributing Co., 707 W. 74th St., Kansas City, Mo.

BEAUTIFUL white Pomeranian pups for sale. J. P. Hughes, Delta, Mo.

BIG Money in Pigeons and Squabs. Free book tells you all about it. Write today. Start profitable business of your own. Demand unlimited. Investment is small. Write today for Free Book. Indiana Squab Co., Dept. 110C, Terre Haute, Ind.

RAISE skunks in city or country. Odorless method. Illustrated circular P free. Skunk Development Bureau, Chicago.

SQUABS are raised in one month, they sell for fancy prices. Write at once for big free book telling how to make money breeding squabs. Plymouth Rock Squab Co., 634 Howard St., Melrose Highlands, Massachusetts.

LEADING varieties Poultry. Eggs for hatching, stock for sale, prices reasonable. Catalogue free. H. P. Roth, Souderton, Pa.

RAISE Belgian Hares for Us. Big profits. We furnish stock and pay you \$2.00 each. Also Carvers, mink, skunk, fox, squabs, frogs, etc. Two booklets and contract for dime. None free. Address the Belgian Hare, 31 Main Street, Holmes Park, Mo.

COLLIES—Stock, farm and watch dogs. Pedigreed; circular free. Nighorn Kennels, St. Peter, Minn.

PERSONAL

WM. FALCONER—Billie, why did you leave me as you did? Have you trouble? If so let me help you. Come home and rest up, and then we will move to any place you want to go. All your things and books are here. Please do let me hear from you at least. As ever, F.

BROTHER—Discovered root cures tobacco habit. Gladly send particulars. F. Stokes, Mohawk, Florida.

STOP Using Tobacco. Complete treatment \$1. Squirly Bros., Des Moines, Iowa.

GOLD Seal No. 10 kills the desire for tobacco and snuff. Wonderful success. Sworn testimonials. Originated by a Pharmacist. A guaranteed vegetable treatment \$2.25. Our book "A" tells why you should quit tobacco and snuff sent Free. Write today. Address: Inland Chemical Co., Bismarck, N. Dak.

GOLD Midget emblem buttons. Nickel silver pocket pieces. Leading societies 25c. Stanlee Cornhill, Boston.

FREE—Stop using Tobacco. Free. We will give free information how to conquer the habit easily and permanently. Results Guaranteed. Anti-Tobacco League, 618 Paxton Block, Omaha, Nebr.

MINERAL Water. Looks like whiskey, keeps forever. Suffers Skin, throat and stomach troubles: Stop taking drugs and order a 50c 30-dose bottle from A. L. Teeters, Wynne, Ark.

ANTIQUES AND RELICS

GENUINE Sioux Indian Beadwork and Relics. Send us 25c and we will mail you a piece of Indian Beadwork or some other Indian-made relic, besides a complete list of our Indian Stock. Strong Curio Co., Gordon, Nebr.

PLINT Lock Guns and Pistols. War and Indian relics. Many other antiques. List for 2c stamp. Davis Brothers, Kent, Ohio.

FLORIDA Sea Shells, 25c and \$1.00 box prepaid. Florida Shell Company, DeLand, Florida.

MISCELLANEOUS

LUMINOUS Paint. Shines like fire in the dark! Make your watches, clocks, electric switch plates, crucifixes, etc., visible at night. Latest discovery. Only 25c bottle. Particulars free. (Agents wanted.) Luminous Paint Co., Douglas Park Station (B 2), Chicago, Ill.

FOUNTAIN Pens—All makes—repaired. Nichol, 1016 Chestnut, Philadelphia.

TATTOOING Supplies. Write at once for my Catalogue. Don't be fooled by amateur manufacturers and imitators. Only reliable machines and outfits manufactured. Prof. J. Barber, 70½ Brush St., Detroit, Mich.

CUTS anybody can make. Simple, cheap process. Specimens, particulars for stamp. M. Day, Windfall, Ind.

PINYON Nuts; deliciously good; sample package 10c. American Pinyon Co., Albuquerque, N. Mexico.

C. S. A. MONEY. I guarantee what I handle are not Reprints of Confederate Money. Write for price list. Frank Shilling, Navarre, Ohio.

SEND 10c for blue printed details of class combination drawing board and library table containing 2 secret drawers. Also lot of valuable technical information. R. W. Spaulding, 318 Ferry, W. Detroit, Mich.

ESCAPE King's set of Three Keys will open most ordinary doors. 25c complete set. Padlock Opener, 10c. Chicago Novelty Works, 3310 North Herndon St., Room 115, Chicago.

NEW \$2.50 Automatic Adding Machine. Circular free. Bassett, 3921-E Indiana Ave., Chicago.

CASH paid for butterflies, insects. 8-cms \$1 to \$7 each. Easy work. Even two boys earned good money with mother's help and my pictures, descriptions, price list, and simple instructions on painless killing, etc. Send 2c stamp at once for prospectus. Sinclair, Box 244, D6, Los Angeles, Cal.

SEND 10c for booklet containing valuable information needed in everyday life. Special prices on billboards. Churchside Press, Binghamton, N. Y.

RUBBER stamps, seals, adjustable stencils, metal badges. Catalogue 10c. Precan nuts. Samples 10c. Walter Karstaedt, Dayton, Ohio.

GRANDFATHER'S Clocks. Build your own Grandfather's Clock with our free blue prints. Works, Dial, etc., \$5 and up. Others with chains at all prices. Write for free offer. Clock Co., 1671 Ruffner St., Philadelphia, Pa.

LOCKSMITHS. How to unlock cylinder and all locks, 100 tricks of the trade \$1.00; money back if dissatisfied. Houston, 205 Brook St., Oakland, Cal.

TOO LATE TO CLASSIFY

SURVEYING Instruments rebuilt. Transits and Levels. Sprengnether Instrument Co., 205 Ozark Bldg., St. Louis, Mo.

LEARN RAG TIME

Let me teach you Rag-Time Piano Playing by Mail. You learn easily—in just a few lessons, at home. My system is so simple you'll play a real ragtime piece at your 5th lesson. Whether you can play now, or not, I'll teach you to play anything in happy ragtime. "Money Back Guarantee." Write at once for special low terms and testimonials.

AXEL CHRISTENSEN, "Czar of Ragtime,"
20 E. Jackson Blvd., Dept. C-10, CHICAGO, ILL.



Ford Instruction Book

For Every Ford Owner, Dealer, Salesman and Repairman

Deals fully with construction, operation and repair of the Model T Ford Car.

Cloth—300 Pages—100 Illustrations
Price, \$1.00 Postpaid

POPULAR MECHANICS BOOK DEPT., 6 N. Michigan Ave., CHICAGO

ELECTRICAL

Electricity, **THE BLISS ELECTRICAL SCHOOL**, with its well-equipped shops and laboratories, is peculiarly well qualified to give a **condensed course** in Electrical

ENGINEERING

including Mathematics, Steam and Gas Engines, Mechanical Drawing, Shop Work, and Theoretical and Practical Electricity, in all branches. Students actually construct dynamos, install wiring and test efficiency of electrical machinery. Course, with diploma, complete

IN ONE YEAR

For practical young men with limited time. 25th year opens Sept. 26th. Catalogue on request. 304 Takoma Ave., Washington, D. C.



LEARN TO RUN-BUILD & SELL AUTOMOBILES WE SET YOU UP IN BUSINESS

Own a Garage and Repair Shop! Make from \$3,000 to \$10,000 a Year!

The Automobile Industry is the Big Business of Today and has an *unlimited future*. Why don't you get into it? Only six weeks of personal instruction at the **BIG COLVIN INSTITUTE** and you are an Automobile and Farm Tractor Expert. After graduation *we will assist you in starting a Business of your own*. That shows our absolute confidence in your ability to make good as the proprietor of a Garage and Repair Shop after Colvin training. The great resources back of this Company make it possible for such a wonderful offer.

OUR COURSE INCLUDES FARM TRACTOR ENGINEERING.

Farm Tractor Experts make big money as do Chauffeurs, Mechanics and Salesmen—from \$75.00 to \$300.00 per month and up. You can do as well with C. A. I. Training. Thousands of Tractors are being sold. The demand for trained men exceeds the supply. We could easily place 500 more graduates right now if we had them!

Send for our Big Free Book obligates you in no way, but you owe it to yourself to get all the facts. Don't let others monopolize prosperity; *get your share*. Make the start now by sending a letter or a postal for the Big Free Book, Today.

COLVIN AUTOMOBILE INSTITUTE,

Dept. 28

St. Louis, Mo.

**BIG FREE BOOK
HOW TO
RUN AND
BUILD AUTOS**

Trained DRAFTSMEN WANTED!

READ THIS LETTER

If you doubt the great opportunities open to the young men of this generation, read President Morey's letter below. Never before in America were the conditions so favorable.

"I have been asked to state what, in my opinion, will be the opportunities of the next few years for the man who takes up Engineering, Architecture, Contracting, Drafting, etc. I can best forecast the future by looking at the past.

For many years it has been impossible to secure enough trained draftsmen. By trained draftsmen I mean men who can go ahead and do things right. Such men are worth their weight in gold. Good draftsmen, men who are trained right, quickly advance out of the drafting room and become engineers, superintendents, managers, etc., where salaries of \$10,000 or \$15,000 per year are common.

More than a decade ago, with other engineers, I established the Chicago Technical College for the sole purpose of training up good draftsmen for our engineering offices. Since then hundreds of men, now drawing big salaries, have secured their start in our day and evening classes and hundreds of others have become expert draftsmen through home study. I have employed many of them in my own engineering office and have placed the others in equally good positions.

But it is still impossible to get enough trained draftsmen. I have calls for men every day. The engineering firms, architects and contractors associated with me are constantly asking for our graduates. They know what these men can do. Will the call for men continue? It certainly will. America has only begun to realize her possibilities. The next few years will witness a wonderful development of her resources. The demand for trained men will be even greater than heretofore. The young man of today has an opportunity that was undreamed of a few years ago. Will he improve it? The far-seeing ones are already doing so."

Charles W. Morey

President Chicago Technical College
Manager Morey & Co., Engineers

A CHANCE TO LEARN DRAFTING FREE

On account of the rapidly increasing demand for trained draftsmen, President Morey has issued orders that instruction be furnished to a limited number of young men who are inclined along engineering or architectural lines.

The College has set aside a limited number of Free Scholarships and will give the regular 245 Course in Mechanical Drafting, FREE, with any of the Home-Study Courses named in the coupon below. A complete drafting outfit of highest grade is also included. This offer will be withdrawn as soon as allotted number of FREE Scholarships has been awarded. Send NOW for full information—it's FREE!

SCHOLARSHIP COUPON MAIL TODAY

Mr. Morey: Without any obligation on me, please send FREE information. Show me how I can quickly become an expert in the branch marked.

- ARCHITECTURAL DRAFTING
- MACHINE DRAFTING
- ELECTRICAL DRAFTING
- STRUCTURAL DRAFTING
- CIVIL ENGINEERING
- BUILDERS' COURSE
- PLAN READING
- ESTIMATING
- SHEET METAL DRAFTING
- SURVEYING

Name _____

Address _____

Town _____ State _____

College or Home-Study Course _____

Address CHARLES W. MOREY, President

Chicago Technical College

1050 Lake View Bldg., 116 S. Michigan Ave., Chicago



CHARLES W. MOREY
President of the College
and head of a large Chicago firm of civil, mechanical and electrical engineers and contractors.

You can get this same training in your own home by the new "Chicago Tech." method.



Please Mention Popular Mechanics

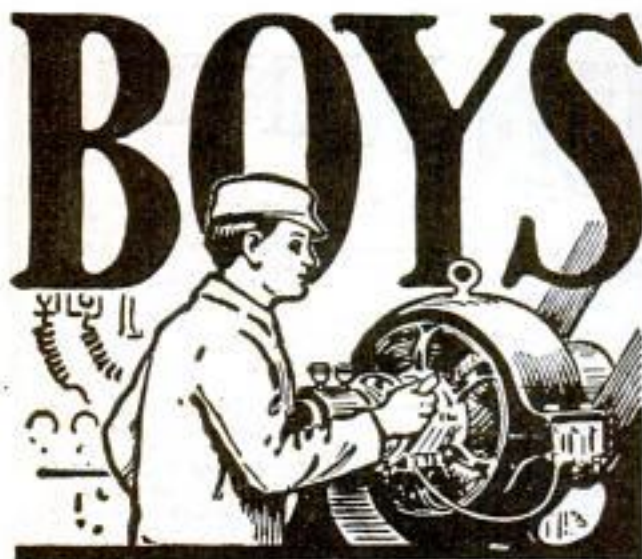

Big Money in Electricity

The Electrical industries offer wonderful opportunities to boys with a liking for Electricity. The salaries paid to trained men are large, promotion comes rapidly and, best of all, the work is fascinating.

The discovery and development of new lines (such as wireless telegraphy and telephony), from time to time, promise attractive and paying fields to those who wish to specialize. The *will to do* and *Special Training* will bring success to you.

The International Correspondence Schools can help you to become an expert in electrical work, no matter what branch you like best. Thousands of young men have already won success through I. C. S. help. You can do as well as anybody, *if you try*. Everything is made so clear that you can learn in your spare time, regardless of where you live or what your work. No books to buy.

There's big money in Electricity. Get after it by marking and mailing the Coupon today. *Finding out costs you nothing.*

INTERNATIONAL CORRESPONDENCE SCHOOLS

Box 5556, SCRANTON, PA.

Explain, without obligating me, how I can train for the position below which I mark X.

- ELECTRICAL ENGINEER
- Electrician
- Electric Wiring
- Electric Lighting
- Electric Car Running
- Electric Machine Designer
- Telegraph Engineer
- MECHANICAL ENGINEER
- Mechanical Draftsman
- STEAM ENGINEER
- GAS ENGINEER
- CIVIL ENGINEER
- Structural Engineer
- CHEMICAL ENGINEER

- ARCHITECT
- Architectural Draftsman
- Blue Foreman or Supt.
- Business (Complete)
- Bookkeeper
- Stenographer
- Advertising Man
- Salesmanship
- Window Trimmer
- Civil Service
- AGRICULTURE
- Poultry Raising
- AUTOMOBILES
- Auto Repairing

Name _____

Present Occupation and Employer _____

Street and No. _____

City _____ State _____

If name of Course you want is not in this list, write it below.

A 'Steel Trap' Memory

One that takes a tight grip on facts, figures, names, details of every kind and hangs onto them through life—that's the kind of memory you ought to have and the kind you can have if you will give me ten minutes of your spare time daily for a few weeks. I will make your mind an infallible classified index of the things it is to your advantage to remember—give you power to concentrate, overcome self-consciousness, enable you to think on your feet, and address an audience intelligently without hesitancy and without notes.



The Key to Success

Stop forgetting

Henry Dickson, Principal, Dickson School of Memory

During the past 29 years I have trained thousands of people to STOP FORGETTING—aided them to greater business and social success—I know positively that the person with a strong, tenacious memory, though he be far behind at the beginning of the race for success, advances and soon outdistances his forgetful rival. The demands of commercial and professional life are so exacting in their details of facts and figures to be remembered, that to succeed or even hold your own you simply must possess a good memory.

Get My Remarkable Memory Test Free

I've had this test—most ingenious and most exclusive memory test ever devised—copyrighted. I'll send it to you, free, also a copy of my book "How to Remember" and tell you how to obtain a copy of my De Luxe edition, "How to Speak in Public," a handsomely illustrated \$2 book, absolutely free.

HENRY DICKSON, Principal, Dickson School of Memory, 1705 Hearst Bldg., Chicago

STAMMERER

Attend no school until you read my book "How To Stop Stammering." A practical, modern Method that kills the fear of stammering. The Hatfield Institute, 109 North Dearborn St., Chicago, Ill.



Voice Thrower 10c

Learn to throw your voice into a TRUNK, under the bed, out in the hall or anywhere. Lots of FUN fooling the Teacher, Janitor, Policeman, Parents, Neighbors, or Friends.

THE VENTRILO

is a little instrument that fits into the mouth out of eight. BOYS or GIRLS can use it. NEVER FAILS! A 32 page book on Ventriloquism sent with the VENTRILO for TEN Cents.

Royal Novelty Co., Dept. 92, So. Norwalk, Conn.



IN 10 WEEKS' SPARE TIME

We can teach you the entire subject by mail and help you to get a good position. ONE MILLION AUTOMOBILES will be built this year. The demand for trained help next spring will be tremendous. **Sample Lessons Free — Write for Them Today** (Owners—we supply competent men.)

Franklin Auto Institute, Dept. W803, Rochester, N. Y.

Please Mention Popular Mechanics

CYCLOPEDIA of ENGINEERING VOL I STEAM BOILERS CONSTRUCTION TYPES STEAM PUMPS

CYCLOPEDIA of ENGINEERING VOL II STEAM ENGINES INDICATORS VALVE GEARS

CYCLOPEDIA of ENGINEERING VOL III GAS ENGINES AUTOMOTIVE MOTOR TRUCKS

CYCLOPEDIA of ENGINEERING VOL IV PIPES FITTING

CYCLOPEDIA of ENGINEERING VOL V COMPRESSED AIR MACHINERY REFRIGERATION COLD STORAGE

CYCLOPEDIA of ENGINEERING VOL VI

CYCLOPEDIA of ENGINEERING VOL VII ELECTRICITY LIGHTING WIRING INDEX

Stationary Engineer

Marine Engineer

Locomotive Engineer

AMERICAN TECHNICAL SOCIETY

Everything the Chief Knows!

HERE in seven volumes is all the knowledge you need to pass the examination for a Stationary or Marine Engineer's license, or to obtain a position as Locomotive Engineer. *Every fact* on steam engineering is tabulated and carefully cross-indexed so it is always at your fingers' tips. These great books were written by 27 experts. Seven volumes; 3300 pages (7 by 10 inches); 2500 illustrations, full page plates, diagrams, etc. *Hundreds of valuable tables and formulas.* Handsomely bound in half red morocco, gold stamped. Covers the construction and operation of stationary, locomotive, marine engines, and boilers; the use of gas and gasoline engines for power and locomotion; the transformation of steam and gas power into electricity, and the application of steam and gas power to refrigeration, compressed air, etc.

\$125 to \$250 a Month Are ordinary salaries in the engineering field. With these books you can actually prepare for one of these high-salaried positions during your spare time. A set of books that is invaluable to the steam engineer—or one preparing for one of these high-salaried positions. Send the coupon for free examination.

Steam Engineering

With the growth of the electrical industry and the complicating of steam engines, the chief engineer must have the up-to-date knowledge that is contained in these seven great volumes. If you

would be the chief engineer, this opportunity to get these books is a golden one. Here is all the information you need—and written in simple, easily understood English.

Consulting Service FREE!

In addition to the set of books we also give you—free of all charge—a year's consulting membership in the American Technical Society. This entitles you to the privilege of bringing every perplexing problem to a corps of experts. Ask as many questions as you wish for an entire year.

50c A Week

We will ship you the entire seven volumes, prepaid, right to your own home upon your simple request. Do not pay a penny until

after you have used them for seven days, then send only \$2.00 or return the books at our expense. Pay the balance at the rate of \$2.00 a month—50c a week. The present rock-bottom price of the entire set of books is only \$19.50—a reduction of \$15.50 from the regular price of \$35.00.

Send the Coupon Today

Put your name and address in the coupon now and send it to us. This offer to send the entire set of books, prepaid, is open to every one within the boundaries of the United States and Canada—you cannot afford to pass it by. Act now. This is opportunity.

American Technical Society, Dept. S 1193, Chicago, U.S.A.

American Technical Society

Dept. S 1193 Chicago, U.S.A.

Please send me the seven volume set of the Cyclopaedia of Steam Engineering for seven days free examination. If I decide to buy, I will send \$2.00 within seven days and balance at \$2.00 a month until \$19.50 has been paid. Then you will send me a receipt showing that the set of books and the consulting membership are mine and fully paid for. If I think that I can get along without the books, I will return them after 7 days at your expense.

Name.....

Address.....

Reference.....

Sweeney School First in the Field

Owen Magnetic Car Added to Equipment

YOUNG MAN, if you are interested in learning the automobile and tractor business, and earning \$3 a day, up to \$200 a month, you want to come to the school that *Stands in Front*; and now this month's announcement that we have just bought a \$3500 Owen Magnetic Car, to teach our men the principles of the great new change or improvement in electrical transmission, means that this is the *only school* that has an Owen Magnetic and can teach you this remarkable new development. Come to the school that's *Up-to-the-Minute*; the fact that 1400 men this very day are working here proves that we are headquarters for automobile instruction; that we have the prestige; and our men go out from here in six weeks and make good. **YOU CAN'T** account for our success except by the fact that our students succeed when they leave school.

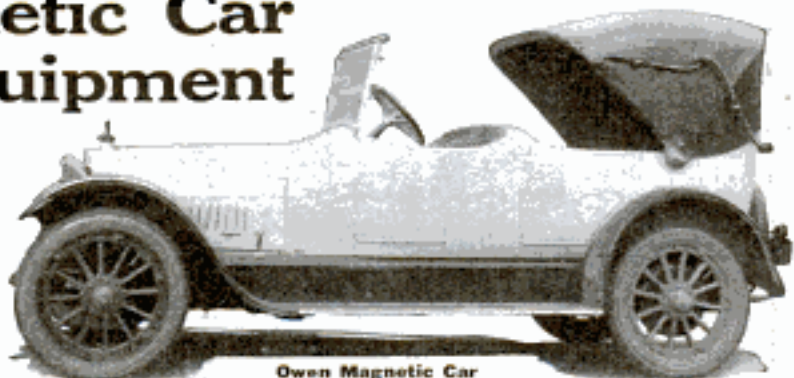

Owen Magnetic Car

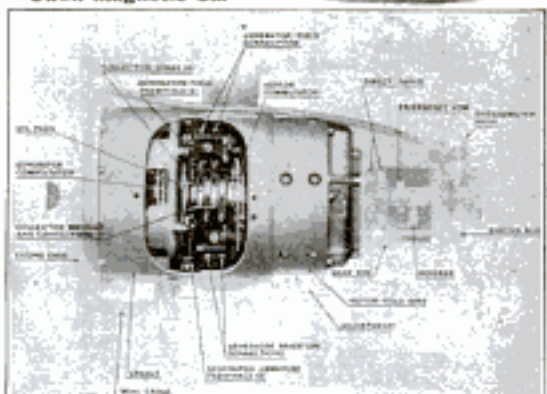

Owen Transmission

Men Wanted to Learn Auto and Tractor Business by Sweeney System of Practical Instruction

Tools Furnished
FREE

No Books
Used

1400 Men Now in School Training for Big Money

THE Sweeney System of teaching the automobile business to men mechanically inclined means in a few words to learn by actually doing the work in a School where you get into the grease to your neck. It is the only way to learn it. And say, you need up-to-date equipment, too. My \$80,000.00 equipment consists of all types of automobiles, from a one cylinder up to the \$3500 Owen Magnetic Car. I actually have these cars here, with their ignition and starting systems, everything complete. It also includes working in different departments under competent instructors, such as electric starters and storage batteries, valve grinding, piston ring fitting, babbitting and bearing departments, also oxy-acetylene welding. My equipment consists of ten oxy-acetylene welding machines; tire vulcanizing, lathe work, gear cutting—in fact, I teach you to properly take care of a car and to repair it, so that you can make almost any part, if you are mechanically inclined, and if during your life you have had that longing to some day be able to fix machinery and work on it, write for my catalog, which describes the Sweeney System of teaching the automobile business; how I put you in the shop with overalls on, make your own tools, and have a competent instructor right at your elbow to first tell you, then show you, and then you do the work yourself. This is so different from the average way of teaching in School. If you are afraid of work or grease don't come here, because when you work on automobiles you get dirty.

Do It Now If you will sign and mail the coupon attached or write me a postcard, I will send you my big free book and full details of my \$50 free Traction Engineering Scholarship. Remember, we have 9 tractors and in our own factory build the Sweeney Iron Horse. This book will survey the whole field and the certificate will entitle you to the \$50 saving in case you enroll this fall. It will not obligate you in any way. As a matter of fact I won't take a cent of a man's money until he has personally inspected the school and has satisfied himself.

The book pictures the wonderful equipment of the Sweeney School. It shows how you are taught, shows the class of men you will associate with, portrays various phases of the automobile industry, explains how, when and where you begin to earn money, in a word, is a complete encyclopedia of the subject. I don't urge you to send for it unless you really want it, but to every young man mechanically inclined I will be very glad indeed to mail it free, together with my regular magazine. Simply send name and address.

E. J. SWEENEY, President

Sweeney Automobile School

Largest and Best Equipped in the World

1162 E. 15th St. KANSAS CITY, MO.



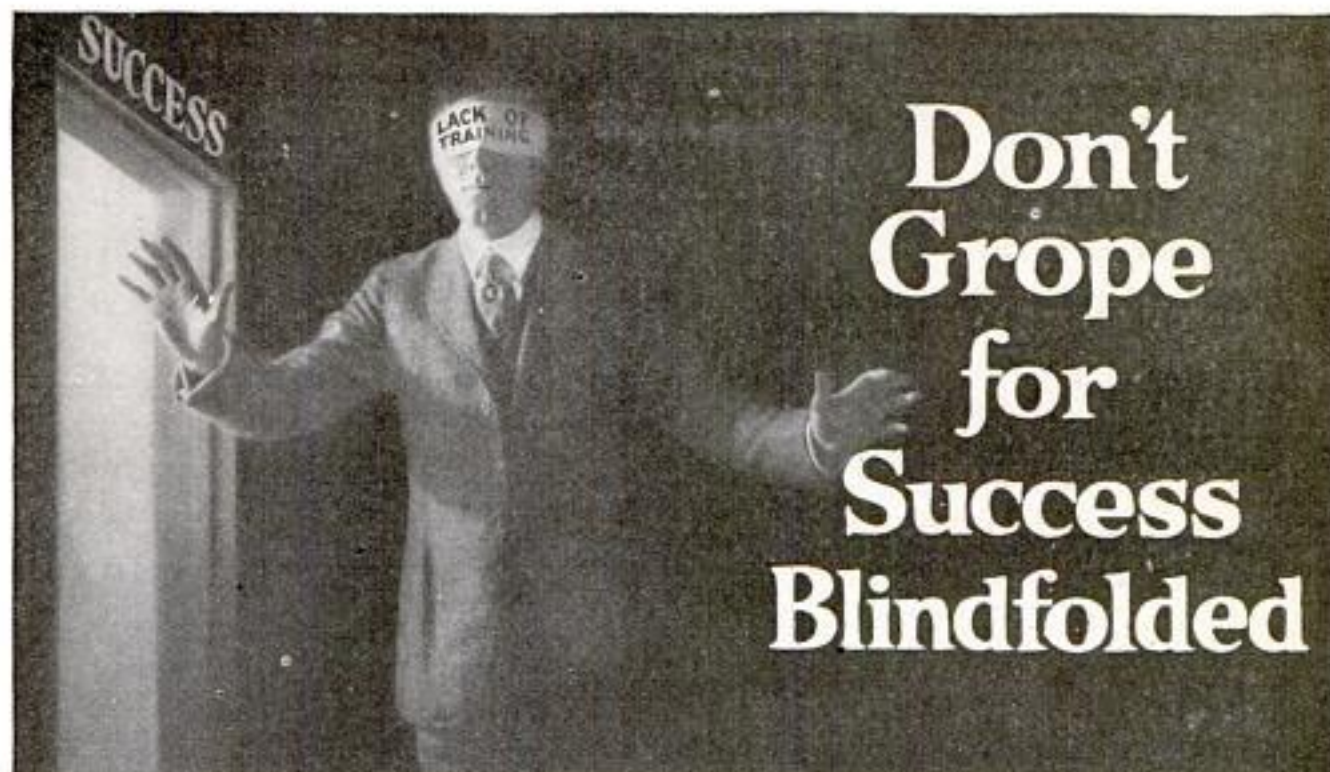

Your chance to *be somebody*, to hold a position of responsibility, to have an income that will provide every comfort of life, is within your reach.

Just one thing keeps you from finding it, grasping it: you're not *prepared*. Through the door of opportunity big jobs are waiting in every field of work. But only trained men will get them.

Don't play blindman's buff with your future! Start today and train yourself to do some one thing better than others.

You can get that training in spare time through the International Correspondence Schools, just as others have done for twenty-five years—just as more than 130,000 ambitious men and boys are doing right now.

Choose your own career. The I. C. S. will train you for the position you want in the work you like best. And you need not lose a day or a dollar in your present occupation.

Tear off that blindfold!

Your chance is here. The time to start is now. The way is to ask the I. C. S. to show you what they can do for you. Mark and mail this coupon—it costs nothing, but the evidence it will bring you will open your eyes.

I. C. S., Box 5555, Scranton, Pa.

TEAR OUT HERE

INTERNATIONAL CORRESPONDENCE SCHOOLS
Box 5555, SCRANTON, PA.

Explain, without obligating me, how I can qualify for the position, or in the subject, before which I mark X.

<input type="checkbox"/> ELECTRICAL ENGINEER	<input type="checkbox"/> SALESMANSHIP
<input type="checkbox"/> Electric Lighting	<input type="checkbox"/> ADVERTISING MAN
<input type="checkbox"/> Electric Car Running	<input type="checkbox"/> Window Trimmer
<input type="checkbox"/> Electric Wiring	<input type="checkbox"/> Show Card Writer
<input type="checkbox"/> Telegraph Expert	<input type="checkbox"/> Outdoor Sign Painter
<input type="checkbox"/> Practical Telephony	<input type="checkbox"/> RAILROADER
<input type="checkbox"/> MECHANICAL ENGINEER	<input type="checkbox"/> ILLUSTRATOR
<input type="checkbox"/> Mechanical Draftsman	<input type="checkbox"/> DESIGNER
<input type="checkbox"/> Machine Shop Practice	<input type="checkbox"/> BOOKKEEPER
<input type="checkbox"/> Gas Engineer	<input type="checkbox"/> Stenographer and Typist
<input type="checkbox"/> CIVIL ENGINEER	<input type="checkbox"/> Cert. Public Accountant
<input type="checkbox"/> Surveying and Mapping	<input type="checkbox"/> Railway Accountant
<input type="checkbox"/> MINE FOREMAN OR ENGINEER	<input type="checkbox"/> Commercial Law
<input type="checkbox"/> Metallurgist or Prospector	<input type="checkbox"/> Traffic Management
<input type="checkbox"/> STATIONARY ENGINEER	<input type="checkbox"/> GOOD ENGLISH
<input type="checkbox"/> Marine Engineer	<input type="checkbox"/> Teacher
<input type="checkbox"/> ARCHITECT	<input type="checkbox"/> Common School Subjects
<input type="checkbox"/> Contractor and Builder	<input type="checkbox"/> CIVIL SERVICE
<input type="checkbox"/> Architectural Draftsman	<input type="checkbox"/> Railway Mail Clerk
<input type="checkbox"/> Concrete Builder	<input type="checkbox"/> Textile Overseer or Supt.
<input type="checkbox"/> Structural Engineer	<input type="checkbox"/> Navigator <input type="checkbox"/> Spanish
<input type="checkbox"/> PLUMBING AND HEATING	<input type="checkbox"/> AGRICULTURE <input type="checkbox"/> German
<input type="checkbox"/> Sheet Metal Worker	<input type="checkbox"/> Poultry Raising <input type="checkbox"/> French
<input type="checkbox"/> CHEMICAL ENGINEER	<input type="checkbox"/> AUTOMOBILES <input type="checkbox"/> Italian

Name _____

Occupation & Employer _____

Street and No. _____

City _____ State _____

If name of Course you want is not in this list, write it below.

Please Mention Popular Mechanics

LEARN AUTOS

Where Autos are Made

Detroit is a city of motors. Eighty-five per cent of the motor cars in the United States are said to be made here. Here are located 40 or more auto factories, hundreds of parts makers. Detroit *makes* automobiles, *sees* automobiles, *thinks* automobiles day and night. Detroit is the *place* to learn the auto industry, and the Detroit Y. M. C. A. Auto School is the *school* at which to learn it.

Backed by Automobile Factories

The automobile men of Detroit endorse our work without hesitation. The Studebaker, Buick, Hupp, Ford, Packard, Gray Motor, Disco, Zenith, Chalmers, and many others have contributed to our equipment their latest models and designs. Can you ask stronger proof of a school's standing than the fact that the *men who know* give freely their time and money to co-operate with it and aid in its growth.

Not Operated for Profit

The Y. M. C. A. Auto School is not run for profit. Our purpose is to give our students the training necessary to get and hold good paying positions in the rapidly growing automobile industry. Tuition goes to procuring the highest class of instructors and the best of equipment. The automobile business is crying for trained men,—testers, chauffeurs, inspectors, salesmen, assemblers, repair men, bearing scrapers, motor mechanics of every description. Factories, dealers and garages join in the call. We fit you for these positions. Will you take advantage of this opportunity?

Tuition Includes Membership in the "Y"

Tuition at the Y. M. C. A. Auto School is low — and includes a year's membership in the "Y." Our big Club House is at your disposal during time off. Reading rooms, lounging rooms, gymnasium, swimming pool, billiard and pool tables, bowling alleys, with five floors of dormitories and restaurant at low rates. You are assured of not only thorough and competent instruction, but good companionship and clean living conditions with the comforts of home and club life combined.

Don't Visit Detroit Without Seeing Us

You want to consider everything carefully before you enroll for any course of instruction. Come and look us over, whatever purpose brings you to Detroit. Get all the particulars of this school, get the records of our instructors, hear what auto factories and automobile men have to say about us, see for yourself our comfortable quarters and big equipment. We will be glad to see you and show you around whether you enroll or not. Day and night classes. Start at any time. The average time required is 6 weeks for day course, and 12 weeks for night course.

WRITE TODAY FOR FULL PARTICULARS. Address
Educational Director, Box 305, Y. M. C. A., Detroit, Mich.



Main Building Y. M. C. A.
Detroit



Students Working on Axle
and Transmission



Block Testing and Motor
Department



"Y" Auto School Repair Shop



Lecture and Demonstration
of Chassis





Learn Electricity!

in the Great Shops of Coyne

Practical training is the golden road to quick success. No mere books or theory can fit you to hold the big paying jobs. Here in our great shops you learn Electricity from the bottom up—under actual working conditions—as every great electrical expert must learn to completely master it. Here you handle actual equipment! Here you actually do the work that pays

\$125 to \$300 a Month

Think of the difference! No correspondence! No books and papers! No long hours of tedious grind. The work at Coyne is vibrating with life—charged with electricity. Experts show you everything. They work with you—show you how. You imitate these masters! You learn by doing. It's amazing how quickly you progress. From the simplest door bell to the mighty motors—dynamos—electrical locomotives—everything is mastered with remarkable ease. Hundreds of successful graduates prove this fact. Many finish in 4 to 5 months.

Day or Evening Courses

LOW COST—
EASY TERMS

Come to the great Shops of Coyne. Enter day or evening courses! Nothing bars you! Our tuition is so low it will astound you. You don't have to pay cash! We arrange acceptable easy payments if necessary. All tools and equipment are furnished free. Think of it! Your opportunity to thoroughly learn Electricity is right before you.

FREE Employment Bureau!

Don't let anything stop you! We maintain a Free employment bureau. We help worthy—serious young men get work while studying. We also help place graduates in big jobs.

BENNETT WELLINGTON COOKE
Director

COYNE NAT'L TRADE SCHOOLS

Dept. 1193, 39-51 E. Illinois St., CHICAGO

Our courses also include practical training in ALL branches of

**Drafting
Plumbing
and
Motion
Picture
Operating**

Check coupon below and mail for details.

MAIL COUPON FOR FREE BOOK

Get this book of Opportunity!

From cover to cover it tingles with interest. Tells about our great shops! Covers many jobs open for Coyne trained men! Tells of great successes of Coyne graduates. Get this book by all means! It's free. Merely fill in the coupon, stating which trade you are interested in, and mail it now—at once!

B. W. COOKE, Director, COYNE NAT'L TRADE SCHOOLS
Dept. 1193, 39-51 E. Illinois St., CHICAGO

Please send at once your big Free Book of Opportunity. I am interested in—
 Electricity Drafting Plumbing Motion Picture Operating

Name.....
Address.....
Town.....
State.....



Take a Pencil and make an "X"

A LITTLE X, like the one shown here, has marked the starting point for a good many big successes. It's an easy thing to make. Your pencil will make it in a jiffy BUT it may mark the turning point in your life.

These days the thing that puts a man above his fellows is TRAINING.

And this little "X" when marked on the coupon below will bring you a handsome free book that will tell just exactly how YOU can get the training that has put THOUSANDS of men into high positions. It won't be necessary for you to leave your home to get this training. For twenty years the American School has been giving ambitious men practical training that started them on the road to success

Send the Coupon

Take a pencil now and mark an X before the position for which you want to qualify yourself. Let us tell you how we have given other men the training that enabled them to hold these positions. Let us tell you how you can get THIS VERY TRAINING right in your own home during your idle hours. You will be under no obligations by sending the coupon.

Find out for yourself what the American School will do for you. Make your mark in the coupon now for the sake of your ambition and the man you want to be. Opportunity is calling. Your ambition is saying, send the coupon. Do it now.

American School
of Correspondence, Chicago, U.S.A.

Dept. G9193, Chicago, U. S. A.

Mark an X and Mail Today

American School of Correspondence, Dept. G9193 Chicago, U. S. A.
Gentlemen: Without obligation please send me booklet and tell me how I can qualify for position marked X.

- | | |
|--------------------------------|----------------------------|
|Electrical Engineer |Business Law |
|Elec. Light & Power Supt. |Business Manager |
|Hydroelectric Engineer |Auditor |
|Telephone Engineer |Accountant |
|Architect |Cert'f'd Public Acc't |
|Architectural Draftsman |Stenographer |
|Building Contractor |Bookkeeper |
|Building Superintendent |Fire Ins. Inspector |
|Structural Engineer |Fire Ins. Adjuster |
|Structural Draftsman |Fire Ins. Expert |
|Mechanical Engineer |Sanitary Engineer |
|Mechanical Draftsman |Master Plumber |
|Civil Engineer |Heat and Vent. Eng. |
|Steam Engineer |Plumb. and Heat, Est. |
|Shop Foreman |Reclamation Engineer |
|Shop Superintendent |Automobile Engineer |
|Sheet Metal Draftsman |Automobile Repairer |
|Lawyer |High School Course |

We also prepare for civil service examinations in all engineering subjects.

Name.....

Address.....

Are You Interested In Automobiles-Driving? Motoring-Repairing?

THIS ROSE GOLD FINISHED FOB



Do you drive and take care of your own car? Are you an expert Auto Mechanic? Are you going to buy a car soon? Are you in the repair business? No matter what interest you have in Automobiles, THE AMERICAN CHAUFFEUR "America's Greatest Monthly Auto Paper," gives pointers and information each month that will

Save Several \$100 Yearly

In operation, upkeep and repairs. It's the clearing house for money-making and money-saving ideas not published elsewhere, is written in common-sense language, explains clearly how to adjust valves, magnetos, carburetors, etc., tells how to have repairs made at a saving. Technical knowledge told so you can understand.

FREE FOB Special OFFER

Originally designed Auto Watch Fob, real rose gold finish with seal Grain Leather Strap (like illustration, 5 inches long.)

ACT QUICKLY, NOW. Send 25 cents in stamps or coin for 3 month's subscription to the American Chauffeur and we will send you the above fob absolutely free. Your money back if you are not satisfied. The American Chauffeur Pub. Co. 83 Butler Bldg., Cincinnati, Ohio



Be a Taxidermy Artist

Marvelous FREE Book Sent

You can now learn Taxidermy, the wonderful art of mounting birds, animals, tanning skins, etc. Learn at home, by mail. The free book tells how. Mount your own trophies. Decorate home and den. Hunters, trappers, nature lovers, you need taxidermy. Interesting, fascinating, big profits. Join our school. 55,000 students. Success guaranteed. Get our free book, without delay. Send right now—today.

N. W. School of Taxidermy, 1194 Elwood Bldg., Omaha, Neb.

BOYD SHORTHAND IN 30 DAYS

Shorthand simplified. Learned at home in 30 DAYS. Boyd Syllable System, based on Syllables. No shading—no position. Writers hold World's Record. Two of the largest Mail Order Houses have installed the Boyd System. 100 to 150 words a minute guaranteed. Write today for Special Offer, Free Catalog and Sample Lesson. Chicago Home Study Schools, 504 Reaper Bldg., Chicago, Ill.

LAW STUDY AT HOME

Complete Resident University Course by mail. Also Lawyers' Law Course, L.L.B. Degree conferred. Indorsed by Bench and Bar. Strong Faculty of Distinguished Jurists and Lawyers. Catalog free

Oklahoma City University, 908 Concord Building, Oklahoma City, Okla.

LEARN WATCHMAKING and ENGRAVING

Earn while learning. Most practical watch school. Individual instructions. Graduates in great demand. Book free. Chicago School of Watchmaking, 63 E. Van Buren St., Chicago

DOUBLE THROAT 10c New Invention. Fits roof of mouth. Greatest thing out. Astonish and mystify your friends. Make dogs or cats talk. Neigh like a horse, sing like a canary. Imitate any Bird or Beast of field or forest. Price 10c; 4 for 25c postpaid NATIONAL CO., Dept. 31, 3422 Lyndale St., CHICAGO, ILL.

Learn How to WRESTLE

In Your Own Home By Mail Yes, learn to become an expert wrestler right in your own home, by mail, from the greatest wrestlers the world has ever known. Be an athlete, be strong, be healthy. Learn how to throw and handle big men with ease. Learn to defend yourself. All taught in our course of lessons, and illustrated with hundreds of charts and actual photographs by

Farmer Burns and Frank Gotch

Farmer Burns, "the grand old man of the mat," taught Frank Gotch, the present World's Champion, all he knows about wrestling, so Gotch says. He will now teach you Scientific Wrestling—Physical Culture—Jiu-Jitsu—Self Defense. Every man and boy in America, no difference what age, needs this wonderful course of lessons. Write today—your name, age and address on a postcard or letter brings you our fine book absolutely free—no obligations of any kind. A splendid book on wrestling and physical culture. Write today stating your age.

Farmer Burns School of Wrestling, 1193 Range Bldg., Omaha

This Wrestling Book FREE

HELP WANTED

\$65 to \$150 Month—Life Jobs

The United States Government wants thousands of Railway Mail Clerks, City Carriers, Postoffice Clerks, Customs, Internal Revenue Clerks, Clerks at Panama Canal and Washington, D. C.

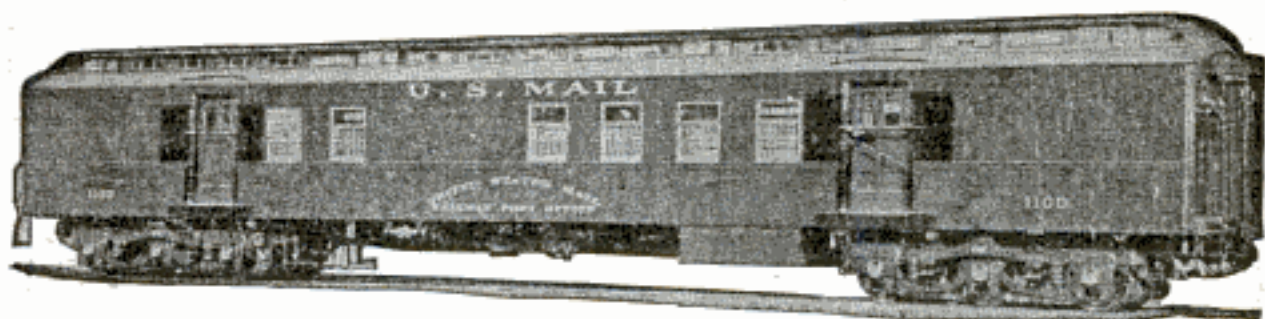

Railway Mail Clerks Have Pleasant Work— Travelling Continually

Government positions have Summer vacations with full pay. Promotion to Big Paid positions is very rapid. The position is not affected by strikes, wars or the whims of some petty boss.

Country residents and city residents stand the same chance for appointment—common education is sufficient—Pull is not required.

Write us today for schedules showing dates and places of March and April general examinations in your locality.

Don't Delay Every day you delay lessens your chance of immediate appointment.

**WE COACH FREE
CANDIDATES**

FRANKLIN INSTITUTE
Dept. W 105
Rochester, N. Y.

Kindly send me, without any obligation whatever on my part, and entirely free of charge, (1) a full description of the position checked below; (2) Sample examination questions; (3) Free copy of copyrighted book, "Government Positions and How to Get Them;" (4) A list of U. S. Government Jobs now easily obtainable; (5) Directions telling me how to get free coaching for the position checked; (6) Schedules showing dates and place of the March and April examinations in my locality.

- | | |
|---|-------------------|
|Railway Mail Clerk | (\$900 to \$1800) |
|Postoffice Clerk | (\$800 to \$1200) |
|Postoffice Carrier | (\$800 to \$1200) |
|Rural Mail Carrier | (\$500 to \$1200) |
|Bookkeeper | (\$800 to \$1800) |
|Customs Positions | (\$800 to \$1500) |
|Internal Revenue | (\$700 to \$1800) |
|Stenographer | (\$800 to \$1500) |
|Clerk in the Departments at Washington
or at Panama Canal | (\$800 to \$1800) |

Name.....

Address.....

Use This Coupon Before You Mislay It—WRITE PLAINLY—W 105

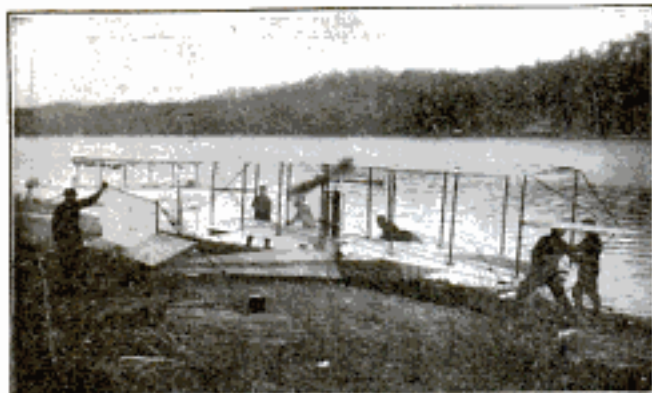

Learn Mechanics of Aviation

YES, right in your own home, in your spare time, you can learn all the principles, the theory and the mechanics of Aviation. You can prepare yourself for flying, if you wish. Or you can gain all the practical knowledge to equip you to enter the big paying and fascinating business of aeroplane construction and as aero-mechanical engineer. Send the coupon at once! Find out how our wonderful course in Aviation will give you the knowledge necessary to enter this field. Everybody planning to enter the Aviation fields needs the knowledge which this course offers. This is the first time that anyone has had the opportunity to gain this instruction at home—and without great sacrifice of time and expense. Waste no time in sending coupon.

Big Opportunities NOW!

What Course Covers:

Aero History—Aero Physics—Aero Dynamics—Wing Designing and Construction—Aero-plane Assembling—Balloon Building and Operating—Aero-nautical Wireless.

Now is the time for every man who has considered Aviation to get into the field. Each day presents new opportunities. The pioneers are going to reap the rich rewards. Automobile history, railroad history, motion picture history will repeat itself in Aviation. The men who get in early are the men who will amass the fortunes. Right now there are opportunities for men who are experts in the mechanics of Aviation that pay anywhere from \$50 to \$500 a week. In aeroplane factories, government branches, aero societies, repair shops. Only trained men will do. Heretofore this was obtainable only at a great sacrifice of time and expense by field training. Now you may secure this

same training at home—in much shorter time, a mere fraction of the expense, and without interfering with your regular work.

Endorsed by Aviation Authorities!

Leading aviators and flying organizations have endorsed this course as a quick and reliable means of training for the business and practice of Aviation.

American School of Aviation
431 So. Dearborn St.
Dept. 1183, CHICAGO

Gentlemen:—Please send me, free and without obligation, full particulars of your course in Aeronautical Engineering and details of your special limited offer.

Name.....

Address.....

Special Offer

Send the Coupon

Those who write at once will still be able to take advantage of the special limited offer which is now in force by which they may secure a large tuition reduction. Write now while this offer lasts for full particulars. Send coupon—no obligation.

American School of Aviation
431 S. Dearborn St.
Dept. 1183
CHICAGO, ILL.

MECHANICAL DENTISTRY

•LIGHTS THE WAY TO SUCCESS•

Men of all ages are needed right now on account of the insistent demand upon us to furnish more Mechanical Dentists. For 24 years we have successfully taught **MECHANICAL DENTISTRY**. Our graduates earn \$25 to \$75 and up, weekly. They Are in Big Demand because of our recognized teaching ability. **PRACTICAL INDIVIDUAL INSTRUCTION. NO BOOKS START ANY TIME, DAY OR NIGHT.** Complete course in 3 months; easy payments. Tools, Materials and Equipment free with cost of instruction. **WE GUARANTEE** that you can earn while learning. The surest way to raise your salary is to increase your skill. We can do it. **INVESTIGATE—Visit or write for instruction catalog P. BODEE DENTAL TRADE SCHOOL, 15 W. 44th St., N. Y.** Under supervision of the University of the State of New York.

Electrical Meter Engineering

"The Profession With a Future"

Now learned at home. Big demand for competent men. Pleasant, interesting, fascinating employment all the year 'round, with exceptional opportunities for advancement. Success guaranteed. High salaries offered. No experience necessary.

Special Offer! In order to get more men to train for good positions, we are making a great special offer to a limited number. Write today for full particulars—FREE. No obligations. Be a Meter Engineer, the man who fixes, not the one who is fixed. No boss. Write today. **Fort Wayne Correspondence School Dept. 1123 Fort Wayne, Indiana**

LEARN WATCHMAKING

and become independent. Good-paying positions secured. Easy to learn. Send for **FREE CATALOG.** **ST. LOUIS WATCHMAKING SCHOOL, Dept. 5, ST. LOUIS, MO.**

Mr. A. R. Patterson, whose advertisement appears below, was for eight years a Civil Service Secretary-Examiner, and is well qualified to help YOU secure a Government Position.

FREE BOOK OF GOV'T POSITIONS

Earn \$75 to \$150 a Month

WRITE TODAY

Be a Railway Mail Clerk, Post Office Clerk or Carrier, Rural Mail Carrier, Internal Revenue Officer, Clerk at Washington, D. C., or Panama Canal, or accept any other good Civil Service position with Uncle Sam, world's greatest and best employer.

Good Pay, Easy Work, Vacations, Position for Life

Earn \$75 to \$150 a month from the start. Rapid advancement. Work 8 hours or less a day. 15 to 30 days vacation with full pay. No strikes, no "lay-offs," no "straw bosses." No politics, no "pull" needed. Only any education sufficient. American citizens 18 or over **WANTED.**

PATTERSON PREPARES YOU

Only school offering help of former Civil Service Sec'y-Examiner. Quick appointment certain. Sure position or no pay. Send coupon or postal **NOW** for book free.

FREE! Tells what positions are open. How to prepare easily and quickly for job you like best. Don't be satisfied with a small pay, uncertain job. Write for book of Uncle Sam's positions and get on a easy street. Mail coupon or postal **NOW.** Address.....

PATTERSON CIVIL SERVICE SCHOOL
83 Howe Bldg., Rochester, New York.

Please Mention Popular Mechanics

*****COUPON*****
Send me Free Book of Government Positions.
Name.....
Address.....



Law-Trained Men Rule In Business and Public Life

Who are the best paid among all professional men? **LAWYERS.** Who occupy the highest positions in business life? **LAW-Trained men.** Who are our leading executives

—Governors of States, Congressmen, Senators, Cabinet Officials? Men with **LEGAL** training. And why? Because it is now generally recognized that the **LAW-Trained** man has a keener grasp of affairs and is better able to cope with modern business and civic problems which demand intelligent solution than the man without legal training. Then what profession offers the broadest possibilities for **YOUR LAW**, of course. **LAW** has opened the way to positions of honor and profit for more men than any other profession or business.

Earn \$3,000 to \$10,000 a Year

ACT! Enter this success-winning, big-income-producing profession **NOW!** Today, more than ever before, **LAW** offers the shortest route to the greatest success—and with the least expenditure of time and money. Don't remain in the small-job, small-pay class any longer. Begin **NOW** to build a career of prosperity, power and independence.

Formerly the opportunities to turn a legal education into money were limited to court practice, but today thousands of the choicest places in the field of professional, political and commercial activity are being filled by law-trained men. They are chosen for leadership, because of their grasp of the fundamentals of law; because they know what can be done legally; because their legal training equips them to analyze a proposition and direct and control affairs that cannot be successfully handled by others.

We Train You By MAIL!

at home, in your spare time to acquire a legal training and become a practicing lawyer, successful business man, prominent statesman, or to qualify as a Legal Counselor, retained by big institutions, corporations, etc.—or as Attorney-at-Law, deriving a big income from defending and prosecuting law suits.

Our method of Home Training insures your success—first because the LaSalle text is edited and written in plain, easy-to-understand language. Second, because it is prepared by such noted legal educators as James Parker Hall, Dean of University of Chicago Law School; James DeWitt Andrews, former member faculty Northwestern

FREE Complete Course In Public Speaking

Our training by mail, will positively teach you the fine art of persuasive speech. Every Lawyer—every successful man—should be a forceful speaker. Our Course is prepared by Frederick B. Robinson, A. B., A. M., Ph. D., Professor Public Speaking at College of City of New York. Write and learn how you can **NOW** secure this valuable Course, absolutely free, if you become one of our law students. You owe it to yourself—to your future—to learn all the facts regarding the LaSalle Law Course and how easily you can master it. Mail the coupon and let us send you our two big, illustrated books—valuable "Law Guide" and "Evidence" together with letters from hundreds of our successful law students. Mail coupon **NOW**.

LaSALLE EXTENSION UNIVERSITY,
Dept. 364-F Chicago, Ill.
The World's Greatest Extension University

University, and over 20 Law School Deans; Professors in famous resident colleges, and famous legal authorities of Bar and Bench. Third, because we guarantee to coach free until successful any graduate failing to pass bar examinations.

Money-Back Guarantee Bond

So thorough is the LaSalle Home Study Course—so exceptional has been the success of LaSalle students—that we issue a legal, binding guarantee to refund the entire tuition fee, if after you complete the Course, you are not perfectly satisfied. This guarantee is backed by our entire capital and resources of more than two million dollars, which assures your absolute success. Don't let the lack of ready money interfere—the total cost of this University Grade Course is surprisingly small, and we make easy payment terms to suit you.

We have successfully trained thousands of men and women in law. Among our graduates are men enjoying positions of honor in political, public and business world. It doesn't matter what your vocation is now, we can help you to the same end. Send coupon for facts that tell how.

Modern Law Library Included FREE

14 massive law volumes—"AMERICAN LAW AND PROCEDURE"—standard size—9½x6½ inches—bound in ¼ sheep. All branches of Law are fully covered. This work cost us over \$50,000.00, but is FURNISHED YOU AT ONCE on your enrollment WITHOUT ADDITIONAL COST.

LaSalle Extension University,
Dept. 364-F Chicago, Illinois

Without obligation on my part, send me by return mail, information concerning your Course in Law with the free books, "Evidence" and Valuable Law Guide—also your offer of FREE Course in Public Speaking to students enrolling now.

Name.....

Address.....

City.....State.....

TYPEWRITE THE NEW WAY!



Free Book Tells How
To Learn
At Home

**80 to 100 Words a Minute
Guaranteed!**

Learn at Home—10 Easy Lessons

A wonderful new method of acquiring skill on the typewriter has been discovered. Almost over night it has revolutionized the whole typewriting situation.

Already thousands of stenographers and other typewriter users who never exceeded thirty to forty words a minute, are writing 80 to 100 words with half the effort and with infinitely greater accuracy than they ever could before, and their earnings have increased in proportion.

Nothing Else Like It

Don't confuse this new way in typewriting with any system of the past. There has never been anything like it before. It is as different from the old touch systems as day is from night. Special *Gymnastic Finger-Training Exercises* bring results in days that ordinary methods will not produce in months. It is the greatest step in typewriting since the typewriter itself was invented—already its success has become nation-wide.

Doubles and Trebles Salaries

Among the thousands of operators who have taken up this system are hundreds of graduates of business colleges and special typewriting courses—many were so-called touch writers—yet there has not been a single one who hasn't *doubled* or *trebled* his or her speed and accuracy, and the salaries have been increased from \$8 to \$15 a week (their former pay) to \$25, \$30 and even \$40 weekly. And the new way is *amazingly easy* for anyone—there are only 10 lessons and they can be quickly learned at home without interfering with your present work.

Valuable Book Free

We cannot describe here the secret principle of this new method. But we have prepared a book which tells all about it in complete detail, which is *free* to those interested if 4c in stamps is enclosed to cover cost of wrapping, mailing, etc. It is a big 32-page book, brimful of eye-opening ideas and valuable information. It explains how this unique new method will quickly make your fingers *strong and dexterous*, bring them under *perfect control*, make them *extremely rapid* in their movements—how in a few short weeks you can transform your typewriting and make it *easy, accurate and amazingly speed*—all this and much more is told in detail. No instruction book ever written, no matter what it cost, ever told so plainly the real **WHY** and **HOW** of expert typewriting.

If you are ambitious to get ahead—if you want to make your work easier—if you want to put more money in your pay envelope—get this book at once. It will be a revelation to you as to the *speed and salary* that is possible to typists. Mail the coupon or a postal today—*Now*. Address, The Tulloss School, 123 College Hill, Springfield, Ohio.

USE THIS FOR BIGGER PAY

THE TULLOSS SCHOOL, 123 College Hill, Springfield, Ohio
Please send me your Free Book about the New Way in Typewriting. This incurs no obligation whatever on my part. I enclose 4c in stamps to cover wrapping, mailing, etc.

Name.....
Street.....
City..... State.....
Occupation.....

Men Wanted for Auto Business

The Auto business is growing rapidly. There are not nearly enough trained auto men in the country. Splendid opportunities everywhere for men who know.

You can be an experienced auto man and command a good income. We train Repairmen, Chauffeurs, Garage Managers, Auto Salesmen, etc.—18 branches. Actual work and practical experience under experts. Individual instruction—no overcrowding. Special training in all **Lighting and Starting Systems, Acetylene Welding, Brazing, Vulcanizing, etc.** Only 8 to 10 weeks required. Employment guaranteed for competent graduates.

Big Auto Book—Free: "How to Succeed in the Automobile Business." A mine of practical information. Sent free. With today.
Greer College of Motoring Department M
1519 Wabash Ave., Chicago

ENGINEERING MECHANICAL ELECTRICAL

One Year Practical Courses. Day and Evening classes. Splendid equipment and instruction. Low tuition. For particulars address

DETROIT TECHNICAL INSTITUTE
Box 308, Y. M. C. A. Building, DETROIT, MICH.

The Student Illustrator



a practical art magazine publishes lessons and articles on every phase of cartooning, designing, lettering, newspaper, magazine and commercial illustrating. It is an art education in itself. The latest and most up-to-date methods in the big paying field of commercial art thoroughly explained by experts. Amateur work published and criticized. Satisfaction guaranteed or money refunded. \$1.00 per year. Three months' trial 25 cents.
Del. E. Schwartz Bldg., Washington, D. C.

MEN and WOMEN WANTED

\$65 to \$150 Month

U. S. Gov't Wants Help

**Railway Mail Clerks
City Mail Carriers
City Postal Clerks
Custom House Clerks
Panama Canal Clerks**

**March and April
Examinations Everywhere**

Send coupon IMMEDIATELY for schedule showing dates and places of the March and April examinations in your section and the valuable features mentioned.

**We Will Coach a Limited
Number of Candidates
Free of Charge.**

This 2-cent stamp may bring you
a BIG PAY LIFE JOB!

FRANKLIN INSTITUTE
Dept. W 103
ROCHESTER, N. Y.

COUPON
FRANKLIN INSTITUTE, Dept. W 103, Rochester, N. Y.
Kindly send me, without any obligation whatever on my part, and entirely free of charge, (1) a schedule of the dates and places of the March and April examinations in my section and the valuable features mentioned; (2) a list of U. S. Government jobs now easily obtainable; (3) directions telling me how to get free coaching for the positions checked.
Name.....
Address..... (W 103)
Use this before you lose it
Write plainly

Customs Positions	(\$800 to \$1500)
Internal Revenue	(\$700 to \$1800)
Stenographers	(\$800 to \$1500)
Clerk in the Departments	(\$800 to \$1500)
Clerk at Washington	(\$800 to \$1500)
Railway Mail Clerk	(\$900 to \$1800)
Postoffice Clerk	(\$800 to \$1200)
Postoffice Carrier	(\$800 to \$1200)
Rural Mail Carrier	(\$800 to \$1200)
Bookkeeper	(\$800 to \$1200)

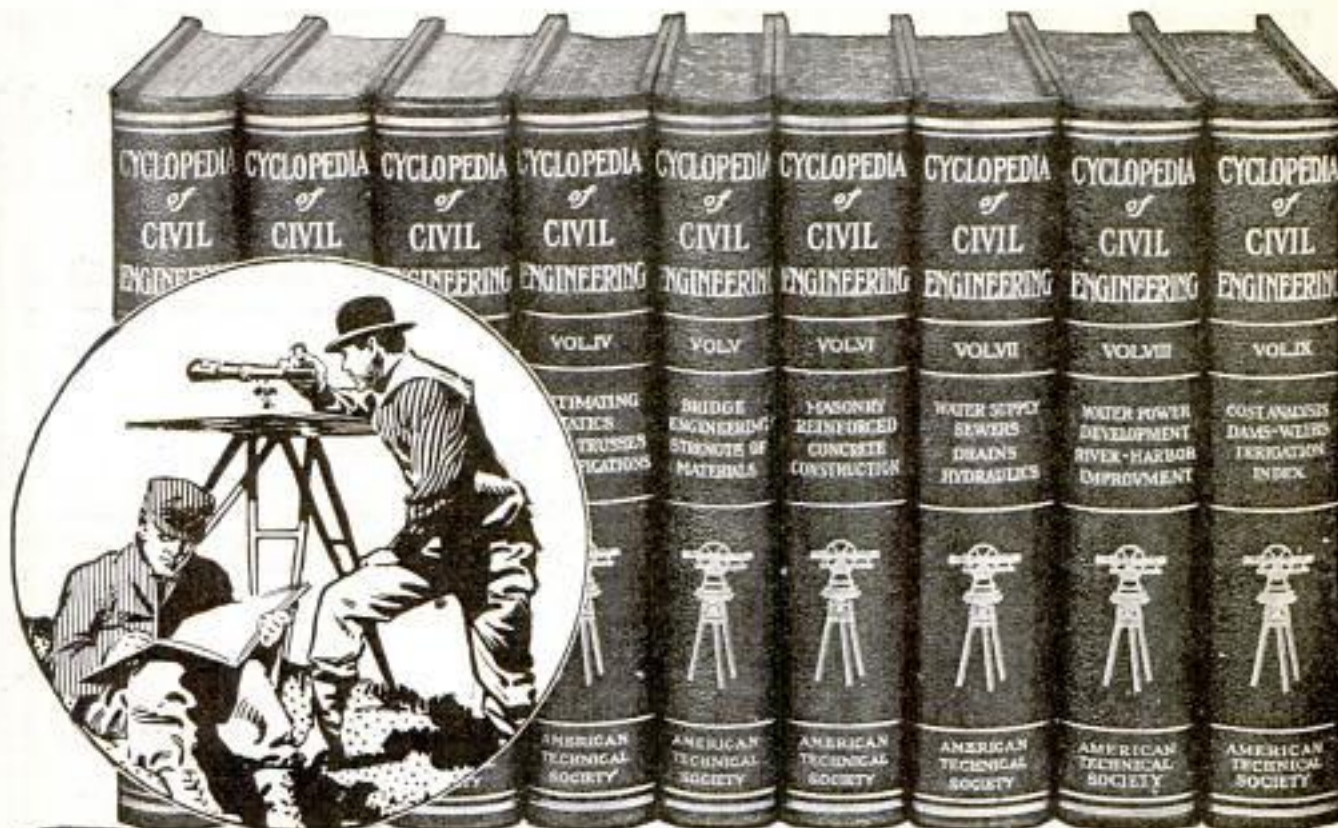

Civil Engineers Earn \$1500 to \$5000 a Year!

DON'T take our word for it that these books will fit you to earn \$1500 to \$5000 a year as a Civil Engineer. Get them into your home—free of all charges—and determine their value for yourself. The books themselves, not what we say, must convince you that you need them. Send the coupon now for your free-examination set of the brand-new *Cyclopedia of Civil Engineering*. The demand for Civil Engineers was never greater than today. The enormous development of reinforced concrete construction insures steady employment at big pay to thousands of trained men. The nine thick volumes illustrated above will give you the knowledge you need to qualify for one of these jobs. Send for them today.

50c a Week This trivial sum—less than most of us pay for tobacco—will soon pay the low introductory price of the *Cyclopedia of Civil Engineering*. But you must act now! This liberal offer can't be continued indefinitely, so mail the coupon while you can buy this valuable set at a great reduction—and on the easiest of easy-payment plans.

Use Them 7 Days! Free Consulting Service

The entire nine volumes will be sent to you by prepaid express for seven days' free examination. Don't send a penny—just the coupon! The books are handsomely bound in half red morocco leather, gold stamped, and contain 3909 7 x 10-inch pages and 3099 illustrations, plates, maps, diagrams, etc.

These big, thick volumes contain everything you need to know to become a successful Civil Engineer. They cover surveying, highway construction, railway engineering, earthwork, specifications, estimating, contracts, bridge engineering, masonry, reinforced concrete, water supply, sewers and drains, water power equipment, river and harbor improvements, irrigation engineering, etc., etc. Every line is written in plain, simple English. Every technical point is made perfectly clear.

Don't Send a Penny—Just the Coupon!

All you need to do to get the *Cyclopedia of Civil Engineering* is fill in and mail the coupon. Then the entire nine-volume set will come to you by prepaid express for a full week's examination. If you keep it, send only \$2.00 within seven days, and then \$2.00 a month—50c a week—until the introductory price of \$29.50 has been paid. This is \$15.50 less than the regular price of \$45. If you don't want the books, send them back at our expense and you won't be out a penny.

This is a remarkable opportunity to prepare yourself—in your spare time—for the fascinating, highly-paid work of a Civil Engineer. If you live within the borders of the United States and Canada, fill in and mail the coupon today—now!

American Technical Society, Dept. C1193, Chicago, U.S.A.

With each set of this new *Cyclopedia* we give without charge a year's Consulting Membership in the American Technical Society. This entitles you to the privilege of submitting your perplexing problems to our corps of Civil Engineers. Such a membership regularly costs \$12.00, but in connection with this special offer you don't pay a cent for it. Remember, this service is absolutely unlimited. Ask as many questions as you wish for an entire year. Send the coupon now—see for yourself what this opportunity means to you.

**American Technical Society
Dept. C1193 Chicago, U.S.A.**

Please send me the nine volume set of *Cyclopedia of Civil Engineering* for seven days' free examination. If I decide to buy, I will send \$2.00 within seven days and the balance at \$2.00 a month until \$29.50 has been paid. Then you send me a receipt showing that the set of books and the \$12.00 consulting membership are mine and fully paid for. If I think that I can get along without the books after the seven days' trial I will return them at your expense.

Name

Address

Reference



Child Pianist Amazes Audiences

Mother of 13-Year-Old Prodigy Explains Daughter's Remarkable Skill

THE extraordinary skill exhibited by little Mayme Morrison, pianist, in her first public appearance has challenged the wonder of thousands who have heard her. Surprise becomes amazement when her admirers are informed that she never had a teacher, but has acquired her wonderful ability by a new, easy method for learning music at home by mail. Miss Morrison is a pupil of the U. S. School of Music of this city, and her mother was recently invited to tell the story of her daughter's success. The following letter was received in reply:

"Dear Sirs: You can't conceive with what heartfelt thanks I write you concerning my daughter, Mayme. When she began taking lessons from your school she did not even know middle C on the organ. I just thought then how proud I would feel when she had learned to play a few selections correctly. I never grew tired of hearing her practice her lessons, and I took so much pride in her skill that the cares and worries of raising my little family grew lighter. My greatest hopes for Mayme have been more than granted by hearing her play in public with

perfect success, and to hear her audiences praise her. She has also been featured in many concerts, so you see I have great reasons to be glad because she took up your course of music.

"Yours with best wishes,

"(Signed) MRS. MINNIE MORRISON.

"P. S. It was through the letters written by some of your pupils that I was induced to take the course for my daughter, and if you think this letter will do you any good in that respect, you are welcome to publish it."

FREE Lessons MUSIC

New, Easy Method

The most remarkable offer in the history of music schools. No previous study is necessary. You learn, right in your own home and without a teacher, how to play by note and you pay not one penny for your instruction while this offer lasts. Thousands of pupils write like Miss Morrison's mother. Free lessons to a limited number of new pupils to advertise our new system of teaching. Start now and before the winter is over you can be a finished player of your favorite instrument. You can delight your family and friends and be sure of the cordial welcome everywhere extended to those who can entertain. Think of the pleasure you can yourself derive through all the years to come. We grade you before you start and fit your instruction to your special individual needs. All lessons prepared by eminent masters of music. If you came to New York to study under these famous teachers—Wilcox, Kohler, Bickford, Clark, Knoll, Newman—you would have to pay hundreds of dollars for your instruction. Yet on this extraordinary advertising offer these same teachers give you lessons by our new simplified method. Free by mail.



PLAY BY NOTE—ANY INSTRUMENT!

Guitar Cello Clarinet Trombone Piccolo Flute Piano Violin Banjo Organ Cornet Harp Mandolin Sight Singing

LEARN AT HOME

Already thousands have learned music by our new, simple Home Study method. No tiresome, "dry" exercises, no inconvenience, no drudgery, no "trick" music, no "numbers"—but fascinating lessons that even a child learns quickly. Choose your own hours for study and practice.

Act Now!

before it is too late. In return for your Free Instruction all we ask is that you tell your friends about this School and our new, easy Home study method.

Your only expense is postage and for sheet music required for your lessons, averaging less than 15c weekly—about 12c. Send the coupon for our new 32-page book explaining the secret principles of our new system by which many have not only learned to play, but are now making money by teaching others.

U. S. SCHOOL OF MUSIC
Dept. 132, 225 Fifth Ave., New York City

U. S. School of Music
Dept. 132, 225 Fifth Avenue
New York City

Please send me your free book, "Music Lessons by Mail," explaining how I can learn to play. I would like to learn how

to play the.....

Name.....

Address.....

Chief
Electrician

YOUR GREAT CHANCE BE A TRAINED ELECTRICIAN

Learn at Home

You wide-awake boys and men—think what a glorious opportunity I offer you! You know that this is the Electrical Age—that the watchword of the day is "Do It Electrically!" The field is widening daily. Each day sees some new electrical discovery, some new application of the magic "juice." Greater and greater grows the need for electrical men! Public utilities, municipalities, manufacturers and contractors are calling for the man who knows electricity. Then why not answer the call, when it means big pay for you and the kind of work you'll be proud of? Why not prepare yourself, when I, a well-known Electrical Expert of many years' experience, offer you this opportunity to learn electricity quickly, thoroughly and expertly at home in your spare time.



Earn \$2400 to \$5000 a Year I Will Teach You Personally by Mail

I am revolutionizing the teaching of electricity. My new personal method of instruction is making a profound impression. You learn during your spare time. If you are working, you can keep on drawing your salary while learning. You can qualify in a short time to command a nice, big salary—\$50 to \$100 a week as a trained electrician! I instruct you personally. I make the whole matter so simple for you that you can't help but learn. I show you not only how to do and supervise electrical work, but also how to estimate on jobs so that you can take contracts at big profits and establish a business of your own if you wish. Don't think that you have to have some electrical knowledge or be employed in some electrical work to take up my instruction. If you are ambitious, and can read and write, I will teach you successfully. My instruction is bound to be practical, as I am a practical electrician.



A. W. Wicks, E. E.

Formerly with the General Electric Co.; former General Manager of company manufacturing Jenney Electric Motors; also formerly with Fairbanks, Morse & Co.; now Consulting Engineer and Director of the Wicks Electrical Institute.

20 Complete Lessons FREE!

Think of it! My personal and individual instructions for 20 lessons without a cent of cost to you if you act quick. No charge to you for these 20 lessons, now or later. I make this sensational offer to secure a few more live students at once, and to prove, too, how quickly I can make you a high-salaried electrician. But you must act at once! This offer is strictly limited. Remember, these free lessons are not merely sample lessons, but are a regular part of my full and complete course in electricity. Send the coupon or drop me a postcard.

Send This Free Coupon Today!

Put your name and address on the free coupon, or a letter, or a postcard, and mail it to me today. I will send you absolutely free, full particulars of my sensational offer of 20 free lessons. I will also send you, postpaid free, my great book on electrical instruction and the opportunities that are open to the electrical man. This is without doubt one of the most remarkable works on the subject ever written. It describes my course and method of instruction in full. You assume no obligations of any kind in sending the coupon. So write today without fail. Send the coupon before you turn this page.

ALBERT WOOD WICKS, E. E. Director
WICKS ELECTRICAL INSTITUTE,
81 West Randolph St., Dept. 278 Chicago, Ill.



MAIL NOW! COUPON NOW!

A. W. WICKS, E. E. Director
Wicks Electrical Institute
Dept. 278

81 West Randolph St., Chicago, Ill.

Without any obligation on me whatever, please send me full description of your personal instructions in Electricity and particulars of your special offer of 20 of your lessons free.

Name.....

Street No.....

City..... State.....

Please Mention Popular Mechanics

A Big Job For a Little



Take Ten Lessons— then decide

TAKE your pencil now—and make an X in the coupon before the position in life that you want to fill. You will be under no obligation. This little X is an easy thing to make but it will bring to you a vital, inspiring message that will tell just exactly how you can qualify yourself, right in your own home, to fill the position that you are dreaming about.

We'll tell you, too, how you can start this training and get ten complete lessons. And, then, if you don't think the course is going to put you into the position you want, we'll refund every cent you have paid.

Nowadays, the thing that puts a man in a high position is training! There isn't one man in a thousand who can get this training without help.

This advertisement brings to you the chance to get the help that has put thousands on the road to success. And you can prove it to yourself. You can take ten lessons and, if you are not satisfied, we'll refund your money.

Send the Coupon

Make an "X" in this coupon now before the position you want to fill. Find out for yourself what the American School has to offer to you. Find out how the hard places have been made easy and how thousands and thousands of men all over the world are now making their marks in the business world—because they have training. You will be under no obligation by sending the coupon. Send it now.

**American School
of Correspondence, Chicago, U.S.A.**
Dept. G1193

American School of Correspondence, Dept. G 1193 Chicago, U. S. A.

Gentlemen: Please send me booklet and tell me how I can fit myself for the position marked X.

- | | |
|--------------------------------|-------------------------------|
|Electrical Engineer |Business Law |
|Elec. Light & Power Supt. |Business Manager |
|Hydro-electric Engineer |Auditor |
|Telephone Engineer |Accountant |
|Architect |Cert'd Public Acc't |
|Architectural Draftsman |Stenographer |
|Building Contractor |Bookkeeper |
|Building Superintendent |Fire Ins. Inspector |
|Structural Engineer |Fire Ins. Adjuster |
|Structural Draftsman |Fire Ins. Expert |
|Mechanical Engineer |Sanitary Engineer |
|Mechanical Draftsman |Master Plumber |
|Civil Engineer |Plumbing & Heating Est. |
|Steam Engineer |Heating & Vent. Engineer |
|Shop Foreman |Reclamation Engineer |
|Shop Superintendent |Automobile Engineer |
|Sheet Metal Draftsman |Automobile Repairer |
|Lawyer |High School Course |

We also prepare for civil service examinations in all engineering subjects

Name.....

Address.....

"A Train Load of Books" What Clarkson is Doing for the Book Buyer



IN several hundred thousand libraries, in the homes of people in every walk of life—from the day laborer to the college professor and high government official, from the persons who buy a few books of popular fiction to the persons who pride themselves on having the complete works of all the standard authors in De Luxe Sets artistically printed and bound, almost every book was bought from me. WHY? Because I have no agents and sell you just the book you want—all new—many at a saving of from 50 to 90 per cent. You examine the books in your own home for five days before paying for them. If not satisfied, return them at my expense—and see me nothing.

Sample Prices:

When a Man a Man. Publisher's price, \$1.35. My price, 90c.
Eyes of the World. My price, 50c.
Famous Pictures. \$3.00—\$1.40.
Encyclopedia of Quotations. Pub. price, \$2.50. My price, 80c.
What All Married People Should Know. \$1.00—75c.
Buffalo Bill's Own Story of His Life and Deeds. \$1.50—85c.
Famous Orators. \$2.50—\$1.25.
Law Without Lawyers. Pub. price, \$2.00. My price, 65c.
Shakespeare, 24 vols., 24mo. Limp Leather. \$2.40.
When a Man Comes to Himself—Woodrow Wilson. 50c.
Jiu-Jitsu, or Art of Self-Defense. \$1.25—60c.

Here are De Luxe Sets, Morocco bound, complete works, many of them at less than 25 cents on the dollar. Hugo, Kipling, Poe, Eliot, Dickens, Thackeray, Stevenson and scores of others.

Key to the Bible. \$3.75—90c.
Library of Wit & Humor. \$1.50—50c.
Huckleberry Finn and Other Mark Twain Books. \$1.75—\$1.25.
Brazz: The Immortal. 2 vols. \$2.25.
History of the World. 8 vols. \$12.00—\$2.75.
Memory: How to Develop. 80c.
Century Book of Health. Pub. price, \$3.50. My price, \$1.50.
New Americanized Encyclopedia, 15 vols., 3-4 Leather. Pub. price, \$75.00. My price, \$14.75.
Century Dictionary and Encyclopedia, 12 vols., 3-4 Leather. Pub. price, \$120.00. My price, \$39.50.
New American Encyclopedic Dictionary, 5 vols., 3-4 Leather. Pub. price, \$21.00. My price, \$4.75.

Get My Big, New Catalogue

My new catalogue, sent free for the asking, tells you how to save 50 to 90 per cent on thousands of books. It is a course in literature, giving nationalities, date of birth and death of authors, the author's life and standing in literature, etc. Hundreds of sets and thousands of single volumes listed. I sell more books direct to the booklover—the individual reader—the rich man who insists upon his dollar's worth—the man who watches his pennies—and sell them for less money—than any other man in America. Every book new and fresh, and guaranteed to please you—you to be the judge. I do not quibble, and would rather have a book or set of books returned at my expense than to have a dissatisfied customer.

DAVID B. CLARKSON, The Book Broker,
316 Clarkson Building, Chicago, Illinois

I Want
1000 Men
To Prepare for Jobs Paying
\$75 to \$300
Per Month



The boom is on. Bosses are paying more and more to get men skilled in auto mechanics to work for them. Garage owners stand ready to pay big money for Expert Repairers. Gas Engine manufacturers are short on trained workers. Thousands of tractors are ready to go on the farms—and there are only a few experts to run them. A million new cars are to be built this year and good drivers will be scarce. From everywhere comes the demand for men—trained men. If you are ambitious, I will train you quickly at home in your spare time for one of these big jobs. I will teach you to

Be an Expert Auto Mechanic

**Repair Man, Chauffeur,
Traction Engineer, or
Farm Lighting Expert,**
in shortest possible time. Big jobs are ready and waiting for you. With I. M. I. training you can quickly qualify as an expert in any of the above lines—prepare for a job paying up to \$300 a month.

I will give you 25 Lessons Free. But you must act at once. Only 1,000 Partial Scholarships will be given away, and only one in each locality. Rush coupon and get details of FREE offer. Investigate. Write today. Results guaranteed.

**25
LESSONS
FREE**

HARRY WELLS, Gen. Mgr.
International Motor Institute,
137 Kenner Building, Chicago

Send me full details of your 25 Free Lessons Offer, also Enrollment Blank.

Name.....

Address.....

Please Mention Popular Mechanics

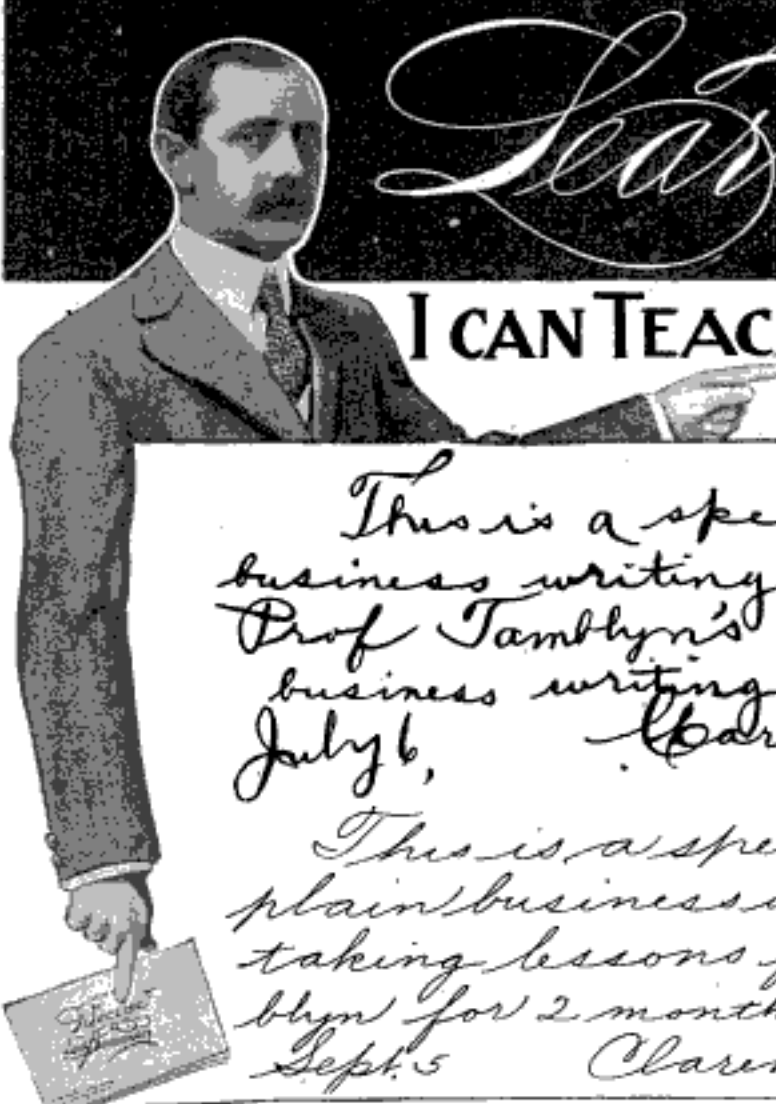

Learn^{TO} *Write*

I CAN TEACH YOU AT HOME
During Spare time

This is a specimen of my business writing before taking Prof Tambllyn's course in business writing
July 6, *Clarence P. Weber.*

This is a specimen of my plain business writing after taking lessons from F. W. Tambllyn for 2 months
Sept. 5 *Clarence P. Weber*

FREE BOOK

My 32-Page book "How to Become a Good Penman" is FREE to anyone who wants to write better. Contains copies and information that will help you, and beautiful specimens that will make your eyes twinkle with delight.

WRITE FOR IT—use the coupon below—or a postal will do—but

Send at Once!

If you enclose a stamp, I will write your name on a card with white ink, making one of the prettiest specimens of penmanship you ever saw

F. W. TAMBLYN

418 Ridge Bldg., KANSAS CITY, MO., U.S.A.

"A Wonderful Bargain" "It is now about two months since I began your course, and while I am not quite half through with Business Writing, I am delighted with my improvement, which is quite marked as you will see by comparing my present writing with the specimen written when I began. My parents objected to my taking it up, but now see I'm getting a wonderful bargain."

—CLARENCE P. WEBER, Middletown, Del.

Good Writing Is the Very Foundation of Business Success

I can make a good penman of you at your own home, in your spare time, no matter where you live or how poorly you now write. Ever fail to secure a good position because of poor penmanship? Ever know of better positions you could have stepped into if you only wrote a good hand? If not, you're an exception. The advantage of good penmanship is seen all around us.

I have been teaching penmanship by mail over 20 years. I know that any ambitious person can master penmanship just as quickly and thoroughly by my system at home as if in a schoolroom under the personal instruction of the teacher.

BEGIN NOW to learn good handwriting and be ready for the next better position that comes your way. Learn right at home—in your own room, outside of working hours. Your spare time is all I ask.

I teach Spelling and Letter Writing also.

Mr. Weber's wonderful improvement shown in the specimens above was made in 2 months. Hundreds and hundreds of others in all parts of the country are doing the same.

YOU CAN DO AS WELL

This Brings FREE BOOK

F. W. TAMBLYN, 418 Ridge Bldg., KANSAS CITY, MO.

I am interested in improving my penmanship. Send me your Free Book, "How to Become a Good Penman," postpaid.

Name.....

Address.....



33,000 sq. ft. of Additional Floor Space

Come to Detroit

The Automobile Center and

LEARN THE AUTOMOBILE BUSINESS

DETROIT
trained men get preference and get jobs quickly. No other city can give what Detroit offers. Think what it means to learn in the Michigan State Auto School. Factories endorse our school, glad to employ our graduates or offer them territory in which to sell cars and start garages. Unlimited opportunities. 71% of Automobiles are made in Detroit. You're right in the Heart of the Auto Industry. Men are needed everywhere as testers, repair men, chauffeurs, garage men, and salesmen. Hundreds of our graduates start in business for themselves.

Get Better Job—or—Go in Business

We teach you to handle any auto proposition. You graduate in from ten to twelve weeks. Our equipment is new, up-to-the-minute, and complete. No old, obsolete motors, chassis or electrical equipment used. Students actually build cars from start to finish, getting factory training in assembling, block-testing, road-testing, everything. Special complete course in Oxy-Acetylene brazing, welding and cutting, separate from regular course. Learn to time motors, rebore cylinders, adjust carburetors, magnetos, valves and bearings quickly and accurately. Six-cylinder Lozier, Chal-

mers "6," Detroit "6," Overland, and 8-cylinder King are used for road instruction. We have a new Chalmers "6-30" chassis with 3400-r. p. m. motor, the latest thing out, Willys-Knight 1917 chassis, Saxon "6" 1917 chassis, Studebaker "6" 1917 chassis, Maxwell 1917 chassis, Hudson Super-Six 1917 chassis, Oldsmobile "8" 1917 chassis, Cole "8" 1917 chassis, Briscoe 1917 chassis, Detroit Electric 1917 chassis, Winton "6" chassis. All completely equipped for students to work on. We have more than 25 motors in our block test department—2 cyl., 4 cyl., 6 cyl., 8 cyl., and 12 cyl. Our electrical department is complete, having every standard starting, lighting, and ignition system, including Delco System as used in Buick, Hudson, and Packard Twin "6."

Detroit Is the Place to Learn—Start Any Time

There are 44 auto factories in Detroit and 140 accessories and parts factories. Our students have the privilege of going through any or all of them. We now operate Westinghouse, Auto-Lite and Bijur Service Stations. This has added thousands of dollars' worth of equipment and makes our electrical department unequalled. Students get actual experience in handling all kinds of electrical auto equipment and taking care of trouble. We have just installed a Sprague Electric Dynamometer for block-testing purposes for students' use. Ours is the only Auto

school having this equipment. Auto factories need Dynamometer men constantly. Factories and garages are paying big salaries to men who know how to handle electrical equipment quickly and properly. Detroit is the automobile center. You get practical instruction. School open all the year. Enter classes any time, any day. Three classes daily; morning, afternoon, evening. All instructors are members of the Society of Automobile Engineers (S.A.E.) There is a great demand for Michigan State Auto School students. Auto factories write and phone for men constantly.

Follow the Crowd to the Michigan State Auto School. Come to Detroit

Money-Back Guarantee
We guarantee to qualify you in a short time for a position as chauffeur, repair man, tester, demonstrator, garage man, or automobile dealer, paying from \$25 to \$300 monthly or refund your money. We have constantly more requests for Detroit trained men at \$6000 salaries than we can supply.



THIS IS ONE OF THE JANUARY 1916 CLASSES'

Additional Building and Equipment
Thousands of dollars' worth of new equipment, plenty of room for students to work, at 687-89-91 Woodward Ave., in addition to our building at 11-19 Selden Ave. Our school has grown by leaps and bounds, students come from all over the world. We are constantly adding new equipment. Our electrical department is thorough and complete.

Auto Factories Endorse Our School
The Leading Automobile factories in Detroit, as well as in other cities, endorse our school. They have been watching our school and graduates for years and are satisfied. They are putting their latest model, complete chassis in our school for students to work on. They are employing our graduates in their factories and service stations and assisting them in opening garages and salesrooms. They allow our students to go through their factories. They need trained, competent men and are asking for more of our graduates constantly. The Michigan State Auto School in Detroit, the heart of the Auto Industry, is endorsed by the Leading Auto Factories, is receiving their hearty co-operation. What better endorsement could you ask?

Factory Co-Operation
We have completed arrangements with the Auto factories to put them in touch with men who intend going into business for themselves. Men who know the auto business from A to Z are in biggest demand. Remember, the price of course is based on giving full value. Graduates in the complete auto course are competent to handle farm tractors.

Act Quickly—NOW!
Fill in the coupon; get full particulars, "Auto School News" and New Catalog. All absolutely free. Or better still, jump on the train, as hundreds have done, and come to the "Heart of the Automobile Industry," and learn right. We have no branches. Write or come direct to this school.

SEND THIS COUPON TODAY

MICHIGAN STATE AUTO SCHOOL
303 Auto Bldg., 687-89-91 Woodward Ave.
DETROIT, MICHIGAN, U. S. A.

Gentlemen: Send me absolutely FREE "Auto School News" and New Catalog, or better still, you can expect

me about.....

Name.....

Street.....

Town..... State.....

Michigan State Auto School

The Old Reliable School A. G. ZELLER, Pres.
303 Auto Building
687-89-91 Woodward Avenue
DETROIT, MICHIGAN, U. S. A.

DETROIT
THE HEART OF THE AUTO INDUSTRY



THE AUTOMOBILE CENTER OF THE WORLD

44 AUTOMOBILE FACTORIES 140 ACCESSORY FACTORIES

EARN \$75. TO \$300. A MONTH

With the New Building and Thousands of Dollars Worth of New Equipment, Our's is the Largest Exclusive Auto School in the Country



We teach the newest and best way to re-bore cylinders as a part of the complete Auto Course. No need to have big, heavy, expensive machines. This is very important instruction.



This is a partial view of our Chassis room showing eight up-to-date chassis for students' use.



These men are getting final instructions after they have taken down and rebuilt a new up-to-date 6 cyl. motor.



A new 12 cyl. motor connected to our Sprague Electric Dynamometer in Block Test Dept. for students' use.



DECEMBER 1916 CLASS IN MECHANICAL LECTURE ROOM

This is the first work a student receives. A 6 cyl. 1917 Saxon "Cut-open" chassis is used to make perfectly clear and practical the first instructions. There were 350 men set for this picture. The Electrical Lecture room is the same size. The classes are divided so that more intense work can be done on each subject. Every man is given personal help and his progress through the school is watched carefully.



This is a section of the Brazing, Welding and Cutting Department. Each man handles the torches and works with an individual outfit.



View showing about 18 motors in the Block Test Department. Sprague Electric Dynamometer shown in center background.

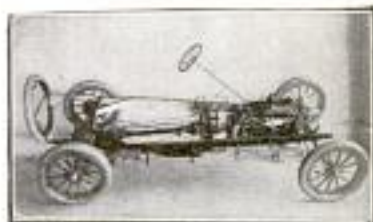

A close view of Saxon "Cut-open" chassis used in Mechanical Lecture room. Hidden parts are cut open and electric lighted.



Students getting personal instructions on Willys-Knight 1917 chassis.



Students making final test on Maxwell 1917 unit power plant motor.



Complete working Delco System as used in Buick, Hudson, and Packard Twin "6."



Battery Charging room, showing lighted switchboard and distilled water rack.

These cuts were all made from actual photographs taken in our school.

Use the Coupon on left-hand page **Don't Even Hesitate**

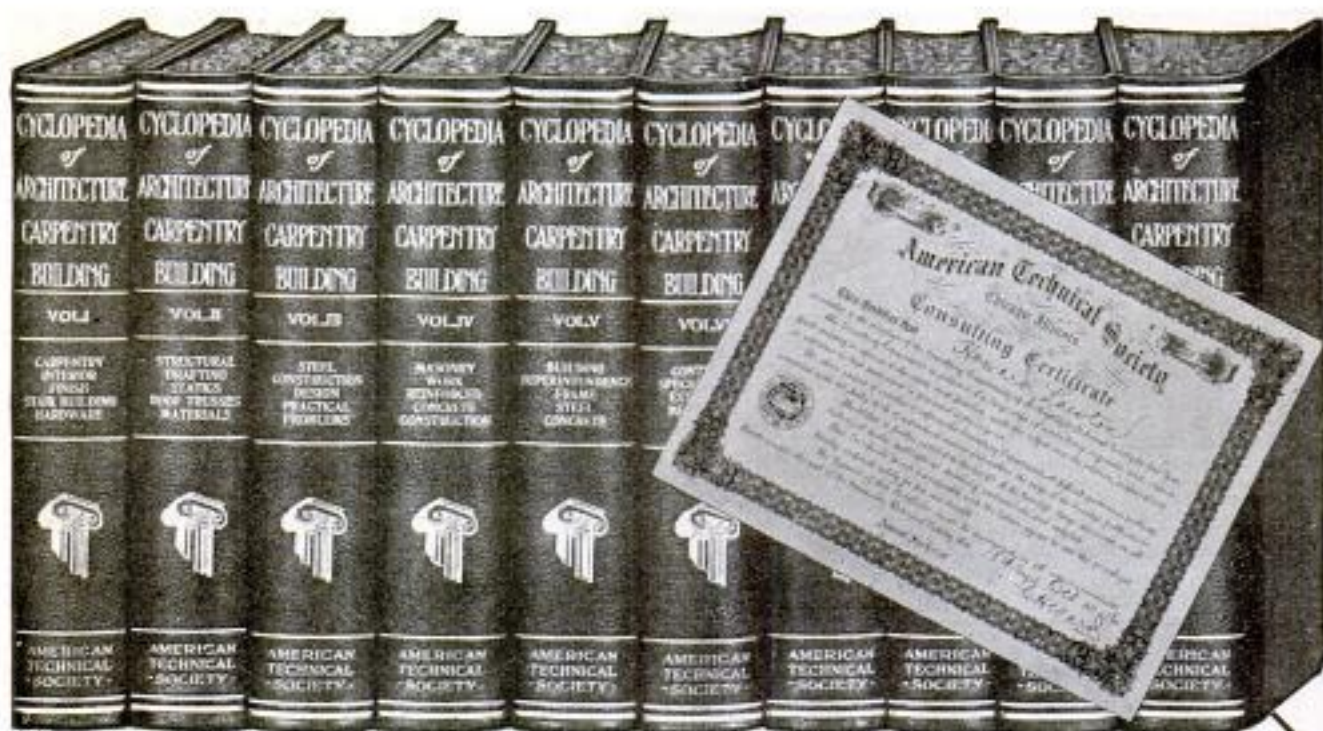

50 Cents A Week

FOR this insignificant sum—less than most of us spend for tobacco—this ten-volume Cyclopedia of Architecture, Carpentry and Building is yours. Yes, and with every set is included—**free of charge**—a year's Consulting Membership in the American Technical Society. The Consulting Membership gives you the privilege of submitting your perplexing problems to a corps of experts for a whole year free. This Consulting Membership regularly sells for \$12, and puts at your disposal a wealth of information and the knowledge of men high in the profession.

Fletcher Cunningham, Shreveport, La., writes: "After receiving the books I decided that with their help I could go into the contracting business for myself. I have just closed a contract on which I expect to clear about \$112.00 for two weeks' work."

Use Them Seven Days FREE

The entire ten-volume Cyclopedia will be sent to you by prepaid express upon receipt of the coupon below. Don't send a single penny—just the coupon! Use the books for seven full days before you decide whether or not you want them. If you keep them, you may pay the advertising price of \$24.50 in easy monthly installments of \$2.00—**50c a week**. The regular price of this massive set is \$50.00. Remember, if you don't want the books they may be returned at our expense and you won't be out a penny.

Partial Table of Contents

Mechanical, Free Hand, Perspective and Architectural Drawing, Lettering, Pen and Ink Rendering, The Orders, Superintendence, Strength of Materials, Masonry, Reinforced Concrete, Carpentry, Stone Building, Hardware, Steel Construction, Roof Trusses, Practical Problems, Estimating, Contracts, Specifications, Building Law, Sanitation, Sheet Metal Work, Electric Wiring and Lighting.

Everything About Carpentry and Building

Contained in the Cyclopedia's ten splendid volumes is everything about carpentry and building, from the first rough sketch of the architect to the acceptance of the finished structure. They include wood, stone, steel and reinforced concrete construction; estimating and contracting; interior finishing and decorating; and modern house lighting and sanitation. Every line is written in plain, understandable language—every difficult point is made clear. The books are handsomely bound in half red morocco leather, gold stamped, and contain 4,760 pages (7x10 inches), and 4,000 illustrations, full-page plates, building plans, diagrams, etc. Every subject is cross-indexed so it can be referred to in an instant.

Just Send the Coupon

Don't send us a single penny. Just fill in and mail the coupon. Then we will send the books to you by prepaid express for seven days' free trial. Remember, you don't assume a single obligation—we are glad to have you see the books for yourself before you decide whether or not to buy. This offer is open to anyone within the boundaries of the United States and Canada. Send the coupon today—**now!**

American Technical Society, Dept. R1193, Chicago, U. S. A.

American Technical Society
Dept. R-1193 CHICAGO

Please send the Cyclopedia of Architecture, Carpentry and Building for seven days' examination. If I decide to keep it I will send \$2 after 7 days and \$2 a month until \$24.50 has been paid, when you will send me a receipt showing the \$20 set and Consulting Membership are mine and fully paid for. Otherwise I will return at your expense.

Name.....

Address.....

Reference.....



Train for a Job Like This

Don't be content to stay in a job that almost any man can fill. Prepare yourself for a position in a **new profession**—for a position that **needs you**—wants you.

There are 500,000 Firms that need the services of Expert Accountants. There are only 2,000 certified public accountants in America. The field is unlimited; the demand many times greater than the supply; the salary far in excess of that earned in other fields.

**We
Train
You By
Mail**

**Be An Expert
ACCOUNTANT**
At \$3,000 to \$10,000 a Year

**Your Instruction
Will Be Under
Direct
Supervision of
William
Arthur Chase,
C. P. A.**

—in spare time at home to qualify for one of these positions. You can advance as quickly as your time permits.

The expert accountant is the big man in the office—one of the most important factors in the conduct of any business. His knowledge of the innermost secrets of a business makes him indispensable to the boss. He is one of the first men to be consulted in all matters of management and finance and is confidential adviser in important executive affairs. His salary is anywhere from \$3,000 to \$10,000 a year.

Our training is made personal and individual. It takes into consideration your present knowledge or lack of knowledge and is fitted to serve your exact requirements. We prepare you from the ground up; provide complete and comprehensive training according to your individual needs from the simplest bookkeeping principles to the most advanced accounting problems. We will give you whatever training, instruction or review on the subject of bookkeeping you may personally need—and without any extra expense to you.

Small Cost—Easy Terms

In this course all needless text-book theory has been eliminated. It is practical, directly to the point, giving you such instruction as you need in the shortest possible time. The cost is surprisingly small, and the terms so easy that you will scarcely miss the money. You owe it to yourself to learn all the facts about this course and the truly remarkable opportunities it opens up in the business world today. We have published a book which tells the whole story. Explains state examinations, state regulations, salaries paid expert accountants, etc.—also gives complete information regarding the course. We will be glad to mail you a copy free, without the slightest obligation to you. Write your name and address in the coupon, mail it and learn how quickly you can, if you will, say good bye forever to hard grinding work, long hours, low wages with little or no chance for advancement and enter a field where there is plenty of room, where you can give orders instead of take them, and draw a real man's salary. Take the first step now. Mail the coupon today.

LaSalle Extension University, Dept. 364-H Chicago
"The World's Greatest Extension University"

Ex-president of the National Association of C. P. A. Examiners and Ex-Secretary of the Illinois State Board of Examiners in Accountancy, and other experts who rank among the highest. No expense has been spared to make this the easiest-to-understand, simplest to master, and most complete Home Study Accountancy Course ever prepared. It covers thoroughly every phase of Practical Accounting, Theory of Accounts, Auditing, Cost Accounting, Business Organization, Business Management, Business Laws, etc.

Hundreds of accountants, bookkeepers, clerks, cashiers, correspondents and office men in subordinate positions have developed into executives of rare ability and today are commanding handsome salaries—all because of LaSalle training. What we have done for others we can do for you.

The LaSalle Guarantee

We give you a written agreement signed by our Treasurer that upon your satisfactory completion of the course, should you fail to pass the certified Public Accountant's examination held in any state, we will give you special instruction and help—without additional charge—until you do pass. We further agree to refund entire amount of tuition, according to our Guarantee Bond, if dissatisfied with the course.

MAIL COUPON TODAY

LaSalle Extension University,
Dept. 364-H Chicago, Ill.

Send at once without cost or obligation to me, your valuable book of accounting facts and full details of your course in Higher Accountancy; also advise me about Special Reduced Rate and Convenient-Payment Plan.

Name.....

Street and No.....

City.....State.....

Please Mention Popular Mechanics



\$125 to \$300 a Month

Send the coupon below and find out about the opportunities in the profession of Signal Engineering. *Big salaries are being paid*—\$125 to \$300 a month is an ordinary salary for the man who has the proper training. You can get just this kind of training right in your own home—during your spare time. Men are needed. Send the coupon for the book that tells you all about it. You owe it to yourself to find out about the opportunities that are offered to you. Send the coupon today—now.

Be a Signal Engineer!

Be the man who gets the fat pay envelope. The profession of Signal Engineering is only in its infancy. There are thousands of miles of block signals to be installed. Signal Engineers, supervisors, inspectors and foremen are required to superintend this installation. Hundreds of maintainers and battery men are needed to maintain the systems already in use.

Two Big Outfits FREE

Complete Signal Engineer's Outfit and Complete Draftsman's Outfit given away absolutely free to each student.

Your duties may take you from coast to coast. Railroad men are always in a fortunate position to travel and see the world because free transportation is liberally awarded. You can accept a position where you will be located steadily at one place, if you prefer—the position of authority—the high place and the fat pay envelope may be yours. Send the coupon today for the free Signal Book.

Department of Signaling

Room 1193, 1810 Wilson Ave.
Ravenswood Station, Chicago

Gentlemen:—Please send me absolutely free and prepaid your big new book on Signal Engineering. Also full particulars about your great special free outfit offer. It is distinctly understood that I assume no obligations of any kind.

Name.....

Address.....

Age..... Occupation.....

Men Are Needed

The profession of Signal Engineering is calling to ambitious men. Our ranks are not overcrowded. Block signal systems are no longer in the experimental stage. All over the country they are being installed. Some States have legislated to compel the railroads to install systems. In our profession you will have the chance you have been looking for.

We are calling you. Send coupon today for big Free Signal Book and full details.

Send Coupon for Big New Book

Put your name and address on the coupon or on a letter or a postcard now, and send it to us. Absolutely no obligations of any kind. We will send you our big new Book absolutely free, and prepaid. Read about this fascinating profession. Read about the opportunities that await you. The book is free. Send the coupon for it now—it's the first step toward the realization of your ambition. Send your name and address at once.

Department of Signaling

Room 1193, 1810 Wilson Ave., Ravenswood Station, CHICAGO

\$2000—\$5000—\$10,000 a Year

—Men Who Sell Always Command Biggest Incomes

Salesmen are paid highest salaries—because the Salesman is a direct producer of profits. If you are dissatisfied with your present position—salary—if your prospect of advancement is slight—you owe it to your future to investigate the service offered by the National Salesmen's Training Association. A crying need for trained Salesmen exists in the business field today. Where other professions are over-crowded—the Sales field offers unparalleled opportunities to the man of ambition. Big firms are actually bidding for the services of the trained Salesman. Our Employment Bureau has on hand right now more requests for men than it can possibly fill. If you would make success *sure*—train for the selling field. Just how this training may be secured is told in full in our book, "A Knight of the Grip"—a copy of which will be sent without charge if you mail the coupon below.

Be A Salesman

For the Salesman—life is worth living. He travels on finest trains—lives at best hotels—rubs elbows with the big men of the country—is his own boss. While other lines of work are over-crowded with good men—the Trained Salesman is always in demand. He it is who brings in the orders—who makes the dividends possible.

Salesmanship Now Taught By Mail

And *Now* it is possible to study Salesmanship by mail—to learn at home—at the cost of only a few dollars and a bit of your spare time—to fit yourself for success in this remunerative, independence-bringing profession. Many of the Master Salesmen in the country today received their start in N. S. T. A. Training. As Mr. Wood says in his letter reproduced at the right: "I wish I could invest more dollars that would bring me the big returns those invested in your Course did."

We Find Good Paying Positions For Our Members

Every possible problem of Selling is covered in full by our thorough instruction methods. A few of the many subjects covered are—how to approach prospects—how to manage the interview—how and when to close—how to handle sales correspondence—how to be a good mixer. And more than making you a *real Salesman*—we find a good paying position for you. Employers universally recognize the value of N. S. T. A. Training. We not only put you in touch with good positions while you are still a student—but more than helping you secure a connection—we *help you make good*.

"A Knight of the Grip" **FREE** 64-Page Book—Sent

You can mail the coupon below without obligating yourself in any way—and we will mail our big **FREE** illustrated book "A Knight of the Grip" and the large special list of the many lines of businesses in which good positions are now open for Salesmen, paying \$2,500 to \$10,000 a year. Delay may mean opportunity lost. Prepare yourself—Mail the coupon *before you turn the page*. Address nearest office—Dept. 507G.

NATIONAL SALESMEN'S TRAINING ASSOCIATION
Chicago New York San Francisco

For Bigger Pay—Mail This Coupon

National Salesmen's Training Association, Dept. 507G, Chicago—New York—San Francisco
(Send your request to the office nearest your home.)

With no obligation on my part, please send me your big **FREE** illustrated book—"A Knight of the Grip."

Name _____

Address _____



I Am in the \$2,500 to \$10,000 Class

"I was a carpenter, am now a Salesman and can proudly say I am in the \$2,500 to \$10,000 a year class. Wish I could invest more dollars that would bring me the big returns those invested in your Course did."—J. E. Wood, Rooms 322-54 Pacific Bldg., San Francisco, California.

I Now Earn as High as \$100 a Day

"I took your Course two years ago. Was earning \$15 a week clerking. Am now selling many of the largest firms in the U. S. I have earned more than \$100 in a day. You secured me my position. Our Sales Manager is a graduate of yours."—J. L. Debonis, 1850 So. Harding Ave., Chicago, Illinois.

Made Him a Real Salesman

"Was clerking in a general store. Your Course made a real Salesman of me. Am on the road and doing fine."—Willis R. Osborn, 1985 Atlantic Ave., Long Beach, Cal.

Your Course Makes Success Easy

"More than two years ago I joined the N. S. T. A. You secured me a good position with one of the best firms in their line. Am making fine wages. Former experience is unnecessary—Your Course makes success easy."—Wm. H. Kessler, 199 N. 16th St., East Orange, N. J.

From Shop Work to High Salaried Salesman

"I have charge of the Boston Sales Branch of my firm and the fact that I have made good and have received so many advances in salary shows what your Course did for me. I wish to recommend your School to all."—J. A. Christian, P. O. Square Bldg., Boston, Mass.

I Earned \$6,500 This Year

"Last year I only earned \$800 as a clerk. This year I have earned \$6,500 and have been promoted to Sales Manager and done it by studying your Course during spare time. Your Employment Bureau offers one many good positions."—C. W. Birmingham, 4 Lamar Apts., Dayton, Ohio.

From \$80 to \$300 a Month

"From R. R. Accountant at \$80 a month to Salesman at \$300 a month is the result of taking your Course."—C. W. Dumson, 4027 N. Kedvale Ave., Chicago, Ill.



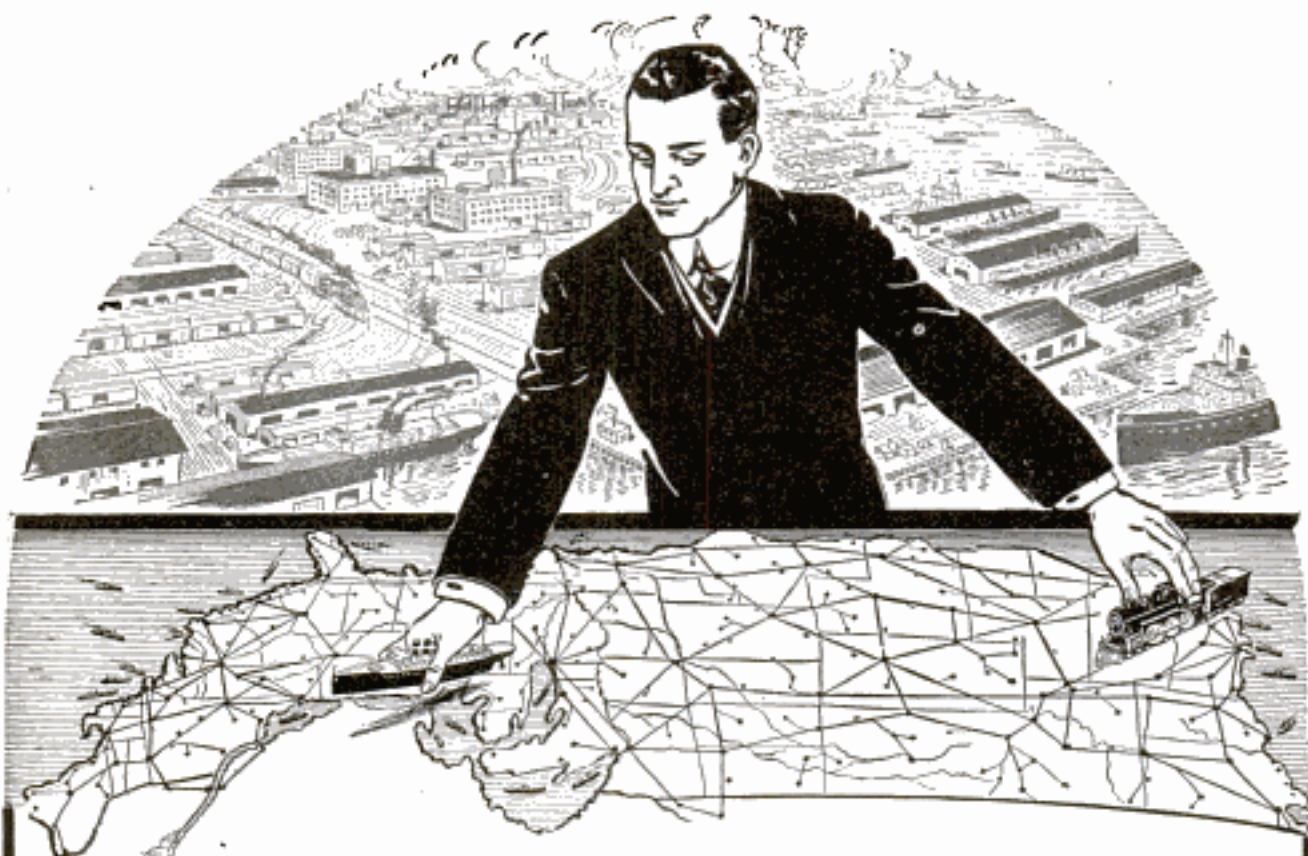

This Man Earns \$100 a Week

He knows how to open up large markets and help his employers outstrip competition in business because he knows how to route shipments, obtain shortest mileage, lowest rates, and quickest deliveries. He knows how to classify goods and reduce transportation costs. His knowledge of traffic laws and transportation saves his employers thousands of dollars annually.

Here's your chance to qualify for the same kind of a position at the same salary. Don't let this chance go by. Few men have this traf-

fic knowledge. The demand far exceeds the supply. In fact, over half a million firms need men who can classify commodities and secure ratings most economically. You can be able to answer this call for trained traffic men quickly by means of the LaSalle Home Study Course. We guide you step by step. With the LaSalle Extension University behind you, you can qualify in a comparatively short time. The expense is so small and the terms so easy you will scarcely miss the money. Qualify for a bigger job—at home—in spare time.

Be a Traffic Man

At \$35 to \$100 a Week

Send In the Coupon

For proof that our graduates, because of the thoroughness of their training through our course, qualify for the best positions and increase their earning capacity. Let us send you letters from students and full details concerning the LaSalle University Home Course in Traffic Management. Send in the coupon now and receive our free book "Proof," letters and full details by return mail.

Free Book Coupon

LaSalle Extension University,
Dept. 364-C Chicago, Ill.
"The World's Greatest Extension University"

Send Free Book about opportunities now open to TRAFFIC EXPERTS with LaSalle University Training. It is understood that I am not obligating myself in any way.

Name

Address

City..... State.....

There seems to be no limit to the salaries expert traffic men are paid. Some concerns pay their directors of traffic \$10,000 or more a year. Salaries of \$35 to \$100 a week are commonly paid to traffic managers. Splendid positions with high salaries for competent, trained men are open everywhere.

We Train You By Mail For a Big Traffic Job

You need not leave your present position. You may keep on earning while learning.

Our course is recommended and endorsed by railroad executives and big business concerns throughout the country. Your training is under the supervision of a large corps of the most prominent traffic experts in the country, headed by N. D. Chapin, until his present connection with us, Chief of Tariff

Bureau New York Central Lines. The Course gives you also a thorough understanding of Interstate Commerce Laws and prepares you for every duty required of a high grade traffic manager—how to route shipments, obtain shortest mileage, classify goods, secure quickest deliveries and lowest rates—in fact, trains you so that you can qualify for an immediate high-salaried railroad or industrial traffic position.

LaSalle Extension University,
"The World's Greatest Extension University"
Dept. 364-C Chicago, Ill.

Please Mention Popular Mechanics



H. J. RAHE
President

The Training For YOU!

Come to the School of Complete Equipment

— and let me train you to earn big money in the Automobile and Tractor Business. The supply of men to fill the many open positions and waiting opportunities is far short of the demand. Now is the time to start. I'll help you—I'll train you **right**. My success in training thousands of ambitious men is known throughout the country. I have been right here in Kansas City for a number of years and I rightly claim more successful graduates than any similar institution in the world. I am always ahead with complete equipment—with plenty of floor space and more expert instructors. My graduates earn from

\$75 to \$350 a Month

YOU CAN DO THE SAME if you have ambition and determination to learn. **Rahe's Original Practical Method of Automobile Training and Experience** is everywhere recognized as the most efficient method of training ever devised. Remember—it's not theory—there are **no books or printed lessons**. My training is unique and distinctive—it's the **actual doing**—getting into overalls and starting at the bottom under the guidance of expert instructors.

Only a Few Weeks Required

That's all—just a few weeks and you will have a thorough understanding of the basic principles of this wonderful business. You will then be ready for a position, paying good money right from the start—with a world of opportunity before you. My original practical method is all simple and easy. You get the full instruction in easy stages and you have the wonderful advantages of complete equipment—Automobiles, Tractors, Welding Plants, Big Drill Presses, Power Lathes, Forges, etc. Two big garages and repair shops. Cars of all kinds for my students' practical use. Every type of motor is represented in my equipment—block mounted so they are easy to get around, easy to take apart. It's the Rahe method—

Practical—Efficient—Complete

This twin-six motor is block mounted.

Then there are the Eight and many other motors for my

students' special training and experience. These motors are in the practice room. All Types of lighting and self-starting devices—full equipment, so that you learn all easily. Tire vulcanizing, Oxy-Acetylene welding—training and experience in all branches of the automobile business. My students do practical work. They handle welding torches under the guidance of master-welders. Don't bother with any training that gives you only a little—come here and I'll hand you a kit of tools—not printed books.

All types of motors—Block-mounted. Easy to get around.

17 Complete Welding Outfits. Big Demand for Expert Welders.

Both types of Tractors, Kerosene and Gasoline. Big Drills, Big Practice Field

Tractor Engineering

I want to enroll the full capacity of my school a month earlier this year, and to all students enrolling now I am giving a free scholarship for complete instruction in **Tractor Engineering, Power Farming, Gas and Stationary Engineering**. The development of the farm tractor and its growing popularity is second only to the automobile itself. Come and see my large tractor practice field and complete tractor and farm equipment. With this added knowledge you can reap new profits in an entirely new field. Remember—it's **FREE** when you enroll for my automobile course.

Get My 80-Page Catalog

Use the coupon below or post card, but send now for my new catalog. Filled with Copper Engravings of men at work in the various departments—views of equipment—three big buildings and big tractor farm. Let me start you. **Let me help you to be the success you can be**—if you have backbone and ambition. Send for the book at once and read letters from men like yourself—who came to me without previous experience and are now earning big money.

H. J. RAHE, President

Rahe's Automobile Training School

(World's Greatest Auto Training School)

1028 Locust St. Kansas City, Mo.

OPPORTUNITY COUPON

H. J. RAHE, Pres.,

Rahe's Automobile Training School.

1028 Locust St., Kansas City, Mo.

Send me your new 80-page catalog, fully illustrated, telling of your Practical Training and big money opportunities in the Automobile and Tractor Business.

Name.....

Town.....

Street or R. F. D..... State.....

HAVE YOU SEEN JEAN CRONES?



\$1,000 Reward!

is offered for this man. Other large rewards are standing for men wanted throughout the country. The latest and most reliable method now used for identification is the finger print system. Be a Finger Print Expert. Earn your share of these big rewards.

Finger Prints — The New Profession

Write — send the coupon at once, or just your name and address. Find out about the opportunities that await you in this new and fascinating profession. Find out how you can quickly equip yourself at home, in your spare time, to fill the big positions that have sprung up almost over night. A big demand has arisen in large factories, industries and banks, in police departments all over the country, for men who know Finger Prints and their classification.

Wanted: Experts

You can earn from \$25 to \$50 a week in this new profession. Fame awaits you, too. The rapid spread of the use of finger prints makes the demand for experts immediate and imperative. You can fill one of these good paying positions. You can equip yourself at home. Our thorough and complete course in finger prints teaches you all about this valuable and interesting subject in your spare time. Endorsed by the country's biggest police authorities. Don't miss this opportunity. Send the coupon at once for full particulars.

Free Book

Send the coupon at once (or just your name will do) for our valuable and interesting free book on the



finger print subject (mailed in plain envelope). It tells all about finger prints. Shows you how easily our course gives you complete training in the subject. Shows you where the big opportunities in this new profession lie. Get this information now. It means fame, independence for you, to find out.

Send Coupon

We are making an attractive special offer now that is very limited. Get the free book and full details while this offer lasts. Send at once.

EVANS UNIVERSITY
Finger Print Dept.
Desk 1193
1810 Wilson Ave.
Chicago, Ill.

Name.....

Address.....

Age..... Occupation.....

Please Mention Popular Mechanics

Learn to PAINT SIGNS and SHOW CARDS

Get into this interesting, profitable and fascinating business where the field is not crowded.

Thousands of cards used weekly. Department stores, clothiers, movie shows, etc., pay big prices—work done quickly and easily—profits large—hundreds of jobs all around you. My students can more than pay for course doing jobs in spare time while studying. Increase your salary, get a better job or go into business for yourself.

Earn \$18.00 to \$45.00 a Week—Easily

I will train you to fill a big salaried job. I personally correct every lesson. 17 years' successful teaching. Thousands of successful graduates all over the world. No town too small, no job too big for my graduates. Get my training—start now.

Big Money in Card, Sign and Bulletin Business

No other profession pays such profits—work comes to you in abundance—no job will stump you—my students learn all. All the newest, sweetest designs, how to run the business, how to hire men, how to keep records, in fact gives you a complete training. You can finish my course in a short time. Read my guarantee—don't be out of a job or work at low wages any longer—

FREE Outfit
Write now for special literature and prices on 5 courses—terms, testimonials, sample lesson and Free Outfit offer. **All Free**—Don't delay, act quickly.

Get Started Now.

Guarantee
I guarantee to place competent graduates at \$85.00 to \$175.00 monthly. The demand for trained competent men is far greater than the supply.

Detroit School of Lettering, Dept. 203, Detroit, Mich.

LAW High-Grade Instruction by CORRESPONDENCE

Prepares You for the Bar—Est. 1892

Four Courses: College, Post-Graduate, Business Law and Bar Ex. Review. Classes begin each month. Approved by Bench and Bar. University Methods, Unabridged Text-Books, Cases. Course in Oratory, Public Speaking and Most Court FEEL with regular course. Graduates now practicing in every State. Write today for Catalog and Rules for Admission to the Bar. CHICAGO CORRESPONDENCE SCHOOL OF LAW, 520 Reaper Block, CHICAGO



MUSIC TAUGHT FREE

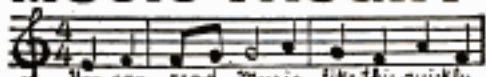

You can read Music like this quickly

IN YOUR OWN HOME

Piano, Organ, Violin, Mandolin, Guitar, Banjo, etc. Beginners or advanced players. One lesson weekly. Illustrations make everything plain. Only expense about 2¢ per day to cover cost of postage and music used. Write for FREE booklet which explains everything in full.

AMERICAN SCHOOL OF MUSIC, 51 Lakeside Building, CHICAGO

IF YOU STAMMER

attend no stammering school till you get my large FREE book and special rate. Largest and best school in the world curing by natural method. Write today.

Lee Walls Millard, Pres., North-Western School, Inc. 2317 Grand Avenue Milwaukee, Wis.

Learn to be a Finger Print Expert

Increase your income. We teach the subject thoroughly from A to Z and guarantee to make you a finished expert. Study under the original Finger Print School. THODE SCHOOL OF FINGER PRINTS 2067 Grove St., San Francisco, Cal.

BE A BANKER

Prepare by mail for this high profession, in which there are great opportunities. Six months' term. Diploma awarded. Send for free book. How to become a Banker. EDGAR G. ALGORN, Pres. AMERICAN SCHOOL OF BANKING 419 East State Street, COLUMBUS, OHIO

LEARN WATCH REPAIRING



You can learn by our modern and original system of instruction every part of the Watch Repairing Trade at home as good or better than at a shop. You can earn money while learning and secure a well paying position or start in business after completing our course of instruction. Good watch repairs are always in demand and earn from \$20 to \$35 per week. For particulars apply to the Wisconsin School of Watchmaking, Stroh Bldg., Milwaukee, Wis.

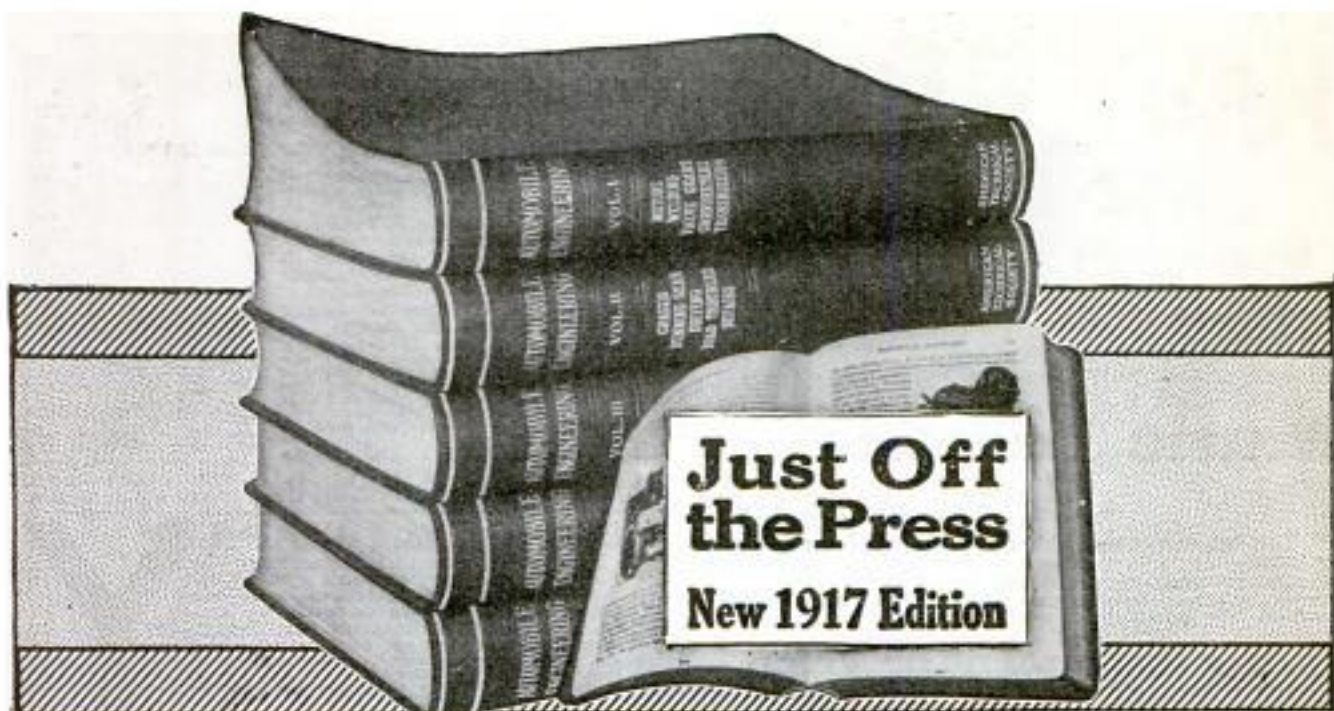

Automobile Engineering

50c a Week

YES, you may get this newly-written automobile library for only 50c a week (\$3 a month.) The five thick volumes—which have just been printed—contain 2200 pages (8½x9¾ in.) and 2000 illustrations, diagrams and charts. Flexibly bound in genuine leather, gold stamped.

Here is the newest and most complete library of automobile repairing obtainable. Every part of the modern automobile is described in simple, easily understood language—every up-to-date repair method is explained. Contains hundreds of pages on ignition, starting and lighting, as well as on welding and vulcanizing. We'll send the books to you prepaid, without a penny down.

And for a limited time we are making an astounding offer. The regular price is \$25.00 but on a limited number of sets, we are making the very special price of \$16.50—and you can pay this rock-bottom price in easy monthly payments.

Shipped Free

On 7 Days' Trial

We'll send you the entire set, prepaid, for seven days' examination. Use the books just as if they were your own. See what it will mean to you to have this set always at your elbow. Then, if you decide you can do without it, send it back at our expense. However, if you decide to buy, send us \$2.00 after seven days and the balance \$2.00 a month.

Partial List of Subjects:
 Explosion Motors, Welding, Motor Construction and Repair, Carburetors and Settings, Valves, Cooling, Lubrication, Fly-Wheels, Clutch, Transmission, Final Drive, Steering, Frames, Tires, Vulcanizing, Ignition, Starting and Lighting Systems, Wiring Diagrams, Shop Kinks, Commercial Garage Design and Equipment, Electric, Storage Batteries, Cars and Buses, Motorcycles, Commercial Trucks, Glossary.

FREE Consulting Service!

With each set we give you, absolutely free, a year's consulting membership in the American Technical Society. The regular price is \$12.00, but you get it free with this set. Put your perplexing problems up to a staff of experts. Ask them any motor question you wish. The solution of one problem might easily be worth more than you pay for the books. Ask as many questions as you wish during the year.

Send the Coupon!

Your name and address on the coupon brings the five books to you, express prepaid, for seven days' free trial. This offer is open to every resident in the United States and Canada. Act quick—while the offer lasts! Send the coupon today—NOW!

American Technical Society Dept. A-1193
 Chicago, U.S.A.

American Technical Society
 Dept. A-1193 Chicago, U.S.A.

Please send me the 5 volume Automobile Engineering for 7 days' free examination. If I decide to buy, I will send \$2.00 within 7 days and the balance at \$2.00 a month until \$16.50 has been paid. Then you send me a receipt showing that the \$25 set of books and the \$12.00 consulting membership are mine and fully paid for. If I think that I can get along without the books after the seven days' trial I will return them at your expense.

Name.....

Address.....

Reference.....



Music Lessons Sent FREE

You, too, can now quickly and easily satisfy your musical ambitions—learn to sing or play your favorite instrument, whether for pleasure, social prestige or to teach music, by our wonderful home study lessons under great American and European teachers. The lessons are a marvel of simplicity and completeness, endorsed by Paderewski and other great authorities.

Any Instrument or Voice

Write us the course you are interested in, age, how long you have taken lessons if at all, etc., and we will send you six lessons, free and prepaid, any of the following Complete Courses: Lessons in PIANO (students' or teachers' courses) by the great Wm. H. Sherwood, HARMONY by Dr. Protheroe and Rosenbecker, PIPE ORGAN by Clarence Eddy, VOICE COURSE (with aid of phonograph) by Crampton, PUBLIC SCHOOL MUSIC, by Frances E. Clark, VIOLIN, CORNET, MANDOLIN, GUITAR, BANJO, REED ORGAN, CHORAL CONDUCTING, by equally eminent teachers.

This offer is free—we do not ask you to pay one cent for the six lessons, either now or later. We want to prove in this remarkable way what fine lessons they are—SEEING IS BELIEVING. This offer is limited, so write today. A few Special Introductory Scholarships now being awarded by our Faculty. Full particulars sent along with free lessons. Send no money.

SIEGEL-MYERS SCHOOL OF MUSIC,
CLARENCE EDDY, Dean

2151 Siegel-Myers Building

CHICAGO, ILL.



Learn a Paying Profession

that assures you a good income and position for life. For twenty-two years we have successfully taught

PHOTOGRAPHY

Photo-Engraving and Three-Color Work

Our graduates earn \$20 to \$50 a week. We assist them to secure these positions. Learn how you can become successful. Terms easy—living inexpensive. Write for catalogue—NOW!

ILLINOIS COLLEGE OF PHOTOGRAPHY, 999 Walsh Avenue, Effingham, Ill.

Make this car your office—

there is \$900.00 to \$1800.00 a year in it for you

Examinations will likely be held everywhere soon

Rapid advancement to higher Government Positions. "No layoffs" because of STRIKES, FINANCIAL FLURRIES or the WHIMS OF SOME PRETTY BOSS. THE POSITION IS YOURS FOR LIFE.

Country residents and city residents stand the same chance for immediate appointment. Common-sense education sufficient. Political influence NOT REQUIRED.

We will prepare 25 candidates FREE! Write immediately for schedule showing the places and dates of all Winter and Spring examinations. Don't delay. Every day you lose means the loss of just so much coaching before the rapidly approaching examinations.

FRANKLIN INSTITUTE, Dept. W 97, Rochester, N. Y.



Hundreds of Railway Mail Clerks Needed Soon

COUPON

Franklin Institute (The pathway to plenty), Dept. W 97, Rochester, N. Y.

This coupon, filled out as directed, entitles the holder to (1) free specimen questions; (2) a free copy of our copyrighted book, "Government Positions and How to Get Them," (3) a list of positions now easily obtainable, and (4) to consideration for Free Coaching for the examination here checked.

..... Railway Mail Clerk (\$800 to \$1800) Customs Positions (\$800 to \$1500)
..... Bookkeeper..... (\$500 to \$1000) Stenographer..... (\$800 to \$1500)
..... Postoffice Clerk..... (\$800 to \$1200) Internal Revenue..... (\$100 to \$1800)
..... Postoffice Carrier..... (\$800 to \$1200) Clerk in the Department at Washington (\$800 to \$1500)
..... Rural Mail Carrier..... (\$500 to \$1100)	

Name..... Address..... W 97
Use this before you lose it. Write plainly.

All About Motor Cars

Construction, Operation, Care and Repair
This very latest authoritative book gives ALL the information in 16 easy lessons.

The Automobile Instructor

By Clyde H. Pratt, B. Sc., M. E., Member Nat'l Society of Auto Engineers, 296 pages, illustrated, cloth bound. Shipping wt., 22 oz.

New 1917 edition out Jan. 3. The standard work for home-study, class-room and reference, for amateur and expert. A complete course for all who desire to master this profitable profession.

LEARN AT HOME HOW TO DRIVE AND REPAIR ALL CARS

Invaluable pointers for every car owner, driver, garage man and repair man. Adopted by Cleveland and other Auto Schools and by Boards of Education as their standard text-book. The author will answer your auto inquiries FREE. This book is guaranteed to be just what you want or your money back. (Auto schools, write for quantity prices.)

Price, postpaid \$1.50

Shrewsbury Publishing Co.

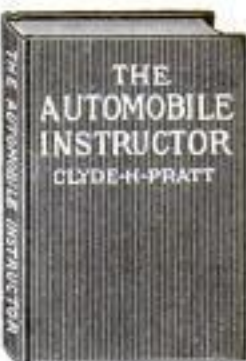

Motor Craft Encyclopedia

Illustrated. Tells how to build and operate Motor Boats. Best book on boats. Price, \$1.00.

5525 West Lake St., CHICAGO, U. S. A.

EARN TELEGRAPH

Morse and Wireless—R. R. Accounting (Station Agency) taught. Splendid opportunities. Positions secured. Marconi Co. contracts to employ graduates. We own and exclusively occupy two large modern buildings equipped with R. R. and Western Union wires and complete 2 K. W. Marconi Wireless Station. Largest school—established 42 years. Investment \$25,000. Endorsed by Railroad, Marconi and Western Union Officials. Expert practical teachers. Low living expenses easily earned if desired. Tuition low. Easy payments. Correspondence courses also. Catalogs free.

Dodge's Telegraph, Ry. & Wireless Institute
8th Street, Valparaiso, Ind.

The University of Chicago

HOME STUDY

in addition to resident work, offers also instruction by correspondence. For detailed information address

25th Year U. of C. (Div. V) Chicago, Ill.



Learn Watchwork, Jewelrywork and Engraving.

A fine trade commanding a good salary, and your services are always in demand. Address HOROLOGICAL, Dept. P, Bradley Institute, Peoria, Ill. for our latest catalog.

LEARN TO WRITE ADVERTISEMENTS EARN \$25 to \$100 A WEEK

We can positively show you by mail How to increase your salary. BOOK MAILED FREE. PAGE-DAVIS CO., 112 Page Building Chicago, Ill., or 159 Nassau St., New York



Do You Like to Draw? Cartoonists Are Well Paid

We will not give you any grand prize if you answer this ad. Nor will we claim to make you rich in a week. But if you are anxious to develop your talent with a successful cartoonist, so you can make money, send a copy of this picture, with 5c in stamps for portfolio of cartoons and sample lesson plate, and let us explain.

The W. L. Evans School of Cartooning
821 Leader Bldg., Cleveland, O.

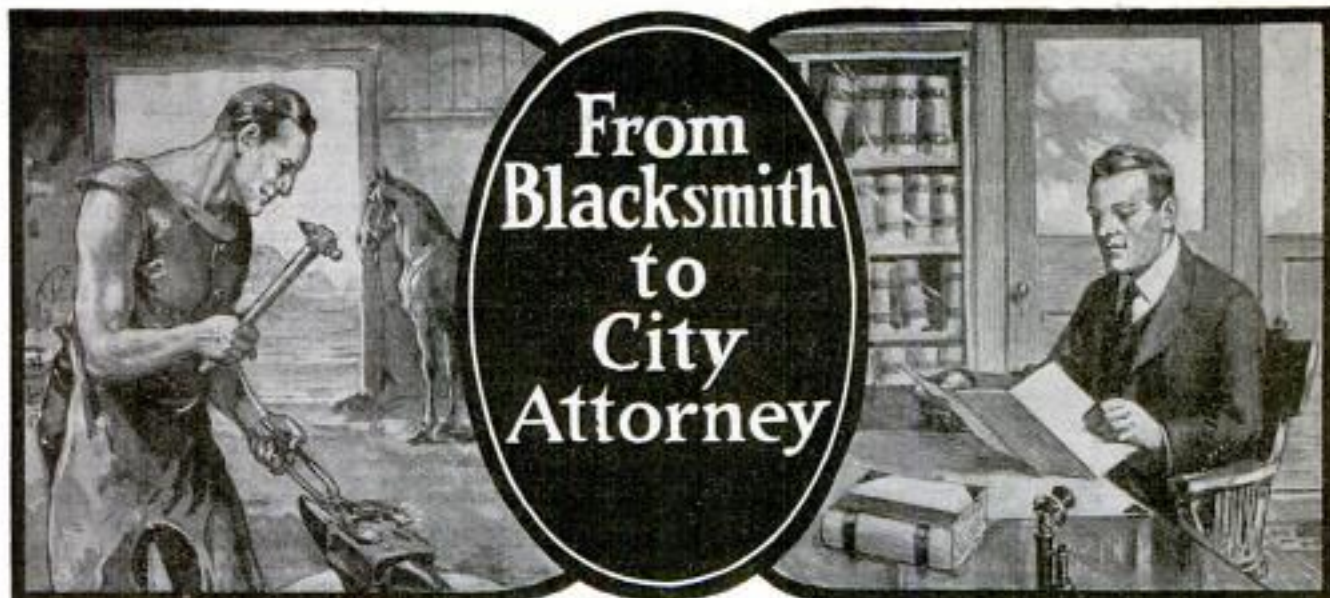

From Blacksmith to City Attorney

Income in 5 Months Jumps to more than \$4000 Per Year

"I was appointed City Attorney in June. The salary is only \$1600.00 per year, but the prestige obtained through the appointment brings me a goodly practice. I have recently been retained by a firm of this City and . . . to defend some of their members, and they have sent me a retainer of \$2500.00—I opine that this is not so bad in view of the fact that last May I was blacksmithing for standard trademen's wages. I finished your course and was admitted to the bar in just ten days less than three years. I can never say too much for your school—it is easily worth \$20,000.00 to me—that is the instruction I received through it."

Full name, address and entire letter included in our "Gilt Edge Evidence"—the most remarkable collection of endorsements ever published by any institution of learning.

Why Not be a Lawyer Yourself

Today is the legal age. Scarcely a business move is made until the lawyer is consulted, his opinion secured and carefully weighed. Railroads are demanding legally trained men to handle their intricate interstate commerce laws. Credit men cannot expect to become proficient unless they have a knowledge of the law. Real estate men must know about deeds, abstracts, leases, mortgages, etc. The banker requires a training in banking laws. Every officer of the law will find it to his distinct advantage to know criminal law. Young man, you cannot name a vocation where a thorough legal training will not assist you wonderfully in climbing to the top. And there is not an institution of learning in America where you can acquire such a training more economically, more thoroughly and quicker than through the Extension Course of Law now offered you by the Hamilton College of Law.

\$3,000 to \$10,000 Per Year

are not excessive incomes for the successful attorney-at-law. Many of our graduates are already in this class. Others are prominent young business men, who are studying law as the quickest and shortest route to the top of the ladder. There is a constantly growing demand for bright, legally trained young men. The world is waiting for them to present their credentials. Will you be one of them? Or are you a satisfied man.

What the Hamilton College of Law Offers You

It is the only Law School of its kind in America. It is the ONLY recognized resident law school in the United States conferring Degree of Bachelor of Laws, LL. B.—by correspondence, strictly on the merits of its course. ONLY law school in U. S. conducting standard resident school and giving same instruction by mail.

ONLY law school giving over 500 class-room lectures to its extension students.

ONLY law school giving a full 3-Year, University Law Course, by mail, having an actual faculty of over 30 prominent lawyers in active practice.

ONLY law school in existence giving a Complete Course in Oratory and Public speaking in conjunction with its law course.

Other Excellent Features

Our Law Library consists of 24 volumes of Students' Standard Text Books, two volumes bound together under one cover, making a total of 12 books. These books were prepared at an enormous cost especially for the students of the Hamilton College of Law, by one of the largest and best law book publishers in America. This is the only set of text books ever prepared exclusively for students' use.

We give an absolute written guarantee to prepare our students to pass bar examinations.

Our Course in Oratory and Public Speaking, absolutely free to all Hamilton Students, has been prepared and written by Prof. Oscar G. Christgau, LL. M. (Master of Laws) the regular resident school professor in charge of this work. Knowing law, from a lawyer's standpoint, he has prepared this series of 36 lectures to meet all the requirements of the practicing attorney.

30 Days Free Trial

Let us convince you without it costing you a penny, that we have the only, real, genuine, bonafide Extension Course in Law in America. Mail the coupon and get all the evidence—then judge for yourself. Study with us 30 days, at our expense and be satisfied you are getting more than value received, before obligating yourself.

Hamilton College of Law
100 Advertising Building, Chicago, Illinois

Gentlemen: Kindly send me your Illustrated Prospectus and full particulars regarding your 30-day Free Trial Offer.

Name.....

Address.....

Please Mention Popular Mechanics

Come to Akron, Ohio The Tire Center and



MONEY-RACK GUARANTEE

We guarantee to qualify our students to go into business for themselves or to hold positions paying \$18.00 to \$40.00 weekly or return their money. The demand for trained repairmen is greater than the supply.

© THE TIRE REPAIR BUSINESS

Make big money in this big field. No other field offers such opportunities. Autos run the year around. Tires need constant repairing. Profits are large and work comes easily. Every job is easily and quickly done. There are locations everywhere, right in your home town. We show you how to find best locations. Help you to get jobs paying from \$3.00 to \$6.00 a day if you don't want to open a repair shop. Tire repair shops are as necessary as gasoline stations. Auto owners drive their cars more than ever. They need more work done constantly. Over a Million New Autos put in use this year. More tire repair shops and men will be needed. Get into this big profit business and become Independent.

MAKE \$2500 TO \$10,000 YEARLY

There is no limit to what a man can make. Men are becoming rich in this business. You can start business with small capital. Work comes easily, profits are big, business grows fast. Trained tire repair men get work quickly and hold customers. Our graduates are qualified to handle all makes of Cord Tires and can get factories O. K. School open all the year—Enter classes any day. Graduate in 4 to 6 weeks.

GRADUATES ARE COMPLETELY SATISFIED

San Antonio, Tex., Nov. 4th, 1916.
The Akron Tire Repair School:
Gentlemen: I did not know a thing about an automobile tire when I entered your school. But under the able and plain instructions of your chief instructor, I have mastered the course in tire repairing in the comparatively short time of four weeks. One thing about the Akron Tire Repair School is that it teaches how to repair Silverstone and Goodyear Cord Tires, a feature that the prospective student will not learn in any other tire repair school in existence. That part of the instructions alone has more than repaid me for my long trip to Akron.

Yours, etc.,
A. C. ROSS.

AKRON TIRE REPAIR SCHOOL:

Gentlemen: I must say that you certainly have fulfilled your agreement to the letter. I am fully satisfied. The clear, concise instruction and the carefully supervised practice in your excellently equipped place, will be of great value to me. I think that many tire-repair men already in the business could save themselves money by taking your course, that section which deals with cord tires being alone worth the time spent.

Yours sincerely,
ALEXANDER M. DUNCAN.

Detroit, Mich., October 14th, 1916.

WEEK TRIAL SPECIAL OFFER

We are making a special offer for a limited time. Our tuition price is low, but we are making a SPECIAL WEEK TRIAL OFFER which is the most liberal ever offered by a reliable School—Write at once for "Week Trial Special Offer," school literature and students' letters—All absolutely Free.

THE AKRON TIRE REPAIR SCHOOL

The Largest and Best Equipped, Exclusive Tire Repair School
A. G. ZELLER, President 63 Tire Bldg., 46-48 Main St., AKRON, OHIO

AKRON, OHIO THE HEART OF THE TIRE INDUSTRY



Stronger, Clearer Voice for You!



Weakness, huskiness and harshness banished. Your voice given a wonderful strength, a wider range, an amazing clearness. This done by the Feuchtinger Method, endorsed by leading European musicians, actors and speakers. Use it in your own home. Simple, silent exercises taken a few minutes daily impart vigor to the vocal organs and give a surpassing quality to the tones. Send for the facts and proofs.

Do You Stammer?

If you have any voice impediment this method will help you. You need not stammer or lisp—if you will follow our instructions.

WRITE

Send the coupon and get our free book and literature. We will tell you just what this method is, how it is used and what it will do for you. No matter how hopeless your case may seem the Feuchtinger method will improve your voice 100 per cent. No obligation on you if you ask for this information. We gladly send it free, postage prepaid. Just mail the coupon.

Perfect Voice Institute
1810 Wilson Av.
Studio 1193
CHICAGO

Name

Address

Perfect Voice Institute
Studio 1193 - 1810
Wilson Av., Chicago
Send me the book and facts about the Feuchtinger Method. Have put X opposite subject that interests me most.
 Singing Speaking
 Stammering Lipping

A GOOD POSITION

with UNCLE SAM is most desirable. Life positions, pleasant surroundings, good pay, steady work, short hours, promotions on merit. Both sexes. No political pull. Thousands of appointments yearly. Most thorough preparation \$5. Returned if not appointed. Full information and questions used by the Civil Service Commission free.

AMERICAN CIVIL SERVICE SCHOOL

WASHINGTON, D. C.



MEN WANTED

Prepare as Firemen, Brakemen, Electric Motormen, and colored Train Porters. First Class Standard Roads. Hundreds put to work—\$65 to \$150 a month without any experience. 500 more wanted. Uniforms and passes arranged for when necessary. Enclose stamp for Application Blank. Name position you want.

I. RAILWAY C. I., Dept. 35, Indianapolis, Ind.

Be an Artist

Comics, Cartoons, Commercial Newspaper and Magazine Illustrating. Pencil and Crayon Portraits. Earn \$25 to \$200 a week. By our simple method your talent is quickly developed without interfering with present work. By Mail or Local Classes. Small sums you now fritter away pay your tuition. Write for terms, list of successful pupils and instruction method FREE. ASSOCIATED ART STUDIOS, 2203 Flatiron Building, New York

STAMMERERS

Our course of private lessons will correct your impediments.
BOSTON STAMMERERS' INSTITUTE
Founded 1867. Samuel D. Robbins, Principal.
246 Huntington Ave. BOSTON, MASS.

JEWELRY ENGRAVING

We teach you, by our new and original method of instruction, this clean, fascinating and profitable business right at your home, and furnish you all tools needed absolutely free. Write for free book to the WISCONSIN SCHOOL OF ENGRAVING, 57th Bldg., MILWAUKEE, WIS.

Please Mention Popular Mechanics

Our Graduates are Making

\$80 to \$250 We
AND MORE PER MONTH



THE Best Paying Positions in the Auto business are secured through this school. Our thorough and practical instruction has placed many of our graduates in positions where they are getting up to \$12,000 and \$20,000 a year in salary, or in profits from their own business.

Many others are Expert engineers, Chauffeurs, Race drivers, Shop foremen and Final testers for White, Chandler, Ford, Willys-Overland, Chalmers, Peerless, Cadillac, Stearns and other leading factories. 15 of our June class are now truck drivers for the Government at \$100 to \$150 a month and all expenses.

We have calls for more and more men from *all parts* of the country—because our School is known to rank *highest* in careful, thorough and up-to-date training. Wonderful opportunities are developing in the Auto business right along—but you must have the *right training by actual experience*, and the place to get it is the



Race Driver



Tester



Master of 12-cyl. Motor



Private Chauffeur



Established 1903
Individual Instruction

Up-to-date Equipment
13 Years of Success

4000 Graduates Making Good

Ours is one of the most completely equipped schools in the country; a dozen cars at the disposal of students; we teach every point worth knowing, including machine shop practice, taking apart and putting together complete cars, Knight type, 12 and 8 cyl. motors; latest starting and lighting equipment, Ambu trouble shooter, Phillips testing set, etc., etc. Just installed newest Akron-Williams tire repair equipment—same as used and sold by the leading tire companies.

CLEVELAND LEADS

in all parts and accessory, and high grade car manufacture, and is gaining fast in new factories; Grant, Jordan, Abbott, Denmo truck, H. A. L. 12—and others building.

TRAINING IN 4 WEEKS

Tuition low; board and room \$5 and \$6 per week near school; congenial company and surroundings; we help you get located. New classes forming. Come and join us now.

We Absolutely Guarantee

to qualify you for a good paying position in the Auto business on completion of our course.

Cleveland Automobile School

CLYDE H. PRATT, President, Dept. 3, 2338 Euclid Ave., CLEVELAND, OHIO



Auto Dealer or Salesman

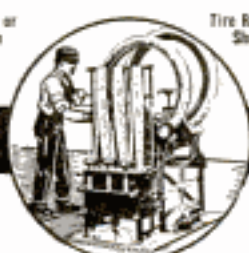

Tire Repair Shop



Garage Owner or Manager

Own

A Business

Send This Coupon

CLEVELAND AUTO SCHOOL
Dept. 3
2338 Euclid Ave.
CLEVELAND

You may send me FREE catalog, terms, etc.

Name.....

Address.....

Please Mention Popular Mechanics



A High School Course In Two Years

YOU men and women who never went to high school will welcome this opportunity to get—in your spare time—the valuable training you missed. A high school course insures greater success in business—is vitally necessary if you want to go to college. And you can now get a thorough high school course in your own home—and complete it in two years!

This simple home-study course covers the same subjects as the leading preparatory schools and high schools, including the subjects required for entrance into all colleges and universities. By this new and simplified method of home instruction you will be able to gain a thorough education that will be of inestimable value—even if you don't intend to go to college. It gives you the foundation that is necessary for later success—and it is within the reach of all.

Use Only Your Idle Hours

The course is so arranged and so written that you may read at home during your idle hours. It was prepared by leading professors and instructors who have made a life work of correspondence instruction, and every line is written so that you can understand it easily and gain from it the maximum amount of good. You will marvel at its completeness. When once you start the lessons, you will be fascinated.

Meets College Requirements

With this new course you can prepare yourself for either a literary or an engineering education. All the required subjects are covered in detail—and you are given just the kind of training that colleges and universities demand. At the present time, we are preparing hundreds of men and women for college—but even if you are not going to college, you should investigate this opportunity to get the fundamental education that you feel the need of every day. Here is an opportunity to get it in your own home—at a small expense and in a short time.

Send the Coupon

American School of Correspondence
Dept. P. 1193
Chicago, U. S. A.

Gentlemen:—Please send me your new Bulletin and tell me how I can get a high school course in two years.

Name

Address

For New Bulletin

Send the coupon or a letter or post card now for our new bulletin. Read of the opportunity that you have to get a general education. Read what it means to you and then decide. Getting the new bulletin will put you under no obligation—and you will find a new inspiration when you read it. Send the coupon NOW!

American School of Correspondence
Dept. P. 1193
Chicago, U. S. A.

Please Mention Popular-Mechanics

You May Now Use

this valuable art. Others are using Lichtentag Paragon as a daily convenience. Executives and business men find it very useful. Because of its remarkable simplicity you can learn the entire

LICHTENTAG PARAGON

SHORTHAND

In your own home, during the evenings of one week. **Speed comes with use or practice.** Wonderfully easy to read. Paragon Writers are stenographers in service of U. S. Gov. and offices of corporations, also in court reporting. System already adopted by number of cities for high schools. Write for full proof.

7 DAYS

What Others Say

"The study of Paragon is a fascinating pastime."

"I was able to use it in making my private memoranda, though slowly, even before the end of the week."

"So simple and legible that in a week I could read all the shorthand matter, even before starting speed practice."

"By practice I have already developed a speed of 175 words a minute."

"The highest I was able to reach, on a four minutes' dictation of new matter, was 260 words per minute."

THE PARAGON INSTITUTE
293 Calhoun St. New Orleans, La.



Send a Dollar Today

ART MAGAZINE

For Artists and Art Students

Publishes cash art assignments, articles and lessons on Cartooning, Designing, Illustrating, Lettering and Chalk-talking. Criticizes amateurs' work. Interesting, helpful, artistic. Satisfaction guaranteed or money refunded.

10c a copy, \$1 a year. Send \$1 NOW, stamps or bill, to G. H. LOCKWOOD, Editor
Dept. 235, Kalamazoo, Mich.

LEARN WATCH REPAIRING

Be a watchmaker—you can learn this profitable trade by correspondence in a few weeks in your own home by the DeSelms Chart System. After you complete the course you will know a watch from A to Z. You will know just what the matter is and how to repair one. When you graduate you will be a practical watchmaker and repairer and competent to fill any position. Positions for our graduates.

Ask for our Free Book. It explains our system and terms.

THE DeSELMS WATCH SCHOOL
23 Perry Street ATTICA, INDIANA



Men Wanted To Learn Automobile Business

EARN BIG MONEY—\$75 to \$300 Per Month

Only a few weeks required to train you. In six weeks I teach you to run and repair properly any automobile made. Learn to be repairman, demonstrator, garage manager and salesman. I teach thoroughly, practically and personally on real automobiles in everyday use. No books used. Tools furnished free. Actual practice on big, powerful cars brought here for inspection and repairs. SEND FOR BOOKLET, "Making You Master of the Auto." Free upon request.

WM. H. ANSELGER Milwaukee Motor School, 217-21 Seventh St., Milwaukee, Wis.

AT HOME
Learn TO SING Send 2-cent Stamp for Helpful Booklet, "The Voice Made Beautiful."
HARVEY SUTHERLAND, 1832P 49th St., BROOKLYN, N. Y.

Baker's Show Card Book \$3.00
EARN \$20 TO \$60 A WEEK
LEARN TO MAKE SHOW CARDS Salary or business of your own. My book teaches all the tricks of the trade. No simple anyone can learn. Elaborately illustrated. Earn while learning. Send today. Money refunded if not satisfied.
WM. J. BAKER, HENRY BUILDING, PORTLAND, ORE.

LANGUAGES Quietly Learned AT HOME by the Original Phonographic Method
German—French—English—Italian—Spanish
Learned by the Cortina Method at home with Disc-Cortina-Phone Language Records. Inquire at your local phonograph dealer who carries or can get our records for you, or write to us for FREE booklet today; easy payment plan.
CORTINA ACADEMY of LANGUAGES
Suite 2105, 12 E. 40th Street, N.Y.
CORTINAPHONE

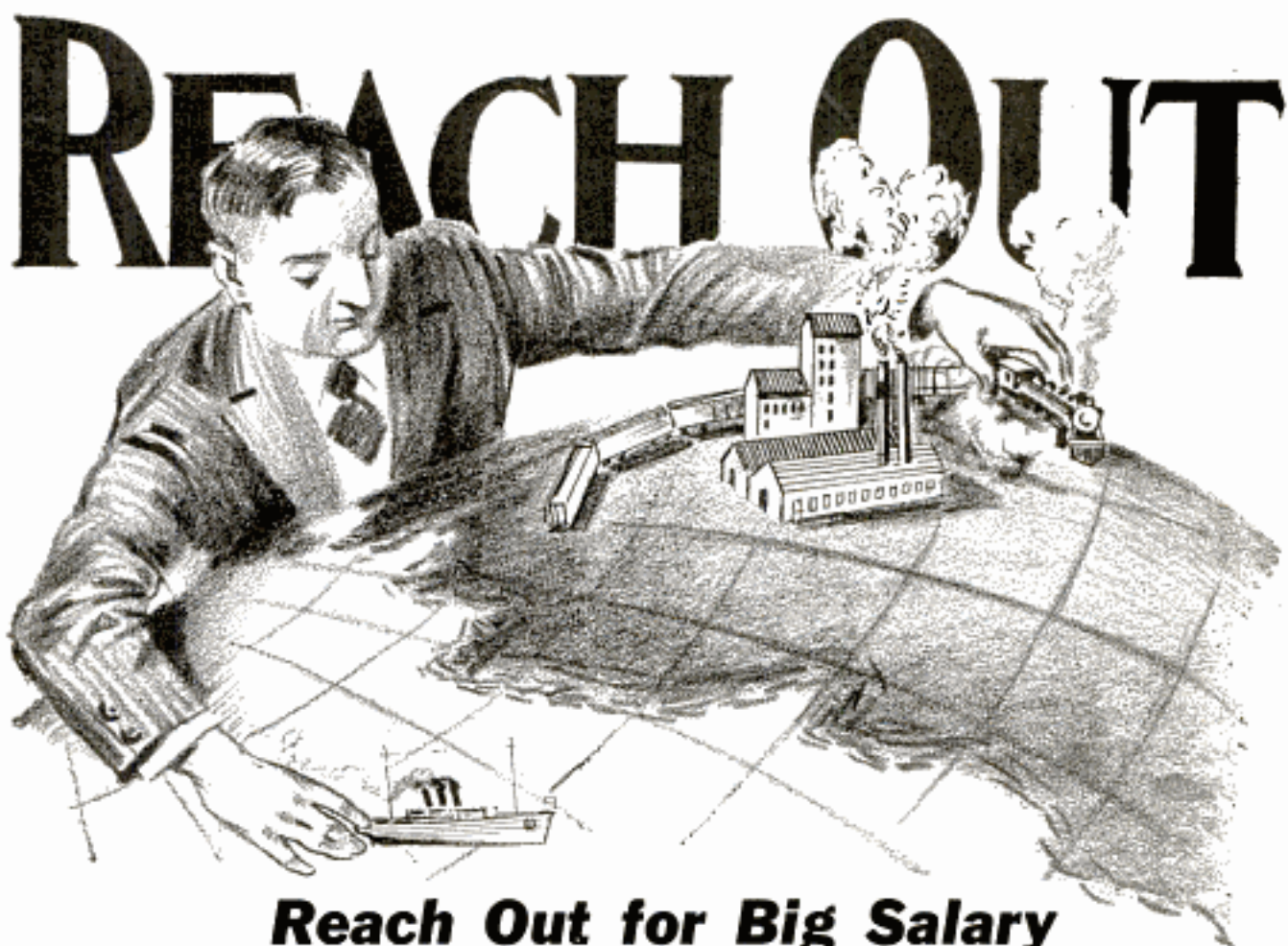

Reach Out for Big Salary Become a **TRAFFIC MANAGER** —and a Member of This Association

Digest of Traffic

The Association has compiled the only digest of traffic ever produced. This work required the co-operation of over three hundred traffic experts—took five years and over \$100,000 has been expended. This great reference and working library is for the exclusive use of its members.

The great European war has suspended the commerce of several of the great nations. America has profited thereby immensely. The U. S. has won the trade thus lost by the European nations and is now supplying the greater part of the world with food, supplies and manufactured articles. It is also furnishing the warring nations with vast quantities of munitions. **MEN ARE REQUIRED** who **KNOW** how to **SHIP** goods.

Thousands of Positions Now Waiting

Never before have there been such a variety and number of splendid opportunities for young, and middle aged, men. This is especially true in manufacturing and in **SHIPPING**. Live men who **START NOW** are assured of **GOOD** salary.

SALARY

The salary of trained traffic men is from \$2,500 to \$10,000 a year. The work is always interesting because it is not routine work. The traffic man is an executive—not a subordinate.

Gorged — Shipments Tied Up

The shipments of food, supplies, manufactured articles, munitions of war, etc., for European and other foreign delivery, are so **LARGE** that the shipping departments of thousands of factories—railroads—warehouses—seaboard wharves—are **GORGED**. In addition our Interstate shipping is tied up. Shippers are crying for help.

Trained Men, Only

These thousands of positions are for **TRAINED** men **ONLY**—men who understand **TRAFFIC**—shipping. Men are wanted who are fully informed—who know how to get **QUICK ACTION**—who know how to **SAVE** freight money.

We Will Train — YOU

Our Association will instruct you—tell you **JUST WHAT** is required—and **JUST HOW** to do it. We give you individual "coaching" and **TRAIN YOU** by our "experience" method.

Don't Delay — Apply NOW

Now is the time—today. It is not difficult to make good—if you don't it will be **YOUR OWN** fault. Send the **COUPON** now for complete instructions by **RETURN MAIL**.

American Commerce Association

Dept. 47, 206 So. Wabash Ave.,
CHICAGO, ILL.

Send me **FREE**—and without obligation—complete information concerning the Association and how I can train as a traffic man.

Name.....

Occupation.....

Address.....

City..... State.....

American Commerce Assn. (Dept. 47) 206 So. Wabash Ave., Chicago, Ill.

Please Mention Popular Mechanics



"I have watched the progress of the International Correspondence Schools almost from the very beginning, and while their rapid growth might be marvelled at by some, to me it is easily understood because I realize the practical value that is back of it, and know something, too, of the success attained by many ambitious men who have taken I. C. S. courses."

Thomas Edison

Edison Knows!

He knows the worth of spare time study. He knows what stuff men are made of who use their spare hours to train themselves for the bigger jobs ahead. And he knows what the International Correspondence Schools will do for the man with the grit to say, "I will."

All big men who have made their mark in the world had the ambition—the determination—to improve their spare time, to train themselves for big work. Edison did. You, too, can possess power, money and happiness if you'll only make the effort.

Put it up to us without paying or promising. Let us send you the details of others' success through the I. C. S. Mark and mail this coupon now.

TEAR OUT HERE

INTERNATIONAL CORRESPONDENCE SCHOOLS

Box 5561, SCRANTON, PA.

Explain, without obligating me, how I can qualify for the position, or in the subject, before which I mark X.

- | | |
|---|--|
| <input type="checkbox"/> ELECTRICAL ENGINEER | <input type="checkbox"/> SALESMANSHIP |
| <input type="checkbox"/> Electric Lighting | <input type="checkbox"/> ADVERTISING MAN |
| <input type="checkbox"/> Electric Car Running | <input type="checkbox"/> Window Trimmer |
| <input type="checkbox"/> Electric Wiring | <input type="checkbox"/> Show Card Writer |
| <input type="checkbox"/> Telegraph Expert | <input type="checkbox"/> Outdoor Sign Painter |
| <input type="checkbox"/> Practical Telephony | <input type="checkbox"/> RAILROADER |
| <input type="checkbox"/> MECHANICAL ENGINEER | <input type="checkbox"/> ILLUSTRATOR |
| <input type="checkbox"/> Mechanical Draftsman | <input type="checkbox"/> DESIGNER |
| <input type="checkbox"/> Machine Shop Practice | <input type="checkbox"/> BOOKKEEPER |
| <input type="checkbox"/> Gas Engineer | <input type="checkbox"/> Stenographer and Typist |
| <input type="checkbox"/> CIVIL ENGINEER | <input type="checkbox"/> Cert. Public Accountant |
| <input type="checkbox"/> Surveying and Mapping | <input type="checkbox"/> Railway Accountant |
| <input type="checkbox"/> NINE FOREMAN OR ENGINEER | <input type="checkbox"/> Commercial Law |
| <input type="checkbox"/> Metallurgist or Prospector | <input type="checkbox"/> Traffic Management |
| <input type="checkbox"/> STATIONARY ENGINEER | <input type="checkbox"/> GOOD ENGLISH |
| <input type="checkbox"/> Marine Engineer | <input type="checkbox"/> Teacher |
| <input type="checkbox"/> ARCHITECT | <input type="checkbox"/> Common School Subjects |
| <input type="checkbox"/> Contractor and Builder | <input type="checkbox"/> CIVIL SERVICE |
| <input type="checkbox"/> Architectural Draftsman | <input type="checkbox"/> Railway Mail Clerk |
| <input type="checkbox"/> Concrete Builder | <input type="checkbox"/> Textile Overseer or Supt. |
| <input type="checkbox"/> Structural Engineer | <input type="checkbox"/> Navigator <input type="checkbox"/> Spanish |
| <input type="checkbox"/> PLUMBING AND HEATING | <input type="checkbox"/> AGRICULTURE <input type="checkbox"/> German |
| <input type="checkbox"/> Sheet Metal Worker | <input type="checkbox"/> Poultry Raising <input type="checkbox"/> French |
| <input type="checkbox"/> CHEMICAL ENGINEER | <input type="checkbox"/> AUTOMOBILES <input type="checkbox"/> Italian |

Name _____

Occupation & Employer _____

Street and No. _____

City _____ State _____

If name of Course you want is not in this list, write it below.

Please Mention Popular Mechanics

THE LAW TRAINED MAN

A new book
for ambitious men

"THE Law Trained Man" tells you of the advantages of a law training in business and in politics. Also how you can become a successful lawyer.

It tells you of the Modern American Law Course and Service of the Blackstone Institute—the only course in law that has the unqualified endorsement of resident law schools, the legal profession and prominent business men everywhere.

This new 168-page book is free. Send for your copy today.

Blackstone Institute

106 Dearborn Street

Chicago, Ill.

DON'T TAKE A COURSE IN MACHINE DRAFTING

Until you have read my proposition. You want to learn the kind of drawing that enables you to earn money. I am employed by a large and progressive company, making drawings for actual manufacture, and can teach you to earn money the same way. Instruments I send FREE are guaranteed best furnished by any concern. Terms very reasonable. Pay a part after in position as draftsman. Inclose stamp, and I will send copies of student drawings and letters from satisfied pupils all over the country.

DRAFTSMAN, 252 South Corona St., DENVER, COLO.

NATIONAL DENTAL TRADE SCHOOL

506 S. Wabash Ave., CHICAGO, ILL.

MEN AND YOUNG MEN LEARN IN 3 MONTHS

Earn \$1200 to \$2000 yearly in mechanical dentistry. A big and growing demand everywhere for mechanical dentists—like a gold mine, unexplored. Attend this school any time of the day or evening; be taught individually and learn by actual practice, without book study. Our System, the most complete in the world, is used exclusively in this school. We are constantly called upon to fill high-salaried positions. Why not qualify for one? Be fair to yourself; find out more about exceptional opportunity we offer. Visit the school or write for booklet II.

LETTER WRITERS WANTED

You can become an expert correspondent. Big Pay—fascinating. Positions open all the time. FREE Information. Write for details today. Montgomery School, 415 Schwind Bldg., Dayton, O.

Book Authors

We can consider book Mrs. of fiction, biography, travel, poetry, etc., also groups of short stories for volume issue. Please send prepaid with return postage. THE McLEAN CO., 100 Rippel Bldg., BALTIMORE, MD.



VENTRILOQUISM

LEARNED BY ALMOST ANYONE AT HOME SMALL COST Send today 2c stamp for particulars and proof. O. A. SMITH, Room D 148, 823 Bigelow St., PEORIA, ILL.



Let me think!

HAVE YOU ever been in that distracted state of mind when it seemed impossible to collect your thoughts—when ideas became tangled and confused in your brain—when you seem powerless to **THINK CLEARLY AT A CRUCIAL MOMENT**? Perhaps at some vitally important time this **CONFUSION OF THOUGHT**, to which so many men are victims, has caused you to *lose out* where you might have *won* with *Concentration*.

Learn How To Concentrate

Written by **THERON Q. DUMONT**
World-Renowned Mental Scientist

The writer is one of the world's leading authorities on the subject of mind-culture and mind-science. He has produced many works on this subject, but "**Power of Concentration**," is probably his greatest achievement. You cannot help but admire and appreciate the simple directness and conciseness of the manner in which this marvelous book instructs you.

FREE Examination

All we ask is that you send for this great book **now**—look it over—read a few chapters—and then if it does not impress you as being a **valuable asset to your future career**, simply return it to us and we will consider you under no obligation whatever. This **Liberal Free Examination Offer** makes it easy for you to **convince yourself** of the real worth and amazing helpfulness of this book. See for yourself how it will teach you to build up your **Thought Power** and consequently your **Earning Power**.

This is your opportunity at last to get away from inefficiency of mind and make your brain power a real force for accomplishment. Send the coupon. **Concentrate now** on this slight task. The simple mailing of the coupon of this ad, if followed with **concentration**, is sure to lead to greater things. It will help you to do more, earn more—**be more**. Get this wonderfully instructive book while our Special Offer lasts—examine it carefully—verify what we say about it—then send us the **SPECIAL PRICE OF \$2.00**.

MAIL THIS COUPON
Don't send us a single cent

This Book Teaches You

It is wonderfully well written—expressed so that you can **understand** it. "**Power of Concentration**" is a practical exposition of the rudiments of Thought-Discipline by a **master mind**. You can actually learn from this wonderful book the elements of mind control and development through **Concentration**. You will find the methods of learning how to concentrate are simple and understandable when you read this great book.

Contents:

Here are a few of the chapter titles indicating the nature of the things taught by "**Power of Concentration**":

- ☞ Self mastery and self direction through concentration.
- ☞ A quick way to develop concentration.
- ☞ How to overcome destructive forces.
- ☞ Concentration molds your environments.
- ☞ How to exclude all distracting thoughts.
- ☞ Concentration overcomes bad habits.
- ☞ Business results gained through concentration.
- ☞ Concentration develops courage.
- ☞ Concentration improves your memory.
- ☞ Ideals developed by concentration.
- ☞ Simple rules for happiness and success.
- ☞ Practical methods of developing the will.

Advanced
Thought Publishing Co.
160 North Michigan Ave.
Dept. 216, Chicago, Illinois

Gentlemen: Send me at once special edition of the **Power of Concentration**. If, after examining it for five days, I am not satisfied, I may return it to you and owe you nothing. If I decide to keep the book I will send you the special price of \$2.00.

Name

Address

This X Will Prove Your Ambition

THIS little "X" has marked the way to success for thousands of ambitious men. It marked the day when they stopped *dreaming* and began *acting*. Merely dreaming about the job ahead won't help you get it. But marking "X" in the coupon proves your ambition—and shows that you are ready to put your dreams into action to earn success.

The job you dream about can be yours. Not through favor or pull or some lucky chance—but through *training*. Thousands are proving it every day.

And it is easy for you to get that training.

It isn't necessary to make a *drudge* of yourself. The first step is to mark your "X" before the job you want, and we will show you the way to success.

Make Your Mark Now

Mark an "X" before the job you want, and mail the coupon to us now. We'll show you your way to success—more simple and easy than you have dreamed. You'll be under no obligation and for the sake of your ambition you should act today. Make your mark now. Send the coupon.

**American School
of Correspondence, Chicago, U.S.A.**
Dept. G8193

American School of Correspondence, Dept. G8193, Chicago, U.S.A.

Gentlemen: Please send me booklet and tell me how I can fit myself for the position marked X.

- | | |
|--------------------------------|-------------------------------|
|Electrical Engineer |Business Law |
|Elec. Light & Power Supt. |Business Manager |
|Hydroelectric Engineer |Auditor |
|Telephone Engineer |Accountant |
|Architect |Curt'd Public Acc't |
|Architectural Draftsman |Stenographer |
|Building Contractor |Bookkeeper |
|Building Superintendent |Fire Ins. Inspector |
|Structural Engineer |Fire Ins. Adjuster |
|Structural Draftsman |Fire Ins. Expert |
|Mechanical Engineer |Sanitary Engineer |
|Mechanical Draftsman |Master Plumber |
|Civil Engineer |Plumbing & Heating Est. |
|Steam Engineer |Heating & Vent. Engineer |
|Shop Foreman |Reclamation Engineer |
|Shop Superintendent |Automobile Engineer |
|Sheet Metal Draftsman |Automobile Repairer |
|Lawyer |High School Course |

We also prepare for civil service examinations in all engineering subjects

Name.....

Address.....

Please Mention Popular Mechanics

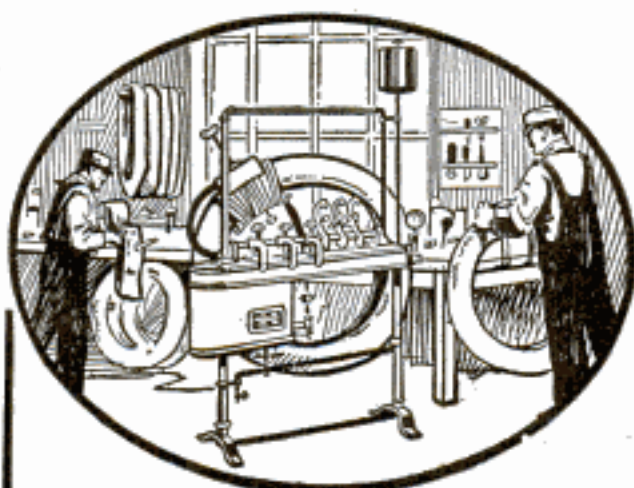

Big money for you

Think of the auto owners in your own locality who are eager to have their tires repaired! Open a repair shop with a Shaler Tire Repair Outfit. Earn \$250.00 per month. No experience necessary. We make it easy for you to start right away. You have your own business.

Free Book Tells How

Write for our wonderful book, "How to Open a Tire Repair Shop." It will open your eyes! Shows you how easy the work is. Shows you the big money that can be made. Write for this book today. A post card will do.

C. A. SHALER COMPANY

2002 Fourth Street

Waupun, Wis.

Disston Saws

ERECTOR THE TOY LIKE STRUCTURAL STEEL

BOYS: Write for facts about the Big Prize Contest and get Erector Tips, the boys' magazine, FREE. THE A. C. GILBERT COMPANY, 104 Fox St., New Haven, Conn.

San-Tox

"San-Tox for Purity"

That's the meaning of the San-Tox Nurse face seen on over 125 toilet and health preparations.

De Pree Chicago

Why Pay Full Prices for Diamonds

Diamond Banking We lend money, taking diamonds as security. When loans are not paid, the diamonds are offered for sale. For as few years, we have offered beautiful diamonds 40 to 50 per cent lower than market prices. Some quantities for which full prices are paid. Free examination.

1/8 - 3/8 kt. blue-white perfect cut, brilliant diamond solitaire, Lady's 1 1/2 kt. brand new white gold top ring. Try to match it at \$140. Guaranteed Cash Loan \$60. Unpaid \$72.50

Loan Price.....

Write Today for New Bulletin! No obligations.

Send your name and address.....

Jos. DeRoy & Sons 1824 DeRoy Bldg. Pittsburgh, Pa.

Reference by permission: *Business Dep.*

Nat. Bank Marine Nat. Bank, and Pittsburgh Daily Newspaper



Every man stands on the threshold of SUCCESS

—which life do
YOU
choose?



The decision is with you. You can get the most out of life if you get the most out of yourself. Do you know the full extent of your own powers? There is only one way for you to find out—only one way to master yourself and secure success in life and business.

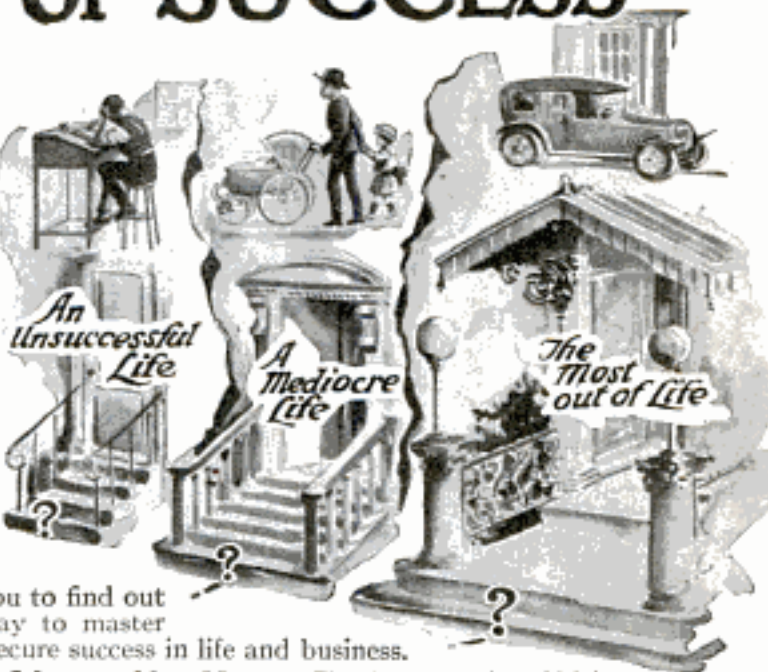

Look Into Yourself. How? That is the question which is answered as never before in masterful book, "Everybody Ahead" or "Getting the Most Out of Life."

A wonderful new prescription for success by Dr. Orison Swett Marden, whose writings have inspired millions

Dr. Marden is a self-made success, a student of success and a friend and counselor of the Nation's most successful men. Such men as Charles M. Schwab, John Wanamaker, Judge Lindsey, Edwin Markham, Hudson Maxim, Luther Burbank, and others, acknowledge their debt of gratitude to him. 25 years of his life have been spent in studying success. He knows what makes success. He has applied these principles himself. He has taught the principles to thousands of others by teaching them how to look into themselves.



Orison Swett Marden

The man who holds the unchallenged American championship in optimism. Author of a dozen famous upward and onward books, that have been sold by the million. Apostle of the smile. Preacher of the glad hand. Captain of a helpful life—a decidedly successful man.

A few of the absorbing chapters in Dr. Marden's Great New Book—"Everybody Ahead!"

Backing up the Brain; Training for Masterfulness; How to measure your Ability; Foundations of Success; Timidity and Sensitiveness, and how to overcome them; Can you Finance Yourself?; Are you an Original or a Duplicate?; The Quality which opens All Doors; Why Can't I do it?; How to Talk Well—a Tremendous Asset; Are you a Good Advertisement of Yourself; The Man with Initiative; The Climbing Habit; Courage and Self-Faith—How to Cultivate Them; The Will that Finds a Way; Taking Habit into Partnership; Your Giving Up Point; Worry, the Success Killer—How to Cure; Success as a Tonic; Will it Pay to go to College? What other People Think of You and Your Career; When Discouraged What to Do, and other vital subjects.

all charges prepaid (I have Dr. Marden's permission to do this.) You can glance through it or read it all the way through, just as you choose. Even a hasty perusal will prove of profit to you. When at the end of five days you decide to keep the book, forward me \$3.50 and the book is yours forever. Or at the end of that time return the book to me.

Special Limited Offer to Men of Quick Decision

For a limited time only I will send absolutely free to purchasers of "Everybody Ahead" an attractive little copy of the world-famous book, "The Magic Story," bound in half leather. W. P. Werheim, of Pratt and Lambert, Inc., Buffalo, N. Y., said of "The Magic Story"—"This book is worth \$25 to any man, and to some \$2,500." Others have said that it is the most gripping, the most engrossing, the most genuinely inspiring business story ever written. 100,000 copies of "The Magic Story" have already been distributed. This book is FREE to you and yours to keep without extra cost when you remit for "Everybody Ahead." Send the coupon now while the matter is fresh in your mind. One of the very things which may be holding you back in life is that you do not do the things you intend to do. You may intend to send for "Everybody Ahead" and then let the matter slip your mind. Write NOW and you can't forget. Use the coupon. ACT!

Frank E. Morrison, Publisher, Dept. 51, 1133 Broadway, New York

"Everybody Ahead," or "Getting the Most Out of Life"

that means everybody ahead of his present position. This is not the ordinary sermon-like "preachy" sort of a book on "How to Succeed." It goes right to the root of things.

It makes an exhaustive study of every possible cause for failure and prescribes the cure. It not only shows you how to look into yourself, it actually carries you right through yourself and you run up against your failings with a bang and a lot,—and better still, you are made to see the way to overcome them.

Men who thought they knew all their own failings, men who actually considered themselves successful have read this book with astonishment. They were amazed to find weaknesses in themselves the existence of which they never suspected—amazed to find strength which they had never used.

And it is the sort of book that you can easily understand—full of principles that you can actually apply to your own everyday life. Read what some of the world's greatest men say:

Charles M. Schwab says: "I owe a great deal of my success to Dr. Marden's writings."

Luther Burbank says: "Of the many valuable books which you have written this seems to me to be the most valuable and thoroughly practical of them all."

John Wanamaker says that he would have gone without a meal a day if necessary, to save the money to buy one of Marden's books.

Lord Northcliffe says, "I believe that your books will be of immense assistance to all ambitious men."

It Will Cost You Nothing to Read This Book

You would deem it a privilege well worth paying for to read a single chapter of this book. Five minutes spent in reading wherever your eye happens to fall will prove of tremendous advantage to you. AND YOU MAY HAVE THE PRIVILEGE OF READING THE WHOLE 535 PAGES OF THIS BOOK FOR NOTHING.

SEND NO MONEY Simply mail me your name and address on the coupon. I will then send you the book with

SEND THIS COUPON TODAY—SPECIAL LIMITED OFFER

Name.....
Address.....

Frank E. Morrison,
Publisher,
Dept. 51,
1133 Broadway,
New York.

Send me, postpaid and without obligation, Dr. Marden's great New Book, "Everybody Ahead" or "Getting the Most Out of Life." I will either return the book within five days after receipt or keep the book and send you \$3.50 and you will then send a copy of "The Magic Story" absolutely free.

Learn **TIRE** Repairing **FREE**



Come To The Haywood School

At Indianapolis you can learn Tire Repairing **Absolutely FREE**—without one cent for tuition. I'll teach you a National Tire Repair System—a system that every autoist recognizes. A few weeks at my school will equip you to handle the most difficult jobs—to do all kinds of repairing. You become a Haywood Expert in Retreading, Vulcanizing and Repairing of Tires. All you need beside this training is a little equipment. You are then ready to supply the demand for Haywood Tire Repair Service. Classes are always open. Start any time. Write for particulars today.

Make \$2500 to \$4000 a Year

Many men operating under the Haywood system are making this and better. Here is the business for you—a business from which you can become independent. No guess work about it. Wherever there are automobiles there is a big demand for tire repair work. Autoists everywhere demand it—want it—will come to you to get it. The minute you open your doors—put out "The Sign of the Man and Machine"—the recognized mark of Haywood Tire Repair Service, your success is practically certain.

15 MILLION TIRES TO REPAIR

Fifteen million tires are to be made this year. Every one will need repairing. Think what an opportunity. Every repair you make pays a big profit. Here is good business, winter and summer. No seasons to tide over. Money comes in from one year's end to another. The business grows bigger and better. Be the first in your town. Come to Indianapolis and learn this business.

A NATIONAL TIRE REPAIR SERVICE

Haywood's Tire Repair Service has been advertised for years in national magazines. It is known the country over as tire repairing that lasts—that's durable—that saves motorists money. It's the tire repair service you don't have to sell.

WRITE QUICK FOR FACTS

Simply send your name and address. Mail the coupon—a letter or post card. Get my big book of valuable money-making information. This is the biggest year in the automobile business. 1917 to be bigger. Get started now. Write at once.

M. E. HAYWOOD
HAYWOOD TIRE & EQUIPMENT CO.
688 N. Capitol Ave. INDIANAPOLIS, IND.

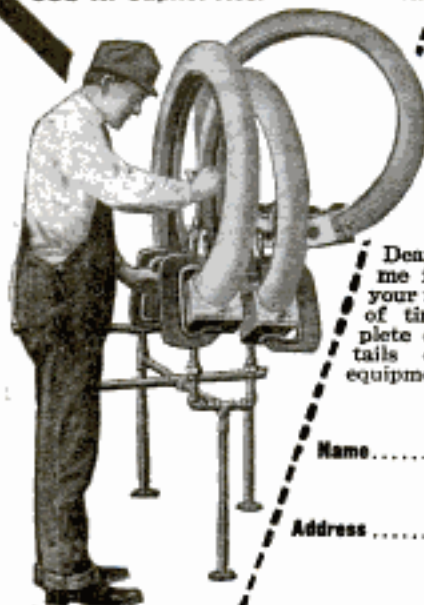

MAIL THIS COUPON

M. E. Haywood
HAYWOOD TIRE & EQUIPMENT CO.
688 N. Capitol Ave.
INDIANAPOLIS, IND.

Dear Sir:—Please send me full information of your free training school of tire repairing, complete catalog and all details of the Haywood equipment.

Name

Address

Please Mention Popular Mechanics



Voice Thrower 10c

Learn to throw your voice into a TRUNK, under the bed, out in the hall or anywhere. Lots of FUN fooling the Teacher, Janitor, Policeman, Parents, Neighbors, or Friends.

THE VENTRILO

is a little instrument that fits into the mouth out of sight. BOYS or GIRLS can use it. NEVER FAILS! A 32 page book on Ventriloquism sent with the VENTRILO for TEN Cents.

BIG WONDER PACKAGE



1 Great North Pole Game, 1 Big Roll Stage Money, 1 Game Authors, 1 Cribbage Board, 1 Checker Board and Men, Pinochle Game, 37 other Games, 19 Lessons in Magic, 1 Set of Dominoes, 27 Autograph Verses, 12 Money Making Secrets, Wireless Telegraph Code, 25 Pictures of Pretty Girls, 2 Puzzles, 100 Conundrums. All the above with large catalog for 10c

NEW FORD JOKE BOOK 1917

All the latest jokes on the Ford Auto. Hundreds of them and all good ones. Spring a new one on your neighbors.

Large book with colored cover by mail, 10c.



STRADDLE BUG



The most startling Novelty ever gotten out. When it goes off, it would scare the heart out of a wooden Indian. Don't try it on the women folks, or they will faint. Can be wound up in one instant for another victim. 10c Great novelty. Sample by mail

ROGEN X RAY

Price 10 cents



HERE, BOYS, is just what you want. With this instrument you can apparently see through clothes, see the bones in your fingers. Think of the fun you can have with it. Sample by mail, TEN CENTS.

SKULL RING



Here is a handsome, up-to-date Ring, representing a Skull and Cross-bones. Has stones in the eyes and looks something frightful. Women won't like it, but for men or boys it is a great novelty.

Sample by mail, 15c

Gee! What a Wad!



This is STAGE MONEY.

Looks like the GENUINE STUFF. Some Green backs and some Yellow backs. Create a BIG sensation among your friends. The girls will all be after you when they see the wad. BIG roll of 15 pieces by mail 10 cents.



Boys Own Toy Maker and Nine Other Books for 10c

Tells how to make a Telephone, Magic Lantern, Kites, Sail Boat, Stilts, Electric Telegraph, Pop Gun, Red Fire, Galvanic Battery and many other things. This book with nine other interesting books mailed for 10c.

All the above goods can be secured from

ROYAL NOVELTY CO.

225 East Ave., SOUTH NORWALK, CONN.

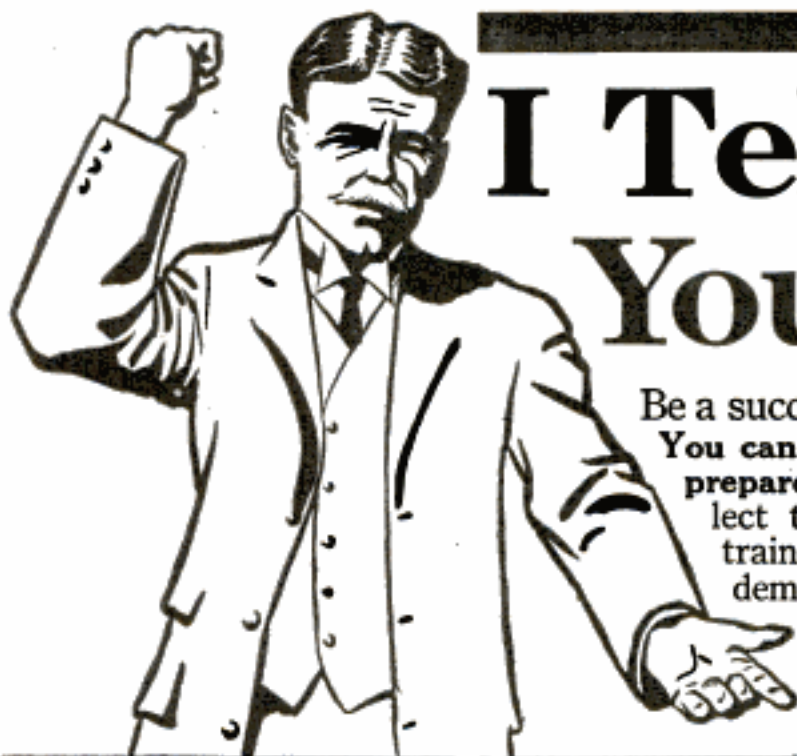

I Tell You You Can!

Be a success and command big pay. You can easily do it if you will **only prepare yourself!** Why will men neglect to prepare themselves, when trained **electricians** are always in demand at big pay? When employers are **searching** for \$3,000 and \$10,000 men, while this country is crowded with poorly-paid men who could easily qualify for these positions!

\$50 to \$200 a Week

As a Trained

ELECTRICIAN

If you have a common school education you can easily qualify **at home** by my new Course in Electricity, no matter if you know nothing at all about electricity now. My Course, while complete and absolutely scientific, explains everything so clearly that any one can understand it and do the work. But this Course is designed to give you a **real** electrical education, to help men become **bigger, better men** — men who can command big pay.

And remember, I give every student a **GUARANTEE BOND** which insures you satisfaction or every dollar of your money refunded. We can make such a guarantee because we know our Course and what it does for our students. Send for free illustrated book telling all about it. **PART OF YOUR SPARE TIME** devoted to this interesting work is all that is needed. You will find it most fascinating, and in a short time your earning power will be greatly increased.

\$17⁰⁰ Electrical Outfit Free:

Every student who enrolls with me now gets a \$17.00 outfit of electrical equipment, instruments and material—**FREE**; also my Quick Money-Making Electrical Course **FREE** as soon as enrolled, so you can earn while learning; you also get **FREE** Employment Service; **FREE** \$100 Scholarship opportunity; **FREE** 5-year Advisory Service. And besides all this I have a pleasant and truly valuable surprise, **FREE**, for every student who answers this ad. Send in the coupon now.

You have one life to live—and time is passing. Make the most of it. Prepare for success. Aim high; you can hit the mark if you will only try. **Do it! Tear off the coupon now!**

CHIEF ENGINEER

Chicago Engineering Works
439 Cass St., Dept. 7, CHICAGO, ILL.

Dept.

CHIEF
ENGINEER

Chicago Engineering Works
439 Cass St.

Chicago, Illinois

Without obligation on my part kindly send at once, fully prepaid, particulars of your complete Practical Home Study Course in Electricity.

USE THIS FREE "OUTFIT" COUPON

Name

Address

Town State

TRAFFIC MEN earn \$3,500 to \$10,000 Yearly



TRAFFIC MANAGER



R. R. TRAFFIC MEN



TRAFFIC BUREAU



COMMERCE CLUB TRAFFIC SEC'y

No other field or profession offers such advantages as are open to trained Traffic Men, Railroads, Factories, Jobbers. Commerce Clubs are taking all the trained men they can find. They are paying from \$3,500 to \$10,000 and more yearly for competent men. There are now more than 95,000 Traffic positions open in all parts of the country. We are training men in a short time to fill these positions. Only spare time is needed. The work is easy to understand; you begin to earn more after your first few lessons. The course is thoroughly practical. Anyone who understands common every day language will succeed. Positions are permanent, with opportunities for continual salary increase.

Learn from Practical Traffic Men

Every one of our instructors are practical, experienced traffic men. Been in the work for years. Made a big success, and are teaching men the things that make success. Every student gets the personal attention of our faculty. Successful graduates prove our claims. One man wrote us: "I saved my firm \$4,000 from August 1st to December 1st." It was his first traffic position and he made good. Our instructors help graduates for two years after they have graduated. We have over 100,000 tariffs on file in our library. Rates, routing and classifications can be quoted from any two points in the U. S., Canada and Mexico. This immense library, together with our practical instructors, gives an advantage found in no other school. Our graduates can handle any problem.

Why Traffic Men Are Needed

Large and Small Factories, Auto Manufacturers and Wholesale Houses are extending their territory. Every

extension means new rates, new routing, a different classification or changed packing methods. The Interstate Commerce Commission and the Railroads are constantly changing rates and classifications. Concerns opening branch houses meet new problems. It takes a trained Traffic man to handle problems like these. Only men who have been in the Traffic business for years, men who have grown up with this big high-salaried business, are competent to train men. The Traffic business will never grow smaller. There will always be a demand for trained, competent Traffic Men.

Post Graduate Course Free Our Students and Graduates have the privilege of coming to our School for Post Graduate Work. They may stay as long as they like. They get actual experience in rates, routing, classification and packing. This work is absolutely free. It is not essential, but is very helpful. This privilege is not found in any other school. **FREE** Our Booklet, "TRAFFIC," color and full information. **FREE** all. **ABSOLUTELY FREE.** Make up your mind now to get started. Get our literature at once.

Traffic Men	Salaries range from \$3,000 to \$25,000 yearly.
Traffic Bureaus	Bureaus make \$2,000 to \$10,000 yearly.
R. R. Traffic Men	Salaries vary from \$1,500 to \$12,000 yearly.
Commerce Club Traffic Secretaries	\$2,500, \$3,000, \$4,500, \$5,000, \$15,000 and up.

MEN WITH VISIONS

James J. Hill was a man with a vision. He saw the possibilities of a railroad through the northwest; he accomplished his vision. Cecil Rhodes visioned an immense railroad in South Africa. He lived to see his vision come through.

Thomas Jefferson saw a vision of the U. S. reaching from ocean to ocean. He accomplished this.

Abraham Lincoln saw great visions in the law practice and by hard knocks reached his goal.

The vision of these great men made it possible for them to stand the hard knocks and overcome every obstacle. They were pioneers and it took a lifetime for them to win out. No one guided them or told them how.

Think of the possibilities for you in the traffic field. Think how quickly you can reach the big salary. Make up your mind to be a traffic man. Get started and don't let anything change your vision. Let our seasoned pioneer practical traffic instructors train you for a big traffic position. It's a vision worth while. Graduates of the Interstate Traffic School are competent to handle any traffic position.

INTERSTATE TRAFFIC SCHOOL, 23 Traffic Bldg., Fort Wayne, Ind., U.S.A.

"I Can Succeed!"



What other men have accomplished through I. C. S. help, I can. If the I. C. S. have raised the salaries of other men, they can raise mine. To me, I. C. S. means "I CAN SUCCEED."

Get the "I Can Succeed" spirit, for the International Correspondence Schools can raise your salary—whether you're a dollar-a-day man or a dollar-an-hour man. No matter where you live, what you now do, or how little time or money you may have, the I. C. S. have a plan and a

Course of Training to fit your needs. Hundreds of thousands of ambitious men have been prepared for and have achieved success through I. C. S. help in the past 25 years—over 130,000 are now studying, getting ready for the big job ahead. Join them and make your life something to be proud of—you can do it. Just mark and mail the coupon TODAY and find out how; it won't obligate you in the least.

TEAR OUT HERE

INTERNATIONAL CORRESPONDENCE SCHOOLS, Box 5560, Scranton, Pa.

Explain fully about your Course in the subject marked X:

- | | | |
|---|---|---------------------------------------|
| <input type="checkbox"/> Electrical Engineering | <input type="checkbox"/> ADVERTISING | <input type="checkbox"/> CHEMISTRY |
| <input type="checkbox"/> Mechanical Engineering | <input type="checkbox"/> Salesmanship | <input type="checkbox"/> Illustrating |
| <input type="checkbox"/> Mechanical Drafting | <input type="checkbox"/> Commercial Law | <input type="checkbox"/> Farming |
| <input type="checkbox"/> Civil Engineering | <input type="checkbox"/> Bookkeeping | <input type="checkbox"/> Poultry |
| <input type="checkbox"/> Stationary Engineering | <input type="checkbox"/> Stenography | <input type="checkbox"/> French |
| <input type="checkbox"/> Mining Engineering | <input type="checkbox"/> Civil Service | <input type="checkbox"/> German |
| <input type="checkbox"/> Architecture | <input type="checkbox"/> Ry. Mail Service | <input type="checkbox"/> Italian |
| <input type="checkbox"/> Architectural Drafting | <input type="checkbox"/> AUTOMOBILES | <input type="checkbox"/> SPANISH |

Name _____

Address _____

The New **Encyclopaedia Britannica** is a library of knowledge on all subjects. Write for booklet. THE ENCYCLOPAEDIA BRITANNICA, 120 W. 32nd St., NEW YORK

Big Money for You in the Automobile Business

Every day offers greater opportunity for the trained man either to start a paying business of his own, or be a repair man, tester, timer, chauffeur, or salesman.

It's EASY to learn, and we make it EASY to pay your way. Write quickly—today—for catalog telling about our course and how we meet you "50-50."

INDIANAPOLIS MOTOR SCHOOL 203 Southeastern Ave. INDIANAPOLIS IND.

Dr. Charles P. Steinmetz says—"There is an enormous field for the electrical workers, but the big opportunities are for the expert, not for the dabbler in electricity."

The Only Way to Learn Electricity

You cannot become an expert in any field by simply reading a book. You must "learn by doing." That's the way electricity is taught at the New York Electrical School. Our concentrated work with actual apparatus under actual conditions will put you abreast of men with from 5 to 10 years' experience in the electrical field. 4500 of our students have gone forth into electrical success.

Learn by Doing

This method makes you an expert, able to command a high salary. All instruction is individual. You go ahead as fast as you can learn. Good students complete the course in seven months. Send today for FREE 64 page book. Tear out this advertisement and mail it with your name and address.

NEW YORK ELECTRICAL SCHOOL
44 West 17th St. NEW YORK, N. Y.



The New York Electrical School

\$100⁰⁰ EARNED BY YOUNG = ARTIST IN 2 DAYS

Conscientious,
careful training by members
of our Faculty made this possible.

Earn \$25, \$35, \$50, \$75 a Week and More

A well-executed drawing of strong appeal in a magazine or catalogue often sells thousands of dollars' worth of merchandise. That's why the business and publishing world pays big prices for good designs and forceful illustrations. That's also why artists with trained ability such as Franklin Booth, Coles Phillips, Leyendecker, James Montgomery Flagg, Fanny Steadman, and others earn extraordinary incomes.

**Federal Course Nine-Tenths Experience,
One-Tenth Theory** Our copyrighted method of home instruction is a proven result-getter. It is fascinating, easy to learn and easy to apply. It fits you to earn money. It is the concentrated experience of well-known, successful commercial artists and advertising experts.

Federal Training Pays!

Walter M. Stickey says: "Before completing my Federal Course I secured my present position on the staff of artists with the Chicago Tribune. I am positive I secured same through what the School has done for me."

Micot J. Bahlwin, Abingdon, Ill., writes: "Though I have completed only the Third Bulletin, the instruction and help you have given me has made it possible for me to earn up to this time, over seven times the cost of the course."

Write Today for "Your Future" Free

This book explains the wonderful opportunities those with training can grasp; tells of the splendid successes Federal Students everywhere are making. It shows how easily you can devote spare time you may now be wasting, to develop a high-salaried ability.

Every young man and woman should read it before deciding on their life work. Parents should read it with the future of their children in mind. Are you living toward a future—or just living? Start today toward a brighter future—a more successful life. Send for this book. Mail the coupon NOW.

**Federal School of
Commercial Designing, Inc.**
618 Warner Bldg., Minneapolis, Minn.



P. H.
**Free
Book
Coupon**

Federal School of
Commercial Designing, Inc.
618 Warner Bldg., Minneapolis, Minn.
Please send me free book
"Your Future," also your
portfolio of Commercial Illustrations.

Name.....
(Write your address in margin)

Please Mention Popular Mechanics

MAIL THIS COUPON !

BENNETT WELLINGTON COOKE, Director
Dept. 1193, 39-51 E. Illinois Street, CHICAGO

Please send your amazing book on *Drafting Free of cost and without obligation.*

Name.....

Address.....

City.....State.....

I prefer details about course checked:

- Electricity
 Plumbing
 Motion Picture Operating

Get this Amazing Book **FREE!**

DRAFTING

HOW YOU CAN GET IT OF GRATIS
CALL FOR IT NOW



COYNE

1124 W. W. 11th St. Chicago

One of the most inspiring books ever written. Points out the big possibilities of drafting in the future. Tells of hundreds of instances where ambitious men with practical training can earn

\$125 to \$300 a Month!

Fully describes our great practical courses in Mechanical Drafting and Machine Design—Architectural Drafting—our big Builders Course and others. Most complete practical courses in America. Shows pictures and tells of successes of young men who have forged ahead through the practical training received in the great shops at Coyne.

No Correspondence Course!

No mere copying of plates at home. You come to this institution for your training. You train under practical men—experts. You work in the big Shops—in the practical atmosphere. Experts give you individual attention—work with you—show you everything. You see everything in a practical way. You progress with amazing rapidity—because everything is explained **on the spot**. No waiting. Many students finish in 3 months in our day school.

Low Cost! Our low tuition will astound you! Day or evening courses. Free employment Bureau helps worthy young men to earn while they learn. Also helps graduates secure positions. This is the training you want.

Mail Coupon above Get our big special offer. Small, easy payments. Get the big book on Drafting that tells all about our wonderful courses. No cost! No obligation. Merely sign, mail the coupon—NOW.



Bennett Wellington Cooke, Director

Coyne National Trade Schools

Dept. 1193
39-51 E. Illinois St., Chicago

Write at once for details of our practical courses in—

**Electricity
Plumbing
Motion Picture
Operating**

Finest equipment in America.



Public Speaking Taught at Home

WRITE now for special offer. We train you in spare time, by mail. Be a forceful, compelling speaker—convince men—persuade them to do your will and think your way. Overcome timidity and "stage fright." You can do it. We will show you how you can dominate all who hear you by the sheer force and power of your own personality. You can be the man who guides, directs and controls. No matter where you may be or what the situation, you can be master. Our scientific and intensely practical Course in

Effective Public Speaking and Mental Development

will quickly and easily train you in the privacy of your own home, to become an effective, self-reliant speaker, either in public or in private. It will show you how to talk before your club or lodge—how to make entertaining after-dinner speeches—how to sell more goods with less effort—how to write better letters—how to become an engaging conversationalist—how to enlarge your vocabulary—how to avoid common errors—how to develop supreme self-confidence—a strong, masterful will—a keen, reliable memory. All this can now be yours by following a few easy suggestions that will bring immediate results. There are no tiresome exercises or tedious study.

Special Offer—Write Today

Write at once for full particulars of the Special Limited Offer we are now making. We will also send you free, many interesting facts and pointers (that you can actually use) about the power of effective speech and its relation to your success. Write for particulars while Special Offer lasts.

Public Speaking Dept. American Correspondence School of Law,
Dept. 1193 Manhattan Bldg., Chicago, Ill.

Publisher's Announcement

The date on which Popular Mechanics Magazine is due simultaneously on news stands in all parts of the country is the 20th of each month.

The traffic congestion on all railroads is simply unprecedented, and while the Publisher, the distributing News Companies and Railroad Officials are using every possible effort and sparing no expense, it is impossible to maintain our schedule of the 20th at all points every month. It is a condition which simply cannot be entirely avoided.

At such points as the magazine is a few days late, we ask the patience and forbearance of our readers.

Newsdealers are requested not to return unsold copies until the succeeding issue is received, and are reminded of our policy which puts no time limit whatever on returns.

POPULAR MECHANICS MAGAZINE,
H. H. WINDSOR, President.

Chicago, Feb. 5th, 1917.

A CLEAR TRACK TO

SUCCESS!

FOR THE TRAFFIC INSPECTOR

Learn this new profession in 3 to 4 months with our complete course. Prepare for big pay—promotion—success. Railroads everywhere are watching for good traffic inspectors. The training obtained in this work leads to sure opportunities for advancement.

Get Ready for the Success that Awaits You

Earn big pay with short hours. Travel at no expense. Our Employment Bureau helps successful graduates obtain positions. Write now for Booklet G2, giving full information.

FRONTIER PREP. SCHOOL, BUFFALO, N. Y.

I.C.S. NEWS

SCRANTON, PA.

MARCH, 1917

Nearly every draftsman employed by the Warner Gear Company, Muncie, Ind., is a student in the International Correspondence Schools.

More students were graduated from the I.C.S. in 1916 than from any other institution of learning in the United States.

The Standard Motor Construction Company, Jersey City, N. J., has made arrangements with the I.C.S. for the instruction of their employes.

W. G. Ritzer, Montreal, Canada, who enrolled as a clerk, age 19, for the I.C.S. Chemistry Course, has been made head chemist of the Montreal Locomotive Works, Ltd.

The Packard Motor Car Company, Detroit, Mich., has written the I.C.S. that they have positions for 25 I.C.S. trained toolmakers and designers at salaries of \$100 and better per month.

Ira G. Whipple, Topeka, Kans., has been promoted to Assistant Chief Engineer of the Topeka Edison Company. His salary has been increased 150 per cent. since he enrolled for his I.C.S. Course in Steam-Electric Engineering.

The National President of the National Association of Stationary Engineers, Walter H. Damon, Springfield, Mass., became an I.C.S. student while working as an oiler. He is proud of the Schools that helped him climb to the top.

A. M. Bowyer, Indianapolis, Ind., has tripled his salary since he took up his I.C.S. Mechanical Engineering Course. He was a telegraph operator and is now Draftsman for the Nordyke & Marmon Co., makers of Marmon Motor Cars.

James Leroy Stevens, an I.C.S. Civil Engineering student, has been appointed City Engineer of Mishawaka, Ind. He wants as an assistant a young man who has been taking the same I.C.S. Course that prepared him for his new position.

Earnest R. Conrad, Denver, Colo., who enrolled when a bookkeeper, receiving \$15 a week, for the I.C.S. Advertising Course, has been appointed Advertising and Sales Manager of the International Rubber Company and Colorado Tire and Leather Company at \$3,000 a year.

From toolmaker to Vice-President of Engineering of the Packard Motor Car Company is the record of advancement of I.C.S. Student Jesse G. Vincent. He is the designer of the famous "Twin Six" motor. Mr. Vincent says the I.C.S. prepared him for his opportunity.

Robert E. Ramsay has been climbing fast since studying Advertising with the I.C.S. A few years ago he was a clerk in Norfolk, Va. Now he is Advertising Manager of the Art Metal Construction Company, Jamestown, N. Y. He gives full credit to the Schools for his success.



"You Get The Job"

"We've been watching you, young man. We know you're made of the stuff that wins. The man that cares enough about his future to study an I. C. S. course in his spare time is the kind we want in this firm's responsible positions. You're getting your promotion on what you know, and I wish we had more like you."

The boss can't take chances. When he has a responsible job to fill, he picks a man trained to hold it. He's watching you right now, hoping you'll be ready when your opportunity comes.

The thing for you to do is to start today and train yourself to do some one thing better than others. You can do it in spare time through the International Correspondence Schools. Over 5000 men reported advancement last year as a result of their I. C. S. training.

The first step these men took was to mark and mail this coupon. Make your start the same way—and make it right now.

TEAR OUT HERE

INTERNATIONAL CORRESPONDENCE SCHOOLS

Box 5558, SCRANTON, PA.

Explain, without obligating me, how I can qualify for the position, or in the subject, before which I mark X.

- | | |
|---|--|
| <input type="checkbox"/> ELECTRICAL ENGINEER | <input type="checkbox"/> SALESMANSHIP |
| <input type="checkbox"/> Electric Lighting | <input type="checkbox"/> ADVERTISING MAN |
| <input type="checkbox"/> Electric Car Running | <input type="checkbox"/> Window Trimmer |
| <input type="checkbox"/> Electric Wiring | <input type="checkbox"/> Show Card Writer |
| <input type="checkbox"/> Telegraph Expert | <input type="checkbox"/> Outdoor Sign Painter |
| <input type="checkbox"/> Practical Telephony | <input type="checkbox"/> RAILROADER |
| <input type="checkbox"/> MECHANICAL ENGINEER | <input type="checkbox"/> ILLUSTRATOR |
| <input type="checkbox"/> Mechanical Draftsman | <input type="checkbox"/> DESIGNER |
| <input type="checkbox"/> Machine Shop Practice | <input type="checkbox"/> BOOKKEEPER |
| <input type="checkbox"/> Gas Engineer | <input type="checkbox"/> Stenographer and Typist |
| <input type="checkbox"/> CIVIL ENGINEER | <input type="checkbox"/> Cert. Public Accountant |
| <input type="checkbox"/> Surveying and Mapping | <input type="checkbox"/> Railway Accountant |
| <input type="checkbox"/> WINE FOREMAN OR ENGINEER | <input type="checkbox"/> Commercial Law |
| <input type="checkbox"/> Metallurgist or Prospector | <input type="checkbox"/> Traffic Management |
| <input type="checkbox"/> STATIONARY ENGINEER | <input type="checkbox"/> GOOD ENGLISH |
| <input type="checkbox"/> Marine Engineer | <input type="checkbox"/> Teacher |
| <input type="checkbox"/> ARCHITECT | <input type="checkbox"/> Common School Subjects |
| <input type="checkbox"/> Contractor and Builder | <input type="checkbox"/> CIVIL SERVICE |
| <input type="checkbox"/> Architectural Draftsman | <input type="checkbox"/> Railway Mail Clerk |
| <input type="checkbox"/> Concrete Builder | <input type="checkbox"/> Textile Overseer or Supt. |
| <input type="checkbox"/> Structural Engineer | <input type="checkbox"/> Navigator <input type="checkbox"/> Spanish |
| <input type="checkbox"/> PLUMBING AND HEATING | <input type="checkbox"/> AGRICULTURE <input type="checkbox"/> German |
| <input type="checkbox"/> Sheet Metal Worker | <input type="checkbox"/> Poultry Raising <input type="checkbox"/> French |
| <input type="checkbox"/> CHEMICAL ENGINEER | <input type="checkbox"/> AUTOMOBILES <input type="checkbox"/> Italian |

Name _____

Occupation _____

& Employer _____

Street _____

and No. _____

City _____ State _____

If name of Course you want is not in this list, write it below.

Please Mention Popular Mechanics

Are You
a
MISFIT
?



—a peg in
a hole?

Do you believe your work is the work you should be doing? Do you know what your services would bring if sold to the best advantage? Few men or women do; because few know for what work they are best fitted. Eight years ago, Grace, now president of Bethlehem Steel, was a Railroad switchman. Now he is one of the highest salaried men in the country—because he found himself.

How to Sell Your Services

How to get the most for your time and effort is a vital question we can help you answer. Nine out of ten are in the wrong position. Our

Free Personal Analysis

will put you right, will put you in the line of work nature intended you to do. We have arranged with one of the leading Vocational Directors to personally analyse men and women who are seeking bigger opportunities. This personal analysis service will be given free to every purchaser of our new book "How to Sell Your Services," by Napoleon Hill. This remarkable book, the first of its kind ever published, contains live, concrete facts; not theories. In it such men as Andrew Carnegie, John Wanamaker, Vice-President Marshall, Champ Clark, John D. Rockefeller, and others of equal prominence tell you how to sell your services. The advice from these men alone is worth many times \$3, the cost of this book.

Advertising & Salesmanship

If your personal analysis shows that you are eligible for our Extension Course in Advertising and Salesmanship, and if you decide to enroll, we will give you a free copy of "How to Sell Your Services." If you purchase this book and later take our course we will allow you full credit for the \$3.00.

Send Coupon and \$3.00 for a copy of the book. If you do not believe that it is the best investment you ever made, return the book. We will refund your money, and give you the personal analysis free.

Bryant & Stratton College

Established 1856 The school of 100,000 graduates
1026 Bryant & Stratton Bldg., CHICAGO

CLIP AND MAIL THIS COUPON

BRYANT & STRATTON COLLEGE Pop. Mech. March '17
1026 Bryant & Stratton Bldg., CHICAGO

- Enclosed is Three Dollars (\$3) for Book "How to Sell Your Services." I am to get personal analysis free.
- Place a cross here if you wish only information about our Home Study Course in Advertising and Salesmanship.

Name and Address Below

MEN WANTED FOR NEW JOBS

Short hours. Easy work. No strikes, no hard times, no layoffs. No petty bosses. No politics—no pull. Ordinary education sufficient. 15 and 30 day vacations each year with full pay. Sick leave with full pay. Positions for life with

Bigger Pay

steady income, rapid advancement. Earn \$75 to \$150 a month to start. Earn up to \$4000, \$8000 or more later. These are but a few of the many attractive features of working for the U. S. Government in the Mail Service, Post Office Service, Custom House Service, Internal Revenue Service, Panama Canal Service, R. F. D. Service and other divisions.



Write Now!

If you are an American Citizen 18 or over, send in your name for all facts about Government Positions and how to get one. Send no money—this book is free. Tells how A. R. Patterson has successfully prepared thousands for government service, how you can prepare for coming examinations at home in spare time. Mr. Patterson was U. S. Civil Service Secretary-Examiner for 8 years and has students and graduates in practically every State in the Union in all branches of Government Service. Not one cent if you do not secure a position. Don't be satisfied with uncertain job and small pay when you can so easily secure a permanent position with Uncle Sam. Mail Postal NOW for Free Book and special 20-Day Offer! Address

PATTERSON CIVIL SERVICE SCHOOL
373 News Building Rochester, N. Y.

LAW UNIVERSITY EXTENSION LAW SCHOOL

ESTABLISHED 1897
Our Simple Experience Method of Home Training in Law prepares you for the Bar or Business Law. A complete Standard Law Library Free to every student. Low tuition costs. Free consultation privilege. Law prepares you for bar examination in any state. Our business course will qualify you to act as legal adviser for corporations and firms. Pay in monthly installments. Money refunded if dissatisfied. Write today for catalogue

UNIVERSITY EXTENSION LAW SCHOOL
Dept. 52, 206 S. Wabash Ave. CHICAGO, ILL.

60 BOOKS Bound in \$1.00 After Trial The world's greatest literature now shipped to you FREE on approval, not a penny in advance. The masterpieces of Kipling, De Maupassant, Stevenson, G. Bernard Shaw, Victor Hugo and dozens of others. Each book bound in genuine limp leather, pocket size. Write postal now for offer.
LITTLE LEATHER LIBRARY, 193 Marzette Bldg., 23rd St., New York

Mammoth Jubilee Book Free

Picturing 5152 Home Things
Make your own Credit Terms—1 to 3 years' time.
SPIEGEL, MAY, STERN CO., 1409 W. 35th St., Chicago

AMAZING BOOK Of Energy Secrets—Free

Swoboda has published for distribution a remarkable book which explains his system of Conscious Evolution and what it has already done. Write for this book—not because Conscious Evolution has meant so much to 200,000 other men and women, not because there is scarcely a prominent family in the country that hasn't at least one member a pupil of Swoboda, including Chas. E. Hughes, Woodrow Wilson, Rockefeller, the Vanderbilts, the Goulds, the Huntingtons, the Armour, the Cadalys, the Swifts—but write for the book because it means so much to you in multiplied living power, earning power, and resisting power. It is a big book filled from cover to cover with the vital facts about yourself and how you can acquire the degree of perfection in body and mind that you so much desire. It exposes the dangers of excessive deep breathing, excessive exercise, and excessive muscular development.

Regardless of how young you may feel, of how efficient you may think you are—regardless of how active, energetic, and alert you may consider yourself—regardless of how happy, how contented you may pride yourself on being—regardless of how healthy, wealthy, or successful you may be, you cannot afford, in justice to yourself, to miss the interesting and instructive secrets explained for the first time in this startling new book.

Write NOW. Address **ALOIS P. SWOBODA, 2020 Aetlian Bldg., New York City**



Creator of
Conscious
Evolution

\$4,000,000⁰⁰
Farming Facts Yours

INFORMATION about practical farming that cost the U. S. Government \$4,000,000 and more than ten years to collect—every fact worth knowing about agriculture—positive U. S. Dept. of Agriculture facts—yours on a wonderful offer.

See our "10 Days' Reading" offer. Learn how to put these facts right into your hands. Yes, and more besides. A book written by Hon. F. D. Coburn to help you study the Cyclopedic to the best advantage. And free advice by this master farmer. This instructive book and Mr. Coburn's advice free, if you subscribe now.

FARMING METHODS
 SOILS
 FERTILIZERS
 IRRIGATION
 ROTATION
 BUILDINGS
 FARMERS' HOME AND EDUCATION INDEX

FARM ANIMALS
 FEEDING
 CARE
 DAILY FARMING

DOUBLE DAY PAGE & CO.

The Farmer's Cyclopedic

(Authentic Records, U. S. Dept. of Agriculture)

These 7 big volumes, containing over 5000 pages, 3,000,000 words and hundreds of pictures, give you in condensed but complete form the most valuable data which the government has gathered at this enormous expense.

Verified facts about every branch of farming are given with all theories cut out. Just the methods which have proved best in actual practice are explained. Minutely indexed so that every fact is accessible in an instant.

10 Days' Reading Offer NOW

Sign and mail the coupon with \$1.00. It will bring you this great library of farming facts to examine for 10 days. Pay the net transportation charges. Read the 7 big volumes at your leisure. Then, if you decide to keep them, pay only \$2 monthly payments until \$29.50 is paid. Otherwise return the books to us and we'll return your dollar. Send for the Farmer's Cyclopedic on this special offer and see how this great library answers practically every farming question you may ask. If you have had puzzling failures it will show you how to trace the causes. If you are dissatisfied with your yield of crops, or the results from your dairy, your hogs, your sheep, your poultry or your orchard, it will explain the scientific methods for securing a larger production. One fact may save you from a mistake which might cost 10 times the price of the books. Another may show you how to cut out waste. Still another may tell how to add 25 per cent or more to your profits in some direction you have not thought of. The experience of thousands of successful farmers—gathered and tested by the Government—is now yours at a trifling cost. And 10 days' examination first.

Partial List of Contents:

Feed and Care of Dairy Cows—This alone worth the price.
Feed and Feeding for Beef—A wonderful work.
Diseases and Insect Pests—How to protect cattle and crops against them.
Profitable Hog Raising—A complete theory on the hog.
Success with Sheep—Every question answered.
Poultry Problems Solved—No other books on poultry ever need be read.
Fruit—How to get a larger yield. How to avoid insect pests.

And thousands of other subjects of vital interest and value.

Special!

For one payment extra, you can also have a full year's subscription to *Country Life in America* (regular price, \$4 a year).

Latest Facts and Investigations on Every Farm Product—Insures bigger, better crops with less labor.
Every Phase on Farm Management—From government experiments and researches.
Soils and Fertilization—Make your land yield more.
Farm Buildings—How to plan and build on the farm.
Domestic Science—Comfortable, economical farm housekeeping. Lightens the work of the housekeeper.

TODAY—SEND COUPON WITH ONLY \$1.00
 We will ship the books direct to you. Examine them for 10 days—then decide. Then pay only \$2.00 monthly. You run no risk. So grasp this opportunity to get the benefit of the books while paying for them. Accept while the offer lasts. Mail the coupon.

Valuable Book FREE

With the Cyclopedic you get absolutely free an important Manual written especially as an aid to systematic study by America's famous authority on farming, **Hon. F. W. Coburn**, who says of the Cyclopedic: "It contains the most valuable agricultural information ever gathered together." A complete course in Agriculture ready for you to place on your library shelves—ready to help you to be a better farmer, and to make more money.

Coburn's Advice

Your order gives you the privilege of asking Mr. Coburn for advice at any time. No charge for this—**you get his help and co-operation in addition to the Cyclopedic—when ever you want it.**

Doubleday, Page & Co.
 Dept. 303, Garden City, N. Y.

Send me the complete set of *Farmer's Cyclopedic* (Authentic Records of U. S. Dept. of Agriculture) in 7 big, thick volumes. If I keep the books, I will pay you \$2 monthly until \$29.50 is paid. If not satisfactory, I will tell you so in 10 days and you will tell me where to return the books. I understand that Coburn's Manual and advisory service is free if I keep the Cyclopedic. I enclose \$1.00 as first payment—to be returned if I do not keep the books.

Name.....

Address.....

If you also want *Country Life in America* for one year as offered, write "Yes" here.....

Doubleday, Page & Co., Dept. 303, Garden City, N. Y.

YOUR OPPORTUNITY

- TO LEARN THE AUTOMOBILE BUSINESS
- TO SEE AND KNOW NEW YORK CITY
- TO MAKE FROM \$75 TO \$300 A MONTH
- TO GET INTO A BUSINESS FOR YOURSELF

Get out of that rut into a profitable business. The automobile field offers more opportunities for the **TRAINED MAN** than any industry today—and they are getting bigger every year. **THINK—SERIOUSLY—NOW**—if this isn't just the opportunity you've been seeking. Automobile men are combing the country for trained men for every branch of this mammoth business.



—Learn in New York City—

Visit New York City—see the sky scrapers—the gigantic ocean liners—old Broadway—the Statue of Liberty—the world famous sky line—and the million and one things you have heard people talk about. Right now **YOU ARE** planning to go somewhere to train yourself for a well paying position or a business of your own. This **IS** your opportunity to become thoroughly acquainted with New York and at the same time **SETTLE THE QUESTION OF YOUR FUTURE PAY ENVELOPE.**

Make \$75 to \$300 a Month

This old world won't give you any more than you will walk up and take, but when you step up and say, "I'm after mine," and put "pep" into your action, the world hands it right over. A thorough training in the automobile business immediately puts more money in your pay envelope—and the more you know the bigger the pay envelope.

Our Course—Our Motto

Think of it—a full five weeks' practical course under the most competent instructors available, in the most complete and up-to-date school in the country—right off Broadway in the heart of New York City—Day and Night classes. We have lists of desirable places, conveniently located to school, for you to stay while learning. Our dealings with our students have been our mainstay and built for us the fine school we now have. Everybody gets a square deal and thorough personal instruction.

Be Independent—

Start a Business of Your Own

Once you are trained the **Stewart** way you need not work for the other fellow—you have sufficient knowledge to start a business yourself—in every city there is a great opportunity for the live fellow who will get out and hustle—and there's big money in it.

Don't Delay—Act Quickly— Write Today

Write at once for our catalog giving detailed information about our course—how we help our students. Start any time, but **don't wait** a minute to ask for our catalog which contains just the proposition you have been seeking.

THE STEWART AUTOMOBILE SCHOOL

Department 1, 225 West 57th Street, at Broadway, NEW YORK CITY

Established nine years—the old dependable school. Founded on honor—Prosperes on merit.



Oh, You Skinny!

Why stay **thin** as a rail? You *don't* have to! And you *don't* have to go through life with a chest that the tailor gives you; with arms of childish strength; with legs you can hardly stand on. And what about that *stomach* that flinches every time you try a square meal? Are you a *pill-feeder*?

Do you expect **Health and Strength** in tabloid form—through pills, potions and other exploited piffle?

You can't do it; it can't be done.

The only way to be well is to build up your body—all of it—through nature's methods—not by pampering the stomach. It is not *fat* that is making you a failure; it's that poor, emaciated body of yours; your half-sickness shows plain in your face and the world loves healthy people. So be *Healthy—strong—vital*. That's *living*. Don't think too long; send 4 cents in stamps to cover mailing of my book, "INTELLIGENCE IN PHYSICAL AND HEALTH CULTURE," written by the *strongest physical culture instructor in the world.*

LIONEL STRONGFORT

PHYSICAL CULTURE EXPERT

No. 66 Park Bldg. Newark, N. J.

"FORGING AHEAD IN BUSINESS" FREE

This 128 page book, which we will send you free, tells of the wonderful help which the Modern Business Course and Service is to every man in business from manager to clerk; tells *how* it helps; tells who are back of this great institution, who are enrolled, and what they say about it. **Send for this Free Book today**

ALEXANDER HAMILTON INSTITUTE
616 Astor Place, New York



Learn the Tire Repair Business

Earn \$3,000 to \$8,000 a year in a business of your own. Write for new catalogue.

THE RELIABLE TIRE REPAIR SCHOOL
103 Reliable Bldg. Detroit, Michigan

FINLAY ENGINEERING COLLEGE

1001 Indiana Ave., KANSAS CITY, MO. Only School of the Kind in the West

The old reliable, practical, technical college. Courses from the simple Auto to Electrical Engineer. Specialties, Electricity, Steam, Gas. Also Auto-Tractor work. Time required for regular courses, 3 months, 1 year, and 2 years.

HERE'S WHAT WE TEACH:



Electricity



Steam



Gas



Automobile



SPECIAL 6 WEEKS' COURSES in wiring, Armature winding, Lathe Work, Oxy-acetylene Welding, operation of Steam, Gas, and Electric Machinery.

Any student enrolling in any of the above courses will be entitled to an **AUTO STARTING COURSE FREE**

This Is How We Teach: By books, by models, by professors, by regular shop work and by actual machines in operation. **Make your start to a big salary at once!** Investigate our school before going elsewhere. **ENROLL ANY TIME.** Day and night classes. Anything you want any time you want it. From a week to two years. Spring term begins April 1st. Write for Catalogue F. Address **H. FINLAY, Pres., 1001 Indiana Ave., KANSAS CITY, MO.**



QUEEN OF SHEBA'S VISIT TO KING SOLOMON

The Queen of Sheba's Visit to King Solomon is one of the most famous incidents in the history of the ancient world. The beautiful picture shown herewith from Ridpath's History illustrates but one event of all the thousands in the complete work. Truly it may be said of the merits of this history as was said of the splendor of King Solomon's Court: "The half has never been told." All nations, ancient and modern, are embraced in the world-famed publication

Ridpath's History of the World

DR. John Clark Ridpath is universally recognized as America's greatest historian. Other men have written histories of one nation or period; Gibbon of Rome, Macaulay of England, Guizot of France, but it remained for Dr. Ridpath to write a history of the entire World from the earliest civilization down to the present day.

Price Soon To Be Advanced

ON account of the tremendous increase in the cost of paper and leather, occasioned by the European War, it becomes necessary to advance the price in order to cover the increased cost of manufacture. This is your last opportunity to buy Ridpath's History of the World at our present low price and easy terms of payment. We will name this low price only in direct letters to those who mail us the coupon below. Tear off the coupon, write your name and address plainly and mail now before you forget it. You incur no obligation whatever. We employ no agents as our low price does not permit the payment of an agent's commission. The beautiful sample pages will give you some idea of the splendid illustrations and wonderfully beautiful style in which the history is written.

Six Thousand Years of History

RIDPATH takes you back to the dawn of History, long before the Pyramids of Egypt were built; down through the romantic troubled times of Chaldea's grandeur and Assyria's magnificence; of Babylonia's wealth and luxury; of Greek and Roman splendor; of Mohammedan culture and refinement to the dawn of yesterday. He covers every race, every nation, every time, and holds you spellbound by his wonderful eloquence.

The European War

IF you would know the underlying causes which have led up to this conflict, the great racial antipathies, the commercial rivalries, the sting of past defeats, the vaulting ambitions for world empire, then embrace this opportunity to place this History in your home.

Ridpath's Graphic Style

RIDPATH pictures the great historical events as though they were happening before your eyes; he carries you with him to see the battles of old; to meet kings and queens and warriors; to sit in the Roman Senate; to march against Saladin and his dark-skinned followers; to sail the southern seas with Drake; to circumnavigate the globe with Magellan. He combines absorbing interest with supreme reliability.

**WESTERN NEWSPAPER ASSOCIATION
CHICAGO**



FOLD HERE, TEAR OUT, SIGN AND MAIL

NAME

ADDRESS

**FREE
COUPON**

**WESTERN
NEWSPAPER
ASSOCIATION**
H. E. SEVER, Pres.
140 SO. DEARBORN ST.
CHICAGO, ILL.

Please mail, without cost to me, sample pages of Ridpath's History of the World, containing photographs of Napoleon, Caesar and other great characters in history, and write me full particulars of your special offer to Popular Mechanics readers.

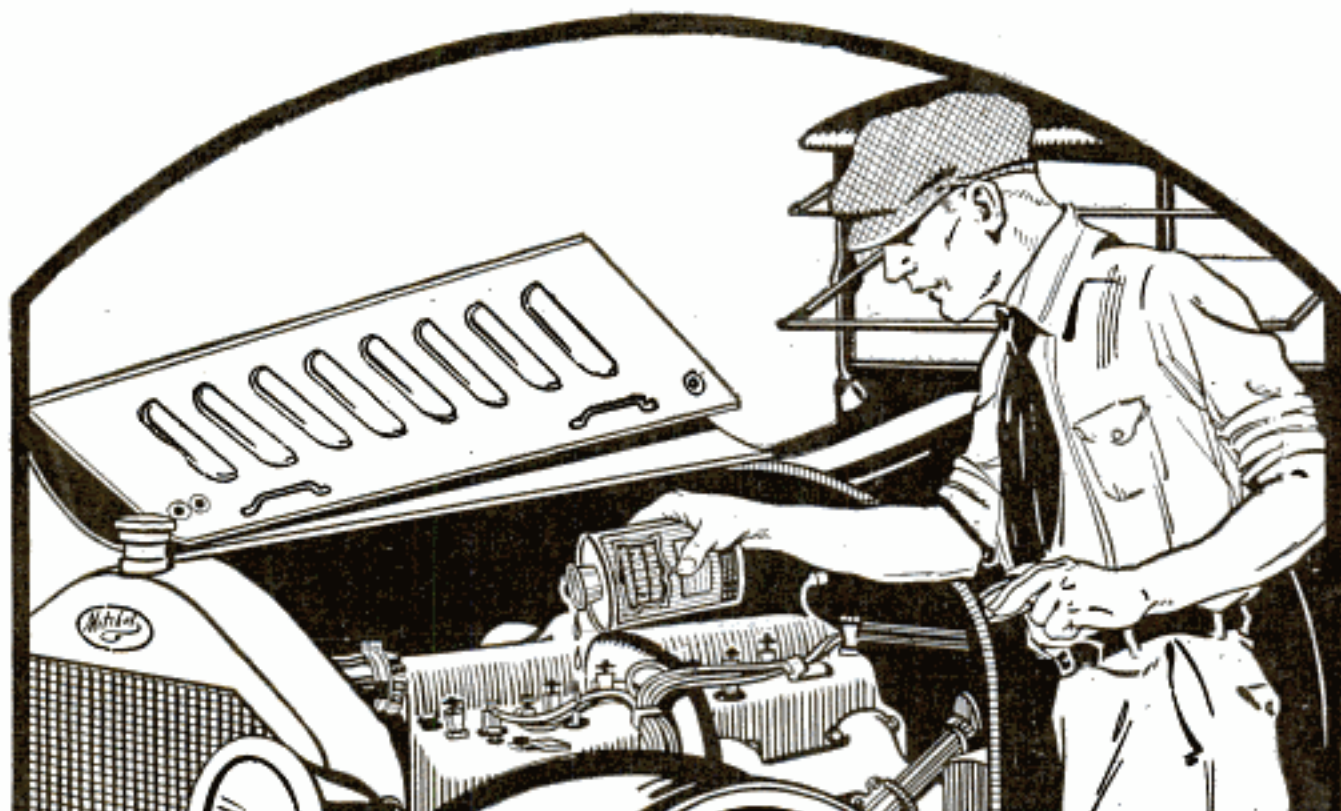

Put New Life In Your Engine

A DOSE of Johnson's Carbon Remover—the engine laxative—will increase the power of your car—improve acceleration—stop that knocking sound—quiet your motor—save your batteries—and reduce your gasoline consumption from 12% to 25%.

JOHNSON'S CARBON REMOVER

Is a harmless liquid to be poured into the cylinders. It softens the carbon and releases it from the metal. It then burns, powders and is blown out through the exhaust. Five minutes' time and no labor required. You will save from \$3.00 to \$5.00 over any other method, without loss of time and with very much better results.

If you will use Johnson's Guaranteed Carbon Remover every 1,000 miles you can keep your motor clean and sweet and always at its highest efficiency and you will secure the maximum power and speed from the minimum amount of fuel.

Special Offer

If your dealer cannot supply you with Johnson's Carbon Remover use attached coupon. For a limited time we will include gratis, a half-pint sample of Johnson's Stop-Squeak Oil—our new product. It instantly penetrates between the leaves of springs thoroughly lubricating them and giving perfect spring action.

S. C. JOHNSON & SON, Dept. PA3, Racine, Wis.

I enclose \$1.00 for which please send me, postpaid, enough Johnson's Guaranteed Carbon Remover to thoroughly clean an ordinary four-cylinder motor three times. Also send half-pint of Johnson's Stop-Squeak Oil free.

Name.....

Address.....

City and State.....

My Dealer is.....

Please Mention Popular Mechanics

Frank L. Nelson
Publicity Dept.
Fox Film Corp.
178 W. 46th St.
New York

Popular Mechanics Magazine

REGISTERED IN U. S. PATENT OFFICE

WRITTEN SO YOU CAN UNDERSTAND IT

Vol. 27

MARCH, 1917

No. 3

3683 Girl Diver Clears Rocks by Narrow Margin

NOT long ago a rather interesting problem was encountered in the course of filming a photoplay on the island of Jamaica, in which one of America's foremost women divers assumed the leading rôle. A large concrete tower had been erected on a coral ledge, and from one of its windows, at an elevation of about 45 feet, the performer was to plunge into the sea below. The base of the structure was about 12 feet from the edge of the reef, which it had been estimated could easily be cleared. Instead of being perpen-

dicular, however, the walls slanted back—for the tower was pyramidal—so that in reality the window from which the dive was to be made was about 24 feet from the outer margin of the coral shelf. Measurements and tests of different sorts indicated that it would be extremely hazardous, if not even suicidal, to attempt the feat from the elevation afforded. Six-foot platforms

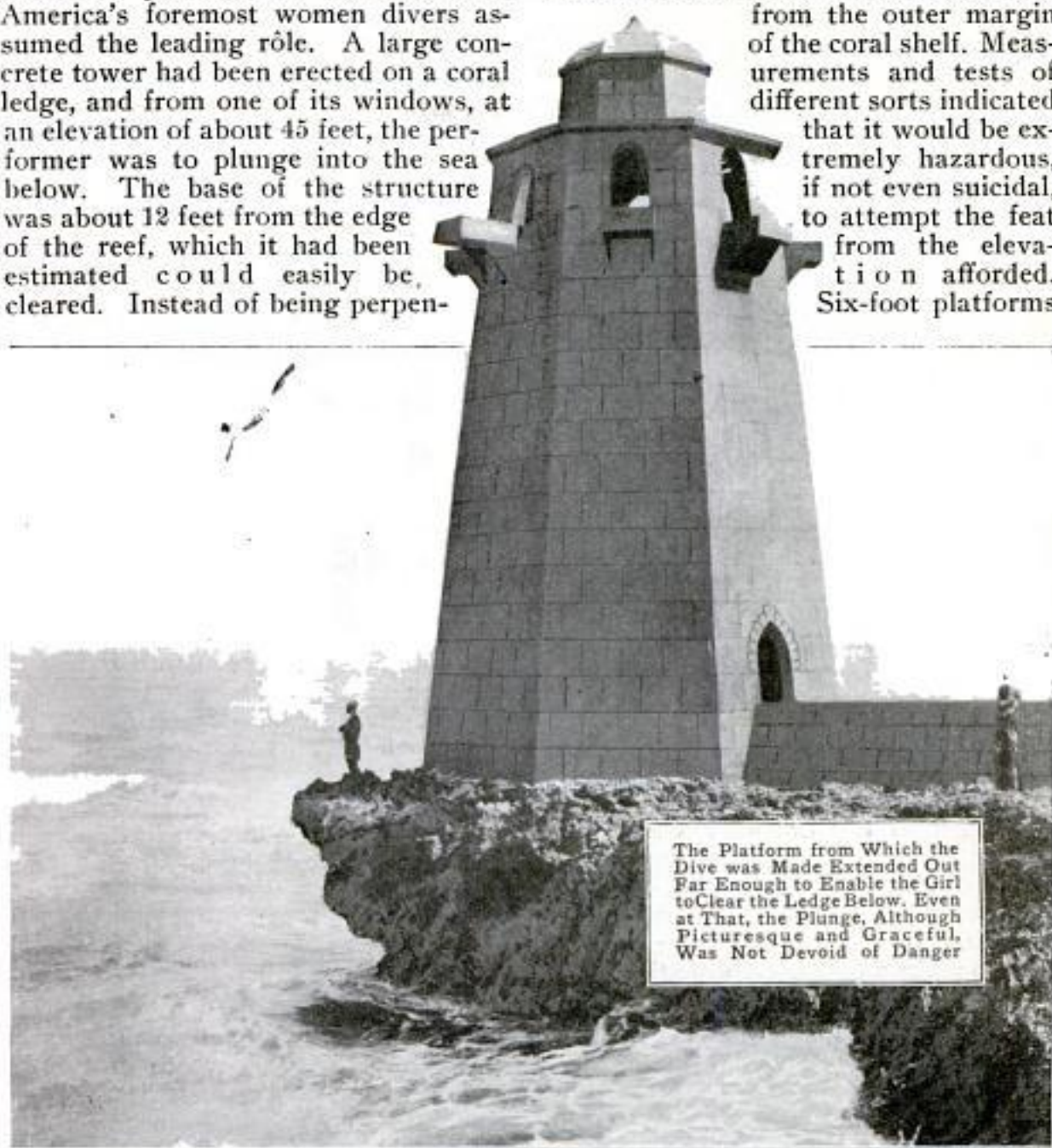

The Platform from Which the Dive was Made Extended Out Far Enough to Enable the Girl to Clear the Ledge Below. Even at That, the Plunge, Although Picturesque and Graceful, Was Not Devoid of Danger

were therefore built out from the windows and the difficulty overcome. Owing, however, to the influence of a strong wind, the girl managed to clear

the rocks only by a short distance when the dive was at last executed. This was final proof that the plunge as first planned would have been fatal.

3249

CIPHER-WRITING MACHINE

TO GUARD SECRETS

Office Appliances 8/19/16
Letters and telegrams that it would puzzle the most expert European censor to decipher can now be exchanged



This Cipher Typewriter was Made for One of the Allied Governments Now at War: The Disk Which Determines the Cipher and Also Deciphers the Message on Receipt is Placed on the Top Plate between the Ribbon Spools

by business men who wish to keep the contents confidential. A typewriter recently placed on the market not only writes in cipher, but makes its own cipher and offers millions of possible combinations for choice. In general appearance the machine resembles an ordinary typewriter, and to make a cipher the message is written on its keyboard in the ordinary way. The cipher is determined by a detachable plate or disk, containing 30 holes in two concentric circles of 15 holes each. For each of these holes there is a pin and to make a cipher combination these pins may be inserted in or left out of any of the holes, as fancy dictates. Then, in writing the copy, the machine may write an "x" for an "a" the first time it occurs, then a "p," and so on. It is impossible to predetermine what code letters will appear in operating the

machine. To decipher a code message the person receiving the communication must have a complementary disk, with pins properly arranged, and one of the machines to reproduce the message as originally written.

3618

WOOD-CUTTING DIES TAKE PLACE OF SAWS

Especially designed dies are now employed by a St. Louis firm in cutting wood into toys, and the like, instead of fashioning the playthings with saws, as has been the common practice. These dies will cut material up to 3/4 in. thick, whether it is plain wood or made of layers glued together. To make one of these cutting tools, the desired outline is cut in a block and then a steel knife with its edge projecting beyond the block is made to conform to the outline, after which a porous-rubber cushion is fitted over the whole die, so that it incases the knife, and is glued in place. The tool is locked in a chase and attached to a press in the usual manner. When the press is started the rubber cushion strikes the wood first, and is compressed until the knife finally cuts down into the material. The rubber, while under compression, helps to prevent the splitting of the wood, and by pressing against the sides of the knife keeps it rigid, even though it may be a very thin blade. When the die is withdrawn the rubber expels the freshly made blank automatically. With some kinds of wood it is necessary to finish the edges of the blanks, while other material is given a satisfactory edge by the die.

ⒸThe War Department has let contracts for \$5,500,000 worth of Vickers machine guns and accessories, and expects to spend \$4,000,000 more for similar equipment. Apparently the much-discussed Lewis guns are not in favor.

Vertical handwritten text on the right margin:
Vickerman 17th & Belmont St. St. Louis.
Inventor of the Vickers Machine Gun.
Patent 1,115,415 N. Y. N. Y. Dr. Lewis.

PICTORIAL STORY OF SHACKLETON EXPEDITION

3643



Caught in the Resistless Grip of Two Enormous Floes, the "Endurance," Its Hull Crushed and Masts Sheared Off, Gradually Slipping from View into the Frigid Waters of Weddell Sea, Leaving Sir Ernest Shackleton and His Plucky Party of Antarctic Explorers on a Shifting Ice Pack in a Region of Perpetual Winter: From the Middle of January to the Last Day of November, 1915, the Vessel was Locked in the Ice. Time and Again It was Squeezed Up Out of the Water, Only to Drop Back, as the Pressure was Relieved, into the Jaws of the Eternal Vise That Ultimately Crushed It. The Photograph, One of the Rarest and Most Gripping of the Kind Ever Taken, Illustrates the Turning Point in an Absorbing Adventure. The Dogs Looked On Wonderingly as the Splintered Timbers and Tangled, Frozen Rigging of the Ship Creaked, Groaned, and Then Disappeared. The Men Faced Drifting Ice Fields and a Sea in Which Floated Menacing Mountains of Crystal White



Feeding the Dogs before Their Snow Kennels alongside the Ice-Locked "Endurance." The Picture was Taken in the Midst of the Long Polar Night When for 92 Days the Sun was Hidden below the Horizon. At the Time, the Ship Was Still Intact and All Was Ready to Take the Dogs Aboard the Moment There Were Signs of the Ice Breaking. It Was Not Long, However, Until the Vessel was being Ground to Pieces and the Men were Salvaging the Small Boats, Taking Off Supplies, and Building a Camp on the Floes



The Care of the Dogs Was No Light Occupation, for There Were 70 of Them Requiring Close Attention. Each was Fed According to a Prescribed Program and Periodically Weighed. Thus There Was No Guesswork Concerning Their Physical Condition. If a Dog Gained or Lost Flesh, It was Noted



Miles upon Miles of Snow-Covered Ice and, Fast in the Middle of It, the "Endurance." During the Months That the Drifting Pack Carried the Party Northward, an Enormous Mountain of Ice Doggedly Followed Along, Threatening Time and Again to Batter through the Floes. After Finally Reaching Elephant Island, Shackleton Picked the Six Hardest of the Men to Accompany Him on His Daring Dash of 750 Miles in an Open Boat to South Georgia—and Help. For More than Two Weeks the Men Battled the Sea in Clothes Soaking Wet



The "Endurance" Became Uninhabitable a Month Before It Finally Sank. So in October the Party Established Its Camp on the Ice alongside the Ill-Fated Vessel. When the Latter Finally Disappeared an Attempt to Proceed Northward Met with Failure, and Ocean Camp, Where the Castaways Remained until Three Days after Christmas, was Founded a Few Miles from the Ship's Grave. When Travel toward the North Again Seemed Possible, Dogs and Men Struggled across Rugged Ridges and Hummocks for Five Days. Unsound Ice Made Them Halt at a Point That Became Patience Camp. Pictured Above Is Ocean Camp, and at the Extreme Left Sir Ernest Shackleton



Before Their Tents at Patience Camp, Sir Ernest, and at the Left, Frank Hurley, Photographer of the Expedition. Here the Men Stayed until April. While the Drifting Pack Carried Them Northward. When Clarence Island was Sighted It was Decided to Stake All and Put Out in Open Boats for Elephant Island, Which was Reached after Two Days of Hardship



From Out of Another World, a Sigh! Sir Ernest Shackleton, after Three Disheartening Failures, Coming across the Water to the Dancing, Jubilant Fellows He Left at Elephant Island Four Months Before. The Party had been Assembling Following the Call of "Lunch O," When the Cry, "Ship O," Caused All Hands to Forget the Soup of Seal's Backbone and Seaweed. Signal Fires were Started When the "Yelcho," the Chilean Government Steamer, Hidden from View Here, Appeared to be Passing Them By. Observe That the Overwhelming Joy of Approaching Succor did Not Cause the Photographer to Miss One of the Best Pictures of the Adventure

358c EFFICIENT POWER UNIT
DRAWS HAND TRUCKS

One of the efficient types of power units which is being used in large in-

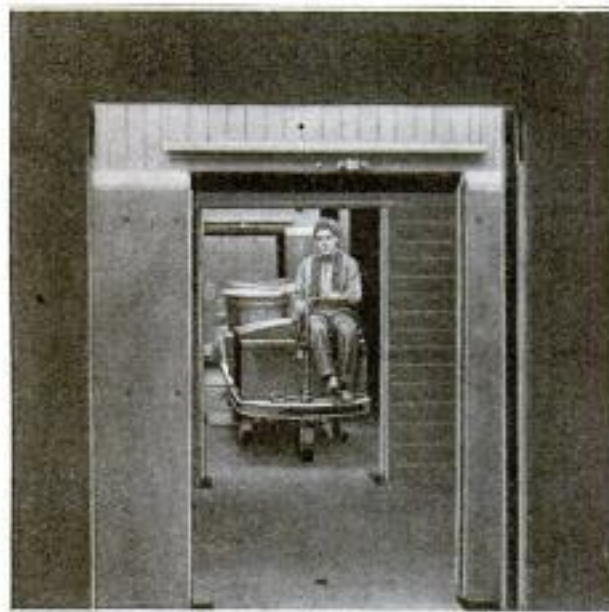

Tractor Drawing Hand Trucks through Freight Cars Placed Side by Side and Suitably Connected to Form a Passageway from a Loaded Car to a Platform

dustrial plants and in railway freight stations in connection with loading and unloading materials, is shown in the accompanying illustrations. The tractor is electrically driven and is em-

ployed in the same manner as a switch engine. That is, it draws its load to the proper destination, and while the train is being unloaded it is employed in making other hauls. One of the simplest and most satisfactory forms of trucks used with this type of tractor is made by equipping an ordinary hand truck with casters and a patent hitching, or coupling, device. The latter is so constructed that it makes each truck follow almost exactly in the path of the truck ahead of it. This feature is of special importance in large factories and on freight platforms where the little trains often have to wind their way along narrow circuitous passages.

3693

NEW TYPE OF BANK DRIVES
OUT "LOAN SHARKS"

Chgo Tribune Jan 11 '17
By competing with "loan sharks" in the field where they make their greatest profit, namely among unpropertied wage earners who must borrow to meet emergencies, money-lending institutions of a new type are now driving out usurers in New York and elsewhere. These banks enable one whose chief asset is his good character and modest earning power to borrow money at a rate considerably less than loan sharks charge. The New York bank of this type, opened only two years ago, made



A Train Composed of Hand Trucks Equipped with Casters and Coupling Devices Which Make Each Unit Follow in the Track of the One Ahead

over 7,000 loans the first year, averaging \$116 each. Chicago capitalists are considering starting a similar institution. An illustration will explain the methods employed. If a person wishes to borrow, say, \$100, an application is filed attesting to the signer's good character and earning power. He must also get two persons to sign his note. The \$100 is then given him, minus \$6 interest deducted in advance, and a fee of \$2 for investigating his case. He also must

purchase savings certificates at the rate of \$2 per week for 50 weeks, at the end of which time he may use

purchase savings certificates at the rate of \$2 per week for 50 weeks, at the end of which time he may use

*See N.Y. Herald Tribune
1918 - p. 2
Copyrighted material*

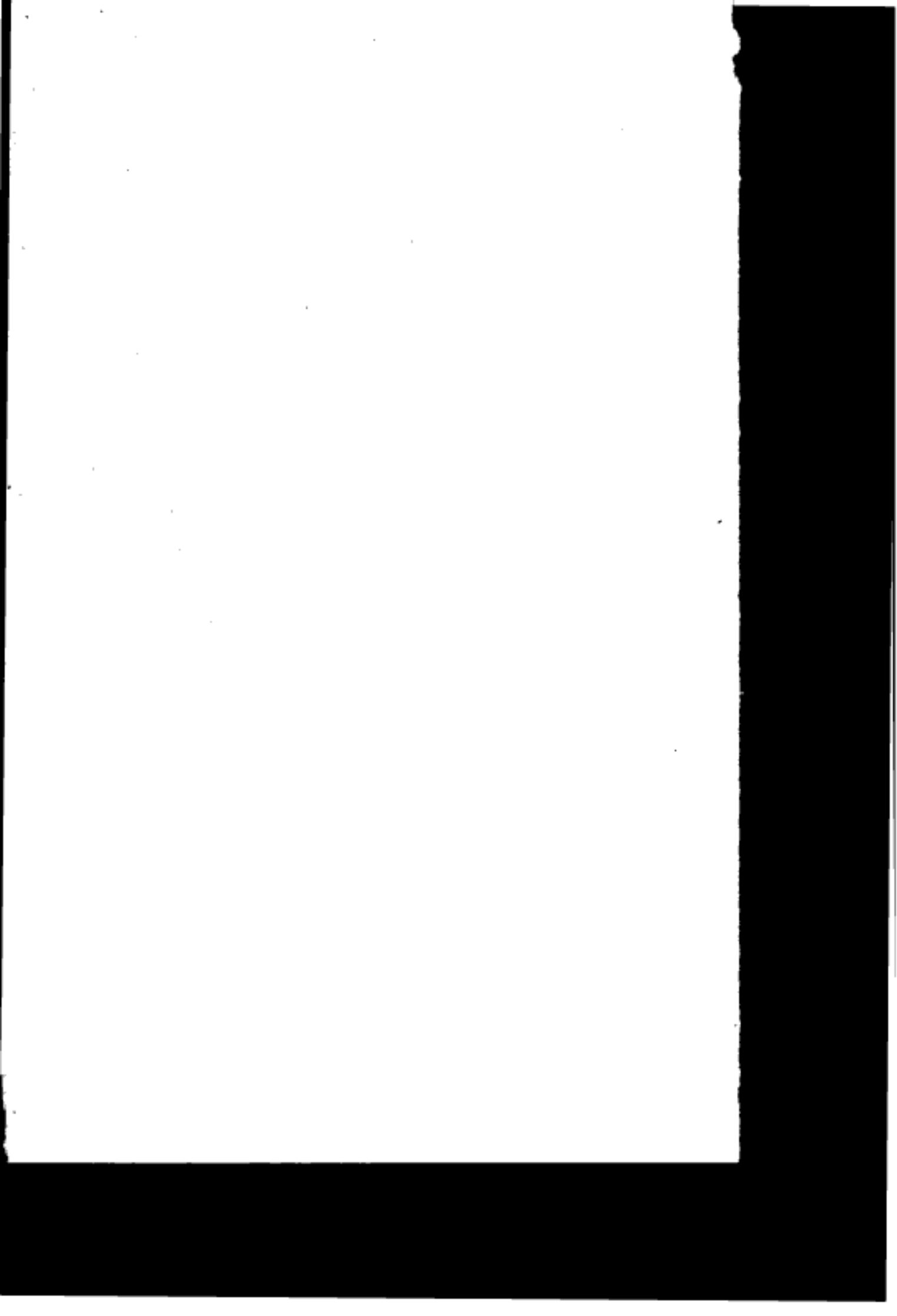

The Morris Plan.

Banks are organized throughout U. S. by:
Industrial Finance Corporation
52 William St., New York.

Clark Williams, President.

Arthur J. Morris, Vice President.

Chas H. Sabin, Treasurer.

Jos. B. Gilder, Secretary.

Subscribed capital \$1,500,000.

Largest auxiliary:

The Morris Plan Co. of New York
(Equitable Bldg.)

120 Broadway, New York

Henry R. Towne, President.

Organized Norfolk Va. - Mch '10

Operated in about forty other cities

Gen. A. Walton G. The Post
259 Washington St
Boston

them, if he desires, to pay his note. Experience shows that 30 per cent of the borrowers continue their savings accounts after paying off their loans.

3635
**MACHINE-GUN CARRIER
FOR MOTORCYCLES**

A new type of machine-gun carrier, which can be quickly attached to or detached from any standard make of motorcycle, was inspected recently by foreign representatives at the testing field of an eastern firearms company. It consists of a low platform of hard wood, carried on a pair of bicycle wheels and recessed in front to receive the rear wheel of the motorcycle, which is left free to ride up and down over road obstructions. The only connection is at the front of the motorcycle. The gun mounting on the platform is so constructed that a complete circle may be described in operating the machine gun, whether shooting horizontally or in the position required for antiaircraft work.

**ELECTRIC SIGN WORN ON
BACK OF THEATER USHER**

By way of experiment the ushers of a Boston theater have been provided with a new electrical device which aids in showing playgoers to their seats. It consists of a small electric sign which is suspended at the usher's back by means of straps over the shoulders. When the wearer presses a button which is connected with the sign the words "This Way, Please" are illuminated. They serve both to attract the attention of the patrons to the usher who is to wait on them, and to light up the aisle when the theater is in semi-darkness.



3
Jas. T. Lester
Thomas J. Donovan, N.Y.

Cygnus Rear Car Co.
Buffalo N.Y.

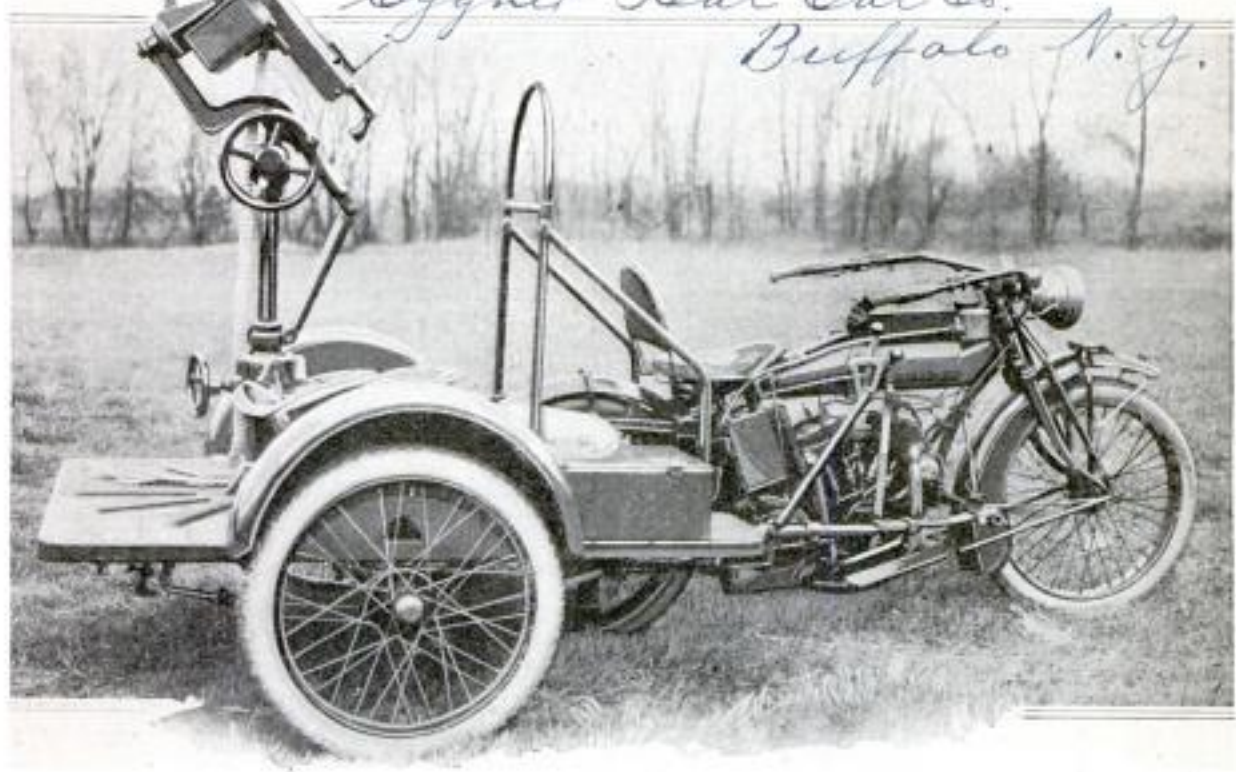

With This New Gun Carrier for Motorcycles the Machine Gun may be Used in Ground Battles, Elevated as in the Picture, or Depressed for Downward Shooting, and Swung around an Entire Circle if Necessary. The Outfit can be Operated by Two Men and Both Car and Gun are Quickly Detachable



At the Crucial Moment a Glass was Blown from the Pilot's Goggles, Blurring His Vision and Causing the Wreck

COPYRIGHT, INTERNATIONAL FILM SERVICE

238 William
N.Y.C.

3576 TIRE VULCANIZING TAUGHT IN PUBLIC SCHOOLS

Some of the pupils enrolled in the vocational-training classes of the Cincinnati public schools are being taught to repair the tires of their fathers' motor cars. Not long ago an automobile concern loaned some of its equipment to the schools with the result that a thorough course in tire vulcanizing and repair has been established. The work, as one might well imagine, appeals to a large percentage of the boys and therefore the course is a popular one. Parents and teachers are taking advantage of the opportunity to have tires mended cheaply.



It doesn't Take a Young Chap Like This One Long to Master the Vulcanizing Machine

ACCIDENT AND THEN RECORD MARK AIRMAN'S FLIGHT

In landing at the Philadelphia Navy Yard, on League Island, H. W. Blakely—one of the 12 army aero-reserve pilots who recently made the 115-mile test flight from Hempstead Plains, N. Y., to the aforementioned point and return—met with a queer accident. As he was nearing the ground a lens was blown out of his goggles, causing him to strike a flagpole. The machine dropped and turned up on its nose, after encountering a ditch. The pilot, and the passenger he carried, escaped injury, while the craft merely suffered a broken wheel. On the return trip the airman lowered the record for flight between the two points by covering the distance in 72 minutes.

3710 CRUMBLING OF BREAKWATER MAY BE DUE TO SALT

Not long after quantities of rock had been placed in a breakwater at Eureka, Calif., it was found that, on exposure to the salt water, some of the rock began to crumble. The material used was a coarse diorite, an igneous rock of crystalline texture, and apparently it was in excellent condition. However, a microscopic examination showed that the feldspar in the crumbling portions

Mining Scientific Journal

*Mercer Motor Wheel Co. Inc.
 Circle Bldg, 59th St. - Lincoln Pl.
 New York City*

was much decayed. This discovery gave rise to the theory that the alternate submersion and exposure of the ballast, due to the tides, left deposits of salt which entered crevices in the surface and dried. It is believed that tiny crystals formed in this way, by their expansion broke down the rock.

3612

ELECTRIC HARBOR BOAT FOR ARTILLERY ARMORIES

An officer of the New York Coast Artillery has built a miniature electric harbor boat, to furnish a target which will move about on armory floors at a uniform rate of, speed slow enough to give the coast-defense gunners good practice in sighting and ranging by means of "plotting boards." The hull and superstructure of the boat are built over, and conceal, a low steel chassis, or framework, which supports the operating and control mechanism, also the operator, who sits inside and steers the boat about the armory floor. Power is furnished by a storage battery of 10 cells, and the driving apparatus consists of a vehicle-type motor rated at 12 volts, 11 amperes, at 800 r.p.m. By means of a simple control lever, three variations of speed ahead and two variations astern can be had. The maximum speed of the apparatus represents, upon the scale of the armories and the plotting boards constructed for use therein, an actual speed of about 18 knots, or 20³/₄ miles an hour. It enables the artillerymen to have vessel-tracking drills, also drills in tug direction and practice in fort signaling.

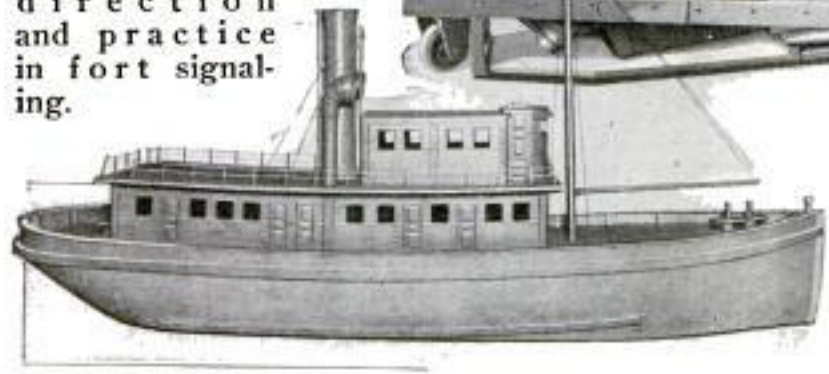

This Miniature Boat is Self-Propelled by Electricity and Moves about an Armory Floor to Furnish a Target for Coast-Artillery Practice in Vessel Tracking: The Concealed Operator and Mechanism are Seen Above

MOTOR WHEEL FOR BICYCLES
3592 **FITS ANY MACHINE**

Any make or size of bicycle can be readily transformed into a motorcycle



An Ordinary Bicycle Converted into a Motorcycle by Substituting a Newly Invented Motor Wheel for the Original Rear Wheel

by changing the rear wheel for a new motor wheel invented by a New York man. This attachment includes a heavy 26-in. bicycle wheel, with a 2-hp. motor plant, and a substantial mud-guard designed to fit into the forks of the bicycle after the original wheel is removed. The motor is of four-cycle type, and weighs only 57 lb. It is claimed that it will make about 100 miles to the gal-



lon of gasoline, will climb the steepest grades, and enable the rider to keep up with fast-moving traffic, while none of the extra weight or vibration falls on the bicycle itself, all being carried by the specially constructed wheel. The motor is

*W. Irving Taylor, Coast Defense Officer,
 National Guard.
 Municipal Bldg. New York*

carried on the left side of the wheel, the crank shaft extends through the hub, and a flywheel on the right side incorporates a built-in magneto.

1943

BARREL STRAWBERRY PATCH FOR CITY BACK YARD

A portion of an especially attractive "barrel strawberry patch" is shown in the accompanying illustration. This

see may 1942-117



One of Several "Strawberry Barrels" in a Los Angeles Back Yard: The Patch Occupies About One-Fifth the Space the Same Number of Vines would, Planted in the Ordinary Way

barrel is one of several owned by a Los Angeles man whose back yard was too small to admit of a regular strawberry bed. It was found that these unusual holders occupied about one-fifth as much space as an ordinary patch containing the same number of plants. To utilize a barrel in this manner, holes, about 12 in. apart, were bored in rows in its sides. Several tin cans, with perforated bottoms, were piled one on the other in the center of the barrel and enough dirt thrown about them to fill the receptacle up to the first row of holes. After the dirt had settled sufficiently, strawberry vines were planted in the holes and allowed to hang outside. This process was repeated until the barrel was full and vines had been set in all the holes and on the top. As the soil was added, cans were piled up through the center to provide an irrigation passageway. A hole was bored in the side near the bottom to allow surplus water to drain off.

SHAPE OF ENGLISH BULLET AFFECTS ALUMINUM MARKET

A peculiar circumstance in the manufacture of English rifle bullets is said to be responsible, in part at least, for the increased price of aluminum. Shortly after the outbreak of the war England gave up making round-nose bullets and produced, instead, a pointed variety with a solid-lead point inclosed in a cupro-nickel jacket. Some time later it was discovered that these missiles were not properly balanced for the English type of gun. After many tests the difficulty was overcome by inserting a little aluminum cone, $\frac{3}{8}$ in. high, in the apex of the cartridge jacket. While the weight of a single cone is, of course, almost negligible the total amount of aluminum required for England's rifle ammunition runs into thousands of pounds. It is this unusual demand that is said to have affected the price of aluminum.

1857

SIMPLE FIRELESS COOKER USED IN GERMANY

A fireless cooker of very simple design, which has recently been brought out in Germany, is shown in the accompanying illustration. It consists of an asbestos cylinder, closed at one end, and an asbestos disk large enough to cover the opening in the cylinder. The disk is placed between the gas, or oil, blaze and the dish in which the food is to be cooked, while the cylinder is used as a cover. After the food has boiled properly the fuel is turned off, but the cooking continues, for the asbestos allows the heat to escape very slowly. Since the device is such a poor conductor of heat it can also be used as a cooler, in which case the interior is lined with a damp cloth.

Wunderglöcke
Eilmachas, Bethmannstr. 21
Frankfurt
L. Nils
Lern



3681 Railway
U. & U.
LARGE BRIDGES ARE SHIFTED QUICKLY



THERE is something more than passing interest to be gleaned from an engineering feat that has been executed at Omaha. A few weeks ago an old four-span, 1,000-ft., 2,750-ton railway bridge extending over the Missouri River and connecting the Nebraska and Iowa shores was replaced with a new one weighing 5,500 tons. The time actually spent in moving the original structure out of the way and slipping the other one onto the piers amounted to 15 minutes, while traffic was actually suspended for less than one hour. The operation is noteworthy because of the size and weight of each of the bridges involved and the fact that they were handled intact instead of in sections. On the upstream and downstream sides of the piers, falsework was erected, in one case to receive the old bridge when it was lifted from its supports, and in the other to carry the new structure during the course of its erection. Five stationary engines and 200 men accomplished the work. Above, the two bridges are shown resting on the falsework, the old one having been moved to the left; and below, the new bridge is in place on the piers.

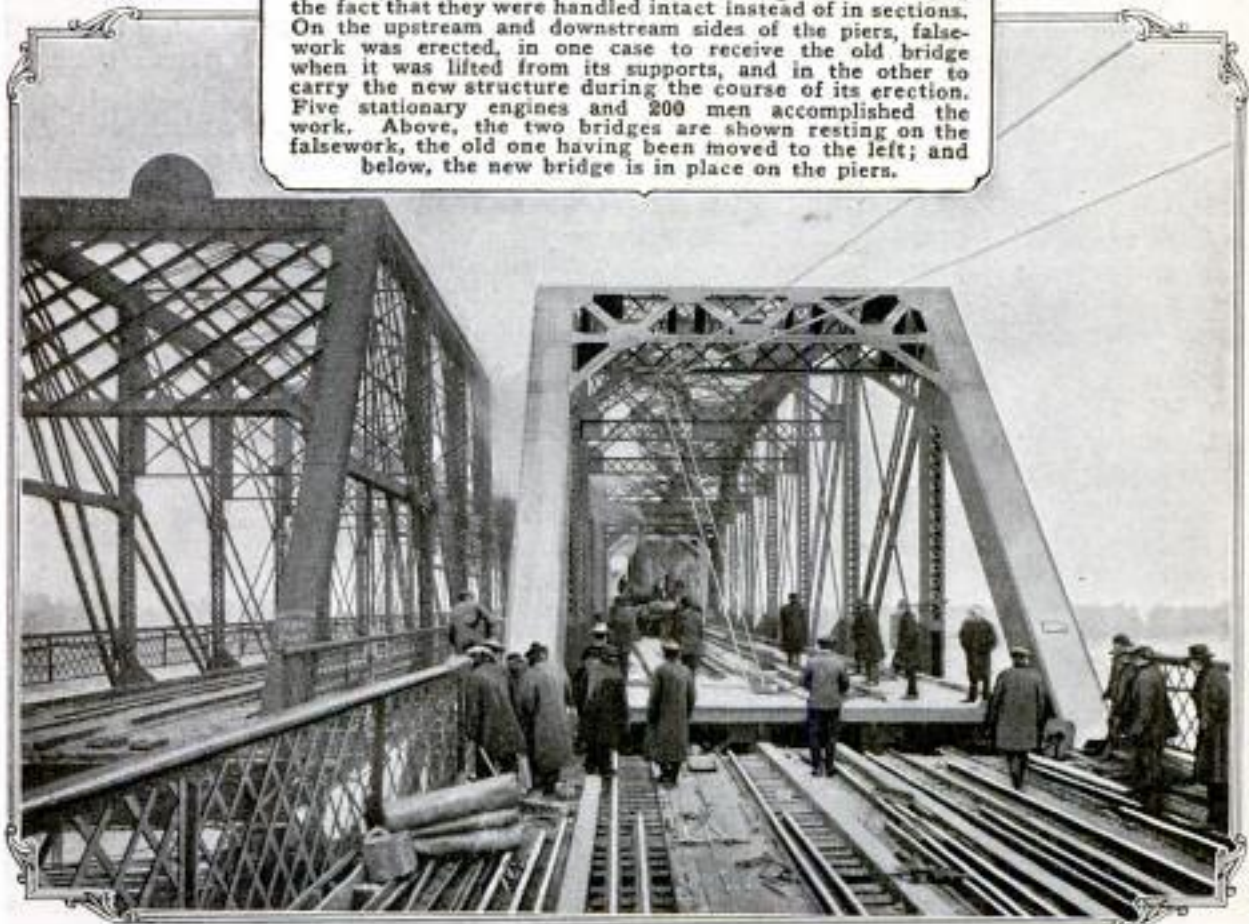

CONVERTIBLE SHUTTERS

3585 **SERVE AS AWNINGS**

A combination window shutter and awning is being manufactured by a New York City company which per-



A View of Convertible Shutters, Showing the Wooden Strips Nested in the Frames, and Hinged Sections Above

The Shutters Used as an Awning: The Thin Wooden Strips Form Protecting Fans at Either Side

mits freer ventilation than a cloth awning, is much more durable, and need not obstruct the view from within. This article differs from the ordinary shutter in that it has a small upper portion which is attached to the rest of the blind by hinges, and in one side of the lower section nest several

wooden strips, 1/8 in. thick and 2 in. wide, that are held together by a bolt at their upper ends. To convert two of these shutters into an awning they are closed and locked together. After releasing certain catches the lower end is pushed out from the window. This causes two iron braces to drop down and hold the shutters in place, while the narrow wooden strips, nested in the frames, spread out like fans on either side of the window so that the latter is protected on both sides as well as in front. When the blinds are not used as awnings the bracing arms serve as hinges.

3676
MUNICIPAL BATHING BEACH FLOODED FOR SKATING

A popular municipal bathing beach in Chicago was flooded to form an ice rink for skaters this winter, being used for the first time on Christmas Day, when a small preliminary crowd of about 2,000 persons appeared on the ice. The space prepared for skating measured about 300 by 400 ft. The beach was first sprayed over on a cold day with water, which froze quickly and formed a holding surface on the sand. This was then flooded with 1 1/2 in. of water and a satisfactory skating surface of ice resulted, to the delight of residents of the neighborhood. Last summer the beach, with its splendid facilities for bathing, represented the acme of comfort to Chicagoans, and crowds of 50,000 a day were frequent during the heated term.



Scene at Clarendon Municipal Beach Last Summer. When Thousands Daily Disported in the Waters of Lake Michigan



INT. FILM Co.

Skating on the Sands of Clarendon Beach, Chicago, This Winter: This Is the Largest Municipal Bathing Beach in the City and was Successfully Transformed into a Winter Resort



COPYRIGHT, BACH PHOTO NEWS, INC.

47 W. 42d. N. Y. C.
ARTIFICIAL MOONLIGHT FOR ITALIAN GARDEN

THIS view of a very beautiful and extensive Italian garden on Long Island gives some conception of the unusual lighting system which has been devised by the owner for the purpose of producing the effect of moonlight. Much study and experimenting resulted in installing electric lights having an aggregate of 500,000 cp., at various points in the garden. They are concealed behind shrubs and screens in so skillful a manner that the effect at night is quite suggestive of soft silvery moonlight. The lights make the statuary, fountains, and pergolas stand out in vivid contrast to the surrounding green foliage. The garden, through the center of which runs a beautiful shaded walk, is more than half a mile long.

3714
**ATLANTIC-TO-GULF CANAL
FOR FLORIDA PROPOSED**

Manufacturers Revere
Agitation in various parts of Florida has aroused interest in a proposed system of canals which would provide an inland waterway through the heart of that state from the Atlantic to the Gulf of Mexico. It is hoped that the active support of some 15 counties can be obtained, and that the state legislature will pass a law creating a canal district with full power to carry the work forward. One of the proposed routes would utilize St. John's River to a point well up toward its source, and, in

the opinion of its advocates, would possess enough strategic value to warrant the giving of Federal aid. One of the contemplated routes to the west coast is via Lake Okeechobee and Caloosahatchee River. It is contended, also, that a canal district should be considered in the same light as a road district, and that if the Federal government is to aid good roads it should also assist in canal digging.

Separate curtains for upper and lower berths are a welcome feature of the sleeping cars on an eastern line's new Chicago-New York trains.

3670
**ICE SKATING ON THE ROOF
OF A HOTEL**

A novel sensation was furnished for the guests of a New York hotel this



COPYRIGHT, INTERNATIONAL FILM SERVICE
 This Ice Rink on the Roof of a New York Hotel Was a Novelty Provided for Guests This Winter and They Evidently Enjoyed the Sport

winter, when an ice-skating "pond" was opened on the roof. The ice was in good condition on December 30, the opening day, and many people enjoyed the healthful and exhilarating sport, with added zest due to the fact that they were skating in the very center of the metropolis, far above the heads of the busy throngs in the streets below. The roof rink became popular immediately.

It is said that aviation in America will be seriously handicapped if two leading aeroplane companies insist on the heavy royalties they are now demanding of smaller manufacturers.

 3711
**NEW LIGHT ON FORMATION
OF COAL**

Optical Journal
 A minute examination of coal has recently given rise to an interesting

theory as to how that fuel was formed. Means have been devised for slicing it into sections so thin that they are almost transparent and can be studied to excellent advantage with a microscope. The use of this instrument revealed but little cellular structure in the coal, and where fragments of plants existed, they seemed to merge directly into the noncellular mass. As a result of the study in the course of which these facts were brought out,

the belief has arisen that in the formation of coal vegetable matter was first entirely decomposed, by bacterial action, into a liquid and then other vegetation, not decomposed, became saturated with this liquid and eventually was changed into fuel.

 3417
**MOTOR-CAR BRIDGE BUILT
ON NEW SAFETY PLAN**

Safety first has been the guiding principle in the construction of a new bridge which carries an automobile highway over an arroyo, or former river bed, near El Monte, Calif. The bridge has been specially designed for the pre-



Left: Note the Wide Curb That Prevents Cars from Running Too Close to the Heavy Railings. At the Right are Shown the Steel Girders of the Bridge Extended above the Floor Level to Form the Side Railings

CONCRETE CHIMNEY STACK WITH NEW FEATURES

vention of motor-car accidents. Its heavy side girders are extended upward, above the floor level of the bridge, to form the side railings; and in order to prevent motor cars from injury, by "hubbing" the railings or their massive supports, a wide concrete curb is built along the inside of the bridge on both sides of the road. It is said that this type of bridge has the additional advantage of costing less than ordinary types of steel-bridge construction, so that it safeguards the local taxpayer as well as the motorist.

3717

CHICAGO MAY USE WASTE TO MAKE BIG PARK AREA

Chgo. Post 12/13-1914
Until the practical basis for the statement is understood, it sounds truly incredible to declare that, if Chicago so desires, within a few years it can have without cost 1,300 acres of newly made park lands, valued at \$46,000,000. This can all be brought about by utilizing the city's waste, composed of excavated earth, street sweepings, etc., in constructing a strip of land along the lake front. The city's annual waste product is estimated at over 3,000,000 cu. yd., of which about one-half is from private contractors, who, it is believed, would pay a fee for the privilege of dumping their excavations, etc., close to shore. The whole scheme has been worked out by the Chicago Plan Commission, and since the city already has many acres of park area made in a similar manner, the project is receiving favorable consideration. To carry out the work, the city would have to build proper retaining walls, which, it is believed, subsequent revenues would pay for. Bathing beaches and drives would be featured in the new park land.

¶ In the United States only one farm in seven, of over 20 acres, now supports sheep, and consequently we import nearly a third of a billion pounds of wool yearly. If one-fourth of the remaining farms would raise one sheep for each three acres, this big importation could be wiped out by home production.

A concrete chimney, 300 ft. high, built recently at the plant of a Texas smelting company, embodies in its construction a number of new ideas. The shell, or walls, forming a true circle and tapering from 20 $\frac{3}{8}$ in. thick at the bottom to 5 in. at the top, were built up with the aid of patent collapsible, or adjustable, steel forms, used in sections, each 7 ft. 6 in. high. These made it easier to secure the exact amount of tapering required as the chimney rose in height, the concrete being mixed and tamped in the forms. The upper part of the chimney was built with a patent top, including a number of 4-in. pipe inlets, regularly spaced around the stack for the admission of air from the outside. This results in arresting many of the products of combustion carried up with the smoke—which then fall down the chimney into a hopper provided near the base. There are iron doors at the grade



This Chimney Rises 300 Feet into the Air at a Texas Smelter, and was Built of Concrete with Adjustable Steel Forms. The Platforms Seen Part Way Up Furnish Means for Testing the Inside Temperature and the Volume of Smoke

level, through which a railway track runs under the hopper, so that a truck can be run in to remove its contents.

PHONOGRAPH WHICH PLAYS ALL MAKES-OF RECORDS

A phonograph has recently been placed on the market which is equipped with a reproducer so constructed that



A Phonograph Having a Reproducer so Constructed That It can be Set at the Angles Required for Either Vertical-Cut or Lateral-Cut Records

a record of any make can be played without using an attachment. Generally speaking, the grooves on a phonograph disk are made in one of two ways: by lateral vibrations of the sound needle, or by vertical vibrations. One type requires that the reproducer shall be placed at a certain angle, while with the other kind of groove it must be set at an entirely different angle. This re-

producer is so hinged to the tone arm that the needle, or jeweled point, can be set in either of these positions. For one kind of record it can be provided with a fiber or steel needle, while if a record is to be played which requires a diamond point or sapphire ball, either of these can be substituted for the needle.

3660

CITY TURNS COAL DEALER BECAUSE OF FUEL FAMINE

The coal shortage, which in recent weeks has threatened to bring about very serious conditions in many parts of the country, has stimulated agitation for municipal coal mines that would supply the schools and the departments of the local governments with fuel, and, in some cases, would sell to individuals as well. This proposal has already been adopted in Terre Haute, Ind., and a mine four miles from the city has been leased from which coal is sold for \$2.75 per ton. An alderman in Detroit has advocated that that city buy or lease a mine, contending that by so doing the city could save \$3 a ton on its fuel. A similar plan has been proposed in Cleveland. The undertaking is regarded as most feasible for municipalities in or near coal-bearing regions.



Teams Employed in Hauling Coal from Terre Haute's Municipal Coal Mine: The Fuel is Sold to Individuals for \$2.75 per Ton

PAGEANTRY, A CIVIC PASTIME

3648

By HENRY B. RONEY, *Pageant Director*

1071 Keland Av., Chicago.

THERE probably is no more wholesome or educational festivity in which whole communities can participate, than pageantry. Based, as these performances are, upon local history, they become a most effectual method of passing stories of valor and glory, in all their wealth of detail, down the ages. In this country many states are now rounding out their first hundred years of history, as such. Centennial celebrations are an old story in the East, but the Middle West is only beginning to count the cycles of its past. This year Mississippi checks off her first century; next year is Illinois' turn; in 1919, Alabama will celebrate; in 1920, Maine; in 1921, Missouri. Last year, all the country rejoiced with Indiana. One of the most notable celebrations of that state is described in the accompanying article, written by the man who directed the performance. Anyone reading the account of the South Bend pageant can grasp the first principles of adapting such an entertainment to his own local conditions—history, talent, and facilities. He can understand how to go about it and how to carry it out. As Mr. Roney hints, pageants should not savor of commercialism. They are based upon a glorious past which is properly the heritage of every citizen. Their purpose is to promote community spirit and patriotism, and, as suggested in the beginning, to transmit the rich traditions of a vigorous people.—Editor.

WHAT is a pageant? Most people have an idea that it is "some kind of a show," and let it go at that. Broadly speaking, there are but two general forms of pageants. One is a procession of horses, riders, floats, tableaux, vehicles, and footmen, appropriately decorated and costumed, representing incidents, stories, and characters in history, fiction, or allegory. The other is a community drama, enacted in the open by dialogue, pantomime, or both, depicting chronologically actual events in the history of a city or locality, or the story of incidents or characters in mythology, tradition, or fiction, with or without allegory and symbolism, with a great number of participants drawn from the community. And there are, of course, many variants of these two main classifications. It is with the community pageant this article will deal.

Modern pageantry is a growth. Its germ origin dates back five centuries to the semireligious, semisuperstitious miracle and mystery plays on "pageant stages" in the public squares of Old England, a function confined largely to tradesmen. Through the years the idea broadened into the passion plays of Selzach in Switzerland and Oberammergau in Bavaria, religious festivals based on the life and passion of Jesus Christ.

The Oberammergau festivals continue with unflagging solemnity every decade, but the community-pageant idea became more and more secularized with the passing years until it burst



Henry B. Roney

forth in full flower in Sherburne, England, in 1905. Others followed at Warwick, in 1906, and Bury St. Edmunds, in 1907. The latter had 2,000 persons in the cast and a general committee of 450, and it took 600 ladies many weeks of hard work to make the elaborate costumes. These pageants were based on local history running back to the time of Caesar. Thus modern spectacular pageantry as we know it began in 1905 and is less than 12 years old.

In 1908 the pageant germ crossed the Atlantic and took root in Philadelphia, where was held what was claimed to be the first pageant given in the United States, celebrating the 225th anniversary of the founding of the city. The same year Quebec celebrated the 300th anniversary of the founding of the city with a gorgeous pageant lasting several days, enlisting citizenry and military in large numbers. Probably 250 real pageants have been given in this country.

The year 1914 witnessed at St. Louis the climax of American pageantry in vastness of numbers of performers and audience—7,500 actors on a stage area nearly 1,000 feet long and 200 feet deep, performing before an audience of 60,000 people at Forest Park. A guarantee fund of \$125,000 was raised for this the greatest drama ever staged, and which will long stand as the record. Pageants are usually more successful in the medium-sized towns where every interest is enlisted. St. Louis furnishes one of the rare in-

stances of civic unity in a city of the first rank.

In 1916, Indiana celebrated her centennial of statehood at each of her 92 county seats, headed by a county chairman appointed by the governor. Some were modest exercises in schoolhouses, churches, and groves; others were pretentious pageants enlisting hundreds of participants. Local and state history was the dominant theme, and this had long been the subject for study by the 564,252 children in the schools.

The South Bend centennial pageant was in preparation nearly a year. The pageant-writing committee of eight or ten began delving into St. Joseph County history in November, 1915. It entered upon executive work the following April, and the pageant was the first week in October. It was financed by guarantee subscriptions underwritten and accepted at the banks. It was at first slow work. South Bend had never had a pageant, and only a few of the workers had a vision of its magnitude or significance. The masses were for months not particularly interested, business men were conservative, and the guarantee fund languished. But South Bend was fortunate in having two enterprising and ably edited daily newspapers. These

contributed uncounted columns of publicity with lavish disregard of free space, while the board of directors and the committees kept hammering away, appealing to civic pride and enlightening the people. Indifference finally gave way to interest.

Important contracts and other work then had to be put through at white heat to be ready for the opening performance. One glance at the race-track ellipse at Springbrook Park, where the pageant was held, was enough to discourage the veriest optimist. The area of the "stage" for the reenacting of the historical scenes was about 1,000 feet long by 500 feet deep, equal to two large city blocks. One-third of it was low marshy ground. The wide race track was as smooth as a ballroom floor. The rest was rubbish-littered, bare ground denuded of every living bush and tree save one noble elm to redeem the landscape. But the enterprising city of automo-

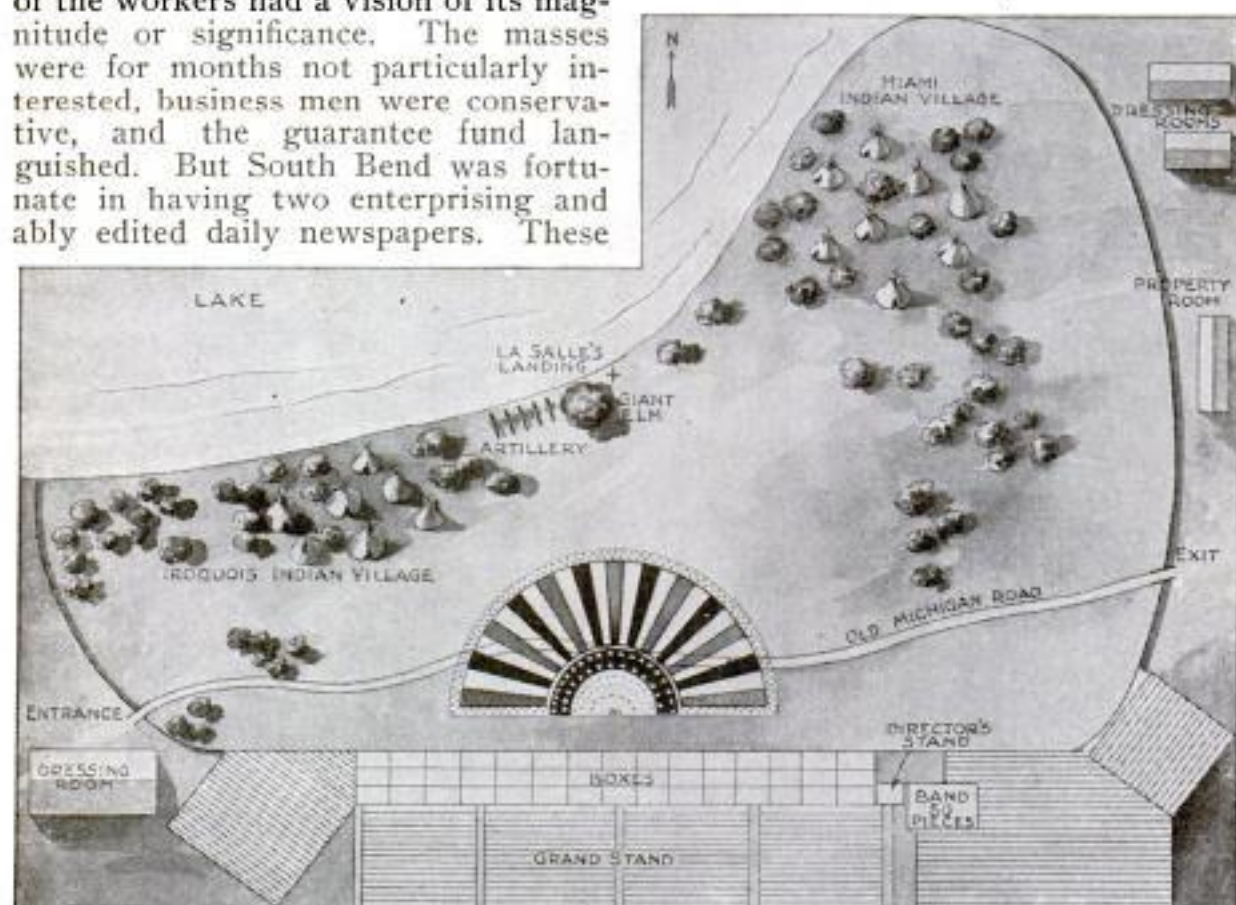

Plan View of the Race-Track Ellipse and a Marsh as Transformed by the City of South Bend into a Suitable Setting for the Centennial Pageant. The Historical Episodes were Enacted at the Point Where the Sunburst is Shown



These Native Indians Are a Few of Those Who Came from the Government Agency in South Dakota to Help Make the South Bend Pageant a Success. Chief Black Hawk, an Hereditary Chief of Fine Character, Is the Central Figure in the Rear Row

biles, chilled plows, agricultural implements, underwear and woolen mills, sewing machines, watch factories, and a hundred other big industries, stops at nothing when once aroused, and a week later the eve of the pageant opening

saw a transformation that rivaled Aladdin's palace. Fences had been removed, grounds cleared and graded, and a dense forest set out, with an eye to forming good entrances, exits, screens, and backgrounds for the dramatic work. In the

place of the marsh was a beautiful lake made by pumping in water from the St. Joseph River, 15 feet below, by a centrifugal pump throwing 800 gallons a minute. A boat landing was dredged and on this pretty sheet of water the

moonlight reflections of many teepees and camp fires through the trees added a realistic touch to the landscape, while Indian canoes, darting hither and thither, made the illusion complete. After the South Benders awoke and

warmed up to the work, the question of "clearing expenses" went to the background. The only thought was to produce a superb performance on a colossal scale regardless of cost. And they did it.

The permanent concrete grandstand was enlarged to a capacity of 13,000 persons. Nearly every pageant I have witnessed had one great weakness—too much dialogue impossible for the multitude to hear, especially if the wind was blowing. When most of the actors are



Sunburst Formed by the Chorus: The Red and White Rays were Formed by Children Wearing Robes of Those Colors; Blue-Robed Persons Formed the Field of the Half Sun, 48 of Them Carrying White Star-Shaped Umbrellas; in Front, at the Center, Were Grouped the Principals of the Cast

unaccustomed to public speaking, as is usually the case, the inability to understand always stimulates talking and confusion. When pageant books are not furnished free, one-half of the audience will be without them and thus un-

largely children, to contrast the privations and meager educational privileges of pioneer days with the splendid cultural advantages afforded by the modern "School City of South Bend," as it rightly calls itself, and to thrill the

multitude with an outburst of song in the patriotic finale, the only adequate climax to the great scheme.

3. Five cannon from Culver Military Academy, to be fired by electricity in the massed choral effects, and a company of cadets and officer to handle them.

4. A telephone system with ten offices and operators, at dressing rooms, entrances, exits, Indian villages, boat landing, artillery and electric-light chief's stations, with switch-board at the director's station. Some of the dressing quarters and

property rooms were nearly a quarter of a mile apart.

5. A great military band of highest rank, of 50 instruments, rich in reeds, wood winds, tympani, and cathedral chimes, to give day concerts, accompany the big chorus, and to illustrate the scenes with interpretative music—pathetic, stirring, tragical, martial, humorous—furnishing local color according to the story, subconsciously playing upon the emotions of the people and increasing the dramatic effect.

6. An electric baton of original design, hereafter described.

The board of directors approved and authorized every recommendation. Every feature "made good" and justified the large expenditure. It was not a commercial pageant. Some splendid industrial parades were features of the three-days' centennial celebration, but they were uptown and not of the pageant proper. The electric lighting was the most costly and elaborate yet attempted in pageantry. A long bridge

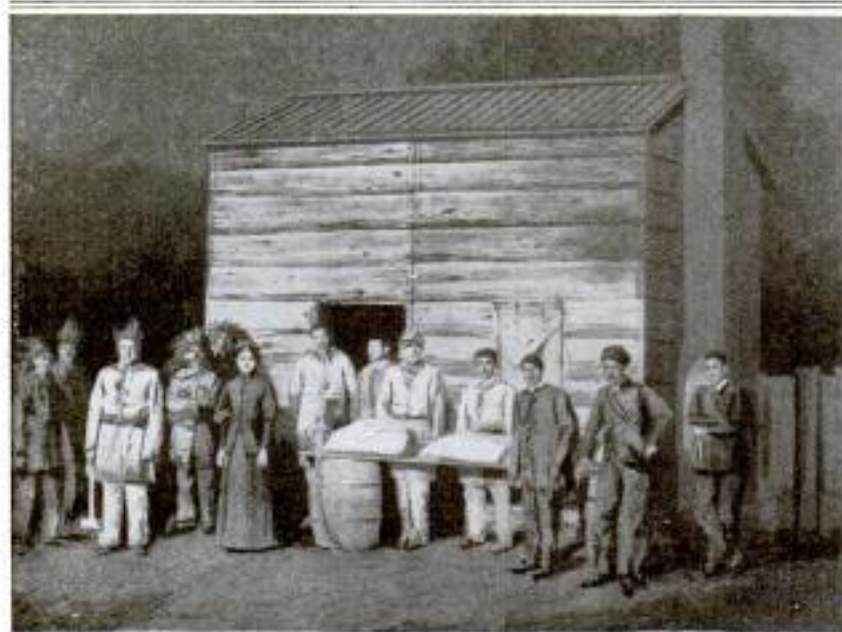

The School Children of South Bend and Vicinity had Read in Their Histories All About the Trading Posts of Pioneer Days, but Since the Great Pageant They Understand Just How Such Posts were Conducted and the Perils Besetting the Men of Old Who Patronized Them

able to follow the story. The pageant committee wisely decided to have the drama almost wholly in pantomime.

Pageant week opened with commemorative services in all the churches, and a union of choirs in a sacred concert in the afternoon at the park. The pageant book was an octavo containing the county's condensed history, and the scenario, divided into 24 episodes running vis-à-vis, and all of the choral music of the pageant. It sold at the trifling sum of 10 cents. Not an advertisement was permitted in the book. Show and street-fair methods were taboo. My plans for the pageant included:

1. A band of real Sioux Indians from the government agency in South Dakota, in native dress under command of Chief Black Hawk, to give war dances, take part in the peace council and lead in the big fight, for no true history can go back very far and get away from the Indian.

2. A chorus of 5,000 or more singers,



Father Marquette Passes on His Last Journey: The Great Missionary to the Indians Was but 38 Years Old at This Time. He Died Shortly after His Passage through St. Joseph County, Indiana. This Sad Episode (1675) was Most Effectively Staged

built on top of the grand stand was filled with searchlights and spot lights, handled by a dozen electricians. Thousands of straw-colored footlights threw a soft amber glow over the enormous stage area, and arc, colored, and bunch lights wherever needed completed the dazzling scheme. The installation of the special lighting cost nearly \$2,000; the band a like amount.

For the patriotic finale the original idea of a living sunburst in national colors was adopted. Five thousand children were to form the radiating "rays," and hundreds of adult singers the "sun." The children were seated on bleachers at either end of the grand stand with their teachers, all previously assigned to certain numbered red, white, or blue rays, according to a diagram given to each singer. They were therefore able to see the entire performance up to the final episode. A telephone message to the artillery station on the shore of the lake sent three signal rockets piercing the sky, and started the singing hosts to their positions to form the rays for the sunburst. Here colored wraps were distributed to the columns to make the red-white-blue-white alternating rays. The stopping points for the head of

the columns were indicated by small red, white, or blue electric transparencies, strung by cable on the ground, indicating the number of the ray of corresponding color. The adult singers, forming the blue field of the half sun, then flowed in from either side, and

48 ladies scattered through the blue raised as many white star-shaped umbrellas. The gorgeous eagle-feathered and beaded Indian chiefs formed a semicircular row inside of this; priests, missionaries and historical characters—La Salle, Joliet, Tonti, Marquette, etc.—followed, and the gigantic sunburst was complete, ready for the choral climax. There were 1,000 in the cast and over 6,000 persons were massed in the closing patriotic tableau.

Cannon were fired by the director while conducting the chorus, by closing a switch, the report coming in exact time on the accented beat of the climaxes at the end of "Old Glory" and "Star Spangled Banner." The effect, not unlike a tremendous bass drum, was

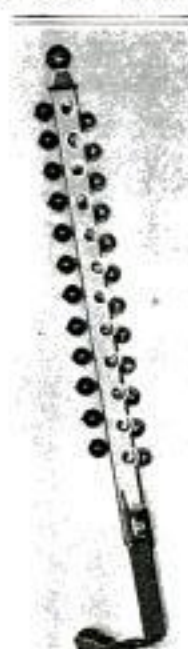

The Electrical Baton, with Which a Great Chorus of 6,000 Persons was Successfully Conducted

startling.

The chorus was directed by an electric baton, a new invention of the director and used on this occasion for the first time. A baton with a tiny electric bulb on the end for conducting

orchestras in darkened theaters is not new, but to direct and hold together a chorus of 5,000 children at night in the open air, is a different proposition. The instrument is triangular, 3 ft. 4 in. long. On one side is a row of blue electric bulbs, on another a row of red, and on the third side a row of white, each giving a continuous shaft of light nearly three feet long. Thumb buttons changed the colors to indicate expression, blue signifying, "sing softly"; red, "sing medium power," and white, "full power." The baton, connected by cable to a five-volt storage battery underneath the director's stand, weighed a little less than three pounds, and was a perfect success. It could be easily seen at the farthest lines of the singing army, and it served the double purpose of arresting the attention of the children by the fascination of its flashing, changing colors.

The South Bend pageant condensed 240 years of intensely interesting local history into a three hours' performance. It lent itself wonderfully to dramatic presentation and had all the elements of a fascinating historical novel. All of the characters of the early priests and missionaries were taken by the faculty and student body of the great University of Notre Dame. Five hundred Indians from the Order of Red Men of Mishawaka and South Bend, led by a score of real Sioux warriors from South Dakota, staged a thrilling fight of 1676 between the Iroquois and Miamis, traditional enemies. Ladies from the auxiliary Order of Pocahontas dressed and painted as squaws, and the youngsters became Indian children. All other episodes were staged by local clubs, military, societies, schools, lodges, and individuals. Five make-up artists from the Chicago Grand Opera Company transformed the pale faces into the aborigines of the forest.

In the wealth of scene and story nothing gave a more powerful tugging at the heartstrings than the prologue which just preceded the great fight. "Father Marquette passes on his last journey, 1675." The intrepid missionary with the hand of Death upon

him, was making his painful way through the wilderness, leaning heavily on a guide, with two companions following, carrying his canoe. They stop to rest, then pursue their slow journey to the landing, followed by the searchlights, while the band intoned the mournfully pathetic "Angelus" of Massenet. Marquette, then in his 38th year, died a few weeks later near St. Joseph, while trying to reach his headquarters at St. Ignace, Upper Michigan.

The landing of La Salle and his retinue, 1679, and their entrance was another splendid scene. A pathetic tragedy was "Jean Beaudoin's run, 1831," showing the young French hero finishing his thrilling run of 160 miles with a broken arm, passing through "the great (Kankakee) marsh" to warn the little village of South Bend of the uprising of Black Hawk and his threats of massacre. Exhausted, he falls in a faint, is revived, and breathes his message. His sweetheart, Poppy Eaton, who has been sent for, comes on horseback at a mad gallop, and he dies in her arms.

Another scene of mournful splendor was "The departure of the Pottawatomies, 1840," where, after the United States government had sold their lands, they were driven out to the Southwest by United States troops. Rounded up by the soldiers and led by Father Bardin, with crucifix raised aloft, the whole tribe with bowed heads and broken hearts slowly took their departure in seemingly countless numbers. The gorgeousness of Indian costumes, from chiefs who led, to the squaws bringing up the rear, presented a scene of aboriginal tribal splendor never equaled in American pageantry. Under the wonderful effects of search and spotlights they disappeared in the far distance. Their camp fires which flickered on the great field of woods and shore died out, and we came back to earth again to realize that it was not fiction but a cruel injustice in our last century's history. And then, on down through the 19th century the episodes marched, showing the first settlements, the burning and rebuilding of Misha-



In This Day of Railroad Trains and Automobiles There Is Little to Remind Us of the Slower and More Picturesque Modes of Travel of 1850. South Bend's Most Illustrious Citizen, Schuyler Colfax, was Impersonated at the Pageant and Appeared in an Old-Time Coach. Colfax Was an Editor. He Served Many Terms in Congress and Was Vice-President under Grant. The Episode of His Return was Staged by a Lodge



Jean Beaudoin Was a Young Frenchman Who Heard of Chief Black Hawk's Plan to Raid the Frontier and Massacre All Whites, Including the Villagers of South Bend. Beaudoin Ran 160 Miles to Warn the Whites. His Arm was Broken en Route and He Died of Exhaustion with His Mission Just Accomplished. His Sweetheart, Poppy Eaton, Heard the News and Came Madly on Horseback, Reaching Her Lover's Side Just as He Expired. This Episode (1831) was Presented by the Notre Dame University, Red Men, Canoe Club, and Woman's Civic League



After Father Jacques Marquette, the Next White Man to Visit the St. Joseph Valley Was La Salle. He Followed the Great Lakes, Coming down Lake Michigan and Turning up the St. Joseph River. With Him Were About 30 Priests, Carpenters, and an Indian Guide. Snow was Falling and They Missed the Portage, the Indian Guide, White Beaver, Being Away Hunting. La Salle Landed and Walked Nearly to Osceola, Looking for the Portage. Staged by Notre Dame University, South Bend Canoe Club, and Red Men



waka, the growth and development of the two cities, with a wealth of local incidents and celebrities, bringing the story down to the present.

One of the most significant features in the South Bend celebration, in addition to the folk dances of all nations at the daily band concert on the courthouse plaza, was the pageant of nations. In this 15 nationalities participated — French, English, Irish, Dutch, Belgians, Scotch, colored, Danish, Italians, Russians, Swedes, Germans, Filipinos, Hungarians, and Polish. While the band played their national airs in turn, they marched by Miss Columbia, guarded by the Army and Navy, deposited their native country's flag, took up the Stars and Stripes

and marched on singing "My Country, 'tis of Thee." It was a polyglot transformation sermon that thrilled.

No large pageant can be put on in a hurry. The details are endless. A year may be required for research, collecting historical data, and writing the scenario—fascinating work, every hour of it. The pageant text is best written in collaboration, as at Oxford and at the University of North Dakota, where different groups of undergraduates each wrote one of the parts. No pageant ever was "perfect." There were hitches at South Bend due to newness and inexperience, but none probably, except the principals, discovered them in that stupendous, colorful, moving panorama of history.

MOTOR-DRIVEN PUMP FOR 3484 FLOODED MANHOLES

When the manholes of the electric-light system in Rochester, N. Y., are

flooded, as often happens in the spring and after heavy rains, a motor-driven pump, carried on



Pump in Position to be Lowered into a Flooded Manhole: An Electric Motor at the Top of the Upright Pipe Runs the Small Pump at the Bottom

one of the light company's electric trucks, is used to remove the water. The apparatus consists of a 1/4-hp. ver-

tical motor and a small centrifugal pump, connected by a 3-in. spiral riveted pipe 7 ft. long. The pipe acts as a support for the motor, and its length permits the pump to be lowered into the water without submerging the motor, while it also conducts the flood water in the manhole from the pump to the street level. The shaft of the motor and the impeller of the pump are connected by a 5/8-in. brass rod running through the 3-in. pipe. The electric truck furnishes power from its battery and carries a small crane, by which the pump can be swung over the manhole and lowered into it by means of a block and tackle.

PORTABLE DISINFECTORS FOR OUR ARMY

The government has recently purchased for our army six disinfectors of a new portable type, each of which is capable of purifying 50 uniforms and kits in 40 minutes. Either steam or formaldehyde and ammonia are employed as germicides. The outfit consists of a 5-hp. upright steam boiler and an airtight chamber, 6 ft. long, mounted on a metal running gear. The rear end of the chamber is provided with a heavy door which can be hermetically sealed. Within is a rack mounted on wheels

*Rochester Railway & Light Co.
Rochester, N. Y.*



Six of These Portable Disinfesting Outfits have been Purchased for the United States Army. Either Dry Steam, or Formaldehyde and Ammonia can be Used as a Germicide. A View of the Air-Tight Door is Shown at the Right

from which clothing can be hung, while small articles can be placed on an iron grating. After the chamber has been filled with dry steam from the boiler for the proper length of time, the garments are dried by a current of sterilized air and are then ready to be removed. Fastened to the side of the disinfesting chamber is a two-compartment tank from which formaldehyde and ammonia gas can be discharged into the inclosure when steam treatment is not desirable. An obvious advantage of an outfit of this sort is that it can be easily moved with the troops by horses or a truck. Several have been sent to Europe since the war began. A New York doctor is the inventor.

ROPE AND CABLE MEASURED BY A MACHINE

A machine that will measure accurately any length from 1 ft. up to 1,000 ft. of any size rope or cable, from the smallest cord up to $1\frac{1}{4}$ -in. Manila rope or wire cable, is now available to those who manufacture or handle such supplies. It consists essentially of a large measuring wheel which is connected to and forms an outside case for registering mechanism, including a dial with two pointers indicating feet and hundreds of feet, respectively. Above there are guide rollers and a weight

wheel to hold the rope in contact with the measuring wheel in its passage through the machine and thus insure the measurement and registration of every foot that passes. When a rope is to be measured, the pointers are set at zero by turning a small knob at the side of the dial, and the end of the rope is inserted between the guide



The Pointers Indicate That 300 Feet of Cable have Passed from a Stock Reel at the Left to the Reel at the Right, Which Has Collapsible Arms for Removal of the Cable

rollers and over the measuring wheel beneath the weight, then carried direct to a reel, by which any length required is pulled through.

*W. C. Thompson,
4724 Fairmount Av., Kansas City,
Mo.*

3475

IMPROVED GAS HEATER FOR RIPENING FRUIT

Commission merchants often find difficulty in securing the proper de-

fruits. This difficulty is said to be obviated by the use of a new gas heater devised by a Normal, Ill., inventor. The heater is placed on the wall of a banana room and is made in a size to conform to the length

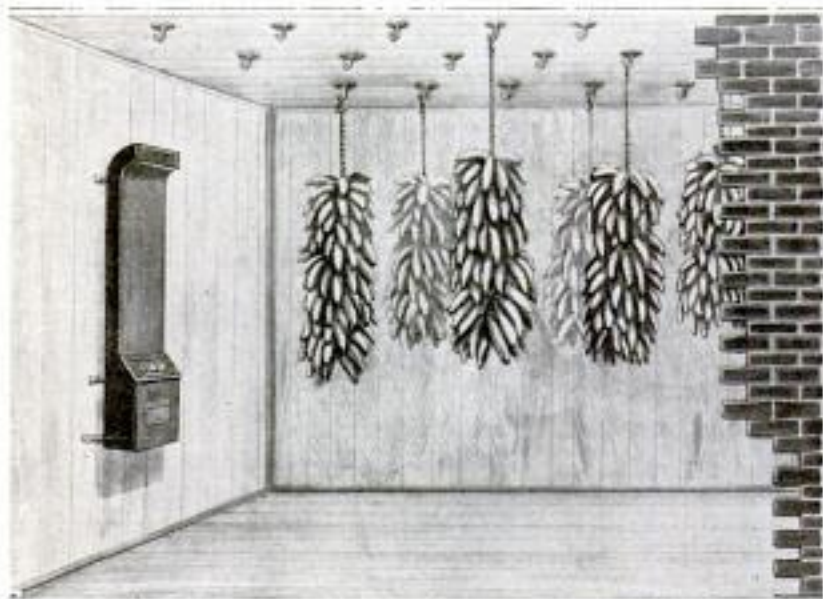

Ripening Bananas with a Gas Heater That Takes the Cold Damp Air from the Floor, Heats It, and Circulates the Heat Evenly over and Down through the Fruit

grees of equable heat in rooms devoted to the ripening of bananas and other

of banana bunches, so that the fruit will not be heated in spots, or cook. An opening at the top, from which the heated air issues, is set about 2 in. above the top of the bunches, so that the heat passes over and down through the bananas, thus ripening them evenly. The gas burners are of the illuminating-flame pattern, to allow more perfect control of temperatures, and also to afford sufficient light in the room through mica windows in front of the heater. One heater is

required to each 1,000 cu. ft. of space in the room to be heated.

3579

PRIMITIVE LOG BRIDGES FOR WESTERN RAILWAYS

The abundance of logs and the scarcity of skilled labor in remote regions of the West have resulted in the con-



A Good Example of the Crisscross Type of Railway Bridges Erected in Many Regions of the West Where Lumber Was Plentiful and Skilled Labor Scarce

tractors for certain pioneer railway lines resorting to quite primitive methods in the building of many bridges and

viaducts. The logs cut from the path of the railroad have been roughly trimmed and piled, crisscross, to the desired height in the gullies and ravines, as shown in the accompanying illustration. The structures are held together by their own weight and by short bracing members which prevent the logs from shifting. At the lower part of the rustic and rather picturesque bridges the big tree trunks are so laid as to allow ample room for water to flow beneath unhindered.

CA novel means of testing a detonator is to hang it so that it touches a lead plate. When the detonator is fired by means of the fuse attached to it, the explosion will cut a small crater in the plate and from this central point will radiate numerous scratches. The extent of the latter is a measure of the force of the explosion.

Sam Raddon, Jr.,
736 E 46th, N., Portland,
Oregon.

California Alligator Farm Los Angeles

COMMUNITY OF ALLIGATORS AT TOURIST RESORT

3515



A Delightfully Accommodating Carryall for the Youngsters, When His Jaws are Safely Strapped Together

The Alligator Farm at Venice, a Resort Place in Southern California, Attracts Large Crowds of Pleasure Seekers, Especially at Feeding Time, an Event That Comes About Three Times a Week for the Young Ones Like Those Above

Small Alligators are Handled by Their Tails with Comparative Ease. Care must be Taken, However, That They don't Get a Chance to Use Their Teeth, for, Like Bulldogs, They Hang On



Riding an Unmuzzled Alligator Is Not the Safest Performance in the World



Grabbing a Piece of Meat between Their Teeth, the Small Alligators Roll Over and Over Until They Succeed in Tearing It Loose



One of the Ways the Young Alligators Enjoy Themselves: They Climb to the Top of the Chute, Await a Signal, and Then Slide Head First



"Louisiana Joe," Pictured at the Right, is Suffering with a Broken Jaw, and "Buffalo Bill," Above, Basking in the Sun, is a Foot Shorter in Tail Length as a Result of a Brawl. The Two Recently Fought Desperately for Five Hours Before They could be Separated by the Trainers



Fellows of the Size of This One, Which is Eight or Ten Feet in Length, Devour 40 or 50 Pounds of Meat at a Time and Then Go a Week or More without Further Nourishment

PAPER MODEL OF BIG TANK SHOWS STRUCTURAL MERITS

Some of those who are unfamiliar with architectural and construction work possibly do not appreciate the



painstaking care that is quite commonly observed in preparing pasteboard models of residences, office buildings, bridges, and other works, before their erection. These structures in the miniature are not the result of idle toying by ingenious, time-killing craftsmen, but are made for definite, important reasons. Frequently a model will disclose a structural fault, or advantageously demonstrate architectural and engineering merits, that cannot well be brought out by blueprints. An interesting example of this form of work is afforded by a paper model of a 60,000-gal. water tank and 75-ft. steel tower built by an engineer connected with a Pennsylvania steel-construction company for the purpose of demonstrating certain principles to members of the drafting-room staff. The small replica is 32 in. high, the tank is 6 in. in diameter, and all other parts are as nearly proportionate as possible. Except for its wire bracing rods, the model is made entirely of heavy drawing paper. It will support a dry load of about 20 lb. without visible distortion. The steel tower and tank, of which it is a model, has been erected in Idaho.

Several vessels in our navy, now equipped with direct-connected turbines, are to be re-engined, the first being two destroyers, the "Henley" and the "Mayrant," which will be provided with geared turbine units.

CARELESSNESS AT GRADE

3716 CROSSINGS SHOWN

Chicago Tribune 12/27-1916
In view of all the agitation which has marked the safety-first movement in recent years it is rather surprising, to say the least, to find that of those persons who pass over grade railroad crossings probably one-half, or more, fail to look to the right or left before moving across the tracks. This estimate is based on the reported findings of investigators for the California Railway Commission. In observing the drivers of 17,000 motor vehicles it was found that over 69 per cent looked neither way before crossing railway tracks. Something over two per cent looked in one direction only, while the remainder, less than 28 per cent, looked both to the right and left. Of 6,300 pedestrians 49 per cent looked neither way and 15 per cent looked only one way. It is believed that these figures may be taken as fairly typical of the country as a whole. They indicate both the menace of the grade crossing and the need of educating both drivers and pedestrians to greater caution.

3213 AMERICAN STREET SHRINE OF CONCRETE BLOCKS

The site of a proposed church in Providence, R. I., is marked by a street shrine similar to



those to be found in many parts of Europe, except that it is more modern in construction. The material for both the walls and the two pillars which ornament the front is concrete blocks. The upper half of the door is glazed and through it can be seen images, candles, etc. On the front of the door is a brass plate having a slot through which offerings can be deposited.

St. Ann's Church
#Wm. M. Strong
"Providence Journal"
Copyrighted material

Berg Auto Truck Specialty Co.
406 Lafayette St.
New York

POPULAR MECHANICS

3578 349
Factory 15-17-19
4th St

WIDENED SWEDISH CANAL

CONVERTIBLE PICNIC

OUTFIT FOR AUTOS

3658 OPENED TO TRAFFIC
Commerce Reports 11/23/16

The Trolhättan Canal in Sweden, which was recently opened after being widened and deepened, is a part of the Göta Canal system that extends across the lower end of Sweden and connects Göteborg on the west with the Baltic Sea, at a point about 90 miles south of Stockholm. What has been done to the Trolhättan Canal calls to mind the fact that in recent years Sweden has been actively engaged in adapting many of her waterways, constructed years ago, to large modern vessels. In this way a stimulus has been given to manufacturing centers that are springing up in great numbers to utilize the electrical energy generated by the plentiful waterpower of the country. Trolhätta Falls, which is near the canal bearing similar name, is one of the greatest of these power producers.

A new type of trunk equipped with dishes and utensils for picnicking mo-



A View of a Smaller Picnic Trunk, Showing Its Shape When Closed and the Straps for Attaching It to the Robe Rail



Automobile Picnic Trunk Which Fastens to the Robe Rail and can be Used as a Table in the Car or on the Ground. It is Fully Equipped with the Necessary Dishes and Utensils

3204
STEEL HUMPS AT CROSSINGS
REGULATE TRAFFIC

In the center of Los Angeles street intersections, at which traffic officers are not stationed, hemispherical disks have been bolted to the pavement for the purpose of regulating vehicular travel and preventing corner cutting. A fine is provided by city ordinance for the motorist who fails to keep to the right of these "mushrooms" in piloting his car in the thoroughfares.



torists is so constructed that when it is open, it serves as a table that can be used either inside or outside the car. After the case has been set on edge and opened, a hinged white-enamel leaf can be drawn up into a horizontal position and held in place by two folding legs, thereby serving as a table top. Knives, forks, spoons, and plates are within easy reach in their respective racks in the upper half of the container, while in that portion of the case which acts as one of the supports for the leaf are cups, bottles in spring-held racks, a pickle jar, and a provision box. The case is strongly made of basswood, covered with enameled duck. A similar case, smaller in size, can be had with less elaborate equipment.

Giant Forest, a privately owned tract of mammoth trees in the heart of the Sequoia National Park, has recently been purchased by the government.



Left: Battery of Nine Boilers Installed on Field to Develop Steam with Which to Combat the Flames.
Right: The Heavy Iron Cap was Moved Forward by Horses and Placed over the Well, Snuffing the Blaze and Controlling the Flow

STEAM USED TO EXTINGUISH FLAMING GAS WELL

Milton A. Bangs, Winfield, Kan.

Nine boilers recently furnished a flow of steam used in extinguishing a burning gas well near Blackwell, Okla., which had been ignited by an electric spark. Ten days were spent by a large crew of men in mastering the fire and capping the well, which has a flow of

about 20,000,000 cu. ft. a day. When the steam had reduced the flames sufficiently to permit it, the iron cap—or "snuffer," as it is called in gas-field vernacular—was moved forward by horses and dropped into place over the roaring gasser, thus stopping the waste.

3557 "DAYLIGHT" LAMPS USED IN ART GALLERY

One of the largest installations of "daylight" incandescent lamps thus far

ing galleries is controlled by means of motor-operated louvres, while in the artificial lighting of the museum the use of "daylight" lamps serves to bring out the true color values of the paintings and art objects when the galleries are illuminated for inspection after dark. In order to get as near to natural daylight as possible 150-watt incandescent lamps of a suitable make are used with hooded

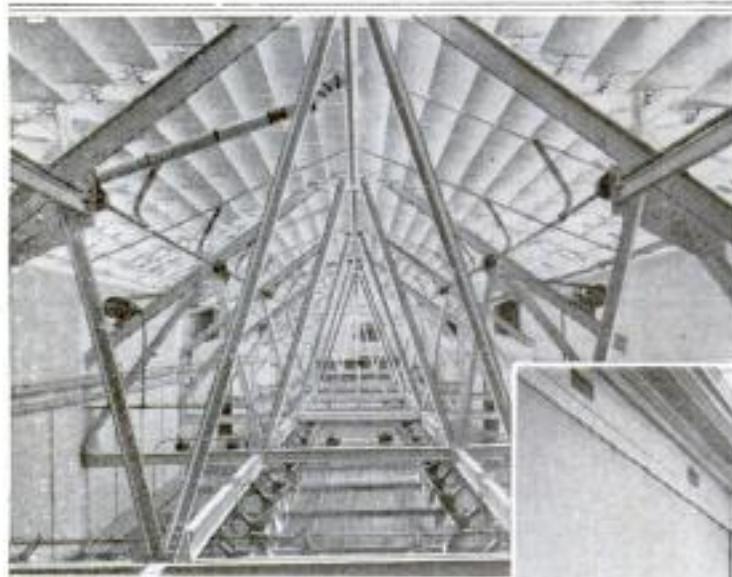

This Shows the Arrangement of the Hooded-Reflector "Daylight" Lamps between the Skylight and the Subskylight of the Cleveland Museum of Art

put into service is in successful operation in the new Museum of Art, in Cleveland, Ohio. The system gives a notable degree of control in the distribution of light, both artificial and natural. The admission of sunshine and daylight to the skylights over the paint-



Interior of One of the Galleries of Paintings, Showing How Perfect Illumination is Secured by the Overhead System

*F. A. Whiting,
Director.*

POPULAR MECHANICS

projector units, or reflectors, placed above the subskylight. A special holder was designed to adjust each reflector to the desired position to secure the best results. One lighting unit was provided for each 3 ft. or 4 ft. of wall length, the lamps were slightly frosted with an etching solution, and scoops were attached to the reflectors to intercept direct light from the lamps. Special means are provided for the appropriate illumination of various courts, loggias, and groups of statuary.

10" 2 ft 18" 13" *with folding legs*
any five or seven-passenger car. The cot frame is hinged at its center and can be folded up and stored back of

1853 SANITARY CHIP BLOWER NEW DENTAL ACCESSORY

Hygiene preachments have brought about the invention of a dentist's blower which appears to be a real improvement over old types so far as the important question of sanitation is involved. Instead of taking in air through the nozzle, a special valve is provided

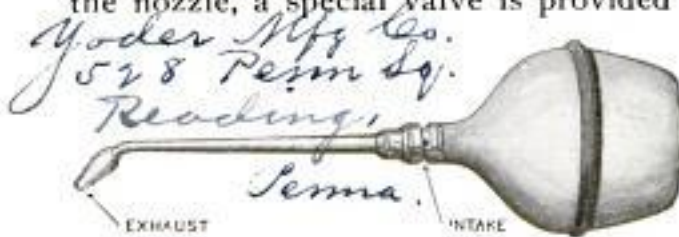

Germ-Laden Matter is Not Drawn into the Bulb, for, as Indicated, the Nozzle Has No Intake Valve

next the bulb and a double-acting one used in the tube, so germ-bearing saliva, blood, pus, and decayed matter cannot be drawn in. The instrument is of the usual pattern and, except for the features mentioned, is not dissimilar to those in general use. It is provided with two points and nozzles, so that one set can be sterilized while the other is in use.

3490 ———
SIMPLE FOLDING COT FOR MOTOR TOURISTS

One of the simple and very serviceable cots for use in connection with automobile touring consists of a frame of metal tubing, across which canvas is tightly stretched. The frame is provided with curved feet, which rest on the backs of the seats and are adjustable so that the cot can be used with

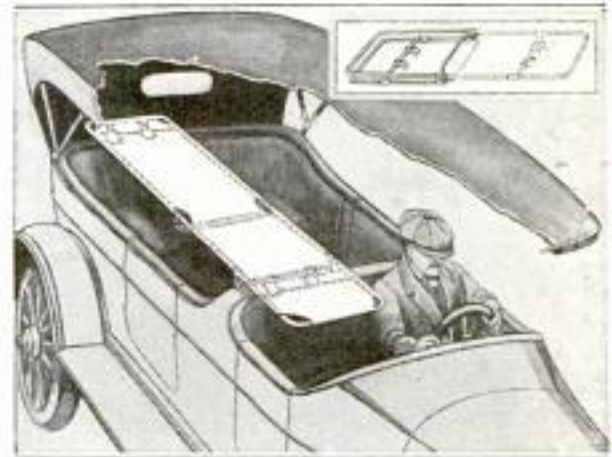

A Folding Cot Which Occupies Little Space in an Automobile: It is Adjustable to Cars of Various Lengths and Consists of a Frame of Metal Tubing over Which Canvas is Tightly Stretched

the front seat or elsewhere. A dust-proof bag is provided to cover it. Two of these cots can be used in a car at one time. If desired, they can be equipped with folding legs—a feature which makes them suitable to camp use.

3489 ———
EIGHT-SIDED BARN WITH FOLDING WINDMILL

An Iowa farmer is the proud possessor of a barn built in the shape of an octagon, or with eight sides instead of the customary four, and the barn is surmounted by a windmill of the vertical folding-blade type. At first sight the windmill structure looks like a water tank, especially when the blades



This Eight-Sided Iowa Barn is Topped by a Very Useful Windmill Which Does Many of the Chores

W. L. Thompson,
Gale, Ill.

are closed against the wind and folded into a cylinder. The power of the wind-mill is transmitted from the central shaft by beveled gearing to a line shaft on the floor of the barn, and used to run the silage cutter, wood saw, feed grinder, and other machines that make life easier on the farm.

3274

LOGGING CHUTE IS BUILT OF STEEL RAILS

Mr. B. Woods Malvern, Ark.

Between forest and mill, in an Arkansas lumbering district, a steep hill, which intercepts the route, presented an obstacle in the way of transporting logs expeditiously. The grade was too precipitous to permit mule teams and loaded wagons to pass down it. Instead, however, of meeting the difficulty with a chute of the usual character, one was constructed with



rails and ties. Four steel rails were laid parallel, about nine inches apart, the outer ones slightly elevated, and all of them inclined toward a common center to form a trough deep enough to prevent the logs from jumping out. This provided a slide which would not be reduced to splinters in a short time. A donkey engine was placed at the summit to help pull the logging wagons up the other side of the hill, while at the bottom and at one side of the chute a loading machine was installed to put the logs onto cars bound for the mill.

A two-reel movie has been prepared showing the United States marines in all phases of their daily work. It is announced that the film will be loaned free of charge to the theaters by the Marine Corps Recruiting Service, with a view to increasing enlistments.

BRITONS INSURED AGAINST

GERMAN AIR RAIDS

Official Journal of Patents 11-22-1
One of the recent developments of the European war is the establishment by the British government of a public insurance scheme, whereby any person who desires to insure his house or other property against the risks of air-craft raids or bombardment may do so, either through his local fire-insurance company or the War Risks Insurance Office in London. The premium rates are the same for all parts of the United Kingdom. Dwelling houses and their contents are insured against air craft at a rate equal to about \$1 for \$1,000, and against both air craft and bombardment at the rate of \$1.50. The premiums are 50 per cent higher in the case of business and manufacturing buildings or farming stocks. Unless the owner of property damaged in a raid is thus insured, no claim for damage will be entertained by the government, now that public insurance is in effect.

3551

ANGLE IRON USED FOR FENCE POSTS

Timber for fence posts being scarce and high in price, an Iowa farmer has met the difficulty by making his posts of angle iron.



End posts for the fences on his farm are made of two pieces of angle iron, placed together and set in cement so that they form a trough-shaped post. The uprights are held together by several crosspieces of strap iron, riveted across the back of the post at intervals of about 2 ft. To make the

tightening of the fence easy, cross-bolts are made to turn in their holes and the square heads are caught by latches after the wires are tightened. One piece of angle iron suffices for all other posts besides the end posts. The wires are fastened by short pieces of wire tied into small holes.

*Wes Fulton
Plover, Ia.*



COPYRIGHT, H. S. TUTTLE

Geneva, N. Y.
 First Known Derailment of a Train by an Automobile: This Picture was Taken at Night, by the Aid of an Acetylene Torch, Before the Wreckage was Disturbed. The Collision Occurred Several Hundred Feet beyond the Auto Light, Seen in the Distance; the Rail Which Caused the Derailment Lies Ahead of the Engine

LOCOMOTIVE DERAILED IN AUTO ACCIDENT

The locomotive, tender, and one car of a passenger train on the Lehigh Valley Railroad were derailed in a recent collision with a speeding automobile at a crossing near Geneva, N. Y. The derailment was caused by part of the wrecked car becoming jammed in the frog of a switch, and the engine then plowed its way along an embankment, carrying the wreck of the automobile and a broken rail along with it, until it finally toppled over on its side. Three men were badly hurt, including

the owner of the auto, his chauffeur, and the baggageman of the train. The chauffeur died of his injuries soon after. So far as is known, this is the first case of derailment of a train by an automobile.

3639 — LONGEST RAILWAY TUNNEL IN NORTH AMERICA

The Connaught Tunnel, driven through the Selkirk Mountains in British Columbia, on the line of the Canadian Pacific Railway, was opened for traffic on December 9, and is the longest railway tunnel on the North



Left: Approach to the West Portal of the New Connaught Tunnel on the Line of the Canadian Pacific in British Columbia. The Ventilating System is Installed Here. Center: Interior of the Great Nozzle through Which Air is Blown into the Tunnel to Clear Out Gases and Smoke. Right: Eastern Entrance of the Tunnel, Showing Gases being Blown Out by the Ventilating Engine and Fan Located at the Other Portal

J. G. Sullivan, Chf. Engr., C. P. R.R.,
 Winnipeg, Manitoba.

American continent. It is exactly 26,400 ft., or five miles, long and carries a double-track line. It shortens the rail route by 4.3 miles, reduces the elevation of the track through the mountain pass by 552 ft., eliminates $4\frac{1}{2}$ miles of snowsheds, and cuts out curves to the extent of seven complete circles. The cost was \$5,500,000, including a ventilating system. Work was started on the main bore Jan. 15, 1914, from both ends. The headings met and passage through the tunnel

was effected Dec. 19, 1915, making a new North American record for rapid work of this character. The tunnel passes under Mount Macdonald, which towers to a height of 6,000 ft. above the new railway grade.

CA government crop specialist has developed a very large variety of Bermuda grass which is to be widely distributed in the South. It will be cultivated as hay and used as a binder for levees.

3760 ROARING MOUNTAIN TORRENT GRAVEYARD OF MOTOR CARS

Albert K. Dawson & Brown + Dawson, Stamford Conn
NO story in contemporary history is more replete with dramatic incidents than that of the passage of King Peter and his countrymen into exile, when Serbia's little army gave way before the overwhelming onslaughts of the Germanic hordes. One of the many spectacular episodes that marked this tragic flight across the mountains is narrated by a correspondent who reached the scene of its enactment, in company with the Bulgarian forces, a fortnight later. It is the account of the last of the Serbian war autos; a description of their abandonment and destruction at the end of a road where many refugees began their exhausting climb along the hazardous trails leading into Albania.

Leaving the last city in the line of retreat, touring cars, limousines, trucks, and ambulances were driven along a road that hugs the brink of a precipice as it follows the course of a roaring torrent through the mountain recesses. The opposite side of this road is sealed by almost perpendicular walls of rock. For several miles it proceeds thus, a splendid, picturesque highway. Then abruptly it stops at the foot of a narrow, steep path that wends up the cliff.

When the motor cars reached the end of this road they were no longer of use to the Serbs. Obviously there was but one thing to be done, and that was to destroy the machines so that

they would not fall into the hands of the enemy. So, one by one, their wheels spinning and their unbridled engines roaring as they leaped through the air, the cars were shot over the edge of the rocky bank to dash themselves against the boulders far below. In all some 300 vehicles made this death plunge.

As a car reached a point near the end of the pass and was relieved of its load, the chauffeur turned its wheels toward the precipice, raced the motor, got out, released the brakes, threw in the clutch, and stepped to one side. Over the wall went the machine, making a flying leap out into the air. Then, turning nose down, it fell like a rocket, struck, and flopped end over end, bursting into flames or diving into the water.

When the Bulgarians arrived two weeks later they found the charred and twisted remains of scores of cars strewn along the rock-set bed of the mountain stream. Here and there they were able to recover a tire or two, now and then an uninjured wheel or appliance, and in one instance a fine French limousine that in some strange manner was but slightly damaged. For the most part, however, they found nothing worth salvaging. As the machines had struck the rocks head first, the motors had been demolished. Then as they "pinwheeled" on toward the water, hitting first on one end and then on the other, the tires had burst.



The End of the Road; The Graveyard of the Serbian War Autos is Illustrated by the Picture Above, Which was Drawn from Sketches and Information Supplied by a Correspondent Who Reached This Point in the Mountains with the Bulgarian Forces Two Weeks After the Serbians had Passed It on Their Flight into Albania. It Shows How the Refugees and the Retreating Army Destroyed Their Motor Cars That They might Not Fall into the Hands of the Enemy

RANDOM GLIMPSES OF WAR CAUGHT BY CAMERA



COPYRIGHT, BROWN & DARGON

Although It Has the Peaceful Appearance of a Harvest-Time Wheat Field, This Picture Shows an Austrian Battle Line. The Quarters of the Men are Protected with Straw so That Aerial Visitors will Pass without Noticing and Save Their Bombs for Other Places



COPYRIGHT, BROWN & DARGON

Here Again Straw Spoils the Airman's View of What Is Below, and Makes an Artillery Battery Look Entirely Harmless from Above

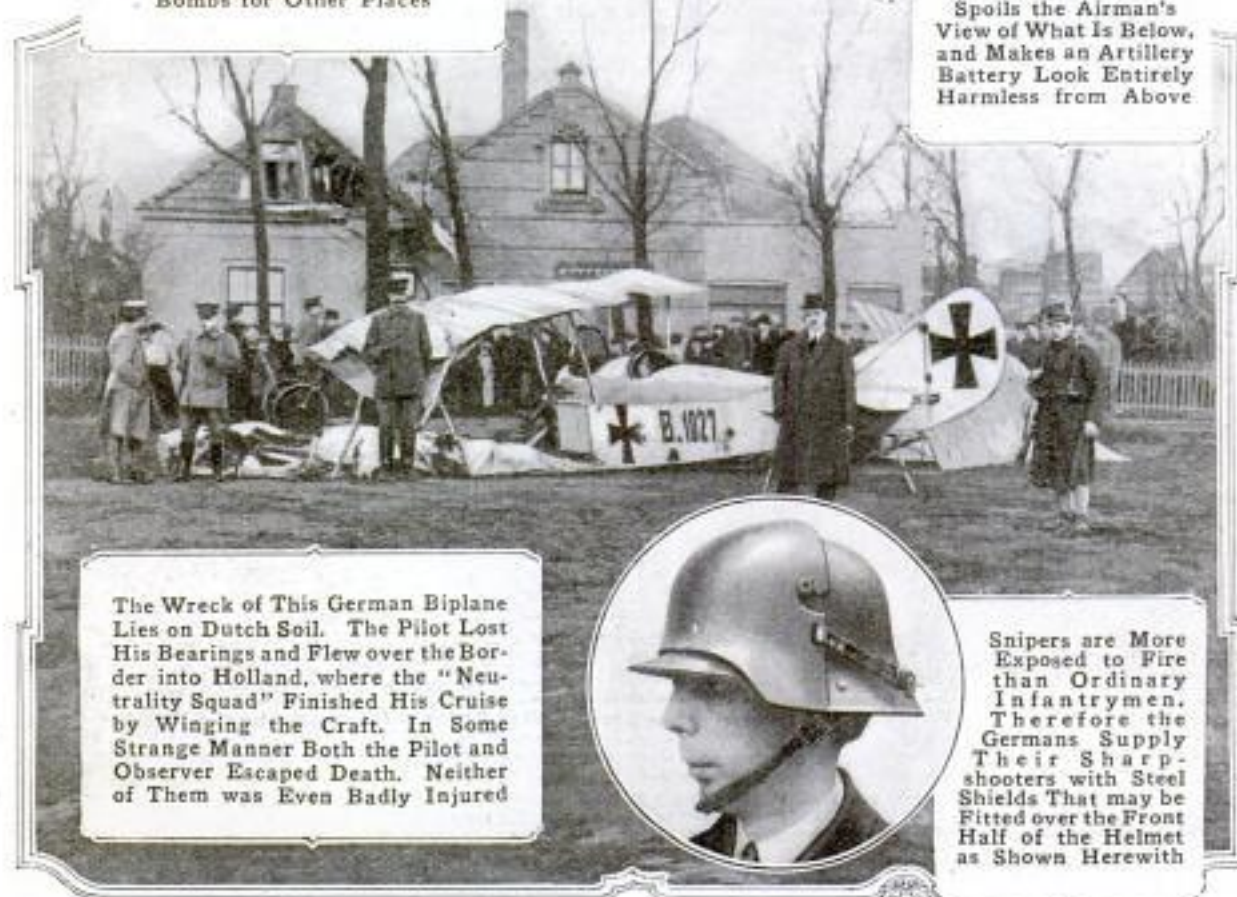

The Wreck of This German Biplane Lies on Dutch Soil. The Pilot Lost His Bearings and Flew over the Border into Holland, where the "Neutrality Squad" Finished His Cruise by Winging the Craft. In Some Strange Manner Both the Pilot and Observer Escaped Death. Neither of Them was Even Badly Injured



Snipers are More Exposed to Fire than Ordinary Infantrymen. Therefore the Germans Supply Their Sharpshooters with Steel Shields That may be Fitted over the Front Half of the Helmet as Shown Herewith

WAR PICTURES OF RARE INTEREST AND NOVELTY



On a Sidetrack at Cairo Awaiting Departure to the Front, a Train Load of the Imperial Camel Corps' Mounts: The Beasts are Held by Headstall Ropes Made Fast to a Cable Extended along the Outside of Each Car. It is Interesting to Note That the Camel, Although Hated by the Tommy, Still Holds Its Own



The Photograph Above Shows One of Several 100,000-Gallon Tanks Installed by the British at Military Camps at Home, in France, and in Belgium. It Indicates How England is Meeting the Perplexing Problem of Supplying Her Troops with Water

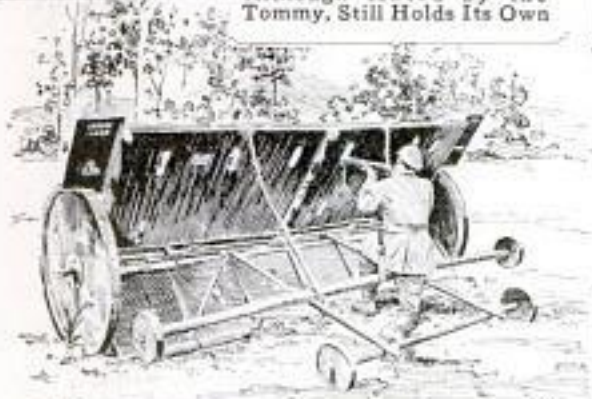

Transportable Steel Barricades of the Sort Pictured in the Sketch have been Found by the Germans at Several Fortifications Captured of Late. It will be Recalled an American Inventor Patented a Similar Device Not Long Ago

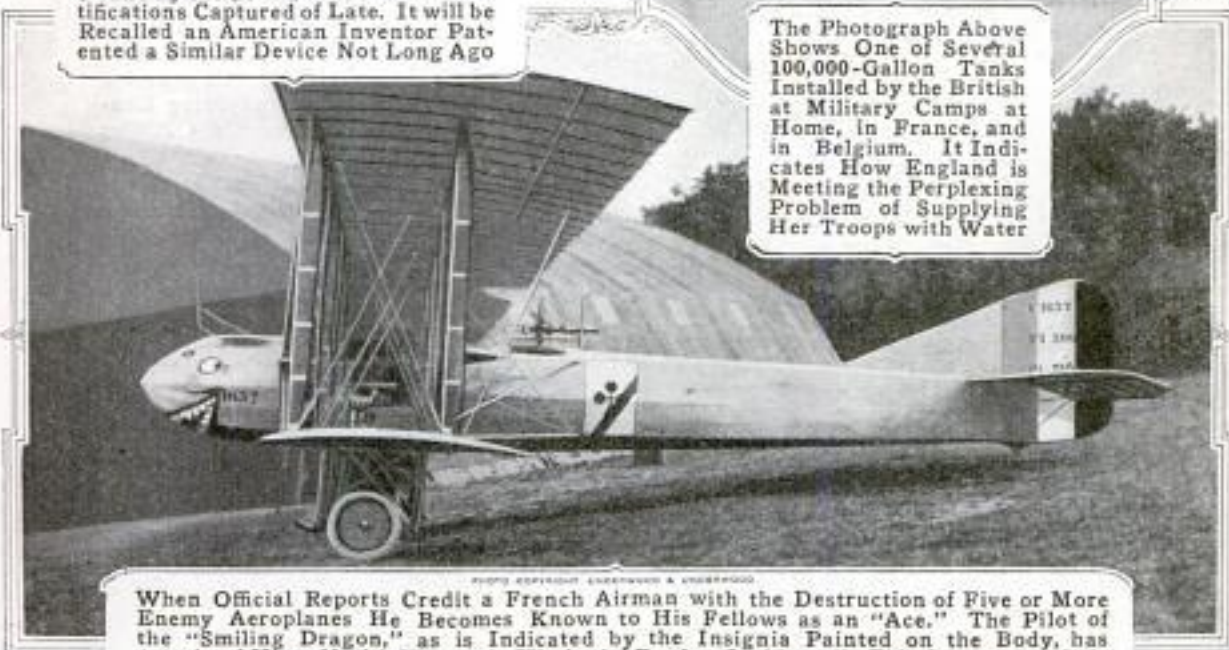

When Official Reports Credit a French Airman with the Destruction of Five or More Enemy Aeroplanes He Becomes Known to His Fellows as an "Ace." The Pilot of the "Smiling Dragon," as is Indicated by the Insignia Painted on the Body, has Acquitted Himself with Honors in His Aerial Duels. Incidentally This Custom Reminds One That the American Indian Neither Wore Feathers, nor Hung Scalps before His Teepee, Solely for the Decorative Effect

"PEACE WITHOUT VICTORY"



White Crosses Such as Those Pictured at the Left Mark the Burial Places of Thousands of British Soldiers Who have Fallen along the Western Front. When the Identity of a Deceased Fighter is Known His Name and the Place of His Late Residence are Printed on the Cross at the Head of His Grave. Likewise the Letters "R. I. P.," an Abbreviation for "Rest in Peace," and the Words, "Killed in Action," Appear

It Is Not Infrequent That a Bottle is Stuck Neck Down into the Ground at the Foot of a French Soldier's Grave. And in Such a Case a Slip of Paper Bearing the Deceased Fighter's Name is Always to be Found Inside



While This Funeral Service was being Conducted over the Bodies of a Group of Allied Soldiers Who had Distinguished Themselves in Battle, the Words of the Regimental Chaplain Who Officiated at the Ceremony were Drowned Time and Again by the Thunder-Clap Roars of Bursting Shells

HOIST FOR UNLOADING

3597 STREET CARS

A special hoist has been erected by the Detroit United Railway which makes the unloading of street cars from a freight train a comparatively simple task for two men. Without means of this sort a large crew would be required to do the work. The hoist is built over a sidetrack and consists of a strong wooden framework that supports motor-driven right and left-hand drums, around which four lifting chains are wound. After a street car to be unloaded has been moved into place beneath the hoisting apparatus, a heavy beam is placed under each end and

attached to the lifting chains. When the load has been raised free of the flat car the latter can be withdrawn and the street car lowered to the tracks. The hoist is also employed in loading rolling stock and handling ma-

at Highland Park Car Shops.

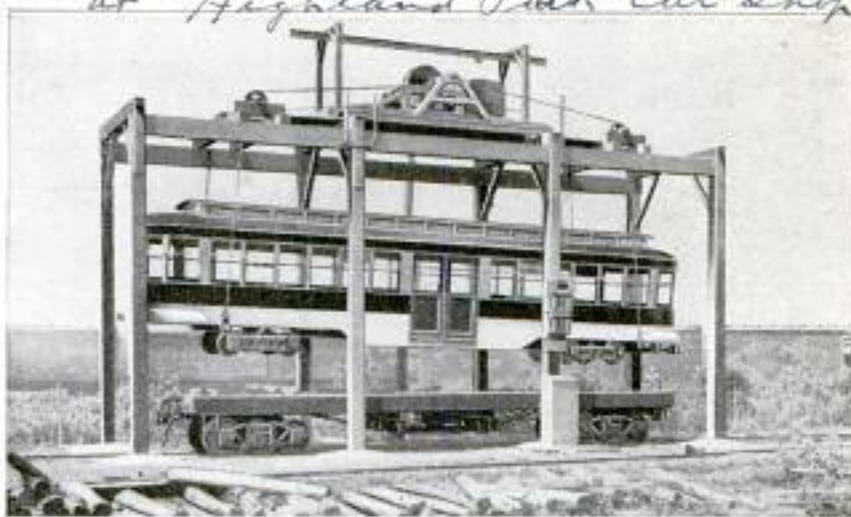

Hoisting Equipment Used to Lift Street Cars and Heavy Machinery on and off Freight Trains. It is Electrically Operated and with It Two Men can Do the Work of a Large Crew

chinery too heavy for the regular shop equipment.

3761

MOTOR HORSE TRAVELS FAST ON SNOW OR ICE

When a North Dakota inventor hitches up his "motor horse," he enjoys a sensation altogether unusual. It was first driven about the streets of Grand Forks and consists essentially of a motor wheel pivoted between a pair of sleigh runners, the rim of the wheel being equipped with studs, or spikes, which furnish rapid traction on either snow or ice. The driver may stand on skis or be seated on a sled or toboggan from 12 to 15 ft. behind the "horse," being drawn along by two ropes, while other lines serve for starting, stopping, steering, and regulating the speed. The complete machine weighs 51 lb. A special gasoline motor is built within and geared directly to the driv-

ing wheel. At one time a distance of 103 miles through deep snow was covered in 3 hr. 12 min. with the driver on skis. Under more favorable conditions much greater speeds have been attained.

H. A. Jonset (I.N.V.)

Box 72

Grand Forks

N.D.

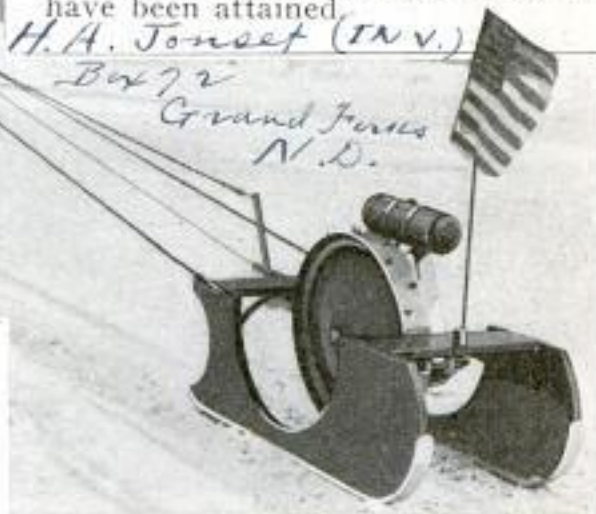

With This "Motor Horse" the Driver has Traveled as Fast as 40 Miles an Hour on Skis, as Seen in the Picture. The Motor is Concealed in the Studded Wheel and Controlled by Lines in the Driver's Hands, Attached to a Lever, as Shown. The Other Lines Serve for Towing

ART GALLERY BUILT LIKE BIG STEEL BRIDGE



New Addition to the Chicago Art Institute, Which Extends across Several Railroad Tracks and Has a Framework Very Much Like a Steel Bridge

An addition recently made to the Art Institute of Chicago constitutes a most unusual art gallery because of the fact that it is really a big inclosed steel bridge spanning a sunken railway right of way. The institute is a symmetrical two-story building in Grant Park, standing close to Michigan Avenue, and at the rear abutting on the sunken tracks of the Illinois Central Railroad. Increasing congestion in the galleries finally made expansion imperative, but an addition could not be erected at either side of the institute without marring its architectural symmetry. In spite of the railway tracks, expansion at the rear was

the most feasible way of gaining more space. Consequently what is virtually a steel bridge was erected across the sunken area. It is 240 ft. long, 50 ft. wide, and two stories high, and cost \$280,000. The addition was an expensive



View of the Sculpture Gallery on the First Floor of the Bridgelike Addition. This Floor is Lighted by Frosted Windows Overlooking the Railway Tracks. The New Section Is 240 Feet Long and 50 Feet Wide

one to construct because its weight had to be supported entirely at the two ends and by a single pier in the center. This involved the sinking of caissons to hardpan, to a depth of approximately 90 ft., so as to minimize the vibrations caused by the passing of trains underneath. The extension increases the gallery space of the institute 40 per cent. Each floor is directly connected with a corresponding level in the main building. The first story is devoted to sculpture and the second to painting. The former is lighted from the sides by sets of double windows, the inner and outer windows being set far enough apart to allow the slanting side beams of the bridgelike frame to pass between them. The glass is frosted to exclude the view of the tracks beneath. The pictures in the upper galleries are finely illuminated by skylights. A feature of the structure is the heating system of the second story, which includes numerous big radiators placed in the loft just under the glass roof.



A Portion of the Loft under the Glass Roof, Showing the Radiators Which Are Part of the Novel Heating System

WORLD WIRELESS SYSTEM BUILT BY INVENTOR

The recently completed wireless station at Funabashi, Japan, is not, as many suppose, part of a government project. The big towers were built as a unit of the Marconi around-the-world system, a private enterprise which has gone far to make wireless a vital as well as convenient factor in international communication. The unusual photographs of the Hawaiian stations, reproduced in the February issue of this magazine, were published by courtesy of the Marconi Company.

3698

MUSIC OF PHONOGRAPH CHARMS RATTLER

While the oriental snake charmer casts his spell over his reptiles with the weird notes of pipes, at least one

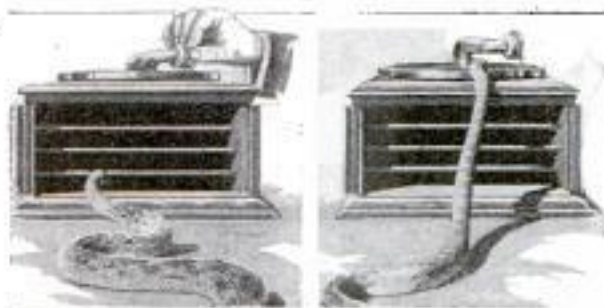

Views of a Pet Rattler of a Ft. Bliss Soldier, Showing the Reptile under the Spell of Phonograph Music

American exercises the same enchantment with the modern phonograph. He is a soldier at Ft. Bliss, Tex., and has a pet rattler, whose fangs have been removed. When the phonograph plays, the creature glides up to it and holds his head erect before the sound box, or tries to rest it on the record.

3746

CEMENT MIXER BUILT FOR END AND SIDE DELIVERY

Convenience in operation characterizes a cement mixer made in Waterloo, Ia., which is so built that it can be set to discharge from either side or from either end, without moving the truck. This labor-saving feature is secured by incorporating a turntable between the

framework of the machine proper and the truck frame. When the operator wishes to change from end to side dis-

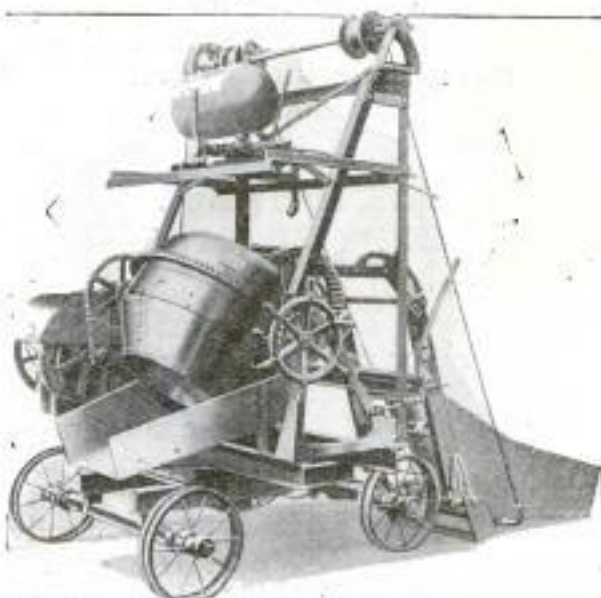

It Is Only a Matter of 10 Minutes' Work to Shift This Machine so That It Discharges from Either Side Instead of from the End. This Change is Made without Moving the Truck

charge, or vice versa, four bolts are removed from the turntable and the mixer is swung about into the desired position, after which the bolts are replaced. This arrangement makes the outfit a convenient one in cramped quarters, and at the same time it can be used to the best advantage on street paving, or in other places where there is plenty of room.

MOTORCYCLING IN WINTER 3771 ON RIVER ICE

When the Vermont roads were covered with snowdrifts this winter, the young men of Brattleboro found a new winter sport in motorcycling on the



COPYRIGHT, INTERNATIONAL FILM SERVICE
Motorcyclists on the Ice of the Connecticut River: Equipped with a Single Runner and Side Seat, the Machines Made a Speed of 50 Miles an Hour

*Waterloo Cement Machinery Co.,
Waterloo, Ia.*

ice of the Connecticut River. By attaching a sleigh runner and a seat to the motorcycle, in place of the familiar sidecar, an ideal vehicle for the ice was evolved, and a speed of 50 miles an hour was made with ease, carrying a passenger in the side seat.

3750

PORTABLE METAL BUFFER DRIVEN BY ELECTRICITY

The manual labor involved in polishing fittings, or ornamentations, of brass or other metal can be reduced to



a minimum and considerable time can be saved by using an electrically operated polisher and buffer. The outfit is particularly serviceable in office buildings, hotels, on shipboard, etc. It comprises a 1/4-hp. motor attached

to a leather harness so that it can be carried on the back like a knapsack. Current is obtained through a lamp cord that can be connected with any near-by light socket. The motor drives a 5-ft. flexible shafting, to the end of which either a buffer or emery wheel can be fastened, according to the nature of the work in hand.

CANADA TEARS UP RAILS

FOR ALLIES' USE

One of the numerous ways in which Canada has shown its readiness to meet emergencies created by the war, is in tearing up long sections of railway track in the Dominion, to provide the allied forces on the western front in Europe with needed transportation lines. The plan for collecting the rails, as reported from Ottawa, contemplated the removal of some 300 miles of government-railroad sidings in the East and also long stretches of track

between Edmonton and the Pacific coast where two railways run parallel, the traffic of both lines to be accommodated on the remaining route. The plan, it was said, owed its origin to the British government, which intimated that prompt action of this kind would probably save thousands of lives, and that new rails could not be obtained because of the demand for steel in making munitions. It was estimated in Ottawa that over 1,000 miles of Canadian track would be torn up in response to the appeal.

REAR SIGNAL FOR AUTOS WORKS AUTOMATICALLY

Automobile owners will be especially interested in a recently invented signal device for cars because it operates entirely automatically and is of simple construction. It consists of a small red semaphore bearing the word "Stop," which is normally concealed behind the tail light and rear license number. It



is connected by a flexible cable and a lever with the rod that operates the brake and the instant pressure is applied to the brake pedal—whether the driver intends to slow down or to stop—the semaphore automatically swings up into a horizontal position, in full view of those at the rear. Thus no special thought or movement is required of the driver. When the brake is released the arm drops out of sight. At night the translucent celluloid letters on the signal are lighted by a flash light, which makes them visible for a distance of 200 feet.

CA slide rule, with slides of various sorts that are interchangeable, is now made of white celluloid impregnated with aluminum, giving it a smooth finish not affected by changes of weather.

"Pantocrat"
Geo. W. Richardson

4212 Copyrighted material

Chicago

Webb
366
Mtz Co.
Ft. 9
Caeniter St.,
Newark, N.J.

A. C. 20-0

Auto Signal Co. for Sale, Chicago

3770
NATION PAYS FINAL TRIBUTE TO ADMIRAL DEWEY



AMID honors equaled on but few occasions in the country's history, the Admiral of the Navy, George Dewey, hero of Manila, was laid to rest at Arlington, January 20, last. Following a private service at the Dewey residence, the casket was borne under escort of the entire brigade of midshipmen to the Capitol, where it was placed in the rotunda during a simple ceremony which was without an oration. A salute of 19 guns was fired at Fort Myer as the caisson carrying the casket entered the cemetery. When the reading of the service ended, a squad of midshipmen fired three volleys. Taps was blown, and the guns again saluted. The picture above shows the casket being borne down the Capitol steps, while that below was taken as the flag-draped caisson turned into Fifteenth Street from Pennsylvania Avenue on the way to Arlington.



PHOTOS COPYRIGHT BY G. V. BUCK, Wash., D.C.

*Long Beach Tuna Canning
Long Beach, Calif.*

MOTORCYCLE TRANSFORMED 3772 INTO A SLEIGH

One of the neatest of the many methods of using the motorcycle on



Motor Sleigh Contrived by an Inventive Canadian When the Snow Was Too Deep to Run His Motorcycle: A Neat Arrangement of Runners Bolted to the Bare Rims

snowy roads in winter has been devised by a resident of Galt, Ont. He removed the rubber tires from the front wheel of his machine and from the wheel of the attached sidecar, then fitted a shapely runner under each of these wheels and bolted it to the rim. The rubber tire was left on the rear wheel of the motorcycle, for driving purposes, the front runner making a track for the tire. The machine made good progress in a foot of snow.

WHALE MEAT SELLS READILY IN WESTERN COAST CITY

Fresh whale meat is being sold in the markets at Los Angeles, while at Long Beach a fish cannery is preparing and packing it for general consumption. This is the first time, so far as can be learned, that the flesh of the whale has been introduced for the American table. In Japan, however, it forms an important part of the diet for the poorer classes, and in New Zealand large quantities of it are canned for South Sea islanders. A humpback whale will yield as much as 80,000 lb. of meat, in addition to blubber, oil, and bone. The flesh is of coarse grain, and when prepared, has a distinctive flavor that is somewhat similar to that of venison. But besides being palatable, 98 per cent of the material it contains is digestible, a ratio that is seven per cent higher than ordinary beef. The aversion which persons in this country usually manifest when attempts are made to encourage the consumption of things known domestically but not popularly looked upon as foods, has not been experienced in California with whale meat. A few weeks ago, five tons of the meat was retailed in Los Angeles at 14 cents a pound.

3741 FEEDER FOR MOTHERLESS LITTER OF PIGS

The rather difficult problem of feeding a litter of little pigs whose mother

ingenious feeder consisting of a strong wooden rack which holds nine long-



A Simple Feeder for Motherless Little Pigs Consisting of a Strong Wooden Rack in Which Nippled Bottles are Held at the Proper Angle a Few Inches above the Ground

neck bottles in a row a few inches above the ground, with the mouth of each pointing downward at a slight angle. Each bottle is provided with a substantial rubber nipple held securely in place by a clamp so that a too eager little pig cannot pull it off. When the bottles are to be filled they are set up-

has died, has been largely solved by an Oregon man who has devised an

right by turning the rack over on its side.

*E. E. Faville,
Editor Western Farmer,
Portland, Oregon*

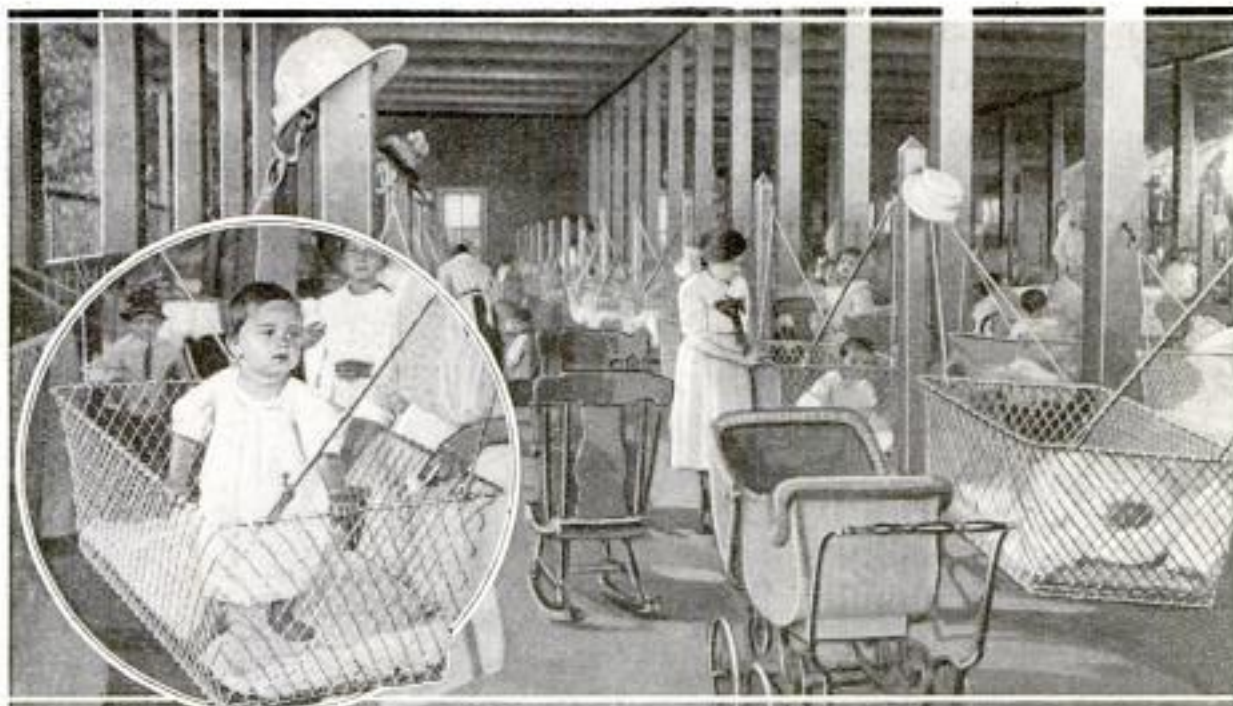

A Chicago Fresh-Air Sanitarium for Babies, Equipped with Woven-Wire Baskets Designed Especially for This Institution. Left, One of the Baskets, Showing How It is Supported. It is Light, Open to the Air, can be Thoroughly Cleansed, and will Not Tip Over Easily

SANITARY WIRE CRADLES FOR BABIES' SANITARIUM

A fresh-air sanitarium in Chicago, where many hundred babies are cared for each summer, has been equipped with cradles designed especially to meet the sanitarium's demand for children's beds that would be light, open to the air, durable, comparatively inexpensive, and capable of being washed thoroughly; that would not tip over easily, and could be stored in a small space. The article finally selected as meeting all these requirements is a woven-wire basket, having high flaring sides, which is suspended by ropes from two posts like a hammock. The beds are finished so that there are no sharp edges or corners on which the little occupants can scratch themselves. In the course of the season many babies occupy the same basket, hence, as often as desired, all the clothing is removed and the wire framework thoroughly cleansed. When not in use, the cradles are removed from their supports and nested into compact stacks. These beds are now being made for use in the home also, and if desired are provided with woven-wire lids that clamp over the tops.

TIGHT SWIVEL COUPLING FOR HOSE

The kinking and twisting which is often so annoying in handling hose and so injurious to the tubing, may be eliminated by use of a patented swivel coupling now on the market. A feature of the invention is that the higher the pressure of the air, water, or steam passing through it, the tighter the joint becomes. The coupling consists of two sets of tubular parts provided with circular members, having lugs and notches, placed radially in such a way that after one tube has been inserted into the other a slight turn will serve to lock them together, without, however, interfering with the swivel action. The parts which lock together are held in place by a coil spring so that they will not accidentally come apart. To disengage the coupling a spring-held sleeve is drawn back and the interlocking members are given a twist. The coupling is provided with special clamps for the hose.



H. E. Millon
 3020 Essex St.
 Lion City, Ill.
 2911 Fullerton St.
 Chicago, Ill.

AUTO WHEELS CHANGED FOR 3674 DRIVING IN SNOW

A New Hampshire motorist devised a new plan of running his automobile



Copyright, International Film Service, Inc.
This Novel Grouping of Automobile Wheels, with Chains around Them and Sleigh Runners in Front, Prevented the Car from Sinking into Deep Snow and Made Winter Driving Possible in New Hampshire

during the winter, when he found it difficult with the ordinary arrangement of wheels to plow through the deep snow. He removed the front wheels of his car and set them farther back under the chassis, just in front of the rear wheels, then ran a set of chains around each pair of tandem wheels. A pair of steel sleigh runners, set in the place of the front wheels and connected with the steering gear, completed the arrangement, with which an average speed of 24 miles an hour was made over the winter roads.

3748 — NEW GAME STIMULATES INTEREST IN ALGEBRA

A card game resembling dominoes has been devised by a school superintendent in Clarendon, Ark., which develops in the players alertness in solving simple algebraic problems. The players in turn lay down numbered cards on the table so that at least one number on the newly placed card matches the number on the end of the row already in position. In calculating the score algebraic operations are necessary, for some numbers are positive and some negative.

✓ Leo L. Parflow

BAD ACCIDENT SERVES AS WARNING TO KITE FLIERS

That a cotton string may serve as a conductor of electricity, thus making kite flying in the vicinity of high-tension wires a dangerous pastime, is one of the lessons to be learned from the nearly fatal experience of a railroad employe at Burton, Kan. The man was trying to measure the distance by which a certain high-tension line cleared the railroad tracks. He tied a small stone to a cotton string, which he supposed was a nonconductor, and tossed it up over the wire that carried 60,000

volts. The shock he instantly received rendered him unconscious and in the 40 minutes which passed before he was revived he seemed wholly paralyzed. The current left a deep burn on his hand and a lighter one on his forearm. In passing from his body it severely burned his toes and heels and the sides of his feet.

HOLDER FOR CROSSED 3674 FLAGS

A convenient holder for crossed flags, which is very serviceable as an aid in



decorating with national emblems, bunting, etc., is made of a strip of metal folded over at the center so that the two halves lie at right angles to one another. The ends are looped to receive the flagstaves. The device can be fastened in place with one or more screws or nails.

Fredic F. Marquand

Northampton, Mass.
Copyrighted material

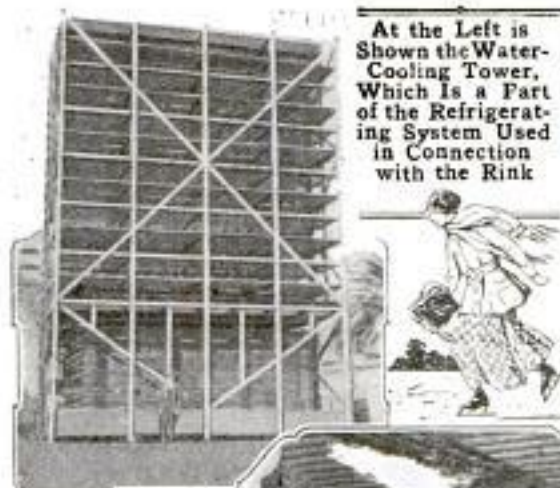

At the Left is Shown the Water-Cooling Tower, Which is a Part of the Refrigerating System Used in Connection with the Rink



This Sheet of Ice is Affording Hundreds of Californians Their First Opportunity to Skate. The Rink has Lately been Opened at Los Angeles and is Proving to Be a Most Popular Resort. It Accommodates Hundreds at a Time

One Corner of the Power Plant That Makes Skating Possible in the Land of Perpetual Summer. Whether or Not It will Be Able to Keep the Ice in Good Condition the Year Around, However, Remains to be Seen



ICE-SKATING RINK OPENED FOR CALIFORNIANS

Skating, by far the most favored of the winter sports, has been introduced in southern California where there are thousands of persons who have never seen ice except in refrigerators and delivery wagons. At Los Angeles a large inclosed rink has lately been opened to the public and is rapidly be-

coming one of the popular places of recreation. To tourists who are escaping the cold of the North, the chance to use ice skates without exposing themselves to severe weather is a new and welcome experience, while to permanent California residents who have never before had a chance to glide and whirl over smooth ice, the institution is a novelty. The rink is 65 by 210 ft. in size.

TRACTOR SNOWPLOW AND STREET GRADER

By a combination of two machines owned by the South Park Commissioners of Chicago, Michigan Avenue and other thoroughfares were rapidly cleared after each heavy snowfall of the passing winter. The first was a motor snowplow, small, compact, and



Electric Tractor Carrying a Snowplow and Hauling a Street Grader on Michigan Avenue, Chicago, after a Snowstorm This Winter: The Man Behind Raises and Lowers the Grade Plow as Required; in Front of Him Is the Seat of the Team Driver, the Grader being Usually Drawn by Horses

Mercury Mfg Co., 4118 So. Halsted,

sturdy, the tractor being of the electric industrial variety now widely used in handling freight. To this was attached as a trailer a street-grading machine, usually drawn by horses, which widened the path cleared by the snow-plow and left a flat smooth surface on the avenue for the automobile traffic which crowds it daily. Two men operated the combined machines, the idea being evolved in the park-board shops.

3732
**NEW AUTOMOBILE TRAILER
 HAS ONLY ONE WHEEL**

Preparations are being made in the East for the introduction of a one-wheel trailer for the motor car. The vehicle is a modern adaptation of the wheelbarrow and designed to serve a wide range of purposes. On overland trips, it may be fitted with fuel, oil, and water tanks and employed as a tender and luggage carrier for the touring car. As a delivery van for the small retailer, a produce cart for the farmer, or a baggage car for the rural or inter-urban salesman, it is equally service-



The New One-Wheel Trailer Attached to a Roadster



Above at the Left is Given a Rear View, and at the Right a Front View, of the Interior Arrangement of the Trailer as Outfitted with Tanks, Drawers, and Compartments for the Overland Tourist

Inw. E.A. Holland, 226 W 52d, New York

able. The body, which is 46 in. in length and width and 40 in. high, is made of sheet iron, japanned to match the finish of the car with which it is used. It is attached to the rear axle of a machine by means of curved shafts which are supplied with a knuckle joint so that they may be raised or lowered to meet varying conditions. The trailer is supplied without interior fittings when desired. Especially for motor tourists, however, it is equipped with a stove, tent, combination bed and table, drawers, and tanks. Detachable wire baskets designed to be attached at the top and sides are provided if wished.

3817
**RISK POLICY "GUARANTEES"
 FAIR WEATHER**

An out-of-the-ordinary policy, which Lloyd's of London recently issued, guaranteed to reimburse the owners of costly floats and others in Pasadena, Calif., if it rained on the dates of the city's rose tournament. The sum of \$23,000 was to be paid by the British association if as much as $\frac{1}{4}$ in. of rain fell during the hours specified. The premium was \$1,000. Though there was a slight drizzle on one of the days in question it was less than the stipulated minimum. Weather reports for the past 30 years were used by the insurers in calculating their risk.

3540
**MAKING A DAM FOUNDATION
 WATER-TIGHT**

In building a huge dam for the improvement of the city water system of

Worcester, Mass., special precautions were taken to make an underlying ledge of hard granite water-tight, the ledge being more or less broken up by fissures, due to the pressure of a near-by hill. After excavations were made to a foundation apparently sound, steam drills were used to test the ledge from 25 to 30 ft. below the bottom of the excavation. Through the drill holes water was forced at a pressure of 60 lb. to determine if any seams were crossed by the holes. If any of the water escaped, a cement grout of thin mixture was forced into the holes by a

grouting machine under 90-lb. pressure, until the seams and fissures accepted no more. This practically insured the water-tightness of the foundation. In some places the drill holes were carried to a depth of over 70 feet, but fortunately none of the holes ac-

cepted more than about one barrel of cement. The masonry section of the dam is to be 375 ft. long and the whole length, including end sections of earth embankment with masonry-core walls,



In the Center of This Picture Workmen are Seen Applying a Water-Pressure Test to the Granite-Ledge Foundation for a Big Dam, before Forcing a Cement Grout into the Drill Holes, to Fill Seams and Fissures through the Two-Inch Pipes Seen in the Holes

will be 850 ft. It will be 120 ft. in maximum height, 80 ft. thick at the base, and 17 ft. wide at the top, with a longitudinal inspection gallery. The dam will impound 3,000,000,000 gal. of water, thus doubling the storage capacity of the city's gravity supply system.

3212
**CONCRETING DITCHES TO
 CONSERVE THE FIELDS**

In spite of the fact that the first cost is considerable, it has been found profitable to line drainage ditches on certain types of farms with concrete walls, thereby immediately putting a stop to the gradual widening of the water-courses which takes place with each succeeding flood, and preventing the formation of numerous small tributaries. These permanent walls soon pay back much of their cost, particularly where the land is valuable, by permitting the farmer to till right up to the

edge of the ditch, which, if not walled, might have a wide-spreading border of marsh on both sides. The manner of putting in this reinforcing varies with local needs. A common way is to make the course V-shaped, bringing the walls just up to the level of the field and making them several inches thicker at the bottom than at the top. In the ditch of this character shown in the illustration, the dirt bed is but 6 in. wide, while at the top the walls are 6 ft. apart. Another way is to make the sides almost vertical, with the bottom composed of cobblestones, set in concrete. In regions subjected to long dry

#C. A. Byers, 4013 Berenice Av.,
 Los Angeles.

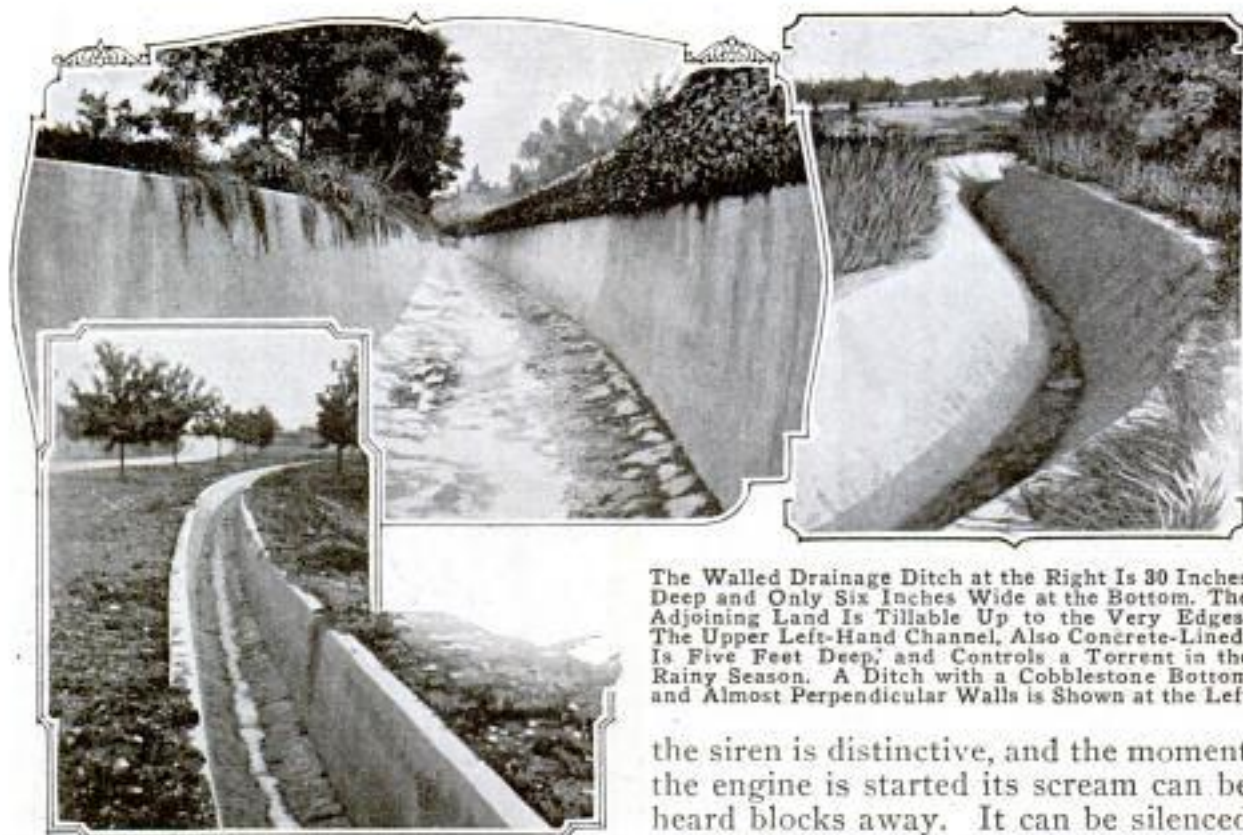

The Walled Drainage Ditch at the Right is 30 Inches Deep and Only Six Inches Wide at the Bottom. The Adjoining Land is Tillable Up to the Very Edges. The Upper Left-Hand Channel, Also Concrete-Lined, is Five Feet Deep, and Controls a Torrent in the Rainy Season. A Ditch with a Cobblestone Bottom and Almost Perpendicular Walls is Shown at the Left.

spells, followed by torrential rains, whole communities sometimes find it profitable to cooperate in constructing artificial courses that are almost as big as canals. An example of a California ditch of this character is shown here, which is 5 ft. deep and has walls 18 in. thick at their lower edges. The bottom is paved with cobblestones and concrete.

3436 —

ATTEMPTED THEFT OF MOTOR CAR SCREAMED BY SIREN

Motor-car thefts have become so alarmingly common that inventors the nation over have turned their attention to the development of devices for the protection of automobiles. One of the most recent of these contrivances is an extremely loud whistle which is blown by exhaust gases of an engine and controlled by a valve mechanism which, when either open or closed, is locked. The sound of



the nation over have turned their attention to the development of devices for the protection of automobiles. One of the most recent of these

contrivances is an extremely loud whistle which is blown by exhaust gases of an engine and controlled by a valve mechanism which, when either open or closed, is locked. The sound of

the siren is distinctive, and the moment the engine is started its scream can be heard blocks away. It can be silenced only by stopping the motor or closing the valve with the key made for it.

3733 —

JAPAN'S RAILWAY GAUGE MAY BE CHANGED

When the railways of Japan were first planned, the narrow gauge of 3 ft. 6 in. was selected for them, because it was cheapest to build and equip and was thought best suited to the country's narrow highways and steep grades. Now the 6,000 miles of Japanese railways, all of narrow gauge, are found to be sadly behind the times, and a movement is on foot to rebuild them to standard gauge, although the cost is estimated at nearly \$450,000,000. At present the trains are slow, the fastest expresses making less than 30 miles an hour, the coaches are low and narrow, and the sleeping cars are cramped and inconvenient; while most of the railway inventions of other nations cannot be used because of the difference in track gauge and size of cars. The director of the imperial railways favors the change, in spite of the cost, and estimates that the main Tokaido line could be converted to broad gauge in 12 years and the other

G + C
Auto Police Whistle Co.
1327 Hennepin Av.
Mpls, Minn.
F.W. Creasey, Sec.

Ry. Age Gazette
et Commerce & Finances
Dr. Soyeda
Tokyo

lines on the main island of Japan within 25 years. The tracks and stations would have to be rebuilt, tunnels widened, and new rolling stock provided; but according to the government director there would be little interruption of traffic. Many business men of the empire oppose the change.

3675

IMPROVED PLOW MAKES UNIFORM FURROWS

By a recent improvement in the construction of plows it is claimed that a remarkably uniform turning of the sod is effected and the plowshare is adjusted automatically when it meets with obstructions. A resident of Janesville, Wis., is the inventor of the new adjusting mechanism. This supports the plowshare flexibly, permits of the regulation of its position by a handle lever, and also allows the plow point to spring back and rise over an obstruction, instead of breaking against it. The plow may be equipped with two shares, which will turn double furrows and do the work in half the time required otherwise. The mechanism is practically self-leveling, there being no adjustments other than the rocking of the front bail to vary the depth of the plow. Thus a level furrow bottom is produced as well as a uniform furrow. Uniformity is insured by a peculiar outward twist, or curve, given to the upper portion or wing of the plowshare, which causes the soil of the furrow to turn over completely, and loosens it up.



These Photographs Show the Evenness and Level Character of the Furrows Made by a New Plow That Works Equally Well When Drawn by Horses or by a Tractor

Alvaro S. Krotz (Inv.) Janesville, Wis.

COMPRESSED AIR USED TO STIR TANNERY VATS

H. C. & Phelps Box 122
Compressed air is employed in a New Jersey tannery to stir the contents of the vats.
Weehawken N. J.



Stirring the Contents of a Tannery Vat with Compressed Air: Air is Forced through the Pipe Held by the Workman at a Pressure of 90 Pounds and Agitates the Fluid More Thoroughly Than could be Done by Hand

tents of large vats in which hides are treated. The device employed consists simply of a 1/2-in. pipe, 8 ft. long, connected by hose with apparatus which compresses air to about 90 pounds per square inch. When the end of the tube is immersed in the solution in the vat and the air is turned on, the liquid fairly boils and a foam forms on the surface.

Motor Sales Co., Inc.
 18 E. Alder St. Walla Walla, Wash.
 (Distributors Dodge 1200)
 372 342 POPULAR MECHANICS
 3735

**STEEP INCLINE NEGOTIATED
 EASILY BY MOTORCYCLE**

During a home-week celebration at Walla Walla, Wash., some time ago, a motor-car dealer erected an incline in



Not Only did a Motorcycle Climb This Incline, but Also It Jumped over the Cornice and Plunged through a Skylight in the Roof Beyond, Shown in the View at the Left



front of his salesroom for the purpose of demonstrating the hill-climbing abilities of certain automobiles. The slanting driveway was extended from the sidewalk curb to the cornice of the one-story building at an angle of about 45 degrees. After several machines had failed in an attempt to reach the top of the incline, a young motorcyclist resolved to try the feat. His machine proved to be even more powerful than he believed. Becoming somewhat confused, he failed to stop the engine at the point he had planned, and instead of dismounting at the top of the incline, he rode entirely over the cornice and part way across the roof of the building. He managed to slide off the seat just in time to escape accompanying the motorcycle as it plunged through a skylight into the salesroom below.

As the result of a canvass of the makers of news-print paper on this continent as to their 1917 plans, it is declared that the proposed increased output of this paper will amount to only 600 tons per day. This would still leave a daily shortage of 300 tons.

**CHINESE BRASS COINS ARE
 MELTED FOR COPPER**

Recent reports from China indicated that a serious monetary situation was developing, due to the enormous export of brass "cash," the coins with square holes in the center that have been the basis of all trade in the interior of China for many generations. The export demand was due to the war-time rise in the price of copper, rendering these brass coins, which usually contain about 89 per cent of copper, more valuable as metal than as a medium of exchange. For some months over 6,000 tons of the coins were exported monthly to Japan alone, where the copper was extracted and shipped, it is said, to the United States. The business was profitable, as the cash were bought in China for about \$12.50 gold per picul of 133 1/3 lb. and were valued in Japan at the equivalent of \$15 gold. The export continues and while there is an enormous quantity of such coins in China the number of cash in circulation at various points in the interior is already far below the requirements of the population, and difficulty is said to be experienced in carrying on ordinary trade.

**3739 —
 NAMES SELECTED FOR NEW
 DREADNAUGHTS**

Marine July 11-9-1916
 The four new battleships to be constructed under the building program of the United States Navy for 1917 will be named respectively after the states of Maryland, Colorado, West Virginia, and Washington. These names are now borne by four cruisers, which will be renamed. The cruiser "Maryland" will hereafter be known as the "Frederick," the "Colorado" as the "Pueblo," the "West Virginia" as the "Huntington," and the "Washington" as the "Seattle." Contracts for the four dreadnaughts were let recently. The "Maryland" and the "West Virginia" will be built at Newport News, the "Colorado" and the "Washington," at Camden, N. J., and all will be pushed to completion.

¹Newport News Shipbuilding and Dry Dock Co.
²New York Shipbuilding Co.

The incline is 40° = 84% grade

Dodge - only auto that reached the top

Hugh Campbell

NEW DIRECTION-FINDING WIRELESS RECEIVER

About 500 feet of wire, strung round a square wooden frame made of boards, and 20 switches by which portions of the wire can be "cut in" or "cut out"—this constitutes the new wireless receiving apparatus with which experimenters in the electrical department of Union College, Schenectady, N. Y., are said to have been able to receive messages during violent storms, and determine the direction from which they come. The wireless waves are received by the wires on this frame just as they are received by antennæ high in the air. They are then transmitted to tuning devices and a telephone receiver in the usual manner. It has been found that by turning the frame about until its axis is in line with the direction of the sending station, the signals are heard most distinctly. This direction-finding fea-

ture, it is believed, will prove of great value in many ways, particularly in cases where several stations are simultaneously signaling one operator, who, to avoid confusion, desires to accentuate one message over another. The

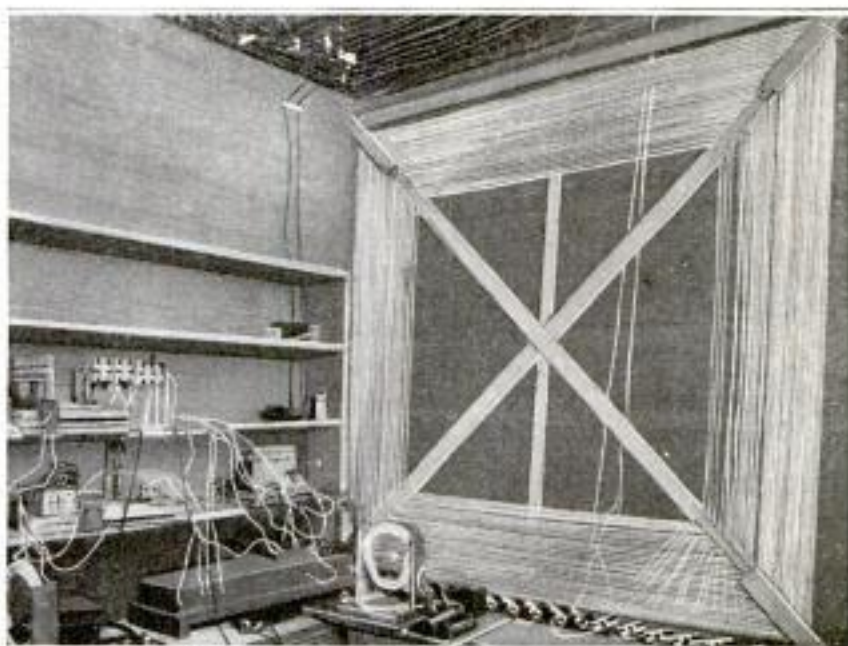

View in an Electrical Laboratory of Union College, Showing the Big Square Wireless Receiving Apparatus Which Operates Regardless of Weather Conditions and with Which can be Determined the Direction from Which a Message Comes

improvement represents an application of certain principles of wireless telegraphy already well known, rather than the discovery of something entirely new.

POLICE CLUB SERVES AS EXTENSION FOR PISTOL

A policeman's club, which is so made that it can also be used as an extension to a pistol barrel, thereby changing the latter into a sort of rifle, has been invented by the sheriff of Alameda County, Calif. The extension has the



A Hollow Police Club, Invented by a California Sheriff, Which can be Quickly Attached to a Pistol Barrel, Thereby Increasing the Range of the Firearm

outward appearance of an ordinary hickory club but contains a steel barrel so fashioned at one end that it can be quickly attached to a pistol's nozzle. It is said that it more than doubles the range of the firearm and makes possible greater accuracy in aiming. It is 14 in. long and weighs a pound. The invention has been officially adopted by the police of Oakland, Calif., and is also in use in several other parts of the country.

CA vessel passed through the Panama Canal on December 17, last year, in 6 hr. 20 min., thereby cutting down by five minutes the best previous record for making the transit.

*Frank Barnett (Sheriff Alameda Co.)
Oakland, Calif.*

Dept of Commerce
Coast & Geodetic Survey
Wash., D.C.

HORSE DENTIST'S "PARLOR" OPENED IN PHILADELPHIA

An establishment known as a horse dentist's "parlor" has been opened in Philadelphia, indicating that another specialized task has been added to the already long list of professions dealing with physical ills. The man in charge seeks to do for horses' teeth many of the things that regular dentists do for human teeth. If grain is lodged in a cavity or between a horse's grinders, a double-action pump is employed to force the foreign substance out. When a tooth is badly decayed it is extracted with big forceps. As yet this specialist does not attempt to fill horses' teeth, but in many cases he cleans them periodically. It is pointed out that one in this profession not only does acts of mercy by treating animals' teeth but

he also restores the beasts to a condition in which they can render better service.

3727 —
**TIDES BUILD UP LAND AT
ROCKAWAY POINT**

A chart of Jamaica Bay, N. Y., near the southwestern end of Long Island, has recently been issued by the Coast and Geodetic Survey, which shows marked changes in shore line that the tides and currents have wrought in the past three-quarters of a century. From 1836 to 1908 Rockaway Point advanced westward more than three miles. Since the latter date the action of the ocean seems to have been confined to consolidating the new territory. With the aid of engineers the resorts in the region have taken profitable advantage of the work of nature and have reclaimed much land. The retarding of the "natural growth" of the point is due, it has been found, to the fact that the shore line now approaches close to the deep-water channel. The chart is particularly for yachtsmen and motor-boat owners.



A Dental Office in Philadelphia Devoted Especially to the Care of Horses' Teeth



Left: Extracting a Bad Tooth. Proper Care of a Horse's Teeth Is Not Only an Act of Mercy but Enables the Animal to Render Better Service. Right: Flushing a Tooth Cavity with a Double-Action Pump to Dislodge Accumulated Foreign Substances

Dr. R. H. Haley
Phila.

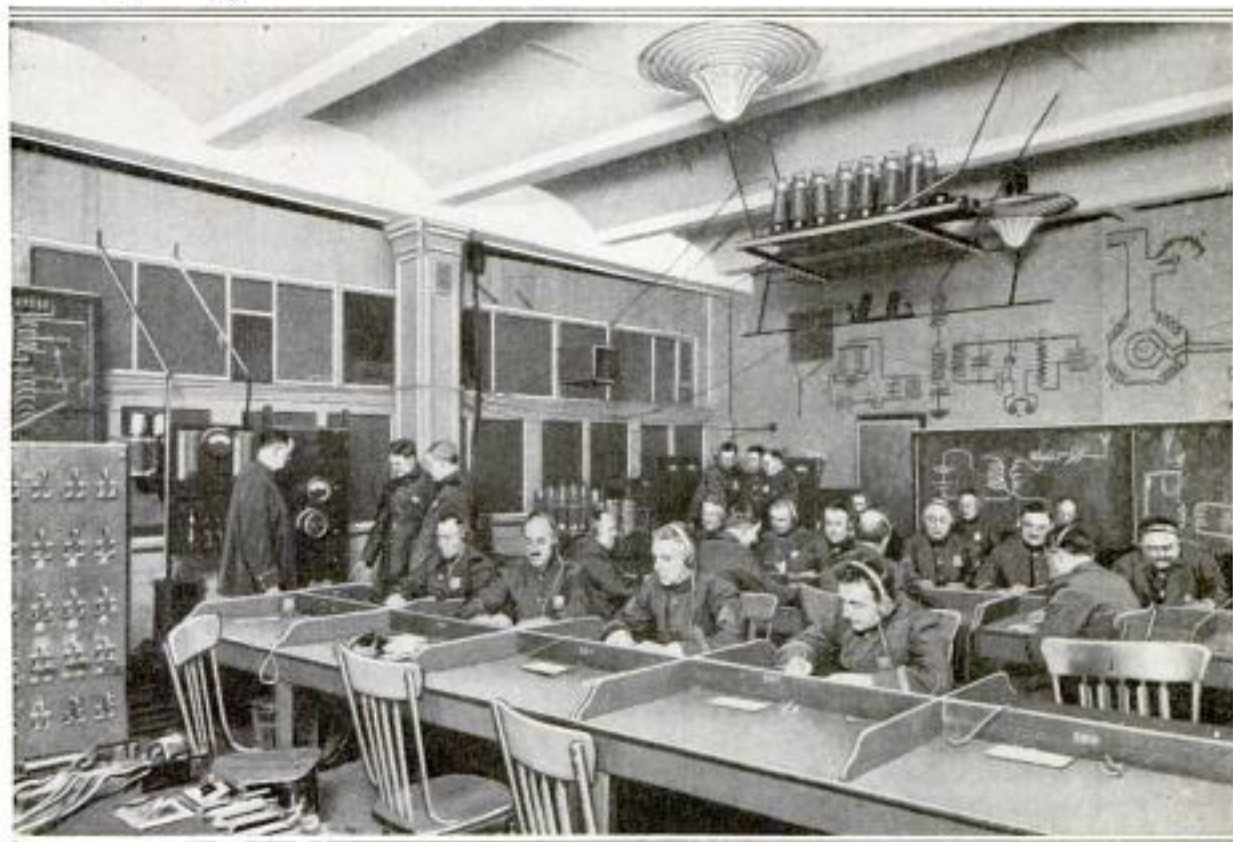

New York Police Officers Learning to Use Wireless Telegraphy in the Police Training School: Note the Instruction Diagrams on Walls and Blackboards and the Sending Apparatus in the Foreground

POLICE OFFICERS TAUGHT USE OF WIRELESS

Instruction in wireless telegraphy is given in one of the classes of the New York Police Department training school, and a wireless apparatus has been set up at headquarters. This is now working with stations in and around New York Harbor and is to be connected with a system of stations in the city. A number of private wireless plants have been placed at the service of the department for emergency work. Motorcycle couriers will carry messages from these plants to the district and precinct offices. There are eight certified wireless operators now on the force and 16 others are under instruction at the training school.

CA Mexican choir and an American choir, standing on opposite sides of the international boundary at Eagle Pass, Tex., on Christmas Eve, alternately sang stanzas of a hymn appropriate to the season.

ADJUSTABLE NONSLIP³³⁷⁵ DEVICE FOR CRUTCH

An attachment has been devised for a crutch, which can be quickly brought into use on slippery walks or pavements, whereas it need not be employed indoors or on other surfaces offering a firm footing. It consists of a sharp-pointed rod that is conveniently fastened to the side of the crutch so that a spring-held handle can be operated by the fingers without the wearer removing his hand from his crutch. By giving the handle a slight turn the rod is released and the point drops down far enough to strike the pavement.



Samuel H. Gilbert
1347 - 140 N. Dearborn,
Chicago

SMALL CRANE FOR FARM WAGON SAVES LABOR

A small crane has been designed especially for use on farm wagons, hav-

Farm Specialty Co., Toledo, O.



A Small Adjustable Crane with Which One Man can Load and Unload Big Shocks of Corn, Bales of Hay, and the Like, without Difficulty

ing a flat-bottomed rack, which enables one man to load large corn shocks,

bales of hay, and the like, without difficulty. The crane is kept upright on the wagon by braces, which also can be made to serve as the rear-end support for the load. The device is

fastened to an iron track, running lengthwise of the wagon, and along this it can be moved according to the demands of the load. The arm can be raised or lowered as desired. Lifting is done with the aid of tackle which fastens to the outer end of the arm. When a shock of corn, for example, has been raised to the right height it is swung around and deposited on the wagon without any undue exertion. The crane is equally serviceable in unloading. If desired a brace can be placed

under the edge of the rack to prevent its tilting downward when produce is being hoisted.

3422

NEW-STYLE PADLOCK FOR TIRE PROTECTION

Spare tires carried on a motor car are protected from theft by a new style



Allith-Provoty Co.

of padlock, which, in its standard form, has a long straight hasp, readily adapted to the shape of the tire. It is self-locking — a push button on the rim, when pushed clear in, springing the lock mechanism. The locking bar is contained entirely within the lock, and to break it open the whole case must be destroyed. It is practically impossible to secure any hold whereby the lock could be forced.

3734

NEW FLASHING APPARATUS FOR LIGHTHOUSES

A new method of occulting a range light—that is, of transforming a fixed light into one that flashes at regular intervals—was successfully tested recently by the United States Bureau of Lighthouses. The experimental outfits were manufactured at the general lighthouse depot, on Staten Island, N. Y. Each consists of a frame placed in front of the lighthouse lens, carrying a number of vertical metal vanes or shutters pivoted on their vertical axes and arranged to be rotated through an angle of 90° by means of connecting rods. They are timed, as in ordinary occulting mechanism, by an operating clock. The shutters, or blinds, open and close instantaneously and make the light flash as desired.

3682

Shepard

CRUISER AND SUBMARINE GO AGROUND ON BAR



COPYRIGHT, INTERNATIONAL FILM SERVICE

WHILE attempting to salvage the submarine "H-3," which struck a fog-hidden shoal off Eureka, California, last December, the cruiser "Milwaukee," flagship of the Pacific fleet's destroyer force, recently foundered. The "H-3," with two other under-sea fighters and its mother ship, the "Cheyenne," was proceeding from Puget Sound to winter quarters at Mare Island when it went aground near the entrance to Humboldt Bay. For eight hours it was battered by heavy breakers and driven shoreward. Members of its crew, consisting of two officers and 25 men, were buffeted menacingly, but none was seriously injured and all were saved when coast guards after heroic work made fast a breeches-buoy line to the diver. Just a month later the naval career of the "Milwaukee" ended when a heavy current carried the ship onto the same treacherous shoal during a fog. A contributing cause of this disaster was a heavy cable that harnessed the "Milwaukee" to the submarine it had been trying to drag into deep water. Above: ill-fated vessels in breakers; below, rescued submarine crew drying clothes.



Charles M. Kimble (Photographer)

Masonic Temple, N. J.
Trenton

378

3148 POPULAR MECHANICS 3601

FILTRATION PLANT PIPING IS PHOTOGRAPHED IN ODD WAY

The apparently confused mass of pipes, large and small, revealed in the

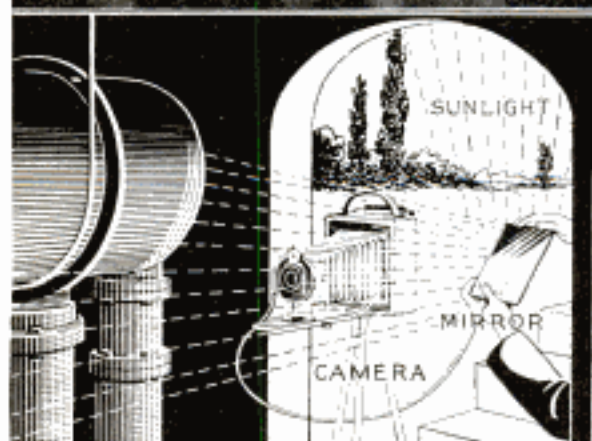
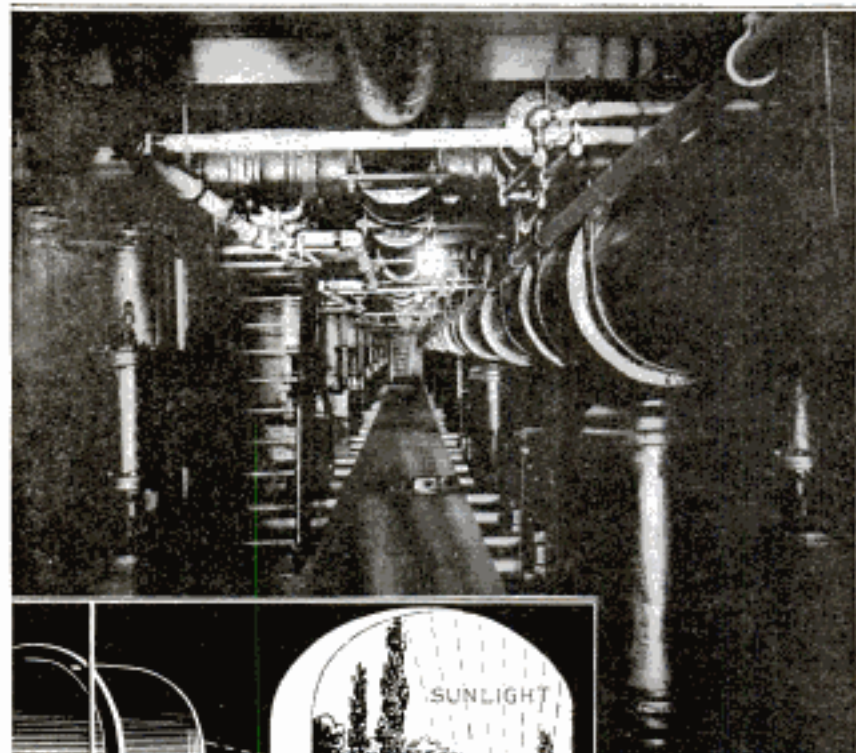

This Sketch Indicates the Way in Which a Mirror was Employed to Reflect Sunlight into a Pipe Cellar While the Unusual Photograph, Shown Above, was being Taken

accompanying illustration is to be found in what is called the pipe cellar of a filtration plant in Trenton, N. J. The room containing these crossing and intersecting tubes is about 200 feet long. This unusual photograph was secured with the aid of a mirror measuring 7 by 10 in. It was so placed that it cast a bright beam of sunlight down the full length of the passageway.

ⒸThe waste bark which remains after the tannin has been extracted from it for leather work is now being used partly to replace expensive rag stock in the manufacture of felt roofing.

HOW IMPROPER COOLING AFFECTS STEEL RAILS

In an investigation which a consulting engineer for an eastern railway has

reported on to the American Railway Engineering Association concerning the conditions producing transverse fissures in the head of rails, the fact is brought out that in winter the low temperature in which rails are cooled in the mill after rolling apparently is one of the factors which produces hidden defects. It is shown that if some rails are allowed to stand longer than others they are liable to be chilled, and so frequently develop imperfections. The investigation shows, further, that in cooling rails on hot beds often insufficient attention is given to spacing them.

When the rails are placed close together those in the center of the group are affected by the heat of adjacent rails and so acquire an excessive curve in cooling. Such irregular ones require several blows of the hammer used to straighten them out. On the other hand, if the rails are set some distance apart, say, 6 in., they are free from contact with each other and they cool nearly straight. Hence they require only a few light blows to perfect their shape and so are less subject to defects.

3219

NEW SEA WALL PROTECTS OCEAN ESPLANADE

To protect the esplanade along the ocean beach near the famous Seal Rocks, the city of San Francisco has completed the first section of a concrete sea wall of novel type. The wide base is in the form of a series of steps, re-

Pitt 72 Hand, New York City, 3047 Grand Central Terminal,



First Section of the New Sea Wall That Protects the Beach Road near the Seal Rocks, San Francisco. Steps Give Access to the Sea-Wall Seats and the Beach

sembling bleachers, which can be used as seats by visitors in summer. Above and behind these is a high incurving wall, which is expected to withstand the heaviest seas of winter. Behind

the parapet, a 20-ft. walk has been constructed, with curb and gutter. Drinking fountains and electric lights are provided and future extensions of the sea wall are planned.

3647

LONG, FLOATING RAILROAD BRIDGE ACROSS CANAL

At Paraiso, a point about two miles northwest of Miraflores, a swinging pontoon bridge carries the Panama Railway across Gailard Cut to the west side of the canal where military posts are situated. So that they would not infringe upon the width of the channel,

the abutments for the approaches were established in pockets excavated in the



The Picture Above, Taken While the Construction Work Was Still in Progress, Shows the Long Pontoon and Trestle Drawn along One Side of the Canal



The Floating Bridge Accommodates Railway Traffic between Opposite Banks of the Canal at Paraiso. When Opened, It is Swung Out of the Channel into a Recess

sides of the waterway, while on the east bank a long recess was dug to receive the bridge when open. This harbor extends south

Earl J. Browne, Major, Corps of Engineers, U.S.A.
1709 G St. Wash., D.C.

of the abutments. Since the bridge is pivoted at the northeast corner, it can thus be swung entirely out of the channel when opened. The pontoon is 378 ft. in length and has a width of 55 ft. It is constructed of heavy timbers, fitted with six longitudinal bulkheads, and supplied with a pumping system for discharging bilge water. The deck, which has a sheathing of 4 by 10-in. timbers, calked, is surfaced with asphalt. An apron, 65 ft. long and weighing 150,000 lb., is hinged at each end of the trestle to effect a rail connection with the piers. These members are raised when the bridge is moved, and when lowered for use are locked in place in such a manner that they are held against vertical and lateral movement. A so-called "wild-cat" wheel and chain, installed at the outer end of the structure, permit the bridge to be opened or closed readily when the operating motors are started by the attendants.

3343 —

CONVENIENT HOUSE BOAT USED ALL YEAR ROUND

A very attractive house boat has been constructed by a resident of Medford, Mass. for use the year round, which is patterned after craft to be found on the Thames River in England.

It is 42 ft. long, 17 ft. wide, and draws 14 in. of water. On the lower deck are six rooms, one of which is a sun parlor, and a bath. On the upper deck are two sleeping rooms and a wide veranda. The boat is electrically lighted, current being generated for storage batteries with the aid of a gasoline engine. This engine also pumps water for the water system. In cold weather the rooms are warmed by steam heat. All of the rooms have beamed ceilings and are tastefully furnished in mission style. The walls are of fiber board.

2842

BUILDS PIPE ORGAN FOR HIS OWN HOME

By rebuilding and adding to an old organ which he purchased from a church in his town, a musician in Girard, Kan. has equipped his home with a pipe organ of excellent quality and pleasing appearance. The old instrument had but one set of keys and its pump was operated by hand. The purchaser built a number of large pipes and a set of pedals, which are played in the same way as keys, and added them to the instrument, that now occupies a prominent place in his living room. In the kitchen a neat cabinet was built to contain a 1/20-hp.



Eight-Room House Boat, Patterned after English Craft, Which is Electrically Lighted, and Steam-Heated

✓ Geo. A. Pennman
Medford, Mass.
(Bldr & Owner)

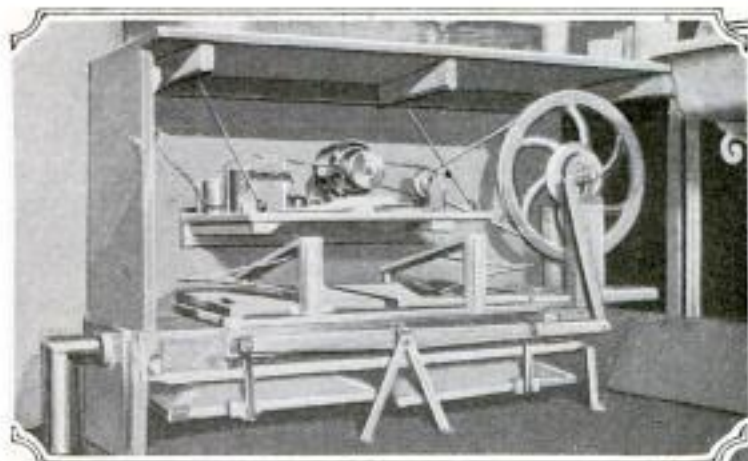

Motor and Homemade Bellows Installed in a Cabinet in the Kitchen, Which Supply the Organ with Air

motor and the bellows by which the organ is supplied with air. The motor operates two large bellows that force the air into two supplementary bellows instead of directly into the organ. These secondary air chambers are under pressure and serve to maintain a steadier air supply for the pipes. Much ingenuity was shown in making the additional parts and in adding them to the reconstructed organ, which has the appearance of a factory-made instrument.

3291—

DANCE TICKET PREVENTS ERRORS BY PARTNERS

A dance ticket, or tabulator, has been designed, the purpose of which is to prevent confusion in claiming partners at a ball. It consists of a strip of cardboard, about eight inches long, divided by transverse perforations into as many sections as there are dances on the program. Each ticket bears at the top a number which is not duplicated on any other ticket. This number is repeated on each of the sections, which are also numbered in rotation, 1 being at the bottom. Each lady is provided with one of these tabulators and as fast as she fills up her program she presents her future partners with sections of the ticket corresponding to the dances which they have engaged. Later, as the dances are called, the gentlemen present their slips and claim their partner, each in his turn. In this way all errors are avoided, for each slip bears

*Edward Ellerman, (Inw.)
Box 42, Osgood, Colo.*

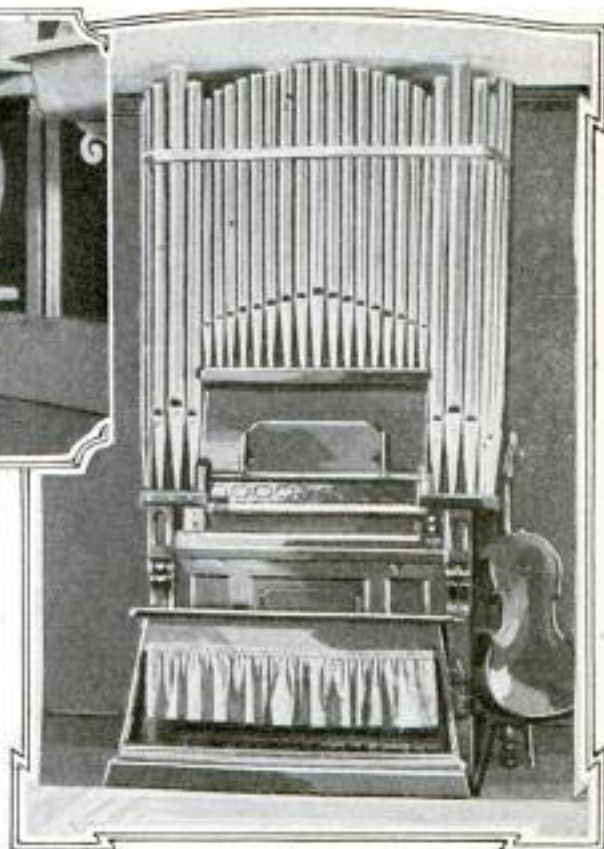

Homemade Pipe Organ Rebuilt from an Old Organ of Smaller Size

the number of a dance and also the lady's number. A dance can be re-



A Dance Ticket, Composed of Numbered Detachable Slips Which are Given Out, by the Lady Wearing the Ticket, to Her Partners as Fast as They Engage Dances with Her

served in advance by marking the corresponding section with "R," if desired.

Buffalo Contracting Plant Corpn.
129 Erie St., Buffalo, N.Y.

382 3251 POPULAR MECHANICS

**ARCH YOKE A FEATURE OF
NEW CLAMSHELL BUCKET**

Eng'g Record 9-2-16

A clamshell bucket has been placed on the market in which have been em-

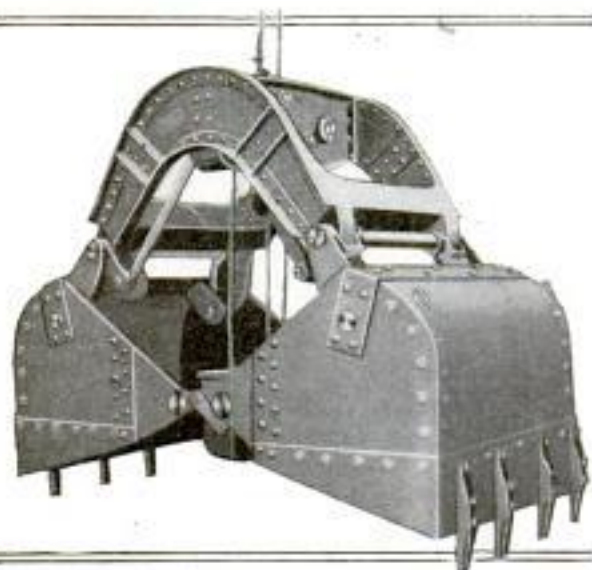

New Type of Clamshell Bucket Having a Steel Arched Yoke and Other Features Which Give It Compactness and Strength

bodied a number of new features for the purpose of giving it compactness, rigidity, and great closing power. The height of the bucket is considerably less than that of types commonly used. The two halves, or bowls, are pivoted to either end of a steel arched yoke and also linked to each other. The clamshell is closed by means of cables which pass about sheaves situated at the juncture of the two bowls. These working parts are entirely inclosed in a cast-steel case which protects them from dirt, gravel, or the like. When the implement is open it forms a continuous, rigid steel arch that can be dropped from a great height so as to drive its blades into the material to be excavated. The distance between the points where the bowls are joined to the arch and the points where they are linked to the working parts referred to, is sufficient to give the bucket unusual closing power.

3650

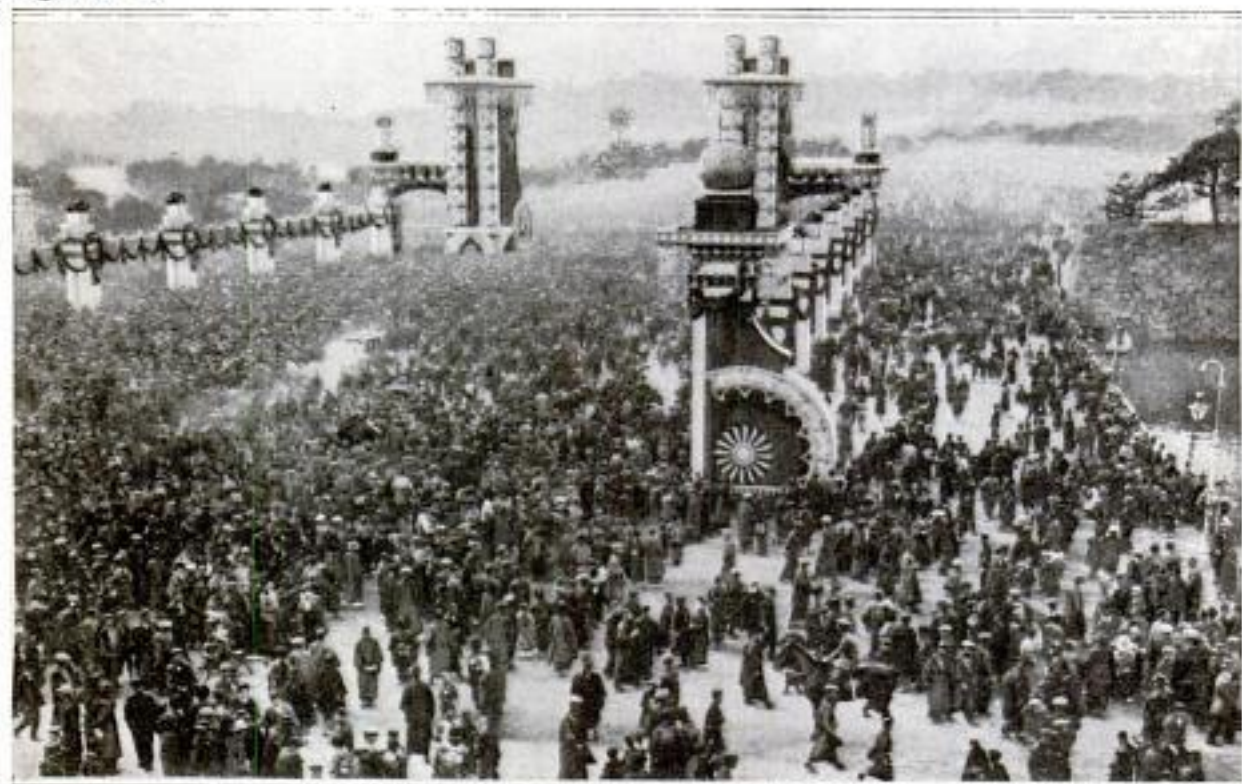

COPYRIGHT, INTERNATIONAL FILM SERVICE, INC.

TOKYO A GALA CITY IN CROWN PRINCE'S HONOR

IMPRESSIVE oriental pageantry, comparable to that accompanying the Japanese coronation, marked the recent formal proclamation of Japan's 16-year-old crown prince as the heir apparent to the throne. A portion of the vast concourse of subjects who waited for the passing of their future ruler on his way to his installation, as it has been called, is shown here, together with some of the distinctive Japanese decorations that surrounded the plaza at Babasaki Gate. At night the whole city of Tokyo, including these and many other festal adornments, was brilliantly illuminated.

2763

WHAT DID THE CENSOR CUT?

Unusual Prize Contest Interests Persons of Many Nationalities and Occupations

ANNOUNCEMENT OF PRIZE AWARDS

FIRST PRIZE, \$200, Walter W. Baker, ^{274 1376 St}Portland, Ore.

"The practical solution of London's aerial defense came with the discovery that searchlights could be used as range finders. The simple range-finding theory that a measured line forms the basis for computing all distance was applied by pinning an airship on the apex of two shafts of light to prove its exact height and distance from a gun battery by its angle. Immediately the highly theatrical searchlight play, together with the ragged, ineffectual gunfire of early raids, was abandoned and London became a vast mathematical chessboard, with a searchlight at each corner and a battery of high-powered aerial guns in the center of every square; both operating to deliver time shells with such grim orderliness and accuracy that aeroplanes may now practically surround the doomed target without fear of themselves being hit."

SECOND PRIZE, \$100, Charles C. Dunning, Pittsburgh, Pa.

"This has been accomplished by locating powerful searchlights at definitely spaced intervals along radial lines centering at the heart of London. Each light sends out a slightly divergent beam which swings back and forth across a predetermined arc of the sky. This results in the lights along a diameter producing a fan-shaped sector of intense illumination which sweeps across the sky, covering an angle of about 120 degrees. The methodical crossing and recrossing of these light sectors render it impossible for a Zeppelin to avoid being located. Once this has been accomplished, certain lights are detailed to follow the doomed airship while the guns and aeroplanes deliver the deathblows."

MANY thousands of readers were interested in the prize contest announced in the recent December issue of Popular Mechanics Magazine, when cash prizes of \$200 and \$100 respectively were offered for the two best answers to the question, "What Did the Censor Cut?" The question referred to a paragraph deleted by the British censor from Lewis R. Freeman's article, "Bringing Down a Zeppelin," which appeared in the same issue, with the place and extent of the deletion clearly indicated. Contestants were required to write and submit suitable "copy" to replace the matter censored, this being a complete paragraph of about 12 typewritten lines of the usual length.

The December magazine appeared on the news stands November 20th, and the contest closed at midnight Dec. 31, 1916, by which time replies had poured in from 47 of the 48 States of the Union (all but New Mexico); from the District of Columbia (Washington); and from eight of the nine provinces of Canada (all but Prince

Edward Island); while Newfoundland and Porto Rico were also heard from. Time was allowed for all replies mailed up to December 31st to reach the office and only a few late arrivals failed to receive consideration by the judges who decided the contest.

Among the contestants were Americans of all ages and conditions, with a fair sprinkling of women, and representatives of many other nationalities, including Austrian, Belgian, Canadian, Danish, Dutch, English, French, German, Greek, Hungarian, Irish, Italian, Jewish, Japanese, Norwegian, Polish, Russian, Scotch, Swedish, Swiss, and Welsh readers. The occupations of the contestants covered a similarly wide range. Replies were received from a bishop of the Episcopal Church, a well-known brigadier general (retired) of the United States Army, a commander in the United States Navy, the commander of a Pacific coast fort (Coast Artillery), an instructor of the United States War College, a manufacturer of aeroplanes, the city engineer of a large municipality, several

professors in large universities, consulting engineers, newspaper editors, and school superintendents.

While so many nationalities and vocations were represented, the neutrality of the great majority of the replies was remarkable. With few ex-

ceptions the contestants made a serious effort to rewrite Mr. Freeman's censored paragraph. Many of them had a high percentage of merit and received final consideration with the prize-winning paragraphs, which were preferred by the judges.

OCCUPATIONS OF CONTESTANTS

(So far as could be determined from their letters)

Advertising Men
Aeroplane Mechanics
Agricultural Students
Airmen
Amusement Managers
Automobile Salesmen

Bishop (1)
Blacksmiths
Bond Salesmen
Bridge Engineers
Brokers
Builders

Carpenters
Cattle Men
Chemists
City Employes
City Engineers
City Firemen
Civil-War Veterans
Clerks
Club Employes
Consulting Engineers
Contractors
Cotton Brokers
County-Employes
Court Reporters

Cowboys
Dentists
Electrical Engineers
Electricians
Engineers
Engravers
Express Agents

Farmers
Foresters

Garage Men
Gasoline Engineers
Grain Brokers

High-School Students
Highway Engineers
Horticulturists
Hotel Employes
Hotel Managers

Inspectors
Instructors
Investigators
Irrigation Men

Jewelers
Lawyers
Linemen
Lumbermen

Machinists
Managers
Manufacturers
Marines
Mechanical Engineers
Mechanics
Metallurgists
Meter Inspectors
Mining Men
Ministers
Motion-Picture Men

Newspaper Men
Newspaper Women

Office Men
Officers of the Army
Officers (Retired)
Oil Men

Physicians
Poultry Men
Printers

Railroad Men
Ranchmen
Real-Estate Agents

Sailors
Salesmen
School Directors
School-Teachers
Soldiers
State Employes
Stationers
Steam Engineers
Stenographers
Stockbrokers
Students

Teachers
Telephone-Company
Employes
Theater Managers
Theologians
Typesetters

Veterans of
European War

Y. M. C. A. Workers
and Members

THE PRIZE WINNERS

WHEN the prize-winning paragraphs had been sifted out from the great mass of manuscripts submitted in the contest, and the awards of the judges were finally made, information was sought regarding the prize winners themselves, and there were more interesting developments as this information came to hand. For while the first prize went to a resident of Portland, Ore., in the far West, the second prize was awarded to the East, in the person of a Pitts-

burgh man; and these two winners were found to represent types of men almost as far asunder as their places of abode.

It needs only a glance at the respective portraits of Messrs. Baker and Dunning to show wherein they differ. The face of the first prize winner is that of a typical out-of-doors man, a lover of the sports of the field, with an adventurous spirit of the pioneer kind—and one is not surprised to learn that Mr. Baker, though by birth a New Yorker, obtained the inspiration for his winning idea from actual hunting experiences in northern India, where he acted as a government interpreter. Later



Walter W. Baker
Winner of First Prize

he traveled throughout the Orient as publicity manager for an amusement enterprise, which he left in Colombo, Ceylon, returning to the United States and taking up his residence three years ago in Portland, where he is now employed by a shipbuilding concern.

The second-prize winner, on the other hand, is essentially a student. Son and grandson of Methodist ministers, Mr. Dunning has spent his years since graduation as an instructor, specializing in physics. In 1910 he received the master of arts degree from his alma mater, Dickinson College, Pa., and is at present in charge of the physics department of the Peabody High School, one of the largest schools of Pittsburgh. He too has served under a government, having spent some time in educational work in Porto Rico for the United States. Mr. Dunning wrote his winning paragraph for the contest, he says, after several days of careful thought on the problem. He hesitated to send it in, doubting its chance of winning a prize, but finally decided to do so, and his letter was received just before the contest closed.

In selecting the winning paragraphs the three judges, without conferring on the matter, each selected Mr. Baker's paragraph as best. Two chose Mr. Dunning's paragraph for second place, and after some discussion, this choice was unanimous.

Mr. Freeman, upon his return from the European war zone, will, undoubtedly, be able to replace the paragraph as he first wrote it. His version, together with those of the two prize winners, will then be published for comparison by our readers.



Charles C. Dunning
Winner of Second Prize

Geo. W. Harding
1115 Washington Bldg.,
3605 POPULAR MECHANICS
Los Angeles.



This Angular Pier has been Erected for Pleasure Purposes at Redondo Beach, California, to Replace an Old Wooden Structure That was Battered to Pieces by the Waves Some Few Years Ago

PIER OF PECULIAR SHAPE BUILT IN CALIFORNIA

Within recent months a recreation pier of unusual form has been erected at Redondo Beach, Calif. It is of reinforced-concrete construction and built much like an open "V." Two diagonal piers, their approaches about 700 ft. apart, project 440 ft. seaward and there converge in a platform that is 200 ft. in width and 160 ft. deep. Erected on this cross pier, the extremity of which is 600 ft. from the shore, is a small sun pavilion and observation tower. The three outer sides of the platform—the base of the so-called "V"—serve as fishing decks, while a landing for pleasure boats extends for a short distance down the seaward side of one of the legs, near the point where it joins the cross pier. At regular intervals along both diagonals, which are 36 ft. wide, and across the shoreward side of the platform, are canopied benches. A continuous promenade, a little over one-half mile in length, is afforded by the shore frontage and pier. Beam and girder type of construction was

followed throughout in designing the work. In length the concrete piles vary from 20 to 85 ft., while their diameters are from 20 in. to 2 ft. The structure was erected to replace an old wooden one, wrecked about three years ago during a severe storm.

— 2639

SPRAY ATTACHMENT FOR BATHTUB FAUCET

IND. Rep. World 8/1/16
A simple attachment for a bathtub faucet has been designed which produces a horizontal spray and so can be used instead of more expensive shower-bath equipment, or in shampooing the hair. It consists of a metal cap, perforated at one side, and provided at one end with a rubber ball. An opening in this ball permits it to be fitted tightly over the spigot. The article should prove a great convenience to travelers.



John Howard McElroy
53 W. Jackson Bldg.
(is my friend) Chicago.
Copyrighted material

3232
**SAFETY IN SAND-BLASTING
 THROUGH NEW DEVICE**

In factories where metal parts are treated with a sand blast in order to



In This Old Method of Sand-Blasting the Workman can Lay Aside the Safety Helmet When He Chooses and Still Do the Work, Though at the Peril of His Health through Inhaling Particles of Sand

produce a smooth surface for painting, as in automobile factories, it has been found difficult to induce the workmen to persist in the use of the safety helmets and other devices adopted. A new method compels the operator to don a safety helmet or he cannot work

at all. This is done by placing the sand-blast work in a compartment of the double-hopper type, while the workman stands outside. The compartment has two doors, one of the ordinary type through which the material is placed inside, and another formed of two sliding metal panels with a canvas curtain hung between them. The operator's safety helmet is made integral with the curtain, so that he cannot see the material inside or work upon it unless he puts his head in the helmet. The parts to be sand-blasted, such as automobile fenders, hoods, and even bodies, are laid on a metal grating in the hopper, under a strong current of air which draws off the finer particles of sand through the top of the hopper, the coarse grains falling to the bottom to be used again. The operator can move along as he works by pushing the sliding doors with his elbows. He sees his work through a fine copper gauze, which is kept clear of sand by the strong suction of air in the hopper. A battery of 12 of these hoppers is installed in one Detroit automobile factory.

¶An alloy of two per cent palladium with silver is said to form a good substitute for platinum in contact and spark devices.

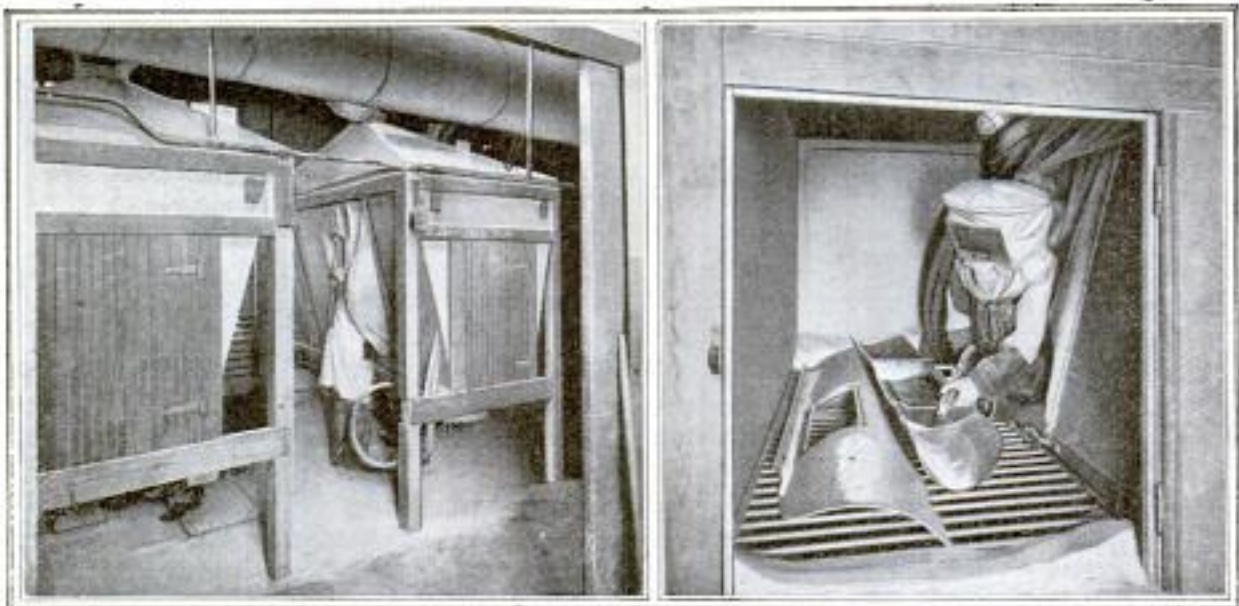

Improved Method of Sand-Blasting, Which Compels the Workman to Don the Safety Helmet to Get at the Work inside the Hopper: He Stands Outside, as Seen at the Left, with Head and Arms Protected Inside, as Shown at the Right

*F. M. Langdon, Cadillac Motor Car Co.,
 Detroit.*

3377
**PHOTOGRAPHS AS BACKGROUNDS FOR
MUSEUM GROUPS**

The use of painted backgrounds for museum groups of mounted animals and birds has become so expensive that photographic backgrounds are being substituted with great success. The director of the Colorado Museum of Natural History, at Denver, originated the idea of using enlarged photographic transparencies as backgrounds for groups of birds and small mammals, and the idea is now being used also in several other institutions. The pictures are of magnificent mountain scenes, typical of the natural habitat of each group displayed.

Each glass transparency forms the back of an exhibit case and is either 26 by 36 or 52 by 36 in. in size. There are already more than 40 such backgrounds, nearly all of them enlarged from 5 by 7-in. negatives. The method of tinting the transparencies is peculiar, but was adopted after other methods were found to apply too much coloring or to produce streaked results. Ordinary tube oil colors are slightly diluted and are applied with the finger tip, which is first made smooth by rubbing it with fine sandpaper. It is desired not to paint the glass picture but only to tint it to resemble nature. Colors are never mixed, as that kills the brilliancy. White is never employed, as the ground glass at the back takes the place of that medium. Shades are obtained by increasing or decreasing the amount of color.

Either artificial or daylight may be used to illuminate the transparency from behind, but electric light is chosen because daylight is too fluctuating. The completed group is viewed by the light which is transmitted through the glass background. The cost of these transparencies is relatively small, that of the smaller size being but \$8.50 each, when bought in half-dozen lots. Tinting approximates an additional \$3 each. The completed groups, exclusive of the case, average about \$50.

A second form of photographic background is employed for 110 groups in the Chicago Academy of Sciences.

These are paper prints, 5 ft. high and 8 to 32 ft. long, enlarged from original negatives, ranging from 4 by 5 to 8 by 10 in. The pictures are taken in the neighborhood of Chicago, often of the very woods, streams, or valleys from

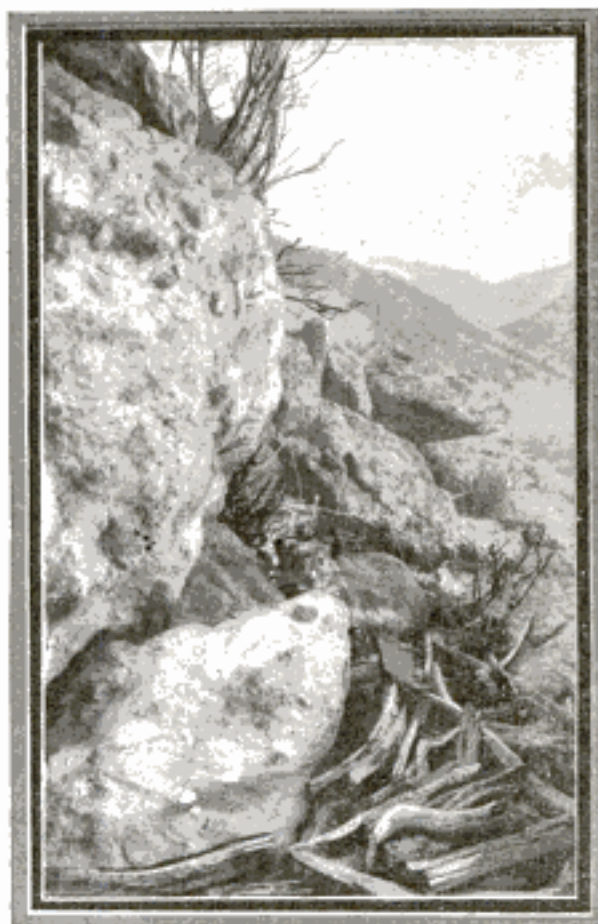

A Mounted Rat Group in the Colorado Museum of Natural History: The Background, with Its Fine Perspective, Is a Transparent Photograph

which the birds or mammals used in the groups were obtained. These backgrounds are absolutely accurate, contain much more fine detail than an artist could be expected to work into a hand-painted canvas, and cost approximately one-fifth of the latter.

Ordinary photographic paper, but of huge proportions, is used for the prints. Special large trays had to be made for developing and other processes, and six men are required to handle each print through the solutions in the trays, to prevent tearing. Each print is pasted upon muslin to strengthen it, and it is then mounted upon a sheet of galvanized iron to give it rigidity and

make it more nearly fireproof. The backgrounds are curved, when set in place within the exhibit cases, so that they cover the back and two sides of



A Photographic Transparency is Here Used to Show a Mounted Winter-Ptarmigan Group in Natural Surroundings

the cases. The mounted birds or small animals are so artfully arranged in front that, together with the natural material, as twigs, grass, and flowers, used in the foreground, they make the observer believe that he is viewing a real outdoor scene.

Each print is tinted by an artist using transparent oil colors, the work being done by artificial light similar to that under which the finished pictures will be displayed. The groups are viewed by reflected light, the electric bulbs being set in a row out of sight above the top of the front of each case. When photographs of the completed groups are desired for illustrative purposes they are made by a ten-minute exposure to the indirect light within the cases.

RIVAL OF POTATO FOUND IN TROPICAL TUBER

Since the much-complained-of high prices have affected potatoes along with other food products, the cultivation of the dasheen, a tropical tuber which has been introduced into the South from Trinidad, will be watched with keen interest. The value of this vegetable, it is believed, will be as a crop supplemental to, rather than a substitute for, potatoes, since it matures some time later than potatoes. The edible portion of the plant consists of a large central corm and a number of small tubers clustering about it. It requires a frostless season of seven months and moist, sandy loam. According to the Department of Agriculture it can be grown as far north as South Carolina. Its food value is comparable with that of the potato, but it contains less water and a greater proportion of protein, starch, and sugar. It can be prepared for table use as potatoes are.

SAFE GAS CONNECTION FOR HOUSEHOLD USE

One of the new devices relied upon by gas men to meet the growing competition of electricity in the home is a system of connecting portable gas appliances which is claimed to be safer than anything yet available in the market. Its basis is a concealing fixture or plate designed as a gas outlet for baseboard, wall, or floor. The union which is a part of the system will also connect to any ordinary gas cock or fixture by means of special

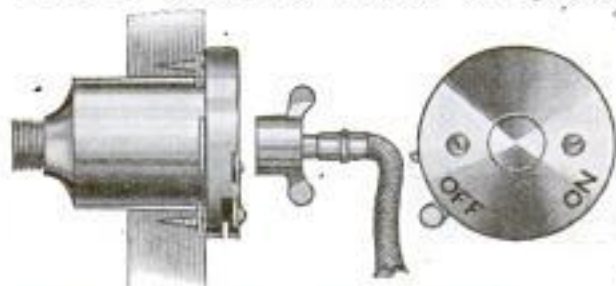

Details of a New Concealing System for Connecting Portable Gas Appliances in the Home

adaptor fittings. One size only is made and the parts are interchangeable, con-

R. Williamson & Co.
601 Washington Blvd.,
Chicago.

*Julien Champagne (Gen. Mgr.)
Westbire Road,
West Hampstead, London N.W.*

sisting of housing, cock, cover, and union. The housing has lugs for screwing to baseboard or wall, where the fixture is inconspicuous. Notches in the cover plate hold the operating lever in "on" or "off" position. When the gas is "off" and the union is removed, a spring on the plug locks the cock by preventing it from rotating.

3376
**AMERICAN DITCH DIGGERS
CUT BATTLE TRENCHES**

Among the various types of trench diggers employed on the battle fields by Germany and its allies is a big machine of American manufacture which before the war probably was used for cutting drainage ditches or making excavations for pipes and conduits. It is of the same general character as some of those used in many of our own cities for more peaceful purposes. Caterpillar treads enable it to negotiate fairly soft fields in spite of its heavy weight, and when working without interruption it is able to dig a trench of considerable depth at the rate of about 370 ft. an hour, or almost a mile between sunrise and sunset. It is equipped with the usual series of buckets about the circumference of a big revolving wheel and is operated by a gas engine mounted at the front end. The buckets are dumped as they reach the top, the dirt falling onto a belt conveyor and being distributed along one side of the excavation—forming a parapet—as the machine travels ahead. Such an apparatus requires the attention of only three or four men and accomplishes the work of a hundred or more. Its military value is therefore obvious.

**FRENCH RADIATOR BUILT
ON NEW LINES**

Htg. Vent. & Mag.
A French concern has recently placed on the market a new type of radiator especially adapted to hot-water heating systems, which is much smaller than ordinary radiators and, in proportion to its size, gives off more heat. It is made of several coils, or sections, in the usual way. They are, however, wider from front to back than common coils, and so shaped that the sides of the radiator as a whole are marked by deep horizontal depressions. Extending diagonally from front to back are a series of partitions between the coils which serve to throw the warmed air out into the room instead of allowing it to rise straight up. The result of this arrangement is that the upper portion of the radiator is surrounded by air that is no warmer than that around the lower portion, and so its entire surface is put to use to heat the maximum amount of cool air. This form of construction, it is claimed, makes possible a saving of fuel.

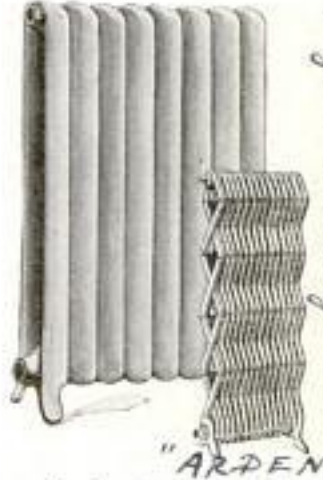

*Mrs. Charles - Elie
5, rue Toffier,
Paris*

*Inv. J. No. SUMMERS
P. O. R. A. I. L. L.
KEYSTONE STEEL & WIRE CO.*



Big Ditching Engines of This American Type are Used by the Germans in Constructing Intrenchments along the Various Battle Fronts

*Buckeye Traction Ditcher Co.
Findlay,
Ohio*

DYNAMITE AND DREDGING BUCKET TEAR HOLE

L R Perry, 2165 Center St., Berkeley, Calif.



Thawing and Drying Dynamite before an Open Fire and, as a Correspondent Observes: "Carelessly Smoking a Cigarette over It." Incidentally Dynamite Burns without Exploding



Whittling a Hole in the End of a Dynamite Stick Preparatory to Inserting a Percussion Cap: An Operation That Curdles the Blood of the Inexperienced, but Which is Really Not Dangerous at All



A Section of Sewer Pipe and Plenty of Dynamite Makes a Good Bomb. The Blasting was Done for the Purpose of Making an Opening in a Stone Breakwater at San Francisco through Which a Large Storm Sewer was to Reach the Bay.



The Sewer Extends for a Mile across a Shallow Bayou to the Breakwater. Above, One of the Bombs is being Carried to the Water's Edge

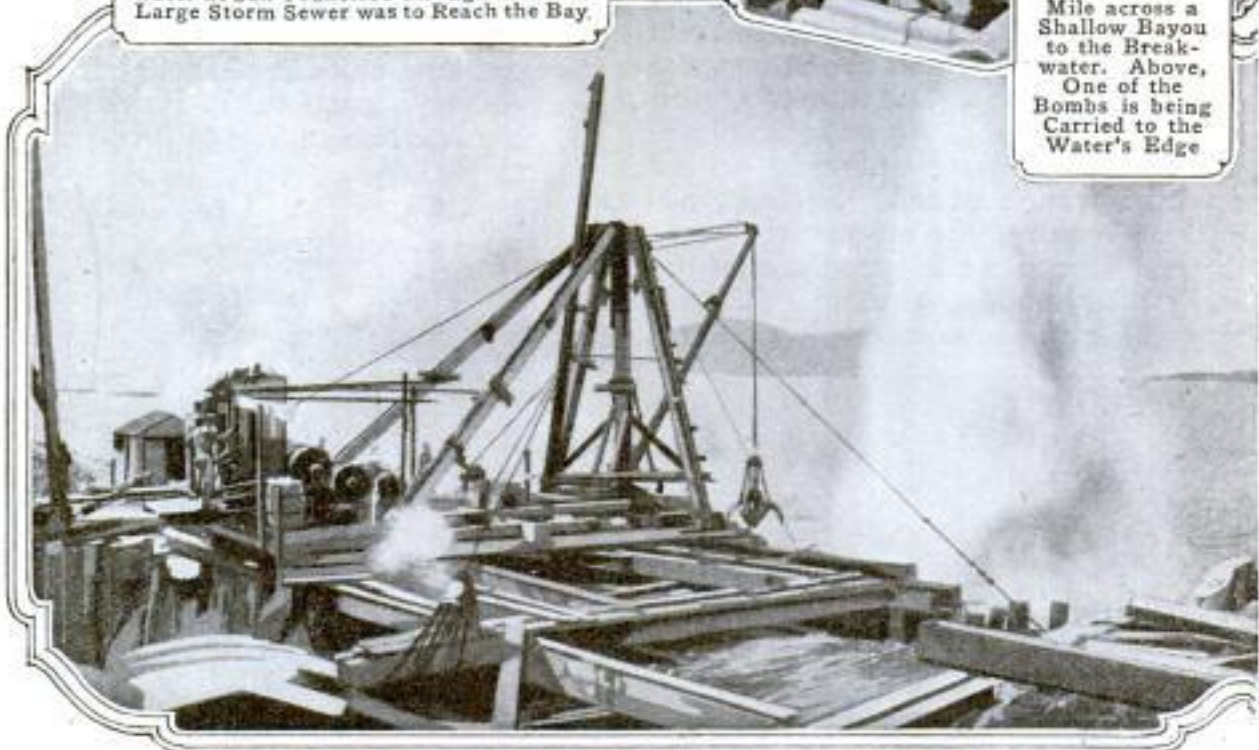

THROUGH BREAKWATER FOR PASSAGE OF SEWER

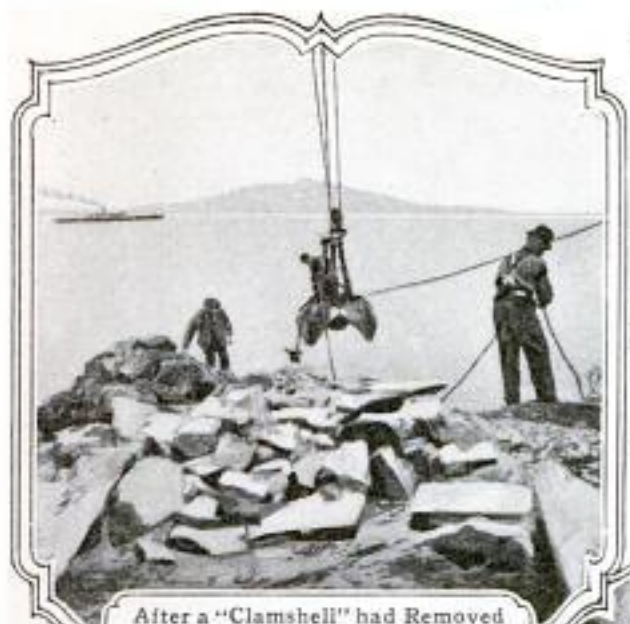

After a "Clamshell" had Removed as Many of the Rocks as It Could, Dynamite was Used to Dislodge Those below the Water. Here an Operator, Clinging to the Dredger Bucket, Is Lowering a Bomb



A Spout of Water Shot Far into the Air Following the Detonation 20 Feet below the Surface. This Loosened and Broke the Rocks so That They could be Grappled by the Dredger



For a Minute or More the Water Boiled as if It were Heated by a Mighty Furnace. After That the Fishing for Rocks with the "Clamshell" was Started



After Enough of the Rocks had been Removed to Permit It, Steel-Pointed Piles were Driven to Form a Foundation. The Conduit Is 10 Feet in Diameter and Drains the Hilly Sections of San Francisco's North Side

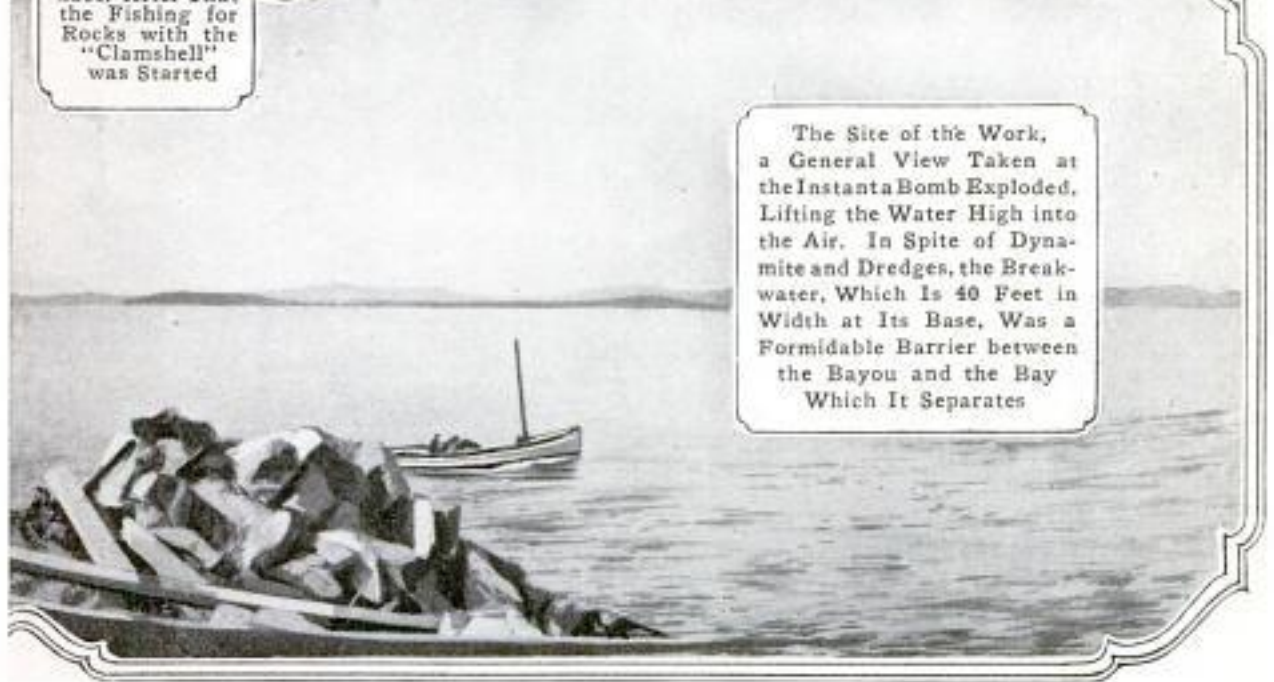

The Site of the Work, a General View Taken at the Instant a Bomb Exploded, Lifting the Water High into the Air. In Spite of Dynamite and Dredges, the Breakwater, Which Is 40 Feet in Width at Its Base, Was a Formidable Barrier between the Bayou and the Bay Which It Separates

3195

FLYING MACHINE AND STEAM ROLLER IN COLLISION

One would imagine it to be safe, in preparing a list of improbabilities, to

A rear-end crash of two so utterly different machines seems extremely incongruous. And yet this is precisely what occurred not long ago at an aviation field near Buffalo. The steam roller was being used on the turf when an airman attempted to make a landing. In doing this he either miscalculated the relative positions of his craft and the heavy roller, or became "object struck," for the nose of the plane was plunged with considerable force against the rear of the other machine. Fortunately no one was badly injured, but the propeller of the

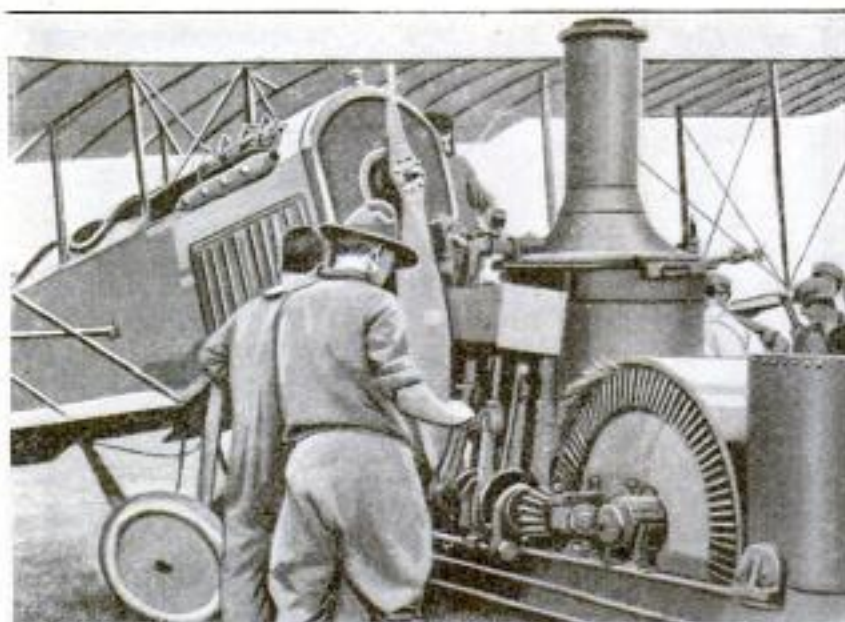

One of the Unexpected Things That Happened: A Rear-End Collision of an Aeroplane and a Steam Roller

include such a thing as a collision between an aeroplane and a steam roller.

air craft was broken, the landing gear wrenched, and the radiator smashed.

3552

PRESSED-STEEL SURFACE FOR STREET PAVING

In repaving a street in Charlotte, N. C., recently a surface of steel sheets was laid as an experiment, according

to a method invented by a civil engineer of Hammondsport, N. Y. The usual foundation of macadam having been provided, the roadway was overlaid with soft concrete and sheets of pressed steel were then placed upon the concrete and sunk in, making practically a steel road. The sheets were cut and pressed in such a way that tabs protruded on the under side and held the steel surfacing fast in the concrete. The roadway was completed in a shorter

time than it usually takes for similar jobs of paving. The test is reported to have been a perfect success. When the concrete hardened it held firmly the new pavement and was not affected by several weeks of freezing weather

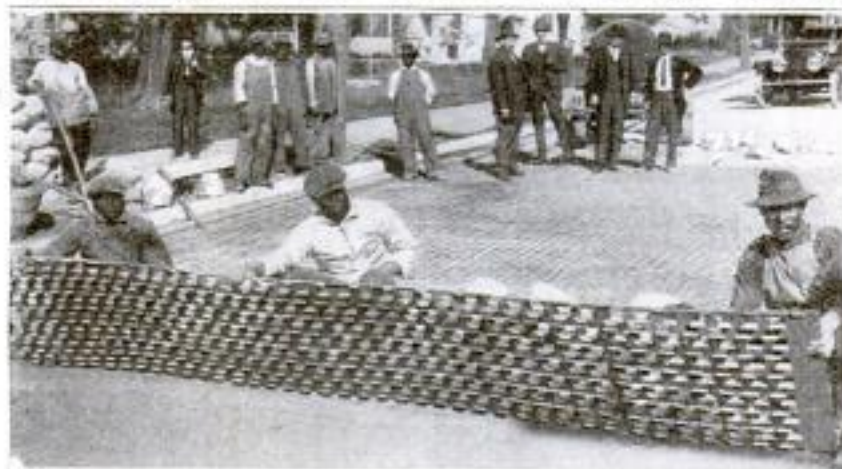

Laying a Steel Pavement on a Street in Charlotte, North Carolina: The Workmen in the Foreground Are About to Place the Pressed-Steel Sheet on Its Bed of Soft Concrete. A Completed Surface is Seen behind Them

which soon followed. Other cities are interested in the experiment.

which soon followed. Other cities are interested in the experiment.

Joseph H. Royce,
Paris, Texas.

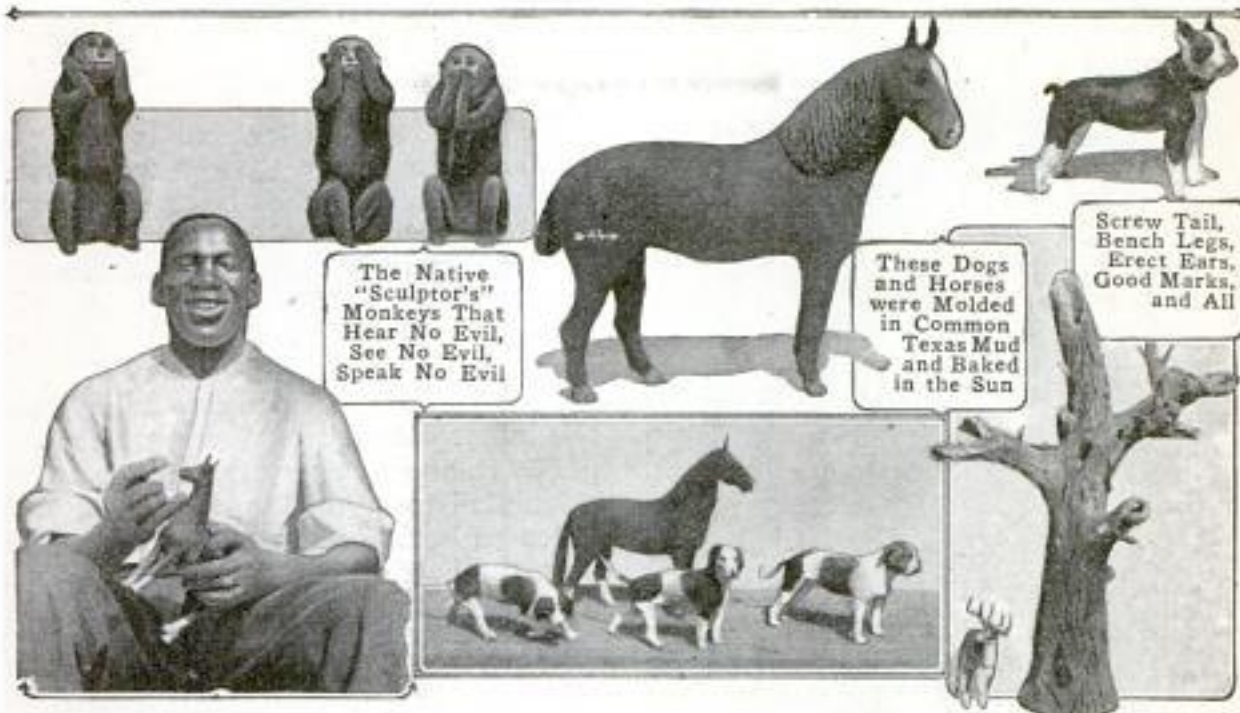

The Native
"Sculptor's"
Monkeys That
Hear No Evil,
See No Evil,
Speak No Evil

These Dogs
and Horses
were Molded
in Common
Texas Mud
and Baked
in the Sun

Screw Tail,
Bench Legs,
Erect Ears,
Good Marks,
and All

"Doc Mud," His Unceasing Grin, and One of His Half-Finished Mud Horses, All Texas Products. "Doc Mud" Stops at Nothing; Even Trees and Wild Animals are Molded, as Shown at the Right

SCULPTOR IN MUD IS NEGRO DOCTOR OF HORSES

While traveling through the blackland district of Texas some time ago, a correspondent, who happened to make a stop at a typical negro cabin, was surprised to find a grinning darky engaged in molding a miniature horse from ebony-colored mud taken from the roadway in front of his shanty. He found that the fellow—a horse doctor by calling—was in fact quite a clever, although totally untrained, "sculptor." Images of dogs, monkeys, pigs, opossums, and other animals, had been fashioned by him in the mud, baked in the sun, and painted in fairly natural colors. Especially good were some of the dogs and monkeys he had molded. In making the former, he had shown considerable appreciation of some of the characteristic postures assumed by hunting dogs and terriers. Among the natives the fellow is known as "Doc Mud."

☐The Bureau of Lighthouses has found by experimenting that at a cost of \$150 a pressed-glass lens for buoys can be made, which is as serviceable as the cut-glass lenses, which cost \$250 more.

WIRELESS TOWER ERECTED WITH COMPRESSED AIR³⁵⁴⁸

Plans for a pneumatically operated portable tower for a wireless outfit have been presented by the inventor to the War Department at Washington. The tower is mounted on an army truck and consists of a series of thin steel tubes which telescope into one another so that when the device is collapsed it is only 10 ft. long. Leather washers give these sections an air-tight fit. To raise the tower it is set upright and connected with an

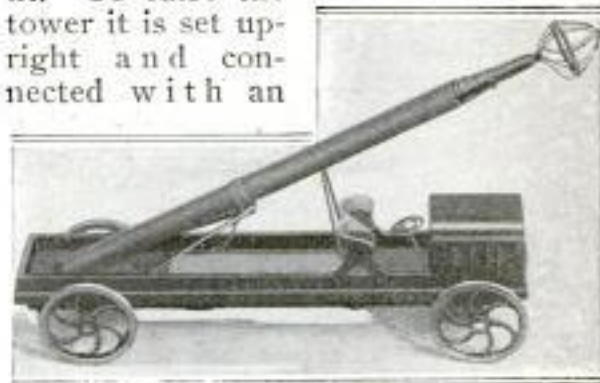

Portable Telescoping Tower for a Wireless Outfit: It can be Extended in Less than a Minute by Pumping Compressed Air into It

engine which pumps compressed air into it. In less than a minute it can be extended to its full height of 100 ft. It can be lowered even more quickly.

R. W. Dean, Desplains, Ill.

3555

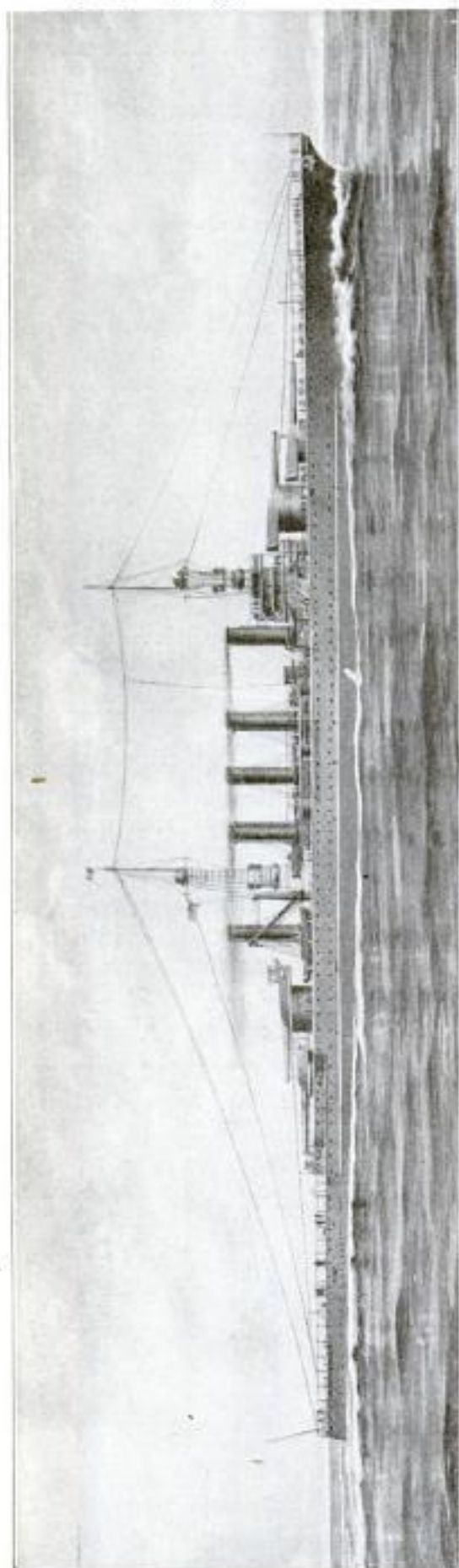

How the New Battle Cruisers of the United States Navy will Look When Completed: Ships of This Type have been Called "the Luxury of a Rich Power." They Are Larger and Much Faster than Battleships, Mount Guns Almost as Heavy, and Cost More. Four of Them are Included in the Naval Building Program for This Year

BATTLE-CRUISER DESIGNS ARE COMPLETED

Designs for the new battle cruisers of the United States Navy were completed recently and indicate that they will be indeed magnificent craft. Four of them were appropriated for in the naval bill for 1917 and six in all will be laid down under the three-year building program of the navy. They will be larger and more expensive than the latest battleships, having a length of 850 ft. and an enormous horsepower, calculated to give them a speed of 40.3 miles an hour, or about 16 miles faster than the battleships.

3657

MAY EMPTY IDLE CANALS AND USE THEM FOR CARS

Engineering News 11/9-1916

A number of cities in the United States seem to be in a fair way of finding a use for the old, insanitary canals which pass through their midst, taking up valuable space, acting as open sewers, and rendering little or no service because the boat traffic on them is negligible. In Cincinnati it is proposed to utilize a portion of the bed of the Miami and Erie Canal for an interurban route. It is said that in Syracuse the old Erie Canal bed will eventually become the route of the New York Central tracks, and a similar change has been projected for Rochester, N. Y., in which case the canal at that point would be turned into a new channel and the old one used for street-car tracks.

2903

WHIRLING "TANGO GIRL" IS NEW AMUSEMENT DEVICE

In response to the constant demand for amusement devices that offer pleasure seekers new thrills, there has been constructed in a Cincinnati amusement park a new "ride," called the "tango girl." It represents a huge female figure having a skirt that spreads out like a big circular tent. The edge of the skirt is surrounded with a platform having seats for 80 persons.



Huge Figure Called the "Tango Girl" Which Sways Its Patrons from Side to Side and Whirls Them Around as It Moves down the Track

Within the figure is electrical machinery which drives it along a broad track. As it runs down this track, special apparatus is employed to tilt the figure from side to side and occasionally give it an exciting whirl, much to the merriment of those on the edge of the outspread skirt.

2834—
**CONVENIENT HOLDER FOR
 NURSING BOTTLES**

A patent has been granted recently for a nursing-bottle holder which is a great convenience to one caring for a child that is being raised on a bottle. The device consists simply of an adjustable wire framework which can be quickly fitted about bottles of various sizes. It has two loops placed at one side which hook onto a strap or cord so stretched across a crib, or baby cab, that the bottle is within the child's reach. When the baby has finished nursing or drops off to sleep, the bottle remains fastened to the cord, instead of falling to one side and being broken or partly emptied of its contents. By

using this simple device it is unnecessary for a mother to remain close by a child while it nurses, nor is it necessary to pick up the bottle repeatedly



A Wire Holder Which Fits about a Nursing Bottle so That It can be Hung from a Strap within Easy Reach of a Baby in a Crib or Cab

after the baby drops it. When the bottle is to be washed the holder can be easily removed.

C. F. Devenny,
 3181 Memphis St., Phila.

Felix J. Kook
Heame Av.
avondale
Cinto, O.

396

3473

POPULAR MECHANICS

LARGE ROUND VENTILATORS IN SIDES OF AUTO HOOD

A novel feature in motor-car design-
ing is to be found in the automobile of
a Cincinnati motorist who has cut a

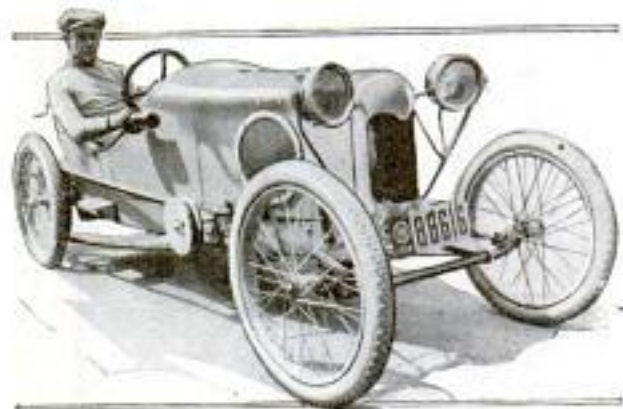

Circular, Screened Ventilators in the Sides of
the Engine Hood Give This Car an
Unusual Appearance

large circular opening in each side of
the engine hood, in place of the usual
ventilators. These apertures are cov-
ered with fine screening which keeps
out most of the dust. When the ma-
chine is driven at high speed the large
volume of air that rushes through the
screens helps materially to keep the
engine cool. The car is of the racing
type, with a low body, and the circular
ventilators give it an unusual and dis-
tinctive appearance emphasized by the
absence of mud guards.

2373 Garage Equip

VULCANIZER THAT CAN BE USED AT THE ROADSIDE

Among the advantages possessed by
a vulcanizer now on the market are that



it occupies comparatively little
space, can be operated out of
doors in the wind, adjusts it-
self to rubber of various thick-
nesses, and is self-locking. The
vulcanizer resembles a seal press in its
construction. The rubber to be re-
paired is pressed between an adjustable

bottom plate and a flat-bottom oil cup.
The latter is raised and lowered by a
lever which holds the cup firmly in
whatever position it is placed. The
cup is heated by oil burned within it,
and is covered with a perforated cap
which prevents the flame from being
blown out by the wind. The device
operates quickly and will vulcanize
patches of various thicknesses equally
well.

3320

FIRE-DEPARTMENT WAGON WITH MANY USES

A recent addition to the equipment
of the fire department in Los Angeles,
Calif., is a motor car called a "squad
wagon," built in the department shops,
and unusual in the completeness of its
equipment. It has five powerful search-
lights, used to assist the firemen in
their work by penetrating smoke and
darkness. Two of these lights are
portable, connected to a reel of 300 ft.
of wire, and can be carried into a burn-
ing building to that distance. These
portable lights are provided with tri-
pods, enabling them to be used in the
manner shown in the photograph. The
car carries storage batteries capable of
furnishing light for seven hours, and a
generator of sufficient power to run all
the lights. The generator is run off
the main drive shaft, with a separate
clutch and silent-chain drive. A switch-
board is conveniently placed over the
generator and the lights can be oper-
ated separately or all together, as re-
quired. A portable oxyacetylene outfit
for cutting metal; a pulmotor for reviv-
ing firemen, or others, overcome by gas
or injury; two smoke helmets, which
enable firemen to work in places dan-
gerously filled with smoke or gas,
stretchers, and numerous other appli-
ances and tools useful in emergencies,
are carried on the car, together with a
reserve supply of gasoline for the fire
engines, extra sections of hose, large
and small nozzles, and an assortment
of increasers and reducers, all being
readily accessible on this well-equipped
squad wagon.

F. L. Gibson, Emerson, Neb.
Francis

base, and a vulcanizing cup positioned upon said pivoted plate for movement into or out of engagement with said plate.

2. In a vulcanizer, a supporting structure having a base, said base extending forwardly of said supporting structure, upstanding ears formed integral with said base, said ears being provided with facial recesses formed in their upper sides, a plate, pins formed integral with the sides of said plate, said pins being mounted in said recesses for pivotally supporting said plate, a vulcanizing cup positioned above said pivoted plate, a plurality of rods connected to said vulcanizing cup and extending vertically therefrom, a head, said rods being rigidly connected to said head and means for raising or lowering said head for raising or lowering said vulcanizing cup into or out of engagement with said pivoted plate.

3. In a vulcanizer, a supporting structure, a base formed integral with said supporting structure and extending forwardly therefrom, upstanding ears formed upon said base, said ears being provided with facial recesses formed in their upper sides, a plate, pins formed integral with said plate, said pins being seated in said facial recesses for pivotally supporting said plate above said forwardly extending base, a vulcanizing cup having a plurality of pins formed integrally therewith and extending upwardly thereinto, a pair of vertical rods detachably connected to said cup, an arm formed upon said supporting structure and slidably supporting said vertically extending rods, a head rigidly connected to the upper end of said rod and positioned upon the upper side of said arm, upstanding plates connected to said arm, a lever pivotally carried by said plates and means associated with said lever for engagement with said head for moving it upwardly or downwardly for raising or lowering said vulcanizing cup into or out of engagement with said pivoted plate.

4. In a vulcanizer, a supporting structure, a base formed integral with said supporting structure and extending forwardly therefrom, upstanding ears formed upon said base, said ears being provided with facial recesses formed in their upper sides, a plate, pins formed integral with said plate, said pins being seated in said recesses for pivotally supporting said plate above said forwardly extending base, a transversely extending arm formed integrally with said supporting structure, said arm being provided with openings extending vertically therethrough, rods slidably seated in said openings, a vulcanizing cup detachably connected to the lower ends of said rods, a plurality of pins extending upwardly into said vulcanizing cup for increasing the heating area thereof, a head rigidly connected to the upper ends of said rod and positioned upon the upper side of said transversely extending arm, vertical plates connected to said arm, a lever pivotally connected to said vertical plates, a cam formed integrally with said lever and provided with a cam shaped opening extending therethrough, said cam shaped opening having a roller seated therein, said roller being rotatably mounted upon a pin, arms supporting said pin, said arms being pivotally connected to said head, for raising said head and said vulcanizing cup upon upward movement of said lever, the periphery of said cam engaging the upper surface of said head for forcing said head and said vulcanizing cup downwardly upon downward movement of said lever.

~~1,155,910. SANDING DEVICE FOR LOCOMOTIVES.
MILES C. GREEN, Greensboro, N. C. Filed Nov. 9, 1914.
Serial No. 811,110 (Cl. 105-263.)~~

~~1. In combination, a sand box, and an air pipe arranged diametrically in the lower portion of said sand box having open ends and a plurality of apertures in the upper portion, and sand traps arranged on opposite sides of said sand box adjacent the open ends of said pipe.~~

~~2. In combination, a sand box, an air pipe having a plurality of apertures in the upper portion thereof and having open ends arranged in spaced relation to the wall of said box, and traps arranged on opposite sides of said sand box adjacent the open ends of said pipe.~~

1,155,908. BOTTLE-CAPPING MACHINE. JOHN J. GAYNON, Indianapolis, Ind., assignor to Progress Machine Company, Indianapolis, Ind., a Corporation. Filed July 20, 1914. Serial No. 851,965. (Cl. 113-2.)

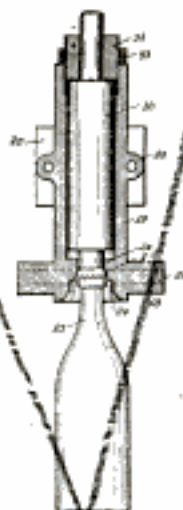

1. A bottle capping machine including a capping plate with a tapering throat in it, a plunger for discharging the bottle and cap with its lower end projecting through the capping plate into the throat thereof, adjustable means for positively limiting the upward movement of the plunger at the instant that the throat of the capping plate limits the upward movement of the cap and mouth of the bottle, and a vertically movable bottle support.

2. A bottle capping machine including a capping plate with a tapering throat in it to receive the cap and mouth of the bottle, a casing extending upward from said plate, a gravity actuated plunger in said casing, adjustable means secured to the upper end of the casing for positively limiting the upward movement of the plunger at the instant that the throat of the capping plate limits the upward movement of the cap and mouth of the bottle, and a vertically movable bottle support.

3. A bottle capping machine including a capping plate with a throat, a casing extending upward from said plate, a gravity actuated plunger in said casing with the reduced end entering said throat and said plate limiting the downward movement of said plunger, a nut which screws into the upper end of said casing for positively limiting the upward movement of said plunger, and a vertically movable bottle support.

1,155,909. VULCANIZER. FRANK L. GIBSON, Pender, Nebr. Filed Oct. 6, 1914. Serial No. 865,353. (Cl. 18-18.)

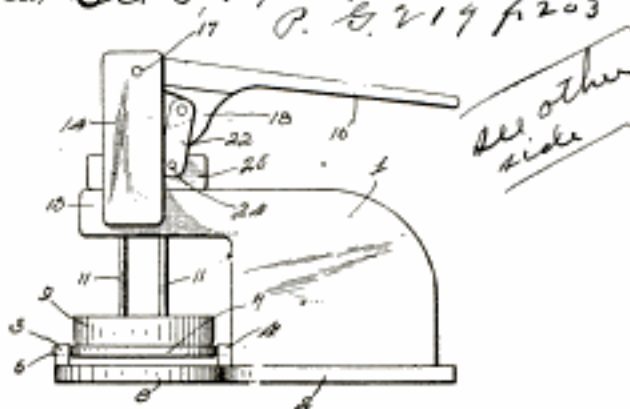

1. In a vulcanizer, a supporting structure having a base formed integrally therewith and extending forwardly therefrom, upstanding ears formed upon said base, said ears being provided with recesses formed in their upper ends, a plate having pins formed integrally therewith, said pins being seated in said recesses for pivotally supporting said plate upon said forwardly extending section of said

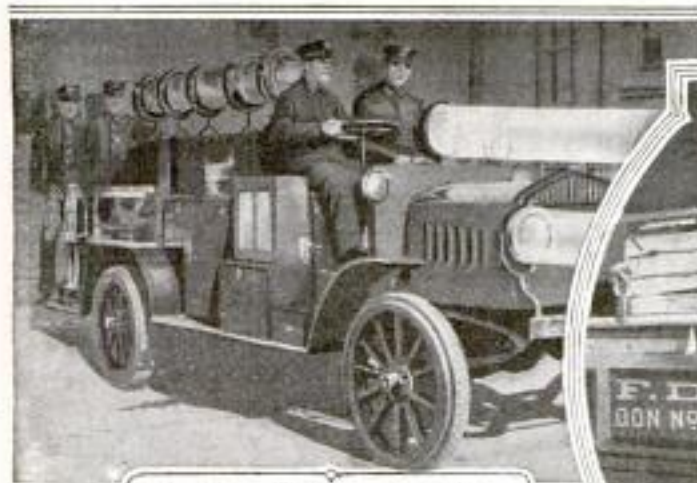

New Squad Wagon of the Los Angeles Fire Department Starting on a Run: The Car was Designed by a Department Engineer and Built in Its Own Shops. The Five Powerful Searchlights, Seen in a Row behind the Driver, Greatly Assist the Firemen at Smoky Fires

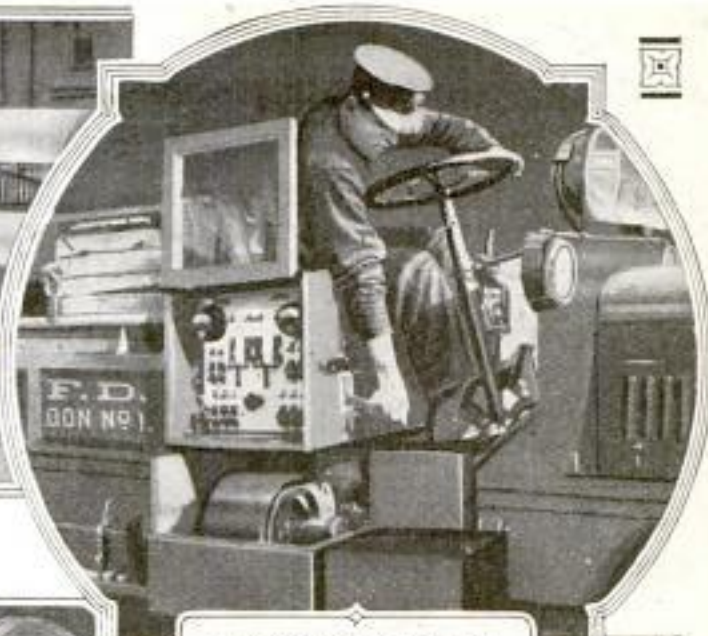

In This Photograph the Driver is Shown in the Act of Throwing the Generator into Gear to Furnish Current for the Searchlights on the Squad Wagon, Two of Which Are Portable. Above the Generator is the Switchboard by Which the Searchlights are Controlled

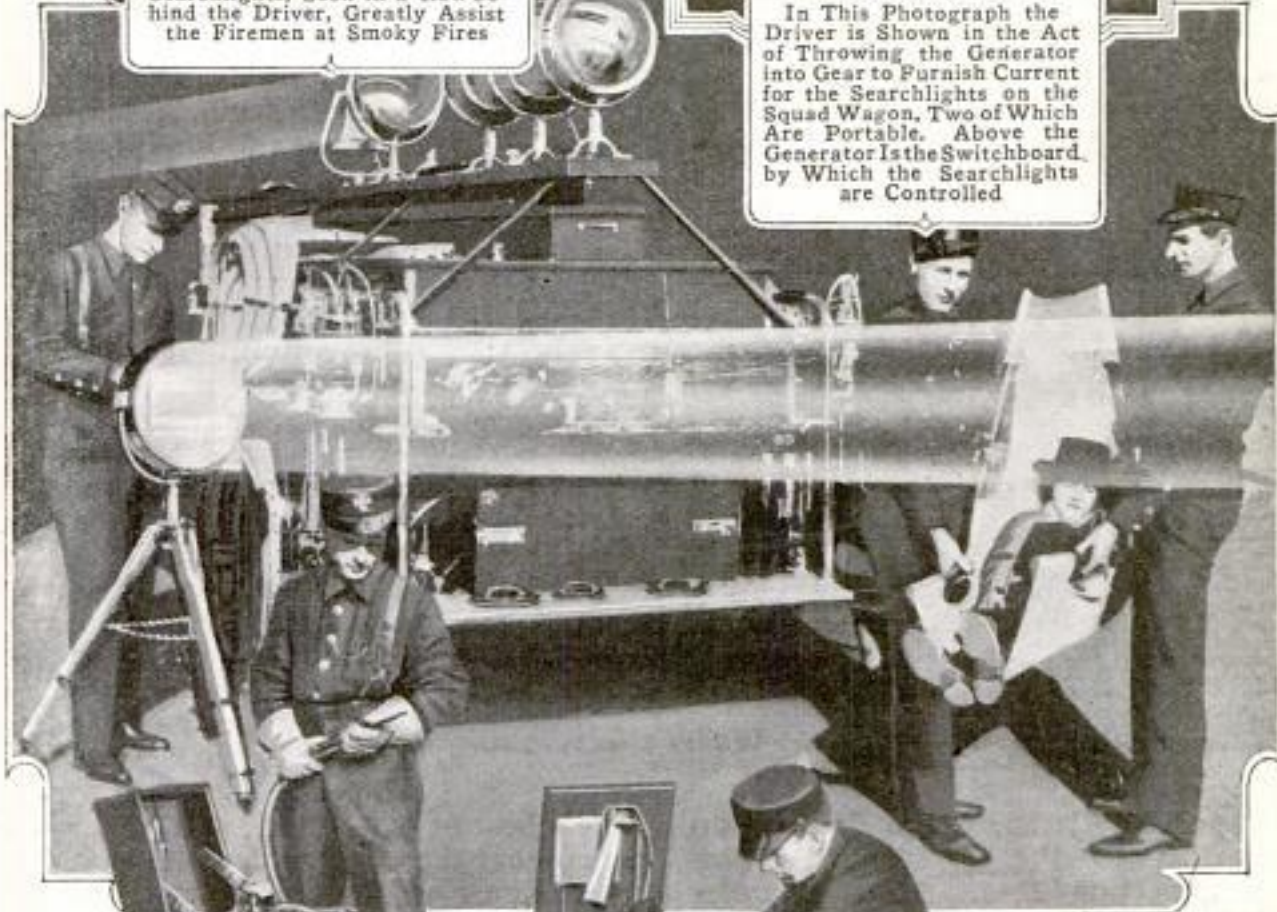

Here One of the Portable Searchlights is Seen in Use on a Tripod, Its Rays Being Strong Enough to Penetrate the Dense Smoke of a Fire and Enable the Firemen to Work to Advantage. At the Right, the Use of a Collapsible Stretcher is Illustrated, Two of These being Carried in a Compartment on the Wagon; the Patient may be Carried in Either a Lying or a Sitting Posture. A Trained Nurse is a Member of Each Crew

At the Left is the Oxyacetylene Apparatus with Which the Squad Wagon is Equipped for Cutting through Metals When Necessary at Fires. At the Right a Fireman is Using the Pulmotor to Induce Respiration and Restore Consciousness in a Person Overcome by Smoke

CARS FOR ALASKAN ROADS SHIPPED FROM SEATTLE

Before the close of the shipping season railway passenger cars were loaded aboard a steamer at Seattle and

HOW BUREAU OF MARKETS IS AIDING FARMERS

The secretary of agriculture in his recent report points out that in the three and one-half years in which the

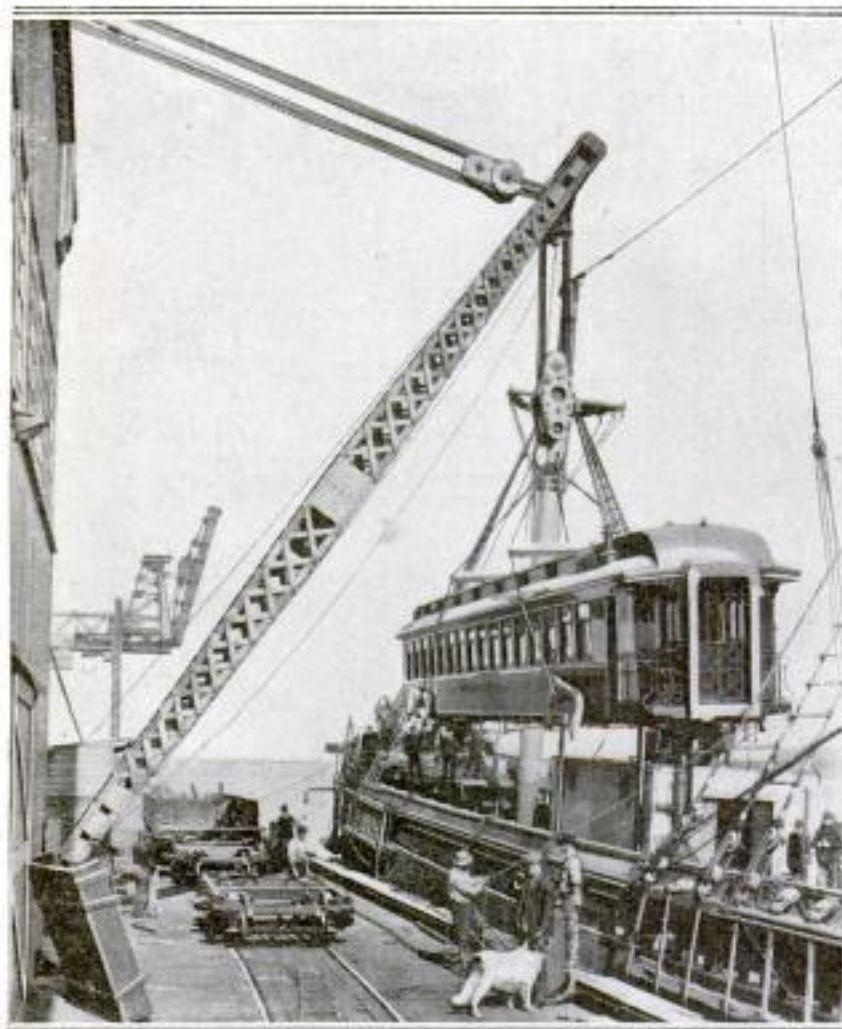

Passenger Cars for the Government's New Railway Lines in Alaska being Loaded onto Steamer at Seattle

Office of Markets and Rural Organization has been in existence it has rendered many important services in the matters of marketing farm produce and of rural finance, and in other agricultural questions. For example, an organization of cooperative fruit growers, corporations, and individual fruit growers has been formed in the Northwest, which aims to secure broader distribution of its products by establishing uniform grades of fruit, and uniform marketing methods. The office has also issued systems of well-tested accounts and records for primary grain elevators and live-stock shipping associations. Systems are being tested for country creameries and cotton warehouses. Monthly cold-storage reports are issued showing the holdings

shipped to Alaska, where they are to be used on the government's new transportation lines. About 85 miles of the latter, extending in two directions from Anchorage, has been constructed. When completed 1,000 miles of new trackage will connect Cordova and Fairbanks as well as the coal fields of the Kuskokwim River district with Susitna and Seward. Linking existing lines, this network will open a section of the country which is rich in natural resources. The late shipment of cars foreshadows another of America's important engineering victories.

of apples, eggs, butter, and cheese throughout the country, together with comparisons with the previous year. The secretary recommends that the name of the office be changed to Bureau of Markets.

— 2945 —
**NAVY BUILDS STURDY FERRY
FOR GOAT ISLAND TRIPS**

To take the place of the somewhat unsatisfactory open-deck tugs heretofore plying between San Francisco and the Goat Island-naval training station, the Navy Department has designed

Man Island



Both at Its Bow and Blunt Stern, the "Admiral Glass" Has Generous Deck Space

and recently placed in service an odd little ferry known as the "Admiral Glass." From its stern the vessel has the appearance of a river house boat, but the bow view shows it as quite trim, although a bit unusual in some respects. With a length of 85 ft. it has a 20-ft. beam and 3½-ft. draft. Twin screws are mounted at its square stern and driven by two gasoline engines which give the craft a speed of slightly more than 10 miles an hour. Four-foot passageways extend on either side of the deckhouse, which is fitted with lateral seats. The little craft can carry about 300 passengers, and it is thought that it has freeboard and housing enough for comfort in rough weather, and sufficient deck space fore and aft for ordinary needs when the water is smooth. It is stanchly built and considered quite seaworthy.

3283

FIFTEEN ACRES OF DAISIES UNWELCOME FLOWER BED

Despite the fact that we buy them by the dozen in the cities, paying a dollar or so for a small bouquet, daisies are a menace to the agriculturist, and a patch or field of them is anything but welcome. A Nebraska farmer, near Beatrice, who wished to obtain a good stand of Kentucky blue grass in his pasture, last season instructed a well-known mail-order house to ship him several bushels of seed. He prepared

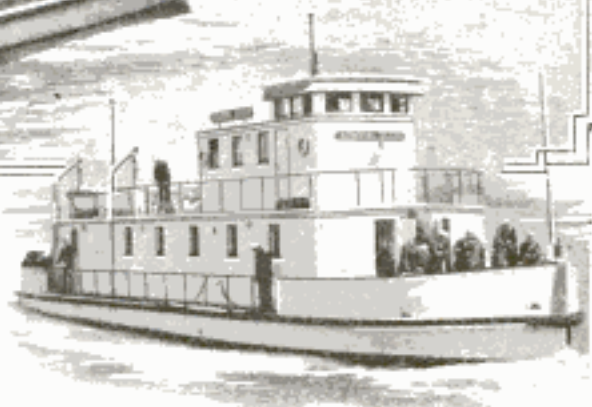

The Odd Little Ferry That Now Plies between San Francisco and the Naval Training Station at Goat Island

15 acres of land and planted it, exercising particular care. The spring rains came, and following them 15 acres of yellow-centered daisies, a luxuriant crop. The unusual sight attracted motorists from miles around and hardly a day passed without parties stopping to pick armloads of the blossoms. It is not clear how the mistake occurred, but mistake—and a serious one—it was. The company, needless to say, promptly made restitution so that the farmer in the end got a liberal return for his unexpected and undesired crop.



Daisies, Millions of Them, Covered the Pasture Sown to "Blue Grass"

USE FIRELESS STEAM ENGINE FOR SAFETY PURPOSES

In the yards of a wood-preserving plant at Orrville, Ohio, a fireless steam locomotive is employed as a safeguard against conflagrations. The engine is

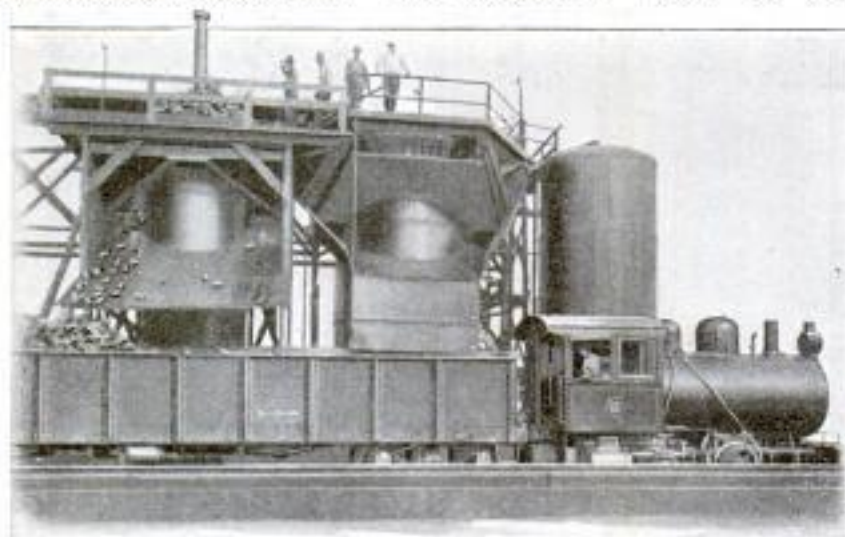

Instead of being Generated by It, Steam is Pumped into This Engine under High Pressure and in Sufficient Volume to Permit Operation for an Entire Day

fact that one of the first of its kind was the subject of much speculation a few years ago when displayed at an Italian exposition. At that time its practicability had yet to be proved. The locomotive does not generate the steam it uses, for its main part consists of a large cylinder—instead of a fire box and boiler—that holds a sufficient quantity of steam under heavy pressure for eight or more hours of operation. Steam is developed at a power plant and pumped into the reservoir before the beginning of the day's work. The piston cylinders are placed at the rear beneath the cab, instead of at the front of the engine, for the purpose of balance. The locomotive in the yards at Orrville weighs 22

interesting not only because it is of unfamiliar type, but on account of the

tons and pulls about a dozen steel gondola cars, fully loaded.

3042

SWINGING BASKET IN MOTOR BABY'S CRIB ON TOUR

Born while its parents were on a cross-country tour, a Chicago baby has the distinction of having become a motorist at the age of two weeks and of making a trip of several thousand miles in an open car without so much as a whimper. Instead of abandoning their overland journey upon the child's birth, the parents continued it, making their way across desert, mountain, and plains to the Mississippi Valley region from the Pacific coast. Throughout this long tour the baby swung peacefully in a comfortable basket

suspended in the tonneau from braces supporting the top. Each morning it had its bath at some cool stream or lake and a brief sunning while reposed on the top of a boulder or stump.



When Two Weeks Old, This Baby Started on a Motor Trip of Several Thousand Miles with Its Parents, Riding in a Softly Lined Basket Suspended in the Tonneau

Briseve

Motor Corp'n
Jackson, Mich.

3596
HEALING WOUNDS BY WASHING AND
BY MATHEMATICS

Louis R. Freeman, 287 Calif. St., Pasadena, Calif.
BY R. J. BJURSTEDT

UNDOUBTEDLY the most important medical discovery made during the war is that of Doctor Carrel, of the Rockefeller Institute, who, working at a hospital maintained by the institute at Compiègne—just behind the battle line in northern France—has perfected a method of sterilizing wounds, so efficacious that, of the hundreds of patients that have so far been treated by it, only one has died. And this one, it is interesting to know, did not succumb to the original shell wound in the back for which he was brought to the hospital, nor yet on account of the trachea and jugular which he severed with a hastily snatched surgical instrument in an attempt at suicide during a fit of madness, but to a violent attack of pneumonia induced by his exposing himself at an open window in the absence of his attendant.

Nothing approaching perfect sterilization of any but the most superficial wounds had ever been effected from the time of the great pioneer, Doctor Lister, down to the beginning of the war, when the infliction of deep and terrible wounds at a rate many thousand times greater than through the ordinary accidents of peace time, made the need of such sterilization vital and immediate. It was to the discovery and perfection of some means of sterilizing wounds—and especially

the yawning, lacerated tears left by shell fragments—that the genius of Doctor Carrel was directed. Working in time of peace, with nothing but dogs and cats and mice and guinea pigs to experiment with, the remarkable method which this distinguished surgeon and scientist has evolved might well have been imperfect at the end of many years; with real men—breathing, bleeding men—at his disposal in an endless stream, his object was practically accomplished before the first anniversary of the war came around. That is to say, the "Méthode Carrel" as practiced today was put in operation in the hospital maintained by the Rockefeller Institute under the supervision of the French Red Cross at Compiègne over a year ago; the interim has been employed in perfecting certain minor details, in bringing it to the attention of other hospitals, and in training visiting surgeons in the working of it. Among the latter, it is interesting to note in passing, has been the head of one of the great railway and smelter hospitals at Pueblo, Colo., who has made preparations to put the "Méthode Carrel" into operation there at the earliest possible moment.

To effect the complete sterilization of a wound Doctor Carrel came to the conclusion that it would be necessary to carry the antiseptic to all parts,



Pierre du Nouy, Who has Discovered a "Law of Cicatrization," Which Makes It Possible to Calculate the Exact Day upon Which a Wound will Heal

rather than only to the surface, as has been the case with the practices hitherto followed. For this purpose an apparatus was perfected, consisting of a glass receptacle, of about 2-qt. capacity, to be suspended several feet above the bed on which the patient under treatment is lying, and a rubber tube to carry the solution to the wound. On reaching the wound this tube divides and sub-divides—by means of glass joints

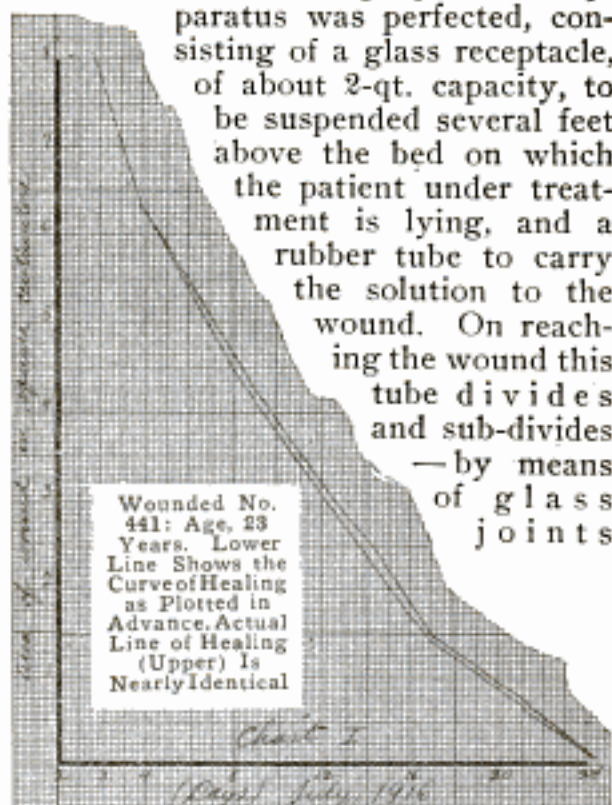

and elbows—into smaller tubes, which are buried in the torn and lacerated flesh under treatment. The small tubes are closed at the ends and perforated at intervals of every half inch or so with small round holes, so that whenever the solution is allowed to enter them the slight pressure which it is under from the elevation of the receptacle above the bed forces it out into and through all parts of

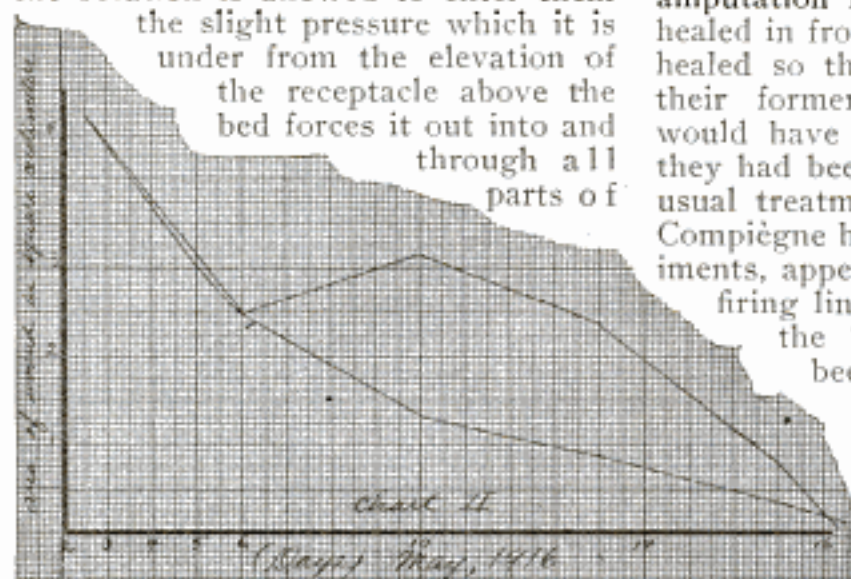

Wounded No. 378: Age, 27 Years. Wounded in the Thigh; Lower Line, Calculated Healing; Upper Line, Actual Curve of Healing. Infected from the Sixth to the Tenth, but Overtook Calculated Curve on Removal of Infection and Healed on Day Reckoned in Advance

the wound. Any excess of the solution drains off—carrying with it the germs of infection, and is absorbed by bandages, which are changed every time the wound is flushed—usually about every two hours.

The antiseptic, on which the great chemist Dr. Henry D. Dakin worked for many months, performing hundreds of experiments before perfecting it, is a .5-per-cent solution of hypochlorite of soda. It is death to the bacteria of infection, on the one hand, and, on the other, absolutely un-irritating to the tender flesh which it must permeate in its hunt for the poison. This solution has the added advantage that something like 35 liters of it can be made at the cost of a franc, or at the rate of about two cents a gallon.

The decrease of the bacteria of infection in the most terrible wounds under treatment by this "flushing" method astonished even Doctor Carrel and his assistants until they came to take its continued success as a matter of course. The bacteria are simply killed and washed away, where, under other treatments, they were left to be taken up by the already vitiated blood. The new way reduces the infection and, of course, hastens healing. Legs and arms that no surgeon would ever have dreamed of treating by anything but amputation in the past, are not only healed in from one to three weeks, but healed so thoroughly as to retain all their former usefulness. Men that would have been cripples for life—if they had been saved at all—under the usual treatments have gone from the Compiègne hospital direct to their regiments, appearing shortly after on the firing line. Indeed, men have left

the "Ambulance Carrel" and been back again with new wounds inside of a fortnight. One such, who was taken with his second wound—a horrible close-range shell gash rapidly turning into gaseous gangrene—to another hospital where the "Méthode

Carrel" was not in use, made such a protest against the amputation of a leg, which he insisted Doctor Carrel could save, that, at the risk of his life, he was sent back to his "first love" at Compiègne. It is gratifying to be able to record that his faith was rewarded. His wound—I saw a color picture of it on a screen thrown from a Lumière slide—though it became for a time one of the worst gaseous gangrene sores ever known, rapidly yielded to the Carrel treatment, and the man was about to be discharged with almost the complete use of the wounded leg when I visited the hospital a few weeks ago.

The accompanying photograph, showing a leg and foot under treatment by the "Méthode Carrel," gives some idea of the astonishing cases that are successfully handled. The unlucky *poilu* to whom it belonged was literally lifted by a shell which struck at his feet and exploded. By some inexplicable trick of fate he escaped complete disintegration, only this leg and foot being caught in one of the freakily spread "jets" from the explosion. A hundred times over it appeared a case for amputation 6 in. above the knee, for not only were both large bones of the leg shattered, but practically every one of the numerous small bones of the foot were either broken or displaced. "The foot and part of the lower leg were simply a pulp," one of Doctor Carrel's assistants told me. "From what we had done in the past, I felt sure we could save the man's life without amputation, but I could not conceive how the member we preserved could be worth preserving. Both myself and Doctor X— were for amputation; but Doctor Carrel thought otherwise.

And, as it turned out, *he* was right, as he always is somehow. It was, of course, absolutely impossible to bring the leg through as good as it was; but what we *did* save was a member which, with the help of very light and readily adjustable braces, is fully 100 per cent better than any artificial limb could ever be."

Perhaps in no military hospital in Europe is the coöperation between clinic



Bacteriologist Taking a "Smear" from Which to Determine by Microscopic Study the Progress of the Elimination of the Infection in a Shell-Shattered Foot and Leg under Treatment by the "Méthode Carrel"

and laboratory so complete as in the "Ambulance Carrel." A "smear" for microscopic examination is taken once a day from every wound under treatment, and a careful record is kept of the decrease in the bacteria of infection. Should these fail to decrease, the microscope reveals the fact even before it would have been notice-

able through a retardation in the rate of healing, and means are at once taken to find what is wrong and apply the remedy. The very day that the laboratory reports that a wound is free of infection, a longer and completer "flush" is given it with the solution, and it is closed for good. No provision for "draining" is necessary, as suppuration is at an end. It is even practicable—and apparently desirable—to close a bacteria-free wound over a knitting bone. Once the infection is gone, the bone appears to knit all the faster for having the flesh closed over it.

So nearly perfect is the action of the Carrel method, so regular is the healing of a normal wound under treatment by the Dakin solution, that it has been found possible to determine in advance the exact day upon which the healing process will be completed. Just as an eminent chemist was given the task of discovering the best solution, so was a mathematician of great ability set that

of discovering this so-called "law of cicatrization or healing." Pierre du Nouy, who bent his energies to this phase of investigation at the instance of Doctor Carrel, found at the outset that the rate of the healing of a wound of an otherwise healthy man under the Carrel treatment varied according to his age, and, unless the man had malaria or the germs of some blood disease in his system, was apparently little affected by anything else. The size of the wound, of course, was an element to be reckoned with, and, basing his calculations upon that and the age of the man, du Nouy was able to work out a decimal which he calls the "index of cicatrization." Putting this "index" into a lengthy algebraic formula in which all the other values are "constants," he gets a result which is the number of days the wound—under normal conditions—should take to heal.

The du Nouy law of cicatrization now enters into the regular practice of the "Méthode Carrel." One of the first things done after a patient enters the hospital is to take a tracing of his wound and compute its exact area in square centimeters. With only that and the age of the man to go by, du Nouy plots a curve on a chart showing the exact size that the wound *should* be at the normal rate of healing every day until it is finally closed. How this is done is shown on the two accompanying charts, on each of which the lower curve is the one plotted in advance to show the rate at which the wound *should* heal, and the

upper line is the curve showing how it actually *did* heal. Ninety-nine per cent of the cases are similar to that shown on chart I, where the curve of cicatrization as plotted in advance is practically identical with the actual curve of healing. That is to say, the wound not only actually healed on the date reckoned in advance, but its size on every one of the intervening days was also according to the preliminary reckoning.

At rare intervals one finds cases like that shown on chart II, where a wound starts to heal as plotted, and then—through accidental infection or some other cause—refuses to continue healing, or even gets worse and grows larger. But here appears the most astonishing thing of all; for when the cause of the retardation has been discovered and removed, the wound, as though ashamed of the trouble it has caused, begins to heal faster than ever and always regains the lost ground and closes as per schedule.

The one regrettable fact that there is to record in connection with the remarkable triumphs attendant upon the practice of the "Méthode Carrel" is the slowness with which it has been taken up by the regular military hospitals of France. The British Admiralty is arranging to use it, physicians from America and Italy have come to study it, and yet the French themselves appear extremely reluctant to adopt a system which—if installed in all of the hospitals of the republic—would save hundreds of lives, thousands of limbs, and millions of francs every month.

3347 IMMENSE GENERATORS IN A MOTOR FACTORY

The largest electrical power-generation plant of its kind in the United States has been completed recently at a motor factory in Detroit. The plant is run on direct current throughout and has a rating of 65,000 kilowatts, total load, at 250 volts. This includes six new generators said to be the largest of their voltage ever built, each having

a rating of 4,000 kilowatts at 80 revolutions per minute. They are of the commutating-pole type with compound field construction. The armature, 15 ft. 6 in. in diameter, carries about a ton and a half of copper in coils, while the commutator, 9 ft. 6 in. in diameter, contains over two tons of copper. Other parts contain a ton and a half more, making a total exceeding five tons of copper used in the construction of one of these machines. The shaft

Ford Motor Co.

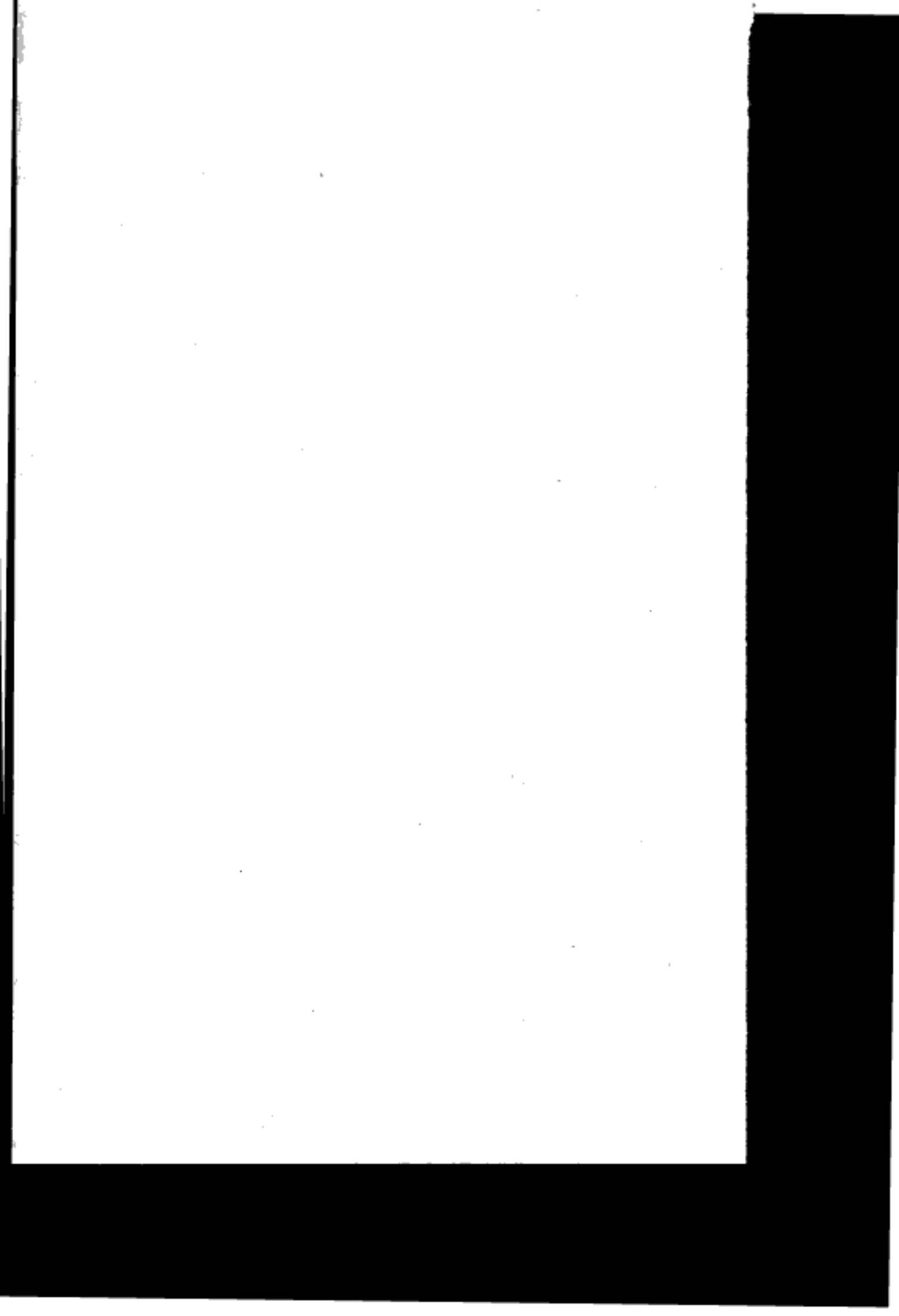

Boilers (under construction) 4000 H.P.
"Dadelhouse" Type

Coal: Mead Morrison Conveyor System
Mead-Morrison Mfg Co.,
East Boston, Mass.

Taylor Stokers
American Engineering Co., Phila.

Engines designed & made under
direction of F. M. Co.
by Hoover, Owens, Rentschler Co.
Hamilton, O.

Generators
Crocker-Wheeler Co., Amper, N. J.

I-T-E Motor Operated Field Rheostat
Mechanisms
Cutler Electrical Mfg Co.
19th + Hamilton, Phila.

Designer W. B. Mays, Engineer F. M. Co.

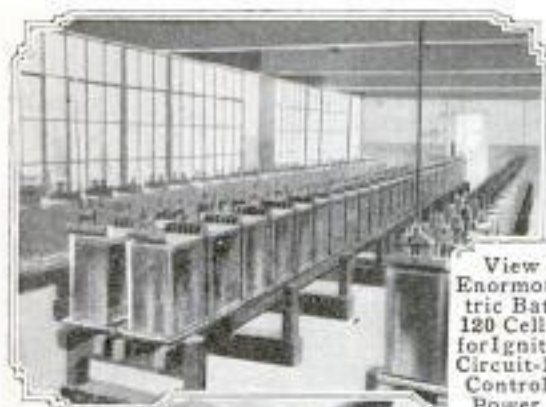

View of the Enormous Electric Battery of 120 Cells, Used for Ignition and Circuit-Breaker Control in the Power House

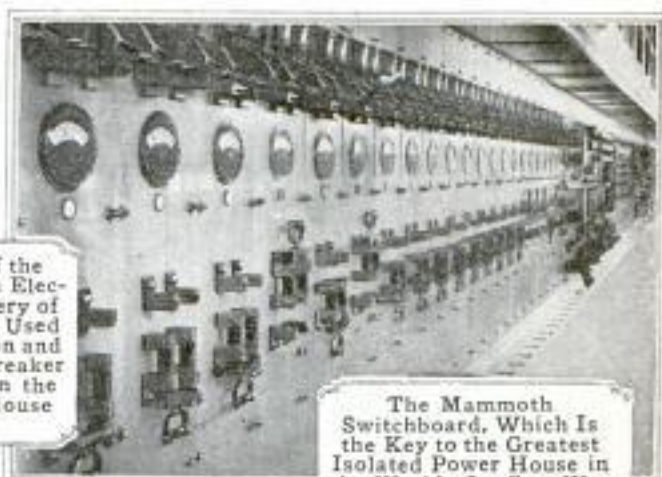

The Mammoth Switchboard, Which Is the Key to the Greatest Isolated Power House in the World: Its Cost Was \$400,000

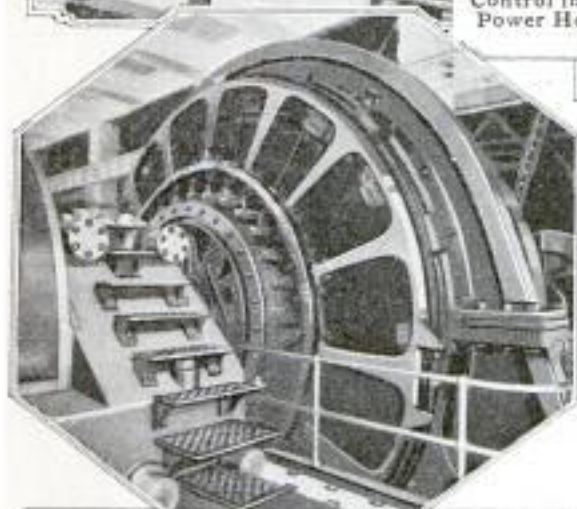

One of the Six Huge Electric Generators Installed in the New Power House of a Detroit Automobile Factory: They Are the Largest 250-Volt Machines of Their Kind Ever Built and Each of Them could Light More than 90,000 Tungsten Lamps

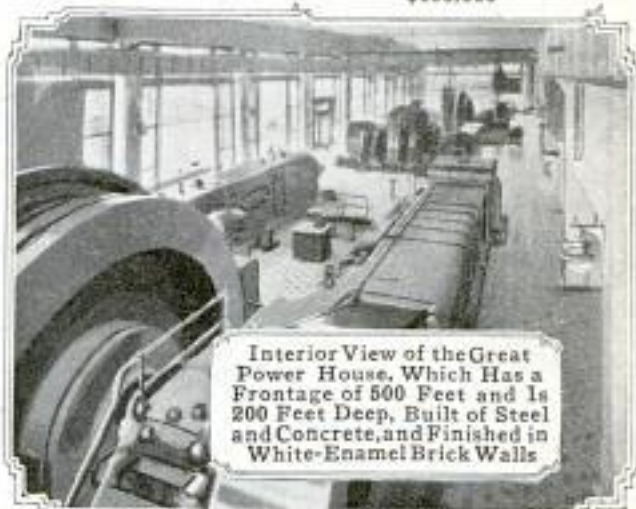

Interior View of the Great Power House, Which Has a Frontage of 500 Feet and Is 200 Feet Deep, Built of Steel and Concrete, and Finished in White-Enamel Brick Walls

carrying the armature is 34 in. in diameter. Such a generator could furnish current sufficient to light a city of more than 100,000 people. It weighs, including the shaft, 135 tons. The switchboard used for control of the plant is 424 ft. long, having 222 panels of Tennessee marble. The power which can be developed is equal to 45,000 hp. The power house is second in size only to that of the Krupp works in Germany. One of its features is the largest ignition battery in the world.

3518

FLOOD PROTECTION FOR RIVER-BED WELLS

A series of 12 wells located in the bed of the San Diego River, Calif., is protected against flood damage by wedge-shaped structures of heavy timber and railroad iron, placed in front of each of the wells, with the nose of the wedge pointed upstream. While

the river is dry in summer, it often becomes a torrent in the winter season, when the superstructure covering each well, with air-lift apparatus, is liable to be torn out by floating débris. In constructing the protecting wedges, three 30-lb. rails were first driven to a depth of about 24 ft. in the sands at each well, and the wedge was completed with heavy planks. Each wedge extends 6

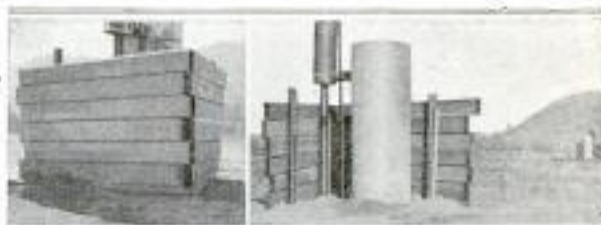

Timber Wedges Provided to Protect Wells in a Dry California River Bed against Flood Damage in Winter

ft. below the surface of the sand and 6 ft. above, thus forming a barrier against shifting sands as well as floating débris.

*A. C. Francis,
City Hall, San Diego, Calif.*

AMUSEMENT-RESORT BOOTH MADE OF REDWOOD LOGS

At Venice, one of the popular sea-side resorts of southern California, a concession booth has been constructed



This Queer-Looking Structure Consists of Two Massive Redwood Logs, Hollowed and Joined Together

from parts of a giant redwood tree. In order to transport them from the forest, two massive trunk segments had to be cut into sections, like a pie. These "slices," covered with the natural bark, were later assembled and the building erected by placing one of the hollowed logs on end and laying the other flat. The two were then connected and doorways provided.

3571 — *W. H. Kane & Anderson* CLAMP FOR PAPER HANGER'S UNHANDY OUTFIT

Among the troubles of the paper hanger in the past has been that of carrying and keeping together his pasteboards, straightedge, and trestles. This is eliminated by a new clamp, or

Kane & Anderson
1113 E. 55th St., Chgo.

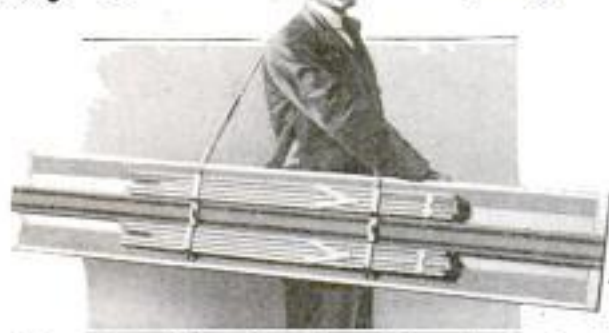

This Shows How the Paper Hanger's Outfit is Securely Fastened Together for Carrying with the New Clamp Bolted through the Boards

pair of clamps, with adjustable carrying straps, recently devised by a Chicago firm. Before applying the clamps for the first time the straightedge is laid longitudinally in the center of the boards, in the carrying position, and holes for bolts are bored 11 in. on either side from the middle, through boards and straightedge, so that the clamps when adjusted and bolted tight are 22 in. apart and the entire outfit, including trestles, is securely fastened together.

3506 FOLDING STEEL STAND FOR SIGNAL LANTERNS

A folding steel lantern stand now being used by contractors, pavers, etc., is a big improvement over the makeshift supports which are commonly employed to hold lanterns that mark open ditches and the like. The stand somewhat resembles a camera tripod, and

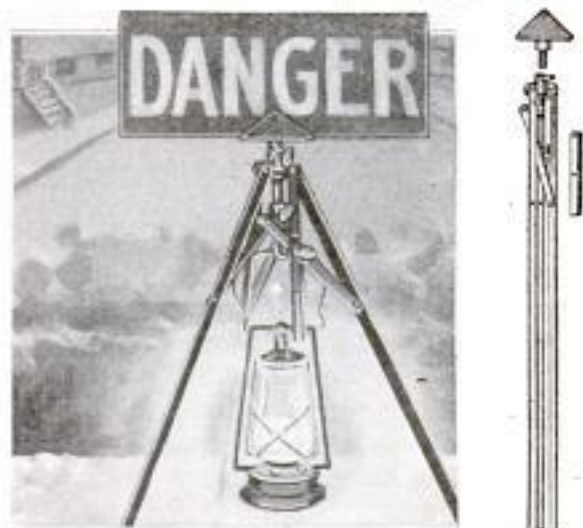

Folding Steel Stand to Which a Sign and a Lantern can be Attached: The Lantern can be Locked to the Frame so That the Latter cannot be Folded Up

extending downward from its apex is a hook on which the lantern is hung. A steel arm is provided that can be inserted through the lantern frame and locked to the stand in such a way that the latter cannot be folded up, nor can the light be removed. This feature lessens the possibility of the device being stolen. At the upper end of the framework is a detachable plate to which a sign can be attached if desired, so that the stand can also be of use by day.

Berger Specialty Mfg. Co.,
16 N. 20th St.,
Richmond, Va.

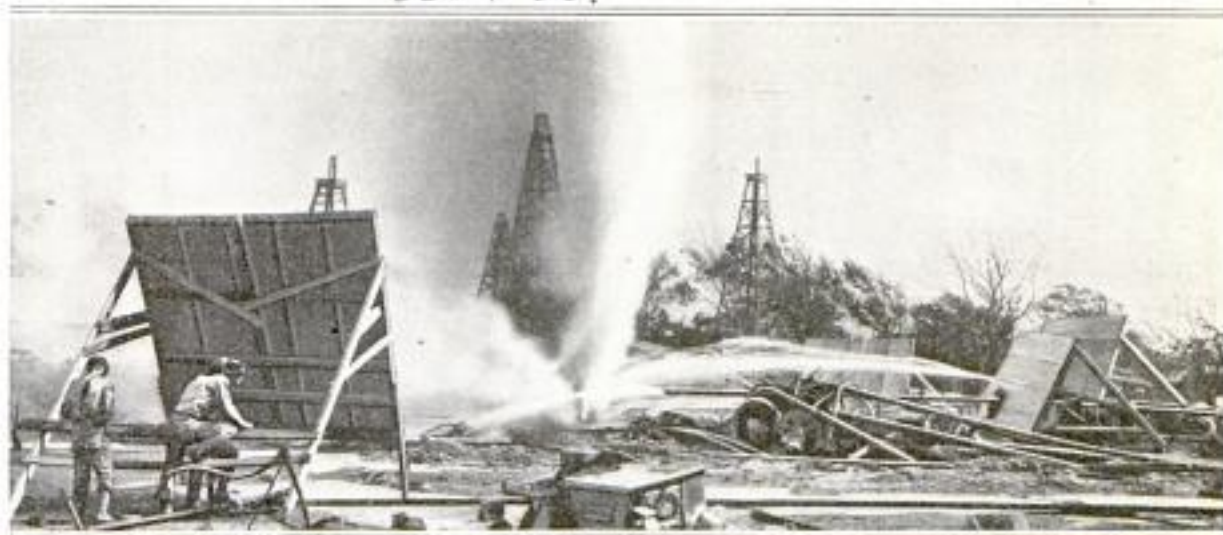

Fighting a Gas-Well Fire with Streams of Water Which are Directed from behind Hastily Erected Screens of Corrugated Iron

FIGHT GAS-WELL FIRE FROM BEHIND SCREENS

Many valuable holdings in the Goose Neck oil fields of Texas were seriously endangered recently when a gas well in the midst of several oil wells caught fire. Streams of water were directed toward the spouting flame and the surrounding ground was flooded, in the fight to gain control of the blaze. That the men might get close to the intensely hot fire, large shields, covered with corrugated iron, were hastily erected, and from behind these the streams of water were controlled.

DREDGE PROPELLED EIGHT MILES WITH ITS DIPPER

A dredge boat on the Mississippi River was bereft of its tug not long ago, and as its crew was anxious to get back to port the clumsy craft, which was without any regular propelling machinery, was drawn upstream eight miles by means of its dipper. The method employed was to run the dipper out to the end of its boom, lower it until it had sunk into the bed of the stream, and then draw the dredge forward a few feet, with the bucket serving as an anchor. By repeating this process again and again, slow but steady progress was made, and the destination was reached after eight hours of labor.

SMALL SHACKS ON RUNNERS USED BY ICE FISHERMEN

Fishing through the ice is one of the sports enjoyed in midwinter by the farmers in the lake region of the north woods. Instead of erecting a canvas screen to shelter them from the wind and cold, they usually construct a small shanty and attach runners to one side of it so that it can be tipped onto them and moved from place to place with the aid of a horse.



When Fishing Grounds are Changed, the Cabin is Tipped onto the Runners and Hitched to a Horse

INDICATOR SIMPLIFIES TESTING OF STEEL

A new device for determining when the critical point has been reached in the heat treatment of steel simplifies a process which in some instances has required the use of special laboratory

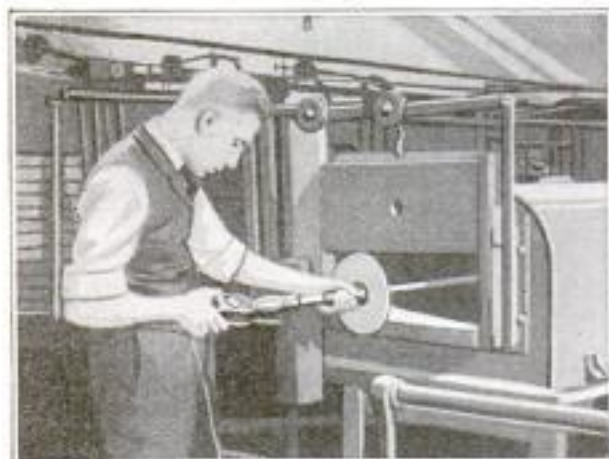

A Device Which Indicates When the Critical Point has been Reached in the Heat Treatment of Steel by Testing It for Its Magnetism

apparatus and the services of skilled men. What is called the critical point is arrived at by raising the temperature of a steel furnace until a chemical combination takes place between the iron and the carbon which are being heated. When this critical point is reached the steel loses the magnetism which it formerly possessed. It is this phenomenon that is taken advantage of when using the new testing device. The instrument consists of a long rod, electrically connected with a transformer, and having at one end magnetic coils which are inserted into the furnace so that a contact is made with the steel. The rod is provided with a magnetic indicator near its handle end. When this member shows that the steel has become entirely nonmagnetic then the workman using the testing device knows that the critical point has been reached and can regulate further treatment accordingly.

3207 MILLS BUILD LARGE DAM TO INSURE WATER SUPPLY

Storage capacity of the west branch of the Penobscot River in Maine has been immensely increased by the construction of a 700-ft. solid-concrete dam by a paper company to insure a sufficient supply of water for its pulp and paper plants at Millinocket. The new dam replaces an old wooden structure and is 92 ft. in extreme height. It creates a storage lake, or reservoir, some 40 square miles in area, and is situated at the head of the Ripogenus Gorge, the outlet of a lake of that name. This is an ideal location for a dam, lying between two mountains. Water is raised at the new dam 60 ft. above its former height, which was about 20 feet over the normal lake surface. Seven former lakes and ponds have been eliminated in forming the new storage lake, which when filled is expected to guarantee an ample water supply for the mills during a two-year period of slight rains. The dam is 64 ft. thick at its base, and has a 16-ft. roadway on top. There are four deep-water gates, 9 by 12 ft., for use in regu-

lating the flow of water. These are operated electrically.

Many million feet of logs are driven down the Penobscot River each season, and provision is made for handling these at the dam by means of a sluice at the eastern end. This sluice is of solid concrete, 450 ft. long, with a drop of about 25 degrees.

The greatest problem which confronted the engineers in this work was that of getting material and supplies to the dam site, which is 46 miles from the nearest railroad station, including 15 miles of water transportation by ferry. Freight carriage over the 31 miles of rough "tote" road was \$10 a ton, and before any work was done on the dam the engineers built a good macadam road to bring in material by motor trucks and so lessen the freight charges. The road cost the company \$250,000, but reduced freight expense to \$2 a ton. Every paper mill and saw-mill in the vicinity, of which there are about 20, will be benefited by the new road and the new dam.



Snubbing One of the Big Motor Trucks Loaded with Building Material down Cyrus Hill on the Way from Lily Bay to the Site of the New Dam at Ripogenus Gorge, near Millinocket, Maine



Thirty-One Miles of This Kind of Highway was Built through the Heart of the Maine Wilderness to Facilitate Transport of Material for the Dam

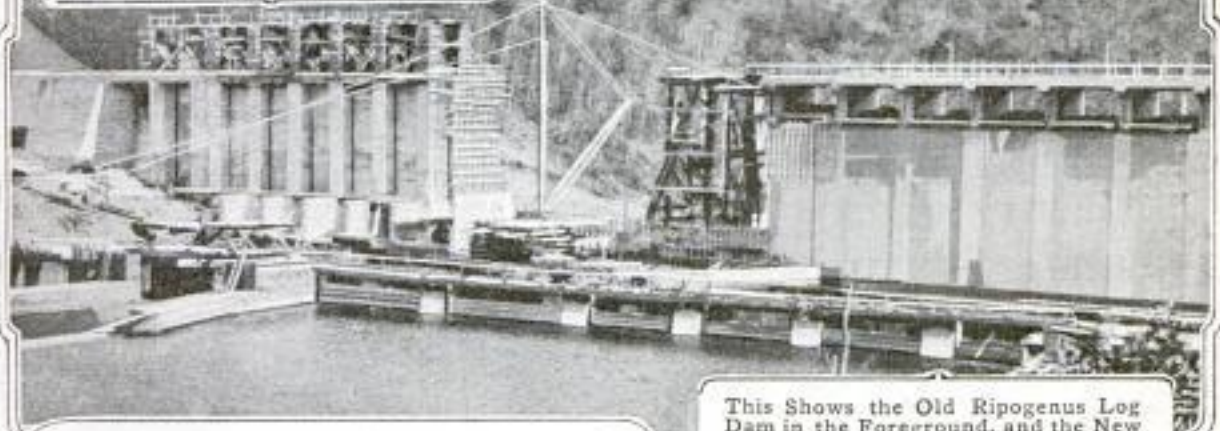

This Shows the Old Ripogenus Log Dam in the Foreground, and the New Cement Structure Rising in the Rear. The Old Dam will Be 60 Feet under Water When the New Lake or Reservoir Fills Up

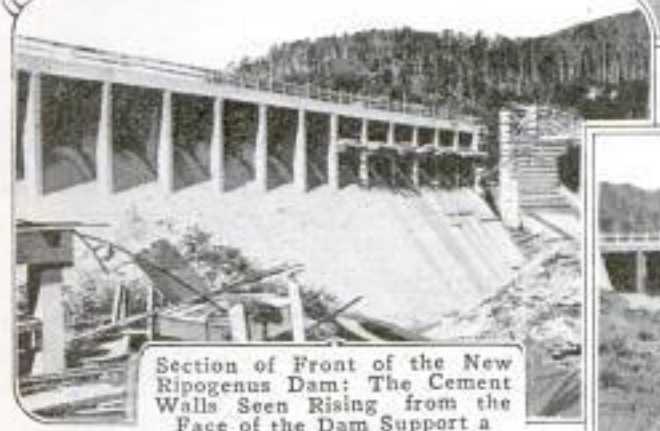

Section of Front of the New Ripogenus Dam: The Cement Walls Seen Rising from the Face of the Dam Support a 16-Foot Roadway



General View of the New Dam, Which will Increase the Storage Capacity of the Penobscot River by 26 Billion Cubic Feet



At the Left, the Log Sluice and Deep-Water Gates. At the Right, a Closer View of the Log Gates at the Head of the Sluice in the New Ripogenus Dam, a 700-Foot Concrete Structure, 92 Feet High



INSPECTORS FIND PRAIRIE HUT IN CHICAGO

What could be more incongruous than the presence of a typical western-Kansas sod house within the corporate



Because of Its Insanitary Condition, This Sod House at Chicago has been Condemned by the City Health Department

limits of Chicago? Such a dwelling was discovered some weeks ago by inspectors from the department of health. The hut, a flat-roofed structure of aged appearance, was condemned because of its lack of sanitation facilities. It had been occupied by a family of six persons.

1751 — CONCRETE-BLOCK MACHINE HAS SPECIAL FACEPLATE

A faceplate for a concrete-block machine has been devised by a resident of Indianapolis which makes grooves on the front of the blocks so that each one appears to be made of several smaller blocks. This effect is produced by ribs that are inserted through slots



Concrete-Block Machine Having a Faceplate with Removable Ribs Which Make Each Block Appear to be Composed of Several Small Ones

in the faceplate. While the block is still in the machine the ribs are withdrawn from the plate, leaving smooth

Chas. E. Phillips

Indianapolis, Ind.

clean-cut grooves. These serve as air passages and prevent any suction that might cause the concrete to stick to the plate. This invention makes possible the use of larger blocks than would be appropriate for many building purposes, because the markings give the impression that much smaller units have been used.

3516 — TEACHING ARITHMETIC BY MECHANICAL DEVICE

Arithmetic is now being taught by means of a mechanical device which, it is claimed, enables pupils to read the sum of figures without adding them, just as they read words without spelling out the letters one at a time. Thus it is said to be just as easy to teach a child that in addition 9-8-3 spells 20 as that c-a-t spells cat. The apparatus has an inner and an outer cylinder, the former covered with combinations or groupings of figures for giving drills in addition, subtraction, multiplication, and division, while the outer cylinder has 20 sliding shutters, the openings of which expose problems. As the inner cylinder is revolved and the problems pass the openings, the pupils call out the answers. The construction is heavy sheet metal, with the exception of the chart of figures and the shutters, these being made of heavy cardboard and fiber material. Noiseless rollers enable the machine to be moved about easily.



3662 — WANT TOPOGRAPHIC ATLAS OF COUNTRY COMPLETED

See. am. 11-25-16
A committee, of which a Harvard professor is the head, has been formed to aid, by all practical means, in hurrying to completion the topographic atlas of the United States. The Geological Survey has devoted many years of ex-

cellent service to preparing these detailed maps, but the task is so great that only 40 per cent of the country has been covered and now some portions of the records are so old as to be of questionable value. From the point of view of national defense, and for many other reasons, a more speedy prosecution of the work is to be urged.

3431

AUTO PROCESSION PASSES THROUGH OHIO SEWER

Seventeen motor cars recently carried a party of city officials and newspaper men through a long storm-water sewer at Columbus, Ohio. The occasion was the formal inspection of the underground passage, a mile and a half in length, which had just been completed to connect the south side of the municipality with the Scioto River for drainage purposes. Nearly two hours were consumed in making the excursion, which was not without incident. The machines were lowered down a steep incline, one by one, with block and tackle, into the mouth of the sewer. After the procession had got well under way one of the leading cars developed engine trouble. This caused a halt, and because the motors of the other cars were allowed to run idly for a while, the passage soon became filled with noxious fumes. Several members of the party escaped through a manhole, while the others coughed and stuck it out until the disabled machine was repaired and the trip resumed.



The Machines were Lowered, One at a Time, with Block and Tackle down a Steep Incline into the Sewer



When the End of the Underground Passage was Reached the Cars Forded the Scioto River

FOREST RANGER GIVES UP HORSE FOR MOTORCYCLE

A forest ranger, whose route lies over many miles of mountain trail not far from Los Angeles, now uses a



Forest Ranger in Southern California Riding over a Rocky Trail on a Motorcycle, Which He Found More Serviceable Than a Horse, and Less Expensive

motorcycle instead of a horse on the journeys which he must take to watch for forest fires and for violators of the fish and game laws. The change in mounts has enabled him to cover the distance in half the time which was required formerly. The machine used is light in weight but with a strong engine, which drives it easily up the steep rocky inclines. Before the motorcycle could be used to the best advantage it was necessary to blast away a few boulders along the path and to grub out some shrubs and bushes.



This Shows How an Airman Flying at the Speed Now Attained by Aeroplanes might Give Timely Warning The Flier is Seen Outstripping the Windstorm Whose Ominous Finger Points Downward in the

PREFER METAL AMERICAN

3544 FLAG TO CLOTH ONE

Because flags of silk or bunting, no matter how good the material, will eventually become faded and torn in spite of the best care, a resident of Boone, Ia., has designed a metal flag which has proven a very satisfactory substitute. It is not angular and inar-

tistic as might be supposed, for the hollow tubing, special wire cloth, brass, tin, and copper of which it is made are combined so skillfully that at a little distance it looks exactly like a cloth flag unfurled by a moderate breeze. The wire cloth is used in such a way that it allows the wind to pass through it, thereby reducing the wind pressure. In spite of the materials used, it is comparatively light. An American flag of this sort flies from the top of a tall bank building in Boone, and it has been found to possess many advantages over a cloth emblem. It needs to be taken down but once in two or three years to receive a fresh coat of paint and remains gracefully unfurled even when there is no wind. It serves as a weather vane and never becomes ragged or twists about the staff.



Metal Flag Which Flies from the Top of a Bank Building in Boone, Iowa

3582
HOW AEROPLANES MAY GIVE WARNING OF STORMS

It is now no uncommon thing for American airmen to outstrip an on-rushing storm in the course of their long and speedy flights, and it is possible that the time is not far distant when due warning of the approach of cyclones and other dangerous storms may be regularly given by aeroplane in the manner pictured above by the imagination of the artist. The machine seen in the illustration, with its trailing smudge as a daylight storm signal and

F. C. Wardall



of a Storm's Approach to the Inhabitants of a Countryside Threatened by Hurricane, Cyclone, or Tornado. Distance, While the People Warned by His Signal Seek Refuge in Cyclone Cellars and Basements

its speed of, say, 120 miles an hour, would be able to warn the inhabitants of a wide stretch of territory, in time for them to seek the shelter of basements and cellars, before the arrival of the storm spreading destruction in the distance. By night, the aeroplane, flying low so that the noise of its engine would be plainly heard and with a signal flare of light, might be equally effective as a life-saver in sections subject to cyclonic storms. At any rate the imaginary scene depicted by the artist is well within the bounds of possibility as an actual occurrence of the near future.

2633

GREASE-SPREADING DEVICE FOR THE CHICKEN COOP

As young chickens peck at the grain in a new type of feeding tray lately devised, their heads come in contact with a wick and are daubed with grease. The preparation, consisting of lard and kerosene, is a specific for vermin and its application in this manner saves much time and labor. The wick is circular in shape, supported above the tray, and kept supplied with grease by a reservoir, which is of such capacity that it requires filling only occasionally.



Oasis Mfg Co.,
Tipton, Ind.

HARVESTING KELP WITH A MOTORCYCLE 3366

Kelp gleaning on the seashore with a motorcycle is the lucrative occupation of a man living in Redondo, Calif. Kelp, as is well known, is valuable because of the potash and other chemicals which it contains, and many machines



A Man Living in Redondo, California, Who Patrols the Beach on His Motorcycle and Gathers Loads of Kelp, Which He Sells to a Chemical Factory

have been invented for harvesting it. But this man uses none of these. Instead, he patrols the sandy beach on his motorcycle and when he finds a number of weeds thrown up by the waves he dismounts and ties them to the rear of his machine so that they trail along behind. When he has accumulated a load, which may weigh as much as several hundred pounds, he drives to a near-by chemical factory and sells it. Within a few hours the rollers toss up another harvest.

Capt. Chas. H. Fuller, Pilot Sillwood Ferry,

414 344V POPULAR MECHANICS
Portland, Ore.

NEW TYPE OF DAVIT PASSES
GOVERNMENT TESTS

One seaman unaided is able to lower a loaded lifeboat quickly and, unless the sea is heavy, safely, with a new type of davit that has lately passed Federal tests at Portland, Ore. Al-

many of those who have seen the apparatus demonstrated have been impressed with its practicability. This does not seem strange when it is known that in actual tests one man has lowered a loaded boat to the water in 48 seconds. The davit has two straight arms that swing in an arc of 90°.

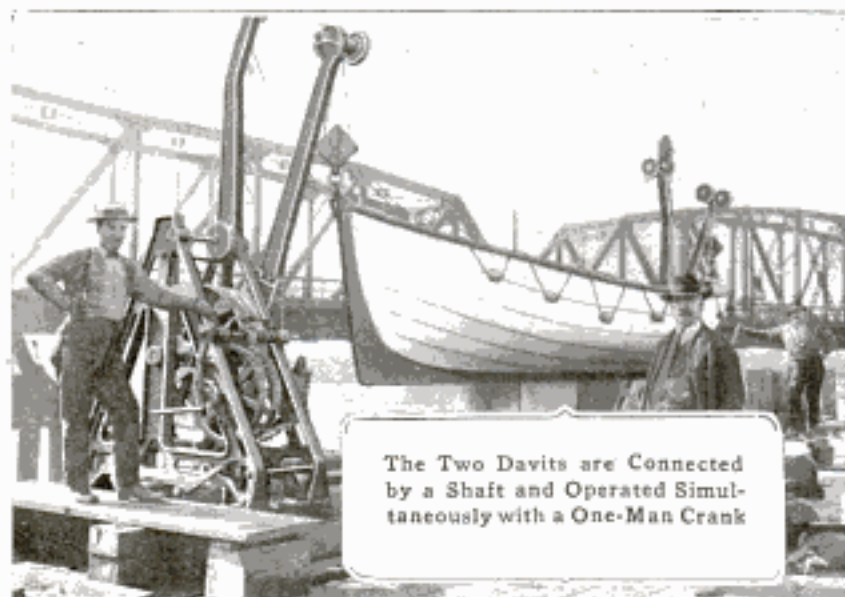

The Two Davits are Connected by a Shaft and Operated Simultaneously with a One-Man Crank

At the upper extremity of each there is a sheave over which the rope passes to a drum. Obviously it is used in pairs, but each set is connected by a shaft so that a crank on either davit operates the separate mechanisms in unison. In normal position the arms are upright. After a boat has been loaded, one of the operating cranks is turned until the craft is raised several inches. The gears are then shifted so that the arms are lowered and the

though it is more complicated mechanically, and doubtless more expensive to install, than the kind in general use,

boat swung free from the ship. The two drums are unreeled simultaneously until the lifeboat touches the water.

2567

PORTABLE FOLDING LADDER FOR ORCHARDS

A portable folding ladder, especially convenient for use in orchards, has

two members, each having rungs, which are fastened together like a step-

ladder. This portion of the device is mounted on a framework which resembles an elongated wheelbarrow except that it has two wheels at the front end instead of one. One of the legs of the ladder is pivotally fastened to the front end of the support. If desired the ladder can be folded up and laid full length in the barrow or it can be



Folding Ladder Which can be Moved About on Its Barrowlike Support, Either in an Upright Position, as Shown on the Left, or Folded Up, as Shown Above

been devised by a California fruit grower. The ladder itself consists of

wheeled about in an upright position from tree to tree.

Wm. H. Mc Crystle,
Vallejo, Calif.

3632

PHILADELPHIA GOLF COURSES AND CLUBHOUSES



Actively Enrolled with the United States Golf Association, and Possessing an 18-Hole Course That Puts Interest into Every Stroke, the Pine Valley Golf Club, Sumner, New Jersey, Has No Closed Season. The Links Roll and Slope, Rise and Drop, and Include Hills and Knolls of Every Variety. The Clubhouse, as may be Seen from the Picture Above, is a Comfortable, Roomy Residence That is Artistically Designed and Beautifully Situated. The Course Has No Hole That is Dull, for Each Has a Different Kind of Approach. Incidentally the Fairway before the Seventh Green, Pictured at the Left, is the Only Stretch of Really Flat Ground to be Found on the Links

Philadelphia has Responded to the Popular Clamor for Public Golf Courses by Establishing a Very Good One in a New Park That has been Opened at the Western Extremity of the City. Two Unpretentious, but Convenient and Well-Arranged Clubhouses, One Intended Solely for Men and the Other for Women, have been Erected. The Links Extend over a 100-Acre Tract of Land That is Broken with Hills, Valleys, and Small Streams. Cobb's Creek, After Which the Park and Course have been Named, has to be Cleared on Five Different Drives. One of the Holes Guarded by the Water, the Third, is Pictured Below at the Right. The Result of a Poor Approach Shot Here can be Clearly Understood



LAWN-TRIMMING TOOL MADE WITH ADJUSTABLE BLADE

For trimming grass along the edges of a sidewalk and around shrubbery



The Wheel Follows the Outer Edges of a Sidewalk so That the Knife Cuts a Straight Groove

and flower beds, an implement has been introduced which materially lessens the work that is usually connected with such operations. It consists of a curved knife, held in an adjustable mounting at one side of a flanged wheel, attached at the end of a long handle. The margin of a sidewalk serves as a track for the wheel and as the tool is pulled the knife makes a straight, clean cut about an inch and a quarter wide and of the same depth.

Arkansas stockmen, during recent cold weather, used electricity to warm the molasses which they mixed with the stock food. The sirup was placed in a vat, which in turn was set in a larger receptacle containing water. Three electric heaters immersed in the water were used to thaw out the molasses, after which one kept it at the right temperature.

SOLDER WORKMEN'S TIME CHECKS TO LUNCH PAILS

Brass time checks have been the means by which the timekeeper for an eastern contracting firm identified a large number of laborers in the concern's employ who could speak scarcely a word of English. However, much confusion was created by the fact that the men frequently lost or misplaced these important bits of metal, so the company hit upon the plan of soldering the checks to the workmen's dinner pails. From that time on no checks were lost or forgotten.

3439

DRAFTSMAN'S RULER FOR MAKING DOTTED LINES

Neat dotted lines can be made as rapidly and accurately as plain ruled lines by using a special draftsman's ruler which has its two edges faced on one side with a corrugated strip of brass. The ruler is used in connection with a ruling pen to which a little device called a leg is fastened. This leg extends downward to within a short distance of the pen point, and when the pen is drawn along the edge of the ruler, the leg rides over the corrugations, causing spaced gaps in the line. One set of corrugations is spaced uni-

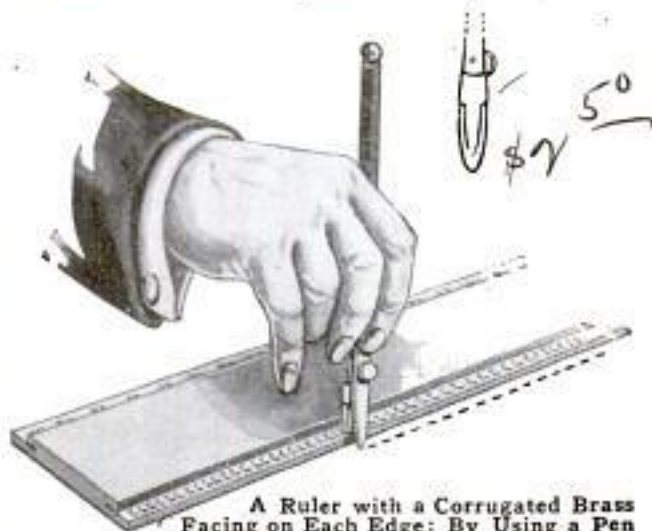

A Ruler with a Corrugated Brass Facing on Each Edge: By Using a Pen with an Attachment Which Rides over the Corrugations, Dotted Lines can be Drawn

formly throughout, while with the other, the ridges are separated by alternately wide and narrow gaps.

Engelbrecht & Brown,
1400 Jackson St.,
Oakland, Calif.

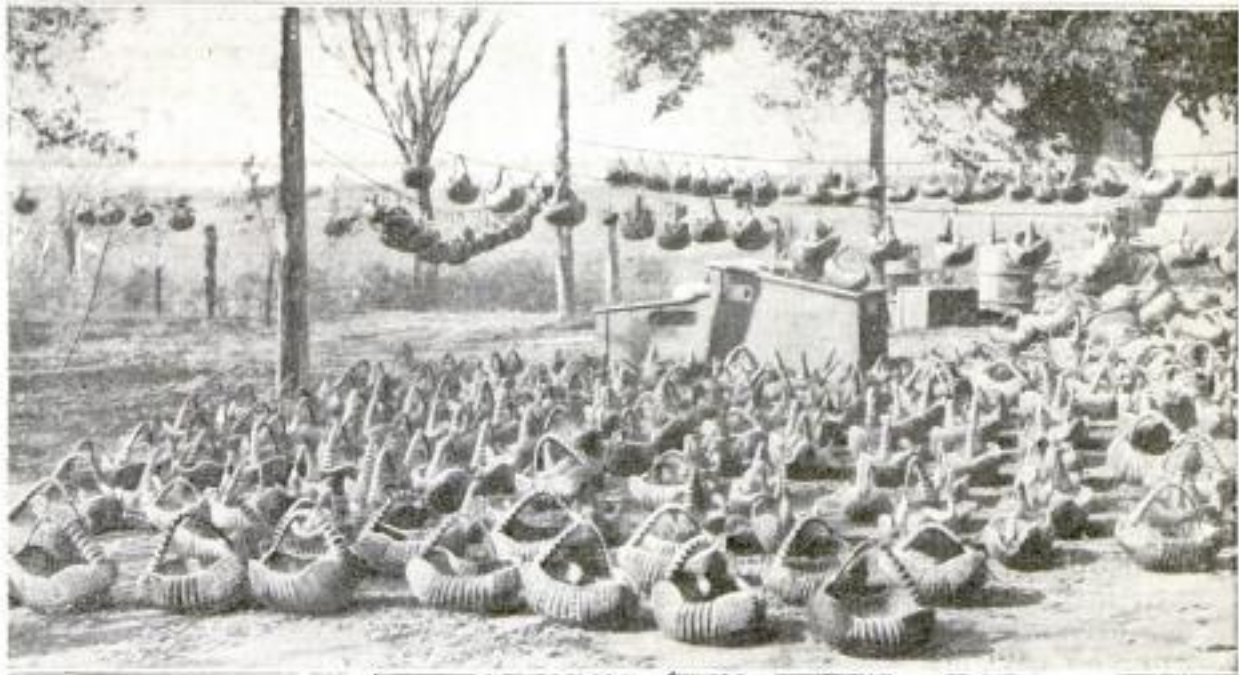

COPYRIGHT, UNDERWOOD & UNDERWOOD *417 Wilmington, N.Y.C.*
 At Times Several Hundred Armadillo Shells are Strung on Wires or Laid on the Ground to be Dried
 by the Hot Rays of the Sun

**ARMADILLO FARM IN TEXAS
 SOURCE OF SHELL BASKETS**

Many of the armadillo baskets shown in the display windows of city shops come from a farm on the Texas frontier, instead of the jungles and plains of South America, as is probably the popular impression. Although these queer mail-clad animals occur chiefly in the forests of Surinam and Brazil, a few species are found as far north as Texas, and these are the ones whose buckled-plate shells are dried, varnished, polished, and shipped as novelties to the northern cities. The armadillo is usually nocturnal, and therefore is most often hunted at night with lanterns much as the negroes of the South search for opossums. They are harmless and offer no fight when captured. The body of the giant armadillo, a species known in the tropics, is about a yard long.

**POWDER PLANT HAS CHUTES
 FOR FIRE ESCAPES**

Fire escapes in the form of large metal chutes have been provided by a powder company at Carney's Point, N. J., for the safety of the men working in its smokeless-powder plant. Just under the second-story windows of the numerous small structures in which the men work, are fire-escape plat-



View of Smokeless-Powder Plant at Carney's Point, New Jersey. Showing the Large Metal Chutes Which Serve as Fire Escapes for the Workmen

forms from which lead several of the metal chutes, placed at a sharp angle.

*E. I. Du Pont de Nemours
 Powder Co.
 Wilmington, Del.*

In an emergency the men can run through the windows and slide safely to the ground in an instant. The dangers of handling smokeless powder are not as great as popularly supposed, for it does not explode like black powder but instead burns rapidly. Consequently the company has taken every precaution against fire. So convenient are the chutes that many men use them daily when leaving the plant.

FRENCH MOTOR HOE RUN 3430 BY OIL ENGINE

F. P. Mann

Among recent improvements in agricultural machinery

An interesting machine shown by the Ivel Agricultural Motors, Limited, of Biggleswade, is a motor-hoe which can be used either in fields, orchards, gardens, or vineyards. The machine is so narrow that it can pass through a space only 25½ in. wide. The engine shown has magneto ignition, and is rated at 2½ horse-power. This firm also show the 24-horse-power agricultural tractor to which the Royal Agricultural Society's silver medal was awarded in 1904. This tractor is capable of hauling a three-furrow plough, or cultivators, reapers, binders, and mowers, whilst it can also be used for driving fixed machinery. The engine has two cylinders, and can be operated either with paraffin, petrol, or alcohol. Both magneto and accumulator ignition are provided.

are also worked by the motion of the motor and the machine when traveling. It is made in two sizes, with 2¾ or 4-hp. engine, and the depth of the hoe is adjustable. The machine has received various awards in France and Great Britain, among them a diploma from the Royal Agricultural Society.

"IVEL-BAYCHE"

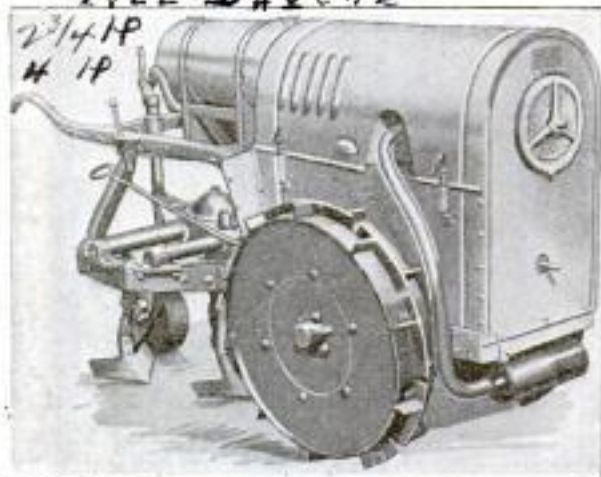

This New Motor Hoe Is a French Invention Which Works Rapidly without Damage to Growing Crops and Is Easy to Handle

UNIQUE SOUTHERN SCHOOL FOR SUGAR EXPERTS

The sugar-cane growers of Louisiana and likewise the educational interests of that state several years ago recognized that the proper development of the sugar-cane industry called for special technical training which no institution in the country was adequately equipped to give. This led to the founding of what is known today as the Audubon Sugar School, which is a part of the Louisiana State University at Baton Rouge. To this splendidly equipped institution have been brought leading sugar experts of the country and its enrollment includes students from sugar-producing lands in distant parts of the globe. While the most of the students' work is done in Baton Rouge, nevertheless the school's experiment station at Audubon Park, New Orleans, plays a very important part in the course and offers items of keen interest to visitors. The sugar school is unique in this country in respect to the completeness of its course in sugar engineering, which stresses equally the engineering and chemical sides of the manufacture of sugar and lays particular emphasis on the engineering methods by which chemical processes can be carried out.

To properly prepare young men to be sugar experts, five years of study is required. Speaking generally, the technical work is divided into three groups, chemistry, mechanical engineering, and agriculture, with about 90 per cent of the work being confined to the first two groups. The work in chemistry teaches the student the scientific processes in manufacturing sugar. The mechanical engineering prepares him to handle with skill the expensive and complicated machinery used in sugar factories. The agricultural work trains him so that he can manage a sugar estate on which there is a variety of crops in addition to cane, and where live stock must be looked after.

Each student must spend 10 weeks of both his fourth and fifth year either at the experiment station at New Or-

*Ivel Agric. Motors Ltd.
Biggleswade
Bedfordshire, Eng.*



Engineering Laboratory of the Audubon Sugar School: This Center for the Training of Sugar Specialists has Won Distinction Because It Stresses Equally the Engineering and Chemical Sides of the Manufacture of Sugar. The Course for a Sugar Engineer Is of Such a Special Character That Five Years is Required to Complete It



Entrance to the Grounds of the Audubon Sugar School, Louisiana State University: This School Is Unique in America in Respect to the Completeness of Its Course in Sugar Engineering. Its Enrollment Includes Students from Sugar-Producing Lands in Many Parts of the Globe



Students Cutting Sugar Cane in a Field Connected with the School's Experiment Station at Audubon Park, New Orleans. One Distinguishing Feature of the Institution Is the Practical Work in the Field and the Sugar House Required during Two Full Seasons



Forge Shop: The Students are Required to Study All the Machinery Used so as to Be Able to Manage a Plantation Which Not Only Grows Cane but is Also Fully Equipped to Make Sugar. In Preparing for Such an Undertaking the Work in This Shop Plays an Important Part

leans, already referred to, or with some large sugar company. The fields of the experiment station are planted with many varieties of cane, much of the work being done by the men themselves. These fields are so laid out that they present various problems in drainage that require special study. The sugar house contains a nine-roller mill, a complete diffusion plant, juice weighers, clarifiers, filter presses, double-

effect evaporators, and much other equipment, the cost of all machinery and apparatus at the station being approximately \$100,000. Before the grinding season starts the students are required to overhaul the entire sugar house, cleaning and repairing all the machinery. After the grinding season has begun each man is assigned in turn to take charge of different parts of the house.

3335
NEW PNEUMATIC ENGINE TO OPERATE CAR DOORS

For opening and closing heavy car doors a pneumatic motor of a new type has been brought out recently by a car heating company. The control of the motor is electro-pneumatic, by means of valves placed on each side. The air is cut off from the engine at each end of

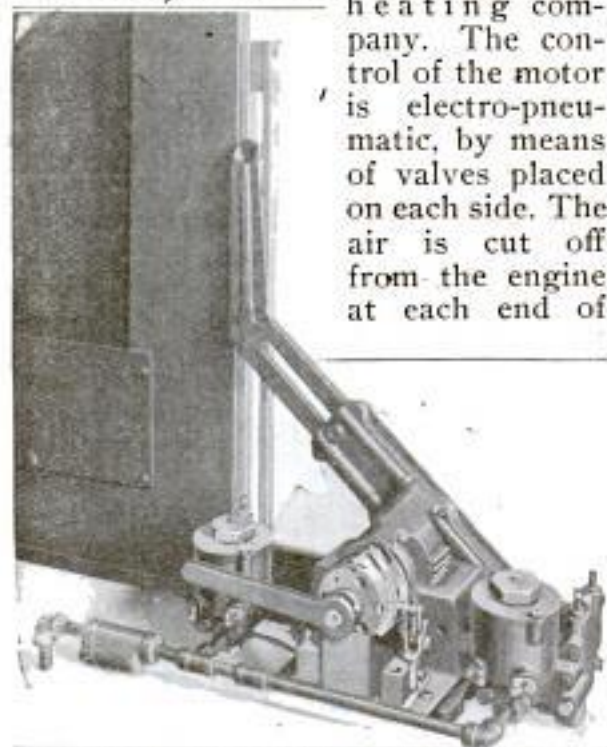

Pneumatic Motor Which Opens or Closes a Railway-Car Door and is Controlled by a Push Button

the stroke, which economizes the air used and also permits atmospheric check, or cushioning, so that the door does not slam. There is a safety feature which permits a passenger to hold up the door in case of premature closing; and if clothing is caught in it, the door may be pushed open 5 in., but this is the limit of emergency opening, as there is a positive stop to prevent a false opening. The engine is extremely

light, the cylinders being of brass tubing. The arm, rack, and pinion are of cast steel. Opening and closing of the door are controlled by a standard push button. A number of the motors are in use on the New York Municipal Railway.

35-60
SPRING SHADE FOR AUTOS PROTECTS THE EYES

Goggles are rendered unnecessary for motorists by a novel auto shade or curtain, which hooks over the top of the windshield and can be rolled up or down as needed. It is essentially a blind with an isinglass window, or "vision shield," fastened to a spring roller and operating just like an ordinary spring blind. A heavy rod along the bottom keeps the curtain from blowing about in a wind, and rubber washers at the ends of the spring roller

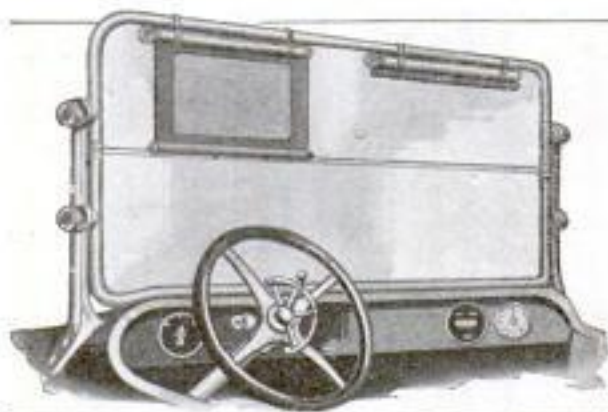

This Shows the New Auto Shade as It Appears When in Use, in Front of the Driver, and Also When Rolled Up Out of the Way

and of the bottom rod keep them from damaging the glass in the windshield.

Invs: F. W. Frame
 3401 Mission Road
 Los Angeles



The "Devil's Dance Floor," a Beautiful but Very Dangerous Stretch of Motor Road in San Bernardino County, near Ontario, California

3449

NEW MOTOR HIGHWAY SCENE OF MANY ACCIDENTS

One of southern California's motor roads has proved so treacherous that it is known as the "Devil's Dance Floor," and is to be reconstructed. It consists of a two-mile stretch of asphalt pavement near Ontario, in San Bernardino County. During the first six months it was open to traffic it was the scene of about 80 accidents. These smash-ups resulted in the death of five, and the serious injury of 32, persons. The highway extends across a low sweep of foggy land between two ranges of hills, and at night invariably becomes damp and slippery, while the roads connecting it at either end are dry because they are surfaced with a different material. As cars glide off the latter pavements onto the wet asphalt, especially when traveling rapidly, they are prone to skid, strike the ground bordering the road, and often turn turtle. One unusual accident occurred when a physician's car crashed against a telephone pole, snapping it off and hurling a lineman, at work at the top, into the tonneau of the machine. The driver was badly hurt and the other man's skull fractured. The highway commission has decided to overcome the difficulty by giving the stretch a corrugated-concrete surface.

APPARATUS FOR TESTING AEROPLANE PROPELLERS

An apparatus, used to ascertain whether or not aeroplane propellers have the proper balance, has been brought out by a well-known English firm. The device fastens to the wall by means of a bracket and embodies a rocking arm that swings on knife-edges. Projecting from the arm is a mandrel on which the propeller to be

W. & T. Avery, Loko Foundry, Birmingham, Eng.

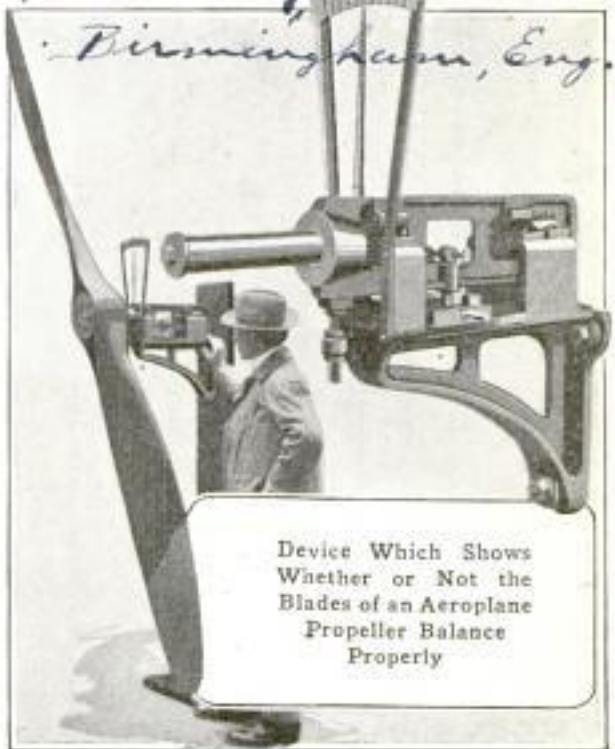

Device Which Shows Whether or Not the Blades of an Aeroplane Propeller Balance Properly

tested is placed. The balance or lack of balance in the air screw is shown by a pointer and quadrant. When the balance is perfect the indicator remains perpendicular and points to zero. A means of control is provided which prevents undue swing of the apparatus, caused by the inertia of the propeller. The screw can be turned around to test the balance in any position, without removing it from the mandrel. The apparatus may also be employed in testing individual layers that go to make up a propeller.

3524 ———
HANDY SCOOP TRUCK FOR ROLLS OF PAPER

Rolls of printing paper are frequently damaged by improper methods

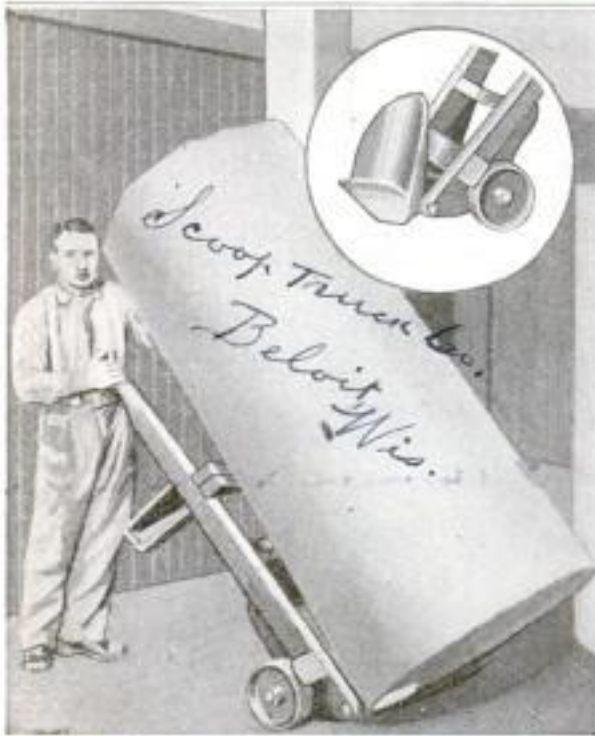

Heavy Rolls of Print Paper, Six Feet High and Weighing Almost a Ton, are Easily Handled with This New Truck and Its Swivel Scoop

of handling from railroad cars to the pressroom, and in the pressroom itself while being shifted about. To eliminate this damage, which is expensive, a new truck has been designed and patented by a paper-mill superintendent, and has already proved its value. Its general form is that of the familiar hand truck, but it is furnished with a tilting, scoop-shaped steel shoe, which

receives the lower end of an upright roll of paper and enables it to be laid upon the truck quickly, easily, and safely. The upper end of the roll rests on a shaped cradle which forms part of the truck.

3581 ———
X-RAY USED TO PROVE AGE OF BOY IN COURT

To physicians connected with the juvenile court of Cincinnati was recently assigned the unusual task of determining the age of a lad by the use of the X-ray. According to the laws of Ohio a boy, 17 or younger, comes under the jurisdiction of the juvenile court, whereas one, 18 or over would be tried, on a criminal charge, in the criminal court. The parent of the boy claimed that he was 17, while the physicians were strongly of the opinion that he was 18 or older. To settle the question X-ray photographs were taken of the bones of his arms and lower limbs. It is a fact, well recognized by the medical profession, that in the transition from childhood to maturity these bones undergo a change that is quite distinct. The photographs in this case showed such a development of bony tissue as to prove conclusively that the boy was 18 years old or over, and consequently his case was turned over to the criminal court.

Eng. 110
IMPROVED ROTARY MOTOR FOR AUTOMOBILES

see *Mech 15-358-854*
 A rotary motor for automobiles, which received mention in this magazine some time ago, has been since developed by its inventor, a resident of Sandusky, Ohio, and was recently given a hard road test from which it is said to have emerged successfully. A car equipped with an 18-hp. engine of this type was driven from Los Angeles, Calif., to Chicago, and completed the trip, it is claimed, with a record of 22½ miles of travel per gallon of gasoline. The car complete weighed 3,000 lb. Advantages claimed for this motor include lightness, freedom from vibra-

11.5. Macomber Motor Co. 235 Alhian St., New Angeles.
 Eagle-Macomber Motor Co. Inc.
 Sandusky, Ohio
 T. J. Dauch, Pres.

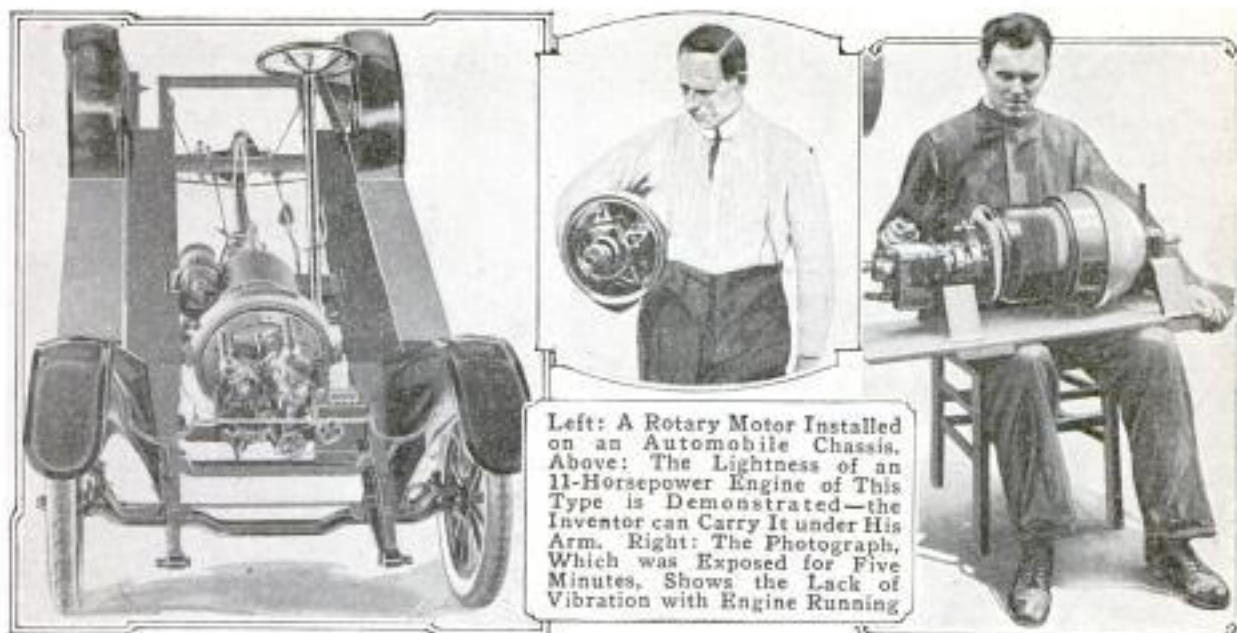

Left: A Rotary Motor Installed on an Automobile Chassis. Above: The Lightness of an 11-Horsepower Engine of This Type is Demonstrated—the Inventor can Carry It under His Arm. Right: The Photograph, Which was Exposed for Five Minutes, Shows the Lack of Vibration with Engine Running

tion, and the elimination of the water-cooling system. Its design is a departure from the usual wheel plan of rotary motors. It is built with either five or any odd number of cylinders, arranged like the barrels of a revolver, each parallel with and clustering around the main shaft. The parts of the cylinders being identical, one cam actuates all valves in succession and one ignition ring serves for firing all the cylinders. By this arrangement, a flywheel effect is obtained without straining the mechanism or interfering with lubrication. *Burner*

PORTABLE GAS PLANT FOR 3505 COOK STOVES

Any cook stove or range can be converted into a gas stove in a few minutes' time by means of a portable gas burner recently placed on the market, which generates gas from coal oil or kerosene and can be installed without the aid of a mechanic. It consists of a simple set of two combined gas generators and burners with valve connections, as shown in the illustration. These burners are placed in the fire box of the stove, connection with the regulating valves being easily made through the stove doors or draft holes by two small, flexible metal pipes. Steel brackets on each end of the burner base

hold the burners rigid in the stove and can be adjusted to any depth or width of fire box. The coal-oil supply tank, of any size from one gallon up, is hung by a hook or nail to the wall near by and connected by a flexible metal feed pipe to the regulating valves. Gas is generated from the oil by the heat within a few seconds after opening the valves and lighting one or both of the burners. The appliance can also be used in heating stoves of the base-burner type.



Cooking with Gas Made in a Coal Stove. The Kerosene Supply Tank is Seen on the Wall and Regulating Valves on the Ledge of the Stove. The Insert Shows Details of the Burner Set in the Fire Box.

*Simplex Gas Plants Co., Inc.,
 754 7th St.
 9 So. Clinton St. Chicago.*

CURIOUS BRIDGE ON THE MEXICAN BORDER

Crossing the boundary line between the United States and Mexico, at Tia Juana, there is a queer ramshackle



This Temporary Double Trestle Serves as a Railway Bridge across the Mexican Border. Note the Rails on Either Side of the Open Center

bridge, built as a temporary substitute for a structure that was washed away by the floods a year ago. It bridges an arroyo and is simply a double trestle, with open space in the center, but serves all kinds of traffic, including the trains of the Mexican Central Railway, automobiles, pedestrians, horse-men, and even herds of cattle and flocks of sheep. Each trestle carries one of the rails of the railway track, the construction being such that trains and automobiles straddle the open space when crossing, and all other traffic must get off the bridge. The structure is 400 ft. long and has a safety platform for pedestrians built out on each side near the center.

ⒸAn observation station in Venice is said to be equipped with electrical microphones with which watchers can detect the approach of Austrian airmen as soon as they leave Trieste, some 60 miles away, and so give the city ample warning.

SPARK FROM MAN'S BODY CAUSES GARAGE FIRE

When a resident of Dubuque, Iowa, wearing a fur coat and rubber boots, walked hurriedly to his garage on a cold morning recently, he did not realize that his movements were storing up a dangerous amount of electricity in his body. But the fact was that the friction of his arms against the coat caused a certain amount of static electricity to be generated, and this was stored in the man's body because it was insulated from the ground by his rubber boots. When he sought to prime the motor of his car with a mixture of gasoline and ether, using a metal squirt can—probably of copper, which is a good conductor of electric current—the can was brought so close to the motor that a spark was produced between it and the priming cup, igniting the gasoline. The can exploded, throwing the flaming liquid over both man and car. The man escaped with severe burns, but the car and garage were completely destroyed.

EAR PHONE ELIMINATES FOREIGN NOISES

An ear phone for the deaf has been designed with a view to eliminating the rumbling and grating noises which are so annoying to many deaf persons using sound-magnifying instruments. The transmitter is worn in an exposed "ANDERPHONE"



The Transmitter and Battery are Here Shown Worn under a Bolero. Right: Cross Section of Transmitter Showing Roundabout Path Which Sound Waves Travel. The Black Portion Is the Drumhead

Carl Anderson Electric Co.
1402 Broadway at 3
Copyright material

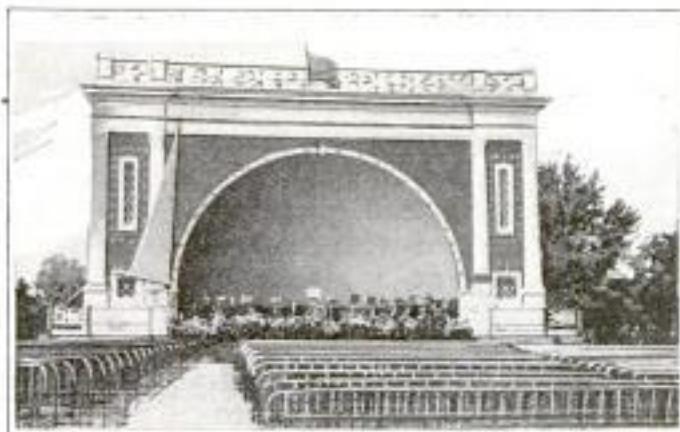

Front and Side Views of Shingled Band Stand Erected in One of Denver's Large Parks. The Iron Benches Arranged before the Structure Furnish Seating Accommodations for 2,000 Persons

position in the usual manner. The sound waves enter through small holes in its face but do not strike the diaphragm directly on account of a protecting wall of steel, which diverts the waves out toward the circumference and thence around to the opposite side of the hollow instrument. Here the waves strike what is called the drum-head, which throws them against the diaphragm. Heretofore, in attempting to eliminate foreign noises, attention has been centered on the microphone, but in this transmitter the sound is altered before it strikes that sensitive member. The drumhead also helps to modify the sound. It is made of brass, rubber, ivory, glass, lead, or other material, according to the sharpness of tone desired. The character of its curve and its thickness are varied according to the needs of the wearer.

3003

GREEN-SHINGLE BAND STAND IN CITY PARK AT DENVER

Iron benches with seating capacity for about 2,000 persons are arranged before a rather attractive band stand erected in the City Park at Denver, where, during the warm months, public concerts are held frequently. The structure is about 65 feet in width and 35 feet high, its exterior finished with green shingles and trimmed in white. The foundation is built of green-glazed brick, and the piers at the sides of tapestry brick. Boxes of blooming flowers extend across the front margin

of the platform, forming a beautiful screen, while others, placed in the windows at the sides of the building, contribute refreshing touches of color. Beneath the arched dome, the platform furnishes sufficient space for about 50 musicians, and at the rear ample dressing-room accommodations are provided.

3547

NEW CONCRETE MIXER RUN BY FOOT POWER

Foot power is employed to run a new small-sized mixer for use in preparing concrete, mortar, and the like. A seat is provided for the operator who revolves the mixing cylinder by means of pedals, while the dumping of the contents through an end spout is controlled by levers. If preferred, two men instead of one can be employed as



A Concrete Mixer, Having a Capacity of from Three to Five Yards of Mortar, Which is Operated by Foot Power

*Green Mch. & Bldg. Co.
Salt Lake City,
Utah*

operators. The machine is ball-bearing throughout and is equipped with a heavy flywheel, so that mixing can be accomplished with much less effort than with a hand-power machine. The capacity of this outfit is from three to five cubic yards.

3630

FIREMEN'S CATS TRAINED TO DESCEND BRASS POLE

A fire company in Boston possesses two pet cats which are especially popular with all the men because they have learned to respond to a fire alarm by sliding down the brass pole in the station just as the firemen do when descending from their sleeping quarters on the second floor to the trucks below.



On hearing the gong the agile creatures will jump to the polished metal rod and throw their legs about it, much as they do when descending a small tree, and

then slide to the floor below like a flash. The pets seem to quite enjoy the trick, as the accompanying photograph shows.

3663

NEW X-RAY APPARATUS AIDS SURGERY

A. T. N. *Jan 1916*
A new X-ray apparatus has been developed in one of the casualty-clearing stations in France, which according to reports appears to supplement present-day X-ray photography at the point where the latter ceases to perform effectively. In other words, in photographing certain hidden parts of the

body a type of picture is obtained which has not been procured heretofore. It is said that in this new work an attempt is not made to delineate such dense tissues as bone, but living organs instead, pictures of which can be obtained with remarkable clearness, showing at a glance by what gross lesions the organs are affected. For example, the wounds in any organ can be pictured. The blood vessels of the brain can be shown, together with a blood clot, if one exists, while the actual substance of the brain is not shown. The apparatus is described as working as long as the body is alive, and even until molecular death has occurred, but after that it does not work.

3572

FILM REWINDER WITH NEW SAFETY FEATURES

An automatic film rewriter has been devised to lessen the dangers of the necessary process of rewinding moving-picture films after every exhibition. It will take films of any make, and was recently approved by the National Board of Underwriters. The machine entirely incloses the film when rewinding, and is driven by an electric motor, also fully inclosed. The construction is simple, there being two cast-aluminum magazines supported on uprights with a heavy iron base. The larger magazine contains the reels, and conforms to their shape; the smaller contains the motor. Reels of any size, up to 2,500 ft. of film, can be rewound. The machine stops automatically when the rewinding of any reel is complete, or if the film should break during the process.



Automatic Film Rewinding Co.,
Harrisburg, Penna.

*Mr. Jas. Shearer, Sergeant Medical Corps,
Scotland*

3409
**PHONOGRAPH MUSIC SPEEDS
 UP TYPEWRITING PUPILS**

The theory has been advanced that just as music helps a soldier to march with more vigor so also it should speed up a person's typewriting. and in conformity with this idea a phonograph has been installed in the typewriting room of the High School of Commerce in Omaha. The instrument stands in the corner of the room and while the pupils practice on their machines a variety of selections is played on it. The aim is to relieve the monotony of

the drill and so prevent the young people from becoming fatigued too quickly. The music is for practice only and is not intended as a permanent feature in connection with practical typewriting.



Pupils in Typewriting Class in Omaha High School of Commerce Practicing on Their Machines While a Phonograph Plays Various Selections

3438
**MOTOR LIFEBOAT IS BUILT
 FOR OCEAN LINER**

Some little attention has been drawn to a motor lifeboat lately constructed in England for one of the Canadian Pacific steamships. The craft, which is 30 ft. in length and 9 ft. 4 in. of beam, is equipped with a three-cylinder, 25-hp. motor that gives it a speed of about 10 miles an hour and sufficient reserve power to tow several lifeboats of the usual type. Buoyancy chambers are installed fore and aft beneath the water-tight decking as well as under the side seats. A cushion of canvas-covered cork also extends around the hull flush with the gunwales. While the boat is not intended to be of the self-righting type, it is provided with a 500-lb. iron keel which gives it unusual stability. Provision has been made for the

installation of a wireless set, which will be housed in a small cabin to be erected forward. The motor is completely covered. Amidships, on either board, relieving trunks with suitable valves are placed, to facilitate the prompt dis-



Seaworthy Motor Lifeboat Built in England and Designed More Especially for Towing than Carrying Purposes. It will be Used by an Ocean-Going Passenger Vessel

charge of shipped water. When fully loaded the boat shows good freeboard. It has successfully passed the rigid tests of the board of trade.

*Norris, Henty & Gardner Ltd.,
 701 Tower Bldg., Water St.,
 Liverpool, Eng.*

23 Conroy-Davis Mfg. Co., Shelbyville, Ind.

FURNITURE WHICH MEETS SPECIAL HOME NEEDS

3631



Card Table with Score Cards Always Visible, but Out of the Way, in Drawers under Glass Tops, as Shown in Detail

Library and Dining Table Combined, with Top That can be Extended to Five Feet



An Odd-Shaped Sewing Stand with Drawers, Side Compartments, and Handles



Light Iron Bed That can be Easily Swung Up into a Vertical Position and Rolled on Its Four Casters into a Closet. It Will Pass through a Small Doorway

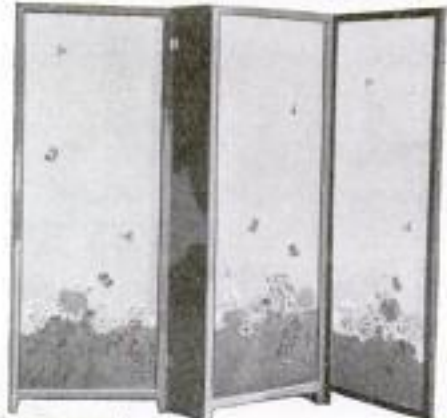

Handsome Folding Screen, the Center Section of Which is Built a Few Inches Deep to Serve as a Small Wardrobe, as Shown at Right, or as a Book and Magazine Rack, as Shown at Left. The Former is Provided with Convenient Drawers for Rubbers or Other Articles. Floral Decorations Make the Front Attractive



1 - Glass Brown
7 - Hot 522 on, N.Y.C.

Ferguson Bros Mfg. Co.
Holman, N.Y.
Mr. D. G. Co. - N.Y.C.
1319 Michigan St., Chicago

720 - 106 Bflo.

Beaver Board Co., Buffalo, N.Y.

2-Beebe Chair Co.
563-565 Turk St.
Van Francisco.

BY ECONOMY OF SPACE OR CONVENIENT DESIGN

Dr. Table 40 x 45"
40 x 55"

3631

Lib. Table 30 x 40"



6
Mission Chair, Convertible into Library or Dining Table by Swinging the Hinged Back into Horizontal Position



7
Folding Portable Writing Desk with Gusseted Leather Pockets and Full Set of Writing Accessories



8
A Disappearing Ironing Board and a Roll-Top Front Are Special Features of This Kitchen Cabinet



9
Cabinet, Resembling Large Phonograph Case, in Which Small Phonograph can be Kept, also Books or Records



10
Octagonal Sewing Stand Having Pockets and Holders on Under Side of Hinged Top



11
Sanitary Kitchen Table with Covered Bread and Flour Bin That Slide Easily, and Bracketed Revolving Seat

8-Breencastle Cabinet Co.
Box 466
Breencastle Ind.

Conroy-Davis Sec 2

7-Alexander Bros., London
Sec 1

9-Theo W. Nottel, Sec
1881 Court & Corn. Parkville
209 So. 4th St.
Chicago

Breencastle Ind. Sec.
"Phonola" with Phonograph
Cabinet brand only 1925

11-Mitchler Bros. Co.
Nappanee, Ind.

TRAFFIC SIGNS ADORNED WITH FLOWER BOXES

Many towns and cities have signposts at the intersection of important



Flower Boxes at the Base of Traffic Signposts Which Give an Artistic Touch to the Street Intersections

streets, for the purpose of keeping the traffic moving in the right way. Few communities, however, have realized

that these posts can be utilized to beautify the streets, but in Valparaiso, Ind., flower boxes have been built about the bases of the posts. In them hardy flowers have been set out which seem to have thrived. The bit of color in the midst of the glare of the broad, hard pavement is very pleasing.

3156—

BRICK-WALLED STALLS IN AUTO-TESTING SHED

Connected with an automobile factory in Detroit is a large building so constructed that the engines of 30 or more cars can be tested in it at one time. The structure resembles a public garage with a broad passageway leading down the center, while on either side are numerous stalls. These are separated one from the other by solid brick walls so that a running engine in one compartment can be heard only faintly in the adjoining compartments. This arrangement makes it possible for a large force of experts to examine engines at one time, each being so shut off from the rest that he can readily detect a foreign sound in the car he is testing. The walls also serve to greatly diminish the fire risk.

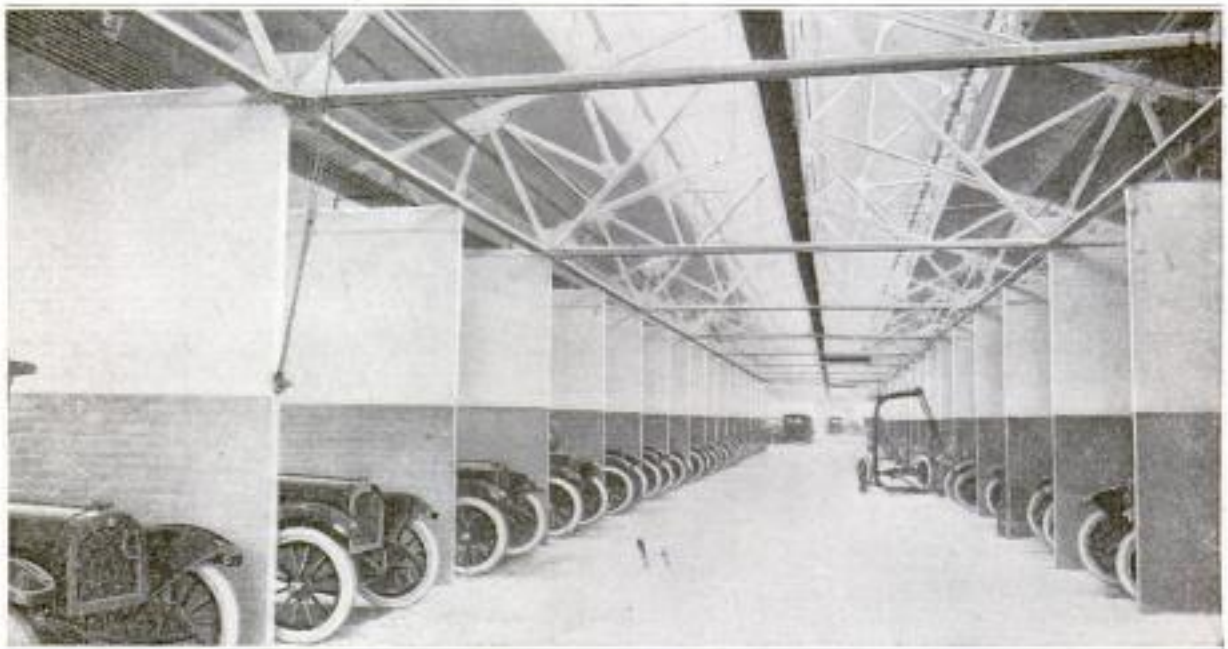

Engine-Testing Building Connected with a Detroit Automobile Factory in Which the Fire Risk is Minimized by the Brick Walls Separating the Compartments. Here, at One Time, Several Experts can Test an Engine without being Disturbed by the Noise from Other Engines

STREET ROLLER OPERATED BY ELECTRICITY

A heavy roller which is operated by electricity is employed by the street-railway managers of St. Louis in the construction of pavement adjacent to their car tracks. Electricity is used because it is both convenient and economical for this particular work. The machine has two heavy rollers, to one of which is geared a regular street-car motor. Suitable provision is made for speed variation. Power is obtained for the motor through a cable which is hooked over the trolley by means of a long pole. The circuit is completed by a second cable connecting the motor with one of the rails. These two leads are each nearly 100 ft. long and so allow the machine



ample range of movement without shifting the connections. When not in use they are wound on a reel mounted on the framework of the machine. The roller is carried to the scene of operation on a flat car and then,

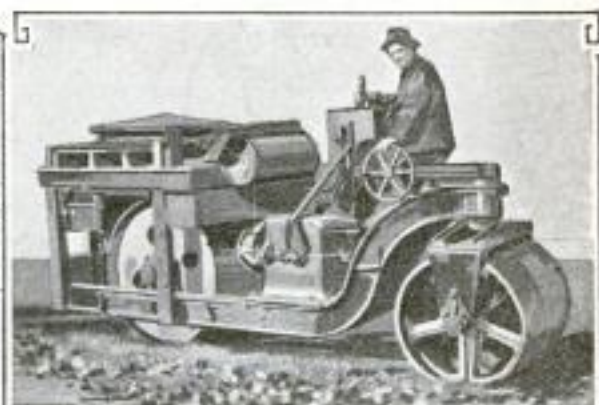

Roller Used on the Streets of St. Louis Which Derives Its Power from a Near-By Trolley Wire, View at Left Showing How the Cable is Attached to the Trolley Wire

under its own power, descends on an incline platform to the street. It is likewise loaded by its own power.

3296

CLASSIC TEMPLE AND HUGE RELIEF MAP IN GUATEMALA

In the city of Guatemala, in Central America, a beautiful classic edifice has been erected, called the Temple of Minerva. It was built in commemoration of the educational progress which has been made in that country, due in part to the recent expenditure of several millions for public instruction. The structure, like the Greek temples after which it is patterned, is without walls, the massive roof being supported by Ionic columns. It stands in a large open area not far from a most unusual

relief map, which covers a quarter of an acre of ground and reproduces in remarkable detail the physical features of the Republic of Guatemala. A special observation platform has been erected near by.

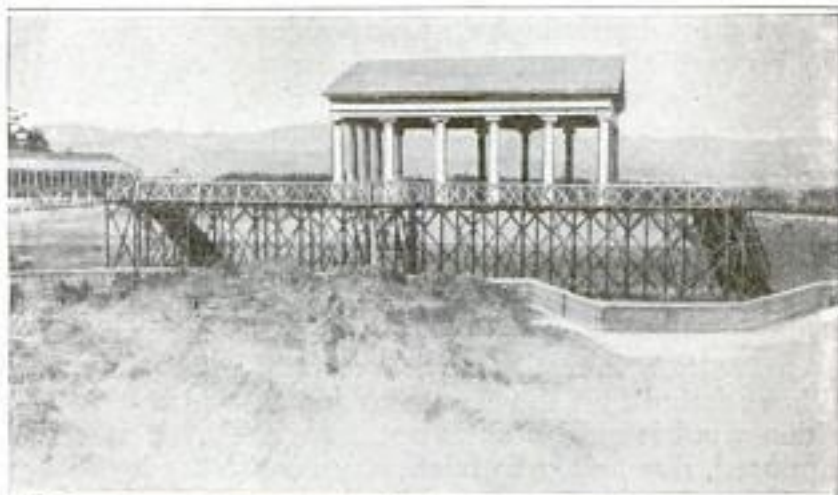

View Showing the Ionic Temple in the City of Guatemala, Central America, and, in the Foreground, a Portion of a Relief Map Which Covers a Quarter of an Acre

PULL-SOCKET OUTFIT FOR INDIRECT LIGHTS

Most of the indirect-lighting fixtures in the market do not permit of the use of the convenient pull-socket, or but-

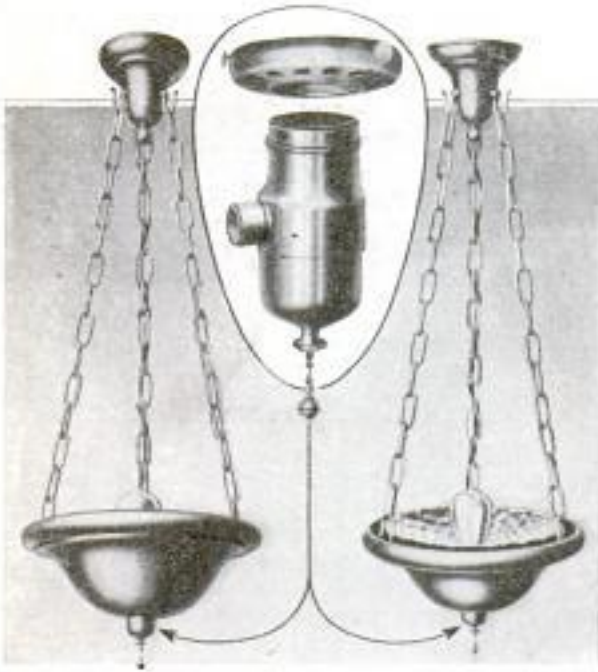

New Socket for Use with Pull Chain. The Lower Pictures Show How It is Applied to Indirect-Lighting Fixtures

ton, switches which have become so popular. But a new arrangement for this purpose has appeared in which a pull socket with its chain guide fits snugly into the bottom of the bowl of an indirect fixture, and protrudes through it just enough to enhance the artistic effect. The socket has a threaded bead on which a shade holder can be readily mounted. The bottom chain guide, with a pull chain hanging only the necessary length below the bowl, provides a most convenient form of local control. This style of socket can also be used on a side-wall fixture by attaching it directly to a nipple extending from the outlet.

ⒸAn English investigator is reported to have found that the electrification to which wool is subjected is not, as was supposed, due solely to friction among the fibers, but is also caused by drying, followed by the lowering of the temperature.

CITY PLANNING AIDED BY FLYING BOATS

Photographs of Santa Barbara, Calif., were recently taken from a flying boat to be used in working out an elaborate plan for beautifying that city and as a help in examining possible locations for a proposed sewer outfall. The irregular topography of the region was well depicted in these pictures, and they show at a glance the city's position with relation to the sea and the mountains. The success of the effort has suggested to engineers that the same method might be employed on an even larger scale, as for example, in the region of the Colorado River, which changes its channel at many points after each flood and leaves bottomless lakes of mud, that can be traversed neither on foot nor by boat. To obtain by surveying the information that pictures taken from a flying boat would supply, would often require weeks of work.

Engr. Record 11/11/1916

2112

ELECTRIC DIRECTION ARROW FOR AUTOS

An automobile direction indicator has been devised consisting of a movable arrow, enameled red, which attaches to the front fender. It is operated by electromagnets, current for which is obtained from the regular batteries, and is



controlled by a switch attached to the steering wheel. When a motorist approaches a street intersection and desires to turn to the right, for example, he indicates this to the traffic officer, or others in the street, by pointing the arrow to the right. At night the device is illuminated from within. At the head of the arrow is a red lens and at the tail a green lens so that in the darkness there may be no confusion as to the position of the indicator.

Inventor Zachariah Keough, (Pres.)

Los Angeles

Keough Automobile Directional Indicator Co. 306-7 Bond St. N. E. C. No. Adams, Mansfield, O.



Guess Who's Here: That Is One of the Ways Those Participating in a Cotillion of Advertising Characters of National Renown Helped to Make the Evening an Unusual and Lively One

TOTS AND GROWN-UPS OF AD WORLD IN LIVELY GAMBOL

Franklin One of the country clubs in a Chicago suburb recently entertained its members and guests with a most interesting cotillion. All of the participants appeared costumed to represent advertising characters of magazine, newspaper, and billboard fame. Nearly all of the well-known children and grown-ups of the advertising world, even those of dusky hue, unconventional attire, and bygone days, were impersonated. Obviously the evening proved one of rollicking fun, so refreshing a departure was it from the conventional affairs that repeat themselves throughout the social seasons year after year. No one, unless appropriately costumed, was permitted on the floor until a late hour. Thereby the spirit of the frolic was carried out without being marred by the presence of evening apparel. So successful, and so simple to execute, was this convention of trade-mark characters, that it seems to offer unlimited opportunities for use elsewhere.

Prizes for the best make-ups, as well as for the winners of possible guessing contests, are ideas that might be incorporated.

2094

HAND-MADE HORSESHOES AS GOOD-LUCK PIECES

The hobby of an expert horseshoer in Martinsburg, Pa., is the making of miniature horseshoes which are scarcely larger than a dime and weigh about six grains. They are of steel and are hammered out with great skill. Their exact size is shown in the accompanying illustration. The maker of these tiny emblems of good luck has presented one to each crowned head of Europe and to a large number of noted persons in this country. The usual



reward for each gift is an autograph letter. In the course of years the smith has made a large and interesting collection of autographs from these letters of thanks.



Only by Costuming to Impersonate Some Character of "Advertising Section" or Billboard Fame could One Appear on the Floor at the Club While the Gambol Was at Its Height

3607 SOME NOVEL AND LITTLE-KNOWN ACCESSORIES

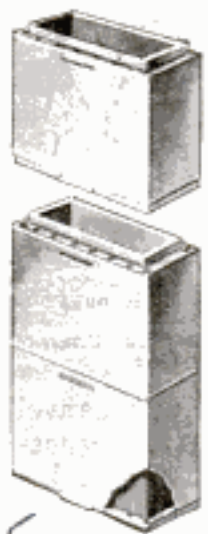

5 The Joints of This Furnace Pipe are Self-Locking, so the Expense of Soldering is Eliminated and the Labor Cost Cut When It is Installed

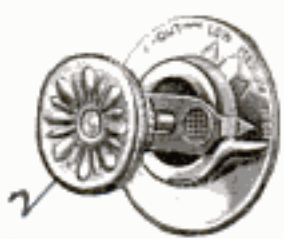

2 Oil-Stove Flame Control Keeps Wick at Whatever Height It is Set, Simplifying Heat Regulation. Three-Burner Stove. \$13

1 Attached to Outside of Door. This Holder Prevents Theft or Contamination of Milk After Bottle is Delivered

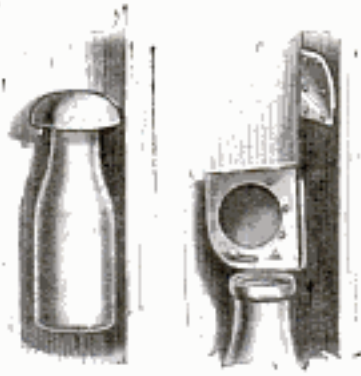

3 Steel Tape with Self-Holding Reel. Ring End of Ribbon Also Has Gripping Point



4 Mahogany Fruit Bowl with Removable Glass Lining and Set of Pearl-Handle Knives. Price Is \$11



6 Patented Wire Handle for Milk Bottle That Enables Latter to be Hung Out of Reach of Animals When Delivered. Can be Made for 15 Cents a Dozen



8 For Nursery or Toilet. Scales of Adequate Capacity and Small Size. A Revolving Dial Is Visible through a Glass Aperture in Top of Case. Price: \$10



7 Suction Cup Worn on Thumb to Assist in Holding Book or Magazine Open without Tiring Hand. Available for 10 Cents

9 Bluebirds and Frogs are Used in the Decorative Scheme of This Attractive Aquarium and Stand Intended for the Nursery

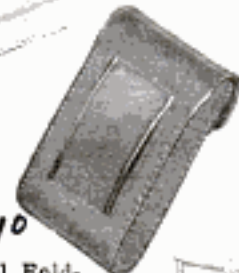

10 For the Small Folding Camera, a Sole-Leather Case That Fastens to One's Belt. Price: \$1.50



12 Double Pans for Baking Bottom Pie Crust Separately Before Filling is Put In. Makes Pastry Light, Flaky, and Greaseless. Price 35 Cents

This Kitchen Cabinet is Supplied with a Flour Bin That may be Lowered in the Convenient Manner Shown When It is to be Filled. Price \$39

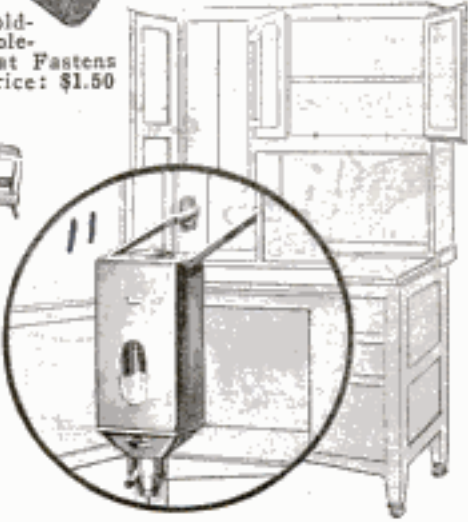

DATA MARCH NOVELTIES

- 1 BOTTLE LOCK-- Wetzel Milk Lock Co., Shamokin, Pa.
- 2 PURITAN OIL COOK STOVES-- Standard Oil Co., Chicago
- 3 STEEL TAPE--Crogan Mfg. Co., Bangor, Me.
- 4 FRUIT BOWL-- Mark Cross, 404 5th. Ave., N. Y.
- 5 FURNACE PIPE-- Michigan Safety Furnace Pipe Co., Detroit,
113 Fort St., East.
- 6 BOTTLE HANDLE-- Invt. by:Henry Heitman, Wellsville, Ohio,
R. F. D. 1
- 7 VACUUM GRIP--John Gibbons, Scotia, N. Y.
- 8 SCALE-- Chicago Scale Co., 7700 S. Chicago Ave., Chicago
- 9 AQUARIUM-- A. L. Randall Co., Wabash and Lake Sts., Chicago
- 10 CAMERA CASE--Eastman--Rochester
- 11 KITCHEN CABINET--Sellers & Sons Co., Elwood, Ind.
- 12 PIE PLATES--National Enameling & Stamping Co., Chicago, Etc. ^{378 W. King in St.}
- 13 PEN HOLDER--Invt by: R. W. Stevens, 126 Brussels St.,
St. John, N. B.
- 14 SEWING BAG--Cross, London
- 15 SLIPPERS--Daniel Green Felt Shoe Co., 116 E. L3th. St., N. Y.
- 16 SIGNET RING--Charles Packer & Co., 76-78 Regent St., W, London
- 17 CLOTHES BRUSH--Milwaukee Dustless Brush Co., Milwaukee
- 18 MOTOR SUIT-- ~~British School of Motoring, 5 Coventry St., London~~
- 19 SHUTTLE WINDER-- Gem Winder Co., 101 6th. St., Portland, Ore.
- 20 WHISK BROOM HOLDER-- Mayfair Inc., 4th Ave. and 52 St., N. Y.
- 21 KNIFE, FORK, & SPOON-- CROSS, London
- 22 ENGLISH WORK BASKET-- Dryad Works, Leicester
- 23 NIGHTROBE-- H. B. Glover Co., Dubuque, Ia.
- 24 GAS HOT PLATE-- Spengler, Leemis Mfg. Co., 58 Washington, Chicago

[The body of the page contains extremely faint and illegible text, likely bleed-through from the reverse side of the document. The text is too light to transcribe accurately.]

T.C.H.

18

The Sketch

3602

Nov. 29, 1916

TRIPLE COMBINATION MOTOR SUIT
 Specially Designed by
"SELFRIDGE'S"
 FOR B.S.M LADY MOTOR DRIVERS



One suit which can be worn 3 ways

1. Tailor made walking suit 2. Motor driving suit with new Muffler collar and wind cuffs in sleeves. 3. Motor mechanic suit, the skirt being easily removed by unbuttoning down the front leaving breeches loosely fitting, giving freedom of action, with ample pockets.

TO BE OBTAINED AT SELFRIDGE'S DEPT 557.

MADE IN KHAKI CLOTH 50/- BREECHES 10/- MADE IN EXTRA QUALITY 65/- BREECHES 14/-
 ALSO MADE IN HEAVY NAVY SERGE OR TWEEDS.

LADY MOTOR DRIVERS ARE URGENTLY NEEDED
 TO OCCUPY WELL PAID POSITIONS OF NATIONAL IMPORTANCE TO RELEASE MEN FOR THE
 ARMY. FULL PARTICULARS, FEES ETC. FOR THE NECESSARY TUITION IN MOTOR DRIVING
 TO BECOME A CERTIFICATED B.S.M LADY MOTOR DRIVER MAY BE OBTAINED AT
THE BRITISH SCHOOL OF MOTORING LTD
 5 COVENTRY STREET PICCADILLY CIRCUS LONDON W

WRITE OR CALL

Curryton's

Nov. 29, 1916

TH

Swan & Edgar Ltd

The Leading West End Drapers,
REGENT STREET and PICCADILLY, W.

JB SIDE SPRING CORSETS

ALL SHAPES
ARE KEPT
IN STOCK
TO SUIT
DIFFERENT
FIGURES

*Selections
sent on
approval.*

Sizes of Waist :
19 ins. to 38 ins

*Specialists
in Outsizes
in
Everything
for
Ladies'
Wear.*



TYPE 71X.—Sky with White
Pink, designed for medium
Exquisitely cut. Sizes 19
to 38 ins.

Type 1104.—
One of the most
charming Models
of the Season.
In Black with
White Spots, also
Blue, Broché
Coutil, 21/-
to 38 ins.

Just Published.
**"How to Dress
with Good Taste"**
Autumn & Winter, 1916.
Beautifully Illustrated. 80 Pp
16 Pages of Furs in Colour
POST FREE ON REQUEST



15
Felt Slippers That may be Worn in Two Styles, as Illustrated, According to the Demands of the Occasion. For Women: \$2.25; for Men: \$2.50



14
Dainty and a Bit Unusual Is This Sewing and Knitting Basket of Plaited Raffia. It is Lined with Silk and Priced at \$6.75



13
New Type of Holder Which Permits a Pen to be Inserted or Removed without Trouble



17
When It is Needed for Removing Spots, Benzine Feeds into the White Tufts from a Reservoir in the Back of the Clothes Brush. Price \$1

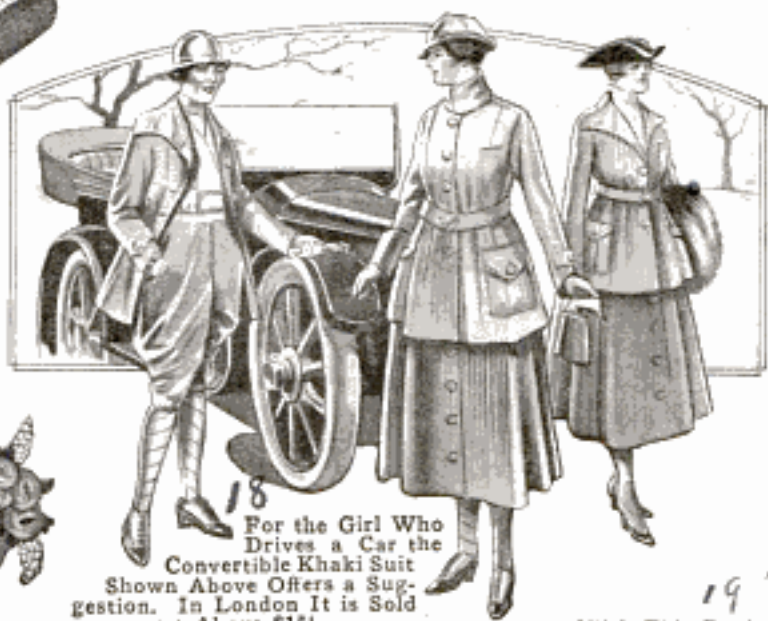

18
For the Girl Who Drives a Car the Convertible Khaki Suit Shown Above Offers a Suggestion. In London It is Sold at About \$18



16
With Space within It for a Small Photograph: A Signet Ring That Is Uncommon



20
Attractive in Color and Odd in Design, a Whisk-Broom Holder That Conceals. Offered at \$3.75



19
With This Device It Is a Simple Matter to Wind the Bobbin of a Tating Shuttle. The Price Is 15 Cents

Folding Knife and Fork That Nest with a Spoon and Fit within a Leather Case. Price \$3.25



English Workbasket Attractively Fashioned and Tastefully Lined in Silk of Pleasing Color and Pattern. Price, at Leicester, About \$4



21
Fitted with a Special Fuel-Conserving Burner and Supplied with a Drip Pan, a Hot Plate for Gas Users. In the Butler's Pantry It is Especially Useful. The Price Is \$1



23
Intended for Open-Air Sleeper, a Night Robe with Warm Pockets for the Feet. It may be Had with or without the Hood at Prices Ranging to \$5

BREATHING MASK DESIGNED AS DISEASE PREVENTIVE

To provide a means of safeguarding against the transmission of bronchial and allied diseases, a respiratory shield



When Worn by a Dentist or a Barber the Respiratory Shield Lessens the Danger of Either the Operator or the Patient Breathing the Foul Air Exhaled by the Other

is made for barbers, dentists, and others whose work brings them in close contact with many persons daily. The device, which is made of aluminum and celluloid, fits over the nose and has two air passages with openings near the ears of the wearer. In inhaling and exhaling, air is drawn and discharged at the sides of the face instead of at the front. Provision is made within the shield for holding cotton saturated with disinfectant, so that the air exhaled from the lungs is sterilized as it is discharged, and that drawn in by inhalation purified before reaching the nostrils.

3562

BIRD FLIES LONG DISTANCE WITH ADDRESS

A rancher living near Red Lodge, Mont., last August brought down with his rifle a large bird, probably some species of hawk, which was flying over his place. On picking up the creature he discovered that it had been stunned by the shot but was otherwise unin-

jured. Instead of killing it he tied to its neck a little bottle in which he sealed a paper bearing his name and address. Two months later a letter came from Bogota, Colombia, South America, signed by one Luis Felipe Rulda, saying that he had shot the bird carrying the Montana man's address. Red Lodge and Bogota are considerably more than 3,000 miles apart by a direct air route, and this incident shows in an unusual and striking way what great distances birds travel.

2524

FIRE-ALARM BOX DESIGNED TO BE MEDDLER-PROOF

A special fire-alarm box has been invented by a Philadelphia municipal employe, the purpose of which is to prevent malicious or mischievous persons sending in false fire alarms. The box requires no key and is equipped with an outer and an inner door, both of which must be opened before an alarm can be turned in. The outer door is unlatched by pulling down a lever which serves as a handle and is held in position by a spring within the box. This lever operates a simple mechanism that rings a big gong fastened to the inside of the door. Hence the door cannot be opened without sounding this gong, the noise of which is very apt to summon a policeman or passer-by. Persons inclined to send in false alarms purposely will not be apt to take chances with this device.

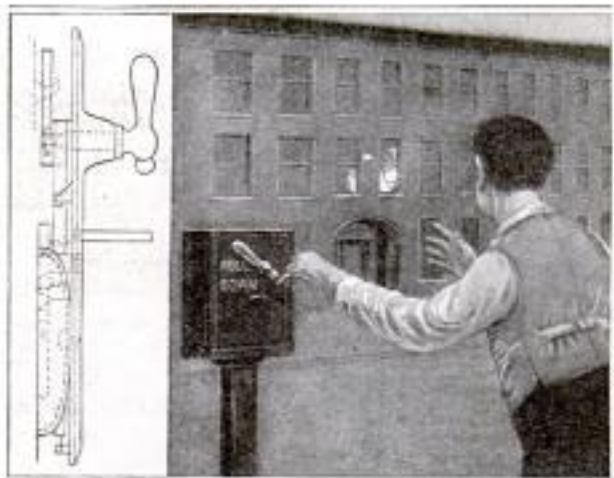

A Fire-Alarm Box so Constructed That It cannot be Opened without Ringing a Big Gong Fastened to the Inside of Its Outer Door

Jas. F. McLaughlin,
 Chief Elect. Bureau,
 Phila.

1981

**SPORTSMAN'S CHART SHOWS
GAME LAWS SIMPLIFIED**

On the back of the hunting licenses issued by the state of Wisconsin has lately been printed a chart which shows in a very clear and simple manner the open and closed seasons for game to be found in the state. The names of fishes, birds, and beasts are listed in a column at the left of the chart, and following each are 12 small squares representing the 12 months of the year. The months or portions of months in which it is lawful to hunt or fish the creatures named are indicated in white, while all the rest of the squares are black. At the right of the squares are data about the bag limit for various kinds of game. Other information is given

below. Formerly the licenses had no charts, the dates for the various open seasons being stated in printed form. In addition to the diagram is a table showing the time of sunrise and sunset for each day in September, October,

Open Spaces Indicate Open Season.	JAN	FEB	MAR	APR	MAY	JUN	JUL	AUG	SEP	OCT	NOV	DEC	BAG LIMIT.
White-tailed Deer, Moose, Other Deer, Mule Deer, Sika Deer, Elk, Caribou, Moose, Sheep, Goat, Wildcat, Badger, Skunk, All Other Mammals	■	■	■	■	■	■	■	■	■	■	■	■	1 For Resident License Holder, Mixed Bag Of 20 Birds For Non- Resident, Mixed Bag Of 30 Birds, Unlaw- ful To Transport Un- less Accompanied.
Buck Deer in certain counties only	■	■	■	■	■	■	■	■	■	■	■	■	1
Plover, Snipe, Red, Green, Blue, Curlew, Sandpiper	■	■	■	■	■	■	■	■	■	■	■	■	15
Pintail, Ruffed Grouse, Spruce Hen	■	■	■	■	■	■	■	■	■	■	■	■	10
Prairie Chicken, Sharp-tailed Grouse	■	■	■	■	■	■	■	■	■	■	■	■	5
Pheasant (exceptions)	■	■	■	■	■	■	■	■	■	■	■	■	
Muskrat (exceptions)	■	■	■	■	■	■	■	■	■	■	■	■	
Fisher, Marten, Mink	■	■	■	■	■	■	■	■	■	■	■	■	
Rabbit, Squirrel (exceptions)	■	■	■	■	■	■	■	■	■	■	■	■	
Trout of any variety (exceptions)	■	■	■	■	■	■	■	■	■	■	■	■	45
Game fish (exceptions)	■	■	■	■	■	■	■	■	■	■	■	■	15

Resident Hunting License \$100. Non-Resident Hunting License, Small Game \$10, Large Game \$25.
Non-Resident Fishing License \$100. Maximum Size Of Game Fish: - Bass 10", Pike 13", Pickerel 16", Catfish 15",
Trout 7", Muskeg 5" Pounds Weight Or 4 1/2" Dressed For Exceptions And Detailed Information See Game Law.

Chart Which Appears on the Back of the Wisconsin Hunting Licenses, Showing the Open and Closed Seasons for Various Kinds of Game

2894

**WATER SYSTEM KEEPS CAR
RADIATOR WELL FILLED**

With a view to preventing the overheating of an automobile engine due to lack of sufficient water in the radiator, a water system has been devised which keeps the radiator full at all times. The system does not require refilling, except perhaps after a long interval, and can be installed in any car. The apparatus consists of a tank containing a condensing coil, which is installed under one of the seats or on the running board, and is connected by a copper tube with the overflow of the radiator. After connections have been made the radiator is filled with water and the tank filled halfway, and all

and November, hunting and fishing being unlawful when the sun is below the horizon. Charts similar to this are used in Europe.

caps are screwed down tight. On high speed or when climbing a hill, the water heats and expands quickly, causing the steam and water to flow through the copper tube into the condensing coil and tank. When the speed

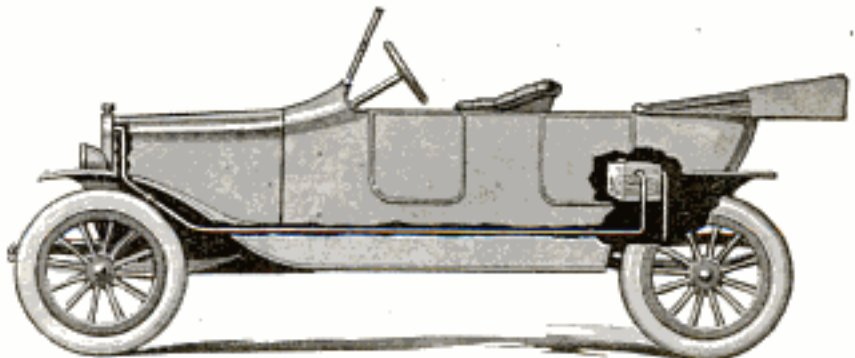

A Water System for Automobiles of Any Make Which Keeps the Radiator Well Filled and Requires No Refilling

of the engine lessens and the water cools, the vacuum created draws the water back into the radiator, which thus is kept full at all times regardless of changing conditions.

Amos Claar,
Kendler, Perma

DISAPPEARING FOOTLIGHTS FOR SCHOOL OR CHURCH

Footlights especially adapted to meet the requirements peculiar to the platforms in schools, churches, public

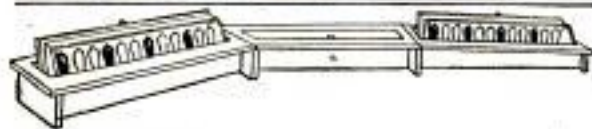
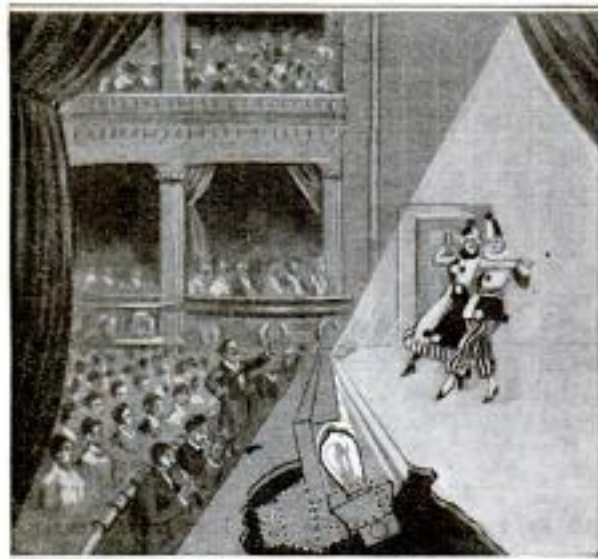

When Not in Use These Footlights may be Turned Down so That the Platform is Not Obstructed When Used for Other than Entertainment Purposes

halls, or theaters also used for other purposes, are being made in sectional form. In addition to providing efficient illumination when in use, they have the advantage of being out of the way when not needed, and when a platform is being employed for other than entertainment purposes. The sections are inserted in a gutter cut for them in the floor, their tops, when turned down, completely covering the space and forming an inconspicuous, solid panel that is flush with the surrounding platform. Each of these covers is hinged so that it may be turned up somewhat like a trapdoor. The lamps, arranged in galvanized-iron reflectors attached to the under side of the panels, are brought into position and raised a trifle more than three inches above the floor when this is done. The sections are made in lengths of from 10 feet to five feet, and are provided with either single or double rows of lamps.

OXYGEN OBTAINED FROM AIR WITH NEW CATALYZER

La Nature 6-3-1916

From an authentic source it has been learned that a French authority has produced a chemical compound which, when maintained at a certain high temperature, readily absorbs oxygen from the atmosphere and liberates it upon being subjected to a current of superheated steam. Several catalytic agents of this kind have been found commercially impracticable, but considerable importance seems to be attached to this latest method of tapping the world's storehouse of oxygen. It is understood that the compound consists of a plumate and a sodium permanganate, the former salt preventing the mixture from losing its porous consistency. Air, freed of carbonic acid, is directed into a chamber containing the catalyzer. Oxygen is absorbed and the nitrogen expelled. After air has been blown into the tank for a few minutes, the supply pipe is closed and superheated steam turned in, liberating the element, which is collected in a gasometer. Since the chemical absorbs and liberates the gas at the same temperature, the operation is a quick and economical one.

3440

COMPRESSED-AIR GUN FIRES LIQUID-OXYGEN SHELL

As a result of the examination of a rather new type of high-explosive artillery shell invented by a youthful worker in an ammunition plant at Dayton, Ohio, the War Department has become sufficiently interested to schedule the weapon for thorough tests. Until these have been made, the actual merits

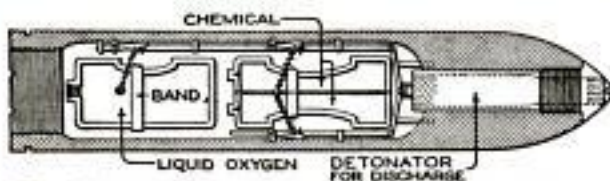

The Diagram Shows the Design of the Projectile and Indicates How Its Internal Mechanism is Operated

of the projectile will be an unknown quantity. Its character is interesting

Howard G. ...
Hyde Park, Cincinnati, O.
Copyrighted material.

W. E. Meadwell (N.Y.)

P.O. Box 391

Ithaca, N.Y. 439

POPULAR MECHANICS

3397 Adv. 711 gr

STEEL ERASER NESTS IN FOUNTAIN-PEN CAP

Morse Chain Co.

enough, however, to be worthy of note. The bursting charge, instead of being black powder, or some other common explosive, consists of certain chemicals and liquid oxygen held in separate chambers. When these are united, by means of a lever and spring mechanism actuated by what is apparently a percussion detonator, the chemical reaction results in an instantaneous explosion. Another important thing is that compressed air, not powder, is used in firing the shell from a gun. A six-inch projectile of this type weighs 72 pounds.

3124 HOW WEIGHT OF ENGINES IS BEING LESSENED

By Master Mechanic

One of the problems which has arisen in connection with the great increase in the size and power of locomotives has been how to lessen the tremendous stresses produced by the reciprocation, or revolution, of various heavy parts. In at least one type of powerful engine constructed in recent years an attempt was made to counteract these stresses by especially constructed counterweights. This effort was pronounced unsuccessful in many important respects, because it subjected the engine, and also the track, to new but equally serious strains. In recent months engine designers have turned their attention to the question of lighter construction. The use of forged and rolled-steel pistons has been proposed as one means of securing the desired lightness without sacrificing strength. These pistons are made solid and are cut with one or more dovetail grooves in the face, in which are inserted segments of malleable bearing metal, that is hammered firmly into place. Another means of lightening reciprocating parts of big engines has been to use hollow piston rods.

During the past winter, when there was a shortage of fuel in many places, a manufacturing plant in Stoneboro, Pa., met an emergency by having coke shipped to it by express. One consignment weighed 8,100 pounds.

A recently patented eraser for the cap of a fountain pen, ink pencil, or the like, consists of a small two-edged blade mounted on a plunger. A slit is cut in the side, and another in the end, of the cap to be fitted with this device. The blade is nested in the cap so that it can be pushed in or out through the end slot by means of a knob that extends through the side slot. When the pen is not in use the cap, with its eraser concealed, is placed over the writing end of the pen in the usual manner. In some cases the fountain-pen caps now in use are not long enough to be provided with this device.

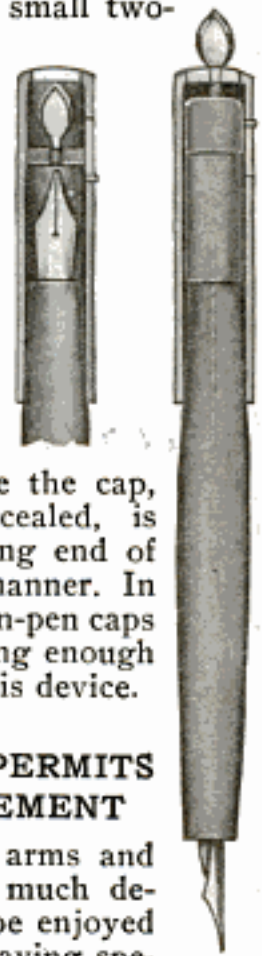

3364 NEW GOLF COAT PERMITS FREE ARM MOVEMENT

Free action of the arms and shoulders, something much desired by golfers, can be enjoyed if one wears a coat, having special sleeves, which has been put on the market recently by a ~~Detroit~~ firm. The sleeves are attached at the shoulders and back by means of plaits which automatically fold inward when not expanded. When an ordinary coat is worn, a full swing of a golf club causes the garment to bind across the shoulders, while with this coat there is entire freedom of movement. In design the article resembles a Norfolk coat. The plaited inserts are so made as not to seem bulky. The garment is suited to motoring, trapshooting, and other pastimes, as well as golf.



English Woollen Mills Co. Detroit

W. Weinberg & Sons 69 Nassau St. N.Y.C. Copyrighted material

3603 VARIOUS ACTIVITIES OF BOYS AND GIRLS AND
Hotel Majestic

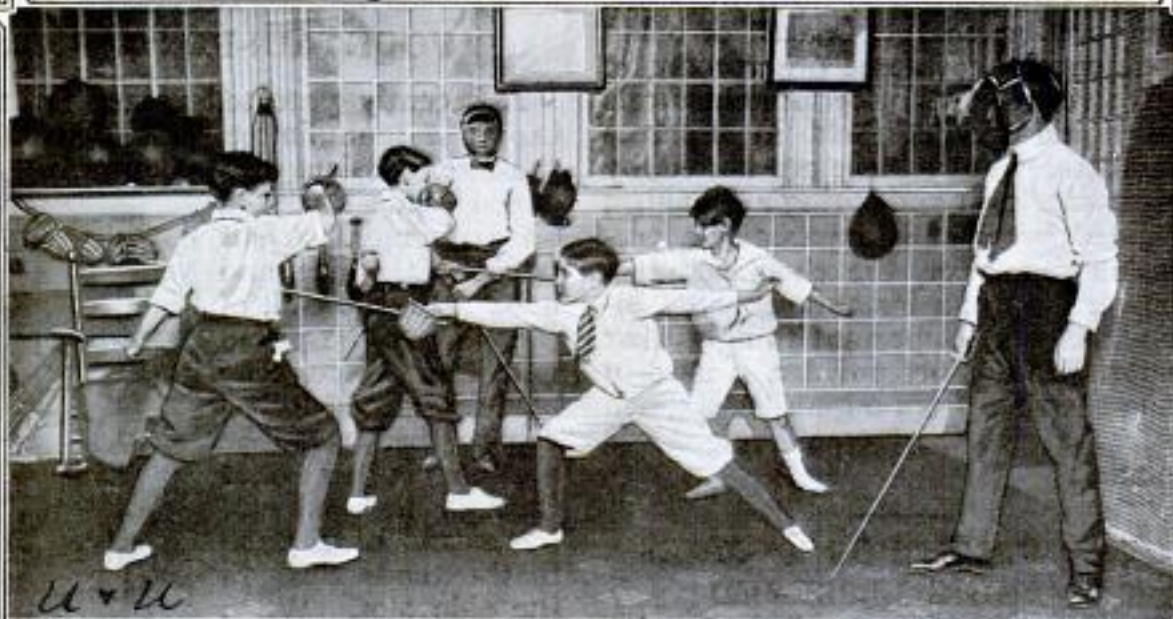

U+U

A Big Eastern Hotel Has a Gymnasium on Its Roof, and Boys Who Happen to be Stopping at This Hotel with Their Parents can Go Up There and Play. The Young Guests Shown Above are being Taught to Fence



COPYRIGHT, BOSTON PHOTO NEWS CO.

This is Elva Gowen, a Little Red Cross Girl—Pretty Nearly the Youngest in America. She is Only Three Years Old, but When the American Red Cross Had a Big Campaign in Boston for Members She Signed an Application Card All by Herself



*Paul Thompson
 10 Street
 N.Y.C.*

The Little Maiden at the Right Wanted to Look at the Ships Far Out on the Ocean but She Was so Small and the Telescope Was so Big That She Had to Stand on a Chair to Do It

Chin Chin is a Baby Elephant Who Plays in a Theater and in One Act Has to Stand on Some Ice. This is Too Cold for Him and So These Men are Measuring Him for Shoes to Protect His Big Round Feet



U+U

*New York Hippodrome
 X H.V. Scates My Shoe Dept.
 Wm. A. Filene's Sons Co., Boston*

U+U



In Spain Boy Scouts are Taught the Same Drills American Boys Learn. Two Young Princes Belong to the Spanish Troop Shown Above. They and Their Comrades are Giving an Exhibition for Members of the Royal Family

This Checkered Schoolhouse Is Near Ashville, New York. Some Folks Wanted It Painted One Color, It is Said, and Some Another. So It was Decided to Use Both Colors



A Whittling Club in Portland, Oregon: The Man in the Group Is an Expert at Whittling, and Likes to Show the Boys How to Use Their Jack-knives. Some of the Objects They Have Carved are Shown



Central News Photo Service

Stone Lodge Rural School

Johannes Hansen,
Portland, Me.

S. De Vingo
453 S. 11th Av.

3298⁴⁴²

POPULAR MECHANICS 3626
Mt. Vernon N.Y.

SANITARY NECK PROTECTOR FOR USE IN BARBER SHOPS

A sanitary bib or protector has been designed to be worn about the neck of a person being barbered, the special



features of which are that it prevents hair from falling inside the clothing at the neck; and it is made of washable material so that each person may be provided with a clean protector. The article is really composed of two bibs of similar size and shape attached to a single collar band and having free ends that interlap at the front. The band is provided with several clasps so positioned that the protector can be adjusted to any desired size. The apron thrown about the person wearing the bib is tucked in between the cloths.

2688

VOCATIONAL TRAINING FOR MEN IN THE ARMY

Vocational training in the army, according to the 1916 report of the secretary of war, is to be given added emphasis. The recent National-Defense Act provides that opportunity shall be given soldiers in active service to receive educational instruction that will increase their military efficiency and enable them to return to civil life better equipped for industrial, commercial, and general-business occupations. Many men enlist in the army for but a single term and then, on returning to civil life, find themselves handicapped as compared with young men who have given all their time to their chosen work. Particularly in the stations of the Coast Artillery substantial progress has been made in the matter of educational work, and it is predicted that a mode of army life having many desirable features will be developed.

SCHOOLS INSTRUCT PUPILS IN CIVIC BETTERMENT

Better citizens and an improved city are apparently the aims of educators at

schools have been banded into a quasi organization known as the Improvement League. It is a part of their routine work to act as sanitary inspectors, and under the supervision of their instructors visit scores of places about the city in quest of unhealthful and detrimental conditions. Garbage disposal and the work of the health and police departments have been studied, poor sections of the city visited and housing conditions investigated, and bakeries, groceries, and other food-distributing business places inspected. When either unsavory or particularly commendable situations are found, photographs are taken, notes made, and reports filed with the teachers.



Four Des Moines High-School Girls Taking Notes on the Sanitation Conditions Found in a Hollow in Close Proximity to Residences

Des Moines, Ia., where boys and girls are being given first-hand insight into the commonplace problems of civic management. A thousand or more of the pupils attending three local high



Fence Extension at Tidewater Stream

By B. FRANCIS DASHIELL

PREVENTING stock from passing around the end of a fence between adjoining fields at a tidal-river bank proved difficult until the fence extension, shown in the sketch and the diagram, was built. It adapts itself to the varying heights of the water, and may even be used in a lake, or a river of not too swift current and with little floating debris, to meet the varying depths of the water in different seasons.

A fence of woven wire, graded down to the bottom to keep out smaller stock, was built to extend a short distance from the shore line at low water. A post was set, about 25 ft. beyond the last fence post, so that it projected above the surface at high water, and was guyed strongly. A slide rod of round iron was fitted to

each of these posts, as shown in the diagram, being made long enough in each case so that the ends extended beyond the limits of the water's vertical movement. A barbed wire was fitted with

suitable floats of wood, and provided with rings to engage the slide rods. It was stretched into place as shown, and was made free to float easily with the change in the water level.



The Barbed Wire is Supported by Floats and Accommodates Itself to the Changing Water Level

Planting Bulbs Conveniently

To set out a large number of bulbs is quite a job, especially when they are to be planted in a lawn which should not be injured. I used a 2-in. iron

pipe about 2 ft. long, with the end ground sharp, to cut the holes for the bulbs. A mark was painted on the pipe, 4 in. from the cutting end, so that

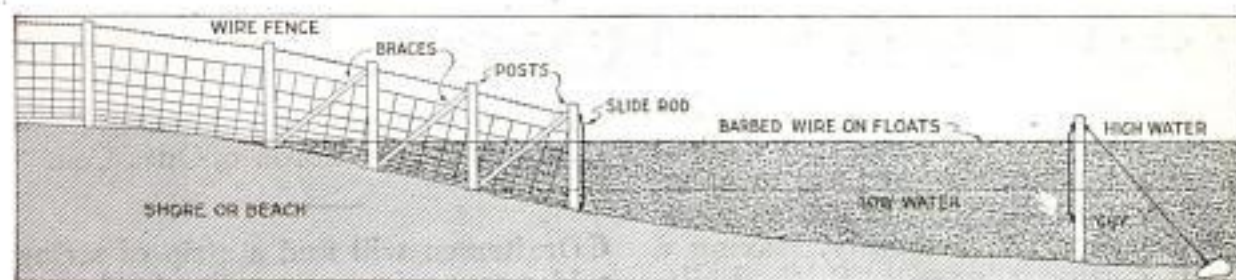

Sectional Diagram Showing the Arrangement of the Fence, Posts, and the Barbed-Wire Barrier

I could easily drive it down to the proper depth. After the bulb was dropped in the hole the earth was replaced by rapping the pipe. This necessitated only a slight cutting of the lawn.—A. E. Holaday, Naugatuck, Connecticut.

Sharpening Scissors on a Grinding Wheel

Scissors may be sharpened quickly and effectively on a grinding wheel,

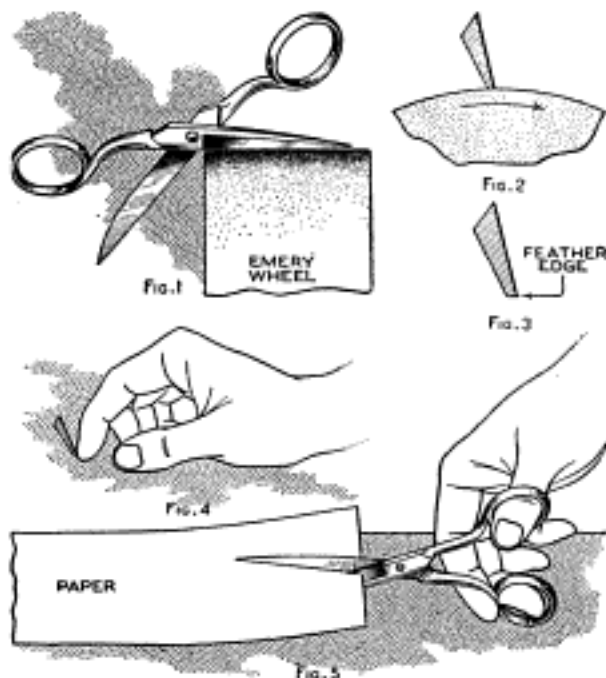

The Blades are Ground to a Feather Edge, and This is Removed by Cutting Carefully into a Piece of Paper

and this method is especially useful where several pairs are to be put into shape. Hold the scissors on the wheel, as shown in Fig. 1, the direction of the wheel being as indicated in Fig. 2. A feather edge, or extension, will be produced, as suggested in Fig. 3. Test the edge to make certain that a slight feather edge is ground throughout the cutting edges of both blades. This may be done by passing the finger nail along the edge, as in Fig. 4. Then remove the feather edges by using the scissors in cutting paper; apply oil to the edges before closing them or using them in this manner. The feather edges will be removed smoothly, leaving a sharp cutting edge.—R. B. S., Philadelphia, Pa.

Hinged Drawer Front Is Convenient

A large drawer in a bench was used for tools of various sizes, and it was difficult to remove those placed in the back of the drawer. As a result most of the tools were placed in the front part, often making it inconvenient to open the drawer. The front of the drawer was arranged to swing forward on hinges, and compartments were provided so that the tools had to be put in carefully. This increased the usefulness of the drawer and made it easier to get at the tools.—Charles C. Brabant, Detroit, Mich.

Hood on Chimney Increases Draft

Large smokestacks are often provided with an arrangement near the top to increase the draft. I devised the one shown in the illustration for use on a residence chimney, and it gave good results. A hood of sheet metal was built around the top of the chimney, flaring out to a spread of 15 in. from the bricks, and with an opening of about 3 in. at the upper end. The resulting draft through the hood has a tendency to draw the air and smoke up out of the

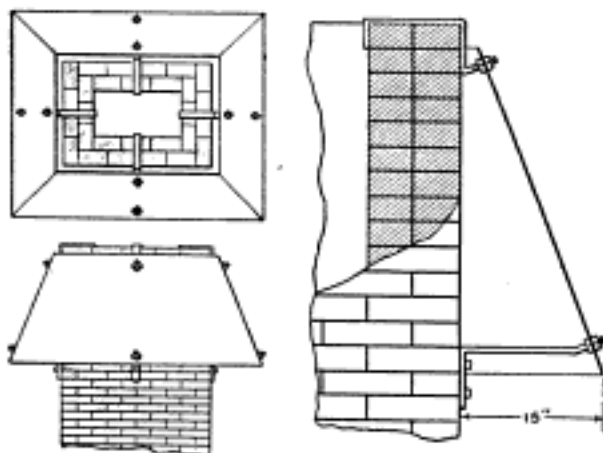

This Hood on a Chimney Increases the Draft and Tends to Overcome Down Draft

chimney, counteracting down draft.—James E. Noble, Toronto, Ont., Can.

Ⓒ Draftsmen will find a strip of string solder convenient as a spline for laying out irregular curves

Hardening Small Carbon-Steel Tools

Special care must be taken in the tempering of small tools of carbon steel. A small gas furnace, inclosed, with a chamber for the heating of the tools, is desirable, but a coal or coke fire properly banked is satisfactory. The fire must be burned down to a bed of live coals, and it is best to insert a section of tubing into the fire to protect the tools from the direct blast. The quenching heat may be determined accurately by instruments, but where these are not available, the use of a magnet is suggested. When the magnet no longer has an attraction for the steel being heated at the part in the fire, the proper point for quenching may be determined by permitting the steel to remain in the fire a few moments longer. The point at which the magnet ceases to attract is about 1,425° F., and the best heat for tempering is 10° above that temperature.

Cracked and damaged tools in the hardening process frequently result from the failure to relieve the strain on the steel after quenching, and the moment that it has cooled sufficiently to harden. While still grasping the tool in the cooling bath, the instant that the tremor from the sudden plunge stops, the piece should be withdrawn quickly, and permitted to cool in the open air. The steel will still be too hot to hold in the hand. This is only necessary, of course, when the steel is not to be drawn to temper on the original heating.—A. Dane, Pottstown, Pa.

Saving a Fallen Tree at a River Bank

Continued high water softened a river bank in a park, so that several trees toppled over into the water for want of good root anchorage. A willow at one point was especially desirable, and it was brought back to its former position by the method described. High up on the trunk, well out over the water, a threaded eyebolt, B, was sunk into the tree, and a good bearing secured by means of a large

washer screwed down tightly with a nut. This afforded a hold for a double

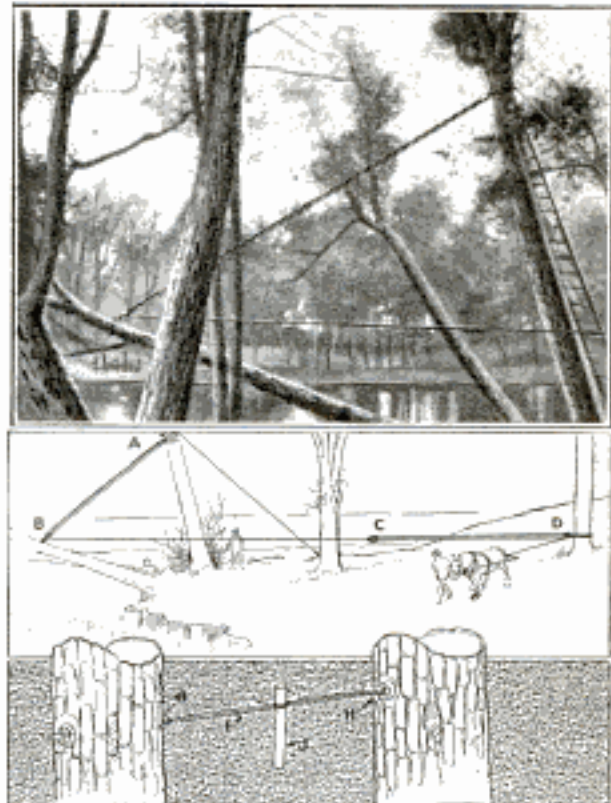

A Fallen Tree at a River Bank was Raised and Braced by the Method Shown

block, while a single block, A, was roped to a near-by tree. Then tackle was adjusted between the blocks, and the free end thereof hitched to a triple set of blocks and tackle, C and D, secured to a tree at some distance from the river bank. This gave a good purchase, and a horse hitched to this second tackle could exert a very heavy pull upon the fallen tree. By careful work the tree was brought to its former position without a mishap. The raised tree was permanently tied to the tree that held the single block by means of stout wire connecting the eyebolt G, in the former, with an eyebolt, H, sunk into the latter. This wire I was run through the eyes in four strands and twisted to the proper tension with a stick, J. The tree was also anchored to the base of a near-by elm.—C. L. Meller, Fargo, N. D.

Make it a rule to reset the tailstock on a lathe immediately on completing a taper job.

Gravity Water System

for a Summer Cottage or Camp

By G.E. Kastengren



THE gravity water system described in this article and shown in the illustrations was built for a summer home in the Olympic Mountains. The principles underlying its construction, and the general details, may be used directly or with slight adaptation in various other mountain or rolling-hill regions, or other places where a suitable flow of water is available. The source of the water supply was a small spring-fed creek, with a minimum flow of 15 gal. a minute, and situated at an elevation of 800 ft. above the house to which the water was conducted, as shown diagrammatically in the large illustration. The water is conveyed a distance of 1,440 ft. and is stored in a 25-bbl. oak cask, obtained from a brewery for \$15. This was set at an elevation of 92 ft. above the house, on a strong platform built of logs, across

flume, constructed as shown in the detail sketch. Views of the flume and of the tank are shown in the photographs reproduced in the headpiece. A pipe line conducts the water from the storage tank to the house.

Galvanized-iron pipe, secondhand, was obtained for the pipe line and other pipe sections and fittings, 2-in. and 1½-in. pipe being used. It was conducted from the bottom of the tank, as shown, and joined with the usual unions. At the end near the house, a 1½-in. nozzle was placed, for fire protection and sprinkling. The joints were made with various fittings to accommodate the line to the ground, with a minimum of supports. A globe valve was fitted at the outlet from the tank and a ladder was provided in lieu of a depth gauge in the tank.

To convey the water from the intake to the tank, I devised a flume of the special type shown in detail, and it proved well suited to the conditions. It leads through a heavy forest of fir and cedar, and occasional windfalls, especially during the winter, are likely to break parts of it. It was therefore necessary to construct the flume so that it could be repaired easily and quickly. It is made in sections of 16-ft. length. They are not nailed together, but the lower end of each rests on the upper end of the next section below, and a broken section may thus be quickly replaced. Since the area for the passage of the water would be reduced considerably at the joints if they were set together as originally made, portions were cut away by beveling the adjoin-

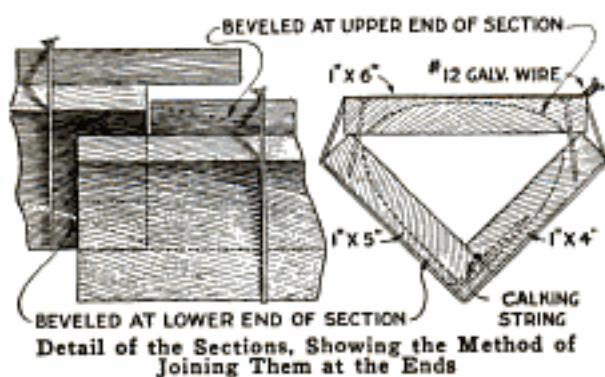

a gully, about 4 ft. deep and leading almost directly to the house. This made unnecessary a great deal of excavation otherwise essential, as an excellent trench was thus provided for the pipe line. The water is conveyed from the intake to the tank by means of a

ing ends, as shown by the dotted curves in the detail sketch. The lower edge of the cover was beveled to a distance of about 3 in. at the upper end of each section. The upper edges of the trough were beveled similarly at the lower end of each section. The ends were telescoped, as shown, and the covers of the adjoining sections set to cover the joints on top. The lower portion of the flume was made of two strips, one 1 by 4 in. and the other 1 by 5 in., nailed together, and a calking string was inserted in the joint. The cover board is 1 by 6 in., and serves to brace the sections. It is nailed down and further reinforced by galvanized-wire stays, tightened around the sections as shown. No difficulty was experienced with the sagging of the sections as the cover and trough, joined rigidly, form a strong hollow beam. The capacity of the flume is about that of a 3-in. pipe, and 20 board ft. of lumber were required for each section.

The sections were all built at the house and carried to their places over a hastily broken trail. The work was planned systematically so that all of the pieces were cut first, and the similar parts and processes handled at the same time. The most difficult part of the work was the carrying

of the sections to their destinations, and in this work it is well worth while to make a fairly good trail.

The plans for this system include extension of the pipe line 250 ft. up the hill with $2\frac{1}{2}$ -in. pipe, con-



The Water is Conducted by a Wooden Flume from a Spring to the Storage Tank, and Then to the House by a Pipe Line



nected to a larger tank there. This will give a head of 255 ft., for the development of 500 watts of electric current, during the hours when lights or power are needed. A minimum flow of 25 gal. a minute is available for this purpose. The cask will be used in this arrangement as formerly,

a $\frac{3}{4}$ -in. pipe line being installed to conduct the water to the house. This will not interfere with the power line by reason of the use of a regulating valve, opened only when water is needed for the cask. The cost of this installation, exclusive of labor, was \$109, and the investment has increased the utility of the place immensely, and enhanced its value probably \$800. A valuable consideration also is the added security of the wooden buildings from the danger of fire.



Snow-Melting Device for Roofs

When three feet of snow fell in a region unaccustomed to heavy snow-



Damage to Glass Roofs was Avoided by Melting the Snow in a Heavy Snowfall as It Drifted on the Roof

falls much damage was done and several roofs collapsed under the strain. Many glass-roofed greenhouses suffered. The owner of several such buildings saved his property from damage by further snowfalls by extending the steam pipes that heated the interior, through the roof, as shown in the illustration. With a good head of steam in the boilers, he kept the pipes hot, and as fast as snow drifted on the glass roofs it melted away.

Reboring a Large Gear without Machinery

It was desired to rebores a gear, 40 in. in diameter, fitted to a 2-in. shaft, to fit a 2 $\frac{1}{8}$ -in. shaft, and the local shops were not equipped with

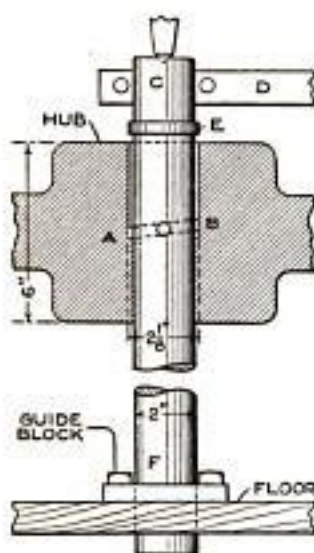

machinery suitable for this work. The rigging shown in the diagram was set up, and the job completed in a short time with success, and without the use of ordinary boring, or special machinery. The gear was placed on two strong shop horses, and bolted to the floor, leveled carefully, so that the

bored bearing in it was vertical. A hardwood block was bolted to the floor directly below the bearing hole, and a 2-in. hole was bored into it. Strong braces were set against the gear. A vertical boring shaft was fitted to the bearing hole as follows: A 2-in. shaft, C, was bored to fit a $\frac{5}{16}$ by 2 $\frac{1}{8}$ -in. piece of tool steel, tempered and ground, and set at an angle, as at A-B, so that the end A became a cutter. The lower end of the shaft was set in the hole at F, which extended through the floor. The inclination of the cutter gave the cutting edge a $\frac{1}{16}$ -in. lead, and the hole was bored true by centering the cutting bar at the beginning of the cut. A ring, E, 2 $\frac{1}{8}$ in. in diameter, was fitted on the shaft and acted as a follower. Power was applied on the arm D, 5 ft. long.—L. M. Drake, Daytona, Florida.

Push Button Varies Tone of Electric Horn

In residential sections the loud blast from an electric automobile horn is an unnecessary nuisance, but on long

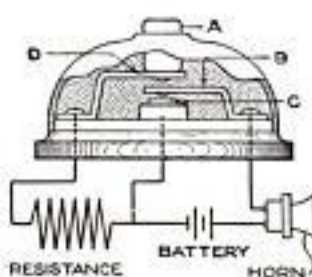

stretches of country road, at sharp turns, or in crowded, noisy city streets a penetrating blast is often desirable. A push button designed to control the horn's tone at the operator's will can be constructed easily, as indicated in the diagram. The usual push button A has a contact point, C, and a spring-brass strip, B. When the button A is pushed downward, C and B make contact, and a circuit is established through the battery and horn. A second brass strip, D, similar to B, is added, and placed above B. A small resistance is then placed in series between C and D. The amount of this resistance can be determined by experiment. The horn is operated as follows: A pushes D against B, and a high-resistance circuit through the battery and the horn is es-

tablished. The horn then gives the subdued tone. A slightly harder push on A will bring B in contact with C, cutting out the resistance, and impressing full battery voltage on the horn. A full-toned warning will thus result.—K. M. Coggeshall, Webster Groves, Missouri.

Straightedge Arched for Leveling Concrete

When troweling the surface of a concrete walk, or similar area, many of the strokes start or end in the center of the panel. Care is necessary to prevent the center from becoming lower than the edges, forming a lodging place for water. If the straightedge, used to strike off a level surface before troweling, is arched, a level walk will be more easily obtained. The arching of the under side of the straightedge gives a slight crown, and subsequent troweling brings the surface down to a level.—J. J. O'Brien, Buffalo, N. Y.

Preventing Back Draft in Fireplace

If a fireplace smokes, or does not "draw" properly, the cause may usually be found in that the portion known as the choke is too large. To remedy this quickly and at slight cost a false back is provided in the fireplace, as shown in the sketch. A sheet of tin plate is fastened to the back wall, a few inches above the hearth level, and extended upward, on a slight forward curve, to a point about 2 in. above the lower edge of the facing. This sheet should be the full width of the back wall. At the lower edge it is nailed to the mortar and at the top it is fastened to a cross rod. Cut the sheet the width of the back wall of the fireplace, and of a length corresponding to the vertical distance to be covered, allowing 1 in. to be used for a loop on the cross rod. A right-angle turn of 2 in. is then made on each end of the rod, which is 4 in. longer than the width of the fireplace, forming a springing resistance against the walls. The lower edge of the apron is then nailed, the sheet of

metal being curved as shown. The opening into the flue can thus be reduced in size as desired, by moving the

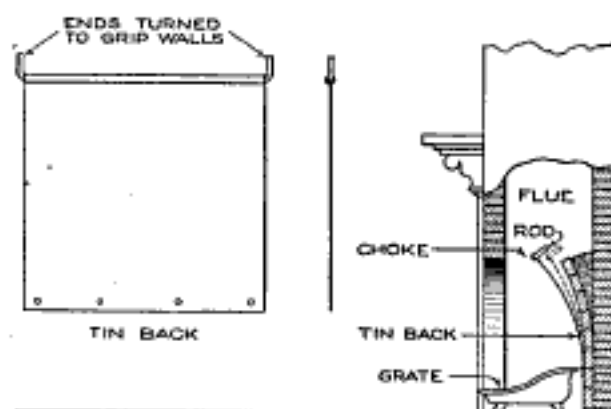

The Draft in a Fireplace may be Regulated to Prevent Smoking by Means of the Adjustable Sheet-Metal Guard

cross rod, care being taken to create just the necessary draft to prevent smoking.—Charles Alma Byers, Los Angeles, Calif.

Indicator Holder with Five Positions

Having purchased an indicator, I found that I needed a number of attachments to make any considerable use of it. These were expensive, so I made the holder shown in the illustration, and was able to do many kinds of work with it. It has five positions for the indicator, as shown by the numbering on the sketch. The holder was made of a $\frac{3}{8}$ by $\frac{3}{8}$ by $1\frac{1}{2}$ -in. strip of machine steel. The holes in it were tapped to fit a thread by means of which it was supported in its various

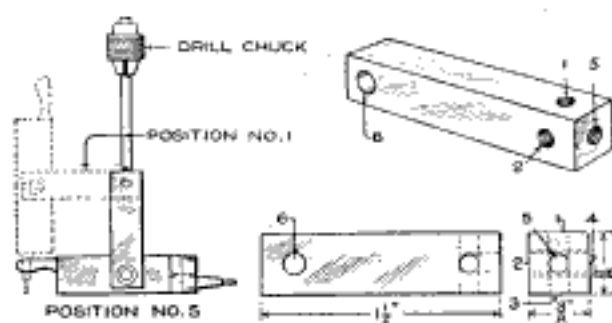

This Simple Holder Enlarged the Usefulness of an Indicator without Special Attachments

positions. The holder is fastened to the indicator by means of a thumb-screw set in hole No. 6.—Arthur Whittier, Norwood, Mass.

Safety-First Alarm System for Shops

In emergencies it is often desirable to stop the machinery in a shop quickly,



and, if the establishment is a large one, a signal arrangement between the engine room and the shop is practical. Serious accidents or loss of life may thus be averted. A simple arrangement which any workman could use in an emergency is shown in the sketch. The box with its code lettered to be seen at a distance should be located so that it may be reached quickly, and painted a conspicuous color.—J. R. Minter, Washington, Ind.

Auxiliary Vise Jaw for Holding Irregular Pieces

A block of hard wood, shaped to match the upper end of the vise jaw and pivoted at the center, as shown in the sketch, will add to the usefulness of many vises. The block will

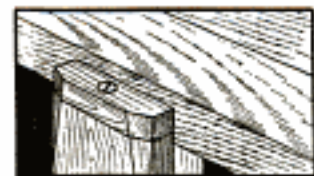

adjust itself to pieces of unequal width and will save needless wear on the vise, as the block may be quickly renewed when worn out.

Anchor Bent from Round Bar

A form of anchor that can be made easily from a bar of round iron is shown in the sketch. The original was made of 2-in. bar iron, but the method of forming the anchor can be applied to

smaller stock for use on a rowboat or other small craft. The ends of the rod

are heated and upset by striking them on the end. They are then pointed as shown, and the bar is bent into shape with an eye at the top to fit a ring.—J. Harger, Honolulu, H. I.

Electrical Ground Made of Flowerpot

A ground suitable for wireless apparatus, lightning arresters, and similar electrical devices, may be made quickly

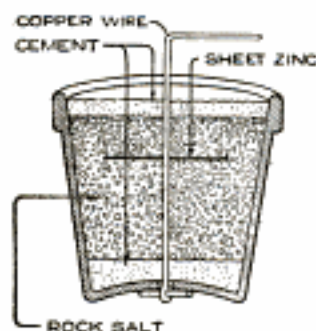

as shown in the sketch. The heavy copper wire of the ground is fitted into a large flowerpot, and a wire is fixed to its end to hold it in place. The bottom of the pot is covered to a depth of about 1 in. with cement. Rock salt is then poured in and a disk of sheet zinc is imbedded in it in contact with the wire. A 1-in. layer of cement is poured in on top. Salt will draw moisture and for this reason a ground made as described will give good results. The clay flowerpot tends to hold the moisture.—A. Gemmill, Ansonia, Conn.

Rodent-Proof Support for Corncrib

To prevent the inroads of rats and mice, and, at the same time, provide a

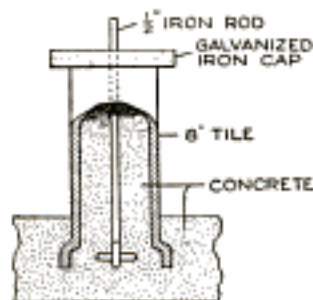

substantial support, a foundation for a corncrib was made of 8-in. tile set in concrete, as shown in the sketch. The tile was placed with the flange down, and a 1/2-in. iron rod was imbedded in the concrete with which it was filled. A galvanized-iron cap was fitted over the top and the iron rod passed through it to form a substantial fastening for the sills of the crib.—R. W. Smith, Minneapolis, Minn.

Adaptation of Motorcycle for Home and Shop Use

By J. H. SEEGER

A MOTORCYCLE that is used only for transportation or pleasure jaunts is not giving the fullest service to its owner. By providing suitable rigging and devices, all easily made in the home workshop, I use my motorcycle the year round, for a large variety of home and shop duties. The arrangement shown in Fig. 1 permits the use of the engine for driving a cooling fan, an emery grinder, and an ice-cream freezer. Many other home and farm machines may be driven similarly. The work of wash day made lighter by the use of the motorcycle engine is shown in Fig. 2, and a detail of the driving pulley in Fig. 3. The machine fitted to a truck for use on railroad tracks is shown in Fig. 4. The vehicle is not impaired for its ordinary use, and the devices used with it are quickly disconnected.

The installation for the grinder and freezer was made in the shop. The grinder is a handy shop machine and is driven at great speed and with sufficient power for most ordinary grinding. The fan on the opposite spindle of the grinder is used to cool the engine when it is used for continuous duty on work other than the driving of the grinder. If it is desired to cool the engine while grinding, the fan should be incased for the safety of the operator. The freezer, or other light machine, such as a churn, is connected to a line shaft by gearing. Other suitable means of transmitting the power are readily installed. The drive pulley on the engine is $4\frac{1}{2}$ in. in diameter, and the pulley on the line shaft 13 in. The drive pulley was supported by braces of strap iron, fixed to the engine as shown in the detail view.

In connecting the engine to the washing machine and the wringer, it is necessary to gear the speed down considerably, hence large pulleys are used, and a further reduction made between

the line shaft and the pulleys on the shafts of the wringer and the washing machine. The pulley below the machine is 10 in. in diameter. In all of these arrangements, the motorcycle

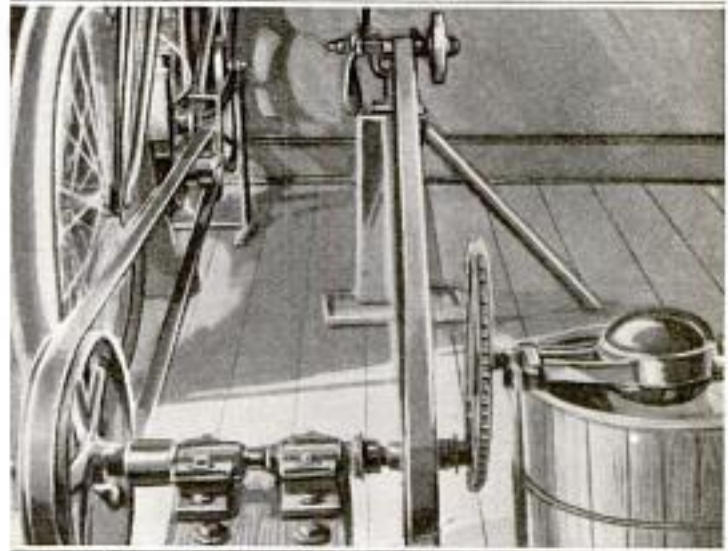

FIG. 1
Grinder, Fan, and Ice-Cream Freezer Driven by a Motorcycle Engine, the Speed Adjusted by Pulleys and Gears

must be mounted on a strong rear-wheel stand, or other rigid frame, from which it may be released easily. If necessary, the frame may be bolted to the floor, as in the workshop installation. The sprockets, chains, and other



FIG. 2
The Work of Wash Day Made Lighter by the Belting of Motorcycle to the Washing Machine and Wringer

machine parts used, were picked up from old machines, separators, farm tools, and similar devices, at practically no expense.

The car for use on railroad tracks is of simple construction. It will carry three workmen, and operates smoothly

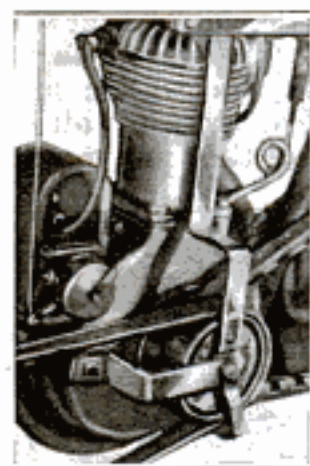

FIG. 3

and speedily, even in bad weather. Three flanged wheels, like those commonly used on small hand cars, were used. An iron bar, fitted with a small roller bearing against the inner side of the rail, guards the motorcycle from slipping off the rail in taking a curve.

The rear wheel only comes into contact with the rail, and furnishes satisfactory traction with the ordinary rubber tire. It can be raised to operate the engine, without traveling, by the usual stand. The car and the framework supporting the carrying rack are arranged to be set up or removed quickly for use with the motorcycle,

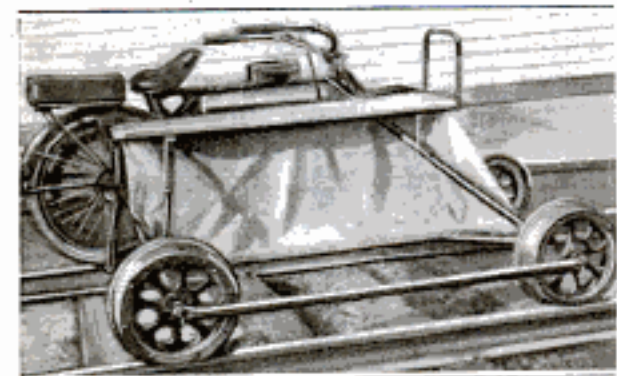

FIG. 4

Motorcycle Rigged to Run on Railroad Tracks and Accommodating Three Persons

by bolt fastenings. This enables the rider to travel a part of his journey on rail, and the rest over roads, in an emergency.

CA piece of heavy cardboard, about 6 in. square and having a $\frac{1}{2}$ -in. hole through it, is useful in locating splinters or small particles of foreign matter in the hand. Hold the hand in front of a strong light and locate the splinter by observation through the opening.

Focusing and Caring for Headlights

The adjustment of headlights should be made at night and without interference from other light. The vehicle should be headed toward a wall, or other similar surface, with the lamps 10 ft. from it. If the lamps are properly focused, the light thrown on the surface will be in the form of a circle, about 3 ft. in diameter, and having a very bright spot in the center, 3 or 4 in. in diameter. When this is not the case, the lamps are out of focus and should be moved forward or backward in the reflectors. If they are too far back, the rays of light will diverge, so that a large area is illuminated, but the light will be unsatisfactory for driving; if they are too far away from the reflectors, the rays of light will converge, so that there will be excellent light, a few feet ahead of the car, but not satisfactory for driving.

An adjustment of the lamps for maximum illumination on a point 150 ft. from the car will give good results for general driving. The two reflectors should be so adjusted that they will throw their light directly ahead of the car, and slightly toward the ground. Lamps having concentrated filaments are desirable, as a better focus is possible, in that the light is confined to a small spot. If the reflectors are dirty, they may be cleaned by rubbing them lightly with a piece of fine cotton dipped in alcohol. Rub from the outer edge toward the center or the reverse, never around the reflector.—P. D. Norem, Chicago, Ill.

Wire Substitute for Latticework

Fine galvanized-iron wire mesh may be used with good effect to replace old-style wood latticework in inclosing the lower portions of a porch, stairs, or similar places. It makes a satisfactory appearance, and if well painted, will last longer than wood. It is also easily fitted and fastened in place. Climbing plants are afforded a good hold, and the fine mesh keeps out small animals.—James M. Kane, Doylestown, Pa.

Motor Attachment and Brake for Sewing Machine

A small battery motor using a current of about six volts was fitted to a sewing machine and provided with a brake and pedal, as shown in the sketch. The arrangement gave thorough satisfaction and was constructed in a short time, with materials readily available. The motor was bolted to a wooden base, which was in turn connected to a block support with a strap hinge. A stop was provided to keep the base in a horizontal position, and a coil spring was fitted under it, to hold it down, except when the foot is pressed upon the pedal. The motor was belted to the pulley on the end of the spindle of the machine, and a brake pad of wood was fitted to the base, to engage the flywheel. The pedal is connected to the back end of the base with a hinge, and pressure upon it, in front of its pivotal point, causes the base and motor to be raised, releasing the belt and bringing the machine to a quick stop by the action of the brake. The machine may thus be stopped without shutting off the current to the motor, but a small switch should be mounted near the operator to control the current supply. A small trans-

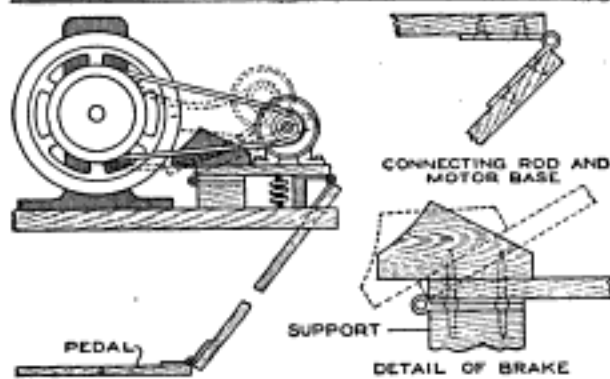

The Motor is Controlled by Pressure on the Pedal, the Brake at the Same Time Acting on the Flywheel

former may be used to reduce 110-volt lighting current, or it may be supplied by a storage battery.

Always joint a saw to insure a straight cutting edge before filing the teeth.

Adaptable Jig for Turning Pulleys in a Lathe

After several castings for light pulleys had been broken while attempting to turn them up in a lathe by the com-

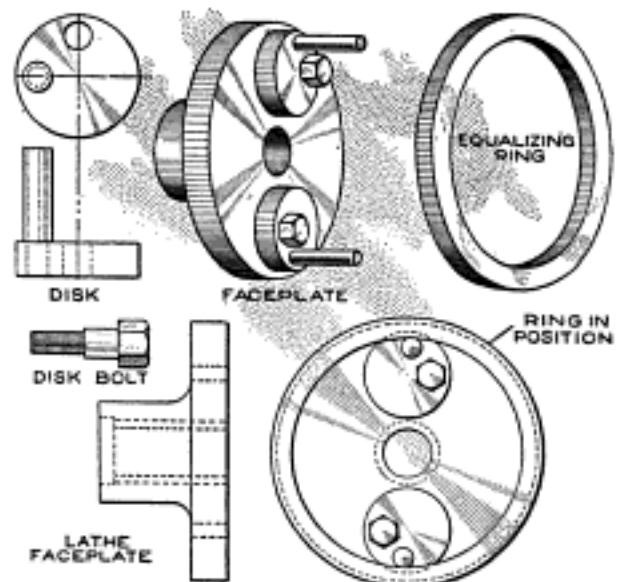

The Eccentric Disks and the Ring Equalize the Strain in Turning Up Light Pulleys in a Lathe

mon method of mounting them on an arbor and faceplate with a stud, the device shown in the sketch was made, and proved satisfactory. A faceplate was turned up and threaded to fit the lathe spindle. Two disks provided with studs, set close to their edges as shown in the detail sketch, were fixed to the faceplate with machine bolts, so as to pivot easily. They were mounted eccentrically. An equalizing ring was made and fitted over the disks and studs, as shown. The operation of turning up the pulleys was then carried out as follows:

The pulley was mounted on an arbor and placed on the faceplate so that each of the studs rested against a spoke, with the ring in position. The pressure of the spokes against the studs forces them against the ring, which equalizes the strain, giving a uniform pull on opposite sides of the pulley. The faceplate may be used for various sizes of pulleys, by drilling and tapping holes at suitable distances from the center, to accommodate the studs. Three disks for very light pulleys may also be used.

Roofed Watering Tank of Concrete

A large concrete watering tank, having a frame superstructure over it, was found practical on an Iowa farm. Its

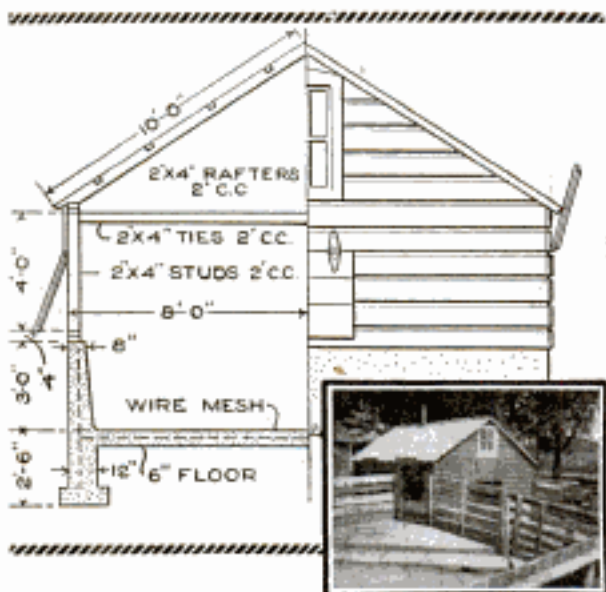

The Concrete Watering Tank was Built at the Center of the Barnyard, Giving Access to Stock in the Various Sections

large size enabled the farmer to use plenty of water in spite of adverse weather when the windmill could not be operated. The roof over the water kept it cool in summer, and aided in keeping the water supply pure. The original was made 16 by 20 ft., but the method of construction may be applied readily to smaller tanks.

A strong foundation of concrete, having a 24-in. footing and a 12-in. wall, tapering to 8 in. at the top of the tank, was poured in forms and served as the tank proper. The 6-in. floor and the walls were reinforced with heavy wire mesh. The tank was made to extend 3 ft. above the floor level, and bolts were set into the top of it, to provide a fastening for the frame portion. The lat-

ter was made of 2 by 4-in. material, with double pieces for the sills. The rafters and other details are of standard construction. Windows were set in the gables, for light and ventilation, and several doors, to be raised in opening them, were fitted in the sides and ends. The sides and ends were finished with matched siding, set horizontally.

The openings are spaced in relation to the fenced parts of the barnyard, so that each type of cattle has separate access to the tank. The tank was set in the center of the adjoining sections of the barnyard for this purpose.

The top of the concrete wall should be leveled carefully, to provide a satisfactory foundation for the frame structure. The tank should be finished, especially inside, with a smooth coating of a creamy mixture of cement and water, three days after pouring the concrete in the forms, the latter being removed at that time. The intake and overflow pipes must, of course, be provided for when the forms are set up.

Platform Facilitates Taking Down of Automobile

A platform used in an automobile factory, and which has practical applications for use in repair shops and garages, is shown in the illustration. After the car has been tested and certain parts removed it runs onto the platform and down the incline, where it drops onto a truck, resting on its axles. The car uses its own power in this process, and the same platform is used to unload the chassis when it is painted and ready for the body, the process being reversed.

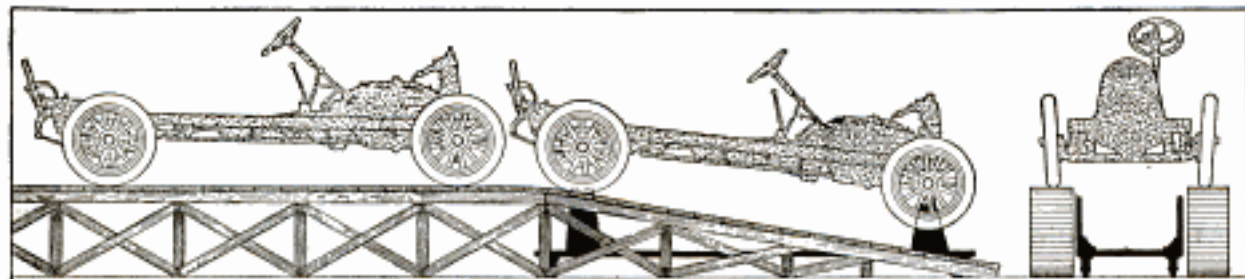

The Automobile is Run onto the Platform by Its Own Power and Set on the Truck for Taking Down before Painting the Chassis

Indoor Air Supply for Furnace Heating Systems

Many hot-air furnace heating systems provide for two sources of fresh-air supply. In moderately cold weather an outdoor intake is used while during severe cold spells, or when the wind is in such a direction that it blows into the intake, air is drawn from a duct in the basement. The air taken in from this source is not desirable, hence a better plan of using already warmed air is to take it from a duct connected with the front hall, rather than the basement.

A Book Fumigator and Sterilizer

Of recent years public libraries and schools have come to realize the danger of books as germ carriers. In larger institutions, special rooms and apparatus may be fitted up for this purpose, but in smaller ones, sterilizing books is a problem. The book fumigator shown was designed so that an ordinary carpenter could make it at moderate expense, and is suitable for use in a large room without incommoding the occupants.

Excessive and continued heat provides a fairly certain method of sterilizing a book, but this treatment is so severe that the bindings are usually injured. If the books are placed as shown, in a suitable cabinet, with the covers spread apart so that the leaves swing free, and are then subjected to a strong fumigating gas overnight, excellent results may be obtained. The fumigator consists of a closely fitted cabinet, divided vertically by a central partition. The two doors are paneled, and each one carries two strong crossbars. Instead of being hinged directly to the cabinet each hinge is fastened to a square block, which in turn is hinged to the sides. This arrangement permits the doors being forced against a strip of felt extending around each door casing. The method of clamping the doors is shown. When not in use, the bars stand vertically. If more pressure is required,

give these bars one or more half turns to the right. The inside space should be closely papered and the exterior

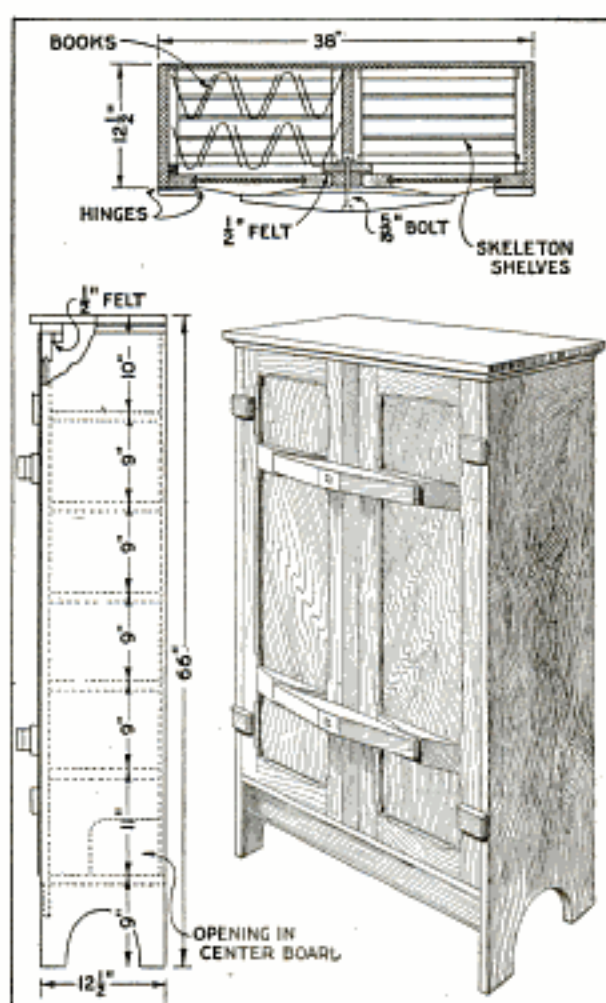

The Books are Arranged in the Cabinet with Leaves Exposed for Thorough Fumigation

varnished, or shellacked. The shelves may be made adjustable, greatly increasing the utility of the cabinet.

To provide the fumigating gas, place a few spoonfuls of formaldehyde solution in a saucer, and just before closing the doors drop a little permanganate of potash or chlorinated lime into the solution, which will immediately generate a powerful germicidal gas. The common sulphur torch or formaldehyde generator involving a flame should not be used.—John D. Adams, Phoenix, Ariz.

Ⓒ Gasoline and kerosene used in mixtures should be kept well stirred because the kerosene will otherwise settle.

Base for Swage Block

The usefulness of a swage block is considerably increased if it is set upon a strong and easily portable base. In

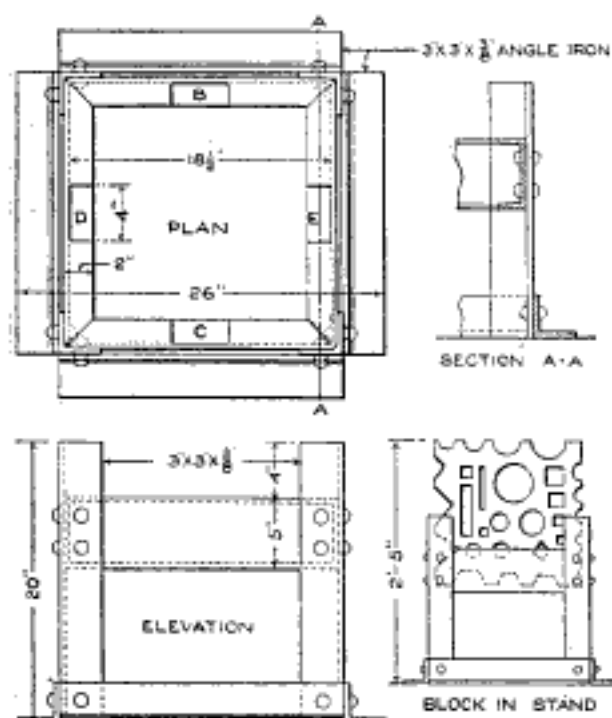

This Strong Frame Increased the Usefulness of the Swage Block

many shops this tool is set on a wooden block, or placed upon any makeshift available. I devised the base shown from 5-in. channel bars and 3 by 3-in. angle iron. The channel bar was mitered at the corners to form a frame, as shown in the plan. Four legs were riveted to it and braced at the bottom with angle iron. Portions were cut out of the upper flange of the channel bar, as at B, C, D, and E, to fit the block, in two positions. When it is desired to use it in a horizontal position, the block is rested on the channel-bar frame.—A. E. Dowden, Worcester, Mass.

Storage Areas Marked on Floors

The method used in a large warehouse to keep the piles of stored goods from encroaching on the aisle space is as follows: A white 2-in. stripe is painted on the floor bordering the space which must be kept clear, such as trucking aisles, approaches to fire exits, and valves controlling the automatic

sprinkler system. Special attention is called to valves by lettering the name on the floor with a large arrow pointing to the valve.

High-Speed Foot-Power Grinder

An old bicycle wheel, weighted with a lead pipe around its rim, was used to provide a flywheel for the bench grinder shown in the sketch. The ratchet part of a coaster-brake bicycle hub was used for the axle and ratchet device. The axle was mounted in the brace at the end of the workbench, and the support for the grinder was set on the bench in line with the flywheel. A rope was used as a belt and runs in the grooved rim of the wheel. Holes were cut in the top of the bench to permit the rope belt to pass through. The ratchet device was arranged between the flywheel and the brace on the bench, a block being set against the brace to bring the ratchet out sufficiently to make room for the treadle. The latter was pivoted in the rear leg of the bench, and a section of bicycle chain fixed to it as shown, to act with the ratchet. A coil spring, like those used on doors, was fastened to the end of the drive chain and to the end of the treadle. The high gearing of the belt from the large drive pulley

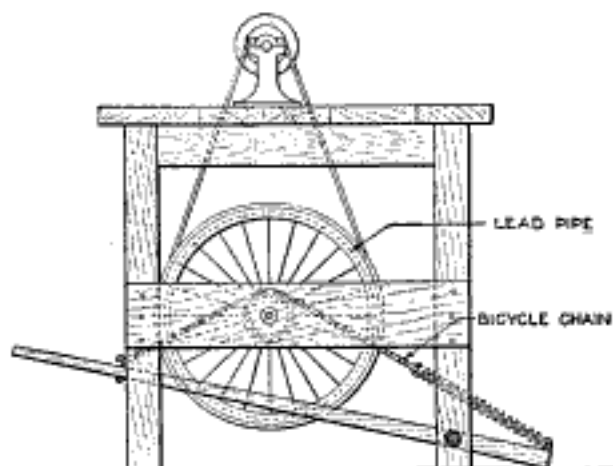

Parts of a Coaster Brake from a Bicycle were Used to Make This High-Speed Grinder, Fitted to the End of the Workbench

to the small one on the grinder gives great speed, which is desirable in a small grinder of this type.—N. Michels, Chicago, Ill.

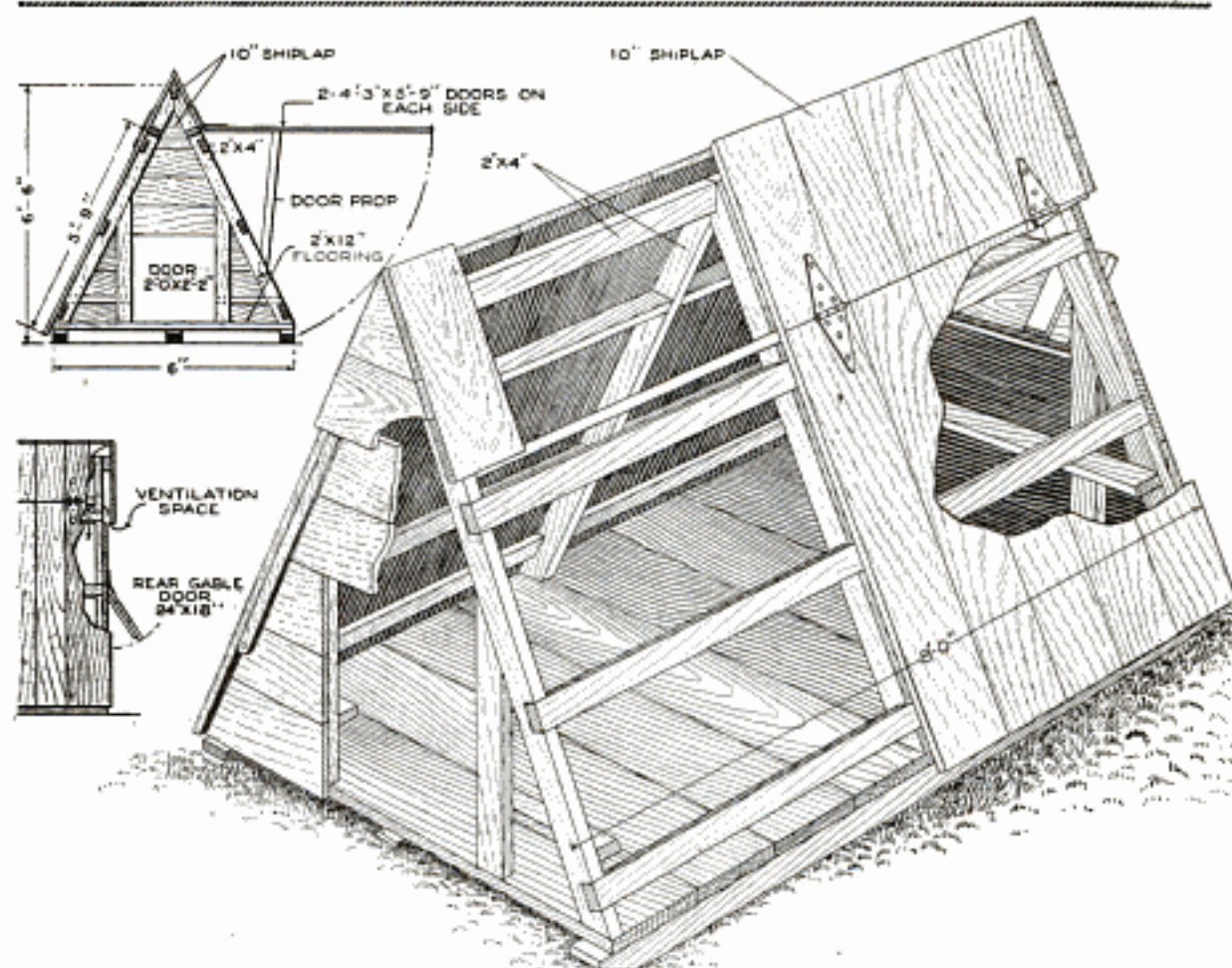

This Portable Hog House may be Constructed Readily in the Farm Workshop and Provides a Clean, Well-Ventilated Shelter

An Individual Hog House

Farmers will find the individual hog house shown in the sketch practical, since it is easy to build, and can be moved from place to place readily on the skids provided. The frame is built up of 2 by 4-in. stuff, braced with $\frac{7}{8}$ -in. strips. Three A-frames give the main support to the house, and the cross braces are notched into them. It is 8 ft. long and 6 ft. wide, with a door at one end, and ventilating doors on the sides and the other end. The frame is covered with siding, shiplap, or plain $\frac{7}{8}$ -in. boards. The floor is of heavy planks. The construction provides for ventilation spaces at the gables of the ends, as shown in the lower detail sketch. The side doors are hinged at the top and can be raised and set under props fastened to the ends of the house, permitting the air and sunlight to enter

freely, and making it convenient to clean. Fenders should be built around the inside, about 8 in. above the floor, to protect the young shoats.—W. E. Frudden, Charles City, Iowa.

Drawing the Temper in Small Taps and Reamers

The proper way to hold a tap or reamer in drawing the temper is with the threaded, or fluted, end in a round pair of tongs, the squared end to the flame. Draw the tool to the proper degree at the point. When drawn to the proper color, quench it in oil or lukewarm water. This gives the cutting part of the tool the hardness necessary for standing up under the cut, and the shank the strength and toughness necessary to prevent breaking. For tapping cast iron, draw to a light straw, and for steel, to a light brown.

Powerful Wrench Used in Dismantling Large Pipe Line

In removing a line of about 4,000 ft. of 6-in. and 8-in. pipe with screwed joints which had been in place for

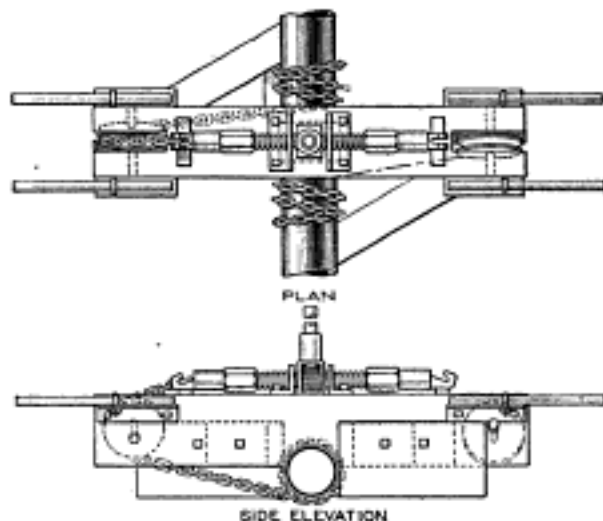

This Rigging Is Useful in Taking Down Pipe Structures and may be Adapted for Assembling Pipe

about five years, the pipe wrench shown in the illustration was rigged from a steamboat jack and a 12 by 12-in. timber, 6 ft. long. With this rig it was possible for one man to start the joints on 8-in. pipe. The device offers suggestion for use in joining or disassembling other large and small-pipe structures.

In operation, the wrench was placed astride the pipe, and centered over the coupling. Then the chains were given several turns around the pipe and over the sheaves at the ends, and hooked into the special hooks on the ends of the jack. The screw was given a few turns' hold in each sleeve at the start. Then, by means of the handle and ratchet, the chain was quickly tightened up and the joint broken, in most cases with a jump. The sleeves are kept from turning over by the short bars on the bottom of the hooks. The short diagonal pieces on each side rest against the pipe and take the pull of the chains. The handle used was about 3 ft. long. Two short pipe handles at each end provide means for carrying the device from place to place. For clearness, the chain is shown on one-

half of the sketch only, the other half being the same. This rig could also be used for tightening joints in pipe laying by reversing the chains and the diagonal pieces or braces.—E. C. Entler and James Ryan, Keokuk, Ia.

Solid-Tire Rubber for Making Heels

When the rubber-block tires on the motor trucks of a large company are renewed, the old tires are returned to the garage with the vehicle fitted. The workmen trim the rubber blocks to $\frac{7}{8}$ in. thickness on the band saw, cut them to the shape of rubber heels, and nail them to their shoes. These inexpensive heels afford much comfort, and are an aid to safety in that they give a more secure footing, and withstand heavy wear.—Theodore J. Becker, Kansas City, Mo.

Gauge for Plastering Trowel

Plaster, stucco, cement, and similar finishes applied in layers of uniform thickness, can be applied quickly and easily with a trowel fitted with gauges like the homemade ones shown in the sketch. They are of $\frac{1}{16}$ -in. sheet iron, and provided with slots to fit the ends of the trowel, so as to make the layer of plaster $\frac{1}{8}$, $\frac{1}{4}$, or $\frac{1}{2}$ in. thick, as desired. The gauges are fastened with knurled screws. After the roughing application is made, the surface of the plaster must be smoothed with a plain trowel to remove the tracks of the gauges.—Alfred J. Miller, Albuquerque, N. M.

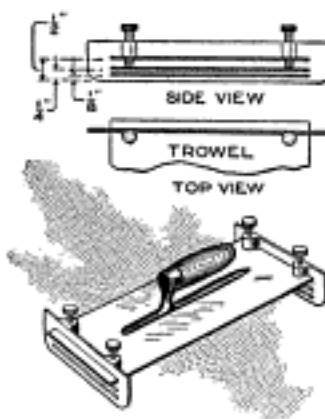

Scissor blades may be kept at the proper tension by placing a small flat spring under the head of the screw which holds the parts together.

Title Stamp for the Drafting Room

Every draftsman well knows the tediousness of lettering in the drawing titles by hand. There is, also, an unavoidable lack of uniformity, when there are several draftsmen employed. A standard title, applied to the drawings by means of a hand stamp, shown in the sketch, and permitting of filling in to suit the particular job, overcomes these difficulties in a practical and efficient manner. The drawing for the title should be made three times the size of the zinc etching, which is to be made from it, and used in the stamp. Ordinary printing ink is used on the cut.

A suitable base for the stamp is made of a piece of wood, 5 in. wide and 16 in. long. The lever, to hold the cut or type block, is 3 in. wide and 16 in. long, one end being hinged to the base. The type block is fastened to the lever with screws, as shown, and a piece of blotting paper is placed under the drawing when an impression is to be made. Ink is kept in a tube, and a small quantity spread on a piece of plate glass, from which it is worked onto the roller, and applied to the type block. The stamp applied to trac-

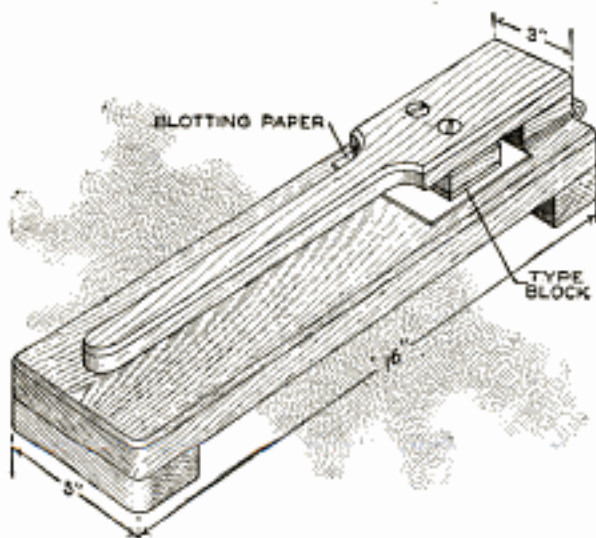

A Standard Type Block for the Titles of Drawings is Mounted in the Stamp for Convenient Application to Tracings

ings will reproduce white on blueprints, and will be clean-cut, in distinction to the blurred appearance of titles printed with a rubber stamp.—E. E. Stevenson, Los Angeles, Calif.

Handy Containers for Distilled Water

Having use at times for a large quantity of distilled water and not wishing to go to the expense of purchasing

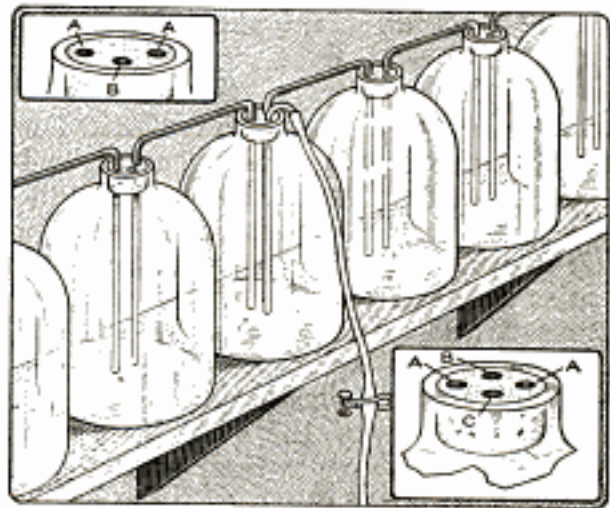

Distilled Water was Kept in Large Bottles Provided with a Siphon Tube

the amount of block tin necessary to line a tank sufficiently large, I hit on the following scheme: I had a number of 5-gal. bottles—the spring-water kind—and I fitted each of these with a three-hole cork; two of the holes, A, receive glass tubing, and the third, B, is plugged loosely with cotton, in order to allow the entrance of air and at the same time keep out dust. Each piece of glass tubing was bent in two right angles, and was of such a length that it reached to the bottom of each bottle and allowed the bottles to stand close together. When the first bottle was partly filled with distilled water, from a still, it was easy to run some into the second bottle by siphoning through the glass tube. Later on the water was conducted into the other bottles in order. They were placed on a shelf, and a glass tube, with rubber tubing and a pinchcock, conducted the water as needed from a fourth hole, C. This is an inexpensive means of providing storage for a large supply of water.—William G. Kennedy, Albany, New York.

☞ Care in the handling of lathe centers will save regrinding them and prevent inaccuracies from damaged points.

Spring Stripping Attachment for Power Presses

By GEORGE P. BREITSCHMID

A FORM of stripper widely used on power punch presses, to remove the product after the dies have been applied, is that fixed to the die by means of four screws. Such a device was in use in a large manufacturing establishment using many presses, and proved costly from various considerations: The device was dangerous to the workman; caused great wear on tools; required that dies be frequently dressed, and made it impossible to see the work in process as readily as is desirable. Cost of production was high, and the profit of the operators was relatively low because their production quantity was kept down. By the introduction of the simple spring stripping device shown in the illustrations, together with jigs for the economical production of its many variations, a striking improvement was made in all of these points. The stripper consists of a flat steel plate, cut to provide clearance for the punch, and is shown fixed to the ram of the press in Fig. 1. The stripper, shown at A, has an opening at its center for a punch of oblong face, a slight clearance being provided all around its edge. The stock of the punch is fixed in the central opening of the ram B, and is clamped by means of the screws. A jig for boring and counterboring the stripper, for fastening it to the ram, is shown in Fig. 2; three views of a jig for marking the center opening with clearance for the punch are shown in Fig. 3, together with details of the adjustable handle.

The ram of the press B was first bored for two heavy screws, C, and counterbored at the top and bottom, the heads S of the screws being counter-sunk at the top and chambers provided at the bottom for $\frac{5}{16}$ -in. square helical springs, D, of tool steel, $1\frac{1}{16}$ -in. pitch, tempered. The latter are compressed between the collars E and the upper surface of their chambers, by the pressure of the ram in operation. They are adjusted by means of a steel rod,

inserted in the cross-bored sockets. The action of the springs upon the stripper, which is fixed to the lower ends of the large screws by means of smaller ones, is to thrust the punched work from the punch. The stripper is made of $\frac{3}{8}$ -in. machine steel; the length is standard, 8 in., as shown in Fig. 1, and the holes in it are bored 6 in. apart on centers. The width may be suited to the dies.

The jig for boring and counterboring the strippers accurately and uniformly, so that they may be used interchangeably on various presses, is shown in Fig. 2. It consists of a metal base, F, to which are fitted clamps, G, held in place by screws. The clamps are adjustable at the slots in them, and the blank from which the stripper is to be made is fitted under the clamps, the ends of the blank being set against two stops, H. Hardened steel bushings, J, are fitted into the base as guides for the boring of the stripper. The smaller holes are bored on 6-in. centers, with the base inverted. The counterboring is done with the base in the position shown. The stripper is indicated by the dotted outline.

The jig for marking the opening in the stripper, through which the punch passes, and for allowing the necessary clearance of $\frac{1}{16}$ in. all around the punch, is shown in Fig. 3, in top, front, and side views.

The device consists of a base, K, carrying a vertical post, L, dovetailed to a vertical sliding member, M. The latter can be adjusted vertically and tightened in position by the threaded rod N, which is held firmly by the spring plate O. The plate is shown in detail at the upper part of Fig. 3.

In operation, the stripper, drilled by the use of the jig shown in Fig. 2, is fitted over the pins P, which fit snugly into the holes in the stripper. The sliding gauge Q is moved to hold the edge of the stripper, the jaw R being undercut to hold the stripper down as

well as from the side. The punch S, inserted into its holder, or a split bushing if the punch has a small shank, is

now be fastened into place on the ram of the press, as shown in Fig. 1.

The stripper is made of varying

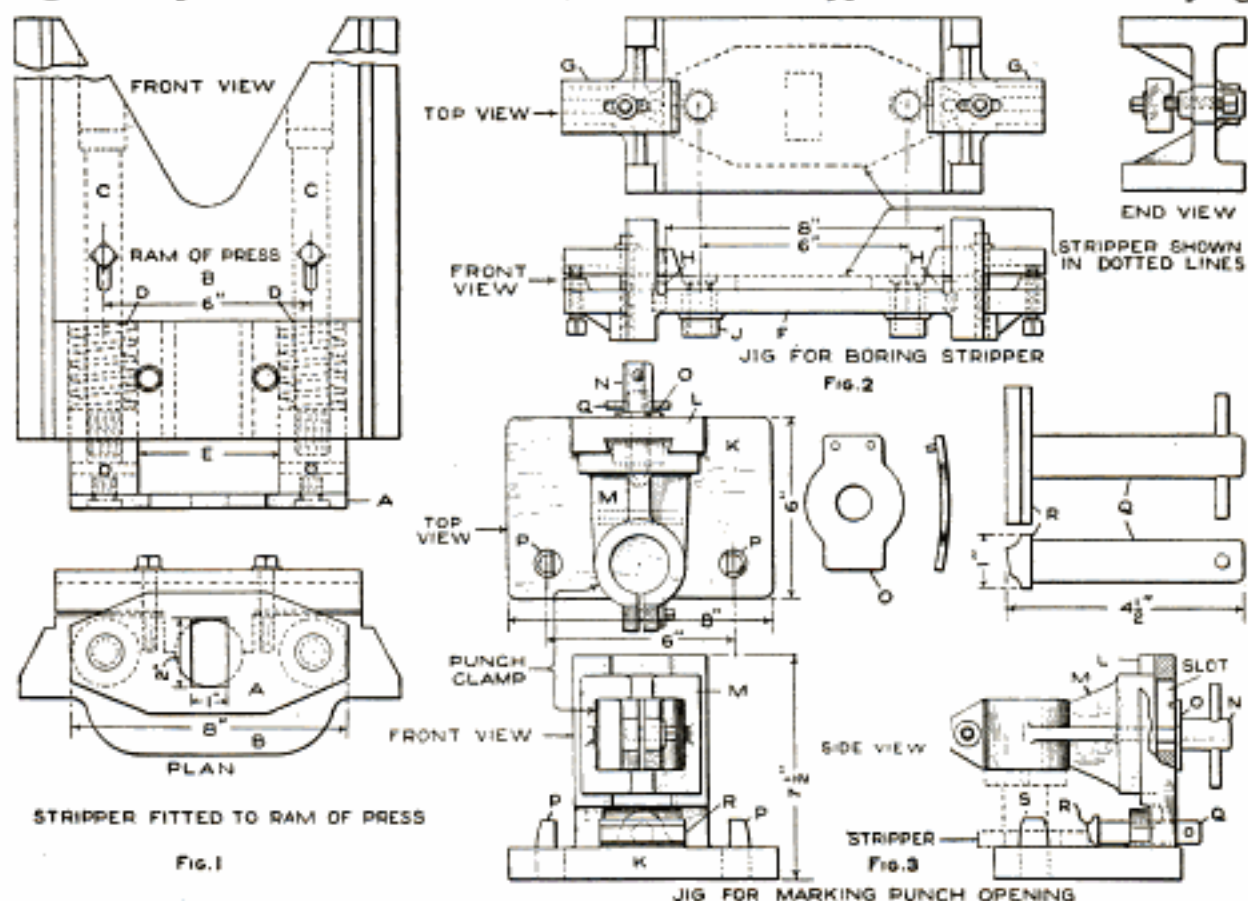

The Spring Stripper Makes for Safety, Economy in Production, and a High Grade of Work on Power Presses. Fig. 1 Shows the Stripper Fixed to the Ram of the Press. A Jig for Boring the Fastening Holes in the Stripper is Shown in Fig. 2, and a Jig for Marking the Clearance Hole for the Punch is Shown in Fig. 3, with Details of Parts

placed in the clamp of the sliding member M. It is lowered to rest upon the stripper blank, and, with a scribe, a line is scratched around the punch on the surface of the stripper. Clearance of $\frac{1}{16}$ in. all around is allowed, and the clearance hole is drilled out and filed smooth. The stripper may

widths to accommodate it to different jobs, but since the fastening holes and the length are standard, the jigs may be used for a large variety of work. The stripping attachment may be fitted to various types of punch presses, and is suitable for blanking, perforating, or bending operations.

Wall Crane for Small Shop or Garage

In garages and machine shops where it is necessary to handle heavy machine parts, a small crane saves much time and effort. The illustration shows a wall crane, built largely of 2-in. pipe and fittings, that can be made readily, and has a wide range of use if properly located on the shop wall. The dimensions may be varied to suit special conditions, and a length of about 10 ft. for

the arms is satisfactory. This size will lift objects weighing up to 1,000 lb. with safety. The arms of the bracket are fitted at their upper and lower ends into tees, to form a right angle, and to give a fastening at the top for the brace, which is an iron rod. It is fixed at its upper end to a plug screwed into the tee, and at its lower by bolting it to the turned-up end of the horizontal member. The vertical support is carried at its lower end in an elbow, and near its upper end in a tee, fitted into

a flange and bolted to the wall. A suitable trolley and tackle may be pro-

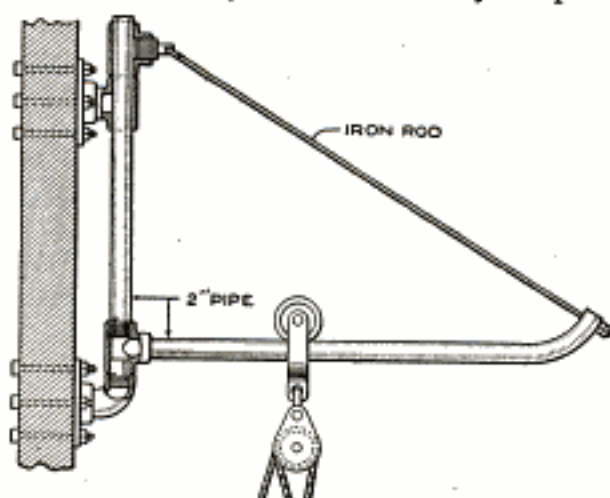

This Wall Crane, Made of Pipe and Fittings, will Carry a Load Up to 1,000 Pounds, if Carefully Made

vided either by making the pulleys and fittings or purchasing them.—Thomas W. Benson, Philadelphia, Pa.

Truck Arranged for Hauling Long Stock or Ladders

Under traffic laws in various localities, vehicles are not permitted to carry long articles that extend over 5 ft. at the rear, without hanging on a danger signal. To overcome this, and for convenience in handling long beams, lumber, etc., a transportation company fitted its trucks with doors in the front end, permitting long pieces to be passed through and extend along the radiator, as shown in the illustration. This helps

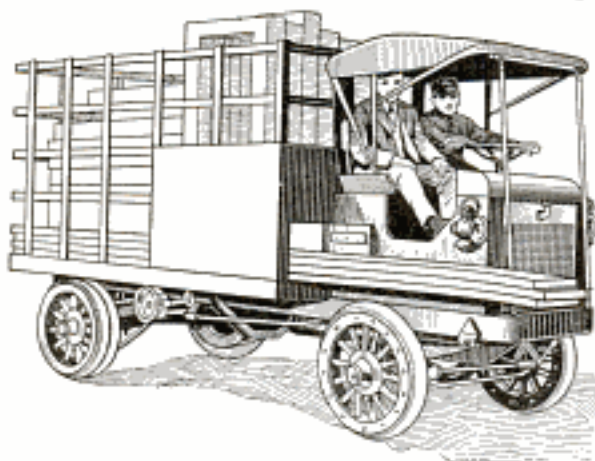

Beams, Planks, and Other Long Objects are Carried Conveniently by Reason of the Door

to balance the load and prevents it from dragging along the road.—J. C. Grindell, St. Louis, Mo.

Repairing Ratchet on Steering Post

On account of the severe wear on the steering-post ratchet of a "jitney" driver's automobile, he was forced to devise a method of using the worn ratchet in an emergency. He wound a heavy brass wire around it, the wire resting in each of the cogs. The follower engaged the wire just as it had the ratchet teeth, and the repair was so satisfactory that it was unnecessary to replace the part.

Cap for Screwdriver Reduces Marring of Work

The slipping of a screwdriver from the slot of a screw being fastened into a finished surface usually results in a severe injury to the finish. This condition was met in automobile work in putting screws into highly finished surfaces on bodies and other fittings. The screwdriver, shown in the



illustration in several forms, was devised for the purpose of overcoming this, and proved quite satisfactory. The lower end of the screwdriver, in the simplest form, was ground as shown at the left, and a sleeve fitted over it, as shown above. The sleeve was made fixed for certain kinds of work, and movable on a pin and spring for work requiring this adjustable feature. The screw is driven in the usual manner. For larger screws, the sleeve was enlarged at its lower end, as indicated in the lower sketches. The device is useful also in driving screws in rough work, enabling the workman to work quickly with less danger of the driver slipping from the slot.—Charles C. Brabant, Detroit, Mich.

Draw enameled wire between a folded piece of sandpaper to remove the insulation.



Garden Plow Made of Pick-Up Material

By T. T. STURGEON

THE labor of spading a garden of even moderate size is sufficient to warrant the person who undertakes the job in making a hand plow like that shown in the illustration, for it will serve many years, with reasonable care. I made one worth about \$5 at an outlay of 25 cents, gathering the necessary wood and metal from among old machine parts and pick-up material.

An old wheelbarrow provided the 16-in. wheel. The handles were made from a $\frac{7}{8}$ by 4-in. strip of spruce, 5 ft. long. They were marked on the strip so that one of the curved grips was at each end, on opposite edges. The curved parts of the grips were cut with a keyhole saw, and when a kerf long enough to admit a large rip saw was cut, the board was ripped into the two handles. They were smoothed and the grips trimmed with a sharp knife. A section of broomstick was cut for the upper brace. The lower one is made of a strip of iron, $\frac{1}{4}$ by $1\frac{1}{4}$ by 12 in., drilled for $\frac{1}{4}$ -in. bolts, and bent at right angles, $1\frac{1}{2}$ in. from each end. Drill a $\frac{1}{4}$ -in. hole at the middle, to engage a bolt on which the vertical strip is supported, and adjusted to the operator, as shown in Fig. 1.

Cut a strip, $\frac{1}{4}$ by $1\frac{1}{4}$ by 18 in., for the vertical support, shown in Fig. 5. Drill four $\frac{1}{4}$ -in. adjusting holes, 1 in. apart, at the upper end, and three $\frac{1}{4}$ -in. holes at the lower end for fastening the strip to the moldboard, as shown in Fig. 3. Drill a $\frac{5}{16}$ -in. hole at the $7\frac{1}{2}$ -in. mark, for bolting the strip to the braces, the other ends of which are fitted on the $\frac{3}{8}$ by 10-in. bolt used as an axle. Cut the two braces 14 in. long, of $\frac{1}{4}$ by $1\frac{1}{4}$ -in. strips, and drill a $\frac{3}{8}$ -in. hole in

the forward end of each, to fit the axle, and a $\frac{5}{16}$ -in. hole in the opposite ends, 1 in. from the ends in each case. Cut

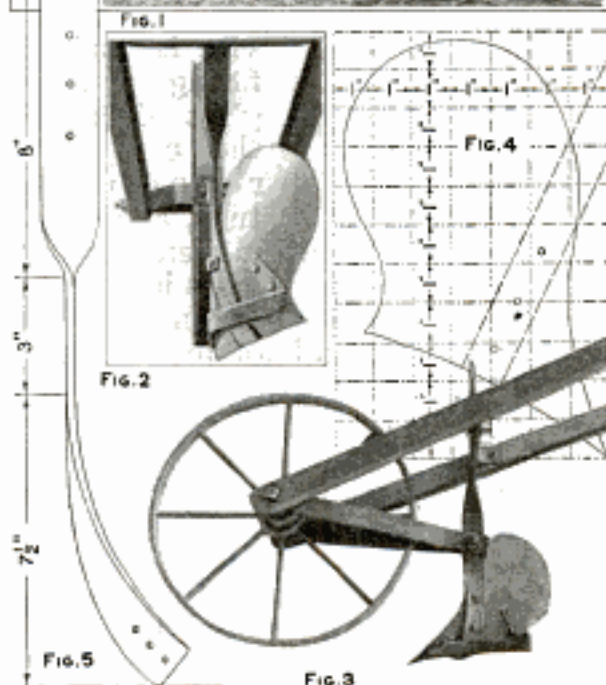
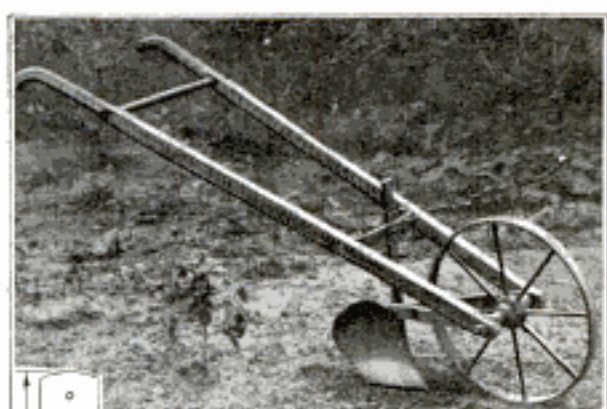

This Hand Garden Plow was Made of Old Material, a Shovel being Used for the Making of the Moldboard

a strip, $\frac{1}{8}$ by $\frac{3}{4}$ by 12 in., for the land-side, as shown in Fig. 2, bent under the moldboard, and bolted to it. The proper angle can best be bent after the moldboard is made and fitted.

The method of marking the shape of the moldboard on the blade of an old shovel is shown in Fig. 4. Make a pattern of cardboard, marking it into 1-in. squares. Draw the shape of the moldboard by tracing the outline through the corresponding squares, using the diagram as a guide. Mark the position of the bolt holes, for fastening it to the vertical support, indicated by the dash lines at the right. Cut out the pattern and trace around it on the shovel, using the thickest part for the point of the share. Cut out the outline, smooth the edges, and point up the cutting edge. Drill holes for fastening the moldboard to the vertical strap with $\frac{1}{4}$ -in. bolts,

and for the fastenings to the landside, with $\frac{3}{16}$ -in. bolts.

Curve the moldboard into shape and fit it to the various supports so that it sits properly, as shown in Fig. 1, seen from the furrow side, in Fig. 2, from the rear, and in Fig. 3, from the land side. Bend the 12-in. strip into shape, as shown in Fig. 2, and bolt it into place, to form the landside. Assemble the parts, being careful that the wheel and landside are set in line, as shown in Fig. 2, and that the rear edge of the latter is raised slightly, as in Fig. 3. The plow should be given a coat of paint, and the cutting parts made smooth, and oiled.

An Interesting Water Telescope

A water telescope is easy to make and will afford much pleasure in exploring plant or animal life in comparatively shallow water. The device is made by fitting a heavy glass disk into the end of a round metal tube, about 2 in. in diameter. The glass is fitted between two rings of metal, preferably with a small flange set against the glass. A waterproof cement is used to fix the glass between the rings. To use the "telescope," rest it on the side of a boat or other convenient place at the water, and set the lower

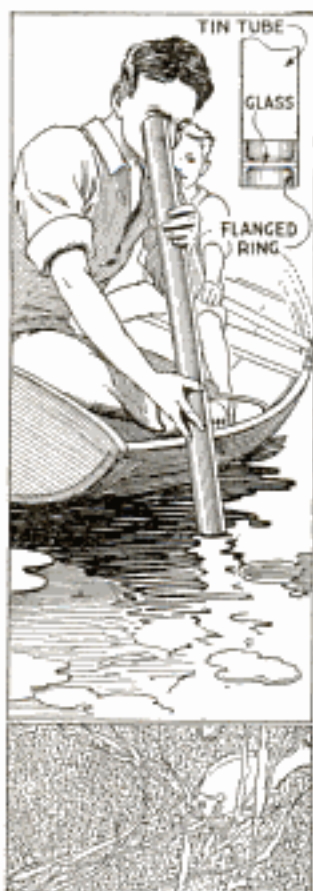

end, containing the glass, under the water. Remarkably clear views may be had in this way.—S. Leonard Bastin, Bournemouth, England.

Writing on a Moving Train

Writing legibly on a fast-moving train is difficult to a person unaccustomed to it. The railroad conductor knows the trick of it and manages to get along quite satisfactorily. He prefers to write in a standing position and holds his right elbow firmly against his side. The reason for this is that in a sitting posture there is too much lateral movement in the trunk of the body, while in a standing position this is more easily controlled. When the arm swings freely, as in ordinary writing, several joints of the body are affected in the process, each of which is capable of its own motion. Holding the elbow against one's ribs "breaks" these motion tendencies, except that of the wrist, which movement is necessary in writing, and thus the pencil, or pen, is more easily controlled.

The same principles modified apply in using a typewriter on a moving train. Many traveling men, news correspondents, and others, carry portable typewriters and do much of their writing while traveling on trains, not to mention the various railroad and government men who travel in office cars and necessarily must get out their correspondence en route. It is extremely difficult to execute neat typewriting on a moving train with free-arm movement, even though the central portion

of the car where the vibration and swing is less severe, is selected. As I am employed in such capacity, I had to evolve some plan to expedite the work. I am able to do typewriting quite rapidly by resting the palm of the hands, near the wrists, against the front edge of the typewriter frame surrounding the keyboard, and using the swing of the fingers instead of that of the whole arm, as in ordinary typewriting.—Victor Labadie, Dallas, Tex.

A Revolving Window Display

A jeweler attracted passers-by and not a few customers by placing a revolving display in his window,



which was kept in motion by means of the arrangement shown in the sketch. A 10-in. cut-glass bowl was placed, upside down, near the front of the show window. An inverted tumbler was set upon it and a small tin box was pivoted on the tumbler by means of a needle soldered inside of it. Six arms of wire were soldered to the box, and watches were suspended from them. The carefully balanced frame revolved easily on the point of the needle. It was kept in motion by the draft from a fan hidden behind a mirror.—H. S. Hart, Shreveport, La.

A Horse-Drawn Sod Cutter

The cutting of a considerable area of sod is tedious work when done by hand, and it is difficult to make the sections of uniform thickness and size. These important features are provided for by the use of the homemade sod cutter shown in the sketch. To start a cut

across a meadow or lot, a notch is cut in the turf for the blade, and the device is set into place, stamping it down to give a good start. The operator stands

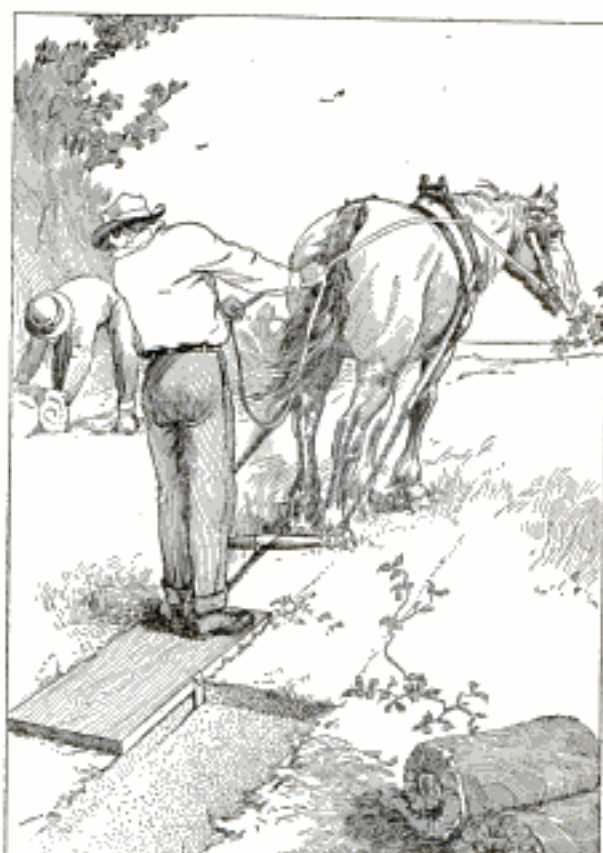

With This Device Sod may be Cut Quickly and of Uniform Width and Thickness

on the plank in front of the blade, and a little practice will soon determine the best position for ease in operation. When a cut has been completed, the cutter is dragged to a fresh starting place, the driver turning it over on the upper side. The strips are cut into suitable lengths and piled conveniently for removal with a stone boat or wagon.

The device may be made of any suitable width; 15 in. between the inner edges of the blade, and the latter set to cut a depth of about $2\frac{1}{2}$ in., being desirable. The board is a 2-in. plank, about 4 ft. long. The blade should be set with the cutting edge slanting slightly downward so as to make the device "bite" into the ground. A smaller cutter may be made for use by boys, several of whom may draw it.—F. H. Sweet, Waynesboro, Va.

Homemade Talking-Machine Cabinet

An old six-foot folding screen, three-ply $\frac{1}{4}$ -in. panels from a packing box,



This Cabinet was Made by an Amateur Woodworker at a Cost of \$16.35 for Materials

and parts from secondhand talking machines, were used to make the cabinet shown in the photograph reproduced. The screen was cut down to form a

framework of the desired height for the sides and back. Other parts of the screen were used for the frames of the doors on the front, and for the top. The

panels were made from a good quality of three-ply stock, with a hardwood face, which was scraped, sandpapered, and brought to a very smooth finish. The material happened to have a pretty grain, and this added to the effect when it was stained and varnished. Pieces of this stock were used for the sounding horn and for other interior fittings, such as the shelves for records and the drawer below the horn. Space is provided for a large supply of records.

A secondhand two-spring motor, a turntable, and a sound arm from a disk machine were fitted into the cabinet, and gave excellent service. Care in staining the woodwork, shel-lacking, and varnishing it with several coats, gave the cabinet almost a commercial finish, and at a cost of \$16.35 for all materials.

Eggshells as Flowerpots

A novel method of caring for small plants until they are ready to be set out in the garden is shown in the photograph reproduced. Holes were bored in the bottom of the till of an old trunk and eggshells fitted into them. Seeds

them. The arrangement is compact, and when the plants are ready for planting, the shells may be broken, and the plants set without disturbing the roots.—Charles Darlington, Des Moines, Ia.



Seeds were Planted in the Eggshells, Which were Broken without Disturbing the Roots When Transplanted

were planted in the shells and the names of the varieties were marked on

A Recording Annunciator Target

In rifle practice it is often desirable to provide a target which will indicate to the marksman when the bull's-eye is struck. The device shown in the sketch, arranged behind an ordinary card target, has given satisfactory results on a private range, and can easily be adapted for other uses.

Referring to Fig. 1, A indicates a wooden base, 4 by 8 by $\frac{1}{2}$ in., on which is mounted a strap hinge, B, $6\frac{1}{2}$ in. long, by means of a block, $1\frac{3}{8}$ in. high. An opening, C, $1\frac{1}{2}$ in. in diameter, is provided in the base, and a plate, D,

$1\frac{3}{4}$ in. square, is riveted to the strap hinge opposite to the opening. An electromagnet, E, obtained from an electric bell, is mounted upon the base under the small end of the hinge. A standard, F, provided with a cross arm, G, is secured upon the base between the opening and the magnet. A thumb-screw with a locknut extends through the cross arm, engaging the rear side of the strap hinge, and permits an adjustment of distance between the core of the magnet and the surface of the hinge. A bell or buzzer, H, is connected as indicated, through the battery circuit. The electromagnet is connected through the battery and push button J.

The strap hinge normally rests against the electromagnet. The force of any projectile passing through the opening against the plate closes the bell circuit and indicates to the marksman that the bull's-eye has been hit. By the closing of the magnet circuit, the strap hinge is drawn again into normal position and the bell circuit is broken. Figure 2 shows a front view of the circuit-closing device. The device may be mounted in any suitable box, as suggested in Fig. 3. The front

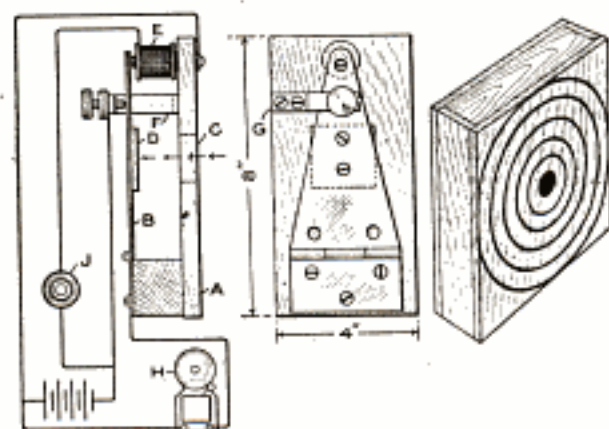

Fig. 1 The Bullet Forces the Hinge against the Thumb-screw, Causing the Bell to Ring

of the box is covered with sheet metal, $\frac{1}{16}$ in. thick, and the standard target card is mounted thereon.—John B. Brady, Washington, D. C.

CA convenient method of holding paper in a roll is to fasten a wire clip at each end near the edge of the piece.

Scraper for Tennis Court

In order to level and scrape a tennis court, which was in bad condition, the two-man scraper shown in the sketch

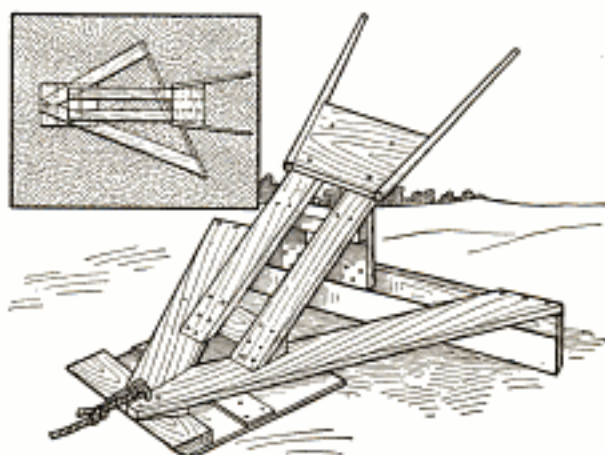

A Tennis Court was Smoothed and Leveled by the Use of This Scraper, Made Quickly of Rough Lumber

was made. It is built of rough lumber, and a metal shoe is fixed to the lower edge of the scraping blade at the rear. The bearing at the front is on a flat-bottom sled of wood, and the depth of the cut is regulated by pressure on the handle. The scraping blade is set at an angle, as shown in the smaller sketch. By lifting the handle slightly, the operator is able to deposit dirt in holes so that when the court is rolled they are filled evenly. Where a large number of courts are to be smoothed, the device may be adapted and made large enough to be drawn by a horse.—Edward R. Smith, Walla Walla, Wash.

Barrel Staves as Springs for Play Auto

I made springs for a small foot-power automobile by using barrel staves joined together in the shape of pointed oval wagon springs. Two strong staves were nailed together at each end and braced with a block where they were nailed. Two of these springs were placed over the rear axle and one of them was set over the front axle extending in the direction of its length. The wooden springs made the automobile ride comfortably.—Charles Delbridge, St. Louis, Mo.

A Sail-Rigged Wind Motor

By E. R. HENDERSON

AMPLÉ power for driving light machines in a repair shop was obtained by the use of a wind motor like that shown in the sketch and in the detail drawings. The device has numerous other applications, particularly as a substitute for wind motors that require a high tower, as in the driving of a pump. As an interesting and inexpensive means of providing power for a home or boy's workshop, or as an

experimental device, the motor is also worth while making. The materials used are easily obtainable, and the construction can be carried out with ordinary tools, for the most part. The driving connections may be obtained from old machine parts. The dimensions given are for a motor of considerable size, and may, of course, be reduced proportionately for a lighter machine. If the device is made by boys, the framework and

other parts should be made one-half as large as the sizes indicated. The wood used should then be three-fourths as thick as that shown. The roof of the structure upon which the device is mounted must be well braced and strong enough to stand the strain. The sails are headed toward the wind, like

those on a sailboat, when the motor is at rest, by means of a control rod, F, shown in the working drawing.

The main structural portion is a vertical beam, or tower, tapered at the ends and built up of 1 by 1-in. rods, strongly braced, especially in the lower portion, as indicated. It is 14 ft. high, and built around an 18-in. square board, A, notched at the corners to receive the posts. A similar 14-in. square, B, is

built into the lower portion. The lower end of the tower is pivoted on the ridge of the roof on a hollow shaft made from a section of iron pipe, D, and provided with a metal bearing washer, E. The pipe D is split at its upper end, as shown in detail, and fastened to the wooden plate B. The control rod F passes up through the pipe D, and is fixed to the control wires, reaching the sails, by means of a leather strap, from which an iron swivel, C, is

suspended, as shown in the detail at the left. The ends of the strap pass over pulleys, fixed to the lower side of the plate A, and connect with the sail-control wires. Spiral wire springs are attached to the wire connected to each end of the strap, as shown only at the right sail beam, and aid in controlling

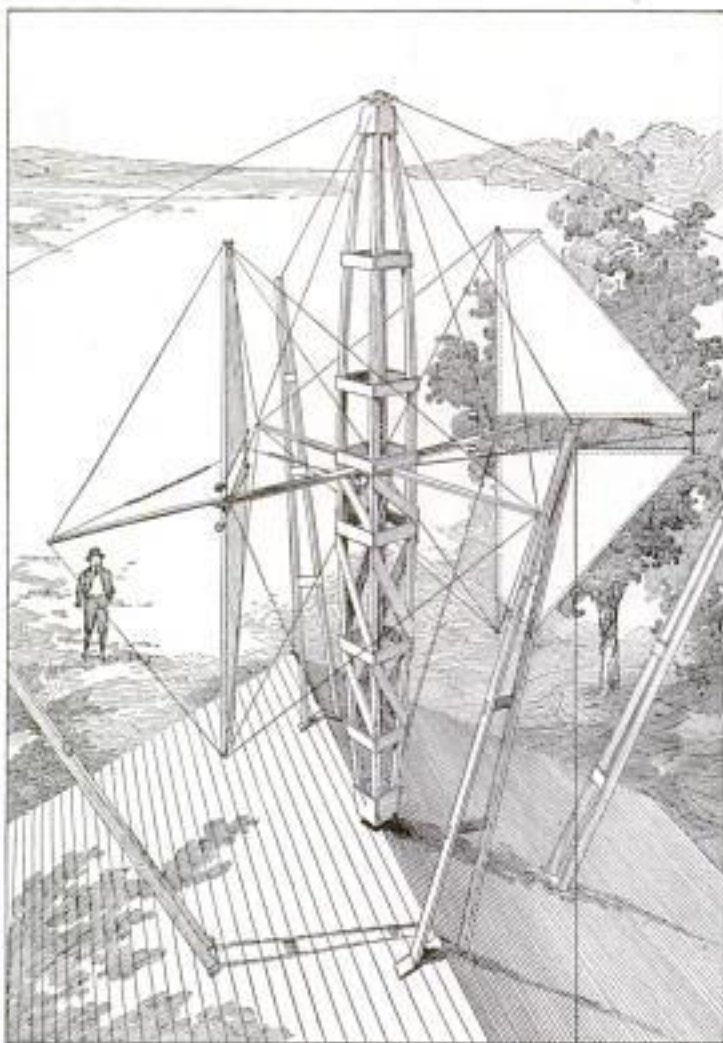

This Novel Wind Motor Developed Power for the Driving of Machines in a Repair Shop, and can be Made in Various Sizes for Work or Play Purposes

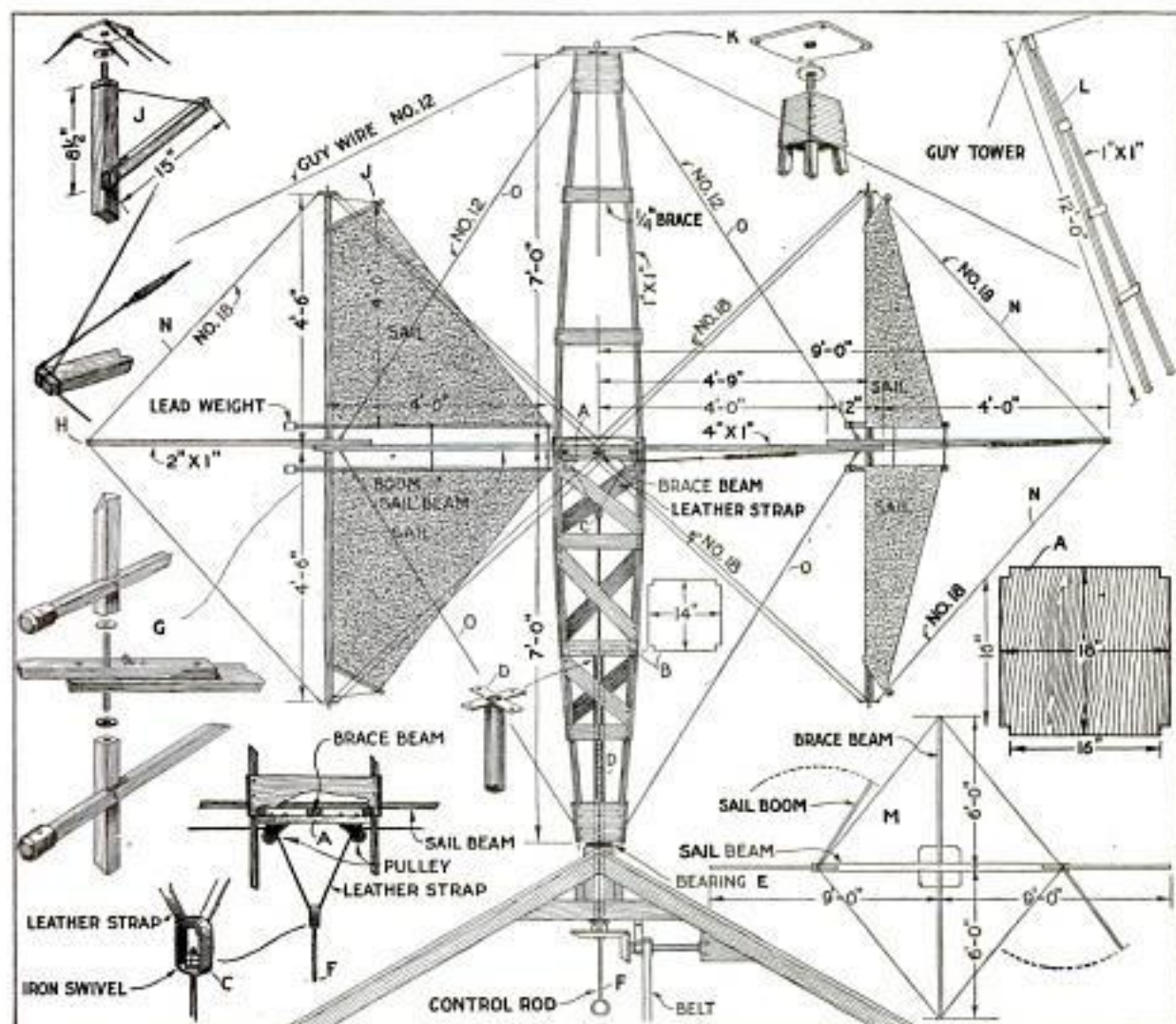

The Method of Construction is Shown in Detail: By Using the Perspective Sketch in Connection with These Working Drawings, the Arrangement of the Parts is Readily Understood

the sails. These springs are adjusted so that when the control rod is drawn down to its lowest extent, the sails will be with the edge "into the wind," thus neutralizing each other, and causing the sail beam to be at rest.

The sail beam extends 9 ft. out from the center of the tower, and is built up of three pieces. The center section extends through the tower, above the plate A, and the brace beam, which crosses it at right angles, as shown in the perspective sketch and also at the detail of the strap arrangement. The center section is of 1 by 4-in. stock, and the end portions are of 1 by 2-in. stuff, fastened securely, as shown at detail G. The sails are supported on masts, 1 in. square, pivoted at their junctions with the sail beam, as shown

at detail G, and in guy-wire plates at their extreme ends, as shown at detail J. The fastening and bracing of the gaffs at the mast ends is also shown at J.

The canvas sails are 4 by 4 ft., and mounted on the booms, gaffs, and masts. The ends of the booms nearest the masts are weighted with lead, as shown at detail G, and extend beyond the masts. The outer ends of the booms are joined in pairs, and connect to the spring and strap control. The guy wires N, of No. 18 wire, supporting the masts are fixed to the ends of the sail beam and to the ends of the brace beam, as shown in the sketch and the working drawing. The fastening at the ends of the sail beam is made as shown at detail H, which also shows

one of the coil springs. All of the braces for the masts should be fitted carefully, so as to have the proper tension without interfering with the action of the sails, before the tower is set into its place. The device should be tested on the ground, with the pivot shaft set in a suitable support, before attempting to mount it on a roof, or other structure. The support for the bearing should be fitted into the roof, as shown. The power from the shaft is transmitted to the bevel gears, and from them to the drive shaft and the belted pulley.

The main tower is supported on the roof by means of strong guy wires, set over four built-up guy towers of 1 by 1-in. wood, and 12 ft. long, as shown in detail L. The towers must be set so

that the sail beam has proper play, and be secured firmly to the roof. The top of the main tower is fixed to the guy wires by means of a guy plate, shown in detail K. A plan of the arrangement of the sail beam, brace beam, and sail booms is shown at detail M. The sail beam is braced by No. 12 guy wires, O, attached at the top of the main tower, at the junction of the two sections of the beam, and similarly at the bottom of the main tower. The fastenings of the wires and braces should be made carefully, and they should be examined thoroughly both before and after the device is mounted in place. Grease the pivoted and other moving parts, and start the device slowly, bringing the sails into the wind as required for the desired speed.

Lawn Benches Made from Old Bedsteads

Old bedsteads were converted into serviceable lawn, or porch, benches, as shown in the photograph reproduced, by the addition of a suitable seat. prop-

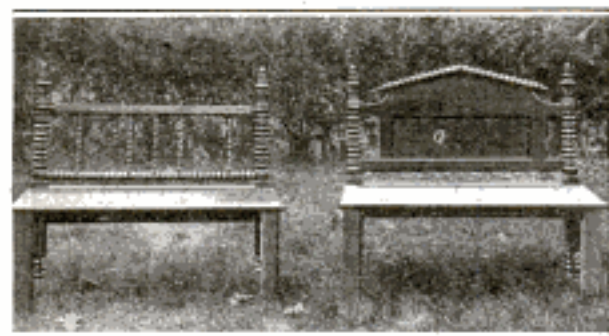

Painted Green, These Rebuilt Bedsteads Served as Lawn Benches

erly supported. The transformation was a simple one. Only the foot and headpieces of the bedsteads were used. The front legs and other pieces were made from other wood. The front legs are of square stock, about $2\frac{1}{2}$ by $2\frac{1}{2}$ in. The crosspieces, supporting the wide board seats, are mortised into the legs and fastened with glue and screws. The seat is fastened from the under side by cleats. The lumber was carefully planed and sandpapered so that the benches presented a smooth finish

when painted green, to match other outdoor furniture.—F. E. Tuck, Nevada City, Calif.

Repairing Wood-Wind Instruments

Wood-wind instruments sometimes "leak" at the joints or keys and make playing of the instrument difficult. Many such instruments are made in sections, with ends that telescope to form a tight fit. This fit is maintained by the use of a cork band cemented around the tenon end of the telescoping joint. The renewal of these cork joints, and the addition of new pads on the keys, will make an old instrument nearly as good as it was when new, so far as playing is concerned, provided the work is correctly done and the wood of the sections themselves has not cracked. Many musicians have spare time and can do this work themselves. The outlay for materials for the job is from 75 cents to \$1.00. A small alcohol, or even a kerosene, lamp and an old knife, or old file, are required.

All traces of the old cork on the joint can be removed with sandpaper, leaving it as shown at the left. The cork comes in strips of about the proper thickness, and wide and long enough to allow for trimming. The ends of the

strip should be beveled to make a $\frac{1}{4}$ -in. lap joint.

A small quantity of the cement is heated over the lamp and six drops poured on the joint; then with the end of the file, which should be heated also, it is spread to give an even, thin coating. The beveled ends of the strip are similarly treated. By working quickly and carefully, the coating on the joint and strip are brought to a plastic state by holding in the flame, and the strip is quickly laid in place. Before the cement has time to harden, press the cork in, forming a neat joint. Bind a rag around the cork, leaving it until the cement is thoroughly set.

The corked joint will be too large to go into the joining section of the instrument. File and sandpaper it to a twisting fit. Though the cork should be truly cylindrical, it may be tapered a trifle smaller at the forward end. A coating of tallow applied to the joint will make it easy-fitting, but air-tight and moisture-proof.

The pads are disks of felt incased in thin sheepskin. After long usage, they become too hard to make an air-tight fit. Repadding should, therefore, be anticipated. Shellac will give good results in putting on pads. It is heated until liquid and poured into the key recess. The new pad is pressed into the liquid shellac, care being taken to have it well

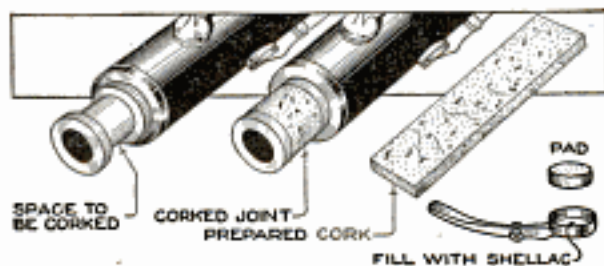

The Cork is Fitted Carefully into Place, and Glued

centered. For different keys, it will be necessary to use varying quantities of shellac to make the pad sit higher or lower, as required.—Donald A. Hampson, Middletown, N. Y.

☞ A simple method of bracing a screen door is to stretch a stout wire diagonally across the lower portion of it.

Rustic Trellis to Shade Door or Window

Proper preparation in the early spring will make it possible for the householder to shade doors and win-

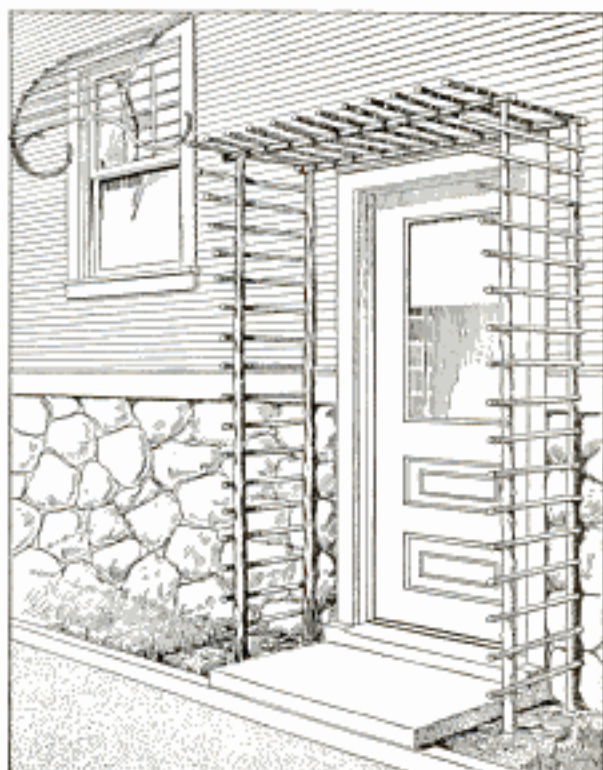

Rustic Trellises are Easily Constructed and When Covered with Vines Add to the Attractiveness of the Home

dows from the hot summer's sun by means of inexpensive rustic trellises that add not a little to the beauty of the home. A suggestion for a trellis at a doorway and one for a window are shown in the illustration. They are made of straight tree trunks and small limbs, having the bark on them. The curved portions of the window trellis may be made easily by using twigs that are somewhat green. Morning-glories, or other suitable climbing plants, may be trained over the trellises.—J. G. Allshouse, Avonmore, Pa.

Making Scale Enlargements with a Rubber Band

For reducing or enlarging maps, and similar drawings of irregular design, the device shown in the illustration will replace the ordinary instruments, and enable the draftsman to turn out a

given amount of work in much less time than required when proportional dividers are used. The materials needed are an eraser, a rubber band,

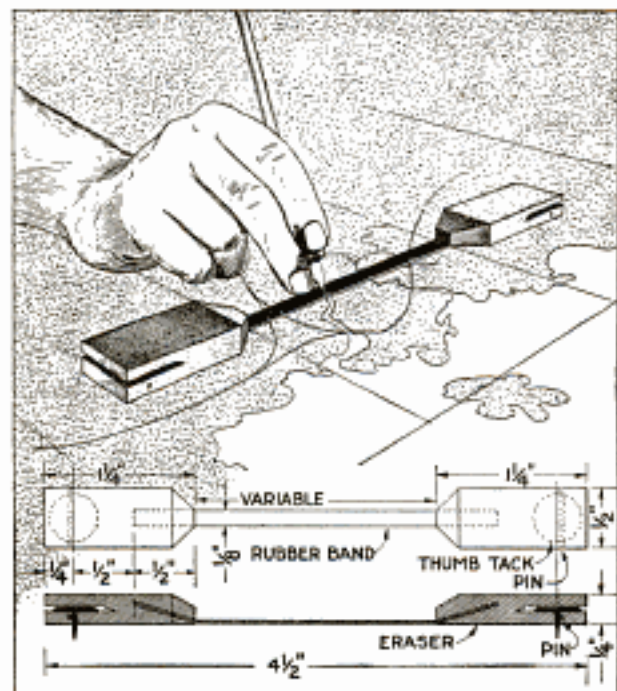

This Simple Device Is Useful in Enlarging or Reducing Drawings and Maps

two pins, two thumb tacks, and a few drops of rubber cement. From the eraser two pieces are cut, as shown in the sketch, about $\frac{1}{4}$ by $\frac{1}{2}$ by $1\frac{1}{4}$ in. Cut deep slits in each end of these pieces. Insert the end of the rubber band, cut at the splice, in one of these slits and place a thumb tack in the other. A pin is thrust through the eraser and trimmed close, to prevent the thumb tack from tearing the eraser. Cement the slits with rubber cement, and place the assembled device under a book weight, until the cement has set.

Assuming that a contour map is to be enlarged, the rectangular divisions of the original map, ordinarily section lines or the boundaries of quarter sections, are drawn on the larger sheet as a base for the reproduction. Place the device on the original map, as indicated, the edge of the rubber band touching a "horizontal" section line between two "vertical" ones, the rubber band under slight tension. On the black surface of the band, dot white

points, with water color, along the section line at which the contour lines intersect it. Also place a dot at each end of the band to indicate the position of the two "vertical" section lines between which the band is set.

Transfer the device to the same relative position on the enlargement, stretching the rubber band. Make dots at each end, denoting the "vertical" section lines, for the corresponding lines on the enlargement. The series of intermediate points along the band will be in the same relative position on the enlargement as they were on the original. They can be connected on the enlargement with as accurate a result as obtained by the use of proportional dividers, and more rapidly.

After the points are indicated upon the enlargement, the reproducing device is removed and the surface of the rubber band cleaned instantly by touching it with a moist cloth. The exposed part of the rubber band is a variable, and the device can be made with this dimension adapted to the work. It is capable of enlarging or reducing at a ratio not greater than six to one, above which the rubber band approaches its elastic limit.—H. L. Wiley, Seattle, Wash.

Signal Telegraph with Green and Red Lights

By arranging a circuit with batteries, lights, and keys, as shown in the diagram, a signal telegraph may be made that will afford much pleasure to boys and may be used for practical purposes. The keys A and B are wired into the circuit with a battery C and a

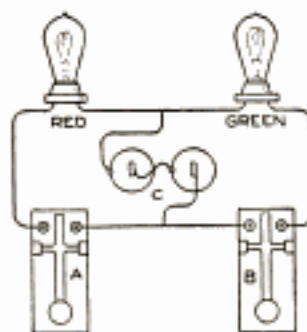

red and a green incandescent lamp. A simple set of signals may be devised easily so that messages may be sent in the code.—James R. Townsend, Itasca, Texas.

Laying Out a Horizontal Sundial Plate

To make a sundial accurately it is necessary to lay out the lines for the particular locality where it is to be used, as a dial will vary slightly according to the latitude. The parts may be made of wood, metal, or stone. A good method is to have a bronze casting made from a wooden pattern. The lines may be cut with a lathe and planer in a machine shop, or engraved by hand.

The illustrations show how the dial is made. The lines, as indicated in Fig. 1, should be laid out very carefully, first on a pattern. Draw a horizontal line near the top which represents the six-o'clock line, A-VI, in Fig. 2. Then lay out another line AH, at right angles to A-VI. Take a point C at any convenient place and construct the right-angled triangle ABD. The angle CAB should be equal to the degree of

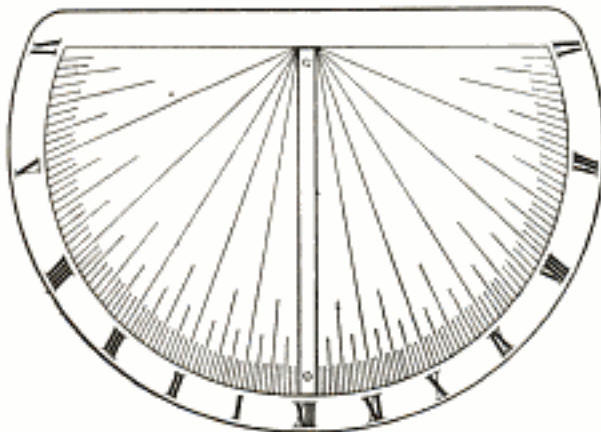

FIG. 1

Lay Out the Dial Plate Symmetrically, Allowing Space for the Style

latitude of the place. The angle CBD equals CAB. Take a compass and set it to a radius equal to the side BD, and draw the quadrant DF from E. From D draw the line DG out for same distance and parallel with A-VI. Now divide the quadrant DF into six equal parts. Draw the lines E1, E2, E3, etc., and where they intersect the line DG, draw the lines from A, as A-I, A-II, A-III, etc. These are the hour lines. Divide each of the six divisions of the quadrant into four parts, and draw the lines, as shown between the 3 and 4 divisions. These are the 15-minute

parts. Each of these parts may be divided in turn, and this is best done by eye, unless the dial is quite large.

This will complete one-half of the

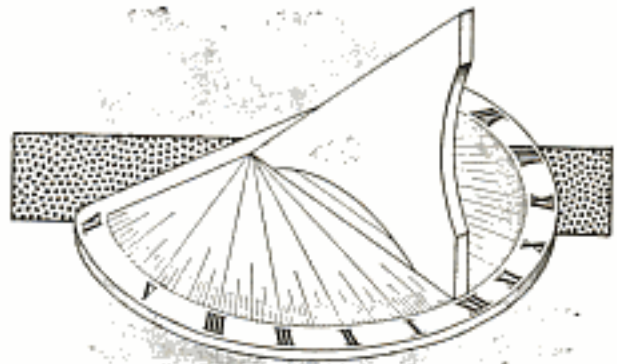

The Dial is Mounted Horizontally with the High End of the Style toward the North

dial. The other half is done in the same manner, leaving a space between the line AH and its corresponding line for the other side of the dial. This space should be equal to the thickness of the upright shadow-casting piece, or style. The style has its base equal in length to the line AH, and its angle, S, equal to the latitude, or the angle CAB. It is mounted in the space with the high end at 12 o'clock. It may be fastened to the dial with screws passing through the base. Mount the dial horizontally on a suitable pedestal. The style should be exactly north and south, with 12 o'clock toward the north. The dial will be fast or slow over clock time. This is corrected by consulting

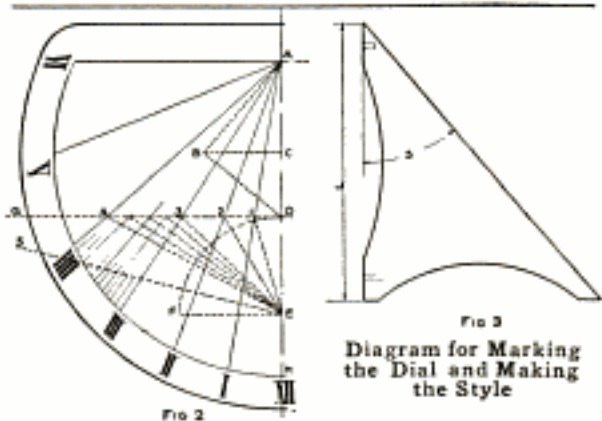

FIG. 3
Diagram for Marking the Dial and Making the Style

an almanac and setting the clock accordingly from the dial. A correction plate may thus be made and mounted on the pedestal.—F. B. Walters, Baltimore, Md.

Wire-Mesh Support for Flower Centerpiece

Pansies, violets, or other short-stemmed flowers cannot easily be shown to advantage in a table centerpiece unless properly supported. By placing a frame of wire mesh in the dish, as shown in the sketch, the stems of the flowers may be set in the openings, giving a neat and effective display.—Victor Carpenter, South Bend, Ind.



False Bottom for Emptying Wastebasket

In order to avoid handling paper and other material which sometimes sticks in a wastebasket, I arranged a false bottom in the receptacle, as shown in the sketch. A hole was cut in the bottom of the basket and a square board, nearly as large as the bottom, was fitted over it, and a leather handle provided. The basket may be emptied quickly by forcing out the false bottom, without the hands touching the contents.—Harold Laughlin, Reading, Michigan.

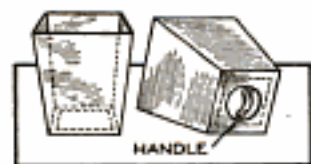

Making Use of Refrigerator in Winter

By fitting a 3-in. pipe into the lower part of a refrigerator so that a draft of cool air from outdoors is available in cold weather, it may be used without ice for a considerable part of the year. The top is left open slightly, and a piece of cheesecloth is tied over the outside end of the pipe, to prevent dust from entering. A tin shutter is placed on the inside of the refrigerator to close



the pipe in extremely cold weather. This arrangement has proved quite satisfactory for the winter storage of food.—R. R. Dowsley, Prescott, Canada.

Inkwell Base Made from Fuse Socket

Workers in the munitions industry frequently devise small useful or ornamental objects in imitation of, or from, discarded parts on which they work. The inkwell shown in the sketch was made from a rejected fuse socket of a shrapnel shell. It was fitted with a glass container and fastened into a wooden base.

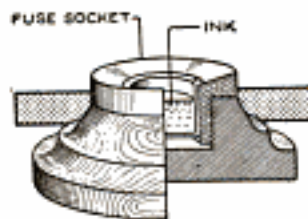

Valve-Bottom Pail for Dipping Water

An ordinary pail may be converted into a convenient device for dipping water by fitting a valve into the bottom, as shown in the sketch. Fasten a piece of soft leather to the bottom of a block, 3 in. square, and fix this to the bottom of the bucket by means of a small hinge. By pushing the bucket bottom down into the water, the latter rises up through the valve until the bucket is full. By lifting it the valve is closed. This device fitted to a tall milk pail is especially convenient.—R. S. Matzen, Fort Collins, Colo.

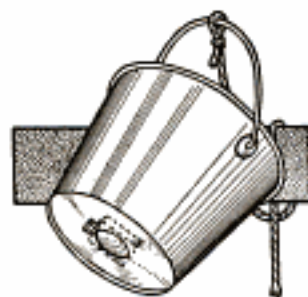

A Shoe-Polishing Strop

It is awkward to shine one's shoes with a long strip of cloth as is done by a shoe shiner to produce a high polish. An effective substitute method is to suspend from the wall a strip of cloth, about 5 in. wide, doubled to a length of 30 in., and rub the shoes on it before putting them on.

A Photographic Printing Machine

By L. B. ROBBINS

A PRINTING machine for "gas-light" papers, to be used in localities not equipped with gas or electricity and where printing is to be done after daylight, is shown in the sketch. The measurements given are only approximate, as conditions will determine its size. That shown is made as follows: First procure a 6½ by 8½-in. or 8 by 10-in. printing frame. Remove the brass clips from the pad and fasten one end of the pad to the frame, by a pair of small hinges, with the glass in the frame. Procure a box, about 12 by 15 in., by 8 in. deep, with one side open. Cut a rectangular opening through the 12 by 15-in. side a bit smaller than the printing frame, and secure the frame in place over the opening with screws. Saw a slot ¾ in. wide through the top of the box—the end nearest the hinged end of the printing frame pad—running it the full width and about 3 in. from the front.

Nail cleats along the inside of each side of the box, placing them vertical and parallel, and about ¾ in. apart, so as to form a slide groove in conjunction with the slot. This groove is to receive a frame or curtain constructed of stock, 2 in. wide and ½ in. thick. The outside dimensions of the curtain are a trifle smaller than the inside measurements of the box itself. Cover the frame with orange paper, and when finished insert it through the slot in the top of the box. Build a frame as indicated, on the outside of the box. Along the inside of

the uprights fasten cleats, thick enough to come flush with the ends of the slot. These serve to steady the curtain when raised. Make a suitable baseboard and secure the box to it. Then with sheet tin construct a lamp house extending from the back of the box and of sufficient size to accommodate a round-wick lamp. Leave an opening in the top to admit the chimney, provide holes for ventilation, and a door by which the lamp may be adjusted. When completed, paint the interior of the box and lamp house white, to intensify the printing quality of the light.

Tie a piece of stout cord to a screw eye inserted in the upper end of the sliding curtain, lead it through two pulleys fastened as shown, and down to the hand lever. The latter is pivoted at the rear end by a bolt. Attach a spring to the lower end of the hinged pad on the printing frame. This holds the pad out of the way when not in use. A curtain-

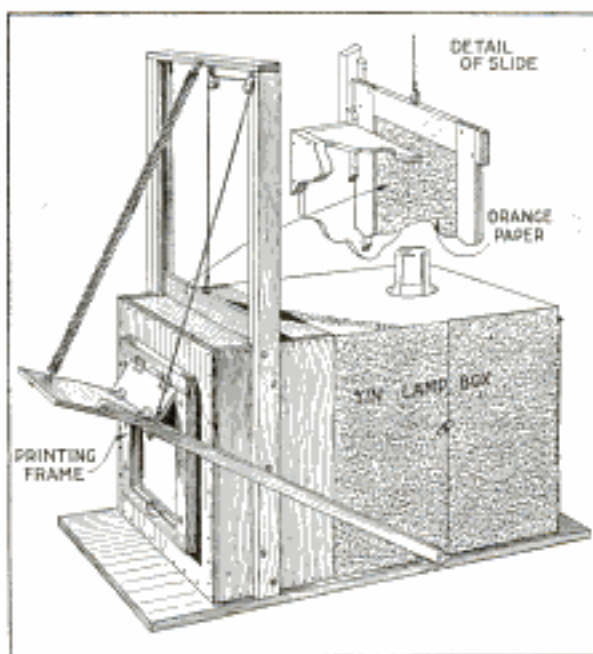

Photographic Printing may be Done Rapidly by the Systematic Use of This Machine

roller spring is suitable for this purpose.

To operate the machine, place the negative and paper in position, and, with the left hand, bring the pad down. Pull down the hand lever with the right hand, raising the orange curtain. When the required exposure is made, release the lever, shutting off the direct light. While nearly all light is shut out by means of the lamp house, the paper may be handled safely and easily by means of that admitted through the orange curtain. By systematic ar-

rangement and handling of materials, it is surprising what an amount of work can be turned out by the aid of this machine, especially if one person attends to the exposing and another to the developing.

A Small Variable Condenser

The condenser shown in the diagram combines the large capacity of a fixed condenser with the gradual capacity

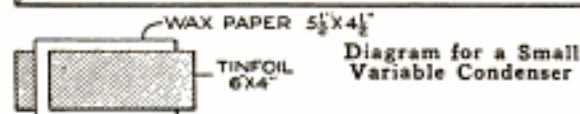
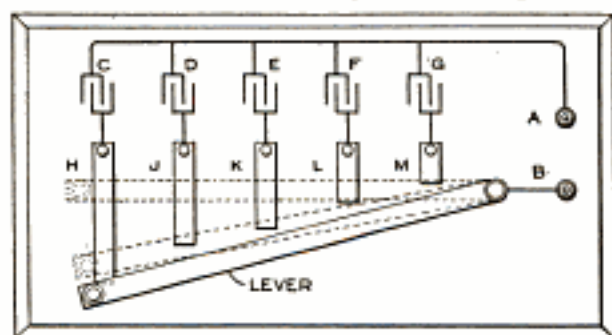

variation of a variable one. It is suitable for a wireless receiving circuit, or to shunt around the vibrator of an induction coil, by making the units considerably larger. It is made up of several fixed condensers, connected in parallel, a lever being the means whereby the capacity is varied. Five or more units may be used, each being a small condenser, built up of 10 sheets of waxed paper and nine sheets of tin foil. A convenient size for the tin foil is 6 by 4 in., and for the paper, $5\frac{1}{2}$ by $4\frac{1}{2}$ in. The latter should be a good grade of very thin linen paper and should be carefully prepared by dipping it in hot paraffin. The sheets of tin foil and paper in each unit are piled up alternately, allowing about $\frac{1}{2}$ in. on each tin-foil strip to project beyond the paper for making connections. The pile is covered with heavy paper, and a heated flatiron is passed on the top of each unit until the paraffin begins to melt. Upon cooling, the units are compact.

The connections necessary are shown in the diagram. The condenser units C, D, E, F, G, each have one side connected to a common terminal A. The

other sides of the condensers are connected to the copper strips H, J, K, L, M. They are $\frac{1}{2}$ in. wide and $\frac{1}{16}$ in. thick. A copper lever, $\frac{1}{8}$ by $\frac{1}{2}$ by 8 in., is pivoted on one end so that it will connect two or more of the condensers in parallel. The pivoted end is connected to the terminal B. The dotted line shows different positions of the lever. The apparatus is mounted in a wooden box.—Peter J. M. Clute, Schenectady, N. Y.

Lighting a Candle without Touching the Wick

A candle may be lighted without the match flame touching the wick, as follows: Light the candle, let it burn a bit; then blow it out. A small column of smoke will rise from the wick. Touch the match flame to this, a little above the wick, and it will ignite, travel down, and relight the wick from the burning oil gas.

Emergency Lifting Device of Rope and Lever

When block and tackle, chain hoists, or similar equipment are not at hand,

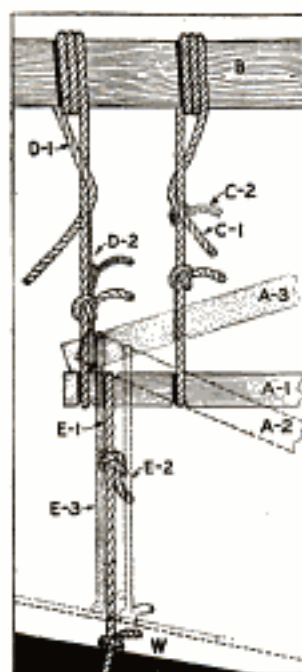

the simple arrangement shown in the sketch is useful for lifting heavy loads. Make the lever A of a piece of 2 by 4-in. stuff, and cut notches into it for the ropes, as indicated. From a suitable support, B, fix the ropes C and D to the lever A at the proper notches, permitting the ends C-1 and D-1 to be drawn down and

the rope E to the load W, and suspend it from the lever A at the proper notch by means of a loop, E-1. To raise the load, bear down on the end of the lever when it is in its original position A-1, bringing it to the position A-2. This will bring the lower rope to position E-2. Draw up the slack in rope D, to bring the loop to position D-2, and fasten it. Then lift the lever A from its position A-2, to the position A-3, and draw up the slack in rope C to bring the loop up to position C-2. The lower rope will be brought to position E-3. By repeating this process, the load may be raised gradually. The ropes may, of course, be of various lengths within the range of the support and the operators.

Mucilage Brush and Container Made of a Test Tube

An ordinary test tube, about $\frac{5}{8}$ by 6 in. in size, may be made into a mucilage container and brush that economizes the material and does not get the fingers sticky. The end of the tube is covered with a piece of soft cloth after the tube is filled, as shown in the sketch. A convenient way to care for the device is to keep it in a small tumbler.—A. H. Carrington, Trenton, N. J.

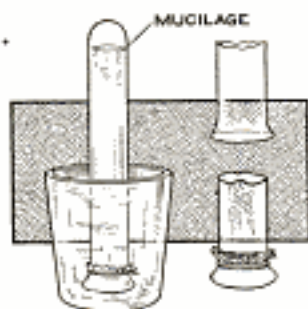

Holder for Household Ice Pick

An ice pick is often a source of danger, if left lying about the home, and should be kept at a place convenient to the ice box, where it will not be likely to cause injury. The small bracket on which the ends of the roller curtain are supported is a satisfactory holder for the pick. It may be fastened to the wall with nails, or screws, so that the pick may be suspended in the center hole.—Robert J. Donnelly, Cincinnati, Ohio.

Swing Made of Hickory Sapling

A swing, so durable that it has become a virtual landmark, was made from a long, straight hickory sapling suspended from the limb of a tree. The sapling was split part of its length, as shown in the illustration, and a bolt put through it to prevent the upper portion from cracking. The lower end was smoothed off, so as not to injure the hands, and mortised through a slab of wood, as shown in the detailed sketch. A safe hook from which to suspend the swing is suggested. It is made from a bolt fixed through the limb and curled at the hook end so that the swing may be taken down in bad weather.—Hubert Kann, Pittsburgh, Pa.



Match Safe of Miniature Cannon Shell

The match safe shown in the sketch was made by a worker in a munitions plant. The container was shaped like a small cannon shell and was set into a bracket supported on a prettily grained board, stained and varnished, and supported by a chain.—J. H. Moore, Hamilton, Can.

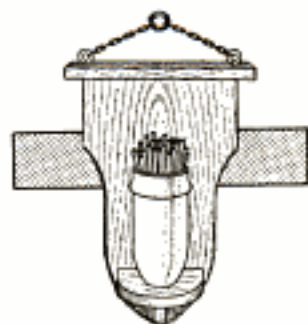

Reel for Use with Seed-Planting Guide String

Many gardeners derive as much pleasure from the orderly arrangement of the plants in their "farms" as from

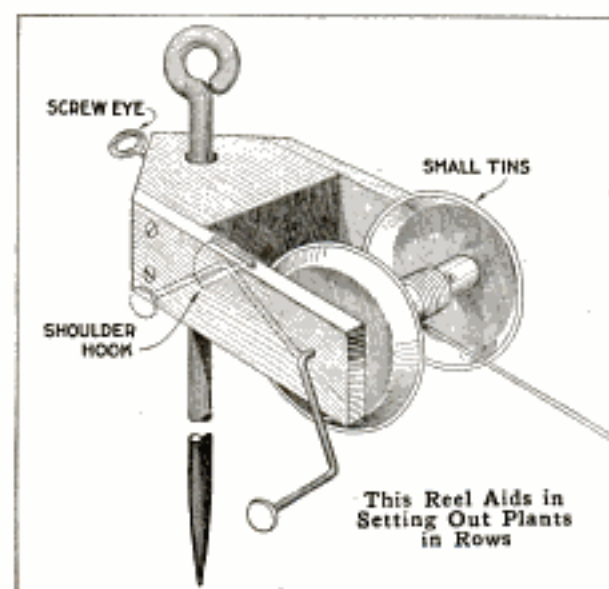

any other feature of this home diversion, and I am one of them. In order to facilitate the planting I made a reel like that shown in the sketch. The frame is of wood, and the reel is made of a piece of broomstick to which two small tins, or box covers, are nailed. A wire handle made of a long nail is fitted to one end, and a shoulder hook is used as a stop for the handle when it is desired to check the line. A screw eye driven into the back of the frame holds it at various heights on the stake. This device is far superior to the common use of two stakes for the planting cord.—James M. Kane, Doylestown, Pennsylvania.

Kinks on the Care of Umbrellas

Deriving long use from an umbrella depends in part on proper selection, care of the cloth and frame, and precautions against loss or theft. A silk cover is desirable to shed rain, and a cotton one for a sunshade. The hot sun dries out the silk and heats the metal ribs under it, quickly destroying it. If silk is used for sun protection, wet the cover occasionally. Always

set an umbrella to dry, handle down, if there is not space to dry it open.

A broad ribbon loop on the handle of a woman's umbrella permits carrying it on the wrist and prevents forgetting it. An umbrella with a removable handle can be folded into a suitcase, and putting the handle in the pocket when leaving the umbrella in any public place makes it less liable to theft. An umbrella should bear the name and address of the owner.

A Bell-Ringing Mail Box

The annoyance of watching for the arrival of the mailman was overcome by the fitting of an electrical alarm to the mail box, as shown in the sketch.

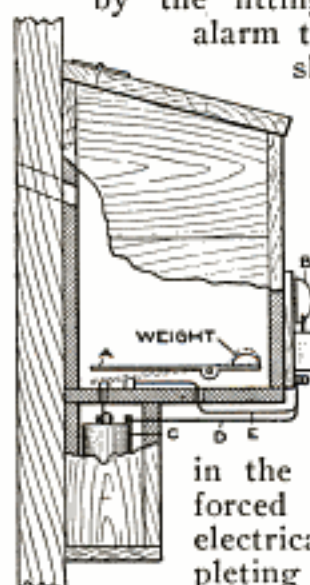

A strip of metal, A, was pivoted in the box and weighted on one end. A bell, B, was wired to dry cells in the box below the container for the mail. When the mail is dropped in the box the end A is forced down, forming an electrical contact and completing the circuit from the cells C through the wire D and back through the wire E. When the mail is removed the weight raises the metal strip.—James E. Noble, Portsmouth, Canada.

A Simple Polarity Indicator

An ordinary compass, fitted flush in a wooden frame as shown in the sketch, forms the basis for the polarity indicator described. The N, or north, and S, or south, points of the compass should run lengthwise with the frame, with the former on the end farthest from the binding posts, C and D. Five turns of No. 18 gauge, or any similar, wire are wound lengthwise around the frame and over the compass. The ends of the wires terminate at the two bind-

ing posts. Begin at C and wind toward the compass, binding the wire at D.

If the two ends of a wire are free, and it is desired to know whether there is any current present, and if so, its polarity, fasten one wire to the post C and the other to D. Before connecting the wires, hold the compass and frame in such a way that the needle is over the N point on the compass dial. If, after the wires are connected, the needle moves, there is a current flowing. If the needle is deflected toward



the east, the negative wire is on C; if it is deflected toward the west, the positive wire is on C. When it is desired to ascertain the polarity of a wire, which is covered by a floor, ceiling, or molding, hold the compass as explained, and either directly above or below the wire. Then turn on the current. If the instrument is above the wire, the wire extending parallel with it north and south, and the needle is deflected toward the west, the current is flowing from the north to the south end of the wire. If the wire runs east and west and the needle is deflected to the west, the current is running from west to east.

If the wire runs on a diagonal between the directions mentioned, and the needle is deflected toward the west, the current is flowing from the quadrant between N and W on the compass dial toward the quadrant between S and E. If the instrument is held over the wire and the needle is deflected toward E, the polarity is the opposite to that last indicated. Should the instrument be held below the wire, if the needle goes toward W, it is equivalent to going toward E when above the wire.—H. Sterling Parker, Brooklyn, New York.

¶If the white of an egg is used to seal an envelope which has no mucilage on the flap, it cannot be opened by steaming it.

Flash Light Used as a Bedroom Night Light

To save groping about in the dark for my flash light when suddenly awakened in the night, I devised the arrangement shown in the sketch and by which a "flash" is used as a wall night light, without lessening its common uses. The holder B and the board A are of wood, and into the box is fitted a metal clip, C, to hold the light. A round hole of proper size is cut through the top of the box and the light set through it so that the bottom end rests in the clip, the tin ferrule pressing against it firmly. A light spring, D, makes contact with the upper terminal of the push switch without closing it. The apparatus is fastened to the wall, and insulated wires, soldered, one to the clip C, and the other to the spring D, are connected to a switch placed in a convenient position. This switch replaces that on the light. The ceiling serves to reflect and distribute the light rays.—B. L. Dobbins, Harwich, Mass.

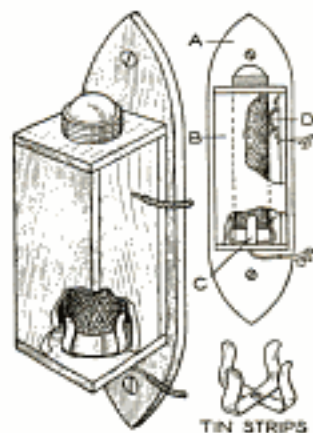

Pie-Plate Gas Heater

A satisfactory gas heater to take the chill out of the air in a small room by fitting a pie plate over a gas burner was made by me, as shown in the sketch. The wires which formerly held the glass shade were fitted into holes punched in the rim of the plate. It could thus be removed quickly when not needed and the glass shade put back in place.—Morris Tinsky, Chicago, Illinois.

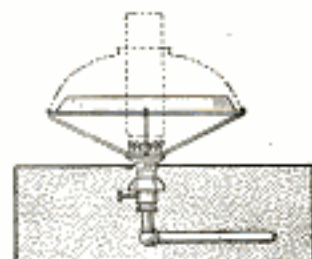

3533

Conrad Schneider
Congress Park, Ill.

DISTINCTIVE ARCHITECTURE IN MODEST HOUSE

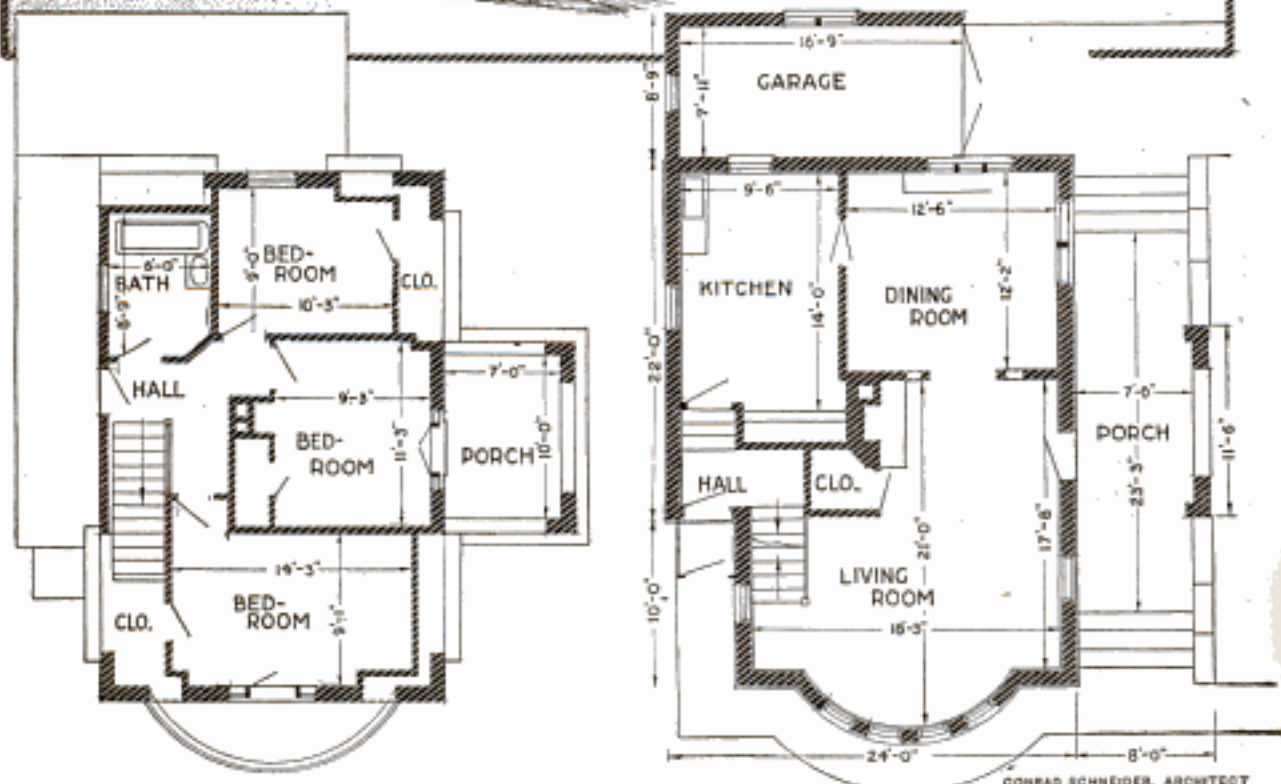
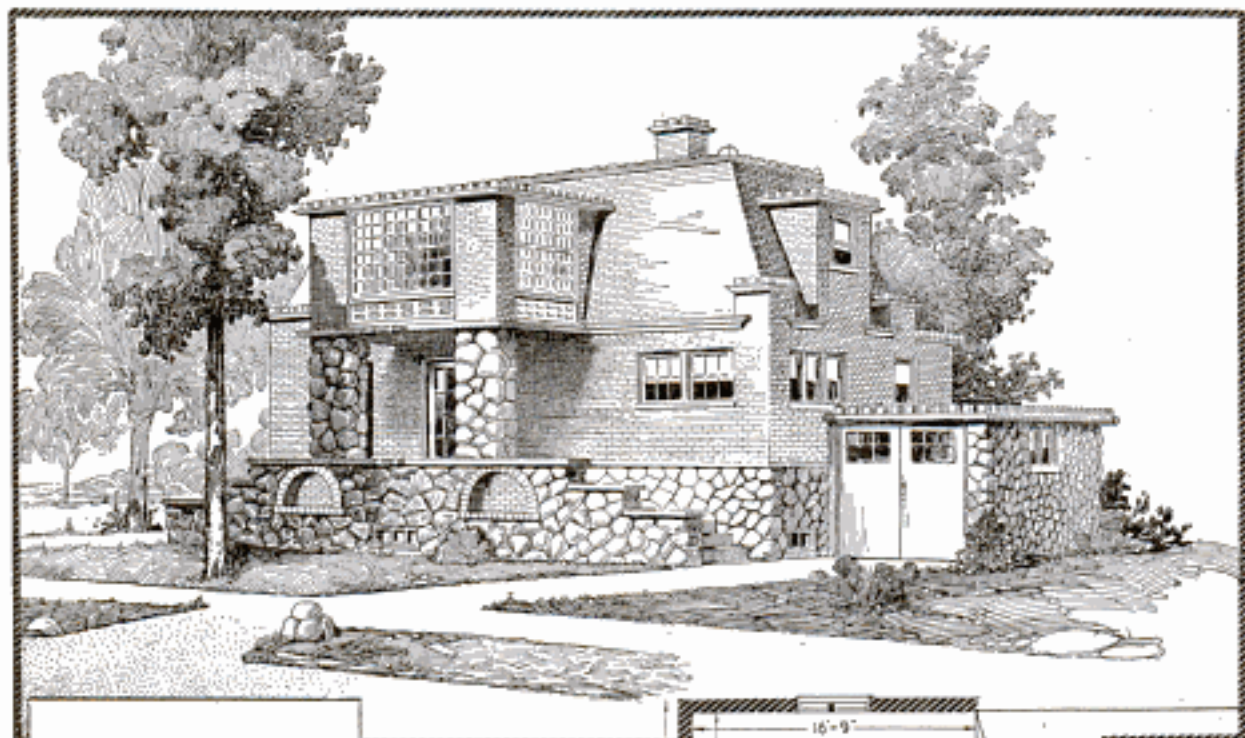

RELIEF from the monotony of stereotyped lines has been attained in a residence of moderate cost erected in one of Chicago's suburbs. Boulders form the foundation, porch, and garage walls, and support a large sleeping porch that overhangs the veranda. The main walls are finished in brick, that is surmounted by the tile of the steep-sided roof. Steps at either end of the porch give access to the front door, which opens into a large living room. The garage, a part of the building, is connected with the kitchen. Adequate light, roomy closets, a conveniently located toilet, and a general absence of waste space are attractive points pertinent to the arrangement. The cost of construction is about \$3,600.

IN accordance with the editorial policy of this magazine never to accept compensation in any form for what appears in our reading pages, and also to avoid all appearance of doing so, we are obliged to omit the name of the maker or the seller of any article described. This information, however, is kept on file and will be furnished free, by addressing Bureau of Information, Popular Mechanics Magazine, Chicago. [Editor.]

How I Raised My Earnings from \$30 to \$1000 a week

*The Story of a Young Man's
Remarkable Rise, as Told by Himself*

THREE years ago I was earning \$30 per week. With a wife and two children to support it was a constant struggle to make both ends meet. We saved very little, and that only by sacrificing things we really needed. Today my earnings average a thousand dollars weekly. I own two automobiles. My children go to private schools. I have just purchased, for cash, a \$25,000 home. I go hunting, fishing, motoring, traveling, whenever I care to, and I do less work than ever before.

What I have done, anyone can do—for I am only an average man. I have never gone to college, my education is limited, and I am not "brilliant" by any means. I personally know at least a hundred men who are better business men than I, who are better educated, who are better informed on hundreds of subjects, and who have much better ideas than I ever had. Yet not one of them approaches my earnings. I mention this merely to show that earning capacity is not governed by the extent of a man's education and to convince my readers that there is only *one* reason for my success—a reason I will give herein.

One day, a few years ago, I began to "take stock" of myself. I found that, like most other men, I had energy, ambition, determination. Yet in spite of these assets, for some reason or other I drifted along without getting anywhere. My lack of education bothered me, and I had thought seriously of making further sacrifices in order to better equip myself to earn more. Then I read somewhere that but few *millionaires* ever went to college. Edison, Rockefeller, Hill, Schwab, Carnegie—not one of them had any more schooling than I had.

One day something happened that woke me up to what was wrong with me. It was necessary for me to make a decision on a matter which was of no great consequence. I knew in my heart what was the right thing to do, but something held me back. I said one thing, then another; I decided one way, then another. I couldn't for the life of me make the decision I knew was right.

I lay awake most of that night thinking about the matter—not because it was of any great importance in itself, but because I was beginning to discover myself. Along towards dawn I resolved to try an experiment. I decided to cultivate my will power, believing that if I did this I would not hesitate about making decisions—that when I had an idea I would have sufficient confidence in myself to put it "over"—that I would not be "afraid" of myself or of things or of others. I felt that if I could smash my ideas across I would soon make my presence felt. I knew that heretofore I had always begged for success—had always stood hat in hand, depending on others to "give" me the things I desired. In short, I was controlled by the will of others. Henceforth, I determined to have a strong will of my own—to demand and command what I wanted.

But how shall I begin? What shall I do first? It was easy enough for me to determine to do things—I had "determined" many times before. But this was a question of will power, and I made up my mind that the first step was to muster up enough of my own will power to stick to and carry out my determination.

With this new purpose in mind I applied myself to finding out something more about will power. I was sure that other men must have studied the subject, and the results of their experience would doubtless be of great value to me in understanding the workings of my own will. So, with a directness of purpose that I had scarcely known before, I began my search.

The results at first were discouraging. While a good deal had been written about the memory and other faculties of the brain, I could find nothing that offered any help to me in acquiring the new power that I had hoped might be possible.

But a little later in my investigation I encountered the works of Prof. Frank Channing Haddock. To my amazement and delight I discovered that this eminent scientist, whose name ranks with James, Bergson and Royce,

had just completed the most thorough and constructive study of will power ever made. I was astonished to read his statement, "The will is just as susceptible of development as the muscles of the body!" My question was answered! Eagerly I read further—how Dr. Haddock had devoted twenty years to this study—how he had so completely mastered it that he was actually able to set down the very exercises by which anyone could develop the will, making it a bigger, stronger force each day, simply through an easy, progressive course of Training.

It is almost needless to say that I at once began to practice the exercises formulated by Dr. Haddock. And I need not recount the extraordinary results that I obtained almost from the first day. I have already indicated the success that my developed power of will has made for me.

But it may be thought that my case is exceptional. Let me again assure you that I am but an average man, with no super-developed powers, save that of my will. And to further prove my contention, let me cite one or two instances I have since come across, which seem to show conclusively that an indomitable will can be developed by anyone.

One case that comes to my mind is that of a young man who worked in a big factory. He was bright and willing, but seemed to get nowhere. Finally he took up the study of will training, at the suggestion of Mr. W. M. Taylor, the famous efficiency expert of the Willys-Overland Company, and in less than a year his salary was increased 800%. Then there is the case of C. D. Van Vechten, General Agent of the Northwestern Life Insurance Company, Cedar Rapids, Iowa. Just a short time after receiving the methods in will development suggested by Prof. Haddock, he felt that they would be worth from \$3,000 to \$30,000 to him.

Another man, Mr. H. D. Ferguson, residing in Hot Springs, Ark., increased his earnings from \$40 a week to \$90 a week in a remarkably short space of time after he began the study of will training. These are but a few—there are many other equally amazing examples which I personally know about. And aside from the financial gain, this training has enabled thousands to overcome drink and other vices almost overnight—has helped overcome

sickness and nervousness, has transformed unhappy, envious, discontented people into dominating personalities filled with the joy of living.

Prof. Haddock's lessons, rules and exercises in will training have recently been compiled and published in book form by the Pelton Publishing Co., of Meriden, Conn. Mr. Pelton has authorized me to say that any reader who cares to examine the book may do so without sending any money in advance. In other words, if after a week's reading you do not feel that this book is worth \$3, the sum asked, return it and you will owe nothing. When you receive your copy for examination I suggest that you first read the articles on: the law of great thinking; how to develop analytical power; how to perfectly concentrate on any subject; how to guard against errors in thought; how to drive from the mind unwelcome thoughts; how to develop fearlessness; how to use the mind in sickness; how to acquire a dominating personality.

Some few doubters will scoff at the idea of will power being the fountainhead of wealth, position and everything we are striving for, and some may say that no mere book can teach the development of the will. But the great mass of intelligent men and women will at least investigate for themselves by sending for the book at the publisher's risk. I am sure that any book that has done for me—and for thousands of others—what "Power of Will" has done—is well worth investigating. It is interesting to note that among the 150,000 owners who have read, used and praised "Power of Will," are such prominent men as Supreme Court Justice Parker; Wu Ting Fang, Ex-U. S. Chinese Ambassador; Lieut.-Gov. McKelvie of Nebraska; Assistant Postmaster-General Britt; General Manager Christeson, of Wells-Fargo Express Co.; E. St. Elmo Lewis; Governor Arthur Capper of Kansas, and thousands of others.

As a first step in will training, I would suggest immediate action in this matter before you. It is not even necessary to write a letter. Use the form below, if you prefer, addressing it to the Pelton Publishing Company, 13-F Wilcox Block, Meriden, Conn., and the book will come by return mail. This one act may mean the turning point of your life, as it has meant to me and to so many others.

PELTON PUBLISHING COMPANY

13-F Wilcox Block, Meriden, Conn.

I will examine a copy of "Power of Will" at your risk. I agree to remit \$3 or return the book in 5 days.

Name

Address

Please Mention Popular Mechanics

\$989

for this 7-Room
ALADDIN

Price
Includes
all
Material

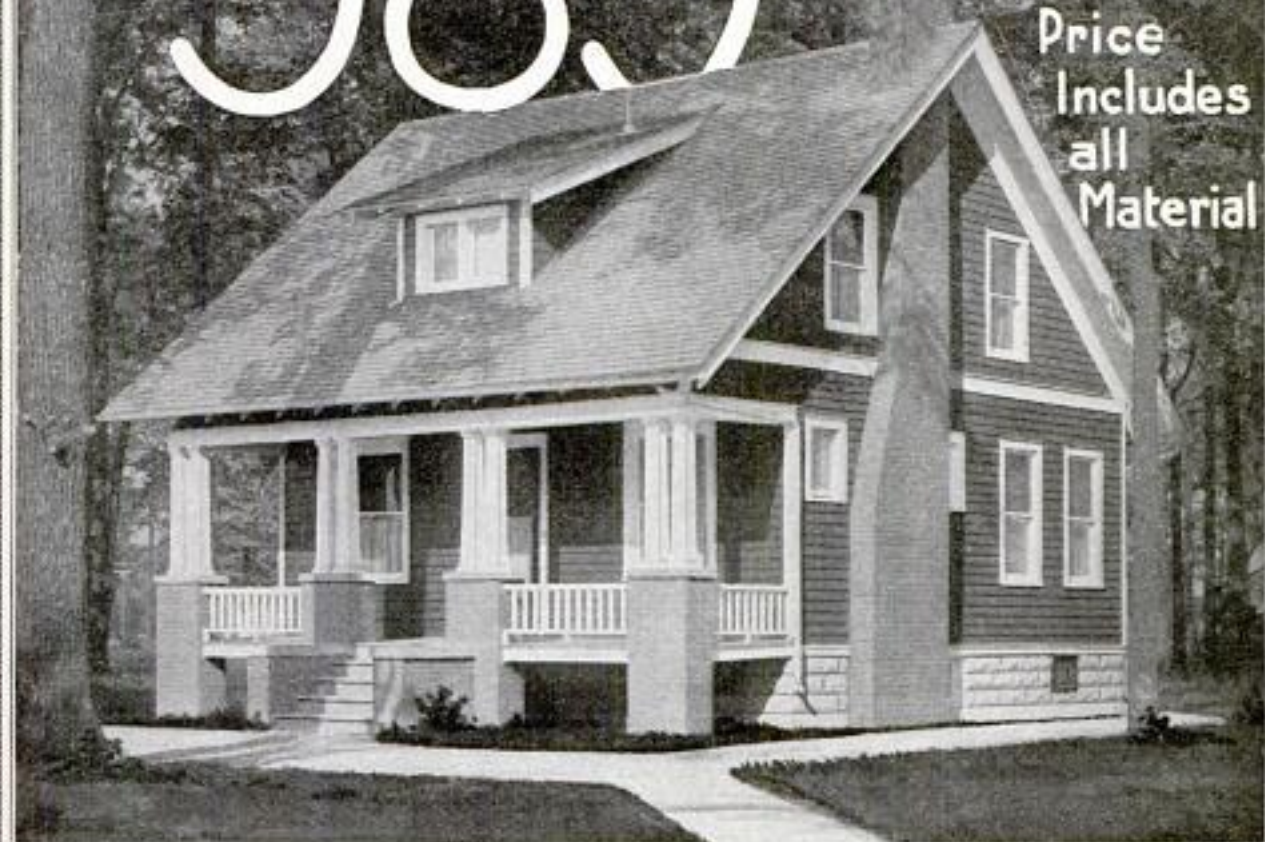

ALADDIN Houses Save \$200 to \$800

Think of the big saving you can make building this ideal, attractive home on the Aladdin System! You can buy this cozy bungalow home complete for \$989. Notice the floor plan. It contains large living room, large dining room, convenient, work-saving kitchen, three bed rooms and bathroom. Aladdin saves every owner of this home \$200. All material is cut to fit, ready to nail in place—no waste of lumber or labor. The big book "Aladdin Homes" No. 180 gives full information and illustrations of this and a hundred other homes. Send stamps today for your copy.

Dwellings, Bungalows, Garages

Get a copy of the big book "Aladdin Homes" No. 180. You will be delighted with the many illustrations, floor plans and descriptions of truly American homes; attractive dwellings of many types, snug and cozy bungalows built on California lines; low priced summer cottages, garages, etc. And Aladdin prices for complete material—cut-to-fit—will surprise you and show big savings over regular market prices. Don't delay—send for your copy of this book now!

What You Get Aladdin price includes all lumber, millwork, flooring, outside and inside finish, doors, windows, shingles, lath and plaster, hardware, locks, nails, paint, varnishes. Your home is shipped in a sealed box car, complete. Ready-Cut, ready to erect. Safe arrival of the complete material in perfect condition is guaranteed. Floor plan arrangement and complete description of the house shown above will be found in the Aladdin Book of Homes. Send stamps today for the book, "Aladdin Homes," No. 180.

THE ALADDIN CO. Homebuilders to the Nation

829 Aladdin Ave.

Bay City, Mich.

Can. Branch: Sovereign Cos't Co., C. F. R. Bldg., Toronto, Ont.

Eliminate Waste of Lumber

The average waste of lumber in building a house is 18%. \$18.00 out of every \$100 of your money goes into the waste pile. You pay \$100 and get \$82 value. The Aladdin Ready-Cut System saves you this loss. It puts the \$18 into the house. It gives you a better house for less money. Aladdin Houses are cut-to-fit in our mills—no sawing on the ground is necessary.



Enclosed find stamps for a copy of your book, "Aladdin Homes" No. 180.

THE ALADDIN CO., 829 Aladdin Ave., Bay City, Michigan

Name _____ Street _____ City _____ State _____

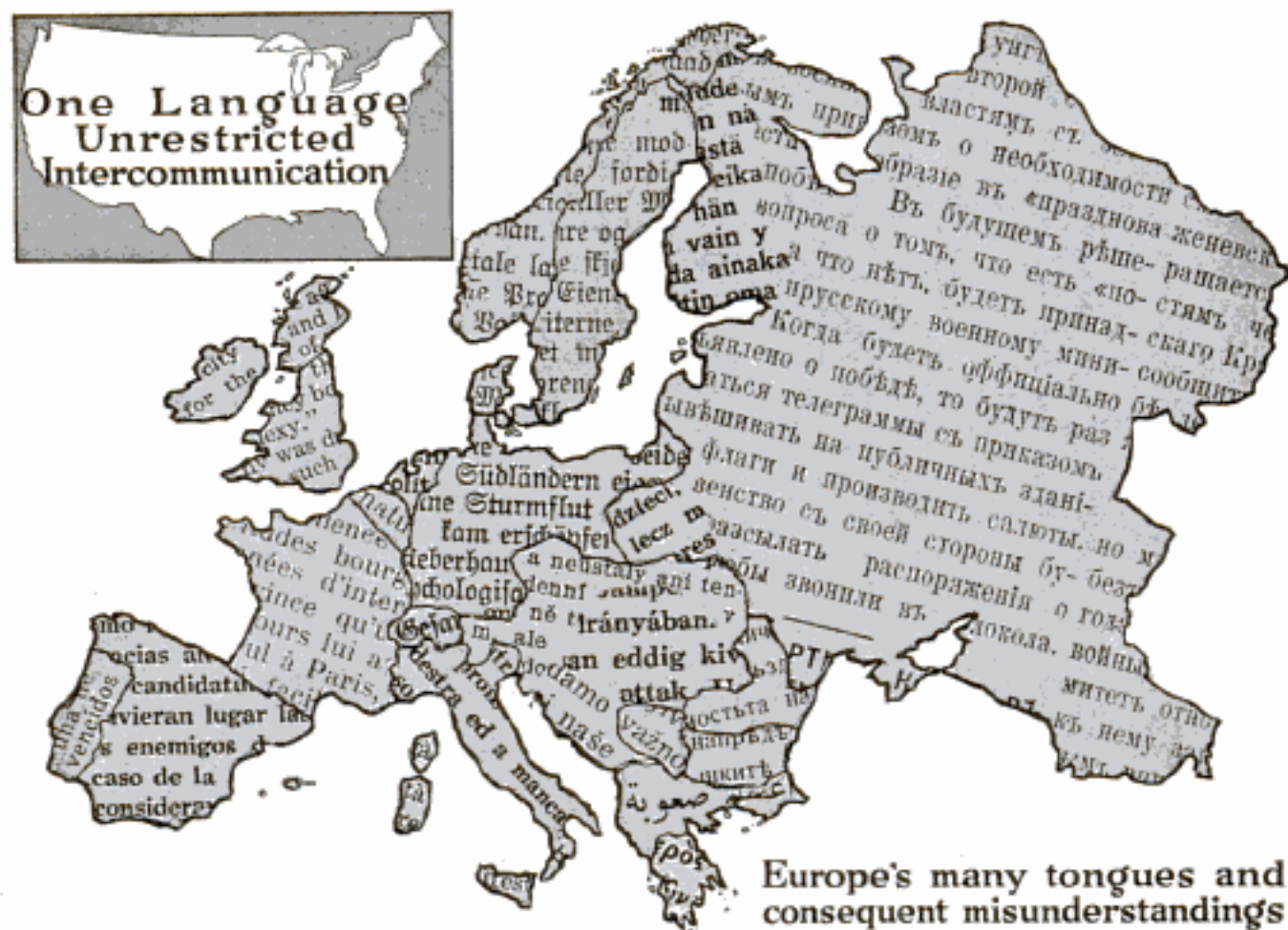

The Fruits of Understanding

Throughout the vast area of this country prevails a common tongue. The whole of Europe hardly exceeds our territory, yet Europe has more than a score of nationalities and many different languages.

In the United States the telephone, as exemplified by Bell System, renders a matchless service in its mastery of distance and in encouraging the use of a universal language. This accomplishment is in spite of the great influx of population from every country in the world.

In Europe the independent countries, separated by barriers of language,

and lacking efficient telephone service, suffer from inadequate facilities for inter-communication.

We now talk from the Atlantic Coast to the Pacific, and eliminate more than three thousand miles. In Europe, contending with a babel of voices and unrelated telephone systems, a bare quarter of that distance has been bridged with difficulty.

The ideal of the Bell System has been day by day to extend its service in the interest of all telephone users. Its efforts have resulted in providing the facilities to unite cities and rural districts in true American democracy.



**AMERICAN TELEPHONE AND TELEGRAPH COMPANY
AND ASSOCIATED COMPANIES**

One Policy

One System

Universal Service

Plaza before the
Bureau of Engraving,
Washington, D. C.

A Dollars and Cents Proposition

The greater proportion of that vast army of Goodyear Tire users—the largest single group of tire-buyers in the world—acts from a purely business motive.

They buy Goodyear Tires because they expect more from Goodyear Tires for the dollars they give—and they *get* more.

Get more—in miles, in comfort, in satisfaction—in untroubled travel, in unblemished service, in downright *tire value*.

All the effort, the activities, the aims of the tremendous Goodyear factories are centered upon producing a quality product in which these virtues shall be unfailingly present.

There is no groping, no uncertainty in the process. Accomplishment now is as sure as mathematics.

Any Goodyear Tire will prove this—and on your car, will prove it to *your* economic benefit.

Goodyear Tires, Heavy Tourist Tubes and "Tire Saver" Accessories are easy to get from Goodyear Service Station Dealers everywhere.

The Goodyear Tire & Rubber Co., Akron, Ohio

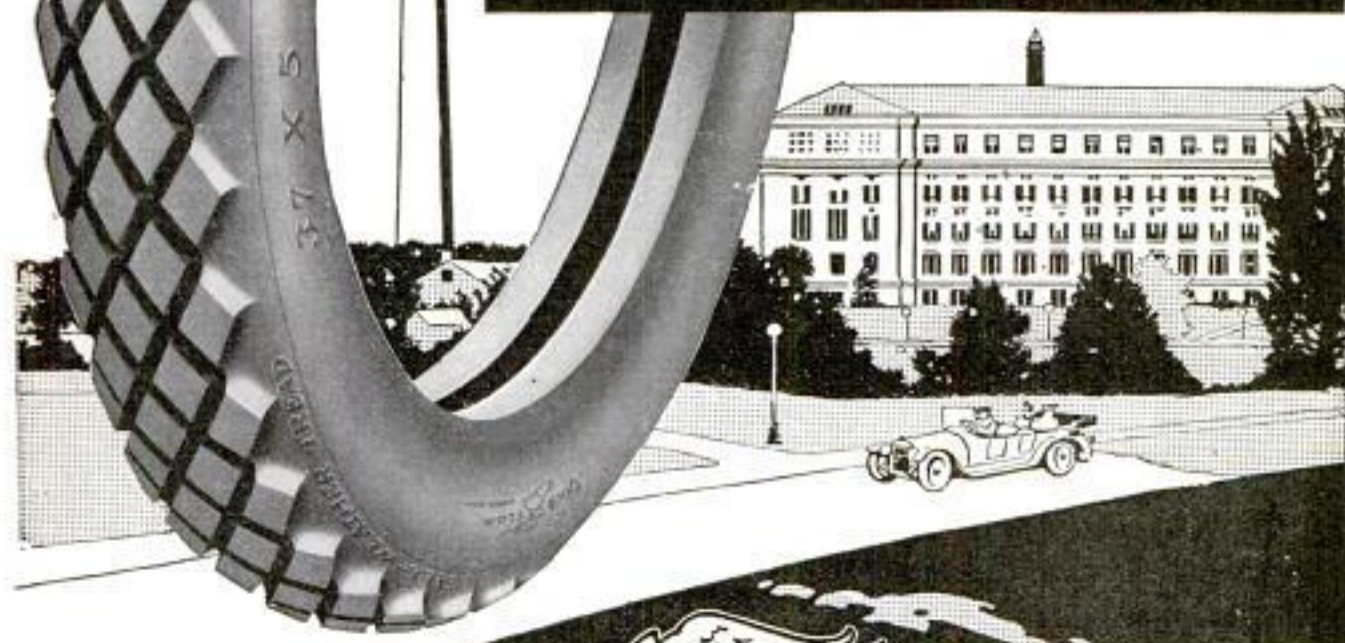

GOODYEAR
AKRON

Please Mention Popular Mechanics

Clean Your Plugs This Easy Way

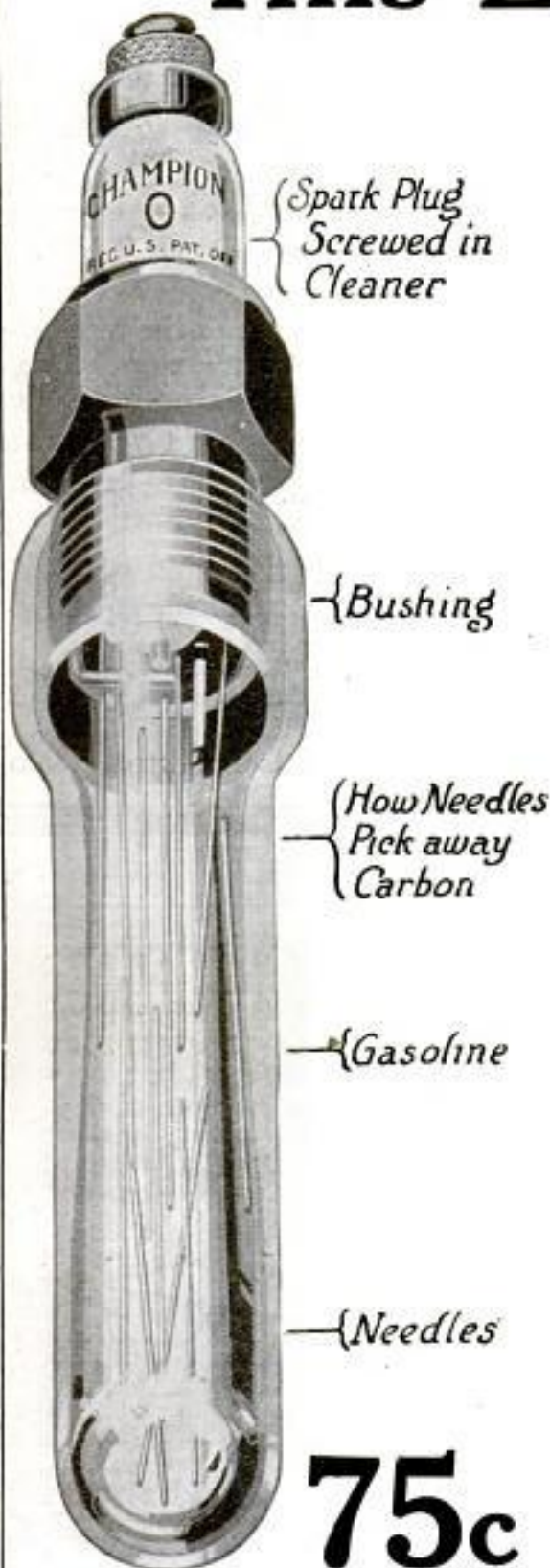

Patent Pending
Reg. U. S. Pat. Office

Fill the tube half full of gasoline—
screw the plug into the bushing
at the end—then shake.

That's all you have to do to clean
your plugs when you use the

CHAMPION "MINUTE" Spark Plug Cleaner

In a minute or two you can clean a
whole set.

Think what an improvement over the
dirty, grimy task it used to be!

You don't even have to take the plugs
apart.

The needles in the tube pick the carbon
off the porcelain and the gasoline dis-
solves the oil.

The Champion "Minute" Cleaner saves a
whole lot of time, temper and trouble.

It's a worry-less, work-less way of clean-
ing your plugs.

You want a Champion "Minute" Cleaner.
Get one now.

Comes packed in a wooden carrying case.

For sale by your jobber or dealer.

If not, please write to us.

Champion Spark Plug Co.
1000 Upton Ave. Toledo, Ohio
Manufacturers of Champion-Toledo Spark Plugs

SOMETHING NEW

a complete Electric Sewing Machine



—no larger than a typewriter

—can be carried from room
to room

—guaranteed 10 years

Costs **\$35**
Only

(\$37 west of the Rockies)

Western Electric Portable Sewing Machine

In designing this wonderfully compact machine every disadvantage of the old-fashioned sewing machine was thrown aside. You don't have to pedal it—a pressure on the foot control starts the motor, regulates the speed and stops motor instantly. You can sew all day without tiring—and at a cost of about one-half cent an hour for current.

It is never in the way, for it can be put on the closet-shelf when not in use. You can use it wherever there is an electric light socket. In its essential parts it is a full-sized, high-grade sewing machine capable of as fine work as any machine. And the cost is less than that of most any of the well-known makes of foot-power machines.

If your lighting company, electrical dealer or department store cannot show you this wonderful machine, send coupon to nearest office.

**WESTERN ELECTRIC
COMPANY, Inc.**

New York Chicago Kansas City San Francisco
Houses in all Principal Cities

**WESTERN
ELECTRIC
COMPANY
Inc.**

Gentlemen:
Please send me Booklet
No. 505-AW, describing your port-
able electric sewing machine.

Name _____

Address _____

Please Mention Popular Mechanics

For the "One Woman" Top



RAYNTITE Single Texture Top Material

Rayntite is more than the ideal one-man top material. It is also ideal for the "one-woman" top.

All far-sighted automobile manufacturers recognize the growing importance of the woman in the choice of cars.

Witness the increase in the use of colored bodies, graceful designs, ornamental interiors of closed cars, and moorish finish Fabrikoid for upholstery.

A Rayntite top is light enough for the average woman to handle, yet guaranteed not to leak for one year, and built to last as long as the car.

Trade Authority Tells of Trend

From the show number of *The Automobile* of January 4, 1917, we clipped the following:

long in arriving.

Tops Are Lighter

Tops are tending to be lighter. The old-fashioned top consisted of two layers of material, each being thick and massive. Now there are many cars with only one thickness of material, just as waterproof, less attractive to dust, and a good third lighter.

Why make your car top heavy, and the "one-man" top a joke, by using material twice as heavy as it needs to be?

Now Made in Two Varieties

RAYNTITE No. 1—Single texture with Fabrikoid surface—and

RAYNTITE No. 2—Single texture with Fairfield Rubber surface.

Each is guaranteed one year against leakage.

If the car you are considering is not topped with Rayntite, find out whether you or your wife can really handle the one-man top.

Samples of either variety on request



Du Pont Fabrikoid Company

WILMINGTON, DELAWARE

Works at Newburgh, N. Y., and Fairfield, Conn.
Canadian Sales Office and Factory, Toronto

Make Your Own Movies

\$29⁷⁵

Equal in performance to the best professional machine costing \$1000.00 or more



The World's first and only Practical Moving Picture Camera for the Amateur

Movette Will Get YOU!

See what a famous young inventor has done! He has turned the world of photography topsy-turvy! No more dead, still pictures for you. Now you can make motion pictures—pictures that pulsate with the action and light of life—easier than an ordinary snapshot.



Every Dealer Sells It—You Can Buy It Everywhere!

Easier than a snapshot?—YES! No focusing—no adjustments. Sight your object in the finder—then turn the crank. Movette has got it for you—for all time—any time

The scene is yours. You can make it re-live itself all over again—in clear cut, true-to-life action pictures—next week, next year—yes, twenty years from now!

See the flashing, dimpled smile of Baby—now grown to manhood or womanhood! Review the glorious days of childhood! See Father and Mother in almost flesh-and-blood reality.

And think of it! Movette is so simple—so "foolproof"—a child can operate it. It's the scientific wonder of the age.

Movette takes 50 feet of action pictures for \$1.50—equal to two minutes of the best professional film. Sixteen hundred snapshots in all—EVERY ONE PERFECT; 32 for 3c.—anyone of which can be enlarged for 25c. Send the coupon for full details of this newest fascinating sport.

Movette Camera Corporation

Largest Makers of Moving Picture Cameras in the World

1170 University Ave., Rochester, N. Y.

Actual size of Movette Camera:
7" long; 5" high; 2½" wide.



**Tear Out-
Sign and
Mail**

**Read this
Guarantee**

Investigation Coupon

Movette Camera Corporation, Rochester, N. Y. Pop. Mcc. 3-17
Gentlemen: I am interested in Movette. Will you kindly send me further details regarding the fascinating Movette Moving Picture Camera outfit and your interesting new book, "The Scientific Wonder of It"—FREE.

My Dealer's name is.....

His address is.....

My name is.....

Address.....

City.....State.....

Please Mention Popular Mechanics

SAXON ROADSTER

A CAR COMPLETELY EQUIPPED WITH EVERY MODERN FEATURE

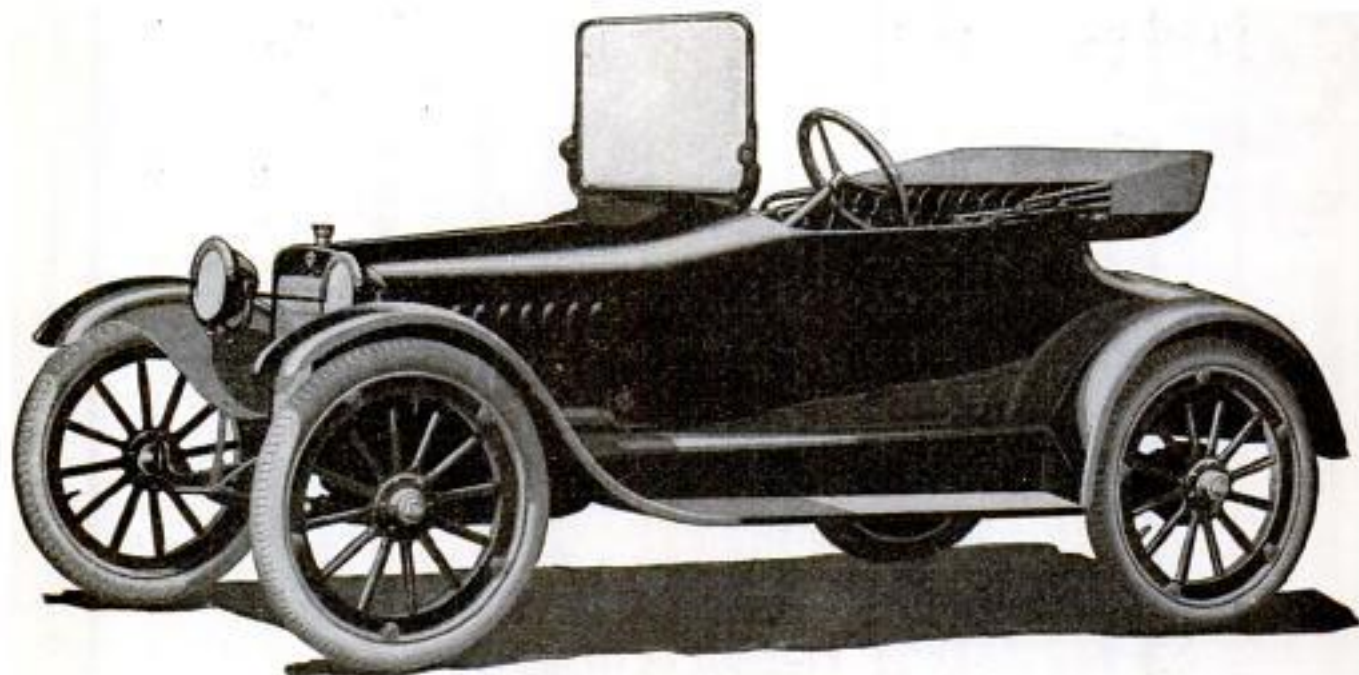

Never Before So Fine a Car At So Low a Price

You may think you've seen big motor car values before. But you've never seen the equal of this car—this new series Saxon Roadster.

It's the biggest dollar-for-dollar value ever put on the market.

Look at the body lines—pure stream-line design of faultless beauty. Look at the finish—glossy lustre of ever-newfreshness.

And then watch it perform on the road. Note how smoothly the motor pulls "on high" or "in low." Note how the car holds the road when you've got the accelerator button glued to the floor boards.

Look at the number and quality of its features—every one a costly car attraction. This new series Saxon Roadster you'll

observe has a Wagner 2-unit starting and lighting system. There's none better to be had.

Then there's the three-speed transmission; 30 inch by 3 inch tires; demountable rims; high-speed Saxon motor, Continental manufacture; Reichenbach carburetor; Hyatt Quiet bearings; honeycomb radiator; Atwater-Kent ignition system; long cantilever springs of fine vanadium steel; new style top; 40-inch wide seat; electric horn; speedometer; extra tire carrier; ventilating windshield, and twenty more refinements.

The Saxon Roadster is \$495; Saxon "Six" Touring Car, \$865; Six Sedan, \$1250, f. o. b. Detroit. Canadian Prices—Six Cylinder Touring Car, \$1175; Touring Sedan, \$1675; Four-Cylinder Roadster, \$665. Price of special export models, "Six," \$915; Four, \$495; f. o. b. Detroit.

(888)

SAXON MOTOR CAR CORPORATION, DETROIT

Please Mention Popular Mechanics

The Famous *Ranger* 1917 Model Motorbike

SENT ANYWHERE ON
30 Days Free Trial

FREIGHT PREPAID

Your Choice of

44 Styles For

Men
Women
Boys
Girls

\$14.75
and Up

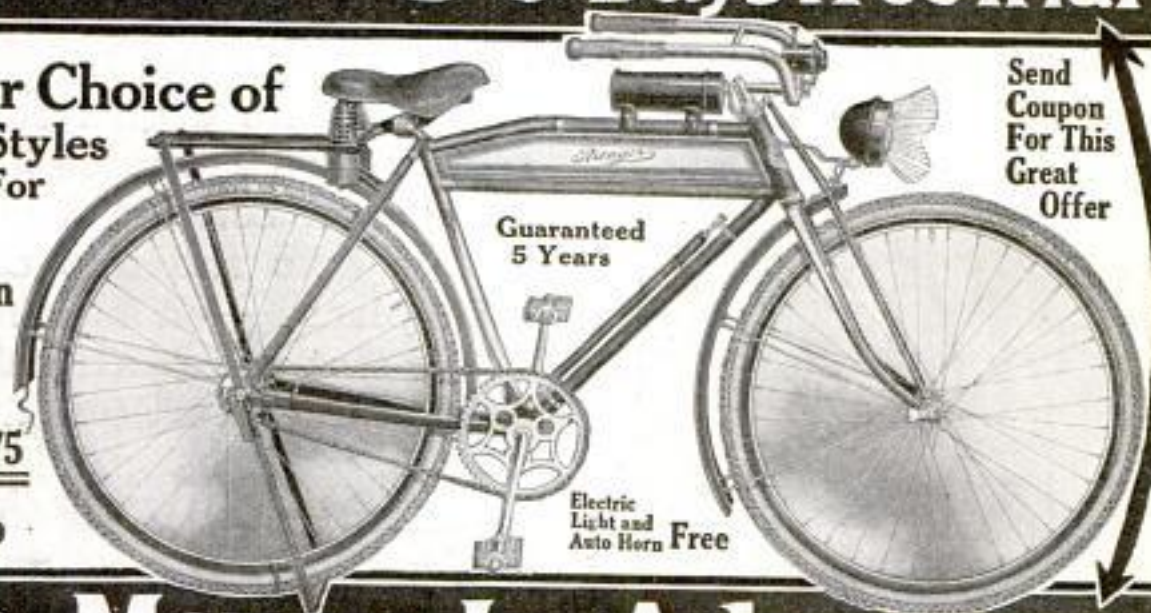

Send
Coupon
For This
Great
Offer

No Money In Advance

Don't hesitate. You can get this famous Ranger Motorbike or any other bicycle you want without one cent in advance—without paying express charges—without obligation or delay of any kind.

There's no string to this proposition whatsoever. Just your mere request brings the bicycle of your choice—the size you want, the color you want, equipped in every particular to suit you.

When the bicycle comes, you can decide to keep it on our 30-Day Free Trial Plan or send it back at our expense. We won't try persuasion, or importune you to buy and keep the bicycle. The bicycle in your own hands, under every day use, under all conditions, must sell itself to you, or we'll take it back, and we won't charge you one cent for the use of it. Don't miss this offer. Mail us coupon now—send for this wonder bicycle—the Ranger Motorbike.

The Greatest Bicycle Ever Built

We have spared no expense to make this the grandest bicycle in the world. How well we have succeeded you can judge by noting its wonderful construction. But it is not only in construction that the Ranger Motorbike excels. It also answers the cry for SPEED. It furnishes extra riding COMFORT. Its ENDURANCE is remarkable. It is a BEAUTY in appearance. Altogether it stands without a rival—master of every occasion, on country roads, on steepest hills, on city boulevards, on field and track.

Note This Wonderful Equipment Free

You'll simply fall in love with every detail—the Special Curved Motorcycle Frame with Reinforcing Top Bar, the Front Fork reinforced with Truss, the Steel Tool Box between Top Bars, which looks exactly like gasoline tank on motorcycles. Carrying out further the motorcycle idea, we have added a sturdy Platform Carrier, Quick Action Stand, and new Motorbike Handle Bars, Grips and Pedals. Special Features are: Coaster Brake, Motorbike Saddle, Improved Brampton Roller Chain, Quick Detachable Mud Guards, Electric Light, Auto Hand Horn, Sampeon Tires. These luxurious fittings represent \$25 worth of actual value not found on any bicycle. We give you also FREE, \$5 Outfit described on this page.

Special—Now If you want this grandest of all Motorbikes or any other model in the Ranger line, including \$5 Premium Set, 5-Year Guarantee, Accident Insurance sent to you FREE—don't delay. Send coupon and get Big Bicycle Book showing scores of styles, sizes, colors from which to choose the model you like best. We'll ship the bicycle of your choice freight charges fully prepaid to your town. If it doesn't please you, don't take it. If it suits you fully and you believe it is the grandest bargain and greatest bicycle ever offered, you may keep it according to our 30-Day Free Trial Plan.

Fill out and send Coupon at once—while our liberal Introductory Offer prevails. No obligation whatever. Write today sure.

FREE \$5. Premium Outfit!

Make up your mind NOW to get a Ranger Motorbike or other Ranger model and we'll send you FREE of cost this \$5 Outfit. \$3 Bicycle Pump and Pump Clips, Sterling Wrench, Hub Shiners, Silver Queen Bell, Corbin Stand Lock, Steel Screw Driver, Trouser Guards, Large Can of Oil, Quick Action Motorbike Stand, Roll of Tire Tape, Spoke Tightening Nipple Grip. All this in addition to the regular tool outfit of wrenches, repair kits, etc.

Rider Agents Wanted Tires, Lamps, Accessories, to ride and exhibit a 1917 Rear Wheels, Inner Tubes, Model Ranger furnished by Coaster Brakes, all equipment at half actual prices. Second Hand Bicycles taken in trade Offer. Write today. sold at \$1 to \$8 each. Write.

MAIL THIS COUPON

MEAD CYCLE COMPANY,
9 N. Canal Street, Chicago, Ill.

Without obligating me in any way, please send me your Big Bicycle Book and particulars of your No-Money-In-Advance, 30-Day Free Trial Plan. Also send me information regarding Special Liberal Terms and particulars of Extra Inducements and Privileges.

Name.....

Address.....

City..... State.....

MEAD CYCLE COMPANY
9 N. Canal St. CHICAGO

Please Mention Popular Mechanics

With Her Beside You



AWAY you go! Over neat boulevards, thru the parks of the city and out beyond to the brown roads of the countryside — now thru a wooded by-path — now between fields, past a lake and into the wild places — enchanting nooks that you reach only by motorcycle. With the

Harley-Davidson

you will revel in the joy that comes only to the motorcyclist. Wonderful sport! Splendid recreation! Ask your dealer to show you the "Master 17."

Look it over — ride it, take your chum with you. Get the full Harley-Davidson idea. Start the

motor — notice the quick, anxious response. Observe the startling getaway, the punch, pull and pep of the new "Master 17" Motor.

Write for Catalog

Harley-Davidson Motor Co.

487 "B" STREET MILWAUKEE, WIS.

Producers of High Grade Motorcycles for More than Fifteen Years

Also Manufacturers of Harley-Davidson Bicycles



\$85 buys this \$125 3-A Graflex with Zeiss Tessar Series 1 C. F. 4.5 Lens. Our Money-saving Camera Catalog is filled with hundreds of values just like this.

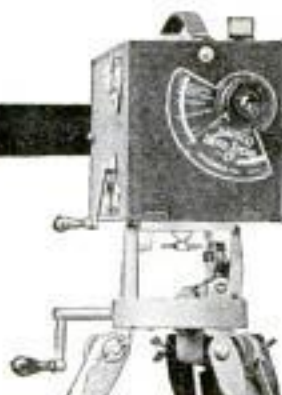

Complete motion-picture camera for only \$110. The Davisco Kimo is the latest, lightest, most compact motion-picture camera made. Best results, clearest pictures. No complicated mechanism.

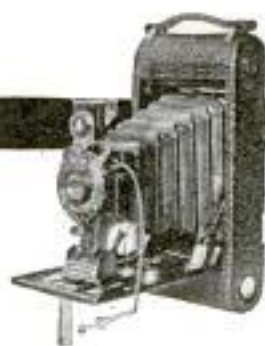

Kodaks all sizes—everything from the vest-pocket size up—at our low direct-to-you prices. We guarantee complete satisfaction and to save you money. Send for our catalog today.

You Can Save 25% to 50% on Any Camera, Lens or Supplies

Mail Coupon NOW for Catalog!

THE day of high camera prices is over. Don't figure on any camera till you have seen our big 1917 Camera Catalog, showing the camera you wish at the lowest price.

**32 Years' Success
Backs Any Offer We Make!**
For 32 years we have served the camera folk of America. Supplying the best quality at the right price. Our enormous business covering the country from coast to coast, selling direct to the user is the reason we can offer such remarkable low prices on articles you know would cost more any place else.

The Book Tells the Story

Every article we sell is backed by 10 days' Free Trial. Your money back if not entirely satisfied. Nearly every camera user in the country knows about our square dealings, our low prices and the high quality of our goods. We know—because they buy from us continuously year in and year out.

FIND OUT FOR YOURSELF!

Just mail the coupon or send a post card to us today. We will show you *too*. Our big, complete catalog means money to you. It's the book every camera user should have. Send for catalog No. 67 today!

DAVID STERN COMPANY

"Everything in Cameras"

1047G Madison St. In Business Since 1885 Chicago, Ill.

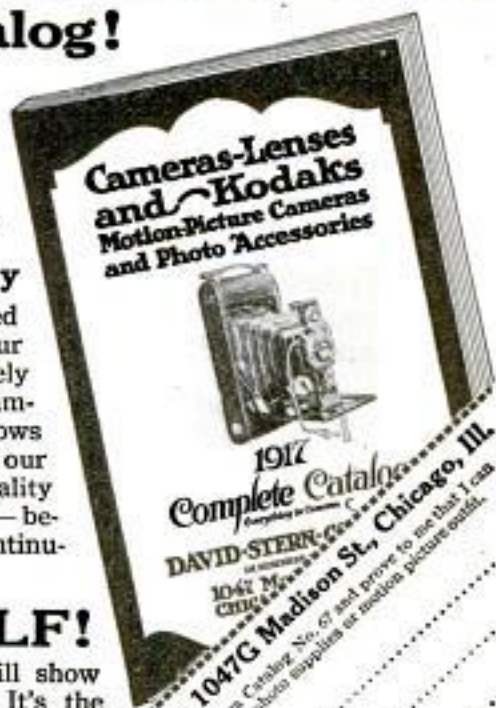

1917
Complete Catalog
Everything in Cameras
DAVID STERN COMPANY
1047 Madison St., Chicago, Ill.
Please send your new 1917 Camera Catalog No. 67 and prove to me that I can
save big money on my camera, lens, photo supplies or motion picture outfit.

Name.....
Address.....
City.....
State.....

10 Days' FREE Trial—Money-Back Guarantee

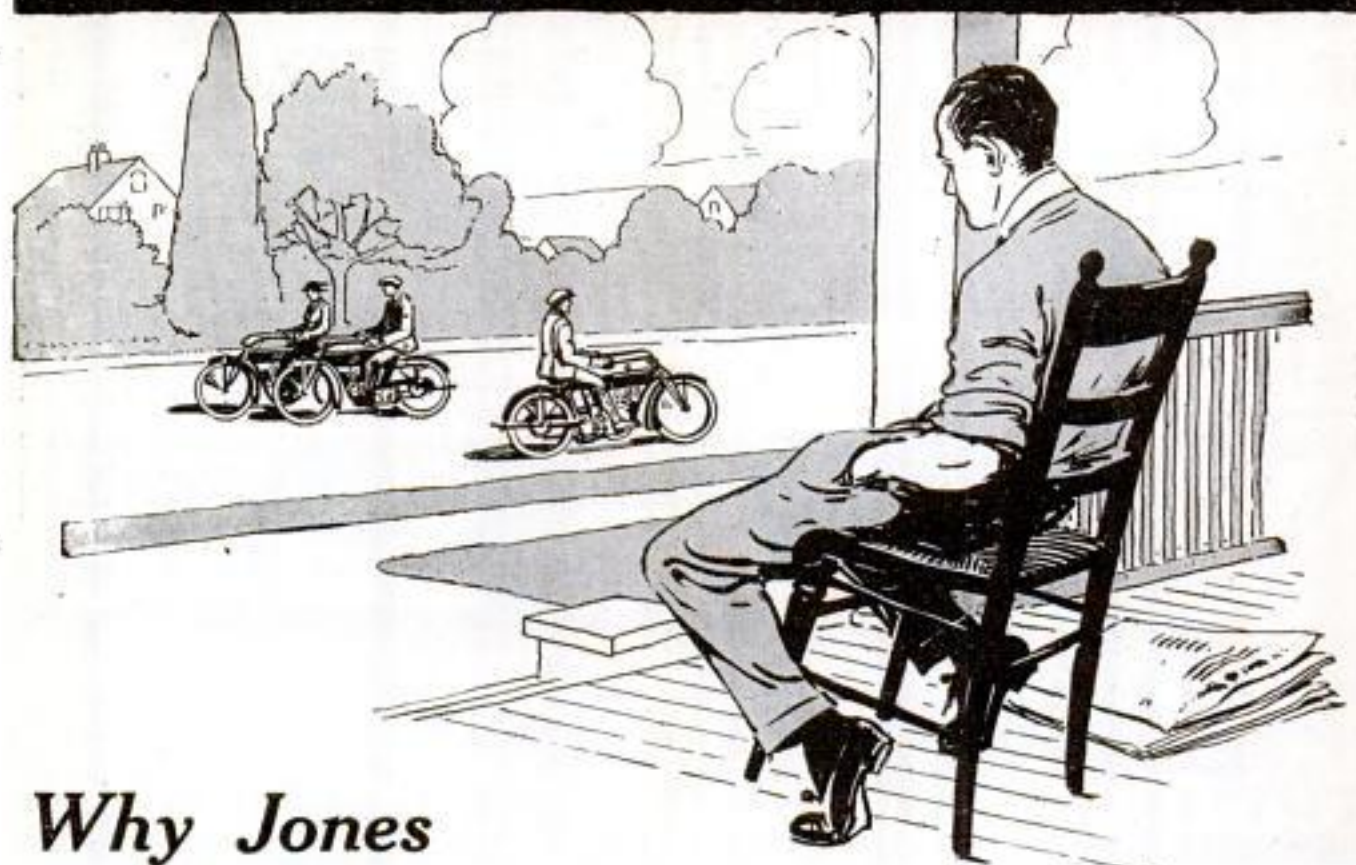

Why Jones Bought An Indian Motorcycle

SUNDAYS and holidays were long days for Jones. After he had read the papers, time hung heavily on his hands.

His chief diversion was sitting on the front porch and watching happy, outdoor-loving boys, men, and elderly gentlemen spin down the road on Indian Powerpluses, Light Twins, and Bicycles.

A lot of machines went by — most of 'em red. Seemed like *everybody* rode Indians. Why shouldn't *he* be an Indian rider, too, and put in his Sundays and holidays as a *real* man should? Acting on the idea, Jones bought a 1917

Indian Motorcycle With Powerplus Motor

There's a 1917 Indian for everybody—young or old. For advanced motorcyclists, the Big Twin with Powerplus Motor with its matchless power, speed, cleanliness, quietness, comfort, stamina, and mechanical simplicity. For those desirous of modified speed and power, but Indian soundness of construction, the easily controlled Light Twin with Four Cycle Opposed Motor. For Bicycle enthusiasts, the Electrically Equipped Indian Bicycle with its Indian

Motorcycle streamline effect—and ten other 1917 model Bicycles from \$26 to \$45.

Take those short spins and long tours you've longed to take. Spend your spare hours outdoors, under the blue sky, in the health-giving, blood-making open. The Indian way is the quickest most comfortable, surest, easiest, most economical, highest quality way. Over 16 consecutive years of engineering thought and initiative behind whatever Indian model you buy.

Send for 1917 Indian Catalog, specifying the model you're most interested in

HENDEE MANUFACTURING COMPANY, 710 State Street, Springfield, Mass.

(Largest Motorcycle Manufacturers in the World)

**One Day—
Well and Strong—**



**The Next—
An Accident Did This!**

DON'T think it's safe to insure yourself against accident some time next week or next month or next year. It isn't. Accident isn't going to wait till *you* get ready. Out of a clear sky—*always* out of a clear sky—it comes like a clap of thunder and strikes down one man in seven each year.

You may be that one in seven—this year. You will have no warning and you will have no time to prepare when the accident comes.

Now is the time—now—while you are well—while you are thinking about it—today—this minute. Send this coupon. Make yourself safe—



AETNA-IZE



Three cents a day between you and worry about money. On this \$10 Combination three cents a day will bring, if you are in a "Preferred" occupation and under 50 years of age, \$1,250 to \$3,250 in case of death by accident; \$5 to \$10 weekly income for disability due to accidental injuries, plus \$1,000 to \$3,000 for loss of two limbs or eyes; or the income plus \$500 to \$1,500 for loss of one hand, foot or eye; or \$250 for death from any cause. You can make these amounts as much larger as you like by paying more than

three cents daily. (\$50 added to above payments for death if you insure while under 40 years of age.)

It means nothing to you to spend 3 cents a day now. It may mean much to get the return from AETNA later on. Don't be forced to say, "I wish I had Aetna-ized while I had a chance."

**Send this coupon today,
while the chance is here.**

AETNA LIFE INSURANCE COMPANY
Drawer 1341 HARTFORD, CONN.

The largest company in the world writing Life, Accident, Health and Liability Insurance

Agency opportunities for all Casualty and Bonding lines
An AETNA agent has a national advertising campaign working for him all the time

Name.....
Occupation.....
Bus. Address.....
AETNA LIFE INSURANCE COMPANY
Drawer 1341 HARTFORD, CONN.
I have marked the kind of insurance I
wish to know about: Accident ,
Health , Disability , \$50
Life Certificate . My
age is.....years. I am
in good health.

P.M. 3-17

20

Please Mention Popular Mechanics

A Motorcycle Aristocrat

The Progressive Lightweight at a Popular Price

You've waited for this; you want it; it's ready for you. Look where you will, you cannot find a lightweight, low-priced motorcycle that has the originality in design, the quality in construction and the beauty in finish and workmanship of the Cleveland Lightweight.

It is the only motorcycle that has a straight line worm drive with no auxiliary gears or chains to transmission or magneto. Weighing about 150 pounds and designed by automobile engineers, it has the lowest center of gravity, the fewest number of parts and the finest specifications of any light motorcycle on the market. Silent, clean, easy to ride as a bicycle, safe and comfortable, it is the universal motorcycle.

Specifications:

Two-stroke motor; two-speed transmission; multiple disc clutch; Bosch magneto; S. K. F. ball bearings; Firestone non-skid tires; Brown & Barlow carburetor; aluminum castings; drop forged frame fittings; non-gran bronze; straight line worm drive; demountable power unit; spring fork; automatic lubrication; heat treated alloy steels; full motorcycle guarantee; price \$160.00; with Kick Starter \$170.00. F. O. B. Cleveland. Dealers wanted.

*The Cleveland
Lightweight*

Almost Free Transportation

Making 75 miles on a gallon of gasoline, the Cleveland Lightweight opens up every travelled road, in the city or country, for business or pleasure, at a negligible expense; cheaper than street cars or railroad fare; no limitations in distance or destination.

THE CLEVELAND MOTORCYCLE MFG. CO.
7202 Platt Avenue, Cleveland, Ohio

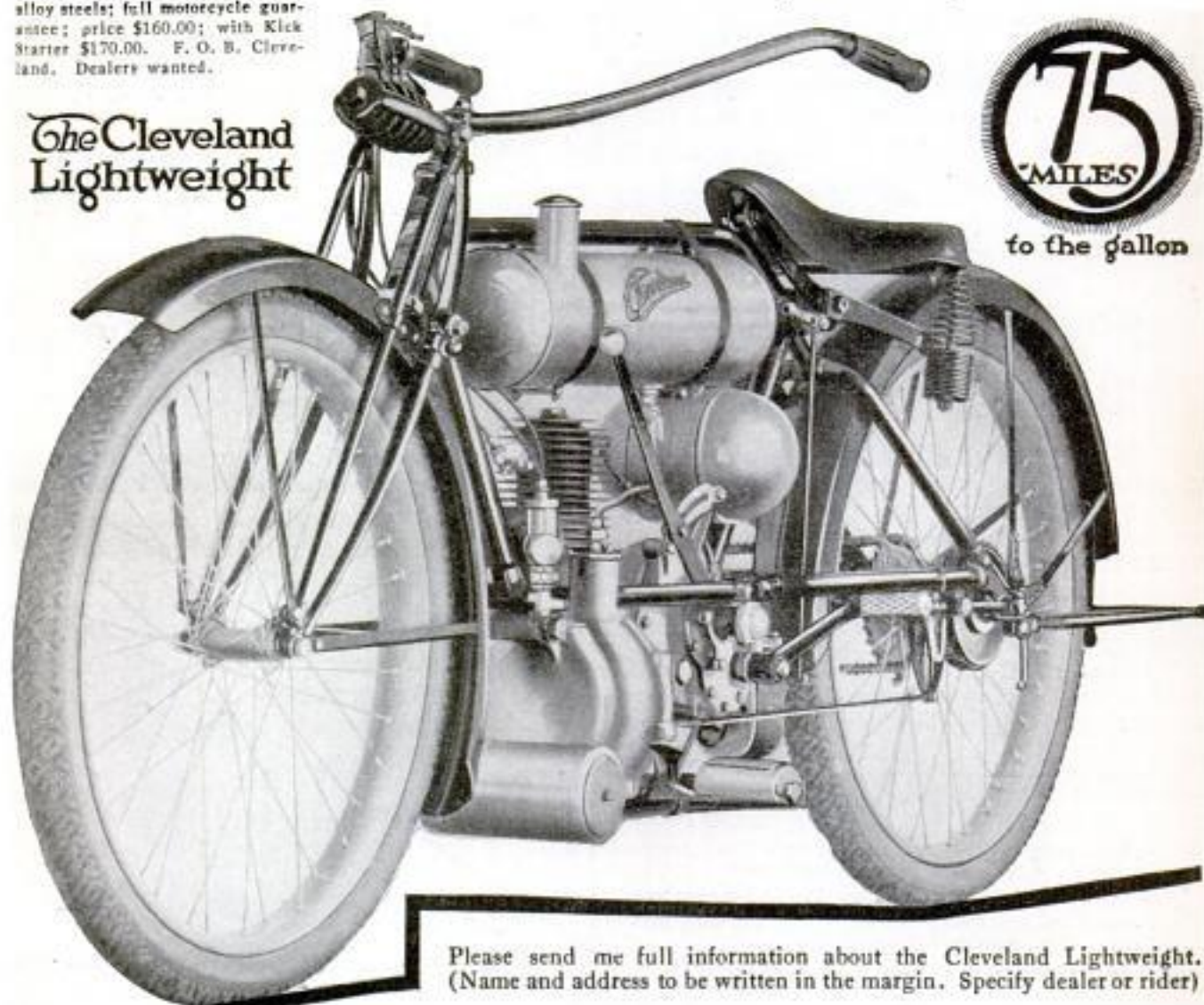

Please send me full information about the Cleveland Lightweight.
(Name and address to be written in the margin. Specify dealer or rider)



Your Choice
of
38 Styles
of

The Wing Piano
and Player Piano



On Four Weeks' Trial

Yes, we'll ship you on 4 weeks' absolutely free trial a Genuine highest grade Wing piano **DIRECT** from **our own factory, freight prepaid**. The most surprising—most amazing offer ever made. An offer that puts you on the same footing as the largest piano dealer—and at the very **rock-bottom DIRECT** wholesale factory price. Since 1868—for 40 years—we have been building Wing Pianos, renowned everywhere for their sweetness of tone and sterling merit—and we now make you this greatest of all offers on the Wing, guaranteed for 40 years.

We will allow you to use any Wing piano—your own choice of 38 superb new styles in any shade of mahogany, walnut or oak—in your own home for four full weeks at our expense. A Wing Upright, a Wing Grand or a wonderful Wing Player-Piano that plays all the greatest concert and opera selections (you can play it perfectly the first day without taking music lessons).

No Money Down —Not a Cent of Freight

We ask no money down—nothing on arrival—no freight either way—no deposit. Just choose any Wing from our large catalog. We employ **no salesmen** of any kind to visit and annoy you. We'll ship the instrument **no money down—freight prepaid**. While the piano is in your home use it just as if you owned it. Compare with description in the Wing catalog—but note the **rock-bottom direct-wholesale-factory price** is quoted in the personal letter to you. Play the piano—let your friends play it. Examine it carefully—thoroughly—inside and outside. Take music lessons on it if you like. Note the perfect **bell-like** tone, the remarkable easy regularity of the action, the deep resonance of the base, the timbre of the treble—note all this—then—

At the end of the 4 weeks' trial, if you wish, you may return the piano at our expense. We pay return freight to New York. Not a penny to pay for the pleasure of using the piano four weeks. No salesmen to influence you—you and you alone are to judge. Now write for the piano book (free).

Valuable Book on Pianos—Free

"The Book of Complete Information About Pianos"

The New York World says: "This is a book of educational interest everyone should own." Would you like to know all about pianos—how they are made, how to judge the fine points of quality and price in buying a piano? Then send the coupon for the piano book which we are sending **FREE** for the present. This book of 149 pages tells about materials, manufacture, assembling, patented devices and what they do, all about sound-board, action, case, in fact every detail connected with a fine, high-grade piano. Tells how to answer the arguments of piano salesmen. This magnificent 149 page book is a complete encyclopedia on the piano; the most complete and costly book ever published on the piano business.

(Est. 1868)

Wing & Son

We will also send free our beautiful catalog showing new art styles and full explanation of our rock-bottom prices on the Wing Piano.

Dept. 1193 Wing Building
9th Ave. & 13th St., New York City

We will take your old organ or piano in exchange at a liberal allowance. Get our offer.

Name.....

Address.....



Wing & Son

(Established 1868) Wing Bldg,
9th Avenue and 13th Street
Dept. 1193 New York

Gentlemen: Please send me free and prepaid "The Book of Complete Information About Pianos," the complete encyclopedia of the piano. Also send full particulars of your Rock-Bottom offer on the Wing piano and catalog of latest art styles.

Please Mention Popular Mechanics



Neolin Saves Money Neolin Saves Feet

YES, Neolin is better than leather—a fact apparent enough when leather was good—and increasingly apparent now that leather quality is *not*.

Particularly apparent, for instance, to those who can least afford to buy inferior leather—and who so invariably are forced to get it.

For Neolin is always the same—on a Ten Dollar Shoe—on a Three Dollar Shoe.

Offering the same wear, providing the same modern appearance-standard.

Remaining the same saver of your own and your children's shoe-bills.

Neolin the last-long sole—the waterproof and winter-proof sole. Neolin which is foot-easing, pliant, flexible, springy and needs no breaking in. Which never cramps a foot and never draws one. Which *does* grip. Which doesn't slip.

For grown-ups and children. On new shoes or for new soles. Retailers or shoe-repairers have Neolin Soles or can get them—and they cost no more.

To avoid imitations, *mark* that mark; stamp it on your memory: Neolin—

*the trade symbol for a never changing
quality product of*

The Goodyear Tire & Rubber Co., Akron, Ohio

Neolin

Trade Mark Reg. U. S. Pat. Off.

Better than Leather



Please Mention Popular Mechanics

Unparalleled Suit Offer

*Compare This Suit With Any
\$25 Suit You Ever Saw*

WE will tailor a suit *to your own measure* from your choice of the newest wools. *Get it on approval.* Compare it in every way with any \$25 suit that you ever saw. If you are not enthusiastic about—if you think its quality one particle less than you have been accustomed to get in \$25 or \$30 clothing, send it back at our expense.

Genuine
All-Wool
Serge **\$15.50**

But send the coupon now and get the benefit of our Spring opening prices—before prices go up. Others have already raised their prices. And we may be forced to raise our price at any time. Order now.

Write today for our Spring Style Book and see samples of the latest all wool fabrics from which you have to choose. Glenn Urquart Plaids, Tartan Plaids, Shepherd Plaids, fancy and pencil stripes, two-tone stripes—your choice of fabrics, plain or fancy weaves, rough finish or smooth—all tailored to your measure—at astounding prices.

Guaranteed All Wool!

There is not a cotton thread in any of our fabrics. We guarantee it. Nothing but pure wool and pure silk goes into fabrics from which Babson suits are made.

Three Months To Pay!

Don't decide to buy until you have seen the suit yourself and compared it with other high grade clothing. And, while you buy at the *direct* bargain prices, we also give you time on your payments. (Just as local dealers in your town give their best customers.)

Send the Coupon for Spring Style Book

Put your name and address on a letter or postcard and get our new colored Style Book and 44 large samples of the real cloth from which you have to choose. You will be delighted with the Spring Style Book. It is handsomely printed in full colors and with it goes large generous samples of the fabrics themselves. Send the coupon now for Spring Style Book. No obligations on your part.

Babson Bros., Dept. 1193 19th St., Chicago



Babson Brothers
Dept. 1193 19th St., Chicago

Gentlemen:—Please send me your free Colored Style Book 44 cloth samples of the real goods for suits. Also explain your easy terms.

Name.....

Address.....

FAIR LIST PRICES



FAIR TREATMENT

What "Cord" Means In GOODRICH SILVERTOWN CORD TIRES

TO settle exactly what the carelessly used, much abused term 'cord tire' really means, we have here stripped back the thick, tough tread of a Silvertown Cord Tire, and laid bare its flexible *two-ply, rubber-saturated, cable-cord* body.

Mark the sturdy *size* of the cord, and that it is *cross-wrapped round* the tire into a base of *two layers* Only.

As *each extra ply* in a tire means *extra* internal heat, which is the great tire destroyer. — Silvertown with but two plies is bound to outlast *many-ply* tires with their *multiplied* heat

Seek this durability with elegance, comfort, freedom from tire trouble, mileage, in Silvertowns marked with the RED-DOUBLE-DIAMOND. You *cannot afford* to be without them.

The B.F. Goodrich Company Akron, Ohio

*Also makers of the famous fabric tires
Goodrich Black Safety Treads*

10 Silvertown Cord X-cels

- | | | |
|------------------------------------|------------------|-----------------------------------|
| 1 Increased engine power. | 4 Speedier. | 7 Easier to guide. |
| 2 Smoother riding. | 5 Coast further. | 8 Give greater mileage. |
| 3 Fuel saving. | 6 Start quicker | 9 More resistive against puncture |
| 10 Repaired easily and permanently | | |

"Silvertowns make all cars high-grade"

Please Mention Popular Mechanics

Heat Your Home The Moistair Way!

Could Your Family Live in a Dry Kiln?

Hardly! Yet thousands exist under conditions *little better!*

Cold weather arrives. Doors and windows are shut *tight*. Fresh air is excluded. The heat is turned on—and the whole family hibernates! Now for a winter of hot, stuffy air—air with the dryness of a dry-kiln—unhealthy, dangerous! The air is breathed over and over! It fairly reeks with "dead" gases—poisonous, disease breeding. And then come coughs, colds, headaches, lung diseases, sickness, inefficiency—and the doctor.

Avoid all this! When you build or replace your present heating plant see that your heating system furnishes healthful air; that is, fresh, warm, moist air.. Install a

ROUND OAK Moistair Heating System

The Only Heating System that Automatically Ventilates and Humidifies

The Round Oak Moistair Heating System solves the heating problem for a lifetime! It floods your home with cheery warmth and comfort, regardless of outside blizzards. It cuts down your fuel bills—burns any fuel. It keeps your house free from dirt, dust and coal gas. It is convenient, cleanly, easy to operate—has nothing to ever get out of order. It sends an ever-changing current of warm *fresh* air circulating through the house. And besides all this, it Automatically humidifies—keeps the air both fresh and moist.

SAVES FUEL BY THE TON

Warm, fresh air properly humidified as it is by the Round Oak, is more comfortable at 68 degrees than dry air at 75 degrees. The saving of 7 degrees thus effected by the Round Oak Automatic Humidifier and other features listed opposite literally means a fuel saving of **one ton in every nine.**

Consider that more 60,000 Round Oak Systems are in use and that **every one**, so far as we know, is giving satisfaction. Reflect that they are backed by 46 years of experience and that they are made by the makers of the famous Round Oak STOVE—then

WRITE for VALUABLE FREE Book and Heating Plan

Handsome illustrated book describes this modern plant. With book goes a blank, which filled out and returned to us will shortly bring you a scientific Heating Plan drawn by expert engineers to meet your exact requirements. Cost of installation, etc., goes with Plan. And with no obligations to you. Send coupon NOW! With book we also send name of nearest authorized dealer selling and installing Round Oak Moistair Heating Systems. Many dealers sell on easy payments. To get the genuine, look for the trade-mark which shows the Round Oak Indian.

The Beckwith Co.

Round Oak Folks

Established 1871

44 Front Street,
Dowagiac, Mich.



Makers of Good
Goods Only.



Five Star Points of Round Oak Supremacy

- * **Health** Only Heating System that automatically ventilates and HUMIDIFIES.
- * **Comfort** Delivers pure, warm ever-changing moist air, free from dust, gas, smokes—fitted with gas-tight doors and dampers.
- * **Economy** Longest fire travel all inside casing; Improved hot blast **Rising** extra deep fire pot; extra large combustion chamber affords perfect combustion; most heat on minimum of fuel.
- * **Convenience** Simple regulator controls entire system. Self-cleaning. Ash pit dust-proof—seamless; fitted with sprinkler. Non-leak door, frame cast on—not belted. Easy to operate.
- * **Durability** Materials used withstand highest physical tests. All hinge pieces drilled, not cast. Never a bolt where a rivet will do! Tight fittings guaranteed. Good for generation of service.

Clip Coupon. Mail NOW!

The Round Oak Folks
44 Front St., Dowagiac, Mich.

Gentlemen: Without obligation, I would appreciate receiving your latest book, which fully explains the advantages of Round Oak Moistair Heating System.

Name

Address



ROBERTS MOTORS FOR BOATS

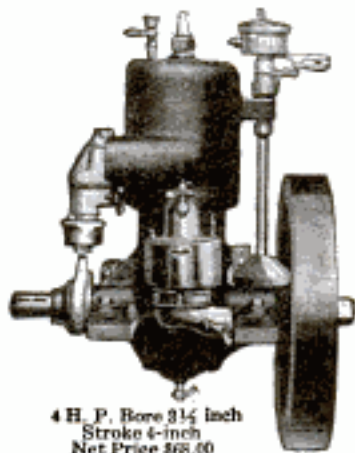

4 H. P. Bore $3\frac{1}{4}$ inch
Stroke 4-inch
Net Price \$68.00

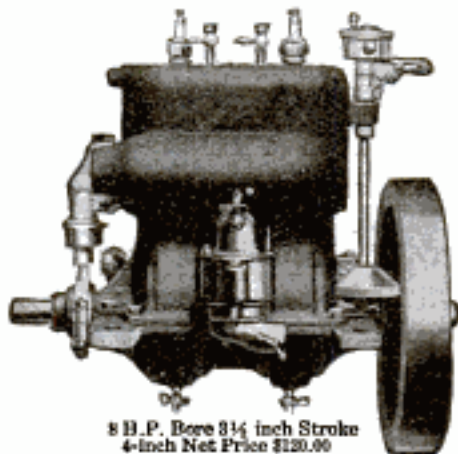

8 H. P. Bore $3\frac{1}{4}$ inch Stroke
4-inch Net Price \$120.00



16 H. P. Bore $3\frac{1}{4}$ inch Stroke
4-inch Net Price \$240.00

THREE new engines for 1917, more refined, more powerful but with Roberts Dependability built right into them. Neat, compact, extremely simple, the Roberts Motor is an ideal power plant for YOUR boat.

Ask Your Boatbuilder What He Thinks About Roberts Motors

He will give you expert advice, he has had an opportunity of comparing Roberts Motors with others, he has seen Roberts Motors in daily use for the past ten years. He will tell you that he is hardly ever called upon to replace a part of a Roberts Motor, that he does less repair work on Roberts Motors than any two others, despite the fact that there are more Roberts Motors in use in his district than any other.

In other words, he will prove with facts that the Roberts Motor is a dependable, powerful and simple motor to use in YOUR boat, a motor that is completely modern, quiet, free from vibration and absolutely reliable. Full details will gladly be supplied if you will write to the factory at Sandusky.

ROBERTS MOTORS

1700 ROBERTS BLDG.

SANDUSKY, OHIO



Don't Take Chances!

I own and operate the largest exclusive engine factory in the world selling direct to user.

ED. H. WITTE.

**My Prices are Lowest
On High-Grade Engines
My Terms are EASIEST**

GASOLINE ENGINES
2 to 22 H.P.

I save you \$25 to \$100, considering WITTE Engine construction. I save you weeks of waiting when you want an engine quick. I save you the trouble of "trying out" engines you know nothing about. I save you future trouble, because my past record of 30 years selling only high-grade engines is a guarantee in itself, that I will make good to you and to every buyer. I save you putting off buying by having four plans of purchase—Cash—Easy Payments—Bank Deposit or No Money Down, letting the engine you select earn its own cost.

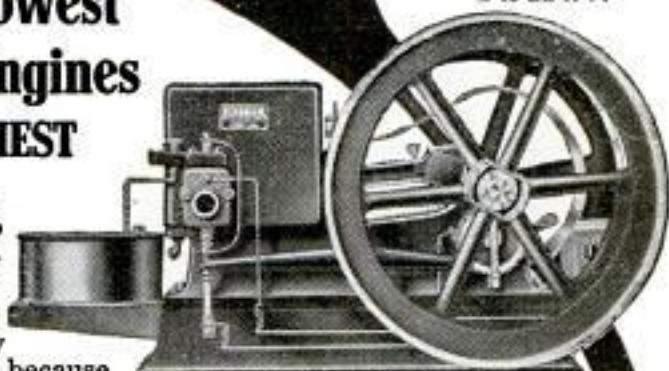

WITTE HIGH-GRADE ENGINES

Are Built to Operate on Kerosene, Gasoline, Naphtha, Distillate Oils, Natural or Artificial Gas.



KEROSENE ENGINES
2 to 22 H.P.

My engines are exclusive in design, different than any other engine sold direct, easy to understand and operate, and proven doubly desirable through 30 years of selling reliable engines for farm and shop power. I make nothing but engines—give you 100 per cent efficiency in engine building. I buy everything for cash. My factory equipment includes the finest engine making machinery obtainable, especially selected to reduce manufacturing cost. You take no more chance in buying an engine from me than in taking your money from one bank to another. The WITTE 5-Year Signed Guarantee has a million dollar factory back of it, and the factory has a definite future before it. Furthermore, if you want an engine at once,

**BUY
ON YOUR
OWN
TERMS**

ing your money from one bank to another. The WITTE 5-Year Signed Guarantee has a million dollar factory back of it, and the factory has a definite future before it. Furthermore, if you want an engine at once,

Write To WITTE

I can ship immediately—any size or style. Kerosene or Gasoline, Stationary or Portable. Don't make any mistake on the engine you choose, or the price you pay. Get my prices and terms. Try a WITTE 90 days. Learn just what a WITTE high-grade engine will do, and why the WITTE is better on account of better factory equipment, better workmanship, better materials, and sold on better terms.

Read my Free Book, "How To Judge Engines," which fully explains why and how I save you \$25 to \$100.—ED. H. WITTE,

WITTE ENGINE WORKS,

1746 Oakland Avenue,
1746 Empire Building,

Kansas City, Mo.
Pittsburgh, Pa.

FREE BOOK COUPON

ED. H. WITTE, WITTE ENGINE WORKS,
1746 Oakland Ave., Kansas City, Mo.
1746 Empire Bldg., Pittsburgh, Pa.

Please send me your Free Book,
"How To Judge Engines."

Name

Post Office

State

St. or R. F. D.

Please Mention Popular Mechanics

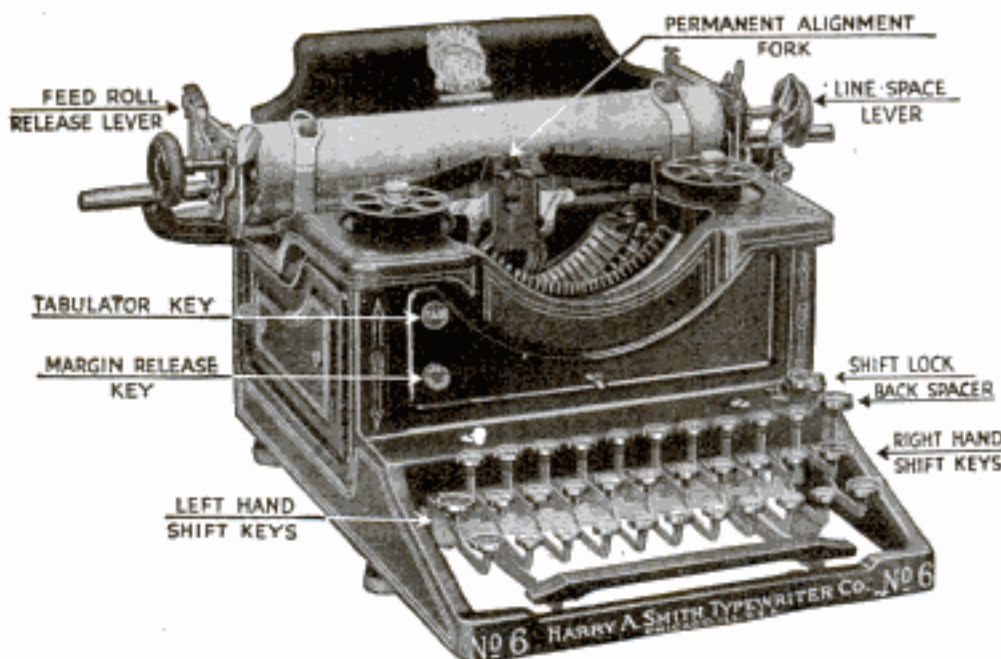

I want, through this advertisement, to establish as friendly business relations with you as I possibly can. I want you to realize also that it is my earnest effort and intention to give you full honest value for every dollar that you spend with me. This is the only way I can succeed. My advertisement has appeared in this magazine continuously for more than four years.

I am building up my business on the foundation of good value and square dealings. I am saving thousands of satisfied customers thousands of dollars, by supplying perfect—late style—visible writing—typewriters, at remarkably low prices.

All my transactions are handled throughout by personal correspondence. I assure you every courtesy and consideration in your dealings with me. Your order will have my prompt, careful, personal attention. I will be glad to do business with you.

Harry A. Smith

TYPEWRITER SENSATION

Free TRIAL—Use As You Pay

Send me only \$2.00 a month until the low total price of \$34.15 is paid, and the machine is yours

This is absolutely the most generous typewriter offer ever made. Do not rent a machine when you can pay \$2.00 a month and own one. Think of it—Buying a \$100.00 machine for \$34.15. Cash price, \$32.30. Never before has anything like this been attempted.

Standard Visible SMITH Model No. 6

Perfect machines, Standard Size, Keyboard of Standard Universal arrangement, writing 84 characters—universally used in teaching the touch system. The entire line of writing completely visible at all times, has the tabulator, the back spacer; in fact, every late style feature and modern operating convenience. Comes to you with everything complete, tools, cover, operating book and instructions, ribbon, practice paper—nothing extra to buy. You cannot imagine the perfection of this beautiful typewriter until you have seen it. I have a thousand of these perfect latest style Model No. 6 typewriters at this bargain price, and each purchaser fortunate enough to secure one of these beautiful machines must try it out in home or office for five days before deciding to buy. I will send it to you F. O. B. Chicago for five days' free trial. It will sell itself, but if you are not satisfied that this is the greatest typewriter bargain you ever saw, you can return it at my expense. You won't want to return it after you try it—you cannot equal this wonderful value anywhere.

H. A. SMITH
Room 510-231 N. Fifth Ave.
CHICAGO, ILL.

Ship me a No. 6 Smith F. O. B. Chicago, as described in this advertisement. I will pay you the \$28.00 balance of the SPECIAL \$34.15 purchase price, at the rate of \$2.00 per month. The title to remain in you until fully paid for. It is understood that I have five days in which to examine and try the typewriter. If I choose not to keep it I will carefully repack it and return it to the express agent. It is understood that you give the standard guarantee for one year.

You Take No Risk—Put In Your Order Now

When the typewriter arrives deposit with the express agent \$6.15 and take the machine for five days' trial. If you are convinced that it is the best typewriter you ever saw, keep it and send me \$2.00 a month until my bargain price of \$34.15 is paid. If you don't want it, return it to the express agent, receive your \$6.15 and return the machine to me. I will pay the return express charges. This machine is guaranteed just as if you paid \$100.00 for it. It is standard. Thousands and thousands of people own and use these typewriters and find them the best ever manufactured.

The supply at this price is very limited, the price will probably be raised when my next advertisement appears, so don't delay. Fill in the coupon today—mail to me—the typewriter will be shipped promptly. There is no red tape. I employ no solicitors—no collectors—no chattel mortgage. It is simply understood that I retain title to the machine until the full \$34.15 is paid. You cannot lose. It is the greatest typewriter opportunity you will ever have. Do not send me one cent. Get the coupon in the mails today—sure.

HARRY A. SMITH, 510-231 N. Fifth Ave., Chicago

Name

Address

Pop. Mech. Mar.

Please Mention Popular Mechanics

6 Months To Pay 6

Tailor-Made To-Measure

Send for Measurement Blank and Cloth Samples Today

This is the most sensational Tailor-Made Suit Offer ever made. You can now have any garment you want—cut and fit in the very latest style—to your individual measurements—and from your own choice of the season's latest patterns, novelties, checks, stripes, etc.—and take **six months to pay** for it, if, after trying it on, you decide to keep it.

Think what this means to you. No longer need you pay exorbitant cash prices for best Tailor-Made Clothes. We positively give you six months' credit and save you from \$15 to \$25 on any suit you may order. Furthermore, we will send you any suit you may want on receipt of

Only \$1.00

Send coupon for free Style Book which explains this wonderful offer. No matter what price, style or pattern suit you may want, we will make it to your order and send it to you on receipt of **only \$1**. After suit arrives and you are convinced that it is the biggest bargain you ever heard of, you may pay the balance of our rock-bottom price on easiest, most liberal credit terms ever devised.

Even if you don't need a suit of clothes right away, don't fail to send for this wonderful book. It gives inside facts about Tailor-Made Clothes that you should know. Tells you how to judge quality; how Stanley-Rogers Clothes are Tailor-Made of the best materials throughout—highest grade interlinings, body and sleeve linings, ivory buttons, carefully hand-sewed buttonholes, etc. Book also shows you how to take your own measurements to insure a perfect fit—and proves to you that we actually

Save You \$15 to \$25

on any garment you may order. We buy all materials in enormous quantities, direct from the mills, at rock-bottom prices. We do our own designing, cutting and tailoring. And by making every suit in our mammoth establishment and selling direct to the man who wears the clothes, we eliminate all waste and save you the dealer's profits.

\$1,000 Reward

We will give \$1,000 in gold to anyone who proves that we do not make to order all our men's clothes to individual measurements of each customer. We study your figure from the measurements you send us and meet your individual requirements so that, whether you be tall or short, stout or thin or "just medium," you will be fitted perfectly because each garment is specially made for each person.

Send This Coupon NOW

STANLEY-ROGERS COMPANY,
1015 Jackson Boulevard, Dept. 544 Chicago, Ill.

Please send me FREE, your new Spring and Summer Style Book showing latest Metropolitan Styles, also Cloth Samples and full particulars of your great \$1 down with 6-Months-To-Pay Offer.

Name.....

Address.....

Town..... State.....



Remarkable Tailor-Made Suit ONLY

\$14.³⁵

STYLE BOOK



STANLEY-ROGERS CO.

of cloth samples today—sure.

STANLEY-ROGERS CO.,
1015 Jackson Boulevard,
Dept. 544 Chicago, Ill.

Big Style Book and Cloth Samples Free

This is the big Fashion Book you must have if you want to see how to dress in the latest fashion at a big saving and on the easiest terms ever offered. Book shows page after page of men's garments designed by our own designers—a wonderful assortment of fabrics—the very cream of the weaves from foreign and domestic mills! Just imagine how swell you would look in a suit from one of our exquisite patterns when made up to your measurements. Mail coupon for wonderful Style Book and big assortment

Please Mention Popular Mechanics



House on Fresh Pond Parkway, Cambridge, Mass. Charles R. Greco, Architect, Boston, Mass.

ALL woods have certain uses for which they are especially adapted by reason of the peculiar qualities and characteristics which nature has given them; and on their proper selection for these uses, hinges the whole problem of economy in wood construction.

Three centuries of experience in this country have demonstrated that no other wood lasts as long or gives such satisfactory service as

WHITE PINE

for outside finish lumber—siding and corner boards; window sash, frames and casings; outside doors, door frames and casings; outside blinds; all exposed porch and balcony lumber; cornice boards, brackets, ornaments and mouldings; and other outside requirements, *not* including shingles.

If your lumber dealer is unable to supply White Pine, we should appreciate the opportunity of being helpful to you in securing it.

Address WHITE PINE BUREAU,
1326 MERCHANTS BANK BUILDING, ST. PAUL, MINN.

Representing
The Northern Pine Manufacturers'
Association of Minnesota, Wisconsin
and Michigan, and The Associated
White Pine Manufacturers of Idaho



"White Pine in Home-Building" is beautifully illustrated and full of valuable information and suggestions on home-building. Send today for this booklet—free to all prospective home-builders.

"The Helen Speer Book of Children's White Pine Toys and Furniture"—a fascinating children's plan book, from which a child may build its own toys and toy furniture. Prepared by Helen Speer, the toy expert. If there are children in your home, sent free on request.

Please Mention Popular Mechanics

No Money In Advance

Hartman's Grand Bargain Specials

To prove what wonderful values you get when you deal with the House of Hartman, we will send you any one of these specials without one cent in advance—without deposit—no C. O. D.—without references like other ask—without obligation of any kind. Our capital and resources of over \$12,000,000 and our enormous purchasing power enables us to buy entire factory and mill outputs. We have over 2,000,000 customers and do such an immense volume of business that we can and do sell our merchandise for a great deal less than you would ordinarily expect to pay for such high quality. Try the Hartman way and enjoy this advanced method of getting what you want on the most liberal credit terms ever devised.

5-Piece Dining Set Bargain

At our low bargain price and on such easy terms, most any home can now have a new dining set. To prove its real value we send the set without advance payment, security or references like others ask. Just send the coupon and we'll ship complete set or chairs or table only as desired. After 10 days' use pay only 50c on account or return at our expense.



CHAIRS—Order by No. MA275. Full box seat solid oak dining chairs, upholstered in guaranteed imitation Spanish leather. Has genuine quarter-sawn oak banisters and top slats. Seats 18x18 in., height of chair 37½ in. Your choice of golden oak gloss or fumed finish. Price \$1.95 each. Terms: 50c in 10 days. Bal. (4 or 6 chairs) 75c per month.

EXTENSION TABLE—Order by No. MA276. Solid Oak Mission Design Extension Table. 45 in. top—extends to 6 ft. Has Hartman easy-running slides. Base measures 7 in.—supported by 4 legs in popular mission style. Full set of solid oak leaves furnished. Golden oak gloss or fumed finish. Price only \$9.89. Terms 50c in 10 days. Bal. 75c per month.

COMPLETE SET AS SHOWN. Order by No. MA265. Choice of golden oak, gloss or fumed finish. Price only \$17.50. Terms: 50c in 10 days. Balance \$1.50 per month.

Only 50¢ in 10 Days

Brussels Rugs Special

Rug of beautiful design—in a rich, oriental medallion pattern. Colors are rich in tone, embracing a combination of shades with greens, tans and browns predominating. The worsteds used in its weaving present a surface that will render very fine service. A wonderful bargain—4 sizes.



Order by No. MA260.
Size 6x9 ft. Price \$11.75.
Terms: 50c in 10 days.
Balance \$1.00 per Month.
8 ft. 3 in. x 10 ft. 4 in. Price \$18.35. Terms: 50c in 10 days. Bal. \$1.50 per Mo.

State size wanted.
9x12 ft. Price \$19.65.
Terms: 50c in 10 days.
Balance \$1.50 per Month.
11 ft. 3 in. x 12 ft. Price \$26.85. Terms: 50c in 10 days. Bal. \$2.00 per Mo.

42-Piece Aluminum Ware Bargain

Just mail coupon and we will immediately ship you this wonderful 42-piece Aluminum Set for free trial. Each piece thoroughly guaranteed—is seamless—will not scald, chip or crack. Complete set comprises 9 piece Combination Outfit consisting of 2-piece self-basting roaster, pierced tray with 5 egg poachers or custard cups and dairy pan; 7-cup Coffee Percolator with inset (2 pieces); 6-qt. Preserving Kettle; 2 Bread Pans; 2 Pie Plates; 1-qt. Lipped Sauce Pan; 2-qt. Lipped Sauce Pan; 1 Ladle; 2 Jelly Cake Pans with loose bottoms (4 pieces); 1 Caster Set, consisting of salt and pepper shakers, toothpick holder and frame (4 pieces); 1 Measuring Cup; 1 Combination Funnel (6 pieces); 3 Measuring Spoons; 1 Tea and Coffee Strainer; 1 Sugar Shaker; 1 Grater; 1 Cake Turner; 1 Lemon Juice Extractor.



Complete 42-Piece Set. Order by No. MA261. Price \$9.95. Terms: No Money In Advance. 50c in 10 days. Bal. 75c per Month.

Wonderful Bargain Book FREE

Filled with thousands of wonderful bargains in Home Furnishings, all sold on the Hartman Liberal Credit Plan, backed by the \$12,000,000 Hartman Guarantee. Book shows articles exactly as they look—Furniture, Carpets, Cloaks, Draperies, Silverware—everything for the home. We send it to you FREE—whether you buy direct from this page of "get-acquainted" offers or not. Send for it today.

HARTMAN FURNITURE & CARPET CO.
3945 Wentworth Ave., Dept. 270 Chicago

Mail This Coupon

Hartman Furniture & Carpet Co.,
3945 Wentworth Ave., Dept. 270 Chicago, Ill.

Without any money in advance, please send me article named below. If I keep it, I will pay 50c in 10 days after arrival of shipment and balance in monthly payments as per price and terms quoted in this advertisement. If I decide not to keep it, I will return it to you at your expense.

Name of article wanted..... No.....

My Name is.....

Address.....

If Catalog only is wanted, write "Catalog Only" on blank line above, fill in name and address and mail coupon today.

HARTMAN WILL TRUST YOU

Please Mention Popular Mechanics



FIGHTING TRIM

WHETHER your battle is fought in the trenches, behind an office desk or in the home *you need to keep fit.*

It's comparatively easy for the soldier to keep up to scratch. The civilian—man or woman—has a harder task. Sedentary habits, insufficient exercise, too much food and too much hurry about eating it, combine to cause a more or less chronic condition of constipation.

Don't think you can dispose of constipation with a cathartic pill. Laxatives and cathartics cause more constipation than they cure and their persistent use is likely seriously to undermine your health.

NUJOL relieves constipation effectively and has none of the objections which are common to all drug remedies. It acts as an internal lubricant, preventing the bowel contents from becoming hard and facilitating the normal processes of evacuation.

NUJOL, put up in pint bottles only, is sold at all drug stores. Refuse substitutes—look for the name NUJOL on bottle and package.

Dept. 68

STANDARD OIL COMPANY
(New Jersey)

Bayonne New Jersey

NUJOL

FOR CONSTIPATION

Send for booklet, "THE RATIONAL TREATMENT OF CONSTIPATION." Write your name and address plainly below.

Name Address City State

Please Mention Popular Mechanics

\$100 Model UNDERWOOD

WITH BACK SPACER—TWO
COLOR RIBBON AND TABULATOR

FOR

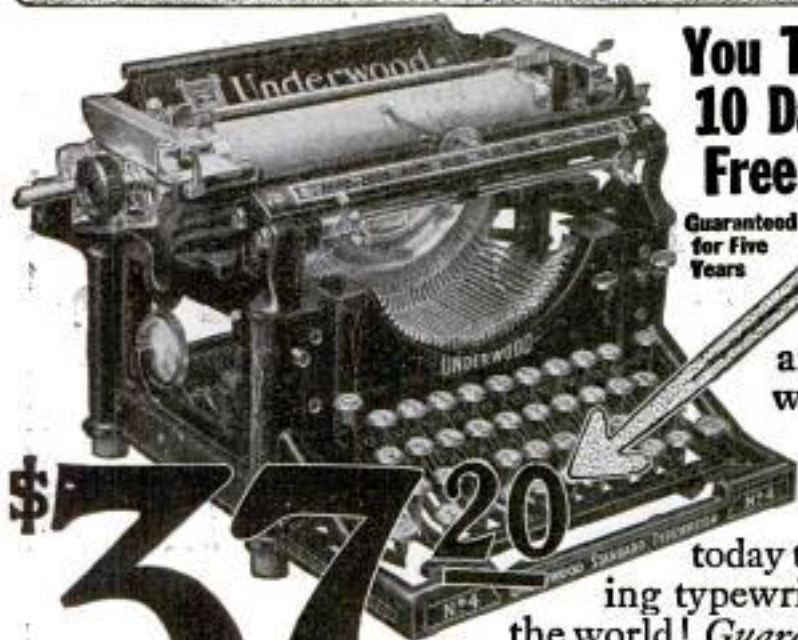

**You Try It
10 Days
Free**

Guaranteed
for Five
Years

**Think What
You Can Get
Now for \$37.20**

A genuine No. 4 Underwood—the standard visible typewriter, with back spacer, two-color ribbon and tabulator—*complete* with waterproof cover, new ribbon and special touch typewriting instruction book—the machine that is

today the leading typewriter of the world! *Guaranteed* to be delivered in perfect condition! Fully guaranteed for five years.

You May
RENT APPLYING RENT ON PURCHASE PRICE
OR
BUY FOR CASH OR ON EASY PAYMENTS

'Way Under 1/2 Manufacturer's Price

Moreover, you don't have to buy it to try it! We will send one to you on Ten Days' Free Trial. Write all you please on it for ten days and then if you are not *perfectly* satisfied, send it back at *our expense*. What's more, if you do not care to buy, you may rent it at our low monthly rates. If later you want to own it, we will apply *six months'* rental payments on the low purchase price. Any national bank in Chicago, or any Dun's or Bradstreet's Agency anywhere will tell you that we are responsible. Learn *all* the facts about this remarkable offer. Write us today—send us your name and address on the attached coupon—or a post card. Ask for Offer No. 52

Our Other Plan Brings You This Underwood

This is a new plan—Our Agency Plan. You are not asked to do any canvassing—no soliciting of orders. You simply co-operate with us. Become one of our nation-wide organization. You can easily get your Underwood *free* by this new plan. Write tonight—send your name and address on the coupon or a post card and learn all about Offer No. 52

FREE

Typewriter Emporium, 34-36 W. Lake St., Chicago
Established for a Quarter of a Century

Send me *immediately* full facts about your Offer No. 52

Name _____
St. or R.R. No. _____
City _____
State _____

Please Mention Popular Mechanics

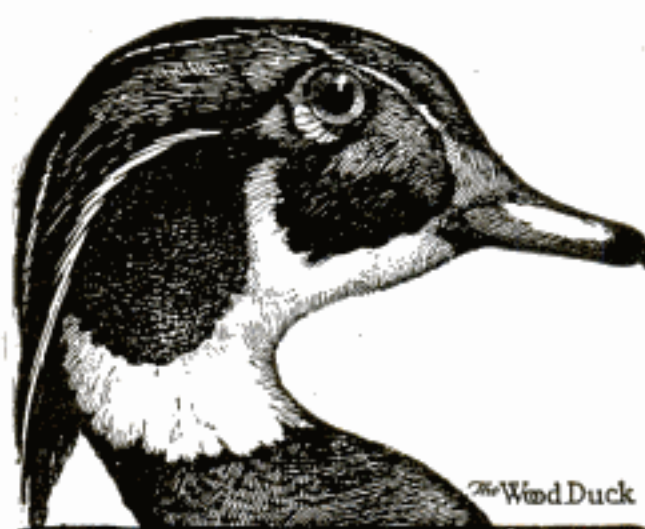

The Wood Duck

Become a Game Farmer

Write for these two books which tell all about this interesting and profitable work. "Game Farming for Profit and Pleasure," is sent free on request. It treats of the subject as a whole; describes the many game birds, tells of their food and habits, etc. "American Pheasant Breeding and Shooting," is sent on receipt of 10c in stamps. It is a complete manual on the subject.



HERCULES POWDER CO.

1025 Market Street
Wilmington Delaware



B-E-T-T-E-R MUSIC

Williams' Sounding Board

Placed under record on any disc phonograph.

SEND \$1.50 TO

O. B. WILLIAMS CO., Seattle, Wash.
U. S. A.
Manufacturers Sash and Doors.

BUILD YOUR OWN GRANDFATHER'S CLOCK WITH OUR HELP

We furnish blue prints, finishing material and instructions. Buy the works, dial, weights and pendulum from us at surprisingly low prices. You make a fine profit building artistic clocks for your friends.

Complete Works \$5.00. Others with Chimes at all prices. Ask for our attractive Free Offer
CLOCK CO., 1673 Ruffner St., Philadelphia, Pa.



HERMAN'S U.S. ARMY SHOES

Munson Last

Demonstrated by the Army of Defense — adopted by the

"Army of Industry"

From private to General no U. S. Army man is permitted to wear in service any other shoe than

The Munson Last

Thousands of civilians buy the shoe from us or from our dealers and obtain foot comfort almost beyond belief. Wear Herman's Munson yourself and forget you have feet.

Write for the name of a Herman dealer near you. Or you can buy from us by mail — fit and satisfaction guaranteed. Munson's, black or tan.

Catalog of All Styles

FREE — Write for it.

Jos. M. Herman Shoe Co.
Army Contractors
1000 Albany Bldg.
Boston, Mass.



COIN RINGS 50 Cents POST PAID

Made of dimes, beautifully embossed. Big hit! Agents, big discount. Send for circular, coin jewelry.

WM. COMERFORD, 44 Seneca St., BUFFALO, N. Y.

HEALTH—BEAUTY—VIGOR

Health, beauty and vigor are now yours. The body can be kept active and vigorous by proper use of vibrator. Nothing restores and keeps the whole system in such prime condition as regular use of Nu-System Vibrator in home or office. Ten minutes daily does trick. It rests and invigorates tired and overworked people, restores to health the nervous and sickly, and is sold at a price within the reach of all.

\$15.00 Nu-System Electric Vibrator \$9.85
Special Introductory Price 9

Something entirely new, electrically operated, is clean, light weight (made of aluminum) will last a life time. No motor, no wear, no oiling, no care. Only one moving part. So simple a child can operate. Does the work of a \$75 vibrator. Is absolutely safe. Guaranteed for a year but will never wear out.

SPECIAL 30 DAY FREE TRIAL OFFER

We have enough materials to make this 30 day free trial offer to those who act quickly. Regular price is \$15.00, special price \$9.85. Send money order today, or write for literature and Special 30 Day Free Trial Offer. Don't delay.
NU-SYSTEM VIBRATOR CO., 23 Butler Bldg., Detroit, Mich.

WHENEVER you see a bicycle equipped with **KOKOMO** Tires you'll know that the owner wanted the best — knew the best — and got it! Ask your dealer for **KOKOMOS**.
KOKOMO RUBBER CO.
Kokomo, Ind.

LONG-LIFE
Kokomo
BICYCLE TIRES

Our 21 Jewel SMASHES PRICES



Every fighting vessel in the U. S. Navy has the Burlington Watch aboard. Many have over 100 Burlingtons—a few over 200. This includes every torpedo boat—every submarine as well as the big Dreadnaughts.

Send Your Name on This Free Coupon

Get the Burlington Watch Book by sending this coupon now. You will know a lot more about watch buying when you read it. You will be able to "steer clear" of the over-priced watches which are no better. Send the coupon today for the watch book and our offer.

Burlington Watch Co.

19th St. & Marshall Blvd., Dept. 1193, Chicago, Ill.

Look!

- ☞ 21 Ruby and Sapphire Jewels—
- ☞ Adjusted to the second—
- ☞ Adjusted to temperature—
- ☞ Adjusted to isochronism—
- ☞ Adjusted to positions—
- ☞ 25-year gold strata case—
- ☞ Genuine Montgomery Railroad Dial—
- ☞ New Ideas in Thin Cases.

Only \$2.50 A Month

And all of this for \$2.50—only \$2.50 per month—a great reduction in watch prices—direct to you—positively the exact prices the wholesale dealer would have to pay. Think of the high-grade, guaranteed watch we offer here at such a remarkable price. And, if you wish, you may pay this price at the rate of \$2.50 a month. Indeed, the days of exorbitant watch prices have passed.

See It First

You don't pay a cent to anybody until you see the watch. You don't buy a Burlington Watch without seeing it. Look at the splendid beauty of the watch itself. Thin model, handsomely shaped—aristocratic in every line. Then look at the work! There you will see the masterpiece of the watch makers' skill. A perfect timepiece adjusted to positions, temperature and isochronism.

Burlington Watch Co.

19th Street and Marshall Blvd.
Dept. 1193 Chicago, Ill.

Please send me (without obligation and prepaid) your free book on watches with full explanation of your cash or \$2.50 a month offer on the Burlington Watch.

Name.....

Address.....

Last chance at old prices—date prices go up will be announced—write at once for catalog.

Please Mention Popular Mechanics

NATIONAL Gets Big Hatches

Peter Kilpatrick, Nazareth, Pa., writes, "Have made better hatches than anyone here."

Money cannot buy greater hatching value

Hot water heat—double wall—dead air space—asbestos lining—self regulating—ventilating—double glass doors—safety lamp—egg tester. **No extras to buy—easy to operate—will not warp or shrink.** Strongest, most durable incubator made.



40 DAYS' TRIAL
12 Years' Guarantee

Freight Paid East of Rockies

Take no chances. The National is built on U. S. Government specifications. A proven cold weather hatcher. The World's Greatest Incubator Bargain. Send postal today for **Free 1917 Catalog and Poultry Book**—worth dollars to every poultry raiser—or order direct from this ad and save time. **Incubator and brooder both prepaid \$12.50.** Comes set up ready to run, with book of instructions. You take no risk, **satisfaction guaranteed or money refunded.** Don't delay. **SEND FOR POULTRY BOOK TODAY SURE.**

NATIONAL INCUBATOR CO., Box 155, Racine, Wis.

Greider's Fine Catalogue
of fine bred poultry for 1917; 67 breeds illustrated and described; information on poultry, how to make hens lay, grow chicks—all facts. Low price on stock and hatching eggs. Incubators and brooders. 25 years in business. This book only **10 cts.** *Send today.*
R. H. GREIDER, Box 19, RHEEMS, PA.

\$8.55 **World's Champion**
BUYS Belle City Incubator
140-Egg Size—Hot Water—Double Walled—Self-Regulated—with **\$4.85** Hot-water 140-chick Brooder—both **\$12.50.** Freight Paid East of Rockies. **Satisfaction Guaranteed.**
\$1000 in Prizes
Conditions easy—Save time—Order Now. Write for Free Book "Hatching Facts" today. A postal will do. **Jim Rubin, Pres.**

Belle City Incubator Co., Box 164, Racine, Wis.

How to Get 640 Acres One Mile Square—FREE— From Your Uncle Sam

The Great Divide, the National Land Paper of America, in every issue contains all that you need to know about the new 640-acre grazing homestead act. Experts edit every department. Most valuable paper in the U. S. if you want free government homestead. All necessary legal blanks for filing and copy of 640-acre law and one year's subscription—52 issues—for 50 cents in the U. S.; \$1.00 in Canada.

THE GREAT DIVIDE, 200 Post Bldg., Denver, Colo.

20 New Features That Assure Bigger Hatches!

Get Free Book. Learn all about the 1917 X-Ray Incubator. Five improvements absolutely new in incubator design. Ask for 1917 Book No. 82.



X-RAY INCUBATOR CO.
Box 82 Des Moines, Ia.

Express Prepaid

Please Mention Popular Mechanics

\$5 Starts You Raising Poultry

The wonder of the poultry world. A neat, all-steel, mechanically correct incubator. Fifty egg capacity—hatches as large a percentage of eggs as any high priced machine.

BABY GRAND INCUBATOR

is built with the same care as our world-famous Old Reliable. Has double top, thoroughly insulated, double walls, positive heat and moisture regulation, perfect ventilation. Sent ready to start, by parcel post or express, charges paid, on receipt of \$5 cash, check or money order. This machine will surely satisfy you. Requires little attention. Write for it today. Write for big illustrated catalog.

RELIABLE INCUBATOR & BROODER CO.
Box B-81, QUINCY, ILL.

SHOEMAKER'S BOOK ON POULTRY



and Almanac for 1917 has many colored plates of fowls true to life. It tells all about chickens, their prices, their care, diseases and remedies. All about incubators, their prices and their operation. All about poultry houses and how to build them. It's an encyclopedia of chickendom. You need it. **ONLY 15c.**

C. C. SHOEMAKER, Box 1107, Freeport, Ill.

RAISE GUINEA PIGS
Big Demand Thousands needed weekly. Government figures show a profit of \$9.00 each annually. Experience or special knowledge unnecessary. Send for our money making proposition and big free illustrated book which explains all.
Laboratory Supply Co., Dept. B, 2841 Ridge Ave., Phila., Pa.

Lassen Peak, commonly referred to as Mt. Lassen—the only semiactive volcano in the United States—should properly be called by the former name, since the mountain and surrounding territory was officially known as Lassen Peak National Monument and Lassen Peak National Forest, recently combined into Lassen National Park.

POULTRY PAPER

44-124 PAGE periodical, up-to-date; tells all you want to know about care and management of poultry for pleasure or profit. **Four months for 10 cents.** **POULTRY ADVOCATE, Dept. 98, SYRACUSE, N. Y.**

HOW TO MAKE POULTRY PAY Our latest book fills the bill. Your success assured. We also want you to see our fine poultry paper. Sold on all First-Class News-Stands. Send 10c today for 4 months' trial subscription. Regular price 50c a year. Address **Inland Poultry Journal, 30 Card Bldg., Indianapolis, Ind.**

BEES PAY BIG PROFITS
Raise your own honey. We start you right. Send today for Bee Supply Catalog. Sent **FREE.**
DADANT & SONS Box 50 HAMILTON, ILL.

DON'T KILL or SELL YOUR LAYING HENS

The Potter System is the greatest discovery of the century. It tells you **How to Pick the "Layers"** from the loafers or diseased hens. Used by over 50,000 poultrymen. Simple and certain. Save food and build up a flock of all layers. New 100 page Potter System Book explains it. Circular free.

POTTER & CO., 70 Forest Ave., Downers Grove, Ill.

Profit With Chickens

A sure income, pleasant work. Get Johnson's Book—the A B C of poultry profits; tells all.

OLD TRUSTY
Incubator, 700,000 in use. Long trial, small price, big hatches in any weather. Write for **FREE** book today.
M. M. Johnson Co., Clay Center, Neb. **We Pay the Freight**





THIS Cut Coal Cost \$ 50.00 HERE



With a Great Deal More Comfort Into the Bargain!

Open space all around this big 10-room house. And in a part of the country where the mercury tries to drop clear through the glass in winter. Makes no difference to the Williamson UNDERFEED, though. A fifty dollar coal-saving and more comfort in spite of it all. Read the letter:

*"Mine is a ten-room house, and always cost me over \$100 to heat with the old boiler. This winter cost \$50 with the UNDERFEED, and we had a great deal more comfort, 72 or over in the coldest weather. A fuel saver, time saver and dirt saver."
(Signed) DR. W. J. MORGAN, Mineral Point, Wis.*

WILLIAMSON UNDERFEED Furnaces Boilers Cut Coal Bills $\frac{1}{2}$ to $\frac{2}{3}$ Guaranteed

Please let this fact sink in: A $\frac{1}{2}$ to $\frac{2}{3}$ saving in coal cost is actually guaranteed with the Williamson UNDERFEED, whether you heat with warm air, hot water, steam or vapor.

That is partly because the UNDERFEED burns the cheaper grades of coal as effectively as others burn the costlier grades. That's a big saving at the very outset—money you save by keeping it in your pocket. Another reason is the scientific principle of combustion. In the UNDERFEED coal is fed from below. The hot, clean fire is always on top—never smothered or chilled by fresh coal being dumped on. All smoke, soot and gas must pass up through the fire and so be transformed into clean, usable, effective heat.

No waste whatever. No clinkers. No partly burned coal. No soot-encrusted pipes.

Money-Saving Book Free

And a boy of twelve can operate the UNDERFEED successfully. No stooping. All done from a standing position. There's an interesting book, "From Overfed to UNDERFEED," which pictures and describes it all. Free for the asking. Simply send coupon. It will save you many a dollar when you come to install that new heating system. Remember, $\frac{1}{2}$ to $\frac{2}{3}$ coal cost actually guaranteed with a Williamson UNDERFEED. Send the coupon, now.

THE WILLIAMSON HEATER CO.
35 Fifth Avenue CINCINNATI, O.

THE WILLIAMSON HEATER CO.

35 Fifth Avenue, Cincinnati, O.

Tell me how to cut my coal bills from $\frac{1}{2}$ to $\frac{2}{3}$ with a Williamson UNDERFEED.

Warm Air..... Steam or Hot Water.....
(Mark X after System interested in.)

Name.....

Address.....

My Heating Contractor's Name is.....

Heating Contractors: Let us tell you about the Williamson UNDERFEED and our new proposition. Both are winners.

36278 \$150.
36043 \$100.
36254 \$50.
36226 \$25.
36071 \$55.

36034 \$45.
Beautiful Genuine DIAMONDS \$2.00 a month
ON CREDIT—NO MONEY DOWN—FREE EXAMINATION
YOU DON'T PAY A CENT until you see and examine the article. If perfectly satisfactory, pay 1-5 of purchase price and the balance in 8 equal monthly payments. If not entirely satisfactory, return at our expense. A guarantee certificate as to quality with each diamond. Exchange at any time at an INCREASE OF 7 1-2 PER CENT. MORE THAN YOU PAID
Send for free catalog DeLUXE No. 6 containing over 1000 illustrations of diamonds, watches, silver ware and other gift articles. Make a selection either for yourself, friend or loved one. We will send the article for your examination all fully prepaid. You assume no responsibility and are under no obligations. Everything at rockbottom prices direct to you. Send for catalog today. It's Free.
L. W. SWEET & CO., Inc., Dept. 6
2-4 MAIDEN LANE, NEW YORK CITY
THE WORLD'S GREATEST DIAMOND MERCHANTS

36030 \$25.
36184 \$100.
36055 \$300.
36211 \$90.
36080 \$100.

Please Mention Popular Mechanics

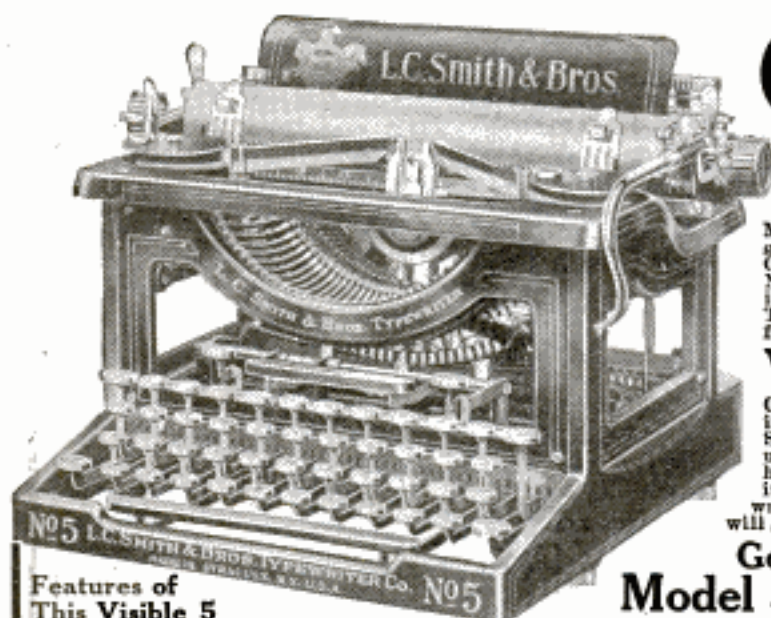

Features of This Visible 5

Include—Ball bearing throughout, Typewriter segment shift, rigid carriage, Automatic ribbon adjustment, Flexible paper feed, Lighting escapement, Elastic key touch, Inbuilt tabulator and biller, Marginal release key, Automatic paper fingers.

Easy Payments—Save \$36—30 Days' Trial

You are the sole judge of the merits of this Model 5. Write on it 30 days. Return it at our expense if you are not convinced of its superiority. Small monthly payments and a saving of \$36. This we guarantee. You assume no obligation by sending this coupon now for our introductory offer.

Larkin Co. Desk TPM-317, Buffalo, N. Y.

Please tell me about the Model 5 L. C. Smith Typewriter and quote the "special" Introductory Factory-to-Family price.

Name.....

Address.....

6 Railroads Use This Typewriter

These great railway systems each use from 250 to 500 Model 5 L. C. Smith Visible Typewriters. When such great railroads as the Baltimore & Ohio, C. M. & St. Paul, Chicago & N. W., C. B. & Q., Chicago, B. I. & P. and the N. Y. Central adopt this Typewriter, need you go farther in your search for a modern, dependable writing machine? Their work requires a Typewriter of great efficiency; they found it in this Model 5 which we now offer to you.

We Use 500 Visible 5's

Our own nation-wide Factory-to-Family business requires in serving our two million customers 500 Model 5 L. C. Smith's in our correspondence departments. We have used this Typewriter exclusively for years. We know how it responds to every conceivable demand made upon it by modern business. Therefore we offer you a Typewriter in this Model 5 which our own experience tells us will give you absolute satisfaction.

Get the Introductory Price On Model 5 L. C. Smith Typewriters

In the brief time which has passed since we contracted with the Model 5's makers to distribute this Typewriter throughout the United States on a Factory-to-Family plan, we have found Typewriter users eager to learn of our money-saving plan and to accept it. We want some one in every community to soon have a Model 5. To that person we will name for introductory purposes a "special" Factory-to-Family price. Ask today for that "special" price and all the details of this genuine factory-rebuilt Model 5 L. C. Smith. You will appreciate so much the bargain gotten in this Typewriter that you will gladly recommend our offer to your friends. Hence the "special" price.

100 New 5's Made Each Day

More than a million Typewriters have been made by the makers of the Model 5. They are makers of long experience. Each day they make 100 new Model 5's. Here then, in the factory-rebuilt Model 5 we offer you, is a down-to-the-minute Typewriter. Tens of thousands of this same Model 5 are in daily use by scores of America's greatest institutions. Get the price and terms on the Model 5.

SPECIAL — Model 2's at \$45.30



Old Violins



A Rare Opportunity

We have received some fifty exceptional old masters, ranging from \$75 to \$750. These are remarkable values.

Write for our complete list comprising some of the most famous old instruments in the world.

The Rudolph Wurlitzer Co.

Dept. 1193 E. 4th St., Cincinnati, O. S. Wabash Ave., Chicago

IF IT ISN'T

AN EASTMAN

IT ISN'T A KODAK



ONLY THING FOR THE DEN

Here's where you find all the curios and odd things hung upon the walls. By using

MOORE PUSH-PINS

and Push-less Hangers, you can fill every inch of wall space with Prints, Pictures, Knickknacks of every description, without defacing the walls. Suggestions and samples free.

Moore Push-Pins. Made in 2 sizes
Glass Heads, Steel Points

Moore Push-less Hangers. 4 sizes
The Hanger with the Twist

10c pkts.
EVERYWHERE
OR BY MAIL

MOORE PUSH-PIN CO., Dept. 36, Philadelphia, Pa.

Red or Black "Vulcan" Ink Pencils

The ONLY perfect, non-leakable ink pencils at moderate prices.

Two Sizes—
4 1/4 and 5 1/2 inches.
Extra Size—8 inches
(black only) \$1.25.
Your name in gold inlay 35c.
FREE—liberal supply of ink with retail orders. Agents Wanted. Big Profits.

Order today \$1

J. G. ULLRICH & CO., 27 Thames St., New York

SUPERIOR SINCE 1904

Over 100,000 in Use

Mostly sold through recommendation. For PERSONAL DESK or GENERAL OFFICE. It checks mental calculations. Buy through your Stationer. Write for 10-day trial offer.

E. GANCHER, A. A. M. CO.
148 Duane Street, NEW YORK

AGENTS WANTED

Golden Gem
PORTABLE \$10
Adding Machine

Multiplies—Subtracts

Deafness Is Misery

I know because I was Deaf and had Head Noises for over 30 years. My invisible Anti-septic Ear Drums restored my hearing and stopped Head Noises, and will do it for you. They are Tiny Megaphones. Cannot be seen when worn. Easy to put in, easy to take out. Are "Unseen Comforts." Inexpensive. Write for Booklet and my sworn statement of how I recovered my hearing.

A. O. Leonard, Suite 226, 150 5th Ave., N. Y. City

A Profitable Vocation

Learn to letter Price Tickets and Show Cards. It is easy to do rapid, clean-cut lettering with our improved Lettering Pens. Many persons make good money by lettering price tickets and show cards for the smaller merchant, outside of regular working hours. Practical lettering outfit consisting of 3 Marking and 3 Shading Pens, 2 colors of Lettering Ink, sample Show Card in colors, instructions, figures and alphabets, Prepaid \$1.00.

Practical Compendium of Commercial Pen Lettering and Designs

100 pages, 8x11, containing 122 plates of Commercial Pen alphabets, finished Show Cards in colors, etc., also large list of crisp business Advertising Phrases—a complete instructor for the Marking and Shading Pen. Prepaid, \$1.00. Catalogue free. Address,

NEWTON AUTOMATIC LETTERING PEN CO., Dept. A, Pontiac, Mich., U.S.A.

TRADE MARK



A Pencil Directed the Joining of the Atlantic and Pacific

A good pencil is more than an instrument. It is the director-general of hundreds of men.

DIXON'S ELDORADO

"the master drawing pencil"

insures good, clean working plans. The lines are clear and do not smudge. It is long-wearing and saves time and money. Made in seventeen degrees. Send 14c in stamps for samples worth double the money.

JOSEPH DIXON CRUCIBLE CO.
Dept. 10-J, Jersey City, N. J.

DIXON'S BEST WHITE N° 352
writes white on blueprints



BECOME AN EXPERT ACCOUNTANT

The Profession that Pays Big Incomes

Never before have there been so many splendid opportunities for trained accountants—men whose training combines a knowledge of Auditing, Cost Accounting, Business Law, Organization, Management and finance. Few professions offer better opportunities to young men of ambition and intelligence. The tremendous business growth of this country has created a rich field for the expert. There are only 2,000 Certified Public Accountants to do the work of the half million concerns needing their services. The expert accountant is also needed today in every big executive organization.

Knowledge of Bookkeeping Unnecessary To Begin

If you are ambitious, we will train you for one of these big positions. Our course and training is under the personal supervision of William Arthur Chase, Ex-President, National Association of C. P. A. Examiners, Ex-Secretary Illinois State Board of Accountancy, and other experts who rank among the highest who will give you whatever training, instruction or review on the subject of bookkeeping you may personally need—and without any extra expense to you. Our big, free book on the accountancy profession fully explains how we train you from the ground up, according to your individual needs, from the simplest bookkeeping principles to the most advanced accounting problems. All text material supplied in the course has been especially prepared in clear, easy-to-understand language, so you can readily master the principles by home-study.

Small Cost—Easy Terms

Mail the coupon now and get our free book which fully describes our expert training course and tells all about our Money-Back Guarantee, C. P. A. examinations, state regulations, salaries, and incomes, and how you can qualify for a high-grade accounting position without interference with your present job. Send in the coupon and find out how we have helped over 100,000 ambitious men, and learn what we can do for you.

Remarkable Book FREE

A prominent Chicago Executive says: "Get this book (Ten Years' Promotion in One), even if it costs you \$5.00 for a copy." Let us send it to you FREE, with literature explaining how you can train for a Higher Accountancy job without interference with your present duties. Send coupon today—NOW.

La Salle Extension University,
Dept 364-HA Chicago, Ill.
"World's Greatest Extension University"

TEN YEARS' PROMOTION IN ONE

Free Book Coupon

La Salle Extension University, Dept. 364-HA Chicago
"World's Greatest Extension University"

Send at once, without cost or obligation to me, your valuable book, "Ten Years' Promotion in One," also your book of accounting facts and full details of your course in Higher Accountancy. Advise me about Special Reduced Rate and Convenient-Payment Plan.

Name.....

Street and No.....

City..... State.....

Please Mention Popular Mechanics

BIG CHANCE FOR AGENTS



You can earn BIG MONEY

selling the most complete line of guaranteed transparent handle Knives and Razors with Photo, Name and Lodge Emblem—also full line of cutlery. Write today for catalogue and terms. Golden Rule Cutlery Co., 212 N. Sheldon St., Dep. 355, Chicago, Ill.

TYPEWRITERS SAVE FROM \$25 to \$75

Up-to-date machines of standard makes—Remingtons, etc., thoroughly rebuilt, trademarked and guaranteed the same as new. We operate the largest rebuilt typewriter factories in the world. Efficient service through Branch Stores in leading cities insures satisfaction. Send for catalogue.

American Writing Machine Co., Inc., 339 Broadway, N. Y.



Don't Wear a Truss

Brooks' Appliance, the modern scientific invention, the wonderful new discovery that relieves rupture will be sent on trial. No obnoxious springs or pads.

Brooks' Rupture Appliance

Has automatic Air Cushions. Binds and draws the broken parts together as you would a broken limb. No salves. No lies. Durable, cheap. Sent on trial to prove it. Protected by U. S. patents. Catalogue and measure blanks mailed free. Send name and address today.

C. E. BROOKS, 126 State St., Marshall, Mich.



You Take No Risk

This Razor is
GUARANTEED FOR LIFE

This Shumate "Barber" razor is so good that we dare guarantee it to you for life. Here's the reason—the blade is made from Tungsten Alloy Steel, which takes a keener edge than any ordinary steel can—and it holds it. You can use it for years without honing. The secret of this wonderful steel is *ours* alone, and we guard it jealously.

Here's our *unqualified guarantee*: Buy a Shumate "Barber" razor and use it—not once, but as long as you like. If you say after an exacting trial that you don't like it, we'll exchange it *without a word*.

Sent postpaid, \$2.00

In remitting, mention your dealer's name, and a chamois lined, rust-proof case will be included with your razor.

State whether you want light, medium or heavy blade. Heavy blade for very strong beards.

Established 1884
Output 6,000 razors daily

Shumate Razor Co., 721 Locust St., St. Louis, U. S. A.

You clean them
instantly



Say
good-bye
to laundry bills

CHALLENGE CLEANABLE COLLARS

Made of cotton cloth—not starched but waterproofed. Stitched edge finish. All that a "linen" collar is, and more. Rain, snow, soot and grease cannot harm. Instantly cleanable, with a bit of soap and water. 25¢ each, a year's supply \$1.50. A \$5.00 to \$10.00 annual saving. Your dealer's or direct. State size and style. Try a half-dozen. Booklet on request.



THE ARLINGTON CO.
725 Broadway New York

MONEY
IN
MUSHROOMS

FREE BIG BOOKLET TELLING
HOW TO GROW
MUSHROOMS

at home all the year. Big profits.
Take advantage of this wonderful
opportunity to become independent. Write
Nat'l Spawn Co., Dept. 12, Boston, Mass.



Runs on Alcohol Kerosene, Gasoline, or Gas

No electricity, wires or springs. Convenient. Much cheaper to operate than other fans. Roller bearing. Reliable. Brings genuine comfort and satisfaction. Ideal for the sick room. Fourth season. A proved success. The Wonder Fan. Model A, 12" blades, \$16.50. Model B, 21" blades, \$22.50. Cash with order only, F. O. B. Chicago.

Lake Breeze Motor, 546 W. Monroe St., Chicago

A Baseball
Jersey



Be the First in Your Club

School, City or Town, to wear this pure, all wool sweater, double collar and cuffs. Your choice in colors. This jersey was selected by 10,000 of my customers for last season. Your club will recommend it. Send for my big illustrated catalogue. Write me and learn my offer for your club's order. Popular Prices. Best Grade Sporting Goods—Baseball, Basketball, Tennis, Golf, Football, etc.

WRITE ME NOW.

JACK SHANNON CO., Dept. 46, 54 E. Monroe St., Chicago

Bausch and Lomb BALOPTICON

THE PERFECT STEREOPTICON

Bausch & Lomb Optical Co., 576 St. Paul St., Rochester, N. Y.

WEAR

Trade Mark

Registered

B.V.D.

U. S. Patent Office

and Foreign Countries

UNDERWEAR

EVEREADY
SAFETY LIGHTS

American Ever Ready Works
of National Carbon Co.
Long Island City, New York

AGENTS—Make \$100 to \$300



per month easy selling our new Triplicate
Sauce Pan. Cooking utensil for 3 different
foods on one burner. 400 Specialties—all
Whirlwind sellers. Write quick for ex-
clusive territory and large catalogue.
AMERICAN ALUMINUM MFG. CO.
Div. H-T LEMONT, ILL.

Hand
Forged
Razor Steel
Blades. No. 57



This \$2 KNIFE 83¢
DIRECT AT FACTORY PRICE

Handy shaped
blade makes this knife best
for mechanics, sportsmen and farm-
ers; light but strong; resharpen-
ed easily. Stag handle, German
silver finish; blades file tested, hand
forged from razor steel and warrant-
ed. Sample No. 3 for \$2 postpaid.
Cheapest post \$2 each.
Send for our 80 Page List
and "How to use a Razor" FREE

MAHER & GROSH CO., 106 A. St., Toledo, Ohio.

Throw the Crank away.



Make Your Phonograph Electric

Get an Arnold Phonomotor—a small, powerful electric motor that revolves the turntable of any disc phonograph without altering or harming the machine in any way

Arnold Phonomotor

can be attached or detached instantly. Gives you all the benefit and pleasure of high-priced electric machines at fraction of their cost. Reproduces every record perfectly and is absolutely noiseless. There are no fluctuations—no discordant sounds. Starts and stops at the touch of a button. The greatest improvement on phonographs ever devised.

Write for 10-Day Trial Offer and Low Price

Send today for particulars. Find out how you can test this wonderful motor on your own phonograph for ten days at our risk. Write today.

Arnold Electric Co.
1457 W. 12th St.
Racine, Wis.



There is Big Money for you in Automatic Card Printing

Everybody—everywhere—wants cards—for Business, Social, Professional, and thousands of other uses. Our wonderful press feeds and prints automatically any card from smallest to post-card size—100 a minute—Almost All Profit. Investigate this clean All-Year-Round, good-paying business. Get our free booklet No. 11.

S. B. FEUERSTEIN & CO.
Patentees and Manufacturers
542 W. Jackson Boulevard CHICAGO



INDOOR CHEMICAL CLOSET

NO SMELL—NO GERMS—SANITARY

Use in any room. Needs no plumbing, sewerage or running water. Chemicals in closet kill germs. Fine for the sick and old folks.

DESTROY OUTDOOR CLOSET

Put in a warm, Indoor Sanitary Closet. Empty twice monthly. Only attention necessary. Satisfied users and Boards of Health endorse it. Fully Guaranteed. **30 Days' Free Trial.** Write now for FREE LITERATURE.

SANITARY CLOSET CO., 23 Cellar Bldg., TOLEDO, OHIO



Deafness



Perfect hearing is now being restored in every condition of deafness or defective hearing from causes such as

Relaxed or Sunken Drums, Roaring or Hissing Sounds, Perforated, Partially Destroyed Drums, etc.

Wilson Common-Sense Ear Drums

"Little Wireless Phones for the Ears"—require no medicine but effectively replace what is lacking or defective in the natural drums. They are simple devices, which the wearer easily fits into the ears where they are invisible. Soft, safe and comfortable to wear at all times.

Write today for our 168 page FREE book on DEAFNESS, giving you full particulars and plenty of testimonials.

WILSON EAR DRUM CO., Incorporated
533 Inter-Southern Building LOUISVILLE, KY.



Let Us Send You a Conn Instrument Like Those used in Sousa's Band

WRITE today for the Conn Book and see handsome illustrations of all the Conn instruments that we will send to you on 10 days' trial. These instruments are actually the *master products* of the great instrument maker. Conn is the maker of all kinds of band instruments and practically every famous bandman in America uses a Conn instrument. Sousa's, Washington Marine, Pryor's, Conway's and hundreds of other bands of international fame use Conn instruments. Practically every grand prize offered during the last generation has been won by Conn instruments when they were in competition with the world at the great exposition.

And these are the instruments that will be sent to you on 10 days' trial.

Convenient payments in small amounts may be arranged.

Send the Coupon for the Conn Book

C. G. CONN, Ltd.
Dept. 1193
ELKHART, INDIANA

Put your name and address in the coupon or on a letter or a post card now and send it to us today. We'll send you the new Conn Book free and prepaid. The Conn Book is free. Merely tell us the instrument in which you are interested and send your name.

Gentlemen:

Please send me the new Conn Book and tell me how I can get a Conn Instrument sent to me on 10 days' trial and how I may pay for it in small amounts.

Send the Coupon Now
C. G. CONN, Ltd.
Dept. 1193
ELKHART, IND.

Name

Address

I am interested in

(name of instrument here)

Please Mention Popular Mechanics

3 Prime Reasons for -

The Supremacy of BISSELL'S Vacuum Sweeper

First, the carpet sweeper element, embodying the merit of all Bissell sweepers.

Second, adequate suction produced by three powerful bellows pumps.

Third, the mechanically correct and clever union of brush action and suction plus real workmanship. The soft bristle brush gently agitates the nap of rugs and carpets, sweeping the coarser substances into the litter-pan and leaving the fine dust in perfect condition to be pumped up through the suction nozzle.

Used regularly, Bissell's Vacuum Sweeper keeps rugs and carpets thoroughly clean in a sanitary manner, preventing the accumulation of dirt which necessitates drastic cleaning methods.

Bissell's Carpet Sweeper is the greatest household convenience ever invented, the device that has saved millions of women from the drudgery of sweeping. Except for kitchen or porch, discard your broom and use a Bissell's for little sweeping jobs that must be done two or three times daily. It makes housework easy.

Vacuum Sweepers \$7.50 and \$9. "Cyclo" Bull-Bearing Carpet Sweepers, \$3 to \$5.50. A trifle more in the West, South and Canada. Booklet on request. **BISSELL CARPET SWEEPER CO.** Oldest and Largest Exclusive Mfrs. of Carpet Sweeping Devices in the World. Dept. 339, GRAND RAPIDS, MICH. Made in Canada, too. (314)



See October and December Popular Mechanics for advertising of

The Pullman Company

BUY PLUMBING and HEATING SUPPLIES



at **WHOLESALE**

Will Save You 30%

Don't pay retail prices. Full stock on hand for prompt shipment. Send for free catalog.

B. P. KAROL, 800-802 South Kedzie Ave., CHICAGO

Send For  Free Book

INSURED
THE SCOTT ROOF

Protected Against Fire Loss

Here is positively the biggest roofing value ever offered. The only roofing that can with certainty be guaranteed to last 10 years and absolutely guaranteed against fire loss.

We will refund every penny if Asteroid Roofing gets brittle, cracks, becomes soggy, rots, warps or pulls apart at the seams — no matter how intense the heat or cold — or if subjected to heavy rains or snows.

"ASTEROID" PREPARED ROOFING

is so pliable and resilient it accommodates itself to all weather conditions, in any climate. It contains no coal tar. Is made of genuine asphalt with a base of pure wool felt. Has smooth surface, the appearance of rich, grain leather. Comes in 1, 2 and 3 ply. Nails and cement free. Can be laid over old shingles.

Get Our Freight Paid Prices

Send for Free Book and Special Freight Paid Prices — on the best, most durable, greatest fire-resisting roofing the world has ever known. Costs less than inferior prepared roofing. Write for facts. **THE SCOTT ROOFING & MFG. CO.** 300-350 Culvert Street CINCINNATI, OHIO

Trapshooting and gun clubs have something like \$40,000,000 invested, or about \$10,000,000 more than is engaged in baseball, it is estimated.

KEROSENE Gas Lamps

BURNS KEROSENE or GASOLINE

one just as well as the other; or the two mixed. Make their own gas. 300 to 600 C. P. at 1/2 an hour. Family or Business use.

WRITE FOR COMPLETE ILLUSTRATIONS

BRILLIANT GAS LAMP CO.
1009X So. Wabash Ave., CHICAGO, ILL.



Save Money



Quick Shipment

direct from manufacturers. Highest quality warm air furnace at wholesale price. Write for catalog filled with helpful hints on home heating and telling how you can save money on this powerful heating plant. One register — easy to install. **We pay freight.** Cash or easy payments. Write for Catalog No. 936

KALAMAZOO STOVE CO.
MANUFACTURERS
KALAMAZOO, MICH.

A Kalamazoo
Direct to You

DIAMONDS - WATCHES ON CREDIT

EIGHT Months To Pay

Plus, Blue-white Diamond while paying for it on our easy terms of **20% DOWN - 10% A MONTH**

Any honest person given credit. No security required. Goods sent prepaid, subject to approval. Binding Guarantee with each Diamond covering quality and value and permitting the exchange at full purchase price. 10% DISCOUNT for cash. Write today for FREE CATALOG No. 5 containing 4000 Photographs of Diamonds, Watches, Jewelry, Silverware, etc. Transactions confidential.

1506 \$37.25

3237 \$100

7079 \$25

7078 \$45

9738 \$85

9734 \$50

JAMES BERGMAN
1896 37-39 MAIDEN LANE
NEW YORK CITY

Going to Build? Send for These Two Free Books

Get latest building and remodeling ideas from our big catalog. Shows most advanced styles in building material; quotes money-saving prices direct to YOU. Plan book shows modern houses, bungalows, barns. Tells how to get free plans. Satisfaction guaranteed. Both books are FREE. Write today; give occupation.

MILLWORK CATALOG HOUSE PLANS

CHICAGO MILLWORK SUPPLY CO.
AMERICA'S GREATEST SASH AND DOOR HOUSE

1444 W. 37TH ST., CHICAGO, ILL.



Design No. 524
by Jud Yoho.
Estimated Cost
\$2800.

ALL ABOUT BUNGALOWS

BUNGALOW BOOK, 1916 De Luxe Edition
Contains the cream of 1000 practical and distinctive bungalows actually built for \$400 to \$4000, suited to any climate, with photos of exterior and interior views, plans, size of rooms, cost, etc. Also valuable suggestions on bungalow building written by an expert.

\$1.00

The largest exclusive Bungalow Book published. 112 pages. Price..... Postpaid
Worth many times its cost to any prospective builder. A smaller edition of same, only 50 cents. Send check, money-order or stamps. Money back if not satisfactory.

JUD YOHO, The Bungalow Craftsman, 66 Bungalow Bldg., SEATTLE, WASH.

KEITH'S \$1 Offer

1st—A folio of 25 new artistic and very attractive Bungalow Designs. 2nd—A big book containing up-to-date designs for 100 Artistic HOMES.



3rd—A 4-months' subscription to the well known leading authority for home builders, Keith's Magazine, \$2.50 a year, 25c copy.

On newsstands. ALL THE ABOVE, SPECIAL \$1.00

KEITH'S, 993 McKnight Bldg., MINNEAPOLIS, MINN.

THIS BUNGALOW \$900 CAN BE BUILT FOR

This and many others in my new book, Building Plans for Modern Homes, will save you hundreds of dollars. One of the most complete and comprehensive books of plans ever published by any architect. Fifth edition just off the press. Two hundred and fifty floor plans and photographs of bungalows, etc., costing from \$200 up; gives sizes and cost to build. Sent postpaid for \$1.00



FREDERICK H. GOWING
ARCHITECT
18 Tremont St., BOSTON, MASS.

JOHNS-MANVILLE
Asbestos



FREE TRIAL

White's RED CEDAR Chests

protect the finest garments, furs, etc., from moth and other vermin. Finest Gift. Send for FREE catalog today.



Free Trial.

J. A. WHITE LUMBER CO., Box 33, WARSAW, ILL.

No Hands Can Wash so Clean as This



"So Clean"

Absolutely spotless! Even shirt-band and cuffs perfectly clean. The Thor Electric Washing Machine makes everything cleaner than you could wash them by hand. If you have ever had a doubt about a washing machine just try the Thor. Learn what 150,000 other women have learned—that it will do an average family washing in an hour and do it perfectly. Don't put off writing for full information.

The Thor

Electric Washing Machine

Push a button and it does the washing. Also the wringing. No work for you or a maid to do. Costs only 3 cents an hour for electricity. No rubbing at all. Saves wear on clothes. Also saves cost of help. Actually pays for itself by savings it makes.

On Credit Any Thor dealer will sell you a machine for a small payment down. Then easy monthly payments. Special motor furnished to run the Thor if you have an electric light system of your own.

Send Coupon

The coupon will bring name of nearest dealer who can show you the Thor. Also big 48 page Book on Washing. Tells how to save money, time and work. All sent for the coupon. Mail it today—now.

Hurley Machine Co.
Dept. 1193 — 29 South
Clinton Street, CHICAGO
147 W. 42nd St., NEW YORK
413 Yonge St., TORONTO
You may send me your big
48-page book. Also name
of nearest Thor dealer.

Hurley Machine Co.

Dept. 1193 — 29 South
Clinton St., CHICAGO

147 W. 42nd St., NEW YORK

413 Yonge St., TORONTO

Manufacturers also of
Thor Electric Ironing
Machines and THOR
Electric Vacuum
Cleaners.

Name.....

Address.....

Please give name of a dealer in your city
who sells electrical supplies!

Please Mention Popular Mechanics

Get This ALUMINUM SET FREE

OR
CHOICE OF OTHER
USEFUL PREMIUMS WITH YOUR
1917 IMPERIAL RANGE

A special offer with every Imperial Range—anelegant Pure Aluminum Cooking and Roasting Combination. Seamless and Sanitary—4 pieces. Makes 12 useful kitchen utensils, as illustrated.

**30 DAYS FREE HOME TEST
PAY US NO MONEY IN ADVANCE**

We take all the risk. Choose any range you want from over a hundred styles. Try it, test it for 30 days before you decide to keep it. Send it back if not satisfied.

**FACTORY PRICES—WE PAY FREIGHT
TO YOUR HOME TOWN**

Choose Your Own Terms if you decide to keep your Imperial—Cash or Credit. By dealing direct with our factory you pay manufacturer's prices only, and no freight. You easily

SAVE \$10 TO \$20 By our new 26th Century methods. 100,000 Imperials now in use. Housewives delighted. IMPERIAL RANGES are made of highest grade materials. 365 DAY GUARANTEE. Will not warp or crack. Have the marvelous even baking Old Dutch Oven modernized—a STONE OVEN BOTTOM—which holds heat like a Fireless Cooker. Great fuel savers and new kind of PERFECT OVEN HOOD. Test all these without risk in your home before buying any range. Write at once for

BIG FREE CATALOG
with "No-Money-Risk" Trial offer. Also valuable Premiums and complete description of Imperial Ranges and their new 1917 improvements—You need this book to intelligently select a range. Write today. A letter or postal bill do.

**THE IMPERIAL
STEEL RANGE
COMPANY**
769 Detroit Ave.
CLEVELAND, O.



SMALL ENGINES

Perfected Gasoline Engines—K, L and M b. p.—for Farm and Shop use. Price \$19.50 and up. Also

WASHING MACHINES

We ship on trial. Send for Booklet and Special Offer.

SIEVERKROPP ENGINE CO.
1224 18th St. RACINE, WIS.

STARTER for FORD CARS



Fastest, cleanest, most saving Fireless Cooker possible to buy—at a big price saving. My new Book shows big, full page photographs of cooking in a R A P I D. Send your address today and

**Get This
FREE
BOOK**

Makes Every Woman Happy

Cut down your meat and grocery bills; have better tasting food with half the work. One trial convinces every housewife. Extra size 3-compartment Cooker Outfit of "Wearever" Aluminum Cooking Utensils. Covers and every part of interior pure aluminum.

Rapid Fireless Cooker

30 Days' Free Trial

I guarantee to suit you or send your money back. Roasts meats a perfect brown. Bakes cakes, pies, vegetables, desserts—everything in every way. Cuts gas bills from hours to minutes. Write today for my new Book and direct factory price.

William Campbell Company Dept. 164
Detroit, Mich.



**300 Candle Power of Light
at a Cost of 1-8c Per Hour**
Burns Kerosene or Gasoline

This lamp generates and burns its own gas from ordinary kerosene. "QUICKLIT" gasoline lamps can be lit with an ordinary match like city gas.

Write today for illustrated catalog of our complete line of kerosene and gasoline lamps, lanterns and lighting systems. **Agents Wanted**

The Nagel-Chase Mfg. Co.
176 East Erie St., Chicago

**LIGHT YOUR HOME
LIKE DAY—COST 1c**
for 6 hours. Pure white 100 candle power light from common Kerosene.

**THE BEACON LAMP MAKES
AND BURNS ITS OWN GAS**

Better, brighter, safer, cheaper than Gas, Gasoline or Electricity. Every home interested. 500,000 satisfied users. Agents wanted. Write quick for selling plan, exclusive free territory and trial offer.

HOME SUPPLY CO., 111 Home Building, KANSAS CITY, MO.

The "BEST" LIGHT

Positively the cheapest and strongest light on earth. Used in every country on the globe. Makes and burns its own gas. Casts no shadows. Clean and odorless. Absolutely safe. Over 200 styles. 100 to 2000 Candle Power. Fully Guaranteed. Write for catalog. **AGENTS WANTED EVERYWHERE.**

THE BEST LIGHT CO., 324 E. 5th St., CANTON, O.

ACORN UNI-LITE

Turns night into day. 300 candle power. Carry as a lantern; use anywhere as a lamp. Weather proof. For house, barn, garage, camp and around the farm. Write for big, free offer. Special opportunity to farmers, Stockmen and motorists. Agents make big money.

WRITE TONIGHT for new 1916-1917 offer.

ACORN BRASS MFG. CO., 817 Uni-Lite Bldg., Chicago

WHITE FLAME

BURNERS make your old kerosene lamps and lanterns give a brilliant white light better than electricity or gas. Doubles your light. Saves oil. **NO MANTLE TO BREAK.** Guaranteed Safe and Reliable. Delights every user. Send now for complete sample postpaid 35 cents, stamps or coin. 3 for \$1. **MONEY BACK IF NOT SATISFACTORY.** Live Representatives Wanted. Exclusive Territory.

WHITE FLAME LIGHT CO., 68 Clark Bldg., Grand Rapids, Mich.

My New Cut Price

Sent Only Direct From Factory



Genuine Blue-White Perfect Cut

Diamonds



\$88.00
PER CARAT

Our Wonderful Offer

Send for my 1917 Diamond Book, in which I quote prices on genuine blue-white perfect cut diamonds at a saving of 35% from jewelers' prices. The book tells diamond facts needed to buy safely and intelligently. Get a copy at once. When it arrives choose any diamond, in any setting, and I will ship it for **Free examination** so you can make comparisons.

NOTE THESE SPECIALS!

- 1/8 Carat at \$5.88, \$6.25 and \$9.00
- 1/4 Carat at \$13.50, \$15.50 and \$22.50
- 1/2 Carat at \$40.25, \$59 and \$77.00
- 3/4 Carat at \$64.25, \$96 and \$128.00



MONEY-BACK GUARANTEE
given with every diamond that you can take to any bank in America and cash in on your diamond investment if you want to. References: Lake and State Savings Bank of Chicago, or your bank, or any Commercial Agency. Send for Diamond Book today—now—and see what we have to offer you at lowest prices ever quoted.

BARNARD & CO. Dept. 2569C
N. W. Cor State and Monroe Sts., CHICAGO

I will send my 25 cent BOOK

STRONG ARMS

for 10c in stamps or coin

Illustrated with 20 full-page halftone cuts, showing exercises that will quickly develop, beautify, and gain great strength in your shoulders, arms, and hands, without any apparatus.

PROF. ANTHONY BARKER

644 Barker Bldg., 110 W. 42d Street, NEW YORK

"I Would Not Part With It for \$10,000"

So writes an enthusiastic, grateful customer. "Worth its weight in gold," says another. In like manner testify over 100,000 people who have worn it.

The Natural Body Brace

For MEN and WOMEN

Develops erect, graceful figure; overcomes **WEAKNESS** and **AILMENTS** of Women & Men.

Brings womanly beauty and manly strength, restful relief, ability to work and enjoy life.

Makes You Feel Good and Look Good

Does away with the strain and pain of standing and walking; replaces and supports misplaced internal organs; reduces enlarged abdomen; straightens and strengthens the back; corrects stooping shoulders; develops lungs, chest and bust; relieves backache, curvatures, nervousness, ruptures. Easy to wear.

Wear It 30 Days Free at Our Expense

Write today for illustrated booklet measurement blank, etc., and read our very liberal proposition.

HOWARD C. RASH, Pres. Natural Body Brace Co.
223 Rash Building SALINA, KANSAS



For Children Also



Larkin Co. Dept. PM317
Buffalo, New York

Tell me about the Larkin Easy Payment Plan and send the Catalog describing the instrument I have checked. Also name your Introductory Factory-to-Family price.

Piano Player Piano Symphonola

Name.....

P. O.....

State.....

St. or R. D.....

Address.....

TODAY
Mail This Coupon

This brings all interesting details of the Larkin Easy-Payment Plan, which places in your home soon your choice of three musical instruments at the "special" Introductory Factory-to-Family price. Thousands of homes are now happier since owning the Symphonic Piano played by hand, the Symphonic Player Piano played by hand or without previous practice with music rolls and the Symphonola which plays all Victor and Columbia records. There's a place in your home for a Symphonic or Symphonola.

Symphonic Pianos — Symphonolas
Symphonic Player Pianos

On Easy Payments — 1 to 4 Years' Time

Two million customers find it profitable to deal the Larkin Factory-to-Family way. Let us prove how our plan saves you much money on these sweet-toned instruments; how every obstacle to a purchase is removed by our extremely easy monthly payment plan. From the moment you make your first payment until the last, the Larkin offer protects you. Let us tell you how. Be sure to send the coupon today for the Symphonic or Symphonola Catalog.



"Brings me \$50 to \$60 per week"

So writes M. A. GIFFORD of his Ten-Pinnet business.



World's
Greatest
Bowling Game

YOU can start in the same business for small investment. Draw the crowds! Get the money! Everybody plays Ten-Pinnet. It's new, fascinating, healthful! Alleys 38 to 50 ft. long installed in any room in half day. Entirely automatic — no pin boys or upkeep expense — just someone to take in money. Write quick for free illustrated book, "Big Ten-Pinnet Profits," giving low prices.

THE TEN-PINNET CO., 82 Draper St., INDIANAPOLIS, IND.

Please Mention Popular Mechanics



\$100 TO \$150 SAVED ON MEISTER PIANOS

Let us send this beautiful instrument to you on

30 Days' Free Trial Freight Prepaid

Eight beautiful styles to choose from. If it proves highly desirable to you, we will sell it to you on

Small monthly payments. No cash deposit down.
No interest or extras. Stool and scarf FREE.

THREE YEARS TO PAY!

A binding guarantee of high-class material and workmanship. Write today for our beautiful 100-page illustrated catalog. IT'S FREE.

Rothschild & Company Dept. Chicago, Ill.



I PRINT MY OWN

Cards, circulars, menus, book, paper, etc. Press \$5. Larner \$18. Rotary \$60. Save money. Print for others, big profit. All easy, rules sent. Write factory today for illustrated catalog presses, TYPE, cards, samples. **THE PRESS CO. D-37. MERIDEN, CONNECTICUT**

Enormous Profits



START GROWING MUSHROOMS

Learn the latest authoritative way to make still bigger profits than you ever thought possible or ever made growing mushrooms. Add \$10 to \$75 a week to your income. Adults, men, women and children can do it in spare time in city or country. Grow in basements, cellars, sheds, boxes, etc. Start now. Demand bigger than supply. Send for big free book of expert authority. **The Truth About Mushrooms.** Write to

BUREAU OF MUSHROOM INDUSTRY
Dept. 369 1342 N. Clark St. Chicago



One Man and This Machine WILL EARN \$50 to \$100 DAILY PROFIT

Eakins' profits \$1500 in one month making Crispettes in a store window. Palmer sold \$680 worth on Labor Day; Kunkle's sales over \$7000 in less than year. One machine — a small investment starts you. You learn in a day. Turn out batch after batch. Sell at 5c a package and clear about 4c profit.

Makes Popcorn Crispettes

SEND FOR THIS FREE BOOK NOW!

It tells the whole story—how to succeed, gives experience of others, etc. It's worth reading. If you're looking for a money-making business write today. Send post card or letter.

W. Z. LONG CO.
1315 High St. Springfield, Ohio



\$8,000 to \$10,000 YEARLY



Make Money Out of Others' Fun

Pleasing the Public Pays Big Profits and owners of our famous attractions frequently make from \$8,000 to \$10,000 every year. We make everything in the Riding-Gallery and Carouselle line from the smallest to the highest grade. Bring in hundreds of dollars daily. It is a delightful, attractive, big paying, healthful business. Just the thing for the man who can't stand indoor work, or is not fit for heavy work.

Just the business for the man who has some money and wants to invest it to the best advantage. Our goods are finest appearing, easiest running, and most attractive line manufactured. They are simple in construction and require no special knowledge to operate. Our latest new 1917 Carouselle is mounted on trucks to facilitate and reduce cost of moving and shipping. It reproduces exactly the running horse motion. Greatest Novelty out. If you want to get into a money-making business write today for catalog and particulars.

HERSCHELL-SPILLMAN COMPANY

PARK AMUSEMENT OUTFITTERS

333 Sweeney St., N. Tonawanda, N. Y., U. S. A.

ELECTRIC HOME, FARM, PICTURE THEATRE, HOTEL & STORE LIGHT PLANTS.
Auto Starter Storage Batteries & Chargers. All Cars. Ask Price.
Dynamo, Power Motors, Belts, Engines, Railways, Furnaces & Traveling Motion Picture Machines.
OHIO ELECTRIC WORKS, CLEVELAND, O.

Relief to Ruptured People

Any appliance is a truss. Ruptured people must wear a support. Our New Spongy Rubber Pad (pat'd) is velvety, soft to the skin, pliable, camouflaged, extremely comfortable, adapts itself to ruptured parts with less pressure, is sanitary, long lived. Massage and strengthens muscles, allows blood circulation and produces many cures.

Scrotal Pad Needs No Leg Strap
Our New Akron Spongy Rubber Scrotal Pad (pat'd) holds & out of 10 cases of scrotal hernia perfectly without strap between the legs.

Free Sample Pad & Sample Akron Spongy Rubber Truss Pad will be sent absolutely FREE upon request, also booklet "Relief to Truss Users." It's full of help. Ask your dealer, or write us. **THE AKRON TRUSS CO. 63 TRUSS BLDG. Akron, Ohio**

Better Quality

At Wholesale Prices
Direct from manufacturers, who can save you \$10 to \$30 on the best range made. Newest designs—white enamel splasher backs, etc. Write for Catalog. Take a Kalamazoo on our 30 days' trial plan and see what you can save. We pay freight—quick shipment. Ask for Catalog No. 473. **KALAMAZOO STOVE CO. Manufacturers Kalamazoo Michigan Direct to You**





Tobacco Habit BANISHED

in 48 to 72 Hours

Immediate Results

Trying to quit the tobacco habit unaided is a losing fight against heavy odds, and means a serious shock to your nervous system. So don't try it! Make the tobacco habit quit you. It will quit you if you will just take Tobacco Redeemer according to directions.

It doesn't make a particle of difference whether you've been a user of tobacco for a single month or for 50 years, or how much you use, or in what form you use it. Whether you smoke cigars, cigarettes, pipe, chew plug or fine cut or use snuff Tobacco Redeemer will positively remove all craving for tobacco in any form in from 48 to 72 hours. Your tobacco craving will begin to decrease after the very first dose—there's no long waiting for results.

Tobacco Redeemer contains no habit-forming drugs of any kind and is the most marvelously quick, absolutely scientific and thoroughly reliable remedy for the tobacco habit.

Not a Substitute

Tobacco Redeemer is in no sense a substitute for tobacco, but is a radical, efficient treatment. After finishing the treatment you have absolutely no desire to use tobacco again or to continue the use of the remedy. It quiets the nerves, and will make you feel better in every way. If you really want to quit the tobacco habit—get rid of it so completely that when you see others using it, it will not awaken the slightest desire in you—you should at once begin a course of Tobacco Redeemer treatment for the habit.

Results Absolutely Guaranteed

A single trial will convince the most skeptical. Our legal, binding, money-back guarantee goes with each full treatment. If Tobacco Redeemer fails to banish the tobacco habit when taken according to the plain and easy directions, your money will be cheerfully refunded upon demand.

Let Us Send You Convincing Proof

If you're a slave of the tobacco habit and want to find a sure, quick way of quitting "for keeps" you owe it to yourself and to your family to mail the coupon below or send your name and address on a postal and receive our free booklet on the deadly effect of tobacco on the human system, and positive proof that Tobacco Redeemer will quickly free you from the habit.

Newell Pharmacal Company
Dept. 300, St. Louis, Mo.



**Mail Coupon NOW
for FREE Booklet**

NEWELL PHARMACAL CO.,
Dept. 300, St. Louis, Mo.

Please send, without obligating me in any way, your free booklet regarding the tobacco habit and proof that Tobacco Redeemer will positively free me from the tobacco habit.

Name

Street and No.

Town

State

Please Mention Popular Mechanics

One of the World's Greatest Inventions

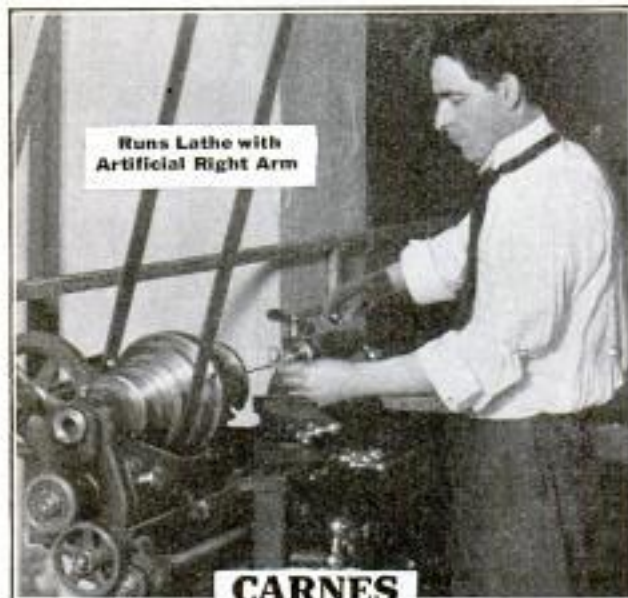

Runs Lathe with Artificial Right Arm

CARNES

Artificial Arm

The only artificial arm and hand that you can really do so many things with and without assistance of natural hand. The only artificial arm with full finger motion hand, turning and bending wrist and bending elbow. Comfortable to wear. Easy to operate. Perfect fit guaranteed. Recommended by wearers the world over. Endorsed by surgeons. Awarded Gold Medal, San Francisco, San Diego, London, Eng. Write for illustrated catalog B. 2 5 of this wonderful invention.

CARNES ARTIFICIAL LIMB CO.

31 Carnes Bldg., 904-906 E. 12th St., Kansas City, Mo.

STOP USING A TRUSS

Do Away With Steel And Rubber Bands

FREE TRIAL



Inner surface is made adhesive to secure the PLAPAO-PAD firmly to the body, keeping the PLAPAO continually applied and the pad from slipping. No straps, buckles or springs attached. Soft as velvet—easy to apply.

It's the Non-Slipping, yet Non-Rigid Pad and What is Within It That Counts

PATD APRIL 6 1909

FREE to 5,000 Truss Sufferers

To the extent of 5,000 sufferers who may apply I will send, ABSOLUTELY FREE, a sufficient quantity of the Plapao to positively convince them that this is the only logical, commonsense way of treating rupture. Plapao is a highly straining medication placed within the Plapao-Pad and being absorbed through the skin, creates a wonderful feeling of relief and at the same time tends to strengthen the weakened muscles and thus permanently close the rupture opening. The process of recovery is natural, so you'll have no use for a truss—you can throw it away forever! Old and young have testified under oath that the Plapao-Pads cured their rupture—many of them long-standing, aggravated cases—without delay from work. Patent allowed in U. S. and foreign countries. Awarded Gold Medal at Rome and Grand Prix at Paris.

Send No Money—for a sufficient quantity of the Plapao is sent without charge to enable you to give it a thorough test; you pay nothing for this trial now or ever. Write for it and full information today. Address Plapao Laboratories, Block 1427 St. Louis, Mo.

AGENTS—\$5.00 to \$25.00 a Day—It's Easy

Grand Invention. 150% Profit. Great Excitement Recognized as most phenomenal seller

Experience Unnecessary. Spare time can be devoted if desired

LISTEN: One man's orders \$2,650.00 one month—profit \$1,650.00

Lowry, of Montana, who sold 25 dozen the first two weeks (without previous experience) and made \$187.50, enthusiastically writes: "Why, I could sell this article blindfolded and with a gag in my mouth."

Mere boy in Pa. made \$9.00 in 2½ hours. "I do not see how a better seller could be manufactured," reports Parker J. Townsend, Minn. "Started out at 10 a.m., sold 35 by four o'clock," says J. R. Thomas, Colo. "Sold 131 in two days."

G. W. Handy, New York. See what a wonderful opportunity. These remarkable reports proven absolutely true by oath-covered evidence—proven to satisfy you beyond a doubt. You can make this money. Work for us and get rich. We want representatives—Agents, Salesmen, Managers—everywhere. Write today. Territory in all sections of the United States, Canada, Mexico and foreign countries to be assigned.

The New Easy Wringer Mop tremendously in demand by housewives. Every woman exclaims in delight: "Just what I want!" No more tiresome, back-breaking, miserable mopping days. Dredgey actually transformed into pleasure. The greatest, grandest, most necessary household article ever invented. No need to recite selling arguments. Talking hardly necessary at all. Simply show—order's landed.

This is indeed a wonderful opportunity. Establish yourself in this business at once. Send your name and address on a postal now—right now.

Think of it

A Self-Wringing Mop. Two turns of the crank wrings out every drop of water. Mopping is now a pleasure.



Think of it

A Self-Wringing Mop. Two turns of the crank wrings out every drop of water. Mopping is now a pleasure.

U. S. MOP CO., 465 Main St., TOLEDO, OHIO

Go INTO MOVING PICTURE BUSINESS

Small Capital Starts You

on our easy payment plan. Begin now and get your share. We sell everything. Write TODAY.

Atlas Moving Picture Co. Dept. 22, 525 S. Dearborn St., Chicago

"Best" Hand Lantern

A powerful portable lamp, giving a 300 candle power pure white light. Just what the farmer, dairyman, stockman, etc., needs. Safe—Reliable—Economical—Absolutely Rain, Storm and Bug proof. Burns either gasoline or kerosene. Light in weight. Agents wanted. Big Profits. Write for Catalog.

The Best Light Co., 324 E. 5th St., Canton, O.

AGENTS 500% PROFIT

Gold and Silver Sign Letters

For store fronts, office windows and glass signs of all kinds. No experience necessary. Anyone can put them on and make money right from the start.

\$30.00 to \$100.00 A WEEK!

You can sell to nearby trade or travel all over the country. There is a big demand for window lettering in every town. Send for FREE Samples and full particulars.

Metallic Letter Co., 406 No. Clark St., Chicago

Please Mention Popular Mechanics

The Cold That Comes from Being Overheated

is often checked by Luden's. Relieves dryness in the throat. Sweetens the breath.

In the Yellow Package 5c



LUDEN'S

MENTHOL CANDY COUGH DROPS

Luden's great popularity is due to its being more than an ordinary cough drop. You'll find many new uses.

By WM. H. LUDEN, Mfg. Confectioner, READING, PA.

Unusual Trial Offer for 10c

Best Kodak Finishing, any size roll developed 10c. Six prints free with first roll. OR, send 6 negatives, any size, and 10c (stamps) for 6 prints. 8x10 Enlargements, 25c. ROANOKE CYCLE COMPANY, 54 Bell Avenue, ROANOKE, VA.

Erickson Artificial Limb Co., 38 Wash. Av. N., Minneapolis, Minn.



We are Under Govt. Bond

THE MONO X-RAY



With this eye glass you can apparently see thro cloth or wood, see the bones in the body, makes the flesh look transparent. An optical illusion.

BY MAIL 10 CENTS, STAMPS OR COIN

THE ARDEE CO., Box 229, Stamford, Conn.

NO MORE BALD HEADS



WHEN our VACUUM CAP is used a few minutes daily. We accept no pay until you have tried the Cap 30 days and are satisfied. The Vacuum Cap is an appliance that draws the blood to the Hair Roots and starts a new healthy crop of hair. It stops Dandruff, stops the hair from falling out.

Bought by Doctors and men who know that it is the only reasonable HAIR GROWER known to science. No Drugs Used. Write for application blank, testimonials, and booklet on "HAIR" sent sealed in plain envelope. FREE.

THE MODERN VACUUM CAP CO.

N. 559 BARCLAY, DENVER, COLO.

ANY WATCH YOU WANT ON CREDIT



1917 Models

WALTHAM
HAMILTON
ELGIN, MILLER
Illinois, Howard

Sent on 30 Days Free Trial

No Money Down

Express Prepaid in Advance by Me

You take no chances with me. I am "Square Deal" Miller and I trust the people. That is why I am doing the greatest Credit Watch, Diamond and Jewelry business in the country. Suppose you want any one of the country's best makes of watches? Name any one, I have it for you. No Money Down, Express Prepaid. A full month to carry it in your pocket and the easiest of Long Time Payments. That's the best that tells. All these watches GUARANTEED 25 YEARS

I Smash the Terms

No References Demanded

My terms are made to suit you. You get unlimited credit, with no red tape, notes or collectors. All unnecessary detail left out.

An "Open Charge" Account

the same kind of credit you get from your grocer. No matter where you live or what your income is, you can now own the finest watch, a beautiful diamond or any rare jewelry and never miss the money.

Costly Catalog FREE

Send me your name and address so I can mail you, Free and postpaid, the most beautiful catalog of its kind ever printed. I want you to have this book. It's a gem. It illustrates all makes of valuable Watches, Elegant Genuine Diamonds, and a vast assortment of Beautiful Jewelry, all on the easiest and most liberal terms

Square Deal MILLER
PRES.

811 Miller Bldg., Detroit, Mich.

BE THRIFTY
BUY A DIAMOND
PAY MONTHLY

MONEY REFUNDED
IF YOU CAN BUY
CHEAPER FOR CASH.



Fine Diamonds

SQUARE DEAL
MILLER
PRES.

Fine Diamonds

Our diamonds are all perfect cut beautiful stones, white in color and lots of fire.

You cannot buy by mail better diamonds at any price than we are selling on credit.

FREE CATALOG COUPON

SQUARE DEAL MILLER, Pres.
811 Miller Bldg., Detroit, Mich.

Please send me your 1917 Catalog and explain fully your 30 Day Trial Plan and Easy Terms

Name.....
Address.....

PATENTS THAT PROTECT and PAY

Send for FREE BOOKS.

WATSON E. COLEMAN, Patent Lawyer, 624 F St., Washington, D. C.

Read the following strong testimonials as to my work and promptness:

PERU, ILLINOIS, November 29, 1916.
I wish to thank you very much for the prompt and proper attention you have given my case. I have taken out patents before through other attorneys who have taken nearly two years to get an allowance. **ELMER A. BENSON.**

WOODBURN, OREGON, Dec. 13, 1916.
I express many thanks for your excellent work and promptness in getting my patent. It was put through even quicker than I expected. **G. S. MCGONEGAL.**

JAMESTOWN, N. Y., Dec. 19, 1916.
I wish to thank you for your prompt attention and services rendered me while I was in Washington. I have been engaged in numerous business deals requiring the services of attorneys but I have not as yet been able to find any firm that ever gave me the prompt attention and quick results as you gentlemen have. **F. D. NEWBERRY, Broker.**

THE SANITARY MAUSOLEUM COMPANY
Incorporated.

READING, PA., Nov. 28, 1916.
I wish to thank you for the promptness in which you handled this patent matter as it has been handled in a better way than anything I have ever had go through the Patent Office. **THE SANITARY MAUSOLEUM COMPANY,**
By **U. J. SMITH, (Gen. Mgr.)**

NEW YORK, December 6, 1916.
I must congratulate you on your very prompt and efficient service in securing my patent. Rest assured my appreciation of same runs very high, and I shall, with the greatest amount of pleasure and pride, recommend you to anyone that I may know or meet who may have something to patent and who needs a real patent attorney.
CALEB A. MORALES, 623 West 207th St., New York.

AMERICAN SHEET AND TIN PLATE COMPANY,
FARRELL WORKS.

FARRELL, PA., Nov. 9, 1916.
I have received my patent and wish to now state that your services have been highly satisfactory in every way. Your speed and accuracy in presenting the application and, above all, your very courteous replies to my questions surely impressed me. **H. V. HAINES.**

ROCHESTER, PA., October 12, 1916.
I could not have selected a better man or men for my patent business. You surely live up to your motto "prompt and proper attention." There are surely no dead ones in your office. **W. E. SPRATLEY, R. 1.**

PHILADELPHIA, PA., Oct. 13, 1916.
I received my patent on hoisting apparatus and thank you very much for having secured it in so short a time. I shall gladly recommend you as a patent attorney.
JOSEPH QUINN, 8634 N. 3rd St.

EAST ST. LOUIS, ILL., Aug. 26, 1916.
I acknowledge receipt of your letter enclosing notice of allowance of my application for patent. It is needless to say I am very much pleased with the dispatch in which you have handled this matter and any future business will be surely turned over to you. **L. C. ELLIS, 2917 Virginia Place.**

HILLSDALE, ORE., Aug. 11, 1916.
Allow me to assure you that I appreciate the quick and efficient way in which you have handled my patent work. I shall recommend you to my friends. **O. A. KRATZ.**

SUNBURY, PA., December 7, 1916.
I received my patent papers today for which please accept my congratulations. You surely did good work in getting out my drawings and specifications and it did not take you long to do it, and it was done right, too.

H. A. YEABICK, 229 S. 3rd St.

SULPHUR, KY., July 17, 1916.
I sincerely thank you for your integrity and executive ability which we don't think can be surpassed by any attorney in Washington. **BENJAMIN F. HAWKINS.**

THE R. C. MAXWELL CO.

TRENTON, N. J., July 7, 1916.
We are very well pleased with the manner in which you have handled our business and if anything should come up in the future we know of no other than yourself with whom we would like to trust our patent business.

THE R. C. MAXWELL CO.
By **R. C. MAXWELL, President.**

ABBY W. HODGE

Investor and Manufacturer of
Hodge's Road Plane, "The Plane That Planes!"

CHROMWELL, IND., July 3, 1916.
I greatly appreciate the work you did for me on the patent on the road drag. By securing as broad claims as you did, I was able to organize a stock company for \$40,000.00 and we are now placing on the market the best road drag in the world and now have orders on hand for more than we can supply. None of the stock is for sale. **ABBY HODGE.**

GUNN MUSIC HOUSE
794 Woodward Avenue, Detroit.

DETROIT, MICH., Oct. 14, 1916.
The tracker mechanism for player pianos works fine and I have as good as sold it. I only wish the other patent attorneys were of the hustling class, but they are far and few such as you. **J. R. DENOVELLES.**

SHELDON LEAVITT, M. D.
4665 Lake Ave., CHICAGO

April 23d, 1916.
I am both pleased and surprised at the grasp of the situation you have shown and the clear way in which you have put the matter. I appreciate as well the promptness and courtesy shown. **SHELDON LEAVITT.**

RUPERT, IDA., May 1, 1916.

I wish to thank you for the good work and promptness in securing my patent on the animal trap. I am well satisfied and was surprised to learn how quickly it went through. **D. W. SHEPARD.**

HUNTER BROTHERS
Hotel Advertising Agents.

ANN ARBOR, MICH., January 3, 1917.
We take pleasure in acknowledging receipt of Letters Patent and desire to express our gratitude to you for the prompt and satisfactory manner in which you handled our case. **W. T. HUNTER.**

MANNINGTON, W. VA., February 9, 1916.

My papers to hand today concerning my patent. You sure did get it through in record time. Filed the papers September 15, 1915, and on February 8, 1916, patent was granted. Many thanks for your diligent attention to the business. **GEORGE W. LONG.**

PATENTS THAT PROTECT and PAY

Send for FREE BOOKS.

ALL BUSINESS GIVEN PROMPT AND PROPER ATTENTION

A large list of strong recommendations furnished free

WATSON E. COLEMAN, Patent Lawyer, 624 F St., Washington, D. C.

PATENTS SECURED OR ALL FEES RETURNED!!

Protect Your Idea!

DON'T DELAY!

We Issue a Contract with Each Favorable Report to Return ALL FEES!

Actual Search FREE of the Patent Office Records, and Report as to Patentability Free!

Send data at once by registered mail and we will promptly advise how our clients proceed to make fortunes.

PATENTS SOLD FREE:

Write Today For Our FREE "Patent Sales Department" Bulletin! PROOF GIVEN.

Our client, A. D. LONG, just states: "You secured BROAD claims for me in my patent. I sold it for \$25,000.00."

We Help Sell Our Clients' Patents FREE!

PATENT BUYERS please write Our "Patent Sales Department" Today! Excellent Opportunities! Patents advertised Free in Popular Mechanics, and further promoted if applied for thru us in 1917; write us at once and be one who secures this valuable free service.

We write manufacturers for you—We don't wait until they write us!

WE LEAD — WE ARE LIVE WIRES!

"Vrooman" Clients' Patents SELL! Over \$625,812.00 made by our clients.

Foreign Patents Guaranteed

BRANCH OFFICES all over the world. Write for prices under guarantee.

OUR OFFICES ACROSS STREET FROM PATENT OFFICE

CREDIT GIVEN Under Our CREDIT PLAN. 2 WONDERFUL PATENT BOOKS FREE Don't miss these books! Mail postal today!

E. E. Vrooman & Co., Patent Lawyers, 87 I F St., Washington, D. C.

(Old-Established Firm, and Practitioners Before Supreme Court of U. S.)

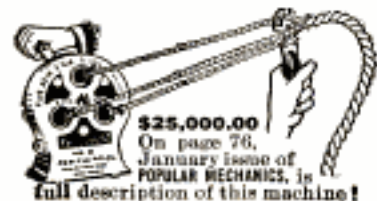

Wanted—Ideas

Inventors! Send for these Remarkable FREE BOOKS, Today

"Inventions Needed"

This book lays before you a description of the active and profitable field of invention. It tells you the inventions the world needs today, the devices manufacturers are seeking for their business, the ideas for which the public will pay big money.

"How to Get Your Patent"

This book is a guide to the inventor. If you have invented something and desire to learn what it will cost you to get your patent and what you must do to find your market, read this book.

"Special Bulletin of Patent Buyers"

This bulletin contains letters from men who are seeking to purchase patents. We act as intermediary without one cent of charge, between the man who invents and the man who invests.

Send Model or Sketch and description of your invention for Free Opinion as to patentability

Rejected and Difficult Cases are Our Specialty

RANDOLPH & CO.

600 F St., N.W., Washington, D.C.

RANDOLPH & CO.
600 F St., N. W., Washington, D. C.

Gentlemen: Please send me without obligation on my part, the books indicated on margin of this coupon. (Write on margin of coupon, names of books desired.)

NAME
STREET.....
CITY.....STATE.....

Please Mention Popular Mechanics

INVENTIONS WANTED

Manufacturers and Private Individuals Want to Buy Patents for New and Useful Inventions. Read and See if You Can Supply the Demand

A firm of patent attorneys located in Washington, D. C., is making a specialty of finding parties who wish to buy inventions. They supply the names and addresses of these parties to their clients free of charge. In this way they help the inventor and at the same time help themselves, because the inventors who wish to find patent purchasers will naturally turn to them when in need of a patent attorney. The method employed in finding patent purchasers is very simple. These patent attorneys have the following advertisement constantly appearing in some of the leading newspapers of the country.

"MANUFACTURING OPPORTUNITIES—Our clients have numerous patented devices of excellent merit which can be purchased outright or manufactured on royalty; write for information and also our book on patents. CHANDLEE & CHANDLEE, Washington, D. C."

The replies to this advertisement run into the thousands, and these attorneys have them classified according to the kind of inventions that are wanted. As soon as an inventor applies for a patent through this firm they send him a list of those persons who have asked for patents in the class to which his invention belongs. This is a straight business proposition, both the inventor and the attorneys getting the benefit of the plan. The files of these letters from patent purchasers are open for personal inspection by inventors or other interested parties at all times. Here are copies from some of these letters recently received:

Chandlee & Chandlee, Washington, D. C.

Gentlemen: Replying to yours in the Chicago Tribune. If you have anything of merit on file in the hardware line we should be interested in hearing from you. We prefer either an office or automobile specialty. Yours truly,
Modern Appliance Co.

Gentlemen: In accordance with your ad in Chicago Tribune, I wish you would please send me particulars of any meritorious patents your clients have for disposal appertaining particularly to small farm implements or attachments. I would also be interested in new automobile accessories and if possible would prefer to know the royalty or manufacturing proposition desired by your client. Awaiting the favor of your reply.
Yours very truly, J. E. Stevens.

Gentlemen: We have large factories and desire to add to our manufactures patented articles that abundant capital may make profitable; metal goods, stamped, drawn, etc. When you know of something you can recommend, please address
J. Fred. Pierson, Pres. Pierson & Co.

Here are some more inventions that have been requested in letters received by Chandlee & Chandlee: Track cleaners for car lines, a guard to prevent breaking of lamp chimneys, improved oil burner for locomotives and furnaces, improved light weight gas engines, hot plate lifter, bucket that may be emptied without tipping, improved milking machine, a simple machine for making concrete tiles, sewer pipes, fly trap, improved window screen that may be adjusted to windows of different sizes.

Inventions of all kinds are wanted by the parties who have written to Chandlee & Chandlee. Their book, "What to Invent," which will be sent free of charge to any address, is made up entirely of articles that have been requested in letters received as a result of the above mentioned advertisement. Their book, "How to Obtain a Patent," will also be sent free of charge. Write for these two books.

Here Are Examples of What Some of Their Clients Have Done with Their Inventions:

A "Little Idea" Sold 135,000 Horse Collars—Made Inventor a Small Fortune

George B. Goetz, Ranson, West Virginia, has been making leather horse collars for years. He also made a few canvas horse collars. The canvas collars were much cheaper. But, they would not hold their shape. Then—leather prices advanced. The necessity for a cheaper collar made Mr. Goetz turn his attention to stiffening canvas collars. The idea of adding a steel band came to him. It cured the defect. Where he sold only a few dozen canvas collars each year he has in the past seven months sold more than 135,000 canvas collars. And yet he only made a small improvement.



This "Little Idea" is Bringing Fine Royalties to the Inventor

E. P. Hoffman, of Uniontown, Pa., noticed boys playing with pasteboard milk bottle stoppers and collecting quantities of them. The thought occurred to him, "Why not provide a use for the stoppers?" The result was the toy pistol shown. You may say it is not much of an invention, but the royalties he receives from the Arcade Manufacturing Co. are entirely satisfactory to him.

A Nice Weekly Income for Mr. Knapp

In almost every housefurnishing store in the United States you will find on sale this simple little fruit and jelly strainer. It consists of a metal bracket that may be secured to the back of a chair to support a jelly strainer into which is poured the material to be strained and from which it will drip into a suitable vessel placed on the seat of a chair. Probably very few people know that a man named Knapp invented it. But Mr. Knapp and the manufacturer know just how many dollars this little thing brings to Mr. Knapp each week in royalties.



Chandlee & Chandlee have been practicing before the United States Patent Office for twenty-one years. Remember, the books "What to Invent" and "How to Obtain a Patent," will be sent to you free of charge. Write for them.

If you have an invention, send them a rough sketch and description of it for a free report regarding patentability. Address Chandlee & Chandlee, 1011 F St., Washington, D. C.

WANTED IDEAS

Inquiries from Manufacturers and Other Buyers of Patents
Who Are Looking for Good Ideas

Protected by Owen Patents

Are constantly being received. Hundreds of ideas are wanted—a market exists for them to-day. YOURS may be one of them. Send for my free books and see for yourself—read the requests for inventions protected by me. Many are simple. You can help supply this demand.

As soon as my clients' rights are protected I aid in every practicable way, without charge, to sell. Their applications are advertised free—their patents are called to the attention of the proper prospective buyers—every necessary thing is done. Get my booklets and see.

THESE ARE FREE

You will incur no obligation by writing me. A simple request will bring them to you—the finest, most reliable and instructive patent books published. A postal will do.

"Successful Patents"—a 72 page guide book, tells how to proceed; describes my advantageous business methods; gives references, testimonials, etc.

"Stepping Stones"—gives hundreds of hints of inventions wanted; articles from interviews of noted authorities; tells the truth about prizes for inventions.

"Patent Promotion"—tells you how to sell; why some inventors fail; discusses the value of your idea; how I aid my clients; manufacturing aids furnished you; recent successful patents, etc.

"Patent Buyers"—Publishes letters, and abstracts of letters, from over 400 of the many manufacturers, and other patent buyers, who wish to buy, or obtain on royalty, Owen Patents on innumerable inventions of interest to them.

You will also be sent from time to time, as new inventions are wanted, full information concerning them. Only in this way can you keep up to date.

WRITE FOR THESE TO-DAY—Advice costs nothing. All communications confidential. Your work will receive my personal supervision—but my fees are no higher than others.

Results Speak Loudest—But Here Are Some References

Columbia National Bank,
Washington, D.C.
National Locktile Co.,
Washington, D.C.
The Carnahan Press,
Washington, D.C.
Lightning Gun & Cycle Works,
Oklahoma City, Okla.

Antholene Mfg. Co., Hutchinson, Kan.
National Rack Co.,
61 Hanover St., Boston, Mass.
The C. J. Loftus Co.,
13 Spring Common, Youngstown, Ohio.
Whitehead Hosiery Mills,
Burlington, N. C.
Dickinson Mfg. Co., Des Moines, Iowa.

A LARGE NUMBER OF OTHERS IN MY BOOKLETS.

RICHARD B. OWEN 9-303 OWEN BLDG.
WASHINGTON, D.C.

Inventors submitting their inventions to me are protected in a tangible manner until their applications are filed.

Nuts for You to Crack

Invent something for which a demand exists—for which there is a waiting market. Here are abstracts from a few recent requests—hundreds are published in full in my literature. Can you invent any of these? Watch this list each month.

An investor with money writes, "I am looking for a window burglar alarm or something small that will be a fair seller."

A large manufacturer wants patents upon "novelties, machines, etc., which could be retailed from one cent to fifty dollars."

A financier wants to purchase inventions—along the lines of toys, household and office novelties, and mechanical devices which could be handled by a mail order house."

Still another manufacturer wants to get in communication with any clients of mine "that have obtained patents on tricks, puzzles, or novelties." They also state "we are always interested in any new articles of this kind and are in a position to place anything of a practical nature on the market." There is a big field for the right article.

SPECIAL FREE REPORT

Send sketch or model of your invention for free report on patentability, practicability, etc.

PATENTS TRADE-MARKS AND COPYRIGHTS

LARGEST PATENT FIRM
IN THE WORLD

SPECIAL OFFER

Free Opinion as to Patentability

Before sending your invention to any attorney or manufacturer or disclosing your invention, write for our free blank form **PROOF OF CONCEPTION** in order to protect your invention and secure your rights. This should be signed and witnessed and returned to us, together with a model or sketch and description of your invention, and we will give a **FREE OPINION** as to the patentability of the invention. If we report the invention patentable we will furnish a Certificate of Patentability.

VICTOR J. EVANS

This Certificate of Patentability, together with our blank form Proof of Conception will protect the inventor and serve as proof of the invention until the case can be filed in the U. S. Patent Office.

Obtaining Assistance for Inventors—Our certificate is of great assistance to inventors who require financial aid to obtain patents.

OUR FIVE BOOKS MAILED FREE

(See Coupon Below)

to any address. Send for these books—the finest publications ever issued for free distribution.

How to Obtain a Patent

Our illustrated eighty-page Guide Book is a book of reference for inventors and contains 100 mechanical movements, illustrated and described. Tells how to invent for profit.

What to Invent

Contains a valuable list of inventions wanted and suggestions concerning profitable fields of inventions; also information regarding prizes offered for inventions amounting to **One Million Dollars**

Millions in Trade-Marks

Shows the value of Trade-Marks and information regarding unfair competition.

We Advertise Our Clients' Inventions Free in a list of Sunday newspapers, in manufacturers' journals and in World's Progress. Sample Copy Free. We save you time and money in securing patents. After the patent is granted we assist you to sell your patent.

List of Patent Buyers

Contains requests from manufacturers, mail order houses and promoters for patents secured by us and suggestions as to **New Ideas** they wish to purchase. We place our clients in touch with capital free of charge. We have recently received over 300 requests from manufacturers.

Foreign Patents

We have direct agencies in all the principal foreign countries and secure foreign patents in the shortest possible time and at the lowest cost. Write for our illustrated Guide Book on Foreign Patents, sent free to any address.

WANTED NEW IDEAS

Prepare Now to meet the Demands of Industry in All Fields for New Ideas and New Inventions. We are constantly receiving requests from manufacturers who consult us when purchasing patents for inventions in all lines. We invite manufacturers and promoters to address our Sales Department regarding the purchase or leasing of a number of meritorious patents secured by us.

VICTOR BUILDING



FREE COUPON!

VICTOR J. EVANS & CO.

New York Offices: 189-191 Broadway
 PATENT ATTORNEYS
 Pittsburgh Offices: 514 Empire Bldg.
 Philadelphia Offices: 1429 Chestnut St.
 Main Offices: 765 Ninth St., N. W., WASHINGTON, D. C.

Name..... Address.....

Please Mention Popular Mechanics

U.S. PATENTS FREE BOOK & FORM EVERY INVENTOR SHOULD USE:

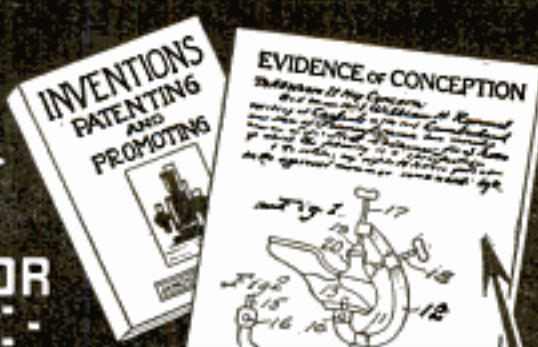

LANCASTER & ALLWINE
REGISTERED ATTORNEYS
SERVICE

OUR CO-OPERATION

With an inventor is, **First**, to help him establish his rights before sending a sketch, drawing or model to any attorney; **Second**, to give a frank opinion whether it will pay to patent his idea, based upon our extensive knowledge of the patent laws, manufacturers' wants and facilities; **Third**, to obtain for him on reasonable terms, a patent that absolutely protects; and, **Fourth**, advise and assist him in making the invention a source of profit by outright sale, territorial grants, obtaining royalty, or the independent manufacture of the invention.

**DON'T
LOSE
YOUR
RIGHTS**

Before disclosing the invention to anyone, sign, witness and deposit in our fireproof safe, the form "Evidence of Conception" and establish your rights. A completed sample form in our book shows you clearly how to protect your invention. All are free. Just ask for them on a postcard or simply mail coupon below.

Without charge or obligation, we will give you our frank opinion on any questions you may put to us touching on patent, trade mark and copyright matters. You may ask, "Should I protect myself by a patent, or register under the trade mark or copyright laws? What kind of a patent should I obtain? What will it cost? Will it sell?" and many other questions that may occur to you. These are vital points to consider, and questions will be cheerfully answered. If you want suggestions on what to invent, in our **Bulletins of Improvements Wanted**, which are sent free to all on our mailing list, you will find the wants of progressive manufacturers and valuable information. All matters are held strictly confidential, and personal services are assured by our **Service Guarantee Contract**. References: 2nd National Bank, Washington, D. C.; John P. Roth Packing Co., Cincinnati, Ohio; Duskill Mop Co., Paducah, Kentucky; North Capitol Savings Bank, Washington, D. C. Listed in the Bankers' and Brokers' Directory.

LANCASTER & ALLWINE
245 Ouray Building Washington, D. C.

COUPON

LANCASTER & ALLWINE, 245 Ouray Bldg., Washington, D. C.
Send me free book "Inventions—Patenting and Promoting," Bulletin of Improvements Wanted and blank form "Evidence of Conception."

Name.....
Address.....

Patents Secured by a Former Examining Official of the U. S. Patent Office
Norman T. Whitaker
Attorney-at-Law and Mechanical Engineer
No printed literature. Inquiries Invited.
27 Legal Building - - Washington, D. C.

PATENTS C. L. PARKER
Formerly Member Examining Corps, U. S. Patent Office
PATENT LAWYER
MCGILL BLDG.
WASHINGTON, D. C.
Patents, Trade Marks, Copyrights, Patent Litigation
Handbook for Inventors, "Protecting, Exploiting and Selling Inventions," sent free upon request.

Send for **FREE BOOK** { **WHAT TO INVENT**
WHAT NOT TO INVENT
HOW TO SELL YOUR PATENT
Copies of nearest Patents and report in every case without charge
H. L. WOODWARD, 9th and G Sts., WASHINGTON, D. C.

PATENTS
MASON, FENWICK & LAWRENCE, oldest U. S. firm having main office at Washington, D. C. Also New York and Chicago. Established 1861. Best References. Trade-Marks Registered. *BOOKLET and Information FREE.*

Protective Patents
Procured Promptly. No fee refund, no guarantee certificate, no so-called prize or free search schemes used in our business. Inventors 104 page Blue Book sent on request.
Robb & Robb, 211-215A Southern Bldg., Washington, D. C.



Four New Booklets for Inventors

Chock full of ideas and practical advice. Tell what to invent and where to sell it. "Patents and Patent Possibilities," and "Practical Suggestions for Inventors" are bristling with facts that every inventor should have. They explain how many of my clients have made money from patents procured by me. What I have done for them I can do for you. If you have **inventive genius** and the **will power** to use it. The "**Inventors Loose Leaf Record File**" will enable you systematically to preserve evidence to prove priority of invention on your part in the event of a controversy. These booklets are unlike anything ever issued for inventors, they were prepared with the idea of **Service**. If you are interested in inventions send for these books; they are free while they last. My service is individual, prompt, efficient and satisfactory. (16 years' experience). I am frank in my opinion on the value and patentability of inventions. Every expedient is employed to secure patents at the least possible cost.

INTERNATIONAL PATENT SOLICITOR

H. S. HILL,
802 Madison Bldg., WASHINGTON, D. C.
Send all four of your booklets to

Name.....
Address.....

Please Mention Popular Mechanics

PATENTS TALBERT & PARKER

That Protect **PATENT LAWYERS**

INVENT SOMETHING IT MAY BRING WEALTH

There Is Always a Demand for Valuable Inventions

Now is the time to patent a meritorious invention. We are constantly receiving letters from manufacturers and investors who are on the alert for new devices, and specialties that are protected by strong patents and can be turned into money through proper handling.

WRITE US TODAY FOR A FREE COPY OF OUR 104 PAGE BOOK—

“How to OBTAIN A PATENT and What to Invent”

or send us a Sketch, Model, or Photograph with written description of your invention for a

FREE SEARCH OF THE PATENT OFFICE RECORDS

and report as to patentability of your invention. If patentable we will send you our Certificate of Patentability which may prove of value and assistance to you.

If you require money with which to secure a patent, ask us to explain our CREDIT SYSTEM, by means of which you will be able to file your application and proceed with your case without delay.

PATENTS SECURED BY US ARE ADVERTISED AT OUR EXPENSE IN POPULAR MECHANICS MAGAZINE

WRITE FOR FREE BOOK OR SUBMIT YOUR INVENTION TODAY

TALBERT & PARKER PATENT LAWYERS 4623 Warder Bldg. (Successors to WASHINGTON, D. C. WATERS & CO.)

HIGH-VALUE PATENTS

—the ONLY kind Wanted and BOUGHT by Manufacturers. Send 8c postage for new book of Extraordinary Interest to Inventors. R. S. & A. B. LACEY, 51 Barrister Bldg., Washington, D. C.



GEARS ALL KINDS SMALL

The most accurate made and prices reasonable. We carry a complete line of gears in stock for immediate shipment. Can also quote on special gears of all kinds. Send us your inquiries.

WRITE FOR CATALOGUE.

CHICAGO STOCK GEAR WORKS
16 S. Fifth Av. CHICAGO



SETS OF CASTINGS OF MODEL ENGINES
ALL METALLIC
GEAR WHEELS & PARTS OF TOYS
WILHELM F. WICHTMANN & CO.

MECHANICAL SUPPLIES AND MATERIAL of all kinds. EXPERIMENTAL AND LIGHT MACHINE WORK to order. 132 MILK STREET. BOSTON



Models and Supplies

We make working models of any description and material, also dies, tools and sheet metal stampings. Send your drawing or sample for estimate. Write for catalog of gears and model supplies. The Pierce Model Works, 3405 Pierce Ave., Chicago, Ill.

PATENTS SECURED OR FEE RETURNED

Latest and Most Complete Patent Book Ever Published for Free Distribution

WRITE FOR IT

Compare My SERVICE and TERMS with Those of Any First Class Attorney

Send Sketch, Photograph, or Model of your invention for an ACTUAL SEARCH of the Records of the Patent Office and report as to patentability — FREE. I give every detail of every case my closest personal attention and do not entrust your interests to assistants. Impartial advice on your ideas. I help you sell your patent. Terms moderate. My 90-page book (1917 edition) tells what inventors should know before they apply for a patent.

GEORGE P. KIMMEL, Patent Lawyer, 200 Barrister Bldg. Washington, D. C.

TYPEWRITERS



\$10
To
\$50

All Makes Rebuilt by the
Famous "Young Process"

Look Like New
Good As New

Don't pay high, exorbitant Prices. Investigate. Our New Illustrated Catalog shows you what we have in all makes of Rebuilt Typewriters, with Prices marked in plain figures. It costs you nothing to look into this Saving Opportunity. If you are in the market for a Typewriter, it will surely mean an economical investment for you.

SEND FOR CATALOG TODAY

Our immense business and equipment enables us to sell one machine or a hundred for quick delivery. All Makes rented or sold at a sharp reduction; and rentals apply on purchase price. Prompt, courteous service. Address—

YOUNG TYPEWRITER CO.

Dept. 73 62 W. Madison St. CHICAGO



Compare It With a Diamond

*If You Can Tell the Difference
—Send it Back at Our Expense*

THESE new, man-made gems will be a revelation to you. After centuries of research, science has at last produced a gem of dazzling brilliance that so closely resembles the diamond that you'll not be able to distinguish it. You may see it for yourself—without charge.

We will send you any of the Lachnite Gems that you may select for a ten days' free trial. We want you to put it to every diamond test. Make it cut glass—stand the diamond file, fire, acid—use every diamond test that you ever heard about. Then, if you can distinguish it from a diamond, send it back at our expense. Write for our new, free jewelry book.

Pay As You Wish

If you wish to keep the remarkable new gem, you may pay the rock-bottom price at the rate of only a few cents a day. Terms as low as 3½ cents a day without interest. No notes, mortgages or red tape. You pay only the direct, rock-bottom price—a mere fraction of what a diamond costs.

Set in Solid Gold

Lachnite Gems are never set in anything but solid gold. In our new jewelry book you will see scores of beautiful rings, La Vallieres, necklaces, stick pins, cuff links, etc., etc. from which you have to choose.

Send Coupon For New Jewelry Book

Put your name and address in the coupon or on a letter or post card now and get our new jewelry book absolutely free. You will be under no obligations to buy anything—or to pay for anything. The jewelry book is free. Send your name and address now.

Harold
Lachman Co.
12 N. Michigan Ave.
Dept. 1193
Chicago, Illinois

Harold
Lachman Co.
12 N. Michigan Av.
Dept. 1193 Chicago

Gentlemen: Please send me absolutely free and paid your new jewelry book and full particulars of your free trial, easy payment plan. I assume no obligations of any kind.

Name.....
Address.....

KEROSENE

\$30 a Week
EASY

Men and Women Wanted to Sell
**PERFECTO
Kerosene Irons**



No experience necessary. Big profits selling this wonderful self-heating satisfaction guaranteed iron. Easy to operate and demonstrate. Sells itself. Use Kerosene (Coal Oil) or Gasoline with same satisfactory results. Absolutely safe, no smoke or odor. Get facts in detail and let us tell you how to obtain Free Sample and start you in a big paying business. Sample case FREE to Agents.

PERFECTO SOD IRON FACTORY
Dept. P. 128 So. Clinton St., CHICAGO, ILL.

INDOOR CLOSET

More Comfortable, Healthful
and Convenient than the Out-Door Closet

Eliminates the out-door closet and open vault. They are breeding places for germs. Have a warm, sanitary, odorless toilet right in your house. No going out in cold weather. A boon to invalids. Endorsed by State Boards of Health.

W. M. Davis writes: "Your indoor closet is giving absolute satisfaction. It is certainly the thing for a home without sewerage."

**Absolutely Odorless
Put It Anywhere in the House**

The germs are killed by a chemical process in water in the container, which you empty once a month. Absolutely no odor. No more trouble to empty than dishwasher. Closet absolutely guaranteed. Write for full description and price.

Agents Wanted — Big Profits Wonderful opportunities in every town, village and in the country. Best season just at hand. Every home is a good prospect. Sell eight out of every ten you call on. Ernest Kidwell writes, "I have ten orders." G. A. Dismann says: "Ship at once twenty closets and fifteen washstands. Sell them all in one community." Sells itself. Everybody hates the outdoor closet. Everybody wants a Ro-San Indoor Closet. Write quick for territory and full particulars.

ROWE SANITARY MFG. CO., 305 Sixth St., Detroit, Mich.
Ask about the Ro-San Washstand—Hot and Cold Running Water Without Plumbing

Please Mention Popular Mechanics

FINCK'S "DETROIT-SPECIAL" OVERALLS

They Wear Like a Pig's Nose



Overalls . . \$1.50
Jackets . . 1.50
Combination
Suits . . . 2.50

THE solid comfort that comes from big, roomy garments, with plenty of pocket space; the solid satisfaction that comes from a durability that outwears three pairs of ordinary garments. That's what Finck's "Detroit-Special" work-garments mean to you.

Ask Your Dealer

If he hasn't them, send price and size, and we'll forward by prepaid parcels post.

W. M. FINCK & COMPANY

1154 Gratiot Avenue

Detroit, Michigan



A complete line of appliances for the transmission of Power. Anything from a bolt to a complete mill or factory outfit. Send for catalogue. Largest Manufacturers of Pulleys in the country.
W.A. Jones Foundry & Machine Co. 1400 W. North Ave. CHICAGO

A FINE CREED—"Of two things one is certain: either you're mobilized or you're not mobilized. If you're not mobilized, there is no need to worry; if you are mobilized, of two things one is certain: either you're behind the lines or you're on the front. If you're behind the lines there is no need to worry; if you're on the front, of two things one is certain: either you're resting in a safe place or you're exposed to danger.

"If you're resting in a safe place there is no need to worry; if you're exposed to danger, of two things one is certain: either you're wounded or you're not wounded. If you're not wounded there is no need to worry; if

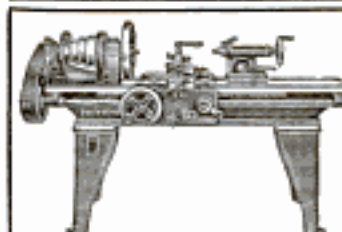

South Bend Lathes
For the Machine and Repair Shop

How to Run a Lathe
A 50 cent book for 10 cents.
Postpaid, stamps accepted.

Straight or Gap Beds. Send for free catalog giving prices on entire line.
SOUTH BEND LATHE WORKS
423 Madison St., South Bend, Ind.

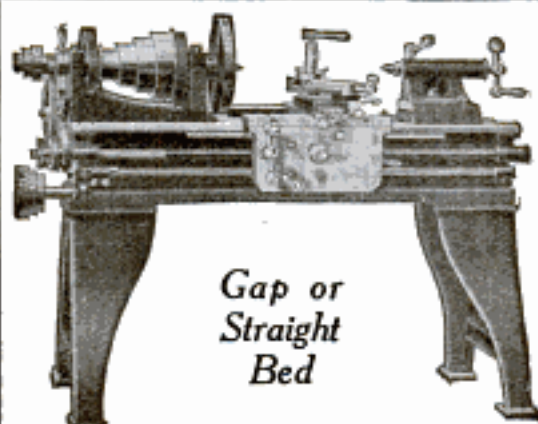

Gap or
Straight
Bed

Sebastian ¹⁵ Inch Lathe

Do you know that there are more "Sebastian" Lathes used in Garage and General Repair Shops than any other make

?

THE SEBASTIAN LATHE CO.
107 Culvert St. Cincinnati, Ohio, U.S.A.

Sixty-one years of development with the ablest mechanical minds have placed

CRANE VALVES AND FITTINGS

on a vantage-ground of excellence that has not been equalled by competition.

FOUNDED BY R. T. CRANE, 1866

CRANE CO.
836 S. MICHIGAN AVE.
CHICAGO

Branches in 51 leading cities

you are wounded, of two things one is certain: either you're wounded seriously or you're wounded slightly.

"If you're wounded slightly there is no need to worry; if you're wounded seriously, of two things one is certain: either you recover or you die. If you recover there is no need to worry; if you die you can't worry."

This is the "Litany of the Poilu," as set forth by Miss Kathleen Burke, who is writing, in "Land and Water," a series of articles descriptive of her visit to the French front. Its serene philosophy interprets as well as words can do the spirit of France.—The Aeroplane, London.

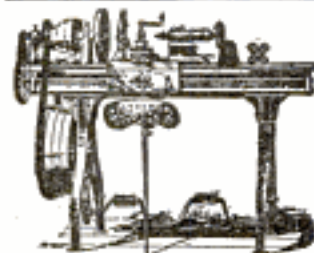

LATHES

9 to 18-inch Swing

List price \$75 and up according to size. When ready to buy send for Lathe Catalog and prices.

W. F. & John Barnes Co.
100 Ruby Street, ROCKFORD, ILL.

DIVINE Red Devil Water Motor

4-inch size
6-inch size

A perfect small motor — made like the big turbines — wonderful power.

No muss—no fuss—no mechanical complications. Attach in cellar or at any faucet.

4-inch size for Polishing 6-inch size for Power

Only Motor
to do
This Work

**For Mechanics, Tradesmen,
Doctors, Dentists,
Shop and Home**

Anyone can install. We also supply pulley, emery and buffing wheel. **Free Booklet describes work it can do.**

Write today and give size of faucet, water pipe and water pressure and work to be done.
Divine Water Motor Co., Dept. P, Utica, N. Y.



American Supremacy In Machinery

This supremacy has been gained and held by quantity production, enabling American manufacturers to dominate the world-market in spite of paying the highest wages. It is the toolmaker that has made this quantity production possible.

In the constant search for better tools, a most noteworthy advance is made in the design of the Gun Tap shown below. Here is a tap in which *breakage is almost entirely eliminated*. Think of that for a minute, remembering that the breakage of ordinary taps runs about 90%.

The Gun Tap cuts with a shearing action, the only true cutting, and a new feature in taps. This makes it the easiest cutting tap on the market. It shoots the chips ahead—whence the name "Gun" Tap—instead of jamming them into the flutes. Thus the flutes can be shallow, and this, with the easy cutting, makes it almost unbreakable.

For further information as to these details, its unequalled accuracy, and the possibilities of increasing production, send for Bulletin entitled "The 'Gun' Tap."

Greenfield Tap and Die Corporation Gages-Taps-Dies

Threading Machines, Reamers, etc.
Greenfield, Massachusetts



The "Gun" Tap

(Trademark
Registered)

*The tap
that wears
out before it
breaks. Patented
Dec. 28, 1915.*

AMERICA FIRST

Please Mention Popular Mechanics

WHITING-ADAMS BRUSHES



**GIVE PAINT
and VARNISH
A Square Deal**

The BEST of paint or varnish will look BETTER and wear LONGER if it is put on by the best way.

The best way means with
Whiting-Adams Brushes

Nearly all painters
and varnishers use them

They have learned by many years' experience that **WHITING-ADAMS** on a brush means satisfaction. We have been satisfying particular painters and varnishers for over a hundred years.

Send for Illustrated Literature

JOHN L. WHITING-J. J. ADAMS CO.
BOSTON, U. S. A.
Brush Manufacturers for Over 100 Years

Whiting-Adams Brushes awarded Gold Medal and Official Blue Ribbon, the highest award at Panama-Pacific Exposition, 1915.

"IDEAL" Lawn Mower Grinder

Big Money-Maker
Many of our customers
make \$300 in one season.
YOU CAN DO AS WELL.

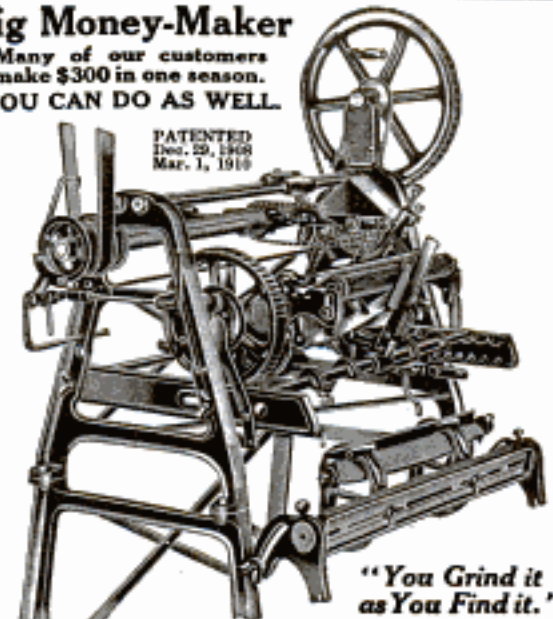

PATENTED
Dec. 29, 1909
Mar. 1, 1910

**"You Grind it
as You Find it."**

Grinds all makes of Mowers perfectly in 15 minutes without removing wheels, ratchets or reel knife, BETTER, QUICKER and EASIER than it can be done by hand. Has perfect Skate Sharpener Attachment. Run by hand or power. Nearly 10,000 in use. Price, only \$40. Sold on easy-payment terms. Also makers of the "Peerless" Horse Mower Grinder.

WRITE TODAY for catalog and full information

THE ROOT-HEATH MFG. CO., Plymouth, Ohio

A valuable asset to the Tool Kit

"Red Devil" Mechanic's Combination Plier



No. 325—5½ in.

A 5½ inch drop forged steel tool combining burner grip, flat-nose and side cutting pliers. Scientific handles fit hand like a glove and prevent slipping. From dealers, or if not from us for 70c. Tool literature sent free on request.

SMITH & HEMENWAY CO., Inc. 97 Chambers St. NEW YORK CITY

How About a UNION Tool Chest



An actual help in your every-day work. A roomy, compact tool chest that will stop the nuisance of lost tools. Has a place for every tool. You know immediately if one is mislaid or borrowed.

Unconditional Money-Back Guarantee

Write for our Catalog and Prices and Special Offer if we have no dealer near you.

Union Tool Chest Works
22 Railroad St. Rochester, N. Y.

Style G—2 sizes 17 other styles and sizes. Built of selected plain or quartered oak or leatherette covered, some with mahogany fronts. Correctly designed. Perfectly fitted drawers. Many sizes.

THE AWL YOU WANT

See That Reel



Is the genuine MYERS \$1.00 "Lock Stitch" Sewing Awl with the exclusive feature. See thread reel in front of handle under the finger tips. Natural tension. Sews heavy or light material, diamond point, full grooved needles used to protect the thread when sewing.

C. A. MYERS COMPANY, 6339 University Ave., Chicago, Illinois

Drilling Wells is a Year Round Business



Drilling Water Wells is a profitable, healthful, year-round business. There are wells all around you to be drilled. Don't you want to get into a money-making business for yourself? Write for particulars.

STAR DRILLING MACHINE CO.
664 Washington St. AKRON, OHIO

Water Pumps Water

with a Rife Ram. Plenty of it for every purpose about your farm and country home — day and night, winter and summer, without fuel, labor, freezing or repairs. The

RIFE RAM

is operated by any small stream having a fall of three feet or more and a supply of three or more gallons per minute. Fills high elevated tanks or operates air pressure system.

Easy to install. First cost the only cost. Always on the job; over 11,000 in daily use. Tell us your water supply conditions. Ask for free estimate and catalog. Now is the time to install. Write today.

RIFE ENGINE CO., 3131 Trinity Building, NEW YORK





Empire Power Grindstone

Built to run
by gas engine.

use of tools of proven quality. Don't
buy your grindstones haphazard.

This
Trademark
identifies the
Genuine

Berea and
Huron Stones.



The Cleveland Stone Co.
1111A Leader-News Bldg. Cleveland, Ohio

COW CONQUERS AIRMAN—A dispatch from Kiev, Russia, states that when a German aeroplane landed in a field near Lutsk, a terrified cow charged the propeller with its horns and smashed it up, with the result that the airman and his machine were captured.

The record price of five pesos (\$2.50) for admission to a moving-picture show was paid recently at Buenos Aires at the first performance of a recently released American spectacle of great magnificence.

Reinforced Sides

Long, Strong Tail



Price 10c

Do you take advantage of exceptional opportunities?

If so, send 10c for sample dog. We feel confident a sample will result in continued reorders. Size 3/8 in.
THE WHEELER TOOL CO., 133 Water St., SOUTH NORWALK, CONN.

Acetylene Blow Torch Prest-O-Torch

Quicker and cheaper than
a gasoline blow-torch for
brazing and soldering

For factories, repair shops, linemen, dentists, jewelers, the Prest-O-Torch saves time and money. Used with Prest-O-Lite Tanks—ready-made gas. Intense, concentrated flame instantly lighted. No depreciation, safe and convenient. Style "A", price, 75c (Canada, 85c) will braze up to 3/8 inch round rod. Style "C" for heavier work, \$2.25 (Canada, \$2.75). Special styles for dentists. Write for literature or send order now. Money refunded if not satisfied.

The Prest-O-Lite Co., Inc. 816 Speedway
Indianapolis, Ind.
Canadian Main Office and Factory, Merrittton, Ont.



"Yes, sir, that vernier caliper has seen thirty-five years of active service and it's still the same dependable tool it was when I bought it. What make, did you say? Why

A Brown & Sharpe Tool of Course

like the rest of my kit."



This mark is your guarantee of permanent accuracy.

Whether you are an apprentice, skilled machinist, or just have a little workshop of your own for your own pleasure or profit you'll find your work better and easier with Brown & Sharpe tools.

Our Catalog 27 should be in your hands. Send for your copy today. FREE.

Brown & Sharpe Mfg. Co.
PROVIDENCE, R. I.

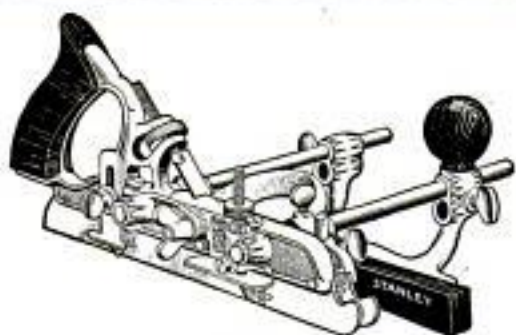

STANLEY "45" PLANE

SEVEN TOOLS IN ONE

1—Beading and Centre Beading Plane. 2—Rabbit and Filletster Plane. 3—Dado Plane. 4—Flow Plane. 5—Matching Plane. 6—Sash Plane. 7—Superior Slitting Plane.

A very practical and useful tool for Carpenters, Joiners, Cabinet Makers, Pattern Makers, or any artisan interested in wood working of any description.

For Sale by All Hardware Dealers

Send for special 12-page Booklet describing in detail this most interesting tool

STANLEY RULE & LEVEL CO.
NEW BRITAIN, CONN. U.S.A.



TOOL CASES

For Up-to-Date TOOLMAKERS and MACHINISTS

We carry the finest and most complete line of mechanics' toolcases and tools in the country. We guarantee to please you or refund money. Write for free catalog.

J. M. WATERSTON

75 Woodward Ave., E., Detroit, Mich.

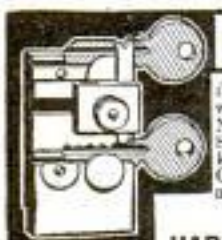

Duplicate Keys

for all Pin Tumbler Locks made in one minute with Harrison M.L.P. Key Filing Machine. No misfits. Thousands in use. \$3.50 net. Special diamond-shaped files for angular cut keys, 40c each; 3 for \$1.00. Harrison U.K. Key Clamp duplicates all common keys without a caliper. Price, \$1.00. Parcel post prepaid.

Money returned if not satisfactory.

HARRISON & CO., 81 New St., New York

Every Builder and Contractor Needs this Level

10 Days' Free Trial

We have been makers of transits and levels since 1868 and our instruments are the standard of the world. Prove the superior quality of the Aloe Convertible Level by giving it a 10 days free trial. Use it on your every-day work laying out buildings, leveling up foundations, walls and floors, aligning, shafting walls, piers, etc., for getting angles or levels anywhere.

Easy Monthly Payments

If you decide to keep it, the instrument will earn its way while you make monthly payments so small that you hardly feel them. Costs no more than to pay all cash. No red tape about it, no embarrassing questions, everything confidential.

Aloe Convertible Level

is the finest instrument ever offered at anywhere near its price. Permits taking of sights both above and below the horizontal. For taking vertical sights it is provided with a special convertible bracket rigidly and permanently attached to the cross bar. The telescope is fitted with permanent axis which rests in bracket bearings and is held by clasp easily and quickly released.

Aside from being a level, it is a modified transit that permits a much wider range of work than is possible with the ordinary architect's level. With it the man without technical training can obtain the same absolutely accurate results as the expert. Write today for descriptive circular.

A. S. ALOE CO.,
620 OLIVE ST., ST. LOUIS, MO.



HOW TO OVERCOME RED TAPE—From time to time, a story comes along from "Somewhere in England" or "Somewhere in France," or "Somewhere elsewhere," which shows that the "official routine of the official department" is receiving much buffeting in these times. A certain commander on a certain front decided, after careful thought, that he needed certain things, and needed them very much, says the Christian Science Monitor. He sent his list to headquarters, and, after a long delay, came a sheaf of official forms full of detailed inquiry as to why he wanted each thing he had asked for. The commander thought over the matter for a day or two. Finally he took his courage in both hands, and a

SAMPLE 75c

THE SPEEDY Stitcher



The greatest invention with which the unskilled man can repair leather goods or any heavy material. Needles and thread are inside the handle. **FAST SELLER.**

Agents Wanted Foreign trade solicited. Advertising circulars in different languages.
Stewart-Skinner Co., 26 Fern St., Worcester, Mass., U.S.A.

SIMONDS "The Saw Makers"

Have one saw that's always keen for business; one that holds its edge through thick and thin. Then you can do your best work. For a Hand Saw, Circular, Coping, or Hack Saw, or File, use Simonds Brand.

Write for free copy of "How to File a Hand Saw."

SIMONDS MFG. CO., Fitchburg, Mass.
Established 1832

5 Factories 11 Branches

"I Tell You It's A Great Saw"

DO YOU OWN THESE CRESCENT TOOLS?



The mechanic who knows the value of **quality** in tools, orders these three Crescent tools by name:

Crescent Adjustable Wrench

Crescent Double-End Wrench

Crescent Hamr-Handl Screw Driver

Good dealers everywhere sell Crescent Tools. Our illustrated catalog, sent free on request, shows many others, equally useful and dependable.

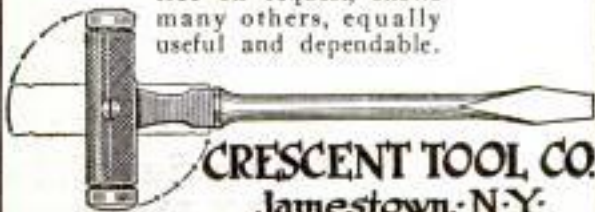

CRESCENT TOOL CO.
Jamestown, N.Y.

blue pencil in one of them, and, so the story goes, wrote across each of the forms the legend, "I want these things because there is a war on over here." He got them, without further question.

ELECTRIC COOKING AMONG BIRDS—It is reported by a California publication, that recently two transmission-line short circuits were caused by birds dropping small snakes across the bare cables. In each instance the snakes were beautifully toasted.



ToolCases for Toolmakers and Machinists

Keep your tools orderly arranged in a Gerstner Portable Tool Case. There's a place for every tool in one of the felt lined drawers. Every up-to-date mechanic needs one and you'll find our Cases the best built, neatest and most practical on the market. We guarantee to please or refund all money. Write for our booklet

Gerstner & Sons

Mfrs. of Mechanics' High Grade Tool Cases
808 Columbia St., DAYTON, OHIO

Braces
Drills

MILLERS FALLS TOOLS

Hack Saws
Mitre Boxes

Do Better Work and Last Longer

Write for catalog showing complete line

MILLERS FALLS CO., Millers Falls, Mass.

LEPAGE'S
GLUE 10¢
BETTER THAN MUCILAGE

Checking Up Progress



Good work requires frequent testing to insure accuracy in progress; and skilled carpenters know by experience that they can do their best work with



Starrett Tools

From use on the simplest operation in squaring up stock to the laying out and measuring of complicated joints and framing jobs, these tools have proved their efficiency. The line includes for carpenters, steel tapes, rules, squares, levels, marking gages, builders' combination tools, etc.

Starrett Combination Square

Here is one tool in particular that every carpenter should have—it is really five tools in one—a rule, square, level, bevel, and depth gage. These and all other Starrett Tools are for sale at good hardware stores. 42-601



Send for
Free Catalog
No. 21AP.

THE L. S. STARRETT CO.
The World's Greatest Tool Makers
ATHOL, MASS.



Please Mention Popular Mechanics

Great
For
Hard
Jobs



"YANKEE"
TOOLS
Make
Better
Mechanics

YOU'LL not need to take work apart or remove surrounding sections to drill holes if you have this "Yankee" Ratchet Hand Drill No. 1530.

It works in places and under conditions where it is impossible for other drills to operate. It's the ingenious "Yankee" Ratchet Shifter that does the trick.

There are five adjustments to this drill, con-

trolled by position of Ratchet Shifter. First notch, Plain Drill; second, left-hand ratchet; third, right-hand ratchet; fourth, double ratchet; fifth, gears locked.

The wonderful double ratchet movement is a big time-saver on many jobs. Here every crank movement forward and back, even through so small an arc as one inch, causes the drill to cut continuously.

"YANKEE" Ratchet Hand Drill

No. 1530—Price, \$3.25 Measures only 10½ inches, weighs 1¼ pounds. Magazine in detachable handle for drill points. You purchase drill points as needed. Three-jaw hardened steel chuck holds round shanks up to 3/16" diameter.

Your Dealer Can Supply You

"Yankee" Tool Book, showing all "Yankee" wood- and metal-boring and screw-driving tools, sent free.

NORTH BROS. MFG. COMPANY, Philadelphia

Models
and
Gears

Experimenters—Inventors

Developing inventions and making working models our specialty. Well equipped shop and staff of experts at your service. Carry complete stock of gears. Shipments same day order received. ESTABLISHED 1882.

UNION MODEL WORKS, 121 S. Clark St., CHICAGO



OUR famous *Lutesite* Hollow Handle Tool Set. Has 7½ inch handle of polished cocobolo, 10 real quality tempered steel tools. Strong, nickel plated chuck. Handy around home or shop. Worth \$1.50. Order direct from this ad by No. 85Z1334. Shipping weight 1¼ pounds. Satisfaction Guaranteed—or Money Back.

1,000 TOOL BARGAINS

In our New Tool Book. Write for it. Address nearest house.

Montgomery Ward Co. Dept. A.H. 133
NEW YORK CHICAGO KANSAS CITY
FT. WORTH PORTLAND, ORE.



BARNYARD FOWLS IMITATE HISS OF FLYING SHELLS—A singular and very interesting fact has been chronicled in an English publication recently, says *Our Dumb Animals*. A soldier, stationed at a farm in France, in a letter states: "We often hear the sound of a shell coming and yet there is no burst." He eventually traced this sound to the fowls in the farmyard—first to a hen, afterward to a cock. They had learned to make the noise since the war began; and the French farmer told him they often kept it up for a long time—surely a most curious instance of bird mimicry. The fact is vouched for by an authority, however.

CRESCENT WOOD WORKING MACHINERY

is high in quality, moderate in price, and always satisfactory.

Ask today for catalog of band saws, jointers, saw tables, planers, disk grinders, swing cut-off saws, shapers, planers and matchers, borers, hollow chisel mortisers, variety wood workers, universal wood workers.

THE CRESCENT MACHINE CO.
93 Columbia St., Leontia, Ohio

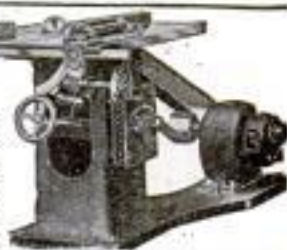

Portable Cases

**FOR TOOL MAKERS
AND MACHINISTS**

Twelve styles, felt lined drawers, solid brass trimmings, best of material, beautiful finish, low prices, satisfaction guaranteed. Ask for booklet of cases built for service.

The Pilliod Lumber Co.
SWANTON, OHIO

DEMING WATER SUPPLY SYSTEMS

Furnish home, barn or country estate with a steady, dependable supply of clear, pure water under high pressure.

The Deming catalog of hand and power operated water supply equipments is free to

THE DEMING CO., Pump Specialists for 35 years 130 Depot St., Salem, Ohio



The tool with 5 big features

WHEN you thread pipe, do it with the least labor, bother and complication possible. For twenty-five years we have been specializing on pipe-threading—steadily working to reduce those three elements. The result is

OSTER Bull-Dog Die-Stocks

the tools with the 5 big features—(1) Self-locking, adjustable dies; (2) Self-centering guides, lever-operated; (3) Dies open up after cut (to lift off pipe without backing up) and reset automatically to size; (4) no loose bushings to lose or mislay; (5) No small, breakable parts. For all the facts in condensed form, ask for "The Bull-Dog Tale."

THE OSTER MFG. CO.
2100 E. 61st St., Cleveland, Ohio, U. S. A.

The Bull-Dog Line includes 11 tools, plain and ratchet, each threading from 4 to 8 sizes of pipe.



Kindly send me (free) "The Bull-Dog Tale"

Name

Address

City..... State.....

Occupation..... (2100)

PROTECTION for your WIFE, your FAMILY—and especially your PIPE. While they closely resemble a revolver they are really BEAUTIFUL METAL-PIPE CASES intended to protect the Clay Pipe. Each CASE is fitted with an imported absorbent pipe with rubber mouth piece. LARGE AND SMALL sizes each 50¢. Send Money Order or 2¢ stamp for Circular. THE MONARCH SERVICE CO - 15 CORNHILL - BOSTON - Mass.



Engineer Whitcomb, his giant engine, his famous watch
One of the World's finest trains running between Chicago and Los Angeles makes a "mile a minute" slip with a famous "Santa Fe Special" Watch in the cab. Whitcomb says: "BEST WATCH I EVER CARRIED"

WRITE FOR FREE WATCH BOOK TODAY—

21 JEWEL \$3.50
"Santa Fe Special" A MONTH

The REAL Triumph of watch manufacturing—Write NOW for FREE watch book, showing newest case designs in 4-colors. Read the so-called secrets of watch making. Read how you can save from one-third to one-half of your money. Buy "Direct" at factory cost—cutting out the wholesale Jeweler's profit.

Buy the Best Railroad Watch
the "Santa Fe Special"

the only watch that's "GUARANTEED FOR LIFE," thin model, all sizes, ADJUSTED to positions, ADJUSTED to isochronism, ADJUSTED to temperature, ADJUSTED to the second.

See THIS WATCH FIRST
Sent without one penny down

EASY PAYMENTS to suit you. Write today. Your name on a postal brings the FREE watch book.
Santa Fe Watch Co., Dept. 36, Topeka, Kan.

Perfect Hearing for the

DEAF

SCIENCE has found a way for you to hear—perfectly. The wonderful Little Gem Ear Phone

doubles the joy of living. Look at it and you SEE the simplest and smallest hearing device in the world; use it and you FEEL you have the most wonderful piece of mechanism yet devised for afflicted humanity.

The absolute superiority of the Little Gem was recognized at the Panama-Pacific Exposition, where it received the Gold Medal, highest award for ear phones, in competition with the world.

Write for booklet "Cause This Ear to Hear" and learn how you may obtain our \$10 Auto Ear Massage FREE.

Gem Ear Phone Co., Inc.
802-L Marbridge Building, Broadway and 34th Street.

New York

\$100 TO \$300 NET PROFIT PER MONTH REPAIRING AUTOTIRES

With Practically No Capital You Can Start an Independent Business of Your Own That Pays You Big Profits Right From the Beginning.

In the last few years, with the launching upon the market of hundreds of thousands of low-priced motor cars, the demand for tire-repair work has completely outdistanced the available service. Millions of dollars are spent annually for repairing blowouts, vulcanizing old casings, retreading, mending punctures, etc.

Take Advantage of This Golden Harvest of Profit—Send for Catalog of Badger Tire Repair Equipment and Learn How We Help You Start a Business.

Learn how you can establish yourself in a five, money-making business with unlimited possibilities—a business that's practically all cash and over 75% profit. If you don't care to give all your time to it at first, start at home in your "off" hours, using a spare room, attic, basement or shed. This handsome profit is insured by the famous Badger Solid Pad System, with the celebrated Attached Sliding Hinge Clamp and the many other improved, exclusive, up-to-the-minute features. Get the details—learn all about our complete money-making **Free Aid Service**—our special time, labor and money savers—the many helps and hints we give you to get and hold the business.

Mail this Coupon for free catalog and full particulars.

TIRE REPAIR EQUIPMENT CO.

Tire Repair
Equipment Co.
740-744 Johnson St.
Appleton, Wis.

740-744 Johnson St.
APPLETON
WIS.

Gentlemen:—Please send me Free Catalog of your Badger Attached Sliding-Hinge-Clamp Steam Vulcanizer and information on how to start a tire repair business.

NAME.....

ADDRESS.....

CITY.....STATE.....



Save Your Worn Tires

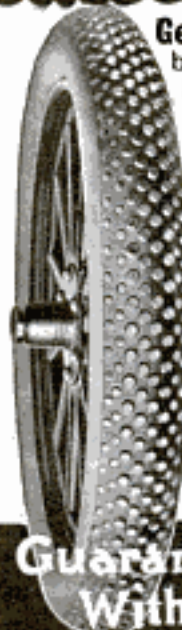

Get 5,000 Miles More Service by "half-soleing" them with Steel Studded Treads the same as European Motorists have been doing for over 3 years. 30,000 American Motorists have done this in the last 8 months and are saving \$50 to \$200 a year in tire expense. **5,000 Miles** without puncture is the signed guarantee you get with every Durable Steel Studded Tread.

We Deliver Free without a cent deposit, prepay the express and allow you to judge.

Special Discount offered to motorists in new territory on first shipment direct from the factory.

Stop throwing away your worn tires—mail the coupon below for details—be sure and put in your tire sizes.

Guaranteed 5000 Miles Without Puncture

MAIL TODAY—SAVE THE DISCOUNT

The Colorado Tire & Leather Co.
344 Tread Bldg., Denver, Colo.
C-44 Transportation Bldg., Chicago, Ill.
720-443 Woolworth Bldg., New York City

Without obligation send me free catalog, copy of guarantee, sample and booklet "10,000 Miles on One Set of Tires."

Name.....

Address.....

My Tire Sizes are.....

Please Mention Popular Mechanics

TWIN Always on the Job FIRE Banishes Plug Trouble

PUT a set of Twin Fire Spark Plugs in your motor, then forget them. You'll be surprised at the way they overcome "shooting oil" and sooting trouble. If one point fouls the other continues, cleaning the fouled point. The Twin Fire fires double intense sparks. Ask your dealer today; if he cannot supply you send direct. Give size required.



Ordinary plugs are dead when clogged with oil or sooted.

Twin Fire always fires. One point cleans the other.



ing the fouled point. The Twin Fire fires double intense sparks. Ask your dealer today; if he cannot supply you send direct. Give size required.

Twin Fire Spark Plug Co.
660 Woodward Ave., Detroit, Mich.

Dealers—Here's your opportunity for increased profits. Quick turn-overs and liberal profits. Demand big. Write or wire for particulars.

PRICE \$1.00

NEW-DISCOVERED MESOPOTAMIAN TABLET GIVES STORY OF DELUGE—New light has been thrown on the story of the deluge by the discovery among the stores of Mesopotamian texts of the Smithsonian Museum of a small tablet of earlier date than

STANWELD Cold Drawn Seamless Steel TUBING

Lightest, smoothest, strongest Steel Tubing made. World's largest manufacturers of bicycles, motorcycles and automobiles use it exclusively. Send for Folder "A."

THE STANDARD WELDING COMPANY
Main Office and Factory CLEVELAND, OHIO

Cut Down Tire Expense!

Get a
5,000-MILE Guarantee
With Every Tire

for your Ford. 4,000-mile guarantee with all other sizes. Save money by buying **RIVERSIDE TIRES** Supreme quality—tough fabric, with selected up River Para Rubber, extra thick tread. **Unconditionally Guaranteed Satisfactory or Money Back.** Send for

The Money-Saving Auto Book

Shows you how to save dollars and dollars on high-grade auto accessories of all kinds. Write today.

Write House
Nearest You

Montgomery Ward & Co. Dept. C133
NEW YORK CHICAGO KANSAS CITY
FORT WORTH PORTLAND, ORE.



Dayton Motor Bicycle

HERE is the greatest recent achievement in the Motorcycle world—a practical front wheel drive Motor Bicycle. Light in weight, simple to operate, easy to control, low in first cost and upkeep, and built of best materials throughout.

Motor, 1 3/4 h. p. four-cycle, air cooled. Magneto ignition. Steel clincher rims with 2 in. extra heavy corrugated tread tires. Not a motor attachment for a bicycle, but a complete Motor Bicycle of special construction throughout.

World's Lowest Priced \$100 Complete Motor Vehicle
(WITH CLUTCH \$110)



Built to stand hard, every-day service. Clean and comfortable to ride. Speed range, 5 to 25 miles per hour. Men's and Ladies' models.

We Need Young Men

There is a real opportunity open to one young man (or firm of young men) in each town where we are not now represented. The exclusive agency for the Dayton Motor Bicycle offers a bona-fide opportunity for you to get into a real business for yourself. Write for our agency proposition.

Cycle Department
The Davis Sewing Machine Co.
411 Newcom Ave. Dayton, Ohio

most deluge inscriptions. It seems to form a sequel to another tablet found some time ago also in the museum.



BIG PROFITS In Charging Auto Storage Batteries
Hundreds of garage owners are clearing from \$25.00 to \$50.00 profit each month with the H.B. Charging Set. Current costs 15 cents per battery and you get from 75 cents to \$1.50 for each battery charged. H.B. places this money-maker in your garage—the balance in monthly payments of \$25.00 each. Every H.B. outfit fully guaranteed. Send in this ad with your name and we will send details.
NOBART BROS. CO. Box 62 TROY, OHIO

Effecto FINISHES

MAKE OLD AUTOS NEW



Convert Your Bicycle into a Motor-Cycle. Motor fits any wheel. BEST, MOST RELIABLE. Best hill climber. More STEFFEYS in use than all others. Stamp for circulars. STEFFEY MFG. CO., 5007 Brown Street, PHILA., PA.



This Trade-mark is on the highest quality of all kinds of rubber goods.

Iver Johnson

REVOLVERS SHOT GUNS
BICYCLES MOTORCYCLES

Send for 84-page Man's Book—Free

Iver Johnson's Arms & Cycle Works
307 River Street FITCHBURG, MASS.

ROOFING

At Rock-Bottom Prices

Get Our Freight Paid OFFER

Don't consider investing your money in roofing, ceiling, siding, etc., until you have received our Roofing Book which quotes

Lowest Prices Ever Made on World's Best ROOFING

We sell direct to you from the largest sheet metal plant in the world. We save you all middlemen's profits. We prepay freight and give you a binding guarantee against lightning losses. Send coupon for free book—and read our proposition in full.

Lightning-Proof, Fire-Proof and Rust-Proof

Edwards Tightcote Roofing can be bent, twisted, or struck with lightning, and galvanizing will not crack or flake. Bend it or hammer it, you can't loosen or scale galvanizing. This means an everlasting galvanized roofing that will last as long as building.



GARAGE \$69.50 and up
Lowest price ever made on Ready-Made Fire-Proof Steel Garages. Set up any place. Postal brings Garage Book showing all sizes, styles, etc.

will convince you that we can save you a lot of money on any kind of roof you need, also on ceiling, siding, wallboard, etc. Fill out coupon and mail today. Ask for Book No. 350.

The Edwards Manufacturing Company
300-350 Pike Street CINCINNATI, OHIO

BARGAIN BOOK COUPON

The Edwards Manufacturing Company
300-350 Pike Street, CINCINNATI, OHIO
Largest Makers of Sheet Metal Products in World
Please send FREE Samples, Freight Paid Prices and World's Greatest Roofing Book No. 350.

NAME.....

ADDRESS.....

Please Mention Popular Mechanics



"Reo" Metal Cluster Shingles



Spanish Metal Tile



Corrugated Sheets



Edwards Patent "Grip-Lock"

"REO" Metal Shingles

are rust-proof on edges as well as sides. One man can lay them. They interlock; cannot come off. Nail holes all covered by upper layer. Forever wind and weatherproof. Hammer and nails only tools needed.

Samples FREE

Send coupon for World's Greatest Roofing Book and Free Samples. Book



Don't Monkey With the Buzz-Saw

and don't experiment with an unreliable brake. It is dangerous business. Experienced cyclists for the past sixteen years have given consideration to only one brake—the



DUPLEX COASTER BRAKE

Its reliability is known. It has proved itself dependable thousands and thousands of times under all riding conditions. Cyclists know they can trust it, because it has never failed. Through actual service it has earned its reputation as the standard brake equipment—100% efficient.

"Corbin Control Means Safety Assured"

Powerful, durable and sure; smooth in action, easy of operation, gradual or instant of grip. There is no doubt about it, the Corbin Duplex is the only brake you can afford to equip to your bicycle—old or new. It doubles the fun and safety of riding. Insist on the Corbin Duplex. It is the only brake for you to use. At all bicycle dealers'. Ask for it.

The Corbin Screw Corporation

The American Hardware Corp., Successor
200 High Street New Britain, Conn.
Branches: New York Chicago Philadelphia
Makers of Corbin-Brown Speedometers



MAKE YOUR BIKE A MOTORCYCLE

at a small cost, by using our attachable outfit. Fits any Bicycle. Easily attached. No special tools required.

"Used His Four Years"

Harry A. Hyatt, of Boreas River, New York, writes: "About four years ago I received my motor attachment, and wish to say that I am satisfied with it in every way, for it has certainly given me good service. Anyone wanting a motorcycle or attachment, I would recommend them to the Shaw Manufacturing Co."

FREE BOOK Write today for bargain list and free booklet, fully describing the SHAW Bicycle Motor Attachment. Motorcycles all makes, new and second-hand, \$35.00 up.

SHAW MANUFACTURING CO.
Dept. 6 GALESBURG, KANSAS



Veeder COUNTERS

register reciprocating movements or revolutions. Any mechanical engineer will tell you that the word Veeder stands for the best constructed and most accurate counting devices in the world.

There are many kinds of Veeder counters, to suit practically every need. Send for our Free Booklet, which illustrates our counters and gives much interesting information.

Cyclometers, Odometers,
Tachometers. All kinds of
counters. Fine Die Castings
VEEDER MFG. CO.
4 Sargeant Street, Hartford, Conn.



**Full Size
\$1.25**

The Boy's Junior Power Driven Automobile

You can build it yourself or buy it complete already assembled. 1917 Model

Parts inexpensive.
Send 20c for blue print and price list of parts.



**SYPPER
MFG. CO.**
146 Warren St., Toledo, Ohio



MOTORCYCLE BARGAINS!

Single and Twin. Hendersons, Harleys, Indians, Excelsiors, Kullures, Embicars, Terns, Pops, All makes guaranteed. A-1 shape. Tuned up ready to ride. \$75 to \$100. Motorcycle tires \$3, Lamp \$3. Automobile tires \$2. Bicycles \$5, Tandems \$20. Old motorcycles taken in trade. Highest prices allowed for them. Swap in yours. SEND FOR CATALOG.

DENINGER, The Price Cutter, ROCHESTER, N. Y.



Folding Truck Body

For Fords and Other Light Roadsters. Strong, Serviceable, and Attractive. Easily Attached. Folded, looks like a regular roadster. Open, it's an efficient light delivery truck.



Butler All Metal Garage

Fireproof, portable, easily erected. For one or more cars. Round or Gable Roof. Write for free booklets.
BUTLER MFG. CO. 604 Butler Bldg., KANSAS CITY, MO.
911 Sixth Ave., S. E., MINNEAPOLIS, MINN.

Please Mention Popular Mechanics



"Somewhere in France"

Thousands of Stromberg-equipped cars are enduring heart-breaking service and performing miraculous feats in the great world war—where 100% reliability, service and speed are absolute necessities. In America thousands upon thousands of Stromberg-equipped cars are performing **equally** wonderful feats.

Send us the name, year and model of your car and learn how to insure easy starting, better service and gasoline economy this winter.

STROMBERG MOTOR DEVICES CO., Dept. 314, 64 E. 25th St., Chicago, Ill.

"Everywhere in America"



New **STROMBERG** Does it!
CARBURETOR

Russel Internal Gear Drive Axle



The most serviceable and economical motor truck axle made. Write for convincing reasons why your truck should be equipped with the Russel Axle.

RUSSEL MOTOR AXLE COMPANY, Central Ave., North Detroit

RIDE A BICYCLE *THIS YEAR* GET THIS FREE BICYCLE CATALOG



GET acquainted with the joys of cycling through the countryside on your own bike. Get out in the open and secure this excellent exercise. Do it *this year*. Start right now by sending for your copy of our big free Catalog of Bicycles.

We don't believe you'll find better bicycles than those we sell, or lower prices than we quote. There are some unusual points about our great line of bicycles that you will appreciate. But you must get the book. Why not send for it today?

Just mail us a postal card bearing our name on one side and your name and address on the other, with the words: "Send me your free Catalog of Bicycles No. 830P."



SEARS, ROEBUCK AND CO. CHICAGO

1917
ARROW

Send the coupon. Get full details of the wonderful 1917 ARROW—the biggest bicycle value ever built. Read below the description of the new motorcycle type. All sizes for boys, men and women.

Electric Light Motorcycle type, frame, saddle, handle-bars, pedals, mud-guard, stand and luggage carrier. Fish Thermo-Proof Non-Skid tires. Adherlon or New Departure Coaster Brakes. Tool kit and tire pump. Other new features.

Send coupon for catalog—see many other models.

Great Bicycle Offer—

We ship the wonderful 1917 ARROW to you *without a penny down*. If you do not agree when you see the 1917 Arrow that it is the biggest bicycle bargain you ever saw, send it back at our expense. You be the judge. Send coupon for catalog.

Pay As You Ride

If you decide to keep the ARROW, start riding and enjoying it right away. And pay the special rock-bottom price—a small amount each month while you ride. Think of it—the rock-bottom cash price on easy payments. Don't pay all cash for a bicycle. Get this offer.

Free Catalog!

Send the coupon for free 1917 ARROW catalog, giving full descriptions of all models. Learn the details of our rock-bottom, Pay-As-You-Ride offer. Send coupon *now while this offer lasts*.

Arrow Cycle Co.
Dept. 1193-19th St.
and California Ave.
Chicago, Ill.

Name.....
Address.....

Please send me free catalog of the new 1917 ARROW and full particulars of your rock-bottom "Pay-As-You-Ride" Offer. No obligations.

William Desmond and Margery Wilson, New York Motion Picture Corp. Stars, enjoying a "spin" on a Prest-O-Lite equipped "Indian."



Prest-O-Lite
for
Motorcycles

Solves Your Lighting Problem

Prest-O-Lite is the solution to your motorcycle lighting problem. It will give you brilliant, dependable, convenient light at least cost and perfect service and satisfaction at all times and under all conditions.

Enables you to ride at night with ease, comfort and safety, at any speed. Gives you a clear vision of the road ahead—will not suddenly blow out or fail you when you need it most. Road shocks, jolts and vibration do not injure it—is as sturdy as your motorcycle.

Aside from these advantages, it is thoroughly simple to operate and costs little to buy and use.

Easily, Quickly Attached

To any make of motorcycle you can quickly and easily attach Prest-O-Lite. Necessary equipment can be readily obtained at your dealer's. He can probably make you a special price on "A Prest-O-Lite tank, a lamp and a good mechanical horn." This is the equipment that will give you the greatest satisfaction in strenuous service.

Our literature on motorcycle lighting will prove of great interest to you. It is yours for the asking.

The Prest-O-Lite Co., Inc.
World's Largest Makers of Dissolved Acetylene
265 Speedway Indianapolis, Ind.
Canadian Office and Factory, Merritton, Ont.
Prest-O-Lite Exchange Agencies Everywhere

Please Mention Popular Mechanics



MODEL OU
Open Express Body

Ford-Highlandize Your Delivery Work

YOU can't do it better or more cheaply than by a combination of the wonderful Ford chassis with the sturdy, stylish, dependable Highland delivery body. Highland bodies have been made for over twenty-five years. They are built right—and they are priced at about what you'd expect to pay for an ordinary makeshift body.

Write for catalog on your business stationery.

Highland Body Manufacturing Co.
302 Elmwood Place Cincinnati, Ohio

Pope Send for 1917 Catalogs **Columbia**
Motorcycle and Bicycle
WESTFIELD MFG. CO. 15 Luzier Avenue
WESTFIELD, MASS.

\$19.95 and up

New Service Bicycle
Speedy—easy running. Sturdily built of seamless steel tubing—triple truss forks. With motorcycle type, anti-skid, puncture-resisting tires. Beautifully enameled and striped. Satisfaction guaranteed or money back. \$19.95 from Chicago. Write for our Bicycle Book, bicycles shown in colors! **FREE!** Address house nearest you.

Montgomery Ward & Co. Dept. G133
New York Chicago Kansas City
St. Louis Portland, Ore.

Send for **FREE** Book

THE BUELL
EXPLOSION WHISTLE

New Design Signal Rules the Road

A whistle—not a horn. More easily controlled than any other type of warning device—possesses wider sound range—utters a low musical 3-tone chime to gain attention in "close quarters"—or abrupt, penetrating "shrill" when instant action is imperative. Operates directly by explosion through priming cap. No soot. No dirt. No clogging. No cleaning. **Never** fails. **Absolutely** dependable. No disadvantages. **Costs nothing to operate**—nothing for repairs. **Outlets** car. Easily installed. **Amazingly** low cost considering high state of mechanical perfection—and protection positive operation assures. Thousands used. Every motorist needs it for **certainty, safety, economy.** Send now. Prepaid upon receipt of \$4.25 for single tone or \$6.00 for chime. Money back in 30 Days if not satisfied.

THE BUELL CO., 1610 Michigan Ave., CHICAGO

GET IN THIS BIG MONEY MAKING BUSINESS QUICK



Here is an opportunity to start in a business of your own at very little cost. It gives you the chance to be independent, make big, quick, easy money with an Empire Candy Floss Machine. Hundreds making big success. Profits enormous—over 1,000%. Candy Floss fast seller. Greatest money making business ever.

Read What Others Are Doing

N. M. Wendle averaged \$75 to \$128 a day profit; W. F. Mountain made \$100 in 3 days; Sam Gordon took in \$2,000 at White City in a few weeks; F. C. Gardner made and sold 2437 sacks of Candy Floss in ten hours—sales \$121.85—profits over \$115.00—had machine nine years; G. A. Barton made \$411.00 on one barrel sugar costing only \$23; A. J. Model averaged \$25.00 to \$40.00 per day net. Had machine two years.

Write Quick

for our book. It tells you how to start in this Big Money Making Business that makes 1,000% profit with small amount of money. Big discount in unrepresented territory. Don't delay. Write today.

EMPIRE CANDY FLOSS MACHINE CO.

2360 Milwaukee Avenue
Dept. 333, Chicago, Ill.



DIAMONDS ON CREDIT



Get in the Ring Give Her A LOFTIS' PERFECTION DIAMOND RING

Loftis' Perfection Diamond Rings VERY DISTINCTIVE IN BEAUTY BRILLIANCY AND CUT WONDERFUL VALUES AT

\$25 \$40 \$50 \$75 \$100 \$125

EASY CREDIT TERMS

Send for Catalog telling all about how easy we make it for you to wear and own a Genuine Diamond, fine watch or other handsome Jewelry. There are over 2,000 illustrations of Diamonds, Watches, Jewelry—Diamond Rings on credit terms as low as \$2.50 a month; Diamond La Vallieres as low as \$1 a month; Diamond Ear Screws, Studs, Searf Pins at \$2 a month, etc. All our Diamonds are characterized by dazzling brilliancy and wide-spread effect, and are set in solid gold and platinum. Also solid gold Watches, as low as \$3.50 a month; Wrist Watches, \$1.50 a month, etc. Whatever you select from our Catalog will be sent, all shipping charges prepaid. You see and examine the article right in your own hands. If perfectly satisfied, pay one-fifth of the purchase price and keep it, balance divided into eight equal amounts, payable monthly. If not just what you wish, return at our expense. SEND FOR CATALOG TODAY. IT IS FREE.

LOFTIS BROS. & CO., The National Credit Jewelers

Dept. L894 100 to 108 N. State Street, Chicago, Illinois
Established 1858 Stores in: Chicago; Pittsburgh; St. Louis; Omaha

FIBRE LEGS

4-LB. FIBRE LEGS—ON EASY TERMS

Orthopedic braces for all deformities. Send for booklet.

MINNEAPOLIS ARTIFICIAL LIMB CO., 638 Dean Bldg., MINNEAPOLIS, MINN.



1900 Motor Washer

Electric or Water Power

on Free Trial to Readers of Popular Mechanics

Reduce household expenses by using this great laundry outfit. Cuts cost of washing to 2 cents per week. Write for Free Book, giving full details, to

1900 WASHER CO., 6331 Court St., Binghamton, N. Y.
Address Canadian 1900 Washer Co., 355 Yonge St., Toronto
If you live in Canada



HERE YOU ARE, BOYS

A meditation pin of Foxy Grandpa. Everyone will notice it on the lapel of your coat and try to get a closer look at it. All you have to do is press the bulb.—Foxy Grandpa will finish the job by squirting a fine stream of water over the inquisitive one. Will squirt 20 feet. Greatest joke out. Order one today and fool your friends. Price 15c. Foxy Grandpa and Hooligan both for 25c. 4 for 50c or 1 doz. for \$1.00. A beautiful fountain pen free with every \$1.00 order.

AMERICAN SUPPLY CO., ST. PAUL, MINN.

Build a WAR Aeroplane

"Ideal" accurate Scale Drawings enable you to EASILY build 3 Ft. Flying Models of Aeroplanes now used in the European War. Students of Aeronautics, everyone with an inquiring turn of mind, should construct one of these fascinating Models.

Prices of 3 Ft. Scale Drawings

Curtiss Flying Boat 25c	Beriev Monoplaner 15c
Curtiss Military Tractor 25c	Taube Monoplaner 25c
" Hydroaeroplane 35c	Wright Biplane 25c
Nieuport M's plane 25c	Ce II Peoli Racer 25c

Complete Set of Eight, \$1.50 postpaid
Get 50-page Aeroplane Book, containing full information about models, parts, etc., by postpaid.

Ideal Aeroplane & Supply Co., 82-84 West Broadway, New York



UNCLE SAM WANTS YOU



Get a U. S. Government Job

\$75 to \$150 a Month

Rapid advancement to higher Government Positions. No "Layoffs" because of STRIKES, WARS, FINANCIAL FLURRIES or THE WHIMS OF SOME PETTY BOSS. THE POSITION IS YOURS FOR LIFE.

Country residents and city residents stand the same chance for immediate appointment.

Common sense education sufficient.

March and April examinations everywhere.

We Will Coach 25 Candidates Free of Charge

Write immediately for full list of many positions now easily obtainable. Don't delay. Every day you lose means the loss of just so much chance of early appointment.

FREE COACHING COUPON

FRANKLIN INSTITUTE, Dept. W 96, Rochester, N. Y.

This coupon, properly filled out, entitles the sender to (1) full list of positions now obtainable, (2) a free copy of our valuable copyrighted book, "Government Positions and How to Get Them," (3) free sample examination questions; and (4) to consideration for FREE COACHING for the Civil Service position here checked.

... Railway Mail Clerk (\$900 to \$1800)	... Customs Positions (\$650 to \$1500)
... Postoffice Clerk (\$800 to \$1200)	... Internal Revenue (\$700 to \$1800)
... Postoffice Carrier (\$800 to \$1200)	... Stenographer (\$800 to \$1500)
... Rural Mail Carrier (\$600 to \$1200)	... Clerk at Wash., D.C. (\$900 to \$1500)

Name.....
Address.....

Use this before you lose it. Write plainly.

Please Mention Popular Mechanics

No Money In Advance

This Marvelous Camera on FREE TRIAL!

Only 10,000 of these marvelous, instantaneous picture-taking and making cameras to be sent out absolutely on approval without a penny in advance just to prove that it is the most wonderful invention—the camera sensation of the age. So you must send for it quick! Don't think of it—the new Mardel-ette takes and makes finished pictures



INSTANTLY!

You press the button, drop card to developer and in one minute take out a perfect, finished post card photo, 2 1/2x 3 1/2 inches in size. Camera, itself, is about 4 1/2x3 1/2 inches. Loads in daylight 16 to 20 post cards at one time. No film—no plates—no dark room. Not a bit of the mess and bother of the ordinary kodak or camera. It is instantaneous photography. Universal focus lens produces sharp pictures at all distances. Pictures develop and print automatically. Can't overdevelop; results simply amazing.

WE TRUST YOU

No difference who you are, where you live or what your age, we will send you the complete "Mardel-ette" outfit absolutely on approval and give you 10 days to test it. If not satisfactory return it. But when you see what elegant pictures it takes—so quick, so easy, with no trouble at all—if you wish to keep it just simply send us \$1.95 per month until our special price

of only \$5.00 is paid. Easy Payments—no References. No red tape of any kind. Monthly payments so small you'll not notice them. Lots of fun and big profits. No Experience Required. Plain instructions and everything complete with outfit so you can begin taking pictures the moment it arrives. We guarantee that even a child can operate it. Mail coupon right now. No risk or obligation to keep camera.

The Chicago Ferrotype Co., Box 348, Ferryville Bldg., Chicago, Ill.

Send me at once one complete model Mardel-ette Camera outfit, including supply of post cards and instructions. I agree to examine and test it thoroughly and if satisfied keep it and pay you \$1 a month until your special price of \$5 is paid. Otherwise I will return it at the end of 10 days.

Name

St. and No.

City

OUR CATALOGS OF Wireless and Electrical Apparatus



are an introduction which will lead to everlasting friendship. Two catalogs and a bulletin of Storage Battery Chargers sent for 6c stamps to cover mailing.

Clapp-Eastham Co., 147 Main St. CAMBRIDGE, MASS.
 Western Representatives { Southern Calif. Elec. Co., Los Angeles
 Berk Electric Co., Portland, Oregon

Learn from CHEMCRAFT the wonders of modern chemistry

CHEMCRAFT Your Own Chemical Laboratory — \$1.50
A Big Complete Chemical Outfit for only \$1.50
 Chemcraft No. 1 is the name of this brand new outfit. It contains 14 different chemicals, test tubes, glass tube, measures, etc., and a valuable instruction book with directions for 17 experiments. Just think of the fun you can have working all these wonderful chemical experiments. You can manufacture black and colored writing inks, make colored fire and fire ink, change water into wine and wine into water, and do dozens of other interesting things. You can invent new experiments of your own, too. If your dealer doesn't carry it, Chemcraft No. 1 will be delivered to you anywhere in the United States or Canada for only \$1.50. Foreign \$2.00.



CHEMCRAFT No. 2 Sent Postage Free West of the Mississippi River, \$2.50.
A LARGER OUTFIT Canada, \$3; Foreign, \$3.50.
 Be sure to get Chemcraft. Description sent on request.
The Porter Chemical Co., Dept. A, Rogerstown, N.J.



DUCK'S BIG 300 PAGE No. 11 Electrical and Wireless Catalog

Mailed on receipt of 8c in stamps or coin which may be deducted on first dollar purchase. Great cost of catalog and low prices prohibit distribution otherwise.

What This Big Catalog Contains:
 160 pp. Wire-ss Apparatus; 10 pp. Raw Material; 5 pp. Transformers; 8 pp. Storage Batteries; 15 pp. Telegraph Insts.; 42 pp. Motors and Dynamos; 10 pp. Miniature Lamps; 8 pp. Flashlights; 5 pp. Massage Vibrators; 10 pp. Miniature Railways; 5 pp. Lighting Plants; 10 pp. Ammeters and Voltmeters; 25 pp. Electrical and Mechanical Books; 12 pp. Telephone Equipment; 10 pp. Auto Accessories; 13 pp. Victrolas on Easy Payment Purchase Plan; 30 pp. General Electrical Supplies.

THE WILLIAM B. DUCK CO., 223-227 Superior St., TOLEDO, OHIO

DEPENDABLE KNAPP "Marvelectric" Experimental Laboratory

A complete outfit for performing innumerable experiments. Demonstrates Magnetism, Solenoids, Resistance, Motors, Dynamos. Strong, durable, well made. Fascinating and instructive. If you are interested in electrics, you should have one. **\$4.50**
 At all live dealers. If your dealer cannot supply you, order direct from us. Send for FREE Illustrated Catalog. **KNAPP Electric & Novelty CO., 519 W. 51 St., N. Y. City**



RECTIFIERS for garages. All sizes. Charge from alternating current 1 to 8 batteries. \$12.00 upwards. AMERICAN BATTERY CO., 1137 Fulton St., Chicago. (Est. 1881)

An airman narrowly escaped death recently when he attempted to drop a wreath near the coffin of another airman, who had been killed a few days earlier, at San Diego, Calif. A gust of wind drove the iron wiring of the wreath against the motor, short-circuiting the ignition circuit and thus stopping the engine. By skillful volplaning, however, the airman descended safely on the bay.

ELECTRICAL HANDY BOOK AND CATALOGUE FREE

WORTH 25 CENTS TO ANYBODY
 The BIG BOOK you need and want. Describing positively the finest and most complete line of wireless, novelty, and experimental goods ever listed in any catalog and containing besides, innumerable tables, hook-ups and treatises of inestimable value to the experimenter. Absolutely Free. Send No Postage. **THE ELECTRO-SET COMPANY, Leader Bldg., Dept. P-10 Cleveland, Ohio**

THE AMERICAN MODEL BUILDER

WRITE FOR CATALOG
The American Mechanical Toy Co., 303 E. First Street DAYTON, OHIO

SENT ON APPROVAL

NO MONEY DOWN \$2 — A — MONTH

Buy a genuine Elgin Now. 17, 19 and 21 Jewels — 25 year gold cases direct to you at rock-bottom prices. Write today for **New Free Catalog**
 Our Special Offer enables you to own a fine Elgin or any other standard watch or a perfect Diamond without missing the money. 200,000 satisfied customers. Get posted. Write today. **HARRIS-GOAR JEWELRY CO., Dept. 2086 Kansas City, Mo.**



Holtzer-Cabot Radio Phones

Meet every requirement. Weight, only 10½ ounces. They excel both in tone and loudness. They will increase your range. Sold with "Money Back" guarantee.

Send for Booklet "P" Today

The Holtzer-Cabot Elec. Co.
BOSTON and CHICAGO

Wireless Receivers?

Get a *Murdock* 2000-ohm **\$4** complete double set for and prove to your own satisfaction that there are no better 'phones obtainable at DOUBLE the prices. Fourteen days' trial allowed and money back without question if you are not sufficiently convinced of the remarkable value to keep them.

Our catalog is free. Ask for a copy.

WM. J. MURDOCK CO. 10 CARTER ST. Chelsea, Mass.

BOYS! HAVE DAD GET STRUCTO

Structo—Mechanics in miniature—will turn the trick. With it you can build that bridge or derrick, and a hundred other models that really work. Write for Free illustrated book. **STRUCTO MFG. CO., Dept. 118, FREEPORT, ILL.**

THORDARSON Wireless Transformer

Gives greater sending range—steadier current flow—more accurate adjustment. Expert operators always prefer the THORDARSON. Sold completely assembled; no chance for mistakes or burnouts. Five sizes, ½ to 2½ K.W., 10,000-20,000 volts, any cycle desired.

WRITE FOR SPECIAL BULLETIN AND PRICES

THORDARSON ELECTRIC MFG. CO.
518 So. Jefferson St., Chicago, Ill.



GIVEN TO YOU WITHOUT EXPENSE

Any one of these splendid pieces of furniture would cost you \$8 or \$10 at retail. We give your choice with a \$10 purchase of

Send for New Catalog IT'S FREE

Larkin Home Supplies

Your copy is just off the press. Describes and illustrates the 600 Products and 1600 Premiums and our astounding money-saving offers. Ours is the solution of the high cost of good living.



Send Coupon Today to Nearest Address

Larkin Co. Buffalo Chicago Peoria

Send me your Catalog No. 148.

Name

Address

G. P. 345.....

Buy a Brandes Head Set on Trial

Test it out against any other make. Test it for sensitiveness, clearness and distance. If within ten days you're not fully satisfied but enthusiastic—back comes your money without a question. We can afford to give this money-back guarantee, because we build real quality into our receivers. The two diagrams toned exactly alike, strengthen the weak signals, prevent "hissing." Send us today for Catalog P, describing Brandes Matched Tone Receivers in detail.

C. BRANDES, INC., Room 817, 32 Union Sq., New York

BRANDES WIRELESS HEAD SETS

"THE RECEIVERS WITH MATCHED TONE"

Send 10c for Copy of Our New Wireless Manual P. 9

YOU GET YOUR MONEY BACK ON AN ORDER OF \$1.00



It contains 180 pages and tells how to erect and maintain wireless telegraph stations. Shows a number of diagrams. Has the Morse and Continental Telegraph Codes. Illustrates the best instruments to use; tells what they are for and how to use them. Has many new diagrams and other valuable information not contained in any other book. Do not wait. Send your request now. Get the best 10c value you will ever buy.

Send for Our Pocket Catalog P28

It contains 248 pages, with over 1,000 illustrations, and describes in plain, clear language all about Bells, Push Buttons, Batteries, Telephone and Telegraph Material, Electric Toys, Burglar and Fire Alarm Contrivances, Electric Call Bells, Electric Alarm Clocks, Medical Batteries, Motor Boat Horns, Electrically Heated Apparatus, Battery Connectors, Switches, Battery Gauges, Wireless Telegraph Instruments, Ignition Supplies, Etc.

MANHATTAN ELECTRICAL SUPPLY COMPANY, Inc.

NEW YORK, 17 Park Place

CHICAGO, 114 So. 5th Ave.

ST. LOUIS, 1106 Pine St.

San Francisco, 604 Mission St.

Oxy-Acetylene Welding and Cutting



Operator welding sheet metal chemical container. All seams, flanges and nipples were welded by the Prest-O-Lite Process.

Welded Tanks Are Leak-Proof and Cost Less

A large manufacturing company constructed a number of tanks, like that shown above, to contain a searching chemical liquid. All seams and joints were welded. Searching tests proved the tanks positively leak-proof. Besides this important advantage, the tanks cost much less to make by welding than by other methods.

This is a typical instance of the all-around usefulness of the oxy-acetylene process. In thousands of shops and factories, it is displacing the rivet, bolt and threaded joint on a large variety of work.

In routine production, it is invaluable—simplifying construction, lowering costs, giving neater and more permanent work.

For "on the spot" repairs, it is unequalled. Also profitable for reclaiming and putting back into service valuable "waste" material from your junk pile.

Prest-O-Lite PROCESS

Employs both gases (acetylene and oxygen) in portable cylinders. Prest-O-Lite Dissolved Acetylene (ready-made carbide gas) is backed by Prest-O-Lite Service, which insures prompt exchange of full cylinders for empty ones. Provides dry, purified gas, insuring better welds, quicker work, and lower cost, and also avoids the large initial outlay and heavy depreciation incurred in making crude acetylene in a carbide generator.

Necessary equipment is not expensive. We furnish high-grade welding apparatus for \$60 (Canada, \$75); acetylene service at additional cost. Adaptable for oxy-acetylene cutting by the addition of special cutting blow-pipe. Thorough instructions are furnished free to every user of Prest-O-Lite Dissolved Acetylene—any average workman who understands metals can learn the process quickly and easily.

Send for literature on the Prest-O-Lite Process, illustrating the economies now being effected in your own or similar lines of work.

Get Into the Welding Business

There is a wide and growing demand for oxy-acetylene welding. It offers a splendid opportunity for enterprising mechanics to get into a live and highly profitable business of their own. Write for details.

The Prest-O-Lite Co., Inc.

World's Largest Makers of Dissolved Acetylene

U. S. Main Office and Factory
816 Speedway, Indianapolis, Ind.

Canadian Office and Factory, Merriton, Ont.

53 Branches and Charging Plants



Own a Thoroughbred!

Every "Old Town" Canoe is a thoroughbred—sired by the graceful, tough Indian canoes—the master work of master canoeists. Strong, light and beautiful, it is built to give maximum comfort and safety with minimum trouble. Made of long-length cedar, seasoned and tightly fitted; canvas covered, there is no danger of leaking, buckling or warping.

"Old Town Canoes"

are guaranteed easy to paddle and manage. Our "Sponson" Canoes cannot turn over. The kind that especially suits your needs is described in our picturesque catalog. Write for it. 4000 canoes, \$34 up, ready to ship. Buy from dealer or factory.

OLD TOWN CANOE CO.

1663 Middle Street, Old Town, Maine, U. S. A.

HAND SAVED BY RING—An officer of the U. S. fuel ship "Maumee," when testing the ship's engine recently, had his left hand caught in the gear. But for the fact that he wore a heavy gold signet ring, his hand would probably have been mangled, but the ring stopped the machinery for an instant and he withdrew his hand, losing only one finger.

POWER



The two horse-power Benninghofen Engine offers even economical power for every purpose. Many new, exclusive features, including "auto-throttle governor" not hit and miss governed. Surprisingly low cost. Burns kerosene or gasoline. Runs machinery, pumps water, saws wood, runs separator, churns, etc. Catalogue and details free.

C. BENNINGHOFFEN & SONS
Dept. 125 A HAMILTON, OHIO

WEBER THROTTLE- GOVERNED KEROSENE ENGINES

4-Cycle Lowest Priced Throttle-Governed Engine on the Market—Cash or Payments

Save Half In Fuel. The 1917 model Weber solves the problem of low cost power for all time. Power and speed controlled by throttle, same as steam. No waste of fuel—no violent explosions. Throttle regulates amount of fuel to size of load.

Sold on a Five-Year Guarantee—Two Months' Trial

in shop or on farm. Shipped direct from factory at a big saving. **FREE BOOK**—"How to Use Kerosene" and Engine Folder, sent post-paid. Address



WEBER ENGINE CO.
Dept. 1718
Kansas City, Mo.

ROWBOAT MOTOR

FERRO

Make Your Own Motorboat—It's Easy

You can equip it with a complete power plant, Bosch high-tension magneto, full-boat feed carburetor, telescopic muffler, wood-proof propeller, rudder and tiller at small expense. Simply clip up the Ferro on your rowboat. Speedy, reliable, easy to operate. Selling Ferro Motors is pleasant, profitable work. You only need buy one motor for demonstration. Some fine territory open for the first-owners. Ask for agency proposition No. 215.

\$90 with Bosch high-tension magneto.
\$70 with water-proof batteries.

The Ferro Machine & Foundry Company
843 Hubbard Avenue Cleveland, Ohio



DON'T GO ROWING - GO FERROWING

Unsinkable! Kennebec Canoes

Kennebec sponson canoes are roomy, graceful, light, easily handled with paddles or oars. They are unsinkable and cannot be tipped over. The whole family can enjoy them in perfect safety. For canoe sailing on salt water or large lakes and for fly fishing they are far superior to all other models. Illustration shows Kennebec sponson equipped with motor. Prices that guarantee satisfaction. Write today for our new Free Illustrated catalog of canoes covered canoes for all waters; rowboats and accessories. Address, Kennebec Boat & Canoe Co., 49 H. R. Square, Waterville, Maine.



Motor Perfection

is what you get in Watkins Class "B" all iron motors. Especially fine for canoes and light boats. Constant and efficient.

3 H. P. single cylinder	45 lbs.
6 H. P. double cylinder	85 lbs.
12 H. P. four cylinder	155 lbs.

Are light, at the same time strong, accomplished by using semi-steel castings, high carbon steel shaft, bronze bearings, high class workmanship.

THE WATKINS MOTOR CO.
897-899 W. 6th Street Cincinnati, Ohio



GALLOWAY MASTERPIECE ENGINES

Are powerful, durable, reliable. Designed and constructed by master engine builders for hard, continuous, heavy-duty service. Use any fuel. Develop way above rated h.p. Easy to start—no cranking. Heavy weight, large bore, long stroke, low speed, wide bearings. All sizes at wholesale prices. From 1 1/2 to 16 h.p. portable, stationary, saw rigs, etc. Sold on five selling plans, cash or time.

WM. GALLOWAY COMPANY Box 965 WATERLOO, IOWA



4 H.P. Cushman Weighs Only 190 lbs.
8 H.P. 2 Cylinder Only 320 lbs.

Discussing light-weight motors recently, the Scientific American said: "Efficiency means light weight, reduced friction, and above everything else, lowered operating cost." Cushman Light-weight engines are today recognized as the leading American light-weight, high efficiency, all-purpose motors, challenging comparison in minimum weight per horsepower, reduced friction, quality of material and cost of operation. Sizes 4 to 20 H. P. Throttle Governor. Schebler Carburetor. Forced Water Cooling System. Moving parts enclosed and run in bath of oil. Not cheap engines, but cheap in the long run. ENGINE BOOK FREE.

Cushman Motor Works
882 N. 21st St., LINCOLN, NEB.

Double Cylinder 8 H.P. Weight 320 lbs.

Handy Truck

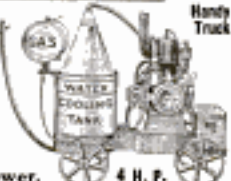
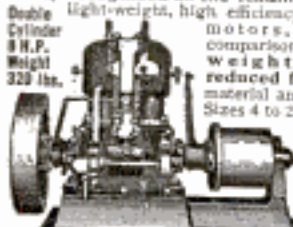
Here's Health

—vim, vigor, vitality! The keen, vivid relish of youth for work and pleasure! Snap, ginger, punch in every thought and action! The joy of glorious health, strength, power, life—yours through vibration.

Wake up that sluggish circulation! Send the rich, red blood leaping along through every vein and artery! Tune up those jangled nerves! Stir up those sluggish organs! Flood your whole body with health! Don't be satisfied with mere existence! **Begin to live!**

Arnold Vibrator

Try this wonderful machine yourself. Test it on your own body. Notice the difference after the very first treatment. See how pleasant and easy it is to use—how marvelous the results. And don't forget that these results are permanent because vibration gets right at the cause of things—goes to the very root of the trouble. Aches and pains vanish like magic. You don't need to take anybody's word for these things—you can find out for yourself.

10 Days' Trial Free

Get the facts about our generous free trial offer. Learn how you may get these things yourself at our risk, and if you are familiar with the prices asked for ordinary vibrators you will be amazed to find how much less it costs to own the genuine guaranteed Arnold Vibrator. When there is so much at stake why risk buying an imitation unknown machine? Insist on the Arnold. Ask for it by name.



80-Page Book Free

Your name and address on the coupon or a postal or letter brings you valuable 80-page book on Vibration free and full particulars of our special offer.

ARNOLD ELECTRIC CO., 1438 W. 12th St., Racine, Wis.

Mail Coupon For FREE Book

ARNOLD ELECTRIC CO., 1438 W. 12th St., Racine, Wis.

Please send me your big illustrated Book and 10 days' TRIAL REDUCED PRICE OFFER, all free.

Name

Street

City State

Please Mention Popular Mechanics

Copyrighted material

SPEEDIER THAN THE AVERAGE LAUNCH



A big claim? Yes. Exaggeration? Not a particle. That the famous 2-cylinder Koban is speedier than the average launch is borne out by the experience of thousands of Koban users in all parts of the world.

The Great 2-CYLINDER KOBAN ROWBOAT MOTOR

A Koban owner at Madison, Wis., writes: "We can easily pass a good number of the larger launches on the lakes."

Another user says: "There was not another outboard motor on the lake that could keep up with us."

Develops a full 3 H. P. Makes 10 to 12 miles an hour on a good-sized boat. Insures wonderful fuel economy. Starts, reverses, "picks up" and throttles down with perfect ease. The 2 opposed cylinders fire simultaneously, neutralizing all vibrations.

Send for Catalog showing 1917 Models.
Agents wanted at every watering point.

KOBAN MANUFACTURING CO., 291 South Water Street
MILWAUKEE - WIS.
Write for Descriptive Circular on our 2-cylinder 3 H. P. VIBRATIONLESS Inboard
Marine Engine for small launches, canoes, etc.

Extra money for you now



You need more money this summer—and here's a dignified, easy way to get it. Take orders for the

Wisconsin Detachable Row Boat Motor

Equip your boat with a guaranteed Wisconsin—enjoy yourself while demonstrating and making money. Thousands in use. Everyone interested. Has many exclusive features including self-locking tiller and patented top adjustment, which make the Wisconsin the best row boat or canoe motor to use, and the easiest to sell. Ask for our agents' plan. Ask for catalog Q.

WISCONSIN MACHINERY & MANUFACTURING COMPANY
Minor Street, Milwaukee, Wisconsin

Highest Award Panama-Pacific Exposition. Purchased by U. S. Government, after competitive tests.

BOAT KERMATH MOTORS



\$225.00
to
\$395.00

4 Cylinder 4 Cycle
10 to 25 H.P.

Used and recommended by all of the best boat builders. An engine which insures you the most pleasure and service. Extremely smooth operating perfectly controlled and quiet. Catalog on request KERMATH MFG. CO. 95 E. Fort St. Detroit Mich.



GET THIS CATALOG

FULL OF VALUABLE INFORMATION TO EVERY BOAT OWNER ON

RACING PROPELLER WHEELS,
REVERSE GEARS AND
MARINE ACCESSORIES

LARGE CATALOG FREE. SEND TODAY
MICHIGAN WHEEL CO.
1135 MONROE AVE. GRAND RAPIDS, MICH.



Universal MARINE MOTOR

9-12 H. P. 4 Cycle 4-Cyl-inder. Speed range 300 to 1800 R. P. M. Adapted to boats from 14 to 30 feet. Write to

UNIVERSAL MOTOR CO.
OSHKOSH, WIS. Dept. P

For Bulletin No. 25 giving full description



EVINRUDE



Detachable rowboat and canoe motors. Magneto—Built-In Fly-Wheel Type. Silencer and Automatic Reverse.
Catalog Free Over 80,000 Sold

EVINRUDE MOTOR COMPANY
563 Evinrude Block Milwaukee, Wis.

Write for New L-A Engine Book

Your Engine Makes or Mars Your Motoring Pleasure

So don't decide definitely on the engine for your boat until you have read the new L-A Engine Book—new—just off the press.

It fairly bristles with valuable suggestions and interesting engine information. This new L-A Engine Book describes and depicts in detail the complete line of L-A inboard and outboard motors for launches, row-boats, work-boats, etc. It provides you with complete particulars covering our

30 DAYS' TRIAL PLAN

which allows you the privilege of proving the performance of L-A motors before making your final decision. Write for your copy to-day.
LOCKWOOD-ASH MOTOR COMPANY, 1439 Horton Avenue, Jackson, Mich.



AN L-A ENGINE FOR EVERY
PURSE AND PURPOSE

The Highest-Developed Rowboat Motor Built



THERE are so many exclusive features found in the Caille 5-speed Rowboat motor that it is universally acknowledged the leader in its class. 2 speeds ahead, neutral and 2 reverse without changing speed of motor—unthought-of flexibility. Water-cooled silencer, Caille starter and other refinements that make it easy to run, economical and thoroughly dependable. Motor boating is the greatest of all outdoor sports—and there's a heap of genuine fun in store for every Caille owner.

COMPLETE CAILLE LINE

Write for Caille 5-speed motor catalog, also for catalog describing complete line—2 to 30 H. P. 1 to 4 cylinders, 2 and 4 cycle. Write today.

Caille Perfection Motor Company
1523 Caille Street Detroit, Michigan

Dealers: There's a widespread demand—bigger than ever before—for the wonderful Caille motors, and our dealers' proposition enables you to make a handsome profit and helps you to do it.

Write for particulars today.

Hildebrandt Baits Hook and Land 'Em

USE Hildebrandt Baits and catch fish. Made in 302 sizes and kinds—three styles—six finishes, any size. Interchangeable flies—reversible "Spin so Easy" blades suitable for any kind of fishing. Send for a Free 1917 Tackle Catalogue, shows our entire line in actual sizes and colors. A two cent stamp brings it.

John J. Hildebrandt Co., 1343 High St., Logansport, Ind.

OTTAWA ENGINES Kerosene-Gasoline

With my Kerosene Engine you can get more power from a gallon of 6c Kerosene than you can from a gallon of 20 or 25 cent gasoline in any gasoline engine. No cranking, no batteries, easy to start, easy to operate.

Valuable Free Book Every farmer who owns an engine or expects to buy one should know how to figure exactly what an engine is worth—Why I use the valve in the head design, the off-set cylinder construction and larger valves.



90 DAYS' TRIAL.
10-YEAR GUARANTEE
Largest sold direct from factory to user. Before you buy any engine get my newest and best book and money saving offer. Write today. **GEO. E. LONG,**
OTTAWA MFG. CO.
536 King St. Ottawa, Kans.

10 Days Free Trial

YES, we will send you the Violin of your choice for full 10 days' free trial. Play on it—test it in every way before you decide whether you wish to buy or not. Compare it with other instruments—then if you are not more than satisfied. Send it back at our expense. You do not pay us a penny for the use of the violin. Write for circular.

Your Choice of Instruments

Write today for our new Violin catalog and see handsome illustrations in full color of all the superb instruments that you have to choose from. There you will find illustrated products of the leading violin makers of the world—

Rare Old Violins

Our collection of rare old violins is one of the largest in America. Write today for Special Art Catalog.

Farny, Bander, Glier, Heberlein, Fiedler, Wurlitzer and many others. Violins of the highest grade, as well as those of moderate prices—all special values. Priced from \$2.75 to \$50.00, and from \$50.00 to \$250.00.



WURLITZER

200 years of instrument making

Get the benefit of our mammoth facilities for buying in large quantities. The house that supplies the United States Government now makes a startling money-saving offer direct to you. Write for circular.

Pay as You Wish

If you decide to keep the violin you have selected after you have tested it out for ten full days, pay the rock bottom price at the rate of only a few cents a day. No red tape. No collectors or mortgages. Your credit is good with the House of Wurlitzer.



10c a Day

now buys this superb Lyric Cornet. Exquisite triple silver-plated long model Lyric Cornet direct to you on a startling offer. Ten days free trial before you decide to buy. Liberal allowance for old instruments. Write today for 225-page Catalog—showing 2581 instruments that you have to choose from.

Send the Coupon

Put your name and address on the coupon now and indicate catalogue matter you wish us to send you. Absolutely no obligation in sending the coupon. Do it now. Find out about the startling money-saving offer we are making. Write today—send Coupon or a Letter or a Post-card.

The Rudolph Wurlitzer Co.
Dept. 8193

East 4th Street,
Cincinnati, O.
So. Wabash
Avenue,
Chicago

The Rudolph Wurlitzer Co.
Dept. 8193
S. Wabash Av., Chicago
4th St., Cincinnati

Gentlemen—Please send me without obligation, free and prepaid the catalog matter checked below:

- The special violin circular.
 Special low priced violins under \$15.00
 Your 225 page illustrated catalog of musical instruments.
 Catalog of music stands, cases and other styled instrument accessories.
 Art catalog of rare old violins.

Name _____

Address _____

Please Mention Popular Mechanics

Of Course You'll Want a Boat

"JOIN IN THE NATION'S MOST
POPULAR SPORT—
BOATING"

WATER AUTOMOBILING will be the big sport this season. Those who like to be out of doors have learned that the lake, ocean and river have a charm all their own that crowded boulevards and dusty roads cannot equal. You will want your boat to be a Mullins not only because

MULLINS STEEL BOATS CAN'T SINK

but also because beauty of design and efficient and dependable power plants properly installed, have given Mullins boats an enviable reputation for comfort, service and speed.

Built of tough steel having greater resistant qualities than one-inch oak planking, powered with 2 and 4-cycle engines bearing world-famous name plates, Silent Underwater Exhaust, Mullins boats can't leak, water log, dry out, warp or open at the seams and never require calking.

There are now more than 65,000 enthusiastic owners of Mullins boats. Forty models now ready for delivery.

Let us send you our big catalog of steel and wooden motor boats, rowboats and canoes—free.

THE W. H. MULLINS COMPANY
52 FRANKLIN STREET SALEM, OHIO

World's Largest Manufacturers of Steel and Wooden Pleasure
Boats and Builders of the Celebrated Mullins Outboard
Special 14-Foot Steel Boat.



Build Your Own Boat



The above 17-footer, complete
K. D. frame, together with all
hardware to finish the boat . . . **\$48**

Fastest Boats in the World
V-bottom Models from 15 to 22 Feet Long

WE furnish knock-down boats complete—all kinds and sizes—everything cut to shape and fitted—with full sized paper patterns and illustrated instructions for the amateur builder. There's both pleasure and profit in boat building. You save over $\frac{2}{3}$ the cost.

Send for Our **FREE** Catalog

BROOKS MFG. COMPANY
8203 Ship Street Saginaw, Michigan
The largest plant of its kind in the world

Please Mention Popular Mechanics

Racine^{Wis}



America's Finest Canoe

Speed, lightness and beautiful finish combined to the highest degree. Write for free catalog showing the many distinctive features of the Racine^{Wis}.

Racine Boat Company, Dept. O, Racine, Wis.

Comfort Indoor Closet

Odorless, Sanitary, Germ-proof. Can be placed anywhere in home. A guarantee of healthy, sanitary conditions.

SWAT FLY BREEDING CLOSET

Have city conveniences. Germ-life killed instantly by chemicals. Emptied once a month. Needs no other attention. Boards of Health endorse. Write for literature.

Agents wanted—exclusive territory
COMFORT CHEMICAL CLOSET CO. 383 Factory Bldg. TOLEDO, OHIO



DEAF?

If your hearing is failing, or has failed, you are **One of 6,349,240 in the U. S. A.** who would be greatly helped by our new invention to aid deafness.

Transparent Imperceptible **AUDI-SHELLS** Wt., only 1/16oz. Safe and Sanitary

Nothing to insert in the ear, no headbands, cords or batteries. Nothing to break or get out of order. The Audi-Shells are a wonderful help in all degrees of deafness, comfortable to wear and are not as conspicuous as eye-glasses. They are endorsed by eminent aurists and sold by mail at \$5.00 per pair. Write for testimonials of users.

Globe Ear-Phone Co., 82 Tremont Street BOSTON, MASS.

PATENTS

IF YOU HAVE AN INVENTION which you wish to patent you can write fully and freely to Munn & Co. for advice in regard to the best way of obtaining protection. Please send sketches or a model of your invention and a description of the device, explaining its operation.

All communications are strictly confidential. Our vast practice, extending over a period of seventy years, enables us in many cases to advise in regard to patentability without any expense to the client. Our Hand-Book on Patents is sent free on request. This explains our methods, terms, etc., in regard to *Patents, Trade Marks, Foreign Patents, etc.*

All patents secured through us are described without cost to the patentee in the *SCIENTIFIC AMERICAN*.

MUNN & CO.
SOLICITORS OF PATENTS
672 WOOLWORTH BLDG., NEW YORK
and 625 F STREET, WASHINGTON, D. C.

AGENTS \$60 WEEKLY
Robinson Folding Bath Tub, Big-seller. Costs little, no plumbing, little water. Weight 25 pounds, folds into small roll. Full length baths, far better than tubs. Guaranteed 10 years. \$10 a day easily made. Write for free tub offer.
ROBINSON CABINET MFG. CO. 4593 Factory Bldg., Toledo, Ohio

Crown Your Teeth
with our tooth shells. Slips over tooth easily. Apparently resembles imitation gold crown. Boys and girls fool everyone in town. Big joke. Agents make big money selling at theatres, entertainments, etc. Sample 10c, 12 for 50c. Act quick.
P. E. Crown Supply House, 2062 W. North Ave., Chicago

YOU CAN HAVE THIS
wholly visible (42 key) single shift typewriter, for your own, if you will show it to your friends and let them see wherein it excels other \$100 typewriters, and tell them of our most liberal offer ever made on a strictly modern typewriter and a Woodstock at that. By post card or letter simply say, "Mail Particulars."
WOODSTOCK TYPEWRITER CO., Dept. M 617, CHICAGO, ILL.

FREE CLOTH SAMPLES

Big selection of cloth samples—Guaranteed all-wool Serges, new fancy Worsteds, stylish Cassimeres, all latest shades and patterns—everything good dressers wear—Free. Postal will bring it. We make fine clothes for men to individual measure, absolutely guaranteed to fit and please at prices that will astonish you. Don't buy suit or overcoat anywhere at any price—until you have got our selection of cloth samples, fashion models, tape line, everything Free. Stop paying high prices for clothes. Write quick for our amazing suit offer.
THE CAPITOL TAILORS, Dept. 111, Chicago, Ill.

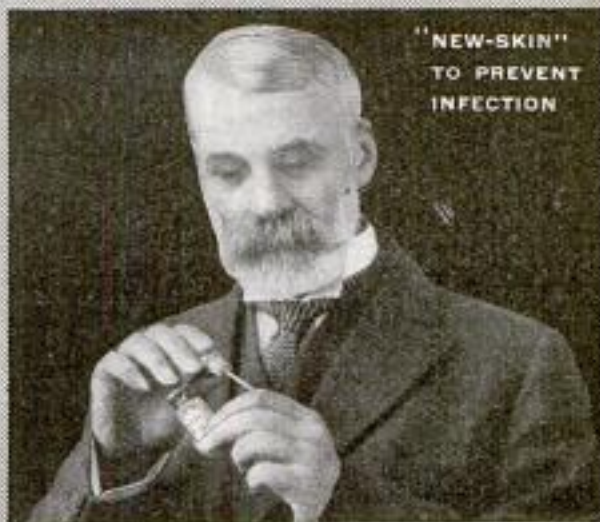

"NEW-SKIN"
TO PREVENT
INFECTION

"New-Skin" For Hang-nails

"I applied New-Skin to a laceration of the skin near a finger-nail," writes a sportsman, "and like it so well that I am going to take a supply for a big-game hunting trip."

At all druggists, in 10c. and 25c. sizes.

NEWSKIN CO., NEW YORK



"I'll Tell You What's Holding
YOU Down, Jim"

"To be frank, you're short on headwork. You are good at packing and nailing up boxes, but many of our men can do as well. What we need right now is a Traffic Manager—a man who knows freight and express rates, classifications, and routing of shipments. Such a man could save us thousands of dollars every year, and we could well afford to pay him a good salary. But you can't fill that job—you haven't the training. If you had looked ahead of your job and prepared in spare time for such work, there would be a good position with a good salary open to you right now."

For 25 years the International Correspondence Schools have been a good friend to men situated like Jim. No matter where you live, what your work, how little education or spare time you have, the I. C. S. can help you get ready for advancement and better pay. Without obligating yourself, just mark and mail the coupon and find out how.

TEAR OUT HERE

INTERNATIONAL CORRESPONDENCE SCHOOLS, Box 5559, Scranton, Pa.

Explain fully about your Course in the subject marked X:

- | | | |
|---|--|---------------------------------------|
| <input type="checkbox"/> TRAFFIC MANAGEMENT | <input type="checkbox"/> ADVERTISING | <input type="checkbox"/> SELLING |
| <input type="checkbox"/> Business Law | <input type="checkbox"/> Bookkeeping | <input type="checkbox"/> Stenography |
| <input type="checkbox"/> Architecture | <input type="checkbox"/> Civil Service | <input type="checkbox"/> CHEMISTRY |
| <input type="checkbox"/> Architectural Drafting | <input type="checkbox"/> Ry. Mail Service | <input type="checkbox"/> Illustrating |
| <input type="checkbox"/> Electrical Engineering | <input type="checkbox"/> Steam Engineering | <input type="checkbox"/> Farming |
| <input type="checkbox"/> Mechanical Engineering | <input type="checkbox"/> Civil Engineering | <input type="checkbox"/> Poultry |
| <input type="checkbox"/> Mechanical Drafting | <input type="checkbox"/> AUTOMOBILES | <input type="checkbox"/> Languages |

Name _____

Address _____

\$495⁰⁰ PARTIN PALMER

28 H.P. ROADSTER **34 H.P. TOURING CAR**

FULL FLOATING REAR AXLE

32" WHEELS \$695

110 INCH WHEEL BASE

"THE BIG BUY of the YEAR!"

Class in every line. Luxurious seating comfort. Restful riding qualities. A high-gear hill climber. Velvet action multiple disc clutch. Electric starting and lighting system. 8-point suspension. One-man top. Equipment complete in every detail.

For 5 Years PARTIN-PALMER CARS Have Stood the Test of Service in All Parts of the World

To see this car is to wax enthusiastic. Buyers simply can't resist it. Makes selling so easy that experience is unnecessary. **YOU** will profit through the interesting and liberal agency proposition which we offer. Opportunity is knocking. Write for Booklet "H."

Commonwealth Motors Co., CHICAGO U. S. A.



\$1 a week pays for the BLACK-BEAUTY-BICYCLE

The Black Beauty Bike can't be described in words. You have to see it—you must ride it—to appreciate how different it is. The distinctive color scheme, the substantial frame construction, the "notched" finger grips, the famous Firestone non-skid tires—all get the boys a-talking. And go!—you can beat the best of them.

Direct from Factory—on Approval

Let us send (freight prepaid) a Black Beauty on trial. If you don't like it return at our expense. If you do like it, you pay **ONLY \$1.00 A WEEK.**

Guaranteed for Five Years

by the Largest Exclusive Cycle House in America. **FIVE MODELS. PRICES.. \$30 up**

FREE—Get our beautiful **COLOR CATALOG** telling you all about Black Beauty.

HAVERFORD CYCLE COMPANY
Dept. F. Established 1896. Philadelphia, Pa.

SARGENT
REG. U. S. PAT. OFF.

Automatic-Set Bench Planes

A new and superior type said to be the best by mechanics who have used them



Intended for both heavy and very fine cuts and especially adapted for working against the grain on cross-grained hard wood.

The features are the automatic set, a great time saver; the rigidity, which insures good work; and the ease of adjustment.

These features are fully explained and the six sizes of these Planes described in the Sargent Plane Catalogue, a copy of which will be sent free on request.

SARGENT & COMPANY
49 Water St., New Haven, Conn.

Please Mention Popular Mechanics

Bush Car Delivered Free

Five-Place, 34.7 H. P. Ride in a Bush Car. Pay for it out of your commissions on sales, my agents are making money. Shipments are prompt. Bush Cars guaranteed or money back.

Write at once for my 48-page catalog and all particulars.

Address J. H. Bush, Pres. Dept. 317

114-inch Wheelbase
Detco Ignition—Elect. Ste. & Ltg.

BUSH MOTOR COMPANY, Bush Temple, Chicago, Ill.

FREE—**BOOK TELLS HOW TO MAKE \$150 TO \$1000 PER MONTH**

Making celebrated **Flavo Nature-Flavored Flour** in rural communities or small towns with **AMERICAN MARVEL Flour Mill** (Self-Contained)

You can quickly become a member of Community Marvel Millers. We start you. Help you. 30 days' free trial. Investment and terms easy to handle. Write for fully illustrated book.

ANGLO-AMERICAN MILL CO., Inc.
135-141 Trust Bldg. Owensboro, Ky.

Edwards Steel Buildings

Everything from Garages to Factories

Erected easily and quickly. Taken down just as readily and moved to any desired new location. Weatherproof, fireproof, timeproof. Wonderfully durable. Whatever the need—garage, booth, bathhouse, office, storehouse, school, cottage, barn, hospital, or factory, there's an Edwards Steel Building for the purpose. Write today for descriptive literature and prices.

The Edwards Manufacturing Company
1320-1370 Eggleston Avenue Cincinnati, Ohio



"Dad, Why Don't We Have Bicycles?"

"There's Bob and his father going for a spin on their new wheels. Just think how fine it would be if we had bicycles.

"You could ride yours to the office every day, and I could go to school on mine. I wouldn't mind running errands for Mother if I had a bicycle. And on Sundays we could go for long rides in the country. Wouldn't it be swell, Dad? And it would be great exercise, too."

But Be Sure You Get a MIAMI-MADE Bicycle

No other bicycle on the market has combined in one bicycle all the special features you find in MIAMI-MADE Bicycles.

Light, yet sturdy enough to withstand the hardest wear, easy riding, perfectly balanced, and with an equipment that is the best that money and experience can produce, a MIAMI-MADE is the only kind you want.

There Are Four Lines of MIAMI-MADE Bicycles

The Miami, the Hudson, the Flying Merkel and the Racycle. Each one has special distinctive features that you will like.

If there is no dealer in your city, fill out the attached coupon and we will send you one of our beautiful catalogs free.

THE MIAMI CYCLE & MFG. COMPANY

1021-1037 Grand Avenue, Middletown, Ohio, U.S.A.

(19)

Fill Out This Coupon

Kindly send me
FREE one of your
beautiful catalogs for
line I have checked.

Name.....

Address.....

City.....State.....

Kindly check the line you are interested in.

.....Miami.Hudson.
.....Racyle.Flying Merkel.

THE MIAMI CYCLE & MFG. CO.
1021-1037 Grand Ave., Middletown, Ohio



50¢ a week

Before you buy a watch write for our catalog. We can save you money and make terms to suit. The Illinois Rockland is the best watch made in the world for the price. We guarantee it.

The Illinois Rockland SPECIAL

19 genuine ruby and sapphire jewels, thin model, adjusted to positions, temperature, isochronism; has Illinois double roller, steel escape wheel, double sunk dial. Guaranteed 20 year gold case. Guaranteed to keep accurate time.

Send for catalog now —
we can save you money.

LENOX JEWELRY CO.
373 WASHINGTON STREET, BOSTON.



Get 25% More "Go" Out of Gasoline

Cut 1/4 off your fuel cost. The Oxygenerator makes it possible—the greatest dollar-saver ever offered. Improved principle for eliminating carbon. Secures **20% more speed — 20% more power — easier starting — better acceleration.** Thousands of users getting greater satisfaction from engine — reducing cost and care of running machine. For all cars, quickly attached. Send for one today. Enclose \$10.00. Give make, model and year of car. Full particulars free. **THE OXYGENERATOR CO., Dept. A2, 1914 S. Michigan St., Chicago**



Be Your Own Boss

Do as many others have — Operate a Kingery Peanut Roaster and Corn Popper. Over 50 styles. Liberal terms, excellent profits. No. 50 catalog tells you all about it.

KINGERY MFG. CO., Pearl, East of Broadway, Cincinnati, O.



Vitalize yourself with Violet Rays

Vigor, health and beauty in marvelous, delightful Violet Rays. Any good physician will tell you. Thousands are prescribing Violet Rays. Send for instruction book and learn what it will do for you.

Sent on Free Trial

Violetta is the perfected instrument. Produces soothing, invigorating, curative Violet Rays. Used and endorsed for private use by physicians. Use it anywhere. Sent to you on Free trial. Special low price offer.

Write for New Free Book

Send for the book on Violetta. Read what physicians say. Post card letters book and all particulars of special offer free. Write today.

BLEADON-DUNN CO.
208 N. Fifth Ave., Dept. C4, CHICAGO



\$43⁸⁵

10 DAYS FREE TRIAL

Not a penny to pay until you've examined and actually tried this rebuilt machine. Then you only pay our special cash price of \$43.85—less than half manufacturer's price. Let us ship you a late model

UNDERWOOD TYPEWRITER

Guaranteed for 5 years

Two-color ribbon, back spacer, tabulator — everything complete. We pay all freight. You risk nothing. Pay as you wish

— cash or easy terms.

Write us today — you will surely be satisfied.

Metro Typewriter Company

72 Front St., Brooklyn, N. Y.



MAZDA Always etched on electric lamps to which MAZDA Service has been applied.

Health? Take Turkish Bath at Home—Only 2 Cents



Physicians are abandoning drugs for this new treatment. If your mind or body is tired, open your pores and feel the rapid change in your condition, at cost of 2c a bath. The Robinson Bath Cabinet is the only scientifically constructed bath cabinet ever made for the home. **Great \$2 Book Sent Free**—"The Philosophy of Health and Beauty." Write today. Agents Wanted. **ROBINSON MFG. CO.**
901 No. 12th St. TOLEDO, O.



Amazing Profits In Mushrooms

Anybody can add \$10 to \$40 per week to their income, in spare time, entire year growing mushrooms in cellars, sheds, barns, boxes, etc. I tell you where to sell, at highest prices.

Free Illustrated Instruction Booklet

HIRAM BARTON

Desk 2, 329 W. 48th St., New York

FREE



Fine Tone

\$20 UKULELE MANDOLIN, VIOLIN, GUITAR OR CORNET

We have a wonderful new system of teaching note music by mail. To first pupils in each locality, we'll give a \$20 superb Violin, Mandolin, Ukulele, Guitar or Cornet absolutely free. Very small charge for lessons only expense. We guarantee to make you a player or no charge. Complete outfit free. Write at once—no obligation.

SLINGERLAND SCHOOL OF MUSIC, Dept. 190, Chicago, Ill.

Please Mention Popular Mechanics

Wonderful Bargains

From the Great UNIVERSAL Catalog

— Each Sent Direct Only

50¢

Automote Swing Special

Here is a new idea in Porch Swings. A large, roomy, comfortable swing that possesses patented features not found on any other swing, and is offered at a price so low that every home can enjoy its healthful rest and comfort. Swing is operated by slightest pressure of foot on foot rest. Is constructed of hard wood in popular fumed finish. Has attractive panel ends, equipped with non-rusting chains and ceiling hooks. Length 4 ft. Seat 18½ in. deep, Arms 21½ x 3½ in.; back 17½ in. high. Folds flat for shipment.

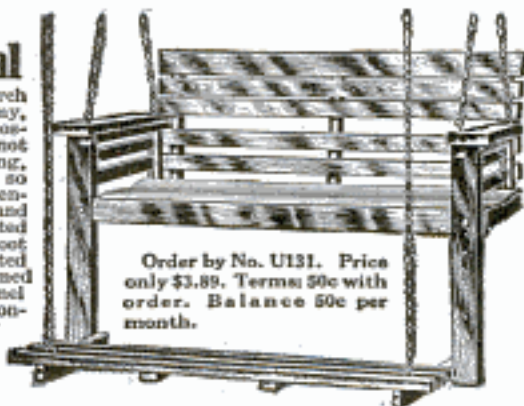

Order by No. U131. Price only \$3.89. Terms: 50c with order. Balance 50c per month.

Remarkable Sale of Dishes

Good quality white Porcelain, exquisitely decorated with latest rose floral pattern in many natural colors and gold.



Six dinner plates, 9¼ in.; 6 breakfast plates, 7¼ in.; 6 cups; 6 saucers; 6 fruit dishes, 5¼ in.; 6 new style deep soup coupes; 6 butter plates; 1 deep open vegetable dish, 9¼ in.; 1 meat platter, 11½ in.; 1 meat bowl and cover, (2 pieces); 1 cream pitcher. Every piece guaranteed full size for family use. This 48-piece set is a wonderful value at our low price and easy terms.

Order by No. U127. Price only \$3.69. Terms: 50c with order. Balance 50c per month.

Grand Bargain In Elegant Brussels Rug

A wonderful value. Woven of high grade yarns in handsome medallion design. Colors beautifully blended—tans, browns, reds, greens predominating. Harmonizes with all furniture, carpets and draperies. Your choice of four sizes—sent for only 50c and the coupon.

Order by No. U135. State size wanted. Size 6x9 ft. Price \$12.65. Terms: 50c with order. Balance \$1.25 per month. Size 8 ft. 3 in. x 10 ft. 6 in. Price \$17.45. Terms: 50c with order. Balance \$1.70 per month. Size 9x12 ft. Price \$18.95. Terms: 50c with order. Balance \$1.85 per month. Size 11 ft. 3 in. by 12 ft. Price \$26.85. Terms: 50c with order. Bal. \$2.65 per month.

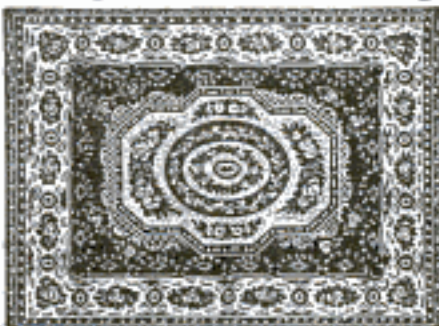

Kitchen Cabinet Bargain

This handy Kitchen Cabinet embodies many features that can add to the convenience and lighten the work of the housewife's kitchen duties. Made of kiln dried solid oak with beautiful golden glass finish. Hardware is of copper, latest design. Height 63 in.; base top 42x26 in. Contains 1 cutlery drawer; 1 bread drawer; large cupboard space for cooking utensils; closet with door which contains rolling pin and pan rack; 1 bread board, 18x20 in.; portable 40-lb. flour bin with sifter attached; 1 china closet with 2 paneled and art glass doors; 1 7-lb. tilting sugar bin; 2 spice drawers. Drawer bottoms, back, etc., built of 3-ply non-warping lumber. Order by No. U126. Price only \$14.85. Terms: 50c with order. Balance \$1.45 per month.



Order One of These Special Bargains

Here is a plan for beautifying the home that marks the most advanced step ever taken in the history of merchandising. For only 50c we will send you any of the remarkable bargains shown on this page. If more than one is wanted send 50c for each item. You may use what you order for 30 days at our risk. If you then decide to keep it, pay the balance in small monthly payments. If you decide not to keep it return it at our expense and we will return your 50c—the 30 days use of the goods costs you nothing.

This small 50c deposit does not obligate you in any way, but is merely asked as an indication of good faith and to protect ourselves against irresponsible people ordering at random. You run absolutely no risk in sending in your order. Ours is a big, successful firm that is reputable, responsible and trustworthy in every way. And every article you order from us is backed by our legal binding guarantee which insures your absolute satisfaction. Send us your order today—only 50c and coupon for each item desired.

SPECIAL BARGAIN BOOK FREE

Send for Special Bargain Book picturing and describing everything for the home—at rock-bottom prices—and on the most wonderfully liberal terms imaginable. We will trust you for anything you want on our liberal, easy-to-pay, credit plan.

UNIVERSAL MAIL ORDER CO.

145 W. 39th St.
Dept. 296
Chicago



If only catalog is wanted put an X in this square, fill in name and address on lines below and mail coupon.

Universal Mail Order Co.

145-153 W. 39th St., Dept. 296 Chicago

Gentlemen: Enclosed find 50c for each item marked below. If satisfactory after 30 days examination I agree to pay the balance as per prices and terms printed in this advertisement. If not satisfactory I will return goods to you.

U131. Automote Swing. U127. 48-piece Dinner Set.
U135. Rug—Size..... U126. Kitchen Cabinet.

Name.....

Address.....

City.....State.....

NOTE—Put line like this — in front of items wanted.

**THIS
IS THE
WELL**



that holds all moisture
and gives you a clean,
cool, dry smoke *every*
time you smoke

The
Wellington
THE UNIVERSAL PIPE

Many shapes
from which
you can choose.

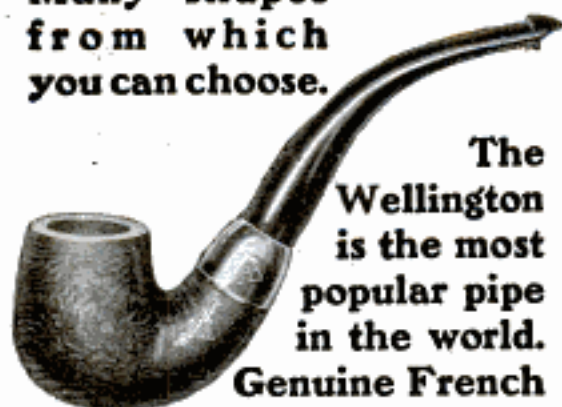

The
Wellington
is the most
popular pipe
in the world.
Genuine French
Briar—35c, 50c
and up.

This trade-mark is not only
on the Wellington, but is
also the mark of greatest
pipe value on many other
grades of pipes.



Good dealers
everywhere
sell W. D. C.
Pipes.

WM. DEMUTH & CO.
New York

MAKE BIG MONEY Concreting In Your Section

You can easily earn \$8 to \$20 a day with a Sheldon Batch Mixer. Our customers are doing it right now. The jobs go to the man with a Sheldon Mixer every time. Saves labor of 1 to 4 men, according to size of job. Or, if you buy machine for your own use, you can make many times its cost in a season by renting it to your neighbors.

Build Your Own Walks, Floors, Foundations, Buildings, Silos, Tanks, Troughs, etc. out of concrete with a Sheldon Batch Mixer. The ideal machine for all small jobs. Will pay for itself on first small job. Beats hand mixing a mile. And it's a lot cheaper, too. Takes the backache out of concrete. Makes possible those many small improvements about the place; you wouldn't do without it. Improvements that save time, labor and money and add many dollars to the value of your property. Just the machine you need.

Make Your Own Concrete Mixer.

At a cost so low you cannot afford to mix concrete by the shovel method.

Along with our iron parts we send **Free Plans** and permit for making your own machine. Or, we will sell you the complete machine. Two styles, hand or power. Will mix 2½ cu. ft. a minute. Keeps 1 to 6 men busy. Has chain drive, self-tilting dump, easily moved, and all parts guaranteed. Does work equal to \$400 machines, costs less than 1-10 as much. No other machine like it. Patented.

Write for **FREE Catalog and Special Offer**

Shows our full line. Sold direct to you on strong guarantee, backed by 30 days' trial. Ten men wanted in every county right now to accept our special offer, which will help you secure a machine at little or no cost. Write us today for catalog and particulars of offer.

SHELDON MFG. CO.
Box 5578 NEHAWKA, NEB.



\$11.50 up **Sheldon Batch Mixer**

CORONA The Personal Writing Machine weighs 6 lbs. Writes all kinds of correspondence. \$50 with carrying case. Write for booklet No. 32. Corona Typewriter Co., Inc., Groton, N. Y.

¾ c diamond \$8.25
¾ c diamond \$17.50
¾ c diamond \$31.25
¾ c diamond \$45.00
¾ c diamond \$67.50
1 c diamond \$97.50

**GENUINE PERFECT CUT
Diamonds \$97.50 PER CARAT**

Buy direct from Basch, the importer, and save 35%. Any diamonds shipped for **Free examination**. Iron-clad **Money-Back Guarantee** with every purchase. Handsome 1917 Diamond Book mailed free upon receipt of name and address. Write now to
L. BASCH & CO. Dept. G-3470
State & Quincy Sts. CHICAGO, U. S. A.

Save \$20 to \$50 on **COAL BILL**

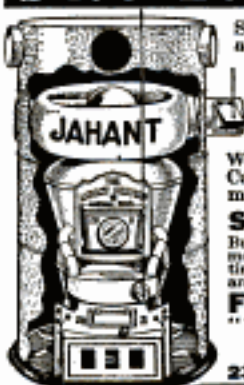

Save \$20 to \$50 on winter coal bill with a New Scientific Down Draft Jahant Furnace. Lasts a lifetime. Heats every room evenly. Burns oxygen, saves coal. Burns coal to fine ash. Heats quickly in morning.

WE PAY THE FREIGHT

We pay freight anywhere in U. S. or Canada. Price includes entire equipment cut to fit. Easily installed.

Sold on Monthly Payments

Buy a Jahant now, a payment down, rest may monthly payments. It will pay for itself in short time. Sold on 90 day Money-back, Legal Guarantee Bond. Engineers' advice FREE.

FREE! Complete set of erecting tools Free with each Jahant. Get book, "WHAT USKES SAY," and literature, all free.

JAHANT HEATING CO.
23 Jahant Bldg., AKRON, OHIO, U. S. A.

Oh, Fellows there's a "Harley-Davidson Bicycle"



That's what the boys will all say when you ride by on your new Harley-Davidson bike. Built in the same splendid way as the Harley-Davidson motorcycle—the machine that has led them all for more than 15 years, smashing record after record for speed and endurance.

The new Harley-Davidson is a bicycle to be proud of—a beauty from handle bar to tire tread. The very finest equipment throughout. The model in the picture—the "Motorcycle"—has Firestone non-skid, black-tread, red side-wall, motorcycle-fabric tires which sell for \$9 a pair.

Write for catalog showing all models of Harley-Davidson bicycles.

Harley-Davidson Motor Company
492 Harley-Davidson Bldg
Milwaukee, Wis.

Get This CAR And the AGENCY For YOUR Territory



Drive a new 1917 Model Birch Motor Car. Pay for it out of your commissions and make big money on sales. Special offer now. Write quick for Big Free Book and full information. Address

Ralph Birchard, Pres.

Birch Motor Cars, Dept. 319, 81 E. Madison St., Chicago

DON'T SCRAP ALUMINUM PARTS

SO-LUMINUM

repairs cracks, breaks or defects in aluminum in 1/2 the time and cost of acetylene welding. Parts so mended are stronger at welded joint than elsewhere. Gasoline torch only thing necessary. No flux needed.

Send 50 cents for sample bar. Money refunded if not satisfactory. Booklet on request.

SO-LUMINUM MFG. & ENG. CO., Inc.

Room 12, 1790 Broadway, NEW YORK CITY



MAKE A MOTORCYCLE OUT OF YOUR BIKE

Cyclemotor WITH OUR ATTACHMENT

1917 MODEL NOW READY

No special tools required. Fits right in the frame of any single or double bar bicycle. Weighs only 15 pounds (including magneto). Runs 80 to 100 miles per gallon gasoline. Write now for FREE CATALOGUE and special offer for introducing first machine in your locality.

CYCLEMOTOR CORPORATION ROCHESTER NEW YORK

THE ONLY 2-STROKE HIGH-SPEED BIKE MOTOR

10 Cents a Day



Here you can get any known musical instrument sent to you for full 10 days' free trial in your home. And every article is offered at the rock-bottom price. You will be astonished at these values. And then—this rock-bottom price may be paid at the rate of only a few cents a day. Ten cents a day buys an exquisite triple silver-plated Lyric Cornet.

But first write for our new catalog.

WURLITZER

100 years of instrument making

The name "Wurlitzer" stamped on musical instruments has stood for the highest quality for nearly two centuries. We are manufacturers of every known musical instrument and every one is sold direct to you at the rock-bottom, direct-from-the-manufacturers price. We supply the U. S. Government.

10 Days' Free Trial

Try out the instrument of your choice in your own way before you decide to buy. Compare it with other instruments. Test it. Use it just as if it were your own. Then after the free trial—either pay a little each month or send it back.

Your Choice of Instruments

On this great special offer you have over 2000 instruments to choose from. Any one of these will be shipped to you for 10 days' free trial in your own home. The Cornet, Violin, and Saxophone illustrated here are but three out of thousands of remarkable offers that are being made.

Send the Coupon But first put your name and address on the coupon now and get our big, new catalog absolutely free. Just state what instrument you are interested in and we'll send you the big 194-page book FREE and prepaid.

The Rudolph Wurlitzer Co.

Dept. 9108
E. 4th St., CINCINNATI, O.

The Rudolph Wurlitzer Co.

Dept. 9108
E. 4th St., CINCINNATI, O.

S. Wabash Ave.
CHICAGO, ILL.

The Rudolph Wurlitzer Co.

Dept. 9108
E. 4th St., Cincinnati, O.
S. Wabash Ave., Chicago, Ill.

Gentlemen: Please send me your 194-page catalog absolutely free. Also tell me about your special offer direct from the manufacturer.

Send the Coupon today

Name.....

Address.....

I am interested in.....
(Name of instrument here.)

Please Mention Popular Mechanics

Build This Speedster Yourself

For
\$4⁰⁰

From Any Ford

of materials bought at any hardware store, using **Red-i-Kut** patterns. Disk-wheel patterns included.

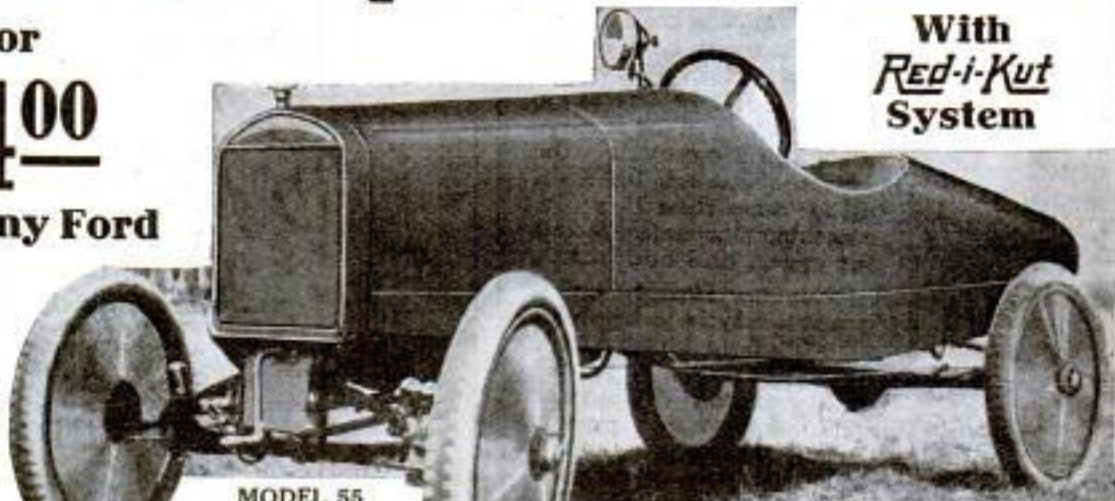

MODEL 55
From an Actual Photograph

With
Red-i-Kut
System

With the aid of a hammer, a saw, a screw-driver and **Red-i-Kut** Patterns you can easily and quickly convert any Ford into a classy, individual roadster like these pictures. Full size **Red-i-Kut** Patterns and simple instructions sent prepaid upon receipt of price. Send today to the originator. Money back if not satisfactory. **FORD AGENTS:** Write for our special proposition.



MODEL 22
Classy Roadster
Complete Patterns **\$2³⁵**

MODEL K9

Low and rakish in line. Snappy. Rear end has the true semi-spherical or bullet shape formed by special pressed metal finale sent with the patterns. Full size complete patterns..... **\$6⁰⁰**



The Kuempel Co., Design Dept. 3
Dubuque, Iowa

TIFNITE GEMS

Brilliant and Durable as Diamonds

A Tifnite Gem and a diamond are as near alike as two peas. Nothing else in the world so near a diamond in looks, brilliancy and every diamond test. Tifnite Gems cut glass like diamonds; won't file; won't melt. Guaranteed to last forever, and are guaranteed not glass. To quickly introduce them to 10,000 men and women, we make a test never before heard of. We have made up four exquisite items, latest style designs, guaranteed solid gold mountings, each set with one genuine Tifnite Perfect Diamond Cut Gem. We will send you your choice with privilege to

WEAR IT TEN DAYS FREE

Send no money whatever. Just state which item you want—Ring, Pin or La Valliere—and we will send it to you at once. If ring, send string showing size around finger. State lady's or gent's. If you think it's worth all we ask, simply pay \$3 on arrival and balance \$3 per month until our special Bargain Introductory Price is paid in full. Otherwise, return it to us at end of 10 days. Will promptly refund your money. Send no money—simply your request brings a magnificent Tifnite Gem to you for 10 days' free wear. These pictures show mountings and rock bottom prices. You are to be sole judge. Send for yours today—now—while supply lasts.

THE TIFNITE GEM CO.,
Rand McNally Bldg., Dept. 94 Chicago

LA VALLIERE—Solid Gold, 15 in. Chain, one-half carat Tifnite Gem, black enamel mounting, \$14.25—\$3.00 upon arrival. \$3 per Mo.

Ladies' Ring
Tiffany Mounting
Solid Gold. One
Carat Tifnite Gem
\$12.25—\$3.00
Upon Arrival
\$3 per Mo.

Gent's Ring
Claw Mounting
Solid Gold. One
Carat Tifnite Gem
\$12.25—\$3.00
Upon Arrival
\$3 per Mo.

Smart
Pin,
Solid
Gold,
open
circle
mounting
Half
Carat
Tifnite
Gem
\$12.25
\$3.00
upon
arrival.
\$3.00
Per Mo.

Learn Mechanics of Aviation

Write today. See how you can learn the principles of Aeronautical Construction and Engineering in your spare time at home. Save all the time and expense of laborious field training. Big opportunities now for trained Aviation Experts in different branches of the service. \$50.00 to \$250.00 a week.

Write At Once! Big tuition reduction offer now open. Write for details while this offer lasts. No obligations. American School of Aviation, Dept. 7183 431 S. Dearborn St., Chicago, Ill.

HUNTERS!! Send for free folder of Remington UMC Repeating Rifle, Model No. 14½, for game up to and including deer—just the arm for moderate range shooting. THE REMINGTON ARMS UNION METALLIC CARTRIDGE COMPANY Dept. P-5, Woolworth Building, New York



\$6⁰⁰ ELECTRIC FAN COMPLETE!

Price includes plug and 8 ft. cord. Universal motor good on alternating or direct current. Finished in black enamel, 11 inches high. Weighs 7 pounds. **AGENTS AND DEALERS WANTED!** Big money will be made this summer by men who represent us on this \$6.00 Fan. WRITE FOR OUR OFFER TODAY.

Kardon Electric Co., 29 E. 21st St., New York

ART PICTURES

For the Den and Commercial Use
Men Wanted to represent us. \$25 to \$50 a week easily made. Be your own boss. Send for our agent's proposition and

ILLUSTRATED BOOK AND FREE PHOTOGRAPH

Send ten cents to cover postage and packing costs and we will mail you our illustrated book showing 50 large halftone illustrations of our many genuine photographs and different poses, also a fine picture of one of our most famous beauties.

ART PHOTOGRAPH CO.
Tower Bldg., Chicago, Ill.

Write
Today

Please Mention Popular Mechanics

These cuts are made from photos showing comparative growth of pear trees from Spring of 1913 to August, 1914, Bellefont Orchards, Inc., Norfolk, Va.



Save a Year or More

Experience demonstrates that trees planted in blasted ground grow faster—are healthier—and bear earlier than trees planted in spade dug holes. Prove this fact for yourself by using

Save Your Shade Trees

Life is difficult for city trees. Side walks and pavements limit moisture area and check their growth. Die-back destroys them. Prevent this destruction by blast-rejuvenation. If instructions are carefully followed this work can be safely done within a few yards of houses or water mains. Find out how now



DU PONT

Red Cross Farm Powder

when planting trees. First year results will surprise you. First year losses average 3% compared with 33% of spade set trees. The reason is simple, logical and practical. Blasting shatters the heavy "hard-pan" under the top soil and provides for better rootage, increased nourishment and greater moisture control.

Don't Pot Your Trees

Give them a chance to grow and expand. Our big book tells how. It's a revelation in the use of Red Cross Farm Powder in orchard or farm. Write today for Handbook of Explosives No. 248.

E. I. Du Pont de Nemours & Co.
WILMINGTON, DELAWARE

Please Mention Popular Mechanics

EXCELSIOR SERIES 18

Price \$275, F. O. B. Chicago

Electrical Equipment
\$35.00 Extra

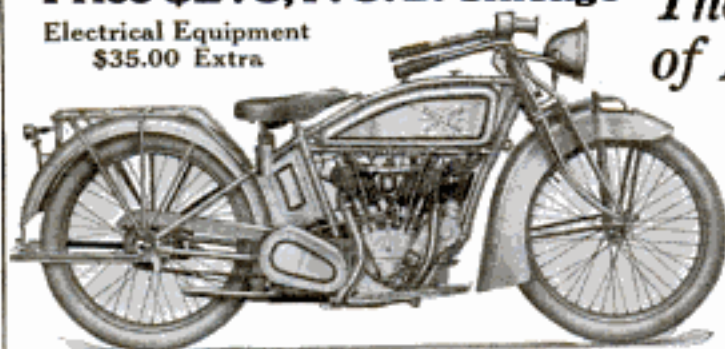

*The High Water Mark
of Motorcycle Efficiency*

In this the Latest and Greatest X, are developed to the highest degree of efficiency all the good features of every other motorcycle in addition to the many exclusive details of EXCELSIOR QUALITY.

The powerful twin motor, automobile type three speed transmission, Foot Starter, Cradle Spring Front Fork, Powerful Double Brakes and Permanent Sidecar Lugs are developed to a point far ahead of any other motorcycle. The Nickel Steel Frame with Removable Center Bar, Automatic Compression Control, Instantaneous Primer and Quickly Removable rear wheel are

Exclusively Excelsior

EXCELSIOR SIDECAR

To meet the rapidly growing demand for a sidecar of EXCELSIOR design and quality, we have perfected the new Series 18 Sidecar, brim full of new features.

Write for the new catalogs or see the dealer

Excelsior Motor Manufacturing & Supply Co.

3702 Cortland Street, CHICAGO



PIRATES!

Now is the time for Outdoor Play, with Pirate Caves and Buried Treasure and Bound Captives. And Don't Forget Your Auto-Wheel Coaster Wagon

No pirate band can get on without one. The very thing for hauling the picks and shovels and the "treasure." The Roller-Bearing Wheels, with real automobile hub caps, make it the speediest coaster and the lightest puller. Not a toy—a real wagon built for fun, and built to last.

FREE: FELT PENNANT—for names of three wagon dealers in your town. Write NOW. Address

BUFFALO SLED CO.

137 Schenck St.
R. Tonawanda, N. Y.
In Canada:
Preston, Ont.



Get Book Telling All About Wagons. It's free too.

Please Mention Popular Mechanics

Fortunes in Mushrooms

Anybody can grow them. Easiest Money-Making proposition you can find. Marvelous returns from small outlay. Others making big money in spare time. **WHY NOT YOU?** No experience necessary. Can be grown in Boxes, Cellars, Barns, etc. Write today for FREE booklet.



MUSHROOM CULTURE CO. 631 Knickerbocker Bldg. NEW YORK

CASH FOR OLD GOLD

Send us old rings, locket and other jewelry and silverware of no use to you. We will estimate value and send money at once. If you are not satisfied we return your jewelry same day we hear from you. Refer to publisher this magazine or to Stapleton National Bank as to our fair dealing and integrity. Send what you have for estimate NOW. Tear this out to remind you.

C. A. TURPISCH & SONS, Jewelers, 13 Bay St., Stapleton, N. Y.

"Interlox" Just the RULE

MASTER SLIDE RULE
For CARPENTERS, MECHANICS, ENGINEERS, etc.

Inexpensive and practical. Takes inside and outside measurements (doors, windows, walls, ceilings, etc.) A strong, rigid rule, trimmed in brass. Made in all lengths from 2 to 8 feet. If dealer hasn't it, send 18c per lineal foot (in U. S. A.) and get one by mail. Send for free descriptive circular.

Liberal Proposition to Dealers and Agents.
DAHL MFG. CO., 51A E. 42d St., NEW YORK



Buy an Akron-Williams

Tire Repair Outfit. Get into this profitable business with the same equipment that is used and endorsed by 90 per cent of the big tire manufacturers and successful repair shops. Write for book giving full details.

The Williams Foundry & Machine Co.
50 Cherry Street AKRON, OHIO

Free Try-On

OF

AMERICAN METAL SHOES

Yes, free try-on in your own home of these light, water-proof, rust-proof, wear-proof metal shoes; save your money, your feet, your health. No more tired, sore, wet feet. Always warm, dry and comfortable. Warm in winter—cool in summer. One pair outwears many leather pairs. The world's most economical work shoe for men and boys.



SAVE \$30.00
ON SHOE BILLS

The Best School Shoe

Steel Or Aluminum Soles

Made in all sizes and heights. Guaranteed to fit. Patent rocker bar gives the natural tilt—that light, springy step. Easier to walk in than heavy shoes or boots. We manufacture the largest and most complete line of metal shoes in the world. Send postal today for

FREE—Shoe Book—FREE

It describes these money saving, health protecting, comfort giving, ever wearing shoes. Don't buy a work shoe of any kind at any price until you get this book. It tells all about our free try-on offer to every man and boy. Address postal to

AMERICAN METAL SHOE CO.

(Combined with Racine Aluminum Shoe Co.)
30 12th Street RACINE, WIS.



\$100 Phonograph MAKE IT YOURSELF

Complete set of parts as illustrated here . . . \$7.85

Send for catalog. Don't delay. See our ad on page 203, Feb. issue.

ELECTRO MECHANICAL PARTS CO.
57 E. Jackson Blvd., Dept. 5247, Chicago, Ill.

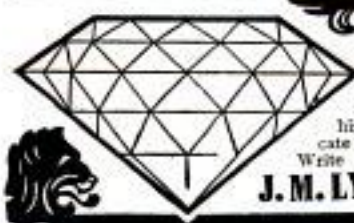

Diamonds on Credit

20% Down; 10% a Month

Every customer is protected by our written guarantee to refund his money if his dealer can duplicate our diamond at our price.

Write for Illustrated Catalog No. 3.

J. M. LYON & CO. 71-73 Nassau St. New York City

GET THIS SUIT

made to your own measure. It won't cost you one single cent. We will give it to you so you can show it to your friends. It will be a big advertisement for us. You can easily make from **\$35 to \$50 EXTRA Every Week**

and besides that be the best dressed man in your town. It's an opportunity you cannot afford to overlook. Even if you only want to order a suit for yourself, don't fail to

Write For Our Big Offer

Don't delay a minute. Drop us a line or send us your name on a postcard, and we will send you absolutely free, our wonderful style book, containing 64 beautiful samples to choose from. Write now.

The Process Tailoring Co., Dept. 581 Chicago



Please Mention Popular Mechanics

New Profits from Waste

EVERY scrap of paper that goes into your waste basket is worth money. Common mixed paper sells as high as \$16 a ton when baled—and this cash is added to your net profits if you own a Woodall Baler. His companies all over the country are making their Waste paper pay big dividends.

Baling Press

Not only paper, but rags, excelsior, scraps and other marketable waste is readily sold when baled. Use the Woodall Baler as a depository for this waste. When you have the press full, merely pull the lever, hook the wires and the bale is ready. Send the coupon now for details.



30 Days' Free Trial!

We'll send you a Woodall Baler on 30 days' trial. Find out what it is going to mean in your business before you decide to buy.

Send for FREE Catalog

Send the coupon, a letter or a post card for our new circular—it is free—but will show you how to make money from your waste paper, rags, etc. Write today. Don't wait another minute.

Woodall Mfg. Co.
Dept. 1193
Davenport, Iowa

Woodall Mfg. Co.

Dept. 1193 — Davenport, Iowa

You may send me your free circular which tells about profits in waste paper.

Name.....

Address.....



Universal Electric Motors

Complete with carbide wheel, buffing wheel, cord plug and pulley. For spark gaps—grinding—polishing, and to drive small machinery, sewing machines, fans, etc. Operates on A. C. or D. C.—110—130V. Speed 6000 R.P.M. **MONEY BACK IF NOT SATISFIED**

CATALOG FREE

Omega Electric Co. 53 W. Jackson Blvd. CHICAGO

BARTLETT Drop Forged Compound Lever SNIPS

The cutting power of these snips is three times that of the common straight snip. They are Drop Forged from Crucible Tool Steel. Cut 18 ga metal easily.



Size: 7, 8, 10, 12 & 14 in. long
Prices: \$1.20, \$1.80, \$2.70, \$3.60, \$4.20, Prepaid

BARTLETT MANUFACTURING CO.
19 East Lafayette Ave. DETROIT, MICH.

You Can Earn \$250 A MONTH with This NEW MACHINE

Make \$1,000 a year and more to start. You need no experience. Open a Tire Repair Shop with Haywood Equipment. Let the money roll in. Business grows fast. You're soon a real manufacturer. Every auto sold means more tires to mend. Demand for your work ahead of supply.

SEND FOR BIG FREE BOOK

This gives all the facts. Tells how to start. How to succeed. A valuable guide to riches and wealth. Write today. A postal will do. Get your FREE copy.

HAYWOOD TIRE & EQUIPMENT COMPANY
671 Capitol Ave. Indianapolis, Ind.



Make \$1,500 to \$3,000 This Winter

Work Right In Your Own
County, All or Spare Time

Profits Start First Day—Success Assured

Wonderful new business—a golden opportunity for one good hustler in every county. **No experience required. No risk.** Samples furnished—just follow easy instructions and work honestly—for yourself. If you want a high-class position—if you want to make the winter months count—if you want **\$1,500 to \$3,000 cash** for five months, write today.

Amazing New Home Invention

The Shafer Ventilated Chemical Indoor Closet

No plumbing—no waterworks—no cesspool. **Banishes the outdoor closet.** Revolutionizes living conditions in country and village homes. Solves the one humiliating and perplexing country home problem. An imperative necessity to health, comfort and convenience. Perfected by heating and ventilating engineer. **Tested in 2000 homes for three years.** Gives positive satisfaction. **Demanded everywhere.** A sale at every home. **Thirty days' free trial guarantee.** Low priced—warranted for ten years. Illustrated book free, showing pictures of homes and rooms containing this wonderful device, complete description, letters of endorsement from health authorities, doctors, editors, and scores of users with full names and addresses. This book is free—send for it today—investigate!

\$112 In Eight Hours

That's the record of one man in a single day. **The same man has never sold less than five closets for any half day's work.** Every home a prospect. Every sale makes **dollars**—not pennies—of profit. Biggest money-making opportunity ever offered. Liberal commission. Permanent business. **Exclusive agency contract.** Territory free. Cooperation, advertising, assistance. Business supplies the capital.

Agents' Outfit FREE

Send no money. No order required to start. We start you **FREE.** We teach you how to make amazing success. Write now. Secure your county under exclusive contract. **Don't delay.** Write a letter or card giving name of your county and mail it today. Risk a stamp to get complete free information. **Do it right now—your part.**

THE SHAFER MFG. CO.
463 Colton Bldg. Toledo, Ohio



No Plumbing
No Waterworks

AUXILIARY VENTILATORS. Chemicals, which are furnished with the closet, and air currents do the work, automatically.

Price
Complete
Only \$15

I Want 200 Exceptional Men



I have openings right now for men of mechanical ability—who want to be something better. If you have "stick-to-it-iveness"—determination to succeed—a little money—I will teach you the best business now open to young men.

A Nation-Wide Demand

Through national advertising I have created a nation-wide demand for my Standardized Tire Repair Service. Right now there are at least 200 important centers where autoists are demanding my service and cannot get it. I want good men for these centers. I sell you a machine to do this work—you become its sole owner. I teach you either by mail or in my FREE training school. You become an expert—you know the construction—the inner mechanism of the tire and tire building. If you have a little selling ability—your success is assured. Auto owners will flock to your place of business—they will give you the preference because they know you are a trained man.

BIG PROFITS

There is almost no limit to the profits. You can add accessories to your line and sell tires besides repairing them. I am prepared to help you do this. If you see no metal sign of the "Man and Machine" write me personally and I'll tell you how to get started. Don't delay—write me today.

M. HAYWOOD, Pres.
THE HAYWOOD TIRE & EQUIPMENT CO.
658 N. Capital Ave., INDIANAPOLIS, IND.



Small Steam Engine Castings

For $\frac{1}{8}$ and $\frac{1}{4}$ H. P., with Screws and Blueprints. Write for Circular of Latest American Model.

Modern Model Engineering Co.
3001 No. Central Park Avenue, Chicago, Ill.

Every 1915-16 Ford Needs a

Gives Strong Light at Low Speed

VAN SICKLEN
AUTOMATIC
HEAD LIGHT CONCENTRATOR
FOR FORD CARS

Plenty Light on the Worst Roads

ASK YOUR DEALER

THE VAN SICKLEN CO., Elgin, Illinois



Big Money In AVIATION

Send the coupon below at once. Find out about the big opportunities that are awaiting you in this newest industry. The day of aviation is here! It is no longer a science or a stunt—it is a business! Fame, fortune is awaiting those who are the pioneers in this new field. Get in early. Start now at salaries of from \$50 to \$250 a week as an aero engineer—and grow to independence with a rapid expansion of the industry.

Everywhere aviation experts are in demand. Government and private enterprises are taking up aviation seriously. They need men who know.

NOW You May Learn At Home!

Yes, you may learn the science of aviation right in your home and in your spare time. No longer need you sacrifice time and money by years of practical experience on the flying field. Send the coupon and find out how we have condensed into a short course, all the knowledge which is necessary to equip you to take your place upon the field as a practical aero engineer. We will tell you just how you can save years of time and much money. We will show you how you can gain this knowledge in your spare time, at home, without interfering with your regular work.

This Partial List

shows you the character of the subject which our course covers:

Physics of the Air
Dynamics of the Air
Wing and Aeroplane Designing and Construction
Balloning (covers building and operating of balloons)
History of Aeronautics, etc.

International Flyer Teaches You Personally

A famous aviator, who has won laurels for flying, both here and abroad, supervises the instruction of every one who takes this course. You have the privilege at all times of free consultation with this aviator. Write now and get full particulars.

Send Coupon—Free Information

No matter in what business you are now engaged, if you are mechanically inclined, or interested in aviation, you should at least find out, *now*, about this great course. Learn the opportunities that are opening every day for trained aero engineers and get particulars of this course which revolutionizes the training of aviation experts. We are making a special offer now. Write for this information *while it lasts*.

National Aero Institute

Dept. 1193
Morton Bldg.
Chicago, Ill.

Name

Address

National Aero Institute
Dept. 1193
Morton Building
Chicago, Ill.

GENTLEMEN: Please send me absolutely free and prepaid, full particulars of your course in aviation and details of your special limited offer.



The New Way—It's a Big Hit KEEPS OUT THE COLD

The Perfect Garage Door Hanger Set

Allows use of full door opening without risk of damage to car or door, and door cannot swing or blow shut, as it automatically fastens itself open. No extended run-way on either side of building, and no sticking or getting out of order. Can be opened to any width desired, and is weather-tight when closed. Efficient all the year round—particularly so in cold weather, and in this respect, as in all others, it surpasses any other type of hanger. No sawing or cutting of holes necessary to attach.

Ask your hardware dealer—Also send today for descriptive circular, surprisingly low price. DEALERS—Good Profit in This Device.

It sells on sight and the good word is passed along. Architects will want it the minute they see it. Write for terms.

Safety Door Hanger Co., 103 Topping Bldg., Ashland, Ohio

\$25 TO \$50 DAILY PROFIT

Making Cement Drain Tile

Here is a chance for every ambitious man to make big money—to own and operate a factory—to join the ranks of America's biggest money-makers. No previous experience is necessary and but little capital. You start with this machine—the Richmond. It makes Cement Tile. Works easy. Tile requires no burning like clay tile—no tamping. Makes 1500 to 2500 perfect tile a day.



Every Farm Needs Under-Drainage

Under drainage means earlier and easier cultivation besides perfect insurance of crops. It removes the surplus water from the land. It pays big dividends—increases value of land 30% to 300%. Thousands of acres right around you need Cement Tile for this purpose.

ENORMOUS DEMAND. Millions to be spent. You can share in this mammoth fortune, if you write at once.

FREE BOOK—FREE TRIAL

Let us tell you all about this big profitable business—this great business opportunity open to you. Our Free Book explains the business from A to Z—tells how Cement Tile is made—how it is sold, and how we help you make a success. Get our liberal, No-Money-Risk Free Trial Offer. Send a postal or letter Now.

Farmers' Cement Tile Machine Co.
Dept. 113 ST. JOHNS, MICHIGAN



1917 Spring Suit

Free

A WONDERFUL
amazing
OFFER

If you are a live wide-awake man we want you to get one of our elegant Spring suits, made to YOUR measure, absolutely FREE. All we ask you to do is to wear it, show it to your friends and take a few orders for our high grade, Made-to-Measure Clothes.

\$25 EXTRA A WEEK AND YOUR OWN CLOTHES FREE

Does it look good to you for a little spare time? Write at once or simply send us your name on a postal and we will send details of this STARTLING OFFER. We will also send you FREE a large assortment of cloth samples and dozens of fashion plates to choose from NOTHING LIKE IT EVER OFFERED by any other Tailoring House. We don't ask you to spend your cash profits for your clothes. Give us a few and better than. Write at once, be the first in your town to get this FREE suit.

SPENCER HEAD COMPANY
Dept. 1689 CHICAGO



Indoor Toilet

PLACED IN YOUR HOME
Sanitary and Odorless on ten days'

FREE TRIAL

NO MONEY DOWN - NO DEPOSIT

No more outside back yard inconveniences. No chambers to empty. No sewer or cess-pool. Chemical process dissolves human waste in water. No trouble. Kills disease germs. Prevents flies, filth and bad odors of outhouse. A real necessity for old, young or invalids. Preserves health.

COSTS 1 CENT A WEEK to Operate per Person

Place in any room, hall or closet. No trouble to install. Guaranteed sanitary and odorless. Endorsed by thousands of users, doctors, sanitary experts, health boards, etc. Send today for free trial offer and literature.

KAWNEAR CABINET CO.

730 Kawnear Bldg., KANSAS CITY, MO.

ODORLESS



AGENTS WANTED

in shops and factories to sell a marvellous remover of grease, ink and stains from the hands—

Grit HIKE DIRT. It is as harmless as water to the skin.

Also General Agents wanted for **Plain HIKE DIRT.** which will clean anything that

does not require scouring: clothes, carpets, furniture, etc. Correspondence solicited. **HIKE DIRT COMPANY, Franklin, Penna.**

GREEN AUTOMATIC MACHINE



LARGE PROFITS FROM SMALL CAPITAL

Start a business of your own bringing an income of \$5 to \$10 a day with practically no experience or overhead expense.

The GREEN AUTOMATIC MACHINE

Sharpens, Honors, and Strops all kinds of safety razor blades, in one operation, from four to six blades per minute. For both Quality and Quantity this machine is in a class by itself. There is nothing like it on the market. Let us send you our free booklet explaining everything, including the "AMERICAN" Key Cutter—cuts square, angular or round slots.

AMERICAN SHARPENING MACHINE CO. (Inc.), Dept. 3, 184 W. Washington St., CHICAGO



"AMERICAN"
Key Cutter

I Want To Make You A Present of This Acorn Uni-Lite!

And I Am Organizing an Army of Money-Winners! Do You Want to Join?

**300
Candle
Power**



Yes—you get the Uni-Lite without paying a penny for it.

But that's not all! I want to help you join my army of money-winners—my big band of men who are "coining money" without interfering with their present work—without doing much of anything except calling on their fellow townspeople and talking neighbor-like to them.

I want to tell you all about it. But, before I can do that, I want you to send me your name and address on the coupon (or a post card) so I will know where to mail you complete information telling you how you get your Acorn Uni-Lite free.

The Light That Shames Electricity

A new and astonishing light. Thousands exported to foreign countries every month! Adopted by U. S. forces along border! Gives brilliant, steady radiance equal to the combined light of 20 ordinary lanterns or lamps. Burns 15 hours on one filling! Costs only 1/4 of a penny per hour. Burns common kerosene or gasoline. Storm-proof, bug-proof, rain, sleet and snow-proof. Use as a lamp—or carry as a lantern. Handsome in finish—neat in design—durable in construction. A wonderful light for in and around homes—farms—garages—barns—shops—in camps—driving on dark roads—boating—for night watchmen—hunters, railroad men, etc. And my New 1927 Offer tells you how you can get one free.

Just Answer This Ad—Just Follow My Plan—I'll Show You and Back You!

Just the same as I have done for thousands of other men—men just like yourself. It's no trick at all. Anyone can succeed with this plan for making money. It's simple and straightforward. I'll tell you all about it, just as soon as you send me your name and address. Don't put this off. Do it now. It won't take a minute.



ADDRESS
Acorn Brass Mfg. Co.

Clyde E. Padden
SALES MANAGER
618 Uni-Lite Bldg., Chicago, Ill.

Clyde E. Padden, Sales Manager, ACORN BRASS MFG. CO., 618 Uni-Lite Bldg., CHICAGO, ILL.

I want to get an Acorn Uni-Lite FREE—and join your band of money-winners.

Name.....
E. R. or Street No.....
City.....
State.....

Tougher than Elephant Hide

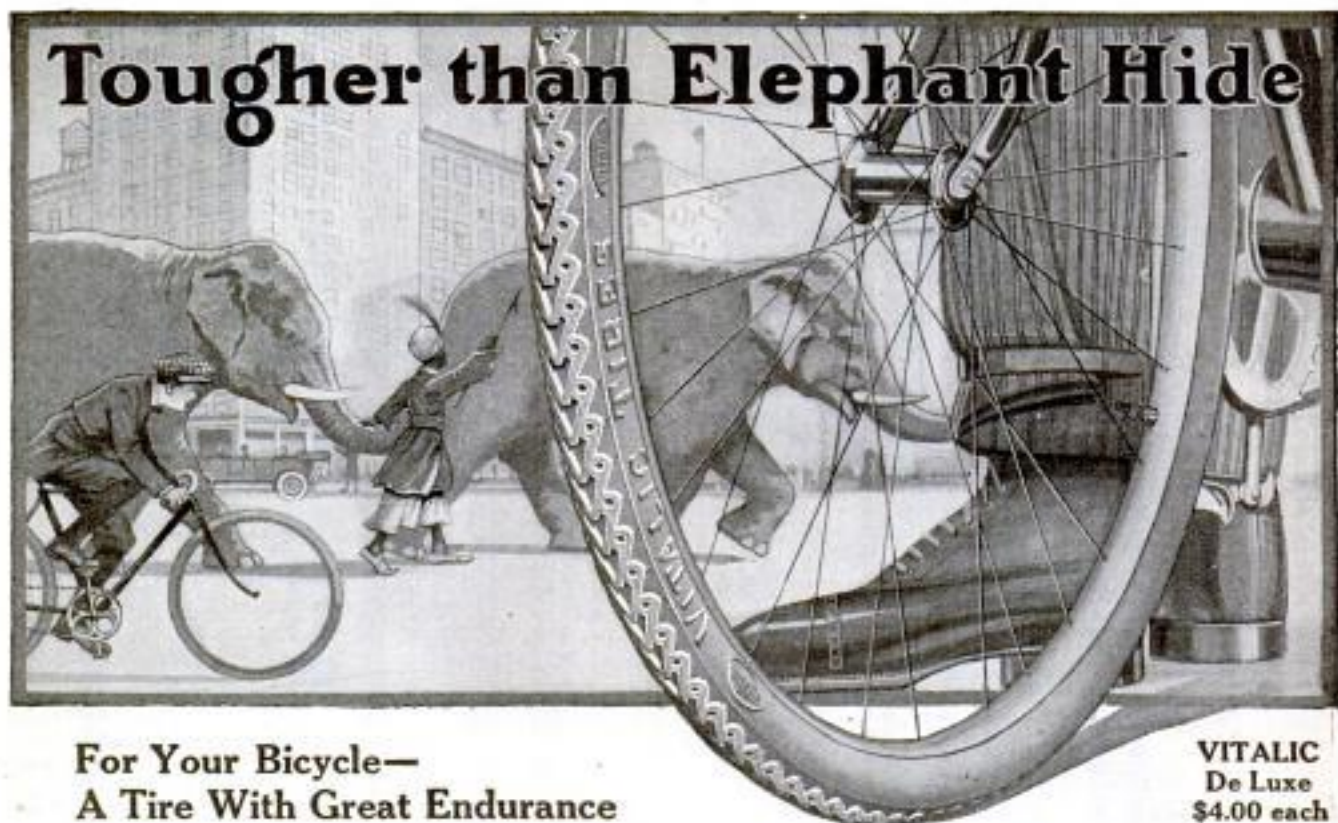

**For Your Bicycle—
A Tire With Great Endurance**

**VITALIC
De Luxe
\$4.00 each**

Like the elephant in might, in length of life, in rugged, genial service. Vitalic Tires are to the bicyclist what elephant hide is to the elephant as he roves the jungle, immune from splintered trees and hostile claws. Vitalic Tires mean safeguarded going over bad roads—a dependable armor against stones, ruts, time and wear. Vigor and value from tread to tube. Resilience blends with resistance in the stern, double thick, motorcycle tire fabric. Send for testing section—note the triply-twisted thread. Examine each layer of rubber and fabric—thicker than elephant hide.

VITALIC Bicycle Tires



Vitalic Brigadier
\$2.50 each

Three great tires bear the great name *Vitalic*. Each wholly worthy the name. Each sturdy, long-lived—good for thousands of miles. Each easy to recognize. The *Vitalic De Luxe*, with heavy V-shaped suction non-skid all-white tread, brings you enormous friction-resisting tire-evity—\$4.00 each. The *Vitalic Brigadier* is a stalwart tire with white, heavy, studded tread and gray walls, built for hard knocks for those

Real Foot Ease on Vitalic Pedal Rubbers

Vitalic Pedal Rubbers put new ease—new energy—into pedaling. Best for a quick getaway. Restful on long jaunts.

Vitalic Grips Save Slips and Cramp

Once you ride with Vitalic Grips, you'll never change. Big enough and with just enough yield.

There's Life and Last to Vitalic Inner Tubes

They're without flaw or weakness. Layer upon layer of lively, long-lived rubber. Full of vim and vitality.



**Send Today for This
Free Testing Section**

Continental Rubber Works, 1964 Liberty St., Erie, Pa.

Vitalic Automobile Tires, Too

Please Mention Popular Mechanics

If This White Cross Vibrator Could Talk, It Would Say:

I am used by the builders of the world.
 I help add years to your life and life to your years.
 I am the great exerciser and stimulator of circulation.
 I believe I can prove this to you with one demonstration.
 I improve Health and Beauty—*Let me do it for you!*
 I put strength and endurance into weak muscles and nerves—*Let me do it for you!*
 I put rosy cheeks on women without paint or powder—*Let me do it for you!*



You should read some of the hundreds of wonderful letters written about me by people who have experienced remarkable benefit. Nothing short of genuine appreciation could prompt such conservative people to make these statements voluntarily. But take nobody's word for it. *Try me yourself.*



To Those Who Think They Can't Afford Me

I am not an expense, I am an investment. By helping you keep well and improving your energy, I create money. I have a way of making your brain more clear so that it hits on all cylinders. That "tired feeling" runs away. You go to work with the better strength that your highest ambitions yearned for. Doctors, sanitariums and hospitals have found Vibration so successful that most of them keep me in their office. Vibration tones all the organs. It stimulates and builds up without medicine. It helps to make better health and good health is the only basis of a big brainy mind. You are entitled to perfect health. I want you to use me to help obtain it. I want you to feel at least once in your life the exhilaration of better circulation and health. Our combination outfits give you three of the greatest natural curative agents in the world—vibration, faradic and galvanic electricity. Can be connected to electric light socket as easily as a lamp, or will operate on its own powerful batteries.

Send for Free Book "Health and Beauty"



The man or woman that desires better health, better circulation, and better complexion, stronger nerves and muscles, and a better formed figure, should mail the coupon attached for the free book, "Health and Beauty." This book describes and illustrates how health, beauty and development can be obtained in the privacy of your home through White Cross Electric Vibrator. If your health is not right up to the minute, ask for this book.



Send for this Book

Lindstrom, Smith Co.
 Dept. 1193
 1100 S. Wabash Ave., Chicago

Without any obligation at all, please send me, free and prepaid, your free book on Vibration, and full particulars of the White Cross Vibrator.

Name.....

Address.....

Lindstrom, Smith Co., Dept. 1193, 1100 S. Wabash Ave. Chicago

We also manufacture White Cross Electric Stoves, Iron, Hair Dryers, Electric Lanterns, Electric Fans, Electric Automobile Horns, Electric Curling Irons, Heating Pads, Small Motors, etc., etc. Dealers write.

My Electrical Dealer's Name is.....

THE EXPO WATCH CAMERA



The most wonderful and ingenious Camera made

It is but little larger than a watch, which it closely resembles. You can carry the Expo about in your pocket and take pictures without any one being the wiser.

One Cent a Picture

The Expo loads in daylight with 10 or 25 Exposure Films, costing 15c and 25c respectively, and thus the picture taking part of a whole day's outing may be had for a very nominal sum — One cent a picture.

Easy to Manipulate

It is simplicity itself to operate. Takes pictures through the lens, where the Rapid Fire Lens is located. The photos (5/8x1/8) may be enlarged to any size.

Operated as quick as a flash Time and instantaneous shutters; Enclosed by amateurs and professionals the world over. Thoroughly practical—printing and developing of films just the same as ordinary cameras—in daily use by the police, newspaper reporters, detectives, and the general public. Important hints have been secured with the Watch Camera by enterprising reporters. Produces clear, sharp negatives indoors or outdoors equal to any camera on the market, size or price notwithstanding. Sold Under a Positive Guarantee.

Expo Watch Camera \$2.50 FILMS, 10 Exposures 15c, 25 Exposures, 25c postage 10c Leather Pocket Carrying Case, 35c

MAILED TO ANY ADDRESS IN THE WORLD

JOHNSON SMITH & CO., 7155 North Clark Street, CHICAGO

JAPANESE ROSE BUSHES

The Wonder of the World

Japanese Rose Bushes bloom all the year round. Just think of it. Six weeks after planting the seed, the plants will be in full bloom. It may not seem possible, but we positively guarantee it to be so. They will bloom every ten weeks, Summer or Winter, and when three years old the bush will be a mass of roses, bearing from five hundred to a thousand roses on each bush. The flowers are in three shades—white, pink, and crimson. The plants will do well both in and out doors. We guarantee at least three bushes to grow from each packet of seed. Price, 10c packet, 3 pkts. for 25c postpaid.

Shoo Fly Plant

A very remarkable botanical curiosity you should have. Though quite odorless, flies will not remain in a room where it is grown. Bears very pretty blossoms, summer and winter. Grows rapidly from seed. SEEDS 15c, packet, 3 for 40c, postpaid.

Weather Plant

NATURE'S WEATHER PROPHECY By mysterious changes that take place, this remarkable plant accurately forecasts the weather many hours in advance. Will grow anywhere all the year around. An interesting house plant. Bears large, fragrant, pink, butterfly shape flowers. SEEDS, 15c packet, 3 for 40c, postpaid

GROUND ALMONDS

Amazingly Prolific—Easily Grown From Seed The Ground Almond has a flavor that is MOST EXCELLENT, resembling the coconut. The meat is snow white, covered with a shell or skin of brown color. It grows close to the surface and anything from 200 to 300 Almonds may be expected from a single pot. There is no trouble whatever in growing anywhere and in any kind of soil. May be planted any time, and in eight or ten weeks from time of planting you will have an ENORMOUS CROP of the MOST DELICIOUS ALMONDS YOU EVER TASTED. SEEDS 15c Pkt.

Perfume Plant

Blooms only at night, giving forth the most delightful scented fragrance for quite a distance. Grows on a bush or garden. Also valuable because of rare perfume made from it. SEEDS, 10c pkt., 3 for 25c.

Musk Plant

Another charming floral novelty of the sweet scented variety. Equally suitable as house plant or garden. Makes the most delightful perfume. SEEDS, 10c pkt., 3 for 25c.

The Wonderful Sensitive Plant

The Marvel of the Philippine Islands. Almost human in its nervous susception. Leaves curl, and fronds droop when touched. Apparently resents interference; it dislikes strong odors, and is painfully affected by artificial heat and electricity. Has graceful foliage and fluffy pink flowers. It is a handsome shrub for house or garden and very curious and interesting; blooms all the year round. SEEDS 15c pkt., 3 pkts. for 40c postpaid

NITTO'S PLANT & FLOWER FOOD

NITTO'S PLANT FOOD is clean, odorless, and highly concentrated. It is used in liquid form on all kinds of plants, shrubs, roses, ferns, bulbs, berries, lawns, fruit, flower and vegetable gardens. It changes ill-nourished plants into LUXURANT BEAUTIFUL ones, producing masses of blooms that will equal any. Causes plants to bloom early and ahead of others. Your friends will marvel at your success. Makes no difference how healthy or how delicate your plants may be. Nitto's Plant Food will bring out New Fallage and Flowers, and cause a Marvellous Transformation. 15c, 3 for 40c

Johnson Smith & Co., 7155 N. Clark St., Chicago Only Concern of its Kind in America

Automatic Repeating Rifle

Fires 20 Shots in One Loading



This is a regular size automatic revolver. Shoots B. B. shots obtainable anywhere, same as other rifles and guns. Repeats 20 times with one loading. Hand-somely finished in gun metal. No caps or load necessary, as it works with a spring and shoots with rapidity and accuracy. Simply load with 20 B. B. shot, then press the trigger. Nothing to explode — absolutely harmless and safe. Remember, it is not a mere toy, but the same size and shape as a REGULAR AUTOMATIC. Sent complete with a round of shot for ONLY 25c postpaid. Extra shot, 10c a package.

Only 25c Postpd

It is simplicity itself to operate. Takes pictures through the lens, where the Rapid Fire Lens is located. The photos (5/8x1/8) may be enlarged to any size. Operated as quick as a flash Time and instantaneous shutters; Enclosed by amateurs and professionals the world over. Thoroughly practical—printing and developing of films just the same as ordinary cameras—in daily use by the police, newspaper reporters, detectives, and the general public. Important hints have been secured with the Watch Camera by enterprising reporters. Produces clear, sharp negatives indoors or outdoors equal to any camera on the market, size or price notwithstanding. Sold Under a Positive Guarantee.

THE FIGHTING DREADNAUGHT

Sensationally Realistic! Exact Model of Modern Warship

The greatest toy sensation of the day. The Fighting Dreadnaught is an exact model of Uncle Sam's latest fighting monster. It carries eight big guns, each of which flashes, at correct intervals, from twelve to twenty times. Extra ammunition always obtainable. Absolutely harmless. Can be operated indoors or out. Now, boys! Here's your chance to see a battleship in action, and the best of it is you can OWN the ship and command the firing yourself! By having two or more Battleships, you can arrange EXCITING NAVAL BATTLES in your own home. Price of Warship and Ammunition, 15c, three for 40c, or a fleet of 12 ships for \$1.50 postpaid. Extra Ammunition, 5 cents per pkg.



Nu-Face Masks

12 COMPLETE DISGUISES FOR 95 CENTS, 85c on and off in an instant. No end of fun. Puzzle your friends. ABSOLUTELY UNRECOGNIZABLE. They change the shape of your face beyond belief. Cool and comfortable. For Parties and Masquerades. Pairs, Car Edden, Mask Balls, Amateur Theatricals, they are simply immense. There are SIX MASKS FOR UPPER HALF OF FACE, AND SIX FOR LOWER, as follows: 101, Clown; 102, Sherlock Holmes; 103, Foxy Grandpa; 104, The Colonel; 105, The Firt; 106, The Smiler; 201, The Count; 202, The Doctor; 203, The Scept; 204, The Babe; 205, Weary Willie; 206, Mr. Dookey. Price, 10c each, or the complete set of 12 Masks for only 95c postpaid.



New Vamping Card

Persons having neglected their Musical Education need not despair, for with the aid of our new VAMPING CARD (placing the card upright over the piano keys), you can at once VAMP with the ease of a Professional Musician. No knowledge of music is required. After using it a few times, you will be able to dispense with the aid of the Vamping Card entirely. The price of this very clever invention is only 15 cents postpaid.



Persons having neglected their Musical Education need not despair, for with the aid of our new VAMPING CARD (placing the card upright over the piano keys), you can at once VAMP with the ease of a Professional Musician. No knowledge of music is required. After using it a few times, you will be able to dispense with the aid of the Vamping Card entirely. The price of this very clever invention is only 15 cents postpaid.

All the Latest Surprising and Joke Novelties

- | | | | |
|---|-----|---|-----------|
| Pharo's Serpents Eggs, box . . . | 10c | X Ray Novelty | 10c |
| Mimicry Water Pistol | 15c | Trick Pencil | 15c |
| Cleopatra's Snake (very lifelike) . . | 15c | Rubber Tacks (a good joke) . . . | 10c |
| False Mustache (fool your friends) . | 6c | Messmerized Penny (defies the law of gravitation) | 20c |
| Big Roll Stage Money | 10c | Carthus's Shooting Powder | 10c |
| Ford Auto Puzzle (Latest) | 10c | Mysterious Tumbler and Vanishing Coin Trick | 25c |
| Magic Plate (anyone can play it) . . | 15c | Enchanted Bottle (won't lay down) . | 5c |
| Rubber Razor (very formidable) . . . | 25c | Magic Plate Lifter | 20c |
| Rubber Dagger (sensational) | 25c | Imitation Gold Teeth | 3 for 10c |
| Window Strangers (great joke) . . . | 25c | Grant Eclipse Puzzle | 10c |
| Pocket Detective (see behind you) . . | 10c | Wire Puzzles, 10c, 25 different, \$1.50 | |
| Great Mind Reading Mystery Cds. . . | 10c | | |
| Thurston's Mystery Trick Cds. . . . | 10c | | |
| Fighting Roosters, pair | 10c | | |
| Cover the Spot Trick, a scene, nov. . . | 10c | | |

Large catalog (300 pages) of unique, novel and useful articles (unobtainable elsewhere) free with all orders, or mailed on receipt of five-cent stamp. Agents and Dealers write for wholesale prices. Mail order dealers and beginners supplied with 33, 44 or 148 page catalogs at cost. Send 10 cents (credited) for sample of each and particulars of our proposition.

Johnson Smith & Co., 7155 N. Clark St., Chicago

Read the next page, too

WE ARE HEADQUARTERS FOR ELECTRICAL GOODS and WIRELESS APPARATUS

Send Today for a Copy of Our Unrivalled 232 Page Catalogue



THIS IS THE Experimenter's Reference Book

It's the latest edition of the famous Amco Catalogue, contains over 200 pages and is fully illustrated. Complete description and prices of the latest electrical and experimental apparatus—Storage Batteries, Rectifiers, Transformers, Induction Coils, Wireless Apparatus, Lamps, Flashlights, Meters, X-Rays, Books, Tools, Electric Railways, Steam Engines, Water Motors, Dynamos, Motors, Telegraphs, Telephones, Electrical Stipples, Model Aeroplanes and Parts for building your own apparatus.

Our prices will save you money and our prompt deliveries will save you time.

So in stamps will bring you this wonderful book. Best catalog of Wireless and Electrical Apparatus, etc., published. Send for this catalog right away. Our prices will save you money. **6c IN STAMPS BRINGS IT BY RETURN MAIL.**

Send for this catalog today. You need it.



FUN WITH ELECTRICITY

Here is a rare chance to get started right in your study of electricity. This wonderful outfit contains 16 page book of instructions and all the apparatus for performing 60 interesting and spectacular experiments which will give any boy a practical knowledge of electricity. **Price Only 50c. Postage 10c Extra.**

FUN WITH MAGNETISM

This outfit contains 32 page book of instructions and all the apparatus for performing 81 fascinating experiments. It will give you some new ideas about electricity and magnetism in such an interesting way you can't help remembering it. **Price only 25c. Postage extra 5c.**



ADAMS-MORGAN COMPANY, "The Experimenter's Supply House"

LOTS OF FUN FOR BOYS!

35 volt, 2 C. P. TUNGSTEN lamp, switch, socket, 30 ft. insulated wire and 3 cells of dry battery all ready to install. **May be used to light a dark closet or hall.**

LITTLE GIANT MOTOR

is nearly 3 in. high. Runs at high speed on a single cell of battery. Very powerful and may be used to run small toys, etc. Just the motor every boy has been looking for. **Price 50c. Postage 10c extra.**

THE SIMPLEX TELEGRAPH OUTFIT

An opportunity for every boy to learn to telegraph and to put up a line with his class. This is a full sized telegraph set, consisting of a fine key and sounder, mounted on a polished base. Will work any distance. An excellent Field Telegraph for Boy Scouts. **Price, \$1.00. Postage Extra. Weight 2 lbs.**

UPRIGHT STEAM ENGINE

A fine engine of the best materials. 9 in. high. The Right Engine for Any Boy. Runs at high speed. Each engine tested at factory and fully warranted. **Price 60c. Postage 10c extra.**

SIMPLEX WIRELESS OUTFIT

Every boy wants a wireless. Get in this interesting game and read the messages flying around you. This outfit is the greatest bargain ever offered. Consists of a large double slide tuner, a sensitive detector, condenser, telephone receiver and cord. **Weight 3 lbs. Special Price, Complete, \$2.90. Postage Extra.**

UNICOIL ELECTRIC MOTOR

This motor will run for hours at high speed on a single cell of battery. Develops considerable power. Embodies a new principle in toy motors. The best motor value on the market. **Send Postpaid for 50c. Don't Forget to Send for a Catalog.**

25 Alvin Place, UPPER MONTCLAIR, N. J.

\$3.95 WORLD'S BEST SHOE VALUE

\$3.95 FOR REGULAR \$5.00 SHOES

Ruthstein's Scientific Shoes for men—featuring men's Gun-Metal Calf Shoes, New English last, Dull Calf Top, Leather Sole, Goodyear Welt sewed, C to EE widths, sizes 6 to 11—**\$3.00 Value, \$3.95.**

200 OTHER SHOE BARGAINS

For Men, Women, Boys and Girls

Also complete line Ruthstein's Famous "Steels." Big, New 1917 Scientific Footwear Catalog shows over 200 styles and how to save 20% to 50% on shoes for the whole family—**FREE** on request.

Ruthstein Scientific Shoe Co.
America's Greatest Mail Order Shoe Factory
Dept. 640 RACINE, WISCONSIN



We Retail at Less than Wholesale Shoe Prices

\$42 The Famous FOX

The lightest running typewriter in the world.

Latest Rebuilt Model 24

—from our Factory to your office or home for \$42. Send any amount with order you can spare and pay the balance \$5 monthly. No interest. No red tape. 3 years' guarantee.

Mention Popular Mechanics.

FOX TYPEWRITER CO., Grand Rapids, Mich.



AGENTS Get Next to This!



A Big Money Maker

The biggest, fastest, snappiest sellers in the world. A big box of the finest

Toilet Soaps, and give a pair of Patented Tension Shears **free** with each sale. Hundreds of other

Big Snaps, Makes selling easy. Beginners cleaning up \$5 to \$6 a day. Start while new. Outfit furnished free. Write today.

A WORLD BEATER AMERICAN PRODUCTS CO., 7739 3rd St., CINCINNATI, O.

Big Money-Making Opportunity



Buy a Wilt Blade Sharpener—become independent. Large field, big profits. Small investment (\$135 complete with motor). Sharpens, hones and strops all safety razor blades. Act now!

WILT MACHINE CO.
74 Bagley Ave. Detroit, Michigan

BE OIL WISE — GET 50¢ SIZE

You'll get as much 3-in-One as if you bought 8 of the 10c bottles. And 3-in-One never loses its quality—never thickens, gums or turns rancid. Always sweet, fresh and good. 3-in-One has for 16 years been the leading Household Oil—Lubricating, Cleaning and Polishing, and Preventing Rust.

Use for oiling sewing machines, bicycles, talking machines, guns, reels, locks, clocks, etc. Use for cleaning and polishing fine pianos, tables, chairs, any furniture. Use for preventing rust on any metal surface.

FREE On receipt of your dealer's name we will send you free of cost a generous sample bottle and the valuable 3-in-One Dictionary. Try this good oil at our expense.

3-in-One is Sold at all Good Hardware, Drug, Grocery and General Stores

Three-in-One Oil Company

42CNH. Broadway, New York

Money Grows if rightly planted



A Yearly Income For Every Man and Woman

Would you invest a moderate amount in monthly, quarterly or semi-annual installments to suit your convenience if you felt assured it would earn for you an income from \$1000.00 to \$5000.00 annually according to your investment? This without a stroke of work on your part. You do not have to leave your present business or employment unless you choose.

A Dixie Estate of fancy grapefruit, oranges and avocados should do this for you after it begins bearing. Past and present prices for these fruits prove this a very CONSERVATIVE STATEMENT.

Picture for yourself a cozy home in balmy Florida, beneath beautiful skies, among flowering shrubs and luxuriant money-producing fruit trees. SUCH IS A DIXIE ESTATE, which awaits you whenever your inclination draws you to it.



Invest Now—While You Can

We will plant only a few hundred of these Dixie Estates and bring them into bearing for their fortunate owners. Will you be one? Think of this great and unparalleled opportunity!!!

TERMS—3 TO 6 YEARS' TIME IF YOU WANT IT

You are not paying out or spending your money, but saving and investing it in a safe, money-making property—a highly developed fruit grove, which according to statistics should within a few years bring you a substantial income. Think what this really means to you—figure it out for yourself.

A DIXIE ESTATE IS FUTURE INSURANCE

Here is an investment which must appeal to every man and woman. Even if you already have an independent income, you cannot afford to miss this chance to own a Dixie Estate.

Citrus fruit and avocado trees are long lived. This is not a temporary investment, but one which will enhance in value yearly as its earnings increase. Compare this with any investment you have ever heard of—you will have to admit a similar offer has never before been made.

You Are Planting Money Rightly When You Invest in Dixie Estates

LOCATION—The best in all Florida, near Tampa—70,000 population, growing so rapidly that it is destined to become the Los Angeles of the South. Dixie Estates are near paved boulevards, railroad stations, schools and churches.

SOIL—You could not buy better land for fruit growing no matter how much you paid for it.

CLIMATE—Most healthful and charming the year round.

THE TREES—All budded, pedigreed stock, grown by experts. Owning extensive nurseries and having years of experience, enables us to develop these Dixie Estates in the most approved, up-to-date manner.

Fancy oranges and grapefruit are well known money-producers, when brought into bearing by expert, scientific methods. The Avocado (commonly called alligator pear) is known as the aristocrat of fruits. In winter they sell at \$1.00 to \$2.00 each in northern markets. It is no doubt the highest priced fruit known.

The Thomas Nurseries, Inc.

8th Floor, Tower Bldg., Dept. PM, Chicago, Ill.

You are offered an unheard of opportunity to derive a splendid YEARLY INCOME FOR A COMPARATIVELY SMALL INVESTMENT. The proof is what you want!!! We have it and will gladly send it to you FREE.

Your Dixie Estate receives expert and scientific care and attention for four years. Thereafter if you do not wish to take personal charge we will care for your Dixie Estate—its development and marketing of fruit indefinitely—for a percentage of the profits. You receive the benefits of this truly marvelous proposition even if you never intend to live in Florida.

Every reader of this magazine will want a Dixie Estate after reading our illustrated booklet—therefore act at once and be certain of obtaining one of the limited number to be planted. Mail the attached coupon today. We will mail you full information—FREE.

Own a splendid money-making Dixie Estate in the most attractive, most healthful, and delightful district to be found anywhere in America.

FILL IN AND MAIL COUPON NOW

THE THOMAS NURSERIES, Inc.
8th Floor, Tower Bldg., Chicago

PM 3-17

Please mail me detailed information and free booklet on Dixie Estates. This does not obligate me in any way.

Name.....

Street and Number.....

City..... State.....



The Penalty of Corns

No need now to waste
time soaking your feet so often.
Nor run the risk of paring.

BLUE-JAY plasters have ended millions of corns. This very night thousands of people will say goodbye to painful corns forever. Touchy corns are needless, even foolish.

Blue-jay brings instant relief. And in 48 hours the average corn is gone. Only a

few stubborn ones require a second or third treatment.

A Blue-jay plaster, with its healing wax, is applied in a jiffy. No soreness, no inconvenience. The pain is not temporarily eased, as with paring. There is no danger, as with harsh liquids. Decide to join the happy crowd tonight which has won freedom the Blue-jay way

BAUER & BLACK
Chicago and New York
Makers of Surgical Dressings, etc.

Blue=jay

Stops Pain — Ends Corns

15c and 25c at Druggists

Also Blue-jay Bunion
Plasters

"Bristol" De Luxe Fly Rod and Meek No. 2 Reel

A special "Bristol" silk wound steel fishing rod put through extreme tests for strength, durability and resiliency — silk wound, waterproofed and beautifully finished — the rod with 40% more strength and with the hang, action and feel of a high class bamboo rod. Full jeweled. \$25.00 in Washable silk lined glove leather case.

The full-jeweled Meek Reel is world famous among fishing experts. An exquisite piece of mechanism. Price \$32

Two Catalogs FREE describing 61 different rod and reel models.

THE HORTON MFG. CO.
196 Horton St. BRISTOL, CONN.

CACHOO! Make the whole family and all your friends "just sneeze their heads off" without knowing why, with Cachoo, the new long distance harmless snuff. Sent anywhere for 10c. 3 for 25c. 1 doz. and special premium for 90c. **AMERICAN SUPPLY CO., St. Paul, Minn.**



Increase Your Efficiency

POINTER No. 1: "Keep Your Pocket in Order"

"THIS-WEEK" is the name of a valuable "Pocket Orderly" that will definitely increase your personal efficiency!

AN ENTIRELY NEW DEVICE: It serves systematically as Pocket, Calendar, Diary, and as a record of Appointments, Reminders, and Expenses: ALL FOR PERMANENT FILING. Less than 1/16" thick, yet Roomy and Substantial. Without a vestige of complication.

HOWEVER! What YOU have to do is....

Get One! Use it! And be convinced!

SAMPLE mailed with Personal Efficiency Pointers 2, 3 and 4, for

10c

THE FOLLOWS EFFICIENCY BUREAU, E. End Trust Bldg. Pittsburgh, Pa.



Watch
will be
Delivered
on First
Payment



10c DOWN and You keep the watch

New easiest watch selling plan. Pay us only 10 cents and we will deliver to you right off the reel, a real watch, fit for a King—the highest grade watch—an Illinois watch—and at a less cost than you would ordinarily pay for spot cash. These are not big, clumsy 18 size watches. They are the latest and most up-to-date gentleman's thin model watches 16 or 12 size. A regular spot cash \$25 Illinois watch.

\$22.50 Only 10c Down

and a dime added to a dime each week. *This is the easy plan of payment:*

17 JEWEL ILLINOIS
High Grade Movement,
(Adjusted) Steel Escape Wheel
fitted with Gold Filled Double
Stock 20 Year Guaranteed Case

This offer is open to every honest
person of legal age in the U. S.

\$.20 the 2nd week	\$.90 the 9th week	\$1.60 the 16th week
\$.30 the 3rd week	\$1.00 the 10th week	\$1.70 the 17th week
\$.40 the 4th week	\$1.10 the 11th week	\$1.80 the 18th week
\$.50 the 5th week	\$1.20 the 12th week	\$1.80 the 19th week
\$.60 the 6th week	\$1.30 the 13th week	\$1.80 the 20th week
\$.70 the 7th week	\$1.40 the 14th week	\$1.80 the 21st week
\$.80 the 8th week	\$1.50 the 15th week	\$22.50—Total

Ladies' high grade up-to-date bracelet watches \$18. Ladies' full-jeweled open-face Illinois watches \$16.50. Hunting case \$18. All sold on same easy plan. Send a dime today and get your watch on this easy plan.

THE WHOLESALE JEWELRY CO., 5707 South Blvd., Dept. 5247, Chicago, Ill.

Learn Mechanics of Aviation

Write today. See how you can learn the principles of Aeronautical Construction and Engineering in your spare time at home. Save all the time and expense of laborious field training. Big opportunities now for trained Aviation Experts in different branches of the service. \$50.00 to \$250.00 a week.

Write At Once! Big tuition reduction offer now open. Write for details while this offer lasts. No obligations.
American School of Aviation, Dept. 7193 431 S. Dearborn St., Chicago, Ill.

Large Profits From POULTRY

can be made when you thoroughly understand practical poultry culture and know the proper way to select, rear, house, feed and mate your fowls. In our course of 48 complete lessons, Prof. Quisenberry teaches you how to make a good profit from a flock of hens properly cared for.

Our Free Illustrated Book—"Dollars and Sense in the Poultry Business," tells you how to make money in the poultry business. It leaves nothing to chance or guess work. Write today. No obligation. No agents to bother you.

AMERICAN SCHOOL OF POULTRY HUSBANDRY
Box 75, LEAVENWORTH, KANS.

DOLLARS
SENSE
IN THE
POULTRY
BUSINESS

WE PAY CASH for Scrap PLATINUM and Old False Teeth

On rubber or metal plates. Highest cash price paid for old Gold, Silver, contact points, crowns, bridge work, mercury and broken jewelry. Send your package today by parcel post to

The Mutual Smelting and Refining Company
116 North Front Street, Columbus, Ohio

FREE!-3 Books on BOATS

1—Special Boats of 130 Leading Boat Builders.
2—Gray 2 and 4 cycle Motor Engine Catalogue.
3—Book of Boat Models for work, fishing, cruising.
Ask for any (or all) of them if you are interested in boating for pleasure, or profit. Book 1 shows more boats than motor show.

Gray Motor Company
345 Gray Motor Bld'g.
Detroit, Mich.

Electric Light for Your Home

Uni-Lectric lighting plant generates standard 110-volt direct current; operates from one to 50 lights, electric motor, electric iron, vacuum cleaner, electric toaster, force pump, churn, washing machine, etc.

No Batteries — No Switch-Board

and a better machine for less money. High speed gasoline motor, generator and automatic governor, all complete in one small, compact unit. Uses standard lamps and fixtures. Simple, easily installed, dependable, economical. Costs less than other systems to buy and to operate.

WATERMAN MOTOR COMPANY
182 Mt. Elliott Ave. DETROIT, MICH.

Write today for full description and low price.

Uni-Lectric
GASOLINE-ELECTRIC UNIT
LIGHTING SYSTEM



Please Mention Popular Mechanics

White House

Coffee and Teas

Brand

*"A Man's Coffee
is his
Breakfast"*

Sold in the whole bean, ground or pulverized, never in any package but the 1, 2, 3 or 5-lb. All-Tin cans. White House Tea, $\frac{1}{4}$ and $\frac{1}{2}$ -lb. All-Tin cans, all varieties, as good as White House Coffee.

DWINELL-WRIGHT CO.

Wholesale Coffee Dealers BOSTON - CHICAGO

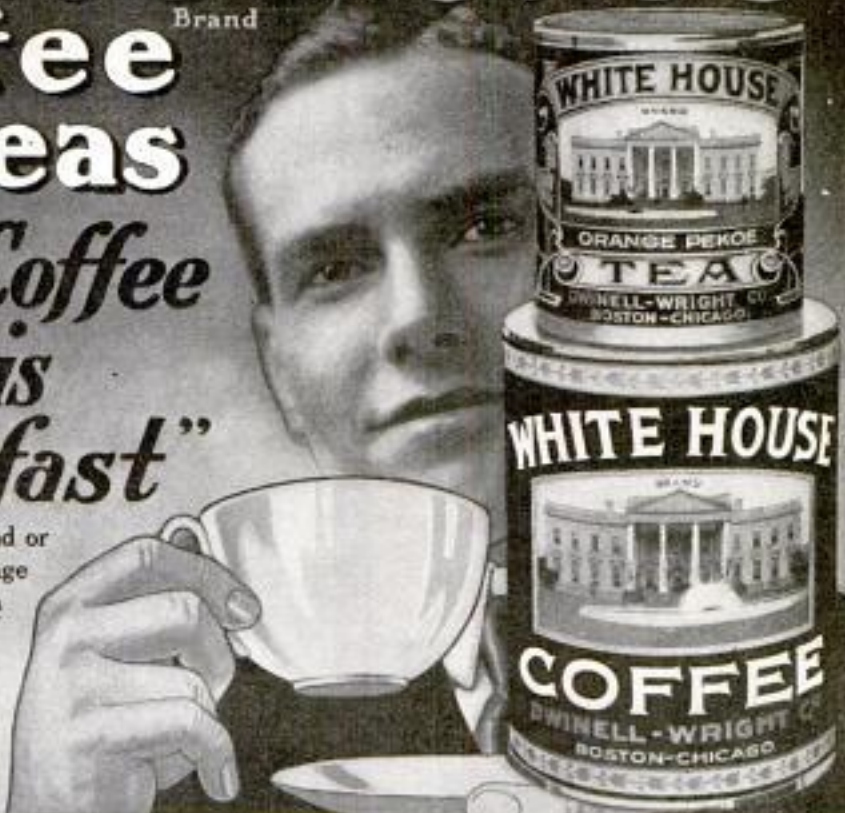

LOCK YOUR OPEN WINDOWS

Simple little device can be attached by anyone in a few seconds—absolutely burglar proof.

Leave windows open, let the fresh air in, keep intruders out. Locks upper and lower sashes, adjustable various heights. All metal. 50 cents apiece, 5 for \$2.00. SENT ON APPROVAL. Pay if satisfied or return. Write today. Address

1324 West Eighth Street SAFETEE LOCK CO. KANSAS CITY, MISSOURI



Attached in 10 Minutes

(PATENTS PENDING)

Anyone, anywhere, can replace their broken back window without tools—at less expense by this method than any other.

Remove protecting "holland" when ready to attach. Moisten gum edges with gasoline and apply without removing curtain. Goes on like a postage stamp—sticks like a bulldog.

Money back if it don't stick after attaching as instructed. Stronger than stitching or metal fasteners. Wt. 3 ozs. Faultless appearance. Water tight—wind tight. Buy of your dealer. If he doesn't carry them

WE SEND PREPAID AT FOLLOWING PRICES:

Ford Window, \$1.25. Oval, with mohair binding for Buick, Overland, Maxwell, etc., \$1.75.

Is your window now broken? Order today.

The Cincinnati Auto Specialty Co.
Dept. M37 Cincinnati, Ohio

BUY YOUR HOME

Machine-cut direct from Factory
AT THE INSIDE PRICE

Home builders can save money by dealing direct with the producer. Get around the high cost of building. Dodge the exorbitant prices—compounded profits—extra labor—extravagant waste—and tedious delays of the old-fashioned building method. Investigate this newer, better, quicker system.

LEWIS-BUILT HOMES

Machine-Cut-to-Fit

are the result of modern efficiency methods applied to the building business. We will send you catalog of 100 houses, cottages, bungalows; make your selection—then we ship complete house direct to you, ready-out, with all materials complete, at factory price.

Modern Method of Home Building

Machine cutting saves 40% carpenter labor. No waste. No delays. Everything finished for complete house—first-grade materials throughout. Free plans and instructions. Send 4c postage for catalog of flow plans, pictures and prices. (Also Home Furnishings Catalog on request.)

LEWIS MFG. CO.

Dept. 378 BAY CITY, MICHIGAN

\$749
6 Rooms



Every Boy Knows

that the best bicycle in the world is incomplete without the best tires. That is why he always insists on his dealer stocking the twelve different makes of

United States Bicycle Tires

Heavy Service Traction Tread
United States Cord
U. S. No. 77 Chain Tread
U. S. Blue Dual Tread
U. S. Road Racer
U. S. Giant Stud
Overland Thornproof Oil Resisting

Nonpareil
G & J Double Clinch Chain Tread
G & J Double Clinch Corrugated
G & J Double Clinch Herringbone
Tread
Single Clinch (G & J style) United
States Brand

Because they not only are the very best, but also because *they meet every need of price and use.* Send for our free and beautifully illustrated catalog **Today.**

Be Sure and Ask for One of the Twelve

United States Tire Company

*United States Single Tube Bicycle Tires
Original Indianapolis Brand G & J Clincher Bicycle Tires*

1790 Broadway, New York



An All-around Companion— the Bicycle



A good, dependable, knock-about friend, useful in work, unequalled in sport.

A health builder, a time saver, a convenience and a recreation. Such is the

Columbia Bicycle

Why is it that year after year these bicycles, the first to be made in America, maintain their leadership, and steadily grow in popularity?

The reason is plain: Columbia bicycles have proved themselves—behind them is a service record of thirty-nine years. All that is best and most progressive in bicycle construction is found on them.

Another thing: People are more interested in bicycling than ever before. They are devising ways and means to offset the influences of workday confinement—to get recreation out in the open—and to make the most of their holiday and leisure moments.

To attain these ends there is nothing more ideally adapted to the needs of man than the bicycle. And the bicycle is yet to be made that can serve these needs more satisfactorily and dependably than the Columbia.

Your dealer will show you a complete line of new models. Ask to see the Superb, Arch Bar, Roadster and Juvenile. Prices from \$60.00 to \$26.00. Send today for catalog.

WESTFIELD MANUFACTURING CO.

Department 15

Makers of Pope Motorcycles

Westfield, Mass.

"When a Feller Needs a Friend" — By Briggs



Send for the Briggs Book

— full of cartoons of boys having fun with Kings; containing story of the air rifle and how it is made, and listing the full King line with prices.

Send 2c stamp to Dept. E

The MARKHAM AIR RIFLE CO.
Plymouth - - Michigan

MOTHER must think that shelling peas comes under the head of "indoor sports!" Claire isn't saying a word, but you can see he has his eye on that new King Air Rifle. Shell away, Claire! Save your nickels and pretty soon you'll have a King of your own.

Everybody wants to chum with the boy who owns a King. But every boy ought to have one of his own, for Drilling, Scouting, Camping Out, Target Shooting and all 'round fun.



1000
Shot Repeater,

No. 5 King—the famous "Repeating" air rifle—is the most popular model. Lever action. Automatic loading. Frame and barrel one piece of nickel-plated steel. Walnut stock. Light, strong, accurate. At your dealer's or direct from factory, \$2.50 prepaid for

KING
AIR RIFLES

TEMCO



"Our foreman reports it the best electric drill he has tried."

Any way, it's a mighty good tool. It works fast and does much besides drilling in metal and wood. It also taps threads, drives and draws screws, grinds valves, and sharpens small tools.

An auto repair man says he occasionally puts his Temco Tool in a vise and uses it as a motor, driving a small lathe from its pulley. It is one of those intensely practical tools that save time and money in big and little factories everywhere, in maintenance departments, public buildings, repair shops, etc.

5 sizes weighing 9 to 19 pounds

Capacities to 1/2 inch drilling in steel. One and two speed, and instant motor reverse type—direct or alternating current. From dealers and jobbers, or direct

THE TEMCO ELECTRIC MOTOR COMPANY
136 Sugar Street, LEIPSIK, OHIO

Makers also of Temco-Alta Shock Absorbers, and Temco Shock Absorbers, Master Vibrators and Lock Switches for Ferris.



THE TOOL OF MANY USES

Please Mention Popular Mechanics

A Birthday Present

If you are racking your brains to think of a suitable birthday present—stop. Go to any dealer and ask to see Ingersoll watches. There are eleven kinds from a \$1 to \$3.

DODGE BROTHERS MOTOR CAR

JENKINS BAND AND ORCHESTRA INSTRUMENTS

are world famous. Own a Cornet, Trombone, Clarinet, Drum, Saxophone, Violin, Guitar—any Band or Stringed Instrument. **PLAY WHILE YOU PAY** a little a day on the Jenkins Plan. **SAVE BIG MONEY. FREE Lesson Certificate** with each instrument.

FREE Complete Cornet and Viola parts from Jenkins' *Beginners' Band Book and Instructor* and Jenkins' *Beginners' Orchestra Book and Instructor*. All instructions to start and make a row band or orchestra. A big success. Easy to play pieces for a starter. Band instrument parts, each 25c; orchestra, 50c; piano, \$1.00. Jenkins' instruments and music stock the largest and best in the country. **CATALOG** Write for big Catalog of instruments and latest music lists. A test will prove us best. Address **JENKINS MUSIC CO., 90 JENKINS BLDG., KANSAS CITY, MO.**



AGENTS WANTED

for our independent hollow-wire lighting systems for homes, stores, public buildings, etc. Use common gasoline. Best and cheapest illumination known.

AKRON LIGHTING SYSTEMS

are most improved, simplest and safest of all. Shed a clear, soft, bright light of high candle power. Also complete line of portable and street lamps and lanterns. Fully guaranteed. Our Agency Proposition cannot be beat. Exclusive territory. Send quick for catalog and terms.

Agents' Outlet **Akron Gas Lamp Co., 822 So. High St., Akron, O.**

WANTED! WE WANT 300 AGENTS AT \$35 TO \$70 A WEEK

NEW INVENTION—just out. Needed in every home every day. Patent just applied for. Nothing else like it. Supplies what every housewife has wished for for years. Perfected after long experimental work by mechanical experts. Low priced—anyone can use it—**sells on sight**. We want three hundred representatives at once—men or women hustlers—to advertise, accept orders and manage deliveries for our new **Quickedge Knife and Shear Sharpener**. Sharpens any kitchen knife, paring knife, carving knife, bread knife or shears and scissors in **ten seconds**. Agents are taking orders at every house—**wiring for rush shipments**. Write today for this opportunity to make \$10 to \$20 every day.

MAKE \$300 NEXT MONTH

This little machine is a mechanical masterpiece. A child can use it. Just put knife in slot—turn crank—**grinds automatically**—draws blade to keen, sharp, perfect, lasting edge **at absolutely correct bevel for daily use**. Nothing to adjust—nothing to change, nothing to get out of order—**absolutely guaranteed**—will last for years. Once they see it and use it, women will not do without it for several times its cost. One agent wrote: "It was easier for me to learn to sell the **Quickedge** than it was to learn to tear open my pay-envelope in my former dollar-a-day job." Get out of the dollar-a-day class. Get this position, where profits start the first day.

No Experience Required Just take one of the machines to any house and show it—give a ten-second demonstration upon the dulllest knife in the house; **the order is yours right on the spot; instantly**.

No talking necessary. No argument. The machine simply sells itself, **and stays sold**. Every customer becomes your friend. They tell others, your profits double and multiply. Leave one hundred on trial over night. Collect the cash for every one of them next day. **The machine will do its own talking**; it is so easy to operate, no explanations or instructions are necessary. Secure your county now; **free**. Get started right now and

Make as Much Money Next Week as These Men are Making Now

J. C. Lewis, of Kansas, says: "**I have sold one hundred Sharpeners in four days.**" Hobart Kerr, of Md., writes: "The women can hardly wait till they get them." Herbert Cain, of Ky., sold nine after supper. At the end of his first day, J. W. Gordon, of Pa., writes: "I sold two dozen, and **I sold to every one I saw.**" Wm. G. Hall, of N. J., says: "I think it is great. I sold six in about one-half hour. The machine is a mighty fine proposition. **I am a mechanic and I know what I am talking about.**" Peter Courtland, of Mich., writes: "I received your sharpener and opened it in a barber shop. I ground his shears and I got an order for one right on the spot." H. A. Henkel, of Va., says: "I have examined it and find it a wonderful little machine. **The workmanship is simply perfect.**" Frank King, Colo., says: "Sample received Saturday. Sold ten today. Sell to most every house." Forest Webb, of Pa., says: "Went out Monday afternoon for about three hours and received one dozen orders. **Profit \$12.00.**" H. Tillery, of Tenn., wrote: "I took three orders first hour. When you sharpen an old, dull knife, dull as a hoe, in less than a minute, **they sit up and look.**" Ray Carter, of Mass., writes: "I went out two days and have orders for thirty sharpeners." **Profit \$30.00 for first two days.** John Durr, of Wis., also says: "**I have sold thirty in two days.**"

You can make this money. **Send now. Territory free.**

GET BUSY. WRITE TODAY.

The Quickedge Sharpener Company

No. 664 Sharpener Building
215 N. Desplaines St., Chicago, Ill.

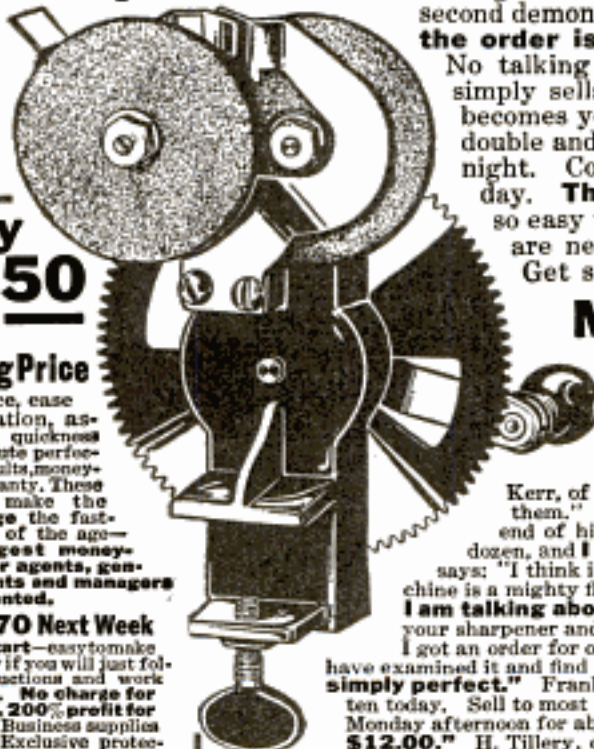

The
Quick-
edge
Knife
and Shear
Sharpener

Grinds any Kitchen Knife
or Shears in 10 Seconds

Absolutely Guaranteed

Only
\$1.50

Selling Price

Low price, ease of operation, astonishing quickness and absolute perfection of results, money-back guaranty. These things make the **Quickedge** the fastest seller of the age—the biggest money-maker for agents, general agents and managers ever invented.

Make \$70 Next Week

Easy to start—easy to make big money if you will just follow instructions and work faithfully. **No charge for territory, 200% profit for agents.** Business supplies capital. Exclusive protection, co-operation and assistance. Failure impossible. Nothing to risk. Success assured. **Easy to demonstrate**—and every woman is anxious to see it work—then she would not do without it. No talking necessary. Just show the machine and take the order—**one dollar profit on every call you make.**

Send for application blank and complete information today—**free**. Investigate. **Get the proof.** Don't delay. Write a postal card or letter right now. **Territory is being assigned very fast.** Get your county now—**free**. Write today.

BERNARD-HEWITT & CO.,
 Desk F23, 424-434 So. Green St.,
 CHICAGO, ILL.

Please send me your new Spring style book with 70 samples free — also full details of your special lining offer.

Name

Address

MAIL COUPON

For Spring and Summer
STYLE BOOK

**70 SAMPLES
 FREE**



Handsome \$25 Blue Serge Suit Made to Measure only \$15

A SPECIAL proposition to introduce the wonderful values offered by our system of tailoring. We have no agents — no dealers — no traveling salesmen — our values make their own customers — and once a Bernard-Hewitt customer always a Bernard-Hewitt customer. That's why, to secure your first order, we are willing to make to your individual measure, a handsome, all pure wool worsted blue serge suit (usual \$25 value) for only \$15 and line it with a

**WE PAY
 SHIPPING
 CHARGES**

\$4 SATIN LINING FREE

Remember this suit is made to your individual measure from the very finest all wool blue, light blue, black or gray serge, in the latest approved Chicago style, and by the very best tailors in this whole city.

But perhaps you don't care for a serge suit. Well, our big book which we will send you free contains generous samples of the latest fabrics; plain and fancy mixtures, the up-to-the-minute offering of leading woolen mills.

The \$4.00 Satin Lining free offer goes no matter what selection you make — and we pay all shipping charges. We take all the risk — you none — for this is



OUR GUARANTEE You Don't Pay Us One Cent

Unless you are more than pleased in every particular in fit — in style — in workmanship and in materials. Could anything be fairer? Write today — wear real tailor-made clothes — dress better and save money.

Take Your Own Measure — Save \$10

Write for Your Copy of Our Big Book Today

Our big new Spring and Summer book is ready for you — contains 70 samples latest woolens — also lowest prices on men's hats, shoes and furnishings. It is your guide to correct and economical clothes buying. Mail coupon above or send post card for your copy. Please mention POPULAR MECHANICS so that we can identify this special offer.

BERNARD-HEWITT & COMPANY

424-434 So. Green St.

Desk F23

CHICAGO, ILLINOIS



Much Depends on the Rear Tire

THE rear tire gets all the strain of starting and stopping, all the traction, most of the slewing and slipping, most of the weight and sometimes all the weight of an extra passenger.

Firestone

MOTORCYCLE TIRES

are designed and constructed as if they were all to be used as rear tires, that is they are built to resist the greatest strains, the emergency strains.

Extra fabric, extra rubber, 30 per cent more angles against skid, mean to you more confidence, more safety, more comfort, and to your mount greater efficiency, speed, and road grip, less skidding, slipping and vibration.

These leading manufacturers furnish Firestone Tires on their machines without extra charge.

Cleveland	Henderson
Dayton	Schickel Indian
Emblem	Reading Standard
Excelsior	Smith Motor Wheel
Harley-Davidson	Thor

See your dealer.

FIRESTONE TIRE AND RUBBER COMPANY
AKRON, OHIO Branches and Dealers Everywhere



MOTORCYCLISTS

**Make this Chart your guide
Look for it on your dealer's wall**

YOUR Oil runs low. You stop for a fresh supply.

You now come to a vital question. What oil will the dealer supply you? Will it be just "oil"—or will it be the correct lubricant for *your* engine?

Among thousands of dealers this is what happens:

The dealer asks the make of your motorcycle. He runs his finger down the Vacuum Oil Company's Chart (shown above in miniature) until he finds your motorcycle's make and model. Then he supplies you with the grade of Gargoyle Mabiloils specified for your motorcycle by the Chart. This oil will effectively seal your

piston rings against power-waste, gasoline-waste and oil-waste.

Why are thousands of dealers placing such reliance in this Chart?

Experience has taught them that something like 50% of all engine troubles are due to incorrect lubrication.

They realize that scientific lubrication is a problem for specialists. Since the dealer has neither time nor equipment for studying this intricate subject he draws on the experience of a recognized authority.

That is why you find on his walls the large Chart of Recommendations, issued by the Vacuum Oil Company.

If you inquire about the Chart you will find this:

The Vacuum Oil Company for 50 years have specialized in scientific lubrication. Today their world-wide leadership in lubrication matters is unquestioned in scientific circles.

For years their Chart of Recommendations has been recognized as the only standard guide to correct automobile and motorcycle lubrication.

In keeping this Chart up to date, each new model of every motorcycle is carefully analyzed. This work involves lengthy and painstaking engineering study by the Vacuum Oil Company's Board of Engineers. The recommendations of this Chart are proven correct by repeated practical tests.

But nothing has given dealers such faith in this chart as their experience with the oils themselves. For no one knows better than the dealer how difficult it is to secure efficient lubrication—and how much efficient lubrication means.

Write for new 56-page booklet containing complete discussion of your lubrication problems, list of troubles with remedies and complete Charts of Recommendations for Automobiles, Motorcycles, Tractors and Marine Engines.



In buying Gargoyle Mobiloils from your dealer, it is safest to purchase in original packages. Look for the red Gargoyle on the container. If the dealer has not the grade specified for your motorcycle, kindly write our nearest branch, giving dealer's name and address.

VACUUM OIL COMPANY

Rochester, N. Y., U. S. A.

Specialists in the manufacture of high-grade lubricants for every class of machinery. Obtainable everywhere in the world.

Domestic Branches:

Detroit New York Philadelphia Minneapolis Boston Chicago
Indianapolis Pittsburgh Kansas City, Kan. Des Moines

Correct Motorcycle Lubrication

Explanation: The four grades of Gargoyle Mobiloils for engine lubrication, purified to remove free carbon, are:

- Gargoyle Mobiloil "A"
- Gargoyle Mobiloil "B"
- Gargoyle Mobiloil "E"
- Gargoyle Mobiloil "Arctic"

In the Chart below, the letter opposite the motorcycle indicates the grade of Gargoyle Mobiloils that should be used. For example, "A" means "Gargoyle Mobiloil A," "Arc" means "Gargoyle Mobiloil Arctic," etc. For all motorcycle transmissions use Gargoyle Mobiloil "C." The recommendations cover all models of the same make, unless otherwise noted.

MODEL OF MOTORCYCLES	1917		1916		1915		1914		1913	
	Summer	Winter	Summer	Winter	Summer	Winter	Summer	Winter	Summer	Winter
A. M. C.										
American			B	A	B	A	B	A	B	A
Amer. Peugeot (2 cyl.)									B	B
" (4 cyl.)									B	A
Arrow									B	A
Autoped	B	B	B	A						
Auto Tri.									B	A
Bailey Flyer									B	B
Black Hawk									B	A
Cleveland	B	B	B	B						
Crawford									B	A
Curtis									B	A
Cyclomotor	B	B	B	B					B	A
Cyclone					B	A				
Dayton	B	A	B	A	B	A	B	A	B	A
De Luxe (1 cyl.)									B	A
" (2 cyl.)			B	A	B	A	B	A	B	A
Eight					B	A	B	A	B	A
Endless (1 cyl.)			B	A	B	A	B	A	B	A
" (2 cyl.)			B	A	B	A	B	A	B	A
Excelsior			B	A	B	A	B	A	B	A
" (Lightweight)			B	B	B	B				
Freiburg										A
Flantern						B	A	B	A	A
F. N.									B	A
Genl.									B	A
Greyhound									B	A
Harley-Davidson	B	A	B	A	A	A	A	A	A	A
Henderson	A	A	A	A	A	A	A	A	A	A
Indian (1 cyl.)			B	B	B	B	B	B	B	B
" (2 cyl.)	B	A	B	A	B	A	B	A	B	A
Iver Johnson			B	A	B	A	B	A	B	A
Jefferson									B	A
Limited									A	A
Magotic									B	A
Marvel									B	B
Maxim Triar									B	A
Merkel	B	A	B	A	B	A	B	A	B	A
Miami (Power Bicycle)	B	A	B	A						
Michalson					B	A	B	A	B	A
Milnair			A	A						
Minneapolis									B	A
M. M.									B	B
Monarch					B	A	B	A	B	A
Motomoto					E	E	E	E		
New Era									B	B
New Hudson									B	B
N. S. U. (1 cyl.)									B	A
" (2 cyl.)									B	A
Olax	B	B								
P. E. M.									B	A
Peugeot									B	B
Pierce (1 cyl.)									B	A
" (4 cyl.)									A	A
Pirate									B	B
Pope	B	A	B	A	B	A	B	A	B	A
Reading Standard	B	A	B	A	B	A	B	A	B	A
Reliance										
Schickel	B	A	B	A	B	A	B	A	B	A
Scott									B	B
Shaw									B	A
Smith (Motor Wheel)	A	A	A	A	A	A			B	A
Thorn									B	A
Thor (1 cyl.)	B	A	B	A	B	A	B	A	B	A
" (2 cyl.)	B	A	B	A	B	A	B	A	B	A
Tiger Automobile			B	B					B	A
Wagner			B	A	B	A	B	A	B	A
Yale (1 cyl.)									B	A
" (2 cyl.)									B	A

Outfit No. 36
 Latest model concealed horn instrument. Finished in beautiful fumé oak—elegantly polished. 12 5/8 in. high, 12 1/2 in. wide, 18 in. long.
 Price, with 12 Blue Amberol Records, only \$36.00. (See terms in the coupon on opposite page.)

Your Choice Sent on Free Trial

See Coupon on Opposite Page

An astounding offer—your choice of these three outfits of the New Edison, Mr. Edison's great new phonograph with the new Diamond Stylus reproducer, and twelve brand new Blue Amberol Indestructible Records sent to you on *absolutely free trial*.

Send no money—just fill out the coupon on opposite page. Send it at once. We will send you the complete outfit which you choose immediately. Entertain your family and friends with the latest song hits of the big cities. Laugh at the side-splitting minstrel shows. Hear anything from Grand Opera to Comic Vaudeville. Then, if you choose, send the whole outfit back to us *at our expense*.

Only \$1.00 After Trial

If you wish to keep Mr. Edison's superb new instrument after the free trial, send us only \$1.00. Pay the balance for the complete outfit in small monthly payments. (See terms in coupon on opposite page.)

Think of it—a \$1.00 payment, and a few dollars a month to get an outfit of Mr. Edison's new phonograph with the Diamond Stylus reproducer, the life-like music—the wonderful Blue Amberol Records. The *finest*, the *best* that money can buy at very much less than the price at which imitations of the Genuine New Edison are offered.

After years of labor on his favorite invention, Mr. Edison has made the music of the phonograph true to life. There is no reason, now—especially since we make this rock-bottom offer—why you should be satisfied with anything less than Mr. Edison's genuine instrument.

Send This Coupon TODAY!

Special Offer
 On This Great Outfit

Outfit No. 475 New Model Instrument and handsome record cabinet complete—two pieces. An entire phonograph outfit, just like the very highest priced instruments and at one-fifth the price! Cabinet finished in dull brown fumé oak. Capacity 50 records. Height of outfit complete 42 3/4 in., width 14 1/4 in., length 17 1/2 in. Price, complete, with 12 Blue Amberol Records, only \$47.50. (See terms in coupon on opp. page.)

Please Mention Popular Mechanics

Copyrighted material



Thomas A. Edison

Mr. Edison's
Wonderful New
Phonograph

Send No
Money — Just This Coupon



Outfit
No. 56

A superb instrument; wonderful bargain. Hand some ly plated and polished. Richly ornamented. Size 15 1/4 inches high, 14 7/8 inches wide, 19 5/8 inches long. Regularly finished in mahogany and golden oak. May be had also in weathered oak or fumed oak. Price with 12 Blue Amberol Records, \$56.00. (See terms in coupon below.)



Convince yourself first. Get the New Edison in your home on free trial. See for yourself how much happier it will make your home. Just fill out the coupon and send it in. No money down, no C. O. D. You pay us nothing on the instrument or records unless you decide to keep the outfit. Send it back if you wish at our expense. Or pay only \$1 after the trial, and balance in easy monthly payments as explained below. Send the coupon now.

F. K. BABSON, Edison Phonograph Distributors, 1193 Edison Block, Chicago, Ill.

Canadian Office: 355 Portage Avenue, Winnipeg, Manitoba

No obligation to buy in sending this coupon; this is just an application for a Free Trial

F. K. BABSON, Edison Phonograph Dists., 1193 Edison Block, Chicago, Ill.

Dear Mr. Babson:—As per your offer, I should like to hear Mr. Edison's wonderful new style phonograph with the new Diamond Stylus reproducer in my own home on free trial. Send me the outfit which I have checked below, including the twelve Blue Amberol records. If I decide to keep the outfit, I will have the privilege of the rock-bottom price direct from you on your special terms. I agree merely to take the outfit promptly from the depot, pay the small freight or express charges, and if I do not find it thoroughly satisfactory, I reserve the right to return the outfit at once at your expense. Otherwise, I will send the first payment of \$1.00 within forty-eight hours after the free trial or as soon as possible, in no case exceeding one week, and make monthly payments thereafter of (Check the square below to the left of the outfit which you wish to have us ship).

Outfit No. 36 \$3.50 for 10 months. Complete price \$36.00. **Outfit No. 475** \$4.50 for 10 months, \$1.50 for 11th month. Complete price \$47.50. **Outfit No. 56** \$5.50 for 10 months. Complete price \$56.00. Send me the outfit finished in ..mabogany...golden oak...weathered oak...fumed oak

The outfit is to remain your property until the last payment has been made.

My name..... My post office..... State.....

Shipping Point..... Ship by..... Occupation.....

Age..... Married or single..... If steadily employed at a salary please state.....

How long a resident in your neighborhood and your vicinity?..... If there is any possibility of changing

your address during the next year, what will be your next address?.....

Please Mention Popular Mechanics

BLUE STREAKS



\$3.00

e a c h



Guaranteed

That bicycle you used to ride—is it rusty and dusty in your garret or woodshed?

Bring it back again into service with Goodyear Blue Streak Tires: Get it out! For Blue Streaks have met that bicycle tire bugaboo.

You may now buy really dependable tires—Goodyear Blue Streaks—everywhere. Tires that let you forget that former high cost of bicycle upkeep.

Goodyear has done that for bicycle folk by making only one bicycle tire, and making that one tire really good. Blue Streaks hold fast to a high quality standard. And, they're packed with happy, healthy miles that make your heart glad.

Even with material prices as high as they are today Blue Streaks cost only \$3.00.

*Blue Streaks are standard everywhere.
One quality, one guaranty, one price.
At any Goodyear Dealer's.*

The Goodyear Tire & Rubber Company, Akron, Ohio

GOODYEAR
AKRON

Please Mention Popular Mechanics



After Meals—Billiards!

Of all the hours in the day the "Billiard Hour" is best. Then fathers and mothers gather with their happy brood around the Brunswick Carom or Pocket Table, now the life of thousands of homes.

Dull care vanishes when Billiards starts, and sport is King till bed time comes.

For parties, holidays and leisure hours—for health and happiness—*your home needs billiards!*

BRUNSWICK HOME BILLIARD TABLES

Live cushions, true angles, fast ever-level bed—on Brunswick Tables your skill will triumph most.

A Size for Every Home

"Quick Demountables" can be set up easily anywhere and folded away in a closet when not in use.

"Baby Grand" and "Regulation Grand" for homes with space to spare for a table.

Beautifully built of mahogany and oak. Cues, Balls, Markers, etc.—complete playing outfit included *free!*

Write for Color-Catalog

Low prices, easy terms and home trial offer all explained in our handsome billiard book and catalog—"Billiards—The Home Magnet."

Get this book by return mail free. Send today.

The Brunswick-Balke-Collender Co.
Dept. 46L, 623-633 S. Wabash Ave. Chicago

Send Your Address For Catalog

The Brunswick-Balke-Collender Co.
Dept. 46L, 623-633 S. Wabash Ave., Chicago

Send free, postpaid, a copy of your billiard book and color catalog—"BILLIARDS—THE HOME MAGNET" and tell about your home trial offer.

Name.....

Address.....

Please Mention Popular Mechanics



If Your Bathroom is Modern so is Your Home

No More Cold Bathrooms

Nothing makes home more inviting or more healthful during the cold winter months than warm, toasty, even heat. Keeps everybody healthy and happy.

Install One of Our Heating Plants—Cut to Fit

No loss or waste—hot water, steam, or air. Send for our free estimate. We can save you 1/2. We furnish simplified installing plans, specifications, and instructions, and lend you the tools. Any handy man can do the installing the new Hardin Easy Way.

Mail Coupon for Free "HANDY-MAN" Book

Every House Owner, Factory, Hospital, Hotel, Office Building, Farmer, Engineer, and Mechanic needs one. It shows a complete line of all the Latest Improvements and Different Designs in Guaranteed heating and plumbing outfits, water supply systems, sinks, roughing-in-goods, pipe, fittings, valves, etc., and all parts and repairs at Wholesale Prices. It also contains practical and exclusive information on How to Do Your Own Plumbing and Heating our new Hardin Easy Way.

Our Engineers Will Help You Plan and Install

Draw a rough sketch of your plan for any heating or plumbing installation, and our staff of engineers will show you the easiest, cheapest way, and supply easy installing plans absolutely free to YOU. Any handy man can do the work with the help of our engineers and save all plumbing bills. We make all shipments promptly, direct from our nearest factory.



HANDY-MAN BOOK
 F. N. HAR.
 FREE "Handy-Man" BOOK COUPON
 The Hardin-Lavin Co.
 4540-508 Cottage Grove Ave., Chicago

Buy Direct—Save One-Half

Remember, everything we sell is Grade A. Highest Quality Guaranteed Goods at prices that will surprise you. You save not only on the cost of the goods but on the cost of labor. Our practical experience of 40 years enables us to furnish heating plants with new, original features, combining quality, economy, simplicity, easy installing, and lasting durability.

"Handy-Man" Free Book

This book has been written for the handy man about the home. Aside from being our Catalogue, it contains many pages of practical information and money-saving suggestions pertaining to home improvements. It's worth a dollar of any man's money, but, if you are interested in up-to-date plumbing and heating goods, we send it FREE. Send for this valuable book and learn how to buy all plumbing and heating supplies on a time-saving, labor-saving, money-saving basis.

BONDED GUARANTEE
 Our guarantee label appears on every fixture we ship. It is your assurance of a square deal. We will replace, without cost to you, any fixture or part that proves defective or not as represented. We guarantee satisfaction. Everything we sell is grade A. "Highest Quality at Wholesale Price" is our motto.



Immediate Delivery This is as much a part of our special service as our guaranteed quality or wholesale prices.

40 Years in Business at the same address is a record to be proud of. It speaks volumes for our wholesale price policy and money-back guarantee. Send for free "Handy-Man" Book and full particulars. \$500,000 plants behind our guarantee.

The Hardin-Lavin Co.
 40 Years at 4540-508 Cottage Grove Ave.
CHICAGO

Please send me your "Handy-Man" Free Book showing everything in plumbing and heating supplies at lowest wholesale prices.

Name _____

Address _____

SIGN, TEAR OFF AND MAIL

Please Mention Popular Mechanics

Why Slave for Wages Now?

MONEY CALLS YOU HERE

M-Answer and be Happy

This Puts New Joy Into Living for Men or Women

We can tell you the names of hundreds of men and women, representing us, who are now proud to write us of the cash profits they are making like the following:

"Bought an Automobile"

—writes a young man from Texas in December.

"Paid for My Home"

—wrote a good, ambitious woman from Pennsylvania in October.

"First Life Success"

—wrote a man of forty-five whose previous business had failed to make him money.

"Paid College Course"

—says a young man now well equipped with this special business all his own, representing us.

We Tell You How

Everything is made plain and simple and easy for you to start at once. If you are the right person for this opportunity there is no reason why you should not be just as successful as hundreds of others are being.

Please do not fail to investigate and find out.

If this were not a fine, clean-cut and independent line of money-making work we would not offer it to you. This may be truly the very best offer and opportunity of your lifetime. It certainly costs you nothing to find out. Our reputation and standing in the commercial world is behind this offer.

Write Today

What You Have Wished

\$ DOLLARS in cash, bringing plenty and regular income, may now be yours very easily, on part time or all of your time, if you accept this wonderful opportunity. You, like hundreds of others, young or old, men and women, may this way gratify

The Ambition to Play You can be your own boss. Stop slaving long hours for wages. Divide your hours of recreation and work to suit your own good judgment on when and where to go after immediate cash profits that are waiting for you.

The "Big Joys" of Life A limited number of opportunities to represent one of the largest concerns in America and be independent on the increasing profits from your work should allow you to now begin to get some of the "Big Joys" of living.

Live Anywhere—Go Anywhere Stay where you are, or travel as you please. Wherever you are or go, we tell you from the start just how and where the biggest money-making possibilities can easily be found.

Start At Once Our new 1917 special proposition is yours for the asking. If you are not the right man or the right woman to be successful we will tell you so when you tell us about yourself and your wishes after you get our splendid proposition — sent at once postpaid, free, no matter where you live.

No Experience Needed Please do not get the idea that we want experts. We would rather have good, live, honest men or women with ambition to better themselves and be absolutely independent, than to make this offer to ordinary so-called "experts" without imagination or push in their systems. Write today.

FREE

Oliver Millions Back You

THE OLIVER TYPEWRITER COMPANY
Dept. 1407, Oliver Typewriter Building, Chicago, Ill.

Send No Money

Special Attention: Dept. 1407. Please send me your special 1917 offer, telling complete facts on how I may represent you and how others are making good independent incomes this way in cities, towns and rural communities.

NAME

ADDRESS

TOWN.....STATE.....

TEAR OUT AND MAIL NOW FOR COMPLETE OFFER—FREE

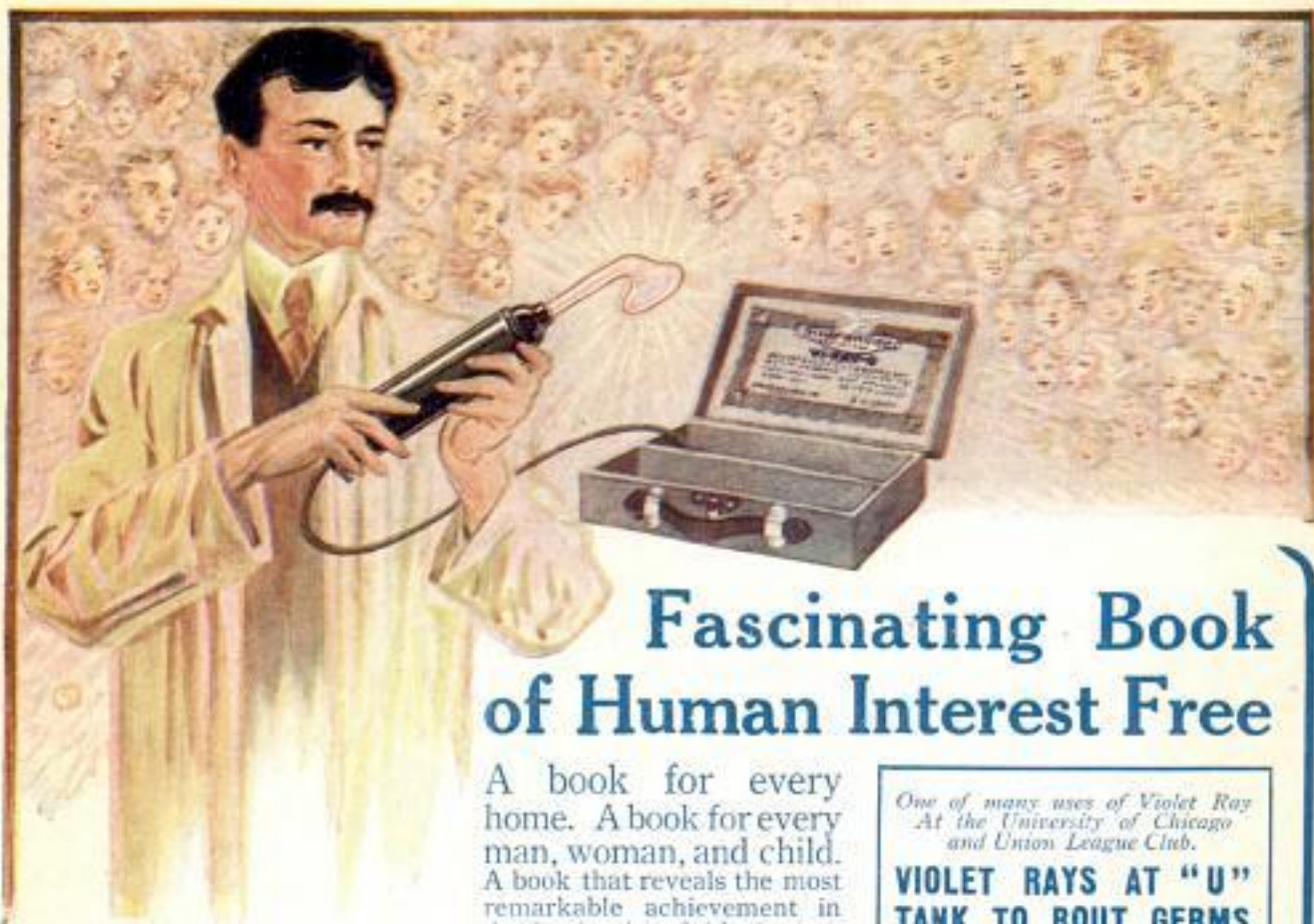

Fascinating Book of Human Interest Free

A book for every home. A book for every man, woman, and child. A book that reveals the most remarkable achievement in the fascinating field of scientific discovery for the home and for human happiness. A story of intense interest and gripping power. It is a book of instruction to be read, remembered, and kept for reference. It should be in your hands. Everyone should know what the Violet Ray is and what it will do. We will give away this entire edition of the book free. Send coupon or your name on a postcard and get it free.

of intense interest and gripping power. It is a book of instruction to be read, remembered, and kept for reference. It should be in your hands. Everyone should know what the Violet Ray is and what it will do. We will give away this entire edition of the book free. Send coupon or your name on a postcard and get it free.

Charming Story of the Marvelous Violet Ray

Truth is indeed stranger than fiction. The true story of the Violet Ray is a revelation of the result of secret labors that have gone on in the world-famous laboratories for 46 years. The scientific world stood in awe when the brilliant colors of the Violet Ray were shown for the first time, leaping out of a glass vacuum and penetrating the human body with a refreshing sensation never known before. It purified air and water. It created ozone. It penetrated every substance and destroyed germs and bacteria everywhere. How to use this new, wondrous influence for the benefit of humanity? This was the task the scientists set before themselves. After 46 years of labor and research the story of their wonderful discoveries is now charmingly told in the book *Virayo* by a fellow scientist. You will understand the importance of this book when we quote one sentence from one of the world's greatest electrical masters. He said: "The Violet Ray is the kindest gift of nature that science has conferred upon humanity."

One of many uses of Violet Ray At the University of Chicago and Union League Club.

VIOLET RAYS AT "U" TANK TO ROUT GERMS

Violet Rays will purify the waters of the Ida Noyes natatorium, the girls' swimming tank at the University of Chicago after this. One of the three large Violet Ray purifying machines in the country is being installed there. One of the others is in the far west and the third is in the tank at the Union League Club, Chicago. As the water flows into the tank the Violet Rays will kill the germs in it.—*Chicago Tribune.*

The greatest value of the Violet Ray is in the home and for personal use. The small *Virayo*, the new perfected Violet Ray machine has hundreds of uses in the home for every member of the family as told in the booklet *Virayo*.

Free Book Coupon

Clip this coupon and mail it or copy it on a piece of paper or a postcard. Mail it today.

WESTERN COIL COMPANY

180 N. Dearborn St., Dept. 5247, Chicago, Ill.

GENTLEMEN: Please send me a free copy of the book *Virayo* the story of the marvelous Violet Ray, and explaining its hundreds of uses in the home. Also particulars of your special offer on *Virayo* instruments for home and personal use, all postpaid free to me.

Name.....

Ad. 78.....

All the expense of publishing and distributing the edition of the book *Virayo* for home and personal use is paid by the Western Coil Company, the wholesale manufacturers of the Violet Ray and X-Ray devices and equipments of all kinds. You are under no obligation whatever in asking for a copy of this remarkable book postpaid free to you.

How to Get This Book

Fill out the coupon or copy it on a piece of paper, or a postcard and mail it to us. This edition of *Virayo* is absolutely free.

Virayo is also the name of the perfected Violet Ray instrument for home and personal use. The book explains the many uses of the Violet Ray and its importance to you. It also explains our special offer to you on small instruments for personal use. Write for book and get all particulars; write today.

WESTERN COIL COMPANY

180 N. Dearborn St., Dept. 5247, Chicago, Ill.