

# POPULAR MECHANICS MAGAZINE

WRITTEN SO YOU CAN UNDERSTAND IT

REDA PATOFF







**\$767** buys the material to Build this Home

**NO MONEY IN ADVANCE!!**

When you "Build-To-Stay—The Harris Way," you secure the *utmost possible* in Quality, Economy and Service. Why? Simply because you profit directly—*immediately*—by our 24 years experience. You get the benefit of our practical knowledge as the *originators* of the "Direct-to-You" Home Building Industry. We were the *first* to sell Lumber and Material direct to Home Builders at one small profit. We were the *first* to reduce this vitally important industry to a *perfect system* and extend the benefits uniformly to the people of the nation.

**"THE HARRIS WAY"** has exclusive merits—special advantages for the shrewd and careful Home Builder—possessed by no other plan or method. It is the best, safest and most sensible way to build your ideal home right without sacrifice of quality—or the waste of a single penny! Thousands have built the "The HARRIS WAY" with profit and satisfaction.

**SEND LUMBER BILLS** Our ten million dollar buying power gives Harris customers an overwhelming price advantage. We can—and do—undersell all others. The proof? Easy! Just send us your lumber bills—for any kind of building you may be planning and get our prices. Compare them item for item, and let the test be the proof. Write us today!



Here's an Ideal Home Combining Beauty and Utility. The Harris Book of Plans Shows 100 Others. Each Representing the Individual Charm that Make All Harris Home Designs Notable.



Another Tempting Effect that Strikes a Responsive Chord in the Fancy of Many True Home Lovers: a Beautiful yet Practical House that can be Built at Low Cost—"The Harris Way."



You will be Delighted with the Description of This One in The Harris Book of Plans and Specifications, too, when you learn how easily this Beautiful Home is Within Your Reach.



Still another Attractive Design Selected from the Free Harris Book of Plans. Merely a suggestion of the Rich Treat in Store for those who are wise enough to send for this Book.

**\$10,000 BOOK OF PLANS FREE**



**Your Home Sensibly Cut-To-Fit Shipped Complete in One Car**

The material used in building all Harris Homes is prepared by us, complete for your use in a way that is instantly—and easily understood. It is sensibly cut-to-fit with *absolute accuracy* and *positive elimination of all waste*. You pay for nothing you do not get—you pay our bed rock low, one-small-profit bargain price *only* for what is needed to do the work *right*—"The HARRIS WAY."

Our mammoth material stations, in the heart of the finest lumber tracts are always filled to overflowing with brand new, quality material. These stations are centrally located for quick and economical deliveries, "DIRECT-TO-YOU," no matter where you live, at the *lowest possible freight charge*.

**FREE Beautiful New \$10,000 Book Of Over 100 Harris Homes**

Be sure to mail free coupon for the latest edition of the famous \$10,000 HARRIS HOME PLAN BOOK, now ready. A golden guide to Quality, Service and Economy in Home Building. Explains—fully and freely—everything about building economy. Contains 100 modern Harris Home Designs, with descriptions, material specifications, prices, etc., and explains how we save you \$50 to \$75 on our Special Free Architect's Plans. Think twice before you pass this opportunity.

**Mail Free Coupon Now!**

Coupon, Letter or Post Card request brings the Harris Home Plan Book FREE. Send for it today without fail.

**Harris Bros. Co.**  
Dept. DK 7 Chicago

Please send me free—without the slightest obligation—the Harris Home Plan Book, and show me how to save big money in building my home.

Name \_\_\_\_\_

Address \_\_\_\_\_

**Harris Brothers Co., 35th & Iron Sts., Chicago**





**This intensely human picture  
stands for all that is best in music**

It is a picture with a message—a living message of absolute fidelity.

"His Master's Voice" is inseparably associated with the highest attainments in the musical art; with the exquisite renditions of the world's greatest artists; with the world's best music in the home.

It is the exclusive trademark of the Victor Company. It identifies every genuine Victrola and Victor Record.

There are Victor dealers everywhere, and they will gladly demonstrate the different styles of the Victor and Victrola—\$10 to \$400—and play any music you wish to hear.

**Victor Talking Machine Co., Camden, N. J., U. S. A.**  
 Berliner Gramophone Co., Montreal, Canadian Distributors

**Important warning.** Victor Records can be safely and satisfactorily played only with *Victor Needles or Tungstone Stylus* on Victors or Victrolas. Victor Records cannot be safely played on machines with jeweled or other reproducing points.

New Victor Records demonstrated at all dealers on the 28th of each month

# Victrola



This One



K502-SD8-ZGF4

Please Mention Popular Mechanics

Copyrighted material.



## *"Pecky" Cypress Used as Interior Trim!*

on one of the most artistic of America's great estates.

NO. 1 in SERIES SHOWING "PECKY" CYPRESS IN MR. HENRY FORD'S NEW RESIDENCE.

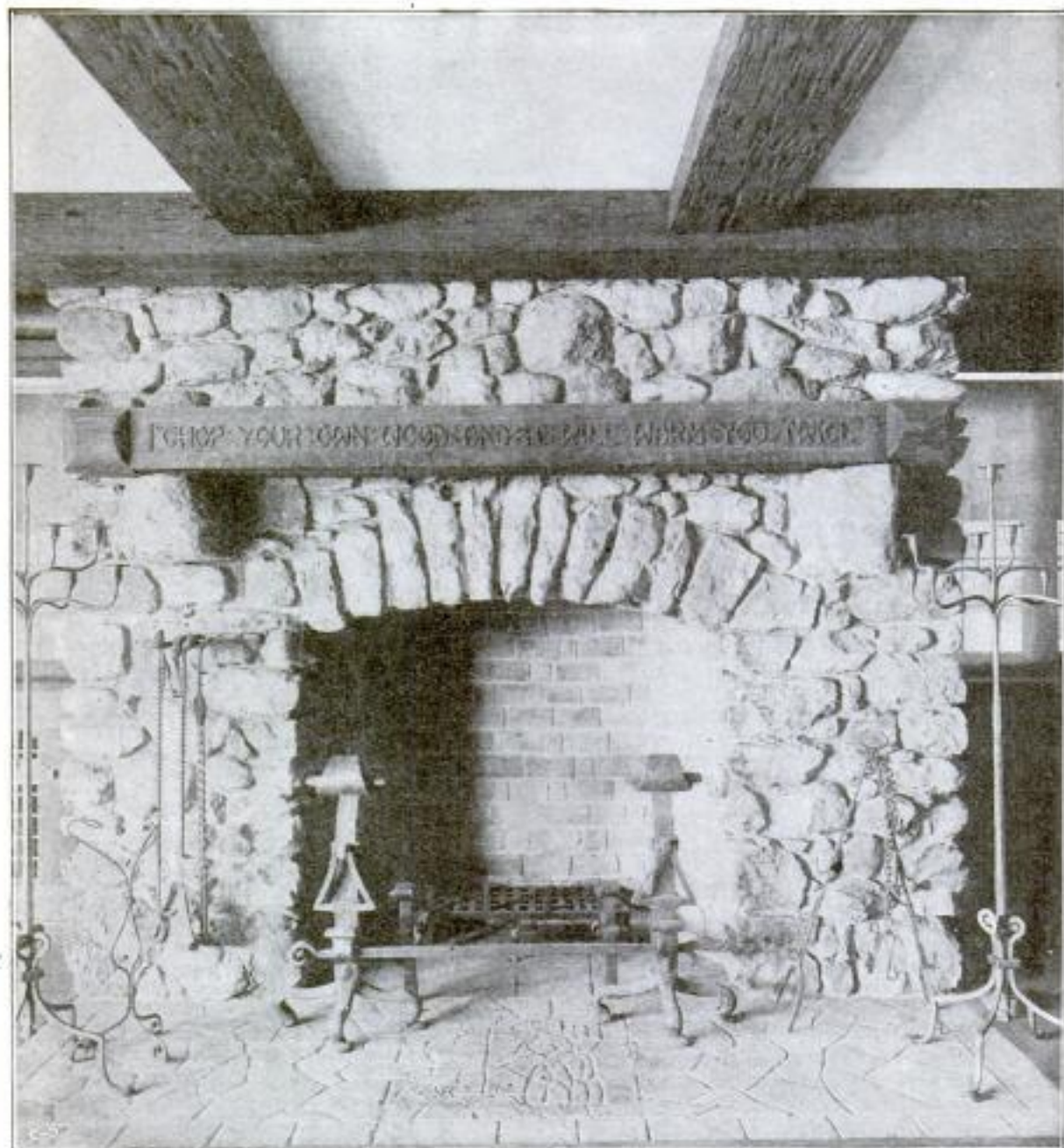

THE TROPHY ROOM: ESTATE OF HENRY FORD, ESQ., DEARBORN, MICHIGAN.  
MR. W. H. VAN TINE, ARCHITECT, DETROIT.

Why should the fact that "Pecky" Cypress is the Innermost Heart of the larger Cypress trees (many hundreds of years old) interest you? What is "Pecky" Cypress, anyhow? Certainly nothing NEW—except perhaps to you. Volume 2 tells you ALL ABOUT IT.

JUST WRITE FOR VOL. 2—IT'S A FASCINATOR AS WELL AS A MONEY-SAVER.

("Pecky" Cypress is the LOWEST GRADE of Cypress, "the Wood Eternal"—but it's fine for what it's good for.)

Let our "ALL-ROUND HELPS DEPARTMENT" help YOU. Our entire resources are at your service with Reliable Counsel.

**SOUTHERN CYPRESS MANUFACTURERS' ASSOCIATION**

1219 Hibernia Bank Building, New Orleans, La., or 1219 Heard National Bank Bldg., Jacksonville, Fla.

INSIST ON CYPRESS AT YOUR LOCAL LUMBER DEALER'S. IF HE HASN'T IT, LET US KNOW IMMEDIATELY



# Popular Mechanics Magazine

6 N. Michigan Avenue, Chicago, U. S. A.

EDITED BY H. H. WINDSOR

England: The International News Co.  
5 Breams Bldg., Chancery Lane, London, E. C.

Australia:  
The Australasian News Co.

ISSUED MONTHLY

SUBSCRIPTION:

SINGLE COPY, 15 CENTS

In United States, and its possessions, Cuba and Mexico, per year, postpaid - - - - \$1.50  
To Canada - - - - - 1.75  
To all other countries in the Postal Union - - - - - 2.50

All subscriptions are discontinued at expiration. Please examine the date printed on your wrapper.

Entered as Second Class Matter Sept. 15, 1903, at the Post Office at Chicago, Illinois, under Act of March 3rd, 1879.

Entered as Second Class Matter at the Post Office Department, Canada.

Published monthly by POPULAR MECHANICS CO.

Copyright, 1917, by H. H. WINDSOR.

Copyright, in France,

*Historical Data, List (P. K. H.)*

*filler*

*252*

## Contents for February, 1917

Accident Toll Shown by Automatic Display.....	268	Drinking Cups, Individual, for City Horses.....	244
Adding Machine with Simple Keyboard.....	263	Drug Thief is Captured by Electric Trap.....	219
Advertising Schemes, Wideawake Outdoor.....	246	Egg Candling Device, Rapid.....	251
Aeroplane, Blériot's, Five Foot Model of.....	194	Electric Lanterns Fail in Railway Tests.....	184
Airman, First Hawaiian, Gets Pilot's License....	258	Electric Pad, Pliable, Has Heat Controller.....	279
Airmen, The Training of, by H. G. Gilpatric....	195	Employment System, Public, is Proving Its Value.....	186
Ambulance, Novel, for Wounded Horses.....	230	Envelopes, Simple Device for Sealing.....	211
Amusement Park Ruins Put on Display.....	231	Eyeglasses, Ten States Have No Laws about Fitting.....	222
Animals, Fur Bearing, Smoking Out Now Profitable.....	199	Fender, Safety, for Auto Busses and Trucks.....	254
Animals—Guernsey Steers Taught to Perform....	225	Ferry, Great Railroad, on Pacific Coast.....	248
Automobile, Oldest, Exchanged for Latest Model	249	Fire Damages Wisconsin University Hall.....	232
Automobile Parts, Standard Names Adopted for.	253	Fire Hose, Removing from Case Turns On Water	267
Automobile's Fuel Consumption Shown by Special Gauge.....	216	Fish, Artesian Well Brings Up after Earthquake	273
Baskets, Waste Paper, Made of Palm Stalks.....	233	Fish—Popular New Sea Food Has Strange History.....	164
Baths, Hot Water, in Sands at Border for Soldiers.....	178	Fishing Platform, New Jersey Postmaster's.....	232
Blanket, Rubber, for Road or Camp Service.....	233	Football Game, Army and Navy, Setting the Stage for.....	215
Bridge, Great Cantilever, Unusual View of.....	224	Forest Products, Many Little Known Uses for..	278
Bridge, Running Gear Used to Make on Ranch....	177	Forests, White Pine, Blister Rust Ravaging....	236
Building, One, Four Homeless Banks Occupy....	264	Fruit Stand for Displaying and Storing.....	231
Burner, Foundry, Has Special Features.....	241	Fuel, Light Airship, Big Gift for Discovery of..	262
Burns, New Treatment for Considered Remarkable.....	184	Furnace Combines Virtues of Hot Air and Steam	277
Cafeteria Patrons, Belt Carries Trays of.....	266	Furniture, Handsome, for Various Rooms.....	270
Calendar, Safety First, for Schoolrooms.....	208	Gate Designed to Guard Drawbridge Approaches	223
California Wheat Growing Days, Reminders of..	174	Goggles, Open Front Auto, Protect Eyes from Wind.....	176
Camera for Aeroplanes of Military Type.....	241	Gun—Rifle, New Naval Antiaircraft, Tested.....	253
Camera, Panoramic, for Motion Pictures.....	252	Guns—Many Weapons Confiscated in Massachusetts.....	242
Cans of Liquid, Convenient Server for.....	250	Helmet, Bowl, and Digger, Combination Steel... 169	
Car, Casket, Used between Trolley Line and Grave.....	168	Hinge, Improved Door, Saves Fingers.....	276
Car, Homemade, Driven by Air Propeller.....	188	House—Bungalow, Comfortable, Pleasing Shingled.....	320
Chair in Which Patients Relearn to Walk.....	193	House—Bungalow, Compact, with Folding Rooms	204
Children and Things Which Concern Them, Pictures of.....	280	House is Built of Straw by Western Farmer.....	218
Chimney Stack, Big, Falls as Derrick Falls.....	175	House is Halved, Old and New Contrasted When	256
Cistern, Abandoned, Incubator Installed in.....	185	House of Pueblo Style Built on Steep Slope....	222
Clubhouses and Golf Courses, America's Attractive.....	238	Hydroplane—Water Sled, Speedy, Rides on Floats.....	240
Coffee, Hot, Served on Trains in Paper Cups....	207	Ice Stations, Portable, for Hot Weather.....	187
Coffeepot, Vacuum Bottle Principle Used for... 197		Incinerator, Refuse, for Army Camp.....	232
Compass, Large Measuring, Used for Farm Purposes.....	208	Jack, Powerful Pole, for Linemen's Use.....	233
Concrete Mixer of Barrel Pattern.....	191	Jewelry and Novelties, Marine Designs in, by Ruth K. Rice.....	269
Crane, Fighting Masts Hoisted onto Ships by... 161		Keys, Duplicate, Quickly Made by Machine....	225
Dam, Great Multiple Arch Destroys Western Falls.....	236	Ladder, Traveling Steel, is Made for Silos.....	236
Dancing with Death above the Skyscrapers.....	183	Lath, Fireproof, Made of Wire Cloth and Clay.. 249	
Dial, On Hotel, Distance to Many Points Told by.....	279	Lawn Mower, Crocheted Model of Sent to Attorney.....	201
		Light, Heat Removed from by Air Current....	194

[Continued on Page 6]

Popular Mechanics offers no premiums; does not join in "clubbing offers," and employs no solicitors to secure subscriptions. It is for sale by nearly every newsdealer in the United States and Canada.



# WHAT DID THE CENSOR CUT?

## ANNOUNCEMENT OF PRIZE AWARDS

THE following awards have been made by the judges in the contest for the two best paragraphs to replace one cut by the censor from Lewis R. Freeman's article, "Bringing Down a Zeppelin," published in the December number of Popular Mechanics Magazine:

**FIRST PRIZE, \$200, Walter W. Baker, Portland, Oregon.**

**SECOND PRIZE, \$100, Charles C. Dunning, Pittsburgh, Pa.**

The winning paragraphs will be published in the March issue of the magazine.

### [Contents—Continued]

Light, Powerful New, on Alaska Coast.....	242	Snowplow Attaches to Front of Motor Car.....	243
Lock, Door, New Device Records Time of Operating.....	272	Soda Fountain, Coin Operated.....	224
Map, Railway, Sixty-Nine Feet Long.....	217	Spark Plug, Insulator of Made Detachable.....	180
Map, Tall and Short Posts on Show Land Values.....	272	Spark Plug, New, Turbine Fan Feature of.....	282
Metals, Handy New Cutting Tool for.....	205	Splint, Sheet Metal, New First Aid Accessory.....	202
Monument, Granite, Erected to Unsung Heroes.....	212	Sprinkler Heads Need to be Inspected.....	250
Motorcycle Corps, Airmen Now Have Support of.....	216	Standpipe, Lumbermen's Methods Used in Felling.....	213
Motorcycle Gun Carriage Mounts Rifle and Shield.....	203	Statue of Liberty Now Illuminated at Night.....	103
Music, Player Piano, Made with Small Machine.....	178	Statue of Lincoln, Heroic, Modeling a.....	245
Newspaper, Local, Printed on Red Cedar Shingles.....	178	Statue of Lincoln, Large, Presented to Ohio City.....	207
Novel Accessories for the Home and Its Members.....	274	Statue of Telegraphy.....	184
Oilcloth Rack Equipped with Special Features.....	276	Statues, Bronze, Medieval Method Still Used to Cast.....	254
Oiler, Electrically Operated, Promotes Safety.....	282	Stool, Electrically Lighted, for Shoe Stores.....	278
Orchestra Pit, Elevator, Used in Movie House.....	211	Sun, Late Discovery Shows to Be Variable Star.....	192
Ostrich Team, Breaking for City Driving.....	189	Target to Keep Hunters from Shooting at Signs.....	185
Oven, Rustic, for Use by Beach Parties.....	245	Thallium Used in Making Tungsten Bulbs.....	205
Park Seats Reserved for Women and Children.....	207	Theater, Distinctive, for Motion Picture Plays.....	208
Phonographs, Flash Light Attachment for.....	162	Tire Carrier, Simple, for Motor Cars.....	241
Pins to Eastern Covers on Cocks of Ahalfa.....	243	Tonoscope—Guiding the Ear by the Eye in Learning to Sing.....	156
Pipe Line, Transatlantic, Proposed.....	276	Tower, Observation, Built in Texas Back Yard.....	192
Pipes, Color Scheme Prevents Pipes being Confused.....	278	Toys are Used in Court to Describe Accident.....	240
Port, New Siberian, to Aid Russia in War.....	176	Tractor, Storage Battery, to Displace Hand Trucks.....	212
Post Cards, Comic, Photos of Friends Added to.....	277	Train Service, Miniature, for City Parks.....	176
Power Project, Great, for Big Horn Cañon.....	219	Trapshooting as a Sport, by John Anson Ford.....	169
Press, Car, Makes Room for Orange Boxes.....	266	Tree—Elm, Century Old, Concrete Road Builders Spare.....	168
Printing—Display Type Faces Cast on Slugs by Machine.....	191	Trees, Walls Protect from Dirt Filling.....	254
Rabbit, New Type of, in Western Kansas.....	208	Trunk, Folding, Is Lock for Motor Car.....	226
Radiator Covers, Steam Heat Controlled by.....	244	Typewriter Marks Boxes or Packages.....	216
Railroad, New, Penetrates Great Oregon Lumbering District.....	234	Vacuum Cleaning Plant for Home Use.....	226
Railroads Not in Favor of "Daylight Saving".....	226	Viaduct, Concrete, Built along Boulevard.....	188
Range Finder, Small, Made for General Purposes.....	194	Voting Machine, New, Used in Class Election.....	214
Rats under Jail, Kill with Boiling Water.....	207	War, European:	
Revolver Range, Police Use Corridor as.....	218	Sailors' Sensations in Battle, by Lewis R. Freeman.....	179
Road to Yosemite Park, Incline to Shorten.....	268	Salvaging Human Wrecks from War's Scrap Heap, Part III—Reeducating the Maimed.....	257
Road—Trail, Novel, Motorists are Puzzled by.....	188	Trench Digger, Powerful, at Work in Field.....	167
Rock, Castle, Scenery Lover Buys and Cuts Trail to Top.....	198	Watch Which Winds Itself.....	273
Ruins—Sun Temple of Great Age Uncovered in West.....	190	Watch, Wrist, Made to be Carried in Pocket Also.....	267
Sand Dune Park for the Nation, by I. E. Murphy.....	227	Watches, Winding Indicator for.....	203
School—Spelling Lesson is Made Pleasant Pastime.....	162	Water, Desert, Settling Basins Clear of Silt.....	263
Seed, Sweet Clover, Harvest for Use in West.....	218	Water Mains of Wood Placed Overhead.....	214
Ship, Interned, Propeller of Is Moss Covered.....	237	Watering Cups, Individual, for Cattle Stalls.....	252
Ships in Fog, Near By, Device Records Location of.....	166	Wheel, Trail Measuring, Used by Foresters.....	217
Shoemaker Enables Afflicted to Walk.....	248	Wheel with Cushioned Steel Rim.....	251
Signs, Universal Highway, Proposed for Adoption.....	273	Wire Barriers for Trenches, Device for Cutting.....	269
Sleeping Bag, New, Adopted for Army Use.....	193	Wireless Stations, Big, Link East with West.....	200
		Work, Aged Persons Given by Gotham Association.....	165

[Contents Continued on Page 8]

IN accordance with the editorial policy of this magazine never to accept compensation in any form for what appears in our reading pages, and also to avoid all appearance of doing so, we are obliged to omit the name of the maker or the seller of any article described. This information, however, is kept on file and will be furnished free, by addressing Bureau of Information, Popular Mechanics Magazine, Chicago. [Editor.]



# BLUE STREAKS



## Motorcycle Tires With the Family Likeness

Goodyear Blue Streak Motorcycle Tires are little brothers of Goodyear Automobile Tires.

They have the same fine traits that characterize all the other members of the Goodyear family.

Honesty, courage and loyalty are built into every ounce of them.

Ask any automobile owner what he thinks of Goodyear Automobile Tires.

Goodyear Blue Streak Motorcycle Tires occupy the same position in the motorcycle field as Goodyear Automobile Tires do among motorists.

This is the reason that every motorcycle manufacturer in the country uses Goodyear Blue Streaks as standard equipment.

You can't say any more for a tire than this.

The Goodyear Tire & Rubber Co., Akron, Ohio

GOODYEAR  
AKRON

*Please Mention Popular Mechanics*



## The Automobile Business is Growing

More help needed and big pay. No other business offers such opportunities. It's easy to learn. An Auto Repairman is not a machinist—his work consists of adjustments and re-fitting worn parts, "knowing the principle," that's the thing. One of our students writes: "Before I started with your course I was a clerk at \$50 per month. After finishing I followed your instructions, started a repair shop and cleared \$122 the first month—pretty good for the first month." Let us show you this and many other letters.

## Learn the Automobile Business during your spare time

### WE CAN HELP YOU IN 3 WAYS:

- 1st We can teach you quickly and thoroughly.
- 2nd After we teach you, we have a plan to assist you in getting started in the actual practical line of work and assist you in getting actual driving experience.
- 3rd While we are teaching you we show you how to make money right on the start.

### THE DYKE METHOD

of teaching by mail is a new invention—a new idea—we use real 4 and 6 cylinder engine models—11x11½ inches—on which you can actually see all parts moving—it is the only system of its kind in the world.

This is one of the 7 real models used, in addition to 50 simplified instructions with hundreds of illustrations, charts and manikin.

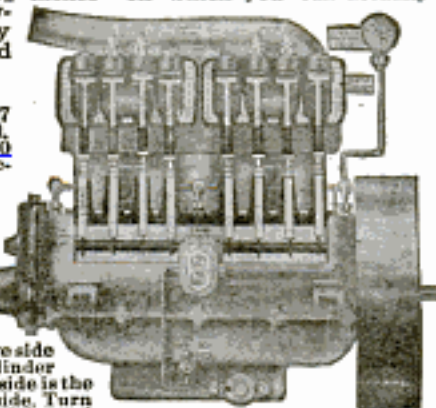

This is the valve side of the four cylinder model. The other side is the crank and piston side. Turn the crank and all of the real metal parts actually operate. The six cylinder engine model is similar.

This system is endorsed by Barney Oldfield, Elwood Haynes, Chas. Duryea and other motor authorities.

Mr. Dyke has been identified as a pioneer inventor, supply man, etc., with the auto industry since its beginning. He originated the first auto supply Co. and manufactured and marketed the first float type carburetor in America. No other man with such experience is today teaching others.

If we prove to you that we have started hundreds of others into the repair business and as chauffeurs—who had no previous experience and who knew no more about an auto than you do right now—you must admit we can do the same for you. Write me TODAY—NOW—and LET ME PROVE IT.

### Write for DYKE'S FREE BOOKLET

It is interesting and instructive in itself. Fully illustrated. Learn how you can get all this training for only \$18. Fill out below or write a postal—but do it NOW.

Dyke's Correspondence School of Motoring  
Box 188, Roe Bldg.  
St. Louis, Mo.

Send me your free 32-page booklet about your New Idea Working Model Course and testimonials and proofs. It is understood I am under no obligations in sending for this.



Name.....

Address.....

Deal with the originators. Beware of imitators.  
This school is a department of the firm of A. L. Dyke, Pub. and Importer,  
Box 188, Roe Bldg., St. Louis, Mo.

## (Contents—Continued from Page 6)

### SHOP NOTES

Auto Repairs, Casters on Footboard for Use in.....	285
Automobile Gear Box Repair.....	291
Automobile—Shifting Fork Repair.....	300
Blowtorch, Oil Burning, for Sheet Metal Work.....	292
Cart, Garden Dump, of Varied Uses.....	300
Concrete, Garden Seats of.....	295
Doors, Adjoining, Rollers Prevent Marring of.....	301
Drawings, Holder for Examining.....	302
Drill, Portable Electric, Used as Drill Press.....	290
Engine, Cranky, Spinning.....	300
Fan, Exhaust, for Workbench Aids in Removing Dust.....	280
Gasoline Engines, Eliminating Pounding in.....	294
Gate, Nonsagging Board.....	286
Grease, Hard Lubricating, Jig for Cutting.....	293
Heating Garage from Residence Hot Water System.....	292
Joint, Double Shaft Universal.....	294
Lamp Wick, Notch in Improves Flame.....	302
Locking Four Drawers with Plate Hasp.....	300
Mitered Corner That does Not Show Wear.....	301
Motor Cylinder Repaired with Copper Strip.....	302
Parcels, Device for Tying.....	290
Pens, Ruling, Bottle Stopper and Filler for.....	301
Post, Inexpensive Traffic Light.....	286
Pump Blower, Air, Driven by Punch Press.....	299
Roller, Small Printing Press, Substitute for.....	290
Sanding Block for Interior Trim and Floors.....	302
Sanding Drum for the Wood Shop.....	287
Scarf, Movable, for Building and Painting.....	285
Shipping Case Insures Carrying Batteries or Liquids Upright.....	301
Skidding Heavy Boiler or Machine.....	286
Soldering Patches on Tanks or Large Objects.....	291
Spark Plugs, Kinks in the Care of.....	284
Stove Linings, Preserving.....	292
Telephone Bells, Noisy, Remedy for.....	290
Telephone Linemen, Portable Safety Platform for.....	291
Threads, Cutting without Tap or Die.....	292
Trolley and Tackle, Portable, for Freight Transfer.....	283
Valve Grinding, Spring Aids in.....	286
Wheelbarrow, Safety Device for.....	294
Wood, Tool for Boring Large Holes in.....	284

### AMATEUR MECHANICS

Aerial Cableway, Compensated.....	306
Asbestos Table Mats Reinforced with Wire Netting.....	319
Bicycle Runner for Winter Use.....	316
Blotter Attached to Wrist Saves Time.....	315
Board, Caster, for Scrubbing and Floorwork.....	313
Bottle, Glass, as Candle Lamp.....	311
Chick Brooding House, Shield for Heater in.....	315
Corrugating Strips, Device for.....	319
Cushion, Emery Needle, on Sewing Machine.....	305
Desk, Folding Wall.....	312
Drawings, Tracing Cloth, Mounting on Muslin.....	316
Drinking Glass Holders Easily Made.....	305
Fence, Portable, for Baby's Play Area.....	303
Lamp Cooker.....	314
Lamp, Piano or Reading.....	310
Lantern Pictures, Enlarged, as Guides for Scenic Painting.....	317
Leggings, Birch Bark, Made in the Woods.....	319
Maps, Road, Celluloid Cover for.....	315
Miter Box, Placing on Workbench.....	314
Paper Warships, Toy.....	313
Protector, Book and Document.....	314
Pump, Tire, Made of Gas Pining.....	317
Rack, Sewing, Attached to Rocker.....	311
Reflectors, Light, White Blotting Paper Improves.....	304
Rheostat, Water, for Small Electrical Devices.....	304
Ruling Uniform Cards or Sheets, Aid in.....	318
Sandpapering Square Edges on Small Machine Bases.....	316
Sewing Stand with Workbag in Top.....	313
Snowshoe Toe Clips, Homemade.....	316
Staples, Tinned, for Bell Circuit Wiring.....	318
Stretcher for Drving Small Fur Hides.....	319
Truck, Three Caster, for Moving Crates and Furniture.....	317
Typewritten Bound Sheets, Inserting or Correcting on.....	317
Vises, Two Simple, for the Home Workbench.....	305
Wall Paper, Kink for Removal of.....	315



# Make \$25 to \$50 Per Week

**Begin now to master machine shop practice. You can do this easily and quickly with records of actual practice.**

**Have the Machine Shop Library sent to you free for ten days' trial.**

**Small monthly payments if you are satisfied.**

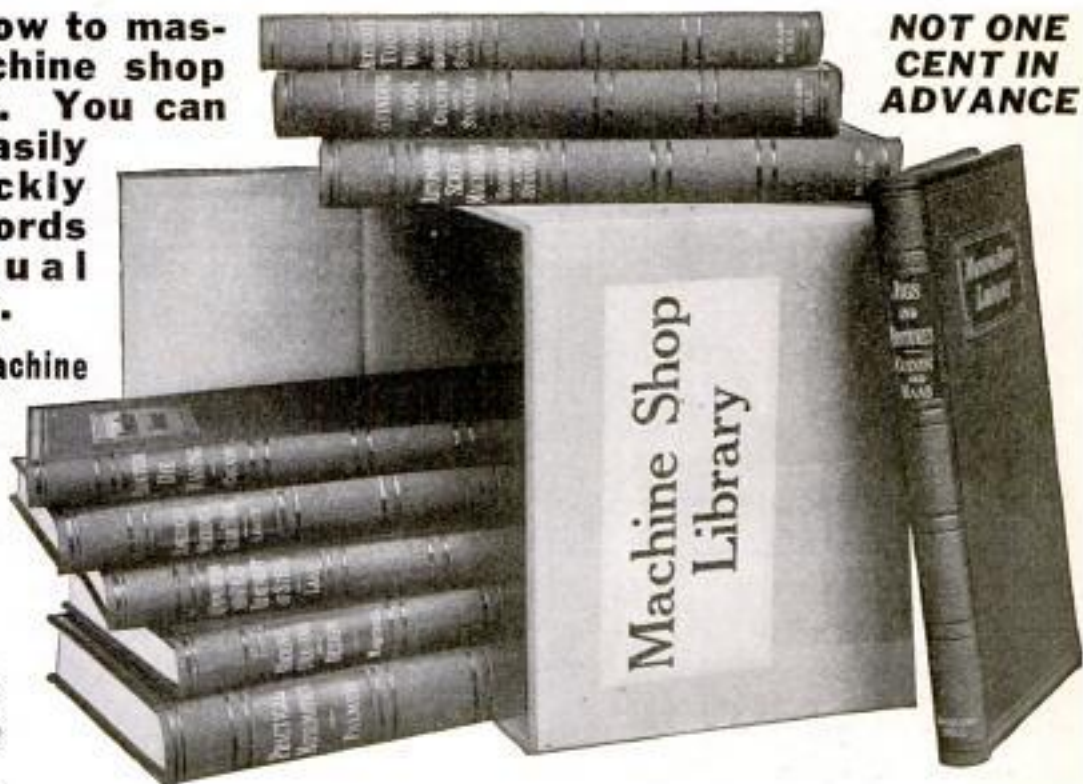

**NOT ONE CENT IN ADVANCE**

**I**N the world's history no such activity in machine shop work as that of today has ever before been recorded. And as we look forward into the future we see a never-ending increase in this unheard-of activity. Therefore the demand for the efficient machine shop worker is almost inconceivable. Both small and large shops throughout the country show a shortage of men. America is the country that will more and more be looked to by the other nations for all those products which originate in our inexhaustible sources of metal supply. No such opportunities in any field of endeavor have ever before presented themselves to the ambitious man who will train himself properly in machine shop work.

**Now is the time to get ready** Today is the day to start preparing yourself for a position in the machine industry. The Machine Shop Library, formed by eight of the leading authorities on machine work, and contributed to by over two hundred other expert shop men of America, is now accepted as the standard medium for acquiring quickly and surely a knowledge which places one in the highest positions.

### 3000 Pages — 3000 Illustrations

Everything you need to know about machine shop practice is now in nine compact and handy volumes, durably and beautifully bound. Every item of information is so plainly written that the very beginner can understand. Every illustration was drawn especially for these books, and serves to make this the clearest and most practical set of books on machine shop work ever constructed.

### Direct to your home without deposit. Ten days for examination

We not only agree to pay the forwarding expense on the books to you, but to send you return charges if you are not satisfied that the nine volumes will tell you everything you want to know about machine shop practice. Return them for any reason whatsoever. We will not argue. The books speak for themselves. It is nearly impossible for anyone in the machine profession, or anyone who expects to take up the work, to convince himself that he can get along without these books after seeing them. Upon first glance it can be readily observed that they furnish the essentials of success in machine shop work.

**Small Monthly Payments** After thoroughly satisfying yourself that you need the books send us small monthly payments which you will not miss.

**McGraw-Hill Book Co., Inc.**

**Publishers of Books for Machinists Since 1876  
239 W. 39th Street, NEW YORK**

### Just a few minutes of your time each day

Every day you delay sending the coupon below means something to you. You can earn \$25 to \$50 per

week just as easy as you can earn a few dollars a week, if you will give up a little of your time each day to the Machine Shop Library.

Let us prove this absolutely, at our expense. Return this coupon now. You do not risk one cent.

Signature.....

Your Address.....

City and State.....

Name of Employer.....

His Address.....

Your Position..... P. M. Feb.

**COUPON — NOTHING TO PAY IN ADVANCE**

**McGraw-Hill Book Company, Inc.**  
239 W. 39th St.,  
NEW YORK

Gentlemen: — I am interested in your Machine Shop Library. You may send me the nine volumes, charges paid, for my inspection. If satisfactory I will send \$2 in ten days and \$2 per month until I have paid the price of the books, \$16. If the books are not what I want, I will write you for shipping instructions.



# Why Live an Inferior Life?

I know that I can easily, quickly and positively prove to you that you are only half as alive as you must be to realize the joys and benefits of living in full; and that you are only half as well as you should be, half as vigorous as you can be, half as ambitious as you may be, and only half as well developed as you ought to be.

**T**HE fact is that no matter who you are, whether you are young or old, weak or strong, rich or poor, I can prove to you readily by demonstration that you are leading an inferior life, and I want the opportunity to show you the way in which you may completely and easily, without inconvenience or loss of time, come in possession of new life, vigor, energy, development and a higher realization of life and success.

## Become Superior to Other Men

The Swoboda System can make a better human being of you physically, mentally, and in every way. The Swoboda System can do more for you than you can imagine. It can so vitalize every organ, tissue, and cell of your body as to make the mere act of living a joy. It can give you an intense, thrilling and pulsating

CREATOR OF CONSCIOUS EVOLUTION



*Swoboda*

nature. It can increase your very life. I not only promise it, I guarantee it. My guarantee is unusual, startling, specific, positive and absolutely fraud proof.



## Why Take Less Than Your Full Share of Life and Pleasure?

Are you living a full and successful life? Why not always be at your best—thoroughly well, virile, energetic? Why not invest in yourself and make the most of your every opportunity? It is easy when you know how. The Swoboda System points the way. It requires no drugs, no appliances, no dieting, no study, no loss of time, no special bathing; there is nothing to worry you. It gives ideal mental and physical conditions without inconvenience or trouble.

## Your Earning Power

—your success, depend entirely upon your energy, health, vitality, memory and will power. Without these, all knowledge becomes of small value, for it cannot be put into active use. The Swoboda System can make you tireless, improve your memory, intensify your will power, and make you physically just as you ought to be.

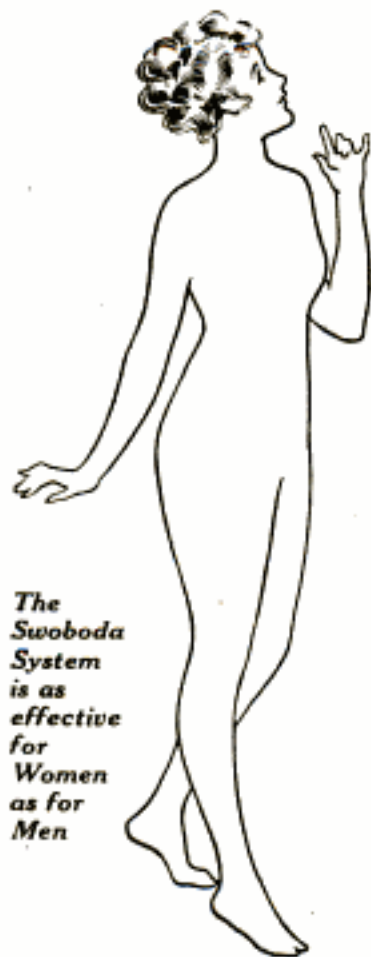

The Swoboda System is as effective for Women as for Men

## What Others Have to Say:

"Worth more than a thousand dollars to me in increased mental and physical capacity."

"Effect was almost beyond belief."

"I have been enabled by your System to do work of mental character previously impossible for me."

"Last week I had a reading of my blood pressure, and was gratified to learn that it was fully ten points below the previous reading."

This was a surprise to me as well as to my physician, who did not believe that my blood pressure could be reduced because of my advanced age."

"I was very skeptical, now am pleased with results; have gained 17 pounds."

"The very first lessons began to work magic. In my gratitude I am telling my croaking and complaining friends, 'Try Swoboda.'"

"Words cannot explain the new life it imparts both to body and brain."

"It reduced my weight 29 pounds, increased my chest expansion 5 inches, reduced my waist 6 inches."

"Very first lesson worked magically."

"My reserve force makes me feel that nothing is impossible; my capacity both physically and mentally is increasing daily."

"All your promises have been fulfilled."

"Your System developed me most wonderfully."

"I believe it will do all you claim for it; it has certainly made me feel ten years younger."

## A Few of Swoboda's Prominent Pupils

F. W. Vanderbilt  
W. G. Rockefeller, Jr.  
William Barnes, Jr.  
Gen. W. A. Kobbe  
Gen. J. F. Bell  
Franklin Murphy  
Howard Gould  
W. R. Hearst  
John B. Stanchfield  
John C. Spooner  
Alfred I. du Pont  
Percy A. Rockefeller  
A. W. Armour  
Charles F. Swift  
E. A. Cudahy

Oscar Straus  
Simon Guggenheim  
A. Lewisohn  
Mrs. G. P. Huntington  
Mrs. Archer M. Huntington  
Countess de Locquenille  
Mrs. Herman Oelrichs  
Maxine Elliott  
Anna Held  
Mrs. H. C. Chatfield Taylor  
Clarence Buckingham  
W. P. Clyde  
Nat C. Goodwin  
Jacob A. Cantor  
Oscar Hammerstein

## My New Copyrighted Book Is Free

It explains the SWOBODA SYSTEM OF CONSCIOUS EVOLUTION and the human body as it has never been explained before. It will startle, educate and enlighten you.

My book explains my new theory of the mind and body. It tells, in a highly interesting and simple manner, just what, no doubt, you, as an intelligent being, have always wanted to know about yourself.

You will cherish this book for having given you the first real understanding of your body and mind. It shows how you may be able to obtain a superior life; it explains how you may make use of natural laws to your own advantage.

My book will give you a better understanding of yourself than you could obtain from a college course. The information which it imparts cannot be obtained elsewhere at any price. It shows the unlimited possibilities for you through conscious evolution of your cells; it explains my discoveries and what they are doing for men and women. Thousands have advanced themselves in every way through a better realization and conscious use of the principles which I have discovered and which I disclose with my book. It also explains the dangers and after-effects of exercise and excessively deep breathing.

### Mail the Coupon To-day

Write to-day for my Free Book and full particulars before it slips your mind. You owe it to yourself at least to learn the full facts concerning the Swoboda System of conscious evolution for men and women. Mail the coupon or a post card now, before you forget.

**ALOIS P. SWOBODA**  
1995 Aeolian Bldg., New York City



.....  
**ALOIS P. SWOBODA**

1995 Aeolian Bldg., New York City

Please send me your free copyrighted book, "Conscious Evolution."

NAME.....

ADDRESS.....

CITY.....STATE.....



# These books will help you to greater

# Electr

## PARTIAL CONTENTS OF THE 10 GUIDES

**No. 1.** Contains 240 pages, 246 illustrations. Electrical signs and symbols—static and current electricity—primary cells—conductors and insulators—resistance and conductivity—magnetism—induction coils—dynamo principles—classes of dynamo, etc.

**No. 2.** Contains 218 pages, 256 illustrations. Armatures—windings—commutation—brushes—motor principles—armature reaction—motor starting—calculations—brake horsepower—selection and installation of dynamos and motors, etc.

**No. 3.** Contains 276 pages, 280 illustrations. Galvanometers—standard cells—current measurement—resistance measurement—voltmeters—wattmeters—watt hour meters—operation of dynamos—operation of motors, etc.

**No. 4.** Contains 308 pages, 423 illustrations. Distribution systems—wires and wire calculations—inside, outside, and underground wiring—sign flashers—lightning protection—rectifiers—storage battery systems, etc.

**No. 5.** Contains 278 pages, 379 illustrations. Alternating current principles—alternating current diagrams—the power factor—alternator principles—alternator construction—windings, etc.

**No. 6.** Contains 272 pages, 538 illustrations. A. C. motors—synchronous and induction motor principles—A. C. commutator motors—induction motors—transformers—losses, construction, connections, tests—converters—rectifiers, etc.

**No. 7.** Contains 320 pages, 460 illustrations. Alternating current systems—switching devices—circuit breakers—relays—lightning protector apparatus—regulating devices—synchronous condensers—inducting devices—meters—power factor indicators.

**No. 8.** Contains 288 pages, 330 illustrations. Wave form measurement—switch boards—alternating current wiring—power stations—turbines—management, selection, location, erection, testing, running, care and repair.

**No. 9.** Contains 576 pages, 849 illustrations. Telephones—telegraph—wireless—electric bells—electric lighting—photometry—electric railways—electric locomotives—car lighting—trolley car operation, etc.

**No. 10.** Contains 704 pages, 730 illustrations. Miscellaneous applications—motion pictures—gas engine ignition—automobile self-starters and lighting systems—electric vehicles—elevators—cranes—pumps—air compressors—electric heating—electric welding—soldering and brazing—industrial electrolysis—electro-plating—electro-therapeutics—X-rays, etc.

Also a complete ready reference index of the complete library.

The work of the world today is done by electricity. Electricity runs our machines; transports our goods; lights our homes, shops and factories; heats our buildings—is indispensable in hundreds of ways. Opportunities in electricity are greater than ever before. Exact electrical knowledge means more money and greater success for you.

## HAWKINS ELECTRICAL GUIDES

give you ALL the electrical information you want, in the shortest, most concise form—namely, by means of questions and answers and unlimited illustrations. No matter how great or how little your previous knowledge of the subject at hand, you "get the point" at once in Hawkins Guides. They are absolutely complete—brought right up-to-date—the last volumes are just off the press.

### FLEXIBLE POCKET-SIZE TEXTS Arranged for Home Study and Reference

They are the handiest books to read and to use, ever produced. In flexible, black covers, leather binding—just the right size—5x6½ inches—to fit in your pocket, so that you can carry each single volume about with you until you have mastered its contents. The whole set fits easily in the hollow of your arm, and still there are actually 3,500 pages and 4,700 illustrations.

**10 Practical Volumes. 3500 Pages. 4700 Illustrations**  
**\$1 Per Volume—Payable \$1 Per Month**



# success through

# electricity

## WHAT USERS SAY

"Every Electrician, Operating Engineer or Student who wants to advance himself in the Electrical field should have a set of these books."

JOHN KELLEY, 116 Union St., Newark, Ohio.

"For the man not getting a college training, and even in that case, I can sincerely say I do not believe there is a better set of books on the market today."

LLOYD D. HUFFMAN, Dayton, Ohio.

"We consider Hawkins Electrical Guides the most compact and complete set of electrical references in the market."

NOGOLA ELECTRIC WORKS, Monterey, Cal.

"Hawkins surely knows the art of condensing information."

ELDRIDGE F. BALL, Buckland, Conn.

"I think they should be in the hands of everyone who has anything to do with Electricity."

T. E. MURPHY, Orange, Va.

"For the practical electrician, they are the best books published—worth many times their price."

L. C. WAGNER, Wyoming, Ill.

"I have gained valuable information from them which has helped me directly in my line of work."

HERMAN NODENBERG, Hoboken, N. J.

"They are wonderful value. Everything is so clear and concise. Even one who had no knowledge of Electricity would have no difficulty in grasping the facts."

F. L. TAYLOR, Amesbury, Mass.

"It is the best work an apprentice can study if he wants to get ahead in his trade. As a reference for the experienced worker HAWKINS ELECTRICAL GUIDES are unexcelled."

I. MCCLELLAN, Chillicothe, Mo.



**THE ENTIRE SET of  
10 VOLUMES**

**SHIPPED TO YOU FREE**

Send no money. Examine the books first. Use them for seven days in connection with your work, and decide for yourself that they are the most complete, the most helpful and the clearest written electrical books ever published. This unusual offer is a sign of our confidence in the Guides.

**EASY PAYMENTS** Accept the offer now—mail the coupon today. If you decide to keep the books you can make settlement at only \$1 per month until paid for.

**THEO. AUDEL & CO.**  
72 Fifth Avenue  
NEW YORK N.Y.

**THEO.  
AUDEL & CO.,**  
72 Fifth Avenue, N. Y.

Please submit me for examination Hawkins Electrical Guides (Price \$1 each). Ship at once, prepaid, the 10 numbers. If satisfactory I agree to send you \$1 within seven days and to further mail you \$1 each month until paid.

Signature.....

Occupation.....

Business Address.....

Residence.....

Since we have not yet had the pleasure of business relations with you, we shall appreciate your giving us name of reference on line below

Reference.....

P. M. Feb. 17

Please Mention Popular Mechanics



# FREE BOOK

## How To Learn Piano

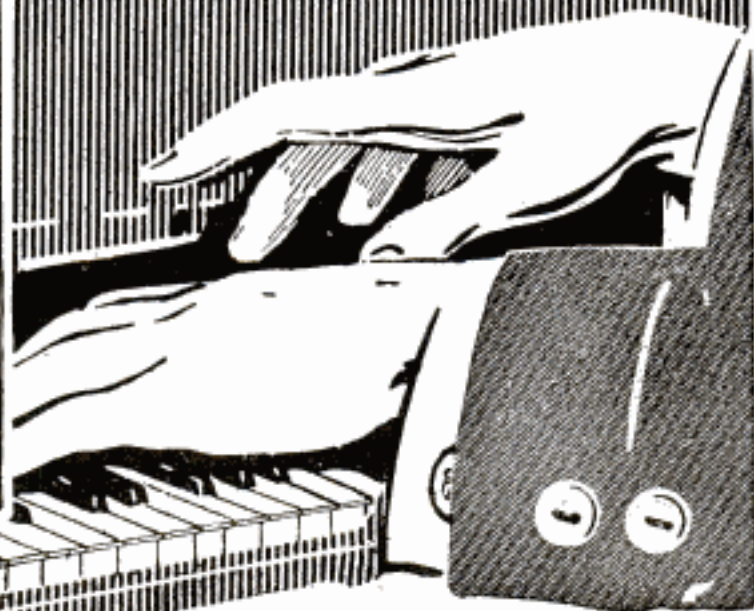

## This Interesting Book

shows how you can learn to play the piano or organ in your own home, in one-quarter the usual time and at *one-quarter the usual cost*. It explains the profound pleasures and well-known social advantages of musical training, and contains much information which will be *extremely interesting* to you whether you are already an accomplished player or do not know a single note. Send letter, postcard or coupon below for *your* copy of this valuable 64-page book. It is free.

### Music As A Career

Our free book tells you of the concert career which may be open to you. It explains the great and increasing demand for professional players and tells how you can earn \$25 to \$100 weekly through your own playing skill or by giving musical instruction to others in spare time.

It fully describes a method of home study which brings you all the advantages of the best foreign conservatories at *less than 43 cents a lesson*. Send for this free book at once.

**FREE  
BOOK  
COUPON**

M. L. Quinn Conservatory  
Box 650KN, Chicago, Ill.

Please send me without cost or obligation, your 64-page *FREE* Book, "How to Learn Piano or Organ," and full particulars regarding Dr. Quinn's Course in Piano or Organ by the *Written Method*, and special *Twenty-Fifth Anniversary Offer* now open.

Write  
Today



Name .....

Address .....

### Dr. Quinn's Famous **WRITTEN METHOD** for Piano or Organ

has revolutionized the study of music. By the use of Dr. Quinn's remarkable device, the **COLOROTONE** (patented), you save three-quarters of the time, effort and money usually required for learning piano or organ. You play chords immediately and a complete piece, *in every key*, within *four lessons*. Investigate without cost by sending for free book.

#### Endorsed by Distinguished Musicians

Dr. Quinn's **WRITTEN METHOD** has been proving its merit by **RESULTS** for 25 years. Among our graduates are thousands of accomplished amateur players, as well as leading composers, distinguished virtuosos and heads of conservatories. The method is endorsed by prominent musicians and educators who can *speak with authority*. It is scientific and systematic, yet practical and easy to understand. It is fully illustrated. It is equally effective for beginners or experienced players, children or adults. All necessary music is included **FREE**. You practice in spare time at your own convenience. Progress as rapidly or slowly as you wish. Diploma of recognized value is granted.

#### Investigate Without Cost

Write today, using postcard, letter or free book coupon, for our 64-page book, explaining everything you want to know about "How To Learn Piano Or Organ," and giving full particulars of our **COURSE**. Special reduced terms this month on account of our **Twenty-Fifth Anniversary Offer**. Investigate without cost or obligation **NOW**.

**Marcus Lucius Quinn Conservatory**  
Box 650KN  
Chicago, Ill.



# The Only Girl Who Commanded a Nation's Armies



A simple little girl of sixteen played one day in a little lost village. The next year, in supreme command of all the troops of France, she led them in triumph to victory. No woman—no man in all the world's story has done so wonderful a thing. Great dukes bowed before this girl who could not read. Sinful men, men who had cursed and drank and murdered all their days, followed meekly her every order.

It is the most dramatic, the most amazing story in the whole story of human life. In the dim, far-off past, Joan of Arc went her shining way in France—and her story was never told as it should have been, till it was told by an American—

## MARK TWAIN

To us whose chuckles had turned to tears of pathos at "Huckleberry Finn"—to us who felt the cutting edge of a "Connecticut Yankee"—to us who saw the keen vision in "Innocents Abroad"—the coming of "Joan of Arc" from the pen of Mark Twain was no surprise. The story began in an anonymous romance in Harper's Magazine, but within a few months the secret was out. Who but Mark Twain could have written it? Who else could have written this? It has a whimsical touch which makes it human. So

that Mark Twain's "Joan of Arc" is no cold statue in a church—no bronze on a pedestal, but a warm, human, loving girl. Our hearts break for her awful fate. Read "Joan of Arc" if you would read the most sublime thing that has come from the pen of any American. Read "Joan of Arc" if you would know Mark Twain in all his greatness. It is not a history, in the true sense, and yet it is as accurate as any history. It is a story told by one of Joan of Arc's followers. You will feel all through as though it were your grandfather talking to you in a kindly, simple way.

### Send Before the Half Price Stops

This is Mark Twain's own set. This is the set he wanted in the home of each of those who love him. Because he asked it, Harper's have worked to make a perfect set at a reduced price. Before the war we had a contract price for paper, so we could sell this set of Mark Twain at a reduced price. The last of the edition is in sight. The price of paper has gone up. There can be no more Mark Twain at the present price.

### Send the Coupon Without Money

Get the 25 volumes now, while you can. Every American has got to have a set of Mark Twain in his home. Get yours now and save money. This is the first announcement of the final closing of the sale. Your children want Mark Twain. You want him. Send this coupon today—now—while you are looking at it.

Pop. Mech. 2-17  
 Harper & Brothers New York  
 Send me, all charges prepaid, a set of Mark Twain's works in 25 volumes, illustrated, bound in handsome green cloth, stamped in gold, gold tops and deckled edges. If not satisfactory, I will return them at your expense. Otherwise I will send you \$1.00 within 5 days and \$2.00 a month for 12 months, thus getting the benefit of your half price sale.

**HARPER & BROTHERS**  
 1817-1917  
**NEW YORK**

Name.....  
 Address.....

## Make this car your office—

there is \$900.00 to \$1800.00 a year in it for you

Examinations will likely be held everywhere soon

Rapid advancement to higher Government Positions. "No layoffs" because of STRIKES, FINANCIAL FLURRIES or the WHIMS OF SOME PETTY BOSS. THE POSITION IS YOURS FOR LIFE.

Country residents and city residents stand the same chance for immediate appointment. Common-sense education sufficient. Political influence NOT REQUIRED.

We will prepare 25 Write immediately for schedule showing the places and dates of all Winter and Spring examinations. Don't delay. Every day you lose means the loss of just so much coaching before the rapidly approaching examinations.

FRANKLIN INSTITUTE, Dept. T 97, Rochester, N. Y.



Hundreds of Railway Mail Clerks Needed Soon

### COUPON

Franklin Institute (The pathway to plenty), Dept. T 97, Rochester, N. Y.

This coupon, filled out as directed, entitles the holder to (1) free specimen questions; (2) a free copy of our copyrighted book "Government Positions and How to Get Them"; (3) a list of positions now easily obtainable, and (4) to consideration for Free Coaching for the examination here checked.

- ..... Railway Mail Clerk (\$900 to \$1500)
- ..... Customs Positions (\$800 to \$1500)
- ..... Bookkeeper..... (\$800 to \$1800)
- ..... Stenographer..... (\$800 to \$1500)
- ..... Postoffice Clerk..... (\$900 to \$1250)
- ..... Internal Revenue..... (\$700 to \$1000)
- ..... Postoffice Carrier..... (\$800 to \$1200)
- ..... Clerk in the Departments at Washington (\$900 to \$1600)
- ..... Rural Mail Carrier..... (\$500 to \$1100)

Name..... Address..... T 97

Use this before you lose it. Write plainly.

Please Mention Popular Mechanics



## Come to Akron, Ohio The Tire Center and

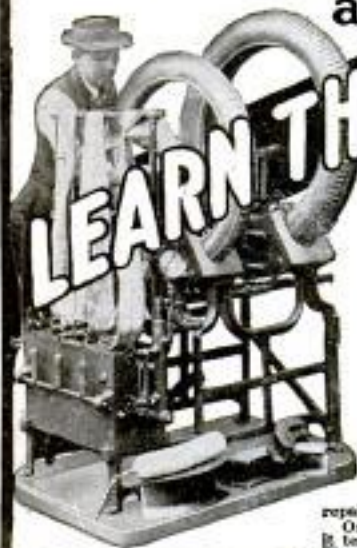

### MONEY-BACK GUARANTEE

We guarantee to qualify our students to go into business for themselves or to hold positions paying \$18.00 to \$40.00 weekly or return their money. The demand for trained repairmen is greater than the supply.

# THE TIRE REPAIR BUSINESS

Make big money in this big field. No other field offers such opportunities. Autos run the year around. Tires need constant repairing. Profits are large and work comes easily. Every job is easily and quickly done. There are locations everywhere, right in your home town. We show you how to find best locations. Help you to get jobs paying from \$3.00 to \$6.00 a day if you don't want to open a repair shop. Tire repair shops are as necessary as gasoline stations. Auto owners drive their cars more than ever. They need more work done constantly. Over a Million New Autos put in use this year. More tire repair shops and men will be needed. Get into this big profit business and become independent.

## MAKE \$2500 TO \$10,000 YEARLY

There is no limit to what a man can make. Men are becoming rich in this business. You can start business with small capital. Work comes easily, profits are big, business grows fast. Trained tire repair men get work quickly and hold customers. Our graduates are qualified to handle all makes of Cord Tires and can get factories O. K. School open all the year—Enter classes any day. Graduate in 4 to 6 weeks.

### GRADUATES ARE COMPLETELY SATISFIED

San Antonio, Tex., Nov. 4th, 1936.

The Akron Tire Repair School:

Gentlemen: I did not know a thing about an automobile tire when I entered your school. But under the able and plain instructions of your chief instructor, I have mastered the course in tire repairing in the comparatively short time of four weeks.

One thing about the Akron Tire Repair School is that it teaches how to repair Silverstone and Goodyear Cord Tires, a feature that the prospective student will not learn in any other tire repair school in existence. That part of the instructions alone has more than repaid me for my long trip to Akron.

Yours, etc.,

A. C. ROSS.

### WEEK TRIAL SPECIAL OFFER

Our tuition price is low, but we are making a SPECIAL WEEK TRIAL OFFER which is the most liberal ever offered by a reliable School—Write at once for "Week Trial Special Offer," school literature and students' letters—All absolutely Free.

### THE AKRON TIRE REPAIR SCHOOL

The Largest and Best Equipped, Exclusive Tire Repair School  
A. G. ZELLER, President 62 Tire Bldg., 46-48 Main St., AKRON, OHIO

Detroit, Mich., October 16th, 1936.

Akron Tire Repair School:

Gentlemen: I must say that you certainly have fulfilled your agreement to the letter. I am fully satisfied. The clear, concise instruction and the carefully supervised practice in your excellently equipped place, will be of great value to me.

I think that many tire-repair men already in the business could save themselves money by taking your course, that section which deals with cord tires being alone worth the time spent.

Yours sincerely,

ALEXANDER M. DUNCAN.

We are making a special offer for a limited time.

Write at once for "Week Trial Special Offer," school literature and students' letters—All absolutely Free.



## I Want 1000 Men To Prepare For Jobs Paying \$75 to \$300 Per Month

The boom is on. Bosses are paying more and more to get men skilled in auto mechanics to work for them. Garage owners stand ready to pay big money for Expert Repairers. Gas Engine manufacturers are short on trained workers. Thousands of tractors are ready to go on the farms—and there are only a few experts to run them. A million new cars are to be built this year and good drivers will be scarce. From everywhere comes the demand for men—trained men. If you are ambitious, I will train you quickly at home in your spare time for one of these big jobs. I will teach you to

## Be an Expert Auto Mechanic

**Repair Man, Chauffeur, Traction Engineer, or Farm Lighting Expert.** in shortest possible time. Big jobs are ready and waiting for you. With I. M. I. training you can quickly qualify as an expert in any of the above lines—prepare for a job paying up to \$300 a month.

I will give you 25 Lessons Free. But you must act at once. Only 1,000 Partial Scholarships will be given away, and only one in each locality. Rush coupon and get details of FREE offer. Investigate. Write today. Results guaranteed.

HARRY WELLS, Gen. Mgr.  
International Motor Institute,  
135 Kesner Building, Chicago

Send me full details of your 25 Free Lessons Offer, also Enrollment Blank.

Name.....  
Address.....

## LEARN WATCH REPAIRING

You can learn by our modern and original system of instruction every part of the Watch Repairing Trade at home as good or better than at a shop. You can earn money while learning and secure a well paying position or start in business after completing our course of instruction. Good watch repairers are always in demand and earn from \$20 to \$35 per week. For particulars apply to the

Wisconsin School of Watchmaking, Strub Bldg., Milwaukee, Wis.

## LANGUAGES

Quietly Learned AT HOME by the Original Phonographic Method

German—French—English—Italian—Spanish

learned by the Cortina Method at home with Disc-Cortinaphone Language Records. Inquire at your local phonograph dealer who carries or can get our records for you, or write to us for FREE booklet today; easy payment plan.

**CORTINA ACADEMY OF LANGUAGES**  
Suite 2104, 12 E. 46th Street, N.Y.

## Be an Artist

Comics, Cartoons, Commercial Newspaper and Magazine Illustrating. Pastel and Crayon Portraits. Earn \$25 to \$200 a week. By our simple method your talent is quickly developed without interfering with present work. By Mail or Local Classes. Small sums you now fritter away pay your tuition. Write for terms, list of successful pupils and instruction method FREE.

**ASSOCIATED ART STUDIOS, 2203 Flatiron Building, New York**

## "Linene"

TRADE MARK

### SEND 2 CENTS

in United States stamps to pay postage and we will send you FREE a SAMPLE COLLAR of our New Style "Copley." State size wanted.

**REVERSIBLE COLLAR CO., Dept. U, BOSTON, MASS.**



# Finish This Story For Yourself—

The girl got \$6 a week and was lonely. "Piggy"—you can imagine his kind—was waiting downstairs. He knew where champagne and music could be had. But that night she didn't go. That was Lord Kitchener's doing. But another night?

## O. HENRY <sup>12</sup> Volumes

tells about it in this story, with that full knowledge of women, with that frank facing of sex, and that clean mind that has endeared him to the men and women of the land. From the few who snapped up the first edition at \$125 a set before it was off the press, to the 120,000 who have eagerly sought the beautiful volumes offered you here — from the professional man who sits among his books to the man on the street and to the woman in every walk of life—the whole nation bows to O. Henry—and hails him with love and pride as our greatest writer of stories.

**This is but one of the 274 stories, in 12 big volumes, you get for 37½ cents a week, if you send the coupon**

To Those Who Are Quick

## KIPLING <sup>6</sup> Volumes GIVEN AWAY

Never was there an offer like this. Not only do you get your 274 O. Henry stories in 12 volumes at less than others paid for one volume of the first edition, but you get Kipling's best 179 short stories and poems and his long novel—without paying a cent. You get 18 volumes, packed with love and hate and laughter—a big shelf full of handsome books.

**Send the Coupon and you will understand why O. Henry is hailed as "The American Kipling."**

From East to West; from North to South; by all the peoples of the world, O. Henry has been eagerly seized upon as their own. The millionaire and the man who stoically wonders where the next mouthful is coming from, the budding debutante, and the wayward sister, all feel in common the kindly touch of the human heart in O. Henry's stories. One and all have felt that at last here was the chance to see the hearts of every kind of person, to get a world of pleasure, and a library of the best and most worthy literature obtainable.

**Send the Coupon and you will understand as never before why other nations are going wild over him.**

Why memorials to him are being prepared; why universities are planning tablets to his memory; why text books of English literature are including his stories; why colleges are discussing his place in literature; why theatrical firms are vying for rights to dramatize his stories; why newspapers all over the country are continually offering big sums for the right to reprint his stories.

**Send the Coupon Without Money**

We will ship the complete sets so that you can look them over in your home and then decide whether or not you wish to buy. If you are not delighted with O. Henry and the free Kipling notify us and we will take the sets back as cheerfully as we sent them. How could any proposition be more fair?

### The Cloth Binding

If you prefer the set of O. Henry in cloth binding change price \$19.50 to \$15.00, and change monthly payments from \$1.50 to \$1.00. There is so small a difference however between the price of the cloth and the beautiful half leather that we strongly urge our customers to buy the half leather.

FOLD HERE, TEAR OUT, SIGN AND MAIL

## INSPECTION COUPON <sup>2</sup> 17

THE RIVERSIDE PUBLISHING CO.  
543-549 Marquette Bldg., Chicago, Illinois

Please ship me on approval the Works of O. Henry, 12 volumes, half leather binding, gold tops. Also the 6 volumes set of Kipling bound in silk cloth. If I keep the books I will pay you \$1.00 as first payment within 10 days after books are received and \$1.50 per month until your special price of \$19.50 for the O. Henry set only is paid, and it is agreed I am to retain the Kipling set without charge. If not satisfactory I will notify you within 10 days and return both sets to you as soon as you give me shipping instructions as offered readers of Popular Mechanics Magazine.

Name \_\_\_\_\_

Address \_\_\_\_\_

Occupation \_\_\_\_\_

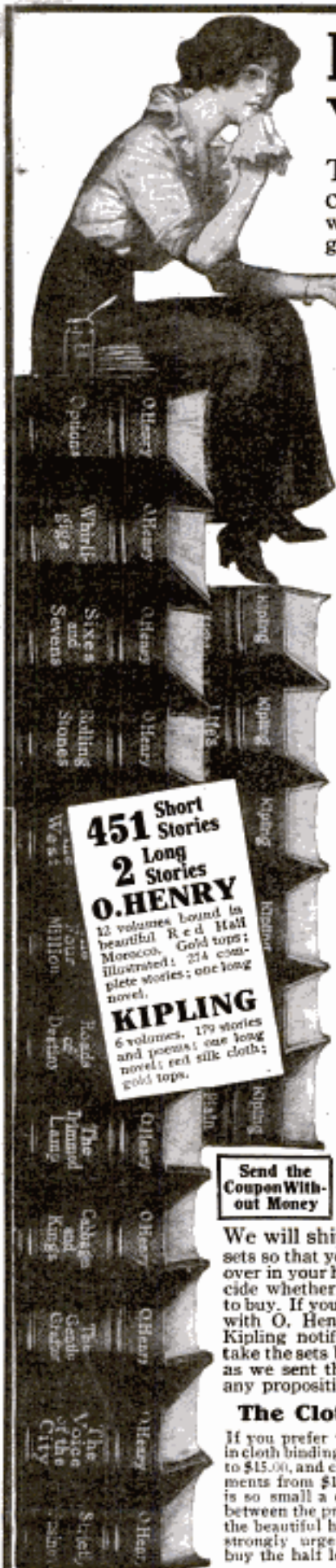

451 Short Stories  
2 Long Stories  
**O. HENRY**

12 volumes bound in beautiful Red Half Morocco. Gold tops; illustrated; 274 complete stories; one long novel.

**KIPLING**  
6 volumes, 179 stories and poems; one long novel; red silk cloth; gold tops.



# YOU Should be Earning More Money!



## Let Me Help You to a Bigger Salary—I Have Helped Thousands!

Are you discouraged with your job? Are you just a cog in the machinery, working long hours and getting starvation wages? I will train you for a splendid, worth-while position. I will show you how to double your income. You can be a success among big, successful men and women. You can get the best out of life and be somebody! Here's my advice:

## You Can Easily Learn Telegraphy—Morse and Wireless—Be Successful!

You can here learn to be a station agent, Western Union and railroad operator or a wireless operator all at the same time. I also give you a course of typewriting and penmanship free of additional charge. Expert instructors. Individual instruction with practical work every day. I have two large modern buildings equipped with railroad and Western Union wires and two complete, late, modern, large Marconi Radio sets for instruction of wireless students. Splendid positions awaiting you with great chances for advancement. Wireless offers unusual opportunity for world travel.

## Positions Secured—Marconi Company Takes Our Wireless Graduates.

I have a contract with the Marconi Company whereby my students are given preference for positions as Wireless Operators on the Great Lakes and the Gulf of Mexico. Hundreds of our graduates now holding responsible positions. All attest to the efficiency and thoroughness of this school. No matter where you live you can reap the benefit of this institution's courses of training. It is the—

## Largest School—43 Years Old—Tuition Low—Easy Payments

600 students enrolled annually. \$25,000.00 investment. Valparaiso is an ideal, home-like town of 8,000 people. Come here, study a few months, change your whole life. Make a success of yourself! Correspondence courses, also. Be sure to write today.

**DODGE'S TELEGRAPH, RAILWAY AND WIRELESS INSTITUTE**

8th Street, Valparaiso, Indiana

**Write Me a Personal Letter Today—Get Free Illustrated Catalog**

*I want you to write me a long, heart-to-heart letter, telling me all about yourself and your present job. I assure you that I will do everything in my power to help you make the greatest success. Tuition rates are low. You can earn your living expenses while you are here. Many students are self-supporting.*

Sincerely,  
G. M. DODGE,  
Pres.

## New Automobile Books

### For OWNERS, DRIVERS and REPAIR MEN

The new equipment makes the old books obsolete. We will send any or all of the following books prepaid upon receipt of price.

#### BROOKES' AUTOMOBILE HANDBOOK

Revised by H. P. MANLY

715 pages, of which 400 pages are devoted to practical information on new equipment. 335 illustrations and diagrams. Special articles on carbureters, ignition starting and lighting, and every new device used.

Pocket size, leather, round corners, red edges, gold stamping. Price, postpaid, \$2.00

#### AUTOMOBILE STARTING and LIGHTING

By HAROLD P. MANLY

Every starting and lighting device in the market is covered in this work in a practical manner, for the owner, operator and repair man. The principal subjects treated are as follows: Electric Lighting and Engine Starting

Equipment; Lighting Dynamos and Starting Motors; Storage

Batteries; Lamps and Wiring; Control Parts; Dynamo and Motor Drives; Current Measuring and Indicating Devices; Starting and Lighting troubles.

200 pages, illustrated. Pocket size. Cloth, postpaid, \$1.00

Full leather, red edges, gold stamping, postpaid, \$1.50

#### AUTOMOBILE CATECHISM AND REPAIR MANUAL

By G. F. SWINGLE and H. A. TARANTOUS

Part I comprises questions and answers. Part II is devoted entirely to automobile repairs. It gives complete instructions for locating troubles and making adjustments and repairs of all kinds. Motor knocks, carburetion, ignition, valve troubles, fitting piston rings, and tires.

Pocket size. Leather, stamped in gold. Red edges. 165 pages. Fully illustrated. Price, postpaid, \$1.25

Send for our catalogue of practical mechanical books for Electricians, Engineers, Telephone Men, Machinists, Railroad Men, Automobiles, Carpenters, Plumbers, Sign and Card Writers, Scene Painters, etc. It is **FREE**

**FREDERICK J. DRAKE & CO., 1008 Michigan Ave., Chicago**

Please Mention Popular Mechanics



Learn to FLY

## Build Your Own Bi-Plane Glider

**NOW** Many of the famous birdmen first learned to fly with a GLIDER. It is the initial step in aviation—and the small cost of material to construct such a machine—and the ease with which it can be built, places it within the reach of everyone.

Send to-day for copy of book "How to Build a 20-ft. Bi-Plane Glider" and get full particulars, with detailed drawings—Postpaid

60c

**SPON & CHAMBERLAIN**

123 P. M. Liberty St., NEW YORK



**THIS JOB PAYS \$25-\$50 Weekly**

## IN 10 WEEKS' SPARE TIME

We can teach you the entire subject by mail and help you to get a good position. ONE MILLION AUTOMOBILES will be built next year. The demand for trained help will be tremendous. **Sample Lessons Free—Write for Them Today** (Owners—we supply competent men.)

**Franklin Auto Institute, Dept. T 803, Rochester, N. Y.**



*You must act quickly  
to get a set of the New*  
**Encyclopaedia  
Britannica**  
Handy Volume Issue

No more India paper!

Act now if you want the  
Britannica printed on  
genuine India paper!

Over 160,000 sets already  
sold! Only a few thou-  
sand sets remain unsold!

No more can be offered  
on India paper when  
these are sold!

India paper makes this  
great work five times  
more valuable to you.

(See Inside Pages)



# Act Now

# A rare chance World's Great

## WARNING!

Sets of the new Britannica printed on the last genuine India paper obtainable are selling fast. No promise can be given as to how long the remaining sets will last.

Therefore we urge you to act immediately as the only way of getting the new Britannica in the popular "Handy Volume" form, printed on genuine India paper. You certainly want it in this, its most useful form.

India paper is the most wonderful, most useful paper made. It is *light-weight, thin and strong*. Its use for the new Britannica was a near-miracle in book publishing. It made it possible to put this great Library of *all Knowledge* in convenient form—29 compact volumes, requiring only 29 inches of shelf space.

And remember—when the sets now on hand are sold, no more can be offered printed on this famous paper. Because—war has entirely cut off the supply of the special kind of flax necessary to manufacture this beautiful paper. This flax is grown only in Great Britain, Belgium and Germany—and *no more can be had*.

That's the whole story. This difficulty was not foreseen. When the Britannica was put into "Handy Volume" form, the publishers thought they would be able to get all the India paper needed to print as many sets of the Britannica as could be sold. The fact is that the remaining sets, printed on the last obtainable India paper, will meet only a fraction of the demand.

*You can't afford to wait until "tomorrow" to own a set—the time to act is now—today.*

## The Encyclopaedia Royal Road

**H**OW much do you *know*? How much do you *earn*? Are you above or below the line of "average-intelligence, average-income?"

If you are keeping step with Twentieth-century progress, you realize that you must know *more and more* every day. And what you know must be facts. Generalities don't help you out.

It is obvious that you can't accumulate all the knowledge you need by traveling and talking to others—nor can you carry in your head all you want to know outside your own personal experiences. Therefore, the new Britannica is *indispensable* to you—

**BECAUSE**—it deals with life and civilization and progress in the broadest sense. Its scope is universal—comprising the sum and substance of human thought and activity. It covers everything under the sun—and the sun itself.

This great *library of knowledge*—consisting of 30,000 pages teeming with facts and information—is the work of 1500 master minds, the world's foremost experts in every line. Its contents are too comprehensive to be adequately described here. Sufficient it is to say that the Britannica discusses in a way you can understand every branch of science and industry, literature and art, religion and philosophy, invention, engineering, history, biography, geography, geology, architecture, astronomy, law, botany, education, electricity—EVERYTHING.

The new Britannica is a book for men and women in all walks of life—for the millionaire as well as for the wage-earner, for the expert as well as the student, for the clerk as well as for the merchant, for the bank

This line shows sets of the Britannica already sold

This line shows the few remaining sets of the Britannica printed on genuine India paper

# For full information mail



# to own the greatest Library

# Act Now

## Britannica Is the Key to Success

president as well as for the bank clerk—for the home as well as the office.

You probably have some idea of how useful the Britannica would be to you—just as its daily practical value is proved in the case of its 160,000 present owners.

Andrew Carnegie has said: "A half-hour a day spent on a particular line of study is the best investment any man can make."

Whatever your "particular line" is, the Britannica will equip you to become proficient in the highest degree. Whether you are interested in the stars above or in coal mining, in electricity or chicken raising, in house building or carpet manufacture, the Britannica is an invaluable aid. You need it—you should have it.

Carnegie's "half-hour a day" spent with the Britannica will soon make you a more intelligent, more interesting man or woman. It will expand your power to think and talk and do. Thus you will become more successful—life will grow to be more and more worth while.

You can't afford to miss this chance to own the new Britannica. You should have this great work—and of course you want it printed on genuine India paper.

Don't wait until to-morrow, Act now. Cut out the coupon on the next page—sign it—send it in.

Charles M. Schwab, President of the Bethlehem Steel Corporation and one of the leading self-made Americans, says of the popular "Handy Volume" Issue of the Britannica that it brings "the most important and authoritative work of its kind in the world within the reach of those who need it most—the men who are raising themselves from the ranks to positions of responsibility."

Here is the sum and substance of all human knowledge — 41,000 articles, 30,000 pages, 15,000 illustrations, 500,000 indexed facts

## How Many "10 Cents" Do You Spend and Get Nothing for Them?

Realize that this small sum daily will, in a very short time, give you the outright ownership of the world's greatest book of knowledge—the new Britannica, in the popular "Handy Volume" form.

You obtain the entire set (29 volumes) on a first payment of only **\$1** and you pay the balance in small monthly amounts averaging 10c a day (for the cheapest binding).

Whatever your business or profession, the Britannica will increase your practical knowledge along any line—it will enable you to be a more profitable factor in your work—it will make you more efficient, more successful.

Do you say that you "can't afford it"?

Considering the many advantages it offers you (and your family), can you afford *not* to own it?

Considering the low price asked for the remaining sets of the Britannica printed on the famous India paper, and the easy payment plan, can you afford *not* to own a set?

Think this over—read the preceding paragraph again.

Half an hour or so a day spent in reading the Britannica will soon make you realize that it actually pays for itself.

"It is a great thing for education to have this unrivalled Encyclopaedia reduced to really popular prices."

RICHARD C. MACLAURIN

President, Massachusetts Institute of Technology.



coupon on next page today →



# Quick!

Rush the coupon for full details how you can obtain one of the remaining sets of the Britannica printed on genuine India paper.

Do it *now*—  
right off!



SEARS, ROEBUCK AND CO., Chicago

Gentlemen:—Please send me, free, "**The Book of 100 Wonders**," illustrated, giving interesting information on a hundred subjects, and full information about THE ENCYCLOPAEDIA BRITANNICA. Also, tell me what I have to pay for one of the remaining sets of the "Handy Volume" issue of THE BRITANNICA printed on genuine India paper.

Name \_\_\_\_\_

Address \_\_\_\_\_

E-18

You can't afford to let this opportunity go by—send the coupon.

(See Inside)



# CLASSIFIED ADVERTISEMENTS

WORLD'S BEST WANT AD MEDIUM

We have records to prove that a classified ad in these columns will find a buyer for almost anything which can be sold. Doubtless you have some article of value to some one else which you no longer need. Why not turn it into money?

Advertisements in this section, 18 cents per word, each insertion, minimum 10 words, payable in advance. To insure ads being inserted under proper classified head in the March issue, copy must reach this office not later than January 31st.

Popular Mechanics Magazine, Chicago, Ill.

Gentlemen: Before advertising in your magazine, I was very skeptical and regarded the ad of Patent for Sale almost as a joke. This was in judging from the result I had from similar advertising in other publications. I changed my mind now, as my ad in your magazine was a great success. I even received letters from Europe. I will recommend Popular Mechanics Magazine to all my friends.

Very truly yours, ERNEST KOHLER.

## AUTOMOBILES

**AUTOMOBILE Repairs**—Automobile owners, Garages and Repairmen should subscribe for the Automobile Dealer and Repairer; 150-page illustrated monthly devoted exclusively to the care and repair of the car. The only magazine in the world devoted to the practical side of motoring. The "Trouble Department" contains five pages of numbered questions each month from car owners and repairmen which are answered by experts on gasoline engine repairs. \$1 per year; 15c per copy. Canadian subscription, \$1.50. Postals not answered. Charles D. Sherman, 50 Windsor Road, Hartford, Conn.

FOR 25 cents I will tell you how to save gas and increase power of your car. Engineer, 907 Palace Bldg., Erie, Pa.

**A REAL Automobile:** The American Junior; with a real gasoline engine. Two passenger. Eighteen miles per hour, ninety miles on a gallon of gas. Just the thing for Juniors, Salesmen, School Teachers, etc. Price, \$1.00. Send for Catalogue. Some good territory open for dealers. American Motor & Vehicle Co., La Fayette, Ind.

**READ** about cross continent trip of wonderful new car with Rotary Motor that spins around; this month's Motor Mechanics, Cleveland, Ohio, page 107. Also covers Farm Tractors, Motorcycles, Gas Engines, Power Machinery. Sample copy, 10c. Six months' trial, 50c.

**AUTOMOBILE** chauffeurs and students attention: new pocket-size edition of auto catechism. Just out. Answers 697 questions on crooked and legitimate mechanical and electrical repairs. Clothbound. Price, \$2.50, postpaid. Frank Kutenauer, 321 Mitchell Ave., Detroit, Mich.

**CYLINDERS** reground, new pistons and rings fitted. Restores lost power. Prompt and efficient service given. Write for prices, giving make and model. The Everts Machine Company, No. 20 Hicks St., Hartford, Conn.

**LIVE** agents wanted. Entirely new, guaranteed, money-back proposition for automobile owners. A trouble eliminator and money saver. Birks Supply House, 5214 Lake Park Ave., Chicago.

**CYLINDER** Grinding, pistons and rings our exclusive specialty. Long experience, coupled with a most completely equipped plant, is at your service. Our prices will interest you. "The grinding that puts the punch in your motor." Bridgeport Piston Ring Co., Connecticut Ave., Bridgeport, Conn.

**PATENTS** for Automobile Improvements are in great demand. We have special Automobile Department in charge of experts who are in touch with demands of trade. Write for "What To Invent and List of Patent Buyers," sent free. Victor J. Evans & Co., 158 Ninth, Washington, D. C.

**LARGEST** Automobile School in the East. Send for folder. New York School of Motoring, Utica, N. Y.

## CYCLECARS AND MATERIAL

**MOTORBOB** or Cyclecar Motor. New. Complete. Bargain. Adams, 4126 Larchwood, Philadelphia.

**FOR Sale**—Cyclecar parts. 10 h. p. "V" Motor, \$27.50; Wheels, \$9.00 per set; all other parts at very low prices. This is a well known successful Cyclecar. Send two cents for catalog. Tribune Engineering Co., Oswego, Tioga County, N. Y.

## AUTOMOBILE SUPPLIES

**AUTOMOBILE** Parts for the following and a great many others that we do not list: Maxwells, R. M. F., Flanders, Paige 25, Buicks, 10, 17, 19, 20 and 25, Overlands, 38, 37, 45, 49 and 59, Cadillacs, '09, to 1912, Moon, Moline, Parry, Glide, Warren, Regals, 1909 to 1913, Oakland, Jeffery, Mitchells 1907 to 1913, Empire, Elmore, Chalmers, 1909 to 1913, Auburn, Kline, Dorris, R. C. H., Jackson 35, Interstate 30, and many others, Pistons, Connecting Rods, Cam Shafts, Crank Shafts, Cylinders, Axles, Bearings, and gears for most any make of car. Write us your needs. Satisfaction guaranteed. Auto Parts Company, 4116-18 Olive St., St. Louis, Mo. No connection with any other Auto Parts Companies.

**FOUR** Cylinder Studebaker Garford Engine, \$30. Model N Ford, \$39. Jackson two cylinder, \$26. Stessen, Marshall, Ill.

**AUTO** Drivers, Motormen. Wet wind shield bother you? Send dime (coin only) for cheapest method. Positively secures clear vision. Chandler P. White, Liberty Bldg., Seattle.

**EXPLOSION** Whistle. Fits printing cup. Most powerful signal made. Rapid seller, owing to real value. See display ad page 140. Buell Manufacturing Co. (Dept. J1), 1610 Michigan Blvd., Chicago.

**CARBON** eliminated by controlling oil. Results guaranteed. Write for folder. Automobile Accessories Co., Baltimore, Md.

**NEW** Ford rear springs \$5. 1916 Ford engine \$100. Other 4 cylinder engines from \$50 to \$100. Parts for 100 models of autos. Auto Salvage Parts Co., 1436 Wabash Ave., Chicago, Ill.

**UNUSUAL** Bargains in Automobile Repair Parts. Axles, Bearings, Carburetors, Complete Engines, Cylinders, Differentials, Magnets, Pistons, Radiators, Springs, Valves, Wheels and other parts for Buick, Cadillac, Chalmers, Interstate, Maxwell, Mitchell, Moon, Overland, Packard, Peerless, Regal, Studebaker, Thomas and other cars at a fraction of factory cost. Maxwell Bros., 2931 Olive Street, St. Louis, Mo.

**AUTO** Top Roof and Back Curtain Roadster, \$6.95; touring, \$8.95. Parcel post paid. Our instructions make it easy to apply. You save \$7. Samples and catalogue free. S. H. Top Co., 439 Hunt, Cincinnati, Ohio.

**MOTORS,** magnets, coils, carburetors, radiators, axles, transmissions, etc., cheap. Radger Motor Co., Milwaukee, Wis.

**TEN** Dollar Service: 12 Cents. Wm. C. Keim, Los Angeles, writes: "My motor was badly carbonized. Started to have it cleaned for ten dollars. 12c worth of Gids did the work. Am still on my first Dollar Can. As mileage is now going, I will get with 'Gids' 1,000 miles more on the same amount of gasoline." \$1 can treats 100 gallons. Postpaid. No samples. Agents wanted, quick seller. Fred M. Giddings, Manufacturer, (Dept. M2), Galesburg, Ill.

**TIRES**—Double Tread Guaranteed for 3,500 miles. Absolutely Puncture-Proof. Big—Strong—Extra, heavy 30x3 tire, \$5.00; 30x3 1/2, \$6.00; 33x4, \$9.00; 34x4, \$9.25; 36x4 1/2, \$12.00; 37x5, \$13.00. Big saving on other sizes and tubes also. Trade in your old tires. Discount to dealers. 10% deposit required on C. O. D. orders. Send for list now! State size and brand of tire. Max Leben & Co., 205B West 48th Street, New York.

1916 4-CYLINDER Detroit power plant complete, \$95. Gregory Fay, 1044 Bellerue Ave., Syracuse, N. Y.

**AUTOMOBILIST:** Have you tried "The J. M. Pease Lubricant Carbon Remover"? Less gas; smooth running; money-back guarantee. Price \$1.00 per can. Send five cents for Free Trial Sample to cover cost of mailing. Shannon Sales Co., 205 East 96th Street, New York City.

**AUTOMOBILE** Repair yours and keep bright, small expense. Write Weyburn Sales, 701 Association Bldg., Chicago.

**ONE** Car Owner in every locality can buy 6,000 MILE guaranteed hand-made American tires at factory cost for advertising purposes. Investigate. Dept. A, American Rubber Corporation, 1974 Broadway, New York.

**AUTOMOBILISTS** by thousands endorse "Air-Cure" self-vulcanizing patch. Send 25c for regular 50c outfit. Wild Mfg. Co., 1307 Nicollet, Minneapolis, Minn.

"**FLOSSY**" Personal Invention for Chauffeurs. See our advertisement, Page 166.

**AUTOMOBILE** Repairing Made Easy—The most needed and useful book on automobiles ever written. Only book of its kind—just out. Covers every phase of automobile repairing practice. 1,056 pages (5 1/2 x 8 in.), 1,000 engravings. Cloth. Price \$3.00 postpaid. Send for complete description of this and other reliable automobile books. Popular Mechanics Book Dept., 6 N. Michigan Ave., Chicago.

**AUTO** Engines: 4 cylinder—30 H. P., water cooled, \$35.00—6 cylinder, air cooled, \$60.00. Other sizes, low price. Bosch Magnets: 4 cylinder, \$29.00—6 cylinder, \$35.00. Write for list, Johnston, West End, Pittsburgh, Pa.

**GEARS** for all purposes; transmission gears, bevel-drive gears, sprockets, axles. Special machine work. Must have old parts or drawing. Turley Gear Plant, 1505 N. 16th St., St. Louis, Mo.

**VULCANIZER** for shop. Bargain. Vanderpool's, Springfield, Ohio.

**INSYDE** Tyres, inner armor for Automobile tires, double mileage and prevent punctures and blowouts. Quickly applied. Cost little. Demand tremendous. Profits unlimited. Details free. American Automobile Accessories Co., Dept. P2, Cincinnati, O.

## TO FORD OWNERS

**FORD** Rear Axle Trouble. Ekern's Drive Shaft Tube Supports will remedy your troubles. Send for catalogue and prices. Ekern Bros. Mfg. Co., Flandreau, S. D.

**WANTED**—Ford car owner in every county to demonstrate the all steel \$10 Ajax Ford Starter. \$39 to \$59 weekly. Write for territory to the Ajax Ford Starter Co., Keene, N. H.

**BE** our agent. Buy the Safety Ford Starter for \$4.50. Retail for \$15.00. Try one; write for particulars. Safety Ford Starter Corporation, Columbia Theatre Bldg., New York.

"**RED-I-KUT**" Speedster, see full description on page 184 this issue.

## FORD ACCESSORIES

**SPLENDID** up-to-date Roadster or Speed Body for Ford, Exceptional bargain. J. C. Edwards, Box 216, Aurora, Ill.



# FREE Complete \$15<sup>00</sup> Set of Drawing Instruments

**Y**ES, I will give you this complete set of drawing instruments absolutely free. They are regular working instruments—the kind I use myself and they do not cost you a cent.

And besides the instruments in an exquisite plushlined leather case, I will give you absolutely free a 20x25 inch drawing board, a 24 inch T square, a 12 inch rule, a supply of drawing paper, two triangles and a French curve, pencils, erasers, thumb tacks, etc., etc. A complete draftsman's working outfit. And I give it to the men who get my personal instruction absolutely free.



## Be a Draftsman!

**Draw \$125 to \$175 per Month**

There is an urgent demand for skilled draftsmen. Companies are issuing calls every day for men to fill positions paying from \$125.00 to \$175.00 per month. Work is light, pleasant and profitable.

## Chief Draftsman Will Instruct You Personally

I am Chief Draftsman of a large and well known firm. I have been doing the highest paying expert drafting work for a quarter of a century and I know just the kind of training that is demanded from men who get the big salaries. I will give you personal instruction, deal individually with you and give you up-to-date, practical working plans just as your ability and advancement require. I train you by giving you actual work—practical work, the kind that you must be able to do in order to hold permanent, big paying positions. I give you my individual instruction. If your work is right, I will advance you rapidly. If it is wrong, I will show you where, and make you do it right, and do all I can to make you an expert draftsman and designer in a short time.

**Write Today Without Fail**  
**Pay as You Wish!** What I want is the RIGHT KIND of men. Don't bother about expense. I will give you the working outfit free if you get in at once. I charge a very small fee for training you to be an experienced draftsman. You can pay the small cost as suits you best. My object is to develop experienced draftsmen.



**Chief Draftsman Dobe**  
Engineer's Equipment Co.  
Div. 1192 Chicago, Ill.

Without any obligation on me whatsoever, please mail your book "Successful Draftsmanship" and full particulars of your liberal "Personal Instruction" offer to a few students. It is understood that I am obligated in no way whatever.

## Send the Coupon for My Big New Book

Put your name and address on the free coupon or a letter or a post card and send it to me today. I will send you absolutely free and postpaid my new book "Successful Draftsmanship," and the great special offer that I am now making on which you get the \$15.00 Draftsman's Working Outfit absolutely free. You assume no obligations of any kind in sending in the coupon. Get in line now for a big paying position. Getting the book and full particulars of the special offer is the first step. Write today—now.

**Chief Draftsman Dobe**  
Engineer's Equipment Co., Inc., Div. 1192, CHICAGO, ILL.

NAME.....

ADDRESS.....



## MOTORCYCLES, BICYCLES &amp; SUPPLIES

1917 EXCELSIOR, 16 Horsepower, electrically equipped, demonstrator, practically new, high-grade equipment, \$115. 1916 Harley-Davidson, 16 Horsepower, High-grade equipment, perfect running. Snap, \$135. 1916 Indian Powerplus, 16 Horsepower, Electric, highly equipped, demonstrator, like new, \$110. 1914 Indian, 8 Horsepower, high-priced equipment, enamel motor, like new, bargain, \$65. Henderson Four-Cylinder Short-Coupled. Expensive equipment, ridden two thousand miles. Act quickly, \$98. Other excellent serviceable motorcycles, equipped, \$25. Accessories sacrificed. Any goods not satisfactory will be exchanged or money refunded. Largest motorcycle establishment in United States. Large Inventory Bulletin with cuts and prices just out. Write! W. E. Wanderssee Company, Main Store, 129 Gratiot Ave.; Branches, 1561-63 and 2098 Woodward Ave., Detroit, Mich.

VALUES Extraordinary! Cooled herewith are five real, simon-pure bargains. Not specially selected, but samples of many, many more we have (just now) on hand. Re-hauled, in splendid condition, thoroughly equipped and sold on our personal guarantee of money refunded if not as represented and satisfactory in every respect. Read carefully. 1913 Indian, 7 H. P., magneto, \$90; 1915 Indian, 7 H. P., 2 speed, \$135; 1915 Harley-Davidson, 9 H. P., \$135; 1914 Eagle, 9 H. P., like new, \$140; 1916 Powerplus Indian, Elec., \$225. Full details on request. Bank reference, Hyde Park National, Crout Motor Co., 791 River St., Mattapan, Mass.

DON'T buy a Bicycle Motor Attachment until you get our catalogue and prices. Shaw Mfg. Co., Dept. 27, Galesburg, Kansas.

BIG bargains in second-hand motorcycles, \$25 up. Indians, Harleys, Thors, Excelsiors and Mercks. Write for description. Howard A. French & Co., Baltimore, Md.

MOTORCYCLE Bargains. Single and Twins. Hendersons, Harleys, Indians, Excelsiors, Kultures, Emblems, Thors, Pops. All makes guaranteed. A-1 Shape, tuned up ready to ride. \$25 to \$100. Motorcycle tires, \$3. Lamps, \$5. Automobile tires, \$3. Bicycles, \$5. Tandems, \$20. Bicycle tires, \$1. Bicycles and motorcycles at Factory Prices. Old motorcycles taken in trade. Highest prices allowed for them. Swap in yours. Designer, the Price Cutter, Rochester, N. Y. Send for Catalog. Free.

USED motorcycles on easy payments. Stroganoff Co., Schenectady, N. Y.

FOR Sale—Harley-Davidson motorcycle, 1913 model, twin cylinder. All equipped, good condition. Cheap for cash, \$125. Clint Patterson, R. 3, Elkader, Ia.

1915 TWIN Harley. Good condition. \$150. Geo. Buman, Harlan, Iowa.

OVERSTOCKED—300 Used and rebuilt motorcycles, Harley-Davidsons, Indians, Excelsiors, Thors, etc. Must be sold at once. Write for our latest catalog. Easy terms. Myerow Bros., 149 Berkeley St., Boston, Mass.

MOTORCYCLISTS by thousands endorse "Air-Care" self-vulcanizing patch. Send 15c for regular 25c outfit. Wild Mfg. Co., 1307 Nicollet, Minneapolis, Minn.

1915 "HARLEY" and side car, \$375; \$175. Earl Collier, Shreveville, Mo.

GREATEST Clearance Sale of used motorcycles ever held. Look at these: 1913 Indian Twin, \$75; 1914 Yale Twin, \$50; 1913 Indian single, nearly new, \$45; 1913 2-speed Thor twin, \$75; 1914 R-8 twin, \$69.50; Excelsior single, fine shape, \$30. Hundred others, all guaranteed. Big new list just off the press, free for the asking. Buy now! Buy here! Western Supplies Company, 26 Hayutin Bldg., Denver, Colo.

A REAL bargain in second-hand motorcycles. We have an overstock of all makes, such as Indians, Harley-Davidsons, Excelsiors, Pops, Mercks, and 4-cylinder Hendersons. All are in A-1 condition and fully equipped. If interested in buying a motorcycle write for our Bargain Bulletin No. 5 giving description and prices from \$35 up. Gotham Sporting Goods Co., 57 Warren St., New York City.

WRITE for list of bargains on used motorcycles. Little Falls Motorcycle Co., Little Falls, N. Y.

MOTORCYCLES—\$25. If you want a high grade New or Used Motorcycle and have \$25 Cash, write quick for Bulletin "K"; lowest prices, easiest terms. Peerless Motorcycle Co., Boston, Mass.

BARGAINS in second-hand motorcycles. Harley-Davidson and Indian in two and three speed models, electrically equipped. All machines guaranteed to be in A-1 condition. If interested, write for our list which gives complete description of each machine and price from \$35.00 up. Harley-Davidson Sales Company, 1616 Third Ave., Birmingham, Ala.

I SAVE you half on parts and accessories for all makes. Jones, "The Parts Man," Box 702, Brockton, Mass.

THIRTY Uses. Motorcycles—Must be sold at once. Biggest bargains ever offered. Write for list. Seaber & Hoffelms, Buffalo, N. Y.

USED and rebuilt motorcycles—all makes. Yales \$50.00 up; Harley Davidsons \$35.00 up; Indians \$25.00 up; Reading-Standards \$25.00 up. Get our Bulletin No. 2. W. J. Walker, 178-182 Columbus Ave., Boston, Mass.

EASY terms on new and rebuilt motorcycles, side cars, tandems and lighting outfit. Motorcycle Investment Company, 802 Center St., Brockton, Mass.

THOR single for sale \$30. Ames, R. 2, Willimantic, Conn.

NEW 1917 Big-Valve Excelsior Bacer, \$165. 1914 9hp. Thor \$45. 9hp. Deluxe, \$45. Box 1689, Atlanta, Ga.

BARGAINS in used motorcycles. Photo. R. H. Sunderlin, Goldfield, Colorado.

1917 EAGLE motorcycle now ready. Get Circular M2, and agency proposition. Eagle Motorcycle Company, Brockton, Mass.

MOTORCYCLES. 1914 Merkel Side-Car, \$25; 1912 M. & M. Single, reground, new reciprocating parts, clutch, battery ignition, \$40; 1912 R-S. Single, reground, new reciprocating parts, clutch, battery ignition, \$40; 1912 M. & M. Single, Schebler carburetor, clutch, belt drive, battery ignition, \$25; 1913 Twin H-D., lights, foot boards, \$85; 1911 Single H-D., magneto ignition, Schebler carburetor, \$35; 1912 Twin Excelsior, belt, electric lights, \$40; 1913 Twin H-D., lights, tandem, speedometer, \$100; 1913 Twin Indian, lights, foot boards, \$75; 1915 Twin Indian, three speed, electric lights, speedometer, \$135; 1912 Single H-D., belt, magneto, clutch, \$40; 1917 Twin Excelsior, side-car, electric lights, speedometer, \$250; 1914 Twin two-speed Merkel, side-car, lights, speedometer, \$110; 1911 Single H-D., belt, battery, \$25. Numerous 1915-1916 H-D. outfits with and without side-cars. Write for circular of 200 used motorcycles and side-cars not listed here. We furnish folder of satisfied customers from Alaska, Canada, and all parts of the States as reference. The Place of Satisfaction, Mueller Cycle & Supply Co., Largest and Oldest Dealers in the Northwest, 726-730 National Ave., Milwaukee, Wis.

LARGE stock of rebuilt motorcycles, new parts for all makes 25% discount; second-hand parts, good as new, 50% discount. Motorcycle Parts Mfg. Co., 2127 Michigan Ave., Chicago.

BIG bargains in good motorcycles we have taken in exchange on new ones. Send for special bargain list. Shaw Mfg. Co., Galesburg, Kansas.

NEW Motorcycle Book—Just Published—Motorcycles, Side Cars and Cyclecars, Their Construction, Management and Repair—550 pages, cloth, 350 illustrations. The Dealer, Mechanic and Rider will find this treatise a work of reference without an equal. Price \$1.50 postpaid. Popular Mechanics Book Dept., 6 N. Michigan Ave., Chicago.

MOTORCYCLE cylinders reground, fitted with new piston and rings, \$5.00, guaranteed. Muncie Piston Co., Muncie, Ind.

WANT to sell your motorcycle? I have a method which has sold many. Write me today for free information. F. W. Johnson, Room 900, 78 E. Madison St., Chicago.

WANTED: We pay cash for used motorcycles or take them in on exchange for new machines. Write with complete description. State condition of tires, frame, motor, make and model. Shaw Manufacturing Co., Dept. 157, Galesburg, Kans.

## WELDING

ONYACETYLENE Welding Equipments and Acetylene Generators. Hamilton Welding & Mfg. Co., Hamilton, Ohio.

WELDING Plants for All Purposes. Small Cash Payment. Balance to Suit. Bermo Co., Omaha, Neb.

WELDING Accessories and Supplies. Cutting Torches, Welding Torches, Acetylene Reducing Valves, Oxygen Regulators, Cast Iron Welding Rods, Aluminum Welding Rods, Phosphor Bronze Rods, Manganese Bronze Rods, Naval Bronze Rods, Tobin Bronze Rods, Norway Welding Wire, Swedish Welding Wire, Silver Welding Wire, Silver Solder Wire, Spelter Solder Wire, Copper Welding Wire, Brass Welding Wire, Brass Spelter Solder, Silver Solder, Aluminum Solder, Aluminum Flux, Brazing Flux, Cast Iron Flux, Graphite Plates and Sticks, Gloves, Goggles, Rubber Tubing, Asbestos Cloth and Paper. Satisfaction assured. Wm. Crowell Co., Van Horn Street and Central Railroad, Jersey City, N. J.

WELDING—Automobile Welding with the Oxy-Acetylene Flame—Just Out—167 pages, fully illustrated. Price \$1.00 postpaid. Explains the actual welding of all automobile parts in a manner understandable by everyone. Popular Mechanics Book Dept., 6 N. Michigan Ave., Chicago.

DAY'S Welding Solder. For scored cylinder, aluminum, potmetal, and all metals. Write for circular. Sample bar, 50c or \$1.50 per pound. Bellingham Solder Co., Bellingham, Wash.

A BIG guarantee. Trial bar with full directions, 50c. Don't scrap aluminum parts. Save them with So-Luminum, new, great welding compound, 3/4 time and cost of acetylene. No flux—use gasoline torch. Booklet 1, So-Luminum Mfg. Co., 1790 Broadway, New York.

OXY-ACETYLENE Welding and Cutting. Electric and Thermit Welding. Brand new book of practical instruction in this process. The workman will find all necessary information for handling any kind of welding. 215 pages, fully illus. Cloth, \$1.00; Leather, \$1.50 postpaid. Popular Mechanics Book Dept., 6 N. Michigan Ave., Chicago.

SIMPLE Soldering, both hard and soft—82-page book telling how to join metals. Do your own repairing. 52 illustrations. 25c postpaid. Popular Mechanics Book Dept., 6 N. Michigan Ave., Chicago.

## AERONAUTICS

PROPELLERS—I manufacture standard aeroplane propellers for professional and practice work. Laminated of best selected material, true to pitch, etc. Performance assured. Sizes up to 6 ft. diameter, \$1.50. \$2.00 for each additional foot length. These are professionals. The practice type run \$5.00 less account size. A thoroughly practical propeller, but not so highly finished. Copper sheathed for hydro work, \$5.00 extra. Hubs are plain bored if ordered. If interested write for information. The Crawford Motor & Aeroplane Mfg. Co., Pittsburgh, Pa.

MODEL Aeroplanes—materials, supplies. Motor-driven Scout Monoplane. Submarine diving boat. Send 5c for catalogue. Wading River Mfg. Co., 313 Sumpter St., Brooklyn, N. Y.

1916 ROBERTS Motor, new, 65 H. P., radiator, propeller, \$675. 50 H. P. Roberts, guaranteed, radiator, propeller, Solbrig, Aviator, Davenport, Iowa.

LEARN flying. Aero Club license guaranteed. Flying instruction given students daily and Sunday. Tractor Biplanes and Monoplane used. United Eastern Aeroplane Corporation, 1251 DeKalb Avenue, Brooklyn, N. Y.

ASK about our Home Study Engineering Course. Star Motors and Junior Tractors. Chicago Aero Works, Bonheur Bldg., Chicago.

AEROPLANE motor and propeller, 40 H. P. Write Petzlik, Horton, Kansas.

"LEARN to Fly" from men of long practical experience. Write Ecker School of Flying, Syracuse, N. Y.

HEATH Aerial Products and Supplies. Why are they the best and cheapest? It's the old story—quantity production. Aeronautical supply catalogue, 6 red stamps; propeller catalogue, 3 red stamps. Heath Aeroplane Co., formerly Heath Aerial Vehicle Co., Chicago.

WHY waste time and money building models? Why not build a full size machine? Cost small. Easy to build. Full size drawings and instructions for Tractor-Biplane, twenty-five dollars. Guaranteed correct or money returned. Elmira Aeroplane Co., Box 248, Elmira, New York.

GET our latest Aeroplane Book containing full information about "Ideal" Model Aeroplanes, parts, plans, etc. 5c postpaid. Ideal Aeroplane Co., 82 1/2 West Broadway, N. Y.



**AEROPLANE and Modelbuilders!** Send 5 cents for 1917 Catalogue, describing new models and supplies. Morane, Curtiss, Taube, U. S. Hydro, 3 ft. Scale models flying 300 feet, complete blueprints and instructions, 25 cents each—working drawings of every standard full size machine kept in stock, \$1.00 each. State your needs. International Aeroplane Supply Co., 142½ Cooper St., Brooklyn, N. Y.

**WRECKED motor or aeroplane wanted.** Glenn L. Dewey, R. No. 4, Mansfield, Pa. 8' MAHOAGANY "Paragon" propeller, never used, \$15.00; cost \$35.00. Christian Weyand, 48 Dodge St., Buffalo, N. Y.

**AEROPLANE supplies, propellers, plans, fittings, etc.** Illustrated catalog eight cents postpaid. Chicago Aeronautical Supply Co., Chicago.

**PATENTS Wanted in Aeronautics—U. S. Government spending millions in this class for Army and Navy.** Our Aeronautic Department will give full information on this subject upon inquiry. Write for "What to Invent," sent free. Victor J. Evans & Co., 163 Ninth, Washington, D. C.

**AVIATION Motors, all makes, up to 150 H.P., \$250 up.** Complete aeroplanes, all types, \$500 up. State your needs. Aero Exchange, 38 Park Row, N. Y. C.

**BUILDING and Flying an Aeroplane—160-page handbook covering the building of small models and full-sized gliders and machines.** In both biplane and monoplane models the well-known Curtiss and Bleriot types are followed. Fully illustrated with detail drawings. Price, \$1 postpaid. Popular Mechanics Book Dept., 6 N. Michigan Ave., Chicago.

#### BOOKS AND PERIODICALS

**TECHNICAL Books at Cut Prices—Model T Ford Car, 300 pages, 85c; Modern Gasoline Automobile, 806 pages, \$1.95; Automobile Repairing Made Easy, 1,054 pages, 1,600 illustrations, \$2.40; Automobile Starting, Lighting, Ignition Systems, 508 pages, 295 engravings, \$1.20; Automobile Questions, Answers, 638 pages, \$1.25; Author, Victor W. Page, Automobile Charts, "Page," five for 90c; Henley's 20th Century Recipes, Formulas, Processes, \$2.40; Self Taught Mechanical Drawing and Elementary Machine Design, 339 pages, 215 engravings, \$1.65; Gas, Gasoline and Oil Engines, "Hiscox," 630 pages, 435 engravings, \$1.95; Practical Pattern Making, 350 pages, 170 illustrations, \$1.65; Wireless Telegraphy, Telegraphy Simply Explained, "Morgan," 154 pages, 85c; Practical Electricity, "Sloane," 768 pages, 610 engravings, \$1.95; Arithmetic of Electricity, "Sloane," 160 pages, \$1.95; Hydraulic Engineering, "Hiscox," 326 pages, \$2.95; Locomotive Break-downs and Remedies, 294 pages, "Bowler," 85c; Modern Machine Shop Construction, Equipment, Management, "Perrigo," 460 pages, 225 engravings, \$3.95. Quick shipment; circulars, 4c stamps. McCarthy, 1236 Arhur Avenue, Chicago, Ill.**

**MAGAZINES at rock bottom prices.** Send today for our free catalog. Agents wanted. S. C. Hansen Magazine Agency, 4926 Kinzie St., Chicago.

**ENGINEERS' questions and answers for license by Hobson, for twenty-five cents, postpaid.** Send stamps. Reilly's Book Store, Philadelphia, Pa.

**PERPETUAL Motion.** Old, honored mechanical problem. All about it. History, explanation, prophecy. Descriptive literature with beautiful cuts. Free. Enlightenment Specialty Co., 411 Olive St., St. Louis, Mo.

**THE Smallest Bible on Earth.** Size of postage stamp, 10c. F. & S. Co., 1317 Spraight, Madison, Wis.

**BOYS—Big 9x12 boy's magazine one year 10c. Canada, 20c.** Dandy stories, mechanics, stamps, electricity. Country Boy Magazine, 2314 Mailers Bldg., Chicago.

**CORRECT English Magazine, ten cents.** Correct English Publicity Dept., Evanston, Ill.

**SOMETHING New in Mathematics—Comparative Cancellation Calculator.** Solves all Arithmetical and Geometrical problems in one simple operation. Large Saving of Figures, 145 pages, \$1.00 postpaid. Refunded if dissatisfied. Herrick & Horton, Publishers, Princeton, Illinois.

**ROPE splicing, knots, hitches; 100 illustrations, 20c.** G. Brady, 764 Jackson, Chicago.

**FORD Joke Book, 48 pages illustrated, 10c.** Agents wanted. Richard Lavery, Asbury Park, New Jersey.

**CASH for Complete Advertising Course.** Write Box 302, St. Louis, Mo.

**THE Herb Doctor.** Contains a rare collection of valuable formulas for man, woman and child. Tells how to make and where to buy Nature's pure medicines, 25 cents, postpaid. H. Petersdorf, Muscatine, Ia.

**U. S. ARMY—Infantry Drill Regulations, including Manual of the Bayonet; illustrated, 246 pages, 50 cents silver.** C. Bubb, Detroit.

**30 DIFFERENT Magazines, value \$3.00.** All late issues. Yours for 35c. Eastern Bureau, New Egypt, N. J.

**BOOK, How to Dress Becomingly in Style for Less Money, 25c.** Nonpareil Press, Erie, Pa.

**REESE Publishing House, Mt. Pleasant, Pa., can supply any book published.** Catalogs free.

**BINDER for Popular Mechanics magazines.** Best adjustable magazine binder on the market made especially to hold any number from one to six copies of this magazine with name "Popular Mechanics" in gold letters on front cover. No laces or cutting or perforating of pages necessary. Simple, unique adjustment; handsome, durable and neat. We buy in quantities and can offer our readers this regular \$1.50 binder for \$1.25, all shipping charges prepaid. Address Popular Mechanics Book Dept., 6 N. Michigan Avenue, Chicago.

**USED Books, Bargains, Catalog.** Higen's, A-2411 Pugt, San Francisco, (Books bought.)

#### EDUCATIONAL AND INSTRUCTION

**SPLENDID chance to become drugless physician.** Wanted: Strong, healthy young men and women to work in our Institutions on the "Exchange Plan." Three year courses in all branches of natural healing. We give room, board, wages, and full tuition in our college in exchange for services. High School Certificate required. Write for particulars. Lindlahr Nature Cure Institute, Inc., 525 So. Ashland Blvd., Chicago, Ill.

**CARTOONISTS—Applause-getting, turn-over, trick drawings.** Evolutions, caricatures, scenes, laughable stunts. Samples. Chalk Talk Magazine, Elmcrest, Nebraska.

**BOOKKEEPING, Expert Auditing, Rapid Arithmetic, 50c.** Garfield Commercial School, 1916 Germantown Ave., Philadelphia.

**SHORTHAND in 5 lessons; complete, \$1.00; accurate, rapid, reliable; no rules, lines or shading; author 10 years official stenographer of Harvard University; method copyrighted, H. McKinley, 708 Buckingham Place, Chicago.**

**PRACTICAL, Thorough Courses in Mechanical Drafting, also Map Drafting and Lettering.** Unique method. Big demand; high salaries. Columbia School of Drafting, McLaughlin Building, Washington.

**EXPERT Assaying done.** Students wanted. E. W. Meyer, Niles, Calif.

**STUDY Public health, sanitation, bacteriology, chemistry, pharmacy, optics.** Much work may be done at home. Positions pay \$1,500 to \$5,000. Illinois Medical College, Box 7, 3741 Cottage Grove Ave., Chicago, Ill.

**TOUCH typewriting simplified.** Write to C. B. Livingston, Elkhorn, Wis.

**AUTO Engineering, Chauffeur's and Mechanic's Course.** Other courses: Steam and Gas engineering, Preparatory, Commercial, Stenography, Teachers' High School. Free Tuition to one student from each Post Office, also courses by mail. Write for catalogue. Address, University of Southern Minnesota, Dept. M., Austin, Minn.

**MOULDS, Models.** Simplified and inexpensive methods of reproducing works of art. Ornamental casting of novelties, statuary, garden fixtures in cement, Italian marble, etc. Free illustrations. Beaux Art Moulds Co., 436 Broadway, Brooklyn, N. Y.

**ARE you ambitious? You can earn good money in vaudeville.** Valuable information mailed free. London, 739 Crilly Bldg., Chicago.

**PERSONAL Instructions in show-card writing by experienced man, short course, original methods, results guaranteed.** C. L. McKie, Dept. M, Ypsilanti, Mich.

**BOOKLET "For Better Job and Higher Pay"** free. Foundation Drawing Course, Washington, N. J.

**BIG Income Writing Advertising.** Complete Course 18 lessons only \$1.00. Worth \$10.00. Educational Bureau, New Egypt, N. J.

**FINGER Print Instructor—A text book for the guidance of finger print experts and an instructor for persons interested in the study of finger prints.** Book based on the Henry System and prepared by an expert. Cloth, 155 pages, illus-rated. Price, \$2.00 postpaid. Popular Mechanics Book Dept., 6 N. Michigan Ave., Chicago.

**SHORTHAND—International Unigraph is the most rapid readable system and most quickly learned.** Send for particulars. Unigraph School, CB271, Princeton, N. J.

**WANTED—New Ideas.** Write for list of Patent Buyers and Inventions Wanted. \$1,000,000 in prizes offered for inventions. Our Four Books sent free upon request. Victor J. Evans & Co., 167 Ninth, Washington, D. C.

**IDEAL Atlas—Just Published—Contains large scale maps, yet is a book of handy size.** Has special maps of all war zones in addition to all regular maps found in a good atlas. Is self-revising, that is, contains a certificate entitling the purchaser to a supplement of new maps after the war is over. Genuine flexible leather binding, 512 pages, 256 pages of maps, 256 pages of text. Price \$1.65 postpaid. Popular Mechanics Book Dept., 6 N. Michigan Ave., Chicago.

**WAR Atlas—Large 20-page (11x15 in.) Atlas of the War in Europe, containing large colored scale maps of the Battle-ground, showing Europe, Austria, Serbia, Germany, England, Belgium, France, Russia, Italy, Greece, the World, etc.** Special data showing comparison of armies and navies involved, pictures of rulers, etc. Price 30 cents postpaid. Popular Mechanics Book Dept., 6 N. Michigan Ave., Chicago.

**LEARN Drafting—One of the most practical subjects, and indispensable in many occupations.** Individual study at home without an instructor may be successfully carried on with the aid of our book, "A Practical Course in Mechanical Drafting," 160 pages, 157 drawings, Cloth, Price 50 cents postpaid. Popular Mechanics Book Dept., 6 N. Michigan Ave., Chicago.

**ARTIFICIAL MARBLE, sanitary flooring, complete instructions, \$1.** Ornamental casting, concrete, plaster, papiermache, decorations, garden furniture, statuary, rubber moulds, electrometallurgy. Particulars, 200 illustrations free. Mahler, D-721 Woodland Ave., Woodhaven, L. I., New York.

#### TRADE SCHOOLS

**COME to Seattle, the gateway to Alaska and the Orient.** Learn practical electrical and gas engineering, mechanical drawing, machine shop practice, automobile construction. Splendid openings for ambitious students when competent. Seattle Engineering School, Seattle, Washington.

**ELECTRICITY, Plumbing, Bricklaying, Mechanical, Architectural and other Drafting Courses.** Motion Picture Operating taught by practical work. Largest, best equipped practical trades school in America. Short time to learn. Small cost, easy payments. Write for big illustrated book; it's free. Coyne National Trade Schools, Dept. 8192, Chicago, Ill.

**BECOME Auto and Tractor Experts.** Practical work; no books; tools furnished; no special education required; free tractor, farm lighting and electric starter courses to all who enroll for auto course; free catalog. Lincoln Auto School, 3110 "O" St., Lincoln, Neb.

**AUTOMOBILE School—Learn in 6 weeks.** Thorough—Practical—Free catalog. National Automobile Training Association, 2814 No. 20th St., Omaha, Neb.

**HILES' Watchmaking and Engraving School, the largest and best-equipped school in the West.** 717 Market Street, San Francisco, Cal.

#### AGENCIES WANTED

**AGENCY wanted by factory representative, one or two additional lines.** Hardware specialties and Automobile accessories for California territory. F. E. McCourt, Commercial Bldg., 833 Market St., San Francisco, Calif.

**LET us represent you in Chicago.** Tell us your needs. Chicago Mfg's Agents, R. & G. Austin, 3224 W. Polk St., Chicago, Ill.

**MANUFACTURER wants agencies for a new milk-bottle cap and carrier.** Carney Novelty Co., 291 Division St., Pawtucket, R. I.



## TELEGRAPHY

**TELEGRAPHY**—Learn at home. Our semi-automatic teaching machine with correspondence course turns the trick. Write for particulars. Simplex Company, Station A, Jacksonville, Florida.

**PRACTICAL Railroad Telegraph School.** Circular free. 1034 Arch St., Philadelphia, Pa.

**TELEGRAPHY**—Morse and Wireless—also Station Agency taught. Graduates assisted. Cheap expense—easily learned. Largest school—established 42 years. Correspondence courses also. Catalog Free. Dodge's Institute, 15th St., Valparaiso, Ind.

**TELEGRAPHY**—Morse and Wireless—taught at home in half usual time. The Omnigraph Automatic Transmitter combined with sounder or buzzer sends you messages, any speed, just as expert operator would. Used by U. S. Gov't to examine all applicants for licenses. Trifling cost. Catalog free. Omnigraph Mfg. Co., 41-G Cortlandt St., New York.

## WIRELESS

**SEND for Bargain Wireless Bulletin 2.** Everything in Wireless. Our 3,500 meter power coupler receiving station is a wonder. Improved coupler enables closest tuning. Mounted on mahogany polished base with fixed condenser and crystal detector; size, 2 1/2x2 1/2. Special, \$2.99, with a copy of "Radio Stations of World" free. Tel-Radium Co., 32 Union Square, New York.

**I CAN save you money on any wireless apparatus.** Quotations free. Try me. L. B. Stratton, Oneida, N. Y.

**WIRELESS Set, How to Make**—96-page book telling how to construct at small cost an outfit suitable for transmitting four or five miles. Price, 50 cents, postpaid. Popular Mechanics Book Dept., 6 N. Michigan Ave., Chicago.

**MAKING Wireless Outfits**—Become a wireless constructor. This book tells how. 61 pages, 27 illustrations. 25c postpaid. Popular Mechanics Book Dept., 6 N. Michigan Ave., Chicago.

## PICTURES, POSTCARDS, PENNANTS

**RECEIVE scenic postcards by joining the Rose Postcard Society,** 631 East Morrison St., Portland, Oregon. Membership 10c.

**RECEIVE pretty postcards from everywhere.** Join best card club. Membership 10c. Jolly Card Exchange, Decatur, Indiana.

**MOVIE Stars!** 25 Post-card photos 25c. Charles Crane, Racine, Wisconsin.

**COLLEGE and State Pennants,** 9 1/2x26 inches. 15 assorted 50c; 6 assorted 25c. Postpaid. Hood-Lynch Co., Great Falls, Mont.

**PRETTY view cards from many cities, towns and countries.** Membership and 6 pretty cards, 10c. Riverside Club, Knoxville, Md.

**FUN, Pleasure, Amusement.** Membership, 10c. United Post Card Exchange, Phila.

**SIX beautiful post cards and trial membership in the Monarch Exchange,** 15c, 1383 E. 55th St., Cleveland, O.

**10 VIEWS of Hershey, Chocolate Town,** 10c. V. N. Gingrich, Hershey, Pa.

**6 COMICAL Post Cards on "Fords,"** 10c; Catalog Free. "Busy Bee," Rockland, Wisconsin.

**IF you really want to exchange postcards, try our splendid club.** Lists circulate in many countries. Membership, 10c. Halcyon Club, Box 133, Erie, Pa.

**CROSS-SECTIONAL view of ocean liner "Britannic,"** showing interior arrangement of ship in colors, size, 14x20 inches, on heavy plate paper for framing or hanging. Very interesting. Reproduced from front cover design of July, 1914, Popular Mechanics. Will be sent postpaid to any address in the world on receipt of 4 cents in stamps to cover packing and mailing. Popular Mechanics Magazine, 6 N. Michigan Ave., Chicago.

**200 ILLUSTRATIONS free, beautiful art casts.** Mahler, K-721 Woodland Ave., Woodhaven, L. I. New York.

**SEND photograph, will reproduce same on 25 Photograph Postcards for \$1.** J. Kerns, 419 Ditmars Ave., Long Island City, N. Y.

**BIGGER than ever, more names, stories, etc.** 1,000 names to select each issue. Enrollment 6,000; rapidly growing. Trial 10c. Elite Postcard Exchange, B-43, 3684 Milwaukee Ave., Chicago.

## CAMERAS AND PHOTO SUPPLIES

**FILMETTES.** Enlarged photographs from moving-picture film. Celebrities as they appear on screen. Beautiful hand-painted cut-outs, artistic dolls, full length pictures of film stars, unusual and original novelties; hand painted \$1.50, or if you wish to do painting, 50 cents. Small sample pictures, ten cents. Send us your moving picture film, positive or negative; will make enlarged photographs to your order. Filmettes, 5643 Santa Monica Blvd., Los Angeles, Calif.

**Do you take pictures?** Write for free sample of our big magazine, showing how to make better pictures and earn money. American Photography, 789 Pope Bldg., Boston, Mass.

**SATISFACTION guaranteed or money back** is Trilux Exposure Meter proposition. Tells instantly, accurately, and easily the correct time for all exposures, indoors and out. Nothing to break or lose, no confusing tables. At your dealers or postpaid, \$2.00. Trilux Co., 1401E Marquette Bldg., Chicago.

**EQUIP your camera or Kodak with a Wollensak lens and shutter and obtain the best possible results.** Beautiful descriptive catalogue "B" sent on request gratis. Wollensak Optical Co., Rochester, N. Y.

**GET my tanks, make big money developing films.** Cost 1/2c per roll. Particulars free. Gillett, Roscobel, Wis.

**DON'T Pay High Prices for Cameras!** We guarantee to save you 10% to 50% on any camera or lens. Trade the camera you don't want for the one you do. Our New Money-Saving Bargain Bulletin will open your eyes, show you real savings on anything needed for photography. 10 Days' Trial backs every purchase. Money back if you are not entirely satisfied. Camera users everywhere save big money buying at our low, direct-to-you prices. Send for Bargain Bulletin No. 10 Now. See for yourself the money you can save. David Stern Company, 1047M Madison St., Chicago, Ill.

**AMATEUR Photographers—buy Arico, a metal substitute.** \$3.00 lb., \$1.35 3/4 lb., postpaid. Wright Photo Supplies, Racine, Wis.

**CAMERAS**—Graflex, Kodaks; save 20 to 50 per cent on new and used Kodaks; trade in your old camera. Acme Camera Exchange, 94 Griswold, Detroit.

**PHOTOGRAPHIC enlargements equal to contact prints.** Send film and 10c for 1x11 or 8x10 sample. Myland, 2125 N. Front, Philadelphia.

**KODAK films developed, 7 cents each,** any size. Prints, three cents each, all sizes. 8 by 10 enlargements 25 cents. C. C. Smith, Tarrytown, N. Y.

**WE buy, sell and exchange—Microscopes, Telescopes, Binoculars, Cameras, etc.** Bargain List. Kahn & Son, 19 John St. New York. Established 1850.

**FILMS Developed, 10 cents; Prints, 3 to 5 cents.** Write for valuable information, and how to get a Free Enlargement. The Salsbery Studio, Cherokee, Iowa.

**PERFECTLY titled negatives assured.** New Magic process. 2c. Greenhalgh, 2961 Gale, Indianapolis.

**EMCUE Developer—Results Guaranteed;** Trial, 25c; Ounce, \$1. Ashton Photo Works, Ashton, Illinois.

**SPECIAL:** 6 Prints and enlargement made from film roll or negatives for 20c, to show our high quality work. Emil Sprauer, Hamilton, Ohio.

**FILMS developed, any size, 5c.** Any size prints, 3c. Work returned same day. Enlargements, 8x10, 25c. Eastman Kodaks and Supplies. Address Camera Shop, Box 69, Ann Arbor, Michigan.

**\$25 EASTMAN Postcard Kodak \$13.50.** Used equal to new Kodaks at a Price. Buy, sell, exchange. Write us. Camera Exchange, 621 Oliver St., Minneapolis, Minn.

**POCKET Photo Outfit.** Cute French novelty. Prepaid, 10 cents. Warfel, Photographer, Cadiz, Ohio.

**KODAK Finishers:** Closing out plant; bargains in Apparatus. Photo Shop, 3159 Indiana Avenue, Chicago.

**PRINTS, 2c, any size.** Rolls developed free. Nice work. Quick service. Ideal Photograph Co., Winston-Salem, N. C.

**YOU want good pictures—then use "Jon-pho Quality Developing Service."** Rolls developed 10c. Printing 2 1/4x3 1/4—3c; 2 1/4x4 1/4 and 3 1/4x4 1/4—4c; 3 1/4x5 1/4—5c; unmounted 8x10 enlargements, 25c. 100 postcards from any 4 negatives, \$2. Jones Photo Co., Jamaica Plain, Mass.

**ROLL Film developed, 10c a roll.** Packs 20c each; Prints, Brownies, 2c; 1a, 3x4, 3x5 and Post Cards, 3c each. Work returned next day. Postage paid. Kodak Film Finishing Co., 112 Merchants Station, St. Louis.

**INVENTIONS Wanted in Motion Pictures and Photography.** Special department for these classes of invention. Advice, What to Invent and List of Patent Buyers sent Free. Victor J. Evans & Co., 159 Ninth, Washington, D. C.

**BIG Money Saved on Photographic Lenses and Apparatus—goods exchanged; repairing done.** Ralph J. Golsen, 5123 Kenmore Ave., Chicago, Department F.

## MOTION PICTURES

**FOR Sale, Edison Home Kinetoscope with eight reels of film, \$30.** Victor Portable Stereopticon, \$29. Victor Portable Moving-Picture Projector, \$60. Above apparatus shop-worn only. Literature furnished. P. E. Slocum, 406 Main St., Peoria, Ill.

**LANTERN Slides, for all purposes; best grade of work, prices reasonable. Quick service.** United Print Co., 312 S. Hamilton Ave., Chicago.

**MOTION Picture Outfits Half Price.** Bargain Lists. National Equipment Company, Duluth, Minn.

**MAKE Big Money in moving-picture business.** We start you and furnish guaranteed outfit on easy payment plan. Easy to accomplish. Catalog free. Monarch Film Service, 228 Union Ave., Dept. P, Memphis, Tenn.

**PHOTOPLAYS in demand. Make extra money.** We show you how. Details free. Rex Publishers, Box 175, H-13, Chicago.

**POWERS 5 machine, Bargain, \$50.** Thacker, 2270 Lincoln Ave., Chicago.

**WRITE Moving Picture Plays; constant demand; big prices paid; past experience or literary ability unnecessary; details free.** Glace Co., 290 Whiteman St., Cincinnati, Ohio.

**MOTION picture film developed and printed, Film Titles; Cartoons; Film Expert Camera Men furnished.** Scenarios produced. All work guaranteed. Camera Bargains, Standard Motion Picture Co., Suite 1629, Malters Bldg., Chicago.

**FOR Sale—Late Model Edison Picture Machine complete for electricity or gas, also twenty reels film, \$150.00 for outfit.** Doc Graham, Colonial Hotel, Birmingham, Ala.

**WRITE for free catalog of best books on writing and selling photoplays, short stories, poems.** Atlas Publishing Co., 804, Cincinnati.

**BIG Profit Nightly—Moving Picture Business—small capital starts you, easily accomplished. Teach you—furnish everything.** Ralph J. Golsen, 5123 Kenmore Ave., Chicago, Dept. M.

**ARE You a Movie Type? Many of the greatest stars were discovered by accident.** You want to know if you have the natural qualifications that bring \$50,000 salaries. The book Motion Picture Acting tells you this, also 191 screen favorites show you how they register 490 human emotions. Use of cosmetics, costume requirements and color schemes also treated. Price leather \$1.10, cloth 75 cents postpaid. Popular Mechanics Book Dept., 6 N. Michigan Ave., Chicago.

**MOTION Picture Operation, Stage Electricity and Illusions—The only practical handbook and guide published for motion picture operators, theater electricians and managers.** A thoroughly practical and useful book, covering the subject comprehensively. Pocket size, leather, 393 pages, fully illustrated. Price \$2.00 postpaid. Popular Mechanics Book Dept., 6 N. Michigan Ave., Chicago.

**LIGHTING Arc and Battery Charging Generators sold on easy payments.** Hobarts, Box MF, Troy, Ohio.

**MAKE money writing Photo-plays; details free to beginners. No correspondence course.** Producers League, 239 Wainwright, St. Louis.

## MAIL-ORDER SUPPLIES

**100% PROFIT—Sample and plan, 10c.** Howell, Box 34 M. Newton, Ill.

**ART Photos of moving-picture stars; latest novelty, 10 samples 10c.** Ad. Smith, 2414 First Ave., Seattle.

**INCREASE your sales. Place your proposition before the readers of "Cartoons Magazine,"** 20,000 copies guaranteed every month. Classified rate 5c per word. Mail in a trial ad today. Cartoons Classified Dept., 78 E. Madison St., Chicago.

**SELL Joker's Novelties! 16 samples, 10c.** Chambers Works, Plainwell, Mich.



## BUSINESS OPPORTUNITIES

**TRAILERS**—The solution of the delivery problem for farmers, merchants and every business man with delivery work. We want one or two good men in each state—preferably men with Ford cars—to handle the well-known, advertised Matco trailers. Can be attached to Ford or any other car.  $\frac{1}{2}$  to  $1\frac{1}{2}$ -ton capacity. Every community a fertile field. Exceptional opportunity for extract or similar men covering good territory. Plenty of sales and big returns on each one. Write quick. Michigan Auto Trailer Co., 226 Twenty-first St., Detroit, Michigan.

**INDEPENDENCE** and fortune quickly attained in the Manufacturing Mail Order business. I furnish Formulas, Manufacturing Processes and Trade Secrets in all lines. Sold under positive guarantee; 18 years' practical experience. Revision and improvement of Formulas and Processes—reduction of manufacturing cost—utilization of waste materials, etc., a specialty. Booklet, Formula List, and Valuable Information Free. W. L. Cummings, Ph. D., 127 Standard St., Syracuse, N. Y.

**MANUFACTURERS**, Promoters and Patent Buyers are invited to write us stating the line of invention in which they are interested, as we can supply their wants in any class of patents. Victor J. Evans & Co., 142 Ninth St., Washington, D. C.

**WE Loan Money**—Making Books, Mail-Order Plans, Schemes, Instruction Courses and Formulas, selling from 25c to \$15.00. Fee, 2c weekly. Library Catalog Free. Business Library, 441 East 16th, New York.

**LEARN** the real estate business. Our complete instruction book teaches: listing, appraising, management, salesmanship, insurance, brokerage, advertising, renting agency forms, etc. 121 subjects. Excels \$20.00 correspondence course. Booklets cover, \$1.00; silk cloth, \$1.25 postpaid. Catalogue free. Realty Book Company, Dept. 29, Cleveland, Ohio.

**NEW Way to Paint Signs**—Our patterns do the work. No experience required. Complete outfit, prepaid, \$5.00. Satisfaction Guaranteed. Butts Advertising Co., 614 Gumbel Bldg., Kansas City, Mo.

**MONEY** made making and selling Bird Houses. Blue Prints for Making, 40c. C. S. Blue Print Co., 1209 Third Avenue, Detroit, Mich.

**AFTER** years of manufacturing, we now offer our Face Cream and Hand Lotion formulas to others who wish to make toilet goods, at home. Both formulas for 50 cents. Druggists Supply Co., 16601 Tacoma Ave., Cleveland, Ohio.

**PHOTOPLAYS** in demand. Make extra money. We show you how. Details free. Rex Publishers, Box 175, H-12, Chicago.

**"HIRE Yourself as Boss."** Big corporation will back you in a money-making mail-order business selling guaranteed, quick sale goods. Start at home or at your office in spare time. Very small investment will prove the selling plan a winner. No stock to carry, as we will ship direct to your customers if you wish. Handle everything by mail; no interference with your regular work. Experience unnecessary. My valuable instructions telling you just what to do and how to do it are free. Write for instructive booklet, "Foreful Facts." It's free. Wm. J. Dick, Mgr., Dept. P-10, 29 W. Lake, Chicago, Ill.

**NEW Worm-Driven Rotary Disc Valve Gasoline Motor.** Need capital to build simple motor—business manager to start corporation. Can be seen by appointment. Koster, 1121 Bedford Ave., Brooklyn, N. Y.

**CHEMICAL** analyses. Manufacturing problems solved. Research work. Submit your problem for free advice and estimate. Chemist, 30 Puntine Ave., Jamaica, New York.

**GOOD** monthly income easy in spare time manufacturing letters for signs. Free particulars. J. P. McPherson, 677 Brown Avenue, Butler, Penn.

**LARGE** hardware manufacturer desires to manufacture marketable articles, patented preferred. Must be meritorious and profitable. Not necessarily tools, yet must be confined to hardware line. State number and date of patent, cost and selling price, and give model or sketch. H. C., Room 909, 78 E. Madison St., Chicago.

**MAKE** and sell your own goods. I tell you how. 4 2c stamps for list. Duncan, Box 1655, Richmond, Va.

**WE** will start you in the cleaning and dyeing business; little capital needed, big profits. Write for booklet. Ben-Vonde System, Dept. C, Charlotte, N. C.

**WANTED**—Electrical, automobile or other clever specialties. Will buy business or goods outright. Immense sale assured. International organization. S. C., Room 920, 6 N. Michigan Ave., Chicago.

**SPLENDID** Mail Order novelty for sale, just patented, including over \$100 worth Tools, Dies, etc. Great opportunity. M. W. Smith, 112 Smith Street, Millville, N. J.

**DOLLARS** yearly in your backyard. No guessing, mushroom dope. New ideas. Investigate. Particulars free. C. Metz, 313 East 89, New York.

**A NEW Money Maker.** Will some one take General Agency for this New article? Cost 10 cents, sells for one Dollar. 20,000 sold in Minnesota. Send 10 cents for Dollar sample. The Chemist Co., 2341 No. Thomas, Minneapolis, Minn.

**MANUFACTURE** Latest High-Grade Automobile Specialties from my Guaranteed Reliable Formulas, with full Manufacturing Information of every Automobile Specialty sold, including wonderful Carbo-Cide, Automobile Fuel, Tablet Form, Fibro-Vac, Efficient Automatic Puncture Plugger, Greatest Possibilities—300 to 300% profit. Miller, Manufacturers' Chemist, Tampa, Florida.

**YOUNG Men**—We build our big organization from ranks. Lifetime business, big income before any live intelligent man in our company. We are establishing branches everywhere. We train you; start you right. \$1,500 to \$5,000 yearly, at home or elsewhere. No capital required, though possession of \$200 to \$500 gives better chance. Rogers, Thurman & Company, 55 East Madison St., Chicago.

**500 FORMULAS**, including Restoring Mirrors—Renewing Dry Batteries, Luminous Paint, 25c. Ideal Book Shop, B-2 Irving Station, Chicago.

**FOR** Sale, Cheap—Large, wealthy territory, near New York City, for best known auto. Established repair and accessory business. Wonderful field for hustler. Personal reasons. V. M., Room 910, 6 N. Michigan Ave., Chicago.

**IN** your spare time start a Collection Business. New System of collecting by mail. Wonderful results. Full details sent free on request. Capitol Rating Association, Dept. P, 56 East Randolph Street, Chicago.

**FOURTEEN** in this! If you think all advertised plans are impracticable or misrepresented, get mine and be undeceived! Business permanent and profitable. Easily worked during spare time; no canvassing. You can start with less than \$10. Plans with samples—25c. Circular free. Andrews, 215 Cornelia, Chicago.

**PATENTABLE** Ideas Wanted—Send for 3 free books. R. B. Owen, 30 Owen Bldg., Washington, D. C.

**FILM** Company establishing agencies throughout the United States. Offers unusual opportunities. Hudson Film Company, 1547 Broadway, New York.

**ANYBODY** can earn \$3 daily, raising mushrooms in cellars, sheds, barns. Success guaranteed. Free Booklet, Hiram Barton, 324 West 48th St., New York.

**LUMINOUS** Paint. Shines in the dark. Make and sell your own Luminous articles, watches, clocks, electric switch plates, crucifixes, etc. Visible at night. Only 25c sample bottle. Circular free. Luminous Paint Co., Dept. P, Douglas Park Sta., Chicago, Ill.

**NEW \$2.50** Automatic Adder, sells quick from demonstration. Big profits, no competition. Every business man buys. Bassett, 5921-C Indiana Ave., Chicago.

**START** in carpet or clothes cleaning business. We show you how. Only \$125.00 capital needed to earn good income. Thurman Vacuum Cleaner Co., Manufacturers all types cleaners, Dept. H, St. Louis.

**INVENT** Something. It may bring wealth. Free book tells what to invent and how to obtain a patent through our Credit System. Waters & Co., Succeeded by Talbert & Parker, 4102 Warder Bldg., Washington, D. C.

**GOOD** money easily earned at home, sparetime, silvering mirrors; No capital. Free instructive book tells how. Patterson & Co., Brooksville, Ky.

**SPARETIME** Money-makers. Unlimited possibilities. Little capital required. Complete set of formulas 10c. Particulars free. Chester Zell, Springfield, O.

**BECOME** a Playground Instructor. We train you by mail; small charge; thousands of positions; good salary; particulars free. National Playground Institute, 747 S. 16th, Newark, N. J.

**"BOOSTER"** may contain the money-making plans, formulas, ideas, suggestions and inspiration you need! Published since 1909. Send 10c for copy and make more money. Booster Magazine, Northwestern Bldg., Chicago.

**HUGE** Opportunity to make money, new simple ways. Blue Ribbon Scheme Book, Particulars free. Sheridan Company, 417 E. 151st St., New York.

**THE** New Mail Order Poultry Business earns Big Profits on Little Capital. Write National Poultrymen's League, 2121 Times Bldg., Chicago.

**OUR** advertisement under Agents Wanted will interest you. Read it. Marshall Dobbins & Co.

**\$500** to \$5,000 a year; splendid spare-time business; little capital required; full particulars—dime. C. Gilmore, Santa Barbara, Calif.

**YOUR** own boss this year. General agent to appoint sub-agents. New office specialty, 150% profit, \$5,000 to \$10,000 yearly. Small investment required. Write quick. Sales Manager, Tomahawk, Wisc.

**ENTER** a new business. Earn \$3,000 to \$6,000 yearly in professional fees making and fitting a foot specialty, openings everywhere, with all the trade you can attend to; easily learned by anyone at home in a few weeks, at small expense; no further capital required, no goods to buy, job hunting, soliciting or agency. Address Stephenson Laboratory, 11 Back Bay, Boston, Mass.

**CONDUCT** a profitable Candy Kitchen; very small capital required; booklet free. Kennon School, 509 Wells St., Dept. A, Chicago.

**LEARN** the "Practical" Advertising Business and become independent. I teach you how to establish yourself without capital, and furnish you original plans and methods to work upon; rare opportunities; booklet free. Dawson, Avenue 3, Stockton, California.

**BIG** money in promoting inventions. Write Adam Fisher Mfg. Co., 2601D Railway Exchange, St. Louis, Mo.

**MAIL** Order Dealers. Let the 4 in 1 coupon plan increase your profits. Sell valuable instruction systems by cut price coupon under money back guarantee. Big margin, small selling expense. Complete plan, sample coupons and bargain bulletin sent on request. Mail Dealers' Coupon System, 519 So. Dearborn St., Chicago.

**EARN** good money at home silvering French mirrors; no capital. Free instructive booklet. D. Mallin, 284 Pacific, Brooklyn, N. Y.

**INCORPORATE**—Congress laws for D. C. and all States; cheap, raise money easily, advice free. Collections and legal matters everywhere. All courts and Government Departments. U. S. Legal Corporation, Washington, D. C. Representing \$1,225,000.00.

**ADVERTISERS**, Mail Dealers. Our New Rate Book lists 2,900 Principal Publications, rates, circulation. Includes 30 Mail-Order Plans. Free. Dearborn Advertising Agency, 210 Franklin Bldg., Chicago.

**INVENTORS**: We develop and perfect inventions, make models, dies, tools. Metal stamping and special manufacturing. Gerding Bros., Lion Bldg., Cincinnati, O.

**WE** start you in business furnishing everything; men and women make handsome income weekly operating our "New System Specialty Candy Factories" home or small room anywhere; no canvassing. Opportunity lifetime; booklet free. W. Ragsdale Co., East Orange, N. J.

**LEARN** to collect money. Good income; quick results. Send for free booklet, "Skillful Collecting." Collectors' Association, Long Street, Newark, Ohio.

**START** Profitable Mail Order Book Publishing Business. Original, exclusive, dignified; big money, small capital. Easily operated. Unlimited possibilities. Efficiency Library, P98, New Egypt, N. J.

**MAIL** Order Business is your opportunity. Start as side line, the Bronner way, gradually earn good income. Business like dealings, common sense, honest help, exclusive plan to every client; proved successes. Send 25c for information worth a dollar; no free circulars. Bronner, 302 A, Walnut, Philadelphia.

**DURING** 1916 I made good income in my sparetime evenings, writing articles for trade papers. Good opportunity for anyone. No experience necessary. Particulars and list for 3 red stamps, Box 296, Ft. Collins, Colo.

**"FLOSSY"** New Invention for Everybody. See our advertisement, Page 168.



**CHEMICAL** Analysis taught in few lessons by mail. Practical, specific, clear cut instructions written in simple language which you understand. No hairsplitting theories. No previous knowledge required. Excellent opportunities. Durant Laboratories, Berkeley, Cal.

#### TO MANUFACTURERS

**WANTED** Party to Manufacture the only Sanitary Cuspidor made, which does away with the old system of cleaning by using Paper Fillers in a wire frame. A Fortune in this for the One Who Acts. Bott & Clemens, Box 861 Walla Walla, Wash.

**WANTED** contract or royalty manufacturers who can do drop-forging and machine work on pliers or pinchers. "Patented tool." Address J. W. Ferguson, Jacobs Creek, Pa.

**WANTED**—I want a good mail-order article. H. J. Bibler, Florence, Kansas.

**WE** are expert and successful distributors, with representatives in the principal cities of the country. You as a producer need our service. We can sell more of your goods at a greatly reduced cost. Nothing too large or too small to receive careful consideration. No charges for full information. International Service Corporation, 221 West Lake St., Chicago.

#### FOR ADVERTISERS

**INCREASE** your business. Advertise in 24 Metropolitan Newspapers. Cost \$10. Circulation nearly 3,000,000. Results big. Write for booklet "B." also our suggestions and analysis How to Increase Your Business. Guesenher-Bradford & Co., (Est. 1885), Advertising Agents, 64 W. Randolph St., Chicago.

**30 WORDS** in 100 monthlies \$1; 100 weekly \$3; 30 Sunday papers \$9; all \$12. Cope Agency, St. Louis.

**YOUR** ten-word adv. in our 9x12 magazine, reaching 50,000 boys, for 5c. Extra words, 5c. Country Boy Magazine, 2875 Mallers Bldg. Chicago.

**IT'S** Different—1c per word. United Post Card Magazine, Phila.

**20-WORD** advertisement in 120 monthly magazines for \$1. Continent Exchange, Hollywood, Calif.

**20-WORD** Ad. in over 100 monthlies, \$1.40. National Opportunity, Stratford, Wis.

**ADVERTISING** Pencils. Stamp brings sample. Graybill & Co., Lancaster, Pa.

**"TWENTY** words in ten big Sunday papers, \$2; extra words, 10c. Other snaps. Best lists—lowest rates. Stanford Agency, Canonsburg, Pa.

**ADVERTISERS**—Here's your opportunity. Your proposition placed before the readers of "Cartoons Magazine" for only 5c per word. Circulation 29,000 copies guaranteed. Send a trial ad for our next issue. Cartoons Classified Dept., 6 N. Michigan Ave., Chicago, Ill.

**YOUR** Thirty-Word Ad. in our big post-card magazine, 25c. Inch display, 50c. Elite Exchange, 3694 Milwaukee Ave., Chicago.

#### ART AND ADVERTISING SERVICE

**A** FORCEFUL, result-getting advertising service; sales letters, folders, booklets; mail-order campaigns. What are your needs? Satisfaction guaranteed. Harry Stern, 1660 Gaylord, Denver. (Tenth year.)

**ADVERTISING**—Copy Prepared—Expert Service. Brewton Business Builder, 46 S Street N. W., Dept. 25, Washington, D. C.

#### BUSINESS SERVICE

**TRANSLATING** from and into foreign languages. Homedes, 811 Corinthian Ave., Philadelphia.

**INCORPORATE.** Our lawyers do the work, saving you time, annoyance and money in incorporating under the most liberal laws of Arizona. Laws and forms free. Southwestern Securities & Investment Co., Box D488, Phoenix, Ariz.

#### BUSINESS FOR SALE

**FOR** Sale at Low Figure—Old established and paying, new and second-hand Machinery and Rental Business. (Incorporated.) Fine location. Plenty of business, can be greatly extended if desired. Present owner's time needed elsewhere. Present value about \$26,000. Address Box 296, Joplin, Mo.

#### AGENTS WANTED

**TAILORING** Agents Wanted—Big complete sample outfit and case, nearly 300 large cloth samples, 3 piece lists and everything needed for canvassing or use in store, free to live agents. \$25.00 to \$50.00 a week; may make more. Write us today for free elegant outfit to begin, cloth samples, wholesale prices, special offer on a suit for yourself and full information—see our wonderful values, beautiful fabrics and styles. Established 28 years. Every garment made to measure—everything guaranteed and express prepaid. Just send a postal. American Woolen Mills Co., Dept. 214, Chicago.

**INSIDE** Tyres, inner armor for Automobile tires, double mileage and prevent punctures and blowouts. Quickly applied. Cost little. Demand tremendous. Profits unlimited. Details free. American Automobile Accessories Co., Dept. P, Cincinnati, O.

**AGENTS**—Managers! Stop here! Sell the Perrin No-Glare for Auto Headlights. Takes out the "glare" without reducing driving light. Used on every machine. Low in price—sells like lightning. Makes night driving safe and easy. Passed and recommended by city and state police everywhere. Only practical auto-glare device. Put on without tools—never wears out. 200,000 in use. Listen: Davis, Texas, cleared \$81 one week. Wallace, Michigan, made \$14 first day. Big, quick profits and we guarantee sales. Write today for information. Perrin Mfg. Co., 975 Woodward Ave., Detroit, Michigan.

**100% PROFITS** easily made taking orders for our new patented Vacuum Sweeper. No travelling; experience unnecessary. Bailey made \$150 last week. Write quick. United Vacuum Sweeper Co., 1815 West Congress, Chicago.

**MEDALLIONS**—300% profits. Make up your own goods and be independent. Catalogue free. Resag Co., 1205 Randolph St., Chicago.

**AGENTS**—Our gold window letter proposition beats 'em all. Staibrite Co., Dept. P, 1115 Second Ave., N. Y. Established 1905.

**STOP** Here! Just out—Eisen Regulator for Ford Headlights. Selling like wild fire everywhere. Gives splendid driving light at low speed—keeps bulbs from burning out—works entirely automatically. Needed on every Ford. Big profits quick. Listen: Hopkins, Tenn., cleared \$16.20 first day; White, Michigan, \$134.00 one week. No experience or capital needed. We show you how; sales guaranteed. Hurry—don't delay. Write now for special information. Address Eisen Instrument Co., 354 Valentine Bldg., Toledo, Ohio.

**GOOD** income refinishing chandeliers, brass beds, automobiles, etc. By new method, producing amazing results. No capital or experience necessary. Particulars free. Gunmetal Co., Ave. G, Decatur, Ill.

**AGENTS** Wanted: Sell Polishing Cloths, Rust Remover, Food Flavors, etc. 130 household necessities, guaranteed line, big profits, quick repeater, permanent business. Stuart & Co., 16 Main St., Newark, N. Y.

**AGENTS** make \$100 monthly selling our 500 handy household articles. Catalogue free. Scheff Company, Deshaines, Ill.

**AGENTS**, sell reliable custom-made raincoats. Big commission. Complete sample line free. Temple Raincoat Co., Box 62, Templeton, Mass.

**"1916'S SENSATION!"** Eleven piece toilet article set selling like blazes at \$1.50 with \$1.00 carrying set free! Enormous profits! Tremendous hit! Engle made \$51.00 first week. Write quick! Pierce Co., Dept. P, 206 Lake St., Chicago.

**SOMETHING** new and different: Shure Shine for Automobiles, Furniture, etc. Fast seller. Enormous field. Exclusive territory to hustlers. For particulars and sample write Daydark Co., Desk 84, St. Louis, Mo.

**WANTED**—New Ideas. Write for list of Patent Buyers and Inventions Wanted. \$1,000,000 in prizes offered for inventions. Our Four Books sent free upon request. Victor J. Evans & Co., 165 Ninth, Washington, D. C.

**LARGE** Manufacturer wants representatives to sell shirts, underwear, hosiery, dresses, waists, skirts, direct to homes. Write for free samples. Madison Mills, 586 Broadway, New York City.

**AGENTS**, Either Sex, the greatest 25c proposition on earth. Send six two-cent stamps for sample, particulars. Ideal Specialty Co., Duluth, Minn.

**TAKE** orders for men's custom tailoring, part time or all time. We furnish samples and everything needed to make a success without experience. Low prices; fit guaranteed or money refunded. You make good money on every order. You can wear swell clothes for almost nothing. Write quick for samples and all information if you live in a town smaller than 5000 or on R. F. D. Knickerbocker Tailoring Co., Dept. 549, Chicago.

**AGENTS**—"Exclusive features" are what make easy sales—I can gain attention, close the sale and collect the money on six customers with the exclusive features of my non-alcohol flavoring extracts, while you are struggling with one customer on the old commonplace line of talk. So can you! Prove it! Write today—big summer sellers—extra summer profits. J. M. Pitkin Co., 626 B. St., Newark, New York.

**AGENTS**: Biggest moneymaker. "Treasure Support"—new invention. Guaranteed to please. M. & M. Mfg. Co., Greenville, Ohio.

**LARGE** Manufacturer wants agents to sell made-to-measure raincoats direct to customers; cheapest prices; outfit free. Standard Raincoat Co., 345 Broadway, New York.

**AGENTS**—Men and women Make \$30 to \$50 weekly selling the New Improved Mondor Self-Heating Iron—the "World's Best." Over 850,000 in use. Positively the easiest, fastest selling, lowest priced, best known iron made. Binding guarantee. Big profit for all or part time. Evans, N. Car., sold two dozen on Saturday. Mrs. Nixon, Vt., sold eight first half day. Liberal terms. Exclusive territory. Sample outfit free to workers. Write today. The Monitor Sash Iron Co., 826 Wayne St., Big Prairie, Ohio.

**AGENTS** to travel by automobile to introduce our 250 fast-selling, popular-priced household necessities. The greatest line on earth. Make \$10 a day. Complete outfit and automobile furnished to workers. Write today for exclusive territory. American Products Co., 9539 3rd St., Cincinnati, O.

**WANTED**—Agents—men or women in every town to sell high-grade Phonographs. Direct from factory; earn \$50 to \$200 per week. Northwestern Phonograph Works, 177 E. 44th St., Chicago.

**MEN, Women**, \$19.00 day taking orders for large, warm, flannel blankets, 60x70, at \$2.25 pair; your profit \$1.00 pair; gray, tan, white; beautiful colored borders; everybody needs blankets; biggest seller out; send \$2.25 for sample, sell shop friends and others; money refunded if not pleased. National Supply Company, Box 792, Richmond, Va.

**AGENTS**—\$42.00 weekly selling guaranteed article housewives cannot resist. C. E. Mever, Bellwood, Pa.

**AGENTS**, if \$1 an hour looks good, write N-I Mfg. Co., St. Louis, Mo.

**ARE** you tired of inside work? We need a man in your vicinity, permanently. Commission paid weekly. No delivering or collecting. "Leads" furnished. Write today. Dept. P, Brown Brothers Nurseries, Rochester, N. Y.

**SELL** first-class household necessity, Mohawk Specialty Co., Whitesboro St., Utica, N. Y.

**AGENTS**: Cooper made \$314 last month; \$91 last week, selling "Kantleak" Raincoats. New proposition. We deliver and collect. Sample cost free to workers. Corner Mfg. Co., 26 Paige St., Dayton, Ohio.

**AGENTS**, Either Sex: Sell our New Luminous Cross Picture. Whole or part time. Cross shines brilliantly in dark. Mysterious and impressive. Big profits. Sample prepaid 25c. Particulars free. Hyde Art Co., 4335 N. Ashland, Chicago.

**AGENTS**—Send for sample "Fretnot"—the wash day wonder. Be convinced you can do a whirlwind business. You can clear at least \$20 to \$100 weekly, according to spare or whole time. You don't have to talk; if she doesn't buy at sight, leave sample; she will be looking for you long before you are able to make the rounds again. Samples furnished free. Premiums for your customers. Exclusive territory granted to agents who can produce. Credit given. Don't call. P. M. Motter & Sons, 2215 Warren Ave., Chicago.

**WE** Pay \$80 Monthly Salary to those who qualify and furnish rig and expenses to introduce guaranteed poultry and stock powders. Bigler Company, X268, Springfield, Ill.



**AUTO Owners**—We want a few live motorists who drive their own cars to introduce International Half-Sole Tires in their territory. Greatest Tiro Cost reducer ever offered to the motoring public. Practically sells on sight. Our sales pumped 400% in ninety days. For details write the International Rubber Company, 21 W. Tennessee, Denver, Colo.

**LARGE Manufacturer** wants agents to earn good pay selling high-grade custom-made raincoats. Goods sell themselves. No experience nor capital necessary. Deliver to customer. Prices defy competition. Guarantee every sale. 1917 Outfit free. Amer-Europ. Raincoat Co., 175 E. Broadway, N. Y., Desk P.

**AGENTS** can make big money selling hosiery of exceptional quality at prices that cannot be secured elsewhere. Big repeater. Write Fisher Hosiery Co., 123 Sterling Place, Brooklyn, N. Y.

**MAIL Order Truths**—A 36-page exposition of the Business, sent free. It's an Eye-opener! Address, Mail Order Corporation, Newburgh, N. Y.

**TAILORING Agents**: Get our Spring and Summer Samples. Men's suits to order. Greatest line retailing at \$15.00. Only big producers wanted. Leeds Woolen Mills, Chicago, Ill.

**CAR Owner Agents Wanted**. Write for details about the Funnel-Vac Gas Saver and Carbon Eliminator. Get going before the Spring rush season. Big repeater. The Funnel-Vac Mfg. Co., Box 451, Denver, Colo.

**AGENTS**: 100 to 300% profit selling Duo Toilet Articles, Perfumes, Spices, Soaps, Family Medicines and Specialties. Big every-day sellers. Exclusive territory. Outfit free. All or spare time. Big chance. Full instructions. Write quick. Duo Factories, Dept. C, 58, North Java, N. Y.

**233% PROFIT** selling Jubilee Spark Intensifiers to automobile owners, garages. Sure cure for Spark Plug troubles. Sells like wildfire. Brand new. Exclusive territory. Write today. Jubilee Mfg. Co., Dept. M-3, Omaha, Nebraska.

**BIG Money Easy Selling Uni-Lites**. Agents can make \$50 to \$100 weekly in spare time. Equals 20 ordinary lamps or lanterns—300 candlepower. Used in house and outdoors. Get new free Uni-Lite offer. Acorn Brass Mfg. Co., 1155 Uni-Lite Building, Chicago.

**AGENTS**—\$5 daily selling our Handy Tool, 12 articles in one. Lightning seller. Sample free. Thomas Mfg. Company, 762 North St., Dayton, Ohio.

**AGENTS**: 300% profit. Wonderful little article. Sells like wildfire. Can be carried in pocket. Write at once for free sample. H. Mathews, 462 North St., Dayton, Ohio.

**PHOTO Pillow Tops, Portraits, Frames, Sheet Pictures, Photo Plates, Pennants, Subjects credited. Prompt shipments; samples and catalogues free to agents; 30-days' credit. Jas. C. Bailey Co., Desk C, Chicago.**

**AGENTS**—With selling experience to sell direct to consumer made-to-measure suits, \$12.50 and \$16.50; if you want independent business with big money, answer at once before territory is taken; outfits furnished free. Midland Tailoring Co., Dept. E-9, 19 S. 5th Ave., Chicago.

**BIG Textile Mills** want ambitious men and women everywhere to show latest dress fabrics, neckwear, hosiery, underwear, and sweaters. 400 styles. Easy sales. Values beat stores. Many making over \$30 weekly. All or spare time. Complete sample outfit starts you. Steadfast Mills, 30 Remsen St., Cohoes, N. Y.

**A MARVELOUS Selling Article!** Used in every home. Silver, the polish that actually rubs on Sterling Silver. Big profits. New selling plan. A good article to handle. Send 25c for sample outfit. F. Silvrn, 157 Cedar, New York.

**AGENTS** make 500% profit handling Auto Monograms and Initials, Changeable Signs, Novelty Signs, and Window Letters. Catalog Free. Hinton Co., 6142 46th Court, Chicago, Ill.

**WANTED**—Agents to sell our choice printed stationery. Visiting and address cards and commercial work. Send for outfit. Foreman Printery, Box 693P, Waterbury, Conn.

**COAL** is high—Our self making gas burner placed in cook stoves makes better, steadier heat and is cheaper. Agents coin money. U. S. Mfg. Co., Dept. P, Columbus, Ohio.

**CAN** you demonstrate the use of a merchant's commercial slide rule? Big commission. Richardson, 4202 24th Place, Chicago.

**AGENTS**. Get in touch with proposition paying \$5.00 daily. Experience unnecessary. People's Supply Co., Dept. "M," Lock Box 409, Pittsburgh, Pa.

**LADY** or gentleman in each town to represent reliable concern; permanent; no capital needed. Bohmer Sutter, 715 Rush St., Chicago.

**GASTINE** eliminates carbon, purifies gasoline, gives 30% more mileage. In tablet form. Use one tablet in each gallon of gasoline. 100 tablets \$1.00. Good agents wanted. Liberal commission. Gastine Company, Bridgeton, N. J.

**DEMONSTRATE** Demaco Gas Savers to auto owners. Big seller. Big profits. Results guaranteed. Refund to agents for price of Demonstrator. Write quick. Decatur Mfg. Co., Box 355, Decatur, Ill.

**AGENTS**—Self-threading needles; sell at sight; package and terms 10c. Clarence Maugans, Anderson, Ind.

**SELL** every woman's friend. "Handy" dish washer. Attaches to water faucet. 100% profit. Other specialties. Write Pangburn Specialty Co., Box 163, Dept. P, Scranton, Pa.

**SELLING** one dozen Cake Mixers per day; means \$7.50 daily. Sample and territory \$1.00, prepaid. Beck & Company, Sullivan, Wis.

**EVERYBODY** Needs Rubber Stamps. Make them yourself. Big profits. Quick, easy, simple process. Circulars free. Central Stamp Works, Newcastle, Indiana.

**AGENTS** wanted to sell "Air-Cure" self-vulcanizing patch for auto tires. Wild Mfg. Co., 1367 Nicolet, Minneapolis, Minn.

**AGENTS**—Here's the best line of food flavors, perfumes, soaps, toilet preparations, etc., ever offered. Complete outfits furnished free to workers. Write today for full particulars. E. M. Feltman, Sales Mgr., 9329 3rd St., Cincinnati, O.

**AGENTS**, to sell Photo Pillow Tops, Pennants, Crucifixes and all Luminous Goods. Photo Pillow Top Co., 2134 Gladys Ave., Chicago.

**SELLS** like hot cakes, brand new ironing wax, perfumes clothes; clamps to ironing board; has asbestos from rest. Working outfit 5c. Waxenrad, Lynbrook, N. Y.

**AGENTS** make 500 per cent profit selling our Auto Monograms and Initials, Window Sign Letters, Changeable Signs, and Show Cards. 1,000 Varieties, Enormous Demand. Sullivan Co., 1123 Van Buren St., Chicago, Ill.

**AGENTS**: You can make big money taking orders for our fine made-to-measure clothes, so write quick for 60 beautiful cloth samples. 32 smart styles in rich colors, wholesale and retail price lists, lowest prices and best offer to agents, \$5.00 to \$10.00 a day easy. Big outfit, over 250 samples free to live wires. No experience needed—no capital. We furnish everything free—pay postage or express charges—back you, boost you, show you how and clearly explain everything. Costs nothing to try. Let us make you a stylish suit to measure to prove our fine quality and style. Send postal or letter today. Paragon Tailoring Co., Dept. 214, Chicago.

**AGENTS**—Sign painters, answer: "Chimax" medium; new invention; transfers colors to glass; marvelous results, enormous profits; free samples. Wadhams, 70 Broadway, Brooklyn.

**A GOLD** mine for hustlers, nine months of the year. Food product of highest quality which saves one half the cost to householder. Sales made by sampling. Very little talk required. Men wanted to handle counties. Small capital needed. Write for particulars. Steuben Manufacturing Company, A. Bath, N. Y.

**HE** who has a prosperous 1917 is the Davis agent. Join the Happy Throng. Postal parts you next our Business Building Plans. E. M. Davis Co., 505 Davis Bldg., Chicago.

**SIDE** line goods to carry in vest pocket. Sell, get spot cash, make 100% guaranteed. Harcla Co., Kalamazoo, Mich.

**BE** lucky, Sell Marvel Shaving Soap. Lather. Shave without razor or brush. Samples 25 cents. Sell Marvel Bat and Mouse Exterminator. Marvel Mfg. Co., Springfield, Ill.

**AGENTS**, Salesmen, make \$35 to \$45 per week writing orders for guaranteed made to measure raincoats; new proposition; we deliver and collect; new 1917 swatches free. Peinsoof Co., 235 Main St., Findlay, Ohio.

**UNNEEDED** Expanding Cuff Buttons. Presto slip your cuffs up forearm without unbuttoning same. Cuffs positively stay placed. Lowered they close automatically. Great laundry saver. Indispensable for all latest styles of shirts. A guaranteed necessity that appeals to all. Worn and approved by over 50,000 satisfied users. A sensational seller. Large profits and fine mail seller. Clean, high grade proposition. Also 25 other high grade agents' specialties. Flexo Manufacturing Corporation, Sheboygan, Wis.

**AGENTS**: Money talks—how much are you making? If less than \$200 a month you will positively be delighted with our Sentinel Burglar Alarm proposition. Many agents easily earn \$15.00 daily. Brand new invention. Sells quickly on sight to homes, offices. Patented. No competition. Free exclusive territory. Instantly attached any door knob. Impossible turn knob without ringing bell. No batteries, screws, nails. Handsomely nickel-plated. Retail \$1.00. Provides cheap burglar insurance. It's a big money maker. Let us prove why. Write today for liberal terms to agents. Marshall Dobbins & Co., Manufacturers, 1422 Marquette Bldg., Chicago.

**\$5.00 TRAVEL** Accident Policy costs \$5 yearly. Weekly benefits \$25 for 26 weeks. Every person who rides in street, elevated, subway or railroad cars, steamboats or ferries should have one of our policies. Issued to men and women, ages 16 to 70. Big commission. Representatives wanted in Pennsylvania, New Jersey, New York, Illinois, Maryland, District Columbia, Rhode Island, Massachusetts, Delaware, West Virginia. \$250,000 State Deposit. Fred J. Schaefer & Company, 1123 Broadway, New York.

**QUICKEST** selling, easiest demonstrated auto-accessory: "Klear-Glas" (guaranteed money-back chemical product, in tin tube like shaving soap), smeared on windshield sheds Rain, Fog, Snow, Frost; one application insures clear vision 24 to 48 hours any weather; prevents accidents; sells 50c every Auto-owner, Motorman, Engineer. Circular Free; sample, 50c. Agents everywhere 100% profit. Wilder Co., 51 Second St., San Francisco.

**AGENTS**—Sell Eg-Save; biggest repeater on market; 25c box takes the place of three dozen eggs; unlimited possibilities. Sterns made 60c an hour; Bush sold 12 dozen in less than three days; every housewife a prospective customer; guaranteed under pure food law; write quick. Eg-Save Co., Department P, 186 Oak Street, Buffalo, N. Y.

**MANUFACTURE** and Sell Zeroo-salZ—New Guaranteed Egg Preservative (powdered). Beats Cold Storage. Wizard Washing Tablets. No Wax, Lye, Lime, Potash—No Rubbing, Bluing, Egg-o-Lene—Pure Food Egg Substitute (nine cents dozen). Carbo-Cide Guaranteed Automobile Gasolene Fuel. Fibro-Vac-Sure, Successful Automatic Puncture Plugger. Particulars for manufacturing these; Formula lists of others producing Bankable Results—stamp, Miller, Analytical Chemist, Tampa, Florida.

**\$61.50 WEEKLY**, introducing and selling a new gas light burner for kerosene lamps. Beautiful light. No chimney. No mantle. Samples free. Luther Manufacturing Co., Dept. 274, Cincinnati, Ohio.

**HOUSEWIVES** can't resist. Tremendous seller. Write today. Franklin Co., Dept. 4, Three Rivers, Mich.

**SELL** California Rosebuds. Swell line. Large profits. Send for catalog today. Mission Seed Co., 2819PM, West Pico, Los Angeles, Calif.

**FAST** Selling "Kantleak" Raincoat proposition. Cooper earned \$60 in 5 days. Bridge \$88 in 6 days. We deliver and collect. New 1916 swatches free. Write today. Comer Mfg. Co., 126 Paige St., Dayton, Ohio.

**AGENTS**: Sell California Floral Beads. Best sellers; immense profits. Particulars free. Universal Supply House, Inc., Box 1743-1, Los Angeles, Calif.

**\$150.00 SALARY** for 60 days' work paid woman or man in each town to distribute free circulars, and take orders for White Ribbon Concentrated Flavoring. J. S. Ziegler Co., 7-P E. Harrison St., Chicago.

**MONEY** made spare time selling Safety Razor Sets. No cash. Service Sales Company, 2831 Broadway, New York.

**WANTED**—Responsible representatives for new specialty every stenographer needs. Quickly demonstrated, absolutely convincing. Liberal proposition in return for ability. Sales Department, Box 468, Asheville, North Carolina.



**EXCLUSIVE** selling rights given for our Wonderful Triplex Folding handbag and other sellers. None sold in stores. Write for terms and catalogue. Diamond Bros., 35 West 21st Street, New York.

**AGENTS** write for particulars fastest selling household necessity. Good profits; assured sales. Peck Specialty Co., Dept. 3, North Haven, Conn.

**AGENTS** paid \$25 a day. Inventive wonder. Half million sold and sale just started. Agents coining money. \$25-\$40-\$30-\$20 are actual proven first day records. Everybody wants new, scientific shoe scraper on doorstep. Works like magic. Automatically removes mud, snow, saves drudgery, carpets, shoes. Has 10 blades, 10 dirt outlets, adjustable brushes on compound springs. Rotates for sweeping. If \$25 daily interests you write quick for territory, catalog—great \$1,000 offer—all free. Security Mfg. Co., Dept. 385, Toledo, Ohio.

**GUARANTEED** Custom Raincoats. Biggest Commissions. Largest Line. Lowest Selling Prices. Best Free Offers. Guaranteed Raincoat Co., Dept. A, Boston, Mass.

**CURLY** Hair. Wonderful Hair Curling Fluid, perfected by great German Chemist, imparts beautiful curls however less your hair. Just introduced. Big seller for agents when demonstrated. Particulars, Wave-Curl Co., St. Paul, Minn.

**AGENTS:** Big profits selling our New \$2.50 Automatic adding machine. Quick sales. Ten a day easy. No competition. Anyone having adding to do is positive customer. You'll be glad you wrote us. Bassett Company, 5921 Indiana Ave., Chicago.

**LOOK** for our ad under this heading. It will pay you to read it. Marshall Dobbins & Co.

**WOULD** \$150 Monthly as General Agent for \$150,000 corporation and opportunity to earn a Ford auto selling Stock and Poultry remedies, Dips, Disinfectants. Interest you? Then address Royoleum Co-Operative Mfg. Co., Dept. 22, Monticello, Ind.

**\$50 WEEKLY** and up selling Mexican Diamonds. Exactly resemble genuine; Same Rainbow Fire; stand tests; sell at sight; repeat orders. Write quick for Sample Case offer Free. Mexican Diamond Importing Co., S. W. Las Cruces, New Mexico.

**COIN** books for side line. Write for sample and prices. Coin Exchange, New Rochelle, N. Y.

**AGENTS—Salary** or commission. Greatest seller yet. Every user pen and ink buys on sight, 200 to 500 per cent profit. One agent's sales \$620 in six days; another \$32 in two hours. Monroe Mfg. Co., X5, La Crosse, Wis.

**FASTEST** Dollar Seller on the automobile market. 100% to agents. Permanent repair for inner tubes. Every Motorist will buy. Consumers Mfg. & Supply Co., Minneapolis, Minn.

**AGENTS—\$30** a week and expenses; free samples; gold and silver letters for store fronts, office windows and glass signs; anyone can put them on; big demand everywhere; liberal offer to general agents. Metallic Letter Co., 407 N. Clark St., Chicago.

**AGENTS** to sell Handry Dish Washer. Write for particulars. Charles Pursell, 179 Broad St., Newark, New Jersey.

**MAKE** and sell your own goods. Formulas by Expert Chemists. Manufacturing Processes and Trade Secrets. Formula Catalog for stamp. Blake Mystic Company, Washington, D. C.

**AGENTS—Ho-Ro-Co** Skin Soap and Toilet Goods plan beats everything for agents' profits. "Ho-Ro-Co." 112 Locust St., St. Louis, Mo.

**DR. SNYDER'S** Remedial Soap, Toilet Preparations, Extracts and Food Products beat everything for agents' profits. T. H. Snyder & Co., Dept. M, Cincinnati, Ohio.

**EXCEPTIONALLY** good business proposition for agents—ladies or gentlemen; particulars free. The P. Rappe Company, Box 838, Los Angeles, Cal.

**GAS** Aid. Equals gasoline; 3c gallon. Eliminates Carbon, increases mileage, power and Pep. Agents wanted. Mac-O-Cheer Mfg. Co., 1323 N. Dearborn, Chicago, Ill.

**\$150.00 MONTHLY** to agents introducing our line of Household Remedies, etc. Year's Contract. Wagon Free. Poultry Remedy Co., St. Paul, Minn.

**CANVASSING** agents—reliable general agents—handle Philham Laundry Wonder. Only reliable tablet; perfected after decade study in Europe and America. Sure reseller. Co-operation selling plan. Philham Mfg. Co., 815 S. Sixth, St. Louis, Mo.

**SELL** Stedlor Gauges for Ford Cars. Particulars Free. Stedlor Mfg. Co., Canton, Ohio.

**\$100.00 MONTHLY** leaving free packages "Easywash" to grocers. M. Riensl, Cutler St., Newark, N. J.

**AGENTS—If** you are looking for a repeat order business try Derrick's "Kristalline," the magic-chemical cleaner. Make your own goods and all the profits. Derrick, 1126 North Clark, Chicago.

**AGENTS—Investigate** our proposition; big profits, sells in every home; experience unnecessary; write for free particulars. West Specialty Co., 423 West Ave., Buffalo, New York.

**NEW** household necessity; not sold in stores; quick seller; big repeater. Write Eberhart Co., 6530M, Eberhart Avenue, Chicago.

**LOOK** for our ad under this heading. It will pay you to read it. Marshall Dobbins & Co.

**ONE** good man wanted in each small town to take orders for tailoring in spare time or as a regular business. Good profits. Get your own clothes at special inside wholesale prices. Perfect fit and satisfaction guaranteed or no pay. Wonderful opportunity, experience not needed. Beautiful sample book and fashion plates free. Banner Tailoring Co., Dept. 439, Chicago.

**AGENTS:** Make real money this year; not "paper money." Just think! Our Eridium (luminous) Articles Shine in the Dark. We manufacture a complete line so that every call can be turned into a sale. Everyone amazed at the wonderful possibilities of these goods. Our Eridium Bulb is easily attached to any light and "Locates Your Light in a Jiffy" in the darkest room. Our Eridium Crucifix showing the Christ figure in startling outline thruout the night sells to every Catholic. Our Eridium House Numbers (just out) are selling like Ford automobiles. Our Eridium Clock tells the time in the dark. Our Eridium Match Box sells like hot cakes everywhere. Garages, homes, etc. Our Eridium Switch Plate for hotels is a big seller. Write today for best proposition you ever heard of. Sole manufacturers, The Pioneer Corporation, 1259 West 63rd, Chicago.

**DECALCOMANIA** Transfer Initials and Monograms: You apply them on automobile while they wait; cost 2c each; profit \$1.38 on \$1.50 job; free particulars. Auto Monogram Supply Co., Dept. 1, Niagara Bldg., Newark, N. J.

**AGENTS—Steady** income. Large manufacturer of Handkerchiefs and Dress Goods, etc., wishes representative in each locality. Factory to consumer. Big profits, honest goods. Whole or spare time. Credit given. Send for particulars. Freeport Mfg. Co., 59 Main St., Brooklyn, N. Y.

**AGENTS** Wanted Everywhere—To sell our attractive theatre Brass Poster Frames, Changeable Signs, Building Directories, Brass Signs, Brass Railings, Bank Fixtures, Adjustable Electric Light Brackets. Big demand; easy sales. Established 1882. Newman Manufacturing Company, Cincinnati, Ohio.

**EASY,** pleasant work for Mechanics, Shop Men, Clerks, during spare hours, will add many dollars to their salaries. Also want persons who can give full time. Big wages assured. Novelty Cutlery Co., 47 Bar St., Canton, Ohio.

**\$5** to \$15 profit a day selling most complete line Sanitary Household Brushes for every purpose. Our own make. Your territory awaits you. Write for attractive proposition. Puritan Sales Co., Dept. M, 1966 Broadway, New York.

**\$15.00 MADE** first day by 13-year-old boy with Shomescope. Woman made \$8.00 first hour. Particulars free. Shomescope Mfg. Co., 523 W. 18th St., Kansas City, Mo.

**\$1,000 PER** Man per county. Strange invention startles world—agents amazed. Ten inexperienced men divide \$40,000. Korstad, a farmer, did \$2,200 in 14 days. Schleichler, a minister, \$195 in first 12 hours. \$1,200 cold cash made, paid, banked by Stoneman in 30 days; \$15,000 to date. A hot or cold running water bath equipment for any home at only \$6.50. Self-heating. No plumbing or waterworks required. Investigate. Exclusive sale. Credit given. Send no money. Write letter or postal today. Allen Mfg. Co., 311 Allen Bldg., Toledo, Ohio.

**GARRETT** sold Twenty-Nine Spray Pump Auto Washers in Three days. Profits, two dollars each. A Square Deal. Ruster Co., Johnstown, O.

**AGENTS** wanted everywhere, sell Feather Flowers, Clean, Pleasant, Profitable. Big Home Seller. Stores, canvassers, fairs, poultry shows, etc. Sample fifteen cents. DeWitt Sisters, R. F. D. Ten, Battle Creek, Mich.

**EVERY** Home on Farm, in Small Town or suburb needs and will buy the wonderful Aladdin kerosene (coal-oil) mantle lamp; five times as bright as electric; tested and recommended by Government and 34 leading universities; awarded gold medal; one farmer cleared over \$500 in 6 weeks; hundreds with rigs or autos earning \$100 to \$300 per month; no capital required; we furnish goods on time to reliable men; write quick for distributor's proposition, and lamp for free trial. Mantle Lamp Co., 633 Aladdin Bldg., Chicago.

**AGENTS:** Big Hit; Our 5-Piece Aluminum Set is all the rage. Cheaper than Enamel Ware. Sells like wildfire. Guaranteed 20 years. Retail value \$5.00. You sell to housewives for only \$1.83. Biggest seller of the age. 9 sure sales out of every 10 shown. Others cleaning up \$10.00 to \$20.00 a day. Answer this quick to secure your territory. Div. GG5, American Aluminum Mfg. Co., Lemont, Ill.

**WE** require general representatives and local agents to demonstrate and sell our individual lighting systems, portable lamps and lanterns for use in stores, homes, streets, etc., which are distinctly superior to, and more economical than, any other known method of lighting. If you wish to establish a permanent and very profitable business of your own, tell us in confidence, your business experience, age and other qualifications. Pitner Gasoline Lighting Company, 8 East Kinzie St., Chicago.

**AGENTS:** Get an easy seller. Sanitary All-Metal Bread and Pastry Board and Rolling Pin is making big hit. Make \$25 to \$40 every week. Smith, Ohio, sold \$3 one day. Profit \$19.00. Sells at sight. No talking necessary. Free Sample to Agents. Write quick for appointment and territory. Union Mfg. Co., 183 Main St., Cambridge, Ohio.

**AGENTS:** 50 calling cards 10c. F. Shepard, Rome, N. Y.

**AGENTS—\$40%** profit. Sign letters for store and office windows. Samples and particulars free. Inter State Letter, 2453 N. Halsted St., Chicago.

**AGENTS,** Make Big Money; fast office seller; particulars and samples free. One Dip Pen Co., Dept. 2, Baltimore, Md.

**AGENTS:** Earn big commissions selling made to measure suits for \$15.00. No more; No less. Real \$25.00 values. No experience necessary. Chicago Woolen Mills, Dept. C, 833 Jackson, Chicago.

**AGENTS—Sell** rich-looking imported 3x3 68 rugs, \$1 each. Carter, Tenn., sold 115 in 4 days. Profit, \$57. You can do same. Write for sample offer selling plan; exclusive territory. Sample rug by parcel post prepaid, 98c. H. Condon, Importer, Stonington, Maine.

**"GOLDLINE"** Sign Letters—1,000% profit. Particulars free. Johnston Co., Quincy, Ill.

**AGENTS—We** manufacture quick-selling specialties, repeaters, and teach you practical salesmanship free. G. Home, 1957 Warren, Chicago.

**MAKE** and sell "Flavoring Extracts," "Polishes," "Perfumes," "Proprietary Preparations," "Toilet Requisites," etc. Reap entire profits of your labor. Our high-grade manufacturing formulas and trade secrets tell how. Valuable collection of formulas and big catalogue 25c. Ideal Book Shop (D-2), Irving Station, Chicago.

**LOOK—Send** us your address and we will mail you a surprising sample. American Mfg. Co., 201 Sufferin Bldg., Decatur, Ill.

**AGENTS:** Protaktor Burglar-Alarm for doors and windows is a wonderful new patented safety first device. Insures your safety and protects your valuables. Made of steel. Nickel-plated. Attractive appearance. No wires or batteries. Fully guaranteed. Cheapest burglar insurance. Delivered prepaid on receipt of \$1.00. Write for exclusive territory. The Protaktor Co., 20th Century Bldg., Chicago.

**MAN** or Woman to travel for old-established firm. No canvassing; \$1,170 first year, payable weekly, pursuant to Contract. Expenses advanced. G. E. Nichols, Philadelphia, Pa., Pepper Bldg.

**"FLOSSY"** New Invention for everybody. See our advertisement, Page 166.

**"JIFFY"** Curtain Stringer Slips on end curtain rod, strings curtain onto rod one-tenth usual time. See advertisement, page 166.



**AMAZING**, new invention. Marvellous adding machine. Retail \$7.50. Adds, Subtracts, Multiplies. Does work of 200 machine. Five-Year Guarantee. Offices, stores, factories buy from one to dozen. Enormous demand. Every demonstration sells. Write quick for trial offer and protected territory. Dept. PM, Calculator Corporation, Grand Rapids, Mich.

**WANTED**—Active men to sell simplex gas plants; no experience required; can make \$300 to \$500 per month; others are doing it, so can you. Address Simplex Gas Plants Co., 154 Whiting St., Chicago, Ill.

**HIG Profits for You!** Manufacture Barley Crisp, New Confection, 5c package costs you 1c. Machine instructions complete \$7.50 prepaid. Send 10c for samples. Barley Crisp Co., 1295 Broadway, San Francisco.

**AGENTS**—Stamping names on Pocket Key Protectors; sample Check with your name and address, 12c. Stamping Outfits, Emblem Checks, Check Fobs, Name Plates, Hart Mfg. Co., Desk 2, 303 Degraw St., Brooklyn, N. Y.

**EARN \$50 to \$100 monthly** distributing Parker Hosiery to repeat customers at mill prices. All or spare time. Protected territory. Credit, D. Parker Mills, 3733 No. 12th St., Philadelphia, Pa.

**\$5 COMMISSION** each sale and repeat orders. Traveling salesmen every state. Main or sideline. New, rapid selling automobile accessory used all makes cars. Samples loaned. Weekly settlements. Toledo Cable Co., 119 Davis Bldg., Toledo, O.

**YOU can be your own boss** with our Key Check outfit. Good for \$5 a day stamping names on pocket key checks, fobs, etc. Sample check with your name and address, 15 cents. Pease Die Works, Dept. M, Winchester, N. H.

**AGENTS**—500 per cent profit; get our monograms for autos and motorcycles, etc. By transfer method. Western Motorist Accessories Co., Cheyenne, Wyoming.

**OUR line of sanitary brushes, mops and dusters is a winner.** So is our proposition. Rich territory waiting. Agents wanted now. Sanford Brush Co., 544 W. Lake St., Chicago.

**AGENTS**—\$50 a week. Will show you how. Genuine Gold Leaf window letters. Chicago Letter Co., 846 Altgeld St., Chicago.

**STREAM-NO-MORE** for eye glasses, wind shields; every auto owner a customer. Live agents, 200%. Send 10c for 25c sample. Gray's Sales Agency, Port Huron, Mich.

**WHO wants to make more money** selling brushes that every household needs? Special method of getting entrance to demonstrate. Fuller Sanitary Brushes are nationally advertised—largest output—best terms and prices—western distributing stations. Your territory is valuable. Write, Fuller Brush Company, Hartford, Conn.; Rock Island, Ill.

**TURN spare time into dollars.** Something new. No canvassing or investment. Daydark Co., Desk 55, St. Louis, Mo.

**HUGE profits** selling Nibco Sanitary Brushes, Auto Washers, Crown Beauty Adjustable Floor Mops, Dustless Dusters, and other specialties. Big line. Fast sellers. Write today. Silver-Chamberlin Company, Department M, Clayton, New Jersey.

**SIGN Letter Agents and Painters:** 500% Profit Gold and Silver Sign Letters for Stores and Office Windows. Anyone can put on. Big demand. Free samples. Metallic Letter Co., 404 N. Clark St., Chicago.

**MERCHANTS** wild over them. Kellner of Chicago sold the first ten "in no time." He says the Ever-Ready changeable sign is the greatest seller he ever handled. Profits 55c on every \$1.50 sale. If you are making less than \$2.00 an hour write for our proposition. Changeable Sign Co., 581 E 102nd, Cleveland.

**WANTED**—Reliable Men and Women to place our Engine in stores and appoint sub-agents. Takes the place of eggs in baking and cooking at less than 7c doz. Chas. Morrissey Co., 4463-5 Madison St., Chicago.

#### SALESMEN WANTED

**WANTED**—Salesmen, prefer men with clothing, tailoring or retail experience, to take charge of an agency for new proposition to be placed in every county. No investment required. If you can qualify it means at least \$25.00 to \$40.00 weekly. Profitable, permanent business. McGregor Co., 511 E. Franklin, Chicago.

**SALESMEN** Wanted—Get into automobile necessary business. Act as district representative Doyle Fuel Regulator, also Doyle Speed Governor. Two quick selling, big profit-makers. Each sells \$5. You make \$2.50 each—100% on investment. Fuel Regulator increases mileage of car 25% to 75%. Speed Governor regulates speed delivery cars—saves tires, reduces up-keep. Hugh Miller, Syracuse, made \$47 first three days. Your opportunity, too. Send \$2.50 for Fuel Regulator or \$5 both devices. Return C. O. D. if you can't sell first car owner you meet. Big advertising campaign helps you. Leads furnished. Territory going fast. Hurry! Doyle Auto Products Co., 1675 Broadway, New York.

**SALESMEN** To sell Groceries, Paints, Lubricating Oils, Stock Remedies, Automobile Supplies to farmers, ranchmen and other consumers at wholesale; profitable, steady, desirable, satisfaction guaranteed; 45 years in business. Write for particulars. Lovell & Browne Co., 1718 S. State St., Chicago.

**NEW \$2.50 Automatic Adder** sells quick from demonstration. Big profits, no competition. Every business man buys. Bassett, 5921-D, Indiana Ave., Chicago.

**ATTENTION:** If you live within 75 miles of Philadelphia, earn exceptional profit selling "New Idea" Sanitary Brushes, 67 Varieties. Household necessities. Original method of gaining entrance to demonstrate secures ten sales from fifteen calls. Fuller Brush Company, Philadelphia, Pa.

**WANTED**—One responsible man in each county for exclusive sale Automatic Grain Separators direct to farmers. F. A. Lester, P. O. Box 385, Chicago.

**WHERE you ever offered a grocery store?** Our proposition is better. Let us tell you how you can handle Flour, Canned Goods, Provisions—an entire line of Groceries, as well as Paints, Roofing, Stock Foods, Automobile and Machinery Oils and Greases. No rent to pay, no investments in stock. Large orders taken from samples. Goods of guaranteed and proven quality. Selling experience not necessary. Very profitable work for "workers." Address R. S. Hill, President, Hitchcock Hill Co., Chicago. Reference: Any bank or express company.

**OUR advertisement under Agents Wanted** will interest you. Read it. Marshall Dobbins & Co.

**\$200 PER Month** side line, selling useful low-cost gift and advertising specialty. Attractive. Entirely new. Patent pending. Every smoker and every family wants it; Invisible Safety Match-box Holder. Two styles, 6 of each, \$1.00 postpaid, deducted first order. Fred M. Gliddings, Manufacturer, (Dept. M-2), Galesburg, Illinois.

**SALESMEN**—Acquainted with grocery trade. Large demand; liberal commission; pocket sample. Wirth Salesbook Co., Dept. P, Chicago.

**10c RAZOR Strapper**—Hones and Straps all razors and blades. It's New—Simple—Efficient. Postpaid, One Dime. Salesmen Wanted. Webster & Nobbs, 74 Broad St., Boston, Mass.

**FORD Specialties.** Local representatives of good character desired every State. Miller, 101 West 163d Street, New York.

**SALESMEN:** Your clothes furnished free of cost for soliciting applications for our Tailoring line during spare time, in all towns you make. Our line features 300 patterns, half of which can be profitably retailed from \$15 to \$20. Write for full information. United States Tailoring Co., 219 W. Jackson Blvd., Chicago.

**SALESMEN**—We require at once, men of character and ambition for permanent position; cover small territory and live at home; a very fine income and opportunity is assured. Rex Typewriter Co., Sales Dept. P, Steger Bldg., Chicago, Ill.

**YOUNG men** everywhere as cigar salesmen. Start \$20 Weekly. Neway Sales Co., Hoboken, Mass.

**SALESMEN:** The Nelson Pinkless clothes line puts the old-fashioned clothes pin into the discard. Simple, indestructible. The greatest boon to housewives invented in a decade. Are you alive to something new, something big? Get ground-floor terms and territory now. John Nelson, Patentee & Mfr., Stamford, Nehr.

**\$50.00 PER month** selling the Emil Gum Case as a side line. Sample 25c. Emil Co., Box 603, San Francisco.

**\$7.50 COMMISSION** each sale and repeat orders; traveling salesmen among general mercantile trade, every state; weekly settlement; no competition; pocket sample. Toledo Cable Co., 208 Davis Bldg., Toledo, O.

**WANTED**—Capable Men to Sell "Best" Automobile accessories direct to car owners. Good commission. Reliable men only. No free samples. Jackels Campbell Co., Kansas City, Mo.

**SALESMEN**—Wanted everywhere to sell Ajax Chemical Fire Engines, Minimum Commission \$40 on every Engine sold. An average of one or two machines a week would earn you \$2,000 to \$4,000 a year. Factories, Stores, Industrial Plants, Private Estates, etc. all use Ajax Engines. No capital required. Goods well advertised. Ajax Fire Engine Works, 95 W. Liberty St., New York.

**SALESMEN** Wanted—Broom straw has gone up. Our Fibre and horse-hair broom is the best house to house proposition on the market today. Easy seller. Costs 57c each C. O. D. P. O. B. Chicago, sells for 75c. Write at once. Territory protected. Jos. Hergetreth & Son, 57 E. 43d St., Chicago, Ill.

**SALESMEN**—Sell beautiful 28x58 Artkraft felt rugs for \$13.50 per doz. Your profit \$2.50 per doz. Kelso, Battle Creek, Mich., sold 30 doz. last week, his profit \$75. Prepaid sample, \$1.00. E. H. Condon, Mgr., Stonington, Maine.

**SALESMEN**—Get our plan for Monogramming Automobiles and motorcycles by transfer methods. Very large profits. Motorists' Accessories Co., Mansfield, O.

**WANTED**—Representatives everywhere. Exclusive territory. Gold sign letters for stores and office windows. Any one can put on. Write today for free sample. Mettelle Letter Co., 403 N. Clark St., Chicago.

**EXCLUSIVE county rights.** Sell Tankli; modern auto fuel. Profitable. Tankli Chemical Co., Cleveland, Ohio.

**"FLOSSY,"** New Invention for Everybody. See our advertisement, Page 165.

**EARN \$5,000 to \$20,000 yearly.** New business necessity. Retail \$5 to \$200. 100-200% profit. Purchaser satisfied or money refunded. No competition. Exclusive territory. Free samples. Sayers, 408 Wainwright, St. Louis.

#### HELP WANTED

**WANTED:** Young men seventeen to twenty years old to learn the trade of couler in iron foundry making high-grade machinery castings. Term of service, three years, with attractive and steadily increasing pay while learning trade. For further particulars, write The Hendey Machine Company, Torrington, Conn., Foundry Dept.

**\$25.00 WEEK** paid chauffeurs. Learn while earning. Sample lessons free. Franklin Institute, Dep't T-502, Rochester, N. Y.

**GOVERNMENT Employees Wanted**—Big pay, sure work. I will prepare you in a short time at small cost. Must be American citizen. Write for my free book FC-29 today. Earl Hopkins, Washington, D. C.

**GOOD Income** refinishing chandeliers, brass beds, automobiles, etc. By new method, producing amazing results. No capital or experience necessary. Particulars free. Gunmetal Co., Ave. H, Decatur, Ill.

**WANTED**—Young Men as Railway Mail Clerks. \$75.00 month. Sample examination questions free. Franklin Institute, Dep't T-21, Rochester, N. Y.

**GOVERNMENT Examinations.** Most thorough preparation, \$5; returned if not appointed; particulars free. American Civil Service School, Washington, D. C.

**GOVERNMENT Positions** are easy to get. My free booklet BY-29 tells how. Write today—Now. Earl Hopkins, Washington, D. C.

**PHOTOPLAYS** in demand. Make extra money. We show you how. Details free. Rex Publishers, Box 175, H-11, Chicago.

**THOUSANDS Men, Women**—Wanted. \$100 month. Government jobs. Vacancies constantly. Write immediately for list positions obtainable. Franklin Institute, Dep't T-21, Rochester, N. Y.

**GOVERNMENT** pays \$900 to \$1,500 yearly. Prepare for coming "exams" under former Civil Service Examiner. New Book Free. Write Patterson Civil Service School, Box 2020, Rochester, N. Y.

**CIVIL Service Examinations** open the way to good Government positions. I can coach you by mail at small cost. Full particulars free to any American citizen of eighteen or over. Write today for Booklet CE-29. Earl Hopkins, Washington, D. C.



YOU silver mirrors, plate tableware home. Easy money way. Clarence Sprinkle, Dept. 28, Marion, Ind.

THOUSANDS of Statues made with one rubber outfit. Instructions free. Joseph Roth, 45 Frost St., Brooklyn, New York.

WANTED. Men and women to qualify for Government positions. Several thousand appointments to be made next few months. Full information about openings, how to prepare, etc., free. Write immediately for booklet OG-29. Earl Hopkins, Washington, D. C.

INVENT Something. It may bring wealth. Free book tells what to invent and how to obtain a patent through our Credit System. Waters & Co., Succeeded by Talbert & Parker, 4162 Warder Bldg., Washington, D. C.

RAILWAY Mail Clerks Wanted. \$75.00 month. Sample examination questions free. Franklin Institute, Dep't T-21, Rochester, N. Y.

ADDITIONAL income monthly to factory employees, without interfering regular work, positively no canvassing or investment. E. M. Co., 1482 Broadway, New York.

THE way to get a Government Job is through the Washington Civil Service School. We prepare you and you get a position or we guarantee to refund your money. Write to Earl Hopkins, President, Washington, D. C., for Book FK 29, telling about 292,296 Government Positions with lifetime employment, short hours, sure pay, regular vacations.

GOOD Openings for Men or Women—Young or Old—Particulars free. Stephens, Box 101-A, Madison Square, New York City.

OUR advertisement under Agents Wanted will interest you. Read it. Marshall Dobbin & Co.

"UNCLE SAM" wants Men-Women, 18 or over, as Government Clerks. \$100.00 month. Write immediately for list positions now open. Franklin Institute, Dep't T-21, Rochester, N. Y.

NO Strike: 8 Hour Day, Men Everywhere. Firemen, Brakemen, Baggage-men, \$120. Colored Porters. Experience unnecessary. 810 Railway Bureau, E. St. Louis, Ill.

NEW occupation for steady workers at home. Whole or part time. No selling. J. Lord Company, Baltimore, Md.

MEN—Women—Wanted everywhere. U. S. Government Jobs. \$75.00 to \$150.00 month. Vacations. Common education sufficient. Write immediately for free list of positions now obtainable. Franklin Institute, Dep't T-21, Rochester, N. Y.

GET a sure job with big pay, steady work, short hours, regular vacations, rapid advance. Thousands of positions open with Uncle Sam. I will prepare you in a few weeks at small cost. Write immediately for big free Book DU-29 with special offer. Earl Hopkins, Washington, D. C.

CIVIL Service Information: Prepared by an expert, tells of opportunities, salaries and qualifications for high salaried positions in Western cities. Not a correspondence course, but facts you must know. 25 cents silver. Powell, 449 New York Block, Seattle.

BE a Mirror Expert. Good income; spare time home at first; no capital; we train, start you making and silvering mirrors; French method. Free prospectus. W. P. Derr, Pres., 87 Saratoga Ave., Brooklyn, N. Y.

WANTED—An Ideal! Who can think of some simple thing to patent? Protect your ideas; they may bring you wealth. Write for "Needed Inventions" and "How to Get Your Patent and Your Money." Randolph & Co., Patent Attorneys, Dept. 144, Washington, D. C.

MAKE money writing Photo-plays; details free to beginners. No correspondence course. Producers' League, 259 Wainwright, St. Louis.

#### WANTED

NEW Edison Standard two-minute cylinder phonograph records. State quantity and cash price. Box 172, Cleveland, O.

WANTED—I'll pay 80c per hundred for United Certificates. 6c a tooth for old, broken false teeth. R. Morrison, 123 Post Ave., N. Y. City.

WANTED—Mechanical articles of merit to sell on commission. The Saskatchewan Distributing Co., Regina, Sask., Canada.

WANTED—To buy Buckeye Traction Ditcher. Give price, power, traction, etc. Geo. E. McKay, Friesland, Wis.

NATIONAL Cash Registers wanted. Anton Jensen, Perth Amboy, New Jersey.

#### FOR SALE

USEFUL articles at bargain prices; toilet sets, manicure sets, watches, razors, leather goods, smokers' outfits, etc. Catalogue free. Royal Importing Co., 21 East 14th St., New York.

FIELD, Marine, Day and Night Glasses with beautiful case, 25-mile adjustment, only \$7.50. Money back if not satisfactory. Well's Curiosity Shop, 20 So. Second Street, Philadelphia, Pa.

12 MILK'S floor gum venders, like new, only \$14 to \$20. Operators' belts, \$12, for quick sale. Rare bargain. Auto Vending Co., Minneapolis, Minn.

MERRY-GO-ROUND, first-class condition, \$850. Moore Bros., Lapeer, Michigan.

GRANDFATHER'S clocks, desks, decorated chairs, settees, etc. No reproductions. Antiques, Richland, Pa.

#### SALE OR EXCHANGE

MINING stock for light automobile. M. Conaway, Beyer, Colorado.

WANT to Swap? Send 10 cents for "The Market for Exchange," to Pierre Notley, 141 Milk Street, Boston, Mass. It gives a long list of those who have things to trade or sell. Send list of things you have to trade or sell.

FOR Sale Cheap, good Merry-go-round, would consider property or automobile in exchange. For sale, 1/2 H. P. 110 Vt. D. C. Motor, drill press, several good tents. Cheap. C. J. Murphy, Elyria, Ohio.

#### GUNS, SPORTING GOODS, ETC.

BUY, sell, exchange all sorts old-time and modern Firearms. Stephen Van Benschel, Antiques, 895 Madison Ave., New York.

#### FLOUR & FEED MILLING MACHINERY

SPECIAL bargains in second hand Attrition mills, burr mills, crushers, corn shellers, bran dusters, dust collectors, purifiers, rolls, double, single, 2 and 3-pair high roller mills, sieve bolters, receiving separators, scourers, etc. Write for description and prices. Sprout, Waldron & Co., P. O. Box 429, Muncy, Pa.

#### MACHINERY, TOOLS & SUPPLIES

FOR Sale, used and rebuilt machinery—25 H. Reeves steam traction engine, 22 H. Pitts, 22 H. Wood Bros., 20 H. Case, two 20 H. Rumleys, 18 H. Pitts, 18 H. Advance, 16 H. Huber, 16 H. Gaar-Scott, 15 H. Case, 14 H. Pitts. Most any make of grain thrasher from 25" to 38". Write us for complete list with prices. The Banting Machine Company, 114 Superior St., Toledo, Ohio.

"RED Devil" Mechanic's pillar (drop forged steel). Most efficient, 5" size, 60c. Style 50. Tool booklet free. Smith & Homenway Co., 97B Chambers Street, New York City.

FOR Sale. Four wood pulleys, almost new, at very low price. Size four feet and larger. Box 538, Monmouth, Illinois.

PULLEYS, Gears, Sprockets, Shafting, Hangers. See page 133. W. A. Jones, Foundry & Machine Co., Chicago.

TO buy or sell a machine, write Interstate Machinery Co., Troy, N. Y.

WIRE—all sizes—1/2 to No. 16. Copper, tinned, galvanized and plain steel wire for sale. Cooley Mfg. Co., 555 W. Monroe St., Chicago, Ill.

TOOL-MAKERS' Magnifying Mirrors, swinging handle, die-cast back. Send for circular (\$1.00). Pajaro Mfg. Co., Erie, Pa.

#### ENGINES, MOTORS AND DYNAMOS

REBUILT Engines—We have rebuilt "Buffalo" Engines, guaranteed, at greatly reduced prices. Write for bargain list. Buffalo Gasoline Motor Co., 1293-1305 Niagara Street, Buffalo, N. Y.

ENGINE Lathes; 20"x8" Niles, complete, \$215.00. Western Machinery Co., C. H. Norton, Cincinnati, O.

FOR Sale: A few new 5, 8 and 12 H. P. horizontal, water-cooled engines at cost. Northwestern Steel & Iron Works, Eau Claire, Wisconsin.

ECONOMIZER Engines. Sold on fuel-economy guarantee. Get it and save money. Address, Engine Works, Marcellus, Mich.

TRACTOR Motor, truck type, 25-horse, kerosene. Mosher, 901 Summit, Minneapolis, Minn.

WESTINGHOUSE, Wagner, Fort Wayne, Holzer-Cabot, Emerson, Western, General Electric rebuilt motors guaranteed for one year. Alternating and direct current. All sizes from 1/30 H. P. upwards. Tell us your needs. Satisfaction guaranteed or money refunded. Send for illustrated price list supplies and motors. Hyre Electric Co., 613-CT South Dearborn St., Chicago.

LATEST American Model Steam Engine, 1/4 H. P. Modern Model Engineering Co., 2901 N. Central Park Ave., Chicago.

NEW A. C. 60-cycle, 110-volt motors, fully guaranteed. 1/4 H. P. \$15.00; 1/2 H. P. \$16.50; 3/4 H. P. \$20.00; 1 H. P. \$22.00. Also larger sizes A. C. & D. C. Aaron Electric Co., 15 So. Clinton St., Chicago, Ill.

FOR Sale—25 H. P. Engine, 16 K. W. Dynamo switchboard. Joseph Wall, Oblong, Ill.

NEW 1/2 H.P. A. C. Motors \$15. A few 3/4-H.P. A. C. \$12. D. C. \$11. Price on other sizes in proportion. Headquarters for motors and generators. Electric Sales & Service Co., 719-21 Liberty Ave., Pittsburgh, Penna.

CHARGING Dynamos: Several hundred small machines just received from Bankruptcy Stock. All voltages and sizes—guaranteed new—less than factory cost. 1/4 H. P. A. C. Motors, \$15.00 each. Write for illustrated list. Johnston, West End, Pittsburgh, Pa.

ELECTRIC Arc Generator makes your own current for half. Your engine operates. Easy terms. Hobarts, Box MF, Troy, Ohio.

#### BOATS, LAUNCHES, ETC.

BUILD your own Steel boat from patterns. Material furnished, also finished boats. Catalogue free. Darrow Boat Co., Albion, Mich.

MOTORCRAFT Encyclopedia—A 150-page book that tells 1001 things every motor boatman should know. How to overcome engine troubles. Price \$1, postpaid. Popular Mechanics Book Dept., 6 N. Michigan Ave., Chicago.

#### FOR THE SHOP

SHOP Notes for 1917—Just Published—524 Articles, 422 Illustrations, 224 Pages. Easy Ways to do the Hard Things in every trade and calling. Price 50 cents, postpaid. Popular Mechanics Book Dept., 6 N. Michigan Ave., Chicago.

PATTERN Makers! A book devoted to the principles of pattern and core making and molding. Written by G. H. Willard, a practical pattern maker of years' experience. This book, just published, treats the subject in a much more simple, direct and effective manner than most books along this line. 224 pages, 312 illustrations. Price, \$1, postpaid. Popular Mechanics Book Dept., 6 N. Michigan Ave., Chicago.

FOR That Boy—He will appreciate a copy of the great boy's book, "The Boy Mechanic," that tells about 700 different things for boys to do and has 800 pictures, 480 (7x10) pages, cloth, big, handsome book for the price, \$2.00 postpaid. Popular Mechanics Book Dept., 6 N. Michigan Ave., Chicago.

#### BLACKSMITHS

BLACKSMITHS, Listen! The Blacksmiths come first of all trades. He must make the tools for all, from the Surgeon to the Safe Blower. With Toy's Modern Methods doing hard jobs easy. Forging and making solid welds, hardening and tempering to a standard, with colored tempering charts. All for one dollar. Samples Free. W. M. Toy, Sidney, Ohio.

BE a Tempering Wizard. Tools and springs tempered by my formula, indestructible. Secret method never before divulged. You need it. \$1.00. Nonbreakable cold chisel free to every formula buyer. The Cold Chisel King, Stockton, Illinois.

#### CEMENT

CONCRETE Building Block Machines and Moulds. Free catalogue. 221 So. Main St., St. Louis, Mo.



## ELECTRICAL

**INVENT** Something. It may bring wealth. Free book tells what to invent and how to obtain a patent through our Credit System. Waters & Co., Succeeded by Talbot & Parker, 4289 Warder Bldg., Washington, D. C.

**ILLUSTRATED** price list supplies and motors, free. Write for copy today. Hyre Electric Co., 613-11K South Dearborn St., Chicago.

**"BOY Electrician."** Make Batteries, Dynamos, Engines, Motors, Telephones, Wireless Telegraph Apparatus, etc. 64 pages. 75 illustrations. 10c. Renew Old Dry Batteries. 3 guaranteed processes. 20c. Both, 25c. Ideal Book Shop (B-1), Irving Station, Chicago.

**FINISHED** Parts for making Electric Motor. Dieckmann Company, Box 53, Brooklyn, N. Y.

**PRACTICAL** Electrics—Universal handy book on every-day electrical matters, alarms, batteries, bells, carbons, connections, coils, dynamos, wires, lamps, motors, telephones, etc. 135 pages, 126 illustrations. 25c postpaid. Popular Mechanics Book Dept., 6 N. Michigan Ave., Chicago.

**DRY** Batteries and Their Construction for All Purposes. A practical handbook of 60 pages with 30 illustrations dealing with batteries for automobiles, gas engines, medical and coil work, electric bells, alarms, telephones, experiments, etc. Price 25 cents postpaid. Popular Mechanics Book Dept., 6 N. Michigan Ave., Chicago.

## STAMP COLLECTING

**FREE.** Choose one, 200 different stamps. International assortment, 101 United States, 63 Japanese, 50 Asiatic, Remit 25c, six months subscription, McKele's Stamp Weekly, Beverly, Mass.

**50 DIFFERENT** British Colonials, 25c. R. A. Lee, Box 242, Bloomington, Indiana.

**APPROVALS** 65% discount and premiums. M. D. Place, E. Norfolk, Mass.

**FREE**—60 different stamps, including Newfoundland, China, Japan, Mexico, etc., to applicants for our high-grade approvals. Send 2c stamp for return postage. The Edgewood Stamp Company, Dept. H, Millard, Conn.

**WATERMARK** detector free to approval applicants meaning business. Reference, Harry P. Bridge, Clearfield, Pa.

**FREE!** 5 Parcel Post with 60% approvals, Enclose 2c. Seidenberg, Boecher, Ill.

**AMERICAN** Packet Free—Old Issues, Commemoratives, galore, Dues, Revenues, etc., 2c postage. Midland Stamp Company, Midland, Ontario.

**FINE** stamps on approval at 60% to 80% below catalogue prices. Leon Cass, Great Bend, Pa.

**STAMPS**—12 different from warring nations, 10c; 10 different foreign coins, 15c; 20 Belgian stamps, 10c. Lists free. Toledo Stamp Co., Toledo, Ohio.

**FREE**—5 beautiful French Colonials to approval applicants. "Zu-Vu" packet—15 animals, 15 views—30 worth-while stamps 25c. Perry Stamp Co., Perrysburg, Ohio.

**AMERICAN** Hinges, 10c per 1,000. Roessler, East Orange, N. J.

**STAMPS** sent on approval at 70% discount. Reference required. Emory Renold, Hanover, Pa.

**FREE**—Packet from South American countries with request for Royal Approvals, with reference. Bargain list free. Belmont Stamp Co., 32 South 17th st., Philadelphia.

**SELLING** out low-priced approvals. Premiums with every request and purchase. Riedell, Schenectady, N. Y.

**VENEZUELA** Set free—To those who write for Approvals and give reference. Star Stamp Company, Sandusky, Ohio.

**24 VARIETIES** Cuban stamps, 10 cents. List of 5,000 low-priced stamps free. Chambers Stamp Co., 111 P. Nassau St., New York City.

**STAMPS**, 75, all different, free. Postage 2c. Mention paper. Quaker Stamp Co., Toledo, Ohio.

**PACKET** of 23 stamps; no two countries alike, 500 hinges. Set of \$1 and \$2 U. S. Rev., all for 5c. Mention paper. Miami Stamp Co., Toledo, Ohio.

**LOW** priced approvals. Mention paper and receive unused Department Stamp Free. S. E. Colman, 634 Keefer Place, Washington, D. C.

**A STAMP** Album. A collection of rare Mexican War stamps, incl. Madero, etc., 100-page catalog. Perf. gauge and mill. scale, coupons, etc., all for 5c. App. sheets 60% to 80% comm. Agents Wanted. We buy stamps. Hussman Stamp Company, St. Louis, Mo.

**121 ALL** Different Foreign Stamps, including Guatemala, Honduras, Roumania, Costa Rica, Egypt, Chili, China, Mexico, Peru, Cuba, Russia, Japan, India, Victoria, Portugal, etc., 15c. 200 hinges free. Royal Stamp Co., 48 N. 51st Street, Philadelphia, Pa.

**20 UNUSED** stamps free. All different. Postage, 2c. Fisk Stamps, Toledo, Ohio.

**STAMPS**—165 China, etc., stamp dictionary, list, 2c. Album (500 illustrations) 2c. Bullard, Sta. A., Boston.

**PACKET** "A" 100 varieties foreign stamps, 20c. F. J. Pope, Charlotte, Vermont.

**FOREIGN** Stamps Free! Grand set 10 New Zealand. Send 4c postage, mention Gift H13. "A. B. C." Illustrated Priced Catalogue of stamps of the British Empire (including War Issues) for 1916, nearly 350 pp. 30c post free. Bright & Son, 164, Strand, London, England.

## RARE COINS

**WILL** pay \$2.00 for 1904 Dollar, proof; 10c for 1913 nickels S. Mint; \$108.00 for Dime, 1894 S. Mint. We want thousands of coins and stamps. We offer up to \$1,030.00 for certain dates. Send 4c now for our large Illustrated Coin Circular, Numismatic Bank, Dept. H, Fort Worth, Texas.

**50,000** COINS, notes, newspapers, almanacs, guns, pistols, engravings, relics. Catalogue 4c. Collectors' Exchange, 1554 Willington, Philadelphia.

**OLD** Coins—I buy all kinds; save all before 1910. Send 10c silver for New 1917 Premium Book. It may mean your fortune. E. A. Harr, Nora Springs, Iowa.

**FIVE** Villa Coins and Bills, 35c. Villa Silver Dollar, \$1.35. Moore Coin Company, Commerce, Texas.

**CALIFORNIA** Gold, quarter size, 27c. 3/4 size, 53c. Large cent before 1821, Columbian nickel and price list, 10c. Norman Schultz, King City, Mo.

**1917** COIN catalog sent on request. Coin Exchange, New Rochelle, N. Y.

**\$4.25 EACH** Paid for U. S. Flying Eagle Cents dated 1856. We pay cash premiums on hundreds of Old Coins. Send ten cents at once for New Illustrated Coin Value Book 4x7. It may mean your fortune. Clarke & Co., Coin Dealers, Box 15, Le Roy, N. Y.

**COINS**—Antique Relics, 5 curious rare coins with catalogue, 10c. Ray Chapin, New Berlin, N. Y.

**OLD** Coins. Large Fall Coin Catalogue of Coins for Sale, free. Catalogue quoting prices paid for coins, ten cents. William Hesslein, 101 Tremont St., Boston, Mass.

**CARDBOARD** Money, used by Mexican Revolutionists, complete set 3 pieces, 10 cents (coin or stamps). S. B. Hopkins, Laredo, Tex.

## GAMES AND ENTERTAINMENTS

**ELECTRICAL** Stage Effects—Clouds, Ripples, Snow, Rain, Cyclone, Fire, Waterfalls, Waves, etc.; Spotlights, Stereopticons, Nitrogen projectors. (Stamps for catalogue.) Stagecraft, 395 West 15th St., New York.

**MAGIC** tricks for parlor or stage. High class goods at right prices. Catalogue free. Dealers supplied. Sylvania Magic Shop, R-192, Clifford, Providence, R. I.

**MAGIC**, Sensational escapes, amusements. Catalog free. Heaney Magic Co., Berlin, Wisconsin.

**MAGIC** Tricks for pocket, parlor and stage. Largest assortment in the world. Thurston's Book of Pocket Tricks, 25c. Book of Card Tricks, 25c postpaid. Send 2c stamp for catalogue. A. Felsman, 115 So. State, Chicago.

**INK** erasing blotters fool every one—formula 10c. Hobson, P. O. Box 1543, St. Louis, Mo.

**45 HOT** Air Cards and the "Tango Table," the latest craze in jokes. Both for 10c. Aurora Novelty Shop, Aurora, Illinois.

**47 TRICKS**, 250 jokes, riddles, 73 toasts, \$ Fortune Telling secrets, 52 money-making secrets, 22 funny readings and big catalog 10c. Ideal Novelty Shop (C-2), Irving Station, Chicago.

**ARE** you ambitious? You can earn good money in vaudeville. Valuable information mailed free. London, 734 Crilly Bldg., Chicago.

**TRICKS**, Puzzles, Jokes, Magic Goods, Games, Plays, Wigs, Stage Supplies, Mind-reading Acts, Sensational Escapes, and Illusions. Free large illustrated 1917 Catalog. Oaks Magical Co., Dept. 379, Oshkosh, Wis.

**"SLEIGHTS."** New fifty-cent Magic Book 45c. Photo, Ten cents. Moose, Cross-lid, N. J.

**ESCAPE** from any Handcuffs, Apparatus 50c postpaid. Ray J. Fink, Reading, Penna.

**SEALED** letter reading explained, 15c. Stanton Rippey, 2527 Ocean View Ave., Los Angeles, California.

**PLAY** Pajaro; beautiful cards, fascinating games. Postpaid, 55 cents. Pajaro, Hasbell, Texas.

**TRICKS** and Stage Money, Magic Bargain Catalog 2c. Twenty Greenbacks 10c. Gilmore, Morgan Park, Chicago.

**NOTELO**, Music teaching game. Teaches names and values of notes and rests. Fine for parties and home. Easily learned. 25 cents. Hofer Music Co., Manhattan Kansas.

**SEND** 10c for two Standard Puzzles. Receive Free, 2 Card, 2 Coin, 2 Joke Tricks; Apparatus and Catalogue, Chicago Puzzle Works, 3310 Herndon St., Room 139, Chicago.

**\$10.00** APPARATUS. Call or send 6c for 1917 Catalog. Horrmann Magic Store, 470 8th Ave., New York.

**AUCTION** Declarations including the laws of 1917, by Milton C. Work. Just out—the one book that reduces auction bridge to an easy system for making the best bid with any hand, 300 pages, cloth, \$1.00 postpaid. Govee leather, silk marker, \$2.00 postpaid. Popular Mechanics Book Dept., 6 N. Michigan Ave., Chicago.

**PLAYS**, Vaudeville Sketches, Monologues, Dialogues, Speakers, Minstrel Material, Jokes, Recitations, Tableaux, Drills, Musical Pieces, Entertainments for all occasions. Make-Up Goods. Large Catalog Free. T. S. Denison & Co., Dept. 11, Chicago.

**MORE** Funabout Poets—New book of funny "Ferd Stories." The popularity of Funabout Poets has resulted in the publication of an entirely new collection of about 100 of these stories that the whole nation has laughed at. Either book 25 cents postpaid or both books for 50 cents postpaid. Popular Mechanics Book Dept., 6 N. Michigan Ave., Chicago.

**MAGIC**—Tricks, Books and Supplies. For Amateurs as well as the Great Professionals. Any one can learn through our instructions. Feature Acts in Mind Reading, Spiritualism, Rope Ties, etc. Large illustrated Professional Catalogue, 10c. Chicago Magic Co., Dept. B, 72 West Adams St., Chicago, Illinois.

**SHOW** them what a wad you carry. Big bunch greenbacks 10c, 4, 25c. Howes, 3684 Milwaukee Ave., Chicago.

## FOR BOYS

**"SLIMMY SLIVERS"** Metallic Frame Kite. Big value for a dime. Thayer Mfg. Co., Dept. B, Jackson, Mich.

**JUST** Issued—Amateur Mechanics No. 8. How to make 132 different interesting things such as electric fountains, bird houses, model monoplanes, porch swing, kites of various kinds, fishing rods, camp outfits, scarecrow, shocking machine, etc., 128 pages, 234 illus. Price 25 cents, postpaid. Also all preceding numbers in the series at same price. Popular Mechanics Book Dept., 6 N. Michigan Ave., Chicago.

**BIG** New Book for Boys—The Boy Mechanic, Vol. II—Just Out—A sequel to, but containing nothing found in Vol. I. Tells all about 1,000 interesting things to make and do, 480 pages; 995 illus. Cloth. Price, \$2.00, postpaid. Send for descriptive circular. Popular Mechanics Book Dept., 6 N. Michigan Ave., Chicago.

## HONEY

**WHITE** Clover Honey, 30 pound can, \$3.50; 60 pounds, \$6.60; 120 pounds, \$12.60. Satisfaction guaranteed. E. B. Rosa, 29 10th Street, Monroe, Wis.

**FINEST** Quality White Clover Honey, crop of 1916, thirty lb. can \$3.60, two or more cans \$3.45 each. Sample 10c. Satisfaction guaranteed. Price list free. M. V. Facey, Preston, Minn.



## SAFETY BLADES SHARPENED

RESHARPENED by our "New Process" 2c each. Guaranteed better than new. Each blade honed, hair-tested, sterilized, wrapped individually. Jones Kesledge, Dept. A, Jamaica Plain, Mass.

SAFETY Blades sharpened 2c each. Razors ground, honed and set 40c. Work guaranteed. Ten years in cutlery business. Maspeth Grinding Co., 25 Linden St., Maspeth, N. Y.

SAFETY razors sharpened; two cents each. Guaranteed. Blade box free. Electro Stropping Co., 134 Shelby St., Detroit, Mich.

## FOR THE HOME

MODERN Plumbingless Water-closets for country homes, cost  $\frac{1}{2}$  less. Free circulars. Pavlik, Westminster, Colorado.

GUAVA Jelly, 10c a package. Carr Brothers, 2343-D, Havana, Cuba.

FURNITURE Patterns—Full size for 5 pieces. Blue print, instructions. \$1.00 postpaid. Henry Brothers Cabinet Co., Pottsville, Pa.

FREE: Guava Jelly. One 50c package free. Carr Brothers, Havana, Cuba.

DELICIOUS Pinyon Nuts. Large package 10c. American Pinyon Co., Albuquerque, N. Mexico.

MISSION Furniture—Make your own at little expense. Complete instructions, working drawings and stock lists for 36 different pieces. Price \$1.50 postpaid for set of three books. Send for complete descriptive matter. Popular Mechanics Book Dept., 6 N. Michigan Ave., Chicago.

## DIAMONDS, WATCHES AND JEWELRY

MONTANA Sapphires in the rough direct from the Miner. Specimens 25c. Gems \$1 each. Richard Stingle, Phillipsburg, Montana.

## PHONOGRAPHS AND RECORDS

\$12 COLUMBIA Hornless Disk Talking Machine and six Columbia double-face 10-inch records. Tone equal to any \$50 machine. Sent C. O. D. anywhere, subject to examination. Well's Curiosity Shop, 20 So. Second Street, Philadelphia, Pa.

MAKE Your Own Phonograph; I furnish all mechanical parts and instructions for \$9.85. Stewart Typewriter Exchange, Mattoon, Illinois.

BUILD Your Own Phonograph. Any type. Big saving. Patents expired. Profits making and selling them. We furnish parts you can't make. Full instructions, dimension drawings, illustrations, parts—price list only 25c. Circular Free. Associated Phonograph Co., Dept. P, Cincinnati, O.

## PIANOS AND MUSICAL INSTRUMENTS

YOU can tune and keep your own piano or player piano in perfect condition. Van Atta's book on The Piano and Player Piano not only tells you but shows you every movement in their care, repair and tuning, 154 Pages. 54 Illustrations. Cloth. Price \$1.50 postpaid. Popular Mechanics Book Dept., 6 N. Michigan Ave., Chicago.

## MUSIC

RECORDS for Victor, Columbia, Edison disk or cylinder talking machines bought, sold, exchanged. Edison Standard 1c. Blue Amberol 25c. Victor 15c up. Well Permanent Jewel Needle \$1.00. Victrola or Grafonolas Jewel Point attachment to play Edison disk record \$2.00. Send for record list. Well's Curiosity Shop, 20 So. Second Street, Philadelphia, Pa.

PORTFOLIO Music Free with each copy "When I'll Forget to Remember You." Send 15c. Success Music Co., 260 Euclid Ave., Akron, Ohio.

"CIRCLES." Two-step for piano—16c. Howell, Box 34P, Newton, Ill.

"LOVELY Hawaiian Moon" song, 15c. Dissatisfied, return in 5 days; money refunded. F. Remple, 2827 Myrtle St., Oakland, Calif.

IF you really want good Sheet Music try our Century Edition. Price per copy, 14c. Write for Free Catalog. New Jersey Sales Co., Box 243, Passaic, N. J.

FAVORITE Old Home Songs—No home in the land should be without this book of 280 of the familiar old songs everybody loves. Words and music complete in a substantial volume 9 $\frac{1}{2}$ x7 inches in size. Price 50 cents postpaid. Popular Mechanics Book Dept., 6 N. Michigan Ave., Chicago.

## FORMULAS AND TRADE SECRETS

POLISHING Cloths, Rust Remover, Silver Polish, Washing Compound, Perfumes, Tube Flavors, full line of Toilet Products, etc., under your own label cheaper than you could manufacture. Pitt Laboratories, 790 Newark, New York.

BE your own manufacturer and make big profits. I supply money-making formulas, analyses, working processes. Upcher Smith, Analytical and Consulting Chemist, St. Paul, Minn.

FORMULA for Recharging worn-out Electric Dry Batteries, less than one cent. Send two dimes or stamps. A. Bohner, 1089 So. Wabash, Chicago.

HIGHGRADE manufacturing formulas. 1,000 Subjects. Price \$1. Satisfaction guaranteed or money refunded. "Bestorval Formula Service," 3315-B, Belleplaine Ave., Chicago.

EXPERIMENTERS: Many interesting and valuable experiments with Lumino. Shines in the dark; hundred uses. Formula and full instructions, 25c. Byron Long, Salem, Iowa.

A-1 FORMULA for polishing automobiles, postpaid for \$1. J. R. DeNoyelles, No. 61 Willis East, Detroit, Mich.

FORMULAS—Trade secrets. We have thousands of them at our finger tips. Ten cents each. Write us what you want to know and enclose coin. Your query answered or money back immediately. The Paul G. Howes Laboratory, Stamford, Conn.

1,000 FORMULAS, 25c. 75 Manufacturing Secrets, 10c. Resilvering Mirrors—Renewing Dry Batteries—Snore Powder—Itch Powder—20c each. Entire Collection, 50c. Satisfaction guaranteed. Big Catalog, 2c. Ideal Book Shop, (B-2) Irving Station, Chicago.

FORMULAS for everything. Guaranteed. Be your own Chemist. Staff of former U. S. Government experts for analyses and consultation. United Chemical Laboratories, 13 H St. N. W., Washington, D. C.

20,000 FORMULAS, price \$1. Postpaid. Complete list 4c stamps. Edm Bromley, Watervliet, N. Y.

## TYPEWRITERS AND SUPPLIES

TYPEWRITERS, all makes factory rebuilt by famous "Young Process." As good as new, look like new, wear like new, guaranteed like new. Our big business permits lowest cash prices. \$10 and up. Also, machines rented—or sold on time. No matter what your needs are we can best serve you. Write and see—now. Young Typewriter Co., Dept. 1960, Chicago.

TYPEWRITERS—Prices wrecked. All Makes. Nearly New and Rebuilt, \$5.00 up. Coronas and other portable machines, \$10.00 up. Write for catalogue. Heran Typewriter Co., 595 W. Washington St., Chicago.

MULTIGRAPH Ribbons Reinked, 50c each. \$5 dozen. Typewriter Ribbons Reinked, 20c each. \$1.50 dozen. Monon Reinkers, 740 Monon Bldg., Chicago.

GUARANTEED Typewriter Ribbons, 2-color, Black, Blue, Purple; 3 for \$1. Acme, 449 S. Dearborn, Chicago.

STARTLING values in Typewriters. \$10 to \$15 up. Factory rebuilt. All makes. Shipped on trial. Write for our Special Offer No. 87-F. Whitehead Typewriter Co., 186 N. LaSalle St., Chicago.

ALL Makes on monthly payments. See special L. C. Smith offer on page 118. Harry A. Smith.

LARGEST Stock of Typewriters in America. Underwoods, one-fourth to one-half manufacturer's prices; rented anywhere, applying rent on purchase price. Free trial. Installment payments if desired. Write for catalogue 7c. Typewriter Emporium, estab. 1892, 34-36 W. Lake St., Chicago, Illinois.

SEND for list of Typewriter Bargains, new and rebuilt, cash, time or rent. 10 days' Free trial. American Typewriter Exchange, 14 N. Dearborn St., No. 4, Chicago.

## MAILING LISTS

FOR results mail your proposition to latest list Penna. auto owners. \$2.00 per 1,000. Frank J. Suter, Hill Station, Harrisburg, Pa.

1,000 LIVE Agents \$2.50; Prosperous Farmers \$1.50. Also other classifications. Modern Name Supply, Milwaukee, Wis.

1,000 TYPEWRITTEN Mail Order Agents or Buyers' names, guaranteed 95% correct, postpaid \$1.50. Ljebau, Drawer 587, Erie, Pa.

## DUPLICATORS AND DEVICES

"MODERN" Duplicator—A Business Getter. Saves money, time, trouble. No glue or gelatin. Always ready. Easy to operate. 35,000 firms use it. 50 to 75 copies from pen, pencil, typewriter. Letter size complete. \$4.50. Satisfaction or money back. You need one. Write for free booklet now! J. E. Durkin & Rees Company, Pittsburgh, Pa.

MIMEOGRAPHERS, Underwood Duplicators, Rotary Neostyles \$15, slightly used. Guaranteed. Office Specialty Co., The Bourse, Philadelphia.

\$300 MULTIGRAPH like new for \$100. Guaranteed. Russell Baum, Philadelphia Bourse, Philadelphia.

## PRINTING, ENGRAVING AND MULTIGRAPHING

MULTIGRAPH Letters, Letterheads—1,000 complete, \$3. Letters purple, heads black. Samples for stamp. Perfection Letter Company, Muncie, Indiana.

IMITATION Typewritten Letters, \$3 1,000. Acme Letter Service, 440 S. Dearborn, Chicago.

CIRCULARS: 3x6, 75c; 4 $\frac{1}{2}$ x6, \$1.00; 6x9, \$1.50 1,000 delivered, Owl Press, Malden, Mass.

PREPAID to you—500 fine bond letterheads, \$2.00; 1,000, \$3.50. Typewriter letters same. Send money order. Dixie Press, Vicksburg, Miss.

EXTRA Good Quality—50 letterheads, 50 envelopes, 50 return envelopes, 50 cards. All neatly printed for \$1.00 postpaid. Rittenhouse Press, Belvidere, New Jersey.

1,000 4x6 CIRCULARS printed two colors. \$1.00. Karns, Portland, Colorado.

100 ENVELOPES printed, 50c postpaid. Samples. Lincoln Novelty Co., Rochester, N. Y.

50 IVORY cards, 25c; 100, 35c; 300, \$1. Card case free. 100 white envelopes, 40c. Agents wanted. Samples. Satisfaction guaranteed. Howard Trimmell, Newfield, N. J.

CIRCULARS—1,000, 3x6, 90c; 4 $\frac{1}{2}$ x6, \$1.15; 6x9, \$1.75. Chas. Walter, Lancaster, Ohio.

OUR Specialty—Magazines and Catalogues. Get our prices. The Tobacco Growers' Pub. Co., Tippecanoe City, Ohio.

200 LITHO Letterheads \$1.25, postpaid; samples stamp. Riggs, Vesay, Ind.

150 BOND noteheads and 150 envelopes printed for \$1.50, postpaid. "Brown," Stoutland, Mo.

PRINTED Gummed Labels our specialty. Any business. Wetzel, Box 101-A, Madison Square, New York City.

PRINTING—125 each of any two kinds, \$1.10 postpaid—envelopes, letterheads, noteheads, billheads, statements, business or visiting cards. Berg Company, Dept. E2, Hendrum, Minn.

GOOD Printing—1,000 Quality Letterheads, Envelopes, \$2.50 up. 10,000 Circulars, 200 words, \$5.00. Folders, Booklets, Multigraph Letters, low prices. Stox Press, Odell Illinois.

PRINTING traded for anything of value. The Tipton, Tippecanoe City, Ohio.

GOOD Printing, 1,000 Letterheads, Billheads, Statements or Cards, \$2.00. Samples free. Argos Press, 169 West Monroe, Chicago.

1,000 IMITATION Typewritten Letters, heading black, body purple, \$3.25; Ad Slips, \$1.15. Elegant Samples and Bargain List Free. Good's Printery, Harrisonburg, Va.

AT Last! Beautiful Lithography for small users. 1,000 Letterheads, 1,000 Billheads and 1,000 Statements, \$9.90. Engraving Free. Kaydee Lithographing Co., 744 Teutonia, Milwaukee.

500 LINEN Finish Letterheads \$1.75; printed 2 colors, \$2.50 postpaid. Samples. Starb Printing Co., Hamilton, Ohio.

MONEY-SAVING. Prepaid Price-list. Samples 2c. Superior Printing Co., 821 Park Ave., Brooklyn, N. Y.

STATIONERY that individualizes your business. Describe your business; we submit sketches and suggestions. Expert service. Franklin Printing House, Lima, Ohio.

PRINTING Outfits—Presses, type, supplies, type novelties. Send stamp for catalogue. Model Press, York, Penna.

GUMMED Labels direct from the producers; 3,000, 75c. Catalog No. 162 on request. Royal Label Company, 468 Cherry, Philadelphia.



**QUALITY** Printing Prepaid. 500 either envelopes, noteheads, cards, statements, \$1.35; 1,000, \$2.25; 1,000 envelope slips, \$1.25; 1,000 6x9 circulars, \$1.85; 500 linen-finish letterheads or envelopes, \$2.25; 1,000, \$3.50. Prepaid. Typewriter letters. Stamp brings samples. Model Company, Manchester, Iowa.

350 **BUSINESS** Cards \$1.00. August Fischer, Keller Bldg., Louisville, Ky.

**BUSINESS** Courtesy Seals, 50 samples, 10 cents. Circular free. Helmers Company, Hoboken, N. J.

**GOOD** Printing at low prices. 1,000 good letterheads, envelopes, card, billheads, labels, circulars, \$2.50. Samples free. Catalogues, booklets and circulars our specialty. Ernest L. Fantus Co., 523 S. Dearborn St., Chicago.

**PRE-USED** Printing Presses. Type. Supplies; good material, lowest prices. List for stamp. Popular Bargains, Richmond, Pa.

1,000 **ENVELOPE** Slips, book paper, \$1.00; 3x6 Folders, \$2.75. Nonpareil Press, Erie, Pa.

**ILLUSTRATE** your printing; cuts made from photographs, 85c. We print anything. Samples free. Commercial Press, Batavia, Ohio.

#### PATENT ATTORNEYS

**SEND** for "Words of Value to Inventors," free, before selecting your Patent Attorney. John B. Woodworth, Washington Loan Trust, Washington, D. C.

**PATENTS** secured or all fees returned. Do not miss the generous offers in E. E. Vrooman & Company's display ad on page 153.

**PATENTS** that protect and pay. Advice and books free. Rates reasonable—highest references; best results. Watson R. Coleman, Patent Lawyer, 624 F St., N. W., Washington, D. C.

**PATENTS**—Herbert Jenner, patent attorney and mechanical expert, 606 F St., Washington, D. C. I report free of charge if a patent can be had and its exact cost. Send for circular.

**HIGH-VALUE** Patents. See R. S. & A. B. Lacey's advertisement on page 152.

**PATENTS** and inventions for sale or on royalty. My clients have valuable inventions for market. No better investment for manufacturers or individuals. Full information without charge. Mention line of invention interesting you and data will be sent. Richard B. Owen, Patent Lawyer, Owen Building, Washington, D. C.

**THE** Patenteer is free. An education in obtaining patents. Established 1865. Anderson & Son, Attorneys, 707 7th St., Washington, D. C.

**INVENT** Something. It may bring wealth. Free book tells what to invent and how to obtain a patent through our Credit System. Waters & Co., Succeeded by Talbert & Parker, 4280 Warder Bldg., Washington, D. C.

**UNPATENTED** inventions sold or no fee. Inventor's Advocate—D. Washington, D. C.

**PROTECT** Your Invention. Honest advice. Personal service. Write today for booklet, "The Truth About Patents," J. R. Kelly, Patent Attorney, 743a Woodward Bldg., Washington, D. C.

**SEND** for "Words of Value to Inventors," free, before selecting your Patent Attorney. John B. Woodworth, Washington Loan Trust, Wash., D. C.

**PATENTABLE** Ideas Wanted—Send for 2 free books, R. B. Owen, 30 Owen Bldg., Wash., D. C.

**PATENTS** Wanted. Write for list of Patent Buyers who wish to purchase patents and what to invent with List of Inventions Wanted. \$1,000,000 in prizes offered for inventions. Send Sketch for free opinion as to patentability. Write for our four Guide books sent free upon request. Patents advertised Free. We assist inventors to sell their inventions. Victor J. Evans & Co., 156 Ninth, Washington, D. C.

"**PATENTS** and Patent Possibilities" is a 72-page treatise which tells all about patents, what to invent and where to sell it. It gives honest advice to inventors and tells about the successes of some of my clients, also explaining what are frequent causes of failure. Manufacturers are constantly writing for protective patents upon all kinds of sound inventions. Can you help supply their wants? The book is free. Write for it today. H. S. Hill, 905 McLachlen Building, Washington, D. C.

**MANUFACTURERS** want new inventions. I secure valuable patents and help make your invention a success when patented. Send for booklet "Pointers about Patents." Lester Lyman Sargent, 700 9th St., Wash., D. C.

**PATENTS** on Easy Payments. Send sketch for free opinion as to patentability. Write today for our new book on what to invent and how to protect your invention under our new easy payment plan. C. C. Hines & Co., 591-A Victor Bldg., Washington, D. C.

**PATENTS** without advance attorney's fees. Send sketch for free report. Books free. Frank Fuller, Washington, D. C.

**KEEP** up with progress. Promote your patent. Send \$1.00 for year's subscription to best inventor's magazine, "Invention and Manufacturing." United States Patent Corporation, Washington, D. C.

**PATENTS** Secured or Fee Returned. Actual search free. Send sketch or model. 1917 Edition, 90-page patent book free. My patent sales service gets full value for my clients. It should never require more than two days to report upon the patentability of your invention; nor longer than ten days to prepare your application for filing. Longer delay amounts to gross neglect and the jeopardizing of your rights. For prompt personal service write: George P. Kimmel, 212 Barrister Building, Washington, D. C.

**PATENTS**—Send sketch for free search and report. Books on patents and book of reference letters sent free. John S. Duffie & Co., 610 F St., Washington, D. C.

**PATENT** Your Ideas—\$3,000 offered for certain inventions. Books, "How to Obtain a Patent," and "What to Invent," sent free. Send rough sketch for free report as to patentability. Manufacturers constantly writing us for patents we have obtained. We advertise your patent for sale at our expense. Established 29 years. Address Chandler & Chandler, patent attorneys, 1050 F St., Washington, D. C.

**INVENTORS**: Write our Patent Dept. Adam Fisher Mfg. Co., 2061C Railway Exchange, St. Louis, Mo.

**INVENTIONS** developed; see ad under classification "Models and Model Supplies." The Wm. Gent Machine Co.

**INVENTORS** Attention—Get particulars of my system before applying for patent through others. It saves you money, and keeps you in touch with, and in control of, your case at all times. W. N. Roach, Jr., 950 McGill Bldg., Washington, D. C.

**PATENT** what you invent. It may be valuable. Write me. No attorney's fee until patent is allowed. Estab. 1882. "Inventor's Guide" Free. Franklin H. Hough, 522 Loan & Trust Bldg., Washington, D. C.

**PATENTS** procured on square deal fee plan with real service. We help sell the patent. Free booklet and advice. Milo B. Sterens & Co., 685 F St., Washington; 313 Monadnock Bldg., Chicago. Est. 1864.

**PATENTS** bring riches; protect your invention. Attorney's fee payable when patent allowed. Plain advice and "Patent Facts" free. Trade-marks registered. Jaynes & Jaynes, 653 Kellogg, Washington, D. C.

**PATENTS** obtained through D. Swift being promptly sold to manufacturers. Write today for free books of "Inventions Needed," and surpassing references. D. Swift, 317 Seventh St., Washington, D. C.

**DON'T** lose your rights to patent protection. Before proceeding further send for our blank form Evidence of Conception to be signed and witnessed. Book, suggestions and advice free. Lancaster & Allwine, 221 Ouray Bldg., Washington, D. C.

C. L. PARKER, Ex-member Examining Corps, Patent Office, Patent Attorney, McGill Bldg., Washington, D. C. Inventor's handbook, "Protecting, Exploiting and Selling Inventions," sent free upon request.

**PATENTS**: Send model, sketch or drawing. Advice, 100 Mechanical Movements and 50 Perpetual Motions, Free. Fred G. Dieterich & Co., 61 Ouray Bldg., Washington, D. C.

#### FOR INVENTORS

**INVENTIONS** Developed—Real co-operation given you in handling all experimental work. Any mechanical device—no matter how intricate—developed and finished. Complete models built. Write us about your needs. Spies Special Machine Works, 602 Goddard Building, Chicago.

**INVENTIONS** commercialized on cash and royalty basis. Patents secured. Models, experimental work and contract manufacturing. Inventors should write at once, Adam Fisher Mfg. Co., 2061A Railway Exchange, St. Louis, Mo.

**WANTED**—Information regarding good Patent for sale. Northwestern Business Agency, Minneapolis, Minn.

**INVENTORS**—We specialize in manufacturing new patented articles—make models—dies—and do experimental work. Leo J. Gerding Mfg. Co., Dept. D, Opera Place, Cincinnati, Ohio.

**WRITE** for prices on mechanical drafting. The Snyder Drafting Department, A, Canton, Ohio.

**INVENTORS** can interest us in salable article whether patented or not. Send details in first letter. Harris Engineering Company, Bridgeport, Conn.

**HIGH-VALUE** Patents. See R. S. & A. B. Lacey's advertisement on page 152.

**PATENTS** secured or all fees returned. Do not miss the generous offers in E. E. Vrooman & Company's display ad on page 153.

**INVENTIONS**—Patenting and Promoting. A book containing practical advice and directions for inventors and manufacturers. Book, suggestions and advice free. Lancaster & Allwine, 221 Ouray Bldg., Washington, D. C.

**CASH** for ideas. List of needed inventions and book on Patents free. Sanders, 7 Webster Bldg., Chicago.

**INVENT** Something. It may bring wealth. Free book tells what to invent and how to obtain a patent through our Credit System. Waters & Co., Succeeded by Talbert & Parker, 4280 Warder Bldg., Washington, D. C.

**UNPATENTED** inventions sold or no fee. Inventor's Advocate—E. Washington, D. C.

**PATENTABLE** Ideas Wanted—Send for 3 free books, R. B. Owen, 30 Owen Bldg., Washington, D. C.

**PATENTS, Trade-Marks and Copyrights**. Our handbook on patents will be sent free on request. All patents secured through us are described without cost to the patentee in the Scientific American. Munn & Co., Patent Attorneys, 672 Woolworth Bldg., N. Y. Washington, D. C., office, 625 F St.

**PATENTS** Wanted. Inventors write for Free Booklet. Tells how to get the cash value of your invention. E. Wooten, 814 F., Philadelphia, Pa.

**No** Attorney fees until patent allowed. Send sketch for free report. Books free. Frank Fuller, Washington, D. C.

**PATENTS** on Easy Payments. Send sketch for free opinion as to patentability. Write today for our new book on what to invent and how to protect your invention under our new easy payment plan. C. C. Hines & Co., 591-A Victor Bldg., Washington, D. C.

**HAVE** You An Idea? If so, you should protect it by a patent. Send us a model or sketch for free opinion as to patentability. Write for our Four Books sent free to any address. Victor J. Evans & Co., 157 Ninth St., Washington, D. C.

**INVENTIONS** developed; see ad under classification "Models and Model Supplies." The Wm. Gent Machine Co.

**HAVE** you a Patent to sell? You'll be interested in my proposition. Write now for free particulars. Don't call. F. W. Johnson, 8 N. Michigan Ave., Chicago.

**WANTED**—An Idea! Who can think of some simple thing to patent? Protect your ideas; they may bring you wealth. Write for "Needed Inventions" and "How to Get Your Patent and Your Money." Randolph & Co., Patent Attorneys, 629 F St., Washington, D. C.

"**FLOSSY**," New invention for everybody. See our advertisement, Page 164.

**WANTED** to buy Patent direct from owner. (Edwa. or M. O. article.) Submit details. C. Nestle, 180 N. Dearborn, Chicago.

#### PATENTS FOR SALE

**PENHOLDER**, extracts old pen, holds fresh pen. Costs no more to manufacture than the ordinary. Royalty: Checker (gamepiece) novelty. Patent 1,170,109. Offer. Office door sign holder, all-metal, very useful (2 Patents allowed). Outright or royalty. Circular free. John F. Rogers, St. Paul Hotel, New York.



**THE Standard Signal Lamp** for motor vehicles. Rear-lamp, signal apparatus and license bracket combined. Electrically operated. Costs \$1.35 to manufacture. Patent pending. Sell outright or royalty. C. R. Lumley, 1429 31st South, Seattle, Washington.

**PATENTS for Sale.** William Gessler, 1966 Clinton Avenue, New York.

**FOR Sale—Patent No. 1,261,901.** Radius and tapering attachment for lathes. C. C. Veronee, Box 174, Summerville, S. C.

**INTERCHANGEABLE Scissors.** Composed of two parts, handle shanks and blades. This invention enables a person to use different sized scissor blades. Blades are easily changed and securely fastened. Milton B. Graham, Windfall, Ind.

**SIMPLE** patent device preventing step ladders from falling. Costs 12 cents to manufacture. B. B. Keith, Mansfield, Ohio.

**OUTRIGHT** or royalty, cheap; Carpet-beater; nothing like it on the market. E. Smith, 18 Hoyt St., Newark, N. J.

**OCCUPANT** Propelled Vehicle. Propelled by rocking motion of user; is adapted for all class of people; is designed to be manufactured for Roller Chairs, Boys' Toy Automobiles and Auto Coasters. Light running and high speed. John Hearttigan, Tighman Street, Allentown, Pa.

**NEW** adjustable embroidery hoop; any proposition considered. Folding berry box for sale or trade for land. Box 295, Garner, Iowa.

**PATENT** No. 1,180,952, Florists' Tool, simple and efficient. Cash or royalty. Address W. R. Welander, 3253 45th Ave., South Minneapolis, Minn.

**PATENT** of merit for sale. No. 39,230, suitable for mail-order business. A. S. Carlson, 938 Blaine St., Los Angeles, Cal.

**EXTENSION** Crutch—Outright or royalty. Adaptable for hospitals, etc. Strong, compact and rigid construction. Simple to manufacture. Same principle applicable to canes. E. F. E., Box 1244, Station A, Lincoln, Nebr.

**PATENT** Station and Street Indicator for railway passenger cars. Indicates distance in miles. Outright or royalty. Address, Box 222, Spencer, W. Va.

**PATENT** for Sale—Exceptionally good kitchen device. O. R. Durrant, 238 Kendall Ave., Oshawa, Canada.

**PULLEY** Line Puller, outright or on royalty. Patent pending. A. W. Hilding, Amston, Conn.

**JUST** patented Sanitary Detachable Drinking Fountain. Millions to be sold; big profit. Will sell patent outright. W. C. Edwards, Palms Hotel, Denver, Colorado.

**DIRECTION** Indicators for Automobiles of simple construction. Patent allowed. Particulars, address Joseph W. Davis, 224 3rd St., San Francisco, Calif.

**WHO** wants to purchase New Invention that will be the best selling household article? Emery, 270 Parker St., Newark, N. J.

**LOOK!** Patent Buyers: Perfected patented device, ready to manufacture, automatic turning Auto-lite. Outfits for all cars electrically lighted. Write now to Lloyd E. Gerrish, East Lebanon, Me.

**FORD** gasoline gauge (patent pending). Shows amount in tank without removing cushion; all metal; can be manufactured very cheaply. Send for circular. J. F. Rogers, St. Paul Hotel, New York City.

**"GAS** Iron." Very practical. Recently patented. Eight claims granted. Chas. Gridley, Columbus, Ohio.

**CANADIAN** design, Patent U. S. pending. Electric Globe for automobiles and other uses. B. Brock, Vashon, Wash.

**FISH** Controller Device. Used for handling fish after being caught with hook. Makes it easy to remove hook. Has attachment for cleaning and scaling. (Sportsman article.) Owen E. Hulehan, Deer River, Minn.

**CREAM** and egg-whipping device. Electrically operated. Will whip one quart of cream or the whites of fifteen eggs in three minutes. A hotel and restaurant article of real merit. Wm. H. Robertson, 121 South Hamilton St., Madison, Wis.

**FOR** Sale or Lease. Revolutionary improvement in Claw hammer. Extremely practical and simple. Just patented. Millions will be sold. Address J. P. Walton, Bastrop, Texas.

**PATENT** rights to Non-Refillable Bottle for sale on cash or royalty. Good manufacturing proposition. Address Talbert & Parker, Patent Lawyers, 10308 Warder Building, Washington, D. C.

**UNITED** States and Canadian Patent on Adjustable Snap Button for Gloves, etc. Far superior to anything on the market. Splendid opportunity. Klett, Parkersburg, Pa.

**NEW** patent for sale: Medicine cabinet for sick rooms and hospitals. Joseph Amato, Ossining, N. Y.

**OUTRIGHT** or royalty, Grapple Hook. Patent pending. Useful. Big demand. Henry K. Webster, Edmon J. Crowley, Sebree, Ky., R. 1.

**FOR** Sale—U. S. Patent No. 1,265,687. Necessary tool for carpenters, cabinet makers, etc. No tool like it. Canadian Patent applied for. James Verhey, Pella, Iowa.

**CANADA** patent that costs about penny to manufacture. Lee Collins, Eighteenth and Maple, Louisville, Ky.

**INVIOABLE** Seal prevents adulteration or falsification of liquids kept in garrafones, carboys, etc. Can be used once only. Enrique Hernandez, Sta. Clara, Sto. Domingo, Cuba.

**CANADIAN** Rights. Patent Automatic Roller for Awnings and Drop Curtains. Works from inside or outside of building; eliminates all Ropes, Pulleys, Cranks and Cogs. Will demonstrate. 176 North Green St., Chicago.

**ELECTRIC** Self-surfacing Floor Machine, for smoothing terrazzo or cement floors. A machine that is in great demand. Jas. Hampton, P. O. Box 64, Evanston, Ill.

**PRACTICAL** indicator for trolley cars. Patent No. 1,188,934 for sale outright. Automatically indicates each succeeding street along the line of travel of car. C. C. Hays, 962 Atchison St., Trinidad, Colo.

**FOR** Sale or Royalty—Ash-retaining cigarette and cigar patent. Monopolize the industry. Geo. H. Brown, Box 52, Wilkesburg, Pa.

**3 AWNING** patents with materials. Nugent, 439 West 26th St., New York City.

**PATENTED** pan-holder, cheaply manufactured. Especially useful for wash-pans. Investigate further. Chas. Wankel, Virginia, Illinois.

**SCREEN-DOOR** attachment; keeps flies out of house. Millions in it. Everett Wiley, Yates City, Ill.

**FOR** Sale, Canadian Patent on a Combined Dishpan and Drainer. A household necessity. Now being manufactured and sold in the U. S. A. Large profits to investor. Address R. H. Sletsema, Little Rock, Iowa, U. S. A.

**PATENT** Buyers are invited to address our sales department for information on any class of Patents they wish to purchase or lease on a royalty. We have secured a number of valuable patents in all lines of invention. Mail Order, Department Store and Household Novelties a specialty. Victor J. Evans & Co., 160 Ninth St., Washington, D. C.

**WE** have some money-making inventions for placing on royalty; outright sale or trade. Write Adam Fisher Mfg. Co., 2061B Railway Exchange, St. Louis, Mo.

**NEW** Package Tie. Simple, efficient. Millions used when introduced. F. W. Sawtelle, Oshkosh, Wis.

**PARTNER** or buyer for a new patent useful article for home and office. Joe St. John, E. 6 St., Austin, Tex.

#### MODELS AND MODEL SUPPLIES

**INVENTIONS** developed. The specialists who develop Auto accessories, gasoline engines, electrical appliances, electric signs, repeating rifles, automatic cigarette-making machines, weighing, vending, photograph, moving picture and lead pencil printing machines; turbines, air, electric and steam motors and other intricate devices are at your service. They'll handle your development, drawings, experimental work, patterns, models, special tools, dies stampings, castings, plating, forging and spinning in our big plant—covers two acres. Make any metal novelty. Complete organization for developing and manufacturing. Advice backed by 30 years' experience free. Send drawings or samples. The Wm. Gent Machine Co., Cleveland, Ohio.

**WANTED—New Ideas.** Write for list of Patent Buyers and Inventions Wanted. \$1,000,000 in prizes offered for inventions. Our 700 Books sent free upon request. Victor J. Evans & Co., 165 Ninth, Washington, D. C.

**MODELS, Punches and Dies.** Patents Perfected. The Sachs-Lawlor Co., Inc., Established 1881, 1543 Larimer St., Denver, Colo.

**WE** make working models for inventors; also dies and stamping of specialties, and carry a complete stock of brass gears and model supplies. Send for catalogue. The Pierce Model Works, 3405 Pierce Ave., Chicago, Ill.

**PERFECT** models sell inventions. We make them. Write Adam Fisher Mfg. Co., 2061E Railway Exchange, St. Louis, Mo.

**NEW** Lithographic Model of a Monster Mallet Compound Locomotive. All parts shown and numbered. Size, 7x10 in. in colors. Other models in series are, Atlantic Type Locomotive—Steamship—Gas Engine—Steam Engine—Steam Turbine—Dynamo—Wireless Telegraph. Price, 56c each or set of 8 for \$3.50, postpaid. Popular Mechanics Book Dept., 6 N. Michigan Ave., Chicago.

**PRODUCE** of Results: Inventions developed. Models, Experimental work, anything special in metal to order, novelties, spinning, forging, castings in any material, electrical devices, patterns of all kinds, plating, general manufacturing, designing, special tools, punches and dies, stampings. Send drawing or sample. Expert information free. The John's Machine & Stamping Works Company, Dept. C, Cleveland, Ohio.

#### MANUFACTURING

**WE** will develop, manufacture and market any salable article of merit. Send details in first letter. Harris Engineering Co., Bridgeport, Conn.

**WANTED.** Light Metal Manufacturing. Lorenze Manufacturing Company, 220 West Huron Street, Chicago.

**PATENTED** Articles, Models. Brass Work, Dies made. Baum's Metal Specialties, Kansas City, Mo.

**INVENTIONS** manufactured under contract. Write Adam Fisher Mfg. Co., 2061F Railway Exchange, St. Louis, Mo.

**INVENTIONS** developed; see ad under classification "Models and Model Supplies." The Wm. Gent Machine Co.

**WIRE** Goods, all kinds, made to order. Cooley Mfg. Co., 553 W. Monroe St., Chicago.

#### REAL ESTATE AND FARM LANDS

**YOUR** chance is in Canada—rich lands and business opportunities offer you independence: Farm lands, \$11 to \$30 acre; irrigated lands, \$35 to \$50; Twenty years to pay; \$2,000 loan in improvements, or ready made farms. Loan of live stock; Taxes average under twenty cents an acre; no taxes on improvements, personal property, or live stock; Good markets, churches, schools, roads, telephones; Excellent climate—crops and live stock prove it. Special homeseekers' fare certificates. Write for free booklets, Allan Cameron, General Superintendent Land Branch, Canadian Pacific Ry., 39 Ninth Av., Calgary, Alberta.

**FOR** Sale—640 acres wild grass land—none broken—20 miles N. E. of North Platte, Nebraska. Land is rolling and good pasture land. Already fenced on two sides; 160 acres of more, level and suitable for farming. \$5.50 per acre. Address H. H. Windsor, Popular Mechanics Magazine, Chicago.

**FLORIDA**, where orange and grape fruit thrive, eastern DeSoto County, below frost line. Ideal climate. Two railroads coming. Have good "Furry," \$33 per acre. Now is the time. Free trip east of Mississippi. C. E. Berg, 688 7th St., S. E., Minneapolis, Minn.

**TIDEWATER** Virginia Farms. Fine truck gardening section. Low freights. D. M. Cheatham, Norfolk, Va.

**YOU** can do better on a southern farm. Send for a year's subscription free to our beautifully illustrated magazine, "The Southern Homeseeker," which tells all about good, low-priced land and Southern opportunities. Write P. H. LaBaume, Agri. Agt., N. & W. Ry., 250 Arcade Bldg., Roanoke, Va.

**ARE** you weary of the north?—Then come to Fruitland Park, Florida, a vicinity ideal for a home and for grapefruit and orange growing with big profits, where you can develop a grove with practically no expense and where the first crop you raise should pay for your land. For book of actual photographs and conservative data write today. Lake Co. Land Owners' Association, No. 93 Mack St., Fruitland Park, Florida.



**LANDOLOGY**, a magazine giving the facts in regard to the land situation. Three months' subscription, free. If for a home or as an investment you are thinking of buying good farm lands, simply write me a letter and say, "Mail me Landology and all particulars free." Address Editor, Landology, Skidmore Land Co., 40 Skidmore Bldg., Marinette, Wis.

**LANDS**—Northern Realty Company, Duluth, Minn., dealers in Northern Minnesota lands, timber; also iron lands.

**FREE Government Lands**—Our official 112 page book "Vacant Government Lands" lists and describes every acre in every county in U. S. Tells location, place to apply, how secured free. 1216 diagrams and tables, new laws, lists, etc. Price 25 cents postpaid. Webb Publishing Co., Dept. 71, St. Paul, Minn.

**SNAP**—5,000 acres good agricultural land, \$15.00 acre, easy terms, low interest and taxes; general farm crops, dairying, poultrying, trucking; delightful climate, neighbors, schools, churches; free booklet. W. Johnson, Pincora, Ga.

**MONEY-MAKING Farms**, 15 states, \$10 to \$30 an acre; stock, tools and crops often included to settle quickly. Write for Big Illustrated Catalogue, E. A. Strout Farm Agency, Dept. 3043, New York.

**FOR Sale**—10, 20 and 40-acre farms at Los Indios in the Isle of Pines, just off Florida Coast. Two crops a year. Soil and climate specially suited for growing big-profit fruits, such as grapefruit, avocados, etc. Delightful outdoor climate all the year around, 99% of land owned by Americans. Shipping rates low, market quickly reached, only deep water harbor at Los Indios accommodates ocean liners. Attractive terms, titles guaranteed. For further information address E. G. Allen, Room 72, 117 Wisconsin St., Milwaukee, Wis.

**100 ACRES**, Clover, Wheat and Corn land, 2 1/2 miles from Dover, Colo., on the Union Pacific, Fenced. With small house and other buildings, \$15 per acre. Geo. Hitzelner, Dover, Colo.

**FOR Sale**—Minnesota's finest Summer Resort, Money maker, Baker-Seaton, Andrus Building, Minneapolis, Minnesota.

**CALIFORNIA** little farms near Los Angeles for sale, easy payments. Write E. R. Waite, Shawnee, Oklahoma.

**CALIFORNIA** land \$1 per acre cash. Balance purchase 90c month per acre. Immediate possession given. No taxes, no interest. Level San Joaquin Valley. Only four hours from San Francisco. 5 acres up. Clear; ready to plow; open ditch irrigation \$1 acre per annum. Particulars, maps, photographs, free. Stevenson Colony, Desk D, 785 Market St., San Francisco.

**TEXAS** school land for sale by the state at \$3 an acre; 50 per acre cash, and balance in 40 years at 3 per cent; send 5c postage for further information. Investor Pub. Co., Dept. 4, San Antonio, Texas.

**FLORIDA**—Twelve-acre truck farm, improved, irrigated and water protection. F. C. Armstrong, Terra Cels, Fla.

A **SMALL** farm in California will make you more money with less work. You will live longer and better. Delightful climate. Rich soil. Hospitable neighbors. Good roads, schools and churches. Write for our San Joaquin Valley Illustrated folders free. C. L. Seagraves, Industrial Commissioner, AT&SF Ry., 1933 Ry. Exch., Chicago.

I **HAVE** a successful way of selling farms and farm lands. Write me for free particulars. No obligation whatever. Don't call. E. J. Zimmer, 925 Tower Bldg., Chicago.

**SELL** your property quickly for cash, no matter where located. Don't pay big commissions. Particulars free. Real Estate Salesman Co., Desk B, Lincoln, Neb.

#### DOGS, BIRDS, POULTRY AND PETS

**RAISE Guinea Pigs.** We furnish stock, show you how and buy all you raise. Big demand. Thousands needed yearly. Easy to raise, very prolific and profitable. Particulars and contract for two-cent stamp. Carles Distributing Co., 707 West 74th St., Kansas City, Mo.

**BOUNDS** for any game. On trial. Guaranteed. Three States Kennels, Somerset, Kentucky.

**BOYS**—Send \$1 for two pair white mice. Fine pets. Easily raised. Neat cages. Sell to your friends. R. I. Shaw, Yellow Springs, Ohio.

**BEAUTIFUL** colliers from imported and champion stock, farm raised sires and dams, fine workers, companions, Yearlings and pups. References. Testimonials. Maple Hill Farm, Lancaster, Wis.

**RAISE** skunks in city or country. Odorless method. Illustrated circular P free. Skunk Development Bureau, Chicago.

**SQUABS** are raised in one month, they sell for fancy prices. Write at once for big free book telling how to make money breeding squabs. Plymouth Rock Squab Co., 614 Howard St., Melrose Highlands, Massachusetts.

**RAISE** Canaries. Interesting and profitable business. Complete book on breeding, training, etc. Price \$1.00. Particulars free. B. Whritener, Oakland, N. J.

**LEADING** varieties Poultry. Eggs for hatching, stock for sale, prices reasonable. Catalogue free. H. P. Roth, Souderton, Pa.

**TRAINED** Rabbit Hounds, Foxhounds, Coon, Opossum, Skunk, Squirrel Dogs, Setters, Pointers, Ferrets. Catalogue, 100 Brown's Kennels, York, Pa.

"**HOW to Make 100-Egg Electric Incubator.**" Illustrated, 25c. E. Bailey, Kerrisdale, B. C.

**RAISE** Belgian Hares for U. S. Big profits. We furnish stock and pay you \$2.00 each. Also Carles, mink, skunk, fox, squabs frogs, etc. Two booklets and contract for dime. None free. Address the Belgian Hare, 31 Main Street, Holmes Park, Mo.

**EGG-O-HATCH** applied to eggs during incubation strengthens the chick and weakens the shell. It supplies free oxygen, absorbs the carbon dioxide and rots the shell. Makes better hatches of stronger chicks. Booklet free. Sample, treats 100 eggs, 10 cents. Package, treats 600 eggs, 50 cents, postpaid. Geo. H. Lee Co., 506 Lee Bldg., Omaha, Neb.

**COLLIES**—Stock, farm and watch dogs. Pedigreed; circular free. Nighborn Kennels, St. Peter, Minn.

**RAISE** Guinea Pigs. We furnish stock, show you how and buy all you raise. Big demand. Thousands needed yearly. Easy to raise, very prolific and profitable. Particulars and contract for two-cent stamp. Carles Distributing Co., 707 West 74th St., Kansas City, Mo.

#### PERSONAL

**ST-STU-T-T-TERING** and stammering cured at home. Instructive booklet free. Walter McDonnell, Room 48, 817 Fifteenth St., N. W., Washington, D. C.

**FREE**—Stop using Tobacco. Free. We will give free information how to conquer the habit easily and permanently. Results Guaranteed. Anti-Tobacco League, 618 Paxton Block, Omaha, Neb.

**MINERAL** Water. Looks like whiskey, keeps forever. Sufferers Skin, throat and stomach troubles: Stop taking drugs and order a 50c 30-dose bottle from A. L. Testers, Wynne, Ark.

**BROTHER**—Accidentally discovered root cures tobacco habit. Gladly send particulars. F. Stokes, Mohawk, Florida.

#### ANTIQUES AND RELICS

**MINERAL** Specimens and collections bought and sold. Specimens from 5c up. Send for list. Globe Mineral Co., Box 299, Beverly, N. J.

**2,500 ANTIQUE** firearms, China, Sheffield, furniture, List free. Antique Shop, 33 South 18th, Philadelphia.

**FLINT** Lock Guns and Pistols. War and Indian relics. Many other antiques. List for 2c stamp. Davis Brothers, Kent, Ohio.

**INDIAN** Beadwork and Curios. Largest collection of genuine Sioux work in the World. Send 10c for price list. Strong Curio Co., Gordon, Neb.

**INDIAN** Baskets, and Relics. Price free. Gilham, Highland Springs, Cal.

#### MISCELLANEOUS

**LUMINOUS** Paint. Shines in the Dark! Make your watches, clocks, electric switch plates, crucifixes, etc., visible at night. Latest discovery. Only 25c bottle. Circular free. Luminous Paint Co., Douglas Park Station, Chicago, Ill.

**BAMBOO** Fountain Pen: \$1. Free Trial, Self Filler, Gold Point, Unique Quality, Guaranteed. Millions will be sold; be among the first. Free trial. Acme Co., Monon Bldg., Chicago.

**RUBBER** stamps, sign markers, Catalogue 10c. Florida paper-shell pecan nuts \$1.25 lb.; samples 10c. Walter Karstaedt, Dayton, Ohio.

**PRINTING** Cuts—2x3, \$1.00. Joe Bek, 118 Gazette Ave., Lexington, Ky.

**GOLD** Teeth—10 cents (coin) each. Manly Foster, Newark, Ohio.

**GRANDFATHER'S** Clock Works, \$5. Slightly shop-worn, quantity limited, others with chimes, all prices; exceptional bargains. Clock Company, 1675 Ruffner St., Philadelphia, Pa.

**FALSE** Teeth—When you break your plate in any way, mail it to me and I will repair it like new for \$1.50. M. Wagner, Dental Laboratory, Phelan Bldg., San Francisco, Cal.

**TATTOOING** Outfits, \$1 up. Electric and hand. Roberts Company, 635 West Ave., Buffalo, N. Y.

**ESCAPPI** King's set of Three Keys will open most ordinary doors, 25c complete set. Padlock Opener, 10c. Chicago Novelty Works, 3310 North Herndon St., Chicago.

**BUY** your hats direct from factory. Panamas and felts for men and women. Send for catalog. The A. C. Wilson Hat Co., Orange, N. J.

**CUTS** anybody can make. Simple, cheap process. Specimens, particulars for stamp. M. Day, Windfall, Ind.

**LOCKSMITHS.** How to unlock cylinder and all locks. 100 tricks of the trade \$1.00; money back if dissatisfied. Routson, 2005 Brook St., Oakland, Cal.

**TATTOOING** Supplies. Write at once for my Catalogue. Don't be fooled by amateur manufacturers and imitators. Only reliable machines and outfits manufactured. Prof. J. Barber, 70 1/2 Brush St., Detroit, Mich.

## WEBSTER'S NEW INTERNATIONAL DICTIONARY

G. & C. MERRIAM CO., SPRINGFIELD, MASS.

Please send me specimen pages and FREE POCKET MAPS

NAME

ADDRESS

Whatever your question;—be it the pronunciation of a new term; the spelling of a puzzling word; the location of Nigeria, the meaning of tractor, white coal etc.—this New Creation contains a clear, accurate, final answer.

REGULAR AND INDIA-PAPER EDITIONS

Pop. Mech.



Over 400,000 Words Defined  
2700 Pages  
6000 Illustrations



# YOU ARE WANTED

at a **BIG SALARY!** GET READY FOR PROSPEROUS TIMES



**CHARLES W. MOREY**  
President of the College  
Head of the firm of  
Charles W. Morey & Co.,  
Consulting Engineers.



**WM. T. HOOPER**  
Architect, Vice-Pres.  
of College, Head of  
Dept. Architecture.



**E. OTTOMANN, Jr.**  
Consulting Engineer  
Secretary of College



**M. M. CASE**  
Consulting Engineer  
Head of Mechanical and  
Electrical Depts.

Prosperous times are coming—they're here now. Far-seeing men are getting ready for boom times. You can—you must—share in this prosperity. You will if you are ready. Training is the key.

**Here are men who can help you** The men at the head of this school are doing real work—big work—every day. They are in active touch with big contractors where trained help is needed. They conduct their own offices and are in charge of important construction work at all times. They are the men you get to know personally. Let them help you to

## Earn from \$3000 to \$5000 a Year.

You can do it. There is such a position for you if you have the training. All branches of **DRAFTING, ENGINEERING** (Civil, Electrical, Mechanical, Architectural) are calling for trained men. We can't fill all the applications we get. If you will put in your spare hours in study for a short time we will help you.

**HERE'S  
YOUR  
CHANCE  
TO LEARN**

# DRAFTING

Hundreds of men are in daily attendance in the day and evening schools of the College. In your own home you can do the same work these men are doing and the same experts that teach them will teach you. These well known architects and engineers know exactly the practical training you need, and they train you—they prepare your instruction matter—your work is examined and approved by them.

### **STUDY AT HOME** Your Spare Time is Enough

It will cost you nothing to get full information; an inquiry will not obligate you in any way. It is up to you and you alone whether you fit yourself for the big job—whether you draw the big pay. Let us make you a big earner. Prosperity and opportunity are here NOW. Fit yourself to grasp big things. Sign, tear and mail the coupon now.



Complete \$15 Drawing Outfit **FREE**

**MAIL COUPON TODAY!**

**CHICAGO TECHNICAL COLLEGE**  
1050 Lake View Building, Chicago, Ill.

A few readers of this magazine—only a few—who are prompt in making application will secure a

### **\$45 Scholarship Free** In Mechanical Drawing.

This offer will be withdrawn as soon as the limited number of scholarships have been awarded.

## BIG SALARY COUPON

**CHICAGO TECHNICAL COLLEGE**  
1050 Lake View Building

Without any obligation on me, please send me full particulars about your **FREE SCHOLARSHIP**.

I have marked subject in which I am interested.

- Machine Drafting
- Electrical Drafting
- Architectural Drafting
- Structural Steel Drafting
- Builders' Course
- Plan Reading
- Estimating
- Sheet Metal Drafting
- Civil Engineering
- Surveying

Name .....

Address .....

Town.....State .....

College or Home Study?.....

Please Mention Popular Mechanics



# 414 PAGES 145 ILLUSTRATIONS

I.C.S.  
ELECTRICAL ENGINEERS  
HANDBOOK

# 50¢

## ELECTRICITY!

HERE'S just the book on Electricity that you need to answer your many questions—to solve your knotty problems, to teach you new kinks, to be your memory for tables, rules, formulas and other Electrical and Mechanical facts that some people try to carry in their heads—and fail.

With this "Little Giant" I. C. S. Electrical Engineer's Handbook in your pocket, tool chest, on your work bench, drawing table or desk, an hour or a day need not be lost "digging up" some forgotten rule, some unfamiliar fact; you'll just turn to the very complete index and get

it "in a jiffy." Just a few of the subjects treated are:

Electricity and Magnetism; Electrical Symbols; Batteries; Circuits; Magnets; Direct and Alternating Currents; Dynamos and Motors; Belts; Shafting; Electroplating; Electrical Measurements; Meters; Arc and Incandescent Lamps; Mercury Arc Rectifiers; Transformers; Insulation; Electric Cars; Single and Multiple-Unit Control; Transmission; Rail Welding; Tables of Wires—Sizes, Capacities, etc.—Mathematical Rules, Formulas, Symbols; Tables of Constants, Equivalents, Roots, Powers, Reciprocals, Areas, Weights and Measures; Chemistry; Properties of Metals; Principles of Mechanics; First Aid, etc.

The Electrical Engineer's Handbook is one of 22 I. C. S. Handbooks covering 22 Technical, Scientific and Commercial subjects, all crowded with value. They have the contents of a full-size book condensed into pocket-size ready to go with you anywhere and be at your instant command. They are substantially bound in cloth, red edges, goldleaf stamping, printed from new, clear, readable type on good quality book paper. There is an illustration at every point where a picture will help. Hundreds of thousands have been sold on a money-back guarantee of satisfaction.

The regular price is \$1.25, but for a LIMITED TIME you can buy the ones you want, postpaid, delivery guaranteed, for only 50 cents each.

You Run No Risk! Money Back if Desired!

International Correspondence Schools

Box 5554, Scranton, Pa.

### INTERNATIONAL CORRESPONDENCE SCHOOLS

Box 5554, SCRANTON, PA.

I enclose \$\_\_\_\_\_ for which send me postpaid the Handbooks marked X, at 50c. each. I may return any or all and get my money back within ten days from receipt:

- |   |   |
|---|---|
| <input type="checkbox"/> Electrical Engineer's          | <input type="checkbox"/> Advertiser's               |
| <input type="checkbox"/> Teleph. and Telegr. Engineer's | <input type="checkbox"/> Business Man's             |
| <input type="checkbox"/> Mechanic's                     | <input type="checkbox"/> Bookkeeper's               |
| <input type="checkbox"/> Steam Engineer's               | <input type="checkbox"/> Steno. and Correspondent's |
| <input type="checkbox"/> Westinghouse Air Brake         | <input type="checkbox"/> Salesman's                 |
| <input type="checkbox"/> Civil Engineer's               | <input type="checkbox"/> Window Trimmer's           |
| <input type="checkbox"/> Coal Miner's                   | <input type="checkbox"/> Cotton Textile Worker's    |
| <input type="checkbox"/> Concrete Engineer's            | <input type="checkbox"/> Farmer's                   |
| <input type="checkbox"/> Building Trades                | <input type="checkbox"/> Poultryman's               |
| <input type="checkbox"/> Plumber's and Fitter's         | <input type="checkbox"/> Mariner's                  |
| <input type="checkbox"/> Chemist's                      | <input type="checkbox"/> Automobile                 |

Name \_\_\_\_\_

Street and No. \_\_\_\_\_

City \_\_\_\_\_ State \_\_\_\_\_

## WANTED MEN FOR RAILWAY MAIL SERVICE

BOOK FREE  
WRITE TODAY

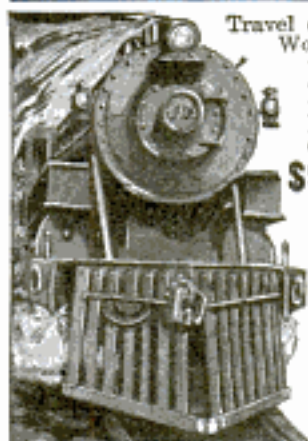

Travel everywhere. See the country. Work a week, then have a week off with full pay. 15 days' vacation each year with full pay. No politics, no "pull", no strikes, no hard times, no straw bosses, easy work.

### \$900 to \$1800 Per Year

Uncle Sam pays \$75 to \$150 per month with excellent chances for promotion. The money comes regularly — you have no fears of being out of work. Only American Citizens 18 or over, 5 feet 5" tall or over, weight 130 pounds or over, are eligible to examinations. If you qualify on these points, get in touch at once with Arthur K. Patterson, for 8 years U. S. Civil Service Sec'y-Examiner. Let him prepare you for coming examinations, as he has prepared thousands of others.

**JOBS OR NO PAY** Mr. Patterson agrees to refund the small fee for his preparation if you are not employed by the Government after taking his course. You risk nothing. Arthur L. Johnson, Hammondsport, N. Y., was appointed 10 days after rating was received.

**Free Book Tells All** Read why Railway Mail Service offers such wonderful opportunities; get facts about Patterson preparation and guarantee of position or no pay. Examinations coming without fail. Just write postal quick—NOW—for free book of facts. No obligation. Do it NOW. Address

**Patterson Civil Service School, 302 News Bldg., Rochester, N. Y.**



### Boy Craftsman

10c Tells how to make all kinds of Toys. New Book just printed. How to make Canoe, Railroad Model, Talking Machine, Telephones, Electric Motor, Bicycle Boat, Pocket Flashlight, and hundreds of other things. Fully illustrated. Sent postpaid for 10c. 4 for 25c.

NATIONAL CO., 3422 Lyndale Ave., Dept. 38, CHICAGO

### SPEAK A FOREIGN LANGUAGE!!!

The War has created unlimited opportunities for those who know Spanish, French, German or Italian. Better your position or increase your business. You can learn quickly and easily, at home, during spare moments, by the



### LANGUAGE-PHONE METHOD

And Rosenthal's Practical Linguistry

(Highest Award Panama-Pacific Exposition, 1915)

You listen to the living voice of a native professor pronounce the foreign language, over and over, until you know it. Our records on all talking machines. Write for Booklet, particulars of Free Trial.

The Language-Phone Method, 951 Putnam Bldg., 2 W. 45th St., N.Y.

### Auto and Tractor School

Oldest, best equipped; positions for graduates; conducted by Kansas City's first auto mechanic; 2 blocks east of Union Station. Call or write

CLIFF HOGAN, Director

KANSAS CITY AUTO SCHOOL

2328 Grand Ave. KANSAS CITY, MO.

### Cartoonists, Illustrators, Designers, Art Supervisors, and Students everywhere

heartily endorse **The Student Illustrator**

The best art magazine published. Every branch of cartooning and illustrating thoroughly covered by experts. Full of instruction, inspiration and advice. Per year.... **\$1.00**

Dept. B, Schwartz Bldg., Washington, D. C.

Please Mention Popular Mechanics





VIOLIN

Taught by Mr. C. W. Wilcox, who has had as wide an experience in the use of this instrument and in its instruction as any other violinist of note in America.



PIANO AND ORGAN

Taught by John Koehler, who studied under Amadeo van der Hoya, a favorite pupil of Rubenstein.



MANDOLIN, GUITAR

Also Banjo. Taught by Mr. Myron A. Bickford, who is without doubt the foremost authority on these instruments in this country today.



CORNET

Taught by A. H. Knoll, famous from ocean to ocean as a soloist and bandmaster. Awarded \$200 in gold at Detroit, Mich., in contest, leading all his competitors.



HARP

Taught by Melville A. Clark, who took up the study when 7 years old. Has appeared before vast audiences. Has prepared wonderful instruction for our pupils.



SIGHT SINGING

Taught by Madame Newman, who perfected her musical education under world-famous teachers. Has had classes of over a thousand pupils.

# LEARN MUSIC AT HOME

## EASY LESSONS FREE

Learn from Master Musicians, how to play by Note, the Piano, Organ, Violin, Guitar, Banjo, Mandolin, Harp or Cello, Piccolo, Clarinet, Trombone, Flute, Sight Singing. Send Coupon Today.

No longer need the ability to play music be shut out of your life! Now, at last you can learn music at home from master musicians without coming to New York and without having a teacher at your elbow. By our wonderful home study method we have made it easy for you to play by note the Piano, Organ, Violin, Banjo, Mandolin, Guitar, Cornet, Cello or learn Sight Singing. And just think! You learn by note, by our new, easy method, in your own home, in a remarkably short time, without paying a cent for lessons. No tiresome "dry" exercises, no inconvenience, no trick music, no "numbers," yet simple, wonderful, easy for even a child.

## 200,000 People Taught

Learning music successfully by our Home Study method is a positive, proven fact. Thousands who never knew one note from another before taking the lessons have developed into expert musicians. The average yearly enrollment for the past two years has been over 25,000 pupils. We grade you before you start and fit the instruction to your special needs. A beginner gets entirely different lessons than one who has had lessons. If you came here to New York to study under the members of our faculty personally, you would have to pay \$5 to \$10 a lesson. Yet on our special offer, explained below, these same teachers will give you lessons in your own home through our wonderful Courses—FREE! And their home study lessons, instead of being a drudge, are so interesting, so truly fascinating that hundreds of pupils write: "I can hardly wait for the next lesson."

### Wonderful Free Offer

We want to have one pupil in each locality at once to help advertise our wonderful easy system of teaching music. For a limited time we are therefore making a special advertising offer, to teach you music in your own home FREE! The only cost is for postage and sheet music, which averages 12½¢ weekly. We can do this because our course makes friends—pupils recommend it to others and then we make our profit. We make this offer only on condition that you tell your friends how you learned to play and that you give them our name and address when they ask you. This special offer may be withdrawn at any time. If you write at once, you will be assured of getting the lessons free.

### Mail Coupon To-day

Let us send you our new 24-page book, which describes the secret principles of our wonderful New System of Music Teaching from beginning to end, and contains scores of letters from pupils who have become expert players as a result of the Course. We cannot explain this great plan here—you must see the book. It's Free. Clip the coupon and mail it to-day or send a postal card before you turn this page and forget.

**U. S. SCHOOL OF MUSIC**  
Dept. 132 225 Fifth Avenue, NEW YORK

### What People Say

#### WONDERFUL SYSTEM

"I just got home from my vacation, and the folks at home are delighted to hear me play the organ so well. They say you have a wonderful system of teaching music."

—M. F. ALLARD, Carquet, N. Y.

#### LESSONS ARE FINE

"Since I've been taking your lessons I've made over \$60.00 with my violin. Your lessons surely are fine."

—MELVIN VERRELAND, Macopin, N. J.

#### PLAYS ANYTHING

"I finished your course of lessons on Cornet. Some time ago I intended writing to let you know how I got along. When I started then I knew nothing about the Cornet or Music, but now I can play almost any piece of music."

—KASSON SWAN, Denmark, Col. Co., Nova Scotia.

#### HEARTIEST APPROVAL

"I want to extend the heartiest approval of your Piano Course. It has done more for me than years of other lessons. So complete in every way. I certainly can recommend it to others, and certainly will do so."

—MORRIS N. LEWIS, 319 Jefferson, Neosha, Mo.

NOTE: These are but a few of the thousands of enthusiastic letters sent in by pupils. Our free book contains many more. Send coupon or postal today

## FREE LESSONS COUPON

**U. S. SCHOOL OF MUSIC**  
Dept. 132, 225 Fifth Ave., New York

Please send me your free book, "Music Lessons by Mail," explaining how I can learn to play for 12½¢ weekly. I would like to learn how to play the instrument checked.

Piano  Violin  Guitar  Harp  Banjo  
 Cornet  Sight Singing  Mandolin  Cello  
 Organ  Piccolo  Clarinet  Flute  Trombone

Put an X in the square before the instrument you want to play.

Name.....

Address.....

City..... State.....





# Come to Detroit

## The Automobile Center and

DETROIT

trained men get preference and get jobs quickly. No other city can give what Detroit offers. Think what it

means to learn in the Michigan State Auto

School. Factories endorse our school, glad to employ our graduates or offer them territory in which to sell cars and start garages. Unlimited opportunities.

You're right in the Heart of the Auto Industry. Men are needed everywhere as testers, repair men, chauffeurs, garage men, and salesmen. Hundreds of our graduates start in business for themselves.

## Earn \$75 to \$300 a Month

33,000 sq. ft. of  
Additional  
Floor  
Space

We teach you to handle any auto proposition. You graduate in from ten to twelve weeks. Our equipment is new, up-to-the-minute, and complete.

No old, obsolete motors, chassis or electrical equipment used. Students actually build cars from start to finish, getting factory training in assembling, block-testing, road-testing, everything. Special complete course in Oxy-Acetylene brazing, welding and cutting, separate from regular course. All leading types of starting, lighting and ignition systems in operation. Learn to time motors, rebore cylinders, adjust carburetors, magnetos, valves and

bearings quickly and accurately. Six-cylinder Lozier, Chalmers "6," Detroit "6," Overland, and 8-cylinder King are used for road instruction. We have a new Chalmers "6-30" chassis with 3400-r. p. m. motor, the latest thing out, Willys-Knight 1917 chassis, Saxon "6," 1917 chassis, Studebaker "6" 1917 chassis, Maxwell 1917 chassis, Hudson Super-Six 1917 chassis, Oldsmobile "8" 1917 chassis, Cole "8" 1917 chassis, Buick 1917 chassis, Detroit Electric 1917 chassis, Winton "6" chassis. All completely equipped for students to work on. We have more than 25 motors in our block test department—2 cyl., 4 cyl., 6 cyl., 8 cyl., and 12 cyl. Our electrical department is complete, having every standard starting, lighting, and ignition system, including Delco System as used in Buick, Hudson, and Packard Twin "6."

## Detroit Is the Place to Learn—Start Any Time

There are 44 auto factories in Detroit and 140 accessories and parts factories. Our students have the privilege of going through any or all of them. We now operate Westinghouse, Auto-Lite and Bijar Service Stations. This has added thousands of dollars' worth of equipment and makes our electrical department unequalled. Students get actual experience and training in handling all kinds of electrical auto equipment and taking care of trouble. We have just installed a Sprague Electric Dynamometer for block-testing purposes for students' use. The Michigan State Auto School is the only Auto school having this equipment.

Auto factories need Dynamometer men constantly. Factories and garages are paying big salaries to men who know how to handle electrical equipment quickly and properly. Detroit is the automobile center. You get practical instruction. Come to our school and learn the auto business right. School open all the year. Enter classes any time, any day. Three classes daily: morning, afternoon, evening. There is a great demand for Michigan State Auto School students. Garages throughout the country write us for men. Auto factories write and phone for men constantly to fill permanent places.

Follow the Crowd to the Michigan State Auto School. Come to Detroit

### Money-Back Guarantee

We guarantee to qualify you in a short time for a position as chauffeur, repair man, tester, demonstrator, garage man, or automobile dealer, paying from \$75 to \$300 monthly or refund your money. We have constantly more requests for Detroit trained men at GOOD salaries than we can supply.



THIS IS ONE OF THE JANUARY 1916 CLASSES

### Additional Building and Equipment

33,000 sq. ft. of additional floor space, thousands of dollars' worth of new equipment, plenty of room for students to work, at 687-89-91 Woodward Ave., which we are now occupying in addition to our building at 11-19 Selden Ave. Our school has grown by leaps and bounds, students come from all over the world. Men have left after graduating and started in business for themselves; others have accepted good jobs both in Detroit and over the country. Their work has proven that we train them right. We are constantly adding new equipment. Our electrical department is thorough and complete and in charge of the most competent instructors.

### Factory Co-Operation

We have completed arrangements with the Auto factories to put them in touch with men who intend going into business for themselves. Think of getting inside information. The factories are looking for trained men to represent them. Men who know the auto business from A to Z are in biggest demand. Come here and start right—get the information first-hand and don't wait. Remember, you can enter classes any time, any day. The price of course is based on giving full value. Graduates in the complete auto course are competent to handle farm tractors.

Act Quickly—Now—Don't Wait

### SEND THIS COUPON TODAY

**MICHIGAN STATE AUTO SCHOOL**  
302 Auto Bldg., 687-89-91 Woodward Ave.  
DETROIT, MICHIGAN, U. S. A.

Gentlemen: Send me absolutely FREE "Auto School News" and New Catalog or better still, you can expect

me about.....

Name.....

Street.....

Town..... State.....

Fill in the coupon and mail it now; get full particulars, get "Auto School News" and New Catalog. They are both absolutely free. Or better still, jump on the train, as hundreds have done, and come to Detroit, the "Heart of the Automobile Industry," and learn right. We have no branches. Write or come direct to this school.

## Michigan State Auto School

The Old Reliable School A. G. ZELLER, Pres.  
302 Auto Building  
687-89-91 Woodward Avenue  
DETROIT, MICHIGAN, U. S. A.

### DETROIT THE HEART OF THE AUTO INDUSTRY



44 AUTOMOBILE FACTORIES 140 ACCESSORY FACTORIES



**EARN \$75. TO \$300. A MONTH**

With the New Building and Thousands of Dollars Worth of New Equipment, Our's is the Largest Exclusive Auto School in the Country



We teach the newest and best way to re-bore cylinders as a part of the complete Auto Course. No need to have big, heavy, expensive machines. This is very important instruction.



These men are getting final instructions after they have taken down and rebuilt a new up-to-date 6 cyl. motor.

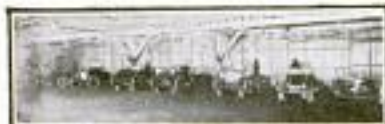

This is a partial view of our Chassis room showing eight up-to-date chassis for students' use.



A new 12 cyl. motor connected to our Sprague Electric Dynamometer in Block Test Dept. for students' use.



**DECEMBER 1916 CLASS IN MECHANICAL LECTURE ROOM**

This is the first work a student receives. A 6 cyl. 1917 Saxon "Cut-open" chassis is used to make perfectly clear and practical the first instructions. There were 350 men set for this picture. The Electrical Lecture room is the same size. The classes are divided so that more intense work can be done on each subject. Every man is given personal help and his progress through the school is watched carefully.



This is a section of the Brazing, Welding and Cutting Department. Each man handles the torches and works with an individual outfit.



View showing about 18 motors in the Block Test Department. Sprague Electric Dynamometer shown in center background.

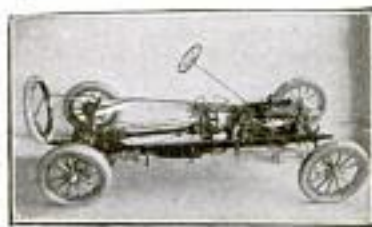

A close view of Saxon "Cut-open" chassis used in Mechanical Lecture room. Hidden parts are cut open and electric lighted.



Students getting personal instructions on Willys-Knight 1917 chassis.



Students making final test on Maxwell 1917 unit power plant motor.



Complete working Delco System as used in Buick, Hudson, and Packard Twin "6."

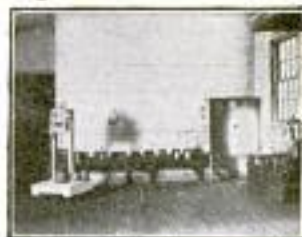

Battery Charging room, showing high ed switchboard and distilled water rack.

These cuts were all made from actual photographs taken in our school.

**Use the Coupon** on left-hand page **—DO IT NOW** **Don't Even Hesitate**



# Marking the Coupon

**T**WENTY years ago, in the city of Boston, a group of men met to discuss an educational problem. A new condition of affairs had come into existence. In many lines of business it was a vital necessity to find more trained men. The progress of these businesses was slow because trained men could not be found. For economic reasons, it was impractical for a large percentage of the population to attend residential schools.

There was a crying need for a new system of education that would bring thorough training to ambitious men at a trivial cost.

The result of this conference was the founding of the American School of Correspondence. In 1897, under the laws of the Commonwealth of Massachusetts, this now world famous school was chartered as an educational institution.

## The Vital Need of Training

**T**HE need for trained men that the founders of the American School saw in 1897, is more evident today than ever before.

All lines of business are like giant armies. At the sound of a martial air hundreds of thousands will rally to the colors. Yet, without skilled officers, the efforts of these patriots offer but puny resistance to an organized attack directed by officers who have learned the game of war.

In modern business the privates are the untrained men who hold the smaller positions. The men who direct the work of the "privates" are trained men. They know the "Reasons why" and have a thorough, broad and comprehensive understanding of the entire business.

It is men like this that are needed.

One "man who knows" can direct the work of hundreds of skilled workmen.

Modern business like armies, needs thousands of officers. Even though the master mind of the general may conceive the plan for accomplishing certain work, and even though the privates be men who know how to shoot and how to march, thousands of colonels, majors, captains and lieutenants must direct the work of these privates and see that the privates carry out the orders of the general, or the army is a failure.

It is lieutenants, captains, majors and colonels that are needed in a modern business.

## You Need More Than Skill

**A**ND it does not necessarily follow that because a man is a good workman that he will become "a good boss." A man can become so skilled in the operation of a machine that his work will be considered perfect. Yet, if he has not the fundamental, broad, comprehensive knowledge of what the business is doing he cannot become "the boss." Of course, a knowledge of the work the employes are doing is vitally important, and skill in doing this work is one of the most valuable assets that a man can have.

But skill alone is not enough to make a man "the boss." To get the broad, comprehensive knowledge of the business and to understand why each operation is necessary, a man must have training. Some men are trained to become leaders before they enter business. Others become workmen first and these men, who have the practical experience will find golden opportunities through the course of training in the American School.

For twenty years the faculty of the American School have been giving men the kind of training that they need in order to hold the higher positions. They have investigated every line of business in which they offer courses to ascertain just exactly the knowledge that a man must have in order to lead. This is compiled into small,

**American School**  
of Correspondence, Chicago, U.S.A.



# —and What it Means

compact lessons and written in simple, easily understood English so that a man can grasp it instantly during his idle hours.

## The Reward of Training

**T**HE hours that are spent in getting this fundamental training are repaid many, many times over. Skilled men are paid higher salaries.

If you were to calculate the number of hours that were required to attain the training and the advance in salary that this training brought about, you would find that the hours spent in study were the most richly rewarded in a man's life.

The educational standard for men who hold higher positions is becoming higher each year. Employers are demanding more because the rate of competition is harder. Employers are buying the finest materials and the finest machinery. To direct the work of this fine machinery and to use these fine materials, more skilled employes are needed.

But what is more important: highly skilled men with practical experience who have a broad, comprehensive knowledge of the business, must be found to *direct* the work of these employes.

Today there are golden opportunities for every ambitious man in America to answer the call that is being sent out for trained men. The American School offers the way for you to get that training during your idle hours.

## The Way Is Well Marked

**D**URING the last twenty years thousands and thousands of men have found their way to success through the courses of training offered by the American School. The home study offered by this institution is not untried. Students from all over the world have read the words of inspiration that were written in our advertisements. They made their marks in coupons, re-

ceived the bulletin and today are filed still with thousands of letters that tell stories of success.

Everywhere you look, in every line of business, you will see how men have risen to high positions by getting broad, comprehensive training in addition to their practical experience. What these men did points the way for you. The same men who worked to put other men into high positions, are waiting to serve you. After years of study, we know just the things that you need in order to obtain a high position. Now they are offered to you. It is not necessary to give up your present employment or make a drudge of yourself.

Just make your mark in the coupon now. Check the position that you want to fill and we will tell you how you can fit yourself for it during your idle hours. You will be under no obligation.

## Make Your Mark In the Coupon

**W**HY postpone sending the coupon another hour? All about you is the proof that the only way to success is thorough *training*—and this coupon brings you a vital, inspiring story of how to get that training right in your own home. Others have shown the way.

Making the coupon has meant the dawn of a golden day to thousands all over the world. Their successes are beacon lights to guide you.

And they are calling this very hour. Your ambition is calling you. Opportunity is at your door and saying, "send the coupon—it has meant a great deal to others." Find out what it will mean to you.

Sending the coupon puts you under no obligations. Send it now. Just put an "X" before the position you want to fill—and we'll tell you how you can fit yourself for it. Send the coupon.

American School of Correspondence, Dept. G1192 Chicago, U. S. A.

Gentlemen: Please send me booklet and tell me how I can fit myself for the position marked X.

..... Electrical Engineer	..... Business Law
..... Elec. Light & Power Supt.	..... Business Manager
..... Hydroelectric Engineer	..... Auditor
..... Telephone Engineer	..... Accountant
..... Architect	..... Cert'f'd Public Acc't
..... Architectural Draftsman	..... Stenographer
..... Building Contractor	..... Bookkeeper
..... Building Superintendent	..... Fire Ins. Inspector
..... Structural Engineer	..... Fire Ins. Adjuster
..... Structural Draftsman	..... Fire Ins. Expert
..... Mechanical Engineer	..... Sanitary Engineer
..... Mechanical Draftsman	..... Master Plumber
..... Civil Engineer	..... Plumbing & Heating Est.
..... Steam Engineer	..... Heating & Vent. Engineer
..... Shop Foreman	..... Reclamation Engineer
..... Shop Superintendent	..... Automobile Engineer
..... Sheet Metal Draftsman	..... Automobile Repairer
..... Lawyer	..... High School Course

We also prepare for civil service examinations in all engineering subjects

Name.....

Address.....

**American School**  
of Correspondence, Chicago, U.S.A.

Dept. G. 1192



## 30 DAY COURSE IN TIRE REPAIRING FREE

Complete Tire Repair Outfit  
Less Than \$250.00

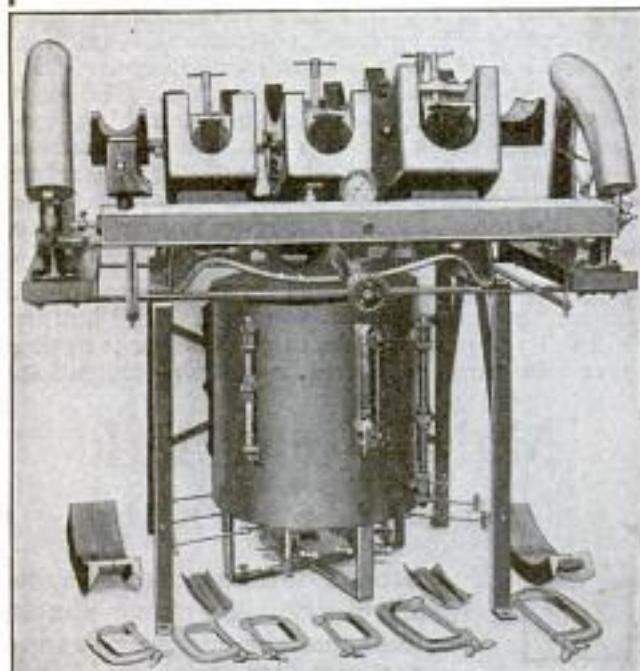

With this outfit and our course of free instruction, you can start up a good business.

## Learn to Repair Tires

Bigger opportunities than in any other branch of the Auto business. A broad claim, but easy to prove. Only stop and think!—you know it's true. Listen! Not one single Auto factory can build cars fast enough. Everybody is car crazy, and the craze is growing. 2,000,000 autos now in use. Four tires to each car. That means 8,000,000 tires to repair. Just think of it—8,000,000 tires! Each car wears out its cost in tires alone. Punctures and blowouts are common. Vulcanizing, patching, retreading, etc., must be done. Retreading alone—the new and better process—brings big money.

## Earn \$3000 to \$8000 a Year

Begin now. In almost every city, town, village, and cross corners, there is a fine chance to start. We know the places and put you next. Just a little money starts you in a business of your own. We guarantee to make an expert of you in 30 days free of charge. Write today for free catalog, or why not take a run over to Detroit and investigate personally? Don't let the chance slip by. Investigate now.

### Reliable Tire Repair School

102 Reliable Bldg., DETROIT, MICH.

FATHERS! This is a great opportunity for that boy of yours. Start him in the Tire Repair business. You'll always be glad. When in Detroit, look us up. We'll be glad to show you through.

#### COUPON

RELIABLE TIRE REPAIR SCHOOL

Send me your free catalog and full particulars about the tire repair business.

Signed.....

Address.....

P. M.

Please Mention Popular Mechanics

Only 10 easy lessons  
bring speed of 80 to  
100 words a minute  
guaranteed.

# The Newwrite Way

A WONDERFUL new method of acquiring skill on the typewriter has been discovered. Already thousands of stenographers and other typewriter users who never exceeded 30 to 40 words a minute are writing 80 to 100 words with half the effort and with infinitely greater accuracy than they ever could before and they're earning salaries increased in proportion.

## Earn \$25 to \$40 Per Week

Special *Gymnastic* Finger-Training Exercises bring results in *days* that ordinary methods will not produce in *months*. Among the thousands of operators who have taken up this system are hundreds of graduates of business colleges and special typewriting courses—many were so-called touch writers—yet there has not been a single one who hasn't **doubled** or **triple** his or her speed and accuracy, and the salaries have been increased from \$8 to \$15 a week (their former salaries) to \$25, \$30 and even \$40 weekly. And the New Way is *amazingly* easy for anyone—there are only ten lessons and they can be quickly learned at home.

### FREE—Wonderful New Book

If you are ambitious to get ahead—if you want to make your work easier—if you want to put more money in your pay envelope—get this book at once. It will be a revelation to you as to the *speed* and *salary* that are possible to typists. Address

THE TULLOSS SCHOOL, 122 College Hill, Springfield, Ohio

STUDENTS

## ART MAGAZINE

Publishes cash art assignments, lessons and articles on Cartooning, Designing, Illustrating, Lettering, and Chalk-Talking. Criticizes amateurs' work. Full of interesting and helpful information for artists and art students. Satisfactory or money refunded. 10 cents a copy. \$1 a year.

Send \$1 NOW, stamps or bill.

STUDENTS ART MAGAZINE, Dept. 234, Kalamazoo, Mich.

## LEARN TO WRITE ADVERTISEMENTS EARN \$25 to \$100 A WEEK

We can positively show you by mail How to increase your salary. BOOK MAILED FREE.

PAGE-DAYES CO., 112 Page Building Chicago, Ill., or 159 Nassau St., New York

## LAW STUDY AT HOME

Complete Resident University Course by mail. Also Lawyers' Law Course. LL.B. Degree conferred. Indorsed by Bench and Bar. Strong Faculty of Distinguished Jurists and Lawyers. Catalog Free.

Oklahoma City University, 306 Concord Building, Oklahoma City, Okla.

## Learn How to WRESTLE

In Your Own Home By Mail

Yes, learn to become an expert wrestler right in your own home, by mail, from the greatest wrestler the world has ever known. Be an athlete, be strong, be healthy. Learn how to throw and handle big men with ease. Learn to defend yourself. All taught in our course of lessons, and illustrated with hundreds of charts and actual photographs by

### Farmer Burns and Frank Gotch

Farmer Burns, "the grand old man of the mat," taught Frank Gotch, the present World's Champion, all he knows about wrestling. So Gotch says. He will now teach you Scientific Wrestling—Physical Culture—Jiu-Jitsu—Self Defense. Every man and boy in America, no difference what age, needs this wonderful course of lessons. Write today—your name, age and address on a postcard or letter brings you our free book absolutely free—no obligations of any kind. A splendid book on wrestling and physical culture. Write today asking your copy.

Farmer Burns School of Wrestling, 1192 Range Bldg., Omaha

This Wrestling Book FREE



# You Men Who Want to Find Success Through ELECTRICITY

Three minutes spent in reading this article will be well repaid



Dr. Charles P. Steinmetz, A.M., Ph.D.  
Chairman Advisory Board  
New York Electrical School

"There is an enormous field for the electrical worker"—says Dr. Charles P. Steinmetz, the foremost Electrical Engineer in the world, whose salary with the General Electrical Company is reputed to be over \$100,000.00 a year.

It is indeed an enormous field—a field of unlimited opportunity—a field which has hardly as yet begun to grow. With all the modern applications of electricity to railroads, transportation, power drive, automobiles, telephones, telegraphy, signalling, lighting, heating, household conveniences, and thousands of other applications, new uses are still being rapidly developed.

There are, in fact, more big money-making opportunities in this field today than there are men trained to fill them. Men ask us about the opportunities for success in the electrical field. We have seen hundreds of men with little or no electrical experience and other men, who for years had been plodding along in an electrical rut, go out into the world after a few months of proper training, and start to make things hum. We have hundreds of letters from just such men. Here is what some of them say:

## Letters from Successful Men

"I have done well since leaving school and am now Superintendent of the light, telephone and steam heat company here."

"Ten months after I left you I was given charge of this station. I saved at least 3 years by taking your course instead of working up as an apprentice."

"I have been in the contracting business here in Aven since Jan. 1st, 1914, and am doing fine."

"I have sole charge of all motors, lights, electrical devices and appliances, and in being able to hold this position I give all credit to the New York Electrical School and your personal interest in me, which until lately I did not realize would be so wonderfully beneficial to me."

"We had no electrical experience before taking your course and just one year since leaving school are working side by side with men of from five to ten years' experience."

"I am thanking you for the service you did for me while attending school as I accepted a position as Sales Engineer for the New England Appliance Co., of Boston, Mass. My position takes in all of New England territory."

"Since graduating from your school, I have been able to handle successfully any problem that has come before me in my line of electrical work and I wish to express my feelings for the school and its methods of training."



The New York Electrical School

What is this school which gave these men and four thousand five hundred others such a splendid start in the electrical field? It is the NEW YORK ELECTRICAL SCHOOL. It is like no other school or college in the country. It is a school which cuts out long years of apprenticeship or long years of study by its unique method of instruction—the "learn by doing" method.

**Learn by Doing** To learn Electricity you must handle the actual apparatus with the help of a practical man who knows. You must do the real work which you will be paid for later on. In other words you must learn by doing. That is the method of the New York Electrical School—a method proved successful by our graduates.



In the New York Electrical School you learn in a few months—seven months is the usual time required—what would take you years to learn plodding along in an electrical apprenticeship. You waste no time doing over and over again the same old task. You go ahead all the time. Here at the New York Electrical School you are doing something different every minute, and you do everything thoroughly.

You do the actual work. If you are learning to wire a house you have actual floors, walls and ceilings in an actual ten-room apartment to work with. If you are learning how to run compound generators in parallel, you have the same type of machine and the same type of load as used in power houses. The work you do is actual work, and you learn to do it right. All the time a competent instructor stands behind you to see that you miss no point of importance.

Don't you think that with this kind of training you are assured of success in the electrical field?

Our course begins with primary cells, magnetism and electrical measuring instruments. Then you pass on to the installation and operation of every possible system of bells and annunciators, together with the practical operation of telegraph and telephone systems, wireless telegraphy and wireless telephony. Electrical drafting gets its share of attention, and you continue with interior light and power wiring, electrical illumination and testing, electrical signs and flashers.

A most important part of the course is estimating and contracting, including business methods in contracting, estimating cost of material and labor, how to submit estimates for work and methods employed in getting work, with lessons on how to compile information on work done to assist in estimating on future work.



As the course progresses you learn to erect switchboards and to operate motors and generators of every type. You learn the methods of their installation and maintenance. You take up storage batteries—the manufacture of modern types, different rates of charging and discharging efficiency, rules governing output, care of accumulators. Direct and alternating current practice are covered in full detail.

And last of all you make a thorough review of the work, with practice of armature winding and experience in general repair and machine shop work. In this way the knowledge that you gain stays with you.

Our equipment for all this work is complete and up-to-date. The seven floors of our building make up one complete and tremendous workshop, with every facility for thorough and accurate electrical work.

**You Start Higher Up** When you graduate from the New York Electrical School you are ready to step right into a position of responsibility. You are an expert, not a dabbler in electricity. Yet the course is so simple that anyone with a common school education can take it. We have no requirements for entrance.

The length of the course we have mentioned is seven months. But that depends on you. You can start any time and work as fast or as slow as you like. You do not have to keep up with anybody else. No one holds you back. Your work is entirely individual all the way through and you can stay till you feel you have learned it all. Whether you devote seven months or more than a year to the course, the cost is the same.

We have both day and night sessions, but most of our men take the day sessions because it naturally enables them to complete the course quicker.

**New York the Center** We are located in the heart of New York City and you can see the advantage of that. New York is the heart of everything electrical—there are big plants nearby, electrical exhibitions, libraries and facilities for good, quick work in an atmosphere of industry.

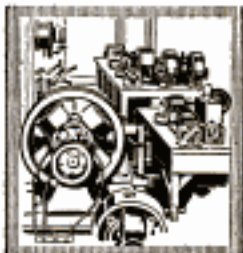

A large number of our students come from other cities, from all over the United States. They realize the advantage of coming to New York to learn electricity. About 4500 in all have gone out from our school into success. You can do the same. We believe that with us you can learn more thoroughly and more quickly than anywhere else because we give you practice. We teach you only what you use.

**And Now** If you have an ambition to make a name for yourself in the electrical field you will want to join the New York Electrical School. It will be an advantage to you to start with our February sessions. Then you should hurry to send for our 64-page book which tells you all about the school, with pictures of our equipment and students at work, and a full description of the course. You need not hesitate to send for this book. It is FREE to everyone interested in electricity. It will not obligate you to send for it. Send the coupon or write us a letter. But write us now while you are thinking about the subject of electricity. Address—NEW YORK ELECTRICAL SCHOOL, 44 West 17th St., New York, N.Y.

Mail this coupon today for free book

NEW YORK ELECTRICAL SCHOOL, 44 W. 17th St., New York  
Please send FREE and without obligation to me your 64-page book.

NAME.....

ADDRESS.....





**"Smith, There's Your Office  
Your Salary to Start  
Will Be  
\$3500.00"**

## **"You Are The Man We Want"**

*"We have lost a lot of money on shipments this last year, and we've hired you because we know you can save us money."*

Many a trained traffic man has been talked to like this by the "big chief." Plenty of similar jobs waiting for trained men to fill them. The position is one of importance and dignity. The T. M. "sits in" at many a Directors' meeting because of that very importance, and when the job is important the pay is big. Why don't you become a Traffic Manager?

## **95,000 Trained Traffic Men Are Needed Now**

There are 500,000 shippers in the United States. 100,000 are able to employ Traffic Managers. There are now 3,000 to 5,000 Traffic Managers in the country. That leaves 95,000 shippers without Traffic Managers; a man they need; a trained man who can save them money.

### **Study Under A Master**

H. E. Fairweather, Dean of the Interstate Traffic School, is an expert of national repute with years of practical experience behind him. He is master of tariffs, having in the past served some of the largest railroads in the country. You get practical instruction—not theory. Over 37,000 Tariffs in our files. Each student's lesson paper is graded personally by actual Traffic managers. Unlimited consultation service for two years after graduation.

### **Are You On The Wrong Job?**

Thousands of men are on the wrong job; right perhaps as far as the work is concerned, but wrong where the pay comes in. Few men can be contented with a job that doesn't pay well or offer a good chance for steady and sure advancement.

Far sighted, ambitious men are climbing out of ruts and seeking opportunities in special fields. The man who specializes today is the big man of tomorrow. To become a successful and highly paid Traffic Manager you don't need "special talent" — only a common school education and an hour or two a day of your spare time.

## **PREPARE NOW FOR THE BIG JOB**

Thousands of shippers realize their need of a trained traffic manager. But the supply of trained men doesn't begin to meet the demand. Ask any shipper if the Trained Traffic Manager isn't highly important and well paid. Ask him if it wouldn't be a good profession for you to get into.

### **Prepare Now**

Send for our free catalog. It tells who we are, what we teach, and how we do it. We'll train you to fill an important, responsible position at big pay and help you find a place when you are trained.

### **FREE—New Book**

Our free book on Traffic tells all about it; explains clearly, concisely. Don't pass this opportunity. Use the coupon NOW. You'll always be glad.

**Interstate  
Traffic School  
102 Traffic Bldg.  
Ft. Wayne, Ind.**

Gentlemen: Send me absolutely free and prepaid your new book on the Traffic Profession.

NAME.....

ADDRESS.....

**INTERSTATE TRAFFIC SCHOOL**

**102 Traffic Bldg. FT. WAYNE, INDIANA**



# Our Graduates are Making

**\$80 to \$250**  
AND MORE PER MONTH

We



**T**HE Best Paying Positions in the Auto business are secured through this school. Our thorough and practical instruction has placed many of our graduates in positions where they are getting up to \$12,000 and \$20,000 a year in salary, or in profits from their own business.

Many others are Expert engineers, Chauffeurs, Race drivers, Shop foremen and Final testers for White, Chandler, Ford, Willys-Overland, Chalmers, Peerless, Cadillac, Stearns and other leading factories. 15 of our June class are now truck drivers for the Government at \$100 to \$150 a month and all expenses.

We have calls for more and more men from *all parts* of the country—because our School is known to rank *highest* in careful, thorough and up-to-date training. Wonderful opportunities are developing in the Auto business right along—but you must have the *right training by actual experience*, and the place to get it is the



**Cleveland**

**Auto School**

Established 1903  
Individual Instruction

Up-to-date Equipment  
13 Years of Success

## 4000 Graduates Making Good

Ours is one of the most completely equipped schools in the country; a dozen cars at the disposal of students; we teach every point worth knowing, including machine shop practice, taking apart and putting together complete cars, Knight type, 12 and 8 cyl. motors; latest starting and lighting equipment, Ambu trouble shooter, Phillips testing set, etc., etc. Just installed newest Akron-Williams tire repair equipment—same as used and sold by the leading tire companies.

### CLEVELAND LEADS

in all parts and accessory, and high grade car manufacture, and is gaining fast in new factories; Grant, Jordan, Abbott, Denmo truck, H. A. L. 12—and others building.

### TRAINING IN 4 WEEKS

Tuition low; board and room \$5 and \$6 per week near school; congenial company and surroundings; we help you get located. New classes forming. Come and join us now.

**We Absolutely Guarantee**

to qualify you for a good paying position in the Auto business on completion of our course.

## Cleveland Automobile School

CLYDE H. PRATT, President, Dept. 2, 2338 Euclid Ave., CLEVELAND, OHIO

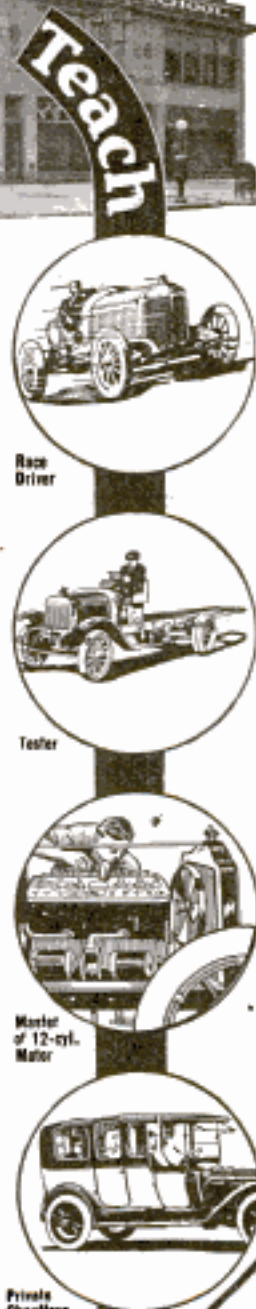

Race Driver

Tester

Master of 12-cyl. Motor

Private Chauffeur

Send This Coupon

CLEVELAND AUTO SCHOOL  
Dept. 2  
2338 Euclid Ave.  
CLEVELAND

You may send me FREE catalog, terms, etc.

Name.....

Address.....

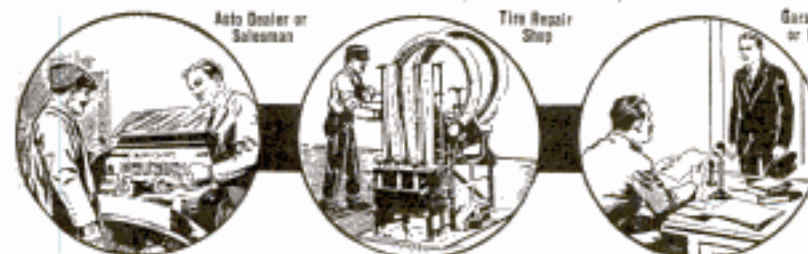

Auto Dealer or Salesman

Tire Repair Shop

Garage Owner or Manager

**Own A Business**

Please Mention Popular Mechanics



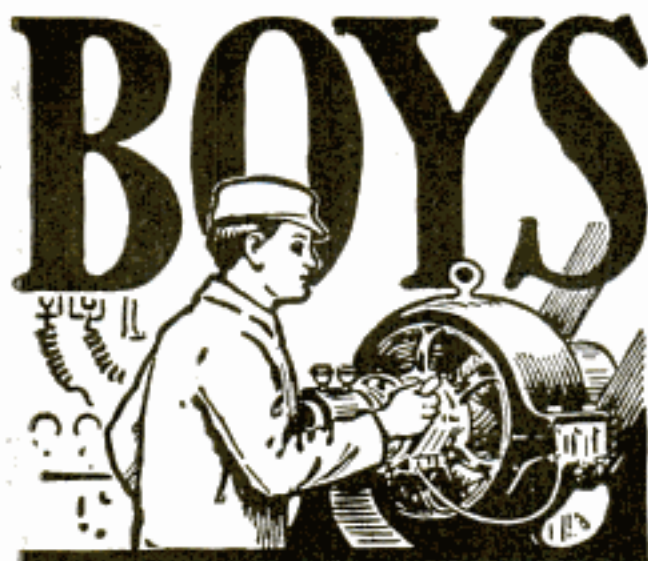

## Big Money in Electricity

The Electrical industries offer wonderful opportunities to boys with a liking for Electricity. The salaries paid to trained men are large, promotion comes rapidly and, best of all, the work is fascinating.

The discovery and development of new lines (such as wireless telegraphy and telephony), from time to time, promise attractive and paying fields to those who wish to specialize. The *will to do* and *Special Training* will bring success to you.

The International Correspondence Schools can help you to become an expert in electrical work, no matter what branch you like best. Thousands of young men have already won success through I. C. S. help. You can do as well as anybody, *if you try*. Everything is made so clear that you can learn in your spare time, regardless of where you live or what your work. No books to buy.

There's big money in Electricity. Get after it by marking and mailing the Coupon today. *Finding out costs you nothing.*

### INTERNATIONAL CORRESPONDENCE SCHOOLS

Box 5550, SCRANTON, PA.

Explain, without obligating me, how I can train for the position before which I mark X.

- |  |  |
|--|--|
| <input type="checkbox"/> ELECTRICAL ENGINEER       | <input type="checkbox"/> ARCHITECT               |
| <input type="checkbox"/> Electrician               | <input type="checkbox"/> Architectural Draftsman |
| <input type="checkbox"/> Electric Wiring           | <input type="checkbox"/> Elec. Foreman or Supt.  |
| <input type="checkbox"/> Electric Lighting         | <input type="checkbox"/> Business (Complete)     |
| <input type="checkbox"/> Electric Car Running      | <input type="checkbox"/> Bookkeeper              |
| <input type="checkbox"/> Electric Machine Designer | <input type="checkbox"/> Stenographer            |
| <input type="checkbox"/> Telegraph Engineer        | <input type="checkbox"/> Advertising Man         |
| <input type="checkbox"/> MECHANICAL ENGINEER       | <input type="checkbox"/> Salesmanship            |
| <input type="checkbox"/> Mechanical Draftsman      | <input type="checkbox"/> Window Trimmer          |
| <input type="checkbox"/> STEAM ENGINEER            | <input type="checkbox"/> Civil Service           |
| <input type="checkbox"/> GAS ENGINEER              | <input type="checkbox"/> AGRICULTURE             |
| <input type="checkbox"/> CIVIL ENGINEER            | <input type="checkbox"/> Poultry Raising         |
| <input type="checkbox"/> Structural Engineer       | <input type="checkbox"/> AUTOMOBILES             |
| <input type="checkbox"/> CHEMICAL ENGINEER         | <input type="checkbox"/> Auto Repairing          |

Name \_\_\_\_\_

Present Occupation and Employer \_\_\_\_\_

Street and No. \_\_\_\_\_

City \_\_\_\_\_ State \_\_\_\_\_

If name of Course you want is not in this list, write it below.

Please Mention Popular Mechanics

## Are You Interested In

### Automobiles-Driving? Motoring-Repairing?

Do you drive and take care of your own car? Are you an expert Auto Mechanic? Are you going to buy a car soon? Are you in the repair business? No matter what interest you have in Automobiles, **THE AMERICAN CHAUFFEUR**, "America's Greatest Monthly Auto Paper," gives pointers and information each month that will

### Save Several \$100 Yearly

In operation, upkeep and repairs. It is the clearing house for money-making and money-saving ideas not published elsewhere, is written in common-sense language, explains clearly how to adjust valves, magnets, carburetors, etc., tells how to have repairs made at a saving. Technical knowledge told so you can understand.

### FREE FOB Special OFFER

Originally designed Auto Watch Fob, real rose gold finish with seal Grain Leather Strap (like illustration, 3 inches long.)

**ACT QUICKLY, NOW.** Send a dollar, check or money order for a whole year's subscription to the **American Chauffeur** and we will send you the above fob **absolutely Free.** Your money back if you are not satisfied. **The American Chauffeur Pub. Co., 83 Butler Bldg., Cincinnati, Ohio**

THIS ROSE GOLD FINISHED FOB FREE



## COPY THIS SKETCH

and let me see what you can do with it. Illustrators and cartoonists earn from \$20 to \$125 a week or more. My practical system of personal individual lessons by mail will develop your talent. Fifteen years' successful work for newspapers and magazines qualifies me to teach you. Send me your sketch of President Wilson with 6c in stamps and I will send you a test lesson plate, also collection of drawings showing possibilities for you.

**The Landon School of Illustrating and Cartooning**  
1438 Schottel Building, CLEVELAND, O.



## DOUBLE THROAT 10c New Invention.

Fits roof of mouth. Greatest thing out. Astonish and mystify your friends. Make dogs or cats talk. Neigh like a horse, sing like a canary. Imitate any Bird or Beast of field or forest. Price 10c; 4 for 25c postpaid

**NATIONAL CO., Dept. 31, CHICAGO, ILL.**



## PAY \$75 to \$150 MONTH

U. S. GOVERNMENT WANTS

Railway Mail Clerks — City Mail Carriers — Postoffice — Customs — Internal Revenue Clerks.

Common education sufficient. Send coupon immediately. We are coaching candidates free.

This coupon, filled out as directed, entitles the sender to free sample questions; a free copy of our book, "Government Positions and How to Get Them," a free list of positions now easily obtainable; and to consideration for Free Coaching for the examination here checked.

COUPON		SEND COUPON BELOW	
.. Railway Mail Clerk	[\$900 to \$1800]	.. Customs Positions	[\$800 to \$1500]
.. Postoffice Clerk	[\$800 to \$1200]	.. Internal Revenue	[\$700 to \$1800]
.. Postoffice Carrier	[\$800 to \$1200]	.. Stenographer	[\$800 to \$1500]
.. Rural Mail Carrier	[\$500 to \$1200]	.. Clerk in the Departments at Washington	[\$800 to \$1500]
.. Bookkeeper	[\$900 to \$1800]		

Name.....

Address..... T-105

Use this before you lose it.

Write plainly.



# Stop Forgetting!

**Make  
Yourself  
Master  
of  
Every  
Situation**



**Perfect Your Memory  
—and Command  
What Salary You Will**

Your earning power—your position in life—depend upon your memory. The ability to recall needed facts and figures—to concentrate on matters on hand—to grasp the details of a proposition instantly—to be able to make decisions quickly and safely—means everything to the achievement of success.

## Men of Power Are Men of Trained Memories

Roosevelt, Wilson, Edison—America's men of power are uniformly men of trained memories. Train your memory the *Dickson way*, and you endow your personality with that "divine spark" that enables you to make your mind "forget-proof"—to overcome self-consciousness and bashfulness—that gives complete mastery over every situation—that will make you a power to be reckoned with in social, business or public life.

## I Will Give You a "Steel Trap" Memory

A tenacious memory cannot rightfully be called a "gift." My experience with 50,000 students—men with exceptionally poor memories who have developed them to amazing perfection—men with remarkably good memories who have made them even better—has proven the value of systematic training of the Memory. What Dickson training has done for these men, it will do for you—will teach you to think and talk connectively—will increase your earning power.

## Special Offer! "How to Speak in Public"—FREE

If you enroll at once for this course in memory training you'll receive—absolutely FREE—this valuable book, "How to Speak in Public," DeLuxe edition, handsomely bound. Teaches you to express yourself clearly and convincingly whether talking to one person or a thousand. Full particulars of this offer, together with my remarkable booklet, "How to Remember," and a copy of my unique copyrighted "Memory Test," are yours free—simply fill in the coupon, tear off, and mail.

## Dickson Memory Training Endorsed by Noted Men

**Elbert Hubbard:** "Good memory is essential to all achievement. The Dickson System of Memory Training—if I understand it—and I do understand it—is very simple. If you want to enlarge your arm to increase the power and strength of your muscle, you exercise it. The same with your mind."

**Carl F. Schader, California:** "I have been improved physically and mentally beyond my own expectations by the continued studying of your course. I unhesitatingly recommend it to those who desire to increase their Power of Personality."

**Wm. H. Weeks, New York Attorney:** "After a thorough trial of your method of mental and memory training, I find it to be not only first class—simply wonderful I can truthfully say that I would not be again without the benefits I have received from your study for \$10,000."

**For FREE Book—  
"How to Remember"  
Mail the Coupon**



**PROF. HENRY DICKSON,**  
Principal, Dickson School of Memory,  
1705 Hearst Building, Chicago

Please send me free of charge and without obligation your booklet, "How to Remember," and a copy of your copyrighted "Memory Test." Give me facts on your special offer of a free copy of "How to Speak in Public."

Name \_\_\_\_\_

Address \_\_\_\_\_



Please Mention Popular Mechanics

Copyrighted material





## Learn Mechanics of Aviation

**Y**ES, right in your own home, in your spare time, you can learn all the principles, the theory and the mechanics of Aviation. You can prepare yourself for flying, if you wish. Or you can gain all the practical knowledge to equip you to enter the big paying and fascinating business of aeroplane construction and as aero-mechanical engineer. Send the coupon at once! Find out how our wonderful course in Aviation will give you the knowledge necessary to enter this field. Everybody planning to enter the Aviation fields needs the knowledge which this course offers. This is the first time that anyone has had the opportunity to gain this instruction at home—and without great sacrifice of time and expense. Waste no time in sending coupon.

## Big Opportunities NOW!

### What Course Covers:

Aero History—Aero Physics—Aero Dynamics—Wing Designing and Construction—Aeroplane Assembling—Balloon Building and Operating—Aeronautical Wireless.

same training at home—in much shorter time, a mere fraction of the expense, and without interfering with your regular work.

### Endorsed by Aviation Authorities!

Leading aviators and flying organizations have endorsed this course as a quick and reliable means of training for the business and practice of Aviation.

American School of Aviation  
431 So. Dearborn St.  
Dept. 1192, CHICAGO

Gentlemen:—Please send me, free and without obligation, full particulars of your course in Aeronautical Engineering and details of your special limited offer.

Name.....

Address.....

## Special Offer

### Send the Coupon

Those who write at once will still be able to take advantage of the special limited offer which is now in force by which they may secure a large tuition reduction. Write now while this offer lasts for full particulars. Send coupon—no obligation.

American School of Aviation  
431 S. Dearborn St.  
Dept. 1192  
CHICAGO, ILL.

## THE LAW TRAINED MAN

A new book  
for ambitious men

"THE Law Trained Man" tells you of the advantages of a law training in business and in politics. Also how you can become a successful lawyer.

It tells you of the Modern American Law Course and Service of the Blackstone Institute—the only course in law that has the unqualified endorsement of resident law schools, the legal profession and prominent businessmen everywhere.

This new 168-page book is free. Send for your copy today.

**Blackstone Institute**

105 Dearborn Street

Chicago, Ill.

## DON'T TAKE A COURSE IN MACHINE DRAFTING

till you have read my proposition. You want to learn the kind of drawing that enables you to **earn money**. I am employed by a large and progressive company, making drawings for **actual manufacture**, and can teach you to earn money the same way. Instruments I send **FREE** are **guaranteed best** furnished by any concern. Terms very reasonable. **Pay a part after in position as draftsman**. Inclose stamp, and I will send copies of student drawings and letters from satisfied pupils all over the country.

**DRAFTSMAN, 252 South Corona St., DENVER, COLO.**

## ENGINEERING MECHANICAL ELECTRICAL

One Year Practical Courses. Day and Evening classes. Splendid equipment and instruction. Low tuition. For particulars address

**DETROIT TECHNICAL INSTITUTE**  
Box 308, Y. M. C. A. Building, DETROIT, MICH.

## GOVERNMENT DAIRY FACTS

Free for examination. The famous Farmer's Cyclopedea, which gives most reliable information on dairy farming. Also facts on all other branches of farming. Facts that cost the government \$4,000,000.00. Information direct from U. S. Dept. Agriculture. See these 7 big books, 6 1/2 in. x 9 in., 5000 pages, hundreds of pictures. If you buy send only 50c down. Then \$2 monthly until \$29.50 is paid. Otherwise return at our expense. Send no money now. Examination is free.

**DOUBLEDAY, PAGE & COMPANY, Dept. 1191, Garden City, New York**



## Men Wanted To Learn Automobile Business

**EARN BIG MONEY — \$75 to \$300 Per Month**

Only a few weeks required to train you. In six weeks I teach you to run and repair properly any automobile made. Learn to be repairman, demonstrator, garage manager and salesman. I teach thoroughly, practically and personally on real automobiles in everyday use. No books used. Tools furnished free. Actual practice on big, powerful cars brought here for inspection and repairs. **SEND FOR BOOKLET**, "Making You Master of the Auto." Free upon request.

**WM. H. ANHELGGER Milwaukee Motor School, 217-21 Seventh St., Milwaukee, Wis.**



# \$50 to \$200 a Week Waiting For You



## Learn By Mail How to Fill One of These Big Jobs

The boom is on. Thousands upon thousands of men are needed in the Electrical Field. This is your opportunity to get in NOW—while big jobs are ready and waiting for you. Mail me the coupon and I will send you valuable information how to

qualify for these positions in your spare time at home. I will also arrange to give you free tuition so you can get into a big job as quickly and easily as possible.

Accept my offer at once. The sooner you begin, the quicker you can qualify as Installation Engineer, Chief Electrician, Consulting Engineer, Supt. Electrical Construction, Armature Winder, Electrical Foreman, Lamp and Meter Tester, Illuminating Engineer, Electric Sign Expert, Electrical Contractor, Switchboard Operator, etc., etc., and command a higher salary than is paid in any other trade or calling. Or you can go in business for yourself—there's big money in it for you. \$50 to \$200 a week is only a beginning. This is the big future I open up before you. Write me at once. It is your first move to

## Be a Trained ELECTRICIAN

I'll give you Free Lessons if you accept my proposition, also give you simple instructions which will teach you the business from A to Z. After the first few lessons you can make big money on odd jobs installing inter-communicating telephone systems, annunciators (and other signal appliances), burglar alarms, door bell outfits in factories, offices, hotels and homes. These jobs run from \$20 up to \$100 each. While you are earning this money you are learning to qualify for the biggest and best positions in the business. Electrical knowledge means money to you. This is your chance to get it. No matter who you are, or where you live, or what you do—you can become just as expert in electrical work as others who learned under my new, simple method of home instruction. In order to help fill the demand for electricians as quickly as possible, I will give you

### 20 Free Lessons

With these 20 Free Lessons you have your big START for success. Say you will accept my offer and make ready for the big salaried positions in the Electrical field. There's nothing difficult about learning practical electricity. No previous experience is necessary. If you can read or write you can learn right in your own home—evenings. You don't have to take a minute from your regular work or give up your present salary.

This 20 Free Lessons Offer includes all privileges of my course, all diagrams, etc., that go with the 20 Lessons, just as if you paid full price and all cash for them. Don't fail to take advantage of this opportunity. You can Be a Trained Electrician if you want to—and now is the time. Send coupon today for full details. Do it NOW.

A. W. WICKS, E. E., Director  
**Wicks Electrical  
Institute**

Dept. 265  
81 W. Randolph St. Chicago, Ill.



CHIEF  
ELECTRICIAN



ELECTRICAL  
CONTRACTOR



ARMATURE  
WINDER



ELECTRIC  
SIGN  
EXPERT



SWITCHBOARD  
OPERATOR

Mail  
This  
Coupon

A. W. Wicks, E. E., Director,  
**Wicks Electrical Institute**  
81 W. Randolph St., Dept. 265  
Chicago, Ill.

Without any obligation to me whatever, please send me full description of your personal instructions in Electricity and particulars of your Special Offer of 20 Lessons Free.

Name.....

Address.....

City..... State.....

Please Mention Popular Mechanics









## You Can't Get On By Looking On

—But you can put yourself in a position of responsibility and big pay if you will devote some of your spare time now to making preparation for it. Never before have there been so many splendid openings for trained accountants. The tremendous business prosperity of the country has created a field that is truly rich with remarkable opportunities. There are now over half a million concerns requiring the services of expert accountants, yet there are only 2,000 certified public accountants in America to do the work. There are many certified public accountants whose incomes are from \$10,000 to \$25,000 a year. The United States Steel Corporation paid one accounting firm \$250,000 for installing its cost and accounting systems.

## Learn Higher Accounting The Profession of Big Incomes

Our graduates are capable of filling good positions as Auditors, Consulting and Cost Accountants, Financial Advisers, or to go into business independently as Certified Public Accountants. Their training with us qualifies them to be consulted on all matters of finance and management, to be one of the most important factors in the conduct of any business—to be indispensable to the firm.

### We Train You By Mail

In spare time—evenings—at home, without interference with your present duties and while you are drawing your present salary. Our training is made personal and individual. It takes into consideration your present knowledge or lack of knowledge. We provide complete and comprehensive training according to your individual needs from the simplest bookkeeping principles to the most advanced accounting problems. We will give you whatever training, instruction or review on the subject of bookkeeping you may personally need—without any extra expense to you.

### Small Cost—Easy Terms

Write today and learn how our easy-payment plan places this splendid course within reach of every ambitious person who possesses a real desire for advancement and the kind of organized "brain power" that commands big rewards in business everywhere. Get our free book which fully describes our expert training course and tells about our Money-Back Guarantee, C. P. A. examinations, state regulations, salaries, and incomes and how you can qualify for a high grade accounting position without interference with your present job. If you want to enter an uncrowded field that offers trained men a real opportunity for worth while advancement, send coupon and learn what we have done for others and can do for you.

**LaSALLE EXTENSION UNIVERSITY**  
"The World's Greatest Extension University"  
Dept. 264-H Chicago, Ill.

### Your Instruction Will Be Under Direct Supervision of Certified Public Accountants

Wm. Arthur Chase, Ex-Pres. Nat'l Ass'n of C. P. A. Examiners, Ex-Sec'y Ill. State Board of Examiners in Accountancy; John B. Tanner, C. P. A., Vice-Pres., Wis. State Board of Accountancy; Former Accounting Director, Wis. State Board of Public Affairs; Formerly of Naa, Tanner and Rusk, Cer. Pub. Acc'ts and other experts who rank among the highest. No expense has been spared to make this the easiest-to-understand, and most complete Home Study Accountancy Course ever prepared. Covers every phase of Practical Accounting, Theory of Accounts, Auditing, Cost Accounting, Business Organization, Business Management, Business Laws, etc.

## FREE Book Coupon

**LaSALLE EXTENSION UNIVERSITY, Dept. 264-H Chicago**  
"The World's Greatest Extension University"

Send at once, without cost or obligation to me, your valuable book of accounting facts and full details of your course in Higher Accounting; also advise me about Special Reduced Rate and Convenient Payment Plan.

Name .....

Street and No.....

City.....State.....

Please Mention Popular Mechanics



# LEARN AUTOS

*Where Autos are Made*

Detroit is a city of motors. Eighty-five per cent of the motor cars in the United States are said to be made here. Here are located 40 or more auto factories, hundreds of parts makers. Detroit *makes* automobiles, *sees* automobiles, *thinks* automobiles day and night. Detroit is the *place* to learn the auto industry, and the Detroit Y. M. C. A. Auto School is the *school* at which to learn it.

## Backed by Automobile Factories

The automobile men of Detroit endorse our work without hesitation. The Studebaker, Buick, Hupp, Ford, Packard, Gray Motor, Disco, Zenith, Chalmers, and many others have contributed to our equipment their latest models and designs. Can you ask stronger proof of a school's standing than the fact that the *men who know* give freely their time and money to co-operate with it and aid in its growth.

## Not Operated for Profit

The Y. M. C. A. Auto School is not run for profit. Our purpose is to give our students the training necessary to get and hold good paying positions in the rapidly growing automobile industry. Tuition goes to procuring the highest class of instructors and the best of equipment. The automobile business is crying for trained men,—testers, chauffeurs, inspectors, salesmen, assemblers, repair men, bearing scrapers, motor mechanics of every description. Factories, dealers and garages join in the call. We fit you for these positions. Will you take advantage of this opportunity.

## Tuition Includes Membership in the "Y"

Tuition at the Y. M. C. A. Auto School is low — and includes a year's membership in the "Y." Our big Club House is at your disposal during time off. Reading rooms, lounging rooms, gymnasium, swimming pool, billiard and pool tables, bowling alleys, with five floors of dormitories and restaurant at low rates. You are assured of not only thorough and competent instruction, but good companionship and clean living conditions with the comforts of home and club life combined.

## Don't Visit Detroit Without Seeing Us

You want to consider everything carefully before you enroll for any course of instruction. Come and look us over, whatever purpose brings you to Detroit. Get all the particulars of this school, get the records of our instructors, hear what auto factories and automobile men have to say about us, see for yourself our comfortable quarters and big equipment. We will be glad to see you and show you around whether you enroll or not. Day and night classes. Start at any time. The average time required is 6 weeks for day course, and 12 weeks for night course.

WRITE TODAY FOR FULL PARTICULARS. Address  
Educational Director, Box 305, Y. M. C. A., Detroit, Mich.



Main Building Y. M. C. A.  
Detroit



Students Working on Axle  
and Transmission



Block Testing and Motor  
Department



"Y" Auto School Repair Shop



Lecture and Demonstration  
of Chassis





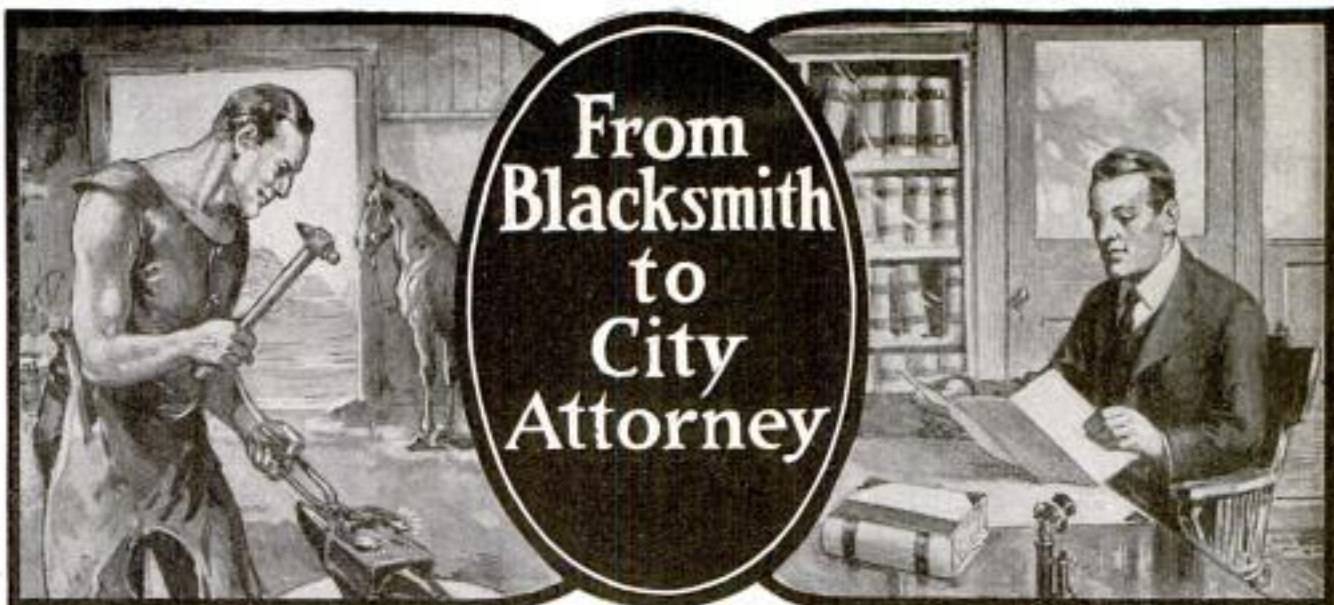

## From Blacksmith to City Attorney

# Income in 5 Months Jumps to more than \$4000 Per Year

"I was appointed City Attorney in June. The salary is only \$1600.00 per year, but the prestige obtained through the appointment brings me a goodly practice. I have recently been retained by a firm of this City and, . . . . . to defend some of their members, and they have sent me a retainer of \$2500.00—I opine that this is not so bad in view of the fact that last May I was blacksmithing for standard trademen's wages. I finished your course and was admitted to the bar in just ten days less than three years. I can never say too much for your school—it is easily worth \$20,000.00 to me—that is the instruction I received through it."

Full name, address and entire letter included in our "Gilt Edge Evidence"—the most remarkable collection of endorsements ever published by any institution of learning.

### Why Not be a Lawyer Yourself

Today is the legal age. Scarcely a business move is made until the lawyer is consulted, his opinion secured and carefully weighed. Railroads are demanding legally trained men to handle their intricate interstate commerce laws. Credit men cannot expect to become proficient unless they have a knowledge of the law. Real estate men must know about deeds, abstracts, leases, mortgages, etc. The banker requires a training in banking laws. Every officer of the law will find it to his distinct advantage to know criminal law. Young man, you cannot name a vocation where a thorough legal training will not assist you wonderfully in climbing to the top. And there is not an institution of learning in America where you can acquire such a training more economically, more thoroughly and quicker than through the Extension Course of Law now offered you by the Hamilton College of Law.

### \$3,000 to \$10,000 Per Year

are not excessive incomes for the successful attorney-at-law. Many of our graduates are already in this class. Others are prominent young business men, who are studying law as the quickest and shortest route to the top of the ladder. There is a constantly growing demand for bright, legally trained young men. The world is waiting for them to present their credentials. Will you be one of them? Or are you a satisfied man.

### What the Hamilton College of Law Offers You

It is the only Law School of its kind in America. It is the ONLY recognized resident law school in the United States conferring Degree of Bachelor of Laws, LL. B.—by correspondence, strictly on the merits of its course. ONLY law school in U. S. conducting standard resident school and giving same instruction by mail.

ONLY law school giving over 500 class-room lectures to its extension students.

ONLY law school giving a full 3-Year, University Law Course, by mail, having an actual faculty of over 30 prominent lawyers in active practice.

ONLY law school in existence giving a Complete Course in Oratory and Public speaking in conjunction with its law course.

### Other Excellent Features

Our Law Library consists of 24 volumes of Students' Standard Text Books, two volumes bound together under one cover, making a total of 12 books. These books were prepared at an enormous cost especially for the students of the Hamilton College of Law, by one of the largest and best law book publishers in America. This is the only set of text books ever prepared exclusively for students' use.

We give an absolute written guarantee to prepare our students to pass bar examinations.

Our Course in Oratory and Public Speaking, absolutely free to all Hamilton Students, has been prepared and written by Prof. Oscar G. Christgau, LL. M. (Master of Laws) the regular resident school professor in charge of this work. Knowing law, from a lawyer's standpoint, he has prepared this series of 36 lectures to meet all the requirements of the practicing attorney.

### 30 Days Free Trial

Let us convince you without it costing you a penny, that we have the only, real, genuine, bonafide Extension Course in Law in America. Mail the coupon and get all the evidence—then judge for yourself. Study with us 30 days, at our expense and be satisfied you are getting more than value received, before obligating yourself.

Hamilton College of Law  
100 Advertising Building, Chicago, Illinois

Gentlemen: Kindly send me your Illustrated Prospectus and full particulars regarding your 30-day Free Trial Offer.

Name.....

Address.....

Please Mention Popular Mechanics





# One Man —or Two?

## Finger-prints Tell

Here are two men. Alike in every particular — except their finger-prints. A few years ago it would have been difficult to identify them positively. Today they are infallibly distinguished by their finger-prints.

Wherever it is necessary to establish people's identity, finger-print systems are being installed. Large industries, railroads, banks, government institutions — all businesses where a large number of people are employed — are installing finger-print systems under the guidance of finger-print experts.

## Be a Finger-print Expert

You can earn from \$25 to \$50 a week in this fascinating profession. With the development of the science of finger-prints and its increasing use all over the country, the demand for trained men is growing by leaps and bounds. You can train yourself for this lucrative and virgin field in your spare time at home. Find out about this attractive profession.

## Free Book on Finger-prints

**EVANS UNIVERSITY**  
Finger-print Department  
Desk 1192

1810 Wilson Ave., Chicago

Gentlemen: Please send me, absolutely FREE and PREPAID, your new book on finger-prints. Also particulars of your special offer. I assume no obligations whatever.

Send the coupon now for our valuable, absorbing book telling all about the uses of finger-prints in business and for purposes of identification. Find out how you can become a finger-print expert in a very short time at home. Special limited offer now in force. Write for this free book now, while this offer lasts. No obligations.

**EVANS UNIVERSITY**  
Finger-print Department  
Desk 1192  
1810 Wilson  
Avenue  
CHICAGO

Name.....

Address.....

## All About Motor Cars

Construction, Operation, Care and Repair  
This very latest authoritative book gives ALL the information in 16 easy lessons.

## The Automobile Instructor

By Clyde H. Pratt, B. Sc., M. E., Member Nat'l Society of Auto Engineers. 256 pages, illustrated, cloth bound. Shipping wt., 2 1/2 lbs.

New 1917 edition out Jan. 3. The standard work for home-study, class-room and reference, for amateur and expert. A complete course for all who desire to master this profitable profession.

## LEARN AT HOME HOW TO DRIVE AND REPAIR ALL CARS

Invaluable pointers for every car owner, driver, garage man and repair man. Adopted by Cleveland and other Auto Schools and by Boards of Education as their standard text-book. The author will answer your auto inquiries FREE. This book is guaranteed to be just what you want or your money back. (Auto schools, write for quantity prices.)

Price, postpaid ..... \$1.50

**Shrewsbury Publishing Co.**

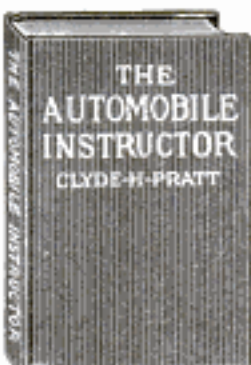

**Motor Craft Encyclopedia**  
Illustrated. Tells how to build and operate Motor Boats. Best book on boats. Price, \$1.00.

5525 West Lake St., CHICAGO, U. S. A.



## Do You Like to Draw? Cartoonists Are Well Paid

We will not give you any grand prize if you answer this ad. Nor will we claim to make you rich in a week. But if you are anxious to develop your talent with a successful cartoonist, so you can make money, send a copy of this picture, with 9c in stamps for portfolio of cartoons and sample lesson plate, and let us explain.

**The W. L. Evans School of Cartooning**  
821 Leader Bldg., Cleveland, O.

## LAW High-Grade Instruction by CORRESPONDENCE

Prepares You for  
the Bar—Est. 1892

Four Courses: College, Post-Graduate, Business Law and Bar Ex. Review. Classes begin each month. Approved by Bench and Bar. University Methods, Unabridged Text-Books, Cases, Course in Oratory, Public Speaking and Most Court FREE with regular course. Graduates now practicing in every State. Write today for Catalog and Rules for Admission to the Bar. CHICAGO CORRESPONDENCE SCHOOL OF LAW, 529 Super Bldg., CHICAGO



## CIVIL SERVICE

positions are in all parts of the country. Good pay, steady work, life positions, congenial surroundings, promotions on merit, short hours, annual vacation and sick leave with pay. Many thousands appointed yearly. Both sexes. No political pull. Nearly 300,000 classified positions. Common school education sufficient. Full information and questions used by the Civil Service Commission free.

**COLUMBIAN CORRESP. COLLEGE, WASHINGTON, D. C.**

## MUSIC TAUGHT FREE

**IN YOUR OWN HOME**

You can read music like this quickly  
**Piano, Organ, Violin, Mandolin, Guitler, Banjo, etc.**  
Beginners or advanced players. One lesson weekly. Illustrations make everything plain. Only expense about 2c per day to cover cost of postage and music used. Write for FREE booklet which explains everything in full.

**AMERICAN SCHOOL OF MUSIC, 51 Lakeside Building, CHICAGO**

## STAMMERER

Attend no school until you read my book "How To Stop Stammering." A practical, modern Method that kills the fear of stammering.  
**The Hatfield Institute, 109 North Dearborn St., Chicago, Ill.**

## FREE BOOK ON BANKING

Tells of the great opportunities in this wonderful profession, and how you can learn by mail. Six months' term. Diploma awarded. **EDGAR G. ALGORN Pres., AMERICAN SCHOOL OF BANKING**  
490 East State St., Columbus, Ohio

## LEARN WATCHMAKING AND ENGRAVING

Earn while learning. Most practical watch school. Individual instructions. Graduates in great demand. Book free.  
**Chicago School of Watchmaking, 63 E. Van Buren St., Chicago**

Please Mention Popular Mechanics



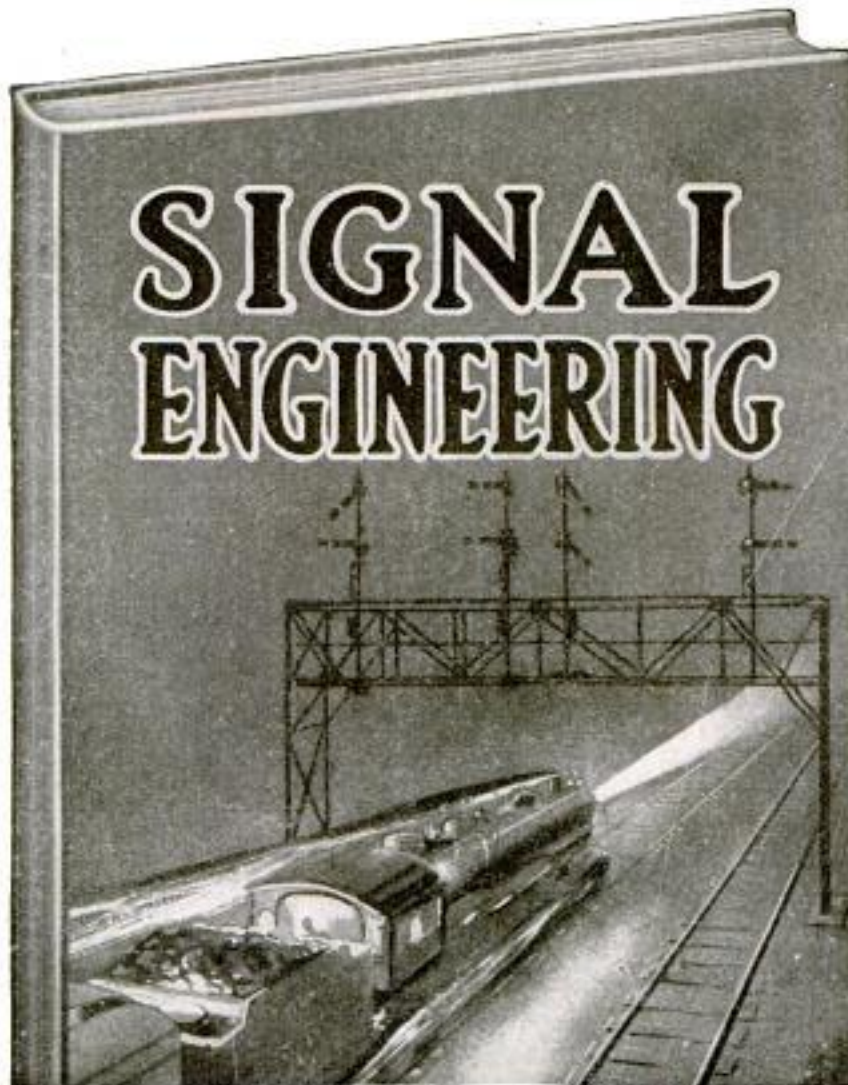

# Free Book on Signal Engineering

**T**HERE are thousands of miles of railroad that must be equipped with block signal systems. To superintend these installations and to maintain the systems now in use thousands of men are necessary. *Golden opportunities are offered.* Every ambitious man in America should write for the free book on Signal Engineering. It will be sent to you prepaid—without obligation. Send the coupon now.

## Men Are Needed to Accept High-Salaried Positions

When you stop to consider that, at the present time, less than one-fourth of the passenger lines in this country are equipped with automatic block signal systems—and when you read that the day is fast coming when the law will compel railroads to install them, you will realize what remarkable opportunities are offered to ambitious men in the profession of Signal Engineering. The work is big—broad—high salaries are paid. \$250.00 a month is an ordinary salary for a Signal Engineer.

## Send the Coupon!

Put your name and address in the coupon, or a letter or post card *now* and get the free book about Signal Engineering. Too, we will tell you how you can get the training that you need in order to become a Signal Engineer. You will be under no obligation by writing for this free book. **Do it now.**

**Department of Signaling** Dept. 1192 — 1810 Wilson Avenue  
Ravenswood Station, Chicago, Illinois

**Department of Signaling**  
Dept. 1192—1810 Wilson Avenue  
Ravenswood Station, Chicago, Illinois

Gentlemen: — Please send me absolutely free and prepaid your big new book on Signal Engineering. Also full particulars about your great special free outfit offer. It is distinctly understood that I assume no obligations of any kind.

Name .....

Address .....

Age ..... Occupation .....



HOW TO ACQUIRE  
A LEGAL TRAINING



# Free Book on the Law

**EVERY** ambitious man in America should have our free book on law. It tells vital facts you need in order to realize your ambition. The place the law-trained man occupies in the modern business world is fully explained. Fascinating stories are told of other men who have reached the goal of their ambition. The book is free. Merely send us your name and address, either on the coupon or a letter or postcard. We'll send the book to you free and prepaid. You will be under no obligations.

## Law Trained Men Lead

All of us are reading and hearing that it is the law-trained man who is the leader today. Our free book tells why. It explains why law-trained men are being chosen for the high positions—and how you can qualify yourself exactly like other trained men who are now holding these positions qualified themselves.

## Invest Your Spare Time

Your idle hours can be made golden ones. Right in your own home you can read law under the direction of Masters—and fit yourself to hold the high position you are dreaming about. You will not make a drudge of yourself. American School training has been made simple—and easily understood so that you can get a thorough training in law during the hours after you have finished the day's work. The American School law course was written for you.

American School  
of Correspondence  
Dept. L1192, Chicago, U.S.A.  
Without any obligation  
on my part, please send me  
your Free Book, "How to  
Acquire a Legal Training."

## Send the Coupon

Put your name and address in the coupon, or on a letter or postcard now and get our Free Book on Law. You need it. It points a way for you to realize your ambition, and for your own sake you can not afford to be without it. You will be under no obligation by sending for the free book. Put your name and address in the coupon.

Name.....

Address.....

American School of  
Correspondence  
Dept. L1192  
CHICAGO, U.S.A.



## Learn a Paying Profession

that assures you a good income and position for life. For twenty-two years we have successfully taught

## PHOTOGRAPHY

Photo-Engraving and Three-Color Work

Our graduates earn \$20 to \$50 a week. We assist them to secure these positions. Learn how you can become successful. Terms easy—living inexpensive. Write for catalogue—NOW!  
ILLINOIS COLLEGE OF PHOTOGRAPHY, 999 Wabash Avenue, Effingham, Ill.

ESTAB. 1892

## BODEE TRADE DENTAL SCHOOL

15A W44<sup>th</sup> ST. NEW YORK CITY

Under Supervision of the University of State of N. Y.  
**YOU TOO CAN EARN \$25 TO \$75 WEEKLY**  
Great demand in new profession of Mechanical Dentistry. Anyone can learn now by our new method without book study. Complete course given in 3 months. Knowledge gained by actual work individually. Day and night classes. Easy payments. Tools, materials, and equipment free. We guarantee that you can earn before completion of the course. The demand is like a gold mine (unrealized). We are constantly called upon to fill good salaried positions. Why not qualify for one. Visit or write the school and ask for our special short course catalogue "P." Do it now.

## Practical Electrical Education in 1 Year

Expert Engineers train you to get and keep the big-pay jobs. Enter at any time no matter what your education. Individual instruction. Course is complete, practical and thorough. Unnecessary theory eliminated. Positions paying \$1500.00 waiting for graduates. Write for Free Catalog. Spring term opens Feb. 1917.

School of Engineering of Milwaukee, 301 Stroh Bldg., Milwaukee, Wis.



## The University of Chicago

**HOME STUDY** in addition to resident work, offers also instruction by correspondence.

For detailed information address

25th Year U. of C. (Div. V) Chicago, Ill.



## Learn Watchwork, Jewelrywork and Engraving.

A fine trade commanding a good salary, and your services are always in demand. Address HOROLOGICAL, Dept. P, Bradley Institute, Peoria, Ill., for our latest catalog.

## DRAWING

Learn by Mail in YOUR OWN HOME

Newspaper, Magazine and Commercial Illustrating, Cartooning, Water Color and Oil Painting. Learn drawing or painting for profit and pleasure. We can develop your talent. This school has taught thousands. Free Scholarship Award—special limited offer. Your name and address rings you full explanation and our handsome illustrated Art Annual by return mail. Don't delay, write today.

Fine Arts Institute, Studio 562, Omaha, Neb.



## MEN

Send today for this Book

It tells of big openings—for live men—in a business full of opportunities and not overcrowded.

And it tells how we assist you to get started earning \$25 to \$50 a week. Write today.

PRACTICAL AUTO SCHOOL, 68 Beaver St., New York







# Learn <sup>TO</sup> Write

## I CAN TEACH YOU AT HOME During Spare time

*This is a specimen of my business writing before taking Prof Tamblin's course in business writing.*  
July 6, Clarence P. Weber

*This is a specimen of my plain business writing after taking lessons from F. W. Tamblin for 2 months.*  
Sept. 5 Clarence P. Weber

### FREE BOOK

My 32-Page book "How to Become a Good Penman" is FREE to anyone who wants to write better. Contains copies and information that will help you, and beautiful specimens that will make your eyes twinkle with delight.

WRITE FOR IT—use the coupon below—or a postal will do—but

Send at Once!

If you enclose a stamp, I will write your name on a card with white ink, making one of the prettiest specimens of penmanship you ever saw

**"A Wonderful Bargain"** "It is now about two months since I began your course, and while I am not quite half through with Business Writing, I am delighted with my improvement, which is quite marked as you will see by comparing my present writing with the specimen written when I began. My parents objected to my taking it up, but now see I'm getting a wonderful bargain."

— CLARENCE P. WEBER, Middletown, Del.

### Good Writing Is the Very Foundation of Business Success

I can make a good penman of you at your own home, in your spare time, no matter where you live or how poorly you now write. Ever fail to secure a good position because of poor penmanship? Ever know of better positions you could have stepped into if you only wrote a good hand? If not, you're an exception. The advantage of good penmanship is seen all around us.

I have been teaching penmanship by mail over 20 years. I know that any ambitious person can master penmanship just as quickly and thoroughly by my system at home as if in a schoolroom under the personal instruction of the teacher.

**BEGIN NOW** to learn good handwriting and be ready for the next better position that comes your way. Learn right at home—in your own room, outside of working hours. Your spare time is all I ask.

I teach Spelling and Letter Writing also.

## F. W. TAMBLYN

418 Ridge Bldg., KANSAS CITY, MO., U.S.A.

Mr. Weber's wonderful improvement shown in the specimens above was made in 2 months. Hundreds and hundreds of others in all parts of the country are doing the same.

**YOU CAN DO AS WELL**

#### This Brings FREE BOOK

F. W. TAMBLYN, 418 Ridge Bldg., KANSAS CITY, MO.

I am interested in improving my penmanship. Send me your Free Book, "How to Become a Good Penman," postpaid.

Name .....

Address .....





## Music Lessons Sent FREE

You, too, can now quickly and easily satisfy your musical ambitions—learn to sing or play your favorite instrument, whether for pleasure, social prestige or to teach music, by our wonderful home study lessons under great American and European teachers. The lessons are a marvel of simplicity and completeness, endorsed by Paderewski and other great authorities.

### Any Instrument or Voice

Write us the course you are interested in, age, how long you have taken lessons if at all, etc., and we will send you six lessons, free and prepaid, any of the following Complete Courses: Lessons in PIANO (students' or teachers' courses) by the great Wm. H. Sherwood, HARMONY by Dr. Protheroe and Rosenbecker, PIPE ORGAN by Clarence Eddy, VOICE COURSE (with aid of phonograph) by Crampton, PUBLIC SCHOOL MUSIC, by Frances E. Clark, VIOLIN, CORNET, MANDOLIN, GUITAR, BANJO, REED ORGAN, CHORAL CONDUCTING, by equally eminent teachers.

This offer is Free—we do not ask you to pay one cent for the six lessons, either now or later. We want to prove in this remarkable way what fine lessons they are—SEEING IS BELIEVING. This offer is limited, so write today. A few Special Introductory Scholarships now being awarded by our Faculty. Full particulars sent along with free lessons. Send no money.

**SIEGEL-MYERS SCHOOL OF MUSIC,**  
CLARENCE EDDY, Dean

2146 Siegel-Myers Building CHICAGO, ILL.

Mr. A. R. Patterson, whose advertisement appears below, was for eight years a Civil Service Secretary-Examiner, and is well qualified to help YOU secure a Government Position.

# FREE BOOK OF GOV'T POSITIONS

Earn \$75 to \$150 a Month



WRITE TODAY

Be a Railway Mail Clerk, Post Office Clerk or Carrier, Rural Mail Carrier, Internal Revenue Officer, Clerk at Washington, D. C., or Panama Canal, or accept any other good Civil Service position with Uncle Sam, world's greatest and best employer.

Good Pay, Easy Work, Vacations, Position for Life

Earn \$15 to \$150 a month from the start. Rapid advancement. Work 2 hours or less a day, 15 to 30 days vacation with full pay. No strikes, no "lay-offs," no "straw bosses." No politics, no "pull" needed. Ordinary education sufficient. American citizens 18 or over WANTED.

**PATTERSON PREPARES YOU** Only school offering help of former Civil Service Sec'y-Examiner. Quick appointment certain. Sure position or no pay. Send coupon or postal NOW for book free.

**FREE!** Tells what positions are open. How to prepare easily and quickly for job you like best. Don't be satisfied with a small pay, uncertain job. Write for book of Uncle Sam's positions and get on easy street. Mail coupon or postal NOW. Address

**PATTERSON CIVIL SERVICE SCHOOL**  
82 News Bldg., Rochester, New York

\*\*\*\*\*COUPON\*\*\*\*\*  
Send me Free Book of Government Positions.  
Name.....  
Address.....

Please Mention Popular Mechanics

## SHORTHAND IN 30 DAYS

We absolutely guarantee to teach shorthand complete in only thirty days. You can learn in spare time in your own home, no matter where you live. No need to spend months as with old systems. Boyd's Syllabic System is easy to learn—easy to write—easy to read. Simple. Practical. Speedy. Sure. No ruled lines—no positions—no shading as in other systems. No long lists of word signs to confuse. Only nine characters to learn and you have the entire English language at your absolute command. The best system for stenographers, private secretaries, newspaper reporters and railroad men. Lawyers, ministers, teachers, physicians, literary folk and business men and women may now learn shorthand for their own use. Does not take continual daily practice as with other systems. Our graduates hold high grade positions everywhere. Send today for booklets, testimonials, etc.

**Chicago Correspondence Schools**  
969 Unity Bldg., CHICAGO, ILL.

## High School Course in Two Years

LEARN in your own home. Here is a thorough and simplified high school course that you can complete in 2 years. Meets college entrance requirements. Prepared by leading members of faculties of universities and academies.

### Study in Your Own Home

This course was prepared especially for home training. What if you did not get a high school education? You can make up for lost time now. Idle evenings can be spent in pleasant reading that will give you a thorough high school training.

Write For Our Booklet! Send your name and address today for our booklet and full particulars. No obligations. Write NOW!

**American School of Correspondence, Dept. P116, Chicago, U. S. A.**

**ELECTRICAL ENGINEERING** men with training are always in demand. Having trained over 5000 young men in the past 23 years in the fundamentals of Applied Electricity, The Bliss Electrical School, with its well-equipped shops and laboratories, is peculiarly well qualified to give a condensed course in Electrical



including Mathematics, Steam and Gas Engines, Mechanical Drawing, Shop Work, and Theoretical and Practical Electricity, in all branches. Students actually construct dynamos, install wiring and test efficiency of electrical machinery. Course, with diploma, complete

### IN ONE YEAR

For practical young men with limited time. 24th year opens Sept. 7th. Catalogue on request. 104 Takoma Ave., Washington, D. C.

## Learn to PAINT SIGNS and SHOW CARDS

I teach you personally, by mail, in a short time. Oldest and largest School. Big field, work interesting. You can **EARN \$18 TO \$45 A WEEK**. Fritzer, Minn., writes: "Did job after first lesson, cost \$10, profit \$7.66." Crowl, H. C., says: "Earned \$200.00 while taking course." Get literature, samples, guaranteed—all FREE.  
**DETROIT SCHOOL OF LETTERING**  
Established 1899. 202 D. S. of L. Bldg. DETROIT, MICHIGAN



## FREE 10 Lessons In Public Speaking

Write for particulars of this extraordinary offer. 10 lessons in public speaking absolutely free. Remarkable opportunity. Become a powerful speaker in spare time by mail. Overcome "stage fright," enlarge your vocabulary, train your memory, gain self-confidence. Increase your earning power, popularity. We have trained hundreds.

**Offer Limited** This offer is made strictly for advertising purposes and may be withdrawn at any time. Write at once, while this free lesson offer lasts. Big saving if you act now.  
**Public Speaking Dept. American Correspondence School of Law**  
Dept. 1192 Manhattan Bldg. Chicago

## LEARN WATCH REPAIRING

Be a watchmaker—you can learn this profitable trade by correspondence in a few weeks in your own home by the DeSelms Chart System. After you complete the course you will know a watch from A to Z. You will know just what the matter is and how to repair one. When you graduate you will be a practical watchmaker and repairer and competent to fill any position. Positions for our graduates.

Ask for our Free Book. It explains our system and terms.  
**THE DeSELMS WATCH SCHOOL**  
23 Perry Street ATTICA, INDIANA





In Business

In the Courts

In Public Life



# Picture Yourself as a **LAW TRAINED MAN**

Doesn't it make you feel successful—a man of affairs—just what you want to be? Then let this picture be your inspiration.

With the LaSalle Extension University behind you, you can acquire a law training of University grade that gives you the equipment and qualifications to build up a successful career—to be a leader in Business, sought after in Court Practice, or honored with positions in Public Life.

## Enter This Field of Big Incomes!

No other training equips a man with greater qualifications for success than a legal education. Law is a splendid profession in itself, but from it you will find more big thinkers, more big incomes, more leaders in business and public affairs than have come from any other modern profession. The legally-trained man is in greater demand today than ever before, because he knows the rules of safe conduct in all forms of human endeavor. He is, therefore, gifted with the ability to govern, to guide, to administer and direct. Men, corporations, firms and business enterprises by the hundreds are daily falling into the pitfalls of ruin for lack of legal guidance. IF YOU ASPIRE TO A POSITION OF DIGNITY, RESPONSIBILITY AND BIG INCOME, STUDY LAW. Under our plan the cost is within the reach of the most limited income. We allow you to make small monthly payments to suit your convenience.

### We Train You By Mail

At home—in spare time—evenings. No special education is required. Our graduates pass bar examinations in any state and have attained highest records in competition with graduates of leading resident schools. In fact, we guarantee to coach free, until successful, any graduate failing to pass bar examinations. Among our graduates are men enjoying positions of honor in professional, public and business life. It doesn't matter what your vocation is now, we can help you to a bigger, better future. Send coupon for facts that tell how.

The LaSalle text is edited and written in plain, easy-to-understand language by such noted legal educators as James Parker Hall, Dean of University of Chicago Law School; James DeWitt Andrews, former member faculty Northwestern University and over 20 Law School Deans, Professors in famous resident colleges, and famous legal authorities of Bar and Bench.

### Complete Course In Public Speaking **FREE**

Our training by mail will positively teach you the fine art of persuasive speech. Every lawyer—every successful business man—should be a forceful speaker. Our course is prepared by Frederick B. Robinson, A. B., A. M., Ph. D., Professor Public Speaking at College of City of New York. Write and learn how you can NOW secure this valuable course, absolutely free if you become one of our students.

LaSalle Extension University, Dept. 264-F Chicago, Ill.  
"The World's Greatest Extension University"

### Modern Law Library **FREE!**

It is not necessary for you to buy text material of any kind. We supply all the law books, lectures, quizzes and lesson material needed in the entire Course, including our fourteen massive law volumes—**"AMERICAN LAW AND PROCEDURE"**—standard size 9½x6½ in., bound three-quarter sheep. All branches of law are fully covered. This work cost us over \$50,000 but is **FURNISHED COMPLETE WITHOUT ADDITIONAL COST** as soon as you enroll.

Take your first step toward a bigger, better future by mailing this coupon right now—today.

LaSalle Extension  
University

"The World's Greatest  
Extension University"

Dept. 264-F Chicago, Ill.

Please send me—**FREE**—copy of your big, illustrated books, "EVIDENCE" and "VALUABLE LAW GUIDE" at once. Also send me full particulars of your free Public Speaking Course offer.

Name .....

Street and No.....

City.....State.....

Please Mention Popular Mechanics



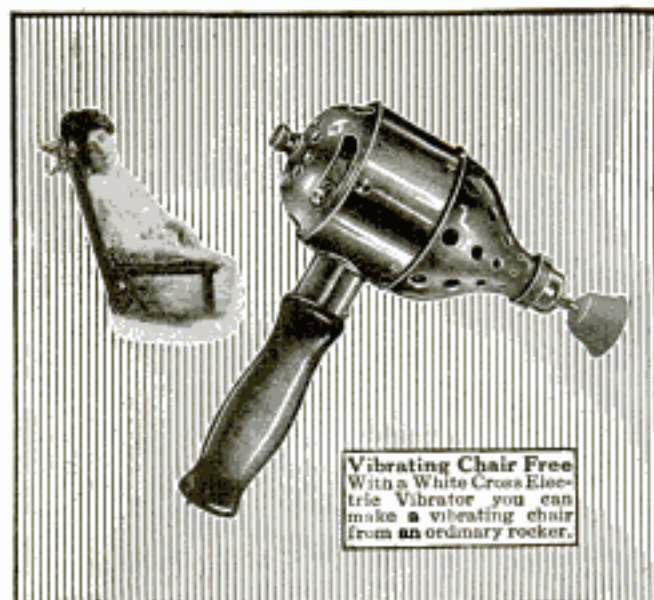

Vibrating Chair Free  
With a White Cross Electric  
Vibrator you can  
make a vibrating chair  
from an ordinary rocker.

Only **\$10<sup>00</sup>**

For Our New No. 21B Model

## White Cross Electric Vibrator

**T**HE marvelous instrument that has been such a boon to the medical and scientific world. Endorsed by prominent physicians everywhere. On a great special offer you may now get this new model No. 21B for only \$10. Send coupon now for the free book that tells you all about it. We have over a dozen different types of vibrators for you to choose from and our prices are so very low that you need wait no longer. Any one can now afford a vibrator.

**WHITE CROSS**  
ELECTRIC VIBRATOR



Can be connected up as easily as an electric lamp—or if your home is not wired for electricity it will run perfectly on its own dry cells. With this superb instrument you can make a perfect vibrating chair from an ordinary rocker. This is but one of the exclusive features of the great White Cross Electric Vibrator. Send the coupon for the book that tells you all about it.

## Vibration Is Life

Vibration is part of the very foundation of our existence. When your nerves are all tangled up try vibration. You will find how restful it is. You see more clearly—your think more keenly—you act more quickly. Full of the real joy of living, your efficiency and earning power increases.

Free  
Coupon

Lindstrom-Smith Co.  
1100 So. Wabash Ave.  
Dept. 1192, Chicago, Ill.

Without obligation send me free your new book, "Health and Beauty." Also particulars of special offer on the White Cross Electric Vibrator.

Send the Coupon  
For New Book "Health and Beauty"

Send us your name and address on a letter or a postal or the coupon and we will send you absolutely free and prepaid the new book on vibration "Health and Beauty," also our special offer. No obligations of any kind. Send the coupon today—now.

Lindstrom-Smith Co.  
Dept. 1192  
1100 S. Wabash Ave.  
Chicago, Ill.

We also manufacture  
White Cross Electric  
Irons, Hair Dryers,  
Stoves, etc.

Name.....

Address.....

Dealers  
write  
now.

My Electrical Dealer's Name and Address.....

## BE AN ARTIST

We can teach you **DRAWING** in your own home during your spare time.

Our 28 years of successful teaching prove our ability. 10 Courses in Commercial and Illustrative Drawing. Teachers Normal and Applied Art. Endorsed by high art authorities. Students trained by members of our Faculty are filling high-salaried positions. Artist's Outfit **FREE** to Enrolled Students. Fully Equipped Residence School. Write today for Art Year Book.

**OUR HANDSOME ART YEAR BOOK "FREE" TO YOU**

**SCHOOL OF APPLIED ART**  
APPLIED ART BLDG. NO. 55, BATTLE CREEK MICH.

## A GOOD POSITION

with **UNCLE SAM** is most desirable. Life positions, pleasant surroundings, good pay, steady work, short hours, promotions on merit. Both sexes. No political pull. Thousands of appointments yearly. Most thorough preparation \$5. Returned if not appointed. Full information and questions used by the Civil Service Commission free.

**AMERICAN CIVIL SERVICE SCHOOL WASHINGTON, D. C.**

## BOYD SHORTHAND IN 30 DAYS

Shorthand simplified. Learned at home in 30 DAYS. Boyd Syllable System, based on Syllables. No shading—no position. Writers hold World's Record. Two of the largest Mail Order Houses have installed the Boyd System. 100 to 150 words a minute guaranteed. Write today for Special Offer, Free Catalog and Sample Lesson. Chicago Home Study Schools, 504 Reaper Bldg., Chicago, Ill.

## MEN WANTED

Prepare as Firemen, Brakemen, Electric Motormen, and colored Train Porters. First Class Standard Roads. Hundreds put to work—\$65 to \$150 a month without any experience. **500 more wanted.** Uniforms and passes arranged for when necessary. Enclose stamp for Application Blank. Name position you want.

**I. RAILWAY C. I., Dept. 35, Indianapolis, Ind.**

## SHOW CARD WRITERS

EARN \$80 TO \$200 A MONTH  
**LEARN FREE!**

We will furnish a thorough course in Show Card Writing and Lettering absolutely free to introduce our colors if you will purchase an assortment of Alpha Colors to use while practicing. Particulars for stamp.

**ALPHA COLOR COMPANY, Inc., Dept. K, 81 East 125th St., N.Y. City**

## AT HOME Learn TO SING

Send 2-cent Stamp for Helpful Booklet, "The Voice Made Beautiful."

**HARVEY SUTHERLAND, 1832P 49th St., BROOKLYN, N. Y.**

## JEWELRY ENGRAVING

We teach you, by our new and original method of instruction, this clean, fascinating and profitable business right at your home, and furnish you all tools needed absolutely free. Write for free book to the

**WISCONSIN SCHOOL OF ENGRAVING, 5th Bldg., MILWAUKEE, WIS.**

## IF YOU STAMMER

attend no stammering school till you get my large **FREE** book and special rate. Largest and best school in the world curing by natural method. Write today.

**Lee Wells Millard, Pres., North-Western School, Inc., 2317 Grand Avenue Milwaukee, Wis.**



# LET ME TRAIN YOU

for the **Automobile and Tractor Business**

**M**EN come to my big school from every part of the United States and many foreign countries to get my Original, Practical Method of Automobile Training and Experience.

They come because they find after investigation that mine is the ONE METHOD that insures success and big pay. It's all because the RAHE ORIGINAL METHOD OF PRACTICAL AUTOMOBILE TRAINING AND EXPERIENCE is nothing more or less than the actual doing—getting into overalls and "digging in" under the guidance of expert instructors in a school with

**More Equipment      More Floor Space**  
**More Expert Instructors**

I know the value of complete equipment and plenty of room in my big machine and repair shops, around the forges and lathes and drill presses. It's training like this that enables my graduates to earn from

## \$75 TO \$300 A MONTH

as ignition experts, testers, demonstrators, oxy-acetylene welders, general repair men, drivers, managers of garages, and repair shops—or in business for themselves running their own garages and acting as factory representatives and dealers for the large automobile and tractor manufacturers. My graduates succeed because my training is right and is the acknowledged standard.

### Only a Few Short Weeks Required

### No Books or Printed Lessons Used—No Tools to Buy

### \$50 SCHOLARSHIP For Tractor, Gas & Stationary Engineering, Home Lighting FREE

I have a limited number of these Free Scholarships available. WRITE ME AT ONCE and I'll reserve one for you. NO EXTRA CHARGE FOR OXY-ACETYLENE WELDING COURSE. Others charge a tidy sum for welding instruction but I give it to you without a penny extra.

SEND FOR MY BIG BOOK

## 80-Page Catalog Free



Let me send you my latest and best book, "MAKING MONEY IN THE AUTOMOBILE BUSINESS"—filled with fine Copper Engravings, showing my Three Big Buildings, Tractor Farm, Machine Shops, men at work making all kind of repairs. **WRITE AT ONCE—NOW—TODAY.**

H. J. RAHE, President

**Rahe's Automobile School**  
1028 Locust St., Kansas City, Mo.

**FREE SCHOLARSHIP COUPON**

H. J. RAHE, President  
**RAHE'S AUTOMOBILE TRAINING SCHOOL**  
1028 Locust St., KANSAS CITY, MO.

Send me your Big Catalog, Free Scholarship Certificate, and full information—all Free and postpaid.

NAME.....

STREET OR R.F.D.....

TOWN.....STATE.....





# 50 Cents A Week

**F**OR this insignificant sum—less than most of us spend for tobacco—this ten-volume Cyclopedia of Architecture, Carpentry and Building is yours. Yes, and with every set is included—free of charge—a year's Consulting Membership in the American Technical Society. The Consulting Membership gives you the privilege of submitting your perplexing problems to a corps of experts for a whole year free. This Consulting Membership regularly sells for \$12, and puts at your disposal a wealth of information and the knowledge of men high in the profession.

Fletcher Cunningham, Shreveport, La., writes: "After receiving the books I decided that with their help I could go into the contracting business for myself. I have just closed a contract on which I expect to clear about \$112.00 for two weeks' work."

## Use Them Seven Days FREE

The entire ten-volume Cyclopedia will be sent to you by prepaid express upon receipt of the coupon below. Don't send a single penny—just the coupon! Use the books for seven full days before you decide whether or not you want them. If you keep them, you may pay the advertising price of \$24.80 in easy monthly installments of \$2.00—50c a week. The regular price of this massive set is \$50.00. Remember, if you don't want the books they may be returned at our expense and you won't be out a penny.

### Partial Table of Contents

Mechanical, Free Hand, Perspective and Architectural Drawing, Lettering, Pen and Ink Rendering, The Orders, Superintendence, Strength of materials, Masonry, Reinforced Concrete, Carpentry, Stair Building, Hardware, Steel Construction, Roof Trusses, Practical Problems, Estimating, Contracts, Specifications, Building Law, Sanitation, Sheet Metal Work, Electric Wiring and Lighting.

## Everything About Carpentry and Building

Contained in the Cyclopedia's ten splendid volumes is everything about carpentry and building, from the first rough sketch of the architect to the acceptance of the finished structure. They include wood, stone, steel and reinforced concrete construction; estimating and contracting; interior finishing and decorating; and modern house lighting and sanitation. Every line is written in plain, understandable language—every difficult point is made clear. The books are handsomely bound in half red morocco leather, gold stamped, and contain 4,760 pages (7x10 inches), and 4,000 illustrations, full-page plates, building plans, diagrams, etc. Every subject is cross-indexed so it can be referred to in an instant.

## Just Send the Coupon

Don't send us a single penny. Just fill in and mail the coupon. Then we will send the books to you by prepaid express for seven days' free trial. Remember, you don't assume a single obligation—we are glad to have you see the books for yourself before you decide whether or not to buy. This offer is open to anyone within the boundaries of the United States and Canada. Send the coupon today—now!

**American Technical Society, Dept. R1192, Chicago, U. S. A.**

American Technical Society  
Dept. R-1192 CHICAGO

Please send the Cyclopedia of Architecture, Carpentry and Building for seven days' examination. If I decide to keep them I will send \$2 after 7 days and \$2 a month until \$24.80 has been paid, when you will send me a receipt showing the \$24.80 and Consulting Membership are mine and fully paid for. Otherwise I will return at your expense.

Name .....

Address .....

Reference .....





# Salesmen Get the Big Pay

The Man Who  
Makes the Goods

—and the Man  
Who Sells Them

## \$2,500 to \$10,000 Positions Always Open to Men Who Can Sell

Salesmen command the largest incomes. Go over the pay-roll of any company—note the \$3,000—\$5,000—the \$10,000 men—most of the big salaries go to men identified with the selling side of business. And it is only natural. The salesman is the direct producer of profits—he it is who brings in the orders—dividends depend on his ability. The man who can sell goods never lacks a position—thousands of concerns are ready—yes, eager to pay well for his services.

### Read These Letters:

#### I Now Earn as High as \$100 a Day

"I took your Course two years ago. Was earning \$15 a week clerking. Am now selling many of the largest firms in the U. S. I have earned more than \$100 a day. You secured me my position. Your School is entitled to the full credit for my success."—J. L. Dobson, 1550 S. Harding Ave., Chicago Ill.

#### I am in the \$2,500 to \$10,000 Class

"I was a carpenter, am now a Salesman and can proudly say I am in the \$2500 to \$10,000 a year class. Wish I could invest more dollars that would bring the big returns those invested in your Course did."—J. E. Wood, Rooms 202-54 Pacific Bldg., San Francisco, Cal.

#### I Earned \$6,500 This Year

"Last year I only earned \$900 as a clerk. This year I have earned \$6500 and have been promoted to Sales Manager. This I accomplished by studying your Course during spare time. Your Employment Bureau offers me many good positions."—U. W. Birmingham, 129 Bank St., Dayton, Ohio.

#### Your Course Makes Success Easy

"More than two years ago I joined the N. S. T. A. You secured me a good position with one of the best firms in their line. Am making fine wages. Former experience is unnecessary—your Course makes success easy."—Wm. H. Kessler, 199 N. 16th St., East Orange, N. J.

#### From Shop Work to High Salaried Salesman

"I have charge of the Boston Sales Branch of my firm and the fact that I have made good and have received so many advances in salary shows what your Course did for me. I wish to recommend your School to all."—J. A. Christian, P. O. Square Bldg., Boston, Mass.

## Be a Salesman

Training will fit you to hold down a big paying position in this uncrowded field—training that now may be secured in leisure time study. Training will bridge for you the gap between low salaried drudgery and a big paying sales position—training that may be partly acquired through the rough-hard-knocks-route—or by the thorough, shorter, easier way—through membership in the National Salesmen's Training Association. Read at the left the letters from members of this Association—typical instances taken from thousands in our files—proving the merit of our course. What these men have done—you can do. Mail the coupon for complete facts.

### Study at Home—In Spare Moments

Our Course of Instruction in Scientific Salesmanship, planned by Master Salesmen—gives you just the training necessary to qualify for the big paying position. Among the many subjects covered are the following—How to Prepare a Selling Talk—How to Approach the Prospect—How to Manage the Interview—How and When to Close—How to Handle Sales Correspondence—How to be a Good Mixer. Every lesson is prepared with but a single idea—to increase the earning power of our students.

### Good Paying Positions Found for Our Members

The service offered by our Free Employment Bureau is a most valuable one. Employers everywhere recognize the value of N. S. T. A. Training. We have constantly on file more requests for salesman than we can possibly fill. We put you in touch with good positions while you are still a student—and more than helping you secure a good connection—we help you make good.

### This Book—FREE

Our Free Book, "A Knight of the Grip" tells the whole story. It contains testimonials from members earning from \$100 to \$1000 monthly and will be accompanied by a Special List of the many lines of businesses in which good positions are now open for Salesmen paying from \$2500 to \$10,000 yearly. A position as Salesman is ready for you—prepare yourself now—mail the coupon below—delay may mean opportunity lost. Address Dept. 507 "E."

#### NATIONAL SALESMEN'S TRAINING ASSOCIATION

Chicago New York San Francisco

National Salesmen's Training Association, Dept. 507 "E," Chicago—New York—San Francisco  
(Send your request to the office nearest your home)

With no obligation on my part, please send me your Big FREE Illustrated Book.

Name \_\_\_\_\_

Street \_\_\_\_\_

City \_\_\_\_\_

State \_\_\_\_\_





# MEN ONLY

## Learn to Run and Repair Automobiles and Tractors by the Sweeney System

**T**HE Sweeney System of teaching the automobile business to men mechanically inclined means in a few words to learn by actually doing the work in a School where you get into the grease to your neck. It is the only way to learn it. And say you need up-to-date equipment, too. My \$89,000.00 equipment consists of all types of automobiles, from a one cylinder up to a twelve cylinder Packard. I actually have these cars here, with their ignition and starting systems, everything complete. It also includes working in different departments under competent instructors, such as electric starters and storage batteries, valve grinding, piston ring fitting, babbitting and bearing departments, also oxy-acetylene welding. My equipment consists of ten oxy-acetylene welding

machines; tire vulcanizing, lath work, gear cutting—in fact, I teach you to properly take care of a car and to repair it, so that you can make almost any part, if you are mechanically inclined, and if during your life you have had that longing to some day be able to fix machinery and work on it, write for my catalog, which describes the Sweeney System of teaching the automobile business; how I put you in the shop with overalls on, make your own tools, and have a competent instructor right at your elbow to first tell you, then show you, and then you do the work yourself. This is so different from the average way of teaching in School. If you are afraid of work or grease don't come here, because when you work on automobiles you get dirty. Think of the opportunities offered you in changing your

occupation from something you do not like to something that you do like. Every man has to make a living; so why not make it in the way that you enjoy? Then life will be a pleasure. There is no trade in the world today that pays as good money with steady work, and in which the opportunities are as good for a young man as in the gas engine business. Every up-to-date farmer in five years, will have a tractor, automobile and track. Think of the great opportunities.

At this School I teach tractor engineering. I have my own tractors; I have my own factory. For this there is no extra cost. There is no extra charge for oxy-acetylene welding; there is no extra charge for vulcanizing; there are no books or tools to buy. The low price of my tuition covers everything.

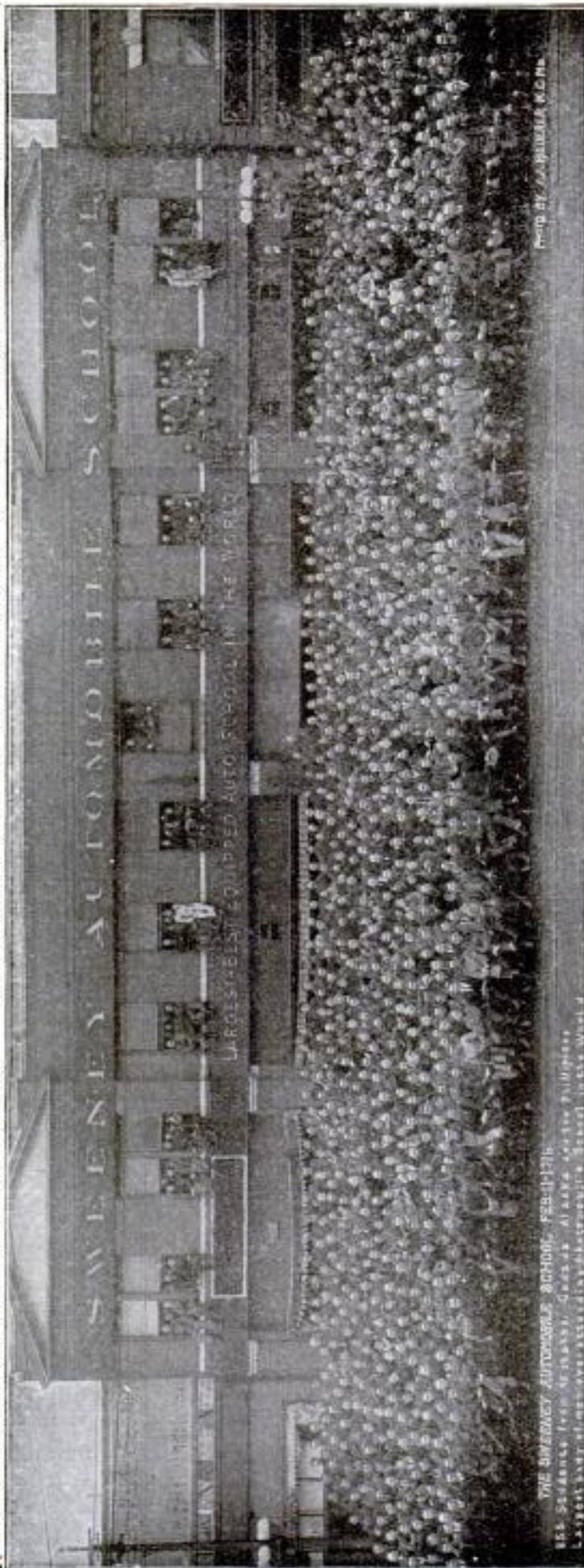

THE SWEENEY AUTOMOBILE SCHOOL, KANSAS CITY, MO.  
 111 SWEENEY ST., KANSAS CITY, MO. 441-1111  
 SWEENEY AUTOMOBILE SCHOOL, KANSAS CITY, MO.

**T**HE above picture shows men from 43 States, and from foreign countries, who came to Kansas City to learn the automobile business. I have had as many as five boys out of one family, one after the other. I have had fathers who completed my course, and then sent their sons; sons who have completed the course, went home and sent their fathers. I believe this is one of the greatest recommendations that any School can have. I have written a catalog, full of illustrations—pictures of the students actually at work. Pictures tell more than words. Drop me a postal. I will send you one absolutely free, also a certificate for a free course in gas tractor work. This was the first

Automobile School in the world to teach gas traction engineering, and for a limited time there will be no extra charge. I can give you real experience in a factory because I own one.

If you believe that you are of a mechanical turn of mind, like to work around machinery better than anything else, this is the business for you to take on, the sooner you take it up the quicker you will start to enjoy life, by making a living at some-

thing you like, instead of working at something you dislike. Why is it you go out hunting, lay in the mud all day in the rain and cold, almost freeze to death, walk about twenty or thirty miles back home, and say you had a good time? That is because you like the work. Why not make a living at something that you will enjoy just as well? So drop a card for my catalog, which will give you full particulars. Do it now.

**SWEENEY AUTOMOBILE SCHOOL Largest and Best Equipped in the World**  
 1161 E. 15th St., KANSAS CITY, MO.



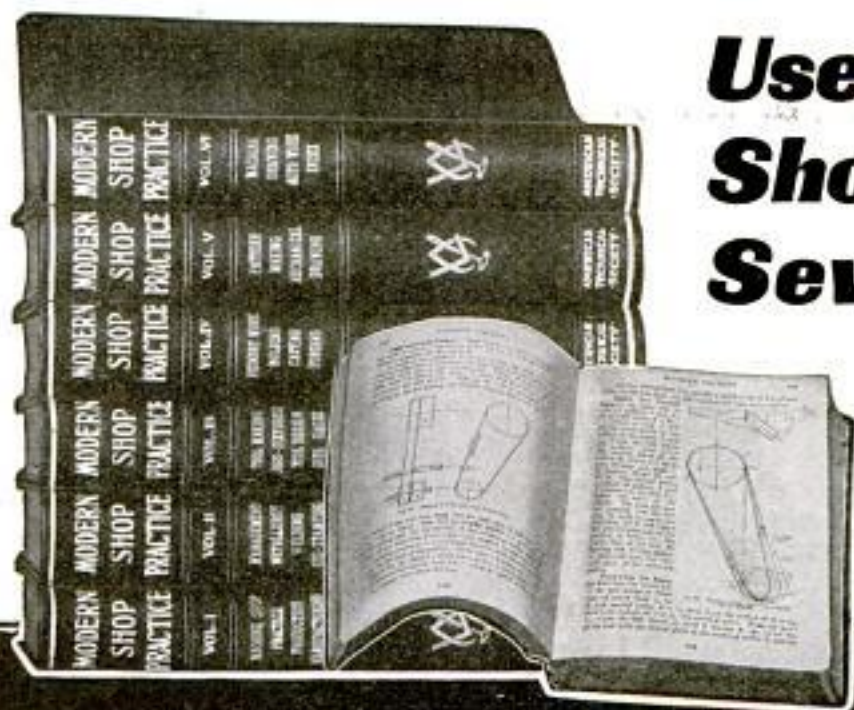

**Use These  
Shop Books  
Seven Days  
At Our  
Expense**

## Shop Methods—Worth Thousands—Now Yours

**L**ABOR-SAVING methods that big manufacturers spent thousands to develop. Facts that you can use in everyday work.

Information that fits you to earn bigger pay. All this now yours in the new 6-vol. set of *Modern Shop Practice*. Sent on a very special offer if you order while the present edition lasts. A full week's examination absolutely free whether you buy or not. Simply a sensational offer. Get in on it now. You can't lose. You don't risk a penny. See the books before you buy. 6 thick volumes—2300 pages—2500 illustrations. Flexibly bound in genuine Bagdad leather, gold stamped. The coupon brings them, express prepaid. Mail it now!

**50c a Week Consulting Service  
FREE!** And here is something more.

is all you pay if you keep the books. And they will pay for themselves many times over. Every line tells you something that makes you worth more money to your boss. Every detail of modern shop practice is given. Facts you wouldn't learn in years of practical experience now placed at your fingers' ends. And we are so confident that you will see the pay-raising value of these books that we send them free—for 7 days' examination. You are the sole judge. You don't have to spend a penny unless you buy. Then only 50c a week.

**Treats These  
Subjects  
in Every Detail**  
Machine Shop Work—  
Machine Shop Manage-  
ment—Tool Making—  
Foundry Work—Pat-  
tern Making—Machine  
Drawing, etc., etc.

As a buyer of these books you get a year's consulting membership in the American Technical Society—regular price \$12.00. Think what it means! The free advice and assistance of our entire staff of experts. Whenever a puzzling problem comes up these experts will help you solve it. They will give you the benefit of their vast experience. You know what such experts get when called into consultation by railroads, manufacturers and public service corporations, \$25 to \$100 a day or more. But you get this service absolutely free with your set of *Modern Shop Practice*.

## Send No Money—Just the Coupon

Sign and mail the coupon now. Get these brand new shop books for seven days' free examination, returnable at our expense if they fail to please. Only \$2.00 down, if you decide to keep them. Then \$2.00 a month—50c a week—until the introductory price of \$17.50 has been paid. The regular price of these books will be \$30.00. In fairness to yourself, send the coupon. It may mean a better job and bigger pay for you. This offer is open to every person within the boundaries of U.S. and Canada.

**American Technical Society**  
Dept. M-1192 CHICAGO, U. S. A.

**American Technical Society**  
Dept. M-1192 Chicago, U. S. A.

Please send me a set of *Modern Shop Practice* for seven days' free examination. If I decide to buy, I will send \$2.00 within seven days and the balance at \$2.00 a month until \$17.50 has been paid. Then you send me a receipt showing that the \$50 set of books and the \$12.00 consulting membership are mine and fully paid for. If I think that I can get along without the books after the seven days' trial I will return them at your expense.

Name .....

Address .....

Reference .....



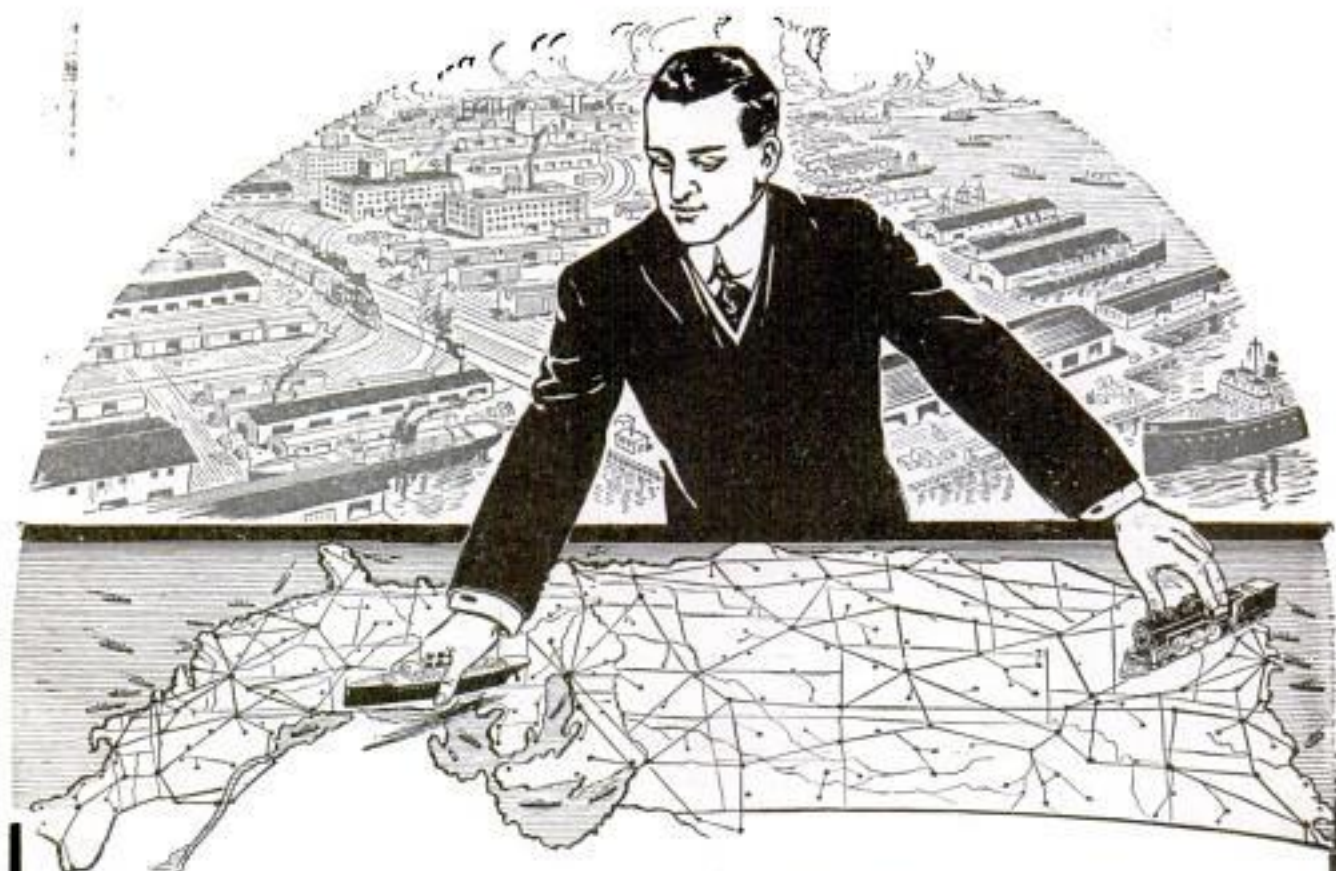

## This Man Earns \$100 a Week

He knows how to open up large markets and help his employers outstrip competition in business because he knows how to route shipments, obtain shortest mileage, lowest rates, and quickest deliveries. He knows how to classify goods and reduce transportation costs. His knowledge of traffic laws and transportation saves his employers thousands of dollars annually.

Here's your chance to qualify for the same kind of a position at the same salary. Don't let this chance go by. Few men have this traf-

fic knowledge. The demand far exceeds the supply. In fact, over half a million firms need men who can classify commodities and secure ratings most economically. You can be able to answer this call for trained traffic men quickly by means of the LaSalle Home Study Course. We guide you step by step. With the LaSalle Extension University behind you, you can qualify in a comparatively short time. The expense is so small and the terms so easy you will scarcely miss the money. Qualify for a bigger job—at home—in spare time.

# Be a Traffic Man

## At \$35 to \$100 a Week

### Send In the Coupon

For proof that our graduates, because of the thoroughness of their training through our course, qualify for the best positions and increase their earning capacity. Let us send you letters from students and full details concerning the LaSalle University Home Course in Traffic Management. Send in the coupon now and receive our free book "Proof," letters and full details by return mail.

There seems to be no limit to the salaries expert traffic men are paid. Some concerns pay their directors of traffic \$10,000 or more a year. Salaries of \$35 to \$100 a week are commonly paid to traffic managers. Splendid positions with high salaries for competent, trained men are open everywhere.

### We Train You By Mail For a Big Traffic Job

You need not leave your present position. You may keep on earning while learning.

Our course is recommended and endorsed by railroad executives and big business concerns throughout the country. Your training is under the supervision of a large corps of the most prominent traffic experts in the country, headed by N. D. Chapin, until his present connection with us, Chief of Tariff

Bureau New York Central Lines. The Course gives you also a thorough understanding of Interstate Commerce Laws and prepares you for every duty required of a high grade traffic manager—how to route shipments, obtain shortest mileage, classify goods, secure quickest deliveries and lowest rates—in fact, trains you so that you can qualify for an immediate high salaried railroad or industrial traffic position.

**LaSalle Extension University,**  
"The World's Greatest Extension University"  
Dept. 264-C Chicago, Ill.

### Free Book Coupon

**LaSalle Extension University,**  
Dept. 264-C Chicago, Ill.  
"The World's Greatest Extension University"

Send Free Book about opportunities now open to TRAFFIC EXPERTS with LaSalle University Training. It is understood that I am not obligating myself in any way.

Name .....

Address .....

City.....state.....





## A Dozen Brand-New Handbooks

Although prepared especially for the experienced worker by recognized authorities, these twelve pocket-size handbooks are written in such simple language that even the beginner may learn from them. They are free from puzzling technical terms, and all difficult points are made perfectly clear.

The books are handsomely bound in flexible morocco leather, gold stamped, and contain many instructive illustrations, tables and diagrams. Reliability considered, they are the most reasonably-priced books of their kind on the market today.

<b>Automobile Driving and Repairing</b> . . . . .	254 pages	217 illus.	\$1.50	<b>Gas Engines and Producers</b> 360 pages	177 illus.	\$2.00
<b>Automobile Ignition, Starting and Lighting</b> . . . . .	402 "	325 "	2.00	<b>Refrigeration</b> . . . . .	288 "	124 " 1.50
<b>Plumbing</b> . . . . .	240 "	254 "	1.50	<b>Pattern Making</b> . . . . .	232 "	384 " 1.50
<b>Machine Shop Work</b> . . . . .	352 "	401 "	1.50	<b>Steel Construction</b> . . . . .	372 "	215 " 2.00
<b>Elements of Electricity</b> . . . . .	242 "	240 "	1.50	<b>Heating and Ventilation</b> . . . . .	232 "	177 " 1.50
				<b>Tool Making</b> . . . . .	304 "	453 " 1.50
				<b>Reinforced Concrete</b> . . . . .	240 "	119 " 1.50

Each of the books listed above is fresh from the press—is literally crammed with brand-new material. If you don't see the one you want, send a postal for our 48-page catalog. This catalog describes in detail our 88 pay-raising handbooks, many of which are priced as low as \$1.00.

### Your Dealer Has Them

Hundreds of progressive bookdealers stock our handbooks. If your dealer can't supply you, send us his name and address, together with the price of the book you want, and we'll send it to you postpaid. Examine it carefully—use it at your work for five full days. Then if it fails to meet with your expectations, return it and get your money back.

This offer is our best guarantee that the books are exactly as represented. Why not take advantage of it? Send in your order and remittance today—NOW!

**AMERICAN TECHNICAL SOCIETY**  
Dept. H 1192, CHICAGO, U. S. A.

### Five-Day Examination Coupon

American Technical Society, Dept. H1192, Chicago, U. S. A.

Please send me.....

for which I enclose \$..... My dealer's name and

address is .....

.....

My name is.....

Street and No.....

Town and State.....





MR. R. R. SHUMAN  
Pres. Shuman Advt's  
Company

## -Meet Mr. Shuman!

Mr. R. R. Shuman, President of the Shuman Advertising Company, is one of the instructors and one of the men who helped organize our new Extension Course in

# Advertising & Salesmanship

Mr. Shuman has had a long, varied experience in the advertising field. Formerly he was Advertising Manager of such well known concerns as the Liquid Carbonic Company, manufacturers of soda fountains, and Carson, Pirie, Scott & Company, one of Chicago's leading department stores. Mr. Shuman brings to you who want to learn the advertising business, the full benefit of his 20 years' experience. He has spent millions of dollars in advertising for himself and his clients in acquiring this experience. The knowledge he has thus gained is yours if you are eligible for admission to our course.

## Free Personal Analysis

To determine definitely whether you are eligible and whether you are qualified to succeed as an Advertising or Sales Manager, we have arranged with a well known Vocational Director to personally analyze each applicant free of charge. This course is not open to every one who has the tuition fee—only those qualified to succeed are enrolled. The acceptance of your enrollment practically guarantees your success.

## First Practical Course

This is the first course in Advertising and Salesmanship organized by practical men. Not one of our instructors is a "professional" teacher. All are actually engaged in the work of advertising and selling. The practical atmosphere of their daily work fills all their lessons. You are given practical experience all through the course because you are required to do actual work. You will write copy for advertisements, booklets, folders, etc., you will learn how to analyze markets, and plan sales and advertising campaigns; conduct a mail order business, and write strong, convincing "human interest" sales letters. Entering this course will be like going to work as an assistant to a master sales or advertising manager in a big corporation.

## You Save 10 Years' Time

Under our practical instructors you will learn more about advertising in twelve months than you might otherwise learn in a life time. You can easily clip off ten years' hard work. They will help you develop the vision, the creative power, the "selling sense" of a successful Advertising and Sales Manager.

**Send Coupon** for complete list of instructors, free personal analysis chart, and full particulars of our Home Study Course in Advertising and Salesmanship.

**Bryant & Stratton Business College**  
1022 Bryant & Stratton Bldg., Chicago, U. S. A.

**SIGN, CLIP AND MAIL THIS COUPON**

Bryant & Stratton Business College  
1022 Bryant & Stratton Bldg., Chicago  
Gentlemen: Please send me names of instructors in your course of Advertising and Salesmanship, free personal analysis chart, and full particulars.

Name and Address Below

Please Mention Popular Mechanics

## Cornet Free!

We teach you and will give you a **Beautiful Cornet** or any brass Band Instrument absolutely **FREE**. You pay weekly as lessons are taken. Instrument is sent with first lesson. Graduates in every state. Hundreds of enthusiastic testimonials. Write to-day for our booklet and wonderful tuition offer.

INTERNATIONAL CORNET SCHOOL, 637 Music Hall, BOSTON, MASS.



## FINLAY Engineering COLLEGE

10th and Indiana Ave., Kansas City, Mo.

Special midwinter courses. Day and night classes. Armature winding, conduit work, lathe work, auto tractor, oxy-acetylene welding, Operation steam, electric, gas machinery. Anything you want, any time you want it. Low rates. Write for catalog "F."

## ARTISTS Earn \$20 to \$50 a Week

Big demand for Illustrators, Cartoonists, Designers. We teach you how—at home—by mail—and then assist you to the job. Big illustrated book FREE. Write today.

WASHINGTON SCHOOL OF ART, 941 F St., Washington, D. C.

## LAW

University Extension Law School, Est. 1897  
Our Simple Experience Method of Home Training in Law prepares you for the Bar or Business Law. A complete Standard Law Library Free to every student. Low tuition costs. Pay in monthly installments. Money refunded if dissatisfied. Write today for catalogue.

University Extension Law School, Dept. 52, 206 S. Wabash Ave., CHICAGO, ILL.

## Baker's Show Card Book \$3.00

EARN \$20 TO \$60 A WEEK  
LEARN TO MAKE SHOW CARDS Salary or business of your own. My book teaches all the tricks of the trade. No single anyone can learn. Elaborately illustrated. Earn while learning. Send today. Money refunded if not satisfied.  
WM. J. BAKER, HENRY BUILDING, PORTLAND, ORE.



LEARNED BY ALMOST ANYONE AT HOME SMALL COST  
**VENTRILOQUISM**  
Send today 2c stamp for particulars and proof.  
O. A. SMITH, Room D 147, 823 Bigelow St., PEORIA, ILL.

# Stronger, Clearer Voice for You!



Weakness, huskiness and harshness banished. Your voice given a wonderful strength, a wider range, an amazing clearness. This done by the Feuchtinger Method, endorsed by leading European musicians, actors and speakers. Use it in your own home. Simple, silent exercises taken a few minutes daily impart vigor to the vocal organs and give a surpassing quality to the tones. Send for the facts and proofs.

## Do You Stammer?

If you have any voice impediment this method will help you. You need not stammer or lisp—if you will follow our instructions.

# WRITE

Send the coupon and get our free book and literature. We will tell you just what this method is, how it is used and what it will do for you. No matter how hopeless your case may seem the Feuchtinger method will improve your voice 800 per cent. No obligation on you if you ask for this information. We gladly send it free, postage prepaid. Just mail the coupon.

Perfect Voice Institute

1810 Wilson Av.,  
Studio 1192  
CHICAGO

Perfect Voice Institute  
Studio 1192 - 1810  
Wilson Av., Chicago

Send me the book and facts about the Feuchtinger Method. Give me 2 opposite subject that interests me most.

Singing  Speaking  
 Stammering  Lipping

Name .....

Address .....



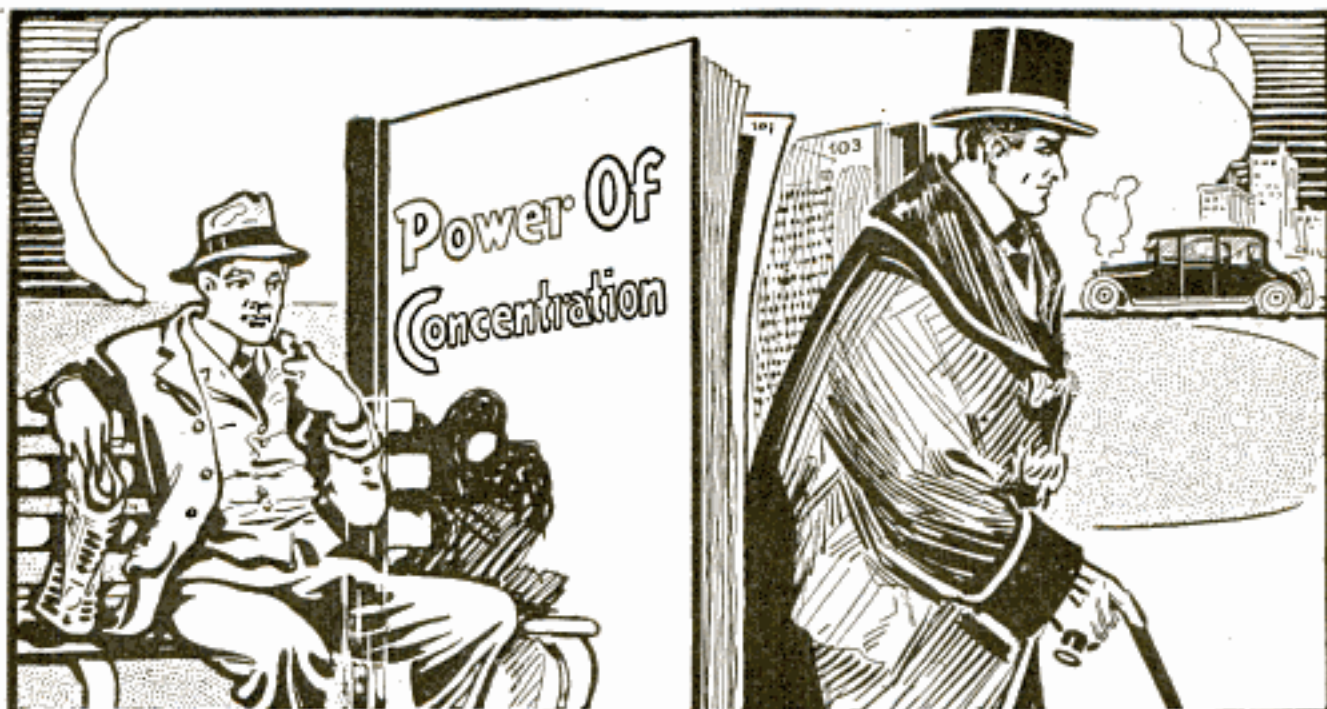

## THIS BOOK found him a failure and made him a SUCCESS

What is it that is keeping you from success, that is lowering your efficiency, making you waste your time, robbing work of its reward and making it hateful? It is lack of power of concentration. You don't know how to concentrate your mind, your energies, your powers on your tasks. You cannot think clearly, act decisively, definitely. Concentration is not born in you. It is a habit which can be learned; a power that can be acquired.

How many times have you tried to focus your mind on a problem, but found that a thousand distracting thoughts robbed you of your ability to solve it?

Lack of power of concentration makes nervousness, changeableness; creates mental instability, confusion of ideas; causes lack of will power, lack of stick-to-it-iveness.

Concentrate, and you banish these weaknesses that are fatal to success.

This book teaches you HOW TO CONCENTRATE. It opens wide the portals to SUCCESS.

### This Great Book Will Teach You How to Concentrate

The Power of Concentration, written by the world famous mental and psychological scientist, Theron Q. Dumont, is a practical, down-to-earth, concise, "show-how" series of instructions on how to concentrate. It tells you in such a way you cannot forget, simple, easy methods for bringing your whole mental and physical forces together so that you will be able to apply the full capacity of your energy

and strength definitely upon any proposition you have to handle.

It is said of Edison that he is able to concentrate himself so completely on whatever he may be doing that he forgets to get hungry or to become sleepy. His genius is in his ability to concentrate.

Masterpieces, great achievements, steadiness, the ability to do a thing on the spur of the moment are the offspring of the power of concentration.

You'll be happier, and healthier, your mind and body will become more robust, you'll think more clearly, see more sharply, you'll make minutes worth hours, you'll become the companion and inside friend of OPPORTUNITY, you'll discover Success, when you know how to concentrate. And you can know how! THIS BOOK WILL TEACH YOU HOW.

## FREE EXAMINATION

Let us send you Power of Concentration on approval—for you to see before you buy. Look this book over. Keep it five days, and then if you feel that you need it, send us the special price of \$2.00. The worth of this book is far beyond the price; indeed, its value cannot be reckoned in dollars and cents. Not only in your business, but in all your affairs will you profit its small cost a hundred fold time and again.

### Send Coupon—No Money

Merely sign your name and address to the coupon and mail it today. We do not want you to pay for the book until you decide that you want it. If you are willing to part with it after examining it for five days, then just return it to us and you will owe us nothing. Send for the Power of Concentration at once. It will mark the turning point in your life towards the goal of better things.

### COUPON

Advanced Thought Publishing Co.  
168 North Michigan Ave.,  
Dept. 201 Chicago, Illinois.

Gentlemen: Send me at once special edition of the Power of Concentration with the understanding that if after examining it for five days I am not satisfied, I may return it to you and owe you nothing. If I decide to keep the book I will send you the special price of \$2.00.

NAME.....  
ADDRESS.....

### Power Of Concentration

#### Some of the Contents of The Power of Concentration

Self mastery and self direction through concentration. A quick way to develop concentration. How to overcome destructive forces. Concentration molds your environments. How to exclude all distracting thoughts. Concentration overcomes bad habits. Business results gained through concentration. Concentration develops courage. Concentration improves your memory. Ideas developed by concentration. Simple rules for happiness and success. Practical methods of developing the will. How to awaken and organize your hidden ability.



# THE SPEEDWAY TO SUCCESS

## Master The Automobile At Indianapolis Motor School

Come to Indianapolis the home of the famous auto speedway, where the Kings and Demons of the track yearly thrill tens of thousands with their daring; where auto men of genius have reared giant factories, employing thousands of men—the Cole, Stutz, National, Premier, Empire, Herff-Brooks, Marmon, Pathfinder, Waverly, etc., and make your start where thousands have made theirs.

Sketch of the famous speedway

More men are needed. Trained men. Men who

**Be One of These Men** Learn the business from the ground up, and get in while it's still young and growing fast. Be somebody! Make the money you've been wanting. You can—you will—if you go after this thing right. A first class automobile man never looks for a job—the jobs look for him. Then there's the tractor field—getting bigger all the time. We teach that, too.

**Be a Trained Mechanic** Think of the tremendous opportunities for repair men who know their business, who can explain to a car owner what is wrong with his machine and how it should be fixed. Think of the hundreds and

**INDIANAPOLIS MOTOR SCHOOL, 202**

Men are making fortunes—building cars, selling cars, repairing cars. It's the biggest and surest business in the country.

See it when you come to town

know the why and wherefore of motor construction.

hundreds of openings for the "men who know"; at the head of service stations, in garages, as high class chauffeurs, either for private or commercial work. Everywhere there are good paying jobs in the automobile and tractor business for trained men. We are equipped to teach you the automobile business from the beginning to the end. That's our business and we have the machinery and men to do it.

**Guaranteed Training** We mean what we say. Here's our proposition: Come to Indianapolis, pay one-fourth the tuition fee down. Start your course, pay the balance when you're satisfied. That's meeting you more than "50-50" and it's fair to all. Anyhow investigate. Send a postal for catalog and do it right now. Now is the time to start.

**Southeastern Ave., INDIANAPOLIS, IND.**

## "FORGING AHEAD IN BUSINESS" FREE

This 128 page book, which we will send you free, tells of the wonderful help which the Modern Business Course and Service is to every man in business from manager to clerk; tells how it helps; tells who are back of this great institution, who are enrolled, and what they say about it.

Send for this Free Book today  
**ALEXANDER HAMILTON INSTITUTE**  
198 Astor Place, New York



## Debates and Orations

Essays and orations, about 1,000 words; debates on either side of any subject, about 1,500 words; one-dollar each. Addresses for all occasions prepared to order. All work done by college graduates. Satisfaction guaranteed or money refunded. Let us know your wants. Questions for debates free.

**COLUMBIAN INFORMATION BUREAU, WASHINGTON, D. C.**

## LEARN TO DANCE!

Fox-Trot, One Step, Waltz, Two-Step, and latest dances taught by mail. New, Simple Method. No music needed; everything made easy; thousands taught successfully. Learn at home in spare time; same way I teach society leaders. **WRITE FOR SPECIAL TERMS.** Send today for free information and surprisingly low offer.

**PROF. W. C. PEAK, Graduate of Castle House**  
Room 14, 821 Crescent Place, CHICAGO, ILLINOIS

## STAMMERERS

Our course of private lessons will correct your impediments.  
**BOSTON STAMMERERS' INSTITUTE**  
Founded 1867. Samuel D. Robbins, Principal.  
246 Huntington Ave. BOSTON, MASS.

## EARN BIG MONEY REPAIRING AUTOMOBILE Storage Batteries

**EARN MONEY WHILE LEARNING.**  
I teach you in twelve lessons. My introductory offer of 25c for first lesson should interest you. **Write now—TODAY!**  
**C. H. WILKS, Instructor, 175 W. Fourth St., St. Paul, Minn.**



## \$100<sup>00</sup> EARNED BY YOUNG ARTIST IN TWO DAYS

Conscientious, careful training by members of our Faculty made this possible. You, too, should succeed—with the right training.

### Earn \$25, \$35, \$50, \$75 a Week and More

Become a Commercial Designer. The business world pays big prices for good designs and illustrations. Learn to draw during your spare time by the "Federal" home-study method—a course endorsed by high authorities.

**Easy to Learn, Easy to Apply** Write today for "Your Future," a book every young man and woman should read before deciding on their life work. Free for the asking.

**Federal School of Commercial Designing, Inc.**  
617 Warner Building Minneapolis, Minn.



# \$25,000 Men

## How I Pick Them

### Frank A. Vanderlip

"Personality first," replied Frank A. Vanderlip, President National City Bank of New York, when asked how he picked \$25,000 year men for his great institution. "By personality I mean a man's ability to make people feel he is frank, human, capable, honest, red-blooded, a broad-gauged man."

YOU, yes, YOU can develop such a personality right now — right at home. You can increase your chances for success a thousand fold. It is being done by ten thousand men and women. Look around you at the men and women that have succeeded in a business and social way — always the one dominant factor is their winning personality — the ability to make people believe in them.

There is a big position waiting for you. Prepare for it! You can do it. You must learn the fundamental principles for developing a winning personality. You will be glad to know that a great psychologist has co-operated with us in placing within your reach a wonderful course in "Culture of Personality" — giving the secrets and fundamental principles used by the world's most successful men.



### Partial Contents

**Note!** We can give only a few of the subjects covered in this startling work. Get the books on 5 days' free trial and see everything for yourself

How to develop Mental and Moral Courage  
 How to overcome Shyness and Fear  
 How to Assert Yourself in Business, Social and Family Life  
 How to bring out your hidden forces  
 How to have Self-confidence, poise and "presence"  
 How to Make Others Believe in You  
 How to Make Yourself liked by others  
 How to Win Powerful friends  
 How to Influence Others  
 How to Stop Worry  
 How to Master Habit  
 How to Develop a Magnetic Voice  
 How to Renew Nerve Force  
 How to Develop Moral and Physical Power  
 How to Be the Master Man on all Occasions

### "Culture of Personality"

By Prof. Theron Q. Dumont, the great French Authority and Psychologist, is a complete course in personality development in 43 fascinating lessons, compiled in two amazing books. The course is the result of over ten years' study and research — yet written so simply that anyone can understand and apply the principles used by the most successful men in the world.

Get the course on our 5 day free trial offer. There is no man or woman who will not be benefited by sending for the course. "Meant \$25,000 more business for me last year," writes Mr. W. A. Neer, President Detroit Stock Exchange. "Was elected president of a business association and the course helped." "I made the investment pay me 100% the first week." "Helped me socially," writes a society leader from Washington, D. C. These are only a few statements that we have received from the users of this amazing and startling work.



Adams  
Publishing  
Co.

1192 Morton Bldg.  
Chicago, Ill.

Gentlemen:—Please send me the two books of Prof. Dumont's Course, "Culture of Personality." I am to have the books on 5 days' free trial. If I keep them, I agree to remit \$3.00, or I shall return the books to you within 5 days.

## Send No Money Just the Coupon

You don't have to send a penny. You don't obligate yourself to keep the course. Just fill out the coupon and we will send these two amazing and startling books on 5 days' free trial, all charges prepaid. Although "Culture of Personality" in two volumes, 399 pages, contains the same material as the author's \$25.00 correspondence course — the price for both books is only \$3.00. Send no money now. Just mail coupon, enclosing your business card or give a reference. If after five days' examination you have decided to keep the books, send us \$3.00. If you are not delighted and surprised with the results, if you don't think the books are worth many times the price to you, just mail the books back and you owe us nothing. This is positively a free trial offer, no strings to it whatever. Mail the coupon NOW.

**The Adams Publishing Co.**

1192 Morton Bldg.

CHICAGO, ILL.

NAME.....

ADDRESS.....





Your chance to *be somebody*, to hold a position of responsibility, to have an income that will provide every comfort of life, is within your reach.

Just one thing keeps you from finding it, grasping it: you're not *prepared*. Through the door of opportunity big jobs are waiting in every field of work. But only trained men will get them. Don't play blindman's buff with your future! Start today and train yourself to do some one thing better than others.

You can get that training in spare time through the International Correspondence Schools, just as others have done for twenty-five years—just as more than 130,000 ambitious men and boys are doing right now.

Choose your own career. The I. C. S. will train you for the position you want in the work you like best. And you need not lose a day or a dollar in your present occupation.

Tear off that blindfold! Your chance is here. The time to start is now. The way is to ask the I. C. S. to show you what they can do for you. Mark and mail this coupon—it costs nothing, but the evidence it will bring you will open your eyes.

TEAR OUT HERE

### INTERNATIONAL CORRESPONDENCE SCHOOLS Box 5551, SCRANTON, PA.

Explain, without obligating me, how I can qualify for the position, or in the subject, before which I mark X.

- |   |  |
|---|--|
| <input type="checkbox"/> ELECTRICAL ENGINEER        | <input type="checkbox"/> SALESMANSHIP              |
| <input type="checkbox"/> Electric Lighting          | <input type="checkbox"/> ADVERTISING MAN           |
| <input type="checkbox"/> Electric Car Running       | <input type="checkbox"/> Window Trimmer            |
| <input type="checkbox"/> Electric Wiring            | <input type="checkbox"/> Show Card Writer          |
| <input type="checkbox"/> Telegraph Expert           | <input type="checkbox"/> Outdoor Sign Painter      |
| <input type="checkbox"/> Practical Telephony        | <input type="checkbox"/> RAILROADER                |
| <input type="checkbox"/> MECHANICAL ENGINEER        | <input type="checkbox"/> ILLUSTRATOR               |
| <input type="checkbox"/> Mechanical Draftsman       | <input type="checkbox"/> DESIGNER                  |
| <input type="checkbox"/> Machine Shop Practice      | <input type="checkbox"/> BOOKKEEPER                |
| <input type="checkbox"/> Gas Engineer               | <input type="checkbox"/> Stenographer and Typist   |
| <input type="checkbox"/> CIVIL ENGINEER             | <input type="checkbox"/> Cert. Public Accountant   |
| <input type="checkbox"/> Surveying and Mapping      | <input type="checkbox"/> Railway Accountant        |
| <input type="checkbox"/> MINE FOREMAN OR ENGINEER   | <input type="checkbox"/> Commercial Law            |
| <input type="checkbox"/> Metallurgist or Prospector | <input type="checkbox"/> GOOD ENGLISH              |
| <input type="checkbox"/> STATIONARY ENGINEER        | <input type="checkbox"/> Teacher                   |
| <input type="checkbox"/> Marine Engineer            | <input type="checkbox"/> Common School Subjects    |
| <input type="checkbox"/> ARCHITECT                  | <input type="checkbox"/> CIVIL SERVICE             |
| <input type="checkbox"/> Contractor and Builder     | <input type="checkbox"/> Railway Mail Clerk        |
| <input type="checkbox"/> Architectural Draftsman    | <input type="checkbox"/> AGRICULTURE               |
| <input type="checkbox"/> Concrete Builder           | <input type="checkbox"/> Textile Overseer or Supt. |
| <input type="checkbox"/> Structural Engineer        | <input type="checkbox"/> Navigator                 |
| <input type="checkbox"/> PLUMBING AND HEATING       | <input type="checkbox"/> Poultry Raising           |
| <input type="checkbox"/> Sheet Metal Worker         | <input type="checkbox"/> AUTOMOBILES               |
| <input type="checkbox"/> CHEMICAL ENGINEER          | <input type="checkbox"/> Auto Repairing            |

- |                                  |
|----------------------------------|
| <input type="checkbox"/> Spanish |
| <input type="checkbox"/> German  |
| <input type="checkbox"/> French  |
| <input type="checkbox"/> Italian |

Name \_\_\_\_\_

Occupation & Employer \_\_\_\_\_

Street and No. \_\_\_\_\_

City \_\_\_\_\_ State \_\_\_\_\_

If name of Course you want is not in this list, write it below.

Please Mention Popular Mechanics

## You May Now Use

this valuable art. Others are using Lichtenstag Paragon as a daily convenience. Executives and business men find it most useful. Because of its remarkable simplicity you can learn the entire

### LICHTENTAG PARAGON

## SHORTHAND

In your own home, during the evenings of one week. **Speed comes with use or practice.** Wonderfully easy to read. Paragon Writers are stenographers in service of U. S. Gov. and office corporations, also in court reporting. Systems already adopted by number of cities for high schools. Write for full prof.

### What Others Say

"The study of Paragon is a fascinating routine."

"I was able to use it in making my private memoranda, though slowly, even before the end of the week."

"So simple and legible that in a week I could read all the shorthand matter, even before starting speed practice."

"By practice I have already developed a speed of 175 words a minute."

"The highest I was able to reach, on a forty minutes' dictation of new matter, was 200 words per minute."

THE PARAGON INSTITUTE  
280 Louisiana St. New Orleans, La.

# 7 DAYS

## LEARN THE SECRETS OF RIGHT LIVING AND RIGHT THINKING

The Davis System of Right Living and Right Thinking shows how to become absolute master of yourself—to face life's most trying problems with every confidence—how to get well and stay well—to become thoroughly efficient, mentally and physically—to make every day a success—to increase or decrease your weight—to attain a useful, healthful, vigorous old age.

It removes chronic ailments and gives the healthy man or woman greater energy, endurance and mind power. Endorsed strongly by successful men and women.

Send for the FREE booklet, "SUPREME LIVING." Address, VIRGIL A. DAVIS, M.D. 209 Minor Bldg., 280 Louisiana St. Kansas City, Mo.

## LEARN RAG TIME

Let me teach you Rag-Time Piano Playing by Mail. You learn easily—in just a few lessons, at home. My system is so simple you'll play a real ragtime piece at your 5th lesson. Whether you can play now, or not, I'll teach you to play anything in happy ragtime. "Money Back Guarantee." Write at once for special low terms and testimonials. AXEL CHRISTENSEN, "Czar of Ragtime," Room B10 526 So. Western Ave., Chicago, Ill.



## The AMERICAN BOY

"—the biggest, brightest, best magazine for boys in all the world." Gives you a whole year of fun for \$1.50. Brimful of thrills, stories and articles that you will just "eat up." Get somebody to subscribe for you today. Sprague Pub. Co., 83 American Bldg., Detroit, Mich.

## The Library of Original Sources

at a great bargain 10 beautiful, big volumes. Easy monthly payments. See our ads on page 59 February issue and page 56 March 1916 issue Popular Mechanics.

UNIVERSITY RESEARCH, Dept. G, Milwaukee, Wisconsin

## LEARN WATCHMAKING

and become independent. Good-paying positions secured. Easy to learn. Send for FREE CATALOG.

ST. LOUIS WATCHMAKING SCHOOL, Dept. 5, ST. LOUIS, MO.

## Book Authors

We can consider book Miss. of fiction, biography, travel, poetry, etc., also groups of short stories

for volume issue. Please send prepaid with return postage. THE McLEAN CO., 100 Rippel Bldg., BALTIMORE, MD.

## DRAWING

Calligraphy, Cartoon, Comic, Commercial, Fashion, Newspaper and Magazine Illustrating taught by mail. Illustrated book 50 in stores. THE BOSTON SCHOOL OF DRAWING, 755M Boylston St. BOSTON, MASS.





# Be A Practical ELECTRICIAN

**Your Future**  
is in Electricity—Obey  
that "Hunch."

Get a Move on Yourself  
—Here's Your Chance—

*If You Act Quick I Will  
Give You Special Per-  
sonal Training at Home.*

Only a Limited Number  
of Students Can Secure  
My Special Instruction  
—ACT NOW.

## MY OFFER TO YOU:

If you act quick I will accept you among a few more students to complete Home Study class now forming. Grasp this wonderful opportunity. Fit yourself by a few months' fascinating Home Training to be a REGULAR CERTIFICATED ELECTRICIAN.

I have a splendidly attractive proposition for you. I GUARANTEE you satisfaction in the study of this great profession. Decide to enter it while you can do so on terms especially advantageous to you. Plan a glorious future. Secure for yourself the assured independence, the handsome income, the agreeable working conditions, the easy professional hours and the unlimited opportunities of the trained and experienced Electrician.

As my student you will enjoy exclusive and unusual advantages. . . . FREE employment service; FREE \$100.00 scholarship opportunities; FREE five year Advisory Service; and FREE electrical equipment, instruments and material. In addition to the above I have a wonderful SURPRISE in store for every student I enroll in the near future. THIS FREE ELECTRICAL OUTFIT IS VALUED AT \$17.00.

I haven't the space here to tell you all the advantages, benefits and privileges GUARANTEED to my students. If you are ambitious to make a big success in the greatest profession on earth—if you are ready to start right in and study Electricity the "easy" way—at home—mail me the FREE "OUTFIT" coupon without delay. I will send you full particulars of my personal instruction plan, my splendid laboratory and educational facilities, my wonderfully complete and fascinating course of bed-rock lessons, and my thoroughly practical method of making Electricity easy to understand and master. Write me NOW.

**CHIEF ENGINEER**  
Chicago Engineering Works  
439 Cass Street  
Dept. 6, CHICAGO, ILL.



CHIEF ENGINEER  
Your Instructor

**Qualify at Home**  
— With My Help.

**STUDY BY MAIL**  
My New Course and a  
Common School Edu-  
cation All You Need.

*Fit Yourself in Spare  
Time to Earn \$50.00  
a Week and Up.*

**SPECIAL**  
**Earn While You Learn**  
Right After You Are Enrolled  
I Will Give You a Short Course  
in Quick Money-Making Elec-  
trical Branch—FREE.

**USE THIS FREE "OUTFIT" COUPON**

Dept. 6  
CHIEF ENGINEER  
439 Cass St.  
Chicago, Illinois

Without obligation on my part kindly send at once, fully prepaid, particulars of your complete Practical Home Study Course in Electricity.

My Age is.....

My Occupation is.....

NAME.....

ADDRESS.....

TOWN..... STATE.....





## “Don't tell me you never had a chance!”

“Four years ago you and I worked at the same bench. I realized that to get ahead I needed special training, and decided to let the International Correspondence Schools help me. I wanted you to do the same, but you said, ‘Aw, forget it!’ You had the same chance I had, but you turned it down. No, Jim, you can't expect more money until you've trained yourself to handle bigger work.”

There are lots of “Jims” in the world—in stores, factories, offices, everywhere. Are you one of them? Wake up! Every time you see an I. C. S. coupon your chance is staring you in the face. Don't turn it down.

Right now over one hundred thousand men are preparing themselves for bigger jobs and better pay through I. C. S. courses.

You can join them and get in line for promotion. Mark and mail this coupon, and find out how.

I. C. S., Box 5552, Scranton, Pa.

### INTERNATIONAL CORRESPONDENCE SCHOOLS Box 5552, SCRANTON, PA.

Explain, without obligating me, how I can qualify for the position, or in the subject, before which I mark X.

- |   |  |
|---|--|
| <input type="checkbox"/> ELECTRICAL ENGINEER        | <input type="checkbox"/> SALESMANSHIP              |
| <input type="checkbox"/> Electric Lighting          | <input type="checkbox"/> ADVERTISING MAN           |
| <input type="checkbox"/> Electric Car Running       | <input type="checkbox"/> Window Trimmer            |
| <input type="checkbox"/> Electric Wiring            | <input type="checkbox"/> Show Card Writer          |
| <input type="checkbox"/> Telegraph Expert           | <input type="checkbox"/> Outdoor Sign Painter      |
| <input type="checkbox"/> Practical Telephony        | <input type="checkbox"/> RAILROADER                |
| <input type="checkbox"/> MECHANICAL ENGINEER        | <input type="checkbox"/> ILLUSTRATOR               |
| <input type="checkbox"/> Mechanical Draftsman       | <input type="checkbox"/> DESIGNER                  |
| <input type="checkbox"/> Machine Shop Practice      | <input type="checkbox"/> BOOKKEEPER                |
| <input type="checkbox"/> Gas Engineer               | <input type="checkbox"/> Stenographer and Typist   |
| <input type="checkbox"/> CIVIL ENGINEER             | <input type="checkbox"/> Cert. Public Accountant   |
| <input type="checkbox"/> Surveying and Mapping      | <input type="checkbox"/> Railway Accountant        |
| <input type="checkbox"/> PIPE FOREMAN OR ENGINEER   | <input type="checkbox"/> Commercial Law            |
| <input type="checkbox"/> Metallurgist or Prospector | <input type="checkbox"/> GOOD ENGLISH              |
| <input type="checkbox"/> STATIONARY ENGINEER        | <input type="checkbox"/> Teacher                   |
| <input type="checkbox"/> Marine Engineer            | <input type="checkbox"/> Common School Subjects    |
| <input type="checkbox"/> ARCHITECT                  | <input type="checkbox"/> CIVIL SERVICE             |
| <input type="checkbox"/> Contractor and Builder     | <input type="checkbox"/> Railway Mail Clerk        |
| <input type="checkbox"/> Architectural Draftsman    | <input type="checkbox"/> AGRICULTURE               |
| <input type="checkbox"/> Concrete Builder           | <input type="checkbox"/> Textile Overseer or Supt. |
| <input type="checkbox"/> Structural Engineer        | <input type="checkbox"/> Navigator                 |
| <input type="checkbox"/> PLUMBING AND HEATING       | <input type="checkbox"/> Poultry Raising           |
| <input type="checkbox"/> Sheet Metal Worker         | <input type="checkbox"/> AUTOMOBILES               |
| <input type="checkbox"/> CHEMICAL ENGINEER          | <input type="checkbox"/> Auto Repairing            |

Name \_\_\_\_\_  
 Occupation & Employer \_\_\_\_\_  
 Street and No. \_\_\_\_\_  
 City \_\_\_\_\_ State \_\_\_\_\_  
 If name of Course you want is not in this list, write it below.



Why are some men chosen to hold the important town, city, state, and government positions while others who are just as able fail? It's all a question of a knowledge of politics. If you don't know practical politics you can't win out against those who do. Nearly every important public official owes his success to having learned politics early in life—a knowledge indispensable to every candidate for office, in his lodge or for the presidency of the United States. And now all the rules, knacks, and methods used by the most successful political leaders are within your reach.

## How To Be Elected

Do you want to become a member of your state legislature, a state official, mayor, county trustee, a member of the school board, assessor, county or city treasurer, selectmen—do you want to become a leader in your lodge or club? Then here is the very help you need. Learn politics from the inside. A remarkable new home-study course in Practical Politics has just been prepared by a political expert of national reputation who has himself been through the mill and has shown others how to be elected to dignified well-paying positions in the public service. He shows you exactly what to do to succeed, where the best opportunities are, just what steps to take, and gives you the knowledge you need to win the office you want—and it can all be mastered at home in a few moments a day for a few short weeks.

**Free Book** Our free book Practical Politics tells about this remarkable course and explains the golden opportunity that awaits you. Send for it now—it's free. If you write quick we will make you a special 30 day offer. Send postal or letter NOW.

R. W. LOCKWOOD, Sec'y, Dept. 72, 460 Fourth Ave., N. Y. C.

## MEN and WOMEN WANTED

\$65 to \$150 Month

### U. S. Gov't Wants Help

- Railway Mail Clerks
- City Mail Carriers
- City Postal Clerks
- Custom House Clerks
- Panama Canal Clerks

VACATIONS WITH PAY  
Easy Work Short Hours

Send coupon IMMEDIATELY for schedule showing dates and places of the Fall examinations in your section and the valuable features mentioned.

We Will Coach a Limited Number of Candidates Free of Charge.

This 2-cent stamp may bring you a BIG PAY LIFE JOB!

**FRANKLIN INSTITUTE**  
Dept. T 103  
ROCHESTER, N. Y.

FRANKLIN INSTITUTE, Dept. T 103, Rochester, N. Y.  
 Kindly send me, without any obligation whatever on my part and entirely free of charge, (1) a full description of the position checked below, (2) Sample examination questions, (3) Free copy of copyrighted book "Government Post-offices and How to Get Them", (4) A list of U. S. Government Jobs now easily obtainable; (5) Directions telling me how to get free coaching for the position checked.  
 (8900 to \$1800) Railway Mail Clerk  
 (8800 to \$1200) Postoffice Clerk  
 (8800 to \$1200) Postoffice Carrier  
 (8500 to \$1200) Rural Mail Carrier  
 (8800 to \$1500) Bookkeeper  
 (8800 to \$1500) Customs Positions  
 (8700 to \$1800) Internal Revenue  
 (8800 to \$1500) Stenographer  
 (8800 to \$1500) Clerk in the Departments at Washington  
 USE THIS BEFORE YOU LOSE IT  
 WRITE PLAINLY  
 Name.....  
 Address..... (T 103)



# PEACE

**Its coming means big things to you, young man—How?—Think.** This greatest war in history has affected the commerce of the world. The great merchant fleets of the Central Powers are tied in their harbors by steel bands of hostile warships. The deadly torpedo has sent hundreds of the Allies' ships to the bottom of the seas. The powerful hand of war holds London, Bremen, Marseille, Constantinople, Trieste, Vladivostok and other world ports in a grip of iron. Great is the confusion in traffic and shipping.

The U. S. has reaped a harvest of gold from the European fields of destruction. Our Internal Commerce has increased by thousands of millions of dollars. Our Foreign Commerce has reached vast sums—too vast for comprehension. The shipping departments of thousands of factories—warehouses—railroads—seaboard wharves—are gorged with immense quantities of supplies for the warring nations. These supplies must be delivered—**shipped.** This work requires **trained traffic men.** Thousands of positions cannot now be supplied because every available and competent traffic man is now employed.

**And now comes peace—** and with its coming will come a **great commercial war of competition** between the U. S., England, Germany and Russia—a war in which the trained soldier will give away to the manufacturer, the salesman and the shipper, or **trained traffic man—** and without the latter, competitive commerce is impossible.

**Now is your chance, young man.** Never before have there been such splendid opportunities for young, and middle aged men. But these chances are for **trained men—only.** Thousands of traffic positions are now waiting in the U. S. for men qualified to save freight money. Trained men are scarce—for this reason salaries are growing higher—and will go still higher when the other great nations bid for traffic brains. Start now to be a traffic man. We will train you. This means you. Ordinary brains, ability and determination are all you need. Our training is so simple that you can't help but learn—our coaching so efficient you can't help but succeed.

**Sign and send in the coupon at once—we will** mail you complete explanation concerning the work, positions, members and the Association. Also tell you just how you can join the Association and become a Trained Traffic Man.

**Mail Coupon Today** 

**American Commerce Association**  
206 So. Wabash Avenue, Chicago

Please Mention Popular Mechanics

## Salary

The salary of trained traffic men is from \$2,500 to \$10,000 a year. The work is always interesting because it is not routine work. The traffic man is an executive—not a subordinate.

## We Have Thousands of Members

The American Commerce Association is the largest organization of its kind in the world. The leading traffic men of the U. S. are members. The Association is the only one recognized by the national organization of traffic men. It has thousands of members now holding positions with the big shipping concerns of America. It is substantial and responsible.

## Digest of Traffic

The Association has compiled the only digest of traffic ever produced. This work required the co-operation of over three hundred traffic experts— took five years and over \$100,000 has been expended. This great reference and working library is for the exclusive use of its members.

## American Commerce Association

Dept. 46, 206 So. Wabash Ave.  
CHICAGO, ILL.

Send me **FREE**—and without obligation—complete information concerning the Association and how I can train as a traffic man.

Name.....

Occupation.....

Address.....

City.....State.....





## Mental Demons Are They Holding You Back?

Does a host of mental demons bar your path to success? Do you feel yourself incapable to meet important situations? Do you lack the power to make people recognize you—to make others see things *your way*—to compel people to listen to you? Are you weak in a crisis?

Most men have the brains and the ambition to do big things—but a weak personality—a lack of self-confidence—timidness—poor vocabulary—unreliable memory—"stage fright"—hazy, unorganized ideas—*ineffective speech*—are holding them back from the success they deserve.

### RESULTS!

"Your Course is a most valuable training to anyone who desires to be able to speak in public without embarrassment."  
—C. C. HOFFPAUIR, Att'y, Texas.

"Not only has it enabled me to speak in public in a way that is most gratifying to me, but it has helped me in business so well."  
—G. M. COBBITT, Banker, Illinois.

"It has given me greater confidence in my own ability, a better memory, a more polished vocabulary, and a stronger personality."  
—W. L. WILDEK, Mgr., Chicago.

"Your Course is a splendid training for the salesman or sales manager, and I heartily recommend it."  
—O. F. BOURGEOIS, Pres., Chicago.

"A fascinating and practical training that overcomes one of the common weaknesses of business men— inability to express themselves."  
—GUY H. SHEARER, Banker, Idaho.

We have hundreds of similar testimonials in our files from men in every walk of life. Send the Coupon today. You owe it to yourself to find out what this Course will do for you.

Send the coupon below at once and let us tell you how you can drive these mental demons away forever—how you can occupy a place among men who do things—how you can learn to express your ideas forcefully and convincingly—how you can acquire a powerful, magnetic personality—how you can develop a strong dominating will—how you can become a powerful, public speaker. Our new scientific Course in

## Effective Public Speaking and Mental Development

will quickly train you to speak forcefully and convincingly in public

- talk before your club or lodge
- address board meetings
- propose and respond to toasts
- tell entertaining stories
- make after-dinner speeches
- converse effectively
- write better letters
- sell more goods
- train your memory
- enlarge your vocabulary
- develop self-confidence and a winning personality
- strengthen your ambition and will power
- become a clear, accurate thinker
- develop your power of concentration, diligence and self-control
- equip you with power to be the master of any situation.

This Course and Service is under the personal supervision and direction of R. E. Pattison Kline, Dean of the Public Speaking Department, Columbia College of Expression, Chicago, one of the foremost authorities in the country on public speaking and mental development. You can now secure the personal instruction of this eminent authority right in your own home, by mail, in spare time. Hundreds have acquired a powerful address and a winning personality through his instruction.

### Public Speaking Department

American Correspondence School of Law—1192 Manhattan Building, Chicago, Ill.

Gentlemen: Please send me without obligation full details of your Course in Effective Public Speaking and Mental Development, as well as particulars of your Special Limited Offer.

Name.....

Address.....

## Special Offer—Now

Send the Coupon

Mail the coupon today for full particulars of the Special Limited Offer we are now making. This unusual offer may be withdrawn at any time. We will also send you, free, many interesting facts and pointers that you should know about effective public speaking and mental development—information that you can use. Free and no obligations of any kind. Don't delay. Send the coupon now while this offer lasts.

**Public Speaking Department**  
American Correspondence School of Law  
1192 Manhattan Building - Chicago, Illinois





**The Partition of Poland** was the greatest national tragedy in history. The country was divided between Austria, Russia, and Prussia, shown herewith by the three crowned eagles. Poland is shown by the fallen soldier, the flag of his country trailing in the dust, while the Goddess of Liberty is defending the nation. It is altogether probable this ancient nation may again be re-established as a result of the present European War. All the underlying causes of this mighty struggle and every conflict or achievement in history may be learned from the pages of the famous publication,

## Ridpath's History of the World

DR. John Clark Ridpath is universally recognized as America's greatest historian. Other men have written histories of one nation or period; Gibbon of Rome, Macaulay of England, Guizot of France, but it remained for Dr. Ridpath to write a history of the entire World from the earliest civilization down to the present day.

### Notice Before Advance in Price

ON account of the tremendous increase in the cost of paper and leather, occasioned by the European War, it becomes necessary to advance the price in order to cover the increased cost of manufacture. This is your last opportunity to buy Ridpath's History of the World at our present low price and easy terms of payment. We will name this low price only in direct letters to those who mail us the coupon below. Tear off the coupon, write your name and address plainly and mail now before you forget it. You incur no obligation whatever. We employ no agents as our low price does not permit the payment of an agent's commission. The beautiful sample pages will give you some idea of the splendid illustrations and wonderfully beautiful style in which the history is written.

### Six Thousand Years of History

RIDPATH takes you back to the dawn of History, long before the Pyramids of Egypt were built; down through the romantic troubled times of Chaldea's grandeur and Assyria's magnificence; of Babylonia's wealth and luxury; of Greek and Roman splendor; of Mohammedan culture and refinement to the dawn of yesterday. He covers every race, every nation, every time, and holds you spellbound by his wonderful eloquence.

### The European War

IF you would know the underlying causes which have led up to this conflict, the great racial antipathies, the commercial rivalries, the sting of past defeats, the vaulting ambitions for world empire, then embrace this opportunity to place this History in your home.

### Ridpath's Graphic Style

RIDPATH pictures the great historical events as though they were happening before your eyes; he carries you with him to see the battles of old; to meet kings and queens and warriors; to sit in the Roman Senate; to march against Saladin and his dark-skinned followers; to sail the southern seas with Drake; to circumnavigate the globe with Magellan. He combines absorbing interest with supreme reliability.

**WESTERN NEWSPAPER ASSOCIATION  
CHICAGO**



**FOLD HERE, TEAR OUT, SIGN AND MAIL**

2  
17  
**FREE COUPON**

**WESTERN NEWSPAPER ASSOCIATION**  
H. E. SEVER, Pres't.  
140 SO. DEARBORN ST.  
CHICAGO, ILL.

Please mail, without cost to me, sample pages of Ridpath's History of the World, containing photographs of Napoleon, Caesar and other great characters in history, and write me full particulars of your special offer to Popular Mechanics readers.

NAME .....

ADDRESS .....





For obvious reasons this man's identity is withheld name on request.

# How I Jumped from \$1500 to \$50,000 a Year!

## Personal Experiences

Among 100,000 users of "Power of Will" are such men as Judge Ben B. Lindsey; Supreme Court Justice Parker; Wu Ting Fang, Ex-U. S. Chinese Ambassador; Assistant Postmaster-General Britt; Lieut. Gov. McKelvie of Nebraska; General Manager Christeson of Wells-Fargo Express Co.; E. St. Elmo Lewis, former Vice-President Art Metal Construction Co.; Governor Ferris of Michigan; and many others of equal prominence.

Here are just a few extracts from the thousands of voluntary letters from owners telling what the book has meant to them.

### 800% Increase in One Year

"I recommended 'Power of Will' to a young man and his salary has increased 800% within a year."—W. M. Taylor, Efficiency Expert, Willys-Overland Co.

### Worth \$3,000 to \$30,000

"From what I have already seen I believe I can get \$3,000 to \$30,000 worth of good out of it."—O. D. Van Vechten, Gen. Agent North Western Life Insurance Co., Cedar Rapids, Iowa.

### From \$40 to \$90 Weekly

"Due to suggestions received from this book, I have increased my financial returns from \$40 a week to \$90 a week."—H. D. Ferguson, New Imperial Bath House, Hot Springs, Ark.

### \$897 Profit First Week

"'Power of Will' is a compilation of mighty forces. My first week's benefit in dollars is \$900—cost \$3; profit \$897—(figure what his yearly profit would be)."—J. W. Heistand, 916 Tribune Bldg., Chicago, Ill.

### 50% Salary Raise

"First few pages enabled me to get 50% raise in salary."—Robert B. Laird, Douglas, Wyo.

### Another 50% Increase

"More than a year ago I purchased 'Power of Will' and I firmly believe that it—and it alone—has enabled me to increase my salary more than 50% in that time."—L. C. Hudgens, Principal Mayhew Consolidated Schools, Boswell, Okla.

"Three years ago I was making \$1500 a year and working day and night. Today I make a thousand dollars a week and have time for other things as well. To the lessons in 'Power of Will' more than any other thing do I owe this sudden rise."

These are the exact words of an owner of "Power of Will." His name is not published for obvious reasons, but will be gladly given to those sending for "Power of Will" in confidence on request.

As remarkable as is his experience it might also be called typical of what this wonderful course in Will Training is doing for thousands of men and women in every walk of life who are using "Power of Will" as the stepping stone to greater accomplishment.

## What is "Will Power"?

The Will is the motive power of the brain. Without a highly trained, inflexible will, a man has about as much chance of obtaining success in life as a railway engine has of crossing the continent without steam. The biggest ideas have no value without Will Power to "put them over." Yet the Will, hitherto entirely neglected, can be trained into wonderful power, like the brain or memory and by the very same method, by intelligent exercise and use.

If you held your arm in a sling for two years, it would become powerless to lift a feather, from lack of use. The same is true of the will—it becomes useless from lack of practice. Because we don't use our wills, because we continually bow to circumstance, we become unable to assert ourselves. What our wills need is practice.

## "POWER OF WILL" Send No Money—Examine It First

"Power of Will," by Frank Channing Haddock, the wizard developer of self-powers—a scientist whose name ranks with James, Royce, etc.—is a complete course in will training in 28 fascinating lessons—a course which shows you each step and explains the working of the will so clearly that any one can easily follow the simple directions and become a powerful, dominating personality to whom success cannot be denied. And the wonderful part is that you will secure results from the very first lesson, as thousands of others have testified.



## Make Dreams Come True

"Power of Will" has made dreams of fortune, power and happiness come true almost overnight for thousands upon thousands of users. Last year alone over 100,000 men and women in all walks of life, including leaders in all fields of work, became owners of this remarkable work. Among them were great business giants, lawyers, physicians, teachers, statesmen, governors of states, etc.—to say nothing of thousands of young people with their lives before them. You can scarcely mention a field in which "Power of Will" has not enabled men to double their efficiency—their earning power and their happiness. Read the letters from users in the panel on the opposite page.

### Don't Put It Off

Among the readers of POPULAR MECHANICS are thousands of men who have said to themselves time and again—"I will order that book"—yet it has slipped their memory and they are still without its help.

If you only knew what you are missing—if you only knew what a positive, definite, daily out-and-out force it will prove in your own fight for greater success, you wouldn't put off getting this book another day.

Men don't write letters like those quoted at the left for the mere pleasure of writing them—they write as they do because "Power of Will" has helped them just as it will help you—yet we don't ask you to take our word for a single claim—instead, we make you the fairest offer we know how.

**No Money in Advance** Judge for yourself what "Power of Will" means to YOU. You risk nothing. We will gladly send you a copy, without a penny in advance, for free examination.

400 Pages—Bound in  
Leather—Gold  
Top Leaves

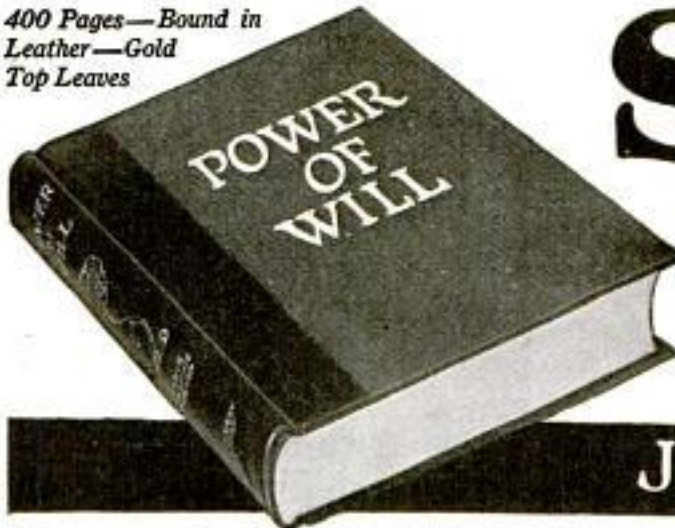

## Partial Contents

The Law of Great Thinking.  
The Four Factors on Which it Depends.  
How to Develop Analytical Power.  
How to think "all around" any subject.  
How to throw the mind into deliberate, controlled, productive thinking.  
Detailed Directions for Perfect Mind Concentration.  
How to acquire the Power of Consecutive Thinking, Reasoning, Analysis.  
How to acquire the Skill of Creative Writing.  
How to guard against errors in Thought.  
How to drive from the mind all unwelcome thoughts.  
How to follow any line of thought with keen, concentrated Power.  
How to develop Reasoning Power.  
How to Handle the Mind in Creative Thinking.  
The secret of Building Mind Power.  
How to test your Will.  
How a Strong Will is Master of Body.  
What creates Human Power.  
The Six Principles of Will Training.  
Definite Methods of developing will.  
The NINETY-NINE METHODS of using Will

Power in the Conduct of Life.  
Seven Principles of Drill in Mental, Physical, Personal Power.  
FIFTY-ONE MAXIMS for Applied Power of Perception, Memory, Imagination, Self-Analysis, Control.  
How to develop a strong, keen gaze.  
How to concentrate the eye upon what is before you—object, person, printed page, work.  
The First Principles for Success in contact with others.  
How to keep the body well-poised.  
How to open the Mind and Body for reception of incoming power.  
The fifty-four Master rules in control of others.  
How to throw off worry.  
How to overcome the tyranny of the Nerves.  
How to secure steady nerves.  
How to maintain the Central Factors of Health.  
The Law of Will-Power in Habits.  
The mental attitude you must hold to impress people.  
Fifteen Methods of Mastering Anger and Irritability.  
Etc., Etc., Etc.  
This is only a partial list—a complete list of contents would nearly fill this page.

# Sent Free

## Just Mail Coupon

### Special Offer

We are so confident that once you examine this wonderful key to success you'd never again be without it, that we don't ask you to send a penny in advance. We want to send you the book to look over in your own home, before you risk a single penny. Send no money. Merely fill out and mail the coupon and by return post, all charges prepaid, "Power of Will" will reach you—keep it five days, then if you feel you can afford to go along without it, mail it back and you will owe nothing. If, on the other hand, you decide to keep it, merely send the small introductory price of \$3. This is a special offer and will be withdrawn within a very short time, so don't delay. Mail the coupon NOW.

**The Pelton Publishing Co.**

13-B Wilcox Block Meriden, Conn.

Send  
it  
NOW

Pelton  
Pub. Co.  
13-B Wilcox  
Block  
Meriden, Conn.

Gentlemen: Please send me a copy of "Power of Will" without charge. I agree to remit \$3.00 or return the book in 5 days.

Name .....

Address .....

City..... State.....



# Learn El



Are you obliged to earn your living? Are you tied to a job with a doubtful future? Are you ambitious to rise out of the ranks—to win position—*independence—success?* Then listen to the call of Electricity—the field of golden promise!

Here is your chance to train while you work—to prepare for a big paying job—for a business of your own—for position—*power—luxury—success.* Earn

## In the Great

# CO

## \$125 to \$300 a Month!

Hundreds of young men graduate from our great shops every year. From every corner of the Union—even from far foreign places they come. Hundreds enter our day school. Hundreds of others earn in the day and train in our big night classes.

Young men who could never succeed by studying technical books—by learning the mere theory of Electricity—progress with amazing rapidity at Coyne.

### No Correspondence Course!

This is no correspondence course! Here you handle actual equipment! Here you do actual work with actual tools. Here you dig into the vitals of electrical apparatus; you learn the parts—their uses—like a surgeon learns the human body.

Here, among the sputtering electrical flashes, you learn the secret of this magic, unseen power. You work with it! You learn to control it—to make it do your will!

From the simplest door bell to the mighty generator—motor—electric locomotive, everything is made simple—understandable. Light—power—heat are mastered easily—quickly—surely. And all at small expense.

### Trained Experts Show You!

They tear aside the veil of mystery! They show you the tricks of the trade. They watch you—work with you—explain everything individually. You merely follow in the footsteps of these masters of Electricity. Interest follows every move. Step by step you progress—until in a few short months you are ready for a big



# COYNE NATIONAL TRADE SCHOOLS



# Electricity

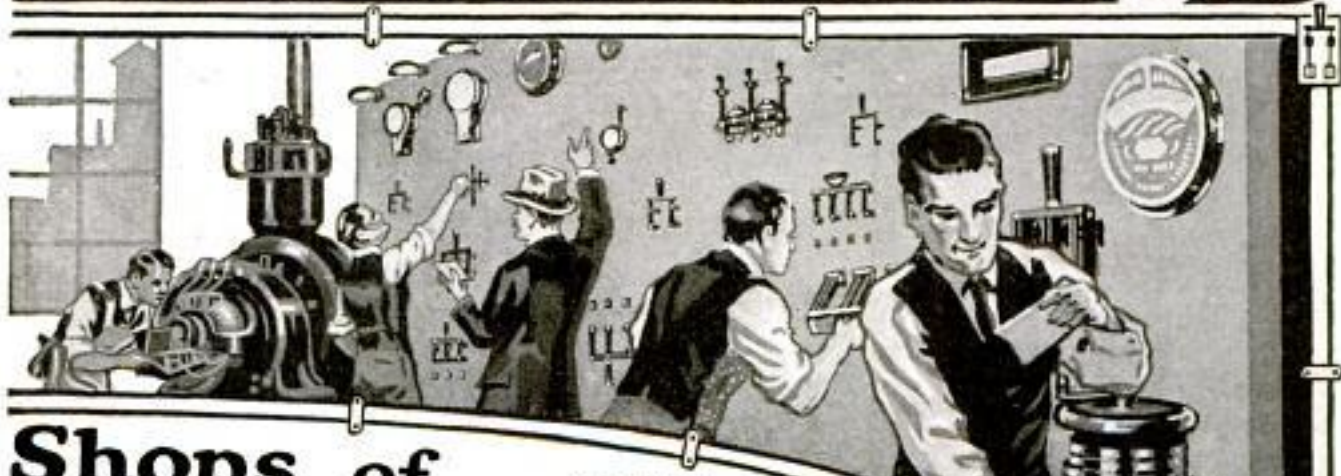

## Shops of YNE

job—and can face your future with confidence. Many of our students finish in 90 days. Your work includes drafting, plan reading, estimating. We turn you out completely equipped.

**All Tools and Equipment FREE!**  
**Small Easy Payments!**

Never was such an opportunity open to ambitious men. Even lack of ready money need not stop you. Coyne makes everything easy. All tools and equipment are furnished Free! There are no extras—no drains on your money supply. The cost is wonderfully low and you pay in easy payments as you go.

### FREE Employment Bureau!

Every worthy, industrious young man receives a welcome at Coyne. If you have no money—our employment bureau will help you get work while you study.

### FREE BOOK OF GOLDEN OPPORTUNITIES

Write for this book at once! Send no money! It's free! Read the details of our mammoth shops—our \$93,000 equipment. Read of the wonderful opportunities for young men in the big trades—Electricity, Plumbing, Bricklaying, Drafting, Motion Picture Operating. Every page is filled with interest. Read the wonderful successes of Coyne graduates. No other book in the world is like this. Get it at once! Fill in the coupon and mail it now! Address Dept. 1192.

## Learn Drafting

### MECHANICAL, BUILDERS, ARCHITECTURAL, STRUCTURAL

Drafting is the stepping-stone to big pay. Many of the greatest designers—engineers—and builders graduated from the drafting table. Trained men are today receiving princely salaries—from manufacturers, engineers, railroad companies! Thousands of positions are open! Draughtsmen are always in demand! Practically trained men are in demand! At Coyne you learn in actual shops. You learn by doing actual work. No mere copy work here! Trained men instruct you—explain everything to you—work with you individually. You learn Mechanical Drawing and Machine Design—Architectural Drawing—Structural Drafting. We have a Carpenters, Builders and Contractors Course. Also a course in Sheet Metal Drafting and Pattern Designing. Mail coupon for special literature, low fee, special terms. Merely check "Drafting" on the coupon below.



Director

**Largest and Best Equipped  
in America**  
**39-51 E. Illinois St. Dept. 1192, Chicago**

**MAIL THIS COUPON NOW!**

**BENNETT WELLINGTON COOKE, Director**  
**COYNE NATIONAL TRADE SCHOOLS**  
**Dept. 1192, CHICAGO**

Send me at once your big Book of Golden Opportunities. I am especially interested in the trade checked

Electricity  Drafting  Bricklaying  
 Motion Picture Operating  Plumbing

NAME.....

ADDRESS.....

TOWN.....STATE.....



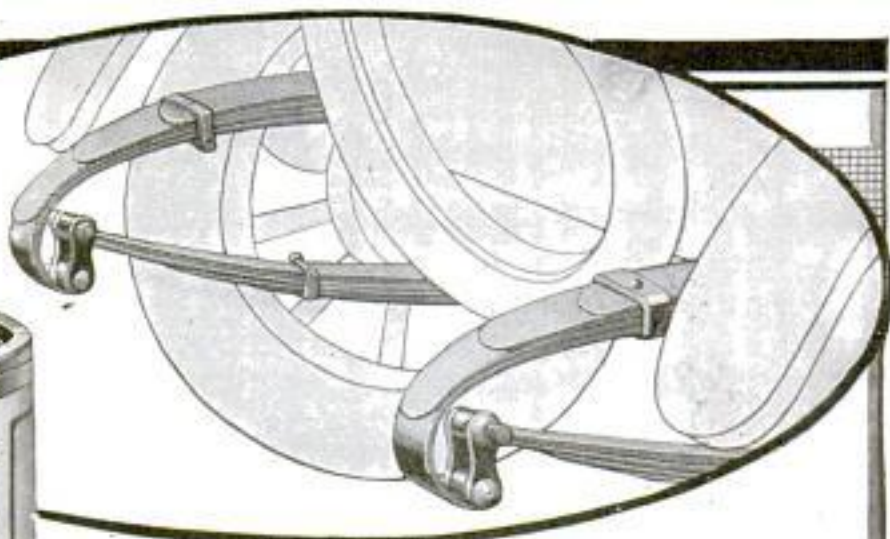

**I**F your springs are not properly lubricated you might as well not have any springs. With Johnson's Stop-Squeak Oil you, yourself, can keep the springs perfectly lubricated. You don't need a tool of any kind—you won't even need to jack up the car.

The springs of every car should be given an application of Johnson's Stop-Squeak Oil once a month. It penetrates between the leaves of the spring removing all rust and depositing a thin layer of grease between each leaf from end to end.

*You can easily demonstrate* the penetrating power of Johnson's Stop-Squeak Oil by applying it to one side of the spring and watching it come out on the other side, driving the rust before it and leaving a thin layer of grease between each leaf.

# JOHNSON'S STOP-SQUEAK OIL

Has the remarkable property of seeping between the spring leaves and to the furthestmost wearing points and it there becomes a heavy-bodied lubricant. It is unexcelled for removing squeaks of all kinds—in **springs, shackle bolts, body, fenders, top, etc.** Just locate the squeak and touch it with Johnson's Stop-Squeak Oil.

## *Makes Your Car Ride Easily*

Johnson's Stop-Squeak Oil is a simple remedy for hard riding cars. Instead of bumping over the road, you can fairly float along if your springs are lubricated so that you get spring action. If the leaves of a spring are rusted together you might as well have a solid piece of steel as a spring. Johnson's Stop-Squeak Oil reduces the liability of spring breakage.

If your dealer cannot supply you with Johnson's Stop-Squeak Oil, fill out the enclosed coupon and we will fill your order direct from Racine by prepaid express. Please give us the name of your dealer.

S. C. JOHNSON & SON, Dept. PA2, Racine, Wis.

Enclosed please find \$1 for which please send me by prepaid express a quart of Johnson's Stop-Squeak Oil.

Name.....

Address.....

City and State.....

My Dealer is.....

**S. C. JOHNSON & SON**  
Dept. PA2  
**RACINE, WIS.**







### FLASH-LIGHT ATTACHMENT FOR PHONOGRAPHS

It frequently happens that while starting a phonograph in the dark or

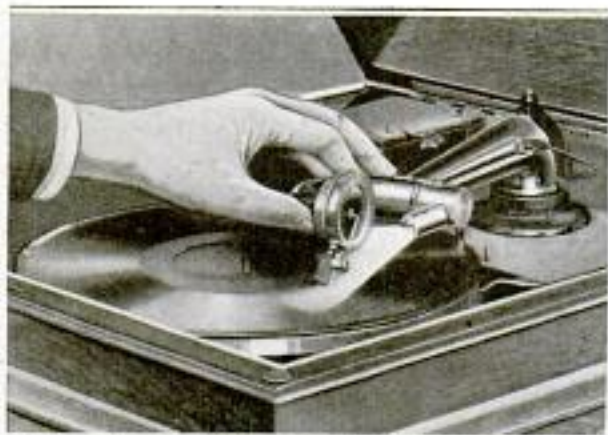

A Flash Light Which can be Easily Attached to the Arm of a Phonograph: It is Designed for Use in a Dark or Dimly Lighted Room

in dim light, a record is injured or the needle is so placed that the first part

of the rendition is spoiled. To overcome this difficulty and yet make it unnecessary to light the room each time a new selection is put on the phonograph, a flash light is being manufactured which can be easily attached to the tone arm of any talking machine. The bulb is inclosed in a small-metal reflector which concentrates all the rays on the disk. It is lighted merely by pressing the finger against a spring contact arm extending along the upper side of the attachment. One can operate it without difficulty while in the act of putting the needle in place, as the accompanying illustration shows. Extending along the tone arm are the electric wires which connect with a small battery. The latter is contained in a case that stands beside the revolving table. The amount of current used is so small that one battery will last a long time.

### SPELLING LESSON IS MADE PLEASANT PASTIME

3485

It is a well-known truth that a child learns more quickly through the medium of play than through dull hours of tedious instruction. To make

*Miss Florence Bidelle*

A teacher in one of the public schools at Columbus, Ohio, some time ago found a way of making her pupils look anxiously forward for the daily spelling lesson. Her plan of teaching is a most novel one and has proved so effective that it has been adopted by



The Youngsters Set Down the Dots and Dashes as They are Ticked Off, and Then Translate Them into Letters and Words

play of work is the endeavor of almost all really successful tutors of little tots.

other instructors in the elementary grades of the city's schools. A telegraph key and receiver are mounted on the teacher's desk. The children have been taught the Morse code and when a word is ticked off in dots and dashes they inscribe the characters on the blackboard and then translate them. Thus ". — . — ." means "fed" to the youngsters, who find it great fun to play telegrapher. A variation of the routine is to have different children tick out the dots and dashes as words are pronounced by the teacher.



3462

## STATUE OF LIBERTY NOW ILLUMINATED AT NIGHT

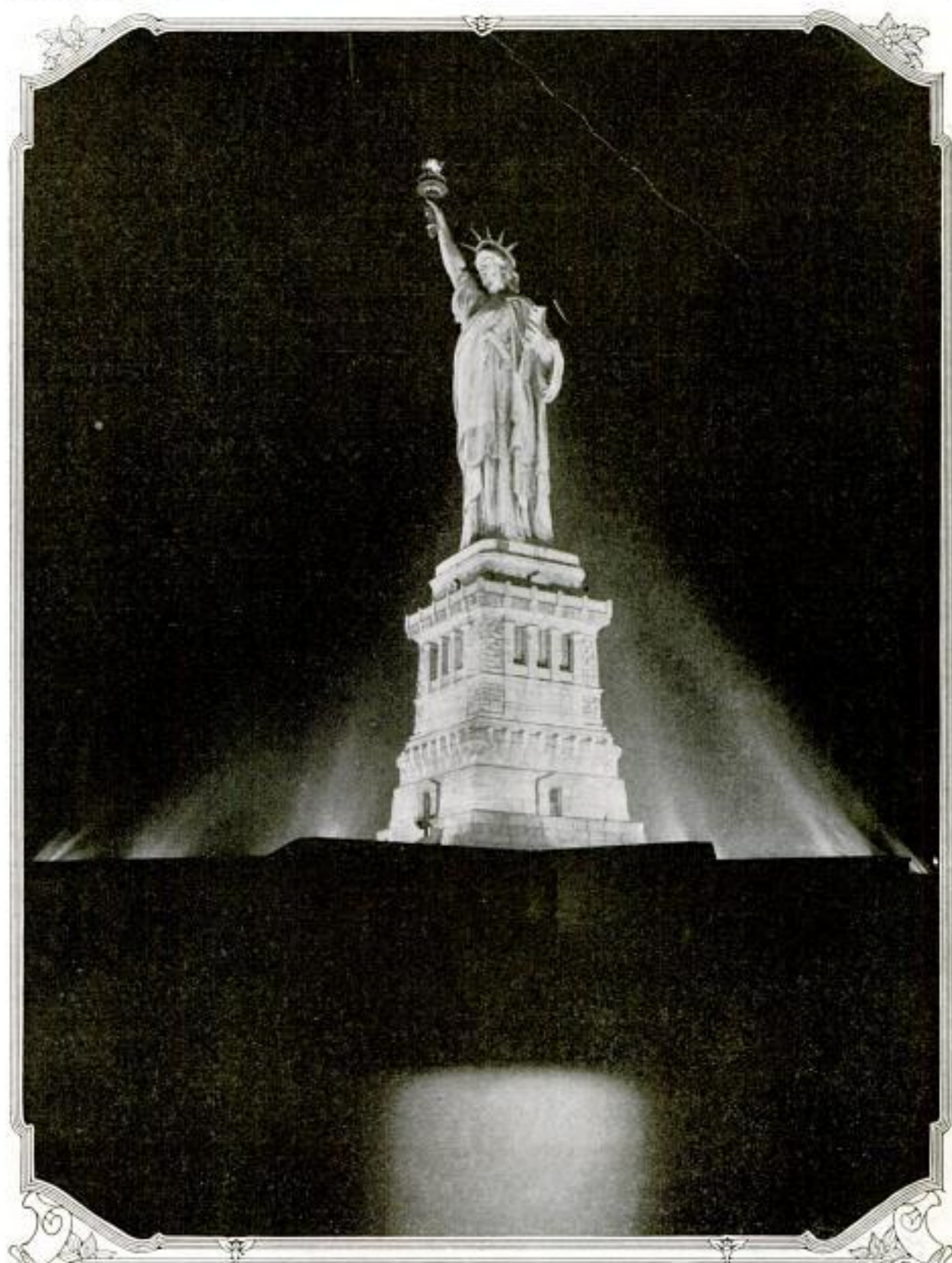

**T**HE Statue of Liberty in New York Harbor is now illuminated at night in a most impressive manner by powerful batteries of electric lights concealed behind the walls surrounding the base of the colossal figure. There are 250 lamps of 250 watts each, arranged in groups of from 4 to 28 around the statue. Reflectors add to the intensity of the illumination. President Wilson from his yacht in the harbor formally inaugurated the lighting system by pressing the key of a wireless instrument. The next instant there was a boom of guns as the warships in the harbor fired a salute. At the same time there was a flash of flame above the statue as Miss Ruth Law, the air woman, circled it in a lighted aeroplane, adding a spectacular touch to the ceremonies. Funds for the new lighting system were raised by popular subscription.

*New York World-Subscription  
Mr. W. C. Harris.*



3216 POPULAR NEW SEA FOOD  
HAS STRANGE HISTORY

What is virtually a fish new to the entire human race has been introduced in many parts of the country within the last few months, largely through

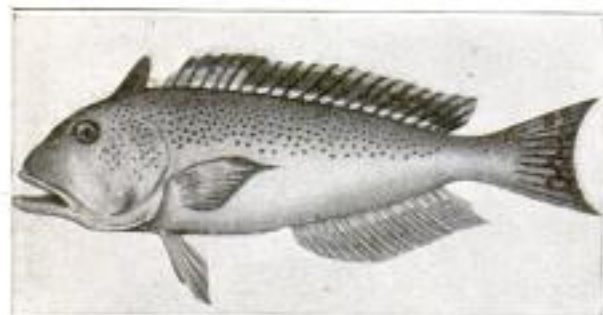

Specimen of Tilefish, an Edible Ocean Fish, Which was Only Recently Rediscovered: Its Brief History has been Marked by a Strange Tragedy

the efforts of the Bureau of Fisheries. It is known as the tilefish and is found in about 600 ft. of water close to the ocean's bottom, where it shelves off to greater depths. The fish averages perhaps 30 in. in length, is beautifully colored, can be caught rather easily, and has a fine flavor. Remarkable circumstances characterize its brief history. So far as is known, the first time any human being ever saw this fish was in 1879, when a captain of a fishing schooner by chance caught several thousand pounds of the strange ocean dwellers. After that discovery many other catches were made. Then in 1882, without warning, hundreds of millions of these fish, dead and dying,

were found floating on the surface of the ocean. It is reliably reported that the area covered by them was 170 miles long and 25 miles wide. It is believed that a change in the course of the Gulf Stream may have chilled the tilefish so that they were all but exterminated. For years little was heard of them. A short time ago it was found that the species had greatly multiplied. As a result of a systematic campaign to inform the American public about this strange fish, a large and profitable tilefish trade is being built up in many parts of the United States, and it is on the menus of the best hotels.

3378—  
FIVE-FOOT MODEL OF  
BLERIOT'S PLANE

A tiny reproduction of the monoplane in which Blériot made his first flight across the English Channel has been built by a resident of Philadelphia, who is of French birth. The model measures 5 ft. long, 5 ft. wide, and 2 ft. high, and weighs 8 lb. without the motor. The materials used are steel, aluminum, and silk, and cost \$225. The machine is constructed in the same manner as a large monoplane is and can be taken apart and reassembled easily. The wheels are provided with ball bearings and rubber tires. All of the parts, save the electric motor and the propeller, were made by the owner, who gave much of his spare time to the task for five years.



Two Views of a Model of the Monoplane in Which Blériot First Crossed the English Channel: The Machine Is Five Feet Long and Five Feet Wide and Weighs Eight Pounds without the Motor

Louis Gerderes  
(Builder) 2032 Chancellor St., Philadelphia



## AGED PERSONS GIVEN WORK BY GOTHAM ASSOCIATION



COPYRIGHT, UNDERWOOD & UNDERWOOD

These Old Men—Every One of Them a Cheerful, Willing Craftsman—Make Toys in the Association's Workshops for a Small Daily Wage

Soaring prices of foodstuffs and other necessities of life have greatly increased suffering in the slums of our big cities. Partly for this reason, partly for others, the work that is being done at New York by a philanthropic association, organized for bettering the lot of those who are needy and destitute, has come to public notice. Through the efforts of this body, old men and women are given clean, respectable work that pays them little in money but much in hope and well-being. Markets have been

opened where poverty-ridden persons can obtain provisions at the lowest possible prices, while kitchens have been established at which cooked foods are sold almost at cost. Toy making is one of the occupations opened to a large number of aged men, while sewing offers many women profitable

employment. These needy old people are not bound by strict factory rules, or expected to make slaves of themselves. They do the best work they can and as much as they are able, accepting in return a moderate wage.



COPYRIGHT, UNDERWOOD & UNDERWOOD

Women Who Need Employment and Otherwise would Be Idle and Possibly Destitute are Given an Opportunity to Earn with Their Needle



Otto C. F. Fricca,  
231 E. 58th St., New York.

### DEVICE RECORDS LOCATION OF NEAR-BY SHIPS IN FOG

A device, which by means of wireless and sound waves will detect the presence of a neighboring vessel in a



fog and record its location and course, has been constructed by a New York inventor. If the invention proves in practical experience to be capable of all that it promises, it means that the grave dangers which threaten all vessels in foggy weather

can be greatly lessened. The instrument is operated by signals sent out simultaneously from the foghorn and the wireless apparatus of a neighboring ship. Hence, to be effective, all ships would have to be equipped to give the proper warnings. The principle on which the invention is based has to do with the difference in time it takes a wireless signal to travel a given distance and a foghorn signal to travel the same distance.

The instrument consists of a flat circular case, inclosing 16 endless belts so placed that they radiate from the center. They are operated by clockwork, and mounted on each are two pens or tinting points, so placed that when a belt begins to move, the two pens travel in opposite directions. The clockwork is adjusted so that a wireless signal from another boat will start all the belts moving, carrying 16 pens toward the circumference, while the other 16 are returning toward the center. When the sound of the foghorn arrives, which is some seconds after the belts have been started by the wireless signal, one, or perhaps two, pens will dot the disk of paper which fits in the top of the instrument. The pen or pens which are actuated to make this record are only those directly in

line with the path which the sound has traveled. The dot or dots show approximately the position of the neighboring ship, while the center of the paper disk represents the position of the vessel carrying the instrument. The circular chart is marked with concentric circles, spaced according to a scale of miles based on the rate at which sound travels and the rate the belts travel. For practical purposes it is assumed that wireless signals are transmitted instantaneously.

Sixteen telephone transmitters placed along the ship's contour, each connected electrically with a corresponding belt, are the instruments which make the pens register as described above. Each receiver is so constructed that it responds only to sounds originating within a limited sector. For this reason signals from directly ahead will be recorded only by the pen traveling toward the bow, and signals from the right side, by the pens traveling in that direction, and so on. After a neighboring ship has given two or three signals, it is easy to ascertain its position, course, and the rate at which the two ships are approaching or receding from each other.

3457 Army

### COMBINATION STEEL BOWL, HELMET, AND DIGGER

A steel helmet, which can also be used as a trench digger or as a mess



bowl, has been invented by a former soldier in the United States Army. It weighs less than two pounds, and yet is strong enough to furnish protection from the smaller missiles that work so much destruction in modern warfare. The headpiece is shaped like a sugar scoop and is worn over a hat, with the pointed end at the back and the handle in front. The invention has been submitted to the ordnance board of the army.



3520 Machinery

# POWERFUL TRENCH DIGGER AT WORK IN FIELD



HEREWITH are presented two views of one of the French army's big trench-digging tractors in action somewhere along the western front, doing the work of hundreds of men. It creeps slowly ahead, cutting a ditch of the desired depth and throwing up a mound of loose earth on either side, one of which is then reinforced with sandbags and quickly made a substantial parapet. Apparatus of similar type has for years been used to dig trenches for sewers, water mains, and telephone conduits in our city streets. The point of interest lies in the way the machine has been assembled to meet the needs encountered on the battle field.



417 5th Av. N.Y.C.



(?) Alvah H. Pulver  
Sodus, N. Y.

**CONCRETE-ROAD BUILDERS  
SPARE CENTURY-OLD ELM**

When the builders of a concrete highway between Elmira, N. Y., and



*Cement World-Aug. 1916*  
Century-Old Elm, in the Center of a Highway: Concrete-Road Builders Decided to Widen the Pavement at This Point Rather than Cut Down the Magnificent Specimen

Mansfield, Pa., had progressed to a certain point they were confronted with a magnificent elm growing squarely in the middle of the road. An exception was made to the usual practice in such cases, and it was decided to let the tree stand. Consequently the road was widened to about double its regular width and laid either side of the beautiful specimen. Provision was made also for the growth of the roots in future years. The tree is said to be 100 years old.

3361

**MOTORISTS ARE PUZZLED  
BY NOVEL TRAIL**

# S. L. Pattison, Annona, Fla.

As an amusement for visiting motorists a novel roadway, or trail, has been constructed at a Florida resort. It is built of lumber and palmettos, and is somewhat of the nature of a labyrinth or maze. To drive into the trail in an automobile is easy enough, but to get

out again is a puzzle for expert drivers as well as novices. There are blind passages and obstacles to block the way unless the proper course is taken, or one may find oneself driving in a circle or taking a back track without getting anywhere. The trail is the first of its kind reported in this country, but it is proving so popular that it will no doubt be speedily copied elsewhere, and in less attractive surroundings than the setting of palm trees and palmettos on the shore of the Gulf of Mexico.

2991

**CASKET CAR USED BETWEEN  
TROLLEY LINE AND GRAVE**

A special car, which is pushed by hand, is now used in Hollywood, Calif., to transport a casket from the funeral car of a trolley line to the cemetery. The body has sides of beveled glass and somewhat resembles the body of a hearse. At the rear is a double door through which the casket is inserted and withdrawn. The running gear is chiefly of steel and the four wheels are rubber-tired. On either side of the car are three handles by which the pallbearers convey the vehicle to its destination. At the rear are two levers, one

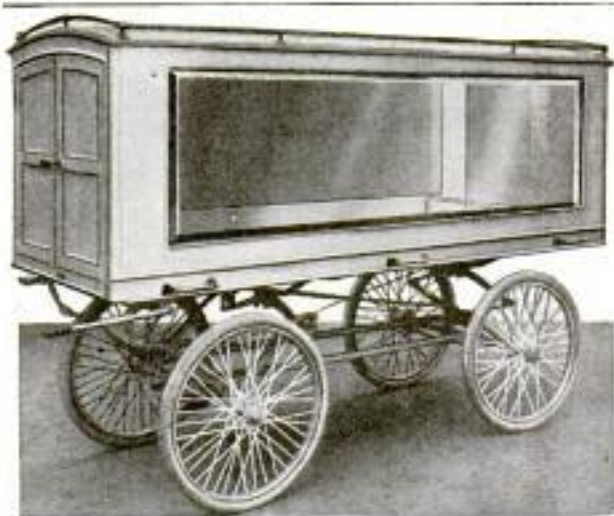

Hand-Drawn Funeral Car Used in a Western City to Convey a Casket from a Trolley Line to the Cemetery

of which serves as a brake and the other as a means of steering the car. Flowers can be carried on the top.

*D.M. Breckenway  
917 S. San Rector St.  
Los Angeles.*



# Trapshooting as a Sport

A DEMOCRATIC PASTIME  
OF MILITARY VALUE

By JOHN ANSON FORD

**W**ITHIN recent years what has rightly been called the most democratic of sports has been gaining in popularity so rapidly that it bids fair, before long, to supersede golf, tennis, football, and even baseball in respect to the number of persons participating in it. The



An Alluring Sport—Trapshooting on the Beach: Young Folks Testing Their Alertness and the Steadiness of Their Nerves, Firing at Targets Thrown by a Hand Trap

and women of various ages, as well as boys and girls—all enthusiastic about trapshooting. They like it better than baseball or football because, for one reason, the formation of teams is not necessary to the enjoyment of the sport, although all who prefer may shoot in

teams when so inclined. This adaptability of the recreation has proven an important factor in its widespread adoption. Furthermore, trapshooting, unlike ball games and tennis, does not call for violent exertion. While golf is a milder game than these others, it must be played on a course that is more or less expensive to acquire and maintain, whereas with only a small equipment anyone can enjoy the zest of shooting clay pigeons. This outdoor recreation, now gaining such widespread favor, has already proven to be the modern substitute for the vigorous training that every pioneer in the early days received because of the dangers as well as the rigors of the wilderness—a training which really was one of the nation's chief sources of preparedness, because it developed men of skill and self-reliance. Modern life has all but deprived the average person of such training, and it has remained for trapshooting, now placed within the reach of the many by reason

A visit to one of the grand American handicap shoots, held annually in various parts of the country and attended by great throngs of people, is a revelation of the popularity which this sport is gaining among people of all walks of life. At these events one finds men

and women of various ages, as well as boys and girls—all enthusiastic about trapshooting. They like it better than baseball or football because, for one reason, the formation of teams is not necessary to the enjoyment of the sport, although all who prefer may shoot in

teams when so inclined. This adaptability of the recreation has proven an important factor in its widespread adoption. Furthermore, trapshooting, unlike ball games and tennis, does not call for violent exertion. While golf is a milder game than these others, it must be played on a course that is more or less expensive to acquire and maintain, whereas with only a small equipment anyone can enjoy the zest of shooting clay pigeons. This outdoor recreation, now gaining such widespread favor, has already proven to be the modern substitute for the vigorous training that every pioneer in the early days received because of the dangers as well as the rigors of the wilderness—a training which really was one of the nation's chief sources of preparedness, because it developed men of skill and self-reliance. Modern life has all but deprived the average person of such training, and it has remained for trapshooting, now placed within the reach of the many by reason



of inexpensive targets and cheap efficient traps, to supply the lack which so vitally affects the life of the American people and their national welfare. One trapshooting club recently displayed this significant motto in its home city: "There are 500,000 trapshooters in the United States. When occasion demands, equipped with rifles, these men will give the nation the best army of sharpshooters the world has ever seen."

A majority of those interested in trapshooting are members of some club. Ten or 12 years ago there were not more than 500 clubs in the United States, while the total today, as already stated, is approximately 4,000, and is increasing rapidly. The five states having the largest number of organizations are Pennsylvania, New York, Illinois, Ohio, and Missouri. In the first two, there are about 400 and 300 clubs respectively—more than the total for the country a decade ago. It is remarkable what a diversity of interests are represented in these clubs. Dartmouth College, Princeton, Yale, and Harvard universities were the first schools of their class to organize shooting clubs. These were followed by Columbia University, Pennsylvania State College, and Williams College. The groups in five institutions, Yale, Princeton, Cornell, Dartmouth, and Harvard, are organized into the Intercollegiate Trapshooting Association, which has greatly stimulated interest in the sport among college men. Such preparatory schools as Mercersburg, Northwestern Academy, Pawling, and Tome, each has active clubs. In quite a different sphere of activity are the members of

the organizations in the United States Navy. There are groups on the "Arkansas," "New York," "Florida," "South Carolina," "Texas," "Wyoming," "Oklahoma," "Cheyenne," and "Glacier." These marksmen held a most interesting tournament last spring in Guantanamo Bay, Cuba, while the Atlantic fleet was at the proving grounds there.

The northernmost of all the clubs under the American flag is at Nome, Alaska. That body frequently holds its shoots on—or in—five feet of snow and has the further distinction of conducting its contests at midnight, although not by artificial light, for the midnight sun supplies the illumination. The popularity of the sport in country towns and small cities is well illustrated by the success of the club organized a few months ago in Wausau, Wis. This group started with a few shooters who depended on a hand trap to throw their targets. Today it has 125 members, owns a fine clubhouse, and is rated one of the strongest organizations in the Middle West. The municipal authorities of



COPYRIGHT, BOSTON PHOTO NEWS COMPANY  
Unusual Trapshooting Tower Owned by a New England Club: Targets are Released from the Top, the Gunners Standing on the Platforms

Sedgwick, Colo., did an unusual thing last year by hiring a professional trapshooter to give exhibitions every Saturday afternoon and so stimulate interest in the sport. The employes in the hardware stores in Sioux Falls, S. D., have formed a club and conduct shoots every week, in season. Farmers in many parts of the country are taking up trapshooting, and many shotguns, that have long hung over the door undisturbed because of the increasing stringency of the game laws, are being used once more.

Outside the membership of the hun-





View Taken at a Grand American Handicap, Which Is the Great Annual Event in the Trapshooting World. Picked Shooters from Leagues in Many Parts of the Country Share in the Invigorating Outdoor Tests of Skill. The Squads of Marksmen are Shown at the Edge of the Open Area, Facing the Low-Lying Trap Houses at the Left of the Picture

dreds of clubs there are many families and small informal groups that enjoy this sport. Besides a gun, shells, and targets, a hand trap, which costs only about \$4, is all the equipment required. The hand trap has done perhaps as much as any one thing to bring the sport within the reach of the many. It is a comparatively simple spring-operated mechanism held in both hands somewhat as one holds a gun. After it has been set and loaded with one of the saucer-shaped clay pigeons, it is discharged by pulling a trigger and will throw the targets in a great number of ways. Even a boy or girl, with training, can operate the trap so as to call forth all the skill of a veteran shooter. The device is employed in a great variety of places. With it targets can be thrown from the deck of a launch while members of the launch party on board try their skill with their guns. Hunting parties often resort to trapshooting when game is scarce, and often picnickers who prefer targetshooting to killing live creatures, find it a splendid pastime. Many a city dweller has found himself too far from the forest or prairie to learn to hunt, or if he has been skilled in the past, he has been unable to keep in practice. To such persons trapshooting is a great

boon. A short trolley ride will usually bring them to a bit of open country where keenness of sight, quickness of thought, and steadiness of nerve can all be brought into play in an exhilarating hour of targetshooting.

Persons of distinction and wealth, no less than the great mass of the common people, are enthusiastic about this sport. King George of England and King Alfonso of Spain are expert trapshooters, and the same is true of many prominent men in this country. On the other hand, boys and girls have won distinction in this field of recreation. Master Bruce Steele, of Birmingham, Mich., when only 12 years old, broke 94 out of 100 targets—a record which perhaps even the royal trapshooters cannot equal. Miss Lucille Meusel, of Green Bay, Wis., when in her fifteenth year, made "straight runs" of 17 and 19 shots and could hit 23 out of 25 targets. She was taught to shoot by her father. Because they both loved the sport, a fine comradeship sprang up between them, and it has not been uncommon for this girl and her father to spend an afternoon together in the open, trapshooting. Another proof of the universal appeal of this pastime is that even crippled persons can engage in it. In the accompanying



illustrations are pictures of two men, each deprived of one arm, who are expert trapshooters.

The history of many trapshooting clubs, large and small, shows that it is a comparatively easy matter to start an organization of this character. A group of two or three interested persons can obtain, free, trapshooting literature which is issued in great variety by powder companies, for distribution among prospective members. The pamphlets explain the advantages of the sport and also outline each step in building up an organization, from the calling of the first meeting to the management of league shoots. Where practical, some companies will sometimes send, without charge, an expert to assist the amateurs in making the right start. In selecting a site for club grounds a location should be chosen which is easily accessible, and it should have no dwellings or outbuildings within 250



These Adjacent Pictures Are Photographs of Two Crippled Men, Both of Whom Are Expert Trapshooters

or 300 yards of the firing line. If possible the grounds should be laid out so that the marksmen face the northeast, toward a clear background.

It is surprising what a small outlay is necessary to start and equip a club. If the members wish to be very economical, they can get along with a shelter costing only a few dollars, while for \$100 they can erect a plain but very satisfactory clubhouse.

Working plans of such a structure, as well as of far more costly ones, can be obtained free from one of the powder companies. The principal item of equipment in addition to the shotguns and the targets, which cost about \$5 per thousand, is the trap. This may be a hand trap, already described; a portable trap, operated by a cord and costing \$6.50, or a so-called automatic trap. The latter is always housed in a low, heavy-walled shelter, called the trap house, with an open side which faces away



It Is Interesting to Note That One Shooter has Lost His Right Arm; the Other, the Left



Even Old Men Are Enthusiastic About Trapshooting: This Marksman Is a Confederate Veteran Living in Oskaloosa, Iowa



A Sport from Which None are Barred: A Middle-Aged Mother can Learn to Shoot, as This Picture Bears Witness, as Well as Her Husband and Children



A Shooter in His Teens Who in a Recent Handicap Proved a Better Marksman Than Many of His Elders





Trapshooting Appeals Alike on Land and on Water: The Simple Device Which Makes Possible the Enjoyment of the Sport in Such a Variety of Circumstances Is the Hand Trap, Which is Shown Here About to be Discharged by the Boy at the Left. The Rise and Fall of the Boat Only Adds to the Zest of the Contest

from the firing stations. A helper, called the "trapper," sits in the shelter of the trap house and loads the machine with clay targets. A man, or boy, known as the "puller," is stationed a few feet behind the firing line and operates a lever which is connected with the trap by means of a rod or wire. The machine is set and re-

leased by the puller, according to the signal of the man about to fire. These automatic traps are made in different styles. One costs \$35 to \$40, while another rents for \$30, for the first year, and \$10 for each succeeding year, with a \$15 refund on the return of the trap. The firing stations at which the marksmen stand are usually five in number



Watching Others in the Squad While She Waits Her Turn: The Gun is being Held in the Proper Way to Avoid Accident

A Familiar Figure at Many Shoots: This Man, Though Deprived of Both Limbs, Is an Expert Referee, His Low Position Giving Him an Advantage in Judging Targets

Miss Lucille Meusel, the Youngest Shooter in the 1916 Grand American Handicap: At 15 She could Hit 23 Out of 25 Targets



and are placed from three to five yards apart on the arc of a circle, the center of which is 16 yards from the stations. The traveling limit of the targets is about 50 yards.

From the foregoing figures it can readily be understood how some clubs have started up with an expenditure as low as \$15 or \$20, where only a hand trap has been used, and that for \$150 other organizations have provided themselves with a neat clubhouse, an automatic trap, and a few accessories. The membership fee in most clubs is \$2 per year. In addition to the purchase of a gun, the cost of which will be from \$20 up, according to the individual taste, each member must pay for the shells he uses and the targets he shoots at. The charge usually made for the latter is from three-fourths of a cent to one cent each, thereby allowing the club to make a small profit. A box of 25 of the less expensive shells sells for about 75 cents.

The grand American trapshooting handicap, held last year in St. Louis, gathered together from the four cor-

ners of the country the best shooters of the various leagues which constitute the national association—a splendid company whose favorite pastime in the outdoors had given them marvelous self-control and alertness. The gathering was inspiring proof of what this most democratic of sports can do for people of all walks of life and was an indication of the great hold that it is to gain in the coming years, resulting in the betterment of thousands of individuals and in making the nation as a whole better prepared to meet the future. For the first time women amateurs contested, 10 shooting in the big events. In the week's scatter-gun tournament, 618 men, women, boys, and girls participated. The winner of the premier event of the meet was a veteran trapshooter who declared that he had been training for that victory for the past 17 years. A splendid thing about trapshooting is that the fine development which those years of recreation had given him differs only in degree from that being acquired by every person who shares in the sport.

3113

### REMINDERS OF CALIFORNIA WHEAT-GROWING DAYS

A strange-appearing reminder of the days when California was one of the great wheat-producing centers of the



These Piles Are Practically All That is Left of the Great Wheat Elevators That Housed Much of California's Wheat Crop in Other Days

# Oscar Lewis,  
2337 McKinley Av.,  
Berkeley, Calif.

world is to be found in the rotting piles that line the shore of upper San Francisco Bay. It was here that wheat, carried by trains and barges from the extensive fields of the interior, was graded and stored before being loaded onto the clippers that crowded the bay, waiting to transport the grain to the markets of the world. Some of the warehouses were three-quarters of a mile long. When at length wheat-growing became unprofitable, the buildings fell into disuse and many of them were pulled down and others burned. Today their sites are marked by the charred and rotting piles that project in long rows above the water.



Henry Blood, Engineer Bureau of Buildings,  
464 Lexington Av., Portland, Oregon, 175  
3350 POPULAR MECHANICS

### BIG CHIMNEY STACK FALLS AS DERRICK FAILS

Through the breaking of a derrick on top of an eight-story office building in Portland, Ore., a section of steel boiler stack, weighing 6,700 lb., which was being hoisted to place above the roof, was



This Shows the Wreckage of the Derrick as It Appeared on the Roof of the Lofty Building after the Accident. Note the Fractured Timber Leg



Section of Steel Smokestack, Weighing Over Three Tons, in the Act of being Hoisted into Position above the Roof of an Eight-Story Office Building. Just Before the Derrick Broke and Let It Drop



Here the Fallen Section of Stack is Seen Where It Fell: It Crashed through the Roof of a Two-Story Building, but Its Fall was Halted by a Concrete Floor

dropped 145 ft. to the temporary wooden roof of a two-story annex below. It crashed through this roof to a concrete floor on the second story, but was there stopped, apparently without damage to the concrete slab. The stack was flattened and had to be returned to the shop. When the accident occurred, the last of three new sections was being added to the chimney of the building in an effort to prevent smokiness. The section of stack was 15 ft. long and 10 ft. 6 in. in diameter. The derrick in use had an A-frame composed of 14 by 14-in. timbers of Douglas fir, with a vertical height of 45 ft. and a spread of 50 ft. It had no stiff legs, but was guyed to the roof with two sets of steel cables, anchored to concrete girders. The boom was a single stick of Douglas fir, 106 ft. long, working on a vertical pin 4 1/8 in. in diameter. Its weight with fittings was about 6,600 lb. The failure came through one leg of the A-frame twist-

ing or tearing off just below the top connection. The boom fell in a vertical line, struck on a fire wall, and broke off a few feet outside. The steel stack section struck the wooden roof below with its nearer side about 40 ft. from the wall. Inspection after the accident showed that the timber of the derrick was not entirely sound, but no real decay was visible. It was seriously weakened by bolt holes.

3466

#### LOCAL PAPER PRINTED ON RED-CEDAR SHINGLES

A special edition of 50,000 copies of a local paper, published in Castle Rock, Wash., was issued recently printed on red-cedar shingles. Castle Rock is in the heart of an extensive shingle-producing country and the present low price of shingles, together with the high price of paper, inspired the publisher to issue this novel edition. It is devoted chiefly to a discussion of the

Cowlitz County Advocate,  
Castle Rock, Wash.



lumber exports and imports of the country under the present tariff and was widely distributed. At the time



Copy of a Special Edition of a Castle Rock, Washington, Paper Printed on Red-Cedar Shingles as Protest against the High Price of Paper and the Effect of the Tariff on the Lumber Market

the "paper" was printed, shingles could be bought wholesale at the rate of about six for a cent.

3346

**OPEN-FRONT AUTO GOGGLES PROTECT EYES FROM WIND**

Automobile goggles which are entirely open directly in front of the eyes and yet afford ample protection against the wind, have been patented by a young man in South Bend, Ind. A wall of celluloid which projects for-



Goggles Which Are Open Directly in Front of the Eyes but Which Have a Projecting Wall of Celluloid That Protects Them Entirely from the Wind

Roy N. Dickey  
(City Electrician)  
R11-City Hall So. Bend, Ind.  
Inv. - Company organized

ward from the face surrounds the eyes and is attached to a leather frame that fits snugly against the forehead and cheeks. This arrangement forms pockets in which the air is practically motionless and as one faces the wind these air cushions protect the eyes so that they scarcely feel the draft at all.

3102

**NEW SIBERIAN PORT TO AID RUSSIA IN WAR**

*Far Eastern Review - Aug. 1916*

Russia has recently opened a new Pacific terminus for its great trans-Siberian railway and thereby hopes to relieve the congestion of shipping which has overwhelmed Vladivostok since the war began. The new port is Nikolaievsk on the Gulf of Tartary, at the mouth of the great Amur River, and about 850 miles north of Vladivostok. Freight received at the new terminus will be sent up the river for some distance and then transferred to a branch railway which connects with the transcontinental line. The immense task of double-tracking the trans-Siberian railway was begun several years ago, but when the war broke out large additional forces were put to work to complete that undertaking. Now that the double-tracking is finished and the new port is open, it is expected that the volume of supplies which will be shipped from Japan and the United States to the Russian fronts will be greatly increased. Until now the wharves and warehouses have been piled high with goods, which Vladivostok could not handle fast enough.

**MINIATURE-TRAIN SERVICE**

3174 FOR CITY PARKS

The miniature auto-drawn trains, which attracted so much attention at the San Francisco exposition in 1915, are being introduced in various city parks and have proven not only a source of entertainment but of convenience as well. Train service of this character was inaugurated in Lincoln Park, Chicago, last summer. Each train consists of a very small but strong automobile and several low cars.

Fadgl Auto Trains, Inc.  
R-768 122 S Mich Av.  
Chicago

Copyrighted material



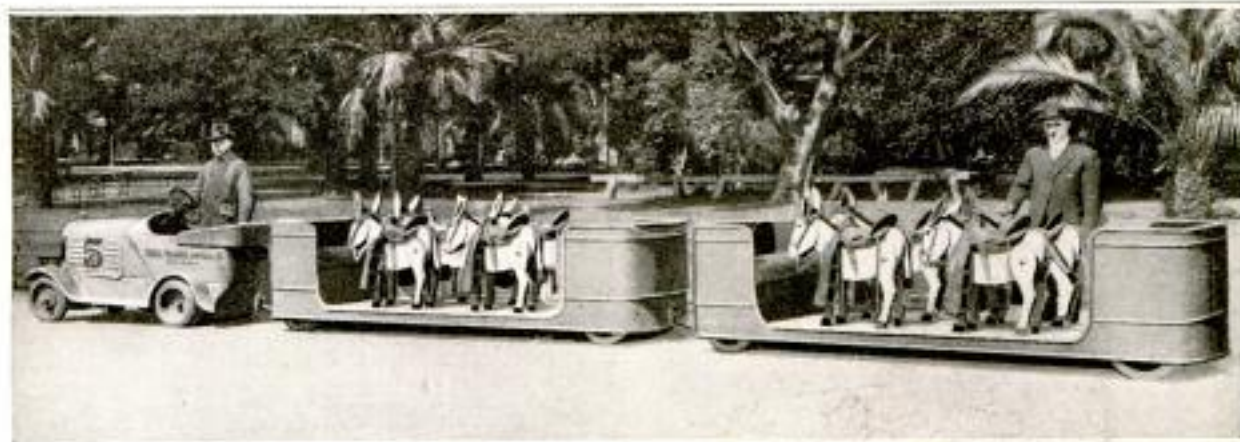

A New Variety of Miniature Auto Train Which has Proven a Source of Much Amusement for the Children of Oakland, California

Most of the cars have long seats placed back to back so that the occupants face either side. A novel variation of this type of conveyance is called an "animal train." Mounted on the car floors are several small wooden donkeys, saddled and bridled. In addition there are cushioned seats at either end. One of these trains is in operation in Oakland, Calif., and has been a source of great delight for many youthful patrons.

3383 \_\_\_\_\_ *Household*  
**RUNNING GEAR USED TO  
 MAKE BRIDGE ON RANCH**

*P. G. Belden  
 Buffalo, Wyo.*  
 The running gear of a wagon serves as the principal feature of an unusual portable bridge employed by a rancher near Buffalo, Wyo., in getting his sheep across streams. The front and back pairs of wheels are separated from each other after they have been drawn to the point where they are to

be utilized. One pair is placed in the stream near one bank and the other pair near the opposite bank. The gap between the two is spanned with logs, and approaches of similar material are provided. A number of sheep dogs assist in rounding up the flock, while men near the approach to the bridge encourage and urge the animals along. This ingenious arrangement is used by the rancher in getting thousands of sheep across streams, and saves the cost of building structures which might be washed away.



A Strikingly Beautiful Scene on a Ranch near Buffalo, Wyoming, Showing a Portable Bridge Made with Wagon Running Gear and Logs and Used in Getting Thousands of Sheep across Streams







# Sailors' Sensations in Battle

by Lewis R. Freeman  
287 E. Calif. St. - Pasadena



"The torpedo fascinated me for a moment. In that marvelously clear water I could note its every detail."

## Being Torpedoed

I HAVE talked in the last few months with many men who have been aboard one kind of craft or another when it was torpedoed—trawlers, cruisers, and ocean liners—but no one of them has been able to give so comprehensive, so illuminative an account of what the experience was like—of what happened to himself, the ship, and to those on board the ship—as Capt. Rupert S. Gwatkin-Williams, the officer who was in command of the converted Irish Channel packet "Tara," when she was sunk by a German submarine in the Mediterranean at the end of 1915. Through the courtesy of the British Admiralty, I interviewed Captain Gwatkin-Williams while he was in London, waiting to proceed to his new command, and the account of the torpedoing of his ship which follows is from his personal diary, written while he was a prisoner of the Senussi, to whom he and his men were handed over by the commander of the German submarine.

"It was a fine morning, and I was on deck looking for Sollum, which we were approaching. Suddenly the lookout in the crow's nest gave a hail and

pointed. Looking over the starboard rail I saw a torpedo, about 300 yards away, leaping toward us. Habit made me look at my wrist watch. It was 10:10 a. m. The torpedo fascinated me for a moment. In that marvelously clear water I could note its every detail. The fishlike body showed bright vermilion in the sunlight, with black square patches on top where the balance chamber was. It seemed to travel along in ever-quickening spurts, and as it got closer and closer I could see the detonating apparatus of striker and 'whiskers' in its nose, and the various valves and levers for adjusting and starting the engines.

"I realized at once that we were a 'goner,' our speed being too slow to dodge. Nothing but the unlikely event of the torpedo failing to explode could save the ship. On rushed the torpedo. The ship was just beginning to gather weigh, when she was struck on the starboard side, fair against the engine room. A dull, mumbling, cracking roar, and a great black column rose as high as the main lower masthead. I suppose that it was formed of water, smoke, coal, and debris, but it was impossible to say. Only its blackness impressed me. A



great yawning hole in the side, the deck blown away, and the aerial of the wireless destroyed—this was the result."

Captain Gwatkin-Williams goes on to tell how a well-aimed shot from his gun on the forward deck forced the submarine, which in the meantime had come to the surface a mile astern, to withdraw its periscope. "We at least had the satisfaction of knowing that the submarine was blind for the time being, and could not torpedo us again without putting up its 'eye.' But it was a poor satisfaction after all. The old ship had steamed her last mile. No answer came from a call down the engine-room voice pipe to order the engineers to come on deck. Only a confused gurgling sound bubbled up the tube. All in the engine room were dead, having been overwhelmed by the explosion and the rush of water. No human hands ever stopped those engines. They were still turning when she made her last great plunge, 100 fathoms deep, into the Mediterranean.

"The ship settled down steadily on an even keel. Suddenly, without any warning, her bow shot up in the air at a sharp angle, and a great wave seemed to rush at us from aft. It was like the bursting of a milldam, and on its foaming crest it bore boats, spars, meat safes, and broken wreckage of all descriptions. This was rather an uncomfortable moment, being unexpected, and I couldn't think what was the most sensible thing to do. However, matters were soon settled for me. Before the avalanche and its battering ram of tossing debris I fled, and was washed down the ladder onto the fo'c'sle, from which vantage point I quickly took a dive overboard. Going overboard into that calm sea looked simple and easy, but I found to my disgust that I was instantly sucked back again, this time with the ship under water, and my head against the very awkward problem of the fo'c'sle awning.

"As she went down, amongst the churning bubbles, I could see the daylight getting farther and farther off. I

had my clothes and boots on. I think if I had been wearing my life belt I would have been drowned. But my life-saving collar was safe in my pocket, uninflated, and, being heavy, I managed to struggle and dive a little deeper and get clear of that all-embracing awning.

"Up, up I went, the gay sunshine getting nearer and nearer once more, till I seemed to feel its warmth. The bubbles raced past me and reminded me of pictures I had seen as a child, depicting people going to heaven, with the silver stars all around in a blue firmament, and a great light above. Up, and the pressure on my lungs got less, till, with a great gasp, I found myself on the surface, shot halfway out of the water, practically none the worse.

"Signs of the ship there were none, only a great heaving and churning of the water, broken every moment by spars and other light objects, disentangled from the sunken ship, hurtling into the air from the depths.

"I swam to the nearest life raft, and from there clambered onto the bottom of an upturned boat. Here I could stand up and survey the desolation. The whole surface was covered with brown oil, as well as with wreckage and swimming figures. Some who were injured were calling out for help, and close by was the body of the cook, floating in his life belt."

Heavy as was the explosion and comparatively small the ship—she was under 4,000 tons—in the case of the blowing up of the "Tara," Captain Williams assured me that the shock of the explosion where he stood—about a hundred feet away—was by no means great; that, had he not seen the torpedo, he might well have thought the ship had touched bottom or run down a smaller boat. "The shock itself," he said, "was not so very different from that which runs through a ship under the impact of a breaking head sea, and I have lurched more unsteadily on my feet from the jolt of a ferryboat entering a slip."

In an explosion of this kind one's



proximity to it has, of course, a great deal to do with the shock, both physical and mental, experienced. To the stricken engineers of the "Tara," none of whom survived to tell what he felt, the explosion must have been little short of primal chaos. Even the wireless operator, whose cabin was wrecked by the torpedo and who was rescued in only the shirt of his pajamas, told me that it was as if the whole ocean had gathered itself into a single huge jet and started to rush up through the ship. "One end of my cabin—I was in bed at the time—was torn right off," he said, "and I was thrown out on the buckled-up floor. Luckily, the door was jammed open, and I had just room to squeeze through into the companionway and make for the saloon."

These two instances cover so completely the experiences of the several dozen survivors of torpedoed ships with whom I have talked that, beyond personal injuries and impressions, there is nothing more that could be added.

#### Being Mined

The effect of a mine on a ship is usually very similar to that of a torpedo striking in the same place. As a mine's contact is almost invariably in the shape of a "clean hit" on one of the bows, the injury is more often "true to type" than that of a torpedo, which may hit anywhere from forefoot to rudder. It is the similarity of the action of a mine and a torpedo which

may give rise to so much uncertainty in the event that the injury is to the forward part of the ship. The finding of a fragment of torpedo in the wreckage is all that has definitely established the cause of the injury in a number of notable cases.

It may be a coincidence, but of men I have talked with, a larger proportion from mined than from torpedoed ships have mentioned the great shock of the explosion. This, however, might be explained by the fact that a properly aimed torpedo strikes more or less amidships, and has more of a chance to expend itself upward in the comparatively open spaces of the engine rooms than in the confined forward bulkheads where the force of a mine is exerted. The "kick" of a mine, too, being more often in the opposite direction to which the ship is traveling, is calculated to produce more of a jar than the broadside "knock" of a torpedo. For the rest, the experiences and sensations of

the man on the mined passenger steamer or warship are not different from those met with in a similar mishap from a torpedo.

#### State of Mind in a Naval Action

The question of what a man is most likely to think about when under fire, or in action, has been much discussed since the battle of Horn Reef. Much evidence has been collected and many theories advanced. Obviously, the answer will depend very much upon the man, what sort of fire he is under, and—especially—what his duties are. Generalizing very broadly from conversations I have had with, and letters I have read from, men who went



"Up, up I went. . . . The bubbles raced past me and reminded me of pictures I had seen as a child, depicting people going to heaven, with the silver stars all around in a blue firmament, and a great light above."



through this greatest of naval battles, I should say that, so far as the British sailor is concerned, the concentration of mind in carrying out in action the duties which he had trained so assiduously for during many years of peace, pretty effectually kept his thoughts from wandering far afield. The following extract from the letter of an officer whose ship gave and took some of the hardest knocks, seems to me to indicate a state of mind fairly typical of the average British sailor in action.

"I suppose I was too busy to think. We just got on with the work and that kept us stretched. When we got a German cruiser, I said 'Our bird,' and I have an idea we passed a word or two when a shell gave our turret a rap that made our teeth grind; but as for 'happy memories of boyhood days' and 'The Little Gray Home in the West'—nothing doing. You've got to keep your mind on one thing, and that isn't 'memories of home,' but your work. If a sailor tells how, with shells exploding and men being killed around him, he was thinking of a girl at home, don't believe him, especially if he is telling it to the girl. One does a bit of thinking on the way home after the battle, and that's when the sailor gets soft and imaginative.

"In some ways you do not even think about the fighting, at least not to call it thinking. You think about what you're doing, and you've a hot sort of interest in the way the fight's running, though that doesn't do you much good, because you know no more than you can see, and you can't see much of anything but smoke and fumes and splashes. There are things, of course, that get fixed in your mind—like when you see a ship go suddenly—and later on these things come out so clearly that you know you will never forget them as long as you live. It may be you've got it a little wrong (that's what leads to argument when men remember differently), but your own impression sticks and you would swear by it. My impression of action? I can't say much except that we were steaming fast, firing fast, and that

there were more shells flying about than I care to think about now. I remember somebody picking up three or four severed legs and throwing them overboard, and thinking that it was the sensible thing to do. I saw bodies in the sea, too. The rest is chiefly smoke and noise."

An officer who recently showed me over a superdreadnaught that had been in action during a part of the Horn Reef battle, said that he had only the vaguest recollections of what went on about him during this time. "This very one of my two 'babies,'" he said, patting affectionately the massive breech of the 15-in. gun he had been explaining to me, "accounted for at least one German destroyer, but I was so much engrossed in keeping them 'talking' that I had no eyes or ears for anything else. The noise must have been something stupendous, but I have no distinct memory of its impressing me. My principal recollections are of how hot it got in the turret after we had fired a few rounds, and how deucedly uncomfortable it was that night—we 'stood by,' hoping to get another crack at the Germans, for the next twenty-four hours—trying to snatch a nap curled on that steel grating."

An officer of a British cruiser which had stood perhaps the heaviest fire of any of the ships not sunk, told me of an interesting incident. "We were under the concentrated fire of two or three German battleships at the same time," he said, "and the detonations of their shells, striking the water and exploding, came to us, even 'tween decks, like the roar of our own secondary batteries. The whole Hun-ward horizon was shut off by a wall of tumbling spray fountains. Unluckily, not all of the shells were striking the water, and among those that came aboard were several charged with some sort of asphyxiating gas. The fumes of one exploding near me were so thick that I could not see my hands before my face, and enough of the stuff was getting under my mask to make me feel very groggy when the blast from



an ordinary shell—although it knocked me off my feet—cleared the air and made it fit to breathe again."

The experiences of the survivors of ships that were sunk in the great battle were very terrible and it is only natural that they are spoken of with reserve. All of the British ships went down with their guns still firing, but one poor chap, who was in some way cut off from whatever had been his regular duties, confessed to me that the greatest relief he ever felt in his life was the deep, cool plunge into the sea out of the hell that was raging on the surface. "Fact is, sir," he told me, when I talked with him in

his lounging chair on the terrace of the hospital where he was resting his shattered nerves, "I was so fed up with it, that I must 'a' ducked under a dozen times before I was picked up, just tu get away fro' the bloody 'ell o' it all."

The doctor of a great superdreadnaught which, though dealing some heavy blows herself, went through the latter stages of the battle without a scratch, was just about the only person I have talked with who confessed to much in the way of introspection, and in his case it was undoubtedly due to inaction. He told me about it in the very operating room where, with his staff, he had waited for the wounded who, mercifully, did not come. "It was rather trying," he said, "standing by down in this little hole, with the guns booming above, the ship fairly throbbing with the vibration of her speeding screws, and never a thing to do but twirl my thumbs and think. I did a lot of it, but it was mostly the aimless sort of reflections that run through one's mind in waiting for a

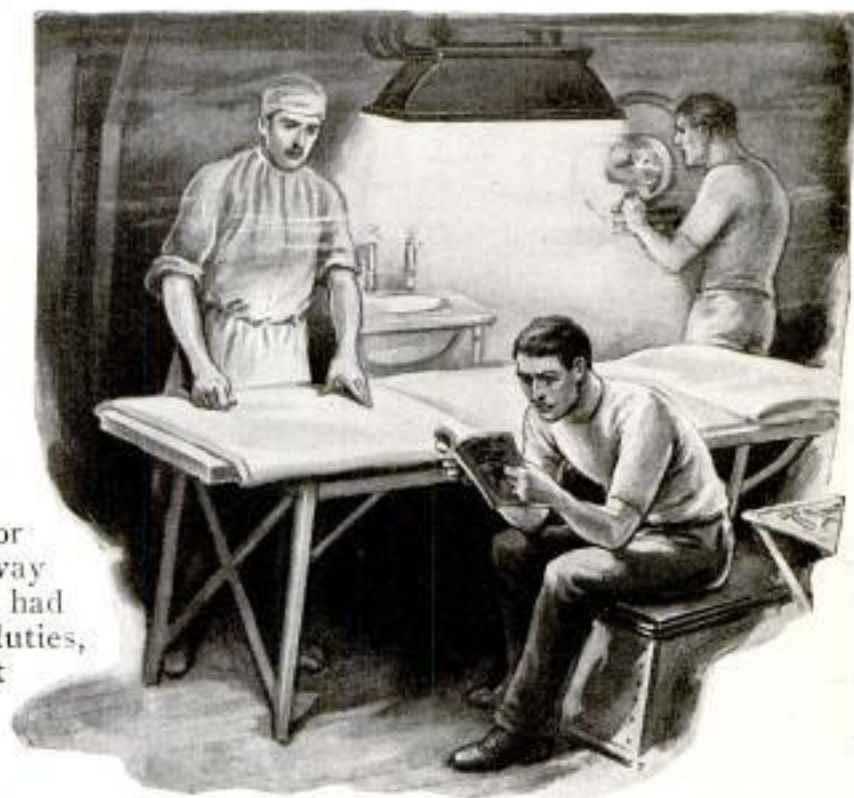

*"One chap, who was devouring a penny dreadful, fairly fascinated me with the pop-eyed wonder with which he followed the story. . . . I realized that he was just a healthy, normal young Briton, taking things as they came."*

tram or a train. But my men did not appear to find the time hanging heavy in the least, nor to be at all tired, or even bored, by the restraint. One was writing a letter, another playing solitaire, and the rest were reading. One chap, who was devouring a penny dreadful, fairly fascinated me with the pop-eyed wonder with which he followed the story. At first I thought his preoccupation was sheer 'swank,' but after I had seen him turn two pages and then stoop down and replace an instrument that the vibration or the jolt of the guns had shaken from the operating table, all without ungluing his eyes from the page, I realized that he was just a healthy, normal young Briton, taking things as they came as a part of 'the day's work.'"

¶ Passengers on German railways have been requested to supply themselves with warm clothing, as the management has announced that, on long trains especially, sufficient steam cannot be supplied in very cold weather.



"AMBRINE"

NEW TREATMENT FOR BURNS

CONSIDERED REMARKABLE

WORLDS WORK DEC 1916

Among the wounded on the battle fields are soldiers with horrible burns caused by bursting projectiles, liquid fire, or scalding water. On the western front the allies transport the worst of these cases to a special hospital near Paris where the men are given the benefits of a new treatment that has lately come to public notice. In the short period of a few weeks, "living corpses" almost without human semblance that enter the institution, leave it without scars and, more wonderful still, with scarcely any visible evidence of the torturous injuries from which they have recovered. The treatment, the discovery of a French physician, is considered to be of inestimable value. Next in importance to the almost unbelievable results it accomplishes, is the fact that it banishes a patient's suffering within a few hours. It is a painless cure for burns of all kinds, including acid ones. After being cleansed with warm water and thoroughly dried with hot air, an atomizer is used to spray the burned flesh with a preparation composed of paraffin and resin, made liquid by heating it to a temperature of about 158° F. This gives the wound a waxlike coating, over which cotton batting is laid in thin strips. The hot liquid is then applied to the latter with a brush, an air-tight sealing thus being provided. This operation alleviates pain quickly and within 24 hours overcomes it. The dressing is

removed daily and the whole treatment repeated. Almost regardless of how serious a burn may be, the flesh grows back with a covering of new, smooth skin when this procedure is carried out properly. The paraffin-resin preparation is very difficult to make, and thus far no one except its discoverer has been able to manufacture it.

Dr. Barthe de Saultfort  
St. Nicholas Hospital,  
155<sup>e</sup> les-Moulines St,  
France



WINGED MESSENGER OF MAN  
Symbolical Bronze Statue, Weighing 16 Tons, That Now Crowns the Tower of the New Telephone and Telegraph Building at New York

3556  
ELECTRIC LANTERNS FAIL IN RAILWAY TESTS

Since portable electric lanterns of certain types are being used extensively in many industries, it is not strange that surprise is frequently expressed at the failure of railway companies to adopt equipment of this kind for trainmen. The idea is not a new one so far as most transportation companies are concerned, and the reason that coal-oil lanterns have not been generally discarded is that electric ones do not seem to be suited for railroad needs. Experiments were conducted some time ago by one of the big western lines for the purpose of determining the advisability of making such a change. The inquiry showed that the operation of electric lanterns would cost the company about seven times more than those of the usual type. It was also found that when an electric-equipped lantern is dropped onto a hard surface from a height of two or three feet the filament in the globe is most liable to break. These two things caused the company in question to abandon the idea. Lamps of the flash-

6. B. ✓



light type include the above objections and also have a third and equally serious one. Their very character, it is contended, would make the revision of the American Railway Association's code necessary before all signals could be rendered with them advantageously. Of course, on several of the big lines electric lanterns are employed by sleeping-car conductors, but that is about as far as their use has ever gone.

2024

### TARGETS TO KEEP HUNTERS FROM SHOOTING AT SIGNS

# R. J. Mitzley, Menlo, Calif.  
Recognizing the fact that many hunters seem to be possessed by an overwhelming desire to shoot at conspicuous signs, regardless of the damage that may result, the Automobile Club of California has provided special targets for such sportsmen in the hope that they will thereby be prevented from mutilating the road signs which the club has erected. The target, which is of the conventional form, is painted on the posts of the signboards. It is far enough below the lettered surface to save the latter from being hit, if a shot is fairly well aimed. Painted near each of these targets are these words: "If You must Shoot, Shoot Here."



Rather than have the Signboard Mutilated by Shot the Makers of This Sign have Provided a Target on the Post for Hunters Incapable of Self-Restraint

### INCUBATOR INSTALLED IN ABANDONED CISTERN

# J. G. McCurdy

A cistern in Port Townsend, Wash., which had been abandoned because of the installation of a modern water sys-



Abandoned Cistern in Port Townsend, Washington, in Which an Incubator has been Installed; Storage for Fruits and Vegetables is Provided Also

tem, is now used as a storeroom and for hatching eggs. The owner dug away dirt at the side of the empty chamber, knocked in a portion of the wall, and built stairs down into it. The entrance was covered with a trapdoor. This transformed the empty cistern into a very desirable storage place that was dry and free from rats and mice, and was always cool without ever being cold enough to freeze. Here fruits, vegetables, and an incubator were kept. In this room the incubator hatched a higher percentage of eggs than ever before.

ⒸThe United States government is to place an electric sign on the upstream face of a railway bridge over the Ohio River at Louisville, warning river voyagers of the dangerous falls about a mile below.



## GUIDING THE EAR BY THE EYE

### IN LEARNING TO SING

SCIENTIFIC AMERICAN

An instrument known as the tonoscope, shown in the accompanying illustrations, projects the vibrations of

especially in training singers and in making scientific investigations on singing.

The singer, standing at the side of a telephone apparatus, sings in front of it, or directly into a speaking tube not shown in the illustration, and the vibrations of the voice cause a little flame in a capsule at the center of the front of the apparatus to flicker so that it actually goes down and rises with every vibration of the voice. Inside of the case is a large drum containing over 18,000 holes arranged in rows so as to represent a series which makes a complete octave. If, for example, the singer sounds middle C, which makes 256 vibrations per second, the line on the drum which has 256 holes will seem to stand still and all the other rows are moving. The line which stands still points to that number on the scale. If he should sing a trifle sharp, then 257, 258, 259, or even a higher line, will stand still, and if he should sing flat a line of lower frequency would stand still, indicating the exact pitch.

The sound is seen exactly simultaneously with the hearing and it is possible to register down to an accuracy of a hundredth of a tone, or even finer.

Educators of the deaf are interested in trying this principle in teaching the deaf to speak with pleasing intonation. A teacher can set a model so that the deaf person can learn to reproduce any given note by sight.

3408

## PUBLIC EMPLOYMENT SYSTEM IS PROVING ITS VALUE

According to an official announcement, the United States Employment Service, which is under the supervision of the Department of Labor, has succeeded



Mechanism of the Tonoscope, Showing the Revolving Screen Which Indicates the Pitch of Musical Sounds

the voice upon a screen, on the principle of moving pictures, in such a way that the singer or speaker can see the pitch of his voice the instant he sings or speaks. The instrument is used



Improved Model of the Tonoscope, by Which the Deaf may Teach Themselves to Sing and Play Correctly, without an Instructor





Scene on a Warm Day at a Portable Ice Station in a Crowded District of Columbus, Ohio,  
 Where Cheap Ice may be Had by All Who Call for It

3368

splendidly since its establishment about two years ago. The purpose of this institution, which is increasing in social and economic importance, is to promote the welfare of wage earners throughout the country and assist business concerns and individual employers in filling their vacancies. For the service it renders no charge is made. Offices are now maintained in 80 different industrial centers, and in order that their scope may not be limited, every post office has been made a local branch where employers and job seekers may obtain application blanks and forward them to the proper destination without postage. The volume and character of the work done at the Chicago headquarters has distinguished it as being one of the most important and efficient bureaus of its kind in the United States. Among other things, this office established the first public teachers' agency and thereby has done much in furthering the "better schools" movement. Careful investigation of all candidates is made before recommending them.

**PORTABLE ICE STATIONS  
 FOR HOT WEATHER**

Small portable ice stations are operated during the summer months by an ice company of Columbus, Ohio, which has found them both useful and profitable, while they are a boon to many families in the districts they serve. The stations are built by a refrigerator company in all sizes. The size used in Columbus is a little building, 16 ft. long and 12 ft. wide. A space, about 12 feet square, is used for the storage of ice—floor, ceiling, and sides being insulated with mineral wool. In front is a small office and platform, where ice is delivered to those who call for it. A sign on each station indicates its purpose, and the ice is sold at the rate of 20 cents per 100 lb., while ice delivered from the company's wagons costs 35 cents per 100 lb. The stations are intended to serve a class of people that do not buy ice regularly from wagons. They are placed for the summer at convenient points in thickly populated districts.

Crystal Mfg. & Cold Storage Co.  
 197 W. Broadway St.

Western Refrigerator Mfg. Co.,

St. Louis, Mo.



### CONCRETE VIADUCT BUILT ALONG A BOULEVARD

As part of the new rapid-transit system of New York City, it became nec-



This Concrete Viaduct of Ornamental Design Carries Elevated Trains for a Mile along Queen's Boulevard, Long Island City, and Is in Striking Contrast with the Ordinary Elevated Steel Structure

essary to run elevated trains along Queen's Boulevard in Long Island City. This being a fine example of the modern automobile highway, 200

ft. wide, it was decided to provide for the elevated railroad something more sightly and more suitable than the ordinary steel structure with its noise, vibration, and uncongenial aspect.

A reinforced-concrete viaduct, in the form of an arcade, or series of vaulted concrete arches, with a solid floor, was decided upon and has now been completed after three years of work. It accommodates three tracks, and is about a mile long, and 44 ft. wide. The spans are from 52 to 65 ft. long, with clearances of 14 ft. for trolley cars. Three stations are built into the viaduct, with a mezzanine below the tracks for ticket booths. The concrete used in the structure was mixed at a central

plant and hauled in buckets in five-car trains by locomotives of 24-in. gauge. Altogether 106,376 bbl. of cement were used in the viaduct.

### 3026 HOMEMADE CAR DRIVEN BY AIR PROPELLER

*Jerome Whetstone, Jr., 1203 Monroe St.*

A young man living in Sandusky, Ohio, has constructed a small car which is driven by an air propeller and can travel at a speed of 28 miles an hour. The car itself is a light homemade cart, 6 ft. long and 40 in. wide. It is equipped with 20-in. bicycle wheels, an automobile steering gear, and a metal body, giving it some

resemblance to a tiny automobile. Mounted behind the driver's seat is a 3-hp. marine motor to which is directly attached a 4-ft. propeller with blades 6 in. wide. The entire outfit weighs only 128 lb. It is the belief of the builder that by substituting a new propeller having blades with a greater pitch, he can increase his present rate of speed considerably.



Light Homemade Car, Driven by a Three-Horsepower Engine and a Four-Foot Air Propeller, Which can Attain a Speed of 28 Miles an Hour

CA train, filled with various exhibitions and carrying 125 leading citizens of Arkansas, is now touring the country by way of advertising the resources of that state.



**BREAKING OSTRICH TEAM FOR CITY DRIVING**



As Docile as Two Old Plow Horses after a Short Term of Training, These Big Birds of the Desert were Driven through the Streets of Los Angeles Some Time Ago Along with Motor Cars and Horses When That City's Gala Event, the Rose Carnival, was Celebrated

Tired Out after a Spirited Trot in the harness, and Resting His Neck across the Shoulders of One of the Trainers: Although He Is Powerful, and Exceedingly Capable of Pulling Heavy Loads, the Long Neck of the Young Ostrich, Before He has been Thoroughly Trained, Easily Becomes Exhausted



Grab an Ostrich by the Neck, If You would Handle Him. It Is Advisable to Remember, However, That He Kicks Forward



In California Everybody Eats Oranges for Breakfast, Even the Ostriches. The Birds, Incidentally, Prefer Their Fruit Served Whole



This Light, Four-Wheeled Rig was Used in Breaking the Team for City Driving so That It Might Participate in the Rose Carnival

To the Tenderfoot There Is Nothing Dull or commonplace about Bird-Back Riding. A Man Must Sit on an Ostrich Just So, or There Is Awful Jolting in Store for Him

*Los Angeles Ostrich Farm*



### INSULATOR OF SPARK PLUG MADE DETACHABLE

One of the special features of a spark plug recently placed on the market is the construction of the insulator and



the body as two separate units. By pulling on a small bail attached to the porcelain insulator, the latter can be instantly removed from the spark-plug shell without the use of a wrench or other tool. In service, both parts fit together tightly and no gasket is necessary; a convex-ground seat in the shell is forced against a ground surface on the porcelain, making the joint leak-proof. The detachable feature of the plug makes it an easy one to clean. It is also convenient for priming cylin-

ders in cold weather, especially where there are no priming cocks on the engine. The insulator is simply slipped out and a few drops of gasoline inserted through the plug shell.

2588

### SUN TEMPLE OF GREAT AGE —UNCOVERED IN WEST

Recent excavations made in the Mesa Verde National Park in southwestern Colorado, under the direction of representatives of the Smithsonian Institution, have brought to light the ruins of a sun temple many centuries old. It seems probable that the structure was erected about 200 years before Columbus discovered the American continent. This estimate is based upon the age of a red-cedar tree which was felled when the excavating was undertaken. The tree, according to expert estimates, was about 376 years old. Furthermore, it had grown on top of the temple, which indicates quite conclusively that the structure was an abandoned ruin in 1540. It is believed that it was constructed about 1300 A. D. Obviously the discovery is a matter of considerable scientific interest.



Six Centuries Old Is This Sun Temple, Lately Uncovered in the Mesa Verde National Park in Colorado

D. Walter Fewkes,  
Smithsonian Institution  
Wash., D.C. Copyrighted material



The Ludlow Typograph Co.  
 3181 Society for Savings Bldg.,  
 Cleveland, O.

3181

**DISPLAY-TYPE FACES CAST ON SLUGS BY MACHINE**

One of the important improvements effected in the printing industry of late has been the invention of a machine for casting display composition on slugs. Some of the advantages are that cost is reduced, an unlimited supply of clean, new type furnished for every piece of work, and time and floor space materially saved. Furthermore, expensive foundry type is conserved, and without reducing the quality of the work. The matrices which are used are set by hand in sticks of a special kind, locked in the machine, and the slug cast. Sticks are made for lines as long as 10 1/2 in., but when these are used, more than one casting is made, the machine taking care of the justification automatically by indenting one slug and overhanging the next. When many duplicates are wanted, as in the cases of blanks, rules, borders, and similar things, the machine will recast until stopped. One large printing establishment has found that the apparatus will produce display work in less time than it can be set from a case, that the elimination of type distribution means a big saving, and that "more matter can be set with \$25 worth of 'mats' than with \$2,500 worth of foundry type." Two of the machines have replaced three sort casters and 350 cases of type, each weighing about 40 lb., in the composing rooms of one of the big western dailies. This has resulted in a saving of about one-half of the floor space.

By the use of angle spaces, italic faces can be used in a line with Gothic or Roman ones, while the readiness with which slugs may be handled greatly simplifies make-up. Forty-eight point matrices are the largest used. The

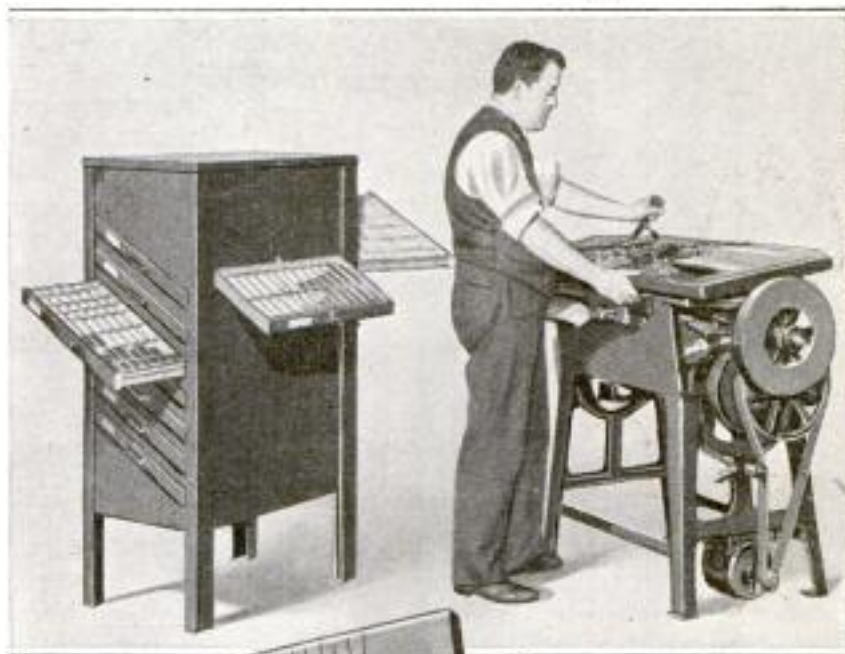

One of the New Type Machines in Use, and at the Left, the Matrix Cabinet. Below is Shown a Partly Filled Stick, Turned Over so That the Type Matter can be Read from Left to Right, Each Matrix having the Letter It Casts Stamped on the Back. Beneath It is a Form Made Up of Slugs Cast by the Machine

system embodies no departure from the ordinary methods of hand composition.

3419 —  
**PORTABLE CONCRETE MIXER OF BARREL PATTERN**

Serviceable for the village contractor on small jobs is a portable concrete mixer of the barrel type that is to be brought out this spring. The apparatus is mounted on a substantial angle-iron frame which is provided with a pair of metal wheels at the front. This enables the outfit to be coupled to a truck or wagon as a trailer and

Barrel Mixer Co.  
 446 Washington Bldg.  
 Madison, Wis.

Messrs. Thaler & Sons, 100 S. Wash. Bldg., N.Y.C. Chicago, Ill. Agents for the West.



Refer to See p. 318 Ex. 822.  
 2/8/14 Sheldon Mfg Co.

Box 3578 Nehawka, Neb.

transported over ordinary roads. Power is supplied by a capable gas engine fixed to a platform at the rear of the

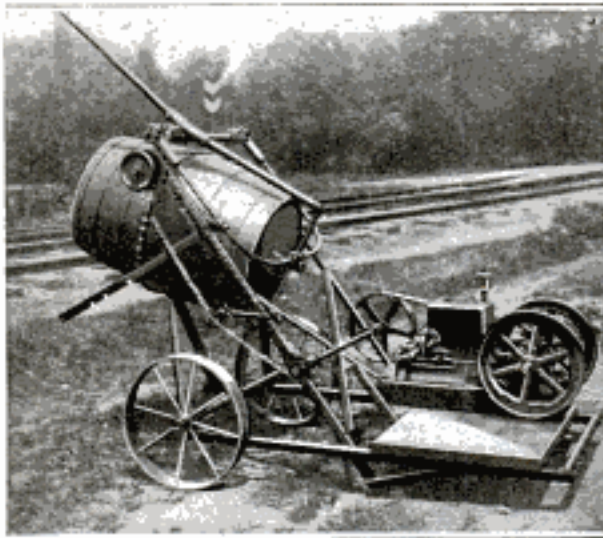

This Portable Mixer will Handle a Wheelbarrow of Concrete at a Time, and can be Carried as a Trailer by a Truck or Wagon

frame. For culvert, curbing, or sidewalk work that requires the services of only five or six men, the equipment is quite adequate and much more satisfactory than an old-style mixing box. Metal baffle plates within the barrel assure the proper mixing of about two and a half cubic feet of material at a time. The mounting is such that the barrel can be revolved while it is tilted to discharge into a wheelbarrow.

3402

**OBSERVATION TOWER BUILT IN TEXAS BACK YARD**

A private observation tower has been erected by a resident of San Antonio, Tex., in his back yard for the express purpose of giving himself and his friends a fine view of the city and surrounding country. On

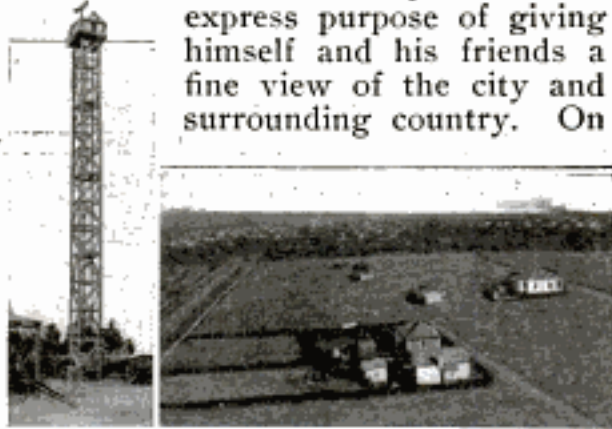

A 75-Foot Observation Tower Built by a Resident of San Antonio, Texas. At the Right is Shown the View from the Summit of the Structure

# H. G. Engelman,  
 Houston + Zaramora Sts.,  
 San Antonio,  
 Texas

a clear day a splendid outlook can be gained from this observation point. The structure is 75 ft. high and is surmounted by a railed platform, 7 ft. square, to which access is gained by a ladder. The corner posts of the tower, which is square, are composed of 4 by 4-in. beams, and the bracing members of 1 by 6-in. planks. The framework is kept steady in the face of varying winds by eight 1/4-in. cables, which terminate at their lower ends in heavy concrete anchors. Each guy wire is drawn taut by means of a turnbuckle. The builder and owner of the structure contemplates offering it to the government for use as a signal station.

3497

**LATE DISCOVERY SHOWS SUN TO BE VARIABLE STAR**

As one result of an exhaustive study of solar radiations by the director of the Smithsonian astrophysical observatory, it has been found that at the earth's mean distance the heat of the sun's rays is sufficient to melt in a year's time a layer of ice 426 ft. in thickness. This, it is announced, indicates that the aggregate heat thrown off by the sun in 12 months amounts to the same as would be obtained by consuming 400 sextillion tons of hard coal. Incidentally, and most fortunately, only a small portion of this tremendous volume of heat reaches us, all but about four ten-billionths of it being lost in space. Another very interesting and important discovery, which is acclaimed the principal result of the investigations, is that the sun is a variable star. The heat emitted by it instead of being constant in intensity, changes from day to day and year to year. It is believed probable that this has a direct bearing upon the climatic conditions of the earth. In the hope of gaining further enlightenment on this score, a South American expedition is to be undertaken this year for the purpose of making additional and more complete observations of solar variation. The work will be undertaken in the most favorable cloudless region.

Wash  
 etc



3567

DANCING WITH DEATH ABOVE THE SKYSCRAPERS



*Bird Millman  
of Ziegfeld  
"Midnight Follies"  
F. Ziegfeld, Jr.,  
1520 Broadway, N.Y.C.*



PHOTO BY PACH PHOTO NEWS CO.

*47 W 42d N.Y.C.*

**B**LOCKING Broadway traffic just for the fun of skylarking—a dazzling, daring wire-walking performance which caused 5,000 persons in City Hall Park to crane their necks and gasp! This is one of the places where composure and strict attention to business count, for it is 250 feet straight down to the nearest pavement. But to this sure-footed girl it is no more difficult to be graceful 22 stories above oblivion than before a sea of opera glasses and a blinding spotlight, except, possibly, when fluffy skirts make a fickle breeze a bit inconvenient. When one is filled with the sickening sense of fear, smiling is far out of the question. But this little maid is really having a rollicking good time of it, laughing and prancing all by herself and happily oblivious of the open-mouthed, nervous New Yorkers far below.



**NEW SLEEPING BAG ADOPTED FOR ARMY USE**

3584

A sleeping bag with decidedly novel and useful features has been adopted recently by the United States Army upon the recommendation, it is said, of the general commanding the forces

along the Mexican border. The bag was designed and is made in Los Angeles, Calif. It is constructed of water-proofed material in two different weights, adapted for different climatic conditions. Though the model for army use weighs only 3 lb., it affords complete protection to the sleeper. The

*Chicago 404 So. 5th St. A  
N.Y.C.*

*Franklin Felt Co.  
New Albany, Ind.*



face is protected by mosquito netting attached to a hood or awning held in place by a small rattan bow. A felt pad, 1 in. thick, contained in a long pocket, serves as a mattress from the



A United States Marine with the Sleeping Bag Folded, Ready to be Placed in the Knapsack



The Man in the Picture, Peering through the Netting, Dons the Sleeping Bag and Disrobes Inside



New Army Sleeping Bag in Use on Sandy Soil: Note the Face of the Sleeper, Visible through the Mosquito Netting

sleeper's shoulders to well below the hip line. There are small pockets for a revolver, watch, flash light, and medicines, etc. The bag is washable, and packs easily into a knapsack.

It is proposed permanently to equip an auditorium in Albany, N. Y., with numerous telephone receivers so that, if need be, the entire legislature can sit and hear words spoken by persons in other parts of the country.

### SMALL RANGE FINDER MADE FOR GENERAL PURPOSES

Not only of value for army and naval purposes, but also suited for the civil engineer and surveyor, is a short-distance range finder of simple character that has lately been protected by the Swedish patent office. Its fundamental principle is that the degree of the angle, formed by the convergence of the lines of vision, depends upon the distance from the eyes to the object viewed. Held between plain glasses, mounted in a frame or field glass, are two cross hairs whose positions, in relation to the eyes of the observer, are known. In use, the cross hairs are adjusted so that their points of intersection coincide as vision is focused upon a specific object. This action is accomplished with a screw, while the amount of the inward motion is magnified by connection with a drum having a spiral line, on which the reading is made. The instrument is supplied with a saddle and a metal strip, the one straddling the user's nose as a spectacle bridge, and the other being held between the teeth. Its compactness enables one to carry the instrument in a pocket.

### HEAT REMOVED FROM LIGHT BY AIR CURRENT

By employing two slightly separated lenses, held in individual mountings, and passing an air current between them, a French authority has been able to free the high-power light of projection machines from the intense heat which has been characteristic of it. The draft of air disperses the heat mechanically and does it so completely that the second lens receives practically a cold light. Objects which are highly sensitive to heat can be exposed to the rays without danger of injury. This makes it possible to use a light of sufficient intensity to permit the reflected projection of the images of different objects in an illuminated room. It also enables the substitution, in the motion-picture industry, of paper ribbons for celluloid films.





# The Training of Airmen

by J. G. Gilpatric,

author of *Blues of America*,  
297 Madison Av.,  
N.Y.C.

ALMOST every one has seen an aeroplane in flight, but with the present-day layman, the interest is centered more on the airman than on the machine with which he does his flying. Naturally, the first question is, "How did he learn to fly?"

Of necessity, the pioneers of aviation taught themselves the then difficult and dangerous art, and all the airmen in the world today owe their flying ability to the Wrights, Blériot, and others of the men who went before. There are flying today a number of airmen who entered the game in the early stages, and who, by luck and perseverance, mastered the art with very little outside assistance. These men were without more than a rudimentary idea of the very principles of flight, and later realized the dangers they had undergone; they knew that the average person could scarcely survive a self-administered course in airmanship. Aviation had come to stay, and a number of firms started regular schools in which the knowledge of the earlier experimenters could be disseminated among the ever-growing numbers of enthusiasts.

There are three basic methods of

teaching flying—the so-called French system, the dual-control system, and a combination of the two largely used today for training war pilots. The French system was the first in general use, and consisted in teaching oneself to fly by the constant criticism, advice, and demonstration of a competent pilot instructor. The pupil was given a heavy, low-powered, and worn-out machine incapable of flying—usually called a "taxi"—and was given practice in running the machine on the ground. In this way he accustomed himself to the speed of an aeroplane, the incessant roar of the motor, and the use of the controls. When the pupil could run down the field in a perfectly straight line, and do it consistently, he was given "hops."

"Hops" were made on a machine but slightly better than the taxi, and consisted in making short jumps across the field at a height of four or five feet. This was the most trying part of the entire course, as

at this point smashes were most likely to happen. If the pupil misjudged his height from the ground, or in his enthusiasm tried to stretch his hop into a sustained flight, the ending was usually disastrous. But if he went about mat-



An Old-Time Single-Control Machine Flown by a Pupil Who was Well Advanced in His Course



ters sensibly, he would soon be promoted to "straights," or flights in a straight line, about half a mile long. The usual height in this work was 25 or 30 feet from the ground.

Having mastered straights, the pupil was given a fairly respectable aeroplane, and set to making circles. Flying three or four hundred feet from the ground, the pupil would now consider himself a finished airman. If this misapprehension did not make the pupil reckless, and result in a thoroughly smashed machine, the rest of the course would be easy. His landing practice—derived from his ground work—would now be confined to landing on a mark, or trying to. His air work would extend into figures of eight, descents with the motor shut off, and other maneuvers necessary to ordinary flying.

At every step during the course the instructor would show just what he wanted done, and the pupil could profit vastly by emulating him. Finally, when the pupil was considered competent by the instructor, he was sent up to fly for his aero-club license.

The license tests consist of two series of figures of eight flown around two flags placed about 1,000 feet apart, and of making landings within a radius of 160 ft. of a mark on the ground. During the landings the motor must be shut off and the machine handled without power.

The French system had the advan-

tage of instilling self-confidence in the pupil, as he was always alone in the machine. Its disadvantages were chiefly the length of time necessary, and the cost of such a course. The very fact that the pupil was alone prevented work in any but the finest weather, and for their own protection the schools were forced to charge for breakage of the machines. This latter item some-

times ran as high as \$1,000, besides the usual \$400 for the course itself. Despite the amount of breakage done by careless or headstrong pupils, surprisingly few were injured. From 1912 to 1914 the writer trained nearly 60 pupils by this system without anyone being so much as scratched.

The dual-control system teaches wholly by demonstration and practice in actual air work. A high-powered machine fitted with duplicate controls is used, and the pupil starts by riding with the instructor and watching him

work. By simply resting his hands and feet on the controls, the novice can feel the amount of motion necessary to handle the machine. Gradually, the machine is given over to the pupil—the pilot being ever on the alert to correct his mistakes and to demonstrate new points. As the pupil becomes more and more skillful, the pilot requires harder evolutions.

The writer believes in actually demonstrating every condition that may cause the pupil a smash when he finally flies alone, and the remedies to employ



Photograph of Toronto, Canada, Taken from a Dual-Control Machine Used for Training Airmen for the British Air Service





Typical Class at a Modern Flying School: Young Men Particularly are Attracted by Aviation Because It Combines Sport with Work

should such conditions arise. When this work is done at a sufficient height from the ground, so that there is always room to regain control of the machine, it may be done with perfect safety.

The dual-control system of teaching is somewhat hard on the instructor, as it often necessitates five and six hours in the air every day for weeks at a time. The average time in the air required to train a pupil by this method is 400 minutes, which is divided into flights of 20 minutes each. It is now used in this country by all the government schools and the private firms.

The combination, or English, system consists of equal parts of ground work alone and air work with the instructor. As the pupil becomes more advanced, the ground work is gradually dispensed with and air work—still with the instructor—substituted. Finally the pupil flies alone and after some practice is sent for his license.

Flying is not hard to learn. The essential assets are common sense and patience—nothing else is required. If a man has common sense he will realize how safe flying has become, and he will enjoy a reasonable self-confidence. If he is patient, he will not hurry through his course. A slipshod knowledge of flying is more dangerous than none at all. By taking things easy, a month or six weeks spent at a good

aviation school will make a raw layman into a fairly well-trained flier—and it will give him the best sport of his entire lifetime.

3 5 6 8

#### VACUUM BOTTLE PRINCIPLE USED FOR COFFEESPOT

Designed particularly for the hotel and dining car, but well suited for the home, a vacuum coffeepot, which keeps its contents hot for many hours, is being introduced. Since it is intended for individual service, it is provided in two sizes which hold a trifle more than one and two cupfuls, respectively. The larger pot is about six and a fourth inches in height and, like the other, has a highly polished nickel finish. It is fitted with an all-metal lid which is hinged and ingeniously fitted so that it acts as an airtight stopper and makes the use of a cork unnecessary. The lines of the pot are shapely, and the inner glass lining is protected against breakage.



ⒸThe supports for a recently constructed New Zealand wharf include 20-ton concrete piles 100 ft. long.

ICY-HOT BOTTLE CO.,  
Dept. W.  
CINTI, O.



### SMOKING OUT FUR-BEARING ANIMALS NOW PROFITABLE

An unusual haul was made by a hunter near Waukon, Ia., last season when he shot 16 skunks which were smoked out of a single den. The prac-



View of the Mouth of a Den near Waukon, Iowa, Taken Immediately After 16 Skunks had been Smoked Out and Shot

3285

### CHAIR IN WHICH PATIENTS RELEARN TO WALK

An invalid's wheel chair has been devised for use by persons who have been temporarily disabled and who must learn over again how to walk. The chair consists of a simple wooden frame, about 5 feet long and 18 inches high, mounted on four wire wheels, and

*Sanitarium Equip. Co.,  
Battle Creek, Mich.*



Chair Designed for Convalescents Who must Learn to Walk Again: The Patient can Push Himself About with His Feet or Walk Leaning on the Sides of the Chair

tice of smoking out animals is being revived in many parts of the country because of the increase in the price of furs. A smoker now much used consists of three detachable parts: a bellows, a smoke chamber, and a nozzle. The chamber is partly filled with rags, old burlap, or corncobs, to which is added a little sulphur or cayenne pepper. This is set afire and the smoke blown into the den after all exits and air passages, save the one being guarded, have been tightly closed. Ten or 20 minutes' blowing will drive the animals out, weak and dazed, so that they can be killed or captured easily. To avoid waste and rapid depletion of the fur-bearing animals, hunters should kill only well-furred creatures.

having a cushioned seat at the rear, quite close to the floor. The frame serves as a back and arms for the seat. A patient seated in this chair can either push or pull himself about with his feet, while he grasps the sides with his hands. As he gains strength he can stand between the sides and lean on them as he walks. Practice of this sort is designed eventually to restore to the patient the normal use of his limbs.

### SCENERY LOVER BUYS PEAK AND CUTS TRAIL TO TOP

In order that a picturesque pinnacle overlooking the Columbia River might be preserved, a westerner some time ago purchased it from a contractor who was making preparations to quarry its stone for building purposes. Since then the man has expended \$20,000 in blasting and carving a trail part of the way up the precipitous walls of the peak toward the summit, which is





A View of "Castle Rock," Overlooking the Columbia River, Which Gives One an Idea of the Magnificent Character of the Local Scenery



The Business of Building a Trail to the Summit of the Peak has Not Been a Simple One: The Walls of the Rock Are Upright, and Workmen, to Safeguard against Falling, Fasten Securely Anchored Ropes about Their Waists

about 850 ft. in height. When completed, this path, some four feet in width, will be nearly a mile in length and represent an investment of about \$30,000. It doubles back about 50 times in making the ascent, and at each of these turns is level and 8 ft. wide. At narrow points, reinforced-concrete slabs have been laid to give the path a uniform breadth. The work has been attended with much difficulty and considerable hazard. When the task is finally finished, the trail, from which a magnificent view is afforded, will be open for the public to enjoy without charge.



*Marconi Wireless Telegraph Co. of America*  
*233 Broadway*  
*New York*



Panoramic View of the Mast Line of the New High-Power Radio Station at Koko Head, Hawaii, Which by the Company for Its Employees. Koko Head, an Extinct Volcano, is Shown at the Extreme

## BIG RADIO STATIONS LINK EAST WITH WEST

Within the last few months another important link in the around-the-world chain of high-power wireless plants has been forged. The opening of the new radio station at Funabashi, near Tokyo, has connected the Orient with the Occident and reduced the minimum rate for trans-Pacific commercial communications from \$1.21 a word—the cable charge—to 40 cents. At present the Japanese-United States service is confined to San Francisco, Hawaii, and Japan. The distance between the Golden Gate plant and that at Kahuku, Hawaii, is 2,087 miles, while in jumping from the latter place to the Japanese station the waves travel 4,140 miles.

It probably is unknown to the majority of persons that Hawaii boasts two separate high-power radio plants.

Both are included in the general system, but for the present only one of them is regularly used in the East-and-West service. At Koko Head, about 10 miles from Honolulu, one of these stations is situated. It was originally planned as the receiving station in Hawaii, but is now used only as the demands of service require. Its erection presented several knotty engineering problems, not the least of which was the transportation of materials. The Japanese aerial towers at this station are interesting. The first two are 430 ft. high and of sectional type. From the latter one, the aerial makes a span of 2,000 ft. to the top of Koko Head, an extinct volcano of 1,194-ft. elevation. Sufficient room was not available for a sectional mast there, so a self-supporting tower was erected

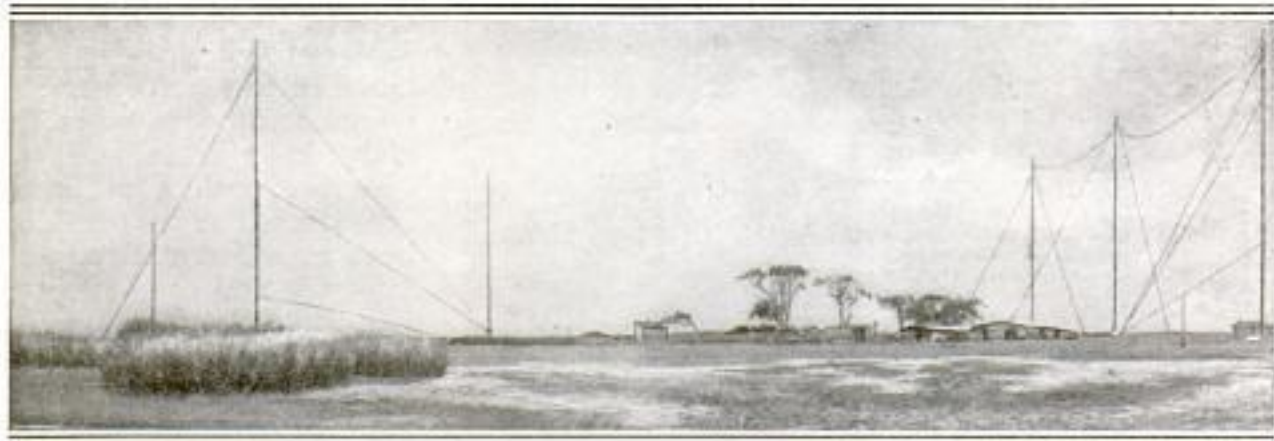

At the Present Time the Wireless Station at Kahuku, Hawaii, Which is Claimed to Be the Largest One in the Japanese and San Francisco Aerials, and the Masts for the Former Each Have a Height of





Is But a Few Miles from Honolulu. The Building Which is Included in the Picture Is a Hotel Erected Right, and on Its Summit, Faintly Visible, Is One of the Towers Supporting the Japanese Aerial

and the anchorage established far down inside the crater. The balancing aerial is on self-supporting towers situated in a pond where it was necessary to sink caissons to establish foundations. The Hawaiian station at Kahuku, the northernmost point of Oahu, is claimed to be the largest wireless plant in operation. It is both a sending and receiving station. Here the San Francisco sending aerial is supported by 12 masts, each 325 ft. in height. The Japanese aerial is also held by a dozen towers, but the height of each is 475 feet.

The idea of circling the globe with wireless plants was evolved about four years ago. It has brought about the erection of the New Jersey stations at New Brunswick and Belmar, which work with corresponding stations in England, and the construction of sending and receiving plants at Bolinas and

Marshall, Calif., which link the Pacific coast with the Koko Head and Kahuku installations and two similar plants to be established at Manila. Stations planned for Marion and Chatham, Mass., are to connect with Stavanger and Naerbo in Norway. The Funabashi station is controlled by the Japanese government and has both civil and military operating staffs.

— 3511 —

### CROCHETED MODEL OF LAWN MOWER SENT TO ATTORNEY

One of the many patent attorneys at Washington was recently the recipient of a most unusual model of a device for which a client sought protection. It was a crocheted reproduction in the miniature of a motor-driven lawn mower invented by a California woman. Being proficient in needlework, but not in drafting, she crocheted a model of

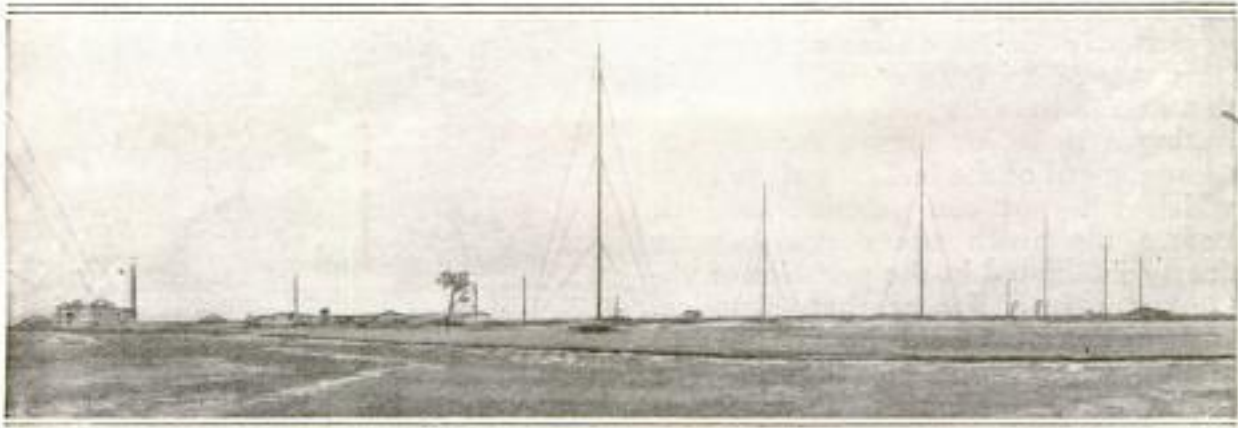

Operation, is Employed Both as a Sending and Receiving Plant. Here 24 Towers are Used in Supporting 475 Feet. This Station Is the Radio Connecting Link between the Orient and the Occident

Mrs. T. H. Pratt  
Vacaville Calif.



The Rosalie Mfg. Co.,  
Lynchburg, Va.

3537

### SHEET-METAL SPLINT NEW FIRST-AID ACCESSORY

Telescoping sheet-metal splints, suited particularly for emergency purposes, have been invented by a Virginia surgeon. They are semicylindrical in shape and provided in three 12-in. sections, the longitudinal edges of which are flanged so that one segment fits into another, and the three, when extended, are held together rigidly. When the separate members are compactly telescoped, a package a foot in length, holding bandages, adhesive tape, pins, scissors, tissue, and other first-aid supplies, is formed. The sections are used according to the conditions presented. One segment, for instance, is sufficient when a fracture of the forearm, head, or ribs is given attention. Two of them, disjointed, are used if a whole arm needs support, while all of them are fitted together to form a splint for a broken leg. Parallel slits in the metal permit strips of

the mower and its propulsion attachment. Every part of the machine was reproduced in her extremely novel piece of needlework, which was subsequently



starched—so that it would have shape as well as the strength to stand alone—and dispatched to the capital. Her work was so well executed that a draftsman experienced no trouble in making detailed drawings of the invention.

— 3569

### BIG GIFT FOR DISCOVERY OF LIGHT AIRSHIP FUEL

A \$10,000 bequest, which at some future time may produce revolutionary changes in the development of aerial navigation, was included in the will of the late Samuel H. Valentine, formerly governor of the Aero Club of America. This veteran aviation enthusiast willed this sum to the club to be used in establishing a prize, or prizes, for the encouragement of the builders of air craft which will not use gasoline as fuel. Before his death the donor became deeply interested in the problem of obtaining a fuel, lighter than gasoline, with which it would be possible to make longer aeroplane flights. The conditions under which the money is to be awarded are left entirely with the Aero Club.



Showing Two Sections of the Metal Splint Applied to a Fractured Arm

bandage to be passed through so that the splint can be securely tied in position.



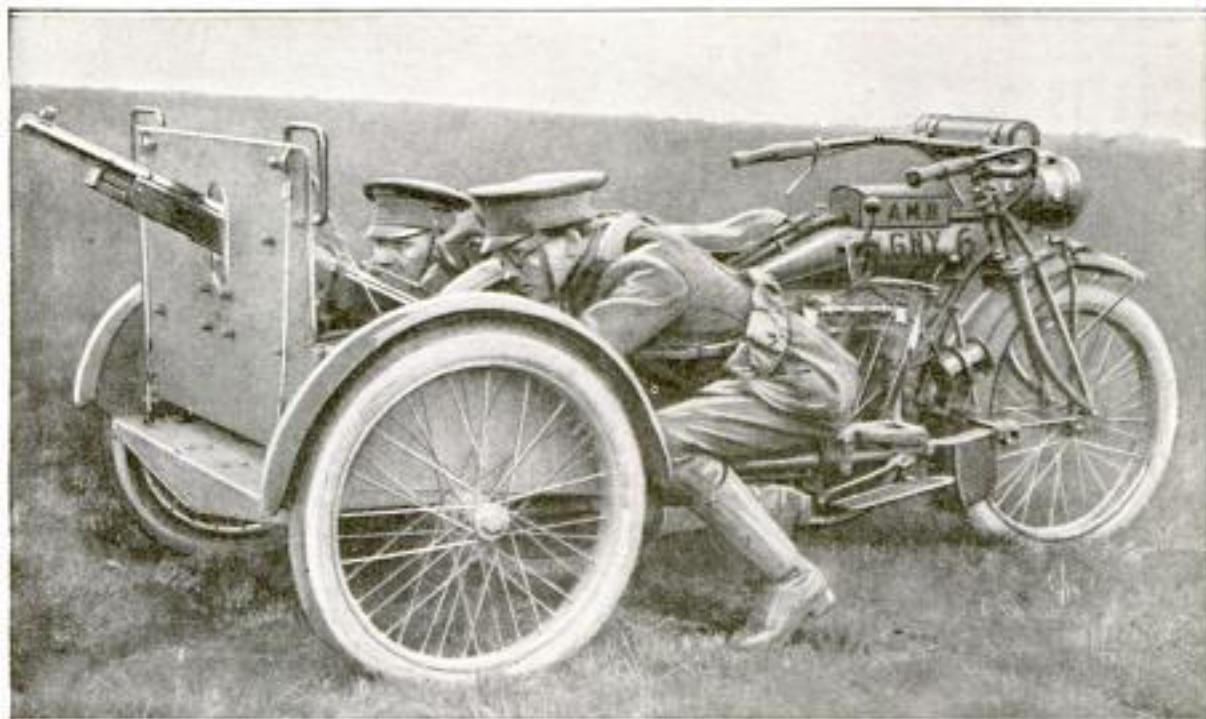

Machine-Gun Outfit Recently Acquired by the First Armored Motor Battery of New York

2778

### MOTORCYCLE GUN CARRIAGE MOUNTS RIFLE AND SHIELD

A motorcycle machine-gun outfit, recently provided the First Armored Motor Battery of New York, has a number of unusual features. The gun carriage is attached as a trailer to a twin-cylinder machine of standard make, and mounts a two-part shield. The latter is so pivoted that the operator is afforded full protection when turning the rifle horizontally. The upper part of the shield is independent of the bottom, and turns with the gun, while the armor is 2 in. thick and will stop rifle bullets at 50 yd. A very simple contrivance holds the gun and shield in place and enables them to be demounted from the carriage in about a half minute. Two legs, hinged to the ends of the bracket which serves as the pivotal mounting for the upper and lower sections of the shield, permit the unit to be used at any angle when placed in firing position on the ground. A solid base for the gun and armor member is formed when the legs are locked. Handles are provided at the top on opposite sides so that two men can carry the unit to a desired place

after removing it from the trailer. Intrenching tools are strapped to the rods connecting the motorcycle and carriage.

3252

### WINDING INDICATOR FOR WATCHES

The tendency to overwind a watch, or on the other hand, not to wind it often enough, has been provided against by a winding indicator with which certain high-grade watches are now being equipped. A dial resembling the second-hand dial, is situated immediately below the figure 12 on these timepieces and is provided with a small hand that slowly revolves to the right or left according as the spring is being wound or unwound, its position indicating how near the watch is to being run down. The device serves as a safeguard against too tight winding.



Joseph Mayer,

Mc Alester, copyrighted material  
1914.



See Mich — 1910 h 331  
 " June — 1911 h 778

3577



26 Crescent Place  
 Wilmette, Ill.

Not Half so Big as Many Private Garages, yet Possessing the Conveniences of a Residence with Five Large Rooms, This Little House is Brimful of Striking Features. Hardly a Square Inch of Its Space is Wasted

### COMPACT BUNGALOW WITH FOLDING ROOMS

*Adam Sut-Hout 2410 Harbraz Av., Evanston, Ill.*

WHEN distinctive qualities embody character and promote comfort, an unusual residence fosters interest. That is the way with a small brick bungalow at Evanston, Ill., a house of swinging walls and disappear-

ing rooms, that has amazed all who have examined it. It is a tiny, sun-flooded "doll's house" with light walls, white woodwork, and attractive, simple hangings.

The bungalow has been erected by a Chicago designer of uncommon dwellings, for the purpose of trying out an idea fundamentally intended for incorporation in city apartments. Its outside dimensions, not including the protuberances, are about 27 by 25 feet. Yet it is a five-room house with a living room, approximately 13 by 25 feet in size; two bedchambers, about 10½ by 14½ feet and 10 by 14½ feet, respectively; a dining room, 10 by 14½ feet, and a kitchen, 7½ by 10½ feet, as well as a toilet room, small hall, one very roomy closet, and a kitchen entryway which accommodates a refrigerator.

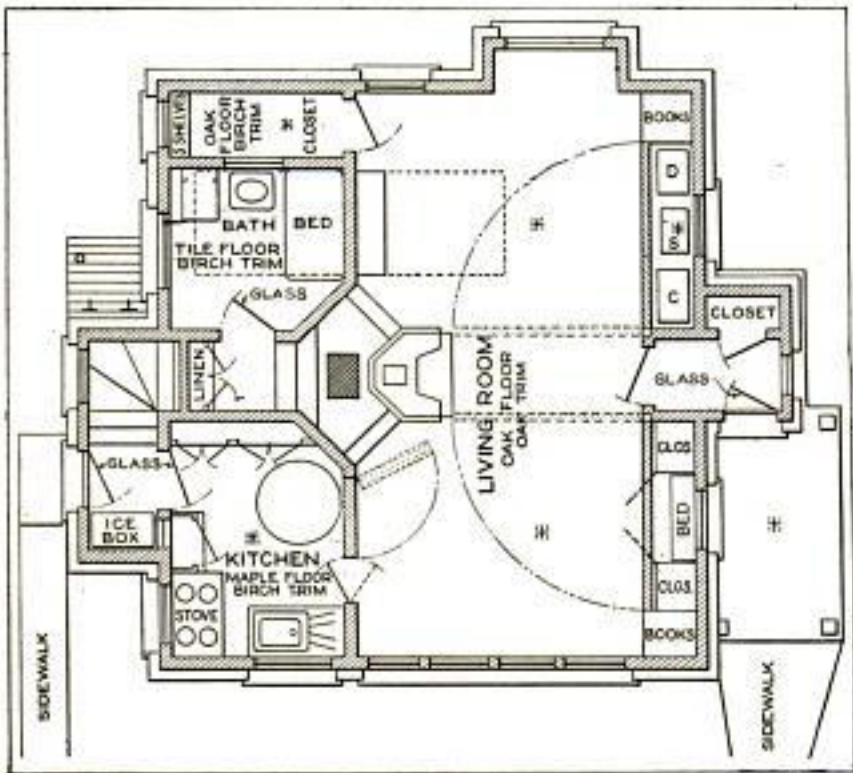

The Arrangement of the Bungalow as Well as an Exposition of the Interesting Ideas It Embodies, are Afforded by the Floor Plan Above



Swinging walls are the secret of all this. The little house is really divided into a living room and kitchen. But only a trifle more time and energy are required in unfolding a fully furnished bedchamber, or a dining room, than attends the opening or closing of a door. The north walls of the living room—which are separated by a doorway opening into a small reception hall—are hung on hinges and supported by heavy

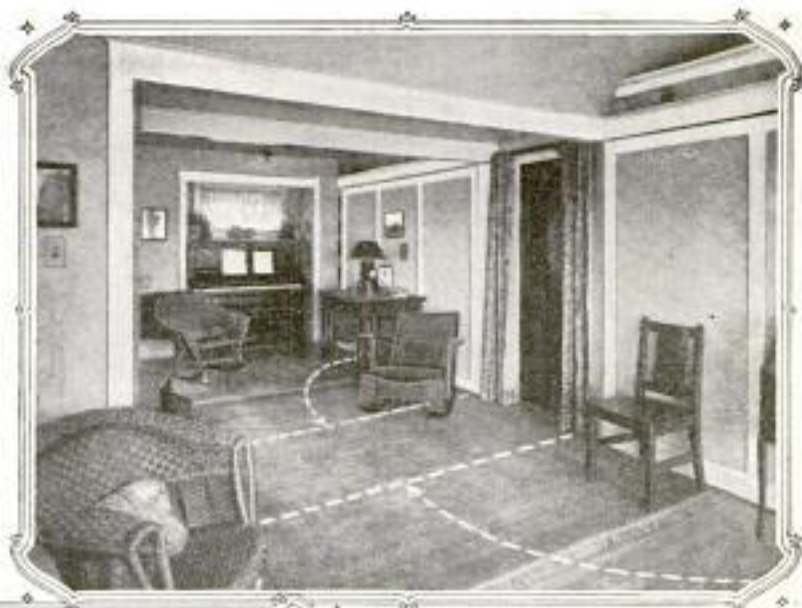

Showing the Full Size of the Living Room. The North Walls—at Right—Swing as Indicated, While Doorway Opens into Small Reception Hall

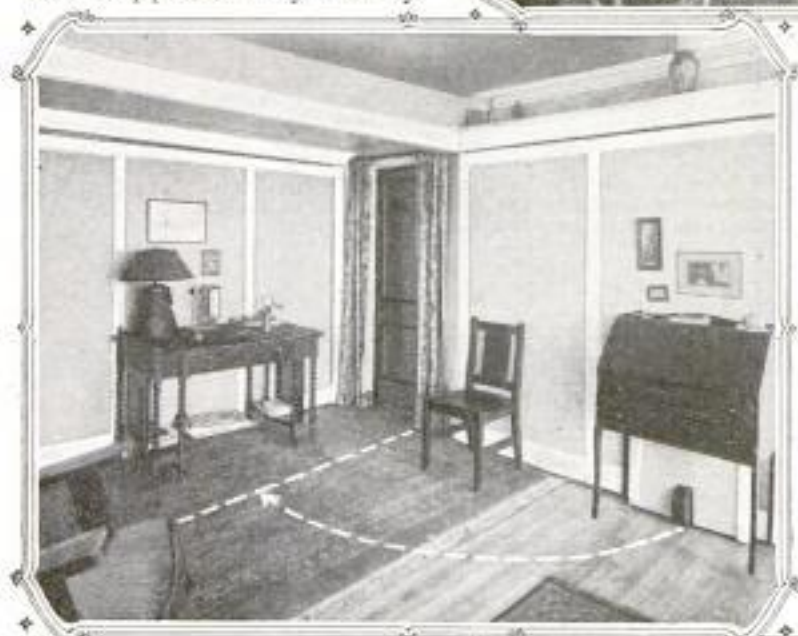

This Is How the Living Room Appears When That Part of It Shown in the Background of the Picture Above is Used as a Bedchamber

and decreases the length of the living room to about 14 feet. A bed, to the foot of which a bench is attached, is then drawn out from the opposite wall. A doorway in one corner gives access to and from the other rooms.

The other—the east—end of the living room is converted into a dining room by a similar operation. When the wall in

ball-bearing rollers. Firmly attached to the wall in the west half of the room, its legs reaching to within a half inch of the floor, is a library table. On the other partition is a writing desk. Concealed behind the former wall are a dresser, chiffonier, and sewing machine. When this wall is swung back to form a bedroom, it fits the beamed opening extending from the hall doorway to the fireplace,

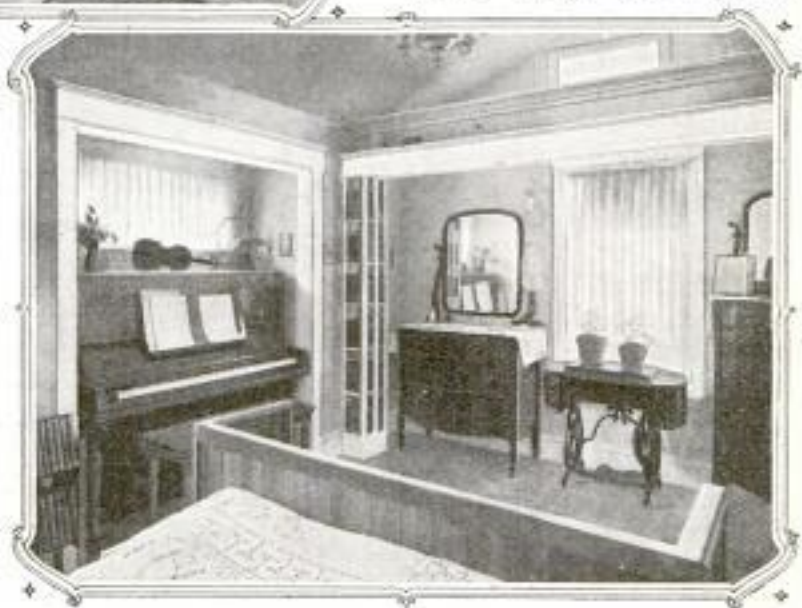

By Opening the Wall and Drawing Out a Settee, This Light, Roomy Bedchamber is Provided. At Other Times Its Furniture is Hidden



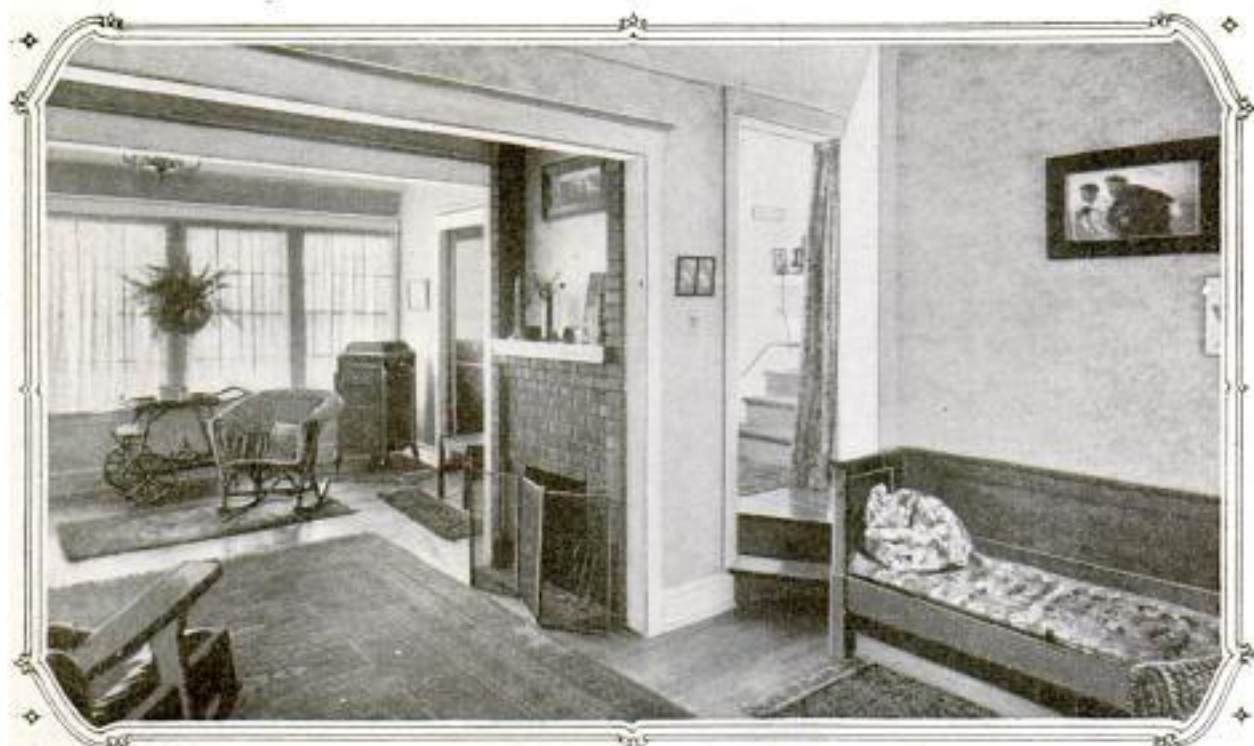

The South Wall and East Exposure of the Living Room: At the Right Is the Settee Attached to One End of the Disappearing Bed. The Doorway Leads to the Bath, While That Adjacent to the Phonograph Opens into the Kitchen

that half of the room is opened back and fastened in place beneath another beam, extending parallel with the first-mentioned one, an attractive built-in china closet is disclosed, and a real dining room provided. Obviously, at such times the west end of the main room becomes the living room. And in this connection it will be observed that the fireplace, library table, and writing desk always appear in the living room, regardless of how the latter is formed. Another hinged wall, this on the south side of what has now become the dining room, permits the dining table to be moved in from

the kitchen. Two glass doors in the middle of the china cabinet disclose a wall bed of full size, when opened. As in the other case, a doorway in one corner gives access to a couple of steps which extend to a landing, whence one reaches the toilet room, which is elevated a few feet, on the other side of

the temporary partition. The ceilings in the living room, on either side of the beams, are vaulted. This gives space for a couple of small windows at the top of the room.

It cost about \$2,200 to erect this house. Application for patents has been made by the architect.

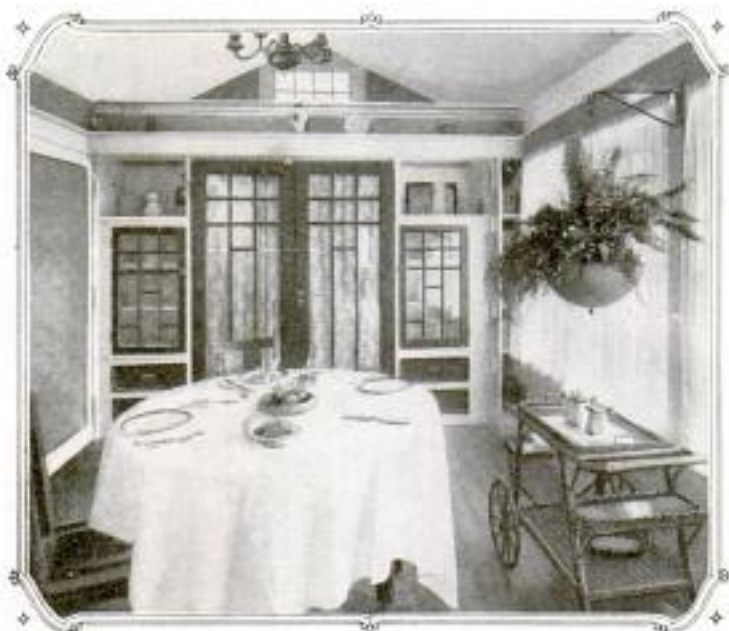

Surprising Dining Room Formed in 10 Seconds by Shutting Off East End of Living Room. Doors in the Middle Hide Another Bed



3532

3624

### KILL RATS UNDER JAIL WITH BOILING WATER

Vast numbers of rats, which have infested the Los Angeles city jail, are believed to have been killed by injecting boiling water into the network of little tunnels which the rodents had made under the building. On one occasion approximately 5,000 gallons of water was drawn from the heating boilers in the basement for this purpose. The unusual procedure was repeated several times. It was the theory of those who worked out this plan that not only would the water scald or drown the animals but they would be satisfactorily buried by the caving in of their passageways.

3496

### HOT COFFEE SERVED ON TRAINS IN PAPER CUPS

The selling of hot coffee in the day coaches of certain trains on the Chicago, Milwaukee, and St. Paul Railway is an innovation which has proven popular with persons taking short trips at night and those who do not care to patronize the diner. The coffee is served from a tray by the news agent, in tall cups of durable paper composition. The cups taper toward the top so that their contents do not spill easily. When they have been used once they are discarded.



Serving Hot Coffee in a Day Coach: An Innovation Recently Introduced on a Western Railway. The Beverage is Contained in Sanitary Paper Cups That are Thrown Away after being Used Once

### LARGE STATUE OF LINCOLN PRESENTED TO OHIO CITY

Within a short time a new full-length statue of Abraham Lincoln will be

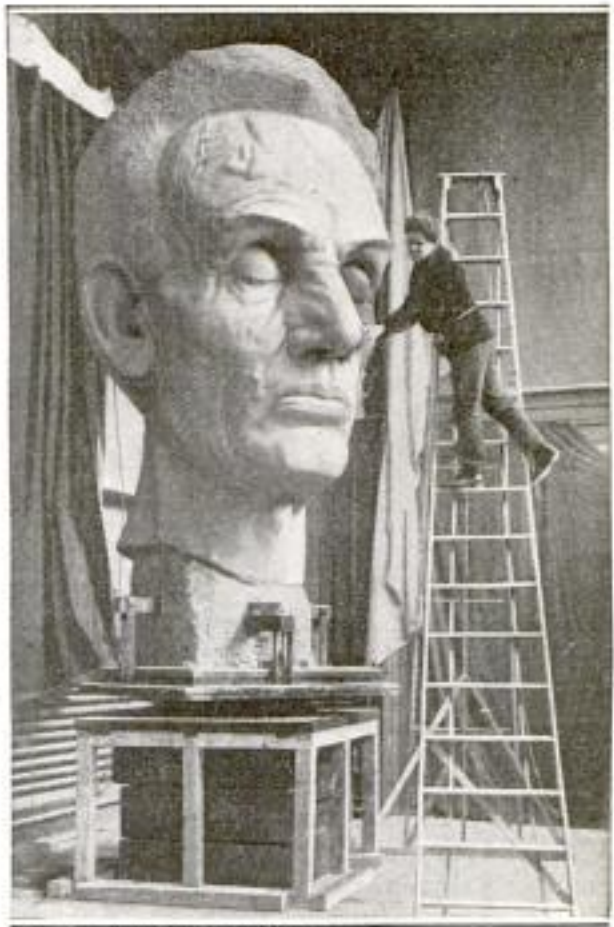

Massive Sculptured Head of New Lincoln Statue Which is to be Erected in a Cincinnati Park

erected in Sinton Park at Cincinnati. It is the work of George Bernhard and a gift to the city by a woman of considerable prominence. The figure is in bronze and is intended to rival the late Augustus Saint-Gaudens' famous conception of the martyred president which was unveiled in Lincoln Park at Chicago about 30 years ago. It is of colossal size and great weight, and is said to be valued at \$100,000.

One of the electric locomotives employed on a section of a western railway which has been electrified, recently made an exceptional run of 339 miles without receiving any special attention en route and at the end of the journey was in condition for the return trip.

*Mr. Bernhard's wife*



### SAFETY-FIRST CALENDAR FOR SCHOOLROOMS

A calendar designed especially for schoolrooms is a feature recently introduced in the safety-first agitation by



A Calendar Which Warns School Children against Trespassing on Railroad Tracks and Gives Some Appalling Accident Statistics

an eastern railroad. It is intended especially to warn children and adults against trespassing. The upper part is occupied by a picture, entitled "The Dangerous Shortcut," and depicts school children crossing a railroad track on which a train is swiftly approaching, when they could have used a near-by bridge. Various safety-first admonitions are printed on the leaves for the various months. Boys are particularly warned against jumping onto moving trains. The calendar also contains some appalling accident statistics.

3546

### NEW TYPE OF RABBIT IN WESTERN KANSAS

From western Kansas comes a report that a new breed of rabbits has appeared in great numbers in several counties. The animals have been called "Bel-rabbits" because it is believed that they are a cross between jack rabbits and Belgian hares. About three years ago two crates containing Belgian hares, which were being shipped to

Colorado, were damaged, and the animals escaped across the Kansas plains. The interbreeding of these creatures with the native rabbits is regarded as the beginning of the new type. The Bel-rabbit is described as being more heavily built than a jack rabbit and hence less fleet, so that occasionally a boy can run one down. As food the animals are very palatable and lack the strong flavor which characterizes the variety native to Kansas. They are fond of many vegetables which jack rabbits do not eat.

3424

### LARGE MEASURING "COMPASS" USED FOR FARM PURPOSES

Few linear-measuring devices are so queer either in appearance or method of use as is a contrivance employed by an Illinois man. It consists of two poles, joined like the legs of a draftsman's compass, and so set that they have a span of 8 ft. 3 in.—one-half rod. For determining distances or computing areas the device is held in both hands and swung so as to describe a continuous series of semicircles; pains, of course, being taken to follow as nearly as possible a straight line. This operation can be performed without difficulty while walking at an easy gait. Although only approximately correct estimates can be made in this way, the results are sufficiently accurate for ordinary purposes on a farm.

Ed. Raabey, R.F. 8, (Ill.)  
Belleville, Mo.

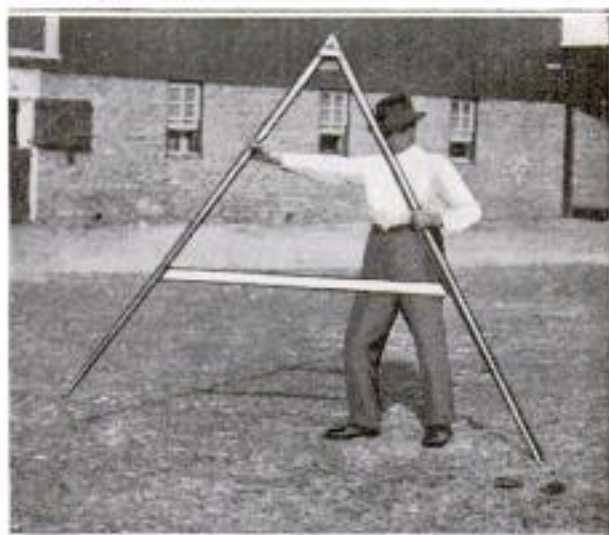

When Only Approximately Correct Results are Needed, This Strange-Looking "Compass" can be Used in Measuring Distances and Estimating Areas

Francis Baxter  
1215 Av. B, East,  
Hutchinson, Kan.



3481 Carl Schön  
109 W. Saratoga St.  
Baltimore, Md.

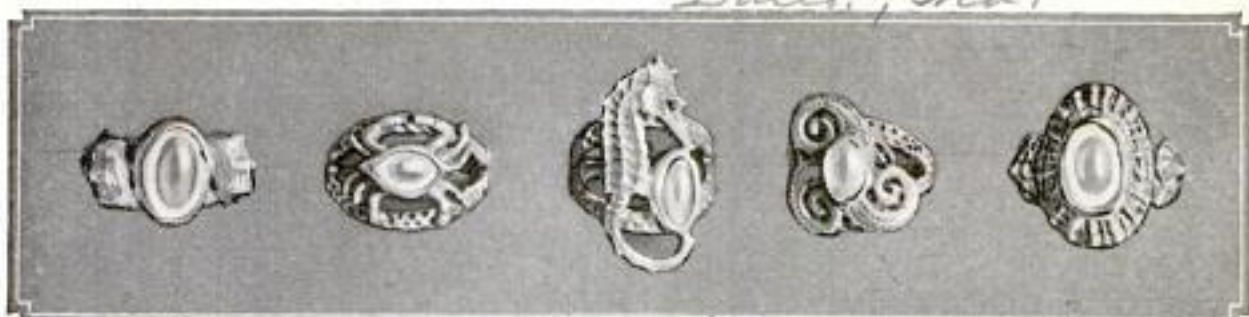

Five Rings in Rare Design: The Mountings are Formed of Silverized Sea Growths, While the Settings Are Submerged Pearls That Appear Convex but Are Really Perfectly Flat

## MARINE DESIGNS IN JEWELRY AND NOVELTIES

By RUTH K. RICE

**I**N the making of artistic novelties, a craftsman of Baltimore uses real shells, coral, or some other product of the sea. Each piece is unique, since nature fashions no two things exactly alike, and each must be constructed as the material at hand allows.

This artist's studio is a most interesting place, for in it are gathered together from all parts of the world many unusual specimens as well as quantities of the well-known varieties of the shell family. Among



A Sea Urchin and a Little Sea Horse, Treated by Electricity to a Bath of Silver, Make This Candlestick

them are marlinespikes from India, mottled brown and cream shells that resemble the sailor's tool of that name. From the Mediterranean come turban shells, marked like a grouse's back. Rainbow-tinted abalone and translucent pearl shells occupy a corner of their own.

There are also tantalizing submerged pearls that appear to be convex and are in reality perfectly flat. These are often set in rings or pins between two tiny snail or clam shells coated with silver. For similar uses are



Left: A Small Loving Cup Made of Two Silvered Urchins and Some Luck-Bringing Sea Horses. Center: A Shell Loving Cup; the Bowl Is a Superb Chambered Nautilus. Right: A Unique Spoon, Having a Pearl-Shell Bowl and a Sea Horse Mounted on a Silvered-Coral Handle



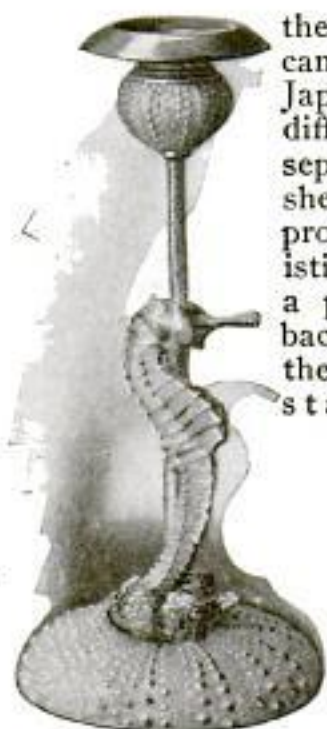

A Candlestick Made of Sea Urchins, a Sea Horse, and Bits of Coral

bunches of cherry blossoms or wistaria, flying birds, or other designs.

As each new article is to be made the possible materials are assembled. These are combined and rearranged until a satisfying result is obtained, which is photographed for a working design. Then silver is deposited by an electrical process wherever it is wanted. Sometimes the entire shell is covered with the metal, without destroying any of the natural markings. Again only a back or a lattice-work of silver is needed to render the article substantial. The union of the parts is also effected by electricity.

The large prickly sea urchins are transformed into sugar bowls or powder boxes. The upper section is sliced off for a cover, to be lifted by a tiny snail shell. Both parts are treated to a bath of silver and given a French-gray finish. Small urchins conceal inkwells or are combined in various ways to

the dainty shell cameos. The clever Japanese utilize each differing tint of the separate layers of shell substance in producing most realistic effects. From a pink or lavender background, about the size of a dime, stand out tiny

make candlesticks. Sometimes a silvered sea horse forms the handle, and again one of these weird beasts reclines against a coral rod that supports a cuplike urchin just the right size to hold a candle.

Loving cups made of shells are most appropriate trophies for yacht races and water sports. A handsome one recently presented was composed of 23 shells. Five large British scallops of pinkish tint surrounded a silver-gilt

bowl that would hold three quarts of liquid. Smaller shells filled the intervening spaces. It rested on a silvered urchin upheld by three polished marlinespikes. The base was another urchin surmounted by a group of rare shells.

But the wonderfully beautiful colorings can only be appreciated when shells are used as shades to conceal electric bulbs. Pieces of pearl shell, cut thin and highly polished, are arranged to simulate the petals of lotus blossoms. One such flower completed by a gracefully arched lily stem of dull silver makes an ornamental



The Lotus Electrolier: The Base is Composed of Three Scallop Shells and Three Marlinespikes, from Which Rises a Gracefully Arched Lily Stem of Dull Silver, Ending in a Single Lotus Blossom with Pearl-Shell Petals



The Back of a Shell Tray: It Has a Lattice-work of Silver to Which are Attached the Silverized Coral Legs



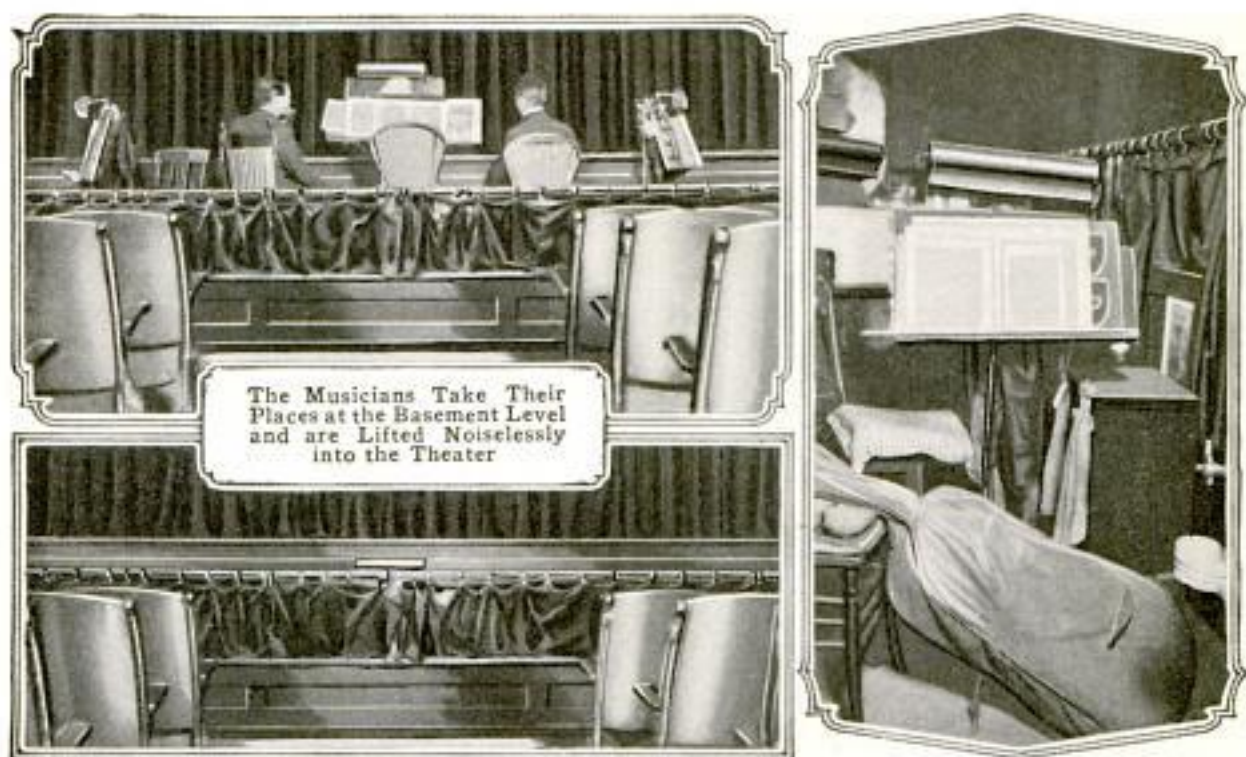

In the Lower Picture the Orchestra Pit has been Dropped from View into the Position Shown at the Right, Where It is Seen About Halfway Down the Shaft

desk light. Several blossoms peeping over the edge of a copper bowl, to be suspended from the ceiling, will brighten a whole room. The artist has also arranged attractive shades of four or six scallop shells. As nature conveniently supplies these in a variety of colors, they can be had to harmonize with the color scheme of almost any room.

### ELEVATOR ORCHESTRA PIT USED IN MOVIE HOUSE

One of Los Angeles' many photoplay houses has lately installed a disappearing orchestra pit which enables the musicians to make their appearance and departure en masse without clambering through the tiny hatch beneath the stage and thereby occasionally distracting an audience. A platform on which a piano, a number of chairs, the music racks, and the traps are arranged in the conventional manner, is raised and lowered by elevator mechanism of the plunger type. The members of the orchestra take their places at the basement level. The machinery does the rest, lifting the platform and its occupants to the curtained-off area in the

auditorium, immediately in front of the stage. The device was installed at a cost of about \$1,500, and the expense of operating it has been found very moderate.

### SIMPLE DEVICE FOR SEALING ENVELOPES

A simple labor-saving device for an office is an envelope sealer which does away with the use of insani-tary sponges, and the like. With it one person can seal as many as 50 let-



ters a minute. The sealer is provided with a handle about the length and diameter of a fountain pen. To this is attached the member that moistens and seals the flap of the envelope, and in it is a narrow slit into which the flap is inserted, where-upon the single operation of drawing it from one end of the envelope to the other, serves to wet the gum and press the moist edge against the body of the letter. There is little in the device to get out of order.

*Baker Iron Works  
Los Angeles*

*Kendall Specialty Co.  
1270 Broadway  
Copyrighted material  
N.Y.C.*



## MEMORIAL SHAFT ERECTED TO UNSUNG HEROES

At the Princes Pier Head in Liverpool, a granite monument has been erected in memory of the valiant deeds of the engine-room heroes of the British navy. In addition to the interest the memorial attracts as a work of art, it is notable for two things. It is one of the very few shafts that have ever been raised anywhere in honor of the many courageous seagoing engineers, mechanics, and coworkers who have stuck to their posts in the face of death and performed their duties

with self-sacrificing patriotism equal to that of any soldier or sailor. The other noteworthy point is that the memorial is the only important English work of its type that has ever been executed solely in granite. It is 48 ft. in height and consists of an obelisk surmounting a heavy base, on two sides of which are sculptured groups representing the different divisions in the personnel of an engine-room staff. The other two sides of the rectangular support carry inscriptions. At the corners of the top part of the base are four figures symbolical of earth, air, fire, and water. Behind these figures and supposedly supported by them is a sea-circumscribed globe, on each side at the back of which a flaming sun is visible. A group of lightly draped feminine figures, holding wreaths, crown the shaft, which at the apex is surmounted by a fiery torch.



COPYRIGHT, STEWART SALE, LIVERPOOL

On Two Sides of the Base Are Sculptured Groups Representing the Different Divisions in the Personnel of an Engine-Room Staff

## 3198 STORAGE-BATTERY TRACTOR TO DISPLACE HAND TRUCKS

A small storage-battery truck is now being made for indoor and platform hauling which greatly reduces the cost of handling freight, or other material, and is designed especially for large manufacturing or wholesale plants. It is used as a tractor



SIR W. GOSCOMBE JOHN, R. A. SCULPTOR

COPYRIGHT, STEWART SALE, LIVERPOOL

This Memorial, the First Important English Work of Its Kind to be Executed Entirely in Granite, has been Raised in Honor of the Engine-Room Heroes of the British Navy



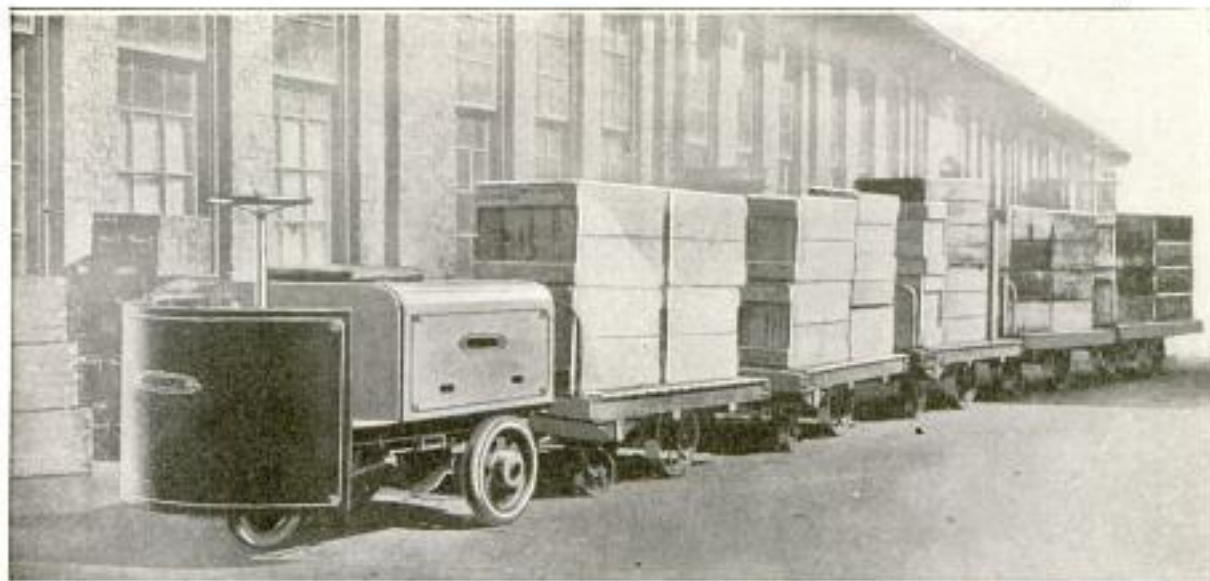

Three-Wheel Storage-Battery Tractor Designed to Haul Trailers in Warehouses, and the Like: With One of These Trains a Few Men can Do Work Which would Require a Large Gang if Hand Trucks were Used

and can draw four or five loaded trailers. The truck has three wheels and is equipped with an automobile steering wheel and a worm-gear drive. Its short turning radius makes it adapted for use on freight-depot platforms and in storerooms where there is limited space in which to move about. A few men and a train, composed of one of these tractors and several trailers, can do the work which otherwise would require a large gang of men using hand trucks. It is claimed that in some cases this storage-battery tractor will pay for itself in a few months.

*Water Tank*  
3/4/3

#### LUMBERMEN'S METHODS USED IN FELLING STANDPIPE

When it became necessary some time ago to remove a 110-ft. standpipe at Hampton, Ia., which for a quarter of a century had served as a reservoir for the municipality's water supply, the task was accomplished in a manner closely similar to the felling of a giant tree. The big steel tank stood in the central part of the city before a public building and immediately adjacent to a street. A safety zone was established, traffic suspended, and the work accomplished quickly. A cable was attached to the upper part of the structure and one side of the foundation removed. A

heavy, steady pull on the steel rope did the work. The tank tilted in the direction the cable was stretched, wavered for a fraction of a second, then crashed with a resounding roar into the street,



After One Side of the Foundation had been Removed, a Steady Pull on a Cable Attached near the Top of the Structure Caused the 110-Foot Standpipe to Crash into the Street

almost exactly in the position that had been contemplated. The work was witnessed by a large crowd of onlookers that jammed the near-by streets.



### NEW VOTING MACHINE USED IN CLASS ELECTION

When the students of an Ohio college voted recently for class officers,

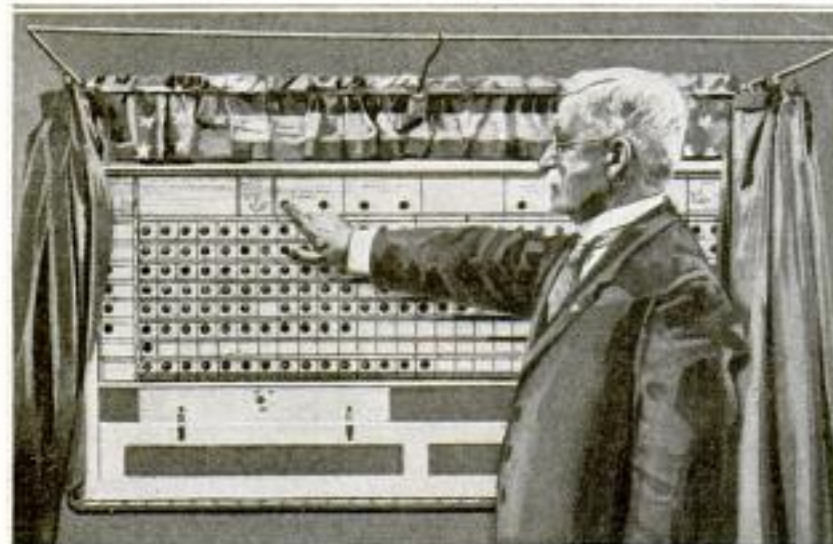

Australian-Ballot Voting Machine, the Invention of an Ohioan, Recently Used by College Students to Elect Class Officers

their ballots were recorded and counted by a voting machine of new design. Two students had charge of the ma-

chine and reported the result of the election within three minutes after the polls were closed. The new machine, which has been patented, is the fourth model made by the inventor, who has been working on the problem for 15 years. It is constructed entirely of light material, almost all aluminum, and is housed in an aluminum case, 2 ft. high, 10 in. deep, and from 4 ft. long to any greater length required by the ballot. In operation, an official ballot is fastened on the face of the machine, within a booth, the ballot being perforated to fit over push buttons which appear above the names of the candidates. The voter casts

his ballot by pushing the buttons of his choice and the mechanism does the rest.

3093

### WATER MAINS OF WOOD PLACED OVERHEAD

A strange example of waterworks engineering is to be found in central

is conveyed from an elevated storage reservoir to various parts of the city through square wooden pipes which serve as water mains. Instead of laying these in or on the ground, they are elevated above the streets in many places, so that pedestrians, animals, and even the street cars, which are not large, can pass under them. Another unusual feature of this water system is that these pipes pass right through houses and places of business in a seemingly very hit-or-miss fashion. It is said that the inhabitants were so glad to have the water brought to them that they were willing to put up with the inconvenience of the pipes.

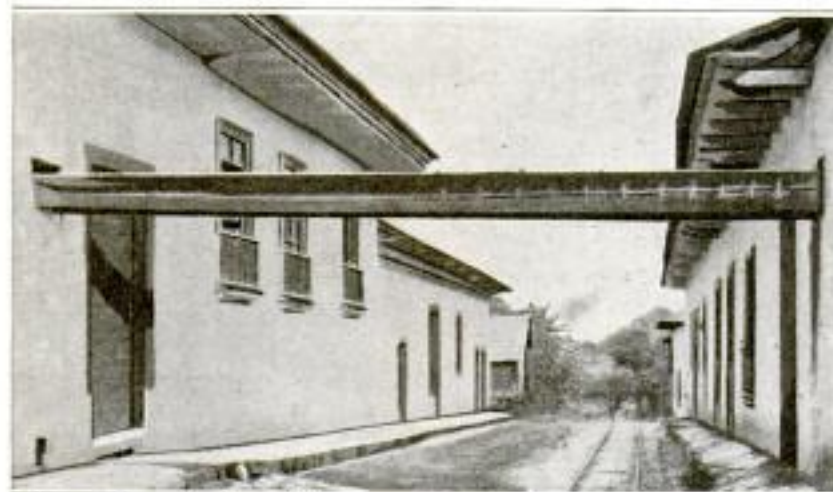

Street Scene in City of Uruapan, Mexico, Showing Square Wooden Water Main Which is Raised Several Feet above Ground and Penetrates the Houses on Either Side of the Thoroughfare

Mexico in the picturesque city of Uruapan, state of Michoacan. Water



3439

Football

## SETTING THE STAGE FOR ARMY AND NAVY GAME

U. S. U. 417 5th Av. N.Y.C.



Plowing through New York Harbor past the Statue of Liberty, the Advance Guard of the Atlantic Fleet Coming In for the Big Event, the Annual Army and Navy Football Game: Following the "New York," Which Heads the Procession, Are the "Texas," "Oklahoma," "Connecticut," "Florida," "Utah," and "Wyoming"

One of the Time-Honored Ceremonies Observed Before the Whistle is Blown for the Kick-Off: The Firing of the Salute. Here, before a Throng of 50,000 Expectant Rooters, All is Ready for the Cannon to Speak



Future Officers of the United States Army, West Point Cadets, at the Polo Ground, before the Opening of the Hard-Fought Gridiron Battle with the Middies from Annapolis, Who Went Down to Defeat after Putting Up a Sporty, Determined Fight for the Honors of the Day



*Frank H. Woodward,*  
*90 Chalmers Motor Car Co.,*  
 216 3405 **POPULAR MECHANICS**  
*Los Angeles.*

**CAR'S FUEL CONSUMPTION  
 SHOWN BY SPECIAL GAUGE**

In view of the high price of gasoline the amount of fuel which an automobile consumes is becoming an increasingly important consideration in the purchase of a car.



Accordingly an automobile salesman in Los Angeles has constructed a device which enables him to show conclusively just the amount of fuel his car will use in a given distance. It consists of a 1/2-gal. gasoline tank

and a glass gauge which are attached near the windshield, in full view of the passengers, and connected with the carburetor into which the fuel feeds directly. The salesman claims that the make of car he sells will travel 18 miles on a gallon of gasoline. To prove this he has marked off the gauge into nine equal parts, each equivalent to a mile of travel, according to his claim. By comparing the gauge with the distance covered, anyone can ascertain if the fuel consumption of the car is as stated.

*3450* *motorcycle*

**AIRMEN NOW HAVE SUPPORT  
 OF MOTORCYCLE CORPS**

Fourteen high-powered motorcycles, each with sidecar equipment, have been purchased by the War Department to form an auxiliary arm of the aviation corps. Among other uses, they are employed to transport mechanics quickly to different points when aeroplanes, because of mechanical trouble, have to make forced landings. They are also used for rushing supplies relatively short distances. Each ma-

*INDIAN*

chine is enameled an olive-drab color of somewhat lighter shade than other cycles in the army service, and bears the insignia of the aviation section. They have been assigned to the fliers now at the Mexican border.

*3330*  
**TYPEWRITER MARKS BOXES  
 OR PACKAGES**

A typewriter of new design for marking or addressing packages and boxes by writing directly upon them, and also for printing bulletins or show cards in various sizes of type, has been produced by an Indiana inventor. The platen furnished with the machine has a flat surface and is mounted detachably behind a type wheel carrying both upper and lower-case letters and operated by a set of keys similar to those of the standard keyboard. The flat platen comprises an arrangement for holding and moving paper or cardboard to be written on, and also for line spacing. When a package or box is to be addressed or marked, the regular platen is removed from its supporting platform, which resembles a camera stand, and the package or box is set in its place, being raised sufficiently by a foot lever to bring that portion on which it is desired to write into the proper position behind the type wheel. By the use of wheels of different sizes, which the design permits, it is possible to write in characters varying greatly in size and style.

*\*Omar M. Highley*  
*Converse*  
*Incl.*

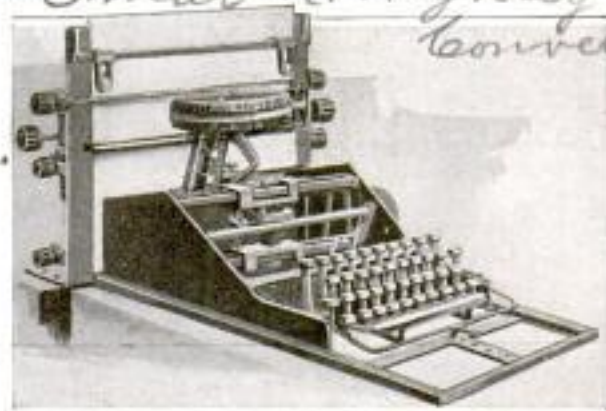

Boxes and Packages may be Marked or Addressed by Writing Directly on Them with This New Typewriter: The Surface to be Written On is Placed behind the Type Wheel in the Position Occupied by the Removable Platen Seen in the Photograph

*Hesler Mfg Co.*  
*Springfield Mass*



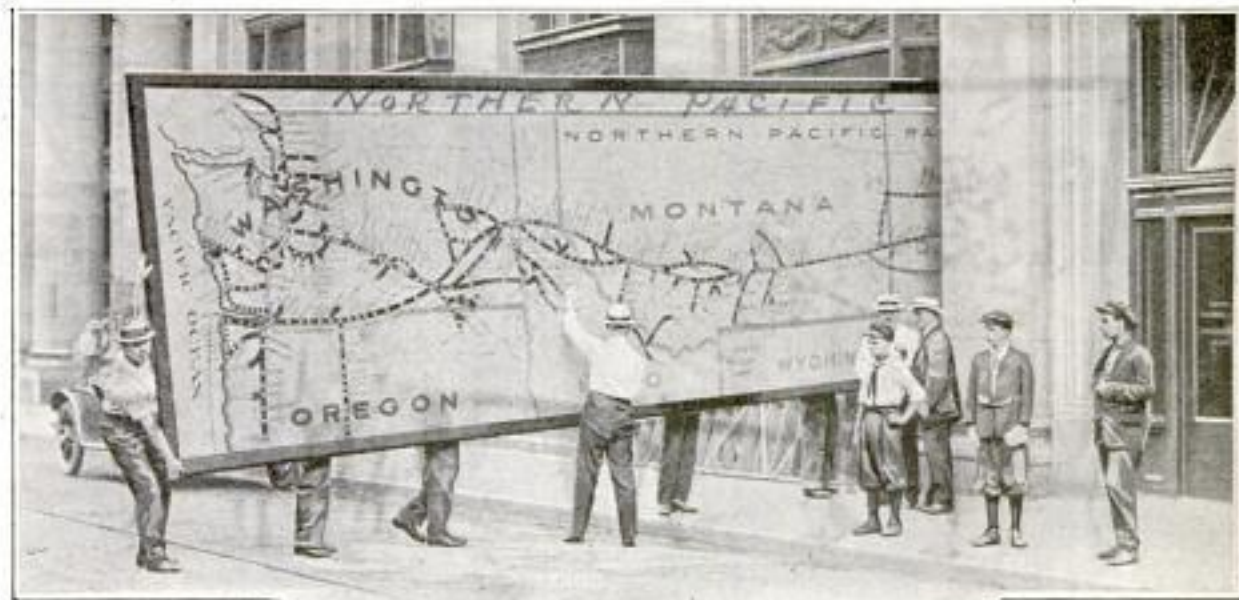

One End of a Big Map of the States of the Northwest, Which has been Installed in the Immigration Department of the Northern Pacific Railway Offices at St. Paul

### RAILWAY MAP SIXTY-NINE FEET LONG

A railway map of enormous size was recently installed in the immigration department of the Northern Pacific Railway offices in St. Paul. It measures 69 ft. long and 11 ft. wide and required the services of nearly a dozen men to carry it. The map shows that portion of the United States between the eastern boundary of Minnesota and the Pacific coast, and the entire Northern Pacific Railway system, including practically every station on the line. The whole representation is done on such a large scale that even the lettering used in the names of the smallest towns can be easily read several feet away.

### TRAIL-MEASURING WHEEL USED BY FORESTERS

A front bicycle wheel, equipped with a suitable handle and a cyclometer, is now employed in a number of the national forests of the West in measuring trails. There are about 22,000 miles of trails, old and new, in these reserved areas, and it is the aim of the Forest Service to measure many of them and mark them with mileposts and other signs. The cyclometer registers miles

and tenths of a mile. The wheel is fitted with a cushion tire so there is no danger of punctures. One ranger pushing this simple outfit through the forest can measure more trail in a day than two men with a surveyor's chain.



A Bicycle Wheel Equipped with a Handle and Cyclometer, with Which a Forest Ranger can Measure More Trail in the Same Time, than Two Men with a Chain, and can Do It More Accurately

# A. G. Jackson #18-1-1918

Wldo., Portland, Oregon.



### POLICE USE CORRIDOR AS REVOLVER RANGE

A long basement corridor, bounded on either side by brick walls, has been



Basement Corridor Fitted Up as a Revolver Range, at a Cost of \$35, by the Police Department of Salem, Massachusetts

fitted up at small expense by the police department of Salem, Mass., as a revolver range. The total cost of making the alteration was but \$35. Because of its convenient location the members of the force have found it easy to keep up their revolver practice. The target end of the corridor was covered with sheet iron over which planks were placed to prevent the bullets from rebounding. The lights were protected with sheet iron also. A plain wooden counter serves to hold the revolvers when they are not in use. When a marksman desires to inspect the target closely it can be drawn nearer on a wire which is stretched from one end of the gallery to the other. The use of this corridor suggests the possibility of similar improvements in other police stations.

### HARVEST SWEET-CLOVER

#### SEED FOR USE IN WEST

CHICAGO TRIBUNE 10-7-16

About 200 bushels of sweet-clover seed were obtained last fall by threshing great quantities of sweet clover which grew on the clay banks of the Chicago drainage canal. This seed is to be used for experimental purposes in an attempt to revitalize the soil of large western tracts used for grazing. It is now generally recognized that sweet clover has nutritive value comparable to that of clover and alfalfa and that animals develop a keen appetite for it. It will thrive in many places where neither alfalfa nor clover will grow. The hope is that by planting the sweet clover on western cattle ranges, their value as pasture land can be greatly increased. In addition to being a good forage crop this plant has blossoms which afford an abundant supply of honey for bees.

3381 - *at Missouri*

### HOUSE IS BUILT OF STRAW

#### BY WESTERN FARMER

*Elmer Kaville*

Bales of cement-covered straw were used some time ago by a Logan County, Colorado, farmer in constructing the walls of a six-room dwelling. The house is 48 by 18 ft. in size and has the exterior appearance of a concrete structure. The bales were laid in the same way as if they were stone blocks, and then cemented over, inside and out, pebbles being added with the final exterior coat. A sufficient number of windows for adequate light and ventilation were fitted in the thick walls and a shingle roof raised. Also the inside walls and the ceilings were plastered. Although crude and somewhat reminiscent of the old sod houses of the Kansas plains, it serves its purpose and is a warm, dry shelter which, if left undisturbed, may stand for years. It cost only \$270, exclusive of the labor.

Hereafter the Naval Radio Service will be known as the Naval Communication Service.



Wm. A. Sloan,  
So. Pasadena,  
3030 Calif.

**DRUG THIEF IS CAPTURED BY  
ELECTRIC TRAP**

Becoming aware of the fact that some habitual drug user was systematically helping himself to morphine tablets kept on a shelf in the prescription department of his store, a pharmacist at South Pasadena, Calif., realized that he might find it difficult to explain the discrepancy in his records to the satisfaction of the authorities. Therefore, instead of concealing all the bottles of the drug so that they could not be found by outsiders, he constructed an electric trap. He did this by devising a spring switch on which he placed one vial holding a dram of morphine. The other bottles were hidden. The switch was connected with an electric buzzer and so arranged that when the bottle was lifted the circuit would be closed. The scheme worked perfectly. While attending to the wants of a customer shortly after

the trap had been set, the druggist's apprentice heard the buzzer. Stepping quietly to the prescription room he found a well-dressed young man of a prominent family with the morphine bottle in his hands. Since the youth



Devising a Simple Electric Trap, a Pharmacist at South Pasadena, California, Easily Caught a Drug User Who had been Systematically Stealing Morphine Tablets from the Shelves in the Prescription Department

was well known and considered beyond reproach, it had been an easy matter for him to stroll back of the partition and reach the vials on the prescription shelves without exciting suspicion or attracting particular notice.

3345 # Railway Review 9-30-1916

**GREAT POWER PROJECT FOR BIG HORN CANON**

*Big Horn Canyon Irrigation & Power Co., Hardin Mont.*

When a settler in the Big Horn Valley of Montana a few years ago dreamed of harnessing the turbulent waters of the Big Horn near the point where they break from a mighty cañon into the broad valley, so as to convert their power to the use of man, his dream was ridiculed in the locality as a fantasy and its realization counted among the impossible. Today the project of that dream is under way, and the building of a huge dam, 480 ft. high, in a narrow gorge of the Big Horn Cañon is promoted with great activity by a power and irrigation company having headquarters at Hardin,

Mont., with the dreamy but practical and far-sighted settler at its head.

The enterprise includes a hydroelectric plant of large output, estimated at not less than 217,500 hp.; the irrigation of approximately 100,000 acres of fertile, high-level bench lands, now without water, and the construction of a railway, 68 miles in length, which has been located from Hardin south to the dam site and north to a point near Custer, on the Northern Pacific. The southern part of the line will be used for hauling materials for construction of the dam and power plant.

Big Horn Cañon is a natural won-



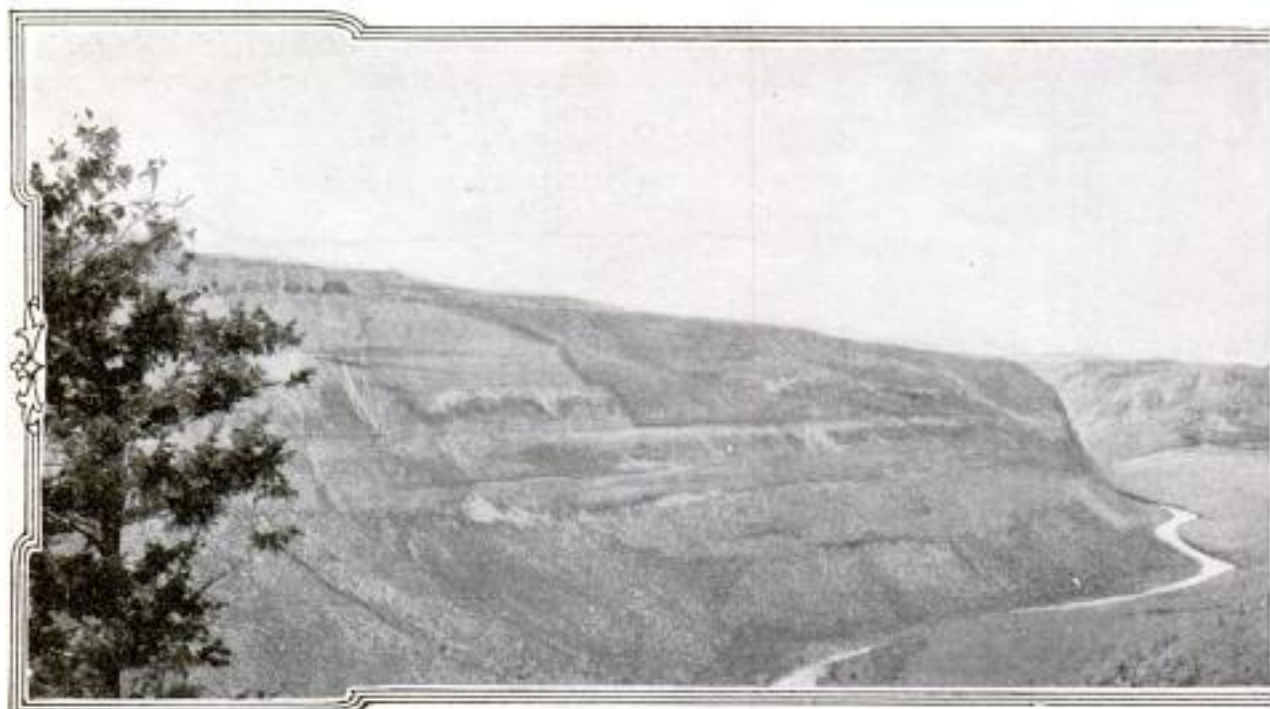

View to the Eastward from the Rim of the Big Horn Cañon, Montana, Showing Six Miles of the Apparently in the Distance. Few Men have Navigated the River,

der—a chasm 1,000 to 3,000 ft. in depth, cut in solid rock by the rushing Big Horn River. Its length, following the river, is 49.7 miles. For much of this

distance the cañon walls stand vertical, and in some places they actually overhang the river. It is a true box cañon, with miles of the most beautiful cañon

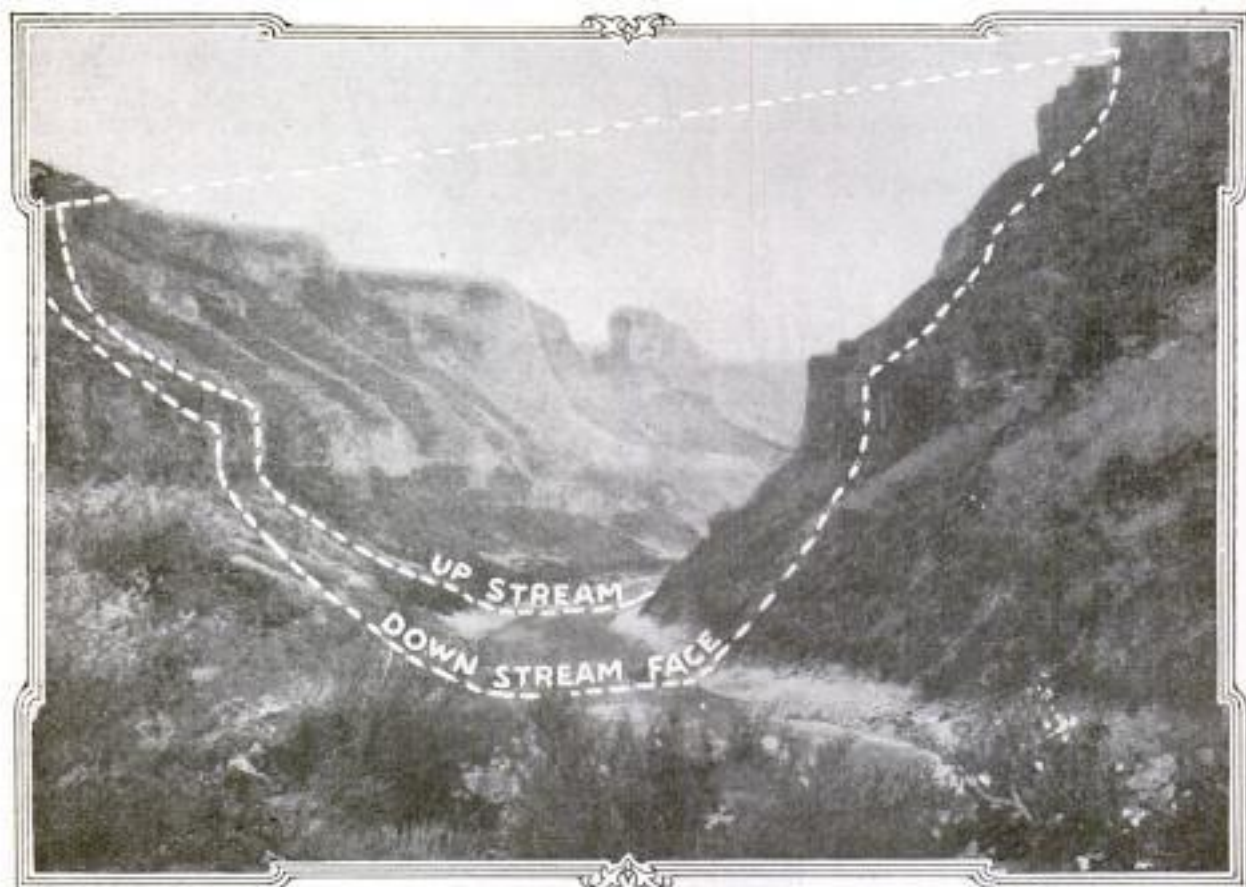

This Shows the Site of the Proposed Dam across the Big Horn Cañon, Looking Upstream: The Length of the Crest, as Indicated by the White Dotted Horizontal Line, will Be 1,300 Feet

PHOTOS BY A. L. SLIVEN





Peaceful, but Really Turbulent, River and Eight Miles of the Cañon. Bull Elk Cañon is Seen to the Right but It Is Soon to be Harassed for Man's Use

scenery in America. Surveys for the dam and railway project have been difficult, as few white men have ever made the entire trip through the cañon,

and a trail had to be cut, in some places with great labor, for a distance of 22 miles, where the rapids of the Big Horn River are most dangerous.



Horseshoe Bend, One of Nature's Many Marvels in the Cañon of the Big Horn: The River Is 200 Feet Wide at This Point and the Photo was Taken from an Elevation of 3,000 Feet above the River



The site selected for the big dam is a point five-eighths of a mile from the lower end of the cañon. Here the river flows between towering cliffs of limestone rock, rising one after another to a total height of about 900 feet. The top of the dam will reach a point about halfway up the higher rows of cliffs; the length of its crest will be 1,300 ft. At low-water stage the river at the dam site is 100 ft. wide and 15 ft. deep. The dam contemplated, according to the Railway Review, will be of the circular-arched gravity type, 716-ft. radius, built of solid rubble concrete. The thickness at the bottom will be 322.8 ft. and the estimate of material required to construct it is 1,480,000 cu. yd. of concrete. In height, 480 ft., it will be the greatest in the world. Solid foundation is easily reached in the rock under the channel, however, and the

engineering problems of construction are said to be simple.

The reservoir formed by the project will extend the whole length of the Big Horn Cañon above the dam and seven miles beyond. The storage capacity, to a level 435 ft. above low water, has been computed at 36,143,749,280 cu. ft. The power plant is expected to develop 217,500 hp., figured at 80 per cent efficiency at the turbines and a load factor of 50 per cent; while for eight months of the year this output probably could be doubled. The cost of the dam, including that of the railway from Hardin to the site, a distance of 37 miles, is estimated at \$12,107,000. The power developed is expected to be used by railroads after electrification, as well as by neighboring towns and rural districts for electric-light and other purposes.

3206

### NEW JERSEY POSTMASTER'S FISHING PLATFORM

*Am. Press & Sun*

When time hangs heavily on the hands of a certain postmaster in New



New Jersey Postmaster's Private Fishing Platform in Rear of the Post Office, from Which He Catches Eels When Business is Slack

Jersey, whose store and post-office building stand on the high bank of a fishing stream, he manages to make the moments pass very agreeably by casting a line into the Peckham River from a little platform which he has built at the rear of the post office. From this point of vantage he is able to return immediately to his postal duties whenever a resident calls for his mail or for stamps, while when trade is slack he can catch in comfort the eels with which the river abounds. It is said locally that there will be numerous applicants for this postmaster's job whenever a vacancy occurs, but the present incumbent asserts that so long as the fishing is good he will continue to handle the mail.

*Billade 2876*

### HOUSE OF PUEBLO STYLE BUILT ON STEEP SLOPE

A dwelling, which almost seems to hang on the side of a steep cliff, is an unusual architectural feature found not far from San Francisco. The west front of this peculiar house faces a street which is nearly 100 ft. higher than the street on which the east front faces. For a dwelling of the ordinary type

*# Monroe Woolley  
2306 Union St. Apr. 6,  
San Francisco,*



A View of the West Front of an Unusual House is Shown on the Right, Facing a Roadway Nearly 100 Feet Higher than the Street on Which the East Front Faces. The East Side is Shown Below

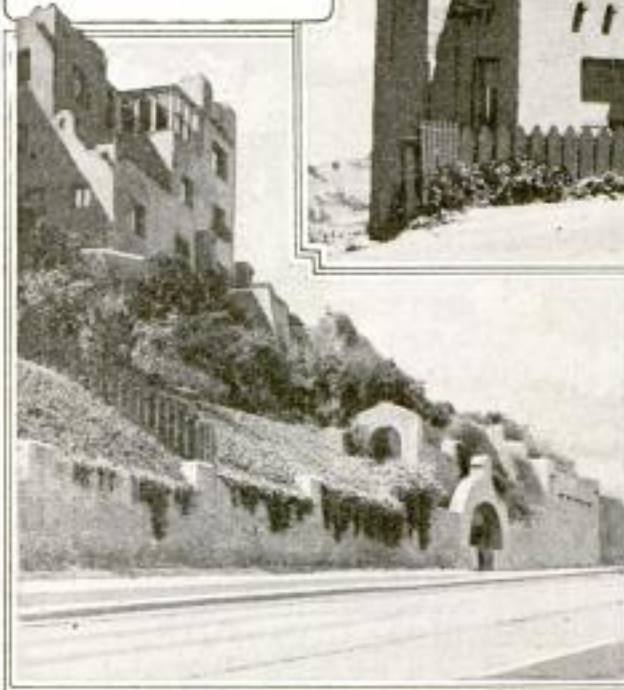

There Is Little in This View of the Residence, Which One Gains from the Upper Roadway, to Suggest That It is Built So as to Face Both a High and a Low Level

this almost perpendicular lot would be practically valueless, but in this case the architect has skillfully adapted the now popular Pueblo Indian style of architecture to the precipitous cliff and has produced a pleasing effect. The materials used are stucco and concrete. From the upper windows a magnificent panoramic view is obtained of the greater part of San Francisco, the bay, the cities across the bay, and the mountain range beyond. On the lower side retaining walls and shrubbery have been employed to good advantage to break the abrupt aspect of the slope. Steps mount to the entrance on this side, by easy inclines.

### 3391 — GATE DESIGNED TO GUARD DRAWBRIDGE APPROACHES

A model of a gate, designed especially to guard approaches to drawbridges when the latter are open, was exhibited in Boston recently, soon after a carload of people were plunged to their death because an open bridge had been left unguarded. The gate

is strongly made and is hinged to a heavy post. At the swinging end is a cable used in locking it across the car track. The cable is fastened to a series of bolts beneath the pavement in such a way that when a car strikes the gate the impact, if violent, will break one after another of these bolts and gradually bring the car to a stop. For a swiftly moving conveyance of any kind to strike an immovable barrier would be sure to result in an accident, but with this arrangement the violence of a shock is lessened by means of the bolts.

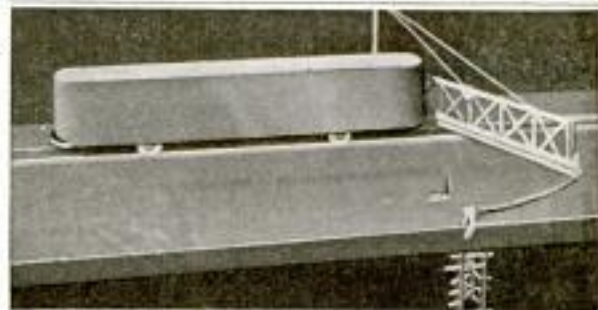

Model of Gate to Guard the Approach to a Drawbridge: When the Gate is Closed It is Fastened to a Series of Bolts beneath the Pavement in Such a Way That a Car Striking It is Brought to a Gradual Stop

# Geo. A. Walton Co. The Post, 259 Wash'n St., Boston.



### UNUSUAL VIEW OF GREAT CANTILEVER BRIDGE

The accompanying illustration gives an unusual view of a portion of the great Queensboro bridge in New York



An Unusual Photograph of the Queensboro Bridge, New York City, Which Suggests the Bigness of the Structure in a Striking Way

City, and conveys to one, better than many more conventional photographs, a sense of the magnitude of this engineering feat. It shows clearly the double-deck construction of the bridge. From the rail at the left one can look down on the trolley track and through its openwork floor are visible, far below, the ground, and the waters of the East River. Above the rail rise the great steel beams of the cantilever framework.

At the request of the Canal Zone authorities the Bureau of Fisheries, by way of experiment, has stocked Gatun Lake with several hundred black bass, rock bass, catfish, and sunfish. If the fish thrive, doubtless many more will be added.

### COIN-OPERATED SODA FOUNTAIN

#### 2171 FOUNTAIN

An automatic soda fountain has been patented by a resident of Houston, Tex., which is operated merely by dropping the proper coin into a slot. Contained in an attractive wooden cabinet are three tanks, one filled with sirup, another with carbonic-acid gas, and a third, which is surrounded with ice, is filled with water. There is also a container filled with paraffined cups. When a coin is dropped into the slot it releases three delicately balanced levers, one after the other. The first allows a cup to drop from the container into an opening, where it is within reach of the customer, and beneath two spouts. When the coin passes the next lever it releases a spring-operated apparatus that allows the proper amount of sirup to flow down into the cup. The third lever operates in the same manner as the second and allows a little less than a cupful of iced carbonated water to flow into the cup. In this way

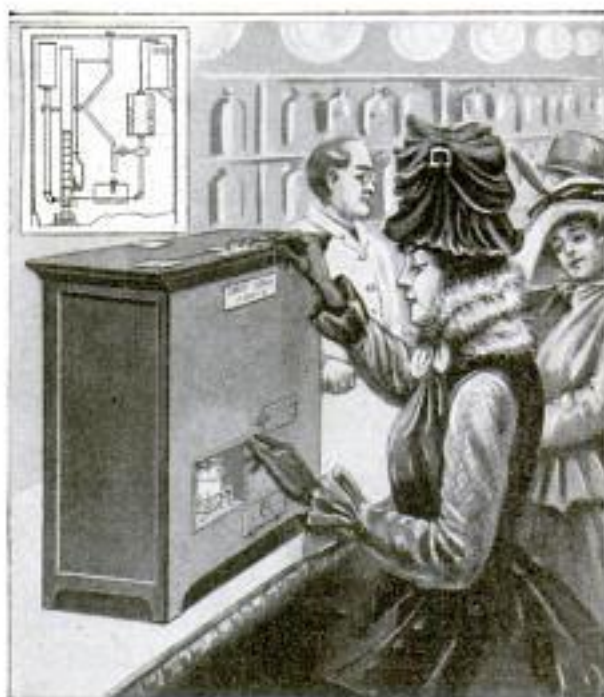

Coin-Operated Soda Fountain Which Automatically Mixes Soda Water in a Sanitary Cup and Places It within Reach of the Customer

the drink is properly mixed in a sanitary way and supplied to the customer without human aid.

Vertical handwritten text on the right margin: "911 Main St. Houston, Tex." and "1134 7/11 May 18-1915" and "1944-27".



## PRICE LIST

PRECISION KEY MACHINE (including one bevel edge cutter and one 18 gauge square edge cutter with corresponding guide discs) complete with hand crank.....\$20.00

Combination hand crank and power wheel, instead of simple hand crank, supplied on request without extra charge.

Weight packed for shipment 15 lbs.

---

Extra bevel edge cutter (for all pin-cylinder-lock keys) ..\$2.00

Extra bevel edge guide disc.....25c.

Extra square edge cutter (any thickness from 14 gauge to 20 gauge). For all cabinet-lock keys, or keys with square notches.....\$1.00

Extra square edge guide disc (any thickness from 14 gauge to 20 gauge).....15c.

Complete set square edge cutters, with corresponding guide discs, consisting of 6 square edge cutters and discs, 14 gauge, 15 gauge, 16 gauge, 17 gauge, 19 gauge and 20 gauge. (18 gauge cutter and disc come with the machine).....\$6.00

Extra hand crank.....\$1.00

Extra combination hand crank and power wheel.....\$1.00

### WARRANTY

Every PRECISION KEY MACHINE is guaranteed. It must do the work for which it is intended. Each machine is tried out before it leaves the factory and is in perfect working order when sent out. Should defects in workmanship or material appear, we stand ready to promptly make them good.

PRECISION KEY MACHINE CO.



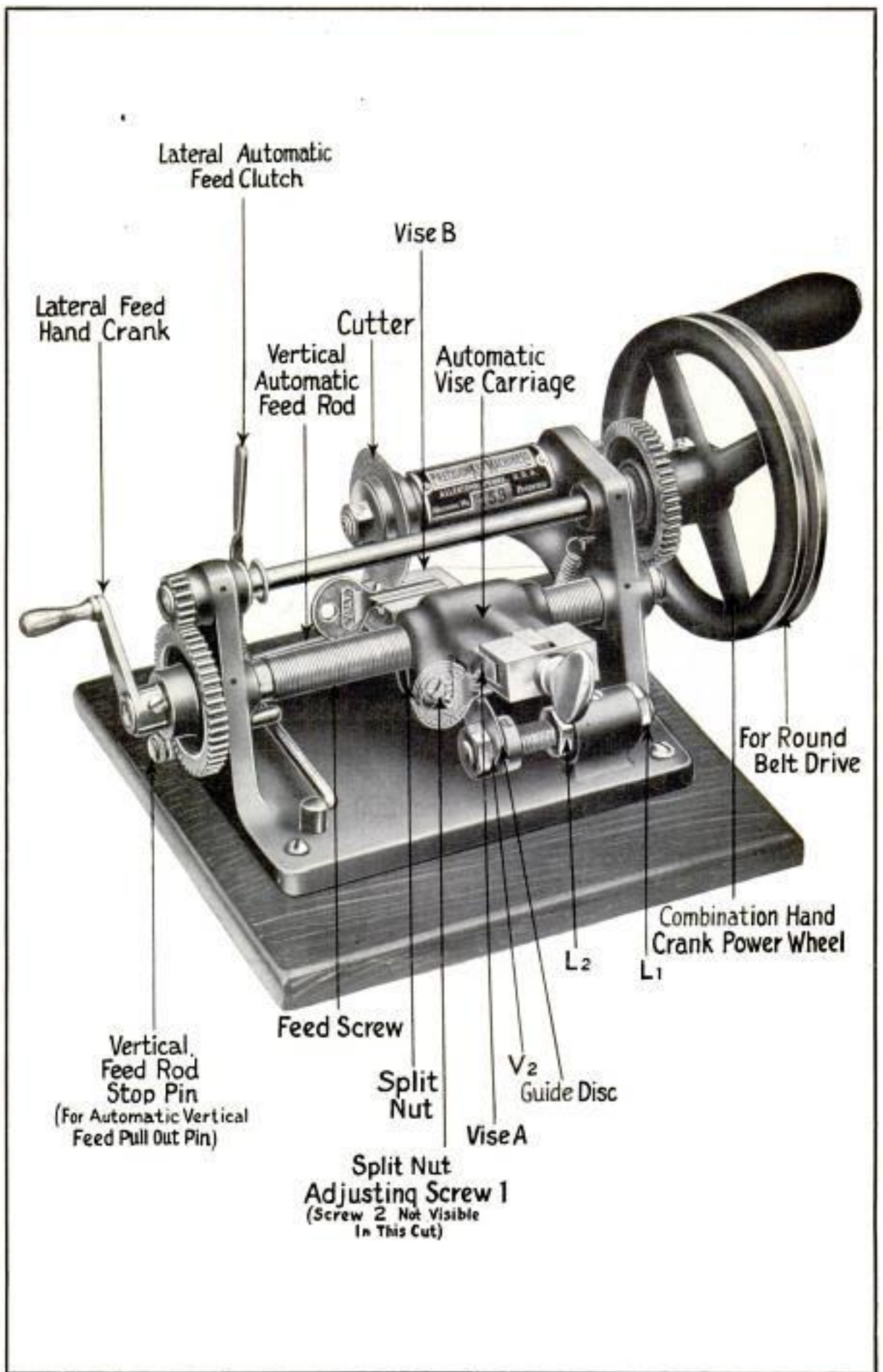





Each Animal has been Taught to Mount His Platform as Shown Above. In Some Cases Instruction has Begun at an Early Age, as Indicated at the Right

Two of a Herd of Trained Guernsey Steers Doing One of Their "Stunts"

### GUERNSEY STEERS TAUGHT TO PERFORM

*Henry Freeman*

A man in West Brookfield, Mass., has done an unusual thing in the line of animal training by teaching a herd of Guernsey steers to do tricks, thereby showing that cattle, which commonly are thought to have a rather low grade of intelligence, can be made to act for exhibition purposes the same as horses can. Individual platforms of heavy planking have been constructed for these animals and each has learned to take his place, just as trained dogs mount their stools. Another of the acts which has been taught these animals is to roll a barrel along the ground by pushing it with the nose.

### DUPLICATE KEYS QUICKLY

3279 MADE BY MACHINE

Filing duplicate keys by hand is a slow process, especially when the key is of the Yale-lock type, which must be cut with extreme accuracy. A better and quicker way is furnished by a small key machine now being used by real-estate and hotel men as well as by lock-

smiths. This device is a carefully designed machine tool built to cut duplicate keys accurately from originals. It will duplicate any Yale-lock key from either an original or a pattern, no matter what the make may be, and will also cut flat cabinet-lock and other keys having square-bottomed bits. In operation, the pattern or key to be duplicated is placed in one vise, the blank in another, and when firmly clamped in place, a cutter, mechanically guided, cuts a perfect duplicate in less than a

*13" x 8" x 4 1/2"*

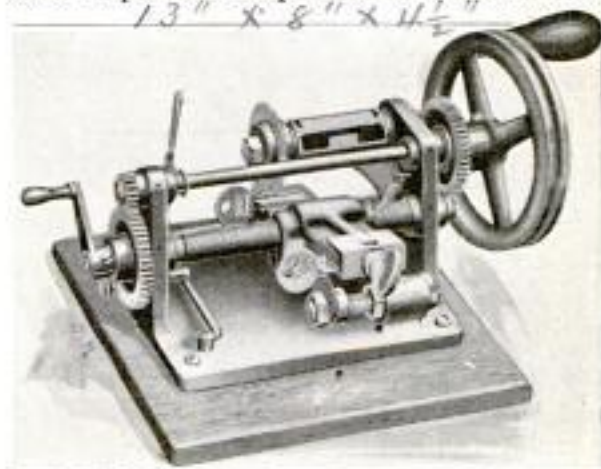

There Is No Waiting on the Locksmith with This Little Machine, Which Cuts a Duplicate Key from a Pattern Inside of a Minute

minute. The machine stands  $4\frac{1}{2}$  in. high, is 8 in. wide, and 13 in. long, and is operated by a hand crank or power wheel, a combination of which is furnished if desired.

*Precision Key Machine Co., Allen Town, Verma.*



2417  
**FOLDING TRUNK IS LOCK  
FOR MOTOR CAR**

To safeguard a car against theft when it is left unattended, and also to provide a safe depository for robes and

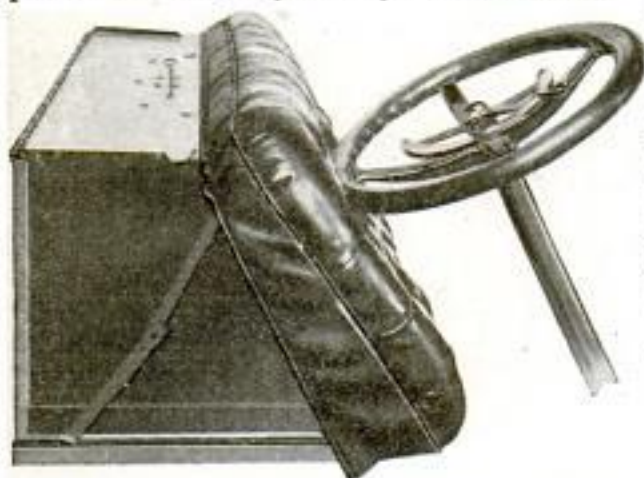

When the Trunk is Raised, Tilting Forward the Seat as Shown Here, Operation of the Car is Prevented

other articles at such times, an <sup>operator</sup> ~~lowan~~ has invented a folding trunk which, when in use, obstructs the steering wheel in such a way that a machine cannot be driven. The appliance is attached to the cushion of the chauffeur's seat and is normally folded beneath it out of sight. When raised and locked in place, it presses the cushion tightly against the wheel. The trunk is constructed of sheet metal and since its dimensions are 35 by 15 by 15 in. it provides storage space for parcels of fair size as well as wraps. It is hinged to swing forward and give ready access to the gasoline tank and tool box when these are situated beneath a seat.

3362  
**RAIL BODY NOT IN FAVOR  
OF "DAYLIGHT SAVING"**

The American Railway Association's committee on standard time has recently made a report on the so-called "daylight-saving" movement, which has for its object the resetting of the clock so that the end of the working period will not approach so near the close of the daylight period. The committee declares that in the event of a nation-wide agitation for the change the railroads should not antagonize the

movement. However, though these men believe that the roads would not suffer serious inconvenience or disarrangement of schedules by the change, they are of the opinion that it is not warranted from a scientific standpoint, and they say definitely that they are not in sympathy with it. The committee feels that the railways should not agree to adopt the scheme until it had previously been adopted by the principal business and municipal centers, together with the state and local authorities. It points out that unless a change such as has been proposed were made on the same date throughout the country, it would lead to confusion and difficulty.

2961  
**VACUUM-CLEANING PLANT  
FOR HOME USE**

A vacuum-cleaning outfit which is now being introduced in many homes possesses many of the advantages of larger central cleaning plants used in hotels, etc., but is of simpler construction and is easily installed. Because it draws all the dirt and dust into a receiver, which is ordinarily located in the basement, none of the dust-laden air that passes through the cleaner is discharged back into the room. The machine for home use stands about 40 in. high. Its electric motor operates a low-velocity turbine fan, which produces the vacuum.



In the baseboard in each room in the house is an inlet valve connecting with tubing that leads to the machine in the basement. A system of installing the tubing has been devised which requires but little cutting of partitions, etc. Electric switches on the various floors give the operator convenient means of control. The outfit includes 25 ft. of hose and a cleaning wand with a variety of nozzles.

General Secy. J. J. Brown,  
Assn. Bldg. 75 Church St.,  
N. Y. C.

Spencer Turbine Cleaner Co.  
Hartford Conn.  
Copyrighted material



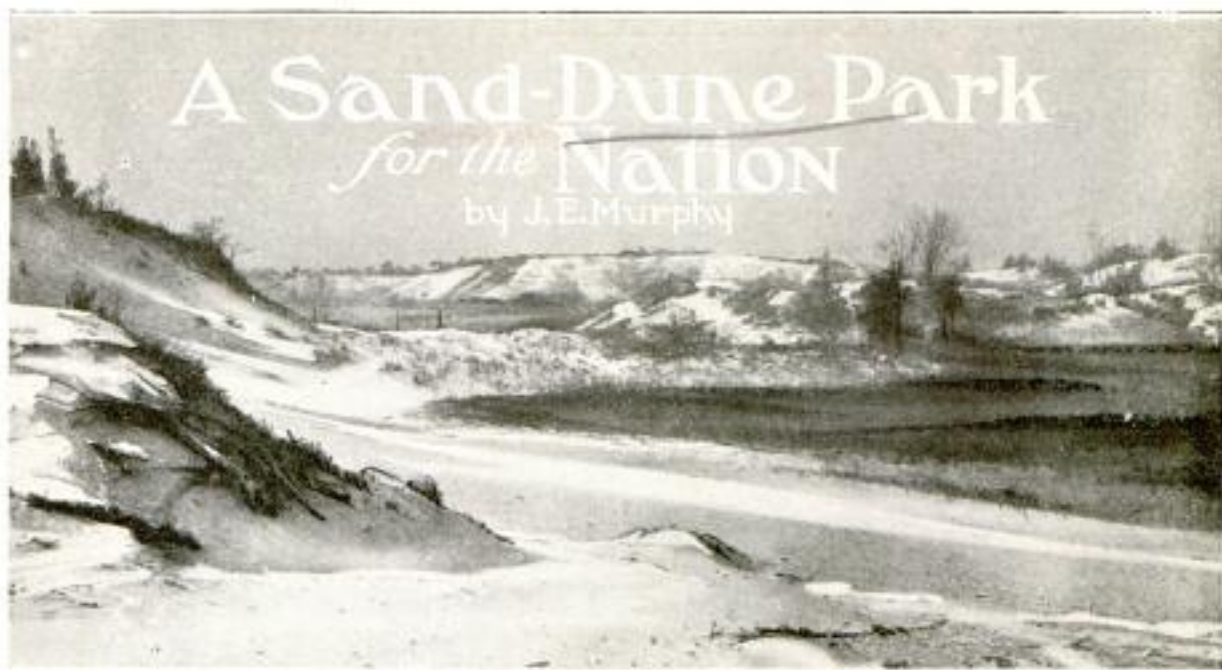

A Scene in the Dunes: What Appears to Be Snow Is Sand Which Stretches Limitlessly in Hills and Valleys

**F**ORMING a fringe about a mile wide along the shore and following the curve of the southern end of Lake Michigan for a distance of more than 18 miles is a range of sand hills, known as the "Sand Dunes of Indiana," a name that is familiar to scientists and travelers of all parts of the world. This is the sand-dune country that is now being investigated under an act of congress with the view to making it into a national park. The statement is often

made that the dunes of this district are the largest in the world. This statement is of little importance whether true or not. There may be larger dunes and there may be ranges occupying greater areas, but it is safe to say that no other sand dunes in the world are so widely known for their picturesque features or so highly prized as a field for scientific investigation. Advocates of the plan for making the district a national park argue that such action



A "Forest" Fire in the Dunes: These Fires do Not Travel Far Because the Shrubbery Is Sparse, but Sometimes They have Ruined Considerable Areas of the Dune Country





A Panorama of the Dune Country, Giving a Fair Idea of the Size and Profusion

would preserve a natural wonder that is in danger of being obliterated for industrial purposes, and that it would provide a national park where, in contrast with other national parks, there are people to enjoy it. It is less than two hours by rail from Chicago to the dune country.

The only way to appreciate the dunes properly is to tramp through them, but even from a distance they are impressive. Viewed from inland, the chain of sand peaks dominate the country to the north and give the observer much the same impression that is received on looking out of a car window and seeing for the first time the distant mountain barrier of the Rockies. From this it is not to be inferred that the dunes are mountains in any sense. They

are sand hills, and the highest peak among them is barely over 200 ft. in height. Their peculiar scenic value lies in the fact that they reproduce the characteristic features of mountain scenery and give the observer the same thrill and stimulus that is experienced in viewing mountains.

Ages have been required for the formation of the dunes, and they are still in process of formation. Driven by the north winds that sweep unobstructed across 300 miles of water, the waves break on the south shore with greater force than at other points along the Great Lakes. Each wave, as it spends itself on the beach, leaves its tribute of sand, and this, as it dries, is blown inland by the wind, carried gradually over the barrier



Dogwood in Full Bloom, an Early Spring Attraction in the Dunes





of the Growth Covering It. Lake Michigan is Seen in the Background at the Right

dune that parallels the shore, and is at last deposited somewhere in the tumbled region of peaks, buttes, and cañons that extends a mile or more back from the lake and constitutes the real dune country.

The southern limit of the dune country is a marsh that serves as a definite boundary between the dunes and the so-called "back country," a district broken by occasional sand hills and marshes and having a general elevation only a few feet above lake level. The barrier dune ranges from 70 to 100 ft. in height, and except at isolated points is too steep to be climbed. At intervals there are cañons leading up through the barrier. These are known locally as "blow-outs," a term that suggests the manner in which they have been formed, being

actually blown out by the winds. When the slope of a "blow-out" is climbed, it will usually be found to have a rounded crest of fine sand, and if the wind is strong there will be a mist of sand continually drifting over the crest and into the shelter of the lee side.

Here one sees the process going on just as it did ages before the French explorers tramped through the dune fastnesses. The dunes that are comparatively permanent in form and location are the ones on which tree growth has taken a firm foot-

hold. Some of these, such as Mount Tom, Mount Holden, and Mount Green, have been permanent features of the landscape for generations. Many of the dunes are continually shifting, the general movement being east and southeast. In this process whole for-



The Beautiful Blue Lupine Blossoms in the Dune Country



ests are engulfed by the sand, to reappear perhaps years later as the sand continues on its journey. No one person knows the entire dune country. There are hundreds of secluded nooks, where grow strange exotic plants, some of them practically unknown.

It is in the study of plant and bird life that the dunes are of the greatest scientific value. The common saying that the dune country is the meeting ground of the plant life of the entire western hemisphere is apparently correct. Cactus from the deserts of the southwest grows side by side with the bearberry from the mountain slopes of Canada. Buried deep in the forests of the oaks that are native to this climate there is occasionally found a tulip tree. At least four kinds of orchids have been found. Many plants native to southern climes may be found along the marsh and in sheltered cañons. How they came there no one knows, but their presence is accounted for in some measure by the carrying of seeds by the migratory birds. One man alone has found and identified more than 200 varieties of flowering plants.

As interesting as the plant life is that

of the migratory birds. Regularly, about the middle of November, the gulls come in flocks with their young and take possession of the beach. Among them are the herring gulls, the ring-billed, and the Bonaparte's gulls. During the day they soar back over the woods and hills, but with the approach of night they return to the water. About the middle of May they suddenly disappear on their long journey to their summer home somewhere near the arctic circle. As the gulls leave, the terns come from the south, those most commonly seen being the Forster's, common, Caspian, and black terns.

A visit to the dunes gives one a feeling of being close to the life that was lived there when the Indians hunted and fought among the hills. Interesting relics are frequently found. Recently the remains of two Indian villages, as well as an Indian trail obliterated in places by the drifting sand, have been discovered. In one of the villages were found three silver crosses such as the French missionaries carried and sometimes gave to the Indian converts.

### NOVEL AMBULANCE FOR 3387 WOUNDED HORSES

An improved ambulance for wounded horses has been invented by a British soldier, and a vehicle built from his plans was recently shipped to the front

in France, for the use of the Blue Cross Society, which undertakes the care of wounded animals. The ambulance is fitted with a reversible body, which turns on a pivot, thus avoiding the necessity of backing the horses out, and has a folding platform at the rear.

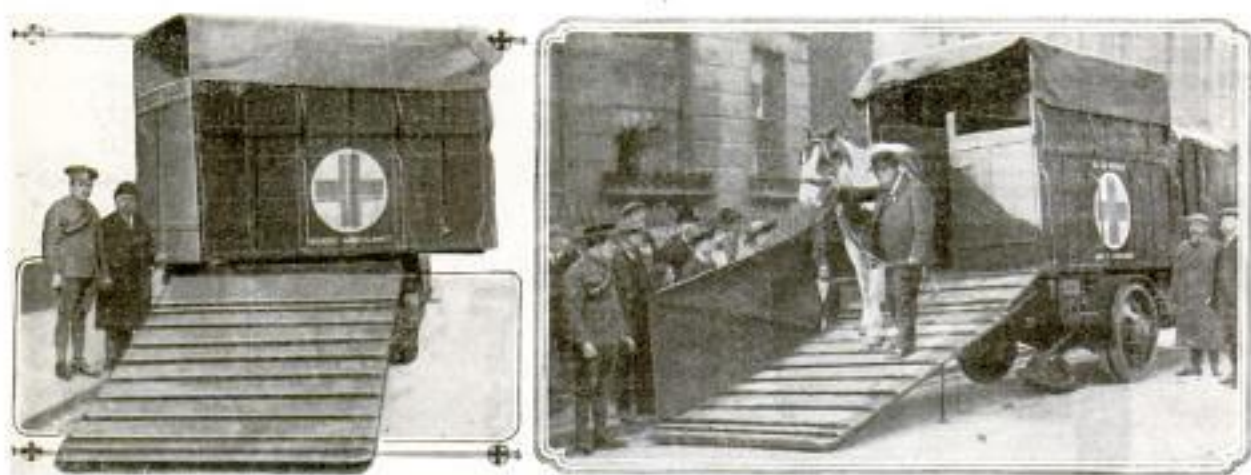

The Body of This Blue Cross Ambulance Swings on a Pivot, So That a Horse can Both Enter and Leave  
by Walking Forward

# Janet M. Cummings, 70 Fifth Ave., N. Y. C.





These Fire Ruins of a Popular Amusement Park Proved a Great Attraction for the People of Cincinnati, Who Paid the Usual Admission Fee to View the Wreckage of Familiar Structures, Indicated by Placards

3372  
**AMUSEMENT-PARK RUINS PUT  
 ON DISPLAY**

*Chester Park*  
 The ruins of an amusement park in Cincinnati, which was recently the scene of a disastrous fire, were turned to good account by a manager who gauged correctly the curiosity of his public regarding the wreckage of a familiar place. The park had been a great popular resort, its buildings familiar to the entire population of the city. When the roadways and paths were partly cleared and signs placed on the ruins of the various buildings and amusement structures, indicating what was left of old landmarks or pointing out freakish effects of the fire, the public cheerfully paid the usual admission fee and swarmed to the place. Temporary fences were constructed where necessary, but the work of clearing and fencing would have been done in any case, so that the enterprising manager's receipts from the show were practically all profit.

2764 —  
**STAND FOR DISPLAYING  
 AND STORING FRUIT**

A stand for attractively displaying fruit has been patented recently, which is so constructed that fruit can be taken from it without disturbing the display. The device consists of a conical wire frame, 24 in. high and 27 in. wide at

the base. Around the bottom, middle, and top are wire shelves on which the dealer's stock can be piled so as to make what appears to be a solid cone. In one side of the stand are two large holes which give access to two compartments where surplus stock can be stored. The oranges, apples, or whatever may be kept in here, can be drawn on without disturbing the fruit on exhibition. These compartments will hold about a box and a half of oranges.

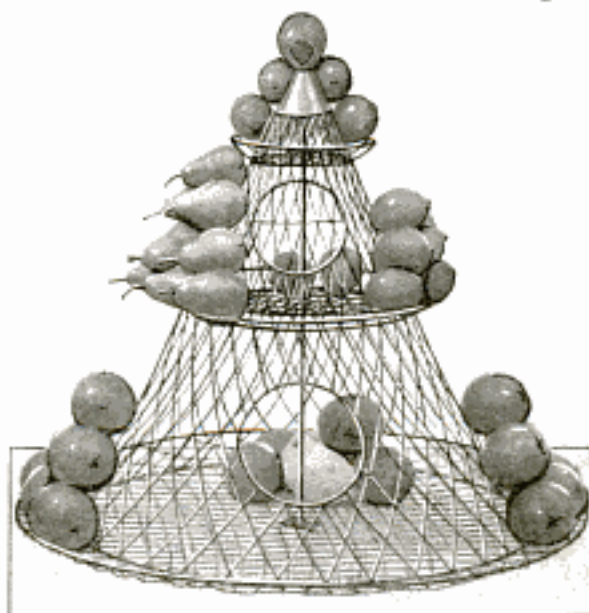

Fruit or Vegetable Rack Having Compartments in Which Surplus Stock can be Stored and Drawn On without Disturbing the Display

If preferred the stand can be hung on a hook. It can also be used for vegetables.

by Edward L. Behring  
 (Inv.) T. V. Wysock, Alton



## 3236 FIRE DAMAGES WISCONSIN UNIVERSITY HALL

A fire which recently destroyed the dome of the University of Wisconsin's



Photograph Taken While Fire was Destroying the Dome of the University of Wisconsin's Main Hall. This Fire was First Discovered by Persons in the State Capitol Eight Blocks Away

Main Hall, at Madison, caused damage estimated at \$25,000. Though more than 1,000 persons, chiefly students, were in the building when the fire broke out, clerks eight blocks away in the state house were the first to see the fire and turn in an alarm. The state capitol and the university hall are situated on elevations at the opposite ends of State Street. The dome finally top-

pled over and then the firemen were able to gain control of the flames. Crossed wires are believed to have started the fire. An American flag hoisted above the dome waved for about two hours while the structure burned, and then dropped to the earth uninjured.

## REFUSE BURNER FOR ARMY CAMP

For the disposal of refuse in United States Army camps a convenient incinerator has been devised which has proved efficient. It is easily constructed by troops in camp, from cobblestones or rocks. The bottom of the incinerator is laid with medium-sized stones; the sides and one end

are constructed of larger stones or pieces of rock, banked up on the outside with a sloping wall of mud which holds the stones in position and fills in the crevices. One end, in the direction of the prevailing wind, is left open for draft. The incinerator is made about 3 ft. wide, 4 ft. long, and 1 ft. high. All kinds of camp refuse may be destroyed by burning in these incinerators. Scraps



Camp Incinerator for the Disposal of Refuse, Constructed at the Training Camp of District of Columbia Troops, Fort Myer, Virginia

# R D Beard 50 W. St., N.W., Wash., D.C.



from the mess table, garbage including liquids, and waste paper are all burned. Discarded liquids from the mess soon evaporate when poured upon the hot stones. An occasional coat of lime improves the appearance of the incinerator, and is sanitary.

2143

**WASTE-PAPER CONTAINERS  
MADE OF PALM STALKS**

Novel and artistic waste-paper baskets have been made from the flat stems of palm branches for use in a western park. The lower ends of the stalks are attached to a circular piece of wood, about one and one-half feet in diameter, which serves as a bottom. Around the base of the container, and also around its middle and top, are bands of wire which help to keep it in shape. These receptacles stand about three feet high and are two feet wide at the top. In the park referred to about 50 of the baskets are in use.



around the base of the container, and also around its middle and top, are bands of wire which help to keep it in shape. These receptacles stand about three feet high and are two feet wide at the top. In the park referred to about 50 of the baskets are in use.

3222

**POWERFUL POLE JACK  
FOR LINEMEN'S USE**

The pulling, straightening, and moving of poles has long been a difficult problem for telephone, trolley, and lighting companies. A new pole jack designed to overcome the difficulty is simple in operation and has a capacity of 15 tons. The jack is pivoted on its base, and the equipment includes a portable, nonslipping I-beam base support, a steel chain, and a steel lever bar. Only one man is necessary in the operation of straightening poles by the use of this jack. In pulling poles, contrary to the usual practice, digging around the base is eliminated. The I-beam base is placed beside the pole and the jack set upon it. The chain is

slung around the pole and pulled tight through a pear-shaped link, and only a



Telephone, Trolley, or Lighting Poles are Pulled or Straightened in a Few Minutes by the Aid of This Pole Jack

few minutes are required to lift the average pole from its place.

3309

**RUBBER BLANKET FOR ROAD  
OR CAMP SERVICE**

INDIA RUBBER WORLD 1/1/16  
Many uses may be found for an automobile blanket of duck, with rubber surface coating on one side, which has lately made its appearance. It comes in one size only, 45 by 72 in., but in two weights, medium and heavy. Folding into a small compact package, it is easily carried under an automobile seat or in the tool box, and in case of trouble requiring a lying position beneath



When a Rubber Automobile Blanket Comes In Handy: When You "Get Out and Get Under" to Fix Trouble beneath Your Car

the car, or when it becomes necessary to change tires in wet or muddy places, the rubber blanket is a friend indeed.

Templeton, Kerlin & Co., Ltd.,  
1020 S. Central Av.  
Chicago.



## NEW RAILROAD PENETRATES GREAT OREGON

## LUMBERING DISTRICT

# STANLEY W. TODD, 327 McDONOUGH ST., BROOKLYN, N.Y.

NO railroad development in the Northwest in the last decade has opened up greater possibilities for the rapid development of that part of the state than the recent completion of a \$13,000,000 extension into the Coos Bay country of southwestern Oregon. Here was an isolated section of Pacific coast territory, possessing a harbor that may some day rival that of San Francisco, and tapping a land rich in timber, minerals, and farm lands, some 400 miles south of Portland. Up to the time that this extension was opened, it had been completely shut off from railroad connection with the rest of the world and was reachable only by sea, or by a difficult overland route through mountainous country by stage from a point on the main line of the railroad into California.

Despite these handicaps, the towns of Marshfield and North Bend, occupying positions similar to San Francisco on San Francisco Bay, grew rapidly in population and prosperity. Thick forests of huge timber in adjacent forest lands made lumbering the chief industry of the bay, with gigantic sawmills convenient to the water. Then there was the pulp business, which in these days of European war has taken on a new importance, and one of the largest mills in the West located itself on the bay. Congress appropriated nearly \$800,000 to the improvement of the bay channel. The agricultural resources of the country, comprising as it did vast acreages given over to many different crops, attracted attention.

So promising was this great territory, that the railroad company, the Southern Pacific, decided to stretch its lines to the bay and end the isolation that had existed for so many years. With a big problem before them, the railroad construction engineers decided to build a spur from the main line at Eugene, although the distance by the "line of least resistance" was at least 120 miles and the mountainous territory brought back recollections of the building of the old Central Pacific near-

ly half a century ago in the early days of the West. There were many rivers to be crossed, mountains to be penetrated, and uncertain, marshy ground to be filled in or trestled.

But modern railroad engineering balks at nothing, even removing mountains when necessary. Owing to the lay of the land, the surveyors and engineers decided that the easiest way was to run the spur directly west from Eugene for about 50 miles and turn southwest, gradually approaching the coast and nearly reaching it at Coos Bay. There were the Suislaw and Umpqua rivers and the bay itself to cross, but that could not be avoided. The construction of the line was started forthwith. The result of this work is now apparent and the Coos Bay extension was officially opened last August.

The final completion of the new line into Coos Bay was regarded as a momentous event and the entire section gave up three days to a railroad jubilee and celebration, in which all the people of Marshfield, North Bend, and neighboring towns took part. The chambers of commerce of San Francisco and Portland ran special excursion trains to Coos Bay so that their members could participate in the celebration and look over the new line and the country through which it ran. At different points along the coast, the new line crosses a series of lakes, which abound throughout the coast country.

The exact distance between Eugene and Marshfield by rail is 121.6 miles. To construct the new extension, it was necessary to build many tunnels and bridges, besides the roadbed. In fact, the total length of the nine tunnels is 13,925 ft., while the total steel used in the 31 bridges required was 8,134 ft. Five and one-half miles of trestles were built, while the other supplies used included 18,000 tons of track steel, 9,100 tons of bridge steel, 40,000 yd. of concrete, 50,000 bbl. of cement, and 20,000,000 ft. of Oregon fir timber.

The time required for the trip between Portland and the Coos Bay



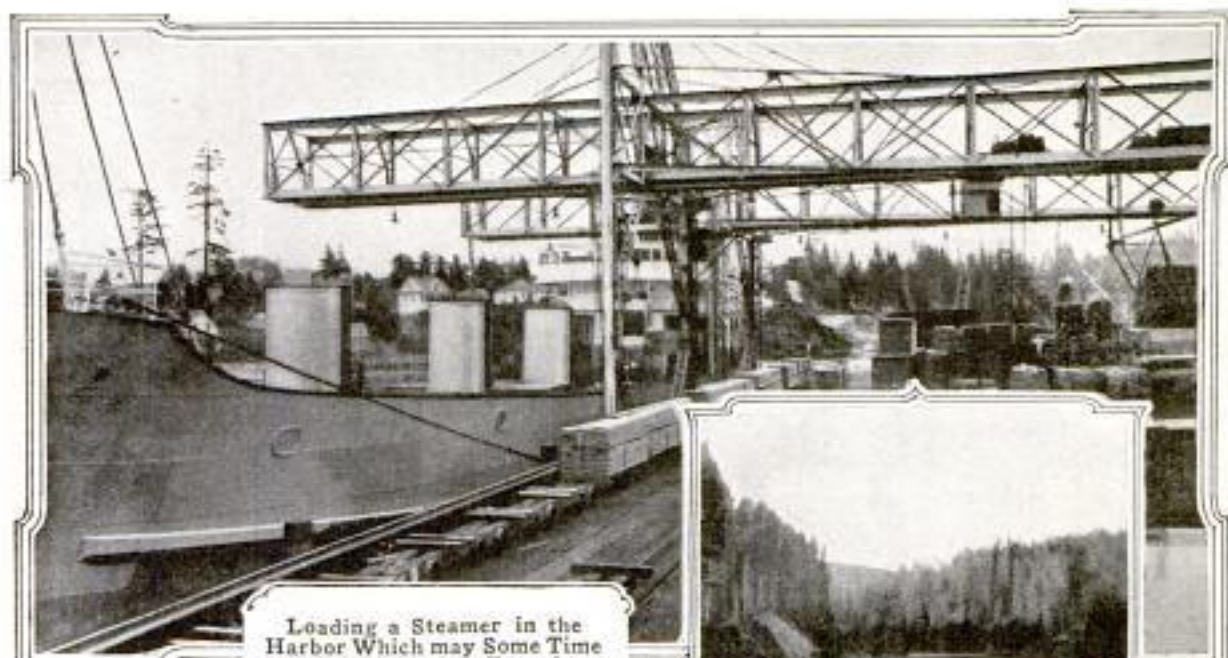

Loading a Steamer in the Harbor Which may Some Time Rival That at San Francisco. The New Line Opens a Potentially Wealthy Territory Heretofore Isolated



Reaching through Mountainous Country of Scenic Splendor, the Road Skirts a Series of Lakes Extending for Miles through the Hills



Forty Cars Loaded with Massive Logs Made Up the Train That Officially Opened the Line to Marshfield. It is Estimated That 21,000,000,000 Feet of Lumber Are Available in This Rich District



This Shows a Section of the Bridge Which Carries the Line over the Umpqua River. At Another Point the Suislaw is Also Crossed



As the Road Nears the Coast and its Terminus, it Crosses Coon Bay. Its Construction Entailed the Boring of Nine Tunnels and the Erection of 31 Bridges and Five and a Half Miles of Trestle



country was cut down perceptibly by the extension. Before the railroad came, it was necessary for the traveler from Portland to take a night train, which would reach Roseburg at 4 a. m., while the stage which left two hours later had a rough "voyage" over the mountains, reaching Scottsburg, a small town, in time to stay all night. Coos Bay was reached the following afternoon. Today the distance can be made by rail in eleven hours. Another significant feature of the extension is that of the freight movement. Heretofore it was possible to send a car from Corvallis, in the same state, to

New York in the same time that it took a San Francisco or Portland shipper to get his consignments into Coos Bay. Now Coos Bay receives its freight in two days. Perhaps the most interesting fact about the new country, which is a third larger than the state of Rhode Island, is the immense timber reserves it opens up to the rest of the country. There are approximately 21,000,000,000 feet standing, the larger part of it privately owned. It is chiefly fir and spruce, tremendous in height and girth, and characteristic of the wonderful timber resources so abundant in that section of the country.

2727

### TRAVELING STEEL LADDER

IS MADE FOR SILOS

*Silo Specialty Mfg. Co., CLINTON, Ia.*  
As a safeguard against the accidents that occasionally occur when ordinary ladders are used in scaling cylindrical

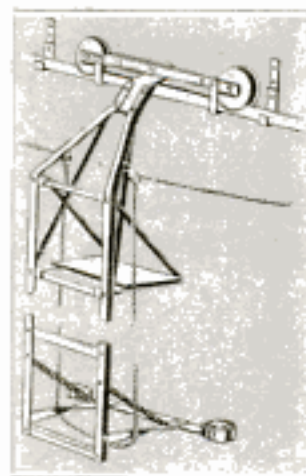

silos, a western firm is bringing out a traveling ladder designed to be permanently attached to such structures. It is constructed of steel and hung in the same manner as the average barn door, operating along a track at the top and kept in proper alignment

by rollers at the bottom. A rope passed about the silo and through pulleys attached to the ladder, enables the device to be moved to right or left without making it necessary for the user to descend to the ground. Thus painting may be done, or the hoops of a silo tightened, without the worker being in constant danger of falling and seriously injuring himself.

CA maker of articles for little folks is putting out a series of pictures on child subjects, strongly framed and covered with unbreakable "celluloid glass."

3273

### BLISTER RUST RAVAGING

### WHITE-PINE FORESTS

The white-pine blister rust, a disease for which there is no known cure, threatens to ravage white-pine and other five-leaved pine forests valued at \$260,000,000. The disease has already secured foothold in Canada, New England, and other eastern states, and has appeared as far west as Wisconsin and Minnesota. New York and Wisconsin have established a rigid quarantine to check the spread of the disease, and the agricultural boards of other states are coöperating with various organizations to prevent the transportation of infected pines or disease-bearing bushes. The spores of the blister rust are blown from infected trees to currant and gooseberry bushes, where they germinate on the leaves and then are carried to other pines, often a considerable distance away.

3110

### GREAT MULTIPLE-ARCH DAM DESTROYS WESTERN FALLS

High up in the Sierra Nevada Mountains of central California an electric-power company has erected a dam which is of twofold interest. It is one of the largest dams of the multiple-arch type ever built, and its erection destroys Silver Lake Falls, one of the most beautiful cataracts in the state and one which many citizens en-

*American Forestry Assoc.,  
1410 H St., N.W.,  
Wash., D.C.*



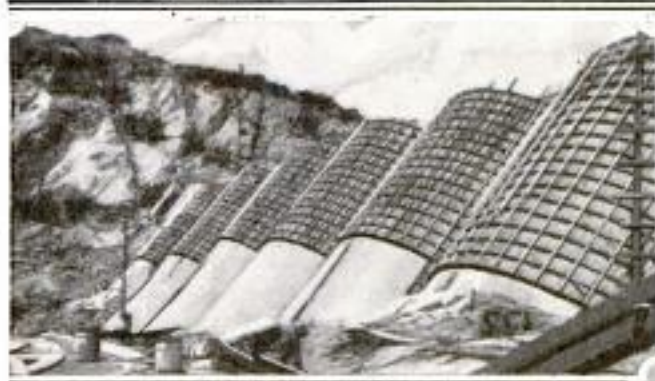

View of the Dam before Its Completion: The Structure Is 680 Feet Long and 70 Feet High, and the Power Plant with Which It is Connected will Eventually Develop 16,000 Horsepower

deavored, without success, to preserve. The falls made a series of plunges totaling more than 2,000 ft., and, as the accompanying illustration shows, at more than one point it spread out over great shoulders of rock in a truly wonderful manner.

The dam which diverts the waters that until a short time ago produced the falls, is 680 ft. long and 70 ft. high, and is composed of 17 reinforced-concrete arches, having a radius of 23 ft. on their upstream face. The first of two units of the power plant has been completed, and its turbines are generating about 5,000 hp. When the second unit is finished, which will be some time next summer, the two will generate 16,000 hp. This dam alone cost \$250,000. One of many great obstacles which have confronted the engineers in carrying out this project has been its distance from the railway. The nearest rail point is 56 miles away. As a first step, the company had to spend \$40,000 in building roads. Over these highways the great bulk of the material was hauled, including 75 carloads of cement.



Silver Lake Falls, Which has been Destroyed by the Completion of a Huge Multiple-Arch Dam That Diverts the Water to Turbines

illustration, which gives a close view of the stern of one of the ships. The vessel evidently is carrying little cargo, for one of the thickly coated propeller blades projects a considerable distance above the water.

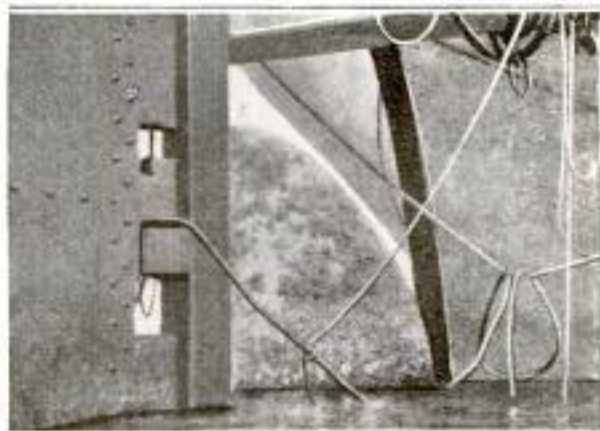

Close View of Stern of German Merchantman Interned in Manila Bay, Showing the Growth Which has Collected on the Blade of the Idle Propeller

3314

### PROPELLER OF INTERNED SHIP IS MOSS-COVERED

Interned in Manila Bay are about 16 German merchantmen, aggregating 36,000 tons, which cannot venture forth on account of the war. As they lie there in idleness their sides and also propellers are collecting barnacles and moss, as shown in the accompanying

# Reg. M. Clutterbuck, P. O. Box 1345, Manila, P. I.



## AMERICA'S ATTRACTIVE COUNTRY CLUBHOUSES



Imposing Home of Blue Hills Golf Club at Kansas City, a Fashionable Playground within Corporate Limits. The Immense Building is of Native Stone and Stucco. An Attractive Feature of It is the Long, Glazed-In Dancing Pavilion Pictured at the Left. The Twelfth Hole, 263 Yards, is Proclaimed the Hardest of the 18. Tall Grass Bordering a Narrow Fairway, a Hollow with a Meandering Ditch, and Rocky Embankment, Conspire against the Golfer



Above and Below are Given Two Picturesque Glimpses of the Peoria, Illinois, Country Club's Splendid Seat. Situated on the Crest of a High Bluff Overlooking the Illinois River, and Surrounded by Magnificent Grounds and Beautiful Trees, the Building Has an Exceptional Setting. More Famed Are the Quarters and Scenery than is the Nine-Hole Golf Course, Which Has No Particularly Distinguishing Feature

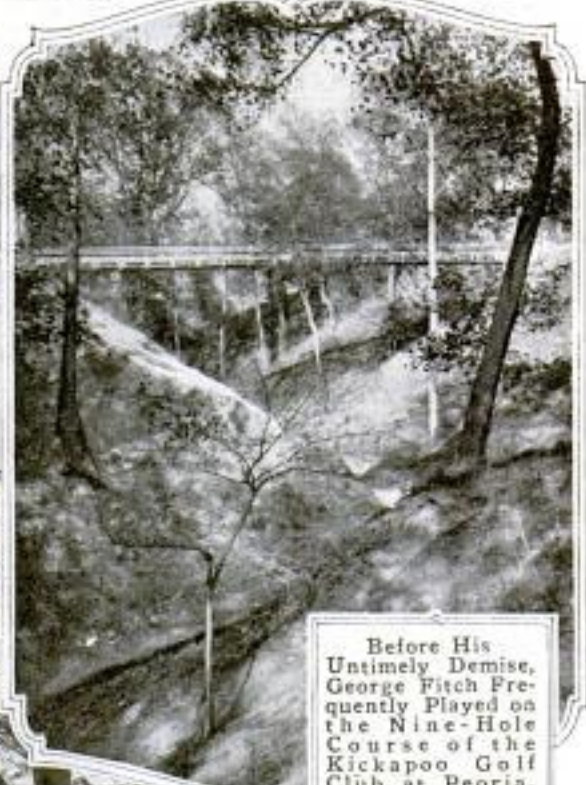

Before His Untimely Demise, George Fitch Frequently Played on the Nine-Hole Course of the Kickapoo Golf Club at Peoria, Illinois. It is in Honor of Him That This Broad, Deep Ravine, before the Sixth Hole, has been Named Fitch Hollow. The Distance from Tee to Green is 120 Yards





## AND SOME OF ITS BEST-KNOWN GOLF COURSES



In Addition to Its Elegant Quarters, the Edgewater Golf Club at Chicago Boasts Interesting, Sporty Links. From the Clubhouse's Broad Verandas the Entire Course Is Visible. Probably the Most Difficult Hole Is the Seventh, 370 Yards. At 200 Yards from the Tee the Fairway is Crossed by a Formidable Bunker Which Slopes into a Small Lake from Which the Picture at the Right was Taken. Trees Guard the Green on Both Sides. While Pits Catch Overdriven Balls



A Large and Very Imposing Colonial Home Situated on a Knoll Overlooking the Whole Course, Harbors the Members of the Exmoor Country Club at Chicago. One of the Aggravating Holes Is the Thirteenth, Which Is Guarded Solely by Water, as Pictured Below. The Lake Is an Artificial One, 40 by 100 Yards in Dimensions. The Distance of the Hole Is 150 Yards. Par for It Is Three, but It has been Played in Two



Few Clubs are Better Known than the South Shore Country Club at Chicago. Its Pretentious, Richly Outfitted, Five-Story Clubhouse beside Lake Michigan Is One of the Finest in America. In Playing the Seventh Hole on the Nine-Hole Course the Artificial Lake Shown Above Offers a Mental Hazard. The Distance of the Hole Is 167 Yards, with Three as Par. It has been Made in Two Strokes a Number of Times. Additional Difficulties are Presented by Trees Which are Encountered by Hooked or Overdriven Balls





1917

TOYS ARE USED IN COURT  
TO DESCRIBE ACCIDENT

During the trial of a damage suit against a railroad company and a jit-



In Testifying to the Court, Each Witness Illustrated His Statements with the Aid of the Street Map, Toy Train, and Car

ney and California streets, to assist witnesses and the attorneys in making their statements clear to the court. A jitney had collided with a passenger train at the crossing, resulting in the

death of four persons. The model was placed on a table before the jury box, and the miniature train and car moved by different witnesses to show graphically the relative positions of the originals when they first saw them, as well as immediately preceding, and at the time of, the tragedy.

The map was drawn to scale and the buildings

ney-bus owner at Long Beach, Calif., a toy train and motor car were used on a map, showing the intersection of Tenth

lining the streets cut from blocks of wood and colored with chalk. The model proved to be very helpful.

3078

SPEEDY WATER SLED  
RIDES ON FLOATS

What has been designated as a hydro-glider is a new water craft, driven by an air propeller, which has been built by two young men in Bellevue, Ky., and tried out by them on the Ohio River. The strange-looking vehicle has a body 24 in. wide resembling an automobile body, and is supported by two

floats. One of these is at the rear and is 6 ft. square, and the other is at the front and is 4 ft. 9 in. long by 4 ft. 4 in. wide. These floats are made of cedar and oak and have a sharp forward edge which is tilted slightly above the water. The craft is equipped with a shallow-draft rudder and an automobile steering wheel. All the control centers in the second of two cockpits. Power is derived from a 30-hp. automobile engine which drives a 6 1/2-ft. air propeller mounted at the rear. The glider weighs 750 lb., is 15 1/2 ft. long, and at rest with a load draws 5 in. of

Robert Cunningham

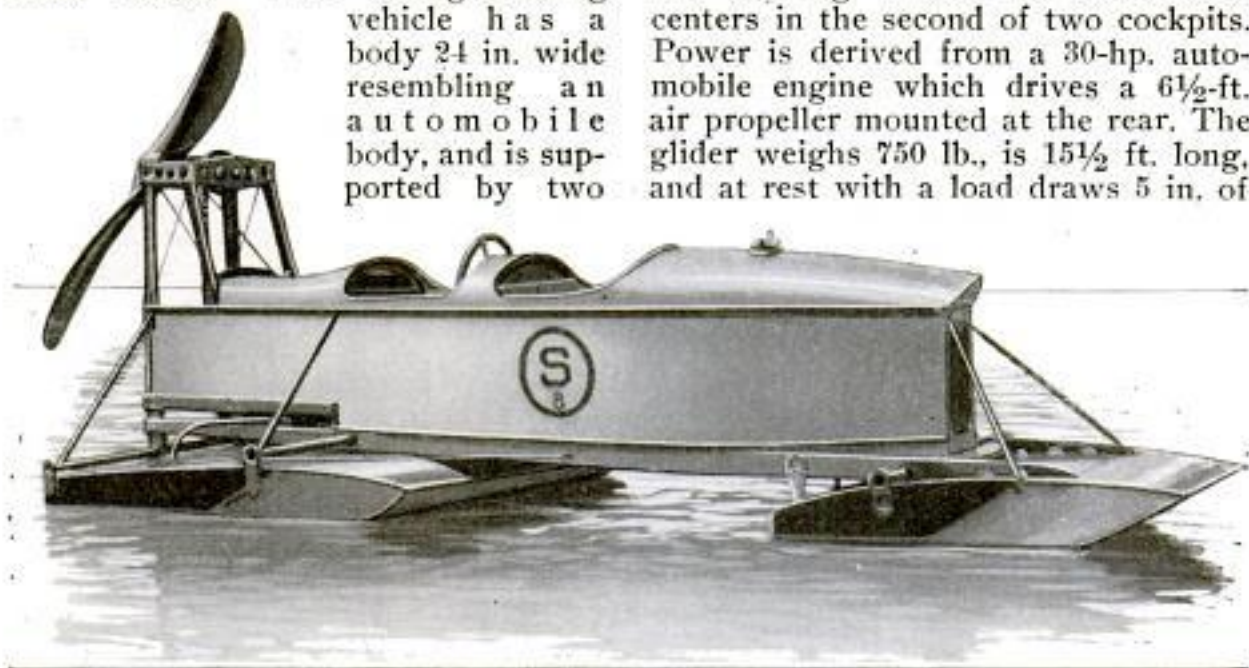

A Water Craft Which Rides on Floats: It is Driven by a 30-Horsepower Automobile Engine and When Traveling Draws About Two Inches of Water



water, while its draft when under way is but 2 in. The builders propose to substitute a more powerful but lighter motor of the rotary type which their tests lead them to believe will drive the glider at more than 30 miles an hour. The craft is so constructed that ice runners can be substituted for the floats.

2832 —

**FOUNDRY BURNER HAS SPECIAL FEATURES**

A portable burner for lighting cupolas in foundries, heating ladles, etc., is now being manufactured, in which are combined a number of desirable features. The burner consumes crude oil, kerosene, or distillate which is discharged in a fine spray produced by compressed air that is pumped into the tank. Three nozzles are included with the outfit, one for skin-drying molds, one for heating ladles, and the third for lighting cupolas. A stand

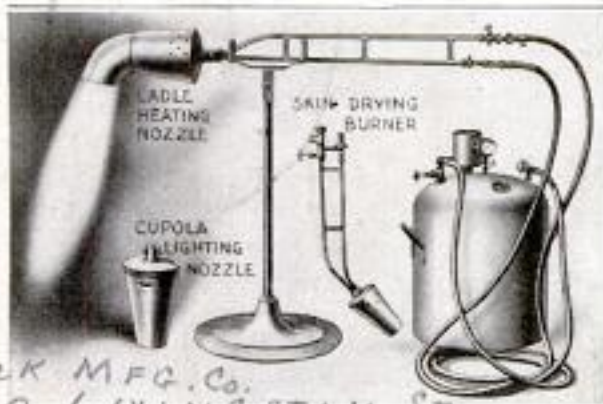

*HAUCK MFG. CO.*  
*140 LIVINGSTON ST.*  
*BROOKLYN, N.Y.*  
 A Burner for Foundries Which Consumes Crude Oil or Kerosene and is Equipped with Three Interchangeable Nozzles

is provided to support the burner when heating a ladle. The tank is equipped with a safety valve, which automatically shuts off the oil supply in case the hose is accidentally cut. The outfit is comparatively light and can be moved about easily.

3209 —

**CAMERA FOR AEROPLANES OF MILITARY TYPE**

A camera recently introduced to the attention of military airmen takes a 4 by 6-in. photograph every four yards during the flight of an aeroplane, and

*Inv: A. J. MOTT LAU*

can keep up that rate for a considerable length of time, according to the inventor. It is designed for use with army machines. An airman flying over the



COPYRIGHT, AM. PRESS ASSN.  
 Camera Designed for Use with Aeroplanes. Taking Photographs Every Few Yards during Flight

enemy's lines could thus obtain photographs showing details of the scenes below that would not be visible to the eye of the keenest observer.

— 3250

**SIMPLE TIRE CARRIER FOR MOTOR CARS**

Spare tires carried on the side of a motor car are generally regarded as unsightly and *Hoover Spring Co., Inc.*

they are often in the way. Hence the growing tendency in favor of rear-end tire carriers. A new carrier of this type, which has lately made its appearance in the West, holds one or two tires in such a manner that there is nothing in contact with them to chafe the casing, no straps, chains, or pans being used. A simple system of toggles or arms is used to hold the tires firmly in place, and a padlock protects tires and rims from theft. To remove a tire it is necessary only to unlock the padlock and push in the toggles, no tools being required.



*TORIC SE*  
*SAN FRANCISCO*



# Geo. A. Walton, % The Post,  
259 Wash'n St., Boston.

242

3055

POPULAR MECHANICS



Collection of Guns and Rifles Confiscated by Massachusetts Game Wardens under New Law Prohibiting Aliens from Having Firearms in Their Possession. They were Recently Taken Out into the Harbor at Boston and Dumped

### MANY WEAPONS CONFISCATED IN MASSACHUSETTS

About a year ago the state of Massachusetts enacted a law prohibiting aliens from using or having in their possession firearms of any character while within the confines of the commonwealth. The purpose of this legislation is to restrict hunting by unnaturalized foreigners and prevent the undue destruction of game and other birds, which are frequently killed in large numbers by such persons. As a result of the ruling a considerable number of rifles and shotguns of different kinds have been confiscated by the authorities. The law carries with it a fine and prison sentence for those found guilty of violating it. For this reason many aliens who have hunted in spite of the ruling have thrown away their guns and taken to their heels upon the approach of game wardens. These weapons, some of them cheap, but a

few excellent pieces, have fallen into the hands of the authorities. Not long ago a collection of some 50 guns and rifles which had been gathered in a very short period, were thrown into the harbor at Boston. Among them was a 20-gauge shotgun fashioned to resemble a walking stick.

### POWERFUL NEW LIGHT

#### ON ALASKA COAST

*3106 House*  
*Commercial Reports 9-22-1916*  
The Cape St. Elias light station, which was recently placed in commission, is an important aid to shipping on the coast of Alaska. For vessels bound for Cook Inlet or Prince William Sound from the Pacific coast of the United States or from southeastern Alaska, it serves as the landfall light. The lamp is of 300,000-cp. capacity, and because of its elevation can be seen more than 15 miles. The fog signal consists of a 6-in. automatic compressed-air siren, in duplicate, each



with a trumpet with a two-way mouth. The light gives a double flash every 20 seconds and the horn a double blast of four seconds each, every minute. The station is located on the south end of Kayak Island, 45 ft. above the level of the sea. Living accommodations for three keepers are provided. An automatic gas light was maintained on an off-lying rock during the construction of the lighthouse.

2861  
**SNOWPLOW ATTACHES TO FRONT OF MOTOR CAR**

# Claude C. Hyde, Otisville, N. Y.

An automobile snowplow, which is capable of rendering good service on snowbound roads, has been invented and tried out with success. Two steel shares, resembling the share of an ordinary walking plow, are attached to the front of an automobile by means of a special fender. The shares are so

199,075. SNOW-PLOW. CLAUDE C. HYDE, Otisville, N. Y. Filed May 29, 1916. Serial No. 100,744. (Cl. 105-131.)

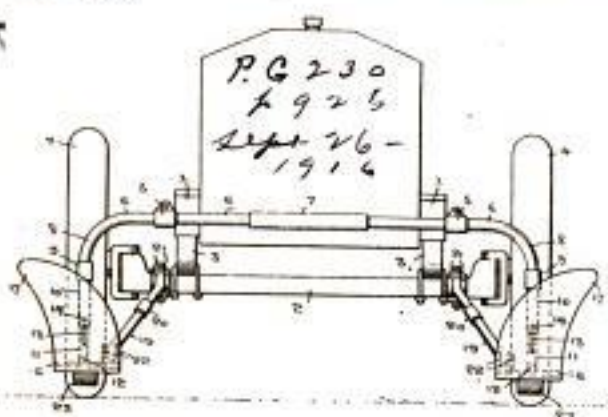

1. The combination with a motor propelled vehicle having wheels thereon, of a pair of plow structures, comprising mold boards, frames carrying said mold boards, adjustable bumper carried by the vehicle, means to justably and yieldingly attach said frames to the ends of the bumper, and adjustable brace bars between said frames and parts of the vehicle.
2. The combination with a motor propelled vehicle having wheels, of a pair of plow structures, comprising mold boards, frames carrying said mold boards, a bumper carried by the vehicle, hollow standards attached to said bumper, shanks attached to said frames and having their ends entered in the standards, yielding means between the shanks and upper ends of the standards, means to limit the longitudinal movement of the shanks, and adjustable means extending between the frames and parts of the vehicle for bracing said frame.
3. The combination with a vehicle having a bumper thereon, and means to adjust the bumper longitudinally, of a pair of plow structures carried by the ends of said bumper, and means between the plow structures and vehicle for bracing the plow structures.

**PINS TO FASTEN COVERS ON COCKS OF ALFALFA**

What is called alfalfa pins are made by a manufacturer of wire goods in the East, to use in fastening canvas covers over the tops of cocks of alfalfa left in the field to cure.



These pins are made of heavy galvanized wire, are 15 in. long, and each has a 3/4-in. eye in one end, so that it can be inserted and withdrawn easily. Four are used for each cover.

Each pin is inserted into the cock for about two-thirds of its length, pointing down at an angle. Then it is brought to a horizontal position and pushed in the remaining distance. This serves to draw the cover down tight, and it is held so securely that the wind cannot remove it. Rings are provided by which each set of four pins can be kept together when not in use.

two clean allow right Un- helps in the o les- car The re-

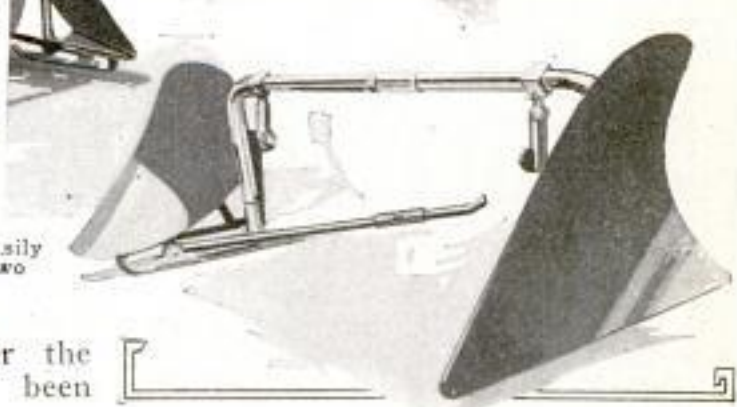



### STEAM HEAT CONTROLLED BY RADIATOR COVERS

An automatic apparatus of novel character, for maintaining room temperatures at a uniform degree, has been



Under This Artistic Covering for a Radiator There Is a Regulator Which Automatically Opens and Closes "Louvres" to Maintain Uniform Temperature in the Room

*The Fulton Co.*

invented and placed on the market in Knoxville, Tenn. Outwardly this is a thoroughly insulated covering, or jacket, which fits over the steam or hot-water radiator, and is made of furniture steel, having a properly designed grill in front. Back of this are placed "louvres," or shutters, which are opened or closed automatically by the concealed regulator, as it responds instantly to the slightest change in temperature of the air circulating over and around it. The regulator is so arranged that it is exposed to the room air. When it opens or closes the louvres, the circulation of air over the radiator is thereby increased or decreased, so that the temperature of the room is held practically constant. Any temperature between 60° and 80° F. can be obtained by setting a regulator dial at the proper point. The dial is found just under the top of the jacket. The apparatus is especially fitted for the maintenance of equable

temperatures in the rooms of hotels, schools, hospitals, clubs, and other large buildings, as well as residences.

### 3179 → *20 military drunk horse* INDIVIDUAL DRINKING CUPS FOR CITY HORSES

# *C. L. EDHOLM 68 W 97 Th St. N.Y.C.*  
An improved drinking fountain for horses has made its appearance in the large cities, where the ugly and insanitary horse trough is a thing of the past. The new fountain has individual drinking cups or bowls, in which the water comes surging up through the bottom of each bowl and keeps it overflowed all the while, so that the muzzle of the horse in drinking does not touch even the brim. There is no return of waste water through the bowl, nor is any water permitted to stand in the bowl or in the large basin of the fountain, for all waste is carried at once through openings in the bottom of the basin to the sewer. Thus the horse is reasonably protected against infection from this source.



Improved Drinking Fountains for the Horse, with Individual Drinking Cups, are Now Installed in City Streets



2971  
Sculptor → Merrill Gage Topeka, Kansas

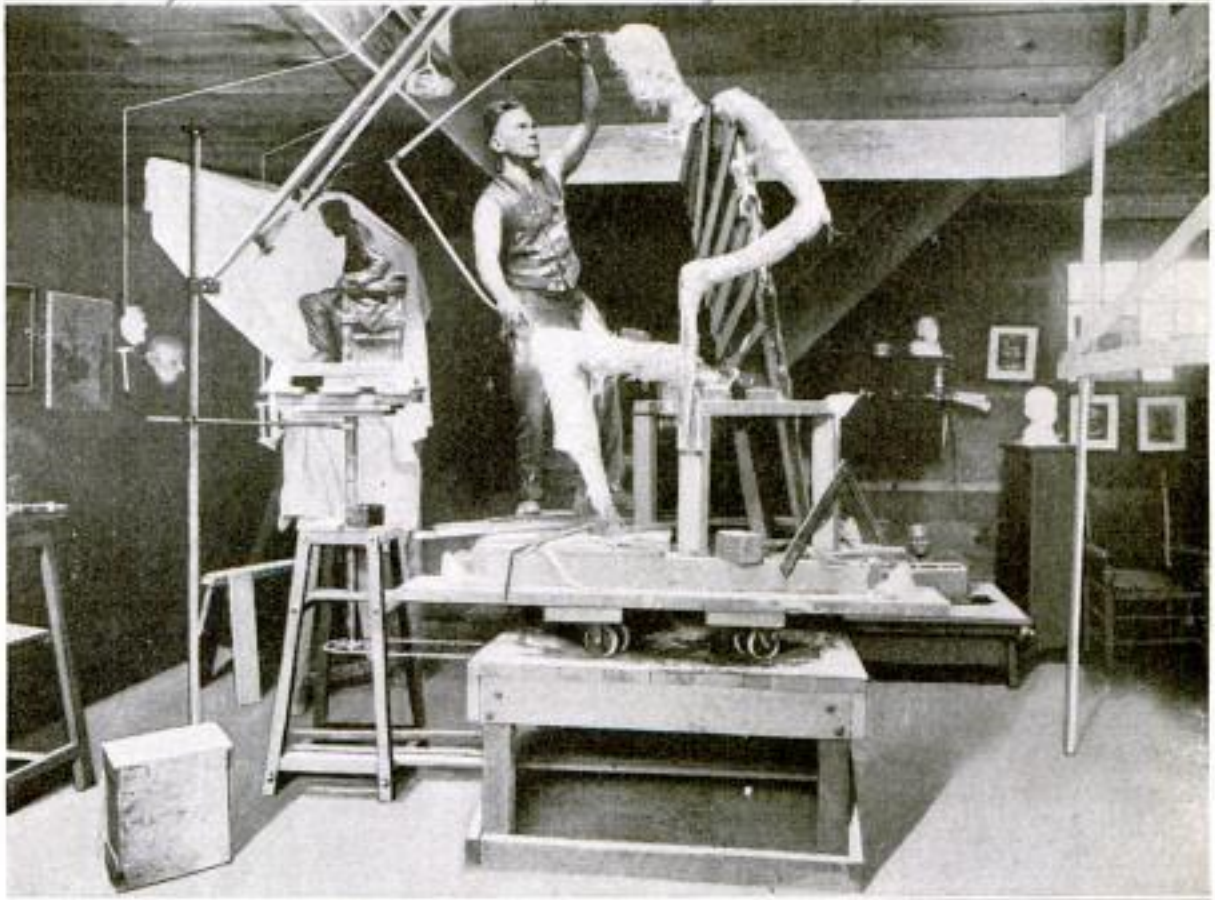

#### MODELING A HEROIC STATUE OF LINCOLN

WHILE the model of a heroic statue is in the making there is little in its grotesque appearance to suggest the beautiful finished product. This is well illustrated in the accompanying photograph of a Topeka, Kan., studio, where the artist is shown constructing a model of a statue of Abraham Lincoln, that is to be erected in the state house grounds. This is a phase of the work which is primarily dependent on mathematics rather than artistic skill, for the sculptor is simply reproducing on a large scale the small model shown at the left of the picture. Eventually the framework which appears so ungainly, but which has been built with a view to exact proportion, will be covered with clay and will be transformed into an enlarged reproduction of the small clay model. School children and public-spirited citizens have shared in bearing the cost of this monument.

#### RUSTIC OVEN FOR USE BY

#### 2979 BEACH PARTIES

A large stone oven, roughly finished, but symmetrical and pleasing in design, has been built on the ocean beach by the city of Santa Monica, Calif., for the use of picnickers. Its cost was not great because rocks were used which had been blasted out while a road was being constructed near by. On the top of the oven are iron gratings which can be used for broiling or roasting, or for warming coffee. The rocks, together with the bricks which form the bottom of the fire pot, are cemented together. The broad, tapering chimney was built high enough to carry off the smoke so it would not annoy persons using the oven.



Substantial Stone and Brick Oven Erected on the Beach by the City of Santa Monica, California, for the Use of Picnickers in Warming Coffee or Cooking Meats

# J. Gordon Jeffery, 622 Calif. Av., Santa Monica, Calif.



## WIDE-AWAKE OUTDOOR ADVERTISING SCHEMES

Montana Power Co.

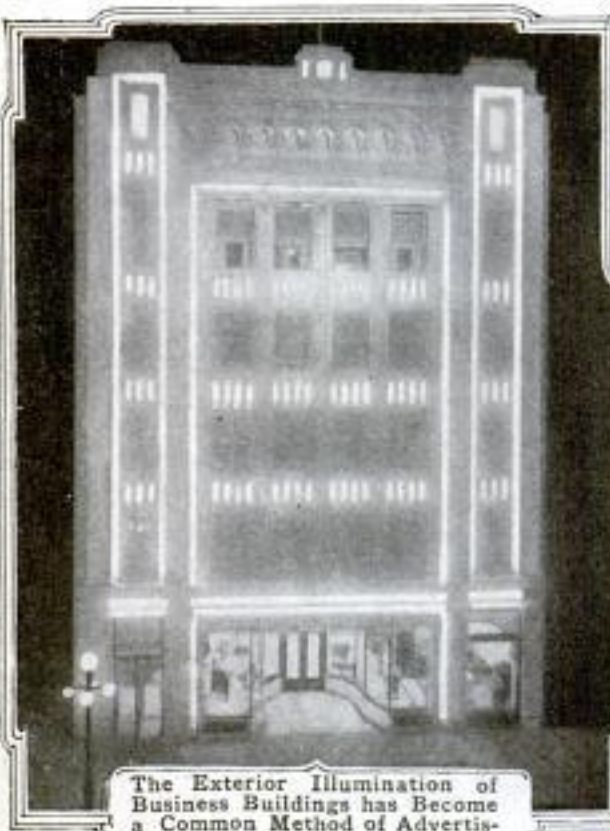

The Exterior Illumination of Business Buildings has become a Common Method of Advertising, but the Artistic Lighting of Them is Somewhat Rare. At Billings, Montana, a Power Company has Obtained Splendid Effects by Arranging Incandescent Lamps in Channels, Cut Vertically and Horizontally in the White Facade of Its Structure, and Covered with Opalescent Glass



This Is Not a Six-Room Modern Cottage of Spanish-Colonial Architecture Surrounded by Landscaped Grounds, but an Outdoor "Stage Setting" Which Advertises a Certain Real-Estate Company. The House and Trees are Signboards



Billboards are Excluded in the "City Beautiful" Plans of Most Municipalities, but Los Angeles Attests That This Ornamental One, in the Heart of an Important District, is Preferable to the Un-sightly Excavation Which it Hides. Arrangements were Made for Erecting a Building on the Site, but Only a Hole was Dug



Some One Once Said: "It Pays to Advertise." This Jam would Indicate as Much. Probably Not All of the Men and Women in the Crowd Immediately Dashed into the Waco, Texas, Department Store to Make Purchases after Witnessing the Style Show Staged on the Canopy in Front of the Building, but Few, if Any, of Them Failed to Learn What the Company was Offering for Sale



THAT HAVE PROVED STRONG DOLLAR MAGNETS



The Telephone Is the One "Caller" That Receives Immediate Attention. That Obtains an Interview Ahead of Those Waiting Their Turn on the Other Side of the Door Marked "Private." Anyway, This Is the Thought Presented by a Telephone Float Used Not Long Ago in an Industrial Parade at Indianapolis

Folks Chronically in a Hurry Invariably Jump at Conclusions: That Is Why One Window-Shade Dealer Has Derived Much Publicity by Being a Bit Facetious. A Roller Curtain, at the Right, is Drawn across the Windshield of His Car When It is Left at a Curb



Modern Office Buildings Are Business Institutions That must be Advertised Like Dry-Goods Stores or Theaters If Leases are to be Made Promptly. A Big Picture of the Structure Completed was Erected before This New York Building to Advertise It during Construction. At Chicago the Idea was Carried Further, Spaces being Provided for Future Tenants' Announcements

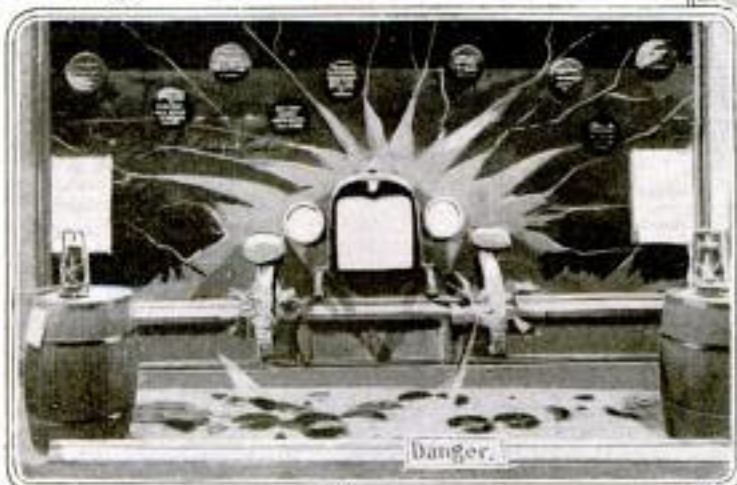

Every Street Crowd Is Brim Full of Curiosity: Therefore This \$25 Window Display Attracted 50,000 Persons and Sold Six Machines for a Philadelphia Motor-Car Agent. The Radiator, Tire Sections, and Lamps are Attached to the Outside of the Window, Which Appears Shattered Because So Painted. Broken Glass Litters the Sidewalk, While Red Lamps and Danger Signs Complete the Illusion



**SHOEMAKER EXPERT ENABLES  
AFFLICTED TO WALK**

Work of truly remarkable character is being done by a shoemaker—an orthopedic expert—of New York, in the fitting of shoes to those who find difficulty in walking in ordinary footgear. For ordinary cases a series of "inner foot molds" has been prepared, in sizes to fit various feet. These resemble ordinary insoles in general appearance, but the upper surfaces are uneven, having indentations and projections that insure a contact anatomically perfect for the soles of the feet. The edges are curved slightly upward. When molds are found in which the feet rest in comfort, supporting the weight of the body in perfect balance, these molds are worn inside shoes of a suitable size. The feet then rest on a sort

ly distributed to the parts of the feet best able to sustain it, all of the foot surface being used. A normal condition for the feet is thus made possible, and the bones, muscles, and ligaments are permitted to move naturally. Some extraordinary cases have also been successfully fitted with footwear after walking had become a burden or a seeming impossibility.

3354 ——— *car*  
**GREAT RAILROAD FERRY  
ON PACIFIC COAST**

A vessel which is claimed to be the largest ferryboat in the world carries trains across Carquinez Straits, between Port Costa and Benicia, Calif., a distance of one mile. It is the property of the Southern Pacific Railway Company and is 433 ft. in length over all, 116 ft. beam over guards, 66 ft.

molded beam, and measures 3,800 tons. The deck has four train tracks with a capacity of 36 freight cars or 24 passenger cars, and two locomotives. Two sets of oil-burning en-

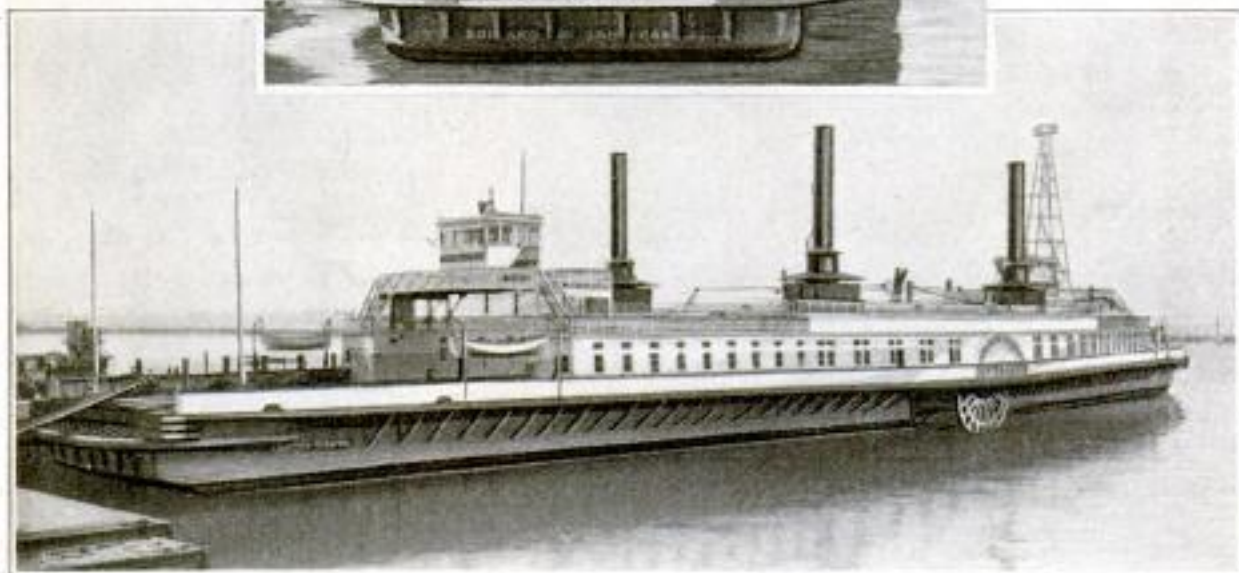
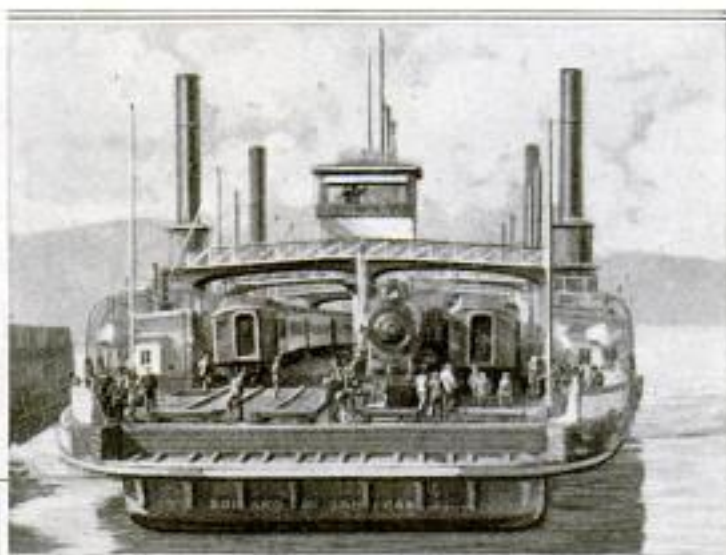

Southern Pacific Ferryboat, the "Contra Costa," Which Carries Two Freight or Passenger Trains with Ease

Mathew Hilgert.  
"Pat-Ami" Shoes  
Pat. of cup-shaped  
1912 cushion and  
Jul 16 are kept from  
Sep 14 pressing un-  
1914 evenly against  
Dec 8 hard, flat sur-  
Dec 8 faces such as  
Dec 8 are found in  
ordinary  
shoes. In foot-  
wear thus  
fitted, the  
weight of the  
body is equal-



Composite Metal Lath Co.  
128 Broadway  
New York

gines, each of 2,500 hp., turn a paddle wheel on each side, by which the boat can be swung around in its own length. Hull and superstructure are of wood and contain 2,000,000 ft. of lumber. There are single timbers measuring 26 in. square and 66 ft. long, and others 18 in. square and 116 ft. long, used in the hull.

3095

**FIREPROOF LATH MADE OF WIRE CLOTH AND CLAY**

*Engineering News 9-28-16*

An improved building material for fireproof construction of various kinds consists of a composite metal lath made of annealed wire cloth on which is pressed a coating of brick clay. This provides a plaster base which is strong and yet flexible. For example, the lath can be wound around a pipe or cable, that requires a fireproof coating, and covered with cement. This lath may also be used to advantage on concrete

structures which are to be covered with plaster or tile. In such cases it is placed as a lining on the forms and

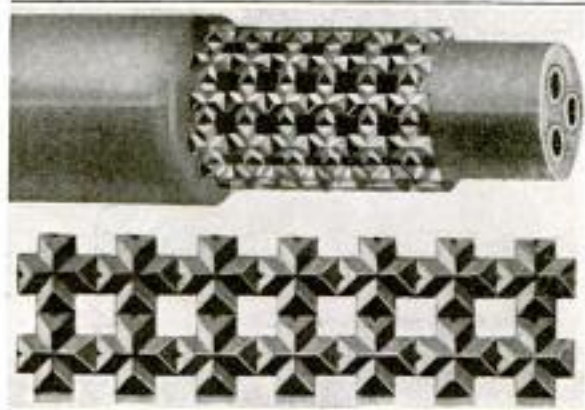

COURTESY OF ENGINEERING NEWS  
A Flexible Metal Lath Designed for Fireproof Construction That is Made of Wire Cloth on Which is Pressed a Coating of Brick Clay

when they are removed the concrete walls will be covered with the lath, which give them a surface well suited to bonding so that they can be covered with the proper finishing materials.

3215

**OLDEST AUTO EXCHANGED FOR LATEST MODEL**

A strange-looking motor car was recently brought to light when an automobile - manufacturing company in Indiana offered to exchange one of its 12-cylinder cars, 1917 model, for the oldest automobile of the same make that could be found. The eager search which followed resulted in the discovery of the vehicle shown in the accompanying illustration. It was owned by a resident of Jeffersonville, Ind., and was purchased in 1897 for \$1,250. The car, which after 20 years appears so antiquated, is equipped with a two-cylinder engine, is guided by a lever, and cranks from the side. Only a few minor repairs were needed to put it in

good condition. It can attain a speed of 18 miles an hour. The vehicle was



Automobile Made in 1897 Which was Recently Exchanged on Even Terms for a 1917 Car of the Same Make: The Old Vehicle was Secured by the Makers for Exhibition Purposes

secured to be exhibited at a good-roads celebration.

*Jas. E. Howard  
Jeffersonville  
Ind.  
Bought in  
1897 by  
Col. E. J. H.  
- father of  
above -  
from  
Haynes  
Apperson  
Co.*

*Haynes Automobile Co.  
Kokomo, Ind.*



**CONVENIENT SERVER FOR CANS OF LIQUID**

For serving liquids packed in cans, especially milk, a new container has



The Act of Lifting Up the Folding Spout Cuts the Can Open, and Closing Down the Lid Locks the Spout in Place

This Shows How a Can of Milk is Inserted in a New Container and Server for Canned Liquids—a Portion of the Paper Label being First Removed as Seen in the Picture

Serving Canned Milk from the Container, Which is Both Sightly and Sanitary and can be Used in This Manner, Just Like an Ordinary Pitcher, with the Can Inside

appeared, which supersedes the old method of opening such a package with a hammer and nail, or a can opener, making two unsightly holes in the lid, and then bringing the can to the table, where the holes promptly gum up and become dangerously insanitary. The new can server comes in the shape of a sightly and healthful creamer, made of steel, copperplated, then heavily nickelplated. The can of liquid is placed inside this server, which is made to fit it. There is a folding spout, with a cutting edge at the bottom, which opens the can as the spout is lifted quickly to place, to be locked by the closing of the cover. Then the contents of the can may be poured as with an ordinary creamer.

3493  
**SPRINKLER HEADS NEED TO BE INSPECTED**

Where sprinkler systems are relied upon for fire protection it is necessary that they be inspected carefully from time to time, to see that the sprinkler heads are in working condition, ready to fuse when the temperature rises to the danger point and to let the water emerge from the pipes in case of fire. There are regular systems of inspection for this purpose and it is by no means uncommon for the inspectors to

discover sprinkler heads so badly corroded, or otherwise injured, that their efficiency is destroyed. This is particularly the case in industrial establishments where the materials used or

the methods of manufacture tend to damage the sprinkler heads. Many examples of useless and depreciated heads are sent by inspectors to the Underwriters' Laboratories in Chicago. Most of these have been damaged by industrial processes, as where they are corroded by various acids used in the arts. But in many cases the neglect of ordinary busi-

nesslike precaution is responsible for their condition; as, for instance, in a factory where sprinkler heads were found so completely gummed up by the varnish frequently sprayed beneath them in the course of the day's work that they would have totally failed to perform their duty in case of fire.

3054  
**OLD AND NEW CONTRASTED WHEN HOUSE IS HALVED**

# Walton (see p 223-242)  
 In Cambridge, Mass., not far from Harvard University, is an old dwelling that has been cut in two lengthwise, and presents a most unusual appearance. It is an odd example of the re-



Old Frame Dwelling in Cambridge, Massachusetts, Which has been Cut in Two Lengthwise to Make Room for a Modern Brick Structure



*Terris Mfg. Co. Wis.  
Wausau,*



Eggs to be Canded are Placed in the Tester as Shown Below: When the Swinging Cover is Closed Down, any Defects are Readily Detected

Candling Eggs with a New and Convenient Tester: The Eggs are Seen with Electric Lights Shining through Them

Cabinet of Tester is Designed to Hold a Standard Trayful, Which is Lifted Direct from Shipping Case, as Shown at Right

sults which sometimes follow the conflict between the promoters of modern improvements and the owners of old-fashioned structures who, because of sentiment or for other reasons, are unwilling to move or to sell their property. In this case the builders of a four-story brick building were able to acquire possession of land up to a line running lengthwise through the middle of the old frame dwelling, but for some reason they did not secure control of the rest of the property. Rather than let the land acquired lie idle the old house was cut in two and one half torn down. The wall of the new building was set so close to the wall of the remaining half that even the chimney, which was also cut in two, had to be joined to the new wall.

3231

### RAPID CANDLING DEVICE FOR EGG DEALERS

An egg candler designed for the use of retail grocers and country merchants enables the dealer to make a rapid test of eggs in the presence of the customer or when buying from a producer. The tester is in the form of a convenient cabinet, which can be placed on the store counter. It carries its own electric-light plant in the base, above which a tray of 36 eggs, lifted direct from a standard egg case, can be placed for examination. A swinging cover is then closed over the eggs and they are inspected through a suit-

able eyepiece in the top of the cover. The electric light beneath the eggs plainly reveals those that are imperfect, which can be picked out easily from the tray. Only a few seconds are required to candle the three dozen eggs handled at one time and the device can be operated by a novice.

*Auto. Car 20*

### WHEEL WITH CUSHIONED STEEL RIM

A comparatively simple substitute for a wheel having a rubber tire has been designed for use on trucks and automobiles. It consists essentially of a strongly built hub and spokes which support a felly, about which is a steel



A Substitute for a Rubber-Tired Wheel Having a Rim of Steel Which Rests on Cushions Placed at the Ends of the Spokes

*INVT  
Fred J. Albert  
964 Sixth  
N.Y.C.*



rim somewhat larger in diameter than the felly. Inserted between this rim and felly, and opposite each spoke, is a cushion of rubber, or other material, which gives the wheel resiliency. Flanges help to hold the cushions in place. The felly and rim are held together by bolts located between the cushions. Each bolt is rigidly fastened to the rim, but is rather loosely inserted in a slot in the felly so that there is play between the rim and felly and yet the former cannot become displaced.

**3363 INDIVIDUAL WATERING CUPS FOR CATTLE STALLS**

Experience of dairy farmers has fairly proved that the maximum yield of milk cannot be secured from a cow unless she has all the water she wants to drink, just when she wants it; that is, after each feeding at least. In cold weather it is poor policy to let cows run out to an icebound common drinking trough, to get chilled; and in all weathers the common trough, with its danger of spreading contagious diseases, is regarded by the knowing farmer as undesirable. Hence a system of using individual watering cups or buckets for cattle stalls is on the in-

crease. By this plan each cow has her own covered cup, the lid being automatically kept closed, except while she is drinking. It is easily opened by the animal in whose stall it is located, but not by a neighbor. The level of the water in the cups is regulated by the quantity of water in a regulating, or control, tank, the level of tank and cups being the same. A regulating valve maintains a uniform level of water in the tank, the supply being taken from any suitable source, such as a well, spring, a stream, or a cistern. Each watering cup is connected to the control tank by a pipe with a flange inside the stall which prevents the water from being splashed out. Each cow gets the water from the protected cup into the cup.

Much interest has been gathered since a booklet recently issued by a large eastern railway, which takes up, according to routes, most of the towns and cities on its lines. Facts about the commerce and resources of the regions traversed are also included.

*James Mfg. Co., Ft. Atkinson, Wis*



An Up-to-Date Cow Barn in Which the Stalls are Furnished with Individual Watering Cups, Which Minimize the Danger of Spreading Contagious Diseases and Afford a Constant Supply of Water

At the Right, an Individual Watering Cup with Its Feed Piping: The Level of the Water in the Cups is Kept Constant by a Regulating Tank and Valve. The Cow can Easily Open the Cup to Drink, but cannot Slop Out the Water

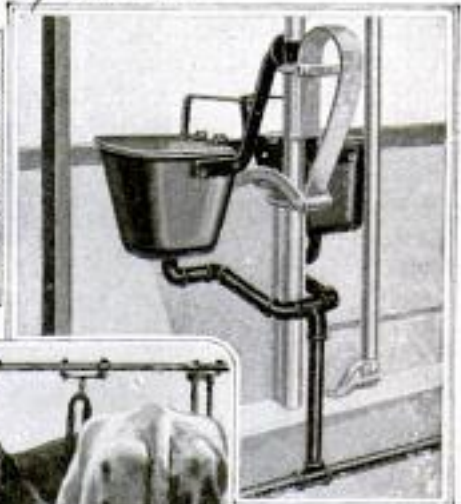

Individual Watering Cups can be Installed in the Open Air for Summer Use, as Well as in a Barn

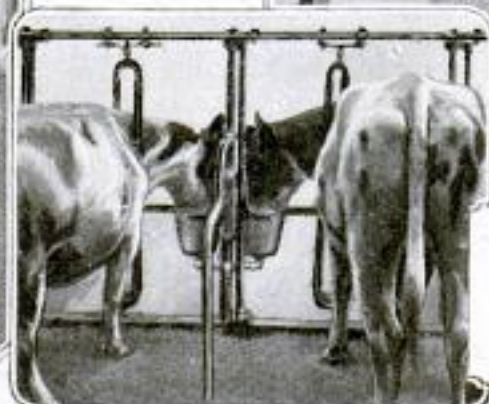

*W 253  
Cow in stall  
The faucet  
blue print*

*James Mfg. Co.  
Ft. Atkinson, Wis.  
Public  
P...*



### STANDARD NAMES ADOPTED FOR AUTO PARTS

### NEW NAVAL ANTIAIRCRAFT RIFLE TESTED

In a timely attempt to standardize the names of automobile parts, a list of about 600 words and phrases has been adopted by the Society of Automobile Engineers and is recommended for general use. The nomenclature included in the list was developed at a series of meetings of engineering and service representatives of leading automobile manufacturers. It comprises the more important parts throughout the whole of a car, minor parts such as bolts and studs being indicated in general terms. Body parts have not been included generally, nor parts of some units, such as the carburetor, which vary so much in construction as to make anything like uniform nomenclature very difficult. The list as published is classified mainly according to functions. It should aid materially in securing uniformity in usage that will prevent many of the delays common in replacing parts, and also tend to greater clearness and brevity in the vocabulary of the automobile. For instance, the use of the name "engine" is recommended rather than "motor," to avoid confusion with electric motors; while the terms "foot brake" and "hand brake" are recommended instead of "service brake" and "emergency brake."

CA congressman-elect recently traveled from Philadelphia to Washington in his own biplane, piloted by an army officer. He says he is the first man to fly to congress.

The present war has wrought many changes in the fighting equipment of all nations and perhaps none are more interesting than those which have been

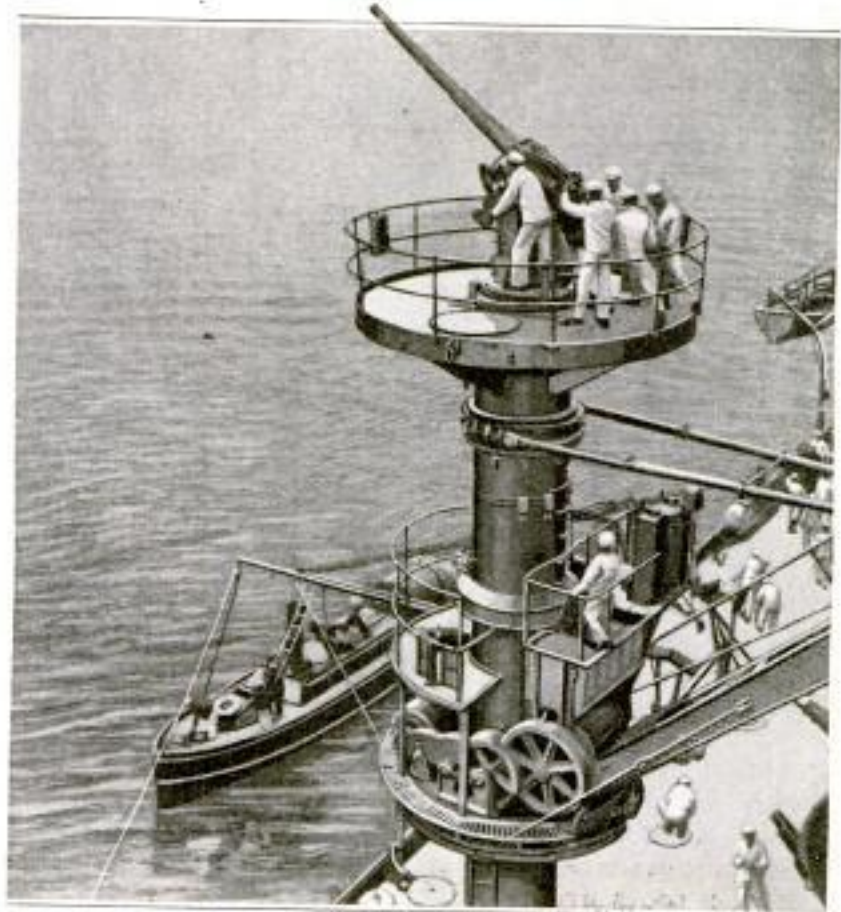

View of the New Three-Inch Antiaircraft Gun Mounted on a Special Platform 40 Feet above the Deck of the "Texas." It Fires 30 Shots a Minute and is Manned by a Crew of Seven Men

brought about because of the conspicuous part played by air craft. One of the weapons which fighting ships now require is the anti-aircraft rifle. The 3-in. gun shown in this illustration, mounted on a special platform, 40 ft. above the deck of the battleship "Texas," is of this type. It is so equipped that it can be pointed upward at a steep angle. The weapon fires 30 shots a minute and requires a crew of seven men to operate it. If tests of this rifle prove satisfactory, other vessels in our navy will be similarly armed, for special means of defense against hostile air craft is now recognized as a necessity.



## WALLS PROTECT TREES FROM

### DIRT FILLING *Trees in Calif.*

*# Maple, 322 Boynton St.*  
 When filling a piece of property in Highland Park, Calif., with several feet of dirt the owner found that a number of fine trees were likely to be injured



Means Used in Highland Park, California, to Protect Trees on a Piece of Land Which was Filled In with Several Feet of Dirt

by the piling of so much earth about their trunks. Rather than lose them, he built an 8-in. concrete wall around each one, about 4 ft. from the trunk and 6 ft. high. This gave the trees plenty of "breathing space," and when they were irrigated the sunken areas served as convenient reservoirs for the water. Horses were allowed to run on this piece of land and so the unusual guard about each tree served to protect the roots from the pawing and stamping of the animals.

## MEDIEVAL METHOD STILL

### USED TO CAST BRONZES

The method of casting bronze statues which Cellini and other Italians brought to such perfection nearly four centuries ago is still rather closely followed by at least one well-known foundry in this country in its production of artistic bronze figures. The first step is to take the original clay statue made by the artist and cut it into pieces from which half-and-half molds can be made. Positive wax casts are then made from these, first by brushing melted wax on the inner surface of the negatives and then by pressing in sheets of wax by hand, forming a coating from  $\frac{1}{4}$  to  $\frac{3}{4}$  in. thick, according to the size of the statue. The various wax parts so made are assembled and form a wax duplicate of the bronze figure to be cast. Unless it is a very small statue the center is filled with a core to save material. Workmen now provide the wax figure with gates and vents in the shape of wax rods. Bronze rods are inserted to serve as chaplets, or braces, to keep the core in place. The next step is to cover the figure with a thick coating of a claylike compound that hardens rapidly. This rounded mass, which bears no resemblance to the statue, is baked over a slow fire, thus melting out the wax and leaving a negative shell and the core



Applying Wax to Inside of Plaster Negative: After Thin Coating has been Brushed On, Thin Wax Sheets are Pressed In by Hand



The Various Wax Parts Assembled, Forming a Duplicate of the Bronze Figure to be Cast



Wax Statue After Wax Rods have been Attached to it to Form Vents. Other Rods of Bronze Serve as Chaplets





Molds Which have been Baked and from Which the Wax has been Melted. After the Bronze has been Poured In and Cools This Outer Coating is Chipped Off



The Final Step: Hand-Finishing the Bronze Figure with a Stiff Brush. The Surface is Usually Chemically Treated Also, to Produce the Color Admired by Artists



Carefully Removing Small Particles of the Molding Compound Clinging to the Surface of the Bronze. All the Work in Making Each Statue is Done by Hand—a Fact Which Adds Considerably to the Expense



Bronze Statue as It Comes from the Mold, Which has been Carefully Broken Away Piece by Piece. The Rods and Gates will be Removed by Hand



Wax Replica Covered with Molding Compound, More of Which is to be Added. After the Outer Coating has been Completed the Object is Baked and the Wax Melted Out and Replaced by Bronze



with a narrow space between. The bronze is poured into this mold and so the statue is formed. When it has cooled, the covering is carefully broken away and the core removed. The task which remains is to remove the various gates, or bronze projections, which formed in the vents and to finish off any slight unevennesses in the surface.

3275  
**FIRST HAWAIIAN AIRMAN  
 GETS PILOT LICENSE**

The first Hawaiian airman to receive an official pilot's license from the Aero Club of America traveled 6,000 miles



COPYRIGHT BY AERO NEWS SERVICE  
**Sen Yet Young, the Only Hawaiian Airman, Recently  
 Made a Successful Solo Flight for His  
 Official Pilot's License**

from Honolulu to make the necessary solo flight at the Curtiss training field, Buffalo, N. Y., recently. His name is Sen Yet Young, his father being a wealthy Chinese resident of Honolulu, where the airman was born. As he is the only Hawaiian who has mastered the art of flight, he remained to study the mechanics of the aeroplane at the Curtiss factory, before returning to Honolulu, where he will have to act as

Fifty replicas of the statue shown in the accompanying illustrations are to be presented as perpetual trophies to the national guards of the various states. The figure is that of Eliphalet Remington, who completed his first rifle in 1816. A large copy of the statue is to be erected in Ilion, N. Y., the home of Remington.

his own mechanic. He will take back an aeroplane to Hawaii and expects to astonish the natives with some spectacular flights.

3349  
**PANORAMIC CAMERA FOR  
 MOTION PICTURES**

With the ordinary moving-picture camera the field of sight is limited to an angle of 30°, but a panoramic camera recently perfected by a Nashville, Tenn., man is capable of taking moving pictures covering a field just five times as wide, or an angle of 150°. Five lenses are used, each set at a different angle, so as to secure the greatest possible range. The film used is 3¾ in. wide, or about three times the standard width, and the two sets of sprocket holes are of the ordinary kind. Operation of the five shutters is centralized and controlled by a single crank, which works similarly to that of the standard camera. The panoramic view is recorded in five sections which appear side by side on the wide film and harmonize perfectly when projected upon a screen of special width. At a private exhibition by the inventor in Nashville recently, the screen used was 75 ft. wide and a remarkable reproduction of a baseball game was shown. The camera had covered the entire field. All the players, the outfield, and even the flight of the ball through the air, could be seen and judged as though the spectators were seated only a few paces behind the home plate. Interior views, for photoplays, may be filmed with the same facility and completeness as outdoor scenes, the new camera being readily adaptable to studio use.



3434

*Johns*

# Salvaging Human Wrecks from War's Scrap Heap

## IN THREE PARTS

By SEARLE HENDEE

### PART III—Reëducating the Maimed

THREE months after the outbreak of hostilities, France began preparations for the reëducation of its "glorious cripples," the army of rebuilt men pouring from the military hospitals into the streets, there to feel the cruellest sting of war. One by one the other belligerent nations took similar steps; some a bit late, but all in due course. Today nearly the whole world is struggling to meet the most appalling human problem that civilization has ever faced, that of converting millions of disabled, broken-spirited soldiers

into useful, self-reliant, and self-supporting civilians.

Several months ago the Danish War Study Society estimated, after careful investigation, that 11,245,300 combatants had been wounded, and of that number, 3,373,700 "hopelessly," during the present conflict. Europe's battles are being waged by men and boys of all walks of life. Leaving the hospitals are throngs of limbless, paralyzed, blind, deaf, and worn-out men. Among them are musicians whose hands are missing, railroad men whose feet are

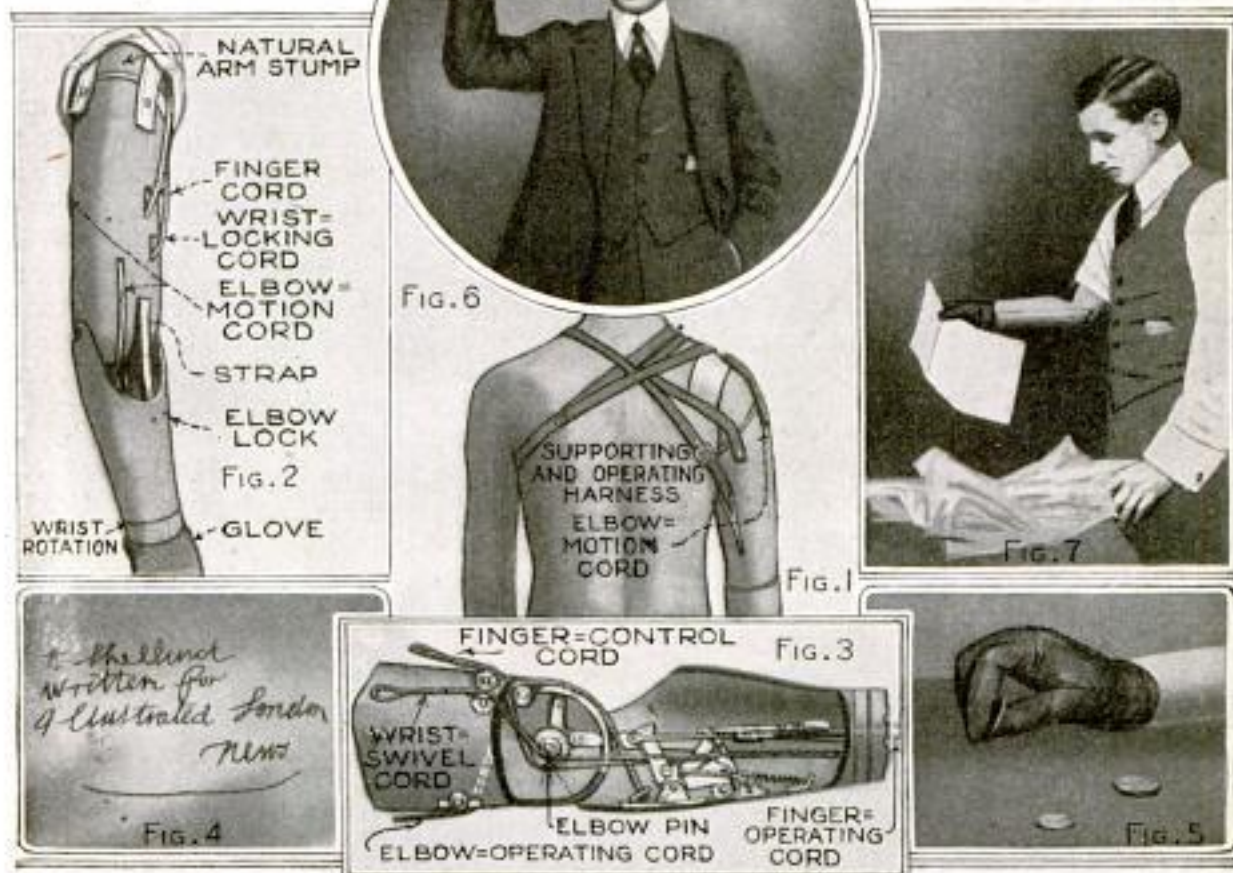

BY COURTESY OF THE ILLUSTRATED LONDON NEWS  
 Figure 1 Illustrates the Supporting and Operating Harness Used with an Artificial Arm of American Invention, Shown in 2; the Elbow, Wrist, and Finger Mechanism is Indicated in 3, While Figure 4 Is a Specimen of the Penmanship of a Man Fitted with This Ingenious Member. Coins can be Picked Up, a Hat Tipped, or Papers Handled with Ease, as 5, 6, and 7 Picture



gone, telegraphers who cannot hear, and machinists who are sightless.

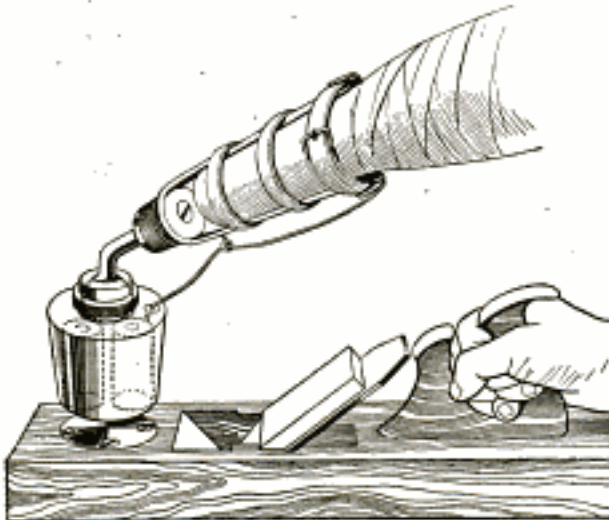

For Certain Kinds of Manual Work, the Magnetic Hand, a German Invention, Seems to be Practical. It is Shown Here in Use by a Carpenter.

Then, too, there are those pitiful wrecks with children's minds.

Fortunately for all concerned, artificial limbs are being perfected which perform to a remarkable degree the functions of the members they replace. They are no longer designed chiefly to lessen the conspicuousness of men's deformities. This is the salvation of Europe and its shattered soldiers. The empty sleeve and the peg leg have

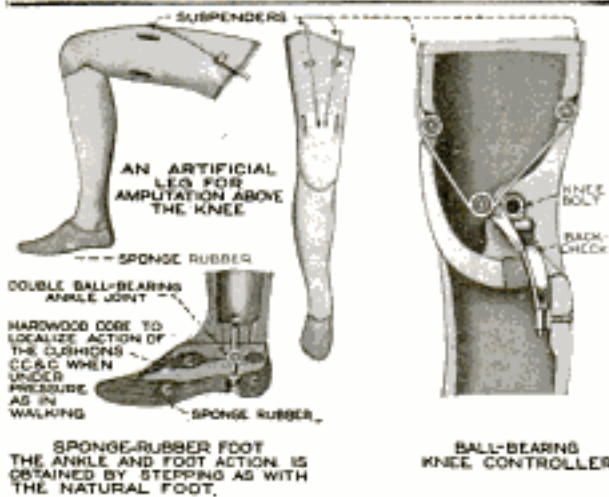

FROM THE ILLUS. LONDON NEWS

These American and European Artificial Limbs Are Among the Best so Far Devised: The Foot of the Leg Has a Sponge-Rubber Sole, a Remarkably Flexible Substitute

passed. In their place are a highly ingenious mechanical arm fitted with a hand almost human in its movements, and a leg, with flexible joints, that ena-

bles its wearer to walk without limping noticeably.

It is gratifying to know that what the French and English consider the most admirable artificial arm yet developed is a product of a Kansas City concern. With this device a large percentage of the ordinary needs are met. Straps that fasten about the shoulders manipulate the arm, causing it to rise, stretch out, bend inward, or drop life-like in the position of rest. The motions are imparted by the shoulder-pull thongs which in turn actuate the mechanism. In the same manner, the hand is opened or closed at will, turned at the wrist, and moved back and forth. By extending the arm the fingers are opened. By then bending or lowering it, they are closed so as to grasp firmly an article of almost any "reasonable" shape. Thus most of the daily needs can be performed quite satisfactorily, while a man who has lost only one arm is enabled to do almost whatever he wishes.

Another wonderful hand is one invented by a Berlin surgeon, Max Cohn, who lost his left forearm through an infection contracted while operating on a wounded soldier. This device is so ingenious that it has allowed its inventor to continue his professional work without serious difficulty. The fingers can be stretched out, separated, brought together, and curled in quite a natural manner, while the hand, in addition to opening and closing readily, can be turned with a wristlike motion from one side to the other. Motive power is supplied from the shoulder by means of a harness. One engineer, who lost both hands and was supplied with artificial ones of this type, found it possible to do his work almost as well as originally.

For tradesmen, farmers, and laborers, devices that bear little or no similarity to the human hand so far as looks are concerned, but which have the necessary strength for heavy work, and in some cases also the agility of motion needed for writing, are made: One of these is essentially a holder for various tools specially designed to be





Although Bearing No Similarity to the Human Arm, These Mechanical Substitutes Enable Their Wearers to Do Work of Various Kinds. Copied from an Actual Photograph, the Sketch Shows a Man Writing Legibly with an Arm Amputated Far above the Elbow, and a Girl, Whose Forearm is Missing, Crocheting. These and Other Equally Delicate Operations can be Performed Readily



The Man Pictured in the Upper Left-Hand Corner of This Page is Using the Type of Arm for Which the Implements Illustrated Above are Intended. The Gloved Hands are Designed Only for "Dress Parade," for Their Fingers Are Actionless and They Merely Tend to Conceal Deformity



PHOTO COPYRIGHT, MEDEM PHOTO SERVICE

Here Is a Well-Known French Motor-Car Driver Who Lost Part of His Right Arm in Battle. The Mechanical Substitute Which He Wears Enables Him to Control a Machine Easily



Mechanics and Others Whose Work Depends Largely upon Their Arms and Legs have been Crippled. But Many of Them are Learning to Pursue Their Occupations with the Aid of Artificial Members



Bicycle Riding is Not Barred to Armless Men: Even Soldiers Who have Lost Both Hands and a Foot can, with the Aid of Artificial Limbs, Use a Cycle. To Many the Vehicle is a Great Benefit



fitted to it. Different forms of grips also permit the use of shovels, carpentering tools, and other implements. Another consists of a jointed steel bar that can be adjusted to different positions. It has a ball-and-socket joint in the stump to which it is fixed, and at the opposite end a crab-claw grip. To most of these a gloved hand can be attached for street wear.

Quite interesting is a magnetic hand, introduced in Germany, that has proved helpful to certain classes of workmen. It is provided with a strong magnet mounted on a ball-and-socket joint so that the poles can be brought

into any necessary position. With it, metallic articles, or those of other materials fitted with metal plates, can be raised, moved about, or held firmly. Current is supplied through a flexible cord and is switched on or off at will. For many operations, such as handling sheet metal for stamping machines, and doing planing, filing, and similar work, the appliance operates very

satisfactorily. Magnetic tweezers, pinchers, and fingers are also used. A portable battery provides current when a lighting circuit is not available.

As for artificial legs, one of the most ingenious can be used almost without exciting notice. A cushioned knee hinge joins the thigh and lower portions, while a lever, pivoted in the former and connected with a spring inside the calf, allows it to be bent naturally. A central ankle pivot, which makes possible an easy stepping movement, is provided in the foot. Rubber cushions beneath the heel and instep absorb the shocks. The foot piece of another leg of this sort has

a double ball-bearing ankle joint which provides for sidewise motion. Similar to this is one with a rubber-ball joint that has almost the pliability of the human ankle.

Not long ago a New York business man who had just returned from central Europe remarked, during a conversation, that he had seen comparatively few maimed soldiers in Germany and Austria. Had this man gone a short distance from Berlin or Vienna, however, he might have discovered whole villages of them. Right at this time war cripples are not being placed on exhibition for American travelers. "Cripple Town" is to be found almost anywhere except in the capitals and big cities of the Continent. In some instances these camps of limbless men are situated on large estates in the countryside. England, France, Germany, and Austria each has 50 or more of them, some accommodating several thousand soldiers and sailors. Belgium has a few, Russia may have



BY COURTESY OF OFFICE APPLIANCES  
Here Is One of the Special Typewriters That have been Devised for Crippled Men: It can be Successfully Operated with One Hand and a Leg

many, and Italy is establishing them. They are the places where the reclaimed soldiers are taught to use their mechanical limbs and make themselves self-supporting civilians.

The reëducation of Europe's millions of maimed thus includes both their mental and physical training, or retraining, as the case may be. In the main there are three general classes of cripples: those who have been accustomed to mental work, those who have done physical work but are capable of the former, and those who have done and must continue to do physical labor. Of the three, the last group offers the greatest difficulty. In all cases, how-

ever, he might have discovered whole villages of them. Right at this time war cripples are not being placed on exhibition for American travelers. "Cripple Town" is to be found almost anywhere except in the capitals and big cities of the Continent. In some instances these camps of limbless men are situated on large estates in the countryside. England, France, Germany, and Austria each has 50 or more of them, some accommodating several thousand soldiers and sailors. Belgium has a few, Russia may have





ever, the first step is to endeavor to devise some means of enabling an individual to resume his former occupation. When this effort fails, the next move is to find work, as nearly analogous as possible to that formerly pursued, that can be undertaken successfully. Often this tests the ingenuity of the instructors and the patience and courage of the apprentice to the extreme.

One of the most interesting things in connection with this great undertaking is that the blind are teaching the blind and the crippled instructing the crip-

The Pictures on This Page Illustrate What is being Done at St. Dunstan's Lodge in Regent's Park, London. Above Is to be Seen the Anatomy Class in Session. The Men, All of Them Blind, are being Given Professional Instruction in the Art of Massage



Gardening, Poultry Raising, and Other Outdoor Occupations are Open to Blind Soldiers. With the Aid of a Guide Line or Board the Sightless Men Quickly Learn to Spade Ground and Plant Vegetables



Push Ball Is a Popular Form of Recreation for the Inmates of St. Dunstan's Lodge. Their Shouts of Triumph and Cries of Laughter Are so Surprisingly Full of Joy and Abandon That One can Scarcely Believe the Players Are Blind



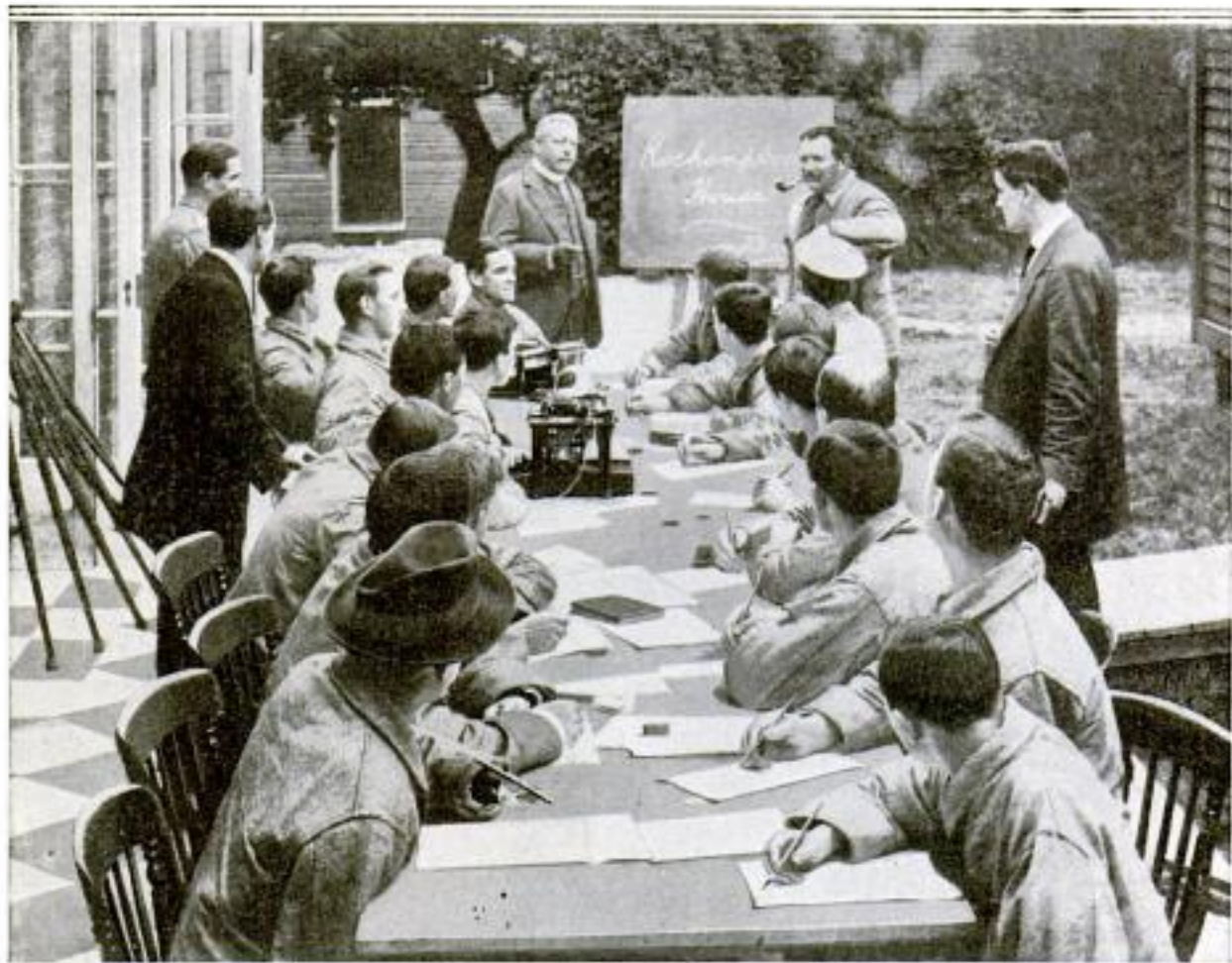

The Presence of Artificial Arms and Legs Instead of Real Ones No Longer Spells Uselessness to the Ex-Service Man. Maimed Soldiers at One of the Cripple Camps are Shown Here Absorbed in Schoolwork

pled. Maimed men are the most successful tutors of the downhearted "amputés" who come fresh from the hospitals, their movements awkward, their courage dying. With a sympathetic bond existing between teacher and pupil, and all of the psychological forces acting in the right direction, veritable wonders are accomplished. When a fellow with legs and arms that work with gears and levers begins to see what his companion in misery can do with similar appliances, he usually gets a grip on himself and lays to with his whole soul. And were it not for such encouragement, many of Europe's maimed could never undergo the metamorphosis that restores manhood and usefulness.

Some of the most marvelous attainments in readapting these men for the workaday world are being wrought at St. Dunstan's Lodge in Regent's Park, London, where the British are teaching

blind ex-service men to do useful, profitable work.

In some of the shops the men are engaged in basket weaving, shoe repairing, wood joining, and mat making. In another department they are taught to read and write according to the Braille system, to operate a Braille shorthand machine, and to use ordinary typewriters. Then there is a model farm on the grounds where instruction in gardening, poultry raising, and the care of stock is given. It seems incredible, but these blind men soon are able to distinguish different fowls by touch, to drive chickens from one coop to another, gather eggs, and attend to an incubator. A knotted string or a notched board is used to enable sightless gardeners to spade plots of ground properly and do the necessary planting.

In determining the kind of work best suited for certain types of cripples, motion study has accomplished much.



### SETTLING BASINS CLEAR DESERT WATER OF SILT

An interesting and important problem which appeared following the development of irrigation projects in the Imperial Valley in southern California, was how to supply drinking water to the population supported by this region which once was desert. The objection to using the water just as it came into the ditches from the Colorado River is apparent, for in its wild race through the Grand Cañon it becomes heavily laden with silt and is chocolate-colored. By the time it reaches Brawley, for example, in the northern part of the valley, it has almost the consistency of molasses. The drinking-water problem for this town of approximately 3,000 persons has been solved by running the water into settling basins about 200 feet square. The amount allowed to flow into the basins when once they are full, is equal to that drawn out, which is about 200,000 gallons per day. At the end of a basin opposite the inlet is a raft which supports a vertical pipe, the end of which is submerged in the water about 6 in. Through this the surface water, which is the clearest, is drawn into a standpipe, that supplies the city mains. About 30 inches of silt will accumulate in one of these beds in a year.



One of the Settling Basins at Brawley, California, into Which Silt-Laden Water is Run before being Pumped into the City's Water Tank

### ADDING MACHINE WITH SIMPLE KEYBOARD

An adding machine with a keyboard of unusual simplicity places the decimal point in a row of figures automa-

*Dalton Adding Machine Co.  
Norwood, Cincinnati, O.*



Adding and Calculating Machine of Simplified Construction, Having Only 10 Figure Keys to Operate, and Capable of High Speed by the Touch Method

ically. There are only 10 figure keys on the keyboard, instead of 80 or 100 as in other cases, and because of this fact it is claimed that the speedy touch method can be used in figuring, thus



View of One of the Emptied Settling Basins, Showing a Deposit of 30 Inches of Silt Which Accumulated in One Year



increasing the efficiency of this calculator for office use. To introduce a number or a series of numbers into the machine, it is necessary only to strike in their natural order the keys corresponding to the figures composing the number. No attention need be paid to decimal order, in writing dollars and cents, for instance, because by an ingenious system of control by levers and stops the mechanism takes care of this, placing the figures in their proper columns—units under units, tens under tens, and so on—without the operator giving it the least concern. The machine also performs all the usual operations of a mechanical calculator, and makes a printed record of the work done.

3149

#### FOUR HOMELESS BANKS OCCUPY ONE BUILDING

The erection of a bank building which housed four rival banks and contained a single brick vault in which their funds were kept, was one of the unusual results of the fire that swept over Paris, Tex., last spring. Included among the 1,440 structures destroyed were the homes of these four banks. Permission was granted them to erect a temporary structure and vault in the public plaza. A short time after the fire, a building, 50 by 100 ft., was begun, and it was ready for occupancy 72 hours later, the work having been

rushed by night with the aid of searchlights, as well as by day. The walls were of hollow tile. The brick vault measured 20 by 24 ft. To meet the emergency, large sums of ready money were expressed to the banks, and their reports showed that they had \$4,000,000 in cash stored in the vault at one time.

— 3228

#### SAFETY FENDER FOR AUTO BUSSES AND TRUCKS

Tests were recently made by a committee of the New York Public Service Commission of an automatic safety fender designed for use on auto busses, auto trucks, and street cars, and its adoption was recommended as a "distinct advance in existing means for safeguarding the lives and limbs of persons who are struck or come in contact with such vehicles." This new fender is operated by means of springs and a trigger trip which simultaneously drops the fender and sets the brake. It consists of a lifeguard hanging vertically in front of the bumper of the car, bus, or truck, and an apron extending horizontally at any required height above the pavement and projecting 26 in. in front of the bumper. In the official tests the apron was carried 7 in. above the pavement. Lifeguard and apron are made of woven wire, with diamond-shaped mesh. The guard is suspended from flat spring

J. W. Lyons  
Elihu Clark  
108-116 W. 43rd St., N.Y.C.  
(Inv. + MFR)



View of Temporary Building Erected after a Big Fire in Paris, Texas, to House Four Banks. The Single Brick Vault in the Structure Contained \$4,000,000 in Cash at One Time





Manual Pickup of a Prostrate Man-Size Dummy in Official Test of New Safety Fender for Motor Trucks in New York. The Fender can be Operated by the Driver, but Also Works Automatically. When Not in Use, It Folds Up, as Seen at the Left

hangers, giving a cushion effect in front of the vehicle, and the apron rests against long coil springs which also serve as a cushion when the fender strikes any person. A simple locking device prevents the fender from tripping automatically on rough paving.

### THALLIUM USED IN MAKING TUNGSTEN BULBS

An interesting example of the use which is being made of various chemical by-products that formerly were thrown away, is found in the utilization of thallium from certain zinc ores. A small amount of a thallium-chlorine compound is used in making a tungsten incandescent lamp. When it has been added in the proper proportion this substance partially volatilizes and slightly decomposes. The chlorine, on being set free, combines with the brown deposit that settles on the inside of the glass bulb, forming a combination of chlorine and tungsten. This compound circulates through the lamp and after a time comes in contact with the incandescent wire and is decomposed there, by the heat, and so the tungsten is deposited on the filament from which it was originally volatilized. In this way, through the agency of this compound, chlorine over and over again causes the tungsten to return to the wire from which it was given off.

3293  
# **HANDY NEW CUTTING TOOL FOR METALS**

484 BRADFORD AV. MILWAUKEE, WIS.

With a new and easily operated tool invented by a Milwaukee man, holes of various sizes can be readily cut through plates of metal, fiber, or slate. It is designed especially for making additional holes in cabinets, lockers, tanks, or cases of any kind, in which it has heretofore proved troublesome to cut holes after they were finished and set up. To use the tool a pilot hole is first drilled



through the material and the stud is inserted. A flange nut is then secured on the opposite side of this stud and a few operations of a ratchet wrench cuts out a neat hole. The knives, which may be adjusted for cutting holes of different diameters, are held in a swing chuck and are fed automatically by means of the spring shown in the illustration between the swing chuck and the sham nut. It is claimed that the tool will do the work of a 6-in. drill press and that many uses will be found for it in various industrial plants.

Bach, (J.M.V.)  
Milwaukee, Wis.  
Copyrighted material



2993  
**BELT CARRIES TRAYS OF  
 CAFETERIA PATRONS**

*Endicott, Johnson & Co.*  
 A belt conveyor has been installed in a cafeteria in Johnson City, N. Y., to carry the trays of its patrons while

front of the food counter and by holding the trays level so that there is no spilling of the contents of the dishes. The cafeteria is conducted by a large shoe factory. The patrons, chiefly employes in the factory, pass in single

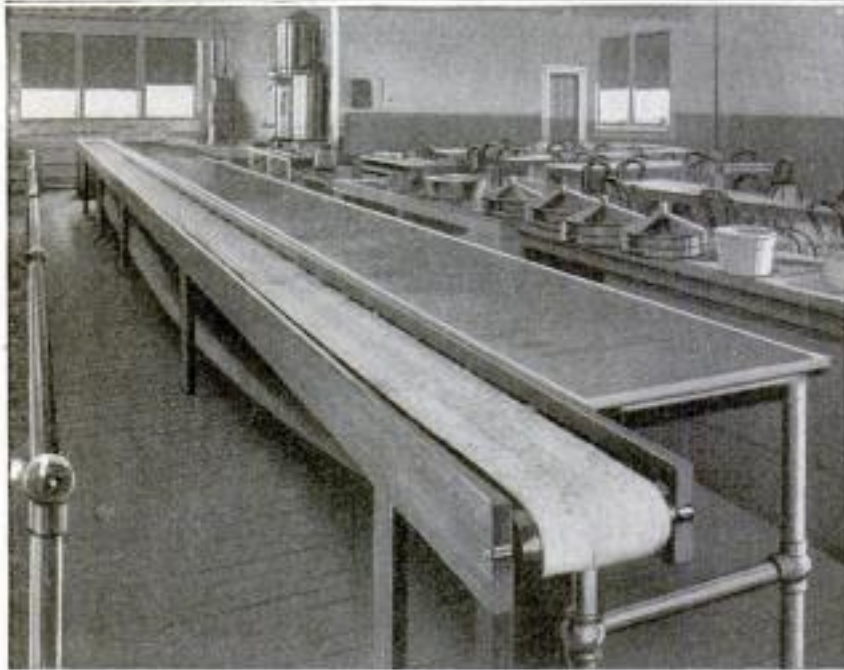

New Conveyor in a Johnson City, New York, Cafeteria Which Carries the Trays of Its Patrons, Thereby Preventing Congestion and the Spilling of the Contents of the Dishes

file in front of a long steam-heated counter on which is the food supply. Between the patrons and this counter is the traveling belt, which is 45 ft. long and is supported on rollers set 12 in. apart. Persons selecting food place their trays on this conveyor and walk along beside them at a moderate pace, while such dishes as they may indicate are placed on their respective trays. On reaching the end of the belt each person carries his meal to a table. Under the new system 840 employes have been served, without confusion, in 45 minutes. Formerly there was much congestion at the noon hour.

they select their food. It serves a two-fold purpose by preventing loitering in

tion, in 45 minutes. Formerly there was much congestion at the noon hour.

3334

*Louis S. Fletcher*  
**CAR PRESS MAKES ROOM  
 FOR ORANGE BOXES**

A frequent cause of damage to oranges in transit to markets has been the rocking of the orange boxes, through loose packing in the car, which resulted in bruising the fruit. An orange-shipper's car press, the recent invention of a Redlands, Calif., man, is therefore proving very useful to the fruit-shipping concerns of the citrus districts of that state, and to the railroad companies. Oranges are usually shipped in refrigerator cars holding 480 boxes. In loading, the boxes are placed in rows two high, and a car tie or strip is nailed across each row to hold them in place. When the rows from each end of the car approach each other in the center, the car press is shoved into

the empty space and operated by hand, after which there is room for three or four additional rows of boxes. When these are inserted, the carload is packed so compactly that the boxes cannot rock and the danger of bruising the fruit is practically eliminated. The press is a framework of heavy wood,

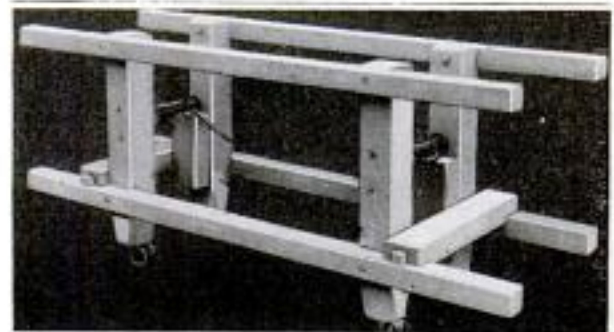

This Car Press Squeezes Outward with a Pressure of Two Tons and Makes Room to Pack California Oranges Tightly in a Car



but easily handled, with jackscrews that squeeze the side timbers outward with a pressure of two tons.

2980

### PARK SEATS RESERVED FOR WOMEN AND CHILDREN

The officials in a western city have set aside certain seats in one of the city parks for the exclusive use of women and children, and their escorts. This fact is announced by a large sign placed in the middle of the walk on which the reserved benches face. This arrangement is similar to that existing in some other cities, which have recognized that women, and children as well, in a public park are not always free from annoyance by strangers. A ruling which excludes all men, except those who are acting as escorts, from certain sections or seats, serves to make a park more attractive to women



Sign in Park Which Designates Certain Benches, Where Women and Children may Rest with Little Risk of being Annoyed by Strangers

and children, and insures for them places where they can sit undisturbed.

2521

### WRIST WATCH MADE TO BE CARRIED IN POCKET ALSO

A wrist watch has been designed by a New York watch manufacturer which can be worn either in the breast pocket of the coat, in the vest pocket, or on the wrist. The convenience of having one timepiece which can be carried when one is dressed for social functions, for business, or for outings, is apparent. Attached to the watch is a neat leather strap which serves as a wrist band or as a chain. On the end of the strap is a special hinged clasp which makes it possible to double the

*Jacques Depollier & Son,  
15 Maiden Lane  
N. Y. C.*

guard into a loop of any desired length after passing it through a buttonhole or through the metal link on the edge of the case, opposite the stem. When



A Watch Designed so That It can be Worn on the Wrist, in the Breast Pocket, or in the Vest Pocket

one desires to carry the watch in the pocket this metal link on the case can be adjusted so that it is practically invisible. If desired, the timepiece can be fitted with a crystal described as unbreakable and made of a substance that is nonexplosive.

3056

### REMOVING FIRE HOSE FROM CASE TURNS ON WATER

A fire-hose cabinet, which has received the indorsement of several fire underwriters, is so constructed that as soon as the hose is drawn out of the cabinet water begins to flow through it. In this way no time is lost in preparing to fight the flames. In the case, at the end of the water pipe to which the hose is attached, is a valve that is connected with the flexible tubing by a short steel cable. When the tubing



1 NY:

*John Eggleston,*

*Westfield, Mass.*



has been removed for practically its whole length, the valve is automatically thrown open and the water begins coursing toward the nozzle. It requires but three seconds to get 50 ft. of hose ready for action. The cabinet is equipped with rubber-covered spring supports which hold the hose in neat, compact folds without injuring it. The outfit is suited for use in a home, as well as in a store or factory.

### 3094 — ACCIDENT TOLL SHOWN BY AUTOMATIC DISPLAY

A mechanically operated safety-first exhibit has been devised by two employes of the labor department of the state of Kansas, which tells in a remarkably vivid manner the need of taking precautions against accidents. It consists of a vertical display case, in the upper half of which is installed an electric bell and an electric light. A printed explanation between the two declares that some one in the United States is injured every time the light flashes, which is every 15 seconds, and that a worker is killed every time the bell rings, which occurs every seven minutes. These calculations are based on the present accident rate. In the lower half of the case a slowly revolving frame brings into view, one at a time, a series of pictures, each of which is accompanied by an appropriate safety-first legend.



Investors:  
B. C. Baird, Deputy Factory Inspector, } Topeka,  
A. Alden Knapp, Chf. Clk. of Dept., } Kan.

### DISTINCTIVE THEATER FOR MOTION-PICTURE PLAYS

*The St. Francis Grand St.*  
A motion-picture theater has recently been opened in San Francisco in which several features common to the ordinary theater have been omitted or altered. The purpose of this has been to provide for the best possible presentation of the films and also to give the playhouse a distinctive character. There is no stage, and not even an archway such as usually sets off a screen. The pictures are thrown upon the wall nearest the street and as one passes through the curtains at the entrance he finds himself at the front row of seats instead of at the rear. Easy inclines take the place of stairs and lead to the balconies at the rear and sides. The pit for the orchestra is set low and accommodates 20 musicians. Organ pipes are concealed behind grillwork either side of the screen. All of the decorations are in pastel shades.

### 2940 — INCLINE TO SHORTEN ROAD TO YOSEMITE PARK

A new mountain road and a double-track incline railway have been projected for Yosemite National Park, which when completed will shorten by 45 miles the route that westbound motorists on the Midland Trail follow when going to the park. The proposed short cut, for which it is believed the government will make the necessary appropriation of \$200,000, will lead from a point north of the valley, known as Porcupine Flat, directly down to the floor of the valley. This direct route is but six miles long. At present cars are required to follow a great loop, 51 miles long, to arrive at the same destination. About five of the six miles will be roadway and the remaining 6,000 ft. will be traversed by a tramway that will be built on a 50-percent grade, which means that it will make a drop of 3,000 ft. Between the Indian Cañon, which the tramway will follow, and the Yosemite Falls is a great shoulder of rock on which it is proposed to erect a hotel. The railway





View in Yosemite National Park with Dotted Line Indicating Route of the Proposed Incline Railway, Which, with a Connecting Road, will Shorten One Route to the Park by 45 Miles

will be operated by a 1,500-hp. plant which will receive its power from one of the minor falls in the region. The cars of the incline will be constructed so that they can carry automobiles, and their estimated capacity will be 500 motor cars a day. The altitude of the starting point of the new road is 8,000 ft. The first two miles of the highway leading up from the head of the incline will be at an 8 and 10-percent grade. The remainder of the route will be practically level.

2890

#### DEVICE FOR CUTTING WIRE BARRIERS FOR TRENCHES

A device for cutting wire entanglements, such as are erected to guard the trenches in Europe, has been invented by a resident of Kansas City, Mo. The cutting parts resemble the toothed blades of a farm mower and are attached to a wooden frame that fastens to the body of the soldier or other person operating it. The frame holds the blades in a vertical position and as the teeth come in contact with an entanglement, a lever is drawn for-

ward and backward, producing a shearing motion which severs the wires.



Device for Severing Wire Entanglements Which will Cut Several Wires at a Time and will Protect the Wearer from Electrical Shocks

The frame being of wood, the wearer is protected against electrical shocks.

It is claimed that one can cut his way through barbed-wire entanglements with this device, as fast as he can walk.



John Wanamaker  
N. Y. C.

Covrey - Davis & Co.  
Shelbyville Ind

3425  
HANDSOME AND USEFUL FURNITURE



1  
Mahogany Sewing Table in Which is Ample Room to Keep Work Materials. The Handles beneath the Leaves Make It a Convenient Table to Move



3  
Smoker's Cabinet Having a Spacious Humidor in the Upper Part. Convenient Shelves Below, and a Pipe Rack on the Inner Side of the Door



W + J. SLOANE  
5th Ave. + 47th N.Y.C.  
San Francisco Cal.  
Washington, D.C.  
(see 6)  
1271

2  
This Handsome Console Table, Together with the Artistic Cane-Back Armchairs, and Mirror, will Give a Suggestion of the English Style of the Early Nineteenth Century



4  
Novelty and Convenience Characterize This Little Writing Desk. When Open, as Shown Above, Places for Writing Paper, Ink, and Pens are Revealed. When the Leaves are Closed, as at the Right, It Occupies Small Space



5  
An Odd-Shaped Table, 32 Inches Long and 25 Inches Wide, with Top and Shelf Decorated with French Prints Covered with Glass. It is Suitable for a Boudoir or Living Room

Heywood Bros + Wakefield Co.  
1415 S. Mich. Av. Chicago

270  
4-10

Copyrighted material

5- The Little Shop - Around the Corner,  
531 Liberty St., Pittsburg, Penna.



3425

FOR VARIOUS ROOMS IN THE HOME

W. & J. Sloane  
See 2 p 270  
Chicago.  
7- One best Furniture Co.,  
840 W. Ontario St.,  
Chicago.



The Slender Lines of This Settee, Together with Its Cane Back, Give It a Very Pleasing Lightness and Grace. The Upholstery and Cushions are Finished in Striped Material Well Suited to the General Design



An Electric Floor Lamp of Beautiful Design: The Elaborate Base is of Carved Wood. While the Heavily Fringed Shade Has Rich, Subdued Colors Which Shed a Soft Light



8 Conroy - This Solid-Mahogany Reading Table, with Adjustable Rack, can Also be Used for Note Taking. The Slanting Surfaces are Hinged and Cover a Compartment for Writing Materials or Books

Davis Co. Shelbyville Ind.



9 An Artistic Telephone Cabinet in Which the Instrument is Mounted on a Shelf on the Inner Side of the Door. A Disappearing Cane Bottom Seat is Provided and on the Top Is a Flower Vase

Gimbel Bros

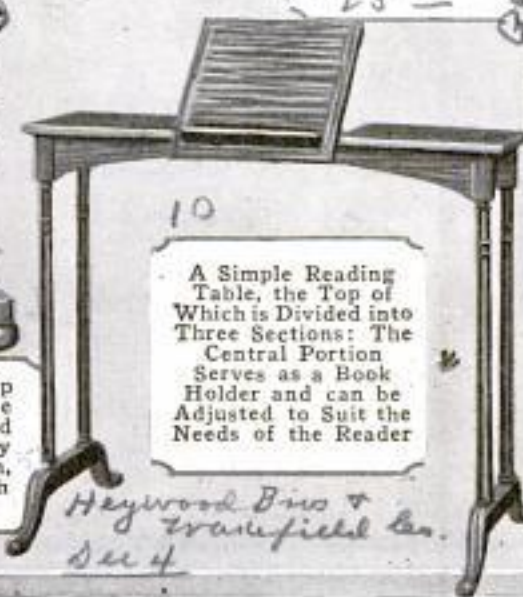

10 A Simple Reading Table, the Top of Which is Divided into Three Sections: The Central Portion Serves as a Book Holder and can be Adjusted to Suit the Needs of the Reader

Heywood Bros & Transfield Co. See 4



11 Boudoir Costumer, Five Feet High, of Carved Wood Decorated in Light Shades. The Base is Weighted to Give Stability

1350

12- Lord & Taylor  
38th & 15th Av.  
N.Y.C.

9- Gimbel Bros.,

N.Y.C.



Nation's Chronograph Co. Inc.  
1844-1846 Commodity Bldg  
111 W. Washington St., Chicago

NV: Chas J. Ryberg, 539 Bickardike St  
Chicago (President N.C. Co.)

### NEW DEVICE RECORDS TIME OF OPERATING DOOR LOCK

An electrical mechanism has been devised, which when attached to a door lock, makes a record each time

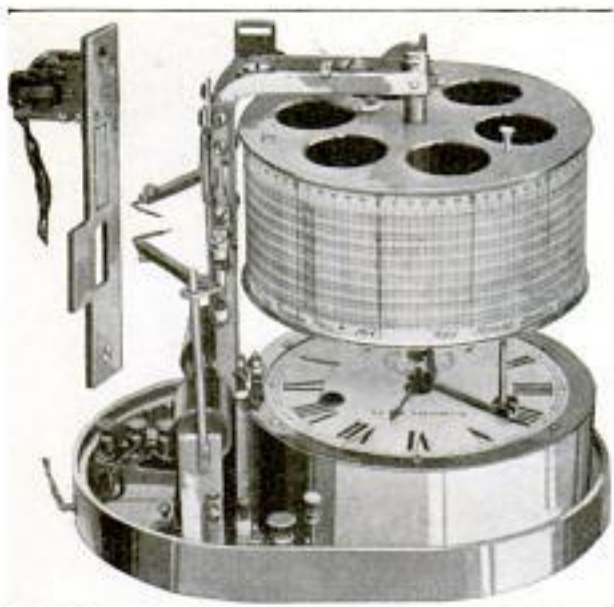

Mechanism Which Makes a Record Each Time a Door is Locked or Unlocked by Puncturing a Revolving Drum. A View of the Electrical Device Connected with the Keeper is Shown at the Left

the door is locked or unlocked. The recording parts can be placed in the proprietor's or manager's office if desired. No supplementary lock is required, such as some similar devices employ. An electrically connected device is attached to the keeper in the door jamb and either the locking or unlocking of the door makes an electrical contact. This causes a needle to puncture a time sheet placed about a revolving drum, which, together with a nine-day clock, constitutes the recording parts of the protector. This mechanism is inclosed securely in a metal case so that it cannot be tampered with. The drum makes two revolutions every 24 hours. The apparatus will run nine days without attention, then the drum must be reset and a new time sheet supplied. The protector is supplemented by an electric bell which is connected by wiring with all windows and doors. If one of these is left unlocked when the person closing the establishment passes out and locks one of the protected

doors, the bell will ring instantly, thus showing that one or more of the windows or doors have not been properly secured. When a watchman is employed to enter the place at stated hours the protected lock is so equipped that the watchman's key will cause a differently shaped needle to puncture the time sheet, while the regular needle does not operate.

1914

### TALL AND SHORT POSTS ON MAP SHOW LAND VALUES

The value of real estate in all parts of Pasadena, Calif., and its suburbs has been graphically portrayed by a novel map that forms a part of a municipal exhibit in that city. The map proper is spread out on a table, 45 in. square. On the face of it have been placed a large number of slender posts of various lengths. They are held upright by needles stuck into the table, and can be moved as occasion warrants. Each quarter of an inch in height represents a front-foot value of \$10, so that the posts show at a glance the relative values of all the land in the city from the down-town property, worth \$1,000 per front foot, to that near the moun-

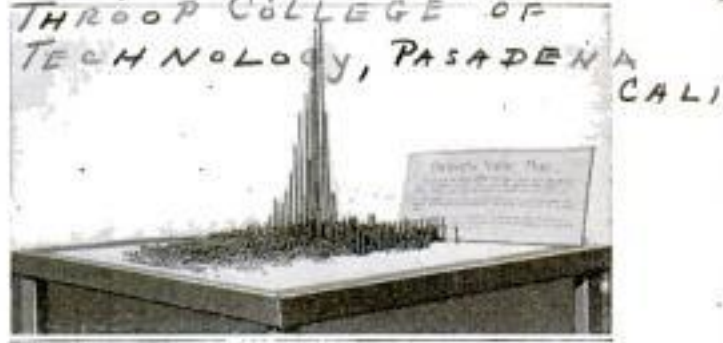

Map of Pasadena Which Shows the Value per Front Foot of Land in All Parts of the City, by Means of Posts of Various Lengths

ains, worth \$5. Small tags attached to each post state the prices so that measuring is unnecessary.

CA magnificent new passenger train, embodying the latest ideas in travel luxury, and said to have cost \$2,500,000, has been put into service between Chicago and New Orleans.



F. W. Stevens

Warren Tenoch

Newton Centre, Mass.

## POPULAR MECHANICS

273



Different Ways of Mounting the Sign so as to Apprise Motorists of Just What to Expect on the Road Ahead are Illustrated beneath the Drawings Presented Above. General Adoption of the System would Eliminate the Ununiform and Confusing Devices of Various Forms Now Used

2771

### UNIVERSAL HIGHWAY SIGNS PROPOSED FOR ADOPTION

As motor-car touring has increased, the need of simplified and standardized traffic signs along our highways has become very apparent. It is therefore interesting to study an ingenious code of signals lately devised in the East. These wordless semaphores clearly suggest the advantages that would accrue with the national adoption of some simple, uniform system. A diamond-shaped sign, with one triangle enameled red and the other white, is utilized. When in vertical position with the red half pointing downward, the sign gives warning of the proximity of a schoolhouse. A reversal of this position indicates a street crossing. Two of the diamonds mounted side by side with their red ends pointing upward announce a railway crossing. A curve to either the right or left in a road is indicated by placing the device horizontally and pointing the red end in the direction of the turn.

3255

### ARTESIAN WELL BRINGS UP FISH AFTER EARTHQUAKE

Following a recent earthquake shock which was felt up and down the Pacific coast an artesian well near Tulare, Calif., has intermittently spouted up small fish. A hundred or more of these creatures have been brought to the surface. They are about four inches long and have no eyes, in which re-

# Jno. E. Hogg

218 S. HIDALGO AV.  
ALHAMBRA,  
CALIF.

spect they resemble fish found in Mammoth Cave, Ky. Biologists in the University of Southern California state that they undoubtedly come from some underground river, the course of which was altered by the earthquake so that its waters have mingled with those of the artesian well.

### 2558 — POCKET TIMEPIECE WHICH WINDS ITSELF

A watch, which relieves the wearer of all responsibility as to winding it, has been invented by a jeweler in New Braunfels, Tex. "PERPETO"

The timepiece will wind itself if worn by a person for an hour or so each day. The motion of the body in walking and in shifting of posture serves to swing a little pendulum back and forth and this in turn operates a simple mechanism which slowly winds up the spring. When the winding is completed this mechanism is disconnected until the watch has partly run down and then it begins to operate again. A third hand on the face of the watch shows to what degree it is wound up. If the watch is not carried long enough to keep it from running down it can be wound by hand in the usual manner.



JOS. THIERS  
P.O. Box 456



3392

**SOME NOVEL AND LITTLE-KNOWN ACCESSORIES**



1  
**Hand-Decorated Drum Aquarium, a Japanese Oddity for the Sun Room. It is Priced at \$6.75**



2  
**This Aluminum Cover Enables a Milk Bottle to be Conveniently Used in Place of an Open-Top Pitcher**

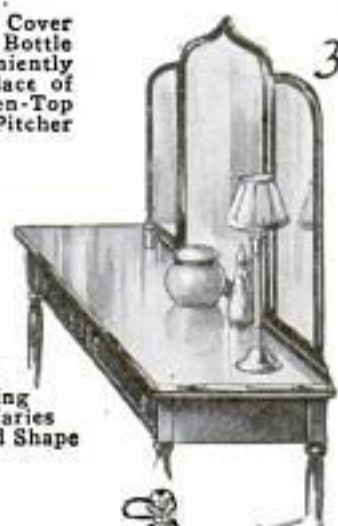

3  
**Plate-Glass Tops for Dressing Tables and Similar Furniture Protect Polished Surfaces without Lessening Their Beauty. Cost Varies According to Size and Shape**



4  
**The Spring Attachment Fitted to This Bill Case Prevents It from Illicit Removal from One's Pocket. Price \$1.50 or \$2, Depending upon Case**



7  
**A Wire Holder Supports the Water-Shedding Paper Garbage Bag While Refuse is Scraped into It. Water Drains through Holes in the Sack. An Enamelled Frame and 33 Bags Cost 60 Cents**



5  
**Dainty Ribbon-Trimmed Slipper Trees with a Novel Coat Hanger, a Gift Suggestion. Available in Different Colors, Artistically Boxed, at \$5**



6  
**Pie Crusts are Bound, Crimped, and Trimmed in a Single Operation with This Utensil, Which Is to be Had Postpaid at 15 Cents**



8  
**Easel Toilet Case, for the Traveling Bag, Which can be Placed in Upright Position on a Dressing Table. Including Articles Illustrated, the Price Is \$10**



9  
**Adjustable Casters Permit a Table or Other Piece of Furniture to Stand Solidly on an Uneven Floor. Set of Four, \$1**



10  
**Cross-Stitch Pattern Sheet Four by Six Inches in Size. Application of Hot Water Causes Material to Vanish After Work has been Finished. A Six-Sheet Package Is 25 Cents**



11  
**This Silver-Wire Holder may be Fastened to a Plate so as to Support a Teacup When Refreshments are Served Informally. It is Offered at \$2**

13  
**Sanitary Medicine Dropper That Serves Also as a Bottle Stopper. It Retalls at Five Cents**



14  
**This Electric Toaster Accommodates Six Full Slices of Bread at One Time. It is Priced at \$32**



12  
**Light Diffuser Which may be Attached to High-Power Incandescent Lamps of Different Types to Shield One's Eyes from Brilliant Rays**



- 1 - JAPANESE AQUARIUM-- Marshall Field & Co., Chicago
- 2 - BOTTLE TOP-- Heberling Novelty Co., Rochester, N. Y., 360 E. Main St.
- 3 - GLASS TOPS FOR TABLES-- G. E. Fox Co., 52 W. Kinzie, Chicago
- 4 - SECURITY POCKETBOOK-- Security Pocketbook Co., 1161 Broadway, N. Y.
- 5 - SLIPPER TREES AND HANGER-- L. N. Doud, Norwalk, Ohio - *98 W. Main*
- 6 - PIE CRUST CREMPER-- Ray Mfg. Co., North Windham, Conn.
- 7 - GARBAGE BAG-- Wayne Paper Goods Co., Ft. Wayne, Ind.
- 8 - TOILET CASE-- Bains, 1028 Chestnut St., Philadelphia
- 9 - CASTERS-- *W. S. Ensign, Inc., 58 19th St*  
W. S. Ensign Corporation, ~~141 5th. Ave.,~~ N. Y. C.
- 10 - CROSS STICH PATTERNS-- Cheshire Co., Worcester, Mass.
- 11 - CUP HOLDER-- B. Altman, N.Y.C., of Wanamaker's
- 12 - LIGHT DIFFUSER-- *Imported by Luminous Specialty Co., Indpls*  
Varney Electric Supply Co., Indianapolis
- 13 - MEDICINE DROPPERS-- SNYDER Rubber Specialty Co., <sup>21120,</sup> 139 N. Clark, Chicago
- 14 - ELECTRIC TOASTER-- Simplex Electric Heating Co., 15 S. DesPlaines, Chi
- 15 - REFRIGERATOR-- Belding-Hall Refrigerator Co., Grand Rapids.
- 16 - TOOTHRUSH-HOLDER-- *J. H. Witmore & Co., N. Y. C. 347 Pearl St,*  
*117<sup>0</sup> 23<sup>rd</sup> - 768 116 Bradford St, Flint, Saranac Lake, N. Y.*  
J. H. Witmore & Co., N. Y. C.
- 17 - FOUNTAIN PEN-- Invt. by Michael Bernstein, Madison & 34th., N. Y. C.
- 18 - BOOK END-- Fayer, Ruhl & Co., N. Y., Chicago, Boston.
- 19 - OVERALLS-- Hilker-<sup>ie</sup> Weichers Mfg., <sup>1256</sup> Mound Ave., Racine, Wis
- 20 - OIL STOVE-- National Stove Co., Lersin, Ohio.
- 21 - DRINKING CUPS-- Nuckell's Safety-First Cup Co., 409 Gould Bld. ~~Atlanta,~~  
Atlanta, Ga.
- 22 - ANKLE SUPPORT-- Brauer Bros. Mfg. Co., St. Louis, 14th. & Pine.
- 23 - TEA SET-- W. A. Pickard, 4853 Ravenswood Ave, Chicago.
- 24 - COAT HANGER-- Ovington's, 314 5th. Ave., New York
- 25 - 'PHONE DESK SET-- ~~Telafon-Body Desk Mfg. Co., 231 Insurance Exch. Bldg~~  
*219 W. Van Buren St*  
Chicago.
- 26 - SUITCASE-- Hartman Trunk Co., 2 E. 33 rd. St., N. Y. C.
- 27 - NAIL BRUSH--
- KITCHEN CABINET-- Campbell-Smith-Ritchie Co., Lebanon, Ind.







INTENDED FOR THE HOME AND ITS MEMBERS



This Refrigerator Has a Sliding Rack Fitted in a Special Compartment for Milk and Butter. Price of 100-Pound Size Is \$30

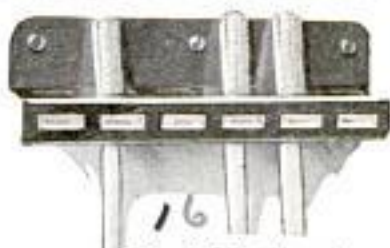

Family Toothbrush Holder with Separate Carded Space for Each Member of Household. This Size, 35 Cents



This Fountain Pen Has a Reservoir Which will Hold a Small Bottle of Ink. It is Not Yet on the Market



This Gaily Decorated Book End Represents a New Handicraft. Ready for Decorating, It is Priced at \$1



For Household Work as Well as for Tinkering with the Car, Overalls—Especially Designed for Women—Are Convenient. They Cost \$1



Ten Sanitary Drinking Cups Bound in Book Form, Very Convenient When Traveling or Motoring. The Package Costs 10 Cents

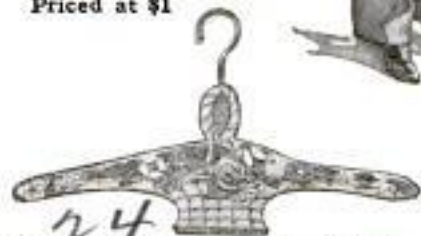

Even Coat Hangers can be Sightly, Not to Say Odd and Artistic, if One Wants Them. This "Flower Basket" Hanger in Colors Costs \$2



This Ankle Brace Differs from the Usual Type in That It is Not a Part of, or Attached to, the Skate. The Price: 75 Cents a Pair



Here is a Decorated China Tea Set Which is Distinctive as Well as Artistic. The Three Pieces are Priced at \$11



This Telephone-Desk Outfit Consists of a Directory, Two-Year Card Calendar, Filing Hook, Loose-Leaf Calendar, Tray for Clips, Pencil Holder, and Memo Pad. Price \$2.50

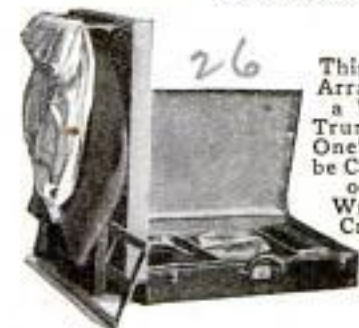

This Suitcase, Arranged Like a Wardrobe Trunk, Permits One's Clothes to be Carried without being Wrinkled and Crushed. The Price: \$25

New Kitchen Cabinet with Small Drawers Nested in One Big One Which Slides Forward When the Top is Extended



Nail Brush with Pumice Stone Fitted to Back. It Costs a Quarter





Dwight W. Johnson,  
Bethany, Neb.  
276 1602

S. J. Murphy Gen Mgr.,  
Tonloche Mfg. Co.  
Drogheda, Ireland,  
32000il

**OILCLOTH RACK EQUIPPED WITH SPECIAL FEATURES**

A convenient cylindrical rack for holding oilcloth has been invented, special features of which are a cutting

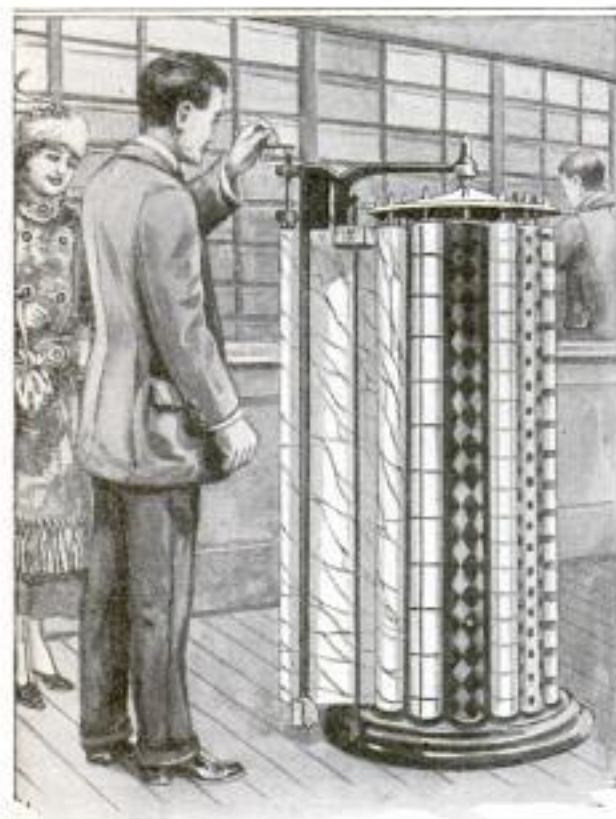

A Revolving Display Rack for Oilcloth, the Special Features of Which Are a Measuring and a Cutting Device

device and a measuring device. The rack has a capacity of 15 rolls, each of which stands on end and is supported by a rod passing through it. When a piece of material is to be cut the rack is revolved on its base until the selected roll is next to the cutting device, which is a part of the frame that holds the revolving portion upright. The free end of the cloth is fastened to a shaft and by turning a crank it is wound onto the shaft, together with a ribbon of paper. The latter is marked off in feet and inches and shows how much material has been unrolled. When the proper amount has been unwound, a knife, which moves along a guide, may be employed to cut off the material without removing the roll from its holder. Another feature of the rack is that it needs little floor space.

**TRANSATLANTIC PIPE LINE**

**PROPOSED**

*TIMES ENG. SUP. 9-20-16 (London)*

An Irish manufacturer has prepared in detail a plan for laying an 18-in. submarine pipe line between the British Isles and America, which, according to estimates, would transmit oil to England at a small fraction of the present transportation cost. As proposed, the pipe would be made of steel ribbon on the helical-tube principle, so as to be flexible. The overlappings of the ribbon as it winds round and round itself would be packed with asbestos twine. The tube would be able to withstand an internal pressure of 2,000 lb. and an external pressure of 10,000 lb. per square inch. Around it would be woven a cotton casing coated with preservative. To give the pipe longitudinal strength a stranded steel cable would be put inside. Twenty vessels would be employed to lay the pipe, each being assigned to a 130-mile section. The scheme calls for an outlay of \$50,000,000. It is estimated that the transportation cost per 1,000 gal. per 1,000 miles would be about 50 cents. By tank steamers it is about \$50.

2505

**IMPROVED DOOR HINGE SAVES FINGERS**

By the construction and arrangement of a door and jamb made possible with a hinge recently patented by a resident of Fort Worth, Tex., there is no crack or vertical opening left to catch and pinch the fingers of children or careless adults. The edge of the door is rounded to fit a corresponding jamb. The hinge proper is formed of metal plates having broad flat bodies or shanks, double side flanges with

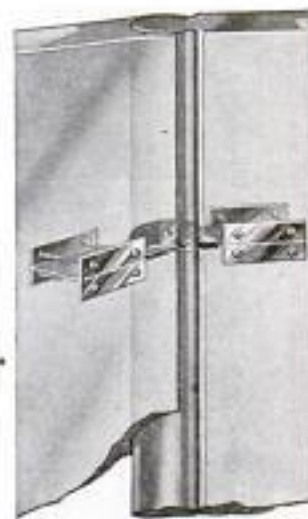

M. B. Cunningham,  
1509 S. Lake St.  
FORT WORTH, TEX.



Originator:

T. J. Hubbard

1165 Cleveland St., Decatur Ill.

screw holes, and flat circular heads which overlap and are pivoted together by a rivet. When secured in place in kerfs cut in door and jamb, three of the hinges support the door firmly, and it may be easily detached if required.

of the figure on the card. The adding of familiar faces to all sorts of bodies

3307 PHOTOS OF FRIENDS ADDED TO COMIC POST CARDS

Comic post cards on which have been pasted tiny photographs of the sender, or his friends, are a novelty which has been introduced among the winter residents and the tourists of Jacksonville, Fla., and elsewhere. In preparing these cards the so-called "penny" photographs are used, which are about the size of postage stamps. The background of each photograph is cut away, leaving only the head and shoulders. This is pasted on the face



Reproduction of a Comic Post Card Which has been Altered by Covering the Faces of the Two Men with Photographs of Friends of the Sender

produces the most laughable effects and by the exercise of ingenuity in posing for the pictures and in the selection of the cards a most amusing variety of caricatures can be obtained.

9650 FURNACE COMBINES VIRTUES OF HOT AIR AND STEAM

In any furnace much heat goes to waste in the gases which pass up the chimney. Especially is this true in the coal consumers which inhabit the average householder's cellar. In an attempt to save some of this heat, a newly patented invention resorts to ingenious expedients.

air will not ordinarily ascend such small pipes, because of the cold air already pocketed in the pipes and on account of the frictional resistances encountered. The inventor of this new

The usual fire box is jacketed with a boilerlike vessel in which steam is generated. The waste gases from the boiler, instead of passing directly to the stack, are first made to go through a second apparatus, which, in general external appearance, at least, much resembles the first device. But here the gases pass through a long U-shaped tube, the large radiating surface of which permits much heat from the gases to be saved. This heat is conducted away to the various rooms of the house by galvanized-iron tubes in the usual manner. These, however, are only 4 in. in diameter, and hot

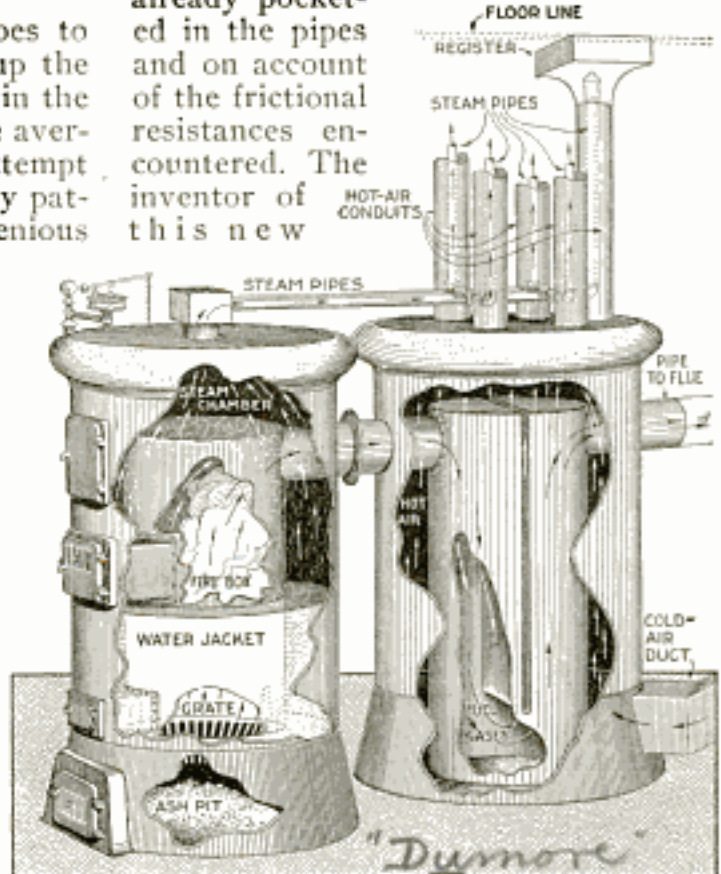

The Furnace is Divided into Two Compartments: In One Steam is Generated, from the Other Hot Air Rises to the Upper Rooms of the House

Dumore Heating & Ventilating Co. St. Louis Mo. 3/15/21

H. V. DEEMAR (INV.)

137 2 1/2 Union Ave. (See No. 1915-668)

ST. LOUIS

40 Aluminum Co. No. E. St. Louis, Ill.



heating system, however, claims to have overcome this objection by running a 3/4-in. iron pipe down the center of each air tube, the pipe having a suitable valve at its outer end to allow dead air to get out ahead of incoming steam. The steam in the small pipe comes from the boiler part of the arrangement and is for heating up the larger tubes, thus starting a current of hot air up the tubes. Both the virtues of hot-air heating systems and those of the steam variety are claimed for this arrangement.

3144

### AN ELECTRICALLY LIGHTED STOOL FOR SHOE STORES

A stool which in general appearance resembles those used by clerks in wait-



Shoe-Fitting Stool Equipped with an Electric Light in the Foot Rest, Which Affords a Customer a Good View of the Shoe being Tried On

ing on customers in a shoe store, has been fitted with an electric light, so placed that the person trying on a shoe can get a good view of it without rising from his seat. The bulb is placed behind a window in the inclined end of the steel that serves as a foot rest. It is lighted by pressing the foot against a plate adjoining the lower edge of the window. The batteries which supply the light with current are concealed in the stool.

JUNE 6, 1916

Chas. C. Schlay, Kansas City, Mo.

PAT. GAZ V. 2 p.

### MANY LITTLE-KNOWN USES FOR FOREST PRODUCTS

There is a far greater variety of uses for wood products than the public realizes and at the present time the discovery of new and interesting applications is progressing rapidly, through the efforts of investigators, many of whom are employed by our government. Powder for munitions or blasting, disinfectants for protection against disease, and artificial silk for clothing, are among the products obtained from wood in whole or in part. The acetone used as a solvent in making nitrocellulose powders is derived from acetic acid, a product of hardwood distillation. Black walnut is so much in demand for gunstocks that other woods, especially birch, are being substituted. It is stated on good authority that in Europe there is a shortage of willow for making wooden legs. The Forest Products Laboratory at Madison, Wis., has conducted extensive experiments in the production of grain, or ethyl, alcohol from wood and has had some success in raising the yield and lowering the cost of production. If this process can be put on a commercial basis it will make available for profitable use millions of tons of sawdust now wasted.

3299

### COLOR SCHEME PREVENTS PIPES BEING CONFUSED

Because no less than 21 different kinds of liquids and gases are piped to various parts of the new building of the Massachusetts Institute of Technology, it has been found necessary to work out a color system for marking the pipes to indicate their contents. Without such a scheme it would be very possible for a person to tap an ammonia pipe, for example, when he intended to tap a water pipe. Altogether there are more than 50 miles of piping in the great building. In the big mechanical-engineering laboratory the various tubes are painted their entire length in the adopted color for each kind. Elsewhere the prevailing

Cambridge  
Mass



color is white, with little patches of distinguishing color at intervals. Pipes for water from the Charles River are painted emerald green; for the Cambridge domestic water supply, light blue, and for the filtered drinking water, light yellow. Other colors used are drab for compressed-air pipes; black or white for high-pressure steam pipes with another color at the joints; ultramarine for brine pipes, and light green for the sulphureted-hydrogen pipes.

3040

### DISTANCE TO MANY POINTS TOLD BY ODD HOTEL DIAL

A well-known hotel in Marblehead, Mass., has a large brass dial set in the floor of one of its verandas, on which are indicated the points of the compass and also the directions in which several important cities lie and their distance away. It shows, for example, that Montreal lies to the northwest approximately 340 miles away, that London is almost due east, 3,785 miles distant, and that 942 miles to the southeast is Bermuda. This unusual decoration in

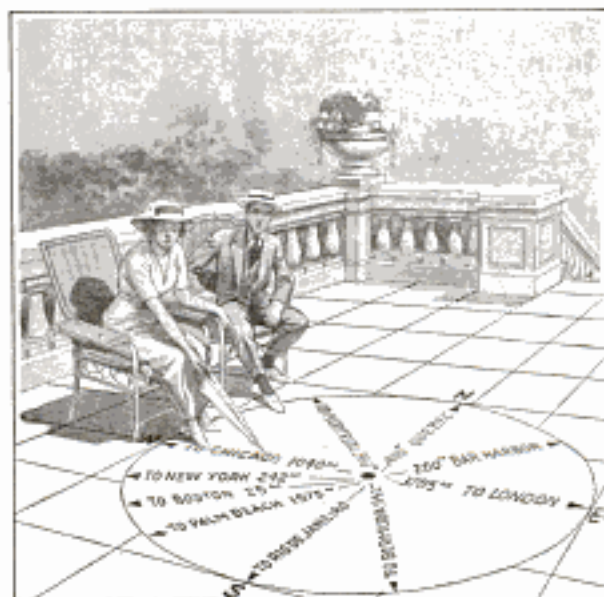

Brass Dial Set in the Floor of a Veranda of an Eastern Hotel, Showing the Points of the Compass, the Distance to Several Important Cities, and the Direction in Which They Lie

the floor of the veranda is a source of much interest to the guests of the hotel, who come from many quarters of the globe.

### PLIABLE ELECTRIC PAD HAS HEAT CONTROLLER

*Multicell Electric Co.*

Pliability and durability are two of several important features of an electrically heated pad which is now on 904 Sinclair Bldg., Steubenville, O.

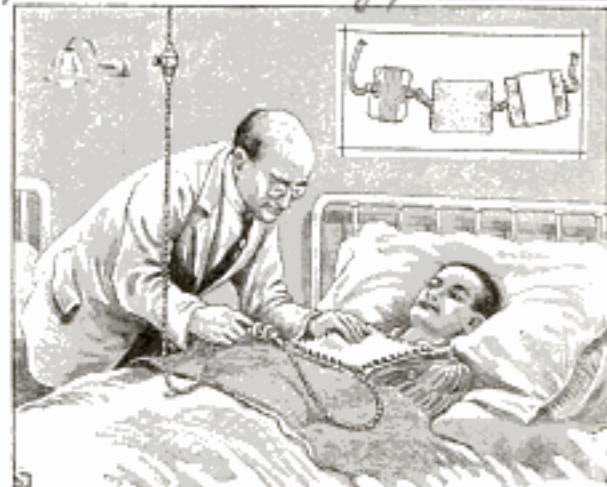

Pliable Electric Pad Having a Regulator in the Cord Which can be Set for High, Medium, or Low Temperature. Three Heating Units are Shown in Insert. The One at the Left Has Asbestos and Metal Protection Removed

the market. It can be folded, rolled, and even crumpled up without putting it out of order. This article, which is intended as a superior substitute for a hot-water bottle, is made of a number of flexibly joined heating units inclosed in a flannel cover. These units consist of small squares of mica, about each of which a single strand of fine resistance wire is wound several times and attached to a large woven-wire band which joins the units. Each mica square is covered with asbestos and then with a band of metal to prevent short-circuiting or setting the pad afire. In the corner of the cover is a thermostat which prevents the heat from becoming excessive. Inserted in the electric cord is a controller which can be set for high, medium, or low temperature.

Government experimenters have recently produced a strong wrapping twine by twisting strips of paper into a cord. Its strength depends on the quality of the paper and the process of treatment. As yet means has not been found of protecting the paper cord against moisture.



Daughter of Charles D. Lanier

Guardian: Miss N.E. Peterson

Toronto, Ont.

3393

# INTERESTING PICTURES OF CHILDREN



This is Miss Becky Lanier, Aged 10, Who is a Fine Horseback Rider. In Many Horse Shows, Including the Recent One in New York, She has Won Honors. When Her Horse Jumps the Hurdles She Knows Just How to Hang On

COPYRIGHT INTERNATIONAL FILM SERVICE



COPYRIGHT INTERNATIONAL FILM SERVICE

The Little Lad Above is a Six-Year-Old Prince of India. Plots in His Father's House have Made It Wise for Him to Come to Canada, under the Care of the British Government, and Go to School. And This is His Full Name: Narasingrae Scindia Maharrata!



The Children Shown at the Left are Attending School on a Train. The Outside of Their "Schoolhouse" is Shown Below at the End of the Work Train. The Fathers of These Pupils Work on the Railroad Track, and as They are Transferred from Place to Place the Children Go with Them—but They Never Miss a Day of School

COPYRIGHT INTERNATIONAL FILM SERVICE



COPYRIGHT INTERNATIONAL FILM SERVICE



The Militia of Mercy  
 Mrs. John Hays Hammond, President.

AND THINGS WHICH CONCERN THEM

3393

This Ambulance has been Donated by the "Militia of Mercy" to Carry Children Stricken with Infantile Paralysis to Hospitals. After being Christened in New York It was Driven to Boston and Put into Service



Here is a Picture of Baby Ellen Anderson, Herself an Infantile-Paralysis Cripple, in New York City, Christening with a Bottle of Milk the Ambulance Shown Above  
 Oct 1, 1926



It is Said That in a Village North of Saloniki, Greece, There is Just One Turk Left, and He a Little Boy. Here is a Picture of Him, Fez, Baggy Trousers, and All

The Little Fellow at the Right is Probably the Youngest Person in America to Ride in an Airship. Billy Thomason is His Name and He is Only 20 Months Old. He was All Bundled Up Like an Airman. Even to Goggles, and Then Johnny Green, Starting at St. Petersburg, Florida, Took Him for a Ride in the Sky



*Aerial age  
 Oct 9/16*



INVENTOR: Geo M. Rogers, 7915 Marquette St., Chicago

# Geo L Goodale, So. State Union of Optometry, Lenox, Ia.

Look up Chicago  
A. E. IVERS, 5605 Princeton Av.,  
A. J. JOHNSON, 5229 MORCAN ST.

282

2837

POPULAR MECHANICS

**ELECTRICALLY OPERATED OILER PROMOTES SAFETY**

An electrically operated oiler has been patented which makes unnecessary the often dangerous practice of

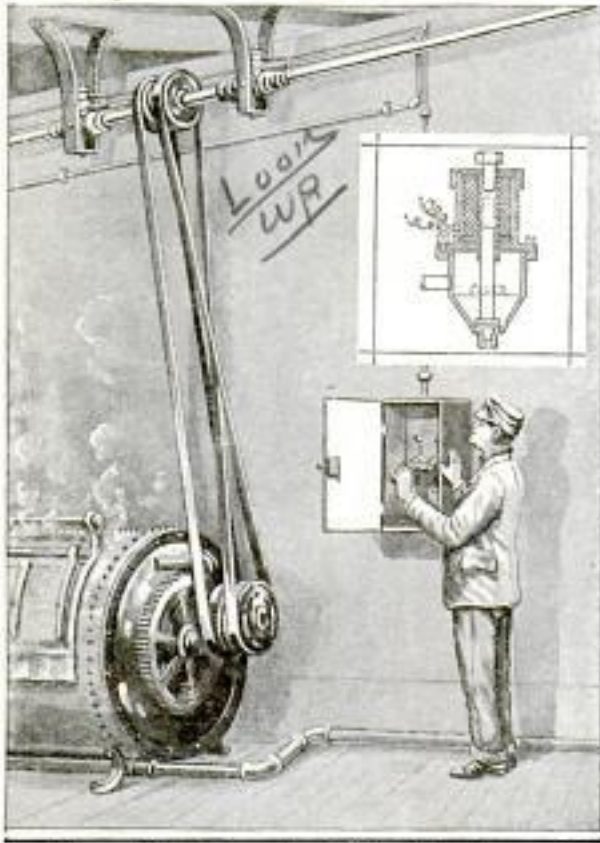

An Oiler which is Opened and Closed by Means of an Electric Switch: It Makes Unnecessary the Often Dangerous Practice of Oiling Running Machinery by Hand

oiling machinery by hand while it is running. Where this invention is used oil is fed from a central tank into as many oil cups as are needed. Each cup is connected with an electric circuit and has a valve that is closed by a small plunger. The circuit is operated by a switch within easy reach of the person in charge of the machine. By closing the switch a small magnet just above each oil cup is energized. This instantly draws up the plunger and so the oil is allowed to flow down into the bearings. As soon as the current is turned off, the plunger drops down again and the oil stops flowing. If desired, the switch can be operated by clockwork. While the installing of this device on machinery would involve extra expense, it is not thought that the

additional outlay would be considered excessive, particularly for types of machinery on which safety devices are of prime importance.

Specimens 3261

**TEN STATES HAVE NO LAWS ABOUT FITTING GLASSES**

That the fitting of glasses for the eyes is today regarded as a profession requiring special knowledge and skill is shown by the fact that all but 10 states in the Union have laws requiring all persons engaged in this work to be duly registered. In two of the 10 states which have no laws on this subject, the matter is now before the state legislatures. These commonwealths are Ohio and Pennsylvania. The eight remaining states are: Wyoming, Texas, Louisiana, Mississippi, Alabama, South Carolina, Kentucky, and Missouri. While the optometry laws of the country are far from uniform, there is apparent a tendency to elevate the standards of the optometrist's profession and in some states all applicants for certificates are subjected to examinations that are quite rigid.

2951

**TURBINE FAN A FEATURE OF NEW SPARK PLUG**

A spark plug which is constructed along decidedly new lines is equipped with a turbine fan loosely mounted on a rod that extends down through the center of the plug. The compression and explosion of the engine cause the fan to rotate rapidly. From the extremity of each fan blade hot sparks are delivered to the bushing. This arrangement not only provides a larger spark area, but is also designed to insure ignition. It is to a large extent self-cleaning, as the fan automatically throws off soot and oil deposits. All the parts are substantially built.



Fan - Fire Spark Plug Co  
YONKERS  
N.Y.  
Copyrighted material





# Shop Notes

## Portable Trolley and Tackle for Freight Transfer

By JOHN W. SHANK

**R**APID and economical loading and unloading of merchandise freight between platforms and railroad cars was accomplished by fitting a portable trolley and tackle into the cars and above the adjoining platform, as shown in the sketch. Heavy packages and crates of goods ordinarily requiring the use of a truck are handled in this way with ease. A sling, or grabhook, is fixed around the load, which is raised from the floor by means of the multiple-pulley block and rope. The rope is locked and the load transported to its immediate destination on the loading platform or in the freight house.

The trolley is supported by means of tongs set into grooves cut in the ridge pole of the car roof, as shown in the detail sketch at the right. The hooks which support the trolley are of forged steel, curved as shown, to fit the trolley wire or rail, and to give clearance for the passage of the hanger. The trolley rail is built up of sections of round iron rod, jointed with a tongue and groove at each joint, and bolted to the hooks with flat-head bolts, as shown in the detail sketch at the left. The rigging may thus be "knocked down" for convenient removal. The curved sections at the turns in the rail are similarly jointed to the main trolley rail, a sup-

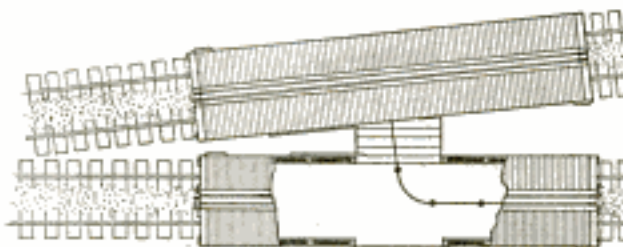
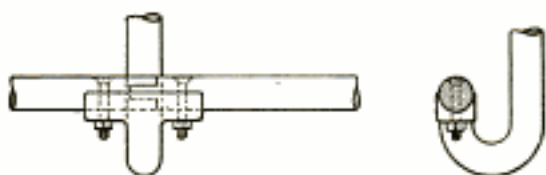
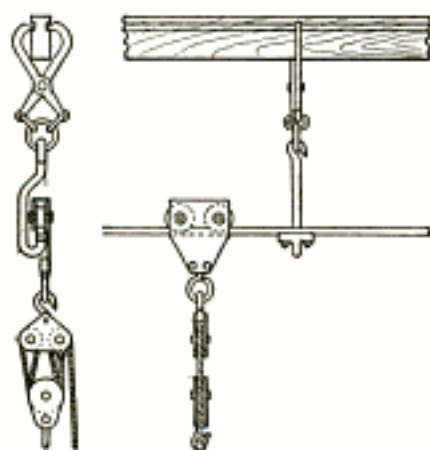
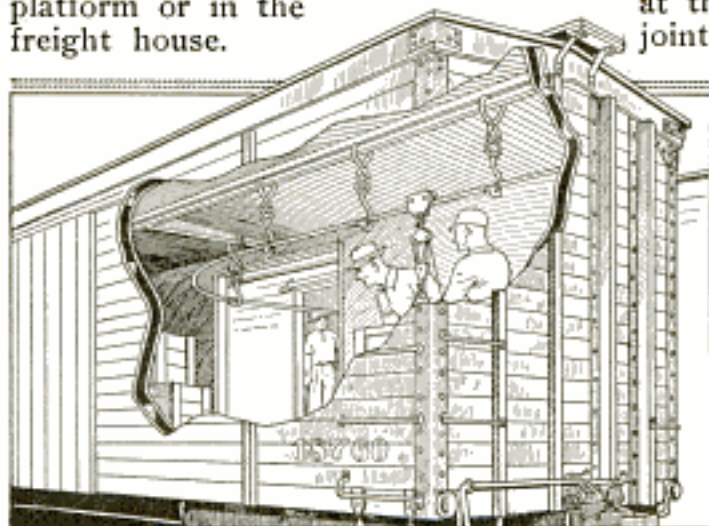

This Portable Rigging for the Handling of Package Freight Saves Time and Physical Energy of the Workmen



porting hook being set at each joint, about 4 ft. apart. The upper sketch shows the device in use in a freight car, and below is shown the use of the rigging between two freight cars, on adjoining tracks.

### Tool for Boring Large Holes in Wood

It is sometimes necessary to cut large round holes through heavy flooring, wooden partitions, or wooden

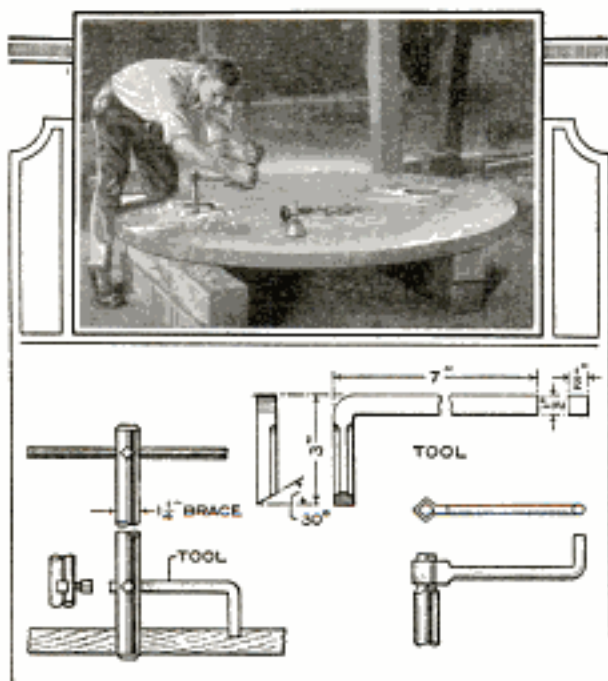

This Tool was Made to Bore Large Round Holes in a Tank Cover, and Has Many Uses

tank covers. With a saw it is difficult to cut a smooth circular hole, and a more accurate tool is required. Such a tool, designed to cut holes 5 to 12 in. in diameter, is shown in the illustration, and is made as follows: Heat a bar of tool steel,  $\frac{1}{2}$  by  $\frac{1}{2}$  by 10 in., to a cherry red; bend it at a right angle, 3 in. from one end, and temper it. The brace is made from  $1\frac{1}{4}$ -in. round bar stock, and its length should suit the work to be done. Drill a  $\frac{1}{2}$ -in. hole through the bar, 4 in. from one end, squaring it afterward with a file, so that the tool may pass through with a snug fit. Perpendicular to this hole, drill and tap a hole for a  $\frac{3}{8}$ -in. set-screw. At the other end of the brace, drill a  $\frac{1}{2}$ -in. hole, and fit a round-bar handle through it.

To cut a 10-in. hole, for instance, through a wooden floor, bore out a  $1\frac{1}{4}$ -in. hole in the exact center of the circle laid out. Then set the tool so that it will be 5 in. from the extreme cutting edge to the center of the brace, and cut out the disk in the center. In the photograph reproduced, holes are being bored in a hard-maple cover, 3 in. thick, for a large tank. As these holes had to be accurate within a small fraction of an inch, they could not be sawed out, and the above described tool was designed and used with excellent results.—K. M. Coggeshall, Webster Groves, Mo.

### Kinks in the Care of Spark Plugs

The failure of a spark plug is one of the most frequent troubles with the automobile engine, hence the autoist should know what to do when this occurs. When the spark plug misses; or fails to fire, the engine is out of tune or balance. This condition is instantly noticed by the irregular vibration set up in the car, and by the loss of power. Generally the trouble is caused by the plug becoming short-circuited through the collection of carbon on the porcelain of the plug. This is termed sooted or dirty, and is caused by several conditions. The carburetor may be out of adjustment, giving too rich a mixture, or there may be too much oil in the cylinder. These possible causes should be looked into if the trouble is chronic.

If the plug is found to have a black

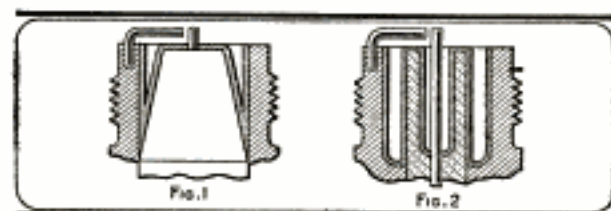

Typical Sections of Spark Plugs, Showing How Carbon Collects on Surface, Causing a Short Circuit

coating clean it thoroughly so that the porcelain is white, and the points quite clean. It will make cleaning easier if the plug is soaked in wood alcohol. Then take a sharp-pointed tool, a knife



answering very well, wrap a piece of rag around it, and scrape the plug all over, getting down into the recesses.

There are various types of plugs, the most common being the porcelain, shown in Fig. 1. The inclosed type of plug will fire longer without the need of cleaning, but it is hard to clean, as it has to be taken apart. When a plug is taken apart, great care must be taken to see that the porcelain is not broken, and when reassembling it, all the joints must be made gas-tight. Fig. 2 shows another type of plug, the possibility of short-circuiting by carbon deposit being indicated.

The modern plug is so made that it will not come apart, and, while it is a little harder to clean the individual parts when they cannot be handled separately, it is not so much trouble in the long run, as it is hard to put the other type together again properly. The insulator of a plug sometimes cracks, and even though it be but a minute crack, it must be thrown away, as the carbon seeps in quickly, and the plug will not fire.

When buying new plugs be sure to get the type that is made for the particular engine to be fitted. In addition to the numerous special plugs, there are two sizes of hexagons in use, one  $\frac{7}{8}$  in. across flats, and the other  $1\frac{1}{8}$  in. across. It is annoying to find that the spark-plug wrench will not fit the new plug intended for use, especially so when one cannot get at the plug to turn it with an adjustable wrench. It is a good plan for the autoist to carry an extra set of spark plugs, so that in case of failure on the road the bad one may be replaced without the necessity of cleaning plugs until the return to the garage is made.

### Movable Scaffold for Building and Painting

The supports for a scaffold shown in the illustration will be found more convenient in many cases than the use of a ladder, or of brackets fastened to the side of a building, to provide a support for workmen. They are made of

2 by 4-in. stuff, and should be arranged so that the lower ends are slanted away from the building sufficiently to pre-



These Supports for a Scaffold Are More Convenient than the Use of a Ladder, Especially for Work at a Comparatively Low Height

vent their slipping, and if desired, for use on smooth footings, braces which can be spiked down may be fastened to the lower ends of the supports.—James R. Townsend, Itasca, Tex.

### Casters on Footboard for Use in Auto Repairs

One of the footboards in an automobile may be converted into a convenient device for use in repairing or examining the under parts of the machine. The board is fitted with four casters, as shown in the sketch, and these enable the workman to rest on the board and shift easily under the car. The device is always available, as it is fitted into its place in the floor of the car when not in use otherwise.—Louis S. Niper, Beach Park, Conn.





### A Nonsagging Board Gate

The usual method of bracing a gate built up of boards is to fasten horizontal



cleats across it, one near the top and another near the bottom, and a third diagonally between them, forming a Z-shape. This is often unsatisfactory in that the gate sags easily by strain in use, as well as from its own weight. A better method of disposing the braces is shown

in the sketch. This was tried out with success, the gate withstanding unusual strain. The lower brace is placed horizontally across the boards and well nailed. The upper brace extends diagonally downward and is notched into an intermediate brace, which in turn is notched into the lower one. The hinges are fastened to the edge, at the left of the sketch.—C. F. J. Charliss, Houston, Tex.

### Spring Aids in Valve Grinding

In grinding gas-engine valves, it is imperative that the stems be lifted frequently from the seating in the cylinder to insure an even distribution of the abrasive material. If the valve is not lifted from time to time, the emery or carborundum dust and oil are apt to form in

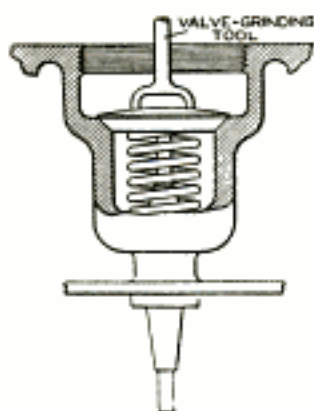

small pellets, producing deep grooves in the valve head and seat, which are hard to remove by grinding. The usual method is to lift the valve stem with one hand, while oscillating

it with the other. A coil spring of moderate tension, placed under the valve head, as shown in the sketch, will lift it automatically whenever the pressure is released from the grinding tool. Only enough pressure to keep the valve head seated, against the resistance of the spring, should be applied.—Victor W. Pagé, Bristol, Connecticut.

### Inexpensive Traffic-Light Post

A traffic-light post that is practical and inexpensive is shown in the sketch.

It is set in a concrete base providing the "isle of safety" and a 10-in. red-glass light globe is supported on an 8-ft. section of 3-in. iron pipe. The connections are made with standard reducers, and the globe is fitted into a 4-in. pipe cap. The wiring is conducted to the globe through a conduit connecting with the post. The pipe cap which holds the globe is drilled and tapped for small machine screws, which hold the globe in place.—H. G. McQueen, Dow City, Ia.

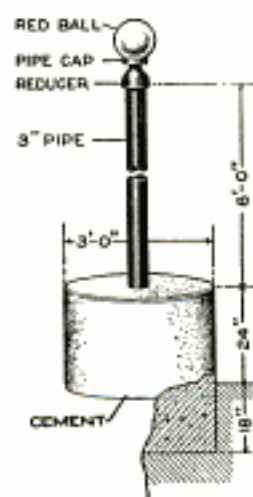

### Skidding a Heavy Boiler or Machine

The moving of a heavy boiler or a large machine without the use of special appliances is sometimes a difficult task. A good way to handle this job is to build a wooden cradle around the object to be moved and mount this on two heavy wooden runners, resting on a well-greased plank. A few other greased planks should be in readiness so that when a couple of teams are hooked to the cradle and it starts to move, the planks can be laid as required just in advance of the runners. The planks may be used repeatedly.—James Skelton, Toronto, Can.



# A Sanding Drum for the Wood Shop

by Charles A. King

A WIDE range of woodwork to be smoothed may be handled to advantage on a sanding drum like that shown in the illustration. It is of simple construction and can be made easily even in a small woodworking shop, the only special fittings required being the shaft, flanges, bearings, and collars. These are readily available from machinery-supply houses, or may be obtained from old machine parts. This machine was used in a job shop for the sanding of ordinary building trim, elaborate bank fittings, and even for high-grade furniture. Flat work, curved pieces of a radius larger than that of the drum, and the edges of stock may be sanded on it, by the use of the table or the edge-sanding rest. The drum revolves in the direction indicated by the arrow at a speed of 600 revolutions per minute. It is driven by a 3-in. belt over a 10-in. pulley, set on the shaft, and an idle pulley provides for shutting off the machine temporarily.

The single table above gives greater freedom of use, and was determined upon after two tables had been tried. Care must, of course, be exercised in sanding work so that the operator may not be endangered by the drum. It is desirable, also, to provide a drive that will leave the top of the drum and the table free from obstructions, and permit the operator convenient access in handling large pieces. The table serves merely as a rest for the stock as it passes over the drum.

The drum is supported in a frame made of hard wood. The legs are of  $2\frac{1}{2}$  by 4-in. stock, braced by 2 by 4-in. pieces, mortised into them, and pinned at the joints with  $\frac{5}{8}$ -in. maple pins. The members A, which carry the drum shaft, are of  $2\frac{1}{2}$  by 4-in. stock, and are fixed to the legs by mortise-and-tenon joints, as shown in the side view, Fig. 2. The edge-sanding shelf B extends slightly beyond the members A, as



shown, and should be set carefully on wedges, so that the center of a  $\frac{7}{8}$ -in. board will extend on a line with a radius of the drum, as indicated by the dotted line at B. To insure accurate edge-sanding on stock of other thicknesses, it is necessary to build up on the shelf so that the edge will not be "out of square."

The table C is built up on a frame of  $1\frac{3}{4}$  and  $2\frac{1}{2}$  by 4-in. stock, fastened at the joints with lag screws, as indicated in Fig. 2, at D and at E. The brace at E is shouldered into the side rails of the table, and its lower edge is beveled to accommodate the drum. The table is braced against the rear legs with 2 by 2-in. pieces, fastened with lag screws. It is 2 ft.  $7\frac{1}{2}$  in. from the floor, and the upper edge of the drum projects  $\frac{1}{2}$  in. above it.

The drum is carried on a  $1\frac{7}{16}$ -in. shaft, keyed to flanges, J, Fig. 4, which in turn are fixed to the drum ends G, with screws. The shaft rests in split bearings, set into the supporting member A. Side motion of the shaft in the bearings is prevented by collars between the flanges and bearings, and set collars, F, Fig. 1, on the ends of the shaft. The body of the drum is built up on the drumheads G, which are of two layers, cross-banded to insure great strength, necessary at the considerable speed of operation. The sanding surface is built up of small strips, H, cut so that their edges are in line with radii of the drum end. The pieces of the drumhead must be fastened together firmly with screws or



bolts, riveted so that the nuts cannot become loosened accidentally. Cut the drumheads out approximately to

The sandpaper is drawn taut and clamped in place by means of the clamping strip K, shown in Fig. 5. The

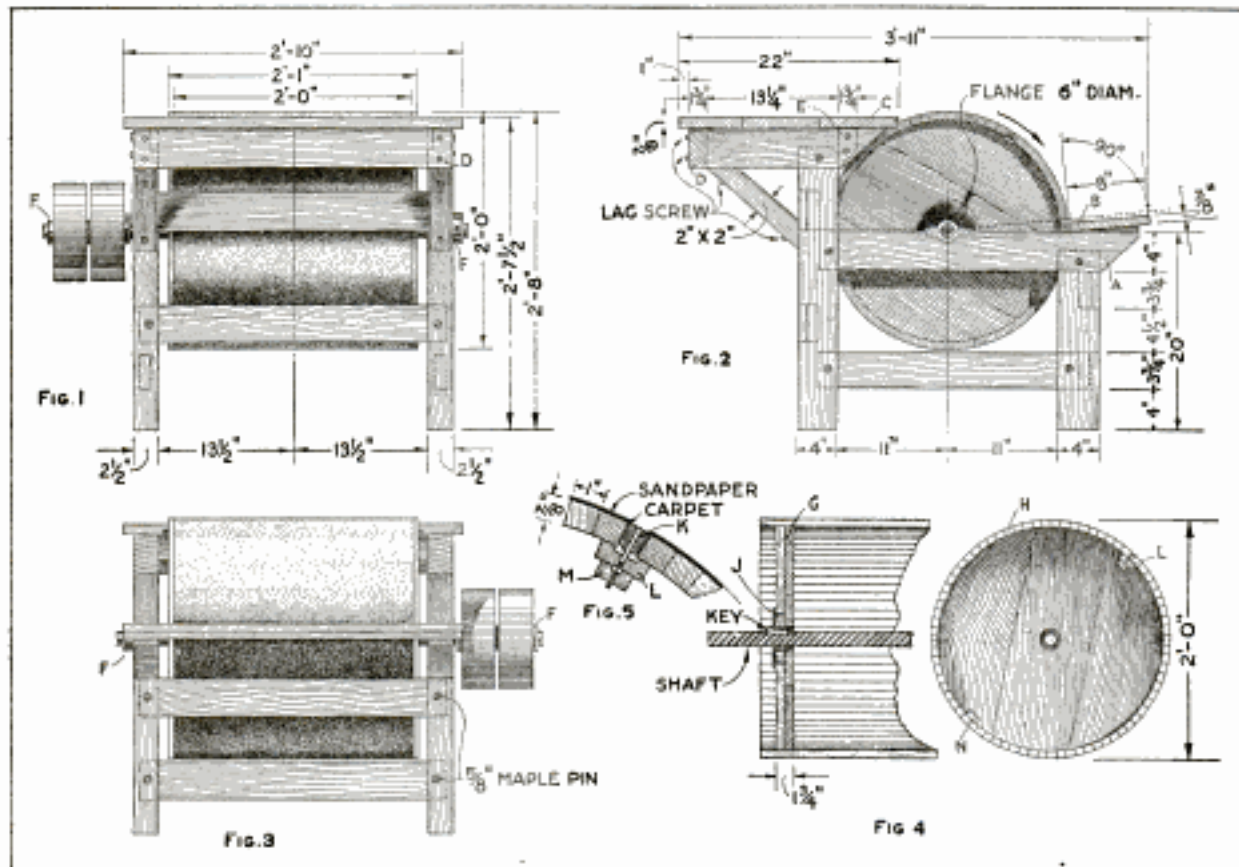

This Sanding Drum Has a Wide Range of Usefulness and can be Made Readily in the Wood Shop at Small Outlay

their finished size. Cut the keyways in the bearings of the flanges and mount the flanges upon the drumheads. Then turn the heads down carefully to their exact finished diameter, which is 1 ft.  $10\frac{1}{4}$  in., if the staves of the drum are made  $\frac{7}{8}$  by 1 in. To do this, set them on the shaft together at one end, keying them, and apply the power by means of the pulley and belt. End motion of the shaft is prevented by the use of the set collars F, which are brought up against the bearings. Place the ends in position and nail the staves in place, setting the heads of the nails carefully, or countersink the screws, if this form of fastening is used. The staves should be of pine or whitewood, fitted tightly, and glued in place as they are fastened.

The sanding surface of the drum is covered with a layer of Brussels carpet, and the sandpaper is placed over this, the carpet providing a cushion.

strip is fitted into a groove so that, when the carpet and sandpaper layers are in place, the upper surface of the strip is just below the surface of the drum, never above it. The strip should be tapered only very slightly, if at all, the sides of the groove being parallel with those of the strip. The lower edge is rounded to prevent tearing the sandpaper. The strip is held in place by flat-head bolts screwed into nuts set in a strip M, fixed to the inner side of the drum. The bolts can thus be released from the outside by means of a screwdriver. They are held snugly in the strip L, being only loose enough to be turned without difficulty.

The clamping device must be counterbalanced by a strip on the opposite side of the drum, as at N, Fig. 4. The clamping device as well as this strip must, of course, be fastened in place before all of the staves are glued finally. They may be fastened tempo-



rarily with screws, and glued in place when the balance strip and clamping strip are in position. The clamping strip and its bolts should then be removed and a strip of the same thickness as those used for the drum should be fixed into place in the groove. The surface of the drum must next be turned smooth, using the machine as a lathe, and removing only as much stock as is necessary. The strip in the groove prevents the breaking of the edges at that point. The surfacing of the drum must be done with great care, for if it is not straight and true, the sandpaper will bubble and crack before it is worn considerably. The ends of the staves should be trimmed off to the proper length by turning. The drum should be in perfect balance to insure good results, and, if necessary, holes may be bored in the heavy side of the drumheads, or weights fastened securely to the lighter side, to correct fault on this score.

The carpet backing for the sandpaper is stretched over the drum and nailed into the clamping groove. The sandpaper is stretched over it, sufficient length being allowed to permit the sandpaper to pass under the clamping strip and against the opposite side of the groove. Slots are cut in the sandpaper to accommodate the bolts in drawing them up firmly. The first sheet of sandpaper should be fitted carefully, and others may be patterned from it. It is desirable to stretch the sandpaper over the drum on a damp day, as it will contract with dry weather, giving a better sanding surface. The paper should never be moistened in applying it, as this ruins it for use in sanding. For ordinary work No. 2 sandpaper is used, and for smoother finishes finer grades may be applied. The machine may be given an oil finish or painted a suitable color. A convenient method of fixing it to the floor is by the use of angle irons.

### Exhaust Fan for Workbench Aids in Removing Dust

Before painting iron castings, or secondhand machinery, it is necessary to remove the rust and foreign substances from the surface. During the cleaning process, the detached rust particles, floating about in the air, are inhaled by the workman, lodge in his eyes, and settle on his clothing. This metallic dust is also injurious to the bearings of machinery which may be near by, to say nothing of its settling on finished or wet painted surfaces. A simple suction device was fitted to a workbench, as shown in the sketch, to eliminate these bad features.

The workbench was constructed with

an iron grating for the working surface, instead of the usual board top. An air-tight, boxlike inclosure was then built below the grating, with the bottom sloping downward. At one side an exhaust fan, driven by an electric

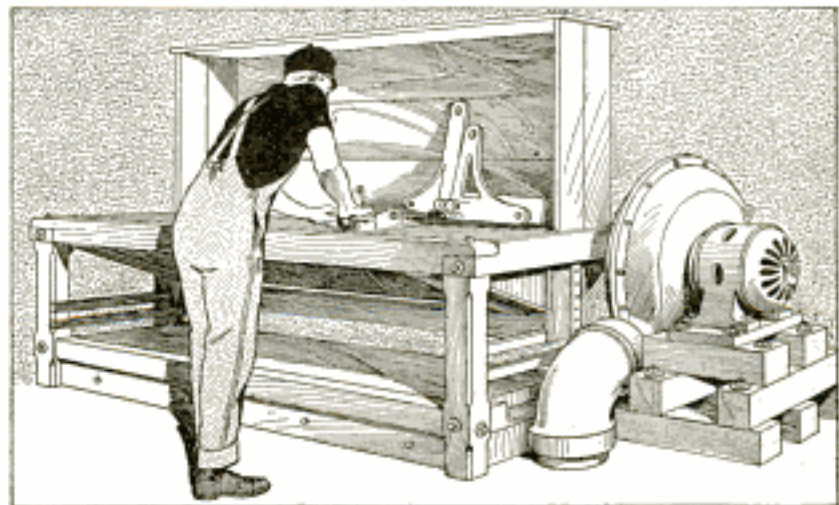

Dust from Cleaning of Castings is Drawn Away through the Grating in the Top of the Bench, Thus Protecting the Workman

motor, was set, and the inlet side connected with the bench inclosure. The exhaust from the fan was piped outside



the building. With the fan in operation, castings are placed on the grating and brushed or sandpapered without inconvenience to the workman. The dust and rust particles are drawn downward through the grating. Such a bench is suitable for use in the removal

of old coats of paint, to clean up machinery parts, or even to finish the surface of woodwork. If chipping or grinding is done, it will be necessary to put up a back stop, as shown, to keep small particles from flying across the room and injuring other workmen.

### Portable Electric Drill Used as Drill Press

Many shops are provided with a portable electric drill, which is a necessity for certain kinds of work, but not

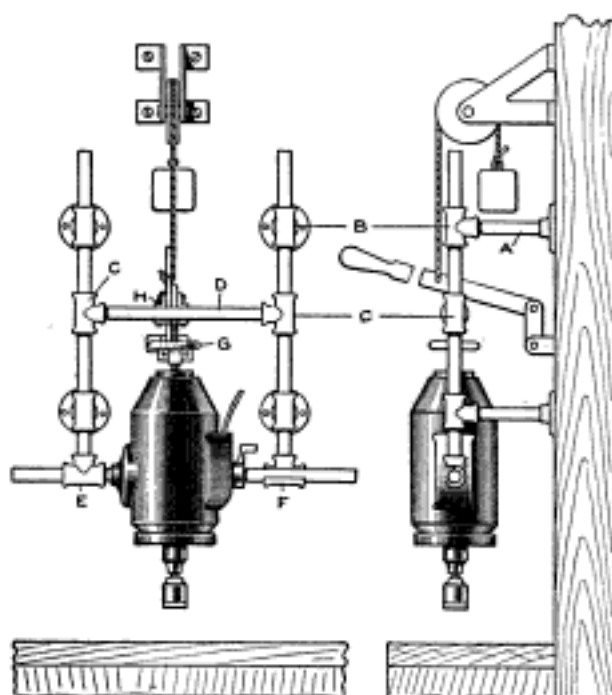

This Frame of Pipe and Fittings Enlarged the Range of Usefulness of a Portable Electric Drill Needed Only Occasionally

used often. The frame shown in the illustration was made to fit a drill of this type, and extended its usefulness to the many kinds of work ordinarily done on a small drill press. Most of the parts of the support and mechanism were made from pipe and fittings. The machine is fixed to a frame of wood, which supports a table on which the work is rested. The wooden support may be arranged so that it can be moved without taking the drill and fittings from it. The drill is supported in a frame which is raised and lowered by means of a lever, fixed to a counterweight.

Four standards, A, made of a section of 1-in. pipe, a flange, and a tee are fixed to the wooden frame. The frame of pipes and fittings which carries the drill is made of pipe of an outside diameter to slide closely in the tees, B, of the standards. Tees, C, are fixed solidly to the center brace D, and the sections of pipe joined to them. The shaft of the drill is rested in a tee, E, and in the tee F, which is cut open so that the shaft may be removed readily. The drill is held securely between the brace D and its bearings by means of the handwheel G, operating on a threaded rod set into a lug on the lower side of the brace.

The handle and its fittings are made of strap iron. The range of the drill is limited by the movement of the handle, which is fitted to the brace D by means of a shoe, H, in which it slides. The counterweight cord is fixed to the handle and passes over a pulley set in a bracket above the pipe frame.—W. A. Ready, Boston, Mass.

### Substitute for a Small Printing-Press Roller

The roller on my printing press became so marred that it could not be used with satisfaction, so I made one which was quite efficient. It can be

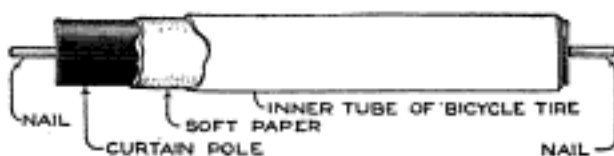

The Rubber Covering may be Removed Easily for Cleaning and Renewed Cheaply When Worn

cleaned easily and was made of materials which are easily obtained. I sawed a piece of curtain rod to the proper length and drove a nail into each end as a bearing, cutting off the



head. Several layers of soft paper were pasted around the roller, as shown in the sketch, and the inner tube of a bicycle tire was then fitted over the roller. The rubber tube can be removed quickly and cleaned, or renewed if desired. Hand rollers may also be made in this way by fitting a handle on the nails at the ends of the roller.—P. F. Harper, Danville, Va.

### Soldering Patches on Tanks or Large Objects

The soldering of patches on tanks and other objects that cannot be taken to the workshop readily is often difficult. The following method overcomes most of the objectionable features: First shape a patch by pressing a piece of tin somewhat larger than the opening, with the ball of a hammer, leaving a small flange around the edge. Tin both the patch and the part to be soldered; fill the hollow in the patch with melted solder and permit it to cool. Then using a pad, or heavy glove, place the patch in the hand, melt the solder with the soldering copper and apply the patch. Sweat it into place in the usual manner.—Charles Straughan, Sprague, Wash.

### Automobile Gear-Box Repair

Trouble was experienced on the gear box of an automobile in that the grease leaked, as shown in Fig. 1. The boss at the left, as indicated in Fig. 2, was tapped, and a brass plug was inserted to cover the end of the shaft. This necessitated shifting the locking screw, as shown in Fig. 2. The tapped hole formerly necessary for the locking screw was plugged. A leather washer was fitted at the end plug to insure a tight joint.

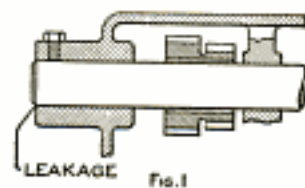

### Portable Safety Platform for Telephone Linemen

To provide utmost safety in handling telephones on private lines when carried over the same poles as are used for electric-power wires, a simple and effective portable safety platform was devised, as shown in the illustration. It is constructed of wood, about 1½ in. thick, 14 in. wide, and 18 in. long, cut out at the inside edge to suit the average standard pole for heavy line service, and insulated with rubber or other suitable material. Two straps are attached to the platform at the inner side to reach around the pole, and are provided with a strong buckle for ready and substantial fastening. A spike driven into the pole serves to keep this support in place. At the outside edge, two heavy leather straps are also provided to carry the weight of the operator on the platform.



The platform is ordinarily used about 2 ft. above the grade, to suit the regulation height of the telephone attached to the pole by means of a strap at a point about 9 ft. above the ground. This platform proved of great value in eliminating the constant danger of electric shock when using the private telephone lines of light and power companies, sometimes exposed to contact with high-voltage transmission lines.—L. R. W. Allison, Newark, N. J.

☞ Caliper a bored hole at several points in its length, as the size at the opening may be misleading.



### Oil-Burning Blowtorch for Sheet-Metal Work

The torch shown in the illustration was designed for use in railroad shops on boiler, tank, freight-car, and other heavy sheet-metal work. By means of it a powerful flame may be directed on a limited area. The device is simple in construction, convenient in operation, and comparatively light. The oil fuel is admitted through the upper pipe, at the right, and the air for the blast through the lower pipe, the flow being controlled by  $\frac{3}{8}$ -in. globe valves. The pipes are braced near the torch and form a strong grip for the operator. The torch proper is a coil of  $\frac{1}{4}$ -in. wrought-iron pipe, fixed into a brass collar, having holes through it, as shown in the detail sketch, and covered with a  $2\frac{1}{2}$ -in. wrought-iron pipe, from which the flame is projected.

The upper sketch shows the general-assembly drawing of the torch; the details are shown in the lower sketches. The cover for the coil is 11 in. long over all. One end of it is fitted with a brass plug, shown in detail at the center, below. Inside of this plug is a second brass plug, shown at the right, and into this are fixed the supply tube and the coiled pipe. The dotted lines in the upper view show how the flame

is heated to the proper temperature for ignition in passing through the coil, and the flame passes out through the center of it.

### Cutting Threads without Tap or Die

Requiring a thread on a small piece of copper wire and a nut to fit it, I found that no tap or die was available. A piece of spring brass was drilled to a size slightly smaller than the wire, and a small rat-tail file was forced into it by gradual turns and then withdrawn with a rotary motion, forming threads. This nut was turned onto the tapered end of the wire, and being slightly harder than the copper in the wire, cut a satisfactory thread.—Thomas A. Hancock, Los Angeles, Calif.

### Preserving Stove Linings

The fire-brick lining of a stove will last much longer and give better service if promptly jointed with fire clay. When the new fire bricks are placed in the stove, set them with the clay, which is mixed to a mortar with water. Burn a few sticks of wood, taking care not to heat the stove too rapidly, and the clay will soon harden. The lining usually begins to deteriorate at the joints, and by filling them with fire clay, the latter may be removed and a

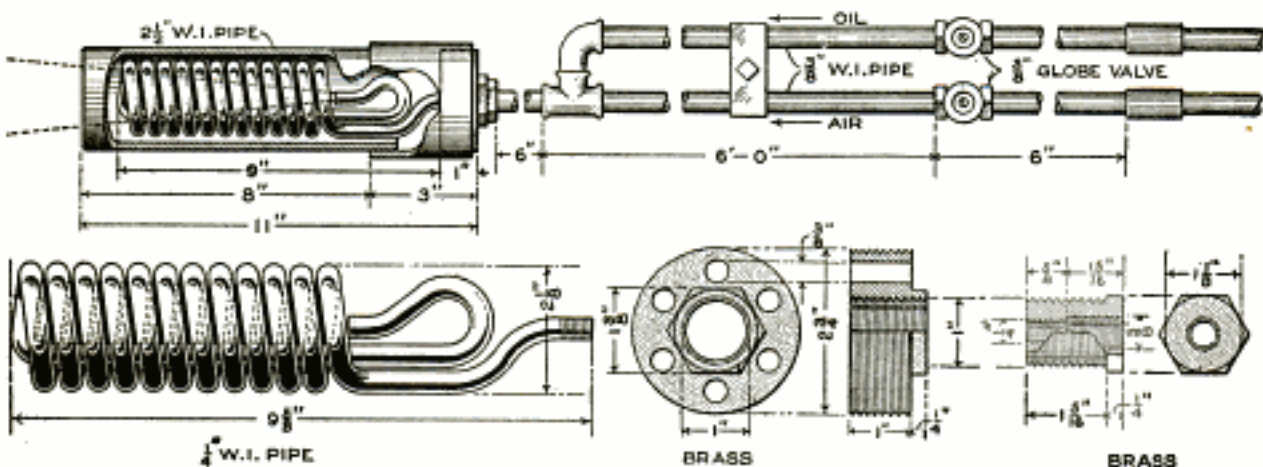

This Torch Produces a Powerful Flame and Is Useful on Heavy Sheet-Metal and Boiler Work

is forced from the end of the coil, which is also shown in detail. It is  $9\frac{5}{8}$  in. long and  $2\frac{1}{8}$  in. diameter. The oil is

new layer inserted when it has pitted or cracked badly.—L. E. Fetter, Portsmouth, N. H.



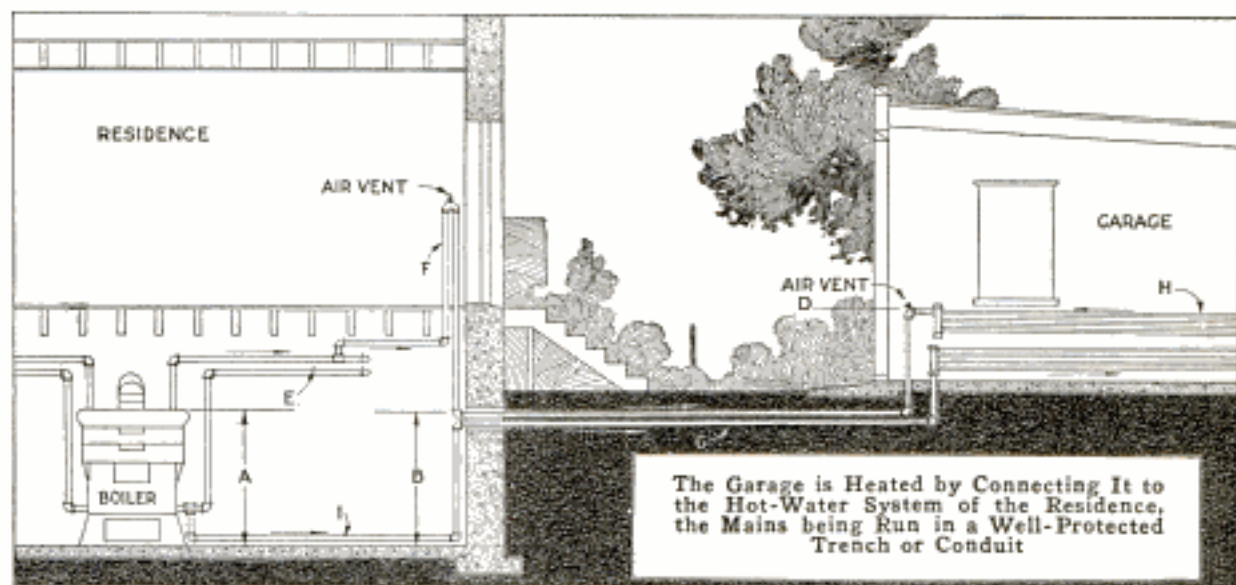

### Heating a Garage from Residence Hot-Water System

The heating of a home garage in winter is a problem that confronts not a few motorists, and the method suggested in the sketch has been found practicable for utilizing heat from the residence heating system for this purpose. The chief difficulty encountered was that the top of the boiler in the basement was too high to permit the flow pipe to be run underground to the garage. In other instances the boiler may be situated so that a pipe extending across the cellar as required would be much in the way. These difficulties were overcome by the installation shown in the diagram.

The flow main to the garage was connected to a flow main, E, in the cellar leading directly from the boiler at the top. The pipe then passes through the floor, forming the loop F, which is provided with an air vent. From this, the pipe passes down to below the grade of the ground outside and into the tile, or other suitable trench, leading to the garage. The top of the loop F must be at least 3 ft. above the intake at D, and more is desirable if convenient to provide it. The circulation to the garage depends in a large measure on the height to which the loop rises. The distance B must not be more than 18 in. less than the distance A.

Run the pipe in the trench as close to the surface as it is possible to do and still provide adequate covering and protection. The arrows indicate that the pipes grade up toward the heads of the former. The main connects with the coils in the garage, as shown, flowing into the upper coil, which is in turn connected with the lower one at the extreme end, not shown. The return main G also is laid in the trench and grades up as indicated by the arrow. It passes through the wall and into the cellar below the flow main and then drops to the floor and returns to the boiler. The return pipe I need not be below the center line of the return tapping on the boiler, unless there are doorways, or other obstructions, making it necessary to drop it to the floor as shown. It must not, however, be connected to any other return pipe at a height above the center line of the return tapping. The loop F and the coil H should be freed of air by means of the vents.

### Jig for Cutting Hard Lubricating Grease

In order to cut hard grease into disk-shaped pieces, about  $\frac{1}{2}$  in. thick and  $1\frac{7}{8}$  in. wide, the jig shown in the sketch was devised in a railroad shop. The principle involved may be used for a variety of similar purposes with slight adaptation. The grease is



shipped in barrels and prepared for use by pressing it through a die to form it into long sticks,  $1\frac{7}{8}$  in. in diameter. These are placed in the jig

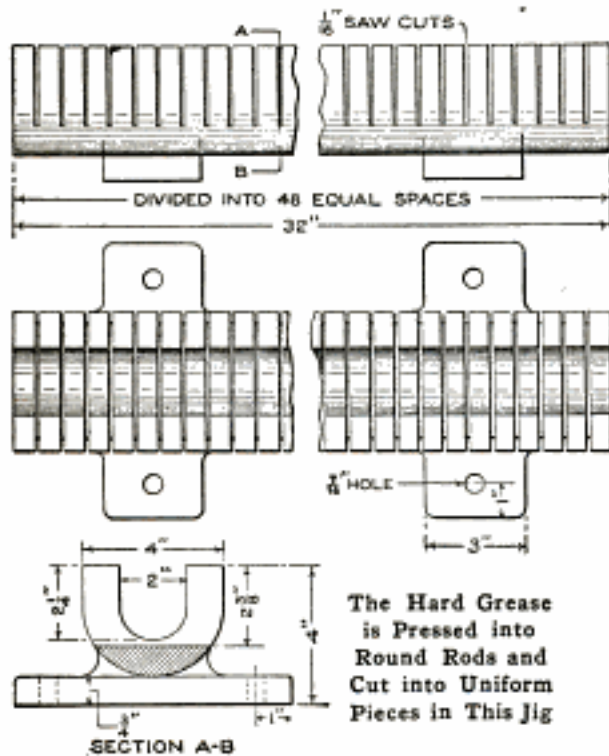

and cut to uniform lengths, each piece weighing one ounce. The pieces of this size are used for the grease cups of locomotive driving rods. The device consists of a casting of iron provided with legs by which it is bolted down. It is 4 in. high, 8 in. wide, and 32 in. long. The guide slots are cut with a saw, cutting a kerf  $\frac{1}{16}$  in. wide. The inside of the jig is finished to make it easy to clean.—J. K. Long, Renovo, Pa.

### Eliminating Pounding in Gasoline Engines

Pounding in a gasoline engine can, in almost every case, be attributed to a loose part within, particularly the various bolts. A careful examination should be made immediately, the bolts and nuts of the connecting-rod bearings, the main-shaft bearings, the bolts that connect the flywheel to the crankshaft end, and other fittings being closely inspected. A loose bolt on a flywheel rotating at great speed, is particularly dangerous, and should be remedied at once.

### Safety Device for Wheelbarrow

When a wheelbarrow is pushed through a narrow passageway the hands of the laborer may be painfully injured by striking against the door jams. To overcome this, nail a block of wood on each handle of the wheelbarrow just in front of the grip. The block should be tapered from the front end.—Victor E. Carpenter, South Bend, Ind.

### Double-Shaft Universal Joint

The universal joint shown in the sketch provides for the use of one shaft within the other, permitting the two sections to be at an angle to each other while in operation. Other features are that the shafts may be run at different speeds, in the same or opposite directions, or one shaft may be run while the other is stopped. The outer shaft is a tube having a fork at the end adjoining the large ring at the universal joint. The forks are mounted on this ring with screws, as shown. The inner shaft is solid and the forks at the end are mounted on a solid steel ball, in the same relation to each other as are the larger forks, mounted on the ring. While largely an experimental device,

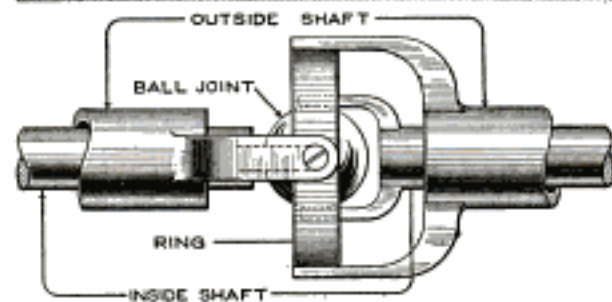

This Universal Joint Houses One Shaft within Another and Has Experimental Interest for Power Transmission

it has interesting possibilities for application to machinery and power transmission.—James O. Tow, Columbia, Missouri.

Electric fans are used for the drying of motion-picture films. The films are wound on large drums which are revolved steadily while the current from the fan is played upon them.



# Garden Seats of Concrete



By EDWARD A. KRUEGER

[This article details the making of two garden seats and gives designs for four others. Information on the various materials, surface finishes, and the mixing of concrete is given in pamphlets furnished gratis by manufacturers of Portland cement.—Editor.]

THE making of cement products is especially practicable for the home worker in that the materials required are inexpensive and easily procured; with reasonable care, excellent results may be obtained, even by a novice. The permanence of concrete, properly mixed and placed, commends it as a constructive material for many objects of use and ornament exposed to the elements.

A garden seat like that shown in Fig. 1, without the paneling on the edges, involves first the making of a plain box form for the top slab. This may be used for the making of two or more supports by nailing partitions in the form, as shown in the sketch and detail drawing, Fig. 2. A smaller form is required for the foundations, which are cast in molds separated by partitions. Make a rectangular form, having inside measurements of  $18\frac{1}{2}$  in. by 8 ft. and  $3\frac{1}{2}$  in. deep, for the top slab. Build up the platform for the form of  $\frac{7}{8}$ -in. flooring, and smooth the top surface to give a good finish to the concrete. Cut the end pieces squarely,  $18\frac{1}{2}$  in. long, and fit them between the sidepieces. Screws, 12-penny common nails, or bolts, as shown in Fig. 2, may be used to hold the form together. Square the form and nail strips across the upper edges to prevent the weight of the concrete from forcing out the sides. Toenail it in place on the platform, clean the interior, removing nails or other obstructions, and smooth off

rough parts with sandpaper. Fill any irregularities in the inner surfaces of the form with plaster of Paris, and permit it to dry. Apply one or two coats of shellac to the inside of the form, to protect it from the moisture. When the shellac is thoroughly dried, apply a uniform coat of linseed oil to the mold and the form is ready for the concrete. If many slabs are to be made with a mold, soak the wood thoroughly in crude oil before making the form.

If the form for the supports is made from new stuff, the process of construction is similar to that described. Set the partitions squarely, 15 in. apart from face to face, nailing them as shown. If the form for the top slab is used for the supports, clean it, and apply fresh coats of shellac and oil for each successive use. The weight of the top slab is usually sufficient to hold it in place. If desired, bolts may be cast into the upper edges of the supports and fitted into holes in the top slab, as shown in Fig. 3.

The top slab is reinforced with heavy wire mesh, or with  $\frac{1}{4}$ -in. round iron rods. The latter extend lengthwise of the slab, set on 3-in. centers, and crosswise on 10-in. centers, their ends being  $1\frac{1}{2}$  in. from the adjacent edges of the slab. They should be wired together to form a mat, or wired to light wire mesh. The reinforcing is placed 1 in. from the lower side of the slab, as shown in the working drawings, Fig. 1. It is important, therefore, that the upper side of the slab be marked when the form is removed, as the reinforcing is less effective if the slab is inverted.



If bolts are used in the supports, set wooden pegs of the proper size at tamping. Fill the mold, tamp the concrete, especially around the edges, and

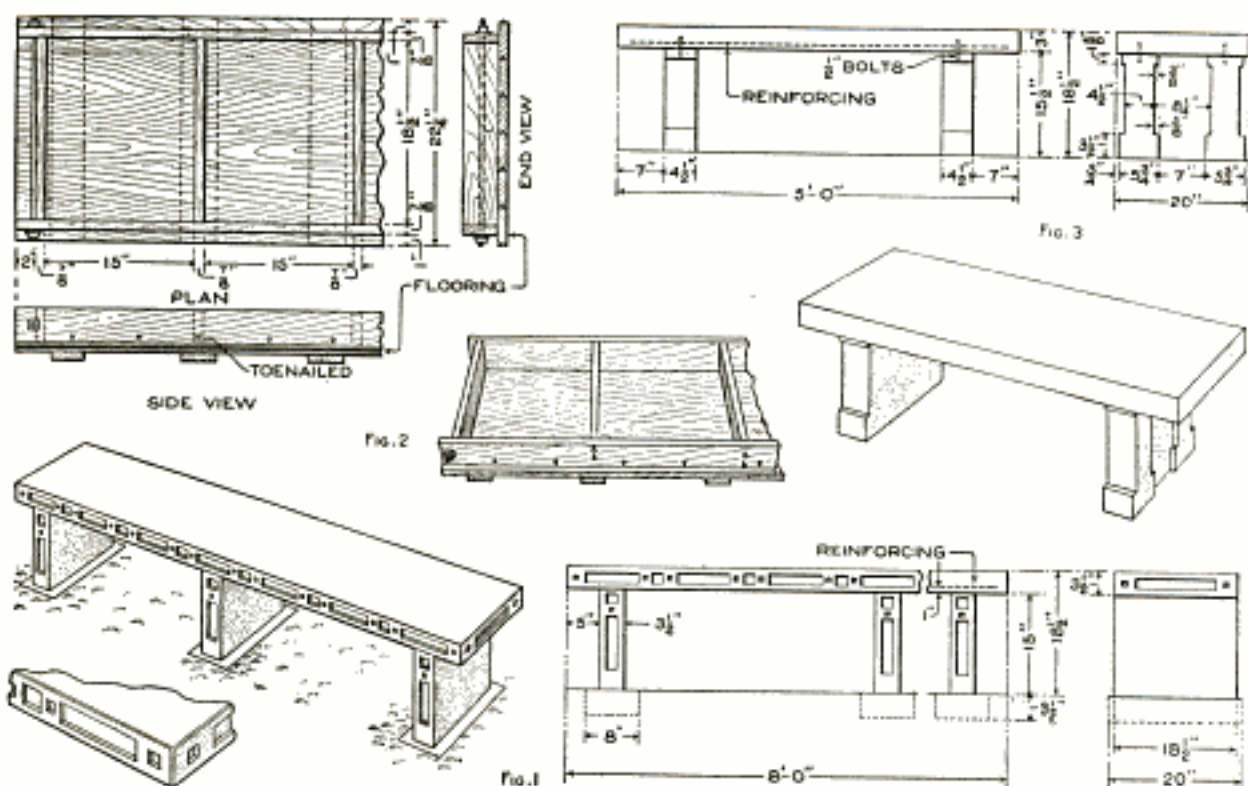

Plain Slabs of Uniform Width, Paneled if Desired, are Used for the Seat Shown in Fig. 1. That Shown in Fig. 3 Involves the Use of Special Forms for the Shaping and Paneling of the Supports

corresponding points in the bottom of the mold.

Prepare the concrete mixture and pour the mold as follows: Mix thoroughly a batch of concrete just sufficient to fill the mold, using one part of Portland cement to three parts of coarse, clean sand, a 1:3 mixture.

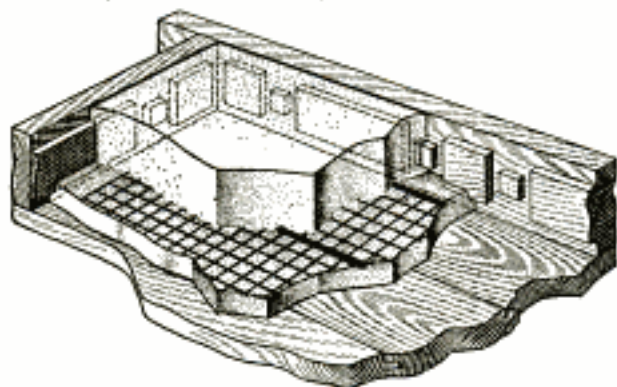

Fig. 4  
The Method of Making the Edge Panels and of Reinforcing the Top Slab

Fill the mold uniformly to a depth of 1 in. and set the reinforcing into place, as shown in Fig. 4. The concrete should be wet enough so that water will rise to the surface with slight

jar it to force the mixture well into the corners. Level the surface with a straightedge, and finish it carefully with a trowel. The edges may be rounded slightly with an edger or struck off at a slight bevel, using the trowel. The supports are made similarly, but without reinforcing. The edges are left square.

Permit the filled mold to remain at least 48 hours, when the sides of the form may be removed. The slab must not be moved from the platform, on which it was cast, for at least a week. If the edges are chipped or corners broken away, patch them by moistening the broken parts and filling the irregularities with the mixture. The slab should be moistened two or three times a day while "curing," and should not be exposed to heat, to a drying wind, or to the sun. Set the foundations, leveling them with great care, and mount the supports on them, set in a course of cement mortar. Set the top slab into place, upon courses of cement mortar, if no bolts are used.



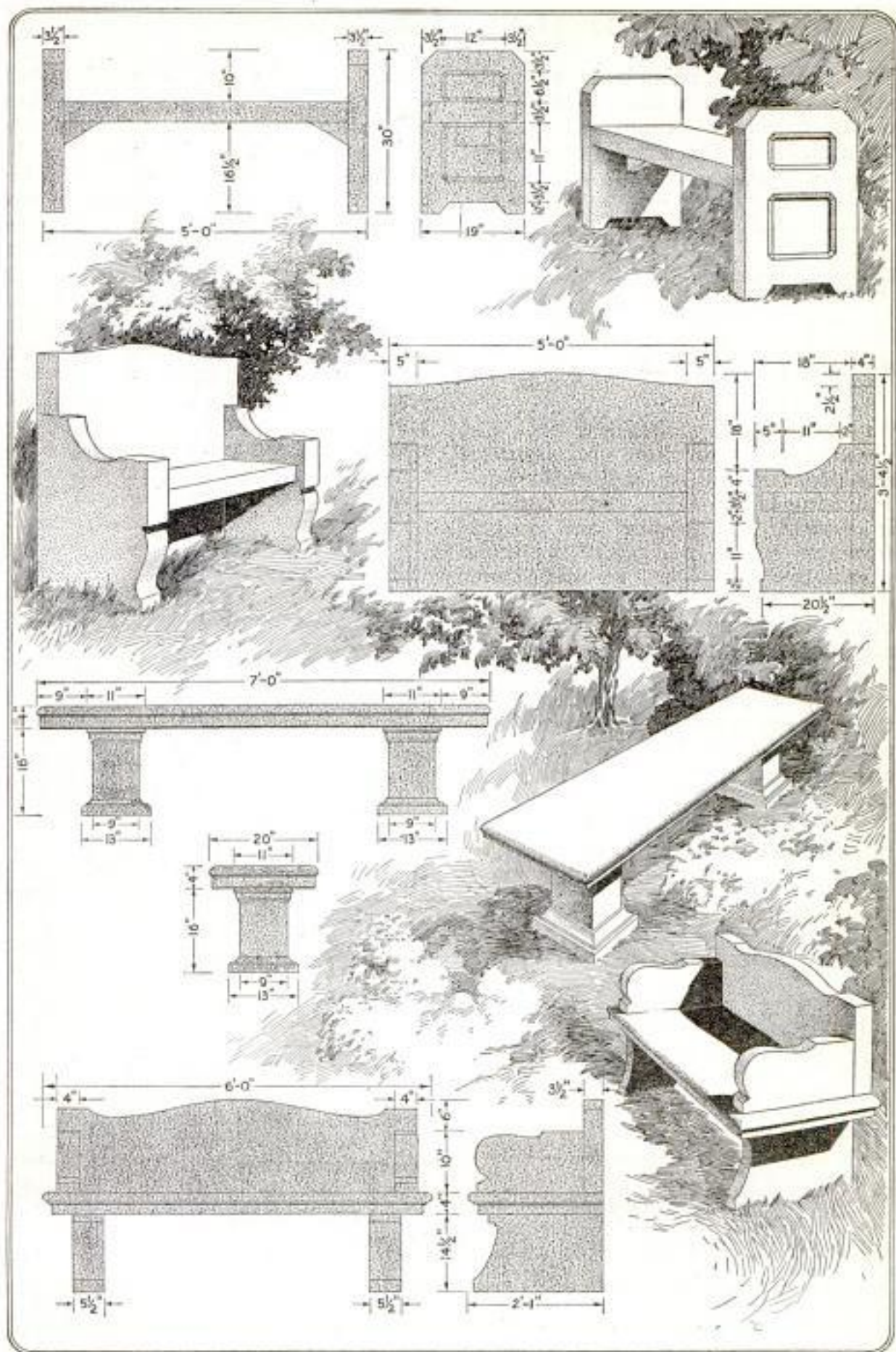

**These Garden Seats and Benches of Simple, Dignified Design may be Made by One of Fair Mechanical Skill at Small Outlay. They Add to the Comfort and Beauty of the Home Grounds, and Are of Substantial Construction, to Withstand the Elements**



The advantage of using bolts is that the seat may be taken down readily and moved to a new setting.

Possibilities for simple ornamental

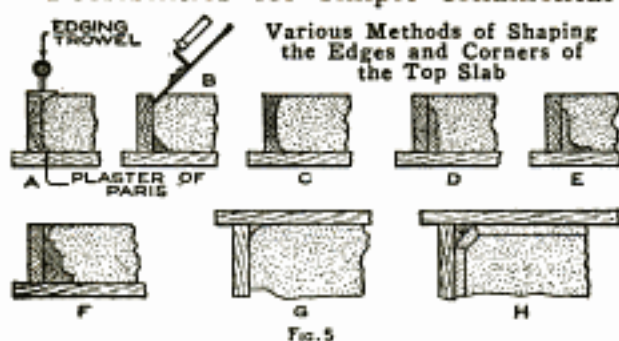

Fig. 5

treatment of this garden seat and slight variation in the finishing of the corners and edges are shown in Figs. 5 and 6. Finishing of the edges of the top slab in curved, straight-line, and molded forms are shown in Fig. 5. The use of a plaster-of-Paris fillet in the lower corner of the mold, and the rounding of the upper edge with an edging tool, are shown at A. The beveling of the lower edge by means of a triangular wooden fillet and the striking off of the upper edge with a trowel are shown at B. Views of the filled mold from above, the corners shaped with fillets, are shown at G and H.

The paneling of the edges of the plain slabs, as shown in Fig. 1, relieves the severe outline and adds a touch of

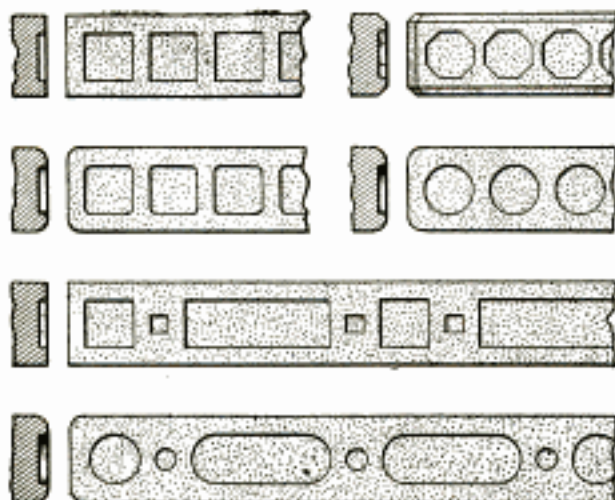

Fig. 6

Several Panel Treatments of the Edges, the Panels and Corners Designed to Harmonize in Each Case

individuality. The panels are  $\frac{3}{8}$  in. in depth and are made by nailing blocks into the form, as shown in Fig. 4. Bevel their edges slightly to produce

"draft" for the easy removal of the form, as indicated in the cross sections in Fig. 6. To insure that the concrete is cast around these blocks, press the mixture into the corners as the mold is filled. Several forms of panels are shown in Fig. 6, the edges of the slabs being shaped to harmonize with them.

New constructive elements are introduced in the forms for the garden seat shown in Fig. 3. The top slab is made 3 in. thick, 20 in. wide, and 5 ft. long, by the process described for the first seat. The supports are  $4\frac{1}{2}$  in. thick, and in their simplest form may be made with a cap and base effect, on the edges only. The working drawings and sketch show pilasters,  $\frac{1}{2}$  in. thick, on the outer sides, produced by panel-

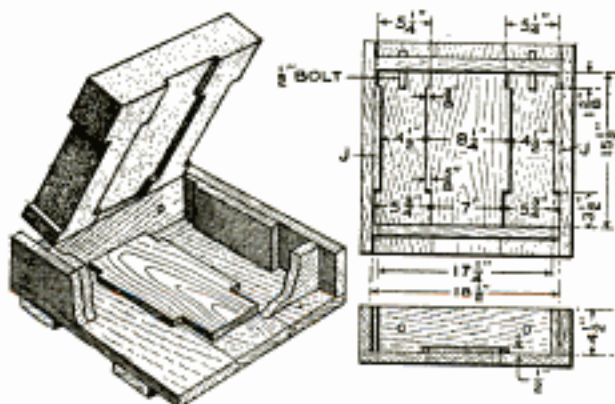

Fig. 7

The Form is Built Up Accurately and the Mold Poured. The Sides of the Form are Removed, the Support being Shown in Diagrammatic Relation to the Form Only

ing the surface. The detailed construction of the form for the supports is shown in Fig. 7. Make the form with inside dimensions of  $15\frac{1}{2}$  by  $18\frac{1}{2}$  in. Make two strips J,  $\frac{5}{8}$  in. thick, with a  $\frac{3}{8}$  by  $1\frac{5}{8}$ -in. rabbet at the upper end, and nail them to the sides of the form, as shown. Make a piece  $\frac{1}{2}$  by  $8\frac{1}{4}$  by  $15\frac{1}{2}$  in. for the panel mold. Rabbet the upper corners  $\frac{3}{8}$  by  $1\frac{5}{8}$  in., and the lower ones  $\frac{5}{8}$  by  $3\frac{1}{2}$  in. Bevel the edges on the sides and at the rabbets to give "draft." Nail the panel carefully into place in the bottom of the mold, centering it to make the pilasters of the columns each  $4\frac{1}{2}$  in. wide. Fix the sides into place with screws. Round off slightly all sharp corners, and set the nails, filling the holes with plaster of Paris. Smooth the inside of the mold,



and clean, shellac, and oil it. Set the bolts which join the top slab and the support into the upper end of the form, and the mold is ready to be poured. Fill the mold with a 1:3 mixture of Portland cement and coarse, clean sand, and proceed in general as in the making of the slabs for the first seat.

### Air-Pump Blower Driven by Punch Press

The pump shown in the sketch was devised for blowing away punchings of a light material and for keeping the parts of the dies clear. The pump was fastened to the shaft of the press by means of the shouldered bolt A, fixed in place with two nuts, as shown. The plunger of the pump B was fastened to the shoulder of A, and the body of the pump was inserted in a clip, C, fixed to the side of the press. The clip was made in the form of an oarlock and bolted to a flange, D. The latter was fixed to the punch press with flat-head screws. The rubber hose connected to the lower end of the pump is just long enough to reach the dies. The pump may be removed from the clip easily

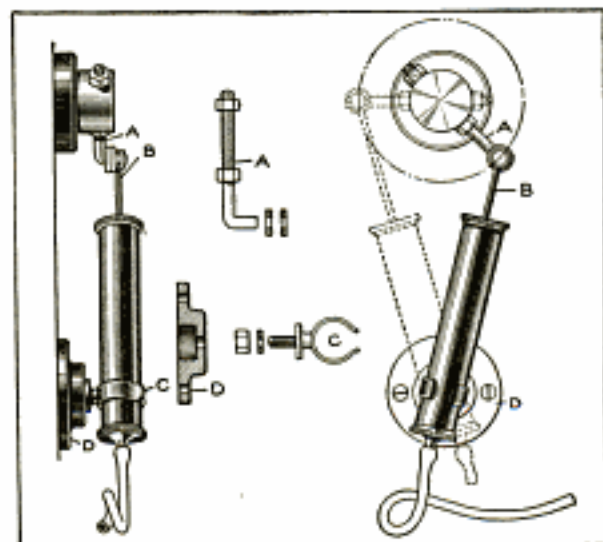

The Pump is Fixed to the Side of the Punch Press so That It is Operated Automatically, and Is Removable by Reason of the Clip C

and released at the shoulder of the bolt A, for use in the ordinary fashion.—George P. Kuhne, East Rutherford, N. J.

### Device for Tying Parcels

The wire clip shown in the illustration was devised for use in tying parcels temporarily, and is especially

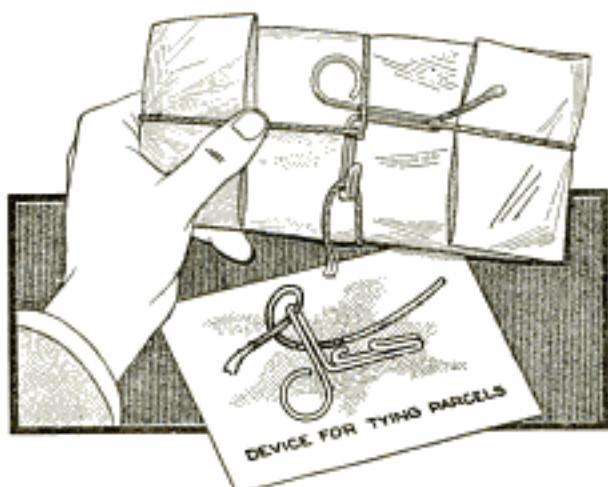

The Cord is Fastened to One End of the Device and is Passed Quickly around the Parcel and Locked at the Hook

convenient for bundles of letters and other small objects. It is bent from a piece of wire to the shape shown, and one end of the tying cord is clamped in the folded portion of the wire. Starting from this point of fastening, the cord is passed around the parcel, hooked to a small projection at the center of the device, passed at right angles around the parcel and clamped under the hook as indicated. The round loop is used in grasping the device and steadying it while the cord is drawn rapidly into place. The cord is released quickly by removing it from the hook, and the device, with cords of various lengths, may be prepared and kept on hand for repeated use.—E. E. Burnham, Amite, La.

### Remedy for Noisy Telephone Bells

In a large office where each desk has its individual telephone the repeated ringing of the various call bells is annoying. Especially is this true if the telephone bells are highly pitched. To eliminate this feature, a large concern, which owned its telephones, had the bells slotted twice with a hacksaw. A metallic, unobjectionable buzzing sound results when the operator rings a station.



### Garden Dump Cart of Varied Uses

The cart shown in the illustration gives better service than a wheel-



barrow, and was made from materials gathered in the barn and home workshop. The fact that it can be tipped to dump off loads readily, as shown in the illustration, makes it handy for hauling dirt for the garden and tennis court, and the transporting of sod. On the lawn it carries tools, grass, and water. In the garden and orchard it is used to carry fruit, vegetables, and other products, its width being such as to fit conveniently between the rows.

The cart was made by cutting off the rims and spokes of an old set of buggy wheels, and nailing double barrel hoops on them. These were covered with old bicycle tires, affording a good protection when the cart is used on lawns. A wooden axle was provided and the braced handle fitted to one end at a height convenient for pulling or pushing the cart.—E. R. Smith, Walla Walla, Wash.

### Spinning a Cranky Engine

After overhauling and tightening the bearings of a marine engine, it was found necessary to crank it by



other means than by hand. The only available power was an automobile, one rear wheel of which was jacked up, the other three blocked, and the motor mounted on skids, placed as shown in the sketch. Its flywheel was set in contact with the tire of the raised

wheel of the automobile. By engaging the clutch gently, the cranky engine was caused to operate, and in a few minutes was running on its own power.

### Locking Four Drawers with Plate Hasp

It is sometimes not practicable to provide separate locks for several adjacent drawers, and under these circumstances the plate hasp shown in the sketch was used with satisfaction. A staple riveted into a plate was fastened to the strips between the drawers, and

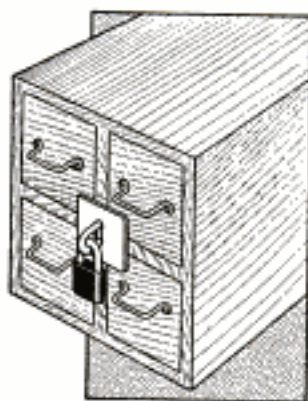

a square plate having a suitable slot cut in it was fitted over the staple. A small lock secured to the staple locks the drawers effectively.—Joseph Prophet, Pittsfield, Mass.

### Shifting-Fork Repair

The shifting fork on an automobile gear box broke at one of the prongs, and a new one was made to replace it, as shown in the illustration. A piece of strip steel was bent to the same shape as the broken prong, and a portion was cut out of the shank of the fork into

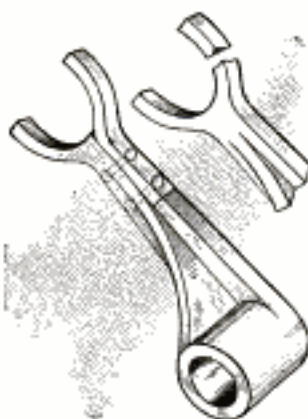

which the strip was fitted. Two  $\frac{3}{8}$ -in. flat-head rivets were used to fix the prong in place. The repaired fork has given satisfactory service under hard usage.

ⒸGraphite and oil will arrest cutting in bronze bearings when oil alone proves ineffective.



### Mitered Corner That does Not Show Wear

In mitering edges subject to constant wear the usual way of having a sharp mitered corner is not satisfactory. In many instances a sharp edge is not desirable, and once it wears, it is unsightly. This is particularly true of tables where strips are mitered onto the edges of the top, either to make it appear heavier or to hide the end grain. The disadvantages of having a sharp miter in such a place results in the common use of a thin strip plain-butted and glued to the edge. This shows the joint and gives the article a cheap appearance.

An effective means of overcoming these difficulties is to make a sharp mitered edge on the main piece, and a rounded mitered edge on the trimming. This affords protection for the end grain and is not easily affected by wear.

### Bottle Stopper and Filler for Ruling Pens

The ordinary quill fixed to a bottle stopper for use in filling ruling pens is unsatisfactory in that it does not deliver a uniform quantity of ink. A stopper that can be adjusted to the depth of the ink in the bottle is made by inserting the glass from an eye dropper through the cork of the bottle. The glass is adjusted to the depth desired and as much ink as is needed may be released by controlling the air supply with the forefinger, at the upper end of the glass.—Francis W. Nunenmacher, Berkeley, Calif.

### Shipping Case Insures Carrying Batteries or Liquids Upright

The shipping case shown in the sketch was devised for a large storage-battery concern after difficulty had been encountered in shipping batteries without pouring out some of the acid. It is useful also as a crate for shipping bottles of liquid which must be transported in an upright position. The

unusual shape of the case attracts attention and it is not likely that it will be placed in any other than the desired position. The handles are provided for

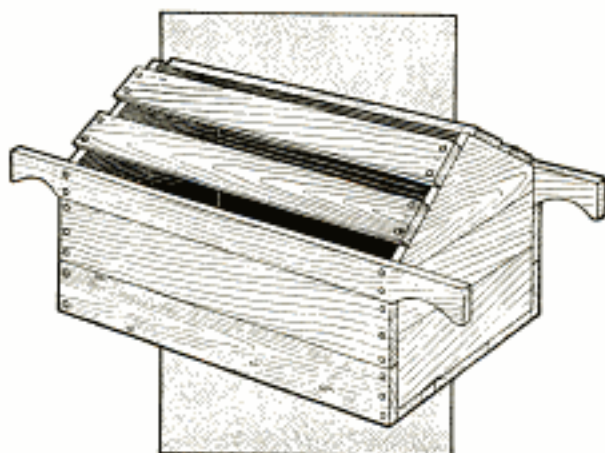

The Peculiar Shape of the Shipping Case Insures That the Contents will be Kept in an Upright Position

convenience in carrying, and the contents may be removed quickly by unfastening the boards at the top.—Joseph P. Bowles, New York City.

### Rollers Prevent Marring of Adjoining Doors

The knobs of adjoining doors frequently cause a marring of the finish and bruising of the woodwork, which may be avoided by the use of the roller device shown in the sketch. A copper strip is placed on each door so that a roller on the other door operates on it. The strips and casters should be placed so that their action will not interfere.

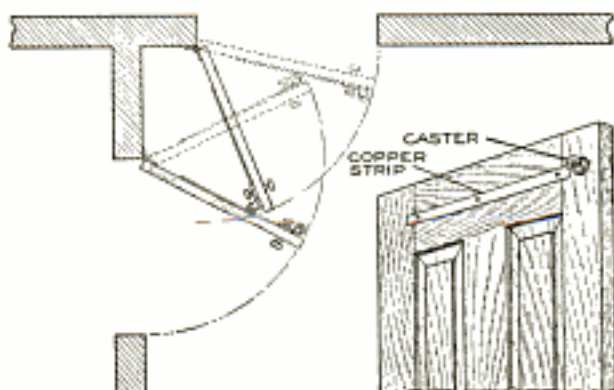

The Action of the Rollers on the Metal Bearing Strips Prevents the Marring of the Doors

If the fittings are selected carefully and installed properly, they will not spoil the appearance of the woodwork.—L. F. Richards, Dorchester, Mass.



### Holder for Examining Drawings

Unnecessary wear on drawings, or blueprints, and considerable inconvenience are often caused in drafting rooms and elsewhere when drawings must be referred to repeatedly, on various parts of a set, or roll. The device

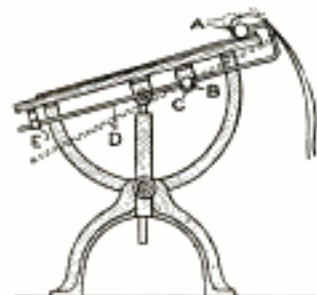

shown in the sketch is a holder that may be fixed to the drafting table, or other convenient place, for examining drawings, and prevents wear as well as makes consulta-

tion of the drawings easy. A wooden cylinder, A, 1½ in. in diameter, and as long as is necessary for the drawings, is supported on two ¾-in. rods, which are fixed to the bar B. The latter is supported by two brackets C, fastened to the under side of the drawing board. A rod, D, is fixed to the bar B and extends to a convenient point at the front of the drawing board, or table. The hook E holds the rod D in position. To release the drawings, unhook rod D and move it downward, pivoting on B, as shown by the dotted lines. The rod D should be so arranged that when it is in the hook E, the proper pressure to hold the drawings is given to the cylinder A.—H. P. Morgan, South Norwalk, Conn.

### Motor Cylinder Repaired with Copper Strip

One of the cylinders of an automobile was scored badly the full length of the stroke by the loosening of a wrist pin.

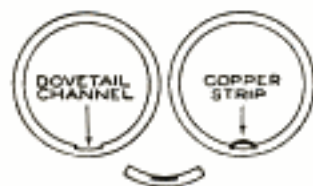

There was not time to have the cylinder rebored, so an emergency repair was undertaken with success, as follows: The cylinder was dismantled and a channel was cut in the shape of a dovetail, as shown in the sketch, ex-

tending from the end of the cylinder to the other end of the scored portion. The channel was made to the depth of No. 18 gauge sheet metal, and the bottom of it was rounded to conform to the curve of the cylinder. A strip of copper was wedged into the channel, as shown, and riveted into place. The surface was then dressed down to the proper curve and scraped smooth. The strip must be curved slightly, as indicated in the sketch at the right, in order to fit into the channel. Nearly the full power was obtained from the cylinder.—Logan E. Anderson, Cove, Ore.

### Sanding Block for Interior Trim and Floors

Sandpapering, especially on large surfaces, such as floors, or door and window casings, etc., is a tedious task when done in the usual way by gripping the sandpaper around a block of wood with the hand.

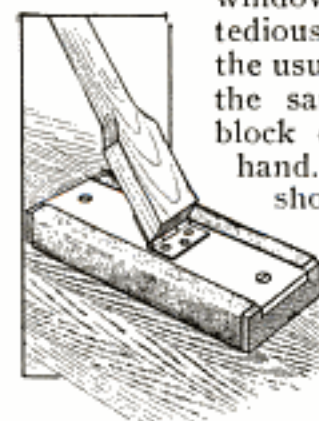

The device shown in the sketch provides a convenient method of applying the sandpaper and is especially useful, by reason of the handle, in reaching casings and other woodwork at a considerable height above the floor. The sandpaper is gripped in the block by inserting it under the piece fastened in the top with screws.—Guy E. Waite, Ottawa, Ill.

### Notch in Wick Improves Lamp Flame

A railroad brakeman who had an unusually bright light in his lantern explained that it was due to the care given the wick. He cut a small notch at the center of the edge of the wick, causing the flame to have a notched outline at its top. This gave relatively more light than the flame from a wick cut square across.—C. E. Drayer, Cleveland, Ohio.





## Portable Fence for Baby's Play Area

By L. N. ROBINSON

**A** CHILD in the "toddler" stage should be provided with a safe place in which to play without disturbing the household routine of the busy mother too frequently. The folding wood-and-wire fence shown in the illustration meets this need in a practical and inexpensive manner. It may be used in the home or out of doors, the fence being especially useful in the latter case, since it protects the child,

and likewise the lawn flowers, which a youngster, unguarded, may injure. The fence is 25 to 32 in. high, strong enough to support a grown person sitting on the edge of it, and incloses an area of about 4 by 6 ft. This is ample for the child, and the folded fence is thus not too bulky to be transported easily. The materials cost less than \$3.50, including hardware for the making of the fence, as shown in the working drawings. The wood used for the main

frames is  $\frac{1}{2}$  by 2 in., and they are covered with wire mesh, the edges of which are nailed under strips, on the outer side of the frames. Care should be taken to insure that none of the wire strands is exposed, thus endangering

the child, or the clothes of passers-by. The frames are hinged together, as shown in the plan, and fold into compact form. Two long and four short frames are required. Cut the top and bottom rails of the long frames 6 ft. in length, and those of the shorter frames and the stiles 25 in. The corner joints are cross-lapped by cutting away one-half the thickness of each strip, as shown at A. The joints at the top and

bottom of the center stile, or vertical piece, are made as shown at B, and the joints at the crossing of the center stiles and the cross braces, as at C. The braces only are notched to fit the stile. Each of the joints is fastened with flat-head screws, countersunk. The ends of the braces are cut to fit flush into the corners of the frames, and are nailed in place. This provides a flat nailing surface for the wire mesh and the strips that cover its edges.

Before putting on the wire mesh, all the exposed corners should be "broken" slightly with sandpaper, the wood wiped smooth, and finished with a coat of shellac. The wood may, of course, be left unfinished. In fixing the 1-in.



A Safe Play Space Either Indoors or Outdoors is Provided for the Child, and the Fence may be Moved Easily. The Construction Is Light yet Stable, and can be Carried Out without Difficulty by the Home Woodworker



wire mesh in place, fasten one end of the piece squarely at the end of the frame, nailing it with staples. Place a strip of wood under each end of the

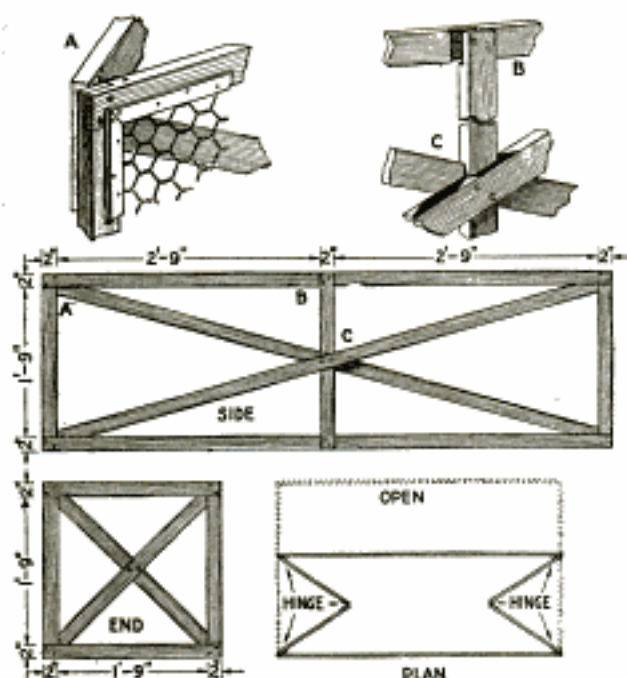

Join the Pieces with Well-Made Lap Joints, and Hinge the Frames as Indicated

frame and bear down on the middle of the frame, or weight it, to produce a bowed effect. Then nail the other end

of the wire securely; on removing the strips, the wire will be drawn taut. Tack the edges down, and repeat this process on the other frames. Next nail the covering strips on the front faces of the frames, mitering them at the corners, as shown at A.

The frames are then joined by means of hinges, as shown in the plan at A. Care should be taken that they are set so that the corners of the fence meet squarely and evenly when it is opened. Metal drawbolts should be fastened horizontally, one on the top of each folding joint between the end sections. These will prevent the child from folding the ends in, and possibly injuring its fingers. The completed fence is then given a final coat of shellac or varnish, the galvanized wire being left unfinished.

The materials required for the fence are as follows, the wood being listed in lineal feet, and smoothed on four sides to the dimensions indicated:

- 155 ft.  $\frac{1}{2}$  by 2-in. clear pine.
- 50 ft.  $\frac{1}{4}$  by 1-in. clear pine.
- 22 lineal ft. 1-in. mesh, 2-ft. wide wire fencing.
- 6 pairs 1 $\frac{1}{2}$ -in. iron plain butt hinges, with screws.
- 2 steel drawbolts, with screws.
- $\frac{1}{2}$  pt. white shellac.

### Water Rheostat for Small Electrical Devices

The rheostat shown in the illustration can be made quickly and at small expense. The

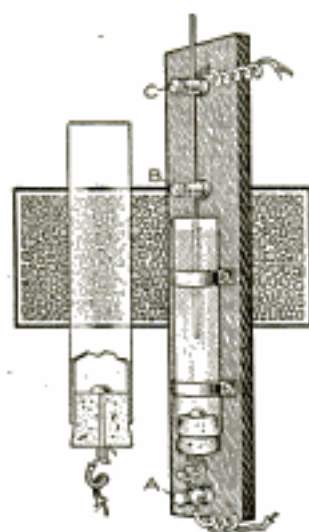

base consists of a piece of wood,  $\frac{1}{2}$  by 2 by 12 in. A glass tube, 1 in. in diameter and 6 in. long, is fastened to this with strips of sheet metal. A large brass tack is driven into a cork, and the cork is inserted in the lower end of the tube. A wire runs from the brass tack to the binding post A. The lower part of the tube should be

paraffined to make it water-tight. A brass or copper rod is placed through the binding posts B and C. The resistance can be changed by sliding the rod up or down. The tube is nearly filled with water having a small quantity of salt dissolved in it. The amount will depend upon the current to be reduced. The rheostat should be fastened to a wall, or other support, and may be used to regulate the speed of small motors and other electrical devices.—R. R. Wayt, Pittsburgh, Pa.

### White Blotting Paper Improves Light Reflectors

In the lecture and classrooms of a large university it was found that reflections of the electric-light bulbs in the glazed porcelain reflectors were extremely annoying to the eyes of students, and concentration of sight on the blackboard was difficult. A num-



ber of tests were made, and the following method proved successful, eliminating the glare and the reflections. Large sheets of white blotting paper were cut to fit the inside of the reflectors, and then glued to their surface. The soft, somewhat rough surface of the blotting paper diffused the light, so that the glare was overcome.—C. M. Hall, St. Louis, Mo.

### Two Simple Vises for the Home Workbench

Boys, and other amateurs, sometimes have need of a vise when a commercial article or one of standard type cannot be had readily. The devices shown in the illustration will give good service and can be made of material easily obtained. The vise shown in Fig. 1 was made of old machine parts, consisting of a bolt and a wing nut. The bolt A was flattened at one end and bent at a right angle. A hole to fit it was bored through the top of the bench B, and the washer C and wing nut D were put in place. The piece to be gripped is clamped under the end A. This device should be fitted near the end and front edge of the bench.

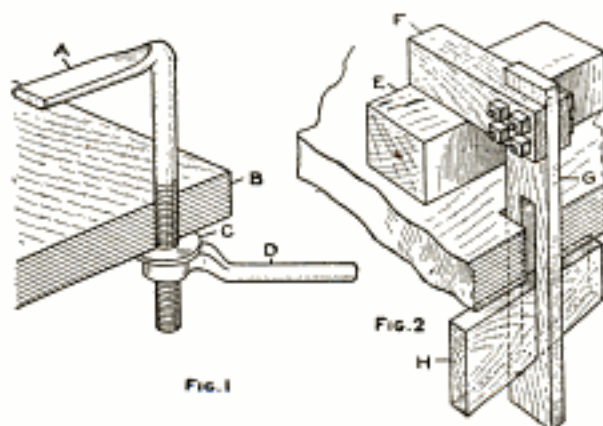

These Vises may be Made Easily of Materials Available in Most Workshops

The vise shown in Fig. 2 grips the block E in the same manner as the first vise. The jaw F is bolted to a vertical piece, G, which is fitted into a mortise cut through the bench top. The wedge H passes through a mortise in the piece G and clamps against the lower side of the bench top.—James E. Noble, Toronto, Can.

### Drinking-Glass Holders Easily Made

Several styles of holders for a drinking glass are suggested in the illustration. They may be made of durable

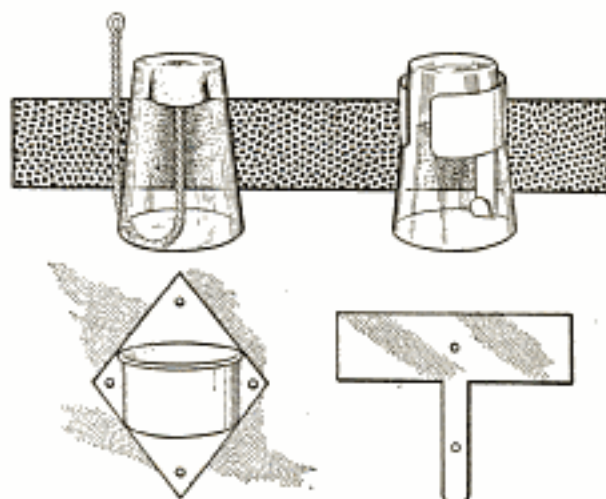

These Homemade Holders for Glasses Are Useful and Quickly Constructed

materials easily obtained in the home workshop. The first is made by twisting a galvanized-iron or brass wire, as shown, with an eye and a loop for fastening it to the wall. A cork is fixed to the upper end, on which to rest the glass. The lower sketch shows a holder of the cup type\*made by riveting a metal cup to a diamond-shaped plate, the latter being fastened to the wall. The holder at the right is made from a piece of sheet metal cut to the shape indicated below. It is bent to the shape shown, and the lower end of the narrow strip is curved upward to provide a rest for the edge of the glass. The upper portion of the holder should be large enough so that the glass may be raised sufficiently to fit into the rest. The holes are provided for a fastening.—Frank L. Matter, Portland, Ore.

### Emery Needle Cushion on Sewing Machine

A convenient emery pad and needle cushion may be made by inclosing the powder in a long sack, about 1 in. in diameter, and sewing it in place around the arm of the machine. It will thus be close at hand and needles and pins may be stuck in the cushion, free from rust, and will not be in the way.



# A Compensated Aerial Cableway



THE possibilities for practical use as well as novelty for play and experimental purposes make the compensated aerial cableway, shown in the illustrations, not only interesting but also worthy of study. The arrangement assembled in its simplest form with two towers, in the page plate, shows how the weight of the car is compensated, so that a fairly level course on the track cable is provided. The various positions of the load and cables, showing the application of the compensating principle, are indicated in Figs. 1 to 5, and a multiple system is shown in Fig. 6. The details of the constructional parts are also shown. The car may be driven by wind power, as shown in Fig. 7, or by a motor, as in Fig. 8, in addition to the simple application of hand power suggested in the page plate. Devices for automatically reversing the course of the cars both for the sail rigging and with the use of electrical power, are shown in Figs. 7 and 8. By their use it is unnecessary to have an operator at each end of the cableway. The constructional features were worked out first by experiments on models in a shop, and then applied to a large rigging spanning over 100 ft. between the A-frames. The sketch in the page plate was made from photographs of this construction. Application of the compensating principle to carrying and transportation problems affords opportunity for interesting engineering, in spanning streams, cañons, or gulleys.

In most types of cableways a considerable sag is allowed in the cable supporting the car in addition to that caused by its own weight. Even in systems of practically constant cable tension, in which the wire is stretched by enormous weights, the loaded car causes a sag in the track cable, and ascends and descends an incline when approaching and leaving a tower. The aim in the compensated cableway is to overcome this sag as much as pos-

sible, and to offer a minimum of resistance to the car in its course.

The simple form of compensated cableway shown in the page plate is made by setting up two A-frames, with wire braces supporting them, and mounting the track and traction cables upon them. A light, flexible compensating cable extends from one tower to the other and is fitted to grooved pulley wheels at the tops of the towers, as shown in the detail at the right. The ends of the cable are fixed to wire hooks, from which the track cable is suspended. The latter is anchored at the ends of the wire braces supporting the A-frames. In order to understand the operation of the system it is desirable that the course of a load be traced in its various stages, as indicated in the diagrams, Figs. 1 to 5. For diagrammatic purposes the load is shown passing from the west slope to the east. As the load passes under the first A-frame, as in Fig. 2, the track cable is drawn down at that point; the corresponding end of the compensating cable is also drawn down, raising the opposite end of the track cable, and taking out most of the sag in the center portion of the track cable. As the load passes to the center position, as shown in Fig. 3, the track cable resumes a more nearly horizontal position. When the second A-frame is reached the load draws the corresponding end of the compensating cable down with the track cable, Fig. 4, and the latter assumes its normal position as the load reaches the end of the course. It is evident from the diagrams that the course of the load is more nearly level than it would be if the sagging of the track cable were not counteracted.

For use with a multiple-frame system, the cables are arranged in units between supports, as shown in Fig. 6. The compensating action is similar, the tendency being to level the entire course of the load. The weight of the



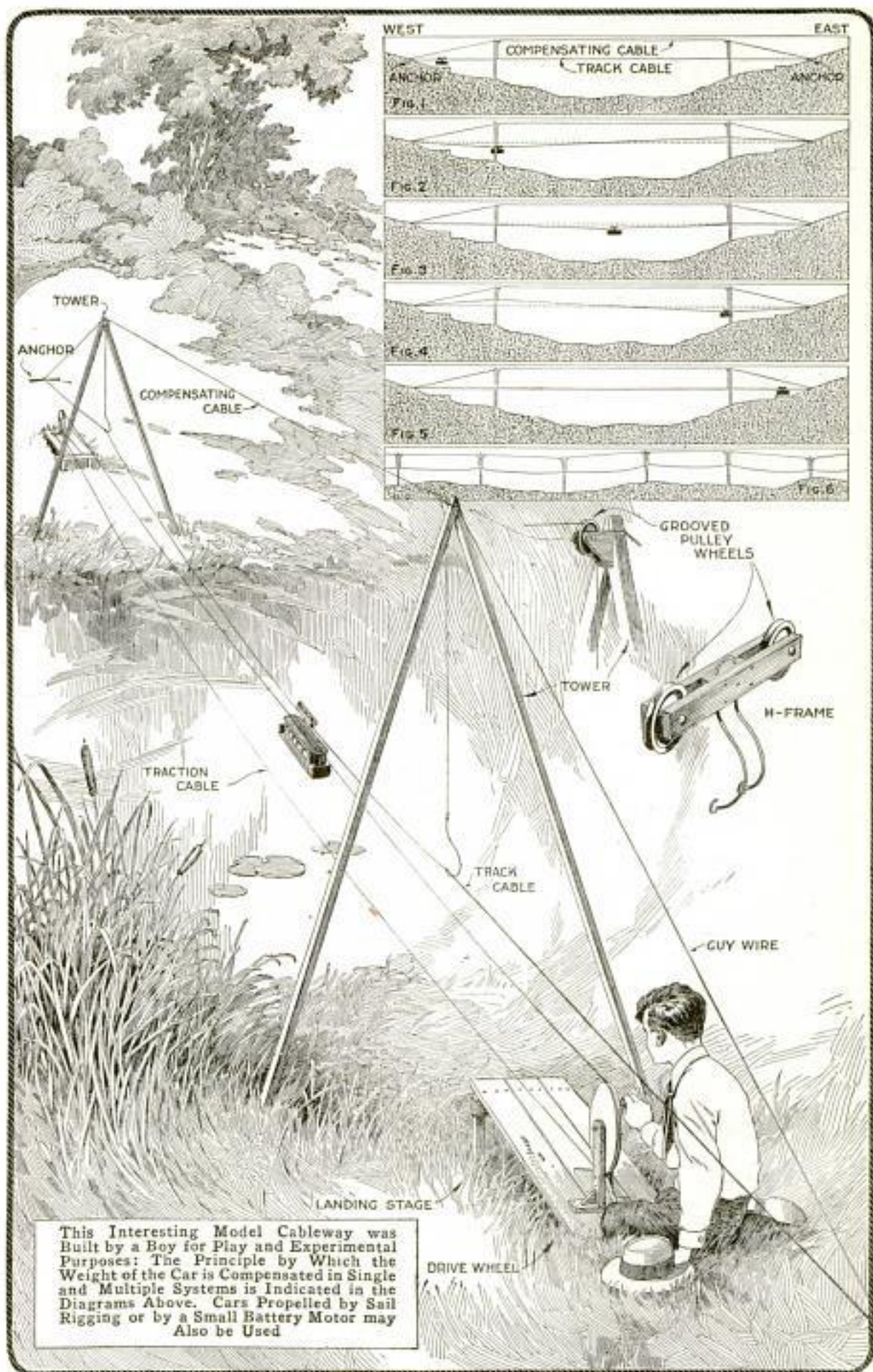

This Interesting Model Cableway was built by a Boy for Play and Experimental Purposes: The Principle by Which the Weight of the Car is Compensated in Single and Multiple Systems is Indicated in the Diagrams Above. Cars Propelled by Sail Rigging or by a Small Battery Motor may Also be Used



car and load only is compensated, and since the weight of the cable will cause a sag, the course cannot be level, but may approach this condition.

A model of the compensated cable-

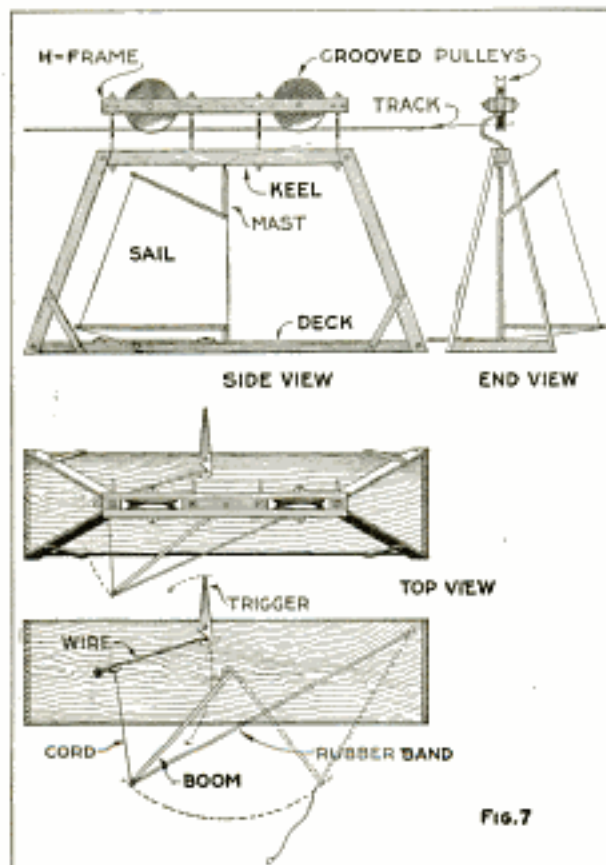

The Car is Propelled by the Wind Acting on a Sail Controlled Like the Main Sheet of a Sailboat in Tacking. The Trigger Device Releases the Sail, Reversing the Course of the Car

way, as shown in the page plate, or on a smaller scale, may be made by a boy of fair mechanical skill. For experimental purposes the detail may, of course, be refined to a high grade of workmanship, if desired. The size and dimensions of the parts need not be proportioned precisely as shown, but may depend more or less upon the materials available. The track cable should be made of galvanized-iron wire, the compensating cable of fish-line, and the towers of 1-in. stuff, the width of the pieces making up the A-frames being increased in proportion to the height. Grooved pulley wheels, set in housings fixed to the top of the A-frames, carry the compensating cable. These may be made of wood, built up in three sections, to provide a flange on each side of the cable groove. The

A-frames should be joined strongly at the top, and braced to anchors, sunk into the ground as shown. The hooks from which the track cable is suspended are made of heavy wire, bent so as not to interfere with the H-frame hanger supporting the car, and looped around the cable.

Various types of hangers may be devised to house the two pulley wheels which ride on the track cable. A simple H-frame hanger is shown in the detail sketch in the page plate. The grooved pulley wheels are set on bolts, and a heavy wire is bent and set through the center block as a support for the car. For experimental purposes, or even for play, when it is not desired to make a more elaborate car, a wooden block or other object of sufficient weight may be used as a load. An interesting feature of the work, especially for a boy, is to devise a realistic coach model, as suggested in the sketch. A wooden block forms the base, and the roof and platforms are made of sheet metal. The windows and doors are painted on the metal. The inventive boy may, of course, build a car with a hollow metal or wooden body, and weight it properly to provide the necessary load.

The motive power is provided by means of a cord, or traction cable, carried around two large grooved pulleys, mounted in supports fixed to the landing stages at each end of the cableway. They are made of wood, a suitable groove being cut around the edge with a saw, and smoothed with a small round file, or sandpaper wrapped over a round rod. The traction pulley is turned by means of a crank, set on the bolt which is used as an axle. The traction cable must be drawn sufficiently taut to provide the necessary pressure on the grooved pulleys, or it will slip. Rosin applied to the pulleys and the cable will tend to prevent this.

If the frames and other fittings have been properly set up, the cableway will support a sail car, shown in Fig. 7, or a two-cell electric car, driven by a small motor, as shown in Fig. 8. The sailing-car arrangement is often fea-



sible, since a stiff breeze is common in gorges, cañons, narrow valleys, or even in ravines where such a cableway might be set up. The hanger is an H-frame having the grooved pulleys bolted in it, and further reinforced by small blocks at the ends. A braced frame, supporting a deck on which a mast is set, is suspended from the hanger by four curved wires, as shown in the side view, Fig. 7. A sail with boom and gaff is supported by the mast. It is arranged to be shifted around the mast, which is accomplished automatically at the end of a run, or "tack," by means of the trigger device shown in the top view. The sail is controlled in relation to the wind much as is the main sheet of a sailboat. The car can be operated in this manner only at right angles to the direction of the wind, or nearly so. For play purposes, a boy stationed at each end of the cableway can shift the sail, but the trigger device shown makes this unnecessary. A rubber band is attached to the boom, as indicated in the top view, and a cord and wire are arranged to engage a trigger. A stop for the trigger is fixed to the A-frame so that it is sprung when the car reaches the end of the run. The rubber band reverses the sail, the car having been set on the cable originally so that the forward end is in proper relation to the wind.

The electric car is especially interesting in that it provides self-contained motive power by means of a battery of dry cells, and a motor belted to the hanger, as shown in Fig. 8. The hanger is of the H-frame type with heavy blocks between the sidepieces to provide for the small grooved driving pulley set on the axle of one of the larger pulleys. A wooden deck, supported by four heavy wires set into the center block of the hanger, carries the motor, and the dry cells are fixed under it. The motor is of the small reversible battery type, and should be provided with a reversing lever. This will make it possible to reverse the car when it reaches the end of its course. The motor and cells should be disposed

so as to balance, tests being made for this purpose before setting them in place finally. A cord or small leather belt connects the drive pulley of the motor with the proper pulley on the

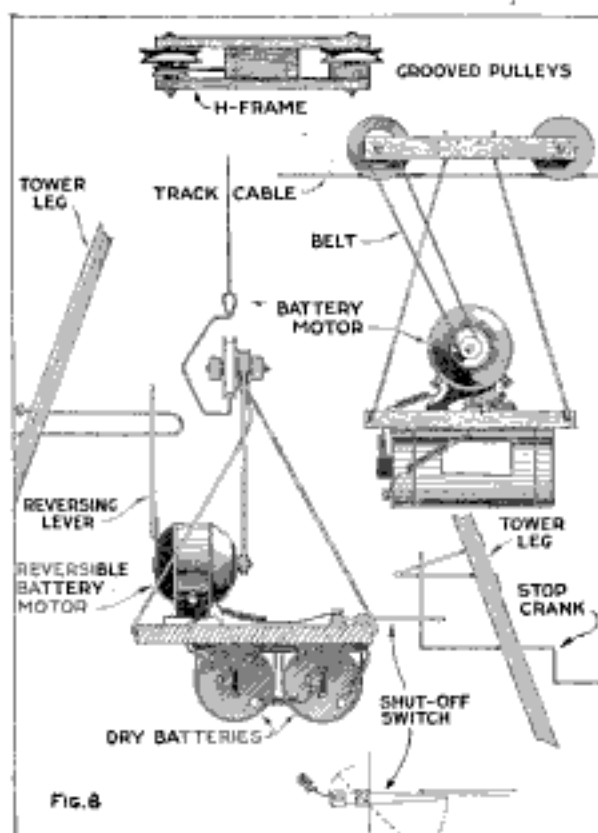

The Electric Car Is Self-Contained and may be Reversed Automatically, if the Motor Is of the Reversible Type, by Contact of the Lever with the Stop Fixed to the A-Frame

hanger. These pulleys should be in line, and that on the hanger should be five times the diameter of the one on the motor shaft. The power is shut off at the end of the course by a shut-off switch which strikes a stop crank attached to the A-frame. When the reversing lever and stop are used, the stop crank is unnecessary. A non-reversing motor can be made to drive the car in a reverse direction by removing the belt from the motor pulley and replacing it to make a figure-eight twist.

¶When babbitt metal is heated some of the tin and antimony in it is burned out, making it unsuited for use in machinery bearings, and similar purposes, after several heatings. The oxidation of the metal is indicated by the formation of a scum on the surface.



## A Piano or Reading Lamp

By WILLIAM E. FINKERNAGEL

THE lamp illustrated was designed for use in reading, the doing of hand work at which one is seated in a chair away from a table lamp, or for lighting a piano rack. It is light, readily moved about, easily made, and

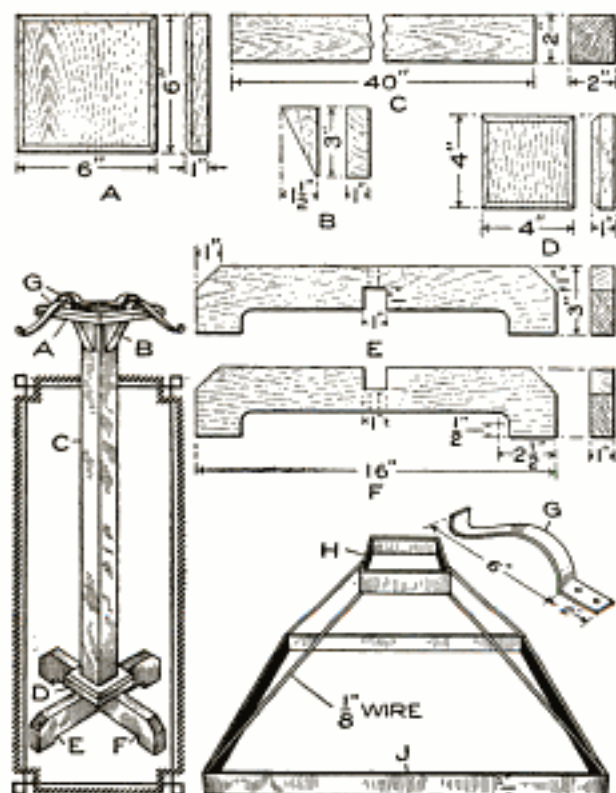

This Lamp of Substantial Construction and Pleasing Design may be Made at Small Cost. The Pedestal Assembled is Shown at the Left and the Details of the Parts and of the Metal Frame for the Shade, Above

of pleasing design. It combines construction in wood and metal, is inexpensive, and within the range of a careful amateur craftsman. The pedestal is shown assembled at the left, and above are detailed sketches of the parts. The construction of the shade, which is 18 in. square, is shown at the right. The central post is 40 in. long and 2 in. square, and the base measures 16 in. on the arms.

The stock bill for the lamp is as follows:

- 1 piece, 2 by 2 in., oak, for post.
- 2 pieces, 1 by 3 by 16 in., oak, for base.
- 1 piece, 1 by 6 by 6 in., oak, for cap.
- 1 piece, 1 by 4 by 4 in., oak, for column base.
- 1 piece, 1 by 2 by 3 in., oak, for braces.
- Copper or brass strip, 1 in. wide and 3/32 in. thick, for shade frame. Wire braces for shade.

Make all the pieces, smoothing and finishing their surfaces with a scraper, before assembling the parts. The cap A may be made first. Square the piece to 6 in. and cut a 1/4-in. chamfer around the upper edge. Cut the 3 by 3-in. block on one of its diagonals and smooth it to form the braces B. Square the ends of the post C to a length of 40 in., and smooth up the sides. Square the column base D to 4 in. and cut a 3/16-in. chamfer around its upper side.

Square up and smooth the cross arms E and F, for the base, to a width of 3 in. and a length of 16 in. Bevel the upper corners 1 in., at an angle of 45°. Bore holes with a 1/2-in. bit to form the rounded ends of the portions cut out from the lower sides of the cross braces. Chisel the wood away between the holes and smooth the resulting surfaces. The half-lap joint, by which the cross braces are joined, may then be made. It should not be made until the lower portions are cut out of the cross braces, and the remaining portions are made of exactly the same width, 2 1/2 in., according to the drawing. The joint must be fitted tightly in what is termed a driving fit, or it will not be strong enough.

The construction may be assembled as follows, although several methods may be adopted that will prove satisfactory: Fix the cap A to the top of the post with glue and 1/2-in. dowels, bored not quite through the cap. Screws may be used for this purpose, but they mar the finish of the upper surface of the cap. Glue the braces B into the corners to support the cap. They should be warmed before applying the glue and rubbed slightly to bring them into place tightly and to distribute the glue evenly. Small brads may be used to nail them in place, but care must be taken not to mar the finish.

The column base D may be fixed to the bottom of the post in the same way that the cap was fixed at the upper end. The cross braces E and F, form-



ing the base, should be glued in the half-lap joint and fixed to the column base with glue and dowels, or screws sunk into sockets from the lower side of the braces.

When the glue has dried, the pedestal should be scraped and cleaned preparatory to a final sandpapering before applying the stain and varnish.

The arms G for the shade holder are made of strips of brass or copper, 1 in. wide and  $8\frac{3}{4}$  in. long, bent to the proper form, as shown in the sketch. The straight end, 2 in. long, is provided with two holes through which screws are fixed into the top of the cap.

The shade is constructed as follows: Make a 4-in. square, H, of brass strip, 1 in. wide, and solder or rivet it at the joint. Make the lower square J of the same material and in the same way, 18 in. on each side. Solder  $\frac{1}{8}$ -in. wire, of a length that will give the desired slant to the shade, at the corners of the squares, forming a rigid frame for the covering. Cloth or silk may be used to cover the frame.

The braces for the shade may then be fastened to the top of the cap, as shown in the assembly sketch, and their ends shaped to hold the frame firmly. The pedestal should be smoothed off immediately preparatory to finishing, and the sharp edges removed slightly. Care should be taken in sandpapering, since rubbing across the grain is ruinous, as is too much sandpapering. The latter particularly smacks of the novice. A coat of stain, one of filler rubbed in thoroughly, a coat of shellac, and a finish coat of wax or varnish will give a satisfactory finish. The shellac and varnish coats should be permitted to dry thoroughly and should then be sandpapered lightly before applying other coats.

The electrical connections for the lamp may be made from a cord extension to a socket fixed in the center of the cap. In some instances it may be desirable to connect the cord from a floor socket. In that case the post should be built up of two pieces of 1-in. thickness, and a groove to admit the cord made in the center of it.

### Sewing Rack Attached to Rocker

A rack like that shown in the illustration is convenient as a support for articles being sewed or repaired by the



The Swinging Rack Folds under the Arm of the Chair When Not in Use

home worker. It was made by fastening two bars from a towel rack to the arm of the rocker by means of a bolt. When not in use, the bars are folded back under the arm of the chair. One of the bars may be provided with hooks so that scissors and other sewing requisites may be placed on them.—Mrs. J. E. McCoy, Philadelphia, Pa.

### Glass Bottle as a Candle Lamp

A candle may be carried in a glass bottle, as shown in the sketch, with little danger of setting fire to surrounding objects, and without permitting the melted wax to leak upon the floor. The bottom of the bottle is cut off and the candle inserted as shown, the neck affording a convenient handle.—Stanley Radcliffe, Laurel, Md.

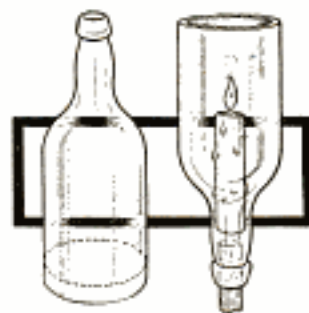



## A Folding Wall Desk

To provide an inexpensive desk in a shop, where space was quite limited, the folding wall desk shown in the sketch was devised. It was cut from a packing box and the hinged lid built up of boards of better quality. To give a good writing surface, a piece of heavy cardboard was fastened to the writing bed with thumb tacks and may be renewed whenever necessary. The inside of the desk was fitted with filing compartments arranged to care for a

large variety of shop forms and stationery. An inkwell holder made of a strip of sheet metal was fixed to the end of the desk and the bottle suspended in it, there being space for additional bottles also. The hinged lid is provided with a hasp and padlock.

When not in use the desk may be tilted upward and locked against the wall with small catches. By using a T-square against the left edge of the writing bed, a convenient drafting table for shop sketching is provided.

The detailed construction, for the making of the desk from stock lumber, by boys, or amateur workers with tools, may be carried out as follows: Determine upon the size of the proposed desk. Convenient dimensions are 30 in. long, 18 in. wide, 7 in. high at the back, and 4 in. high at the front. Use  $\frac{7}{8}$ -in. soft wood; pine and poplar are suitable. Cut and shape all the pieces before beginning the assembling of the

parts. The wood should be planed smooth and may be sandpapered lightly when the construction is completed, before applying a finish. A simple arrangement of the pieces so they can be nailed together is that shown in the sketch, which was used in making the box. First shape the pieces for the sides,  $5\frac{1}{4}$  in. wide at the larger end,  $2\frac{1}{4}$  in. wide at the smaller, and  $16\frac{1}{4}$  in. long. Clamp the boards together, or tack them with two wire nails while

shaping them, so that they will be exactly alike. Make a piece  $5\frac{1}{2}$  in. wide and 30 in. long for the back, and one the same length and  $2\frac{1}{2}$  in. wide for the front. Nail them to the ends, as shown, permitting the slight excess material to project over the upper edges of the sidepieces. Trim off this extra stock with a plane

so that the upper surfaces of the front and back conform to the slant of the sidepieces. Make a strip 4 in. wide for the upper edge of the desk, to which the writing bed is hinged. Cut pieces for the bottom and nail them in place.

Before nailing down the upper hinge strip the interior fittings should be made. Use wood not thicker than  $\frac{1}{2}$  in., and fit the pieces into place carefully, nailing them firmly through the outer faces of the desk. A better method is to make the pigeonholes or compartments with a piece of the thin stock on the ends of the partitions, so that the compartments are built up as

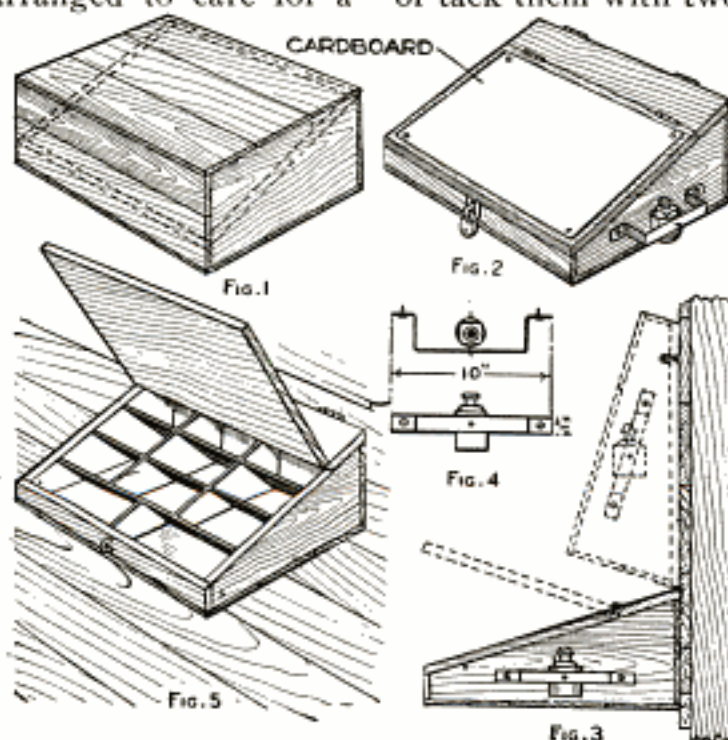

The Packing Box, from Which the Desk was Made, is Shown in Fig. 1. The Dotted Lines Indicate Where It was Cut to Give the Slanting Writing Surface. The Device in Its Normal Position is Shown in Fig. 2; Hooked against the Wall, in Fig. 3, and with the Lid Raised, Showing the Compartments, in Fig. 5.



a unit and slid into the desk, no nails being necessary to hold them.

The lid should be made of sound, dry stock and glued up of strips about 3 in. wide, to prevent it from warping or twisting easily. If the person making the desk has the necessary skill, it is best to fix a strip, 2 in. wide, at each end of the writing bed, to hold the pieces together and to keep the bed in shape.

The holder for the inkwell is made of a 1-in. strip of metal, bent to the shape shown in Fig. 4, and drilled to fit small screws. A can is supported in the holder and the bottle rests in it.

The desk may be finished by painting it or giving it a coat of shellac and one of varnish, either after it has been stained to match adjoining woodwork, or in the natural color.

### Sewing Stand with Workbag in Top

The stand shown in the sketch may be made by using part of a small table, or by building the framework especially for the purpose. It was made for use in connection with sewing and fancy work, and provides for the tools and incidental materials necessary. The stand is 28 in. high and about 15 in. square at the top. The bag built into the frame may be made of any strong, suitable material, and its color should match the finish of the wooden part. A row of nails are set in the top edge of the rails to provide for spools of thread and thimbles. Scissors and other tools are placed on the shoulder hooks fastened on the side of the rail.



When paper sticks to a negative during printing remove it by soaking it in the hypo bath, sacrificing the print rather than the negative.

### Toy Paper Warships

With a pair of scissors, pins, and a newspaper or two, a fleet of warships can be made to sail the seven seas of

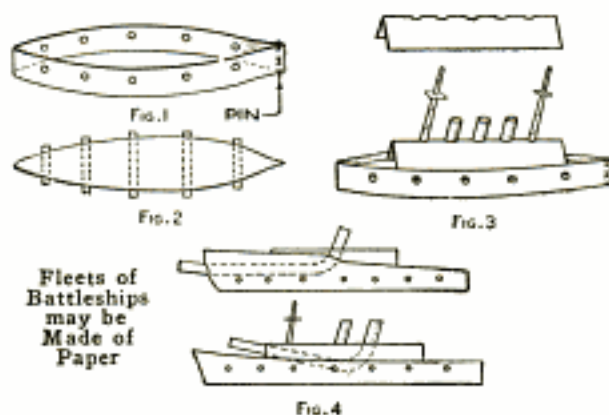

polished floors. Strips of paper, through which holes at opposite points have been cut, and pinned together at one end, as shown in Fig. 1, are used for the sides of the boat. Rolls of paper are slipped through the opposite holes, as shown at Fig. 2, and provide support for the deck, which is a flat piece of paper pointed at the end to fit between the sides of the craft. A second deck fitted with funnels and masts, as shown in Fig. 3, is made of a folded piece of paper with holes cut through it for the masts and funnels, which are rolls of paper. If plain paper is used, the warships may be made in several colors, which adds to the effect of rivalry between the fleets. Other types of craft may easily be devised, two of which are shown in Fig. 4. Not only the youngsters in the household, but their elders as well, may find not a little amusement and diversion in the making of a fleet of such warships, modeled after battleships, destroyers, battle cruisers, and other vessels.

### Caster Board for Scrubbing and Floorwork

A board for use in work that requires tedious kneeling, as in scrubbing, repairing of sidewalk lights, and similar work, may be made as follows: Procure a board,  $\frac{7}{8}$  by 10 by 14 in., and pad it with a section of carpet. Place three casters under it, two being



set at the rear and one at the front edge. If desired, small strips may be nailed at the sides to prevent the knees from slipping off. Such a device enables the user to move along the floor easily without injuring the knees.—R. S. Matzen, Fort Collins, Colo.

### A Lamp Cooker

An ordinary circular-wick kerosene lamp produces enough heat to do considerable cooking, provided the heat is properly utilized. A simple and practicable method of converting such a lamp into

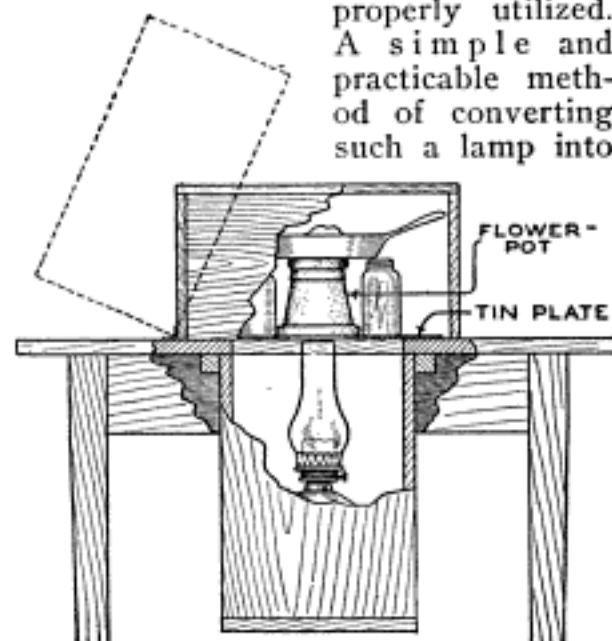

This Lamp Cooker will Prepare Meats and Vegetables Satisfactorily, and Is Useful for the Camper and in Emergencies

a cooker is as follows: Saw a hole, 12 in. square, in the top of a small table, or packing box of about the same height as a table. Cover this with a piece of sheet metal, having a 4-in. hole in the center. Place a 5-in. flower-pot over the hole in the metal, and plug up the hole in the bottom of the pot with fire clay or plaster of Paris. Vegetables in jars may be set around the flowerpot to cook slowly and a roast in a pan on top of it. A wooden box, or metal pail, large enough to cover the arrangement, should be placed over it. Air holes should be provided in the lower box and in the cover.

To operate the device light the lamp and when it is burning brightly, place it under the table, elevating it so that the top of the chimney is in the center

and barely within the rim of the flower-pot. Use little water in the vegetables and keep the caps loosely on the jars. The roast, if well buttered, will brown nicely, and while the cooking will require considerably more time than it would in a range, the results will be as good, if not superior. The natural juices are preserved by the slow cooking at comparatively low temperature. The cover may be lifted to turn the meat occasionally. This device will appeal to campers, summer cottagers, and others.—W. W. Baldwin, New York, N. Y.

### Placing a Miter Box on the Workbench

In placing a miter box on a workbench considerable space is often wasted, and the workman is obstructed. By raising the miter box on the bench, mounting it upon two blocks, about 6 in. high and set back about 18 in. from the front of the bench, small space is utilized, and the tool may be used as conveniently as otherwise. The space under the miter box and the open space in front of it are available for the disposal of ordinary tools, and there is no danger of the saw striking them. By making another stand, the height of the bearing surface of the miter box, and moving this about on the bench, long pieces may be handled with ease. This stand is removed from the bench when not in use.—Henry Simon, Laguna Beach, Calif.

### A Book and Document Protector

A device for punching identification marks in the pages of books or papers, may be made easily by setting pins into a small box filled with sealing wax. The box should be large enough to accommodate the desired wording without crowding, leaving about  $\frac{1}{4}$  in. all around the edge. Cut the box, which may be of cardboard, to a height  $\frac{1}{16}$  in. less than the length of a common pin. Mark the words to be punched on a piece of cardboard which just fits into the box. Punch holes along the letters and transfer them to the bottom of the



box. Insert pins from the outside through the bottom of the box and permit their ends to come out of the holes in the cardboard guide. Cut away enough of the guide piece so that the melted sealing wax can be poured in, setting the pins firmly. The guide piece is then removed, exposing the ends of the pins about  $\frac{1}{16}$  in. If the work is carefully done they will be of uniform length. Place heavy blotting paper or cardboard under the page when using the punch.—D. G. Stevenson, Chicago, Ill.

### Blotter Attached to Wrist Saves Time

The annoyance of having to look for a misplaced blotter or to pick it up each time a signature is to be blotted, may be avoided by the use of the wrist blotter shown in the sketch. It is made by folding a piece of blotting paper, 6 in. wide and 12 in. long, into three sections. A rubber band is placed in the fold of the blotter and passed around the wrist, thus holding it in place until no longer needed. When one portion of the blotter becomes soiled, the folding may be reversed and a new surface exposed.—Frank W. Roth, Joplin, Mo.



### Celluloid Cover for Road Maps

Road maps are easily soiled and torn unless properly protected, and a satisfactory case to hold them should provide for conveniently examining the map. A piece of transparent celluloid about twice the size of the map when folded can be made into a suitable cover. Fold the celluloid into an envelope form and rivet or sew the ends, leaving the fourth edge open. The map is inserted in the cover with the desired section uppermost, affording protection and ready access at the same time.

### Shield for Heater in Chick Brooding House

A shield of sheet metal, having a small heater in the center of it, provides a good means of warming a brooding house for small chicks. The heat is radiated from the shield and the chicks remain at a distance, seeking a comfortable temperature. The device may be made easily by cutting a sheet of metal to form a cone-shaped hood and fitting it with a vent passing out through the roof of the house.—Samuel S. Snelbaker, York, Pa.



### Kink for Removal of Wall Paper

Removing old wall paper, particularly from the ceiling of a room, is a disagreeable task at best, and the device shown in the sketch aids in the process. A board, about 15 in. long and 12 in. wide, was provided with strips at its edges and a pad of flannel was fitted into it. The device is used by moistening the pad and applying it to the wall paper. The paper is loosened thoroughly and may be removed in pieces of considerable size. This method has been found much quicker than that of soaking the paper with a moistened brush.—J. H. Moore, Hamilton, Canada.



A clay pipe may be used as a crucible for melting small quantities of metal. The stem is broken off and a plug fitted into it.



### Bicycle Runner for Winter Use

A bicycle may be used with satisfactory results in winter by arranging a runner under the front wheel, which

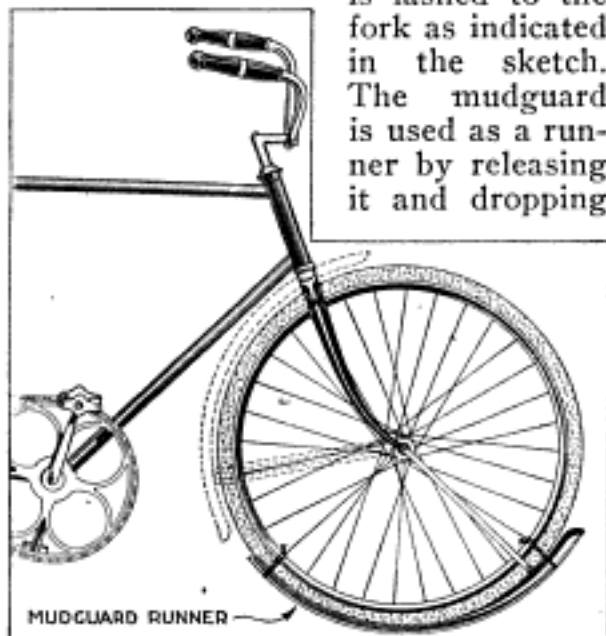

The Mudguard is Fastened to the Rim of the Wheel and Acts as a Runner over Ice and Snow

is lashed to the fork as indicated in the sketch. The mudguard is used as a runner by releasing it and dropping it to the position shown. It is then tied securely to the rim of the wheel and the wheel is tied at the top to the fork. This idea may be adapted by providing a special runner of sheet metal, making it unnecessary to wear the mudguard.—C. H. McCaslin, Portland, Ore.

### Homemade Snowshoe Toe Clips

The uppers from a pair of worn-out shoes may be made into a serviceable set of toe clips for snowshoes by cut-



The Uppers of an Old Pair of Shoes were Used to Make a Set of Toe Clips for Snowshoes

ting them off, as shown in the sketch, and fitting them to the lacing of the snowshoes. The clip is fastened in place by passing the tying strap

through slots in the former, under the lacing of the snowshoe, and then around the ankle in the usual manner of fastening.—Richard F. Lufkin, Dorchester, Mass.

### Mounting Tracing-Cloth Drawings on Muslin

Tracings mounted on muslin will give long wear and are more satisfactory in handling than the unmounted drawings. The method of mounting them is as follows: Stretch a piece of starched muslin, slightly larger than the drawing, on a flat, smooth board, fastening it with tacks. Coat the back of the tracing with a good varnish, and place it, face down, on a flat surface so that it may partly dry and become tacky, which usually takes two hours. Place the tracing upon the stretched muslin, varnished side down, and place a smooth sheet of wrapping paper over it. Using a moderately warm flatiron, and beginning at the center of the tracing, iron toward the edges, applying moderate pressure. To remove the tracing from the cloth, it is necessary to warm the cloth with the iron and strip the tracing and cloth apart gradually.—John W. Grantland, Cincinnati, Ohio.

### Sandpapering Square Edges on Small Machine Bases

The woodwork of small electrical or experimental machines and devices often detracts from the workmanship because proper care is not taken in finishing the edges. To smooth off the ends of a small baseboard squarely, proceed as follows: Square up a piece of 2 by 4-in. stock, 1 ft. long; place a flat sheet of sandpaper on the bench and set the 1-ft. block on top of it, holding it in place with the left hand. Hold the piece to be squared up firmly against the block and rub it on the sandpaper. A square edge of smooth finish will result. The edges should, of course, be planed as smoothly as possible before sanding in this way.—John D. Adams, Phoenix, Ariz.



### Enlarged Lantern Pictures as Guides for Scenic Painting

Scenery for a home-talent theatrical performance was required, and since the services of an expert in that line were not available, an interesting method of obtaining satisfactory sketches for the figures and other objects in the background was devised. Colored lantern slides of scenes suitable for the purpose were selected and projected upon the canvas to be painted, as shown in the illustration. The outlines were drawn around the projected figures, making them as accurate as the original, and far better than would have been possible otherwise by an amateur painter. The colors were applied following the original model, with satisfactory results. By the use



Scenery for an Amateur Theatrical Performance was Made by Painting Outlines Projected from a Lantern

of various portions of slides, it was possible to place figures and outdoor effects on the background which was obtained from the first slide used. A factor which must be considered in using this method is that the picture

on the canvas will be reversed as to right and left positions compared with the original, if a direct-reflection projector of the type used with post cards is employed.—Thomas R. Milligan, Fort Worth, Texas.

### Three-Caster Truck for Moving Crates and Furniture

A convenient truck for handling heavy objects, especially in the home where commercial devices for this purpose are not available, is shown in the illustration. It consists of a frame built up of three  $1\frac{1}{4}$  by 2 by 14-in. strips, fixed to a disk,  $\frac{7}{8}$  by 12 in. in size. Revolving casters are mounted under the ends of the arms, giving great freedom of movement in transporting loads. The three-caster arrangement is better than the use of four casters, because it accommodates itself to irregularities in the floor.—Armydas E. Sturdivant, Muncie, Ind.

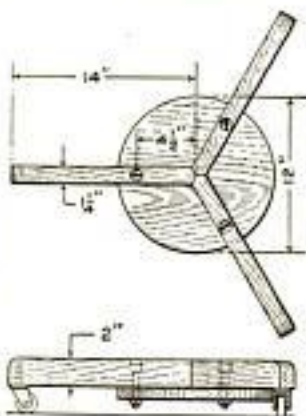

### Inserting or Correcting on Typewritten Bound Sheets

It is frequently necessary that typewritten insertions or corrections be made in papers which have been typed and bound, usually by rivets along the top edge. It is difficult to remove the rivets and replace them satisfactorily. To make such insertions, feed a blank sheet of paper into the typewriter until its feeding edge is even with the upper edge of the guide fingers. Then insert the bottom edge of the sheet on which the correction is to be made, underneath the sheet already in the machine; reverse-feed the sheet to be corrected into the typewriter. Corrections may then be made in the usual manner.—A. J. Cook, Pittsburgh, Pa.

### Tire Pump Made of Gas Piping

A tire pump actuated by the explosions in the cylinder of an automobile engine, and made of materials easily obtainable, is shown in detail in the illustration. A section of iron pipe of a diameter to fit one of the ports, and about 4 in. long, as shown in Fig. 2,

¶The burner of an acetylene bicycle lamp, fitted to an ordinary gas jet, will produce a very hot flame.



is provided with a reducer, a tee, and two caps. The inside of the pipe is turned up true in a lathe and fitted with a piston, the head for which is

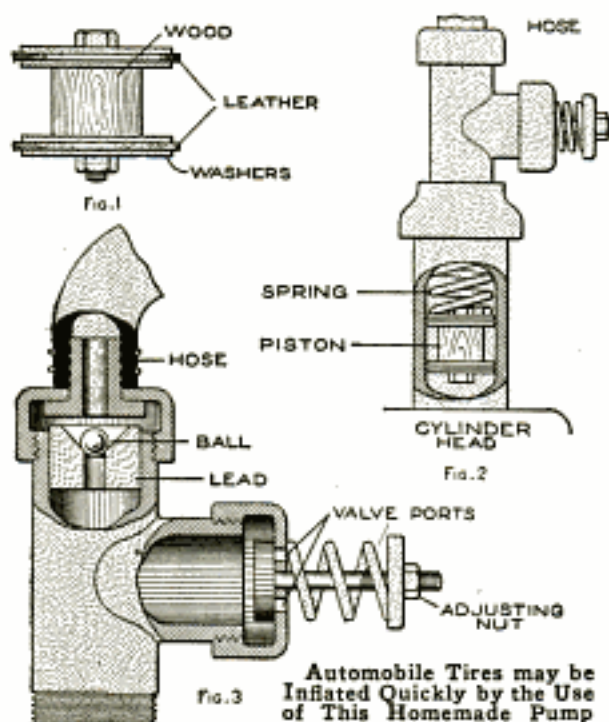

shown in Fig. 1. The head is built up of a wooden drum, washers, and leather packing disks. The washers should be slightly smaller in diameter than the chamber, and the leather disks make it air-tight.

The tee is provided with two valves, as shown in the detail sectional view, Fig. 3, the upper ball valve retaining the pressure in the pipe line, and the other valve admitting air above the piston. The ball valve has a seat of lead, and a ribbed fitting is fixed to the pipe cap above it, to provide a fastening for the hose. The cap of the other valve is fitted with a spring, adjustable on a threaded pin.

A light spring fixed to the upper side of the piston, as shown in Fig. 2, forces the piston back to its lower position after the force of the explosion in the cylinder has acted upon it. The cylinder of the pump should be oiled, and a reinforced rubber hose should be used to conduct the air under pressure to the tire.

The operation is simple: The initial stroke of the engine cylinder draws the piston down, bringing in a charge

of air from the valve ports at the side of the tee; the following compression and explosion strokes drive it back, forcing the air out of the ball valve, as the other valve closes on the upstroke of the piston. A large tire may be pumped up with this device in from five to ten minutes.

### Aid in Ruling Uniform Cards or Sheets

When a number of cards or sheets are to be ruled with either horizontal or vertical divisions, the following method will be found a timesaver: Rule one of the cards as a sample. Place it on the drawing board with its lower edge set against two thumb tacks driven part way in. Rule extensions of the lines on the card to a sheet of paper fastened to the board under the card. Set a third thumb tack at the right edge of the card as a guide. By placing the cards to be ruled against the three thumb tacks in the position of the original card, the rulings may be made quickly with the marks on the paper backing as guides.—W. P. Shaw, Stratford, Can.

### Tinned Staples for Bell-Circuit Wiring

Inexpensive and practical staples for binding wires used in bell circuits, or for similar purposes, may be made from a strip of tinned sheet metal, about  $\frac{1}{2}$  in. wide. The strip is cut on the sides, as indicated in the sketch, and the squares are broken off as needed. They may be bent quickly to the shape shown, and are used by placing them over the wire and driving the



The Strip is Cut into Squares Which are Folded and Driven into the Support, Binding the Wire

points into the wall or other support. If properly made, they will not injure the covering of the wire and are more satisfactory than wire staples.



### Asbestos Table Mats Reinforced with Wire Netting

Ordinarily heavy pieces of sheet asbestos are used for the mats placed under hot dishes on the dining table. These are easily broken if bent, and a simple method of overcoming this breakage is to make mats as follows: Cut two pieces of sheet asbestos, each about one-half the thickness of that usually used, one having about  $\frac{3}{4}$  in. around the edge which may be used as a binder in pasting the sheets together. Cut notches into this edge, at intervals of about 2 in., and insert a disk of wire window screening between the pieces of asbestos. Turn the edges of the larger piece over and paste in place.

### Device for Corrugating Strips

Having a sheet-metal cog rail to make for the adjusting mechanism of an enlarging screen, I built a cog-forming device as shown in the sketch. A block of wood served as the base, and two levers with hinges were fixed to one end of it. Two pieces of hardwood were grooved at their ends as shown in the smaller sketch, to fit over three tenpenny nails, A, held in place on the block by staples. Four small nails, B, were set into the block, as shown, to act as guides for the strip of metal, which was fed between the forming blocks and the nails on the base. By pressing down on the hinge levers, the strip was formed into corrugations or teeth. In order to make the teeth uniform it was necessary to guide the forming pieces by having one of the cogs fit over the first nail. The strip thus formed was fixed to a wooden piece and served as a cog rail. —R. E. Henderson, Walla Walla, Washington.

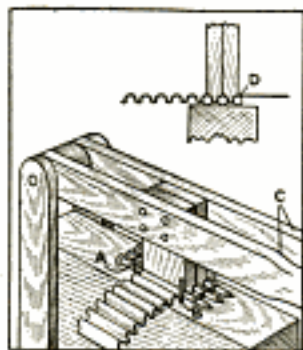

### Birch-Bark Leggings Made in the Woods

An excellent pair of leggings for use in brush and forest land can be made in a few minutes from birch bark cut in the woods. Select a suitable tree, about 6 or 8 in. in diameter, and cut into the heavy bark to obtain two rolls around the circumference of the tree, taking care not to cut deep enough to injure it. Fit these sections around the legs leaving 6-in. portions overlapping. Trim the bark to the proper shape and soak it in water to soften the grain. Place the bark close to the fire until it curls. The leggings are then ready for use.



### Stretcher for Drying Small Fur Hides

Small hides should be dried over a stretcher to give the best results, and the device shown in the sketch will be found useful for this purpose. It is made of two strips of  $\frac{1}{2}$ -in. wood, hinged at the pointed end. Small holes are drilled into the upper surface at the other ends and adjustment is made by means of a wire bent at the ends and inserted in the holes. —Elmer Tetzlaff, East DePere, Wis.

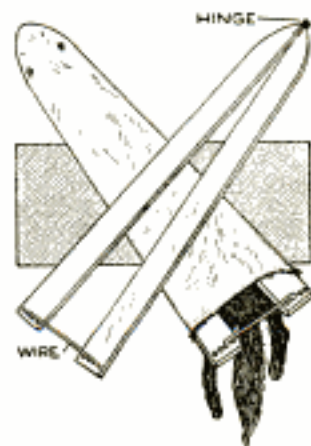

ⒸWire mesh is useful for drawer bottoms in tool cases where dirt is likely to accumulate.



3150

## COMFORTABLE, PLEASING SHINGLED BUNGALOW



Adequate for the Needs of the Average Family of Moderate Circumstances. Attractive, and Comfortable, is This Shingled Bungalow of New England Architecture

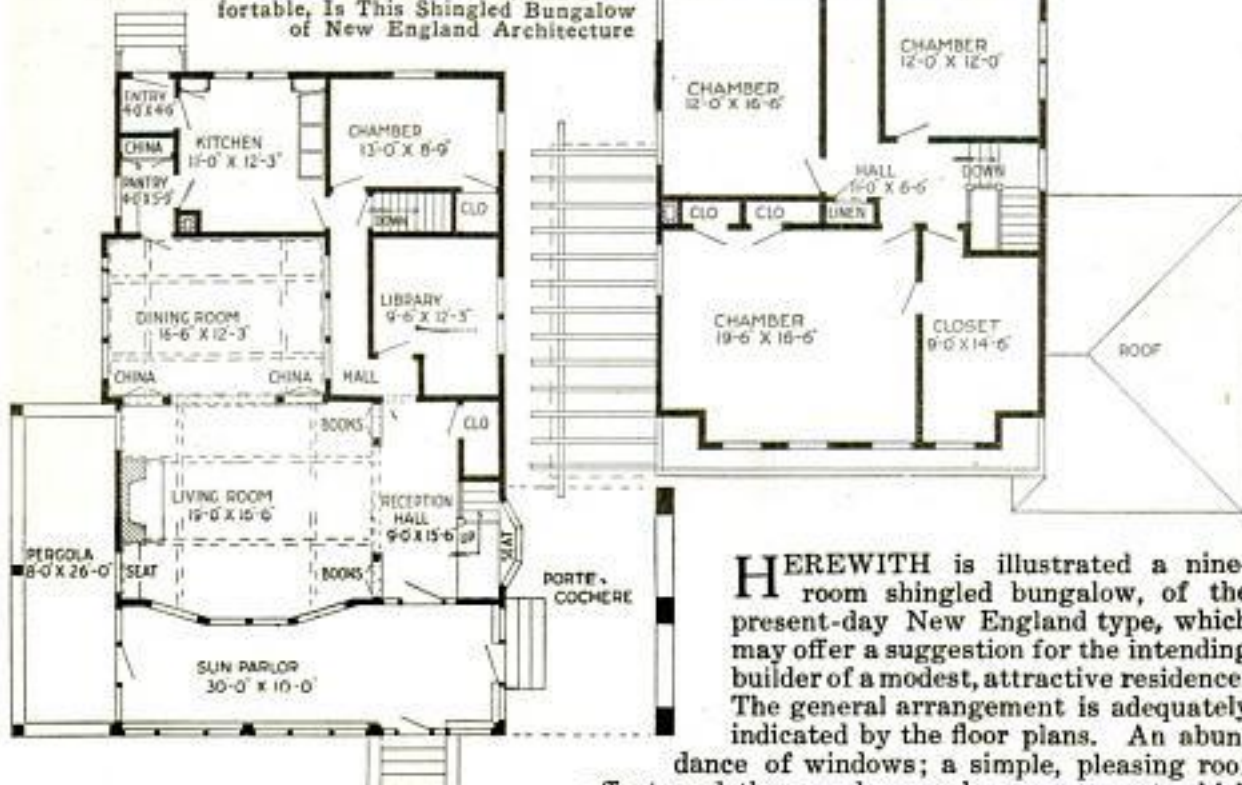

F. H. GORING  
ARCHITECT

18 TREMONT ST.  
BOSTON

HEREWITH is illustrated a nine-room shingled bungalow, of the present-day New England type, which may offer a suggestion for the intending builder of a modest, attractive residence. The general arrangement is adequately indicated by the floor plans. An abundance of windows; a simple, pleasing roof

effect, and the popular porch arrangement which

provides a glazed sun parlor in winter and a screened, open veranda in summer, are some of its outstanding points. At one end of the porch is a pergola, 8 by 26 ft. in size, while at the other end a large porte-cochère spans the driveway. This plan gives breadth and architectural charm to the exterior. Dormer windows solve the ceiling problem for the big bedchamber on the second floor and also add needed height to the front of the house. The sloping roof is responsible for the apparently enormous size of the closets, which, it will be observed, are placed in the corners where waste space cannot otherwise be utilized. This bungalow can be built for approximately \$5,000.



# Why Some Foods Explode in the Stomach

By WILLIAM ELDRIDGE

“THE combinations of food that most people eat three times a day inflict nothing less than a crime against their health and are the direct cause of 90% of all sickness.”

This is the rather startling statement of Eugene Christian, the famous New York Food Scientist, whose wonderful system of corrective eating is receiving so much eager attention throughout the Nation at the present time.

According to Eugene Christian we eat without any thought of the relation which one food has to another when eaten at the same time. The result is that often we combine two foods each of great value in itself but which when combined in the stomach literally explode, liberating toxics which are absorbed by the blood and form the root of nearly all sickness, the first indications of which are acidity, fermentation, gas, constipation, and many other sympathetic ills leading to most serious consequences.

According to Christian, all of this can be avoided if we would only pay a little attention to the selection of our daily menus instead of eating without any regard for the consequences.

This does not mean that it is necessary to eat foods we don't like; instead Christian prescribes meals which are twice as delicious as those to which we are accustomed. Neither does he suggest proprietary or patented foods—he simply tells us which foods when eaten together produce health and energy by removing the cause of sickness.

Not long ago I was fortunate enough to be present when Eugene Christian was relating some of his experiences with corrective eating to a group of men interested in dietetics, and I was literally amazed at what he accomplished

with food alone and without drugs or medicines of any kind.

One case which sticks in my mind was that of a mother and daughter who went to him for treatment. The mother was forty pounds overweight and her physician diagnosed her case as Bright's Disease. She had a sluggish liver, low blood pressure and lacked vitality. The daughter had an extreme case of stomach acidity and intestinal fermentation, was extremely nervous, had chronic constipation, and was thirty pounds underweight.

Christian prescribed the proper food combinations for each. Within a few weeks all symptoms had disappeared, and within three months the mother had lost 33 pounds and the daughter had gained 26 pounds, and both were in perfect health—normal in every particular.

Another case which interested me greatly was that of a young man whose efficiency had been practically wrecked through stomach acidity, fermentation and constipation resulting in physical sluggishness which was naturally reflected in his ability to use his mind. He was 20 pounds underweight when he first went to see Christian and was so nervous he couldn't sleep. Stomach and intestinal gases were so severe that they caused irregular heart action and often fits of great mental depression. As Christian describes it he was not 50% efficient either mentally or physically. Yet in a few days, by following Dr. Christian's suggestions as to food, his constipation had completely gone, although he had formerly been in the habit of taking large daily doses of a strong cathartic. In five weeks every abnormal symptom had disappeared—his weight having increased 6 pounds. In addition to this he acquired a store of physical and mental energy so great in comparison with his former self as to almost belie the fact that it was the same man.



But perhaps the most interesting case that Christian told me of was that of a multi-millionaire—a man 70 years old who had been traveling with his doctor for several years in a search for health. He was extremely emaciated, had chronic constipation, lumbago and rheumatism. For over twenty years he had suffered with stomach and intestinal trouble which in reality was superaciduous secretions in the stomach. The first menus given him were designed to remove the causes of acidity, which was accomplished in about thirty days. And after this was done he seemed to undergo a complete rejuvenation. His eyesight, hearing, taste and all of his mental faculties became keener and more alert. He had had no organic trouble—but he was starving to death from malnutrition and decomposition—all caused by the wrong selection and combination of foods. After six months' treatment this man was as well and strong as he had ever been in his life.

These instances of the efficacy of right eating I have simply chosen at random from perhaps a dozen Eugene Christian told me of, every one of which was fully as interesting and they applied to as many different ailments. Surely this man Christian is doing a great work.

I know of several instances where rich men and women have been so pleased with what he has done for them that they have sent him checks for \$500 to \$1,000 in addition to the amount of the bill when paying him.

There have been so many inquiries from all parts of the United States from people seeking the benefit of Eugene Christian's advice and whose cases he is unable to handle personally that he has written a little course of lessons which tells you exactly what to eat for health, strength and efficiency. This course is pub-

lished by The Corrective Eating Society of New York.

These lessons—there are 24 of them—contain actual menus for breakfast, luncheon and dinner, curative as well as corrective, covering every condition of health and sickness from infancy to old age and for all occupations, climates and seasons.

Reasons are given for every recommendation based upon actual results secured in the author's many years of practice, although technical terms have been avoided. Every point is explained so clearly that there can be no possible misunderstanding.

With these lessons at hand it is just as though you were in personal contact with the great food specialist, because every possible point is so thoroughly covered that you can scarcely think of a question which isn't answered. You can start eating the very things that will produce the increased physical and mental energy you are seeking the day you receive the lessons and you will find that you secure results with the first meal.

If you would like to examine these 24 Little Lessons in Corrective Eating simply write The Corrective Eating Society, Dept. 52, 460 Fourth Ave., New York City. It is not necessary to enclose any money with your request. Merely ask them to send the lessons on five days' trial with the understanding that you will either return them within that time or remit \$3.00, the small fee asked.

The reason that the Society is willing to send the lessons on free examination without money in advance is because they want to remove every obstacle to putting this knowledge in the hands of the many interested people as soon as possible, knowing full well that a test of some of the menus in the lessons themselves are more convincing than anything that can possibly be said about them.

*Please clip out and mail the following form instead of writing a letter, as this is a copy of the official blank adopted by the Society and will be honored at once*

---

#### CORRECTIVE EATING SOCIETY

Dept. 52, 460 Fourth Avenue, New York City

You may send me a prepaid copy of Corrective Eating in 24 Lessons. I will either remail them to you within five days after receipt or send you \$3.

Name..... Address.....

City..... State.....



# \$687 for this 6-Room ALADDIN



## Your Own Home—Build It This Year

**H**ERE is your opportunity to own a home and dodge high building prices. You can do it even though building prices are going up! **THE ALADDIN READI-CUT SYSTEM** of building stands between you and present high prices. It offers you this ideal home or one hundred other attractive homes at substantial savings in price. Think of the home pictured above containing large living room and dining room, large kitchen, three large bedrooms, bathroom and porch for \$687 for complete material, readi-cut. This is only one of a hundred homes with prices from \$200 to \$8000 shown in the handsome book. Let us send you a copy of this book entitled "Aladdin Homes." Send stamps today for your copy.



Here Is the  
Floor Plan  
of Home  
Shown  
at Top  
of  
Page

### Why Pay \$900 for a Home That You Can Buy for \$600?

Why hand over three hundred dollars of your savings to a contractor when you can **keep that money** by having any carpenter put up your Aladdin Read-Cut Home? Your staunch, beautiful Aladdin Home comes **all ready for building**—complete to the last lock screw in the front door. It saves you money because the lumber is cut by **machinery**—the materials bought at **wholesale**. The daily capacity of our mills is 40 Aladdin Homes—we get 18% more out of our lumber than any builder. This great saving becomes **YOURS**.

**What You Get** Aladdin price includes all lumber, millwork, flooring, outside and inside finish, doors, windows, shingles, lath and plaster, hardware, locks, nails, paint, varnishes. Your home is shipped in a sealed box car, complete, Read-Cut, ready to erect. Safe arrival of the complete material in perfect condition is guaranteed. Floor plan arrangement and complete description of the house shown above will be found in the Aladdin Book of Homes. Send stamps today for the book, "Aladdin Homes," No. 180.

# The Aladdin Company

Homebuilders to the Nation  
Canadian Branch C. P. R. Bldg., TORONTO, ONT.

828 Aladdin Ave., Bay City, Mich.





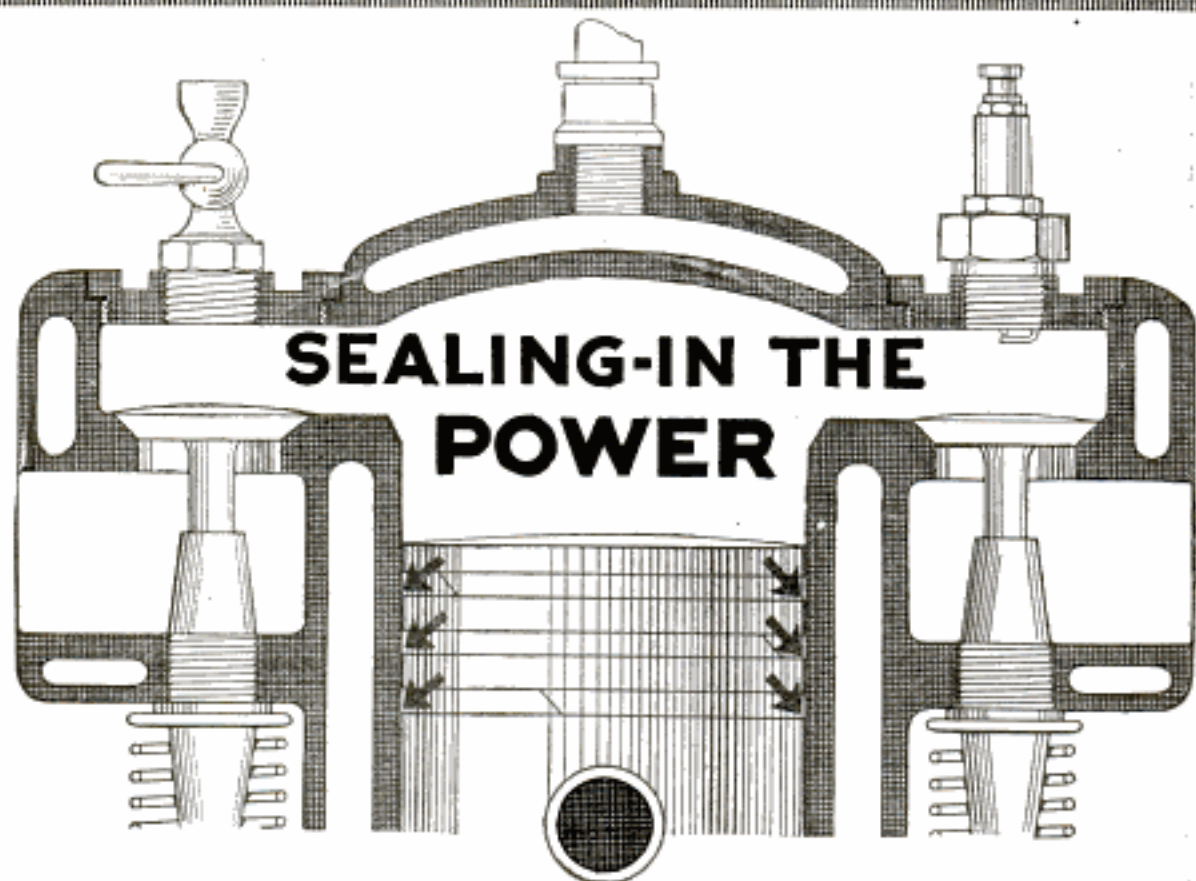

### *Keep the fuel charge where it belongs*

**D**RIP! Drip! Drip! If an accident puts a leak in your gasoline tank, you quickly notice it. The evidence is plain.

But there is another much more serious, and far more common form of leakage. That is leakage of the fuel charge past the piston rings.

No. You can't *see* it. Nor is there usually any tell-tale sound. Every thing *seems* the same as usual. But gas *is* leaking—leaking steadily.

How? Between piston, piston rings and cylinder wall is a small clearance. When you use

the correct oil in your engine this clearance is sealed.

The oil closes it up, effectively retaining the fuel charge above the piston.

But suppose the body of the oil is incorrect. What happens? Only a partial oil seal results.

On compression, part of the fuel charge escapes down past the piston rings. On the power stroke, part of the explosion escapes by the same path.

True, the leakage per stroke is small. But multiplied by over 20,000 piston strokes per mile in the average 4-cylinder motor and the total leakage is clearly a factor to be reckoned with. It tells plainly









## Good Value—Always Growing Greater

As the improvements are made in Dodge Brothers car nothing is said to Dodge Brothers dealers, or to the public, about them.

This is in pursuance of a policy inaugurated by Dodge Brothers at the very outset.

They look upon the progressive improvement of the car as a matter of course.

It is a plain duty they owe to themselves and to the public.

There is no necessity of heralding these improvements in advance.

The public finds out about them in due time, and expresses appreciation and approval.

And so, while the process of betterment goes on every day, nothing is said of it until after it is accomplished.

The car is basically the same car as it was two years ago.

Yet there isn't a bit of doubt but that it is a better car.

The car of today is worth more money than the car of two years ago.

The price is the same, but the car is a better car.

Not because the costs of materials have increased—although they have.

But especially because the standards of construction have been steadily raised—the shop practice made steadily finer.

And still, the buyers of the first cars, and every subsequent car, received full value.

That is proven by the fact that all of the cars, no matter how long ago they were built, are giving good service today.

It is still further proven by the high price they command when sold at second hand.

Any car built by Dodge Brothers commands a high price—whether it was built twenty-two months, or twelve months, or two months ago.

This high valuation on any car bearing Dodge Brothers name, has been fixed, not by them, but by the public.

Dodge Brothers have had few market problems to bother them, and practically nothing to do but make the car better.

They are their own severest critics, and they will never wait for the public to ask for a better car from them.

They try to anticipate—to travel ahead—to give even more than is expected.

No material, no part, and no accessory is barred from Dodge Brothers car because it is too high priced.

The only question asked, the only proof demanded, is of its goodness.

When the car was designed, its parts were chartered and chosen according to quality, and with a total disregard of price.

That policy still prevails, only it has been intensified.

No source of supply can have too high a standard for Dodge Brothers—nothing too good can be offered for Dodge Brothers car.

That policy, plus a process of research, test, refinement and proof, make for continuous progress.

That is why it is still the same car, and yet a much finer car.

That is why it is worth more money than ever, though still sold at the same price.

That is why its value is always growing greater.

Touring Car or Roadster, \$785 In Canada \$1100  
 Winter Touring Car or Roadster, \$950 In Canada \$1335  
 Sedan, \$1185 In Canada \$1685  
*All prices f. o. b. Detroit*

**DODGE BROTHERS, DETROIT**



*Please Mention Popular Mechanics*



*At the Timber Line on the Pike's Peak  
Automobile Highway*

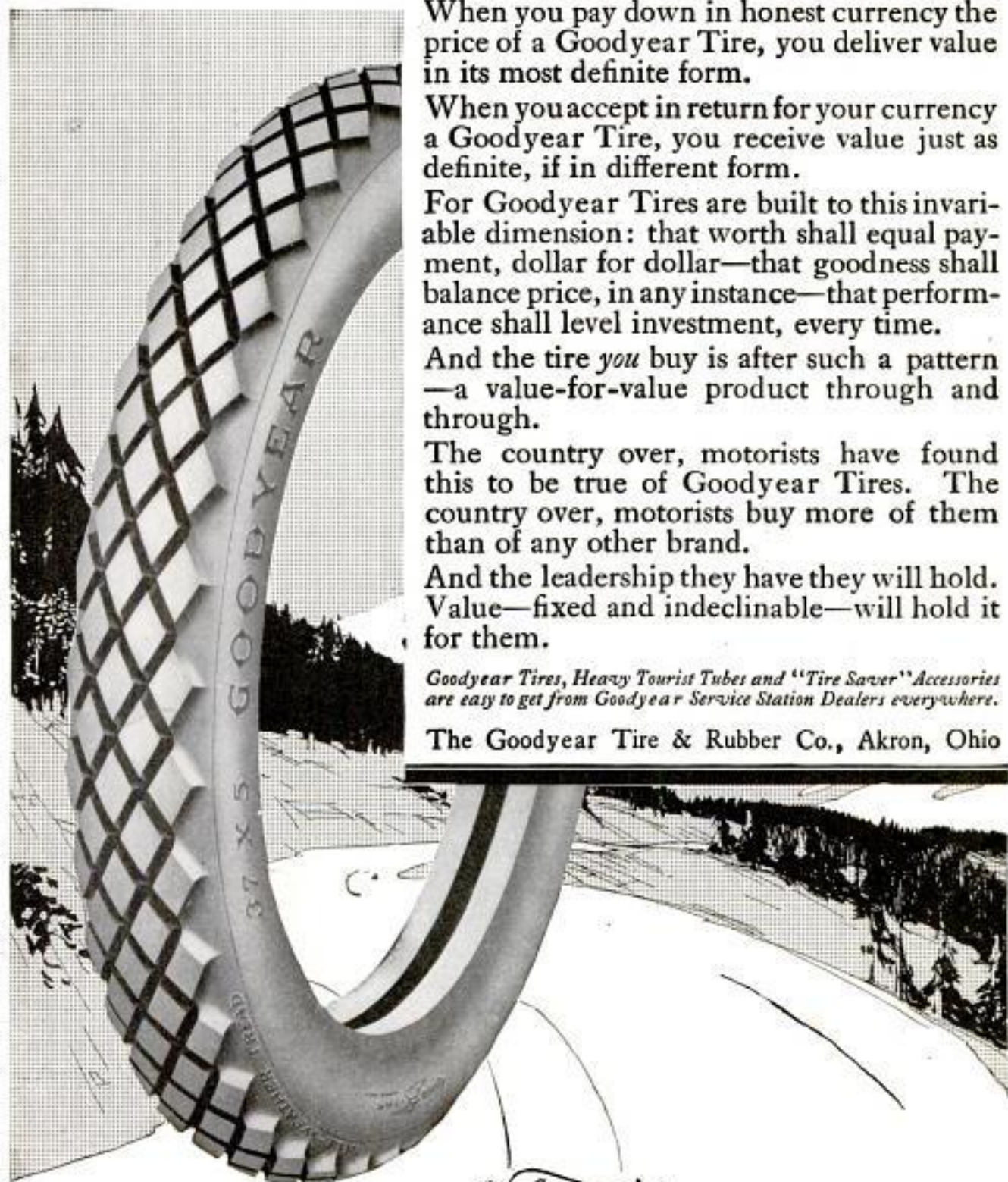

## Your Dollars and Our Tires

When you pay down in honest currency the price of a Goodyear Tire, you deliver value in its most definite form.

When you accept in return for your currency a Goodyear Tire, you receive value just as definite, if in different form.

For Goodyear Tires are built to this invariable dimension: that worth shall equal payment, dollar for dollar—that goodness shall balance price, in any instance—that performance shall level investment, every time.

And the tire *you* buy is after such a pattern—a value-for-value product through and through.

The country over, motorists have found this to be true of Goodyear Tires. The country over, motorists buy more of them than of any other brand.

And the leadership they have they will hold. Value—fixed and indeclinable—will hold it for them.

*Goodyear Tires, Heavy Tourist Tubes and "Tire Saver" Accessories are easy to get from Goodyear Service Station Dealers everywhere.*

The Goodyear Tire & Rubber Co., Akron, Ohio

**GOODYEAR**  
AKRON

*Please Mention Popular Mechanics*





## What's in a Bottle of 3-in-One Oil

If every family in the United States knew what was in a bottle of 3-in-One, for them, years of labor and millions of dollars would be saved. Here are some of the *in-side* facts.

**For Father:** 3-in-One will double the life of father's safety razor blades and make shaving easier and more pleasant. Before and after shaving moisten thumb and finger with 3-in-One and draw edge of blade between them. This prevents rust on the invisible cutting edge. In father's office 3-in-One keeps typewriters, adding machines and all light mechanisms running smoothly. It prevents automobile springs from squeaking. On all tools 3-in-One stops rust from forming; keeps them sharp and working right.

**For Mother:** 3-in-One is a wonderful household aid. Mother can make her own Dustless Dusting Cloths cheaply, quickly, perfectly. Take a half yard of cheese-cloth. Sprinkle with 3-in-One. Let stand till the oil has permeated every part of the cloth. A Polish Mop is just as easy to make. Mother also should use 3-in-One for oiling her sewing machine, polishing mirrors, cleaning her gas range, and for countless other home purposes. See Dictionary of Uses.

**For Son:** 3-in-One Oil makes a bicycle go twice as fast and wear twice as long. It makes a baseball glove hold the ball, roller skates whiz, keeps knives sharp and has fifty other uses. No real boy should be without 3-in-One.

**For Daughter:** 3-in-One keeps the young lady's tennis racket in perfect condition and her golf clubs right. Or if daughter operates a typewriter 3-in-One will make it work smoothly, surely and very much easier. See 3-in-One Dictionary.

**For Baby:** 3-in-One keeps the go-cart from squeaking and makes it run twice as easy.

**FREE**—Send for the *In-side* Facts. Get a sample of 3-in-One and the Dictionary of Uses. Simply drop us a postal saying, "Send *In-side* Facts." Do it now before you forget.

3-in-One is sold by all stores. In bottles, 10c, 25c, 50c. In Handy Oil Can, 25c.

**Three-in-One Oil Company, 42 CNP. Broadway, New York**



# San-Tox



## This Face Will Protect Yours

Smoothly the razor draws across the face and you feel the *shaving-joy* at once.

Yet there is more than simply razor-keenness there. There is a *purity lather* not very far away.

San-Tox for purity!

Try San-Tox Shaving Cream for the comfort of its lasting, soothing lather.]

Try San-Tox Shaving Lotion for the cooling, refreshing tonic of its touch.

Try San-Tox After-Shave Talc, that smoothes out all skin-roughness and suggests the barbered shave.

But then, on any packet of San-Tox blue the smiling San-Tox Nurse face tells the same purity story, just as does each San-Tox druggist by his offer to return you your money on any San-Tox preparation which does not equal your every expectation.

What better proof of San-Tox purity could you get?

What better indication of modern drug-store methods could you have, or of a type of druggist with which it is good to do business?

There are 125 San-Tox purity preparations.

SAN-TOX FOR PURITY  
De Pree Chicago

This Drug Store Sign



Means Better Service



Please Mention Popular Mechanics



# If you are thirty years old



the small sum of \$1.91 (monthly) secures for you a policy for \$1000 in the Postal Life Insurance Company—a standard, legal-reserve Whole-Life Policy, with guaranteed Cash, Loan, Paid-up and Endowment Options, and participation in the Company's surplus earnings.

Every year, during the premium-paying period, you save nine and one-half per cent. of the annual premium as *guaranteed in the policy* (see mail-bag below).

These savings are made possible only because the Postal Life employs no agents and *has no agency expense*; the benefit of this decisive economy goes to the person who takes out the insurance.

## Strong Postal Points

**First:** Resources more than \$9,000,000. Insurance in force, nearly \$40,000,000.

**Second:** Old-line, legal-reserve insurance, not fraternal or assessment.

**Third:** Standard policy provisions, approved by the New York State Insurance Department.

**Fourth:** Operates under strict New York State requirements and subject to the United States Postal Authorities.

**Fifth:** High medical standards in the selection of risks.

**Sixth:** Policyholders' Health Bureau supplies one free medical examination each year, if desired.

## Find Out What You Can Save at Your Age

Simply write and say: "Mail official insurance particulars as per Advertisement in February Popular Mechanics Magazine."

- And be  
sure  
to give
1. Your full name.
  2. Your occupation.
  3. The exact date of your birth.

And bear in mind: No agent will be sent to visit you. The Postal Life does not employ agents; the resulting commission-savings go to you because you deal direct.

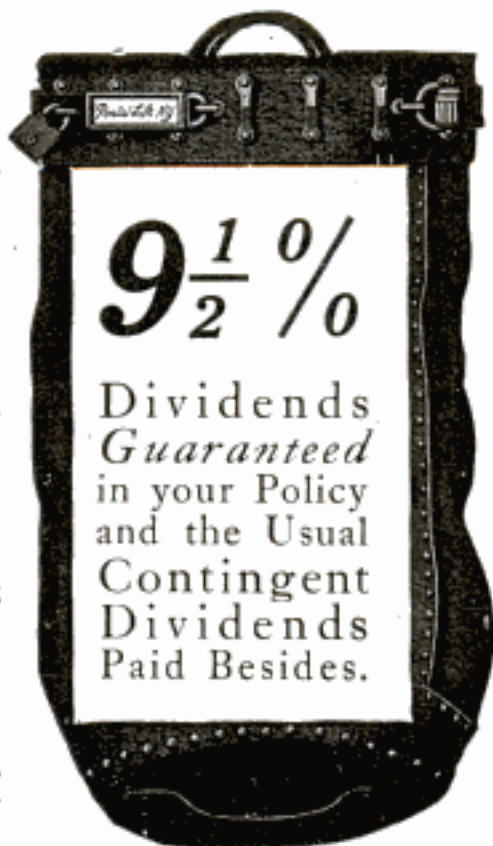

# Postal Life Insurance Company

WM. R. MALONE, PRESIDENT

511 Fifth Avenue, NEW YORK



# Warm Moistair

## The Safer Way to Heat Your Home

WHEN the cold blasts of winter make the timbers creak and the children are shut up inside, there is nothing half so comforting as to know that down in the basement there's a trusty *Round Oak Moistair Heating System* on the job. The

## Round Oak Moistair Heating System

keeps a constant current of delightfully warm, clean, fresh air circulating throughout the house. It also humidifies this air—keeps it moist and healthful, free from dirt, dust, gas and is

## The Only Heating System That Automatically Ventilates and Humidifies



### Five Star Points of Round Oak Supremacy

- ★ **Health** Only Heating System that automatically ventilates and HUMIDIFIES.
- ★ **Comfort** Delivers pure, warm, ever-changing moistair, free from dust, gas, smoke—fitted with gas-tight doors and dampers.
- ★ **Economy** Longest fire travel all inside casing; improved hot blast *Ring*; extra deep fire pot; extra large combustion chamber affords perfect combustion; most heat on minimum fuel.
- ★ **Convenience** Simple regulator controls entire system. Self-cleaning. Ash pit dust-proof—seamless; fitted with sprinkler. Non-leak door frames cast on—not bolted. Easy to operate.
- ★ **Durability** Materials used stand highest physical tests. All hinge pieces drilled, not cast. Never a bolt, where a rivet will do! Tight fittings guaranteed. Good for generation of service.

When you replace your present heating plant, or build, insist on this most healthful system.

It banishes all health-dangers due to stale, breathed-over, poisonous air—is durable—easy to operate—easy to keep clean. Humid air at 68 degrees is more comfortable than DRY air at 75. This fact together with the saving effected by other Round Oak features means literally a saving of *tons* of fuel. Note in panel opposite *other exclusive features!* More than 60,000 Round Oak Systems in use. You know the Round Oak STOVE! The Round Oak Heating System is made by the same makers; and is backed by over 45 years' experience. Investigate.

### VALUABLE BOOK—FREE

also complete *Heating Plan* drawn up by Round Oak Engineering Experts to meet your needs. Book fully explains System—contains Blank which filled out and returned to us brings you without obligation. Plan, full costs, and name of our nearest dealer. Write for book—now.

Sold by many dealers on easy terms. To get the Genuine, insist upon the Trade-mark showing the Round Oak Indian.

## The Beckwith Company Round Oak Folks

16 Front Street, Dowagiac, Michigan

Established 1871



Clip This Coupon and Mail NOW

Give this to:  
16 Front Street, Dowagiac, Michigan  
your nearest dealer, who will explain the advantages of  
Round Oak Moistair Heating System.

Name.....  
Address.....





## The Man on the Dock

**D**OWN on a dock at New York, where ships come from afar to discharge their cargoes of crude rubber, is a man with a strange occupation.

He goes from case to bale marking the rubber.

His wonderful skill rejects or accepts the rubber according to its fitness, and the best of it goes to 47 factories of the United States Rubber Company, **the largest rubber manufacturer in the world.**

The man on the dock is the outpost of a scientific organization, a magnificent body of **260 chemists**, engineers and other technically trained men, who, with **841 inspectors**, stand guard over the integrity of the rubber goods made by the United States Rubber Company.

When the rubber moves from dock to factory it meets the advance guard of these men. They sample and test it by the most exacting methods known to the chemistry and physics of rubber. They divide it into classes according to the varying characteristics of its parts. They blend and treat each huge class to make it uniform.

They select and mix these different classes of rubber to get just the combination of desired properties.

This is because each kind of goods made—tires, shoes, garden hose—

demands its own peculiar group of specialized characteristics.

As these various products move through the factory, they pass at every step under the keen eyes of inspectors, alert for flaws and faults.

But not yet do they reach the selling force. The finished factory products are tested repeatedly to see that they conform to the quality standard set for strength, elasticity, softness, resistance to wear, and the effect of heat and light. They are run on special machines that in a few hours duplicate the wear and tear of months of use; and finally pass the last ordeal of severe actual service tests.

The consummation of all this skill and care is found in every product you buy under the United States Rubber Company's trade-marks.

From the forest tree to the purchaser, this scientific control shines out in all our enormous production—all styles of rubber footwear; canvas rubber-soled shoes; weatherproof clothing; tires for automobiles, motor trucks and all other vehicles; druggists' rubber goods; insulated wire; soles and heels; belting, hose, packing, mechanical and moulded rubber goods of every description.



# United States Rubber Company

*Please Mention Popular Mechanics*



# I Want To Make You A Present of This Acorn Uni-Lite!

And I Am Organizing an Army of Money-Winners! Do You Want to Join?

Yes—you get the Uni-Lite without paying a penny for it.

But that's not all! I want to help you join my army of money-winners—my big band of men who are "coining money" without interfering with their present work—without doing much of anything except calling on their fellow townspeople and talking neighbor-like to them.

I want to tell you all about it. But, before I can do that, I want you to send me your name and address on the coupon (or a post card) so I will know where to mail you complete information telling you how you get your Acorn Uni-Lite free.

## The Light That Shames Electricity

A new and astonishing light. Thousands exported to foreign countries every month! Adopted by U. S. forces along border! Gives brilliant, steady radiance equal to the combined light of 20 ordinary lanterns or lamps. Burns 15 hours on one filling! Costs only 1/4 of a penny per hour. Burns common kerosene or gasoline. Storm-proof, bug-proof, rain, sleet and snow-proof. Use as a lamp—or carry as a lantern. Handsome in finish—neat in design—durable in construction. A wonderful light for in and around homes—farms—garages—barns—shops—in camps—driving on dark roads—boating—for night watchmen—hunters, railroad men, etc. And my New 1917 Offer tells you how you can get one free.

Just Answer This Ad—Just Follow My Plan—I'll Show You and Back You!

Just the same as I have done for thousands of other men—men just like yourself. It's no trick at all. Anyone can succeed with this plan for making money. It's simple and straightforward. I'll tell you all about it, just as soon as you send me your name and address. Don't put this off. Do it now. It won't take a minute.

**300  
Candle  
Power**



ADDRESS

**Acorn Brass Mfg. Co.**

*Clyde E. Padden*  
SALES MANAGER

616 Uni-Lite Bldg., Chicago, Ill.



**ACORN BRASS MFG. CO.**  
Clyde E. Padden, Sales Manager, 616 Uni-Lite Bldg., CHICAGO, ILL.  
I want to get an Acorn Uni-Lite free—and join your band of money-winners!

Name .....

R. R. or Street No. ....

CITY .....

State .....



See Editorial p 190

# Ends all Your Spark Plug Trouble

Here, at last, is the one practical idea in detachable spark plugs. No more puttering around in the grease with wrenches—no more broken porcelains—no more necessity for letting your spark plugs remain dirty. It's the simplest thing in the world to remove this plug from the cylinder. You simply lift up the bail, give the plug a slight turn and out it comes. Think of the conveniences of being able to lift up the hood of your motor and turn the plug  $\frac{1}{4}$  of an inch, and have it before you, ready to inspect or clean, if necessary. You can do this without even loosening the high tension wires.

## P-D-Q PLUG DETACHES QUICKLY SPARK PLUG

The construction of the P. D. Q. is extremely simple, there being only two parts—the shell which screws into the cylinder of the motor and the porcelain which fits into the spark plug shell and is locked there securely by means of the bail. (See illustration). Porcelain of the highest grade.

The P. D. Q. makes the ideal priming plug. Can be removed in ten seconds and gasoline squirted in right at the firing point—more effective than priming through pet cocks.

Easy to clean, easy to inspect and gives a hot, fat spark that will produce maximum efficiency from every charge of gas.

The construction is such that no gasket is necessary—the crown joint holds absolutely tight and the P. D. Q. never loses or leaks compression. Rigorously tested for two years.

Made with standard  $\frac{1}{2}$  inch thread or with  $\frac{3}{8}$  inch S. A. E. or A. L. A. M.

### TRIAL OFFER—Four for \$4.00

These plugs are guaranteed to give satisfactory service

We would like to give you the opportunity of trying them out in your own car.

If not obtainable at your dealer's, send us an order for four plugs, and we will mail them to you, all charges prepaid. Extra porcelains are obtainable at any time at 75 cents each. Get your order in today.

**THE WOLVERINE SPARK PLUG COMPANY**  
800 Boydell Bldg. DETROIT, MICH.

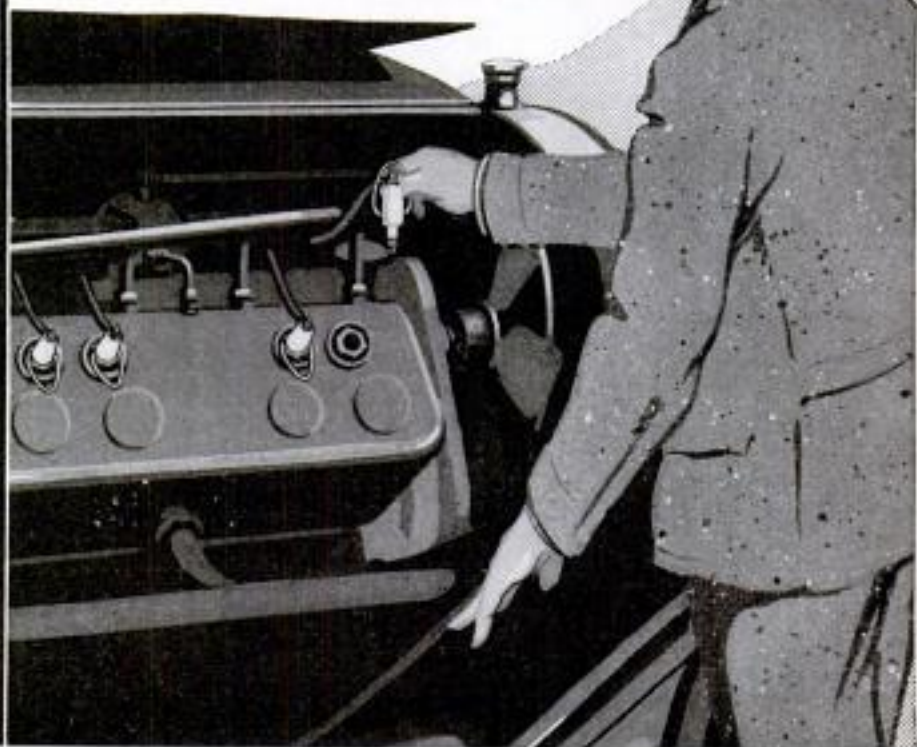
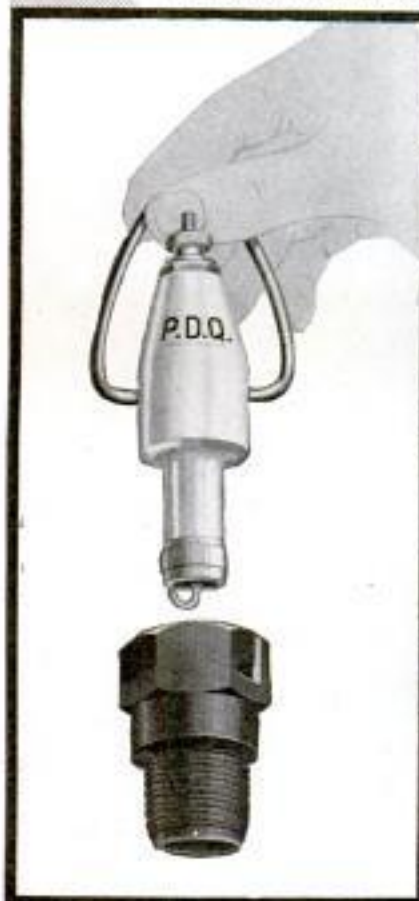

Please Mention Popular Mechanics



# SAXON ROADSTER

A CAR COMPLETELY EQUIPPED WITH EVERY MODERN FEATURE

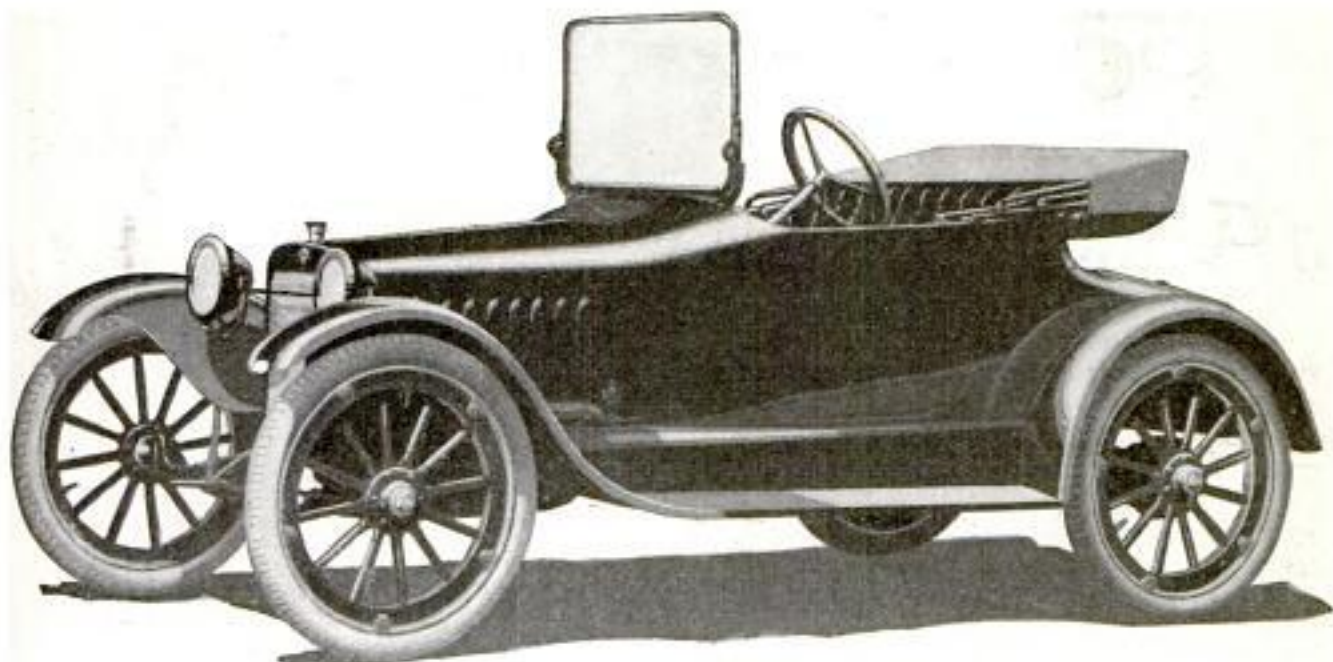

## A Car Completely Equipped to the Last Detail for Less Than \$500

By all means see this new series Saxon Roadster. You will find it no ordinary car. We think it will win you on first sight—on its looks, on its costly car attractions, on the way it acts.

There's plenty of "pepper" to its performance, plenty of speed, plenty of power, and plenty of snap to its "pick-up." There's more room now than ever before. The seat is larger, the body is bigger, there's more leg room.

Look among the high-priced cars, and you will find none which carries more modern features or better features.

Now Saxon Roadster has one of the finest and most efficient 2-unit starting and lighting systems that can be built. It is of the famous Wagner make. It also has demountable rims, and 30x3" tires.

Its motor is of the 4-cylinder, L-head, high-speed special Saxon design, built by the Continental Motor Company—the world's greatest makers of automobile motors.

It has a Reichenbach carburetor of the atomizer type, which represents the biggest advance in gasoline carburetion yet recorded—possesses five

distinct and definite advantages over any other carburetor built.

Saxon Roadster also has three-speed transmission. Among high quality cars this is the only type of transmission used.

Throughout the chassis it has the famous Hyatt quiet bearings—another costly car attraction. And the body is of stream line design.

The honeycomb radiator assures your motor of being kept cool.

Saxon Roadster has the Atwater-Kent ignition system—regarded as one of the best systems on the market. A new style body with Grecian rear bow adds to the attractiveness of this car's appearance.

In addition to these refinements there are such attractions as electric horn, tire carrier at rear, speedometer, ventilating windshield, adjustable pedals, Vanadium steel cantilever springs, and twenty more fine car developments.

The Saxon Roadster is \$495; Saxon "Six" Touring Car, \$865; Six Sedan, \$1250, f. o. b. Detroit. Canadian Prices—Six Cylinder Touring Car, \$1175; Touring Sedan, \$1675; Four-Cylinder Roadster, \$665.

(737)

SAXON MOTOR CAR CORPORATION, DETROIT



# HERCULES

Smokeless Shotgun

# POWDERS

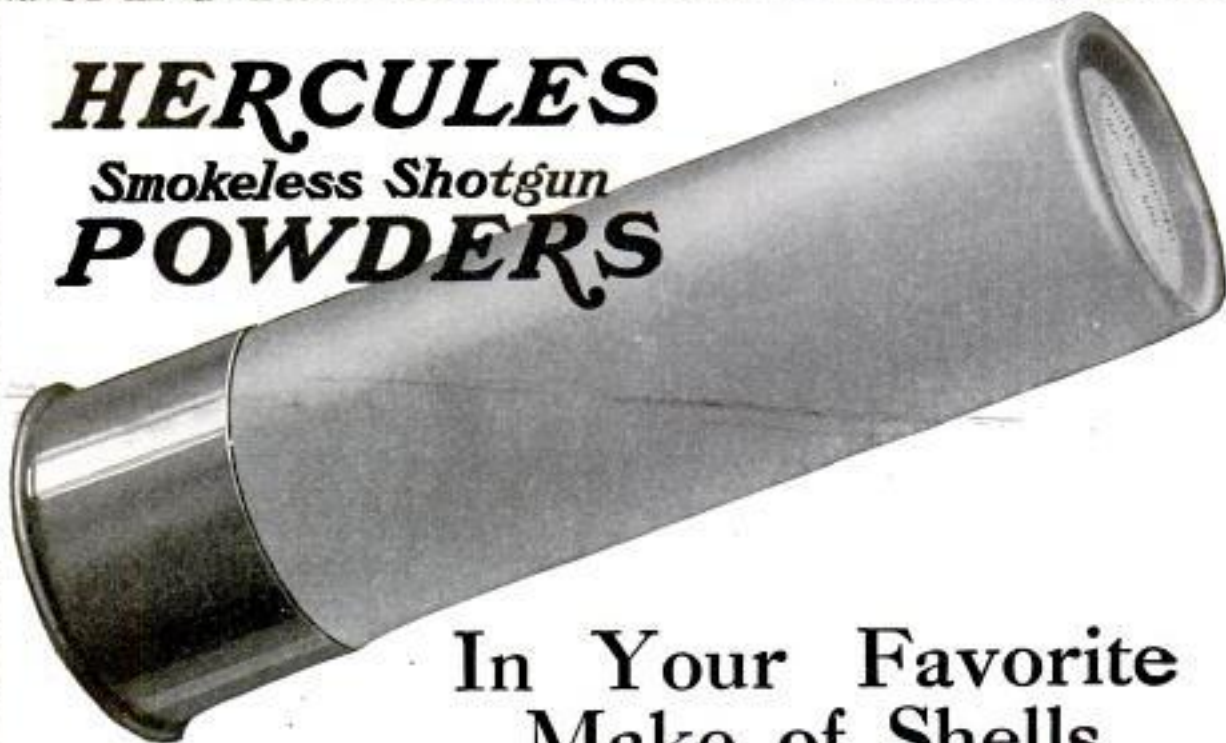

## In Your Favorite Make of Shells

Infallible and "E. C." can be obtained in all of the following makes of shotgun shells.

PETERS  
REMINGTON  
SELBY  
U. S.  
WESTERN  
WINCHESTER

**T**HE fact that you prefer some particular make of shell when shooting at the traps or in the field need not prevent you from enjoying the satisfaction given sportsmen by Hercules Smokeless Shotgun Powders, Infallible and "E. C."

These splendid powders, which are of high and remarkably uniform quality, may be obtained in any standard make of shell. Undoubtedly the shell you use is named in the list given at the left. The next time you order ask for a Hercules Powder in that particular make of shell. You will see the name of the powder stenciled on the box and on the top wad in each shell.

Hercules Smokeless Shotgun Powders give light recoil, high velocity, even patterns. You can't do better than shoot either Infallible or "E. C." Write for a free booklet that describes them fully.

**HERCULES POWDER CO.**

1025 Market Street

Wilmington



Delaware



# Enjoy the Great Outdoors



## The Bicycle Offers You the Only *Real* Way to Do It

**B**UNDLE up good and warm and then off for a brisk ride into the country, away from paved streets and city smoke, out where the air is snappy and invigorating.

No form of exercise that you can take will give you the real, keen enjoyment and at the same time do you the amount of good that you will receive from bicycle riding.

## Be Sure You Get a **MIAMI-MADE Bicycle**

Every piece of material that goes into those bicycles, every step in their manufacture, every part of their equipment is an expression of the purpose to produce the best bicycle that knowledge, skill, care, and experience could make possible.

**There Are Four Lines of MIAMI-MADE Bicycles** —the "HUDSON," the "RACYCLE," the "MIAMI," the "FLYING MERKEL." Each one of these lines has special features. See who the dealers are that handle these lines in your city. Try them all. Pick out the bicycle you like best. But be sure that it is MIAMI-MADE.

If there is no dealer in your city, write direct to us for one of our beautiful catalogs, checking which line you are interested in. SENT FREE.

Hudson?  Miami?  Racycle?  Flying Merkel?

**THE MIAMI CYCLE & MANUFACTURING COMPANY**

1021-1037 Grand Avenue, Middletown, Ohio, U. S. A.

(11)



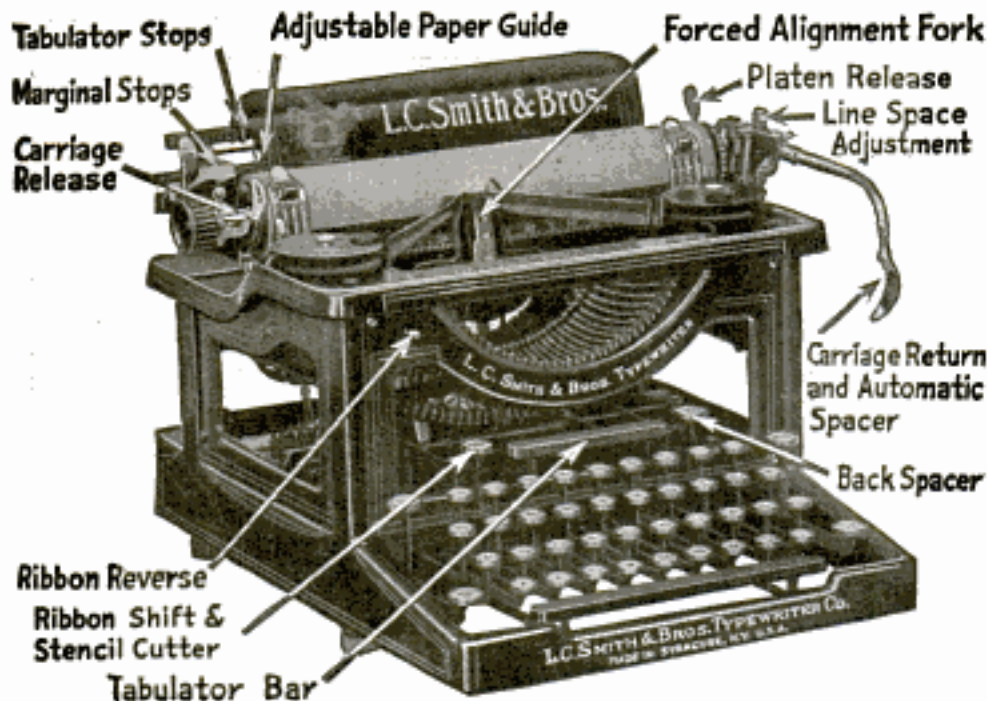

ALL LATEST IMPROVEMENTS

# TYPEWRITER SENSATION

Free TRIAL—Use As You Pay

Send me only \$2.50 a month until the low total price of \$48.80 is paid, and the machine is yours

This is absolutely the most generous typewriter offer ever made. Do not rent a machine when you can pay \$2.50 a month and own one. Think of it—Buying a \$100.00 machine for \$48.80. Cash price, \$45.45. Never before has anything like this been attempted.

**STANDARD L. C. SMITH**  
**VISIBLE**

Perfect machines, standard size, keyboard of standard universal arrangement—universally used in teaching the touch system. The entire line of writing completely visible at all times, has the inbuilt tabulator with billing devices, the two color ribbon—with automatic reverse and key controlled shift, automatic flexible paper feed—automatic paper fingers, the back spacer—ball bearing carriage action—ball bearing shift action—ball bearing type bars—in fact, every late style feature and modern operating convenience. Comes to you with everything complete, tools, cover, operating book and instructions, ribbon, practice paper—nothing extra to buy.

You cannot imagine the perfection of this beautiful reconstructed typewriter until you have seen it. I have sold several thousand of these perfect latest style L. C. Smith machines at this bargain price and every one of those thousands of satisfied customers had this beautiful, strictly up-to-date machine on five days' free trial before deciding to buy it. I will send it to you f. o. b. Chicago for five days' free trial. It will sell itself, but if you are not satisfied that this is the greatest typewriter you ever saw, you can return it at my expense. You won't want to return it after you try it—you cannot equal this wonderful value anywhere.

**H. A. SMITH**  
Room 510-231 N. Fifth Ave.  
CHICAGO, ILL.

Ship me the L. C. Smith F. O. B. Chicago, as described in this advertisement. I will pay you the \$40.00 balance of the SPECIAL \$48.80 purchase price, at the rate of \$2.50 per month. The title to remain in you until fully paid for. It is understood that I have five days in which to examine and try the typewriter. If I choose not to keep it I will carefully repack it and return it to the express agent. It is understood that you give the standard guarantee for one year.

**You Take No Risk—Put In Your Order Now**

When the typewriter arrives deposit with the express agent \$8.80 and take the machine for five days' trial. If you are convinced that it is the best typewriter you ever saw, keep it and send me \$2.50 a month until my bargain price of \$48.80 is paid. If you don't want it, return it to the express agent, receive your \$8.80 and return the machine to me. I will pay the return express charges. This machine is guaranteed just as if you paid \$100.00 for it. It is standard. Over one hundred thousand people own and use these typewriters and think them the best ever manufactured.

The supply at this price is very limited, the price will probably be raised when my next advertisement appears, so don't delay. Fill in the coupon today—mail to me—the typewriter will be shipped promptly. There is no red tape. I employ no solicitors—no collectors—no chattel mortgage. It is simply understood that I retain title to the machine until the full \$48.80 is paid. You cannot lose. It is the greatest typewriter opportunity you will ever have. Do not send me one cent. Get the coupon in the mails today—sure.

**HARRY A. SMITH, 510-231 N. Fifth Ave., Chicago**

Name .....

Address .....

..... Pop. Mech. Feb.

I want, through this advertisement, to establish as friendly business relations with you as I possibly can. I want you to realize also that it is my earnest effort and intention to give you full honest value for every dollar that you spend with me. This is the only way I can succeed. My advertisement has appeared in this magazine continuously for more than four years.

I am building up my business on the foundation of good value and square dealings. I am saving thousands of dollars, by supplying perfect—late style—visible writing—typewriters, at remarkably low prices.

All my transactions are handled throughout by personal correspondence I assure you every courtesy and consideration in your dealings with me. Your order will have my prompt, careful, personal attention. I will be glad to do business with you.

*Harry A. Smith*



# 3 Wonderful Bargains

## From the Great UNIVERSAL Catalog

### — Each Sent Direct Only

# 50¢



### Special 5-Piece Mission Library Set

All five pieces made to match, of seasoned solid oak, fine rich fumed finish. Correct Mission design. Table is a neat design typical of mission style. The rich, dark fumed finish beautifully brings out natural grain of the oak. Each end has 4 panels with attractive cut-out design. Top 34x24 in.; 8 in. book shelf; legs cut from 2 in. stock and fitted with slides. Rocker; seat and back upholstered in imitation Spanish brown leather; seat supported by 6 heavy steel coil springs resting on steel channel bars. Width 25 in., height 38 in., back 24 in. above seat; seat 21x19 in. Chair has same upholstery and construction as rocker. Width 25 in., height 38 in., back 24 in. above seat; seat 21x19 in. Magazine Rack has 4 shelves; 30 in. high; 17 in. wide, 8 1/2 in. deep. Tabourette; top 11x11 in., height 18 in. Order by No. U123. Price, (complete set of 5 pieces as shown) \$17.95. Terms, 50c with order; Balance \$1.75 per month.

# 50¢

### Order One of These Special Bargains

Here is a plan for beautifying the home that marks the most advanced step ever taken in the history of merchandising. For only 50c we will send you any of the remarkable bargains shown on this page. If more than one is wanted send 50c for each item. You may use what you order for 30 days at our risk. If you then decide to keep it, pay the balance in small monthly payments. If you decide not to keep it return it at our expense and we will return your 50c—the 30 days use of the goods costs you nothing.

This small 50c deposit does not obligate you in any way, but is merely asked as an indication of good faith and to protect ourselves against irresponsible people ordering at random. You run absolutely no risk in sending in your order. Ours is a big, successful firm with over \$3,000,000 capital and resources—a firm that is reputable, responsible and trustworthy in every way. And every article you order from us is backed by our legal binding guarantee which insures your absolute satisfaction. Send us your order today—only 50c and coupon for each item desired.

### SPECIAL BOOK FREE BARGAIN BOOK FREE

Send for Special Bargain Book picturing and describing everything for the home—at rock-bottom prices—and on the most wonderfully liberal terms imaginable. We will trust you for anything you want on our liberal, easy-to-pay, credit plan.

## UNIVERSAL MAIL ORDER CO.

145 W. 39th St.  
Dept. 187  
Chicago



If only catalog is wanted put an X in this square, fill in name and address on lines below and mail coupon.

### Universal Mail Order Co. 145-153 W. 39th St., Dept. 187 Chicago

Gentlemen: Enclosed find 50c for each item checked below. If satisfactory after 30 days examination I agree to pay the balance as per prices and terms printed in this advertisement. If not satisfactory I will return goods to you.

No. U123. 5-Piece Library Set  No. U129. Rocker  No. U126. Kitchen Cabinet

# 50¢

Name.....  
Address.....  
City..... State.....

### Sensational Sale High Grade Rockers

An unusually massive, overstuffed Rocker, covered in durable imitation leather, choice of black or brown Spanish. 9 heavy coil springs support seat, attached to frame and reinforced by steel channel bars. Extreme height about 37 in. Extreme width about 31 in. Height of seat from floor 17 in. Distance between arms 21 inches. Size of seat 21x29 in. Size of arms 6x21 in. Height of back from seat 27 in. Mahogany finish frame. Securely packed in a manner to obtain lowest possible freight rate. This is an exceptionally attractive Rocker, and as will be seen from the ample dimensions, a most comfortable one. It is substantially built throughout, strong and durable.

Order by No. U129. Price Only \$9.68. Terms, 50c with order; Balance 95c per month.

# 50¢



### Special Kitchen Cabinet Bargain

This handy Kitchen Cabinet embodies many features that can add to the convenience and lighten the work of a housewife's kitchen duties. Made of kiln dried solid oak with beautiful golden glass finish. Hardware is of copper, latest design. Height 63 in.; base top 42x26 in. Contains 1 cutlery drawer; 1 bread drawer; large cupboard space for cooking utensils; closet with door which contains rolling pin; and pan rack; one bread board 18x20 in.; portable 40-lb. flour bin with sifter attached; one china closet with two panel and art glass doors; one 7-lb. tilting sugar bin; two spice drawers. Draw bottoms, back, etc., built of 3-ply non-warping lumber.

Order by No. U126. Price \$14.85. No money in advance — 50c with order — balance \$1.45 per month.



Please Mention Popular Mechanics



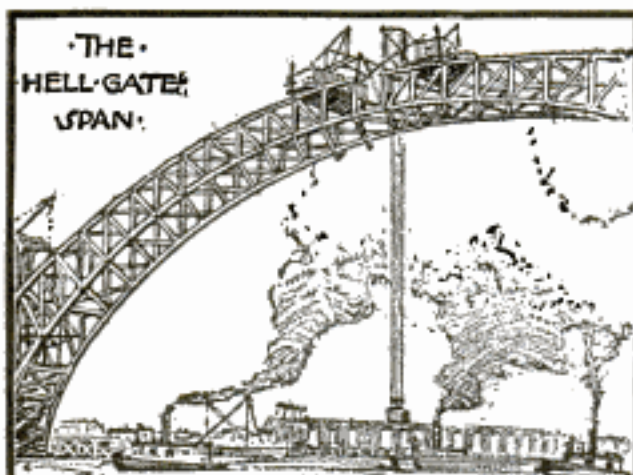

### A Pencil Bridged the River First

A marvel of engineering and draftsmanship was this great span. The details were tedious and necessarily correct. The success of the great span depended on the accuracy of the penciled drawings.

When you are designing intricate problems, you cannot afford to have your lead break, or crumble, or tear the paper. You cannot afford not to have the best pencil.

## DIXON'S ELDORADO

*"the master drawing pencil"*

has received the highest endorsement of architects, engineers and draftsmen all over the country. It is the correct pencil for difficult work. Made in 17 degrees.

Send fourteen cents in stamps for samples worth double the money

**Joseph Dixon Crucible Co.**  
Dept. 10-J, Jersey City, N. J.

**DIXON'S BEST WHITE No 352**  
*writes white on blueprints*

Please Mention Popular Mechanic

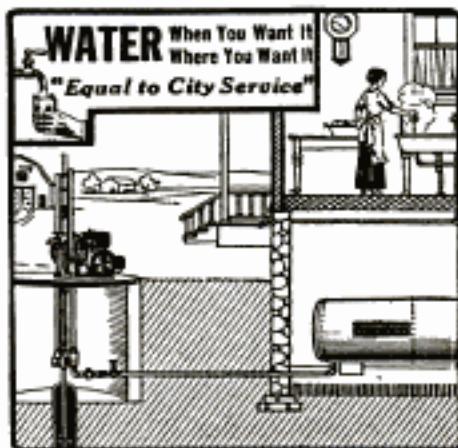

Water under pressure in your home will make housework easier, add to comfort, and increase the property value.

All water requirements of farm homes are met at moderate cost with our pneumatic pressure outfits.

*May we give you details?*

**Fairbanks, Morse & Co.**  
Chicago New York San Francisco  
and other principal cities

(449-61L)

**RADIO STATION INSTALLED AT NAVASSA ISLAND**—A radio station has been installed and is now in operation at the Navassa Island light station, West Indies, now under construction. The call letters are WQN. This radio station is operated at present by the contractors for the erection of the light station, but will be operated by the lighthouse service when the lighthouse is completed.

## POWER



The two horse-power Benninghofen Engine offers even economical power for every purpose. Many new, exclusive features, including "auto-throttle governor" not hit and miss governed. Surprisingly low cost. Burns kerosene or gasoline. Runs machinery, pumps water, saws wood, runs separator, churns, etc. Catalogue and details free.

**C. BENNINGHOFEN & SONS**  
Dept. 125 A HAMILTON, OHIO

**4 H.P. Cushman Weighs Only 190 lbs.**  
**8 H.P. 2 Cylinder Only 320 lbs.**

Discussing light-weight motors recently, the Scientific American said: "Efficiency means light weight, reduced friction, and above everything else, lowered operating cost." Cushman Light-weight engines are today recognized as the leading American motors light-weight, high efficiency, all-purpose motors. Challenging comparison in minimum weight per horsepower, reduced friction, quality of material and workmanship and cost of operation. Sizes 4 to 20 H. P. Throttle Governor. Schlicher Carburetor. Forced Water-Cooling System. Moving parts enclosed and run in bath of oil. Not cheap engines, but cheap in the long run. ENGINE BOOK FREE.

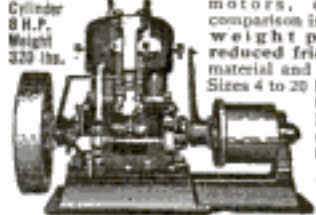

**Cushman Motor Works**  
882 N. 21st St., LINCOLN, NEB.



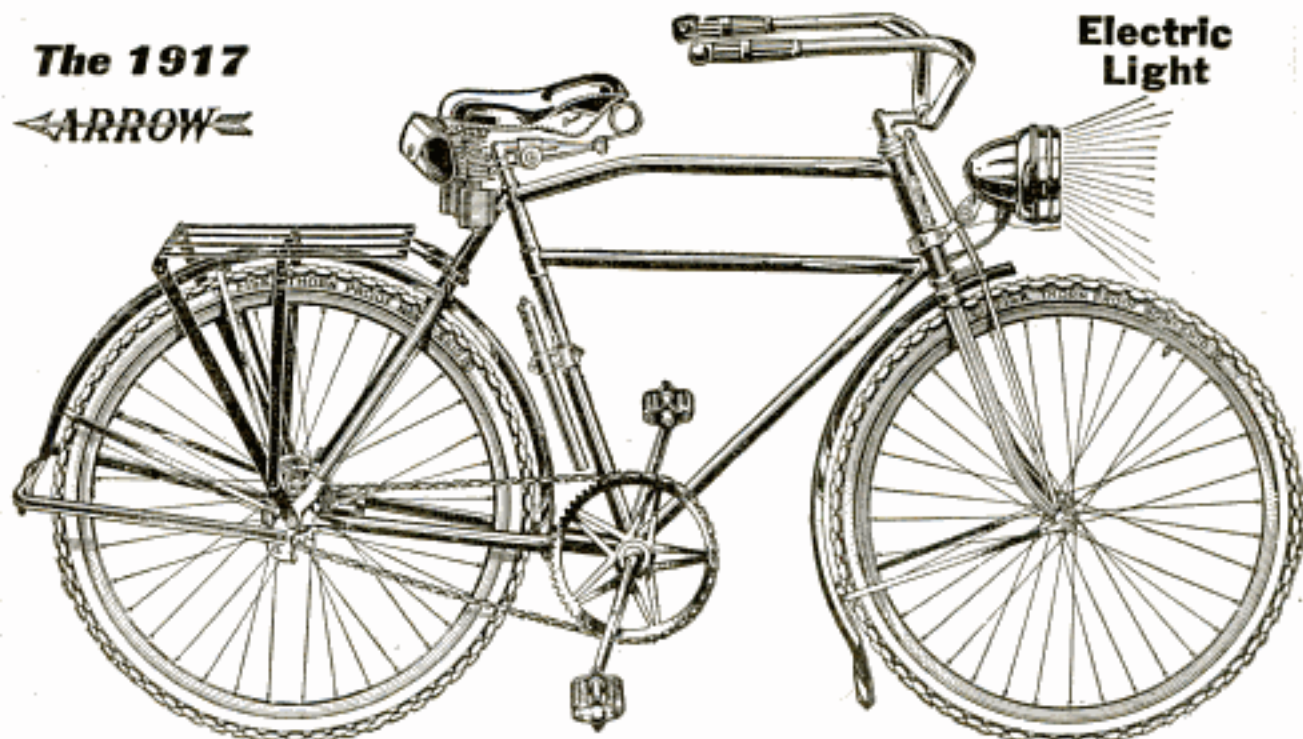

# Great Bicycle Offer

## 1917 Features

### Electric Light

Reinforced motorcycle frame—large, easy motorcycle saddle—long, rubber grip, motorcycle handlebars. New Departure coaster Brake—special motorcycle pedals—motorcycle mudguards, stand and luggage carrier—imported anti-friction chain—Fisk Thorn Proof, Non-Skid Tires—beautiful enamel finish—other new features. Write now.

Send the coupon below today for free catalog of the 1917 Arrow Bicycle. Read the remarkable improvements and new features in the new 1917 model. Note our great pay-as-you-ride offer below. The Arrow is built like the highest grade motorcycles. Guaranteed for 5 years. It offers the utmost in speed, comfort and easy riding. If you ride an Arrow you will have every reason to be proud of your bicycle—no one in your neighborhood will have one to equal it. You can have the Arrow in a wide variety of new models—the motorcycle type shown above and others. All sizes for boys, men and women. Send the coupon today for free catalog.

## Pay As You Ride

Find out about our special, rock-bottom, direct offer on this new 1917 Arrow. A special, 30-day, reduced price offer. We ship the bicycle to you without a penny down. Start riding and enjoying the Arrow right away. And pay the special, rock-bottom, reduced price—a small amount each month—while you ride. Now, why should you even consider paying cash for a bicycle when you can get the wonderful 1917 model Arrow at the lowest, rock-bottom cash price and on small, easy monthly payments while you are riding it. Send the coupon now for new catalog.

## Make Money Riding An Arrow

Just ride your Arrow around. People will admire your handsome bicycle and ask about it. Just answer their questions. You can pay for your Arrow and get extra money besides. Send the coupon for this liberal offer.

## Free Inspection

The ARROW is sent to you without a penny down. If you do not agree when you see it that this new 1917 model Arrow is one of the most wonderful bicycle bargains you ever saw, you may send it back at our expense. You alone will be the judge. It will cost you nothing if you decide you do not want the Arrow.

## Send Coupon-Now! Catalog Showing All Models

Don't delay. Learn about the sensational 1917 Arrow right away. Take advantage of our special, 30-day, rock-bottom price offer. Get full particulars about the wonderful 1917 improvements. Get the free catalog and details of our easy rider-agent offer by which the Arrow will pay for itself. Also full particulars of our liberal, easy-payment offer and rock-bottom prices. See also all the beautiful new Arrow models. No obligations. Send coupon, letter or post card now.

**ARROW CYCLE CO.** Dept. 1192  
19th St. & California Ave. Chicago, Ill.

**Arrow Cycle Co.**  
19th St. & California Ave.  
Dept. 1192, CHICAGO, ILL.

Please send me free catalog of the new 1917 Arrow and particulars of your 30-day, rock bottom "pay-as-you-ride" offer and rider-agent proposition.

Name.....

Address.....



## Send 10c for Copy of Our New Wireless Manual P. 9

YOU GET YOUR MONEY BACK ON AN ORDER OF \$1.00



It contains 180 pages and tells how to erect and maintain wireless telegraph stations. Shows a number of diagrams. Has the Morse and Continental Telegraph Codes. Illustrates the best instruments to use; tells what they are for and how to use them. Has many new diagrams and other valuable information not contained in any other book. Do not wait. Send your request now. Get the best 10c value you will ever buy.

## Send for Our Pocket Catalog P28

It contains 248 pages, with over 1,000 illustrations, and describes in plain, clear language all about Bells, Push Buttons, Batteries, Telephone and Telegraph Material, Electric Toys, Burglar and Fire Alarm Contrivances, Electric Call Bells, Electric Alarm Clocks, Medical Batteries, Motor Boat Horns, Electrically Heated Apparatus, Battery Connectors, Switches, Battery Gauges, Wireless Telegraph Instruments, Ignition Supplies, Etc.

**MANHATTAN ELECTRICAL SUPPLY COMPANY, Inc.**

NEW YORK, 17 Park Place

CHICAGO, 114 So. 5th Ave.

ST. LOUIS, 1106 Pine St.

San Francisco, 604 Mission St.

## Wireless Receivers?

Get a *Murdock* 2000-ohm **\$4** complete double set for and prove to your own satisfaction that there are no better 'phones obtainable at DOUBLE the prices. Fourteen days' trial allowed and money back without question if you are not sufficiently convinced of the remarkable value to keep them.

Our catalog is free. Ask for a copy.

**WM. J. MURDOCK CO.** 10 CARTER ST. Chelsea, Mass.

## THORDARSON Wireless Transformer

new "Type R" is making new records for distance and distinctness. Built with the accuracy of a watch, in the Thordarson laboratories it stands proved as the "best wireless transformer on the market." Exclusive Variable Shunt and Ampere Scale. Handsome new design. Comes completely assembled; no chance for mistakes or burn-outs. Five sizes, 5 to 25 k. w.; 10,000-20,000 volts; any circle desired.

WRITE FOR SPECIAL BULLETIN AND PRICES  
**THORDARSON ELECTRIC MFG. CO.**  
518 So. Jefferson St., Chicago, Ill.



**GAGHOO!** Make the whole family and all your friends "just sneeze their heads off" without knowing why, with *Cokes*, the new long distance harmless snuff. Sent anywhere for 10c. 3 for 25c. 1 doz. and special premium for 90c. **AMERICAN SUPPLY CO.,** St. Paul, Miss.



*Holtzer-Cabot*  
**Radio Phones**  
Meet every requirement. Weight, only 10½ ounces. They excel both in tone and loudness. They will increase your range. Sold with "Money Back" guarantee.

Send for Booklet "P" Today

**The Holtzer-Cabot Elec. Co.**  
BOSTON and CHICAGO

## DEPENDABLE KNAPP Buffing Outfit \$13.50

Consists of Knapp Utility Motor, Emery Wheel, Smoothing Muslin, Polishing Flannel, Felt Cone, Stick Tripoli, and Rouge. For buffing, polishing, grinding, sharpening, and hundreds of other uses.

**AT ALL LIVE DEALERS**

Insist on your dealer showing you the Knapp line—Knapp goods are best. If your dealer cannot supply you, order direct from us.

Send for **FREE** Illustrated Catalog.

Knapp Electric & Novelty Co., 519 W. 51st St., New York



## Brandes "Superior" Set, \$5.50

**Boys: PUT YOUR CHRISTMAS MONEY INTO A BRANDES HEAD SET**

The price is made to fit boys' pockets. But the head set is a professional one, used on ships and on land stations all over the world. With it, you can break the long-distance record in your town.

**Order Now—No Risk** If you're not highly pleased, we guarantee your money back. At least send 4c for our new catalog P of Brandes Receivers.

**C. BRANDES, Inc.,** Room 817, 32 Union Square, NEW YORK

**Brandes Wireless Receivers**  
"THE RECEIVERS WITH MATCHED TONE"

## ELECTRICAL HANDY BOOK AND CATALOGUE FREE

WORTH 25 CENTS TO ANYBODY

The **BIG BOOK** you need and want. Describing positively the finest and most complete line of wireless, novelty, and experimental goods ever listed in any catalog and containing besides, innumerable tables, hook-ups and treatises of inestimable value to the experimenter. Absolutely Free. Send No Postage.

**THE ELECTRO-SET COMPANY**  
Leader Bldg., Dept. P-9 Cleveland, Ohio

**RECTIFIERS** for garages. All sizes. Charge from alternating current 1 to 8 batteries. \$12.00 upwards.  
**AMERICAN BATTERY CO.,** 1137 Fulton St., Chicago. (Estab. 1888)

## BOYS! HAVE DAD GET STRUCTO

Structo—Mechanics in miniature—will turn the trick. With it you can build that bridge or derrick, and a hundred other models that really work. Write for Free illustrated book.  
**STRUCTO MFG. CO.,** Dept. 118, FREEPORT, ILL.

## ERECTOR THE TOY LIKE STRUCTURAL STEEL

**BOYS:** Write for facts about the Big Prize Contest and get Erector Tips, the boys' magazine, **FREE.**  
**THE A. C. GILBERT COMPANY, 104 Fox St., New Haven, Conn.**

**THE AMERICAN MODEL BUILDER**

WRITE FOR CATALOG

**The American Mechanical Toy Co.**  
302 E. First Street DAYTON, OHIO



# \$100 Model UNDERWOOD

WITH BACK SPACER—TWO  
COLOR RIBBON AND TABULATOR

# FOR

You Try It  
10 Days  
Free

Guaranteed  
for Five  
Years

Think What  
You Can Get  
Now for \$37.20

A genuine No. 4 Underwood—the standard visible typewriter, with back spacer, two-color ribbon and tabulator—*complete* with waterproof cover, new ribbon and special touch typewriting instruction book—the machine that is

\$**37.20**

today the leading typewriter of the world! *Guaranteed* to be delivered in perfect condition! Fully guaranteed for five years.

You May  
**RENT** APPLYING RENT  
ON PURCHASE PRICE  
OR  
**BUY** FOR CASH OR  
ON EASY  
PAYMENTS

## 'Way Under 1/2 Manufacturer's Price

Moreover, you don't have to buy it to try it! We will send one to you on Ten Days' Free Trial. Write all you please on it for ten days and then if you are not *perfectly* satisfied, send it back at *our expense*. What's more, if you do not care to buy, you may rent it at our low monthly rates. If later you want to own it, we will apply *six months'* rental payments on the low purchase price. Any national bank in Chicago, or any Dun's or Bradstreet's Agency anywhere will tell you that we are responsible. Learn *all* the facts about this remarkable offer. Write us today—send us your name and address on the attached coupon—or a post card. Ask for Offer No. 52

## Our Other Plan Brings You This Underwood

This is a new plan—Our Agency Plan. You are not asked to do any canvassing—no soliciting of orders. You simply co-operate with us. Become one of our nation-wide organization. You can easily get your Underwood *free* by this new plan. Write tonight—send your name and address on the coupon or a post card and learn all about Offer No. 52

# FREE

Typewriter Emporium, 34-36 W. Lake St., Chicago  
Established for a Quarter of a Century

Typewriter Emporium, 34-36 W. Lake Street, Chicago, Illinois  
Send me immediately full facts about your Offer No. 52

Name \_\_\_\_\_  
St. or R.R. No. \_\_\_\_\_  
City \_\_\_\_\_  
State \_\_\_\_\_

Please Mention Popular Mechanics





Many offers like this in our Catalog. Mail the Coupon today.

Rocker 116050 is given with a \$10 purchase of Larkin Products. Try it at our expense.

## Given To You WITHOUT EXPENSE

Buy your necessary home supplies from Larkin Co. and the saving you make by dealing from

### FACTORY TO FAMILY

is given you in the form of this Rocker or a thousand and one other useful things of your selection.

### BIG BOOK FREE

Mail Coupon today and get our latest Catalog. Everything explained including our Money Back Guarantee.

Send Coupon Today to Nearest Address.

**Larkin Co.** Buffalo Peoria Chicago  
Please send me your Catalog No. 148.

Name.....

Address.....

G. P. 839.....

### BUY PLUMBING and HEATING SUPPLIES



at **WHOLESALE** Will Save You **30%**  
Don't pay retail prices. Full stock on hand for prompt shipment. Send for free catalog.

B. P. KAROL, 800-802 South Kodzie Ave., CHICAGO

## Get Lower STOVE PRICES

**SAVE MONEY** Write for the Kalamazoo Catalog—newest style ranges—new features, white enamel splashers backs, etc. Highest quality at wholesale prices. 300,000 satisfied owners. We pay freight—quick shipment. ASK FOR CATALOG NO. 473.

**KALAMAZOO STOVE COMPANY**  
A Kalamazoo Direct to You Manufacturers, Kalamazoo, Mich.

## 300 Candle Power of Light at a Cost of 1-8c Per Hour

Burns Kerosene or Gasoline

This lamp generates and burns its own gas from ordinary kerosene. "QUICKLIT" gasoline lamps can be lit with an ordinary match like city gas.

Write today for illustrated catalog of our complete line of kerosene and gasoline lamps, lanterns. **Agents Wanted** and lighting systems.

**The Nagel-Chase Mfg. Co.**  
176 East Erie St., Chicago



**ELECTRIC** HOME, FARM, PICTURE THEATRE, HOTEL & STORE LIGHT PLANTS. Auto Starter Storage Batteries & Chargers. All Cars. Ask Price. Drums. Power Motors. Belts. Engines. Railways. Permanent & Traveling Motion Picture Machines.

**OHIO ELECTRIC WORKS, CLEVELAND, O.**



## LIGHT YOUR HOME LIKE DAY—COST 1c

for 6 hours. Pure white 100 candle power light from common Kerosene.

**THE BEACON LAMP MAKES AND BURNS ITS OWN GAS**

Better, brighter, safer, cheaper than Gas, Gasoline or Electricity. Every home interested. 500,000 satisfied users. Agents wanted. Write quick for selling plan, exclusive free territory and trial offer.

HOME SUPPLY CO., 111 Home Building, KANSAS CITY, MO.

## New KEROSENE LIGHT BEATS ELECTRIC OR GASOLINE

10 Days FREE—Send No Money



TWICE THE LIGHT ON HALF THE OIL

your own home ten days; then you may return it at our expense if not perfectly satisfied. You can't possibly lose a cent. We want to prove to you that it makes an ordinary oil lamp look like a candle; beats electric, gasoline or acetylene. Lights and is put out like old oil lamp. Tests by U. S. Government and 34 leading Universities show that it

**Burns 50 Hours on One Gallon** common kerosene (coal oil), no odor, smoke or noise, simple, clean, won't explode. Three million people already enjoying this powerful, white, steady light, nearest to sunlight. **Won Gold Medal** at Panama Exposition. Greatest invention of the age. Guaranteed.

**\$1000 Reward** will be given to the person who shows us an oil lamp equal to the new Aladdin in every way (details of offer given in our circular). We want one user in each locality to whom we can refer customers. To that person we have a special introductory offer to make, under which one lamp is given free. Write quick for our 10-Day Absolutely Free Trial Proposition and learn how to get us too. **Yours FREE**

**Men With Rigs Make** Our trial delivery plan makes it easy. No previous experience necessary. Practically every farm home and small town home will buy after trying. One farmer who had never sold anything in his life before, writes: "I sold 51 the first seven days." Christensen, Wis., says: "Have never seen an article that sells so easily." Norring, Iowa, says: "92 per cent of homes visited bought." Phillips, Ohio, says: "Every customer becomes a friend and booster." Kemering, Miss., says: "No flowery talk necessary. Sells itself." Thousands who are coming money endorse the Aladdin just as strongly. **NO MONEY REQUIRED.** We furnish stock to reliable men to get started. Ask for our distributor's plan, and learn how to secure an appointment and make big money in unoccupied territory. State occupation, age, whether you have rig or auto; whether can work spare time or steady, when can start; townships most convenient for you to work.

**MANTLE LAMP COMPANY, 126 Aladdin Bldg., CHICAGO, ILL.** Largest Kerosene (Coal Oil) Mantle Lamp House in the World



The HOME for YOU will be found in

# KEITH'S

FOR 17 YEARS

The Leading Magazine on Home Building



KEITH'S is a specialized monthly magazine complete in the latest ideas and Plans you cannot afford to miss. Each 72 to 100 page number gives many cuts and plans with interesting detailed write-ups of homes designed by leading architects. Home Decoration Department, edited by Virginia Robie, the well-known authority. New materials and how to use them.

## Big Offer of the Year

Send \$2.50, the subscription price for one year, and we will enter you for 12 Big House Building Numbers and in addition, mail postpaid, YOUR CHOICE of any of

### KEITH'S Dollar Plan Books:

139 Plans of Bungalows	175 Plans costing below \$6000
104 Plans costing below \$3000	125 " " over \$6000
125 " " " \$4000	100 " Cement and Brick
175 " " " \$5000	50 Garages, 40 Duplex & Flats

Keith's Magazine on Newsstands 25c copy. \$2.50 Year. All Eight Books and KEITH'S a Year, \$8.00

KEITH'S, 992 McKnight Bldg., Minneapolis, Minn.



## The BEST LIGHT

Positively the cheapest and strongest light on earth. Used in every country on the globe. Makes and burns its own gas. Casts no shadows. Clean and odorless. Absolutely safe. Over 200 styles. 100 to 2000 Candle Power. Fully Guaranteed. Write for catalog. AGENTS WANTED EVERYWHERE.

THE BEST LIGHT CO., 324 E. 5th St., CANTON, O.

## THIS BUNGALOW \$900 CAN BE BUILT FOR

This and many others in my new book, Building Plans for Modern Homes, will save you hundreds of dollars. One of the most complete and comprehensive books of plans ever published by any architect. Fifth edition just off the press. Two hundred and fifty floor plans and photographs of bungalows, etc., costing from \$200 up; gives sizes and cost to build. Sent postpaid for \$1.00



FREDERICK H. GOWING  
ARCHITECT

18 Tremont St., BOSTON, MASS.



Design No. 524  
by Jud Yoho.  
Estimated Cost  
\$2800.

## ALL ABOUT BUNGALOWS

BUNGALOW BOOK, 1916 De Luxe Edition

Contains the cream of 1000 practical and distinctive bungalows actually built for \$400 to \$4000, suited to any climate, with photos of exterior and interior views, plans, size of rooms, cost, etc. Also valuable suggestions on bungalow building written by an expert. The largest exclusive Bungalow Book published. 112 pages. Price..... \$1.00 Postpaid  
Worth many times its cost to any prospective builder. A smaller edition of same, only 50 cents. Send check, money-order or stamps. Money back if not satisfactory.

JUD YOH0, The Bungalow Craftsman, 65 Bungalow Bldg., SEATTLE, WASH.

# Push Button Washing Done



JUST push a button and you set the Thor Electric Washing Machine at work. It does the washing. Also the wringing. Makes clothes cleaner than you can wash them by hand. Gets an average family washing done in an hour. Finest laces, clothes of any kind, table and bed linens, blankets—all come out perfectly free from dirt—absolutely clean.

## The Thor

### Electric Washing Machine

Costs only 2 cents an hour for electricity. We guarantee that. And the Thor banishes all the drudgery of washday. No work for a woman to do. Saves wet feet, backache, and red hands. Surely you will want to see the Thor before next washday.

No  
Hands  
Can  
Wash  
so  
Clean  
as  
This



## Saves Its Cost

No rubbing when you have a Thor. The saving in wear on clothes and in cost of help pays for the machine.

## On Credit!

Any Thor dealer will sell you a machine on easy monthly payments. If you have an electric light system of your own we will furnish special motor to run the Thor

## Send Coupon for Free Book

Big 48 page book on washing. Tells how to get rid of washday drudgery. Also name of nearest dealer sent for the coupon. Valuable information. Get it now. Just mail the coupon.

### Hurley Machine Co.

Dept. 1192—29 South  
Clinton St., CHICAGO  
147 W. 42nd St., NEW YORK  
413 Yonge St., TORONTO

Manufacturers also of  
Thor Electric Ironing  
Machines and Thor  
Electric Vacuum  
Cleaners.

Name.....

Address.....  
Please give name of a dealer in your city who sells electrical supplies.



# Free Try-On OF AMERICAN METAL SHOES

Yes, free try-on in your own home of these light, water-proof, rust-proof, wear-proof metal shoes; save your money, your feet, your health. No more tired, sore, wet feet. Always warm, dry and comfortable. Warm in winter—cool in summer. One pair outwears many leather pairs. The world's most economical work shoe for men and boys.



**SAVE  
\$30.00**  
ON  
SHOE  
BILLS

The  
Best  
School  
Shoe

## Steel Or Aluminum Soles

Made in all sizes and heights. Guaranteed to fit. Patent rocker bar gives the natural tilt—that light, springy step. Easier to walk in than heavy shoes or boots. We manufacture the largest and most complete line of metal shoes in the world. Send postal today for

### FREE—Shoe Book—FREE

It describes these money saving, health protecting, comfort giving, ever wearing shoes. Don't buy a work shoe of any kind at any price until you get this book. It tells all about our free try-on offer to every man and boy. Address postal to

### AMERICAN METAL SHOE CO.

(Combined with Racine Aluminum Shoe Co.)  
30 12th Street RACINE, WIS.

## FREE Glove Book

Send for free copy of "Glove Styles" showing the very latest Grinnell Gloves.

Morrison-Ricker Mfg. Co., 141 Broad St., Grinnell, Ia.



# Made-to-Measure

EXPRESS PREPAID **\$3.25**

Pants cut in the latest style. Made to your individual measure. Fit, workmanship and wear guaranteed.

### No Extra Charge

for peg tops, no matter how extreme you order them.

**Agents** A good live hustler in every town to take orders for our **Wanted** celebrated made-to-measure clothes. Samples of all latest materials FREE.

### We Pay Big Money

to our agents everywhere. Turn your spare time into cash by taking orders for our stylish clothes. Write today for beautiful FREE outfit.

**THE PROGRESS TAILORING CO.**  
Dept. 753, CHICAGO, ILL.

## GENUINE NORTH STAR Hockey Skates

**\$8.50**



### SHOES ATTACHED

These Nestor Johnson Hockey or Racing Skates are used today by over 75 per cent of professional skaters in the United States. They are made of the finest grade imported Swedish steel and are of the highest quality of construction. Shoes are chrome-tanned leather—soft, pliable and not affected by water. Although designed for speed, they are being used more and more for pleasure skating. The greatest value ever offered at the price.

Write today for a pair of these wonderful skates, giving length in inches of ordinary shoes, or enclose pencil sketch of stocking foot. Other skates ranging from 65c up. Also write for our encyclopedic of sporting goods. Gives full information regarding our basket ball and hunter outfits, also sweaters, home exercisers, etc. (678)

The Brunswick-Balke-Collender Co.  
Dept. 50, 623-633 S. Wabash Ave. Chicago

### A Basketball Jersey



## Be the First in Your Club

School, City or Town, to wear this pure, all wool sweater, double collar and cuffs. Your choice in colors. This jersey was selected by 10,000 of my customers for last season. Your chum will recommend it. Send for my big illustrated catalogue. Write me and learn my offer for your club's order. Popular Prices. Best Grade Sporting Goods—Basketball, Football, Baseball, Tennis, Golf, etc.

WRITE ME NOW.

JACK SHANNON CO., Dept. 46, 54 E. Monroe St., Chicago

# MENNEN'S SHAVING CREAM

Send 10 cents for a medium-sized tube of Mennen's Shaving Cream, a trial can of Mennen's Talcum for Men, and the novel booklet "The Gentle Art of Shaving."

Gerhard Mennen  
Chemical Company  
2900 Orange St., Newark, N. J.  
Canadian Factory,  
Montreal, Que.  
Sales Agents for Canada:  
Harold F. Ritchie & Co., Ltd.,  
Toronto.



MONEY  
IN  
MUSHROOMS

## FREE BIG BOOKLET TELLING HOW TO GROW MUSHROOMS

at home all the year. Big profits. Take advantage of this wonderful opportunity to become independent. With Nat'l Spawn Co., Dept. 12, Boston, Mass.

# EVEREADY SAFETY LIGHTS

American Ever Ready Works  
of National Carbon Co.  
Long Island City, New York

Hand  
Forged  
Razor Steel  
Blades. No. 57



This **\$2 KNIFE 83¢**  
DIRECT AT FACTORY PRICE

Handy shaped blade makes this knife best for mechanics, sportsmen and farmers; light but strong; resharpened easily. Stag handle, German silver finish; blades file tested, hand forged from razor steel and warranted. Sample 50c, 3 for \$2 postpaid. Cheapest razor \$2 each.

Send for our 80 Page List and "How to use a Razor" FREE

MAHER & GROSS CO., 106 A. St., Toledo, Ohio.

Please Mention Popular Mechanics



## LU DEN'S Relieve the Strain on the Voice

Big aid to singers, speakers, teachers, preachers, salesmen. Stop throat tickle—clear the head.

In "Yellow Box"—5c



# LU DEN'S

MENTHOL CANDY COUGH DROPS

Catarrhal throat trouble, hacking coughs, offensive breaths quickly respond to the use of Luden's.

WM. H. LUDEN, Mfg. Confectioner, READING, PA.

## JENKINS' BRASS BAND AND ORCHESTRA INSTRUMENTS



We save you money and give easy payments. Biggest line of Band and Orchestra Instruments; Cornets, Trombones, Clarionets, Drums, Saxophones, Violin, Guitars and all wind and stringed instruments. Send for free catalog of instrument you want. We give a fifty-

lesson FREE certificate with each instrument. Tell us the instrument you wish to play.

JENKINS MUSIC CO., 13 Jenkins Bldg., KANSAS CITY, MO.



## Bausch and Lomb BALOPTICON

THE PERFECT STEREOPTICON

Bausch & Lomb Optical Co., 576 St. Paul St., Rochester, N. Y.



## INDOOR CLOSET

More Comfortable, Healthful and Convenient than the Out-Door Closet

Eliminates the out-door closet and open vault. They are breeding places for germs. Have a warm, sanitary, odorless toilet right in your house. No going out in cold weather. A boon to invalids. Endorsed by State Boards of Health.

W. M. Davis writes: "Your indoor closet is giving absolute satisfaction. It is certainly the thing for a home without sewerage."

**Absolutely Odorless Put It Anywhere in the House**

The germs are killed by a chemical process in water in the container, which you empty once a month. Absolutely no odor. No more trouble to empty than dishwater. Closet absolutely guaranteed. Write for full description and price.

**Agents Wanted—Big Profits** Wonderful opportunities in every town, village and in the country. Best season just at hand. Every home is a good prospect. Sell eight out of every ten you call on. Ernest Ridwell writes: "Have ten orders." G. A. Dismore says: "Ship at once twenty closets and fifteen washstands. Sold them all in one community." Sell itself. Everybody hates the outdoor closet. Everybody wants a Ro-San Indoor Closet. Write quick for territory and full particulars.

ROWE SANITARY MFG. CO., 205 Sixth St., Detroit, Mich.

Ask about the Ro-San Washstand—Hot and Cold Running Water Without Plumbing



Thomas A. Edison

## Mr. Edison's Wonderful New Phonograph

The world's greatest inventor has made the music of the phonograph life-like, at last. Success—after years of labor on his favorite invention! Read our offer on his wonderful new phonograph.



Only

**\$1.00**

and after trial

An astounding offer—the New Edison, Mr. Edison's great new phonograph with the new Diamond Stylus reproducer and your choice of all the brand new Diamond Amberol Records will be sent to you on free trial without a penny down. The finest, the best that money can buy at very, very much less than the price at which imitations of the genuine Edison are offered—a rock-bottom offer direct from us.

## Entertain Your Friends

Hear all the latest up-to-date song hits of the big cities. Laugh at the side-splitting minstrel shows. Entertain your family and your friends with everything from Grand Opera to Comic Vaudeville—then if you choose, send the outfit back to us at our expense.

## Rock-Bottom Direct Offer

If you wish to keep Mr. Edison's superb new instrument, send us only \$1.00 after the free trial. Pay the balance on the easiest kind of monthly payments.

Think of it—a \$1.00 payment, and a few dollars a month to get this outfit of Mr. Edison's new phonograph with the Diamond Stylus reproducer, the life-like music—the same Diamond Amberol Records—all the musical results of the highest priced outfits—yes, the greatest value for \$1.00 down, balance on easiest monthly terms. Convince yourself—a free trial first! No money down, no C. O. D., not one cent to pay us unless you choose to keep the instrument.

## Our New Edison Catalog Sent Free

Your name and address on a postal or a letter (or just the coupon) is enough. No obligations in asking for the catalog. Get this offer—while this offer lasts. Fill out coupon today.

**F. K. BABSON**  
Edison Phonograph Distributors  
1192 Edison Block  
Chicago, Ill.

Canadian Office:  
855 Portage Ave.  
Winnipeg,  
Manitoba.

To  
**F. K. Babson**  
Edison  
Phonograph Distributors  
1192 Edison Bldg.  
Chicago, Ill.

Gentlemen: Please send me your New Edison Catalog and full particulars of your free trial offer on the new model Edison Phonograph.

Name.....

Address.....



# One of the World's Greatest Inventions



Runs Lathe with Artificial Right Arm

CARNES

## Artificial Arm

The only artificial arm and hand that you can really do so many things with and without assistance of natural hand. The only artificial arm with full finger motion hand, turning and bending wrist and bending elbow. Comfortable to wear. Easy to operate. Perfect fit guaranteed. Recommended by wearers the world over. Endorsed by surgeons. Awarded Gold Medal, San Francisco, San Diego, London, Eng. Write for illustrated catalog B. 25 of this wonderful invention.

**CARNES ARTIFICIAL LIMB CO.**

31 Carnes Bldg., 904-906 E. 12th St., Kansas City, Mo.

**A Few Cents Saves Dollars**  
You can easily and quickly hang Pictures, Prints, Draperies, etc., in every room by using

**MOORE PUSH-PINS**  
and Moore Push-less Hangers. Will not mar your walls. The needle points do the trick. Securely holds 100 pounds. Send for free samples.

**Moore Push-Pins.** Made in 2 sizes  
*Glass Heads, Steel Points*

**Moore Push-less Hangers.** 4 sizes  
*The Hanger with the Twist*

**10c pkts. EVERYWHERE OR BY MAIL**

**MOORE PUSH-PIN CO., Dept. 36, PHILADELPHIA, PA.**

I will send my 25c book

## Improve Your Eyes

For 10c stamps or coin

A high-grade exercise and massage method that quickly strengthens and beautifies the eyes.

Also a most beneficial system of exercises that will improve the muscles of the temples and sides of face, thereby facilitating mastication and vocal pronunciation. Completely illustrated. Entirely without apparatus.

### MUSCLE BUILDER

A steel spring exerciser and chest expander, with a complete course of twenty-four selected exercises for developing all the muscles of the body. It is equal to any \$3.00 exerciser. My price for a short time only, \$1.48.

**PROF. ANTHONY BARKER**  
4641 Barker Bldg., 110 W. 42d St., New York

# STOP USING A TRUSS

Do Away With Steel And Rubber Bands

**FREE TRIAL**

TRADE MARK

STUART'S ADHESIVE

PLAPAO-PAD

Inner surface is made adhesive to secure the FLAPAO-PAD firmly to the body, keeping the PLAPAO continually applied and the pad from slipping. No straps, buckles or springs attached. Soft as velvet—easy to apply.

PAT'D APRIL 6 1909

It's the Non-Slipping, yet Non-Rigid Pad and What is Within It That Counts

## FREE to 5,000 Truss Sufferers

To the extent of 5,000 sufferers who may apply I will send, ABSOLUTELY FREE, a sufficient quantity of the Plapao to positively convince them that this is the only logical, common-sense way of treating rupture. Plapao is a highly strident medication placed within the Plapao-Pad and being absorbed through the skin, creates a wonderful feeling of relief and at the same time tends to strengthen the weakened muscles and thus permanently close the rupture opening. The process of recovery is natural, so you'll have no use for a truss—you can throw it away forever! Old and young have testified under oath that the Plapao-Pads cured their rupture—many of them long-standing, aggravated cases—without delay from work. Patent allowed in U. S. and foreign countries. Awarded Gold Medal at Rome and Grand Prix at Paris.

**Send No Money**—for a sufficient quantity of the Plapao to give it a thorough test; you pay nothing for this trial now or ever. Write for it and full information today. Address: Plapao Laboratories, Block 1427 St. Louis, Mo.

WEAR

Trade Mark Registered **B.V.D.** U. S. Patent Office and Foreign Countries

UNDERWEAR

## BIG CHANCE FOR AGENTS



**You can earn BIG MONEY** selling the most complete line of guaranteed transparent handle Knives and Razors with Photo, Name and Lodge Emblem—also full line of cutlery. Write today for catalogue and terms. **Golden Rule Cutlery Co., 212 N. Sheldon St., Dept. 354, Chicago, Ill.**

## KEROSENE

**\$30 a Week EASY** Men and Women Wanted to Sell

### PERFECTO Kerosene Irons

No experience necessary. See profits selling this wonderful self-cooking satisfaction guaranteed iron. Easy to operate and demonstrate. Sells itself. Use Kerosene (Coal Oil) or Gasoline with same satisfactory results. Absolutely safe, no smoke or odor. Get facts in detail and let us tell you how to obtain Free Sample and start you in a big paying business. Sample case FREE to Agents.

**PERFECTO SADDLE IRON FACTORY**  
Dept. P, 128 So. Clinton St., CHICAGO, ILL.

## A Profitable Vocation

Learn to letter Price Tickets and Show Cards. It is easy to do rapid, clean-cut lettering with our improved Lettering Pens. Many persons make good money by lettering price tickets and show cards for the smaller merchant, outside of regular working hours. Practical lettering outfit consisting of 3 Marking and 3 Shading Pens, 2 colors of Lettering Ink, sample Show Card in colors, instructions, figures and alphabets. Prepaid \$1.00.

### Practical Compendium of Commercial Pen Lettering and Designs



TRADE MARK

100 pages, 8x11, containing 122 plates of Commercial Pen alphabets, finished Show Cards in colors, etc., also large list of crisp business Advertising Phrases—a complete instructor for the Marking and Shading Pen. Prepaid, \$1.00. Catalogue free. Address,

**NEWTON AUTOMATIC LETTERING PEN CO., Dept. A, Pontiac, Mich., U. S. A.**



# \$8,000 to \$10,000 YEARLY



## Make Money Out of Others' Fun

Pleasing the Public Pays Big Profits and owners of our famous attractions frequently make from \$8,000 to \$10,000 every year. We make everything in the Riding-Gallery and Carouselle line from the smallest to the highest grade. Bring in hundreds of dollars daily. It is a delightful, attractive, big paying, healthful business. Just the thing for the man who can't stand indoor work, or is not fit for heavy work.

Just the business for the man who has some money and wants to invest it to the best advantage. Our goods are finest appearing, easiest running, and most attractive line manufactured. They are simple in construction and require no special knowledge to operate. Our latest new 1917 Carouselle is mounted on trucks to facilitate and reduce cost of moving and shipping. It reproduces exactly the running horse motion. Greatest Novelty out. If you want to get into a money-making business write today for catalog and particulars.

**HERSCHELL-SPILLMAN COMPANY**

PARK AMUSEMENT OUTFITTERS

333 Sweeney St., N. Tonawanda, N. Y., U. S. A.

Go into **MOVING PICTURE BUSINESS**

**Small Capital Starts You**

on our easy payment plan. Begin now and get your share. We sell everything. Write TODAY.

**Atlas Moving Picture Co.**  
Dept. 22, 525 S. Dearborn St., Chicago

Our Catalog FREE. Show you how to earn \$25 to \$50 per day.

## Card Printing Automatically

**IS PERMANENT BUSINESS**

**ALL YEAR ROUND—BIG PAYING EVERYWHERE**

Our press prints and feeds 100 per minute, 4,000 per hour. Business cards, visiting cards, tickets, postal cards, souvenir postals, announcements, invitations, blotters, programs and many others and practically all profit. Write for our free booklet 11. Get our proposition. Supply houses get our trade offer.

**S. B. FEUERSTEIN & CO.**

Patentees and Manufacturers  
542 W. Jackson Blvd. CHICAGO, U. S. A.

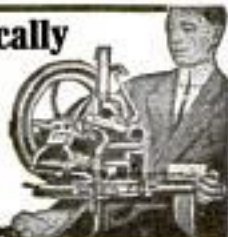

# AGENTS 500% PROFIT

## Gold and Silver Sign Letters

**N** For store fronts, office windows and glass signs of all kinds. No experience necessary. Anyone can put them on and make money right from the start.

**\$30.00 to \$100.00 A WEEK!**

You can sell to nearby trade or travel all over the country. There is a big demand for window lettering in every town. Send for FREE Samples and full particulars.

**Metallic Letter Co., 406 No. Clark St., Chicago**

Please Mention Popular Mechanics

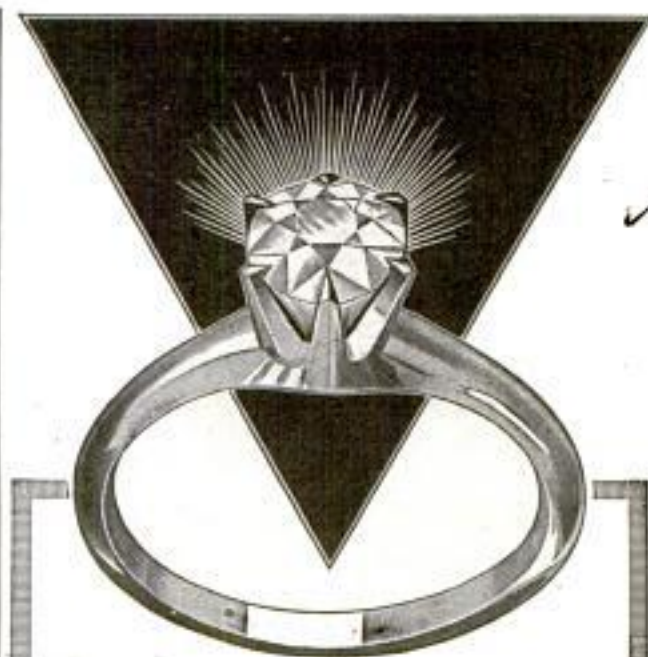

# Save 1/3 or Send It Back!

YOU are the sole judge of these new diamond bargains. We will send you an exceptionally brilliant diamond, perfect in color and cutting, so that you can judge it for yourself. Wear it for 30 days and let your friends judge it. Then, if you do not think that you are saving at least one-third, send it back at our expense. All the latest and newest ideas in diamond jewelry and watches are yours to choose from, and yours to judge.

# DIAMONDS

## Triangle Tested

### Sent on Thirty Days' Trial

Triangle Tested Diamonds must pass three rigid tests before they are offered to you. But, even then, you have 30 days in which to wear a Triangle Tested Diamond and judge it for yourself. You will be amazed at the fiery brilliance of Triangle Tested Diamonds. Your friends will say—"What a wonderful color." But you judge the value. Compare it with the values your local dealer offers—if you don't save one-third, send it back.

**10c a Day** After you have worn a Triangle Tested Diamond 30 days, decide then—and not before—whether or not you wish to buy it. If you wish to keep it, you may pay the low rock-bottom price at the rate of only a few cents a day. Terms as low as ten cents a day. If you don't want to keep it after the 30 days' free trial—send it back at our expense.

## Send Coupon for Diamond Book

Put your name and address in the coupon, or on a letter or post card now and get our new Diamond Book that tells the secret of Triangle Tested Diamonds. Find out how you are three times protected by the House of John A. Sterling & Son. The new Diamond Book—printed in full color—will be sent to you free and without obligation.

**John A. Sterling  
& Son**  
1192 Ward Bldg.  
Chicago, Ill.

**John A. Sterling & Son**  
1192 Ward Building, Chicago

Gentlemen: Please send me your new book that tells me about Triangle Tested Diamonds and how I may get them on 30 days' free trial. It is distinctly understood that I am under no obligation of any kind.

Name .....

Address .....





**\$195**

## \$100 TO \$150 SAVED ON MEISTER PIANOS

Let us send this beautiful instrument to you on

**30 Days' Free Trial** Freight Prepaid

Eight beautiful styles to choose from. If it proves highly desirable to you, we will sell it to you on

Small monthly payments. No cash deposit down. No interest or extras. Stool and scarf FREE.

**THREE YEARS TO PAY!**

A binding guarantee of high-class material and workmanship. Write today for our beautiful 100-page illustrated catalog. IT'S FREE.

Rothschild & Company Dept. 18-2 Chicago, Ill.



**CRANE-220**

The radiator valve that will not leak. Ask about it.



## Cut Your Own Hair

You can now cut your own hair when and how you please and as good as a barber can do it without the barber's bill if you use an

**American Safety Hair Cutter**  
(McDonough's Patent)

This automatic machine is not a clipper. Works like combing your hair, enabling you to cut your own hair quickly and cheaply. Is sanitary. The money you save on nine 35c hair cuts pays for the machine. Future hair cuts cost only two cents each. The only attention required is occasional renewal of blades. Outfit complete with six blades \$3.00—postpaid. If your drug or hardware store cannot supply you, send the money today or write for information.

Dealers and salesmen write for terms.

**AMERICAN SAFETY HAIR CUTTER CO.**  
967 Liberty Ave., Room 225, Pittsburgh, Pa.

Send For  Free Book

**INSURED**  
**THE SCOTT ROOF**

Protected Against Fire Loss

Here is positively the biggest roofing value ever offered. The only roofing that can with certainty be guaranteed to last 10 years and absolutely guaranteed against fire loss.

We will refund every penny if Asteroid Roofing gets brittle, cracks, becomes soggy, rots, warps or pulls apart at the seams—no matter how intense the heat or cold—or if subjected to heavy rains or snows.

**"ASTEROID" PREPARED ROOFING**

is so pliable and resilient it accommodates itself to all weather conditions, in any climate. It contains no coal tar. Is made of **genuine asphalt** with a base of pure wool felt. Has smooth surface, the appearance of rich, grain leather. Comes in 1, 2 and 3 ply. Nails and cement free. Can be laid over old shingles.

**Get Our Freight Paid Prices**

Send for Free Book and Special Freight Paid Prices—on the best, most durable, greatest fire-resisting roofing the world has ever known. Costs less than inferior prepared roofing. Write for facts.  
**THE SCOTT ROOFING & MFG. CO.**  
200-250 Culvert Street CINCINNATI, OHIO

Take home that tin of **HARMONY**  
**PIPE BLEND** tonight! 15 cents.



**10 Cents a Day**

**Pays for This Cornet** An astounding offer! Only 10c a day buys this superb Triple Silver Plated Lyric Cornet. **FREE TRIAL** before you decide to buy. Write for our big offer.

**WURLITZER**  
50 years of continuous making

**Free Band Catalog** Write for our big new 250-page Band Catalog.

Carrying Case Free with this superb triple-silver-plated Lyric Cornet.

Rock-bottom, direct-from-the-manufacturer's prices on all kinds of instruments. Pay for them at the rate of only a few cents a day. **Generous allowance for old instruments.** Free Trial. We supply the U.S. Gov't. Write now  
**THE RUDOLPH WURLITZER CO., Dept. 1922**  
4th St., Cincinnati, Ohio S. Wabash Ave., Chicago

# Deafness



Perfect hearing is now being restored in every condition of deafness or defective hearing from causes such as

Relaxed or Sunken Drums, Roaring or Hissing Sounds, Perforated, Partially Destroyed Drums, etc.

**Wilson Common-Sense Ear Drums**

"Little Wireless Phones for the Ears"—require no medicine but effectively replace what is lacking or defective in the natural drums. They are simple devices, which the wearer easily fits into the ears where they are invisible. Soft, safe and comfortable to wear at all times.

Write today for our 168 page FREE book on DEAFNESS, giving you full particulars and plenty of testimonials.

**WILSON EAR DRUM CO., Incorporated**  
437 Inter-Southern Building LOUISVILLE, KY.

**GREEN AUTOMATIC MACHINE**

**LARGE PROFITS FROM SMALL CAPITAL**

Start a business of your own bringing an income of \$5 to \$10 a day with practically no experience or overhead expense.

**The GREEN AUTOMATIC MACHINE**

Sharpens, Honors, and Strips all kinds of safety razor blades, in one operation, from four to six blades per minute. For both Quality and Quantity this machine is in a class by itself. There is nothing like it on the market. Let us send you our free booklet explaining everything, including the "AMERICAN" Key Cutter—cuts square, angular or round slots.

**AMERICAN SHARPENING MACHINE CO. (Inc.), Dept. 2, 184 W. Washington St., CHICAGO**





# 7 Cents a Day Buys This Standard Visible Oliver Typewriter



## Sensational Reduction

Our enormous purchasing power, tremendous output and the simplicity of our methods make this truly remarkable saving to you possible. Such an offer needs no high-priced salesmen; no collectors. We are willing to let the typewriter do the talking and sell itself. We know from experience that a satisfied customer will pay. The simple coupon tells the story. Sign it and we will ship you one of the splendid machines—perfect in every detail. If it is not what you expected, if it fails to please you in any way, if you are not satisfied that it is the greatest bargain you were ever offered, get your money back. Read the coupon.

## Much Less Than Half Price FREE Trial—10 Year Guarantee

This is positively the best typewriter offer ever made. The typewriter is the genuine Model No. 5 Standard Visible Oliver, with complete and brand new equipment. Perfect machines only. Not shop worn, not damaged, inferior in no way. Back Spacer, Tabulator, Disappearing Indicator, not a feature lacking. Equal in quality in every respect to the \$100 article.

This amazing offer is not on some ancient style of blind typewriter, but on the wonderful Model 5 Oliver, the kind thousands of the world's best business firms are using today.

## Trial Order Coupon

UNITED STATES TYPEWRITER EXCHANGE  
Room 1302, All-Light Building, Chicago, Ill.

Send me by express a No. 5 Oliver Typewriter on approval. I will leave \$4.80 with the express agent when I get the machine, the same to be returned to me in full if I return the typewriter within 10 days. If I keep it, the \$4.80 will apply on the purchase price of \$42.80, and I will pay the balance of \$38 in 19 consecutive monthly payments of \$2 each, commencing 1 month from delivery, title to the typewriter to remain in you until it is totally paid for.

Name..... Address.....

Two References.....

## Compare It With a DIAMOND

Get a genuine Lachnite on ten days' free trial. If you can tell it from a diamond send it back. Put it to every diamond test. Wear it everywhere. The dazzling brilliance of Lachnite is eternal. They are cut by diamond cutters.

### 3 1/3c a Day

Pay only the rock-bottom price at the rate of a few cents a day. Set only to gold paid. Write for new jewelry book. It's free. HAROLD LACHMAN COMPANY, 12 N. Michigan Av., Dept. 1192 Chicago



## Amazing Profits In Mushrooms

Anybody can add \$30 to \$40 per week to their income, in spare time, entire year growing mushrooms in cellars, sheds, barns, boxes, etc. I tell you where to sell, at highest prices.

Free Illustrated Instruction Booklet

HIRAM BARTON

Desk 2, 329 W. 48th St., New York

## "Brings me \$50 to \$60 per week"

So writes M. A. GIFFORD of his Ten-Pinnet business



World's Greatest Bowling Game

YOU can start in the same business for small investment. Draw the crowds! Get the money! Everybody plays Ten-Pinnet. It's new, fascinating, healthful! Alleys 38 to 50 ft. long installed in any room in half day. Entirely automatic—no pin boys or upkeep expense—just someone to take in money. Write quick for free illustrated book, "Big Ten-Pinnet Profits," giving low prices.

THE TEN-PINNET CO., 82 Draper St., INDIANAPOLIS, IND.

## Let Me Quote You a Special Price On My Rapid FIRELESS COOKER



Cook every meal on it. If you are not satisfied and delighted I will refund every cent. Get my

### Special Low Factory Price

direct to you. Cooker is aluminum lined throughout. Full set of famous "Wear Ever" aluminum cooking utensils comes with it. Ask for free book of valuable recipes.

WILLIAM CAMPBELL CO.

Dept. 64 DETROIT, MICH.

The Prophylactic  
Tooth Brush

Tooth Brush

Used every day—note how your smile improves



## American Industries Threatened

American manufacturers have been supreme in turning out high grade machinery and going a long way toward winning the world market, in spite of high labor-cost and of methods in some respects both wasteful and inefficient.

To maintain leadership after the war, our manufacturers *must* correct their methods, eliminate the inefficiencies, adopt standardization.

There is shown below a Thread Limit Gage, one of the many G. T. D. Gages. The two pairs of points are set by standards to maximum and minimum limits respectively and sealed. Any bolt that is too large will fail to pass the upper points, or if too small will fall through the lower ones.

Using Limit Gages, an inexperienced workman can gage thousands of parts in a day, without error in measurement, and the manufacturer *knows* the parts will be interchangeable. Not only is accuracy insured, and material and money saved, but also assembling of parts is much more rapid, and the average quality of the finished product greatly improved.

For information as to Gages and their wide field of uses, send for the Bulletin on Limit Gages.

**Greenfield Tap and Die Corporation**  
Gages-Taps-Dies

Threading Machines, Reamers, etc.  
Greenfield, Massachusetts



Thread  
Limit  
Gage

# AMERICA FIRST

Please Mention Popular Mechanics

## 'IDEAL' Lawn Mower Grinder

### Big Money-Maker

Many of our customers  
make \$300 in one season.  
YOU CAN DO AS WELL.



PATENTED  
Dec. 29, 1908  
Mar. 1, 1910

*"You Grind it  
as You Find it."*

Grinds all makes of Mowers perfectly in 15 minutes without removing wheels, ratchets or reel knife, BETTER, QUICKER and EASIER than it can be done by hand. Has perfect Skate Sharpener Attachment. Run by hand or power. Nearly 10,000 in use. Price, only \$40. Sold on easy-payment terms. Also makers of the "Peerless" Horse Mower Grinder.

WRITE TODAY for catalog and full information

THE ROOT-HEATH MFG. CO., Plymouth, Ohio

## DEMING PUMPS

Over 1000 types and sizes of hand and power pumps covering every pumping need, including complete Hydro-Pneumatic Water Supply Systems. Merely state your need. We will send complete catalog to cover.

THE DEMING COMPANY  
129 Depot Street SALEM, OHIO

FOR  
ALL  
USES



## LATHES

9 to 18-inch Swing

List price \$75 and up according to size. When ready to buy send for Lathe Catalog and prices.

W. F. & John Barnes Co.  
100 Ruby Street, ROCKFORD, ILL.



## A Constant Water Supply For Your Farm Home

Don't depend on a windmill or the back-breaking hand pump to fill your water tank. It's more reliable and economical to install a

## RIFE RAM

and be sure of a constant supply of fresh water, without fuel or attention. The Rife Ram operates by the flow of any stream having a fall of 3 feet or more and a supply of 3 gallons or more per minute. Will maintain air pressure system. Simple to install. Over 11,000 in use. Satisfaction guaranteed.

Write today for catalog and free estimate

RIFE ENGINE CO.  
3131 Trinity Building NEW YORK





## "SEBASTIAN" LATHES

15  
I  
N  
C  
H  
S  
E  
B  
A  
S  
T  
I  
A  
N15  
I  
N  
C  
H  
S  
E  
B  
A  
S  
T  
I  
A  
N

SEND  
for  
CATALOG

We want you to have this informative, finely illustrated booklet of Lathes —

*For Garage, Automobile  
and General Repair Work*

The "Sebastian" is of simple construction, easy to operate and is sold at the right price.

**The Sebastian Lathe Co.**

107 Culvert Street

CINCINNATI, OHIO

## THIS MACHINE WILL EARN \$20 to \$50

### Daily Profit For You

#### Making Cement Bricks and Blocks

Factory owners are the biggest money makers in America and this machine will place you in their ranks. You can start with little capital and even without experience. This machine makes pressed cement bricks and blocks under 80,000 pounds pressure. No tamping and easy work. It makes 1,000 blocks or 100,000 bricks daily. No burning required. Ready for the market in a few days' time. They are necessary for the

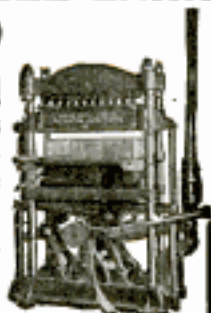

### Helm DRY WALL Building System

This is the system that appeals to builders, contractors and architects. It overcomes the opposition to concrete because it offers absolutely DRY WALL construction. It saves money for builders, as no furring and lathing are required, and it makes rigid walls and fireproof walls. This is the system which is bound to get you business and give you the advantage over all other products. \$50 and up starts you.



### Send for This FREE CONCRETE BOOK

Tear off the corner coupon right now before you turn the page. Let this free book tell you all about

this great opportunity which is open to you today. It will tell you all the details of this system, about the Helm Press and the DRY WALL building system. It will show you how easy it is to start a profitable business. It tells how each product is made, how it is cured and sold. Write today. Limited capital starts you.

**HELM BRICK MACHINE CO.**

322 Mitchell St.  
CADILLAC, MICH.

**Helm Brick  
Machine Co.**  
322 Mitchell St.,  
Cadillac, Mich.

Please send FREE the  
book on concrete and  
Helm Presses.

Name.....

Address.....

## TOOL CASES

For Up-to-Date TOOLMAKERS and MACHINISTS



We carry the finest and most complete line of mechanics' toolcases and tools in the country. We guarantee to please you or refund money. Write for free catalogue.

**J. M. WATERSTON**

75 Woodward Ave., E., Detroit, Mich.

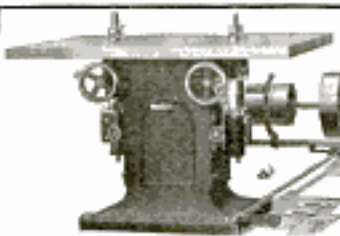

### CRESCENT Wood Working MACHINES

are simple in construction, durable, convenient, economical to operate, and always satisfy particular users. Ask today for catalogue of hand saws, joint, ore, saw tables, planers, disk grinders, swing cut off saws, planers and matchers, post borers, universal borers, hollow chisel mortisers, variety wood worker, universal wood workers.

**The Crescent Machine Co.**  
93 Columbia St., Leotosia, Ohio

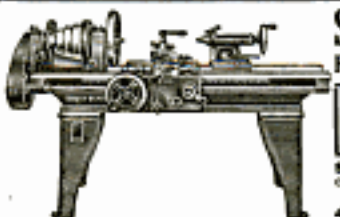

### South Bend Lathes

For the Machine and Repair Shop

**How to Run a Lathe**  
A 50 cent book for 10 cents.  
Postpaid, stamps accepted.

Straight or Gap Beds. Send for free catalogue giving prices on entire line.  
**SOUTH BEND LATHE WORKS**  
423 Madison St., South Bend, Ind.

## Mends All Metals Permanently

A real metal solder, complete in collapsible tube — Ready for quick repairs.



## SOLDERALL

Used by largest manufacturers, electricians, auto-mobilists and mechanics. A recognized necessity for the home. Tube and torch in handsome box sent prepaid for \$1.25. Dealers write for prices.

**Solderall Company, 125 Sussex Ave., Newark, N. J.**



A complete line of appliances for the transmission of Power. Anything from a bolt to a complete mill or factory outfit. Send for catalogue. Largest Manufacturers of Pulleys in the country.  
**W.A. Jones Foundry & Machine Co. CHICAGO**  
1403 N. North Ave.

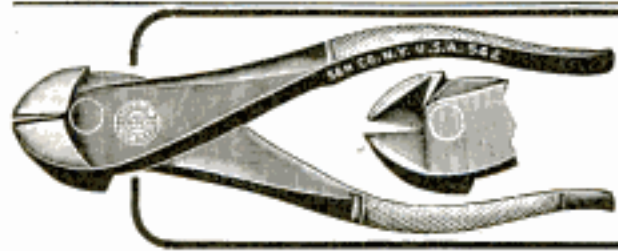

## Most Powerful Nipper Made

1 lb. Handle Pressure = 20 lbs. Cutting Pressure

The strongest cutting plier made for its size. Cuts the toughest wires. Equal to any compound nipper. Polished head; scientifically shaped, gun-metal handles fit the hand like a glove. This is just one of the styles of "RED DEVIL" Mechanics' Tools.

Send 85c for sample "Red Devil" Diagonal Nipper, No. 542, 6 1/2 in. Send for descriptive matter on "Red Devil" Tools.

**Smith & Hemenway Co., Inc., 97 Chambers St., New York City**





## The Test That Tells

**N**OTICE how carefully the measurement is taken and how interested the foreman is in the results. This job like many others in machine shop work calls for such fine limits that a mistake of one-half of a thousandth of an inch would ruin the piece. With reputation and job at stake you cannot afford to work with any but the most reliable tools.

## Brown & Sharpe Tools

have had the confidence of three generations of mechanics. Fill your kit with these tools and you can do your work with a stronger feeling of surety in the accuracy of measurements taken. They will free your mind from worry and increase your efficiency as a skilled workman.

*Our interesting, instructive Catalog 27  
FREE ON REQUEST*

**Brown & Sharpe Mfg. Co.**  
Providence, R. I.

Makers of Machinists' Fine Tools Since 1850



**Stanley  
Tools**



## Stanley Adjustable Try and Mitre Square No. 21

One of the handiest tools in a Carpenter's Kit. Especially useful for doing short work about windows, doors, etc., or in putting on butts or locks.

The *Blade* is adjustable and as it can be reversed, provides any size of try or mitre square within the capacity of the tool. In reversing, it is not necessary to remove the blade from the handle, consequently the tool is always assembled and ready for use.

The locking device is such as to insure the blade being firmly and accurately secured at any point desired. The edges of the *Blade* are machined, graduated in 8ths, 16ths and 32nds of inches, and the tool is square inside and out.

It is also an excellent depth and marking gauge. Both Handle and Blade are nickel plated. Made in three sizes.

*Special Circular Upon Request.*

**STANLEY RULE & LEVEL CO.**  
NEW BRITAIN, CONN. U.S.A.

**CENTENARY OF GREAT LAKES STEAMSHIP BUILDING**—It is just a century since the first Great Lakes steamers were launched, says the Christian Science Monitor. One was constructed at Sackett's Harbor, N. Y.; the other at Ernestown, Canada. The first was named the "Ontario"; the second, the "Frontenac." The latter, which cost \$75,000, was classed among the finest steamboats of the period. It was of 700 tons' burden and 170 ft. in length.

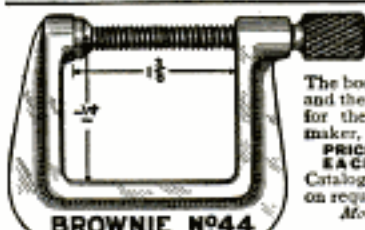

**BROWNIE No. 44**

## BROWNIE Handy Clamps

The body of clamps have steel blue finish, and the screws are die cut. Just the clamp for the handy man, machinist, pattern-maker, etc. Fully guaranteed.

**PRICE EACH 25c PRICE DOZEN \$2.75**  
Catalogue showing 5 different sizes sent on request. For sale at all hardware stores.

*Money back if not satisfactory.*  
**BROWNIE MFG. CO.**  
548-50 W. Lake St. CHICAGO, ILL.

**SAMPLE 75c**



## THE SPEEDY Stitcher

The greatest invention with which the unskilled man can repair leather goods or any heavy material. Needles and thread are inside the handle. **FAST SELLER.**

**Agents Wanted** Foreign trade solicited. Advertising circulars in different languages.  
**Stewart-Skinner Co., 26 Bennet St., Worcester, Mass., U.S.A.**



## ToolCases for Toolmakers and Machinists

Keep your tools orderly arranged in a Gerstner Portable Tool Case. There's a place for every tool in one of the felt lined drawers. Every up-to-date mechanic needs one and you'll find our Cases the best built, easiest and most practical on the market. We guarantee to please or refund all money. Write for our free booklet!

*Gerstner Sons.*

Mfrs. of Mechanics' High Grade Tool Cases  
808 Columbia St., DAYTON, OHIO

Please Mention Popular Mechanics





## Choosing the Right Hack-Saw

In choosing hack-saws for hard use in the shop or for occasional use at home, you want the saw that cuts fastest and lasts longest. Long experience and great care in manufacture enable us to give you just the saw your work requires from the line of

# Starrett Hack-Saws

For every practical requirement we have a saw well suited to the work—cutting iron, steel or brass in the shape of castings, tubing, rolled shapes or sheet stock. Our hand frames give maximum convenience and service in your use of any blade.

Prices including one blade from seventy cents to \$2.00. Send for free catalog No. 21 A. P. describing the full line.

## The L. S. Starrett Co.

*World's Greatest Toolmakers*

**Athol, Mass.**



Please Mention Popular Mechanics

## "YANKEE" Ratchet Tap Wrench No. 250

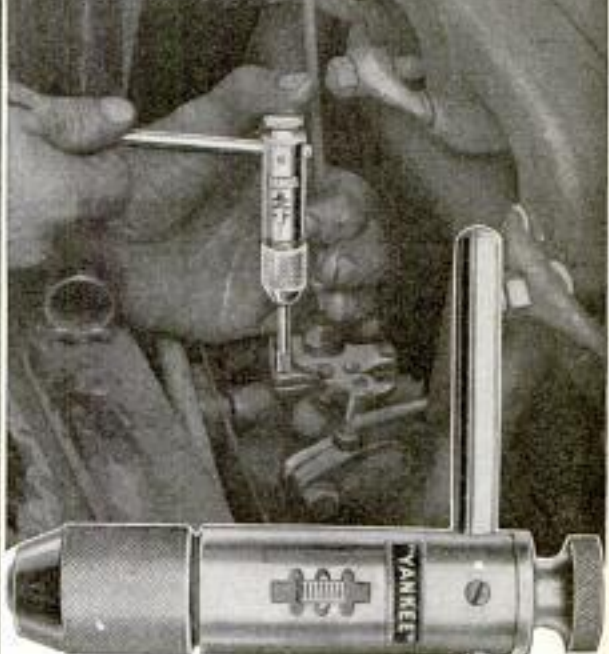

## The "Ratchet" Makes It Possible

to tap holes in tight corners or where structural parts make it impossible to work with ordinary tap wrench without taking the job apart. Exceedingly useful when working about a car.

Three positions of Ratchet Shifter give Right and Left-hand movement or Rigid adjustment for inserting and removing taps. Cross bar is held securely in three positions or can be removed. Knurled thumb piece at top to start or back out taps quickly, has counter sunk center.

## "YANKEE" Ratchet Tap Wrench

**No. 250**

**No. 251**

**No. 1251**

Holds up to 3/16 in. taps. Diameter of chuck, 3/4 in. Length 3 1/4 in. Weight, 6 oz.

Holds up to 5/16 in. taps. Diameter of chuck, 3/4 in. Length 5 in. Weight, 12 oz.

Same as No. 251 in size, except shank, which gives 13 in. reach. Wt., 1 lb. 1 oz.

Price, \$1.25

Price, \$1.75

Price, \$2.25

*Your Dealer Can Supply You*

Write for "Yankee" Tool Book" showing all "Yankee" metal- and wood-boring and screw-driving tools.

North Bros. Mfg. Co., Philadelphia, U. S. A.

**"YANKEE" TOOLS** *Make Better Mechanics*





**Your  
Keenest  
Co-Worker**

Sharp, eager-cutting, sure-of-stroke, it's the ablest co-worker the mechanic can have—the famous product of

## SIMONDS

**The Saw Makers**

The skilled hand loves the "feel" of this saw. Such hang, such poise, such **balance** in a saw: it might be one with your own right arm!

And edge!—how those bright teeth eat the work! How that Simonds-tempered steel holds its edge and saves sharpening!

We make all kinds of saws and files. Sold by Dealers or write for prices. Booklet "Simonds Carpenter Guide" free on request.

**Simonds Mfg. Co.**  
Established 1832  
FITCHBURG, MASS.  
5 Factories 10 Branches

*"I Tell You It's  
A Great Saw"*





## YOU CAN START IT WITH A CRESCENT

**"Each  
Genuine  
CRESCENT  
has the name  
on the  
handle"**

The real test of a wrench comes in starting a nut that has "rusted on"

In such an emergency the wise mechanic prefers a "Crescent" because he knows it will always stand the strain.

**We Guarantee Each Crescent Tool** to give satisfaction and will replace or refund the money on any tool which does not do so. The purchaser to be the judge.

### CRESCENT TOOL CO.

JAMESTOWN · N · Y ·

**ORIGIN OF THE WORD HUMBAG**—It has been stated lately that "uimbog," an Irish word meaning soft metal, which was applied to a base and worthless coin, struck in the reign of King James II of England at the Dublin mint, is the real origin of the word "humbag." The coin, although having a face value of 20 shillings, was worth only twopence, and so it was not unusual to hear some one say: "That's a piece of uimbog (pronounced oombog); you can't pass it on me."

## THE AWL YOU WANT



Is the genuine MYERS \$1.00 "Lock Stitch" Sewing Awl with the exclusive feature. See thread reel in front of handle under the finger tip. Natural tension. Sews heavy or light material, diamond point, full grooved needles used to protect the thread when sewing. C. A. MYERS COMPANY, 6339 University Ave., Chicago, Illinois

## "Interlox" SAVES TIME, TEMPER AND TROUBLE

**MASTER SLIDE RULE**  
The Only Interlocking Rule made—and the Only one whereby inside measurements of doors, windows, etc., can be taken rapidly and accurately. Also superior to all others for outside measurements of walls, ceilings, etc. If your hardware dealer hasn't this Rule, send us his name and 18c per foot (in any length from 2 to 8 ft.) and it will be sent prepaid.

**Liberal Proposition for Dealers and Agents**

DAHL MFG. CO., 51P E. 42nd St., NEW YORK



## Portable Cases

**FOR TOOL MAKERS  
AND MACHINISTS**

Twelve styles, felt lined drawers, solid brass trimmings, best of material, beautiful finish, low prices, satisfaction guaranteed. Ask for booklet of cases built for service.

**The Pilliod Lumber Co.**  
SWANTON, OHIO





**A Progressive Mechanic** has a place for every tool. He knows immediately if any tool is gone, misplaced or borrowed. He should have a

## UNION TOOL CHEST

Compact, durable, perfectly designed. Keeps tools clean, safe, free from bangs, knocks and moisture. Saves time because tools can be so arranged that you only need open the drawer and pick out the tool wanted.

Made of plain or quartered oak or leatherette covered. Highly finished. Specially designed drawers, strong and perfectly fitted, some with felt. Drawer pulls—specially designed, practical and efficient. Space saving fish-ring. Every chest guaranteed to give perfect satisfaction to meet with your entire approval or money back.

Write for our Catalog and Prices of Nineteen Styles and Sizes.

*If there isn't a "Union" Dealer near you, get our Special Offer.*

**UNION TOOL CHEST WORKS**  
22 Railroad Street ROCHESTER, N. Y.

## Disston Saws

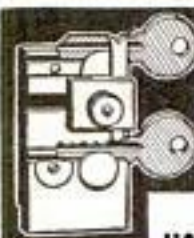

## Duplicate Keys

for all Pin Tumbler Locks made in one minute with Harrison M.L.P. Key Filing Machine. No misfits. Thousands in use. \$3.50 net. Special diamond-shaped files for angular cut keys, 40c each; 3 for \$1.00. Harrison C.K. Key Clamp duplicates all common keys without a caliper. Price, \$1.00. Parcel post prepaid.

*Money returned if not satisfactory.*

**HARRISON & CO., 81 New St., New York**

## Why Pay Full Prices for Diamonds

It's not necessary, says an institution of over 60 years unimpeachable business record. Write for Bulletin—see the amazing bargains we are offering.

**Diamond Banking** makes this possible. We must sell the diamonds on which we loaned money.

**Here is a Sample Bargain:** A truly magnificent perfect cut diamond solitaire of extra high degree of perfection in lady's brand new high set white gold crown ring. Guaranteed high grade blue-white. Exception quality, guaranteed weight 3/16-3/32 ct. Try to match it at \$200. We guarantee a loan of \$110. Our unpaid loan price \$128.40.

**WRITE TODAY FOR LATEST BULLETIN.** Just send your name and address for our new bulletin. No obligations. Write at once. **Jos. DeRoy & Sons, 1923 DeRoy Building, Pittsburgh, Pa.** References by permission: *any*—*vs* Deposit National Bank, Marine National Bank, or any Pittsburgh daily newspaper.



## A Drill For All Work

An all-purpose drill for large and small drilling—practically a hand drill and breast drill combined

## MILLERS FALLS HAND DRILL No. 980

has 3 jaw chuck that takes round shanks up to 3/8 inch. Mushroom head just fits the hand or is usable as body rest. Cut gears—pinion enclosed—ball thrust bearing.

Mechanic's Handbook containing much valuable information never before printed, also pocket catalog—free on request.

## MILLERS FALLS CO.

*"Toolmaker to the Master Mechanic"*

MILLERS FALLS, MASS.

New York Office: 28 Warren Street



Please Mention Popular Mechanics



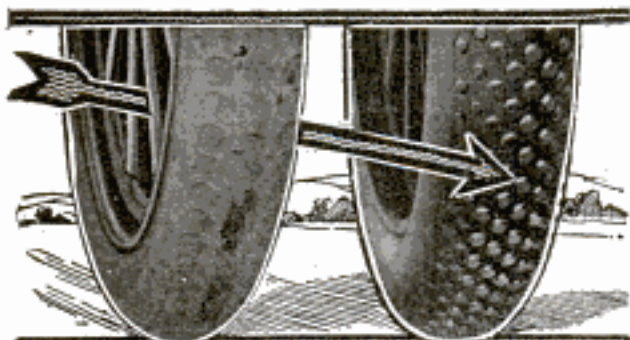

## Save Your Old Tires

Get 5,000 Miles More Service by "half-soled" them with Steel Studded Treads the same as European Motorists have been doing for over three years. 20,000 American Motorists have done this in the last 8 months and are saving \$50.00 to \$200 a year in tire expense.

5,000 Miles Without Puncture is the signed guarantee you get with every Durable Steel Studded Tread.

We Deliver Free Special Discount without a cent deposit, prepay express and allow you to judge. offered to motorists in new territory on first shipment direct from the factory. Mail the coupon below for details. Be sure and put in your tire sizes.

MAIL TODAY—SAVE THE DISCOUNT

The Colorado Tire & Leather Co.

264 Tread Building, Denver, Colorado. R-44 Transportation Bldg., Chicago, Ill. 720-442 Westworth Building, New York City

Without obligation send me free catalog, copy of guarantee, sample and booklet "10,000 Miles on One Set of Tires."

Name .....

Address .....

My Tire Sizes are .....

## \$100 TO \$300 NET PROFIT PER MONTH REPAIRING AUTOTIRES

With Practically No Capital You Can Start an Independent Business of Your Own That Pays You Big Profits Right From the Beginning.

In the last few years, with the launching upon the market of hundreds of thousands of low-priced motor cars, the demand for tire-repair work has completely outdistanced the available service. Millions of dollars are spent annually for repairing blowouts, vulcanizing old casings, retreading, mending punctures etc.

Take Advantage of This Golden Harvest of Profit—Send for Catalog of Badger Tire Repair Equipment and Learn How We Help You Start a Business.

Learn how you can establish yourself in a five, money-making business with unlimited possibilities—a business that's practically all cash and over 75% profit. If you don't care to give all your time to it at first, start at home in your "off" hours, using a spare room, attic, basement or shed. This handsome profit is insured by the famous Badger Solid Pad System, with the celebrated Attached Sliding Hinge Clamp and the many other improved, exclusive, up-to-the-minute features. Get the details—learn all about our complete money-making Free Aid Service—our special time, labor and money savers—the many helps and hints we give you to get and hold the business.

Mail this Coupon for free catalog and full particulars.

TIRE REPAIR EQUIPMENT CO.

Tire Repair Equipment Co.  
740-744 Johnson St.  
Appleton, Wis.

740-744 Johnson St.

APPLETON  
WIS.

Gentlemen—Please send me Free Catalog of your Badger Attached Sliding-Hinge-Clamp Steam-Vulcanizer and information on how to start a tire repair business.

NAME .....

ADDRESS .....

CITY.....STATE.....

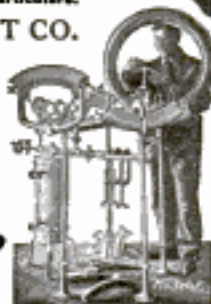

Please Mention Popular Mechanics

## Dayton Motor Bicycle

World's Lowest Priced \$100<sup>00</sup> Complete Motor Vehicle

NOT a motor attachment for a bicycle, but a complete Motor Bicycle of special construction throughout. 1 1/4 h. p. four-cycle motor. Direct application of power through front wheel drive. No power lost as in chain or belt drive. Speed 25 miles per hour. High tension magneto ignition. Has three-stem rocker spring fork. Steel clincher rims with 2" extra heavy, corrugated-tread tires. Built in men's and ladies' models. Weighs only 125 lbs. Single grip control. Easy to ride and guide.

We Need Young Men

There is a real opportunity open to one ambitious young man (or firm of young men) in each town where we are not now represented. If you are of a mechanical turn of mind, have a small amount of money, and realize that the only way to get to the top is to have a business of your own, we are ready to

HELP YOU START IN BUSINESS

with the exclusive agency for the Dayton Motor Bicycle. No competition. No canvassing. No cut-prices. A bona-fide business opportunity for you—backed by a company with more than a million dollars' capital and 50 years' manufacturing experience.

Write for further details.

The Davis Sewing Machine Co.  
Cycle Department  
411 Newton Ave., Dayton, O.



Motorcycle and Bicycle Dealers, Get Our Agency Proposition

## Write for new Booklet "H" Partin-Palmer "32" \$695

Commonwealth Motors Co., Chicago

USE FOR RUINED MUNITIONS—Many American manufacturers went into the munitions business without knowing much about this work, and so it sometimes happened that large quantities of material was spoiled or not up to requirement. Thus a lot of several thousand 18-lb. cartridge cases failed to pass the acceptance test of the British authorities. But the manufacturer was resourceful: The cases were placed in a punch press and formed into shallow cups, whereupon two small curved holders which converted the cartridge cases into attrac-



Convert Your Bicycle into a Motor-Cycle

Motor fits any wheel. BEST, MOST RELIABLE. Best hill climber. More STEFFEYS in use than all others. Stamp for circulars. STEFFEY MFG. CO., 5007 Brawa Street, PHILA., PA.

## STANWELD Cold Drawn Seamless Steel TUBING

Lightest, smoothest, strongest Steel Tubing made. World's largest manufacturers of bicycles, motorcycles and automobiles use it exclusively. Send for Folder "A."

THE STANDARD WELDING COMPANY  
Main Office and Factory CLEVELAND, OHIO



## Folding Truck Body

For Fords and Other Light Roadsters. Strong, Serviceable, and Attractive. Easily Attached. Folded, looks like a regular roadster. Open, it's an efficient light delivery truck.



Butler All Metal Garage

Fireproof, portable, easily erected. For one or more cars. Round or Gable Roof. Write for free booklets.

BUTLER MFG. CO., 804 Butler Bldg., KANSAS CITY, MO.  
911 Sixth Ave., S. E., MINNEAPOLIS, MINN.



## MAKE YOUR BIKE A MOTORCYCLE

at a small cost, by using our attachable outfit. Fits any Bicycle. Easily attached. No special tools required.

### "Used His Four Years"

Harry A. Hyatt, of Boreas River, New York, writes: "About four years ago I received my motor attachment, and wish to say that I am satisfied with it in every way, for it has certainly given me good service. Anyone wanting a motorcycle or attachment, I would recommend them to the Shaw Manufacturing Co."



**FREE BOOK** Write today for bargain list and free booklet, fully describing the SHAW Bicycle Motor Attachment. Motorcycles all makes, new and second-hand, \$35.00 up.

**SHAW MANUFACTURING CO.**  
Dept. 6 GALESBURG, KANSAS

### The Boy's Junior Power Driven Automobile

You can build it yourself or buy it complete already assembled. 1917 Model

Parts inexpensive. Send 20c for blue print and price list of parts.



**SYPPER MFG. CO.**  
146 Warren St., Toledo, Ohio

tive cigar and ash holders, were soldered to the edge, with the result that the made-over cases were sold at a greater profit than if they had passed in their original form.

**Pope** Send for 1917 Catalogs **Columbia**  
Motorcycle and Bicycle  
**WESTFIELD MFG. CO.** 15 Lazier Avenue  
WESTFIELD, MASS.

## Iver Johnson

**REVOLVERS SHOT GUNS**  
**BICYCLES MOTORCYCLES**

Send for 84-page Man's Book—Free

**Iver Johnson's Arms & Cycle Works**  
307 River Street FITCHBURG, MASS.

## Veeder Counters

SMALL SET BACK

(Ratchet or Revolution)

RESET TO ZERO BY A SINGLE TURN

These counters are just as high grade as our large counters, but are lower in price. Price \$4.

There are Veeder counters for practically every purpose. Our booklet describes these uses in detail and shows various instruments. It is interesting and free. Send for it.

The word Veeder stands for the best constructed and most accurate counting devices.

Cyclometers, Odometers, Tachometers. All kinds of counters. Fine Die Castings.

**VEEDER MFG. CO.**  
4 Sargeant St., Hartford, Conn.



Half Size



## There Goes a Man of Power

**EVERYWHERE** the man of power—the healthy, vigorous, manly man—challenges admiration and respect. There is magnetism in his confident, self-reliant poise. The secret of perfect, vital health and power is not in the luck of birth. **You can have it.** Nature is striving all the time to make a manly, masterful man of you. And she needs only a little help to succeed. **And you can give it to her.** Vibration is the secret. It restores power to young men and old—the sparkling, glowing health of buoyant youth. **For vibration is life.**

## THE WHITE CROSS ELECTRIC VIBRATOR

In this machine there is almost magic power to banish disease and pain, to put sound, firm flesh on shrunken bodies, to remove degenerated fatty deposits, to clear the skin, to **tone up and vitalize every part and organ of the body.** Vibration flushes out the poisonous secretions and helps the blood perform its natural repair work. Every nerve and fibre responds to the wonderful force and your whole body tenses with the exhilaration of your own swaying power.



### Send the Coupon For Our New Book

Just put your name and address on the free coupon and mail to us today—we will send you absolutely free and prepaid our big, new book, "Health and Beauty." No obligations. You need the book—it carries a vital message. Write today—now.

**Lindstrom-Smith Co.**  
1100 S. Wabash Ave.  
Dept. 9192 Chicago, Ill.

We also manufacture  
White Cross Electric  
Shavers, Irons, Hair  
Dryers, Electric  
Lampers, Fans,  
Automobile Horns,  
Carling Irons,  
Ironing Pads,  
Small Motors, etc.  
Dealers Write

**Lindstrom, Smith Co.**  
1100 S. Wabash Ave.  
Dept. 9192, Chicago, Ill.

Please send me, absolutely free and prepaid, your new book, "Health and Beauty," and full particulars about the White Cross Electric Vibrator. I assume no obligations of any kind.

Name.....

Address.....

My Electrical Dealer's Name is.....





## SERIES 18

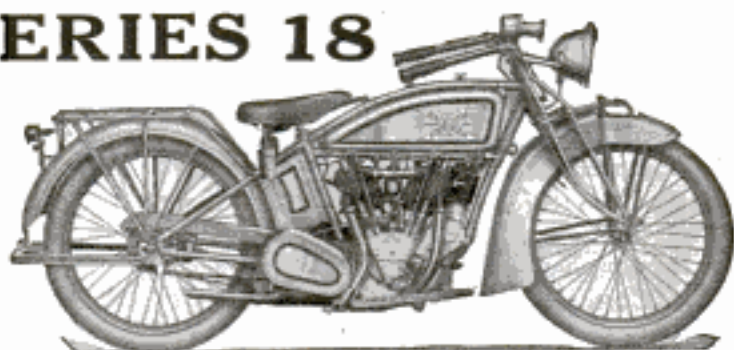

Price \$275 F.O.B. Chicago. Electrical Equipment \$35 Extra

All the best features of all other motorcycles are developed to their highest efficiency in the

## EXCELSIOR

Many features of still greater value, such as Automatic Compression Control, Nickel Steel Frame with Removable Center Bar and Enclosed Motor Drive Chain, are **Exclusively Excelsior**.

### MODEL 18-3 <sup>THREE</sup> SPEED — The Latest and Greatest X is the most perfect motorcycle ever built

In this superb machine is combined Enormous Power and Great Speed with the Utmost Degree of Safety, Comfort and Convenience.

The Powerful Band Brakes, independently operated, insure Safety. The Interlined Chain and Gear Covers, Enclosed Valves and Perfectly Balanced Motor insure silence of operation.

The Automatic Compression Control and Instantaneous Primer insure quick and easy starting, regardless of weather or other conditions.

The extremely low saddle position, Long Folding Foot Boards, Comfort Cushion Seat Post and Cradle Spring Fork provide the Utmost Degree of Comfort. Our new advance catalog describes this and the **EXCELSIOR LIGHTWEIGHT**. Write for it today.

## Excelsior Motor Manufacturing & Supply Co.

3702 Cortland Street, CHICAGO

## Edwards Steel Buildings



Everything from Garages to Factories

Erected easily and quickly. Taken down just as readily and moved to any desired new location. Weatherproof, fireproof, timeproof. Wonderfully durable. Whatever the need—garage, booth, boathouse, office, storehouse, school, cottage, barn, hospital, or factory, there's an Edwards Steel Building for the purpose. Write today for descriptive literature and prices.

The Edwards Manufacturing Company  
1320-1370 Eggleston Avenue Cincinnati, Ohio

**CANDIES FOR SPANISH CORTES**—The Spanish taste for sweetmeats is curiously illustrated by the fact that provision is made in the budget for a moderate sum of money to supply the members of parliament with various kinds of candy, among the favorites being chocolates and mint-flavored caramels. This does not cost much, but now some radical "muck raker" says he has discovered that at least half of the candy supplied is taken home by the deputies for their children or else presented to the ladies who frequent the chamber, and he therefore threatens to introduce a measure at the next session of the Cortes to abolish free candy.



### A New Type Signal

that will revolutionize warning devices. Screws in place of priming cup. Blown by explosion direct. Extremely powerful or moderate as desired. Not affected by vibration. Absolutely certain in operation. Will outlive any car. Shipped prepaid upon receipt of \$4.25 for Single Tone or \$6.00 for Chime. Money refunded if 30 days' use does not prove it the most effective warning made.

**THE BUELL CO.** 1610 Michigan Ave. CHICAGO

## Pulls you out of trouble

Carry this little Pull-U-Out in your tool box and you will be independent of road conditions. With it a boy can, unaided, pull a 5000 lb. car out of ditch or mud. Pays for itself on its first job. Besides pulling autos out of trouble it will do all kinds of lifting and pulling in the factory, garage, on the farm or construction job, etc.

Consists of a winding drum, lever crank, 40 feet of steel cable, two 7 ft. chains and 3 stakes. Weighs only 28 lbs. and goes in space 4x6x14 inches.

A pressure of only 30 lbs. on the handle will lift a ton



Cheaper and better than a chain block. Does jobs no other machine can do.

WRITE FOR BOOKLET — VERY INTERESTING

Tells how and why this marvelous little Pull-U-Out works.

**Pull-U-Out Sales Co., 2035 Market Street, St. Louis, Mo.**

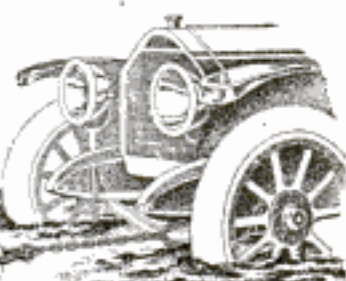



## TWIN FIRE

### The Spark Plug You've Wanted

Here's the plug you've wanted but couldn't get. It adds "pep" to motor and banishes trouble with soot and oil-pumping cylinders. Fires two separate and distinct sparks at the same time. If one clogs, the other goes right on firing and a few hot explosions cleans the fouled point.

### Test It Yourself

Tests under severest conditions show its superiority. You'll be surprised at its performance. Reduces carbon because the two hot sparks make a complete combustion. Buy a

set today—give your motor a chance to develop its full power. The trouble they will save is alone worth the small cost. Ask your dealer—if he cannot supply you send direct. Give size required.

**Twin Fire Spark Plug Company**  
660 Woodward Ave., DETROIT, MICH.

**To Dealers:** We've a splendid proposition for you. Easiest selling plug on market—quick stock turn-over and liberal profits. Write or wire today for particulars.



Old style plugs are dead when sooted or clogged with oil.

"Twin Fire" always fires. One point cleans the other.

## Bicycle Book FREE

A book to delight boys' and girls' hearts. Save money! Offers guaranteed bicycles—\$19.95 and up. Write nearest house. Dept. G 133 New York, Chicago, Kansas City, Ft. Worth, Portland, Ore.

## Buy an Akron-Williams

**Tire Repair Outfit.** Get into this profitable business with the same equipment that is used and endorsed by 90 per cent of the big tire manufacturers and successful repair shops. Write for book giving full details.

**The Williams Foundry & Machine Co.**  
50 Cherry Street AKRON, OHIO

## FORD AUTO GIVEN TO AGENTS

HERE'S an opportunity to earn big money—\$6 to \$12 a day, with easy work, all your time or spare time and obtain a Ford Automobile besides. A straight out from the shoulder business proposition. No voting or guessing contest. We want wide-awake men and women to introduce into every home our famous ZANOL Pure Food Products, Non-Alcoholic Food Flavors in tubes, Toilet Preparations, Perfumes and Soaps; 250 other light weight household necessities.

### Make \$50 a Week Easy

No experience necessary—we teach you how, give you the right start and help you make a success. Absolutely no limit to your earning power. We can use only a certain number of General Agents, so get in touch with us at once. We furnish our representatives with an automobile. Just send postal for particulars and money making offer.

**AMERICAN PRODUCTS CO.**  
8239 Third St., Cincinnati, O.



Two sisters from New York City who recently made a trip from their home to San Francisco on their Prest-O-Lite equipped motorcycles.

## Stands the Test on Longest Trips

In their long transcontinental trip, these riders encountered floods, mountain slides, incessant rains and wrecked bridges, but their perseverance and sturdy machines brought them through safely.

Their motorcycles were equipped with Prest-O-Lite—the only practical lighting system for motorcycles—safe, reliable, simple and able to stand the bumps and jolts. Prest-O-Lite gives a clear vision of the road ahead—penetrates dust, fog or smoke—will not suddenly blow out.

Aside from the many other advantages, Prest-O-Lite is very simple to operate and "costs less to buy and less to use."

## Lighting Equipment for Real Service

Prest-O-Lite can be quickly and easily attached to your motorcycle. Almost every dealer can fit you out with this popular equipment combination—"Prest-O-Lite, a lamp and mechanical horn." This will give you the greatest value and best service for the least money. Ask your dealer about it today.

Interesting literature on Prest-O-Lite for motorcycle lighting will be sent you on request.

## The Prest-O-Lite Company, Inc.

World's Largest Makers of Dissolved Acetylene.

265 Speedway Indianapolis, Ind.

Canadian Office and Factory, Merritton, Ont.

Prest-O-Lite Exchange Agencies Everywhere



## Rider Agents Wanted

We want a Rider Agent in every neighborhood to ride and exhibit the new "RANGER." You can select the particular style suited to your own needs. Boys and young men in all parts of the country are riding "Rangers" and taking orders from their friends. Our great output, perfected methods and machinery enable us to sell "quality" Bicycles at prices below all competitors.

# LATEST MOTORBIKE MODEL

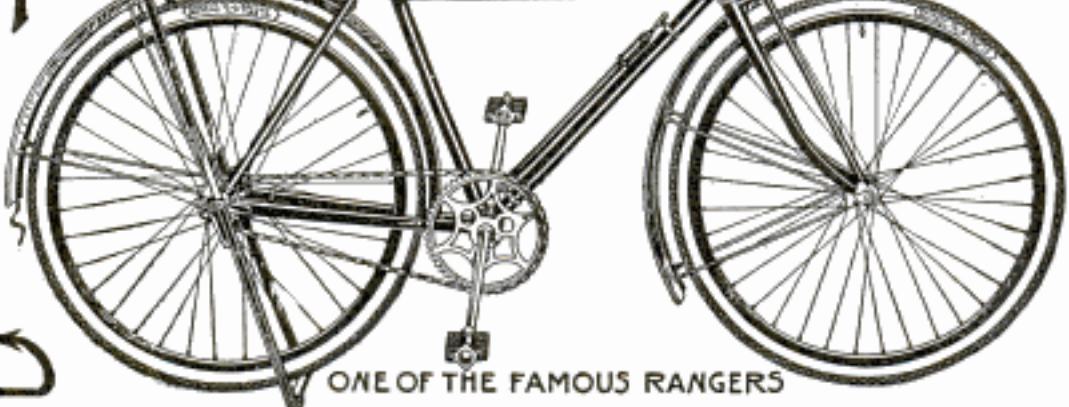

ONE OF THE FAMOUS RANGERS

# 30 DAYS FREE TRIAL

## Your Choice of Forty-Four (44) Styles,

Colors and Sizes in the famous line of "RANGER" Bicycles, shown in full color in our big new 1917 Catalogue just off the press. There are eighty-three (83) others, also, at prices ranging from \$14.75, \$15.75, \$17.75, up. There is a MEAD Bicycle for every rider, at prices made possible only by our FACTORY-DIRECT-TO-RIDER sales plan.

**SEND NO MONEY** but write TODAY for the new 1917 Catalogue of "Ranger" Bicycles, Tires and Sundries at prices so low they will astonish you. Also, full particulars of our great new offer to deliver to you all charges prepaid your choice of any of the 44 kinds of "RANGER" Bicycles you may select, for ONE MONTH'S FREE TRIAL. This wonderful offer is absolutely genuine.

**TIRES, LAMPS, Built-up Wheels** with Coaster-Brakes, Inner Tubes, Electric Lighting Outfits, all the newest ideas in Bicycle equipment and Sundries, as well as the Repair Parts and Combination Offers for refitting your old Bicycle—all shown fully illustrated, at HALF USUAL PRICES. Our new Catalogue is the largest ever issued by any Bicycle concern. Even if you do not need a new Bicycle now, or Repair Parts, Tires, etc., for your old Bicycle, you need this Catalogue to tell you the prices you should pay when you do buy.

**MEAD CYCLE COMPANY, Dept. A108**

**CHICAGO, ILLINOIS**

## Driver Agents Wanted

Five-Pass., 30 H.P.  
32 x 3 1-2 Tires

Ride in a Bush Car. Pay for it out of your commissions on sales, my agents are making money.



Electric Starting  
11.4-inch Wheelbase

Shipments are prompt. Bush Cars guaranteed or money back. Write at once for my 48-page catalog and all particulars. Address J. H. Bush, Pres. Dept. 217.

**BUSH MOTOR COMPANY, Bush Temple, Chicago, Ill.**

## GOODRICH "GIANT"

The best bicycle tire made. Ask your dealer  
The B. F. Goodrich Company, Akron, Ohio

## Models and Gears

## Experimenters—Inventors

Developing inventions and making working models our specialty. Well equipped shop and staff of experts at your service. Carry complete stock of gears. Shipments same day order received. ESTABLISHED 1882.

**UNION MODEL WORKS, 121 S. Clark St., CHICAGO**



## Be Your Own Boss

Do as many others have—Operate a Kingery Peanut Roaster and Corn Popper. Over 50 styles. Liberal terms, excellent profits.

No. 50 catalog tells you all about it.

**KINGERY MFG. CO., Pearl, East of Broadway, Cincinnati, O.**

## PRIZE FISH

are caught on "Bristol" Rods. Here is a well-known Judge with a 5 lb. and 7 lb. Salmon caught on a "Bristol" in Moosehead Lake, Me. He, as do so many thousand real fishermen, depends on

# "Bristol"

The Prize Winning Rods

to bring home the prize fish, because "Bristol" Rods are accurate on the cast, quick on the grab, pliable for playing and so absolutely reliable in the fight for landing money fish. 38 different styles, \$3.50 to \$25. Recommended by 19,000 dealers. Each rod guaranteed 3 years.

**ILLUSTRATED CATALOGUE FREE!**

**THE HORTON MFG. CO.**  
196 Horton St. BRISTOL, CONN.



## Comfort Indoor Closet Odorless Sanitary Germ-Proof

Every home without sewerage needs one. Most convenient, meritorious home necessity in a century. A boon to sick people. Can be placed anywhere in the house.

## Abolish Outdoor Closet

Put a warm Comfort Toilet in your home, a guarantee of healthy, sanitary conditions. Germ-life killed by chemicals in resort. Simplified once a month—no trouble. Needs no other attention. Boards of Health endorse it. Write now for literature, prices, etc.

**Agents Wanted—Exclusive Territory.**  
**COMFORT CHEMICAL CLOSET CO.**  
382 Factory Bldg., TOLEDO, OHIO



Send for Free Trial  
30 days





The Wing Piano

**On 4 Week's Trial To Show You Its Well Proven Quality** (Established 1865)

Any superb Wing Piano or Player Piano, choice of 38 styles, on 4 weeks free trial direct from factory. No money down, all freight prepaid.

Return at our expense, or keep at rock-bottom, direct from factory price. Liberal terms.

**Valuable Book Mailed FREE**

Write today for "The Book of Complete Information About Pianos," Also free catalog of art styles.



(Established 1865)



Wing Building, 9th Avenue & 13th Street  
Dept. 1192 NEW YORK CITY



Dept. 1192  
Wing Bldg., 9th Avenue  
and 13th Street, New York

Gentlemen:—Please send me, free and prepaid, "The Book of Complete Information About Pianos." Also full particulars of your rock-bottom offer and catalog of latest art styles.

Name .....

Address .....

**Art Corners Will Mount Camera and Post Card Pictures Best**

It's Engel's Quick Way. Easy, Artistic;—no paste needed—no muss—no fuss. Slip them on corners of picture—Wet 'em—Stick 'em. That's all. Fine for Album Work. Sample 25¢, 50¢, FREE—with 10 pkg. order, 1 White Art Photo Album

**10¢ Buys 100!!**

Engel Mfg. Co. Chicago, Ill.  
Dept., B17 4711 N. Clark St.



Durable, Workable, Economical, of Pleasing Appearance — that describes

**Southern Yellow Pine**

"The Most Useful Wood"

That is why, in American home building today, there is more Southern Yellow Pine used than all other woods combined. *Keep That in Mind When You Build!*

**SOUTHERN PINE ASSOCIATION**  
670 Interstate Bank Bldg., New Orleans, La.

**THE MONO X-RAY**

**10c**



With this eye glass you can apparently see thro cloth or wood, see the bones in the body, makes the flesh look transparent. An optical illusion.

BY MAIL 10 CENTS, STAMPS OR COIN

**THE ARDEE CO., Box 229, Stamford, Conn.**

IF IT ISN'T  
**AN EASTMAN**  
IT ISN'T A KODAK

**Make this car your office—**

there is \$900.00 to \$1800.00 a year in it for you

Examinations will likely be held everywhere soon

Rapid advancement to higher Government Positions. "No layoffs" because of STRIKES, FINANCIAL FLURRIES or the WHIMS OF SOME PETTY BOSS. THE POSITION IS YOURS FOR LIFE.

Country residents and city residents stand the same chance for immediate appointment. Common-sense education sufficient. Political influence NOT REQUIRED.

We will prepare 25 candidates FREE! Write immediately for schedule showing the places and dates of all Winter and Spring examinations. Don't delay. Every day you lose means the loss of just so much coaching before the rapidly approaching examinations.

**FRANKLIN INSTITUTE, Dept. T 96, Rochester, N. Y.**



Hundreds of Railway Mail Clerks Needed Soon

**COUPON**

Franklin Institute (The pathway to plenty), Dept. T 96, Rochester, N. Y.

This coupon, filled out as directed, entitles the sender to (1) free specimen questions; (2) a free copy of our copyrighted book, "Government Positions and How to Get Them"; (3) a list of positions now easily obtainable; and (4) to consideration for Free Coaching for the examination here checked.

- ..... Railway Mail Clerk (\$900 to \$1800) .....
- ..... Bookkeeper..... (\$900 to \$1800) .....
- ..... Postoffice Clerk..... (\$800 to \$1200) .....
- ..... Postoffice Carrier..... (\$800 to \$1200) .....
- ..... Rural Mail Carrier..... (\$500 to \$1100) .....
- ..... Customs Positions (\$800 to \$1500) .....
- ..... Stenographer..... (\$800 to \$1500) .....
- ..... Internal Revenue..... (\$700 to \$1800) .....
- ..... Clerk in the Departments at Washington (\$800 to \$1500) .....

Name..... Address..... T 96

Use this before you lose it. Write plainly.



## A REAL Ford Starting and Lighting System

Let a Fisher system banish the hard work of cranking your Ford this winter. Except when actually cranking the engine, the motor is at rest. When the engine is in motion it drives only the generator, which charges the storage battery.

### FISHER STARTER for FORD CARS

The lightest, most powerful starting device built. Always positive in action, even in coldest weather. \$35 complete—generator, motor and storage battery installed. No alteration to your car or engine. Ask your dealer about the Fisher system and its years of success.

**FISHER ELECTRICAL WORKS, 38 Lynn St., DETROIT, MICH.**  
**Dealers:** If you aren't selling Fisher starting and lighting systems write or wire today. The biggest selling season is just starting. We've a liberal proposition for you.

## Make Water Pressure Work and Save Your Back



The Divine Red Devil Water Motor built with bucket-wheels like big water wheels—easy to install, has nothing to get out of order and does work at very low cost.

**4 in. Motor Complete, \$3.** Including Emery, Buffing Wheel and Pulley for household use. With pulley for sewing-machine only \$2.50.

**6 in. Motor with Pulley, \$5.** For Mechanics, Tradesmen, Doctors and Dentists and the Home. Will run washing machine easy. Guaranteed to give satisfaction or money back. Order direct NOW or ask for descriptive Booklet FREE. Give size of pipe and water pressure, and work to be done.

**DIVINE WATER MOTOR CO.**  
Dept. P., Utica, N. Y.

## Save Money



### Quick Shipment

direct from manufacturers. Highest quality warm air furnace at wholesale price. Write for catalog filled with helpful hints on home heating and telling how you can save money on this powerful heating plant. One register—easy to install. **We pay freight.** Cash or easy payments. Write for Catalog No. 936

**KALAMAZOO STOVE CO.**  
MANUFACTURERS  
KALAMAZOO, MICH.

**A Kalamazoo**  
Direct to You

## "Best" Hand Lantern



A powerful portable lamp, giving a 300 candle power pure white light. Just what the farmer, dairyman, stockman, etc., needs. Safe—Reliable—Economical—Absolutely Rain, Storm and Bug proof. Burns either gasoline or kerosene. Light in weight. Agents wanted. Big Profits. Write for Catalog.

**The Best Light Co., 324 E. 5th St., Canton, O.**

## Save \$20 to \$50 on COAL BILL



Save \$20 to \$50 on winter coal bill with a New Scientific Down Draft Jahant Furnace. Lasts a lifetime. Heats every room evenly. Burns oxygen, saves coal. Burns coal to fine ash. Heats quickly in morning.

### WE PAY THE FREIGHT

We pay freight anywhere in U. S. or Canada. Price includes entire equipment cut to fit. Easily installed.

### Sold on Monthly Payments

Buy a Jahant now, a payment down, rest easy monthly payments. It will pay for itself in short time. Sold on 360 day Motor-loan, Legal Guaranty Bond, Engineers' advice FREE.

**FREE!** Complete set of erecting tools Free with each Jahant. Get book, "WHAT USKISS SAY," and literature, all free.

**JAHANT HEATING CO.**

22 Jahant Bldg., AKRON, OHIO, U.S.A.

## Learn from CHEMCRAFT the wonders of modern chemistry

### THE BOYS OWN LABORATORY

With this wonderful chemical outfit you can make countless fascinating and instructive experiments in chemistry and chemical magic. How would you like to make ink and soap—manufacture colored fire—make disappearing ink and fire ink—test foods and water—change water into wine and wine into water—fill ten empty glasses with ten different colored liquids from a pitcher of clear water? Get Chemcraft and mystify your friends with these and many other marvelous experiments. Chemcraft contains all the chemicals and apparatus and a big complete instruction book filled from cover to cover with chemical experiments and chemical lore.

### Chemcraft Delivered for \$2.50

If it isn't carried by your toy dealer, West of the Mississippi River, and Canada, add 10c extra for postage. Foreign, \$3.50.

**THE PORTER CHEMICAL CO.**  
Dept. A, HAGERSTOWN, MD.



## "HIRE YOURSELF AS BOSS"

\$200,000 Corporation will back you in a money-making business of your own selling Guaranteed quick sale goods. Start spare time at home or office.

Write for FREE BOOKLET, "FORCEFUL FACTS."

**WM. J. DICK, Manager, Dept. F28, 20 W. Lake St., CHICAGO**

## KEROSENE Gas Lamps



### BURNS KEROSENE or GASOLINE

one just as well as the other; or the two mixed. Make their own gas. 300 to 600 C. P. at 1/2 an hour. Family or Business use.

WRITE FOR COMPLETE ILLUSTRATIONS  
**BRILLIANT GAS LAMP CO.**  
1000X So. Wabash Ave., CHICAGO, ILL.

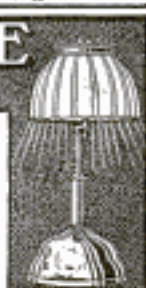

## THE FARMERS' LIGHT

has heretofore been kerosene lamps giving 18 candle power of light. City people use Gas or Electricity up to 200 candle power. Now the farmer is offered a superior light in the "Incandescent" Lamp giving 300 candle power. Descriptive circular and prices on request.

### Agents Wanted.

**FARMERS' BOYS MAKE \$25 TO \$50** weekly selling this marvelous lamp. Everyone a possible customer. SEND FOR OUR OFFER TO AGENTS.

**THE LAWRENCE MFG. CO.**  
No. 9 So. Clinton St. CHICAGO, ILL.



**JEWELRY AT WHOLESALE PRICES** 1/2 SAVED DIRECT FROM MAKER SAVE 1/2

Keep in tune with the times, buy wholesale, save ONE-HALF. Any Diamond you choose, no middlemen to pay, you get Price, Quality and your money's worth. Send to-day for your Diamond, Watch or Jewelry and save ONE-HALF. We ship C. O. D. with Free Examination Privilege. Full money back guarantee within 30 days if not satisfactory. DO IT NOW! WE RETAIL AT WHOLESALE PRICES. SEND FOR CATALOG NO. 112

**SOLID 14 K GOLD WATCH**  
12 size, 17 jew. Bands size. Solid gold Waltham chain, solid gold Kado, rose price \$42.50

**S. RAIVES & CO. EST. 26 YRS.**  
366 FIFTH AVE., NEW YORK.

7 DIAMOND CLUSTER RING, \$19.75  
LOOKS LIKE ONE DIAMOND  
1/2 CT. \$14.25  
1/2 CT. \$13.75  
1/2 CT. \$12.25  
3/4 CT. \$12.75





## Standard Visible UNDERWOOD TYPEWRITER

Shipped you on 10 Days' Free Trial, express charges prepaid, and without one cent advance payment. This machine is equipped with two color automatic ribbon, back spacer and tabulator. There is not the slightest obligation on your part. You don't pay out one cent until you have thoroughly examined and tried out the machine. Our price is less than one half that of the manufacturer and we make the terms of payment to suit you.

All machines guaranteed for 5 years  
Write now for full particulars regarding this sensational offer

**METRO. TYPEWRITER CO.**  
72 Front St., Brooklyn, N. Y.

### "Increase Your Personal Efficiency" POINTER NO. 1: "Keep Your Pocket in Order"



"THIS WEEK" is the name of a valuable "Pocket Orderly" that will definitely increase your personal efficiency! AN ENTIRELY NEW DEVICE: It serves systematically as **Portfolio, Calendar, Diary, and as a record of Appointments, Reminders, and Expenses: ALL FOR PERMANENT FILING.** Less than 1/16" thick, yet Roomy and Substantial, Without a vestige of complication.

HOWEVER! What YOU have to do is....  
Get One! Use it! And be convinced!  
SAMPLE mailed, with Personal Efficiency Pointers 2, 3 and 4, for 10c  
THE FOLLOWS EFFICIENCY BUREAU, E. End Trust Bldg. Pittsburgh, Pa.

## WE PAY CASH for Scrap and Old False Teeth PLATINUM

On rubber or metal plates. Highest cash price paid for old Gold, Silver, contact points, crowns, bridge work, mercury and broken jewelry. Send your package today by parcel post to

The Mutual Smelting and Refining Company  
116 North Front Street, Columbus, Ohio



**AETNA-IZE** Protect yourself and your family in case of sickness or accident. \$50 a week, and as high as \$15,000 for death. Write for particulars.

AETNA LIFE INSURANCE COMPANY  
Drawer 1341 Dept. PM. 2-17 Hartford, Conn.

### Red or Black "Vulcan" Ink Pencils

The ONLY perfect, non-leakable ink pencils at moderate prices.

Two Sizes—  
4 1/4 and 5 1/2 inches.  
Extra Size—8 inches  
(black only) \$1.25.  
Your name in gold inlay 35c.

FREE—liberal supply of ink with retail orders. Agents Wanted. Big Profits.  
J. C. ULLRICH & CO., 21 Thames St., New York

Order today \$1



# 10¢ a Day

now buys this superb **Baader Violin**

AN exquisite instrument—perfect in tone and superbly finished. Made by the great violin maker, J. A. Baader, and now offered direct to you at the rock-bottom price. You may pay this rock-bottom price at the rate of only 10 cents a day. 10 days' free trial—send coupon at once.

## Your Choice of Instruments

This Baader violin is only one of the bargains we have to offer. Write today for our new Violin catalog. There you will find illustrated products of the leading violin makers of the world—Farny, Baader, Glier, Heberlein, Fiedler, Wurlitzer and many others. Violins of the highest grade, as well as those of moderate prices—all special values. Priced from \$2.70 to \$20.00, and from \$90.00 to \$250.00. Write now.

**Rare Old Violins**  
Our collection of rare old violins is one of the largest in America. Write today for Special Art Catalog.

# WURLITZER

200 years of instrument making

Get the benefit of our mammoth facilities for buying in large quantities. The house that supplies the United States Government now makes a startling money-saving offer direct to you. Write for circular.

## 10 Days' Free Trial

You cannot judge a violin by seeing it in a store or by playing upon it once. Play on one of these instruments in your own home, in your own way for ten full days. Then you will be able to decide.

If you are not satisfied send it back at our expense. If you wish to buy, pay only the rock-bottom price—at the rate of only a few cents a day.



## 10c a Day

now buys this superb Lyric Cornet. Exquisite triple silver-plated long model Lyric Cornet direct to you on a startling offer. Ten days' free trial before you decide to buy. Liberal allowance for old instruments. Write today for 226-page Catalog—showing 2563 instruments that you have to choose from.

## Send the Coupon

Put your name and address on the coupon now and indicate catalogue matter you wish us to send you. Absolutely no obligation in sending the coupon. Do it now. Find out about the startling money-saving offer we are making. Write today—send Coupon or a Letter or a Post-card.

**The Rudolph Wurlitzer Co.**

Dept. 9192  
East 4th Street, Cincinnati, O.  
So. Wabash Avenue, Chicago

**The Rudolph Wurlitzer Co.**

Dept. 9192  
S. Wabash Av., Chicago  
4th St., Cincinnati

- Gentlemen:—Please send me without obligation, free and prepaid the catalog matter checked below:
- The special violin circular.
  - Special low priced violins under \$15.00
  - Your 226 page illustrated catalog of musical instruments.
  - Catalog of music stands, cases and other stringed instrument accessories.
  - Art catalog of rare old violins.

Name.....

Address.....



# Protection for the Inventor

Not only must every inventor secure proper patent protection for his invention through a competent patent attorney, but he should also have the proper legal advice not from an attorney in general practice but from a patent attorney qualified to protect him in the promotion or sale of his invention after it has been patented. Messrs. Victor J. Evans & Co. have a special Legal Department for this purpose, and all of their clients are requested and privileged to send any contracts, assignments or agreements they may intend to enter into, to this department in order that these contracts may be thoroughly scrutinized by experts in legal matters and patent law so that the inventor may be properly advised before signing such contracts. It is especially dangerous for an inventor to enter into a contract on a royalty basis without proper legal advice. The following instance will show the necessity of an inventor consulting a patent lawyer before entering into a contract on a royalty basis: An inventor of an ingenious device brought it to the attention of a certain manufacturing concern who agreed to buy it on a royalty basis of five cents for each article manufactured. The only royalty the inventor ever received was five cents. The manufacturer did not want the idea to be carried elsewhere, nor did he want to use it himself because it would necessitate extensive changes in machinery in his plant. Therefore, he wantonly suppressed the invention in such a way that the inventor had no legal recourse. This is only one of a thousand just such cases. If the inventor had submitted his contract to a competent patent attorney before signing he could have secured protection, and the patent attorney would have so amended the contract that the manufacturer would have had to guarantee the manufacture of a certain number of these devices or pay a minimum royalty independent of the number manufactured or used. Furthermore, a contract of this nature should also stipulate that the inventor has the right to examine the books of the manufacturer at specified periods and include a clause nullifying the contract should the manufacturer fail to make payments of royalty fees.

## Relation of Employee and Employer

Inventors should be very careful not to work on an invention while in the employ of any one, if he makes an invention and uses the tools and materials of the employer, for while the employee is still the inventor, the employer has an implied license, not transferable, which gives the employer the right to use the invention in his business. Many manufacturers stipulate in their contracts of employment that all inventions that may be made by their employees, while in their

employ, shall be assigned to the firm. It is always advisable, therefore, for an inventor to work on his invention entirely on his own time and not to use the tools or materials of his employer. Employers are not entitled to the inventions or patents of an employee unless there is a special agreement to that effect, but, as before stated, where an employee has made an invention and put it into practical use in his employer's business or permits the employer to build or use the machine, there is an implied license for the employer to continue the use of said machine. An inventor may employ a mechanic to aid in the construction of a model or working machine, and although such mechanic may furnish suggestions as to details, the product will be the invention of the employer. In other words, the inventor may avail himself of the services of skilled mechanics or mechanical engineers and suggestions coming from them will be considered part of the original invention.

## Proof of Conception

The inventor should not disclose his invention or send any data relating to it to anyone without first protecting himself and establishing his rights by proper EVIDENCE of Conception. We have perfected a blank form which we call "Proof of Conception" for the protection of inventors which we will send free upon request. This form provides a blank space for a rough sketch or to which a photo may be attached and also a space for a description of the invention and can also be used in connection with a model and includes forms to be filled out by witnesses. The importance of such proof of conception is best illustrated by the following incident: An inventor carried a completed plan for a harvesting machine to the office of one of the great agricultural implement works and sought to interest them in his invention. The manager asked time to consider the invention in detail. The inventor left his plans with the manager and in a few days returned for his answer. He was told that his invention was not practical, and his plans were returned to him. Six months later the inventor saw his machine in a harvest field successfully gathering a crop, and upon it was the name plate of the company which had rejected his plan. The inventor realized then what had happened; his plans had been stolen; the three days he had left them with the implement company having been spent in copying them. Of course the inventor protested, but without avail. Had he protected himself by means of a "Proof of Conception" backed by witnesses he could have forced the Company to a settlement. Inventors are invited to submit assignments, contracts, agreements or matters requiring legal advice to the Legal Department of Victor J. Evans & Co.



# PATENTS TRADE-MARKS AND COPYRIGHTS

LARGEST PATENT FIRM  
IN THE WORLD

## SPECIAL OFFER

### Free Opinion as to Patentability

Before sending your invention to any attorney or manufacturer or disclosing your invention, write for our free blank form **PROOF OF CONCEPTION** in order to protect your invention and secure your rights. This should be signed and witnessed and returned to us, together with a model or sketch and description of your invention, and we will give a **FREE OPINION** as to the patentability of the invention. If we report the invention patentable we will furnish a Certificate of Patentability.

**This Certificate of Patentability, together with our blank form Proof of Conception will protect the inventor and serve as proof of the invention until the case can be filed in the U. S. Patent Office.**

**Obtaining Assistance for Inventors**—Our certificate is of great assistance to inventors who require financial aid to obtain patents.

## OUR FIVE BOOKS MAILED FREE

(See Coupon Below)

to any address. Send for these books—the finest publications ever issued for free distribution.

### How to Obtain a Patent

Our illustrated eighty-page Guide Book is a book of reference for inventors and contains 100 mechanical movements, illustrated and described. Tells how to invent for profit.

### What to Invent

Contains a valuable list of inventions wanted and suggestions concerning profitable fields of inventions; also information regarding prizes offered for inventions amounting to

**One Million Dollars**

### Millions in Trade-Marks

Shows the value of Trade-Marks and information regarding unfair competition.

**We Advertise Our Clients' Inventions Free** in a list of Sunday newspapers, in manufacturers' journals and in *World's Progress*. Sample Copy Free. We save you time and money in securing patents. After the patent is granted we assist you to sell your patent.

## WANTED NEW IDEAS

Prepare Now to meet the Demands of Industry in All Fields for New Ideas and New Inventions. We are constantly receiving requests from manufacturers who consult us when purchasing patents for inventions in all lines. We invite manufacturers and promoters to address our Sales Department regarding the purchase or leasing of a number of meritorious patents secured by us.

### List of Patent Buyers

Contains requests from manufacturers, mail order houses and promoters for patents secured by us and suggestions as to **New Ideas** they wish to purchase. We place our clients in touch with capital free of charge. We have recently received over 300 requests from manufacturers.

### Foreign Patents

We have direct agencies in all the principal foreign countries and secure foreign patents in the shortest possible time and at the lowest cost. Write for our illustrated Guide Book on Foreign Patents, sent free to any address.

VICTOR BUILDING



VICTOR J. EVANS



**FREE COUPON!**

## VICTOR J. EVANS & CO.

New York Offices: 189-191 Broadway  
 PATENT ATTORNEYS  
 Philadelphia Offices: 1429 Chestnut St.  
 Pittsburg Offices: 514 Empire Bldg.  
 Main Offices: 765 Ninth St., N. W., WASHINGTON, D. C.

Name..... Address.....

Please Mention Popular Mechanics





# PATENT YOUR IDEAS

A bottle cap seems like a little thing  
—but it made a fortune for one man.  
**Your ideas may be worth money, too.**

You don't have to be an inventor by profession to think of a salable device or an improvement on some existing device —

but you do have to patent your idea before someone else does to get your fair share of the profits from it.

**A C & C Patent will secure your protection.** It may mean independence—even great wealth—for you. Learn what is in demand. Get these FREE BOOKS.



## “What To Invent” and “How To Obtain a Patent”

written by men who have had twenty-one years' experience in obtaining C & C patents. Manufacturers are constantly asking us for new devices. Our book will tell you what manufacturers want to buy.



### Here Are Suggestions of Things Wanted Right Now:

A dustless ash sifter. A good combination padlock. A cooking stove to go over a gas jet. Means for opening window shutters without raising the sash. A good and cheap vacuum cleaner. A detachable shelf for ladders, to hold a bucket. Improvements in rat and mouse traps. An adjustable window screen. Toys and novelties of all kinds. Means for cleaning cuspidors. Means for preventing the glare from auto headlights, yet which will give full light on the road. Means for picking fruit from trees. Insect trap for tree trunks. Improvements in rural mail boxes, with signals

to show automatically when the box contains mail. Poultry feeder, with means for automatically releasing feed at a certain time. An efficient milking machine.

These are only a few of the many inventions which represent a large field of work for those who have ingenuity. Hundreds of other suggestions and a great deal of helpful advice will be found in the book “What to Invent.”

If you have already invented something, send us a rough sketch and we will send you a free report regarding its patentability.

### C & C Patents Are Chandlee & Chandlee Patents

and were first issued over twenty-one years ago for the benefit of small inventors who could not afford the exorbitant fees charged by most attorneys. Because of the great number of patent cases we handle we are able to charge a reasonable fee for each patent, and our experience is far broader than that of attorneys

handling but a few cases each year. In a large measure, this accounts for the great protection afforded by *C & C Patents*.

Do not put off learning all about *C & C Patents*, for your idea will never earn you anything if someone else patents it first. Send at once for the FREE BOOKS and advice.

**CHANDLEE & CHANDLEE,** Patent Attorneys Est. 21 Years 1011 F Street, Washington, D.C.



# WANTED IDEAS

Inquiries from Manufacturers and Other Buyers of Patents  
Who Are Looking for Good Ideas

## Protected by Owen Patents

Are constantly being received. Hundreds of ideas are wanted—a market exists for them to-day. YOURS may be one of them. Send for my free books and see for yourself—read the requests for inventions protected by me. Many are simple. You can help supply this demand.

As soon as my clients' rights are protected I aid in every practicable way, without charge, to sell. Their applications are advertised free—their patents are called to the attention of the proper prospective buyers—every necessary thing is done. Get my booklets and see.

## THESE ARE FREE

You will incur no obligation by writing me. A simple request will bring them to you—the finest, most reliable and instructive patent books published. A postal will do.

**"Successful Patents"**—a 72 page guide book, tells how to proceed; describes my advantageous business methods; gives references, testimonials, etc.

**"Stepping Stones"**—gives hundreds of hints of inventions wanted; articles from interviews of noted authorities; tells the truth about prizes for inventions.

**"Patent Promotion"**—tells you how to sell; why some inventors fail; discusses the value of your idea; how I aid my clients; manufacturing aids furnished you; recent successful patents, etc.

You will also be sent from time to time, as new inventions are wanted, full information concerning them. Only in this way can you keep up to date.

### Write for These To-day

Advice costs nothing. All communications confidential. Your work will receive my personal supervision—but my fees are no higher than others.

### Results Speak Loudest—But Here Are Some References

Columbia National Bank,  
Washington, D. C.  
National Locktile Co.,  
Washington, D. C.  
The Carnahan Press,  
Washington, D. C.  
Lightning Gun & Cycle Works,  
Oklahoma City, Okla.  
Antholene Mfg. Co.,  
Hutchinson, Kans.

National Rack Co.,  
61 Hannover St.,  
Boston, Mass.  
The C. J. Loftus Co.,  
13 Spring Common,  
Youngstown, Ohio  
Whitehead Hosiery Mills,  
Burlington, N. C.  
Dickinson Mfg. Co.,  
Des Moines, Iowa.

A LARGE NUMBER OF OTHERS IN MY BOOKLETS.

**RICHARD B. OWEN** 9-303 OWEN BLDG.  
WASHINGTON, D.C.  
NEW YORK Office: 22nd Floor Woolworth Bldg.

Inventors submitting their inventions to me are protected in a tangible manner until their applications are filed.

### Nuts for You to Crack

Invent something for which a demand exists—for which there is a waiting market. Here are abstracts from a few recent requests—hundreds are published in full in my literature. Can you invent any of these? Watch this list each month.

A large manufacturer wants "to buy or make on royalty toys and novelties made of wood or iron."

A financier is interested in a number of things but particularly in "machines designed for household uses; for instance, dishwashers, washing machines, vacuum cleaners, refrigerators, etc."

Still another manufacturer has just written that he wants at once a universal joint such as is used on automobiles. This must be strongly protected by a good patent.

I am constantly receiving requests for inventions relating to automobiles, automobile accessories, etc. Recently an unusual number of such requests have reached me and I have a large number of such letters on file at the present time.

### SPECIAL FREE REPORT

Send sketch or model of your invention for free report on patentability, practicability, etc.



# PATENTS THAT PROTECT and PAY

Send for FREE BOOKS.

**WATSON E. COLEMAN, Patent Lawyer, 624 F St., Washington, D. C.**

*Read the following strong testimonials as to my work and promptness:*

ARBY W. HODGE  
Inventor and Manufacturer of  
Hodge's Road Plane.  
"The Plane that Planes."

CHROMWELL, IND., April 8, 1916.

"Received your letter saying my patent had been granted. I want to thank you for the way you handled my work. You sure got results in short order. This makes the second patent I have applied for, and this one through you was granted in less than half the time the other was, so I surely appreciated your work and, believe me, if I have any more work, I shall give it to you."

ARBY HODGE.

RINGGOLD, KY., April 16, 1916.

"I wrote to a Congressman, asking for the name of a patent attorney of absolute integrity, and he gave me your name."

CHARLES T. HARR.

MEDFORD, WISCONSIN, April 19, 1916.

"I thank you for your prompt service in getting my patent, and you certainly shall have all my business."

DR. C. E. NYSTRUM.

(His application was filed March 25, 1916, and allowed April 10, 1916—sixteen days).

UTICA, N. Y., April 19, 1916.

"I just received notice that my patent was allowed, and I wish to thank you most heartily for your excellent work."

WILLIAM C. MILLER, 706 Sunset Ave.

SAGINAW, MICH., April 20, 1916.

"I subscribe for the 'American Artisan and Hardware Record of Chicago.' They picture all the patents issued every week, and when I look over them and see how long it took some of them to get a patent, from the time the applications were filed, I am glad I placed my invention in your hands."

ROBERT J. SCHULZ,  
1820 Mackinaw St., W. S.

TUNBRIDGE, VERMONT, April 21, 1916.

"I want to thank you for the excellent work and efficient manner in which you handled my application. If I have any more work, I will be pleased to have you handle the same for me."

HUGH WILLIAMS.

THE COMMERCIAL BANK OF LIBERTY  
Capital \$100,000.00.

LIBERTY, MISSOURI, January 10, 1916.

"Let me express to you our thanks for your very efficient services in our behalf, and if the opportunity arises, you may be assured that I shall be pleased to refer any of our friends to you that may have the need of your counsel."

FRANK D. HAMILTON, Asst. Cashier.

CHARLOTTESVILLE, VA., September 30, 1915.

"Your letter to hand, with the official receipt, in the matter of my application for U. S. patent. I congratulate you on your business-like method of doing things. You surely go after matters with a vim."

J. M. DAVIS, Carlton Ave.

HAWKEYE, IOWA, September 21, 1915.

"Received the notice of the allowance of my application. Was surprised at the speed with which it was handled."

GEORGE E. ALTON.

(Application was allowed in one month after filing in the Patent Office).

HAMILTON, MISSOURI, September 7, 1915.

"Your letter received, together with notice of allowance of application for patent. You can rest assured you will be given my future business, as I highly appreciate your promptness and ability, which brings swift and satisfactory results. The success of the inventor frequently depends greatly on promptness and ability of attorneys to whom he submits his patent affairs."

EDISON McFEE,  
R. F. D. No. 1.

TAMPA, FLORIDA, March 20, 1916.

"We note with pleasure the notice of patent allowed under date of March 11, 1916. To get a patent application through in eighteen days is surely going some."

W. F. BLANCHET, 312 Henderson St.

GLEN WILTON, VA., Feb. 23, 1916.

"Notice of filing of my application was received a few days ago. I think it just to say that in counting time mail was in transit and time I was not acting on the matter, you have just consumed the same number of days as one other patent attorney consumed months in getting a patent of no greater difficulty so far along."

K. B. McNEER.

LINEGUIDE MANUFACTURING CO.  
160 North Fifth Ave.

CHICAGO, December 28, 1915.

"I wish to say further that in the future I expect to entrust all my patent cases with you, as I have tried a number of patent attorneys in the past twenty years, and must say that I am more satisfied with your services than with any of those with whom I have done business heretofore."

J. J. SNYDER.

KOL-ISK KURK COMPANY

Manufacturers of

Kol-isk Koleru Kompond

GETTYSBURG, SOUTH DAKOTA, Jan. 3, 1916.

"We acknowledge receipt of certificates of trade-mark registration. Should we have occasion for the services of an attorney in Washington, we shall certainly bear you in mind, as your services so far have been entirely satisfactory."

F. B. FISK, President.

DENVER, COLORADO, October 13, 1915.

"You are undoubtedly the best patent lawyer ever. The idea of you getting every word, without any change whatsoever, of the entire twenty-three page application, granted and allowed, complete and entire, without the sacrifice of a single clause or claim—that is what rivets and clinches our attention to your sterling worth and attainments. And, directly relating to that which I have just expressed, it is a thoroughly complete and all-embracing application."

WILLIAM H. EADER, 1373 Humboldt St.

WACO, TEXAS, March 23, 1914.

"Your letter of March 18th with notice of allowance of my application for patent was very favorably received."

"It is my first experience of obtaining a patent inside of eighty-eight days from date of application during my experience of FIFTY YEARS AS AN INVENTOR."

"You surely have given me the quickest service and obtained for me more and better claims than any or all combined attorneys who have heretofore done my work at the Patent Office during the past fifty years."

L. S. SHREWIN, P. O. Box 291.

# PATENTS THAT PROTECT and PAY

Send for FREE BOOKS.

**ALL BUSINESS GIVEN PROMPT AND PROPER ATTENTION**

**A large list of strong recommendations furnished free**

**WATSON E. COLEMAN, Patent Lawyer, 624 F St., Washington, D. C.**



# Wanted—Ideas

Inventors! Send for these Remarkable FREE BOOKS, Today

## “Inventions Needed”

This book lays before you a description of the active and profitable field of invention. It tells you the inventions the world needs today, the devices manufacturers are seeking for their business, the ideas for which the public will pay big money.

## “How to Get Your Patent”

This book is a guide to the inventor. If you have invented something and desire to learn what it will cost you to get your patent and what you must do to find your market, read this book.

## “Special Bulletin of Patent Buyers”

This bulletin contains letters from men who are seeking to purchase patents. We act as intermediary without one cent of charge, between the man who invents and the man who invests.

Send Model or Sketch and description of your invention for Free Opinion as to patentability

Rejected and Difficult Cases are Our Specialty

**RANDOLPH & CO.**

600 F St., N.W., Washington, D.C.

**RANDOLPH & CO.**  
600 F St., N. W., Washington, D. C.

Gentlemen: Please send me without obligation on my part, the books indicated on margin of this coupon. (Write on margin of coupon, names of books desired.)

NAME .....

STREET .....

CITY..... STATE.....

**U.S. PATENTS**  
**FREE** →  
**BOOK & FORM**  
**EVERY INVENTOR**  
**SHOULD USE:**

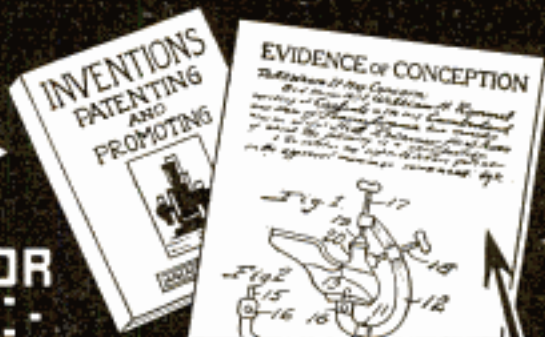

## OUR CO-OPERATION

With an inventor is, **First**, to help him establish his rights before sending a sketch, drawing or model to any attorney; **Second**, to give a frank opinion whether it will pay to patent his idea, based upon our extensive knowledge of the patent laws, manufacturers' wants and facilities; **Third**, to obtain for him on reasonable terms, a patent that absolutely protects; and, **Fourth**, advise and assist him in making the invention a source of profit by outright sale, territorial grants, obtaining royalty, or the independent manufacture of the invention.

Before disclosing the invention to anyone, sign, witness and deposit in our fireproof safe, the form "Evidence of Conception" and establish your rights. A completed sample form in our book shows you clearly how to protect your invention. All are free. Just ask for them on a postcard or simply mail coupon below.

**LANCASTER & ALLWINE**  
245 Oury Building Washington, D. C.

**COUPON**

LANCASTER & ALLWINE, 245 Oury Bldg., Washington, D. C.

Send me free book "Inventions—Patenting and Promoting," Bulletin of Improvements Wanted and blank form "Evidence of Conception."

Name.....

Address.....

**DON'T  
LOSE  
YOUR  
RIGHTS**

**LANCASTER & ALLWINE**

REGISTERED ATTORNEYS

**SERVICE**

Without charge or obligation, we will give you our frank opinion on any questions you may put to us touching on patent, trade mark and copyright matters. You may ask, "Should I protect myself by a patent, or register under the trade mark or copyright laws? What kind of a patent should I obtain? What will it cost? Will it sell?" and many other questions that may occur to you. These are vital points to consider, and questions will be cheerfully answered. If you want suggestions on what to invent, in our **Bulletins of Improvements Wanted**, which are sent free to all on our mailing list, you will find the wants of progressive manufacturers and valuable information. All matters are held strictly confidential, and personal services are assured by our **Service Guarantee Contract**. **References:** 2nd National Bank, Washington, D. C.; John P. Roth Packing Co., Cincinnati, Ohio; Duskit Mop Co., Paducah, Kentucky; North Capitol Savings Bank, Washington, D. C. Listed in the Bankers' and Brokers' Directory.

Please Mention Popular Mechanics





# INVENT SOMETHING

**IT MAY BRING WEALTH**

**There Is Always a Demand for Valuable Inventions**

Now is the time to patent a meritorious invention. We are constantly receiving letters from manufacturers and investors who are on the alert for new devices, and specialties that are protected by strong patents and can be turned into money through proper handling. **WRITE US TODAY FOR A FREE COPY OF OUR 104 PAGE BOOK -**

**"How to OBTAIN A PATENT and What to Invent"**

or send us a Sketch, Model, or Photograph with written description of your invention for a

**FREE SEARCH OF THE PATENT OFFICE RECORDS**

and report as to patentability of your invention. If patentable we will send you our **Certificate of Patentability** which may prove of value and assistance to you.

If you require money with which to secure a patent, ask us to explain our **CREDIT SYSTEM**, by means of which you will be able to file your application and proceed with your case without delay.

## PATENTS

**SECURED BY US ARE ADVERTISED AT OUR EXPENSE IN POPULAR MECHANICS MAGAZINE**

**WRITE FOR FREE BOOK OR SUBMIT YOUR INVENTION TODAY**

**TALBERT & PARKER Patent Lawyers**  
 4614 WARDER BLDG., WASHINGTON, D. C. (SUCCESSORS TO WATERS & CO.)

## HIGH-VALUE PATENTS

—the ONLY kind Wanted and BOUGHT by Manufacturers. Send 8c postage for new book of Extraordinary Interest to Inventors. R.S. & A. B. LACEY, 51 Barrister Bldg., Washington, D.C.

## PATENTS

**C. L. PARKER**  
 Formerly Member Examining Corps, U. S. Patent Office  
**PATENT LAWYER**  
 MCGILL BLDG.  
 WASHINGTON, D. C.

Patents, Trade Marks, Copyrights, Patent Litigation

Handbook for Inventors, "Protecting, Exploiting and Selling Inventions," sent free upon request.

**Reliable Prompt Service By a Competent Attorney**

NO PRINTED LITERATURE. INQUIRIES INVITED.

**NORMAN T. WHITAKER**

Attorney at Law and Mechanical Engineer  
 Former Examining Official of the U. S. Patent Office  
 27 Legal Building WASHINGTON, D. C.

# PATENTS SECURED OR FEE RETURNED

Latest and Most Complete Patent Book Ever Published for Free Distribution

**WRITE FOR IT**

**Compare My SERVICE and TERMS with Those of Any First Class Attorney**

Send Sketch, Photograph, or Model of your invention for an **ACTUAL SEARCH** of the Records of the Patent Office and report as to patentability — **FREE**. I give every detail of every case my closest personal attention and do not entrust your interests to assistants. Impartial advice on your ideas. I help you sell your patent. Terms moderate. My 90-page book (1917 edition) tells what inventors should know before they apply for a patent.

**GEORGE P. KIMMEL, Patent Lawyer**  
 200 Barrister Bldg. Washington, D. C.



**PATENTS SECURED OR ALL FEES RETURNED!!**

**THAT PAY**  
"Trade-Mark"



**Protect Your Idea! Don't Delay!**  
Send data at once by registered mail and we will promptly advise how our clients proceed to make fortunes. Over \$625,812.00 made by clients.  
One client, A. D. LONG, just states:  
"You secured **BROAD** claims for me in my patent. I sold it for \$25,000.00."

We advertise our clients' patents FREE in POPULAR MECHANICS MAGAZINE, Chicago, Ill., and give FREE valuable help in their effort to sell their inventions and patents.

**CREDIT GIVEN Under Our CREDIT PLAN.**  
Just Across the Street from Patent Office.

**E. E. Vrooman & Co., Patent Lawyers, 871 F St., Washington, D. C.**  
(Old-Established Firm, and Practitioners Before Supreme Court of U. S.)

**We Issue a Contract with Each Favorable Report to Return ALL FEES!**  
Actual Search FREE of the Patent Office Records, and Report as to Patentability Free!

**FOREIGN PATENTS Guaranteed!**  
Branch Offices All Over The World.  
Write for prices under guarantee.

**2 WONDERFUL PATENT BOOKS FREE**  
Don't miss these books! Mail postal today!

## Protective Patents

Procured Promptly. No fee refund, no guarantee certificate, no so-called prize or free search schemes used in our business. Inventors 104 page Blue Book sent on request.

Robb & Robb, 211-215A Southern Bldg., Washington, D. C.

Send for **FREE BOOK** { **WHAT TO INVENT**  
**WHAT NOT TO INVENT**  
**HOW TO SELL YOUR PATENT**  
Copies of nearest Patents and report in every case without charge  
**H. L. WOODWARD, 9th and G Sts., WASHINGTON, D. C.**

## PATENTS

**MASON, FENWICK & LAWRENCE**, oldest U. S. firm having main office at Washington, D. C. Also New York and Chicago. Established 1861. Best References. Trade-Marks Registered. **BOOKLET and Information FREE.**

**SETS OF CASTINGS OF MODEL ENGINES**  
FOR THE STUDY OF THE PRINCIPLES OF MECHANICAL SUPPLIES AND MATERIAL of all kinds, EXPERIMENTAL AND LIGHT MACHINE WORK to order.  
**HIGH WORTHMAN & CO.**  
132 MILK STREET. BOSTON

**PRINT MY OWN**  
Cards, circulars, menus, book, paper, etc. Press \$5. Larger \$18. Rotary \$60. Save money. Print for others, big profit. All easy, rules sent. Write factory today for illustrated catalog presses, TYPE, cards, samples.  
**THE PRESS CO. D-37. MERIDEN, CONNECTICUT.**

**GEARS ALL KINDS SMALL**  
The most accurate made and prices reasonable. We carry a complete line of gears in stock for immediate shipment. Can also quote on special gears of all kinds. Send us your inquiries.  
WRITE FOR CATALOGUE  
**CHICAGO STOCK GEAR WORKS**  
16 S. Fifth Av. CHICAGO

## Deafness Is Misery

I know because I was Deaf and had Head Noises for over 30 years. My invisible Anti-septic Ear Drums restored my hearing and stopped Head Noises, and will do it for you. They are Tiny Megaphones. Cannot be seen when worn. Easy to put in, easy to take out. Are "Unseen Comforts." Inexpensive. Write for Booklet and my sworn statement of how I recovered my hearing.

A. O. Leonard, Suite 226, 150 5th Ave., N. Y. City

## INDOOR CHEMICAL CLOSET

**NO SMELL — NO GERMS — SANITARY**  
Use in any room. Needs no plumbing, sewerage or running water. Chemicals in closet kill germs. Fine for the sick and old folk.  
**DESTROY OUTDOOR CLOSET**  
Put in a warm, indoor Sanitary Closet. Empty twice monthly. Only attention necessary. Satisfied users and Boards of Health endorse it. Fully Guaranteed.  
**30 Days' Free Trial. Write now for FREE LITERATURE.**  
**SANITARY CLOSET CO., 22 Celina Bldg., TOLEDO, OHIO**

## Enormous Profits



### START GROWING MUSHROOMS

Learn the latest authoritative way to make still bigger profits than you ever thought possible or ever made growing mushrooms. Add \$10 to \$75 a week to your income. Anyone, men, women and children can do it in spare time in city or country. Grow in basements, cellars, sheds, boxes, etc. Start now. Demand bigger than supply. Send for big free book of expert authority. "The Truth About Mushrooms." Write to

**BUREAU OF MUSHROOM INDUSTRY**  
Dept. 352 1342 N. Clark St. Chicago



## SMALL ENGINES

Perfect Gasoline Engines—1, 1 and 1 1/2 h. p.—for Farm and Shop use. Price \$19.00 and up. Also

## WASHING MACHINES

We ship on trial. Send for Booklet and Special Offer.

**SEVERKROPP ENGINE CO.**  
1224 19th St. RACINE, WIS.

## STARTER for FORD CARS

**FREE BOOKS**

**PRACTICAL SUGGESTIONS**  
**INVENTORS RECORD FILE**  
**MONEY IN PATENTS**  
**PATENTS AND PATENT POSSIBILITIES**  
**SOME ACTUAL SUCCESSSES**

## Four New Booklets for Inventors

Chock full of ideas and practical advice. Tell what to invent and where to sell it. "Patents and Patent Possibilities," and "Practical Suggestions for Inventors" are bristling with facts that every inventor should have. They explain how many of my clients have made money from patents procured by me. What I have done for them I can do for you, if you have inventive genius and the will power to use it. The "Inventors Loose Leaf Record File" will enable you systematically to preserve evidence to prove priority of invention on your part in the event of a controversy. These booklets are unlike anything ever issued for inventors, they were prepared with the idea of Service. If you are interested in inventions sent for these booklets, they are free while they last. My service is individual, prompt, efficient and satisfactory. (16 years' experience). I am frank in my opinion on the value and patentability of inventions. Every expedient is employed to secure patents at the least possible cost.



**H. S. HILL;**  
802 McLachlin Bldg., WASHINGTON, D. C.

Send all four of your booklets to

Name .....

Address .....

Please Mention Popular Mechanics

Copyrighted material



## Every Builder and Contractor Needs this Level

### 10 Days' Free Trial

We have been makers of transits and levels since 1863 and our instruments are the standard of the world. Prove the superior quality of the Aloe Convertible Level by giving it a 10-days free trial. Use it on your every-day work laying out buildings, leveling up foundations, walls and floors, aligning, shafting walls, piers, etc., for getting angles or levels anywhere.

### Easy Monthly Payments

If you decide to keep it, the instrument will earn its way while you make monthly payments so small that you hardly feel them. Costs no more than to pay all cash. No red tape about it, no embarrassing questions, everything confidential.

### Aloe Convertible Level

is the finest instrument ever offered at anywhere near its price. Permits taking of sights both above and below the horizontal. For taking vertical sights it is provided with a special convertible bracket rigidly and permanently attached to the cross bar. The telescope is fitted with permanent axis which rests in bracket bearings and is held by clamps easily and quickly released.

Aside from being a level, it is a modified transit that permits a much wider range of work than is possible with the ordinary architect's level. With it the man without technical training can obtain the same absolutely accurate results as the expert. Write today for descriptive circular.

**A. S. ALOE CO.,**  
620 OLIVE ST., ST. LOUIS, MO.



## Going to Build Remodel or Repair?

YOU can actually make a big saving on your building material bill, so write today for our two free books. Our Building Material Catalog shows latest ideas and most advanced styles for everything in building. We ship everywhere everything in the way of high grade lumber, roofing, doors, windows, porchwork, screens, builder's hardware, paints, wallboard, interior

woodwork, plumbing, heating and water supply outfits — all at wholesale prices direct to you. Plan Book shows skillfully planned homes of all kinds, bungalows, city houses, suburban residences, country homes, barns. Tells you how to get building plans FREE. Write today. No obligation. Let our architects develop plans from your rough sketches. Send your material bills for free estimate prices.



**Material Complete for Houses from \$500.00 Up**

Catalog of 8000 Price Bargains

Beautifully Illustrated PLAN BOOK

CHICAGO MILLWORK SUPPLY CO., 1444 W. 27th St., Chicago, Ill.  
PLEASE SEND ME YOUR FREE BOOKS.

Name \_\_\_\_\_  
Town \_\_\_\_\_  
State \_\_\_\_\_  
Occupation \_\_\_\_\_

St. No. \_\_\_\_\_

**Books Are Free**

## DIAMOND PRICES SHATTERED



**GENUINE PERFECT CUT BLUE WHITE DIAMOND \$2.50 A MONTH**

Diamond sent for inspection without one penny down.

### SEE DIAMOND FIRST

No security required, no red tape; we trust you absolutely. Examine diamond at your leisure — wear it 30 days FREE. Send it back at our expense if not satisfactory. You are not out a penny. Don't pay three or four dealers' profits. We sell "Direct" from diamond cutter to YOU at practically European prices. Save ONE-THIRD to ONE-HALF of your money.

**FREE! DIAMOND ART BOOK SEND FOR IT TODAY**

Read the TRUTH about Diamonds. Read how to judge a good diamond, read about our splendid BUY BACK offer at full value. Read our EASY PAYMENT PLAN arranged to suit you.

### EVERY DIAMOND GUARANTEED

Money put in a diamond is saved and forms one of the best investments on earth. Begin saving NOW. Write today for FREE booklet of diamonds and high grade diamond jewelry.

**SANTA FE WATCH CO.,** Topeka, Kan., Dept. 263

## AGENTS—KEROSENE (COAL OIL) BURNER

MAKES ANY STOVE A GAS STOVE

**FREE Sample to Workers**



Makes its own gas from Kerosene (coal oil). Gives every home a gas stove. Absolutely safe. Cheapest fuel known.

**Cooks a Meal for 2 Cents** Agents just coining money. Women wild about it. No more overheated kitchens. No more danger from gasoline.

**Safe, Clean, Odorless, Cheap** Every home a prospect. Low price makes quick sales. Easy to carry and demonstrate. Big profits. Your territory is open. Write today.

**THOMAS BURNER CO., 2648 Gay St., Dayton, Ohio**

## "I Would Not Part With It for \$10,000"

So writes an enthusiastic, grateful customer. "Worth its weight in gold," says another. In like manner testify over 100,000 people who have worn it.

## The Natural Body Brace For MEN and WOMEN

Develops erect, graceful figure; overcomes WEAKNESS and AILMENTS of Women & Men.

Brings womanly beauty and manly strength, restful relief, ability to work and enjoy life.

### Makes You Feel Good and Look Good

Does away with the strain and pain of standing and walking; replaces and supports misplaced internal organs; reduces enlarged abdomen; straightens and strengthens the back; corrects stooping shoulders; develops lungs, chest and bust; relieves backache, curvatures, nervousness, ruptures. Easy to wear.

### Wear It 30 Days Free at Our Expense

Write today for illustrated booklet, measurement blank, etc., and read our very liberal proposition.

**HOWARD C. RASH, Pres. Natural Body Brace Co.**  
223 Rash Building SALINA, KANSAS



For Children Also





# Tobacco Habit BANISHED

## in 48 to 72 Hours

### Immediate Results

Trying to quit the tobacco habit unaided is a losing fight against heavy odds, and means a serious shock to your nervous system. So don't try it! Make the tobacco habit quit you. It will quit you if you will just take Tobacco Redeemer according to directions.

It doesn't make a particle of difference whether you've been a user of tobacco for a single month or for 50 years, or how much you use, or in what form you use it. Whether you smoke cigars, cigarettes, pipe, chew plug or fine cut or use snuff Tobacco Redeemer will positively remove all craving for tobacco in any form in from 48 to 72 hours. Your tobacco craving will begin to decrease after the very first dose—there's no long waiting for results.

Tobacco Redeemer contains no habit-forming drugs of any kind and is the most marvelously quick, absolutely scientific and thoroughly reliable remedy for the tobacco habit.

### Not a Substitute

Tobacco Redeemer is in no sense a substitute for tobacco, but is a radical, efficient treatment. After finishing the treatment you have absolutely no desire to use tobacco again or to continue the use of the remedy. It quiets the nerves, and will make you feel better in every way. If you really want to quit the tobacco habit—get rid of it so completely that when you see others using it, it will not awaken the slightest desire in you—you should at once begin a course of Tobacco Redeemer treatment for the habit.

### Results Absolutely Guaranteed

A single trial will convince the most skeptical. Our legal, binding, money-back guarantee goes with each full treatment. If Tobacco Redeemer fails to banish the tobacco habit when taken according to the plain and easy directions, your money will be cheerfully refunded upon demand.

### Let Us Send You Convincing Proof

If you're a slave of the tobacco habit and want to find a sure, quick way of quitting "for keeps" you owe it to yourself and to your family to mail the coupon below or send your name and address on a postal and receive our free booklet on the deadly effect of tobacco on the human system, and positive proof that Tobacco Redeemer will quickly free you from the habit.

Newell Pharmacal Company  
Dept. 300, St. Louis, Mo.



## Mail Coupon NOW for FREE Booklet

NEWELL PHARMACAL CO.,  
Dept. 300, St. Louis, Mo.

Please send, without obligating me in any way, your free booklet regarding the tobacco habit and proof that Tobacco Redeemer will positively free me from the tobacco habit.

Name .....

Street and No. ....

Town..... State.....

Please Mention Popular Mechanics



# Make a Pal of the "Master 17"

Have you ever ridden a motorcycle? Did you ever get out in the morning when the dew was still glistening in the fields and meadows along the road? Have you ever heard the song of the Harley-Davidson motor and felt the tingle of the morning air as you sat in the saddle and watched the ever-changing panorama of green and brown flit by? If not, then you have not sounded the keynote of outdoor sports. Let the

## Harley-Davidson

be your pal. Then you can get out under the open sky where the air is filled with the scent of forest, field and stream; with only the sounds of snapping twigs, whispering leaves and rushing streams to break the silence—that is motor-

cycling. That is what it will mean to you to own a Harley-Davidson, for more than 15 years the "Master Motorcycle" and this year better than ever. Greater power, more speed, beautiful military olive drab finish—and perfect in design.

Any Harley-Davidson dealer will be glad to demonstrate for you and will probably make terms to suit your convenience. Write for illustrated catalog.

### Harley-Davidson Motor Co.

484 B Street

MILWAUKEE, WIS.

Also manufacturers of Harley-Davidson Bicycles

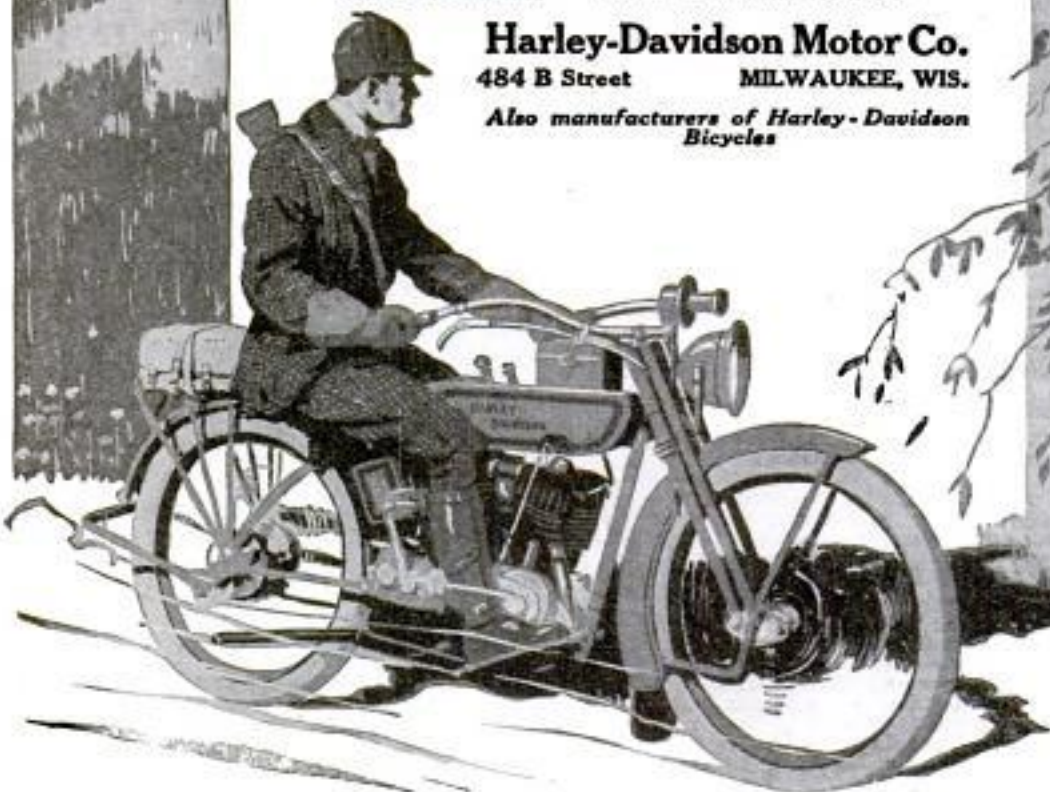

Please Mention Popular Mechanics



# Special Introductory Offer!—



The new Burlington—just out—distributed now for the first time—and on an astounding offer. The superb new model far surpassing everything of the past. 21 jewels, adjusted to positions, temperature and isochronism. New thin design—and all the newest ideas in gold strata cases to choose from. Send coupon today for full particulars.

And—we will send you this master watch without a cent down. If you decide to buy it—you pay *only* the rock-bottom price—the same price that even wholesale jeweler must pay.

**\$250 a Month!**  
Just think of it!  
\$2.50 a month—less than ten cents a day

will pay, at the rock-bottom price, for the New 21-Jewel Burlington—the master watch. This perfect time-piece will be sent to you, prepaid, without a cent deposit so that you can see and examine it for yourself. When you hold it in your hand you will realize what a gigantic value it is—and you will know how the Burlington brought the highest watch value within the reach of all.

## Catalog Now Off the Press

Write today for our new catalog. Read about this gigantic watch value. Learn about watch movements and why 21 jewels are the number prescribed by watch experts. Read what makes a watch movement perfect—and how the Burlington is adjusted to to the second. The watch book is free. Write for it today and get posted on watches and watch values. Send the coupon.

**Burlington Watch Co.** Dept. 1192, 19th St. & Marshall Blvd., Chicago

## 21 Jewels

—adjusted to positions  
—adjusted to temperature  
—adjusted to isochronism  
—adjusted to the second.

Runs almost 2 days in one winding.

On an Iron-clad guarantee.

## Newest

up-to-date ideas in gold strata cases—the master products of the goldsmith's art are illustrated in colors in our new Watch Book. All yours to choose from. Write for the new watch book now.

Burlington Watch Co.  
19th St. and Marshall Blvd.  
Dept. 1192 Chicago, Ill.

Please send me, without obligation (and prepaid), your free book on watches, with full explanation of your cash or \$2.50 a month offer on the Burlington Watch.

Name.....

Address.....

Last chance at old prices—date prices go up will be announced—write at once for catalog.



**BERNARD-HEWITT & CO.,**  
Desk F22, 564 W. Monroe St.,  
CHICAGO, ILL.

Please send me your new Spring style book with 70 samples free — also full details of your special lining offer.

Name .....

Address .....

## MAIL COUPON

For Spring and Summer  
STYLE BOOK

**70** SAMPLES  
**FREE**



# Handsome \$25 Blue Serge Suit Made to Measure only \$15

**A** SPECIAL proposition to introduce the wonderful values offered by our system of tailoring. We have no agents — no dealers — no traveling salesmen — our values make their own customers — and once a Bernard-Hewitt customer always a Bernard-Hewitt customer. That's why, to secure your first order, we are willing to make to your individual measure, a handsome, all pure wool worsted blue serge suit (usual \$25 value) for only \$15 and line it with a

**WE PAY  
SHIPPING  
CHARGES**

**\$4 SATIN LINING FREE**

Remember this suit is made to your individual measure from the very finest all wool blue, light blue, black or gray serge, in the latest approved Chicago style, and by the very best tailors in this whole city.

But perhaps you don't care for a serge suit. Well, our big book which we will send you free contains generous samples of the latest fabrics; plain and fancy mixtures, the up-to-the-minute offering of leading woolen mills.

The \$4.00 Satin Lining free offer goes no matter what selection you make — and we pay all shipping charges. We take all the risk — you none — for this is



**OUR GUARANTEE** You Don't Pay Us One Cent

Unless you are more than pleased in every particular in fit — in style — in workmanship and in materials. Could anything be fairer? Write today — wear real tailor-made clothes — dress better and save money.

**Take Your Own \$10 Measure — Save \$10**

## Write for Your Copy of Our Big Book Today

Our big new Spring and Summer book is ready for you — contains 70 samples latest woollens — also lowest prices on men's hats, shoes and furnishings. It is your guide to correct and economical clothes buying. Mail coupon above or send post card for your copy. Please mention POPULAR MECHANICS so that we can identify this special offer.

## BERNARD-HEWITT & COMPANY

564 West Monroe Street

Desk F22

CHICAGO, ILLINOIS





# Saved \$450

## On This Home

It was built on the Sterling System by a man in New York—(name sent on request.) He says it would have cost \$450 more if built in the ordinary way. All the waste of hand sawing, all the costly mistakes, all unused material, all the "extras" were eliminated. He got his material ready cut, all in shape to erect at once. His price was net. He paid only for what was actually used. He saved on labor also. And he has a fine modern home. Get the facts about the Sterling System by sending the coupon below

# Sterling System of Home Building

The Sterling Ready Cut System of home building is the modern way—the way that saves you money on material and on labor and saves your time. The system that gives you the best designs of the ablest architects without extra cost. Do not build until you see what a big saving you can make by the Sterling System. Compare the Sterling System, which saws the material to exactness with automatic machines with the old handsaw method with all its mistakes (paid for by you). Get the facts. Then decide. We will gladly tell you all about this modern way of building. Let people who have bought Sterling homes tell you of the savings they made. (Names and addresses furnished on request). Get this information without fail before you contract for a home. Also learn how we extend credit, if you want it. Send the coupon now.

# Book of 50 Plans for Homes

With Complete Pictures—10c

Mail the Coupon



This book tells the whole story. It explains how you get the best selected material and pay for only what is actually used in the building. It also shows how you save dealers' and lumber brokers' profits in addition to the saving you make in actual material and time. A real guide to home building. No matter what style of home you build you need it. Send the coupon and enclose ten cents for postage and wrapping.

International Mill & Timber Company  
Dept. 1192 BAY CITY, MICH.

International Mill  
& Timber Company  
Dept. 1192, Bay City, Mich.

I want all the information I  
can get on building especially  
if it will save me money.  
Send your book. I enclose 10c  
for postage and wrapping.

Name.....

Address.....



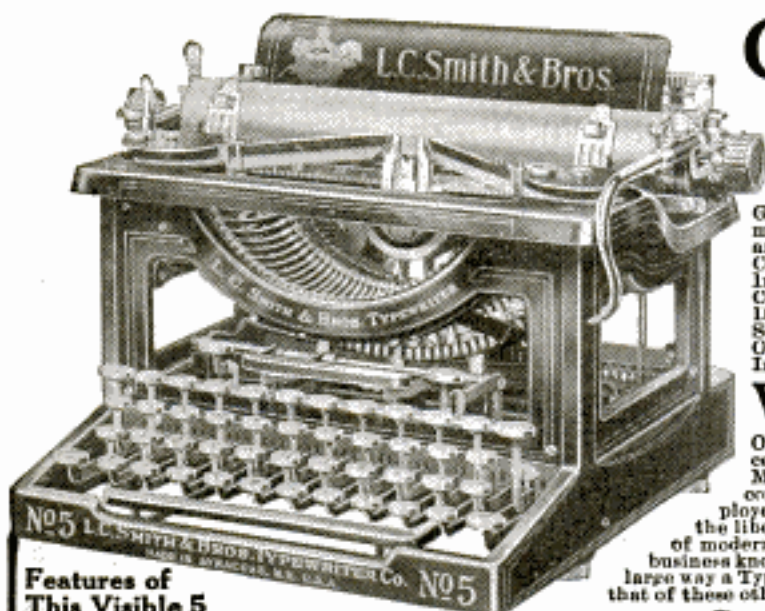

# Great Institutions Use This Typewriter

Therefore you are safe when you use this same Model 5 L. C. Smith Visible Typewriter which scores of this country's greatest institutions, from the United States Government down, use to the number of many thousand machines. Some of the many great users of this Model 5 are Acme White Lead & Color Co., Curtis Publishing Co., Du Pont Powder Co., Firestone Tire & Rubber Co., International Harvester Co., Kellogg Toasted Corn Flake Co., National Biscuit Co., National Surety Co., Parke Davis & Co., Sears Roebuck Co., Sherwin Williams Co., Solway Process Co., A. G. Spaulding & Bros., Standard Oil Co., Swift & Co., Washburn Crosby Co., Westinghouse Interests and six of our greatest railroad systems.

## We Use 500 Model 5's

Our own great business, serving two million customers the celebrated Larkin Factory-to-Family way, requires 500 Model 5's to answer our customers' letters. No one would contend for a moment that our own experts or those employed by other large users of Model 5's could be mistaken in the liberal use of this Typewriter in meeting the complex needs of modern business. Guess has no place in such decisions. Big business knows the merits of all Typewriters before it adopts in this large way a Typewriter as it has Model 5. Profit by our experience and that of these other well known users and possess a Model 5.

## Get the Introductory Price On Model 5 L. C. Smith Typewriters

Just now in assisting L. C. Smith & Bros. Co. in distributing the Factory-to-Family way these factory-rebuilt Model 5's we are quoting to early buyers a "special" Introductory Factory-to-Family price. Knowing the Model 5 as we do from having used it in our own offices for many years, we are certain that Model 5's bought at this "special" price will help us sell many more of the same model to friends of the first purchasers. We know of no Typewriter now on the market which offers such a bargain value as does our offer on this genuine, fully guaranteed factory-rebuilt Model 5. You'll do well to ask now for our introductory offer.

### 100 New 5's Made Each Day

This Model 5 we now distribute direct from the factory to the user, is a current, up-to-date, modern, fully improved Typewriter. This is no obsolete, discarded model, otherwise do you think for a moment that we would conduct our own heavy correspondence with other than the best these makers produce. We have only to state that L. C. Smith & Bros. Co. are making over 100 new Model 5's each day to assure you that this is indeed a down-to-the-minute Typewriter.

**SPECIAL—Model 5's at \$45.30**



### Features of This Visible 5

Include—Ball bearing throughout, Typewriter segment shift, rigid carriage. Automatic ribbon adjustment, flexible paper feed, Lightning escapement, elastic key touch. Inbuilt tabulator and biller, marginal release key. - Automatic paper fingers.

### 30 Days' Trial—Easy Payments—Save \$36

You are to be the sole judge of the merits of this Model 5. Write us in 30 days. If you are not convinced of its great worth, return it at our expense. The trial will have been at our expense, not yours. Our terms permit small monthly payments. Finally, we will show you a decided saving of \$36. Surely you are now interested enough to send the coupon today for all the details of our introductory offer. **DO IT NOW.**

**Larkin Co. Desk TPM-217, Buffalo, N. Y.**

Please tell me all about the Model 5 L. C. Smith Typewriters and quote the "special" Introductory Factory-to-Family price.

Name.....

Address.....

## AGENTS—Make \$100 to \$300



per month easy selling our new Triplicate Sauce Pan. Cooking utensil for 3 different foods on one burner. 400 Specialties — all Whirlwind sellers. Write quick for exclusive territory and large catalogue. **AMERICAN ALUMINUM MFG. CO.** Div. H-T LEMONT, ILL.



## MAKE ANY RANGE A GAS STOVE

Wonderful new device—fits any range or heating stove—burns coal oil like gas. Safe, clean, odorless. Stop carrying coal and ashes. Free literature. Agents wanted.

**COSMIC PRODUCTS CO., 405 S. 4th Street, ST. LOUIS, MO.**

## BLUE-JAY CORN PLASTERS END CORNS IN 48 HOURS

A million corns monthly disappear under Blue-jay. Your own friends employ it. Countless people around you — users of Blue-jay — never let a corn ache twice. 15 and 25 cents at Druggists. Also Blue-jay Bunion Plasters. **BAUER & BLACK, Chicago and New York**

## FIBRE LEGS

**4-LB. FIBRE LEGS—ON EASY TERMS**  
Orthopedic braces for all deformities. Send for booklet. **MINNEAPOLIS ARTIFICIAL LIMB CO., 636 Dear Bldg., MINNEAPOLIS, MINN.**



**SUPERIOR SINCE 1904**

### Over 100,000 in Use

Mostly sold through recommendation. For PERSONAL DESK or GENERAL OFFICE. It checks mental calculations. Buy through your Stationer. Write for 10-day trial offer.

**E. GANCHER, A. A. M. CO.**  
148 Duane Street, NEW YORK

**AGENTS WANTED**

**Golden Gem PORTABLE Adding Machine**

Multiples—Subtracts

# I WANT 200 SALES AGENTS AT \$1200 TO \$3600 A YEAR

To introduce my new Compress and Vacuum Washing Machine to every home in the country, I want 200 additional representatives to begin work at once in their home counties. I consider this machine the most brilliant inventive achievement of the age in household necessities. It is selling faster than anything I have ever heard of—going like wildfire.

## PROFITS START FIRST DAY

No waiting or guessing. The price of only \$1.50 makes a sale at every house—cash business at 200 per cent profit to you. The biggest opportunity ever offered. I want hustlers—men and women who want to make money quick and fast. No large investment needed—business supplies the capital.

**NO EXPERIENCE REQUIRED** Just follow Instructions. Success assured. Frank Greene sold 45 first three days—profit \$45. Mrs. L. O. Marrison made \$90 first three weeks in spare time only. J. H. Goddard took 18 orders first three hours. No talking necessary. Just show it—the order is yours right on the spot.

The Wendell Compress and Vacuum Washer  
Washes Tub of Clothes in Three Minutes

**\$1.50 Selling Price**

Every machine sold on money-back guarantee. A child can use it. Abolishes labor of wash day. Women discard \$15 and \$20 machines for it.

**MAIL YOUR APPLICATION TODAY**

Don't delay. Get your county under contract. No charge for territory. To wait means to lose. Write me a letter or a postal card today. If you are honest and willing to work I will give you the position. Do not let someone else get in ahead of you. I want agents, general agents and managers. Write today—then you will have done your part. Do it right now. Address

**H. F. WENDELL, Pres., Wendell Vacuum Washer Co., 1158 Oak St., Leipsic, Ohio**





# Don't Take Chances!

I own and operate the largest exclusive engine factory in the world selling direct to user.

ED. H. WITTE.

**My Prices are Lowest  
On High-Grade Engines  
My Terms are EASIEST**

GASOLINE ENGINES  
2 to 22 H-P.

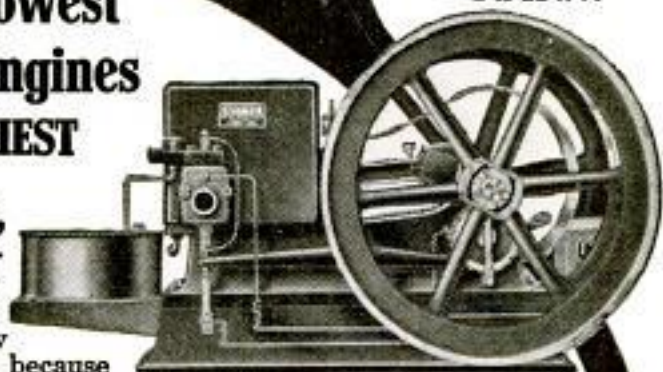

I save you \$25 to \$100, considering WITTE Engine construction. I save you weeks of waiting when you want an engine quick. I save you the trouble of "trying out" engines you know nothing about. I save you future trouble, because my past record of 30 years selling only high-grade engines is a guarantee in itself, that I will make good to you and to every buyer. I save you putting off buying by having four plans of purchase—Cash—Easy Payments—Bank Deposit or No Money Down, letting the engine you select earn its own cost.

## WITTE HIGH-GRADE ENGINES

Are Built to Operate on Kerosene, Gasoline, Naphtha, Distillate Oils, Natural or Artificial Gas.



KEROSENE ENGINES  
2 to 22 H-P.

My engines are exclusive in design, different than any other engine sold direct, easy to understand and operate, and proven doubly desirable through 30 years of selling reliable engines for farm and shop power. I make nothing but engines—give you 100 per cent efficiency in engine building. I buy everything for cash. My factory equipment includes the finest engine making machinery obtainable, especially selected to reduce manufacturing cost. You take no more chance in buying an engine from me than in taking your money from one bank to another. The WITTE 5-Year Signed Guarantee has a million dollar factory back of it, and the factory has a definite future before it. Furthermore, if you want an engine **at once**,

**BUY  
ON YOUR  
OWN  
TERMS**

### Write To WITTE

I can ship immediately—any size or style. Kerosene or Gasoline, Stationary or Portable. Don't make any mistake on the engine you choose, or the price you pay. Get my prices and terms. Try a WITTE 90 days. Learn just what a WITTE high-grade engine will do, and why the WITTE is better on account of better factory equipment, better workmanship, better materials, and sold on better terms.

Read my Free Book, "How To Judge Engines," which fully explains why and how I save you \$25 to \$100.—ED. H. WITTE.

**WITTE ENGINE WORKS,**  
1746 Oakland Avenue, Kansas City, Mo.  
1746 Empire Building, Pittsburgh, Pa.

### FREE BOOK COUPON

ED. H. WITTE, WITTE ENGINE WORKS,  
1746 Oakland Ave., Kansas City, Mo.  
1746 Empire Bldg., Pittsburgh, Pa.

Please send me your Free Book,  
"How To Judge Engines."

Name .....

Post Office .....

State .....

St. or R. F. D. ....

Please Mention Popular Mechanics





## If You Lived As The Cave Man Lived

*Your health would take care of itself.*

The cave man ate coarse food and lived a strenuous life in the open. His digestive apparatus was suited to that kind of an existence.

You inherit from the cave man the same internal mechanism, *but you eat different food and you lead a different kind of a life.*

Hence the almost universal prevalence of constipation and its constant menace to health.

Your problem is to adjust that "cave man" internal mechanism of yours to the sedentary life and concentrated food of civilized man. NUJOL accomplishes this adjustment by preventing the bowel contents from becoming hard, thus making natural movements easy. It doesn't upset the ordinary processes of digestion and it doesn't form a habit.

NUJOL is sold in pint bottles only, at all drug stores. Refuse substitutes—look for the name NUJOL on the bottle and package.

Dept. 68

STANDARD OIL COMPANY

Bayonne <sup>(New Jersey)</sup> New Jersey

# NUJOL

## FOR CONSTIPATION

Send for booklet, "THE RATIONAL TREATMENT OF CONSTIPATION." Write your name and address plainly on the margin below.

*Please Mention Popular Mechanics*



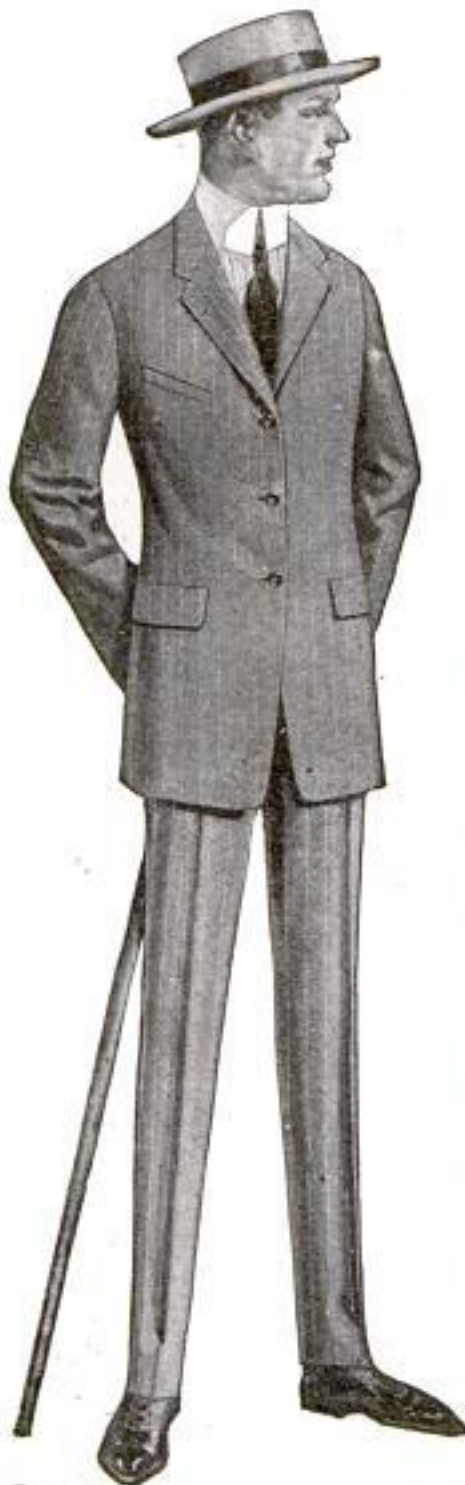

# Genuine, New All-Wool Serge

Made - **\$15**  
to-Order **50**  
For Only **==**

**G**LENN Urquart Plaids—Tartan Plaids, Shepherd Plaids, Fancy and Pencil Stripes, Two tone stripes. Your choice of any cloth, plain or fancy weaves, rough mill finish or smooth finish—tailored to your own measure at prices that will astound you.

## Guaranteed All Wool!

There is not a cotton thread in any of our fabrics. We guarantee it. Nothing but pure wool and pure silk goes into the fabrics from which Babson suits are made.

Send the coupon for our Spring Style Book and read of the remarkable bargains in tailored-to-measure clothing. The newest fabrics—at prices never equaled by any other high-grade house. The All-Wool Serge is but one of the bargains we offer. Just think of it! A genuine All-Wool Serge—made to your measure for only \$15.50.

## On Credit!

Don't decide to buy until you have seen the suit for yourself. Note the perfect fit—note now carefully it is made in the latest style—compare it with any other suit you ever bought—then, if you are not satisfied, send it back.

And, while you buy at the *direct* bargain prices, we also give you time on your payments. (Just as local dealers in your town give their best customers.) Your credit is good with us.

## Spring Style Book and Samples of the Latest Fabrics—FREE

The Spring Style Book is ready. Send the coupon—or a letter or a post card and we'll send the new

Spring Style Book absolutely free. It is handsomely printed in full colors and shows the latest New York styles. With the book comes large generous samples of the all-wool fabrics from which you have to choose. It's just like having a tailor call at your home to get our Spring Style Book. Write for it today. You will be under no obligations.

**Babson Bros.**  
Dept. 1192 Chicago

GENTLEMEN: Please send me your free colored Style Book and 44 large cloth samples of real cloth for suits and overcoats. Also explain your easy credit terms.

## Send the Coupon

For free colored Style Book and 44 large samples of the real cloth for suits and overcoats. We can have your suit ready in 10 days. Send for booklet and free imported samples.

**Babson Bros.** Dept. 1192  
19th Street Chicago

Name .....

Address .....



## NATIONAL Gets Big Hatches

Peter Kilpatrick, Nazareth, Pa., writes, "Have made better hatches than anyone here."

**Money cannot buy greater hatching value**

Hot water heat—double wall—dead air space—asbestos lining—self regulating—ventilating—double glass doors—safety lamp—egg tester. **No extras to buy—easy to operate—will not warp or shrink. Strongest, most durable Incubator made.**



165  
Egg  
Incubator

**Only \$10**

Freight Paid East of Rockies

**40  
DAYS'  
TRIAL  
12 Years'  
Guarantee**

Take no chances. The National is built on U. S. Government specifications. A proven cold weather hatcher. The World's Greatest Incubator Bargain. Send postal today for **Free 1917 Catalog and Poultry Book**—worth dollars to every poultry raiser—or order direct from this ad and save time. **Incubator and brooder both prepaid \$12.50.** Comes set up ready to run, with book of instructions. You take no risk, **satisfaction guaranteed or money refunded.** Don't delay. **SEND FOR POULTRY BOOK TODAY SURE.**

**NATIONAL INCUBATOR CO., Box 155, Racine, Wis.**

## New Kind of Incubator

Wonderful new hatching machine discovered. Poultry profits doubled and trebled. Three-fourths the work, time and money saved. *All the worry cut out.*

### Radio-Round Incubator

Built **ROUND**—nature's way—like the hen's nest. **NO COLD CORNERS.** Triple heating system, wonderful new regulator, **COMPLETE CIRCUIT** radiators, patented heat diffuser **MEAN EVEN HEAT** all through egg chamber, and only *one gallon of oil to a hatch.* Radio Vaporizing Moisture Attachment **BUILT IN,** automatically supplies **JUST ENOUGH** moisture always. Big oil tank filled **ONLY ONCE** for entire hatch. Time saving egg tray; blinged cover with glass panels. Send postal today for **free new FREE** book which describes in detail the 10 wonderful features of the Radio-Round.

**RADIO-ROUND INCUBATOR CO., 282 MAIN STREET, WAYNE, NEB.**



WRITE  
POSTAL TODAY  
**BOOK FREE**

**\$5 Starts You Raising Poultry**

The wonder of the poultry world. A neat, all-steel, mechanically correct incubator. Fifty egg capacity—hatches as large a percentage of eggs as any high priced machine.

### BABY GRAND INCUBATOR

is built with the same care as our world-famous Old Reliable. Has double top, thoroughly insulated, double walls, positive heat and moisture regulation, perfect ventilation. Sent ready to start, by parcel post or express, charges paid, on receipt of \$5 cash, check or money order. This machine will surely satisfy you. Requires little attention. Write for it today. Write for big illustrated catalog.

**RELIABLE INCUBATOR & BROODER CO.**  
Box B-81, QUINCY, ILL.



# ABC

## of Chicken Profits—FREE

Send Johnson your name and get the bedrock facts on making profits with chickens. Learn how Johnson started 700,000 people the simplest and easiest way with

### OLD TRUSTY

Big production makes low price. And Johnson pays freight. Quick shipment—safe arrival guaranteed. Write at once for new book, whether you start now or not. Address

**M. M. JOHNSON CO.**  
CLAY CENTER, NEB.



Tell Me Your Poultry Troubles

Learn About Our 1917 Improvements

## Get 85 Per Cent Hatches!

"We get an 85% hatch every time with our X-Ray Incubator."—Mrs. C. D. McCracken, Greene, Iowa, 1917 model greatest yet. 5 New 1917 Features—each makes greater hatches easier.

### LEARN X-Ray Incubator

—the famous hatcher that takes only one gallon of oil—one filling—for entire hatch. X-Ray Duplex Central Heating Plant—directly underneath—the secret of its phenomenal success.

Express prepaid to practically all ports. Send for 1917 Catalog No. 82. **X-RAY INCUBATOR CO.** Box 82, Des Moines, Iowa

**Get the Free Book**



## DON'T KILL or SELL YOUR LAYING HENS

The Potter System is the greatest discovery of the century. It tells you **How to Pick the "Layers"** from the loafers or diseased hens. Used by over 50,000 poultrymen. Simple and certain. Save food and build up a flock of all layers. New 100 page Potter System Book explains it. Circular free.

**POTTER & CO., 70 Forest Ave., Downers Grove, Ill.**

## Greider's Fine Catalogue

of fine bred poultry for 1917; 67 breeds illustrated and described; information on poultry, how to make hens lay, grow chicks—all facts. Low price on stock and hatching eggs. Incubators and brooders. 25 years in business. This book only **10 cts.** Send today. **R. H. GREIDER, Box 19, RHEEMS, PA.**

## SHOEMAKER'S BOOK ON POULTRY

and Almanac for 1917 has many colored plates of fowls true to life. It tells all about chickens, their prices, their care, diseases and remedies. All about **incubators**, their prices and their operation. All about poultry houses and how to build them. It's an encyclopedia of chickendom. You need it. **ONLY 15c.** **C. C. SHOEMAKER, Box 1107, Freeport, Ill.**

## Large Profits From POULTRY

can be made when you thoroughly understand practical poultry culture and know the proper way to select, rear, house, feed and mate your fowls. In our course of 48 complete lessons, Prof. Quisenberry teaches you how to make a good profit from a flock of hens properly cared for.

**Our Free Illustrated Book—"Dollars and Sense in the Poultry Business,"** tells you how to make money in the poultry business. It leaves nothing to chance or guess work. Write today. No obligation. No agents to bother you.

**AMERICAN SCHOOL OF POULTRY HUSBANDRY**  
Box 75, LEAVENWORTH, KANS.



Please Mention Popular Mechanics



# Smyth's 60 Incubator



On 30 Days' \$  
FREE TRIAL \$  
Holds Full 3<sup>92</sup>  
60 Eggs

To quickly popularize SMYTH'S All Steel 60 Egg Incubator, we will sell 5,000 at only \$3.92 each. Guaranteed to hatch as large a per cent of strong, healthy chicks as any incubator made, regardless of name, make or price. Made of polished steel, with double walled air chamber, 1917 improved disc regulator, standard thermometer visible through glass damper, best safety metal lamp, heat distributing drum around outer edges, water jacketed heat flue and automatic heat regulation insuring even temperature and moisture in every part of egg chamber, and proper heat to eggs all the time. Full directions with SEND \$1.00 deposit and we will send you this high-grade, latest improved SMYTH'S all steel 60 egg incubator by express, subject to examination. Pay balance \$2.92 and express charges to agent after you find the incubator perfectly satisfactory and the greatest incubator bargain in the world, then take it home and TRY IT 30 DAYS at our risk, and if for any reason you are dissatisfied, return at our expense and we will refund your \$1.00 and freight charges. PARCEL POST send \$1.92 and enough money if you want incubator sent by extra to pay the parcel post postage and we'll send on some liberal trial offer as above. Shipping weight 19 lbs. We make very low prices on larger incubators, brooders, and poultry supplies of all kinds in our Big Free Incubator Catalog sent you free upon request.

ORDER INCUBATOR OR CATALOG TODAY.

JOHN M. SMYTH <sup>INC.</sup> CO. 703-792 Washington Blvd. CHICAGO

## 10-Acre Farm Only \$175

\$4 DOWN \$4 MONTH

With 25 fruit trees, abundance of small fruit, 100 chickens. Good soil and water. Best of Markets. Boats and Railroads direct to all main ports and cities. Farm is close to Traverse City, Mich., with 12,000 people. Convenient to depot and canning factory.

FEDERAL REALTY CO., 960 Reaper Bldg., Chicago, Ill.

# RABBITS

Tells all you want to know about Rabbits. Our book: "The Rabbit; How to Select, Breed, and Manage the Rabbit and Belgian Hare for Pleasure or Profit" by breeders of long experience with rabbits. Sixth edition, nicely illustrated, enlarged and much improved. Price 25 cents with sample copy of the American Poultry Advocate containing Belgian Hare Department.

POULTRY ADVOCATE, Dept. 257, Syracuse, N. Y.

## Condon's New Prosperity CABBAGE

Quick as lightning. Hard as stone. One of the earliest in existence. To introduce our Northern Grown "Sure Crop" Live Seeds we will mail you a BIG PACKAGE of Condon's New Prosperity Cabbage and Mammoth 1917 FREE GARDEN and FARM GUIDE.

Send 2c stamp to cover postage.  
CONDON BROS., Seedsmen  
Rock River Valley Seed Farm, Box 743, ROCKFORD, ILL.

HOW TO MAKE POULTRY PAY Our latest book fills the bill. Your success assured. We also want you to see our fine poultry paper. Sold on all First-Class News-Stands. Send 10c today for 4 months' trial subscription. Regular price 50c a year. Address Inland Poultry Journal, 30 Cord Bldg., Indianapolis, Ind.

MONEY IN HONEY—BEES PAY Easy, interesting work. Latest Methods of bee-keeping told in 24-page "Bee Primer." Send 25c for new 3 months' subscription, primer, and bee catalogs to AMERICAN BEE JOURNAL, Box 56, HAMILTON, ILL.

RAISE GUINEA PIGS  
Big Demand Thousands needed weekly. Government figures show a profit of \$9.00 each annually. Experience or special knowledge unnecessary. Send for our money making proposition and big free illustrated book which explains all.  
Laboratory Supply Co., Dept. B, 2841 Ridge Ave., Phila., Pa.



## Join the LARKIN Easy-Payment League

Thousands of homes are happier since accepting our easy payment offers. The Larkin Easy-Payment League now extends to an even greater number of worthy buyers such benefits as "special" Introductory Factory-to-Family Prices, Convenient Monthly Payments, and Liberal Rewards where friends are also induced to accept our offers on

### Symphonic Pianos Symphonic Player Pianos Symphonolas

Which of these three superb instruments would you like to own? Decide now, then we will promptly tell you about the plans of the Larkin Easy-Payment League which permit you to soon have in your home the instrument of your choice. Symphonic Pianos are played by hand, Symphonic Player Pianos by hand or with music rolls, and Symphonolas are playable with Victor or Columbia Records. Why, what enjoyable times you'll soon have with the help of the Symphonic or Symphonola! Please check your choice on the coupon. Send it today. You'll promptly receive the details, and our beautifully illustrated Symphonic or Symphonola Catalog.

Send COUPON for Catalog

Larkin Co. Dept. P-M 217

Buffalo, N. Y.

I am interested in the instrument here checked and also in the plans of the Larkin Easy-Payment League.

Piano  Player  Symphonola

Name.....

P. O. ....

State .....

St. or R. D. ....

Address .....



# Boston Garter

Velvet Grip

Gives men more service and more comfort for its cost than any other article they wear. It's put on and taken off in a jiffy and holds socks neatly and securely. Silk 50; Lisle 25c. At your store or by mail postpaid.  
GEORGE FROST COMPANY Makers Boston

Please Mention Popular Mechanics



# Get This ALUMINUM SET FREE

OR  
CHOICE OF OTHER  
USEFUL PREMIUMS WITH YOUR  
1917 IMPERIAL RANGE

A special offer with every Imperial Range—anelegant Pure Aluminum Cooking and Roasting Combination. Seamless and Sanitary—4 pieces. Makes 12 useful kitchen utensils, as illustrated.

**30 DAYS FREE HOME TEST  
PAY US NO MONEY IN ADVANCE**

We take all the risk. Choose any range you want from over a hundred styles. Try it, test it for 30 days before you decide to keep it. Send it back if not satisfied.

**FACTORY PRICES—WE PAY FREIGHT  
TO YOUR HOME TOWN**

Choose Your Own Terms if you decide to keep your Imperial—Cash or Credit. By dealing direct with our factory you pay manufacturer's prices only, and no freight. You easily

**SAVE \$10 TO \$20** By our new 20th Century methods. 100,000 Imperials now in use. Heavier wire designed. IMPERIAL RANGES are made of highest grade materials. 365 DAY GUARANTEE. Will not warp or crack. Have the marvelous even baking Old Dutch Oven modernized—a STONE OVEN BOTTOM—which holds heat like a Fireless Cooker. Great fuel savers and new kind of PERFECT OVEN BREAD. Get all these without risk in your home before buying any range. Write at once for

**BIG FREE CATALOG**

with "No-Money-Risk" Trial offer. Also valuable Premiums and complete description of Imperial Ranges and their new 1917 improvements. You need this book to intelligently select a range. Write today. A letter or postal will do.

**THE IMPERIAL  
STEEL RANGE  
COMPANY**  
669 Detroit Ave.  
CLEVELAND, O.

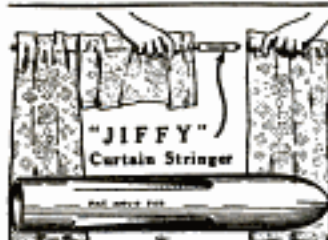
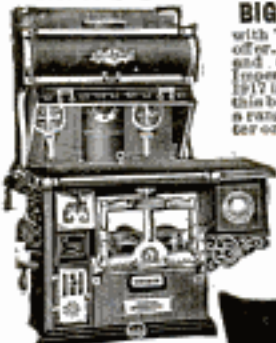

## "Jiffy" CURTAIN STRINGER

"A Handy Thing to Have Around the House"

Slips on to the end of the Curtain Rod, making it possible to string the Curtain on to the Rod in one-tenth the usual time. Protects the Curtain from injury. Fits all standard Curtain Rods. Springs hold it tight to the Rod—it cannot slip off. **Agents Wanted.**

Sample Price, 15c in Coin  
**B. M. Gibson Mfg. Co.,** Nat. Inc.  
Dept. 2, 1702 N. LaSalle St., Chicago, Ill.

Using a  
"Flossy"  
with a  
simple  
bite

Lasts a  
Life-  
time

Easily  
Refilled



Newly invented instrument called

## "FLOSSY"

Cleans where no tooth-brush can reach. 75% of all cavities start between teeth. A sensible and sure way to prevent tooth-decay.

**Reaches All Teeth**

in a simple and sanitary way. Each outfit consists of One Flossy and 15c worth of medicated, perfumed, waxed silk dental floss. An additional supply coupon. A sanitary rubberoid pocket case, and in-50c instructions—all for

**SPECIAL OFFER.**

Six complete "Flossy"

outfits, Mixed-Ebonite-

Vulcanite-Hard-Rubber,

French Ivory and floss sup-

ply coupons postpaid for \$2

Every "Flossy" user perfectly satisfied.  
THE MAKERS OF FLOSSY, Evanston, Chicago, Ill.



**5¢ Or Less  
A Day Will Run The**

## Correct HOVERS

Correct  
HOVER

cost less to buy, less to run. Double-disc tandem thermostat operating double-acting damper (patented) gives perfect self-regulation. Prevents excessive fuel consumption. Requires only one coal supply every 24 hours.

The Correct is self-ventilated, gas-tight, spark-proof. Will accommodate 50 to 1500 chicks and raise them all.

Prices { 42" Canopy \$10.75 | F.O.B.  
          { 52" Canopy 11.85 | Factory

Fully guaranteed. Don't buy unpatented imitations. Interesting FREE literature describes the big value. Write for it today.

**CORRECT HATCHER CO.**  
Dept. 30, LEESVILLE, Carroll County, OHIO.



## AGENTS \$60 WEEKLY

Robinson Folding Bath Tub, Big seller. Costs little, no plumbing, little water. Weighs 15 pounds, folds into small roll. Full length bath, far better than tin tubs. Guaranteed 10 years. \$10 a day easily made. Write for free tub offer.  
**ROBINSON CABINET MFG. CO., 4562 Factoryville Bldg., Toledo, Ohio**

## Big Money In Poultry

My Big Free Poultry Book, "Hatching Facts" tells how you can make money raising chickens—all about My World's Champion Belle City Incubator and Brooder—My Low Price—My

10-Year Money-Back Guarantee and My \$1000 Gold Offers. Your chance to earn extra money. Learn what this means to you before you buy an incubator. Sales to date, \$24,000. Send for this book today. Jim Roban, Pres. Belle City Incubator Co., Box 189 Racine, Wis.



# This 13-year-old Boy built his own Peerless Incubator



My Free Incubator Plan Book tells you exactly how to build the best incubator that can be built. You can build any capacity incubator, single 150-egg size, or Multidek up to 1200-egg capacity—hot air or hot water heated. You can't go wrong and it means a big cash saving to you. I'll supply all the necessary mechanical parts at low cost. They insure you a trouble-proof machine of highest efficiency at lowest operating expense.

**My Sol-Hot Wickless Lamp** is the greatest invention ever offered the incubator world. Makes a clear, blue flame; smokeless, sootless, odorless—intensely hot. Easily attached to any incubator. My Peerless all-metal 60-egg hatcher is inexpensive and insures big hatches. Write at once for my Free Incubator and Brooder Plan Book and Catalog.

**H. M. SHEER CO., Dept. 33, QUINCY, ILL.**





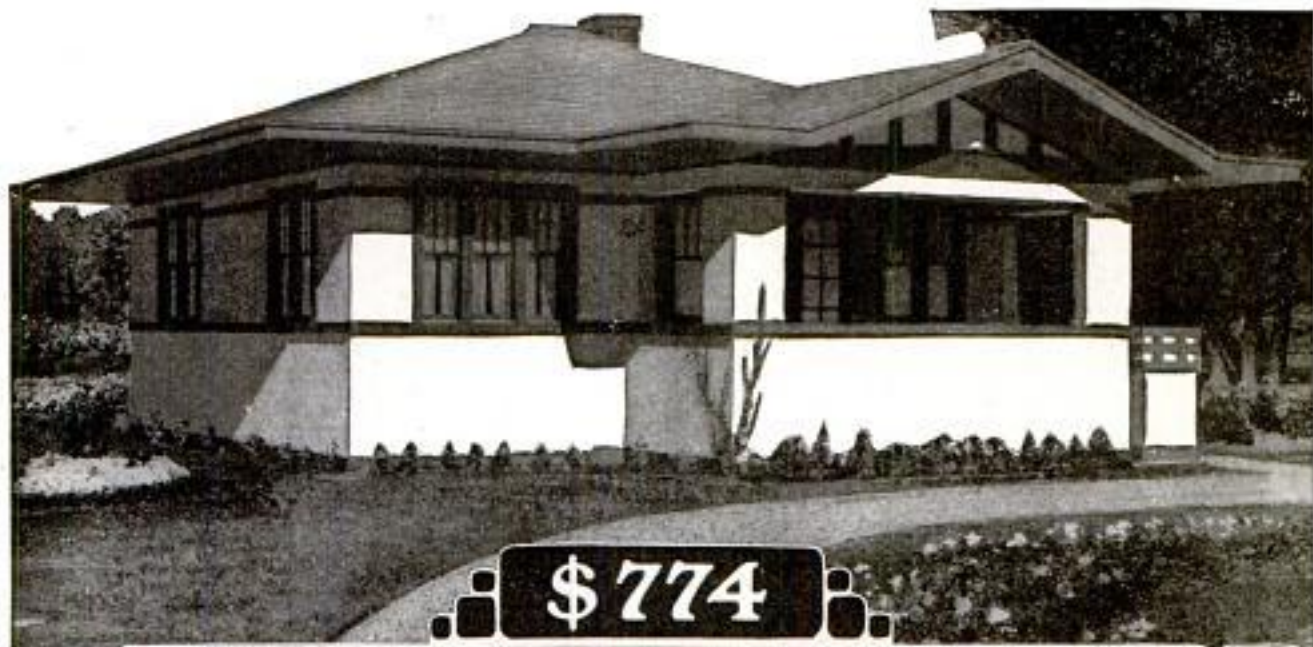

## Distinctive Homes at Guaranteed Costs!

GORDON-VAN TINE HOMES are all sold on a basis of definite, fixed price with everything supplied. We explain fully just exactly what we furnish. No extras to buy—no chance for misunderstanding. And whether you want this house shown or any of our 200 others, you buy at "Mill-direct-to-you" Prices. You save enough to buy your lot. Plans free. Material all highest standard grades; prices lowest. Prompt shipment to you anywhere.

### Write For Mrs. Clara Belle Parker's Advice

Get the help and advice of our Home Building Adviser to Women before you build. She has studied the homes of thousands of American women—the sleeping chambers, the kitchen, a woman's work shop, the living rooms—and if you will tell her your building problems, she can offer you sane, helpful suggestions that will save you construction mistakes.

Tell her approximately what you are going to spend on your new home and perhaps she can suggest to you out of her broad experience, some ideas that had not occurred to you. Address her personally—there is no charge.

### Send For Our New Plan Book—Free!

Our new, free book, "Gordon-Van Tine Homes" is the only plan book pricing houses both Ready-cut and not Ready-cut. Lets you buy either way. Shows over 200 homes—many adapted from plans of America's best architects but for inexpensive building. All tested and proven by being built hundreds of times in every State. Some near you; local references on request. Remember, three banks and over 100,000 customers vouch for our complete trustworthiness. Use the coupon.

2222 **Gordon-Van Tine Co.** 6197 Case Street  
Davenport, Iowa  
Satisfaction Guaranteed or Money Back In Business Over Half a Century

GORDON-VAN TINE COMPANY  
6197 Case St., Davenport, Iowa

Please send me FREE the books checked below:

- Gordon-Van Tine Home Plans  
 Green Houses and Hot Bed for the Home Grower  
 Garages  
 Summer Cottages

Name.....

Street No.....

City..... State.....

Please Mention Popular Mechanics



## "Old Town Canoe"

You folks who appreciate the best canoe will find unlooked-for satisfaction in an "Old Town." It's an Indian canoe, light and swift, yet modern in strength and durability. Skims over the water like a bird, is graceful, easy to paddle, safe, and will last for years.

"Old Town Canoes" are built out of long length, seasoned cedar, close ribbed and clinched with four tacks at each rib. Write for illustrated catalog showing beautiful styles and varieties. 4,000 in stock insure speedy delivery from dealer or factory. \$34 up.

An unusual photograph of an "Old Town Canoe" hull before canvas is put on, showing long length planks.

**OLD TOWN  
CANOE CO.**

1662 Middle St.  
Old Town,  
Maine,  
U. S. A.



## AMERICA'S STANDARD FOUR-CYCLE ENGINE BOAT KERMATH MOTORS



\$225.00  
to  
\$395.00

4 Cylinder 4 Cycle  
10 to 25 H.P.

Used and recommended by all of the best boat-builders. An engine which insures you the most pleasure and service. Extremely smooth operating perfectly controlled and quiet. Catalog on request KERMATH MFG. CO. 95 E. Fort St. Detroit Mich.



## Motor Perfection



is what you get in Watkins Class "B" all iron motors. Especially fine for canoes and light boats. Constant and efficient.

3 H. P. single cylinder	45 lbs.
6 H. P. double cylinder	85 lbs.
12 H. P. four cylinder	155 lbs.

Are light, at the same time strong, accomplished by using semi-steel castings, high carbon steel shaft, bronze bearings, high class workmanship.

**THE WATKINS MOTOR CO.**

837-839 W. 6th Street

Cincinnati, Ohio

## The Engine That Stays in Tune

Absence of vibration is indispensable to continued "sweet-running" of a marine motor.

The Ferro All-Enclosed Four-Cycle "Four" and "Six" for medium-duty are remarkably free from vibration because they are cast in one piece and therefore unusually rigid. This keeps shafts in alignment and gears in perfect mesh, reducing wear and making riding easy. Ferro All-Enclosed Engines have overhead valves, without cages, detachable cylinder heads, removable cylinder sleeves and other distinctive features.

There's a Ferro Engine to Fit Your Boat—Thirteen other models, including 10-H. P. Four-Cycle Four, two-cycle engines from 3 to 25-H. P. and the Ferro Detachable Motor for rowboats.

Write for catalog today. State type of engine in which you are most interested.

**THE FERRO MACHINE & FOUNDRY CO.**  
243 Hubbard Avenue Cleveland, Ohio

**MARINE ENGINES  
FERRO**

## FREE!-3 Books on BOATS

1-Special Boats of 130 Leading Boat Builders.  
2-Gray 2 and 4 cycle Motor Engine Catalogue.  
3-Book of Boat Models for work, fishing, cruising.  
Ask for any (or all) of them if you are interested in boating for pleasure, or profit. Book 1 shows more boats than motor show.

Gray Motor Company  
246 Gray Motor Bld'g.  
Detroit, Mich.



**Racine Wis**



## America's Finest Canoe

Speed, lightness and beautiful finish combined to the highest degree. Write for free catalog showing the many distinctive features of the Racine Wis.

Racine Boat Company, Dept. O, Racine, Wis.

## Write for New SA Engine Book

### Your Engine Makes or Mars Your Motoring Pleasure

So don't decide definitely on the engine for your boat until you have read the new L-A Engine Book—new—just off the press.

It fairly bristles with valuable suggestions and interesting engine information. This new L-A Engine Book describes and depicts in detail the complete line of L-A inboard and outboard motors for launches, row-boats, work-boats, etc. It provides you with complete particulars covering our

**30 DAYS' TRIAL PLAN**

which allows you the privilege of proving the performance of L-A motors before making your final decision. Write for your copy to-day.

LOCKWOOD-ASH MOTOR COMPANY, 1420 Hartou Avenue, Jackson, Mich.



AN SA ENGINE FOR EVERY PURSE AND PURPOSE



## CAILLE 5-Speed Master Motor WHY TAKE LESS?

The Caille 5-speed Rowboat motor is the acknowledged leader in its class. A dozen distinctive features of Caille design and construction lift it from the plaything class into a servicable dependable motor that takes you there and back Every time, and does it on a minimum of fuel.

## 5-Speeds An Exclusive Caille Feature

Why be satisfied with less than the flexibility and ease of operation which the Caille 5-speed feature gives you?

### For Vacation Fun or Business Service

Write today for the Caille Master—motor catalog. Tells all about the full Caille line, which includes Marine motors for all duty from 2 to 30 H. P.

**Caille Perfection Motor Co.**  
1523 Caille Street, DETROIT, MICH.

**To Dealers:** There's a widespread demand—bigger than ever before—for the wonderful Caille Motors and our dealers' proposition enables you to make a handsome profit and helps you to do it.

Write for particulars today.



## Universal MARINE MOTOR

9-12 H. P. 4 Cycle 4-Cylinder. Speed range 300 to 1800 R. P. M. Adapted to boats from 14 to 30 feet. Write to

**UNIVERSAL MOTOR CO.**  
OSHKOSH, WIS. Dept. P

For Bulletin No. 95 giving full description



GET THIS CATALOG  
FULL OF VALUABLE INFORMATION TO EVERY BOAT OWNER ON  
**RACING PROPELLER WHEELS, REVERSE GEARS AND MARINE ACCESSORIES**  
LARGE CATALOG FREE. SEND TODAY  
**MICHIGAN WHEEL CO.**  
1133 MONROE AVE., GRAND RAPIDS, MICH.

## Mullins Steel Boats Can't Sink

When you think of buying a boat, whether it be a 16-foot Runabout, a big 26-foot Auto Boat, or something in between—remember that Mullins Steel Boats are guaranteed for life. They cannot sink, leak, water-log, dry out or open at the

seams—never require caulking. Designed by America's foremost naval architects—built in the largest boat factory in the world. More than 65,000 in use. Big catalog of steel or wooden motor boats, rowboats or canoes, on request.

**THE W. H. MULLINS CO.,** 52 Franklin Street, SALEM, OHIO

## EVINRUDE

Detachable rowboat and canoe motors. Magneto—Built-In Fly-Wheel Type. Silencer and Automatic Reverse.  
Catalog Free Over 80,000 Sold  
**EVINRUDE MOTOR COMPANY**  
563 Evinrude Block Milwaukee, Wis.

## Diamonds \$250 On Credit 2 Month



Your credit is good with us. You wear the Diamond while paying for it at the rate of only eight cents a day.



"DIAMONDS WIN HEARTS"

A Diamond is the ideal gift for a loved one, it lasts forever, and every day reminds the wearer of your regard and good judgment.

### Rock Bottom Prices Easy Credit Terms

Our import prices "direct from the mines to you" cut out all the wholesaler's and retailer's profits. You get the benefit of this saving along with our liberal credit terms—eight months to pay—and you wear the Diamond while paying for it. Our large catalog is free, write for it.

### FREE Examination

You don't pay one cent until you see and examine any article you desire right in your own hands. If you like it pay for it on our easy credit plan. If not entirely satisfied return at our expense.

**GET OUR GREAT 116 PAGE CATALOG.** It contains over 2,000 beautiful illustrations of Diamonds, Watches, Solid Gold Jewelry, Silverware, Novelties, etc.—all the latest and most up-to-date designs at our importer's bargain prices—and easy terms of payment. Send for catalog today before you forget. IT IS FREE.

**LOFTIS** The National Credit Jewelers  
Dept. K894, 108 N. State St., Chicago, Ill.  
BROS & CO. 1523 Street in: Chicago Pittsburgh St. Louis Omaha

## WITHOUT AN EQUAL

The World's Greatest Rowboat Motor

Built on different lines. Has two-cylinder principle which does away with vibration. It does not shake the boat.

### THE GREAT 2-CYLINDER KOBAN ROWBOAT MOTOR

High grade and absolutely dependable. Easy to start and easy to manage—light weight and smooth running—reverses by pressing a button. New devices include tilting device, aeroplane type magneto and many others. Has great speed, yet slows down to a trolling pace. Both cylinders fire at the same time is cause of the absence of vibration. Saves the boat.

Fully explained in new 24-page catalog sent free upon request. **AGENTS AND DEALERS WANTED.**

**KOBAN MFG. CO.,** 291 South Water St., MILWAUKEE, WIS.

Ask about the Great Koban Inboard Motor—A Wonderful Engine for Light Launches or Boats.



Built-In Magneto or Battery Ignition

## WEBER THROTTLE-GOVERNED KEROSENE ENGINES

4-Cycle  
Lowest Priced Throttle-Governed Engine on the Market—Cash or Payments

Saves Half In Fuel. The 1917 model Weber solves the problem of low cost power for all time. Power and speed controlled by throttle, same as steam. No waste of fuel—no violent explosions. Throttle regulates amount of fuel to size of load.

Sold on a Five-Year Guarantee—Two Months' Trial in shop or on farm. Shipped direct from factory at a big saving.

**FREE BOOK—"How to Use Kerosene" and Engine Folder,** sent post-paid. Address

**WEBER ENGINE CO.**  
Dept. 1772  
Kansas City, Mo.

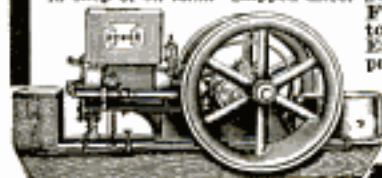

Please Mention Popular Mechanics



# Save Shoe Leather!

Conserve America's Dwindling Supply  
for Its Most Valuable Use!

The world faces a leather famine.

Tremendous war demand, diminished imports, and decreasing supply of cattle have combined to make leather of all grades scarce and precious.

Shoe manufacturers predict that without quick relief, 1917 leather shoes of good grade will retail at \$15.00 to \$20.00 a pair; already prices are up 50% to 100%. Sole leather has already sold for more than one dollar a pound.

The Government is supplying our Navy with shoes having soles made of a leather substitute, and is experimenting with the tanning of sharks' hides to help relieve the leather situation.

## How Motorists Can Help a Lot

The largest leather consuming industry is the shoe business. The second largest is the automobile business. The leather required to upholster the average touring car is enough to make the uppers of three dozen pairs of shoes. The grain leather used on expensive cars makes the best shoe leather. Its increasing scarcity has necessitated large use of split leather in shoe making. The latter is the grade used most in the automobile industry.

The motor-car buyers of America must decide which they will do without—**leather in shoes or leather in automobiles.**

Du Pont Fabrikoid, Motor Quality offers the best solution of the problem. This remarkably successful substitute for leather is already used for automobile upholstery more than all other materials combined. While not yet equal to grain leather it surpasses split leather for upholstery purposes.

Those automobile makers still using split leather admit, to us, that it is inferior to Motor Quality Fabrikoid, but hesitate to adopt it for fear some buyers may still think split leather (commonly advertised "genuine leather") is better. They will gladly adopt Motor Quality Fabrikoid, and thereby greatly conserve the dwindling supply of shoe leather, if you will help.

When buying an automobile tell the dealer you prefer Du Pont Fabrikoid, Motor Quality upholstery. Many dealers in popular makes can and will tell you their cars are so upholstered. Dealers in other cars can get Fabrikoid upholstery if buyers ask for it.

Write us for names of makers now using it.

*If you manufacture any article using leather, ask us if we have a grade of Fabrikoid suitable for your work*

**Du Pont Fabrikoid Company**  
Wilmington, Del. Toronto, Ont.

World's Largest Makers of Leather Substitutes

### Other Ways in Which FABRIKOID is Relieving the Leather Market

For upholstering furniture, buggies, and boats.

For covering books (used by Government Printing Office and hundreds of America's largest binderies).

For making and lining suitcases, satchels, handbags, etc.

For glove gauntlets, sanitary hat sweats, boxes, toys and novelties.

For sock linings, facings and tongues of shoes.

For bathing shoes and slippers.







# Let Me Ship You An Engine To Earn Its Own Cost While You Pay For It!

You don't have to pay war prices for my engine, as the prices are lower than ever before. Careful factory management, labor saving machinery, and help by the men who work for me, has made this possible. Send me your name so I can send you these low prices and the most liberal trial offer I ever made.

GEO. E. LONG

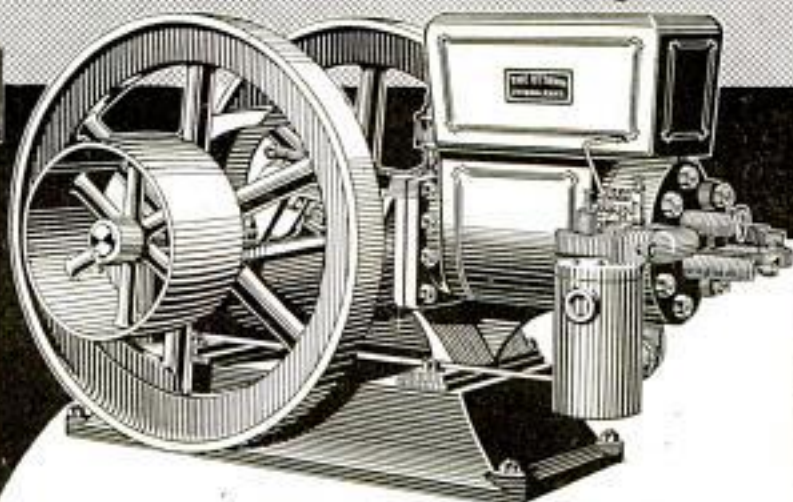

#### Stationary Engines

1½ H.P.	\$ 25.75
2 H.P.	31.95
2½ H.P.	38.90
3 H.P.	49.50
4 H.P.	66.75
5 H.P.	72.50
6 H.P.	93.90
7 H.P.	98.50
8 H.P.	124.75
10 H.P.	139.50
12 H.P.	191.50
16 H.P.	245.50
22 H.P.	369.90

#### Portable Engines

1½ H.P.	\$ 30.40
2 H.P.	36.40
2½ H.P.	44.90
3 H.P.	58.50
4 H.P.	61.75
5 H.P.	99.75
6 H.P.	119.75
7 H.P.	124.75
8 H.P.	149.95
10 H.P.	174.50
12 H.P.	229.50
16 H.P.	289.50
22 H.P.	439.90

## OTTAWA ENGINES

Thousands of men all over this country, in shops, elevators, mills, factories, and on farms, have made my engine pay for itself while they used it. My money-saving terms of purchase make it easier to own an engine than to be without one. Having the largest number of sizes to choose from, you can find a size of engine just suited to your work, and you have your choice of the fuel, for my engines, use

### Kerosene Oil, Gasoline, Distillate, and Gas

My kerosene oil engine is easy to start and as easy to operate as any gasoline engine. With it, you get more power from a gallon of 6 or 8-cent kerosene, than you can get from a gallon of 20 or 25-cent gasoline in any gasoline engine. All sizes are easy to start, easy to understand and manage, and with my lower prices and fuel saving engines, you get the greatest amount of dependable power for years to come, for the small amount of money you put into your engine.

### 90 Days' Trial — 10 Year Guarantee

You have 90 days in which to try my engine at your own work. I have always given my customers this right. Years ago I was the only engine manufacturer selling direct from my factory and the only one who sent every engine out on trial. Now many have imitated my plan of selling, but they haven't built as good an engine, because their engines are still in the experimental stage. You are taking no chances in selecting my engine, as it has been the longest sold direct to the user of any engine in America.

**Cash or Easy Terms** My money saving plan of selling makes it easy for you to own an OTTAWA engine, on terms by which the engine cost can be paid for by the savings of the engine. No need to trade your savings for 5 years to own a good engine when you can get a better built OTTAWA engine to earn its own way while you use it.

**Send for Free Book** You should have a copy of my new book — the most up-to-date book on engine building. Explains how easy my engine starts; how little it costs to operate; how easy to keep it running; cut out coupon and mail to-day and I will tell you the complete story by return mail.

GEO. E. LONG  
OTTAWA MFG. CO.

535 King St.  
Ottawa, Kansas

GEO. E. LONG, Pres.  
OTTAWA MFG. CO.  
535 King St., OTTAWA, KANSAS

Without obligation to me, I would like to receive your latest and finest book "How to Know Better Engines," and your liberal plans of selling.

Name .....

Address .....



The Ottawa gasoline engine on iron wheels equipped with magnets requiring no batteries

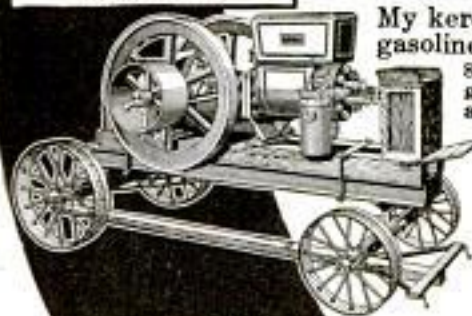

The OTTAWA Kerosene engine on heavy trucks with complete equipment

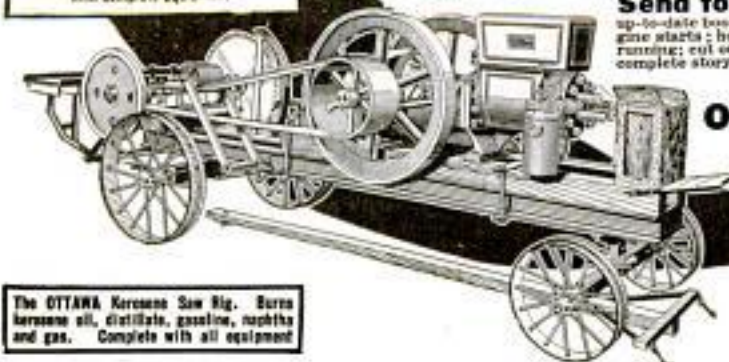

The OTTAWA Kerosene Saw Rig. Burns kerosene oil, distillate, gasoline, naphtha and gas. Complete with all equipment

Please Mention Popular Mechanics



## A Good Bookcase for the price of a good book!



**\$1.75** Per Section and Up  
ON APPROVAL

**Lundstrom**  
IT GROWS WITH YOUR LIBRARY

**The UNIVERSAL BOOKCASE**

Endorsed by Over 100,000 Users

Made for and universally used in the finest homes and offices throughout the country. They are made in sections, combining practical utility, economy and attractive appearance. Above style is beautifully finished in SOLID OAK with non-binding, disappearing glass doors; price: top \$1.25, leg base, \$1.50—combination complete \$8.00. Other styles and grades at correspondingly low prices. On orders of \$10.00 and over we pay freight; freight equalized to extreme western states. Shipped direct from factory ON APPROVAL and at considerable saving TO YOU.

Write for new Catalogue 21-F

The C. J. Lundstrom Mfg. Co., Little Falls, N. Y.  
Mfrs. Sectional Bookcases and Filing Cabinets  
Branch Office: Flatiron Bldg., New York City

**THE BEST AMERICAN MAKE  
ARROW COLLARS**



## Walked On Knees Now Stands and Walks on Feet

**Infantile Paralysis** left Alice Boyles' limbs paralyzed and contracted at the knees. Spinal Curvature also developed. She could not stand, but got about on her knees. Six months' treatment at the McLain Sanitarium enabled her to stand and walk. Look at the pictures. Read what her mother says:

"When I think that Alice used to walk on her knees, and now walks on her feet, I cannot thank you enough."  
MRS. A. BOYLES, Clarendon, Pa.

### FOR CRIPPLED CHILDREN

This is a private institution devoted to the treatment of Infantile Paralysis, Club Feet, Spinal Diseases and Curvature, Hip Disease, Bow Legs, Wry Neck, etc.

**FREE** Our book, "Deformities and Paralysis"—also Book of References. Write

**THE McLAIN ORTHOPEDIC SANITARIUM**  
902 Aubert Ave. ST. LOUIS, MO.

Dredging for coal is carried on quite extensively in the rivers of Pennsylvania, about 250,000 tons being recovered annually. The coal recovered consists of culm waste, lost in the preparation of coal by the so-called wet process. The Lackawanna, the Susquehanna and its north branch, the Schuylkill and the Lehigh rivers carry culm waste for many miles downstream, depositing it in shallows and eddies, back of dams and over valley bottoms.

## Relief to Ruptured People

Any appliance is a truss. Ruptured people must wear some kind of support. Our New Sponge Rubber Pad (pat'd) is velvet, soft to the skin, pliable, cannot slip, extremely comfortable, adapts itself to ruptured parts with less pressure, is sanitary, long lived. Massage and strengthens muscles, allows blood circulation and produces many cures.



**New Scrotal Pad Needs No Leg Strap**  
Our new scrotal pad (pat'd) holds 8 out of 10 cases of hernia perfectly without strap between legs.

**Free Sample Pad** A Sample Akron Sponge Rubber Truss Pad (pat'd) will be sent absolutely FREE upon request, also booklet "Relief to Truss Users." It's full of help. Ask your dealer, or write us.

**THE AKRON TRUSS CO. Dept. 62. Akron, Ohio**

**FREE \$20 Ukulele**



Musicians  
Make  
Big Money

**\$20 Old Masters  
VIOLIN FREE**



Fine Tone

We have a wonderful new system of teaching note music by mail,

and to first pupils in new localities will give a \$20.00 superb Violin, Mandolin, Ukulele, Guitar or Cornet, absolutely free, a very small charge for lessons the only expense. We guarantee to make you a Player or no charge. Complete outfit free. Special offer to first pupil in each locality. Write at once, no obligation.

**SLINGERLAND'S SCHOOL OF MUSIC, (Inc.) Dept. 3,**

**CHICAGO, ILL.**



# No Money In Advance

## Sensational Bargains

Just to prove the high quality of our merchandise and the amazing, unheard-of Hartman bargains in Household Furnishings of all kinds, we will ship any one article on this page without advance payment, without C. O. D., or security of any kind. Make your selection, write name and number in coupon and mail it to us today. **Don't send any money.** We will ship the article promptly. When it arrives, if you consider it a wonderful bargain and you want to keep it, pay only 50c in 10 days and a little each month according to terms in this advertisement. If not satisfactory, return goods at our expense and you will not be out a cent. Remember, only one article on this page to a family, but when you get our Big Bargain Book, you can order whatever you like on the most Liberal Credit Terms offered. Send for book today.

## Special Porch Swing Offer

Here is a full 48-in. Porch Swing, strongly constructed of solid oak, equipped with non-rustable galvanized chains and ceiling hooks. Has attractive panel ends and back. The full shaped comfortable seat is strongly braced underneath by four strong stretchers. This Porch Swing comes in the popular fumed finish, treated with an extra coat of shellac which renders it weather-resisting. Measurements are as follows: length, 48 inches; height of back, 22 inches; arms are 23 inches long by 3 inches wide; seat is 17 inches deep. Comes securely packed in wooden crate.

Order by No. MA272—Price only \$2.98. Terms: No Money in Advance; 50c in 10 days; Balance 50c per month.

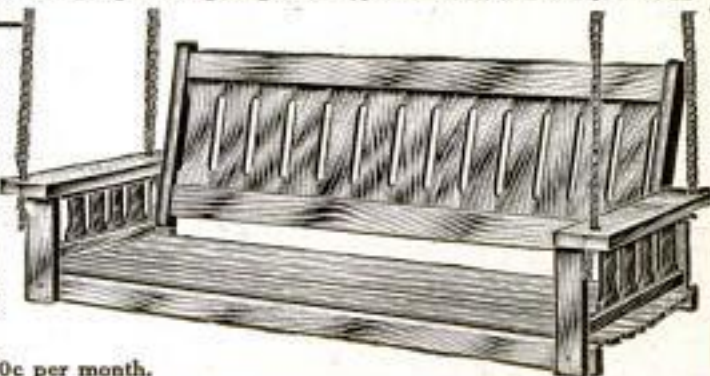

# Only 50¢ in 10 Days

## Collapsible Go-Cart Bargain



Has  
1/2-in  
Solid  
Rubber  
Tires

Nickel  
Hub Caps

Here is a splendid value in a high wood side, full collapsible Go-Cart. Body strongly made of 3-ply veneers, securely fastened by tinned ferrules; neatly enameled and trimmed with gold stripes. Has full tubular pushers, nickel trimmed handle,

sensitive spring, positive foot brake, three position back, adjustable 3-ply hood, nickel hub caps, and many other features found only on higher priced Go-Carts. Has 10 in. wheels; 1/2 in. solid rubber tires; 16 x 28 inch frame; back 11 1/2 x 15 in.; seat 10 x 13 in.

Order by No. MA273—Price only \$10.65. Terms: No Money In Advance; 50c in 10 days; Balance \$1.00 per Month.

## 48-Piece Gold Monogram Dinner Set



Just mail coupon and we will at once ship you the complete set with your monogram initial in gold on every piece. Dishes are of splendid quality pure white Porcelain, decorated with gold bands and your own initial in gold on every piece. Complete set consists of 6 dinner plates; 6 breakfast plates; 6 cups; 6 saucers; 6 fruit dishes; 6 new style soup coupes; 6 butter plates; 1 deep open vegetable dish; 2 meat platters; 1 sugar bowl and cover; 1 cream pitcher. Each dish is full size and guaranteed perfect. Be sure to state initial you wish on your set. Order by No. MA271. Price \$3.98. No money in advance; 50c in 10 days, bal. 50c a month.

## Wonderful Bargain Book FREE



Filled with thousands of wonderful bargains in Home Furnishings, all sold on the Hartman Liberal Credit Plan, backed by the \$12,000,000 Hartman Guarantee. Book shows articles exactly as they look—Furniture, Carpets, Clocks, Draperies, Silverware—everything for the home. We send it to you FREE—whether you buy direct from this page of "get-acquainted" offers or not. Send for it today.

**HARTMAN FURNITURE & CARPET CO.**  
3945 Wentworth Ave., Dept. 148 Chicago

## Mail This Coupon

**Hartman Furniture & Carpet Co.,**  
3945 Wentworth Ave., Dept. 148 Chicago, Ill.

Without any money in advance, please send me article named below. If I keep it, I will pay 50c in 10 days after arrival of shipment and balance in monthly payments as per price and terms quoted in this advertisement. If I decide not to keep it, I will return it to you at your expense.

Name of article wanted..... No.....

My Name is.....

Address.....  
If Catalog only is wanted, write "Catalog Only" on blank line above, fill in name and address and mail coupon today.

# HARTMAN WILL TRUST YOU

Please Mention Popular Mechanics





## Here's Fun, and Lots of It!

You'll like Billiards and Pool better and better as your game improves. Practice makes perfect and everybody, man or boy, wants to play a good game. You'll soon learn to make the draw, follow and cushion shots, the banks, combinations and kisses, if you play at home on your own

# BURROWES

## Billiard and Pool Table

Many famous experts use Burrowes Tables for home practice. They are correct in every detail. The most delicate shots can be made with the utmost accuracy. Burrowes Regis High-Speed Rubber Cushions are unquestionably the finest rubber cushions made.

### \$1 DOWN

Prices of Burrowes Tables range from \$15 up, on terms of \$1 or more down and a small amount monthly. Cues, balls, etc., free. Sizes range up to 4½ x 9 ft. (standard), with smaller sizes for smaller rooms.

### No Special Room Needed

You can put up or take down your Burrowes Table in a moment, on your dining or library table or on its own legs or folding stand.

### FREE TRIAL—NO RED TAPE

On receipt of first instalment we will ship Table. Play on it one week. If unsatisfactory return it, and on its receipt we will refund your deposit. This insures you a free trial. Write for illustrated catalog, giving prices, convenient terms of payment and full information.

**THE E. T. BURROWES CO.**

164 Spring Street, Portland, Me.

Burrowes Tables are now on sale in many cities and towns.

You can inspect them before ordering if you wish.

Please Mention Popular Mechanics

## THE ONLY DIAMOND CUTTERS

IN THE UNITED STATES SELLING  
DIRECT TO YOU BY MAIL



MONEY BACK IN FULL  
ANYTIME WITHIN 1 YEAR

PER CARAT	BUY IN RINGS, PINELETS, ETC.	WEIGHT	BUY THROUGH YOUR BANK
70 <sup>00</sup>	→	1 Carat \$ 5.75 2 Carat \$14.75 3 Carat \$35.00	Genuine Diamonds direct from the Diamond Cutters at Our World's Famous Rock Bottom Prices. As the Only diamond cutters selling Direct we defy competition. Buy Direct, save 40 per cent. We ship on approval anywhere—charges paid. Just send name of bank. Our 176-page catalog explains Our World's Famous Prices. The lowest ever advertised for Diamonds, Watches and Jewelry.
100 <sup>00</sup>	→	3 carat \$27.00 4 carat 58.75 5 carat 75.00	
150 <sup>00</sup>	→	3 carat \$22.50 4 carat 66.00 5 carat 112.00	

**BIG FREE CATALOG**

**J. PRESS & SONS** DIAMOND IMPORTERS  
830 CHESTNUT ST. AND CUTTERS  
PHILADELPHIA, PA. WHOLESALE JEWELERS  
ESTABLISHED 20 YEARS

## TYPEWRITERS

FACTORY  
REBUILT

Buy Right From Our Own Factories  
And Save \$25 to \$75

Up-to-date Machines of Standard Makes thoroughly rebuilt, trade-marked and guaranteed the same as new. Efficient service through Branch Stores in leading cities. Send for latest booklet.

American Writing Machine Co., Inc., 345 Broadway, N. Y.



Bell Telephone highways make you the near neighbor of your farthest-away fellow-citizen.

**AMERICAN TELEPHONE & TELEGRAPH CO.**  
AND ASSOCIATED COMPANIES

One Policy One System Universal Service

## NO MORE BALD HEADS



WHEN our VACUUM CAP is used a few minutes daily. We accept no pay until you have tried the Cap 60 days and are satisfied. The Vacuum Cap is an appliance that draws the blood to the Hair Roots and starts a new healthy crop of hair. It stops Dandruff, stops the hair from falling out.

Bought by Doctors and men who know that it is the only reasonable HAIR GROWER known to science. No Drugs Used. Write for application blank, testimonials, and booklet on "HAIR," sent sealed in plain envelope, FREE.

**THE MODERN VACUUM CAP CO.**

M. 559 BARCLAY, DENVER, COLO.





## The Smoke of the Service

From "rookie" to seasoned trooper—from the old line fighters to the new aerial scouts—every branch of the American army smokes "Bull" Durham. It's part of their equipment in barracks, camp or field. For snappy swing and lively action—for fresh, wholesome, youthful vigor—everywhere our boys in khaki "roll their own" with "Bull" Durham.

GENUINE  
**"BULL" DURHAM**  
 SMOKING TOBACCO

"Bull" Durham is the world's greatest cigarette tobacco. Its mellow-sweet flavor and aromatic fragrance are unique.

"Rolling your own" with "Bull" Durham is a man's art—combining the joys of achievement and of smoking satisfaction.

It's easy to learn—and then you'll know the pleasure of smoking the smoothest, freshest, liveliest cigarette that can possibly be made.

Ask for **FREE** package of "papers" with each 5c sack.



THE AMERICAN TOBACCO COMPANY

Please Mention Popular Mechanics



## WE ARE HEADQUARTERS FOR ELECTRICAL GOODS and WIRELESS APPARATUS

Send Today for a Copy of Our Unrivalled 232 Page Catalogue

THIS IS THE

### Experimenter's Reference Book

It's the latest edition of the famous Amco Catalogue, contains over 700 pages and is fully illustrated. Complete description and prices of the latest electrical and experimental apparatus—Storage Batteries, Rectifiers, Transformers, Induction Coils, Wireless Apparatus, Lamps, Flashlights, Meters, X-Rays, Boats, Yachts, Electric Railways, Steam Engines, Water Motors, Dynamos, Motors, Telegraphs, Telephones, Electrical Supplies, Model Aeroplanes and Parts for building your own apparatus.

**Our prices will save you money and our prompt deliveries will save you time.**

Get in stamps will bring you this wonderful book. Best catalog of Wireless and Electrical Apparatus. etc., published. Send for this catalog right away. Our prices will save you money. **6c IN STAMPS BRINGS IT BY RETURN MAIL.**

**Send for this catalog today. You need it.**

#### FUN WITH ELECTRICITY

Here is a rare chance to get started right in your study of electricity. This wonderful outfit contains 16 page book of instructions and all the apparatus for performing 60 interesting and spectacular experiments which will give any boy a practical knowledge of electricity. **Price Only 50c. Postage 10c Extra.**



#### FUN WITH MAGNETISM

This outfit contains 22 page book of instructions and all the apparatus for performing 51 fascinating experiments. It will give you some new ideas about electricity and magnetism in such an interesting way you can't help remembering it. **Price only 25c. Postage extra 5c.**

#### LOTS OF FUN FOR BOYS!

25 volt, 2 C. P. TUNGSTEN lamp, switch, socket, and 20 ft. insulated wire and 3 cells of dry battery all ready to install. **May be used to light a dark closet or hall.**

**Price only 60c. Postage extra 15c.**

#### LITTLE GIANT MOTOR

is nearly 3 in. high. Runs at high speed on a single cell of battery. Very powerful and may be used to run small toys, etc. **Just the motor every boy has been looking for. Price 50c. Postage 10c extra.**

#### THE SIMPLEX TELEGRAPH OUTFIT

An opportunity for every boy to learn to telegraph and to put up a line with his class. This is a full sized telegraph set, consisting of a fine key and sounder, mounted on a polished base. Will work any distance. An excellent Field Telegraph for Boy Scouts.

**Price, \$1.00. Postage Extra. Weight 2 lbs.**



#### UPRIGHT STEAM ENGINE

A fine engine of the best materials. 9 in. high. The Right Engine for Any Boy. Runs at high speed. Each engine tested at factory and fully warranted. **Price 60c. Postage 10c extra.**



#### SIMPLEX WIRELESS OUTFIT

Every boy wants a wireless. Get in this interesting game and read the messages flying around you. This outfit is the greatest bargain ever offered. Consists of a large double slide tuner, a sensitive detector, condenser, telephone receiver and cord. **Weight 2 lbs. Special Price, Complete, \$2.50. Postage Extra.**

#### UNICOIL ELECTRIC MOTOR

This motor will spin for hours at high speed on a single cell of battery. Develops considerable power. Embodies a new principle in toy motors. The best motor value on the market. **Send Postpaid for 50c. Don't Forget to Send for a Catalogue.**



**ADAMS-MORGAN COMPANY, "The Experimenter's Supply House"**

**25 Alvin Place, UPPER MONTCLAIR, N. J.**



## Vitalize yourself with Violet Rays

Vigor, health and beauty in marvelous, delightful Violet Rays. Any good physician will tell you. Thousands are prescribing Violet Rays. Send for instruction book and learn what it will do for you.

**Sent on Free Trial**

Violetta is the perfected instrument. Produces soothing, invigorating, curative Violet Rays. Used and endorsed for private use by physicians. Use it anywhere. Sent to you on Free trial. Special low price offer.

#### Write for New Free Book

Send for the book on Violetta. Read what physicians say. Post card brings book and all particulars of special offer free. Write today.

**BLEADON-DUNN CO.**  
208 N. Fifth Ave., Dept. CI, CHICAGO



## AGENTS WANTED

for independent hollow-wire lighting systems for homes, stores, etc.; also complete line of lanterns and portable and street lamps. Use common gasoline.

#### AKRON GAS LAMPS

are most improved, simplest and safest of all. Best and cheapest illumination known. Shed a clear, soft, bright, white light of high candle power. Fully Guaranteed. Handy demonstration outfit. Our Agency Proposition cannot be beat. Exclusive territory.

*Write quick for Catalog and Terms*

**Akron Gas Lamp Co., 622 So. High St., Akron, O.**

## 50c TRIAL OFFER FOR 10c BEST KODAK FINISHING

Any size roll developed, 10c. Six prints free with first roll. OR, send six negatives, any size, and 10c (stamps) for six prints. 8x10 Enlargements, 25c.

**ROANOKE CYCLE COMPANY, 54 Bell Ave., Roanoke, Va.**



## DUCK'S BIG 300 PAGE No. 11 Electrical and Wireless Catalog

Mailed on receipt of 8c in stamps or coin which may be deducted on first dollar purchase. Great cost of catalog and low prices prohibit distribution otherwise.

#### What This Big Catalog Contains:

160 pp. Wireless Apparatus; 10 pp. Raw Material; 5 pp. Transformers; 8 pp. Storage Batteries; 15 pp. Telegraph Inets.; 42 pp. Motors and Dynamos; 10 pp. Miniature Lamps; 8 pp. Flashlights; 5 pp. Massage Vibrators; 10 pp. Miniature Railways; 5 pp. Lighting Plants; 10 pp. Ammeters and Voltmeters; 25 pp. Electrical and Mechanical Books; 12 pp. Telephone Equipment; 10 pp. Auto Accessories; 13 pp. Victrolas on Easy Payment Purchase Plan; 30 pp. General Electrical Supplies.

**THE WILLIAM B. DUCK CO., 223-227 Superior St., TOLEDO, OHIO**

The first advertisement, it has been stated, was one written on papyrus 3,000 years ago by an Egyptian who had lost a slave.

## Sunshine Lamp FREE! 300 Candle Power

#### TO TRY IN YOUR OWN HOME

Turns night into day. Gives better light than gas, electricity or 18 ordinary lamps at one-tenth the cost. For Homes, Stores, Halls, Churches. A child can carry it. Makes its light from common gasoline. No wick. No chimney. Absolutely SAFE.

#### COSTS 1 CENT A NIGHT

We want one person in each locality to whom we can refer new customers. Take advantage of our SPECIAL FREE TRIAL OFFER. Write today.

#### AGENTS WANTED

**SUNSHINE SAFETY LAMP CO.**  
703 Factory Bldg. KANSAS CITY, MO.



## DIAMONDS - WATCHES ON CREDIT

1506 \$37.25

3232 \$100

7070 \$25

7075 \$45

9738 \$85

9734 \$50

**EIGHT Months To Pay**  
Pure, Blue-white Diamond while paying for it on our easy terms of **20% DOWN - 10% A MONTH**

Any honest person given credit. No security required. Goods sent prepaid, subject to approval. Binding Guarantees with each Diamond setting. Quality and value and receiving for exchange at full purchase price. **10% DISCOUNT** for cash. Write today for FREE CATALOG No. 5 containing 4000 Photographs of Diamonds, Watches, Jewelry, Silverware, etc. Transactions confidential.

**JAMES BERGMAN** Est'd 1896 **37-39 MAIDEN LANE** NEW YORK CITY



# 6 Months To Pay 6

## Tailor-Made To-Measure

Send for  
Measurement  
Blank and  
Cloth Samples  
Today



This is the most sensational Tailor-Made Suit Offer ever made. You can now have any garment you want—cut and fit in the very latest style—to your individual measurements—and from your own choice of the season's latest patterns, novelties, checks, stripes, etc.—and take six months to pay for it, if, after trying it on, you decide to keep it.

Think what this means to you. No longer need you pay exorbitant cash prices for best Tailor-Made Clothes. We positively give you six months' credit and save you from \$15 to \$25 on any suit you may order. Furthermore, we will send you any suit you may want on receipt of

### Only \$1.00

Send coupon for free Style Book which explains this wonderful offer. No matter what price, style or pattern suit you may want, we will make it to your order and send it to you on receipt of only \$1. After suit arrives and you are convinced that it is the biggest bargain you ever heard of, you may pay the balance of our rock-bottom price on easiest, most liberal credit terms ever devised.

Even if you don't need a suit of clothes right away, don't fail to send for this wonderful book. It gives inside facts about Tailor-Made Clothes that you should know. Tells you how to judge quality; how Stanley-Rogers Clothes are Tailor-Made of the best materials throughout—highest grade interlinings, body and sleeve linings, ivory buttons, carefully hand-sewed buttonholes, etc. Book also shows you how to take your own measurements to insure a perfect fit—and proves to you that we actually

### Save You \$15 to \$25

on any garment you may order. We buy all materials in enormous quantities, direct from the mills, at rock-bottom prices. We do our own designing, cutting and tailoring. And by making every suit in our mammoth establishment and selling direct to the man who wears the clothes, we eliminate all waste and save you the dealer's profits.

### \$1,000 Reward

We will give \$1,000 in gold to anyone who proves that we do not make to order all our men's clothes to individual measurements of each customer. We study your figure from the measurements you send us and meet your individual requirements so that, whether you be tall or short, stout or thin or "just medium," you will be fitted perfectly because each garment is specially made for each person.

### Send This Coupon NOW

STANLEY-ROGERS COMPANY,  
1015 Jackson Boulevard, Dept. 544 Chicago, Ill.  
Please send me FREE, your new Spring and Summer Style Book showing latest Metropolitan Styles, also Cloth Samples and full particulars of your great \$1 down with 6-Months-To-Pay Offer.

Name.....

Address.....

Town..... State.....

Remarkable  
Tailor-  
Made Suit  
ONLY

\$14.<sup>35</sup>

STYLE BOOK



STANLEY-ROGERS CO.

of cloth samples today—sure.

STANLEY-ROGERS CO.,

1015 Jackson Boulevard,  
Dept. 544 Chicago, Ill.

### Big Style Book and Cloth Samples Free

This is the big Fashion Book you must have if you want to see how to dress in the latest fashion at a big saving and on the easiest terms ever offered. Book shows page after page of men's garments designed by our own designers—a wonderful assortment of fabrics—the very cream of the weaves from foreign and domestic mills! Just imagine how swell you would look in a suit from one of our exquisite patterns when made up to your measurements. Mail coupon for wonderful Style Book and big assortment

Please Mention Popular Mechanics

Copyrighted material



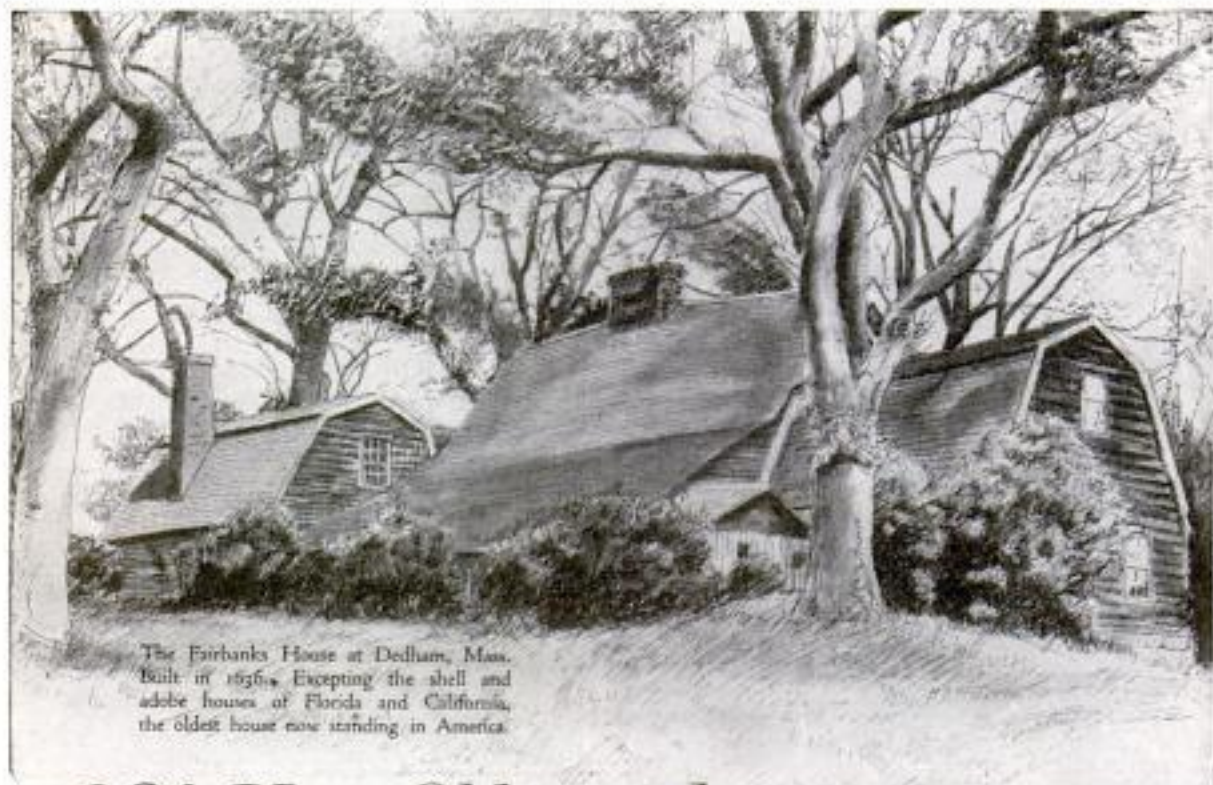

The Fairbanks House at Dedham, Mass. Built in 1576. Excepting the shell and adobe houses of Florida and California, the oldest house now standing in America.

## 281 Years Old—and Still a Comfortable Home

For nearly three centuries this unpainted house has stood exposed to the weather. Continuously occupied and still almost perfectly preserved, it offers convincing proof of the enduring qualities of

# WHITE PINE

Ever since the Pilgrims landed, White Pine has been universally recognized as the wood preferred above all others in home-building. And figuring value in terms of service, it is the most *economical*.

White Pine does not shrink, swell, crack, twist, warp or rot; and once in place it "stays put," after years of exposure, even in the closest fitting mitres and in delicate mouldings and carvings. It takes paints and stains perfectly.

Investigation of the merits of White Pine will well repay anyone seeking a wise choice of building materials.

Send today for our free booklet, "WHITE PINE IN HOME-BUILDING." It is beautifully illustrated and full of valuable information and suggestions on home-building. If there are children in your home, send also for "The Helen Speer Book of Children's White Pine Toys and Furniture," a fascinating plan book, from which a child may build its own toys and toy furniture.

Representing  
The Northern Pine Manufacturers' Association of Minnesota, Wisconsin and Michigan, and The Associated White Pine Manufacturers of Idaho

WHITE PINE BUREAU,  
1226 MERCHANTS BANK BUILDING, ST. PAUL, MINN.



# A New Leaf—

Note  
Corona's  
completeness  
and consider  
that it  
weighs but  
six  
pounds



## Why don't you adopt the modern way of writing?

One hundred thousand people already have been converted to personal typing, and in the year that is before us many more will join the ranks of coronatypists.

You can use Corona without instruction, as the same simplicity which marks its design makes it the simplest machine to operate.

Coronatyped letters are neater, more legible, and more condensed than those written in longhand.

**Corona complete in Case costs \$50**

Write for Catalog 13 and we will send you the booklet illustrated, which tells how to eliminate the drudgery from writing.

**Corona Typewriter Company, Inc., Groton, N. Y.**

New York Chicago San Francisco

Agencies in all principal cities



Please Mention Popular Mechanics





## The New Way—It's a Big Hit KEEPS OUT THE COLD

### The Perfect Garage Door Hanger Set

Allows use of full door opening without risk of damage to car or door, and door cannot swing or blow shut, as it automatically fastens itself open. No extended run-way on either side of building, and no sticking or getting out of order. Can be opened to any width desired, and is weather-tight when closed. Efficient all the year round—particularly so in cold weather, and in this respect, as in all others, it surpasses any other type of hanger. No sawing or cutting of holes necessary to attach.

Ask your hardware dealer—Also send today for descriptive circular, surprisingly low price. DEALERS—Good Profit in This Device.

It sells on sight and the good word is passed along. Architects will want it the minute they see it. Write for terms.

Safety Door Hanger Co., 102 Topping Bldg., Ashland, Ohio

## What Automobile

was first on the American market? What car had the first self-starter? What car holds the world's lowest record for repair expenses? What car is finished to please the taste of each individual buyer? You will find the answers in booklets 74-67, which we will send you gratis upon request.

THE WINTON COMPANY, CLEVELAND, O.



**BIG PROFITS In Charging Auto Storage Batteries**  
Hundreds of garage owners are clearing from \$20.00 to \$50.00 profit each month with the HII Charging Set. Current costs 15 cents per battery and you get from 75 cents to \$1.40 for each battery charged. \$19 places this money-maker in your garage—the balance in monthly payments of \$10.00 each. Every HII Outfit fully guaranteed. Send in this ad with your name and we will send details.  
HOBART BROS. CO. Box 62 TROY, OHIO

## Acetylene Blow Torch Prest-O-Torch

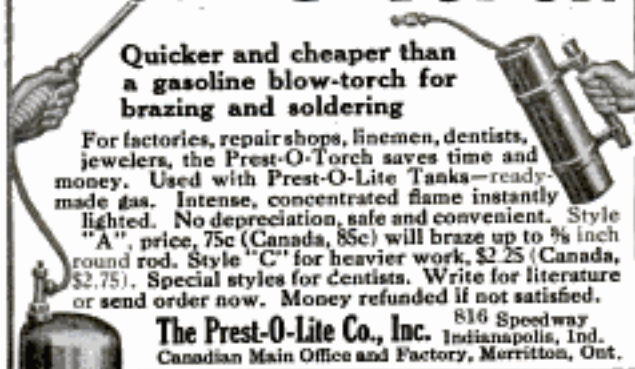

Quicker and cheaper than a gasoline blow-torch for brazing and soldering

For factories, repair shops, linemen, dentists, jewelers, the Prest-O-Torch saves time and money. Used with Prest-O-Lite Tanks—ready-made gas. Intense, concentrated flame instantly lighted. No depreciation, safe and convenient. Style "A", price, 75c (Canada, 85c) will braze up to 3/8 inch round rod. Style "C" for heavier work, \$2.25 (Canada, \$2.75). Special styles for dentists. Write for literature or send order now. Money refunded if not satisfied.

The Prest-O-Lite Co., Inc. 816 Speedway  
Indianapolis, Ind.  
Canadian Main Office and Factory, Merrittton, Ont.

## Look Out! \$350 Hand Horn

No Batteries Needed

For \$225

Equal to ordinary \$3.50 Horns

### RIVERSIDE Hand Horn

Long-life, hardened steel mechanism. Satisfaction Guaranteed or Money Back. Send for FREE AUTO BOOK. Write house nearest you.

Montgomery Ward & Co.

Dept. C133  
New York Chicago Kansas City  
Fl. Worth Portland, Ore.

Made of pressed steel and spun brass

Send today for free book, "The House that Jack Fixed"

Goodell-Pratt Company  
Greenfield, Mass.

Toolsmiths



## NEW MONEY-MAKING PLAN

Write today for special agents' proposition, selling used Motorcycles.

No Money to Invest

C. H. LANG

1704 Michigan Avenue, CHICAGO, ILL.



WHENEVER you see a bicycle equipped with KOKOMO Tires you'll know that the owner wanted the best—knew the best—and got it! Ask your dealer for KOKOMOS. KOKOMO RUBBER CO. Kokomo, Ind.

LONG-LIFE  
**Kokomo**  
BICYCLE TIRES



4 days' use a month pays dividends on the investment if it's an

# OSTER

PIPE-THREADING MACHINE



## No. 300 A

Threads straight pipe, bent pipe, and nipples from  $\frac{1}{4}$  in. up to 2 inches; bolts from  $\frac{7}{16}$  to  $1\frac{1}{4}$  in. Finished with belt or motor drive.

Other sizes thread 1 to 4 in.,  $1\frac{1}{4}$  to 6 in. and  $2\frac{1}{2}$  to 8 in.]

third says: "Saves 40% of former pipe-threading expense." There's a book called "Actual Pipe-Threading Experiences" which tells about these machines in detail in stories told by users. Write for it and get our catalog also.

## The Oster Manufacturing Co.

2100 E. 61st St., Cleveland, Ohio, U. S. A.

Catalog of  
"Bull Dog"  
Die - Stocks  
on Request

Please send "Actual Pipe-Threading Experiences" and catalog to

Name .....

Address .....

City.....State.....

Occupation.....(2100)



**Build a WAR Aeroplane**

"Ideal" accurate Scale Drawings enable you to EASILY build 3 Ft. Flying Models of Aeroplanes now used in the European War. Students of Aeronautics, everyone with an inquiring turn of mind, should construct one of these fascinating models.

Prices of 3 Ft. Scale Drawings

Curtiss Flying Boat 25c	Bleriot Monoplane 15c
Curtiss Military Tractor 25c	Taube Monoplane 25c
Hydroaeroplane 35c	Wright Biplane 25c
Nieuport M'n' plane 25c	Cessal Peoli Racer 25c

Complete Set of Eight, \$1.60 postpaid

Get 50-page Aeroplane Book, containing full information about models, parts, etc., 5c postpaid.

Ideal Aeroplane & Supply Co., 82-84 West Broadway, New York

**for that HACKING COUGH**

Get quick relief from the irritating cough, soothe the throat, stop the tickling and help the bronchial tubes with

**BROWN'S BRONCHIAL TROCHES**

—speedy, effective and harmless—contain no opiates. Handy to carry. Successfully used for over 60 years.

Regular Sizes, 25c, 50c, and \$1.

**New 10c Trial Size Box at your Druggist**

If your dealer cannot supply you, we will mail any size, upon receipt of price.

**John I. Brown & Son**  
Boston, Mass.

Does The Socket Chafe Your Stump?

BUCHSTEIN'S VULCANIZED FIBER LIMB

which is soothing to your stump, cool, neat, light, walls not much thicker than a silver dollar, strong

Guaranteed 5 Years!

Sold on easy payments to good people. D. Buchstein  
Co., 113 6th St. S., Minneapolis, Minn.

**DIAMONDS ON CREDIT**

Let us tell how you can wear a LYON Blue-white Diamond while paying for it. Only 20% down and 10% a month. Sent prepaid for inspection. No Security required. A binding Guarantee Certificate with each Diamond.

ASK FOR CATALOG No. 3  
10% discount for Cash.

**J. M. LYON & CO.**  
71-73 Nassau Street NEW YORK

7174 \$150

7271 \$50

7144-\$100

7261 \$30

7109 \$75

7206 \$50

7120 \$200



See Oct 10  
for 1917

At work and at play,  
out-doors and in, many  
and many a man's best  
friend is his Wellington  
Pipe. Get yours.

*The*  
**Wellington**  
THE UNIVERSAL PIPE

is made of genuine French  
Briar with a solid vulcanite  
bit. Its well catches all  
moisture — insures  
a cool, clean, dry  
smoke — always.

35c and up  
at good dealers

WM. DEMUTH & CO.  
New York

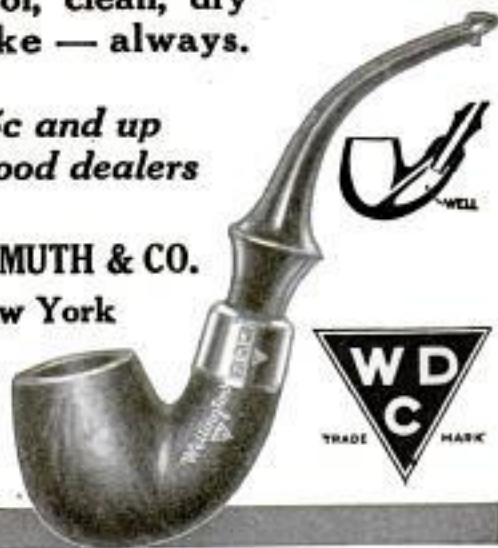

Please Mention Popular Mechanics

**SARGENT**

REG. U. S. PAT. OFF.

## Automatic-Set Bench Planes

A new and superior type said to be  
the best by mechanics who  
have used them



Intended for both heavy and very fine cuts  
and especially adapted for working against  
the grain on cross-grained hard wood.

The features are the automatic set, a great  
time saver; the rigidity, which insures good  
work; and the ease of adjustment.

These features are fully explained and the  
six sizes of these Planes described in the  
Sargent Plane Catalogue, a copy of which  
will be sent free on request.

**SARGENT & COMPANY**  
49 Water St., New Haven, Conn.

**WONDER OF THE 20th CENTURY**

You want this. Great pocket curiosity. Shows lead  
in pencil; you apparently see thru clothes; even flesh  
appears to be transparent and bones can be seen.  
Think of the fun you can have! NEVER FAILS!  
Lasts a lifetime. Complete X-Ray, 10 Cents.

OAKS MAGIC CO. Dept. 376 OSHKOSH, WIS.

## WHITE FLAME

BURNERS make your old kerosene lamps and lanterns  
give a brilliant white light better than electricity or  
gas. Doubles your light. Saves oil. NO MANTLE TO  
BREAK. Guaranteed Safe and Reliable. Delights  
every user. Send now for complete sample postpaid 25 cents,  
stamp or coin. 5 for \$1. MONEY BACK IF NOT SATISFACTORY.  
Live Representatives Wanted. Exclusive Territory.  
WHITE FLAME LIGHT CO., 68 Clark Bldg., Grand Rapids, Mich.



## 1917 Spring Suit

A WONDERFUL  
**Free** *amazing*  
**OFFER**



If you are a live wide-awake man we  
want you to get one of our elegant  
Spring suits, made to YOUR  
measure, absolutely FREE. All we ask  
you to do is wear it, show it to  
your friends and take a few  
orders for our high grade, Made-  
to-Measure Clothes.

**\$25 EXTRA A WEEK AND YOUR  
OWN CLOTHES FREE**

Does it look good to you for a little  
extra time? Write at once or simply  
send us your name on a postal and we  
will send details of this "STARTLING  
OFFER." We will also send you FREE  
a large assortment of cloth samples and  
dozens of fashion plates to choose from  
**NOTHING LIKE IT EVER OFFERED**  
by any other Tailoring House. We don't  
ask you to spend your cash profits for  
your clothes. Ours is a new and better  
idea. Write at once, be the first in  
your town to get this FREE suit.

SPENCER MEAD COMPANY  
Dept. 1689 CHICAGO



# PATENTS

**IF YOU HAVE AN INVENTION** which you wish to patent you can write fully and freely to Munn & Co. for advice in regard to the best way of obtaining protection. Please send sketches or a model of your invention and a description of the device, explaining its operation.

All communications are strictly confidential. Our vast practice, extending over a period of seventy years, enables us in many cases to advise in regard to patentability without any expense to the client. Our Hand-Book on Patents is sent free on request. This explains our methods, terms, etc., in regard to *Patents, Trade Marks, Foreign Patents, etc.*

All patents secured through us are described without cost to the patentee in the *SCIENTIFIC AMERICAN*.

**MUNN & CO.**  
SOLICITORS OF PATENTS  
672 WOOLWORTH BLDG., NEW YORK  
and 625 F STREET, WASHINGTON, D. C.



## Runs on Alcohol Kerosene, Gasoline, or Gas

No electricity, wires or springs. Convenient. Much cheaper to operate than other fans. Roller bearing. Reliable. Brings genuine comfort and satisfaction. Ideal for the sick room. Fourth season. A proved success. The Wonder Fan. Model A, 12" blades, \$16.50. Model B, 21" blades, \$22.50. Cash with order only. F. O. B. Chicago.

Lake Breeze Motor, 548 W. North St., Chicago



## Watches On Credit High Grade WALTHAM and ELGIN MOVEMENTS

We sell the finest watches made. No matter where you live,

### YOUR CREDIT IS GOOD

Better goods at lower prices. Write for Big Free Catalog of Watches, Diamonds, Jewelry, Silverware and our Easy Terms of Payment.

MILLER-HOEFFER COMPANY  
793 Miller Bldg., Detroit, Michigan



## Don't Wear a Truss

**Brooks' Appliance**, the modern scientific invention, the wonderful new discovery that relieves rupture will be sent on trial. No obnoxious springs or pads.

### Brooks' Rupture Appliance

Has automatic Air Cushions. Binds and draws the broken parts together as you would a broken limb. No salves. No lies. Durable, cheap. Sent on trial to prove it. Protected by U. S. patents. Catalogue and measure blanks mailed free. Send name and address today.

C. E. BROOKS, 126 State St., Marshall, Mich.

# Big Bargains in ROOFING

Siding—Ceiling—Wall Board—  
Paints—Garages

Write at once for our Big Roofing Book illustrating and describing every kind of Sheet Metal Roofing and Building Material at Rock-Bottom Prices.

We are the largest manufacturers of Iron and Steel Roofing in the world. We sell direct to you—save you all middlemen's profits—and PAY the FREIGHT to your station. Get our low factory-to-consumer prices NOW!

Reo Metal  
Cluster  
Shingles



Spanish  
Metal Tile

## EDWARDS

### Reo Metal Shingles

cost less, yet outwear three ordinary roofs. Absolutely proof against the elements. All joints and seams are water-tight, because the Edwards Patented Interlocking Device makes them so. No warping, breaking or buckling. Nails are driven through holes which are covered by upper layer. This makes them permanently weather-proof.

### Edwards Exclusive Tightcote Process

makes our products absolutely rust-proof. Not a pin point space of steel exposed to the weather.



Garage  
\$69.50  
and Up

Wide variety of styles, all sizes of Portable Fireproof, Metal Garages, \$69.50 and up. Lowest prices ever made. Postal brings Big Garage Catalog free.

Edwards Patent  
"Grip Lock"



Corrugated

### Edwards Products Stand the Galvanizing Test

Take any other galvanized steel, bend it back and forth several times, hammer down each time, and you'll be able to flake off great scales of galvanizing. Apply this test to Edwards Galvanized Metal Roofing—you'll find no flaking.

### FREE Roofing Book

quotes Rock-Bottom Factory Prices on Roofing, Siding, Ceiling, Wallboard, etc. Send for it. It's the biggest offer ever made. Send coupon for Book No. 250.

**FREE  
Samples &  
Roofing Book**

THE EDWARDS  
MANUFACTURING CO.  
200-250 Pike Street  
CINCINNATI, OHIO

Please Send FREE samples  
Freight-Paid Prices and World's  
Greatest Roofing Book No. 250.

NAME.....

ADDRESS.....

Please Mention Popular Mechanics



# A Pointer from West Point



LIFETIME VALET SERVICE

Less than 1c a Month

TAKE a tip from West Point Cadets, the best turned out men in the world—*press your trousers by a Heatless method*, as they do. Don't let the tailor scorch your trousers with a hot iron while the wet steam rots the cloth. Get the famous West Point trouser crease, knife-like from belt to boot—by automatic heatless pressing. It's only \$1.00 for

## Leahey's HEATLESS Trouser Press

(Protected by U. S. Letters Patent, No. 1,112,922)

No operating cost for this wonderful money-saver. First cost the last cost. No worry, no inconvenience, no loss of time, no skill required.

**New Trousers for Old**  
every day of your life. Be spick and span—be envied for your appearance. Good appearance pays banker or clerk.

**Less Than a Penny a Month**  
Makes you the best-groomed man in your set for the rest of your life. It's a Creaser, a Presser, a Stretcher, and a Hanger, all combined in one.

Fold the HEATLESS Press with trousers in it, in suitcase, closet—over back of chair—ANYWHERE!! Your trousers last 50% longer.

### Cut Out Tailor's Bills

Takes one minute to put trousers in Heatless Press. Automatically ready in the morning. This press pays for itself the first month in tailor's bills saved.

### Try It—At Our Risk

At your dealer's—or mail the coupon. One dealer sells 30,000. Dealers, write at once.

### MONEY BACK COUPON GUARANTEE

AUTO VACUUM FREEZER CO., (Trouser Press Dept.) 22WB W. Broadway, NEW YORK CITY  
Enclosed find \$1, for which please send me postpaid one Leahey's HEATLESS Trouser Press. If at the end of 10 days I do not wish to keep it, I will return it to you and you will return my dollar.

NAME.....

ADDRESS.....

**Elegant 21 Jewel Watch \$5.50**  
21 JEWEL MOVEMENT 14K GOLD PLATE CASE  
5 YR. GUARANTEE OPEN FACE OR HUNTING STYLE

**\$5.50** 21 JEWELS

Thin Model  
C. O. D.



21 JEWELS

Send your name and address, and we will send you this watch by prepaid parcel post or express. When it arrives, pay Agent \$5.50 and watch is yours. If not satisfied after ten days' trial we will refund your money. Order Now. Catalog Free.  
M. BYRNE & CO., Dept. DW, 115 S. Dearborn St., CHICAGO, ILL.

## LOCAL SALESMEN WANTED

by growing manufacturer; selling building trades contractors, dealers, jobbers; cities 5,000 and over. Liberal Commission, exclusive territory. State present line, territory. Address  
MR. VAN, 26H West Lake Street, CHICAGO

## This Used Piano

Splendid bargains—all standard makes—Steinway, Knabe, Emerson, Kimball and others—\$45 to \$195. Also second-hand player-pianos \$195 to \$325. No money down. 30 days' free trial. Lowest payments. 50 free music lessons with every piano.

### Big Piano Book Free

containing beautiful illustrations of new Starck Pianos and a vast amount of piano information. Write today for latest bargain list.

P. A. Starck Piano Co., 92 Starck Bldg., Chicago



## Build Your Own Boat



The above 17-footer, complete K. D. frame, together with all hardware to finish the boat . . . **\$48**

### Fastest Boats in the World

V-bottom Models from 15 to 22 Feet Long

WE furnish knock-down boats complete—all kinds and sizes—everything cut to shape and fitted—with full sized paper patterns and illustrated instructions for the amateur builder. There's both pleasure and profit in boat building. You save over  $\frac{2}{3}$  the cost.

Send for Our FREE Catalog

## BROOKS MFG. COMPANY

8202 Ship Street Saginaw, Michigan

The largest plant of its kind in the world

## Build This Speedster \$4 yourself



From Any Ford of materials bought at hardware stores using our full size Red-i-Kut patterns & simple instructions. Send two \$2 bills today—Write NOW.

THE KUEMPEL CO., Design Dept. 2, Dubuque, Iowa

## MOTORCYCLE BARGAINS!



Single and Twin. Hendersons, Harleys, Indians, Excelsiors, Kutters, Fishbens, Thors, Pops, All makes guaranteed, A-1 shape. Toned up ready to ride. \$85 to \$100. Motorcycle tires \$3. Lamp \$5. Automobile tires \$3. Bicycles \$3. Tap-dance \$25. Old motorcycles takes in trade. Highest prices allowed for them. Swap in yours. SEND FOR CATALOG.

DENINGER, The Price Cutter, ROCHESTER, N. Y.

Erickson Artificial Limb Co., 38 Wash. Av. N., Minneapolis, Minn.



We are Under Govt. Bond

## New Automatic Adder \$2.50

Makes adding easy for anyone. It's accurate, quick, durable and easily operated. Capacity 999,999.99. Saves time, brain work and eliminates errors. Thousands of pleased owners. Guaranteed one year. Delivered complete for \$2.50. ORDER YOURS TODAY. AGENTS WANTED.  
J. H. BASSETT & CO., Dept. 30, 5921 Indiana Ave., Chicago, Ill.



# LEPAGE'S GLUE 10c

HAS HUNDREDS OF USES



**Saves**

**On  
His  
Coal Bill**

**Half**

**Same big Saving guaranteed to you!**



Nine rooms heated with an UNDERFEED at one-half the former cost. Not a mere haphazard saving; but a guaranteed saving—a saving that you, too, can enjoy. Read the letter:

*"The UNDERFEED is heating nine rooms and gives very successful results with about ten tons of soft coal per season. You can always rely on my putting in a good word for the UNDERFEED as it is saving me at least 50% in my fuel bills each season." (Signed) Herman W. Koch, 723 Chestnut St., Burlington, Wis.*

**WILLIAMSON UNDERFEED  
Furnaces and Boilers  
Cut Coal Bills 1/2 to 3/4 Guaranteed**

The burning principle of the UNDERFEED is that of a candle held right end up. The fuel supply is always below the clean, efficient flame. Fire is never smothered or chilled. Smoke, soot and gas—all valuable heat elements—are consumed as they pass up through the flame.

Because of this scientific principle, the UNDERFEED burns the cheaper grades of coal cleanly and effectively—to a white ash—no clinkers or partly burned coals. Clean, uniform, ample heat throughout the house.



**Helpful Book Free**

It is called "From Overfed to UNDERFEED." Pictures and describes it all. Explains how easily operated by a boy. Whether you heat with warm air, hot water, steam or vapor this free book will save you money—for coal cost is actually reduced 1/2 to 3/4, guaranteed with the UNDERFEED. Send coupon for it today—NOW.

**The Williamson Heater Company  
25 Fifth Avenue CINCINNATI, O.**

**The Williamson Heater Co.  
25 Fifth Ave., Cincinnati, O.**

Tell me how to cut my coal bills from 1/2 to 3/4 with a Williamson Underfeed.

Warm Air.....Steam or Hot Water.....  
(Mark X after System interested in)

Name.....

Address.....

My Heating Contractor's Name is .....

Heating Contractors! Let us tell you about the Williamson UNDERFEED and our proposition. Both are winners.

**Pompeian HAIR Massage  
For Dandruff**



**Would You Like to Make Money**

by saving money for others? It is **EGGINE** a sure way and you can do it with **EGGINE**. Takes the place of eggs in baking and cooking, at less than 9c a dozen. Makes finest, richest cake you ever tasted. A pure-food product of highest quality. Expert cooks delighted. Always fresh. Large pkg. and particulars 10c postpaid.

**CHAS. T. MORRISSEY & CO.  
4414 Madison St. Chicago, Ill.**

**DIAMONDS ON CREDIT**

**BEAUTIFUL DIAMONDS SENT ON APPROVAL**

**NO MONEY DOWN.** Order any diamond from our catalogue; we will send it, all charges paid. After you have made a thorough examination and are satisfied as to the quality and value, pay 25 per cent of the price and only 10 per cent per month thereafter. If not satisfactory, return it at our expense. Don't pay a cent until you are satisfied. Certificate furnished guaranteeing the quality of every diamond. Exchangeable at any time for any other article at an actual increase in value of 7 1/2-2 per cent MORE than you paid. Own a genuine Diamond. Send for our Catalogue De Luxe No. 6. It's free. **L. W. SWEET & CO., Inc., 2 & 4 Maiden Lane, New York City**











© 1917 S. M. S. Co.

# No Cash Orders

## Take a Year or More on Home Things

We do not solicit cash orders. Bankers and workers all buy here on credit. Over two million homes have charge accounts here now.

### No Red Tape

No references are required. Simply ask for our catalog and your Credit Card will come

### No Money Wanted

We never ask a customer who is on our books to pay any money down. They wait until after the 30 days' free trial in the home.

The first payment is not due for a month. Our customers get the goods, use them a month, and approve them before paying a penny.

### Fine Steel Bed, Spring and Mattress



A  
Little  
Monthly

\$11<sup>35</sup>

A Year to Pay

Our Spring Bargain Book shows this bed outfit and other remarkable values, too. It tells how to order on a year's credit. Full continuous design steel bed has corner posts and top rails 1-16 inch thick. Five upper filling rods are 5-16 inch thick. Notice circular casting in center. Bed is made of good quality Bessemer steel. Bed stands 57 1/2 inches high at head and 38 1/2 inches high at foot. Can be furnished in either white enamel or famous Vernis Martin all-gold finish. Spring is extra strong link fabric; cotton top mattress is well made.

No. L4B6008. Price, bed, spring and mattress, \$11.35

No. L4B6009. Price, bed only..... \$5.35

## Spiegel, Mau, Stern Co.

1291 W. 35th Street, Chicago

with it. Order then what you want on 30 days' free trial, subject to return.

### Pay 3 Cents a Day

Pay as convenient—a little each month. Do this by saving 2 or 3 cents a day. Take a year or more on each bill. We never hurry people, and never charge interest.

### Save 50 Per Cent Now

Just now we can save you up to 50 per cent. Our present stock was bought on yearly contracts made in 1915. While it lasts we sell at 1915 prices. In a month or two they must enormously advance.

Our Bargain Book shows over 5000 home things, many in actual colors. It costs us with mailing \$1.50 per copy, but we send it free.

Send the coupon now for it. Save this big advance. Never again will such prices be quoted, we think.

### A \$1.50 Book Free

Picturing 5000 Home Things

Furniture	Baby Cabs—Cameras
Carpets—Rugs	Silverware—Clocks
Refrigerators	Chinaware—Lamps
Draperies—Linens	Sewing Machines
Curtains—Bedding	Kitchen Cabinets
Oilcloth, etc.	Stoves—Ranges

SEND COUPON FOR IT

Ask also for our Style Book picturing  
1000 Spring Styles for Women

SPIEGEL, MAU, STERN CO.  
1291 W. 35th Street, Chicago

Mail me your Spring Bargain Book  
Also the books I mark below.

..... Stove Book ..... Watches and Jewelry.  
..... 1000 Spring Styles for Women.

Name .....

Address .....

Check which catalog you want. (1189)



## Oxy-Acetylene Welding and Cutting

This welding repair on broken crank shaft, in large textile mill, saved time and money.



## Makes Large Savings On All Metal Repairs

By oxy-acetylene welding, it cost only 50c to make this broken crank shaft good as new. Welding thus effected not only a considerable saving over ordinary repair methods, but also saved much valuable time.

For quick, permanent repairs to defective castings, broken machinery parts and tools, you will find oxy-acetylene welding most valuable in your plant.

But the profitable uses for welding are by no means limited to repair and reclamation work. Nearly every manufacturer of metal products of any importance now uses oxy-acetylene welding to make his product simpler, stronger, neater, and at lower cost.

Investigate the economies and advantages of welding in the construction of your product, and for hundreds of metal-joining operations in and around your plant.

**Prest-O-Lite**  
PROCESS

Employs both gases (acetylene and oxygen) in portable cylinders. Prest-O-Lite Dissolved Acetylene (ready-made carbide gas) is backed by Prest-O-Lite Service, which insures prompt exchange of full cylinders for empty ones. Provides dry, purified gas, insuring better welds, quicker work, and lower cost, and also avoids the large initial outlay and heavy depreciation incurred in making crude acetylene in a carbide generator.

Necessary equipment is not expensive. We furnish high-grade welding apparatus for \$60 (Canada, \$75); acetylene service at additional cost. Adaptable for oxy-acetylene cutting by the addition of special cutting blow-pipe. Thorough instructions are furnished free to every user of Prest-O-Lite Dissolved Acetylene—any average workman who understands metals can learn the process quickly and easily.

If you are interested in developing extra profits in your plant, find out what welding will do for you. Illustrated literature and specific information sent on request.

### Get in Business for Yourself

Ambitious mechanics can make quick and positive profits doing oxy-acetylene welding for others. There is a large and growing demand for this class of work. Investigate.

### The Prest-O-Lite Co., Inc.

The World's Largest Makers of Dissolved Acetylene

U. S. Main Office and Factory  
816 Speedway, Indianapolis, Ind.

Canadian Office and Factory  
Merritton, Ontario

53 Branches and Charging Plants

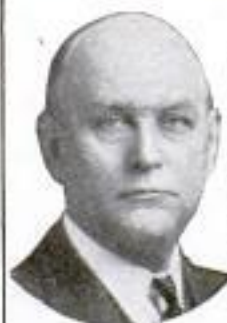

**Let Me Show You That You Can Hear!**

Don't say that it cannot be done— Had Mr. Bell said that, there would have been no telephone. I have shown over 265,000 deaf persons that they can hear distinctly and have thousands of grateful letters from them, mainly because I said to them what I now say to you— "My company does not want a cent from you until you know that the Acousticon will make you hear." Just send a line and say "I will try the Acousticon." We will immediately send you, charges paid, the

**1917 Acousticon for No Deposit FREE TRIAL No Expense**

After you have given it any test that you choose it is entirely for you to say whether you will keep or return it—at least you will know whether you are among the hundreds of thousands of fortunate ones to whom it does restore normal hearing. And it will have cost you nothing to try—not a cent.

**WARNING!** There is no good reason why everyone should not make as liberal a trial offer as we do, so do not send any money for any instrument for the deaf until you have tried it!

The ACOUSTICON has improvements and patented features which cannot be duplicated. No matter what you have tried in the past, send for free trial of the ACOUSTICON today and convince yourself—you alone to decide. Address me personally if you prefer. K. M. TURNER, Pres.,

GENERAL ACOUSTIC CO. 1307 Candler Building, New York

**K E L L Y**

Quick Detachable  
WIRE WHEELS

Safest for the Motorist—Most Profitable  
for the Dealer!

CRAFTSMEN MOTOR CORPORATION  
2815-19 Wabash Ave. Chicago, Ill.

Warner's  
"Infallible  
Automatic"

"The PISTOL that  
SHOOTS and HITS  
THE MARK"



Before buying ask your DEALER about \$10.00 Warner Infallible. Get the best and save at least \$5. Booklet describing this marvelous pistol sent on receipt of stamp. WARNER ARMS CORP., 56 Chambers St. Department P. N., NEW YORK CITY

15  
Quick  
Shots  
  
32  
Cal.

SENT ON APPROVAL

NO MONEY DOWN \$2—A MONTH

Buy a genuine Elgin Now. 17, 19 and 21 Jewels—25 year gold cases direct to you at rock-bottom prices. Write today for **New Free Catalog**

Our Special Offer enables you to own a fine Elgin or any other standard watch or a perfect Diamond without missing the money. 200,000 satisfied customers. Get posted. Write today.

HARRIS-GOAR JEWELRY CO.  
Dept. 2085 Kansas City, Mo.





**The  
Rex**  
—  
**Mail  
Coupon  
for  
"Typewriter  
Secrets"**

# Now \$200

**O**NLY \$2.00 down now puts the brand new Rex typewriter in your possession. Then, small monthly payments. Write for "Typewriter Secrets" and all about this great, new Rex offer. The typewriter which was built because the world's greatest merchandise house wanted a better machine. Absolutely the finest typewriter which can be made. Guaranteed for ten years. (Other typewriters guaranteed for only one year.) Sent anywhere on trial. See it—use it before you make up your mind.

With the brand new Rex, we have smashed typewriter prices. This is a \$100 machine if ever a typewriter was; but we have put the price so low we've made them gasp. A startling, revolutionary figure! Don't think of fooling around with a second hand, rebuilt typewriter when you can have the new Rex (with every good point of every machine and many exclusive points of its own) at a price which will utterly astound you. Our ten years' guarantee should convince you of the supreme excellence of this machine. Used now by leading merchants, banks, railroads and professional men.

## Mail the Coupon For Free Book!

Find out about our amazing typewriter price-smashing. Get "Typewriter Secrets." A book which has set them all on edge. If you want a \$100 typewriter and want it proved to you that it IS a \$100 typewriter, and want it at a price you won't believe possible until you read how we do it—send this coupon. Get our free book. Mail coupon now.

**Rex Typewriter Co.** Dept. 1192 **Chicago**  
Steger Bldg.

**Rex Typewriter Co.,**  
Dept. 1192, Steger Bldg., Chicago  
Please send me your book, "Typewriter Secrets," and your offer on the Rex Typewriter. I assume no obligations in sending this coupon.

Name .....

Address .....



## Our Remarkable Camera Offers Will Save You Money!



Autographic Vest Pocket Kodak special with F. 7.7 Anastigmat lens. Regular \$10 Model for \$8.25. Send today for Bargain Bulletin B

**W**E will absolutely save you from 15 to 50 per cent on any camera you want and back the outfit by 10 days' trial.

Our stock includes everything from a Brownie to a Graflex. Now you can get the better machine that you have wanted. Trade your old outfit to us and get one of the latest models.

Our 30 years' successful camera experience backs you.

Don't continue to pay high prices. Write us today for catalog showing new and used machines. It means money to you. Address

**DAVID STERN COMPANY**

The National Camera Exchange

1047 Madison Street

CHICAGO, ILL.

The **Rockland** SPECIAL

\$2.00 down  
50¢ a week

**S**END for full description of this wonderful Illinois **Rockland**. The finest 19-jeweled thin model watch on the market. You can buy it on easy terms in 20-year gold, dust-proof case at a price that will surprise you. Write today

**LENOX JEWELRY COMPANY**  
20 YEARS OF HONEST DEALING  
373 WASHINGTON STREET, BOSTON



Highest Award Gold Medal San Francisco Exposition

### Your Washing Done for 2c a Week Electric or Water Power Will Do the Work

I have built a new "1900" power washing machine. I consider this machine the most wonderful washer ever put on the market. Tub built entirely of high quality sheet copper, it is the strongest and most durable machine made. It is constructed on a brand new principle and I will guarantee that this machine will not tear clothes, break buttons or fray the edges of the most delicate fabric. It will wash everything from heavy blankets to the finest lace without damage to the goods.

This new "1900" washing machine can be connected with any electric socket instantly and is started and stopped by a little "twist of the wrist" and it will do your washing for 2 cents a week.

I also make a lighter power machine which can be run by water or electric power. On most of these machines the motor will run the wringer too. Just feed in the clothes and this power wringer will squeeze the water out so quickly and easily you will be astonished. It will save 50% time, money and labor every week. The outfit consists of washer and wringer and either electric or water motor, as you prefer, and I guarantee the perfect working of each.

I will send my machine on 30 days' free trial. You do not need to pay a penny until you are satisfied this washer will do what I say it will. Write today for illustrated catalog. Address: H. L. Barker, 6326 Court St., Binghamton, N. Y., or, if you live in Canada, write to the Canadian "1900" Washer Co., 355 Yonge St., Toronto, Canada.

## Kennebec Canoes

give more real pleasure at less cost than most anything else in the world. Send for our free 1917 canoe book.

**KENNEBEC BOAT & CANOE CO., 49 R. R. Sq., Waterville, Me.**

### BOYS! WONDER OF THE 20<sup>TH</sup> CENTURY GIRLS!



**BOYS!** You want this GREAT NOVELTY! Apparently see the bones in your hands, lead in a pencil, see through cloth, etc. Think of the fun you can have. Prices for complete X-Ray and CATALOG 10c, 3 for 25c, 7 for 50c, coin or stamps. AGENTS WANTED. Address

**UNIVERSITY SUPPLY CO., 6151 University Avenue, CHICAGO**

## BAUER KEROSENE ENGINES

Write for free catalogue of the guaranteed, better-built **BAUER Kerosene** engine, before you arrange to try any engine. Sizes, 2, 3, 5, 7, 9, 12, 15 and 18 H.P. Prices average under \$16.50 per horse-power. Cash or Easy Terms. **60 Days' Trial; 5-Year Guarantee.** **A. F. BAUER ENGINE & MFG. CO., 471 Bauer Block, Kansas City, Mo.**

## IMPERIAL SELF HEATING IRON BURNS KEROSENE

Unquestionably the most efficient self-heating iron ever made. Absolutely safe. Simple. No odor. Convenient size and shape—irons 8 hours for 1c! Produces beautiful finish. Soon saves cost. Takes drudgery out of ironing day—saves walking back and forth.

### HIGH GRADE AGENTS WANTED—MEN AND WOMEN

No experience necessary. Every home a prospect. Every housewife, mother, seamstress needs this wonderful iron. Liberal guarantee. Write today for details of quick selling plan. **Imperial Brass Mfg. Co., Dept. 157, 1210 W. Harrison St., Chicago**

Please Mention Popular Mechanics



# Be An Expert Tire Repair Man

## Earn \$2500 TO \$4000 A YEAR

Here's the chance you have been waiting for—the chance to be as big as your ambition calls for—the chance to earn as much money as you think you are worth. Write today. I'll show where the money is in the automobile business. I'll show you how to "cash in" on the opportunity 30,000,000 tires opens for you. Yes, sir, there're 30,000,000 tires to be made this year—all will need repairing—demand expert attention and you can do this work with a Haywood Tire Repair Plant. I have openings now for 200 ambitious, energetic men. I need them at once for 200 centers where motorists are demanding my Tire Repair Service. I am making a limited special offer—have opened my FREE training school where you can learn this business in two weeks without one penny spent for tuition. Remember, you must act at once. Sign and mail the coupon today.



**Come to Indianapolis  
at My Expense  
I'll Teach You  
FREE!**

If you determine to go into the tire repair business, and get a Haywood machine, I will teach you the whole business in my thorough training school. I will pay your railroad fare to Indianapolis up to 300 miles. I will teach you in a week all about tires, and how to repair them. My school is FREE absolutely. No charge whatever for tuition. You can become an expert.

## HAYWOOD'S NATIONAL TIRE REPAIR SERVICE

### Autoists Demand It

Through my national advertising, I have educated motorists everywhere to this superior tire repair service. When you open a Haywood shop, you are established in business—a business of **unlimited profits**—a business you don't have to wait for, that comes with scarcely a bid for it. All you need is one Haywood machine.

Besides this, as you grow, you can add accessories, sell tires, the right tires—the kind auto owners want and which give them the best service. This is the most wonderful year in the automobile industry. More tires being used today than ever before. Costs of operating car is steadily climbing, and every man, regardless of wealth, knows Tire Repairing economy. Tires are the biggest item in up-keep expense. Repairing them is the biggest money-making end of the automobile business.



### Act Quick!

I have a big interesting book to send you—a book about tires—it tells all about them—how they are repaired by the Haywood method—explains this business—gives inside figures and profit. Gives actual proof of success—letters of others who are now operating Haywood shops and making big money. What these men have done, you can do. \$2500 to \$4000 a year is conservative. Sign the coupon and mail it today. Or send a post card or letter.

M. E. HAYWOOD, Pres.

**Haywood Tire & Equipment Co.**  
638 Capital Ave. Indianapolis, Ind.

### My Tire Repair Plants

Haywood Tire Repair Plants are the last word in efficient and economical tire repairing. Haywood experts are recognized as the world's best tire repairers. The machines are complete. Not a detail is lacking. They vulcanize and mend tires from the smallest puncture to retreading, even matching popular treads of tires. One machine will give you a start. Just a small investment—\$50 and up—a trifling amount. You take no chances. It is not a gamble. You can see business around you—everywhere there are automobiles there are tires that need repairing. You know that. All you do is open a shop—put out a Haywood sign, and auto owners will come to you—welcome you and the service you bring them. If you haven't seen the "Sign of the Man and Machine" there is a big opportunity awaiting you.

### Mail Coupon Today

M. E. HAYWOOD, Pres.

**Haywood Tire & Equipment Co.**  
638 Capital Ave., Indianapolis, Ind.

Dear Sir: Please send me your book on Haywood Tire Repair Plants and full particulars of your National Tire Repair Service and details of your free school of tire repairing.

Name .....

Address .....

Please Mention Popular Mechanics



# Make \$1,500 to \$3,000 This Winter

Work Right In Your Own  
County, All or Spare Time

## Profits Start First Day—Success Assured

Wonderful new business—a golden opportunity for one good hustler in every county. **No experience required. No risk. Samples furnished**—just follow easy instructions and work honestly—for yourself. If you want a high-class position—if you want to make the winter months count—if you want **\$1,500 to \$3,000 cash** for five months, write today.

## Amazing New Home Invention The Shafer Ventilated Chemical Indoor Closet

No plumbing—no waterworks—no cesspool. **Banishes the outdoor closet.** Revolutionizes living conditions in country and village homes. Solves the one humiliating and perplexing country home problem. An imperative necessity to health, comfort and convenience. Perfected by heating and ventilating engineer. **Tested in 2000 homes for three years.** Gives positive satisfaction. **Demanded everywhere.** A sale at every home. **Thirty days' free trial guarantee.** Low priced—warranted for ten years. Illustrated book free, showing pictures of homes and rooms containing this wonderful device, complete description, letters of endorsement from health authorities, doctors, editors, and scores of users with full names and addresses. This book is free—send for it today—investigate!

### \$112 In Eight Hours

That's the record of one man in a single day. **The same man has never sold less than five closets for any half day's work.** Every home a prospect. Every sale makes dollars—not pennies—of profit. Biggest money-making opportunity ever offered. Liberal commission. Permanent business. **Exclusive agency contract.** Territory free. Cooperation, advertising, assistance. Business supplies the capital.

### Agents' Outfit FREE

Send no money. No order required to start. We start you **FREE.** We teach you how to make amazing success. Write now. Secure your county under exclusive contract. **Don't delay.** Write a letter or card giving name of your county and mail it today. Risk a stamp to get complete free information. **Do it right now—your part.**

**THE SHAFER MFG. CO.**  
442 Colton Bldg. Toledo, Ohio



Price  
Complete  
Only \$15



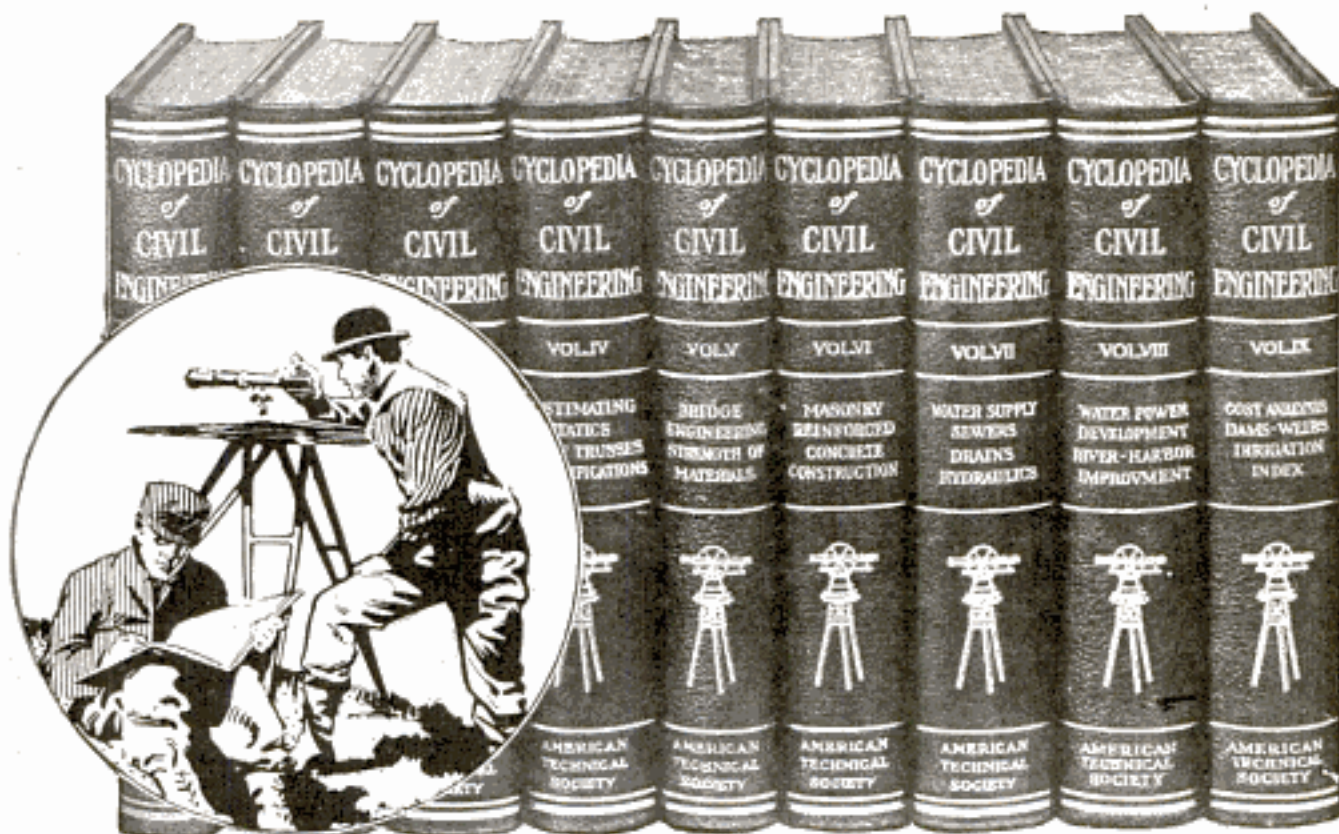

# —50c a Week—

**Y**ES, for this trivial sum, less than most of us spend for tobacco—you can get this magnificent Cyclopedia of Civil Engineering. We are making an astounding introductory offer right now. The regular price of the set is \$45.00 but we are making a special price of \$29.80, only a little more than half, to those who send the coupon immediately. And this special price may be paid at the rate of 50c a week.

## All About Civil Engineering!

In the nine volumes of the Cyclopedia of Engineering you get the information that is needed by the beginner, student, or expert. All written in simple, easily-understood language and carefully cross indexed. Every technical point made clear.

Civil Engineers earn \$1500 to \$5000 a year. These are ordinary salaries. The increased use of reinforced concrete, the growth of the good roads movement and the demands of the reclamation work calls for more men trained as civil engineers. You can fit yourself for one of these high salaried positions through the use of this set of books.

We will send you this complete set, prepaid, upon your simple request. Nine volumes, 3900 pages (7x10 inches), 3000 illustrations, plates, maps and diagrams, bound in half red Morocco, gold stamped. All you need to do in order to get the library on free trial is to put your name and address on the coupon.

### Partial List of Contents

Surveying, Highway Construction, Railway Engineering, Earth-work, Estimating, Bridge Engineering, Masonry, Reinforced Concrete, Water Supply, Sewers and Drains, River and Harbor Improvements, Irrigation Engineering, etc.

## FREE Consulting Service

With each set of the Cyclopedia of Civil Engineering we give you, absolutely free, a year's Consulting Membership in the American Technical Society. The regular price is \$12.00, but you get it free with the set. Ask as many questions as you wish for a year. A corps of experts will help you with your problems.

## Don't Send a Penny Just the Coupon!

Just put your name and address on the coupon—do not send a penny—and we will send you the entire set, prepaid, for seven full days' free examination. If you decide you can get along without the books, send them back at our expense. If you decide to buy, send us \$2.00 after seven days, and \$2.00 a month for the balance. This offer is open to every resident in the United States and Canada. Send the coupon today—NOW!

**American Technical Society** Dept. C 1192 Chicago, U. S. A.

**American Technical Society**  
Dept. C-1192 CHICAGO, U. S. A.

Please send me the nine volume set of Cyclopedia of Civil Engineering for seven days free examination. If I decide to buy, I will send you \$2.00 in seven days and balance at \$2.00 a month until \$29.80 has been paid. Then you will send me a receipt showing that the \$25.00 set of books and the \$12.00 Consulting Membership are mine and fully paid for. If I think that I can get along without the books, will return them after 7 days at your expense.

Name.....

Address.....

Reference.....



# WANTED! WE WANT 300 AGENTS AT \$35 TO \$70 A WEEK

**NEW INVENTION** —just out. Needed in every home every day. Patent just applied for. Nothing else like it. Supplies what every housewife has wished for for years. Perfected after long experimental work by mechanical experts. Low priced—anyone can use it—**sells on sight**. We want three hundred representatives at once—men or women hustlers—to advertise, accept orders and manage deliveries for our new **Quickedge Knife and Shear Sharpener**. Sharpens any kitchen knife, paring knife, carving knife, bread knife or shears and scissors in **ten seconds**. Agents are taking orders at every house—wiring for rush shipments. Write today for this opportunity to make \$10 to \$20 every day.

## MAKE \$300 NEXT MONTH

This little machine is a mechanical masterpiece. A child can use it. Just put knife in slot—turn crank—**grinds automatically**—draws blade to keen, sharp, perfect, lasting edge **at absolutely correct bevel for daily use**. Nothing to adjust—nothing to change, nothing to get out of order—**absolutely guaranteed**—will last for years. Once they see it and use it, women will not do without it for several times its cost. One agent wrote: "It was easier for me to learn to sell the **Quickedge** than it was to learn to tear open my pay-envelope in my former dollar-a-day job." Get out of the dollar-a-day class. Get this position, where profits start the first day.

## No Experience Required

Just take one of the machines to any house and show it—give a ten-second demonstration upon the dullest knife in the house; **the order is yours right on the spot; instantly**. No talking necessary. No argument. The machine simply sells itself, **and stays sold**. Every customer becomes your friend. They tell others, your profits double and multiply. Leave one hundred on trial over night. Collect the cash for every one of them next day. **The machine will do its own talking**; it is so easy to operate, no explanations or instructions are necessary. Secure your county now; **free**. Get started right now and—

Only  
**\$1.50**

Selling Price

Low price, ease of operation, astonishing quickness and absolute perfection of results, money-back guaranty. These things make the **Quickedge** the fastest seller of the age—the biggest money-maker for agents, general agents and managers ever invented.

### Make \$70 Next Week

**Easy to start**—easy to make big money if you will just follow instructions and work faithfully. **No charge for territory, 200% profit for agents**. Business supplies capital. Exclusive protection, co-operation and assistance. Failure impossible. Nothing to risk. Success assured.

**Easy to demonstrate**—and every woman is anxious to see it work—then she would not do without it. No talking necessary. Just show the machine and take the order—**one dollar profit on every call you make**.

Send for application blank and complete information today—**free**. Investigate. **Get the proof**. Don't delay. Write a postal card or letter right now. **Territory is being assigned very fast**. Get your county now—**free**. Write today.

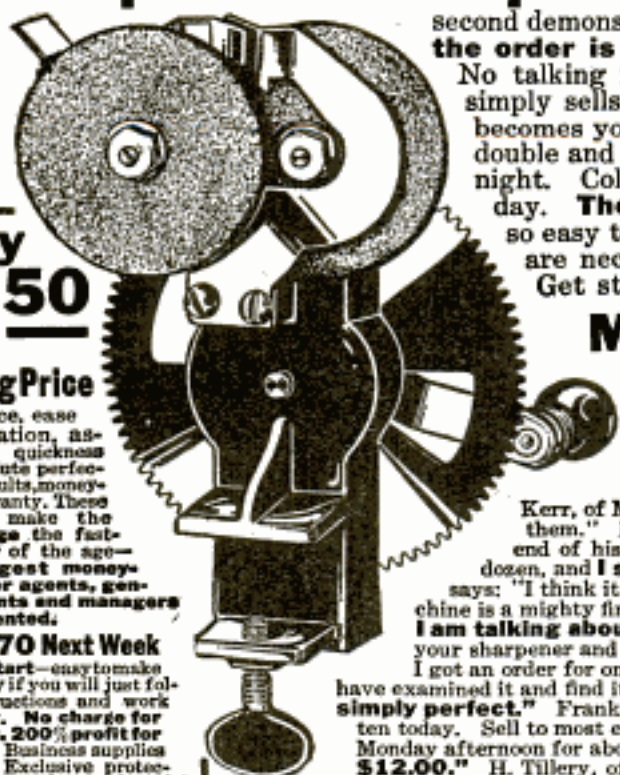

The  
**Quick-  
edge  
Knife  
and Shear  
Sharpener**

Grinds any Kitchen Knife  
or Shears in 10 Seconds

Absolutely Guaranteed

## Make as Much Money Next Week as These Men are Making Now

J. C. Lewis, of Kansas, says: "**I have sold one hundred Sharpeners in four days.**" Hobart Kerr, of Md., writes: "The women can hardly wait till they get them." Herbert Cain, of Ky., sold nine after supper. At the end of his first day, J. W. Gordon, of Pa., writes: "I sold two dozen, and **I sold to every one I saw.**" Wm. G. Hall, of N. J., says: "I think it is great. I sold six in about one-half hour. The machine is a mighty fine proposition. **I am a mechanic and I know what I am talking about.**" Peter Courtland, of Mich., writes: "I received your sharpener and opened it in a barber shop. I ground his shears and I got an order for one right on the spot." H. A. Henkel, of Va., says: "I have examined it and find it a wonderful little machine. **The workmanship is simply perfect.**" Frank King, Colo., says: "Sample received Saturday. Sold ten today. Sell to most every house." Forest Webb, of Pa., says: "Went out Monday afternoon for about three hours and received one dozen orders. **Profit \$12.00.**" H. Tillery, of Tenn., wrote: "I took three orders first hour. When you sharpen an old, dull knife, dull as a hoe, in less than a minute, **they sit up and look.**" Ray Carter, of Mass., writes: "I went out two days and have orders for thirty sharpeners." **Profit \$30.00 for first two days.** John Durr, of Wis., also says: "**I have sold thirty in two days.**"

You can make this money. **Send now. Territory free.**

**GET BUSY. WRITE TODAY.**

**The Quickedge Sharpener Company**

No. 647 Sharpener Building  
215 N. Desplaines St., Chicago, Ill.



# \$500 IN ONE WEEK

## Manufacturing & Wholesaling Crispettes.

### Factory Managers Wanted!!

I want to hear at once from ambitious, energetic men, who seek broader opportunities. If you're such a man, here is what I offer you. **Here is your opportunity for pleasant work, easy hours, independence**—in a business of your own. I'll start you in a business for yourself, manufacturing and wholesaling Crispettes—a delicious popcorn confection. I started here in Springfield—have created a nation-wide demand which has become so great that now Crispettes are sold in all stores wherever candy and confections are handled. **These stores must be supplied almost daily with fresh Crispettes.** Local factories must be established and these I want in charge of competent men who can grasp business opportunities and stand prosperity. I supply the machines and all equipment and require only a small investment. I give you the opportunity of making big money no matter where you are located.

### Own and Operate a Factory of Your Own

When you enter this business you become a real manufacturer—you take your place in the world among the leaders of business. You start small—grow rapidly—own a leading institution just as my factory and store here in Springfield have become. You manufacture Crispettes with the machine I supply you according to my secret formula—do a wholesale business selling to confectionery stores, grocery stores, drug stores, etc. You do business in a wholesale way and make big profits.

### No Experience Necessary

The business is easy to master. One young man in Ohio took orders for \$500 worth of Popcorn Crispettes even before his machine arrived to make them. We have hundreds of letters in our files showing profits of \$200, \$500, and even \$1,000 a month. Business is assured. Everybody likes Crispettes. Thousands buy. Old folks, young folks, children, all like them. They buy at their favorite store—the store buys at wholesale from you. You can start now. Just mail the coupon.

### Come to Springfield at My Expense

**I'll Pay Your Traveling Expenses Up to 300 Miles If You Start in This Business**

See for yourself that all I tell you about this business is true—see the big store that Crispettes have built for me. See my factory where the machines are made. **Make Crispettes yourself and see how easy the work is done.** Meet me face to face and talk over the whole proposition. I'll show you hundreds of letters from others who are now reaping rich rewards in the Crispette business. I'll show you why everybody likes Long's Popcorn Crispettes—why no other similar product is equal because of my secret formula. I'll show you how you can make enormous profits—how you can start a business which nets a big income right at the start.

### FREE BOOK—"The Short Way to Big Profits"

I have published a handsomely illustrated, 52 page book that explains the proposition from A to Z. **The coupon—a postal or letter brings it.** This book will show you how to enter this business from any walk of life. Your age, your education, your present occupation matter little. This book will show you how to leave work that is drudgery, hours that are long, pay that is small, for pleasant work, easy hours and an absolutely certain income, depending on no man's whims, depending only upon your own energy and ambition to become a success. "The Short Way to Big Profits" is the short cut to success. **Mail the coupon for facts, now, before turning the page.**

**This Machine Makes Crispettes and Big Daily Profits**



W. Z. LONG, Pres.

W. Z. LONG CO. 1301 High Street  
SPRINGFIELD, OHIO

### FREE COUPON

W. Z. LONG, Pres.  
W. Z. Long Co. 1301 High Street  
Springfield, Ohio

"DEAR SIR:—I am interested in starting a Crispette factory in this locality. Please send me your free book "The Short Way to Big Profits" and full particulars of the Crispette business.

Name .....

Address .....

Please Mention Popular Mechanics





Mr. H. S. Kramer's Residence, E. St. Louis  
Edward G. Garden, Architect, San Francisco

EAST ST. LOUIS, ILL., Aug. 22, 1910.

"The Stains have proven very satisfactory, and the most noticeable value of Cabot's Stains is to compare the colors of my residence with others in the neighborhood that have been stained with some other kind. I have used the brown No. 249 for both the siding of my house and barn, and the green No. 305 for the shingles on the roofs.

HARRY S. KRAMER."

### Preserve and Beautify Your Shingles

siding, clapboards, and other outside  
woodwork, by staining with

## Cabot's Creosote Stains

They are 50 per cent. cheaper than paint and 100 per cent. more artistic and beautiful. They can be applied twice as fast, halving the labor cost. They are made of Creosote, "the best wood preservative known." The coloring effects are transparent, and bring out the grain of the wood in deep, velvety tones that harmonize perfectly with nature—there is no shiny, painty effect. They wear as long as the best paint, and "grow old gracefully," because they sink into the wood and therefore cannot crack or peel like an old paint coating.

You can get Cabot's Stains all over the country.  
Send for samples on wood and name of nearest agent.

SAMUEL CABOT, Inc., MYing Chemist, 18 Batterymarch Street, Boston, Mass.

## A Wonderful Combined Tool

is this STEWART HANDY WORKER



It combines: A strong and powerful vise, steel faced; a steel pipe vise for up to 1 1/2-inch pipe; big, sturdy anvil; cutting hardie; corundum grinding wheel 5" x 1", 2 speed drill press; 3 speeds, direct, 4 to 1 and 16 to 1.

Weights, boxed, 90 pounds; price f. o. b. Chicago, \$12.50. Send \$2.00 and pay balance when outfit arrives. All money back if not highly pleased. It's a marvelously valuable outfit. Write for circular.

Chicago Flexible Shaft Co.  
A617 N. La Salle St. CHICAGO

NOTE SMALL SIZE



NOT  
"JUST ANOTHER  
HEARING  
DEVICE"

Clearer  
and  
More  
Distinct  
HEARING  
for the

PORT-O-PHONE

is not "just another hearing device." It embodies, through a newly discovered scientific principle, features distinctly DIFFERENT. And these features accomplish what no other instrument has ever before been able to accomplish. Write today for your copy of our intensely interesting

FREE BOOK

A Remarkable Treatise on Deafness

This book explains the many wonderful features of the Port-O-Phone; the 5-year Guarantee; the easiest easy-payment plan; and full details of our exceptional FREE TRIAL offer.

So confident are we that the Port-O-Phone will help YOU, we want you to try it without cost or obligation. Don't send a cent or make a single promise. Write today and we will send you, by return mail, the Port-O-Phone Book.

The Free Trial offer is made in the interest of those who have lost all hope of ever finding a device that is really a help, for if anything will aid you, the Port-O-Phone will help you immeasurably more. We urge you to avail yourself of this opportunity by writing today—NOW, Write at once!

The Port-O-Phone Corporation Dept. B-2  
1919 Broadway, New York City

Proved  
by a

15 DAYS FREE TRIAL

Drink delicious **Coca-Cola** — and be refreshed

1/2 PRICE—To Introduce  
To prove to you that our dazzling blue-white



**MEXICAN DIAMOND**

exactly resembles the finest genuine South African Gem, with same dazzling rainbow-hued brilliancy (GUARANTEED), we will send you this beautiful, high-grade, 12kt gold-filled Tiff. Ring, set with 1ct. gem, regular catalog price, \$4.98, FOR ONE-HALF PRICE, \$2.50

Same gem in Gent's Heavy Tooth Belcher ring, catalog price, \$6.25, for \$3.10. Wonderful dazzling, rainbow brilliancy, GUARANTEED 20 YEARS. Send 50c and we will ship

C. O. D. for FREE EXAMINATION. Money back if not pleased. Act quick. State size. Offer limited — only one to a customer. Catalog Free. Agents Wanted.  
MEXICAN DIAMOND IMPORTING CO., Dept. E. T., LAS CRUCES, NEW MEXICO  
(Exclusive Controllers of the Genuine Mexican Diamond)

## An Easy Way to Make Money

Don't be content to plod along on a small salary. Be independent. Go in the tire repairing business and make \$60 or more a week. One man made \$45 the first day he received his outfit. Others are making \$25 a day and hundreds of wide-awake men are making \$200 to \$500 a month.

No experience needed. We teach you how. Very little capital required. But slight risk, as every car owner in your town is a possible customer. Jobs are plentiful because tires blow out and puncture every day.

**SHALER**

**Tire Repair Outfit, \$60**

will do as much and as perfect work as the big \$250 to \$500 vulcanizing outfits. A boy can vulcanize perfectly with this simple machine. It's the only vulcanizer that has **Automatic Heat Control**. It must vulcanize just right. It can't undercure or overcure a tire. Requires no watching or regulating. You can learn to do expert tire vulcanizing in half an hour with the Shaler.

**WRITE FOR FREE BOOK "HOW TO OPEN A TIRE REPAIR SHOP"**  
which gives full information.  
WRITE QUICK BEFORE SOME HUSTLER GETS AHEAD OF YOU.

C. A. SHALER CO., 2101 Fourth Street, WAUPUN, WIS.





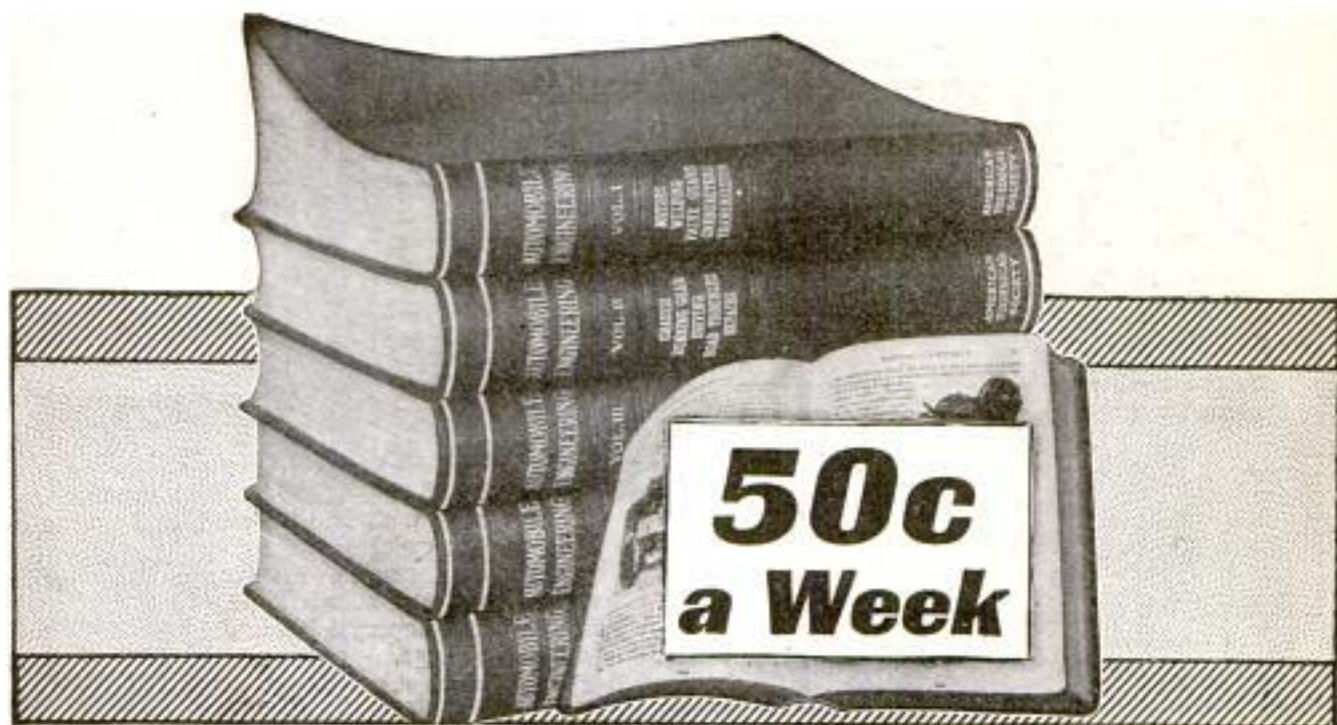

# Automobile Engineering Just Off the Press

**A** GREAT automobile library is just off the press. The most comprehensive set of automobile books ever published is now ready for delivery. It is called **Automobile Engineering**, and in it you will find all about modern automobiles. Every principal—every part—every accessory of every car is explained in simple, easily-understood English.

Hundreds of pages explain all the up-to-date systems of ignition, starting and lighting, Welding; vulcanizing, and commercial garage equipment and operation is thoroughly covered. Carefully cross-indexed, so that the information you want can be referred to instantly. Handsomely bound in flexible morocco leather, gold stamped, these five volumes should be owned by every man interested in automobiles. They contain the combined knowledge of the greatest experts in the business. 2,200 pages (5 1/2 in. x 8 in.)

And now a great introductory offer is open to those who will send the coupon at once. The regular price of this brand-new edition will be \$25.00, but you can get the complete library for only \$16.80 by acting today—now!

## Shipped Free

### On 7 Days' Trial

To those who send the coupon immediately we will send the complete five volumes without a penny deposit—express prepaid. Then you can use the books for seven full days—see what they are going to mean to you. After the trial—if you think you can get along without them—send them back to us at our expense. The trial doesn't cost you a penny. But if you decide to buy—send only \$2.00 and then \$2.00 a month—60c a week—until the specially reduced price of \$16.80 has been paid.

## FREE Consulting Service!

With each set we give you, absolutely free, a year's Consulting Membership in the American Technical Society. The regular price is \$12.00, but you get it free with this set. Put your perplexing problems up to a staff of experts. Ask them any other question you wish. The solution of one problem might easily be worth more than you pay for the books. Ask as many questions as you wish for an entire year.

## Send the Coupon!

Your name and address on the coupon brings the five books to you, express prepaid, for seven days' free trial. This offer is open to every person within the boundaries of the United States and Canada. Act quick—while offer lasts. Send coupon today—NOW!

**American Technical Society** Dept. A-1192  
Chicago, U.S.A.

#### Partial List of Subjects:

Explosion Motors, Welding, Motor Construction and Repair, Carburetors and Mixtures, Valves, Cooling, Lubrication, Fly-Wheels, Clutch, Transmission, Final Drive, Steering, Frames, Tires, Vulcanizing, Ignition, Starting and Lighting Systems, Wiring Diagrams, Shop Kits, Commercial Garage Design and Equipment, Electric Storage Batteries, Core and Repair, Motorcycles, Commercial Trucks, Glossary.

**American Technical Society**  
Dept. A-1192 Chicago, U.S.A.

Please send me the 5 volume Automobile Engineering for 7 days' free examination. If I decide to buy, I will send \$2.00 within 7 days and the balance at \$2.00 a month until \$16.80 has been paid. Then you send me a receipt showing that the 5 set of books and the \$12.00 consulting membership are mine and fully paid for. If I think that I can get along without the books after the seven days' trial I will return them at your expense.

Name.....

Address.....

Reference.....





Sectional view of one of our quarries

## Investigate "Cleveland Grindstones"

Your work demands the best. You cannot afford cheap equipment. Provide yourself with best tools obtainable. If you want a good grindstone and want it when you need it—

drop us a line. You can be sure of perfect satisfaction if you use

**"CLEVELAND GRINDSTONES"**

**THE CLEVELAND STONE COMPANY**  
Leader-News Bldg. CLEVELAND, OHIO

## Electric Light for Your Home

Uni-Lectric lighting plant generates standard 110-volt direct current; operates from one to 50 lights, electric motor, electric iron, vacuum cleaner, electric toaster, force pump, churn, washing machine, etc.

**No Batteries — No Switch-Board** and a better machine for less money. High speed gasoline motor, generator and automatic governor, all complete in one small, compact unit. Uses standard lamps and fixtures. Simple, easily installed, dependable, economical. Costs less than other systems to buy and to operate.

**WATERMAN MOTOR COMPANY**  
182 Mt. Elliott Ave., DETROIT, MICH.

Write today for full description and low price.

**Uni-Lectric**  
GASOLINE-ELECTRIC UNIT  
LIGHTING SYSTEM



Please Mention Popular Mechanics

# TEMCO



## Use It Anywhere

Take this TEMCO Electric Tool to the work, connect cord with lamp socket, and do the job. It's for quick work anywhere—in factories, repair shops, wood and metal shops, maintenance departments and public buildings.

It drills wood or metal, taps threads, drives and draws screws, grinds auto valves, buffs metals and sharpens small cutting tools. It works faster and more accurately than hand powered tools.

Five sizes weighing 9 to 19 lbs. Capacities to 1/2" drilling in steel. One and 2 speed, and instant motor reverse types—direct or alternating current.

FROM DEALERS AND JOBBERS, OR DIRECT.  
**The Temco Electric Motor Company**  
135 Sugar Street Leipsic, Ohio  
Makers also of Temco-Alla Shock Absorbers and Temco Shock Absorbers, Master Valves and Lock Switches for Trucks.



**THE TOOL OF MANY USES**

## Effecto Auto Finishes MAKE OLD AUTOS NEW



**\$29.50 in Two Days**

is what Mr. Ewald, of Illinois, made with our

**Diamond Post Card Gun**

You can do as well. It takes 5 sizes. Photo

Post Cards on Paper **DIRECT WITHOUT**

**PLATES OR FILMS.** Also Button Photos

finished on the SPOT in one-half minute. No canvassing.

Experience unnecessary. 8¢ profit on every dime.

Work at Carnivals, Fairs, Shows, etc. Circulars of this new invention mailed **FREE.**

**International Metal & Ferro Co., Dept. 12P, Chicago**

## NO JOKE TO BE DEAF

— Every Deaf Person Knows That

I make myself hear, after being deaf for 25

years, with these Artificial

Ear Drums. I wear them day

and night. They are perfectly

comfortable. No one sees

them. Write me and I will tell

you a true story, how I got deaf

and how I make you hear. Address

**GEO. P. WAY, Artificial Ear Drum Co. (Inc.)**

11 Adelaide Street, DETROIT, MICH.



Medicated Ear Drum

Pat. Nov. 3, 1908

## 5¢ A DAY BUYS A GIBSON

Terms as low as \$1.00 down and \$1.50 per month. Mandolin or Guitar on approval. Get new **FREE** BOOK. Valuable information for player and teacher. Explains wonderful new violin construction with curved and graduated Top and Back and Stradivarius Arching. Also **FREE** treatise on "How to Practice."

**Make \$1800 to \$5000 a Year**

**Teaching and Selling Gibsons**

Become a teacher. Splendid opportunities for Mandolin and Guitar teachers—either sea, in every

locality, private and class instruction, and sale of

Gibsons. The Gibson has "made" many a teacher

professionally and financially.

**Do Business on Our Capital**

If a teacher, become our agent. Instruments furnished. We help sell. Agents' territory protected. You make profits. We pay the advertising. You pay for goods when sold; return goods not sold. Try our "Still Hunt." Catalog and Thomas List Free. Gibson Mandolin Guitar Co., 162 Harrison Court, Kalamazoo, Mich.



## Stop Wasting Gasoline Money!

Every mile you run your car without the New Stromberg Carburetor means gasoline waste. Its economy records on all kinds of cars prove it absolutely the most economical for any car.

And in speed, acceleration, easy starting and power it has broken world's records. Send name, model and year of your car for information.

**Stromberg Motor Devices Co.**  
Dept. 214  
64 E. 25th St.  
CHICAGO



New **STROMBERG** Saves It!  
CARBURETOR

## Get This CAR And the AGENCY For YOUR Territory



Drive a new 1917 Model Birch Motor Car. Pay for it out of your commissions and make big money on sales. Special offer now. Write quick for Big Free Book and Full Information. Address **Ralph Birchard, Pres.**

Birch Motor Cars, Dept. 219, 81 E. Madison St., Chicago

## YOU CAN HAVE THIS



wholly visible (42 key) single shift typewriter, for your own, if you will show it to your friends and let them see wherein it excels other \$100 typewriters, and tell them of our most liberal offer ever made on a strictly modern typewriter and a Woodstock at that. By post card or letter simply say, "Mail Particulars."

WOODSTOCK TYPEWRITER CO., Dept. F 617, CHICAGO, ILL.



## DEAF?

If your hearing is failing, or has failed, you are **One of 6,349,240 in the U. S. A.**

who would be greatly helped by our new invention to aid deafness.

Transparent Imperceptible **AUDI-SHELLS** Wt., only 1/16oz. Safe and Sanitary

Nothing to insert in the ear, no headbands, cords or batteries. Nothing to break or get out of order. The Audi-Shells are a wonderful help in all degrees of deafness, comfortable to wear and are not as conspicuous as eye-glasses. They are endorsed by eminent aurists and sold by mail at \$5.00 per pair. Write for testimonials of users.

**Globe Ear-Phone Co.,** 82 Tremont Street BOSTON, MASS.



## Net

Prices Direct to You

**A**BSOLUTELY net terms on any diamond you choose. You can now buy direct. No jobbers, no retailers to pay. Write for our net price list and **Diamond Book** showing an exquisite collection of splendid, blue-white

## Diamonds

Rings in all styles, Tiffany, Belcher, etc., La Vallieres, brooches and other diamond jewelry. Every diamond a superb gem. Selected by a famous expert. Perfectly cut to give maximum brilliancy. Richly mounted in solid gold and platinum settings.

**Free Examination** Not a cent down—you see the diamond before you accept it. We want you to compare these diamonds with others at twice their price.

**\$2<sup>50</sup> Monthly** Only \$2.50 a month will make you the wearer of a

beautiful diamond ring. Other terms, \$3.50 \$4.50 and up—and middlemen's profits cut out.

## Write

**For Net Price List and Diamond Book**

Shows the different gems, styles of mountings and gives our best net prices with terms of payment. Do it now—today.

**BURLINGTON WATCH CO.**  
Dept. 1192  
Chicago, Ill.

**Burlington Watch Co.**  
Dept. 1192  
Chicago, Ill.

Without obligations send me your net price offer on diamonds; also send Diamond Book.

Name .....

Address .....





# LEWIS-BUILT HOMES

Machine-Cut Factory to You  
At the Inside Price

**\$694**  
5 Rooms and Bath



## Buy a Lewis-Built Home and Build it This Year!

Live in it—rent it—sell it—you can make money and save money either way. We give Lewis home builders the advantage of materials produced at last year's costs; we furnish everything to build the complete house; you save money at every step.

### Machine-Cutting Saves 40%

of carpenter labor; eliminates waste; prevents mistakes. Modern factory methods replace old hit-and-miss practices; science and efficiency substituted for guess-work. Investigate this newer, better, quicker, cheaper system, already endorsed by thousands.

### Send for Catalog of 100 Houses,

Cottages and Bungalows—\$300 and up, with floor plans, specifications, and terms plainly stated. Accurate plans and full instructions free. **Money-back guarantee of Satisfaction.** Enclose 4c stamps for postage.

(Also Home Furnishings catalog on request.)

**Lewis Manufacturing Company**

Department 278 Bay City, Mich.

Western Branch: **LEWIS-BUILT HOMES**  
Portland, Ore.



Send 4c  
Stamps  
for Catalog

**Universal Electric Motors**

Complete with carbon-diamond wheel, buffing wheel, cord plug and pulley. For spark gaps—grinding—polishing, and to drive small machinery, sewing machines, fans, etc. Operates on A. C. or D.C.—110—130V. Speed 6000 R.P.M.

**\$5**

**MONEY BACK IF NOT SATISFIED**  
CATALOG FREE

**Omega Electric Co.** 53 W. Jackson Blvd. CHICAGO

## Blue Book of Gifts Free

Charming book of up-to-date information on jewelry sent free to you. Valuable guide to the selection of gifts. Tells you how to be correct and how to save on your jewelry, no matter when you buy. More than 1000 photo-illustrations taken from Norris-Allister-Ball's great Blue Book to be found at best jewelry stores everywhere. Ask us to send you this valuable book. It's postpaid free to you. **WRITE TODAY.**

**NORRIS-ALLISTER-BALL COMPANY**  
Largest exclusive wholesale jewelers Dept. 3246, Garland Building, CHICAGO

**Get 25% More "Go" Out of Gasoline**

Cut 1/4 off your fuel cost. The Oxygenator makes it possible—the greatest dollar-saver ever offered. Improved principle for eliminating carbon. Secures **20% more speed — 20% more power — easier starting — better acceleration.** Thousands of users go ting greater satisfaction from engines — reducing cost and ease of running machine. For all cars, quickly cost and ease of running machine. For all cars, quickly cost and ease of running machine. For all cars, quickly cost and ease of running machine. For all cars, quickly cost and ease of running machine.

**THE OXYGENATOR CO., Dept. A1, 1919 S. Michigan Av., Chicago**

## Free Trial

**PIEDMONT RED CEDAR CHESTS**

Your choice of 75 styles of the famous Piedmont genuine Southern Red Cedar Chests. **15 days' free trial.** We pay the freight. A Piedmont protects furs, softens and plumes from moths, mice, dust and damp. Distinctively beautiful. Finest wedding gift. **Write today for big new catalog with reduced prices. Mailed free to you.**

**Piedmont Red Cedar Chest Co., Dept. 34, Statesville, N. C.**

## Charge Storage Batteries from alternating current with

# The Blitzen Rectifier

Safe, Clean, Economical

**\$2.50 and up**

Bulletin for 2c stamps. 2 catalogs of wireless telegraph and electrical apparatus sent for 6c stamps to cover postage.

**CLAPP-EASTHAM CO.**  
147 Main Street Cambridge, Mass.

## A Birthday Present

If you are racking your brains to think of a suitable birthday present—**stop.** Go to any dealer and ask to see Ingersoll watches. There are eleven kinds from a \$1 to \$3.

# Gray Hair FREE

Mary T. Goldman's Gray Hair Restorer restores original color mildly and healthfully. Different from any other. Will not wash off; looks natural; no sediment. Sample and comb absolutely free. Be sure to describe original color of your hair. Large Size Bottle, \$1.00. Prepaid.

**Mary T. Goldman, 342 Selman Bldg., ST. PAUL, MINN.**  
Established 50 Years



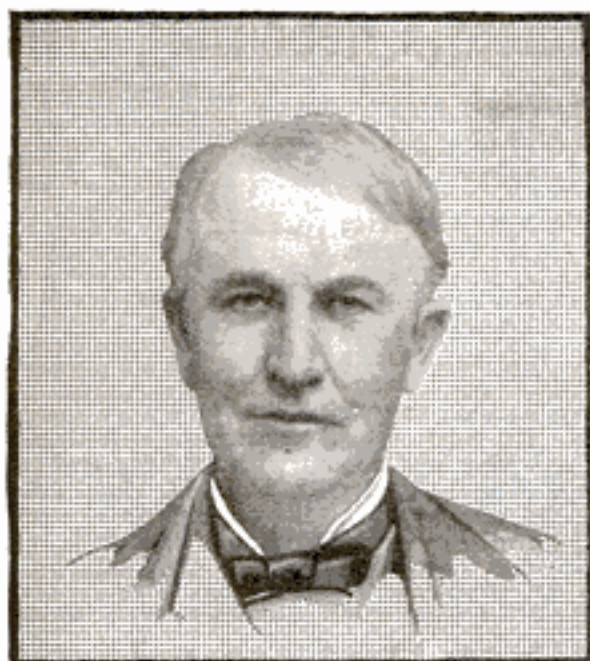

*With kindest regards to all*

*From the Laboratory*  
**Thomas A. Edison,**

*Orange, N.J. September 26th, 1916.*

Mr. Ralph E. Hook, President,  
International Correspondence Schools,  
Scranton, Pa.

Dear Sir:

I am sorry that circumstances prevent me from attending the 25th Anniversary of your wonderful institution.

I have watched the progress of the I. C. S. almost from the very beginning and while your rapid growth might be marvelled at by some, to me it is easily understood, because I realize the practical value that is back of it and know something too of the success attained by many ambitious men throughout the country who have taken your course.

May your splendid institution continue to so grow and flourish that the world will come to appreciate the actual worth of an I. C. S. trained man.

Yours very truly

*Thomas A. Edison*

## Edison Knows!

**H**UNDREDS of thousands of men who have won and are winning success through the International Correspondence Schools will thrill with pride when they read this splendid tribute from Thomas A. Edison.

For Edison knows! He knows the worth of spare-time study. He knows what stuff men are made of who use their spare hours to train themselves for the bigger jobs ahead. And he knows what the I. C. S. will do for the man with the grit to say, "I will."

Wasn't it Edison himself who stayed up half the night to read every get-at-able book on electricity? Didn't he educate himself in spite of every handicap you could ever have?

All big men who have made their mark in the world had the ambition—the determination—to improve their spare time, to train themselves for big work. You, too, can possess power, money and happiness if you'll only make the effort. The reward is great—it's worth it.

Here's all we ask: Merely mail this coupon. Put it up to us without paying or promising. Let us send you the details of others' success through the I. C. S., and then decide. Mark and mail this coupon now.

INTERNATIONAL CORRESPONDENCE SCHOOLS  
Box 5549, Scranton, Pa.

### YEAR OUT HERE INTERNATIONAL CORRESPONDENCE SCHOOLS Box 5549, SCRANTON, PA.

Explain, without obligating me, how I can qualify for the position, or in the subject, before which I mark X.

- |   |  |
|---|--|
| <input type="checkbox"/> ELECTRICAL ENGINEER        | <input type="checkbox"/> SALESMANSHIP                                    |
| <input type="checkbox"/> Electric Lighting          | <input type="checkbox"/> ADVERTISING MAN                                 |
| <input type="checkbox"/> Electric Car Running       | <input type="checkbox"/> Window Trimmer                                  |
| <input type="checkbox"/> Electric Wiring            | <input type="checkbox"/> Show Card Writer                                |
| <input type="checkbox"/> Telegraph Expert           | <input type="checkbox"/> Outdoor Sign Painter                            |
| <input type="checkbox"/> Practical Telephony        | <input type="checkbox"/> RAILROADER                                      |
| <input type="checkbox"/> MECHANICAL ENGINEER        | <input type="checkbox"/> ILLUSTRATOR                                     |
| <input type="checkbox"/> Mechanical Draftsman       | <input type="checkbox"/> DESIGNER  |
| <input type="checkbox"/> Machine Shop Practice      | <input type="checkbox"/> BOOKKEEPER                                      |
| <input type="checkbox"/> Gas Engineer               | <input type="checkbox"/> Stenographer and Typist                         |
| <input type="checkbox"/> CIVIL ENGINEER             | <input type="checkbox"/> Cert. Public Accountant                         |
| <input type="checkbox"/> Surveying and Mapping      | <input type="checkbox"/> Railway Accountant                              |
| <input type="checkbox"/> FIRE FIGHTER OR ENGINEER   | <input type="checkbox"/> Commercial Law                                  |
| <input type="checkbox"/> Metallurgist or Prospector | <input type="checkbox"/> GOOD ENGLISH                                    |
| <input type="checkbox"/> STATIONARY ENGINEER        | <input type="checkbox"/> Teacher   |
| <input type="checkbox"/> Marine Engineer            | <input type="checkbox"/> Common School Subjects                          |
| <input type="checkbox"/> ARCHITECT                  | <input type="checkbox"/> CIVIL SERVICE                                   |
| <input type="checkbox"/> Contractor and Builder     | <input type="checkbox"/> Railway Mail Clerk                              |
| <input type="checkbox"/> Architectural Draftsman    | <input type="checkbox"/> AGRICULTURE                                     |
| <input type="checkbox"/> Concrete Builder           | <input type="checkbox"/> Textile Overseer or Supt.                       |
| <input type="checkbox"/> Structural Engineer        | <input type="checkbox"/> Navigator <input type="checkbox"/> Spanish      |
| <input type="checkbox"/> PLUMBING AND HEATING       | <input type="checkbox"/> Poultry Raising <input type="checkbox"/> German |
| <input type="checkbox"/> Sheet Metal Worker         | <input type="checkbox"/> AUTOMOBILE <input type="checkbox"/> French      |
| <input type="checkbox"/> CHEMICAL ENGINEER          | <input type="checkbox"/> Auto Repairing <input type="checkbox"/> Italian |

Name \_\_\_\_\_

Occupation & Employer \_\_\_\_\_

Street and No. \_\_\_\_\_

City \_\_\_\_\_ State \_\_\_\_\_

If name of Course you want is not in this list, write it below.

Please Mention Popular Mechanics



## THE EXPO WATCH CAMERA

The most wonderful and ingenious camera made

It is but little larger than a watch, which it closely resembles. You can carry the Expo about in your pocket and take pictures without any one being the wiser.

### One Cent a Picture

The Expo loads in daylight with 10 or 25 Exposure Films, costing 15c and 25c respectively, and thus the picture taking part of a whole day's outing may be had for a very nominal sum — One cent a picture.

### Easy to Manipulate

It is simplicity itself to operate. Takes pictures through the store, where the Rapid Fire Lens is located. The photos (5/8 x 7/8) may be enlarged to any size.

Operated as quick as a flash Time and instantaneous shutters; Endorsed by amateurs and professionals the world over. Theoretically practical, printing and developing of films just the same as ordinary cameras — in daily use by the police, newspaper reporters, detectives, and the general public. Important tests have been secured with the Watch Camera by enterprising reporters. Produces clear, sharp negatives indoors or outdoors equal to any camera on the market, size or price notwithstanding. Sold Under a Positive Guarantee.

Expo Watch Camera \$2.50 FILMS, 10 Exposures 15c, 25 Exposures, 25c postage 10c  
MAILED TO ANY ADDRESS IN THE WORLD

JOHNSON SMITH & CO., 7153 North Clark Street, CHICAGO

## JAPANESE ROSE BUSHES

### The Wonder of the World

Japanese Rose Bushes bloom all the year round. Just think of it. Six weeks after planting the seed, the plants will be in full bloom. It may not seem possible, but we positively guarantee it to be so. They will bloom every ten weeks, Summer or Winter, and when three years old the bush will be a mass of roses, bearing from five hundred to a thousand roses on each bush. The flowers are in three shades — white, pink, and crimson. The plants will do well both in and out doors. We guarantee at least three bushes to grow from each packet of seed. Price, 10c packet, 3 pkts. for 25c postpaid.



10 cts.

### Shoo Fly Plant

A very remarkable botanical curiosity you should have. Though quite odorless, flies will not remain in a room where it is grown. Bears very pretty blossoms; blooms summer and winter. Grows rapidly from seed.

SEEDS 15c, packet, 3 for 40c, postpaid.

### Weather Plant

NATURE'S WEATHER PROPHECY By mysterious changes that take place, this remarkable plant accurately forecasts the weather many hours in advance. Will grow anywhere all the year around. An interesting house plant. Bears large, fragrant, pink, butterfly shaped flowers.

SEEDS, 15c packet, 3 for 40c, postpaid

## GROUND ALMONDS

### GROW EASILY FROM SEED

The Ground Almond has a flavor that is MOST EXCELLENT, resembling the cocoanut. The meat is snow white, covered with a shell or skin of brown color. It grows close to the surface and anything from 200 to 300 Almonds may be expected from a single vat. There is no trouble whatever in growing anywhere and in any kind of soil. May be planted any time, and in eight or ten weeks from time of planting you will have an ENORMOUS CROP of the MOST DELICIOUS ALMONDS YOU EVER TASTED. Seeds 15c Pkt.



### Perfume Plant

Blooms only at night, giving forth the most delightful scented fragrance for quite a distance. Causes much comment. For house or garden. Also valuable because of rare perfume made from it. SEEDS, 10c pkt., 3 for 25c.

### Musk Plant

Another charming floral novelty of the sweet scented variety. Equally suitable as house plant or garden. Makes the most delightful perfume. SEEDS, 10c pkt., 3 for 25c.



## The Wonderful Sensitive Plant

The Marvel of the Philippine Islands. Almost human in its nervous susception. Leaves curl, and fronds droop when touched. Apparently resents interference; it dislikes strong odors, and is painfully affected by artificial heat and electricity. Has graceful foliage and lily pink flowers. It is a handsome shrub for house or garden and very curious and interesting; blooms all the year round. SEEDS 15c pkt., 3 pkts. for 40c postpaid



## NITTO'S PLANT FLOWER FOOD

NITTO'S PLANT FOOD is clean, odorless, and highly concentrated. It is used in liquid form on all kinds of plants, shrubs, roses, ferns, bulbs, lawns, fruit, flower and vegetable gardens. It changes ill-nourished plants into LUXURIANT BEAUTIES, producing masses of blooms that will equal any. Causes plants to bloom early and ahead of others. Your friends will marvel at your success. Makes no difference how healthy or how delicate your plants may be, Nitto's Plant Food will bring out New Foliage and Flowers, and cause a Marvelous Transformation. 15c



Johnson Smith & Co., 7153 N. Clark St., Chicago  
Only Concern of its Kind in America

## Automatic Repeating Rifle

Fires 20 Shots in One Loading



This is a regular size automatic revolver. Shoots B. B. shots obtainable anywhere, same as other rifles and guns. Repeats 20 times with one loading. Handsomely finished in gun metal. No caps or load necessary, as it works with a spring and shoots with rapidity and accuracy. Simply load with 20 B. B. shot, then press the trigger. Nothing to explode — absolutely harmless and safe. Remember, it is not a mere toy, but the same size and shape as a REGULAR AUTOMATIC. Sent complete with a round of shot for ONLY 25c postpaid. Extra shot, 10c a package.

Only 25c Postpd.

## Potmend

Stops a leak in a minute  
The finest repaler for Ironware, Agateware, Enamelware, etc. Good for kettles, pots, pans, boilers, and every kind of ironware, also for tin, copper, aluminum, ice boxes, iron pipes, cracks in stoves, broken china, porcelain, brick-a-brac, bisque, crockery, woodware, marble, etc. Will not chip, fry, burn, bake or boil out. THE MEND IS THE STRONGEST SPOT IN THE POT. Could not be simpler: Just mix the powder with water. HARDENS LIKE IRON. Fire-proof, Water-proof. You can fill a big hole or a small crack. Mended places stronger than new. Replaces chipped enamel. Anyone can do it: FAILURE IS IMPOSSIBLE. Better and easier than solder. Three sizes, 15 cents, 25 cents and 50 cents.

## "SAFETY 1st" PINS Book On Rope Splicing Knots and Hitches

A clever novelty. The National Safety First Movement has made them very popular. Wear one and show your sympathy with the movement. Also handy for wearing at amateur theatricals and the like. Two sizes. 1/2 in. (gold plated) and 1 1/2 in. (nickel-plated) 6c each, two for 10c p. pd.

## Vest Pocket Secretary MARVELOUS COMBINATION

Not a toy, but a really useful article you need every day. 12 Articles in one — Pen, Pencil, Paper Knife, Ink Eraser, 4-inch Rule (divided into sixteenths), Compass (can be set for any size circle), Envelope Opener, Mechanical Sharpening Point, Pencil Sharpener, etc. Made entirely of steel, nickel-plated. Fits up into a small space occupying no more room than an ordinary pencil in the pocket. Price 15 cents, 3 for 50c, postpaid.



## TOOTH-ACHE STOP

Easy to Use  
Stops the Pain; Stops the Tooth  
Squeeze a little in hollow of tooth; the Ache Stops Instantly; the paste hardens, forming an antiseptic filling. Absolutely harmless. Have it ready for the next bad attack 25c postpaid.



## PUMI STONE and Brush Combination

Effectively removes dirt, grease, ink, and all other stains from the hands, etc. Keeps fingers nails clean and tidy. Pocket size 17c., wash stand size 30c postpaid



## All the Latest Surprising and Joke Novelties

- |   |   |
|---|---|
| Pharo's Serpents Eggs, box . . . . . 10c                                    | Modern Dancer (ridly) . . . . . 15c                           |
| Miniature Water Pistol . . . . . 10c  | September Morn Squirt King . . . . . 25c                      |
| Cleopatra's Snake (very lifelike) . . . . . 15c                             | X Ray Novelty . . . . . 15c                                   |
| False Mustache . . . . . 5c   | Trick Pencil . . . . . 15c                                    |
| Big Red Snago Money . . . . . 10c   | Rubber Yacks (a good joke) . . . . . 15c                      |
| Ford Auto Puzzle (Latest) . . . . . 15c                                     | Mummified Penny (defies the law of gravitation) . . . . . 25c |
| Magic Plate (anyone can play it) . . . . . 15c                              | Cachoo! Sneezing Powder . . . . . 15c                         |
| Rubber Razor (very formidable) . . . . . 25c                                | Mysterious Tumbler and Vanishing Coin Trick . . . . . 25c     |
| Window Smashers (greatest joke yet) . . . . . 5c                            | Enchanted Bottle (what makes it lay down?) . . . . . 5c       |
| Packet Detective (see behind your Great Mind Reading Mystery) . . . . . 10c | Magic Plate Lifter . . . . . 25c                              |
| Thorston's Mysterious Trick Cds. . . . . 10c                                | Imitation Gold Teeth . . . . . 3 for 5c                       |
| Fighting Roosters, pair . . . . . 10c                                       | Great Kelpie Puzzle . . . . . 10c                             |
| Cover the Spot Trick, a scrien, nov. . . . . 10c                            |   |

Large catalog (300 pages) of unique, novel and useful articles (unobtainable elsewhere) free with all orders, or mailed on receipt of five-cent stamp. Agents and dealers write for wholesale prices. Mail order dealers and beginners supplied with 32, 64 or 148 page catalogs at cost. Send 10 cents (credited) for sample of each and particulars of our proposition.

Johnson Smith & Co., 7153 N. Clark St., Chicago  
Other interesting articles on next page





# LUMINOUS PAINT



## Make Your Watches, Clocks, Etc., Visible by Night

The very latest discovery in the scientific world. Hitherto practically unobtainable except at an exorbitant price, we have at last succeeded in producing this remarkable LUMINOUS PAINT, which, applied to the surface of any article, emits rays of white light, rendering it perfectly visible in the dark. **THE DARKER THE NIGHT, THE MORE BRILLIANT IT SHINES.** Quite simple to use. Anyone—you can do it. A little applied to the dial of your watch or clock will enable you to tell the time by night. You can coat the push buttons or switch plates of your electric lights, match boxes, house numbers and innumerable other articles; make your own Luminous Crucifixes, Luminous Rosaries, etc. All ready for use. Requires no preparation; contains no phosphorus. Luminous effect is positively permanent. Bottle containing sufficient to coat several small articles, **Price 25c.** Larger sizes 50c and \$1.00 Postpaid.

Manufactured by

**JOHNSON SMITH & COMPANY, 7153 North Clark Street, CHICAGO**

### INVISIBLE INK

The most confidential messages can be written with this ink, for the writing **MAKES NO MARK.** Cannot be seen unless you know the secret. Invaluable for many reasons. Keep your posts and other private communications away from prying eyes. Great fun for playing practical jokes. **Only 15c Bottle**



### VANISHING INK

Writing written with this remarkable ink vanishes entirely in a few weeks (sooner if desired), leaving the paper **QUITE BLANK.** 15c per bottle.

### LUMINOUS INK

Writing can be **READ ONLY IN A DARK ROOM**; writes like fire. Quite invisible at daytime. Very remarkable. 15c



**DISSOLVING INK** A new kind of invisible and vanishing ink combined. Writing is quite invisible, but can be made to appear or disappear at will in a very simple yet mysterious manner. Same **PRICE, 15c** postpaid.

### Thumb Brander

**NEW & NOVEL JOKE** to play on your friends. Put on your thumb, and "brand" your victims as you very easily either. Any of these choice epithets: Owl, fool, liar, grouch, baby, chicken, hot air, bull, Safety First. Complete with pad and ink, 17c.

**JOHNSON SMITH & CO., 7153 North Clark Street, CHICAGO**

### INKLESS PEN

**WRITES WITH WATER** 600 words you dip. Makes its own ink. Writes fashionable violet color. Better and cheaper than fountain pens. Writes a long letter with one dip in plain water. No trouble—no bother—no mess. A pleasure to use. With Nickel Plated Reversible Holder **10 CENTS, 2 for 25c**

**JOHNSON SMITH & COMPANY, 7153 N. Clark St., CHICAGO**

# EGG-INE

A REALLY EFFICIENT SUBSTITUTE FOR EGGS

Wholesome — Nourishing — Cheap

You Cannot Tell the Difference

Egg-ine is a substitute for eggs of the very highest order. It is a Pure Food product that makes the finest, richest and most delicious cake you ever tasted. It is equally good for all baking and cooking purposes. It is in powder form, ready for immediate use. All you have to do is to add a little water, and then mix with the other materials the same as eggs. No trouble at all. **Nothing could be simpler.** EGG-INE will keep indefinitely. Does not lose any of its strength or undergo any change in any way. It is made from the purest ingredients, in a thoroughly scientific way, producing practically the same results as eggs. You cannot tell the difference in the finished product—as a matter of fact customers frequently write us that it makes finer and richer cake and puddings than ordinary eggs. For Cakes, Cookies, Fried Cakes, Raisin Dressings, Muffins, Bread Puddings, Gravies, Ice Cream, etc., there is nothing to equal it. Fully guaranteed under the Pure Food Laws. **MUCH CHEAPER THAN EGGS;** one packet is equivalent to a dozen eggs. **NOURISHING, DIGESTIBLE and HEALTHFUL** in every particular. Just try a sample packet, and you will use it regularly. **PRICES: 12 cents per package, or in large cartons 30 cents, four cartons for \$1.00, postpaid anywhere.**



**JOHNSON SMITH & COMPANY, 7153 N. Clark St., CHICAGO**

## Vitalic Bicycle Tires Deluxe

\$8 a pair, Brigadier \$5 a pair — made for endurance

Continental Rubber Works, Erie, Pa.

## W-W-W RINGS

are absolutely guaranteed against settings coming out or chipping. Ask your jeweler to show them to you. **WHITE, WILE & WARNER, Dept. F-275, Buffalo, N.Y.**

We Send Prepaid,  
No Money Down,  
10 Nights' Free Trial

See it, try it, test it in any way you want in your own home, alongside any other light. Then if you feel like parting with it send it back at our expense. The trial costs you nothing. We take all the risk.

**U. S. GOVERNMENT** report shows mantle oil light more than 3 times as efficient as ordinary lamp. The Daylite is whiter and brighter than gas or electric, at 1/4 the cost. **Pays for itself** in a few months in oil saved. No smoke, no dirt, no odor. Uses common wick and is lighted same as ordinary lamp. Simple and safe, cannot explode. **Only oil light guaranteed for 5 years.** Only mantle light with telescoping tube; full details in complete illustrated catalog — **It's FREE.**

**AGENTS WANTED.** No money — no experience — needed. Five out of six buy the Daylite the minute they see it. Wanted in every home. No talking necessary. Sells itself. **No capital required.** We supply stock, all necessary equipment, and protected territory. Men with rigs or autos are making **\$6 to \$15 every day,** month after month. **WRITE NOW FOR LAMP — FREE** for ten nights' trial. Tell us if you have a rig or auto, whether you can work spare time or steady, your age, occupation, what territory you want and when you can start.

**DAYLITE COMPANY, 229 DAYLITE BUILDING, CHICAGO, ILLINOIS**

# SENT FREE! JUST OUT

Whiter-Brighter Than Gas or Electric, at 1/4 the Cost

BURNS  
KEROSENE



# Make Your Own Phonograph

We Furnish All the Working Parts for **\$7.85**

Use a table or other piece of furniture. No secret. We explain all to you. Metal exposed parts heavily nicked. Reproducer alone of this quality cost you \$7.85 to \$15. Plays Victor, Little Wonder, Columbia, and all lateral records up to 12 ins. Motor full force spring with speed regulator. Send today for full set working parts, and all instructions complete. Limited offer, \$7.85.

**Have a \$100 Phonograph in Tonal Quality and Music Value with Your Own Cabinet**

We Furnish Working Drawings Showing You How to Assemble This Easily Yourself. Have the Finest Machine. Astounding Saving.

All sizes spring and electric motors, tone arms and Reproducers. **ELECTRO MECHANICAL PARTS CO.**

REPAIR PARTS for any machine made. **57 E. Jackson Blvd., Dept. 5246, CHICAGO**







## Be An Expert

*Sanitary Engineer  
Heating and Ventilating Engineer  
Drafting and Estimating Manager  
Plumbing or Sanitary Inspector  
Master Plumber*

These high positions are now open to you. We train you to become an expert in your own home—during your spare time.

### Add a Professional and Business Training to Practical Experience

Our courses have been prepared by eighteen of the most brilliant minds in the profession—men who have been through every branch of the game from A to Z.

### We Guarantee You Success

in any State License, Trade Union, Civil Service, or Local Competitive Examination. Let us show you the way to plan, design, estimate, and make capital out of your practical experience.

### All Interested Organizations Endorse Our Courses

They are second to none in the world. You can understand them. They are brand new. They will open up vast opportunities for you. They will prove your best investment.

American School of Correspondence  
Dept. H 1192

CHICAGO, U. S. A.  
Gentlemen: Please send me free new book describing your courses of training in sanitary engineering, plumbing, heating and ventilating engineering, drafting and estimating.

## Send Coupon for New Book

Send the coupon for our new book that describes these four new courses of technical training. Read all about the chances in these uncrowded professions. Here are vital, inspiring facts that are worth their weight in gold to all progressive men. The book is FREE. You're welcome to it and sending the coupon puts you under no obligation. Send the coupon today—NOW.

American School of Correspondence  
Dept. H 1192  
Chicago, U. S. A.

Name .....

Address .....

## Genuine Blue-White Perfect Cut Diamonds



### Our Wonderful Offer

Send for my 1917 Diamond Book, in which I quote prices on genuine blue-white perfect cut diamonds at a saving of 35% from jewelers' prices. The book tells diamond facts needed to buy safely and intelligently. Get a copy at once. When it arrives choose any diamond, in any setting, and I will ship it for Free examination so you can make comparisons.

### NOTE THESE SPECIALS!

- 1/8 Carat at \$5.88, \$6.25 and \$9.00
- 1/4 Carat at \$13.50, \$15.50 and \$22.50
- 1/2 Carat at \$40.25, \$59 and \$77.00
- 3/4 Carat at \$64.25, \$96 and \$128.00



### MONEY-BACK GUARANTEE

given with every diamond that you can take to any bank in America and cash in on your diamond investment if you want to. References: Lake and State Savings Bank of Chicago, or your bank, or any Commercial Agency. Send for Diamond Book today—now—and see what we have to offer you at lowest prices ever quoted.

**BARNARD & CO.** Dept. 2488C  
N. W. Cor State and Monroe Sts., CHICAGO

## The Cleveland Lightweight

The only light, low priced Motorcycle with straight line worm drive. Weighs 150 pounds.

Highest quality throughout. 75 miles to the gallon. 600 sold in one city last year. Price, \$160.00; with Kick Starter, \$170.00. Dealers wanted.

THE CLEVELAND MOTORCYCLE MFG. CO.  
7202 Platt Avenue, CLEVELAND, O.

## Every 1915-16 Ford Needs a

Gives Strong Light at Low Speed

**VAN SICKLEN**  
HEAD LIGHT CONCENTRATOR  
FOR FORD CARS  
ASK YOUR DEALER

Plenty Light on the Worst Roads

THE VAN SICKLEN CO., Elgin, Illinois

## Smith Form-a-Truck

\$350 AND A FORD  
WORLD'S LOWEST HAULING COST



## \$6.00 ELECTRIC FAN COMPLETE!

Price includes plug and 8 ft. cord. Universal motor good on alternating or direct current. Finished in black enamel. 11 inches high. Weighs 7 pounds. AGENTS AND DEALERS WANTED! Big money will be made this summer by men who represent us on this \$6.00 fan. WRITE FOR OUR OFFER TODAY.

Kadens Electric Co., 29 E. 21st St., New York



# Money Grows if rightly planted



## Own a Dixie Estate!

Own one of our specially developed fruit groves called Dixie Estates. Hundreds of Northern wage-earners are grasping this opportunity for an independent income. It is **your** chance, too! You can buy your DIXIE ESTATE on easy payments. Yes, terms so easy that you won't miss the money. This is not an ordinary land selling proposition. It is the great fruit grove development project of one of Florida's foremost nursery companies. Get our free booklet and read the full particulars of our plan.

## Easy Payments!

Don't worry about the money. If you are the kind who will make the most of this opportunity we will make the money question easy for you. A few dollars a month will pay for your Dixie Estate—land, trees, their care, etc. Mail the coupon or a post card and we will send you our free booklet describing Dixie Estates in full and particulars of our startling easy payment plan.

## Near Tampa, Florida's Great City

Best location in all Florida—right in the very vicinity of beautiful Tampa, the coming Los Angeles of the South. Your Dixie Estate will be near fine boulevards, railroad stations, schools, churches, etc. **And the soil!** You could not buy better land for fruit growing at any price. We own big nurseries. **The trees we plant** on your Dixie Estate are the very finest obtainable—budded, pedigreed, guaranteed stock, grown by experts. Climate is wonderful.

### Planted for You to Grapefruit, Oranges, and Avocados

We plant these three money making fruits on your Dixie Estate. The Avocado (commonly called the Alligator Pear) is known as the aristocrat of fruits. Supply so scarce that they bring amazing prices. In December, 1915, Avocados sold in Chicago at the almost unbelievable price of \$3 and \$4 each. Mail coupon for booklet giving further facts and figures.

### A Splendid Income For You the Rest of Your Life

A single acre Dixie Estate, when fully developed, produces from \$1,000 to \$1,500 annually, and proportionately larger for larger sized tracts. These are very conservative figures. You may reasonably expect more than 100% on your investment annually. Think of it! 100% as compared to the 3% or 4% you can get from the bank!

## Free Booklet MAIL COUPON!



Write quick! Only a certain number of Dixie Estates to be sold on this special, easy payment plan. Prices and terms will then go up. Get the free booklet that tells you all. Mail the coupon or a post card.

**The Thomas Nurseries, Inc.**  
804 Tower Bldg., No. 6 North Michigan Ave., Chicago, Ill.

### Live on Your Dixie Estate Or Remain North Where You Are

You don't have to move to Florida unless you wish to. We have a plan whereby we take care of your Dixie Estate for you as long as you desire. But any time you wish to get away from the mean cold winters of the North your money-making Dixie Estate is waiting for you. Mail the coupon now.

#### FREE BOOKLET COUPON

THE THOMAS NURSERIES, Inc. P. M. 2-17  
804 Tower Bldg., 6 North Michigan Ave., Chicago, Ill.

Please send me your free, illustrated Booklet on Dixie Estates and particulars of your special easy payment plan. This does not obligate me in any way.

Name.....

Street and Number.....

City.....State.....



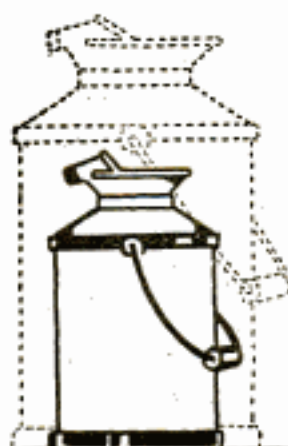

## 42% to 54% Greater Gasoline Mileage

### By Actual Official A.A.A. Tests

Manufacturers of high priced cars have spent hundreds of thousands of dollars in the endeavor to deliver superheated, vaporized gasoline to the engine.

For only through complete vaporization can gasoline reach its highest point of efficiency—and economy.

Now, the Wilmo Manifold, which costs as little as \$7.50, accomplishes all this and more.

Recent official tests, made with various cars, under the direct and exacting supervision of the A.A.A., show increased gasoline mileage of from 42% to 54% as a direct result of Wilmo Manifold use.

In addition, the Wilmo Manifold insures a smoother running engine at all speeds. Gets the car off snappily at the first few turns of the engine. Eliminates practically all valve and carbon troubles.

## Wilmo Manifold

The scientific principle of the Wilmo Manifold is simplicity itself. The exhaust gas heats a plate which in turn superheats and vaporizes the incoming mixture at cylinder port-holes. No cold weather troubles. No carbon. No lost power. Increased efficiency secured from lower grades of gasoline as from costlier grades.

Attached in thirty minutes with a monkey-wrench. No holes to bore. No complicated directions. Prices: \$7.50, Ford size; up to \$15.00, depending on the make of the car.

Ask your dealer or garage man. Also write direct for results of official A.A.A. tests showing increased gasoline mileage and guaranteed saving.

The Whittier Company  
First National Bank Building, Chicago  
Dealers, write for complete data.



THIS  
HOT PLATE  
DOES  
THE WORK

Please Mention Popular Mechanics

## \$25 TO \$50 DAILY PROFIT

### Making Cement Drain Tile

Here is a chance for every ambitious man to make big money—to own and operate a factory—to join the ranks of America's biggest money-makers. No previous experience is necessary and but little capital. You start with this machine—the Richmond. It makes Cement Tile. Works easy. Tile requires no burning like clay tile—no tamping. Makes 1500 to 2500 perfect tile a day.



### Every Farm Needs Under-Drainage

Under drainage means earlier and easier cultivation besides perfect insurance of crops. It removes the surplus water from the land. It pays big dividends—increases value of land 30% to 300%. Thousands of acres right around you need Cement Tile for this purpose.

**ENORMOUS DEMAND.** Millions to be spent. You can share in this mammoth fortune, if you write at once.

### FREE BOOK—FREE TRIAL

Let us tell you all about this big profitable business—this great business opportunity open to you. Our Free Book explains the business from A to Z—tells how Cement Tile is made—how it is sold and how we help you make a success. Get our liberal, No-Money-Risk Free Trial Offer. Send a postal or letter Now.

Farmers' Cement Tile Machine Co.  
Dept. 112 ST. JOHNS, MICHIGAN

## \$500 REWARD

We will pay \$500.00 reward to anyone who can permanently dim the brilliancy of the RAJAH Im. diamond without destroying the stone.

### RAJAH Im. Diamonds

They stand all diamond tests—fire, acid, file, and glass cutting. Their brilliancy is eternal. Guaranteed for a lifetime. Set in solid gold, and sent to you on 30 Days' Free Trial! If you can't tell it from a real diamond, send diamond return it. Send today for our beautiful, fully illustrated jewelry catalog in colors. Write now. KRAUTH & REED, 159 N. State St., Dept. P2 CHICAGO, ILL.



A YEAR  
TO PAY



Be a  
Taxidermy  
Artist

## Marvelous FREE Book Sent

You can now learn Taxidermy, the wonderful art of mounting birds, animals, tanning skins, etc. Learn at home, by mail. The free book tells how. Mount your own trophies. Decorate home and den. Hunters, trappers, nature lovers, you need taxidermy. Interesting, fascinating, big profits. Join our school. 55,000 students. Success guaranteed. Get our free book without delay. Send right now—today.

N. W. School of Taxidermy, 1192 Elwood Bldg., Omaha, Neb.

## Instant Bunion Relief Prove It At My Expense



Don't send me one cent—just let me prove it to you as I have done for 57,532 others in the last six months. I claim to have the most successful remedy for bunions ever made and I want you to let me send you a treatment Free, entirely at my expense. I don't care how many so-called cures, or shields, or pads you ever tried without success—I don't care how disgusted you are with them all—you have not tried my remedy and I have such absolute confidence in it that I am going to send you a treatment absolutely FREE. It is a wonderful yet simple home remedy which relieves you almost instantly of the pain; it removes the cause of the bunion and thus the ugly deformity disappears—all this while you are wearing tighter shoes than ever. Just send your name and address and treatment will be sent you promptly in plain sealed envelope.

FOOT REMEDY CO.  
3535 West 26th Street, Chicago, Ill.



## GET IN THIS BIG MONEY MAKING BUSINESS QUICK

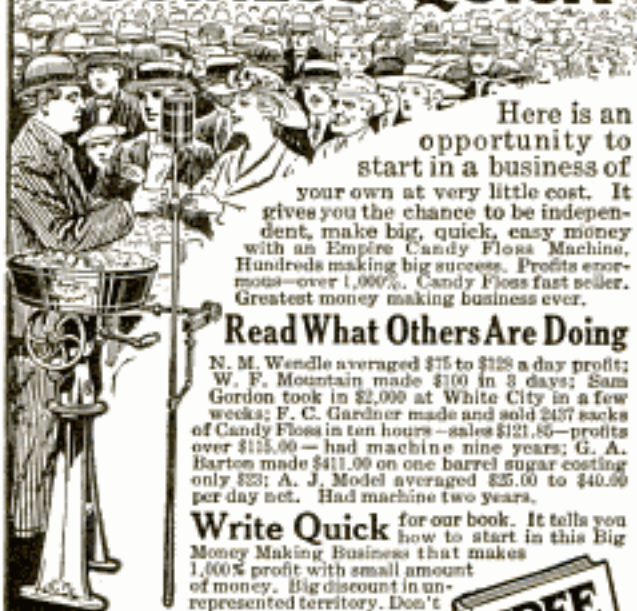

Here is an opportunity to start in a business of your own at very little cost. It gives you the chance to be independent, make big, quick, easy money with an Empire Candy Floss Machine. Hundreds making big success. Profits enormous—over 1,000%. Candy Floss fast seller. Greatest money making business ever.

### Read What Others Are Doing

N. M. Wendle averaged \$75 to \$125 a day profit; W. F. Mountain made \$100 in 3 days; Sam Gordon took in \$2,000 at White City in a few weeks; F. C. Gardner made and sold 237 sacks of Candy Floss in ten hours—sales \$121.50—profits over \$115.00—had machine nine years; G. A. Barton made \$411.00 on one barrel sugar coating only \$23; A. J. Model averaged \$25.00 to \$40.00 per day net. Had machine two years.

**Write Quick** for our book. It tells you how to start in this Big Money Making Business that makes 1,000% profit with small amount of money. Big discount in unrepresented territory. Don't delay. Write today.

**EMPIRE CANDY FLOSS MACHINE CO.**

2360 Milwaukee Avenue  
Dept. 233, Chicago, Ill.

**FREE BOOK**

## 10c And We Send You An Illinois Watch

Send only 10c and get a magnificent Illinois watch, 17 jewel, new thin model, \$22.50. Pay balance only a dime added to a dime a week. Easiest way on earth to buy a guaranteed Illinois watch. Your choice 16, 12, or ladies' size or bracelet watch. Send your dime today and get your watch. **WHOLESALE JEWELRY CO., 5707 W. Lake St., Dept. 5246, CHICAGO, ILL.**

## Drilling Wells is a Year Round Business

Drilling Water Wells is a profitable, healthful year-round business. There are wells all round you to be drilled. Don't you want to get into a money-making business for yourself? Write for particulars.

**Star Drilling Machine Co.**  
664 Washington St. Akron, Ohio

**JOHNS-MANVILLE**

# Asbestos



## FREE CLOTH SAMPLES

Big selection of cloth samples—Guaranteed all-wool Serges, new fancy Worsteds, stylish Casimeres, all latest shades and patterns—everything good dressers wear—Free. Postal will bring it. **We make fine clothes for men** to individual measure, absolutely guaranteed to fit and please at prices that will astonish you. Don't buy suit or overcoat anywhere at any price—until you have got our selection of cloth samples, fashion models, tape line, everything Free. Stop paying high prices for clothes. Write quick for our amazing suit offer.

**THE CAPITOL TAILORS, Dept. 111, Chicago, Ill.**



## Let Us Send You a Conn Instrument Like Those used in Sousa's Band

**WRITE** today for the Conn Book and see handsome illustrations of all the Conn instruments that we will send to you on 10 days' trial. These instruments are actually the *master products* of the great instrument maker. Conn is the maker of all kinds of band instruments and practically every famous bandman in America uses a Conn instrument. Sousa's, Washington Marine, Pryor's, Conway's and hundreds of other bands of international fame use Conn instruments. Practically every grand prize offered during the last generation has been won by Conn instruments when they were in competition with the world at the great exposition.

*And these are the instruments that will be sent to you on 10 days' trial.*

*Convenient payments in small amounts may be arranged.*

## Send the Coupon for the Conn Book

**C. C. CONN, Ltd.**  
Dept. 1192  
ELKHART, INDIANA

Put your name and address in the coupon or on a letter or a post card now and send it to us today. We'll send you the new Conn Book free and prepaid. The Conn Book is free. Merely tell us the instrument in which you are interested and send your name.

Gentlemen: Please send me the new Conn Book and tell me how I can get a Conn Instrument sent to me on 10 days' trial and how I may pay for it in small amounts.

Send the Coupon Now  
**C. C. CONN, Ltd.**  
Dept. 1192  
ELKHART, IND.

Name .....

Address .....

I am interested in .....

(Name of instrument here)

Please Mention Popular Mechanics





## Here's Health

—vim, vigor, vitality! The keen, vivid relish of youth for work and pleasure! Snap, ginger, punch in every thought and action! The joy of glorious health, strength, power, life—yours through vibration.

Wake up that sluggish circulation! Send the rich, red blood leaping along through every vein and artery! Tune up those jangled nerves! Stir up those sluggish organs! Flood your whole body with health! Don't be satisfied with mere existence! **Begin to live!**

## Arnold Vibrator

Try this wonderful machine yourself. Test it on your own body. Notice the difference after the very first treatment. See how pleasant and easy it is to use—how marvelous the results. And don't forget that these results are permanent because vibration gets right at the cause of things—goes to the very root of the trouble. Aches and pains vanish like magic. You don't need to take anybody's word for these things—you can find out for yourself.

### 10 Days' Trial Free

Get the facts about our generous free trial offer. Learn how you may get these things yourself at our risk, and if you are familiar with the prices asked for ordinary vibrators you will be amazed to find how much less it costs to own the genuine guaranteed Arnold Vibrator. When there is so much at stake why risk buying an imitation unknown machine? Insist on the Arnold. Ask for it by name.



### 80-Page Book Free

Your name and address on the coupon or a postal or letter brings you valuable 80-page book on Vibration free and full particulars of our special offer.

ARNOLD ELECTRIC CO., 1430 W. 12th St., Racine, Wis.

### Mail Coupon For FREE Book

ARNOLD ELECTRIC CO., 1430 W. 12th St., Racine, Wis.

Please send me your big illustrated Book and 10 days' TRIAL REDUCED PRICE OFFER, all free.

Name .....

Street .....

City.....State.....



## Japanese Rose Bushes Five for 10c THE WONDER of the WORLD

Rose Bushes with roses on them in 8 weeks from the time the seed was planted. It may not seem possible, but we **Guarantee** it to be so. They will

### BLOOM EVERY TEN WEEKS

Winter or Summer, and when 3 years old will have 5 or 6 hundred roses on each bush. Will grow in the house in the Winter as well as in the ground in Summer. **Roses All the Year Around.** Package of seed with our guarantee, by mail, **only 10c.**



## Voice Thrower 10c

Learn to throw your voice into a TRUNK, under the bed, out in the hall or anywhere. Lots of FUN fooling the Teacher, Janitor, Policeman, Parents, Neighbors, or Friends.

### THE VENTRILO

Is a little instrument that fits into the mouth out of sight. BOYS or GIRLS can use it. NEVER FAILS! A 32 page book on Ventriloquism sent with the VENTRILO for **TEN CENTS.**

## NEW FORD JOKE BOOK 1917

All the latest jokes on the Ford Auto. Hundreds of them and all good ones. Spring a new one on your neighbors.

Large book with colored cover by mail, 10c.



## STRADDLE BUG

The most startling Novelty ever gotten out. When it goes off, it would scare the heart out of a wooden Indian. Don't try it on the women folks, or they will faint. Can be wound up in one instant for another victim. **10c**  
Great novelty. Sample by mail



## ROGEN X RAY

Price 10 cents

HERE, BOYS, is just what you want. With this instrument you can apparently see through clothes, see the bones in your fingers. Think of the fun you can have with it. Sample by mail, **TEN CENTS.**



## SKULL RING

Here is a handsome, up-to-date Ring, representing a Skull and Cross-bones. Has stones in the eyes and looks something frightful. Women won't like it, but for men or boys it is a great novelty.

Sample by mail, 15c



## Gee! What a Wad!

This is **STAGE MONEY.**

Looks like the GENUINE STUFF. Some Green backs and some Yellow backs. Create a BIG sensation among your friends. The girls will all be after you when they see the wad. BIG roll of 15 pieces by mail **10 cents.**



## Boys Own Toy Maker and Nine Other Books for 10c

Tells how to make a Telephone, Magic Lantern, Kites, Sail Boat, Stilts, Electric Telegraph, Pop Gun, Red Fire, Galvanic Battery and many other things. This book with nine other interesting books mailed for **10c.**

All the above goods can be secured from

## ROYAL NOVELTY CO.

225 East Ave., SOUTH NORWALK, CONN.



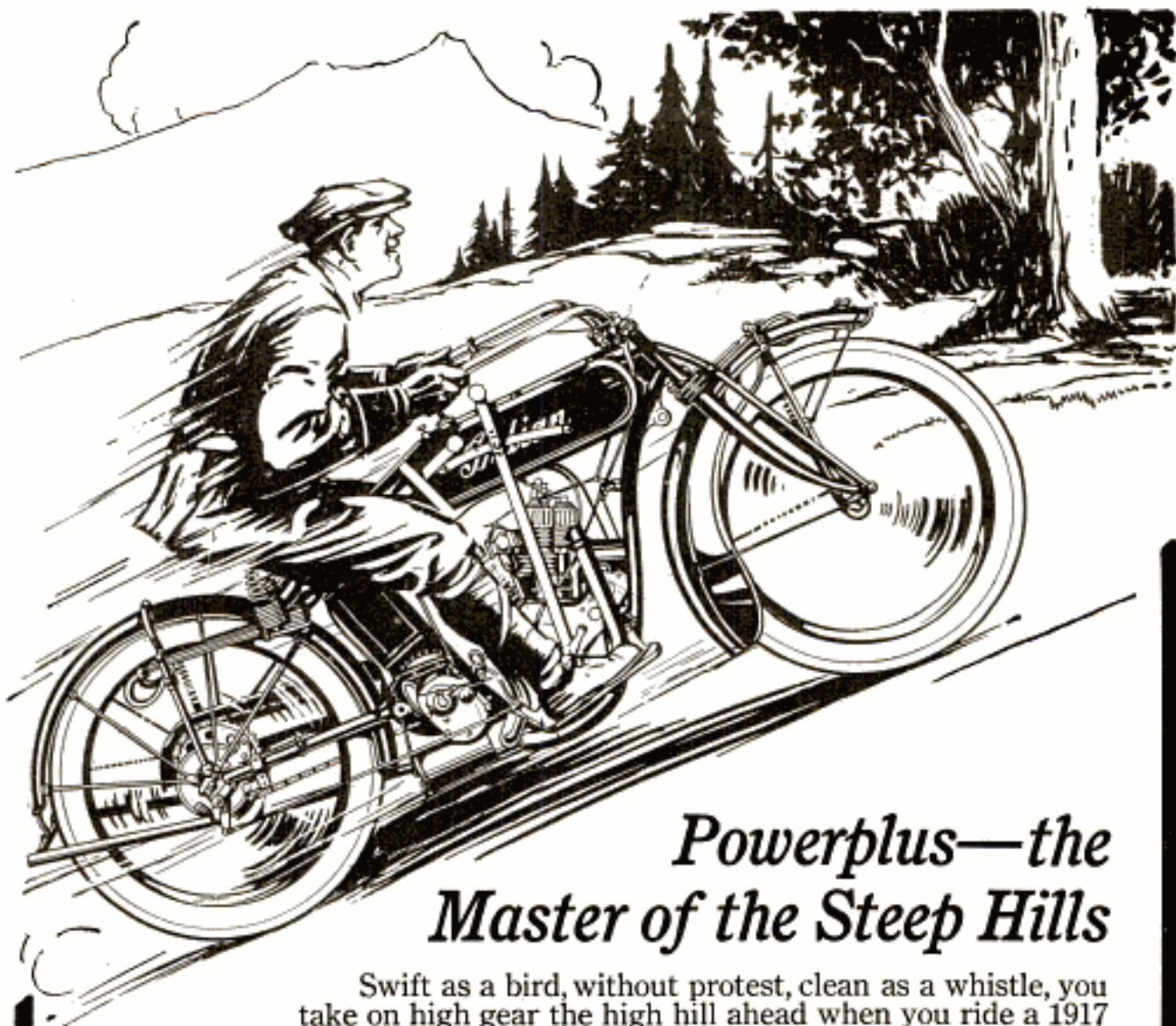

## *Powerplus—the Master of the Steep Hills*

Swift as a bird, without protest, clean as a whistle, you take on high gear the high hill ahead when you ride a 1917

# *Indian* Motorcycle With Powerplus Motor

This speedy, powerful machine gives you access to the world at large, takes you where you elect to go at low cost, in the hammock-like comfort of the *patented*, exclusively Indian *Cradle Spring Frame*—the world's greatest shock-absorber.

We'd be glad to have you visit our dealers and get an actual demonstration of the Big Twin Powerplus's super-efficiency. It would give you a wonderful insight to the greatest advance ever made in motorcycle building.

*Our Dealers are showing 1917 Indian Powerplus, Light Twin, Side Car and Parcel Car. Electrically Equipped and other Bicycles. Write for 1917 Catalog.*

**HENDEE MANUFACTURING COMPANY, 710 State Street, Springfield, Mass.**

*(Largest Motorcycle Manufacturers in the World)*



**Not one cent extra for**  
**Firestone**  
**Tires**  
 on these motorcycles

**E**LEVEN leading motorcycle manufacturers equip with Firestone Tires, at no extra charge. They recognize the rapidly growing demand for the Firestone extra broad tread, the four heavy fabric layers, the resilient rubber.

These manufacturers realize that Firestone Tires are a valuable aid to better motorcycle performance.

Firestone Tires give you a grip on the muddiest road, the most slippery pavement, on straightaway or turns. Your machine moves more smoothly and comfortably. Finally, you get "Most Miles per Dollar."

And Firestone Motorcycle Tires cost no more if ordered on any of the eleven machines listed here.

**FIRESTONE TIRE & RUBBER CO.**  
 AKRON, OHIO  
 Branches and Dealers Everywhere

Please Mention Popular Mechanics





# \$125 to \$250 a Month

**S**TATIONARY, Marine and Locomotive Engineers are needed. Their pay ranges from \$125 to \$250 a month. Why not prepare yourself—in your spare time—for one of these high-salaried positions? All the knowledge necessary to your success is contained in these seven thick volumes. Merely mailing the coupon brings the complete set on *trial*. We send them to you by prepaid express, and you may return them at our expense if they fail to please.

## Steam Engineering

These books contain 3,300 pages (7 x 10 inches), and 2,500 illustrations, charts, tables, diagrams, etc. Handsomely bound in red morocco, gold stamped. This set of books is invaluable to the steam engineer or to the man preparing for one of these high-salaried positions. For a limited time we are making a very special offer. The regular price of this set is \$35.00, but on this offer you can get it for \$19.80, a saving of nearly half. And this rock-bottom price may be paid at the rate of 60 cents a week.

These books were written in simple English by 27 experts. They

**Partial Table of Contents:**  
Construction and operation of stationary, locomotive and marine engines and boilers; the use of gas and gasoline engines for power and locomotion; the transformation of steam and gas power into electricity; the application of steam and gas power to refrigeration, compressed air, etc.

## Consulting Service FREE!

In addition to the set of books we also give you—free of charge—a year's consulting membership in the American Technical Society. This entitles you to the privilege of bringing every perplexing problem to a corps of experts. Ask as many questions as you wish for an entire year.

## 50c A Week

We will ship you the entire seven volumes, prepaid, right to your own home upon your simple request. Do not pay a penny until after you have used them for seven days, then send only \$2.00 or return the books at our expense. Pay the balance at the rate of \$2.00 a month—50c a week. The present rock-bottom price of the entire set of books is only \$19.80—a reduction of \$15.20 from the regular price of \$35.00.

## Send the Coupon Today

Put your name and address in the coupon now and send it to us. This offer to send the entire set of books, prepaid, is open to every one within the boundaries of the United States and Canada—you cannot afford to pass it by. Act now. This is opportunity.

**American Technical Society, Dept. S1192, Chicago, U.S.A.**

**American Technical Society**  
Dept. S1192 Chicago, U.S.A.

Please send me the seven volumes out of the Cyclopedia of Steam Engineering for seven days free examination. If I decide to buy, I will send \$2.00 within seven days and balance at \$2.00 a month until \$19.80 has been paid. Then you will send me a receipt showing that the set of books and the consulting membership are paid and fully paid for. If I think that I can get along without the books, I will return them after 7 days at your expense.

Name.....

Address.....

Reference.....



# A Lightning Edge on Safety Blades

A keener edge than you ever felt. Will flash through the stiffest, wiriest hair. A few strokes works marvels on any blade. A child can sharpen blades on a Stag as well as an expert. Makes old blades better than new. Makes new blades better.

**Stag Sharpener** with barber's hone and strop complete, on our money back guarantee. Complete postpaid

## SHARPEN ANY BLADE

Positively gives new blades a better shaving edge. Puts the oldest, dullest blades in lightning

edge condition. Quickest, Truest, Surest, Safest, and

Easiest way. The wheels of the sharpener

guide the angle. Nothing to adjust

or get out of order. Lasts a life-

time. Our new patented feature

makes the Stag more desirable

than ever. Complete outfit includes

barber's hone and strop, in neat box,

suitable for traveler's kit. Complete postpaid to you only \$1.

Stag Sharpens All Safety Blades



Special \$1 Coupon

Hone and Strop Free

The Stag Company

38 So. State St., Dept. 5246, CHICAGO

GENTLEMEN: Wishing to take advantage of your 10 days' free trial and money-back guarantee, you may send a Stag Sharpener, hone and strop complete. I am sending herewith \$1.

Try a Stag Sharpener at our risk and at our expense. Use it ten days free. Then if you

are not delighted, send it back and get your money

back in full. We gladly assume the risk and

welcome your order on this liberal, free trial,

money back guarantee. Send only \$1 today.

Send Today Enclose only \$1. money order, draft, dollar bill, or check. Send today and make a comfortable shave for yourself. You need a Stag Sharpener. Clip coupon, put in \$1 and get it by return mail.

Sent On Free Trial

### DEALERS

Write to us for special terms to dealers. The Stag is the quickest and best seller on our h. Get the benefit of this advertising and our Dealer Service.



Name.....

Address.....

THE STAG COMPANY

38 So. State Street, Dept. 5246, CHICAGO

## Vitality in Violet Rays

Marvelous, perfected Virayo. For home use. Virayo, the true Violet Ray instrument, endorsed

by leading physicians. Soothing, delightful, nerve toning, health building Violet Rays. Send immediately for book of important health information. FREE.

### VIRAYO

Virayo, the true Violet Ray instrument, recommended by physicians for family use. Use it anywhere. Appliances for every form of treatment by Violet Rays. Special limited introductory offer.

BOOK FREE. You need

this book on Violet Rays. It is free. A new book on health, beauty, vitality and vigor. Book sent free. Special introductory price for limited time; all particulars postpaid free to you with book.



Write today. WESTERN COIL CO., 189 N. Dearborn St., Dept. 5246, Chicago, U.S.A.

## Cut Your ICE BILL

Get a White Frost—30 days' trial—we pay freight. Steel built, white enameled.

### White Frost Refrigerator

Write Today WHITE FROST REFRIGERATOR CO. 272 N. Mackacik St., Jackson, Mich.



## HUNTERS!!

Send for free folder of Remington UMC repeating Rifle, Model No. 14 1/2, for game up to and including deer—just the arm for moderate range shooting.

THE REMINGTON ARMS UNION METALLIC CARTRIDGE COMPANY Dept. P-5, Woolworth Building, New York

## Big Ben



## SMOKERS

BY THOUSANDS NOW KNOW, To Their Delight, That The BREECH-LOADER IS Exactly What We CLAIM And GUARANTEE It To Be, viz., A POSITIVELY DRY, "JUICELESS," "HEELLESS," SWEET, SANITARY SMOKING PIPE; The First Ever Enjoyed. Is Not YOUR Judgment Backed

By OUR GUARANTEE To Meet EVERY Claim. Or REFUND YOUR MONEY, Quite Sufficient For Any REASON-ABLE MAN? Then Send For THIS PIPE TO-DAY! You Can Sustain No Loss, Except By Delay. This Pipe PROVES ABSOLUTELY That SALIVA Never Was Responsible For The "JUICE" NUISANCE In ANY PIPE. Let Us Convince You.

### BREECHLOADER

NEVER BECOMES FOUL or OFFENSIVE

RESTRICTED AIR INLET and ASH OUTLET



A STRICTLY SANITARY PIPE NO NOXIOUS "JUICY" "HEEL"

A Careless Safety Pipe The AUTOMOBILISTS PERFECTO

### A Very Interesting Proposition To ENTERPRISING DEALERS Also.

THE BREECHLOADER Is EXTREMELY SIMPLE. Most Substantial and Practical; Neat and Unique in Design; A Very Desirable Size; 5 1/2 in long With Graceful Curves; A Little on the "Chubby" order. Half Bent; Considerably Lighter, Holding about one fourth more Tobacco than the ordinary pipe of the same size. The Bowl and Breech Plug is made of FIRST QUALITY, GENUINE FRENCH BRILLIANT Green Rich, Natural, Friction Finish; Solid Rubber Stem; Sterling Silver Mounted; Price including Nickel Plated Pipe Companion \$1.00 Postpaid. Or Write for Free Pamphlet.

THE BREECHLOADER PIPE CO., Inc. Suite X, 335 Broadway, New York, N. Y.



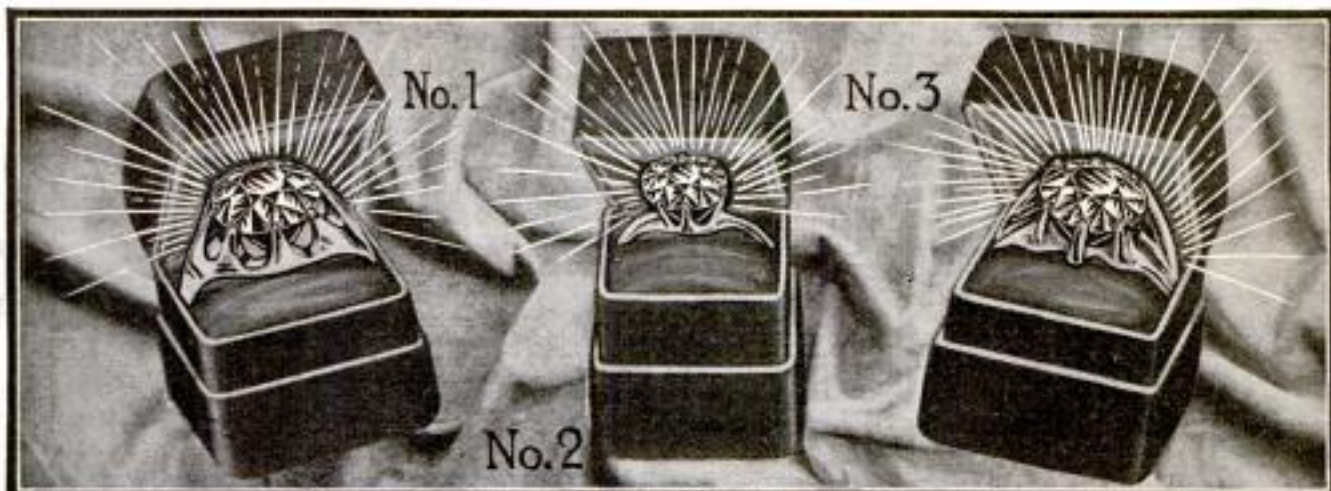

## YOUR CHOICE FOR 10 DAYS' WEAR **FREE**

Here is the most amazingly liberal offer ever made on precious gems. To quickly introduce into every locality our beautiful, TIFNITE GEMS—which in appearance and by every test are so much like a diamond that even an expert can hardly tell the difference—we will absolutely and positively send them out FREE and on trial for 10 days' wear. But only 10,000 will be shipped on this plan. To take advantage of it, you must act quickly.

Send the coupon NOW! Send no money. Tell us which item you prefer—Ring, Pin or LaValliere. We'll send your selection at once. After you see the beautiful, dazzling gem and the handsome solid gold mounting—after you have carefully made an examination and decided that you like it, if you believe you have a wonderful bargain and want to keep it, you may pay for same in small easy payments as described in this advertisement. Then the Ring, Pin, or LaValliere is yours to give away, sell, or wear just as you prefer. If, however, you can tell a TIFNITE GEM from a genuine diamond, or for any reason you do not wish it, send it back at our expense.

## TIFNITE GEMS

### Solid Gold Mountings

are recognized as the closest thing to a diamond ever discovered. In fact, it requires an expert to distinguish between them. In appearance a Tifnite and a diamond are as alike as two peas. TIFNITE GEMS have the wonderful pure white color of diamonds of the first water, the dazzling fire and brilliancy, cut and polish.

They stand every diamond test—fire, acid and diamond file. The mountings are exquisitely fashioned in latest designs—and guaranteed solid gold.

## Send No Money— Send No References

Just send coupon. You do not obligate yourself in any way. The coupon—only the coupon—brings you any of the exquisitely beautiful pieces shown and described here. If you want ring, state whether ladies' or gentlemen's, and be sure to enclose slip of paper showing exact finger measurement as explained below.

Send coupon now and get a TIFNITE GEM on this liberal offer. Wear it for 10 days on trial. They have no artificial backing—absolutely guaranteed not to be made of glass. All set in latest style mountings of pure solid gold. Each is a wonderful bargain. Just send the coupon. Then decide whether you want to keep the TIFNITE on our amazingly liberal offer. Send for yours now—today—sure.

The Tifnite Gem Co.,  
Rand McNally Bldg.,  
Dept. 82, Chicago, Ill.

#### Flat Belcher Ring

No. 1. Solid gold through-out. Eight claw mounting with flat wide band. Almost a carat, guaranteed genuine Tifnite Gem. Price \$12.25; only \$3.00 upon arrival. Balance \$3 per month. Can be returned at our expense within 10 days.

#### Ladies' Tiffany Ring

No. 2. Solid gold through and through. Has a guaranteed genuine Tifnite Gem almost a carat in size. Price \$12.25; only \$3.00 upon arrival. Balance \$3 per month. Can be returned at our expense within 10 days.

#### Tooth Belcher Ring

No. 3. Solid gold, six-prong tooth mounting. Guaranteed genuine Tifnite Gem almost a carat in size. Price \$12.25; only \$3.00 upon arrival. Balance \$3 per month. Can be returned at our expense within 10 days.

#### Ladies' LaValliere

No. 4. Solid gold through-out. Chain 15 inches long. One-half carat guaranteed genuine Tifnite Gem artistically mounted in genuine latest style black enamel/circle. Price \$14.25; only \$3 upon arrival. Balance \$3 per month. Can be returned at our expense within 10 days.

#### Scarf Pin

No. 5. Solid gold through-out. A beautiful open circle mounting. Half carat guaranteed Tifnite Gem. Price \$12.25; only \$3.00 upon arrival. Balance \$3 per month. Can be returned at our expense in 10 days.

## FREE Trial Coupon

THE TIFNITE GEM CO.,  
Rand McNally Bldg., Dept. 82, Chicago, Ill.

Send me.....No..... on 10 days' approval.  
(Ring, Pin or LaValliere)

If satisfactory, I agree to pay \$3.00 upon arrival and balance at rate of \$3.00 per month. If not satisfactory, I will return same within 10 days.

Name.....

Address.....

Please Mention Popular Mechanics



Every  
Piece  
Beautifully  
Set In  
Solid Gold  
Mountings

No. 5

#### In Ordering Rings

To get the right size Ring, cut a strip of heavy paper so that the ends exactly meet when drawn tightly around the second joint of finger on which you want to wear the ring. Be careful that the measuring paper fits snugly without overlapping, and measure at the second joint. Send the strip of paper to us with order coupon.





## A Warm House in the Morning for YOU

A delightfully warm house has announced that it is time to get up. The Little Draft Man does it—

The Draft Man is fastened to the wall directly above the present furnace regulating chains in your house. The installation is very simple and can be accomplished by anyone in a short time with the aid of a screwdriver.

It will work on any kind of a furnace—steam heat, hot air, hot water or vacuum. The workmanship throughout is the highest grade.

**Agents Wanted** Easy sales and big commissions, not a single dissatisfied customer, everyone placed helps to sell more. Write today for particulars.

**The Stalker Furnace Regulator Co.**

715-725 Detroit St.

ANN ARBOR, MICH.



## HEALTH—BEAUTY—VIGOR

Health, beauty and vigor are now yours. The body can be kept active and vigorous by proper use of vibrator. Nothing restores and keeps the whole system in such prime condition as regular use of Nu-System Vibrator in home or office. Ten minutes daily does trick. It rests and invigorates tired and overworked people, restores to health the nervous and sickly, and is sold at a price within the reach of all.

**\$15.00 Nu-System Electric Vibrator \$9.85**  
**Special Introductory Price**

Something entirely new, electrically operated, is clean, light weight (made of aluminum) will last a life time. No motor, no wear, no oiling, no care. Only one moving part. So simple a child can operate. Does the work of a \$75 vibrator. Is absolutely safe. Guaranteed for a year but will never wear out.

**SPECIAL 30 DAY FREE TRIAL OFFER**

We have enough materials to make this 30 day free trial offer to those who act quickly. Regular price is \$13.99, special price \$9.85. Send money order today, or write for literature and Special 30 Day Free Trial Offer. Don't delay. **NU-SYSTEM VIBRATOR CO., 22 Butler Bldg., Detroit, Mich.**

## MEN WANTED

to represent our company. You can easily make from \$25 to even \$50 a week and be your own boss. Send for our agent's proposition and

**ILLUSTRATED BOOK AND FREE PHOTOGRAPH**

Send ten cents to cover postage and packing costs and we will mail you our illustrated book showing 50 large halftone illustrations of our many genuine photographs and different poses, also a free picture of one of our most famous beauties.

**ART PHOTOGRAPH CO.**  
Tower Bldg., Chicago, Ill.



Write Today

## Hildebrandt Baits Hook & Land 'Em



Made in 3 shapes, 11 sizes and 6 finishes. Reversible blades, interchangeable flies, providing outfits for any kind of game fishing.

Send for Tackle Catalogue with color sheet, Logansport, Ind.  
**John J. Hildebrandt Co. 1342 High St**

## Tour Anywhere—Without Hotel Bills

Hitch an Auto-Kamp Trailer to your car. Be at home anywhere, with a completely equipped living and sleeping tent, electric light, two full size beds, cook stove, ice box, complete cooking outfit, dishes, cutlery and dust-proof food compartment that carries an ample supply of food for several people.

## The AUTO-KAMP TRAILER

saves hotel bills, garage expenses, delays and discomfort.

Write today for Free Booklet

**THE AUTO-KAMP EQUIPMENT CO. 2107 Sheridan Ave., SAGINAW, MICH.**

## Landa "New Idea" Billfold

Elegant, Practical Pocketbook  
Modest result of 25 years' experience. Combines currency fold, coin purse, card case, loose-leaf memo pad, 1917 calendar, identification card and transparent photo frame. Made of finest, soft, black Seal Grain Leather—splendid wearing qualities. Compact, thin, flexible. Will fit any pocket—for ladies or gentlemen. Size closed, 3x3 1/2 inches; open, 3 1/2 x 3 1/2 inches. Special price direct to consumer, 50c. 45,00 doz. postpaid. Ordinarily \$1.00 each. Any name or monogram in 23 kt. gold free. Packed in handsome gift box. Landa "Billmore," same in finest Morocco Leather. Special Price, direct to consumer, \$1.00. Worth \$2.50 each. \$10.00 doz. postpaid. Order either kind for yourself and friends. Send today draft, M.O. or postage stamps. Order shipped day received. Write for Landa Leather Goods Catalog and "Landa Reason for Low Prices."

**A. LANDA & SONS CO., Manufacturers Dept. 2K CHICAGO**

Name Engraved FREE—23 Kt. Gold—Postpaid 50c.

## Big Money-Making Opportunity



Buy a Wilt Blade Sharpener—become independent. Large field, big profits. Small investment (\$135 complete with motor). Sharpens, hones and strops all safety razor blades. Act now!

**WILT MACHINE CO.**  
74 Bagley Ave. Detroit, Michigan

## TAYLOR CRANK SHAFT TIRE PUMP

Takes all the labor out of Tire Pumping. No installation cost. Carried in tool box when not in use. Pays for itself in increased mileage.

**TAYLOR MFG. CO., Dept. P. REDFORD, MICH.**

## HIGHLAND

The World's Standard Commercial Body

Just the Delivery Body you want and just the price you want to pay.

**THE HIGHLAND BODY MFG. CO.**  
202 Elmwood Pl. CINCINNATI, O.

FREE

**BOOK TELLS HOW TO MAKE \$150 TO \$1000 PER MONTH**

Making celebrated Flavo Nature-Flavored Flour in rural communities or small towns with

**AMERICAN MARVEL Flour Mill**

(Self-Contained)  
You can quickly become a member of Community Marvel Millers. We start you. Help you. 30 days' free trial. Investment and terms easy to handle. Write for fully illustrated book.

**ANGLO-AMERICAN MILL CO., Inc.**  
135-141 Trust Bldg. Owensboro, Ky.



FREE TRIAL

**White's RED CEDAR Chests**

protect the finest garments, furs, etc., from moth and other vermin. Finest Gift. Send for FREE catalog today.

**J. A. WHITE LUMBER CO., Box 33, WARSAW, ILL.**



Free Trial.

Money Cheerfully Refunded



MADE IN 23 KT. GOLD COIN PURSE TWO CARD POCKETS



# Free Test Lesson

Wonderful  
Opportunity for Every Ambitious  
Man To Decide Whether or Not To—

## Be A Draftsman!



Charles W. Morey  
Pres. of the College  
and Head of a Large  
Chicago Firm of Engi-  
neers and Contractors

Here is, without doubt, the most wonderful offer ever made by a Correspondence or Home Study Institution of any kind. Just think of it! We positively will send you a **Free Test Lesson in Draftsmanship** without any obligation on your part whatever. Just

the coupon brings you **Free Test Lesson**. We don't even ask you to pay postage. We do that. We send you this **Free Test Lesson** at our expense simply because we want you to see for yourself that the Chicago "Tech" Course in Draftsmanship is the most practical, simplest and easiest to master of any course ever written on the subject. This **Free Test Lesson** also positively proves that our Course will fit you for a Draftsman's position in the shortest possible time. It will prove that our Course will give you the practical knowledge necessary to make you an expert in any branch—Architectural, Structural, Machine Drafting or in the Building Line. It will prove to you that in Draftsmanship lies your future.

### Investigate

If you are wide awake to the possibilities of Draftsmanship as a profession—if you are ambitious—you will at once send coupon for this **Free Test Lesson** and investigate the great future for you in this Big Income Paying Profession.

At present, thousands of Draftsmen are needed in all branches. The demand is increasing every day. The wonderful boom in all businesses in this country has created positions for more trained Draftsmen than can be recruited from the ranks for years to come. Our Special Training is the short cut that brings you to the top quickly. If you start NOW—in a comparatively short time you will be qualified to step into these big paying positions and

## Free



Complete Drawing Outfit  
and Full Instructions  
in Mechanical Drawing  
Sent FREE  
on Enrollment

### See for Yourself

This Free Lesson is an absolute test, pure and simple. Send for it today. In the privacy of your home study it, then you will know for yourself whether you are proper material for a successful Draftsman. Other institutions will ask for your money first. You find out later at your own expense, whether you can adapt yourself to the work and succeed in this profession.

We do not charge you one cent for the Test Lesson, either now or later. It is absolutely FREE. Nor do we obligate you in any way whatever by writing for the Free Test Lesson, so send coupon or write postal request today. If you do nothing else but secure the **Free Test Lesson** you will gain such valuable knowledge as will be beneficial to you through life, for the Free Lesson gives the very fundamentals of draftsmanship which are helpful to every man.

## Earn \$25 to \$100 a Week and More

You can do it—with our help. We have successfully trained thousands of ambitious men—fitted them to qualify and hold the best positions in the business. Some of these men attended our school in Chicago—others learned at home—in spare time, evenings, through our simplified, new Correspondence Method. What we have done for these men we will do for you. No special advance training is necessary. The only qualifications you need possess are the ability to read and write. It will pay you to investigate. It means a big future—Independence, prosperity, happiness for you.

**CHICAGO TECHNICAL COLLEGE**  
1025 Lake View Building, Chicago, Ill.

### MAIL THIS COUPON

**CHICAGO TECHNICAL COLLEGE,**  
1025 Lake View Building, Chicago

Without obligation to me, please send me your **Free Test Lesson** in Draftsmanship and other interesting literature covering the subject indicated below.

Mark X opposite work in which you are specially interested.

Architectural Drafting.	Building Superintendence.
Builder's Course.	Structural Steel Drafting.
Estimating.	Sheet Metal Drafting.
Plan Reading.	Reinforced Concrete.
House Planning.	Machine Drafting.
General Contracting.	Surveying.

Name.....

Address.....

City.....State.....

Please Mention Popular Mechanics



## MAKE BIG MONEY Concreting In Your Section

You can easily earn \$8 to \$20 a day with a Sheldon Batch Mixer. Our customers are doing it right now. The jobs go to the man with a Sheldon Mixer every time. Saves labor of 1 to 4 men, according to size of job. Or, if you buy machine for your own use, you can make many times its cost in a season by renting it to your neighbors.

**Build Your Own Walks, Floors, Foundations, Buildings, Silos, Tanks, Troughs, etc.**

out of concrete with a Sheldon Batch Mixer. The ideal machine for all small jobs. Will pay for itself on first small job. Beats hand mixing a mile. And it's a lot cheaper, too. Takes the backache out of concrete. Makes possible those many small improvements about the place; you wouldn't do without it. Improvements that save time, labor and money and add many dollars to the value of your property. Just the machine you need.

### Make Your Own Concrete Mixer.

At a cost so low you cannot afford to mix concrete by the shovel method. Along with our iron parts we send **FREE Plans** and permit for making your own machine. Or, we will sell you the complete machine. Two styles, hand or power. Will mix 2½ cu. ft. a minute. Keeps 1 to 6 men busy. Has chain drive, self-tilting dump, easily moved, and all parts guaranteed. Does work equal to \$400 machines, costs less than 1-10 as much. No other machine like it. Patented.

**Write for FREE Catalog and Special Offer**

Shows our full line. Sold direct to you on strong guarantee, backed by 30 days' trial. Ten men wanted in every county right now to accept our special offer, which will help you secure a machine at little or no cost. Write us today for catalog and particulars of offer.

**SHELDON MFG. CO.**  
Box 3578 NEHAWKA, NEB.



\$1150 up

**Sheldon Batch Mixer**

### Are You Succeeding?

—or just wishing for success? Schwab, Wanamaker, Burbank, Roosevelt and a host of other eminent men adopt and recommend the Marden way to success. Marden's "Everybody Ahead" shows you how to have power, money, happiness—success. Send for free examination plan. Start on the road to fortune today.

**FRANK E. MORRISON, Dept. 60, 1133 BROADWAY, N. Y.**



Have your house warm when you get up in the morning—open your furnace drafts automatically before you awake. Send \$1 for complete instructions for making your own automatic draft-opener. No skill or special tools required. Very inexpensive.

**THE GRAVES CO., 600 Hill Street DUBUQUE, IOWA**

### Russel Internal Gear Drive Axle



The most serviceable and economical motor truck axle made. Write for convincing reasons why your truck should be equipped with the Russel Axle.

**RUSSEL MOTOR AXLE COMPANY, Central Ave., North Detroit**

### \$42 The Famous FOX

The lightest running typewriter in the world.

#### Latest Rebuilt Model 24

—from our Factory to your office or home for \$42. Send any amount with order you can spare and pay the balance \$5 monthly. No interest. No red tape. 3 years' guarantee.

Mention Popular Mechanics.

**FOX TYPEWRITER CO., Grand Rapids, Mich.**



### Healthy Men Employed

They must be dependable—Must be on the job every hour of the day—And every day. We have no time for physical weaklings or nervous wrecks. At the best they are uncertain quantities—So say the captains of industry everywhere to-day. Can you meet these rigid requirements of our modern strenuous life? If not you are already foredoomed to failure in the race. The doors of opportunity are closed to you. The relentless hand of unsentimental business necessity is everywhere turned against you. You are the undesirable citizen.



#### How About You Young Man?

You who have wrecked your future by deplorable habits, not realizing the consequences? Do you know that the **STRONGFORT METHODS** can lift you out of the depths and bring you back to the bloom and vitality of **Real Manhood and Success**. Your half-sickness shows plain in your face and the world loves healthy people. So be **Healthy—Strong—Vital**. That's living. Don't think too long, send for a free copy of my book, "**Intelligence in Physical and Health Culture**." Written by the strongest physical instructor in the world and learn how to fit yourself to command the best positions. Write a short history of your condition, which I will treat in the strictest confidence, and advise you without charge.

**LIONEL STRONGFORT, Physical Culture Expert**  
55 Park Bldg., NEWARK, N. J.

Be Sure It's "**POROSKNIT**"  
**GENUINE SUMMER UNDERWEAR**  
Cool, elastic, comfortable—**GUARANTEED**  
Chalmers Knitting Co., 78 Washington St., Amsterdam, N. Y.

ANHEUSER-BUSCH'S  
*Malt-Nutrine*

—an aid to digestion;  
a nourishing, strengthening  
liquid—food- tonic.



"Bow Legs and Knock-Knees"  
Unsightly Send for booklet showing photos  
of men with and without

**The PERFECT LEG FORMS**

**Perfect Sales Co.,** 140 N. Mayfield Ave., Dept. 3  
Austin Station, CHICAGO, ILL.

**\$150**  
**MAKES**  
**\$1000**  
**QUICK**

**EXHIBIT A WIRELESS U-53**

The public is crazy to see a U-Boat since U-Boats are the most important in the present wars. For \$150 will furnish 3-foot perfect working model Wireless Submarine for exhibition and 10-foot water-tight canvas tank, etc. It is no toy nor experiment. Owners making **BIG MONEY**.

**U. S. WIRELESS SUBMARINE CO., Laboratory, 104 Fifth Ave., New York**

### Hamilton Multimeter

a recording instrument  
of scientific accuracy.

The Hamilton Corporation, Lancaster, Pa., U.S.A.



### Earn Money

this summer demonstrating the  
**Wisconsin Detachable Row Boat Motor**  
with woodless propeller; patented top adjustment;  
rigger mounting or self-locking tiller. Exclusive, sales-  
making features; quick sales, good profits. Act at  
once. Get catalog. Write **WISCONSIN MACH. &**  
**MFG. CO.,** Minor St., Milwaukee, Wis.  
Makers of Marine Motors for 13 years

### World's Best Shoe Value \$325

Ruthstein's Scientific Shoe for Men made of selected Gun Metal Calf; leather sole; Good year Welt Sewed; comfortable, roomy last; Blucher Lace Style D to EE widths. Money back if examination proves otherwise.

**200 OTHER SHOE BARGAINS FOR MEN, WOMEN, BOYS AND GIRLS**

Also Complete Line Ruthstein's Famous Steels Big, New, 1917 Scientific Footwear Catalog shown how to save 25 to 50 per cent on shoes—FREE.

**RUTHSTEIN SCIENTIFIC SHOE CO.**  
We Retail at Less Than Wholesale Shoe Prices  
Dept. 640 RACINE, WIS.



\$325



# Make Your Own Movies!

That's the New Year Message to the Boys and Girls (and grown-ups too) of America. "MAKE YOUR OWN MOVIES"! A wonderful invention has been given to the world. A Moving Picture Camera that will give more fun, more real enjoyment, more marvelous opportunities for pleasure and education than any other invention that ever came from human brain.

No more dead, lifeless photography, no more *wishing* you could make a movie, but now, *living photos*, and you, dear boys and girls (and parents too), your own moving picture makers—

Of everything that lives or moves—sports, games, events, plays, scenes, people, your brothers and sisters, your mother and father, your comrades, your pets, anything, everything you want to make live again upon

the screen in your own home. *You*—just think of it, how marvelous it is!—can take, create and reproduce all these living, moving pictures *yourself*.

And this great invention makes these miraculous possibilities of living photography even more simple than still photography. There isn't a thing to learn that a child can't master in a minute or two. It is all done for you almost automatically by this wonder-working machine called the



Home Movies! That's what you and everybody can have now. The MOVETTE is a *real* moving picture camera. It takes any picture equally as well as a thousand dollar professional camera. But the MOVETTE is so simple and light and compact, you can take it anywhere, and 131 patent claims have been applied for by the inventor of the MOVETTE. It's the most wonderful camera in the world—*what it is and what it does*.

## THINK, A MOVING PICTURE CAMERA for less than thirty dollars!

It's almost too good to be true. Then think of this: You can buy 50 feet of Movette film for \$1.50; that means a two minute living picture—1600 snap shots. Or think of this: You can take one foot of film—32 snap shots for 3 cents, and any of these snap shots you can enlarge for 25 cents!

The MOVETTE is the master-piece of all cameras; you can do anything with it; still photography or moving pictures. No focusing; all you have to do is to keep the picture in the view finder. Daylight

loading in thirty seconds, no dark room necessary. It's a miracle in a metal box—that's what the MOVETTE is. It has given a new meaning to photography. It is the most wonderful invention for entertainment and education ever given to the world—It will amaze you.

Fill out the coupon—Let us tell you more about the MOVETTE—there's a fascinating booklet for you—Free—

Mail the Coupon Today

MOVETTE CAMERA CORPORATION, 1167 University Ave., Rochester, N. Y.

Largest Makers of  
Moving Picture Cameras  
in the World

\$29.75

## TEAR OUT SIGN-MAIL

Movette Camera Corporation, P. M. 2-17  
Rochester, N. Y.

Gentlemen: I'm interested in MOVETTE. Please send me your interesting new book, "The Scientific Wonder of It," and other particulars without cost to me.

Name .....

Address .....

City..... State.....

Every Dealer Sells It—You Can Buy It EVERYWHERE!



# BLUE STREAKS



## Why These Are Good Tires



Suppose we were not giving the best value possible in Goodyear Blue Streak Bicycle Tires. Suppose we scrimped and saved on the material and workmanship that we put into these tires. Now, as you know, the biggest part of our business is in automobile tires.

How could we get around this fact that would meet us at every turn:

*The bicycle riding boy of today is the automobile owner of tomorrow.*

We have got to make a good bicycle tire now if we expect to sell you an automobile tire in the future.

You may be doubly sure that Goodyear Blue Streak Bicycle Tires represent the best possible value when you consider the world-known honesty and fairness of The Goodyear Tire & Rubber Co., which makes them.

The Goodyear Tire & Rubber Co., Akron, Ohio

GOODYEAR  
AKRON

Please Mention Popular Mechanics





# Any Weather Is Billiard Weather! And Any Home Has Room For a BRUNSWICK Table

Carom and Pocket Billiards are a captivating sport, and nowadays the Brunswick Home Table is the family playground. *When school lets out it quickens home-bound footsteps.*

Soon then the clicking balls proclaim that eager eyes are training to debate dad's mastery when he arrives from work.

This manly love of skillful achievement is built right into these scientific Brunswicks. They are packed full of health, they are wrapped with tense moments, and they're brimming over with raillery and laughter!

## Used By Experts

Many professionals use Brunswick Home Tables. Accurate angles, fast ever-level beds and quick-acting Monarch cushions give them expert playing qualities.

Fine oak and handsomely figured mahogany, richly inlaid and built to last a lifetime.

All reproduced in actual colors in our de luxe catalog. Write for free copy today.

## Low Prices—Free Trial

Test any Brunswick 30 days at home and *pay while you play*, if you keep the table. Prices are low because we are selling to thousands.

Balls, Cues, Expert Book of 33 games, etc., given free with each table.

## Mail This Coupon Today

Learn how our "Quick Demountables" can be set up anywhere and put in a closet when not in use. See the "Grand" and celebrated "Baby Grand."

Get full information and color-pictures of tables in our latest catalog—Billiards—"The Home Magnet." The coupon brings a copy free by return mail. Send today.

## BRUNSWICK HOME BILLIARD TABLES

The Brunswick-Balke-Collender Co.,  
Dept. 458, 623-633 S. Wabash Ave.,  
Chicago.

Without incurring any obligation I would  
like to receive a copy of your color-catalog  
"Billiards—The Home Magnet"

Name .....

Address .....

Please Mention Popular Mechanics



# SAVE 1/2 - INSTALL YOUR OWN PLUMBING AND HEATING

NEW HARDIN EASY WAY HARDIN-LAVIN CO  
CHICAGO

## No More Cold Bathrooms

Nothing makes home more inviting or more healthful during the cold winter months than warm, toasty, even heat. Keeps everybody healthy and happy. Install one of our

## Heating Plants Cut-to-Fit

No loss or waste—hot water, steam, or air. Send for our free estimate. We can save you 1/2. We furnish simplified installing plans, specifications, and instructions, and lend you the tools. Any handy man can do the installing the new Hardin Easy Way.

If Your Bathroom is Modern so is Your Home



## Mail Coupon for Free "HANDY-MAN" Book

Every House Owner, Factory, Hospital, Hotel, Office Building, Farmer, Engineer, and Mechanic needs one. It shows a complete line of all the Latest Improvements and Different Designs in Guaranteed heating and plumbing outfits, water supply systems, sinks, roughing-in-goods, pipe, fittings, valves, etc., and all parts and repairs at Wholesale Prices. It also contains practical and exclusive information on How to Do Your Own Plumbing and Heating our new Hardin Easy Way.



New Tankless Flushometer



Drop Apron Lavatory



BATH TUB

## Let Our Service Dept. Help You

Draw a rough sketch of your plan for any heating or plumbing installation, and our staff of engineers will show you the easiest, cheapest way, and supply easy installing plans absolutely free to YOU. Any handy man can do the work with the help of our engineers and save all plumbing bills. We make all shipments promptly, direct from our nearest factory.

## Highest Quality—Wholesale Price

Remember, everything we sell is Grade A. Highest Quality Guaranteed Goods at prices that will surprise you. You save not only on the cost of the goods but on the cost of labor. Our practical experience of 40 years enables us to furnish heating plants with new, original features, combining quality, economy, simplicity, easy installing, and lasting durability.

## Handy-Man Free Book

This book has been written for the handy man about the home. Aside from being our Catalogue, it contains many pages of practical information and money-saving suggestions pertaining to home improvements. It's worth a dollar of any man's money, but, if you are interested in up-to-date plumbing and heating goods, we send it FREE. Send for this valuable book and learn how to buy all plumbing and heating supplies on a time-saving, labor-saving, money-saving basis.

**Immediate Delivery** This is as much a service as our guaranteed quality or wholesale prices.

## 40 Years in Business

at the same address is a record to be proud of. It speaks volumes for our wholesale price policy and money-back guarantee. Send for free "HANDY-MAN" Book, and full particulars. \$500,000 plants behind our guarantee.

**The Hardin-Lavin Co.**  
40 Years at 4540-50L Cottage Grove Ave.  
CHICAGO

## BONDED GUARANTEE

Our guarantee label appears on every fixture we ship. It is your assurance of a square deal. We will replace, without cost to you, any fixture or part that proves defective or not as represented. We guarantee satisfaction. Everything we sell is grade A. "Highest Quality at Wholesale Price" is our motto.



F. M.  
FEB.

FREE  
"Handy-Man"  
BOOK COUPON

The Hardin-Lavin Co.  
4540-50L Cottage Grove  
Ave., Chicago

Please send for your  
"Handy-Man" Free Book  
showing everything in plumbing  
and heating supplies at low-  
est wholesale prices. (This "Handy-  
Man" Book contains much valuable  
information of interest to every handy  
man.)

Name

Address

**HANDY-MAN  
BOOK**

**SIGN, TEAR OFF AND MAIL**

Hardin-Lavin Co.



*It's gettin' old, my easy chair—  
It shorely has seen better days—  
But, like some old time boyhood chum,  
It's sorter learned to know my ways;  
No other chair seems half so soft—  
To hold such welcome arms widespread,  
An' use has hollowed out a place  
Just whar a fellow rests his head.*

*Old things, old friends are ever best—  
A pipe that's reached its seasoned prime—  
Tobacco that has mellowed out  
Beneath the golden touch of time.*

*I hope, Friend Reader, that you, too,  
Have three such trusty pals some-  
where—*

*Age-mellowed Velvet, close  
to hand,*

*A seasoned pipe, an  
easy chair.*

*Velvet Joe.*

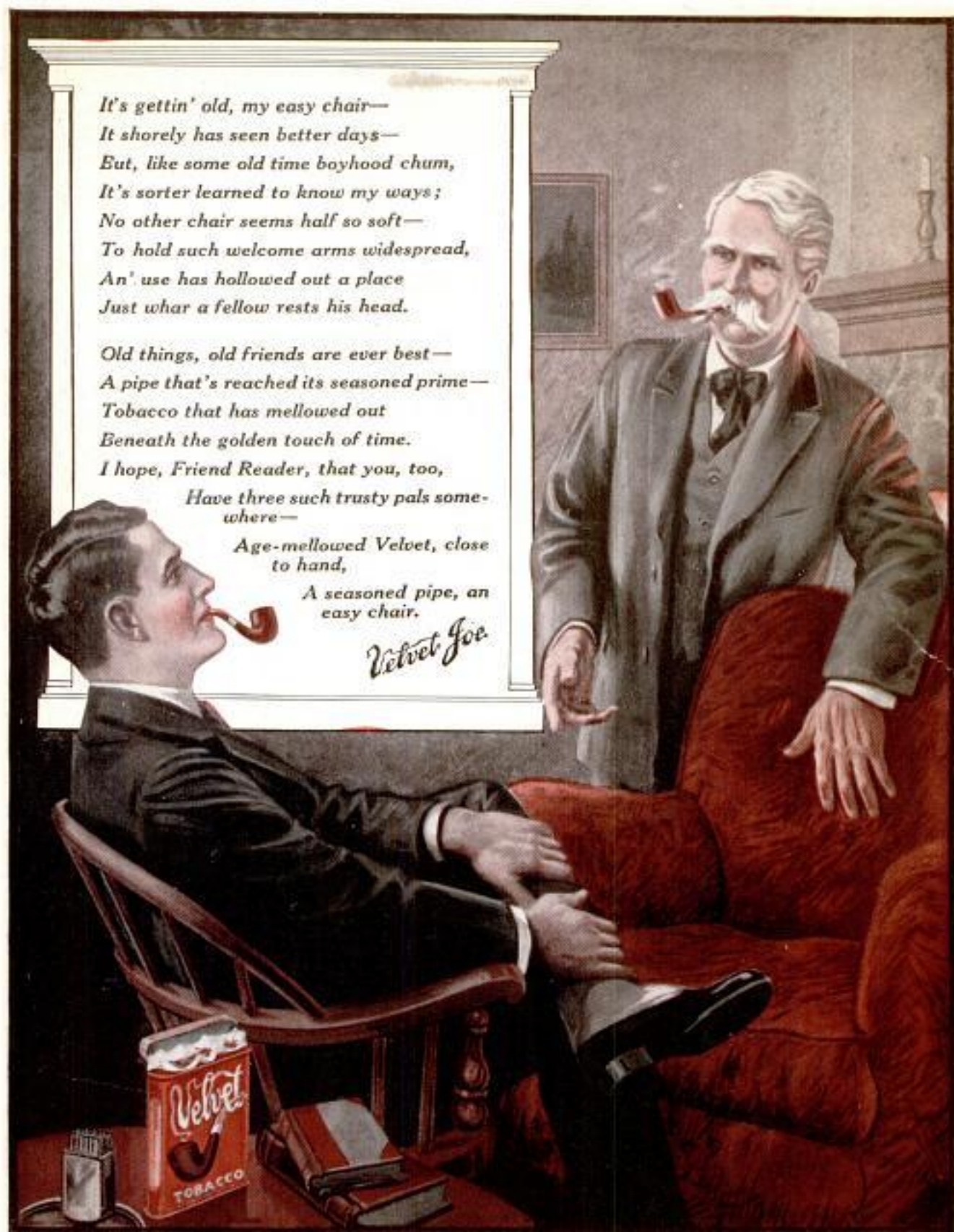

10c Tins  
5c Metal-lined Bags  
One Pound Glass Humidors  
With New Ash Tray Top

**The International Jury of the Panama-Pacific Exposition awarded the GRAND PRIX to VELVET: for its superior quality—the highest award ever given to any pipe tobacco by any International Exposition.**

*Liggett & Myers Tobacco Co.*



THE COLGATE TOILET & PERSONAL SUPPLY CO.  
INCORPORATED IN NEW YORK  
120 N. MICHIGAN ST. NEW YORK, N. Y.

W. F. L. LINDLEY, PRESIDENT  
M. V. WATSON, VICE PRESIDENT  
J. C. WATSON, GENERAL MGR.

# PIONEER LIFE INSURANCE CO

KANSAS CITY, MO.

Refer to Mr. Colgate

Sept 11<sup>th</sup> 1916



Colgate New York

Question - Increase the enjoyment of shaving? It can't be done when one uses Colgate Shaving Cream, you are attempting the impossible when you advocate it.

You are attempting to build up the sale of your Tale Powder, Lilac Imperial Water and Charms Cold Cream on a false foundation. Take your Shaving Cream, a good razor and use plenty of water and you have the acme of shaving enjoyment.

Back up!

Very truly yours  
M. V. Watson

It might have been more nearly correct if we had said "prolong" instead of "increase"

Ask him if he has really tried any or all of these articles after shaving.

Go right along - on high gear.

He evidently knows Shaving Comfort insurance as well as life insurance. No burn after a Colgate Shave

**Increase Your Enjoyment of Shaving**

**Colgate's Tale Powder**  
After shaving—wash the face and dry thoroughly. Sprinkle the Tale Powder on the towel or on the palm of the hand and rub over the face.

**or Colgate's Lilac Imperial Water**  
After shaving—wash the face with a few drops of Lilac Imperial in the palm of the hand; pat the face gently and dry.

**or Colgate's Charms Cold Cream**  
After shaving—wash the face and dry thoroughly. With the cold of the Charms Cold Cream rub the face and skin. Wipe the face dry (some prefer to use water).

This circular inspired the above letter and our comments.  
Colgate & Co., Est'd 1806, New York