

January  
470,000 COPIES

15 Cents

# POPULAR MECHANICS MAGAZINE

WRITTEN SO YOU CAN UNDERSTAND IT

REG. U.S. PAT. OFF.



UNSINKABLE  
LIFE BUOY

SEE PAGE 28





**\$767** buys the material to Build this Home

**NO MONEY IN ADVANCE!!**

When you "Build-To-Stay—The Harris Way," you secure the *utmost possible* in Quality, Economy and Service. Why? Simply because you profit directly—*immediately*—by our 24 years experience. You get the benefit of our practical knowledge as the *originators* of the "Direct-to-You" Home Building Industry. We were the *first* to sell Lumber and Material direct to Home Builders at one small profit. We were the *first* to reduce this vitally important industry to a *perfect system* and extend the benefits uniformly to the people of the nation.

**"THE HARRIS WAY"**

has exclusive merits—special advantages for the shrewd and careful Home Builder—possessed by no other plan or method. It is the best, safest and most sensible way to build your ideal home right without sacrifice of quality—or the waste of a single penny! Thousands have built the "The HARRIS WAY" with profit and satisfaction.

**SEND LUMBER BILLS**

Our ten million dollar buying power gives Harris customers an overwhelming price advantage. We can—and do—undersell all others. The proof? Easy! Just send us your lumber bills—for any kind of building you may be planning and get our prices. Compare them item for item, and let the test be the proof. Write us today!



Here's an Ideal Home Combining Beauty and Utility. The Harris Book of Plans Shows 100 Others. Each Presenting the Individual Charm that Makes All Harris Home Designs Notable.



Another Tempting Effect that Strikes a Responsive Chord in the Fancy of Many True Home Lovers: a Beautiful, yet Practical Home that can be Built at Low Cost—"The Harris Way."



You will be Delighted with the Description of This One in The Harris Book of Plans and Surprised, too, when you learn how easily this Beautiful Home is Within Your Reach.



Still another Attractive Design Selected from the Free Harris Book of Plans. Merely a suggestion of the Rich Treas in Store for those who are wise enough to send for This Book.

**\$10,000 BOOK OF PLANS FREE**



**Your Home Sensibly Cut-To-Fit Shipped Complete in One Car**

The material used in building all Harris Homes is prepared by us, complete for your use in a way that is instantly—and easily understood. It is sensibly cut-to-fit with *absolute accuracy* and *positive elimination of all waste*. You pay for nothing you do not get—you pay our bed rock low, one-small-profit bargain price *only* for what is needed to do the work *right*—"The HARRIS WAY."

Our mammoth material stations, in the heart of the finest lumber tracts are always filled to overflowing with brand new, quality material. These stations are centrally located for quick and economical deliveries, "DIRECT-TO-YOU," no matter where you live, at the *lowest possible freight charge*.

**FREE Beautiful New \$10,000 Book Of Over 100 Harris Homes**

Be sure to mail free coupon for the latest edition of the famous \$10,000 HARRIS HOME PLAN BOOK, now ready. A golden guide to Quality, Service and Economy in Home Building. Explains—fully and freely—everything about building economy. Contains 100 modern Harris Home Designs, with descriptions, material specifications, prices, etc., and explains how we save you \$50 to \$75 on our Special Free Architect's Plans. Think twice before you pass this opportunity.

**Mail Free Coupon Now!**

Coupon, Letter or Post Card request brings the Harris Home Plan Book FREE. Send for it today without fail.

**Harris Bros. Co.**  
Dept. DK 7 Chicago

Please send me free—without the slightest obligation—the Harris Home Plan Book, and show me how to save big money in building my home.

Name \_\_\_\_\_

Address \_\_\_\_\_

**Harris Brothers Co., 35th & Iron Sts., Chicago**





# The Victor Record catalog is the most complete catalog of music in all the world

It has required 19 years of constant research, of steady application, of tireless effort, and the expenditure of more than **Eleven Million Dollars** to place this catalog in your hands

This great book of 506 pages is the recognized authoritative index to the world's best music; to the greatest musical achievements of all time. Its pages are living tributes to the years of unceasing vigil spent in gathering the best music from every portion of the globe. They reflect the hours upon hours which the greatest artists have devoted to recording their superb art for the delight of all generations. They attest to the enormous amount of time and millions of dollars spent in developing the art of recording to its present state of perfection. And through each and every page runs the story and proof of Victor Supremacy.

Every music-lover will want a copy of this great Victor catalog of music

Everybody should have this book, whether or not they have a Victrola. All will appreciate it because of the information about artists, operas and composers, and the numerous portraits and illustrations it contains.

Any Victor dealer will gladly give you a copy of this great catalog of music, or we will mail you a copy free, postage paid.

**Victor Talking Machine Co.**  
Camden, N. J., U. S. A.

Beilner Gramophone Co., Montreal, Canadian Distributors

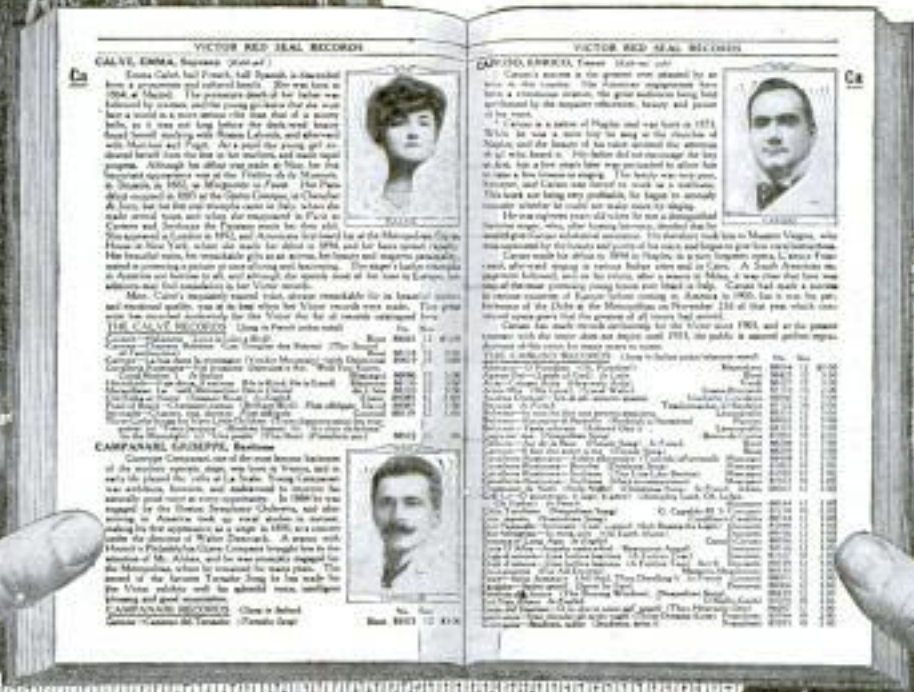

Please Mention Popular Mechanics



# Does Cypress <sup>"The Wood Eternal"</sup> Last

Study These Photographs of an "Ingrowing Fence"



WITHOUT  
OR A FEW

Below is a  
down a  
highway  
road," as  
Remus ca  
near M  
Louisian  
fence has  
It was bui  
ing split  
boards bet  
lings. This  
so many y  
that nobo  
when it wa  
was the la  
genius wh  
Then the t  
and grew,

NOW, PLEA  
larger photo  
see in detai  
fence looks t  
the size of t  
how deeply a  
the ends of  
Cypress rail  
can tell how  
extend in.  
how weathe  
yet they ring  
sound under  
as though  
Were those  
boards so  
money's wo  
should not  
as well with  
money—whet  
building a be  
or just patch  
old place? (US)

"THE PROOF OF  
THE FENCING IS  
IN THE LASTING."



"Build of Cypress Lumber and You Build but C

Let our "ALL-ROUND HELPS DEPARTMENT" help YOU. Our entire resources are at your service with Reliable  
**SOUTHERN CYPRESS MANUFACTURERS' ASSOCIATION**  
 1219 Hibernia Bank Building, New Orleans, La., or 1219 Heard National Bank Bldg., Jacksonville

INSIST ON CYPRESS AT YOUR LOCAL LUMBER DEALER'S. IF HE HASN'T IT, LET US KNOW IMMEDIATELY.

Please Mention Popular Mechanics



# Popular Mechanics Magazine

6 N. Michigan Avenue, Chicago, U. S. A.

EDITED BY H. H. WINDSOR

England: The International News Co.,  
5 Beams Bldg., Chancery Lane, London, E. C.

Australia:  
The Australian News Co.

ISSUED MONTHLY

SUBSCRIPTION:

SINGLE COPY, 15 CENTS

In United States, and its possessions, Cuba and Mexico, per year, postpaid . . . . . \$1.50  
To Canada . . . . . 1.75  
To all other countries in the Postal Union . . . . . 2.50

All subscriptions are discontinued at expiration. Please examine the date printed on your wrapper.

Entered as Second Class Matter Sept. 15, 1903, at the Post Office at Chicago, Illinois, under Act of March 3rd, 1879.

Entered as Second Class Matter at the Post Office Department, Canada.

Published monthly by POPULAR MECHANICS CO.

Copyright, 1916, by H. H. WINDSOR.

Copyright, in France.

## Contents for January, 1917

Accident—Cars Telescope Each Other in Odd Manner . . . . .	97	Clock Dial, Eight Hour, for New Time System . . . . .	77
Accident—Flywheel, Breaking of Wrecks Engine Room . . . . .	65	Clubhouses and Golf Courses, America's Attractive . . . . .	100
Accident—Racing Car Wrecked at Santa Monica . . . . .	43	Coins, Wearing Away of Due to Perspiration . . . . .	33
Accident—Western Airman is Killed in Landing New Biplane . . . . .	14	Construction Outfit Made for Line Work . . . . .	85
Aerial Trip, Daily, Made across English Channel Aero Station for Hawaii Planned . . . . .	86	Copper, Germans Build Engines without . . . . .	18
Aeroplane—Daring Birdman and His Feathered Friends . . . . .	33	Cows, Hood Supplements Spikes on Nose Device for . . . . .	46
Aeroplane Flights, Long, New Air Records Set in Aeroplanes, Aluminum Propellers for . . . . .	55	Cypress, "Pecky," Used for Building Trim . . . . .	15
Airmen, Would-Be French, Tested Scientifically . . . . .	66	Dairy Stable Furnished Like Home . . . . .	76
Airship—Zeppelin Observation Car, by Lewis R. Freeman . . . . .	2	Disease, Curious Fatal, Device Instantly Cures . . . . .	6
Airships—Zeppelin Raiders Face Peril from Own Craft . . . . .	96	Diver Breaks Record in Deep Sea Armor . . . . .	34
Auto Wrecking Outfit, Powerful, on Rear of Car Automobile, Checkerboard Radiator for . . . . .	105	Dog Carried on Bicycle to Protect Messenger . . . . .	117
Automobile, Front Seats of are Easily Removed . . . . .	8	Door Built to Receive Delivered Goods . . . . .	80
Automobile Hood, Device Carries Baggage over Automobile, Lamp Cleaner's Electric, with Ladder . . . . .	39	Election Returns, Novel Method of Showing . . . . .	39
Automobile, Raising from River Bottom . . . . .	6	Electric Generating Set, Portable, Made for English Army . . . . .	98
Automobiles, Flanged Wheel, Salvage Old Rails with . . . . .	62	Electric Radiator, Cheerful Glow Given Off by . . . . .	4
Aviation School, British, Located in Egypt . . . . .	117	Electric Sign Presents Political Debate . . . . .	64
Bathing and Massaging Machine . . . . .	93	Elk Teeth, Costly Jackets Adorned with . . . . .	104
Boat, Shallow Draft, for Use in Marshy Region . . . . .	63	Emeralds More Costly than Diamonds . . . . .	78
Bread, Stale, Cheaper than Meal for Stock . . . . .	104	Ferry, New, Carries Motor Cars on San Pablo Bay . . . . .	106
Bridge, Sixty Ton, Moved Over Two Miles . . . . .	84	File, Indexed Vertical, for Blueprints . . . . .	71
Bridge, Southern Concrete, Has Long Bascule Span . . . . .	72	Fire, Fatal St. Louis, Thousands Watch . . . . .	86
Bromine Wells, Old, Open to Relieve Shortage . . . . .	113	Fire, Railway Bridge, Novel Means Used to Put Out . . . . .	96
Building—Dwelling, Ingenious Method Used to Enlarge . . . . .	31	Files Avoid Rooms with Blue Glass Windows . . . . .	28
Building, Fair, Is Now Handsome Residence . . . . .	70	Flood Waters, Utilizing to Replenish Irrigation Wells, by Victor W. Killick . . . . .	91
Building—Huge Tabernacle Built for Revival . . . . .	42	Forested Lands, Russia's, Barely Touched . . . . .	106
Buoy, Big, Substitute for Lifeboats . . . . .	28	Forests, National, Marking Boundaries of . . . . .	102
Cable, Phone, Nantucket and Mainland Joined by Canal, Find Ship's Draft in Fresh Water of . . . . .	90	Forge, Two Chamber Oil, Burns But One Flame . . . . .	87
Canals, Need of in Peace and War Shown . . . . .	118	Funeral Procession, Strange Setting for . . . . .	107
Car, New Dump, Deposits Load Clear of Track . . . . .	110	Furniture Built for Convenience of Mother and Child . . . . .	88
Card Piling Device Built Like Merry-Go-Round . . . . .	102	Grain, Great Loss Results from Buying Water in Guns—Half of a Great Broadside . . . . .	122
Carts, Heavy Picturesque, Used on Cuban Estates . . . . .	110	Hammer, Glazier's, Window Panes Set Easily with . . . . .	78
Castings, Big, for Ship's Stabilizer . . . . .	34	Headlights, Powerful, Rule Requires on Engines . . . . .	113
Chair, Combination Wheel and Fireside . . . . .	103	Hospital, Large, Building on Novel Plan . . . . .	48
Chicken Feed, Sand Crabs Utilized for . . . . .	62	Hotel, Seek to Make Kitchen in Absolutely Clean House, Build with Varied Panels for Stucco Test . . . . .	73
Children, Interesting Pictures and Ideas for . . . . .	120	Houses, Frame, Varied Exterior Finishes for . . . . .	68
Clock, American, Given to Japan's Heir Apparent . . . . .	96	Images, Minute, are Placed in Tiny Carved Shrine . . . . .	98
		Isinglass Face Shield for Automobilists . . . . .	94
		Jacks to Relieve Strain on Automobile Tires . . . . .	60
		Ladder, Boat, for Rescue of Drowning . . . . .	33
		Lamps, Incandescent, Used for Pageant Lighting . . . . .	79
		Lamps, Large Portable Gas, for Fire Fighters . . . . .	14

**[Continued on Page 6]**

*Popular Mechanics offers no premiums; does not join in "clubbing offers," and employs no solicitors to secure subscriptions. It is for sale by nearly every newsdealer in the United States and Canada.*



## [Contents—Continued]

Light, Motorist's Signal, Worn Like Wrist Watch	90	Shorthand Soon Learned by Using New Machine.	93
Lighting Apparatus, Movie, Carried by Motor Truck	99	Sign, Huge Terra Cotta, Built High in Wall	78
Lighting Equipment for Night Fliers	58	Sign Made of Concrete to Reduce Upkeep Cost	7
Limestone, Big Block of Covers Flat Car	69	Spark Plug Tester That Works No Injury to Car	55
Mail—Trying to Beat the Blockade, by R. J. Bjurstedt	81	Speedway, Two Mile, to be Illuminated at Night	30
Meat Grinder, Covers Keep Dust from	63	Spotlights to Protect Traffic Officers	1
Milking Cows, Improved Pulsator for	42	Statue, Famous, Copy of Erected in Newark	63
Mines, Farms Give Way to in Oklahoma District	94	Statue of Telegraphy Hoisted to Roof	12
Motor, Large Aeronautic, Formally Tested	46	Steel, Amount of in Battleship	16
Motor Truck and Trailer Transport Heavy Boat	31	Street, Congested City, Cutting a Two Mile Slice through, by Thomas H. Russell	35
Motors Run after being Submerged for Hours	10	Stump, Big Cedar, Used as Band Stand	72
Motorcycle and "Wheel," Writer Uses on Trips	55	Stumps, Big, Uprooted by Light Manual Puller	70
Moving Picture Projectors, Eye Shade for Operators of	69	Styles, Smart, in Gowns, Boots, and Hats	44
Nest Made on Bird House Roof and Electric Wire	25	Table, Legless Banquet, Hangs from Ceiling	118
Novel Accessories for the Home and Its Members:		Telephone Receiver, Special Earcap for	85
Bag, Hand, When Open, Resembles Jirikisha	114	Tire Chain Tool, Combination	113
Biscuit Pan and Cutter	114	Tire Inflation, Improper, Prevented by Valve	116
Bottle Capper	114	Trolley, I-Beam, Which Is Detachable	56
Buffer, Rotary Nail	115	Tunnel, Practice, is Bored beneath College Campus	112
"Clothespins," Silver, for Attaching Place Cards to Goblets	115	Umbrella Frame, New, Has Ball and Socket Joint	122
Cravat Holder, Leather	115	Vaults, Floating, Designed for Ocean Steamships	108
Dental Floss, Holder for	115	Ventilator, Thief and Weather Proof, for Car	86
Dish Mop, Fountain, with Soap Compartment	115	Village, German, at Norfolk Navy Yard, Passing of	60
Ironing Board, Folding Sleeve	114	Wagon Bed Removed Easily with Inexpensive Hoist	116
Pouring Lip for Use on Large Cans	114	Wagon, Vending, Resembles Small Auto Truck	90
Rug Holder Keeps Rugs Perfectly Flat	114	War, European:	
Scraper Forms Individual Cones of Butter	114	Aerial Warfare, Odd Side Lights on	53
Shoe Shining Machine, Motor Driven	114	Austro-Italian Conflict, Unusual Aspects of	54
Silver Cream Pitcher and Loaf Sugar Tray	115	British "Tommies," In Field and Camp with	52
Steel Loop Prevents Turning of Door Key in Lock	115	French Lines, Striking Scenes within	51
Telephone, Wooden Figure Serves to Hide	114	German Phases of War Treated Pictorially	49
Vase, Long Stemmed Flower	115	Gunners, Machine, Making of Sharpshooters	50
Workbag, Cretonne and Silk	115	Salvaging Human Wrecks from War's Scrap Heap, by Searle Hendee:	
Yarn Winder, Artistic	115	Part II—Repairing the Maimed	17
Orange, Osage, to be Used in Making Dyes	122	Watch, Moderately Priced, of Calendar Type	111
Ostrich Draws Motor Car and Carries Trainer	97	Water Bags, Canvas, for Use of Foresters	7
Parades, Civic, and Carnival Festivities, High Lights in	74	Water Curtain Shields Mill Men from Heat	64
Park, New National, Opened to Public in Maine	29	Water Main, Big, Lowered under Rail Crossing	77
Pattern for Mammoth Pinion Housing	56	Water Pipe System, Queer Cut-Off Devised for	117
Pavement, New Concrete, Dikes on Save Water	27	Windbreaks, Canvas, for San Francisco's Trees	65
Paving, Inverted Crown, Needs No Curb	71	Window, New Metal, Pleasing Effects Given by	102
Photography, Gauge for Distances in	48	Wireless Phone, Banqueters Hear Music with	40
Pipe Pusher Lessens Ditch Digging	84	Wireless Phone, Underground, of Pocket Size	55
Police Station, Floating, for New York Harbor Force, by Henry Jay Case	11	Wireless Receiver, Tiny, Is Late Invention	27
Posts, Lighted Guard, for Safety Zones	7	Wireless, Self-Generating, for Aeroplanes	16
Pulleys, Cork Inset, Belt Slipping Prevented by	57	Wrecks—Two Fatal Rail Accidents in East	47
Pump, Druggist's, for Filling Bottles	10	Wrench, New Pipe, Convenient Points Found in	118
Pump, Electric, Delivers Oil Free Air to Tires	57		
Radiators Form Borders around Windows	105		
Railroad Crossing, Improved	58		
Railroad Lines, Strategic, being Built in Africa	108		
Refrigerator Charred by Fire Keeps Contents Cool	12		
Road, Government, Crosses Red River Pass	111		
Road Grader Designed on New Lines	32		
Roller Skaters Race for Three Miles in Sewer	73		
Rope, Strong, Inexpensive, Made by Simple Machine	76		
Safety Device, New, Guards against Rail Accidents	119		
Salvage Operations on U. S. Collier "Hector"	59		
Scale, Portable, Weighs Street Sweepings	79		
Sealing Wax Used in Decorative Art	40		
Shelter, Forest, Roof of Made from Hollow Log	107		
Ship—"Arizona" Is in Commission	41		
Ships—Pacific Liners Equipped with Motor Car Garages	25		
Ships—Warships' Ice Plants Source of Danger	46		

[Contents Continued on Page 8]

IN accordance with the editorial policy of this magazine never to accept compensation in any form for what appears in our reading pages, and also to avoid all appearance of doing so, we are obliged to omit the name of the maker or the seller of any article described. This information, however, is kept on file and will be furnished free, by addressing Bureau of Information, Popular Mechanics Magazine, Chicago. [Editor.]



# BLUE STREAKS



## Tires of Miles and Smiles



"Let us make a bicycle tire to sell at \$2.50 each. Let us make this tire the best tire the great Goodyear factory can build, and let us guarantee it to the boys of America."

No sooner had The Goodyear Tire & Rubber Company decided upon this important step than those handsome, speedy, lasting Blue Streak Bicycle Tires were seen on the bikes of the fellows you know. Happy fellows, too, pedaling in the sunshine, far away from the shadows cast by the Gloom Twins—"Tire Trouble" and "Tire Expense".

Lighten your heart and speed up the good old bike!

Get Blue Streaks from your dealer and whistle while you ride.

The Goodyear Tire & Rubber Company  
Akron, Ohio

# GOODYEAR

AKRON

Please Mention Popular Mechanics

This One



UNOA-HXG-Q8Z6







# FREE BOOK

## How To Learn Piano

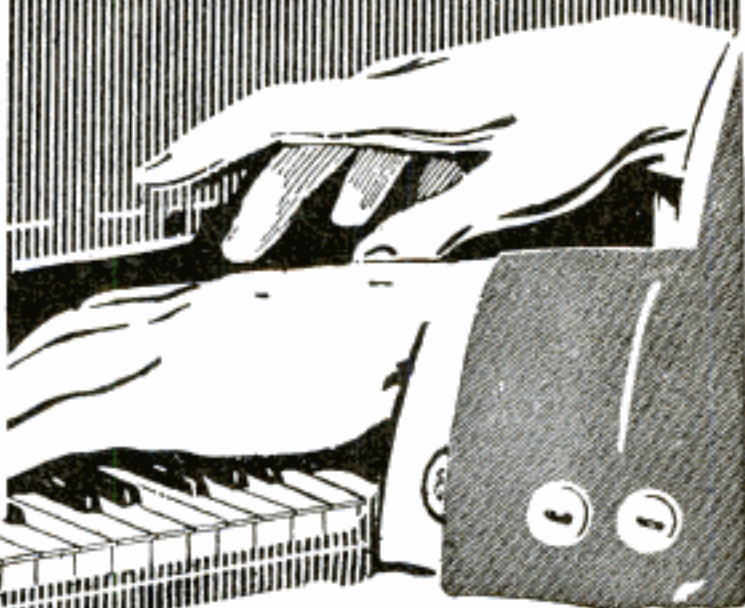

## This Interesting Book

shows how you can learn to play the piano or organ in your own home, in one-quarter the usual time and at *one-quarter the usual cost*. It explains the profound pleasures and well-known social advantages of musical training, and contains much information which will be

### Dr. Quinn's Famous WRITTEN METHOD for Piano or Organ

has revolutionized the study of music. By the use of Dr. Quinn's remarkable device, the COLOROTONE (patented), you save three-quarters of the time, effort and money usually required for learning piano or organ. You play chords immediately and a complete piece, *in every key, within four lessons*. Investigate without cost by sending for free book.

#### Endorsed by Distinguished Musicians

Dr. Quinn's WRITTEN METHOD has been proving its merit by RESULTS for 25 years. Among our graduates are thousands of accomplished amateur players, as well as leading composers, distinguished virtuosos and heads of conservatories. The method is endorsed by prominent musicians and educators who can *speak with authority*. It is scientific and systematic, yet practical and easy to understand. It is fully illustrated. It is equally effective for beginners or experienced players, children or adults. All necessary music is included FREE. You practice in spare time at your own convenience. Progress as rapidly or slowly as you wish. Diploma of recognized value is granted.

#### Investigate Without Cost

Write today, using postcard, letter or free book coupon, for our 64-page book, explaining everything you want to know about "How To Learn Piano Or Organ," and giving full particulars of our COURSE. Special reduced terms this month on account of our Twenty-Fifth Anniversary Offer. Investigate without cost or obligation NOW.

**Marcus Lucius Quinn Conservatory**  
Box 650KM Chicago, Ill.

*extremely interesting* to you whether you are already an accomplished player or do not know a single note. Send letter, postcard or coupon below for *your* copy of this valuable 64-page book. It is free.

### Music As A Career

Our free book tells you of the concert career which may be open to you. It explains the great and increasing demand for professional players and tells how you can earn \$25 to \$100 weekly through your own playing skill or by giving musical instruction to others in spare time.

It fully describes a method of home study which brings you all the advantages of the best foreign conservatories at *less than 43 cents a lesson*. Send for this free book at once.

**FREE  
BOOK  
COUPON**

M. L. Quinn Conservatory  
Box 650KM, Chicago, Ill.

Please send me without cost or obligation, your 64-page FREE Book, "How to Learn Piano or Organ," and full particulars regarding Dr. Quinn's Course in Piano or Organ by the Written Method, and special Twenty-Fifth Anniversary Offer now open.

Write  
Today

Name .....

Address .....





# These books will help you to greater

# Electr

## PARTIAL CONTENTS OF THE 10 GUIDES

**No. 1.** Contains 240 pages, 246 Illustrations. Electrical signs and symbols—static and current electricity—primary cells—conductors and insulators—resistance and conductivity—magnetism—induction coils—dynamo principles—classes of dynamo, etc.

**No. 2.** Contains 218 pages, 256 Illustrations. Armatures—windings—commutation—brushes—motor principles—armature reaction—motor starting—calculations—brake horsepower—selection and installation of dynamos and motors, etc.

**No. 3.** Contains 276 pages, 280 Illustrations. Galvanometers—standard cells—current measurement—resistance measurement—voltmeters—wattmeters—watt hour meters—operation of dynamos—operation of motors, etc.

**No. 4.** Contains 268 pages, 423 Illustrations. Distribution systems—wires and wire calculations—inside, outside, and underground wiring—sign flashers—lightning protection—rectifiers—storage battery systems, etc.

**No. 5.** Contains 278 pages, 379 Illustrations. Alternating current principles—alternating current diagrams—the power factor—alternator principles—alternator construction—windings, etc.

**No. 6.** Contains 272 pages, 538 Illustrations. A. C. motors—synchronous and induction motor principles—A. C. commutator motors—induction motors—transformers—losses, construction, connections, tests—converters—rectifiers, etc.

**No. 7.** Contains 320 pages, 460 Illustrations. Alternating current systems—switching devices—circuit breakers—relays—lightning protector apparatus—regulating devices—synchronous condensers—indicating devices—meters—power factor indicators.

**No. 8.** Contains 288 pages, 330 Illustrations. Wave form measurement—switch boards—alternating current wiring—power stations—turbines—management, selection, location, erection, testing, running, care and repair.

**No. 9.** Contains 576 pages, 849 Illustrations. Telephones—teletype—wireless—electric bells—electric lighting—photometry—electric railways—electric locomotives—car lighting—trolley car operation, etc.

**No. 10.** Contains 704 pages, 730 Illustrations. Miscellaneous applications—motion pictures—gas engine ignition—automobile self-starters and lighting systems—electric vehicles—elevators—cranes—pumps—air compressors—electric heating—electric welding—soldering and brazing—industrial electrolysis—electro-plating—electro-therapeutics—X-rays, etc.

Also a complete ready reference index of the complete library.

The work of the world today is done by electricity. Electricity runs our machines; transports our goods; lights our homes, shops and factories; heats our buildings—is indispensable in hundreds of ways. Opportunities in electricity are greater than ever before. Exact electrical knowledge means more money and greater success for you.

## HAWKINS ELECTRICAL GUIDES

give you ALL the electrical information you want, in the shortest, most concise form—namely, by means of questions and answers and unlimited illustrations. No matter how great or how little your previous knowledge of the subject at hand, you "get the point" at once in Hawkins Guides. They are absolutely complete—brought right up-to-date—the last volumes are just off the press.

### FLEXIBLE POCKET-SIZE TEXTS Arranged for Home Study and Reference

They are the handiest books to read and to use, ever produced. In flexible, black covers, leather binding—just the right size—5x6½ inches—to fit in your pocket, so that you can carry each single volume about with you until you have mastered its contents. The whole set fits easily in the hollow of your arm, and still there are actually 3,500 pages and 4,700 illustrations.

**10 Practical Volumes. 3500 Pages. 4700 Illustrations**  
**\$1 Per Volume—Payable \$1 Per Month**



# success through electricity

## WHAT USERS SAY

"Every Electrician, Operating Engineer or Student who wants to advance himself in the Electrical field should have a set of these books."

JOHN KELLEY, 116 Union St., Newark, Ohio.

"For the man not getting a college training, and even in that case, I can sincerely say I do not believe there is a better set of books on the market today."

LLOYD D. HUFFMAN, Dayton, Ohio.

"We consider Hawkins Electrical Guides the most compact and complete set of electrical references in the market."

NOGGLE ELECTRIC WORKS, Monterey, Cal.

"Hawkins surely knows the art of condensing information."

ELDRIDGE F. BALL, Buckland, Conn.

"I think they should be in the hands of everyone who has anything to do with Electricity."

T. E. MURPHY, Orange, Va.

"For the practical electrician, they are the best books published—worth many times their price."

L. C. WAGNER, Wyoming, Ill.

"I have gained valuable information from them which has helped me directly in my line of work."

HERMAN NODENBERG, Hoboken, N. J.

"They are wonderful value. Everything is so clear and concise. Even one who had no knowledge of Electricity would have no difficulty in grasping the facts."

F. L. TAYLOR, Amesbury, Mass.

"It is the best work an apprentice can study if he wants to get ahead in his trade. As a reference for the experienced worker HAWKINS ELECTRICAL GUIDES are unequalled."

I. MCCLELLAN, Chillicothe, Mo.



**THE ENTIRE SET of  
10 VOLUMES**

**SHIPPED TO YOU FREE**

Send no money. Examine the books first. Use them for seven days in connection with your work, and decide for yourself that they are the most complete, the most helpful and the clearest written electrical books ever published. This unusual offer is a sign of our confidence in the Guides.

**EASY PAYMENTS** Accept the offer now—mail the coupon today. If you decide to keep the books you can make settlement at only \$1 per month until paid for.

**THEO. AUDEL & CO.**  
72 Fifth Avenue  
NEW YORK N.Y.

**THEO.  
AUDEL & CO.,**  
72 Fifth Avenue, N. Y.

Please submit me for examination Hawkins Electrical Guides (Price \$1 each). Ship at once, prepaid, the 10 numbers. If satisfactory I agree to send you \$1 within seven days and to further mail you \$1 each month until paid.

Signature.....

Occupation.....

Business Address.....

Residence.....

Since we have not yet had the pleasure of business relations with you, we shall appreciate your giving us name of reference on line below

Reference.....

P. M. Jan. 17

Please Mention Popular Mechanics



Never Mind How **STRONG**  
You are—  
**What d'ye Know?**



Today it's a battle of wits—and *brains win*. Muscle and brawn don't count so much as they used to.

The great question now is "What do you Know?" It draws the line between failure and success.

What do *you* know? Have you special ability in any one line? Could you "make good" in a big job right now?

For 25 years the International Correspondence Schools have been helping men to get ready for better work and bigger salaries. They can do the same for YOU. No matter where you live, what hours you work, or how little your education—the I. C. S. can train you for a more important and better-paying position.

Mark and mail the attached coupon—it won't obligate you in the least—it won't cost you anything to find out how you can get this salary-raising ability right in your own home, during your spare time.

MARK THE COUPON NOW

TEAR OUT HERE

**INTERNATIONAL CORRESPONDENCE SCHOOLS**  
Box 5544, SCRANTON, PA.

Explain, without obligating me, how I can qualify for the position, or in the subject, before which I mark X.

- |   |  |
|---|--|
| <input type="checkbox"/> ELECTRICAL ENGINEER        | <input type="checkbox"/> SALESMANSHIP              |
| <input type="checkbox"/> Electric Lighting          | <input type="checkbox"/> ADVERTISING MAN           |
| <input type="checkbox"/> Electric Car Running       | <input type="checkbox"/> Window Trimmer            |
| <input type="checkbox"/> Electric Wiring            | <input type="checkbox"/> Show Card Writer          |
| <input type="checkbox"/> Telegraph Expert           | <input type="checkbox"/> Outdoor Sign Painter      |
| <input type="checkbox"/> Practical Telephony        | <input type="checkbox"/> RAILROADER                |
| <input type="checkbox"/> MECHANICAL ENGINEER        | <input type="checkbox"/> ILLUSTRATOR               |
| <input type="checkbox"/> Mechanical Draftsman       | <input type="checkbox"/> DESIGNER                  |
| <input type="checkbox"/> Machine Shop Practice      | <input type="checkbox"/> BOOKKEEPER                |
| <input type="checkbox"/> Gas Engineer               | <input type="checkbox"/> Stenographer and Typist   |
| <input type="checkbox"/> CIVIL ENGINEER             | <input type="checkbox"/> Cert. Public Accountant   |
| <input type="checkbox"/> Surveying and Mapping      | <input type="checkbox"/> Railway Accountant        |
| <input type="checkbox"/> NINE FOREMAN OR ENGINEER   | <input type="checkbox"/> Commercial Law            |
| <input type="checkbox"/> Metallurgist or Prospector | <input type="checkbox"/> GOOD ENGLISH              |
| <input type="checkbox"/> STATIONARY ENGINEER        | <input type="checkbox"/> Teacher                   |
| <input type="checkbox"/> Marine Engineer            | <input type="checkbox"/> Common School Subjects    |
| <input type="checkbox"/> ARCHITECT                  | <input type="checkbox"/> CIVIL SERVICE             |
| <input type="checkbox"/> Contractor and Builder     | <input type="checkbox"/> Railway Mail Clerk        |
| <input type="checkbox"/> Architectural Draftsman    | <input type="checkbox"/> AGRICULTURE               |
| <input type="checkbox"/> Concrete Builder           | <input type="checkbox"/> Textile Overseer or Supt. |
| <input type="checkbox"/> Structural Engineer        | <input type="checkbox"/> Navigator                 |
| <input type="checkbox"/> PLUMBING AND HEATING       | <input type="checkbox"/> Poultry Raising           |
| <input type="checkbox"/> Sheet Metal Worker         | <input type="checkbox"/> AUTOMOBILES               |
| <input type="checkbox"/> CHEMICAL ENGINEER          | <input type="checkbox"/> Auto Repairing            |

Name \_\_\_\_\_

Occupation & Employer \_\_\_\_\_

Street and No. \_\_\_\_\_

City \_\_\_\_\_ State \_\_\_\_\_

If name of Course you want is not in this list, write it below.

Please Mention Popular Mechanics

**GOOD MEN WANTED**

at once to learn the auto business. Big future for you or anyone who makes himself an auto expert. You learn here by doing the work yourself. Lifetime opportunity to learn the highest and most expensive auto work ever given. Omaha's NEW Auto Training College, one of the largest in the west, conducted by experienced Automobile men of Omaha, giving the highest and finest practical auto training work to be found anywhere. Experienced repairers come and take to become experts. We teach expert higher training here regular auto repairment that they don't who teach you prindn't even know. **AUTO** College. **\$900 to \$3,000 a YEAR, Salary or Bus. Profits** in Repairshop or Garage, or as Salesman, Factory Testers, Chauffeurs, Repairmen, Starter Experts or Garage Manager. If ever you are going to make a change to get into a higher paying and more pleasant line of work, DO IT NOW, the opportunities are the best now that they have ever been. Take our wonderful training course now until you are competent, and then go right into the automobile business from here. Positions now open seeking capable men, and we want 25 more good men at once to take up this work. Special \$50 course in Elec. Starting and Tractoring FREE with regular course. Learn here in 6 wks. or more. Tuition small. Life scholarship. Work easy and interesting. Many make expenses while learning. Free catalog at once.

AMERICAN AUTO COLLEGE, 353 Auto Bldg., Omaha, Neb.



**New Book Free**

Write today for the book that tells about the opportunities in the profession of Signal Engineering. Men are needed. Learn, too, how you can get the training that you need to fill the big job.

**\$125 to \$300 a Month**

The free book will give you just the information you want. Write for it now—immediately. Here is a golden opportunity.

Dept. of Signaling Dept. 1191—1210 Wilson Ave. Evanston, Ill.

**COPY THIS SKETCH**

and let me see what you can do with it. Illustrators and cartoonists earn from \$20 to \$125 a week or more. My practical system of personal individual lessons by mail will develop your talent. Fifteen years' successful work for newspapers and magazines qualifies me to teach you. Send me your sketch of President Wilson with 6c in stamps and I will send you a test lesson plan, also collection of drawings showing possibilities for you.

The Landon School of Illustrating and Cartooning  
1433 Schofield Building, CLEVELAND, O.



Mr. A. R. Patterson, whose advertisement appears below, was for eight years a Civil Service Secretary-Examiner, and is well qualified to help YOU secure a Government Position.

**FREE BOOK OF GOV'T POSITIONS**

Earn \$75 to \$150 a Month



WRITE TODAY

Be a Railway Mail Clerk, Post Office Clerk or Carrier, Rural Mail Carrier, Internal Revenue Officer, Clerk at Washington, D. C., or Panama Canal, or accept any other good Civil Service position with Uncle Sam, world's greatest and best employer.

Good Pay, Easy Work, Vacations, Position for Life

Easy \$75 to \$150 a month from the start. Rapid advancement. Work 8 hours or less a day. 15 to 30 days vacation with full pay. No Sirloins, no "lay-offs," no "straw bosses." No politics, no "pull" needed. Ordinary education sufficient. American citizens 18 or over WANTED.

PATTERSON PREPARES YOU

Only school offering help of former Civil Service Sec'y-Examiner. Quick appointment certain. Sure position or no pay. Send coupon or postal NOW for book free.

**FREE!** Tells what positions are open. How to prepare easily and quickly for job you like best. Don't be satisfied with a small pay, uncertain job. Write for book of Uncle Sam's positions and get on easy street. Mail coupon or postal NOW. Address \_\_\_\_\_

PATTERSON CIVIL SERVICE SCHOOL  
81 News Bldg., Rochester, New York

\*\*\*\*\*COUPON\*\*\*\*\*  
Send me Free Book of Government Positions.  
Name \_\_\_\_\_  
Address \_\_\_\_\_



**\$1,500 to \$50,000 Yearly**

"Three years ago I was making \$1,500 a year and working day and night. Today I make \$3000 a week and have time for other things as well. To the lessons in the book 'Power of Will' do I owe this sudden rise." —(Name on request).

**\$897 Profit First Week**

"'Power of Will' is a compilation of mighty forces. My first week's benefit in dollars is \$900—cost \$3; profit \$897."—(Figure what his yearly profit would be).—J. W. Heistand, 946 Tribune Bldg., Chicago, Ill.

**50% Salary Raise**

"First few pages enabled me to get 50% raise in salary."—Robert B. Laird, Douglas, Wyo.

**Worth \$3,000 to \$30,000**

"From what I have already seen I believe I can get \$3,000 to \$30,000 worth of good out of it."—C. D. Van Vechten, Gen. Agent, North Western Life Ins. Co., Cedar Rapids, Ia.

**Another 50% Increase**

"More than a year ago I purchased 'Power of Will' and I finally believe that it—and it alone—has enabled me to increase my salary more than 50% in that time."—L. C. Hudgens, Principal Mayhew Consolidated Schools, Boswell, Okla.

# Increased His Earnings 800%

Not long ago Wilson M. Taylor, the noted efficiency expert of the Willys-Overland Company, loaned a copy of "Power of Will" to a young man of his acquaintance, with the result that the latter's salary increased 800% in less than a year.

Above are just a few other examples of the remarkable financial benefit that thousands of men and women in every field are securing through the application of the great success-achieving principles laid down for the first time in this wonderful book

**Power of Will**

Will Power is the key to success. It is the one qualification without which accomplishment in life is impossible. Man can achieve what he wills to achieve. The will might well be termed the driving force behind the brain.

If you held your arm in a sling for two years, it would become powerless to lift a feather. The same is true of the Will—because we don't use it, it becomes dormant from lack of use. Yet anyone can easily develop his will to a wonderful power when shown how.

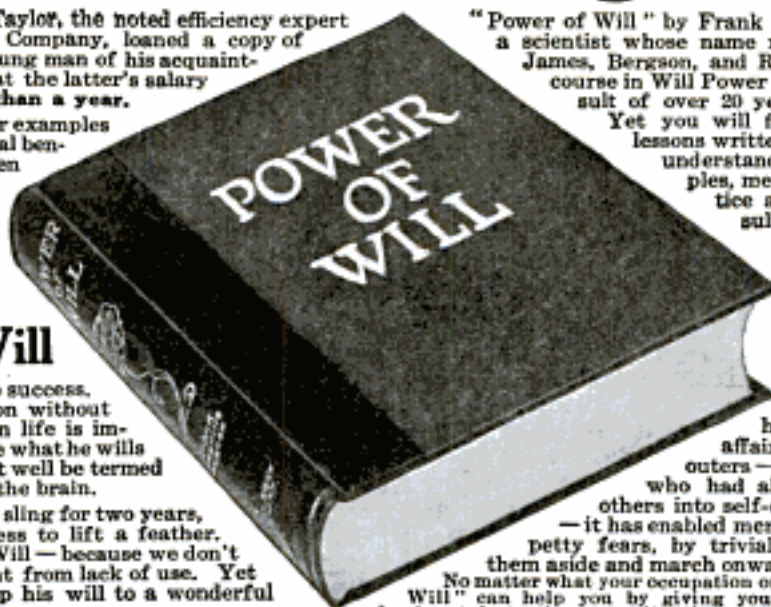

"Power of Will" by Frank Channing Haddock, Ph.D., a scientist whose name ranks with such men as James, Bergson, and Royce, is the first thorough course in Will Power ever devised. It is the result of over 20 years of research and study. Yet you will find every page in the 28 lessons written so simply that anyone can understand them and put the principles, methods, and rules into practice at once with noticeable results right from the start.

The users of "Power of Will" have experienced results through its study which border on the miraculous—it has enabled thousands to win out with big plans which they have worked on unsuccessfully for years—it has made active men of affairs out of pitiable down and outers—it has transformed those who had always been the pawn of others into self-confident, powerful leaders—it has enabled men and women held down by petty fears, by trivial daily incidents, to brush them aside and march onward to Success.

No matter what your occupation or position in life—"Power of Will" can help you by giving you the power to become the dominant factor in every situation.

## EXTRA! The Secret of FREE Brain Energy

To Readers of Popular Mechanics Who Write at Once

Absolutely free to readers of this magazine on this Extra Special Offer—Dr. Haddock's newest wonder book—"BRAIN ENERGY." Look about you at the men who are simply racing forward to success. Brain Energy distinguishes every one of them. Business Power itself is the direct result of dynamic mental energy. Brain Energy will quicken your pace and speed your progress so that you will arrive at YOUR goal in one-half the time you are allowing yourself to reach it. In this new book Dr. Haddock gives you a complete analysis of the brain and shows you how to double your capacity for mental effort. He literally takes your brain apart, exposes its processes and then explains how you can develop that type of mental efficiency

which, when combined with bodily health, enables you to do things that you now believe impossible for you. FREE if you write at once. But do not delay as we reserve the right to withdraw this offer within 30 days without further notice. Send the coupon below, or a postal. With "Power of Will" we will send you a copy of "The Secret of Brain Energy." Return both books if you are not more than satisfied after examining them. Or pay our small special price for "Power of Will" and keep "The Secret of Brain Energy" without charge.

### Send No Money

Although "Power of Will" is a 400-page leather-bound book containing more material than many \$25.00 correspondence courses, the price is only \$3.00 and "The Secret of Brain Energy" is free. The publishers will gladly send a copy without deposit, for five days' inspection. Send no money now. Merely mail the coupon on the right, enclosing your business card or giving a reference. If you decide to keep the two books, send the money. If not mail the books back. Tear out and fill in the coupon NOW before this offer expires.

**Pelton Pub. Co.**  
13-A Wilcox Block  
Meriden, Conn.

GENTLEMEN:—Please send me a copy of "Power of Will" on approval including "The Secret of Brain Energy" without charge. I agree to remit \$3.00 or remail the books in 5 days.

**Some Users:**

Among the users of "Power of Will" are such men as Judge Ben B. Lindsey; Supreme Court Justice Parker; Wu Ting Fang, ex-U. S. Chinese Ambassador; Lieutenant Governor McKelvie of Nebraska; General Manager Christeson of Wells-Fargo Express Company; Assistant Postmaster-General Britt; E. St. Elmo Lewis; Governor Ferris of Michigan; Governor Capper of Kansas, and many others of equal prominence.

**Pelton Pub. Co.**

13-A Wilcox Block  
Meriden, Conn.

Name.....

Address.....

City..... State.....



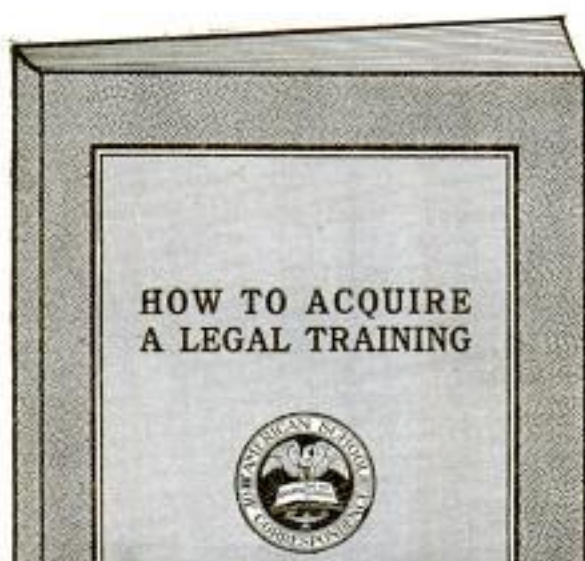

# Free Book on the Law

**EVERY** ambitious man in America should have our free book on law. It tells vital facts you need in order to realize your ambition. The place the law-trained man occupies in the modern business world is fully explained.

Fascinating stories are told of other men who have reached the goal of their ambition. The book is free. Merely send us your name and address, either on the coupon or a letter or postcard. We'll send the book to you free and prepaid. You will be under no obligations.

## Law Trained Men Lead

All of us are reading and hearing that it is the law-trained man who is the leader today. Our free book tells why. It explains why law-trained men are being chosen for the high positions—and how you can qualify yourself exactly like other trained men who are now holding these positions qualified themselves.

## Invest Your Spare Time

Your idle hours can be made golden ones. Right in your own home you can read law under the direction of Masters—and fit yourself to hold the high position you are dreaming about. You will not make a drudge of yourself. American School training has been made simple—and easily understood so that you can get a thorough training in law during the hours after you have finished the day's work. The American School law course was written for you.

**American School of Correspondence** Dept. L1191, Chicago, U.S.A. Without any obligation on my part, please send me your Free Book, "How to Acquire a Legal Training."

## Send the Coupon

Put your name and address in the coupon, or on a letter or postcard, and get our Free Book on Law. You need it. It points a way for you to realize your ambition, and for your own sake you can not afford to be without it. You will be under no obligation by sending for the free book. Put your name and address in the coupon.

Name.....  
Address.....  
American School of Correspondence  
Dept. L1191  
CHICAGO, U.S.A.

Please Mention Popular Mechanics

## All About Motor Cars

**Construction, Operation, Care and Repair**  
This very latest authoritative book gives ALL the information in 16 easy lessons.

## The Automobile Instructor

By Clyde H. Pratt, B. Sc., M. E., Member Nat'l Society of Auto Engineers. 226 pages, illustrated, cloth bound. Shipping wt., 22 oz.

**New 1917 edition out Jan. 3.** The standard work for home study, class-room and reference, for amateur and expert. A complete course for all who desire to master this profitable profession.

## LEARN AT HOME HOW TO DRIVE AND REPAIR ALL CARS

Invaluable pointers for every car owner, driver, garage man, and repair man. Adopted by Cleveland and other Auto Schools and by Boards of Education as their standard text-book. The author will answer your auto inquiries FREE. This book is guaranteed to be just what you want or your money back. (Auto schools, write for quantity prices.)

Price, postpaid . . . . . \$1.50

Shrewsbury Publishing Co., 525 West Lake St., CHICAGO, U. S. A.

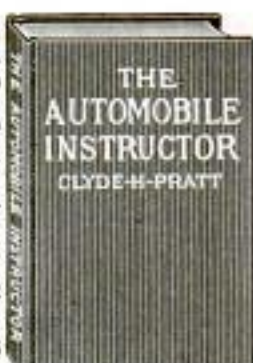

**Motor Craft Encyclopedia**  
Illustrated. Tells how to build and operate Motor Cars. Best book on boats. Price, \$1.00.

**Cartoonists, Illustrators and Art Students**  
Read and endorse **The Student Illustrator** as the magazine of Art. Full of inspiration, suggestions, practical advice, instruction, and ideas. Articles on leading cartoonists, illustrators, etc.  
**\$1.00 per Year**  
**STUDENT ILLUSTRATOR**  
Dpl. E. Schwartz Bldg., Washington, D. C.

## Debates and Orations

Essays and orations, about 1,000 words; debates on either side of any subject, about 1,500 words: one dollar each. Addresses for all occasions prepared to order. All work done by college graduates. Satisfaction guaranteed or money refunded. Let us know your wants. Questions for debates free.

COLUMBIAN INFORMATION BUREAU, WASHINGTON, D. C.

## Shorthand—the New Way

**Learned in 30 days** at your home in spare time. **Boyd Syllabic System.** Easiest method—based on new principles—amazing results. Easy to learn, write and read. Learned in from 1 to 2 weeks, then speed practice, and in 30 days you are ready for a position. We guarantee speed of **100 to 150 words a minute.** Writers hold world's record. Results so certain that we give **money back guarantee.** Costs nothing unless you are satisfied. Send today for special offer, free catalog and sample lesson.

CHICAGO HOME STUDY SCHOOLS, 504 Reaper Block, CHICAGO, ILL.

**\$12500 to \$30000 a Month**  
Write at once. Most wonderful opportunity for the ambitious man. Railroads need hundreds of Signalmen—will pay **Big Money.**  
**Special Offer** We will teach you right at home to be expert. Special offer if you write at once. Two big outfits free. **Write Today** for our free catalog and particulars of our big offer.  
**DEPARTMENT OF SIGNALING**  
1810 Wilson Ave., Room 2197, Revere Station, CHICAGO

## NEW FORD JOKE BOOK 1917

All the latest jokes on the Ford Auto. Hundreds of them and all good ones. Spring a new one on your neighbors.

Large book with colored cover by mail, 10c.

**NEW ENGLAND PUBLISHING CO.**

Box 2, So. Norwalk, Conn.

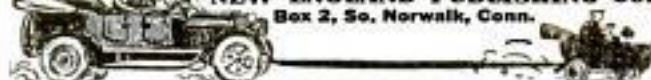

**REVERSIBLE**  
**"Linene"**  
TRADE MARK  
**SEND 2 CENTS**  
in United States stamps to pay postage and we will send you FREE a **SAMPLE COLLAR** of our New Style "Copley." *State size wanted.*  
**REVERSIBLE COLLAR CO., Dept. U, BOSTON, MASS.**



**Chief Engineers  
of the larger power  
plants earn  
\$2500 to \$5000  
PER YEAR**

**Many  
Earn  
More**

**If you are a power plant engineer or expect to become one, here is presented an opportunity to reach the high position. Here is an opportunity to escape the long years of hard work at low pay.**

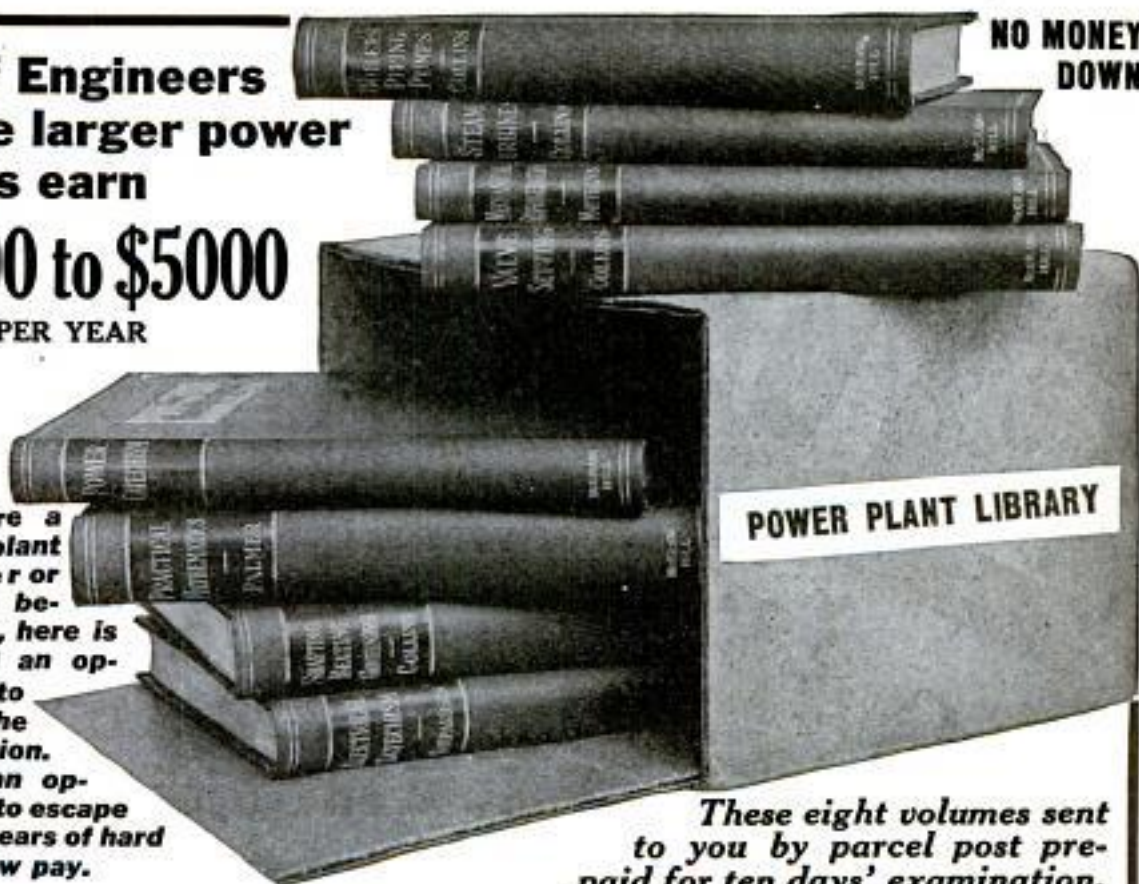

**NO MONEY  
DOWN**

*These eight volumes sent to you by parcel post pre-paid for ten days' examination.*

**The Power Plant Library Only \$1.00 Per Month  
if you are satisfied**

**is the most used engineers' library in existence—because written by practical men**

**T**HE life of the nation depends upon its power plants. With the thousands of new developments in the manufacturing world, where steam, electricity, turbine and refrigerating apparatus are always a part of these improvements, the position of the engineer is becoming more and more important—the salary he commands is soaring to new high levels.

**Backed by forty years' experience** For forty years we have studied the needs of the power plant engineer. The Power Plant Library is the cumulative result of these years of experience and study.

**Every phase of power plant work** Concentrating our efforts toward simplifying for the practical man all the problems met with in the course of his work, we have completed a library of eight volumes, containing nearly 3000 pages, covering in an understandable manner every phase of power plant operation.

**Nearly 3000 pages and 1500 illustrations** The subjects of steam, electricity, turbines and refrigeration — from the simplest duties of the beginner to taking charge of the plant — are worked out in language and figures which will puzzle no one. The 1500 illustrations and drawings bring to a point of absolute clearness each item of information that is not otherwise made plain.

**Over 100 authorities herein represented** The five authors of the Power Plant Library, and the great number of men who assisted in its building, are among the most able and efficient power plant authorities in America. Each understands thoroughly the practical side of the work, and they tell you what you must know to reach the higher position.

**See the books with your own eyes** You will want to examine the Power Plant Library in person. You will want to see with your own eyes the most used engineers' library in existence. Only then will you know why it is accepted as the standard in America. Only then will you recognize its helpfulness and its ability to train you quickly and properly in power plant engineering.

**Absolutely no money in advance** Upon receipt of attached coupon we will send you by parcel post prepaid the entire set of eight volumes, beautifully and strongly bound. You will have ten full days in which to look them over. Then you can return them at our expense if they are not wanted. You go to no expense. If on the other hand you wish to keep them, just send us the small sum of \$1 per month until paid.

**McGraw-Hill Book Co. Inc.**  
Publishers of Books for Engineers Since 1876  
239 W. 39th Street, NEW YORK

**McGraw-Hill Book Company, Inc.**  
239 W. 39th St.,  
NEW YORK

Gentlemen:—Ship the Power Plant Library, eight volumes, for my inspection. If satisfactory after examination, I will send you \$1 in ten days and the balance at the rate of \$1 per month until I have paid the price of the books, \$12. If not satisfactory I will write for shipping instructions.

**HERE'S THE COUPON—WILL YOU USE IT TODAY?**

Signature.....

Your Address .....

City and State.....

Name of Employer .....

His Address .....

Your Position.....

P. M. Jan.



# RUSH

Our limited supply  
of the

## Encyclopaedia Britannica

printed on genuine India  
paper (the last that can be of-  
fered) is rapidly nearing exhaustion.  
Order your set promptly.

Only **\$1**

down and **\$3** a month for  
"Handy Volume" Issue.

Send coupon for full information.

We are publishing this advertisement as a warning that if you want the Encyclopaedia Britannica printed on genuine India paper, you must buy it within a short time. If you were warned that your fire insurance policy was about to expire, you would be quick to renew it. You must also be quick if you would secure the Britannica, which is insurance against ignorance.

We cannot secure more India paper on which to print this monumental work of knowledge. This thin but tough paper has transformed the Britannica volumes into the handsomest, most convenient books you ever saw.

When the comparatively few sets now on hand are gone, as they very soon will be, we cannot renew this opportunity to secure the greatest of all works—the Britannica—in the most valuable form—printed on genuine India paper. This is a bargain that cannot be duplicated—act upon it at once by sending the coupon on the adjoining page.

Whether you buy or not, you should at least investigate. You can do it by simply marking and mailing the coupon on the opposite page.

### War cuts off the supply of India paper

Just as we were about to reprint a further supply of the Encyclopaedia Britannica on this superb paper, word came that no more flax (from which India paper is made) could be obtained because of the war.

The superior grade of flax used for India paper (the kind used in making linen) is grown only in Germany, Belgium and Great Britain. War has crippled the flax industry in the first two countries indefinitely and Great Britain has placed an embargo on her supply. We are advised that this flax cannot be bought in sizable quantities for years to come. Hence the comparatively few sets of the Britannica now on hand are the last printed on India paper that can be offered.

They will be sold to first applicants for only \$1 down and \$3 a month for the "Handy Volume" Issue (for cheapest binding).

The point we wish to emphasize here is not the low price and convenient terms, the vast scope and reliability of the Britannica, or the many advantages of India paper—you can learn all about these points by sending the coupon. What we want to impress upon you here is that the sets now on hand printed on genuine India paper are the last that we can offer and that this is the

**time for immediate action. Send NOW, coupon on next page**



**This is your  
War-time  
Opportunity  
to secure a Rare  
Bargain. Grasp it today.**

**RUSH**

The Britannica will stimulate you to improve your education whether or not you've had a college education. It will furnish you with a teacher of any subject you wish to study—a teacher who is master of his subject and tells what he knows in clear, simple language—a teacher who is always at your command.

It will give you the answer to the thousand-and-one questions that the morning paper, lectures, sermons and books prompt in every active mind. It will make everything you see, read and hear more interesting.

It will put you in touch with all the interesting people in the world, with their work and their ideas. It will give you hundreds of live topics to talk about.

It will help you form an intelligent opinion on all the questions of the day and follow the course of current events both at home and abroad.

It will enable you to lay out a plan of education for your children and keep abreast with their studies.

*Don't "put it off till tomorrow." Send coupon right now for full information on any of the following works—all printed on genuine India paper and all extremely limited in supply. Mark coupon for book describing the work you are most interested in.*

**THE ENCYCLOPAEDIA BRITANNICA**, Cambridge issue, in 29 volumes, 1 inch thick, large pages, large type, 30,000 pages, 41,000 authoritative articles, 44,000,000 words, 1,500 noted contributors, 15,000 illustrations, full-page plates and maps—sent for a first payment of \$5.00 and a limited number of monthly payments of the same amount. (Out of 75,000 sets printed, less than 1500 sets are left.)

The popular edition known as **THE "HANDY VOLUME" ISSUE** is precisely the same as the Cambridge issue in every detail except size, and sells at nearly 60% less. Each volume measures 6 $\frac{1}{4}$  inches wide by 8 $\frac{5}{8}$  inches high by 1 inch thick. It will be sent for a first payment of only \$1.00 and \$3.00 a month for a limited period.

We also have on hand a small supply of the famous **CENTURY DICTIONARY** (revised), the only complete dictionary of the English language. 325,000 words fully defined by 600,000 concise explanations, 10,000 illustrations, more than 8,000 pages—which, by a new invention, have been bound into a single volume for instant and easy reference. Sent for a first payment of \$1.00, to be followed by a few monthly payments of \$3.00.

Sets of the above can be seen at the following offices of the Encyclopaedia Britannica:

NEW YORK, 120 West 32nd Street  
CHICAGO, 920 Manhattan Building  
PHILADELPHIA, N. E. Cor. 15th & Walnut  
CLEVELAND, Society for Savings Building  
SAN FRANCISCO, 783 Monadnock Building

(Put an X in the square for book or books wanted and mail at once.)

**THE ENCYCLOPAEDIA BRITANNICA**  
120 W. 32nd Street, New York

- Please send me, free, your book describing **The Encyclopaedia Britannica, Cambridge issue.** (This is the large-type, large-page, high-priced issue. Out of 75,000 sets printed, less than 1500 sets are left.)
- The **"Book of a Hundred Wonders,"** describing the Encyclopaedia Britannica, **"Handy Volume" Issue.** (This is the popular low-priced issue, of which 75,000 sets were sold in six months.)
- The Century Dictionary, 10 volumes, 8250 pages, bound in one volume.**

Also quote me prices and terms on which these works may be purchased.

Name \_\_\_\_\_

Address \_\_\_\_\_

r-18



# FREE Complete \$15.00 Set of Drawing Instruments

**Y**ES, I will give you this complete set of drawing instruments absolutely free. They are regular working instruments—the kind I use myself and they do not cost you a cent.

And besides the instruments in an exquisite plush-lined leather case, I will give you absolutely free a 20x25 inch drawing board, a 24 inch T square, a 12 inch rule, a supply of drawing paper, two triangles and a French curve, pencils, erasers, thumb tacks, etc., etc. A complete draftsman's working outfit. And I give it to the men who get my personal instruction absolutely free.



## Be a Draftsman!

**Draw \$125 to \$175 per Month**

There is an urgent demand for skilled draftsmen. Companies are issuing calls every day for men to fill positions paying from \$125.00 to \$175.00 per month. Work is light, pleasant and profitable.

## Chief Draftsman Will Instruct You Personally

I am Chief Draftsman of a large and well known firm. I have been doing the highest paying expert drafting work for a quarter of a century and I know just the kind of training that is demanded from men who get the big salaries. I will give you personal instruction, deal individually with you and give you up-to-date, practical working plans just as your ability and advancement require. I train you by giving you actual work—practical work, the kind that you must be able to do in order to hold permanent, big paying positions. I give you my individual instruction. If your work is right, I will advance you rapidly. If it is wrong, I will show you where, and make you do it right, and do all I can to make you an expert draftsman and designer in a short time. **Write Today Without Fail**

**Pay as You Wish!** What I want is the RIGHT KIND of men. Don't bother about expense. I will give you the working outfit free if you get in at once. I charge a very small fee for training you to be an experienced draftsman. You can pay the small cost as suits you best. My object is to develop experienced draftsmen.



**Chief Draftsman Dobe**  
Engineer's Equipment Co.  
Div. 1191 Chicago, Ill.

Without any obligation on me whatsoever, please mail your book "Successful Draftsmanship" and full particulars of your liberal "Personal Instruction" offer to a few students. It is understood that I am obligated in no way whatever.

## Send the Coupon for My Big New Book

Put your name and address on the free coupon or a letter or a post card and send it to me today. I will send you absolutely free and postpaid my new book "Successful Draftsmanship," and the great special offer that I am now making on which you get the \$15.00 Draftsman's Working Outfit absolutely free. You assume no obligations of any kind in sending in the coupon. Get in line now for a big paying position. Getting the book and full particulars of the special offer is the first step. Write today—now.

**Chief Draftsman Dobe**  
Engineer's Equipment Co., Inc., Div. 1191, CHICAGO, ILL.

NAME.....

ADDRESS.....



# CLASSIFIED ADVERTISEMENTS

WORLD'S BEST WANT AD MEDIUM

We have records to prove that a classified ad in these columns will find a buyer for almost anything which can be sold. Doubtless you have some article of value to some one else which you no longer need. Why not turn it into money?

Advertisements in this section, 15 cents per word, each insertion, minimum 10 words, payable in advance. To insure ads being inserted under proper classified head in the February issue, copy must reach this office not later than December 30th.

Popular Mechanics Magazine, Chicago, Ill.

Gentlemen: The results derived through the ad in your popular publication far exceeded my expectations. On the advice of a friend, I ventured in the mail-order business just for the fun of it. I procured 5,000 books at a rock-bottom price from a publisher in New York, and am more than pleased to state that my stock is completely exhausted, with the exception of 83 books. My very first order came from Canada, St. Catharines, Ont., and then the orders came in thick and fast, by the hundreds, from all parts of the U.S.A. This sounds very much as a fairy-tale, but it is as true as I am alive. Just as soon as I can get more books, you may be sure I will favor you with an advertisement. Your popular magazine deserves credit, for it surely is a very good "PULLER" for "RESULTS." A satisfied advertiser,  
ALEXANDER E. FOREDA.

## AUTOMOBILES

CYLINDERS reground, new pistons and rings fitted. Restores lost power. Prompt and efficient service given. Write for prices, giving make and model. The Everts Machine Company, No. 20 Hicks St., Hartford, Conn.

STANLEY boilers, burners, engine parts, miscellaneous models; get list, "Doc" Falne, 1840 Welton, Denver.

GET into the Automobile business, as salesman, chauffeur, garage manager, mechanic. Automobile instruction in four weeks' residence course. Send for booklet P. M., West Side Y. M. C. A. Auto School, 318 West 57th St., New York.

JUST Out—Modern Starting, Lighting and Ignition Systems—A new book on automobile electricity without an equal. Nearly 400 Pages. 250 Engravings. Cloth. Price \$1.50 postpaid. Complete description sent on request. Popular Mechanics Book Dept., 6 N. Michigan Ave., Chicago.

THE Modern Gasoline Automobile—Most complete and up to the minute automobile book published. Recognized as the standard book on construction, operation, maintenance and repair, showing every recent improvement. Over 700 pages, 500 illustrations. Cloth. Price \$2.50 postpaid. Popular Mechanics Book Dept., 6 N. Michigan Ave., Chicago.

LIVE agents wanted. Entirely new, guaranteed, money-back proposition for automobile owners. A trouble eliminator and money saver. Birks Supply House, 5214 Lake Park Ave., Chicago.

CYLINDER Grinding, pistons and rings our exclusive specialty. Long experience, coupled with a most completely equipped plant, is at your service. Our prices will interest you. "The grinding that puts the punch in your motor." Bridgeport Piston Ring Co., Connecticut Ave., Bridgeport, Conn.

PATENTS for Automobile Improvements are in great demand. We have special Automobile Department in charge of experts who are in touch with demands of trade. Write for "What To Invent and List of Patent Buyers," sent free. Victor J. Evans & Co., 158 Ninth, Washington, D. C.

AUTOMOBILE Repairs—Automobile owners. Garages and Repairmen should subscribe for the Automobile Dealer and Repairer; 150-page illustrated monthly devoted exclusively to the care and repair of the car. The only magazine in the world devoted to the practical side of motoring. The "Trouble Department" contains five pages of numbered questions each month from car owners and repairmen which are answered by experts on gasoline engine repairs. \$1 per year; 15c per copy. Canadian subscription, \$1.50. Postals not answered. Charles D. Sherman, 50 Windsor Road, Hartford, Conn.

LARGEST Automobile School in the East. Send for folder. New York School of Motoring, Utica, N. Y.

CYLINDER grinding of the highest quality. New pistons and rings fitted. Service given is of the best. New Haven Machine Corp., New Haven, Conn.

## AUTOMOBILE SUPPLIES

EXPLOSION Whistle. Fits priming cup. Most powerful signal made. Rapid seller, owing to real value. See display ad page 145. Buell Manufacturing Co. (Dept. 31), 1619 Michigan Blvd., Chicago.

AUTOMOBILE Parts for the following and a great many others that we do not list: Maxwells, E. M. F., Flanders, Buicks, 10, 17 and 19, Overlands, Paige 25, Cadillacs, '09 to 1912, Moon, Moline, Parry, Oakland, Rambler, Mitchell's, Empire, Everetts, Elmora, Glide, Warren, Regals, Michigan, Velle, Chalmers, Courier, Auburn, Kline, Dorris, Krit and many others. Pistons, Connecting Rods, Cam Shafts, Crank Shafts, Cylinders, Axles, Bearings, and gears for most any make of car. Write us your needs. Satisfaction guaranteed. Auto Parts Company, 4118 Olive St., St. Louis, Mo. No connection with any other Auto Parts Co's.

BATTERY Chargers bring big profits. Engine or city current operates. Ten dollars places money-maker in your garage. Balance easy terms. Hobart's, Box MJ, Troy, Ohio.

GAS-TONIC formula and sample 25c. Guaranteed reliable. Fred Whitmore, Box 313, Stevensville, Montana.

AUTO Supplies—Do you know what it costs to run your car? Buy The Automobiles' Pocket Companion and Expense Record, enter a few figures daily and you can tell at any time whether your car is operating efficiently or not. Convenient pocket size, limp cover. Price \$1.00 postpaid. Popular Mechanics Book Dept., 6 N. Michigan Ave., Chicago.

AUTOMOBILE Repairing Made Easy—The most needed and useful book on automobiles ever written. Only book of its kind—just out. Covers every phase of automobile repairing practice. 1,956 pages (3 1/2 x 5 in.), 1,000 engravings. Cloth. Price \$3.50 postpaid. Send for complete description of this and other reliable automobile books. Popular Mechanics Book Dept., 6 N. Michigan Ave., Chicago.

TIRES—Double Trend Guaranteed for 3500 miles. Absolutely Puncture-Proof. Big—Strong—Extra, heavy 30x3 tire \$5.00; 30x3 1/2 \$6.00; 33x4 \$8.00; 34x4 \$9.25; 35x4 1/2 \$12.00; 37x5 \$13.00. Big saving on other sizes and tubes also. Trade in your old tires. Discount to dealers. 10% deposit required on C. O. D. orders. Send for list now! State size and bead of tire. Max Liben & Co., 205B West 48th Street, New York.

FOR Sale—Peugeot Type Cylinder Heads for Fords—16 overhead Valves, Rocker Arms and Push Rods. Special Intake Manifold for 1 1/2 inch Carburetor. \$50 F. O. B. Anderson, Indiana. Robert M. Roof, M. E., 919 Meridian Street.

NEW Ford rear springs \$5. 1916 Ford engine \$100. Other 4 cylinder engines from \$50 to \$100. Parts for 100 models of autos. Auto Salvage Parts Co., 1436 Wabash Ave., Chicago, Ill.

KENT Auto Parts Co. Parts for all Maxwells, Buick, Overland, Oakland, Chalmers, Cadillac, Everett, E. M. F., Interstate, R. C. H., Reo, Franklin, Mitchell, Jackson, Peerless, Thomas, Stevens, St. Dayton, Great Smith, Locomobile, Premier, Columbia, and others. Denver, Colo.

AUTO Engines: 4 cylinder—30 H. P., water cooled, \$35.00—6 cylinder, air cooled, \$60.00. Other sizes, low price. Bosch Magneto: 4 cylinder, \$20.00—6 cylinder, \$25.00. Write for list, Johnston, West End, Pittsburgh, Pa.

GEARS for all purposes; transmission gears, bevel-drive gears, sprockets, axles. Special machine work. Must have old parts or drawing. Turley Gear Plant, 1505 N. 10th St., St. Louis, Mo.

DOUBLE Service Tires. Guaranteed 3,500 miles. Sizes 30x3 \$5.00, 30x3 1/2 \$6.00, 33x4 \$8.00, 34x4 \$9.00, 36x4 \$9.00, 36x4 1/2 \$10.00, 36x5 \$11.00, 37x5 \$11.00. Non-skid \$1.00 extra. 10% required on C. O. D. orders. State if Q. D. straight bead or clincher type. Special discount to dealers. I. Jaffess, 1319 H. Fifth Ave., New York.

UNUSUAL Bargains in Automobile Repair Parts. Axles, Bearings, Carburetors, Complete Engines, Cylinders, Differentials, Magnets, Pistons, Radiators, Springs, Valves, Wheels and other parts for Buick, Cadillac, Chalmers, Interstate, Maxwell, Mitchell, Moon, Overland, Packard, Peerless, Regal, Studebaker, Thomas and other cars at a fraction of factory cost. Maxwell Bros., 3931 Olive Street, St. Louis, Mo.

VULCANIZER for shop. Bargain. Vandervoort's, Springfield, Ohio.

INSIDE Tyres, inner armor for Automobile tires, double mileage and prevent punctures and blowouts. Quickly applied. Cost little. Demand tremendous. Profits unlimited. Details free. American Automobile Accessories Co., Dept. P2, Cincinnati, O.

MOTORS, magnetos, coils, carburetors, radiators, axles, transmissions, etc. cheap. Badger Motor Co., Milwaukee, Wis.

AUTO Top Roof and Back Curtain Roadster, \$6.95; touring, \$8.95. Parcel post paid. Our instructions make it easy to apply. You save \$7. Samples and catalogue free. S. H. Top Co., 430 Hunt, Cincinnati, Ohio.

CAR owners! Valuable information free. Protects your radiator through the winter. Send stamp. Mitchell Ebert, Marion, Ohio.

## TO FORD OWNERS

STOP fouling spark plugs; use our never-leak three-in-one piston ring. Two top rings on each cylinder does the work. Guaranteed. \$1.00 each. Agents wanted. Fuller's Garage, Lovington, Ill.

HEATERS for Ford Cars. Brickey patent hot-air heater doesn't cost a penny after installed; put on in few minutes; no holes to cut; no gases used; ride in comfort in coldest weather; only \$4.90 prepaid to your address. Satisfaction or money refunded. Thurston Auto Supply Man'g Co., 3920 Michigan Ave., Chicago.

FREE Trial—Ford Tire Saver. Circulars. J. Davis, Monmouth, Ill.

YOU can get the best Starter ever made for a Ford car, regardless of price, for \$6.00, from Symons Brothers Co., 2611 E. Railroad Ave., Evanston, Illinois.

"RED-I-KUT" Speedster, see full description on page 147 this issue.

WANTED—Ford car owner in every county to demonstrate the all steel \$19 Ajax Ford Starter. \$30 to \$50 weekly. Write for territory to the Ajax Ford Starter Co., Keene, N. H.

## FORD ACCESSORIES

FORDS given double light automatically at low speeds. Salesmen guaranteed \$18.00 per week. North American Instrument Co., 206 Michigan Ave., Grand Rapids, Mich.

FORD and Metz gasoline saver, 30% more mileage, no machining; quickly fitted, \$3.50. Send \$5.00 for 2, 100% profit to agents. Dash Priming tanks \$2.50, Lincoln Holland, Los Angeles, Cal.

SPLENDID up-to-date Roadster or Speed Body for Ford. Exceptional bargain. J. C. Edwards, Box 216, Aurora, Ill.



## CYCLECARS AND MATERIAL

FOR Sale—Cyclecar parts. 10 h. p. "V" Motor. \$27.50; Wheels, \$9.00 per set; all other parts at very low prices. This is a well known successful Cyclecar. Send two cents for catalog. Tribune Engineering Co., Oswego, Tioga County, N. Y.

## MOTORCYCLES, BICYCLES &amp; SUPPLIES

**MOTORCYCLES.** 1914 Merkel Side-Car, \$25; 1912 M. & M. Single, reground, new reciprocating parts, clutch, battery ignition, \$40; 1912 H.-S. Single, reground, new reciprocating parts, clutch, battery ignition, \$40; 1912 M. & M. Single, Schebler carburetor, clutch, belt drive, battery ignition, \$25; 1913 Twin H.-D., lights, foot boards, \$85; 1911 Single H.-D., magneto ignition, Schebler carburetor, \$35; 1912 Twin Excelsior, belt, electric lights, \$40; 1913 Twin H.-D., lights, tandem, speedometer, \$100; 1913 Twin Indian, lights, foot boards, \$75; 1915 Twin Indian, three speed, electric lights, speedometer, \$135; 1912 Single H.-D., belt, magneto, clutch, \$40; 1917 Twin Excelsior side-car, electric lights, speedometer, \$250; 1914 Twin two-speed Merkel side-car, lights, speedometer, \$110; 1911 Single H.-D., belt, battery, \$25. Numerous 1915-1916 H.-D. outfits with and without side-cars. Write for circular of 200 used motorcycles and side-cars not listed here. We furnish folder of satisfied customers from Alaska, Canada, and all parts of the States as reference. The Place of Satisfaction. Mueller Cycle & Supply Co., Largest and Oldest Dealers in the Northwest, 726-730 National Ave., Milwaukee, Wis.

LARGE stock of rebuilt motorcycles, new parts for all makes 25% discount; second-hand parts, good as new, 50% discount. Motorcycle Parts Mfg. Co., 2127 Michigan Ave., Chicago.

BIG bargains in good motorcycles we have taken in exchange on new ones. Send for special bargain list. Shaw Mfg. Co., Galesburg, Kansas.

SEND for latest Bulletin of real Motorcycle Bargains, used and slightly used, all makes, models and prices; if you have \$25 and really want a powerful Motorcycle, send for this Bulletin; hundreds of machines at all prices, new ones on easy payments; tell us what you want and how much you can pay; we can fix you up. Peerless Motorcycle Co., Dorchester, Mass.

HARLEY-DAVIDSON, Good Condition, \$50. Address, Road, 121 E. Ohio St., Chicago.

THIRTY Used Motorcycles—Must be sold at once. Biggest bargains ever offered. Write for list. Seiber & Hofheims, Buffalo, N. Y.

A REAL bargain in second-hand motorcycles. We have an overstock of all makes, such as Indians, Harley-Davidsons, Excelsiors, Pops, Merks, and 4-cylinder Hendersons. All are in A-1 condition and fully equipped. If interested in buying a motorcycle write for our Bargain Bulletin No. 5 giving description and prices from \$35 up. Gotham Sporting Goods Co., 57 Warren St., New York City.

1915 HARLEY-DAVIDSON twin, three speed, electric model, extra equipment, \$150. Rogers, 103 Hancock St., Dorchester, Mass.

EXCELSIOR nearly new, price reasonable. O. C. Betry, Dealer, 209 South St., Iola, Kansas.

NEW Motorcycle Book—Just Published—Motorcycles, Side Cars and Cyclecars, Their Construction, Management and Repair—550 pages, cloth, 350 illustrations. The Dealer, Mechanic and Rider will find this treatise a work of reference without an equal. Price \$1.50 postpaid. Popular Mechanics Book Dept., 6 N. Michigan Ave., Chicago.

1916 INDIAN Powerplus, fully equipped, like new, \$100.00, 1917 Excelsior Twin Demonstrator, fully equipped, \$95.00. Flinders Four Horsepower, good condition, equipped, \$25.00. Thor Twin, good condition, equipped, \$20.00. Other good bargains. Used frames for all makes machines \$5.00 and up; Motors \$20.00 up. Cut prices on accessories. Write for latest Bargain Bulletin with cuts. Western distributors. Any goods not satisfactory will be exchanged or money refunded. W. E. Wandersee Company, Main Store: 129 Gratiot Avenue, Branches: 2996 Woodward Ave., Woodward Ave. and Grand Blvd., Detroit, Mich.

1914 EXCELSIOR Twin, 1913 Harley Twin, Thor Twin, all equipped, perfect condition; choice \$75. Rogers, 103 Hancock St., Dorchester, Mass.

BARGAINS in second-hand motorcycles. Harley-Davidson and Indian in two and three speed models, electrically equipped. All machines guaranteed to be in A-1 condition. If interested, write for our list which gives complete description of each machine and price from \$25.00 up. Harley-Davidson Sales Company, 1616 Third Ave., Birmingham, Ala.

1917 EAGLE motorcycle now ready. Get Circular M. and agency proposition. Eagle Motorcycle Company, Brockton, Mass.

BICYCLE Motors bought and sold, \$15.00 up. Cleveland Motor Repair Works, 2117 Prospect, Cleveland, Ohio.

\$1.38 EACH. Guaranteed Nonskid Bicycle tires. Prepaid. Returnable. Bicycle Bill, 15 Library Street, Grand Rapids, Mich.

I SAVE you half on parts and accessories for all makes. Jones, "The Parts Man," Box 792, Brockton, Mass.

INDIAN 1916 Powerplus 3-speed with Flexible side-car, fully equipped, new in September; fine condition, \$255. Dallas Spence, Waverly, Neb.

GET our list of used Motorcycles, Harleys, Indian, Excelsior, Thor and Henderson, \$25.00 up. W. J. Walker, 174-178 Columbus Ave., Boston, Mass.

EASY terms on new and rebuilt motorcycles, side cars, tandems and lighting outfit. Motorcycle Investment Company, 800 Center St., Brockton, Mass.

MOTORCYCLES at winter prices. 1 4-cylinder Pierce \$95. 1914 Excelsior twin, 9-horsepower \$90. 1913 Indian twin, 9-horsepower \$50. 1913 Excelsior twin, 9-horsepower \$80. 1913 Pope twin, 10-horsepower \$85. 1911 Indian twin \$75. 1912 Thor twin \$75. 1913 Emblem twin, 12-horsepower \$90. 1913 Harley twin \$95. 1911 Yale twin \$60. 28x3 tires \$6. 28x2 1/2 \$3. Best sewed belts \$5. Spark coils \$5. Hand horns \$1. Bicycles \$5. Tandem \$10. Deminger, The Price Cutter, Rochester, N. Y.

DON'T buy a Bicycle Motor Attachment until you get our catalogue and prices. Shaw Mfg. Co., Dept. 27, Galesburg, Kansas.

BIG bargains in second-hand motorcycles. \$25 up. Indians, Harleys, Thors, Excelsiors and Merks. Write for description. Howard A. French & Co., Baltimore, Md.

BARGAINS in used motorcycles. Guy W. Webb, 1023 Marquette, Minneapolis, Minn.

MOTORCYCLE cylinders reground, fitted with new piston and rings, \$5.00, guaranteed. Muncie Piston Co., Muncie, Ind.

WANT to sell your motorcycle? I have a method which has sold many. Write me today for free information. F. W. Johnson, Room 900, 78 E. Madison St., Chicago.

WANTED: We pay cash for used motorcycles or take them in on exchange for new machines. Write with complete description, State condition of tires, frame, motor, make and model. Shaw Manufacturing Co., Dept. 157, Galesburg, Kans.

## WELDING

WELDING Accessories and Supplies. Cutting Torches, Welding Torches, Acetylene Reducing Valves, Oxygen Regulators, Cast Iron Welding Rods, Aluminum Welding Rods, Phosphor Bronze Rods, Manganese Bronze Rods, Naval Bronze Rods, Tuhin Bronze Rods, Norway Welding Wire, Swedish Welding Wire, Silver Welding Wire, Silver Solder Wire, Spelter Solder Wire, Copper Welding Wire, Brass Welding Wire, Brass Spelter Solder, Silver Solder, Aluminum Solder, Aluminum Flux, Brazing Flux, Cast Iron Flux, Graphite Plates and Sticks, Gloves, Goggles, Rubber Tubing, Asbestos Cloth and Paper, Satisfaction assured. Wm. Crowell Co., Van Horne Street and Central Railroad, Jersey City, N. J.

WELDING—Automobile Welding with the Oxy-Acetylene Flame—Just Out—167 pages, fully illustrated. Price \$1.00 postpaid. Explains the actual welding of all automobile parts in a manner understandable by everyone. Popular Mechanics Book Dept., 6 N. Michigan Ave., Chicago.

DAY'S Welding Solder. For scored cylinder, aluminum, potmetal, and all metals. Write for circular. Sample bar, 50c or \$1.50 per pound. Bellingham Solder Co., Bellingham, Wash.

A BIG guaranteed. Trial bar with full directions, 50c. Don't scrap aluminum parts. Save them with So-Luminum, new, great welding compound, 1/2 time and cost of acetylene. No flux—use gasoline torch. Booklet 1, So-Luminum Mfg. Co., 1790 Broadway, New York.

WELDING Plants for All Purposes. Small Cash Payment. Balance to Suit. Berne Co., Omaha, Neb.

OXY-ACETYLENE Welding and Cutting. Electric and Thermit Welding. Brand new book of practical instruction in this process. The workman will find all necessary information for handling any kind of welding. 215 pages, fully illus. Cloth, \$1.00; Leather, \$1.50 postpaid. Popular Mechanics Book Dept., 6 N. Michigan Ave., Chicago.

SIMPLE Soldering, both hard and soft—\$2-page book telling how to join metals. Do your own repairing. 52 illustrations. 25c postpaid. Popular Mechanics Book Dept., 6 N. Michigan Ave., Chicago.

## AERONAUTICS

BUILD yourself a Baby White Monoplane this winter. The smallest, simplest and lowest powered practical machine in America. Flies with motorcycle engine. Plans \$5 per set. White Aeroplane Company, 619 Exchange Building, Los Angeles.

AEROPLANE supplies, propellers, plans, fittings, etc. Illustrated catalog eight cents postpaid. Chicago Aeronautical Supply Co., Chicago.

PATENTS Wanted in Aeronautics—U. S. Government spending millions in this class for Army and Navy. Our Aeronautic Department will give full information on this subject upon inquiry. Write for "What to Invent," sent Free. Victor J. Evans & Co., 169 Ninth, Washington, D. C.

AVIATION Motors, all makes, up to 150 H.P., \$250 up. Complete aeroplanes, all types, \$500 up. State your needs. Aero Exchange, 38 Park Row, N. Y. C.

GET our latest Aeroplane Book containing full information about "Ideal" Model Aeroplanes, parts, plans, etc. 5c postpaid. Ideal Aeroplane Co., 82 1/2 West Broadway, N. Y.

HOW to Make a Biplane Glider—Our book "Amateur Mechanics No. 2" contains a complete detailed description of how to make one. Price of book 25c postpaid. Popular Mechanics Book Dept., 6 N. Michigan Ave., Chicago.

BUILDING and Flying an Aeroplane—160-page handbook covering the building of small models and full-sized gliders and machines. In both biplane and monoplane models the well-known Curtiss and Bleriot types are followed. Fully illustrated with detail drawings. Price, \$1 postpaid. Popular Mechanics Book Dept., 6 N. Michigan Ave., Chicago.

MODEL Aeroplanes—materials, supplies. Motor-driven Scout Monoplane. Submarine diving boat. Send 2c postage for full free catalogue. Wading River Mfg. Co., Wading River, N. Y.

## BOOKS AND PERIODICALS

MATHEMATICAL Hit of Century—"Comparative Cancellation Calculator." Solves all Arithmetic and Geometrical problems with but one simple operation. An eye-opener. Easily learned. Easily applied. 145 pages. \$1.00 postpaid. Refunded if dissatisfied. Circulars free. Herrick & Horton, Publishers, Princeton, Ill.

REESE Publishing House, Mt. Pleasant, Pa., can supply any book published. Catalogs free.

SPANISH Books—every kind—bargains—catalog free. Bernardo Lopez, Kansas City, Mo.

155 VALUABLE Formulas, Tricks, Illustrations, and Household Hints in our interesting magazine for two issues. Sent complete for 10c. Popular Supply House, 49 23rd Ave., Paterson, N. J.

FREE circular describing interesting book. Dunbar, Rowena Street, Boston.

"HOUNDS AND HUNTING"—Monthly Magazine of outdoor life; has five Beagle, Fox and Coon Hound Departments. Sample free, \$1.00 year, Address "Hounds and Hunting," Desk P. Decatur, Illinois.

BINDER for Popular Mechanics magazines. Best adjustable magazine binder on the market made especially to hold any number from one to six copies of this magazine with name "Popular Mechanics" in gold letters on front cover. No laces or cutting or perforating of pages necessary. Simple, unique adjustment; handsome, durable and neat. We buy in quantities and can offer our readers this regular \$1.50 binder for \$1.25, all shipping charges prepaid. Address Popular Mechanics Book Dept., 6 N. Michigan Avenue, Chicago.

BOOKS for Sale. Automobile Owner's Guide and Chauffeur's Manual for Examinations 25c. Energo's Physical Culture Book prepaid 25c. For Books on any Subject at the right price, write Goldman's Book Store, 424 S. Dearborn St., Chicago, Ill.



**COMMERCIAL REGISTER**—The 25th annual edition of Hendricks' Commercial Register of the United States for Buyers and Sellers, which has just been issued, rounds out a quarter of a century of usefulness by this standard publication. The work is especially devoted to the interests of the architectural, contracting, electrical, engineering, hardware, iron, mechanical, mill, mining, quarrying, railroad, steel, and kindred industries, containing about 350,000 names and addresses, with upward of 45,000 business classifications. Full lists are included of producers, manufacturers, dealers and consumers, listing all products, from the raw material to the finished article, together with the concerns handling these products, from the producer to the consumer. There are 1,512 pages of text matter and the index of contents numbers 139 pages, covering over 50,000 trade references. The list of trade names, brands, titles of identification, etc., is published for the first time and numbers 292 pages. This list furnishes ready reference for purchasing agents and prospective buyers to distinctive products manufactured by firms listed in the work. Price prepaid. S. E. Hendricks Co., Inc., Publishers, 2 West 13th St., New York, N. Y.

**MAGAZINES** at rock bottom prices. Send today for our free catalog. S. C. Hanson Magazine Agency, 4926 Kinzie St., Chicago.

**USED BOOKS, Bargains, Catalog.** Higney's, A-2441 Post, San Francisco. (Books bought.)

**YOU** Automobile Repairman, Motorist, Dealer, Chauffeur, Student, Demonstrator, Owner, Sales Agency, and Garage Owner. Here's a booklet free to you. It shows how to make your work easy and better and save money. Auto Electric Systems Publishing Co., Electric Department, Dayton, Ohio.

**HOME Study Books, Catalogue free.** Drift, 651 East 71st, Chicago.

**UNDERGROUND Treasures, how and where to find them; descriptive circular 2c.** Model Co., Morton Bldg., Chicago, Ill.

**BOYS**—Big 9x12 boy's magazine one year 10c, Canada 20c. Dandy stories, mechanics, stamps, electricity. Country Boy Magazine, 2214 Mallers Bldg., Chicago.

**BARGAINS** in Books, List free. P. Isaac Co., Minneapolis, Minn.

**STENOGRAPHY** or Bookkeeping Course, \$5. Self-instructive book, 25c. Home School, B285, Nashville, Tenn.

**MODERN American Railway Practice, 10 volumes, 3/4 leather, new, cost \$24.00. Our special offer \$7.50.** Lyceum Book Exchange, Minneapolis, Minn.

**ROPE-SPLICING**—Knots, Hitches, 100 Illustrations 20c. G. Brady, 744 Jackson, Chicago.

**SECOND-Hand Books** for sale, 20c; some cost \$5.00 new; Medicine, History, Law, Science, Chemistry, Engineering, Text Books, Fiction; interesting reading for cold, dreary winter evenings; circular free; McCarthy, 1236 Arthur Ave., Chicago, Ill.

**ENGINEERS'** questions and answers for license by Hobson, for twenty-five cents, postpaid. Send stamps. Reilly's Book Store, Philadelphia, Pa.

#### EDUCATIONAL AND INSTRUCTION

**MAKE** an adding machine at home in a few hours of your spare time. One that adds or subtracts whole numbers, fractions and decimals. Absolutely correct. Material can be purchased at any hardware store for very small cost. Very simple and easy to make. Pin a dollar bill to your address and receive complete instructions and easy to understand drawings. The Snyder Drafting Department, Canton, Ohio.

**HEAD-OLGY**—How to select honest, efficient help, choose suitable occupation, select a good helpmate, or partner in business. Lots of other things. Five personal questions answered, and one illustrated lesson, 50c. Head-Ology School, 404 Times Bldg., Chicago.

**WANTED**—New Ideas. Write for list of Patent Buyers and Inventions Wanted. \$1,000,000 in prizes offered for inventions. Our Four Books sent free upon request. Victor J. Evans & Co., 167 Ninth, Washington, D. C.

**LEARN** Assaying. New method. Guaranteed. E. W. Meyers, Niles, Calif.

**GIVLER'S** Shortest, Easiest, most accurate, rapid Shorthand. Learned in short time by mail. Instructions through text, \$10. W. H. Givler, Tampa, Florida.

**BOOKKEEPING, Expert Auditing, Rapid Arithmetic, 50c.** Garfield Commercial School, 1016 Germantown Ave., Philadelphia.

**MECHANICAL Drawing Course.** Booklet free. Foundation Course, Washington, New Jersey.

**LEARN** to read French or Spanish. A. M. Smyth, Germantown, Pa.

**BE** a Finger Print Expert—\$25 to \$50 a week in this new and fascinating profession. Write—find out how you can learn at home to supply the big demand for finger print experts in banks, big factories, detective agencies, etc. Special limited offer—write while it lasts. Evans University, Finger Print Dept., Room 1191, 1810 Wilson Ave., Chicago, Ill.

**IDEAL Atlas**—Just Published—Contains large scale maps, yet is a book of handy size. Has special maps of all war zones in addition to all regular maps found in a good atlas. Is self-revising, that is, contains a certificate entitling the purchaser to a supplement of new maps after the war is over. Genuine flexible leather binding, 512 pages, 256 pages of maps, 256 pages of text. Price \$1.65 postpaid. Popular Mechanics Book Dept., 6 N. Michigan Ave., Chicago.

**WAR Atlas**—Large 20-page (11x15 in.) Atlas of the War in Europe, containing large colored scale maps of the Battle-ground, showing Europe, Austria, Serbia, Germany, England, Belgium, France, Russia, Italy, Greece, the World, etc. Special data showing comparison of armies and navies involved, pictures of rulers, etc. Price 30 cents postpaid. Popular Mechanics Book Dept., 6 N. Michigan Ave., Chicago.

**LEARN** Drafting—One of the most practical subjects, and indispensable in many occupations. Individual study at home without an instructor may be successfully carried on with the aid of our book, "A Practical Course in Mechanical Drawing," 160 pages, 157 drawings, Cloth. Price 50 cents postpaid. Popular Mechanics Book Dept., 6 N. Michigan Ave., Chicago.

**LEARN** by mail to be a manufacturers' demonstrator. Write today. Learn about this brand new profession. An uncrowded field. Every big manufacturer needs demonstrators. Both men and women. Salary \$75 to \$125 per month to start. Travel all over. Learn how to demonstrate and sell scores of food products, wearing apparel, household articles—everything. The best stepping stone to successful salesmanship, paying up to \$25,000 per year. Write today. Be ready for some of the early positions. Great opportunity with a brilliant future in a field where the demand is big. Write. Just a postal will do. Simply say "Send me the book 'The Uncrowded Profession.'" We will mail it free and prepaid at once. But write today. Manufacturers' School of Demonstration, 141 E. 4th St., Room 51, Cincinnati, Ohio.

**ARTIFICIAL MARBLE, sanitary flooring, complete instructions, \$1.** Ornamental casting, concrete, plaster, papiermache, decorations, garden furniture, statuary, rubber moulds, electrometallurgy. Particulars, 200 illustrations free. Mahler, D-721 Woodland Ave., Woodhaven, L. I., New York.

**SHORTHAND**—International Unigraph is the most rapid readable system and most quickly learned. Send for particulars. Unigraph School, CL271, Princeton, N. J.

#### TRADE SCHOOLS

**ELECTRICITY, Plumbing, Bricklaying, Mechanical, Architectural and other Drafting Courses.** Motion Picture Operating taught by practical work. Largest, best equipped practical trades school in America. Short time to learn. Small cost, easy payments. Write for big illustrated book; it's free. Coyne National Trade Schools, Dept. 8191, Chicago, Ill.

**AUTOMOBILE School**—Learn in 6 weeks. Thorough—Practical—Free catalog. National Automobile Training Association, 2814 No. 26th St., Omaha, Neb.

**HILES'** Watchmaking and Engraving School, the largest and best-equipped school in the West, 717 Market Street, San Francisco, Cal.

#### TELEGRAPHY

**TELEPHONE** Men in demand, salaries highest. Easily learned by new method. Particulars free. Graphic Telegraphy, 5833 West Circle Ave., Chicago, Ill.

**TELEGRAPHY**—Morse and Wireless—also Station Agency taught. Graduates assisted. Cheap expense—easily learned. Largest school—established 42 years. Correspondence courses also. Catalog Free. Dodge's Institute, 15th St., Valparaiso, Ind.

**TELEGRAPHY**—Morse and Wireless—taught at home in half usual time. The Omnigraph Automatic Transmitter combined with sounder or buzzer sends you messages, any speed, just as expert operator would. Used by U. S. Gov't to examine all applicants for licenses. Trifling cost. Catalog free. Omnigraph Mfg. Co., 41-G Cortlandt St., New York.

#### WIRELESS

**WIRELESS Set, How to Make**—66-page book telling how to construct at small cost an outfit suitable for transmitting four or five miles. Price, 50 cents, postpaid. Popular Mechanics Book Dept., 6 N. Michigan Ave., Chicago.

**MAKING Wireless Outfits**—Become a wireless constructor. This book tells how. 61 pages, 27 illustrations, 25c postpaid. Popular Mechanics Book Dept., 6 N. Michigan Ave., Chicago.

#### PICTURES, POSTCARDS, PENNANTS

**POSTCARDISTS** and Movie Fans' Greatest Exchange. Membership listed immediately, 10c. Universal League, 1809 Rudy, Harrisburg, Penna.

**UNTED** Post Card Exchange, Phila., Pa. Membership 10c. It's different.

**HIGH grade pennants and pillow tops** made to order. Catalogue free. Witt Bros., 419 Iglehart, St. Paul, Minn.

**JOIN** the Rose Postcard Society, 651 East Morrison St., Portland, Oregon. Membership 10c.

**6x18 VIEW** of largest miniature factory in world, 25c; small views 6 for 10c. Sullivan, 595 State St., Bridgeport, Conn.

**WASHINGTON** Views, ten for ten cents. Hunt, 213 Seaton Pl., N.E., Washington, D. C.

**FUN**—Pleasure—Amusement. Membership 10c. United Post Card Exchange, Phila.

**JOKEES!** Your message copied on postcard, mailed Chicago, 5c; 6 for 25c. Warwick, 5819 Race Ave., Chicago.

**COLLEGE** and State Pennants, 9x28 inches; 15 assorted 50c; 6 assorted 25c. Postpaid. Hood-Lynch Co., Great Falls, Mont.

**IF** you really want to exchange postcards, try our splendid club. Lists circulate in many countries. Membership, 10c. Halcyon Club, Box 133, Erie, Pa.

**MEXICAN** revolution, actual photographed postals. Executions, fighting, noted characters, Villa, Carranza, Madero, Bandits. Set, 25c; many varieties. The Willing Sales Co., El Paso, Texas.

**CROSS-SECTIONAL** view of ocean liner "Britannic," showing interior arrangement of ship in colors, size, 14x20 inches, on heavy plate paper for framing or hanging. Very interesting. Reproduced from front cover design of July, 1914, Popular Mechanics. Will be sent postpaid to any address in the world on receipt of 4 cents in stamps to cover packing and mailing. Popular Mechanics Magazine, 6 N. Michigan Ave., Chicago.

**HIGHGRADE** assorted postcards, birthday, greeting, etc., 12 for 10c, 100 for 60c. Big novelty, magic goods and book catalog free. Great Novelty Co., 3531A Madison St., Chicago, Ill.

**PRETTY** view cards from many cities, towns and countries. Membership and 6 pretty cards, 10c. Riverside Club, Knoxville, Md.

**RECEIVE** pretty postcards from everywhere. Join best card club. Membership 10c. Jolly Card Exchange, Decatur, Indiana.

**200 ILLUSTRATIONS** free, beautiful art casts. Mahler, K-721 Woodland Ave., Woodhaven, L. I., New York.

**FREE** Postcard photo of desert scene to every new member. Send 10c now. Sagebrush Postcard Exchange, Goldfield, Nevada.

#### CAMERAS AND PHOTO SUPPLIES

**WE** will save you money on any Camera! Name the outfit you want, no matter what make, size or style, we will positively save you 25% to 50% of the regular cost and guarantee to satisfy you completely. We deal in slightly used cameras and lenses. Every item we sell is carefully inspected by trained experts. 10 Days' Trial Protects You. Write us now for bargain list and low prices. David Stern Company, 1047 (M) Madison St., Chicago, Ill.

**ROLL** Film developed 10c. Packs 20c. Post Cards 3c. Edwin Burke, Windsor, Vermont.



**SATISFACTION** guaranteed or money back in Trilux Exposure Meter proposition. Tells instantly, accurately, and easily the correct time for all exposures. Nothing to break or lose, no confusing tables. At your dealers or postpaid \$2.00. Trilux Co., 14014 Marquette Bldg., Chicago.

**ROLL** Film developed, 10c a roll. Packs 20c each; Prints, Brownies, 2c; 1a, 3x4, 3x5 and Post Cards, 3c each. Work returned next day. Postage paid. Kodak Film Finishing Co., 112 Merchants Station, St. Louis.

**SNOW** White Fluid for opaque or for marking photo albums, prints or mounts. By request, a miniature album with twenty designs, proper pens, pen cleanser and simple directions. 25c coin or stamps. Offer open until April, 1917. J. P. Johnston, Fine Arts Bldg., Rochester, N. Y.

**SPECIAL**—Send film roll or negatives and 20c and get 6 prints and enlargement to show our high quality work. Emil Srauer, Hamilton, Ohio.

**FILMS** developed, any size, 5c. Any size prints 3c. Work returned same day. Enlargements, 8x10, 25c. Eastman Kodaks and Supplies. Address Camera Shop, Box 69, Ann Arbor, Michigan.

**DO** you take pictures? Write for free sample of our big magazine, showing how to make better pictures and earn money. American Photography, 788 Pope Bldg., Boston, Mass.

**INVENTIONS** Wanted in Motion Pictures and Photography. Special department for these classes of invention. Advice. What to Invent and List of Patent Buyers sent Free. Victor J. Evans & Co., 159 Ninth, Washington, D. C.

**"CAMERA** Kinks and Photo Fads." Tells how to make transparent photos on watch caps, chinaware, etc.—Perfectly tilted negatives—Opaque photos—Firelight photos—Instantaneous developer. Direct positive photos—Magic photos—Photo stationery—and other interesting photographic kinks and formulas. Price 25c postpaid. E. Greenhalgh, 2961 Gale Street, Indianapolis.

**FILMS** Developed Free, perfect prints, modern up to the minute methods. We do the best work in this the Photo City. Films developed absolutely free when we make the prints. No matter where you live send us your films. We return all work promptly by parcels post. Bryans Drug House, Rochester, N. Y.

**DOUBLE** your pleasure in picture-making by fitting to your camera a Wollensak lens and shutter. Send for complete descriptive catalogue. B. Wollensak Optical Co., Rochester, N. Y.

**CAMERAS**—Graflex, Kodaks, Lenses. Save 20 to 50%. New or used Cameras Guaranteed. Any make. Acme Camera Exchange, Detroit, Mich.

**YOU** want good pictures—then use "Jongho Quality Developing Service." Rolls developed 10c. Printing 2 1/4 x 3 1/4—3c; 2 1/2 x 4 1/4 and 3 1/4 x 4 1/4—4c; 3 1/2 x 5 1/4—5c; unmounted 8x10 enlargements, 25c. 100 postcards from any 4 negatives. 2c. Jones Photo Co., Jamaica Plain, Mass.

**FILMS** Developed, 10c, all sizes. Prints, 2 1/4 x 3 1/4, 3c; 3 1/4 x 4 1/4, 4c. We give Profit Sharing Coupons, 24 hour service. Work guaranteed. Send negatives for samples. Girard's Commercial Photo Shop, Holyoke, Mass.

**BIG** Money Saved on Photographic Lenses and Apparatus—goods exchanged; repairing done. Ralph J. Golsen, 5123 Kenmore Ave., Chicago, Department P.

#### MOTION PICTURES

**MOTION** Picture Business. We start you. Complete outfit, including film, \$100 and up. Big list rebuilt machines; films \$2.50 reel. Lyric Film Supply Company, Terre Haute, Indiana.

**WRITE** Moving Picture Plays; constant demand; big prices paid; past experience or literary ability unnecessary; details free. Gliss Co., 287 Whiteman St., Cincinnati, Ohio.

**FILMS** for sale cheap. Gordon, 92 Griswold St., Detroit, Mich.

**FOR** Sale, Edison Home Kinetoscope with eight reels of film 50c. Victor Portable Stereopticon \$20. Victor Portable Moving-Picture Projector \$60. Above apparatus shown-works only. Literature furnished. F. E. Slocum, 406 Main St., Peoria, Ill.

**HOW** to write Photo-plays—a new volume devoted to Motion-Picture Playwriting. Contains model scenario, list of 50 buyers, and all information necessary. 35c postpaid. Photoplay Publishing House, 4838 Champlain Ave., Chicago.

**PHOTOPLAYS** in demand. Make extra money. We show you how. Details free. Rex Publishers, Box 175 H-10, Chicago.

**MAKE** Money Writing Moving-Picture Plays. Constant demand. Correspondence course; literary ability unnecessary. Write for free booklet, "How to Write Moving-Picture Plays." Universal Publishing Co., 305 Fergus Falls, Minnesota.

**MAKE** a complete Motion Picture Camera and Projector from instructions given in our book Amateur Mechanics No. 4. Full details given. Not hard to construct. Worlds of enjoyment taking and exhibiting subjects dear to the heart. Price of book only 25c, postpaid. Popular Mechanics Book Dept., 6 N. Michigan Ave., Chicago.

**WRITE** for free catalog of best books on writing and selling photoplays, short stories, poems. Atlas Publishing Co., 804, Cincinnati.

**LANTERN** Slides, for all purposes; best grade of work, prices reasonable, quick service. United Print Co., 312 S. Hamilton, Chicago.

**ARE** You a Movie Type? Many of the greatest stars were discovered by accident. You want to know if you have the natural qualifications that bring \$50,000 salaries. The book Motion Picture Acting tells you this, also 191 screen favorites show you how they register 499 human emotions. Use of cosmetics, costume requirements and color schemes also treated. Price leather \$1.10, cloth 75 cents postpaid. Popular Mechanics Book Dept., 6 N. Michigan Ave., Chicago.

**MOTION** Picture Operation, Stage Electric and Illustrations—The only practical handbook and guide published for motion picture operators, theater electricians and managers. A thoroughly practical and useful book, covering the subject comprehensively. Pocket size, leather, 393 pages, fully illustrated. Price \$2.00 postpaid. Popular Mechanics Book Dept., 6 N. Michigan Ave., Chicago.

**MOTION** Picture Films for sale, \$3 reel up. Box 417, Montpelier, Vermont.

**BIG** Profit Nightly—Moving Picture Business—small capital starts you, easily accomplished. Teach you—furnish everything. Ralph J. Golsen, 5123 Kenmore Ave., Chicago, Dept. M.

**MAKE** Big Money in moving-picture business. We start you and furnish guaranteed outfit on easy payment plan. Easy to accomplish. Catalog free. Monarch Film Service, 228 Union Ave., Dept. P, Memphis, Tenn.

#### BUSINESS OPPORTUNITIES

**\$50** To \$100 a day can be earned with a Long Crispette Machine in any town. Machine a wonder. Makes Crispettes—a new, delicious popcorn confection. Sells at 5c a package—almost 4c net profit. Everybody buys at sight—nickels roll in. All you need is one machine and good location. No experience necessary. Investment small, returns large. Write at once for free book "Dollars & Sense"—a valuable guide to wealth and independence—a start to the ownership of a store of your own. Don't wait. Send postal today. Address, W. Z. Long Co., 1237 High St., Springfield, Ohio.

**MAKE** money in spare time with my up-to-date plan. No capital. Experience unnecessary. Longacre, 215 Bromley Bldg., Omaha, Nebr.

**ENTER** a new business. Earn \$3,000 to \$6,000 yearly in professional fees making and fitting a foot specialty, openings everywhere, with all the trade you can attend to; easily learned by anyone at home in a few weeks, at small expense; no further capital required, no goods to buy, job hunting, soliciting or agency. Address Stephen-Laboratory, 11 Back Bay, Boston, Mass.

**BUILD** a profitable business of your own. Let us start you in the collection business. No capital needed; big field. We teach secrets of collecting money; refer business to you. Write today for Free Pointers and new plan. American Collection Service, 101 State Street, Detroit, Mich.

**FORTUNES** made. Fully explained in book "Fur Farming," 267 pages, 50 illustrations, 70 cents. A. R. Harding, Columbus, Ohio.

**BIG** Incomes making crayon portraits at home, by my self-culture course; small fee. Booklet free. DeLana Walton, L-29, Prairie City, Ill.

**MAKE** and sell something. Good profits. I will send you booklet for a two-cent stamp. Perry Gosley, A114, Frankfort, Indiana.

**ADVERTISE**—25 words in 100 monthlies \$1.25; 100 weeklies \$2.50; 40 Sunday papers \$10. Cope Agency, St. Louis.

**LARGE** hardware manufacturer desires to manufacture marketable articles, patented preferred. Must be meritorious and profitable. Not necessarily tools, yet must be confined to hardware line. State number and date of patent, cost and selling price, and give model or sketch. H. C., Room 906, 78 E. Madison St., Chicago.

**PROFITABLE** Business—We furnish the ingredients for a few cents that will make one quart, superior Blue-Black Ink, acid-proof, water-proof, and does not corrode pens. Sells at 50c or 75c. Send 25c for trial quart, and special wholesale price. Pen-Penn Ink Co., Haddonfield, N. J.

**"HIRE** Yourself as Boss." Big corporation will back you in a money-making mail-order business selling guaranteed, quick sale goods. Start at home or at your office in spare time. Very small investment will prove the selling plan a winner. No stock to carry, as we will ship direct to your customers if you wish. Handle everything by mail; no interference with your regular work. Experience unnecessary. My valuable instructions telling you just what to do and how to do it are free. Write for instructive booklet, "Forceful Facts." It's free. Wm. J. Dick, Mgr., Dept. E-10, 20 W. Lake, Chicago, Ill.

**PLASTOGRAPHY**: Nothing so engaging and profitable; "Plastography" instructions \$2. A model or mould of President Wilson or Lincoln sent free with your order. P. B. Spahr, York, Pa.

**INVENTION** of Century; Woodpulp Milk Bottle; basic patents; honorable management; probably create monopoly milk bottle trade; write for prospectus. Home Securities, First National Building, Oakland, California.

**PHOTOPLAYS** in demand. Make extra money. We show you how. Details free. Rex Publishers, Box 175, H-9, Chicago.

**DOLLARS** yearly in your backyard. No ginseng, mushroom dope. New ideas. Investigate. Particulars free. C. Metz, 313 East 89, New York.

**COMPETENT** Chemical Advice reduces costs, improves products, bridges difficulties. Analyses are inexpensive. We have nothing for sale but our services. Write for information, advice, prices. Formulae. Industrial Laboratories, New Orleans.

**FREE**—Descriptive Booklet—1600 Plans, Formulas, Trade Secrets, Opportunities. Northern, 208 North Fifth Avenue, Chicago.

**MAKE** any color paint, enamel, fumed oak stain, floor wax, auto body polish, metal polish, liquid celluloid, solid alcohol, window frosting, etc. Formulae \$1.00 each. Guaranteed. Paint Chemistry Co., Box 20, Indianapolis, Ind.

**WE** are confident through the intellectuality of Popular Mechanics' readers to close all United States territory at once. An extraordinary magnanimous business opportunity. Experience unnecessary. Teach, equip, cooperate. City territories are mint. Kulekbecker Contracting Company, 1547 Broadway, New York City.

**MERRY-GO-ROUND** and Ferris Wheel, big bargain for both "MooreMade" Striking Machines, greatest money earners. Catalogue, Moore Bros., Lapeer, Michigan.

**"BOOSTER"** may contain the money making plans, ideas, suggestions and information you need! Published since 1909. Send 10c for copy and make more money! Booster Magazine, Northwestern Building, Chicago.

**CONDUCT** a profitable Candy Kitchen; very small capital required; booklet free. Kennon School, 509 Wells St., Dept. A, Chicago.

**\$30-\$60** PER day made by owners of Sugar Puff Waffle Machines; makes delicious confection, creating sensation in vacant store windows, lobbies, 10-cent stores. Particulars, staggering testimony. Windhorst-Walker, 1208 Pine, St. Louis, Mo.

**MANUFACTURERS** want new inventions. I secure valuable patents and help make your invention a success when patented. Send for booklet "Pointers about Patents." Lester Lyman Sargent, 702 9th St., Washington, D. C.

**FORMULA** Specialist will send good salesman working formulas for money-making specialties. Be your own manufacturer and make big profits. State what you want. Particulars, Usher Smith, Analytical Chemist, St. Paul, Minn.

**20,000** FORMULAS, Recipes, 30p. volume, \$1. 3,000 valuable trade secrets, formulas, 368p. volume, 40c. 1,000 selected formulas, 110p. volume 25c. All three \$1.50. Satisfaction guaranteed. Ideal Book Shop (K-1), Irving Station, Chicago.



**COMPLETE** Course in manufacturing candy and popcorn, one dollar. Anyone can learn. McDonald, Box 333, Gallatin, Mo.

**INVENT** Something. It may bring wealth. Free book tells what to invent and how to obtain a patent through our Credit System. Waters & Co., Succeeded by Talbert & Parker, 4102 Warder Bldg., Washington, D. C.

**LEARN** to make picture moulding; easy to make the most beautiful designs. 50¢ per foot framing made for 5¢. Make your home artistic or make money supplying your friends. For information, E. L. Wallace, Station H, Montreal, Canada.

**WHY** pay more than \$2.00 for dyeing suits, overcoats and dresses? No crocking. Best dyes used, quick service. Return charges prepaid to all parts of United States. Royal Dye Works, Meriden, Conn.

**LEARN** the "Practical" Advertising Business and become independent. I teach you how to establish yourself without capital, and furnish you original plans and methods to work upon; rare opportunities; booklet free. Dawson, Avenue 3, Stockton, California.

**FORTUNES** in this! If you think all advertised plans are impractical or misrepresented, get mine and be undeceived! Business permanent and profitable. Easily worked during spare time; no canvassing. You can start with less than \$10. Plans with samples, 25¢—refunded if dissatisfied. Circular free. Andrews, 2115 Cornelia, Chicago.

**MANUFACTURE**, Sell Fibro-Vac Guaranteed Puncture Plugger—The real success. Formula supplied for this and Carbo-Cole, the most efficient of all Gas Tonics. Increases mileage—eliminates carbon—89% profit. Particulars and latest big formula list of Automobile Specialties. Stamp. Miller, Chemist, Tampa, Florida.

**CHEMICAL** Analyses, accurate, new chemical formulas, guaranteed, duplicates of all commercial products, formula list free. Pele's Laboratories, 1517 S. 57th Ave., Chicago, Ill.

**LEARN** the real estate business. Our complete instruction book teaches: listing, appraising, management, salesmanship, insurance, brokerage, advertising, renting agency, forms, etc. 121 subjects. Excels \$20.00 correspondence course. Buckeye cover. 75¢; silk cloth, \$1.00, postpaid. Catalogue free. Realty Book Company, Dept. 29, Cleveland, Ohio.

**BIG** money in promoting inventions. Write Adam Fisher Mfg. Co., 2061D Railway Exchange, St. Louis, Mo.

**MAIL** Order Dealers. Let the 4 in 1 coupon plan increase your profits. Sell valuable instruction systems by cut price coupon under money back guarantee. Big margin. Small selling expense. Complete plan, sample coupons and bargain bulletin sent on request. Mail Dealers' Coupon System, 519 So. Dearborn St., Chicago.

**PRINTING** trade learn by mail. Northwestern, 1048 N. Lawrence, Chicago.

**DON'T** miss this "Winner" Particulars free. Hingston, Whitesboro, N. Y.

**EARN** good money at home silvering French mirrors; no capital. Free instructive booklet. D. Mallin, 254 Pacific, Brooklyn, N. Y.

**INCORPORATE**—Congress laws for D. C. and all States; cheap, raise money easily, advice free. Collections and legal matters everywhere. All courts and Government Departments. U. S. Legal Corporation, Washington, D. C. Representing \$1,225,000,000.

**ADVERTISERS**, Mail Dealers. Our New Rate Book lists 2,000 Principal Publications, rates, circulation. Includes 30 Mail-Order Plans. Free. Dearborn Advertising Agency, 210 Franklin Bldg., Chicago.

**MANUFACTURERS**, Promoters and Patent Buyers are invited to write us stating the line of invention in which they are interested, as we can supply their wants in any class of patents. Victor J. Evans & Co., 102 Ninth St., Washington, D. C.

**INVENTORS**: We develop and perfect inventions, make models, dies, tools. Metal stamping and special manufacturing. Gering Bros., Lion Bldg., Cincinnati, O.

**MOULDS**. No glue, pure rubber. Thousands of statues made with one Rubber Outfit. Instructions free. Roth, A 45 Frost St., Brooklyn, New York.

**WE** start you in business furnishing everything; men and women make handsome income weekly operating our "New System Specialty Candy Factories" home or small room anywhere; no canvassing. Opportunity lifetime; booklet free. W. Ragsdale Co., East Orange, N. J.

**LEARN** to collect money. Good income; quick results. Send for free booklet, "Skillful Collecting." Collectors' Association, Long Street, Newark, Ohio.

**INDEPENDENCE** and fortune quickly attained in the Manufacturing Mail Order business. I furnish Formulas. Manufacturing Processes and Trade Secrets in all lines. Sold under positive guarantee; 18 years' practical experience. Revision and improvement of Formulas and Processes—reduction of manufacturing cost—utilization of waste materials, etc., a specialty. Booklet, Formula List, and Valuable Information Free. W. I. Cummings, Ph. D., 127 Standard St., Syracuse, N. Y.

**START** an original mail-order or parcel-post business. Honest, independent, small capital. New methods. Big money. Clement Moore, Business Specialist, New Egypt, N. J.

**FORTUNES** in Food Products; Product now selling in 35 States; \$25 invested now may yield big returns. Particulars free. Home Securities, First National Building, Oakland, Cal.

**PATENTABLE** Ideas Wanted—Send for 3 free books. K. B. Owen, 30 Owen Bldg., Washington, D. C.

#### BUSINESS FOR SALE

**BOWLING** Alley and Poolroom, brick building 39'x109', electric light, furnace heat. Only alley in town of 1200 people. Brings 5% clear. Going farming, will sell at a bargain. Geo. W. Seaforth, Box 188, Wolseley, Sask., Canada.

**ICE** and Ice Cream Factory—Made this season 650 tons ice, 18,000 gallons cream; a money maker. Wish to retire account health; half cash; balance 7%. G. R. Dodds, Superior, Nebraska.

#### TO MANUFACTURERS

**REPUTED** Sales Organization will consider good paying proposition for Canada. Cash Dealings. National Specialties, Power Building, Montreal, Can.

**WE** want good mail-order articles to sell through our agents or direct. Give lowest price. I. K. Matchulis, Gen. Del., Racine, Wis.

#### MAIL ORDER SUPPLIES

**MAIL** Dealers, add Watch Circulars; large profits, particulars. Prockter Jewelry Co., Gary, Ind.

**ART** Photos of moving-picture stars; latest novelty. 10 samples 10¢. Ad. Smith, 2114 First Ave., Seattle.

**INCREASE** your sales. Place your proposition before the readers of "Cartoons Magazine," 20,000 copies guaranteed every month. Classified rate 5¢ per word. Mail in a trial ad today. Cartoons Classified Dept., 78 E. Madison St., Chicago.

**SELL** Joker's Novelties! 16 samples, 10¢. Chambers Works, Plainwell, Mich.

#### FOR ADVERTISERS

**ADVERTISING** Pencils. Stamp brings sample. Graybill & Co., Lancaster, Pa.

**TWENTY** words in ten big Sunday papers, \$2.11 extra words, 10¢. Other snaps. Best lists—lowest rates. Stanford Agency, Canonsburg, Pa.

**UNITED** Post Card Exchange, Phila. A trial convinces. Rate 1¢ per word.

**YOUR** ten-word adv. in our 9x12 magazine, reaching 50,000 boys, for 50¢. Extra words 5¢. Country Boy Magazine, 2775 Mallers Bldg., Chicago.

**IT'S** Different—1¢ per word. United Post Card Magazine, Phila.

**ADVERTISERS**—Here's your opportunity. Your proposition placed before the readers of "Cartoons Magazine" for only 5¢ per word. Circulation 20,000 copies guaranteed. Send a trial ad for our next issue. Cartoons Classified Dept., 6 N. Michigan Ave., Chicago, Ill.

#### COLLECTIONS

**COLLECTIONS** anywhere. Commissions only when successful. Beacon Collection Agency, 23 Cedar St., N. Y.

#### ART AND ADVERTISING SERVICE

**A FORCEFUL** Profit-Pulling Advertising Service; sales letters, folders, booklets, that win big results. Relate your problem—Now! Satisfaction guaranteed. Harry Stern, 1060 Gaylord, Denver.

**INCREASE** your business by using good illustrations. Let us make your mechanical or commercial drawings, cuts for circular, magazine or catalogue advertising. Highest quality workmanship guaranteed. Reasonable prices. Send sketch or sample for estimate. The Snyder Drafting Department, Canton, Ohio.

#### BUSINESS SERVICE

**INCORPORATE**. Our lawyers do the work, saving you time, annoyance and money in incorporating under the most liberal laws of Arizona. Laws and forms free. Southwestern Securities & Investment Co., Box D488, Phoenix, Ariz.

#### AGENTS WANTED

**WANTED**—High Grade Specialty Salesmen: We have the newest and biggest profit producing device known to modern merchandising; all-electric popcorn machine; big Department Stores, classy Drugists, Cigar Stores, Movie Shows, Confectioners, Bakers, and many other live merchants operating the Lek-Tro as an adjunct only, are clearing from \$3 to \$10 a day net cash profit on it—no gas, gasoline or steam; occupies only five square feet of floor space and is so handsomely constructed that it enhances the finest surroundings; simple turn of an electric switch starts the whole operation; as little trouble and loss of time as a candy or cigar counter, and five times as profitable. Minimum sale of six machines per month means over \$550 to you—some of our present force are averaging over \$1,000 monthly. To the first two or three real "live wire" salesmen who will give us all their time and otherwise measure up to requirements, we offer splendid virgin territory with liberal contracts for exclusive selling rights therein. Remember! The Lek-Tro is not only a time and labor saver, but commences to earn big cash profits for your buyer the moment it is installed. You must answer quick; first assignment is to have choice of territory. Lek-Tro Sales Company, Inc., Logansport, Ind.

**AGENTS**—500% profit—\$20.00 to \$100.00 a week. That's what our agents are making selling our new metallic Sign Letters for office windows, store fronts and glass signs of all kinds. No experience necessary. Any one can put them on and make money right from the start. One agent says: "Have already put up 14 signs in this little burg and more in sight. Your letters are the best thing I have seen in years. Will soon be in a position to buy in 5,000 lots." Another says: "I am getting all the work I can do and the letters have given entire satisfaction everywhere." We are daily receiving such letters from our agents. This is the only field not overcrowded. There is a big demand for window lettering everywhere. You can sell to near-by trade or travel all over the country. Write today for a free sample and full particulars. Metallic Letter Co., 407 N. Clark St., Chicago, U. S. A.

**TAILORING** Agents Wanted—Big complete sample outfit and case, nearly 300 large cloth samples, 3 piece lists and everything needed for canvassing or use in store, free to live agents. \$25.00 to \$50.00 a week; may make more. Write us today for free elegant outfit to begin, cloth samples, wholesale prices, special offer on a suit for yourself and full information—see our wonderful values, beautiful fabrics and styles. Established 28 years. Every garment made to measure—everything guaranteed and express prepaid. Just send a postal. American Woolen Mills Co., Dept. 114, Chicago.

**LARGE** manufacturer wants agents to sell Aero Raincoats. Little earned \$90 in four days; Jeff earned \$100 in six days. We deliver and collect. 1916 swatches free. Act immediately. Amer-Europ-Raincoat Co., Desk P, 175 E. Broadway, New York.

**AGENTS!** Unprecedented opportunity to make good money selling wonderful Angle Lamps. Bought as soon as seen. Brilliant light below lamp where needed. 16 hours one quart oil. No shadow—smoke—odor. Crackerjack to demonstrate. Send for proposition to Dept. P, Angle Mfg. Co., 244 W. 23rd St., New York City.

**ONE** good man wanted in each small town to take orders for tailoring in spare time or as a regular business. Good profits. Get your own clothes at special inside wholesale prices. Perfect fit and satisfaction guaranteed or no pay. Wonderful opportunity, experience not needed. Beautiful sample book and fashion plates free. Banner Tailoring Co., Dept. 459, Chicago.



**AGENTS:** Make real money this year; not "paper money." Just think! Our Eradium (luminous) Articles Shine in the Dark. We manufacture a complete line so that every call can be turned into a sale. Everyone amazed at the wonderful possibilities of these goods. Our Eradium Bulb is easily attached to any light and "Locates Your Light in a Jiffy" in the darkest room. Our Eradium Crucifix showing the Christ figure in startling outline throughout the night sells to every Catholic. Our Eradium House Numbers (just out) are selling like Ford automobiles. Our Eradium Clock tells the time in the dark. Our Eradium Match Box sells like hot cakes everywhere. Garages, homes, etc. Our Eradium Switch Plate for hotels is a big seller. Write today for best proposition you ever heard of. Sole manufacturers, The Pioneer Corporation, 1259 West 63rd, Chicago.

**GENERAL Agents** capable of calling on the big trade themselves and handling canvassers for the house to house and office to office business, to sell the newest electric specialty on the market; sold everywhere there is electricity, in the home, office, factory, store, hotel; liberal profits; sales-driving sample, weighs a pound, no experience or knowledge of electricity required; shows how to use one light instead of two and get the same results; sells for \$3.50 and \$5.00 and saves the purchaser an investment of \$25.00. Write for particulars. The Handy Light Co., 159 Handy Light Block, Cincinnati, Ohio.

**DECALCOMANIA** Transfer Initials and Monograms: You apply them on automobile while they wait; cost 2c each; profit \$1.38 on \$1.50 job; free particulars. Auto Monogram Supply Co., Dept. 1, Niagara Bldg., Newark, N. J.

**SOMETHING** new and different: Share Shine for Automobiles, Furniture, etc. Fast seller. Enormous field. Exclusive territory to hustlers. For particulars and sample write Daydark Co., Desk 84, St. Louis, Mo.

**EXCLUSIVE** selling rights given for our Wonderful Triplex Folding handbag and other sellers. None sold in stores. Write for terms and catalogue. Diamond Bros., 35 West 21st Street, New York.

**AGENTS—Steady income.** Large manufacturer of Handkerchiefs and Dress Goods, etc., wishes representative in each locality. Factory to consumer. Big profits, honest goods. Whole or spare time. Credit given. Send for particulars. Freeport Mfg. Co., 59 Main St., Brooklyn, N. Y.

**RAINCOATS,** direct from factory to wearer. Agent's price \$2.65 delivered. Retail price \$5.00. Agents average six coats daily. Rainy season now here. D. Lewis Raincoat Co., Cleveland, O.

**AGENTS Wanted Everywhere—**To sell our attractive theatre Brass Poster Frames, Changeable Signs, Building Directories, Brass Signs, Brass Ballings, Bank Fixtures, Adjustable Electric Light Brackets. Big demand; easy sales. Established 1882. Newman Manufacturing Company, Cincinnati, Ohio.

**EASY,** pleasant work for Mechanics, Shop Men, Clerks, during spare hours, will add many dollars to their salaries. Also want persons who can give full time. Big wages assured. Novelty Cutlery Co., 67 Bar St., Canton, Ohio.

**\$5 TO \$15 profit a day** selling most complete line Sanitary Household Brushes for every purpose. Our own make. Your territory awaits you. Write for attractive proposition. Puritan Sales Co., Dept. M, 166 Broadway, New York.

**\$15.00 MADE** first day by 13-year-old boy with Shomescope. Woman made \$8.00 first hour. Particulars free. Shomescope Mfg. Co., 523 W. 13th St., Kansas City, Mo.

**AGENTS:** Big profits selling our New \$2.50 Automatic adding machine. Quick sales. Ten a day easy. No competition. Anyone having adding to do is positive customer. You'll be glad you wrote us. Bassett Co., 5921 Indiana Ave., Chicago.

**\$150.00 SALARY** for 80 days' work paid woman or man in each town to distribute free circulars, and take orders for White Ribbon Concentrated Flavoring. J. S. Ziegler Co., 7-P E. Harrison St., Chicago.

**AGENTS Wanted—Tolliver** Guaranteed Puncture-Proof Inner Tubes sell easily—our Agents make \$5.00 to \$50.00 a day net profits—no competition. If you wish to establish a business of your own that has unlimited possibilities for profit, write us for complete details. Tolliver Puncture-Proof Tube Co., 523-C Foster Bldg., Denver, Colo.

**\$1,000 PER Man** per county. Strange invention startles world—agents amazed. Ten inexperienced men divide \$40,000. Korstad, a farmer, did \$2,200 in 14 days. Schleicher, a minister, \$195 in first 12 hours. \$1,200 cold cash made, paid, banked by Stoneham in 30 days; \$15,000 to date. A hot or cold running water bath equipment for any home at only \$6.50. Self-heating. No plumbing or waterworks required. Investigate. Exclusive sale. Credit given. Send no money. Write letter or postal today. Allen Mfg. Co., 311 Allen Bldg., Toledo, Ohio.

**MAKE** money in spare time with my up-to-date plan. No capital. Experience unnecessary. Longacre, 215 Bromley Bldg., Omaha, Nebr.

**AGENTS** wanted everywhere, sell Feather Flowers, Clean, Pleasant, Profitable. Big Home Seller. Stores, canvassers, fairs, poultry shows, etc. Sample fifteen cents. DeWitt Sisters, R. F. D. Ten, Battle Creek, Mich.

**GARRETT** sold Twenty-Nine Spray Pump Auto Washers in Three days. Profits, two dollars each. A Square Deal. Rusler Co., Johnstown, O.

**EVERY** Home on Farm, in Small Town or suburb needs and will buy the wonderful Aladdin kerosene (coal-oil) mantle lamp; five times as bright as electric; tested and recommended by Government and 34 leading universities; awarded gold medal; one farmer cleared over \$500 in 6 weeks; hundreds with rigs or autos earning \$100 to \$300 per month; no capital required; we furnish goods on time to reliable men; write quick for distributor's proposition, and lamp for free trial. Mantle Lamp Co., 633 Aladdin Bldg., Chicago.

**STOP** here! Just out—Eisen Regulator for Ford Headlights. Selling like wildfire everywhere. Gives splendid driving light at low speed—keeps bulbs from burning out—works entirely automatically. Needed on every Ford. Big profits quick—Listen: Hopkins, Tenn., cleared \$16.25 first day. White, Michigan, \$134.00 one week. No experience or capital needed. We show you how. Sales guaranteed. Hurry, don't delay. Write now for special information. Address Eisen Instrument Co., 329 Valentine Bldg., Toledo, Ohio.

**AGENTS—Wonderful New Invention.** Every Auto owner buys. Plenty of Records. Quick Action necessary. Big money-maker. Hudson Sales Co., 536 Regal Bldg., Chicago.

**SELL** copyrighted comic advertising novelties. 15 samples 10c. Chambers Works, Plainwell, Mich.

**DEATH** Escape: New. Eagerly welcomed everywhere. Silver dime brings outfit with winning proposition. O. E. Brown, Jr., 116 W. 133rd St., New York.

**AGENTS,** \$69 a week to travel by automobile and introduce our 300 candle power coal-oil lantern. Write for particulars of our auto offer. Thomas Co., 862 North St., Dayton, Ohio.

**AGENTS—Sell Kaxo—the Epoch Maker.** Most remarkable invention for shining shoes; just out; simple, economical, eliminating wasteful cans and mussy daubers; soiled hands impossible; 10 shines 1 cent; indispensable for office, home and traveling use; sells readily to men and women; large profits; big repeater; samples postpaid 50c; refunded first order; speed means real money. Dept. O-2, H. Goselo Co., 143 Appleton St., Boston, Mass.

**AGENTS: Big Hit:** Our 5-Piece Aluminum Set is all the rage. Cheaper than Enamel Ware. Sells like wildfire. Guaranteed 20 years. Retail value \$5.00. You sell to housewives for only \$1.83. Biggest seller of the age. 9 sure sales out of every 10 shown. Others cleaning up \$10.00 to \$20.00 a day. Answer this quick to secure your territory. Div. GGS, American Aluminum Mfg. Co., Lemont, Ill.

**AGENTS,** make big money. The best line of food flavors, perfumes, soaps and toilet preparations, etc., ever offered. Over 250 light-weight, popular-priced, quick-selling necessities—in big demand—well advertised—easy sellers—big repeaters. Over 100% profit. Complete outfits furnished free to workers. Just a postal today. American Products Co., 9639 3rd St., Cincinnati, O.

**ATTENTION, Salesmen.** We want live representatives to sell a popular household novelty; retails for \$1.00; sells on sight everywhere; 100 per cent to district agents; 50 to 65 per cent to sub-agents; very little capital required; write at once for particulars; haven't time to talk to any but energetic hustlers. Egg Grip Co., 78 Clinton St., Newark, N. J.

**WOULD \$150 Monthly** as General Agent for \$150,000 corporation and opportunity to earn a Ford auto selling Stock and Poultry remedies, Dips, Disinfectants, interest you? Then address Royoleum Co-Operative Mfg. Co., Dept. 22, Monticello, Ind.

**AGENTS** make 500 per cent profit selling our Auto Monograms and Initials, Window Sign Letters, Changeable Signs, and Show Cards, 1,000 Varieties, Enormous Demand. Sullivan Co., 1123 Van Buren St., Chicago, Ill.

**233% PROFIT** selling Jubilee Spark Intensifiers to automobile owners, garages. Sure cure for Spark Plug troubles. Sells like wildfire. Brand new. Exclusive territory. Write today. Jubilee Mfg. Co., Dept. M-2, Omaha, Nebraska.

**AGENTS and Salesmen—**If you recognize "Old Man Opportunity" when you see him, send at once for proposition on Naspel, the guaranteed silver-plating polish. Nationally advertised—a household name—quick seller—large profits—exclusive territory. Send 25c for large bottle. Naspel, 116 West 52nd St., New York, N. Y.

**AGENTS—Send** for sample "Fretnot"—the wash day wonder. Be convinced you can do a whirlwind business. You can clear at least \$20 to \$100 weekly, according to spare or whole time. You don't have to talk; if she doesn't buy at sight, leave sample; she will be looking for you long before you are able to make the rounds again. Samples furnished free. Premiums for your customers. Exclusive territory granted to agents who can produce. Credit given. Don't call P. M. Motter & Sons, 3215 Warren Ave., Chicago.

**PHOTO** Pillow Tops, Portraits, Frames, Sheet Pictures, Photo Plates, Pennants. Rejects credited. Prompt shipments; samples and catalogues free to agents; 30-days' credit. Jas. C. Bailey Co., Desk A-1, Chicago.

**FAST** Selling "Kantleak" Raincoat proposition. Cooper earned \$60 in 5 days. Bridge \$88 in 6 days. We deliver and collect. New 1916 swatches free. Write today. Cosmer Mfg. Co., 125 Paige St., Dayton, Ohio.

**AUTO Owners:** We want a few live motorists who drive their own cars to introduce International Rubber Half-Sole Tires in their territory. Greatest tire-cost reducer ever offered to the motoring public. Practically sells on sight—our sales jumped 400% in ninety days. For details write the International Rubber Company, 11 West Tennessee, Denver, Colo.

**FACTORY** Agents, want Representatives in every town west of Illinois. Our representatives can become independent. Viker Outlet Company, 228 West Fourth St., Los Angeles, California.

**FASTEST** dollar seller on the automobile market. 100% to agents. Fine side line for salesmen. Live men making big money. Consumers Mfg. & Supply Co., Minneapolis, Minn.

**AGENTS,** to sell Photo Pillow Tops, Pennants, Crucifixes and all Luminous Goods. Photo Pillow Top Co., 2134 Gladys Ave., Chicago.

**MINIATURE** Japanese sword, made of bamboo, for paper-knife and penholder. Sells dozens at sight. Two samples for dime, 24 for \$1. Miyako Company, Akasaka, Tokyo, Japan. Foreign postage letters 5c.

**LUMINOUS** Crucifix—Heatless Pants Pressers: Easy to sell, carry and demonstrate. Samples \$1.00 each. Old Paducah, Paducah, Ky.

**WE** require general representatives and local agents to demonstrate and sell our individual lighting systems, portable lamps and lanterns for use in stores, homes, streets, etc., which are distinctly superior to, and more economical than, any other known method of lighting. If you wish to establish a permanent and very profitable business of your own, tell us in confidence, your business experience, age and other qualifications. Pitner Gasoline Lighting Company, 8 East Kinzie St., Chicago.

**HERE'S** money for you in the fastest self seller known. Housewives can't resist. Completes the home. Territories going. Hurry! Secure yours by writing now, asking for particulars. Franklin Co., Dept. 8, Three Rivers, Mich.

**JOIN** The Big Christy Organization. Sell Household Necessities. Unlimited Demand. Big Specialties. Enormous Profits. Apply Immediately. Arthur N. Christy & Co., Dept. 34, Newark, New York State.



**AGENTS:** A free course in General Salesmanship is given to every man of our Sales Organization. This organization is a body of successful men selling the Handy Light; that unique electrical device which cuts the cost of electric lighting in half. Sells for \$3.50 and \$5.00; is used in home, office, store, factory; weighs only one pound. Sold by demonstration. All agents furnished with well planned methods for gaining interviews. A high-grade business for a man of ability and standing in his community. General Agents preferred. Inquire for our full proposition by addressing The Handy Light Co., 198 Handy Light Block, Cincinnati, Ohio.

**NO BUS** Expanding Cuff Button, spreads two inches; Presto! slip your cuffs over elbows without unbuttoning. Lower, they close automatically. Cuffs positively stay where placed upon the forearm. Indispensable for latest style starched or soft cuffs. Neat, Durable and Guaranteed. Greatest convenience. Laundry and Shirt Saver. Sells like wildfire when shown. Fred DeWilde, Sheboygan, Wis., sold 750 pair in 13 days, profits \$345.00. Wanted: Side-line salesmen selling to the trade as well as live agents everywhere. Flexo Mfg. Jewelers, Dept. P. M., Sheboygan, Wis.

**AGENTS—Earn big money** selling "Ozone" concentrated. One quart makes twenty. Non-injurious. Non-explosive. Beats everything. Half price of gasoline. Exclusive territory. Derrick, 1126 North Clark, Chicago, Ill.

**A GOLD** mine for hustlers, nine months of the year. Food product of highest quality which saves one half the cost to householder. Sales made by sampling. Very little talk required. Men wanted to handle counties. Small capital needed. Write for particulars. Steuben Manufacturing Company, A. Bath, N. Y.

**OUR Household Specialties** are in universal demand. Every family needs and buys them. Hustlers can make over \$150.00 monthly. Samples furnished free to workers. Specialty House Co., Box 1329, Detroit, Mich.

**MANUFACTURE** Wizard Washing Tablets, latest Washing Wonder; enormous sales. Putman's Dry Cleaner, Iron Rust Soap, Radilite Washing Marvel, Non-Alcoholic Tube Flavors, Eggena (wonderful egg substitute), Pyreen Fire Extinguisher, Gas Tonic, Puncture Plugger, Hi-class Automobile Specialties. I furnish correct guaranteed formulas with plain instructions for these and all latest Agents' and Mail-Order Goods. Latest Lists, Stamp, Miller, Manufacturer's Chemist, Tampa, Florida.

**AGENTS Sell Duzwin Washing Paste.** Wonderful compound. Washes and whitens clothes without boiling, rubbing or bluing. Guaranteed absolutely harmless, 100% profit. Splendid repeater. Send for free sample and agents proposition. Duzwin Products Co., Robin St., Utica, N. Y.

**AGENTS and Salesmen:** get in on this new wonderful money-maker. "Nelson's Pinless Clothesline." Great money and labor saver. Nothing like it. Sells to every user of clotheslines. Two minute demonstration closes sale. Big demand everywhere. Write quick for attractive proposition. John Nelson, Stamford, Neb.

**MARVELOUS** new winner—the Daylite Mantle Oil Lamp! Different from all others. Better light than electricity. Five times more efficient than common lamps. Uses common kerosene. Burns over 50 hours on 1 gallon. Guaranteed five years. Elegantly finished. To show it is to sell it. Men with rigs and autos making as high as \$325 every month. No money—no experience needed. You can start on our capital. We furnish stock of lamps on credit to reliable men. Sample lamp free. Exclusive territory. Write quick for particulars free. Daylite Company, 537 Daylite Building, Chicago, Illinois.

**AGENTS—\$5** daily selling our Handy Tool, 12 articles in one. Lightning seller. Sample free. Thomas Mfg. Company, 762 North St., Dayton, Ohio.

**WILL** you work for us and make \$1.50 a day or more? Write Reed & Son, 264 Spring St., New York.

**AGENTS** make 500% profit handling Auto Monograms and Initials, Changeable Signs, Novelty Signs, and Window Letters. Catalog Free. Hinton Co., 6142 46th Court, Chicago, Ill.

**WONDER** Pickpocket Preventer. Invisible; attach any pocket. Cost small, saves you dollars. Send dime for one, or quarter for three now. Wonder Distributor, P. O. B. 360, Hartford, Conn. Agents Wanted.

**\$1,000.00** FOR your next 100 days, spot cash. New money-making invention for agents, general agents, managers. Recently invented, 1,000,000 already sold; 200 more salesmen wanted at once. Amazing automatic Compressed Air Washing Machine. Washes tub of clothes in six minutes. No cranks to turn or levers to push—no rubbing. Works like magic. Price only \$1.50—make sale at every house; 200% profit. L. Palmer, Glen Allen, Ala., put out on trial 108 machines; sold 107. Profit \$167.09. Write today. Wendell Co., 1150 Oak St., Leipsic, O.

**AGENTS:** Get an easy seller. Sanitary All-Metal Bread and Pastry Board and Rolling Pin is making big hit. Make \$25 to \$40 every week. Smith, Ohio, sold 38 one day. Profit \$19.00. Sells at sight. No talking necessary. Free Sample to Agents. Write quick for appointment and territory. Union Mfg. Co., 183 Main St., Cambridge, Ohio.

**MAKE** and sell your own Goods. Formulas by Expert Chemists. Manufacturing Processes and Trade Secrets. Formula Catalog for Stamp. Blake Mystic Company, Washington, D. C.

**AGENTS:** Sell Ford owners direct from factory lowest-priced 3500-mile guaranteed non-skid tires. Start yourself in a big repeating profitable business. Campbell Tire Company, Kansas City, Mo.

**AGENTS—Canvassing farmers** and small towns. Write Burns Mfg. Co., Cincinnati, Ohio.

**GASOLINE** Gauge for Ford Cars, Retail \$1.00. Territory open for county distributors and canvassing agents. Profits fifty-fifty. Backed by \$50,000 advertising campaign. Every Ford owner buys. Demonstrated in a jiffy. No mechanical knowledge necessary. Write for proposition. "Ever-Right" Specialties Co., 933 Real Estate Trust Building, Phila., Pa.

**AGENTS** wanted for our fast office sellers. Sample free. Joseph Cwim, 1807 Flisk St., Chicago.

**AGENTS, Sign Painters:** "Climax" medium. New invention. Revolutionizes sign lettering. Sample free. Wadhams, 90 Broadway, Brooklyn.

**WANTED—New Ideas.** Write for list of Patent Buyers and Inventions Wanted. \$1,000.000 in prizes offered for inventions. Our Four Books sent free upon request. Victor J. Evans & Co., 163 Ninth, Washington, D. C.

**NEW "4-in-1"** interchangeable sign. \$2.00. N. E. S. Co., 260 State, New Haven, Conn.

**AGENTS—\$42.00** weekly easily made selling our new household article. Sells everywhere. Sample free. Write at once, Berg Company, Dept. EL, Hendrum, Minn.

**AGENTS** wanted to sell coal-saving devices for ranges and heaters. Thousands used. Several good county managers wanted. Must be financially responsible. Some men clear \$100 week. Heated Air Co., 115 N. 11th St., Phila.

**RAINCOAT** manufacturer desires agents to sell consumer high-grade made to measure raincoats, quality guaranteed. Big money for live agents. Rainproof Co., Findlay, Ohio.

**AGENTS:** 50 calling cards 10c. F. Shepard, Rome, N. Y.

**AGENTS:** You can make big money taking orders for our fine made-to-measure clothes, so write quick for 60 beautiful cloth samples, 32 smart styles in rich colors, wholesale and retail price lists, lowest prices and best offer to agents, \$5.00 to \$10.00 a day easy. Big outfit, over 250 samples free to live wires. No experience needed—no capital. We furnish everything free—pay postage or express charges—back you, boost you, show you how and clearly explain everything. Costs nothing to try. Let us make you a stylish suit to measure to prove our fine quality and style. Send postal or letter today. Paragon Tailoring Co., Dept. 114, Chicago.

**STATE, County, City Agents** to sell Ford owners 100% efficient, absolutely necessary device, hundreds in use, highly recommended; instantly demonstrated, quickly sold; generous commissions, exclusive territory; state experience and qualifications first letter. Lane Motor Device Co., San Diego, Calif.

**AGENTS—500%** profit. Sign letters for store and office windows. Samples and particulars free. Inter State Letter, 2453 N. Halsted St., Chicago.

**ANYBODY** can sell them, because everybody wants one; Fountain Shoe Dauber; big profits; sample 25c; drop your old dead line. Patent Products Co., Winona, Minn.

**AGENTS,** every city and town in the world, sell automobile owners commodity as constantly used as gasoline, by thousands who have adopted it. Exclusive territory, small capital necessary. Enormous permanent income. Motor Utilities Co., San Diego, California.

**AGENTS!** Grab this 25c household specialty. Lightning seller. One agent sold 160 one day. 130% profit. Write the manufacturers, G. L. Erwin & Co., 2113 Harrison St., Chicago.

**\$35.00 WEEKLY** for "Wise" men. Write quick. Michael Rlenzi, Cutler St., Newark, N. J.

**COUNTY Representatives,** male and female. Mist-ol, universal demand, constant repeats, large profits, exclusive territory. We assist and establish you in permanent, profitable business. Write quick for particulars and allotment. Dept. 195, Magic Mist, 451 West 19th St., New York.

**AGENTS,** sell our waterproof aprons, soaps, toilet articles. Wonderful sellers. Fine profits. Pelham Manufacturing Company, Pelham, N. Y.

**AGENTS,** Huge Opportunity—Philham Laundry Wonder revolutionizes washday; co-operation selling plan, low price and quick repeats insure whopping income; get territory rights, Philham Mfg. Co., 815 S. Sixth St., St. Louis, Mo.

**AGENTS, Make Big Money;** fast office seller; particulars and samples free. One Dip Pen Co., Dept. 2, Baltimore, Md.

**AGENTS:** Cooper made \$314 last month; \$91 last week, selling "Kantleak" Raincoats. New proposition. We deliver and collect. Sample coat free to workers. Comer Mfg. Co., 25 Paige St., Dayton, Ohio.

**AGENTS:** Earn big commissions selling made to measure suits for \$15.00. No more; No less. Real \$25.00 values. No experience necessary. Chicago Woolen Mills, Dept. C, 833 Jackson, Chicago.

**AGENTS—Get** particulars of one of the best-paying propositions ever put on the market; something no one else sells; make \$4,000 yearly. Address E. M. Feltman, Sales Mgr., 9739 3rd St., Cincinnati, O.

**AGENTS—Make** a dollar an hour. Sell Mendets, a patent patch for instantly mending leaks in all utensils. Sample package and catalogue of household specialties free. Collette Mfg. Co., Dept. 404A, Amsterdam, N. Y.

**AGENTS—We** need live-wire salesmen to travel; also in cities, to sell direct to consumer our famous \$12.50 and \$16.50 suits to measure. Success assured. Great selling plan. Complete outfits furnished. Midland Tailors, Dept. 9B, 19 S. 5th Ave., Chicago.

**\$61.50 WEEKLY,** introducing and selling a new gas light burner for kerosene lamps. Beautiful light. No chimney. No mantle. Samples free. Luthar Manufacturing Co., Dept. 250, Cincinnati, Ohio.

**AGENTS:** Money talks—how much are you making? If less than \$200 a month you will positively be delighted with our Sentinel Burglar Alarm proposition. Many agents easily earn \$15.00 daily. Brand new invention. Sells quickly on sight to homes, offices. Patented. No competition. Free exclusive territory. Instantly attached any door knob. Impossible turn knob without ringing bell. No batteries, screws, nails. Handsomely nickel-plated. Retail \$1.00. Provides cheap burglar insurance. It's a big money maker. Let us prove why. Write today for liberal terms to agents. Marshall Dobbins & Co., Manufacturers, 1422 Marquette, Bldg., Chicago.

"POKOLOK" offers unlimited profit to agents who show men that it is possible to protect their Watch, Wallet, Valuables and Penicils against dropping or being stolen from their pockets by an invisible "Pokolok." A fast seller with little effort. Retail for 10c. No competition. Protected territory. Address "Efficiency Engineer," 1200, 616 So. 54th St., Philadelphia, Pa.

**BIG Money Easy Selling Uni-Lites.** Agents can make \$50 to \$100 weekly in spare time. Equals 20 ordinary lamps or lanterns—300 candlepower. Used in house and outdoors. Get new free Uni-Lite offer. Acorn Brass Mfg. Co., 1154 Uni-Lite Building, Chicago.

**AGENTS—Sell** rich-looking imported 36x 68 rugs, \$1 each. Carter, Tenn., sold 115 in 4 days. Profit, \$57. You can do same. Write for sample offer selling plan; exclusive territory. Sample rug by parcel post prepaid, 98c. H. Condon, Importer, Stonington, Maine.

"GOLDINE" Sign Letters—1,000% profit. Particulars free. Johnston Co., Quincy, Ill.



**AGENTS**—To sell the newest electric appliance on the market; sold everywhere there is electricity, in the home and office, store and factory; liberal profits; sales-driving sample, weighs a pound, no experience or knowledge of electricity required; it shows how to use one light instead of two and get the same results; sells for \$5.00 and \$3.50 and saves the purchaser an investment of \$25; write for particulars. The Handy Light Co., 12 Handy Light Block, Cincinnati, Ohio.

**AGENTS**—We manufacture quick-selling specialties, repeaters, and teach you practical salesmanship free. G. Home, 1957 Warren, Chicago.

**WOULD** \$150 monthly, auto of your own to travel in, as General Agent, handling remarkable sellers. Lightning Patch Vulcanizer, Shock Absorber, and Anti-Thief Combination Auto-Switch Lock, thief proof, interest you? Then address Dept. 23, U. S. Manufacturing Co., Wolcott, Indiana.

**SELL** something new. Every merchant buys Ever-Ready Changeable signs. Make 95c on every \$1.50 sale. If you are making less than \$2.30 an hour, write for proposition. Changeable Sign Co., 581 East 102nd, Cleveland.

**AMAZING** new invention. Marvelous adding machine. Retail \$7.50. Adds, Subtracts, Multiplies. Does work of \$290 machine. Five-Year Guarantee. Offices, stores, factories buy from one to dozen. Enormous demand. Every demonstration sells. Write quick for trial offer and protected territory. Dept. PM, Calculator Corporation, Grand Rapids, Mich.

**WANTED**—Tailoring Agents—Everywhere. Spring season 1917. Live wires investigate before making arrangements for coming season. Get on the Nelson band wagon of successful agents—"Nelson System of Special Values." Four prices only. Large assortment to sell for \$15.00. Also big Raincoat line. Nelson Tailoring Co., 241 W. Van Buren St., Chicago.

**AGENTS**—Make what you sell. Save 200%. 24 manufacturing formulas and many money making opportunities. 10c. Mohler, Menon Bldg., Chicago.

**WANTED**—Active men to sell simplex gas plants; no experience required; can make \$300 to \$500 per month; others are doing it, so can you. Address Simplex Gas Plants Co., 154 Whiting St., Chicago, Ill.

**BIG Profits for You!** Manufacture Barley Crisp. New Confection, 5c package costs you 1c. Machine instructions complete \$7.50 prepaid. Send 10c for samples. Barley Crisp Co., 1205 Broadway, San Francisco.

**AGENTS**—Stamping names on Pocket Key Protectors; sample check with your name and address, 12c. Stamping Outfits, Emblem Checks, Check Fobs, Name Plates. Hart Mfg. Co., Desk 2, 363 DeGrauw St., Brooklyn, N. Y.

**EARN** \$50 to \$100 monthly distributing Parker Hosiery to repeat customers at mill prices. All or spare time. Protected territory. Credit, D. Parker Mills, 2733 No. 12th St., Philadelphia, Pa.

**25 COMMISSION** each sale and repeat orders. Traveling salesmen every state. Main or sideline. New, rapid selling automobile accessory used all makes cars. Samples loaned. Weekly settlements. Toledo Cable Co., 119 Davis Bldg., Toledo, O.

**YOU** can be your own boss with our Key Check outfit. Good for \$5 a day stamping names on pocket key checks, fobs, etc. Sample check with your name and address, 15 cents. Pease Die Works, Dept. M., Winchester, N. H.

**SELL** our Stamp, Gum, Match Vending Machines, etc. Liberal commissions. Catalogue Free. Northwestern Novelty Co., Box 943, Morris, Illinois.

**AGENTS**—500 per cent profit; get our monograms for autos and motorcycles, etc., by transfer method. Western Motorist Accessories Co., Cheyenne, Wyoming.

**TAKE** orders for men's custom tailoring, part time or all time. We furnish samples and everything needed to make a success without experience. Low prices; fit guaranteed or money refunded. You make good money on every order. You can wear swell clothes for almost nothing. Write quick for samples and all information if you live in a town smaller than 5000 or on R. F. D. Knickerbocker Tailoring Co., Dept. 549, Chicago.

**INSYDE** Tyres, inner armor for Automobile tires, double mileage and prevent punctures and blowouts. Quickly applied. Cost little. Demand tremendous. Profits unlimited. Details free. American Automobile Accessories Co., Dept. P, Cincinnati, O.

**OUR** line of sanitary brushes, mops and dusters is a winner. So is our proposition. Rich territory waiting. Agents wanted now. Sanford Brush Co., 544 W. Lake St., Chicago.

**AGENTS**—\$50 a week. Will show you how. Genuine Gold Leaf window letters. Chicago Letter Co., 846 Altgeld St., Chicago.

**STREAM-NO-MORE** for eye glasses, wind shields; every auto owner a customer. Live agents, 200%. Send 10c for 25c sample. Gray's Sales Agency, Port Huron, Mich.

**PORTRAIT** Agents: Our goods will make you big profits. Delivery guaranteed. Rejects credited. Prompt shipments. Send for latest catalogue and prices. Adam J. Kroll & Co. 692 Blue Island Ave., Chicago, Ill.

**AGENTS**—Salary or commission. Greatest seller yet. Every user pen and ink buys on sight. 200 to 500 per cent profit. One agent's sales \$620 in six days; another \$32 in two hours. Monroe Mfg. Co., X6, La Crosse, Wis.

**WHO** wants to make more money selling brushes that every household needs? Special method of getting entrance to demonstrate. Fuller Sanitary Brushes are nationally advertised—largest output—best terms and prices—western distributing stations. Your territory is valuable. Write. Fuller Brush Company, Hartford, Conn.; Rock Island, Ill.

**TURN** spare time into dollars. Something new. No canvassing or investment. Daydark Co., Desk 55, St. Louis, Mo.

**HUGE** profits selling Nibco Sanitary Brushes, Auto Washers, Brown Beauty Adjustable Floor Mops, Dustless Dusters, and other specialties. Big line. Fast sellers. Write today. Silver-Chamberlain Company, Department M, Clayton, New Jersey.

**LADY** or Gentleman to Travel for old-established firm. No canvassing. Staple line, \$18 weekly, pursuant to contract. Expenses advanced. G. E. Nichols, Philadelphia, Pa., Pepper Bldg.

**AGENTS**—Ho-Bo-Co Skin Soap and Toilet Goods plan beats everything for agents' profits. "Ho-Bo-Co," 212 N. 2nd, St. Louis, Mo.

**LARGE** Manufacturer wants representatives to sell shirts, underwear, hosiery, dresses, waists, skirts, direct to homes. Write for free samples. Madison Mills, 586 Broadway, New York City.

**AGENTS**—"Exclusive features" are what make easy sales—I can gain attention, close the sale and collect the money on six customers with the exclusive features of my non-alcoholic flavoring extracts, while you are struggling with one customer on the old commonplace line of talk. So can you! Prove it! Write today—big summer sellers—extra summer profits. J. M. Pitkin Co., 626 R. St., Newark, New York.

**MEDALLIONS**—300% profits. Make up your own goods and be independent. Catalogue free. Resag Co., 1205 Randolph St., Chicago.

**100% PROFITS** easily made taking orders for our new patented Vacuum Sweeper. No traveling; experience unnecessary. Bailey made \$150 last week. Write quick. United Vacuum Sweeper Co., 1315 West Congress, Chicago.

**AGENTS**—Our gold window letter proposition beats 'em all. Stahlerte Co., Dept. P, 1115 Second Ave., N. Y. Established 1905.

**GOOD** income refinishing chandeliers, brass beds, etc., by new method, producing amazing results; no capital or experience necessary; write for information. Gunmetal Co., Ave. H, Decatur, Ill.

**AGENTS** Wanted: Sell Polishing Cloths, Rust Remover, Food Flavors, etc. 130 household necessities, guaranteed line, big profits, quick repeater, permanent business. Stuart & Co., 16 Main St., Newark, N. Y.

**SIGN** Letter Agents and Painters: 500% Profit Gold and Silver Sign Letters for Stores and Office Windows. Anyone can put on. Big demand. Free samples. Metallic Letter Co., 404 N. Clark St., Chicago.

**A FEW** reliable men or women to handle my 1916 Business Guide; sells everywhere; beginners clear \$7 per day. 60% commission. Outfit Free. Prof. Nichols, Dept. P. M., Nazerville, Ill.

**AGENTS**, sell reliable custom-made raincoats. Big commission. Complete sample line free. Temple Raincoat Co., Box 62, Templeton, Mass.

**"1916'S SENSATION!"** Eleven piece toilet article set selling like blazes at \$1.00 with \$1.00 carving set! Free! Enormous profits! Tremendous hit! Engle made \$51.00 first week. Write quick! Pierce Co., Dept. F., 906 Lake St., Chicago.

## AGENCIES WANTED

**SPECIALTIES** Wanted. Direct from manufacturers; commission basis. Exclusive agency; N. W. states. Manufacturers Representative, Box 286, Seattle, Wash.

**REPUTED** Sales Organization will consider good paying proposition for Canada. Cash Dealings. National Specialties, Power Building, Montreal, Can.

## SALESMEN WANTED

**WANTED**—A live representative to co-operate with us in promoting the sale of a wonderful product that is most interesting to Auto owners, dealers, garages, etc.—to act as sort of local distributor. Excellent opportunity for the right party. Reference required. Brazel Manufacturing Co., Cincinnati, Ohio, U. S. A.

**\$7.50 COMMISSION** each sale and repeat orders; traveling salesmen among general mercantile trade, every state; weekly settlement; no competition; pocket sample. Toledo Cable Co., 200 Davis Bldg., Toledo, O.

**SALESMEN**: Your clothes furnished free of cost for soliciting applications for our Tailoring line during spare time, in all towns you make. Our line features 300 patterns, half of which can be profitably retailed from \$15 to \$20. Write for full information. United States Tailoring Co., 919 W. Jackson Blvd., Chicago.

**WE** have several good openings for live wire salesmen who can "make good." We want men capable of earning \$3,000 to \$10,000 a year to sell a well-known article used in all public buildings, hotels, clubs, restaurants, theaters, stores, etc. Sales run high; commissions big. One man's earnings last month over \$750. In writing, state age, experience and previous connections. Wear Proof Mat Co., 500 So. Peoria St., Chicago.

**FACTORY** Representative; Manufacturing Company established 30 years in Mechanical Specialties, patented and registered. High Pressure Hose, Couplings and other Specialties for Railroads, industrial plants, contractors, railway and supply trade. Liberal commission over 20%. State age, experience and territory. Address, P. O. Box 4532, West Park Station, Philadelphia.

**WANTED**—Capable Men to Sell "Best" Automobile accessories direct to car owners. Good commission. Reliable men only. No free samples. Jackels Campbell Co., Kansas City, Mo.

**WANTED**—Salesman for live side line for dry goods and general stores; liberal commission. Felt Embroidery Form Co., Department P, Marengo, Illinois.

**WERE** you ever offered a grocery store? Our proposition is better. Let us tell you how you can handle Flour, Canned Goods, Provisions—an entire line of Groceries, as well as Paints, Roofing, Stock Foods, Automobile and Machinery Oils and Greases. No rent to pay, no investment in stock. Large orders taken from samples. Goods of guaranteed and proven quality. Selling experience not necessary. Very profitable work for "workers." Address R. S. Hill, President, Hitchcock Hill Co., Chicago. Reference: Any bank or express company.

**NEW** Ford runabout for \$160 and your spare time distributing Stewart's "Off-On" fire tools. It's easy. Particulars free. Stewart, 130 Cass Ave., Detroit, Mich.

**SALESMEN** Wanted—To sell Oils, Belting, Hose, Paint, Varnish to factories, mills, auto owners, stores, threshers, outside large cities. Excellent proposition. Paid weekly. O. L. Doty, Cleveland, Ohio.

**SALESMEN**—Exclusive territory for oil men. Commission basis. Vega Sales Co., Cleveland, O.

**YOUNG** men in every city to sell distinctive novelty to the trade. Big profits. Salesmen sample 25c. Emitol Co., Box 603, San Francisco.

**SALESMEN**—Wanted everywhere to sell Ajax Chemical Fire Engines. Minimum Commission \$40 on every Engine sold. An average of one or two machines a week would earn you \$2,000 to \$4,000 a year. Factories, Stores, Industrial Plants, Private Estates, etc. all use Ajax Engines. No capital required. Goods well advertised. Ajax Fire Engine Works, 95 W. Liberty St., New York.

**BIG** opportunity for salesmen; rapid seller; good profits. Excellent side line proposition. Territory open. Safety First Check Protector Co., Box 483, Oakland, Calif.



**DOES** your trade use salesboards? We invite correspondence from salesmen who are making their trade regularly; the most remunerative side line; no samples, no collections; \$5.00 commission due as soon as each order is shipped; we want only first-class men; inquirers to receive attention, must state line carried and how long, class of trade called on, territory and how often covered. The K. & S. Sales Company, 154-156 Whiting Street, Chicago, Ill.

**CIGAR** Salesmen wanted in every country. All or spare time. \$20-\$40 weekly; no experience required. We show you. Neway Sales Co., Holyoke, Mass.

**SALESMEN**—Sterilizer, patented, best on market, barbers and doctors; \$5 on each sale. Well advertised. Sold on payments; easy seller; references required. Republic Mfg. Co., 415 Huron Road, Cleveland, O.

**SALESMEN** Wanted—Broom straw has gone up. Our Fibre and horse-hair broom is the best house to house proposition on the market today. Easy seller. Costs 37c each. C. O. D. F. O. B. Chicago, sells for 75c. Write at once. Territory protected. Jos. Hergenrether & Son, 57 E. 43d St., Chicago, Ill.

**\$100 TO \$200** monthly easily made. Double that possible selling the Phonometer, amazing device every long-distance telephone user buys. Experienced salesmen with ability to talk efficiency wanted in all cities. Liberal commission. References required. Graves Timing Device Co., Parkway Boulevard, Philadelphia.

**SALESMEN**—Sell beautiful 25x38 Artkraft felt rugs for \$13.50 per doz. Your profit \$2.50 per doz. Kelso, Battle Creek, Mich., sold 30 doz last week, his profit \$75. Prepaid sample, \$1.00. E. H. Condon, Mfr., Stonington, Maine.

**START** a money making business of your own. We are ready to prove to you that you can make \$4 to \$10 a day. We furnish everything free and teach you how. Write Weeks Nursery Company, Department "P," Lyons, N. Y.

**SALESMAN**—Unusual opening with old concern for experienced specialty man. Staple line for general trade; new features. Write for territory now. The Continental Jewelry Co., 301 Continental Bldg., Cleveland, Ohio.

**SALESMAN**—\$6,000 Accidental Death, \$30.00 Weekly Accident Benefit, \$25.00 Weekly Sick Benefit, \$10.50 yearly, half amount \$3.50, \$250,000 deposited Insurance Department. Experience Unnecessary, steady income for reliable men. Registration Dept. B. Newark, N. J.

**SALESMEN** to sell Automobile Oil. Liberal commissions. Immediate drawing account. The American Turpentine Company, Cleveland, Ohio.

**WANTED**—Someone in every city in United States to sell new specialty that every stenographer needs. Sells itself when shown. Liberal commission. The Neufeed Company, Asheville, North Carolina.

**SALESMEN**—Get our plan for Monogramming Automobiles and motorcycles by transfer methods. Very large profits. Motorists' Accessories Co., Mansfield, O.

**SMOKER** Wanted—We want silent salesmen who will smoke a pipe and get paid for it. Send no money, just write for particulars. M. H. Putnam, 607 West 51st Street, New York City.

**SALESMEN**—To sell highest quality aluminum cooking utensils to dealers; liberal commission; salesman can easily make \$100 weekly; good side line. Address Ipaico, Lemont, Ill.

**SALESMEN**—Acquainted with grocery trade. Large demand; liberal commission; pocket sample. Wirth Salesbook Co., Dept. P, Chicago.

**WANTED**—Representatives everywhere. Exclusive territory. Gold sign letters for stores and office windows. Any one can put on. Write today for free sample. Metallic Letter Co., 403 N. Clark St., Chicago.

#### HELP WANTED

**MEN**—Women—Wanted, \$100 month, Government jobs. Vacancies constantly. Write immediately for list positions obtainable. Franklin Institute, Dept. 8-21, Rochester, N. Y.

**GOVERNMENT** Employees Wanted—Big pay, sure work. I will prepare you in a short time at small cost. Must be American citizen. Write for my free book P C-29 today. Earl Hopkins, Washington, D. C.

**GOVERNMENT** Positions are easy to get. My free booklet BY-29 tells how. Write today—now. Earl Hopkins, Washington, D. C.

**INVENT** Something. It may bring wealth. Free book tells what to invent and how to obtain a patent through our Credit System. Waters & Co. Succeeded by Talbert & Parker, 4102 Warder Bldg., Washington, D. C.

**THOUSANDS** Government Jobs open to Men—Women. \$75.00 month. Steady work. Short hours. Common education sufficient. Write immediately for free list of positions now obtainable. Franklin Institute, Dept. 8-21, Rochester, N. Y.

**FIREMEN**, Brakemen, beginners paid \$120 monthly, permanent; all railroads everywhere. No strike. Railway Association, Dept. 208, Brooklyn, N. Y.

**LADIES**—Make \$50.00 easy. Only a few minutes of your time required. No canvassing. Lockeland Mfg. & Imp. Co., Dept. M, Nashville, Tenn.

**FREE** Illustrated Book tells of about 300,000 protected positions in U. S. service. Thousands of vacancies every year. There is a big chance here for you, sure and generous pay, lifetime employment. Just ask for booklet CS-29. No obligation. Earl Hopkins, Washington, D. C.

**NO** Strike: 8-Hour Day. Men Everywhere. Firemen, Brakemen, Baggage-men, \$120. Colored Porters. Experience unnecessary. 810 Railway Bureau, E. St. Louis, Ill.

**MECHANICS** in any line. We will give you dollars for spare time to demonstrate small article needed wherever building is going on. Our plan creates immediate interest. Get the idea while it's new. Van Expansion Bolt Company, 1209H Fort Dearborn Building, Chicago.

**DO** you want a sure job with big pay, easy hours and rapid advance? Write for my big free book, DW-29, which tells you how you can get a good Government position. Earl Hopkins, Washington, D. C.

**BECOME** Chauffeurs. \$25 week. Learn while earning. Sample lessons free. Franklin Institute, Dept. 8-302, Rochester.

**WANTED** at once. Reliable person to distribute advertising matter. Must furnish reference and like walking. Honest opportunity. One Reed Street, Reading, Pa.

**WANTED**, Men and women to qualify for Government positions. Several thousand appointments to be made next few months. Full information about openings, how to prepare, etc., free. Write immediately for booklet CG-29. Earl Hopkins, Washington, D. C.

**WE** Pay \$80 Monthly Salary to those who qualify and furnish rig and expenses to introduce guaranteed poultry and stock products. Bigler Company, X368, Springfield, Ill.

**WANTED**—Railway Mail Clerks, \$75.00 month. Sample examination questions free. Franklin Institute, Dept. 8-21, Rochester, N. Y.

**PHOTOPLAYS** in demand. Make extra money. We show you how. Details free. Rex Publishers, Box 175 H-8, Chicago.

**A SURE** Job for You with big pay and steady work. Thousands of government positions open this year. Write for big free book DV-29, which tells how to get one. Earl Hopkins, Washington, D. C.

**MAKE** money in spare time with my up-to-date plan. No capital. Experience unnecessary. Longacre, 215 Bromley Bldg., Omaha, Nebr.

**RAILWAY** Mail Clerks Wanted. Commence \$75.00 month. Examinations everywhere soon. Sample questions free. Franklin Institute, Dept. 8-21, Rochester, N. Y.

**GOVERNMENT** pays \$900 to \$1,800 yearly. Prepare for coming "exams" under former Civil Service Examiner. New Book Free. Write Patterson Civil Service School, Box 3020, Rochester, N. Y.

**CIVIL** Service Examinations open the way to good Government positions. I can coach you by mail at small cost. Full particulars free to any American citizen of eighteen or over. Write today for Booklet CE-29. Earl Hopkins, Washington, D. C.

**SILVER** mirrors, Plate tableware, home. Clarence Sprinkle, Dept. 28, Marion, Ind.

**MEN**—Women, 18 or over, write us immediately for free list U. S. Government positions now open to you. \$100.00 month. Franklin Institute, Dept. 8-21, Rochester, N. Y.

**THOUSANDS** of Statues made with one rubber outfit. Instructions free. Joseph Roth, 45 Frost St., Brooklyn, New York.

**CIVIL** Service information: Prepared by an expert, tells of opportunities, salaries and qualifications for high salaried positions in Western cities. Not a correspondence course, but facts you must know. 25 cents silver. Powell, 449 New York Block, Seattle.

**MEN**, Learn the Auto Business—Earn big money or have a business of your own. We teach you by actual practical experience—driving, assembling, repairing, acetylene welding, ignition, battery work, machine-shop practice, etc. Best-equipped auto school in the country. Established 1905. 3,000 successful graduates. We help students earn their living. Write for free catalog and low rates. National School of Engineering, Los Angeles.

**GOOD** Income refinishing chandeliers, brass beds, etc., by new method, producing amazing results; no capital or experience necessary; write for information. Gummel Co., Ave. G, Decatur, Ill.

**BE** a Mirror Expert. Good income; spare time home at first; no capital; we train, start you making and silvering mirrors; French method. Free prospectus. W. P. Derr, Pres., 87 Saratoga Ave, Brooklyn, N. Y.

**GOVERNMENT** Examinations. Most thorough preparation, \$5; returned if not appointed; particulars free. American Civil Service School, Washington, D. C.

**WANTED**—An Idea! Who can think of some simple thing to patent? Protect your ideas; they may bring you wealth. Write for "Needed Inventions" and "How to Get Your Patent and Your Money." Handolph & Co., Patent Attorneys, Dept. 144, Washington, D. C.

#### SITUATIONS WANTED

**A** **COMPETENT** Grocery Department Manager, sixteen years present position, long experience with Spanish-speaking trade, absolute control of temperament, good clean record, investigation solicited, not averse to any country. Invite correspondence. Post-office Box 155, Morenci, Arizona.

#### WANTED

**UNITED** Certificates and United Profit-sharing Coupons wanted. We pay 75c per hundred for certificates. C. Wolf Co., 39 West 18 St., New York City.

#### FOR SALE

**PRINTING** Presses for Boys, \$5.00 and upward. Satisfaction guaranteed. Catalogue free. Excelsior Press Co., 14 So. Fifth St., Philadelphia.

**FOR** Sale—Traction drilling machine. Write at once for particulars. H. C. Wedekamm, Harrisville, W. Va.

**FOR** Sale: Mechanical Toy—Advertising Novelty. Anceel Teeters, Wynne, Ark.

**TYPE** and Printing Material at bargain prices. Now is the time to buy. All sizes rebuilt Job Presses very cheap. Catalogue free. Philadelphia Printers' Supply Co., 14 So. Fifth St., Philadelphia.

**MIMEOGRAPH**s, Underwood Duplicators, Rotary Neostyles \$15. Slightly used. Guaranteed. Office Specialty Co., The Bourse, Philadelphia.

**MODERN** Vacuum Cap, makes hair grow; cost \$25.00, for \$12.50. A. H. Tretini, Milwaukee, Wis.

**FIELD** Glasses—Prism Binoculars—Monoculars—Telescopes—Telescope gun sights. Descriptive circular for red stamp. LaRoy Zehrbach, Dept. PM-1, Leipsic, Ohio.

#### SALE OR EXCHANGE

**WANT** to Swap? Send 10 cents for "The Market for Exchange," to Pierre Notley, 141 Milk Street, Boston, Mass. It gives a long list of those who have things to trade or sell. Send list of things you have to trade or sell.

**2 OR 3** SECTION McCahey Register, Photographers' Portrait Lens, high power Microscope, several sets Depew's "Library of Oratory" and "Grote's Greece," Phonograph, dictaphone, Sewing machines, Typewriters, Motorcycle, Guitar, Banjo, Mandolin, Indian Baskets, Want Burrows Adder, Cash Register, Diamonds, Books, Cameras, Guns, etc. Syd Evans, Klamath Falls, Oregon.

**GRANDFATHER** Clock, onyx clock, superb Indian suit, Colt .25. Want latest Encyclopedia Britannica, Century, Funk-Wagnalls dictionary, Ford tires, rowboat, what? Roney, 1021 Leland Ave., Chicago.

**CHALMERS** model 30. Good condition. Cheap for cash. Trade for diamond. What have you? Information, photo. F. J. Colingwood, Findlay, O.

**START** a "For Sale and Exchange" Agency. Valuable plans free. The Advance, Rolling Prairie, Indiana.



**GUNS, SPORTING GOODS, ETC.**

BUY, sell, exchange all sorts old-time and modern Firearms, Stephen Van Rensselaer, Antiques, 805 Madison Ave., New York.

**TAXIDERMERY**

**TAXIDERMERY.** Learn this pleasant and profitable business for \$1.10 by reading "Home Taxidermy," 248-page book, 107 illustrations, A. R. Harding, Columbus, Ohio.

**FLOUR & FEED MILLING MACHINERY**

**SPECIAL bargains in second hand Attrition mills, burr mills, crushers, corn shellers, bran dusters, dust collectors, purifiers, rolls, double, single, 2 and 3-pair high roller mills, sieve bolters, receiving separators, scourers, etc.** Write for description and prices. Sprout, Waldron & Co., P. O. Box 429, Muncy, Pa.

**MACHINERY, TOOLS AND SUPPLIES**

**FOR Sale—One Westinghouse, D. C. Generator, 125 volts, 48 Amperes. One Eck D. C. Generator, 120 Volts, 27 Amperes. About 200 feet of 2 1/2 inch Shaft, also a lot of pulleys, all sizes. The Basch & Greenfield Co., 67 Seventh Ave., Newark, N. J.**

**WOOD Worker and Stocker, \$65. Wood Planer, \$59. Double Shaper, \$35. Moore Rubbing Sander, \$75. Scroll Saw, \$20. Swing Saw, \$25. Rip Saw, \$25. Gas Engine, 20 H. P., \$100. Gasoline Engine, 4 H. P., \$60. 215 Butler St., Cincinnati, Ohio.**

**PULLEYS, Gears, Sprockets, Shafting, Hangers.** See page 138. W. A. Jones, Foundry & Machine Co., Chicago.

**MARK your tools; new acid process engraves actual signature in steel, copper or silverware. Your name engraved on a brass plate for dime; sample of this process. Complete outfit fifty cents. Walter Engraving Co., Buffalo, N. Y.**

**BARGAINS in Machinery. One 50-H. P. Nash Gas Engine, Tank and Compressor. One 75-H. P. Russell-Massillon Steam Engine. One 100-H. P. Cookson Feed Water Heater. One 35-H. P. Advance Gas Engine. One 25-H. P. Advance Gas Engine. One 9-ft. Sturtevant Ventilating Fan, 3/4 housed, direct connected to 15x10-inch Horizontal Center Crank low-pressure Steam engine. Two 20-inch Tin Shears. The Williamson Heater Co., Cincinnati, Ohio.**

**"RED Devil" five inch Combination Plier with Prestolite Opener; insured two years. 50c. Leather case free. Smith & Hemenway Co., Inc., 95B Chambers St., New York City.**

**FOR Sale—12-in. Jointer. Variety saw. Swing saw. All modern high-class machines. Almost new, \$125 for all. J. H. Beattie, McLean, Va.**

**To buy or sell a machine, write Interstate Machinery Co., Troy, N. Y.**

**WIRE—all sizes—3/4 to No. 16. Coppered, tinned, galvanized and plain steel wire for sale. Cooley Mfg. Co., 353 W. Monroe St., Chicago, Ill.**

**ENGINE Lathes, swings 9 1/2 in., takes 25 in. between centers. Complete set gears cutting all size threads 3 in. to 40 in., \$48.50. Grammes & Sons, Allentown, Pa.**

**ENGINES, MOTORS AND DYNAMOS**

**FOR Sale—A number of new 1/2 H. P. Shunt wound D. C. motors, 48 volts, 1,500 R. P. M., \$4.00 net, each. F. O. B. St. Louis. In good operative condition, just the thing for experimental work. Will furnish data to change for operation on 110 volts, 60 cycle, A. C. Wagner Electric Mfg. Co., St. Louis, Mo.**

**GUARANTEED alternating current rebuilt motor bargains. Reliable makes only. Westinghouse, Century, Emerson, Fort Wayne, Wagner, General Electric, Western. 3/20 H. P. \$7.00; 1/10 H. P. \$11.00; 1/4 H. P. \$13.00; 1/2 H. P. \$15.00; 3/4 H. P. \$18.00. Other bargains, including direct current; three-phase and larger motors. Buy before prices advance. Moneyworth or Moneyback. Hyre Electric Co., 613-RL South Dearborn St., Chicago.**

**HARRIS Coles Engine for sale. 250 H. P., 12-ft. flywheel, absolutely perfect. Inquire at 25 India Sq., Boston.**

**GUARANTEED alternating current motors. 1/20 H. P. \$3. 1/10 H. P. \$5. 1/4 H. P. \$8. 1/2 H. P. \$13. Tell your wants. Box 101 Waterford, Wis.**

**FAIRBANKS-Morse 4-horse kerosene engine, with truck. A. H. Fehr, Olivia, Minn.**

**5 K. W. Generator, direct, 110 volts. Fifty dollars. P. A. Paul, Lewisburg, Ohio.**

**NEW 1/2-H.P. A. C. Motors \$15. A few 1/4-H.P. A. C. \$12. D. C. \$11. Price on other sizes in proportion. Headquarters for motors and generators. Electric Sales & Service Co., 719-21 Liberty Ave., Pittsburgh, Penna.**

**CHARGING Dynamos: Several hundred small machines just received from Bankruptcy Stock. All voltages and sizes—guaranteed new—less than factory cost. 1/4 H. P., A. C. Motors, \$15.00 each. Write for illustrated list. Johnston, West End, Pittsburgh, Pa.**

**REBUILT Engines—We have on hand a number of rebuilt "Buffalo" engines, guaranteed, at greatly reduced prices. Write for bargain list. Buffalo Gasoline Motor Co., 1293-1305 Niagara Street, Buffalo, N. Y.**

**ENGINE CASTINGS AND BLUE PRINTS**

**LATEST American Model. 1/2-H. P. Steam-Engine Castings, with Blueprints, can be completed on 9-inch Lathe and small Drill Press. Modern Model Engineering Co., 3001 No. Central Park Ave., Chicago.**

**CASTINGS and Drawings for small Gasoline Engines. Crown Motor Works, Elgin, Ill.**

**FOR MECHANICS**

**WATERLESS Washer Soap. Removes grease instantly with or without water. The wonderful mechanics' or time saving soap. For \$1.00 we send you enough material to make 16 pounds, prepaid, with instructions. Your money back if not satisfactory. Waterless Washer Laboratories, 1428 Michigan Ave., Chicago, Ill.**

**BOATS, LAUNCHES, ETC.**

**BUILD your own Steel boat from patterns. Material furnished, also finished boats. Catalogue free. Darrow Boat Co., Albion, Mich.**

**MOTORCRAFT Encyclopedia—A 150-page book that tells 1400 things every motor boatman should know. How to overcome engine troubles. Price \$1, postpaid. Popular Mechanics Book Dept., 6 N. Michigan Ave., Chicago.**

**FOR THE SHOP**

**SHOP Notes for 1917—Just Published—524 Articles, 422 Illustrations, 224 Pages. Easy Ways to do the Hard Things in every trade and calling. Price 50 cents, postpaid. Popular Mechanics Book Dept., 6 N. Michigan Ave., Chicago.**

**PATTERN Makers! A book devoted to the principles of pattern and core making and molding. Written by G. H. Willard, a practical pattern maker of years' experience. This book, just published, treats the subject in a much more simple, direct and effective manner than most books along this line. 224 pages, 312 illustrations. Price, \$1, postpaid. Popular Mechanics Book Dept., 6 N. Michigan Ave., Chicago.**

**FOR That Boy—He will appreciate a copy of the great boy's book, "The Boy Mechanic," that tells about 700 different things for boys to do and has 800 pictures, 480 (7x10) pages, cloth, big, handsome book for the price, \$2.00 postpaid. Popular Mechanics Book Dept., 6 N. Michigan Ave., Chicago.**

**BLACKSMITHS**

**BLACKSMITHS, Listen! The Blacksmiths come first of all trades. He must make the tools for all, from the Surgeon to the Safe Blower. With Toy's Modern Methods going hard jobs easy. Forging and making solid welds, hardening and tempering to a standard, with colored tempering charts. All for one dollar. Samples Free. W. M. Toy, Sidney, Ohio.**

**ELECTRICAL**

**ILLUSTRATED wholesale price-list supplies and motors, including switches, sockets, wire, porcelain goods, loom, Hyre Electric Co., 613-MG South Dearborn St., Chicago.**

**DRY Batteries and Their Construction for All Purposes. A practical handbook of 60 pages with 30 illustrations dealing with batteries for automobiles, gas engines, medical and coil work, electric bells, alarms, telephones, experiments, etc. Price 25 cents postpaid. Popular Mechanics Book Dept., 6 N. Michigan Ave., Chicago.**

**PRACTICAL Electricians—Universal handy book on every-day electrical matters, alarms, batteries, bells, carbons, connections, coils, dynamos, wires, lamps, motors, telephones, etc. 135 pages, 126 illustrations. 25c postpaid. Popular Mechanics Book Dept., 6 N. Michigan Ave., Chicago.**

**INVENT Something. It may bring wealth. Free book tells what to invent and how to obtain a patent through our Credit System. Waters & Co. Succeeded by Talbert & Parker, 4280 Warder Bldg., Washington, D. C.**

**STAMP COLLECTING**

**FREE, "Dandy" Packet to approval applicants. "Reference." Murray, Rock Island, Ill.**

**24 VARIETIES Cuban stamps, 10 cents. List of 6,600 low-priced stamps free. Chambers Stamp Co., 111 P. Nassau St., New York City.**

**STAMPS, 75, all different, free. Postage 2c. Mention paper. Quaker Stamp Co., Toledo, Ohio.**

**I'll pay cash for a good collection. Sholley, Linden Hills, Minneapolis.**

**FREE! 4 war stamps with bargain approvals. Riedell, 44 Kelton, Schenectady, N. Y.**

**FOREIGN Stamps Free! 20 different King George British Colonials to collectors sending 4c postage. Mention Gift G241. Bright & Son, 164, Strand, London, England.**

**FREE, 60 different stamps, including Newfoundland, China, Japan, Mexico, etc., to applicants for our high-grade approvals. Send 2c stamp for return postage. The Edgewood Stamp Company, Dept. H, Milford, Conn.**

**20 RARE Stamps—Old United States, Mexico, etc. Catalogue value over \$1.00, only 10c. Bargain lists free. Crystal Stamp Co., Racine, Wis.**

**MEMBERSHIP in the American Philatelic Society means real benefits. Sales Dept., with \$50,000 worth of stamps. Free Journal. Particulars and application blank free. H. A. Davis, Sec'y, Dept. M, Colorado Springs, Colo.**

**200 DIFFERENT stamps 17 cents. Popular approvals. R. Pride, Honeoye Falls, N. Y.**

**FIFTEEN different old Hawaiian stamps, \$1. Send money order or Greenback in payment. James Steiner, Box 1306, Honolulu, Hawaiian Islands.**

**CANADA Packet Free. Early issues, Maple Leaves, War Stamps, etc. Postage 2c. Midland Stamp Company, Midland, Ontario.**

**FREE—Stamp collections. Choose One, 200 different international, 100 United States, 50 Sweden, 60 Japanese, Remit 25c six months' subscription. McKee's Stamp Weekly, Beverly, Mass.**

**FREE! Leader Packet with request for 60% Approvals. 2c return postage. Earle Stamp Co., 1823 Crystal Lake Ave., Minneapolis, Minn.**

**PACKET of 23 stamps; no two countries alike, 500 hinges, 8c of \$1 and \$2 U. S. Rev., all for 5c. Mention paper, Miami Stamp Co., Toledo, Ohio.**

**R. P. SPECIALS. All fine, 150 varieties 15c, 1,000 varieties \$2.75. Want lists filled. Borsch & Potter, 409 Widener Bldg., Philadelphia.**

**STAMPS—13 Var. Nyassa 1901 unused 25c; 20 different animal 12c; 300 diff, 35c; send for bargain list. Approvals, Graeme Ton, 2816 Cleveland Ave., New Orleans.**

**TEN Austria Jubilee stamps free to approval customers. Robert Wright, Clearfield, Pa.**

**FREE—100 Japan, etc., 25c Washington, get 60 per cent approvals. H. C. Ruf, Easton, Pa.**

**A STAMP Album. A collection of rare Mexican War stamps, incl. Madero, etc., 100-page catalog. Perf. gauge and mill, scale, coupons, etc., all for 5c. App. sheets 60% to 80% comm. Agents Wanted. We buy stamps. Hussman Stamp Company, St. Louis, Mo.**

**121 ALL Different Foreign Stamps, including Guatemala, Honduras, Romania, Costa Rica, Egypt, Chili, China, Mexico, Peru, Cuba, Russia, Japan, India, Victoria, Portugal, etc., 15c. 200 hinges Free. Royal Stamp Co., 48 N. 51st Street, Philadelphia, Pa.**

**STAMPS sent on approval at 70% discount. Precanceled, 1/2c each. Reference required. Emory Renoll, Hanover, Pa.**



**FREE**—Packet from Argentine and Salvador, Nicaragua, etc., with request for "Royal Approvals," with reference. Big bargain list free. Belmont Stamp Co., 32 South 17th St., Philadelphia.

**25 DIFFERENT** British Colonials to applicants for stamps on approval. Postage 2c. Nichols, 122 Florida Ave., Washington, D. C.

**20 UNUSED** stamps free. All different. Postage. 2c. Fisk Stamps, Toledo, Ohio.

**STAMPS**—105 China, etc., stamp dictionary, list, 2c. Album (509 illustrations) 3c. Bullard, Sta. A., Boston.

**PACKET "A"** 100 varieties foreign stamps, 20c. F. J. Pope, Charlotte, Vermont.

#### RARE COINS

**\$4.25 EACH** Paid for U. S. Flying Eagle Cents dated 1856. We pay cash premiums on hundreds of Old Coins. Send ten cents at once for New Illustrated Coin Value Book 4x7. It may mean your fortune. Clarke & Co., Coin Dealers, Box 15, Le Roy, N. Y.

**CALIFORNIA** Gold, quarter size, 27c.  $\frac{3}{4}$  size, 53c. Large cent before 1821, Columbian nickel and price list, 10c. Norman Schultz, King City, Mo.

**FIVE** Villa coins and bills, 35c. Villa Silver Dollar \$1.35. Moore Coin Company, Commerce, Texas.

**COINS**—Antique Relics, 5 curious rare coins with catalogue, 10c. Ray Chapin, New Berlin, N. Y.

**CASH** paid for old money of all kinds; \$5.00 for certain eagle cents; \$7.00 for certain 1853 Quarters, etc. Send 4c. Get Large Illustrated Coin Circular. May mean your large profit. Send now. Numismatic Bank, Dept. H, Fort Worth, Texas.

**ALL** for a two-cent stamp. Our new 1917 price list of Coins, Notes, Stamps, Pistols, Knives, Coin Jewelry, Chinese Seeds and Bulbs. Get it today. Coin Exchange, New Rochelle, N. Y.

**OLD** Coins. Large Fall Coin Catalogue of Coins for Sale, free. Catalogue quoting prices paid for coins, ten cents. William Hesslein, 101 Tremont St., Boston, Mass.

#### GAMES AND ENTERTAINMENTS

**PLAYS**, Vaudeville Sketches, Monologues, Dialogues, Speakers, Minstrel Material, Jokes, Recitations, Tableaux, Drills, Musical Pieces, Entertainments for all occasions. Make-Up Goods. Large Catalog Free. T. S. Denison & Co., Dept. 11, Chicago.

**MORE** Funabout Fords—New book of funny "Ford Stories." The popularity of Funabout Fords has resulted in the publication of an entirely new collection of about 100 of these stories that the whole nation has laughed at. Either book 25 cents postpaid or both books for 50 cents postpaid. Popular Mechanics Book Dept., 6 N. Michigan Ave., Chicago.

**JUST** out, Vacuum Rubber Suckers. Glasses will stick to the Bar like glue. Cups to Saucer like cemented. Lots of fun, 25c. Magic tricks and Puzzles, Exploding Jewel Boxes, Trick Matches, Cigars, sneeze powder, small Bombs, 200 others. Send 2c for illustrated catalogue, J. Grandfield, 1238 Theriot Ave., Bronx, N. Y.

**67 TRICKS**, 250 jokes, riddles, 73 toasts, 8 Fortune Telling secrets, 52 moneymaking secrets, 22 funny readings and big catalog 10c. Ideal Novelty Shop (P-1) Irving Station, Chicago.

**TRICKS**, Puzzles, Jokes, Magic Goods, Toys, Games, Plays, Wigs, Stage Supplies, Mind-reading Acts, Sensational Escapes, and Illusions. Free large 1917 catalog. Oaks Magical Co., Dept. 269 Oshkosh, Wis.

**THE** Magic Circle Puzzle. Best Puzzle Out. Has proven a source of great fun and pleasure to both young and old. Very fascinating—practically indestructible—and a puzzle that will not grow old. Many send for a dozen after seeing one. Send ten cents for one today. A. K. Rankin, 1020 No. Main St., Dayton, O.

**GREAT** Rising Cards, 35c; Self-Forcing Deck, 35c; Magician's Trick Cards, 35c; Modern Vaudeville Patter, 15c; Cigarette Tricks, 25c; Helpful Hints to Amateurs, 25c; String Tricks, 25c; America's Best Magic Magazine, 10c; Three Months' Trial, 25c. New Catalogue free. Dealers Supplied. Pentz, 205 Seventh St., Minneapolis, Minnesota.

**VANISHING** Trick Cards 25c. Red hot, just out; get one. Lindhorst Magic Shop, P. M. 205 Nulsen Bldg., St. Louis, Mo.

**MIND-Reading Act**—Mysterious. Wonderful; copyrighted. Send stamp for particulars. The Great Powers, Belvidere, Ill.

**PLAYING** Card to Box of Matches, apparatus and instructions, 25 cents, Bill Klein, New Canaan, Conn.

**MAGIC** Pocket Trick Free, worth 25c. Catalog of 500 Parlor and Stage tricks included. Send 6c stamps. Hornmann Magic Co., Sta. 10, 470 8th Ave., New York.

**SEND** 10c for two Standard Puzzles. Receive Free, 2 Card, 2 Coin, 2 Joke Tricks; Apparatus and Catalogues. Chicago Puzzle Works, 3310 Herndon St., Room 132 Chicago.

**BE** a handcuff king. We teach you. Escape from hand cuffs, boxes, ropes, etc. Secrets of 20 sensational escapes \$1. Particulars free. The Magcraft Co., Dept. A, Box 251, Detroit, Mich.

**TRICKS** and Stage Money. Magic Bargain Catalog 2c. Twenty Greenbacks 10c. Gilmore, Morgan Park, Chicago.

**MAGIC**, mind reading acts, amusement goods, sensational escapes, supplies. Catalog free. Heaney Magic Co., Berlin, Wis.

**MAGIC**—Tricks, Books and Supplies. For Amateurs as well as the Great Professionals. Any one can learn through our instructions. Feature Acts in Mind Reading, Spiritualism, Rope Ties, etc. Large Illustrated Professional Catalogue, 10c. Chicago Magic Co., Dept. B, 72 West Adams St., Chicago, Illinois.

**TRICKS** and Greenbacks. Big Bargain list of magic goods free. Twenty Buffalo greenbacks 10c. Gilbert Magic Co., 11185 So. Irving, Chicago.

**MAGIC** Tricks for pocket, parlor and stage. Largest assortment in the world. Thurston's Book of Pocket Tricks, 25c. Book of Card Tricks, 25c postpaid. Send 2c stamp for catalogue. A. Felsman, 115 So. State, Chicago.

**ARE** you ambitious? You can earn good money in vaudeville. Valuable information mailed free. London, 734 Crilly Bldg., Chicago.

#### FOR BOYS

**"SLIMMY** Slivers" Metallic Frame Kite. Big value for a dime. Dept. B, Thayer Mfg. Co., Jackson, Mich.

**JUST** issued—Amateur Mechanics No. 8. How to make 132 different interesting things such as electric fountains, bird houses, model monoplanes, porch swing, kites of various kinds, fishing rods, camp outfits, scarecrow, shocking machine, etc., 128 pages, 234 illus. Price 25 cents, postpaid. Also all preceding numbers in the series at same price. Popular Mechanics Book Dept., 6 N. Michigan Ave., Chicago.

**BIG** New Book for Boys—The Boy Mechanic, Vol. II—Just out—A sequel to, but containing nothing found in Vol. I. Tells all about 1,600 interesting things to make and do. 480 pages; 955 illus. Cloth. Price, \$2.00, postpaid. Send for descriptive circular. Popular Mechanics Book Dept., 6 N. Michigan Ave., Chicago.

**AUTOMATIC** repeating Pistol shoots 20 B. B. shots in one loading. Handsomely finished in gun metal. Only 25c postpaid, 20 B. B. shots free. Big novelty, magic goods and book catalog free. Great Novelty Co., 331B, Madison St., Chicago.

#### FOR MEN

**WAVECURL** Hair Curling Fluid will make your hair beautifully curly. Send 15c for a sample. Wavecurl Co., Saint Paul, Minn.

**NOVEL** and useful. Gent's calendar watch, gives time, date, change of moon. Sent on receipt of \$4.75. Satisfaction guaranteed. Royal Importing Co., 21 East 14th St., New York.

**CARLSLE** Safety Hair Cutter, 50c. Park Novelty Co., 220 East 88th Street, Chicago.

**UNITED** and Mutual Profit-Sharing certificates and coupons wanted. Will pay 70c per hundred for certificates and 14c per hundred for coupons, etc. We buy all kinds of coupons, etc. State what you have. Zim's Coupon Exchange, 2426 Polk St., Chicago.

#### SAFETY BLADES SHARPENED

**RESHARPENED** by our "New Process" 2c each. Guaranteed better than new. Each blade honed, hair-tested, sterilized, wrapped individually. Jones Keenedge, Dept. A, Jamaica Plain, Mass.

**GILLETTE** Safety Blades sharpened 2 cents each. Mail orders promptly attended to. John M. O'Donnell, 811 S. 20th St., Phila.

**SAFETY** Blades sharpened 2c each. Razors ground, honed and set 40c. Work guaranteed. Ten years in cutlery business. Maspath Grinding Co., 25 Linden St., Masspeth, N. Y.

**SAFETY** Razor Blades resharpened 25c doz. Duplex 35c. Clipper grinding. Phelps, Moberly, Mo.

**SAFETY** razors sharpened; two cents each. Guaranteed. Blade box free. Electro Stropping Co., 134 Shelby St., Detroit, Mich.

#### FOR THE HOME

**PISON** Nuts: Most deliciously flavored nut grown. Large sample package postpaid, 10c. American Pison Co., Box 198, Albuquerque, New Mexico.

**FURNACE** Regulators—Start fire any hour. \$4 complete with clock. Will Haynes, 4057 Forest Park, St. Louis.

**MISSION** Furniture—Make your own at little expense. Complete instructions, working drawings and stock lists for 96 different pieces. Price \$1.50 postpaid for set of three books. Send for complete descriptive matter. Popular Mechanics Book Dept., 6 N. Michigan Ave., Chicago.

**SAVE** Coal and have your house warm when you arise, by installing a Peerless Automatic Draft Regulator. \$3.00 Complete. Manufactured by O. K. Landis, 423 Charlotte St., Lancaster, Pa.

#### HONEY

**FINEST** Quality White Clover Honey, crop of 1916, thirty lb. can \$3.60, two or more cans \$5.45 each. Sample 10c. Satisfaction guaranteed. Price list free. M. V. Facey, Preston, Minn.

#### DIAMONDS, WATCHES AND JEWELRY

**MONTANA** Sapphires in the rough direct from the Miner. Specimens 25c. Gems \$1 each. Richard Stingle, Phillipsburg, Montana.

**GENUINE** Diamond Chip Scarf Pins, 45 cents. Clarence Knudson, Sterling, Colorado.

#### PHONOGRAPHS AND RECORDS

**BUILD** Your Own Phonograph. Any type. Big saving. Patents expired. Profits making and selling them. We furnish parts you can't make. Full instructions, dimension drawings, illustrations, parts—price-list only 25c. Circular Free. Associated Phonograph Co., Dept. P, Cincinnati, O.

**RECORDS** for Victor, Columbia, Edison (disc or cylinder) Talking Machines, bought, sold, exchanged. Edison Standard 9c; Blue Amberol 25c; Victor 15c up. Well Permant Jewel-needle \$1.00, Victrola or Gramofola Jewel-point attachment to play Edison records \$2.00. Send for Record List. Well's Curiosity Shop, 20 S. Second Street, Philadelphia, Penna.

#### PIANOS AND MUSICAL INSTRUMENTS

**YOU** can tune and keep your own piano or player piano in perfect condition. Van Atta's book on The Piano and Player Piano not only tells you but shows you every movement in their care, repair and tuning. 156 Pages. 51 Illustrations. Cloth. Price \$1.50 postpaid. Popular Mechanics Book Dept., 6 N. Michigan Ave., Chicago.

#### MUSIC

**LAUGH** from cover to cover. Get Luke McLuke's book of "Working Girl" Songs. Corn Fed, also his photograph, both for 25 cents stamps or coin. Facts Film Company, 416 First Nat'l Bank Bldg., Cincinnati, Ohio.

**FAVORITE** Old Home Songs—No home in the land should be without this book of 200 of the familiar old songs everybody loves. Words and music complete in a substantial volume 9 $\frac{1}{2}$ x7 inches in size. Price 50 cents postpaid. Popular Mechanics Book Dept., 6 N. Michigan Ave., Chicago.

**LEARN** Hawaiian Steel Guitar Playing. Use any guitar. Complete instructor 50c. Ukulele \$3.50. Frank Littig, 746 Maple, Los Angeles, Calif.

#### FORMULAS AND TRADE SECRETS

**BE** a Tempering Wizard. Tools and springs tempered by my formula, indestructible. Secret method never before divulged. You need it. \$1.00. Nonbreakable cold chisel free to every formula buyer. The Cold Chisel King. Stockton, Illinois.



75 MANUFACTURING Secrets 10c. 1,000 Formulas 25c. Resilvering mirrors—Luminous Paint—sneeze powder—itch powder, make printing cuts 10c each. All 50c. Catalog 2c. Ideal Book Shop, (N-1) Irving Station, Chicago.

**GUARANTEED Rubber Formulas.** We have compounds for any line of Rubber. Auto Tires, Tubes, Repair Stocks, Cements, Toy Balloons, Gloves, Etc. Write for our list. Rubber Compound Bureau, 24 Central Office Bldg., Akron, O.

**RENEW Old Dry Batteries cheaply.** 3 guaranteed processes and 150 formulas, 10c. "Ideal Book Shop" (N-1) Irving Station, Chicago.

20,000 FORMULAS, price \$1. Postpaid. Complete list 4c stamps. Edm Bromley, Watervliet, N. Y.

**RENEW Old Dry Batteries.** Three new processes for renewing old dry batteries at cost of few cents. Dependable guaranteed formulas. Sent postpaid with large list of money-making opportunities for 10c stamps or coin. Western Laboratories, Box 823, Visalia, California.

**ANALYSIS and Essays** honestly and correctly done by L. E. Tenney, Chemist, Potsdam, N. Y.

**OLD dry batteries** renewed easily without tampering, chemicals, expense, or money back. Directions 25c. No stamps. Western Sales Co., Herington, Kan.

**HIGHGRADE chemical specialties** are always in demand. We furnish guaranteed formulas for all lines. Ask for descriptive catalogue. Cole Chemical Company, Chicago.

**FOR a 50c Postal Order I will send you a formula for the best Paint and Varnish Remover in existence:** removes paint and varnish clean to the wood instantly with one application. Easy to make, 200% profit. Bruce Cody, 91 Hiawatha Ave., Toronto, Ont., Canada.

25 GOOD Formulas for 50c. List free. Cal Lutz Manufacturing Co., York, Pa.

#### TYPEWRITERS AND SUPPLIES

**LARGEST Stock of Typewriters in America.** Underwoods, one-fourth to one-half manufacturer's prices; rented anywhere, applying rent on purchase price. Free trial. Installment payments if desired. Write for catalogue 7c. Typewriter Emporium, estab. 1892, 34-36 W. Lake St., Chicago, Illinois.

**STARTLING values in Typewriters.** \$10 to \$15 up. Factory rebuilt. All makes. Shipped on trial. Write for our Special Offer No. 87-E. Whitehead Typewriter Co., 186 N. LaSalle St., Chicago.

**UNUSED typewriters 1/2 prices elsewhere.** Investigate free trials, stating make wanted. Co-operative Union, Covington, Kentucky.

**GOOD, serviceable typewriters, \$10 and up.** Post card brings list. First class ribbons, any standard machine, 35c. Hub Typewriter Co., 285 Devonshire St., Boston.

**FOUR Good Typewriters—Oliver No. 3, \$24.00; Oliver No. 5, \$32.00; Remington No. 6, \$19.00; Remington No. 10, \$40.00.** Will ship any machine C. O. D. Jos. Berg, Hendrum, Miss.

**SEND for list of Typewriter Bargains, new and rebuilt, cash, time or rent, 10 days' Free trial.** American Typewriter Exchange, 14 N. Dearborn St., No. 4, Chicago.

**TYPEWRITERS—Prices wrecked.** All Makes, Nearly New and Rebuilt, \$5.00 up. Coronas and other portable machines, \$10.00 up. Write for catalogue. Beran Typewriter Co., 59 W. Washington St., Chicago.

**ALL Makes on monthly payments.** See special L. C. Smith offer on page 106. Harry A. Smith.

**TYPEWRITERS, all makes factory rebuilt by famous "Young Process."** As good as new, look like new, wear like new, guaranteed like new. Our big business permits lowest cash prices, \$10 and up. Also, machines rented—or sold on time. No matter what your needs are we can best serve you. Write and see—now. Young Typewriter Co., Dept. 1053, Chicago.

#### DUPLICATORS AND DEVICES

**\$300 MULTIGRAPH** like new for \$100. Guaranteed. Russell Baum, Philadelphia Bourse, Philadelphia.

**"MODERN" Duplicator—A Business Get-ter.** Saves money, time, trouble. No glue or gelatin. Always ready. Easy to operate. 35,000 firms use it. 50 to 75 copies from pen, pencil typewriter. Letter size complete \$4.50. Satisfaction or money back. You need one. Write for free booklet now! J. E. Durkin, Reeves & Company, Pittsburgh, Pa.

#### MAILING LISTS

**MAILING Lists of 100,000 Iowa Farmers** arranged in County lists. Up-to-date. Write for prices and counties wanted. L. C. Scott, Bloomfield, Iowa.

**TYPEWRITERS' Farmers' Names 50c** 1,000. Müller, 1052b Germantown Ave., Philadelphia.

**50,000 GUARANTEED names of ministers** and doctors. Classified. \$1.00 per 500. Wm. Bertram, Saint Clair, Mich.

**200 TYPEWRITERS' names and addresses** automobile and garage owners 50c coin. G. Sword, Big Stone Gap, Va.

**1,000 LIVE Agents \$2.50; Prosperous Farmers \$1.50.** Also other classifications. Modern Name Supply, Milwaukee, Wis.

#### PRINTING, ENGRAVING AND MULTIGRAPHING

**STATIONERY** that individualizes your business. Describe your business; we submit sketches and suggestions. Expert service. Franklin Printing House, Lima, Ohio.

**1000 IMITATION typewritten letters,** \$1.75; 6x9 circulars, \$1.50; envelopes, \$1.65; ad. slips, \$1.00. Bargain list and elegant samples free. Good's Printery, Harrisonburg, Virginia.

**PRINTING Outfits—Presses, type, sup-plies, type novelties.** Send stamp for catalogue. Model Press, York, Penna.

**100 BOND Envelopes, printed, postpaid** 4c. Samples. "Fabian's," Hallettsville, Texas.

**BE sure you get our samples before placing** your order for stationery. Lithographed Letter-heads on 28-lb. Bond, \$4.50 per M. Statements, Bill-heads, envelopes, Checks to match, Rubber Stamps, Dept. 19, Nosco, Zion City, Ill.

**500 SWELL Linen-Finish Letterheads** printed two colors, \$2.50. Bond \$2.00, postpaid. Price list. Samples free. Starb & Co., Box P-5, Hamilton, Ohio.

**500 BUSINESS Cards postpaid 75c.** Printery, Finleyville, Pa.

**QUALITY Printing Prepaid.** 500 either envelopes, noteheads, cards, statements, \$1.35; 1,000, \$2.25; 1,000 envelope slips, \$1.25; 1,000 6x9 circulars, \$1.85; 500 linen-finish letterheads or envelopes, \$2.25; 1,000, \$3.50. Prepaid. Typewriter letters. Stamp brings samples. Model Company, Manchester, Iowa.

**PRINTING That Satisfies—100 bond en-velopes and letterheads, \$1.25, prepaid.** Booklets and folders a specialty. Samples. National Printing Co., 501 S. Lafayette St., South Bend, Ind.

**100 CARDS and Leather Case with name in Gold, \$1.00.** California Views, Oil Painting reproductions for framing, 10c each. W. T. Lee Co., Monterey, Calif.

**GUMMED Labels direct from the pro-ducers; 3,000, 75c.** Catalog No. 102 on request. Royal Label Company, 488 Cherry, Philadelphia.

**GUMMED Labels—Printed to order—our** specialty. Get catalog 15. Stephens-Wetzel Co., Madison Square, New York City.

**QUALITY printing prepaid.** 1,000 envelopes \$2.00, 1,000 letterheads \$3.00. Lowest prices on cards, tags, circulars, etc. Samples free. Geo. Foerst, 181 Meserole Ave., Brooklyn, N. Y.

**AT Last! Beautiful Lithography for small** users. 1,000 Letterheads, 1,000 Billheads and 1,000 Statements, \$9.62. Engraving Free. Kayode Lithographing Co., 764 Teutonia, Milwaukee.

**350 BUSINESS Cards \$1.00.** August Fischer, Keller Bldg., Louisville, Ky.

**GUMMED Labels!!! Any size!!! Catalog** Free!!! Edward Harrison, Baltimore, Maryland.

**BUSINESS Courtesy Seals, 50 samples,** 10 cents. Circular free. Helmers Company, Hoboken, N. J.

**150 ENVELOPES, 150 letterheads, size** 6x9 1/2 inches, printed and mailed for \$1.00. Samples free. San Co., East Worcester, New York.

**SPECIAL! 50 Ivory cards printed, 15c;** 100, 25c; 100 white envelopes, 67c, 35c. Satisfaction guaranteed. Howard Trimmell, Newfield, N. J.

**GOOD Printing at low prices, 1,000 good** letterheads, envelopes, card, billheads, labels, circulars, \$2.50. Samples free. Catalogs, booklets and circulars our specialty. Ernest L. Fautus Co., 525 S. Dearborn St., Chicago.

**PRE-USED Printing Presses, Type, Sup-plies; good material, lowest prices.** List for stamp. Popular Bargains, Richland, Pa.

**YOUR name on fifty Styloprint visiting** cards, 25c. Card case free. Bridgen Co., 295 Moody St., Waltham, Mass.

**ENVELOPES, Statements, Billheads,** Cards printed, \$1.50 per thousand. Other printing low. Samples free. J. M. Hunt, Lambertville, N. J.

**200 WHITE Bond letterheads, \$1.00 pre- paid.** Kinnier, Box 206, Brooklyn.

**MULTIGRAPH Letters, Letterheads—**1,000 complete, \$3. Letters purple, heads black. Samples for stamp. Perfection Letter Company, Muncie, Indiana.

**GUMMED labels—3,000, 60c; 50pp, cata- logue, 2c.** MacTaggart, 1233 Arch, Phila- delphia, Pa.

#### PATENT ATTORNEYS

**PATENTS Wanted.** Write for list of Patent Buyers who wish to purchase patents and what to invent with List of Inventions Wanted. \$1,000,000 in prizes offered for inventions. Send sketch for free opinion as to patentability. Write for our four Guide books sent free upon request. Patents advertised Free. We assist inventors to sell their inventions. Victor J. Evans & Co., 106 Ninth, Washington, D. C.

**"PATENTS and Patent Possibilities" is** a 72-page treatise which tells all about patents, what to invent and where to sell it. It gives honest advice to inventors and tells about the successes of some of my clients, also explaining what are frequent causes of failure. Manufacturers are constantly writing for protective patents upon all kinds of sound inventions. Can you help supply their wants? The book is free. Write for it today. H. S. Hill, 905 McLachlen Building, Washington, D. C.

**PATENTS on Easy Payments.** Send sketch for free opinion as to patentability. Write today for our new book on what to invent and how to protect your invention under our new easy payment plan. C. C. Hines & Co., 591-A Victor Bldg., Washington, D. C.

**INVENT Something.** It may bring wealth. Free book tells what to invent and how to obtain a patent through our Credit System. Waters & Co., Succeeded by Talbert & Parker, 4280 Warder Bldg., Washington, D. C.

**HIGH-VALUE Patents.** See R. S. & A. B. Lacey's advertisement on page 135.

**PATENTS secured or all fees returned.** Do not miss the generous offers in E. E. Vrooman & Company's display ad on page 134.

**PATENTS without advance attorney's fees.** Send sketch for free report. Books free. Frank Fuller, Washington, D. C.

**PATENTS and inventions for sale or on** royalty. My clients have valuable inventions for market. No better investment for manufacturers or individuals. Full information without charge. Mention line of invention interesting you and data will be sent. Richard B. Owen, Patent Lawyer, Owen Building, Washington, D. C.

**KEEP up with progress.** Promote your patent. Send \$1.00 for year's subscription to best inventor's magazine, "Invention and Manufacturing." United States Patent Corporation, Washington, D. C.

**PROTECT your Invention.** Honest Advice. Personal Service. Write today for booklet, "The Truth About Patents." J. R. Kelly, Patent Attorney, 740A Woodward Bldg., Wash., D. C.

**MANUFACTURERS want new inventions.** I secure valuable patents and help make your invention a success when patented. Send for booklet, "Pointers about Patents." Lester Lyman Sargent, 709 9th St., Wash., D. C.

**PATENTS Secured or Fee Returned.** Actual search free. Send sketch or model. 1917 Edition, 99-page patent book free. My patent sales service gets full value for my clients. It should never require more than two days to report upon the patentability of your invention; nor longer than ten days to prepare your application for filing. Longer delay amounts to gross neglect and the jeopardizing of your rights. For prompt personal service write: George P. Kimmel, 212 Barrister Building, Washington, D. C.

**PATENTS—Send sketch for free search** and report. Books on patents and book of reference letters sent free. John S. Duffie & Co., 610 F St., Washington, D. C.

**PATENTS—Trade-Marks.** Send for my free book, "How to Get Them." It's full of information you should know. Joshua R. H. Potts, 8 Dearborn St., Chicago; 929 Chestnut St., Philadelphia; 805 G St., Washington.



**PATENT Your Ideas—\$9,000** offered for certain inventions. Books, "How to Obtain a Patent," and "What to Invent," sent free. Send rough sketch for free report as to patentability. Manufacturers constantly writing us for patents we have obtained. We advertise your patent for sale at our expense. Established 20 years. Address Chandler & Chandler, patent attorneys, 1059 F. St., Washington, D. C.

**INVENTORS:** Write our Patent Dept. Adam Fisher Mfg. Co., 2961C Railway Exchange, St. Louis, Mo.

**INVENTIONS developed:** see ad under classification "Models and Model Supplies." The Wm. Gent Machine Co.

**INVENTORS Attention—Get particulars** of my system before applying for patent through others. It saves you money, and keeps you in touch with, and in control of, your case at all times. W. N. Roach, Jr., 950 McGill Bldg., Washington, D. C.

**PATENT** what you invent. It may be valuable. Write me. No attorney's fee until patent is allowed. Estab. 1882. "Inventor's Guide" free. Franklin H. Hough, 522 Loan & Trust Bldg., Washington, D. C.

**PATENTS** procured on square deal fee plan with real service. We help sell the patent. Free booklet and advice. Milo B. Stevens & Co., 485 F. St., Washington; 353 Monadnock Bldg., Chicago. Est. 1884.

**PATENTS** bring riches; protect your invention. Attorney's fee payable when patent allowed. Plain advice and "Patent Facts" free. Trade-marks registered. Jaynes & Jaynes, 653 Kellogg, Washington, D. C.

**PATENTS** obtained through D. Swift being promptly sold to manufacturers. Write today for free books of "Inventions Needed," and surpassing references. D. Swift, 317 Seventh St., Washington, D. C.

**DON'T** lose your rights to patent protection. Before proceeding further send for our blank form. Evidence of Conception to be signed and witnessed. Book, suggestions and advice free. Lancaster & Allwine, 221 Ouray Bldg., Washington, D. C.

**C. L. PARKER,** Ex-member Examining Corps. Patent Office, Patent Attorney, McGill Bldg., Washington, D. C. Inventor's handbook, "Protecting, Exploiting and Selling Inventions," sent free upon request.

**PROTECTIVE** patents procured promptly. 104-page blue book on patents sent on request. Trade-marks registered. Robb & Robb, 211-215 Southern Bldg., Washington, D. C.

**UNPATENTED** inventions sold or no charge. Inventor's Advocate, K. Washington, D. C.

**H. L. WOODWARD—Safe** methods. Paying patents. Write today. 902 G St., Washington, D. C.

**PATENTS:** Send model, sketch or drawing. Advice, 106 Mechanical Movements and 50 Perpetual Motions, Free. Fred G. Dieterich & Co., 61 Ouray Bldg., Washington, D. C.

**PATENTABLE** Ideas Wanted—Send for 3 free books. R. B. Owen, 30 Owen Bldg., Washington, D. C.

**SEND** for "Words of Value to Inventors," free, before selecting your Patent Attorney. John B. Woodworth, Washington Loan Trust, Washington, D. C.

**THE Patent** is free. An education in obtaining patents. Established 1865. Anderson & Son, Attorneys, 707 7th St., Washington, D. C.

**PATENTS** that protect and pay. Advice and books free. Rates reasonable—highest references; best results. Watson E. Coleman, Patent Lawyer, 624 F St., N. W., Washington, D. C.

**PATENTS—Herbert Jenner,** patent attorney and mechanical expert, 696 F St., Washington, D. C. I report free of charge if a patent can be had and its exact cost. Send for circular.

#### FOR INVENTORS

**INVENTIONS** Developed—Real co-operation given you in handling all experimental work. Any mechanical device—no matter how intricate—developed and finished. Complete models built. Write us about your needs. Spies Special Machine Works, 692 Goddard Building, Chicago.

**PATENTS, Trade-Marks and Copyrights.** Our handbook on patents will be sent free on request. All patents secured through us are described without cost to the patentee in the Scientific American, Munn & Co., Patent Attorneys, 672 Woolworth Bldg., N. Y. Washington, D. C., office, 625 F St.

**INVENTORS.** We perfect your invention, make samples, dies, stamping and do manufacturing; easy terms; 22 years' experience. Backer & Gerding Mfg. Co., Dept. B, Opera Place, Cincinnati, Ohio.

**CASH** for ideas. List of needed inventions and book on Patents free. Sanders, 7 Webster Bldg., Chicago.

**INVENT** Something. It may bring wealth. Free book tells what to invent and how to obtain a patent through our Credit System. Waters & Co., Succeeded by Talbert & Parker, 4280 Warder Bldg., Washington, D. C.

**PATENTS** secured or all fees returned. Do not miss the generous offers in E. E. Vrooman & Company's display ad on page 134.

**HIGH-VALUE** Patents. See R. S. & A. B. Lacey's advertisement on page 135.

**PATENTS** Wanted. Inventors write for Free Booklet. Tells how to get the cash value of your invention. E. Wooten, Sta. F., Philadelphia, Pa.

**BOOK** of valuable information to inventors, including "How to Prepare Application for Patent," 25c. Legal Pub. Co., Box 183, Evanston, Ill.

**NO** Attorney fees until patent allowed. Send sketch for free report. Books free. Frank Fuller, Washington, D. C.

**PATENTS** on Easy Payments. Send sketch for free opinion as to patentability. Write today for our new book on what to invent and how to protect your invention under our new easy payment plan. C. C. Hines & Co., 591-A Victor Bldg., Washington, D. C.

**MAIL** Order and general agency articles bought outright or manufactured on royalty. Casburne, 1113 Chestnut, St. Louis.

**DON'T** Waste Your Ideas, time and money by poor designing. Have your mechanical and electrical designs, calculations, and drawings done by expert engineers of high standing. Engineers, 194 Brown St., Pittsfield, Mass.

**INVENTORS:** Experimental Work a specialty, machines, devices, and models perfected and built. L. Darby, 180 Mulberry Street, Newark, N. J.

**WANT** to invest \$10,000 in new invention of merit. What have you? Box 225, Sutherland, Oregon.

**HAVE** You An Idea? If so, you should protect it by a patent. Send us a model or sketch for free opinion as to patentability. Write for our Four Books sent free to any address. Victor J. Evans & Co., 157 Ninth St., Washington, D. C.

**INVENTIONS—Patenting** and promoting. A book containing practical advice and directions for inventors and manufacturers. Book, suggestions and advice free. Lancaster & Allwine, 221 Ouray Bldg., Washington, D. C.

**INVENTIONS** developed: see ad under classification "Models and Model Supplies." The Wm. Gent Machine Co.

**INVENTIONS** commercialized on cash and royalty basis. Patents secured. Models, experimental work and contract manufacturing. Inventors should write at once. Adam Fisher Mfg. Co., 2961A Railway Exchange, St. Louis, Mo.

**COMMERCIAL** Success depends on skilled designing of your special machine or device. Working drawings, tracings. Designer, Box 4798, Philadelphia, Pa.

**HAVE** you a Patent to sell? You'll be interested in my proposition. Write now for free particulars. Don't call. F. W. Johnson, 6 N. Michigan Ave., Chicago.

**UNPATENTED** inventions sold or no charge. Inventor's Advocate—M., Washington, D. C.

**INVENTIONS** developed. Models, Tools, Dies, Special Machinery. Send sketch. I do work promptly. Carl C. Gerlach, 3966 Woodbine, Cleveland.

**INVENTIONS** Developed. Dies, Tools, Stamping, Advertisements Written, Products Marketed; Correspondence Confidential. Akron Metallic Gasket Co., Akron, O.

**PATENTABLE** Ideas wanted. Send for 3 free books. R. B. Owen, 30 Owen Bldg., Washington, D. C.

**WANTED—An Idea!** Who can think of some simple thing to patent? Protect your ideas; they may bring you wealth. Write for "Needed Inventions" and "How to Get Your Patent and Your Money." Randolph & Co., Patent Attorneys, 620 F St., Washington, D. C.

#### PATENTS FOR SALE

**AUTOMOBILE** Transmission. Three speeds forward and reverse. Gear stripping, clashing and that grinding noise impossible. Three Multiple-disc clutches, automatically operated by one speed shifting lever and controlled by one foot pedal, makes this the future Fool-proof Transmission. Broad patent. Model to demonstrate. Royalty preferred. Charles R. Scott, Inventor, Wyandotte, Oklahoma.

**SKIRT-GAUGE,** simple in construction, perfect work, inexpensive. L. V. Watkins, 816 Woodard St., Denison, Tex.

**COMBINED** Electric Hand Warmer and Steering Wheel Cover ("Grip") Laced on. Barnes, Stanbridge East, Quebec.

**CANADIAN** Patent—Rug Shampoo-powder. \$1,200, \$400 cash, balance as made from business. Marvelous demonstrator for stores. Agents, Enormous profits. Dollar package delivered any address 25c. McCombe Brothers, Chemists, 2980 Bainbridge, New York.

**MOBILE** Step Ladder, operated on any step, compact, simple. Eliminates scaffolding. Cart, folded. Sale. Royalty. Merle Faxon, Att'y, Kankakee, Illinois.

**FOR** Sale, Canadian Patent on a Combined Dishpan and Drainer. A household necessity. Now being manufactured and sold in the U. S. A. Large profits to investor. Address E. H. Sietema, Little Rock, Iowa, U. S. A.

**ELECTRICAL** Time Starting Device for Elevators. In satisfactory use over two years. L. E. King, 119 S. Clark St., Chicago, Ill.

**DEVICE** for removing cream from milk bottle. Simple. Cheap. Sanitary. L. E. King, 119 S. Clark St., Chicago, Ill.

**IMPROVED** patented Feed Bag for Horses for sale on cash or royalty. Good light manufacturing or Mail Order proposition. Waters & Co., 16116 Warder Building, Washington, D. C.

**NEW** Patent Target for sale, or on royalty. John Neumann, Amber, Ia.

**SELF-WRINGING** Mop; practical, inexpensively manufactured. Outright or royalty. J. L. Williams, Lock Box 64, DuPont, Wash.

**WANTED** Partner to pay fees on four gas engine patents for half interest. Kelly 7th Ambulance Company, Military Post Office, Columbus, New Mexico.

**PATENTS** Applied For, Chocolate Vending Machine for theatre seats; inexpensive to manufacture. Perfume Vending Machine, absolutely perfect. J. Elmer Lane, Hammondsport, N. Y.

**TOBACCO** and Cabbage growers: Transplanter. Enclose 4c for circulars. Carl Christensen, Windsor, Wis.

**MANUFACTURERS:** Have valuable invention to place on royalty basis. Device prevents ladders tipping or slipping on uneven surfaces. Nelson I. Smith, Winsted, Conn.

**PATENTS** Pending. My two Automobile locks, one for Fords, simplest, most efficient yet devised; no padlock proposition. Cash or royalty. P. Petersen, Box 1409, Los Angeles.

**FOR** Sale or Lease. Revolutionary improvement in Glare hammer. Extremely practical and simple. Just patented. Millions will be sold. Address J. F. Walton, Bastrop, Texas.

**VALUE** Indicator, patented, 1,193,917. Light manufacture, staple, meritorious article. \$5,000. Jasper C. Lawson, Calexico, Calif.

**MACHINE** for cracking nuts. Patented. Costs eighteen cents. Sells for one dollar. McDonald, Box 333, Gallatin, Mo.

**OFFICE** Door Sign Holder (patent allowed). A little all-metal device attaches to wooden part of door and holds name or announcement card flat against ground glass (inside). No more lost thumb-tacks or bent pins. A long-felt want supplied. Send for circular right this minute. You'll be delighted. J. F. Rogers, Hotel St. Paul, New York City.

**PATENT** on new staple article used on every steam engine. Possible sale for millions. Practically no competition. C. E. Edgar, Kansas City, Mo.

**THRILLING** electrical War Game. Royalty preferred. H. Warden, Farragut, Washington, D. C.

**U. S. PATENT** on corn planter and drill to be attached to cultivator for replanting. R. E. Pierce, Brimfield, Ill.

**WANTED—Information** regarding good Patent for sale. Northwestern Business Agency, Minneapolis, Minn.



"CAN Opener." Opens any size. Prevents cutting hand. Patent Pending. Outright or Royalty. Jostah R. Reynolds, P. O. Box 34, South Lakewood, N. J.

"PEERLESS Gasoline Saver." A device made to save gasoline and increase the power of motors. An auxiliary air supply device that works automatically and is adjustable to any size motor. Now on the market and found to be the most practical. Leading men of the Aeroplane field approve and use it. Hawley-Smith Mfg. Co., Watkins, New York.

U. S. PATENT combination ironing board and chair; will sell cheap; seen and demonstrated at 3063 Clinton Ave., Cleveland, Ohio.

PATENT Buyers are invited to address our sales department for information on any class of Patents they wish to purchase or lease on a royalty. We have secured a number of valuable patents in all lines of invention. Mail Order, Department Store and Household Novelties a specialty. Victor J. Evans & Co., 169 Ninth St., Washington, D. C.

WE have some money-making inventions for placing on royalty; outright sale or trade. Write Adam Fisher Mfg. Co., 2061E Railway Exchange, St. Louis, Mo.

WILL sell or trade for real estate. Household novelty. Manufacturing cost cheap. Good seller. Lester Ryan, Smithfield, Neb.

#### MODELS AND MODEL SUPPLIES

HARD rubber articles developed and manufactured. Models quickly and cheaply made in rubber or metal. Working drawings furnished. Send sketch for free estimate. Strictly confidential. Swanberg, 1459 Melrose Street, Chicago.

MODELS, Punches and Dies. Patents Perfected. The Sachs-Lawlor Co., Inc., Established 1881, 1543 Larimer St., Denver, Colo.

WANTED—New Ideas. Write for list of Patent Buyers and Inventions Wanted. \$1,000,000 in prizes offered for inventions. Our Four Books sent free upon request. Victor J. Evans & Co., 163 Ninth, Washington, D. C.

WE make working models for inventors; also dies and stamping of specialties, and carry a complete stock of brass gears and model supplies. Send for catalogue. The Pierce Model Works, 3446 Pierce Ave., Chicago, Ill.

NEW Lithographic Model of a Monster Mallet Compound Locomotive. All parts shown and numbered. Size, 2x19 in. in color. Other models in series are, Atlantic Type Locomotive—Steamship—Gas Engine—Steam Engine—Steam Turbine—Dynamo—Wireless Telegraph. Price, 50c each or set of 8 for \$3.50, postpaid. Popular Mechanics Book Dept., 6 N. Michigan Ave., Chicago.

INVENTIONS developed. The specialists who develop Auto accessories, gasoline engines, electrical appliances, electric signs, repeating rifles, automatic cigarette-making machines, weighing, vending, photograph, moving picture and lead pencil printing machines; turbines, air, electric and steam motors and other intricate devices are at your service. They'll handle your development, drawings, experimental work, patterns, models, special tools, dies stampings, castings, plating, forging and spinning in our big plant—covers two acres. Make any metal novelty. Complete organization for developing and manufacturing. Advice backed by 30 years' experience free. Send drawings or samples. The Wm. Gent Machine Co., Cleveland, Ohio.

PERFECT models sell inventions. We make them. Write Adam Fisher Mfg. Co., 2061E Railway Exchange, St. Louis, Mo.

PRODUCERS of Results: Inventions developed. Models, Experimental work, anything special in metal to order, novelties, spinning, forging, castings in any material, electrical devices, patterns of all kinds, plating, general manufacturing, designing, special tools, punches and dies, stampings. Send drawing or sample. Expert information free. The John's Machine & Stamping Works Company, Dept. C, Cleveland, Ohio.

MODEL making. Inventions developed. Write for estimate. Stearns, Paxton, Ill.

SEE my advertisement under "Manufacturing." Don't fail to write me. It will pay you. R. G. Clyne, Columbia Bldg., St. Louis, Mo.

#### MANUFACTURING

WOOD and Metal Patterns. Metal Specialties on Contract. Iron, Brass, Aluminum Castings. Welch Brothers, North Chicago, Ill.

WANTED—Machine work. Modern plant and foundry. J. & L. equipment. Medium and light punch press work. The Challenge Machinery Co., Grand Haven, Michigan.

INVENTIONS manufactured under contract. Write Adam Fisher Mfg. Co., 2061E Railway Exchange, St. Louis, Mo.

MODELS, tools, devices, machines made as you direct. Ideas prepared for economical manufacture. Thirty years manufacturing experience. Central Specialty Co., Jersey City, New Jersey.

INVENTIONS developed; see ad under classification "Models and Model Supplies." The Wm. Gent Machine Co.

WIRE Goods, all kinds, made to order. Cooley Mfg. Co., 553 W. Monroe St., Chicago.

INVENTORS and Manufacturers: I design and build special machinery, tools, models, patterns, make drawings, tracings and blue prints Efficient Engineering Laboratory—Modern Shop—Expert Workmen. No job too large or too small. R. G. Clyne, Columbia Bldg., St. Louis, Mo.

#### REAL ESTATE AND FARM LANDS

THE South for Farm Profits. Why not look for a farm home in the South? Farm lands, for the time and money invested, pay larger profits than elsewhere. Two to four crops a year, good yields; best prices for products. Good locations in healthiest, most pleasant districts \$15 an acre up. Write for our literature and the special information you wish. M. V. Richards, Ind. and Agr. Comm., Room 64, Southern Railway, Washington, D. C.

WANTED: Fifty young men to build farms on rich cut-over lands in Northern Wisconsin. Price \$25.00 an acre, one dollar an acre cash, balance ten years. Send for booklets published by state of Wisconsin. B. B. Clarke, Madison, Wis.

FOR Sale—640 acres wild grass land—none broken—20 miles N. E. of North Platte, Nebraska. Land is rolling and good pasture land. Already fenced on two sides; 100 acres or more, level and suitable for farming. \$6 per acre. Address H. H. Windsor, Popular Mechanics Magazine, Chicago.

CALIFORNIA—Catalog of Farms, Groves, Suburban homes, sent free. Wagner Farm Agency, 633 South Spring Street, Los Angeles, California.

DO you want land? Irrigated lands are best. Poor man's opportunity. Write Clyde Hensley, Hillrose, Colorado.

FOR Sale—40 Acre Fruit Farm near Benton Harbor; 1,800 trees, 10 acres grapes. L. Hosmer, Coloma, Mich., R. No. 3.

BUY a 5 or 10-acre improved Vegetable Farm in Famous Celery Delta and Flowing Wells District, Sanford, Florida. Immense profits. Agents wanted. Write for Booklet. Howard Brothers, 505 Victoria Building, St. Louis, Mo.

VIRGINIA and North Carolina farms \$15 per acre and up. Easy payments. Fruit, dairy, stock, climate, schools, churches, roads, markets, and neighbors of the best. Get our farm lists, magazine and other interesting literature, all free. Address F. H. LaBaume, Agri. Agt., N. & W. Ry., 250 N. & W. Bldg., Roanoke, Va.

MONEY-MAKING Farms, 15 states, \$10 to \$50 an acre; stock, tools and crops often included to settle quickly. Write for Big Illustrated Catalogue. E. A. Strout Farm Agency, Dept. 3043, 159 Nassau St., New York.

COME away from the snow. Homes, Farms, Lands in Southern States. Big crops. Low prices. Lists free. Geo. M. Heath, 712 American National Bank, Richmond, Va.

IT'S Different—New Port Richey surpasses anything in Florida; on the Gulf Coast and navigable river; unexcelled boating, fishing and hunting; tropical scenery, ideal climatic and health conditions; high rolling pine and hammock lands; on Dixie Highway, within two hours' ride from Tampa and St. Petersburg; fastest growing town in state—and prices have not yet gone sky high. Send for Booklet, Board of Trade, Box 103, New Port Richey, Fla.

SMALL truck farm for sale. F. H. Gifford, Fair Oaks, Ind.

LANDOLOGY, a magazine giving the facts in regard to the land situation. Three months' subscription, free. If for a home or as an investment you are thinking of buying good farm lands, simply write me a letter and say, "Mail me Landology and all particulars free." Address Editor Landology, Skidmore Land Co., 40 Skidmore Bldg., Marinette, Wis.

KANSAS Wheat Land; best wheat belt in U. S.; one crop pays for land. Box 653, Kansas City, Mo.

1,000 ACRES, Alabama, \$6,000. Terms, Investment, farm or Southern home in the making. Thomas Pankey, Galesburg, Illinois.

CALIFORNIA Government land, free, for you. Booklet dime. Joseph Clark, Sacramento, Cal.

CALIFORNIA land \$1 per acre cash. Balance purchase 90c month per acre. Immediate possession given. No taxes. No interest. Level San Joaquin Valley. Only four hours from San Francisco. 5 acres up. Clear; ready to plow; open ditch irrigation \$1 acre per annum. Particulars, maps, photographs, free. Stevinson Colony, Desk D, 785 Market St., San Francisco.

CALIFORNIA suburban farms near Los Angeles for sale, easy payments. E. R. Waite, Shawnee, Oklahoma.

BEAUTIFUL Seashore Homesites only \$20. Special sale lots at Alamo Beach, Texas, famous Bayshore resort. First 100 lots \$20. Terms \$1 cash, \$1 monthly. Lots 50x140 feet. Splendid investment. Write for free literature and views. Alamo Beach Company, 412 First National Bank, Houston, Texas.

TEXAS school land for sale by the state at \$2 an acre; 5c per acre cash, and balance in 40 years at 3 per cent; send 5c postage for further information. Investor Pub. Co., Dept. 4, San Antonio, Texas.

FLORIDA—Twelve-acre truck farm, improved, irrigated and water protection. F. C. Armstrong, Terra Ceia, Fla.

A SMALL farm in California will make you more money with less work. You will live longer and better. Delightful climate. Rich soil. Hospitable neighbors. Good roads, schools and churches. Write for our San Joaquin Valley Illustrated folders free. C. L. Seagraves, Industrial Commissioner, AT&SF Ry., 1933 Ry. Exch., Chicago.

I HAVE a successful way of selling farms and farm lands. Write me for free particulars. No obligation whatever. Don't call. E. J. Zimmer, 925 Tower Bldg., Chicago.

SELL your property quickly for cash, no matter where located. Don't pay big commissions. Particulars free. Real Estate Salesman Co., Desk B, Lincoln, Nebr.

#### GINSENG

GINSENG: Best \$10.00; Golden Seal \$5.00 pound. Fortune raising. Learn nature, habits, raising. Book Ginseng and other Medicinal Plants, 367 pages, 100 illustrations, \$1.10. A. R. Harding, Columbus, Ohio.

#### DOGS, BIRDS, POULTRY, PETS

TRAINED Rabbit Hounds, Foxhounds, Coon, Opossum, Skunk, Squirrel Dogs, Setters, Pointers, Ferrets. Catalogue, 10c. Brown's Kennels, York, Pa.

"HOW to Make 100-Egg Electric Incubator." Illustrated. 25c. E. Bailey, Kerrisdale, B. C.

RAISE Belgian Hares for Us. Big profits. We furnish stock and pay you \$2.00 each. Also Cavies, mink, skunk, fox, squabs, frogs, etc. Two booklets and contract for dime. None free. Address the Belgian Hare, 31 Main Street, Holmes Park, Mo.

PEDIGREED Airedales, R. Dare, 2235 Fillmore St., N. E., Minneapolis, Minn.

\$1.00 A PAIR. We pay that for Belgian Hares. Particulars for stamp. Address Northwest Rabbitry, WF161, Sunnyside, Wash.

PEDIGREED Scotch Collie Dogs, Walter B. Beck, 153 Ford Ave., Detroit, Mich.

BELGIUM Shepherd Puppies. Cheap. Eight months old. 4690 Prairie Ave., Chicago.

FERRET Facts—Splendid book on raising, training for rats, rabbits, skunk, etc. Post-paid, 75 cents. A. R. Harding, Columbus, Ohio.



# Trained DRAFTSMEN WANTED!

## READ THIS LETTER

If you doubt the great opportunities open to the young men of this generation, read President Morey's letter below. Never before in America were the conditions so favorable.

"I have been asked to state what, in my opinion, will be the opportunities of the next few years for the man who takes up Engineering, Architecture, Contracting, Drafting, etc. I can best forecast the future by looking at the past.

For many years it has been impossible to secure enough trained draftsmen. By trained draftsmen I mean men who can go ahead and do things right. Such men are worth their weight in gold. Good draftsmen, men who are trained right, quickly advance out of the drafting room and become engineers, superintendents, managers, etc., where salaries of \$10,000 or \$15,000 per year are common.

More than a decade ago, with other engineers, I established the Chicago Technical College for the sole purpose of training up good draftsmen for our engineering offices. Since then hundreds of men, now drawing big salaries, have secured their start in our day and evening classes and hundreds of others have become expert draftsmen through home study. I have employed many of them in my own engineering office and have placed the others in equally good positions.

But it is still impossible to get enough trained draftsmen, I have calls for men every day. The engineering firms, architects and contractors associated with me are constantly asking for our graduates. They know what these men can do. Will the call for men continue? It certainly will. America has only begun to realize her possibilities. The next few years will witness a wonderful development of her resources. The demand for trained men will be even greater than heretofore. The young man of today has an opportunity that was undreamed of a few years ago. Will he improve it? The far-seeing ones are already doing so."

*Charles W. Morey*

President Chicago Technical College  
Manager Morey & Co., Engineers

## A CHANCE TO LEARN DRAFTING FREE

On account of the rapidly increasing demand for trained draftsmen, President Morey has issued orders that instruction be furnished to a limited number of young men who are inclined along engineering or architectural lines.

The College has set aside a limited number of Free Scholarships and will give the regular \$45 Course in Mechanical Drafting, FREE, with any of the Home-Study Courses named in the coupon below. A complete drafting outfit of highest grade is also included. This offer will be withdrawn as soon as allotted number of FREE Scholarships has been awarded. Send NOW for full information—it's FREE!

## SCHOLARSHIP COUPON MAIL TODAY

Mr. Morey: Without any obligation on me, please send FREE information. Show me how I can quickly become an expert in the branch marked.

- ARCHITECTURAL DRAFTING
- MACHINE DRAFTING
- ELECTRICAL DRAFTING
- STRUCTURAL DRAFTING
- CIVIL ENGINEERING
- BUILDERS' COURSE
- PLAN READING
- ESTIMATING
- SHEET METAL DRAFTING
- SURVEYING

Name \_\_\_\_\_

Address \_\_\_\_\_

Town \_\_\_\_\_ State \_\_\_\_\_

College or Home-Study Course \_\_\_\_\_

Address CHARLES W. MOREY, President

**Chicago Technical College**

1050 Lake View Bldg., 116 S. Michigan Ave., Chicago

A Drafting Class at the Chicago Technical College

You can get this same training in your own home by the new "Chicago Tech." method.



CHARLES W. MOREY  
President of the College  
and head of a large Chicago firm of civil, mechanical and electrical engineers and contractors.

A Group of High Salaried Draftsmen in our Engineering Office

Please Mention Popular Mechanics



## Continued from Page 32

**EGG-O-HATCH** applied to eggs during incubation strengthens the chick and weakens the shell. It supplies free oxygen, absorbs the carbon dioxide and rots the shell. Makes better hatches of stronger chicks. Booklet free. Sample, treats 100 eggs, 10 cents. Package, treats 600 eggs, 50 cents, postpaid. Geo. H. Leo Co., 506 Leo Bldg., Omaha, Neb.

**RELIABLE Poultry Magazine**, 28th year; best writers, most practical and helpful; tells how to feed, house and raise poultry successfully; beautifully illustrated; 50c year, three months' trial, 10c; sample free. Poultry Success, Dept. N., Springfield, Ohio.

**COLLIES**, St. Bernards, dunes, fox terriers, poodles, rat terriers, Boston terriers, bull terriers, pointers, and setters. Write for price list. Violet Hill Kennels, York, Pa., Route 2.

**RAISE Frogs**; interesting and profitable. Our book tells how; \$1.00. W. T. Lee Co., Monterey, Cal.

**MINIATURE Pomeranian puppies**, pedigree, \$35 upwards. 6833 Ellis Ave., Chicago.

**COLLIES**—Stock, farm and watch dogs. Pedigreed; circular free. Nighborn Kennels, St. Peter, Minn.

**TRAINED Hunting Dogs**. Game Chickens. Walter Odorn, Durant, Miss.

**MAKE money** breeding Plymouth Rock squabs. 1917 markets highest on record. We teach you how to sell best as well as raise. Write at once for big free book to the founder of the squab industry, Plymouth Rock Squab Co., 634 Howard St., Melrose Highlands, Massachusetts.

**RAISE Guinea Pigs** for us. We furnish stock reasonable, and buy all you raise at \$1.00 a pair. Interesting literature free. Address Kline's Caviary, Dept. 22, Holmes Park, Mo.

**GOLDFISH**, plants, globes, aquariums. Circulars free. Aquariums to order. Dealers write for wholesale prices. Pioneer Goldfish Hatchery, Racine, Wis.

**PEDIGREED Airdale Pups**. Green Tree Farm, Clementon, N. J.

**RAISE Guinea Pigs**. We furnish stock, show you how and buy all you raise. Big demand. Thousands needed yearly. Easy to raise, very profitable and profitable. Particulars and contract for two-cent stamp. Cavies Distributing Co., 707 West 74th St., Kansas City, Mo.

## PERSONAL

**MINERAL Water**. Looks like whiskey, keeps forever. Sufferers skin, throat and stomach troubles; Stop taking drugs and order a 50c 30-dose bottle from A. L. Teeters, Wynne, Ark.

**BROTHER**—Accidentally discovered root cures tobacco habit. Gladly send particulars. F. Stokes, Mohawk, Florida.

**FALCONER**, Wm., electrician, formerly of St. Louis, is requested to send his present address, "J. G." % Popular Mechanics Magazine, Chicago.

**ST-STU-T-T-TERING** and stammering cured at home. Instructive booklet free. Walter McDonnell, Room 40, 817 Fifteenth St., N. W., Washington, D. C.

## ANTIQUES AND RELICS

**FLINT Lock Guns and Pistols**, War and Indian relics. Many other antiques. List for 2c stamp. Davis Brothers, Kent, Ohio.

**INDIAN Relics**. Clearing-out sale. 40-page list free. A. D. Grutzmacher, Mukwonago, Wis.

**INDIAN Beadwork and Curios**. Largest collection of genuine Sioux work in the World. Send 10c for price list. Strong Curio Co., Gordon, Nebr.

**INDIAN Baskets and Relics**. Price free. Gilham, Highland Springs, Cal.

## MISCELLANEOUS

**OPALS**—Fire brilliant. Imported direct from Mexico, neatly packed, 25c each. Mexican pottery, statuettes, typical Mexicans, decorative for mantle or drawing room, \$2.50 postpaid. Revolutionary photo postals, battles, actual executions, noted characters, sets 50c for ten. The Willing Sales Co., El Paso, Texas.

**ONE Hundred Personal or Professional Cards Fifty Cents**. Genuine leather card case free with each order. Write for samples and type list. Elite Card Print Co., Sta. 4, Jackson, Mich.

**NEW \$2.50 Automatic Adding Machine**. Circular free. Bassett, 5921-B Indiana Ave., Chicago.

**CUTS** anybody can make. Simple, cheap process. Specimens, particulars for stamp. M. Day, Windfall, Ind.

**RUBBER Stamps**. Manufacturer to user. Stamp for catalog. F. G. Bonds, Middletown, N. Y.

**LEARN to Entertain**—Send 25c for marvellous billiard ball trick. They multiply and vanish. One of four leaders. Any of our wonderful tricks will mystify your friends and prove a passport to society. Illustrated catalog free. The Bailey Co., 120 Lisbon Building, Cambridge, Mass.

**MAIL \$1.00** for latest improved 14-K gold self-filling fountain pen, guaranteed against defects. Money refunded after two weeks' trial. Anton A. Frank, Fountain Pen Headquarters, Established 1893, 110 N. Dearborn St., Chicago.

**SEND 10c** for blue printed details of classy combination drawing board and library table containing 2 secret drawers. Also lot of valuable technical information. R. W. Spaulding, 318 Ferry, W. Detroit, Mich.

**NAME Plates** 3x3, fancy chipped glass, any name or numbers, sent to any address postpaid for dollar bill. Box 405, Caldwell, Ida.

**RUBBER Stamps**—Quick Service, Best Prices. Samples Mailed. Responsible agencies wanted. Ashland Stamp Works, Ashland, Ohio.

**ADVICE** or reliable information on any subject; Business, Educational, Social, etc. Satisfaction guaranteed or money refunded. National Information Bureau, 112-C No. LaSalle St., Chicago.

**LOCKSMITHS**. How to unlock cylinder and all locks, 100 tricks of the trade \$1.00; money back if dissatisfied. Boutson, 3005 Brook St., Oakland, Cal.

**KEY Ring**, Hook and Name Check, with your name, address and lodge initials on, postpaid 25c. R. Wiese, Atlantic, Iowa.

**ESCAPE King's set of Three Keys** will open most ordinary doors. 25c complete set. Padlock Opener, 10c. Chicago Novelty Works, 3310 Herndon St., Chicago.

**TATTOOING Supplies**. Write at once for my Catalogue. Don't be fooled by amateur manufacturers and imitators. Only reliable machines and outfits manufactured. Prof. J. Barber, 70% Brush St., Detroit, Mich.

**RUBBER Stamps**, Sign Markers, Catalogue 10c. Florida papershell pecan nuts, very delicious, \$1.25 pound; samples 10c. Walter Karstaedt, Dayton, Ohio.

**WE make glass specialties** and lens mirrors to order. H. Pirr, 39 Dale St., Rochester, N. Y.

**CUTS** anybody can make. Simple, cheap process. Specimens, particulars for stamp. T. Day, Windfall, Ind.

**FALSE Teeth**—When you break your plate in any way, mail it to me and I will repair it like new for \$1.50. M. Wagner, Dental Laboratory, Phelan Bldg., San Francisco, Cal.

**GRANDFATHER'S Clock Works**, \$5. Slightly shop-worn, quantity limited, others with chimes, all prices; also several nice grandfather's clock cases, exceptional bargains. Clock Company, 1673 Ruffner St., Philadelphia, Pa.

## FINLAY ENGINEERING COLLEGE

1001 Indiana Ave., KANSAS CITY, MO.

Only School of the Kind in the West



## Special 6 Weeks' Courses

in wiring, Armature winding, and operating Steam, Gas, and Electric Machinery. Any student enrolling in any of the above courses will be entitled to an

## Auto Starting Course Free

Night and day classes — enroll any time.

The old reliable, practical, technical college. Only school of the kind in the West. Courses from the simple Auto to Electrical Engineer. Specialties, Electricity, Steam, Gas. Also Auto-Tractor work. Time required for regular courses, 3 months, 1 year, and 2 years.

## HERE'S WHAT WE TEACH:



Electricity

Steam

Gas

Automobile

## THIS IS HOW WE TEACH:

by books, by models, by professors, by regular shop work and by actual machines in operation. Make your start to a big salary at once! Investigate our school before going elsewhere. Not crowded. Write today for catalogue F.

H. Finlay, Pres., 1001 Indiana Ave., Kansas City, Mo.



# Learn Electricity! Plumbing—Bricklaying

## Earn \$125 to \$300 a Month

That's what many of our graduates earn right from the start. That's what **YOU** can earn if you become a **COYNE** trained man. All of these trades offer exceptional opportunities. Thousands of high-salaried positions are open. We are constantly receiving calls for our graduates. On small capital you can start a business of your own and become entirely independent.

Any man between the ages of 15 and 50 who is ambitious, can learn one of these big paying trades thoroughly in a short time in our \$93,000.00, perfectly equipped shops, at small expense. No special education necessary.

16 YEARS OF SUCCESS



TRADE MARK

# COYNE

## National Trade Schools

### Largest and Best Equipped in America

Every year for 17 years we have sent hundreds of men out as skilled mechanics to help supply the rapidly increasing demand.

We teach all these big paying trades under actual working conditions. No classes; no books; no correspondence teaching. Each man is instructed individually right in our big shops. You learn by doing actual jobs with actual tools which we furnish free. Trained men show you every step. Many students

## FINISH IN 3 MONTHS

Drafting, Estimating and Plan Reading included in ALL courses. We charge a small tuition fee which can be made in easy payments if desired. All equipment and material furnished by the school FREE. Our institution is open all year round. You can enter any time. Day and Evening classes. Many of our students earn a part or all of their expenses while attending. Our employment bureau is always ready to assist a man to earn expenses, without charge.

**Motion Picture Operating,  
DRAFTING COURSES  
Practically Taught**

These new big paying trades are demanding more and more trained men everywhere and our graduates are sought after by theatre managers and Engineering firms throughout the country. Free Book of Trades explains all.

## Send for FREE Book of Trades



MAIN BUILDING

Fill in this coupon and mail today. Tells all about our courses, terms, etc. Points out wonderful opportunities for ambitious young men. Help us meet the demand for men trained the Coyne way.

ADDRESS

BENNETT WELLINGTON COOKE Director  
**COYNE NATIONAL  
TRADE SCHOOLS**  
DEPT. 1191  
39-51 E. Illinois St., CHICAGO



## SEND THIS COUPON

Bennett Wellington Cooke, Director  
**COYNE NATIONAL TRADE SCHOOLS**  
Dept. 1191, 39-51 E. Illinois St., Chicago

Without obligation to me please send at once your wonderful Manual of Trades. I am particularly interested in

- Electricity  Plumbing  
 Bricklaying  Drafting  
 Motion Picture Operating

(Check course that interests you.)

Name.....

Address.....

Please Mention Popular Mechanics





## "What y' Doin' Now, Bill?"

You don't have to ask that question of a *trained* man, because you *know* his position is a permanent one—that he is not at the mercy of conditions that affect the *untrained* man.

You can always be sure of a good position and a good salary if you have the *special training* that puts and keeps you in demand. The International Correspondence Schools will bring *special training* to you, no matter where you live, or how little spare time or spare cash you have.

To learn *how* the I. C. S. can help you, and how you can easily qualify for success in your *chosen occupation*, mark and mail the attached coupon today. Doing so costs you only the postage. You assume no obligation. If you *think* you're ambitious, marking the coupon will *prove* it. Do it NOW.

I. C. S., Box 5546, Scranton, Pa.

TEAR OUT HERE

### INTERNATIONAL CORRESPONDENCE SCHOOLS

Box 5546, SCRANTON, PA.

Explain, without obligating me; how I can qualify for the position, or in the subject, before which I mark X.

- |   |  |
|---|--|
| <input type="checkbox"/> ELECTRICAL ENGINEER        | <input type="checkbox"/> SALESMANSHIP              |
| <input type="checkbox"/> Electric Lighting          | <input type="checkbox"/> ADVERTISING MAN           |
| <input type="checkbox"/> Electric Car Running       | <input type="checkbox"/> Window Trimmer            |
| <input type="checkbox"/> Electric Wiring            | <input type="checkbox"/> Show Card Writer          |
| <input type="checkbox"/> Telegraph Expert           | <input type="checkbox"/> RAILROADER                |
| <input type="checkbox"/> MECHANICAL ENGINEER        | <input type="checkbox"/> ILLUSTRATOR               |
| <input type="checkbox"/> Mechanical Draftsman       | <input type="checkbox"/> DESIGNER                  |
| <input type="checkbox"/> Machine Shop Practice      | <input type="checkbox"/> BOOKKEEPER                |
| <input type="checkbox"/> Gas Engineer               | <input type="checkbox"/> Stenographer and Typist   |
| <input type="checkbox"/> CIVIL ENGINEER             | <input type="checkbox"/> Cert. Public Accountant   |
| <input type="checkbox"/> Surveying and Mapping      | <input type="checkbox"/> Railway Accountant        |
| <input type="checkbox"/> MINE FOREMAN OR ENGINEER   | <input type="checkbox"/> Commercial Law            |
| <input type="checkbox"/> Metallurgist or Prospector | <input type="checkbox"/> GOOD ENGLISH              |
| <input type="checkbox"/> STATIONARY ENGINEER        | <input type="checkbox"/> Teacher                   |
| <input type="checkbox"/> Marine Engineer            | <input type="checkbox"/> Common School Subjects    |
| <input type="checkbox"/> ARCHITECT                  | <input type="checkbox"/> CIVIL SERVICE             |
| <input type="checkbox"/> Contractor and Builder     | <input type="checkbox"/> Railway Mail Clerk        |
| <input type="checkbox"/> Architectural Draftsman    | <input type="checkbox"/> AGRICULTURE               |
| <input type="checkbox"/> Concrete Builder           | <input type="checkbox"/> Textile Overseer or Supt. |
| <input type="checkbox"/> Structural Engineer        | <input type="checkbox"/> Navigator                 |
| <input type="checkbox"/> PLUMBING AND HEATING       | <input type="checkbox"/> Poultry Raising           |
| <input type="checkbox"/> Sheet Metal Worker         | <input type="checkbox"/> AUTOMOBILES               |
| <input type="checkbox"/> CHEMICAL ENGINEER          | <input type="checkbox"/> Auto Repairing            |
|   | <input type="checkbox"/> Spanish                   |
|   | <input type="checkbox"/> German                    |
|   | <input type="checkbox"/> French                    |
|   | <input type="checkbox"/> Italian                   |

Name \_\_\_\_\_

Occupation & Employer \_\_\_\_\_

Street and No. \_\_\_\_\_

City \_\_\_\_\_ State \_\_\_\_\_

Please Mention Popular Mechanics

## Learn to PAINT SIGNS and SHOW CARDS

Get into this interesting, profitable and fascinating business where the field is not crowded. Thousands of cards used weekly. Department stores, clothiers, movie shows, etc., pay big prices—work done quickly and easily—profits large—hundreds of jobs all around you. My students can more than pay for course doing jobs in spare time while studying. Increase your salary, get a better job or go into business for yourself.

**Earn \$18.00 to \$45.00 a Week—Easily**  
I will train you to fill a big salaried job. I personally correct every lesson. 17 years' successful teaching. Thousands of successful graduates all over the world. No town too small, no job too big for my graduates. Get my training—start now.

**Big Money in Card, Sign and Bulletin Business**  
No other profession pays such profits—work comes to you in abundance—no job will stump you—my students learn all. All the newest, sweetest designs, how to run the business, how to hire men, how to keep records, in fact gives you a complete training. You can finish my course in a short time. Read my guarantee—don't be out of a job or work at low wages any longer—**Get Started Now.**

**FREE Outfit**  
Write now for special literature and prices on 5 courses—terms, testimonials, sample lesson and Free Outfit offer. **All Free—Don't delay, act quickly.**

**Guarantee**  
I guarantee to place competent graduates at \$85.00 to \$175.00 monthly. The demand for trained competent men is far greater than the supply.

**Detroit School of Lettering, Dept. 201, Detroit, Mich.**

## LAW High-Grade Instruction by CORRESPONDENCE

Prepares You for the Bar—Est. 1892

Four Courses: College, Post-Graduate, Business Law and Bar Ex. Review. Classes begin each month. Approved by Bench and Bar. University Methods, Unabridged Text-Books, Cases. Course in Oratory, Public Speaking and Moot Court FREE with regular course. Graduates now practicing in every State. Write today for Catalog and Rules for Admission to the Bar. CHICAGO CORRESPONDENCE SCHOOL OF LAW, 529 Reaser Block, CHICAGO

## Be a Finger Print Expert

Write today. Seize this opportunity to enter a new, fascinating, influential profession. Be a finger print expert. Earn \$25 to \$50 a week as the confidential adviser of bankers, capitalists, detective agencies, etc. Install finger print systems in big factories and industrial firms. Learn in spare time at home.

**Special Offer Now Open** to those who write quick. Send now while this offer lasts for free book and details of offer. No obligations.

**Evans University, Finger Print Department**  
Room 9191 1816 Wilson Avenue Chicago, Illinois

## IF YOU STAMMER

attend no stammering school till you get my large FREE book and special rate. Largest and best school in the world curing by natural method. Write today.

**Lee Wells Millard, Pres., North-Western School, Inc.**  
2317 Grand Avenue Milwaukee, Wis.

## DON'T TAKE A COURSE IN MACHINE DRAFTING

till you've read my proposition. Practical, experienced Draftsman, regularly employed in large modern works, will teach a few men by mail. Best way to become a well-paid Draftsman. Special course in Mathematics also. Instruments furnished. Rates very reasonable. Pay a part after in position. **Draftsman, 252 S. Corona St., Denver, Colo.**

## FREE BOOK ON BANKING

Tells of the great opportunities in this wonderful profession, and how you can learn by mail. Six months' term. Diploma awarded. **EDGAR G. ALCOCK Pres., AMERICAN SCHOOL OF BANKING**  
490 East State St., Columbus, Ohio

## Learn Watchmaking At Home

You can learn by our modern and original system of instruction every part of the Watchmaker's Trade at home as good or better than at a shop. You can earn money while learning and secure a well paying position or start in business after completing our course of instruction. Good watchmakers are always in demand and earn from \$20 to \$35 per week. For particulars apply to the Wisconsin School of Watchmaking, 518 1/2 W. Milwaukee, Wis.



# Are YOU Making \$5000 a year?

## Don't Merely Think it Over —Put it Over!

Get This **FREE**  
**BOOK**

**TEN YEARS'  
PROMOTION  
IN ONE**

The huge growth of business in America has created thousands of high grade positions paying \$1,500 to \$5,000 or more a year. The need is for men with executive training—men who are experts, who have specialized in some important department of business. A recent advertisement in a big daily for a \$15 a week man brought one hundred and seventy-one (171) answers. An advertisement for a \$5,000 man on the same page did not bring a single applicant—NOT ONE. You can see, therefore, that the \$15 a week man had one hundred and seventy other men competing for the same job. The \$5,000 a year position went begging. One big captain of industry recently said, "Our great difficulty is to find \$10,000 a year men."

### We Train You By Mail for Executive Positions

Big employers have come to learn that "the school of experience" alone, cannot begin to supply the men needed for high-grade positions. For that reason there is hardly a state in the Union where employers are not urging ambitious men to take the short cut to executive training offered by the various courses of the LaSalle Extension University. Manufacturers, corporations, railroads, mercantile and banking institutions are always in need of department and business managers, legally trained men, auditors, expert accountants, traffic managers, business and sales correspondents, and high grade office men to fill permanent positions with handsome salaries.

### Earn While You Learn

You can keep on drawing your present salary while we train you for an executive position. You can learn in your spare time, in your own home. Our courses are thorough in every feature—simple, easy, and quickly mastered. The cost is small. Easy monthly payments. There is no reason in the world why you cannot advance yourself now, if you are ambitious, will use some of your spare time and are willing to invest a few dollars in brain power and self capitalization.

Big employers know that LaSalle training is thorough; that behind the LaSalle courses stand assets of over \$2,000,000, and an organization of more than 300 business experts, professional men, text writers, instructors and assistants, including recognized authorities in all departments.

## Get This Valuable Book "Ten Years' Promotion In One" **FREE**

Hundreds of men who have read this book say it does more to inspire the ambitious man for big things than any other book they have ever read. A prominent Chicago business man recently made this statement regarding it: "Your book 'Ten Years' Promotion In One,' presents a big, practical object lesson which should profit 99 of every 100 men in this country. It would pay every person of ambition to get and carefully read this remarkable book

even if he has to pay \$5 for a copy—the moral of success contained in it is so plain, so true and convincing."

We will send this book without cost if you will indicate your interest in promotion by using the coupon below and naming position for which you wish to qualify. We will also send, free and postpaid, complete literature explaining how you can train for your chosen work without interference with your present duties.

## Earn \$35 To \$200 a Week

Which One of These Positions Would You Like To Fill?

**No. 1. Business or Office Manager** This course and service gives that broad business training for the higher executive positions which require administrative ability and that general knowledge necessary to manage department heads, minor executives, or a complete business organization—lays the foundation for advancement to the highest business positions available.

**No. 2. Executive Accountant** (C. P. A.) \$50,000 firms provide unlimited opportunities for expert cost and administrative accountants and auditors. Only 2,000 certified public accountants in the U. S. to do the work. We prepare you for expert accounting work or C. P. A. examinations.

**No. 3. Traffic Manager** Recently enacted rate laws and Interstate Commerce regulations have created thousands of high salaried positions with the railroads and big industrial shippers. Our training is endorsed by leading railroad officials and traffic experts, and prepares you to hold an important railroad or industrial traffic position.

**No. 4. Banking** 30,000 banks constantly need men with banking and financial training. New banks, trust companies and financial institutions are being organized daily. Our training will assist you to climb quickly to any position requiring a thorough knowledge of modern banking practice.

**No. 5. Legal Counsellor or Attorney At Law** Legally trained men win high positions in business and public life. Our course is of University grade. The 14 volumes of text books supplied free, are edited and written in plain, comprehensive language by noted legal experts, judges and famous law professors.

**LaSALLE EXTENSION UNIVERSITY**  
The World's Greatest Extension University, Dept. 164-R Chicago, Ill.

Degree of LL. B. conferred. We guarantee to coach free until successful, any graduate failing to pass any state bar examination.

**No. 6. Business and Sales Correspondents**

There is always a big demand for good correspondents who have a command of effective, business-getting English. Our course gives you quick training for a high-grade position as expert sales and collection correspondent, or copy writer. There is hardly an employee who cannot profit largely by taking our course in Effective Business English.

### Act Today!

Make up your mind now to train for a position of dignity and good pay. We have made the way easy for you. Our corps of expert instructors will direct you step by step, and give you unlimited personal guidance.

Mail the  
Coupon  
NOW!

### Free Book Coupon

**LaSalle Extension University,**  
The World's Greatest Extension University  
Dept. 164-R Chicago, Ill.

Gentlemen:—Please send me, free and postpaid, copy of "Ten Years' Promotion in One." I am interested in increasing my earning power and would thank you to send me, also, particulars regarding your home-study course

No. \_\_\_\_\_ which is the course I am most interested in.

Name.....

Firm employed by.....

Address.....





33,000 sq. ft. of  
Additional  
Floor  
Space

# Come to Detroit The Automobile Center and

# LEARN THE AUTOMOBILE BUSINESS

DETROIT trained men get preference and get jobs quickly. No other city can give what Detroit offers. Think what it means to learn in the Michigan State Auto School. Factories endorse our school, glad to employ our graduates or offer them territory in which to sell cars and start garages. Unlimited opportunities.

You're right in the middle of the greatest auto activities. Men are needed everywhere as testers, repair men, chauffeurs, garage men, and salesmen. Hundreds of our graduates start in business for themselves.

## Earn \$75 to \$300 a Month

We teach you to handle any auto proposition. You graduate in from ten to twelve weeks. Our equipment is complete. Students actually build cars from start to finish, getting factory training in assembling, block-testing, road-testing, everything. Special complete course in Oxy-Acetylene brazing, welding and cutting, separate from regular course. All leading types of starting, lighting and ignition systems in operation. Learn to time motors, re-bore cylinders, adjust carburetors, magnetos, valves and bearings quickly and accurately. Six-cylinder Lozier, Chalmers "6," Detroit "6," Overland, and 8-cylinder King are used for road instruction. We have a new Chalmers "6-30" chassis with 3400-r. p. m. motor, the latest thing out, Willys-Knight 1917 chassis, Saxon "6" 1917 chassis, Studebaker "6" 1917 chassis, Maxwell 1917 chassis, Hudson Super-Six 1917 chassis, Oldsmobile "8" 1917 chassis, Cole "8" 1917 chassis, Briscoe 1917 chassis, Detroit Electric 1917 chassis. All completely equipped for students to work on. We have more than 25 motors in our block test department—2 cyl., 4 cyl., 6 cyl., 8 cyl., and 12 cyl. Our electrical department is complete, having every standard starting, lighting, and ignition system, including Delco System as used in Buick, Hudson, and Packard Twin "6."

## Detroit Is the Place to Learn—Start Any Time

There are 44 auto factories in Detroit and 140 accessories and parts factories. Our students have the privilege of going through any or all of them. We now operate Westinghouse, Auto-Lite and Bijur Service Stations. After careful consideration the Westinghouse Electrical & Mfg. Co., the Auto-Lite Co. and the Bijur Co. decided that our school was the best place in Detroit to handle their service stations. This has added thousands of dollars' worth of equipment and makes our electrical department unequalled. Students get actual experience and training in handling all kinds of electrical auto equipment and taking care of trouble. We have just installed a Sprague Electric Dynamometer for block-testing purposes for students' use. The Michigan

State Auto School is the only Auto school having this equipment. Auto factories need Dynamometer men constantly. Factories and garages are paying big salaries to men who know how to handle electrical equipment quickly and properly. Detroit is the automobile center. You get practical instruction. Come to our school and learn the auto business right. School open all the year. Enter classes any time, any day. Three classes daily: morning, afternoon, evening. There is a great demand for Michigan State Auto School students. Garages throughout the country write us for men. Auto factories write and phone for men constantly to fill permanent places. Why not fit yourself for one of these good paying positions?

Follow the Crowd to the Michigan State Auto School. Come to Detroit

### Money-Back Guarantee

We guarantee to qualify you in a short time for a position as chauffeur, repair man, tester, demonstrator, garage man, or automobile dealer, paying from \$75 to \$300 monthly or refund your money. We have constantly more requests for Detroit trained men at GOOD salaries than we can supply.



THIS IS ONE OF THE 1916 CLASSES

### Additional Building and Equipment

33,000 sq. ft. of additional floor space in our new building, thousands of dollars' worth of new equipment, plenty of room for students to work. This comes with our new building at 687-89-91 Woodward Ave., which we are now occupying in addition to our building at 11-19 Selden Ave. Our school has grown by leaps and bounds, students come from all over the world. Men have left after graduating and started in business for themselves; others have accepted good jobs both in Detroit and over the country. Their work has proven that we train them right. We are constantly adding new equipment. Our electrical department is thorough and complete and in charge of the most competent instructors.

### Factory Co-Operation

We have completed arrangements with the Auto factories to put them in touch with men who intend going into business for themselves. Think of getting inside information. The factories are looking for trained men to represent them. Men who know the auto business from A to Z are in biggest demand. Come here and start right—get the information first-hand and don't wait.

Remember, you can enter classes any time, any day. The price of course is based on giving full value. Graduates in the complete auto course are competent to handle farm tractors.

### Act Quickly—Now—Don't Wait

## SEND THIS COUPON TODAY

### MICHIGAN STATE AUTO SCHOOL

301 Auto Bldg., 687-89-91 Woodward Ave., Detroit, Mich., U. S. A.

Gentlemen: Send me absolutely FREE "Auto School News," and New Catalog or better still you can expect

me about.....

Name.....

Street.....

Town..... State.....

33,000 sq. ft. of additional floor space.

Fill in the coupon and mail it now; get full particulars, get "Auto School News" and New Catalog. They are both absolutely free. Or better still, jump on the train, as hundreds have done, and come to Detroit, the "Heart of the Automobile Industry," and learn right. We have no branches. Write or come direct to this school.

## Michigan State Auto School

The Old Reliable School A. G. ZELLER, Pres.

301 Auto Building  
687-89-91 Woodward Avenue  
DETROIT, MICHIGAN, U. S. A.

### DETROIT THE HEART OF THE AUTO INDUSTRY







# 50 Cents A Week

**F**OR this insignificant sum—less than most of us spend for tobacco—this ten-volume Cyclopedia of Architecture, Carpentry and Building is yours. Yes, and with every set is included—**free of charge**—a year's Consulting Membership in the American Technical Society. The Consulting Membership gives you the privilege of submitting your perplexing problems to a corps of experts for a whole year free. This Consulting Membership regularly sells for \$12, and puts at your disposal a wealth of information and the knowledge of men high in the profession.

Fletcher Cunningham, Shreveport, La., writes: "After receiving the books I decided that with their help I could go into the contracting business for myself. I have just closed a contract on which I expect to clear about \$112.00 for two weeks' work."

## Use Them Seven Days FREE

The entire ten-volume Cyclopedia will be sent to you by prepaid express upon receipt of the coupon below. Don't send a single penny—just the coupon! Use the books for seven full days before you decide whether or not you want them. If you keep them, you may pay the advertising price of \$14.80 in easy monthly installments of \$1.99—**50c a week**. The regular price of this massive set is \$50.00. Remember, if you don't want the books they may be returned at our expense and you won't be out a penny.

### Partial Table of Contents

Mechanical, Free Hand, Perspective and Architectural Drawing, Lettering, Pen and Ink Rendering, The Orders, Superintendence, Strength of Materials, Masonry, Reinforced Concrete, Carpentry, Stair Building, Hardware, Steel Construction, Roof Trusses, Practical Problems, Estimating, Contracts, Specifications, Building Law, Sanitation, Sheet Metal Work, Electric Wiring and Lighting.

## Everything About Carpentry and Building

Contained in the Cyclopedia's ten splendid volumes is everything about carpentry and building, from the first rough sketch of the architect to the acceptance of the finished structure. They include wood, stone, steel and reinforced concrete construction; estimating and contracting; interior finishing and decorating, and modern house lighting and sanitation. Every line is written in plain, understandable language—every difficult point is made clear. The books are handsomely bound in half red morocco leather, gold stamped, and contain 4,750 pages (7 x 10 inches), and 4,000 illustrations, full-page plates, building plans, diagrams, etc. Every subject is cross-indexed so it can be referred to in an instant.

## Just Send the Coupon

Don't send us a single penny. Just fill in and mail the coupon. Then we will send the books to you by prepaid express for seven days' free trial. Remember, you don't assume a single obligation—we are glad to have you see the books for yourself before you decide whether or not to buy. This offer is open to anyone within the boundaries of the United States and Canada. Send the coupon today—**now!**

American Technical Society, Dept. 81191, Chicago, U. S. A.

American Technical Society  
Dept. R-1191 Chicago

Please send Free Plan Book, also Cyclopedia of Architecture, Carpentry and Building for review and examination. If I decide to keep them I will send \$2 after 7 days and \$2 a month until \$24.80 has been paid. When you will send me a receipt showing the \$24.80 set and Consulting Membership are mine and fully paid for. Otherwise I will return at your expense.

Name.....

Address.....

Reference.....

Please Mention Popular Mechanics

Copyrighted material



# Learn to Write

GOOD hand-writing has been truly called the "Bread and butter of a business education." It should be the determination of every body to learn to write at least a good business hand. Good writing is the very foundation of business success.

**Easy to Learn** By my system you can become a good penman at home, in your own room during spare time. Don't be content with the notion that good penmen "are born" such. Because one's ancestors may have been noted for poor penmanship, is no excuse for him to remain an illegible scribbler. My system is original, unique, and highly successful—the result of 25 years' experience.

**Your Spare Time** Just your spare moments—that's all I ask. If you follow my instructions you will soon be able to write a beautiful hand that will be a source of pride to yourself and envy to your friends. Notice the improvement shown in Mr. Campbell's writing below.

*Leland M. Campbell*

"I am astonished at the improvement I've made by means of The Tamblin System in so short time."

LELAND M. CAMPBELL,  
Campbelltown, Ohio.

*Leland M. Campbell*

Mr. Campbell wrote his upper signature July 20, and the lower one November 10—a little less than 4 months apart. Hundreds and hundreds of others in all parts of the world are doing as well with my system.

I have had unbounded success in making poor writers good ones and good writers better penmen than they thought possible.

32  
PAGES  
HIGHLY  
ILLUSTRATED.



FREE  
BOOK  
WRITE  
FOR IT  
TODAY

Penmanship is particularly adapted to correspondence instruction, and I absolutely guarantee satisfactory improvement. Distance no barrier. Ladies taught just as successfully as men.

Don't wait, don't delay, begin now to prepare for that position where good penmanship will be required. Send today for my Free Book, "How to Become a Good Penman," which contains copies and beautiful specimens and tells how others have become good penmen by means of the Tamblin System. Your name will be beautifully written on a card with white ink if you enclose stamp.

F. W. TAMBLYN,  
418 Meyer Building,  
Kansas City, Mo., U.S.A.



*F. W. Tamblin*

## FREE BOOK COUPON

F. W. TAMBLYN, 418 Meyer Bldg., Kansas City, Mo., U. S. A.  
I am interested in improving my penmanship. Please send me free your Book "How to Become a Good Penman."

Name .....

Address .....

Sign and mail this today, before you forget it.

Please Mention Popular Mechanics

# "LEARN BY DOING"

Five minutes of Actual Practice properly directed is worth more to a man than years and years of book study. Actual Practice is the only training of value. Graduates of The N. Y. Electrical School have proven themselves to be the only men that are fully qualified to satisfy EVERY demand of the Electrical Profession.

At this "Learn by Doing" School a man acquires the art of Electrical Drafting; the best business methods of Electrical Contracting; together with the skill to install, operate and maintain all systems for producing, transmitting and using electricity.

School open all year. Individual instruction.  
A school for young and old. Write for information.

## The N. Y. ELECTRICAL SCHOOL

44 West 17th St. NEW YORK CITY



## Learn a Paying Profession

that assures you a good income and position for life. For twenty-two years we have successfully taught

## PHOTOGRAPHY

Photo-Engraving and Three-Color Work

Our graduates earn \$20 to \$10 a week. We assist them to secure these positions. Learn how you can become successful. Terms easy—living inexpensive. Write for catalogue—NOW!

ILLINOIS COLLEGE OF PHOTOGRAPHY, 999 Wabash Avenue, Effingham, Ill.

## The University of Chicago

**HOME STUDY** in addition to resident work, offers also instruction by correspondence.

For detailed information address  
25th Year U. of C. (Div. V) Chicago, Ill.



## EARN TELEGRAPH

Morse and Wireless—R. R. Accounting (Station Agency) taught. Splendid opportunities. Positions secured. Marconi Co. contracts to employ graduates. We own and exclusively occupy two large modern buildings equipped with R. R. and Western Union wires and complete 2 K. W. Marconi Wireless Station. Largest school—established 42 years. Investment \$15,000. Endorsed by Railroad, Marconi and Western Union Officials. Expert practical teachers. Low living expenses easily earned if desired. Tuition low. Easy payments. Correspondence courses also. Catalogs Free.

Dodge's Telegraph, Ry. & Wireless Institute  
8th Street, Valparaiso, Ind.

## DRAWING

Caricature, Cartoon, Comic, Commercial, Fashion, Newspaper and Magazine illustrating taught by mail. Illustrated book 5c in stamps.  
THE BOSTON SCHOOL OF DRAWING,  
755M Boylston St. BOSTON, MASS.



## Men Wanted To Learn Automobile Business

EARN BIG MONEY — \$75 to \$300 Per Month

Only a few weeks required to train you. In six weeks I teach you to run and repair properly any automobile made. Learn to be repairman, demonstrator, garage manager and salesman. I teach thoroughly, practically and personally on real automobiles in everyday use. No books used. Tools furnished free. Actual practice on big, powerful cars taught here for inspection and repairs.

SEND FOR BOOKLET, "Making You Master of the Auto." Free upon request.



WM. H. AMELGEN Milwaukee Motor School, 217-21 Seventh St., Milwaukee, Wis.



# HELP WANTED

## \$65 to \$150 Month—Life Jobs

The United States Government wants thousands of Railway Mail Clerks, City Carriers, Postoffice Clerks, Customs, Internal Revenue Clerks, Clerks at Panama Canal and Washington, D. C.

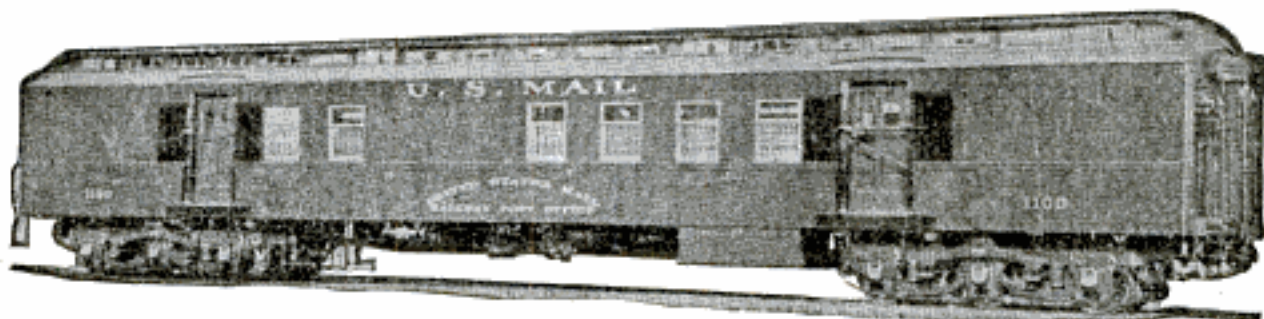

### Railway Mail Clerks Have Pleasant Work— Travelling Continually

Summer vacations with full pay are allowed. Promotion to Big Paid positions is very rapid. The position is not affected by strikes, wars or the whims of some petty boss.

Country residents and city residents stand the same chance for appointment—common education is sufficient—Pull is not required.

Write us today for schedules showing dates and places of the coming examinations in your locality.

**Don't Delay** Every day you delay lessens your chance of immediate appointment.

**WE COACH FREE CANDIDATES**

FRANKLIN INSTITUTE  
Dept. S103  
Rochester, N. Y.

Kindly send me, without any obligation whatever on my part, and entirely free of charge, (1) a full description of the position checked below; (2) Sample examination questions; (3) Free copy of copyrighted book, "Government Positions and How to Get Them"; (4) A list of U. S. Government Jobs now easily obtainable; (5) Directions telling me how to get free coaching for the position checked; (6) Schedules showing dates and place of coming examinations in my locality.

.....Railway Mail Clerk	(\$900 to \$1800)
.....Postoffice Clerk	(\$800 to \$1200)
.....Postoffice Carrier	(\$800 to \$1200)
.....Rural Mail Carrier	(\$500 to \$1200)
.....Bookkeeper	(\$800 to \$1800)
.....Customs Positions	(\$800 to \$1500)
.....Internal Revenue	(\$700 to \$1800)
.....Stenographer	(\$800 to \$1500)
.....Clerk in the Departments at Washington or at Panama Canal	(\$800 to \$1800)

Name.....

Address.....

Use This Coupon Before You Mislay It—WRITE PLAINLY—S 103





## Music Lessons Sent FREE

You, too, can now quickly and easily satisfy your musical ambitions—learn to sing or play your favorite instrument, whether for pleasure, social prestige or to teach music, by our wonderful home study lessons under great American and European teachers. The lessons are a marvel of simplicity and completeness, endorsed by Paderewski and other great authorities.

### Any Instrument or Voice

Write us the course you are interested in, age, how long you have taken lessons if at all, etc., and we will send you six lessons, free and prepaid, any of the following Complete Courses: Lessons in PIANO (students' or teachers' courses) by the great Wm. H. Sherwood, HARMONY by Dr. Protheroe and Rosenbecker, PIPE ORGAN by Clarence Eddy, VOICE COURSE (with aid of phonograph) by Crampton, PUBLIC SCHOOL MUSIC, by Frances E. Clark, VIOLIN, CORNET, MANDOLIN, GUITAR, BANJO, REED ORGAN, CHORAL CONDUCTING, by equally eminent teachers.

This offer is Free—we do not ask you to pay one cent for the six lessons, either now or later. We want to prove in this remarkable way what fine lessons they are—SEEING IS BELIEVING. This offer is limited, so write today. A few Special Introductory Scholarships now being awarded by our Faculty. Full particulars sent along with free lessons. Send no money.

**SIEGEL-MYERS SCHOOL OF MUSIC,**

CLARENCE EDDY, Dean

2141 Siegel-Myers Building

CHICAGO, ILL.



## Earn \$125. to \$250 a Month

in the Steam Engineering field. Prepare in your spare time for a Stationary or Marine Engineer's license, or position as Locomotive Engineer. These great books, written by 27 experts, contain all the information necessary for you to take up this fascinating, high-salaried work. We send them free!

## Steam Engineering

7 volumes: 3300 pages, 7x10 inches; 2500 illustrations, full page plates, drawings, etc.; hundreds of valuable tables and formulas. Handsomely bound in half red morocco, gold stamped. Covers the construction and operation of stationary, locomotive and marine engines and boilers; the use of gas and gasoline engines for power and locomotion; the transformation of steam and gas power into electricity; and the application of steam and gas power to refrigeration, compressed air, etc.

### Sent FREE—Just Mail the Coupon

The entire seven volumes will be sent, express prepaid, to any resident of the U. S. or Canada, on receipt of the coupon below. Look these books over for a whole week free. Then decide whether or not you want them. If you do, send us \$2.00 within seven days and \$2.00 a month until the special price of \$19.80 has been paid. Otherwise we'll take them back at our expense. In addition to this liberal discount from the regular price of \$35.00, we include with each set a \$12.00 Consulting Membership. This entitles you to the advice of a staff of experts for a whole year free.

American Technical Society, Dept. 51191, Chicago, U. S. A.

Please send Encyclopedia of Steam Engineering for 7 days' free examination. I will send \$2.00 within 7 days and \$2.00 a month until I have paid \$19.80; otherwise I will notify you and hold the books subject to your order. Title not to pass until fully paid.

NAME.....  
ADDRESS.....  
REFERENCE.....

## Practical Electrical Education

We teach by practical work and scientific methods under practical working conditions, all branches of Electrical Science and Engineering.

Students enter at any time for full or special courses. No matter what your education is, we start you at the very point you are competent to begin. By our system of individual instruction, you can complete our course as quickly as your ability warrants. We have more calls for trained students than we can fill. Many of our students have started earning from \$1500 a year and up, immediately upon the completion of their course.

New classes organize January 4th.

Write for Free illustrated catalog and terms today.

**Home Study Course**—If you cannot come to us or do not want to give up your present occupation, we will furnish you by mail at small cost our theoretical course. Will deduct all payments made when ready to enter our school at Milwaukee. Get full particulars. Mention age and education.

School of Engineering of Milwaukee, 297 Stroh Building, Milwaukee, Wis.

## BE AN ARTIST

We can teach you **DRAWING** in your own home during your spare time.

Our 18 years of successful teaching prove our ability. 10 Courses in Commercial and Illustrative Drawing. Teachers Normal and Applied Art. Endorsed by high art authorities. Students trained by members of our Faculty are filling high-salaried positions. Artist's Outfit FREE to Enrolled Students. Fully Equipped Residence School. Write today for Art Year Book.

OUR HANDSOME ART YEAR BOOK "FREE" TO YOU

**SCHOOL OF APPLIED ART**  
APPLIED ART BLDG. NO. 51, BATTLE CREEK MICH.

## A GOOD POSITION

with **UNCLE SAM** is most desirable. Life positions, pleasant surroundings, good pay, steady work, short hours, promotions on merit. Both sexes. No political pull. Thousands of appointments yearly. Most thorough preparation \$5. Returned if not appointed. Full information and questions used by the Civil Service Commission free.

AMERICAN CIVIL SERVICE SCHOOL

WASHINGTON, D. C.



## MEN WANTED

Prepare as Firemen, Brakemen, Electric Motormen, and colored Train Porters. First Class Standard Roads. Hundreds put to work—\$65 to \$150 a month without any experience. 500 more wanted. Uniforms and passes arranged for when necessary. Enclose stamp for Application Blank. Name position you want.

I. RAILWAY C. I., Dept. 35, Indianapolis, Ind.

## BE A BANKER

Prepare by mail for this high profession, in which there are great opportunities. Six months' term. Diploma awarded. Send for free book, "How to Become a Banker." EDGAR G. ALGOEN, Pres. AMERICAN SCHOOL OF BANKING 419 East State Street. COLUMBUS, OHIO

## LEARN WATCH REPAIRING

Be a watchmaker—you can learn this profitable trade by correspondence in a few weeks in your own home by the DeSelms Chart System. After you complete the course you will know a watch from A to Z. You will know just what the matter is and how to repair one. When you graduate you will be a practical watchmaker and repairer and competent to fill any position. Positions for our graduates.

Ask for our Free Book. It explains our system and terms.  
**THE DeSELMS WATCH SCHOOL**  
23 Perry Street ATTICA, INDIANA



Please Mention Popular Mechanics





# Learn Electricity

## Earn \$2500 to \$4000 a Year

Your CHANCE has come! Your chance for big money. Your chance to do the kind of work you'll be proud of. Your chance to go into business for yourself. Think of it! You can now qualify AT HOME for that most wonderful of all fields open to the ambitious man—the great field of ELECTRICITY! Yes, no matter who you are, where you live or what you do, I will take you in hand and make you a TRAINED ELECTRICIAN so that you should easily earn \$2,500 to \$4,000 a year and more. And I'll do it so quickly and with so little effort on your part that you'll wonder how it was possible.

## LEARN AT HOME

What if you don't know a thing about electricity! What if you've never had a bit of electrical experience. All I ask is that you give me a little of your spare time. I will instruct you personally and make the whole matter so simple for you that you can't help but learn. You don't have to buy a lot of books or equipment. You can master MY personal instructions easily right at home. I've solved this question of teaching electricity. I'll show you I have by giving you 20 personal lessons ABSOLUTELY FREE. Almost from the very first instructions you will have the knowledge and skill to do practical, electrical work—work that you can demand good money for doing. You can earn as you learn—more than pay for your instruction as you go along.

## Be An Electrician

Think! When you have finished my instructions you are a TRAINED ELECTRICIAN! You are right then and there ready to take a big paying job or start in for yourself. I will train you until you consider yourself competent regardless of the time it takes. I not only show you how to do expert electrical work but show you how to estimate on jobs so you can take contracts at big profits. That's what it means to be personally trained by a man of my practical experience in every phase of electricity. Decide today to take advantage of my big free 20 personal lessons offer. Don't let the question of money bother you. I make the cost so small and the payments so easy that you won't miss the money.

**MEN WANTED** Wherever you go there's always urgent demand for Expert Electricians and at big pay. That's because the watchword of the age is, "DO IT ELECTRICALLY." Electricity advances so fast that there's a big shortage of competent electricians. And the demand is constantly increasing every day.

## 20 Complete Lessons FREE!

That's the sensational offer I am making now to a few more ambitious men. I make it for two reasons. 1st. To show you how easy my personal instructions are to master. 2nd. To secure quick action on the part of a few more prospective students. This offer means that you get 20 complete personal lessons ABSOLUTELY FREE! But you must act quick. The offer closes in 23 days. Send coupon or postcard at once. I'll send full particulars immediately. Mail coupon today—sure!

**A. W. WICKS, E. E., Director Wicks Electrical Institute,  
81 West Randolph St., Dept. 252, Chicago, Ill.**

Send this  
Coupon

**A. W. WICKS,  
E. E., Director,  
WICKS ELEC. INSTITUTE,  
81 West Randolph St.,  
Dept. 252, Chicago, Ill.**

Without any obligation on my whatever, please send me full description of your personal instructions in Electricity and particulars of your special offer of 20 of your lessons free.

Name.....

Street and No.....

City.....State.....

Please Mention Popular Mechanics

Copyrighted material





## Train at Home For This Big Job

Over half a million large shippers need **TRAINED Traffic Men**—men who know how to route shipments, obtain shortest mileage, secure quickest deliveries, classify goods—and secure lowest rates. The demand is greater than the supply. Big positions are waiting for competent men to fill them. The work is so pleasant—salaries so large—and the prestige so great—that you can't afford to hold back.

Your great chance is here. Take it. We make the way easy and smooth for you. With the LaSalle Extension University behind you, you can fit yourself for any one of the thousands of big traffic jobs now open. You can qualify in a comparatively short time. The expense is so little, that you'll never miss the money. Easy monthly payments if desired. And you learn it all—at home—in spare time.

## Be A Traffic Manager Earn \$35<sup>00</sup> to \$100<sup>00</sup> Weekly

Our course is endorsed and recommended by railroad executives and big concerns throughout the country. Prepared by some of the greatest traffic and transportation experts in America. Covers thoroughly everything you should know to be a high grade traffic manager—trains you so that you can qualify for an important, high salaried railroad or industrial traffic position while holding your present job.

Send in the coupon for students' letters and full details concerning the LaSalle University Home Study Course in Traffic Management. We will also send you

### A Remarkable Book Free

"Ten Years' Promotion In One." Hundreds of men who have read this book say it does more to inspire the ambitious man for big things, than any other book they have ever read. A prominent Chicago business man recently said, "It would pay every ambitious person to get this book even if it cost him \$5.00 for a copy." Let us send it to you **FREE**, with literature explaining how you can train for a Big Traffic Job without interference with your present duties. Send in coupon **TODAY—NOW**.

LaSalle Extension University, Dept. 164-C Chicago  
"The World's Greatest Extension University"

## Free Book Coupon

LaSalle Extension University, Dept. 164-C Chicago  
"The World's Greatest Extension University"

Send Free proof about opportunities now open to **TRAFFIC EXPERTS** with LaSalle University training—also valuable book "Ten Years' Promotion In One." It is understood that I am not obligating myself in any way.

Name .....

Address .....

Please Mention Popular Mechanics

## SHORTHAND IN 30 DAYS

We absolutely guarantee to teach shorthand complete in only thirty days. You can learn in spare time in your own home, no matter where you live. No need to spend months as with old systems. Boyd's Syllabic System is easy to learn—easy to write—easy to read. Simple. Practical. Speedy. Sure. No ruled lines—no positions—no shading as in other systems. No long lists of word signs to confuse. Only nine characters to learn and you have the entire English language at your absolute command. The best system for stenographers, private secretaries, newspaper reporters and railroad men. Lawyers, ministers, teachers, physicians, literary folk and business men and women may now learn shorthand for their own use. Does not take continual daily practice as with other systems. Our graduates hold high grade positions everywhere. Send today for booklets, testimonials, etc.

Chicago Correspondence Schools  
969 Unity Bldg., CHICAGO, ILL.

## LEARN MUSIC AT HOME!

Lessons Free



**New Method—Learn To Play By Note—Piano, Organ, Violin, Banjo, Mandolin, Cornet, Harp, 'Cello, Guitar, Piccolo, Clarinet, Trombone, Flute, or to sing.** Special Limited Offer of free weekly lessons. You pay only for music and postage, which is small. No extras. Money back guarantee. Beginners or advanced pupils. Everything illustrated, plain, simple, systematic. Free lectures each course. 16 years' success. Start at once. Write for Free Booklet Today—Now. **U. S. SCHOOL OF MUSIC, Box 132**  
225 Fifth Avenue, New York City

**ELECTRICAL ENGINEERING** men with training are always in demand. Having trained over 2000 young men in the past 23 years in the fundamentals of Applied Electricity. The **Bliss Electrical School**, with its well-equipped shops and laboratories, is peculiarly well qualified to give a condensed course in Electrical



**ENGINEERING** including Mathematics, Steam and Gas Engines, Mechanical Drawing, Shop Work, and Theoretical and Practical Electricity, in all branches. Students actually construct dynamos, install wiring and test efficiency of electrical machinery. Course, with diploma, complete

### IN ONE YEAR

For practical young men with limited time. 24th year opens Sept. 21st. Catalogue on request. 164 Takoma Ave., Washington, D. C.

## Learn Watchwork, Jewelrywork and Engraving.

A fine trade commanding a good salary, and your services are always in demand. Address **HOROLOGICAL**, Dept. P, Bradley Institute, Peoria, Ill., for our latest catalog.



## Do You Like to Draw? Cartoonists Are Well Paid

We will not give you any grand prize if you answer this ad. Nor will we claim to make you rich in a week. But if you are anxious to develop your talent with a successful cartoonist, so you can make money, send a copy of this picture, with 5c in stamps for portfolio of cartoons and sample lesson plate, and let us explain.

The W. L. Evans School of Cartooning  
821 Leader Bldg., Cleveland, O.

## MEN

Send today  
for this Book

It tells of big openings — for live men—in a business full of opportunities and not overcrowded.

And it tells how we assist you to get started earning \$25 to \$50 a week. Write today.

**PRACTICAL AUTO SCHOOL, 68 Beaver St., New York**





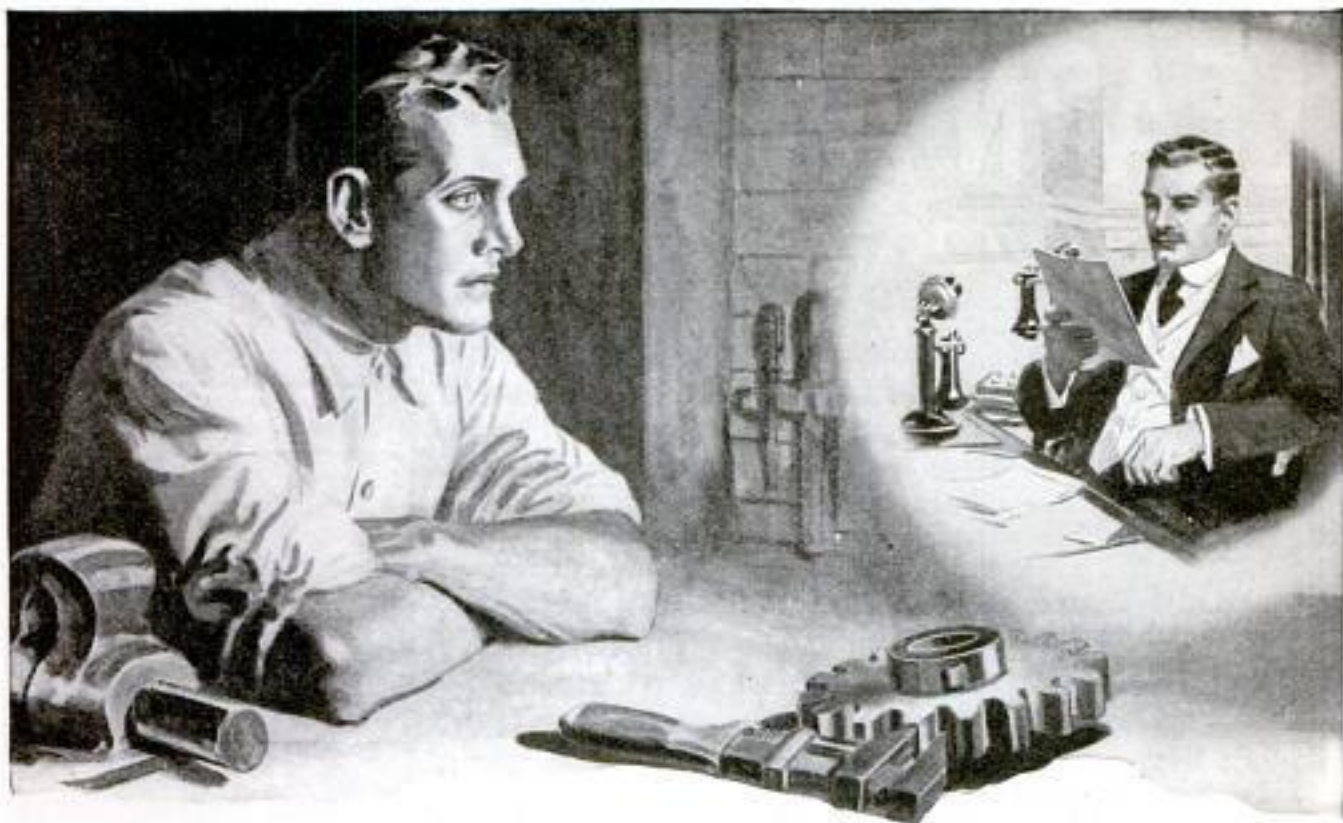

## “Think Beyond Your Job!”

“There is not a man in power at the Bethlehem Steel Works today,” says Charles M. Schwab, in the American Magazine, “who did not begin at the bottom and work his way up. These leaders rose from the ranks. They won out by using their normal brains to *think beyond* their manifest daily duty.

“Eight years ago Eugene Grace was switching engines. His ability to *out-think* his job, coupled with his sterling integrity, lifted him to the presidency of our corporation. Last year he earned more than a million dollars.

“Jimmie Ward, one of our vice-presidents, used to be a stenographer. But he kept doing things out of his regular line of duty. He was *thinking beyond his job*, so I gave him a better one. And he has gone up and up. The fifteen men in charge of the plants were selected, not because of some startling stroke of genius, but because day in and day out, they were *thinking beyond their jobs*.”

What about you? Are you satisfied just to hang on where you are? If so, rest assured that's as far as you'll ever get. But if you want to be somebody, to climb to a position of responsibility, *get ready for it*. Do what you are doing *now* better than the men beside you and *train for the job ahead*. You can do it—in spare time—through the International Correspondence Schools.

For 25 years men of ambition with I. C. S. help have been making spare hours the stepping-stones to successful careers. Last year more than 5,000 reported that their studies had won for them advancement and increased salaries. In the Bethlehem Steel Works alone over 100 men right now are putting their spare time on I. C. S. courses and *thinking ahead*, getting ready for the better positions that surely await them. And over 130,000 others in offices, shops, stores, mines and mills and on railroads all over America are preparing in the I. C. S. way to take the next step upward.

Join them! All you need is just ordinary brains, the will to do, and the firm resolve to *think ahead of the job you now hold*. The I. C. S. are ready to make the rest easy. Make your start, take the first step right now. Mark and mail this coupon.

### INTERNATIONAL CORRESPONDENCE SCHOOLS BOX 5543 SCRANTON, PA.

Explain, without obligating me, how I can qualify for the position, or in the subject, before which I mark X.

- |  |  |
|--|--|
| <input type="checkbox"/> ADVERTISING MAN             | <input type="checkbox"/> ELECTRICAL ENGINEER                             |
| <input type="checkbox"/> Salesmanship                | <input type="checkbox"/> Electric Lighting                               |
| <input type="checkbox"/> Commercial Law              | <input type="checkbox"/> Electric Car Running                            |
| <input type="checkbox"/> BUSINESS (Complete)         | <input type="checkbox"/> Electric Wiring                                 |
| <input type="checkbox"/> Certified Public Accountant | <input type="checkbox"/> Telegraph Expert                                |
| <input type="checkbox"/> Higher Accounting           | <input type="checkbox"/> Practical Telephony                             |
| <input type="checkbox"/> Bookkeeper                  | <input type="checkbox"/> Railroader                                      |
| <input type="checkbox"/> Stenographer and Typist     | <input type="checkbox"/> Mine Foreman or Engineer                        |
| <input type="checkbox"/> Railway Accountant          | <input type="checkbox"/> Metallurgist or Prospector                      |
| <input type="checkbox"/> WINDOW TRIMMER              | <input type="checkbox"/> ARCHITECT                                       |
| <input type="checkbox"/> Show Card Writer            | <input type="checkbox"/> Contractor and Builder                          |
| <input type="checkbox"/> Outdoor Sign Painter        | <input type="checkbox"/> Architectural Draftsman                         |
| <input type="checkbox"/> Common School Subjects      | <input type="checkbox"/> Concrete Builder                                |
| <input type="checkbox"/> Good English                | <input type="checkbox"/> Structural Engineer                             |
| <input type="checkbox"/> Teacher                     | <input type="checkbox"/> Plumbing and Heating                            |
| <input type="checkbox"/> Civil Service               | <input type="checkbox"/> Sheet Metal Worker                              |
| <input type="checkbox"/> Railway Mail Clerk          | <input type="checkbox"/> CHEMICAL ENGINEER                               |
| <input type="checkbox"/> CIVIL ENGINEER              | <input type="checkbox"/> Illustrator                                     |
| <input type="checkbox"/> Surveying and Mapping       | <input type="checkbox"/> Designer  |
| <input type="checkbox"/> MECHANICAL ENGINEER         | <input type="checkbox"/> Textile Overseer or Dept.                       |
| <input type="checkbox"/> Mechanical Draftsman        | <input type="checkbox"/> AGRICULTURE <input type="checkbox"/> Spanish    |
| <input type="checkbox"/> Machine Shop Practice       | <input type="checkbox"/> Navigator <input type="checkbox"/> German       |
| <input type="checkbox"/> Stationary Engineer         | <input type="checkbox"/> Poultry Raising <input type="checkbox"/> French |
| <input type="checkbox"/> Gas Engineer                | <input type="checkbox"/> AUTOMOBILES <input type="checkbox"/> Italian    |

Name \_\_\_\_\_  
 Present Occupation \_\_\_\_\_  
 Street and No. \_\_\_\_\_  
 City \_\_\_\_\_ State \_\_\_\_\_

If name of Course you want is not in this list, write it below.

Please Mention Popular Mechanics



# LEARN AUTOS

*Where Autos are Made*

Detroit is a city of motors. Eighty-five per cent of the motor cars in the United States are said to be made here. Here are located 40 or more auto factories, hundreds of parts makers. Detroit *makes* automobiles, *sees* automobiles, *thinks* automobiles day and night. Detroit is the *place* to learn the auto industry, and the Detroit Y. M. C. A. Auto School is the *school* at which to learn it.

## Backed by Automobile Factories

The automobile men of Detroit endorse our work without hesitation. The Studebaker, Buick, Hupp, Ford, Packard, Gray Motor, Disco, Zenith, Chalmers, and many others have contributed to our equipment their latest models and designs. Can you ask stronger proof of a school's standing than the fact that the *men who know* give freely their time and money to co-operate with it and aid in its growth.

## Not Operated for Profit

The Y. M. C. A. Auto School is not run for profit. Our purpose is to give our students the training necessary to get and hold good paying positions in the rapidly growing automobile industry. Tuition goes to procuring the highest class of instructors and the best of equipment. The automobile business is crying for trained men,—testers, chauffeurs, inspectors, salesmen, assemblers, repair men, bearing scrapers, motor mechanics of every description. Factories, dealers and garages join in the call. We fit you for these positions. Will you take advantage of this opportunity.

## Tuition Includes Membership in the "Y"

Tuition at the Y. M. C. A. Auto School is low — and *includes a year's membership in the "Y."* Our big Club House is at your disposal during time off. Reading rooms, lounging rooms, gymnasium, swimming pool, billiard and pool tables, bowling alleys, with five floors of dormitories and restaurant at low rates. You are assured of not only thorough and competent instruction, but good companionship and clean living conditions with the comforts of home and club life combined.

## Don't Visit Detroit Without Seeing Us

You want to consider everything carefully before you enroll for any course of instruction. Come and look us over, whatever purpose brings you to Detroit. Get all the particulars of this school, get the records of our instructors, hear what auto factories and automobile men have to say about us, see for yourself our comfortable quarters and big equipment. We will be glad to see you and show you around whether you enroll or not. Day and night classes. Start at any time. The average time required is 6 weeks for day course, and 12 weeks for night course.

**WRITE TODAY FOR FULL PARTICULARS. Address**  
**Educational Director, Box 305, Y. M. C. A., Detroit, Mich.**



Main Building Y. M. C. A.  
Detroit



Students Working on Axle  
and Transmission



Block Testing and Motor  
Department



"Y" Auto School Repair Shop



Lecture and Demonstration  
of Chassis







## You Can't Get On By Looking On

—But you can put yourself in a position of responsibility and big pay if you will devote some of your spare time now to making preparation for it. Never before have there been so many splendid openings for trained accountants. The tremendous business prosperity of the country has created a field that is truly rich with remarkable opportunities. There are now over half a million concerns requiring the services of expert accountants, yet there are only 2,000 certified public accountants in America to do the work. There are many certified public accountants whose incomes are from \$10,000 to \$25,000 a year. The United States Steel Corporation paid one accounting firm \$250,000 for installing its cost and accounting systems.

## Learn Higher Accounting The Profession of Big Incomes

Our graduates are capable of filling good positions as Auditors, Consulting and Cost Accountants, Financial Advisers, or to go into business independently as Certified Public Accountants. Their training with us qualifies them to be consulted on all matters of finance and management, to be one of the most important factors in the conduct of any business—to be indispensable to the firm.

### We Train You By Mail

In spare time—evenings—at home, without interference with your present duties and while you are drawing your present salary. Our training is made personal and individual. It takes into consideration your present knowledge or lack of knowledge. We provide complete and comprehensive training according to your individual needs from the simplest bookkeeping principles to the most advanced accounting problems. We will give you whatever training, instruction or review on the subject of bookkeeping you may personally need—without any extra expense to you.

### Small Cost—Easy Terms

Write today and learn how our easy-payment plan places this splendid course within reach of every ambitious person who possesses a real desire for advancement and the kind of organized "brain power" that commands big rewards in business everywhere. Get our free book which fully describes our expert training course and tells about our Money-Back Guarantee, C. P. A. examinations, state regulations, salaries, and incomes and how you can qualify for a high grade accounting position without interference with your present job. If you want to enter an uncrowded field that offers trained men a real opportunity for worth while advancement, send coupon and learn what we have done for others and can do for you.

**LaSALLE EXTENSION UNIVERSITY**  
"The World's Greatest Extension University"  
Dept. 164-H Chicago, Ill.

### Your Instruction Will Be Under Direct Supervision of Certified Public Accountants

Wm. Arthur Chase, Ex-Pres. Nat'l Ass'n of C. P. A. Examiners, Ex-Sec'y Ill. State Board of Examiners in Accountancy; John B. Tanner, C. P. A., Vice-Pres., Wis. State Board of Accountancy; Former Accounting Director, Wis. State Board of Public Affairs; Formerly of Nau, Tanner and Rosk, Cer. Pub. Acc'ts and other experts who rank among the highest. No expense has been spared to make this the easiest-to-understand, and most complete Home Study Accountancy Course ever prepared. Covers every phase of Practical Accounting, Theory of Accounts, Auditing, Cost Accounting, Business Organization, Business Management, Business Laws, etc.

## FREE Book Coupon

**LaSALLE EXTENSION UNIVERSITY, Dept. 164-H Chicago**  
"The World's Greatest Extension University"

Send at once, without cost or obligation to me, your valuable book of accounting facts and full details of your course in Higher Accountancy; also advise me about Special Reduced Rate and Convenient Payment Plan.

Name .....

Street and No. ....

City.....State.....

Please Mention Popular Mechanics

Copyrighted material





# Shipped Free

## Don't Send a Penny! For These New Pay Raising Shop Books

Read these pay-raising books before you send us a penny. Then decide if you can afford to be without them. Modern Shop Practice is the name of these six splendid volumes and they contain a complete and detailed description of all modern shop methods. All the newest machinery and tools are discussed in simple, understandable language. Money saving methods are explained. **Everything is arranged in A-B-C order** so that it is always at your fingers' tips. And we will send you all six of these handsomely bound volumes—if you will put your name and address in the coupon. **Read them first**—for seven full days. **Then decide** if you can afford to part with a set of books that contains everything your boss knows—and more!

### All About the Shop Consulting Service FREE

This new edition of Modern Shop Practice is just off the press. It is up to the minute in every detail. Bound in genuine Bagdad leather with limp covers that will last a lifetime. Handsomely lettered in gold. 2300 pages—2500 illustrations—all vital information to the shop man. Here you will find described and explained in detail the newest and most efficient shop methods. The latest inventions and improvements in machinery all treated at length. All tabulated and indexed so that you can find what you want immediately.

For a limited time we are giving away with each set of Modern Shop Practice, a full year's consulting membership in the American Technical Society. This entitles you to the advice and counsel of our entire corps of experts. Ask any question you wish concerning your business or mechanical problems. We are actually a clearing house for information, and our experts will render you the same valuable service as they give to regular subscribers. The \$12.00 membership is yours without a penny extra cost.

## 50c a Week

Yes, that is all you pay if you decide to keep the books after the 7 days' free trial. Just send \$2.00 after the trial and then \$2.00 a month (50c a week) until \$15.80 has been paid.

American Technical Society  
Dept. M1191, Chicago, U. S. A.

Please send me set of Modern Shop Practice for 7 days' free examination. If I decide to buy, will send \$2 in 7 days and balance \$2 a month until \$15.80 has been paid. Then you will send me a receipt showing that the \$30.00 set of books and the \$12.00 consulting membership are mine and fully paid for. If I think that I can get along without the books I will return them after seven days at your expense.

But don't buy the Shop Library if you think that you can afford to get along without it. **Get it on free trial**—without a penny down—then decide. This offer is open to every resident of the U. S. and Canada. When you fill out the coupon please be sure to give us a reference as the by-laws of the society makes it necessary that we have a reference before the books can be shipped.

**Treats These Subjects In Every Detail**  
Machine Shop Work  
Machine Shop Management  
Tool Making  
Foundry Work  
Pattern Making  
Machine Drawing

### Send the Coupon

Put your name and address in the coupon now. Send no money. Just fill out the coupon and we'll send the whole set of books prepaid—right to your home.

Name .....

Address .....

Reference .....

**AMERICAN TECHNICAL SOCIETY**  
Dept. M1191, CHICAGO, U. S. A.





# \$125 to \$300 a Month

Send the coupon below and find out about the opportunities in the profession of Signal Engineering. *Big salaries are being paid*—\$125 to \$300 a month is an ordinary salary for the man who has the proper training. You can get just this kind of training right in your own home—during your spare time. **Men are needed.** Send the coupon for the book that tells you all about it. You owe it to yourself to find out about the opportunities that are offered to you. Send the coupon today—now.

## Be a Signal Engineer!

Be the man who gets the fat pay envelope. The profession of Signal Engineering is only in its infancy. There are thousands of miles of block signals to be installed. Signal Engineers, supervisors, inspectors and foremen are required to superintend this installation. Hundreds of maintainers and battery men are needed to maintain the systems already in use.

### Two Big Outfits FREE

Complete Signal Engineer's Outfit and Complete Draftsman's Outfit given away absolutely free to each student.

Your duties may take you from coast to coast. Railroad men are always in a fortunate position to travel and see the world because free transportation is liberally awarded. You can accept a position where you will be located steadily at one place, if you prefer—the position of authority—the high place and the fat pay envelope may be yours. Send the coupon today for the free Signal Book.

## Men Are Needed

The profession of Signal Engineering is calling to ambitious men. Our ranks are not overcrowded. There are opportunities—golden ones, awaiting the men who answer the call. Block signal systems are no longer in the experimental stage. All over the country they are being installed. Some States have legislated to compel the railroads to install systems immediately. In our profession you will have the chance you have been looking for. **We are calling you.** Send coupon today for big Free Signal Book and full details.

## Send Coupon for Big New Book

Put your name and address on the coupon or on a letter or a postcard now, and send it to us. Absolutely no obligations of any kind. We will send you our big new Book absolutely free, and prepaid. Read about this fascinating profession. Read about the opportunities that await you. The book is free. Send the coupon for it now—it's the first step toward the realization of your ambition. Send your name and address at once.

### Department of Signaling

Room 1191, 1810 Wilson Ave., Ravenswood Station, CHICAGO

### Department of Signaling

Room 1191, 1810 Wilson Ave.  
Ravenswood Station, Chicago

Gentlemen:—Please send me absolutely free and prepaid your big new book on Signal Engineering. Also full particulars about your great special free outfit offer. It is distinctly understood that I assume no obligations of any kind.

Name.....

Address.....

Age..... Occupation.....



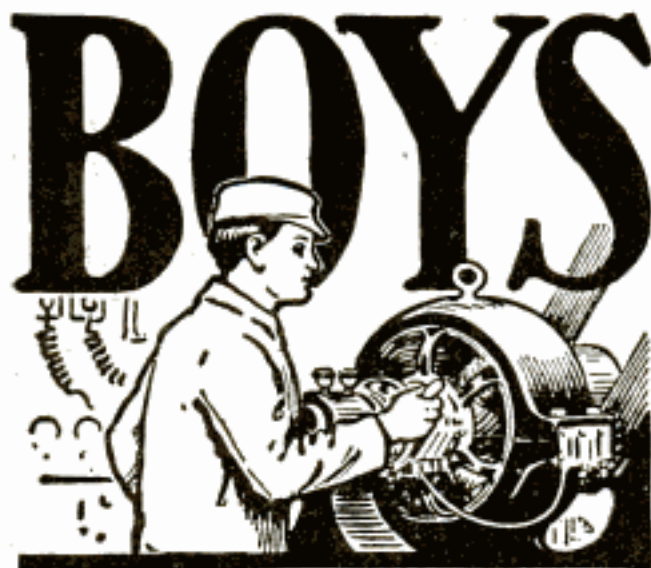

## Big Money in Electricity

The Electrical industries offer wonderful opportunities to boys with a liking for Electricity. The salaries paid to trained men are large, promotion comes rapidly and, best of all, the work is fascinating.

The discovery and development of new lines (such as wireless telegraphy and telephony), from time to time, promise attractive and paying fields to those who wish to specialize. The *will to do* and *Special Training* will bring success to you.

The International Correspondence Schools can help you to become an expert in electrical work, no matter what branch you like best. Thousands of young men have already won success through I. C. S. help. You can do as well as anybody, *if you try*. Everything is made so clear that you can learn in your spare time, regardless of where you live or what your work. No books to buy.

There's big money in Electricity. Get after it by marking and mailing the Coupon today. *Finding out costs you nothing.*

### INTERNATIONAL CORRESPONDENCE SCHOOLS

Box 5545, SCRANTON, PA.

Explain, without obligating me, how I can train for the position before which I mark X.

- |  |  |
|--|--|
| <input type="checkbox"/> ELECTRICAL ENGINEER       | <input type="checkbox"/> ARCHITECT               |
| <input type="checkbox"/> Electrician               | <input type="checkbox"/> Architectural Draftsman |
| <input type="checkbox"/> Electric Wiring           | <input type="checkbox"/> Mine Foreman or Supt.   |
| <input type="checkbox"/> Electric Lighting         | <input type="checkbox"/> Business (Complete)     |
| <input type="checkbox"/> Electric Car Running      | <input type="checkbox"/> Bookkeeper              |
| <input type="checkbox"/> Electric Machine Designer | <input type="checkbox"/> Stenographer            |
| <input type="checkbox"/> Telegraph Engineer        | <input type="checkbox"/> Advertising Man         |
| <input type="checkbox"/> MECHANICAL ENGINEER       | <input type="checkbox"/> Salesmanship            |
| <input type="checkbox"/> Mechanical Draftsman      | <input type="checkbox"/> Window Trimmer          |
| <input type="checkbox"/> STEAM ENGINEER            | <input type="checkbox"/> Civil Service           |
| <input type="checkbox"/> GAS ENGINEER              | <input type="checkbox"/> AGRICULTURE             |
| <input type="checkbox"/> CIVIL ENGINEER            | <input type="checkbox"/> Poultry Raising         |
| <input type="checkbox"/> Structural Engineer       | <input type="checkbox"/> AUTOMOBILES             |
| <input type="checkbox"/> CHEMICAL ENGINEER         | <input type="checkbox"/> Auto Repairing          |

Name \_\_\_\_\_

Present Occupation and Employer \_\_\_\_\_

Street and No. \_\_\_\_\_

City \_\_\_\_\_ State \_\_\_\_\_

If name of Course you want is not in this list, write it below.

## How much Money do you want?



Do you want to climb to a \$3,000 to \$10,000 a-year-job?—do you want to get out of an overcrowded trade into a position that will keep you deeply interested, and where there is always lots of action—no monotony?

Of course, you'll have to be trained—but a man of average intelligence and ambition, can become a successful and well-paid

### Railway Traffic Inspector

A new and uncrowded profession. Positions always open. Travel over continent. If you wish, with expenses paid. For the right men, rapid promotion is certain. Here's your BIG chance. We both train you and give you practical experience to earn BIG money and advancement.

**\$2000.00**

Our FREE BOOKLET, D-6, simple and brief, explains your opportunity. Ask for it now, lest you forget.

FRONTIER PREP. SCHOOL, BUFFALO, N. Y.



**THIS JOB PAYS \$25-\$50 Weekly**

### IN 10 WEEKS' SPARE TIME

We can teach you the entire subject by mail and help you to get a good position. ONE MILLION AUTOMOBILES will be built next year. The demand for trained help will be tremendous. **Sample Lessons Free — Write for Them Today** (Owners—we supply competent men.)

Franklin Auto Institute, Dept. S 803, Rochester, N. Y.

## CIVIL SERVICE

positions are in all parts of the country. Good pay, steady work, life positions, congenial surroundings, promotions on merit, short hours, annual vacation and sick leave with pay. Many thousands appointed yearly. Both sexes. No political pull. Nearly 300,000 classified positions. Common school education sufficient. Full information and questions used by the Civil Service Commission free.

COLUMBIAN CORRESP. COLLEGE, WASHINGTON, D. C.

## MUSIC TAUGHT FREE



IN YOUR OWN HOME

You can read music like this quickly. Piano, Organ, Violin, Mandolin, Guitar, Banjo, etc. Beginners or advanced players. One lesson weekly. Illustrations make everything plain. Only expense about 2c per day to cover cost of postage and music used. Write for FREE booklet which explains everything in full.

AMERICAN SCHOOL OF MUSIC, 51 Lakeside Building, CHICAGO

**Be an Artist**

Comics, Cartoons, Commercial, Newspaper and Magazine Illustrating, Pastel and Crayon Portraits. Earn \$25 to \$200 a week. By our simple method your talent is quickly developed without interfering with present work. **By Mail or Local Classes.** Small sums you now fritter away pay your tuition. Write for terms, list of successful pupils and instruction method FREE.

ASSOCIATED ART STUDIOS, 2203 Flatiron Building, New York

**LEARN TO WRITE ADVERTISEMENTS EARN \$25 to \$100 A WEEK**

We can positively show you by mail How to increase your salary. BOOK MAILED FREE. PAGE-DAVIS CO., 112 Page Building Chicago, Ill., or 154 Nassau St., New York

## JEWELRY ENGRAVING

We teach you, by our new and original method of instruction, this clean, fascinating and profitable business right at your home, and furnish you all tools needed absolutely free. Write for free book to the WISCONSIN SCHOOL OF ENGRAVING, 5th Bldg., MILWAUKEE, WIS.

Please Mention Popular Mechanics



# Our Graduates are Making

**\$80 to \$250** We  
**AND MORE PER MONTH**



**T**HE Best Paying Positions in the Auto business are secured through this school. Our thorough and practical instruction has placed many of our graduates in positions where they are getting up to \$12,000 and \$20,000 a year in salary, or in profits from their own business.

Many others are Expert engineers, Chauffeurs, Race drivers, Shop foremen and Final testers for White, Chandler, Ford, Willys-Overland, Chalmers, Peerless, Cadillac, Stearns and other leading factories. 15 of our June class are now truck drivers for the Government at \$100 to \$150 a month and all expenses.

We have calls for more and more men from *all parts* of the country—because our School is known to rank *highest* in careful, thorough and up-to-date training. Wonderful opportunities are developing in the Auto business right along—but you must have the *right training* by *actual experience*, and the place to get it is the

**Cleveland**

Established 1903  
Individual Instruction

**Auto School**

Up-to-date Equipment  
13 Years of Success

## 4000 Graduates Making Good

Ours is one of the most completely equipped schools in the country; a dozen cars at the disposal of students; we teach every point worth knowing, including machine shop practice, taking apart and putting together complete cars, Knight type, 12 and 8 cyl. motors; latest starting and lighting equipment, Ambu trouble shooter, Phillips testing set, etc., etc. Just installed newest Akron-Williams tire repair equipment—same as used and sold by the leading tire companies.

### CLEVELAND LEADS

in all parts and accessory, and high grade car manufacture, and is gaining fast in new factories; Grant, Jordan, Abbott, Denmo truck, H. A. L. 12—and others building.

### TRAINING IN 4 WEEKS

Tuition low; board and room \$5 and \$6 per week near school; congenial company and surroundings; we help you get located. New classes forming. **Come and join us now.**

**We Absolutely Guarantee**

to qualify you for a good paying position in the Auto business on completion of our course.

## Cleveland Automobile School

CLYDE H. PRATT, President, Dept. 1, 2338 Euclid Ave., CLEVELAND, OHIO

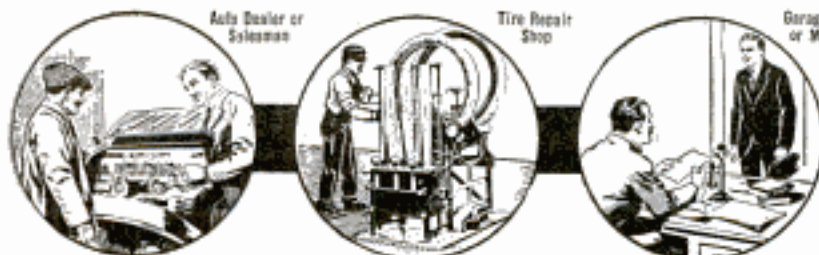

Auto Dealer or Salesman

Tire Repair Shop

Garage Owner or Manager



Race Driver



Tester



Master of 12-cyl. Motor



Private Chauffeur

Send This Coupon

**CLEVELAND AUTO SCHOOL**  
Dept. 1  
2338 Euclid Ave.  
CLEVELAND

You may send me FREE catalog, terms, etc.

Name.....

Address.....

**Own A Business**

Please Mention Popular Mechanics





## "You Are The Man We Want"

"We have lost a lot of money on shipments this last year, and we've hired you because we know you can save us money".

Many a trained traffic man has been talked to like this by the "big chief". Plenty of similar jobs waiting for trained men to fill them. The position is one of importance and dignity. The T. M. "sits in" at many a Directors' meeting because of that very importance, and when the job is important the pay is big. Why don't you become a Traffic Manager?

### 95,000 Trained Traffic Men Are Needed Now

There are 500,000 shippers in the United States. 100,000 are able to employ Traffic Managers. There are now 3,000 to 5,000 Traffic Managers in the country. That leaves 95,000 shippers without Traffic Managers; a man they need; a trained man who can save them money.

#### Study Under A Master

H. E. Fairweather, Dean of the Interstate Traffic School, is an expert of national repute with years of practical experience behind him. He is master of tariffs, having in the past served some of the largest railroads in the country. You get practical instruction—not theory. Over 37,000 Tariffs in our files. Each student's lesson paper is graded personally by actual Traffic managers. Unlimited consultation service for two years after graduation.

#### Are You On The Wrong Job?

Thousands of men are on the wrong job; right perhaps, as far as the work is concerned, but wrong where the pay comes in. Few men can be contented with a job that doesn't pay well or offer a good chance for steady and sure advancement.

Far sighted, ambitious men are climbing out of ruts and seeking opportunities in special fields. The man who specializes today is the big man of tomorrow. To become a successful and highly paid Traffic Manager you don't need "special talent"—only a common school education and an hour or two a day of your spare time.

#### Prepare Now For The Big Job

Thousands of shippers realize their need of a trained traffic manager. But the supply of trained men doesn't begin to meet the demand. Ask any shipper if the trained Traffic Manager isn't highly important and well paid. Ask him if it wouldn't be a good profession for you to get into.

Interstate  
Traffic School  
101 Traffic Bldg.  
Ft. Wayne, Ind.

Gentlemen:

Send me absolutely free and prepaid, your new book on the Traffic Profession.

Name \_\_\_\_\_

Address \_\_\_\_\_

Prepare Now. Send for our free catalog. It tells who we are, what we teach and how we do it. We'll train you to fill an important, responsible position at big pay and help you find a place when you are trained.

#### FREE—New Book

Our free book on Traffic tells all about it; explains clearly, concisely. Don't pass this opportunity. Use the coupon NOW. You'll always be glad.

INTERSTATE  
TRAFFIC SCHOOL  
101 Traffic Bldg.  
Ft. Wayne,  
Indiana

Please Mention Popular Mechanics

# Jobs Now Open for Men Who Can Sell

Pick up any newspaper—note the large number of Want Advertisements for Trained Salesmen.

Talk with any business executive—he will tell you his firm can always find a place for a Trained Salesman. Other professions are overcrowded with good men—the Trained Salesman is always in demand—can always command a large salary.

### Big Pay—Pleasant Work

A Salesman is a direct producer of profits—it is only natural that he is well paid. He travels on finest trains—lives at best hotels—has plenty of leisure hours—is independent. Our Home Study Course in Scientific Salesmanship gives you just the training necessary to qualify for a big paying position as Traveling Salesman. Among the many subjects covered are the following—how to prepare a "Selling Talk"—how to approach the prospect—how to manage the interview—how and when to close.

### FREE EMPLOYMENT SERVICE

Employers everywhere recognize the value of N. S. T. A. Training. We have constantly on file more requests for Salesmen than we can possibly fill. Surely you can make good. Write today for free book, "A Knight of the Grip," together with list of hundreds of good openings offering opportunities to earn Big Pay while you learn. Address nearest office—Dept. 997.

National Salesmen's  
Training Association  
Chicago New York  
San Francisco

#### Members Say:—

"From mechanic to high-salaried Salesman for the best firm in its line is what your Course did for me."—  
A. CHRISTIAN, 79  
Milk Street, Boston,  
Mass.

"Last year I earned \$800 as a clerk. This year I have earned \$2500. Your training made this possible."—  
C. W. BIRMINGHAM,  
129 Bank Street, Dayton,  
Ohio.

"We are enjoying the fruits of success made possible by your training. From common labor to \$1000 a month goes 'for speed'."—  
JAMES BAHRIGER, 21  
So. Valley St., Kansas  
City, Kans.

"I was a carpenter. Your Course made me a Salesman. I earn bet-  
ter than \$2500 a year."  
J. H. WOOD, Rm. 322  
Pacific Bldg.,  
San Fran-  
cisco,  
Cal.



## New Book Free

Write today for the book that tells about the opportunities in the profession of Signal Engineering. Men are needed. Learn, too, how you can get the training that you need to fill the big job.

### \$125 to \$300 a Month

The free book will give you just the information you want. Write for it now—immediately. Here is a golden opportunity.

Dept. of Signaling Dept. 1198 —1810 Wilson Ave.  
Riverwood Bldg., Chicago, Ill.



## Learn to Be a Chauffeur

A well-paid, pleasant occupation that brings you above the ordinary mechanic. This book, compiled by experts, tells how to operate a car; how to repair it in every part; how to get a license; how to get a good job. Gives the names of every part of a car, and what they do; all the up-to-date pointers that all good chauffeurs should know. The most complete book of its kind on the market.

Sample copy by mail, 10c

ROYAL BOOK CO., 250 East Ave., SO. NORWALK, CONN.

## High School Course in Two Years

LEARN in your own home. Here is a thorough and simplified high school course that you can complete in 2 years. Meets college entrance requirements. Prepared by leading members of faculties of universities and academies.

### Study in Your Own Home

This course was prepared especially for home training. What if you did not get a high school education? You can make up for lost time now. Idle evenings can be spent in pleasant reading that will give you a thorough high school training.

### Write for Our Booklet!

Send your name and address today for our booklet and full particulars. No obligations whatever. Write NOW!

**American School**  
of Correspondence, Chicago, U.S.A.

Dept. 9997



# Ambition

-take a Lesson  
from Life



You men of ambition—you who are taking thought of the future and have considered taking up law either as a profession or as a means of attaining greater success in the business world—you do not need to be reminded that law always has been, and is today, the foremost profession. That law has raised more men to positions of power and eminence than any other calling; that today law offers more and broader avenues for a successful career than ever; that lawyers' yearly incomes of from \$3,000 to \$10,000 are by no means uncommon. You know these things from daily observation. You feel that you could make your influence felt in the legal profession, in business, in politics, if you had but the necessary legal education. And so you could.

# LAW

## At \$3,000 to \$10,000 a Year Is Your Opportunity

Right now you may be debating the question as to where you can best learn law. Let us help you answer that question. Let us tell you how, through our simplified Home Study Course, we have revolutionized the study of law. Let us explain fully, just how easily this great law course can be mastered right in your own home, during spare time; how we have taken the hard, grinding work out of the study of law and have made it as fascinating and absorbing as a work of fiction.

There are many things about this really remarkable home study law course which you should know. For instance—

### Do You Realize—

That the LaSalle Home Study Text and Course are prepared by some of the ablest law professors, jurists and legal experts in the country? The list includes such men as James Parker Hall, Dean of University of Chicago Law School; James DeWitt Andrews, former member faculty Northwestern University, and other famous legal authorities, and professors in such colleges as Harvard, Leland Stanford, University of California, Michigan, Wisconsin, Etc.

That it is the only home study law course in existence that is of university grade and that gives you the same kind of legal instruction and training—the same kind of individual lessons, class talks, quizzes and examinations—that you would receive at the most famous resident law schools in America?

That, under the laws of the State of Illinois, we are authorized to confer the degree of LL. B. on our graduates?

That LaSalle graduates taking bar examinations in states where the requirements are most rigid, and in competition with graduates of the best known resident law schools of the country, are among those who have passed with highest honors?

That, should a student fail to pass the bar examination in any state, we guarantee to give him additional instruction and coach him free of charge until he does pass?

That we further give a legal binding guarantee to refund the entire amount of tuition paid, if the student is dissatisfied with course?

That there are, in practically every state in the Union, LaSalle Law graduates who are today highly successful practicing lawyers?

That, as a part of the course, and immediately upon enrolling, we furnish a magnificent law library consisting of 14 massive volumes bound in ¾ sheep—the preparation of which cost us over \$50,000?

Do you grasp the full significance of what it means to you to be able to obtain this thorough, practical course of university grade on terms so easy that you would scarcely miss the money? And the total cost is so surprisingly small you will wonder how it is possible.

### FREE Complete Course In Public Speaking

Every lawyer—every successful man—should be a forceful speaker. Mail coupon at once for full particulars of how, by your acting promptly, we will give you, absolutely free, a complete course in public speaking that will quickly train you in the fine art of persuasive speech. Course prepared by Frederick B. Robinson, A. B., A. M., Ph. D., Professor Public Speaking at College of City of New York.

### You Owe It To Yourself—To Your Future—To Get All the Facts

They are interestingly told in our remarkable book which is yours, free for the mailing of the coupon. Mail the coupon. It imposes not the slightest obligation upon you—and the book, together with our book, "Evidence" and letters from hundreds of successful graduates which we will send you, also free—will give you a clearer insight of the wonderful work of this great institution and of the high educational ideas it has set and is maintaining.

ACT! Take your first step toward greater success today. Mail coupon.

**MAIL NOW!**  
COUPON

LaSalle Extension University  
Dept. 164-F Chicago, Ill.

Without obligation on my part, send me by return mail, information concerning your Course in law together with the free books: "Evidence" and Valuable Law Guide —also your offer of FREE Course in Public Speaking.

Name.....

Street and No.....

City.....State.....

LaSALLE EXTENSION UNIVERSITY, Dept. 164-F Chicago, Ill.  
The World's Greatest Extension University

Please Mention Popular Mechanics



# 414 PAGES 145 ILLUSTRATIONS

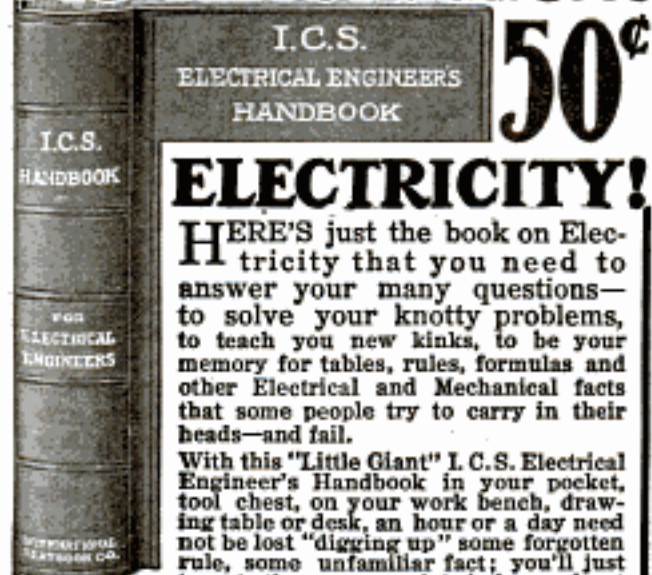

I.C.S.  
ELECTRICAL ENGINEERS  
HANDBOOK

# 50¢

## ELECTRICITY!

HERE'S just the book on Electricity that you need to answer your many questions—to solve your knotty problems, to teach you new kinks, to be your memory for tables, rules, formulas and other Electrical and Mechanical facts that some people try to carry in their heads—and fail.

With this "Little Giant" I. C. S. Electrical Engineer's Handbook in your pocket, tool chest, on your work bench, drawing table or desk, an hour or a day need not be lost "digging up" some forgotten rule, some unfamiliar fact; you'll just turn to the very complete index and get

it "in a jiffy." Just a few of the subjects treated are:

Electricity and Magnetism; Electrical Symbols; Batteries; Circuits; Magnets; Direct and Alternating Currents; Dynamos and Motors; Belts; Shafting; Electroplating; Electrical Measurements; Meters; Arc and Incandescent Lamps; Mercury Arc Rectifiers; Transformers; Insulation; Electric Cars; Single and Multiple-Unit Control; Transmission; Rail Welding; Tables of Wires—Sizes, Capacities, etc.—Mathematical Rules, Formulas, Symbols; Tables of Constants, Equivalents, Roots, Powers, Reciprocals, Areas, Weights and Measures; Chemistry; Properties of Metals; Principles of Mechanics; First Aid, etc.

The Electrical Engineer's Handbook is one of 22 I. C. S. Handbooks covering 22 Technical, Scientific and Commercial subjects, all crowded with value. They have the contents of a full-size book condensed into pocket-size ready to go with you anywhere and be at your instant command. They are substantially bound in cloth, red edges, goldleaf stamping, printed from new, clear, readable type on good quality book paper. There is an illustration at every point where a picture will help. Hundreds of thousands have been sold on a money-back guarantee of satisfaction.

The regular price is \$1.25, but for a LIMITED TIME you can buy the ones you want, postpaid, delivery guaranteed, for only 50 cents each.

You Run No Risk! Money Back if Desired!  
International Correspondence Schools  
Box 5547, Scranton, Pa.

INTERNATIONAL CORRESPONDENCE SCHOOLS  
Box 5547, SCRANTON, PA.

I enclose \$\_\_\_\_\_ for which send me postpaid the Handbooks marked X, at 50c. each. I may return any or all and get my money back within ten days from receipt:

- |  |  |
|--|--|
| <input type="checkbox"/> Electrical Engineer's         | <input type="checkbox"/> Advertiser's              |
| <input type="checkbox"/> Teleph. and Teleg. Engineer's | <input type="checkbox"/> Business Man's            |
| <input type="checkbox"/> Mechanic's                    | <input type="checkbox"/> Bookkeeper's              |
| <input type="checkbox"/> Steam Engineer's              | <input type="checkbox"/> Stone and Correspondent's |
| <input type="checkbox"/> Westinghouse Air Brake        | <input type="checkbox"/> Salesman's                |
| <input type="checkbox"/> Civil Engineer's              | <input type="checkbox"/> Window Trimmer's          |
| <input type="checkbox"/> Coal Miner's                  | <input type="checkbox"/> Cotton Textile Worker's   |
| <input type="checkbox"/> Concrete Engineer's           | <input type="checkbox"/> Farmer's                  |
| <input type="checkbox"/> Building Trades               | <input type="checkbox"/> "Goultryman's"            |
| <input type="checkbox"/> Plumber's and Fitter's        | <input type="checkbox"/> Mariner's                 |
| <input type="checkbox"/> Chemist's                     | <input type="checkbox"/> Automobile                |

Name \_\_\_\_\_

Street and No. \_\_\_\_\_

City \_\_\_\_\_ State \_\_\_\_\_

Please Mention Popular Mechanics

## New Automobile Books

For OWNERS, DRIVERS and REPAIR MEN

The new equipment makes the old books obsolete. We will send any or all of the following books prepaid upon receipt of price.

### BROOKES' AUTOMOBILE HANDBOOK

Revised by H. P. MANLY

715 pages, of which 400 pages are devoted to practical information on new equipment. 325 illustrations and diagrams. Special articles on carburetors, ignition starting and lighting, and every new device used.

Pocket size, leather, round corners, red edges, gold stamping. Price, postpaid....\$2.00

### AUTOMOBILE STARTING and LIGHTING

By HAROLD P. MANLY

Every starting and lighting device in the market is covered in this work in a practical manner, for the owner, operator and repair man. The principal subjects treated are as follows: Electric Lighting and Engine Starting

Equipment; Lighting Dynamos and Starting Motors; Storage

Batteries; Lamps and Wiring; Control Parts; Dynamo and Motor Drives; Current Measuring and Indicating Devices; Starting and Lighting troubles.

200 pages. Illustrated. Pocket size. Cloth, postpaid.....\$1.00

Full Leather, red edges, gold stamping, postpaid.....\$1.50

### AUTOMOBILE CATECHISM and REPAIR MANUAL

By G. F. SWINGLE and H. A. TARANTOUS

Part I comprises questions and answers. Part II is devoted entirely to automobile repairs. It gives complete instructions for locating troubles and making adjustments and repairs of all kinds. Motor knocks, carburetion, ignition, valve troubles, fitting piston rings, and tires.

165 pages. Fully illustrated. Price, postpaid.....\$1.25

Send for our catalogue of practical mechanical books for Electricians, Engineers, Telephone Men, Machinists, Railroad Men, Automobileists, Carpenters, Plumbers, Sign and Card Writers, Scene Painters, etc. It is FREE

FREDERICK J. DRAKE & CO., 1008 Michigan Ave., Chicago

**\$12500 to \$30000 a Month**  
Write at once. Most wonderful opportunity for the ambitious man. Railroads need hundreds of Signal men—will pay Big Money.  
**Special Offer** We will teach you right at home to be expert. Special offer if you write at once. Two big outfits free. Write Today for our free catalog and particulars of our big offer.  
DEPARTMENT OF SIGNALING  
1010 Wilson Ave., Room 9191, Ravenswood Station, CHICAGO

**DRAWING**  
Learn by Mail in YOUR OWN HOME  
Newspaper, Magazine and Commercial Illustrating, Cartooning, Water Color and Oil Painting. Learn drawing or painting for profit and pleasure. We can develop your talent. This school has taught thousands. Free Scholarship Award—special limited offer. Your name and address brings you full explanation and our handsome illustrated Art Annual by return mail. Don't delay, write to-day.  
Fine Arts Institute, Studio 561, Omaha, Neb.

**Learn How to WRESTLE**  
In Your Own Home  
By Mail  
Yes, learn to become an expert wrestler right in your own home, by mail, from the greatest wrestler the world has ever known. Be an athlete, be strong, be healthy. Learn how to throw and handle big men with ease. Learn to defend yourself. All taught in our course of lessons, and illustrated with hundreds of charts and actual photographs by  
**Farmer Burns and Frank Gotch**  
Farmer Burns, "the grand old man of the mat," taught Frank Gotch the present World's Champion, all he knows about wrestling, so Gotch says. He will now teach you Scientific Wrestling—Physical Culture—Jiu-Jitsu—Self Defense. Every man and boy in America, no experience what age, needs this wonderful course of lessons. Write today—your name, age and address on a postcard or letter brings you our free book absolutely free—no obligations of any kind. A splendid book on wrestling and physical culture. Write today stating your age.  
Farmer Burns School of Wrestling, 1191 Range Bldg., Omaha





## Learn to FLY

### Build Your Own Bi-Plane Glider

**NOW** Many of the famous birdmen first learned to fly with a GLIDER. It is the initial step in aviation—and the small cost of material to construct such a machine—and the ease with which it can be built places it within the reach of everyone.

Send to-day for copy of book "How to Build a 20-ft. Bi-Plane Glider" and get full particulars, with detailed drawings—Postpaid

**60c**

**SPON & CHAMBERLAIN**  
123 P. M. Liberty St., NEW YORK



## New Book Free

Write today for the book that tells about the opportunities in the profession of Signal Engineering. Men are needed. Learn, too, how you can get the training that you need to fill the big job.

**\$125 to \$300 a Month**

The free book will give you just the information you want. Write for it now—immediately. Here is a golden opportunity.

Dept. of Signaling — 1810 Wilson Ave.,  
Riverside Station, Chicago, Ill.

## The AMERICAN BOY

"—the biggest, brightest, best magazine for boys in all the world." Gives you a whole year of fun for \$1.50. Brimful of thrills, stories and articles that you will just "eat up." Get somebody to subscribe for you today.

Sprague Pub. Co., 63 American Bldg., Detroit, Mich.

## Baker's Show Card Book \$3.00

EARN \$20 to \$60 A WEEK

LEARN TO MAKE SHOW CARDS. Salary as business of your own. My book teaches all the tricks of the trade. No simple anyone can learn. Elaborately illustrated. Earn while learning. Send today. Money refunded if not satisfied.

WM. J. BAKER, HENRY BUILDING, PORTLAND, ORE.

**I Want  
1000 Men  
To Prepare For Jobs Paying  
\$75 to \$300  
Per Month**



The boom is on. Bosses are paying more and more to get men skilled in auto mechanics to work for them. Garage owners stand ready to pay big money for Expert Repairers. Gas Engine manufacturers are short on trained workers. Thousands of tractors are ready to go on the farms—and there are only a few experts to run them. A million new cars are to be built this year and good drivers will be scarce. From everywhere comes the demand for men—trained men. If you are ambitious, I will train you quickly at home in your spare time for one of these big jobs. I will teach you to

## Be an Expert Auto Mechanic

Repair Man, Chauffeur, Traction Engineer, or Farm Lighting Expert, in shortest possible time. Big jobs are ready and waiting for you. With I. M. I. training you can quickly qualify as an expert in any of the above lines—prepare for a job paying up to \$300 a month.

I will give you 25 Lessons Free. But you must act at once. Only 1,000 Partial Scholarships will be given away, and only one in each locality. Rush coupon and get details of FREE offer. Investigate. Write today. Results guaranteed.

**25  
LESSONS  
FREE**

HARRY WELLS, Gen. Mgr.  
International Motor Institute,  
122 Kesner Building, Chicago

Send me full details of your 25 Free Lessons Offer, also Enrollment Blank.

Name.....

Address.....

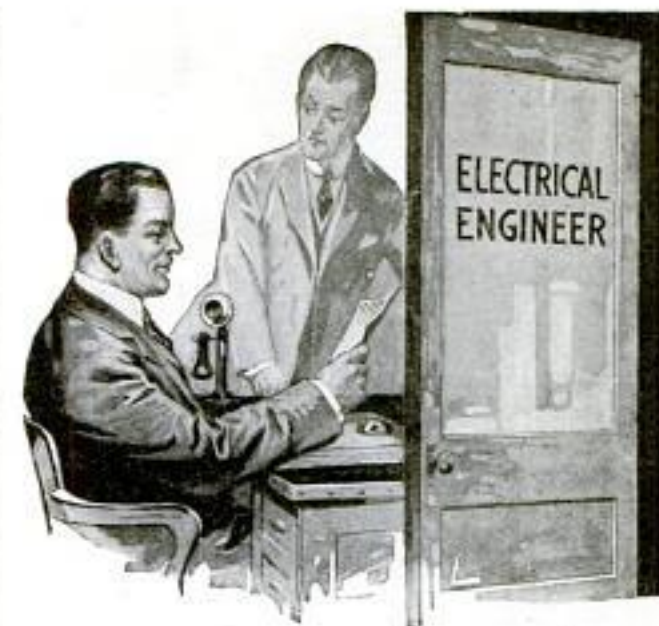

## The Electrical Engineer Is the Man of the Hour and the Future!

**EVERYWHERE** electricity is now being used for power, light and heat.

All other agents are out of date. Nevertheless, Thomas A. Edison says that we have only begun to realize the tremendous possibilities in the field of electricity. Golden opportunities await the Electrical Engineer. His work is fascinating—and big salaries are paid. The Electrical Engineer is the man of the hour and the world pays him accordingly.

**\$2,500 to \$5,000 a Year**

That's an ordinary salary for an Electrical Engineer. All over the civilized world men with a thorough knowledge of electricity are in demand and naming their own salaries. And the training that you need to put you in one of these positions can be obtained right in your own home.

## Practical Training— Right in Your Own Home

By our new thorough complete course of instruction you can get practical training in Electrical Engineering right in your own home. Electrical Engineering has been simplified. You do the experiments yourself just as if you were actually engaged in the work. You learn theories, too, and graduate a full-fledged Electrical Engineer.

## Send the Coupon For Our New Book

Put your name and address on the coupon or on a letter or postcard and get our new book on Electrical Engineering. It will tell you about the golden opportunities that are awaiting you. The book is free and it carries a vital message to every ambitious man. Put your name and address on the coupon now. Opportunity is calling and saying, "Send the coupon."

American  
School of  
Correspondence  
Dept. E1191 Chicago

Please send me your  
free book on Electrical  
Engineering.

Name.....

American  
School of  
Correspondence

Dept. E1191  
Chicago,  
U. S. A.

Address.....

Please Mention Popular Mechanics

Copyrighted material





## \$100.00 EARNED BY YOUNG ARTIST IN TWO DAYS

He was trained by members of our Faculty. You, too, if you like to draw, should make a success of Commercial Designing and Illustrating — *with the right training.*

### A Real Future Awaits You!

Salaries \$25.00 to \$75.00 a week, and *more.* Thousands of advertisers, periodicals, publishers and others use millions of dollars' worth of designs and illustrations every year. The field is uncrowded. The prices paid for good work and ideas will surprise you.

With our thoroughly practical and original home study course, personally conducted by well known and successful commercial artists and advertising experts, you can master this dignified, pleasant and profitable profession in your spare time. Easy to learn and apply, endorsed by eminent authorities.

#### Send for Free Book "Your Future"

A book every young man and woman should read before deciding on their future—a book parents should read with the future of their children in mind. Tells of wonderful opportunities open to those with training — cites instances of success won by our students in all parts of the country — describes the ease with which you can become expert through our home study method. Opens the way to greater success in life for you. *Mail the coupon — NOW.*

**Federal School of Commercial Designing, Inc.**  
616 Warner Bldg. MINNEAPOLIS, MINN.



P. M.  
**Free Book  
Coupon**

Federal School  
of Commercial  
Designing, Inc.  
616 Warner Bldg.  
Minneapolis, Minn.

Please send me free book  
"Your Future," also your  
portfolio of Commercial Il-  
lustrations.

NAME.....

(Write your address in margin)



# \$100<sup>00</sup> EARNED BY YOUNG = ARTIST IN 2 DAYS

He was trained  
by members of our Faculty.

You, too, if you like to draw, should  
make a success of Commercial Designing  
and Illustrating — with the right training.

## Opportunities Unlimited

Salaries \$25.00 to \$75.00 a week and more. Thousands of advertisers, periodicals, publishers and others use millions of dollars' worth of designs and illustrations every year. The field is uncrowded. The prices paid for good work and ideas will surprise you.

With our intensely practical and original home-study course, personally conducted by well-known and successful commercial artists and advertising experts, you can master this dignified, pleasant and profitable profession in your spare time. Easy to learn, easy to apply, endorsed by eminent authorities.

### Training Counts

"I am still a Federal Student, and before completing the course secured my present position on the staff of artists with the Chicago Tribune. I am positive I secured same through what the School has done for me."  
WALTER M. STICKNEY,  
Chicago, Ill.

"Although enrolled in your School but a short time, I have sold quite a number of drawings. I wanted to do something other than teaching school, and I feel perfectly safe in saying that now I see the dawn of a brighter day."  
LAURA J. STARR,  
Duluth, Minn.

### Send for Free Book, "Your Future"

Every young man and woman should read it before deciding on their future — parents should read it with the future of their children in mind.

Tells of wonderful opportunities open to those with training — cites instances of success won by our students in all parts of the country — describes the ease with which you can become expert through our home-study method. With the book we will send a handsome portfolio of Commercial Illustrations. Opens the way to greater success in life for you. **Mail the coupon—NOW**

**Federal School of  
Commercial Designing, Inc.,  
616 Warner Bldg., Minneapolis, Minn.**



P. M.  
**Free  
Book  
Coupon**

Federal School of  
Commercial Designing, Inc.,  
616 Warner Bldg., Minneapolis, Minn.

Please send me free book  
"Your Future," also your  
portfolio of Commercial Illustrations.

Name.....  
(Write your address in margin)

Please Mention Popular Mechanics

Copyrighted material





## Don't Send a Penny

### For This Civil Engineering Library

**H**ERE is a set of books that will fit you to hold a position as a Civil Engineer at a salary of from \$1500 to \$5000 a year. Read them and study them for a whole week before you send us a penny. Then decide if you can afford to be without them. With the rapid increase of reinforced concrete construction, more Civil Engineers are needed. Here is the knowledge that you need—a complete Civil Engineering Library, compiled by experts and recognized by technical schools, universities and Civil Engineers as the final authority. If you decide to buy, you pay only the reduced price—and at the rate of 60c a week, \$2.00 a month.

## All About Civil Engineering

Whether student, worker or expert, you can gain from these nine volumes an intimate knowledge of Civil Engineering. The library consists of nine handsome volumes, bound in half red Morocco, gold stamped, printed in large clear type on special quality of paper. 3500 pages, 7x10 inches, 3000 illustrations, full page plate diagrams, etc. And they are yours for a full week if you just send the coupon.

**50c a Week** If you decide after the seven days' trial that you cannot afford to get along without them, you may pay for them at the rate of \$2.00 a month—60 cents a week. Send the coupon below today.

### Use Them a Week

Do not send us a penny. Merely fill out the coupon and send it to us. We will send you the entire library, prepaid, along with a \$12.00 Consulting Membership in the American Technical Society. After you get the books in your own home or office, read them 7 days. Then, if you think you can get along without them, send them back to us at our expense. If you decide to keep the books, send \$2.00 and then \$2.00 a month until reduced price of \$29.50 is paid. The regular price is for a limited time only. The regular price of the Cyclopedia is \$45.

### Consulting Service FREE

In connection with this offer, we give with each library, a year's consulting service in the American Technical Society, absolutely free. This entitles you to ask all the questions you want for an entire year without charge.

#### Important Subjects Covered

Plane Surveying—Plotting and Topography—Highway Construction—Railroad Engineering—Earthwork—Steel Construction—Estimating for Steel Buildings—Structural Trusses—Civil Specifications and Contracts—Bridge Engineering—Strength of Materials—Masonry and Reinforced Concrete—Water Supply—Sewers and Drains—Hydraulics—Water Power Development—River Improvement—Harbor Improvement—Cost Analysis—Engineering—Plans and Specs—Erection Engineering.

## Send the Coupon

Fill out the coupon and send it to us at once. Don't send a penny. Merely send the coupon and we will ship to you the entire nine volumes prepaid. The seven days' trial does not cost you a penny. But send the coupon now—for your own sake. This offer is open to everyone within the boundaries of the United States and Canada. Act NOW!

American  
Technical Society  
Dept. C1191  
Chicago, U. S. A.

American Technical Society  
Dept. C1191 CHICAGO

Please send me the nine volumes set of Cyclopedia of Civil Engineering for 7 days' free examination. If I decide to buy, I will send \$2.00 within 7 days and the balance at \$2.00 a month until \$29.50 has been paid. Then you send me a receipt showing that the \$45.00 set of books and the \$12.00 consulting membership are mine and fully paid for. If I think that I can get along without the books after the 7 days' trial, I will return them at your expense.

Name .....

Address .....

Reference .....

## Are You Interested In Automobiles Motoring Driving Repairing



and the hundreds of things which are of interest to automobilists? "THE AMERICAN CHAUFFEUR," a monthly magazine devoted to automobiles, is of vital interest to Owners who drive, Garagemen, Repairmen and Chauffeurs. Technical features appear in each issue, written by men who have made life studies in their special departments. Every article that appears in this magazine is thoroughly practical—chuck full of sound, solid, meaty, common sense, and in each issue there appear discussions of proper lubrication, fuels, tires, engines, carburetors, axles, lighting and cooling systems, adjustments, repairs, good roads and all the valuable information you should know about. They come down to facts and tell you just what's what. They help and urge you in every way to know more about automobiles.

### SPECIAL OFFER Get This Attractive FOB ABSOLUTELY Free

Send us 25c in stamps or coin for a three months' trial subscription to the American Chauffeur, we will send you this beautiful original designed, real rose, gold plated Automoblist Watch Feb, with Seal Grain Leather Strap like illustration. Absolutely FREE. Your money back if not satisfied.

AMERICAN CHAUFFEUR  
61 Butler Bldg., Cincinnati, Ohio

## BODEE TRADE DENTAL SCHOOL

ESTAB. 1892

15A W44th ST. NEW YORK CITY

Under Supervision of the University of State of N. Y.  
**YOU TOO CAN EARN \$25 TO \$75 WEEKLY**  
Great demand in new profession of Mechanical Dentistry. Anyone can learn now by our new method without book study. Complete course given in 2 months. Knowledge gained by actual work individually. Day and night classes. Easy payments, tools, materials, and equipment free. We guarantee that you can earn before completion of the course. The demand is like a gold mine unexplored. We are constantly called upon to fill good salaried positions. Why not qualify for one. Visit or write the school and ask for our special short course catalog - P. 14 Do it now.



## New Book Free

Write today for the book that tells about the opportunities in the profession of Signal Engineering. Men are needed. Learn, too, how you can get the training that you need to fill the big job.

**\$125 to \$300 a Month**

The free book will give you just the information you want. Write for it now—immediately. Here is a golden opportunity.

Dept. of Signaling Dept. 1191—1610 Wilson Ave., Ravenswood Sta., Chicago, Ill.

## ART MAGAZINE FOR ARTISTS AND ART STUDENTS

Publishes cash art assignments, articles and lessons on Cartooning, Designing, Illustrating, Lettering and Chalk-talking. Criticisms anatomical work. Interesting, helpful, artistic. Satisfaction guaranteed or money refunded. 10c a copy, \$1 a year. Send \$1 NOW, stamps or bill, to G. H. Lockwood, Editor, Dept. 232, Kalamazoo, Mich.



## 60 BOOKS Bound in \$1.00 Leather After Trial

The world's greatest literature now shipped to you FREE on approval, not a penny in advance. The masterpieces of Kipling, De Manassant, Stevenson, Shakespeare, Oscar Wilde, Maeterlinck, G. Bernard Shaw, Coleridge, Robert Burns, Victor Hugo and dozens of others. Each book bound in genuine limp leather, pocket size. These are books you will read and reread a score of times. Write postal for list of titles and Free Examination offer, no money down.

### LITTLE LEATHER LIBRARY

1912 Mercantile Bldg. 23rd Street, NEW YORK

Please Mention Popular Mechanics



## A 'Steel Trap' Memory

One that takes a tight grip on facts, figures, names, details of every kind and hangs onto them through life—that's the kind of memory you ought to have and the kind you can have if you will give me ten minutes of your spare time daily for a few weeks. I will make your mind an infallible classified index of the things it is to your advantage to remember—give you power to concentrate, overcome self-consciousness, enable you to think on your feet, and address an audience intelligently without hesitancy and without notes.



The Key to Success

Stop forgetting

Henry Dickson, Principal, Dickson School of Memory

During the past 29 years I have trained thousands of people to STOP FORGETTING—aided them to greater business and social success—I know positively that the person with a strong, tenacious memory, though he be far behind at the beginning of the race for success, advances and soon outdistances his forgetful rival. The demands of commercial and professional life are so exacting in their details of facts and figures to be remembered, that to succeed or even hold your own you simply must possess a good memory.

### Get My Remarkable Memory Test Free

I've had this test—most ingenious and most exclusive memory test ever devised—copyrighted. I'll send it to you, free, also a copy of my book "How to Remember" and tell you how to obtain a copy of my De Luxe edition, "How to Speak in Public," a handsomely illustrated \$2 book, absolutely free.

HENRY DICKSON, Principal,  
Dickson School of Memory, 705 Hearst Bldg., Chicago

## LANGUAGES

Quietly Learned AT HOME by the Original Phonographic Method

German—French—English—Italian—Spanish learned by the Cortina Method at home with Disc-Cortinaphone Language Records. Inquire at your local phonograph dealer who carries or can get our records for you, or write to us for FREE booklet today; easy payment plan.



CORTINA ACADEMY of LANGUAGES  
Suite 2102, 12 E. 46th Street, N.Y.

CORTINAPHONE



## ARTISTS \$20 to \$50 a Week EARN

Big demand for Illustrators, Cartoonists, Designers. We teach you how—at home—by mail—and then assist you to the job. Big illustrated Book FREE. WRITE TODAY.

WASHINGTON SCHOOL OF ART, 1000 F St., WASHINGTON, D. C.

## FREE 10 Lessons In Public Speaking

Write for particulars of this extraordinary offer. 10 lessons in public speaking absolutely free. Remarkable opportunity. Become a powerful speaker in spare time by mail. Overcome "stage fright," enlarge your vocabulary, train your memory, gain self-confidence. Increase your earning power, popularity. We have trained hundreds.

Offer Limited This offer is made strictly for advertising purposes and may be withdrawn at any time. Write at once, while this free lesson offer lasts. Big saving if you act now.

Public Speaking Dept. American Correspondence School of Law  
Dept. 1191 Manhattan Bldg. Chicago

## TYPEWRITE THE NEW WAY

80 to 100 Words a Minute GUARANTEED

Totally new system. Based on Gymnastic Finger Training! Brings amazing speed—perfect accuracy—BIG SALARIES. Easy for anyone. First day shows results. Learn while working. Illustrates and explains all. Gives 48-Page Book Free letters from hundreds with salaries doubled and tripled. A revelation as to speed and salary possible to typists. Postal will do, but write today—NOW.

Tullness School of Typewriting, 121 College Hill, Springfield, Ohio



# Power for YOU!

Power from within! Strength that is more than mere muscular strength—the strength of better health, abundant nerve force—the strength of the perfect man. Don't you want it?

Nine people out of every ten are only half alive! How about yourself.

## All the Exhilarating Joys of Life Strength Youth

Do you feel just right? If you do not—if you haven't that vigorous "go ahead" feeling all the time—don't fail to send the coupon for full particulars about the White Cross Electric Vibrator. In vibration there exists many of the secrets of life. You now have an opportunity of seeing what vibration will do for you—how every nerve, every fibre in your whole body will fairly tingle. Try this remarkable instrument for yourself—test it. Now is the time for YOU to send for the free book, "Health and Beauty." Thousands have received it. You are invited to write for it, too.



With our Combination Outfits, you may give yourself Swedish Movement, Vibrating Chair Treatments, Electric Baths, Paraffin or Galvanic Treatments—right in your own home.

### The White Cross Electric Vibrator

is the result of years of work and experiment. If you have your house wired for electricity, you connect it up as easily as an electric lamp; if not, we can supply you with models operated on their own batteries.

### Special Offer for a Limited Time

For a short time only we are making a remarkable Special Introductory Offer on the White Cross Electric Vibrator, in order to place at least one of these splendid instruments in every city, town, village in the country.

### Free Book Sign the coupon and mail it today. Get our splendid big

FREE book telling you all about the marvels of Vibration. Read what scientists say. Post yourself on what it will do for you. Learn all about the White Cross Electric Vibrator and our limited offer. No obligations at all—send the coupon or a post card or letter today.



Send for This Book

LINDSTROM, SMITH CO.

1100 S. Wabash Avenue  
Dept. 1191, Chicago, Ill.

Without any obligations on my part, please send me, free and prepaid, your free book on Vibration, full particulars of the White Cross Vibrator and your Special Offer.

Lindstrom, Smith Co.  
1100 South Wabash Avenue  
Dept. 1191, Chicago, Ill.

We also manufacture White Cross Electric Stoves, Irons, Hair Dryers, Electric Lamps, Electric Fans, Electric Automobile Horns, Electric Curling Irons, Heating Pads, Small Motors, etc. Dealers write.

Name.....

Address.....

My Electrical Dealer's Name is.....

Please Mention Popular Mechanics



## Burton Butted In



### From Elevator Boy to the Traffic Department of a Trunk Line Railroad in Five Months

Such was the experience of A. L. Burton who in a competitive examination with more than 80 men of railroad and industrial traffic experience passed at the head of the list and secured a position in the traffic department of the Chicago, Milwaukee and St. Paul R. R. as a result. Mr. Burton's letter follows:—

"I take the opportunity of sincerely thanking the American Commerce Association for the assistance you rendered me since I became a member. I was at that time running an elevator. After sending in my sixth lesson paper, I took the examination of the Chicago, Milwaukee and St. Paul Railway, and made a mark of one hundred per cent. Since that time I have had a promotion as a result of the additional technical knowledge derived from my A. C. A. Training service. I am now earning twice as much as I did when I first became a member of your Association, and I expect another increase within a short time. Previous to becoming a member I had never had any traffic or railroad experience of any kind, so that whatever I have accomplished is due entirely to the Association." Signed—A. L. BURTON.

The American Commerce Association through its experience method in Traffic training makes just such instances as this possible. For the man in Henry Ford's plant who tightens the third nut on the left-hand side to become an expert mechanical engineer is no more impossible than it is for the man who makes out bills or checks up carloads to become a traffic expert. It is the thousands of years of combined experience of hundreds of thousands of doctors, not the experience of one man, that makes medicine a science. It is the combined experience of more than 300 traffic experts gathered together, and put into print, that makes the training service of the American Commerce Association such a valuable one. A few months' training qualified Burton to earn a large salary. Just as the A. C. A. helped this man to succeed.

### The American Commerce Association Can Help You to Succeed

We have received letters from more than 500 students who have given evidence as to just what this training service has done and is doing for them. More than 300 of America's foremost traffic experts have expressed their approval of the training service of the American Commerce Association. Let us send you

#### The Unimpeachable Evidence of 500 Students and 300 Traffic Experts

that will convince you of our ability to help you succeed. The American Commerce Association is an organization formed by a group of nationally known Traffic Managers for the express purpose of training men for this field—and to uphold the standards of the Traffic Profession. Through our home training service—combined with the facilities offered for obtaining practical experience—it is made easy for you to become a Traffic Expert.

#### Our Experience Method Training Service Fits You for \$35 to \$100 a Week Positions

The present business prosperity has created an unparalleled expansion of commerce—which has brought a demand for more men trained in Traffic. A half million shippers—railroads—corporations—manufacturing concerns everywhere are asking for men who know how to figure the lowest shipping rates—and the American Commerce Association is the only organization supplying this information so essential to success in Traffic work.

#### The Opportunity is Before You

High salaried positions are unfilled today because of the lack of Trained Traffic Men. Write to us and we will tell you just what you want to know about this wonderful new field—the opportunities it offers to intelligent young men. Mail the coupon—TODAY.

#### AMERICAN COMMERCE ASSOCIATION

American Commerce Building, 206 So. Wabash Avenue, Dept. 45, CHICAGO, ILL.

**SEND THIS NOW**

AMERICAN COMMERCE ASSOCIATION  
American Commerce Bldg., Dept. 45, Chicago, Ill.  
Please send me entirely without charge or obligation information as to how your course in Traffic Efficiency will train me to become a traffic expert.

Name \_\_\_\_\_  
Address \_\_\_\_\_  
Age \_\_\_\_\_ Occupation \_\_\_\_\_  
City \_\_\_\_\_ State \_\_\_\_\_

## WANTED MEN FOR RAILWAY MAIL SERVICE

BOOK FREE  
WRITE TODAY

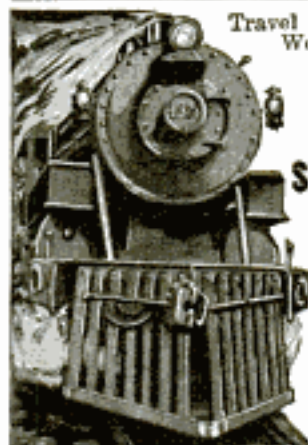

Travel everywhere. See the country. Work a week, then have a week off with full pay. 15 days' vacation each year with full pay. No politics, no "pull", no strikes, no hard times, no straw bosses, easy work.

### \$900 to \$1800 Per Year

Uncle Sam pays \$75 to \$150 per month with excellent chances for promotion. The money comes regularly—you have no fears of being out of work. Only American Citizens 18 or over, 5 feet 5" tall or over, weight 130 pounds or over, are eligible to examinations. If you qualify on these points, get in touch at once with Arthur R. Patterson, for 8 years U. S. Civil Service Sec'y-Examiner. Let him prepare you for coming examinations, as he has prepared thousands of others.

**JOBS OR NO PAY** Mr. Patterson agrees to refund the small fee for his preparation if you are not employed by the Government after taking his course. You risk nothing. Arthur I. Johnson, Hammondsport, N. Y., was appointed 10 days after rating was received.

**Free Book Tells All** Service offers such wonderful opportunities; get facts about Patterson preparation and guarantee of position or no pay. Examinations coming without fail. Just write postal quick—NOW—for free book of facts. No obligation. Do it NOW. Address

**Patterson Civil Service School, 301 News Bldg., Rochester, N. Y.**

### \$12500 to \$30000 a Month

Write at once. Most wonderful opportunity for the ambitious man. Railroads need hundreds of Signalmen—will pay Big Money.

**Special Offer** We will teach you right at home to be expert. Special offer if you write at once. Two big outfits free. Write Today for our free catalog and particulars of our big offer.

DEPARTMENT OF SIGNALING  
1810 Wilson Ave., Room 9191, Ravenswood Station, CHICAGO



LEARNED BY  
ALMOST  
ANYONE  
AT HOME  
SMALL COST

### VENTRILOQUISM

Send today 2c stamp for particulars and proof.  
O. A. SMITH, Room D 146, 823 Bigelow St., PEORIA, ILL.



### Learn to be a Finger Print Expert

We teach the subject thoroughly from A to Z by correspondence course and guarantee to make you a finished expert. Send for particulars.

THODE SCHOOL OF FINGER PRINTS  
2067 Grove St., San Francisco, Cal.

AT HOME  
**Learn TO SING**  
Send 2-cent Stamp for Helpful Booklet, "The Voice Made Beautiful."  
HARVEY SUTHERLAND, 1832P 49th St., BROOKLYN, N. Y.

**SHOW CARD WRITERS  
EARN \$80 TO \$200 A MONTH  
LEARN FREE!**



We will furnish a thorough course in Show Card Writing and Lettering absolutely free to introduce our colors if you will purchase an assortment of Alpha Colors to use while practicing. Particulars for stamp.

ALPHA COLOR COMPANY, Inc., Dept. K, 81 East 125th St., N.Y. City





He  
made  
his  
Mark

## From Pick and Shovel to Consulting Engineer

**I**N 1908 a "common laborer" became dissatisfied with his position in life. He saw others who were no smarter climb to higher positions. When he looked for the reason he saw that it was because they had training. But it seemed almost impossible that a "common laborer" could become trained. In those days Karl Riddle did not know about the American School. But one day he saw an American School advertisement. He made his mark in the coupon and on July 3rd he became a student. A few months later he had learned the principles of Electrical Engineering and accepted a position as interior wireman.

Today Karl Riddle is a partner in the company of Riddle and Riddle, consulting engineers. They hold practically all the high paid engineering positions in the city and county governments. His income is many times as much as he received as a "common laborer."

Karl Riddle is the kind of a man that every American admires. He has "made good" through his own efforts, and represents the highest type of American manhood.

*Karl Riddle has made his mark!*

## Make Your Mark In the Coupon!

Successes like Mr. Riddle's are being made all around you. There is no secret way to success that other men follow which is not open to you. The thing you need is **training**—and the American School offers it to you—right in your own home. Send the coupon today. Make an "X" before the position for which you want to fit yourself. And we'll tell you how you can get it. You will be under no obligations. Send the coupon **now**—today. Opportunity and your ambition are both calling you.

**American School**  
of Correspondence, Chicago, U.S.A.

Dept. G 1191

American School of Correspondence, Dept. G1191, Chicago, U. S. A.  
Gentlemen: Without obligation please send me booklet  
and tell me how I can qualify for position marked X.

- |                                 |                             |
|---------------------------------|-----------------------------|
| ..... Electrical Engineer       | ..... Lawyer                |
| ..... Elec. Light & Power Supt. | ..... Business Law          |
| ..... Hydroelectric Engineer    | ..... Business Manager      |
| ..... Telephone Engineer        | ..... Auditor               |
| ..... Architect                 | ..... Accountant            |
| ..... Architectural Draftsman   | ..... Cert'f'd Public Acc't |
| ..... Building Contractor       | ..... Stenographer          |
| ..... Building Superintendent   | ..... Bookkeeper            |
| ..... Structural Engineer       | ..... Fire Ins. Inspector   |
| ..... Structural Draftsman      | ..... Fire Ins. Adjuster    |
| ..... Mechanical Engineer       | ..... Fire Ins. Expert      |
| ..... Mechanical Draftsman      | ..... Sanitary Engineer     |
| ..... Civil Engineer            | ..... Plumber               |
| ..... Steam Engineer            | ..... Reclamation Engineer  |
| ..... Shop Foreman              | ..... Automobile Engineer   |
| ..... Shop Superintendent       | ..... Automobile Repairer   |
| ..... Sheet Metal Draftsman     | ..... High School Course    |

We also prepare for civil service examinations in all engineering subjects.

Name .....

Address .....



LEARN THE AUTOMOBILE BUSINESS BY 

# The Sweeney System of Practical Experience

at the World's Greatest Automobile School

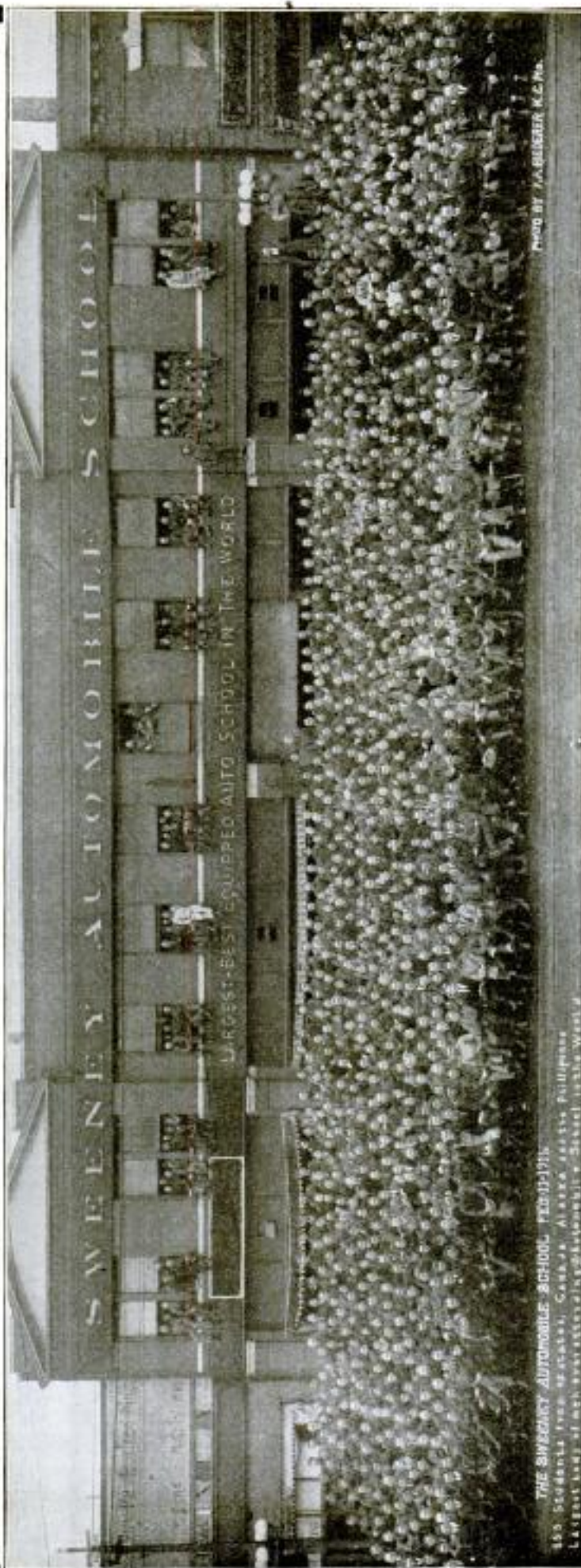

THE SWEENEY AUTOMOBILE SCHOOL, KANSAS CITY, MO.

123 Students from 45 states, Canada, Alaska, British Columbia, and the largest body of men ever attending an automobile school in the world.

Photo by J.A. BISHOP, K.C., Mo.

**Students from 45 states. Class of February, 1916. Largest body of men that ever attended an automobile school**

**T**HAT there's money in the automobile business for you is proven by the experience of thousands of successful graduates. If you want to make \$5 a day—earn from \$60 to \$150 a month—or own an independent business, the Sweeney System of practical instruction will fit you in 8 weeks to accomplish your aim.

There's only one place in the world to learn by the Sweeney System; and that is at the School of practical experience where you learn without textbooks and by doing the work with your own hands; and that's the Sweeney Automobile School at Kansas City, Mo. I want every young man mechanically inclined to send today for my big catalog. It costs me 50 cents, and is a complete encyclopedia on the subject. It is like a moving picture as the 123 actual photographs show men at work in every department, at every job. It explains the wonderful Sweeney System. I will send it free, to those who answer this announcement, together with a special advantageous offer. A \$50 Tractor Scholarship Free. Use Coupon Today—NOW.



# The Sweeney System of Practical Auto Instruction

## Twin Six Packard

is now universally recognized as the most thorough, practical and interesting course of automobile, gas engine instruction leading to certain and profitable employment. It embraces every point worth knowing, including vulcanizing, brazing, oxy-acetylene welding, lathe work, machine shop practice, testing, driving, truck repairing, and operating, etc. **And You Learn** by doing the work on **Real Cars** under the watchful eyes of skilled instructors. **All for One Price.**

I started seven years ago teaching a couple of young men in a little shop. I had one **BIG IDEA.** That was to teach them by practical experience. Not merely to TELL them how, but to **SHOW** them how and then have them do the work with their own hands, over and over until they could do it perfectly. And that is the **EASIEST WAY** to learn — because the right way is always the easiest.

I taught my young men how to do everything that any mechanic is ever called on to do about a car. Not merely to drive but to repair. Not merely to make his own tools. Everything from blacksmithing up. And then over and above that I taught them how to manage for themselves — how to make money in the business — how to run a garage, and so on.

Today I point to thousands of men who have made good under my system of practical instruction. I can point to what I claim is the biggest school of its kind in the world. The school with the most complete and best equipment obtainable. The school with 32 instructors. The school with pupils from almost every state in the Union and some from foreign countries.

But in **ONE RESPECT** things haven't changed. We still teach by "Practical Experience," you see what makes the wheels go round. We don't use books, we furnish free tools to the men and they learn by doing the work with their own hands under skilled instructors. I make them finished mechanics with a trade that's good for \$50 to \$150 a month or an independent business of their own.

### First in the Field

Here's another thing: We've always been first in the field. We claim to be the first to teach traction engineering; all types of self-starters; stationary engineering; the first to develop FARM engineering and FARM mechanics. We were the first to operate a truck line. We claim to be the first and only school that owns an 8 cylinder Cadillac; the first and only school to own a **TWIN SIX PACKARD**; the first to install all the elaborate and expensive machine shop equipment that the trained automobile man must know how to handle.



**E. J. SWEENEY**  
President of the School,  
Originator of the Sweeney  
System

The Sweeney School claims the most complete equipment of any school in the world; it claims to have more pupils, more successful graduates, to afford better practical instruction. We want every young man to investigate these claims and to see for himself before he pays down one cent of tuition. To show you how we keep up to date — we have the new 12 Cylinder Packard, and had the first delivered in Kansas City. This alone represents a substantial investment.

We own 7 tractors and in our own factory are building the famous Sweeney Tractor (\$985), thus giving students a wonderful advantage in factory experience. This feature alone offers a unique opportunity to young men who wish to become experts in the tractor field.

We have spent thousands of dollars this summer on new equipment. For instance, we have put in a new 8-cylinder Buick Motor, a Fellowes Gear Shaper, 18-inch American Quick-Change Lathe, and a 24-inch Planer, new Rumely, Emerson-Brantingham and Case Tractors. In our machine shop, we make our own gears, in a word the very latest developments are put in the hands of our students, as we know our success depends on making you competent to handle any mechanical proposition and of being strictly abreast of the very latest developments.

### Save \$50

And now about my special offer. To advertise the school and also to give special training in a branch that is getting more important all the time, I will give a complete \$50 scholarship in Traction Engineering free with an enrollment for the regular automobile school course. Now, as you know, we not only have 7 tractors here but I have a big factory where we build the famous **Sweeney Iron Horse.** You are taught by men who know how. So this tractor scholarship means real value.

### Do It Now

If you will sign and mail me the coupon attached or write me a postcard, I will send you my big free book and full details of this scholarship offer. This book will survey the whole field and the certificate will entitle you to the \$50 saving in case you enroll this fall. It will not obligate you in any way. As a matter of fact I won't take a cent of a man's money until he has personally inspected the school and has satisfied himself.

The book pictures the wonderful equipment of the Sweeney School. It shows how you are taught, shows the class of men you will associate with, portrays various phases of the automobile industry, explains how, when and where you begin to earn money, in a word is a complete encyclopedia of the subject. I don't urge you to send for it unless you really want it, but to every young man mechanically inclined I will be very glad indeed to mail it free, together with my regular magazine. Simply send name and address.



CATALOG

**Sweeney**  
AUTOMOBILE  
SCHOOL

KANSAS CITY  
MISSOURI

THE WORLD

**Sweeney Auto School, 1160 E. 15th Street, Kansas City, Mo.**  
Send free and without obligation your catalog and tractor scholarship certificate.

Name .....

Address .....

**Auto 1160 E. Kansas City, Mo.**  
**Sweeney School 15th St.**  
**THE WORLD'S GREATEST AUTOMOBILE SCHOOL**





## The Writing on the Wall

It was at the famous feast of Belshazzar, King of Babylon, that the prophet Daniel read the awful dictum—"Mene, Mene, Tekel Upharsin." That night Cyrus and his army captured the city, but not until thousands of years later was unearthed the inscribed cylinder that told the real story of the "Fall of Babylon." This curious account, which is very different from the popular version, is but one of many thousand "original documents" contained in

## The Library of Original Sources

now for the first time available to the general public. This remarkable Library had previously been sold by subscription, but by purchasing the *entire unsold edition* from the publishers we secured it at an *absolutely unheard of reduction*. We offer a few sets to Popular Mechanics readers at an

### EXTRAORDINARY BARGAIN

Send us the attached coupon AT ONCE, and we will tell you how to get the Library on EASY MONTHLY PAYMENTS, and mail you FREE a book of rare documents showing curious inscriptions of the Ancients. There are only a limited number of sets, so act quickly. Mail the coupon NOW. You assume no obligation. No salesman will call. The book is FREE.

**THIS MARVELOUS WORK** gives the authoritative, rock-bottom sources of our knowledge on ALL SUBJECTS OF HUMAN INTEREST from the earliest civilization down to today—the inside facts which the average person has never even heard of.

OVER 100 RESEARCH SPECIALISTS spent 10 years gathering the contents of this great work. Ancient and remote civilizations in all parts of the globe, age-buried hieroglyphics on monuments, tablets and sun-baked bricks yielded their secrets; untiring workers ransacked the hidden literature of every age to find these "original documents." Nothing like it has ever been attempted or thought of before. You'll be amazed at the wealth of information this unique library contains.

#### MAIL THIS COUPON FOR FREE BOOK

UNIVERSITY RESEARCH, Dept. G, P. M. 1-17  
Milwaukee, Wis.

Send me the FREE book of rare documents showing inscriptions of the Ancients and tell me of your easy payment offer. I assume no obligation; the book and all you send me is to be free, and no salesman is to call.

Name.....

Address.....

U.S. Patent  
No. 1,204,836  
Any infringement  
in manufacturing  
or selling will be  
prosecuted

Beware of  
Imitations

## There's Only One Correct - Hover

Its correctness is protected by U.S. Patent.

When you buy a Correct, you get the only original and genuine coal-burning hover—the hover others try to imitate but cannot duplicate because of our patents. Perfect regulation and ventilation. Spark-tight, gas-proof. Portable. Costs but 5c or less a day to run.

42" Canopy.....\$10.25  
52" Canopy.....\$11.82

Write for FREE booklet.

**CORRECT HATCHER CO.,** Dept. 30, Leesville,  
Carroll County, Ohio

## MAKING POULTRY PAY

depends more on the knowledge you have of Poultry Culture than on expensive equipment or extensive space.

Let Director Quisenberry teach you how to raise poultry successfully and make a good living and a nice profit from a flock of thrifty hens.

If you want to save money and make money in the poultry business write us today for our large illustrated Free Book, "Dollars and Sense in the Poultry Business." It points the way to success.

American School of Poultry Husbandry  
Box 75 Leavenworth, Kansas



## Let me put you on the map as a Poultry Raiser

"Hatching Facts" biggest poultry book published, in color, explains everything—tells about My World's Champion Belle City

Incubator—my low price—

My 10-year Money-Back Guarantee.

also My \$1000 in Gold Offers. Your chance to make Big Poultry Profits. Write me today for Free Book. Jim Rehan, Pres.

Belle City Incubator Company, Box 164 Racine, Wisconsin



Big Hatches  
Sure

### Get this Free Book that Tells How

and why you can get bigger hatches of sturdier chicks with the 1917 X-Ray Incubator. 1 gallon oil—one filling—teach hatch. Express prepaid to practically all points.

X-RAY INCUBATOR CO.  
Box 82  
Des Moines, Iowa



## Greider's Fine Catalogue

of fine breed poultry for 1917; 67 breeds illustrated and described; information on poultry, how to make hens lay, grow chicks—all facts. Low price on stock and hatching eggs. Incubators and brooders, 25 years in business. This book only 10 cts. Send today.

R. H. GREIDER, Box 19, RHEEMS, PA.

**\$25.00** and more may be made each week raising guinea pigs in spare time. Big demand. Experience or special knowledge unnecessary. Big illustrated book and particulars free.

LABORATORY SUPPLY CO., Dept. B, 2841 Ridge Ave., Phila., Pa.

## GOODRICH "GIANT"

The best bicycle tire made. Ask your dealer  
The B. F. Goodrich Company, Akron, Ohio



**CORONA** The Personal Writing Machine weighs 6 lbs.

Writes all kinds of correspondence.

\$50 with carrying case. Write for booklet No. 32.

Corona Typewriter Co., Inc., Groton, N. Y.

Take home that tin of HARMONY  
PIPE BLEND tonight! 15 cents.



# Be A Certificated ELECTRICIAN

**Your Future**  
is in Electricity—Obey  
that "Hunch."

**Get a Move on Yourself**  
—Here's Your Chance—

*If You Act Quick I Will  
Give You Special Per-  
sonal Training at Home.*

Only a Limited Number  
of Students Can Secure  
My Special Instruction  
—ACT NOW.



CHIEF ENGINEER  
Your Instructor

**Qualify at Home**  
— With My Help.

**STUDY BY MAIL**  
My New Course and a  
Common School Edu-  
cation All You Need.

*Fit Yourself in Spare  
Time to Earn \$50.00  
a Week and Up.*

**SPECIAL**  
**Earn While You Learn**  
Right After You Are Enrolled  
I Will Give You a Short Course  
in Quick Money-Making Elec-  
trical Branch—FREE.

## MY OFFER TO YOU:

If you act quick I will accept you among a few more students to complete Home Study class now forming. Grasp this wonderful opportunity. Fit yourself by a few months' fascinating Home Training to be a **REGULAR CERTIFICATED ELECTRICIAN**.

I have a splendidly attractive proposition for you. I **GUARANTEE** you satisfaction in the study of this great profession. Decide to enter it while you can do so on terms especially advantageous to you. Plan a glorious future. Secure for yourself the assured independence, the handsome income, the agreeable working conditions, the easy professional hours and the unlimited opportunities of the trained and experienced Electrician.

As my student you will enjoy exclusive and unusual advantages. . . . **FREE** employment service; **FREE** \$100.00 scholarship opportunities; **FREE** five year Advisory Service; and **FREE** electrical equipment, instruments and material. In addition to the above I have a wonderful **SURPRISE** in store for every student I enroll in the near future. **THIS FREE ELECTRICAL OUTFIT IS VALUED AT \$17.00.**

I haven't the space here to tell you all the advantages, benefits and privileges **GUARANTEED** to my students. If you are ambitious to make a big success in the greatest profession on earth—if you are ready to start right in and study Electricity the "easy" way—at home—mail me the **FREE "OUTFIT" coupon** without delay. I will send you full particulars of my personal instruction plan, my splendid laboratory and educational facilities, my wonderfully complete and fascinating course of bed-rock lessons, and my thoroughly practical method of making Electricity easy to understand and master. Write me **NOW**.

**CHIEF ENGINEER**  
**Chicago Engineering Works**  
439 Cass Street  
Dept. 5, CHICAGO, ILL.

**USE THIS FREE "OUTFIT" COUPON**

Dept. 5  
CHIEF ENGINEER  
439 Cass St.  
Chicago, Illinois

Without obligation on my part kindly send at once, fully prepaid, particulars of your complete Practical Home Study Course in Electricity.

My Age is.....

My Occupation is.....

NAME.....

ADDRESS.....

TOWN..... STATE.....







# LET ME TRAIN YOU

for the **Automobile and Tractor Business**



**H. J. RAHE**  
President



Famos TWIN-SIX (12 cylinder engine) block mounted for my students to work on. Only one detail of my complete equipment.



The EIGHT or "V" Type Engine. Block mounted. My students take them apart and put them together for practice and training.



The "SUPER-SIX" equipped with Delco Starter. Equipment like this enables me to give you practice and experience in all branches of the business.

**M**EN come to my big school from every part of the United States and many foreign countries to get my Original, Practical Method of Automobile Training and Experience. They come because they find after investigation that mine is the ONE METHOD that insures success and big pay. It's all because the RAHE ORIGINAL METHOD OF PRACTICAL AUTOMOBILE TRAINING AND EXPERIENCE is nothing more or less than the actual doing—getting into overalls and "digging in" under the guidance of expert instructors in a school with

**More Equipment      More Floor Space**  
**More Expert Instructors**

I know the value of complete equipment and plenty of room in my big machine and repair shops, around the forges and lathes and drill presses. It's training like this that enables my graduates to earn from

## \$75 TO \$300 A MONTH

as ignition experts, testers, demonstrators, oxy-acetylene welders, general repair men, drivers, managers of garages, and repair shops—or in business for themselves running their own garages and acting as factory representatives and dealers for the large automobile and tractor manufacturers. My graduates succeed because my training is right and is the acknowledged standard.

**Only a Few Short Weeks Required**  
**No Books or Printed Lessons Used—No Tools to Buy**  
**\$50 SCHOLARSHIP** For Tractor, Gas & Stationary Engineering, Home Lighting **FREE**

I have a limited number of these Free Scholarships available. WRITE ME AT ONCE and I'll reserve one for you. NO EXTRA CHARGE FOR OXY-ACETYLENE WELDING COURSE. Others charge a tidy sum for welding instruction but I give it to you without a penny extra.

SEND FOR MY BIG BOOK

## 80-Page Catalog Free



Let me send you my latest and best book, "MAKING MONEY IN THE AUTOMOBILE BUSINESS"—filled with fine Copper Engravings, showing my Three Big Buildings, Tractor Farm, Machine Shops, men at work making all kind of repairs. **WRITE AT ONCE—NOW—TODAY.**

H. J. RAHE, President

**Rahe's Automobile School**  
1028 Locust St., Kansas City, Mo.

**FREE SCHOLARSHIP COUPON**

H. J. RAHE, President  
**RAHE'S AUTOMOBILE TRAINING SCHOOL**  
1028 Locust St., KANSAS CITY, MO.

Send me your Big Catalog, Free Scholarship Certificate, and full information—all Free and postpaid.

NAME.....

STREET OR R.F.D.....

TOWN.....STATE.....

Please Mention Popular Mechanics



## Can You Equal This Girl's Achievement?



**Miss E. Stoutenburgh**  
450 Oakdale Ave., Chicago,  
winner of first prize in  
Bryant & Stratton ad-  
vertising contest.

Miss Stoutenburgh was a young stenographer of ordinary education and no previous experience in advertising when she began our course. She wrote the remarkable piece of advertising literature which won first prize in our contest before she had completed two months of our course in

## Advertising & Salesmanship

This course was organized by ten big advertising men who are in personal charge of it. There is not a "professional" teacher among them. The practical atmosphere of their daily work fills all their lessons. You can see how well they are training students in practical Advertising and Salesmanship if you send the coupon below for a copy of Miss Stoutenburgh's prize winning advertisement.

## If Eligible, Enroll

This course is not open to every one who has the tuition fee, but only to those who are qualified to succeed as Sales or Advertising Managers. If you earnestly want to make your mark in this field—a field in which salaries average \$3000.00 to \$10,000.00 a year—send for our Personal Analysis Examination Blank to fill out. Your answers will be analyzed by an experienced Vocational Director. This analysis is free whether you are eligible for our course or not. The requirements are not rigid; they do, however, exclude all but the earnest and the determined.

## You Learn by Actual Work

Not only Miss Stoutenburgh but all our students are making rapid progress. They are actually writing advertisements and planning advertising and sales campaigns. You learn by actually doing the work. By this method, and with the help of our practical instructors, you clip off at least 10 years of hard experience.

**Send Coupon** for a copy of Miss Stoutenburgh's prize winning piece of advertising literature; for Free Personal Analysis Chart; and for booklet, "From Poverty to \$10,000 a Year." Write now.

**Bryant & Stratton Business College**  
1015 Bryant & Stratton Bldg., Chicago, U. S. A.

CLIP AND MAIL THIS COUPON

**Bryant & Stratton Business College** Pop. Mech. Jan., '17  
1015 Bryant & Stratton Bldg., Chicago  
Gentlemen: Please send me copy of Miss Stoutenburgh's  
prize winning advertisement. Also, Free Personal Analysis  
Chart, and booklet, "From Poverty to \$10,000 a Year."

Name and Address Below

## AUTO BUSINESS NEEDS TRAINED MEN

Over 3,900,000 automobiles in this country need trained men to keep them going. No other business offers such big opportunities. Get your training at the GREER COLLEGE OF MOTORING—a high-class school where you get from-the-ground-up training in eighteen branches of the automobile business.

We teach you the "how" and "why" of everything. Actual experience in Overhauling and Repairing, Acetylene Welding and Vulcanizing. Over 14 electric Lighting and Starting Systems. Practice on 8 and 12-cyl. engines, "Silent" Knight and stationary gas engines. Automobile Salesmanship and Garage Management fit you for the big jobs.

The GREER COLLEGE OF MOTORING was established in 1902. Over 9,000 successful graduates. Our equipment is up to date; our master system the result of 14 years of practical experience. Only 8 to 10 weeks required to make you a trained man. Complete courses, \$60 to \$75—no extras.

### GREER COLLEGE OF MOTORING THREE REASONS WHY

We train by practical methods on actual machines. "Experience is the best teacher."

Individual instruction—limited enrollment—no overcrowding. We take a personal interest in the success and welfare of every student.

Employment department places students with good records in paying positions or helps them get started in business.

### "How to Succeed in the Automobile Business"

Carries a vital, success-compelling message for every ambitious man. A lesson, "How to Drive an Automobile," included. Explains our system of locating engine troubles and their remedies; practical pointers for auto owners and mechanics. "Shop Notes" has 46 valuable hints. FREE! Send for this booklet today and get our special offer to students.

**GREER COLLEGE OF MOTORING**  
1519 Wabash Ave. Dept. 4 CHICAGO, ILL.

**\$12500 to \$30000 a Month**

Write at once. Most wonderful opportunity for the ambitious man. Railroads need hundreds of Signalmen—will pay Big Money.

**Special Offer** We will teach you right at home to be expert. Special offer if you write at once. Two big outfits free. Write Today for our free catalog and particulars of our big offer.

**DEPARTMENT OF SIGNALING**  
1810 Wilson Ave., Room 2191, Ravenswood Station, CHICAGO

**Velvet** THE SMOOTHEST SMOKING TOBACCO

**Stop Eating Poison!** Wrong food combinations are poisonous and destroy health—right combinations build health. Eugene Christian's 24 lessons in Correct Eating tell how to eat for health, strength and efficiency. Send for Free Trial No Money in Advance offer. Write today. **Corrective Eating Co.** Dept. 31, 480 Fourth Ave., New York City

## What Kind of Man Are You?

You, young man? Are you prepared to meet face to face what life has in store for you and make a success of it, or are you going to fall in behind with the grand army of incompetents—physical and mental weaklings who never get anywhere? Rarely, if ever, has a man succeeded in life without health. You will find physical wrecks by the wayside of life suffering for their early mistakes and errors. There is a reason for this.

**I Am a Builder of Men**  
Make it re-builder if you like—the results are the same because they are based on a system which has taken a lifetime to study out and perfect. I, personally, am the result of that system. I experimented first with myself, because I wanted to be sure. Then I tried it on others with the same marvelous results. I have never had a failure among the many thousands who have placed themselves in my hands. I annihilate physical ills, and in many cases, mental ills. There are no drugs in my prescription. "Throw physics to the dogs." If ever there was a royal road to health, strength, energy and vitality, it is that known as the Strongfort System by which each pupil receives individual instruction.

**Are You Interested in Yourself?**  
Have you made a mistake at some time in your life as a result of which you are now suffering and paying the penalty? What are you going to do about it? Do you know that I can help you and will! In all earnestness and sincerity I beg of you to

**Let Me Re-Build You**  
There is a liberal education in my book, "Intelligence in Physical and Health Culture." It will be sent FREE to all who need it.

**Lionel Strongfort** Master of Physical Culture  
33 PARK BUILDING, NEWARK, N. J.

Please Mention Popular Mechanics



## THE LAW TRAINED MAN

A new book  
for ambitious men

"THE Law Trained Man" tells you of the advantages of a law training in business and in politics. Also how you can become a successful lawyer.

It tells you of the Modern American Law Course and Service of the Blackstone Institute—the only course in law that has the unqualified endorsement of resident law schools, the legal profession and prominent businessmen everywhere.

This new 168-page book is free. Send for your copy today.

**Blackstone Institute**

104 Dearborn Street Chicago, Ill.

**1916 Indian Motorcycles** With New Power-plus motor and cradle spring frame. Write for catalog.  
**HENDEE MFG. CO., 711 State Street, SPRINGFIELD, MASS.**

### BOYS! HAVE DAD GET STRUCTO

Structo—Mechanics in miniature—will turn the trick. With it you can build that bridge or derrick, and a hundred other models that really work. Write for Free illustrated book.  
**STRUCTO MFG. CO., Dept. 118, FREEPORT, ILL.**

**3 Satin Striped \$4<sup>50</sup> Shirts, \$6 Value**

Highest grade self figured satin-striped shirting, dark blue and lavender stripes. Perfectly tailored, hand laundered, French soft cuffs, full cut body, coat style, sizes 14 to 17, never sold for less than \$2, one shirt \$1.75, three shirts (transportation charges paid) for \$4.50.

**BERNARD HEWITT & COMPANY**  
Furnishing Goods Dept. F21  
564 West Monroe St. CHICAGO  
We sell six standard collars for 57 cents.

## \$12.50 a Month Buys a Wurlitzer Harp, Style I

Acknowledged by experts the standard of the world. Only \$12.50 to \$30.00 a month, according to style. Made by the master harp-builders—extra string lengths, re-enforced body and neck construction—used by renowned harpists in America and Europe—finest harp built. Superbly elegant—perfect in tone and construction. Our Style OC, extended sounding board, priced at \$1,000.00, is illustrated here—other harps priced on a special offer from \$500.00 up. Easy to learn—new way—complete book of instruction free. One man, after a few months' study, earned \$80.00 a week. Harp teachers and harpists are in big demand—big fees for playing—higher salaries for teaching. Learn the harp! No other instrument approaches it in beauty of harmony and melody. The sweetest, the grandest of all music.

Write for Our New Harp Book illustrating all styles. No charge—no obligation.

**THE RUDOLPH WURLITZER COMPANY**  
Dept. 8191, South Wabash Ave., Chicago



## Special Sale!

### Electrical Books at Publisher's Prices

**PRICES smashed!!** The great electrical authority—the Cyclopedia of Applied Electricity is now being offered for \$19.80. For a limited time we are offering a few sets at about **one-half** the regular price. Ordinarily sold for \$35.00, you can now get the set for \$19.80. This offer is made to every man within the boundaries of the United States and Canada.

## All About Electricity

Here is the knowledge of 27 experts who have spent their lives in the study of electricity. All written in plain language, from the wiring of a door bell to the most complex wireless machinery. Tabulated and cross-indexed so you can find what you want immediately. Seven volumes, 7 x 10 inches, 3200 pages, 3000 illustrations. Bound in half red Morocco leather, gold stamped.

### Shipped Free—Use 7 Days

We will send you the complete set, not a sample volume, prepaid—for seven days free examination. Just send the coupon—don't send a penny in advance. If you think you can do without them send them back. If you want them pay only the rock-bottom price and at the rate of \$2.00 a month.

## 50c a Week

If you keep the books send us \$2.00 after seven days and then \$2.00 a month (50c a week) until the special price of \$19.80 has been paid. But use them seven days free.

### Partial Table of Contents

Elements of Electricity  
Underwriter's Electrical Requirements—  
Electrical Machinery—  
Electric Lighting—  
Power Transmission—  
Electric Railways—  
Switchboards and Switching—Wireless Telegraphy and Telephony, etc., etc.

### FREE Consulting Membership

With each set is included free a year's consulting membership, regular price \$12.00. Ask as many questions as you wish for an entire year of our experts.

## Send the Coupon

Send the coupon today. Examine the books before you decide. Send the coupon now—before it is too late.

**American Technical Society**  
Dept. E-1191  
Chicago, U.S.A.

Name.....

Address.....

Reference.....

**American Technical Society**  
Dept. E-1191 Chicago, U.S.A.  
Please send me the complete set of the Cyclopedia of Applied Electricity for 7 days free examination. If I decide I do not want them I will return them at your expense, otherwise I will send you \$2.00 after 7 days and \$2.00 a month until \$19.80 has been paid. When you will send me a receipt showing that the \$19.80 set and Consulting Membership are mine.

Please Mention Popular Mechanics

Copyrighted material



# THE SPEEDWAY TO SUCCESS

## Master The Automobile At Indianapolis Motor School

Come to Indianapolis the home of the famous auto speedway, where the Kings and Demons of the track yearly thrill tens of thousands with their daring; where auto men of genius have reared giant factories, employing thousands of men—the Cole, Stutz, National, Premier, Empire, Herff-Brooks, Marmon, Pathfinder, Waverly, etc., and make your start where thousands have made theirs.

Sketch of the famous speedway

More men are needed. Trained men. Men who

**Be One of These Men** Learn the business from the ground up, and get in while it's still young and growing fast. Be somebody! Make the money you've been wanting. You can—you will—if you go after this thing right. A first class automobile man never looks for a job—the jobs look for him. Then there's the tractor field—getting bigger all the time. We teach that, too.

**Be a Trained Mechanic** Think of the tremendous opportunities for repair men who know their business, who can explain to a car owner what is wrong with his machine and how it should be fixed. Think of the hundreds and

Men are making fortunes—building cars, selling cars, repairing cars. It's the biggest and surest business in the country.

See it when you come to town

know the why and wherefore of motor construction. hundreds of openings for the "men who know"; at the head of service stations, in garages, as high class chauffeurs, either for private or commercial work. Everywhere there are good paying jobs in the automobile and tractor business for trained men. We are equipped to teach you the automobile business from the beginning to the end. That's our business and we have the machinery and men to do it.

**Guaranteed Training** We mean what we say. Here's our proposition: Come to Indianapolis, pay one-fourth the tuition fee down. Start your course, pay the balance when you're satisfied. That's meeting you more than "50-50" and it's fair to all. Anyhow investigate. Send a postal for catalog and do it right now. Now is the time to start.

**INDIANAPOLIS MOTOR SCHOOL, 201 Southeastern Ave., INDIANAPOLIS, IND.**

# Study Law 30 Days Free

Let Us Prove to Your Entire Satisfaction, at Our Expense, that we Actually Offer the Most Complete and Efficient Extension Course in Law in America

After this 30-day free trial you can compare our course with any other law course in existence—then decide. You can never have the least conception of the excellence and thoroughness of this law course until you have actually tried it. There is absolutely no similarity between this course and others, and we can easily and readily convince you of this fact, without it costing you a penny.

### Special and Exclusive Features

Only recognized resident law school in the United States conferring Degree of Bachelor of Laws—LL. B.—by correspondence. ONLY law school in the U. S. conducting standard resident school and giving same instruction by mail. Only law school giving over 500 class-room lectures to its extension students. ONLY law school giving a full 3-year, University Law Course, by mail, having an actual faculty of over 30 prominent lawyers in active practice. ONLY law school in existence giving Complete Course in Oratory and Public Speaking, in conjunction with its law course.

### Our Degree LL. B.

We confer this Degree of Bachelor of Laws—LL. B.—only when the student has completed our full course with the necessary credits, to the satisfaction of the Faculty, exactly the same as in our resident school. Our correspondence graduates receive identically the same sheepskins as our resident school graduates. At our Annual Commencement, June 6, 1918, a number of our correspondence school graduates came to Chicago and graduated with our resident school class.

### Direct From Class-Room to Student

is the way we teach law. We are the only school doing this. A student can if he chooses, take part of our course by mail and finish in our resident school where he will receive full credit for all work done by mail.

We give an absolute written guarantee to prepare our students to pass bar examinations. The Hamilton College of Law is a regular, thoroughly recognized, bona-fide College of Law and NOT an "institute."

"correspondence school," or a corporation selling sets of law books under the guise of teaching law.

This College occupies the entire third floor of the New Advertising Building, where its large and commodious Class Rooms, Extensive Library and Executive Offices are located. School and Course Highly recommended by Government Officials, Business Men, Noted Lawyers, Graduates, and Students.

### Course in Oratory Free

This course has been prepared and written by Prof. Oscar G. Christgau, LL. M. (Master of Laws), the regular resident school professor in charge of this work. Knowing law, from a lawyer's standpoint, he has prepared this course to meet all the requirements of the practicing attorney. This Course in Oratory and Public Speaking sells, individually, for \$30.

### Our Law Library

Consists of 24 volumes of Students Standard Text Books, two volumes bound together under one cover for convenience, making a total of 12 books. These law books were prepared at an enormous cost especially for the students of the Hamilton College of Law, by one of the largest and best law book publishers in America. This is the only set of law text books ever prepared exclusively for students' use.

### Mail Coupon Today

and get our Big, Beautifully Illustrated Prospectus and Our 30-Day Free Offer. Read this carefully and get the truth about law schools. Then make us prove every statement we make without obligating yourself in any way.

### HAMILTON COLLEGE OF LAW

1051 Advertising Bldg., Chicago, Ill.

Gentlemen:—Kindly send me your Illustrated Prospectus and 30-Day Free Trial Offer.

Name.....

Address.....



## DAY OF THE "STRONG MAN" HAS PASSED

New York, Nov. 21st.—Contrary to popular belief the man of today is not always as energetic, strong or muscular as many who are not half so strong or muscular. As Swoboda, the world's greatest builder of men, says "lifting heavy weights or any other vigorous exercise will give a man big muscles—but at the expense of a diseased heart, high blood pressure, hardening of the arteries, a sluggish, slow-thinking mind. People are learning how to acquire balanced strength of mind and body through conscious evolution."

## How to Be a Giant in Health and Mind

Without drugs or medicines or dieting, without excessive exercise, without giving up any of the pleasures of life, over 200,000 men and women from nine to ninety, have been shown by Swoboda how to revitalize, re-energize, restore every cell, tissue and organ of the body. By his amazing system of Conscious Evolution Swoboda has enabled weaklings to become GIANTS in health and mind.

**Book Free!** The secret of wealth, health and happiness is fully explained in Swoboda's new book, "Conscious Evolution." In it, hundreds of pupils tell what this great discovery has meant to them in increased earnings, increased ability to live the well-rounded, wholly successful life. This great book will be sent free to all who are interested in greater health and mental power. Write today—now—before you forget.

ALOIS P. SWOBODA, 1987 Aedlian Hall, New York City



Creator of  
Conscious  
Evolution

## New Book Free

Write today for the book that tells about the opportunities in the profession of Signal Engineering. Men are needed. Learn, too, how you can get the training that you need to fill the big job.

**\$125 to \$300 a Month**

The free book will give you just the information you want. Write for it now—immediately. Here is a golden opportunity.

Dept. 1191 — 1810 Wilson Ave., Chicago, Ill.

## GOVERNMENT DAIRY FACTS

Free for examination. The famous Farmer's Cyclopedia, which gives most reliable information on dairy farming. Also facts on all other branches of farming. Facts that cost the government \$4,000,000.00. Information direct from U. S. Dept. Agriculture. See these 7 big books, 6 1/4 in. x 9 in., 8000 pages, hundreds of pictures. If you buy send only 50c down. Then \$2 monthly until \$29.50 is paid. Otherwise return at our expense. Send no money now. Examination is free.

DOUBLEDAY, PAGE & COMPANY, Dept. 1191, Garden City, New York

**LAW** University Extension Law School, Est. 1897 Our Simple Experience Method of Home Training in Law prepares you for the Bar or Business Law. A complete Standard Law Library Free to every student. Low tuition costs. Pay in monthly installments. Money refunded if dissatisfied. Write today for catalogue. University Extension Law School, Dept. 52, 266 S. Wabash Ave., CHICAGO, ILL.

**CACHOO!** Make the whole family "just sneeze their heads off" without knowing why, with Caches, the new long distance harmless snuff. Sent anywhere for 10c, 3 for 25c, 1 doz. and special premium for 90c. AMERICAN SUPPLY CO., St. Paul, Minn.



## Lost Voices Restored

IMPERFECT VOICES MADE PERFECT

Is your voice weak, harsh or husky, or do you stammer? By a simple system of silent exercises, the vocal organ can be developed and strengthened.

**Free Book.** If you would like to possess a fuller, stronger voice, our method will fill your desire. Write today for our free Booklet and literature.

PERFECT VOICE INSTITUTE, Dept. 1191, 1810 Wilson Avenue, CHICAGO, ILL.



## Learn Mechanics of Aviation

**YES**, right in your own home, in your spare time, you can learn all the principles, the theory and the mechanics of Aviation. You can prepare yourself for flying, if you wish. Or you can gain all the practical knowledge to equip you to enter the big paying and fascinating business of aeroplane construction and as aero-mechanical engineer. Send the coupon at once! Find out how our wonderful course in Aviation will give you the knowledge necessary to enter this field. Everybody planning to enter the Aviation fields needs the knowledge which this course offers. This is the first time that anyone has had the opportunity to gain this instruction at home—and without great sacrifice of time and expense. Waste no time in sending coupon.

## Big Opportunities NOW!

Now is the time for every man who has considered Aviation to get into the field. Each day presents new opportunities. The pioneers are going to reap the rich rewards. Automobile history, railroad history, motion picture history will repeat itself in Aviation. The men who get in early are the men who will amass the fortunes. Right now there are opportunities for men who are experts in the mechanics of Aviation that pay anywhere from \$50 to \$500 a week. In aeroplane factories, government branches, aero societies, repair shops. Only trained men will do. Heretofore this was obtainable only at a great sacrifice of time and expense by field training. Now you may secure this same training at home—in much shorter time, a mere fraction of the expense, and without interfering with your regular work.

same training at home—in much shorter time, a mere fraction of the expense, and without interfering with your regular work.

## Endorsed by Aviation Authorities!

Leading aviators and flying organizations have endorsed this course as a quick and reliable means of training for the business and practice of Aviation.

## Special Offer

Send the Coupon

Those who write at once will still be able to take advantage of the special limited offer which is now in force by which they may secure a large tuition reduction. Write now while this offer lasts for full particulars. Send coupon—no obligation.

American School of Aviation  
431 S. Dearborn St., Dept. 1191  
Chicago, Ill.

American School of Aviation  
431 So. Dearborn St.  
Dept. 1191 CHICAGO  
Gentlemen:—Please send me, free and without obligation, full particulars of your course in Aeronautical Engineering and details of your special limited offer.

Name.....

Address.....



## 30 DAY COURSE IN TIRE REPAIRING **FREE**

Complete Tire Repair Outfit  
Less Than \$250.00

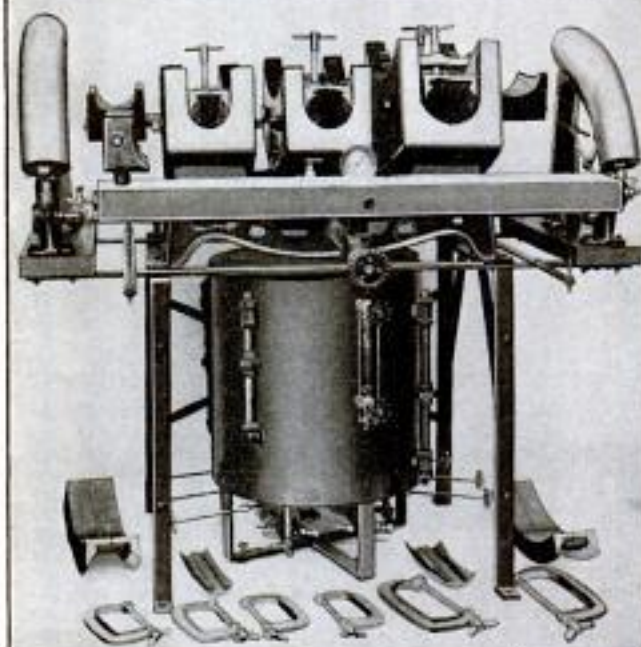

With this outfit and our course of free instruction, you can start up a good business.

## Learn to Repair Tires

Bigger opportunities than in any other branch of the Auto business. A broad claim, but easy to prove. Only stop and think!—you know it's true. Listen! Not one single Auto factory can build cars fast enough. Everybody is car crazy, and the craze is growing. 2,000,000 autos now in use. Four tires to each car. That means 8,000,000 tires to repair. Just think of it—8,000,000 tires! Each car wears out its cost in tires alone. Punctures and blowouts are common. Vulcanizing, patching, retreading, etc., must be done. Retreading alone—the new and better process—brings big money.

## Earn \$3000 to \$8000 a Year

Begin now. In almost every city, town, village, and cross corners, there is a fine chance to start. We know the places and put you next. Just a little money starts you in a business of your own. We guarantee to make an expert of you in 30 days free of charge. Write today for free catalog, or why not take a run over to Detroit and investigate personally? Don't let the chance slip by. Investigate now.

## Reliable Tire Repair School

101 Reliable Bldg., DETROIT, MICH.

**FATHERS!** This is a great opportunity for that boy of yours. Start him in the Tire Repair business. You'll always be glad. When in Detroit, look us up. We'll be glad to show you through.

### COUPON

#### RELIABLE TIRE REPAIR SCHOOL

Send me your free catalog and full particulars about the tire repair business.

Signed.....

Address.....

P. M.

## Do You Want a Salary Boost?

Then write to us and learn what we've got to tell you. Learn what astonishing things have been done for 15,000 men and women by Har-

ington Emerson's great, new Course in Personal Efficiency. A course which opens the way to a successful future and greater power. One man says this course produced for him an increased business of \$50,000 in one year. Another declares it to be worth \$25,000 to him. Salary boosts of 50 per cent with more to come are common. Men declare that they are twice as efficient as they were.



## Learn Personal Efficiency

You can get it right at home. During your spare hours you can learn those things which have done so much for others. "It's worth 100 times what it costs," writes one enthusiastic student. "Increased my capacity 200 per cent," says another. And still another: "I made \$2,700 out of my small investment."

**Write Today** A postal or letter brings the free book, "Where's the Money Coming From?" No matter what you are doing now or what you are earning now—even if you are a \$10,000 a year man or working for \$10 per week—you need this book. Get it and read it. Don't pass up this opportunity. Write at once.

The Review of Reviews Company

36 Irving Place Dept. 1191 New York, N. Y.



## New Book Free

Write today for the book that tells about the opportunities in the profession of Signal Engineering. Men are needed. Learn, too, how you can get the training that you need to fill the big job.

**\$125 to \$300 a Month**

The free book will give you just the information you want. Write for it now—immediately. Here is a golden opportunity.

Dept. of Signaling Dept. 1191—1810 Wilson Ave. Evanston, Ill., Chicago, Ill.



## Why Not Spend Spring, Summer, Fall

gathering insects, butterflies, for me? I pay highest cash prices for 750 kinds. Don't mail insects alive. Some worth \$1—\$7. Men! Women! If you mean business, send 2c stamp for literature. It may mean big profits and easy outdoor work for you. Get posted NOW for Spring season.

**SINCLAIR, Entomologist,**  
Box 244, D-6, LOS ANGELES, CAL.



## MIAMI-MADE BICYCLES

Stand at the top of the bicycle world.  
RACYCLE, HUDSON, MIAMI, FLYING MERKEL.  
Write for our catalog.  
THE MIAMI CYCLE & MFG. CO., MIDDLETOWN, OHIO

## Electrical Specialties

Wireless apparatus, electric fixtures at trade discounts.  
WRITE FOR CATALOG.

KANDEM ELECTRIC COMPANY  
30 East 21st Street, NEW YORK CITY

## POULTRY PAPER

44-124 PAGE periodical, up-to-date; tells all you want to know about care and management of poultry for pleasure or profit. Four months for 10 cents.  
POULTRY ADVOCATE, Dept. 98, SYRACUSE, N. Y.



**HUNTERS!!** Send for free folder of Remington U M C Repeating Rifle, Model No. 14 1/2, for game up to and including deer—just the arm for moderate range shooting.  
THE REMINGTON ARMS UNION METALLIC CARTRIDGE COMPANY  
Dept. P-5, Woolworth Building, New York



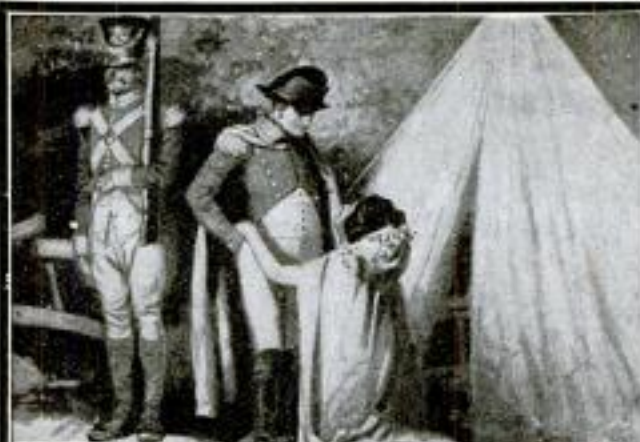

## When Louise of Prussia Went to Napoleon

**Napoleon Bonaparte's** name fills more pages in the world's solemn history than that of any other mortal. After conquering nearly all of Europe it remained for the beautiful Queen of Prussia to accomplish that which Prussia's mighty armies had failed to acquire. The story of her visit to Napoleon is one of the most interesting in history. This is only one of thousands of incidents of interesting and dramatic power in the history of Europe to be found in the famous publication, Muhlbach's

# Historical Romances

**You Should Have** these fascinating volumes of Muhlbach, because they will bring you a wealth of charming hours. Read the delightful pages that tell of rare, old, fragrant love stories of "fair women and brave men" of Long Ago; of bluff old King Hal, he that loved not wisely but too well; of the stirring battles of Frederick the Great and his resistless soldiers; of the "love that lies in woman's eyes," whether in the marble courts of Queen Hortense and Empress Josephine or in the liberty-loving huts of Andreas Hofer and his Tyrolean fighters; of the scarlet gleam of the French Revolution, the gay laughter of noble ladies, the flights, elopements, abductions, the roar of approaching mobs, and the rumbling prison carts, and the tragic ride of Marie Antoinette to the guillotine.

**Read How Destiny** led Napoleon, the poor Corsican boy, to the head of an Empire; how he conquered and lost alike in love and war; how an emperor could love, and how he could break a woman's heart—all this you'll find in these enchanting pages, rich in the splendor of courts, the clash of battle, and the pulsating heart throbs of many of the most dashing men and the most lovely women of all history.

**The Encyclopaedia Britannica** says: "Muhlbach's works show a talent for lively description and narration that gives enduring popularity and a power in weaving alluring romances from those stirring times that is unsurpassed."

### Contents

1. Napoleon Bonaparte.
2. Empress Josephine.
3. Napoleon & Blucher.
4. Queen Hortense.
5. Marie Antoinette.
6. Prince Eugene.
7. Daughter of Empress.
8. Joseph II and Court.
9. Mohammed Ali.
10. Henry VIII & Court.
11. Berlin & Sans Souci.
12. Goethe and Schiller.
13. Merchant of Berlin.
14. Louise of Prussia.
15. Old Fritz & New Era.
16. Andreas Hofer.
17. Frederick the Great.
18. Frederick the Great.
19. Youth of Elector.
20. Reign of Elector.

20  
Volumes



10,000  
PAGES

## Here Is Our Bargain Offer

Just sign and mail attached coupon and we will ship you the complete set of this beautiful edition for five days' examination in your own home. You can decide then for yourself whether or not you wish to buy. You can return the set at our expense if it fails to give you entire satisfaction. Should you desire to purchase send us \$1.00 as first payment and pay the balance at the rate of \$2.00 per month for only 12 months until our special price of \$25.00 is paid. The regular subscription price is \$40.00. Thousands of sets have been sold at this figure. The reason we are able to cut the price to only \$25.00 is that our method of sale by mail eliminates all middle men's profits. There is neither a dealer's profit nor an agent's commission involved in the transaction. We ship direct from factory to consumer and guarantee satisfaction in every way. **Mail coupon promptly.**

**THE RIVERSIDE PUBLISHING COMPANY  
CHICAGO, ILL.**

## Send No Money

We do not want your money until you have seen this beautiful set of books and have decided to buy. Just sign and mail the attached coupon and we will ship the set with no more obligation on your part to buy. If after examining the books for five days you find them satisfactory, you can then mail us \$1.00 and only \$2.00 per month thereafter for twelve months. This is an exceptional bargain on this beautiful set of books.

Name .....

Address .....

1  
17

The  
Riverside  
Publishing  
Company  
Marquette Bldg.  
Chicago, Ill.

Please ship me for examination and approval one set Muhlbach's Historical Novels, twenty volumes, silk cloth binding. If satisfactory, I will send you \$1.00 after five days' examination and \$2.00 a month thereafter for twelve months. If the set does not meet my entire approval after five days' examination, I will notify you and hold subject to your shipping instructions as offered Popular Mechanics readers.

FOLD HERE. TEAR OUT. SIGN AND MAIL.





# Your Engine is in the Grip of the "Black Plague" (Carbon)

**T**HAT'S the principal reason your car starts so hard this cold weather. You can overcome 80% of your trouble by simply pouring into each cylinder an ounce of—

## JOHNSON'S CARBON REMOVER

Five minutes' time and no labor required. It will increase the power of your car—improve acceleration—stop that knock and reduce your gasoline consumption from 12% to 25%.

### OUR GUARANTEE

No matter how much you use or how you use it, Johnson's Carbon Remover cannot injure any part of your motor. It contains no acids—does not in any way affect lubrication or injure the oil in the crank case. It has no action on any metal.

### USE IT EVERY 1,000 MILES

If you will use Johnson's Carbon Remover every 1,000 miles you can keep your engine clean and sweet and always at its highest efficiency.

### SPECIAL OFFER

If your dealer cannot supply you, send us \$1.00 and we will forward you by prepaid express enough Johnson's Guaranteed Carbon Remover to clean your engine three times. Write for testimonial folder and further information.

(PATENT APPLIED FOR)

**S. C. JOHNSON & SON, Racine, Wis.**  
Dept. PA1  
LONDON - SYDNEY

S. C. JOHNSON & SON, Dep. PA1, Racine, Wis.

I enclose \$1.00 for which please send me by prepaid express enough Johnson's Guaranteed Carbon Remover to thoroughly clean an ordinary four cylinder motor three times.

Name.....

Address.....

City and State.....

My Dealer is.....



# Popular Mechanics Magazine

REGISTERED IN U. S. PATENT OFFICE

WRITTEN SO YOU CAN UNDERSTAND IT

Vol. 27

JANUARY, 1917

No. 1

3238

## Spotlights to Protect Traffic Officers.

*# Wm G. Rice 3501 Washington St., St. Louis.*

AT certain street intersections in St. Louis, where traffic officers have frequently been struck by passing automobiles in dark and foggy weather because of their low visibility, they are now protected by searchlights installed on near-by buildings, which clearly reveal their presence to approaching motorists. The lights are of the nitrogen-tungsten variety, high-powered, and mounted in reflectors. Placed at the second or third story of a corner building they flood with a bright white light the spot where the officer stands. At one street corner in the West End the light is

mounted at the top of a seven-story hotel. The spotlights were adopted after several other methods had failed.



Spotlight System  
Used in St. Louis to  
Protect Traffic  
Officers in Dark and  
Foggy Weather.  
Luminous White  
Gloves and White  
Oilcloth Coats. Pre-  
viously Tested Out.  
Failed to Render the  
Officers Visible in  
Dense Fogs



3187 *Revised*

## THE ZEPPELIN OBSERVATION CAR

By LEWIS R. FREEMAN

287 E. California St., Pasadena, Calif.

SO far as giving any hint of what it really was to the farmers of the east coast of England who first discovered it, the Zeppelin observation car recently on exhibition in London might well have dropped from another planet. It had been rumored ever since the raids on England began that the Zeppelins were provided with some sort of contrivance which could be lowered below a screen of clouds for observation purposes, while the airship itself hovered in the comparative security of the higher altitude. Possibly the British authorities possessed full knowledge of what this contrivance really was, but certainly it would be hard to imagine a picture more differing than was the popular conception of the observation car from what the real thing proved to be. Pictures drawn of it—from fancy, of course—in the newspapers, and even in the scientific press of England, always showed it as something of the nature of an armored miner's cage, a steelplated box capable of withstanding the fire of heavy artillery at fairly close range; whereas the real thing proved to be made of sheets of aluminum so thin that one might hope to puncture it with a vigorous thrust of a penknife blade, and so light that, standing under it where it was suspended, I was able to take the whole weight of it—not much over a hundred pounds—on the heel of my upraised hand.

The 3,000 feet or more of  $\frac{3}{8}$ -in. cable, together with the aluminum winch upon which it was wound, could be lifted with ease by one hand. The cable, which is made of several small wires of what appeared to be an aluminum alloy, wound round a somewhat larger central wire, is extremely light and pliable, winding onto the winch like oiled-silk fishline, and with as little tendency to kink. The central wire served for telephone communication between the car and airship, a combination receiver and transmitter having been found in the former.

For a description of the observation

car itself I cannot do better than give that of the man who first chanced upon it while out rabbit hunting. "When I looked through the hedge," he said, "I saw this queer-looking thing with its nose in the ground among the stubble. It had evidently fallen lightly, skimming over the ground for several yards. The wire was trailing off across the field out of sight. I guessed it might have been left by the enemy, and so cocked my gun while I looked to see if anybody was at home.

"It was a snug box of aluminum, shaped like a headless fish. Into its blunt end was let two small windows of mica. There were two more such windows at side, bottom, and top. Each window was curtained, and between them—on the bottom of the car—was a mattress upon which the observer had lain. By slipping a curtain he could look out in any direction he wished. Within easy reach from the mattress were a compass, clock, glasses, three or four electric batteries, and a sort of shelf holding some wire-bound equipment of various kinds. Two electric-light bulbs were so placed as to throw light in any direction. Into a part of the fore end was stuffed some sort of grass.

"Behind the mattress, where the car tapered down to the tail, there was empty space. The length was 14 ft., and the diameter at the head about four feet. On the outside of the tail was a sort of four-flanged extension, like a double fin, evidently designed to keep the car steady in the wind or when in motion."

There is not much to be added to this description. The car was suspended by wires looped under the head and tail, and where the four ends were joined to the cable reaching up to the Zeppelin there was a stout steel spring—about four inches in diameter and a foot long—doubtless intended to take up the vibrations and make the car ride easier.

It appears not to be definitely known just how this car came to be aban-



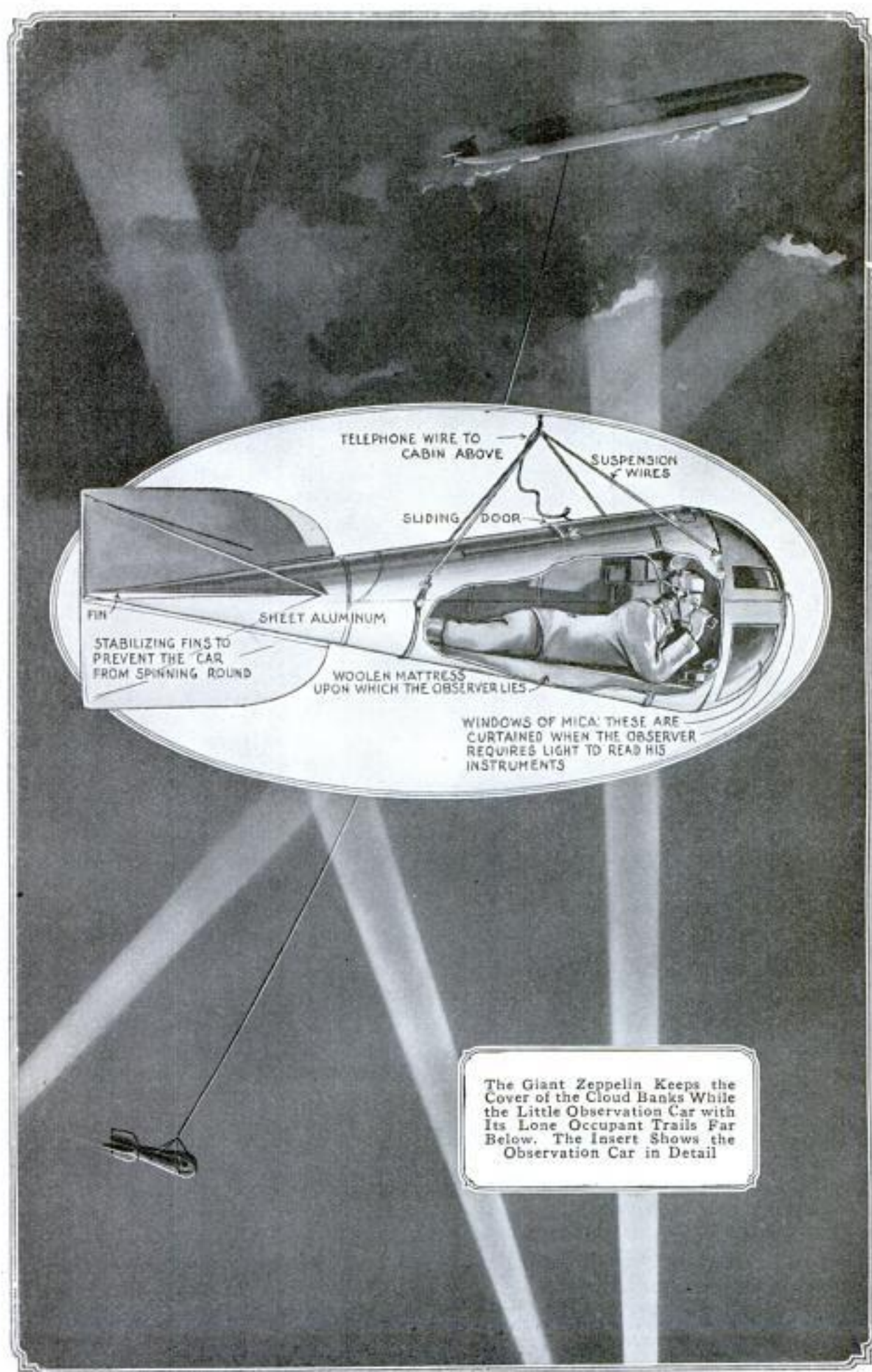

The Giant Zeppelin Keeps the Cover of the Cloud Banks While the Little Observation Car with Its Lone Occupant Trails Far Below. The Insert Shows the Observation Car in Detail



done in England, though the fact that what was the upper end of the wire shows evidences of having been cut would seem to indicate that it may have been dropped by a hard-hit Zeppelin desirous of ridding itself of all unnecessary weight before venturing back over the sea. No trace of the observer has ever been discovered, and it is not believed he was in his place at the time the car was cut loose.

3234

### CHEERFUL GLOW GIVEN OFF BY ELECTRIC RADIATOR

Convenient during crisp mornings in spring and fall when steam and hot-water systems are either not in service or slow in generating heat, is a portable electric radiator of a new type. It



A Separate Switch Controls the Incandescent Lamp so That It may be Used or Not, According to the Wish of the Individual

is finished in nickel, and near the top, in a curved deflector, is supplied with a frosted globe that gives off a warm, cheerful glow. This makes the device well suited for use on a magazine table cool evenings, for not only does it throw off heat, but the light from the lamp is quite adequate for reading purposes. In this capacity it is an especial comfort for the woman who is subject to feeling chilly about the

The fact that no observation cars have been reported as being found among the wreckage of any of the three Zeppelins recently brought down in England would seem to indicate that this contrivance is only employed by special "scout" airships, whose duty is to see rather than destroy, and to report their observations to the fleet with which they are operating by wireless telegraphy.

shoulders and requiring a light wrap when seated in a slightly underheated room. The appliance is 20 in. high, a foot in width, and has a handle near the top by which it may be carried from one room to another as needed. It may be attached to any lighting socket conveniently located, and will, it is said, take the chill out of a room of moderate size in a comparatively short time.

3304

### NEW AIR RECORDS SET IN LONG FLIGHTS

Two remarkable aeroplane flights resulted recently from attempts made, first by a man and then by a woman, to fly without a stop from Chicago to New York. While neither succeeded in doing all that was planned, new American nonstop records were set, first by one and then by the other, final honors resting with the woman. On November 2, Victor Carlstrom started from Chicago at sunrise in a 200-hp. Curtiss military biplane and flew to Erie, Pa., a distance of 452 miles, without a stop in 4 hr. 17 min. 30 sec., which made a new cross-country record. Again descending at Hammondsport, N. Y., for the night, he continued to New York next morning, landing on the parade ground at Governors Island at 8:55 a. m., in the presence of Maj. Gen. Leonard Wood, commanding the Department of the East. The total distance flown by Carlstrom was 967 miles and his flight time 8 hr. 28 min. 30 sec.; average speed, 114 miles an hour. He carried mail from Chicago for the Post Office

Chicago Tribune } 11/1/16  
Herald }  
Central News Photo Service }  
26 Beaver St. N.Y.C. }

Delaware 322 E. Ohio Chgo.





Victor Carlstrom Making His Landing at Governors Island, New York Harbor, after a Record-Breaking Flight by Military Biplane from Chicago. The Insert Shows Major General Wood Photographed with Carlstrom

Department, which was interested in the time and method of the trip.

Ruth Law, flying from Chicago at 8:25 a. m. on November 19, made her first stop, at Hornell, N. Y., 590 miles away, in 5 hr. 45 min., and thus captured the American nonstop record from Carlstrom. She descended again at Binghamton, N. Y., as night came on, but continued to New York next morning, landing at Governors Island at 9:40 a. m. Her actual flying time from Chicago to New York was 9 hr. 1 min. Prior to this flight Miss Law had never flown a greater distance than 25 miles at one time, and her achievement was all the more remarkable because the aeroplane she used was an old-model Curtiss, with the pilot's seat on a projection in front, where she was exposed to the weather save for a small aluminum foot shield. Carlstrom in the latest model Curtiss biplane was seated in an inclosure, protected from the weather by an aluminum cowl, while his machine had a spread of wings more than double that of the antiquated model used by Miss Law. Her winning of the nonstop record therefore speaks volumes

for her daring and skill as a pilot, and Carlstrom was one of the first to congratulate her on her success.



COPYRIGHT, INTERNATIONAL FILM SERVICE  
Ruth Law in the Small Curtiss Scout Biplane in Which She Made the Nonstop Record of 590 Miles during Her Flight from Chicago to New York



6 3272

## POPULAR MECHANICS

### RAISING AN AUTOMOBILE FROM RIVER BOTTOM

When a midnight accident sent a limousine to the bottom of the Chicago River recently, through an open draw of the Twelfth Street bridge, steps



INTERNATIONAL FILM SERVICE  
Three Bodies Were Recovered from This Automobile. It Was Raised by a Derrick from the Muddy Depths of the Chicago River

were promptly taken to recover it, in order to remove the bodies of three persons, a man and two women, believed to be drowned in the car. A city diver soon located the limousine, 20 ft. from the bank of the river, and a scow bearing a large derrick was towed over the spot. The diver then rigged hoisting lines around the car, as it lay in the mud at the bottom, and it was raised to the street level. Four lives in all were lost in this accident, while two women who were thrown clear of the car as it fell saved themselves by swimming to piles along the river bank. The body of the owner and driver of the car was found floating a short distance from the bridge.

*Dr. Henry S. Plummer  
of Mayo Clinic  
# H. J. Harvick, Pres. Mgr.  
Mayo Clinic  
3290 Rochester Minn.*

### DEVICE INSTANTLY CURES CURIOUS FATAL DISEASE

An eminent surgeon, connected with a world-renowned clinic, has developed an apparatus for treating persons afflicted with cardiospasm, which effects

a cure so suddenly that to the layman it appears little short of miraculous. Cardiospasm is a disease in which a contraction occurs at the point where the esophagus joins the stomach. Normally when food enters the lower portion of the esophagus a muscular ring, previously closed, relaxes and allows the food to enter the stomach. In this disease it does not open up normally and the food is retained above the ring. In some cases a huge pouch is formed by the accumulating food, while the patient slowly starves to death. In many such cases death has been attributed to cancer. Rather curiously, if a sound is lowered into the esophagus its

weight may cause it to pass the contracted point, as though there were no obstruction there.

The device which treats the disease so successfully is an expanding dilator, which, after being inserted to the contracted point, is distended with water to a point where it paralyzes the muscle. Earlier attempts along this line were made with metal dilators but were found to be attended with some risk. A single treatment, or, in rare instances, a few treatments, completely relieve the condition. No pain accompanies the use of the dilator and no anesthetic is given. Patients unable to walk and literally starving to death have, in an instant, been restored



to a normal condition so far as bodily functions go, and immediately begin to regain health. One young woman receiving this treatment gained 17 lb. the first week.

3067 ———  
**SIGN MADE OF CONCRETE  
 TO REDUCE UPKEEP COST**

In view of the fact that it is an item of considerable expense to keep an ordinary large sign in first-class condition by repainting and repairing it, a large manufacturer in the Middle West has used concrete in constructing a sign of large proportions. It is located on a steep embankment so that its tall letters and figures are clearly visible to all passers-by. The background was given a dark hue by mixing lampblack with the cement. The white letters are formed of fresh-water clamshells imbedded in the smooth dark surface of the concrete. If prop-



Large Sign of Concrete and Clamshells: These Materials were Selected for the Purpose of Reducing the Upkeep Cost of the Sign

erly made, a sign of this character should last for many years without requiring any repairs.

3768 ———  
**CANVAS WATER BAGS FOR  
 USE OF FORESTERS**

A canvas water bag that can be carried conveniently on a pack horse has been devised for the use of members of the United States Forest Service when it is necessary to transport water to places remote from a regular supply for drinking and cooking purposes. It can also be used to quench incipient fires, by means of a small hand pump carried along with it. The container is made of heavy cotton fabric without

seams or patches, rendered water-tight by treatment with a mixture of paraffin and turpentine. Each bag has a ca-

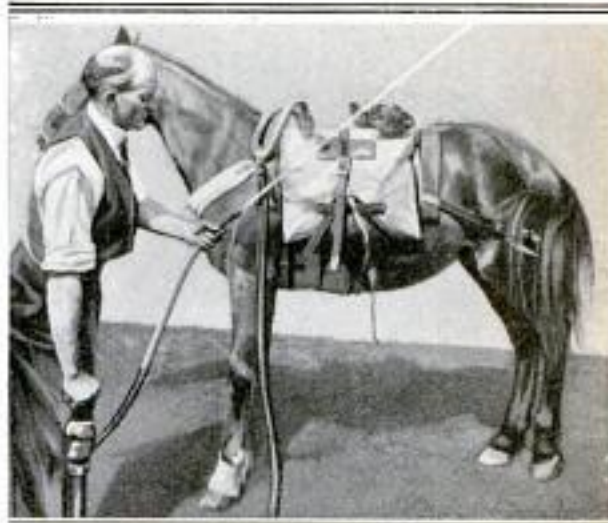

Canvas Water Bags and a Hand Pump, Carried by a Pack Horse, are Used by the Forest Service to Quench Small Fires in Remote Places

capacity of 10 $\frac{3}{4}$  gal. of water, and weighs when filled about 98 pounds. Thus a pack load of two bags weighs nearly 200 pounds, exclusive of packsaddle and blanket.

3114  
**LIGHTED GUARD POSTS  
 FOR SAFETY ZONES**

Illuminated guard posts, protecting the zones of safety in the middle of the streets where pedestrians stand to take street cars, have recently been installed in Oakland, Calif.

These posts are approximately three feet high and are made of heavy cast iron to withstand the shock of possible collisions. A strong grated cap, within which are two powerful electric globes, forms the top of each guard. The lamps are lighted at night so that the posts can be seen by drivers of vehicles. The caps can be removed to permit cleaning of globes.



Wash., D.C.

Universal Portland Cement Co.  
 Security Bldg.  
 Minneapolis.



## FRONT SEATS OF MOTOR CAR ARE EASILY REMOVED

Removable front seats, one of the features incorporated in the latest



Plenty of Room for a Perambulator or Small Crib is Provided  
When the Seat is Eliminated

model of a standard motor car, prove very convenient at times, especially when there is a baby in the family that needs to be taken along on drives and

short tours. By removing the seat at the right of the steering wheel, adequate space is provided for a small perambulator, or specially designed basket crib, that can be lifted into place, or taken out easily. This arrangement is particularly good when the tonneau is filled with passengers, or when a mother wishes to take a morning drive into the country with her baby. In this car the front seats can also be reversed so that they face the rear one. By doing this and folding down the collapsible auxiliary stools in the middle of the tonneau,

plenty of room is available for a table about which five or six persons can gather conveniently when refreshments are served en route.

## 7188 NANTUCKET AND MAINLAND JOINED BY PHONE CABLE

Telephone wires now connect Nantucket with Marthas Vineyard Island, and through it, the mainland of Massachusetts. This has been brought about within recent months by the extension of a submarine telephone cable, the longest underwater one in the United States, across Muskeget Channel. At the same time a new 12-conductor cable was laid across Vineyard Sound to Marthas Vineyard Island. The latter has the distinction of being one of the heaviest ever employed for transmission purposes. It weighs 10.6 lb. to the foot and is 2.69 in. in diameter, the size and weight being considered necessary on account of the strong tides encountered in the sound. The Nantucket cable carries six conductors and weighs about five pounds to the linear foot. The lead sheath in each instance is  $\frac{5}{32}$  in. thick and heavily insulated with jute roving and armor wire.

The work was done by the cable ship "Robert C. Clowry." The cable was wound from the landing stage at Woods Hole to a large reel, of about three-mile capacity, situated on the forward deck of the boat. As the winding was done from the smaller spools the separate lengths were spliced. Subsequently the cable was payed out through a block attached to the outer end of a derrick boom. When it came to landing the cable, the vessel was anchored a short distance from shore in direct line with the cable box, situated about 150 feet back from the water's edge on the bank. A launch carried a line attached to a steel cable inshore. After being drawn onto the beach, the line and cable were passed through a block and carried back to the steamer's winch. As these were pulled in, the telephone cable was payed out, landed, and finally extended through a trench to the box.



Boston Photo News Co.  
114 State St., Boston, Mass.



One of the First Steps in the Ordinary Process of Splicing a Cable



The Cable House on Marthas Vineyard Island, Situated a Short Distance from the Water's Edge: One Terminal of the Under-water Line

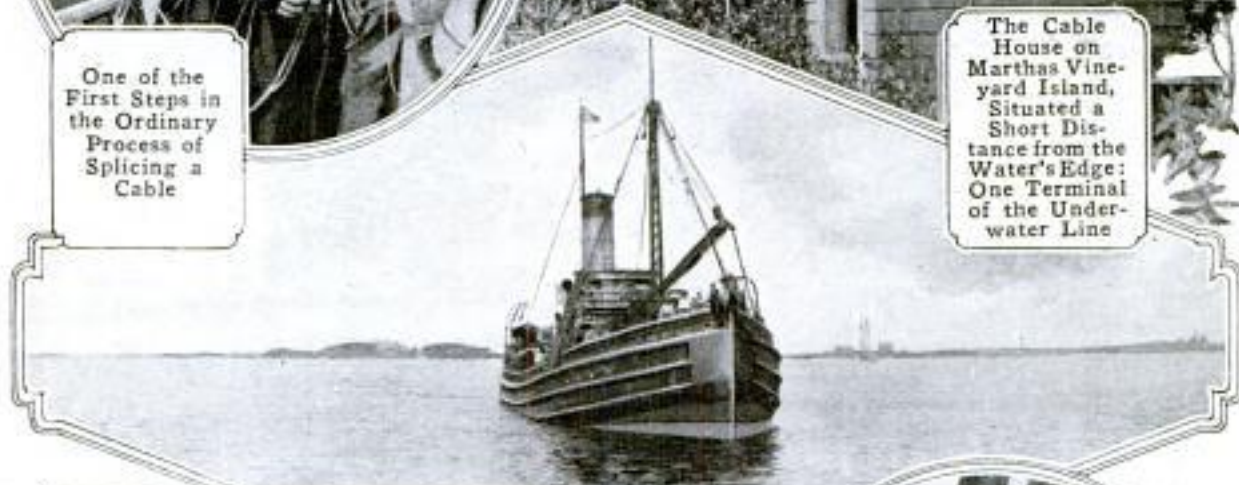

The Cable Steamer "Robert C. Clowry," Which Laid the Heavy Cables across Vineyard Sound and Muskeget Channel to Connect Marthas Vineyard Island and Nantucket with the Mainland



Splicing Two Cables aboard the "Clowry": Coating the Heavily Insulated Conductors with Liquid Paraffin

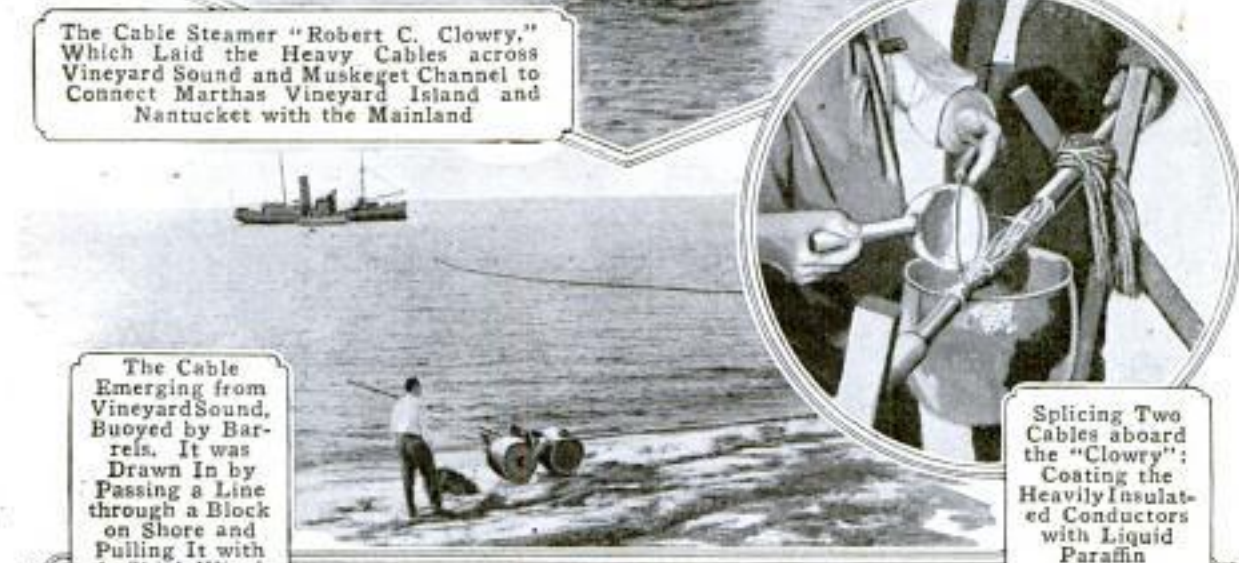

The Cable Emerging from Vineyard Sound, Buoyed by Barrels. It was Drawn In by Passing a Line through a Block on Shore and Pulling It with the Ship's Winch



The Vessel, Its Prow Barely Visible Here, Taking Aboard Cable from Reels Mounted on Flat Cars Alongside. This in Turn was Payed Out from a Large Spool on Deck through a Pulley Block Attached to the Ship's Derrick Boom. The Boat Handled Some of the Heaviest Cable Ever Laid



3180

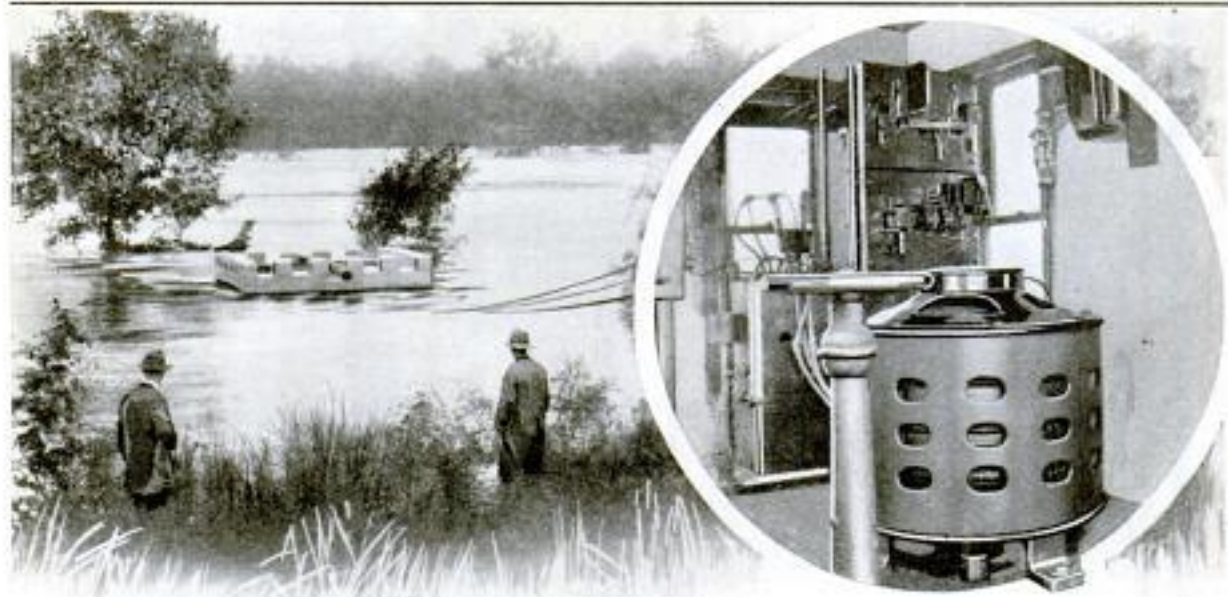

View of the Flood at Its Height, Showing the Water Almost as High as the Roof of the Concrete Power Station. When the River Receded the Motors were Coated with Mud. Insert Shows Part of Electrical Equipment Which was Put in Operation without being Allowed to Dry Out, after having been Submerged for 36 Hours

2989

### DRUGGIST'S PUMP FOR FILLING BOTTLES

The filling of a small bottle from a large one or the pouring of a thick liquid, such as glycerin, into a narrow-mouthed



bottle, is made quite easy by the use of a pump which has been designed for drug stores by a resident of St. Cloud, Fla. The device is made of brass and consists of a tube, to one end of which is attached a pump

barrel containing a plunger held in position by a coil spring. To operate, the pump is allowed to rest on the bottom of the large container. By pressing the plunger down with the hand and then releasing it, so that the spring can raise it up to its former position, the liquid is forced through the pump and out the curved end, which serves as a spout. When not in use the spout can be turned upward to prevent dripping.

# INN. W. E. Arnold  
St. Cloud  
Fla.

3180

### MOTORS RUN AFTER BEING SUBMERGED FOR HOURS

After having been submerged by a recent flood for 36 hours, three electric motors, which supply the city of Rock Hill, S. C., with water, started up promptly when current was applied, in spite of the fact that the coils and equipment had been given no opportunity to dry. Water from the Catawba River rose to the roof of the city's power plant which housed the three motors, two of which were 100-hp. and the third 7½-hp. When the flood receded linemen found the switches, instruments, and connecting bars, as well as the motors and their oiling systems, clotted with river mud. As the water in the standpipe was low, it was necessary to start pumping almost immediately to prevent a shortage. Accordingly the equipment was hastily cleaned with a hose and brushes, and a new intake pipe laid to supplant the one filled with mud. Then the current was applied and the motors started up without any trouble.

CA n investigation by the Department of Agriculture shows that blight-killed chestnut wood is just as durable as healthy timber.

*General Electric Co.  
Schenectady, N. Y.*



## FLÖATING POLICE STATION FOR NEW YORK HARBOR FORCE

By HENRY JAY CASE

*Isis N. Y. Police Department.*

NEW YORK CITY harbor police have a station house that goes to sea and passengers homeward bound from Europe need not think they have "got 'em again" when they meet it, green lights and all, rolling toward them on the deep Atlantic. It is not built of brick, to be sure, nor four stories high, with stone steps and pillars, but it has the familiar front office with the lieutenant's desk and blotter, the captain's room, the back room for the reserves, and the dormitory upstairs.

The New York harbor police have over 500 miles of waterway to patrol in and around the rivers, the Upper and Lower bays, the Sound and the distant reaches of the Atlantic, all inside the Greater City. This territory is divided into four harbor subprecincts, "A," "B," "C," and "D," all of which until recently had their station houses in permanent locations ashore. But last summer Arthur Woods, the present police commissioner, in his plans for police preparedness, directed that "Harbor B," as they refer to the

Harlem River station, should go afloat so that in emergencies it might be possible to tow it to any location desired on East or North River, Long Island Sound, Upper, Lower, or Jamaica bays. Thereupon, he turned back to the city a \$300,000 piece of water-front property on which the old station had stood for years and set the harbor police to work building a new station house on a deep-sea wrecking barge, 40 by 70 feet.

The station went into commission late in October. It is lighted by electricity and heated by stoves. Provision is made for steam connections to heat the house when the station is so moored as to be able to take such heat from whatever is alongside. The harbor men come and go in boats. The platoons or squads are "turned out" in crews, and when a call for help comes in it is received by telephone, wireless, or wigwag, and the response made by jumping the reserves to the scene of action in one of the lead-colored patrol launches. Sometimes the object of the call is a chase after river



COPYRIGHT, INTERNATIONAL FILM SERVICE  
 Harlem River Floating Station House of New York City's Harbor Police Force: It Replaces a River-Front Building Situated on Property Valued at \$300,000, Which has been Turned Back to the Municipality



pirates; sometimes a fight; sometimes a search in the inky darkness beneath the wharves.

When not on emergency work, the floating station house, "Harbor B," will be moored off Randalls Island, in Harlem River, opposite the foot of East 125th Street. Here the police have also built a machine, blacksmith, and paint shop, a big wharf and a marine railway on which to pull up and store the boats that come into their possession through larcenies, or otherwise.

At the present time the harbor police navy consists of one 235-ton steamer, "The Patrol," which is the flag ship, six launches on continuous patrol duty, and one launch on reserve. The flag ship carries two one-pounders, besides machine guns, and each launch is equipped with a machine gun, and all with service ammunition. The crews have been instructed by United States

naval officers in handling these guns, and have been given a course in wig-wag communication for signaling passing steamers and sail craft, and for keeping in touch with the shore stations.

With such distances as exist in New York Harbor and in the work cut out for them, harbor-police patrol stations are often far removed and out of touch with headquarters. The new floating precinct station will eliminate this inconvenience because it may easily be towed to any location where it is necessary to establish a temporary station. The wireless plant will make it possible to keep in touch with police headquarters in Centre Street, which already has a powerful wireless plant, a corps of licensed policemen operators and sixteen police "rookies" studying for their certificates in the police training school.

3221

### ICE BOX CHARRED BY FIRE KEEPS CONTENTS COOL

A refrigerator which recently went through a fire that partly destroyed a



Refrigerator as It Appeared When Opened Three Days after a Fire Which Charred Its Exterior. The Food It Contained Was in Good Condition and Even the Ice was Not All Melted

*McCray Refrigerator Co.  
Kendallville, Ind.*

dwelling in Marfa, Tex., proved to be so substantially made that though the exterior was badly charred, the interior was unharmed and the contents was in no way affected by the unusual heat. Shortly before the fire broke out the ice compartment had been filled with 100 lb. of ice. The box was not opened until three days later and then it was found that there was about 25 lb. of ice left. The butter contained within the well-insulated walls of the box was sweet and firm, and all the other food was also in first-class condition.

3246

### STATUE OF TELEGRAPHY HOISTED TO A ROOF

When a huge bronze statue typifying the wonders and progress of telegraphy was raised to the roof of the new Western Union Telegraph Building 16 Dey Street, New York, recently, thousands of spectators witnessed the operation. The statue is entitled "The Genius of Telegraphy," and is 30 ft. in height. It presents the figure of a man of heroic strength and power, mounted upon a terrestrial sphere.



The wings of the wind spring from his shoulders and in his left hand he grasps the lightning, while in his right are the coils of wire which harness it to earth and to the needs and purposes

German locomotive, built before the war made copper so scarce in central

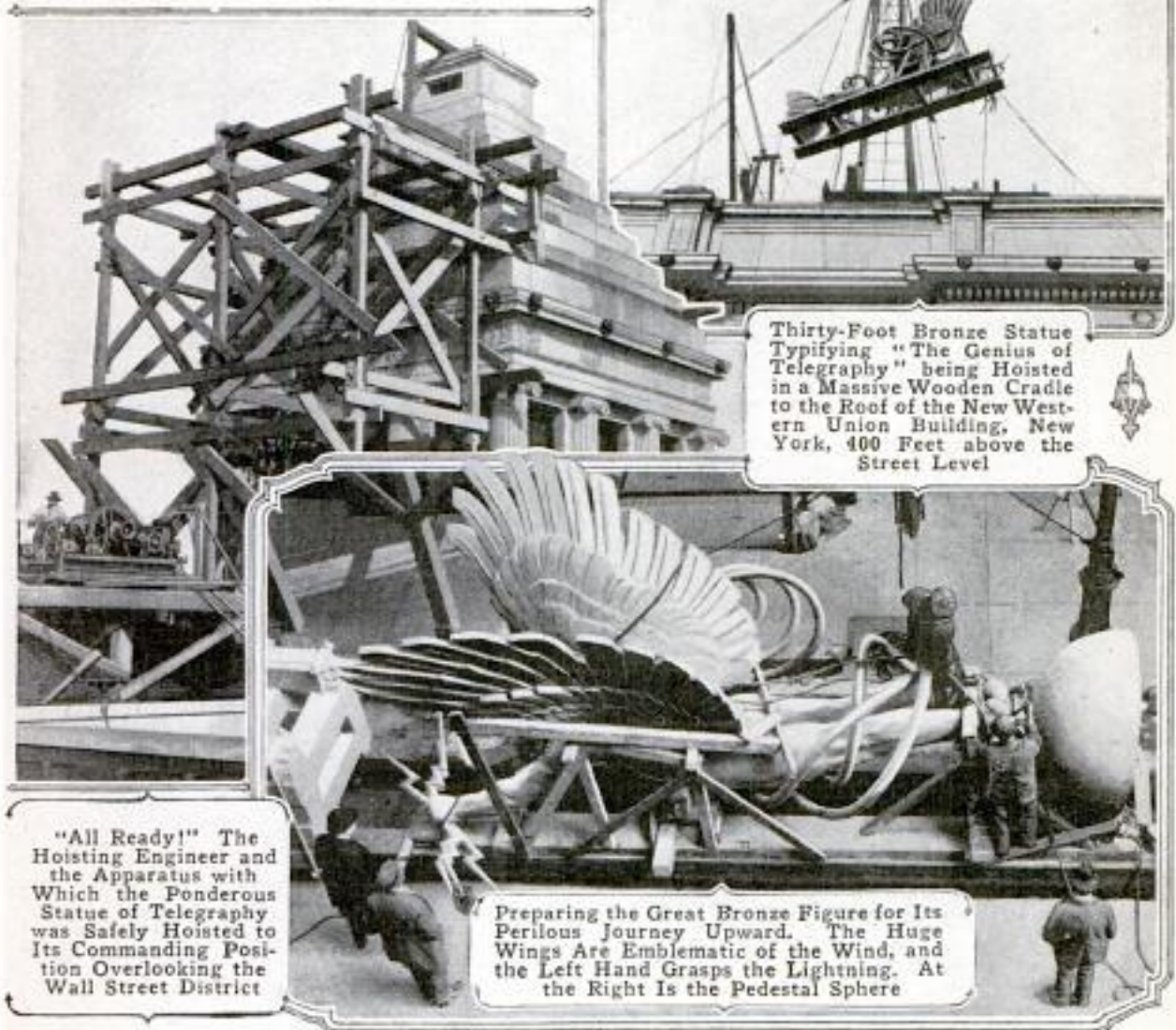

Thirty-Foot Bronze Statue Typifying "The Genius of Telegraphy" being Hoisted in a Massive Wooden Cradle to the Roof of the New Western Union Building, New York, 400 Feet above the Street Level

"All Ready!" The Hoisting Engineer and the Apparatus with Which the Ponderous Statue of Telegraphy was Safely Hoisted to Its Commanding Position Overlooking the Wall Street District

Preparing the Great Bronze Figure for Its Perilous Journey Upward. The Huge Wings Are Emblematic of the Wind, and the Left Hand Grasps the Lightning. At the Right Is the Pedestal Sphere

of man. The massive figure was raised by a derrick 400 ft. from the street level to the commanding position which it now adorns.

**GERMANS BUILD ENGINES WITHOUT COPPER**

Reports from abroad indicate that in their persistent search for a substitute for copper to be used in the construction of locomotives, the German engine builders have had at least a measure of success, although the question has been raised as to how long their copperless engines will last. The average

European, contained six per cent copper, by weight. Now the fire boxes and stays, formerly of that metal, are of cast iron. All the smoke and steam tubes, the oiling cocks, and thin pipes are of weldless drawn steel. For rod bracings, axles, grease boxes, and bracing parts cast iron is used together with a special alloy called flange metal, which is a mixture of tin, lead, and antimony. To avoid possible danger in the use of this metal, it is thought that pin and axle journals are bushed with white metal. In making other parts also, the use of copper has been dispensed with.

# Chemical Engineer Manufacturer Oct 16  
(Ex Iron Age)



Carbic Mfg Co., Duluth, Minn.  
Br at-52 Vanderbilt Av.  
N.Y.C.

14

3316

POPULAR MECHANICS

LARGE PORTABLE GAS LAMPS  
FOR FIRE FIGHTERS

Portable gas lamps of about 3,000 candlepower, fitted with straps so that



they may be carried on the backs of firemen, have been adopted by the Cincinnati fire department. One of these devices weighs about 35 pounds, and furnishes a dependable, penetrating light for a period of six hours without requiring attention. The body is elongated and tapered, so that it will stand by itself when required as a spot or flood lamp. The burner, backed by a reflector, is held at one end of a pipe that may be adjusted to different vertical angles. This projects well above the fireman's head when the lamp is strapped in place, and allows the light to be cast in whatever direction is necessary. The equipment is suited not

only for illuminating the interior of smoke-filled buildings, when electric circuits and gas service have been cut off, but also for exterior purposes.

3305

### WESTERN AIRMAN IS KILLED IN LANDING NEW BIPLANE

Several weeks ago while trying out a new biplane, Silas Christofferson, a builder of air craft and aeronautical motors, was killed at Redwood City, Calif. By a strange coincidence the airman met his death in a machine that had been constructed for a Nevada ranchman who was killed three days earlier at the same field while navigating one of Christofferson's military tractors. The birdman's unfamiliarity with the system of control installed in the new plane was responsible for the tragedy. He was accustomed to flying a machine equipped with a standard type of control operated with the shoulders. In the ill-fated craft the feet were used in regulating flight. Upon reaching a height of about 200 feet and attempting to make a landing, after a descent of several hundred yards, the airman momentarily forgot himself and tried to guide the craft to the ground with his shoulders, when he should have used his legs. The mistake came at a most critical instant and caused the biplane to plunge headlong against the earth. The flier was

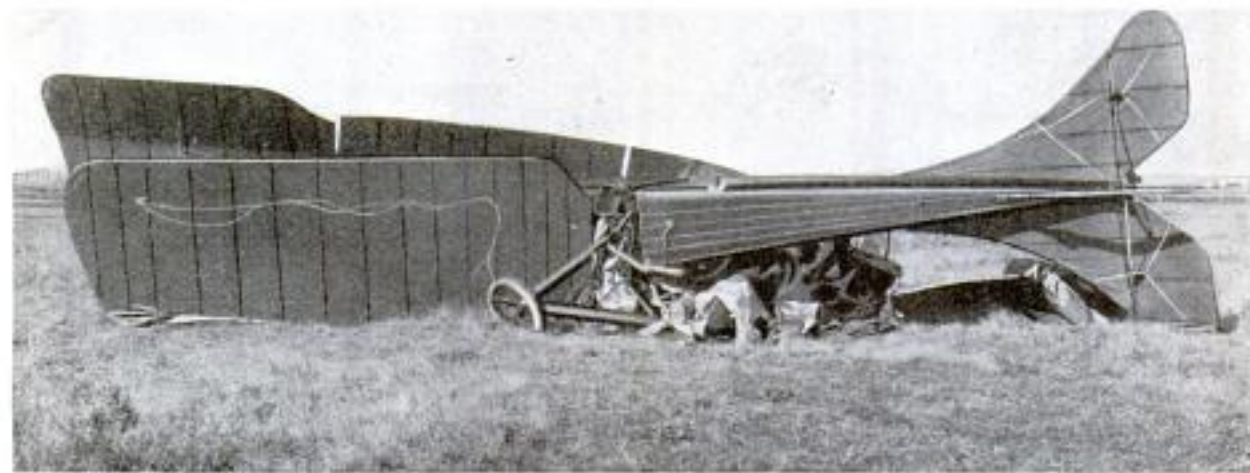

Wreckage of New Biplane in Which Silas Christofferson, Builder of Air Craft and Aeroplane Engines, Met His Death Recently at Redwood City, California



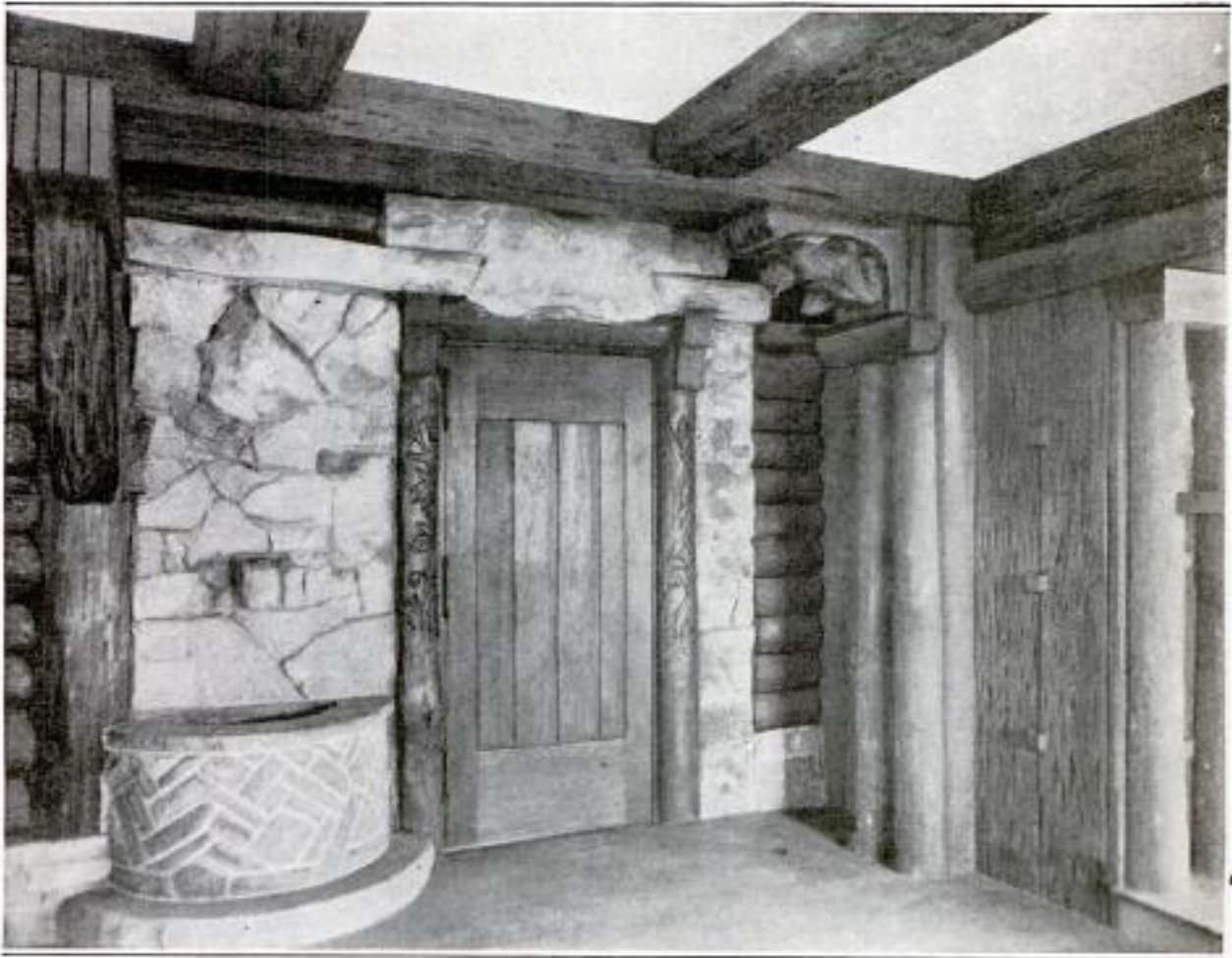

Fountain Corner of a "Field Room" in a Michigan Residence. Finished in "Pecky" Cypress. Note the Longitudinal Holes in the Wood of the Door to the Right and in the Ceiling Beams

conscious when removed from the debris and gasped to his wife, who had been the first to reach him, the cause of the accident. He died at a hospital a few hours later and was subsequently buried beside Lincoln Beachey at a local cemetery.

3317

### "PECKY" CYPRESS USED FOR BUILDING TRIM

"Pecky" cypress is a grade of cypress lumber in which the wood looks decayed, because of numerous holes filled with a brown powder, but its appearance is highly deceptive, for it is in reality one of the most decay-resisting woods known in this country. After it is once cut from the tree it does not change in character, and as it resists all kinds of atmospheric and soil changes, it is much used in the South for planking, foundation tim-

bers, fencing, railroad ties, farm buildings, greenhouses, and cold frames. Now the architects of the North are beginning to discover its possibilities for artistic use as exterior and interior trim. Several rooms in one of the largest residences in Michigan have recently been finished in pecky cypress with remarkable effect, as may be seen in the illustration. The pecky wood appears to be full of holes, varying in width from  $\frac{1}{4}$  to  $\frac{3}{4}$  in., these holes being found in the heart wood of the tree only, and then not until the trees have reached an age of 125 years or thereabout. The holes extend longitudinally up and down in the trunk, parallel with the wood fibers, and most frequently are 4 to 5 in. in length. They are separated from one another by layers of perfectly sound wood. When the brownish powder has been brushed out of the holes, the wood looks as if holes had been gouged into it.

*Southern Cypress Mfg. Ass'n  
1719 Hibernia Bldg.  
New Orleans, La.*



### CHECKERBOARD RADIATOR FOR AUTOMOBILE

A novel decoration for an automobile and one which is sure to attract attention is a radiator on which



An Unusual Decoration for a Radiator Which It Took Three Days to Paint

checkerboard pattern has been painted. The task of painting such an unusual adornment is more arduous than one might suppose, due to the fact that the inside of each hole in the radiator must be painted to correspond with the front surface. In the automobile front shown in the accompanying illustration there are approximately 3,000 tiny hexagons. The entire radiator was given a coating of white enamel and then the painter set about painting the black squares. Three days were required to finish the work.

### THE AMOUNT OF STEEL IN A BATTLESHIP

Nearly 151,000 gross tons of steel will be needed to build the 66 various new battleships, destroyers, and submarines, bids for the construction of which were taken by the United States Navy on Oct. 25, 1916. When these are added to our navy they will make it one of the most formidable in the world. In each of the four new battle

cruisers there will be 15,025 tons of steel; in each of the four new battleships there will be 13,761 tons of steel; in the 20 new destroyers, 325 tons of steel each, and in the 30 new submarines, 186 tons each. A hospital ship and an ammunition ship will need 4,000 tons of steel each.

These figures give some idea of the loss in steel alone when one of these is sunk in battle or by a submarine. Taking \$70 per ton as the average price of steel at present, these vessels mean an outlay of not less than \$10,000,000 for the steel only.

### SELF-GENERATING WIRELESS FOR AEROPLANES

Officers of the aerial branch of the United States Army are testing the value of various devices for generating wireless power for aeroplanes. In one device the principal new feature is a large fan, which is conveniently attached to the body of the aeroplane, spins around when the machine is in flight, and by means of a belt and suitable mechanism revolves the dynamo that furnishes current, and thus generates power for the wireless system. The rate at which the fan revolves depends of course upon the speed of the flight. The importance of the wireless in military aeroplanes causes all suggestions for its improvement to be examined with great care.

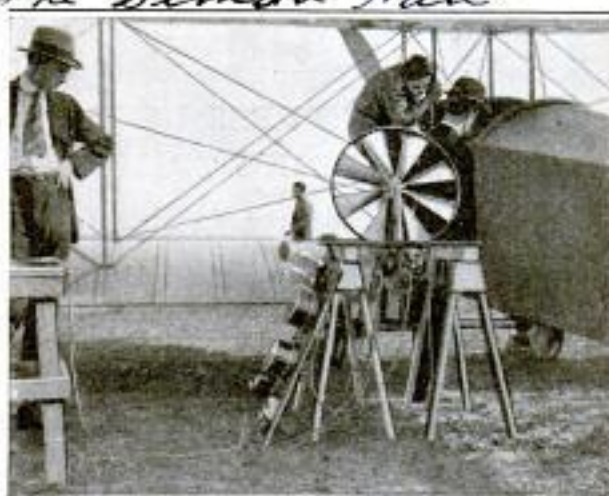

Latest Device for Generating Wireless Power for Aeroplanes, in Which a Large Air-Driven Fan Serves to Generate Current

*Patented Automobile Co.  
1319 S. Grand St.  
Los Angeles*

*3197*

*The "Simon Fan"*

*# F. Cone  
C. Iron Age  
239 W. 39th St.  
N. Y. C.*

*225 W. 39th  
New York*



2607

# Salvaging Human Wrecks from War's Scrap Heap

## IN THREE PARTS

By Searle Hendee

### PART II—Repairing the Maimed

THOSE who have visited the capitals of Europe during the present cataclysm have witnessed a revelation. They have seen the meanest of soldiers under the care of world-famed practitioners. They have found that the war's human wrecks are being repaired, even rebuilt, without regard to class or racial distinctions, and that no man, whether friend or foe, is left in the trenches to die so long as a spark of life remains in him.

Horror and wonder are the primal impressions that bombard the mind, however, as the marvelous work of the war surgeons is studied at close hand; horror at what has been done, and wonder at what can be done. Men with metal jaws screened behind false beards, with artificial noses, ears, cheeks, eyes, and limbs, form the armies of the rebuilt. By means of plastic surgery whole new faces are made for some who are woefully disfigured, while others, maimed beyond hope of facial repair, are kept alive and fitted with copper masks. These sculptors of flesh-and-blood men work with amazing finesse. But some of their

"studios" are chambers of unspeakable horror.

The nature of present-day warfare and the enormous number of soldiers in active service combine to make the harvest of dead and wounded in single battles greater than the losses incurred during whole campaigns in our Civil War. Thus it has been possible for specialism to be carried out to a previously unheard-of degree. Entire hospitals are devoted exclusively to the treatment of some one kind of injury.



Unfortunately This Is Not an Unusual Picture, but a Very Common One. The Hospitals of Europe Hold Hundreds of Maimed Soldiers with Ghastly Facial Disfigurements, Many of Them Far More Awful than This One of a German Fighter Whose Rehabilitated Jaw is Being Fitted with New Teeth

In London, for instance, at one institution attention is directed to wounds of the jaw. Soldiers whose injuries involve the eyes, ears, nose, or throat are received at special hospitals. Those with maimed limbs are taken elsewhere, and so on.

Methods of transporting the wounded from field to hospital and administering to them while en route are now so well developed—except in the Alpine regions—that the surgeons often have opportunity to work on their patients

while the wounds are still fresh and free from infection. Both medical and surgical men today are far better equipped





The Home-Coming, Another Common Picture: These German and Austrian Soldiers, All so Badly Maimed as to Make Further Military Service Impossible, have been Exchanged by the British, through the Courtesy of the Swedish Government, for Wounded "Tommys" Imprisoned by the Enemy

in every way than members of their professions ever were before. The X-ray, photography, electricity, new antiseptics and anesthetics, and greater understanding and skill are at their disposal. These are some of the many reasons why the wounded are getting excellent care and the surgeons are enabled to perform veritable marvels.

Every conceivable kind of ailment and injury is being confronted. But

contrary to the popular impression, war, while creating multitudes of monsters and causing the art of surgery to

make great strides of advancement, develops few, if any, new maladies. It does, however, make very common some diseases which normally are rare, and moreover it aggravates those that are usual. Much attention, for instance, has been attracted to the large number of soldiers killed and disabled



It Isn't Necessary to Serve in the Trenches to Become One of War's Great Army of Maimed. The Little Fellow in the Middle of the Picture, a Serbian, Was an "Innocent Bystander" Who Suffered from a Bursting Shell, Fell into the Enemy's Hands, and Became a Prisoner of War





COPYRIGHT, UNDERWOOD & UNDERWOOD

Off to Meet Their Daddies: A Joyful, Eager Procession of French Children being Escorted to a Railway Station. The Fathers, However, Are Not the Same Men Who Months Before Went Away to Fight. They are Hopelessly Crippled Men Who are being Returned through Switzerland from German Prison Camps

without outward manifestations of injury. Cases of this kind are generally due to what has come to be termed "shell shock,"

the concussion resulting from the bursting of high-explosive projectiles of big caliber. Deaths, brain afflictions, internal disorders, and the injury of certain organisms such as those of sight, hearing, and speech, are frequently brought about in this way. The condition is not a new

one, neither is it peculiar to war, but it has become extraordinarily common.

Soldiers affected in this manner re-

quire the constant attention of specialists. They go insane, become partly paralyzed, lose their memories, grow unable to give or execute orders, and suffer general breakdown. For the less aggravated cases, complete rest away from the front often suffices as treatment.



COPYRIGHT, MEDEM PHOTO SERVICE

Home from the Front: This Father cannot See His Children, but He Has Lots of Time to Spend with Them, for He Is Blind and Jobless. He is Reciting the Thrilling Story of the Encounter in Which He Lost His Eyesight



Change of surroundings and freedom from noise and excitement bring about a gradual readjustment of the nervous

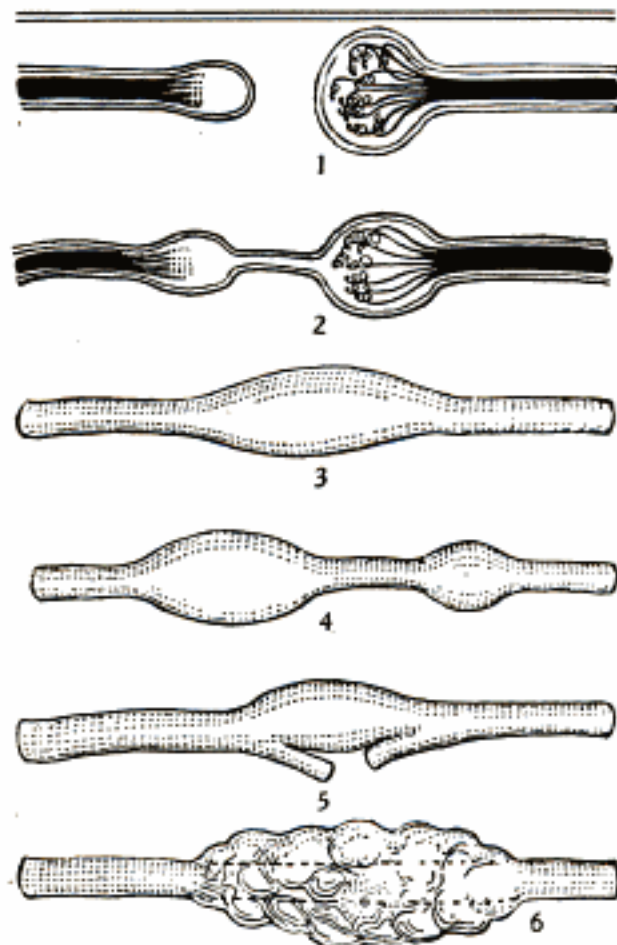

Ruptured Nerves: 1. A Nerve Entirely Severed; 2. Seemingly Connected, but Nonfunctioning; 3. Swollen by Concussion and Partly Impaired; 4. Same as 3; 5. Partly Severed Nerve Causing Partial Paralysis; 6. Bruised Sheath Responsible for Partial Disablement

system and sometimes enable a soldier to return to the trenches after a short leave. Not always so fortunate, however, are those whose nervous organisms are naturally weak. Years may be required and expert surgical treatment needed before balance can be restored. Autopsies performed on men who have been killed outright by shell shock have uncovered serious internal lesions, organic changes, ruptured blood vessels, and hemorrhages of the brain. Injuries about the spinal cord and the nerve centers are found in those who have lost their sanity. Coming from the trenches in an almost unbroken stream are men of lost personalities, men whose memories are completely blank, men who can write

but not speak, men who are stone-deaf, men in a stupor, men who resemble sickening imbeciles, and others who are childish. Not all of them are successfully reclaimed, and eventually many of them may grow ravingly insane, but hundreds upon hundreds of them are being benefited through surgical attention and special treatments given under the supervision of famed neurologists.

To be distinguished from shell-shock afflictions are the cases in which nerves have been severed or damaged by bullets or shrapnel. Injuries of this nature not only impair the brain in ways similar to those cited above, but also cause radial paralysis. Recovery of the patients depends upon the repair of the nerve itself. And in doing this the war surgeons are accomplishing some of their best work, for they are making strong, normal men out of many of those who otherwise would be either totally or in part helpless throughout the remainder of their lives. The tremendous number of cases of damaged nerve tissues has been responsible for the discovery of improved methods of repair which are proving to be of great importance.

A Berlin professor is the originator of a new way of mending nerves which has been found highly valuable. The operation consists in removing a section of an artery from some animal, filling it with embryonal nerve tissue, and employing it as a casing into which the disconnected nerve ends are inserted.

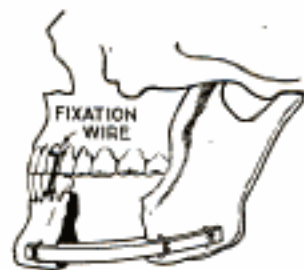

One of the Ways in Which Shattered Jaws are Repaired. The Inserted Bone was Removed from the Patient's Shin and Fitted into Grooves Cut for It

When this is done the members reunite with surprising rapidity, it has been found, and the previously paralyzed muscle or muscles again function. In one instance which serves as a particularly astonishing example, nearly two and a half inches of the ulnar nerve, which passes down the inner side of the arm and



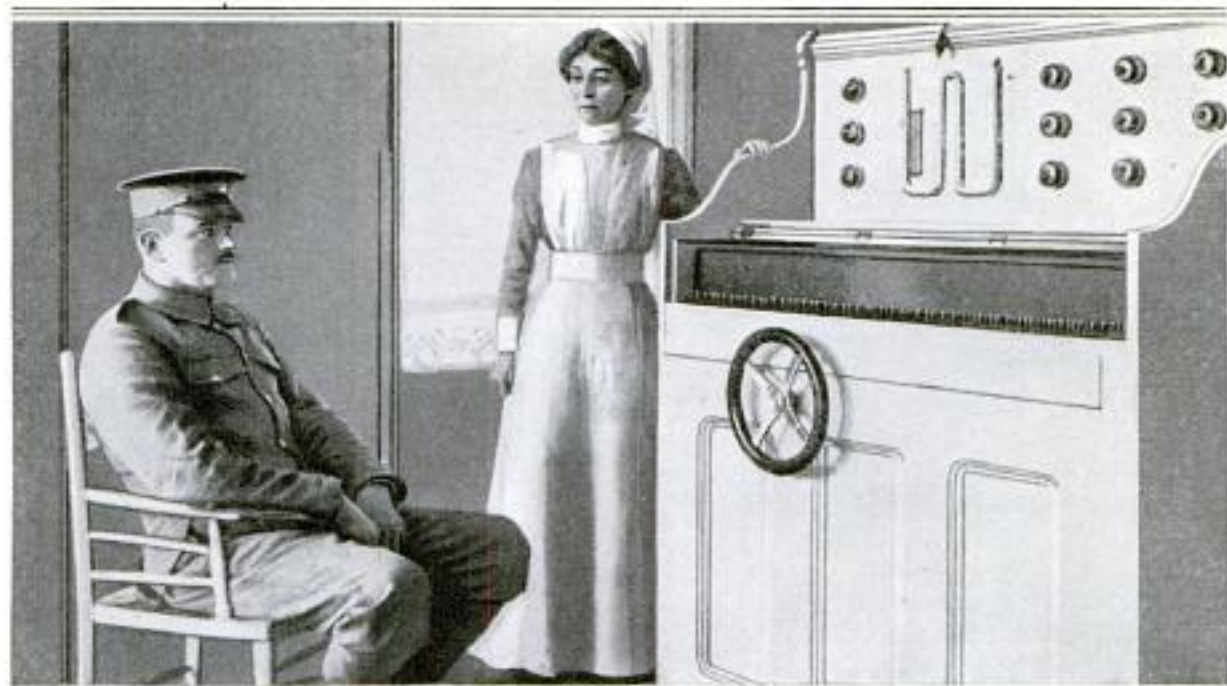

Shell-Deafened Soldiers are Cared For in a Special Military Hospital at London Where Various Devices have been Made for Restoring Lost Hearing. Here a Machine Which Produces Sound and Electric Waves of Different Lengths is being Employed in the Treatment of a Patient

forearm, had been excised. Function was restored to the muscles within a few weeks after the operation had been performed.

Another German authority reports many cases in which he has successfully mended severed nerves by a lately devised method of suture. The process is especially noteworthy because it enables the nerve ends to be reunited without tension or hemorrhage, regardless of the distance between them.

Most of us during recent years have watched with admiration the strides made by some of our specialists in plastic surgery. We have read of, and some of us seen, how malformed noses have been reshaped, deformed mouths made almost normal, and deep scars partly eradicated. Wonders far greater than any of these are now being

wrought almost daily in the hospitals of Europe, where whole faces are being reconstructed from the most heart-sickening masses of shredded flesh and pulverized bone. Engaged in this wonderful work are the most renowned orthodontists and dentists of the world, some of them Americans. Famed sculptors are also supervising the work in hospitals devoted to prostheses for hideous disfigurements of the face. The College of Sculpture, at Charlottenburg, near Berlin, is now a hospital in which the rebuilding of human faces is accomplished. After nature has been made to do all it can, the repairing is completed by transplanting bone taken from another part of the body, flesh from the abdomen, and skin usually from an arm. When it comes to providing teeth and a



Soft Rubber Castings are Made to Fill the Malformed Cavities When a Soldier's Eyes are Torn Out by a Shell. They Back the Hard Artificial Fronts and Form Elastic Contact with the Lids and the Bottom Parts of the Sockets



palate for the mouth, dentists usually take charge of the work.

An English ophthalmic surgeon has attained splendid results in using celluloid as a material for filling cavities, leveling depressed scars, and making up for the loss of bone. He has employed it both in solid and liquid form in many operations, and has had striking success in using it to replace bone

when building up new noses. By placing plates of celluloid beneath them, he has been able to flatten deeply shrunken scars and in some cases has almost obliterated them. Of late, however, for work of this kind he has used the fluid preparation chiefly. In constructing new noses, the celluloid plates are used to form bridges. The arch thus provided is covered with whatever flesh of the original nose remains intact and by a wedge-shaped flap cut from the forehead. The latter is always left attached by a pedicle and turned down. Slits are cut along the outer sides of the wound to receive the edges of the plate so that they will not cut through the parts sewed together. The fluid preparation is celluloid dissolved in acetone. This is injected by a syringe through a tunnel cut from the edge of the normal skin to a point beneath the scar. When the latter rises above the adjacent surface, the syringe is withdrawn, the place smoothed, and the wound covered with collodion.

Lesions of the jaw are particularly common in the present war. Frequently the lower member is entirely shot away, making it necessary to supply an artificial one made of metal. When only a section is missing, however, repair is possible. One way of doing this is to cut grooves across the

parts that remain and bridge the gap by inserting a piece of bone taken from the shin. The latter is shaped to fit the gutter provided for it and is tied in place. Until these mortised bones have had time to unite, the upper and lower jaws must be fastened rigidly together to prevent them from being moved. Flesh and skin are placed over the bone, the inside of the mouth built up, and artificial teeth ultimately supplied.

Francis Derwent Wood, the well-known sculptor, has supervision of the work that is being done in a London hospital devoted to prosthesis, or the supplying of artificial members or parts, for facial disfigurements. He and his staff devise ways of hiding the scars and gaping holes that have not, for one reason or another, been made sightly by the surgeons. When noses, cheeks, eyes, and lips are missing, he fashions a copper mask to cover exactly the disfigured portions of a face. Shields of this kind are plated with silver and then tinted so artfully that they have actual flesh color. An interesting phase of this work is that the masks are not stereotyped in form, as one might suspect. By

means of photographs taken of the patient previous to his being wounded, one of these devices is made almost to duplicate the missing parts so that a man whose face is half metal may nevertheless have the same general appearance he possessed originally. Spectacles especially designed for the purpose are generally employed to hold the covering in place.

Plastic surgery is accomplishing much more for the maimed in war than is even hinted at here, but no more than other branches of surgery. The



COPYRIGHT, INTERNATIONAL FILM SERVICE

The First Step: A Young Soldier Learning to Use Substitutes for Legs





Baths and Massage Treatments are Extensively Used in German Military Hospitals. Wounded Soldiers are Pictured Here Taking Electric Baths in One of the Berlin Hospitals



Wounded French Fighter Equipped with a Bracket Brace Designed to Hold a Fractured Arm in the Most Advantageous Position for Mending

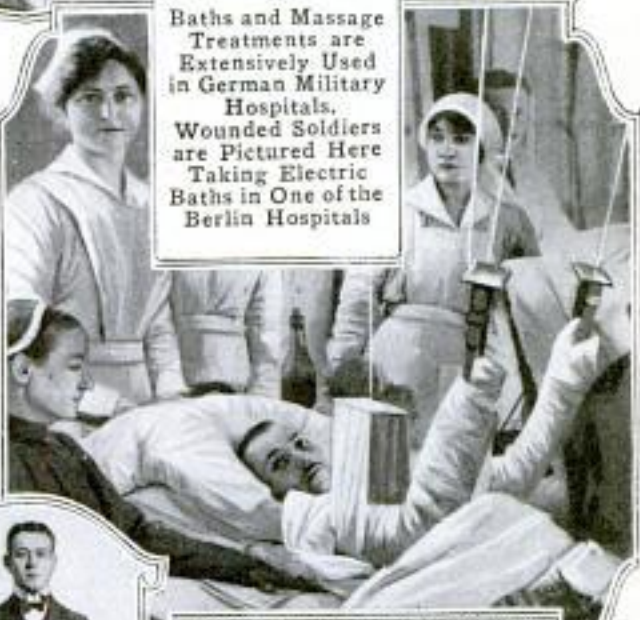

Slings Devised in an American Hospital in France for Supporting the Shell-Mangled Arms of a Soldier Who Also is Suffering with General Paralysis. Due, No Doubt, to Severed Nerves

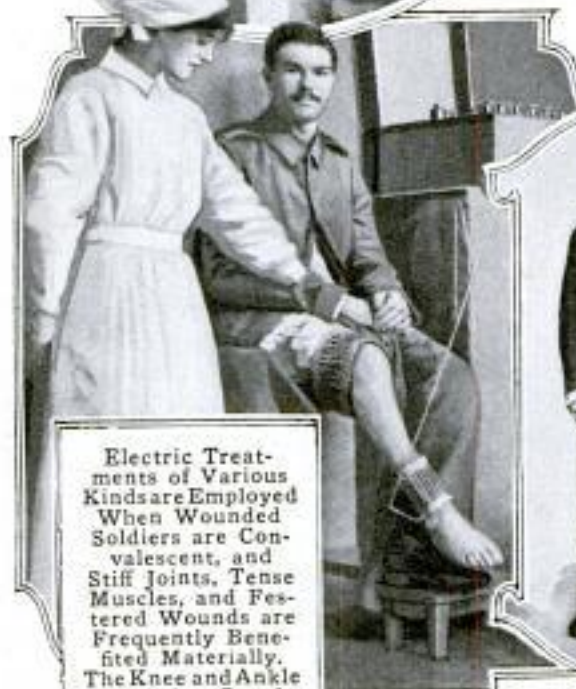

Electric Treatments of Various Kinds are Employed When Wounded Soldiers are Convalescent, and Stiff Joints, Tense Muscles, and Festered Wounds are Frequently Benefited Materially. The Knee and Ankle are being Cared for Here



Weighing a Pound and Three-Quarters, This Pressed-Paper Limb is 10 Pounds Lighter than the Wooden One It Replaces



Spring Harness Fitted to Frozen Hands of French Soldier. The Apparatus Also Renders Paralyzed Hands Useful



An Apparatus Used in Military Hospitals of France to Enable Patients to Exercise Their Frostbitten Feet Consists of a Sling, Rope, Pulley, and Weight



lives of whole armies of men are being preserved, even though parts of their bodies die. Fewer amputations, it is interesting to observe, are being made, in proportion to the number of cases brought before the surgeons, than one would dream were possible. Of some 3,000 operations performed at one of the large military hospitals in London, primary amputations have been carried out only in 25 instances. It is becoming universally recognized that a stiff, crippled limb is almost always better than any artificial apparatus that could be made to replace it. Therefore, as a general rule, amputations are now made almost exclusively for the purpose of saving life.

In all of the warring countries much attention is being directed to physical therapy. Massage, electric treatments, passive exercises, hydrotherapy, and mechanotherapy include some of the many systems of treatment that are being followed. Special institutions for administering to the wounded in these ways have been established, while at convalescent homes and general field and base hospitals elaborate apparatus is usually installed. Machines for exercising different parts of the body, loosening stiffened joints, and strengthening weakened muscles and limbs are employed extensively. Many of them are highly ingenious contrivances of fairly new character. Most interesting in this connection are the artificial sun baths that are being used, especially in Germany. A quartz lamp that gives off medically valuable rays is one of the recent inventions that seems to be of real importance. It is intended to flood a patient with light which is comparable to mountain sunlight, bathing the body with the rays that are ordinarily absorbed by the thick atmosphere characteristic of all cities. An electric arc producing a cold bluish light is employed in combination with lamps that radiate warmth. Extensive wounds, even of grave nature, respond quickly to the light treatment and are said to heal with surprising quickness.

One of the final steps in the recon-

struction of the maimed soldiers consists in fitting artificial members to those who have lost arms, legs, or some other part of the body. Remarkable progress has been made during the past year or more and now mechanical hands and feet that function in an astonishingly lifelike way, instead of merely hiding deformities, are produced. A special hospital is operated at Roehampton where the latest devices of this kind are provided. The same arrangement obtains elsewhere, and soldiers who have given up an arm or leg while fighting are supplied with the most ingenious substitutes that inventive skill can develop. Then come the finishing touches, the final adjustment of the rebuilt soldier before he is discharged from the hospital. Engaged in this peculiar work are many resourceful men and women who strive to accomplish the little things that have either been left undone through oversight or lack of ingenuity on the part of some one.

But wonderful as is the work of the war surgeons, consider the result. A man, possibly of middle age, a machinist, a bank clerk, or a stenographer, has been rebuilt; that is, his life has been preserved and his missing parts replaced with artificial ones. His country can no longer use him, and he has given it the tools with which he formerly supported himself and possibly a family. He has not yet learned to use cleverly his new arms and legs; he has no idea how he can make a living. Shall he commit suicide, now that he is unwatched by hospital attendants, or shall he turn beggar or crook?

Two years ago these were questions which the individual might decide for himself. Not so today, however. Europe has awakened, and for the first time in history the maimed soldier is commencing to get a fair deal.

How the warring nations are obliterating the stigma that has always been cast upon cripples, and are reeducating these men so that they may fill useful and even important niches in civil life, is the absorbing topic next to be considered.



Great Northern Pacific S. S. Co.  
 Pittsboro Bldg Portland, Oregon  
 Call Bldg, San Francisco.  
 POPULAR MECHANICS 25  
 S. S. "Great Northern" & "Northern Pacific"

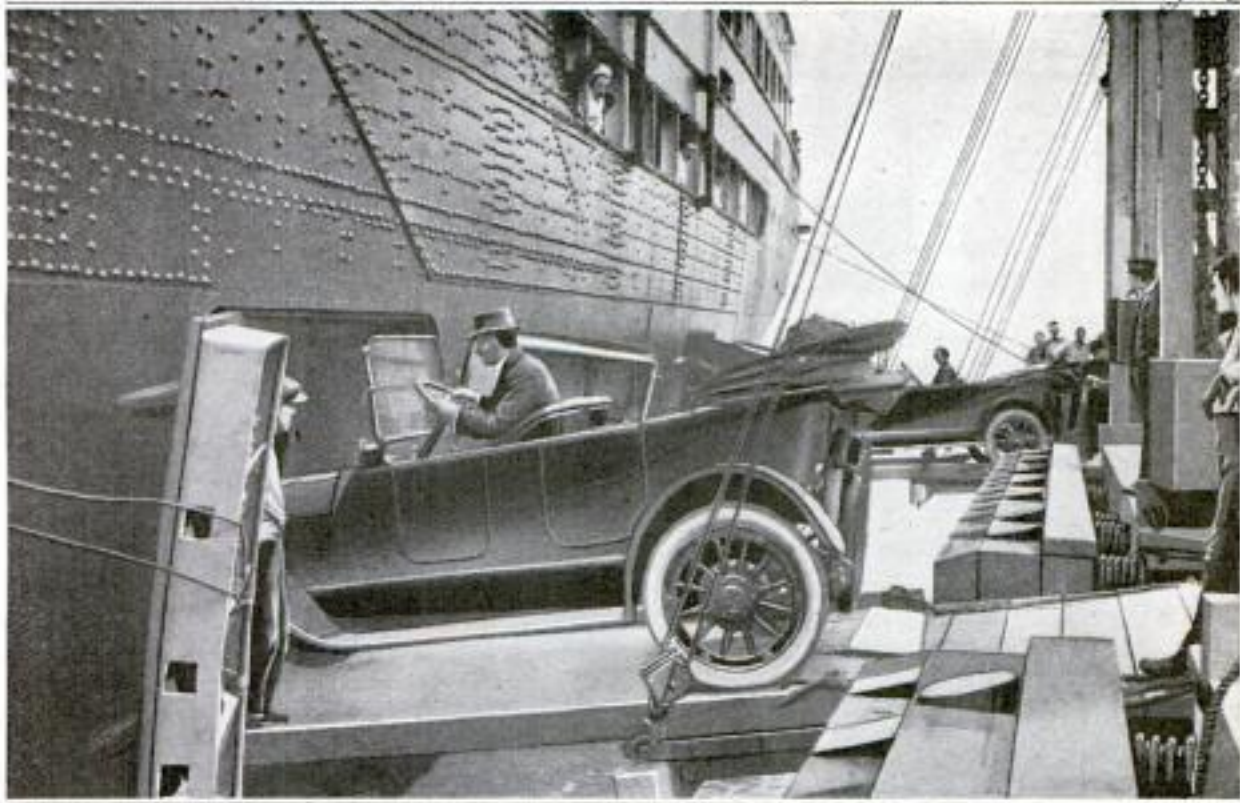

328- Cars are Driven into the Ship's Garage through the Gangways and Stowed for the Voyage 2902

### PACIFIC LINERS EQUIPPED WITH MOTOR-CAR GARAGES

One of the trans-Pacific steamship companies, which handles a large volume of the Hawaiian and Oriental tourist business, has fitted its liners with garages for the accommodation of motor cars owned by passengers. The compartments are so situated that ready access to them is afforded by the gangways. This permits a car to be driven directly from a dock into the hold of one of the vessels and stowed away for the voyage. Space for about 40 machines is afforded in one of these garages. The provision is more or less an innovation and has been brought about by the increasing practice among tourists to have their motors accompany them on their travels. In the past it has been a common practice to crate the machines and lower them through a hatch into a ship's hold from the deck. In addition to being an inconvenient and more expensive arrangement, the scheme occasionally proved hard on the cars, fenders being smashed and enamel marred.

### NEST MADE ON BIRD-HOUSE ROOF AND ELECTRIC WIRE

The placing of a bark-covered bird house over the entrance to a busy carpenter shop in Nashua, Ia., last summer caused a robin to build its nest in an unusual place. Instead of making its home in the shelter provided, as might have been expected, the bird chose to build just above the house, so that part of the nest rested on the little roof and part on a large electric wire which was close by. Here eggs were laid and hatched. The bird seemed undisturbed by the passers-by.



#Tells Bobolink  
 Charles City, Ia.

CA captain in the United States Navy has made a proposal for the building of a 600-ft. battleship which would be semisubmersible.



3158

Rowleship

**HALF OF A GREAT BROADSIDE**  
**A** DECIDEDLY peaceful view on the deck of the "Pennsylvania," showing six of the twelve 14-in. guns composing the dreadnaught's great broadside. The caliber of these rifles is exceeded by those on some of the newest vessels of England and Germany, which are equipped with 15-in. guns, but because of the fact that this ship and its sister ship, the "Arizona," each possesses 12 of these powerful guns these two dreadnaughts rank among the most powerful of all fighting machines afloat in respect to their broadside.

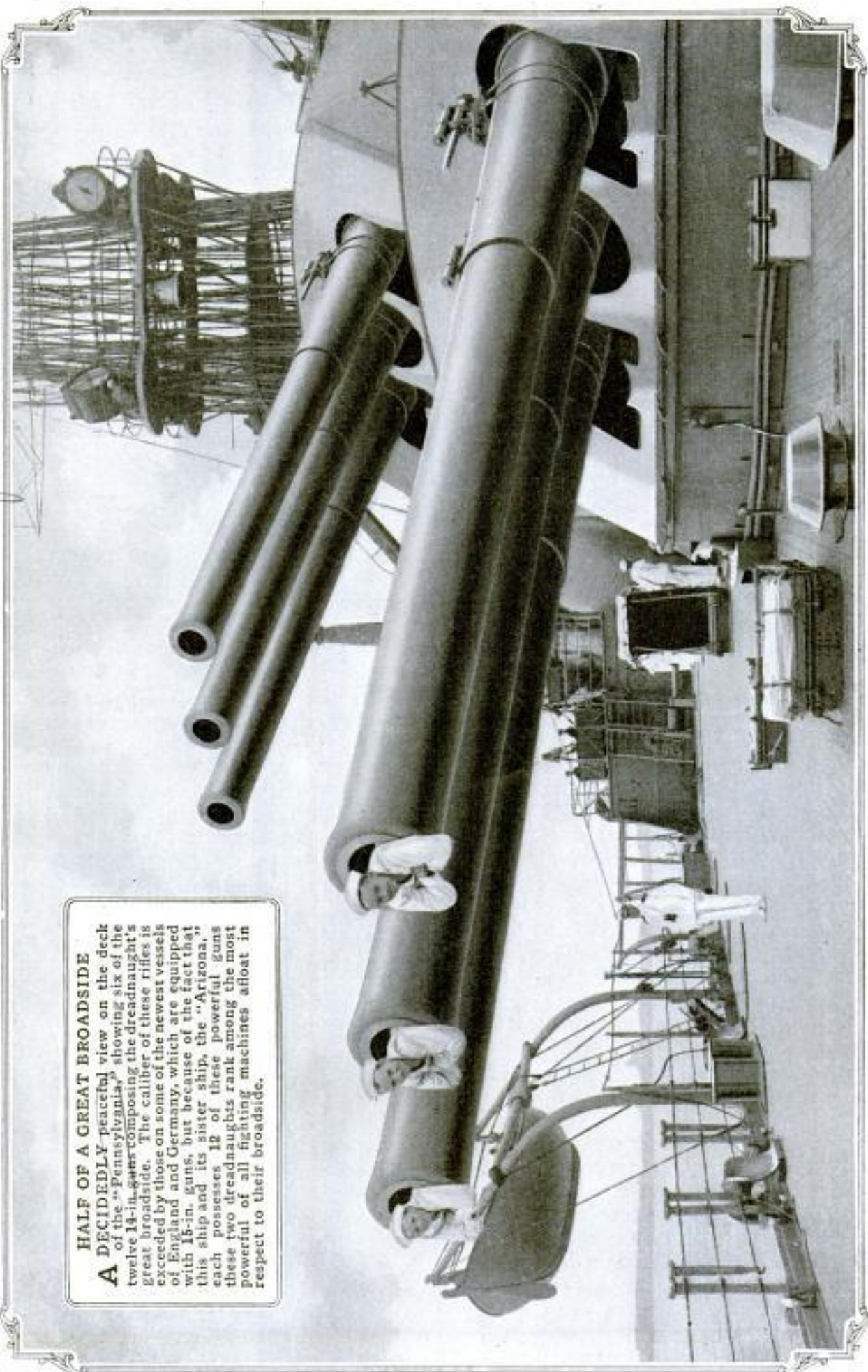

COPYRIGHT, E. MULLER, JR.

114 Fulton St. N. Y. C.



Dr. Lee De Forest, 1391 Sedgewick St N.Y.C.  
 Forest Radio Telephone & Telegraph Co.  
 1391 Sedgewick St New York.  
 2996

**TINY WIRELESS RECEIVER  
 IS LATE INVENTION**

One of the very well-known American pioneers in radio development has lately invented a tiny wireless receiver which makes it possible for a man in the streets to pick up messages sent out from any station in the immediate vicinity. The device has the appearance of a fountain pen and is of about the size of one. Its interior arrangement is remarkably compact and ingenious. At one end are a magnetic coil and diaphragm connected with three diminutive batteries. Back of these the antenna and ground wires project through opposite sides of the tubing at the middle. Near the antenna post is a filament switch. The rear end of the casing is occupied by a stopping condenser, tuning coil, and miniature audion amplifier, upon which the success of the instrument depends. In use, the

antenna wire is extended down a coat sleeve and through a cane to its ferrule. The ground wire passes down a trouser leg and is connected with a metal plate attached to the heel of one shoe. By pressing the diaphragm

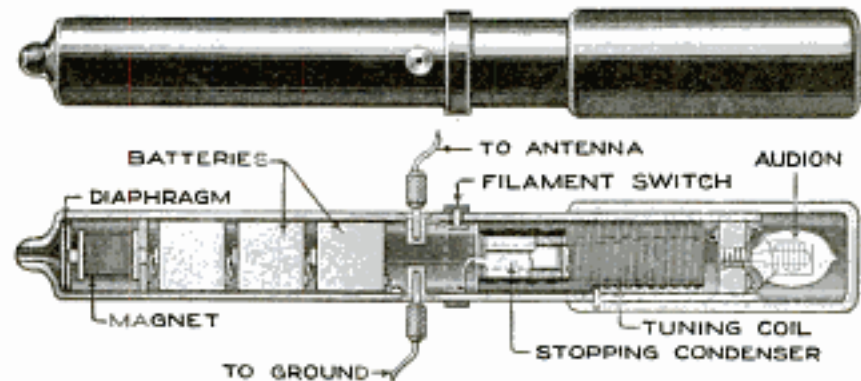

Having the Size and Appearance of a Large Fountain Pen, This Is in Reality a Miniature Radio Receiver

end of the instrument into one ear, holding the cane antenna at arm's length into the air, and standing with the heel plate against a fire plug or some other metal object which will provide a good ground, messages can be picked up without difficulty. A ring encircling the tube offers a means of adjusting the tuning coil to receive vibrations of various lengths.

3061

**DIKES ON NEW CONCRETE  
 PAVEMENT SAVE WATER**

The accompanying illustration shows a variation from the common practice followed in flooding a concrete pave-



By Making Double Dikes near the Edges of This Newly Laid Concrete Pavement, Less Water was Required to Cover the Curved Surface than if a Single Dike had been Made

ment with water so that it will set and dry properly. The usual method is to throw up a single barrier or dike of earth around each square and then flood it with enough water to cover even the highest portion. Since the center of the pavement is usually some inches higher than the sides, this requires a good deal of water. In irrigated regions where water is scarce, the plan has been followed of making two parallel dikes near each edge of the pavement. In this way less water is needed to cover the crown of the roadway.

A stray dog in Mt. Carmel, Pa., which has assumed the task of voluntarily watching certain mail bags while the carrier is absent, has been awarded a suitably inscribed collar by the postmaster general.

F. R. Ritchie & Co.,  
 Chronicle Bldg.,  
 San Francisco.



## BIG BUOY A SUBSTITUTE FOR LIFEBOATS

A life buoy capable of sheltering 40 persons has been on exhibition recently in the Willamette River at Portland, Ore. It is intended as a substitute for

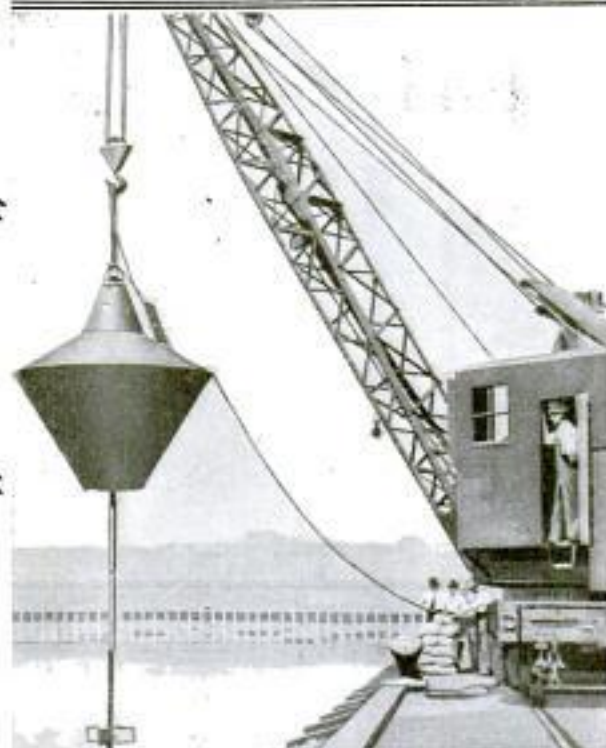

Below: Steel Top-Shaped Buoy Which can Shelter 40 Persons and Also Enough Provisions to Supply Them Several Days. Above: View of the Life Buoy, Showing Anchor That Serves as a Ballast and Is a Means of Keeping the Buoy Upright in the Roughest Sea

a lifeboat, and its inventor claims that it is unsinkable, noncollapsible, and will ride upright in the roughest sea. The device is made entirely of steel

and resembles a huge top. Entrance is gained through a trapdoor which is water-tight when closed. The buoy is intended to be kept on a vessel's deck and if in time of danger there is no opportunity to launch it, passengers need only get inside and wait for it to take the water as the boat sinks. The upper portion is fitted with windows and serves as a conning tower, where lights or other distress signals can be displayed. A storage battery supplies current for lights and for a ventilating fan that periodically expels air through a vent in the tower. The vent can be regulated by a person acting as a lookout. Circular tiers of seats are provided for the occupants. There is also space for storing water and provisions enough to last a week or ten days. The anchor consists of three heavy pipes which telescope one within the other and can be drawn up by a winch. The lower end of the anchor is filled with cement for ballast. The buoy weighs 2,000 pounds.

3339

## FLIES AVOID ROOMS WITH BLUE-GLASS WINDOWS

ENGINEERING 9-29-16

That flies will avoid a room which is lighted with windows of certain colors is the conclusion recently reached by two English experimenters. A room was fitted with blue-glass windows, having horizontal axes, and it was found that when they were placed obliquely so that the light inside looked blue from the outside, hardly any flies entered the room. On the other hand, when the windows were of white, yellow, or orange hue, the flies entered in large numbers and seemed at ease. The conclusion drawn from these and similar experiments was that white, yellow, and orange rays are light to the fly while the other colors, particularly blue, are dark to it. If further investigation should confirm these conclusions, it is possible that louvers of light-blue glass could be provided for workshops, stores, and even hospitals, where abundant ventilation is desirable, and so make screens unnecessary.

C. Galaine  
C. Houlbert

Comptes Rendus  
7-31-16

U. S. Under & Over Seas Life Buoy Co.  
Portland, Oregon  
" "  
Inv. R. A. Wrench

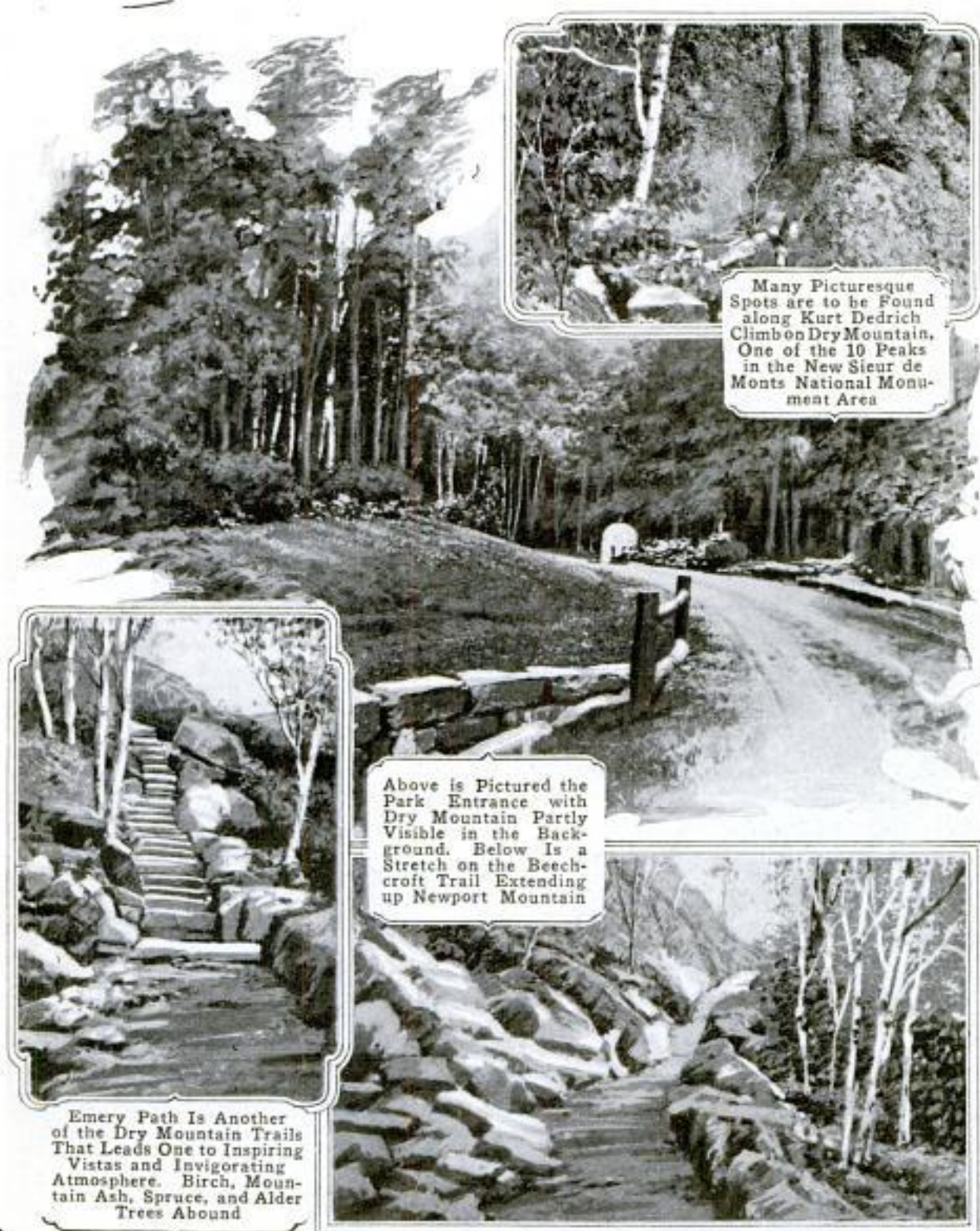

NEW NATIONAL PARK OPENED TO PUBLIC IN MAINE

Many Picturesque Spots are to be Found along Kurt Dedrich Climb on Dry Mountain. One of the 10 Peaks in the New Sieur de Monts National Monument Area

Above is Pictured the Park Entrance with Dry Mountain Partly Visible in the Background. Below Is a Stretch on the Beechcroft Trail Extending up Newport Mountain

Emery Path Is Another of the Dry Mountain Trails That Leads One to Inspiring Vistas and Invigorating Atmosphere. Birch, Mountain Ash, Spruce, and Alder Trees Abound

More than 5,000 acres of land on Mount Desert Island, Maine, south of Bar Harbor, comprise the Sieur de Monts National Monument, which was created in July of last year by presidential proclamation. Ten mountains

and four beautiful lakes are included in the reservation, which is not only of historical interest but also of much scenic splendor. The area forming this new national playground has been turned over to the government for the



benefit of the public by the owners, who style themselves the Hancock County Trustees of Public Reservations. The island itself was discovered and named by Samuel de Champlain in 1604 and more than 80 years later granted by Louis XIV to Sieur de la Mothe Cadillac. The plans for the development of the park area include the construction of some 300 miles of motor roads and foot trails to the summits of the mountains and to the several lakes. A biological laboratory, a botanical garden of trees, and a herbarium are to be established, an old beaver pond restocked, and other undertakings of a similar nature carried out. So far, through public subscription, several trails have been established on Dry and Newport mountains and named in memory of well-known families. The entrance to the park is within the village limits of Bar Harbor, while the borders touch Northeast Harbor, Southwest Harbor, and Seal Harbor.

## TWO-MILE SPEEDWAY TO BE ILLUMINATED AT NIGHT

The two-mile Sheepshead Bay automobile speedway, near New York City, together with its 160-acre infield, are to be artificially illuminated by 370 powerful electric lights, making it perhaps the largest area in the world lighted in this way for amusement purposes. Arrangements are being made to hold races and other events here at night. On 30-ft. poles, set around the whole of the course, will be 224 of these lamps, which are of the gas-filled type, equipped with reflectors that can be manipulated so that they will illuminate the whole field with light estimated to be 50 times as bright as moonlight, or their rays can be concentrated on the track in such a way that the racers will not see the bulbs. Extra-bright illumination will be supplied in front of the grandstand by 114 lamps, set in the upper part of that structure. There will be 32 extra lamps over the repair pits also. National Guard maneuvers at night and 24-hour races are among the events planned for the course. A large attendance is anticipated.



View of the Grandstand at Night Exposed Long Enough to Show the Location of the Lights



Grandstand of Sheepshead Bay Speedway in the Daytime, Showing Lights Located along Upper Bank of Seats



Remarkable Lighting Effect Produced by a Number of the Lights Turned on the Infield of the Speedway

General Electric Co.  
Schenectady, N. Y.



Owner of boat

Carl Rishoff

POPULAR MECHANICS

Grand Av. & 13th St., Los Angeles

31

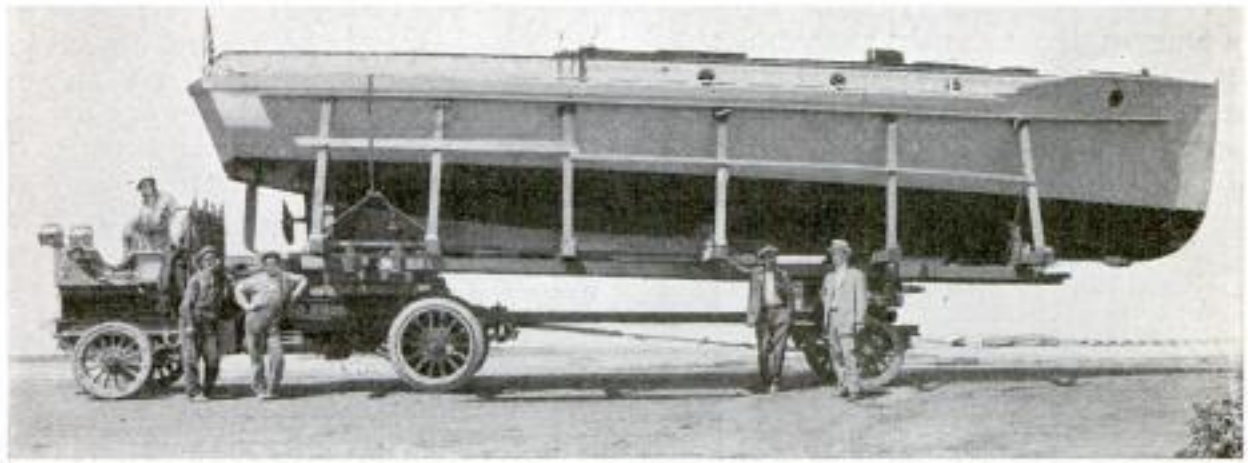

Held Upright in a Large Cradle and Carried on a Motor-Truck Trailer, This Bulky 11-Ton Fishing Boat was Taken across Country from Los Angeles to the Ocean

3310

### MOTOR TRUCK AND TRAILER TRANSPORT HEAVY BOAT

With a motor truck and trailer the problem of transporting a 42-ft. fishing boat, weighing 11 tons, from a point near Los Angeles, where it had been constructed, overland to Long Beach, where it was to be used, was worked out satisfactorily and without difficulty. For six months the craft lay on the ways waiting for the evolution of a feasible plan of moving it to the seashore. Then a special trailer was constructed, a big cradle built to hold the vessel steadily, and the trip made without accident.

3160

### INGENIOUS METHOD USED TO ENLARGE DWELLING

A simple and ingenious method was employed by carpenters in Great Neck, N. Y., to enlarge one of the rooms in a dwelling house in that place. After laying the floor beams of the new portion of the room they sawed off the end of the wing to be altered. When it had been completely severed it was held in position by a rope which was fastened to the attic-window casement and the chimney of the attic. The rope was slowly payed out until the wall leaned about 15°. Then crowbars were used to pry the bottom along on string pieces that had been coated with

soft soap, until the partition was again in a vertical position. Braces were so placed that they prevented the wall from falling back against the building. These steps were repeated until the partition had been brought out to its final position. Then the space between it and the rest of the building was inclosed.



Wing of a House Which was Enlarged by Cutting Off the End and Moving It Out on String Pieces with a Rope and Crowbars, After Which the Intervening Space was Walled In

Owner Fred Hornung, Great Neck, N. Y.

Copyrighted material

Copyrighted material



1179,090 *Apr 11-1916 - filed 11/6/15 - Ser. 59902*  
1 NV. *Gay V.225-594*  
*Niel Gray, Jr., Oswego, N. Y.*

32 3096 *2962* POPULAR MECHANICS

**DEVICE CARRIES BAGGAGE  
OVER AUTOMOBILE HOOD**

One of the recently patented automobile accessories is a baggage carrier which can be attached over the hood

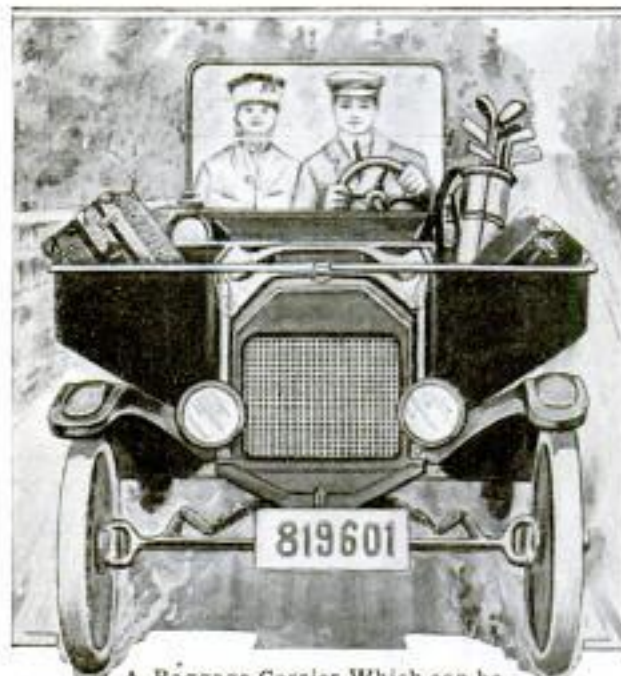

A Baggage Carrier Which can be Attached above the Hood of an Automobile and so Makes It Unnecessary to Occupy Space in the Tonneau with Suitcases or Other Luggage

of a car. It is suitable for transporting suitcases, bundles, or a camping outfit, and, of course, leaves just that much more room in the tonneau. The carrier is composed of two pockets which are supported above the hood, so that they do not touch it, by a horizontal framework that is connected with the dash by brackets. It is also supported by posts fastened to the chassis frame.

A Road Grader Having a Rotary Conveyor Which Receives the Dirt Dug Up by the Plow and Deposits It on the Opposite Side of the Machine

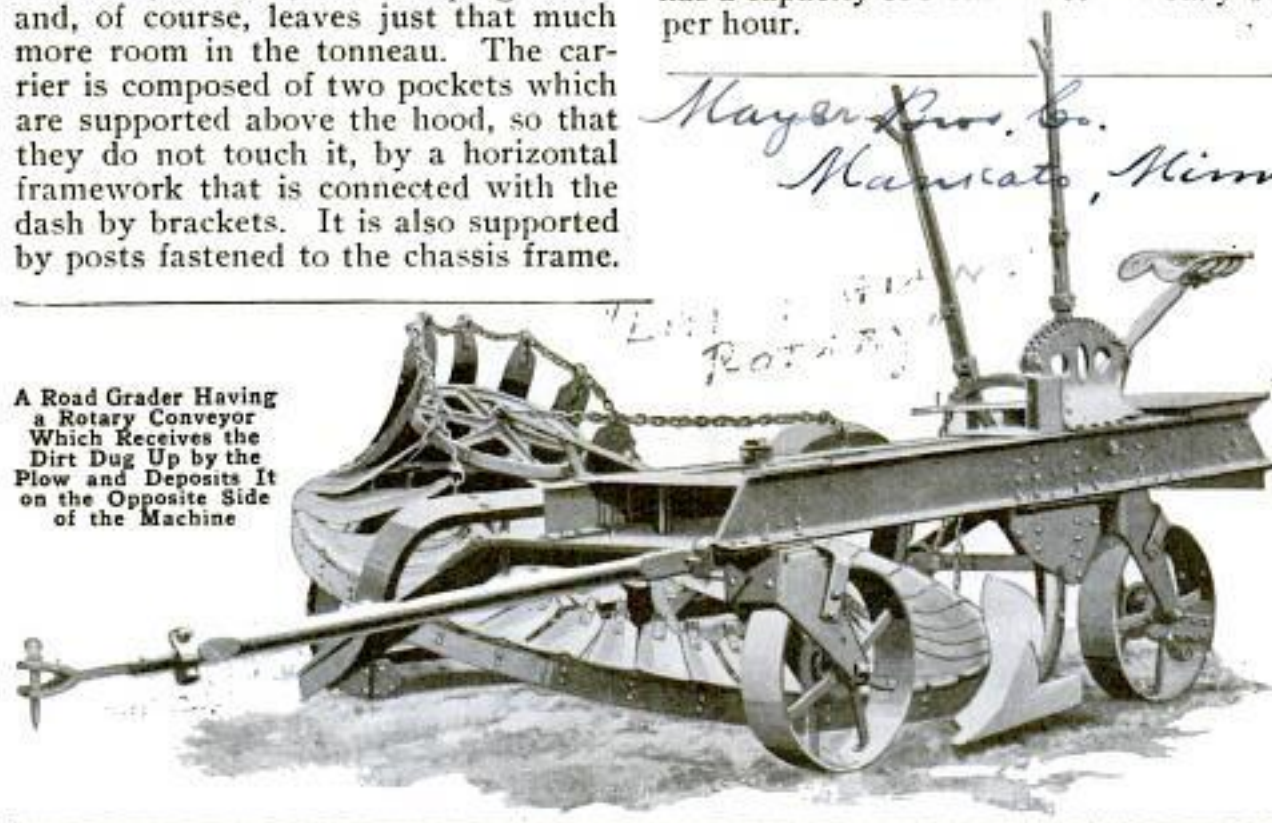

**ROAD GRADER DESIGNED  
ON NEW LINES**

New ideas in construction have been incorporated in a road grader now on the market, for which it is claimed that it does much more work than graders of the blade type. Under one side of the frame is a plow which can be raised or lowered by the driver. As the plow is drawn through the soil it discharges dirt onto a circular carrier, or platform, which lies almost level with the ground and is rotated by friction with the ground on the plow side, and by the rim of a supporting wheel on the other side. The revolving carrier is made in sections, and as the dirt is carried to the opposite side of the grader, these sections are tilted up on end and the dirt drops off onto the ground. In this way the machine can be used to round off the crown of a highway by running the plow in the ditch and depositing the dirt higher up in the center of the road. The dirt can be dropped any desired distance from the plow within a range of from 5 to 10 ft. The machine can be used for making roads up to 30 ft. in width. It has a capacity of from 200 to 300 cu. yd. per hour.





DARING BIRDMAN AND HIS FEATHERED FRIENDS

A MELANCHOLY interest attaches to this photograph of birds of a feather flocking together—an aeroplane and its owner at the Exposition Grounds, San Diego, Calif., surrounded by a flock of pigeons that seem to recognize the birdman as a kindred spirit. The picture was taken just before the last successful flight of Joe Boquel, a skillful but reckless airman who fell to his death on his next attempted flight at San Diego, November fourth.

3199

## WEARING AWAY OF COINS

## DUE TO PERSPIRATION

*La Nature 7/8/16 (ex Nature)*

According to an investigation recently made by a British official the chief cause for the wearing away of coins is not the mechanical rubbing due to long-continued use, but is produced by the fatty acids contained in the perspiration, conveyed to coins by the fingers of the persons handling them. These acids slowly corrode the baser metals, particularly copper, with which the precious metal of the money pieces are alloyed. The corrosion, according to this authority, gives the coins a pitted or spongy surface which easily rubs off, exposing new portions of alloy.

3327

BOAT LADDER FOR RESCUE  
OF THE DROWNING

A recent German invention enables men in a boat to take a drowning person from the water without leaving their seats or otherwise disturbing the balance of the boat, this being a decided

advantage in any kind of a sea. A framework resembling a ladder is floated overboard, attached to a rope. The person in danger of drowning is pulled near it and placed on it backward, floating safely until the ladder with its load is pulled into the boat by



Taking a Drowning Person from the Water with a Rescue Ladder, Easily Hoisted by Its Towline and Pulleys

means of the towline and an arrangement of small pulleys attached to the gunwale.

INV: Herr Otto Schuchmacher  
Cuxhaven, Germany



INVENTOR MFR. B.F. Leavitt  
 Leavitt Diving Armor Co. Toledo, O.  
 34 3376 POPULAR MECHANICS, Brooklyn, N.Y.  
 \$25/10 now info by Leavitt Deep Sea Salvage Co. Temple Bar Annex, Brooklyn, N.Y.

## DIVER BREAKS RECORD IN DEEP-SEA ARMOR

A new deep-sea diving record was set recently by a resident of Toledo, Ohio, who descended to a depth of 361 ft. in Grand Traverse Bay in a newly patented diving armor of his own in-

face. A telephone apparatus in the helmet keeps the diver in constant communication with the surface. During the test in Grand Traverse Bay the inventor talked freely from the bottom with the members of his party on a steamer overhead, and stated that he suffered no inconvenience. It required only three minutes to lower him to the depth of 361 ft. and five minutes to raise him. With this armor, it is claimed, a diver can remain submerged for four hours at a time. It weighs 125 lb. and the shoes 16 pounds.

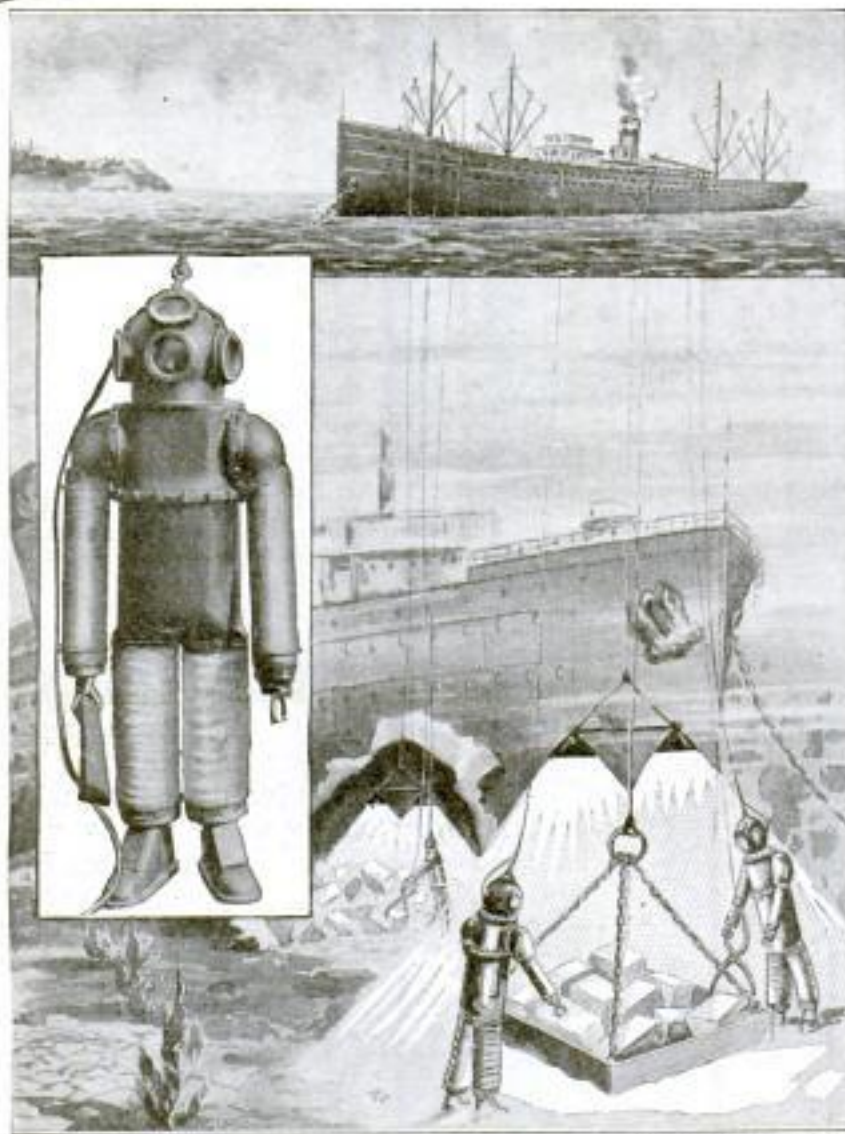

PHOTO BY AM. PRESS ASSN.  
 How Divers may Work on a Submerged Wreck at Great Depths in the New Rigid Diving Armor Invented by a Toledo Man. No Air Tube is Needed, as the Diver Carries His Own Tank of Oxygen

vention. The armor is rigid and designed especially for salvage work at great depths. Unlike the usual diving dress, it requires no air tube; an oxygen tank attached to the armor supplies the diver's needs. The helmet, body, and feet are constructed of manganese bronze, while the armored legs and arms are flexible and provision is made for grasping objects beneath the sur-

face. The helmet keeps the diver in constant communication with the surface. During the test in Grand Traverse Bay the inventor talked freely from the bottom with the members of his party on a steamer overhead, and stated that he suffered no inconvenience. It required only three minutes to lower him to the depth of 361 ft. and five minutes to raise him. With this armor, it is claimed, a diver can remain submerged for four hours at a time. It weighs 125 lb. and the shoes 16 pounds.

## 3125 BIG CASTINGS FOR SHIP'S STABILIZERS

Two gyroscopic stabilizers being installed in a United States Navy transport now under construction, have castings which are said to be the largest ever made for this purpose. Subjected as these parts are to very severe tests, great care had to be taken at every stage of their production. One of the castings weighed 56,000 lb. as it left the foundry. It is 10 ft. in diameter, and 27 in. thick on its face. Since it will revolve at 1,150 revolutions per minute it was necessary to

make it absolutely sound. The heading was made more ample than is usual, five large heads being put on the outside rim, so that the actual metal used was nearly twice the weight of the casting. Since practically the entire surface must be machined, special care was taken to prevent blowholes or shrinkage cavities. The metal used was plain carbon open-hearth steel.

Sperry Gyroscope Co.  
 Manhattan Bridge Plaza  
 Brooklyn, N. Y.



## CUTTING A TWO-MILE SLICE THROUGH A CONGESTED CITY STREET

By THOMAS H. RUSSELL

**T**HIRTY-SEVEN thousand pieces of property have been assessed to bear their share of the cost of a great street-widening project now under way in the city of Chicago as part of its plan for a "City Beautiful." These are all situated in the area to be benefited by the improvement, which is the widening of an old and important business thoroughfare, Twelfth Street, from Michigan Avenue to Ashland Avenue, a distance of over two miles. The former width of the street for the greater part of the distance was only 66 ft. between the building lines. This is being increased to 108 ft., giving a roadway 78 ft. wide and allowing 30 ft. for sidewalks. To get this width the south side of the street was selected for sacrifice, and a longitudinal slice, 42 ft. wide, is being cut through the buildings on that side for a distance of approximately a mile and a half.

The general scope of the operations along this portion of the street may perhaps better be described as shaving off the fronts of the buildings—shaving them 42 ft. deep—since this has actually been done in many cases, although a large number of buildings of solid construction have been moved back to new foundations, while others have been torn down to be rebuilt farther back, and still others have simply disappeared under the wreckers' hands. It is a district of congested "foreign" population, and in the work of dismantling the old frame buildings along the line of the improvement, the wreckers have had the cheerful assistance of thousands of women and children who swarmed over the ruins daily and gleaned full harvests of winter fuel.

At the eastern end of the street, beginning at Wabash Avenue, only a short distance from Lake Michigan, the



Children Collecting Fuel from Wrecked Twelfth Street Structures: The Little Foreigners of the District Swarm over the Ruins, but None of Them has been Injured So Far



thoroughfare is carried over scores of railroad tracks by means of a long, unsightly steel viaduct, and over the Chicago River by a bridge. This portion of the street is included in the widening project and contracts have been let for the new viaduct and bridge required, which together will be somewhat under a mile in length. Property belonging to 18 or 20 railroad companies, whose tracks are spanned by Twelfth Street, has been condemned by the city for the improvement, and while some of the companies have appealed to the Supreme Court in an effort to get more compensation, it is not likely that the law will delay the building of the new viaduct. The old Twelfth Street viaduct has been a source of danger and an eyesore to Chicago for many years. The new structure is expected to furnish a worthy approach to the great Field Museum, now under construction on the lake front at the foot of Twelfth Street.

Many great cities have cut a swath of improvement through their busy streets. London, Paris, all the world's capitals, from time to time have undertaken similar operations. But in the opinion of the engineers engaged in the Chicago project—some of whom have assisted in important city improvements in Europe, notably in the beautiful city of Budapest—the Twelfth Street widening is unique in many respects. The number of buildings successfully moved to new locations; the unusual rapidity of the work; the extent and value of the property affected, and the diversity of the building and engineering operations going on at the same time in the district under improvement, are all equally remarkable and set a record for the engineers and officials in charge. For instance, when the president of the Board of Local Improvements, under whose auspices the work is done, assumed his office in the spring of 1915, he was told that it would take at least six years to get started on the Twelfth Street widening. After only 18 months the project was half completed, and in 18 months more it will be done.

The number of separate pieces of property condemned by the city and taken over for the improvement was 301. The owners were paid at a fair rate for the buildings and grounds taken, and they were then assessed back for their due share of the cost of the improvement. There was a city bond issue of \$1,750,000 to help in taking care of the property owners. The bonds were all sold at par within six weeks, and every property owner was paid for the ground he released to the city as soon as he turned it over clear of buildings and gave the city a quitclaim deed. In this way the good will and coöperation of most of the property owners were secured and the progress of the work facilitated.

When the owners were appeased the problem frequently was to get rid of the tenants, so that the buildings could be torn down, shaved off, or removed. Then there was the problem of sanitary improvements. In many of the old buildings which the owners desired to move, amazing conditions were discovered. There were buildings, 80 ft. long, with windows only in the front and the rear. With the coöperation of the Building and Health departments these conditions were remedied. Owners were compelled to put in light shafts and remodel the buildings so as to give light and air in every room. Ramshackle buildings on rear lots had to go, to make room for structures in front to be moved back on new foundations, and there was a general sanitary cleaning-up of the entire district affected by the street improvement.

The house-moving operations were so numerous as to become commonplace. In several instances a whole row of stores, wide open and flourishing, with two or three floors of domestic establishments above, all going on as usual, gradually drew back from the old street line under the pressure of the movers' jacks, until the new alinement of the street was reached, 42 ft. back. In a typical case of this kind, a three-story building containing a drug store, a grocery, and four other stores, besides the overhead population,





This Four-Story Block of Stores and Flats on Twelfth Street, Chicago, is Shown during the Process of Moving It Back 42 Feet to Make Room for the Widening of the Street, and the Scene is Typical of Many Similar Operations along the Mile-and-a-Half Route of the Improvement from Ashland Avenue to the Viaduct and Bridge, Crossing Many Railroad Tracks and the Chicago River. Business was Carried On as Usual and Family Life Upstairs was Undisturbed



Here the Same Block as Above is Seen Soon After It Began Its Backward Journey to a New Site in the Rear. The Jackscrews Are in Place below the Sidewalk Level, and Interested Spectators are Watching the Workmen



At This Corner a Three-Story Block Containing a Drug Store and Several Other Retail Places, with Well-Filled Residence Apartments Overhead, was Moved Back So Skillfully That the Bottles on the Druggist's Shelves were Unshaken. In This Picture the Old and the New Widths of Twelfth Street can be Compared. The Building at the Left was Moved Back 42 Feet



the druggist declared that the bottles on his shelves were not even shaken by the moving operations. Another three-story building with cracked, thin stone-slab facings, and containing several stores, was moved to its new location without widening a crack or breaking a pane of glass. At Throop and Twelfth streets a four-story building of 240-ft. frontage, containing many stores and residence flats, all densely crowded, was moved back 42 ft., by horizontal screw jacks, in the manner shown in a photograph, while "Business as Usual" was the standing sign in the stores of the druggist, the jeweler, the hardware merchant, the laundryman, the butcher, the tailor, the printer, and the dealer in paints and oils—and none of them was in the least concerned over the safety of his family upstairs. So far no accidents have occurred during the operations, in spite of the influx of women and children to secure spoils among the wreckage.

At one point a large brick German Catholic Church, with a heavy steeple,

is to be moved back the required distance of 42 ft. from the building line. Near by the synagogue of the Congregation Anshe Kalvaria has been torn down, and all the buildings condemned will soon be out of the way. There are then two miles of sidewalks to be laid, for which a concrete retaining wall is built as fast as the buildings are cleared away; also new sewers, new paving, and new street-car tracks. The total cost of the improvement will probably amount to \$10,000,000, including the shares of the city, the property owners, and the street-railway company. The steam railroads contributed \$800,000 toward the cost, and the largest award of damages by the city for property taken was \$416,000, which was paid for a 50-ft. lot with its improvements at the corner of Twelfth Street and Michigan Avenue. But when completed Twelfth Street will be a creditable modern thoroughfare, with real-estate values enhanced and a new knowledge of the building and sanitary powers of a great city.

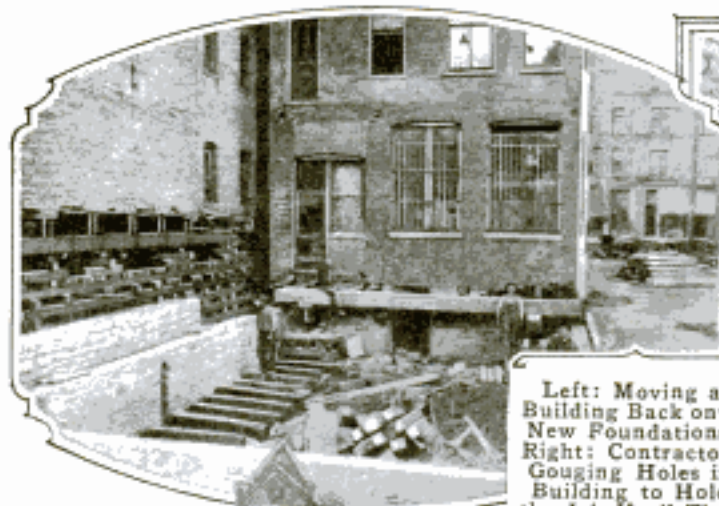

Left: Moving a Building Back onto New Foundations. Right: Contractors Gouging Holes in Building to Hold the Job Until They can Get to It



The White Line on the Building at the Left Indicates the Shave It Underwent. This Was a Substantial Four-Story Structure. There Was Not Room to Move It Back, So Part of the Building had to be Sacrificed







A Specially Built Asbestos Booth Housed the Projector That Flashed the Returns on Election Night in November at a Street Crossing in Down-Town Chicago. The Photograph Shows Message Which Drove the Watchers Home Fully Convinced That Mr. Hughes was Elected President

### NOVEL METHOD OF SHOWING ELECTION RETURNS

On election night, when the results of the recent presidential campaign were eagerly awaited by great street crowds in Chicago, one of the operating stations from which returns and motion pictures were displayed by a newspaper was installed in a small house of asbestos board, set up on a motor truck near the intersection of Fifth Avenue and Madison Street. Electric current was secured from a near-by building and a telephone line was run into the asbestos hut to carry the returns, which were written on stereopticon slides and projected on a screen hung by a gas-pipe frame to the structure of the elevated railway.

### 3342 LAMP CLEANER'S ELECTRIC CAR WITH LADDER

# Edholm

When a street-lamp inspector and cleaner makes his rounds in Fall River, Mass., he travels in comfort with an 8-ft. ladder pivoted upon the bonnet of his electric runabout. With this ar-

angement, the ladder is available for instant use, by simply swinging it upright on its swivel and leaning it against the lamp-post. As it does not rest on the ground, but on the vehicle, the operator may use it without getting down to the sidewalk or pavement, which adds to his comfort in rainy weather or when the streets are incumbered with mud or slush. Also the ladder may be 4 ft. shorter than if it were used from the level of the street.

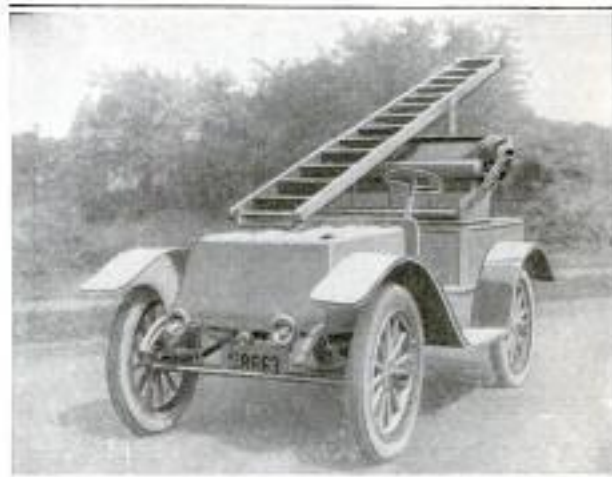

Street-Lamp Cleaner's Outfit Used in Fall River, Massachusetts: When Not in Use the Ladder is Propped Back over the Seat of the Runabout

Ward Motor Vehicle Co.  
So. Fulton Av., New Vernon  
(J. C. Bayers, Sales Mgr.) N. Y.



Dr. Lee de Forest  
1391 Sedgebrook Av.  
New York

40

3326

## POPULAR MECHANICS

### BANQUETERS HEAR MUSIC WITH WIRELESS PHONE

A commercial organization in New York City recently had the novel ex-



Dr. Lee de Forest and His Wireless Telephone Apparatus Which was Used in Entertaining a Company of Banqueters Recently. With This Equipment Selections Played on a Phonograph in a Distant Studio could be Heard Distinctly

COPYRIGHT, UNDERWOOD & UNDERWOOD

perience of being entertained by phonograph music transmitted to its

banqueting room by wireless apparatus. The equipment used was similar to that described in Popular Mechanics Magazine some time ago, which has as an essential feature the audion in-

candescent amplifiers. Arrangements were made with a phonograph company to play a selection of records on a phonograph in its studio. In the horn of the instrument special transmitters were installed which carried the sounds to a wireless instrument, whence they were discharged into the air. On the roof of the hotel in which the banquet was being held the electrical impulses were gathered up by special receivers and carried by wires to the banquet room. By means of microphones

and horns the audience was able to hear distinctly.

### 3335 SEALING WAX USED IN DECORATIVE ART



Top View: Compote Dish and Candlestick of Paper Rope, Finished and Decorated with Sealing Wax. Lower View: Pasteboard Boxes and Flowerpot Decorated with Black Gummed Paper and Sealing-Wax Flowers

Sealing wax and gummed paper are combined to make many pleasing forms in a new style of decorative art. The materials are easily procurable and the only utensils needed are a shaping stick and an alcohol lamp. Sealing wax can be obtained in 72 shades, and the gummed paper in many colors also. With a little practice good results can be secured, similar to those shown in the illustrations. Flowers may be imitated in sealing wax and are a favorite form of this decoration. The paper is made into a variety of shapes and decorated with sealing wax, or a shape of pasteboard or other material—for instance, a box—may be taken as the groundwork for ornamentation with both paper and sealing wax of various hues. Articles made and decorated in this way make welcome gifts.

Derrison Mfg Co.  
Frammingham, Mass.  
62 E. Randolph, Chicago



3388 Bottle

## FIGHTING SHIP "ARIZONA" IS IN COMMISSION



New United States Dreadnaught "Arizona" Passing down East River from the New York Navy Yard on Its First Voyage into the Atlantic. The Ship Is One of the Most Formidable War Vessels Afloat and has Been in Commission Only a Few Weeks. It was Launched in June, 1915, and Christened with a Bottle of Water—the First to Flow through the Spillway of the Roosevelt Dam. The "Arizona" Is 608 Feet in Length and Mounts Twelve 14-Inch Rifles. Insert Shows One of Its Bombproof Fighting Tops, an Innovation for Which the Offensive Use of Air Craft in Modern Naval Engagements Is Responsible



Universal Milking Machine Co.,  
18 W. Mound St., Columbus, O.

Inv. Jno. S. Edlundh.

42

3352

POPULAR MECHANICS

### IMPROVED PULSATOR FOR MILKING COWS

In an improved milking machine the pulsator is a simple three-movement vacuum pump which milks two teats



One Man can Milk 18 to 30 Cows an Hour with This Double-Unit Milking Machine, Which is Operated by a Vacuum Pump

at each stroke of the piston, instead of milking four at once, then running back empty. This gives the pulsator an even-running motion and puts much less strain on the cow. The complete installation of this milker comprises the single-cylinder vacuum pump, a small

storage tank, and a single  $\frac{3}{4}$ -in. pipe, which can be run to any part of the cattle barn. Newly designed teat cups are used, of one size for all cows. They have a pure-rubber lining and are so constructed that the teat is massaged perfectly at each stroke of the pulsator, thus eliminating the possibility of congestion.

3331

### HUGE TABERNACLE BUILT FOR A REVIVAL

When Billy Sunday, the sensational evangelist, opened his great Boston revival November 12, to continue for three months, a force of 2,000 well-drilled ushers was required to seat the people in this great structure of brick and wood, erected for the revival campaign by its supporters. It is the largest temporary building ever constructed for religious worship, and outside of the great cathedrals the largest house of worship ever built, at least in modern times. It has seats for a congregation of 13,100 persons and also 2,500 seats for the great choir, the largest body of singers brought together in Boston since the days of the



This Immense Building of Brick and Wood, Seating More than 13,000 Persons, is Filled Daily with the Crowds Attracted to Billy Sunday's Revival Meetings in Boston, and Is the Largest Tabernacle Ever Built

114 State St., Boston  
COPYRIGHT, BOSTON PHOTO NEWS CO.



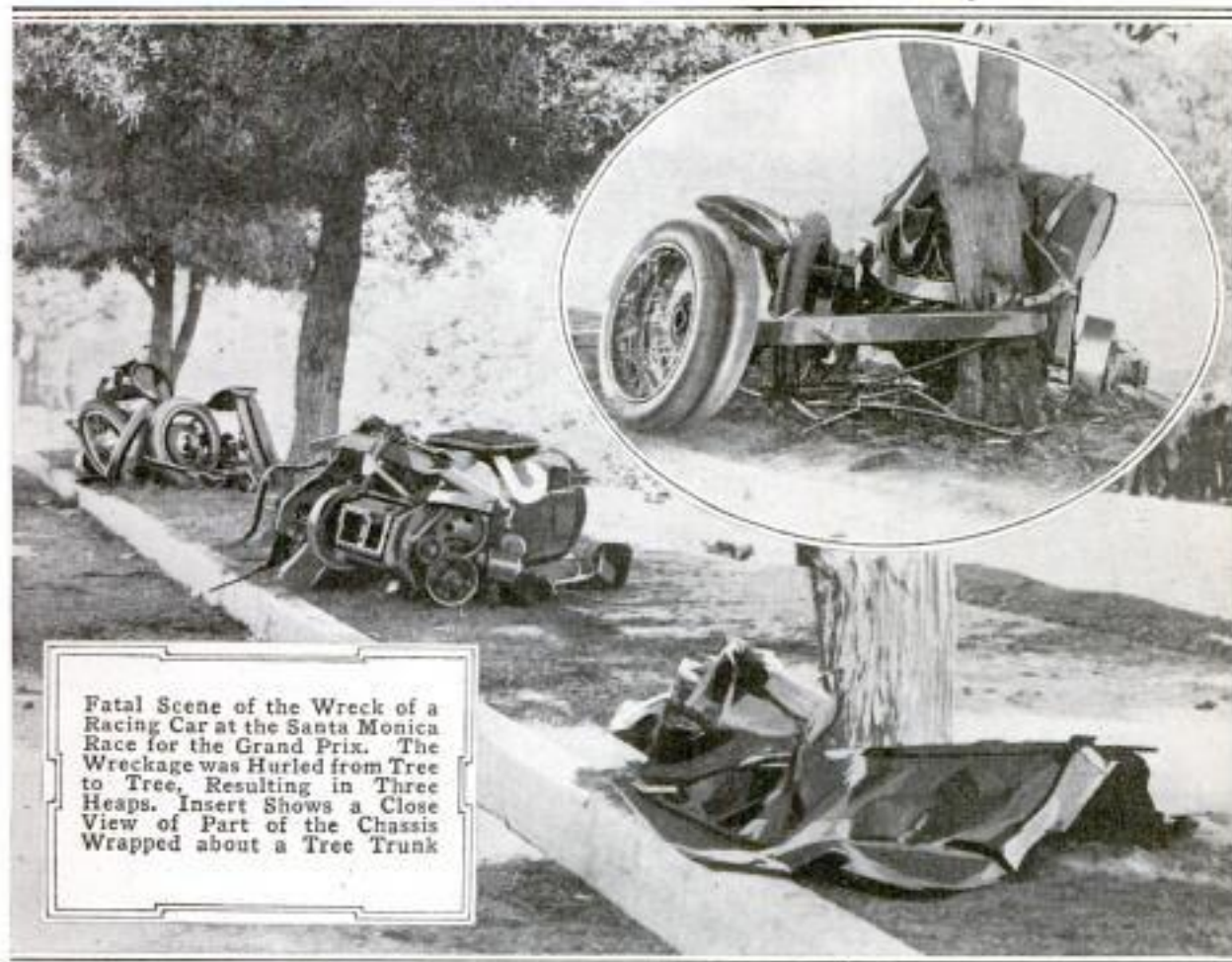

Fatal Scene of the Wreck of a Racing Car at the Santa Monica Race for the Grand Prix. The Wreckage was Hurlled from Tree to Tree, Resulting in Three Heaps. Insert Shows a Close View of Part of the Chassis Wrapped about a Tree Trunk

great Peace Jubilee. There is nothing ornate about the building, which has plain brick walls and a wooden roof covered with roofing paper. A specially constructed sounding board, or "augophone," in six pieces resembling half horns, is placed directly over the pulpit. There is standing room for 2,000 to 3,000 more people.

3407

### RACING CAR WRECKED AT SANTA MONICA

Leaving the track on the thirteenth lap of the Grand Prix automobile race at Santa Monica, Calif., November 18, a car driven by Lewis Jackson pursued a most erratic course for a few moments that proved fatal to the driver and three others. The car was traveling at a speed of over 100 miles an hour when it swerved from the road at a slight turn, broke through two trees, one almost 18 in. in diameter, and a lemonade stand, and then wound itself

around a third tree, where the driver was killed. The motor and radiator were hurled some distance farther, to another tree, striking and killing a spectator. A moving-picture camera man was killed by the fall of the second tree, and the proprietor of the lemonade stand, a woman, was hurled 100 ft. to her death. The mechanic seated by Jackson was thrown clear of the wreck and escaped with minor injuries, but two other spectators were severely injured. A few minutes before the accident the driver broke a wheel, which was replaced in great haste.

☐ The longest stretch over which commercial wireless messages have ever been sent extends from Hawaii to Tokyo, a distance of 3,355 miles. Wireless communication was established between the United States and Japan November 15, via this route, when the president sent greetings to the Japanese emperor.







AND HATS FOR THE GIRL OF THE MINUTE

3306

"Purline"

Designed by One Co.  
1182 Broadway N.Y.C.  
(K) 582-7th av.

Designed by Covert  
136 Haverhill St  
Newcom, N.J.

Kahn's  
1204-6 Elm St  
Dallas Texas



Smart Turban, Neck-piece, and Muff Suitable for the Dressy Young Matron Who Demands Distinctive Apparel. Incidentally the Turban Is More than It Appears to Be. There Are Two Pockets in It for Coins and Tickets and a Separate Place for Concealing the Indispensable Powder Puff

High Lace Boots with Puttee Effect, Which Gives Them a Distinctly Military Appearance. Primarily Intended for Motoring but Equally Suited for Walking and Driving, They Are Available in Neutral Gray and Vici Kid. The Heels Are of Comfortable but Not Extreme Height

This Attractive Coat Is Not Merely Stylish and Comfortable, but Convertible Besides. It is Made of Brown Cheviot Velour, is Lined with Velvet, and can be Worn Inside Out. Furthermore, When There Is a Flurry of Snow in the Air, the Broad, Soft Collar can be Turned Up over the Head to Form a Snug, Warm Hood. The Heavy Cuffs Serve as an Improvised Muff When Needed. Because of the Different Ways the Garment may be Worn, It Easily Takes the Place of Two, or Even Three, Ordinary Coats, and Fits In Splendidly for Various Informal Occasions







## TWO FATAL RAIL ACCIDENTS OCCUR IN EAST

26 &amp; 26.

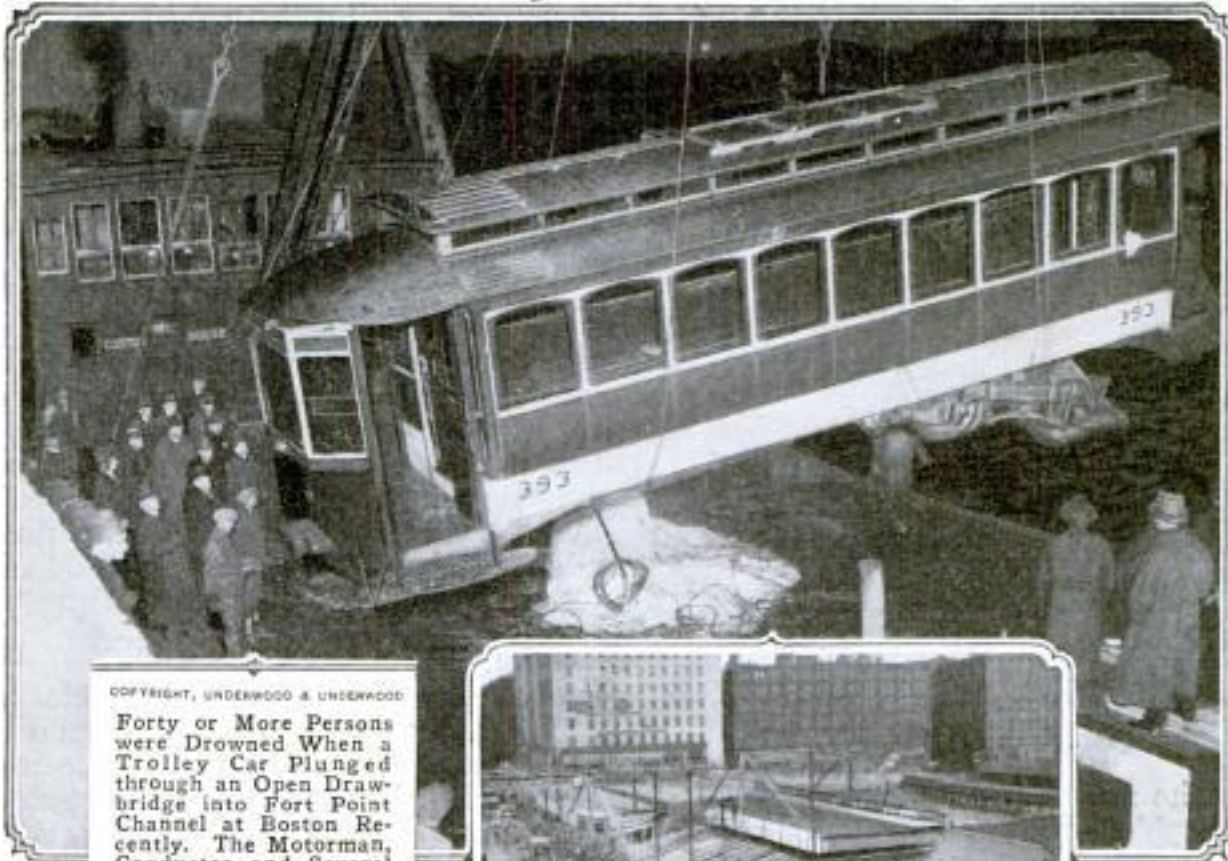

COPYRIGHT, UNDERWOOD &amp; UNDERWOOD

Forty or More Persons were Drowned When a Trolley Car Plunged through an Open Drawbridge into Fort Point Channel at Boston Recently. The Motorman, Conductor, and Several Passengers Standing on Platforms Leaped from the Car and Survived. In Less than 12 Hours the Car, Shown Here, was Recovered from the Water Only Slightly Damaged



Near South Station Terminal, Scene of Boston Tramway Tragedy. The Motorman Claims Signal Lights were Not Showing and He Had No Warning of Open Span



Herewith is Shown Part of What Remained After 60 Heavy Freight Cars Broke Loose at the Top of a Steep Incline near Altoona, Pennsylvania, and Crashed into Four Big Locomotives Standing on the Tracks Below. The Accident, Which Occurred November 6, the Day before the Boston Disaster, Resulted in the Death of 10 Persons and the Serious Injury of a Score of Others



Burns & James, Inc.  
 240 E. Ontario St.  
 Chicago.

48

3340

POPULAR MECHANICS

GAUGE FOR DISTANCES IN PHOTOGRAPHY

An instrument for quickly and accurately measuring distances of objects



When the Two Images Seen Coincide, a Pointer in the Thumbscrew Indicates the Distance

to be photographed is in the form of a small rectangular metal box containing two mirrors, one of which is placed at a fixed angle while the other moves on an axis operated by a knurled screw which contains the distance gauge and a pointer. In using the instrument the photographer looks through a small square opening in the back at the object to be photographed. Two images are seen—first, the object itself, and second, a reflection in the smaller mirror of a portion of the object. These two images do not coincide until the pointer indicates the exact distance of the object from the instrument, which is called a telegauge. The method of its use is shown in the picture.

3369

LARGE HOSPITAL BUILDING ON A NOVEL PLAN

The new seven-story building of St. Joseph's Hospital, at Kansas City, Mo., now nearing completion, has been erected from novel and interesting plans. It occupies an entire city block and has been designed with a view to

*George A. Fuller Construction Co.  
 1012 Sharp St.  
 Kan. Cy  
 Mo.*



Star-Shaped Building of St. Joseph's Hospital, Kansas City, Missouri, in Which Every Patient's Chamber Is an Outside Room with Telephone and Electric-Light Signals to a Central Station on Each Floor

extend to the four corners of the block, each terminating in a wide and roomy sun porch. The entrances and general offices are in the center of the hospital, on the ground floor. All stairways and elevators are also in the central part. There are diet kitchens on each floor and five operating rooms on the top floor. All patients' chambers are outside rooms. The construction is of steel and reinforced concrete, with face-brick, tile, cut-stone, and terra-cotta trimming, and a gravel roof. The building cost \$500,000 and is connected by a tunnel with a power plant and laundry erected separately at a cost of \$50,000.

furnishing an abundance of light and ventilation for every room. The floor plan—which is the same on all floors—has been likened to a calfskin stretched out, and also to a four-pointed star. From a rectangular central portion, or body of the building, four oblong wings

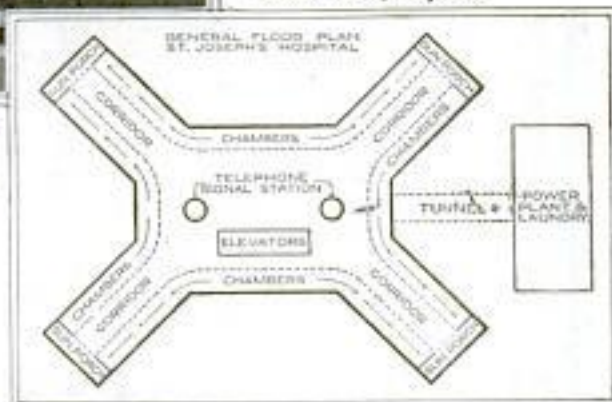

General Floor Plan of the Hospital, Which has been Compared to an Outstretched Calfskin



## GERMAN PHASES OF WAR TREATED PICTORIALY

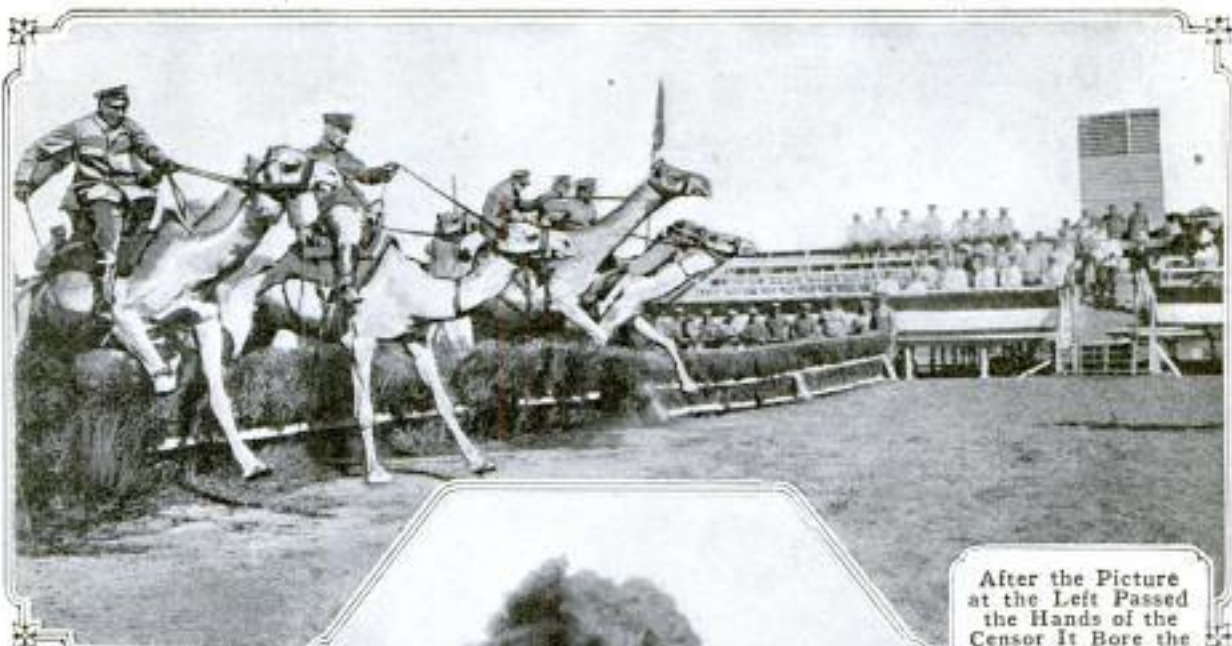

While the Russians have Used Camels on the Snow Fields of Transcaucasia, and the British have Depended upon Them in Egypt and Elsewhere, the Germans have Employed Them in East Africa. Above, German Soldiers are Competing in a Hurdle Race



After the Picture at the Left Passed the Hands of the Censor It Bore the Illuminating Information: "Explosion of Ammunition Depot of Germans." Even the Conventional "Somewhere in France," or "Somewhere in Something Else, Was Missing, Nevertheless the Picture Tells an Interesting Story

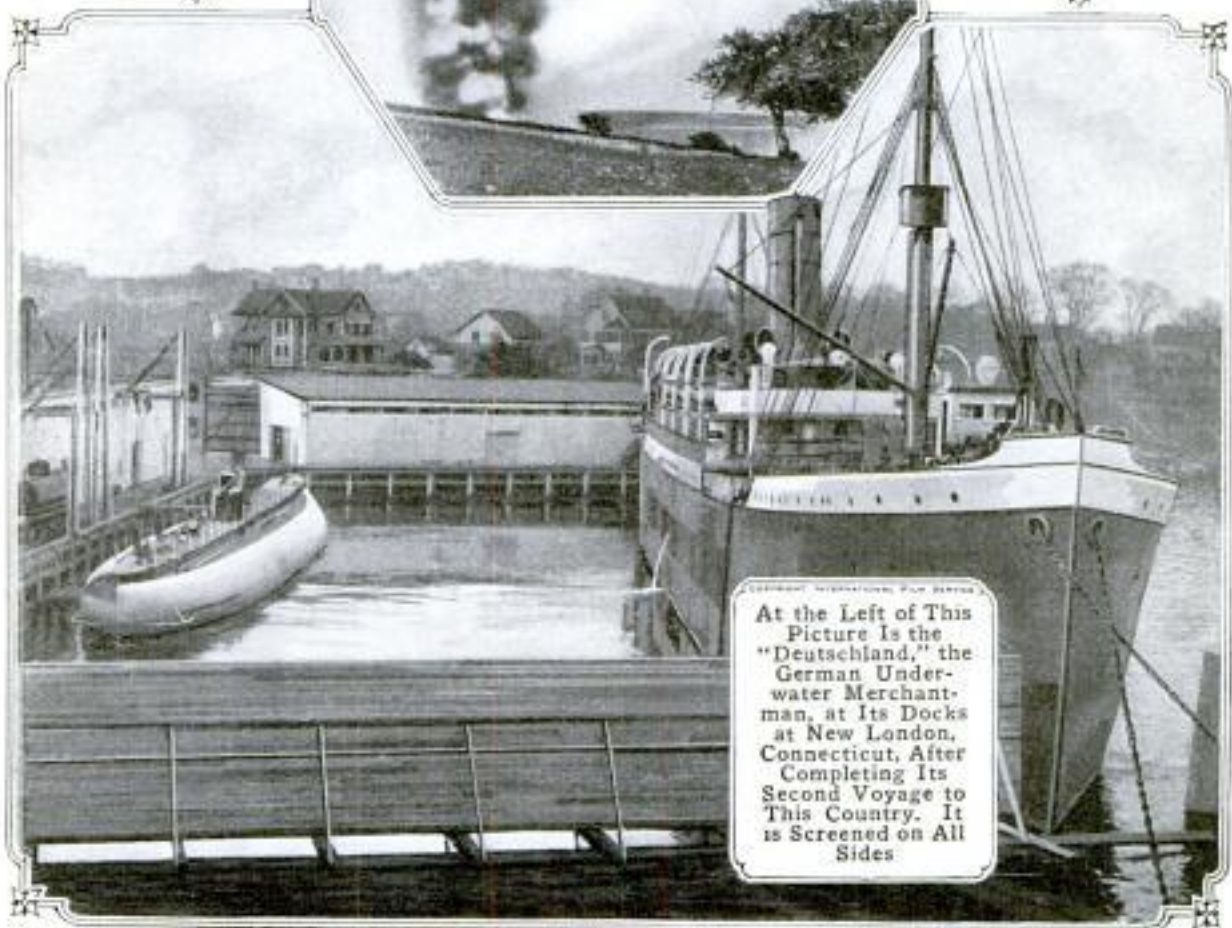

At the Left of This Picture is the "Deutschland," the German Underwater Merchantman, at Its Docks at New London, Connecticut, After Completing Its Second Voyage to This Country. It is Screened on All Sides



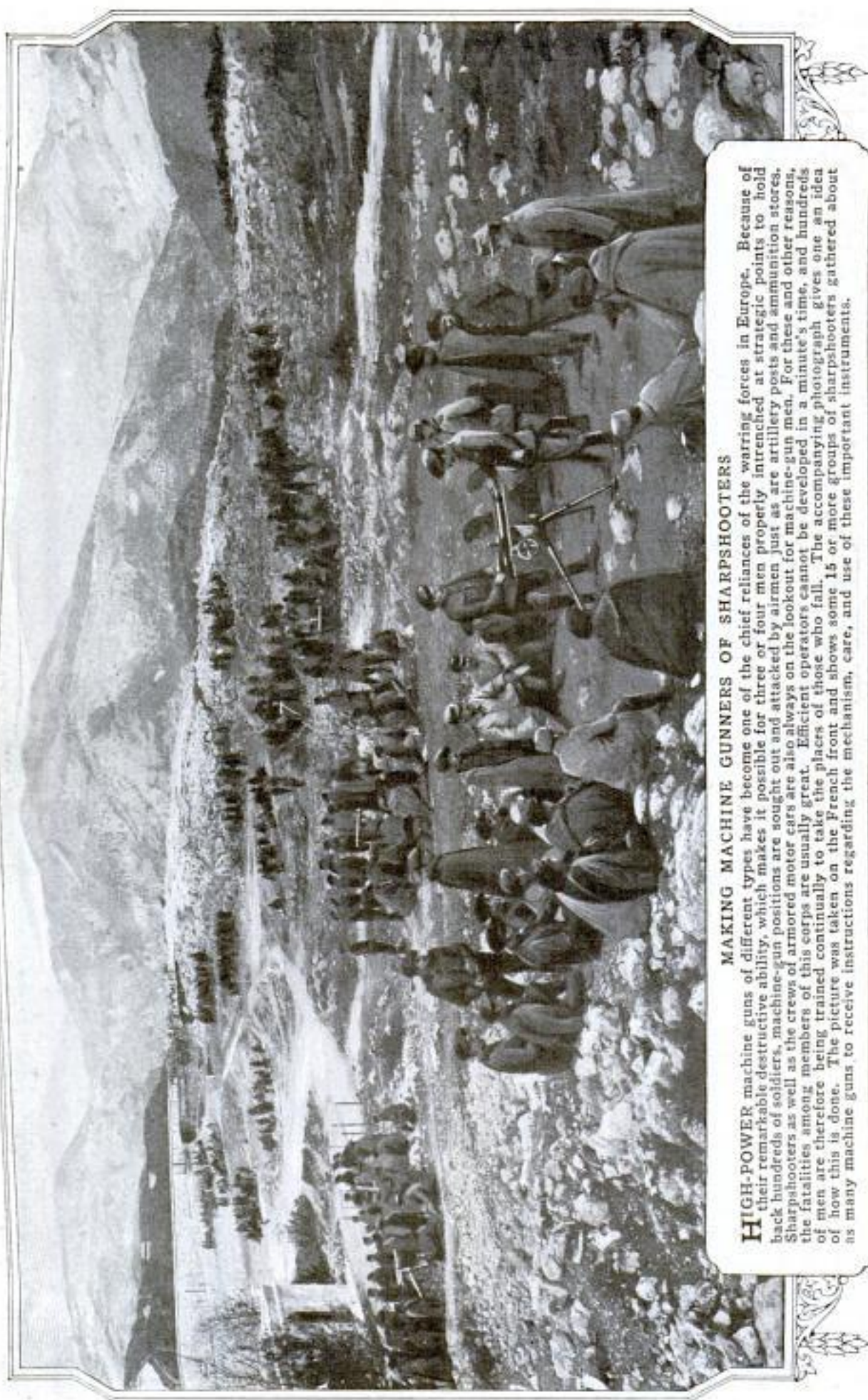

#### MAKING MACHINE GUNNERS OF SHARPSHOOTERS

**H**IGH-POWER machine guns of different types have become one of the chief reliances of the warring forces in Europe. Because of their remarkable destructive ability, which makes it possible for three or four men properly entrenched at strategic points to hold back hundreds of soldiers, machine-gun positions are sought out and attacked by airmen just as are artillery posts and ammunition stores. Sharpshooters as well as the crews of armored motor cars are also always on the lookout for machine-gun men. For these and other reasons, the fatalities among members of this corps are usually great. Efficient operators cannot be developed in a minute's time, and hundreds of men are therefore being trained continually to take the places of those who fall. The accompanying photograph gives one an idea of how this is done. The picture was taken on the French front and shows some 15 or more groups of sharpshooters gathered about as many machine guns to receive instructions regarding the mechanism, care, and use of these important instruments.



## STRIKING SCENES WITHIN THE FRENCH LINES

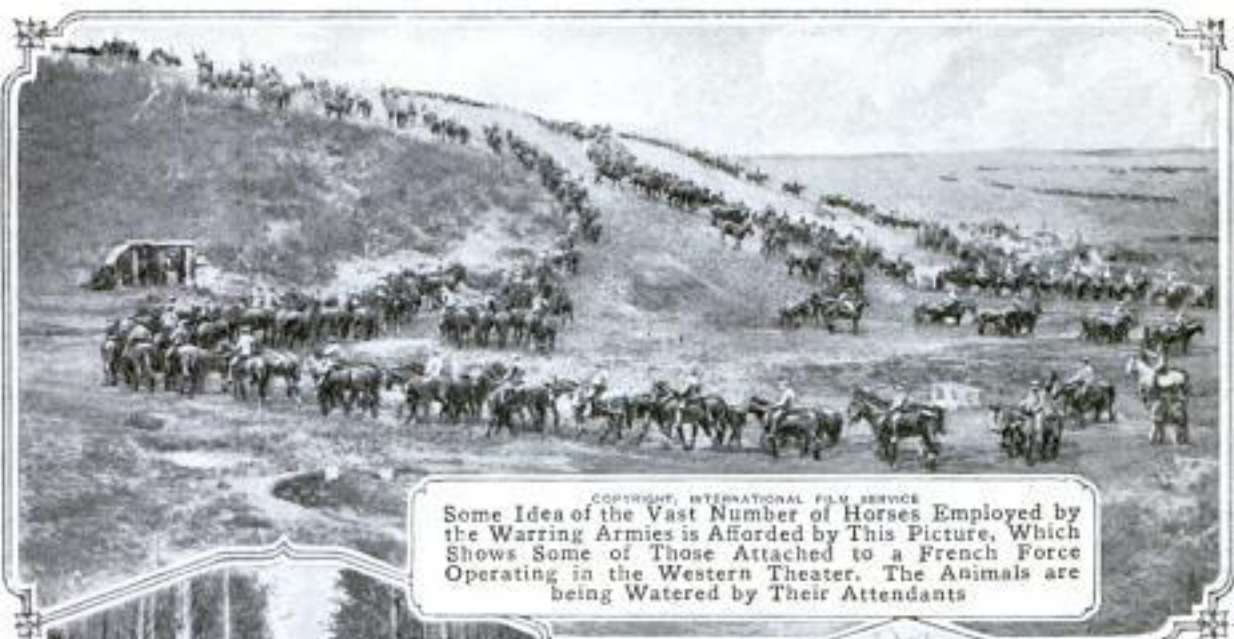

COPYRIGHT, INTERNATIONAL FILM SERVICE  
 Some Idea of the Vast Number of Horses Employed by the Warring Armies is Afforded by This Picture, Which Shows Some of Those Attached to a French Force Operating in the Western Theater. The Animals are being Watered by Their Attendants



France, along the Line of the Western Battle Front, is Now a Network of Light Railways. This is an Interesting Double-Track Cable Line in the Vosges



In a French First-Line Trench on the Somme Front: While His Comrades Stand at Attention, a Soldier is Decorated



War's Scrap Heap: The Skeletons of French and German Soldiers Who Fell on "No Man's Land" during the Months of Fighting That Preceded the French Offensive along the Aisne. Until the Germans Fell Back and the French Came into Possession of the Ground, the Fighting Was Too Severe for the Bodies to be Cleared Away. This Shows Remains About to be Buried



## IN FIELD AND CAMP WITH BRITISH "TOMMIES"



Lacking Facilities for Combating a Fire Which Raged in a British Camp at Saloniki, the Soldiers Saved Much from Destruction by Quickly Loading Supplies onto Trains and Conveying Them to Another Point



Covered with Heavy Woven-Wire Fabric, This Ambulance, Used by the British in the Western Theater, Is Proof against Shrapnel



CROWN COPYRIGHT RESERVED  
"Tommys" Advancing to Erect Entanglements in Front of Newly Won Trenches. The Rods with Spiral Ends can be Screwed into the Ground Quickly to Form Supports



This Picture Affords One a Glimpse of the British Supply Base Maintained at Sheik Said for the Troops Operating in Mesopotamia. Rations for Both Fighters and Animals, Sufficient for Several Weeks, and Stores of Ammunition and Equipment, Are at Hand. Supply Trains Go Forth to the Front Daily from Here



## ODD SIDE LIGHTS ON AERIAL WARFARE



COPYRIGHT, CENTRAL NEWS PHOTO SERVICE  
**Funeral of an Ill-Fated Zeppelin's Crew in England: The Bodies of the Enemy Airmen are being Carried with Military Honors to a Cemetery near London. The Men were Killed When Their Craft was Felled during an Attack Somewhere on the English Coast**



**Prussian Eagle Stabbed by Staffs of Allies' Flags, a Large Design Worked with Colored Pebbles and Sea Shells on the Ground at Saloniki by French Soldiers. It Bears the Legend: "Wait!! We will Pluck You Yet"**

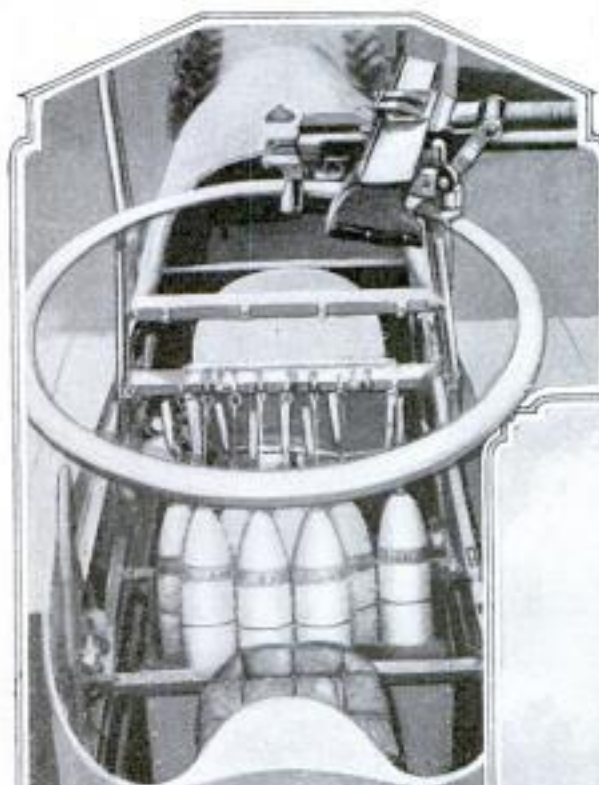

COPYRIGHT, UNDERWOOD & UNDERWOOD  
**Cockpit of a French Military Aeroplane, Showing Store of Bombs Ready for Launching, and Novel Mounting of Machine Gun. The Latter is Held on a Revolving Ring so That It may be Fired in Any Direction**



**Some of the Belgian Aerial Scouts Have Their Machines Decorated with Amusing Figures Which Serve as Mascots. One of the Painted Caricatures Is That of "Monsieur Brownie," Camera in Hand**



## UNUSUAL ASPECTS OF AUSTRO-ITALIAN CONFLICT



Seamen Lined on the Deck of an Austrian Man-of-War to Hear Mass Conducted by the Ship's Chaplain. This Photograph was Brought to America from Germany by the Under-Sea Merchantman "Deutschland"



The Barbarism of "Civilized" Warfare is Partly Illustrated by These Bludgeons, Said to have been Used by Austrians in the Battle of Gorizia



Italians Covering a Pontoon Bridge with Grasses in Order to Make It Resemble the Shore Line to Enemy Aerial Scouts. When Needed for Use the Floating Structure can be Swung across the Stream, to Connect the Opposite Banks, in Short Order



Explosion of an Austrian Shell near the Parapet of an Italian First-Line Trench in the Alps: It will be Noticed that the Soldiers are Crouching Close to the Ground, Seeking Protection from the Raining Fragments of the Bursting Projectile. Their Rifles are in Place along the Upper Part of the Parapet



**ALUMINUM PROPELLERS  
FOR AEROPLANES**

In view of the fact that American airmen with the expeditionary force in Mexico have had much trouble with wooden propellers because of the intense heat in the region in which they have been operating, an effort is now being made to provide metal propellers. One advantage which they possess is that they will not splinter. A prominent aeroplane company in the East has received for experimental purposes a two-blade propeller made of solid aluminum alloy, which is said to be lighter than wood. Other types which are to be tested by the same concern are sheet-steel propellers, a wooden propeller with metal-sprayed tips, one covered with celluloid, and one of solid celluloid.

*2753*  
**SPARK-PLUG TESTER THAT  
WORKS NO INJURY TO CAR**

The testing of a spark plug on an automobile with such a tool as a screwdriver may subject the secondary windings and condensers of the ignition circuit to too heavy a strain. For this reason a simple tester has been devised which will not do such damage. It consists of a round piece of wood, about three inches long, to one end of which is attached a brass cone, or cap. A brass wire passes through the wood from side to side and projects

*257 "Simplex"*



*Pat appl for*  
the cone end at an angle. The other end of the wire is looped up like a "U," and terminates close to the base of the cap. In testing, the brass cone is placed against the terminal of a plug and the wire is placed against the base. Sparking takes place between the cone and the "U"-end of the wire. Too wide a spark-plug gap will be indicated by a heavy spark, and too narrow a gap by a small spark.

*Plug Test Co.*  
*Newark N. J.*

**UNDERGROUND RADIO PHONE  
OF POCKET SIZE**

Although only little information concerning it is so far available, considerable importance has been attached to the development, by one of America's established inventors, of a remarkably compact, portable, wireless subterranean telephone. It is understood that the instrument has been produced as a result of the attempts of its designer to devise a wireless-signal system for fire protection in

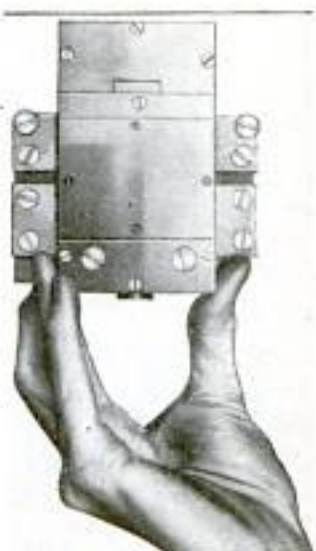

COPYRIGHT, UNDERWOOD & UNDERWOOD

the national forests. While thus engaged he is said to have discovered a new principle of transmission. It is stated that its application is very broad, making possible telephonic communication even between ships at sea and moving trains. The outfit is apparently of the utmost simplicity, consisting, in its present form, of an ordinary transmitter, a battery, and a small instrument representing the secret of the invention. The equipment is small enough to be carried in a coat pocket and when in use is connected with a ground wire.

*3111*  
**WRITER USES MOTORCYCLE  
AND "WHEEL" ON TRIPS**

There are few vocations off the stage which make the simultaneous use of a motorcycle and bicycle expedient, but there is a certain Californian who frequently finds it advisable to carry a light cycle with him while riding a motor-driven one. The man devotes his attention to writing articles on motorcycling and bicycling, and often relies upon the speed and range of the one to carry him to and from places where the other is to be used. A typi-

*Juan Eduardo*  
*Alhambra*  
*Calif.*

*M. V. Dr. H. Baringer Co.*  
*Bufford Hills, N. Y.*



cal example of this is afforded by a recent trip made from Alhambra, where the man resides, to the seashore, a distance of about 25 miles. He



For Getting to and from His Bicycling Fields, This Man Employs a Motorcycle, Carrying a Light "Wheel" Slung over One Shoulder

wished to gather material for a story of a day spent bicycling in some of the beach towns. So he hung a "wheel" over one shoulder, mounted his motorcycle, and chugged away to the ocean. Arriving at the beach, he abandoned the big machine until evening and spent the day on the bicycle. Without the motorcycle, most of the time would have been consumed in making the jumps to and from the seashore. With it, however, the round trip was a matter of only about an hour, and plenty of time was left for the real purpose of the expedition.

3123 — Street Car

### I-BEAM TROLLEY WHICH IS DETACHABLE

An I-beam trolley which is detachable has been designed for use on tracks that have no open end, so that it can be quickly removed and placed elsewhere when occasion demands. It is provided with four flanged wheels, two of which ride on either side of the

beam. These two pairs of wheels are joined together by arms which extend downward and are hinged to each other at a point directly beneath the beam. A pin holds the two in a rigid position in relation to one another, so that the trolley cannot be taken from the track, except by removing the pin. This allows the two pairs of wheels, together with the arms, to be spread apart and disengaged from the I-beam.

3083 —

### PATTERN FOR MAMMOTH PINION HOUSING

Four skilled patternmakers in Youngstown, Ohio, were recently engaged for nearly four months in making one of the largest patterns ever constructed in that section of the country. This huge model is for a pinion housing and is almost as large as a four-room cottage, since it measures 16 by 18 by 20 ft. Nearly 8,000 ft. of lumber was used in building it. The pattern is to be used in connection with the construction of a mammoth bar mill that is to be built for a steel company in Japan. The accompanying illustration shows only half of the pattern, its length being just twice that shown here.

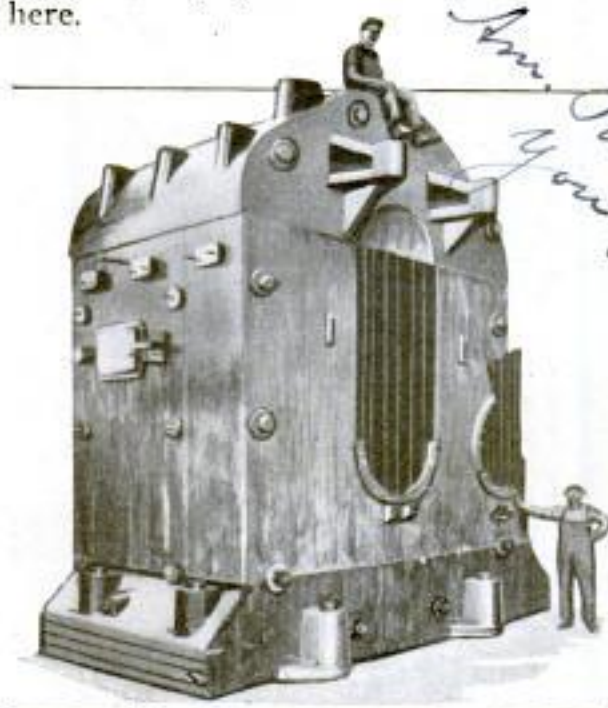

Portion of a Pattern for a Huge Pinion Housing Which It Took Four Men Nearly Four Months to Construct

Chisholm & Moore Mfg Co  
5046 Lakeside Av.  
Cleveland, O.



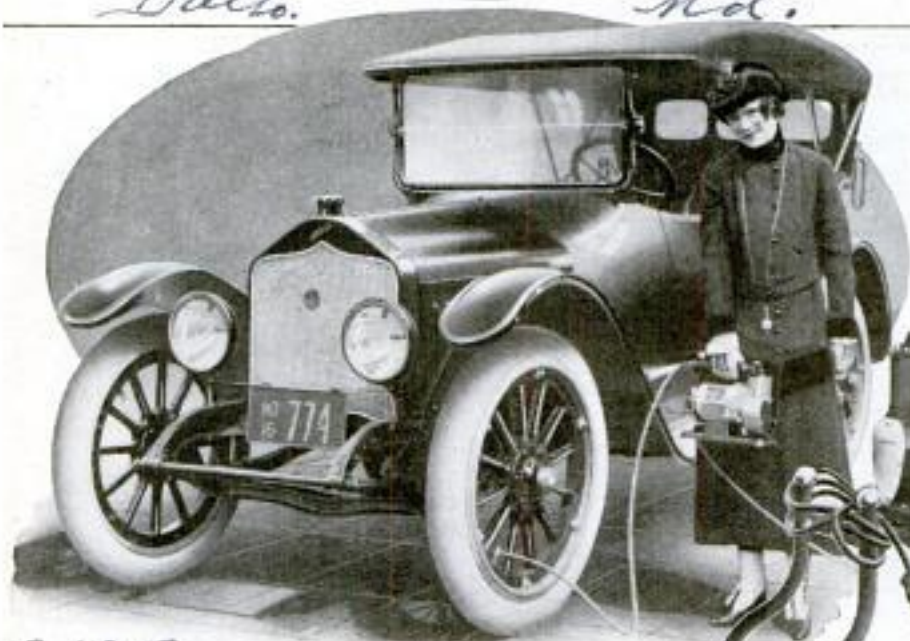

The Small Pump, Intended for Private Garages, is Shown in Use at the Left. While the Big One, Mounted on a Steel Carriage, is Illustrated Below

3135

**ELECTRIC PUMP DELIVERS OIL-FREE AIR TO TIRES**

Designed in sizes suitable for both public and private garages, an electric tire pump of very compact and convenient form has been developed. Its parts consist of a universal motor, an air compressor, a gear box, and a condensing chamber, assembled within a single housing and cooled without water. A capillary lubricating system is employed and this, it is claimed, prevents the possibility of oil-bearing vapor being driven into tires. The apparatus may be connected with any 110-volt circuit, and is light enough in weight to be lifted from one place to another in a garage without trouble. The small pump of this type, intended especially for private use, is easily carried even by a woman. The other, when desired, is supplied with a light steel carriage, fitted with a tool tray, and may be wheeled from car to car in a large garage. Both pumps are fitted with gauges and will inflate tires to 150-lb. pressure quickly, and at low cost.

What is declared to be the largest radio-telegraph station in the Pacific is nearing completion in Hawaii. It will be able to communicate with Manila, San Francisco, and distant South Pacific points.



3053

**BELT-SLIPPING PREVENTED BY CORK-INSET PULLEYS**

The slipping of heavily laden belts on their pulleys is a source of constant loss both in power and output in manufacturing plants. To overcome this waste a Philadelphia company now makes steel pulleys in which there are a number of cork insets that serve greatly to reduce slipping. The corks are set in staggered rows and are firmly fastened in the steel by a patented method which does not add to the weight of the pulley. The insets are practically unaffected by dust, oil, or water and are said to wear almost indefinitely. Tests show that a steel pulley with cork insets has much less belt slip than one without the insets.



*Canadian Distributors:  
 Northern Electric Co. Ltd.  
 P.O. Drawer 2040 - Montreal*

*Am. Pulley Co.,  
 4200 Wissahickon Av.,  
 Phila.*



*Q. 52*  
*A. 52*  
**LIGHTING EQUIPMENT FOR  
NIGHT FLIERS**

To lessen the dangers of flying by night and enable landings to be made

secures them to either the upper or the lower plane, at its leading edge. With this fitting the lights can be tilted in a vertical plane, making it possible to use them for signaling purposes as well as in making landings. They are controlled by a push switch of special design, placed within easy reach of the pilot. The switch is normally held open by a spring, which in signaling is operated like a telegraph key, while by giving the top a quarter turn it locks in a closed position when desired.

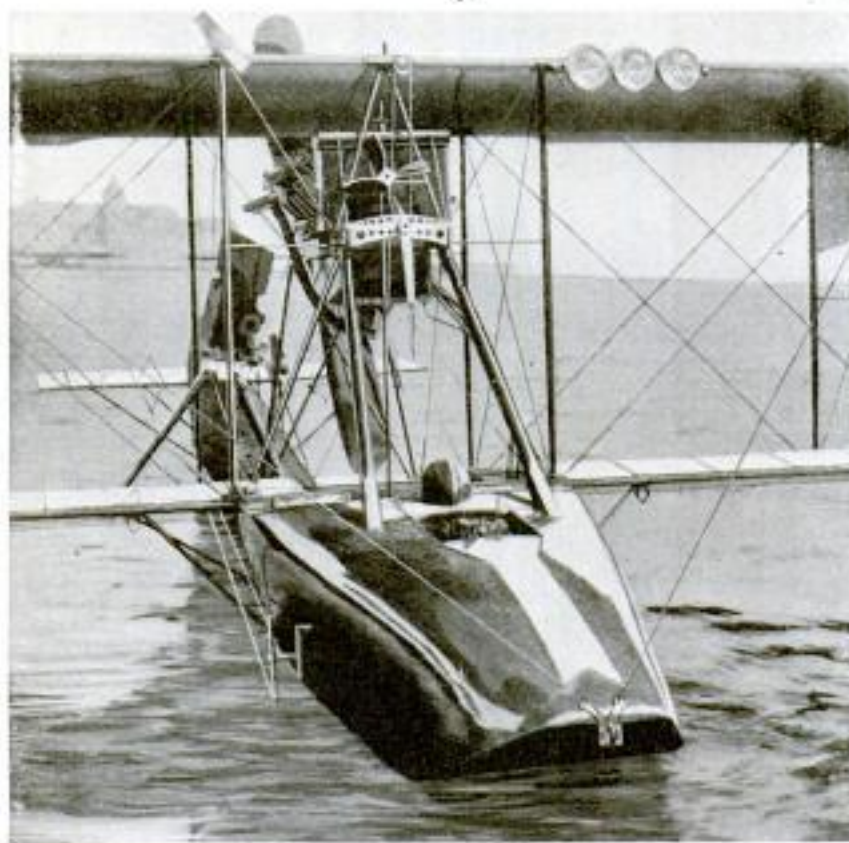

Curtiss Flying Boat Equipped with Special Lighting Outfit for Night Flying, Including a Bank of Three Searchlights on the Leading Edge of the Upper Plane, with an Air Turbine to Drive the Generator

safely after dark, a special lighting equipment has been designed for aeroplanes and hydroplanes. In the illustration the outfit is shown attached to a Curtiss flying boat. It consists of a bank of three streamlined searchlights, with parabolic reflectors which project the light beams to a useful distance. Current is obtained from a generator of 150-watt capacity, conveniently mounted and driven by means of an air turbine, at 4,000 revolutions per minute. The lights are mounted on a special fitting which

*3147*  
**IMPROVED RAIL-  
ROAD CROSSING**

Recognizing the fact that ordinary railroad-track intersections are a source of much severe wear on rolling stock and are repeatedly in need of costly repair, a firm in Clinton, Ill., has constructed a crossing for railroads which is designed on a new principle. At each of the four intersections, which exist where one track crosses another, is placed a rail only a few inches long, which is mounted on what might be

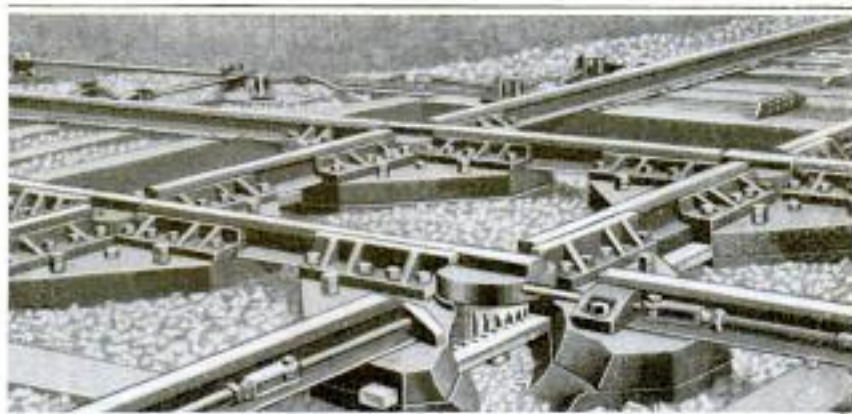

Railroad Crossing Having Four Short Rails at the Intersections, Which are Used to Make Either of the Two Tracks Continuous. The Cost of Operation and Maintenance Is Small

*Alexander Crossing Co.,*  
*Clinton, Ill.*





Salvage Machinery and Supplies Placed on the Wreck of the Naval Collier "Hector" Which Foundered off Charleston, S. C., during a Hurricane



Storm Waves, Washing over the Wreck, Repeatedly Spoiled the Work of the Salvors and Drove Them Away

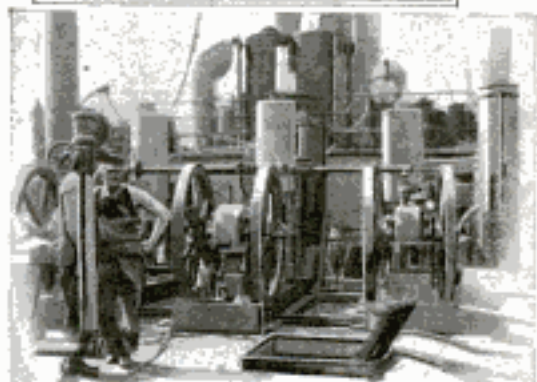

Trying to Raise the Wreck of the "Hector": At the Left, a Navy Tug Standing by the Wrecking Barges. At the Right, a Battery of Air Compressors Installed on the Wreck to Clear the Holds of Water

called a miniature turntable. These four short rails are all controlled by a single lever in the interlocking tower near by. When a track is to be set for "clear," these four rails are swung around so that they make a continuous track for the route which is to be traversed. When the other track is to be used a movement of the lever swings the four short rails around so that the second line is ready for traffic. Each of the four short rails is turned by a rack which meshes with cogs in the side of its base. When they are set, each rail is locked by a simple device which keeps it in perfect alignment. The jar which this crossing produces and the cost of maintaining it are said to be much less than those of ordinary crossings.

AN automobile transportation company operating 13 passenger and freight cars, is building up a profitable business between points not more than 20 miles distant from an important Indiana city, despite competition from two steam railways and an interurban line.

### SALVAGE OPERATIONS ON U. S. COLLIER "HECTOR"

After salvage operations had been carried on for two months at the scene of the wreck of the United States naval collier "Hector," which sank in 33 ft. of water off Charleston, S. C., and broke completely in two during a hurricane last July, attempts to raise the vessel were postponed until next spring. Two wrecking companies combined their efforts at salvage, but the severe storms which swept the Atlantic rendered futile their efforts to float the great hull. Cofferdams and hatch covers were built several times in attempts to pump out the holds in the stern portion of the vessel, but the work was destroyed each time a storm arose and the lives of the men were endangered. Three large wrecking barges were employed in the operations and air compressors, run by crude oil, were installed on the deck of the wreck to force air into the holds and drive the water out. These efforts will be renewed after the winter season.



### JACKS TO RELIEVE STRAIN ON AUTOMOBILE TIRES

A simple automobile jack has been devised to keep cars raised off the floor

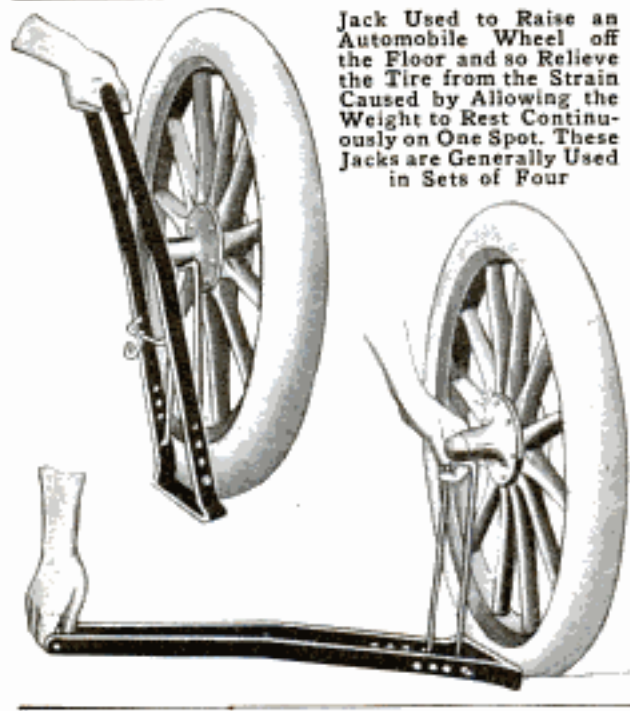

Jack Used to Raise an Automobile Wheel off the Floor and so Relieve the Tire from the Strain Caused by Allowing the Weight to Rest Continuously on One Spot. These Jacks are Generally Used in Sets of Four

while standing in the garage, and thereby relieve the tires of the strain which comes from allowing the weight to rest on one point for several hours or days at a time. The jack consists of a rectangular iron frame, 28 in. long and 9 in. wide at the base, to which an adjustable arm is pivotally attached near the lower end. To raise a wheel the jack is laid down on the floor with its base against the outer face of the wheel and the arm in a vertical position so that its free end is under the hub. By raising the end of the frame which is farthest from the wheel, the jack will act as a lever and lift the wheel off the floor. The weight will serve to keep the support steady, and tight against the wheel. These jacks are sold in sets of four. Not only do they prevent strain on tire fabric, while a machine is mounted on them, but they keep the tires out of the oil which is apt to accumulate on a garage floor. Each jack is provided with a hook to lock it in an upright position.

3229  
**PASSING OF GERMAN VILLAGE AT NORFOLK NAVY YARD**

Until some few weeks ago, when the converted Teutonic cruisers, "Kronprinz Wilhelm" and "Prinz Eitel Friedrich," were transferred to Philadelphia, a German village of unusual interest flourished within the confines of the Norfolk, Va., Navy Yard where the two vessels and their crews were interned. It was called Eitel Wilhelm and had a population consisting of about 1,000 seamen. Its destruction came with the removal of the cruisers to the Philadelphia Navy Yard.

Eitel Wilhelm was built on land allotted to the sailors as an exercise ground, and out of waste materials thrown out from the shipyards to be burned. For weeks the men devoted practically all of their spare time to the crection of the quaint little place, which was scrupulously neat, distinctly German, and gay with paint of all colors. Surrounding each house there

was a picket fence bordering a small, trim lawn. Adjacent to nearly every dwelling was a vegetable garden, while about the porches were vines and shrubs. Also there were chicken runs, dovecotes, rabbit hutches, kennels, and bird houses. Nor were the buildings in the village limited to dwellings. An odd little church was situated on one street and a big windmill on another. Also there were a telegraph office, mayor's office, police station, and a marriage-license bureau. The principal streets were Prinz Eitel Weg, Jungfernstieg, Kronprinz Weg, and Kleiner Kiel. It is probable that the village will be reconstructed at the Philadelphia yard.

CA large hardware firm has added an out-of-the-ordinary feature to its catalog by placing at the bottom of each page some literary quotation or a statement of scientific or historic interest.





As may be seen by the Gang-plank Extended from the Ship to the Dock, It Was but a Step from the Interned Cruisers, "Kronprinz Wilhelm" and "Prinz Eitel Friedrich," to the Strange Little Village Erected by the Sailors at Norfolk Navy Yard



No German Village would Be Complete without a Mill, so This One was Constructed, Although More for Appearance than Utility



Glimpse of the Principal Street in the Queer Village of Eitel Wilhelm, a Name Derived from Those of the Interned Commerce Raiders, One of Which is Partly Shown in the Background. The Place Had a Population of Nearly 1,000 Persons, All Adults and Seamen



This Flagpole was Erected Supposedly for Drying the Ships' Bunting. The Bunting was Usually "Dried" on Occasions of German Victories Abroad



A Fire Station was Not Needed Because of the Proximity of the Ships, but There Were a Police Station, a Marriage-License Bureau, and the Quaint Church Shown Above



In the Middle of the Plaza Was an Open Stand Where Concerts by the Ships' Bands were Held in the Evenings. This Picture Gives One a Fair View of the Village



**SAND CRABS UTILIZED  
 FOR CHICKEN FEED**

Sand crabs which swarm the beaches of California are caught by the owner



Catching Sand Crabs for Chicken Feed, by Means of a Trap Resembling a Dustpan with Wire Bottom Which Removes Them from the Surf

of a large chicken ranch and converted by a simple process into nutritious food for his fowls. Having conceived the idea that the little crabs would make good food, he caught a few and fed them to his chickens as an experiment. Then, finding the experiment a success, he built a crab trap, resembling a large dustpan with a wire-screen bottom. With this it is only necessary to wade into the surf on a beach at low tide and drop the crab

trap into the water, with the open end toward the shore. As each wave recedes from the beach and the crabs are carried along with it, the water and sand pass through the netting of the trap, but the crabs are caught. A peck or more of them are often landed at a dip. At the ranch they are boiled for 20 minutes, then spread on screens to dry, and afterward ground up to about the consistency of coarse cornmeal and further dried in the sun for 48 hours. The finished product looks very much like red sand. Fowls are said to fatten quickly on it and to lay well when fed on the crab food exclusively. The raw material costs the ranchman nothing.

2987  
**SALVAGE OLD RAILS WITH  
 FLANGED-WHEEL AUTOS**

An interesting example of the profitable use on a railway line of an automobile equipped with flanged rims is to be found in Montana. The recent increase in the price of steel made it worth while for a transcontinental railway to salvage an abandoned branch which had been built to connect with a once prosperous lumber region. The forestry regulations forbade the use of any but oil-burning locomotives in this district, whereas the engines avail-



Two Views of Automobile Truck, Equipped for Track Service and Attached to a Trailer: The Outfit was Used to Salvage the Rails on an Abandoned Railway Line and Traveled 108 Miles a Day, Its Loads Being 12 Tons Each

McLaughlin the Tractor  
 No. 1000 - 6. 13. 1910

The White Co.,  
 Cleveland, O.



able for the work of moving the old rails were of the wood-burning type. The contract for transporting the metal portion of the track to the main lines was finally let to a local transfer company. This concern equipped a two-ton automobile truck with flanged steel tires and installed it on the unused track. A small flat car was used as a trailer. The outfit made an average of 108 miles, or two round trips, a day, climbing several grades as steep as seven per cent. The loads averaged 12 tons each. In the first month the truck covered 3,300 miles.

*Blair Hills Transfer Co.  
Newport News.*

3057

**COVERS KEEP DUST FROM MEAT GRINDER**

An attachment has been devised for a meat grinder which protects it from

dust and flies when it is not in use. The device is intended especially for grinders in butcher shops that are operated many times a day. It consists of a hinged cover which closes over the perforated end of the machine and a cap shaped to fit tightly down into the bowl, or hopper. Both parts are attached to a ring which clamps about the body of the machine. The cap over the bowl is supported by a long curved arm having a sliding joint which permits the cap to be raised or lowered and makes it useful in pressing the meat down into the hopper, as well as in covering the opening.



*Sanitary Appliances Co.  
501 Mill Street  
Brooklyn, Penna.*

2985

**SHALLOW-DRAFT BOAT FOR USE IN MARSHY REGION**

EDHOLM

In constructing a subway and cable system from Brooklyn to Hammels, Long Island, across the swampy land in the vicinity of Flatlands and Barren Island, a telephone company found it-

*New York Telephone Co.*

self greatly in need of a power barge which would carry a heavy load but would draw very little water. To meet this requirement a craft was con-



A Boat Having a Propeller Located in a Tunnel Chamber: When Carrying a Load of 6,000 Pounds It Draws But 15 Inches of Water

structed having a tunnel chamber in its otherwise flat bottom. In the recess the propeller was placed so that it projected some distance above the water level. When the boat is carrying a 6,000-lb. load of telephone cables, or other material, it draws but 15 in. of water and so can easily navigate in the shallow waters in the vicinity of the construction work.

3049

**COPY OF FAMOUS STATUE ERECTED AT NEWARK**

In commemoration of its two hundred and fiftieth anniversary, a splendid copy of Verrocchio's equestrian statue of the Venetian general Bartolomeo Colleoni has been presented to the city of Newark, N. J., and erected in Clifton Park. The bronze figures of horse and armored rider, 20 ft. in height, surmount a 25-ft. marble pedestal. Even the cracks, stains, and other marks on the original statue, which stands in the Campo SS. Giovanni e Paolo at Venice, have been reproduced. Colleoni was an Italian soldier of fortune who fought at different times for Venice and Milan, as well as for himself. At the time of his death in 1475 he left a considerable fund of money to the Venetians for

*Christian Feigenbaum (Owner)*



the Turkish war with the understanding that an equestrian statue of himself be erected. Critics have pro-



Copy of Verrocchio's Renowned Equestrian Statue Erected in Clifton Park at Newark, New Jersey, to Commemorate the City's Two Hundred and Fiftieth Anniversary

nounced the work one of the finest of its kind in the world. The copy lately presented to Newark was produced at a cost of about \$70,000, it is understood.

3338

### ELECTRIC SIGN PRESENTS POLITICAL DEBATE

Without question electric signs played a more prominent part in the recent presidential campaign than in any previous one. A variety of electric displays bearing political messages were used in New York, Chicago, Louisville, and elsewhere, but the one in Indianapolis probably proved the most effective. The other signs were used for some one party, this one for three causes in turn. A feature of the electric board was a motograph section that permitted a display of 45 words which would move across the face of the sign in brilliant electric letters. The lighting company operating it arranged with three prominent In-

diana authors to furnish copy of a political nature for this sign. Each was allowed to state his argument in not more than 45 words. A message favoring the democrats appeared one week, a message for the republicans another week, and one for woman's suffrage a third week.

—3062

### WATER CURTAIN SHIELDS MILL MEN FROM HEAT

Decreased discomfort for workers in a rolling mill and hence increased production have been obtained by using what is called a water curtain to shield the men from the intense heat of the furnaces. The device is intended for use in summer and consists of a large rectangular piece of sheet metal suspended in front of the furnaces by means of door hangers that run on a track. Two openings are cut in the metal sheet to correspond to the furnace doors. Extending along the upper edge of the curtain is a perforated pipe from which a thin sheet of water flows down the outside of the metal curtain and into a trough at the bottom. The water is diverted to either side of the openings by angle irons fastened to their upper edges. The device serves to reduce the heat materially in front of the furnaces. In the winter it can be lifted from the track and stored.

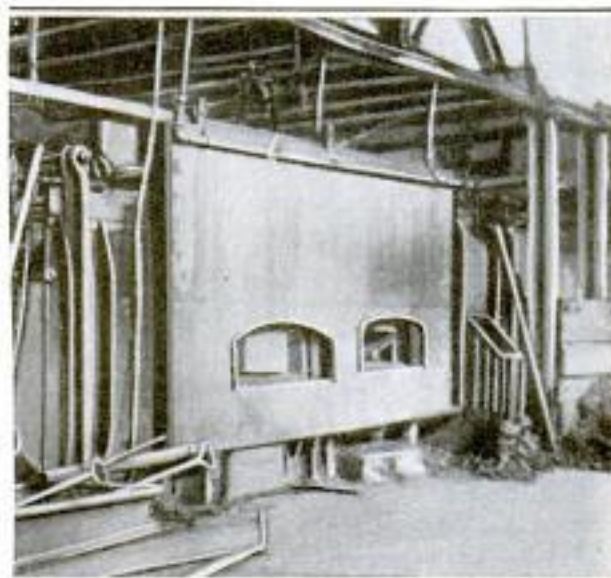

Sheet-Metal Shield Hung from a Track in Front of a Furnace: Down the Front of the Curtain Flows a Thin Sheet of Water to Protect the Workmen from the Intense Heat

Not patented or  
on market

Merchants Heat & Light Co.  
Indianapolis, Ind.



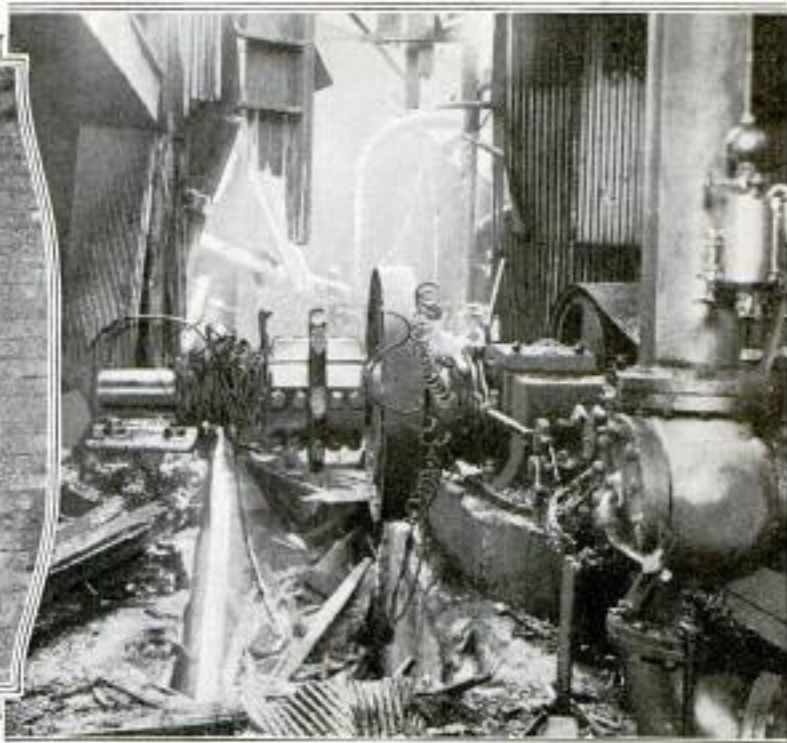

The View on the Left Shows a Big Hole Broken in a Brick Wall by a Section of the Shattered Flywheel. On the Right Is the Interior of the Engine Room after the Accident. The Shaft Which Drove the 30-Ton Wheel is Shown Wound with Wire

3177  
**BREAKING OF FLYWHEEL  
 WRECKS ENGINE ROOM**

An accident to the governor of an engine in a Newport, Ky., rolling mill recently released the machinery from proper control and as a result the 30-ton flywheel was shattered into many pieces and the interior of the engine room was instantly reduced to a mass of wreckage. One man was seriously injured and the damage done was estimated at \$25,000. Portions of the great wheel were hurled through the brick wall of the building, one of them making an opening almost large enough for an automobile to drive through. Another section landed in a vacant lot a fifth of a mile away.

2624  
**CANVAS WINDBREAKS FOR  
 SAN FRANCISCO'S TREES**

In spite of the fact that the high winds of early summer have dwarfed many trees and shrubs in exposed places in San Francisco, the park authorities of that city are determined not to be defeated in their efforts at

*Presidio Parkway*

tree planting. Consequently they have erected huge windshields on the ocean side of trees in the principal parkways so that they can take strong root and develop normally. Special attention has been given to oaks and lindens. On the Presidio Parkway, for instance, every tree is sheltered on its windward side. These windbreaks



Shields Erected on the Ocean Side of Exposed Trees in San Francisco to Protect Them from Strong Winds That Prevail at Certain Seasons

consist of burlap or canvas, stretched on large wooden frames set in the ground and securely braced.

ⒸThe Department of Agriculture finds that only 209 rods of untrimmed hedge waste an acre of land, whereas for the same expenditure of land one can run 473 rods of barbed-wire fence.



# 2275 WOULD-BE FRENCH AIRMEN TESTED SCIENTIFICALLY

*Ill. London News May 27-1916*

**I**NSTEAD of limiting the examination of applicants for the aerial service in France to the customary medical tests required in the army and navy, a far-reaching probe of a highly scientific character is made to determine the actual fitness of candidates for this particular type of work. The result is that men who are potentially unsuited for the exacting, strenuous duties of the military flier are eliminated.

Special instruments which determine the acuteness of sight, hearing, feeling, as well as the nerve strength

and ability to resist fatigue, are used. One of these is the chronoscope, which has a dial divided into 100 units and an indicator hand that makes one revolution a second. The examiner holds a small electromagnetic hammer which sets the device in motion when struck against a small metal box. The subject holds two curved strips of metal which, when pressed together, arrest the instrument. Upon hearing the impact of the hammer, the candidate stops the indicator hand in the way explained. The dial then shows in terms of hundredths of seconds the time required by the applicant to record the impression.

His sense of feeling is tested with this same instrument, the hammer be-

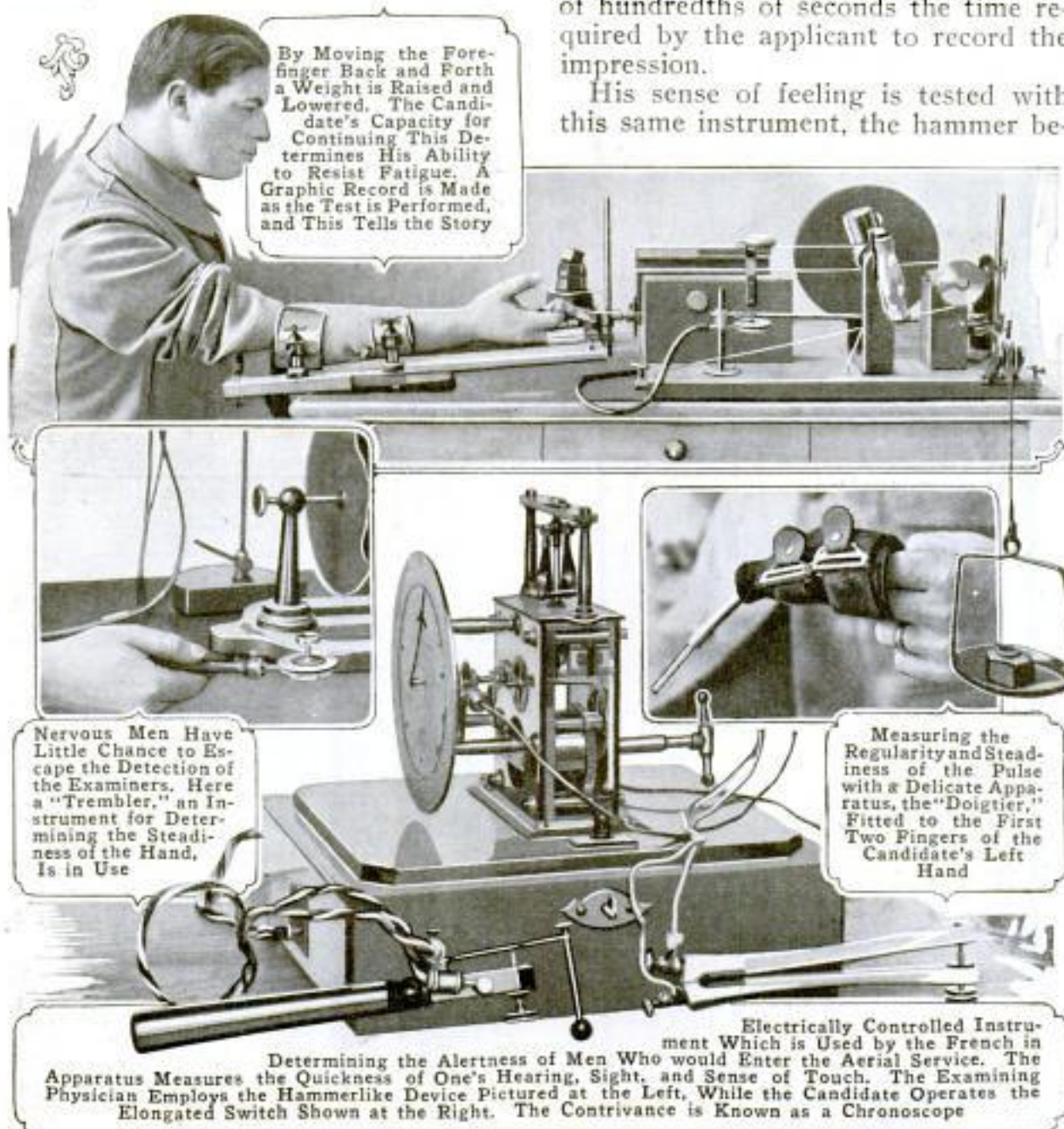

By Moving the Fore-finger Back and Forth a Weight is Raised and Lowered. The Candidate's Capacity for Continuing This Determines His Ability to Resist Fatigue. A Graphic Record is Made as the Test is Performed, and This Tells the Story

Nervous Men Have Little Chance to Escape the Detection of the Examiners. Here a "Trembler," an Instrument for Determining the Steadiness of the Hand, Is in Use

Measuring the Regularity and Steadiness of the Pulse with a Delicate Apparatus, the "Doigtier," Fitted to the First Two Fingers of the Candidate's Left Hand

Determining the Alertness of Men Who would Enter the Aerial Service. The Apparatus Measures the Quickness of One's Hearing, Sight, and Sense of Touch. The Examining Physician Employs the Hammerlike Device Pictured at the Left, While the Candidate Operates the Elongated Switch Shown at the Right. The Contrivance is Known as a Chronoscope



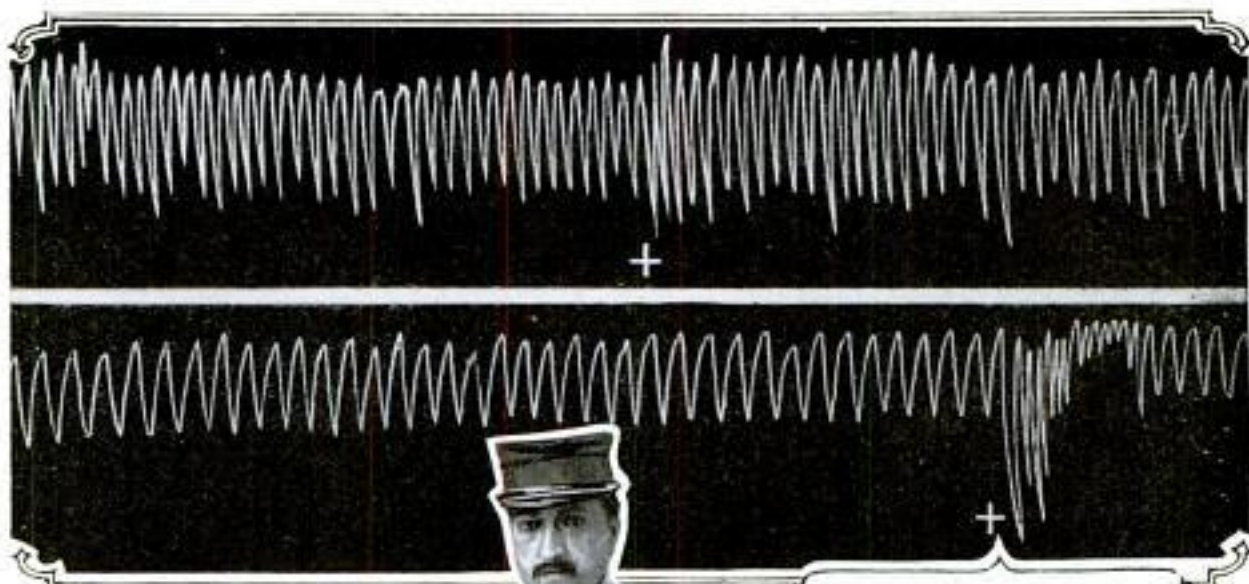

Above: Respiratory Records of Two Men Who Took Test Explained Below. The First Is Good, the Second, Bad. At the Crosses are Indicated the Effects the Shots Had on the Men's Nerves. The First Man Barely Flinched; the Second, Who Normally Breathes More Slowly, but with Less Regularity, was Greatly Startled and Spent Several Seconds in Regaining His Poise, as Shown by the Short, Uneven Lines



Men Who can Maintain Complete Composure When a Revolver is Unexpectedly Discharged behind Them Have Strong, Steady Nerves. It Is Men of This Kind That France Wants for Its Aerial Service. The Test is a Severe One, for as Shown Here, Graphic Records are Made of the Respiratory, Pulse, and Nerve Actions When the Shot is Fired, a Pneumograph, "Trembler," and "Doigtier," Each Connected with a Recording Machine, being Used

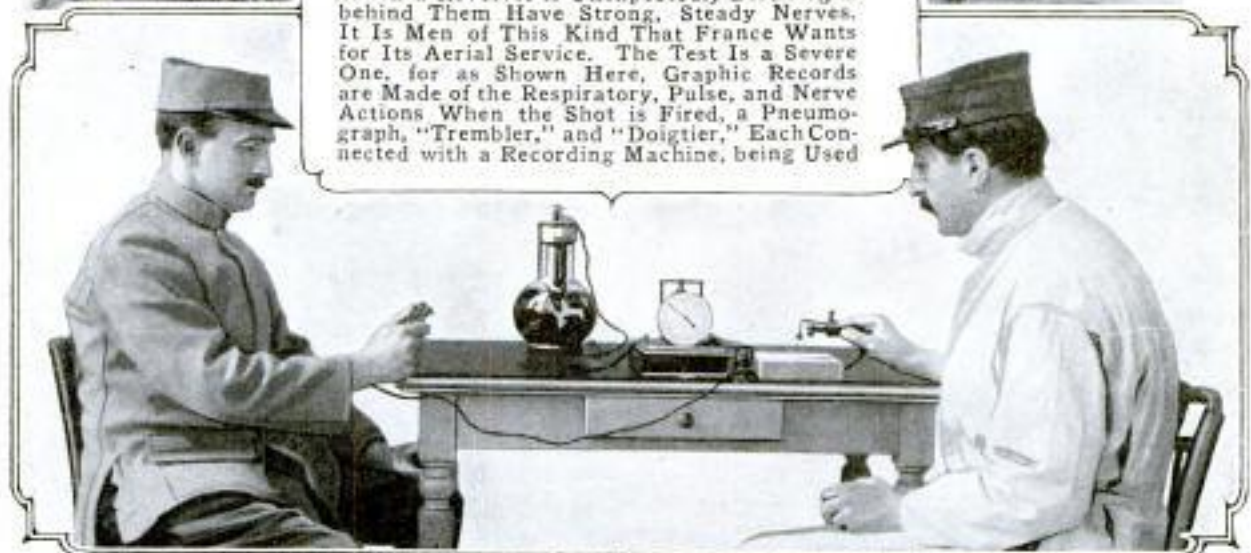

Quickness of Hearing Is an Important Attribute of an Airman. Here a Candidate is being Tested with a Chronoscope. As the Physician Taps a Metal Box with His "Hammer," the Indicator Hand on the Split-Second Dial Begins Moving. The Instant the Subject Hears the Sound He Presses the Switch, Which He Holds in One Hand, and Stops the Timer. The Dial Then Shows at a Glance, in Terms of Hundredths of a Second, How Soon the Man Responded to the Sound



ing tapped without warning upon some portion of the subject's body. Sight is examined similarly, the subject stopping the indicator when he sees the physician has touched the hammer against the table.

The rate of respiration and the heart action are ascertained by a pneumograph and "doigtier" (from the French word "doigt," finger) and an instrument known as a "trembler." The first is fastened about the chest, the second fitted over the first two fingers of the left hand, and the third held in the right hand. Each is connected with a separate stylus that acts on a revolving drum coated with a lampblack preparation. The effect upon the nerves when a photographer's flash light is unexpectedly ignited or a pistol fired from behind is thus recorded by the lines drawn on the drum. The ability of the nerves and muscles to resist fatigue is determined by another device in which the applicant inserts a finger and upon bending it raises a light weight. The finger action is continued until fatigue prevents further movement. Recording instruments in-

dicating whether a man has sufficient endurance properly to manipulate the controlling levers of an air craft for long periods.

2555—

### BUILD HOUSE WITH VARIED PANELS FOR STUCCO TEST

A patchwork building, whose walls are marked off into 56 stucco panels, each of which differs from the others either in material or the method of its construction, is being built in Washington by the Bureau of Standards for the purpose of testing many kinds of stucco. These sample panels of a building material which is rapidly increasing in popularity have been made with bases ranging from concrete to metal lath. The permanence of some kinds of stucco and the rapid deterioration of other kinds have been an incentive in making this test, which is being conducted by the bureau's building-material experts, with the advice of a committee of practical builders from all parts of the country. In the interior, plaster mixtures are being similarly tested on various bases.



A Structure Having 56 Stucco Panels, No Two of Which Are Exactly Alike. Built for the Purpose of Testing Various Kinds of Stucco and the Bases to Which It is Applied



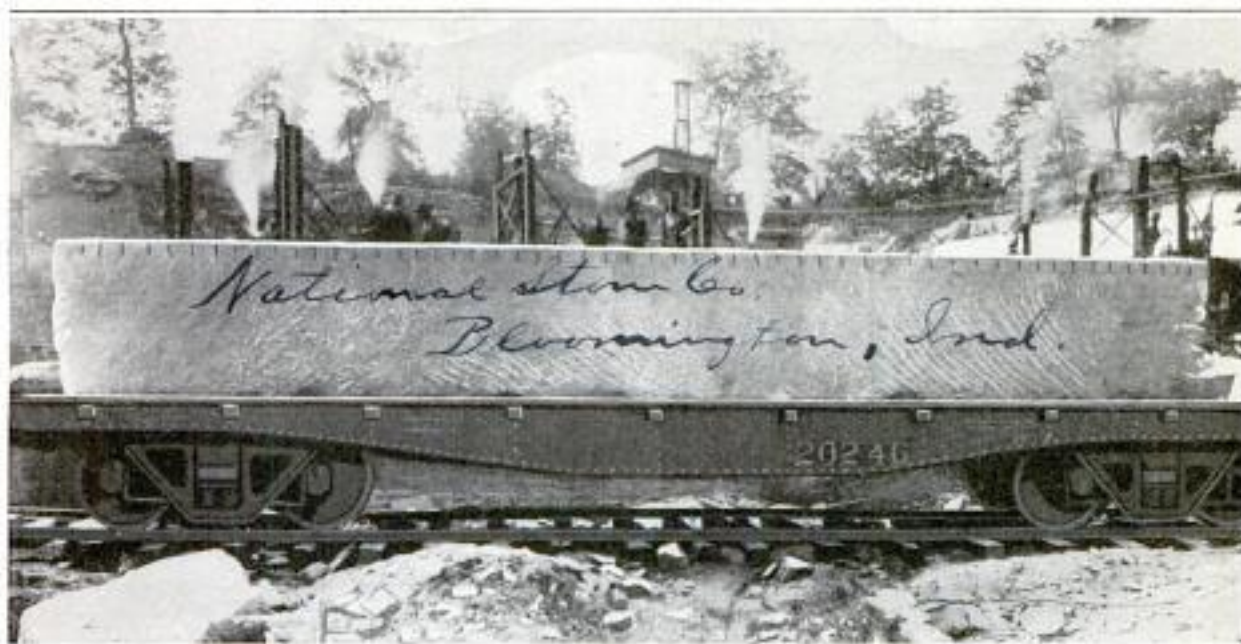

A 66-Ton Block of Limestone, Quarried at Bloomington, Indiana, Which Is to be Made into a Column for a New York Business Building

2914  
**BIG BLOCK OF LIMESTONE  
 COVERS FLAT CAR**

A block of limestone, almost as big as the large steel flat car on which it was loaded, was recently cut in a quarry near Bloomington, Ind. The huge piece of stone contained 776 cu. ft. and weighed 66 tons in the rough. In loading it, the workmen proceeded with great care, two hours being consumed in rolling it 130 ft. However, the stone company filled the order with dispatch, for it was only 33 hours after receiving it that the stone was on the car ready to be shipped. The block was sent to a stone sawmill to be turned into a column for a business building in New York.

2586  
**EYE SHADE FOR OPERATORS  
 OF MOVIE PROJECTORS**

The eyestrain to which many motion-picture operators are subjected because of the necessity of carefully observing the way in which the intense light from the lamp house is focused on the films, may be eliminated by the use of a movable glass screen which has been invented by an operator in Hardin, Mo. It consists of a pane of colored glass set in a metal frame and hinged to the

front of the lamp house by a universal joint so that it can be swung into any position desired. The use of this screen is said to prevent the dimness of vision or partial blindness which often exists for a time immediately after operating a motion-picture projector.



A Colored-Glass Screen Fastened to the Front of the Lamp House Enables the Operator to Watch the Beam of Light, Where It Strikes the Film, without Eyestrain

Inw: A. A. Hughes  
 40 Dr. Chas. D. Weasley  
 Hardin, Mo.



7542

### BIG STUMPS UPROOTED BY LIGHT MANUAL PULLER

For clearing logged-off lands, a very simple and powerful stump puller is made that can be operated successfully

of reasonable size. Its portability, ease of operation, and comparatively low cost are pointed out as features



The Device Attached to Block Cable, Which is Anchored to Stump at Right. Stump to be Pulled Not Shown in Picture

which make it especially suitable for the average farmer who is opening up new acreage. Essentially it consists of a steel framework holding a pair of soft-steel clamps that grip and pull upon a block cable as the operating lever is actuated. When in use, it is securely anchored and a pull cable is looped about the top part of the stump to be withdrawn and made fast to the block. There is no waste motion, since both forward and backward movements

by one man. Exclusive of the cables used with it, the contrivance weighs less than 100 lb., and yet is said to be capable of removing in a few moments either green or old deep-rooted stumps

of the lever operate the mechanism. A distinctive feature of the apparatus is that its speed and power may be regulated to suit different working conditions as they arise.

### FAIR BUILDING IS NOW HANDSOME RESIDENCE

In one of the suburbs of Portland, Ore., is an imposing residence which formerly was the Massachusetts state building at the Lewis and Clark Exposition, held in Portland some years ago. While most exposition buildings are demolished when they have served the purpose for which they were built, this one so appealed to a wealthy patron of the fair that it was purchased and moved five miles to its present site. It was set in the midst of spacious

grounds, and such alterations were made as were required for the convenience of its new owner. The dwelling is regarded as one of the handsomest in the Northwest.



Handsome Residence in a Suburb of Portland, Oregon, Which Was Formerly the Massachusetts State Building at the Lewis and Clark Exposition

# Emma Norton Zimmer  
408 Beck Bldg, Portland, Ore.

House. D. P. ...



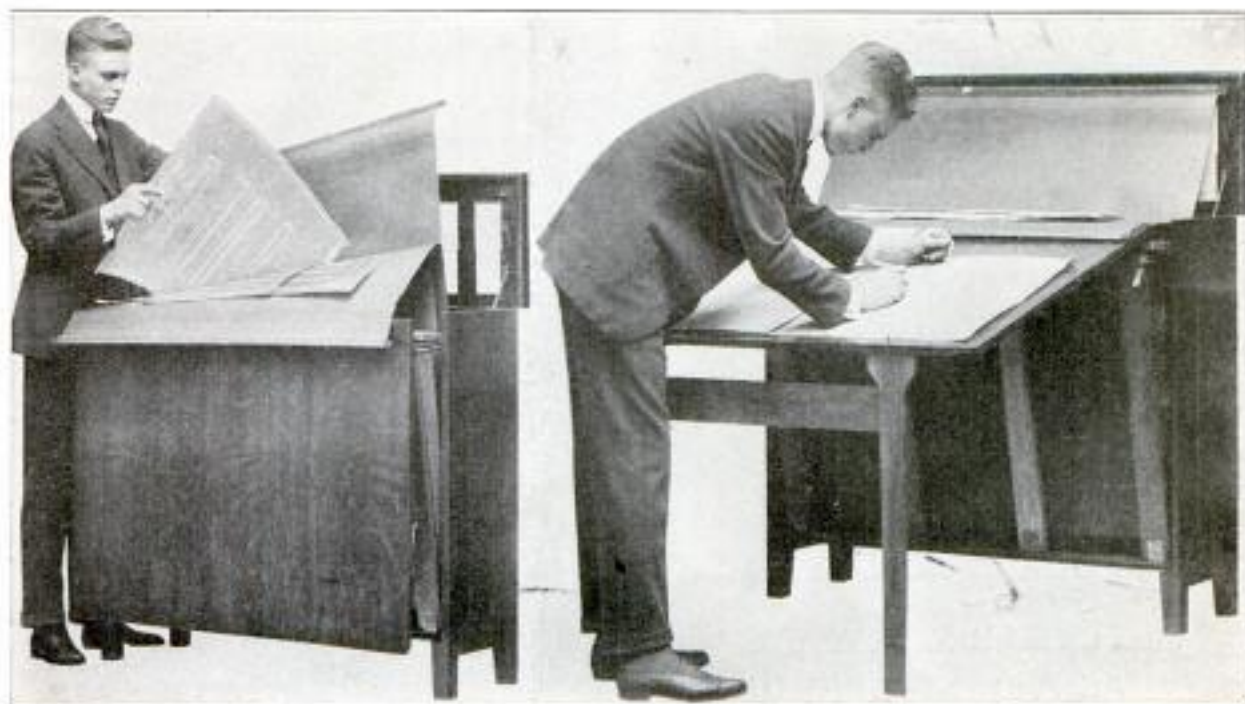

Two Views of a Vertical Filing Case for Blueprints: At the Left the Top has been Turned Back and One of the Pockets, Containing Prints, Lifted from Its Supports. At the Right, the Front Side is Shown Drawn Up to Serve as a Table

3059

**INDEXED VERTICAL FILE  
 FOR BLUEPRINTS**

A careful study of the problem of storing blueprints, drawings, sketches, etc., has resulted in designing a file which, when closed, occupies but 4 sq. ft. of floor space. Material kept in it is not apt to be torn, and remains flat and free from dust. The case stands about 3 feet high and has a hinged top and an especially designed hinged front. The lifting of the top reveals a number of large reinforced Manila pockets, suspended from supports at either side of the cabinet. Each pocket is numbered and contains certain prints which are indexed on cards fastened to the inside of the cover by means of convenient metal holders. By releasing a spring latch the upper end of the front side can be drawn out about 6 inches, thus making more room to get at the pockets. By taking hold of the lower edge of the front side it can be drawn up into a slightly inclined position, thereby transforming it into a drawing or display table, for which two hinged legs are provided. Cabinets are made either of wood or steel.

2783

**INVERTED-CROWN PAVING  
 NEEDS NO CURB**

The streets of a new residence district in Cedar Rapids, Ia., have been improved recently with an inverted-crown concrete paving. That is, the center of the street is a trifle lower than the sides, so that the water drains down through the middle of the thoroughfare. This makes curbs unnecessary and is said to have proven very satisfactory. In case a pavement that is laid without curbs has the usual curved crown the water will eventually wash away the earth under



Newly Laid Concrete Paving in a Residence District in Cedar Rapids, Iowa, Which Slopes toward the Center and Requires No Curb

the edges. This concrete was laid 5 in. thick and 18 ft. wide, with expansion joints inserted every 30 feet.

*Anderson Land Co.*  
 408 Masonic Temple  
 Cedar Rapids, Ia.



3021



Chattanooga's New 2,500-Foot Reinforced-Concrete Bridge, across the Tennessee River, Which  
 Bascule Span of

~~3065~~ ~~3065~~  
**BIG CEDAR STUMP USED  
 AS A BAND STAND**

A city park in Tacoma, Wash., boasts of a band stand which is of very unusual, if not unique, design. It consists of a huge cedar stump on which has been placed a platform with a rustic railing. The stump, which is 15 ft. in diameter, was brought from a near-by forest and placed on a concrete foundation. It has been hollowed out so that it contains a room 10 ft.



A Cedar Stump, 15 Feet in Diameter, Which Serves as a Band Stand in a Tacoma, Washington, Park

square. This interior has been furnished with a table, benches, and racks, and serves as a shelter for picnickers.

~~3065~~  
**SOUTHERN CONCRETE BRIDGE  
 HAS LONG BASCULE SPAN** 3021

To establish a connecting artery between North Chattanooga and the city proper, a long reinforced-concrete bridge is being erected across the Tennessee River. The structure is particularly of interest because the center span, bridging the main channel, is a jackknife bascule of 300-ft. reach. On account of its vertical clearance, which is 72 ft. when the river is at normal level, it will be unnecessary for the span to be opened for navigation except when the water is unusually high. Electric motors controlled by a single engineer will operate the leaves during such periods. The bridge, when completed, will be about 2,500 feet in length and in addition to the central steel section will consist of four arches of 180-ft. reach, two 165-ft. ones, and nine 40-ft. spans, the latter forming the approaches. It will provide a 36-ft. roadway for vehicular traffic, and on either side will have 6-ft. passages for pedestrians. The floor, which is to be paved with wood blocks, will also support a two-track car line. Work on the structure was begun two years ago and is now approaching completion. Peculiar conditions encountered in the river bed, and exceptionally high stages of water, have combined to make the construction an engineering problem of much difficulty.

Yang Const'n Co.,  
 Chattanooga,  
 Tenn.



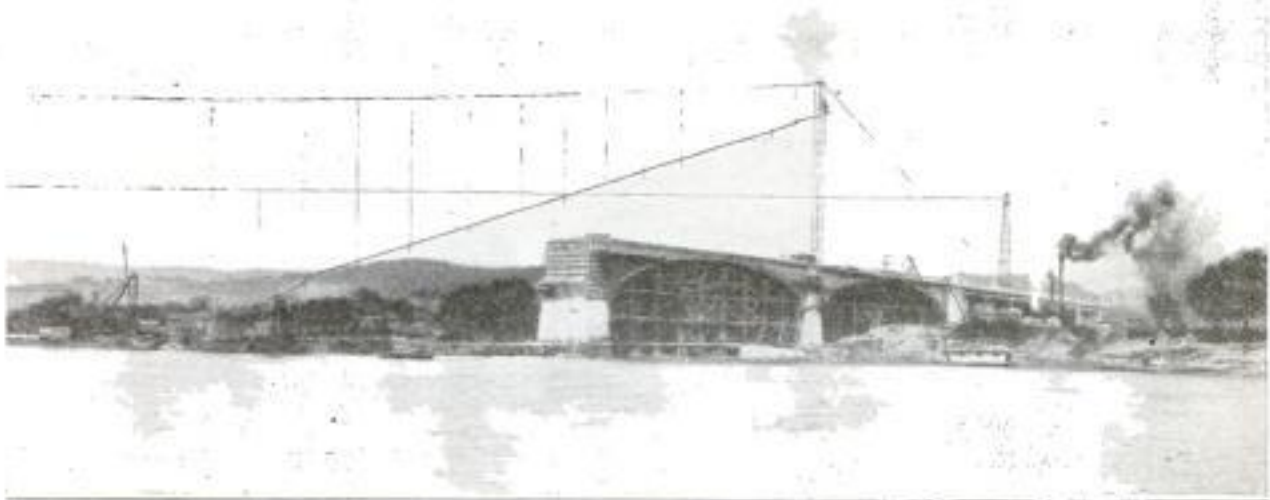

is Now Nearing Completion. The Main Channel of the Stream is to be Bridged by a Jackknife  
Noteworthy Length *3165*

### SEEK TO MAKE KITCHEN IN HOTEL ABSOLUTELY CLEAN

Sanitary precautions, the equal of which perhaps have never been taken by any other hotel, are to be observed in equipping and operating the kitchen of a very large hotel to be erected in New York City. No food of any sort will remain uncovered in the kitchen, unless being cooked in an open dish, and yet all food will be in full view behind or under conveniently pivoted glass covers. All raw materials will be conveyed from one receptacle to another by machinery. The bulk of the work, which helpers and cooks have formerly done by hand, will be done by machines, such as paring fruits and vegetables, making bread, cutting butter patties, mixing salads, etc. All employes will be trained to be as scrupulously clean as attendants in a hospital operating room. Each one will be required to take a bath every morning at the hotel and to pass a daily examination by a health inspector.

*3010*

### ROLLER SKATERS RACE FOR —THREE MILES IN SEWER

A big storm sewer in Pasadena, Calif., recently served as the course for a very unusual race. Three young men on roller skates raced through the concrete-lined passageway from Colorado

Street to the outlet in South Pasadena, a distance of three miles. Each skater illuminated his way with a flash light. The concrete floor of the big tube was not very smooth in spots, and the contestants found some rather rough going. In spite of this the winner, who was a high-school boy of 15, covered the distance in 16 minutes. His two opponents, both skaters of local reputation, finished about a quarter of a mile behind him.



Three Pasadena Young Men Racing on Roller Skates through a Big Storm Sewer. The Winner Covered the Prescribed Distance of Three Miles in 16 Minutes

*Beit Gould*  
*Frank Donaldson*  
*Wilbur Keith* | *Pasadena*

*Hotel Commonwealth*







# FESTIVITIES CONDUCTED FROM COAST TO COAST

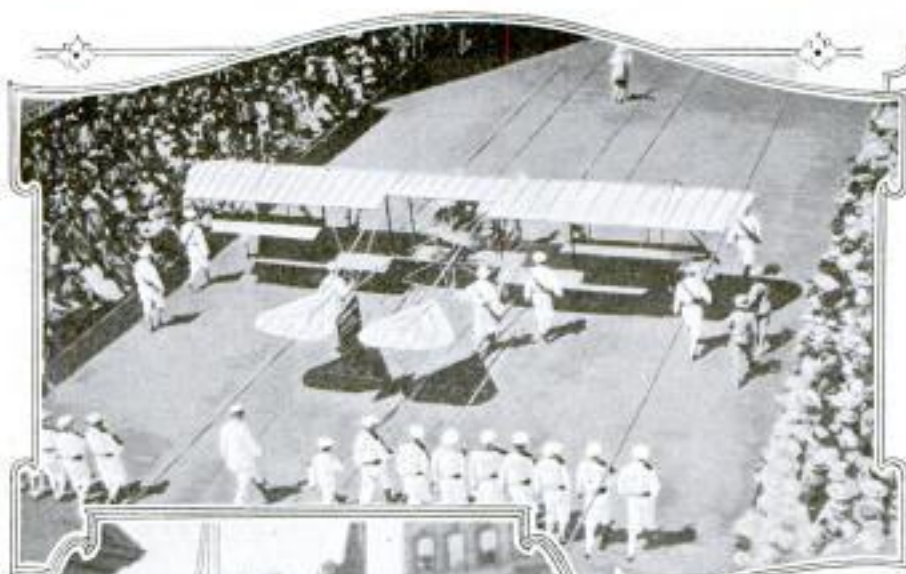

Military Biplane Proceeding under Its Own Power during the Preparedness Parade Conducted at Los Angeles Some Time Ago. The Sight of the Big Machine Traveling in the Streets, Much as if It Were a Motor Car and Entirely Accustomed to Paved Thoroughfares, Evoked Surprise. It was Closely Followed by Marines Who Assisted in Turning the Craft When Corners were Negotiated



PHOTO COPYRIGHT INTERNATIONAL FILM SERVICE  
 Mobile Wireless Plant of Police Signal Corps as It Appeared Recently When 3,000 Khaki-Clad Members of the New York Police Department Passed down Fifth Avenue upon Their Return from Staten Island, Where They had Spent Their Vacations as Rookies. They were Reviewed by City, State, and Federal Officials. It is the Intention to Keep the Radio Equipment in Commission for Possible Emergency



PHOTO COPYRIGHT UNDERWOOD & UNDERWOOD  
 This Odd and Rather Effective Monument, Covered with Fruits and Vegetables, was Erected on the State Fair Grounds at Syracuse, New York, by Upstate Farmers and Orchardists. Although a Mongrel, Architecturally, the Richness and Variety of Its Colors Made It Attractive in Appearance



Headed by Veteran Riders of Old "High Wheelers," 500 Cyclists Participated in a Procession That Was One of the Features of the San Francisco Bicycle-Day Exercises and Races at Golden Gate Park



### DAIRY STABLE FURNISHED LIKE A HOME

Several features strike the visitor to the stable of a certain dairy in Port-



Striking Features of This Dairy Stable Are the Ferns above the Stanchions, Pictures on the Walls, Curtains at the Windows, Screens over All Openings, and a Washstand with Running Water

land, Ore., as quite remarkable. Pictures hang upon the walls; ferns are placed above the stanchions; the windows are screened and covered with

freshly washed curtains; the doors are doubly screened and at one side of the stable is an enamel washbowl with running water. Such unusual conditions are due, in part at least, to rivalry which has sprung up among Portland dairymen, who must obey rigid city rules regarding the production of clean milk. At this dairy each cow is bathed before entering the stable and her bag washed with warm water, soap, and a freshly laundered cloth. The milk is strained through sterilized cotton batting. The cows are never hurried or frightened, and on returning from the pasture are allowed to move along leisurely.

The milk in this dairy has improved considerably in purity, the number of bacteria found in it being much lower than in milk from the average dairy.

2825

### STRONG INEXPENSIVE ROPE MADE BY SIMPLE MACHINE

A simple twisting machine, which is being introduced among farmers particularly, can be used in making a number of useful articles. It is patented and is employed chiefly in making rope from binder twine, and such cordage is said to be not only stronger than ordinary rope, but also cheaper. The cord or twine that goes to make up the principal strands of the rope are first caught over hooks that project from a side of a circular iron case containing gearing. By turning a crank the hooks are made to revolve. A device called a threader is used with the machine which is simply

a handle, at one end of which are two short diverging arms over which the loops of twine are caught. In preparing to twist a rope the twine is threaded back and forth over the hooks and the corresponding arms of the

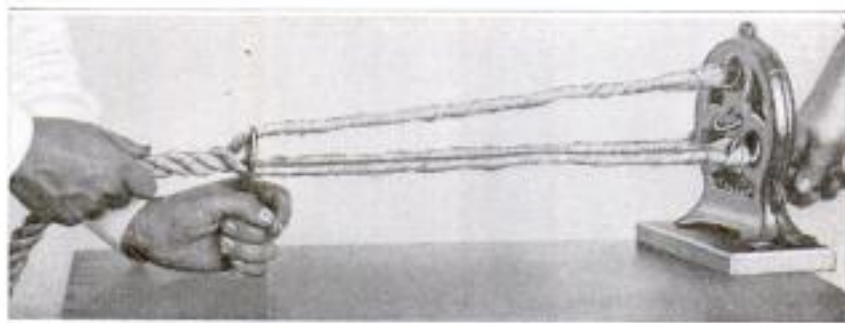

Making Rope from Binder Twine: A Simple Machine Which Twists the Strands About One Another. The Threader, at the Left, is Used to Keep the Strands Separate and to Make Them Twist Evenly

threader until the desired number of principal strands, which generally is three, will have the desired number of individual strands of twine. When this has been done, one person begins turn-

New Era Mfg Co.  
Plymouth Bldg  
Minneapolis, Minn. Copyrighted material





Above: View Showing a Section of the Main being Lowered into the End of the Trench. Left: Crane Lifting a Section Weighing Four and One-Half Tons

ing the machine while another holds the threader. As the cords in each group twist about one another, so too the strands, which are being made in this way, will tend to twist about each other at the far side of the threader. To make an even rope the threader is moved toward the machine at a slow, even speed. A fourth central hook in the machine is used to finish off the ends so they will not unravel. Fish-line, rag-rug rope, silken cords, etc., can all be made with this machine. It can also be used for splicing rope and thus often proves itself a valuable time saver in emergencies.

3034

### BIG WATER MAIN LOWERED UNDER RAIL CROSSING

The recent elimination of a grade crossing in Cleveland involved the lowering of a 36-in. high-pressure water main to a depth of 24 ft. This was a task calling for considerable skill, since some of the sections of the main weighed four and one-half tons. The trench in which this big pipe was relaid was 10 ft. wide at the bottom, to give plenty of room for the workmen and also to allow for bulging that might take place if the earth gave way and pressed against the temporary retaining walls which were placed at either side. Bracing beams were placed from wall to wall at frequent intervals and all sections of the big main were lowered by a crane at one

end of the trench and then moved along into position. Six men, with the aid of the crane, laid practically all the pipe at the crossing in one day. A centrifugal pump, with a capacity of 10,000 gal. an hour, kept the ditch dry by carrying off water that seeped into the cut.

3076

### EIGHT-HOUR CLOCK DIAL FOR NEW TIME SYSTEM

A San Francisco jeweler has been exhibiting a clock with an eight-hour dial. This novelty in timepieces is constructed to illustrate a proposed system of timekeeping whereby the day is divided into three eight-hour periods, the first beginning at midnight, the second at 8 a. m., and the third at 4 p. m. Near the center of this eight-hour dial is an opening in which the letter M, for "morning," appears during the first period, N, for "noon," during the second period, and E, for "evening," during the third period. These periods correspond roughly to the rest, work, and recreation hours of the average person's day, and so in that respect the new system does not suggest a radical change.



COPYRIGHT, J. P. BECKER

Sorenson & Co.  
715 Market St  
San Francisco

Under N. Y. C. & St. L. R.R.



## HUGE TERRA-COTTA SIGN BUILT HIGH IN WALL

The office building erected by one of Omaha's leading banks is so situated that one of its outside walls overlooks



A Conspicuous Sign Which is Made of Terra Cotta: It Measures 14 by 44 Feet and Stands 200 Feet above the Street

a number of low shops and can be seen a long distance in the business district. Taking advantage of this conspicuous wall space, the owners have built the name of the bank into a blank panel in the wall situated near the top of the structure. This sign is made of green terra cotta and is 14 ft. high and 44 ft. long. The letters project 1 in. from the wall, which is of white brick, and so are made very prominent. Beneath the sign an iron balcony is to be constructed to support powerful electric lights for the purpose of illuminating the lettering at night. The sign is 200 ft. above the street. The upkeep cost of this fine sign probably will be small.

## EMERALDS MORE COSTLY THAN DIAMONDS

In the mind of the average person the diamond is regarded as the most valuable of precious stones, but as a matter of fact large flawless emeralds are a great deal more costly than diamonds of similar size. One of the considerations that makes these rich green gems so high-priced, if perfect, is that they are seldom free from flaws. According to the Smithsonian Institution good diamonds at the present time are worth from \$250 to \$400 per carat, according to purity and size, whereas an emerald varies from \$350 to \$500, the price increasing rapidly with size. Flawless emeralds weighing more than four carats are practically priceless, but diamonds of that size are worth only \$1,000 or \$2,000. Another factor which contributes to the high price of emeralds is that they are hard to imitate and, unlike some green stones, retain their color when heated and when subjected to artificial light. This latter fact makes them particularly desirable for evening wear.

2050

## WINDOW PANES EASILY SET WITH GLAZIER'S HAMMER

For setting panes of glass in window and other frames, a hammer is available which facilitates the work by giving a glazier perfect freedom in driving points, and also lessens the liability of accidental breakage. The tool is but little heavier than an ordinary tack hammer and provided with a double-faced head of trapezoidal form. Because of the shape of the faces, which have angular sides, the handle of the tool slants away from



Because the Head of This Hammer Has Angular Sides, the Handle Slants from the Surface of a Pane of Glass and Permits a Glazier to Work Freely

the flat surface of the glass when being used, thus permitting a workman to strike the points squarely and without difficulty.

W. H. Mays Co.,  
Peru, Ill.



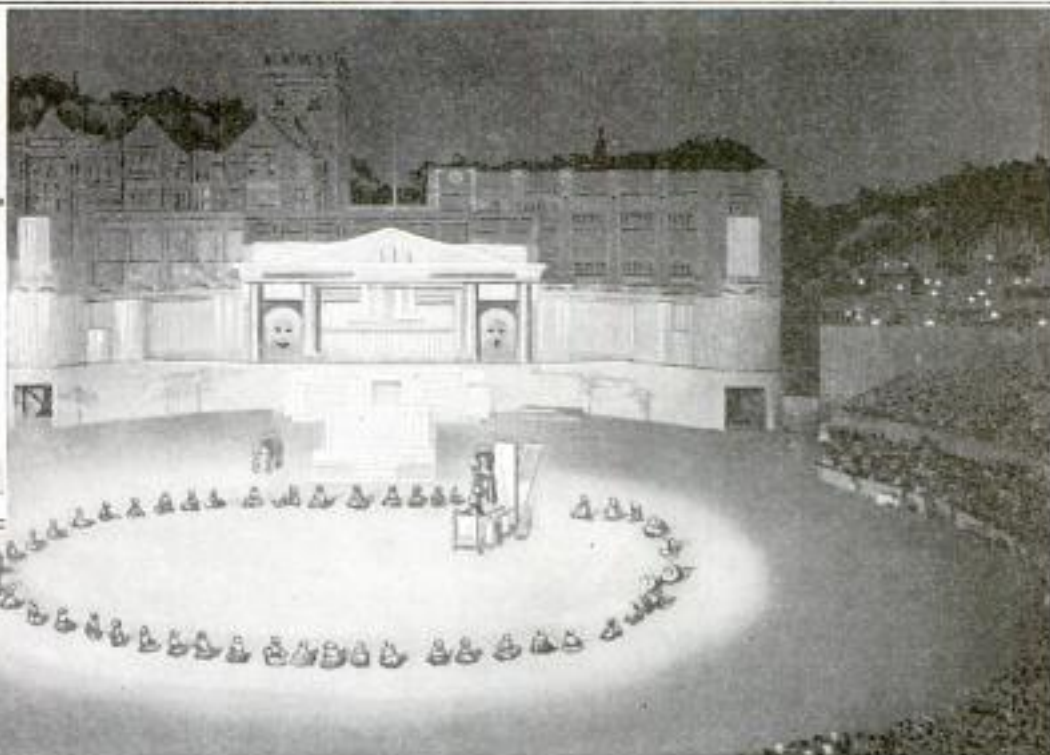

Flood-lighting a Circular Area 100 Feet in Diameter in the Middle of the Stadium, Where Much of the Masque was Presented. It was Accomplished with Nitrogen-Filled Incandescent Lamp Projectors Which were Hidden from the View of the Audience so Completely That the Source of the Illumination Was a Matter of Speculation

2947  
**INCANDESCENT LAMPS USED  
FOR PAGEANT LIGHTING**

Splendid lighting effects were obtained during the production of a Shakespearean masque in the stadium at the College of the City of New York some weeks ago. Rather difficult conditions were overcome in a very creditable manner, and the interesting point is that high-power, nitrogen-filled lamp projectors were employed almost to the entire exclusion of arcs. The stadium has seating capacity for about 20,000 persons and presents large areas for illumination. The stage is more than 300 ft. from the tower where the battery of lamps was mounted. In a ring of 100-ft. diameter, in the middle of the stadium, some 1,500 actors performed. The spot was flood-lighted in a most striking way. Varicolored illumination of the different settings, lighting of the stage with scenic effects, and screening the stage from the view of the audience by a curtain of light were some of the other things accomplished. Although abundant light poured upon restricted areas, the

spectators were unable to determine its sources. By telephonic communication with various operators, the stage director controlled the lighting effects. Several lamps with glass-lined reflectors were placed in front of the stage settings and directed toward the tiers of seats while the audience was filling the stadium. Because of their distance from the spectators, their glare was not objectionable, although sufficient to screen the stage completely. By concentrating spot and flood lights so that the attention of the spectators was riveted upon the performers, removal of used and the setting of new scenes could be carried on without notice. Then, by dimmers, the light was dissolved from one setting to another.

— 2960  
**PORTABLE SCALE WEIGHS  
STREET SWEEPINGS**

A portable spring scale of unusual design has been constructed for the Citizens' Street Cleaning Bureau, Chicago, and is employed in weighing the sweepings deposited in the various

615 Old Colony Bldg  
Chicago.



refuse boxes, which are set along the street curb. The device consists of an

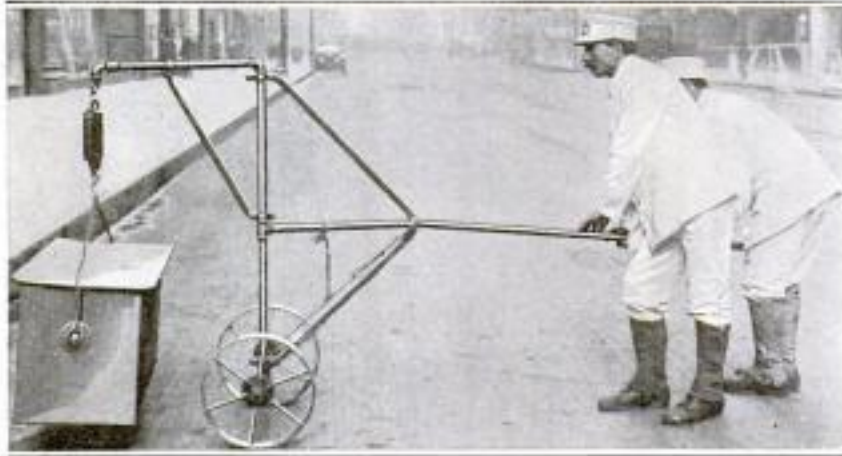

An Unusual Type of Portable Scale Used in Chicago to Ascertain the Amount of Work Done by Each Employee of a Street-Sweeping Association

iron framework supported by two wheels and having an arm projecting in front from which a spring scale is

suspended. The truck is pushed about by a long handle. When a box is to be weighed a chain is fastened to the knobs projecting from either end of the container, and the hook of the scale is caught in the chain. To throw the weight onto the spring it is only necessary for the sweeper to press down on the handle, which results in lifting the refuse box off the ground. The device is used from time to time in ascertaining the exact amount of sweeping

each workman does and also the amount of refuse which collects in various blocks.

2853  
**DOOR BUILT TO RECEIVE  
 DELIVERED GOODS**

The problem which arises when the delivery boy finds no one at the address to which he is to deliver a package, has been solved by constructing a



Left: The Door from the Kitchen Side, Showing the Manner in Which Parcels can be Left in It Even When the House is Locked. Right: View of the Kitchen Door from the Outside

kitchen door with which has been combined a sort of cupboard. The lower half of the outside of this door is divided into hinged panels, each of which, when opened, reveals a small compartment. These are of various sizes and labeled on the outside for meat, groceries, laundry, the daily paper, milk, etc. The shallow cupboard, which is made up of these compartments, projects but a short distance into the kitchen. Access to the cupboard from the kitchen side is gained through a single large door. It will be found that this device will save both the delivery boy's time and the housewife's time, since all packages can be deposited in it without delay. It also does away with the necessity of allowing strangers to enter the kitchen. The hinged panels are left open when a delivery is expected, and after being pushed shut by the delivery man cannot be opened from the outside.

On its return trip the "Gullfoss," the first Icelandic ship to sail to America in historic times, included in its cargo a consignment of musical instruments from Chicago.

*Sollitt Kitchen Door Co.  
 407 Recovery Bldg.,  
 Chicago*



2806

# Lewis R. Freeman  
28 Montague St. Russell Sq.  
London, W. C.

# TRYING TO BEAT THE BLOCKADE

287 E Calif. St. Pasadena Calif.  
Things the Drognet of the British Postal Censorship Catches in the  
First-Class Mail

By R. J. BJURSTEDT.

IT was early in the present year that a search of the baggage of a German lady who was booked to sail from New York to Rotterdam by a Dutch liner revealed the astonishing fact that three of her 15 trunks were filled with sole leather and the remaining 12—of an aggregate weight of over a ton—with hunks of crude Para rubber. In her stateroom were found a suitcase full of dental rubber and a box of honey jars filled with rubber solution. To cap the climax, several hundred yards of pure-rubber surgeon's bandage—weighing close to fifty pounds—swathed her body from hips to shoulders. She was led into the searching room a stout waddling Fräulein of apparently 200 pounds, her ample figure fairly bursting the hooks and seams of her fashionable traveling suit; she came out five minutes later a scrawny dame of 150 floundering in the folds of the same suit like a contestant in a sack race.

I told this story to an official of the British postal censorship in the course

of a recent visit I paid his remarkable establishment through the courtesy of the war office.

"Very well," he laughed; "you have seen what the Germans have tried to do with the females in order to get the rubber and other things of which they are short. Now you shall see what they have tried to do with the mails. I will show you practically every article, from imitation pearls and brass jewelry to bags of rice and rolls of tanned cow-hides, that you might expect to find in a modern German industrial exposition; indeed, I am able to show you a few things that have heretofore not been displayed in any kind of an exposition, such as, for instance, models of little steel hooks to be mixed with oats and fed to horses."

It is not my purpose here to touch upon the technical aspects of the British blockade, but merely to mention a few of the things which have been stopped by England in their passage through the first-class or letter mail and let my readers draw their own con-



One Corner in the British Postal Censor's "Library" and "Museum." Classified in the Cases at the Left Is Propaganda Matter of Every Description, and at the Right, German Goods Taken from Outgoing Mail



clusions as to whether the action is justified or not. I might mention in passing that the presence of some of



Rice and Ham Caught by the Censor. The Wrapper in Which the Meat was Mailed, at a Cost of Four Dollars, is Shown at the Left. The Rice was Packed in a Roll of Newspapers: A, Sack of Rice; B, Rolls of Paper, and C, Newspaper Wrapping

the bulkier articles in letter mail, at first-class rates, throws an illuminative side light on Germany's needs of certain lines for which all her ingenuity has failed to provide entirely satisfactory substitutes.



Pair of Shoes, Wrapped in a Large Piece of Sole Leather and Mailed at the Letter Rate, About \$2.50. Thousands of Such Articles Are Kept in the Censor's "Museum"

times in value or weight by similar things stored away in great ware-

houses. That black chunk of Para rubber represents the many tons of the valuable caoutchouc that had tried to make its way to Germany in the letter mail; that tube of red litharge, many tons of the valuable oxide of lead; that pair of stout shoes, many thousand cases, and so on. One of the most arresting displays is a 10-ft. long roll containing a single cowhide, the wrappings still bearing something over 40 dollars' worth of American stamps.

This hide, with other articles such as boots, beltings, and bars of various metals, were evidently sent quite openly in the hope that the fact that they were consigned to the letter post would carry them through in any event. Other things—especially since it became known abroad that the British were searching the first-class mail bags—displayed the greatest ingenuity in the

manner in which they had been disguised or concealed. One of the cleverest things was a "honeycomb" made of pressed sheets of thin yellow rubber, filled with a "honey" of rubber dissolved in benzene. In several instances the "honey" was even found to

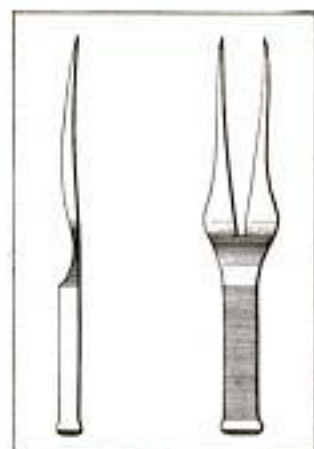

Tiny Grain-Colored Steel Porks Found by French in Oats Shipped from America. Deaths of Many Army Horses from Perforation of Bowels Caused Discovery

have been sweetened by the addition of a little corn sirup, something that could easily be "washed" out as occasion arose for the solution again to perform its functions as rubber. Thin sheets of superfine dental rubber often appeared stuck between cardboards, and the corrugations of the pasteboard used to protect photographs made convenient nests for slender bars of nickel and aluminum, hundreds of pounds of both of which have been snagged in the censor's net. Photographs were formerly passed along unopened, but



the discovery of the extent to which they were being employed as "carriers of merchandise" finally brought them under the ban. Now practically nothing from a post card up goes unscrutinized.

Many of the most ingenious schemes for smuggling appear to have been worked out in Germany and transmitted to overseas Germans by post; indeed, several of them were discovered through the reading in England of outgoing letters from the Fatherland. It was in this way that the first hint was obtained of the plan to mix the small steel hooks in the oats that were being bought by the allies to feed their cavalry horses. Models of these hooks, similar to that shown in the accompanying cut, were found in the mails to both New York and Buenos Aires, with the gruesome commentary that "exhaustive experiments had proved their absolute efficiency." There were also drawings of the machinery by which they should be made, directions for giving them a "protective" yellow coloring in some kind of a chlorine bath, and suggestions as to the best means of "planting" them "where they would do the most good." Although such precautions as were

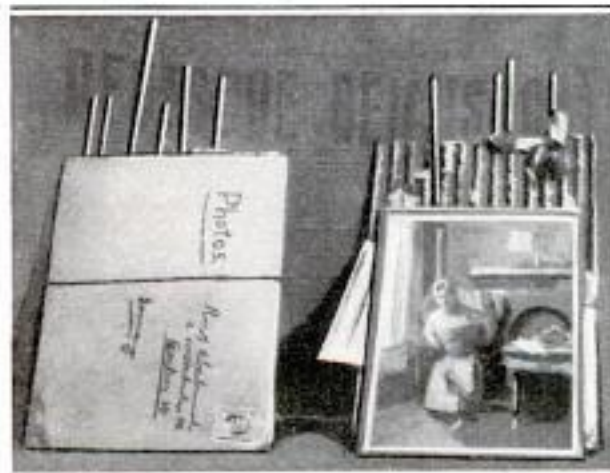

Bars of Nickel, a Much Needed Metal in Germany, Found Concealed in the Corrugations of the Cardboards Protecting a Photograph Mailed to a Private Address in Berlin

practicable at the time were taken to minimize the danger from this menace, considerable quantities of these cruel devices appear to have been success-

fully "planted," and a few—mercifully, a very few—to have effected the terrible end for which they were designed.

Rice has been appearing in rapidly increasing quantities in the recent



Rubber in Different Forms, Even Molded in the Shape of Golf Balls, Culled from the First-Class Mail Matter by Alert Censors

seizures, and the similarity of the methods employed in concealing the bags, which are mailed from all quarters of the globe, seems to indicate the "Made in Germany" origin of the very clever scheme. About a pound of rice is sewn up in a little cylindrical bag approximating an inch in diameter and a foot in length. At each end of this, whorls of tightly rolled newspaper of the same diameter are placed, and around this central core several heavy newspapers are wrapped and bound firmly with a network of stout twine. The stamped and addressed package, with its ends open for inspection as required, looks perfectly innocent, and feels perfectly innocent, and it is probable that a good many of the fat rolls of foreign newspapers went through unsuspected until a leak gave one of them away one day and resulted in holding up the whole stream for "the duration of the war."

So popular have ukuleles become that the Hawaiian output of these musical instruments has increased in a year from approximately 500 to 1,600 a month, without being able to meet the demand.



# A. N. Brown.

Mo. Valley, Ia.

84

2976

POPULAR MECHANICS

SIXTY-TON BRIDGE MOVED OVER TWO MILES

A highway bridge, mounted on trucks, was recently drawn through the



crete floor and weighed 60 tons, was mounted on three mover's trucks, two at the forward end and one at the rear. It was drawn slowly along the thoroughfare by means of a cable and capstan, turned by a team of horses. Braces were fastened above the rear end of the bridge to prevent sagging of the frame.

streets of Missouri Valley, Iowa. Instead of erecting a new bridge at a certain site, the unusual procedure of moving this structure from its original base to the new location was proposed. To do this the bridge, which was of steel construction with a con-

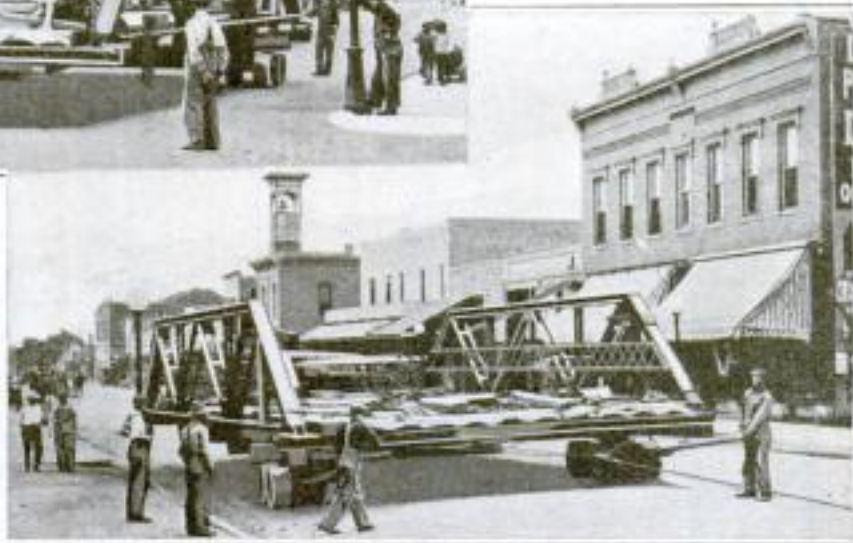

Above Is a Rear View and Below Is a Front View of a 60-Ton Highway Bridge on Its Journey of Two and One-Half Miles through Missouri Valley, Iowa

1735

PIPE PUSHER LESSENS DITCH DIGGING

A pipe pusher has been devised which is intended to lessen the amount of ditch digging necessary to lay water and gas

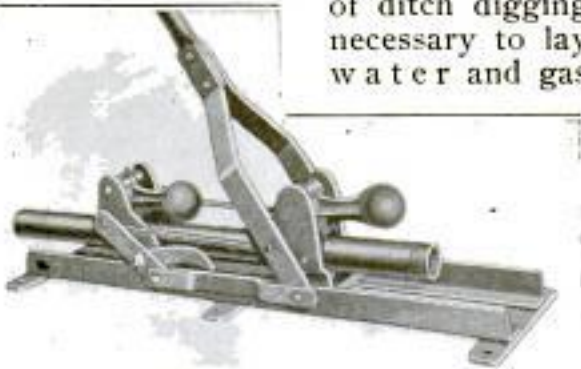

A Machine with Strong Leverage That Forces Pipe through the Ground, Thereby Lessening the Amount of Digging Necessary to Lay the Pipe

pipe. It consists of a set of clamps and levers mounted on a metal framework which can be staked securely to the ground. The pipe is inserted between the clamps and, by operating a handle back and forth, it is forced into the ground a few inches at each stroke. It is claimed that a pipe can be driven 50 or 100 ft. in this way. Thus it can be pushed through the earth from a cellar to a main in a street, or to a cistern near by. The machine can be employed also to draw out old or damaged pipe.

(The War Department has recently purchased 27 American-made cars of the caterpillar type.

Giant Mfg. Co., Council Bluffs, Ia.



**CONSTRUCTION OUTFIT MADE FOR LINE WORK**

To lessen the labor cost and facilitate the reconstruction and extension of telephone lines, a cable-handling and general-construction machine has been devised which enables three or four men to accomplish quickly what ordinarily requires a gang of a dozen or more a longer time to complete. The equipment, mounted on a stanchly built horse-drawn wagon, will load and transport cable or wire reels of various sizes, wind or unwind them, and wind from one spool onto another. Furthermore, it is designed to pull cables through or out of underground conduits, and wind up or down aerial cables or wires. It includes a hoisting apparatus which permits a 60-ft. pole to be lifted on end and lowered into a hole, or removed and placed on the ground. A stationary gas engine supplies the operating power. The frame and lifting lever are supported by the rear axle, which is U-shaped and made of forged steel. A strong pulley is attached to this shaft and connected with a sprocket on the drum shaft by a chain, when winding is to be done. The derrick is 18 ft. in length and when mounted for use rests across the reel shaft. The hoisting rope is extended from the drum through a sheave at the end of the boom and fastened near the boom seat. It requires little labor to remove a reel and rig the derrick.

**SPECIAL EARCAP FOR TELEPHONE RECEIVER**

With a view to making a telephone receiver transmit sounds more clearly under varying conditions, a special earcap has been invented, which takes the place of the regular earcap on the receiver. In shape this device resembles the part which it displaces, except that there are several vents or indented channels which radiate from the center of the cap to the rim. These allow the passage of air in and out of the ear, even though the receiver is pressed close against it. The purpose of this is to prevent indistinct or conflicting sound waves striking the ear drum. It is the claim of the inventor that this form of an earcap relieves sensitive parts of the ear from strain in using a telephone and prevents the deafness and even general nervous disorders that sometimes afflict switchboard operators.



*Construction Phone Co. Inc. New York.*

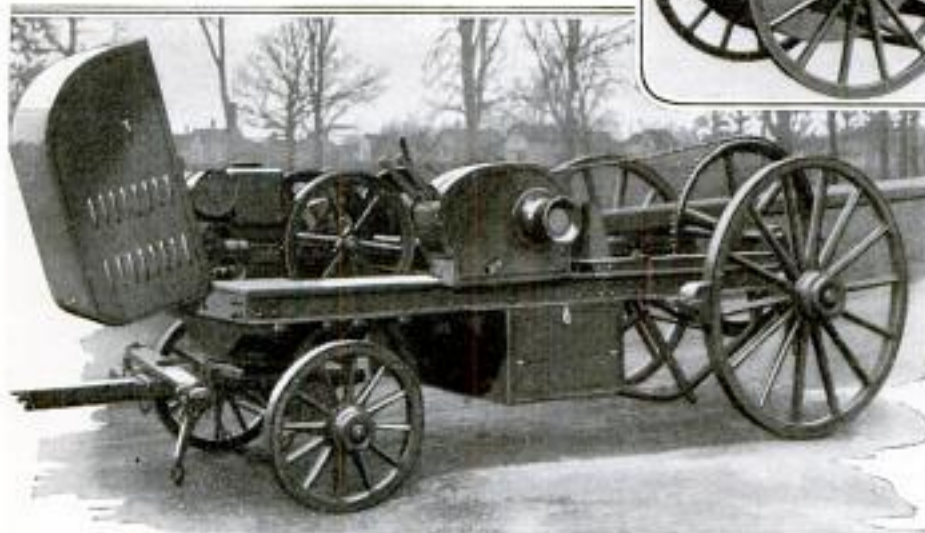
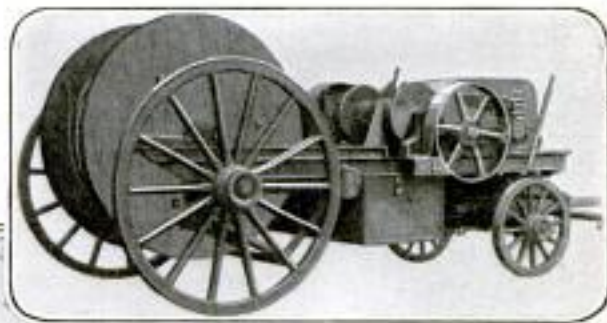

Two Views of the Telephone Construction and Cable-Handling Apparatus, the One Above Showing a Reel in Place for Unwinding, and That at the Left Indicating How the Derrick is Mounted. In Addition to Placing and Removing Poles, the Equipment is Arranged to Pull Lines through and Out of Underground Conduits and Do Other Work. It is Said to Cut Labor Cost Materially



**THIEF AND WEATHER-PROOF  
VENTILATOR FOR CAR**

Weather-proof car-ventilating shutters constructed of malleable iron and so designed that they can be sealed



Ventilating Shutter can be Sealed in Any Position and Provides an Opening of Generous Size Which is Also Said to be Burglar-Proof

either when opened or closed, are being introduced. The appliance is produced in two types, one of which is intended solely for ventilating purposes, and the other supplied with an opening that facilitates the loading of lumber and similar materials. As a ventilator, the device is suited for either box or fruit cars. Its installation is not restricted to the ends of a car, for if it is desired, the appliance may be put in the side walls and made to take the place of ventilated doors. The two types are made of standard parts heavily riveted, are interchangeable, and provide air passages of generous proportion. Furthermore, whether opened or closed, they are claimed to be burglar-proof. The ventilators should outlast the cars to which they are applied.

**DAILY AERIAL TRIPS MADE  
ACROSS ENGLISH CHANNEL**

*Phila. Ho. American 10/4/16*

In writing from France some weeks ago, one of the American correspondents gave a detailed account of how the British replenish their supply of air craft on the Somme front by flying new planes across the channel from factory to field. During favorable weather the trips are made almost daily, a dozen or more machines being driven into France, the pilots returning to England by steamer, after making the delivery, to repeat the routine the following day. The particular flight of which he writes was completed in 17 minutes, although better time is made when the crossing is undertaken at a narrower point. To those who recall the pioneer days of the aeroplane, these daily flights from England to France, made in as matter of fact a way as if motor trucks were being delivered overland from South Bend to Chicago, hold deep significance. It is only about seven years since the whole world cheered Louis Blériot when he flew a midget monoplane from Baraques to Dover and won the London Mail's \$5,000 prize. Blériot traveled about 23 miles in 37 minutes with a fragile craft, the framework of which weighed only 42 lb. It was powered with a three-cylinder, 22 1/4-hp. motor of 132 lb. The contrast shows in a most striking way the progress attained in aerial navigation during a most brief span of time.

3130

**THOUSANDS WATCH FATAL  
ST. LOUIS FIRE**

One of the most spectacular fires which St. Louis has witnessed in years took place recently when flames completely gutted the central building of Christian Brothers College in that city. Ten persons lost their lives. The building was situated on a high hill and was surmounted by a large dome, visible far and near. Thousands of persons assembled at distant points and on the school campus to watch the fight which the firemen waged against

# Jos. R. Eisen  
700 Dolph Bldg.  
3436 Montana St.  
St. Louis.





View of Wrecked Rotunda of College Showing Unharmed Statue of St. La Salle



View of Main Entrance After the Roof Collapsed. The Line of Hose Seen on the Steps was Cut by Falling Debris



One Man Jumped to His Death When He might have Used the Fire Escape Shown at End of Wing

the flames. For some reason the fire walls in the building did not stop the progress of the blaze and it ate away the supports of the dome, which fell down through the rotunda and through the main floor into the basement. Later an interior wall collapsed, killing six of a group of firemen located on a lower floor. One of the unusual features of the fire was the fact that a statue of St. La Salle, founder of the order of Christian Brothers, escaped damage. The statue stood at one side, in the rotunda, and when the dome fell it brought with it large portions of the railed balconies on the various floors, but the figure of the saint was hardly touched. One man lost his life leaping from a fifth-story window when he might have used a fire escape not far away. The total damage to building and equipment was \$275,000, it is estimated.

2670—  
**TWO-CHAMBER OIL FORGE  
 BURNS BUT ONE FLAME**

An oil-burning forge has recently been manufactured in which a single flame is made to do nearly twice the amount of heating that it does ordinarily. This increase in efficiency has been secured by placing a second heating chamber above the one commonly found in such forges and by so direct-

ing the flame that it heats both compartments. The temperature in the chamber immediately above the oil burner is, of course, slightly higher than in the upper one. For this reason the work is first heated in the upper chamber and then brought to the final



An Oil Forge Which Has Two Chambers Instead of One and Yet Requires Little Additional Fuel

temperature in the lower compartment. This increased capacity of the forge requires but little more fuel than a single-chamber model.

*Ingersoll-Rand Co.  
 11 Broadway  
 New York*



2-3-11-0  
 Conroy-Davis Mfg Co.  
 Shelbyville, Ind.

3184  
 ARTICLES OF ORIGINAL AND ARTISTIC DESIGNS

1-5-8-9-10  
 Steinfeld Bros.  
 116 W. 32nd St. New York

Manufactured by

Steinfeld

see top

see top

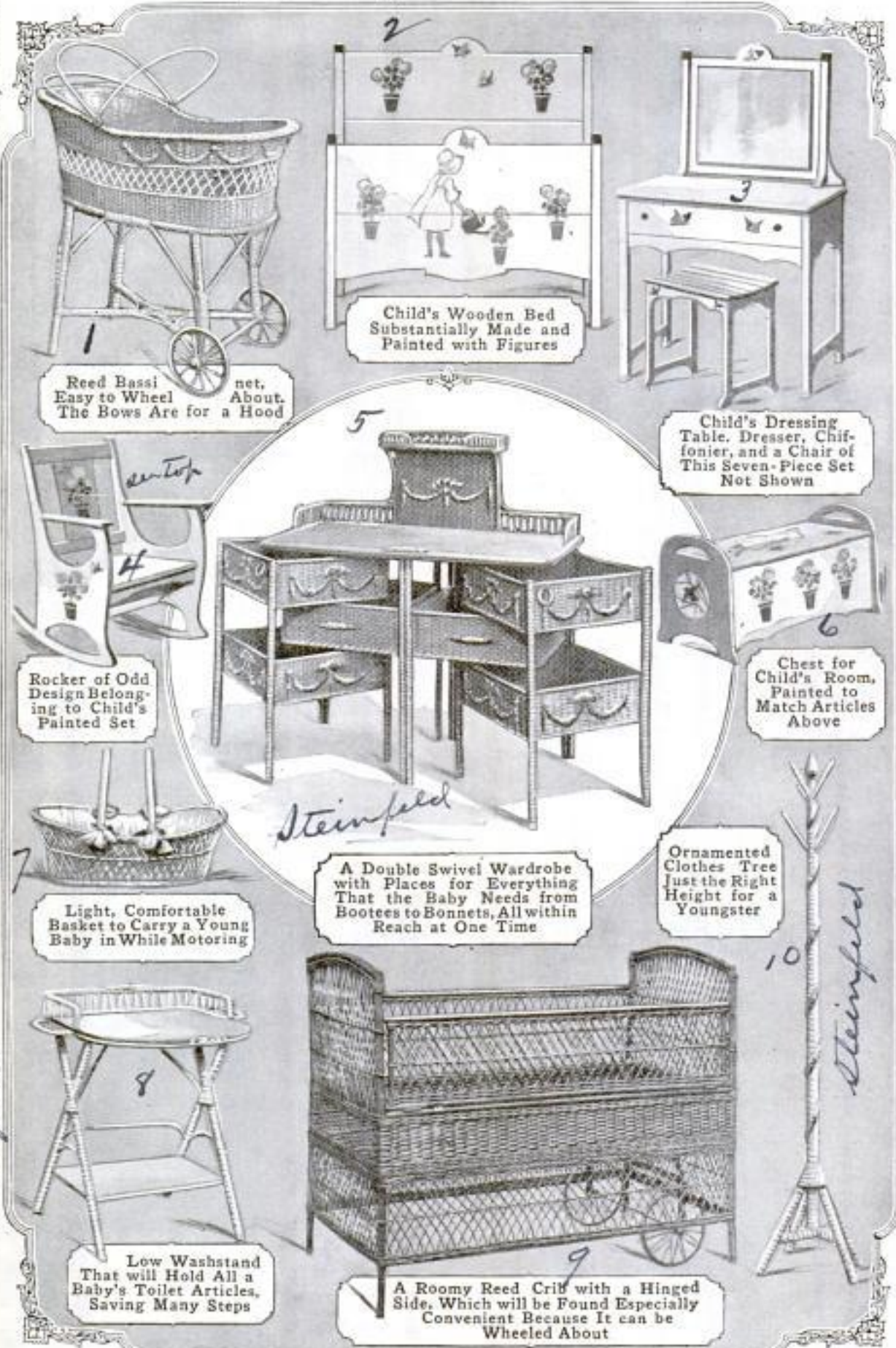

1  
 Reed Bassinet, Easy to Wheel, The Bows Are for a Hood.

2  
 Child's Wooden Bed Substantially Made and Painted with Figures

3  
 Child's Dressing Table, Dresser, Chiffonier, and a Chair of This Seven-Piece Set Not Shown

4  
 Rocker of Odd Design Belonging to Child's Painted Set

5  
 A Double Swivel Wardrobe with Places for Everything That the Baby Needs from Bootees to Bonnets, All within Reach at One Time

6  
 Chest for Child's Room, Painted to Match Articles Above

7  
 Light, Comfortable Basket to Carry a Young Baby in While Motoring

8  
 Ornaments Clothes Tree Just the Right Height for a Youngster

8  
 Low Washstand That will Hold All a Baby's Toilet Articles, Saving Many Steps

9  
 A Roomy Reed Crib with a Hinged Side, Which will be Found Especially Convenient Because It can be Wheeled About

10  
 Steinfeld

Steinfeld



Englander Spring Bed Co. Brooklyn, N. Y.  
 Bush Terminal, Chicago - & San Francisco 3184  
 BUILT FOR CONVENIENCE OF MOTHER AND CHILD

Kittlinger Furniture Co.  
 Buffalo, N. Y.

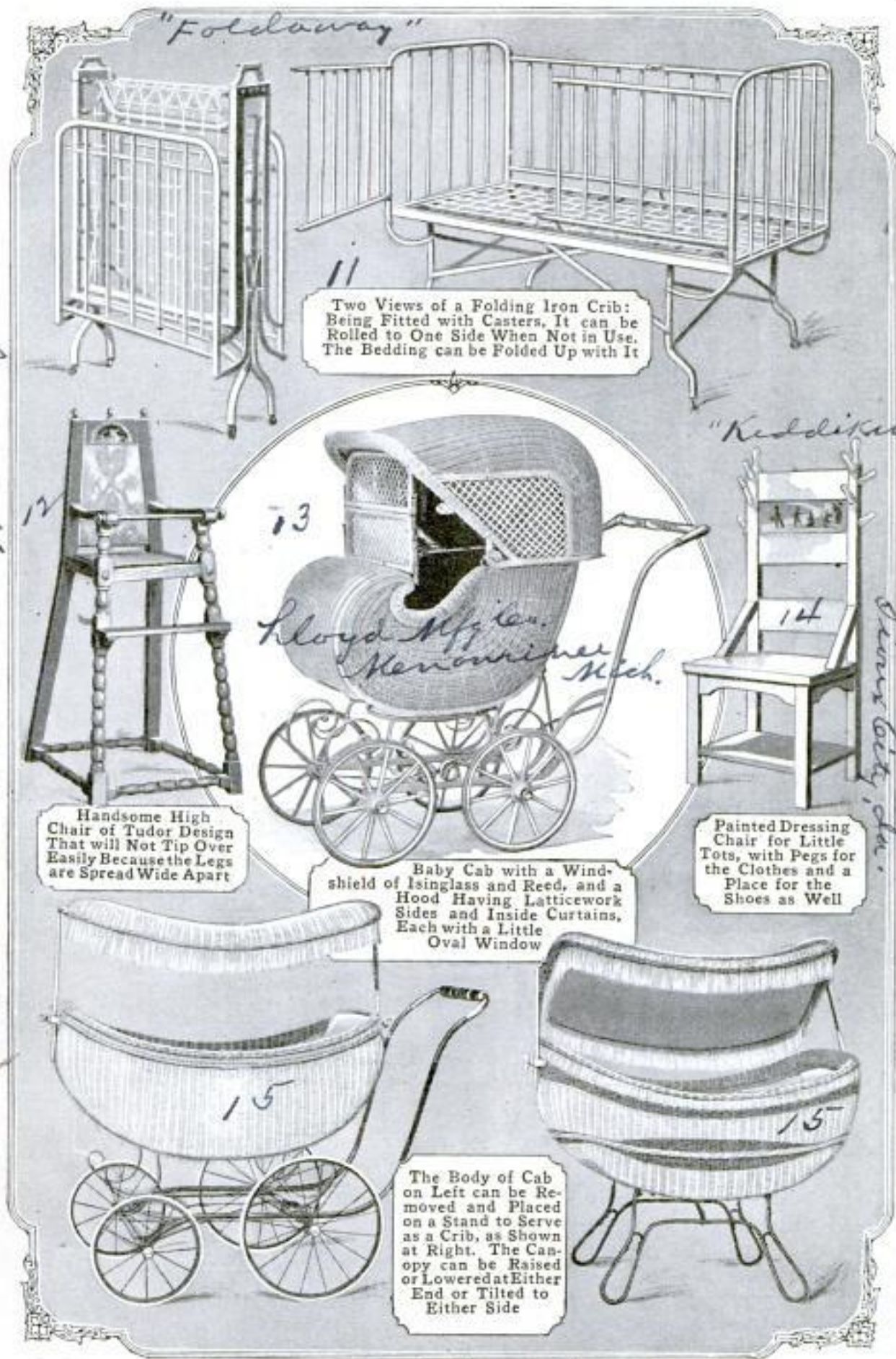

Two Views of a Folding Iron Crib: Being Fitted with Casters, It can be Rolled to One Side When Not in Use. The Bedding can be Folded Up with It

Handsome High Chair of Tudor Design That will Not Tip Over Easily Because the Legs are Spread Wide Apart

Baby Cab with a Windshield of Isinglass and Reed, and a Hood Having Lattice-work Sides and Inside Curtains, Each with a Little Oval Window

Painted Dressing Chair for Little Tots, with Pegs for the Clothes and a Place for the Shoes as Well

The Body of Cab on Left can be Removed and Placed on a Stand to Serve as a Crib, as Shown at Right. The Canopy can be Raised or Lowered at Either End or Tilted to Either Side

"Kiddikammy" \$5.50

Kiddikammy Co. Patent  
 90 Waverly St. Boston  
 1801-7 Grant St.  
 Newark City, N. J.

Childrens Vehicle Corp'n.  
 East Templeton, Mass.



**VENDING WAGON RESEMBLES  
SMALL AUTO TRUCK**

A vending wagon which looks like a small automobile truck has been built by a man in Old Orchard, Me., for



Vender's Wagon Built to Resemble a Small Automobile Truck and Containing Compartments for Frankfurters, Rolls, Peanuts, and Popcorn

dispensing popcorn, peanuts, Frankfurters, and rolls. The body of the car, which is 7½ ft. long and 3 ft. wide, has a number of compartments, and is mounted on four bicycle wheels. What appears to be the engine hood, is an oven in which rolls and Frankfurters can be kept warm by a gasoline burner. Immediately behind this hood, which is of polished copper, is a container for peanuts, with a capacity of one bushel. The chauffeur's seat is occupied by a large doll. A cash register is part of the equipment. In the lower part of the body of the wagon is storage space for sausage and rolls. At the rear is a burner and a corn popper. The vehicle is pushed and steered from the rear.

3154

**FINDING SHIP'S DRAFT IN  
FRESH WATER OF CANAL**

It is quite a complicated problem to compute the difference between the draft of a ship in salt water and fresh water, and so, for practical purposes, the government's representatives located in the Canal Zone have adopted

this simple formula: For fresh water add one-fourth of an inch for each foot of draft in sea water. This is used in calculating the draft of ships as they pass through the fresh-water sections of the canal. A ton of clean fresh water contains approximately 36 cu. ft. and a ton of clean sea water contains approximately 35 cu. ft. These figures were used in arriving at the above rule, but there were other facts to be taken into consideration also, namely, that there is sediment suspended in the water in the canal cut, due to dredging operations, and that the water-plane areas are smaller near a vessel's keel than near the surface. For practical purposes the above rule makes sufficient allowance for these factors.

3075 — *Little (area)*  
**MOTORIST'S SIGNAL LIGHT  
WORN LIKE WRIST WATCH**

A small electric lamp, which is carried on the back of the hand, has been designed for use at night by automobile drivers. The habit of holding out the hand when about to stop or turn a corner is almost instinctive with every motorist, but in the dark such a signal may be wholly invisible. This lamp, which is 3 in. in diameter and 1 in. thick, is worn like a



wrist watch, except that it is fastened by an elastic to the back of the hand instead of to the wrist. Its two-candle power bulb is supplied with current through a fine silken cord attached to the dash. The lamp is equipped with a ruby bull's-eye which is sure to attract attention. The words "Safety First" are cut into the face of the lamp around the bull's-eye.

Discarded motor-car tires are being used by New England fishermen as fenders for their boats.

*Pittsburgh Electric Appliance Co.  
Pittsburgh, Pa.*



## UTILIZING FLOOD WATERS TO REPLENISH IRRIGATION WELLS

By VICTOR W. KILLICK

**M**UCH devastation has occurred in years past on valuable horticultural properties in the Southwest through flood waters that come tearing down the mountain cañons and ravines during violent rainstorms. Annually, many tons of water have gone to waste, doing millions of damage to property.

With the rapid development of this

section, its startling increase in population, and vast investments, such conditions are destined to be controlled. In fact, the flood-water menace has in so many places become a source of profit by its use for irrigation purposes, that today claims have been filed for the right to use all flood water coming out of every mountain cañon in southern



Several Wells Which Barely Bubbled Before, Flowed Like This After the Water Was Spread

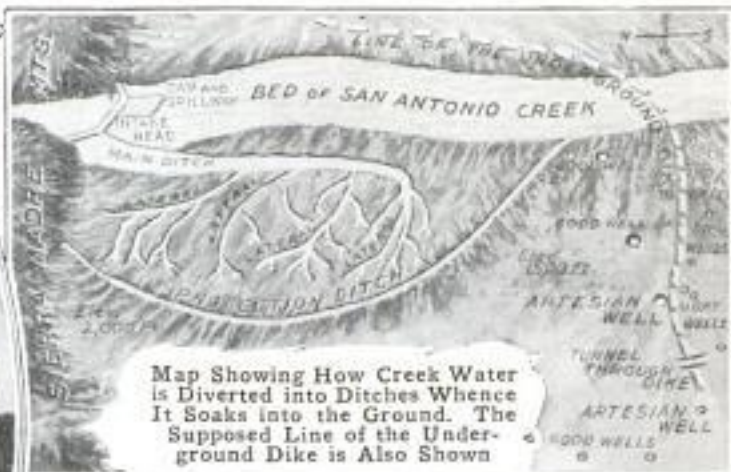

Map Showing How Creek Water is Diverted into Ditches Whence It Soaks into the Ground. The Supposed Line of the Underground Dike is Also Shown



A View of San Antonio Creek Bed, Which is Almost Dry, with Dam in Foreground, Which Diverts Flood Water to the Right. This Rocky Soil is Well Adapted to Absorbing the Water



California. Many legal contests have occurred between the claimants, but the courts have established a precedent of awarding claims to those parties or concerns who can show their ability to make the widest possible use of the flood water.

Recently the Los Angeles courts awarded flood-water rights to a company in the Pomona Valley because it was able to demonstrate the existence of a natural, underground range of clay hills in the valley, which acts like a dike, or dam, tending to create a subterranean reservoir for underground waters. Their idea is to spread the flood water uniformly over this area that it may collect in the big underground basin and so replenish irrigation wells at lower points in the valley. Pomona Valley lies at the foot of the Sierra Madre Mountains and in the path of San Antonio Creek, one of the largest and most damaging flood-water streams along the whole range.

As soon as the legal fight was won, the company bought about 2,000 acres of rocky, sagebrush-covered land at little expense. This was immediately on the west side of San Antonio Creek and abutting the foot of the mountains. A concrete dam was next constructed across the mouth of the creek with a flood-water intake just west of it. From the intake heading a wide shallow ditch, a mile long, was run parallel with the creek. From this, at uniform intervals, lateral ditches were made running westward, and as these extended over the ground they gradually subdivided into smaller and smaller tributary ditches until the porous granite soil drank up all the water distributed. A large protection ditch was then made to bound the extreme western edge of the distributing ground so that if any water got away it would be diverted back into San Antonio Creek at a point below, and thus save possible damage to other property.

During 1915, 18,000 acre-feet of flood water was taken in at the intake and spread over 600 acres at an operating cost of only \$2,216. An increase in the

water levels of the wells at lower elevations was noted within six months. Wells formerly pumping at lifts of from 60 to 90 ft. now had lifts of only 10 to 20 ft. Other wells of shallow lifts became artesian and flowed above the surface without pumping. Careful calculation showed that of the amount of waters spread, fully 35 per cent was recovered in the wells during the season. The project was affecting the wells which supplied 12,000 acres with irrigating water and five cities with domestic water—a territory of approximately 20,000 persons.

To a country where water for orange groves costs from \$5 to \$50 a year, this has been a tremendous profit, not counting the saving in damage to property which the uncontrolled storm waters were wont to create.

This system of flood-water conservation could be readily applied with effect in many other localities at the base of mountain cañons, even where the topographical features may not be as favorable as are those in the Pomona Valley.

The big Lake Hemet dam in the San Jacinto Mountains, which impounds 4,000,000,000 gal. received from a watershed of 65,000 acres, cost, with its conduit systems, approximately \$2,000,000 and effects the irrigation of 10,000 acres in the Hemet and San Jacinto valleys. The Bear Valley dam in the San Bernardino cost, with its entire network of distributing conduits, about \$4,000,000. It impounds 22,000,000,000 gal. and effects the irrigation of 15,000 acres.

The water-spreading project of the Pomona Valley people has cost less than \$50,000 to construct and is accomplishing results far out of proportion to the amount of money expended. Its financing, so far, has been met by voluntary contributions of the land owners forming the company. Hundreds of people living in the region are receiving the benefits of the project without paying a cent, but those who are paying consider they are getting more than their money's worth out of the results.



**BATHING AND MASSAGING MACHINE**

A machine has been invented which is designed to bathe the body quickly and thoroughly and at the same time give it a massage. The device is inclosed in a vertical cylinder having hinged double doors through which the bather enters. He stands on a platform, which can be adjusted so that his head projects above the cylinder, and is surrounded by long cylindrical brushes placed on end. These can be made to revolve rapidly by turning an electric switch which controls a motor. By opening a tap, water is allowed to flow into the brushes which throw it against the body. Under the platform is a basin from which the used water flows off through a drain. If, after the water is shut off, the brushes are allowed to revolve, they and the bather

are soon dried without the use of towels. The apparatus can be sterilized by running boiling water through it. Because it occupies but little space, its inventor believes it suited for use

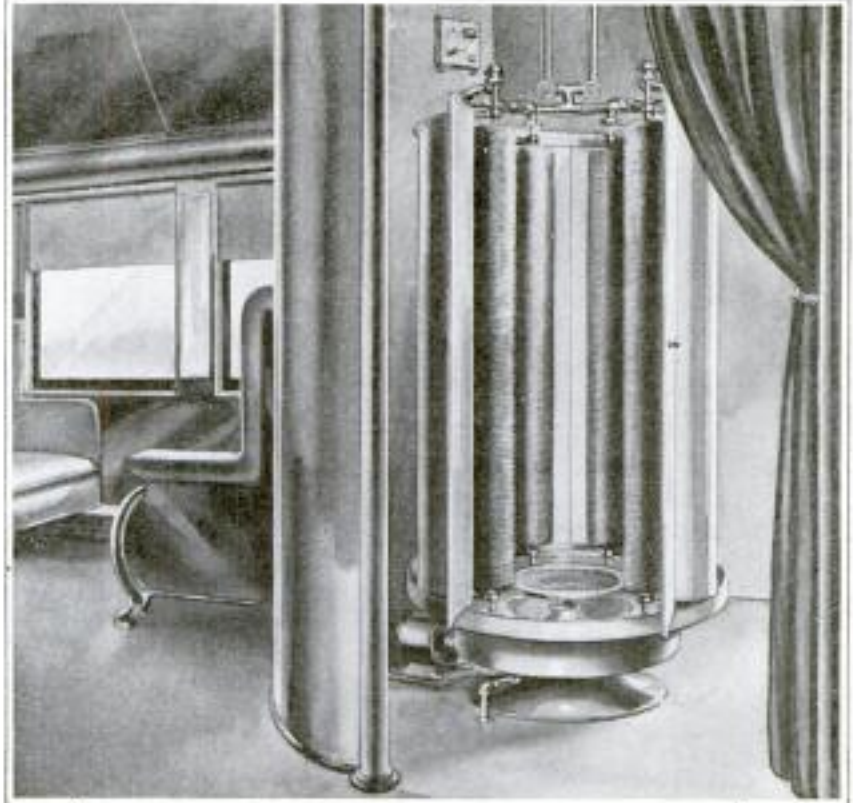

A Machine Which Bathes and Massages the Body Quickly, and Dries It without the Use of Towels. Because It Occupies Little Space It is Intended for Use in Sleeping Cars as Well as Private Residences

in sleeping cars, on passenger boats, etc., as well as in private houses.

2420

**SHORTHAND SOON LEARNED BY USING NEW MACHINE**

A machine for writing shorthand has been brought out recently which "Shortwriter"



A Machine Which Writes Shorthand: The Code Used is so Simple That One can Learn to Read It in a Few Minutes. The Characters are Printed on a Paper Ribbon, a Word to a Line

employs a code so simple that one can learn to read it in a few minutes, though of course speed in using the machine requires practice. In the center of the keyboard is the spacer. To the left is a group of keys used to represent the initial sounds of words. In front of the spacer are four keys labeled with the vowels except U, which is written "IE." To the right are keys used to represent the final sounds of words. Many keys represent two letters of similar sound and are marked with characters designed by combining the two letters. For example, one key represents M and N and is marked with a character in which those two letters, have been

37037 Myeliff

1162689 - Nov 30, 1915  
 Gay V. 22071675

Inv: Alrah B. Edwards & F.K. Russell, Assignors

Standard Phonotype Co., Dallas, Texas  
 by Shortwriter Co., 401 Garland Bldg, Chicago, Ill.  
 6109 N. Walnut St. 55 E. Washington St.



# Geo. R. Wright  
2310 Ogden St.  
Omaha, Neb.  
2751

combined. Another key represents S and Z, and so on. Words are written according to sound, and all the keys used for a word or syllable are struck at once. This is what makes speed in writing possible. "Begin" is spelled "begn" and is written by pressing the "b" key on the left, the "e" in the vowel group, and the "g" and "n" in the right-hand group, all at one time. The machine prints its characters on a narrow paper ribbon, one word to a line. As the keys are released the paper is spaced automatically. It is said a speed of 175 words a minute can be acquired within a short time.

3161 — *Sturton*  
**ISINGLASS FACE SHIELD  
FOR AUTOMOBILISTS**

Isinglass face shields are now being introduced among automobilists to be



worn instead of goggles. The new protector consists of a sheet of isinglass, measuring 14 in. long and 7 in. wide, which fastens about the head and is worn under the hat or cap. The edges are bound with felt, and rubber bands at the back help hold it in place. The shield protects the whole face from wind, dust, and rain and does not subject the eyes to the strain that is sometimes caused by certain kinds of goggles.

**FARMS GIVE WAY TO MINES  
IN OKLAHOMA DISTRICT**

During the past year the promising lead and zinc-mining town of Picher has risen out of the grain and hay fields in the northeastern corner of Oklahoma some 10 miles nearer the border than Miami. Already the place boasts a railway, a hundred or more one-story frame dwellings and store buildings, a population of about 500 persons and a hard-surfaced motor road most of the way to Joplin, Mo., making communication with that city a matter of an hour's drive. In addition, there is a large concentrating plant equipped with thoroughly modern machinery. Plans are also being made by a Missouri traction company to extend its interurban lines to the point, while a second railroad is said to have purchased a right of way to Picher. The community has changed rapidly from a quiet agricultural one to a busy, excited mining district. Where smoke but a short while ago curled from the stacks of threshing engines, drilling rigs—probably 150 of them—now puff away constantly.

The story of Picher is typical of those of many other southwestern towns in the oil and ore belts. The first drilling was started in the fall of 1914. Deposits of ore were found in loose, open ground of blue and brown flint composition. It was soon after this that extensive preparations were made for the development of the field. On 12 sections of land lying between Picher and Commerce, 28 mills are in operation. The average capacity of



Seven Out of Eight Holes Sunk in This 40-Acre Tract Uncovered Ore. Enough has been Mined to Keep a Fair-Sized Mill Busy Two Years



Each of These Rigs is Working a Separate Holding. In the Background is Shown One of the New Mills That has Lately been Erected

W.V. Frank W. Huelckson,  
Sturton, Calif.





These Two Piles of Lead and Zinc Ore are Valued at About \$24,000. The Mine is Located near Picher, Oklahoma, on 40 Acres of Ground Leased from the Owner for \$5,000, and is Giving Up "Jack" That Assays About 40 Per Cent

Forcing Air under Pressure into Drilled Holes in Order to Force Water, with Which to Run the Power Plant, to the Surface. During the Final Week in June, Last Year, 300,910 Pounds of Lead were Shipped from This Mining Property, which has been in operation only a short time



Where the Mining Interests are Gradually Forcing the Farmer into the Background. Here Five Drills are Working in an 80-Acre Field. Promising Mines and Busy Mills Surround This Tract

Piles of Very Rich Ore Taken from One of the Picher District Mines, Awaiting the Erection of a New Power Mill. It is Not Unusual to Find Lumps of Pure Metal and the Heaps Shown Here Contain Many Such



Samples of Earth, Rock, and Ore from One of the Bores; Specimens are Taken Every Five Feet as the Drilling Progresses, and Marked with Paddles on Which the Depths are Recorded. When Traces of Ore are Struck, Samples are Taken Every Three Feet



these is about 250 tons for a 12-hour shift. Shallow ore has been mined at a depth ranging from 92 to 100 ft. at one mine in the Picher district, while drillings have disclosed a lower run between 180 and 200 feet.

2916

### AMERICAN CLOCK GIVEN TO JAPAN'S HEIR APPARENT

Among the many beautiful presents received by the royal family of Japan on the occasion of the recent coronation,



is a clock given by residents of Washington, Montana, and Alaska, and built according to the order of the Japanese Association of North America. The clock stands 4 ft. 9 in. high, and has four sterling-silver dials. Its frame is made of steel, the ornamentation of bronze, and three of the panels in the standard are of onyx. A fourth panel is of beveled glass, through which practically all the mechanism can be seen. The four dials show,

respectively, the time at Tokyo, Puget Sound, New York, and Greenwich. Surmounting the timepiece is a globe which makes one revolution every 24 hours. The sun's position in relation to the earth is indicated by a gilded ball mounted at one side of the globe. The clock was made in Seattle, and its works are operated by weights. It was a gift to the heir apparent and accompanied costly gifts to the emperor and empress.

*Joseph Mayer & Bros.,  
Seattle, Wash.*

### ZEPPELIN RAIDERS FACE

#### PERIL FROM OWN CRAFT

*Chgo Tribune 9-26-16*

It is not generally recognized that besides the dangers which fire from the enemy subjects Zeppelin raiders to, there is extreme hardship to be endured and also a grave peril which is inherent in the dirigible itself because of the high altitude at which it must fly. From a recently published interview with a Zeppelin commander it appears that the German people have been complaining that the dirigibles have been inactive. The officer indignantly declares that if the dissatisfied ones could be made to share in just one raid, their complaints would never be renewed. "At the great altitude necessary," says this commander, "the cold is so severe that the men are covered with icicles. The danger is great, for, apart from the shells, the rareness of the air causes it to penetrate into the gas holders, with the consequence that the hydrogen and oxygen form an explosive gas mixture which catches fire from the least spark." "For this reason," the commander adds, "the men have to wear felt boots, as nailed boots might draw a spark by touching some metal object in the gondola. It is almost impossible to send the same crew on two successive expeditions, for their nerves will not stand it."

3131

### NOVEL MEANS USED TO PUT OUT RAILWAY-BRIDGE FIRE

A railway engineer in New Brunswick was commended recently for his quick wit in employing unusual means to put out a fire that he discovered burning the ties of a railway bridge over which he was driving a train. After stopping the train he moved the locomotive so that its ash pan stood directly over the blazing ties. He then flooded the pan with water from the ejector. As it trickled down from the pan it put out the blaze, and what might have proven a serious loss was averted. On reaching the next station, a man was sent back to see that the fire had not started up again.

*Jno. Stewart,  
Engineer.*

*Montreal, N. B.*





COPYRIGHT, UNDERWOOD & UNDERWOOD

H 17 S H 60. N. Y. C.

CARS TELESCOPE EACH OTHER IN ODD MANNER

*Accident*

ABOVE is a view taken shortly after a collision between two New York subway trains on the elevated structure near a tunnel entrance. The accident occurred when a train, ~~traveling~~ at a rapid rate, crashed into an empty three-car train that was not moving. In spite of the violence of the impact the side walls of the foremost of the moving cars remained practically intact. It rode up on top of the rear car of the standing train, its side walls spreading out slightly and enveloping the car beneath it. The motorman driving the moving train is said to have jumped to safety. Thirteen persons were injured. This accident happened some weeks ago, but this picture, which was crowded out of our December issue, is well worth studying.

3009

**OSTRICH DRAWS MOTOR CAR AND CARRIES TRAINER**

For the purpose of deciding a wager regarding the strength of an ostrich, a bird from a California ostrich farm was harnessed to an automobile to see if it was able to pull so heavy a load. About its neck and breast was placed an ingenious harness which was hitched to the axle of a medium-sized car. In the first trials the trainer, who rode on the back of the bird, kept a sack over its head and the creature

refused to pull. But when the sack was removed it strained at the harness and soon was pulling the automobile along the boulevard, up a slight grade. The bird did not stop until commanded.



Ostrich Demonstrating Its Strength by Carrying Its Trainer and Drawing an Automobile up a Slight Grade



# Sidney Armer

417 Montgomery St

Berkeley Calif

98

2913

POPULAR MECHANICS

San Francisco

### MINUTE IMAGES ARE PLACED IN TINY CARVED SHRINE

Japanese miniature carvings are always interesting to those who enjoy the clever handiwork of the deft Ori-



An Actual-Size Picture of the Handiwork, and an Enlargement Which Shows the Details

ental artisans. An odd specimen of some of this craftsmanship is a cheap little pocket shrine, no larger than a watch charm, that, with other curios,

has made its way across the Pacific. Miniature images of the Crucifixion and the Virgin and Child are held in two rice hulls supported in a tiny altar carved from some light wood. The figures themselves are only about an eighth of an inch in height and their details are not distinguishable except when magnified. A small capsulelike case fits over the trinket, protecting it and inclosing all but the base.

— 2179

### PORTABLE GENERATING SET MADE FOR ENGLISH ARMY

Portable generating sets of a type particularly suited for field conditions have been installed at many of the machine shops of the British army at the front. The unit develops current for both power and lighting purposes and is of simple design and stanch construction. An 18-kw. dynamo is driven by a four-cylinder, water-cooled motor-car engine which is controlled by a governor. The motor is started with gasoline, but when it has become warm, kerosene is used as fuel, the latter being vaporized with the heat given off by the exhaust manifold. The water circulates through a standard motor-car radiator and is conducted to and from the cylinders through wire-bound hose. A special motor operates the radiator fan, which is inclosed. Directly coupled with the engine is the dynamo, and the two members are

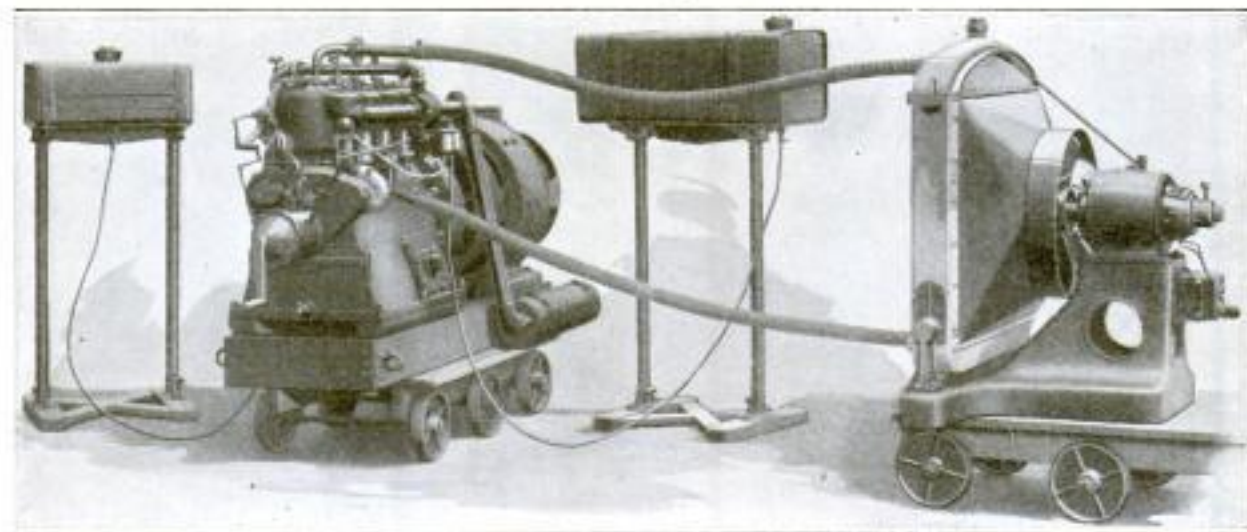

The Plant is Arranged so That It may be Quickly Assembled after being Transported to a New Position

The Austin Motor Co., Ltd.  
Northfield, Birmingham, Eng.



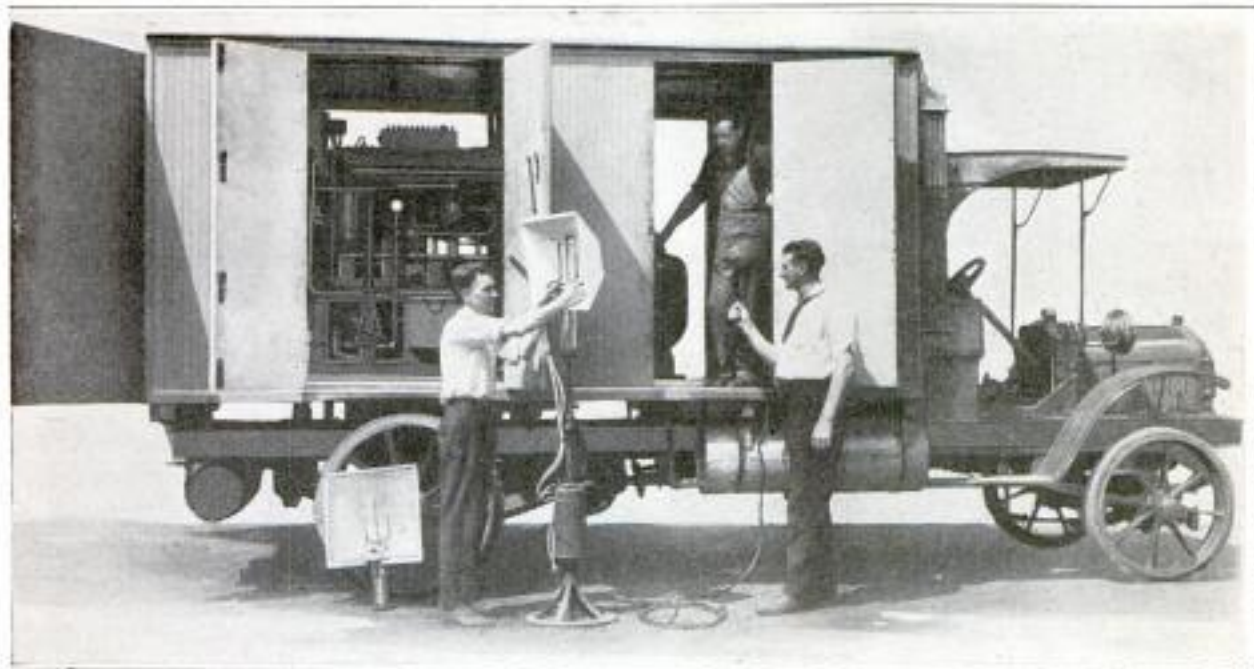

This Portable Lighting Plant Facilitates the Filming of Movie Dramas, Staged in Remote Sections Away from Electric-Transmission Lines

mounted on the same truck, while a separate bed is provided for the radiator and its motor. Two fuel tanks, one containing gasoline and the other kerosene, are held on standards.

3164 ———  
**AERO STATION FOR HAWAII  
 PLANNED**

The commander of the government's forces in Hawaii has sent a request to the War Department for 24 biplanes, with a view to establishing an aviation corps in that island territory. If the officer's plan, which is the result of a careful investigation, is carried out, it will mean that Hawaii will have one of the largest aerial research stations maintained by the United States. In operating it the Weather Bureau will cooperate with the military authorities, according to the plan. In connection with the establishment of this station an effort will be made to organize an aero club with the support of business and professional men of Hawaii. Such a club would be a great help in strengthening the aerial branch of the island's defenses.

COak is considered the most suitable wood for carving on account of being tough and durable, but not too hard.

2908  
**MOVIE LIGHTING APPARATUS  
 CARRIED BY MOTOR TRUCK**

One of the eastern moving-picture producing companies has developed a mobile lighting equipment which overcomes one of the greatest handicaps commonly encountered in filming photoplays outside of a studio. The outfit consists of an electric generating plant mounted on a large covered motor truck. The body of the van is divided into two compartments. In the rear one a 50-hp. gasoline engine has been installed. This drives a dynamo located in the forward compartment. The interior of the housing is lined with sheet metal, as protection against fire, while the floor is covered with rubber insulating mats. With this equipment it is possible to go into remote rural or mountain sections, away from electric-transmission lines, and do satisfactory photographic work without much difficulty. A battery of mercury-arc or nitrogen-filled incandescent lamps mounted on standards and fitted with studio reflectors can be set up in a few minutes and connected with the lighting circuit. In this way interiors can be taken anywhere, and outdoor scenes filmed at night.

Brig. Gen. R. K. Evans



## AMERICA'S ATTRACTIVE COUNTRY CLUBHOUSES



The Airy, Inviting Little Home of the Phoenix, Arizona, Country Club is Pictured at the Left. On the Hill Back of the Tree Shown in the Illustration Above is the Fifth Tee of the Nine-Hole Course. The Canal Which It Overlooks is Crossed Three Times and Catches the Balls of Many Unwary Golfers



Hospitable Seat of the Oleander Country Club, Situated near Galveston, and the Scene of Many Charming Affairs. The Tee for the Sixth Hole on This Course is Pictured Below at the Left. It is a Short, but Difficult, Hole Because Two Large Trees Stand in the Fairway Directly in Line with the Green, and 40 Yards from the Tee



A Homelike, Restful Atmosphere Pervades the Residential Quarters of the Druid Hills Golf Club at Atlanta, Shown at the Left. Above is an Interesting Stretch on the Links. Woods on One Side and a Winding Creek on the Other Make a Clean, Straight Drive Imperative in Playing the Seventh Hole



## AND SOME OF ITS BEST-KNOWN GOLF COURSES



Distinctive as Well as Pleasing Are the Quarters of the Roebuck Golf and Country Club at Birmingham, Alabama. Important Improvements have been Made Since This Picture was Taken. Although Short, the Third Hole on This Course is Considered the Most Difficult



Vine-Covered Plaster Home of the Birmingham, Alabama, Country Club, Situated on One of the Many Hills Surrounding the Golf Course. The Eighth Hole is Pictured Below at the Right. A Drive of 130 Yards, if Straight, will Clear the Water. The Green Slopes and is Surrounded by a Sand Trap, Making the Approach Difficult



New Country Establishment of Atlanta Athletic Club. A Splendid Course, Crossing and Recrossing a Small Lake, Encircles the Building. Pictured Above Is the Island Hole, a Particularly Hard One. The Green is Situated on Ground 60 by 30 Yards in Size and Surrounded by Water. The Distance Is 165 Yards





Richey, Brown & Donald  
2101 Flushing Av.  
New York

Daniels & Fisher Streets  
Denver Colo.

102

2253

POPULAR MECHANICS

2909

### PLEASING EFFECTS GIVEN BY NEW METAL WINDOW

Attractive features are incorporated in a new type of window that has lately been adopted by several promi-



At the Left is Shown an Interior View of the Window Partly Open; in the Middle, the



Lighting and Ventilating Advantages Gained by Grouping Several of Them, and at the Right the Simple Way in Which Both Surfaces of a Pane can be Cleaned from the Inside

nent architects for installation in buildings and residences in different states. It is of metal construction, has successfully passed the tests of fire underwriters, and shown itself to be dust-proof, water-tight, and air-tight. In appearance it is very similar to a certain form of casement window, but does not properly come within this classification, according to the inventor. It is divided vertically into two equal sections which are held together by a brass hinge that extends the full height of the window. These members are supported at the top and bottom by steel arms extended from a stationary upright placed in the center of the frame, and operate simultaneously. Pulleys, weights, chains, and gearing are absent, and a slight outward pressure, or an easy pull, is sufficient for opening and closing. The operation is practically noiseless, both surfaces of the glass can be washed from the inside of a room, and, by means of a simple arrangement, a screen may be mounted on the interior without interference. The window may be opened to any degree and locked securely so that it will not rattle.

### CARD-FILING DEVICE BUILT LIKE A MERRY-GO-ROUND

A revolving card-filing device, which bears some resemblance to a miniature merry-go-round, has been devised for the convenience of a bookkeeper in a large Denver dry-goods store. It consists of a circular platform, pivoted at the center and supported at its edges by small rubber-tired, ball-bearing wheels. On the platform 24 filing cases are arranged in two circles, one within the other, the inner circle being raised a few inches higher than the outer one. The platform is located beside the bookkeeper's desk and by merely turning it about any one of the hundreds of cards can be brought within easy reach, without the user rising from his chair. Figures are placed conspicuously on the side of



A Card-Filing Device Which Places Hundreds of Cards within Easy Reach of the Person at the Desk

each filing case to assist in finding the one desired as quickly as possible.

1989

### MARKING BOUNDARIES OF NATIONAL FORESTS

The placing and maintaining of the boundary markings of the national forests is one of the tasks of the forest rangers which often prove arduous. The Forest Service requires that signs with proper descriptions shall be posted at all section corners, and at in-





A Forest Ranger, with His Camp Outfit, on a Boundary-Marking Expedition



One of the Boundary Signs Erected by the National Forest Rangers



At the End of the Day's Tramp a Camp is Made in the Forest

tersections with trails, roads, streams, and ridges. Each notice must face outward, that is, from the forest. Where there is no timber to which signs can be fastened, posts must be set to show the boundary. The total distance around the various parks ranges from 150 to 300 miles, according to the size of the reserved area. One ranger's share of a park means that he has from 30 to 60 miles of boundary

to keep marked, a task involving long tramps. In the winter, while engaged in this work, he often packs his entire equipment on a hand-made sled and hauls it with him as he goes from point to point. At night he camps in some convenient spot, shoveling away the snow to make a place for his tent, while the snowshoes, skis, etc., are placed within easy reach, preparatory to resuming the journey.

## COMBINATION WHEEL AND 2986 FIRESIDE CHAIR

A low four-wheel truck having a steel frame is a useful accessory for the home where there is an invalid. It has been devised to be used in connection with a fireside reed chair so that the latter can serve also as a wheel chair. The truck's wheels are 10 in. in diameter and rubber-tired. The forks of the two forward ones are pivoted to the truck so that it can be steered in any direction. When the wicker seat is placed on the truck for the purpose of wheeling it about, the back legs rest in sockets that keep it from slipping off, and the front legs on a wide platform. A leg rest, made to match

the reed work, can be clamped over the front wheels and platform, thus making a portable steamer chair. If desired, the chair can be used without the truck or leg rest, or with the latter alone.

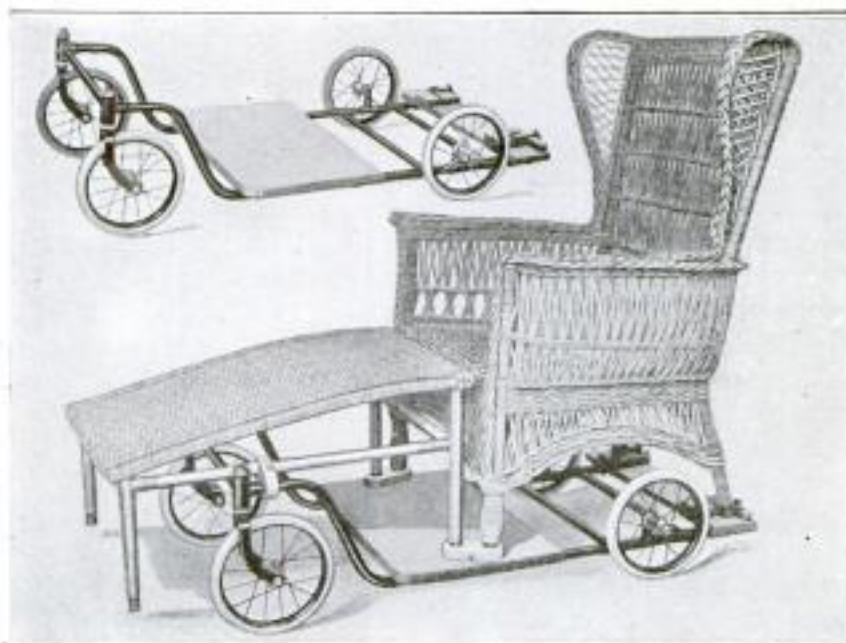

A Wheel Chair Which with Its Separate Leg Rest can be Removed from Its Steel-Frame Truck, so That It can Serve as a Fireside or Steamer Chair

*The Worthington Co.,  
Elyria, O.*



### COSTLY JACKETS ADORNED WITH ELK TEETH

Elk teeth, now commonly worn as an emblem of a large fraternal order,



Nez Percé Squaw Dressed in Festal Garb Which is Adorned with 150 Elk Teeth

have long been prized as articles of adornment by certain Indian tribes. The Nez Percé squaws, for example, use them extensively in decorating their jackets, hanging them in festoons about their shoulders and sewing them to the fabric. Garments decorated in this manner are worn by these Indian women at the annual round-up of the tribe at Pendleton, Wash., and on other festal occasions. A well-shaped elk tooth is worth as high as \$12. Each year these teeth are becoming less plentiful, because the elks are more scarce and the laws designed to conserve them are more strict. Indian jackets adorned with these unusual decorations range in price from \$500 to \$2,000. Some of the garments are almost covered with the trophies. The one shown has about 150 teeth.

### STALE BREAD CHEAPER THAN MEAL FOR STOCK

Stale bread is now being used in various forms as a food for stock and poultry, the demand for it being very strong because at the present time it is less expensive than meal. In some cases it is fed to animals with skimmed milk, and in others it serves as a base for some brand of stock food. The bread utilized for these purposes is what is returned unsold by the retail dealers to the bakeries. The bakers take these stale loaves and break them up and dry them for several days on the tops of ovens. The dried pieces are then put in bags and sold by carload lots. On a large farm near Pittsford, Vt., about 100 very fine hogs are raised for market each year. These animals are fed largely on stale bread and skimmed milk, the bread being shipped, tons at a time, from New York City.



Above Is a Partial View of a Bin on a Farm near Pittsford, Vermont, Containing Several Tons of Dried Stale Bread, Which Is a Principal Article of Food for 100 Pigs. A Few of the Animals Are Shown Below



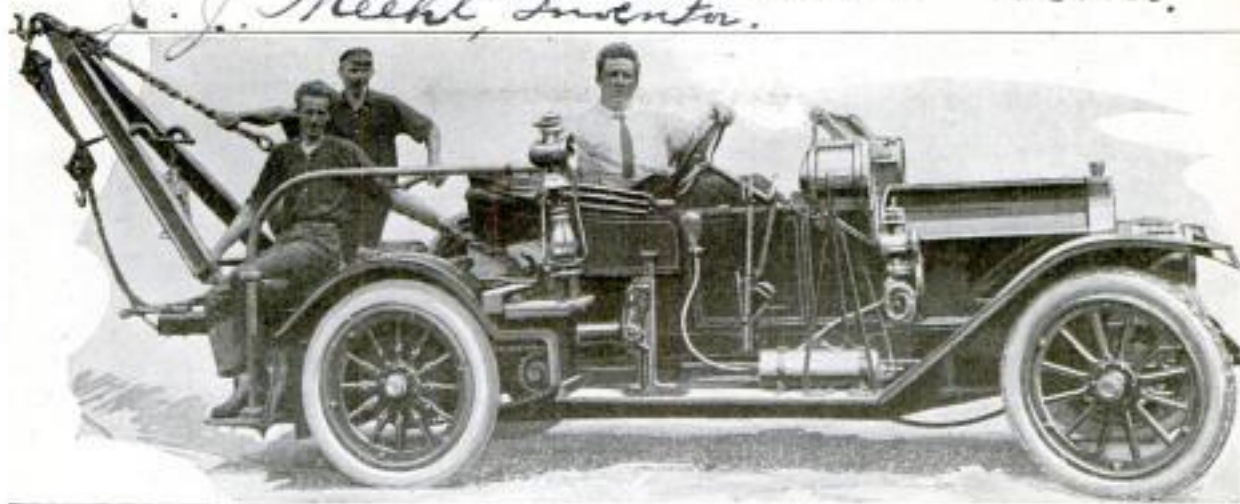

A 50-Horsepower Car Equipped with a Wrecking Outfit That Includes Jacks, Ropes, Tow Wheels, a Powerful Crane, and Extra Lights for Working at Night

2833

### POWERFUL AUTO-WRECKING OUTFIT ON REAR OF CAR

An automobile-wrecking outfit has been constructed by a concern in Greenwich, Conn., which takes up comparatively small space and is powerful and efficient. It occupies the rear of a 50-hp. car and is composed of all the apparatus necessary to right and transport cars that are disabled or have been overturned into a ditch. The equipment includes a tow cart, tow wheels, a powerful crane, bars, ropes, jacks, and extra lights for working at night. The crane is fastened to the rear of the auto body and is supported by a heavy chain, which is attached just in front of one of the rear wheels. A rear step and handrails are provided for the convenience of the crew riding with the outfit.

3163

### RADIATORS FORM BORDERS AROUND WINDOWS

A large number of iron radiators such as are necessary to heat a spacious hall or auditorium often add an inharmonious element to an interior which is otherwise very artistic, and they also take up valuable space. These undesirable features have been overcome in planning a Masonic hall in La Grange, Ill., by arranging the radiators around the sides of large windows. The recessed areas, the centers of which are occupied by the

windows, are perhaps 12 ft. high and 6 in. deep, so that the radiators which form a border for each, do not project out into the room but stand about even with the wall. This arrange-

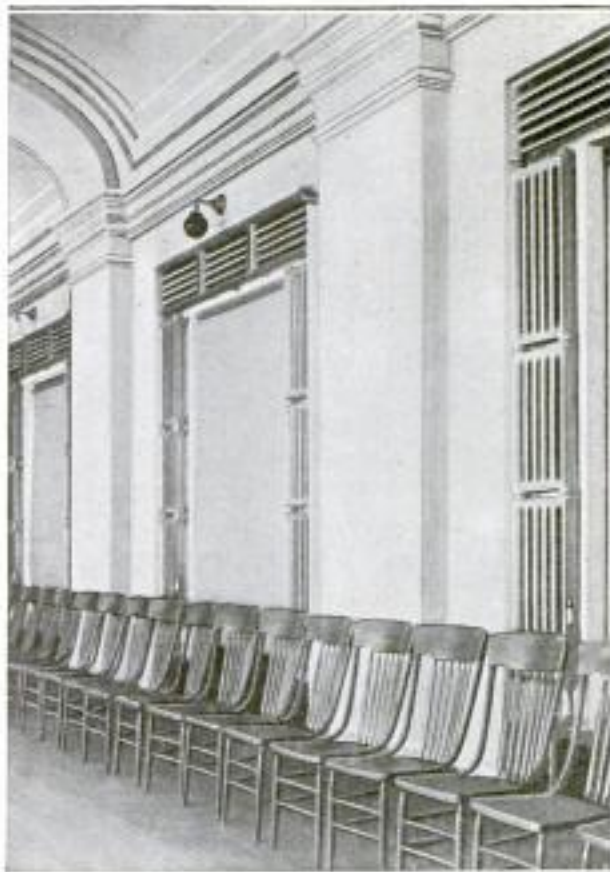

Radiators Arranged in an Artistic Manner about Recessed Windows of a Lodge Hall so That They do Not Take Up Floor Space

ment has not interfered with the heating of the hall, and the general effect from an artistic standpoint is rather pleasing.

*Douglas Heating Co.,  
166 N. Dearborn St., Chicago.*



## NEW FERRY CARRIES MOTOR CARS ON SAN PABLO BAY

Increasing traffic on San Pablo Bay between the Marin and East Bay shores, in California, has been respon-

pactly housed so that ample space is provided for four lines of vehicles and a three-foot passageway. The upper deck is margined by a 12-ft. promenade, while the housing in the middle of it is divided into a saloon for ladies,

smoking rooms, a grill, and other compartments. In over-all length the ferry is 169 ft., and is able to accommodate about 50 motor cars and 500 passengers. It will make two trips an hour over a route that is slightly more than three miles long.



The Motor-Car Ferryboat Leaving the Ways at Benicia, California, Where It Was Constructed

sible for the construction of a large ferry especially designed for the accommodation of motor cars and other vehicles. Until a number of months ago such service was not provided, and as a result the route was an inaccessible one to automobile tourists. After an antiquated vessel had been employed for a short time, however, the need of first-class facilities became apparent, and the new ferry was built. The boat is a double-ended one of the side-wheel type with rudders at either stem. The machinery is mounted in the middle of the main deck and com-

For example, it is estimated that in European Russia, Finland, Poland, and the Caucasus there are 549,000,000 acres of forested lands, and that in western Siberia there are 465,000,000 acres. In European Russia the government owns 285,000,000 acres, and 360,000,000 acres in Asiatic Russia. Other holdings bring the total number of acres of forest owned by the government to almost a billion. It is reported that two large companies are being organized in Russia to engage in exporting lumber, and that they will compete in American markets.

3090  
**RUSSIA'S VAST FORESTED LANDS BARELY TOUCHED.**  
*Far Eastern Review Feb'y '16*

Russia is said to stand first among the nations of the world in the extent of its timber resources, possessing such vast areas of forested lands that even the value and quality of many of them have not been ascertained. So great are the figures relating to these tree-covered regions in the north of Europe and Asia that the mind cannot fully grasp them.



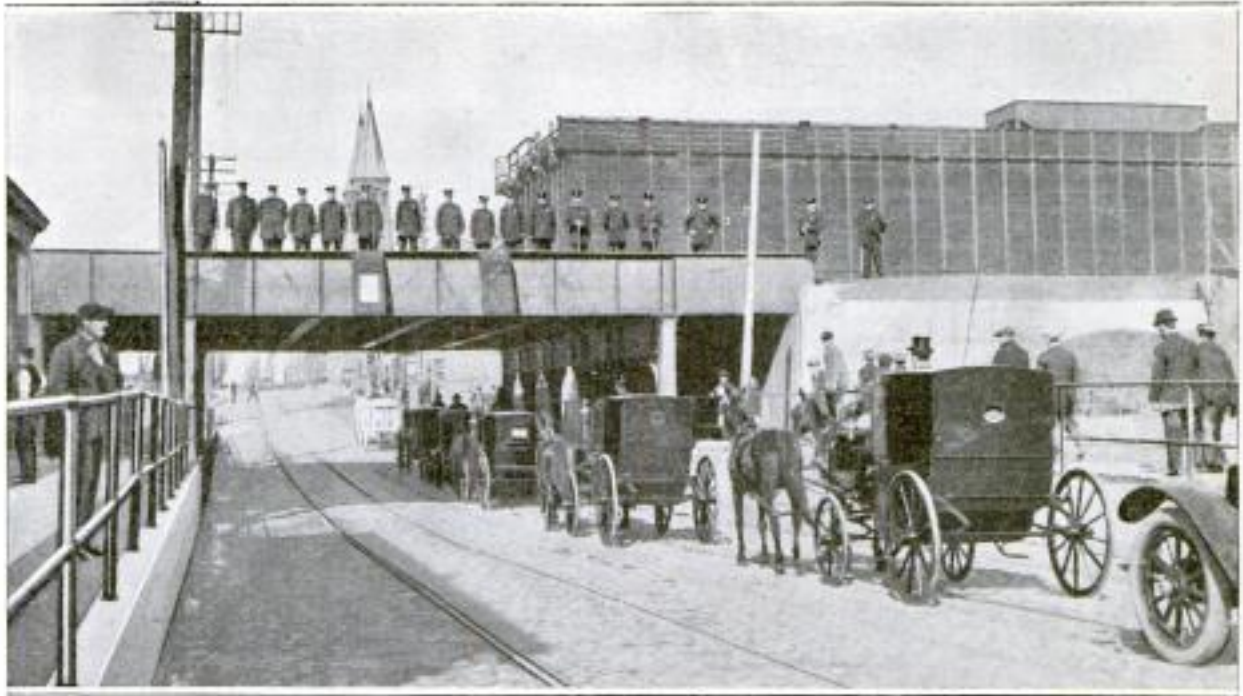

COPYRIGHT, INTERNATIONAL FILM SERVICE

## STRANGE SETTING FOR FUNERAL PROCESSION

PERHAPS never before has a funeral procession had such an oddly arranged setting as that presented in the above picture. Silent, almost motionless, policemen line the railway viaduct under which the hearse and carriages are passing on their way to the cemetery. The funeral is that of a woman in Bayonne, N. J., who, while watching the police quell a strike disturbance, was accidentally shot. The unusual guard shown here, together with another stationed about the bereaved home, was established to prevent any disorderly demonstration during the funeral.

2920

ROOF OF FOREST SHELTER  
MADE FROM HOLLOW LOG

Up on the side of Mt. Baker, within 50 yd. of the Roosevelt glacier, is a shelter of unusual design, erected for the convenience of forest rangers, hunters, and others. The novel feature of this roughly built structure is the roof. When the forest rangers were building it they found no timber in the vicinity suitable for splitting up into shakes or shingles. However, the discovery of a large hollow tree solved their problem. It was cut to proper lengths and then split into sections, which were placed so that their edges overlapped. Alternate sections were laid with the hollow side up,

so that they served as troughs to carry off the water. A fireplace in front of the shelter furnished a safe place for building a campfire. This hut, like the others built by the rangers, is located



Campers' Shelter on the Side of Mount Baker, Having a Roof Made from a Large Hollow Tree

within easy reach of an abundance of fuel and pure water.

*Forest Service,  
(at Portland, Ore.)*



## 1579 STRATEGIC RAILWAY LINES

## BEING BUILT IN AFRICA

# Lewis R. Freeman

Instead of being a hindrance the war has been a great stimulus to the building of railways in many parts of Africa, especially in those regions



Preparing to Build a Temporary Military Bridge across a Stream in Western Africa: The Ropeway Serves for Transporting both Men and Materials

where railroad lines have been needed for military purposes. In the campaign against German Kamerun the British, in Nigeria, have been especially active in railway building. Several hundred miles of temporary track have been laid with a view to the strategic advantage to be gained. Later it will be made permanent. The accompanying illustration shows preparations which have been made for building a temporary bridge across the Sewa River, a tributary of the Niger.

## 2994 FLOATING VAULTS DESIGNED FOR OCEAN STEAMSHIPS

As a means of preventing registered mail and valuable articles owned by passengers from being lost when a steamship founders, two Italian inventors at Chicago have developed a system of floating safes for installation in ocean liners. The arrangement consists in part of a large, cylindrical steel casing placed vertically in the middle of a ship, the top flush with the upper deck and covered with a loose-fitting, easily lifted cap. The bottom of the well is closed by a concave head of considerable strength. Within the shaft is a perforated shell of considerably less diameter. In the lower part of the inner casing there is a hermetically sealed float. This bears the name of the vessel and is attached to one end of a flexible cable wound about a reel. Arranged above this is a series of nonsinkable vaults. Doors are provided in both the outer and inner casings at the various decks so that ready access is gained to the safes. Should a ship, thus equipped, sink, water would enter the well and cause the floating vaults to shoot out of the tube and rise to the surface, according to the inventors. The purpose of the float in the bottom of the shaft, which has the cable attached, is to serve as a marker, indicating the position of the wreck and identifying it. To demonstrate that the system would work if put to the test, one of the builders recently allowed himself to be locked inside one of the floating safes. This was held in a double casing, of the kind just described, and dropped off a raft into Lake Michigan. Scrap iron and a large anchor were secured about the outer steel cylinder to cause it to sink to the bottom. In 80 seconds the safe reached the surface, shooting about five feet into the air. A moment later the man was liberated.

It has been proposed to construct a canal from the White Sea, through Russian Lapland and Finland, to the Gulf of Bothnia, a distance of 186 miles.



1,166,145. OCEAN FLOATING SAFE. <sup>X</sup>MENOTTI NANNI  
and GIUSEPPE BERTOLINI, Chicago, Ill.; said Bertolini  
assignor to said Nanni. Filed June 26, 1914. Serial  
No. 847,429. (Cl. 9-10.)

1. The combination with a ship, of an outer casing let  
into a deck of the ship; an inner foraminated casing; and  
a float in said inner casing adapted to contain articles,  
substantially as described.

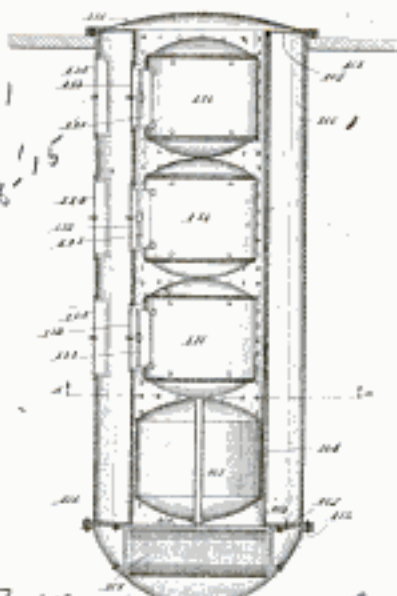

X 4717 W. Harrison St. Chgo.

2. The combination with a ship, of an outer casing let  
into a deck of the ship; an inner foraminated casing; a  
float in said inner casing adapted to contain articles; and  
a sealed closure for said float, substantially as described.

3. The combination with a ship, of an outer casing let  
into a deck of the ship; an inner foraminated casing; and  
a plurality of floats in said inner casing adapted to con-  
tain articles, substantially as described.

4. The combination with a ship, of an outer casing let  
into a deck of the ship; an inner foraminated casing; a  
plurality of floats in said inner casing adapted to contain  
articles; and a sealed closure for each of said floats, sub-  
stantially as described.

5. The combination with a ship, of an outer casing; a  
inner foraminated casing; a float in said inner casing; a  
sealed closure in one side of said float; and sealed clo-  
sures in the sides of said casings registering with the  
float closure, substantially as described.

[Claim 6 not printed in the Gazette.]



on said support, a series of steps having at their ends downwardly extending flanges, a railing including a rail pivoted on the support and an upright pivoted at its upper end to the rail and having at its lower end a saddle loosely embracing one of the stringers, a bolt extending through registering openings of the saddle-end of said upright, a flange of one of the steps, and one of the stringers,

221 O. G.—85

extremities of the tubular spoke members being each T-shaped and the hub being slotted to receive the heads of the T-ends and circumferentially grooved to receive the stems of the T-shaped extremities, and a ring inserted in the groove of the hub and suitably secured in place, substantially as described.

1,166,149. BINDING DEVICE FOR PANEL-BOARDS.  
RAYMOND H. OLLEY, Syracuse, N. Y., assignor to Crouse-Hinds Company, Syracuse, N. Y., a Corporation of New York. Filed Nov. 30, 1914. Serial No. 874,855. (Cl. 247—13.)

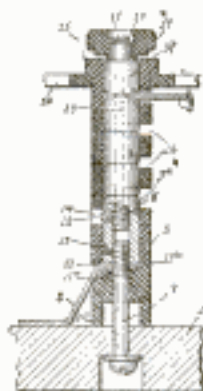

1. A binding device for panel boards comprising a post, spacing rings encircling the post, one above the other, and insulating means encircling the post and including a sleeve encircling the lowermost ring and terminating short of the upper face thereof, an intermediate sleeve encircling the remaining spacing rings with the exception of the topmost and resting on the upper face of the first sleeve and having a cutout in its lower face whereby the edges of the abutting end faces of the lowermost ring and the next ring above the same are exposed, the intermediate sleeve having a transverse slot exposing





Making Ready for the Spectacular Test of the New Floating Vault, Which has been Designed for Installation in Ocean Liners. The Inventor is Shown Taking His Place within the Safe, Which was Subsequently Sealed and Dropped into Lake Michigan

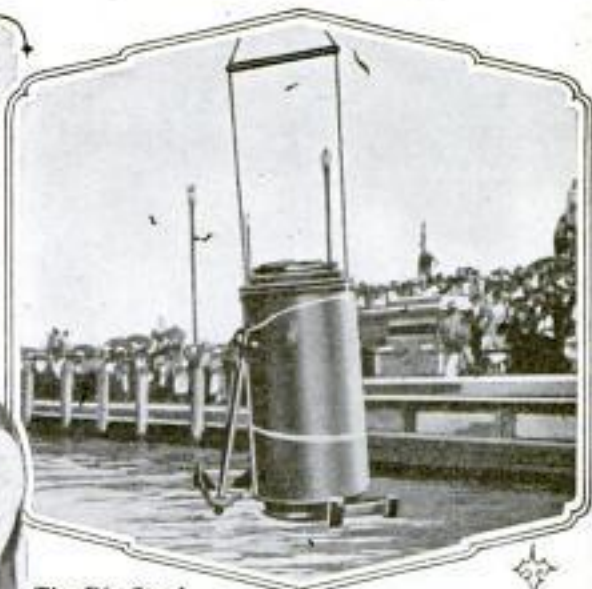

The Big Steel Cylinder, with the Inventor Sealed within It, being Swung Free from a Raft and Plunged into the Water before Hundreds of Spectators at Chicago



The Vault is Intended as a Nonsinkable Depository for Registered Mail, Jewels, and Valuable Articles Owned by Steamer Passengers. The Illustration Shows What would Happen if a Ship So Equipped should Founder



Eighty Seconds After the Big Cylinder Disappeared from Sight, the Vault Contained within It Shot to the Surface. It was Opened and the Man Liberated While Crowds Cheered

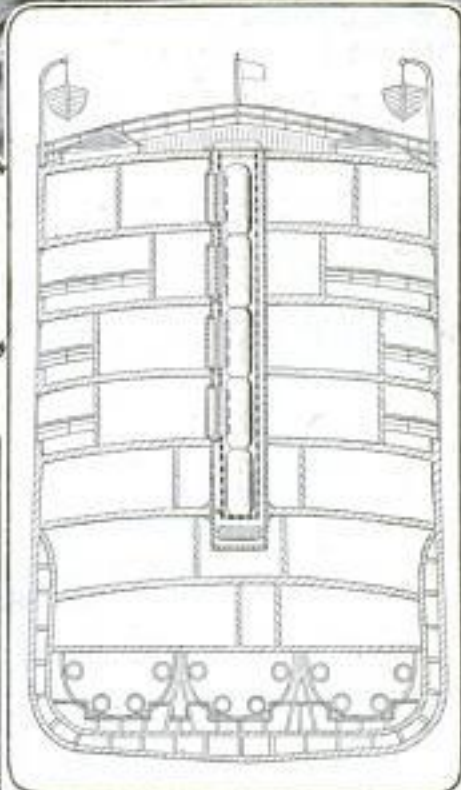

Cross Section of Ship Showing Central Shaft in Which the Separate Vaults are Carried. Doors in the Casings at Various Decks Give Access to Safes



# W. M. Jennings  
1305 Arch St., Phila.

110 2975 POPULAR MECHANICS

## HEAVY PICTURESQUE CARTS USED ON CUBAN ESTATES

In many respects the Cuban plantations are quite up-to-date, but some of them still retain picturesque reminders of less progressive days, as, for example, the huge lumbering carts used to haul loads of sugar cane, and other products.



A Cart on a Cuban Sugar Plantation Loaded with 300 Pounds of Sugar Cane and Drawn by Six Oxen at a Rate of About a Mile an Hour

As the accompanying illustration shows, these two-wheel vehicles are very heavily and rather crudely built. Six oxen are used to haul this cart, the driver walking along beside the beasts. The load consists in this case of sugar cane and weighs about 300 lb. The oxen are able to draw it at the rate of a mile an hour.

2911 Street

## NEW DUMP CAR DEPOSITS LOAD CLEAR OF TRACK

Great economy of labor and time are effected by the use of a new street-rail-

its load. This feature makes it possible to dump a load several inches outside the rails. The car, which has a capacity of 18 cu. yd., is built low, the tops of the sides being only 5 ft. 4 in. above the track. Three-fourths of the load can be shoveled in with the sides drawn up, and since the floor of the car is only 3½ ft. above the rails, the labor of loading is lessened considerably. After the doors have been closed the body can be tilted so as to make it easier to shovel on additional material. The body is divided into three compartments so that part, or all, of the load can be dumped in one place, or may be strewn along beside the track by tilting the body while the

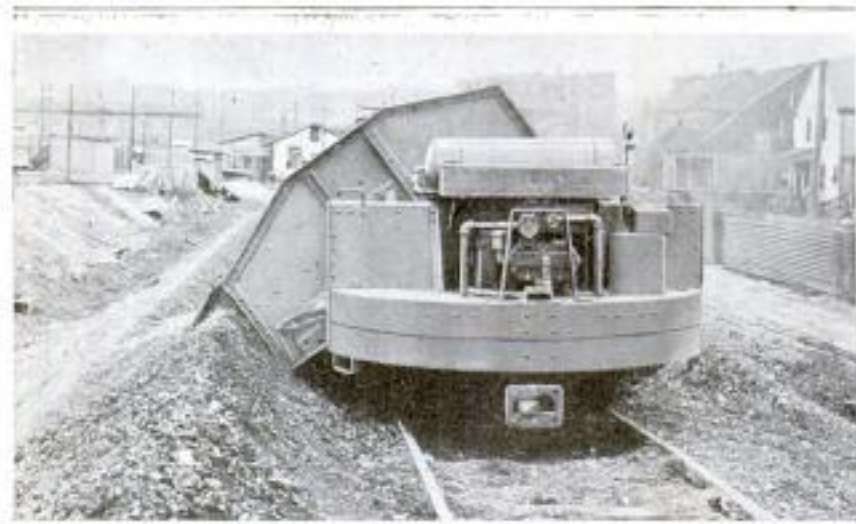

Dump Car Having an Electrically Operated Body Which Moves to One Side before Dumping, so as to Leave the Track Clear. The Capacity of This Dump Car is 18 Cubic Yards. Safety and Efficiency are Promoted by the Fact That the Tilting Body is Always under Full Control of the Motorman

way dumping car, which has a tilting body that can be moved to one side or the other about 3 ft. before discharging

car moves along slowly. A good feature of the dumping mechanism is that it gives the motorman complete con-

Differential Car Co., Inc.  
141 Broadway  
New York



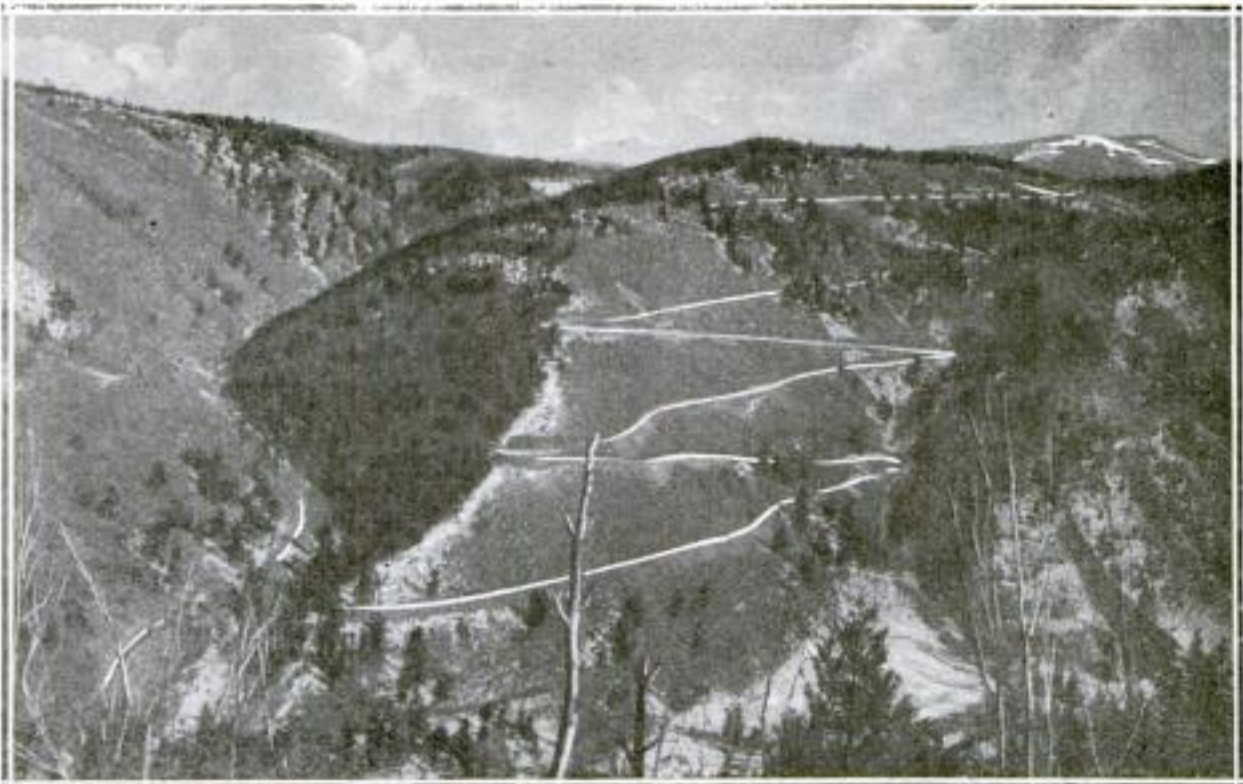

This New Government Road in Taos County, New Mexico, with a Maximum Grade of Seven and a Half Per Cent, Replaces an Old One Nearly Four Times as Steep

trol of the body, no matter at what angle it is tilted. This mechanism is operated from one end of the car where is situated a reversing switch which governs a motor. The latter supplies power by which the body is rolled to either side and tilted before the doors are unlocked.

2780

### GOVERNMENT ROAD CROSSES RED RIVER PASS

On the Red River section of the Questa-Elizabethtown road in Taos County, New Mexico, the Forest Service has surmounted many difficulties and completed the construction of an interesting, scenically beautiful mountain highway. The problem encountered was that of overcoming an 1,100-ft. elevation in a very short distance. It was accomplished by building a series of switchbacks, connected by hairpin turns, up the face of the mountain. This was done on the south slope in order that the artery might not be blocked by the heavy snows that bank the north side of the range in winter. In view of the fact

that the incline amounts to more than a foot for every 30 in., the yardage of earth to be removed was great and the handling of teams rendered difficult. The new road has a maximum gradient of seven and a half per cent, as compared with the 28 per cent of the former one, which extended through the cañon shown at the left in the accompanying picture. The road is about three and a half miles in length and cost slightly less than \$5,000 a mile.

2889 *H. W. ...*

### MODERATELY PRICED WATCH OF CALENDAR TYPE

For those who care for novelty watches, a low-priced instrument fitted with an eight-day movement is being introduced that has some interesting features. In addition merely to indicating the time in terms of seconds, minutes, and hours, it serves as a calendar, showing the days of the week and month. Three dials are arranged on its face, the largest being like that of an ordinary watch except that it bears split-second graduations and is

*Bennett Mfg Co.*  
*175 Broadway*  
*New York*

*Vash. S.C.*

Copyrighted material



2972

equipped with a continuous-sweep second hand. Two small dials are arranged on either side at the bottom of this, one marked with the days of the



Time in Terms of the Days of the Month and Week, and Hours, Minutes, and Seconds of the Day, are Shown

week and the other with the numerals for the days of the month. The instrument is built with an open escapement and provided with an open-face case of either gun metal or nickel.

What is said to be the largest irrigated farm in the country is located in Kansas and contains 50,000 acres.

## PRACTICE TUNNEL IS BORED BENEATH COLLEGE CAMPUS

Without having even to leave the campus, <sup>John</sup> mining students enrolled at the University of California are obtaining practical first-hand experience in subterranean engineering. A bore has been started in a hillside adjoining the mining building, and in carrying out the work the novices gain much of the same training that they would receive in a real mine. Already the adit has been driven more than 100 ft., and according to present expectations the tunnel will eventually be extended several thousand feet in different directions. The student operators devote a certain number of hours each week to work in the tunnel, and this is just as much a part of their course as is laboratory or lecture-hall attendance. Leaving their classrooms they don overalls, work shirts, and heavy shoes and enter the bore to do their tasks, drilling, blasting, shoveling, filling the cars with rock and clay, riding them to the dump, and timbering the bore as conditions require. It is possible that an underground chamber will be constructed and in the future used as a mineralogical laboratory. It is also expected that when the drift has been carried some distance, water will be reached. Should this be the case, and the supply large, it will be made use of by the university.

*University of Calif.*

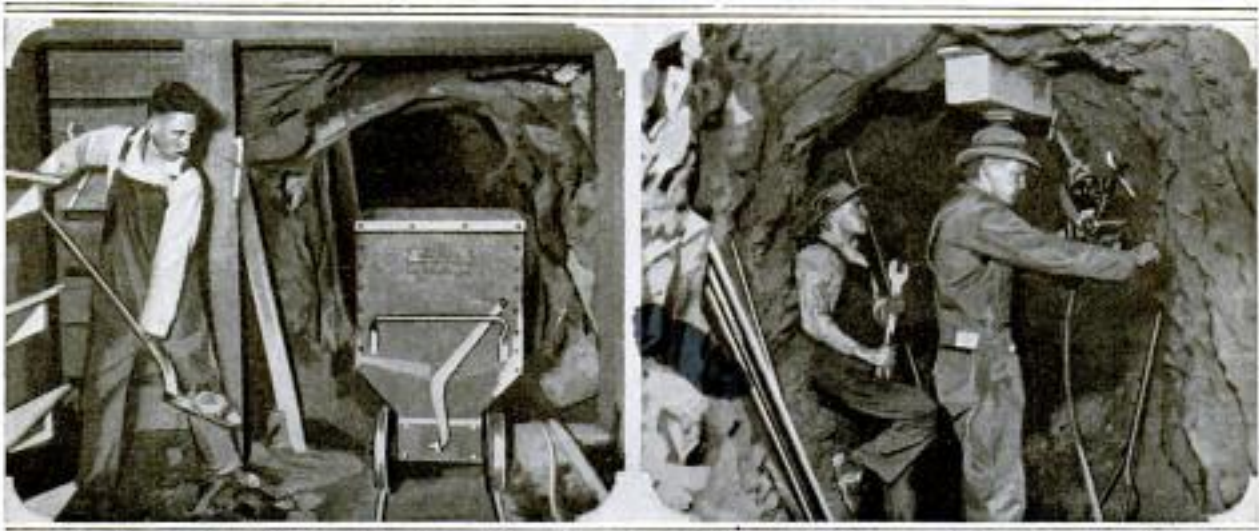

Student Miners Getting First-Hand Experience by Working a Drift beneath the Campus of the University of California



Dr. Thos. H. Norton  
Dept of Commerce  
Wash. D.C.

3122

1918

**OPEN OLD BROMINE WELLS  
TO RELIEVE SHORTAGE**

*Bulletin of Photography July '16*

The shortage of bromine, which both the photographic trade and the medical profession have felt for some time, promises to be relieved, in part at least, by the reopening of bromine wells in Pomeroy, Ohio, and Mason City, W. Va., which have been idle for several years. Their monthly output at present will amount to about five or six tons and it is predicted that within a few months American manufacturers of bromides will be able to meet the normal domestic demand. During the years 1911 to 1914 the average production of bromine in this country was 306 tons. While the importation of this chemical from Europe has never been large, before the war there was a heavy importation of photographic paper from Germany. When the war curtailed these shipments the bromine market necessarily was seriously affected, because this chemical is used extensively in making such paper.

3167

**RULE REQUIRES POWERFUL  
HEADLIGHTS ON ENGINES**

*Phila. Press 8-13-1916*

After a discussion by railroad interests, which has lasted several years, the Interstate Commerce Commission has ordered that all railroad locomotives in road service shall be equipped with headlights which will be strong enough to enable a person in the engine cab to see a dark object the size of a man, a distance of 1,000 ft. ahead of the engine. Labor organizations have strongly favored such a rule and certain roads, chiefly some in the West, already use electric headlights powerful enough to conform to it. On the other hand many operating chiefs have strongly opposed the regulation on the ground that the glare produced by powerful headlights obscures the signal lights and confuses the engineer. The estimated cost to the railroads of the country for new equipment under the new rule is \$6,000,000, not including the labor or expense of making the change.

**COMBINATION TIRE-CHAIN  
TOOL**

A combination tool with which one can apply or remove automobile-tire chains consists of a bar slightly hooked at each end and having an additional

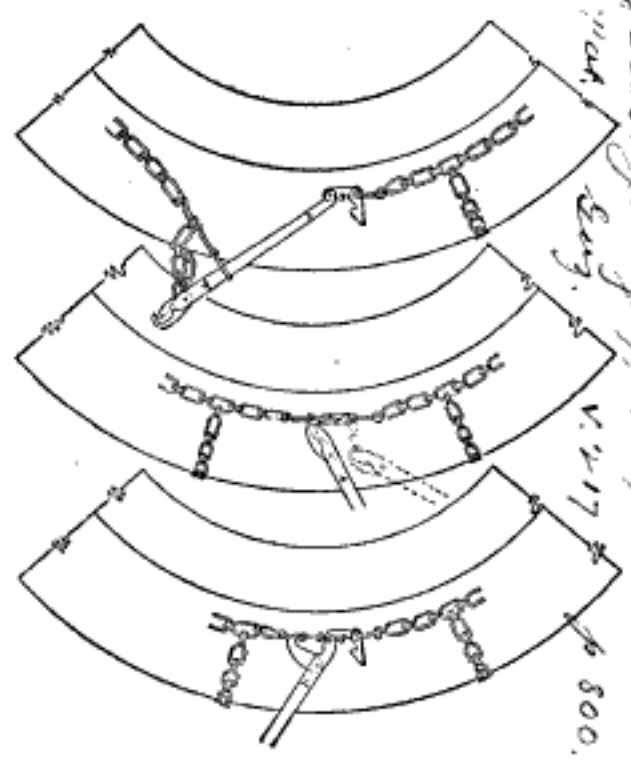

A Hooked Tool Which can be Used as a Lever to Draw the Ends of a Tire Chain Together and as an Aid in Unlocking and Loosening Chains

hook pivotally fastened to its side close to one end. After a chain has been put around a tire and the slack taken up by fastening it on the inner side, the tool is inserted through the unattached end link and then hooked to the first notch of the chain's locking member. The bar can then be used as a lever to draw these two ends together, after which they can be locked easily. The tool can also be used advantageously to pry open the locking device, and to loosen the chain if it is too tight. It occupies very little space in a tool box.

¶ Wealthy Chinese are reported to have acquired a fashionable old residence in Chicago, which they will fit up in luxurious Chinese style, making it over into apartments that promise to fascinate those who share in the present fad for things Chinese.

1150260 Aug 17, 1915  
Walter Featheringill 1404 4th St. San Diego, Calif.  
Filed Jan 17, 1916 Serial 812847. [1150260-73]

*B. Ambrose, Jr.  
116 Nassau St.  
New York*



3271 SOME NOVEL AND LITTLE-KNOWN ACCESSORIES



With This Scraper, Small Spiral Cones of Butter for Individual Use may be Made Quickly and without Waste or Inconvenience. It Is Available at 50 Cents



Rolled Dough is Laid on the Tray and the Biscuits Left in Place as They are Cut. The Scrap Strips are Removed and the Pan Placed in Oven. The Price Is One Dollar



For the Housewife Who Prepares Her Own Catsup and Grape Juice, This Bottle Capper, Costing \$2.75, Proves Very Convenient



This Decorated Wooden Figure Serves to Hide from View a Telephone Instrument of the Desk Type. The Mouthpiece Projects through a Hole Provided for It. The Device Is Inexpensive



Made of Tan Silk and Patent Leather, This Novel Hand Bag is so Designed That When Opened It Assumes the Shape of a Jinrikisha's Body. Price: \$10

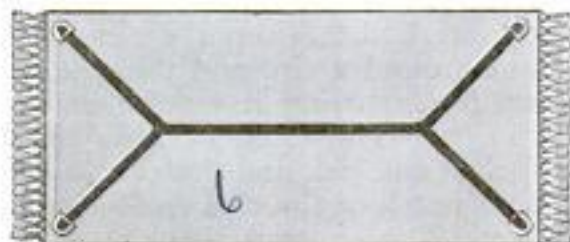

Small Rugs can be Made to Lie Perfectly Flat at All Times by Using Steel Holders of This Type Which Fit into Leather Pockets Sewed to the Corners on the Under Side

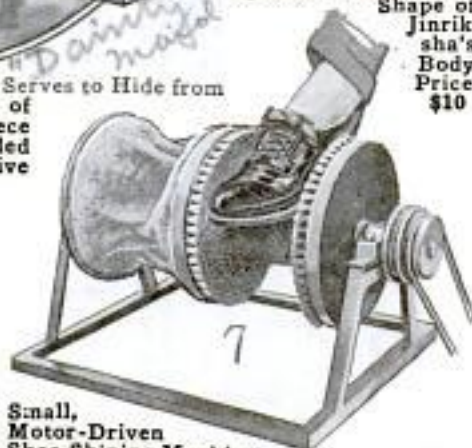

Small, Motor-Driven Shoe-Shining Machine for Household Use. The Polish is Applied in the Usual Way and the Shoe Placed against the Brushes and Then the Flannel-Covered Drum



This Folding Sleeve Board Occupies Little Space and may be Kept in a Drawer Out of the Way When Not in Use. Also It will Fit into a Trunk. The Price Is 50 Cents



Here is a Very Convenient Pouring Lip That may be Readily Attached to the Necks of Large Cans of Various Kinds. It Is Useful for Household, Garage, and Store Purposes, and Costs a Quarter





- BISCUIT TRAY--Columbian Enameling & Stamping Co, Terre Haute, Ind.

7 BOTTLE CAPPER--Enterprise Mfg. Co. <sup>of Penna.</sup> Philadelphia, Pa

*Riviera #*  
4 ~~HANDBAG--~~ *Mrs. Fred Telford Western Springs Ill*  
*Contributor*

5 TELEPHONE SCREEN-- A. L. Randall Co., Waukegan & Lake, Chicago.

6 RUG RETAINER-- Perfection Rug Retainer Co., 1011 Wells St., *Chicago*

7 "De Froment"  
SHOE-SHINING MACHINE-- *J. De Froment, Somerset, Mass.*

8 SLEEVE BOARD-- Queen Mfg. Co., 313 S. Clinton, *Chicago*

9 POURING LIP-- George J. Record, Conneaut, Ohio.

10 CREAMER & SUGAR TRAY-- Corham ~~Co.~~ <sup>10 S. Wabash av.</sup> Chicago. *(Providence R.I.)*

11 NAIL BUFFER-- *J. F. Lapetina* (Inv), Ocean View, Virginia.

12 - *See foot of page*

13 WORK BAG-- ~~Miss Jane Jarvis, Harpers' Bazar Shopping Service, 111 W. 40th St., New York.~~

14 DENTAL FLOSS HOLDER-- The Makers of Flossy, Evanston, Ill.

15 VASE-- *C.D. 141 S. State St.*  
~~Peacock Jewelry Co., Chicago~~

16 SILVER CLOTHES PINS-- Daniel Low & Co., Salem, Mass.

17 Yarn Winder-- Special Orders Shop, 20 W. 39th St. N. Y.

18 DISH MOP-- *Home Mfg. Co. Chicago*

19 Door-Key Lock--Home Craft Shop, 2473 Warren St., Toledo, O.

20 TIE CASE-- Baird North Co., Providence, R. I.







# INTENDED FOR THE HOME AND ITS MEMBERS

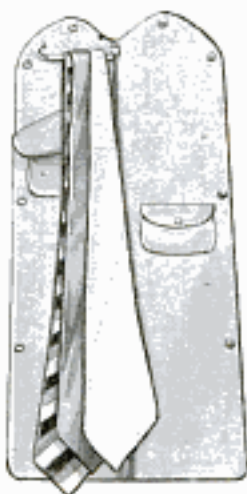

For Cravats This Is a Sensibly Contrived Case, Backed with Black Seal-Grain Leather and Lined with Moreen. The Pockets Are for Collar Buttons and Scarf Pins. The Price Is \$3



Those Who Admire Distinctive Designs will Doubtless Find This a Pleasing Combination. Both the Cream Pitcher and Loaf-Sugar Tray Are of Engraved Silver. The Price Is \$12



For the Manicure Set: A Rotary Nail Buffer That is Easily Operated When in Either Hand



A Work Bag at \$2 That Is Both Dainty and Serviceable. The Lower Part is Made of Flowered Cretonne Trimmed with Gold Braid. The Top Is of Pink Silk



Here Is a Holder for Dental Thread That Permits One to Give the Teeth Proper Attention without the Customary Gymnastics. It Sells for 50 Cents



This Shapely, Long-Stemmed Vase, Fitted with a Wire Mesh Holder, Permits a Few Roses or Carnations to be Grouped Artistically. It may be Had for \$16



Silver "Clothes Pins," Costing 35 Cents Each, are Made for Attaching Place Cards to Tumblers or Goblets



Yarn Winder of Artistic as Well as Serviceable Type. It is Finished in Black with Chinese Lacquer in Gold, and Is Available at \$12.50 and More

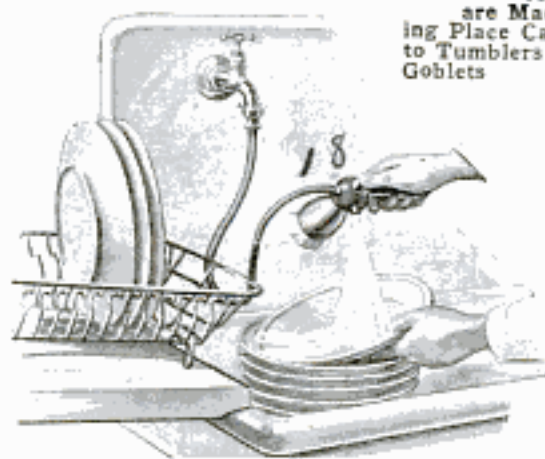

Sanitary Fountain Dish Mop, with Soap Compartment, Connected with Hot-Water Faucet. A Strong, Clear Spray is Afforded by Pressing a Button. It is a Convenient Kitchen Accessory and Costs \$5

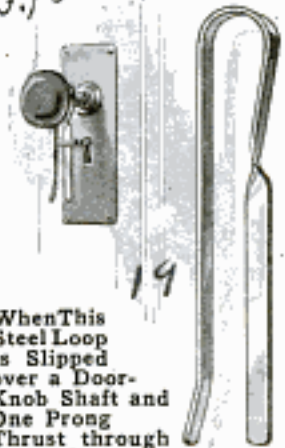

When This Steel Loop is Slipped over a Door-Knob Shaft and One Prong Thrust through the Hole in the Key. It Is Impossible to Turn or Remove the Latter from the Outside. The Price Is 15 Cents



### WAGON BED REMOVED EASILY WITH INEXPENSIVE HOIST

To obviate the heavy lifting that usually attends the work of changing a wagon bed, a simple hoisting device

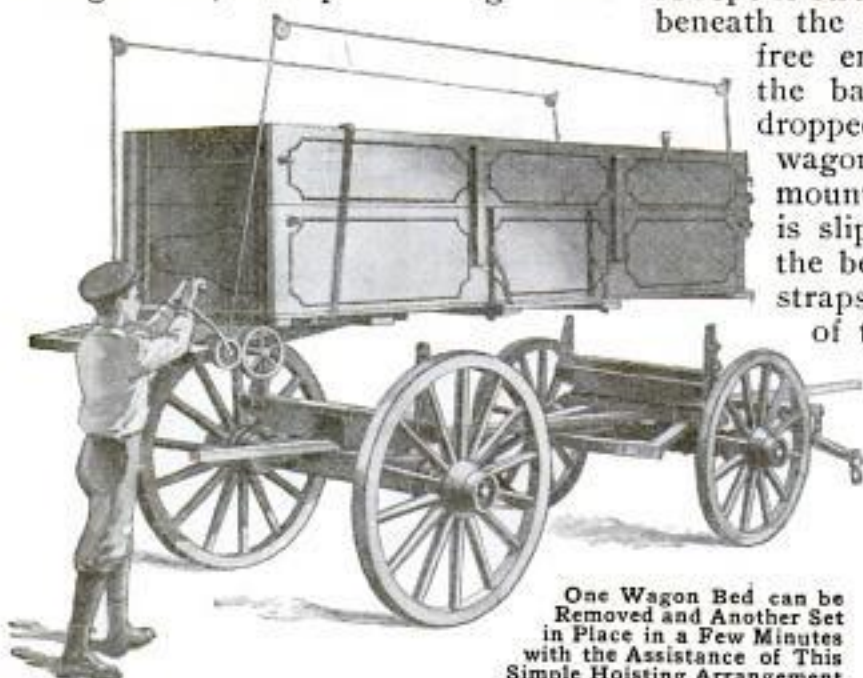

One Wagon Bed can be Removed and Another Set in Place in a Few Minutes with the Assistance of This Simple Hoisting Arrangement

has been brought out which resolves the task into an easy one-man job. Four pulleys are fastened to the rafters of a barn or shelter in positions corresponding to the corners of a vehicle. A rope is strung over these and passed beneath the forepart of the bed, the free ends being drawn across the back pair of pulleys and dropped at the rear of the wagon. A wooden frame mounting a crank-turned shaft is slipped beneath the rear of the bed and fastened by metal straps that hook over the tops of the opposite side boards.

By attaching the loose ends of the rope to the shaft, and revolving the latter by turning the crank, the bed is lifted free from the wagon without difficulty. In a similar manner another bed can then be put in place.

1302

### IMPROPER TIRE INFLATION PREVENTED BY VALVE

To insure the proper inflation of motor-car tires at all times, a North Dakota inventor has developed a pres-

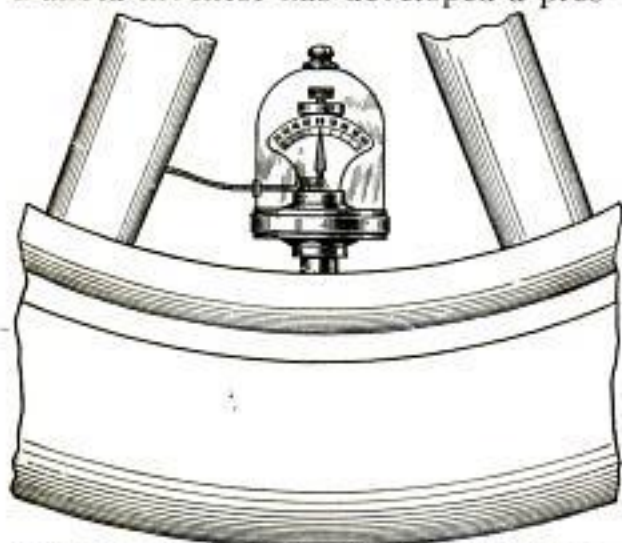

The Valve is Electrically Connected with an Annunciator on the Dash Which Informs a Motorist When the Proper Amount of Air has been Delivered to a Tire sure-indicating and controlling air valve which is capable of being em-

ployed in several ways. Primarily, however, the instrument is supposed to be attached permanently to the valve of each of the four tires of a machine and connected by means of wires to an electric annunciator installed on the dash. It is  $1\frac{3}{4}$  in. in height,  $1\frac{1}{8}$  in. wide, and adjustable so that it is suitable for pneumatics of various sizes and capacities. When a tire equipped with the valve is being filled, it is pumped only to the pressure recommended by its manufacturer, for when this is reached the adjusted valve automatically closes, releasing the further flow coming through the supply tube. At the same time an electric contact is made which trips a leaf on the annunciator, indicating that a specific tire has been adequately inflated. When it is not wished to equip a car with a complete set of the valves, one of them may be used as a pocket gauge. Likewise the device can be attached to the supply tube at a filling station and similarly used.

Ashelman & Johnson  
Broadway & Front Sts, Fargo, N. D.



## BRITISH FLYING SCHOOL

### LOCATED IN EGYPT

*K. C. Star 10/8/16*  
Recent reports from Cairo, Egypt, tell of an aviation school which the British have established at some point in that country, the name of which has not been revealed. The institution's plant is said to be almost complete. As soon as work is begun its officers expect to turn out at least seven qualified airmen each week as long as the war lasts. The school was located in Egypt because it is within easy access to the various theaters of war and the climatic conditions there are such that flying can be undertaken practically all the year round. It is said that this will be one of the largest and best-equipped flying schools in the world.

## QUEER CUT-OFF IS DEvised FOR WATER-PIPE SYSTEM

To safeguard against the bursting of water pipes in a residence or building during an unexpected cold snap, an automatic low-temperature cut-off system has been devised for use in certain sections of the South where freezing weather is the exception rather than the rule during the winter. The arrangement is not one which could be applied advantageously in localities where cold temperatures might prevail for long durations. Briefly, the arrangement consists in part of inserting a U-shaped piece of tubing in the supply pipe, allowing its curved part to project an inch or so above the surface of the ground on the outside of a dwelling. This comprises the cut-off, and is a tapering, flattened member with a broad passage that is only  $\frac{1}{8}$  in. deep at the bend. The water at this point will freeze quickly if the atmospheric temperature drops low, thus shutting off the water supply. An automatic drain is provided in the basement of the dwelling. This is controlled by a spring, which unseats the valve head when relieved from the heavy service pressure and allows the water in the house pipes to flow into a catch basin. That the water may drain

properly, a faucet, fitted with an air valve which opens when the pressure is off, is used at the highest point in

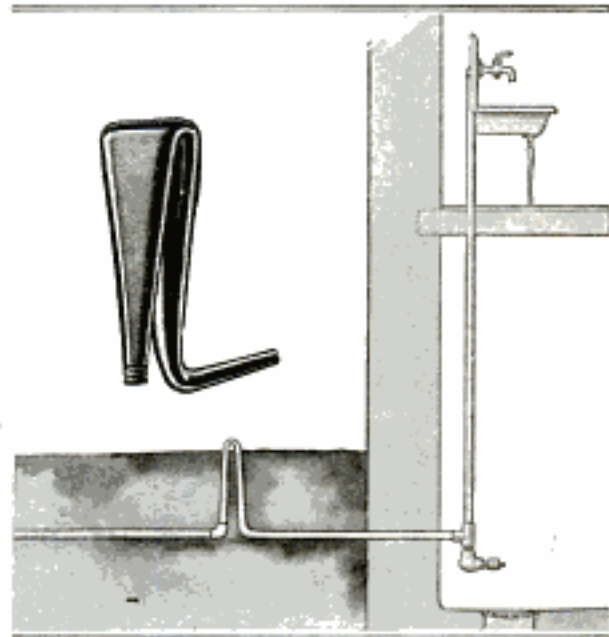

The Passage through the "Cut-Off" Is so Shallow That the Pipe does Not Burst When the Water Freezes within It

the piping system. Both this valve and that in the drain close when the pressure returns.

## DOG CARRIED ON BICYCLE TO PROTECT MESSENGER

A trusted messenger of a Philadelphia contracting firm, who carries large sums of money to gangs of working men in various parts of the city, has devised an out-of-the-ordinary means of protection against robbers. Because



Messenger, Who Carries Large Sums of Money, Takes His Bulldog with Him on His Bicycle Journeys, for Protection

*Cont.*  
#W. C. Lowe, 18 Avery Drive  
Atlanta, Ga.

# Jos. A. Guerin, 1546 S. 15th St., Phila.



3168

of the fact that a large number of persons know that this man carries money in the bag slung over his shoulder, his employers suggested that he purchase a revolver with which to protect himself in case of attack. Instead of buying a weapon he attached a shallow box to the bicycle frame behind the seat, just over the rear wheel. In this he carries his powerful pet bulldog when he goes on these trips, and thus far no one has ventured to molest him.

2328  
**CONVENIENT POINTS FOUND  
 IN NEW PIPE WRENCH**

Several good features are embodied in a heavy wrench that is particularly



designed for work involving air-brake, steam, and water pipes of locomotives or railway cars. It consists of three simple working parts and is entirely free from springs, ratchets, and pins. One of the levers actuates a jaw member through a knuckle-joint connection. The toothed surfaces of the jaws are curved, so that they partly describe a circle when set about a pipe and grip two-thirds of its circumference. This gives the device a great holding power and also obviates the danger of a pipe being crushed. Although the wrench is intended especially to be used on one size of pipe, its usefulness is not limited in this particular. For instance, a  $\frac{3}{4}$ -in. wrench does its best work on pipe of the same size, but will also grip  $\frac{3}{8}$  and  $\frac{1}{2}$ -in. tubes. The tool is a convenient one when work is being done on nested pipes that are close to walls or floors.

**NEED OF CANALS IN PEACE  
 AND WAR SHOWN**

In a recent discussion of what means of transporting materials could be employed by the military authorities of this country in case the railways could not be relied on, a naval officer showed in detail the great need for inland waterways and coastal canals. In making plans at the time the railway strike was pending, he said the Navy Department found that points on the Great Lakes, in Massachusetts, Connecticut, and elsewhere, which furnish quantities of materials and supplies, could be reached by water with little difficulty. On the other hand there were found to be many other points, such as Pittsburgh and cities in Ohio, whose products are of vital importance, which had no adequate water routes. In case of a war, even more than in case of a strike, the isolation of these cities which would result if trains did not run, would be a source of grave weakness. It was pointed out, also, that many merchant ships would soon be helpless without railways to supply them with coal. All these facts were cited to show the need of keeping up our canals, many of which are now neglected, and of building new ones, including coastal canals, for use in times of peace as well as war.

2969  
**LEGLESS BANQUET TABLE  
 HANGS FROM CEILING**

A Milwaukee restaurant keeper has constructed a legless banqueting table. It has no supports beneath but is held firmly in position by two pipes which are fastened to chandeliers immediately above it. The inventor claims many advantages for this sort of banqueting board. By merely unscrewing the pipes from the chandeliers the table can be removed after a meal, and the floor thus cleared for dancing, or entirely occupied by banqueters and others who wish to listen to after-dinner speaking. The advantages of tables like this when the floor is to be cleaned is obvious. When stored, such

Carl Kempf

Milwaukee, Wis.

Mechanical Specialties Co.  
 122 N. Michigan St., Chicago, Ill.  
 Geo. E. Brown

Admiral Benson  
 Atlantic Ocean Waterway  
 Res.





A Legless Banquet Table Suspended from Chandeliers: The Pipes Which Support the Table can be Quickly Detached

tables would occupy small space. After the supporting pipes have been removed, a cap is screwed to the chandelier to conceal the place where the attachment is made.

2105

### NEW SAFETY DEVICE GUARDS AGAINST RAIL ACCIDENTS

Experiments are being conducted by one of the eastern railways with a safety device which a Rochester inven-

tor has evolved for the purpose of eliminating accidents caused by the occasional failure of locomotive engineers to observe danger signals. Particularly during heavy storms and dense fogs, it is extremely difficult for a pilot to see a semaphore. The safety appliance is intended to control the speed of the train mechanically, so that it cannot run into an open switch or collide with another

appliance is installed in a locomotive and consists of an arrangement which permits the steam to be cut off and the brakes applied, when a lever arm, extended adjacent to one of the rails, strikes a trip fixed on the track and regulated either mechanically or electrically by connection with a regular signal system. Thus, when a tower-man sets a semaphore to stop an approaching train, and the engineer of the latter fails to see it, the lever arm

1179521 - April 18, 1916 - Gay V225-792

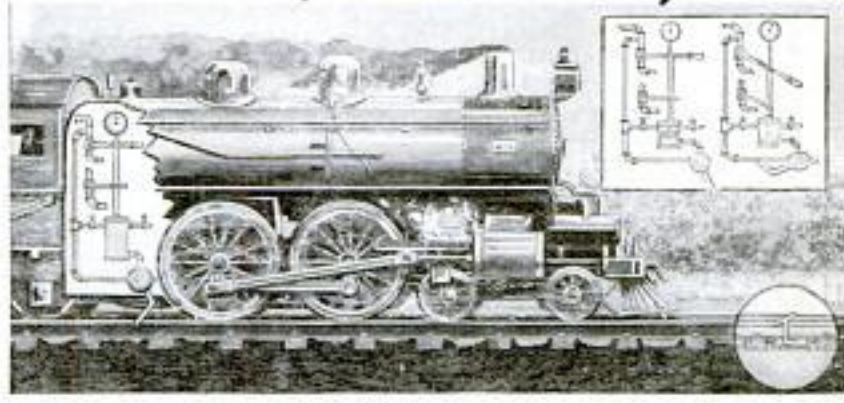

Railway Crashes, Due to the Failure of an Engineer to Observe the Signals, are Avoided by the Use of This Safety Appliance Now being Tested by an Eastern Railroad

of the controlling device hits the trip, and the train is brought to a stop.

Inv. Dr. Hedley C. W. Graham  
96 Plymouth Av., N.,  
Rochester, N. Y.

Buffalo Rochester & Pittsburg Ry Co.,  
W. C. Devane Supdt.  
Rochester, N. Y.







IDEAS FOR CHILDREN OF VARIOUS AGES 3185

*Thrift Purse Co.  
422 Ham St, Dept. Paul, Ill.*



Front View of the Car Pictured in Center of Page, Showing Hooded Recess for the Driver, Who Usually Is the Little Girl's Father



A Seven-Day Purse, Costing 50 Cents, with a Separate Pocket for Each Day's Coins and One Besides for Surplus. This Purse Makes It Easy to Spend Only a Certain Amount Daily and Also to Lay Aside a Few Pennies or Dimes

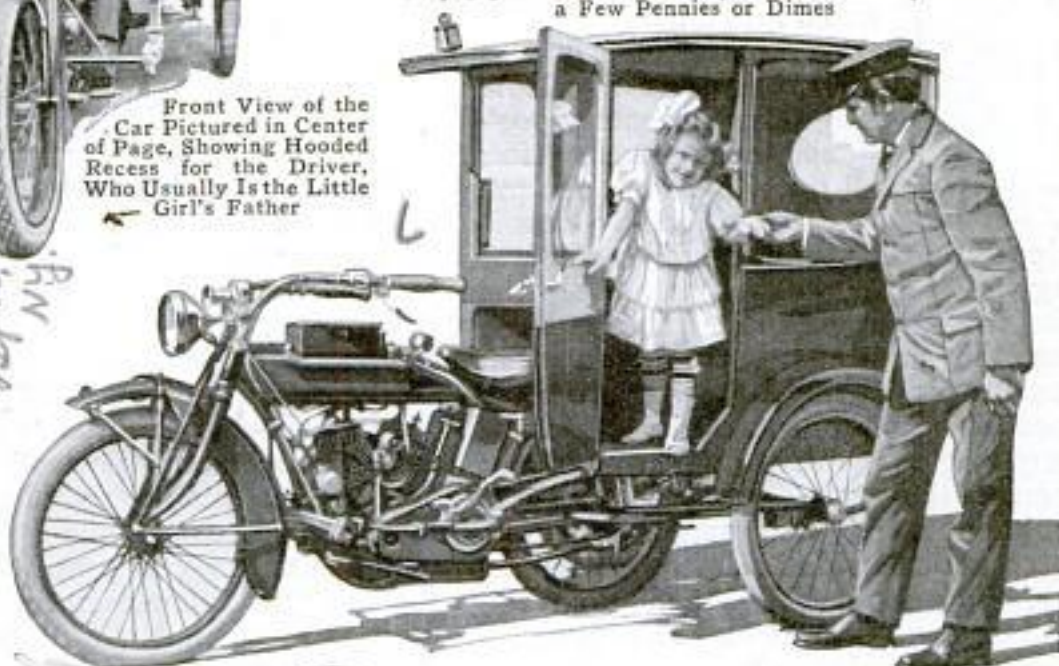

A Novel Car Furnished Just Like a Limousine and Built Especially for the Little Lady in the Doorway, Who Is the Youngest Member of an Eastern Grand Opera Company. If Desired the Motorcycle can be Detached

A Real Motion-Picture Machine That Costs Only \$8; It Has a Set of Dry Cells and a Tungsten Light Which Throws a Picture 10 Feet, Standard-Sized Films can be Used and Since There Is No Blaze There Is Little Danger of Fire

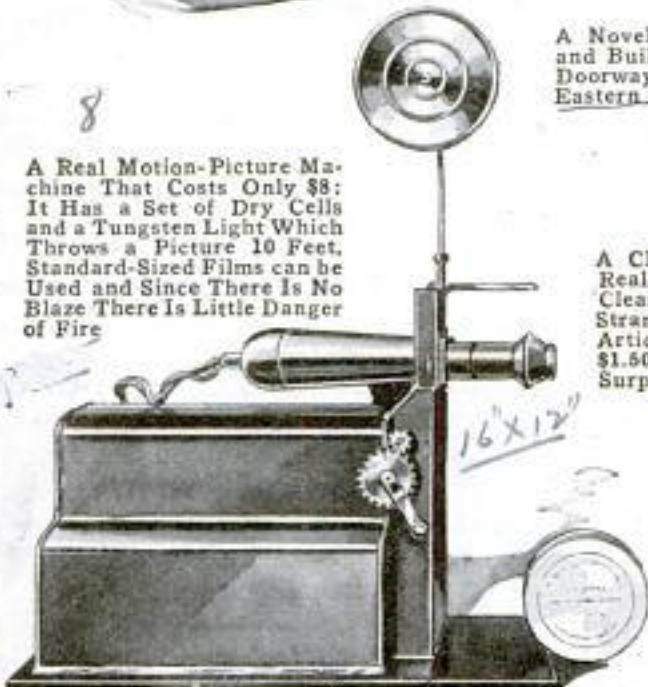

Ferguson Novelty Co., Inc.

A Cloth Kitten That Is Really a Grab Bag Filled Clear to the Top with Strange and Interesting Articles. The Price Is \$1.50 for the Cat and Surprise Packages



*Studios Shop for Things Beautiful  
96 Fifth Ave  
New York 21  
Studios 20-21-23*

*Assigned by, (and built for one of his daughters  
Alice) James Neumann (Cost \$600.)  
"Indian Notary" N.Y.  
Hendler My Co Springfield, Mass.  
Cypress Bear Car Co., Dept. M.,  
1200 Niagara St,  
B'ho, N.Y.*

*Metropolitan Opera House*



# Kinn W. Baxter + 452 4th St.  
L. C. Christmann Toledo, O.

Inv: Moulton Ad. de. 6611111111

### NEW UMBRELLA FRAME HAS BALL-AND-SOCKET JOINTS

The fastening of umbrella ribs to an umbrella staff, or handle, by means of a wire which is threaded through eyelets at the ends of the ribs, is dispensed with in a new type of umbrella, in which the ribs are fastened to the staff by ball-and-socket joints. The end of each rib is fashioned into a ball. Each of these balls fits into a socket in an aluminum ring that is properly positioned on the staff. After all the ribs have been put in place, a locking ring is slipped up next to the member containing the sockets and serves to keep the ribs from dropping out. At the same time they are free to swing into a radial position, as when the umbrella is opened, because of narrow slits in the rings, which are arranged radially around the staff. In case a rib is broken it is only necessary to release a catch which holds the second, or locking, ring in position, and then the broken member can be taken out and a new one substituted. An umbrella of this type can be closed very compactly.

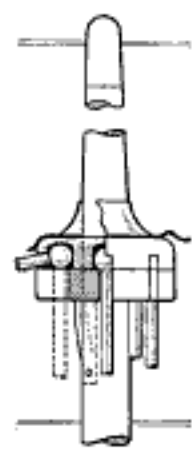

3132

### GREAT LOSS RESULTS FROM BUYING WATER IN GRAIN

Under conditions which today govern the buying and selling of grain, flour, and cotton seed, too much water is apt to figure in the transactions. A farmer shipping five cars of grain having a moisture content of 20 per cent, pays freight on one carload of water, whereas, if by proper treatment he had brought his product down to a 12-per cent moisture content, he would be saving freight on two-fifths of a car of water. Experts of the Department of Agriculture contend that the weight of water, which exists in varying proportions in the products named, should be subtracted and only the dry material

considered in buying and selling. This would be a benefit to the farmer, for now the buyer of grain usually makes his price sufficiently low to allow for loss or for the cost of artificially drying the grain, even though the grower has furnished a very dry product. The department has prepared comparative tables which make it easy to compute values on a dry-matter basis. Such a standard, if adopted, would be an incentive for the farmer to produce drier grains and hence grains less subject to loss from spoiling.

3092

### OSAGE ORANGE TO BE USED IN MAKING DYES

Extensive experiments, which have been in progress for some time, indicate that Osage-orange wood can be utilized for dyeing purposes. It is believed that this fact will not only relieve the situation with regard to the shortage of aniline dyes in certain shades but may eventually replace the use of fustic, a dyewood of which about 4,000 tons are now imported annually from the tropics. It is estimated that the yearly mill waste from the present manufacture of Osage orange is more than 25,000 tons, a fact which gives some indication of the available supply of this wood. The same dye has been found in the Osage orange as in fustic, and in some respects is more uniform than that in the tropical wood. Among the colors for which it can be used are orange-yellow, old gold, deep tan, olive, and chocolate shades. American manufacturing interests are also taking steps to overcome the present shortage in dyestuffs. A large chemical company, now completing an immense plant in the East, has announced that its principal products will be used in the manufacture of dye materials. This plant, it is said, will be the only one of its kind in the United States.

¶To avoid their being confused with other kinds of tractors, an English publication now refers to farm tractors as "agrimotors."

# C. J. Moulton 3/9/12  
# Moulton 3/9/12  
# Moulton 3/9/12





## Homemade Joist-Boring Machine

By CHARLES H. TRAPP

**A**N easily constructed joist-boring machine, which is particularly adapted for boring holes for knob-and-tube wiring in basements, is shown in the illustration. The ordinary joist-boring machine is usually too long for convenient use in a basement, hence the especial value of the one described. The machine is of one-piece construction, that is, it is not jointed as are some borers, which makes it light, and easily transported and handled. It consists essentially of a piece of 1-in. conduit, 6 ft. 6 in. long, two sprockets, 13 ft. of bicycle chain, and a twist bit, these materials being inexpensive and readily obtainable.

The head sprocket, as shown in detail, is mounted on a shaft contained in the bearing of the driving sprocket,

head sprocket is smaller than the bottom one, the machine will "feed" faster, with the same number of revolutions of the bottom sprocket, than when the sprockets are the same. The bearing for the head sprocket being taken from an old bicycle, the shaft to which the sprocket is attached revolves on ball bearings and is adjusted and held in place by cones, washers, collars, and keys. The column supporting the bearing is telescoped into the 1-in. conduit. It is about 1 ft. 6 in. long, and is riveted into place.

The twist bit is inserted into a hole, 1½ in. deep, drilled into the shaft or axle, as shown at the left, and is held rigidly in place by a key driven through the collar. The shank of the bit is first cut off, as shown, and then filed

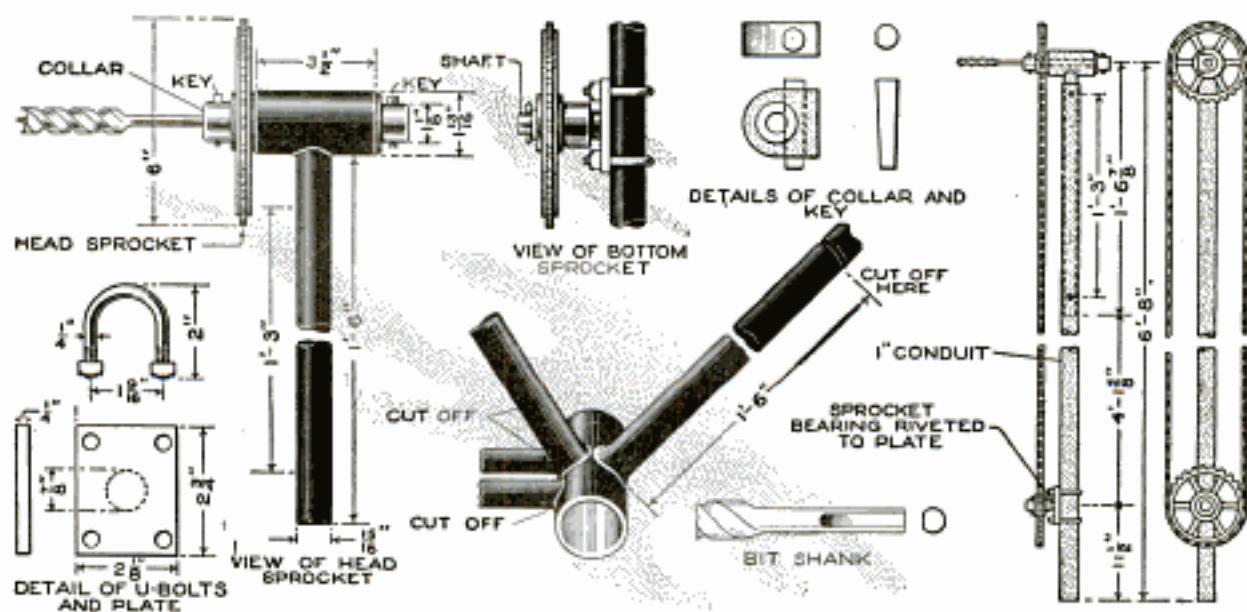

This Practical Joist-Boring Machine was Made of Bicycle Parts and Is Especially Convenient in Knob-and-Tube Work

cut from an old bicycle frame. It is 6 in. in diameter, the same size as the bottom sprocket. Obviously, if the

flat. The bit is inserted in the hole in the shaft, and the key, which also has a flat side, is driven through the collar



so that the flat side of the key rests tightly against the flat side of the bit shank, holding the bit firmly in place.

The bottom-sprocket bearing is riveted to a  $\frac{1}{4}$  by  $2\frac{1}{8}$  by  $2\frac{3}{4}$ -in. iron plate, drilled in each corner for  $\frac{1}{4}$ -in. bolts. The plate is then attached to the conduit frame with two  $\frac{1}{4}$ -in. U-bolts, shown in the sketch. The bottom sprocket is held in place on the bearing and shaft with a nut and washer, secured further by a spring cotter.

When assembling the machine, the head sprocket should first be fixed into place. Then the chain should be assembled and placed over the head sprocket and the bottom sprocket should be adjusted at such a distance from the head sprocket that the chain will be reasonably taut when the machine is operated. It is well to make the borer of such a height—about 6

ft. 8 in. is satisfactory—that it can be used conveniently in basements with low ceilings. If the borer is too short for use in some basements, it can be raised by inserting a rod, of suitable length, in the bottom end of the conduit.

To operate the machine, make the proper adjustments as to height, set it up at the joist to be bored, grasp the conduit frame firmly with the left hand and feed the bit into the joist by pulling down on the chain with the right hand. While boring, pressure should be exerted against the machine with the left hand. This will, of course, cause it to feed faster. When the hole is bored, the machine, still held by the left hand, should be pulled toward the operator while the chain is moved quickly up and down with the right hand, making it easier to remove the bit, and giving a clean-cut hole.

### Stairs for Climbing over Fence

Modern farm fencing is not well adapted for providing a foothold to



The Stairs Built into the Fence Provides a Convenient Method of Climbing over the Barrier

climb over it, and the adaptation of an idea, not altogether new, shown in the

sketch, might be used with profit in many places. When a convenient means of climbing over a fence is provided, damage to the fence by careless climbers is avoided. A stairs built to extend on both sides of the fence is a simple and practical means of travel between adjoining grounds. It is a barrier to stock, and if well made it will prove serviceable and inexpensive.—J. H. Moore, Hamilton, Canada.

### Kink in Overhauling a Gasoline Engine

When overhauling an automobile, or other gasoline, engine extreme care should be taken that the valves be numbered and reassembled to their proper valve stems. Trouble in assembling may thus be avoided, for in not a few instances noisy and sticky valves are traced to errors in assembling apparently identical parts. The valves and parts to which they are fitted are numbered in many engines; when this is not the case, a good plan is to tie numbered paper tags to the parts which correspond as they are separated.—Adolph Klein, New York, N. Y.



### Gauge for Spacing Steel-Marking Punches

Names, or other indications on tools, punched into the surface by the use of individual punches, are often unsightly because it is difficult to align them properly. The device shown in the illustration provides a simple and accurate means of gauging the spacing of the letters or figures, and can be adapted to various sizes of punches.

I have two alphabets,  $\frac{1}{16}$  in. and  $\frac{1}{4}$  in. in height, and for the former I found that a spacing of 12 letters to the inch is satisfactory; for the latter I use five letters to the inch. I made a sliding piece, A, of brass, and brazed an angle, B, to it, as shown. The steel punches fit into the angle, which acts as a guide in conjunction with the spacing gauge marked on the forward strip of the frame. The vertical angle is  $\frac{1}{2}$  in. shorter than the punches and its lower edge is flush with that of the sliding piece. The frame was made of hardwood strips, the end pieces D being fastened to the sidepieces E by means of screws, countersunk. The indications for the spacing of the two sizes of letters were made on the frame and a small pin was fitted to the sliding

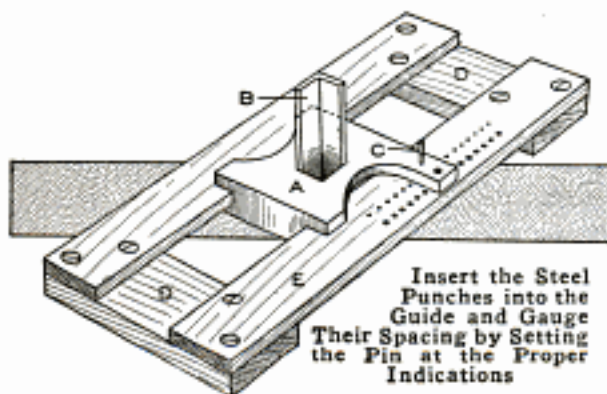

piece to engage the holes. This insures the accurate spacing of the letters, both as to being in a straight line and as to distance apart.—Harry G. Fesenfeld, Black Earth, Wis.

☞ To split off a tight machine nut with a cold chisel is sometimes more economical than to risk ruining the bolt threads.

### Drafting Table Made of Pipes and Fittings

I made and used a drafting table like that shown in the illustration, and

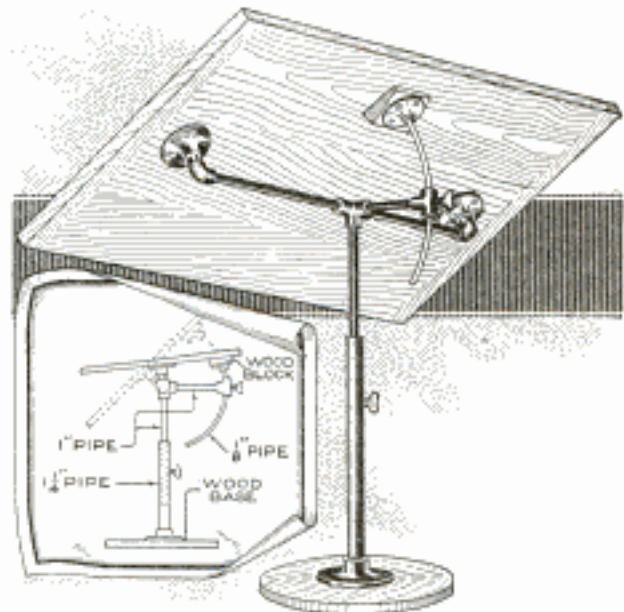

The Height and Slant of the Board may be Adjusted over a Wide Range by Means of the Thumbscrews

it has given complete satisfaction; in fact, I find it as convenient as any commercial table I have ever used. It was made for a large drawing board, but can be adapted to a board of any of the sizes ordinarily used. The base was made of a wooden disk, 20 in. in diameter. A flange and a  $1\frac{1}{4}$ -in. pipe was used for the lower section, and 1-in. pipe for the upper parts of the support. The curved part by which the slant of the top is adjusted was made of a  $\frac{1}{8}$ -in. pipe screwed into a flange which was fastened to the board as shown. The pipes were drilled and tapped for thumbscrews, by means of which the board is held at the desired angle and height.—Armydis E. Sturdivant, Newcastle, Ind.

### Bushing Avoids Marring of Work in Lathe Dog or Chuck

It is frequently necessary to grip highly polished work, such as ground spindles and polished brass pieces, in lathe dogs or chucks. To prevent their marring by the setscrew of the dog or the jaws of the chuck, I have found



the following method to be superior to many others I have tried: A bushing of soft steel is bored and reamed smooth to a push fit, on the shaft or

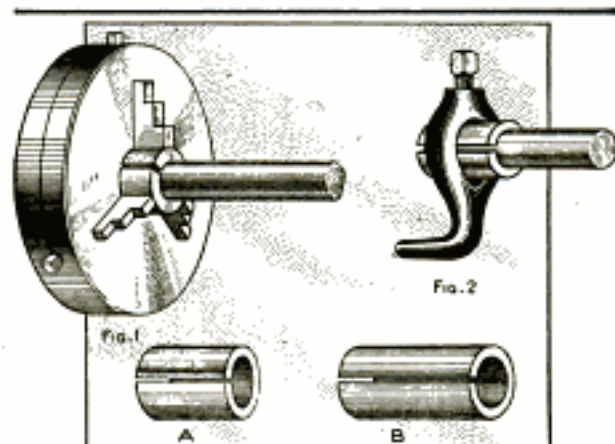

The Smoothly Turned Split Bushings Protect Highly Polished Spindles in the Chuck or Lathe Dog

spindle to be held. This is mounted on an arbor and turned down so as to leave the walls of the bushing  $\frac{5}{16}$  in. thick. A  $\frac{1}{16}$ -in. slot is cut through the bushing, as shown in the sketch at A and B, two useful sizes. The burr is removed and the bushing smoothed carefully with emery cloth. Fig. 1 shows the bushing in use in a chuck, and Fig. 2 in a lathe dog. Where much of this work is done it is desirable to provide several such bushings of standard sizes.—Richard H. Jehlicka, Worcester, Mass.

### A Valve-Cap Wrench

The valve-cap wrench illustrated was made after two other types had

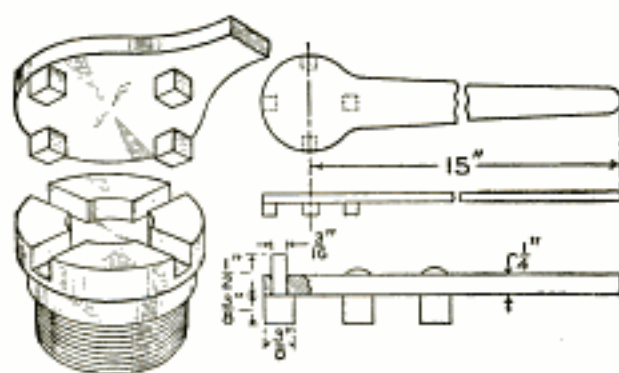

Wrench Made Similar to a Spanner for Turning Valve Caps In and Out of Place

proved failures. The body of the wrench is constructed of  $\frac{1}{4}$ -in. cold-

rolled steel,  $16\frac{1}{4}$  in. long, and the pegs for gripping the slots in the valve cap are made of  $\frac{3}{8}$ -in. square drill rod. The pegs are shouldered so that they can be riveted to the handle. It is a good plan to harden the square end of the pegs, but care should be taken to harden them to a very slight depth.

### Making Small Steel Scales

The mechanic will ordinarily profit by purchasing reliable scales or other precision instruments, but if care is taken and the satisfaction of having an accurate homemade scale, of steel, is appreciated, my experience may be of interest. I use a 2-ft. four-fold scale, accurate enough for all ordinary purposes as a pocket rule, made from corset stays, etched and polished to a finish like that of commercial steel rules. The stays are straightened, polished, and covered with a thin layer of paraffin. The indications are carefully scratched upon them, including the numerals for the inch marks. The strips are then placed in a bath of one part nitric acid, one part sulphuric acid, and 12 parts rain water, and permitted to remain until the indications are etched to a sufficient depth. The holes at the ends of the strips are located carefully and rivets placed in them, making the joints tight enough so that the rule remains extended when unfolded.—R. S. Matzen, Fort Collins, Colorado.

### Self-Acting Blowpipe

The steadiness of the flame is an important factor in successful blowpipe work; thus, in hard-soldering, the point of fusion may be almost reached, when the withdrawal of the flame for the fraction of a second between breaths will cause quite an appreciable cooling. The knack of maintaining a constant air supply without interruption through the breathing of the operator can be acquired only after long experience. In addition to this difficulty, the mouth blowpipe has the fur-



ther disadvantage of being insanitary, and it is sometimes awkward to reach certain portions of the work with it.

The simple nozzle, or burner, shown in the sketch was devised to overcome these disadvantages. It may be slipped into the end of a  $\frac{1}{4}$ -in. rubber tube connected with the gas supply and will produce, without blowing, a long, narrow pencil of blue flame sufficiently hot to melt pins or copper wire quickly. It is apparent that when the tubing is 3 or 4 ft. long, the burner may be used in many positions, and permits one to give undivided attention to the work in hand.

The burner is made from a piece of seamless brass tubing, 5 in. long and  $\frac{1}{8}$  to  $\frac{1}{4}$  in. in diameter, depending on the size of flame desired. For general soldering, or hard-soldering small work, a tube of  $\frac{1}{8}$ -in. diameter is used. This will produce a flame about 2 in. long. About 1 in. from the forward end, two rectangular openings,  $\frac{1}{8}$  in. long, are made opposite one another by filing across the tube with the edge of a flat file. A brass plug is then prepared, with a diameter that will just permit its being pushed into the tube, and a tapering hole through the center, with the forward end half as large as an ordinary pin, and is inserted into the tube at the holes, as shown in the upper view. To do this, tin the plug, slip it into place directly back of the air openings, apply a little soldering acid, and solder it in place over a flame. If the tube is too small to make a good



The Use of This Easily Made Blowpipe Obviates the Difficulty of One Operated by the Breath

connection with the gas tubing, build up the back end for about  $\frac{3}{4}$  in. The flame should be bluish, and if it appears yellow, the small hole is too large, hence it is well to make the hole very small and enlarge it if necessary.—John D. Adams, Phoenix, Ariz.

### Apparatus for Removing Dust in Sand

In railroad shops, and elsewhere where clean sand is required, the

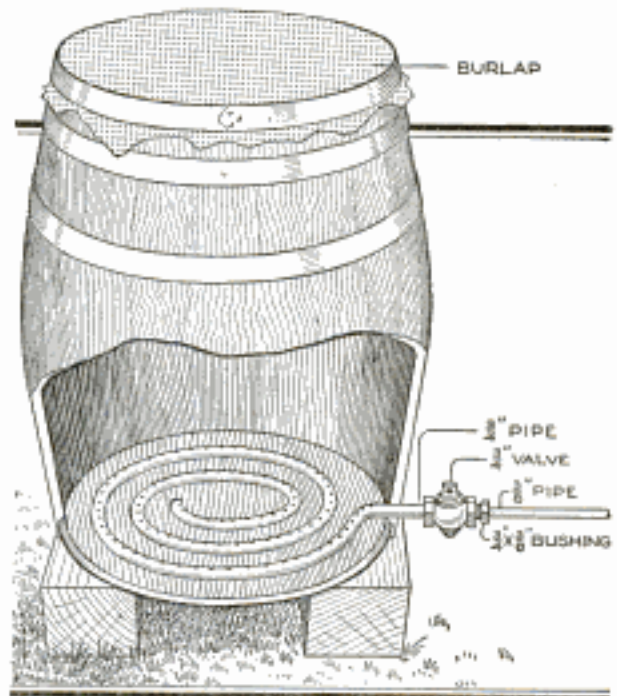

Sand to be Cleaned is Placed in the Barrel, the Air is Turned On, and the Dust Blown Out through the Burlap Covering

apparatus shown in the illustration will be found useful. A strong barrel was fitted with a plugged coil of  $\frac{3}{4}$ -in. pipe, in the upper surface of which  $\frac{1}{4}$ -in. holes were drilled 1 in. apart. The coil was connected to a compressed-air supply, regulated by a valve. The sand is poured into the barrel, a covering of burlap is fitted over the top by means of the upper hoop, and the air is turned on. The dust is blown out through the burlap, cleaning the sand thoroughly.—J. K. Long, Renovo, Pennsylvania.

### Keeping Automobile Warm in Winter

Considerable heat from an automobile engine ordinarily is wasted, and may be utilized in cold weather for heating the tonneau. It is necessary only to remove the floor board back of the engine and permit the heat to pass up into the car. It is not desirable, of course, to close the car so tightly that there is little or no ventilation, since the heated air from the engine is not pure.—Fred Reschke, Racine, Wis.



# A Wing-Joist Frame Barn



By W.E. Frudder

**R**ISING land values and prosperity on the farm are reflected in the farm buildings, the barn as well as the home, and farms generally are provided with better barns for the storage of crops and the housing of animals than a generation ago. However, the construction of farm buildings, especially large barns, has undergone a great change, due largely to the increased cost of labor and the growing scarcity of lumber. The old-fashioned heavy-timber barns built years ago required sufficient lumber for two barns of the type shown in the illustration, and were usually built by a large number of men, gathered for the occasion at the familiar "barn raising." The building of a wing-joint barn requires only a small crew of men, and is economical of lumber. As a result a time-honored neighborly institution is becoming obsolete.

Every piece of lumber that is a part of the barn described is essential to its construction, yet the factors of safety, wind strain, snow loads, and other structural considerations, are amply provided for. The heaviest lumber used in it is 2 in. thick. The frames and other heavier parts are built up of plank, and the small parts may be made of short sections of stock, the waste being thus reduced to a minimum. The truss system used permits construction without crossbeams in the barn, so that the floor is clear except for the braces, and the haymows are free from obstructions. Standard methods are used throughout in the construction, so that any competent carpenter contractor and his men can build the barn properly. The lumber used is of commercial sizes available even in small country lumberyards.

While the wing-joint type of construction is not new, several features

of the design shown are interesting and practical. In most barns of this type the floor joists extend crosswise of the structure, whereas those of the barn described are set lengthwise, on built-up plank girders, set on 14-ft. centers across the barn. The joists near the center, which must bear the greatest load, are spaced 20 in. on centers, and those at the sides are set 2 ft. apart. The trusses are set on 14-ft. centers, and can, of course, be adjusted under this distance to accommodate the spacing to various lengths of barns. They are built on the ground, the parts being cut in batches according to their size and shape, for all of the trusses, before assembling them. This process can be applied profitably to all of the construction, where a number of sections are built up in duplicate. As the parts for the trusses are assembled, they are piled up on the ground, and placed in position on the barn floor, when that stage has been reached in the raising of the barn. The barn is sided and shingled in the ordinary manner. The siding extends vertically, as indicated in the shaded portions of the sketches, and is nailed to the 2 by 8-in. braces, extending horizontally around the barn, as shown in the side and end-framing sketches.

Concrete foundations, upon which the ground floor of the barn is built, as shown in the cross section, are generally used instead of stone. The foundation must, of course, be proportioned to the structure to be placed upon it. That shown in the detail view is designed for a structure 36 ft. wide and 56 ft. long, built as indicated. It should be given a wide footing, at least 2 ft. as suggested, and wider if the ground is not well suited for a foundation. The foundation is run up above the ground sufficiently to keep the lower part of the wooden structure



from the soil moisture and drippings from the roof. The sill is anchored to the foundation by means of bolts, the

across the forms for the concrete. Care should be taken that the upper ends, which are threaded, project above the

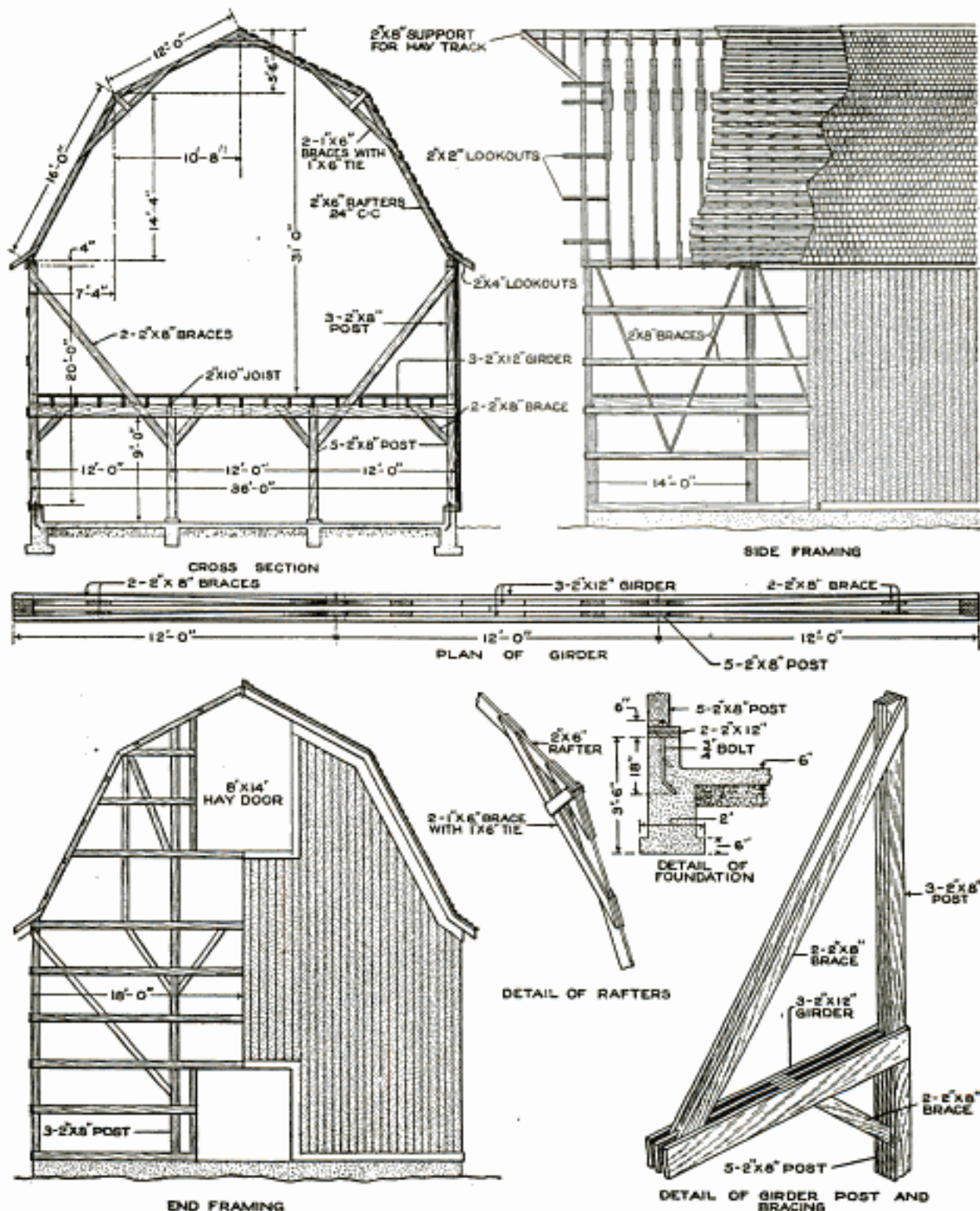

The Heaviest Lumber Used in This Barn Frame is 2-Inch Plank, of Which the Heavier Parts are Built Up. This Method of Construction is Economical of Lumber and the Structure can be Built by Only a Few Men. The 14-Foot Sections may be Figured as Standard Units in the Designing of Similar Barns of Various Lengths

lower ends of which are bent to give a better hold in the concrete. They are set in the concrete when it is placed, and held by templates nailed

foundation sufficiently to pass through the double-plank sill, and provide for the nuts. The concrete floor should be 6 in. thick, finished smooth. It is



desirable to place an 8-in. layer of cinders, or coarse gravel, under the barn floor, to afford good drainage and to provide a footing for animals that is not unduly damp.

Posts built up of five 2 by 8-in. planks support the girders under the floor. They are set on 14-ft. centers, as shown in the side-framing sketch. Their upper ends are arranged so that two of the planks extend between the planks making up the girder, and the others are butted under the lower edges of the outer and center planks of the girder. They are strongly braced by short braces extending to the girders in the center section of the barn, and by long braces extending between the planks of the girder, and fastened to them and to the upper ends of vertical built-up studs or posts along the side of the barn. The construction of the girder is shown in detail in the plan. The long braces are shown in relation to the studs, or side posts, in the detail of the girder post and bracing. The center plank of the stud butts above and below the center plank of the girder. The two outer planks of the stud extend the full length from the eaves to the sills. The outer planks of the girder are nailed over the outer planks of the stud. Cross braces of 2 by 8-in. stuff are placed between the studs to afford support for the nailing of the siding.

The trusses are formed of two rafters, built up of 2 by 6-in. stuff. They are set on 24-in. centers and strongly braced, as shown in the cross section and the side-framing sketch. Lookouts of 2 by 2-in. stock are fixed to the double rafter at the end and to the one adjoining it. Short braced rafters afford a support for the hay-lifting rigging at the end of the ridge. The ridge pole is of 2 by 8-in. plank, and the trolley track for the hay and grain carrier is suspended from the cross braces immediately below it.

The framing of the ends is shown in the lower sketch, and is better understood by referring also to the sketch showing the side framing, to observe the method of building up the corner

posts. They are of five planks below the floor and three planks from the floor to the eaves plates.

The other details of the structure are standard, or may be made in various ways in common use. An 8 by 14-ft. hay door is provided in each gable, and double doors give entrance to the ground story. The roof is made of rough boards covered with shingles or other suitable roofing material.

As a basis for computing the materials required for a barn of this type, a 14-ft. section as shown should be listed. The ends are considered separately and must in each case be added to the amount required for a given number of sections. Two thousand feet of dimension lumber is necessary for each end, and 2,200 ft. of siding. The cost of two ends is approximately \$300, including the foundation. Each truss complete requires about 560 ft. of lumber. The total cost of a 14-ft. section is about \$225, including the foundation, floor, siding, and shingles. The detailed list for a section is as follows:

8 pieces,	2 by 8 in. by 14 ft.,	for sills.
6 pieces,	2 by 8 in. by 14 ft.,	for plates.
6 pieces,	2 by 6 in. by 14 ft.,	for nailing braces.
4 pieces,	2 by 6 in. by 16 ft.,	for braces.
20 pieces,	2 by 12 in. by 14 ft.,	for joists.
14 pieces,	2 by 6 in. by 16 ft.,	for rafters.
14 pieces,	2 by 6 in. by 12 ft.,	for rafters.
28 pieces,	1 by 8 in. by 12 ft.,	for hip braces.
7 pieces,	2 by 6 in. by 6 ft.,	for collar beams.

The total dimension lumber required is about 1,600 ft.; siding 470 ft.; ship-lap flooring 600 ft., and 7,000 shingles.

### Coal Chute Built into Bin

In building a new house I provided a chute into the coal bin that extends from the coal window to the center of the roof of the bin. Instead of it being necessary to enter the bin and shovel the coal away from the wall near the window, as is usually the case, the coal is now distributed evenly in the bin, with the high point of the pile like a pyramid. When the coal is removed from the opening at the lower, inner side nearly the entire pile may be removed without the necessity of shoveling the coal near to the opening.—A. E. Holaday, Naugatuck, Conn.



## Hinge Plates and Escutcheon for Door

An interesting feature of exterior doors on craftsman or colonial-style houses is the heavy hardware, consisting of hinge plates, escutcheon, and knocker plate, made of soft sheet iron. These fittings may be made specially for the particular job, of a design suited to the surroundings and the individual taste. The design suggested in the illustration is suited to both of these types and may be readily modified. The stock is  $\frac{3}{16}$  in. thick, may be cut easily with a hacksaw, and finished on an emery wheel or with a file. The pieces should be cut to the proper width and then laid out, with the points for the holes to be drilled punched with a center punch. The holes are to be countersunk for flat-head wood screws as indicated. The door is supported by its hinges, and the hinge plates are fixed in place at them, the plate at the left being fixed to the frame and the T-shaped strap to the door. An easy method of marking the shape of the pieces on the metal is to lay them out and cut patterns from cardboard, tracing around them to transfer the shape to the iron. Black metal paint protects

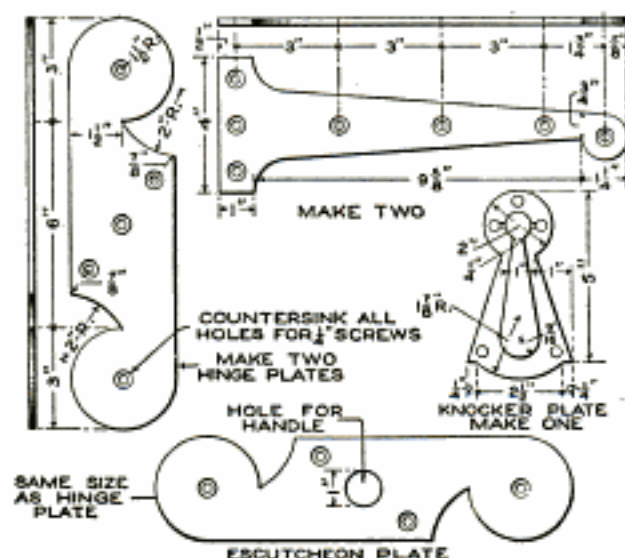

Patterns of Cardboard may be Made for the Pieces, Which are Cut with a Hacksaw

the metal and gives a strong contrast with the door, which may be painted white or stained a rich brown shade.—John E. Cahill, Jr., New York City.

## Pump Operated by Distant Windmill

A California farmer had good locations for a windmill and for a well, but they were situated at different points. The well was located at the bottom of a small cañon, or creek, bed, where there was plenty of water but where the heavy growth of trees and brush formed an effective windbreak. Above the well was a bare knoll of considerable height, and the area surrounding it was clear of trees. The sketch shows how the windmill, located on the knoll, was connected with the pump by the use

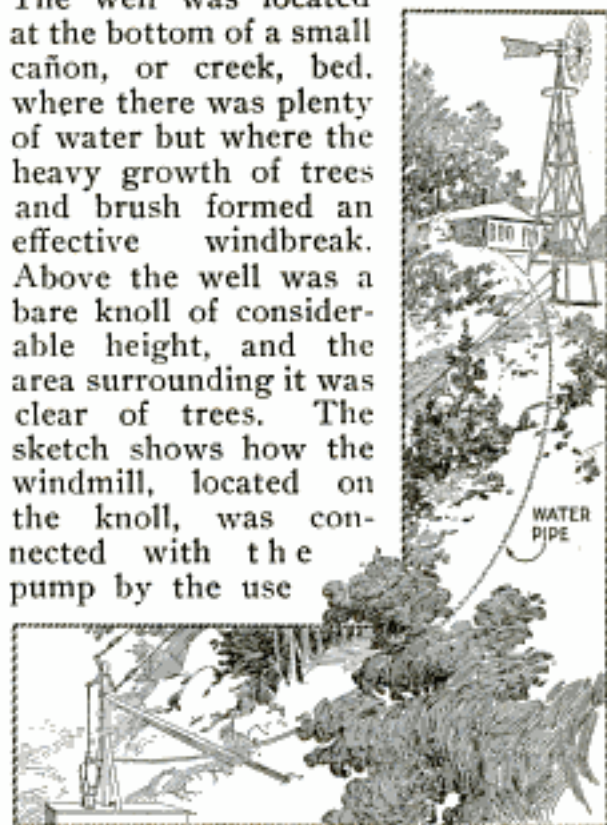

The Power from the Windmill is Applied to the Pump by Means of Wires and Levers

of wires and levers. A lever, shaped somewhat like the letter "T," was fixed to the rod of the pump and supported at its center on a framework set above the well. A similar lever was applied to the power shaft of the windmill. The ends of the upper bars of the levers were connected by wires, as shown, held taut with turnbuckles. This arrangement transmitted the power effectively and was quite simple to install.—John Hoeck, Alameda, Calif.

## Clamp Enables One Man to Nail Siding Readily

It is difficult for one man to nail siding on a house because he must hold the board in place while starting the first nail, as well as when marking and cutting the stock. The device shown in the sketch overcomes this difficulty,



and is made of a steel bar fitted to a weighted section of pipe. The end of the bar is hooked to the studding and clamps the board securely.

The clamp is made as follows: Pro-

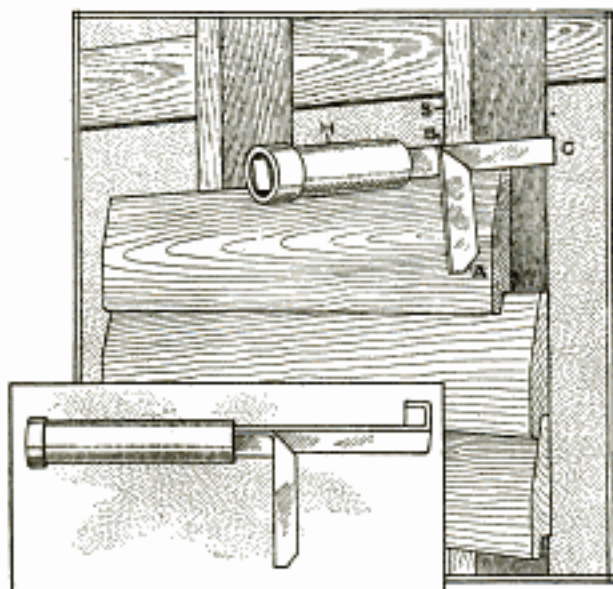

The Clamp Holds the Board Securely While the Workman Marks, Saws, or Nails It

cure a piece of soft galvanized steel bar,  $\frac{1}{8}$  by 1 by 30 in. Bend it together 14 in. from one end, and then bend the shorter part to a right angle, 5 in. from the end, at B. Studding is usually  $1\frac{3}{4}$  by  $3\frac{3}{4}$  in., and the end of the longer part of the bar should be bent to the shape shown, so as to hook around the studding S, at C. Allowance must be made for the thickness of the siding—usually  $\frac{7}{8}$  in.—and  $\frac{1}{4}$  in. additional to give a proper clamping force at A. The handle H is a piece of pipe, 7 in. long. After fitting it over the folded bar, weight it with about 3 lb. of lead.

When the piece of siding is to be fitted into place, hook the clamp on the studding and drop it to bind at A. It will hold boards while marking and sawing them. For long boards, place the clamp near the middle, and in moving boards do not remove the clamp but slide them under it. They will not be scratched if the end is trimmed off at A as shown.—L. M. Drake, Daytona, Fla.

Remove burrs from the slots of screws after driving them in, as they are dangerous to the hands.

### Determining Strength of Rope

The practical method of determining the strength of rope is to put it under strain and run it over a pulley. Used rope, especially, is deceiving, from outside appearance, as it is often dried out and the inner fibers broken. A breaking strain at one end of the rope will not serve to determine its ability, since the ends are least likely to be worn, and a weak spot in the middle may cause disaster. By running the rope over a pulley, however, and raising a weight considerably in excess of that which is to be handled in actual use, every point can be tested out thoroughly.—J. C. Grindell, St. Louis, Mo.

### Adjustable Jig for Drilling Radial Holes

When a number of radial holes are to be drilled accurately in pulleys, or similar machine parts, the jig shown in two forms in the sketch will be found convenient. It was devised for the drilling of holes in a boss, A, as shown in Fig. 1. The jig shown in Fig. 2 was made of a piece of cast iron, drilled at C to fit the boss, and provided with a tempered-steel collar to guide the drill. The lug D was provided to fit into the hole B, as a guide in drilling the hole in the boss. An adaptation of the jig,

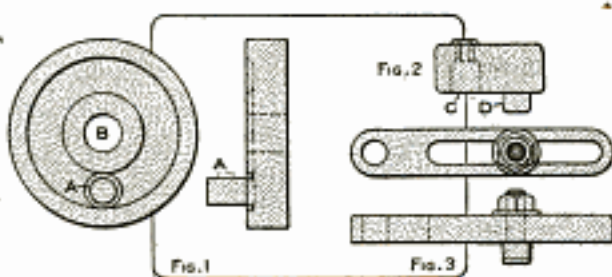

Radial Holes in Pulleys, or Similar Machine Parts, may be Drilled Accurately by the Use of This Jig

which may be adjusted for various sizes of pulleys, or other radial drilled work, is shown in Fig. 3. If holes of various sizes are to be drilled, bushings may be fitted into the guide hole at the end of the jig.—C. Anderson, Worcester, Mass.



# Building an Electrical Generator

By B. FRANCIS DASHIELL

**T**HE making of a small electrical generator affords experience in mechanical and electrical construction that is both interesting and practical. The generator described in this article and shown in detail in the illustrations was designed to be made with comparatively simple machine processes and a minimum use of special tools or devices. It is a 100-watt, direct-current, shunt-wound machine, and the parts are worked out to give a high standard of mechanical practice as well as to withstand hard service. If machine-shop facilities are not directly available, the machining may be done in a commercial shop at small cost. The materials are those in common use for such work, and readily available from dealers.

The making of the patterns and castings should be undertaken first, and only after a close examination of the working drawings in the page plate has been made. The perspective sketch and the assembly views, Figs. 9 and 10, show the general construction and the arrangement of the parts. The patterns are of simple design, and may be made by one familiar with the use of ordinary woodworking tools. Patternmakers' white pine is required for the patterns; glue, screws, brads, and other common means of fastening wooden parts, may be used for this purpose. All nail or other holes in the surfaces must be plugged carefully. The pattern for the field-magnet casting, Figs. 1 and 2, should be made first. It is built up of five parts: the yoke A; the two cylindrical magnet cores B, and the two poles C, which form the sides of the armature tunnel, in which the armature revolves. The dimensions on the drawing are for the finished parts, and allowance must therefore be made for machining the tunnel. Machining is indicated by the standard mark "f." The pattern is cast with the parting of the mold on the center line DE in Fig. 2, hence the tunnel and the flat exterior surfaces must be given a slight draft, to make removal from the sand conven-

ient. The draft is produced by slanting the surfaces from the center line toward the edges, to form a slight crown, like that on the face of a pulley.

The bearings, shown in Fig. 3,

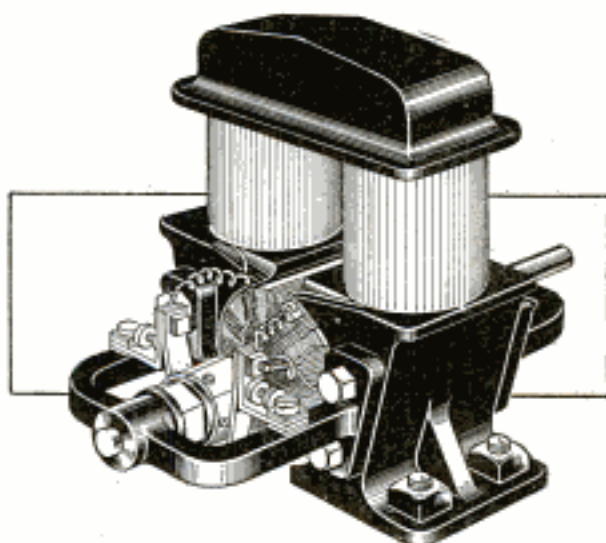

This Direct-Current Generator was Designed to be Made with Comparatively Simple Machine Processes

appear similar in the top view H, but that shown at F is  $1\frac{7}{8}$  in. wide, and that at G,  $3\frac{3}{8}$  in. wide. They are built up of five parts each, as indicated, and allowance must be made for finishing the castings to the dimensions shown.

The field magnet is cast from the pattern in gray iron of a fine texture, and the bearings are cast in hard bronze. Iron bearings must not be used under any circumstances. Examine the castings thoroughly and reject them if they have flaws.

The castings must then be machined to the dimensions indicated. This work must be done carefully to insure satisfactory operation of the generator. The sides of the poles C are planed parallel, to give them a width of 3 in., as shown in Fig. 2. Then place the field in a lathe chuck and bore out the armature tunnel to a 3-in. diameter, and exactly perpendicular to the planed sides. Too much care cannot be taken in this work.

The machine work on the bearings is slight. Machine the flat faces at the bases; they are to be fitted to the sides of the field magnet. Set the bearings



upright on their bases and drill  $\frac{3}{8}$ -in. holes in the shaft-bearing hubs. Then drill the two holes in each of the bases to fit the  $\frac{5}{16}$ -in. cap screw J, to provide for the fastening of the bearings to the poles.

The commutator, detailed in Fig. 7, is made as follows: Select a piece of round hard-rubber rod, 1 in. long and 1 in. in diameter. Drill a  $\frac{1}{2}$ -in. hole through the center for the shaft. Force a piece of brass or copper tube, of  $\frac{1}{8}$ -in. wall and 1-in. inside diameter, over this core. Tap the tube and core to receive 12 No. 4 .11-in. diameter standard fillister-head machine screws. Place six of them at each of the ends,  $\frac{1}{8}$  in. in, and space them equally,  $60^\circ$  apart. The screws are like that shown at K. Divide the tube into six equal segments by making kerfs with a hacksaw, lengthwise between the screws. Each segment is thus insulated from the others by air gaps.

The armature and shaft assembly are detailed in Fig. 6. The armature is built up of laminations in the form of disks, cut from thin sheet iron,  $2\frac{15}{16}$  in. in diameter, as shown in Fig. 5. Each disk has twelve  $\frac{3}{8}$  by  $\frac{3}{8}$ -in. openings cut into its edge, spaced equidistant,  $30^\circ$  apart on center radii. Punch a  $\frac{1}{2}$ -in. hole in the center of each and stack them up to form a compact pile, 3 in. high. Place them in a charcoal fire and heat them to a bright red. Cover them with ashes and permit the fire to die out slowly. On removing the disks they are annealed. Clean them with emery cloth, dip them into a thin solution of shellac, and spread them out so that the shellac can dry hard.

The armature shaft is shown in Fig. 6. It is a rolled-steel shafting,  $\frac{1}{2}$  in. in diameter and 10 in. long. Turn the ends down to  $\frac{3}{8}$ -in. diameter, one end  $1\frac{3}{8}$  and the other  $2\frac{5}{8}$  in. Thread the ends of the center portion to receive the  $\frac{1}{2}$ -in. hexagonal steel nuts. Assemble the armature disks on the shaft and clamp them between the washers and nuts. Fix the commutator into place similarly.

The bearings must be located on the

machined sides of the poles with accuracy. If the armature is found to be out of balance, cut it down or file it slightly in a lathe. Wrap a piece of heavy paper around the armature and fit it into the tunnel snugly. Slip the bearings on the shaft ends, and fit them against the surfaces. Taking care that they do not slip or become displaced, slightly mark the centers of the fastening holes in the pole surfaces with a center punch inserted in the holes. Drill and tap the holes for the screws J. The armature should rotate freely when the bearings are fitted into place. Drill oil holes into the hubs from the upper side, and fit them with cups if desired.

The brushes and brush holders used on this generator are of interesting design, as shown in Figs. 4 and 8. Make the holder of a piece of copper or brass angle,  $\frac{1}{2}$  in. wide. Solder together three or four strips of thin phosphor bronze at their top edges and drill and tap them for an 8-32 machine screw. Bolt this to the vertical leg of the holder. Drill and tap the lower end of the same leg similarly for an adjusting thumbscrew, with which to move the brush to or from the commutator. Drill the other leg as shown in Fig. 8, for a machine screw, as in Fig. 4, at L. The method of insulating the brush is indicated in Fig. 8. Two fiber, or hard-rubber washers are placed on either side of the holder arm; a short piece of fiber, or hard-rubber tube is slipped over the screw. Place a metal washer under the head to prevent cutting the insulation. Screw the holders tightly to the arms of the bearing, in the holes tapped, as shown in Fig. 3.

The winding of the field magnet is next in order. Cut two strips of heavy paper of sufficient width to cover the magnet cores and long enough to be wrapped twice around them. Paste them on the cores with thick shellac. Cut out four heavy blotting-paper washers,  $2\frac{1}{2}$  in. in diameter with  $1\frac{3}{4}$ -in. holes. Cut them in half and join the pieces in pasting them to the upper and lower inner surfaces of the cores, brushing them over thoroughly with



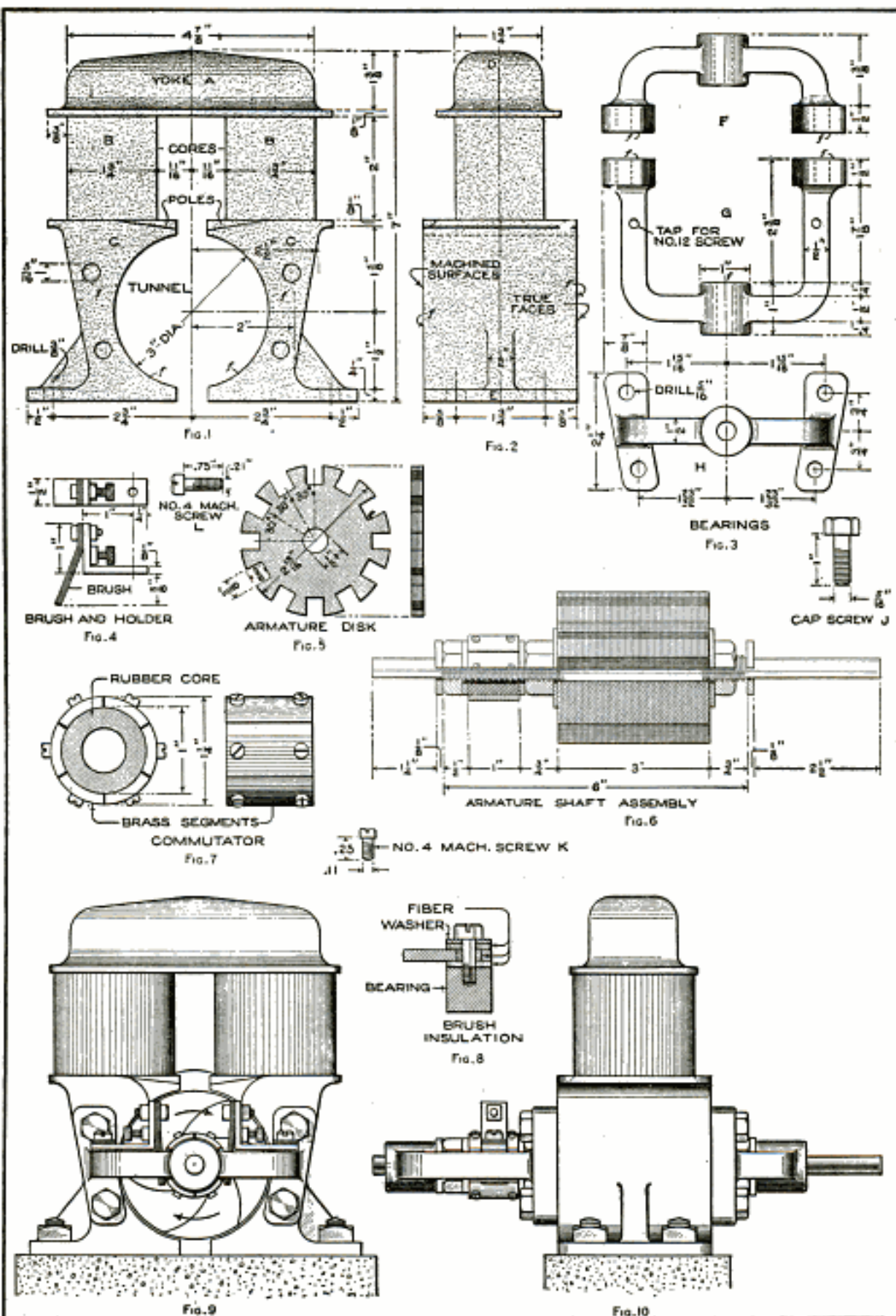

The Assembly Drawings, Figs. 9 and 10, Show the General Arrangement of the Parts, and the Working Drawings Present the Details of Construction. The Pattern for the Field Magnet, Shown in Fig. 1, is Built Up of Five Parts: The Yoke, Cores, and Poles. It is Cast in Gray Iron of Fine Texture, and the Bearings, Shown in Fig. 3, are Cast in Hard Bronze



shellac. The cores are thus provided with an insulating cover. Permit the shellac to dry before winding the coils.

Prepare the armature core by pasting a circle of heavy paper to each end of

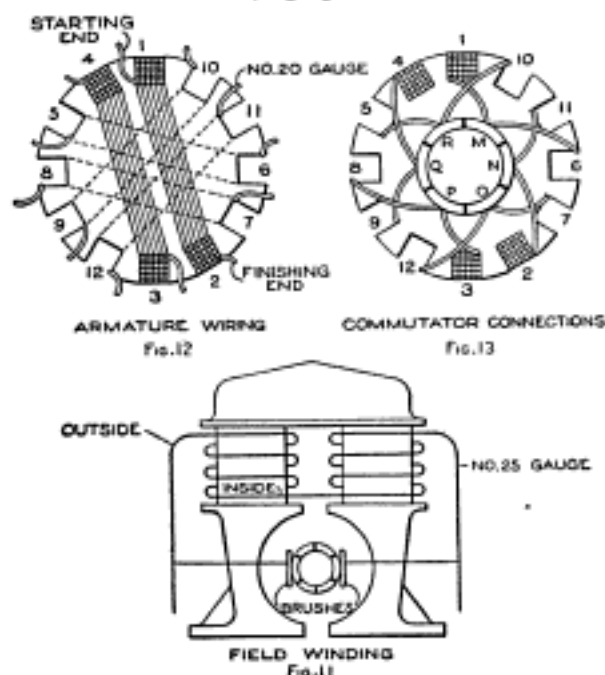

The Field Winding is Indicated in Fig. 11; the Winding of the Coils around the Armature Core is Shown in Fig. 12; and the Connections of the Armature Coils and the Commutator are Shown in Fig. 13

it with shellac. When dry, cut out the square slots. Paste strips of paper, shellacked thoroughly, into the slots their full length, and cover similarly any other exposed parts that may come in contact with the wire in winding.

The winding of the field magnet may now be undertaken. Use No. 25 gauge double cotton-covered copper wire. Wind 16 layers on each magnet core, as shown in the field-wiring diagram, Fig. 11. The wire must be started at the bottom of the core and finished at the lower part of it.

The wiring diagrams must be examined carefully so that errors may be avoided which may require the undoing of considerable work. With this precaution the windings are not difficult to accomplish, even to one inexperienced in this class of work. The two inner ends of the windings are connected, and the two outer ends are wired to the brush connections, as indicated. The inside, or beginning, ends of the wires should have a small rubber tube slipped over them to pre-

vent breaking and to provide proper insulation.

The winding of the armature is more complicated than that of the field magnet, but should present no serious difficulties if the directions are observed step by step. The process, as shown in Fig. 12, is as follows: The armature is held with the commutator end toward the body of the worker, and the roll of wire is placed conveniently on the workbench. Procure  $1\frac{3}{4}$  lb. No. 20 gauge single cotton-covered wire for this purpose. Start the winding in slot No. 1, passing the wire away from the body through the length of the slot, over the opposite end of the armature, and returning the wire in slot No. 2. Continue this winding until the slots are full, which requires about 80 turns. None of the wires must be above the slots or they will interfere when the armature is placed in the tunnel. Turn the armature halfway around to bring slot No. 3 uppermost. Wind as before, passing the wire around the armature in slots 3 and 4, beginning at No. 3. Repeat this process in the slots paired off, as follows: 5 to 6; 7 to 8; 9 to 10; 11 to 12. Turn the armature part way around in each case so that the first of the two slots being used in winding is uppermost. All of the wires must begin at the bottoms of the odd-numbered slots, and end at the tops of even-numbered slots, on the commutator end of the armature. Cover the ends of the wires both at the start and the finish with rubber-tube insulation.

Make the connections to the commutator, as shown in the diagram for this purpose, Fig. 13, which represents the commutator and the end of the armature behind it, as viewed from the commutator end of the armature shaft. Make the connections under the heads of the machine screws at the inner end of the commutator, and solder the screw head, wire, and commutator segment together. Care must be taken that the segments are not soldered together in this process. All the connections must be made very carefully, as a slight error in this phase of the work will prevent the proper operation



of the generator. The commutator must be set on the shaft so that its segments are centered on six alternate slots of the armature, and then clamped by means of the nuts. By beginning with the starting end of the wire in slot No. 1 it may be observed that each of the starting ends is soldered to the inner screw in the commutator segment in advance of the slot. The starting end in slot No. 1 is soldered to segment M; the finishing end of this coil in slot No. 2 to segment N, etc. The finishing end of the wire in each coil is soldered to the commutator segment behind the slot. For example: the finishing end in slot No. 2 is soldered to segment N; that in No. 12 to O, etc. Give the armature and windings a thorough coat of shellac and permit it to dry.

The generator may now be checked to see that all preliminary work has been done, and then assembled for testing. Place the armature in the tunnel and attach the bearings securely by means of the machine screws. Connect a battery of about 12 volts to the field for a minute, magnetizing the poles. Fit the brushes into place, and adjust them to the commutator. Turn on the battery again, and the machine should run as a motor. The commutator must then be given its final adjustment. If

the commutator has not been set very accurately on the shaft, it may be necessary to adjust it slightly so that its segments are centered properly with coil-filled slots Nos. 10, 6, 2, 12, 8, and 4, as shown in Fig. 13. The armature should turn clockwise, when the observer is facing the commutator end. The speed on 12 volts will not be high because at least 20 volts are necessary to obtain full speed. This voltage is satisfactory for test purposes.

The generator is now ready to be run in its normal manner. Fix a pulley of suitable size to the extended end of the armature shaft, by means of a set-screw. The special local conditions will determine the size of pulley used. The generator should be run in the same direction as when it was tested by running it as a motor, as indicated in the assembly drawing, Fig. 9. The proper speed is about 2,000 r. p. m., although it should generate satisfactorily, though not to full capacity, at less speed. At full speed it should generate 25 to 30 volts and four amperes. Both bearings should be kept well oiled. Wipe the commutator with a rag dipped in vaseline to keep it bright and clean. The brushes should be set only tight enough to make a satisfactory contact and collect the current.

### Producing a Blue Finish on Steel

Polished-steel objects may be given a blue finish by placing them in heated charcoal. The surfaces of the metal must be very smooth and clean. The charcoal is powdered and placed in a box made of steel or iron plate. The steel to be blued must be taken out from time to time and dusted with finely powdered whiting. The color should be observed, and when a dark blue is obtained, the work should be permitted to cool, then cleaned and oiled.

☞ Provide a special file for filing babbitt, and oil it slightly to prevent the metal from sticking.

### Removing a Plug from Casting

A steel plug, hardened and fitted to a drive fit into a large casting, was to

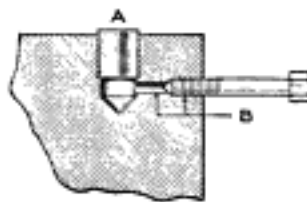

be removed, and the method shown in the sketch was devised for the purpose. A hole was drilled into the side of the casting to a point just below the plug A. The cavity was filled with white lead and oil, and a cap screw, B, was driven into the threaded hole. The result was a miniature ram, which drove the plug out easily without injuring it.—William T. Hummele, Buffalo, N. Y.



### Cornice Rigging to Support Ladder Scaffold

Painters, and others who must work on scaffolds supported from the roofs or cornices of buildings, are familiar

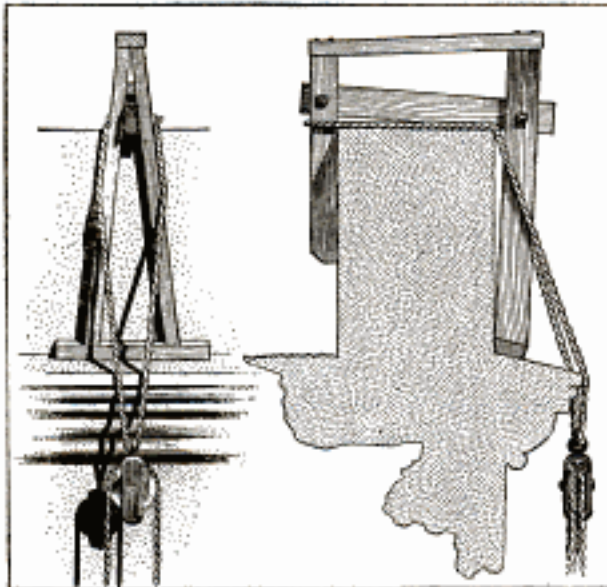

The Framework is Strongly Supported on the Wall and Makes the Use of Hooks Unnecessary

with the difficulty of providing a simple and safe means of attaching the tackle at the roof. The support shown in the illustration is made of 2 by 4-in. stock and fits firmly over the upper edge of the wall. Its front portion consists of an A-shaped frame which bears on the cornice and carries braces near the top. The frame may be made adjustable to various thicknesses of wall by boring additional holes for the bolts in the cross braces. The upper pulleys are supported on ropes secured about the framework.—H. W. Hart, St. Paul, Minn.

### Forging Renews Worn Socket Wrenches

The square sockets of wrenches frequently become worn, and instead of repairing them, the tools are thrown aside. A number of such wrenches were picked up in a shop and the sockets renewed as follows: A piece of steel was ground to a square cross section of the original size of the socket, and the wrenches were heated over a forge fire. The worn edges were

hammered over this core, and when the wrench was smoothed and polished, the socket end was hardened. The wrenches were as serviceable as new ones.

### Sawing Wooden Wheels, or Disks, on Band Saw

It was desired to saw a considerable number of wooden disks of the same diameter, and the following method, as shown in the illustration, was used with success: The disks were to be 10 in. in diameter. A smooth board,  $\frac{7}{8}$  in. thick, 8 in. wide, and long enough to reach across the table of the saw, was procured and clamped securely into place, as shown, after a nail had been driven barely through it so as to project at the center of the upper side and opposite the cutting edge of the saw. The point of the nail was exactly 5 in. from the saw. The stock was cut into square pieces of slightly more than the desired diameter. One of the pieces was placed on the board and pressed down on the nail so that it could be turned on the point. By turn-

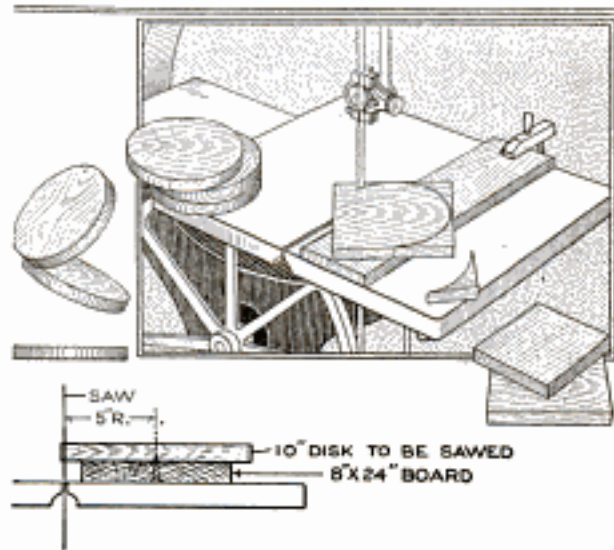

The Disks are Cut of Uniform Size without Marking Out Each Piece Separately

ing the piece of wood carefully, a disk was sawed out, having a smooth circular outline. Duplicates were made quickly in the same manner.—Edwin R. Mason, Danville, Ill.



### Shop Apron with Convenient Spring Belt

Workmen in shops, as well as other persons who must wear an apron occasionally, are familiar with the nuisance of tying and untying apron strings, especially since they are easily broken in handling heavy objects. The use of an apron with a spring of band iron at the top instead of tie strings is quite convenient. The spring is curled slightly outward at the ends and may be slipped about the body quickly. It is not easily broken, and if given the proper tension insures that the apron will remain in place.

### Device for Removing Small Shafts or Arbors

Experiencing difficulty in removing arbors and shafts from small gears and similar constructions in the workshop, I made a frame for removing them, as shown in the sketch. A piece of steel, 3 in.

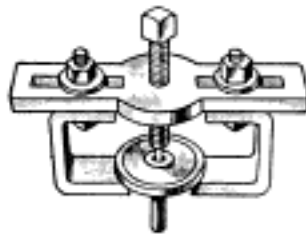

wide, 10 in. long, and  $\frac{3}{4}$  in. thick, was provided with a  $\frac{1}{2}$ -in. hole, at its center, tapped with a 12-gauge thread. Slots,  $2\frac{1}{2}$  in. long and  $\frac{1}{2}$  in. wide, were cut in the plate as shown, and a machine screw fitted to the threaded hole. Two pieces of steel,  $\frac{1}{2}$  in. thick,  $1\frac{1}{2}$  in. wide, and 5 in. long, were forged to a U-shape, and holes bored through their upper ends, to fit bolts clamped through the slots in the upper piece. An opening was left between the lower ends of the U-shaped pieces, and in this the gear, or other object from which a shaft or arbor is to be removed, is placed. By applying pressure on the center screw by means of a wrench, the shaft may be forced from the gear. The device may be made in various sizes.—W. C. Loy, Rochester, Ind.

Ⓒ Rivets should be cut off before being inserted into place, so that just enough metal is available for proper riveting.

### Tongs for Grasping Screws in Starting Them

It is often desired to place screws in corners where the hand cannot reach, and the device shown in the sketch was made and used successfully for this purpose. Strips of iron were twisted and forged at the ends to form tongs. The jaws were cut as indicated, and the two outer portions of each

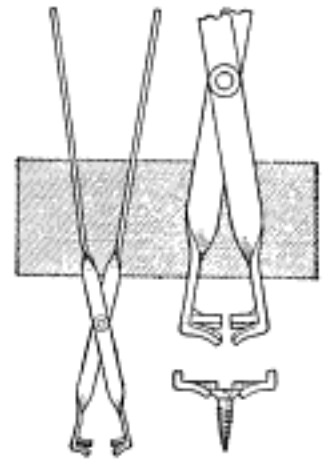

were bent down to receive the head of the screw while gripping it. It was possible by the use of this device to place screws in many places where there was barely room for a long screwdriver.

### Lathe Center with Interchangeable Points

Lathe centers are frequently burned by persons inexperienced in the operation of such a machine, and occasionally even an experienced workman may have this trouble. The center shown in the sketch, with a point that is removable, was

devised for use in a shop where boys were taught to operate lathes, and proved economical. It consists of two main parts: The shank A is turned to fit the taper of the lathe spindle, and the point B is turned to fit a socket in the end of the main portion. A setscrew is provided in the straight portion, C, of the shank, and a hole is drilled to make removal of the point easy. When the point is burned, it may be replaced quickly by a new one.

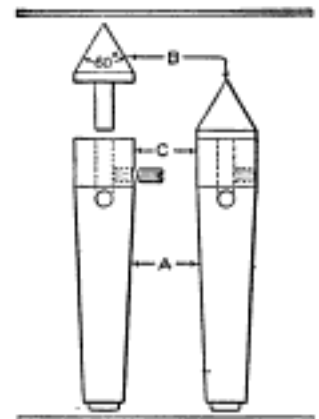



### Arm Pincushion Carried on Bicycle Clip

A tailor devised the arm pincushion shown in the sketch so that he would have pins at hand while fitting garments or working in various parts of the shop. The device was made by fitting a pincushion into a cup and fastening it to an ordinary trouser clip worn by bicyclists. The cushion is carried on



the left arm.—Mrs. Avis G. Vestal, Chicago, Ill.

### Sorting Tray for Nails, Screws, and Bolts

Instead of throwing away stray bolts, screws, and other small pieces used in the workshop, a good plan is to place them in a tray for miscellaneous from which they may be sorted conveniently. A tray for this purpose may be made of a wooden or metal box, about 2 in. deep, 6 in. wide, and 12 in. long. One corner of the bottom should be provided with a small opening covered by a slide, and the upper corner above it should be covered with a triangular section. In sorting the material it is poured from the small opening into the hand and distributed into several receptacles. The triangular covering at the corner prevents the contents of the tray from spilling while being sorted.

### Utilizing the Heat in a Fireplace for a Radiator

A room in which there is a fireplace is usually quite comfortable close to the fire, but is likely to be cold near the far corners, especially in cold weather when a strong wind is blowing. There is much waste heat in a fireplace, and to utilize it under such

conditions, I installed the radiator and hot-water heating system shown in the sketch. The piping is  $\frac{3}{4}$ -in., and is connected with standard fittings.

The grate in the fireplace was made of pipe and fittings, as shown, to fit into the opening, which will, of course, vary, hence no dimensions are given. The cold-water supply was arranged in a corridor adjoining and the pipes connected to the radiator and the grate under the floor, as shown. The circulation of the water is indicated by the arrows.—W. S. Wilson, Cascades, Canada.

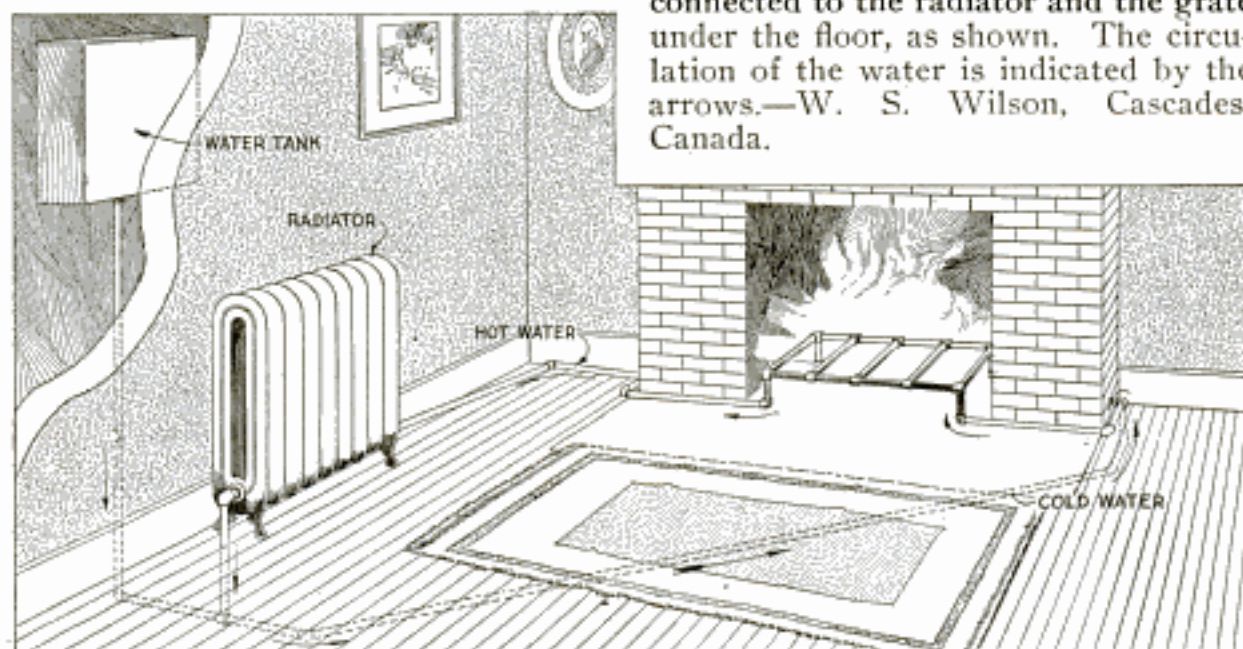

A Grate of Pipe was Built in the Fireplace and Made Part of a Hot-Water Heating System by Which Parts of the Room Remote from the Fire were Heated



### Patching the Printing Surfaces of Woodcuts or Type

A method which I employ almost daily in the shop for repairing wood type, large poster wood engravings, etc., when a miscut is made, and which could be used on wood in many instances where a smooth surface is desired over a patch, is as follows: Fill the holes with hot sealing wax, and when it is cold and hard put some lubricating oil on it and rub the surface down with a piece of pumice stone. The result will be a smooth, level patch, which can be worked like the wood surrounding it.—L. L. Pazourek, Cleveland, Ohio.

### Old Kitchen Boilers Used for Well Casing

A farmer made use of old kitchen boilers for well casings, thus adding another to the many uses to which these cumbersome tanks have been put. They were cheaper than the well casing he had intended to use, and, it is asserted, will last longer. The boilers were removed to a shop in a wheelbarrow, as shown in the photograph reproduced, and the ends were removed by cutting the rivets. They were then butted end on end, and a band of strap iron was riveted on them, as shown. In this form they were lowered into the well, bored by a well driller. Boilers of this type are hard to dispose of, and they were taken



The Old Boilers were Gathered in a Dumping Ground and Used by a Farmer for Well Casings

from a city dumping ground and shipped to the farmer in sufficient number for his well.—John Hoeck, Alameda, Calif.



### Gang Tool for Shaper in Machine Shop

The base of a column, which was too wide to be planed in a shaper by ordinary methods of using the machine,

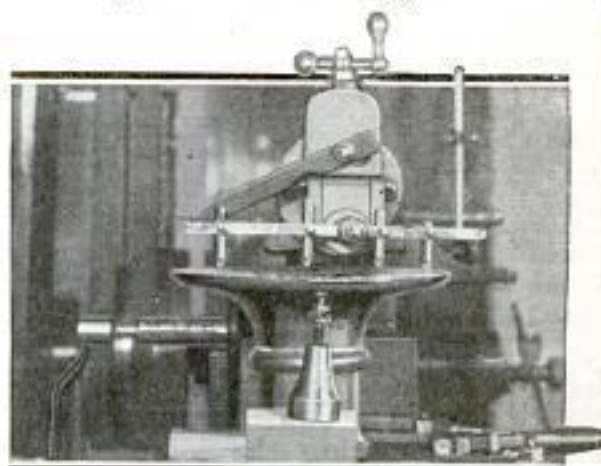

The Base of a Column was Planed Satisfactorily by the Use of the Gang Tool Braced as Shown

was handled satisfactorily by means of a gang tool, as shown in the photograph reproduced. The base was set up in the shaper and supported by a jack. The center of the work was considerably to one side of the center of the ram, so it was necessary to extend the tool holder farther on one side of the tool post than on the other. The base of the column was cored, and the pressure on the cutting tools was not the same during the entire length of the longest cut. In order to prevent the bar supporting the tools from springing under these conditions, the support shown was clamped behind it and fixed to the front of the ram.—Harvey Mead, Scranton, Pa.

### Preventing Frosting of Auto Panes in Winter

The gathering of frost on the windshield of an automobile in cold weather is dangerous. Alcohol added to the cleansing water will aid in preventing the forming of frost. If the shield, and other windows in the car, do not need cleaning apply a coating of three parts alcohol and one part glycerin, and rub it to a polish. This is especially useful in closed automobiles, and may be applied to show windows.



### Scraper for Joints in Brickwork

Scraped joints are in general favor for brickwork, and the best appearance results only when the joints are uni-

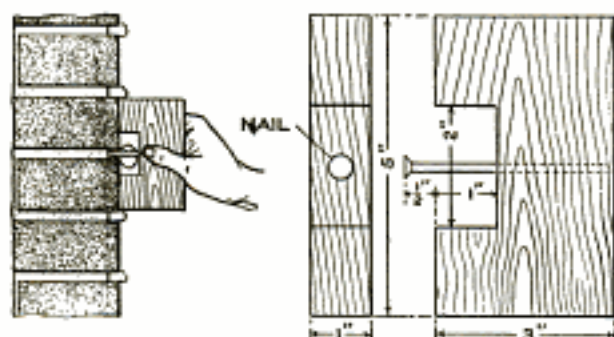

The Joints are Scraped Neatly and Uniformly by Means of the Homemade Scraper

form in depth. The tool shown in the sketch affords a simple means of gauging and smoothing the joints. It is made of a block of wood, 1 by 3 by 5 in., notched at one side, and having a 16-penny common nail driven into it at the notch. It is used in scraping the joints, as shown in the sketch at the left.—Ernest Greenhalgh, Indianapolis, Indiana.

### A Soft-Face Hammer

It is frequently desirable, when it is necessary to pound soft metals like brass or finished metal work, to use a hammer which has a soft face, that is, a face which will not damage or mar the surface pounded. Hammers with babbitt-metal heads are regu-

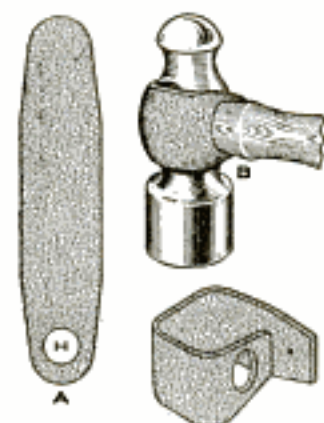

larly manufactured for this purpose and are very convenient, but an improvised soft-face hammer can easily be arranged as suggested in the sketch. First a piece of leather belting is cut as shown at A. The strip is arranged on the hammer head as shown at B. The hole H must be large enough so that the hammer handle will slip through

it. The leather protective strip is fastened by driving a tack through the leather and into the hammer handle. When pounding on objects that should not be marred, the blow is delivered with the side of the hammer head protected with the leather.

### Gauging Automobile-Body Dashes

In assembling sheet-metal shrouds on wooden frames of automobile bodies, trouble was experienced in setting the dash at right angles to the bottom of the body. As the dash is part of the shroud, the latter was clamped in place, and then tested for alinement with a large try-square, its perpendicular edge set against the dash. This method required considerable time and, especially on piece work, proved unsatisfactory. The problem was solved by having all the assembling forms carefully planed up and leveled. Then a triangular frame was made, with three pins of the same length projecting out on one side at each of its corners. The top edge of this frame was carefully made at a right angle to the plane of the pins, and then a small spirit level was fastened to it, as shown in the sketch. In

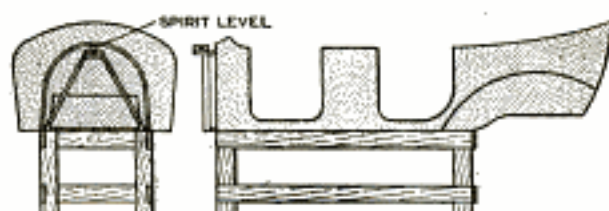

The Triangular Frame is Placed against the Dash and the Test for Alinement Made

testing the dash, the triangular frame is held up against it, two of the pins at the bottom, and the third in the center at the top. By observing the level, the position of the dash may be determined quickly, and proper adjustment made.

Ⓒ Before putting on a tire casing, wipe it out carefully with a moist rag, to insure that the inner tube will not be damaged by dirt or sand lodged in the casing.





## Making a Coasting Toboggan

By A. M. PARKER

**E**SSENTIALS of a good toboggan, whether for coasting or use in transportation, are strength and lightness, and when it is to be made in the home shop, the construction must be simple. That shown in the illustration, and detailed in the working sketches, was designed to meet these requirements. The materials for the toboggan proper and the forms over which it is bent, may be obtained at small expense.

Smoothness of finished surface, freedom from tendency to splinter, and ability to stand up under abuse being requisite qualities in the wood used to make a toboggan, three varieties may be mentioned in their order of merit: hickory, birch, and oak. Birch is softer than hickory and easily splintered, but acquires an excellent polish on the bottom. Oak stands bending well, but does not become as smooth on the running surface as close-grained woods. Do not use quarter-sawed oak because of the cross-grain flakes in its structure.

While the best toboggan is made of a single board, both the securing of

material and its construction are rather difficult. Narrow strips are easily bent to shape, but do not make a durable article. A toboggan made of four boards is practical. The mill bill for one 7½ ft. long by 16 in. wide and for the bending frame, is as follows:

4	pieces,	¾	by 4 in. by 10 ft.,	hard wood.
7	"	1	by 1 in. by 16 in.,	" "
2	"	½	by 1 in. by 16 in.,	" "
2	"	1	by 6 in. by 6 ft.,	common boards.
6	"	1	by 2 in. by 18 in.,	" "
1	cyllindrical block,	12 in. diameter	by 18 in. long.	

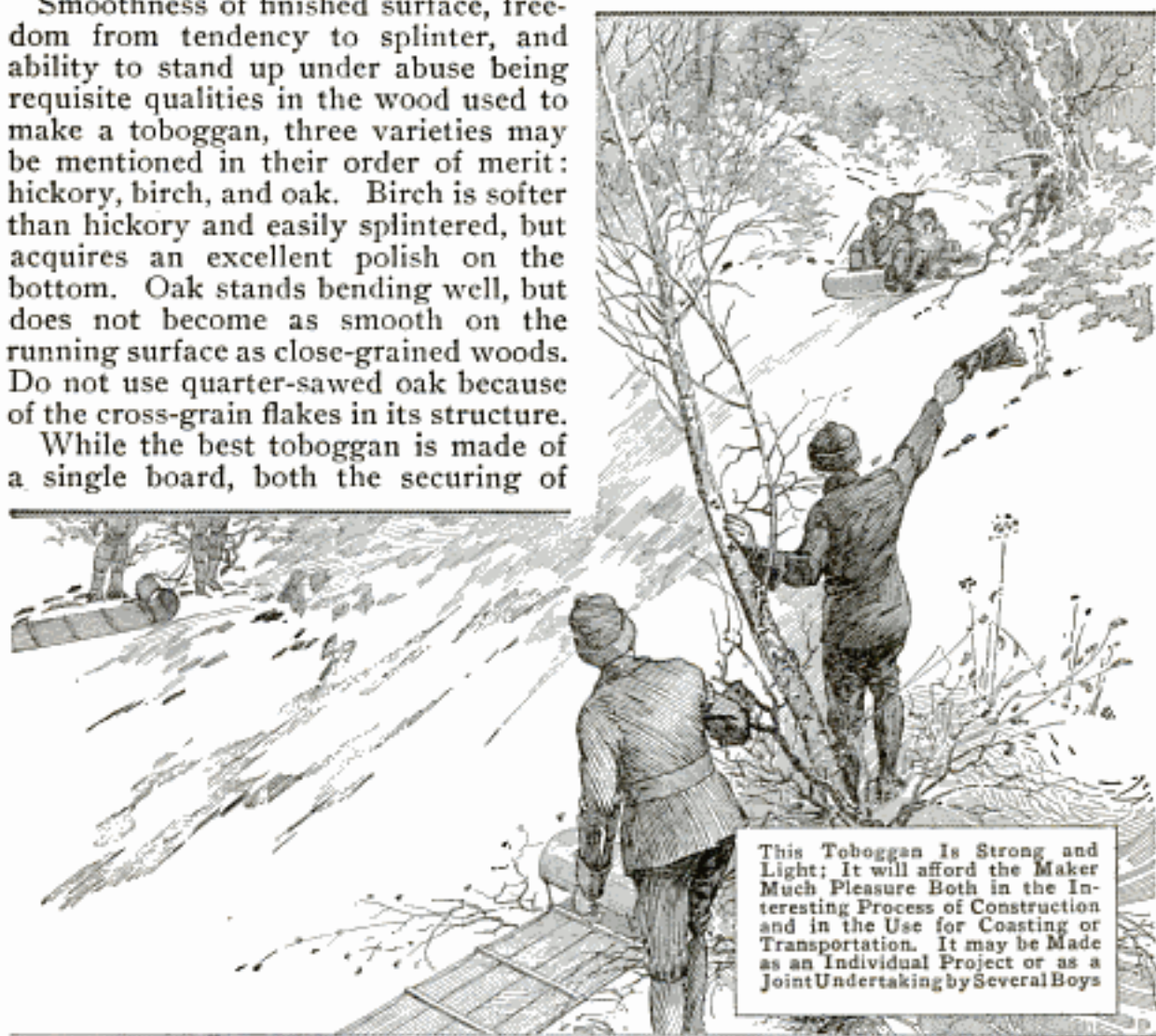

This Toboggan is Strong and Light; It will afford the Maker Much Pleasure Both in the Interesting Process of Construction and in the Use for Coasting or Transportation. It may be Made as an Individual Project or as a Joint Undertaking by Several Boys



The form for the bending of the pieces is made of the common boards and the block. A block sawed from the end of a dry log is excellent. Heat it, if convenient, just before bending the strips. The boards for the bottom should be selected for straightness of grain and freedom from knots and burls. Carefully plane the side intended for the wearing surface, and bevel the edges so that, when placed together, they form a wide "V" joint, half the depth of the boards. The 1 by 1-in. pieces are for cross cleats and should be notched on one side, 1 in. from each end, to receive the side ropes. The two  $\frac{1}{2}$  by 1-in. pieces are to be placed one at each side of the extreme end of the bent portion, to reinforce it.

Bore a gimlet hole through the centers of the 1 by 2 by 18-in pieces, and  $4\frac{1}{4}$  in. each side of this hole, bore

With 3-in. nails, fasten one of the bored pieces to the block between the boards, inserting, temporarily, a  $\frac{1}{2}$ -in. piece to hold it out that distance from the block.

Steam about 3 ft. of the ends of the boards, or boil them in a tank. Clamp, or nail, the boards together, at the dry ends, edge to edge, between two of the 1 by 2-in. pieces, leaving about  $\frac{1}{4}$ -in. opening between boards. Thrust the steamed ends under the cleat nailed on the block, the nails which hold it slipping up between the boards. Bear down on the toboggan carefully, nailing on another of the bored cleats, when the toboggan boards have been curved around the block as far as the floor will permit. The nails, of course, go between the boards.

Now, turn the construction over and bend up the toboggan, following the

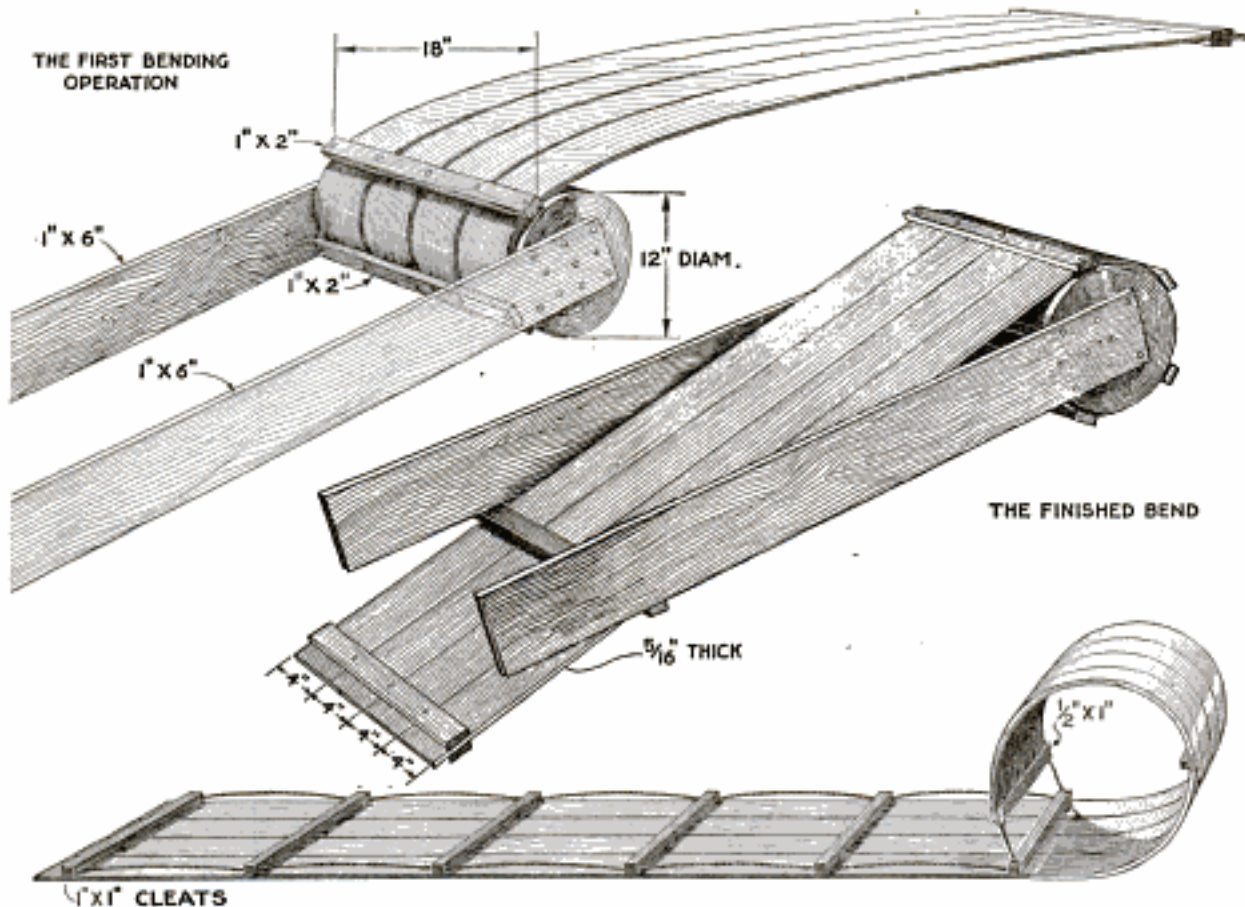

The Boards for the Bottom are Steamed or Boiled at the Bow Ends and Bent over the Form. As the Bending Operation Progresses, the Boards are Nailed to the Form with Cleats, and Permitted to Dry in This Position

two others. Nail the end of one of the 6-ft. boards to each end of the block, so that their extended ends are parallel.

boards around the block with more of the nailed cleats, until the clamped end is down between the two 6-ft. boards,



where it can be held by a piece nailed across. More of the cleats may be nailed on if desired; in fact, the closer together the cleats are the less danger there is of splintering the boards, and the more perfect the conformity of the boards to the mold.

Allow at least four days for drying before removing the boards from the form. Clamp the  $\frac{1}{2}$  by 1-in. pieces one each side of the extreme ends of the bent bows, drill holes through, and rivet them. A 1 by 1-in. crossbar is riveted to the inside of the bow at the extreme front and another directly under the extremity of the curved end. These cleats are wired together to hold the bend of the bow. The tail end crossbar should be placed not nearer than  $2\frac{1}{2}$  in. from the end of the boards, while the remainder of the crossbars are evenly spaced between the front and back pieces, taking care that the notched side is always placed down. Trim off uneven ends, scrape and sandpaper the bottom well, and finish the toboggan with oil. Run a  $\frac{3}{8}$ -in. rope through the notches under the ends of the cross pieces, and the toboggan is completed.

Screws are satisfactory substitutes for rivets in fastening together the parts, and wire nails, of a length to allow for about  $\frac{1}{4}$ -in. clinch, give a fair job. Indians overcome the lack of hardware by the use of rawhide, laced through diagonally staggered holes bored through the crosspieces and bottom boards. Rawhide, which they sometimes stretch over the bow as a protection, affords an opportunity for elaborate ornamentation.

### Wooden Lock with Combination Key

The lock shown in the sketch and detailed drawings is made entirely of wood, and it is nearly impossible to pick or open it without the use of the key. The casing of the lock is 5 by 5 in. and 1 in. thick, of hard wood, oak being suitable for this as well as for the other parts. Three tumblers, a bolt, and a keeper are required. The key is shown inserted, indicating how

the tumblers are raised by it. The bolt is slotted and a screw placed through it to prevent it from being moved too

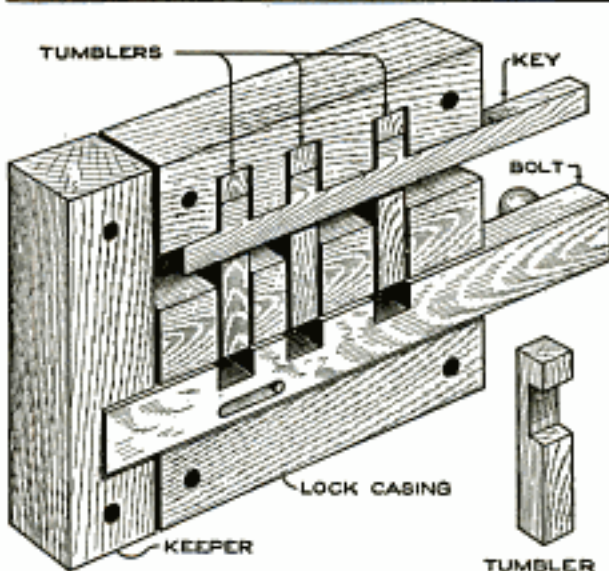

This Lock is Made Entirely of Wood and cannot be Picked Easily

far. The lock and keeper are bolted into place on a door with carriage bolts, the heads being placed on the outer side.

The detailed drawing shows the parts, together with the dimensions of each, which must be followed closely.

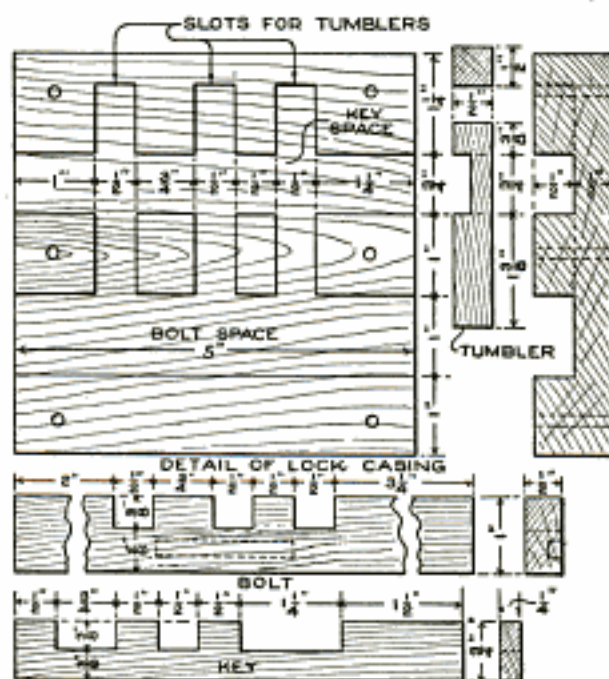

The Details of Construction must be Observed Carefully and the Parts Made Accurately to Insure Satisfactory Operation

The lock casing is grooved with two grooves, extending the length of the grain and connected by open mortises,



all  $\frac{1}{2}$  in. in depth. The spacing of the mortises and the grooves is shown in the views of the casing. Three tumblers,  $\frac{1}{2}$  in. square and  $2\frac{1}{2}$  in. long, are required. The bolt is  $\frac{1}{2}$  by 1 by 8 in., and the key  $\frac{1}{4}$  by  $\frac{3}{4}$  by  $5\frac{1}{2}$  in., and notched as shown. All the parts of the

lock must be fitted carefully, sand-papered smooth, and oiled to give a finish that will aid in the operation, as well as protect the wood. Aside from its practical use, this lock is interesting as a piece of mechanical construction.—B. Francis Dashiell, Baltimore, Md.

### Variety of Uses for an Electric Iron

A milliner, in addition to using her electric iron for ordinary purposes of

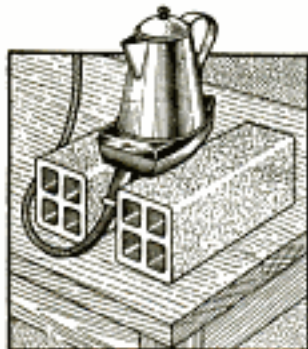

ironing and pressing, inverts it between two hollow tiles and thus makes use of it in steaming velvet trimmings. The tiles not only hold the iron securely in this position, but

also insulate it from overheating or scorching adjoining objects or surfaces. The iron is also used inverted for heating water, cooking coffee, and other liquids, as well as in providing a warm lunch.

### Renewing Dry Batteries with Sal Ammoniac

Finding that dry batteries had increased in price, and requiring a number for experimental purposes, I devised the following method by which I was able to use the old batteries for a considerable period: When the dry cells were nearly exhausted, I punched holes through the zinc covering with a nail, as shown in the sketch. The holes were placed about  $1\frac{1}{2}$  in. apart, and

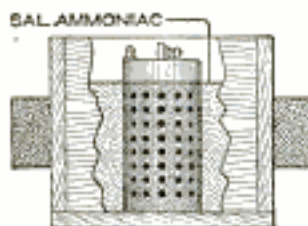

care was taken not to punch them near the upper edge of the container, or the black insulation might thus be injured. The cells were then placed in a saturated solution of sal ammoniac. The vessel containing the liquid must be filled only to

within  $\frac{1}{2}$  in. from the top of the cell, otherwise the binding posts will be corroded, and the cell probably short-circuited. The cells were left in the solution six hours, and then became remarkably live. They must not be connected or permitted to come into contact with each other while in the solution.—H. Sterling Parker, Brooklyn, N. Y.

### A Sliding Board for Coasting

The simple device shown in the sketch can afford youngsters much



SIDE VIEW



TOP VIEW

amusement in coasting down inclines or small hills, either on the snow or on surfaces slightly crusted with ice.

The board is intended for individual use only and should be about 10 in. wide and 26 in. long. It is reinforced underneath by a strip of wood, about  $\frac{1}{4}$  in. thick and smoothed on its lower side. This piece is fastened in the form of a bow by placing a small cleat between it and the upper piece. The strip should be about 3 in. wide, and aids in keeping the sliding board in its course.—John F. Long, Springfield, Mo.

### Electrical Device Transmits Striking of Clock

Converting an ordinary parlor, or mantel, clock into a master clock, from which the striking of the gong is transmitted to various parts of the home, may be accomplished by fitting it with a simple electrical device, as shown in the sketch. The general arrangement of the batteries, single-stroke bells, and



the contact device within the clock case is shown in Fig. 1; a detail of the silk cord and other connections of the contact key and the gong hammer, is shown in Fig. 2. This arrangement has been in operation for several years, and has been found practical.

The various rooms to which the striking of the gong is to be transmitted are wired with No. 18 annunciator wire, run carefully behind picture moldings and in corners. Where the wires must be carried through a partition, a  $\frac{1}{4}$ -in. hole is sufficiently large for the purpose. The single-stroke bells are wired up as shown in the sketch. The number of dry batteries necessary varies with the number of bells in the circuit, and also depends on the length of wire through which the current is carried. A trial should be made with several batteries and more added until the bells are rung properly.

The connecting device may be fitted into the clock case without defacing it by boring holes in its side, and the binding posts are fixed into place neatly. The two sections of the contact key, shown in detail in Fig. 2, are fastened to the back of the clock case with bolts. The upper member is fitted with an adjustable thumbscrew and is stationary on the bolt fastening. The lower arm is made of covered wire and is pivoted on the supporting bolt. Attached to its lower edge, at the pivot, is a small lever arm. This is connected to the hammer rod of the gong with a silk cord. The length of the cord must be determined by careful adjustment so that it will not hinder the action of the hammer H, but will bring the swinging arm into proper contact with the thumbscrew. The contact should be made at the instant the hammer strikes the bell. The contact of the platinum point of the thumbscrew and the swinging arm must be close, but not too strong. Metal posts or tubes fitted over the bolts, at the points where the arms are attached to the back of the clock case, may be used to bring the arms the proper distance forward in the case, so that they will be

in alinement with the hammer rod. The silk cord must not interfere with the action of the pendulum P. To hold

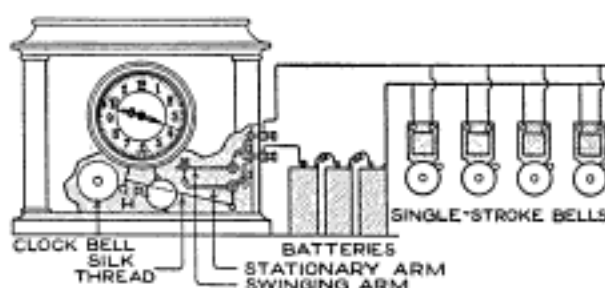

Fig. 1

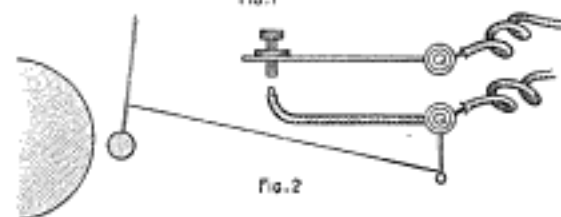

Fig. 2

The General Arrangement of the Apparatus for Transmitting the Striking of a Clock Gong is Shown in Fig. 1, and a Detail of the Contact Device in Fig. 2

the silk cord in place on the hammer rod, drop a small piece of melted sealing wax or solder on the rod.—W. E. Day, Pittsfield, Mass.

### Antique Signboard Made of Headboard of Bed

Some old headboards of beds are of such a pattern that they lend themselves readily for use as signboards, with only slight alteration. Such an adaptation is shown in the sketch, and was fitted to a bracket of ornamental iron, the whole producing a striking effect. The sign was made of black walnut and was, by reason of its age,

A Signboard Which Attracts Attention was Made of the Headboard of a Walnut Bed

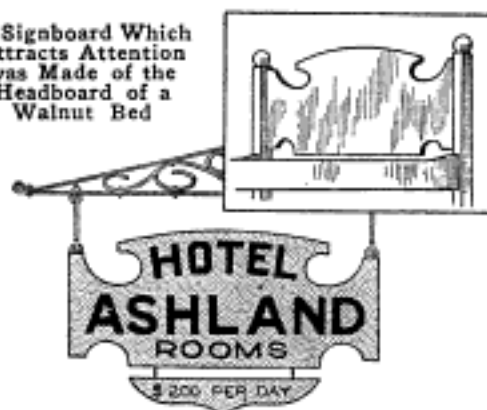

well seasoned. It was treated with several coats of linseed oil to withstand the action of the weather better.



# A Model Stiff-Leg Derrick

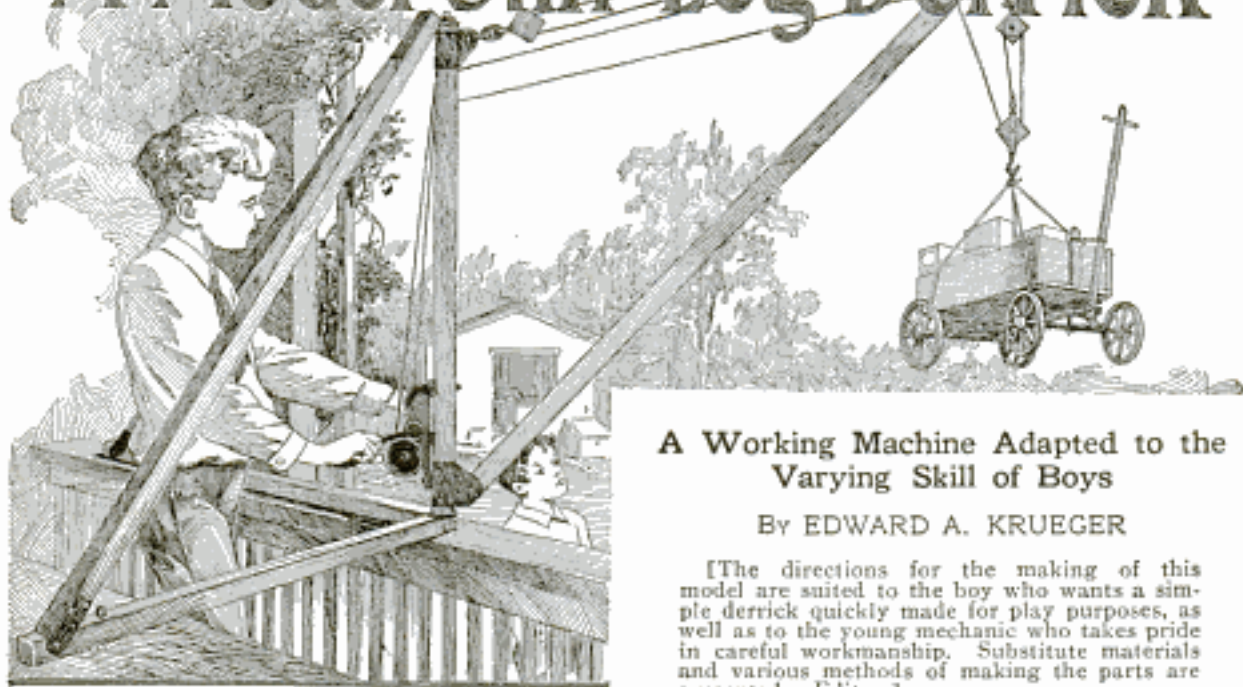

## A Working Machine Adapted to the Varying Skill of Boys

By EDWARD A. KRUEGER

[The directions for the making of this model are suited to the boy who wants a simple derrick quickly made for play purposes, as well as to the young mechanic who takes pride in careful workmanship. Substitute materials and various methods of making the parts are presented.—Editor.]

A HUGE derrick handling heavy objects seldom fails to attract attention, if it is within range of passers-by. To the boy it has a special appeal, whether perched hundreds of feet above the street on a skyscraper skeleton, lifting whole wagon loads of dirt from a deep excavation, raising heavy blocks of stone from a seemingly bottomless quarry, moving logs from a ship like cordwood, or hoisting a great black boiler as if it were a tin can. The real boy admires power and skill applied on large jobs. He looks forward to the time when he can take part in great building and construction projects. The derrick in its many forms is typical of this big work.

While a boy cannot join directly in such activities, he can, with the aid of his friends, tackle big jobs of his own, as a "contractor," "builder," or "engineer." He may make his miniature derrick and with it do real work, that is extremely interesting play. The model derrick shown in the illustration was designed for this purpose. It is operated by hand, and known as a stiff-leg derrick. The details of its construction are not exact duplicates of those used on large derricks, but are adapted from them, to be within the constructive ability of boys.

The parts can be made without the use of machinery or tools other than those in nearly every boy's workshop. The description and discussion of the construction and uses of the derrick are suggestive as well as definite. If a boy uses the suggestions presented to invent methods of his own, to use new and possibly better materials, and especially to devise interesting and original jobs on which to do work with the derrick, he will get far more benefit, as well as fun, than by merely making the model in detail as described.

However, the boy who does not have even ordinary tools and who cannot work out the parts as shown, may make a derrick that will work by using material available. Suggestions for some of these are given in this article. All of the fittings are not essential in a small model, though they should be made if possible. Likewise, the method of construction may be simplified, as outlined in the detailed description of the parts.

Typical uses of derricks on actual big construction jobs are shown in the three reproductions of photographs. They are of the stiff-leg type, though not alike in detail. That shown in Fig. 1, handling stone at a quarry, is operated by a steam drum engine, and has a



bull wheel by which it is turned. Dirt from a tunnel excavation under a street is being handled by the derrick shown in Fig. 2. The huge steel derrick, shown in Fig. 3, illustrates the use of built-up steel beams in a stiff-leg derrick for the handling of very heavy structural members.

Before beginning the construction of the model it is necessary that the general arrangement of the parts be understood. The headpiece shows these clearly. The two larger sketches in the page plate show the derrick with the boom extended directly in line with one side. The side elevation shows the lengths of the wooden beams and the arrangement of the parts as viewed from the side. In the front elevation, the middle portion of the boom is cut away to show the pulleys and fittings at the top of the mast.

The construction should begin with the getting out of stock for the beams, all of which are 1-in. square in section. A fine straight-grained hard wood, like maple or birch, is best for a high-grade model, but other woods—oak, ash, hickory, or even softer varieties—free from knots and defects, are suitable. Cut the beams to length, as shown in the side elevation: boom, 3 ft. 8½ in.; two sills, 2 ft. 1 in.; two stiff legs, 2 ft. 7 in.; mast, 1 ft. 9¾ in. Note that the lower ends of the stiff legs are butted against the upper surface of the sills and cut at an angle.

To insure that all the parts will fit properly, a good plan is to make a full-size drawing of the side elevation on a large sheet of wrapping paper. The parts may then be fitted directly to the drawing. Patterns may be made of paper for each of the metal fittings. In order to avoid confusion, the crab, pulleys, and rigging need not be placed on the drawing until the beams and the metal fittings have been made. This method will save time, especially for workers not thoroughly familiar with detail drawings.

Fit the sills together with a half-lap joint, at A, in the side elevation. This is covered and held together by a bearing plate, B. This, like all the metal

side plates and similar fittings, is made of sheet metal ⅓₂ in. thick. Sheet iron is suitable and readily obtained from old cans, bands of tubs, or cut

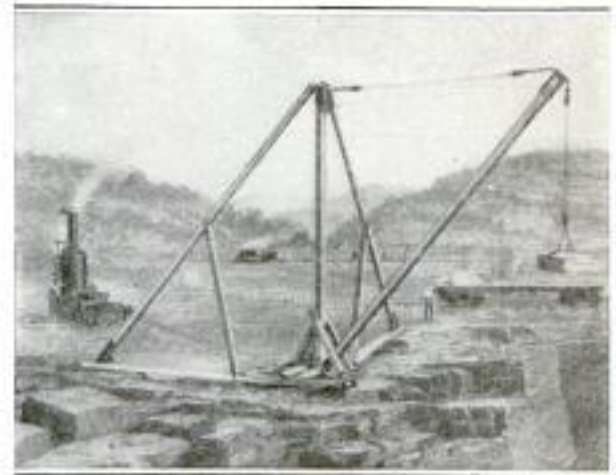

Fig. 1. Lifting Stone from a Quarry: The Boom is Slew'd by Means of the Bull Wheel and Rope Drive Connecting It to the Steam Hoist; Grabhooks Grip the Load

from new stock. The arms of the bearing plate B, like other supporting plates, are as wide as the beams. To make the plate, cut a 2-in. square of the metal and cut out a ¼-in. and a ½-in. square at opposite corners, as shown in the detail sketch. Drill a ¼-in. hole for the lower pin of the mast in the center of the corner portion, and drill or punch holes for bolting it. Make



Fig. 2. Handling Dirt from a Tunnel Excavation: The Use of a Platform and the Tip Bucket Are Suggestive

the diagonal cut at the inner corner. Mark the dotted lines and bend the plate into shape over a hard square-cornered wood block, or a metal block.







Slight allowance is made for the thickness of the metal in bending it. The lower pin of the mast extends nearly through the joint, and aids in steadying it. Simpler methods of making this fastening at the joint are to fit a flat angle plate over the joint, or fasten the latter with two screws and place a washer around the pin of the mast.

The four plates C, by means of which the stiff legs are bolted to the sills, should be made next. Cut them 1 by  $2\frac{3}{4}$  in., and round off the lower ends. Drill, or punch,  $\frac{3}{32}$ -in. holes for the bolts, and  $\frac{1}{8}$ -in. holes for the fastening bolt near the rounded end. Next make the two flat plates D, and the two top irons E, for the stiff legs. The plate D is 1 by 3-in., with holes, as indicated, for the top iron E, in its 3-in. section. The top irons are cut 1 by 4 in.; a  $\frac{1}{4}$ -in. hole is drilled in the center of the 1-in. end, to receive the top pin of the mast, and the end is bent to fit the angle of the stiff legs.

The foot block F is bent from a strip, 1 by 3 in. A  $\frac{1}{4}$ -inch hole is drilled in the center, for the pin of the mast. Holes are made for screws, by which it is fastened into place. The plates for the boom seat G are cut from pieces,  $2\frac{1}{4}$  by  $2\frac{1}{2}$  in. Cut out the  $\frac{1}{4}$  by  $\frac{7}{8}$ -in. portion at the left to receive the lower brace of the crab. These parts may be made of slightly heavier metal, as they must stand considerable strain.

The mast-top iron H is bent from a piece,  $6\frac{13}{16}$  in. long and 2 in. wide. Allowance is made for the thickness of the metal, so that the square section will fit closely around the 1-in. square mast. This is shown in the sketch of the piece in place. The iron is fixed into place by means of bolts. The  $\frac{1}{4}$ -in. holes for the chain, attached to the block near the iron H, should be drilled through both pieces at once, after the metal has been bent into shape. The side plates J, for the pulleys in the mast, are 1 by  $5\frac{1}{2}$  in. and drilled as shown. They are not essential, but provide a strong support for the axles on which the pulleys are mounted.

The lower end of the boom is fitted

with two plates, K, 1 by 2 in., with  $\frac{1}{4}$ -in. holes to fit the pivot pin, and sunk flush with the sides of the boom. The two side plates L, on the upper



Fig. 3. Seventy-Five Ton Girder Handled by Steel Derrick: Twenty-One Parts of Line are Used with Double Blocks in the Load and the Boom Lifts

end of the boom, are 1 by  $5\frac{1}{4}$  in., as shown in the detail sketch of the boom end. The boom-end iron M is cut from a 3 by 3-in. piece of sheet metal, and should be at least  $\frac{1}{16}$  in. thick.

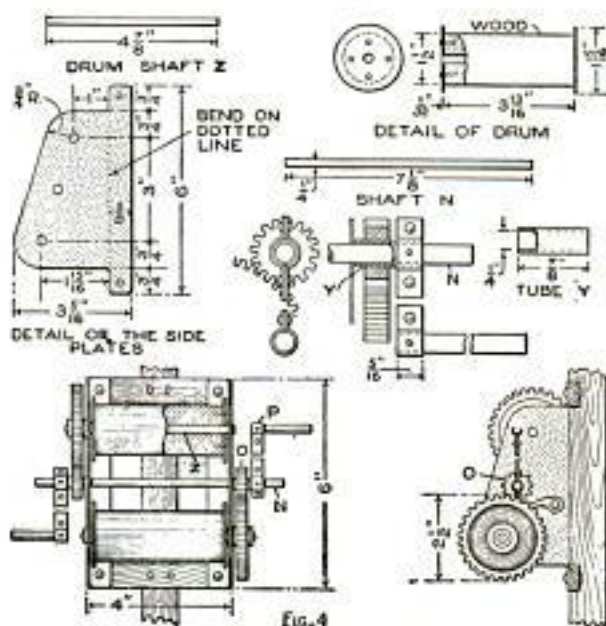

Details of the Hoisting-Drum Mechanism, or Crab: By Setting the Gears Properly Both Drums may be Operated Together

The preliminary fitting together of the beams and the fixing of some of the



fittings into place may be undertaken when these parts are made. Bolt the bearing plate B into place, and bore

H, and the plates J into place. Bore  $\frac{1}{4}$ -in. holes in the ends of the mast and drive the pivot pins into them about

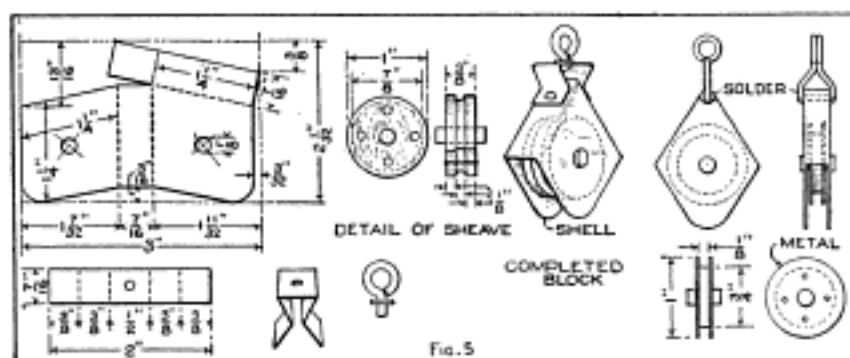

Two Simple Methods of Making the Blocks: The Sheaves are Made of Wood or Metal; the Shells are of Metal Fitted to the Sheaves

the  $\frac{1}{4}$ -in. hole for the lower pin of the mast. The bolts used are similar to those used in fastening the other plates and fittings. On commercial derricks they are usually square-head, but these are difficult to obtain in small sizes. Since it is intended that the derrick is to be set up and taken down, like large derricks, in moving them from job to job, bolts must be used for some of the fastenings. Where the part to be fastened need not be removed in "knocking down" the derrick, rivets may be used. The bolts should be  $\frac{3}{32}$  in. in diameter, of steel or brass, like those used in electrical work. They should be  $1\frac{1}{4}$  in. long, round-head, slotted, or hexagonal head, so

that they may be gripped in tightening up the nuts. Screws and escutcheon pins are possible substitutes.

Cut the lower ends of the stiff legs to the proper angle and bolt the plates C into place. Then put on the stiff-leg top irons D and E. Before putting on plates

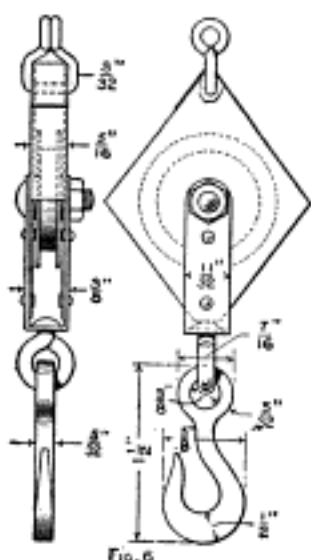

Fig. 6

for the mast, cut the slot for the pulleys, at J. It is  $\frac{3}{8}$  in. wide and  $4\frac{1}{4}$  in. long. Fit the foot block F, the boom seat G, the mast-top iron

H, and the plates J into place. Bore  $\frac{1}{4}$ -in. holes in the ends of the mast and drive the pivot pins into them about 1 in., permitting them to project  $\frac{3}{4}$  in. Cut the pulley slot,  $\frac{3}{8}$  by  $1\frac{1}{2}$  in., through the boom, at L. Put the plates K and L and the boom-end iron M into place. The beams may now be assembled, to test the fittings, and then taken down for greater freedom in completing the details.

Drill  $\frac{1}{8}$ -in. holes for the removable pins or bolts at C and K, and at the bearings for the pulleys in the mast and boom.

The pulleys in the mast and boom are 1 in. in diameter and  $\frac{1}{4}$  in. thick. They may be made by either of the methods shown in Fig. 5, and explained in connection with the block sheaves. If preferred, small pulleys may be purchased or taken from old machinery. The pulleys turn on  $\frac{1}{8}$ -in. bolts as axles. Those in the mast are set  $1\frac{7}{8}$  in. from center to center.

The making of the crab should next be undertaken. Its position on the mast is shown in the side and front elevations. It is supported on a frame made of two wooden strips,  $\frac{1}{4}$  by  $\frac{7}{8}$  by 4 in., and two metal side plates. The plates are riveted to the strips, which are sunk into the mast, as shown in the detailed sketch, Fig. 4, and bolted to it. The crab is of the double-drum type, permitting the hauling in or releasing of the ropes independently for the boom or the load. The drums are driven by means of cranks and gears, the latter being thrown in or out of mesh by sliding the small gear, or pinion, on the center shaft N. The pinion O is set on a tube, as shown in the detail sketch. The tube is fixed to the crank P, which is made of a strip of sheet metal. By placing a pin through the handle and the shaft N, when both pinions are in mesh, the ropes may be wound on both drums at the same time.



The parts of the crab must be made carefully. The gears may be obtained from old machinery or purchased from dealers in model-maker's supplies. The drums are of wood, the ends being metal disks. In order to simplify the construction of the crab, the drums may be turned by means of cranks fixed to their shafts, without the use of gears.

Suggestions for the making of blocks, with wooden or metal sheaves, are shown in Figs. 5 and 6. The shells are made similarly, that for the metal sheave being of less thickness. The layout for the metal bent to form the shell is shown at the left. Cut a piece  $2\frac{1}{32}$  by 3 in., and mark out the outline as indicated. Bore holes for the sheave axle at the centers of the sides. Bend the piece as indicated by the dotted lines, and solder the open corners at the top. Make the strap of metal  $\frac{7}{16}$  by 2 in., fold it as shown, and rivet the eye to it. Rivet the strap to the shell. Build up the wooden sheave 1 in. in diameter, of three  $\frac{1}{8}$ -in. sections; fit it into place, and rivet the axle into the shell. The other type of



block is made as shown, the eye being bent of wire and soldered into the upper corner of the shell. Blocks may, of course, be purchased, or various substitutes made from wheels available

in the boy's workshop. The blocks Q and R, to which the ends of the rope are attached, are similar to those described, but must be provided with an eye at each end. A detail of a block for this purpose, with a load hook, is shown in Fig. 6 and at R another type is suggested. A U-shaped strap is fitted to its lower end, and a swivel eye is riveted to the strap. This permits the hook to turn with the load without twisting the rope. The hook is cut from  $\frac{1}{8}$ -in. sheet metal, the center opening and

the eye being drilled out. Substitutes for it may be made from heavy wire.

In order to join the blocks, chains, and other fittings of the hoisting

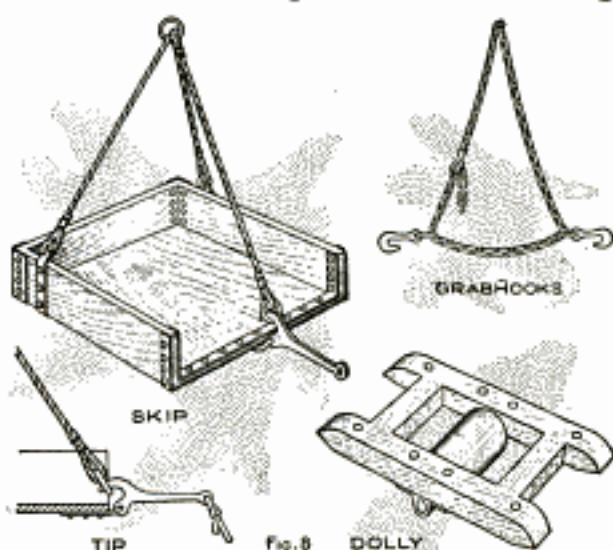

The Grab Hooks are Used with Chains in Handling Steel, Blocks of Stone, and Various Heavy Objects; the Trip Skip for Dirt and Bulk Material, and the Dolly in Bringing Certain Loads within Range of the Derrick

tackle, so that they may be taken apart quickly, the shackle S, shown in Fig. 7, is useful. It is made of  $\frac{3}{32}$ -in. wire, and should be about  $\frac{3}{4}$  in. long. The double-S link T is useful in joining chains temporarily. A swivel, U, made by bending up a strip of sheet metal and riveting an eye to a widened portion at its middle, is also shown.

The necessary fittings being made, the derrick may be assembled completely and the ropes secured to the eyes in the blocks Q and R. Plumb line of about  $\frac{3}{32}$ -in. diameter, or other strong cord, is suitable. Reeve the ropes through the blocks and pulleys of the topping, or boom lift, and the fall, or load lift, as shown in the side elevation; fasten their free ends to the proper drums, and the derrick is ready for work. For handling loads of considerable weight, it is desirable to secure the ends of the sills, or weight them. The boom is turned or "slewed" by means of a rope attached to the load to steady it, or to the boom. Interesting tests may be made in the handling of various loads by the use of blocks having two or more sheaves, or by the use of double blocks, for handling very heavy loads, as shown in



Fig. 3. The same power applied on the drum raises heavier loads when more strands of rope are used between the multiple-sheave blocks. The exact relation of the power to the weight and number of strands may be determined by test, and is outlined in texts or handbooks on mechanics.

Special equipment for handling various kinds of materials and objects

with a derrick is useful. Several typical devices are shown in Fig. 8. Blocks of stone are handled with grab hooks, or with keys set into a dovetail hole in the stone; girders, logs, lumber, etc., with chain or rope slings; dirt, crushed rock, etc., in trip buckets or trip skips. Other equipment may be devised readily for special purposes by observing derricks in use.

### Horizontal Steering Gear for Bobsled

A steering gear for a bobsled set horizontally like the wheel of some aeroplanes and racing automobiles is

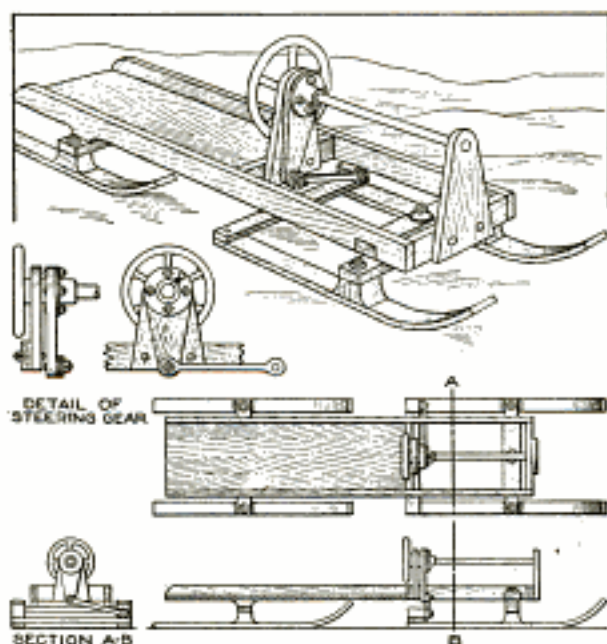

Turn the Wheel Slightly and the Runners are Turned Correspondingly by the Arm and Lever Fixed to the Rear Brace

shown in the illustration. It may be made almost entirely of wood with metal fastenings, or metal may be used for the levers controlling the action. The frame may be covered with sheet metal or thin wood to resemble the front of an automobile.

The steering wheel is mounted on a shaft set in two supports. The shaft is connected to a vertical arm by means of a pipe flange. The lower end of the arm is connected to the rear brace of the front runners by a link of sheet iron, or of iron rod, bolted to the arm. The other details of the sled are suggestive only and the device may be

adapted to many types of sleds. The king-pin on which the sled pivots is a bolt set through the forward brace. When the wheel is turned slightly the action is communicated to the arm and the lever, turning the runners correspondingly.

### Reversing Switch for Toy Motor

The switch shown in the diagram was found satisfactory for reversing a toy motor at a distance, in connection with toys and constructions used by boys. The motor may be fixed to the electrically operated model, and the switch placed where convenient. The motor brushes are wired to the terminals A and B, which are small brass bolts and nuts. They must be insulated with thin washers of mica, fiber, or hard rubber. The field wires are fastened to terminals C and D.

The switch shown may be made of wood or fiber. The levers G are of brass, fastened together loosely with a strip of fiber, K. The contact strip S is of brass, and is secured at F, not touching the small bolt at E. Points 1 and 4 are wired to F, and E is wired

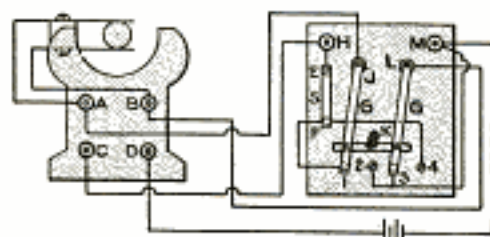

Toys and Other Small Electrical Constructions may be Reversed from a Distance by the Use of This Switch

to terminal H. Points 2 and 3 are wired to terminal M.

In wiring the switch to the motor,



terminal H is wired to the field terminal C. Terminals J and L are wired to the brush terminals A and B, respectively. Field terminal D and terminal M are wired to the batteries, or to the transformer. To reverse the motor, move the levers G to the points 2 and 4. Then press point E of the contact strip S, to close the circuit. If the switch block is made of wood or fiber, the nuts and wiring may be countersunk on the bottom of the block, and covered with sealing wax.—S. Paine, Kansas City, Mo.

### Motorcycle Engine Adapted as a Stationary Motor

Desiring a light, inexpensive, and reliable stationary engine, I procured an old 4-hp. motorcycle power plant and frame. Mounted on a strongly built base, and supported as shown in the photograph reproduced, it gave complete satisfaction. It served all ordinary purposes of a stationary engine, and was adapted to many other uses.

The engine was mounted in the loop portion of the motorcycle frame, and this was supported in an iron framework, fixed to hardwood skids, and strongly cross-braced. A 1-in. countershaft, having babbitt bearings, was fixed to the upper part of the framework, and carries a 36-tooth sprocket, driven directly from the engine shaft by a cycle drive chain. A starting crank engages a lug on one end of the countershaft, and on the other end are keyed two sizes of belt pulleys, affording two speeds. The motorcycle fuel tanks are supported on the upper part of the frame, as shown.

The motor is provided with a governor driven from the countershaft by a small belt. The tension of the governor spring is controlled by a lever, and by means of it various engine speeds may be had. Another lever near the upper part of the frame controls the spark advance and raises the exhaust valve for ease in starting. A 10-in. fan cools the motor. It is mounted at the side and runs on ball bearings, at high speed.

The engine is almost free from vibration and has a speed range of 150 to 400 r. p. m. on the countershaft. The

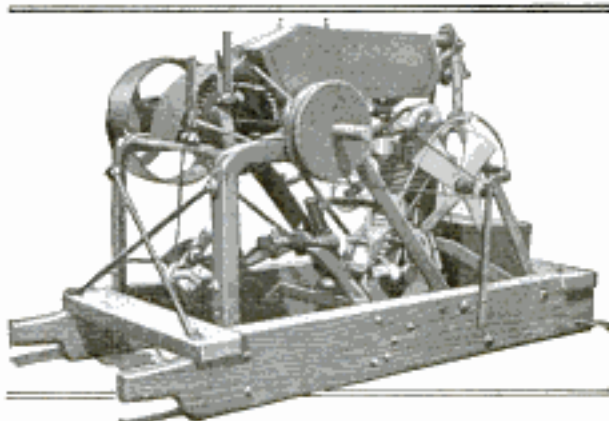

An Old Motorcycle Engine was Mounted on a Frame and Skids for Use as a Stationary Engine That could be Moved Readily

whole arrangement as shown weighs about 200 lb. and develops steady power. An axle at the end of the skids makes it convenient to mount small wheels on it, for transporting the engine.—Jay M. Hare, Delphos, Kan.

### Sanitary Method of Sealing Envelopes

Having quite a number of envelopes to seal, and not wishing continuously to sample the taste of the particular brand of mucilage with which they were gummed, I used a small, flat bristle brush with excellent results. A brush can be had just wide enough to moisten the gummed surface without touching any outside surface of the



envelope. This brush method is a great deal better and cleaner than using a sponge.—James M. Kane, Doylestown, Pennsylvania.



### Clock Device to Record Time of Appointments and Other Events

An ordinary clock, fitted with an electrical device to record the length of telephone conversations or appoint-

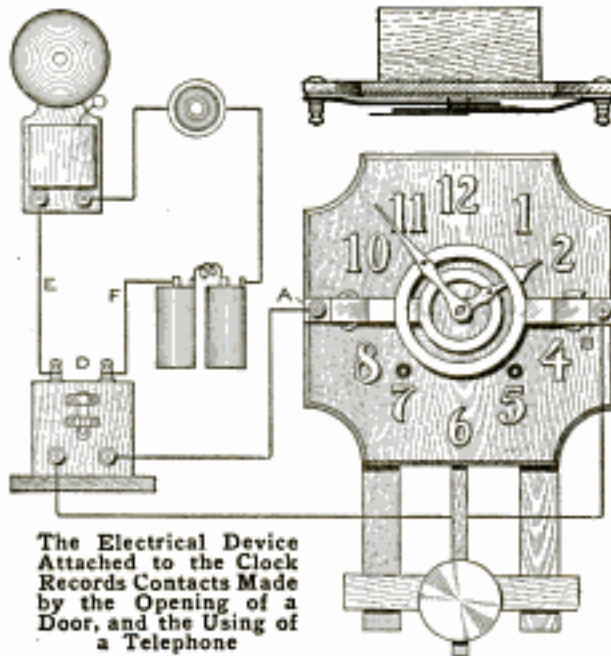

ment hours, or indicate when a door is opened, is shown in the illustration. The record is made by the hands in contact with brass rings attached to the face of the clock, the front of the rings being covered with white paper, dipped in a chemical, on which black dots are caused to appear, at each contact. By examining the dots and noting the items corresponding to them on a memorandum, the length of conversations, etc., may be observed.

Two rings of  $\frac{1}{16}$ -in. brass, one within the other, and having side arms, are mounted on the front of the clock, as shown in the illustration. The ring on arm A should be slipped under both hands, and should have spring enough to hold it in contact with the small clock hand. The ring fixed to arm B must be in contact with the large hand, but must be some distance from the small hand and the smaller ring, so that they will not come into contact when the hands cross each other. An offset in the arm A, and a piece of mica insulation, are provided where the larger ring crosses the bar A. On the surface of each ring, between it and its

respective hand, is glued a piece of white paper, cut to conform with the ring, but  $\frac{1}{16}$  in. larger, so as to extend over the outer edge of the brass rings. The rings of paper are saturated in a solution of potassium chloride and permitted to dry, before being placed on the brass rings.

A high-tension current, passing through the coil D, enters the arm A, passes to the small hand, to the large hand, and out at the terminal on arm B. Black dots will appear on the prepared paper at the position of the hands, when the contact is made.

The primary wires E and F may be attached to a doorbell or to a contact on the door, indicating on the prepared paper the length of time the door was held open, as well as the time at which it was opened. The arms A and B must be well insulated from one another. For greater accuracy in recording time, to within  $\frac{1}{2}$  minute, prepared paper dials, with hour and minute marks, coming into contact with the hands at small projections punched in the hands from their upper surfaces, should be used. An ordinary secondary coil from an automobile may be used, and if the clock has a wooden case, the arms may be fastened directly to it.

### Practical Memorandum for Odd Jobs

Not infrequently home or shop mechanics find that trifling odd jobs are neglected repeatedly, simply because they are not of sufficient consequence to warrant getting out the tools or materials necessary for the work. A convenient method of insuring that these small jobs are not overlooked is to make a memorandum of them and place it with the tools required for the work. For instance, if a small job of soldering is to be done, a memorandum placed with the soldering outfit will not easily be overlooked, and the work may be done while the coppers are hot for use in a larger job. Likewise with small painting jobs. Sometimes only a brushful of paint is needed and one does not care to mix a small quantity



of paint nor clean the brush afterward. A memorandum of the job makes this unnecessary.—John Hoeck, Alameda, California.

### A Homemade Vulcanizer

Tire tubes may be vulcanized satisfactorily in the home garage, or even on the road, with the simple device shown in the sketch. It is made as follows: Obtain a piece of sheet iron,  $\frac{1}{4}$  in. thick, 3 in. wide, and 5 in. long. Drill a  $\frac{1}{4}$ -in. hole at the middle of each end. Fit a strip of similar stock, 1 in. wide and 5 in. long, to the first piece with bolts, as shown. Procure a tin cover without embossing on the top, such as is used on baking-powder cans. Cut several disks to fit in the cover, from heavy cardboard; soak them thoroughly in a saturated solution of saltpeter, and dry them. Wrap each disk in oiled paper, and keep them in a water-tight container.

To use the vulcanizer, clean the area around the hole in the tube with sandpaper, and cut a piece of rubber of the proper size to fit over it. Slip one of the prepared cardboard disks into the tin cover, and clamp the cover and tire with patch into the iron frame, as shown. Touch a lighted match to

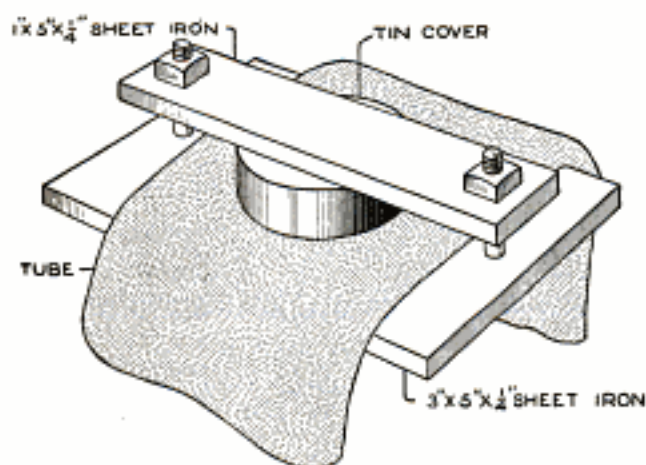

This Homemade Vulcanizer Utilizes the Heat from a Slowly Burning Disk of Cardboard

the cardboard disk, which will burn rapidly, but without flame, supplying sufficient heat to vulcanize the tube.—Thomas W. Benson, Hastings on Hudson, N. Y.

### Rudder for a Toboggan

Learning to steer a toboggan by means of the foot dragged behind it is an interesting feature of the sport, but this method is dangerous at times and

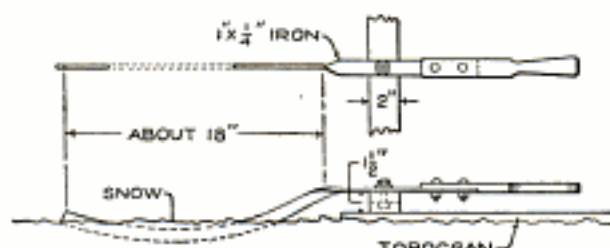
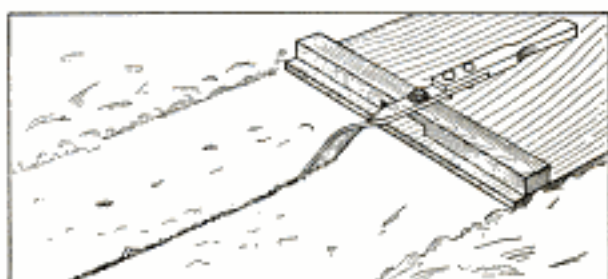

This Rudder for a Toboggan Insures Positive Control, and Prevents Wear on the Shoes and Clothes of the Rider

results in much wear on shoes and clothes. The device shown in the illustration makes this method of steering unnecessary, and gives the rider accurate control over the sled. It consists of a strip of  $\frac{1}{4}$  by 1-in. iron curved to form a rudder at one end and twisted at the middle to provide a flat piece for pivoting it on the rear cleat of the sled, as shown in the working drawing below. A handle is fastened to the front end of the strip with bolts. The rudder should not be curved too deeply or it will cut through the snow and be damaged, or ruin the track.—H. B. McIntyre, Waterville, Me.

### A Window Refrigerator

A simple method of constructing a window refrigerator that will not obstruct the light is shown in the illustration. A box was made the width of the window and was fitted to slides fastened outside the window on the side of the house. The exposed sides of the box were inclosed completely and the inner side was provided with two sliding doors. A handle was fitted to the side of the box so that,



by reaching out of the window, the box could be drawn in front of the opening easily. Several shelves were

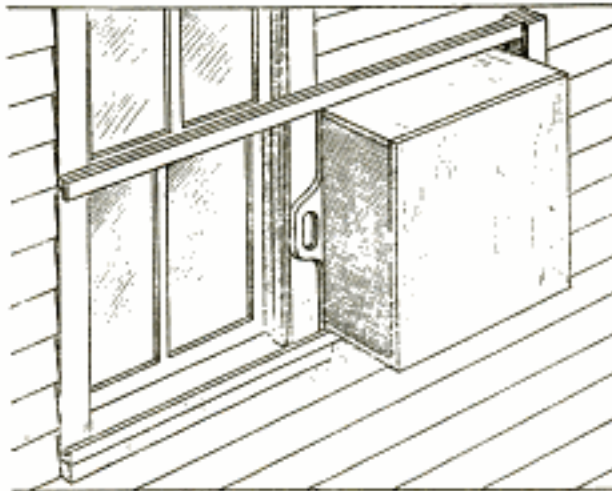

A Box Fitted on the Outside of the Window to Slide in Grooves Provides a Convenient and Inexpensive Refrigerator for Winter Use

fitted into it and the materials stored were not easily molested. Trunk casters attached to the bottom of the box improved the action on the lower rail.—Hubert Kann, Pittsburgh, Pa.

### Toy Paper Glider Carefully Designed

A paper glider is an interesting and useful toy that can be made quickly;

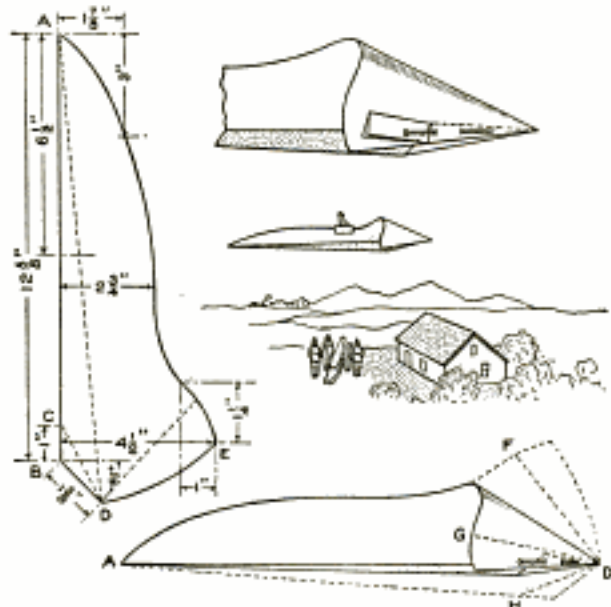

The Glider will Travel 30 Feet, Carrying a Message, if Carefully Made

it may be used out of doors, but occasions when weather conditions make it necessary to remain indoors are

especially good for this form of pastime. The glider shown in the sketch was worked out after considerable testing. With a toss it travels 20 to 30 ft., on a level keel, with a message slipped behind a pin, as shown in the upper sketch. The inventive boy may devise many play uses for the glider, in tournaments, competitions, and for "military" flights, in which the "drivers" of the devices may "annihilate armies." Practical use of the toy was made in a series of air-current tests.

The glider is made as follows: Fold a piece of paper, 10 by 15 in., lengthwise, and mark the outline shown at the left upon it. The dimensions should be followed carefully. Measure first from the end A to the point B, and then draw the slanting line to D, at an angle of  $45^\circ$ . Mark the width to E, and measure the other distances from A and at the middle, to determine the curve of the edge. Mark the dotted lines extending from D, which are guides for the folding of the paper to form the glider, as shown in the lower sketch. Curl the points under the side so that the line FD comes to the position DG, and pin them to the corners H, as shown in the lower sketch. The glider is tossed by holding it between the thumb and forefinger at the middle of the fold underneath it.—S. R. Edwards, Seattle, Wash.

### Cleaning a Clock with Kerosene Fumes

A simple way of cleaning a clock is as follows: Remove the pendulum, and procure a ball of cotton wool, about half the size of a fist. Saturate this with kerosene, and place it in a saucer, or a tin lid, in the case under the works of the clock. Close the case, and leave the cotton for several days. It will then be found that the fumes from the kerosene have brought down the dust from the works; in fact, the cotton will be covered with black specks. It only remains to oil the bearings of the works, and the clock will be quite in order.—S. Leonard Bastin, Bournemouth, England.



### Preserving Leaves in Specimen Book

The common method of preserving leaves by pressing them with an iron rubbed on beeswax may be improved by substituting the following process. Paint the under side of each leaf with linseed oil, ironing it immediately, and then paint and iron the upper side in the same way. This treatment gives the leaves sufficient gloss, while they remain quite pliable. It is not necessary to press and dry the leaves beforehand, but this may be done if desired. The tints may even be well preserved by painting only the upper side of the leaves with the oil and then placing them, without ironing, between newspapers, under weights, to dry.—Caroline Bollerer, New Britain, Conn.

### Removable Drawer Stop

When I least expected it, the small-tool drawers of my tool chest have

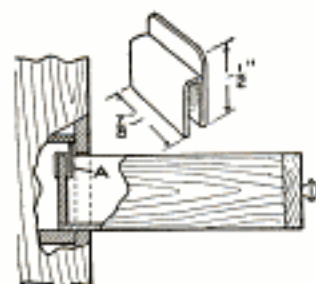

often dropped out, after I had left them partly open. The result was a waste of time in picking up the tools, not to mention the possible injury to them. I made small clips, like that shown in the sketch, and fitted them to the back of the drawers, as at A. When it is desired to remove the clips, the portion that extends above the drawer may be bent forward. This is necessary only where the space above the drawer is small. The clips may be made large enough to fit drawers of various sizes.—J. Harger, Honolulu, H. I.

### Pole Supports Rug Handily for Cleaning

A rug may be handled easily for cleaning if the pole on which it is rolled when purchased is used as a support, as shown in the illustration. Two stout wires are fastened into the ends of the pole and hooked over the tightly

stretched clothesline. The rug is suspended on the roller and is thus kept straight while it is cleaned, the ten-

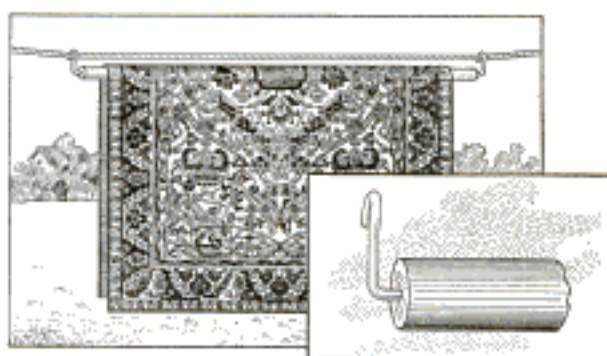

The Roller on Which the Rug is Rolled When Purchased is Used to Advantage as a Support While Cleaning It

dency being, when only a clothesline is used, to crumple at the middle.—John V. Loeffler, Evansville, Ind.

### Disk Talking Machine as China-Banding Wheel

A serviceable wheel for banding hand-painted china may be had by adapting a disk talking machine for the purpose. Three old records are placed on the wheel, so as to bring the surface of the upper one slightly higher than the center pin. The piece of china to be banded is set on the exact center of the disk, with the rings on the record as a guide, and the brush may be rested on the arm of the machine. Care must, of course, be taken not to injure the talking machine.—Mrs. W. Read Elmer, Bridgeton, N. J.

### Emergency Collar Button

Requiring a collar button, and, as usual, having no extra one on hand, I devised the holder shown in the illustration. It proved to be better than a collar button for use at the back of the neckband. It was bent into shape from a hairpin and has the advantage of keeping the collar fixed with little chance of becoming unfastened.—William S. Thompson, Hopkinsville, Ky.





2866

# Albert Marple

222 Boynton St.

Tropico, Calif.

VARIED EXTERIOR FINISHES FOR FRAME HOMES

*House*

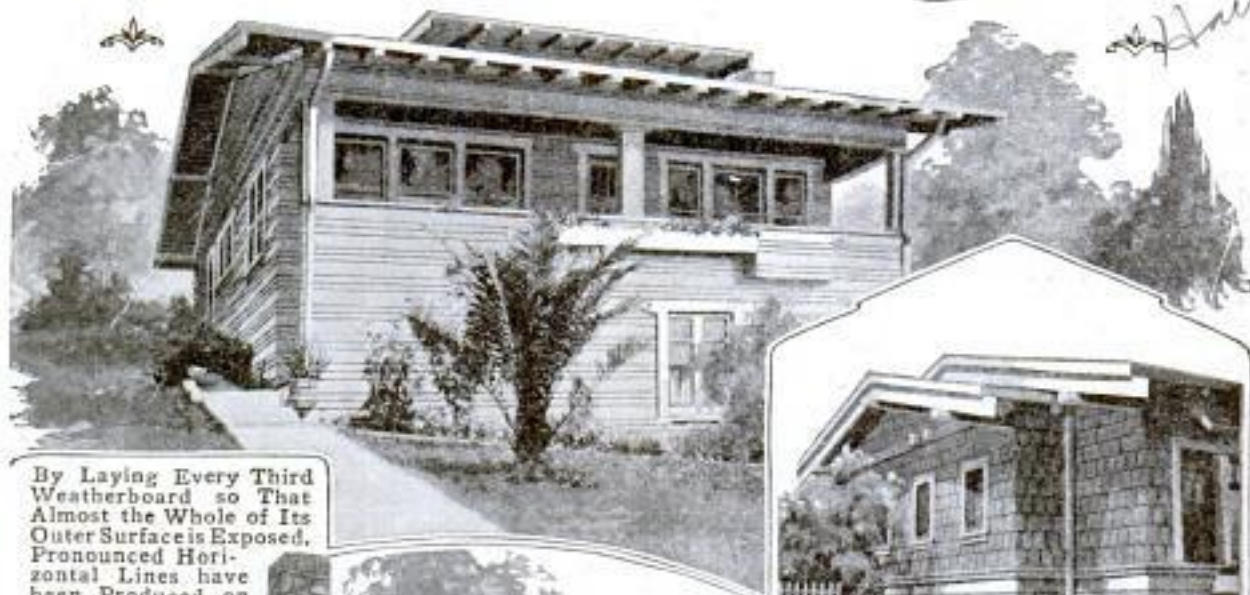

By Laying Every Third Weatherboard so That Almost the Whole of Its Outer Surface is Exposed. Pronounced Horizontal Lines have been Produced on This Bungalow



A Pleasing Combination Consisting of a Shingled Wall and a Base Made Prominent by Clapboards Laid in Groups of Three



Long Shingles, or Shakes, have been Used on the Lower Portions of These Walls and Smaller Shingles on the Upper Portions to Give This Bungalow an Exterior That Is Quite Out of the Ordinary



Individuality has been Secured in This Structure's Appearance by Alternating Wide Shingle Courses with Narrow Ones and Making a Border of Two Narrow Rows under the Eaves



Above is a Dwelling, with Shake-Covered Walls, Which would Be Almost Severely Plain but for Its Vine-Clad Veranda. These Shakes are Exposed 16 Inches



Here an Unusual but Pleasing Effect has been Produced by Using Shingles of Many Widths Laid in Irregular Courses



# ALADDIN Homes

## \$1045



"The Sunshine"

## Make This Your Home-Building Year



Will this year see the attainment of the home you have been waiting for? Of course, you have ideas and plans of what you want. Then take the first step toward their fulfillment by sending for the truly wonderful Book of Aladdin Homes. This most remarkable building book ever published is now ready for mailing.

It pictures and describes over one hundred bungalows, dwellings, summer cottages, and garages at prices from \$138 to \$8,000. It shows how twenty feet of lumber are secured from a sixteen-foot board. It also shows how modern machinery can saw your lumber to fit, faster, cheaper, and more efficiently than your carpenter. Aladdin prices for 1917 will save you from \$200 to \$800 on your home — this book shows how you can secure a better home by the Aladdin system than by ordinary methods. Send for your copy today — now!

### How Aladdin Helps You Build

First, the plan: A hundred homes to choose from and each as interesting, as charming, and as practical as the one shown above. Next, the material: As clear and free from blemish as was ever taken from the forest. And last, the Service: A knowledge and experience gathered from twelve years working with thousands of home builders — everywhere — a service that assists you in every step of your home building.

### 5-Room Winter Home, \$298

You can buy all the material needed to build a cozy, 5-room house complete for \$298. Everything included to finish the house, ready to occupy. Price includes the same high grades of material as furnished for the larger Aladdin Houses.

### Aladdin's Readi-Cut System Offsets Rising Building Costs

Of course, the cost of living has been raised. And so has the cost of building. Yet, you can avoid these higher prices by eliminating waste. The Aladdin Readi-Cut System of Construction eliminates the usual 18% waste of lumber, waste in measuring, cutting and fitting. This saving matched against wasteful methods offsets the higher price of building materials. Twenty feet of lumber from a sixteen-foot board — the Aladdin catalog tells how.

### Aladdin Price Includes

all lumber, millwork, flooring, outside and inside finish, doors, windows, shingles, lath and plaster, hardware, locks, nails, paint, varnishes. Your home is shipped in a sealed box car, complete, Readi-Out, ready to erect. Safe arrival of the complete material in perfect condition is guaranteed. Floor plan arrangement and complete description of the house shown above will be found in the Aladdin Book of Homes. Send stamps today for the book of "Aladdin Homes," No. 180.

**The Aladdin Co.** Home Builders to the Nation  
827 Aladdin Ave., Bay City, Mich.

Canadian Branch, C. P. R. Bldg., Toronto, Ont.

Enclosed find stamps for your book No. 180, Aladdin Homes.

**THE ALADDIN CO., 827 Aladdin Ave., BAY CITY, MICH.**

Name ..... Street ..... City ..... State .....



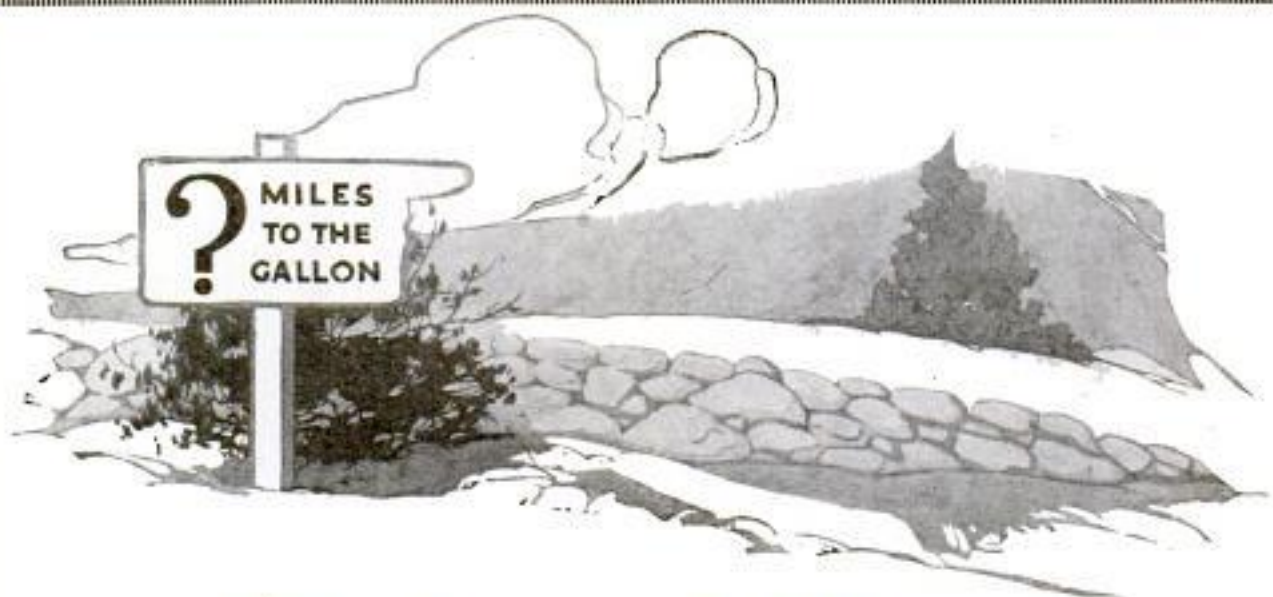

# Higher Mileage

*from both oil and gasoline  
follows lubricating efficiency*

**T**HE careful motorist today wants high mileage from his lubricating oil. For high mileage is significant in many ways.

Higher mileage from an oil means more work, less waste.

Higher mileage results from a more complete piston-ring seal. That means practically eliminating oil working into the combustion chambers. It means cutting down the gasoline waste past the piston rings. It means sealing-in the power, which then acts with full force on the pistons.

And a higher mileage oil must naturally be one which withstands the intense working-heat in the cylinders.

The high mileage from Gargoyle Mobiloils is causing a marked reduction in many annual oil bills. But, much more important, it points plainly to greater lubricating efficiency.

A Massachusetts garage man writes us: "Some motorists say Gargoyle Mobiloils go  $\frac{1}{3}$  to  $\frac{1}{2}$  further. In our seven livery cars we get 20 to 25 miles more per quart than with anything else on the job."

A prominent manufacturer of motor trucks and tractors found that Gargoyle Mobiloils cut gasoline consumption 28% when compared with one oil and 41% when compared with another.

We constantly hear of such experiences.







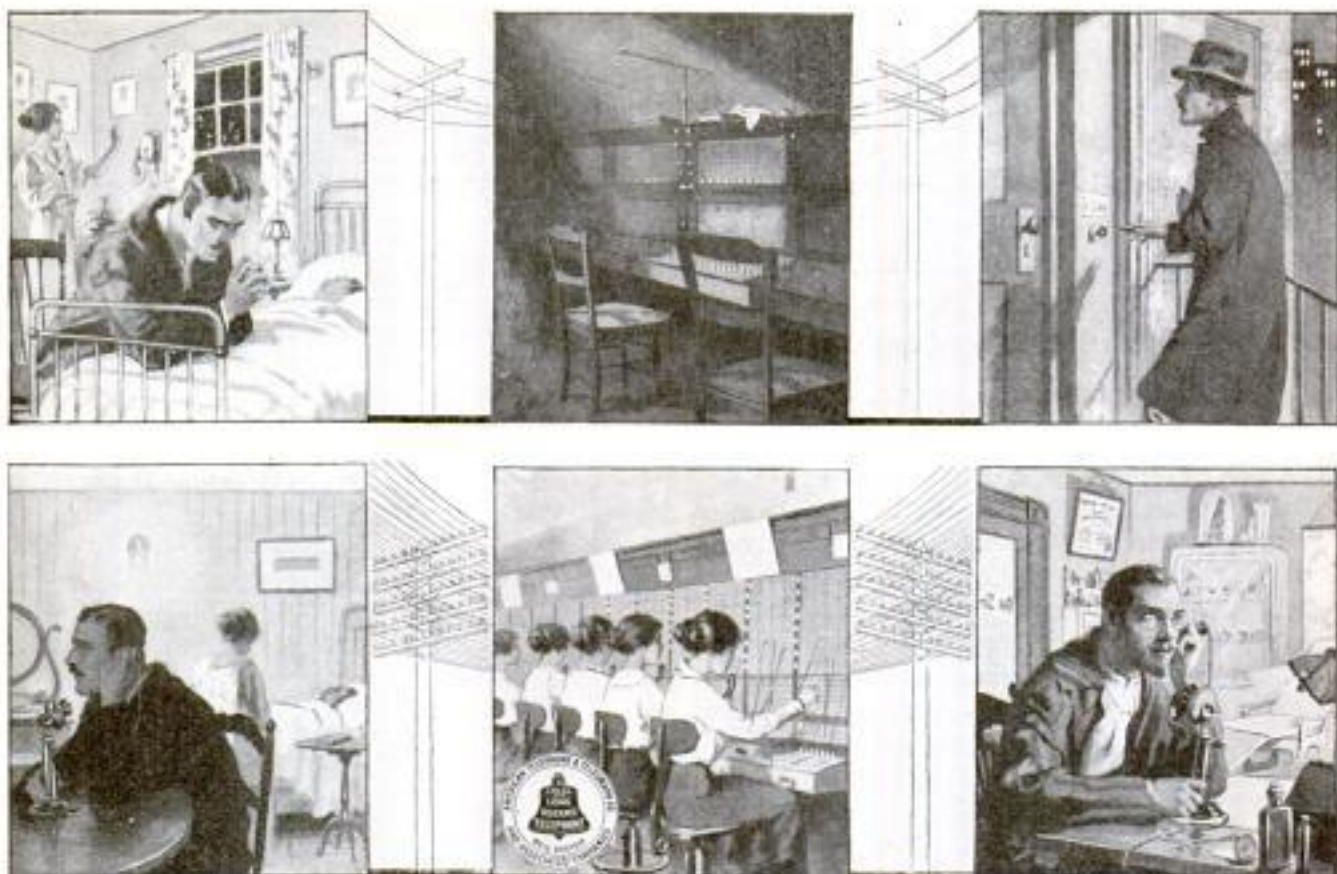

## Best and Cheapest Service in the World

Here are some comparisons of telephone conditions in Europe and the United States just before the war.

### *Here we have:*

Continuous service in practically all exchanges, so that the telephone is available day and night.

A telephone to one person in ten.

3,000,000 miles of interurban or long-distance wires.

Prompt connections, the speed of answer in principal cities averaging about  $3\frac{1}{2}$  seconds.

Lines provided to give immediate toll and long-distance service.

As to cost, long-distance service such as we have here was not to be had in Europe, even before the war, at any price. And exchange service in Europe, despite its inferior quality, cost more in actual money than here.

Bell Service is the criterion for all the world, and the Bell organization is the most economical as well as the most efficient servant of the people.

### *In Europe:*

Nine-tenths of the exchanges are closed at night, and in many cases, at mealtime.

Not one person in a hundred has a telephone.

Not one-eighth as many miles in proportion to population and territory.

In the principal cities, it takes more than twice as long for the operator to answer.

No such provision made. Telephone users are expected to await their turn.

**AMERICAN TELEPHONE AND TELEGRAPH COMPANY  
AND ASSOCIATED COMPANIES**

*One Policy*

*One System*

*Universal Service*



*The last of the Arizona Missions  
—San Xavier Del Bac—shrine  
of the ancient Southwest.*

## Your Tires Are Better Because of Goodyear

Not all the improvements contrived in the tire-making industry in the last decade were developed by Goodyear.

Not all the progress accomplished, nor all the economies realized, are to be credited there.

But—Goodyear's part as pacemaker in the onward march of this business has been so prominent, so emphatically momentous—as to have made the very name *mean* tire virtue, and to have brought Goodyear Tires from obscurity to leadership in the same span of time.

Goodyear improvements—the tire-making machine, special pressure-resisting fabric, the On-Air Cure, the All-Weather Tread, the No-Hook Bead with its braided piano wire base—these, and such as these—what have they meant to tire development, to you?

Think what your tire money bought ten years ago—in fumbling attempt, in faulty construction, in questionable service.

*Now*—think what it buys today!

*Goodyear Tires, Heavy Tourist Tubes and "Tire Saver" Accessories are easy to get from Goodyear Service Station Dealers everywhere.*



# GOODYEAR

AKRON

*Please Mention Popular Mechanics*



# Join the Throng of the Satisfied

**H**ARLEY-DAVIDSON Motorcycle riders are satisfied because they can fill every leisure moment with keen, healthful enjoyment.

They know the swiftly passing panorama of the city streets—the beauty of the wild places—the supreme joy of motorcycling that wipes out the cares of yesterday and the problems of tomorrow. Get a

## Harley-Davidson

Then you, too, will know the incomparable sensation that comes to him who can go anywhere any time, either at a loitering pace or with the speed of the wind—at will. Don't over-

look motorcycling this year. It will open to you a new world of recreation. And be sure that your mount is a Harley-Davidson, for more than fifteen years the "Master Motorcycle" and this year better than ever.

Any Harley-Davidson dealer will be glad to demonstrate for you and will probably make terms to suit your convenience. Write for interestingly descriptive, beautifully illustrated catalogue.

Harley-Davidson Motor Co., <sup>482</sup> B Street Milwaukee, Wis.







Your Choice

of

38 Styles

of

The Wing Piano



## On Four Weeks' Trial

Yes, we'll ship you on 4 weeks' absolutely free trial a Genuine highest grade Wing piano DIRECT from our own factory, **freight prepaid**. The most surprising—most amazing offer ever made. An offer that puts you on the same footing as the largest piano dealer—and at the very **rock-bottom** DIRECT wholesale factory price. Since 1888—for 40 years—we have been building Wing Pianos, renowned everywhere for their sweetness of tone and sterling merit—and we now make you this greatest of all offers on the Wing, guaranteed for 40 years.

We will allow you to use any Wing piano—your own choice of 38 superb new styles in any shade of mahogany, walnut or oak—in your own home for four full weeks at our expense. A Wing Upright, a Wing Grand or a wonderful Wing Player-Piano that plays all the greatest concert and opera selections (you can play it perfectly the first day without taking music lessons).

## No Money Down —Not a Cent of Freight

We ask no money down—nothing on arrival—no freight either way—no deposit. Just choose any Wing from our large catalog. We employ no salesmen of any kind to visit and annoy you. We'll ship the instrument no money down—**freight prepaid**. While the piano is in your home use it just as if you owned it. Compare with description in the Wing catalog—but note the **rock-bottom direct-wholesale-factory price** is quoted in the personal letter to you. Play the piano—let your friends play it. Examine it carefully—thoroughly—inside and outside. Take music lessons on it if you like. Note the perfect **bell-like** tone, the remarkable easy regularity of the action, the deep resonance of the base, the timbre of the treble—note all this—then—

At the end of the 4 weeks' trial, if you wish, you may return the piano at our expense. We pay return freight to New York. Not a penny to pay for the pleasure of using the piano four weeks. No salesmen to influence you—you and you alone are to judge. Now write for the piano book (free).

## Valuable Book on Pianos—Free

### "The Book of Complete Information About Pianos"

The New York World says: "This is a book of educational interest everyone should own." Would you like to know all about pianos—how they are made, how to judge the fine points of quality and price in buying a piano? Then send the coupon for the piano book which we are sending FREE for the present. This book of 140 pages tells about materials, manufacture, assembling, patented devices and what they do, all about sound-board, action, case, in fact every detail connected with a fine, high-grade piano. Tells how to answer the arguments of piano salesmen. This magnificent 140 page book is a complete encyclopedia on the piano; the most complete and costly book ever published on the piano business.

(Est. 1888)

**Wing & Son**

We will also send free our beautiful catalog showing new art styles and full explanation of our rock-bottom prices on the Wing Piano.

Dept. 1191 Wing Building  
9th Ave. & 13th St., New York City

We will take your old organ or piano in exchange at a liberal allowance. Get our offer.

Name.....

Address.....



Free  
Book  
Coupon

**Wing & Son**

(Established 1888) Wing Bldg,  
9th Avenue and 13th Street  
Dept. 1191 New York

Gentlemen: Please send me free and prepaid "The Book of Complete Information About Pianos," the complete encyclopedia of the piano. Also send full particulars of your Rock-Bottom offer on the Wing piano and catalog of latest art styles.

Please Mention Popular Mechanics



B

# DODGE BROTHERS

## CLOSED CAR

A convertible sedan such as you would expect from Dodge Brothers. A pleasing combination of smartness and comfort. Designed and built complete in Dodge Brothers works.

The price of the Sedan is \$1185 (f. o. b. Detroit)  
Canadian price \$1685 (add freight from Detroit)

**DODGE BROTHERS, DETROIT**

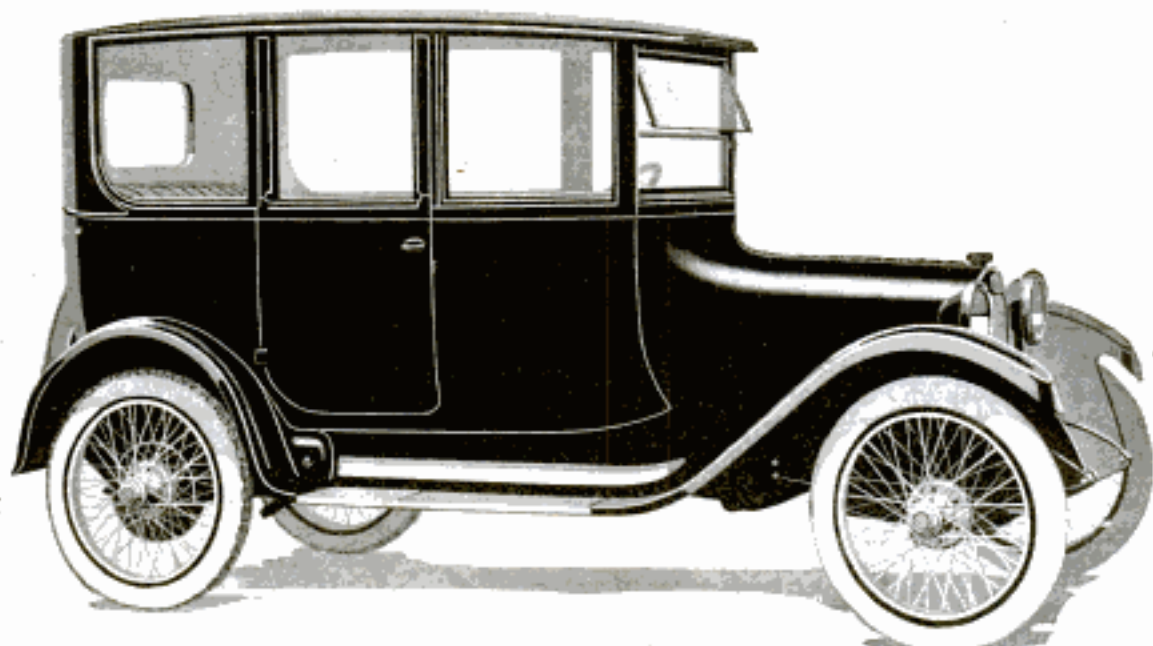

*Please Mention Popular Mechanics*





BERWICK  
*(round corners)*  
TALBOT  
*(square corners)*

# ARROW

*form-fit*

## COLLARS

are curve-cut to fit over the shoulder muscles. This insures a clean cut fit - a collar that does not ride up against the neck or saw at the apex of the front opening. It is an improvement that you will appreciate.

15<sup>c</sup>. each, 6 for 90<sup>c</sup>.

CLUETT, PEABODY & CO., Inc., *Makers*



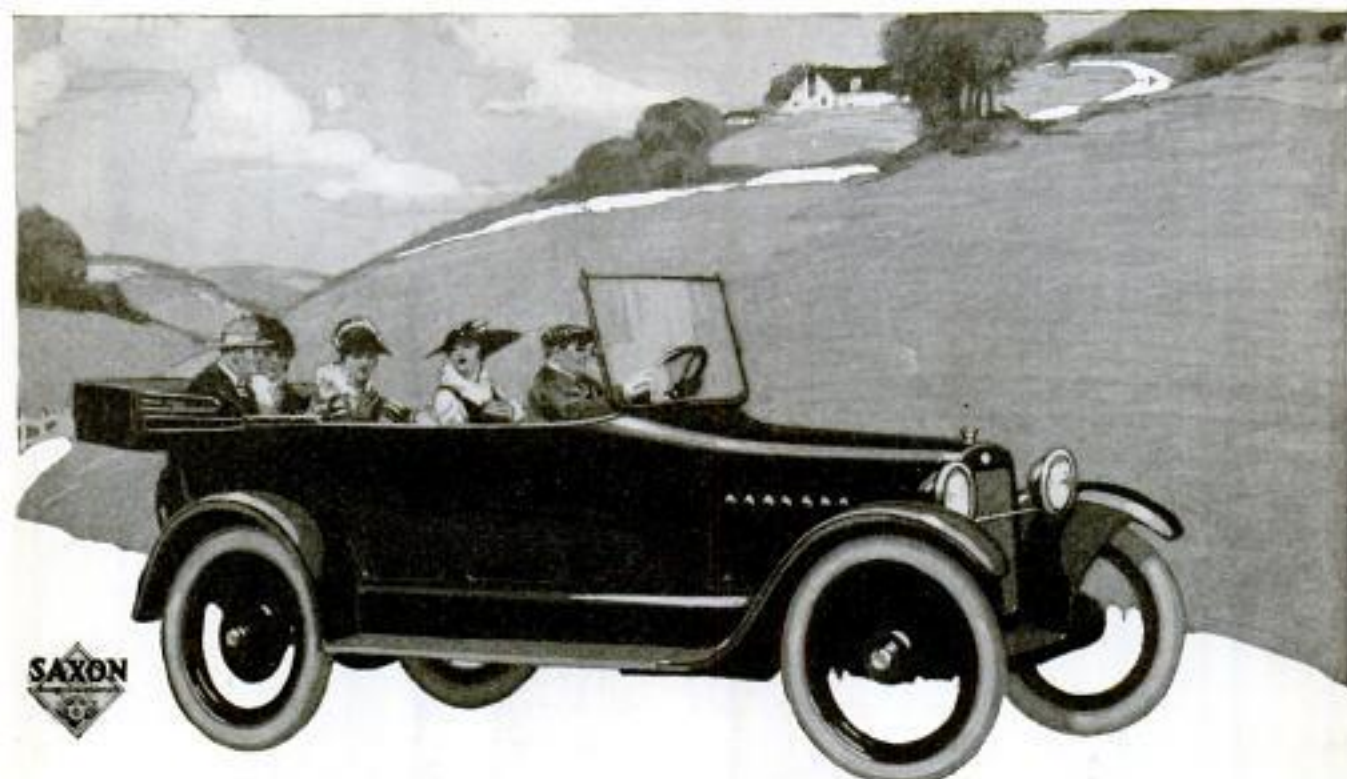

## This Preference for Saxon "Six" Is Based Upon Very Definite Reasons

Throughout the country you will find a very marked preference for Saxon "Six" springing up among motor-car buyers.

Unlike many preferences, it is not flavored with prejudice, but has more the aspect of a conclusion in favor of Saxon "Six" arrived at unhurriedly after careful comparisons.

We have told you time and again that the Saxon "Six" motor—both because of its type and its high development—is far superior to a motor of fewer cylinders.

Evidently this statement has been confirmed by buyers themselves, for a census reveals that 75 per cent of the owners turning in their cars for Saxon "Sixes" formerly drove cars of less than six cylinders.

The reason for this change is found in the superiority of the Saxon "Six" motor.

pulses produced by a "less-than-six-cylinders" motor there are intervals. That is a mechanical truth.

These intervals are responsible for vibration. And vibration is a dread danger to a motor.

It impairs flexibility, slows up acceleration, makes a difference of degrees in the quietness of operation, increases repair-service costs, and finally takes nearly 50 per cent from the standard efficiency of the motor.

In the Saxon "Six" motor, on the contrary, you get a power-flow of uniform, constant torque, that is, perfect smoothness or continuity.

Vibration is practically nil. Briefly, that is why Saxon "Six"

excels in pulling power in acceleration, in high-gear work, in flexibility.

And that is why the cost of repairs on Saxon "Six" is so insignificant.

In this connection it is enlightening to note that the figures on the cost of all repair parts bought by all Saxon "Six" owners during the past two years show that the cost per car averages \$8.50.

You will find the value of the highly efficient Saxon "Six" motor demonstrated in another definite advantage.

And that is in respect to gasoline economy. It extracts full mileage from each drop of gasoline; 23.5 miles is the gallon average established recently by 206 stock model Saxon "Sixes" in a 300-mile non-stop run.

Still another motor advantage is found in the fact that you get higher maximum and lower minimum speed without vibration.

At  $1\frac{1}{2}$  miles per hour "on high" the motor pulls smoothly without "bucking" or jerking. At full speed you feel safe and secure.

Saxon "Six" is \$815 f. o. b. Detroit. (572)

# SAXON "SIX"

A BIG TOURING CAR FOR FIVE PEOPLE

Between the power-im- **Saxon Motor Car Corporation, Detroit**





## “Daddy, Here’s the Ætna Check”

HE was running for a car when he slipped and broke his ankle. It seemed so little a thing, but he thanked his stars that only three months before he had taken out an Ætna Accumulative Disability Policy covering both accident and sickness.

For years he had intended to, and never did, but one day the thought came to him of what might happen to his children if he should be disabled by sickness or accident and his income stopped. At once he took out a policy. Now it seemed as if a kindly Fate had protected and warned him.

For your own sake, for your wife’s sake, for your children’s sake—now while you can—



# ÆTNA-IZE



If you are in a “Preferred” occupation and under 51 years of age, for an annual premium of \$60 we will pay you:

\$50 a week for as long as you are totally disabled by a railway, steamship or burning building accident, or \$25 a week if you are disabled by an ordinary accident. And we will pay you \$25 a week, up to 52 weeks, if you are totally disabled by sickness. Also hospital charges or for a surgical operation.

If you are killed by accident, we will pay your estate from \$5,000 to \$15,000, depending on the character of the accident and on the number of

years you have carried the insurance. If you lose two limbs or both eyes by accident, you will be paid the same amounts.

One-half of these amounts will be paid to you if you lose one hand, one foot or one eye by accident. These payments are in addition to the weekly indemnity payments while you are disabled, between date of accident and time of death or any one of the other losses named.

Send this coupon today and let Ætna do the worrying.

### ÆTNA LIFE INSURANCE COMPANY

Drawer 1341 HARTFORD, CONN.

The largest company in the world writing Life, Accident, Health and Liability Insurance

Agency opportunities for all Casualty and Bonding lines  
An Ætna Agent has a national advertising campaign working for him all the time

Name.....  
Occupation.....  
Bus. Address.....  
ÆTNA LIFE INSURANCE COMPANY  
Drawer 1341 HARTFORD, CONN.  
I have marked the kinds of insurance I wish to know about: Accident  Health  Disability  \$250 Life  Certificate  My age is... years. I am in good health. 16

Please Mention Popular Mechanics





**DU PONT  
FABRIKOID**

# RAYNTITE

## The Ideal One-Man Top Material

The modern one-man top demands light weight.

Rayntite single texture top material weighs about half as much as double texture material of equal waterproofness.

It is guaranteed one year against leakage, but built to last the life of the car.

Its strength is ample to stand the strains of service.

Why make your car top heavy, and the "one-man" top a joke, by using material twice as heavy as it needs to be?

Rayntite has been on the market and in active service on thousands of cars for nearly two years. We have yet to receive the first claim under our guarantee.

### Now Made in Two Varieties

RAYNTITE No. 1 single texture with Fabrikoid surface—and—  
RAYNTITE No. 2 single texture with Fairfield Rubber surface.

Each is guaranteed one year against leakage.

If the car you are considering is not topped with Rayntite find out whether you or your wife can really handle the one-man top.

*Samples of either variety on request.*

**Du Pont Fabrikoid Company, Wilmington, Delaware**  
Works at Newburgh, N. Y., and Fairfield, Conn.  
Canadian Sales Office and Factory, Toronto





## Men who pour white hot metal

protect hands and arms against the molten sputter that gnaws to the bone—with gloves and mittens woven from rock—*asbestos*.

# JOHNS-MANVILLE

# Asbestos

Resistant to heat,

water, wear and weather



**O**NE of the nation's big raw products—just as important in the control of heat as coal in producing heat—just as much a building material as steel, brick or concrete. To transform Asbestos into useful

COVERS THE CONTINENT

shapes has been the work of Johns-Manville. Every product listed below\* is a development from asbestos taken from Johns-Manville mines, manufactured in our own factories, and sold by Johns-Manville Service.

**H. W. JOHNS-MANVILLE COMPANY**

Branches in 54 Large Cities

\* Asbestos Fabrics, Packings, Roofings, Shingles, Brake Linings, Building Materials, Electrical Devices, Heat Insulations, Refractory Cements, Waterproofing.

The Motor Car



The Farm



The Home



Industry



Power Plants



Transportation



Roofings



**When you think of Asbestos you think of  
Johns-Manville**





## Wear Neolin—Neolin Wears

From a mere conception of Science to a staple within fifteen months!

Such is the wonderful record of Neolin soles—which in one respect is not wonderful at all.

For Neolin soles improve on sole-leather by increasing sole-wear. *Wear them for wear.*

Neolin soles emphasize sole-comfort by making soles *pliant*. *Wear them for foot comfort*—for grip-ground tread.

Above all, *wear Neolin soles for waterproof quality*, the quality for which, among other qualities, Neolin triumphed in its Navy test:—Neolin,

different from rubber, different from leather. Neolin which is displacing both because it is better than both.

Neolin soles come for grown-ups and children—in black, white and tan. Their quality is always the same—no matter the price of your shoe. Ask for them now—retailers have them or can get them without extra cost. Ask for Neolin with the accent on the "O". And to avoid imitations, *mark* that mark; stamp it on your memory: Neolin—

—the trade symbol for a changeless quality product of

The Goodyear Tire & Rubber Company  
Akron, Ohio

# Neolin

Trade Mark Reg. U. S. Pat. Off.

## Better than Leather

Please Mention Popular Mechanics



# Mr. Edison's Wonderful New Phonograph

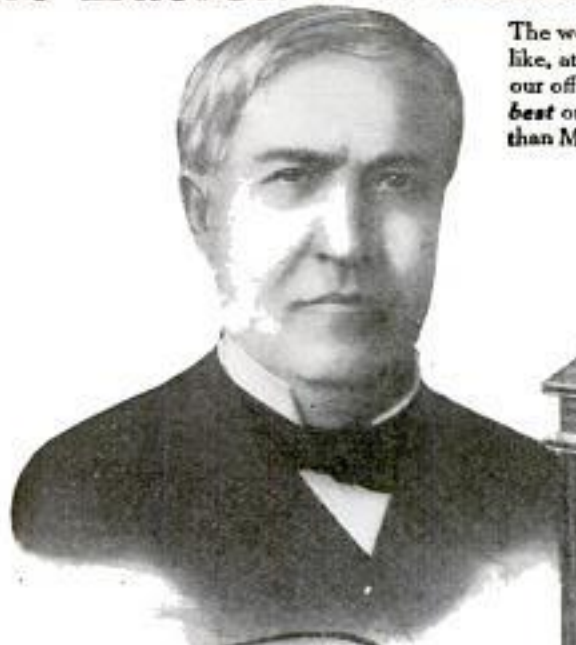

Thomas A. Edison

The world's greatest inventor has made the music of the phonograph life-like, at last. Success—after years of labor on his favorite invention! Read our offer on his wonderful new phonograph. Now that you can have the *best* on this liberal offer, you need no longer be satisfied with anything less than Mr. Edison's great instrument.



Only **\$1.00** and after trial

Yes, we will send you the New Edison, the product of the world's greatest inventor's genius, the phonograph with the wonderful diamond stylus reproducer and your choice of the latest Diamond Amberol Records *free trial without a penny down*. On this offer, you can have the genuine Edison, the instrument which gives you real, life-like music, the finest and best of all phonographs at a small fraction of the price asked for imitations of Mr. Edison's great instrument. *Seize this opportunity. Send the coupon now for free catalog.*

## Rock-Bottom Offer Direct

If, after the free trial, you decide to keep Mr. Edison's superb new instrument, send us only \$1. Pay the balance on the easiest kind of monthly payments.

Think of it—a \$1 payment, and a few dollars a month to get this wonderful new style outfit—Mr. Edison's great phonograph with the Diamond Stylus reproducer, all the musical results of the highest price outfits—the same Diamond Amberol Records—yes, the greatest value for \$1 down, balance on easiest monthly terms. Convince yourself—free trial first! No money down; no C. O. D., not one cent to pay unless you choose to keep the instrument.

## New Edison Catalog Free

Your name and address on a postal or a letter (or just the free coupon) is enough. No obligation in asking for catalog. Find out about Mr. Edison's great new phonograph. Get the details of this offer—while this offer lasts. Write today—now!

**F. K. BABSON, Edison Phonograph Distributors**  
1191 Edison Block, Chicago, Ill.  
Canadian Office: 355 Portage Avenue, Winnipeg, Manitoba

*Get the New Edison in Your Home on Free Trial*  
Entertain your family and friends with the latest song hits, with your favorite, old-time melodies—with everything from grand opera to comic vaudeville. Roar with laughter at the side-splitting minstrel shows. Then, after the trial, send it back at our expense if you choose. Or keep it on our great, rock-bottom offer. *Send the coupon today—now.*

**To F. K. BABSON**  
Edison Phonograph Distributors  
1191 Edison Block, Chicago

Gentlemen: Please send me your New Edison Catalog and full particulars of your free trial offer on the new model Edison Phonograph.

Name.....

Address.....





## Standardizing Machine Shops

The necessity of economical production in our factories is more and more apparent. The war will end sometime, and what then? At best, a struggle for commercial and industrial supremacy in which the careless, old-time methods that made money in spite of waste will be frozen out.

All manufacturers must watch to stop leaks, to reduce waste. Waste of material and labor, in rejections, can be cut down by using accurate gages. Until they are introduced, no shop can effectively standardize metal work.

Yet when really achieved, interchangeability of parts has magical effects on profits. By means of limit gages, standardized interchangeability of metal parts is assured—and a boy can do the work of inspection. This method lowers cost of manufacture, speeds up assembling, improves quality—in short, replaces guesswork with scientific precision.

*Write for Bulletin  
"How to Measure Screw Threads"*

It will give you some new ideas on modern, economical shop methods.

We make a varied line of gages for metal parts.

**Greenfield Tap and Die Corporation**  
**Gages·Taps·Dies**

Threading Machines, Reamers, etc.  
Greenfield, Massachusetts



Thread  
Limit  
Gage

**AMERICA FIRST**

*Prest-O-Lite* for  
Motorcycles



## The Ideal Light for Every Service

The short days and long nights are here. An efficient lighting system is an absolute need, if you spend much time on the road.

For permanent, brilliant light for your motorcycle, you can't beat Prest-O-Lite. It's the truly practical light for motorcycles, and is used by the majority of riders in every service, the country over.

It is not affected by bumps and jolts—always throws a steady, powerful beam of light far ahead; showing up clearly all obstacles.

With all its superiorities, Prest-O-Lite is inexpensive to buy and costs little to use.

## Good Lighting is Essential

Good lighting is essentially an important part of your machine's equipment. See that you have the best—use Prest-O-Lite.

Most any dealer will quote you an attractive price on an equipment combination including Prest-O-Lite. This will save you much time and money,—give you the best of service at little up-keep expense.

*Our motorcycle lighting literature will interest you. Ask your dealer or write us.*

### The Prest-O-Lite Co., Inc.

*World's Largest Makers of  
Dissolved Acetylene.*

265 Speedway, Indianapolis, Ind.

Canadian Office and Factory  
Merritton, Ontario.

*Prest-O-Lite Exchange  
Agencies Everywhere.*





# Our 21 Jewel SMASHES PRICES



Every fighting vessel in the U. S. Navy has the Burlington Watch aboard. Many have over 100 Burlingtons—a few over 200. This includes every torpedo boat—every submarine as well as the big Dreadnaughts.

## Send Your Name on This Free Coupon

Get the Burlington Watch Book by sending this coupon now. You will know a lot more about watch buying when you read it. You will be able to "steer clear" of the over-priced watches which are no better. Send the coupon today for the watch book and our offer.

**Burlington Watch Co.**  
19th St. & Marshall Blvd., Dept. 1191, Chicago, Ill.

### Look!

- ☞ 21 Ruby and Sapphire Jewels—
- ☞ Adjusted to the second—
- ☞ Adjusted to temperature—
- ☞ Adjusted to isochronism—
- ☞ Adjusted to positions—
- ☞ 25-year gold strata case—
- ☞ Genuine Montgomery Railroad Dial—
- ☞ New Ideas in Thin Cases.

# Only \$2.50 A Month

And all of this for \$2.50—only \$2.50 per month—a great reduction in watch prices—direct to you—positively the exact prices the wholesale dealer would have to pay. Think of the high-grade, guaranteed watch we offer here at such a remarkable price. And, if you wish, you may pay this price at the rate of \$2.50 a month. Indeed, the days of exorbitant watch prices have passed.

## See It First

You don't pay a cent to anybody until you see the watch. You don't buy a Burlington Watch without seeing it. Look at the splendid beauty of the watch itself. Thin model, handsomely shaped—aristocratic in every line. Then look at the work! There you will see the masterpiece of the watch makers' skill. A perfect timepiece adjusted to positions, temperature and isochronism.

### Burlington Watch Co.

19th Street and Marshall Blvd.  
Dept. 1191 Chicago, Ill.

Please send me (without obligation and prepaid) your free book on watches with full explanation of your cash or \$2.50 a month offer on the Burlington Watch.

Name.....

Address.....

Last chance at old prices—date prices go up will be announced—no rise at once for outside.

Please Mention Popular Mechanics



# Free Try-On OF AMERICAN METAL SHOES

Yes, free try-on in your own home of these light, water-proof, rust-proof, wear-proof metal shoes; save your money, your feet, your health. No more tired, sore, wet feet. Always warm, dry and comfortable. Warm in winter—cool in summer. One pair outwears many leather pairs. The world's most economical work shoe for men and boys.



**SAVE  
\$30.00**  
ON  
SHOE  
BILLS

The  
Best  
School  
Shoe

## Steel Or Aluminum Soles

Made in all sizes and heights. Guaranteed to fit. Patent rocker bar gives the natural tilt—that light, springy step. Easier to walk in than heavy shoes or boots. We manufacture the largest and most complete line of metal shoes in the world. Send postal today for

### FREE—Shoe Book—FREE

It describes these money saving, health protecting, comfort giving, over wearing shoes. Don't buy a work shoe of any kind at any price until you get this book. It tells all about our free try-on offer to every man and boy. Address postal to

**AMERICAN METAL SHOE CO.**

(Combined with Racine Aluminum Shoe Co.)

20 12th Street RACINE, WIS.

A Basketball Jersey



## Be the First in Your Club

School, City or Town, to wear this pure, all wool sweater, double collar and cuffs. Your choice in colors. This jersey was selected by 10,000 of my customers for last season. Your club will recommend it. Send for my big illustrated catalogue. Write me and learn my offer for your club's order. Popular Prices. Best Grade Sporting Goods—Basketball, Football, Baseball, Tennis, Golf, etc. WRITE ME NOW.

JACK SHANNON CO., Dept. 46, 54 E. Monroe St., Chicago



## Cut Your Own Hair

You can now cut your own hair when and how you please and as good as a barber can do it without the barber's bill if you use an

### American Safety Hair Cutter (McDonough's Patent)

This automatic machine is not a clipper. Works like combing your hair, enabling you to cut your own hair quickly and cheaply. Is sanitary. The money you save on six 35c hair cuts pays for the machine. Future hair cuts cost only two cents each. The only attention required is occasional renewal of blades. Outfit complete with six blades \$2.00—postpaid. If your dealer cannot supply you, send the money today or write for information. MAKES AN IDEAL CHRISTMAS GIFT.

Dealers and salesmen write for terms.

**AMERICAN SAFETY HAIR CUTTER CO.**  
967 Liberty Ave., Room 206, Pittsburgh, Pa.

Hand  
Forged  
Razor Steel  
Blades. No. 57



# BIG VALUES IN SWEATERS

Sweater Coats at Bargain Prices  
Guaranteed by  
"THE HOUSE OF BRUNSWICK"

Jumbo-Stitched, Guaranteed All-Wool Sweater Coat. Full-sized, full-fashioned, full-length sleeves, with two lower pockets and a three-piece, shaker-stitch shawl collar. Reinforced shoulders and faced front to insure strength and permanent shape. Sizes 34 to 46.

Colors: navy, maroon, oxford.  
A duplicate of this jumbo-stitch, all-wool coat would cost not less than \$6.50 anywhere else. **\$4.90**  
Our Special Price—P866

Write for our encyclopedia of sporting goods. It gives information regarding basketball, indoor ball, hunting, fishing, home exerciser outfits, etc.

The Brunswick-Balke-Collender Co.  
Dept. 38, Chicago, Ill. (625)



# MENNEN'S SHAVING CREAM

Send 10 cents for a medium-sized tube of Mennen's Shaving Cream, a trial can of Mennen's Talcum for Men, and the novel booklet "The Gentle Art of Shaving."

Gerhard Mennen  
Chemical Company  
2000 Orange St., Newark, N. J.  
Canadian Factory,  
Montreal, Que.  
Sales Agents for Canada:  
Harold F. Ritchie & Co., Ltd.,  
Toronto.

A Gift That is Sure to Please **THE "VULCAN" INK PENCIL**

Lasts a Lifetime. Guaranteed. Made right to write right. Absolutely non-leakable.



Name or Greeting in Gold Inlay, 3c. Highly polished rubber and safety lock cap. \$1 By Mail. Red or black. Long or short.

J. C. ULLRICH & CO., 27 Thames Street, NEW YORK

## FREE Glove Book

Send for free copy of "Glove Styles" showing the very latest Grinnell Gloves.

Morrison-Ricker Mfg. Co., 141 Broad St., Grinnell, Ia.

Glove Styles

# EVEREADY SAFETY LIGHTS

American Ever Ready Works  
of National Carbon Co.  
Long Island City, New York

WEAR

Trade Mark

Registered

**B.V.D.**

U. S. Patent Office

and Foreign Countries

UNDERWEAR

This \$2 KNIFE 83¢  
DIRECT AT FACTORY PRICE

Handy shaped blade makes this knife best for mechanics, sportsmen and farmers; light but strong; resharpened easily. Stag handle, German silver finish; blades file tested, hand forged from razor steel and warranted. Sample 83c, 3 for \$2 postpaid. Cheapest pearl \$2 each. Send for our 80 Page List and "How to use a Razor" FREE

MAHER & GROSS CO., 106 A. St., Toledo, Ohio.



# \$100 Model UNDERWOOD

This is my special, short-time offer to Popular Mechanic's readers. It means that you get a

## \$37<sup>40</sup>

genuine UNDERWOOD Typewriter—delivered in perfect condition—guaranteed in every way—for *considerably* less than half the manufacturer's price!

Moreover, you don't have to buy it to try it! I will send one to you on 10 Days' Free Trial. Write all you please on it for 10 days and then if you are not *perfectly* satisfied—send it back to me *at my expense*.

What's more, if you do not care to buy, you may rent it at our low monthly rate.

If later you want to own it, we will apply 6 months' rental payments on the purchase price.

Any National Bank in Chicago, or any Dun's or Bradstreet's Agency anywhere will tell you that we are responsible. Write me today—send me your name and address on the coupon or a postcard.

E. W. S. SHIPMAN, *President*

TYPEWRITER EMPORIUM, Est. 1892, 34-36 W. Lake St., Chicago, Ill.



President Shipman

### My Other Plan Brings You This Underwood FREE

Learn about it. There is no canvassing or soliciting involved. You will be surprised at its simplicity. If you want a splendid typewriter and want to get it without taking a penny out of your own pocket, use the coupon—send us your name and address on it or a postcard—*today*.



Mail  
This  
Coupon  
Today

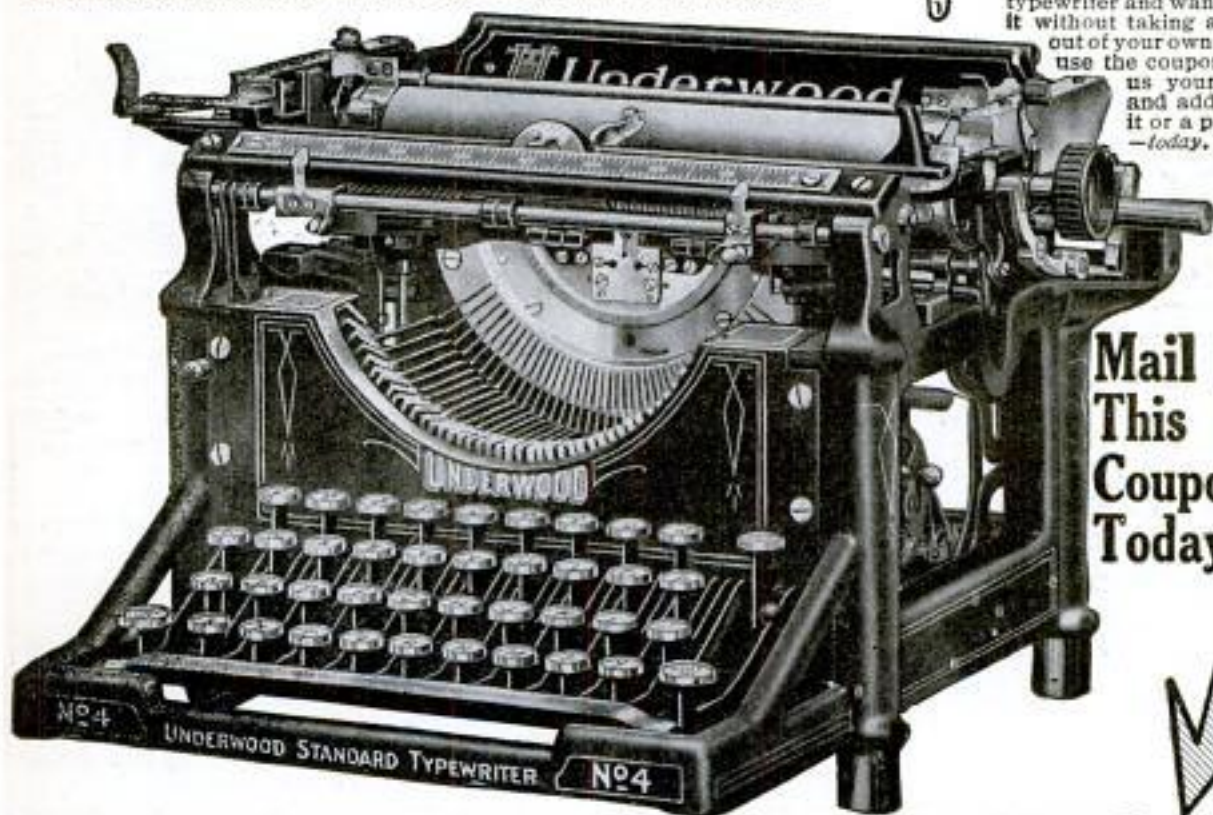

E. W. S. SHIPMAN, President Typewriter Emporium, 34-36 W. Lake Street, Chicago, Ill.

Send me immediately full details of your offer No. 52.

Name \_\_\_\_\_

R. R. or St. No. \_\_\_\_\_

City \_\_\_\_\_ State \_\_\_\_\_

Please Mention Popular Mechanics



# HERMAN'S U.S. ARMY SHOES

## Munson Last

Demonstrated by the Army of Defense—adopted by the

### "Army of Industry"

From private to General no U. S. Army man is permitted to wear in service any other shoe than

### The Munson Last

Thousands of civilians buy the shoe from us or from our dealers and obtain foot comfort almost beyond belief. Wear Herman's Munson yourself and forget you have feet.

Write for the name of a Herman dealer near you. Or you can buy from us by mail—fit and satisfaction guaranteed. Munson's, black or tan.

**\$6 to \$8 Per Pair**

State size and width usually worn. Catalog of all styles free

**Jos. M. Herman Shoe Co.**  
Army Contractors  
1000 Albany Bldg.  
Boston, Mass.



## The "One Dip" Pen

Writes 600 words with one dip of pen

Why use ordinary pens with the never ending dip when One Dip Pens make every penholder virtually a fountain pen? Send 10c for Sample Package.

AGENTS WANTED

**ONE DIP PEN CO.**

34 DAILY RECORD BLDG. BALTIMORE, MD.

## "Brings me \$50 to \$60 per week"

So writes M. A. GIFFORD of his Ten-Pinnet business



World's Greatest Bowling Game

YOU can start in the same business for small investment. Draw the crowds! Get the money! Everybody plays Ten-Pinnet. It's new, fascinating, healthful! Alleys 38 to 50 ft. long installed in any room in half day. Entirely automatic—no pin boys or upkeep expense—just someone to take in money. Write quick for free illustrated book, "Big Ten-Pinnet Profits," giving low prices.

**THE TEN-PINNET CO., 82 Draper St., INDIANAPOLIS, IND.**

## A Profitable Vocation

show cards for the smaller merchant, outside of regular working hours. Practical lettering outfit consisting of 3 Marking and 3 Shading Pens, 2 colors of Lettering Ink, sample Show Card in colors, instructions, figures and alphabets, Prepaid \$1.00.

### Practical Compendium of Commercial Pen Lettering and Designs

100 pages, \$1.10, containing 122 plates of Commercial Pen alphabets, finished Show Cards in colors, etc., also large list of crisp business Advertising Phrases—a complete instructor for the Marking and Shading Pen. Prepaid, \$1.00. Catalogue free. Address,

**NEWTON AUTOMATIC LETTERING PEN CO., Dept. I, Pontiac, Mich., U. S. A.**



TRADE MARK



## Pencil—Plan—Progress

The complicated pencil drawing of a great engine is a permanent record. Engineers and draftsmen who design these plans demand the best pencil. They buy for the lead value alone. There is highest value in every inch of

# DIXON'S ELDORADO

*"the master drawing pencil"*

Value in long-wearing leads. Value in finished drawings. Value in smooth, easy drafting. Value in time saved and pencils saved.

Send fourteen cents in stamps for samples worth double the money.

**JOSEPH DIXON CRUCIBLE CO.**  
Dept. 10-J, Jersey City, N. J.

**DIXON'S BEST WHITE N°352**

*writes white on blueprints*

## W-W-W RINGS

are absolutely guaranteed against settings coming out or chipping. Ask your jeweler to show them to you. **White, Wile & Warner, Dept. J-274, Buffalo, N. Y.**

**RAPHAEL TAPESTRY SOLD FOR \$15**—While rummaging about in an old chest, a woman in a Canadian village found what seemed to be a piece of old carpet which she sold to a New Yorker for \$15. Later it was discovered that the "old rag" was one of two priceless panels by Raphael that were stolen from the Vatican years ago.



## Latest Model No. 5

Over 600 of these visible L. C. Smith and Bros. Typewriters are used in the great Larkin offices to serve our two million customers.

### L. C. Smith Typewriters

Write today for details of our Factory-to-Family easy-to-pay offer on this latest model machine. **Desk YPM 117**  
30 Days' Trial **Larkin Co., BUFFALO, N. Y.**



## Hindoo Flower Pot Trick

Show an empty Flower Pot to your audience for examination. Place pot on table; cover it with Handkerchief; make a few passes over it; remove the Handkerchief, and behold, there is a beautiful Flower Pot in full bloom. We send the whole thing, flower pot, flowers and full directions, by mail, for 15c.

**ROYAL NOV. CO., 250 East Ave., SO. NORWALK, CONN.**





Mounted by our student  
W. T. Holcomb, Warren, Ohio



Beautiful specimens  
mounted by our stu-  
dent Charles Weber

## Sportsmen Mount Your Own Trophies

**B**E A Taxidermist. Learn at home by mail to mount all kinds of specimens absolutely true to life. Save the trophies of wonderful beauty and value that you secure on your hunting and outing trips. Mount them yourself. Save Taxidermist bills, decorate your home, den or office with the choicest art in all the world. Instead of pictures of game for your dining room have actual mounted trophies. Nothing like it! Thousands now learning from our splendid mail lessons. You can learn, too. Here is a real wonderful opportunity. Do not neglect it. **Send the coupon today for free books and full particulars.** You positively learn to

## Mount Birds and Animals

You can learn to mount *game-heads, fishes, reptiles, to tan skins* and make magnificent *rugs and robes*. You enjoy every moment given to Taxidermy. You can learn **easily and quickly at home by mail**. Adapted to everyone, men, women and boys. Learned in spare time only. Enroll in our school and be a real Taxidermist. This is the one and original school, teaching the latest and easiest methods. Over 5,000 graduates. Among our students are the most famous sportsmen, out-door lovers, statesmen, lawyers, doctors, merchants, farmers and mechanics. If you ever hunt or fish, or if you are a bird or nature lover, **don't overlook this marvelous opportunity.**



Mounted by our student  
J. C. Green, Sioux Falls, S. D.

## Learn for Pleasure and Profit

No other art is so interesting and fascinating. Men and women make Taxidermy a hobby. Nothing equals it for a delightful sparetime occupation. If you want to **make big profits** from your leisure time, taxidermy is just the thing. Our students easily earn from \$20 to \$35 a week from spare time alone, mounting trophies for sportsmen, and selling their own mounted game specimens. Professional taxidermists can earn \$3,000 to \$5,000 a year. You will be delighted with this marvelous art, so investigate now. Write for our free books, and see for yourself what a wonderful art Taxidermy really is.

### 55,000 Students Praise Our Schools and Lessons.

George Whitted, the great National League ball player (Philadelphia) says: "I am delighted with your course of lessons. I heartily recommend them."

W. A. Findlay, Edna, Texas, writes: "Have mounted over 100 specimens since taking your course. Would not take \$1,000 for them. I cannot endorse your school too highly."

Charles Weber of Cleveland says: "Your lessons are marvels of simplicity, any man or woman can learn taxidermy perfectly from your course." We have tens of thousands of such letters in our files.

## Mail Coupon Today

Send the coupon today, right now, before you forget it. The coupon will bring you, absolutely free, a magnificent taxidermy book, finely illustrated with photos of game specimens, also a copy of the *Taxidermy Magazine*. Remember these are FREE, no obligations whatever. Mail the coupon or a postal will do. These free books will show you marvels you never dreamed of in the new and easily learned art of taxidermy.

**The Northwestern School of Taxidermy**  
1191 Elwood Bldg., Omaha, Neb.

Our school is Patronized by Paul J. Rainey, the greatest living sportsman, by the Rockefellers, U. S. Govt., State Universities, Museums and Colleges.

Northwestern School of Taxidermy,  
1191 Elwood Bldg. Omaha, Neb.

Without obligation on my part send me copies of your *Free Taxidermy Book* and the *Taxidermy Magazine*, and full particulars about your course of lessons on taxidermy.

Name.....

Address.....



"Be Wise"



# New KEROSENE LIGHT BEATS ELECTRIC OR GASOLINE

**10 Days FREE—Send No Money**

**We don't ask you to pay us a cent until you have used this wonderful modern white light in your own home ten days; then you may return it at our expense if not perfectly satisfied. You can't possibly lose a cent. We want to prove to you that it makes an ordinary oil lamp look like a candle; beats electric, gasoline or acetylene. Lights and is put out like old oil lamp. Tests by U. S. Government and 34 leading Universities show that it**



BURNS  
94%  
AIR

**TWICE THE LIGHT ON HALF THE OIL**

**Burns 50 Hours on One Gallon** common kerosene (coal oil), no odor, smoke or noise, simple, clean, won't explode. Three million people already enjoying this powerful, white, steady light, nearest to sunlight. **Won Gold Medal at Panama Exposition.** Greatest invention of the age. Guaranteed.

**\$1000 Reward** will be given to the person who shows us an oil lamp equal to the new **Aladdin** in every way (details of offer given in our circular). We want one user in each locality to whom we can refer customers. To that person we have a special introductory offer to make, under which one lamp is given free. Write quick **Yours FREE** for our 10-Day Absolutely Free Trial Proposition and learn how to get us free.

**Men With Rigs Make** Our trial delivery plan makes it easy. No previous experience necessary. Practically every farm home and small town home will buy after trying. One farmer who had never sold **\$100 to \$300 Per Mo.** anything in his life before writes: "I sold 51 the first seven days." Christensen, Wis., says: "Have never seen an article that sells so easily." Norring, Iowa, says: "92 per cent of homes visited bought." Phillips, Ohio, says: "Every customer becomes a friend and booster." Kemerling, Minn., says: "No flowery talk necessary. **Sells itself.**" Thousands who are coining money endorse the **Aladdin** just as strongly. **NO MONEY REQUIRED.** We furnish stock to reliable men to get started. Ask for our distributor's plan, and learn how to secure an appointment and make big money in uncultivated territory. State occupation, age, whether you have rig or auto; whether can work spare time or steady, when can start; townships most convenient for you to work.

**MANTLE LAMP COMPANY, 126 Aladdin Bldg., CHICAGO, ILL.** Largest Kerosene (Coal Oil) Mantle Lamp House in the World



## 300 Candle Power of Light at a Cost of 1-8c Per Hour

*Burns Kerosene or Gasoline*

This lamp generates and burns its own gas from ordinary kerosene. "QUICKLIT" gasoline lamps can be lit with an ordinary match like city gas.

Write today for illustrated catalog of our complete line of kerosene and gasoline lamps, lanterns **Agents Wanted**

**The Nagel-Chase Mfg. Co.**  
176 East Erie St., Chicago



## Agents \$60 a Week



A Wonderful Seller

### 300 Candle Power Outdoor Lamp and Safety Lantern

Burns coal-oil (kerosene). Can't explode, can't set fire to anything. Burns in all kinds of weather. Rain-proof, wind-proof, bug-proof. For farmers, teamsters, hucksters, plumbers, dairymen, campers—everybody needs it.

### Big Money Maker

Low price puts it in reach of every home and makes sales easy. Shall working spare time made \$10 and \$12 a night. Jennings sold 5 first evening. Send for sworn proof. Write quick for territory and demonstrating sample.

**Thomas Mfg. Co., 7048 East St. DAYTON, OHIO**



## Powerlight

Again awarded Gold Medal Int. Exp. Only Portable Lamp approved by Underwriters. Highest endorsement—Used by U. S. Gov. Army. Burns Common Kerosene or Gasoline. Equal Safety. 335 C. P. 20 Hrs. 1 qt.

### LOW COST—BIG PROFITS

Positive guarantee—Sells on sight—No experience necessary. 20 Styles—Contract exclusive territory. Samples Loaned.

**POWERLIGHT CO., 543 Broadway, NEW YORK**





## KEROSENE Gas Lamps

**BURNS KEROSENE or GASOLINE**

one just as well as the other; or the two mixed. Make their own gas. 300 to 600 C. P. at 1/2c an hour. Family or Business use.

WRITE FOR COMPLETE ILLUSTRATIONS

**BRILLIANT GAS LAMP CO.**  
1069X So. Wabash Ave., CHICAGO, ILL.





## ACORN UNI-LITE

FREE OFFER

Turns night into day. 800 candle power. Carry as a lantern; use anywhere as a lamp. Weather proof. For house, barn, garage, camp and around the farm. Write for big, free offer. Special opportunity to farmers, stockmen and motorists. Agents make big money.

WRITE TONIGHT for new 1916-1917 offer.

**ACORN BRASS MFG. CO., 615 Uni-Lite Bldg., Chicago**

Morocco has resumed the cultivation of cotton after a lapse of more than 40 years.



## "Best" Hand Lantern

A powerful portable lamp, giving a 300 candle power pure white light. Just what the farmer, dairyman, stockman, etc., needs. Safe—Reliable—Economical—Absolutely Rain, Storm and Bug proof. Burns either gasoline or kerosene. Light in weight. Agents wanted. Big Profits. Write for Catalog.

**The Best Light Co., 324 E. 5th St., Canton, O.**



## WHITE FLAME

BURNERS make your old kerosene lamps and lanterns give a brilliant white light better than electricity or gas. Doubles your light. Saves oil. **NO MANTLE TO BREAK.** Guaranteed Safe and Reliable. Delights every user. Send now for complete sample postpaid 15 cts., stamps or coin. 3 for \$1. **MONEY BACK IF NOT SATISFACTORY.** Live Representatives Wanted. Exclusive Territory.

**WHITE FLAME LIGHT CO., 68 Clark Bldg., Grand Rapids, Mich.**

**ELECTRIC HOME, FARM, PICTURE THEATRE, HOTEL & STORE LIGHT PLANTS.** Auto Starter Storage Batteries & Chargers. All Cars. Ask Price. Dynamos, Peer Motors, Bells, Engines, Railways, Permanent & Travelling Motion Picture Machines.

**OHIO ELECTRIC WORKS, CLEVELAND, O.**



## LIGHT YOUR HOME LIKE DAY—COST 1c

for 6 hours. Pure white 100 candle power light from common Kerosene.

### THE BEACON LAMP MAKES AND BURNS ITS OWN GAS

Better, brighter, safer, cheaper than Gas, Gasoline or Electricity. Every home interested. 500,000 satisfied users. Agents wanted. Write quick for selling plan, exclusive free territory and trial offer.

**HOME SUPPLY CO., 111 Home Building, KANSAS CITY, MO.**





# Tobacco Habit BANISHED

## in 48 to 72 Hours

### Immediate Results

Trying to quit the tobacco habit unaided is a losing fight against heavy odds, and means a serious shock to your nervous system. So don't try it! Make the tobacco habit quit you. It will quit you if you will just take Tobacco Redeemer according to directions.

It doesn't make a particle of difference whether you've been a user of tobacco for a single month or for 50 years, or how much you use, or in what form you use it. Whether you smoke cigars, cigarettes, pipe, chew plug or fine cut or use snuff Tobacco Redeemer will positively remove all craving for tobacco in any form in from 48 to 72 hours. Your tobacco craving will begin to decrease after the very first dose—there's no long waiting for results.

Tobacco Redeemer contains no habit-forming drugs of any kind and is the most marvelously quick, absolutely scientific and thoroughly reliable remedy for the tobacco habit.

### Not a Substitute

Tobacco Redeemer is in no sense a substitute for tobacco, but is a radical, efficient treatment. After finishing the treatment you have absolutely no desire to use tobacco again or to continue the use of the remedy. It quiets the nerves, and will make you feel better in every way. If you really want to quit the tobacco habit—get rid of it so completely that when you see others using it, it will not awaken the slightest desire in you—you should at once begin a course of Tobacco Redeemer treatment for the habit.

### Results Absolutely Guaranteed

A single trial will convince the most skeptical. Our legal, binding, money-back guarantee goes with each full treatment. If Tobacco Redeemer fails to banish the tobacco habit when taken according to the plain and easy directions, your money will be cheerfully refunded upon demand.

### Let Us Send You Convincing Proof

If you're a slave of the tobacco habit and want to find a sure, quick way of quitting "for keeps" you owe it to yourself and to your family to mail the coupon below or send your name and address on a postal and receive our free booklet on the deadly effect of tobacco on the human system, and positive proof that Tobacco Redeemer will quickly free you from the habit.

Newell Pharmacal Company  
Dept. 300, St. Louis, Mo.



## Mail Coupon NOW for FREE Booklet

NEWELL PHARMACAL CO.,  
Dept. 300, St. Louis, Mo.

Please send, without obligating me in any way, your free booklet regarding the tobacco habit and proof that Tobacco Redeemer will positively free me from the tobacco habit.

Name .....

Street and No.....

Town..... State.....

Please Mention Popular Mechanics



# Beating the Barber at His Own Game

Every minute or two the barber reaches for his strop. A third of his working time—all day long—is spent in keeping his razors keen.

**That's Why He SHAVES While You ONLY SCRAPE**

Your hand may never have his skill, but you can get the same results, and enjoy a velvety, refreshing shave every morning without abusing your face.

The picture is all the directions you need. Just go to it—you can't go wrong.



## The LYON Safety Razor Stropper

sharpens any safety razor blade, in a way you have never dreamed you could do. You can't go wrong—you can't cut the strop. A few strokes—you can't help doing it the right way—and shaving will be a delight from the day you own a Lyon.

### The Lyon Safety Razor Stropper Costs \$5

—measure the price by the years of shaving comfort it will give you. We'll prove our case before it costs you a penny. Mail us \$5 and we will at once send you a Lyon Safety Razor Stropper. If you are not perfectly satisfied with it after 15 days' trial, drop us a postal saying you are returning it, and back will go your money the day we get the word.

Everyone is an expert with a Lyon Safety Razor Stropper  
**THE ALLEN MFG. CO. 313 Allen Bldg., TOLEDO, O.**

## KELLY OCTOPUS Water Closet Combination

(PATENTED)



8 water closets in an 8 ft. circle. No skill required to install. Water closets of all kinds. Send for catalog.

**THOS. KELLY & BROS. CHICAGO**  
406 S. Kolmar Ave.



The brand of satisfaction



## Gee! What a Wad!

This is **STAGE MONEY**. Looks like the **GENUINE STUFF**. Some Green backs and some Yellow backs. Create a **BIG** sensation among your friends. The girls will all be after you when they see the wad. **BIG** roll of 15 pieces by mail **10 cents**.

**PIKE NOVELTY CO., Dept. 7, So. Norwalk, Conn.**

## Health? Take Turkish Bath at Home—Only 2 Cents



Physicians are abandoning drugs for this new treatment. If your mind or body is tired, open your pores and feel the rapid change in your condition, at cost of 2c a bath. The Robinson Bath Cabinet is the only scientifically constructed bath cabinet ever made for the home. **Great \$2 Book Sent Free**—"The Philosophy of Health and Beauty." With baby, Agents Wanted.

**ROBINSON MFG. CO. 887 No. 12th St. TOLEDO, O.**



## Amazing Profits In Mushrooms

Anybody can add \$10 to \$40 per week to their income, in spare time, entire year growing mushrooms in cellars, sheds, barns, boxes, etc. I tell you where to sell, at highest prices.

Free Illustrated Instruction Booklet  
**HIRAM BARTON**  
Desk 2, 329 W. 48th St., New York

## DIAMONDS - WATCHES ON CREDIT

**EIGHT Months To Pay**  
Pure, Blue-white Diamond while paying for it on our easy terms of **20% DOWN - 10% A MONTH**

Any honest person given credit. No security required. Goods sent **against**, subject to approval. Binding Guarantees with each Diamond covering quality and value and providing for exchange at full purchase price. **10% DISCOUNT** for cash. Write today for **FREE CATALOG** No. 5 containing 4000 Photographs of Diamonds, Watches, Jewelry, Silverware, etc. Transactions confidential.

**JAMES BERGMAN** Est'd 1896 **37-39 MAIDEN LANE NEW YORK CITY**

1506 337.25  
3237 \$100.  
7070 \$25.  
7079 \$45.  
9738 \$85.  
9734 \$50

Please Mention Popular Mechanics



## No Money Down FREE Trial First A Year to Pay

Visible Writer  
Visible Reader  
Automatic Spacer  
In-Built Tabulator  
Universal Keyboard  
U-Shaped Type Bar  
Handy Back-Spacer  
Writes 84 Letters and Characters  
Lifetime Guarantee

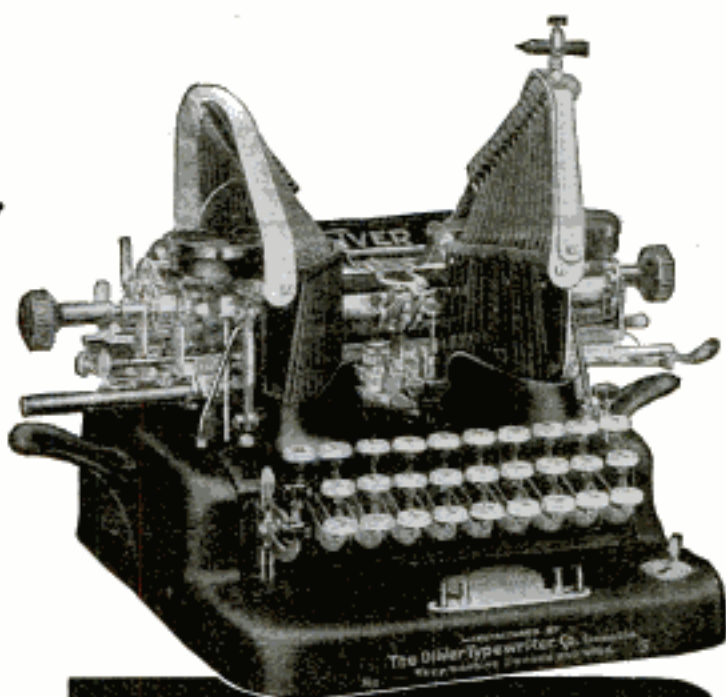

# Rates Now Cut!

**On 1000 Oliver Typewriters—Perfect Machines  
Unbeatable Bargains—Prices We Can't Print**

These world-famous visible writing Olivers are all fresh from the factory. Thousands have been sold at \$100, but on this special lot we propose to save you both the salesman's commission and the agent's commission. We don't dare print our terrific reduction, for we can't tell how long we can supply these typewriters at this price. Hence we ask you to mail us your name and address so we can tell you in confidence. After you get our unbeatable offer, all you have to do is notify us to send one of these superb Olivers *on trial*. You don't need to send a penny until you have tried it. When you are satisfied, we let you remit a trifle once a month till paid for. *Our terms amount to only 13c a day; and surely you'll never miss that.*

## OLIVER Visible Writer Life Guarantee

Why pay others 75 to 78½ per cent more than our price for this standard size Oliver? Why buy a typewriter guaranteed for only one year when we guarantee this Oliver No. 5 for life?

It brings you typewriter triumphs unexcelled by any machine on earth, and will write any form from the size of a postage stamp to a wide legal document.

The down-stroke U-shaped type bar gives double strength and double life and makes more carbon copies than any other machine on the market. Experts marvel at Oliver's light touch—one-third lighter than any other made. Saves your energy—rests your fingers.

Errors in writing quickly and easily corrected by use of handy Back-Spacer. Built-in Tabulator lets you write columns of figures like lightning.

Universal Keyboard writes 84 characters and letters, yet you control them all *with only 28 keys*. Easiest, simplest, handiest keyboard known.

### Accessories Free

Complete Accessory Outfit—Metal Office Case, Brushes, Oil, Screwdriver, Typewriter Ribbon, Carbon Paper, set of instructions, etc., included *free*. We even send practice paper, so it will cost you absolutely nothing to try this master machine. Even the novice can start and write the day this Oliver arrives. No experience necessary.

### This Price While They Last

We'll save you more money than you ever thought it was possible to save on the price of a typewriter. But our secret reduction applies to but 1000 machines. When these are gone your chance is gone. All inquiries will be numbered and answered according to turn. *So don't delay*. Mail the coupon at once—send no money—but get our offer *by return mail*.

Typewriters  
Distributing Syndicate  
Dept. 1301,  
1510 Wabash Ave.  
Chicago

I am interested in owning a typewriter and would like to have your latest cut price and easy payment plan on a No. 5 Oliver. I incur no obligation in asking for your offer.

Name .....

Address .....

**Typewriters Distributing Syndicate**  
Dept. 1301, 1510 Wabash Avenue Chicago

Please Mention Popular Mechanics





# Infantile Paralysis

left 8-year-old Evely Olson so crippled she had to crawl on her knees. Five months' treatment at the McLain Sanitarium restored her

feet and limbs to the satisfactory condition shown in the lower picture. Her mother has this to say:

We feel it our duty to recommend your Sanitarium. Evely is stricken with Infantile Paralysis in August, 1915. March 1, 1916, we carried her to you. Five months later she could walk without crutches or braces. Words cannot express our thanks.

M. and MRS. JOHN OLSON,  
R. D. 7, Grinnell, Iowa.

## For Crippled Children

The McLain Sanitarium is a thoroughly equipped private Institution devoted exclusively to the treatment of Club Feet, Infantile Paralysis, Spinal Diseases and Deformities, Hip Disease, Bow Legs, Knock Knees, Wry Neck, etc., especially as found in children and young adults. Our book, "Deformities and Paralysis," also "Book of References," free on request.

**The McLain  
Orthopedic Sanitarium**

902 Aubert Ave., St. Louis



# STOP USING A TRUSS

Do Away With Steel And Rubber Bands

## FREE TRIAL



Inner surface is made adhesive to secure the PLAPAO-PAD firmly to the body, keeping the PLAPAO continually applied and the pad from slipping. No straps, buckles or springs attached. Soft as velvet—easy to apply.

It's the Non-Slipping, yet Non-Rigid Pad and What is Within It That Counts

## FREE to 5,000 Truss Sufferers

To the extent of 5,000 sufferers who may apply I will send, ABSOLUTELY FREE, a sufficient quantity of the Plapao to positively convince them that this is the only logical, common-sense way of treating rupture. Plapao is a highly astringent medication placed within the Plapao-Pad and being absorbed through the skin, creates a wonderful feeling of relief and at the same time tends to strengthen the weakened muscles and thus permanently close the rupture opening. The process of recovery is natural, so you'll have no use for a truss—you can throw it away forever! Old and young have testified under oath that the Plapao-Pads cured their rupture—many of them long-standing, aggravated cases—without delay from work. Patent allowed in U. S. and foreign countries. Awarded Gold Medal at Rome and Grand Prix at Paris.

**Send No Money**—for a sufficient quantity of the Plapao is sent without charge to enable you to give it a thorough test; you pay nothing for this trial now or ever. Write for it and full information today. Address: Plapao Laboratories, Block 1427 St. Louis, Mo.

## FREE 10 DAYS TRIAL

**UNDERWOOD TYPEWRITER** **GUARANTEED For FIVE YEARS**

Less than 1-2 Manufacturer's price

Equipped with late improvements—two color ribbon, back spacer and tabulator. Shipped to you express charges prepaid, without one cent advance payment. The machine just sell itself. You make no payment until after you have thoroughly examined and tried the machine and are satisfied with it in every way. You can pay for cash or an easy payment plan will be arranged for you. We pay all charges.

Write today about this sensational offer

**METRO TYPEWRITER COMPANY**  
72 Front Street Brooklyn, N. Y.



Design No. 524  
by Jud Yoho.  
Estimated Cost  
\$2800.

## ALL ABOUT BUNGALOWS

**BUNGALOW BOOK, 1916 De Luxe Edition**

Contains the cream of 1000 practical and distinctive bungalows actually built for \$400 to \$4000, suited to any climate, with photos of exterior and interior views, plans, size of rooms, cost, etc. Also valuable suggestions on bungalow building written by an expert. The largest exclusive Bungalow Book published. 112 pages. Price..... **\$1.00** Postpaid. Worth many times its cost to any prospective builder. A smaller edition of same, only 50 cents. Send check, money-order or stamps. Money back if not satisfactory.

JUD YOH0, The Bungalow Craftsman, 64 Bungalow Bldg., SEATTLE, WASH.

Please Mention Popular Mechanics

## ROGEN X RAY

Price 10 cents

HERE, BOYS, is just what you want. With this instrument you can apparently see through clothes, see the bones in your fingers. Think of the fun you can have with it. Sample by mail, **TEN CENTS.**



## SKULL RING

Here is a handsome, up-to-date Ring, representing a Skull and Cross-bones. Has stones in the eyes and looks something frightful. Women won't like it, but for men or boys it is a great novelty.

Sample by mail, 15c  
ROYAL NOV. CO., 250 East Ave., SO. NORWALK, CONN.

## Unusual Trial Offer for 10c

Best Kodak Finishing, any size roll developed 10c. Six prints free with first roll. OR, send 6 negatives, any size, and 10c (stamps) for 6 prints. 8x10 Enlargements, 25c.  
**ROANOKE CYCLE COMPANY, 54 Bell Avenue, ROANOKE, VA.**

## THE MONO X-RAY

10c



With this eye glass you can apparently see thro cloth or wood, see the bones in the body, makes the flesh look transparent. An optical illusion.

BY MAIL 10 CENTS, STAMPS OR COIN

**THE ARDEE CO., Box 229, Stamford, Conn.**

## THIS BUNGALOW \$900 CAN BE BUILT FOR

This and many others in my new book, Building Plans for Modern Homes, will save you hundreds of dollars. One of the most complete and comprehensive books of plans ever published by any architect. Fifth edition just off the press. Two hundred and fifty floor plans and photographs of bungalows, etc., costing from \$300 up; gives sizes and cost to build. Sent postpaid for \$1.00



**FREDERICK H. GOWING  
ARCHITECT**

18 Tremont St., BOSTON, MASS.





**LU DEN'S Stop  
Rainy Day Sneezes**

Feet wet—  
clothing damp?  
Take Luden's  
to prevent  
after effects.  
Give  
Quick  
Relief.

In the  
Yellow **5<sup>c</sup>**  
Box

# LU DEN'S

MENTHOL CANDY **COUGH DROPS**

Coughs and colds quickly respond to Luden's—  
as do other ailments of the throat and nose.

W. H. LUDEN, Mfg. Confectioner, READING, PA.

## Wrestling Book FREE



Learn to be an expert wrestler. Know scientific wrestling, self-defense, and jiu-jitsu. Develop a splendid physique, and have perfect health. Join this popular school and learn by mail. The famous world's champions—the marvelous

**Frank Gotch and Farmer Burns**

offer you a wonderful opportunity. Wrestling is easily and quickly learned at home by mail. Men and boys write now for splendid free book. Learn all the science and tricks. Be able to handle big men with ease. Accept this wonderful offer NOW. Send for free book today, stating your age.

Farmer Burns School of Wrestling, 9191 Range Bldg., Omaha, Neb.

## Bausch and Lomb BALOPTICON

THE PERFECT STEREORILICON

Bausch & Lomb Optical Co., 576 St. Paul St., Rochester, N. Y.

## Free Book on WASHING

Tells how to get a good-sized washing done in an hour with the **Thor Electric Washing Machine**. Also tells how the Thor pays for itself by saving wear on clothes and cost of help. Write for this big 48-page book, fully illustrated. Sent absolutely free. And we will also tell you about the special offer we are making. **Write Today**

Get this book and information now. **HURLEY MACHINE CO., Dept. 1191, Chicago, Ill.**

## WOULD YOU



show this standard high grade 42 key fully visible typewriter to your friends and let them see wherein it excels any \$100 typewriter, if by doing this and other small assistance, you could easily have one to keep as your own? Then by post card or letter simply say, "Mail Particulars."

**WOODSTOCK TYPEWRITER CO., Dept. J617, Chicago, Ill.**

Please Mention Popular Mechanics



# A BIGGER JOB For YOU

Earn from \$35 to \$100 Weekly as a

# TRAFFIC MANAGER

Modern transportation is a jungle of routes and rates calling for specialists who, like the pathfinders of old, have expert knowledge of the trails of traffic. How to route shipments to obtain shortest mileage and quickest deliveries and how to classify goods to obtain lowest rates are two vital factors in business competition. The man who knows how is so valuable to his employer that he commands respect and big remuneration.

## Big Salaries Paid To Traffic Managers

Expert traffic managers command from \$2,500 to \$10,000 a year. Why not prepare yourself to fill one of these lucrative positions?

## New and Uncrowded Profession

Every railroad and over one half million large shippers in the United States need expert traffic men, and this need is recognized as never before because of the recently enacted railroad rate laws and interstate commerce regulations. The demand for trained and efficient traffic men is many times greater than the supply. **There's room for you.**

## Study Traffic and Interstate Commerce

Decide now to become a traffic man. Our Interstate Commerce Course enables you to study at home, without leaving your occupation or sacrificing present income, and to become thoroughly versed and qualified in the strategy of shipping, including routes and classifications, interstate commerce rules and regulations, etc. The instruction is given by some of the biggest traffic managers in the country. The course is easy to grasp and thoroughly practical. Anyone with ordinary intelligence, with reasonable application, can master this new profession.

**FREE PORTFOLIO** Clip coupon below, sign and mail at once, and we will send you FREE, postpaid, a handsome, portfolio containing complete information concerning the opportunities and requirements of this attractive profession. **Get posted at once. Clip coupon.**

**LaSALLE EXTENSION UNIVERSITY, Dept. 164-CA, Chicago**  
"The World's Greatest Extension University"

## FREE PORTFOLIO

**COUPON**  
LaSalle Extension University,  
Dept. 164-CA, Chicago, Ill.

I am interested in the new profession—  
Traffic Management. Please send me full  
information and Traffic Book, free of all  
cost.

Name.....

Occupation.....

Write address on the margin plainly.





## Big Fun— Little Cost!

If you have never played Billiards or Pool you can hardly realize the intense fascination of these fine, clean, interesting games. Just think what it would mean if you could control the balls, make the carom, combination and pocket shots, put the "English" on the ball, and make "follow" and "draw" shots!

It's practice, home practice, that makes the expert Billiard and Pool player. Begin now! Don't you want to "hold your end up" with your friends?

Afford it? Of course you can afford it! Why, it costs only a few cents a day (payable monthly) to purchase a

# BURROWES

## Billiard and Pool Table

These world-famous Tables are magnificently built. The most delicate shots, calling for skill of the highest order, can be executed with the utmost accuracy. In the finest homes in this land, including those of some of the famous experts, Burrowes Tables are used for home practice. Sizes of Tables range up to 4½x9 feet (standard) to fit any size room. No special room is needed—you can put up or take down your Burrowes Table in a moment.

### \$1 DOWN

Prices of Burrowes Tables range from \$15 up, on easy terms of \$1 or more down and a small amount monthly. Cues, balls, and full playing equipment are free with each Table.

### Here's Your Chance—Free Trial

On receipt of first installment we will ship the Table. Play on it one week. If unsatisfactory return it, and on its receipt we will refund your deposit. This insures you a free trial. Write for illustrated catalog, giving prices, terms of payment and full information.

Burrowes Tables are now on sale in many cities and towns, so you can inspect them before ordering if you wish. Write to us and we will tell you all about it.

**THE E. T. BURROWES CO.**  
163 Spring St., Portland, Me.

## If You Have RIG or AUTO, Earn \$83 to \$325 a Month

working spare time or steady in your own locality for largest concern of its kind in the world. Not necessary to be away from home nights. No previous experience necessary. Work consists in leaving in homes on free trial a wonderful new household necessity needed in every rural home Awarded Gold Medal. Greatest invention of the age. Tested by the U. S. Bureau of Standards and thirty leading universities in comparison with article, now in general use, and found to be four times as efficient. Benefits every member of the family; brings cheer and happiness to the home. **No investment or bond necessary.**

Christopher, Wisconsin, says: "Have never seen an article that sells so easily." Nearing, Iowa, says: "22 per cent of homes visited bought." Phillips, Ohio, says: "Every customer becomes a friend and booster." Kemmerling, Minn., says: "No flowery talk necessary. Sells itself."

Send your name and address, stating your regular occupation, age, married or single; whether you have rig or auto; whether you wish to work spare time or steady; how much time you have to devote; when you can start; townships most convenient for you to start to work in. **Sample sent for free trial.**

**A. Y. SHEPPY, Sales Mgr., 168 No. Halsted St., Chicago**



## Be Your Own Boss

Do as many others have—Operate a Kingery Peanut Roaster and Corn Popper. Over 50 styles. Liberal terms, excellent profits.

No. 50 catalog tells you all about it.

**KINGERY MFG. CO., Pearl, East of Broadway, Cincinnati, O.**

## START A MOVING PICTURE SHOW



### MAKE MONEY FAST

COMPLETE OUTFIT, MACHINE, FILM AND EVERYTHING FURNISHED. EASY PAYMENT PLAN. **NO EXPERIENCE NEEDED.** WRITE FOR FREE CATALOG

**MOVING PICTURE SALES CO., Dept. P, 540 Plymouth Place CHICAGO**

## AGENTS—Make \$100 to \$300



per month easy selling our new Triplicate Sauce Pan. Cooking utensil for 3 different foods on one burner. 400 Specialties—all Whirlwind sellers. Write quick for exclusive territory and large catalogue.

**AMERICAN ALUMINUM MFG. CO., LEMONT, ILL.**  
Div. H-T

I will send my 25 cent BOOK

## STRONG ARMS.

for 10c in stamps or coin

Illustrated with 20 full-page halftone cuts, showing exercises that will quickly develop, beautify, and gain great strength in your shoulders, arms, and hands, without any apparatus.

**PROF. ANTHONY BARKER**  
643 Barker Bldg., 110 W. 42d Street, NEW YORK

# Deafness



Perfect hearing is now being restored in every condition of deafness or defective hearing from causes such as

Relaxed or Sunken Drums, Roaring or Hissing Sounds, Perforated, Partially Destroyed Drums, etc.

### Wilson Common-Sense Ear Drums

"Little Wireless Phones for the Ears"—require no medicine but effectively replace what is lacking or defective in the natural drums. They are simple devices, which the wearer easily fits into the ears where they are invisible. Soft, safe and comfortable to wear at all times.

Write today for our 168 page FREE book on DEAFNESS, giving you full particulars and plenty of testimonials.

**WILSON EAR DRUM CO., Incorporated**  
343 Inter-Southern Building LOUISVILLE, KY.



# PATENTS

**I**F YOU HAVE AN INVENTION which you wish to patent you can write fully and freely to Munn & Co. for advice in regard to the best way of obtaining protection. Please send sketches or a model of your invention and a description of the device, explaining its operation.

All communications are strictly confidential. Our vast practice, extending over a period of seventy years, enables us in many cases to advise in regard to patentability without any expense to the client. Our Hand-Book on Patents is sent free on request. This explains our methods, terms, etc., in regard to *Patents, Trade Marks, Foreign Patents, etc.*

All patents secured through us are described without cost to the patentee in the *SCIENTIFIC AMERICAN*.

**MUNN & CO.**  
SOLICITORS OF PATENTS  
672 WOOLWORTH BLDG., NEW YORK  
and 625 F STREET, WASHINGTON, D. C.



## Everything the Boss Knows

Here, in these new books you have all the knowledge that gave the boss his job. All the problems he had to work out by actual experience are classified and indexed so that you can refer to them instantly. The books are called *Modern Shop Practice* and every man interested in shop work will find them money makers and money savers.

Just think what it would mean if you knew all shop methods. Think what it would mean to have all the latest machinery described and explained. That is what you have in these six handsome volumes.

## Modern Shop Practice

In these six volumes you have all the information you need to make you an authority on modern shop methods. You can be the man who gives the money saving—time saving methods—and tells how to operate the most complex machinery. They are bound in genuine binding leather, limp covers, 5½x8½ inches, 2300 pages, 2500 illustrations, full page plates, tables and diagrams, all cross-indexed for quick reference. The regular price of the set is \$30.00 but for a limited time we are offering a few sets at \$15.80, about half price. And you can pay this low price at the rate of \$2.00 a month. This offer is made to every man within the boundaries of the United States and Canada.

### Use Them Seven Days

Upon your simple request we will ship you the entire set, express prepaid, for free examination. Use them seven days—just as if they were your own. Don't send us a penny. Just send the coupon and we'll send the books. Use them seven days—and so for yourself what they are going to mean to you. If you think you aren't throwing away a golden opportunity send them back.

### 50c a Week

But if you decide to keep them send us \$2.00 after the trial and then \$2.00 a month until you have paid \$15.80. And too, if you order now we will also include free a year's consulting service. This entitles you to the advice of a corps of experts for an entire year. Ask as many questions as you wish.

### Send the Coupon

Just mail us the coupon. Don't send a penny. We will send you the entire set, express prepaid, for your examination. Act quick—before the offer is withdrawn.

American  
Technical Society  
Dept. M 9191  
CHICAGO, U. S. A.

NAME.....

ADDRESS.....

REFERENCE.....

**Important Subjects Covered**  
Machine Shop Work—Modern Manufacturing—Machine Shop Management—Metallurgy—Welding—Die Making—Tool Making—Tool Design—Foundry Work (Molding, Casting and Ferging)—Pattern Making—Mechanical Drawing—Auto Shop Work. Nearly two thousand subjects indexed.

American Technical Society  
Dept. M 9191, Chicago, U. S. A.

Please send me the set of Modern Shop Practice for seven days' free examination. If I decide to keep them I will send \$2.00 after seven days and \$2.00 a month until the special price of \$15.80 has been paid. Then you will send me a receipt showing the \$15.80 set of books and the \$12.00 consulting membership are mine and fully paid for. Otherwise, I will return them at your expense.

## SAVE YOUR CIGAR MONEY

### THIS IS A PIPE 10c

This cigar cannot be told from a full-size cigar. Fill with tobacco like any pipe; made of asbestos and will last for years. One paper of tobacco as good as 25 cigars. No ashes to fall over things. Always a nice, long cigar. Great novelty.

Sample by mail, 10c



## THE MEXICAN COBRA

Is the most deadly snake in the world. The bite of the rattlesnake sometimes kills, but the bite of the Mexican Cobra always kills. We have a perfect life like imitation of this snake. Will wiggle across the floor and would scare the heart out of an Indian. We will send a sample of this horrible reptile for 10 cents.

ROYAL NOV. CO., 250 East Ave., So. Norwalk, Conn.

## INDOOR CLOSET

More Comfortable, Healthful and Convenient than the Out-Door Closet

Eliminates the out-door closet and open vault. They are breeding places for germs. Have a warm, sanitary, odorless toilet right in your house. No going out in cold weather. A boon to invalids. Endorsed by State Boards of Health.

W. M. Davis writes: "Your indoor closet is giving absolute satisfaction. It is certainly the thing for a home without sewerage."

**Absolutely Odorless**  
Put It Anywhere in the House

The germs are killed by a chemical process in water in the container, which you empty once a month. **Absolutely no odor.** No more trouble to empty than dishwasher. Closet absolutely guaranteed. Write for full description and price.

**Agents Wanted—Big Profits** Wonderful opportunities in every town, village and in the country. Best season just at hand. Every home is a good prospect. Sell eight out of every ten you call on. Ernest Ridwell writes, "Have ten orders." G. A. Duesman says: "Ship at once twenty closets and fifteen washstands. Sold them all in one community." Sell it itself. Everybody hates the outdoor closet. Everybody wants a Ro-San Indoor Closet. Write quick for territory and full particulars.

ROWE SANITARY MFG. CO., 105 Sixth St., Detroit, Mich.

Ask about the Ro-San Washstand—Hot and Cold Running Water Without Plumbing





**Our Direct Factory to Home**  
plan saves you money.

**WE PAY THE FREIGHT**  
and ship to you any piano or player piano  
you select from our catalog.

**25 YEARS GUARANTEE**  
on all our pianos and player pianos.

**FREE MUSIC LESSONS**  
to all who accept our offer. Write for handsomely illustrated piano catalog and full details of our selling plan.  
**SCHMOLLER & MUELLER PIANO CO.**  
Established 1859 Capital and Surplus, \$1,000,000  
Dept. P. M. 017 Omaha, Nebraska

\*\*\*\*\*Send This Coupon Today\*\*\*\*\*

SCHMOLLER & MUELLER PIANO CO.  
Dept. P. M. 017, Omaha, Nebraska  
Send me your Piano Offer and Free Catalog.

Name .....

Address.....

## Try These for Your VOICE

—and get rid of the hoarseness,  
allay the irritation, soothe  
the "scrapy" feeling and  
strengthen the vocal chords.

### BROWN'S BRONCHIAL TROCHES

help the voices of singers and speakers,  
relieve coughs and bronchial affections. A  
cough remedy—not a candy. Effective and  
convenient. 25c, 50c, and \$1. a box.

**New 10c Trial Size Box at your Druggist**

If your dealer cannot supply you, we **John I. Brown & Son**  
will mail any size, upon receipt of price. Boston, Mass.



## AGENTS 500% PROFIT

### Gold and Silver Sign Letters



For store fronts, office windows  
and glass signs of all kinds. No  
experience necessary. Anyone  
can put them on and make  
money right from the start.

**\$30.00 to \$100.00 A WEEK!**

You can sell to nearby trade or travel  
all over the country. There is a big  
demand for window lettering in every  
town. Send for **FREE Samples** and  
full particulars.

**Metallic Letter Co., 406 No. Clark St., Chicago**



## New Book Free

Write today for the book that tells about the  
opportunities in the profession of Signal Engi-  
neering. Men are needed. Learn, too, how you can  
get the training that you need to fill the big job.

**\$125 to \$300 a Month**

The free book will give you just the information  
you want. Write for it now—immediately. Here is a  
golden opportunity.

Dept. 0191 — 1810 Wilson Ave.  
Beverwood Station, Chicago, Ill.

## BIG CHANCE FOR AGENTS



### You can earn BIG MONEY

selling the most complete line of guaranteed transparent handle  
Knives and Razors with Photo, Name and Lodge Emblem—  
also full line of cutlery. Write today for catalogue and terms.  
**Golden Rule Cutlery Co., 212 N. Sheldon St., Dept. 338, Chicago, Ill.**

Recently the mails have brought a letter from a Belgian  
engineer serving at the front who desires to correspond  
in French with some American girl or young man,  
hoping in this way to dispel the monotony of trench  
life. It seems possible that some student of French  
might profit, as well as spread some cheer, by writing  
the soldier. His name is Henry de Gallaix, and address:  
P/T.A. Belgian Army in Field, Belgium, via France.



## The Enchanted Barrel, 10 cts.

A small wooden barrel is passed around to be ex-  
amined. Borrow a cent and in plain view put it  
in the barrel. Place barrel on table, pass your hand  
over it, mumble "presto begone" and the cent  
disappears. Presto and it is back again. A cent  
can be changed to a dime, etc. They cannot get  
on to it. Sample with directions, **TEN CENTS.**



## WIZARD CARDS

Looks like a full deck of 52 high  
class playing cards, but with  
them you can do the most won-  
derful and mysterious tricks  
which cannot be done with any  
other cards, such as burning a card and finding it  
whole under the cushion of a lady's chair, and  
dozen of other tricks. Sample pack, by mail, **25c**

**ROYAL NOV. CO., 250 East Ave., So. Norwalk, Conn.**

## FREE \$20 Ukulele



Musicians  
Make  
Big Money

## \$20 Old Masters VIOLIN FREE



Fine Tone

We have a wonderful new sys-  
tem of teaching note music by mail,

and to first pupils in new localities will give a \$20.00 superb Violin,  
Mandolin, Ukulele, Guitar or Cornet, absolutely free, a very small charge for  
lessons the only expense. We guarantee to make you a Player or no charge. Com-  
plete outfit free. Special offer to first pupil in each locality. Write at once, no obligation.

**SLINGERLAND'S SCHOOL OF MUSIC, (Inc.) Dept. 3, CHICAGO, ILL.**





# PATENT YOUR IDEAS

A bottle cap seems like a little thing  
—but it made a fortune for one man.

**Your ideas may be worth money, too.**

You don't have to be an inventor by profession to think of a salable device or an improvement on some existing device—

but you do have to patent your idea before someone else does to get your fair share of the profits from it.

**A C & C Patent will secure your protection.** It may mean independence—even great wealth—for you. Learn what is in demand. Get these FREE BOOKS.



## “What To Invent” and “How To Obtain a Patent”

written by men who have had twenty-one years' experience in obtaining C & C patents. Manufacturers are constantly asking us for new devices. Our book will tell you what manufacturers want to buy.



### Here Are Suggestions of Things Wanted Right Now:

A dustless ash sifter. A good combination padlock. A cooking stove to go over a gas jet. Means for opening window shutters without raising the sash. A good and cheap vacuum cleaner. A detachable shelf for ladders, to hold a bucket. Improvements in rat and mouse traps. An adjustable window screen. Toys and novelties of all kinds. Means for cleaning cuspidors. Means for preventing the glare from auto headlights, yet which will give full light on the road. Means for picking fruit from trees. Insect trap for tree trunks. Improvements in rural mail boxes, with signals

to show automatically when the box contains mail. Poultry feeder, with means for automatically releasing feed at a certain time. An efficient milking machine.

These are only a few of the many inventions which represent a large field of work for those who have ingenuity. Hundreds of other suggestions and a great deal of helpful advice will be found in the book “What to Invent.”

If you have already invented something, send us a rough sketch and we will send you a free report regarding its patentability.

### C & C Patents Are Chandlee & Chandlee Patents

and were first issued over twenty-one years ago for the benefit of small inventors who could not afford the exorbitant fees charged by most attorneys. Because of the great number of patent cases we handle we are able to charge a reasonable fee for each patent, and our experience is far broader than that of attorneys

handling but a few cases each year. In a large measure, this accounts for the great protection afforded by *C & C Patents*.

Do not put off learning all about *C & C Patents*, for your idea will never earn you anything if someone else patents it first. Send at once for the FREE BOOKS and advice.

**CHANDLEE & CHANDLEE,** Patent Attorneys Est. 21 Years 1011 F Street, Washington, D.C.



# Patents Trade Marks and Copyrights Secured

## SPECIAL OFFER — Free Opinion as to Patentability

Send us a model or sketch and description of your invention, and we will give a free opinion as to the patentability of the invention. If we report the invention patentable, we will furnish a certificate of patentability.

**This Certificate of Patentability will protect the inventor and serve as proof of the invention until the case can be filed in the U. S. Patent Office.**

### Obtaining Assistance for Inventors

Our certificate is of great assistance to inventors who require financial aid to obtain patents.

### Our Five Books Mailed Free

(SEE COUPON BELOW)

to any address. Send for these books—the finest publications ever issued for free distribution.

#### How to Obtain a Patent

Our illustrated eighty-page Guide Book is a book of reference for inventors, and contains 100 mechanical movements illustrated and described.

#### Money in Patents

Tells how to invent for profit, and gives history of successful inventions.

#### What to Invent

Contains a valuable **LIST OF INVENTIONS WANTED** and suggestions concerning profitable fields of invention; also information regarding prizes offered for inventions, among which is

#### Prize of One Million Dollars

offered for one invention, and \$10,000 for others.

#### Patents That Pay

Contains letters from our clients who have built up profitable enterprises founded upon patents procured by us; also endorsements from prominent inventors, manufacturers, Senators, Congressmen, Governors, etc.

#### We Advertise Our Clients' Inventions Free

In a list of Sunday newspapers with two million circulation, in manufacturers' journals and in the World's Progress. Sample Copy Free. We save you time and money in securing patents. After the patent is granted we assist you **TO SELL YOUR PATENT.**

#### Foreign Patents

**WE HAVE DIRECT AGENCIES IN ALL THE PRINCIPAL FOREIGN COUNTRIES** and secure **FOREIGN PATENTS** in the shortest possible **TIME** and at the **LOWEST COST.** Write for our Illustrated Guide Book on Foreign Patents, sent free to any address.

## PREPAREDNESS

**Prepare Now to Meet the Demand of Industry in All Fields for New Ideas and New Inventions.**

**T**HE demand is already very great, but the future holds possibilities for American Inventors which challenge the imagination. If you have an idea of merit, develop it; patent it, and then you will be ready to reap your reward. We are constantly receiving requests from manufacturers for inventions in all lines. The demand is hourly increasing. Possibly your idea, your invention, your patent will win recognition from these manufacturers.

We have recently received over 260 requests from manufacturers among which are the following:

- 58 REQUESTS for Miscellaneous articles in all classes of invention, too numerous to mention.
- 73 REQUESTS for General Novelties and Mail Order articles.
- 54 REQUESTS for Household Novelties and Specialties.
- 16 REQUESTS for Sheet Metal Novelties.
- 10 REQUESTS for Automobile Specialties.
- 6 REQUESTS for Hardware Specialties.
- 5 REQUESTS for Electrical Specialties.
- 5 REQUESTS for Toys.
- 6 REQUESTS for Machinery.
- 3 REQUESTS for Advertising Novelties.
- 3 REQUESTS for Wooden Novelties.
- 2 REQUESTS for Window Shade Fixtures.
- 2 REQUESTS for Printing and Reproducing Apparatus.
- 4 REQUESTS for Agricultural Implements.

## WANTED NEW IDEAS

Send for **LIST OF PATENT BUYERS** who consult us when purchasing patents. Contains requests from **MANUFACTURERS, MAIL ORDER HOUSES and PROMOTERS** for patents secured by us, and suggestions as to **New Ideas** they wish to purchase. We invite manufacturers and promoters to address our Sales Department regarding the purchase or leasing of a number of meritorious patents secured by us.

### REFERENCES

Second National Bank, Washington, D. C.; Union Savings Bank, Washington, D. C.; Chamber of Commerce, Washington, D. C.; Pitner Gasoline Lighting Co., Chicago, Ill.; R. G. Dun & Co., Washington, D. C.; Smethport Glass Co., Smethport, Pa.; The Melvin Gauge and Signal Co., Scranton, Pa.; M. Winter Lumber Co., Sheboygan, Wis.; National Savings and Trust Co., Washington, D. C.

### FREE COUPON!

## VICTOR J. EVANS & CO., Patent Attorneys

NEW YORK OFFICES: 189-191 Broadway PITTSBURG OFFICES: 514 Empire Bldg. PHILADELPHIA OFFICES: 1429 Chestnut St.

Main Offices: 765 Ninth St., N. W., WASHINGTON, D. C.

GENTLEMEN: Please send me FREE OF CHARGE your FIVE Books as described above.

NAME..... ADDRESS.....



# WANTED IDEAS



Inquiries from Manufacturers and Other Buyers of Patents  
Who Are Looking for Good Ideas

## Protected by Owen Patents

Are constantly being received. Hundreds of ideas are wanted—a market exists for them to-day. **YOURS** may be one of them. Send for my free books and see for yourself—read the requests for inventions protected by me. Many are simple. You can help supply this demand.

As soon as my clients' rights are protected I aid in every practicable way, **without charge**, to sell. Their applications are advertised free—their patents are called to the attention of the proper prospective buyers—every necessary thing is done. Get my booklets and see.

## THESE ARE FREE

You will incur no obligation by writing me. A simple request will bring them to you—the finest, most reliable and instructive patent books published. A postal will do.

**"Successful Patents"**—a 72 page guide book, tells how to proceed; describes my advantageous business methods; gives references, testimonials, etc.

**"Stepping Stones"**—gives hundreds of hints of inventions wanted; articles from interviews of noted authorities; tells the truth about prizes for inventions.

**"Patent Promotion"**—tells you how to sell; why some inventors fail; discusses the value of your idea; how I aid my clients; manufacturing aids furnished you; recent successful patents, etc.

You will also be sent from time to time, as new inventions are wanted, full information concerning them. Only in this way can you keep up to date.

### Write for These To-day

Advice costs nothing. All communications confidential. Your work will receive my personal supervision—but my fees are no higher than others.

### Results Speak Loudest—But Here Are Some References

Columbia National Bank,  
Washington, D. C.

National Locktite Co.,  
Washington, D. C.

The Carnahan Press,  
Washington, D. C.

Lightning Gun & Cycle Works,  
Oklahoma City, Okla.

Antholene Mfg. Co.,  
Hutchinson, Kans.

National Rank Co.,  
61 Hannover St.,  
Boston, Mass.

The C. J. Loftis Co.,  
13 Spring Common,  
Youngstown, Ohio

Whitehead Hosiery Mills,  
Harrington, N. C.

Dickinson Mfg. Co.,  
Des Moines, Iowa.

A LARGE NUMBER OF OTHERS IN MY BOOKLETS.

**RICHARD B. OWEN** 9-303 OWEN BLDG.  
WASHINGTON, D. C.

Inventors submitting their inventions to me are protected in a tangible manner until their applications are filed.

### Nuts for You to Crack

Invent something for which a demand exists—for which there is a waiting market. Here are abstracts from a few recent requests—hundreds are published in full in my literature. Can you invent any of these? Watch this list each month.

A gentleman who is connected with one of the largest manufacturers of pianos and piano players desires to acquire patent rights to improvements in this field. Can you supply this demand?

A large Southern company wants to buy patents on an improved "Ball-Gum Vending Machine, with non-slug fraud device, or trash eliminator, as part of the coin chute or mechanism." They want a machine that can be manufactured at a reasonable price.

Can you devise a new idea in the line of advertising specialties, signs and calendars? A large company has just written for something along these lines adding, "we manufacture goods from paper, cloth, wood, metal and leather."

Improvements in electric spot and seam welders and also patents covering novelties which may be electrically welded instead of riveted are desired by a large Western manufacturer in this field.

### SPECIAL FREE REPORT

Send sketch or model of your invention for free report on patentability, practicability, etc.



**PATENTS SECURED OR ALL FEES RETURNED!!**

**PATENTS THAT PAY**  
"Trade-Mark"



**Protect Your Idea! Don't Delay!**  
Send data at once by registered mail and we will promptly advise how our clients proceed to make fortunes. Over \$825,812.00 clients made.

One client, A. D. Long, just states:  
"You secured **BROAD** claims for me in my patent. I sold it for \$25,000.00."

We advertise our clients' patents **FREE** in a magazine having 2,000,000 circulation, and give free valuable help in their effort to sell their inventions.

Our Offices Just Across the Street from the United States Patent Office.

**E. E. Vrooman & Co., Patent Lawyers, 871 F St., Washington, D. C.**  
(Old-Established Firm, and Practitioners Before Supreme Court of U. S.)

**We Issue a Contract with Each Favorable Report to Return ALL FEES!**

Actual Search **FREE** of the Patent Office Records, and Report as to Patentability **Free!**

**FOREIGN PATENTS GUARANTEED!**

Branch offices all over the world. Write for prices under guarantee.

**2 WONDERFUL PATENT BOOKS FREE**  
Don't miss these books. Mail postal today.

**PATENTS** C. L. PARKER  
Formerly Member Examining Corps, U. S. Patent Office  
**PATENT LAWYER**  
MCGILL BLDG.  
WASHINGTON, D. C.

Patents, Trade Marks, Copyrights, Patent Litigation  
Handbook for Inventors, "Protecting, Exploiting and Selling Inventions," sent free upon request.

Send for **FREE BOOK** { **WHAT TO INVENT**  
**WHAT NOT TO INVENT**  
**HOW TO SELL YOUR PATENT**  
Copies of nearest Patents and report in every case without charge  
**H. L. WOODWARD, 9th and G Sts., WASHINGTON, D. C.**

**Models and Gears**

**Experimenters—Inventors**  
Developing inventions and making working models our specialty. Well equipped shop and staff of experts at your service. Carry complete stock of gears. Shipments same day order received. ESTABLISHED 1882.  
**UNION MODEL WORKS, 121 S. Clark St., CHICAGO**

# PATENTS SECURED OR FEE RETURNED

Latest and Most Complete Patent Book Ever Published for Free Distribution

WRITE FOR IT

Compare My **SERVICE** and **TERMS** with Those of Any First Class Attorney

Send Sketch, Photograph, or Model of your invention for an **ACTUAL SEARCH** of the Records of the Patent Office and report as to patentability — **FREE**. I give every detail of every case my closest personal attention and **do not** entrust your interests to assistants. Impartial advice on your ideas. I help you sell your patent. Terms moderate. My 90-page book (1916 edition) tells what inventors should know before they apply for a patent.

**GEORGE P. KIMMEL, Patent Lawyer, 200 Barrister Bldg. Washington, D. C.**



## GEARS ALL KINDS SMALL

The most accurate made and prices reasonable. We carry a complete line of gears in stock for immediate shipment. Can also quote on special gears of all kinds. Send us your inquiries.

WRITE FOR CATALOGUE.

**CHICAGO STOCK GEAR WORKS**  
16 S. Fifth Av. CHICAGO

Queen Elizabeth, of England, it is said, possessed as many as 3,000 gowns at one time.

## Protective Patents

Procured Promptly. No fee refund, no guarantee certificate, no so-called prize or free search schemes used in our business. Inventors 104 page Blue Book sent on request.

**Robb & Robb, 211-215A Southern Bldg., Washington, D. C.**

# PATENTS THAT PROTECT and PAY

Advice free. Terms reasonable. Highest references. Best results.  
Send sketch or model for **FREE** examination and opinion.

**BONDED** and recommended Patent Lawyer in the Rand-McNally Directory of Bankers and Attorneys Published by Rand-McNally & Co., Chicago, Ill. Recommended Patent Attorney in the Bankers Register and special list of selected lawyers published by the Credit Company, Pontiac Building, Chicago, Sharp & Allen's Directory of Lawyers and Bankers of Philadelphia, Martindale's American Legal Directory of New York City, and the Con. P. Curran Directory of Bankers and Lawyers of St. Louis.

**ALL BUSINESS GIVEN PROMPT AND PROPER ATTENTION**

A large list of strong recommendations furnished free

**WATSON E. COLEMAN, Patent Lawyer, 624 F St., Washington, D. C.**



# Wanted—Ideas

Inventors! Send for these Remarkable FREE BOOKS, Today

## "Inventions Needed"

This book lays before you a description of the active and profitable field of invention. It tells you the inventions the world needs today, the devices manufacturers are seeking for their business, the ideas for which the public will pay big money.

## "How to Get Your Patent"

This book is a guide to the inventor. If you have invented something and desire to learn what it will cost you to get your patent and what you must do to find your market, read this book.

## "Special Bulletin of Patent Buyers"

This bulletin contains letters from men who are seeking to purchase patents. We act as intermediary without one cent of charge, between the man who invents and the man who invests.

Send Model or Sketch and description of your invention for Free Opinion as to patentability

*Rejected and Difficult  
Cases are Our  
Specialty*

**RANDOLPH & CO.**

600 F St., N.W., Washington, D.C.

**RANDOLPH & CO.**  
600 F St., N. W., Washington, D. C.

Gentlemen: Please send me without obligation on my part, the books indicated on margin of this coupon. (Write on margin of coupon, names of books desired.)

NAME.....  
STREET.....  
CITY.....STATE.....



**MONEY IN MUSHROOMS** FREE BIG BOOKLET TELLING HOW TO GROW MUSHROOMS at home all the year. Big profits. Take advantage of this wonderful opportunity to become independent. Write Nat'l Spaw Co., Dept. 12, Boston, Mass.

SETS OF CASTINGS OF MODEL ENGINES, CAR VEHICLES & PARTS OF MODELS. MECHANICAL SUPPLIES AND MATERIAL of all kinds. EXPERIMENTAL AND LIGHT MACHINE WORK to order. 132 MILK STREET. BOSTON

**Models and Supplies** We make working models of any description and material, also dies, tools and sheet metal stampings. Send your drawing or sample for estimate. Write for catalog of gears and model supplies. The Pierce Model Works, 3405 Pierce Ave., Chicago, Ill.

**HIGH-VALUE PATENTS**  
R. S. & A. B. Lacey, Washington, D. C.  
Established 1869 51 Barrister Bldg.  
Patents that Manufacturers Buy  
Send 8 cents postage for new book of Extraordinary Interest to Inventors.

## U.S. PATENTS

FREE BOOK-BULLETINS & ADVICE

REGISTERED ATTORNEYS

**LANCASTER & ALLWINE**

204 OURAY BLDG. WASHINGTON, D. C.

**Don't Lose Your Rights**

We publish forms called "Evidence of Conception" by which you can establish your rights before sending the invention to anyone. It is your best protection. We issue up-to-date bulletins of improvements wanted; aid inventors to promote their rights; render reliable opinions free of charge and secure valuable patents and trade marks on reasonable terms. Personal service assured by our Service Guarantee Contract. References: 2nd National Bank, Washington; John P. Roth Packing Co., Cincinnati.

**SIMPLY MAIL COUPON**

LANCASTER & ALLWINE, 204 Ouray Bldg., Washington, D. C. Send me free, book "Inventions—Patenting and Promoting," Bulletin of Improvements Wanted and blank form, "Evidence of Conception."

Name.....  
Address.....

Please Mention Popular Mechanics





# INVENT SOMETHING

## IT MAY BRING WEALTH

### There Is Always a Demand for Valuable Inventions

Now is the time to patent a meritorious invention. We are constantly receiving letters from manufacturers and investors who are on the alert for new devices, and specialties that are protected by strong patents and can be turned into money through proper handling. Write us today for a free copy of our 104 page book—

## “How to OBTAIN A PATENT and What to Invent”

or send us a Sketch, Model, or Photograph with written description of your invention for a **FREE SEARCH OF THE PATENT OFFICE RECORDS** and report as to patentability of your invention. If patentable we will send you our **Certificate of Patentability** which may prove of value and assistance to you.

If you require money with which to secure a patent, ask us to explain our **CREDIT SYSTEM**, by means of which you will be able to file your application and proceed with your case without delay.

**PATENTS SECURED BY US ARE ADVERTISED AT OUR EXPENSE IN POPULAR MECHANICS MAGAZINE**

WRITE FOR FREE BOOK OR SUBMIT YOUR INVENTION TODAY

**WATERS & CO.** Succeeded By **TALBERT & PARKER**  
**PATENT LAWYERS**

4614 WARDER BUILDING

WASHINGTON, D. C.

## WE PAY CASH for Scrap PLATINUM and Old False Teeth

On rubber or metal plates. Highest cash price paid for old Gold, Silver, contact points, crowns, bridge work, mercury and broken jewelry. Send your package today by parcel post to

The Mutual Smelting and Refining Company  
 116 North Front Street, Columbus, Ohio



## The BEST LIGHT

Positively the cheapest and strongest light on earth. Used in every country on the globe. Makes and burns its own gas. Casts no shadows. Clean and odorless. Absolutely safe. Over 200 styles. 100 to 2000 Candle Power. Fully Guaranteed. Write for catalog. AGENTS WANTED EVERYWHERE.

THE BEST LIGHT CO., 324 E. 5th St., CANTON, O.

## Vitality in Violet Rays

Violet Ray instrument, endorsed by leading physicians and hospitals. Soothing, delightful, nerve toning, health building Violet Rays. Send immediately for book of important health information. FREE.

## VIRAYO

Virayo, the true Violet Ray instrument, recommended by physicians for private and family use. Use it anywhere. Applicable for every ailment treated by Violet Rays. Special limited introductory offer.

### BOOK FREE.

You need this book on Violet Rays. It is free. A new book on health, beauty, vitality and vigor. Book sent free. Special introductory price for limited time; all particulars postpaid free to you with book.

Write today. WESTERN COIL CO., 180 N. Dearborn St., Dept. 5245, Chicago, U.S.A.

Restore your vitality. Instant relief. Marvelous, perfected Virayo. For home use. Virayo, the true

Virayo, the true Violet Ray instrument, endorsed by leading physicians and hospitals. Soothing, delightful, nerve toning, health building Violet Rays. Send immediately for book of important health information. FREE.

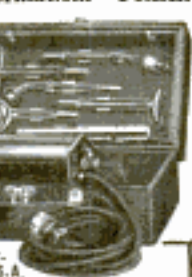

# PATENTS

MASON, FENWICK & LAWRENCE, oldest U. S. firm having main office at Washington, D. C. Also New York and Chicago. Established 1861. Best References. Trade-Marks Registered. BOOKLET and Information FREE.

*The Wellington*  
 THE UNIVERSAL PIPE

## ERECTOR THE TOY LIKE STRUCTURAL STEEL

**BOYS:** Write for facts about the Big Prize Contest and get Erector Tips, the boys' magazine, FREE. THE A. C. GILBERT COMPANY, 104 Fox St., New Haven, Conn.

## FIBRE LEGS ARMS



### 4-LB. FIBRE LEGS—ON EASY TERMS

Orthopedic braces for all deformities. Send for booklet. MINNEAPOLIS ARTIFICIAL LIMB CO., 636 Dean Bldg., MINNEAPOLIS, MINN.

## EXPLODING CIGAR

An imitation Cigar that fills with tobacco. When half smoked, explodes and shoots the tobacco out. Can be filled again as often as you wish. Perfectly harmless. Sample cigar with 10 exploding pellets by mail for..... 10c

ROYAL NOVELTY CO., 250 East Ave., SOUTH NORWALK, CT.

SUPERIOR SINCE 1904

Over 100,000 in Use

Mostly sold through recommendation. For PERSONAL DESK or GENERAL OFFICE. It checks mental calculations. Buy through your Stationer. Write for 10-day trial offer.

E. GANCHER, A. A. M. CO.  
 148 Duane Street, NEW YORK

**AGENTS WANTED**

Golden Gem PORTABLE \$5 Adding Machine

Multiplies—Subtracts

Please Mention Popular Mechanics



# Diamonds on Credit Watches

**For Holiday Presents Special Values**      **Send for Jewelry Catalog—FREE**

This special selection of Diamond-set Jewelry shows the most popular of the season's new mountings. Gorgeously beautiful Diamonds, of fiery brilliancy, set in solid gold. We have cut prices almost to cost. It's your opportunity to save money. Any selection sent on approval, delivery charges prepaid. If satisfied, send one-fifth of the price as first payment, balance divided into eight equal amounts, payable monthly. If not just what you wish, return at our expense. Send for Our Handsome 116-Page Illustrated Catalog. Over 2,000 suggestions for Holiday Gifts, or for personal wear. All the new styles in jewelry—rings, studs, scarf pins, ear screws, brooches, broochlets, watches, chains, watch bracelets, silverware, etc. Liberal credit terms on anything desired. Send for free catalog.

**LOFTIS BROS. & CO.,**  
The National Credit Jewelers  
Dept. H894, 108 N. State St., Chicago, Ill.  
Stores in Pittsburgh; St. Louis-Omaha

120 \$40      125 \$25  
121 \$75      122 \$20      123 \$10      124 \$25  
126 \$50      127 \$14      128 \$28      129 \$75

## New Book Free

**SIGNAL ENGINEERING**

Write today for the book that tells about the opportunities in the profession of Signal Engineering. Men are needed. Learn, too, how you can get the training that you need to fill the big job.

**\$125 to \$300 a Month**

The free book will give you just the information you want. Write for it now—immediately. Here is a golden opportunity.

**Dept. of Signaling**      Dept. 2121—1810 Wilson Ave., Ravenswood Sta., Chicago, Ill.

## MAGAZINES!

J. M. Hanson-Bennett Magazine Agency is the largest in the world. You can save money on the magazine you want by writing for

### This Catalog FREE!

Our New Catalog lists more than 3000 Periodicals and Club Offers. It's a big Money-Saver. Send us your name and address on post card today and get this big free catalog. Do it Now.

**Agents Wanted.** Write for full particulars

**J. M. HANSON-BENNETT Magazine Agency**  
738 Brooks Building      CHICAGO, ILLINOIS

## 150 Parodies ON Latest Songs 10c

Norway, Araby, Old Green River, Come Back Dixie, Sun-Sea Bay, Down Home In Texas, Down Among the Sheltering Palms, Tulp Time In Helianth, Dublin Bay, It's a Long Way to Tipperary, I Didn't Raise My Boy to be a Soldier, Yuki, Little Spark of Love, When You Were a Tulp, Michigan, Night In Dreamland, Maudslayi, International Rag, In My Haven & 131 others, including Comic Dialogs, complete 10c; \$ for 20c.

**J.C. DORN, 731 S. Dearborn St., Dept. 190, Chicago, Ill.**

## CACHOO!

Make the whole family and all your friends "just sneeze their heads off," without knowing why, with CACHOO, the new long distance harmless snuff. Sent anywhere for 10c, 3 for 25c.

## Revolver Pipe

We show here a Smoking Pipe in the shape of a Revolver. Wooden pipe with rubber stem, worth 50c as a smoking pipe and \$2.00 to scare a burglar or tramp with. GREAT NOVELTY. SAMPLE BY MAIL...

**25c**

**ROYAL NOVELTY CO., 250 East Ave., SOUTH NORWALK, CT.**

## BUY PLUMBING and HEATING SUPPLIES

**at WHOLESALE**      Will Save You 30%

Don't pay retail prices. Full stock on hand for prompt shipment. Send for free catalog.

**B. P. KAROL, 800-802 South Kedzie Ave., CHICAGO**

## I PRINT MY OWN

Cards, circulars, menus, book, paper, etc. Press \$5. Larger \$18. Rotary \$90. Save money. Print for others, big profit. All easy, rules sent. Write factory today for illustrated catalog presses. TYPE, cards, samples.

**THE PRESS CO. D-37, MERIDEN, CONNECTICUT.**

## Relief to Ruptured People

Any appliance is a truss. Ruptured people must wear some kind of support. Our New Sponge Rubber Pad (pat'd) is velvety, soft to the skin, pliable, cannot slip, extremely comfortable, adapts itself to ruptured parts with less pressure, is sanitary, long lived. Massages and strengthens muscles, allows blood circulation and produces many cures.

**52 Styles of Trusses 25 Different Pads**

**New Scrotal Pad Needs No Leg Strap**

Our new scrotal pad (pat'd) holds 8 out of 10 cases of hernia perfectly without strap between legs.

**Free Sample Pad** A Sample Akron Sponge Rubber Truss Pad (pat'd) will be sent absolutely FREE upon request, also booklet "Relief to Truss Users." It's full of help. Ask your dealer, or write us.

**THE AKRON TRUSS CO. Dept. 61, Akron, Ohio**

## Make this car your office—

there is \$900.00 to \$1800.00 a year in it for you

Examinations will likely be held everywhere soon

**Hundreds of Railway Mail Clerks Needed Soon**

Rapid advancement to higher Government Positions. "No layoffs" because of STRIKES, FINANCIAL FLURRIES or the WHIMS OF SOME PETTY BOSS. THE POSITION IS YOURS FOR LIFE.

Country residents and city residents stand the same chance for immediate appointment. Common-sense education sufficient. Political influence NOT REQUIRED.

**We will prepare 25 candidates FREE!** Write immediately for schedule showing the places and dates of all winter and Spring examinations. Don't delay. Every day you lose means the loss of just as much coaching before the rapidly approaching examinations.

**FRANKLIN INSTITUTE, Dept. S-96, Rochester, N. Y.**

**COUPON**

Franklin Institute (The pathway to plenty), Dept. S-96, Rochester, N. Y.

This coupon, filled out as directed, entitles the sender to free specimen questions; a free copy of our copyrighted book, "Government Positions and How to Get Them," a list of positions now easily obtained and to consideration for Free Coaching for the examination here checked.

..... Railway Mail Clerk (\$900 to \$1800)	..... Customs Positions (\$800 to \$1500)
..... Bookkeeper..... (\$800 to \$1800)	..... Stenographer..... (\$800 to \$1500)
..... Postoffice Clerk..... (\$900 to \$1200)	..... Internal Revenue... (\$700 to \$1800)
..... Postoffice Carrier..... (\$800 to \$1200)	..... Clerk in the Departments at Washington (\$800 to \$1500)
..... Rural Mail Carrier..... (\$500 to \$1100)	

Name..... Address.....

5-96

Use this before you lose it. Write plainly.



# FINCK'S "DETROIT-SPECIAL" OVERALLS

"They Wear Like a Pig's Nose"



Overalls . . \$1.50  
Jackets . . 1.50  
Combination  
Suits . . . 2.50

A CHRISTMAS gift that will wear like a firm friendship. Give him Finck's "Detroit-Special" overalls—or better still, a combination suit that spells freedom from dirt and perfect comfort.

### At Your Dealers

If he hasn't them, send us the price and we'll forward by prepaid parcels post.

## W. M. FINCK & COMPANY

1154 Gratiot Avenue

Detroit, Michigan



### South Bend Lathes

For the Machine and Repair Shop

**How to Run a Lathe**  
A 50 cent book for 10 cents.  
Postpaid, stamps accepted.

Straight or Gap Beds. Send for free catalog giving prices on entire line.  
**SOUTH BEND LATHE WORKS**  
423 Madison St., South Bend, Ind.

**LAND-RECLAMATION CONTEST FOR BOYS**—An interesting opportunity for boys to turn waste land into fertile fields and to win prizes for their efforts is offered by a private concern. The idea is for the farmer to look over his farm and pick out the bad spots, then turn one acre of it over to his son, or another interested



## LATHES

9 to 18-inch Swing

List price \$75 and up according to size. When ready to buy send for Lathe Catalog and prices.

**W. F. & John Barnes Co.**  
100 Ruby Street, ROCKFORD, ILL.



A complete line of appliances for the transmission of Power. Anything from a bolt to a complete mill or factory outfit. Send for catalogue. Largest Manufacturers of Pulleys in the country.  
**W.A. Jones Foundry & Machine Co.** CHICAGO  
1400 W. North Ave.



## Crescent Wood Working MACHINES

always give such splendid satisfaction that our customers think of CRESCENT first when in the market for additional equipment.

Ask today for catalog of band saws, jointers, saw tables, planers, disk grinders, swing cut off saws, shapers, planers and matchers, borers, universal wood workers, variety wood workers, hollow chisel mortisers, bench jointers.

**THE CRESCENT MACHINE CO.**  
93 Columbia St. LEETONIA, OHIO

## Water Pumps Water

with a Rife Ram. Plenty of it for every purpose about your farm and country home — day and night, winter and summer, without fuel, labor, freezing or repairs. The

### RIFE RAM

is operated by any small stream having a fall of three feet or more and a supply of three or more gallons per minute. Fills high elevated tanks or operates air pressure system. Easy to install. First cost the only cost. Always on the job; over 11,000 in daily use. Tell us your water supply conditions. Ask for free estimate and catalog. Now is the time to install. Write today.

**RIFE ENGINE CO., 3131 Trinity Building, NEW YORK**







## WHITING-ADAMS

Trade VULCAN Mark

# RUBBER CEMENTED SHAVING BRUSHES

"Rubber" means rubber in all VULCAN RUBBER CEMENTED BRUSHES

The bristles and hair are actually held in pure, best quality rubber, no fake preparation of coal tar products used in our factory. The brushes are branded "RUBBER CEMENTED" which means that the butt ends of bristles are immersed in Brauxite Press Rubber in a plastic state, and then vulcanized hard as granite. The process of rubbering and vulcanizing all of our VULCAN RUBBER CEMENTED BRUSHES is our own method, and perfect in all respects. The bristles cannot be pulled out, and the holding parts of these brushes cannot be overcome, also our process of vulcanizing does not burn or injure the bristles.

### JOHN L. WHITING-J. J. ADAMS CO.

BOSTON, U.S.A. Brush Manufacturers for Over One Hundred Years

For 50 cents and this advertisement we will send postpaid a nice Bristle Shaving Brush

## A Wonderful Combined Tool

is this STEWART HANDY WORKER



It combines: A strong and powerful vise, steel faced; a steel pipe vise for up to 1 1/2-inch pipe; big, sturdy anvil; cutting hardie; corundum grinding wheel 5" x 1", 2 speed drill press; 3 speeds, direct, 4 to 1 and 16 to 1.

Weights, boxed, 90 pounds; price f. o. b. Chicago, \$12.50. Send \$2.00 and pay balance when outfit arrives. All money back if not highly pleased. It's a marvelously valuable outfit. Write for circular.

**Chicago Flexible Shaft Co.**  
A617 N. La Salle St. CHICAGO

boy, and let him improve it. The main points of the contest are, to clear the land, improve the soil, and then raise a crop. No special crop is specified, the only restriction being that the work on the one acre must be planned and done, or supervised, by the boy himself. For the purposes of the contest, the country has been divided into five sections, and prizes will be awarded to the boys of each section showing the best results commensurate with cost.

## "Interlox" SAVES TIME, TEMPER AND TROUBLE

**MASTER SLIDE RULE**  
The Only Interlocking Rule made — and the Only one whereby inside measurements of doors, windows, etc., can be taken rapidly and accurately. Also superior to all others for outside measurements of walls, ceilings, etc. If your hardware dealer hasn't this Rule, send us his name and 18c per foot in any length from 2 to 8 ft., and it will be sent prepaid.

Liberal Proposition for Dealers and Agents

DAHL MFG. CO., 51P E. 42nd St., NEW YORK

## THE AWL YOU WANT



Is the genuine MYERS \$1.00 "Lock Stitch" Sewing Awl with the exclusive feature. See thread reel in front of handle under the fingertip. Natural tension. Sews heavy or light material, diamond point, full grooved needles used to protect the thread when sewing.  
C. A. MYERS COMPANY, 6339 University Ave., Chicago, Illinois

## THIS MACHINE WILL EARN \$20 to \$50 Daily Profit For You

Making Cement Bricks and Blocks

Factory owners are the biggest money makers in America and this machine will place you in their ranks. You can start with little capital and even without experience. This machine makes pressed cement bricks and blocks under 80,000 pounds pressure. No tamping and easy work. It makes 1,000 blocks or 100,000 bricks daily. No burning required. Ready for the market in a few days' time. They are necessary for the

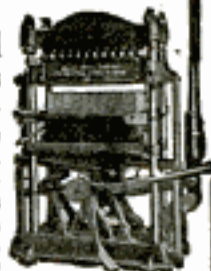

## Helm DRY WALL Building System

This is the system that appeals to builders, contractors and architects. It overcomes the opposition to concrete because it offers absolutely DRY WALL construction. It saves money for builders, as no furring and lathing are required, and it makes rigid walls and fireproof walls. This is the system which is bound to get you business and give you the advantage over all other products. \$50 and up starts you.



## Send for This FREE CONCRETE BOOK

Tear off the corner coupon right now before you turn the page. Let this free book tell you all about

this great opportunity which is open to you today. It will tell you all the details of this system, about the Helm Press and the DRY WALL building system. It will show you how easy it is to start a profitable business. It tells how each product is made, how it is cured and sold. Write today. Limited capital starts you.

**HELM BRICK MACHINE CO.**  
321 Mitchell St.  
CADILLAC, MICH.

**Helm Brick Machine Co.**  
321 Mitchell St.,  
Cadillac, Mich.

Please send FREE the book on concrete and Helm Presses.

Name.....

Address.....



## Tool Cases for Toolmakers and Machinists

Keep your tools orderly arranged in a Gerstner Portable Tool Case. There's a place for every tool in one of the felt lined drawers. Every up-to-date mechanic needs one and you'll find our Cases the best built, neatest and most practical on the market. We guarantee to please or refund all money. Write for our free booklet

**The Gerstner Sons**

Mfrs. of Mechanics' High Grade Tool Cases  
808 Columbia St., DAYTON, OHIO



"Red Devil" No. 90—8 in.

## The Mechanic Needs This "Red Devil" Wrench

Most useful tool on automobiles, motor boats, gasoline engines, wherever a strong, adjustable wrench is needed. Made in 45 degrees, of forged steel. Sample 8 in. sent for 90c. TOOL BOOKLET FREE.

**SMITH & HEMENWAY CO., INC.**, 97 Chambers Street  
NEW YORK CITY



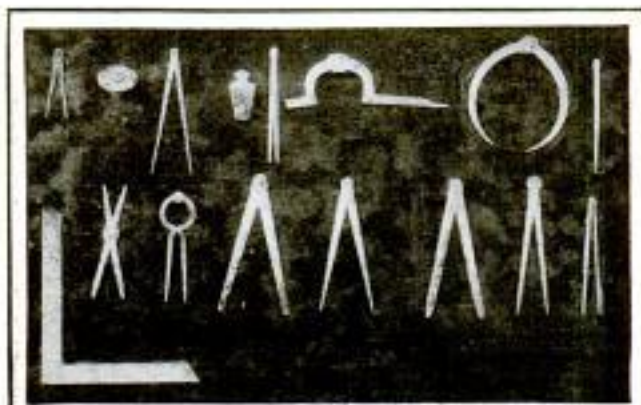

### The Tools of 2000 Years Ago

**A**BOVE are shown replicas of original tools excavated from the ruins of the Roman City of Pompeii. Originals now at the National Museum at Naples. How would you like to depend on such tools in your work today?

### The Tools of Today

No line of present day machinists' tools illustrates more strikingly the wonderful progress in tool making since the days of Pompeii than

## Brown & Sharpe Tools of Accuracy

If you would do your work better and easier make the acquaintance of our line through

CATALOG 27 — IT'S FREE

**Brown & Sharpe Mfg. Co.**  
Providence, R. I., U.S.A.

### The Tools of Today

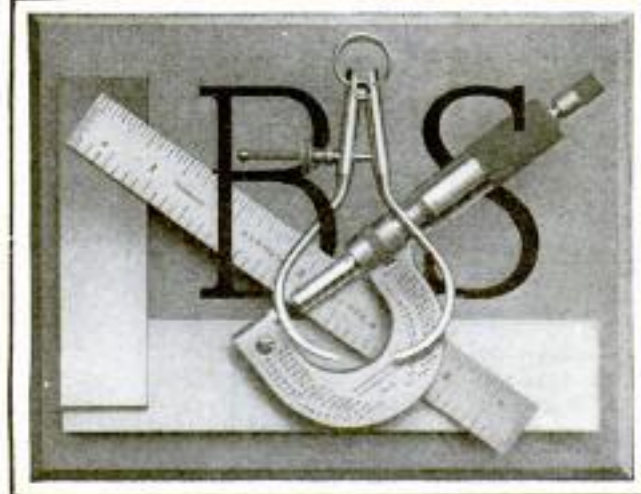

## This Chain Drill Has New Automatic Feed Device

So that the Feed does not operate the feed screw until the Drill actually touches the work. This device is patented. Thus, after the twist drill has been tightened in the chuck and is to be run down to the work or after the drilling is completed and it is desired to back out, the operator can run the drill up or down as fast as he can turn the spindle. Another important feature of this feed is, that it is adjustable to any size of drill within its capacity.



### Write for Free Catalog

and get the full details of this chain drill and our 1500 Good Tools that will make your work easier and more profitable.

**GOODELL-PRATT COMPANY**

*Toolsmiths*

Greenfield, Mass., U. S. A.

Chain Drill  
No. 327

**GOODELL  
PRATT**  
1500 GOOD TOOLS

**NO FOOD FOR ARMY RED CROSS DOGS**—It will be remembered that some time ago the Medical Department of the army received as a gift a litter of pups of the breed used in foreign armies for Red Cross work. By order of the surgeon general the distinguished pups were sent to Fort Ethan Allen, Vt., for Ambulance Company No. 6. As they carried their appetites with them a request was sent for authority to charge to miscellaneous expenses of the Medical Department the cost of a daily allowance for the hungry dogs of six quarts of milk and four loaves of bread, says the Army and Navy Journal. Dogs is dogs, responded the comptroller, and

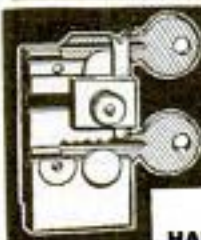

## Duplicate Keys

for all Pin Tumbler Locks made in one minute with Harrison M.I.P. Key Filing Machine. No misfits. Thousands in use. \$3.50 net. Special diamond-shaped files for angular cut keys, 40c each; 3 for \$1.00. Harrison C.K. Key Clamp duplicates all common keys without a caliper. Price, \$1.00. Parcel post prepaid.

Money returned if not satisfactory.

**HARRISON & CO., 81 New St., New York**



## UNION Tool Chests

Mean Great  
Saving of Tools

Compact, roomy, a place for every tool. You know immediately if one is mislaid or borrowed. Drawers strong and perfectly fitted, some lined with felt. Keeps tools safe, clean and free from moisture.

**WRITE FOR OUR CATALOG AND PRICES**  
If dealer near you does not carry "UNIONS" in stock, get our special offer.

**UNION TOOL CHEST WORKS**  
22 Railroad St. ROCHESTER, N. Y.





Do not hesitate when buying a Saw, File, or Planer Knife. Just specify the brand made by

## SIMONDS

"The Saw Makers"

and their guaranty and reputation for making highest grade goods, which must be maintained at all times, is your assurance that you are getting full value for your money and that the Dealer is handling reliable goods.

Students and others interested should write for a free copy of our Manual Training School pamphlet entitled "How to File a Hand Saw."

**Simonds Manufacturing Company**  
Established 1832 Fitchburg, Mass.

5 Factories  
10 Branches

"Tell You It's A Great Saw"

dogs are not included in the appropriation for subsistence supplies nor in the appropriation for the medical and hospital departments. It becomes a question now whether the dogs can hold their appetites until a bill can be passed through congress providing a special appropriation for their benefit.

On account of the war, most of the finest oriental pearls are now being sent direct to America from India, instead of to Paris, as was formerly the case.

**MILLERS FALLS TOOLS**

**Braces Drills Hack Saws Mitre Boxes**

Do Better Work and Last Longer

Write for catalog showing complete line

**MILLERS FALLS CO., Millers Falls, Mass.**

**SAMPLE 75c THE SPEEDY Stitcher**



The greatest invention with which the unskilled man can repair leather goods or any heavy material. Needles and thread are inside the handle. **FAST SELLER.**

**Agents Wanted** Foreign trade solicited. Advertising circulars in different languages.

**Stewart-Skinner Co., 26 Bruce St., Worcester, Mass., U. S. A.**

**TOOL CASES**

For Up-to-Date TOOLMAKERS and MACHINISTS



We carry the finest and most complete line of mechanics' toolcases and tools in the country. We guarantee to please you or refund money. Write for free catalogue.

**J. M. WATERSTON**  
75 Woodward Ave., E., Detroit, Mich.



**How Experts Insure Accuracy**

Fine mechanical work must be laid out accurately and accurately checked up as work progresses. In the finest shops in the world, mechanics maintain accuracy by using

# Starrett

TRADE MARK  
REG. U. S. PAT. OFF.

# Tools

The 2100 styles and sizes in this line include tools for every practical requirement in laying out and measuring mechanical work.

The micrometer shown above is the No. 3, one inch size, with ratchet stop, lock nut, and decimal equivalents. Price \$6.50. Other styles and sizes from \$4.00 up.

Send for free catalog No. 21 A. P. describing the full line.

## The L. S. Starrett Co.

The World's Greatest Toolmakers

**Athol, Mass.**



BY INVITATION MEMBER OF 42-554

NEW YORK, U. S. A.

Please Mention Popular Mechanics



# "YANKEE" TOOLS

*Make Better Mechanics*



**Five Adjustments with this shifter:**

- (1) Plain Drill
- (2) Left-hand Ratchet
- (3) Right-hand Ratchet
- (4) Double Ratchet
- (5) Gears Locked

**Two Speeds**

Besides the various ratchet adjustments, this "YANKEE" Breast Drill has two speeds. The change, fast or slow, is made by a partial turn of this lever, without removing drill from work or changing ratchet movement.

**The DOUBLE Ratchet**

is a big time saver and convenience when work is in close quarters. Any crank, forward or back, causes the drill to cut continuously.

## "YANKEE" Ratchet Breast Drill

No. 555—Two-jaw chuck **Price \$6.25** No. 1555—Three-jaw chuck

appeals to garage men and up-to-date shop workers not only because of the time and labor it saves, as compared with any other tool for like purposes, but because it works with splendid efficiency in ways and places where no other drilling tool can be worked at all.

**"YANKEE" Hand Drills**  
No. 545 and No. 1545—two- and three-jaw chucks. Double speed; and same ratchet movements as above, but made lighter and with polished hardwood handle instead of shank and breast plate. Price, \$5.50

**"YANKEE" Plain Breast Drills**  
No. 455 and No. 1455—two- and three-jaw. Double speed, but without ratchet movements. Price, \$4.00

**Your Dealer Can Supply You**

Write us for "Yankee" Tool Book of Breast and Hand Drills, Bench and Chain Drills, Tap Wrenches, Screw-drivers and other garagetools

**North Bros. Mfg. Co., Philadelphia**

Please Mention Popular Mechanics

# Stanley Tools

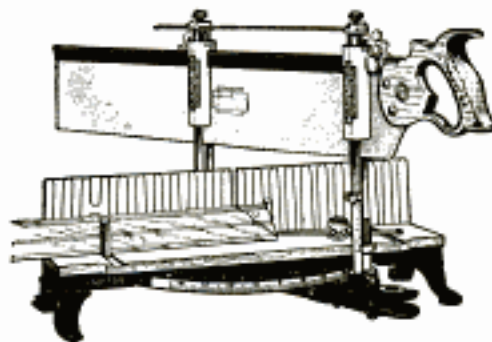

## Stanley Mitre Boxes

are constructed on entirely novel lines and embody exclusive and important features not to be found in any other mitre box. They are thoroly mechanical in design, have all parts made by jig and template, and are interchangeable.

They are compact, strong and durable, are quickly and easily put together or taken apart for ease in carrying, have the greatest strength with the least weight, and will do the widest range of work of any mitre box made. *Special circular upon request.*

MANUFACTURED BY

### STANLEY RULE & LEVEL CO.

New Britain, Conn. U.S.A.

The motor vessel "W. S." was lost in the southern Pacific while on her way from San Diego, Calif., to Mazatlan, Mexico, off Geronimo Island, after having been struck by a whale. The leviathan plunged under the vessel and struck her bottom, opening a large hole. The "W. S." sank quickly, but the crew escaped in life-boats and were rescued by a passing vessel.

## Portable Cases

FOR TOOL MAKERS AND MACHINISTS



Twelve styles, felt lined drawers, solid brass trimmings, best of material, beautiful finish, low prices, satisfaction guaranteed. Ask for booklet of cases built for service.

**The Pilliod Lumber Co.**  
SWANTON, OHIO

## New Book Free

**SIGNAL ENGINEERING**

Write today for the book that tells about the opportunities in the profession of Signal Engineering. Men are needed. Learn, too, how you can get the training that you need to fill the big job.

**\$125 to \$300 a Month**

The free book will give you just the information you want. Write for it now—immediately. Here is a golden opportunity.

Dept. of Signaling Dept. 9191—1810 Wilson Ave. Ravenswood Etc., Chicago, Ill.

## STRADDLE BUG



The most startling Novelty ever gotten out. When it goes off, it would scare the heart out of a wooden Indian. Don't try it on the women folks, or they will faint. Can be wound up in one instant for another victim. **10c**

Great novelty. Sample by mail

## FALSE MUSTACHE & GOATEE



This False Mustache and Goatee will make you look like this picture and your mother would not know you. Can be put on and off in an instant. Mustache and Goatee, both by mail, for **15c**

**ROYAL NOVELTY CO., 250 East Ave., SOUTH NORWALK, CT.**



## CRESCENT TOOLS IN THE MAKING

If you could break a Crescent Wrench, the broken surface would look like the picture at the right, smooth, even texture, tough all the way through.



Ordinary wrench steel breaks more easily because it has a hard outer shell and a porous, brittle interior. (See photograph at left.)

A Crescent Wrench is of uniform hardness and toughness throughout. Crescent heat treating does that and Crescents do not vary, because the steel is made upon our own special formula.



The Crescent name means Quality that never varies, backed by the Crescent Guarantee of Satisfaction or your money back.

Send for free Catalog of Crescent Tools.

CRESCENT TOOL CO., JAMESTOWN, N. Y.



## Acetylene Blow Torch Prest-O-Torch

Quicker and cheaper than a gasoline blow-torch for brazing and soldering



For factories, repair shops, linemen, dentists, jewelers, the Prest-O-Torch saves time and money. Used with Prest-O-Lite Tanks—ready-made gas. Intense, concentrated flame instantly lighted. No depreciation, safe and convenient. Style "A", price, 75c (Canada, 85c) will braze up to 3/4 inch round rod. Style "C" for heavier work, \$2.25 (Canada, \$2.75). Special styles for dentists. Write for literature or send order now. Money refunded if not satisfied.

The Prest-O-Lite Co., Inc. 816 Speedway  
Indianapolis, Ind.  
Canadian Main Office and Factory, Merriton, Ont.

## MECHANIC'S POCKET SECRETARY

Constructed of finest steel. Just push the button and out comes the article you require. Worth \$1.00. Postpaid

15c

Get One Today



15c

10 in 1 -

Adjustable Pencil-pen, paper knife, ink eraser, pencil sharpener, nail file and cleaner, mechanic's marking point, fine compass with screw attachment, foot rule.

ARDEE CO., Dept. 750, STAMFORD, CONN.

# LE PAGE'S GLUE 10¢

BEST BY EVERY TEST

## Going to Build Remodel or Repair?

Write or Send Coupon  
for These Two  
**BIG FREE BOOKS**

Get latest ideas in building from our big 240 page Catalog. It shows most advanced styles in everything from roofing to fine cabinet work—tells you how to save from 1/5 to 1/4 on all kinds of building material. Don't think of building or remodeling without this book. Our Plan Book shows skillfully planned homes of all kinds—bungalows, city houses, suburban residences, country homes, barns. Tells you how to get building plans without one cent of expense—shows the way to big savings in material costs.

Let our architects develop plans from your rough sketches. Send your lumber and millwork bills for free estimate price.



BUILDING  
MATERIAL  
CATALOG

HOUSE

PLANS

CHICAGO MILLWORK SUPPLY CO.  
AMERICA'S GREATEST SASH AND DOOR HOUSE

1444 West 37th Street, CHICAGO

Gentlemen: Please send your FREE Books.

Name.....  
Town.....  
State.....  
Occupation.....

## PIPE-THREADING

5 Big features PLUS the Ratchet make the Bull-Dog Ratchet Die-Stock the handiest, easiest stock for shop, farm, trench, and factory. Every pipe-threading trade knows the 5 big Oster Features—(1) Self-locking dies, (2) Self-centering guides, (3) Dies open up after cut and reset automatically to size—no backing off, (4) No loose bushings, (5) No breakable parts.

Write for catalog  
of 47 hand and  
power thread-  
ing tools—  
gladly  
mailed  
you on  
request.

THE  
OSTER  
MFG.  
COMP-  
ANY  
2100  
East  
61st St.  
CLEVE-  
LAND,  
OHIO,  
U.S.A.

OSTER  
BULL-DOG  
DIE-STOCKS

No. 102R



In use  
without  
ratchet

Catalog,  
please.

Name.....  
Address.....  
City..... State.....  
Occupation..... (2100)

Please Mention Popular Mechanics





## SERIES 18

### The Latest and Greatest X

In Model 18-3 we offer every good feature of every other motorcycle developed to the highest degree of mechanical perfection together with many valuable features that are found in the EXCELSIOR exclusively.

Price \$275.00 F. O. B. Chicago  
Electrical Equipment, \$35 Extra

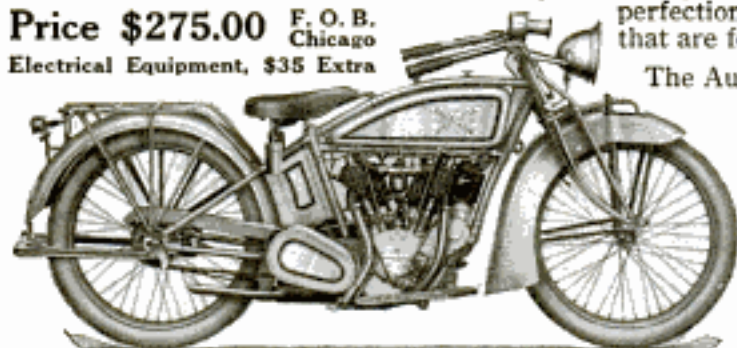

The Automatic Compression Control removes 90% of all the troubles of other types of foot motor starters and enables you to start the motor quickly and easily regardless of weather or other conditions.

The Interlined Chain and Gear Covers eliminate all the noise and rattle incident to the ordinary steel covers.

The New Patented Frame with Detachable Center Bar affords Quick and Easy Access to the cylinders and pistons without removing the motor from the frame or interfering with any part of the crank case or its connections.

The new sidecar lugs, an integral part of the frame forgings, afford a Quick, Secure and Convenient sidecar attachment.

There are many other points, all described in our advance circular. Write for it today.

**Excelsior Motor Manufacturing & Supply Co.**  
3702 Cortland Street, CHICAGO

## \$100 TO \$300 NET PROFIT PER MONTH REPAIRING AUTOTIRES

**With Practically No Capital You Can Start an Independent Business of Your Own That Pays You Big Profits Right From the Beginning.**

In the last few years, with the launching upon the market of hundreds of thousands of low-priced motor cars, the demand for tire-repair work has completely outdistanced the available service. Millions of dollars are spent annually for repairing blowouts, vulcanizing old casings, retreading, mending punctures, etc.

**Take Advantage of This Golden Harvest of Profit—Send for Catalog of Badger Tire Repair Equipment and Learn How We Help You Start a Business.**

Learn how you can establish yourself in a live, money-making business with unlimited possibilities—a business that's practically all cash and over 75% profit. If you don't care to give all your time to it at first, start at home in your "off" hours, using a spare room, attic, basement or shop. This handsome profit is insured by the famous Badger Solid Pad System, with the celebrated Attached Sliding Hinge Clamp and the many other improved, exclusive, up-to-the-minute features. Get the details—learn all about our complete money-making **Free Aid Service**—our special time, labor and money savers—the many helps and hints we give you to get and hold the business.

Mail this Coupon for free catalog and full particulars.

**TIRE REPAIR EQUIPMENT CO.**

Tire Repair  
Equipment Co.  
601 Johnson St.  
Appleton, Wis.

Gentlemen:—Please send me Free  
Catalog of your Badger Attached  
Sliding Hinge-Clamp Steam-Vulcanizer  
and information on how to start a tire re-  
pair business.

NAME.....  
ADDRESS.....  
CITY.....STATE.....

601 Johnson Street  
APPLETON  
WIS.

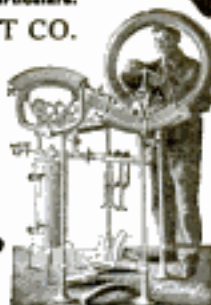

**DEMAND FOR HIGHWAY ENGINEERS**—Owing to the tremendous increase in highway improvement throughout the country during recent years and the growing demand for good roads, highway commissioners report that they anticipate the number of engineers employed by the state-highway departments will be doubled at least, within five years. However, as there has been

## START YOUR FORD FROM THE SEAT

Throw Away Your Crank—  
Start from the Seat with a

### SANDBO 2-Compression STARTER

More than 100,000 sold. Differs from all others.  
Sold on 30 days' trial; positively guaranteed. \$14  
New improved 1937 model. Positive release  
in case of backing. Price, only

**Free** with each Sandbo Starter our wonderful new invention for cold weather starting—the Sandbo Gas Generator. Heats manifold, thus vaporizing the gas, gives warm mixture. Big saving, makes it possible to use cheap gas all winter. Always ready. Genuine attached. Write for particulars. **SANDBO STARTER CO., 86 SANDBO BUILDING, ROCK ISLAND, ILL.**



AGENTS  
DEALERS  
WANTED

**DON'T DO  
THIS**

## VEEDER COUNTERS

register reciprocating movements or revolutions. Any mechanical engineer will tell you that the word Veeder stands for the best constructed and most accurate counting devices in the world.

There are many kinds of Veeder counters, to suit practically every need. Send for our **Free Booklet**, which illustrates our counters and gives much interesting information.

**Cyclometers, Odometers,  
Tachometers. All kinds of  
counters. Fine Die Castings**

**VEEDER MFG. CO.**  
4 Sargeant Street, Hartford, Conn.



**Full Size  
\$1.00**



## Dayton Motor Bicycle

World's Lowest Priced \$100<sup>00</sup>  
Complete Motor Vehicle

NOT a motor attachment for a bicycle, but a complete Motor Bicycle of special construction throughout. 1½ h. p. four-cycle motor. Direct application of power through front wheel drive. No power lost as in chain or belt drive. Speed 25 miles per hour. High tension magneto ignition. Has three-stem rocker spring fork. Steel clincher rims with 2" extra heavy, corrugated-tread tires. Built in men's and ladies' models. Weighs only 125 lbs. Single grip control. Easy to ride and guide.

### We Need Young Men

There is a real opportunity open to one ambitious young man (or firm of young men) in each town where we are not now represented. If you are of a mechanical turn of mind, have a small amount of money, and realize that the only way to get to the top is to have a business of your own, we are ready to

### HELP YOU START IN BUSINESS

with the exclusive agency for the Dayton Motor Bicycle. No competition. No canvassing. No cut-prices. A bona-fide business opportunity for you—backed by a company with more than a million dollars' capital and 50 years' manufacturing experience.

Write for further details.

The Davis  
Sewing Machine Co.  
Cycle Department  
411 Newcom Ave., Dayton, O.



Motorcycle and  
Bicycle Dealers,  
Get Our Agency  
Proposition

## Consulting Accountant Financial Adviser



## Train for This Big Job BY MAIL AT HOME

Give yourself a chance to "get ahead"—to better your position in the world. The LaSalle Home Study Course in Higher Accountancy will prepare you for a permanent position in a new profession—for a position that needs you—wants you.

Just think of it! There are only 2,000 Certified Public Accountants in America. Yet there are over half a million firms that require the services of Expert Accountants. The field is truly unlimited; the demand many times greater than the supply; the salary far in excess of that earned in other fields. With these facts before you, you cannot afford to back back.

## Be An Expert ACCOUNTANT At \$3,000 to \$10,000 a Year

With our training, you can readily qualify for the position of Auditor, Certified Public Accountant, Expert Accountant—be an important factor in the conduct of any business. You will always find the expert accountant is the big man in the office. His knowledge of the innermost secrets of the business makes him indispensable to the boss. He is one of the first men to be consulted in all matters of management and finance, and is confidential adviser in important executive affairs. This is the kind of a position—the kind of a future open to you. Accept the opportunity—NOW!

Our course is under the personal supervision of William Arthur Chase, Ex-president, National Association of C. P. A. Examiners, Ex-Secretary Illinois State Board of Accountancy, and other experts who rank among the highest. We prepare you from the ground up—at small cost and on easy terms. Provide complete and comprehensive training according to your individual needs, from the simplest bookkeeping principles to the most advanced accounting problems. We will give you whatever training, instruction or review on the subject of bookkeeping you may personally need—and without any extra expense to you.

### The LaSalle Guarantee

We will give you a written guarantee that should you fail to pass the Certified Public Accountant's examination held in any state, we will give you special instruction and help—without additional charge—until you do pass. We further agree to refund entire amount of tuition, according to our Guarantee Bond if dissatisfied upon completion of course.

Our big free book tells the whole story. Explains state examinations, state regulations, salaries paid expert accountants, etc.—also gives complete information regarding the course. Take the first step toward greater success by mailing the coupon NOW—today.

LaSalle Extension University, Dept. 164-HA Chicago, Ill.  
"The World's Greatest Extension University."

## Free Book Coupon

LaSalle Extension University, Dept. 164-HA Chicago, Ill.  
"The World's Greatest Extension University."

Send at once, without cost or obligation to me, your valuable book of accounting facts and full details of your course in Higher Accountancy; also advise me about Special Reduced Rate and Convenient-Payment plan.

Name .....

Street and No. ....

City ..... State .....

Please Mention Popular Mechanics

**THE BUELL TOOT! TOOT! TOOT! TOOT!**

**EXPLOSION WHISTLE**

You hear this novel new signal everywhere—a thousand times a day. It's the wonderful Buell Explosion Whistle—the hit of the year. Absolutely different. Operates through priming cup opening in cylinder. Installed in 10 minutes. Never fails. Simply pull cable and it gives loud, powerful blast or soft pleasing note, as you choose. No upkeep cost. Guaranteed for life.

**Free Trial** 3-tone model \$6.00, 1-tone \$4.25. Special Sock Pipe Attachment for Ford \$1.35 extra. Send remittance now—use Buell Whistle 30 days. If not delighted money will be refunded. Live dealers and agents wanted.

Buell Mfg. Co., Dept. H-1, 1610 Mich. Av., Chicago

**THINK** of a detachable bicycle Motor that you can attach to any bicycle in 5 minutes and ride at any speed up to 25 miles an hour—100 to 125 miles on one gallon of gasoline. Thoroughly practical—simple and economical. Full control from one small thumb lever attached to the handle bars of the bicycle.

DESCRIPTIVE LITERATURE ON REQUEST.

**A. O. SMITH COMPANY**  
Motorwheel Division 127  
MILWAUKEE, WISCONSIN

**Garage \$69.50**

10x12feet "Steelcote" Edwards ready-to-use garage, \$69.50 complete. Factory price. Fireproof. Portable. Quickly set up. All styles and sizes of garages and portable buildings. Send postal for illustrated catalog.

**THE EDWARDS MFG. CO.**  
320-370 Eggleston Ave., Cincinnati, O.



## Stop Wasting Gasoline Money!

Every mile you run your car without the New Stromberg Carburetor means gasoline waste. Its economy records on all kinds of cars prove it absolutely the most economical for any car.

And in speed, acceleration, easy starting and power it has broken world's records. Send name, model and year of your car for information.

**Stromberg Motor Devices Co.**

Dept. 114  
64 E. 25th St.  
CHICAGO



New **STROMBERG** Saves It!  
CARBURETOR

## Save Your Worn Tires

**GET 5,000 MILES MORE SERVICE** by 'half-soleing' them with Steel Studded Treads the same as European Motorists have been doing for the past three years. 30,000 American Motorists have done this in the last 8 months and are saving \$50.00 to \$200.00 a year in tire expense.

**5,000 Miles Without Puncture** is the signed guarantee you get with every Durable Steel Studded Tread.

**WE DELIVER FREE** without a cent deposit, prepaid the express and allow you to judge.

**SPECIAL DISCOUNT** offered to motorists in new territory on first shipment direct from the factory.

**THE COLORADO TIRE & LEATHER CO.**

144 Tread Bldg., DENVER, COLO.

A-44 Transportation Bldg. 720-441 Woolworth Bldg.  
CHICAGO, ILL. NEW YORK CITY

**GUARANTEED 5000 MILES WITHOUT PUNCTURE**

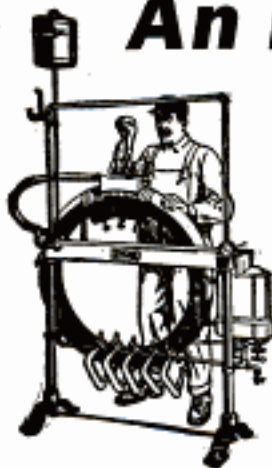

## An Easy Way to Make Money

Don't be content to plod along on a small salary. Be independent. Go in the tire repairing business and make \$60 or more a week. One man made \$45 the first day he received his outfit. Others are making \$25 a day and hundreds of wide-awake men are making \$200 to \$500 a month.

No experience needed. We teach you how. Very little capital required. But slight risk, as every car owner in your town is a possible customer. Jobs are plentiful because tires blow out and puncture every day.

## SHALER Tire Repair Outfit, \$60

will do as much and as perfect work as the big \$250 to \$500 vulcanizing outfits. A boy can vulcanize perfectly with this simple machine. It's the only vulcanizer that has **Automatic Heat Control**. It must vulcanize just right. It can't undercure or overcure a tire. Requires no watching or regulating. You can learn to do expert tire vulcanizing in half an hour with the Shaler.

**WRITE FOR FREE BOOK "HOW TO OPEN A TIRE REPAIR SHOP"** which gives full information.

WRITE QUICK BEFORE SOME HUSTLER GETS AHEAD OF YOU.  
**C. A. SHALER CO., 2011 Fourth Street, WAUPUN, WIS.**

## MAKE YOUR BIKE A MOTORCYCLE

at a small cost, by using our attachable outfit. Fits any Bicycle. Easily attached. No special tools required.

### "Used His Four Years"

*Harry A. Hyatt, of Boreas River, New York, writes: "About four years ago I received my motor attachment, and wish to say that I am satisfied with it in every way, for it has certainly given me good service. Anyone wanting a motorcycle or attachment, I would recommend them to the Shaw Manufacturing Co."*

**FREE BOOK** Write today for bargain list and free booklet, fully describing the SHAW Bicycle Motor Attachment. Motorcycles all makes, new and second-hand, \$35.00 up.

**SHAW MANUFACTURING CO.**  
Dept. 6 GALESBURG, KANSAS



## The Boy's Junior Power Driven Automobile—1917 Model

You can build it yourself or buy it complete already assembled.

Parts inexpensive.

Send 20c for blue print and price list of parts.



**SYPPER MFG. CO.**

146 Warren St., Toledo, Ohio

## \$40 Motorcycles and Bicycles AT CUT PRICES



Second-hand and rebuilt motorcycles, singles and twins, \$25 to \$100. Motorcycle tires, \$3; Automobile tires, \$2. Second-hand bicycles, \$5; tandems, \$10. New bicycles and motorcycles at Factory prices. Day direct, save dealer's profits.

SEND FOR CATALOGUE. **DENINGER CYCLE CO., ROCHESTER, N. Y.**

## STANWELD Cold Drawn SEAMLESS STEEL TUBING

Lightest, smoothest, strongest Steel Tubing made. World's largest manufacturers of bicycles, motorcycles and automobiles use it exclusively. Send for Folder "A."

**THE STANDARD WELDING COMPANY**  
Main Office and Factory CLEVELAND, OHIO



## GET IN THIS BIG MONEY MAKING BUSINESS QUICK



Here is an opportunity to start in a business of your own at very little cost. It gives you the chance to be independent, make big, quick, easy money with an Empire Candy Floss Machine. Hundreds making big success. Profits enormous—over 1,000%. Candy Floss fast seller. Greatest money making business ever.

**Read What Others Are Doing**

N. M. Wendle averaged \$75 to \$128 a day profit; W. F. Mountain made \$100 in 3 days; Sam Gordon took in \$2,000 at White City in a few weeks; F. C. Gardner made and sold 2437 sacks of Candy Floss in ten hours—sales \$121.85—profits over \$115.00—had machine nine years; G. A. Barton made \$411.00 on one barrel sugar costing only \$22; A. J. Model averaged \$35.00 to \$40.00 per day net. Had machine two years.

**Write Quick** for our book. It tells you how to start in this Big Money Making Business that makes 1,000% profit with small amount of money. Big discount in unrepresented territory. Don't delay. Write today.

**FREE BOOK**

**EMPIRE CANDY FLOSS MACHINE CO.**  
2360 Milwaukee Avenue  
Dept. 1, Chicago, Ill.



## The Wonderful New Motorcycle Type

Send the coupon below today for free catalog of the new 1916 "Arrow" Bicycle. Read the sensational improvements in the new 1916 model. Other features, too. Everything to make bicycle riding convenient and a pleasure. Send the coupon for free catalog.

### 1916 Features

#### Electric Light

Reinforced motorcycle frame—large, easy motorcycle saddle—long, rubber grip, motorcycle handlebars—New Departure coaster Brake—special motorcycle pedals—motorcycle mudguards, stand and luggage carrier—imported anti-friction chain—Fisk, Thorn Proof, Non-Skid Tires—beautiful enamel finish—other new features. Write now.

Nothing like this bicycle has ever been offered before. Built with all the durability and elegance of the very highest grade motorcycles. A positive wonder for speed, easy riding and comfort. The biggest bicycle value ever built. All sizes for boys, men and women. Send the coupon today for free catalog.

## Pay As You Ride

Find out about our special rock-bottom direct offer on this New 1916 Arrow. A special 30-day, reduced price offer. We ship the bicycle to you without a penny down. Start riding and enjoying the Arrow right away. And pay the special rock-bottom price—a small amount each month—while you ride. If you do not agree when you see the 1916 Arrow that it is the biggest bicycle bargain you ever saw, send it back at our expense. You be the judge. Send the coupon for free catalog.

**Pays for The coupon brings our liberal Itself:**— rider-agent proposition. The easiest ever! Just ride your Arrow around. People will admire your handsome bicycle and ask about it. Just answer their questions. You can pay for your Arrow and get extra money besides. Just send the coupon for full particulars and New Catalog.

## Send the Coupon Now!

Don't delay. Learn about the sensational 1916 Arrow right away. Take advantage of our special, 30-day rock-bottom price offer. Get the free catalog and details of easy Rider-Agent offer. Send the coupon now while this offer lasts.

**Arrow Cycle Co.**  
Dept. 1191, 19th St.  
and California Ave.  
Chicago, Ill.

Please send me free catalog of the New 1916 Arrow and particulars of your 30-day rock-bottom "Pay-As-You-Ride" Offer and Rider-Agent Proposition.

**Arrow Cycle Co.**

Dept. 1191  
19th Street and  
California Ave.  
Chicago, Ill.

Name.....

Address.....

## Every 1915-16 Ford Needs a

**Gives Strong Light at Low Speed**

**VAN SICKLEN**  
AUTOMATIC  
**HEAD LIGHT CONCENTRATOR**  
FOR FORD CARS  
ASK YOUR DEALER

**Plenty Light on the Worst Roads**

**THE VAN SICKLEN CO., Elgin, Illinois**

## Firestone

### MOTORCYCLE TIRES

Look for the Red Side Wall and Black Tread, the trade mark of Firestone Tires. The same materials and workmanship as in Firestone Automobile Tires.

**FIRESTONE TIRE AND RUBBER CO., AKRON, OHIO**  
Branches and Dealers Everywhere.

## Driver Agents Wanted

Hide in a Bush Car. Pay for it out of your commissions on sales, my agents are making money. Shipments are prompt. Bush Cars guaranteed or money back.



Five-Pass., 30 H. P. 32x3 1/2 tires  
Electric Starting 114-in. Wheelbase  
BUSH MOTOR COMPANY, Bush Temple, Chicago, Illinois

## Build This Speedster \$4 yourself



From Any FORD of materials bought at hardware stores using our full size "Red-i-Kat" patterns and simple instructions. Send two \$2 bills today—Write NOW.

**THE KUEMPEL CO., Design Dept. 2, Dubuque, Iowa**



## Rider Agents Wanted

We want a Rider Agent in every neighborhood to ride and exhibit the new "RANGER." You can select the particular style suited to your own needs. Boys and young men in all parts of the country are riding "Rangers" and taking orders from their friends. Our great output, perfected methods and machinery, enable us to sell "quality" Bicycles at prices below all competitors.

# LATEST MOTORBIKE MODEL

# 30 DAYS FREE TRIAL

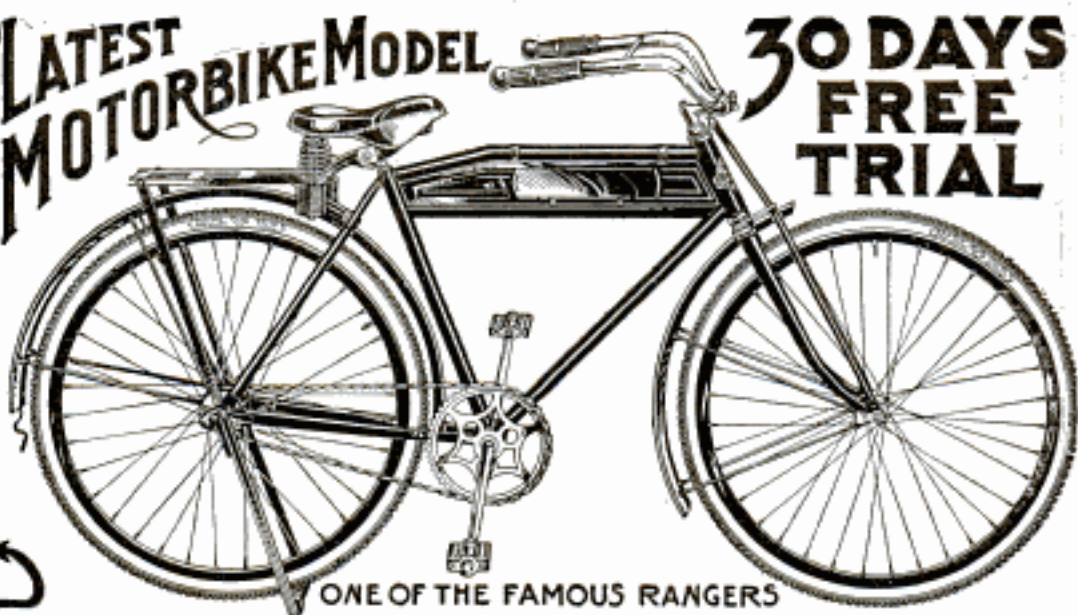

ONE OF THE FAMOUS RANGERS

## Your Choice of Forty-Four (44) Styles, Colors and Sizes in the famous line of "RANGER" Bicycles, shown in full color in our big new 1917 Catalogue just off the press. There are eighty-three (83) others, also, at prices ranging from \$14.75, \$15.75, \$17.75, up. There is a MEAD Bicycle for every rider, at prices made possible only by our FACTORY-DIRECT-TO-RIDER sales plan.

**SEND NO MONEY** but write TODAY for the new 1917 Catalogue of "Ranger" Bicycles, Tires and Sundries at prices so low they will astonish you. Also, full particulars of our great new offer to deliver to you all charges prepaid your choice of any of the 44 kinds of "RANGER" Bicycles you may select, for **ONE MONTH'S FREE TRIAL**. This wonderful offer is absolutely genuine.

**TIRES, LAMPS, Built-up Wheels** with Coaster-Brakes, Inner Tubes, Electric Lighting Outfits, all the newest ideas in Bicycle equipment and Sundries, as well as the Repair Parts and Combination Offers for refitting your old Bicycle—all shown fully illustrated, at **HALF USUAL PRICES**. Our new Catalogue is the largest ever issued by any Bicycle concern. Even if you do not need a new Bicycle now, or Repair Parts, Tires, etc., for your old Bicycle, you need this Catalogue to tell you the prices you should pay when you do buy.

**MEAD CYCLE COMPANY, Dept. A 108**

**CHICAGO, ILLINOIS**



**Buy an Akron-Williams**  
Tire Repair Outfit. Get into this profitable business with the same equipment that is used and endorsed by 90 per cent of the big tire manufacturers and successful repair shops. Write for book giving full details.  
**The Williams Foundry & Machine Co.**  
50 Cherry Street AKRON, OHIO



This Trade-mark is on the highest quality of all kinds of rubber goods.

**Iver Johnson**  
**REVOLVERS SHOT GUNS**  
**BICYCLES MOTORCYCLES**  
Send for 84-page Man's Book—Free  
**Iver Johnson's Arms & Cycle Works**  
307 River Street FITCHBURG, MASS.



Convert Your Bicycle into a Motor-Cycle. Motor fits any wheel. BEST, MOST RELIABLE. Best hill climber. More STEFFEYS in use than all others. Stamp for circulars. STEFFEY MFG. CO., 5007 Brown Street, PHILA., PA.

Write for new Booklet "H"  
**Partin-Palmer "32" \$695**  
Commonwealth Motors Co., Chicago



## The New Way—It's a Big Hit

### The Perfect Garage Door Hanger Set

Allows use of full door opening without risk of damage to car or door, and door cannot swing or blow shut as it automatically fastens itself open.

No extended run-way on either side of building, and no sticking or getting out of order.

Can be opened to any width desired and is weather-tight when closed.

No sawing or cutting of holes necessary to attach.

Ask your hardware dealer—Also send today for descriptive circular, surprisingly low price. DEALERS—Good Profit in This Device.

It sells on sight and the good word is passed along. Architects will want it the minute they see it. Write for terms.

**Safety Door Hanger Co., 101 Topping Bldg., Ashland, Ohio**







15 Cents

1917

QUARTLY  
\$30.00

# POPULAR MECHANICS MAGAZINE



UNSYNCHRONIZABLE  
LIFE BUOY  
SEE PAGE 287

Copyright



# Unusual Homes at Big Savings Costs Guaranteed!

We do more than merely draw beautiful plans. Every Gordon-Van Tine Plan has to be practical—because it must be capable of being figured accurately and because we agree to supply all the material for it at a guaranteed price. On this basis, we have adapted some of the best work of America's leading architects to charming inexpensive homes. Materials, all standard grades and Ready-cut to fit or not Ready-cut as you prefer. Ours is the only book pricing houses both ways. Prompt shipments to you anywhere.

**Write for Our FREE Plan Book** Shows over 200 distinctive homes—cottages, bungalows, town and country houses with photos, plans, Guaranteed Prices. Lists exactly what we supply. Many convenience ideas appealing to women. Over 100,000 customers have built our houses everywhere. Local references. Send for book today. Use coupon.

**Gordon-Van Tine Co.** 6145 Case St., Davenport, Iowa  
Established Half a Century  
Satisfaction Guaranteed or Money Back

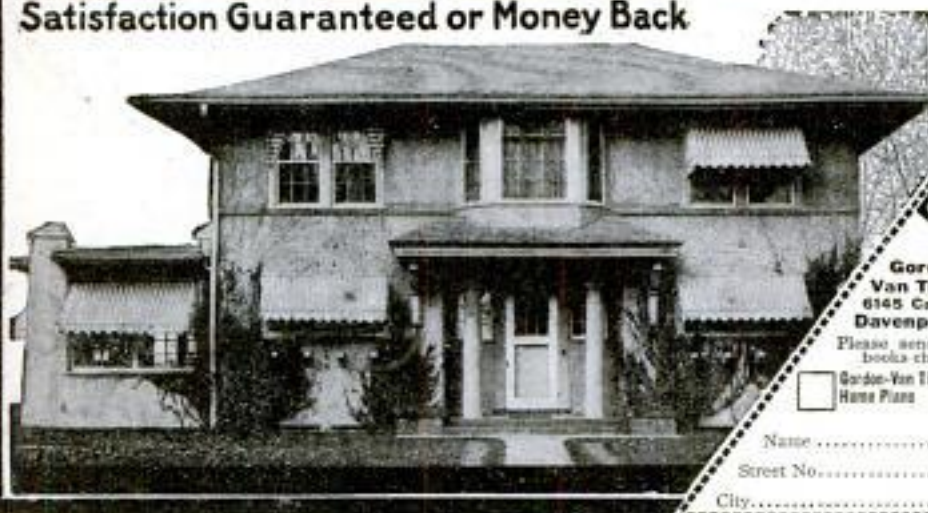

**Gordon-Van Tine Co.**  
6145 Case Street  
Davenport, Iowa

Please send me FREE the books checked below:

Gordon-Van Tine Home Plans  Garages  Greenhouse and Hot Bed for the Home Grower  Summer Cottages

Name .....

Street No. ....

City ..... State .....

A ton of Atlantic Ocean water, evaporated, yields 81 lb. of salt; while equal quantities from the Pacific Ocean and Great Salt Lake, Utah, give 70 and 175 lb., respectively.



## New Book Free

Write today for the book that tells about the opportunities in the profession of Signal Engineering. Men are needed. Learn, too, how you can get the training that you need to fill the big job.

**\$125 to \$300 a Month**

The free book will give you just the information you want. Write for it now—immediately. Here is a golden opportunity.

Dept. 8191 — 1810 Wilson Ave.  
Haweswood St., Chicago, Ill.

## KODAKERS! STARTLING DISCOVERY!

Three simple chemicals added to water develop and fix plates or films in one operation. Automatic and sure; develops until just right, then fixes. Formula \$1.00.

Chromatoscope Co., 51 Adams, Norwalk, Conn.

## Boys' Own Toy Maker

Tells how to make a Talking Machine, Camera, Electrical Motor, Bicycle Boat, Canoe, Boomerang, Bobsled, Wind Mill, Microscope, Water Wheel and Motor, Silla, Toboggan, Snow Coaster and Sail Boat, Telephone, Electric Bell, Railroad Wind Mobile, Paddle Raft, Traps, Kites, etc. All 10c, postpaid.

J. C. DORN, 707 So. Dearborn St., Dept. 80, Chicago, Ill.

# 5¢ A DAY BUYS A GIBSON



Terms as low as \$1.00 down — \$1.50 per month. Mandolin or guitar sent on approval. The wonderful new Gibson violin construction has set the whole Mandolin and Guitar world talking. Get our new Free Book—112 pages—111 illus., a valuable fund of information for player and teacher. Also Free treatise on "How to Practice."

**Exclusive Features That Make Every Gibson Matchless:** Stradivarius arching—scientific graduation from thickness at center to thinness at rim securing strength, sensitiveness, free vibration. **Tilted neck, high bridge and extension string holder** increase the string pressure, vibrate a larger sounding-board securing bigger tone. **Reinforced, non-warpable neck—elevated guard plate or finger rest—easy action—adjustable string bearing** at bridge overcoming sharpening of heavier strings in upper positions.

## Make \$1800 to \$5000 or More a Year Teaching and Selling the Gibson

Become a teacher. Splendid opportunities for either sex in every locality for private and class instruction and sale of Gibsons.

C. V. Bottlerman, Jackson, Mich., Teacher and Director, writes: "A \$3900 Gibson business for mine this year."

Wm. Place, Jr., America's greatest Mandolin Virtuoso, Star Soloist for Victor Talking Machine Co., unqualifiedly endorses the Gibson.

## Do Business On OUR CAPITAL

If a teacher become our agent. Stock furnished. We help sell. Agent's territory protected. You make the profits. We pay the advertising. You pay for goods when sold; return goods not sold. Try our "Sill Hunt."

Catalog and thematic list free. Fill in Coupon NOW.  
**GIBSON MANDOLIN GUITAR CO.**  
161 Harrison Court, Kalamazoo, Mich., U.S.A.

Fill In—Tear Off—Mail Today

**Gibson Mandolin Guitar Co.**  
161 Harrison Ct., Kalamazoo, Mich.  
Gentlemen:—Without obligation, send me free book complete Catalog, free treatise, also information about instrument checked. If teacher check here ( )

- Mandolin  Mando-bass
- Mandola  Guitar
- Mando-cello  Harp-guitar

Name .....

Address .....

Be sure you have checked instrument.

Open—A permanent teaching and business opportunity. Either sex. Other positions pending. Write Promptly.

Please Mention Popular Mechanics



# MOGUL



## Power Cost vs. First Cost

**T**HAT is the principle back of the success and profit of the **Mogul** line of economy engines. The man who buys cheap power is much better off than the one who buys a cheap engine.

**Mogul** engines insure years of satisfaction for purchasers because of their low power cost. They are the most economical engines on the market. They run on kerosene, the cheap fuel; they are famous for their even, steady power under all loads; they are proving their amazing lasting quality, with low cost per year of service.

Write to the address below and we will put you in touch with the nearest branch house, from which you will receive full information. Own a **Mogul** kerosene engine—1 to 50 H. P.

**International Harvester Company of America**  
(Incorporated)

16 Harvester Building CHICAGO U S A

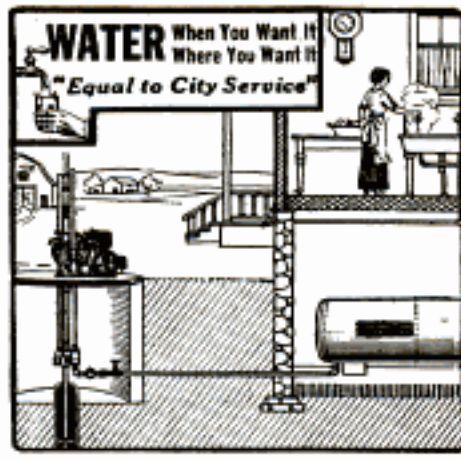

**WATER** When You Want It Where You Want It  
"Equal to City Service"

Water under pressure in your home will make housework easier, add to comfort, and increase the property value.

All water requirements of farm homes are met at moderate cost with our pneumatic pressure outfits.

*May we give you details?*

**Fairbanks, Morse & Co.**  
Chicago New York San Francisco  
and other principal cities

(449-611)

# BAUER KEROSENE ENGINES

Write for free catalogue of the guaranteed, better-built **BAUER Kerosene** engine, before you arrange to try any engine. Sizes, 2, 3, 5, 7, 9, 12, 15 and 18 H.P. Prices average under \$16.50 per horse-power. Cash or Easy Terms. **60 Days' Trial; 5-Year Guarantee.**

**A. F. BAUER ENGINE & MFG. CO., 471 Bauer Block, Kansas City, Mo.**

## SMALL ENGINES



Perfect Gasoline Engines— $\frac{1}{2}$ , 1 and 1 $\frac{1}{2}$  h. p.—for Farm and Shop use. Price \$19.50 and up. Also

## WASHING MACHINES

We ship on trial. Send for Booklet and Special Offer.

**SIEVERKROPP ENGINE CO.**  
1224 18th St. RACINE, WIS.

## STARTER for FORD CARS

## 4 H.P. Cushman Weighs Only 190 lbs. 8 H.P. 2 Cylinder Only 320 lbs.

Discussing light-weight motors recently, the Scientific American said: "Efficiency means light weight, reduced friction, and above everything else, lowered operating cost." Cushman Light-weight engines are today recognized as the leading American light-weight, high efficiency, all-purpose motors, challenging comparison in minimum weight per horsepower, reduced friction, quality of material and workmanship and cost of operation.

Sizes 4 to 20 H. P. Throttle Governor. Schelder Carburetor. Forced Water Cooling System. Moving parts enclosed and run in bath of oil. Not cheap engines, but cheap in the long run. **ENGINE BOOK FREE.**

**Cushman Motor Works**  
882 N. 21st St., LINCOLN, NEB.



Handy Truck

# Don't Wear a Truss



**Brooks' Appliance**, the modern scientific invention, the wonderful new discovery that relieves rupture will be sent on trial. No obnoxious springs or pads.

## Brooks' Rupture Appliance

Has automatic Air Cushions. Binds and draws the broken parts together as you would a broken limb. No salves. No lies. Durable, cheap. Sent on trial to prove it. Protected by U. S. patents. Catalogue and measure blanks mailed free. Send name and address today.

**C. E. BROOKS, 126 State St., Marshall, Mich.**

## GREEN AUTOMATIC MACHINE



## LARGE PROFITS FROM SMALL CAPITAL

Start a business of your own bringing an income of \$5 to \$10 a day with practically no experience or overhead expense.

## The GREEN AUTOMATIC MACHINE

Sharpens, Honors, and Strops all kinds of safety razor blades, in one operation, from four to six blades per minute. For both Quality and Quantity this machine is in a class by itself. There is nothing like it on the market. Let us send you our free booklet explaining everything, including the "AMERICAN" Key Cutter—cuts square, angular or round slots.

**AMERICAN SHARPENING MACHINE CO. (Inc.), Dept. 1, 184 W. Washington St., CHICAGO**



**"AMERICAN" Key Cutter**



## DIVINE Red Devil Water Motor

4 inch size  
6 inch size

A perfect small motor — made like the big turbines — wonderful power.

No muss—no fuss—no mechanical complications. Attach in cellar or at any faucet.

4-inch size for Polishing 6-inch size for Power

Only Motor  
to do  
This Work

For Mechanics, Tradesmen, Doctors, Dentists, Shop and Home

Anyone can install. We also supply pulley, emery and buffing wheel. Free Booklet describes work it can do.

Write today and give size of faucet, water pipe and water pressure and work to be done. Divine Water Motor Co., Dept. P, Utica, N. Y.



## Japanese Rose Bushes

Five for 10c THE WONDER of the WORLD

Rose Bushes with roses on them in 8 weeks from the time the seed was planted. It may not seem possible, but we Guarantee it to be so. They will

**BLOOM EVERY TEN WEEKS**

Winter or Summer, and when 3 years old will have 5 or 6 hundred roses on each bush. Will grow in the house in the Winter as well as in the ground in Summer. Roses All the Year Around. Package of seed with our guarantee, by mail, only 10c.



## Peanuts Can Be Grown

in every State in the Union. Require

no more attention than potatoes.

Plant in January in boxes in the

house; transplant to the garden

in spring. Boys can grow

enough for the family in a

very small garden and can

have some to sell, as they produce

100 bushels to the acre. Package of seed, 10 cents.



JAPAN SEED COMPANY, 250 East Ave., SOUTH NORWALK, CONN.

## New Book Free

Write today for the book that tells about the opportunities in the profession of Signal Engineering. Men are needed. Learn, too, how you can get the training that you need to fill the big job.

**\$125 to \$300 a Month**

The free book will give you just the information you want. Write for it now — immediately. Here is a golden opportunity.

Dept. of Signaling Dept. 8191 — 1010 Wilson Ave., Evanston, Ill., Chicago, Ill.

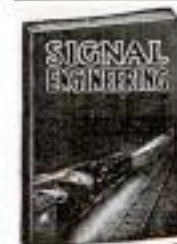

## AGENTS \$60 WEEKLY

Robinson Folding Bath Tub. Big seller. Costs little, no plumbing, little water. Weight 35 pounds, folds into small roll. Full length bath, far better than tin tubs. Guaranteed 10 years. \$10 a day easily made. Write for free tub offer.

ROBINSON CABINET MFG. CO. 4507 Factory Bldg., Toledo, Ohio

## Comfort Indoor Closet

Odorless Sanitary Germ-Proof

Every home without sewerage needs one. Most convenient, meritorious home necessity in a century. A boon to sick people. Can be placed anywhere in the house.

### Abolish Outdoor Closet

Put a warm Comfort Toilet in your home, a guarantee of healthy, sanitary conditions. Germ-life killed by chemicals in retort. Emptied once a month—no trouble. Needs no other attention. Boards of Health endorse it. Write now for literature, prices, etc.

Agents Wanted — exclusive territories.

COMFORT CHEMICAL CLOSET CO. 381 Factory Bldg., TOLEDO, OHIO



Send on Free Trial 30 days

"NEW-SKIN"—  
TO PREVENT  
INFECTION



## "NEW-SKIN"

— for Foot Relief

A man writes us — "I use New-Skin very often on my feet. It's a great trouble-saver to the 'hiker' if applied to the spot when it first starts to rub."

Try it yourself. Paint the tender spots on your feet with New-Skin.

New-Skin forms a tough, elastic, water-proof film over the tender spot. It keeps the shoe away from the skin. And the "shoe is the rub". Have good, comfortable feet in spite of your shoes. You can do it with New-Skin. Two sizes — 10c and 25c.

NEWSKIN CO., NEW YORK

# No Money In Advance

This Marvelous Camera on FREE TRIAL!

Only 10,000 of these marvelous, instantaneous picture-taking and making cameras to be sent out absolutely on approval without a penny in advance just to prove that it is the most wonderful invention—the camera sensation of the age. So you must send for it quick!



Just think of it—the new Mandel-ette takes and makes finished pictures

### INSTANTLY!

You press the button, drop card in developer and in one minute take out a perfect, finished post card photo. Size 2 1/2 inches in size. Camera, itself, is about 4 1/2 x 7 inches. Loads in daylight 16 to 50 post cards at one time. No Film—no Plates—no Dark Room. Not a bit of the mess and bother of the ordinary kodak or camera. It is instantaneous photography. Universal Focus lens produces sharp pictures at all distances. Pictures develop and print automatically. Can't overdevelop! results simply amazing.

### WE TRUST YOU

No difference who you are, where you live or what your age, we will send you the complete "Mandel-ette" outfit absolutely on approval and give you 10 days to test it. If not satisfactory return it. But when you see what elegant pictures it takes—so quick, so easy, with no trouble at all—if you wish to keep it you simply send us \$1.50 per month until our special price.

Payments—no Referrals. No red tape of any kind. No Experience Required. Plain instructions and everything complete with outfit so you can begin taking pictures the moment it arrives. We guarantee that even a child can operate it. Mail coupon right now. No risk or obligation to keep camera.

Send me at once one complete model Mandel-ette Camera outfit, including supply of post cards and instructions. I agree to examine and test it thoroughly and if satisfied keep it and pay you \$1 a month until your special price of \$5 is paid. Otherwise I will return it at the end of 10 days.

Name.....  
St. and No.....  
Town..... State.....



## WE ARE HEADQUARTERS FOR ELECTRICAL GOODS and WIRELESS APPARATUS

Send Today for a Copy of Our Unrivalled 232 Page Catalogue

### THIS IS THE Experimenter's Reference Book

It's the latest edition of the famous Amco Catalogue, contains over 200 pages and is fully illustrated. Complete description and prices of the latest electrical and experimental apparatus—Storage Batteries, Rectifiers, Transformers, Induction Coils, Wireless Apparatus, Lamps, Flashlights, Motors, X-Rays, Books, Tools, Electric Railways, Steam Engines, Water Motors, Dynamom, Motors, Telegraphs, Telephones, Electrical Supplies, Model Aeroplanes and Parts for building your own apparatus.

**Our prices will save you money and our prompt deliveries will save you time.**

So in stamps will bring you this wonderful book. Best catalog of Wireless and Electrical Apparatus, etc., published. Send for this catalog right away. Our prices will save you money. 5c IN STAMPS BRINGS IT BY RETURN MAIL.

**Send for this catalog today. You need it.**

#### FUN WITH ELECTRICITY

Here is a rare chance to get started right in your study of electricity. This wonderful outfit contains 55 page book of instructions and all the apparatus for performing 60 interesting and spectacular experiments which will give any boy a practical knowledge of electricity.

Price Only 50c. Postage 10c Extra

#### FUN WITH MAGNETISM

This outfit contains 32 page book of instructions and all the apparatus for performing 61 fascinating experiments. It will give you some new ideas about electricity and magnetism in such an interesting way you can't help remembering it. Price only 25c. Postage extra 5c.

**ADAMS-MORGAN COMPANY, "The Experimenter's Supply House"**

#### LOTS OF FUN FOR BOYS!

2½ volt, 2 C. P. TUNGSTEN lamp, switch, socket, 20 ft. insulated wire and 5 cells of dry battery all ready to install. May be used to light a dark closet or hall.

Price only 50c. Postage extra 15c.

#### LITTLE GIANT MOTOR

Is nearly 3 in. high. Runs at high speed on a single cell of battery. Very powerful and may be used to run small toys, etc. Just the motor every boy has been looking for. Price 50c. Postage 10c extra.

#### THE SIMPLEX TELEGRAPH OUTFIT

An opportunity for every boy to learn to telegraph and to put up a line with his class. This is a full sized telegraph set, consisting of a fine key and sounder, mounted on a polished base. Will work any distance. An excellent Field Telegraph for Boy Scouts.

Price, \$1.00. Postage Extra. Weight 2 lbs.

#### UPRIGHT STEAM ENGINE

A fine engine of the best materials. 9 in. high. The Right Engine for Any Boy. Runs at high speed. Each engine tested at factory and fully warranted. Price 60c. Postage 10c extra.

#### SIMPLEX WIRELESS OUTFIT

Every boy wants a wireless. Get in this interesting game and read the messages flying around you. This outfit is the greatest bargain ever offered. Consists of a large double slide tuner, a sensitive detector, condenser, telephone receiver and cord. Weight 3 lbs. Special Price, Complete, \$2.50. Postage Extra.

#### UNICOIL ELECTRIC MOTOR

This motor will spin for hours at high speed on a single cell of battery. Develops considerable power. Embodies a new principle in toy motors. The best motor value on the market. Sent Postpaid for 50c. Don't Forget to Send for a Catalog.

25 Alvin Place, UPPER MONTCLAIR, N. J.

## ELECTRICAL



and Radio Telegraph apparatus selected from our catalogs are unequalled as practical holiday gifts. Complete catalogs and bulletin of storage battery chargers sent for 6c stamps.

**CLAPP-EASTHAM CO.**

147 Main Street

CAMBRIDGE, MASS.



**Boy Electrician** with 75 illustrations for making Batteries, Dynamom, Motors, Telegraph apparatus, Telephone, Lights, Bells, Alarms, Coils, "Wireless" Current Reverser, Electric Engine, Etc. By Electrical Experts so that anyone can understand it. With Cat. All 10c Ppd.

J. C. DORN, 705 So. Dearborn St., Dept. 100, Chicago, Ill.

## THORDARSON Wireless Transformer

The best 1 K. W. Transformer ever designed. Result of twenty years of patient experiment by Mr. C. H. Thordarson, the "Transformer Wizard." Its exclusive Variable Shunt and Ampere Scale make it wonderfully accurate in obtaining resonance. Comes completely assembled—no chance for mistakes or burn-outs. Five sizes, ½ to 2½ K. W., 10,000-20,000 volts, any cycle desired.

WRITE FOR SPECIAL BULLETIN AND PRICES  
**THORDARSON ELECTRIC MFG. CO.**  
518 So. Jefferson St., Chicago, Ill.



### THE AMERICAN MODEL BUILDER

WRITE FOR CATALOG

**The American Mechanical Toy Co.**  
301 E. First Street DAYTON, OHIO

## Send 10c for Copy of Our New Wireless Manual P. 9

YOU GET YOUR MONEY BACK ON AN ORDER OF \$1.00



It contains 180 pages and tells how to erect and maintain wireless telegraph stations. Shows a number of diagrams. Has the Morse and Continental Telegraph Codes. Illustrates the best instruments to use; tells what they are for and how to use them. Has many new diagrams and other valuable information not contained in any other book. Do not wait. Send your request now. Get the best 10c value you will ever buy.

## Send for Our Pocket Catalog P28

It contains 248 pages, with over 1,000 illustrations, and describes in plain, clear language all about Bells, Push Buttons, Batteries, Telephone and Telegraph Material, Electric Toys, Burglar and Fire Alarm Contrivances, Electric Call Bells, Electric Alarm Clocks, Medical Batteries, Motor Boat Horns, Electrically Heated Apparatus, Battery Connectors, Switches, Battery Gauges, Wireless Telegraph Instruments, Ignition Supplies, Etc.

**MANHATTAN ELECTRICAL SUPPLY COMPANY, Inc.**

NEW YORK, 17 Park Place

CHICAGO, 114 So. 5th Ave.

ST. LOUIS, 1106 Pine St.

San Francisco, 604 Mission St.





## GET THE FAINT SIGNALS

*Holtzer-Cabot*

### RADIO PHONES

are pronounced by experienced operators to be the most sensitive phones on the market. Satisfaction guaranteed or your money back.

SEND FOR NEW BOOKLET "P."

**HOLTZER-CABOT ELECTRIC CO.**  
BOSTON, MASS.  
1161-63 SO. STATE ST. CHICAGO  
105 PARK AVENUE NEW YORK  
3104 UNION TRUST BLDG. BALTIMORE



## "What's That S. O. S.?"

When you have a Brandes Head Set, the signals come in loud and clear and you're not in doubt. For Brandes Wireless Receivers are extremely sensitive, both receivers in a set

perfectly matched in tone. A "Superior" 2000 Ohm set at \$5.50 will give you more real sport than the money invested any other way.

Send 4c today for 16 page catalog P which explains "Matched Tone."

C. BRANDES, Inc., Room 817, 32 Union Square, NEW YORK

## BRANDES WIRELESS RECEIVERS

*The Receivers with Matched Tone*

## DEPENDABLE KNAPP Dynamo Motor ELECTRIC SPECIALTIES FOR BOYS \$5

For producing current for inductance coils, re-charging storage batteries, electroplating, and hundreds of other uses.

Well constructed throughout, exceptionally smooth running and highly efficient. A good, strong, durable dynamo.

At all live dealers. Or order direct from us.

Send for free illustrated catalog.

KNAPP ELECTRIC & NOVELTY CO.  
619 W. 51 St., N. Y. City



## ELECTRICAL HANDY BOOK AND CATALOGUE FREE

WORTH 25 CENTS TO ANYBODY

The BIG BOOK you need and want. Describing positively the finest and most complete line of wireless, novelty, and experimental goods ever listed in any catalog and containing besides, innumerable tables, hook-ups and treatises of inestimable value to the experimenter. Absolutely Free. Send No Postage.

THE ELECTRO-SET COMPANY  
Leader Bldg., Dept. P-8 Cleveland, Ohio

## Build a WAR Aeroplane

"Ideal," accurate Scale Drawings enable you to build easily EXACT 3 Ft. FLYING MODELS of aeroplanes now used in EUROPEAN WAR. Study aerodynamics.

Build a model man-carrying machine. Building and Flying instructions at following prices:

Curtiss Flying Boat 25c  
Curtiss Military Trainer 25c  
Hydroaeroplane 35c  
Nieuport M'n'plane 25c  
Bleriot Monoplane 15c  
Taube Monoplane... 25c  
Wright Biplane... 25c  
Cecil Peoli Racer... 25c

Complete Set of Eight, \$1.60 postpaid

GET OUR latest catalog of Model Aeroplanes and Supplies, 32 pages, Postpaid, 3c.

BE SURE to read our ad in the December number on page 169.

It illustrates and describes all Ideal Aeroplanes.

Ideal Aeroplane & Supply Co., 82-85 West Broadway, New York

## ANY WATCH YOU WANT on CREDIT



### 1917 Models

**WALTHAM  
HAMILTON  
ELGIN, MILLER  
Illinois, Howard**

Sent on 30 Days Free Trial

## No Money Down

Express Prepaid in Advance by Me

You take no chances with me. I am "Square Deal" Miller and I trust the people. That is why I am doing the greatest Credit Watch, Diamond and Jewelry business in the country. Suppose you want any one of the country's best makes of watches? Name any one, I have it for you. No money Down, Express Prepaid. A full month to carry it in your pocket and the easiest of Long Time Payments. That's the test that tells. All these watches GUARANTEED 25 YEARS

## I Smash the Terms

No References Demanded

My terms are made to suit you. You get unlimited credit, with no red tape, notes or collectors. All unnecessary detail left out.

An "Open Charge" Account

the same kind of credit you get from your grocer. No matter where you live or what your income is, you can now own the finest watch, a beautiful diamond or any rare jewelry and never miss the money.

## Costly Catalog FREE

Send me your name and address so I can mail you. Free and postpaid, the most beautiful catalog of its kind ever printed. I want you to have this book. It's a gem. It illustrates all makes of valuable Watches, Elegant Genuine Diamonds, and a vast assortment of Beautiful Jewelry, all on the easiest and most liberal terms

**Square Deal MILLER  
PRES.**

792 Miller Bldg., Detroit, Mich.

BE THRIFTY  
BUY A DIAMOND  
PAY MONTHLY

MONEY REFUNDED  
IF YOU CAN BUY  
CHEAPER  
FOR CASH.



Fine Diamonds

**SQUARE DEAL  
MILLER  
PRES.**

Fine Diamonds

Our diamonds are all perfect-cut beautiful stones, white in color and lots of fire.

You cannot buy by mail better diamonds at any price than we are selling on credit.

### FREE CATALOG COUPON

**SQUARE DEAL MILLER, Pres.**  
792 Miller Bldg., Detroit, Mich.

Please send me your 1917 Catalog and explain fully your 30 Day Trial Plan and Easy Terms

Name.....

Address.....



**OWN A STORE LIKE THIS! YOU CAN!**

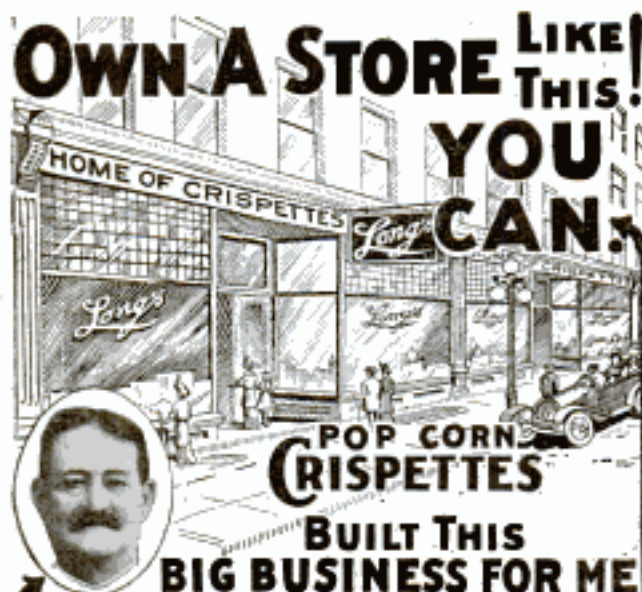

**POP CORN CRISPETTES**

**BUILT THIS BIG BUSINESS FOR ME**

**FREE SECRET FORMULA FOR MAKING CRISPETTES**

Here's a chance for every ambitious man to get into a big money-making business for himself. Requires no experience and but little capital. Once I was just a struggling candy maker. The profits from Crispettes — the new delicious pop corn confection — built this big business for me. The very same proposition that made me should do the same for you. I'll furnish everything — teach you Free — show you how to make Crispettes by my secret formula — show you how to succeed. You can build a business of your own as I did. Get a window — a small store — a cozy nook in a theatre lobby or similar location where the rent is low. Start the business. Keep all the profits.

**Every Nickel You Take In Nets You Almost Four Cents Profit**

The demand for Crispettes is enormous — everybody everywhere likes them. One sale means two, two means four and so it goes. Think of the fortunes made in 3c pieces. It's a great business. I found it so. So should you. Come to Springfield and see all this for yourself. Drop in quietly. Ask anybody about Long about my store. Ask them if what I say isn't the truth. See the Crispette Machine just like I'll furnish you. See Crispettes made. Make a batch yourself. It's so simple, easy. You'll see — know — learn all about this business. Up to a distance of 300 miles I'll pay your railroad fare if you decide to go into the business.

**Send for My FREE Book**

"Dollars and Sense in the Crispette Business." It tells the complete story — gives all information. It's mighty interesting reading. Tells what others have done and what you can do. Write for it today.

**W. Z. Long Company**  
1299 High St., Springfield, O.

This Machine Makes Big Money

**Wireless Receivers?**

Get a **Murdock 2000-ohm \$4** complete double set for and prove to your own satisfaction that there are no better 'phones obtainable at **DOUBLE** the prices. Fourteen days' trial allowed and money back without question if you are not sufficiently convinced of the remarkable value to keep them.

Our catalog is free. Ask for a copy.

**WM. J. MURDOCK CO.** 10 CARTER ST. Chelsea, Mass.

Please Mention Popular Mechanics

**Electric Light for Your Home**

Uni-Lectric lighting plant generates standard 110-volt direct current; operates from one to 50 lights, electric motor, electric iron, vacuum cleaner, electric toaster, force pump, churn, washing machine, etc.

**No Batteries — No Switch-Board** and a better machine for less money. High speed gasoline motor, generator and automatic governor, all complete in one small, compact unit. Uses standard lamps and fixtures. Simple, easily installed, dependable, economical. Costs less than other systems to buy and to operate.

**WATERMAN MOTOR COMPANY**  
182 Mt. Elliott Ave. DETROIT, MICH.

Write today for full description and low price.

**Uni-Lectric**  
GASOLINE-ELECTRIC UNIT LIGHTING SYSTEM



**RECTIFIERS** for garages. All sizes. Charge from alternating current 1 to 8 batteries. \$12.00 upwards. **AMERICAN BATTERY CO., 1137 Fulton St., Chicago. (Estb. 1885)**

**DUCK'S BIG 300 PAGE No. 10 Electrical and Wireless Catalog**

Mailed on receipt of 8c in stamps or coin which may be deducted on first dollar purchase. Great cost of catalog and low prices prohibit distribution otherwise. **What This Big Catalog Contains:**

100 pp. Wireless Apparatus; 10 pp. Raw Material; 5 pp. Transformers; 8 pp. Storage Batteries; 15 pp. Telegraph Instruments; 42 pp. Motors and Dynamos; 10 pp. Miniature Lamps; 8 pp. Flashlights; 5 pp. Massage Vibrators; 10 pp. Miniature Railways; 5 pp. Lighting Plants; 10 pp. Ammeters and Voltmeters; 25 pp. Electrical and Mechanical Books; 12 pp. Telephone Equipment; 10 pp. Auto Accessories; 13 pp. Victrolas on Easy Payment Purchase Plan; 30 pp. General Electrical Supplies.

**THE WILLIAM B. DUCK CO., 223-227 Superior St., TOLEDO, OHIO**

**Better Quality**

**At Wholesale Prices**

Direct from manufacturers, who can save you \$10 to \$30 on the best range made. Newest designs — white enamel splasher backs, etc. **Write for Catalog.** Take a Kalamazoo on our 30 days' trial plan and see what you can save. **We pay freight — quick shipment.** Ask for Catalog No. 473. **KALAMAZOO STOVE CO., Manufacturers Kalamazoo Michigan**

**A Kalamazoo Direct to You**



# Now You Can Own a Camera for Less Money!

# \$8<sup>25</sup>

Buy  
This  
Vest  
Pocket  
Autographic  
Kodak with  
F.7.7 Anastig-  
mat lens—Reg-  
ular \$10 Model.



Get an Eastman Kodak, a Graflex, in fact, almost any camera you want, at 15% to 50% less than regular list price. You can get a perfect, used machine at a wonderful saving.

Trade your old camera to us—save money—own a better camera. For over 30 years professionals and amateurs the country over have saved money through our service.

10 Days' Trial Guarantee backs every outfit. We insist on satisfying you or return your money.

This is without doubt the greatest camera opportunity ever offered. We will positively save you money on any camera. Be sure and write us today. Address

DAVID STERN COMPANY (Established 1885)  
(The National Camera Exchange)  
1047-G Madison Street CHICAGO, ILLINOIS



## New Book Free

Write today for the book that tells about the opportunities in the profession of Signal Engineering. Men are needed. Learn, too, how you can get the training that you need to fill the big job.

**\$125 to \$300 a Month**

The free book will give you just the information you want. Write for it now—immediately. Here is a golden opportunity.

Dept. of Signaling Dept. 9191 — 1810 Wilson Ave.,  
Haweswood Sta., Chicago, Ill.

## "I Would Not Part With It for \$10,000"

So writes an enthusiastic, grateful customer. "Worth its weight in gold," says another. In like manner testify over 100,000 people who have worn it.

## The Natural Body Brace For MEN and WOMEN

Develops erect, graceful figure;  
overcomes WEAKNESS and  
AILMENTS of Women & Men.

Brings womanly beauty and  
manly strength, restful relief,  
ability to work and enjoy life.

### Makes You Feel Good and Look Good

Does away with the strain and pain of standing and walking; replaces and supports misplaced internal organs; reduces enlarged abdomen; straightens and strengthens the back; corrects stooping shoulders; develops lungs, chest and bust; relieves backache, curvatures, nervousness, ruptures. Easy to wear.

### Wear It 30 Days Free at Our Expense

Write today for illustrated booklet, measurement blank, etc., and read our very liberal proposition.

HOWARD C. RASH, Pres. Natural Body Brace Co.  
223 Rash Building SALINA, KANSAS



For  
Children  
Also

# 10 Days Free Trial

YES, we will send you the Violin of your choice for full 10 days' free trial. Play on it—test it in every way before you decide whether you wish to buy or not. Compare it with other instruments—then if you are not more than satisfied, Send it back at our expense. You do not pay us a penny for the use of the violin. Write for circular.

## Your Choice of Instruments

Write today for our new Violin catalog and see handsome illustrations in full color of all the superb instruments that you have to choose from.

There you will find illustrated products of the leading violin makers of the world—

Fanny, Bander, Giller, Heberlein, Fiedler, Wurlitzer and many others. Violins of the highest grade, as well as those of moderate price—all special values. Priced from \$2.70 to \$50.00, and from \$60.00 to \$250.00.

### Rare Old Violins

Our collection of rare old violins is one of the largest in America. Write today for Special Art Catalog.



# WURLITZER

200 years of instrument making

Get the benefit of our mammoth facilities for buying in large quantities. The house that supplies the United States Government now makes a startling money-saving offer direct to you. Write for circular.



10c a Day

now have this superb Lyric Cornet. Exquisite triple silver-plated long model Lyric Cornet direct to you on a startling offer. Ten days free trial before you decide to buy. Liberal allowance for old instruments. Write today for 228-page Catalog—showing 2281 instruments that you have to choose from.

## Pay as You Wish

If you decide to keep the violin you have selected after you have tested it out for ten full days, pay the rock bottom price at the rate of only a few cents a day. No red tape. No collectors or mortgages. Your credit is good with the House of Wurlitzer.

## Send the Coupon

Put your name and address on the coupon now and indicate catalogue matter you wish us to send you. Absolutely no obligation in sending the coupon. Do it now. Find out about the startling money-saving offer we are making. Write today—send Coupon or a Letter or a Post-card.

### The Rudolph Wurlitzer Co.

Dept. 9191  
East 4th Street,  
Cincinnati, O.  
So. Wabash  
Avenue,  
Chicago

### The Rudolph Wurlitzer Co.

Dept. 9191  
S. Wabash Av., Chicago  
4th St., Cincinnati

- Gentlemen:—Please send me without obligations, free and prepaid the catalog matter checked below:
- The special violin circular.
  - Special low priced violins under \$15.00
  - Your 228 page illustrated catalog of musical instruments.
  - Catalog of music stands, cases and other strung instrument accessories.
  - Art catalog of rare old violins.

Address.....

Name.....

Please Mention Popular Mechanics





ED. H. WITTE

## BUY ON YOUR OWN TERMS

I Have Now Made it Possible for Every Worthy, Creditable Man in the United States to Buy a High-Grade WITTE Engine.

ONLY a big successful engine factory, making thousands of engines yearly and selling direct to users, could offer you the engine quality and engine terms that I can. If you need an engine, either Kerosene or Gasoline, for any purpose—Pumping, Grinding, Wood-Sawing, Spraying, Cream Separating, Silo Filling, or you have shop machinery to operate—

**Try a WITTE Engine  
90 Days**

Do your work—Prove that a WITTE Engine is the biggest engine value on the market, that WITTE prices will save you a lot of money. Your WITTE Engine if taken care of will be just as good ten or twenty years from now as the day you start it. Some are using WITTE Engines built 20, 25 and 30 years ago. I guarantee any WITTE Engine you select for **Five Years from Date of Purchase**, and my Guarantee has a Million Dollar Factory back of it.

**NO  
MONEY  
DOWN**  
Easy Payments  
Bank Deposit  
or  
**CASH**

THE low prices I am able to quote are possible only because of the large number of engines I am able to produce and sell. The more engines I can sell, the less it costs to manufacture, the more material I can buy at reduced rates. I make nothing but engines—sell them direct from the factory—and when I tell you that I can save half your engine money, I mean just what I say. You take no more chance in buying from me, than you would to draw money from one bank and deposit it in another. I can ship your engine at once—Save you from \$25 to \$100.

**FREE, Postpaid.** My New 1916 Book, "How to Judge Engines." Tells you how to properly judge engines, and describes the many distinctive and desirable WITTE features that you cannot get in other engines. Write me today for this Free Book.—Ed. H. Witte,

**WITTE ENGINE WORKS, 1747 Oakland Ave., Kansas City, Mo.  
1747 Empire Bldg., Pittsburgh, Pa.**

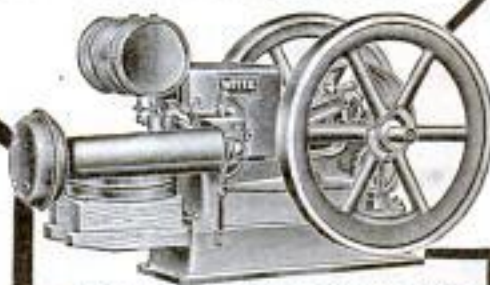

The above shows my latest type Kerosene Engine. Built in Sizes 2, 3, 4, 6, 8, 12, 16 and 22 H.P.

**Generator Sets**  
4 k. w. capacity. Voltage 60 or 110. No flicker. High grade 4-cylinder, 4-cycle motor, fully guaranteed. Write for Bulletin No. 20  
**UNIVERSAL MOTOR COMPANY**  
Dept. P Oshkosh, Wisconsin

**Motor Perfection**  
is what you get in Watkins Class "B" all iron motors. Especially fine for canoes and light boats. Constant and efficient.  
8 H. P. single cylinder . . . 45 lbs.  
6 H. P. double cylinder . . . 85 lbs.  
12 H. P. four cylinder . . . 155 lbs.  
Are light, at the same time strong, accomplished by using semi-steel castings, high carbon steel shaft, bronze bearings, high class workmanship.  
**THE WATKINS MOTOR CO.**  
837-839 W. 6th Street Cincinnati, Ohio

GET THIS CATALOG  
FULL OF VALUABLE INFORMATION TO EVERY BOAT OWNER ON  
**RACING PROPELLER WHEELS,  
REVERSE GEARS AND  
MARINE ACCESSORIES**  
LARGE CATALOG FREE SEND TODAY  
**MICHIGAN WHEEL CO.**  
5129 MONROE AVE. GRAND RAPIDS, MICH.

**FREE!—3 Books on BOATS**  
1—Special Boats of 130 Leading Boat Builders.  
2—Gray 2 and 4 cycle Motor Engine Catalogue.  
3—Book of Boat Models for work, fishing, cruising.  
Ask for any (or all) of them if you are interested in boating for pleasure, or profit. Book 1 shows more boats than motor show.  
**Gray Motor Company**  
146 Gray Motor Bldg.  
Detroit, Mich.

### The Engine That Stays in Tune

Absence of vibration is indispensable to continued "sweet-running" of a marine motor.

The Ferro All-Enclosed Four-Cycle "Four" and "Six" for medium-duty are remarkably free from vibration because they are cast in one piece and therefore unusually rigid. This keeps shafts in alignment and gears in perfect mesh, reducing wear and making riding easy. Ferro All-Enclosed Engines have overhead valves, without cages, detachable cylinder heads, removable cylinder sleeves and other distinctive features.

There's a Ferro Engine to Fit Your Boat—Thirteen other models, including 10-H. P. Four-Cycle Four, two-cycle engines from 3 to 25-H. P. and the Ferro Detachable Motor for rowboats.

Write for catalog today. State type of engine in which you are most interested.

**THE FERRO MACHINE & FOUNDRY CO.**  
143 Hubbard Avenue Cleveland, Ohio

**MARINE ENGINES**  
**FERRO**

### NO MORE BALD HEADS



WHEN our VACUUM CAP is used a few minutes daily. We accept no pay until you have tried the Cap 60 days and are satisfied. The Vacuum Cap is an appliance that draws the blood to the Hair Roots and starts a new healthy crop of hair. It stops Dandruff, stops the hair from falling out.

Bought by Doctors and men who know that it is the only reasonable HAIR GROWER known to science. No Drugs Used. Write for application blank, testimonials, and booklet on "HAIR," sent sealed in plain envelope, FREE.

**THE MODERN VACUUM CAP CO.**  
L. 559 BARCLAY, DENVER, COLO.



**When Physician Meant  
"Physic—Dispenser"**

**I**N Shakespeare's time, if you were sick and went to a doctor he did one of two things. He either bled you or "physicked" you.

Physicians no longer practice bleeding. And the leaders of the profession are equally opposed to the indiscriminate use of laxative and cathartic drugs. In fact, the habitual use of laxatives is now known to be one of the most fruitful *causes* of constipation.

Physicians of the highest standing prescribe Nujol because it relieves constipation without any bad after effects and without forming a habit. It acts in effect as an internal lubricant, preventing the bowel contents from hardening, and in this way facilitating *normal* movements.

All druggists carry Nujol. Avoid substitutes. Write today for booklet, "The Rational Treatment of Constipation" using coupon below.

**STANDARD OIL COMPANY**  
(New Jersey)  
Bayonne New Jersey

# NUJOL

## FOR CONSTIPATION

Send for booklet, "THE RATIONAL TREATMENT OF CONSTIPATION." Write your name and address plainly below. Dept. 68.

Name \_\_\_\_\_ Address \_\_\_\_\_ City \_\_\_\_\_ State \_\_\_\_\_

Please Mention Popular Mechanics



## THE EXPO WATCH CAMERA



Photography made a pleasure instead of a burden. You can carry the EXPO about in your pocket and take pictures without any one being the wiser. It is but little larger than a watch, which it closely resembles.

### One Cent a Picture

The Expo loads in daylight with 10 or 25 Exposure films, costing 15c and 25c respectively, and thus the picture taking part of a whole day's outing may be had for a very nominal sum — One cent a picture.

### Easy to Manipulate

It is simplicity itself to operate. Takes pictures through the stem, where the Rapid Fire Lens is located. The photos (5/8 x 1/2) may be enlarged to any size.

**Operated as Quick as a Flash** Time and instantaneous shutter; weights but 3 ounces; nickel plated. Endorsed by amateurs and professionals the world over. Thoroughly practical—printing and developing of films just the same as ordinary cameras—in daily use by the police, newspaper reporters, detectives, and the general public. Important heads have been secured with the Watch Camera by enterprising reporters. Produces clear, sharp negatives indoors or outdoors equal to any camera on the market, size or price notwithstanding.

### SOLED UNDER A POSITIVE GUARANTEE

The WATCH CAMERA makes an IDEAL GIFT that will be thoroughly appreciated, and cause you to be long remembered.

Expo Watch Camera \$2.50 FILMS, 10 Exposures 15c, 25 Exposures, 25c postage 10c Leather Pocket Carrying Case, 35c MAILED TO ANY ADDRESS IN THE WORLD

JOHNSON SMITH & CO., 7151 North Clark Street, CHICAGO

## LUMINOUS PAINT

Make Your Watches, Clocks, Etc., VISIBLE BY NIGHT

The very latest discovery in the scientific world. Hitherto, practically unobtainable except at an exorbitant price, we have at last succeeded in producing this remarkable LUMINOUS PAINT, which, applied to the surface of any article, emits rays of white light, rendering it perfectly visible in the dark. THE DARKER THE NIGHT, THE MORE BRILLIANT IT SHINES. Quite simple to use. Anyone — you can do it. A little applied to the dial of your watch or clock will enable you to tell the time by night. You can coat the push buttons or switch plates of your electric lights, match boxes, house numbers and innumerable other articles; make your own Luminous Crucifixes, Luminous Rosaries, etc. Bottle containing sufficient to coat several small articles. Price 25c. Larger sizes 50c and \$1.00 postpaid.

JOHNSON SMITH & CO., 7151 North Clark Street, CHICAGO

## INVISIBLE INK VANISHING INK

The most confidential messages can be written with this ink for the writing MAKES NO MARK. Cannot be seen unless you know the secret. Invaluable for many reasons. Keep your postals and other private memoranda away from prying eyes. Great fun for playing practical jokes. Only 15c Bottle



Writing written with this remarkable ink vanishes entirely in a few weeks (sooner if soaked), leaving the paper QUITE BLANK. 15c p. post.

LUMINOUS INK writing can be READ ONLY IN A DARK ROOM; resembling phosphorescence like fire. Quite reliable at day-time. Very remarkable. 15c

**DISSOLVING INK** A new kind of invisible and vanishing ink combined. Writing is quite invisible, but can be made to appear or disappear at will in a very simple yet mysterious manner. Same PRICE, 15c postpaid.

## Thumb Brander INKLESS PEN

WRITES with WATER 600 words every time you dip. Makes its own ink. Writes fashionable violet color. Better and cheaper than fountain pens. Write a long letter with one dip in plain water. No trouble — no bother — no fuss. A pleasure to use. With Nickel Plated Resilient Holder 10 CENTS, 3 for 25c

JOHNSON SMITH & CO., 7151 North Clark Street, CHICAGO

## JAPANESE ROSE BUSHES

### The Wonder of the World

Japanese Rose Bushes bloom all the year round. Just think of it. Six weeks after planting the seed, the plants will be in full bloom. It may not seem possible, but we positively guarantee it to be so. They will bloom every ten weeks, Summer or Winter, and when three years old the bush will be a mass of roses, bearing from five hundred to a thousand roses on each bush. The flowers are in three shades — white, pink, and crimson. The plants will do well both in and out doors. We guarantee at least three bushes to grow from each packet of seed. Price, 10c packet, 3 pkts. for 25c postpaid.

## Shoo Fly Plant Weather Plant

A very remarkable botanical curiosity you should have. Though quite odorless, flies will not remain in a room where it is grown. Bears very pretty blossoms; blooms summer and winter. Grows rapidly from seed.

SEEDS 15c, packet, 3 for 40c, postpaid. JOHNSON SMITH & CO., 7151 N. Clark St., CHICAGO

## Automatic Repeating Rifle

Fires 20 Shots in One Loading



This is a regular size automatic revolver. Shoots B. B. shots obtainable anywhere, same as other rifles and guns. Repeats 20 times with one loading. Handsomely finished in gun metal. No caps or load necessary, as it works with a spring and shoots with rapidity and accuracy. Simply load with 20 B. B. shot, then press the trigger. Nothing to explode — absolutely harmless and safe. Remember, it is not a mere toy, but the same size and shape as a REGULAR AUTOMATIC. Sent complete with a round of shot for ONLY 25c postpaid. Extra shot, 10c a package.

Only 25c Postpd.

## Potmend Stops a leak in a minute

The finest repairer for Ironware, Agateware, Earthenware, etc. Good for kettles, pots, pans, boilers, and every kind of ironware, also for tin, copper, aluminum, ice boxes, iron pipes, cracks in stoves, broken china, porcelain, brick-a-brack, blazes, crockery, woodwork, marble, etc. Will not stain, freeze, bake or boil out. THE BEST IS THIS STRONGEST STOP IN THE WORLD. Would not be simpler, just mix the powder with water. HARDENS LIKE IRON. Fire-proof, Water-proof. You can fill a big hole or a small crack. Mended place stronger than new. Replaces chipped enamel. Anyone can do it! FAILURE IS IMPOSSIBLE. Better and easier than solder. Three sizes, 15 cents, 25 cents and 50 cents.

## "SAFETY 1st" PINS 197 WAYS OF COOKING APPLES

A clever novelty. The National Safety First Movement has made these very popular. Wear one and show your sympathy with the movement. Also handy for wearing at amateur theatricals and the like. Two sizes, 1/2 in. (rod plated) and 3/4 in. (nickel-plated) 6c each, two for 10c p. post.

## Vest Pocket Secretary MARVELOUS COMBINATION

Not a toy, but a really useful article you need every day. 12 Articles in one — Pen, Pencil, Paper Knife, Ink Eraser, 4-inch Rule (divided into sixteenths), Compass (can be set for any size circle), Envelope Opener, Mechanics' Marking Point, Pencil Sharpener, etc. Made entirely of steel, nickel-plated. Folds up into a small space occupying no more room than an ordinary pencil in the pocket. Price 15 cents, 3 for 50c, postpaid.

## TOOTH-ACHE STOP PUMI STONE and Brush Combination

Easy to Use TOOTH-ACHE STOP Stops the Pain; Stops the Tooth Squeeze a little in hollow of tooth; the Ache Stops Instantly; the paste hardens, forming an antiseptic filling. Absolutely harmless. Have it ready for the next bad attack. 25c postpaid.

## All the Latest Surprising and Joke Novelties

- |   |   |
|---|---|
| Pharo's Serpents Eggs, box . . . . . 10c              | Modern Dancer (nifty) . . . . . 15c                             |
| Minutiae Water (trick) . . . . . 15c                  | September Mars Squirt Ring . . . . . 25c                        |
| Chocolate's Snake (very lifelike) . . . . . 15c       | X-Ray Novelty . . . . . 10c                                     |
| Pales Mustache . . . . . 6c                           | Trick Pencil . . . . . 10c                                      |
| Big Bull Stage Money . . . . . 10c                    | Rubber Tacks (a good joke) . . . . . 10c                        |
| Four Ago Puzzle (Largest) . . . . . 15c               | Messmerized Penny (defies the law of gravitation) . . . . . 30c |
| Magic Plate (anyone can play it) . . . . . 15c        | Carbon's Squeezing Powder . . . . . 10c                         |
| Hidden Razor (very formidable) . . . . . 20c          | Mysterious Number and Vanishing Coin Trick . . . . . 25c        |
| Window Smashers (greatest joke out) . . . . . 25c     | Enchanted Bottle (what makes it go down) . . . . . 25c          |
| Pocket Detective (see behind your back) . . . . . 15c | Magic Plate Lifter . . . . . 3 for 5c                           |
| Thurston's Mysterious Trick Cds. . . . . 10c          | Imitation Gold Teeth . . . . . 10c                              |
| Fighting Bombers, pair . . . . . 10c                  | Great Elipso Puzzle . . . . . 10c                               |
| Cover the Spot Trick, a seven nov. . . . . 10c        |   |

Large catalog (300 pages) of unique, novel and useful articles (unobtainable elsewhere) free with all orders, or mailed on receipt of five-cent stamp. Agents and dealers write for wholesale prices. Mail order dealers and beginners supplied with 32, 64 or 148 page catalogs at cost. Send 10c cents (credited) for sample of each and particulars of our proposition.

Johnson Smith & Co., 7151 N. Clark St., Chicago Only Concern of its Kind in America

Please Mention Popular Mechanics



# Save \$20 to \$50 on COAL BILL



Save \$20 to \$50 on winter coal bill with a New Scientific Down Draft Jahant Furnace. Lasts a lifetime. Heats every room evenly. Burns oxygen, saves coal. Burns coal to fine ash. Heats quickly in morning.

**WE PAY THE FREIGHT**

We pay freight anywhere in U. S. or Canada. Price includes entire equipment cut to fit. Easily installed.

**Sold on Monthly Payments**

Buy a Jahant now, a payment down, rest easy monthly payments. It will pay for itself in short time. Sold on 30 day Money-back. Legal Guaranty Bond. Engineers' advice FREE.

**FREE!** Complete set of erecting tools Free with each Jahant. Get book, "WHAT USERS SAY," and literature, all free.

**JAHANT HEATING CO.**

21 Jahant Bldg., AKRON, OHIO, U. S. A.

## FURS

### BIG ADVANCE IN PRICES

Muskrat away up. Skunk higher than a year ago. Fancy prices for all other furs. Biggs pays most. Get Our RAW FUR PRICE LIST FIRST.

**FREE** Send for "Trappers' Exchange," our free monthly Trappers' Magazine. Full of pictures and stories of actual trapping and hunting adventure. Subscription free. TRAPPERS' SUPPLIES—Guns, Ammunition, Traps, Baits at ACTUAL FACTORY COST. CATALOG FREE.

**E. W. BIGGS & CO.**  
667 Biggs Bldg.  
Kansas City, Mo.

**MORE CASH FOR YOUR FURS**

## 8 Cents a Day Buys This

Standard, \$100—1916 Model

**Rex Visible** At Less than Wholesale!

Two-color ribbon, back spacer, tabulator, wide carriage, auto. line lock, etc. No money down, 10-year Guarantee. To boost sales for 10 days, a complete 300 Typewriting Course Free with each 10 days' trial. Don't pay even \$10 for a typewriter until you get our cut-price offer.

**REX TYPEWRITER CO., Dept. 175**  
1504 Steger Bldg. CHICAGO



10 DAY TRIAL FREE

## INDOOR CHEMICAL CLOSET

**NO SMELL—NO GERMS—SANITARY**

Use in any room. Needs no plumbing, sewerage or running water. Chemicals in closet kill germs. Pans for the sick and old folks.

**DESTROY OUTDOOR CLOSET**

Put in a warm, Indoor Sanitary Closet. Empty twice monthly. Only attention necessary. Satisfied users and Boards of Health endorse it. Fully Guaranteed. **30 Days' Free Trial.** Write now for FREE LITERATURE. **SANITARY CLOSET CO., 21 Calum Bldg., TOLEDO, OHIO**



## Free to the DEAF

**DEAFNESS**  
—Its Cause  
Prevention  
and Relief—

PARTIAL CONTENTS  
"Deafness and the Care of the Ear" by Dr. Fanning  
"The Prevention of Deafness" by Dr. John Dighton  
"The Prevention of Hearing" by Dr. Doby  
and 10 other valuable chapters

This valuable compendium of the best information on deafness.  
56 pages, illustrated.

Send a postcard today for this new book if you are deaf or losing your hearing. It is full of practical advice. Simply say: "Send me the new book on Deafness, Free."

ADDRESS \_\_\_\_\_

**GLOBE EAR-PHONE CO.**  
Mrs. of the Audi-Aid and Lognette Phone  
82 Tremont Street BOSTON, MASS.

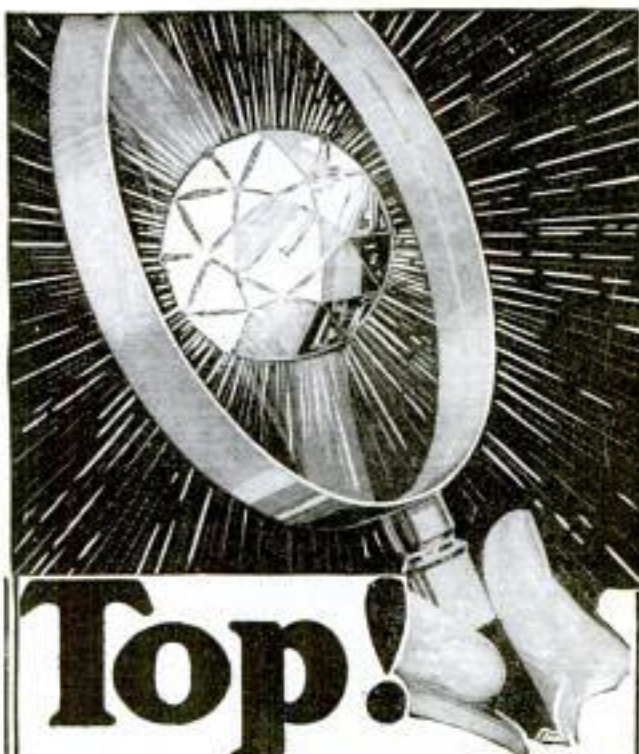

# Top!

Actually top grade in diamonds at prices so low as to be almost startling. Wonderful opportunity to make a big saving now. Our Diamond Book shows how. You should have it. Don't buy until you get it. And see our offering in these top grade stones in the richest gold and platinum mountings. Send the coupon and get it free.

## Net Prices to You

You can buy direct. No storekeepers' profit to pay. Special net price list comes with the Diamond Book. Shows you how to save on rings, in all styles of mountings, Tiffany, Belcher, etc., Brooches, Pins, La Vallieres. Every stone a selected gem. Every mounting a work of most expert artisans.

## Free Examination!

Nothing to pay until you see any diamond you select from the book. Take your pick, and send for it. Compare with other diamonds at higher prices. Then, and only then, decide whether to buy or to return it at our expense. See for yourself what splendid stones these are. Send for the book now. Look over these special offers at your leisure. Get ideas about diamond buying. No obligation—the book is free for the coupon.

# \$2.50 Monthly

Yes, only \$2.50 monthly will give you a handsome ring. Other terms \$3.50, \$4.50 and up. Offers that are really startling in prices and terms. Get all the facts before you buy a diamond. Write today for the Free Diamond Book!

**Send Now!**

Don't put this off if you want a diamond. No obligation to ask for the Diamond Book and Net Price List. Buy only if satisfied. But send for book.

Name \_\_\_\_\_

**Burlington Watch Co.**  
Dept. 1191  
Chicago, Ill.

Address \_\_\_\_\_

**Burlington Watch Co.**  
Dept. 1191 Chicago, Ill.

Without obligations send your net price offer on diamonds; also send Diamond Book.



# 413 PAGES

## 148 ILLUSTRATIONS



I.C.S.  
ADVERTISER'S  
HANDBOOK

# 50¢

## ADVERTISING!

HERE'S just the book on Advertising that you need to be your silent but always-ready assistant, to answer your many questions, to be your memory for details about the rules and practices, tools and accessories of the Advertising business. It will broaden your knowledge; it will save you days of time each year; it will help you keep a tight check on advertising and printing expenditures; it will familiarize you with the technical details of the Advertising and Printing Arts.

The Advertiser's Handbook explains the Principles of Advertising; how to write good "Copy"; how to plan and lay out Advertisements; Type and Printing Styles, Illustrations, Engraving, Printing Methods, proper cuts for different papers, Electrotyping, Stereotyping, etc. It teaches Advertising for Stores, Mail-Order Businesses, Technical and Trade Papers; Street-Car and Outdoor Publicity; Designing and Preparing "Copy" for Circulars, Catalogs, Booklets, Folders, Sales-Letters. It tells how to plan and conduct small and large

Campaigns; how to judge Mediums; how to read Proof; how to Key and Check Advertisements and Publications; the work of the Advertising Agency, etc.

The I. C. S. Advertiser's Handbook is one of 23 I. C. S. Handbooks, treating of 22 Commercial, Technical and Scientific subjects, all crowded with value. They have the contents of full-size books condensed into pocket size, ready to go with you anywhere and be at your instant command. Every statement is clear and concise, every principle is made easy to understand and to apply. They are bound in cloth, red edges, gold-leaf stamping, printed from new, clear type on good book paper, elaborately illustrated and completely indexed.

The regular price is \$1.25, but for a LIMITED TIME you can buy those you want, postpaid, for only 50 cents each. You run no risk! Your money back if desired!

INTERNATIONAL CORRESPONDENCE SCHOOLS, Box 5548, Scranton, Pa.

TEAR OUT HERE

I. C. S., Box 5548, Scranton, Pa.

I enclose \$\_\_\_\_\_ for Handbooks marked X.

- |  |  |
|--|--|
| <input type="checkbox"/> Advertiser's                | <input type="checkbox"/> Chemist's           |
| <input type="checkbox"/> Salesman's                  | <input type="checkbox"/> Building Trades     |
| <input type="checkbox"/> Business Man's              | <input type="checkbox"/> Concrete Engineer's |
| <input type="checkbox"/> Bookkeeper's                | <input type="checkbox"/> Civil Engineer's    |
| <input type="checkbox"/> Steno.'s & Correspondent's  | <input type="checkbox"/> Steam Engineer's    |
| <input type="checkbox"/> Electrical Engineer's       | <input type="checkbox"/> Mechanic's          |
| <input type="checkbox"/> Teleph. & Teleg. Engineer's | <input type="checkbox"/> Farmer's            |
| <input type="checkbox"/> Poultryman's                | <input type="checkbox"/> Automobiles         |

Name \_\_\_\_\_

Address \_\_\_\_\_

**MAZDA** Always etched on electric lamps to which MAZDA Service has been applied.



Agents' Outfit

### AGENTS WANTED

For our independent hollow-wire lighting systems for homes, stores, public buildings, etc. Use common gasoline. Best and cheapest illumination known.

### AKRON LIGHTING SYSTEMS

are most improved, simplest and safest of all. Shed a clear, soft, bright light of high candle power. Also complete line of portable and street lamps and lanterns. Fully guaranteed. Our Agency Proposition cannot be best. Exclusive territory. Send quick for catalog and terms.

Akron Gas Lamp Co., 322 So. High St., Akron, O.



# TYPEWRITER SENSATION

## \$2<sup>50</sup> a Month Buys L. C. Smith

Visible Writing

Perfect machines only of standard size with keyboard of standard universal arrangement — has Backspacer — Tabulator — two color ribbon — Ball Bearing construction — every operating convenience. Five Days' Free Trial. Fully guaranteed. Catalog and special price sent free. H. A. SMITH, 510, 231 North Fifth Avenue, Chicago, Illinois

## One of the World's Greatest Inventions

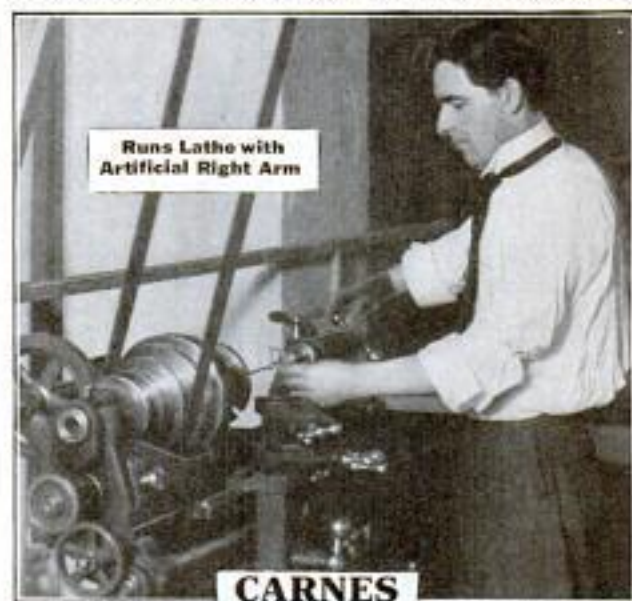

CARNES

## Artificial Arm

The only artificial arm and hand that you can really do so many things with and without assistance of natural hand. The only artificial arm with full finger motion hand, turning and bending wrist and bending elbow. Comfortable to wear. Easy to operate. Perfect fit guaranteed. Recommended by wearers the world over. Endorsed by surgeons. Awarded Gold Medal, San Francisco, San Diego, London, Eng. Write for illustrated catalog B.25 of this wonderful invention.

CARNES ARTIFICIAL LIMB CO.

31 Carnes Bldg., 904-906 E. 12th St., Kansas City, Mo.

IF IT ISN'T  
**AN EASTMAN**  
IT ISN'T A KODAK

**INDOOR TOILET** ✓  
Sanitary and Odorless on ten days  
**FREE TRIAL**

**NO MONEY DOWN — NO DEPOSIT**

No more outside back yard inconveniences. No chambers to empty. No sewer or cesspool. Chemical process dissolves human waste in water. No trouble. Kills disease germs. Prevents flies, filth and bad odors of out-house. A real necessity for old, young or invalids. Preserves health.

**COSTS ONE CENT A WEEK**  
to Operate per Person

Place in any room, hall or closet. No trouble to install. Guaranteed sanitary and odorless. Endorsed by thousands of users, doctors, sanitary experts, health boards, etc. Agents Wanted.

**KAWNEAR CABINET CO.**  
632 Kawnear Bldg., Kansas City, Mo.





**AGENTS—\$5.00 to \$25.00 a Day—It's Easy**  
**Grand Invention. 150% Profit. Great Excitement**  
**Recognized as most phenomenal seller**

**Experience Unnecessary. Spare time can be devoted if desired**  
**LISTEN: One man's orders \$2,650.00 one month—profit \$1,650.00**  
 Lowry, of Montana, who sold 25 dozen the first two weeks (without previous experience) and made \$187.50, enthusiastically writes: "Why, I could sell this article blindfolded and with a gag in my mouth." Mere boy in Pa. made \$9.00 in 2½ hours. "I do not see how a better seller could be manufactured," reports Parker J. Townsend, Minn. "Started out at 10 a.m., sold 35 by four o'clock," says J. R. Thomas, Colo. "Sold 131 in two days." G. W. Handy, New York. See what a wonderful opportunity. These remarkable reports proven absolutely true by oath-covered evidence—proven to satisfy you beyond a doubt. You can make this money. Work for us and get rich. We want representatives—Agents, Salesmen, Managers—everywhere. Write today. Territory in all sections of the United States, Canada, Mexico and foreign countries to be assigned. The New Easy Wringer Mop tremendously in demand by housewives. Every woman exclaims in delight: "Just what I want!" No more tiresome, back-breaking, miserable mopping days. Droggery actually transformed into pleasure. The greatest, grandest, most necessary household article ever invented. No need to recite selling arguments. Talking hardly necessary at all. Simply show—order's landed. This is indeed a wonderful opportunity. Establish yourself in this business at once. Send your name and address on a postal now—right now.



The Easy Wringer Mop (Patented) Hands do not touch the water.

Think of It

A Self-Wringing Mop. Two turns of the crank wrings out every drop of water. Mopping is now a pleasure.

U. S. MOP CO., 464 Main St., TOLEDO, OHIO

**Mammoth Jubilee Book Free**

Picturing 5152 Home Things  
 Make your own Credit Terms—1 to 3 years' time,  
 SPIEGEL, MAY, STERN CO., 1409 W. 35th St., Chicago

**BLUE-JAY CORN PLASTERS END CORNS IN 48 HOURS**

A million corns monthly disappear under Blue-jay. Your own friends employ it. Countless people around you—users of Blue-jay—never let a corn ache twice. 15 and 25 cents at Druggists. Also Blue-jay Bunion Plasters.  
**BAUER & BLACK, Chicago and New York**

**BIG WONDER PACKAGE**

1 Great North Pole Game (size 18x11), 1 Big Roll Stage Money, 1 Game Authors (48 Cards), 1 Cribbage Board, 1 Checker Board and Men, 1 Pack Pinochle cards (48 cards), 38 other Games, 19 Lessons in Magic, 1 Set of Dominoes, 27 Auto-graph Verses, 12 Money Making Secrets, Wireless Telegraph Code, 25 Pictures of Pretty Girls, 2 Puzzles, 100 Conundrums, 85 definitions of Flowers. All the above for 10c, with large catalog.  
**ROYAL GAME CO., Box 35, SO. NORWALK, CONN.**

**AGENTS**

Get Next to This!



**A Big Money Maker**

The biggest, fastest, snappiest sellers in the world. A big box of the finest

Toilet Soaps, and give a pair of Patented Tension Shears free with each sale. Hundreds of other Big Snaps. Makes selling easy. Beginners cleaning up \$5 to \$6 a day. Start while new. Outfit furnished free. Write today.

**A WORLD BEATER**  
**AMERICAN PRODUCTS CO., 7739 3rd St., CINCINNATI, O.**

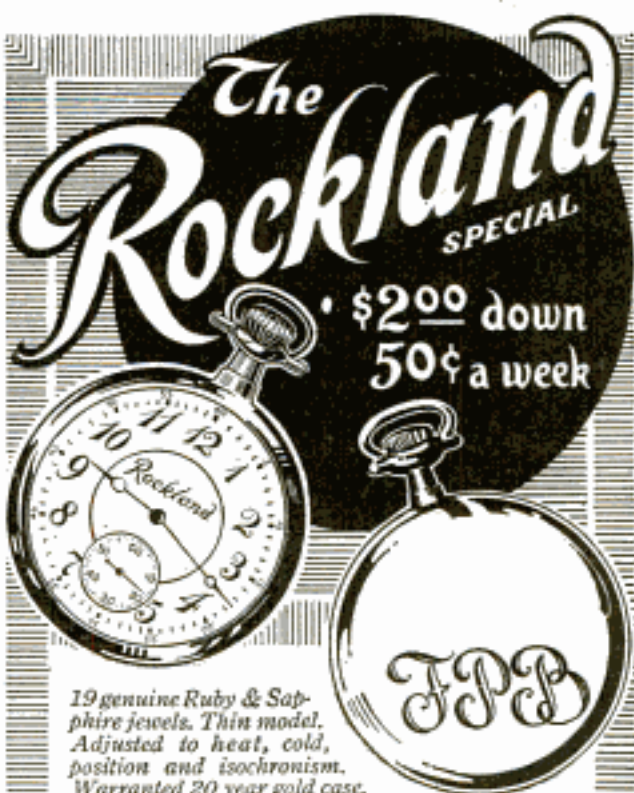

\$2.00 down  
 50¢ a week

19 genuine Ruby & Sapphire jewels. Thin model. Adjusted to heat, cold, position and isochronism. Warranted 20 year gold case. Gold Center Wheel, Steel Escape Wheel, Double Sunk Dial, Genuine Illinois Double Roller.

We absolutely guarantee the "Rockland" to be as accurate, as durable, as reliable, and to represent as high a grade of workmanship as any watch selling for \$50.00.

THE "Rockland" is not a "mail order watch" made to sell at a price and a long profit, but a real time piece manufactured for us by one of the best known watch concerns of this country (Illinois Watch Co.)



**Our Guarantee**

is backed by 20 years of honest dealing and ample financial references.

**Our Liberal Easy Payment Offer**

is open to any honest person anywhere in the

U.S.A. The price is \$26.50 cash or easy payments. Send us \$2.00 with the coupon below and pay balance at 50¢ a week. We will send the "Rockland" on acceptance of first payment with the understanding that if you are not entirely satisfied after one week's trial you can return it to us and we will, without delay or question, return your money.

**Lenox Jewelry Co.**

375 Washington Street  
**BOSTON, MASS.**

(Established 20 years)

Enclosed \$2.00 as first payment for "Rockland" 19-jewel watch in accordance with your offer and guarantee made in POPULAR MECHANICS.

NAME.....

CITY.....

STREET ADDRESS.....

Shipment made immediately on acceptance of first payment.

Please Mention Popular Mechanics



## Oxy-Acetylene Welding and Cutting



Above shows the Prest-O-Lite Process as used for making an "on the spot" repair in shops of P. F. Collier & Co., New York City, publishers of "Collier's Weekly."

## Lowers Repair Costs Saves Valuable Time

By avoiding costly delays and saving expensive replacements, single repairs by welding have oftentimes more than paid the cost of complete welding equipment, in hundreds of shops and factories. The many highly profitable uses to be found both inside and outside your shop for oxy-acetylene welding will amaze you.

More important perhaps than effecting emergency repairs to important tools or equipment is the usefulness of this process in simplifying many manufacturing operations and cutting production costs.

In many instances, it is entirely displacing the rivet and bolt, because welded joints, in nearly all cases, are better, stronger, and neater than those of other methods of metal-joining. Find out about these possible economies for your shop or factory.

## Prest-O-Lite PROCESS

Employs both gases (acetylene and oxygen) in portable cylinders. Prest-O-Lite Dissolved Acetylene (ready-made carbide gas) is backed by Prest-O-Lite Service, which provides dry, purified gas, insuring better welds, quicker work, and lower cost, and also avoids the large initial outlay and heavy depreciation incurred in making crude acetylene in a carbide generator.

Necessary equipment is not expensive. We furnish high-grade welding apparatus for \$60 (Canada, \$75); acetylene service at additional cost. Adaptable for oxy-acetylene cutting by the addition of special cutting blow-pipe. Thorough instructions are furnished free to every user of Prest-O-Lite Dissolved Acetylene—any average workman who understands metals can learn the process quickly and easily.

Write for full information on the Prest-O-Lite Oxy-Acetylene Process. Tell us about the particular work you are contemplating.

### Splendid Opportunity for You

Oxy-acetylene job welding pays positive profits. If you want to start into business for yourself, it will pay you to investigate.

### The Prest-O-Lite Co., Inc.

World's Largest Makers of Dissolved Acetylene

Main Offices and Factory  
816 Speedway, Indianapolis, Ind.

Canadian Office and Factory  
Merritt, Ontario

53 Branches and Charging Plants



OILING

CLEANING  
AND  
POLISH-  
ING

# 3 IN ONE

true to name, has three distinct purposes. 3-in-One lubricates sewing machines, locks, clocks, door hinges, typewriters, tools, adding and addressing machines—everything in the home or office that "works." Can't gum, contains no grease, won't collect dirt and has the right viscosity to stay at friction points.

3-in-One cleans and polishes floors, fine furniture, pianos, mirrors, etc. For making Dustless Dusters or Polish Mops there is nothing like it.

**FREE**—Sample of 3-in-One and Dictionary of Uses.

3-in-One prevents rust or tarnish on any metal surface. Especially is it famous for keeping the shaving edge of razor blades free of microscopic particles of rust that make a razor "pull."



Sold by all stores in Handy Oil Cans for 25c. In bottles 10c, 25c, 50c.

**3-in-One  
Oil Co.,**  
42C.M. B'vy.  
N. Y.

PREVENTING  
RUST

3/4 c diamond  
\$8.25

1/2 c diamond  
\$17.50

1/4 c diamond  
\$31.25

1/8 c diamond  
\$45.00

1/16 c diamond  
\$67.50

1 c diamond  
\$97.50

## GENUINE PERFECT CUT Diamonds \$97.50 PER CARAT

Buy direct from Basch, the importer, and save 35%. Any diamond shipped for free examination. Iron-clad Money-Back Guarantee with every purchase. Handsome 1917 Diamond Book mailed free upon receipt of name and address. Write now to

L. BASCH & CO. Dept. D-3470  
State & Quincy Sts. CHICAGO, U. S. A.

## Card Printing Automatically

IS PERMANENT BUSINESS

ALL YEAR ROUND—BIG PAYING EVERYWHERE

Our press prints and feeds 100 per minute, 5,000 per hour. Business cards, visiting cards, tickets, postal cards, souvenir postals, announcements, invitations, blotters, programs and many others and practically all profit. Write for our free booklet 11. Get our proposition. Supply houses get our trade offer.

S. B. FEUERSTEIN & CO.

Patentees and Manufacturers  
542 W. Jackson Blvd. CHICAGO, U. S. A.



## Vitalize yourself with Violet Rays

Vigor, health and beauty in marvelous, delightful Violet Rays. Any good physician will tell you. Thousands are prescribing Violet Rays. Send for instruction book and learn what it will do for you.

### Sent on Free Trial

Violetta is the perfected instrument. Produces soothing, invigorating, curative Violet Rays. Used and endorsed for private use by physicians. Use it anywhere. Sent to you on Free trial. Special low price offer.

### Write for New Free Book

Send for the book on Violetta. Read what physicians say. Post card brings book and all particulars of special offer free. Write today.

**BLEADON-DUNN CO.**  
208 N. Fifth Ave., Dept. C1, CHICAGO





# Start the Year Right



Pat.  
June 8,  
1915

The  
Modern  
Work  
Garment

Throw away  
your old Over-  
alls and Jacket.

BUY A  
"SENSIBLE"  
Union Made

Comfortable,  
Safe,  
Convenient

Costs about the  
same as a suit of  
Overalls and Jacket  
But It's Lots Better

Order from your dealer  
or direct from us.

Write for Circular  
JOHNSTON & LARIMER  
MFG. COMPANY,  
Dept. PM Wichita, Kan.



Patented but-  
ton-down shirt  
showing a neat  
jacket effect.



Slit up show-  
ing suspenders  
which are at-  
tached to back  
of jacket.



Showing the  
convenient  
drop seat ar-  
rangement.

UNION MADE  
**SENSIBLE**  
COMBINATION WORK SUIT

## 1900 Motor Washer Electric or Water Power

on Free Trial to Readers of Popular Mechanics  
Reduce household expenses by using this great laundry outfit. Cuts cost of washing to 2 cents per week. Write for Free Book, giving full details, to

1900 WASHER CO., 6313 Court St., Binghamton, N. Y.  
Address Canadian 1900 Washer Co., 355 Yonge St., Toronto  
if you live in Canada

## Deafness Is Misery

I know because I was Deaf and had Head Noises for over 30 years. My invisible Anti-septic Ear Drums restored my hearing and stopped Head Noises, and will do it for you. They are Tiny Megaphones. Cannot be seen when worn. Easy to put in, easy to take out. Are "Unseen Comforts." Inexpensive. Write for Booklet and my sworn statement of how I recovered my hearing.

A. O. Leonard, Suite 226, 150 5th Ave., N. Y. City

## New Book Free

Write today for the book that tells about the opportunities in the profession of Signal Engineering. Men are needed. Learn, too, how you can get the training that you need to fill the big job.  
**\$125 to \$300 a Month**  
The free book will give you just the information you want. Write for it now—immediately. Here is a golden opportunity.  
Dept. of Signaling Dept. 2291 - 1810 W. Madison Ave. - Evanston, Ill. - Chicago, Ill.

**3 1/3 c a Day**

now buys a dazzling Lachmite Gem. Their brilliance is eternal—they stand fire and acid tests and cut glass like diamonds. Cost but one-third as much. Set in solid gold. The newest designs. Sold on Free Trial. See our new jewelry book.  
Write for Big Jewelry Book Your name and address is enough. No obligations whatever. Write today—now.  
HAROLD LACHMAN COMPANY  
12 N. Michigan Avenue, Dept. 1191 Chicago, Ill.

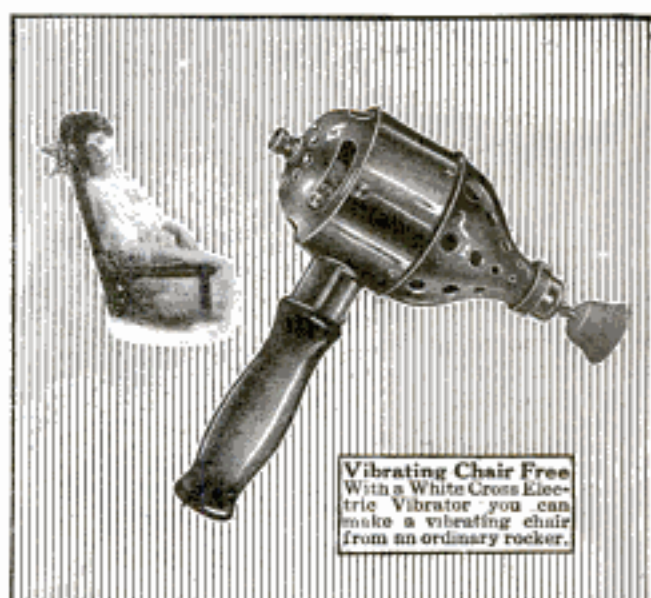

Vibrating Chair Free  
With a White Cross Electric  
Vibrator you can  
make a vibrating chair  
from an ordinary rocker.

Only **\$10.00**

For Our New No. 21B Model

## White Cross Electric Vibrator

THE marvelous instrument that has been such a boon to the medical and scientific world. Endorsed by prominent physicians everywhere. On a great special offer you may now get this new model No. 21B for only \$10. Send coupon now for the free book that tells you all about it. We have over a dozen different types of vibrators for you to choose from and our prices are so very low that you need wait no longer. Any one can now afford a vibrator.

**WHITE CROSS**  
ELECTRIC VIBRATOR



Can be connected up as easily as an electric lamp—or if your home is not wired for electricity it will run perfectly on its own dry cells. With this superb instrument you can make a perfect vibrating chair from an ordinary rocker. This is but one of the exclusive features of the great White Cross Electric Vibrator. Send the coupon for the book that tells you all about it.

## Vibration Is Life

Vibration is part of the very foundation of our existence. When your nerves are all tangled up try vibration. You will find how restful it is. You see more clearly—your think more keenly—you act more quickly. Full of the real joy of living, your efficiency and earning power increases.

Send the Coupon  
For New Book "Health and Beauty" Free Coupon

Send us your name and address on a letter, a postal or the coupon and we will send you absolutely free and prepaid the new book on vibration, "Health and Beauty" also our special offer. No obligations of any kind. Send the coupon today—now.  
Lindstrom-Smith Co. 1100 So. Wabash Ave. Chicago, Ill.  
Lindstrom-Smith Co. Dept. 9191 1100 S. Wabash Ave. Chicago, Ill.

We also manufacture White Cross Electric Irons, Hair Driers, Stoves, etc.

Name.....  
Address.....  
Dealers write now.

My Electrical Dealer's Name and Address.....

Please Mention Popular Mechanics



## Electricity for Light— Why Not for Power?

It's Cheap and  
Always  
Available

Attaches to any  
Electric Light Socket.

No more hand  
work. No wait-  
ing to do quick  
repairing. No lug-  
ging back and forth  
heavy cumbersome pieces for fitting  
or assembling. Carry the tool to the  
work—any place about your shop.

## TEMCO

### Portable Electric Drills

They are always ready for drilling in either metal or  
wood—anytime—anywhere. They add efficiency to your  
shop. They begin saving before you realize it. They  
are strictly portable which adds to their usefulness.

#### Universally Used by All Trades

Manufacturers of metal or wooden products—general  
repair shops of all kinds—sheet metal workers—garages  
and machine shops—plumbers—electricians—contractors  
and many others—all find constant use for them. They  
are universally used by every trade. They are just as  
handy and useful to the small shop as the large one.

See your dealer or write direct. Ask for our new catalog

**THE TEMCO ELECTRIC MOTOR CO.**  
134 Sugar Street, LEIPSIK, OHIO

## Build Your Own Boat



The above 17-footer, complete  
K. D. frame, together with all  
hardware to finish the boat . . . **\$48**

### Fastest Boats in the World V-bottom Models from 15 to 22 Feet Long

**WE** furnish knock-down boats  
complete—all kinds and sizes  
—everything cut to shape and  
fitted—with full sized paper pat-  
terns and illustrated instructions  
for the amateur builder. There's  
both pleasure and profit in boat  
building. You save over  $\frac{2}{3}$  the cost.

Send for Our **FREE** Catalog

### BROOKS MFG. COMPANY

8201 Ship Street Saginaw, Michigan  
The largest plant of its kind in the world

## TYPEWRITERS

FACTORY  
REBUILT

Buy Right From Our Own Factories  
And Save \$25 to \$75

Up-to-date Machines of Standard Makes thorough-  
ly rebuilt, trade-marked and guaranteed the same  
as new. Efficient service through Branch Stores  
in leading cities. Send for latest booklet.

American Writing Machine Co., Inc., 345 Broadway, N. Y.



## If You Use Milk and Cream

separate it  
with the

## SO EZ SEPARATOR

Pints 30c  
Quarts 30c  
2 for 50c



Live Agents Chance

Hardy Mfg. Co., 209 Schultz Bldg., Columbus, O.

**Brighten Your Child's Room**  
Fill the walls with the favorite Pictures, Drawings, Pen-  
nants and Ornaments, by using

## MOORE PUSH-PINS

and for the youngster's Book-shelves, Clock and heavier wall  
decorations, use the Moore Push-less Hangers. Will not  
detach the walls. Samples and picture book free.

Moore Push-Pins. Made in 3 sizes

Glass Heads, Steel Points

Moore Push-less Hangers. 4 sizes

The Hanger with the Twist

10c pkts.

EVERYWHERE

OR BY MAIL

MOORE PUSH-PIN CO., Dept. 36, PHILADELPHIA, PA.

## METAL PIPE CASES



Small size 75¢  
Large size 1.00

Cases are adjustable with  
extension device to fit various  
shapes and length of Clay Pipes  
No odor or ashes. Each CASE is  
enclosed with imported Pipe Free  
—Nice for Christmas Present—  
Send Money Order or 2\*stamp for Cir

to The Monarch Service Co-15 Cornhill-Boston-Mass.



## New Book Free

Write today for the book that tells about the  
opportunities in the profession of Signal Engi-  
neering. Men are needed. Learn, too, how you can  
get the training that you need to fill the big job.

**\$125 to \$300 a Month**

The free book will give you just the information  
you want. Write for it now—immediately. Here is a  
golden opportunity.

Dept. of Signaling Dept. 8191—1810 Wilson Ave.  
Evanston, Ill., Chicago, Ill.

**\$2.00** and you get this **Superb Cornet**  
An astounding offer. This Triple  
Silver Plated Lyric Cornet will be  
sent to you for only \$2.00. Pay the balance at the rate  
of only 10c a day. Free trial before you decide to buy.

## WURLITZER FREE Band Catalog!

Send your name and address and get our big 150-  
page Band Catalog. Buy direct from the manufac-  
turer. Rock-bottom prices on all kinds of instruments

—easy payments. Generous allowance for  
old instruments. We supply the U. S. Gov't.

Write today for Free Band Catalog.

THE WURLITZER CO.,  
Cincinnati, Ohio Dept. 1191 Chicago, Illinois

# DIAMONDS

ON  
CREDIT

20% DOWN

10% A MONTH

The most beautiful Diamonds are the Blue-white, especially  
if absolutely perfect. **LYON DIAMONDS** are 1st Quality, Blue-white. A certificate  
furnished with every Diamond guaranteeing its value and providing for exchange at full pur-  
chase price. Goods sent prepaid for examination and approval. Write for Catalog No. 3,  
10 per cent DISCOUNT FOR CASH

**J. M. LYON & CO.**, (Est'd 1843), 71-73 Nassau St., NEW YORK.





## "IDEAL" Lawn Mower Grinder

### Big Money-Maker

Many of our customers  
make \$300 in one season.  
**YOU CAN DO AS WELL.**

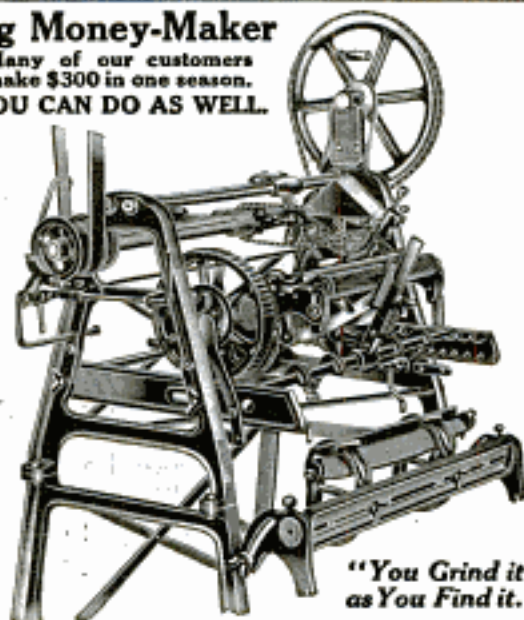

*"You Grind it  
as You Find it."*

Grinds all makes of Mowers perfectly in 15 minutes without removing wheels, ratchets or reel knife, **BETTER, QUICKER and EASIER** than it can be done by hand. Has perfect Skate Sharpener Attachment. Run by hand or power. Nearly 10,000 in use. Price, only \$40. Sold on easy-payment terms.

WRITE TODAY for catalog and full information

THE ROOT-HEATH MFG. CO., Plymouth, Ohio

**Pope**  
*Wheels and Motors*

Send for 1916 Catalogue.  
**WESTFIELD MFG. CO.**  
15 Lozier Ave., Westfield, Mass.

### BIG PROFITS in Charging Auto Storage Batteries

Hundreds of garage owners are clearing from \$20.00 to \$60.00 profit each month with the H.B. Charging Set. Current costs 15¢ per battery, and you get from 70¢ to \$1.50 for each battery charged. Figure your profits.

#### \$10 Places This Money Maker in Your Garage

The balance in monthly payments of \$10.00 each. Every H.B. outfit fully guaranteed. If you are looking for bigger profits, here is an opportunity. Tear out and mail this ad today with your name. We'll gladly tell you more.

HOBART BROS. COMPANY, Box H 12, Troy, Ohio



## EVINRUDE

Detachable rowboat and canoe motors. Magneto—Built-In Fly-Wheel Type. Silencer and Automatic Reverse.  
Catalog Free Over 80,000 Sold

EVINRUDE MOTOR COMPANY  
563 Evinrude Block Milwaukee, Wis.



### Do You Photograph? The TRILUX Exposure Meter

tells instantly, accurately and easily the correct time for all exposures indoors and out.

All timing guesswork is eliminated. Shows instantly, on plainly marked scale. Easy for exposure; used with any film or shutter. Can't get out of order. No sensitive paper. No larger than a roll of film—weighs less than three ounces. Neatly finished in gunmetal and nickel. Use the Trilux and never lose a film. At your dealer's or postpaid, \$2.00. Money back if not satisfied.

SEND FOR CATALOGUE

TRILUX CO., 1401B, Marquette Building, CHICAGO, ILL.

## Lowest Prices Ever Made on World's Best Roofing

Send at once for World's Greatest Roofing Book. We quote Rock-Bottom Prices and pay the freight on Roofing, Siding, Ceiling, etc. Everything the biggest values for the money ever offered.



"Reo" Metal Cluster Shingles

### Edwards Tightcote "Reo" Metal Shingles

outlasts three ordinary roofs. No painting, no repairs. Rot, fire, rust-proof. Guaranteed lighting-proof. Can be laid over old shingles if desired.

Edwards Galvanized Metal Shingles, Roofing, Siding, Ceiling, or finish is extra heavy galvanized by



"Spanish" Metal Tile



Edwards Patent "Grip Lock"

### Our Exclusive Tightcote Process

by which sides and edges are as heavily galvanized as body of sheet. No weak spots anywhere.

By means of our Patent Interlocking Device all nails are driven through under layer of metal only—no exposure—no leaks.



Corrugated



Brick Siding

### The Galvanizing Test

Take any other galvanized steel, bend it back and forth, hammer it down. Great scales of galvanizing will flake off. Apply this test to Edwards Metal Roofing—you'll find no flaking. Edwards products are superior—yet sell for less than other materials.



Garage \$69.50 AND UP

Send for Garage Book showing styles and sizes of Portable, Fire-proof, Metal Garages, \$69.50 and up. Lowest prices ever made.

Send for book—today

Name .....

Address .....

### FREE ROOFING BOOK

will prove to you that we make lowest freight paid prices. Send coupon for Roofing Samples. Ask for copy of FREE Book No. 150.

The Edwards Mfg. Co.  
100-150 Pike St.  
CINCINNATI, O.

### Book Coupon

THE EDWARDS MFG. CO.  
100-150 Pike St., CINCINNATI, O.  
Please send FREE samples, Freight Paid prices and World's Greatest Roofing Book No. 150.

Please Mention Popular Mechanics



# DON'T ALLOW DOUBT

TO STAND BETWEEN YOU AND THE VERY BEST PIPE EVER SMOKED. WE Proclaim it; We PROVE It By The SMOKERS THEMSELVES Or REFUND The MONEY. Take A GOOD LOOK At The FIRST and ONLY POSITIVELY DRY, "JUICELESS," "HEELLESS," CLEAN, SWEET, and REALLY SANITARY Smoking Pipe EVER Devised. Our Standing Back Of OUR CLAIMS With a Bona fide GUARANTEE, Beats Columns of Time-Worn "PIPE TALK." PERFECT COMBUSTION Has Solved The Mooted Problem; The ENTIRE CHARGE Of Tobacco IS Converted Into SMOKE and ASHES; NO DISTILLATION Or SALIVA. No Possible Chance To Lose. Let Us Hear From You.

Never Becomes Foul or Offensive



**Automobilists Perfecto**

## THE BREECHLOADER

Is EXTREMELY SIMPLE, Most Substantial and Practical; Neat and Unique in Design; A Very Desirable Size; 5 1/2 in. long With Graceful Curves; A Little on the "Chubby" order, Half Bent; Considerably Lighter, Holding about one fourth more Tobacco than the ordinary pipe of the same size. The Bowl and Breech Plug is made of FIRST QUALITY, GENUINE FRENCH BRIAR; Given a Rich, Natural, Friction Finish; Solid Rubber Stem; Sterling Silver Mounted; Price Including Nickel Plated Pipe Companion \$1.80 Postpaid. Or Write for Free Booklet.

**THE BREECHLOADER PIPE CO., Inc.**  
Suite B, 335 Broadway, New York, N.Y.

# TIFNITE GEMS

Brilliant and Durable as **Diamonds**

A Tifnite Gem and a diamond are as near alike as two peas. Nothing else in the world so near a diamond in looks, brilliancy and every diamond test. Tifnite Gems cut glass like diamonds; won't file; won't melt. Guaranteed to last forever. Not one particle of glass in them. To quickly introduce them to 10,000 men and women, we make a test never before heard of. We have made up four exquisite items, latest style designs, guaranteed solid gold mountings, each set with one genuine Tifnite Perfect Diamond Cut Gem. We will send you your choice with privilege to

**WEAR IT TEN DAYS FREE**

Send no money whatever. Just state which item you want—Ring, Pin or La Valliere—and we will send it to you at once. If ring, send string showing size around finger. State lady's or gent's. If you think it's worth all we ask, simply pay \$3 on arrival and balance \$3 per month until our special *Bazaar* introductory price is paid in full. Otherwise, return it to us at end of 10 days. Will promptly refund your money. Send no money—simply your request brings a magnificent Tifnite Gem to you for 10 days' free wear. These pictures show mountings and rock bottom prices. You are to be sole judge. Send for yours today—now—while supply lasts.

**THE TIFNITE GEM CO.,**  
Rand McNally Bldg., Dept. 68 Chicago

**LA VALLIERE**—Solid Gold, 15 in. Chain, one-half carat Tifnite Gem, black enamel mounting, \$14.25. Nothing down, \$3 per Mo.

Ladies' Ring  
Tiffany Mounting  
Solid Gold, One  
Carat Tifnite Gem  
\$12.25 Nothing  
Down, \$3 Per  
Month

Gent's Ring  
Claw Mounting  
Solid Gold, One  
Carat Tifnite Gem  
\$12.25 Nothing  
Down, \$3 Per  
Month

**WILLIAMSON CUT COAL BILLS UNDERFEED**  
Furnaces and Boilers 2/3-3/4

Send today for free book, "From Overfed to Underfed." Explains wonderful coal-saving performance of the Underfeed. Guaranteed to cut fuel bills 1/3 to 2/3. Over 35,000 enthusiastic users. Get the facts—write now.

**THE WILLIAMSON HEATER COMPANY**  
65 Fifth Ave. CINCINNATI, OHIO



## BUICK OR \$1000.00 CASH GIVEN

Send me your name at once if you live in the country or town under 10,000, for my new easy plan for getting this New 1917 BUICK or \$1000 in cash. It will surely appeal to you. No money needed. I have already given away 40 autos. Write today for full particulars. **C.F. ALDRICH, Dept. E., St. Paul, Miss.**

## Enormous Profits

**START GROWING MUSHROOMS**  
Learn the latest authoritative way to make still bigger profits than you ever thought possible or ever made growing mushrooms. Add \$10 to \$75 a week to your income. Anyone, men, women and children can do it in spare time in city or country. Grow in basements, cellars, sheds, boxes, etc. Start now. Demand bigger than supply. Send for big free book of expert authority, "The Truth About Mushrooms." Write to **BUREAU OF MUSHROOM INDUSTRY** Dept. 331 341 N. Clark St. Chicago

## When You Build

please bear in mind that there is still plenty of **WHITE PINE**  
Send for our free booklet, "WHITE PINE IN HOME-BUILDING"  
**WHITE PINE BUREAU**  
1626 Merchants' Bank Bldg. ST. PAUL, MINN.

## Get the Newest L-A Engine Book

Your Engine Makes or Mars Your Motoring Pleasure

So don't decide definitely on the engine for your boat until you have read the new L-A Engine Book—new—just off the press. It fairly bristles with valuable suggestions and interesting engine information. This new L-A Engine Book describes and depicts in detail the complete line of L-A in-board and outboard motors for launches, row-boats, work-boats, etc. It provides you with complete particulars covering our **30 DAYS' TRIAL PLAN**

which allows you the privilege of proving the performance of L-A motors before making your final decision. Write for your copy today.  
**LOCKWOOD-ASH MOTOR CO., 1430 Motor Ave., JACKSON, MICH.**

AN L-A ENGINE FOR EVERY PURSE AND PURPOSE

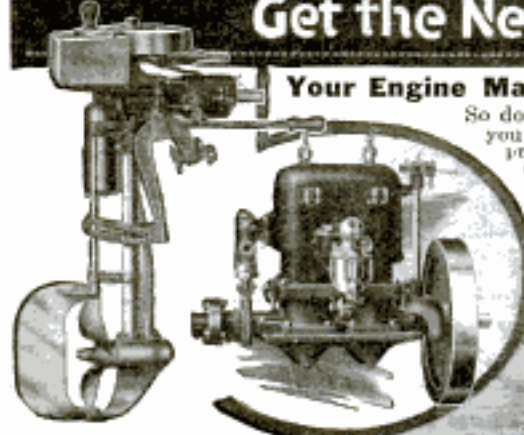





# This will prove your Ambition

THIS little "X" has marked the way to success for thousands of ambitious men. It marked the day when they stopped *dreaming* and began *acting*. Merely dreaming about the job ahead won't help you get it. The only thing that will bring it to you is *training*, and

marking "X" in the coupon will bring full particulars how you can get that training.

## You Can Win

The job you dream about *can* be yours. Not through favor or pull or some lucky chance—but through *training*. Thousands are proving it every day. Thousands of men have made their marks in these coupons and now are holding high positions.

The secret of their success is training—and you can get that training right in your own home.

It isn't necessary to make a drudge of yourself. You can sit at home and spend a few of your idle hours in pleasant study—and actually before you realize it, you will be holding a bigger job. Others have done it—and so can you. The first step is to put an "X" in the coupon and see for yourself what the American School has to offer.

## Make Your Mark Now Send the Coupon

When you stop to consider that over 40,000 men have "made good" by sending in these little coupons, doesn't it seem as if *you* ought to find out what we have to offer you? Sending the coupon will put you under no obligations—but it will bring you the real facts in a handsome book.

Mark an "X" before the job you want, and mail the coupon to us now. We'll show you *your* way to success—more simple than you have dreamed. Start right now—by sending the coupon.

**American School**  
of Correspondence, Chicago, U.S.A.

Dept. G9191

American School of Correspondence, Dept. G9191, Chicago, U.S.A.

Gentlemen: Please send me booklet and tell me how I can fit myself for the position marked X.

.... Electrical Engineer	.... Lawyer
.... Elec. Light & Power Supt.	.... Business Law
.... Hydroelectric Engineer	.... Business Manager
.... Telephone Engineer	.... Auditor
.... Architect	.... Accountant
.... Architectural Draftsman	.... Cert'fd Public Acc't
.... Building Contractor	.... Stenographer
.... Building Superintendent	.... Bookkeeper
.... Structural Engineer	.... Fire Ins. Inspector
.... Structural Draftsman	.... Fire Ins. Adjuster
.... Mechanical Engineer	.... Fire Ins. Expert
.... Mechanical Draftsman	.... Sanitary Engineer
.... Civil Engineer	.... Plumber
.... Steam Engineer	.... Reclamation Engineer
.... Shop Foreman	.... Automobile Engineer
.... Shop Superintendent	.... Automobile Repairer
.... Sheet Metal Draftsman	.... High School Course

We also prepare for civil service examinations in all engineering subjects.

Name.....

Address.....





Champion  
Priming  
Plug

Sold  
Everywhere  
Price \$1.25

## 1/4 Turn Starts You

Champion Dependable Priming Plugs enable you to do away with fussing and delay. You put a drop of gas right smack in the path of your spark. An explosion is bound to result, and your motor starts on the first quarter turn.

 **Champion**  
Dependable Priming Plugs

Champion Priming Plugs are genuine dependable Champion Spark Plugs—with the addition of the priming device.

It's very simple—nothing else so sure.

Put a set of these priming plugs in *your* motor today and get rid of cold weather starting troubles.

**The Champion Spark Plug Co.**

414 Avondale Avenue

TOLEDO, OHIO

Please Mention Popular Mechanics

# THE ONLY DIAMOND CUTTERS

IN THE UNITED STATES SELLING  
DIRECT TO YOU BY MAIL



MONEY BACK IN FULL  
ANYTIME WITHIN 1 YEAR

PER CARAT	BUY IN RINGS, PENCILS	WEIGHT	BUY THROUGH YOUR BANK
70.00	→	1 Carat \$ 5.75 2 Carat \$14.75 3 Carat \$35.00	Genuine Diamonds direct from the Diamond Cutters at Our World's Famous Rock Bottom Prices. As the Only diamond cutters selling Direct we defy competition. Buy Direct, save 40 per cent. We ship on approval anywhere—charges paid. Just send name of bank. Our 176-page catalog explains Our World's Famous Prices. The lowest ever advertised for Diamonds, Watches and Jewelry.
100.00	→	2 carat \$27.00 3 carat 58.75 4 carat 75.00	
150.00	→	1 carat \$22.50 2 carat 68.00 4 carat 112.00	

**I. PRESS & SONS** DIAMOND IMPORTERS  
840 CHESTNUT ST. AND CUTTERS  
PHILADELPHIA, PA. WHOLESALE JEWELERS  
ESTABLISHED 29 YEARS

2 and 4-cycle, air or water-cooled, gasoline engines, 1/2 H. P. up; dynamos, motors, storage batteries; electric light plants, from 10 volts to 110 volts. **Dealers Wanted**  
Send stamp for circulars. **DYNAMIC MANUFACTURING CO.**  
First Nat'l Bank Bldg. CHICAGO, ILL.

## Mullins Steel Boats Can't Sink

When you think of buying a boat, whether it be a 16-foot Runabout, a big 26-foot Auto Boat, or something in between—remember that Mullins Steel Boats are guaranteed for life. They cannot sink, leak, water-log, dry out or open at the seams—never require caulking. Designed by America's foremost naval architects—built in the largest boat factory in the world. More than 65,000 in use. Big catalog of steel or wooden motor boats, run-boats or canoes, on request.

THE W. H. MULLINS CO., 52 Franklin Street, SALEM, OHIO

## \$ 1.80 a Month



Smashing direct price offer. 23 jewels—adjusted to temperature and isochronism—Thin model—Gents 12 size, guaranteed 20-year gold filled case. **No money in advance.** If you decide to keep it, pay only \$1.80 a month. Send today for free examination. Get handsome catalog.

L. W. SWEET & CO., Inc. Dept. 6  
2 and 4 Maiden Lane NEW YORK CITY

## \$ 3.25 World's Best Shoe Value

\$3.25 for Regular \$4.50 Shoes

Ruthstein's Scientific Shoes for Men. Selected gunmetal calf—Indestructible Chrome Leather sole; Goodyear welt sewed; neat, comfortable, roomy last. Blucher lace style; widths D. to E.E. Money back if examination proves otherwise.

**200 OTHER SHOE BARGAINS**  
For MEN, WOMEN, BOYS and GIRLS

Also complete line Ruthstein's Famous "Steels" Big, New 1917 Scientific Footwear Catalog shows over 200 styles and how to save 20% to 50% on shoes for the whole family—FREE on request.

RUTHSTEIN SCIENTIFIC SHOE CO.  
America's Greatest Mail Order Shoe Factory  
Dept. 640 RACINE, WIS.



WE  
RETAIL  
AT LESS  
THAN  
WHOLESALE  
SHOE PRICES



# This Invention Saves $\frac{1}{3}$ of Your Coal Bills

## The ARNOLD Automatic Damper

New invention—automatic mechanical device that is placed in the stove pipe or furnace pipe, and immediately gives your house 25% to 33 $\frac{1}{3}$ % more heat from the same fuel—no matter what type of stove or furnace you use. Makes \$6.00 go as far as \$9.00 now goes in coal or wood bills. **Automatic in operation**—requires no attention after fire is started. Keeps your house at even temperature—no overheating with loss of fuel; no underheating with dangers to health. Absolutely a proved success—saves its cost on first ton of coal or few cords of wood.

## Positively Proved and Guaranteed

Thousands already in use. Every owner a booster. Listen! "We have upward of 600 Arnold Dampers installed in our stations and offices. During the winter we made an actual saving of over \$5000 in our coal bills"—Interborough Rapid Transit Co., New York City. "It

saves from 40% to 50% of fuel for me"—S. C. Stouffer, Portland, Ore. "According to our calculations it saved from 50% to 62 $\frac{1}{2}$ % of fuel"—A. W. Buschmann, Indianapolis, Ind. Hundreds of letters like these—in every mail. Absolute satisfaction—**guaranteed success.**

## 30 Days' FREE TRIAL

You take no risk. Cash return guarantee back of every damper. Order one today for your stove or furnace. Try it 30 days. You are to be the sole judge. If it does not save one-third of your fuel, if it does not do just as we say, if you are not absolutely satisfied—send it back to us C. O. D. for the amount you paid—cash in full.

## Send Coupon Today

Save the high cost of heating. Cut one-third off your coal or wood bills. Eliminate the bother of watching the stove or furnace. Nothing to lose—dollars to gain. **Save this money.** Fill out coupon below—enclose price for stove pipe or furnace pipe damper, give size of your pipe and mail it today. You can put it on—you can try it—you can prove it, or your money back. Do this right now—mail it today.

**The Arnold Automatic Damper Co.**  
508 Damper Building, 215 N. Desplaines St., Chicago, Illinois

Cut out on this line and mail today



### For Stove Pipe

Above is stove pipe style of The Arnold Automatic Damper. Goes in stove pipe. Automatically controls fire. Saves heat now going up the chimney. Keeps fire even, temperature of room the same all the time. Saves one-third of wood or coal. Easily put on. 30 days' money-back trial. Give size of your pipe.

Price, postpaid \$3  
Only



### For Furnace Pipe

Above is furnace pipe style of Arnold Automatic Damper. Easily put on. Keeps fire even. Saves one-third of fuel. Guaranteed for ten years. Eliminates danger of fire from overheated flues. Works automatically. 30 days' money-back guarantee. Order today, giving size of pipe.

Price, postpaid \$5  
Only

THE ARNOLD AUTOMATIC DAMPER CO., 508 Damper Building, 215 N. Desplaines St., Chicago, Ill. Date \_\_\_\_\_ 1917.  
Gentlemen—Enclosed find remittance of \$\_\_\_\_\_ for one (state if for stove or furnace) \_\_\_\_\_ style  
Arnold Automatic Damper, size of pipe \_\_\_\_\_ inches in diameter. It is clearly understood and guaranteed that if I am  
not satisfied upon 30 days' trial, I may ship it back to you C. O. D. for the full amount of my payment to you. Send by Parcel  
Post, prepaid, to the following address

Name \_\_\_\_\_ City \_\_\_\_\_ St. \_\_\_\_\_ State \_\_\_\_\_



# \$100 PHONOGRAPH

In Tonal Quality & Music Value \$785  
With Your Own Cabinet

An amazing money-saving offer on a fine phonograph. New Idea. A grand tone phonograph at the bare cost of the parts. All you need is these fine quality parts.

## MAKE YOUR OWN PHONOGRAPH

We Furnish Working Drawings Showing You How to Assemble This Easily Yourself. Have the Finest Machine. Astounding Saving.

All metal and moving parts sent on this astonishing money-back offer now. \$7.85. Send coupon.

Use a table or other piece of furniture. No secret. We explain all to you. Metal exposed parts heavily nickled. Reproduce alone of this quality cost you \$7.85 to \$15. Plays Victor, Little Wonder, Columbia, and all lateral records up to 12 inches. Motor full force spring with speed regulator. Send today for full set working parts, and all instructions complete. Limited offer, \$7.85.

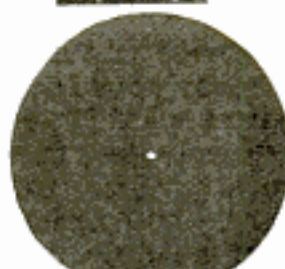

Here are all the working parts of \$100 type phonograph

### Special Coupon

ELECTRO MECHANICAL PARTS CO.  
57 E. Jackson Bldg., Dept. 5245, Chicago

Gentlemen: I wish to take advantage of your special limited offer on complete set of working and moving parts for \$100 quality phonograph, and explanation of phonograph secrets. I enclose \$7.85 and if I am not satisfied, I will return parts and get my money back in full.

Your money back if not satisfied

Name.....

Address.....

## Learn from CHEMCRAFT the wonders of modern chemistry

With chemcraft you can do countless wonderful experiments in chemistry and chemical magic. Manufacture writing ink—make chemical trees and plants grow while you watch—make chemical fire and fire ink—manufacture soap and do many wonderful experiments.

**Chemcraft Outfit \$2.50**  
Delivered to You for

If your toy dealer hasn't chemcraft we will deliver it, upon receipt of price, anywhere in continent at U. S. or Canada, foreign \$1.00.

Outfit contains 123 chemicals, chosen for their useful and interesting reactions, all necessary apparatus and 44 page instruction book of experiments.

Description sent on request

**THE PORTER CHEMICAL CO.**  
Dept. A, HAGERSTOWN, MD.



## PRIZE FISH

are caught on "Bristol" Rods. Here is a well-known Judge with a 5 lb. and 7 lb. Salmon caught on a "Bristol" in Moosehead Lake, Me. He, as do so many thousands of real fishermen, depends on

**"Bristol"**

The Prize Winning Rods

to bring home the prize fish, because "Bristol" Rods are accurate on the cast, quick on the grab, pliable for playing and so absolutely reliable in the fight for landing gamey fish. 32 different styles, \$3.50 to \$50. Recommended by 19,000 dealers. Each rod guaranteed 3 years.

**ILLUSTRATED CATALOGUE FREE!**  
**THE HORTON MFG. CO.**  
196 Horton St. BRISTOL, CONN.



Please Mention Popular Mechanics

# Genuine Blue-White Perfect Cut DIAMONDS

\$88 Per Carat

## January Clearance Sale

Carats	Value	Price	Carats	Value	Price
2 1/2	1-32 \$400.00	\$288.00	3/4	\$95.00	\$64.00
2 3/4	375.00	275.00	3/4	150.00	96.00
2	350.00	238.00	1 1/2	60.00	40.00
1 3/4	750.00	500.00	1 1/2	120.00	77.00
1 3/4	250.00	175.00	3/4	45.00	29.00
1 1/2	225.00	150.00	1/4	25.00	15.00
1 1/2	200.00	135.00	1/4	35.00	22.00
1 1/4	250.00	160.00	1/2	15.00	8.00
1	200.00	140.00	1/2	10.00	6.00
1	150.00	88.00			

## Our Offer Is This

Send coupon for my 1917 Diamond Book, in which I quote prices on genuine blue-white perfect cut diamonds at a saving of 35% from jewelers' prices. The book tells diamond facts needed to buy safely and intelligently. Get a copy at once. When it arrives choose any diamond, in any setting, and I will ship it for FREE examination so you can make comparisons. Also I will give you a Money-Back Guarantee that you can take to any bank in America and cash in on your diamond investment if you want to. References: Lake & State Savings Bank of Chicago, or your bank, or any Commercial Agency. Send for Diamond Book today—now—and see what we have to offer you at lowest prices ever quoted.

**BARNARD & CO., Dept. 2388C, N. W.**  
Cor. State & Monroe, CHICAGO

CLOSED

OPEN

**Folding Truck Body**

For Feeds and Other Light Roadsters. Strong, Serviceable, and Attractive. Easily Attached. Folded, looks like a regular roadster. Open, it's an efficient light delivery truck.

**BUTLER ALL METAL GARAGE**

**BUTLER MFG. CO.** 804 Butler Bldg., KANSAS CITY, MO.  
911 Sixth Ave., S. E., MINNEAPOLIS, MINN.

For one or more cars. Write for Free Booklets.

## Genuine Hawaiian Koa Ukulele \$5.50

Made in Hawaii by native Hawaiian instrument makers. The wonderful Koa wood used exclusively. Only from this wood and from the master skill of these music-loving workmen can the real tone be put into this plaintive Hawaiian instrument. Get your instrument direct from Hawaii. Write today for catalog. We will send, free and postpaid, our catalog showing our complete line of genuine Hawaiian made Ukuleles. A postal or letter with regular United States postage addressed to us will bring the free catalog. Remember, Hawaii is part of the United States and reached by regular United States postal service. So write at once. Do not delay. If you are going to buy an Ukulele, why not get Koa-Koa Company, Box 40, Honolulu, Hawaii at direct from Hawaii!

## KEITH'S \$1 Offer

1st—A folio of 25 new artistic and very attractive Bungalow Designs. 2nd—A big book containing up-to-date designs for 100 Artistic HOMES. 3rd—A 4-months' subscription to the well known leading authority for home builders, Keith's Magazine, \$2.50 a year, 25c copy. On newsstands. ALL THE ABOVE, SPECIAL \$1.00 KEITH'S, 919 McKnight Bldg., MINNEAPOLIS, MINN.



# Money Grows if rightly planted



## You Can Own One of Our Money-Making Dixie Estates!

Learn about our new easy payment plan on our fruit-planted Florida Dixie Estates. A truly wonderful opportunity for every man and woman who wants to realize the home of their dreams and an independent income for life! A few dollars a month now makes you the owner of a Dixie Estate, developed and planted for you to fancy Grapefruit, Oranges and Avocados.

Get in touch with us at once for full particulars of this special easy payment offer and detailed description of Dixie Estates. Write today for our free illustrated booklet. No obligation to you. Note coupon below for your convenience.

## Near Tampa, Florida's Greatest City!

Best location in all Florida. Right in the very vicinity of beautiful Tampa, the coming Los Angeles of the South. Your Dixie Estate will be near fine, paved boulevards, railroad stations, schools, churches, etc. And the soil! You could not buy better land for fruit growing at any price. The trees we plant on your Dixie Estate are the very finest obtainable—budded, pedigreed stock, grown by experts. We own and operate extensive nurseries. Therefore, we give you a big advantage in our development of Dixie Estates. Climate is ideal for fruit-growing and wonderful to live in.

### Oranges, Grapefruit and Avocados!

Three fruits famous as money-makers planted on your Dixie Estate. The Avocado (commonly called Alligator Pear) is known as the Aristocrat of Fruits. The supply is so limited that in the northern cities only the rich can afford to pay the prices it sells for. In December, 1915, Avocados sold in Chicago at the almost unbelievable price of \$3 and \$4 each.

Past and present prices for these three fruits show an earning power of from \$1,000 to \$1,500 a year for one acre Dixie Estates and proportionately upwards of that amount for larger size tracts. Even one-half or one-third of these returns, to be ultra-conservative, would show a profit of nearly 100% on your investment annually.

**Write us today**—or mail the coupon—we will send you without cost or obligation our illustrated booklet giving you full particulars concerning this wonderful proposition. Act today. You have nothing to lose and everything to gain.

**Act Quick!** Mail us the coupon without delay. Get all the facts and figures and decide for yourself. But don't put it off. Only a certain number of Dixie Estates to be sold on this special easy payment plan. Prices and terms will then go up.

**North Tampa Land Co.**  
6 N. Michigan Ave. CHICAGO, ILL.

### Live On Your Estate or In Your Present Home!

Your Dixie Estate can yield you a splendid income without your doing a stroke of work on it! For under our plan of caring for your trees, fruits, etc., you do not have to leave your present home or employment unless you choose. If you wish, you can, of course, live on your Dixie Estate in balmy, winterless Florida, in a cozy home 'neath turquoise skies and amidst the glorious beauties of your flowers and your luxuriant money-producing fruit trees. Such is the life your Dixie Estate offers you and your family.

#### FREE BOOKLET COUPON

**NORTH TAMPA LAND CO.** P. M. 1-17  
6 N. Michigan Ave., Chicago, Ill.

Please send me your free illustrated Booklet on Dixie Estates and particulars of your special easy payment plan. This does not obligate me in any way.

Name.....

Street and Number.....

City.....State.....



# A Lightning Edge on Safety Blades

A keener edge than you ever felt. Will flash through the stiffest, wiriest hair. A few strokes works marvels on any blade. A child can sharpen blades on a Stag as well as an expert. Makes old blades better than new. Makes new blades better.

**Stag Sharpener** with barber's hone and strop complete, on our money back guarantee. Complete postpaid

## SHARPEN ANY BLADE

# \$1

Positively gives new blades a better shaving edge. Puts the oldest, dulllest blades in lightning edge condition. Quickest way. Truest way. Surest way. Safest way. Easiest way. The wheels of the sharpener guide the angle. Nothing to adjust. Nothing to get out of order. Lasts a lifetime. Our new patented feature makes the Stag more desirable than ever. Complete outfit includes heavily nicked sharpener, barber's hone and strop, in neat box, suitable for traveler's kit. Complete, postpaid to you only \$1.

Stag Sharpens All Safety Blades



Special \$1 Coupon

Hone and Strop Free  
**The Stag Company**  
 38 So. State St., Dept. 5245, CHICAGO

GENTLEMEN: Wishing to take advantage of your 10 days' free trial and money-back guarantee, you may send a Stag Sharpener, hone and strop complete. I am sending herewith \$1.

Try a Stag Sharpener at our risk and at our expense. Use it ten days free. Then if you are not delighted, send it back and get your money back in full. We gladly assume the risk and welcome your order on this liberal, free trial, money back guarantee. Send only \$1 today.

**Hone and Strop Free** With every Stag Sharpener we send a barber's hone and strop free. The new, patented, simplified improvements in the perfected Stag and a new broad-width barber's hone and strop in attractive kit-box, all complete only \$1. Two minutes after you open the box, you can enjoy the first soft smooth, silent shave with a lightning Stag edge. You will wonder how you ever got along without a Stag. Send only \$1 today.

**Send Today** Enclose only \$1, money order, draft, dollar bill, or check. Send today and make a comfortable shave for yourself. You need a Stag Sharpener. Clip coupon, put in \$1 and get it by return mail.

**The Stag Company** 38 So. State Street Dept. 5245, Chicago

### DEALERS

Write to us for special terms to dealers. The Stag is the quickest and best seller on our list. Get the benefit of this advertising and our Dealer Service.



Name.....  
 Address.....

## WEBER THROTTLE-GOVERNED KEROSENE ENGINES

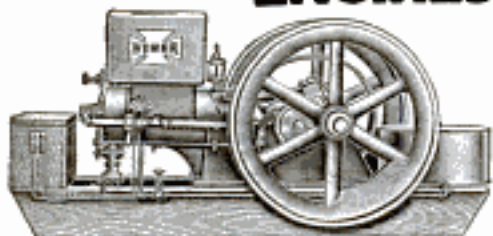

Not a makeshift—a specially designed engine Built To Use Kerosene.

### The Weberator Fuel Mixer Saves Half the Fuel.

THROTTLE regulates speed and power to work like steam. Uses only sufficient fuel for the work being done.

No waste fuel—no violent explosions.

A sturdy reliable engine that you need for steady dependable work.

**2 Months' Trial at Your Work**

Sold only direct from factory to user: Every engine in perfect condition. 5-year guarantee.

Write for Free Book "How to Use Kerosene." Learn about the wonderful Weberator, the great Kerosene Engine Improvement.

**WEBER ENGINE CO.**  
 Dept. 1771 KANSAS CITY, MO.



### BING'S NEW 1917 TRANSFORMER

Has Regulating Switch and Three Secondary-Voltage Terminals, giving you 12 different current strengths. Operates a dozen devices at once. Neatest and safest transformer. Size 4-3/4x2-3/4x2-3/4". Furnished with Separable Plug and 7 feet of Flexible Wire ready to attach to fixture socket. Shipping weight, 6 lbs. Price, \$5.00  
 The Dierichs Co., Dept. A, P. O. Box 58, Brooklyn, N. Y.

## HIRE YOURSELF AS BOSS

\$200,000 Corporation will back you in a money making business of your own selling Guaranteed quick sale goods. Start spare time at home or office. Write for FREE BROCHURE, "FORCEFUL FACTS."  
**WM. J. DICK, Manager, Dept. E28, 20 W. Lake St., CHICAGO**

## POWER



The two horse-power Benninghofen Engine offers even economical power for every purpose. Many new, exclusive features, including "auto throttle governor" not hit and miss governed. Surprisingly low cost. Burns kerosene or gasoline. Runs machinery, pumps water, saws wood, runs separator, churns, etc. Catalogue and details free.

**C. BENNINGHOFEN & SONS**  
 Dept. 125 A HAMILTON, OHIO

## KEROSENE

**\$30 a Week EASY** Men and Women Wanted to Sell **PERFECTO Kerosene Irons**



No experience necessary. Big profits selling this wonderful self-heating satisfaction guaranteed iron. Easy to operate and demonstrate. Sells itself. Use Kerosene (Coal Oil) or Gasoline with same satisfactory results. Absolutely safe, no smoke or odor. Get facts in detail and let us tell you how to obtain Free Sample and start you in a big paying business. Sample case FREE to Agents.

**PERFECTO SOD IRON FACTORY**  
 Dept. P, 126 So. Clifton St., CHICAGO, ILL.

Please Mention Popular Mechanics



# No Money In Advance

**Sensational Bargains** Just to prove the high quality of our merchandise and the amazing, unheard-of Hartman bargains in Household Furnishings of all kinds, we will ship any one article on this page without advance payment, without C. O. D., or security of any kind. Make your selection, write name and number in coupon and mail it to us today. **Don't send any money.** We will ship the article promptly. When it arrives, if you consider it a wonderful bargain and you want to keep it, pay only 50c in ten days and a little each month according to terms in this advertisement. If not satisfactory, return goods at our expense and you won't be out a cent. Remember, only one article on this page to a family, but when you get our Big Bargain Book, you can order whatever you like on the most Liberal Credit Terms offered. Send for book today.



Correct  
William and Mary  
Period Design

## Wonderful 3-Piece Library Set Bargain

Correctly designed William and Mary Period 3-Piece Library Suite—Built throughout of solid oak, properly finished Fumed. Table is made with large 29x38 inch top, trimmed with 3 panel end. Offset by period carvings. Has shapely rim, convenient book shelf. Legs cut from 2 inch stock, fitted with nickel slides. Rocker and Arm chair are extra roomy, splendidly constructed and unusually comfortable. Panel back and seats are upholstered in durable Imitation Spanish Leather, over wood fibre and jute. Dainty carvings will be found on panels in back and front post, as well as deep embossed carvings on top rail and seat rail. Six springs resting on steel channel bars, support seat. Chair and Rocker made with genuine quarter sawed oak arms. Order by No. MA259. Special Bargain Price. \$16.95. No Money in Advance. 50c in 10 days, Bal. \$1.25 Per Month.

# Only 50¢ in 10 Days

## Kitchen Cabinet Bargain

Let us send you this famous Hartman solid oak Kitchen Cabinet to prove what a wonderful bargain it really is. Embodies these up-to-the-minute labor-saving features.

Removable tilting metal flour bin with gifter attachment, 40 lb. capacity. Two large partitioned spice drawers made to represent 6 small drawers. 7lb. Swinging sugar container. Wire rolling pin rack. Removable sliding kneading board. Handy cupboard for utensils, with convenient wire rack on door. Large utensil drawer and convenient bread and cake box with ventilated sliding metal top. Upper section of Cabinet is beautifully trimmed with beveled glass doors. Has roomy, handy cupboard with shelf. White wood top measures 42x26 inches. Extreme height of cabinet 65 inches. Sanitary and strongly built throughout. Entire case Gloss Golden finish.

Order by No. MA258. Price \$16.85. Terms: No Money In Advance. 50c in 10 Days. Balance \$1.25 Per Month.



Solid Oak  
Kitchen Cabinet

## Sensational Sale on Rockers

No. MA251. A well designed overstuffed rocker, expertly upholstered over wood fibre and cotton felt in durable, guaranteed imitation Spanish leather. Seat supported by 9 extra heavy, steel coil springs, individually sewed to burip under seat, supported by heavy steel channel bars. Measurements: Extreme height 36 in., seat 17 in. from floor, back 23 in. from seat; extreme width of back 27 inches; seat 20x19 inches.

Frame, birch mahogany finish. A very fine value at our low price. We especially recommend this rocker as a good example of Hartman quality and money-saving values. Don't hesitate to order. Our free trial offer guarantees your satisfaction. Just mail coupon and we will send rocker at once.

Order by No. MA251. Special Bargain Price only \$7.95. No money in advance. 50c in ten days. Balance 75c per month.



Nine Heavy  
Springs  
Support the Seat

## Wonderful Bargain Book Free



Filled with thousands of wonderful bargains in Home Furnishings, all sold on the Hartman Liberal Credit Plan, backed by the \$12,000,000 Hartman Guarantee. Book shows articles exactly as they look—Furniture, Carpets, Clocks, Draperies, Silverware—everything for the home. We send it to you FREE—whether you buy direct from this page of "get-acquainted" offers or not. Mail the coupon today.

**HARTMAN FURNITURE & CARPET CO.**  
3945 Wentworth, Dept. 103, Chicago

## Mail This Coupon

**HARTMAN FURNITURE & CARPET CO.**  
3945 Wentworth Ave. Dept. 103 Chicago

Without any money in advance, please send me article named below. If I keep it, I will pay 50c in 10 days after arrival of shipment and balance in monthly payments as per prices and terms quoted in this advertisement. If I decide not to keep it, I will return it to you at your expense.

Name of article wanted..... No.....

My Name is.....

Address.....  
If only Catalog is wanted, write "Catalog Only" on blank line above fill in name and address and mail coupon today.

# HARTMAN WILL TRUST YOU



# I Want 200 Exceptional Men



I have openings right now for at least 200 men of unusual ability. I prefer men of the mechanical turn of mind—who want to be something better than mere mechanics drawing so much per day—busy or idle—at the whim of some captain of industry—the biggest asset the man must have that I want is "stick-to-it-iveness"—a little determination to succeed—a little money—and I will teach you the best business now open to young men.

**A Nation-Wide Demand** Through my national advertising which has now been running for six years, I am creating a nation-wide demand for my Standardized Tire Repair Service, which we have demonstrated is the best thing of its kind in the country. I sell you the plant out-right—you become its sole owner—and there are hundreds of such plants scattered all over the country. Right now there are at least 200 important centers where autoists are demanding my service and cannot get it except at long range. I want good men for these centers. All I ask you to do is to buy my machine which we have demonstrated is the best.

**I Create the Demand** I do the advertising in national magazines and periodicals, which brings the autoists to your door. If you buy a machine, I teach you in my thorough training school, absolutely free of charge, the whole business—teach you how to make every possible repair the very best way—how to secure the business—how to hold it—how to develop your expert technical knowledge to sell your customers all their supplies.

**This is the Day of Specialists** When you step out of my school you are an expert—you can cut circles around half of the tire men in the country—you know the constructions—the inner mechanism of the tire and tire building—your knowledge is worth dollars to every automobile owner who draws up to your door—and if you have a little selling ability—if you will follow the course which we so carefully teach—your success is assured—auto owners will flock to your place of business—they will give you the preference because they know that you are a trained man—that they can rely upon your advice—that they can rely upon your repairs—that you are no "Fly-by-night" concern or you would not represent us.

**Big Profits** It gives you a standing in your community—and if you will measure up to the requirements, there is almost no limit to the profits you can make. When I have sold you a machine my interest doesn't lag—I never forget one of my boys—and the minute you are ready I'll teach you how to add accessories to your line—to sell tires—the right tires—the kind the automobile owner wants and that give him the best service. I am prepared to help you. If you so desire, I can fit you out with a stock of tires and accessories—goods that we have demonstrated by test to be as good as the best. If there is not a Haywood Tire Repair Station in your town—if you see no metal sign like the trade-mark appearing in this ad—write me personally and I'll tell you how to get started in this wonderful business—I'll help you—I'll make you a success. This is the most wonderful year the automobile industry has ever known—there are more tires being used today than ever in the history of the world—the cost of operating a car is steadily climbing—consequently every man who owns a car—regardless of his wealth—must consider the biggest item of his upkeep his tire expense. You can reduce it a third to a half.

**Owners Will Come to You** Don't you think that every automobile owner in your locality would listen to you—don't you think that everyone of them would welcome you and your new shop? Then don't delay—write me today—be the first in your town to be up with this wonderful service. Remember, I am increasing the demand in your town every day—spend thousands and thousands of dollars to educate the public to save their tires—come to you.

KEEP YOUR TIRES YOUNG

HAYWOOD  
UNIVERSAL TREAT



## A Business Opportunity Coupon

MR. M. HAYWOOD, Personal  
638 N. Capitol Ave., Indianapolis, Ind.

DEAR SIR: Please send me full details how I may start a Haywood Sundry Supply Store and Tire Repair Shop in this locality.

Name .....

Address .....

The Haywood Tire & Equipment Co.  
638 N. Capitol Ave. INDIANAPOLIS, IND.

Please Mention Popular Mechanics





You don't have to pay war prices for my engine, as the prices are lower than ever before. Careful factory management, labor saving machinery, and help by the men who work for me, has made this possible. Send me your name so I can send you these low prices and the most liberal trial offer I ever made.

GEO. E. LONG

# Let Me Ship You An Engine To Earn Its Own Cost While You Pay For It!

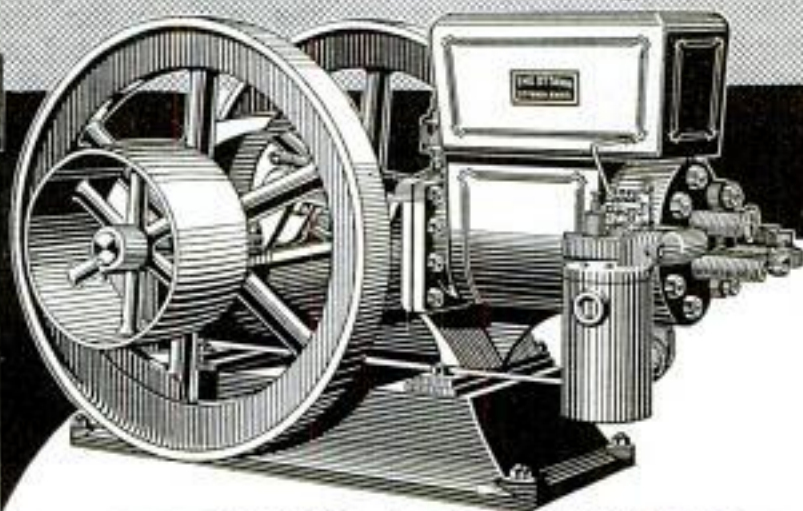

## Stationary Engines

1 1/2 H.P.	\$ 25.75
2 H.P.	31.95
2 1/2 H.P.	38.90
3 H.P.	49.50
4 H.P.	66.75
5 H.P.	72.50
6 H.P.	93.90
7 H.P.	98.50
8 H.P.	124.75
10 H.P.	139.50
12 H.P.	191.50
16 H.P.	245.50
22 H.P.	360.90

## Portable Engines

1 1/2 H.P.	\$ 30.40
2 H.P.	36.40
2 1/2 H.P.	44.90
3 H.P.	58.50
4 H.P.	61.75
5 H.P.	99.75
6 H.P.	119.75
7 H.P.	124.75
8 H.P.	149.95
10 H.P.	174.50
12 H.P.	229.50
16 H.P.	289.50
22 H.P.	439.90

## OTTAWA ENGINES

Thousands of men all over this country, in shops, elevators, mills, factories, and on farms, have made my engine pay for itself while they used it. My money-saving terms of purchase make it easier to own an engine than to be without one. Having the largest number of sizes to choose from, you can find a size of engine just suited to your work, and you have your choice of the fuel, for my engines, use

### Kerosene Oil, Gasoline, Distillate, and Gas

My kerosene oil engine is easy to start and as easy to operate as any gasoline engine. With it, you get more power from a gallon of 6 or 8-cent kerosene, than you can get from a gallon of 20 or 25-cent gasoline in any gasoline engine. All sizes are easy to start, easy to understand and manage, and with my lower prices and fuel saving engines, you get the greatest amount of dependable power for years to come, for the small amount of money you put into your engine.

### 90 Days' Trial — 10 Year Guarantee

You have 90 days in which to try my engine at your own work. I have always given my customers this right. Years ago I was the only engine manufacturer selling direct from my factory and the only one who sent every engine out on trial. Now many have imitated my plan of selling, but they haven't built so good an engine, because their engines are still in the experimental stage. You are taking no chances in selecting my engine, as it has been the longest sold direct to the user of any engine in America.

### Cash or Easy Terms

My money saving plan of selling makes it easy for you to own an OTTAWA engine, on terms by which the engine cost can be paid for by the earnings of the engine. No need to trade your savings for 5 years to own a good engine when you can get a better built OTTAWA engine to earn its own way while you use it.

**Send for Free Book** You should have a copy of my new book — the most up-to-date book on engine building. Explain how easy my engine starts; how little it costs to operate; how easy to keep it running; cut out coupon and mail to-day and I will tell you the complete story by return mail.

GEO. E. LONG

**OTTAWA MFG. CO.**

535 King St.  
Ottawa, Kansas

GEO. E. LONG, Pres.  
**OTTAWA MFG. CO.**  
535 King St., OTTAWA, KANSAS

Without obligation to me, I would like to receive your latest and best book "How to Know Better Engines," and your liberal plans of selling.

Name .....

Address .....



The Ottawa gasoline engine on iron base equipped with magneto requiring no batteries

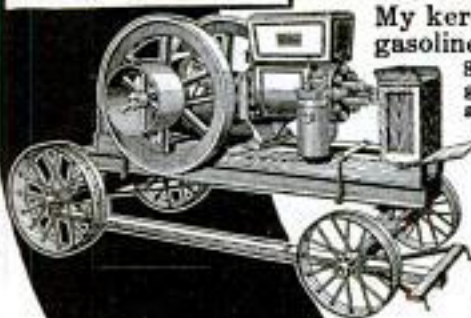

The OTTAWA Kerosene engine on heavy trucks with complete equipment

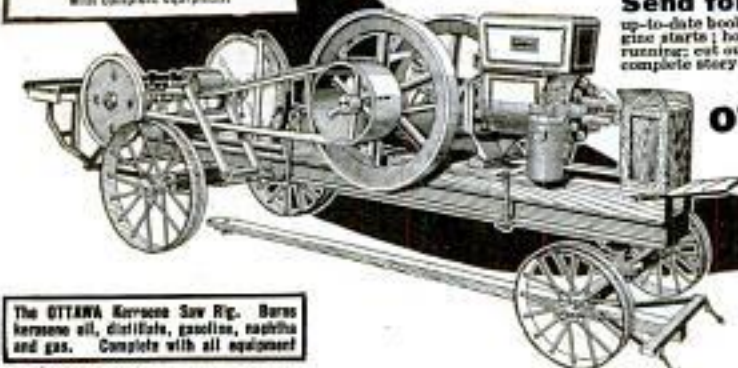

The OTTAWA Kerosene Saw Rig. Burns kerosene oil, distillate, gasoline, naphtha and gas. Complete with all equipment

Please Mention Popular Mechanics



# WANTED! WE WANT 300 AGENTS AT \$35 TO \$70 A WEEK

**NEW INVENTION**—just out. Needed in every home every day. Patent just applied for. Nothing else like it. Supplies what every housewife has wished for for years. Perfected after long experimental work by mechanical experts. Low priced—anyone can use it—**sells on sight**. We want three hundred representatives at once—men or women hustlers—to advertise, accept orders and manage deliveries for our new **Quickedge Knife and Shear Sharpener**. Sharpens any kitchen knife, paring knife, carving knife, bread knife or shears and scissors in **ten seconds**. Agents are taking orders at every house—wiring for rush shipments. Write today for this opportunity to make \$10 to \$20 every day.

## MAKE \$300 NEXT MONTH

This little machine is a mechanical masterpiece. A child can use it. Just put knife in slot—turn crank—**grinds automatically**—draws blade to keen, sharp, perfect, lasting edge at **absolutely correct bevel for daily use**. Nothing to adjust—nothing to change, nothing to get out of order—**absolutely guaranteed**—will last for years. Once they see it and use it, women will not do without it for several times its cost. One agent wrote: "It was easier for me to learn to sell the **Quickedge** than it was to learn to tear open my pay-envelope in my former dollar-a-day job." Get out of the dollar-a-day class. Get this position, where profits start the first day.

## No Experience Required

Just take one of the machines to any house and show it—give a ten-second demonstration upon the dullest knife in the house; **the order is yours right on the spot; instantly**. No talking necessary. No argument. The machine simply sells itself, **and stays sold**. Every customer becomes your friend. They tell others, your profits double and multiply. Leave one hundred on trial over night. Collect the cash for every one of them next day. **The machine will do its own talking**; it is so easy to operate, no explanations or instructions are necessary. Secure your county now; **free**. Get started right now and

## Make as Much Money Next Week as These Men are Making Now

J. C. Lewis, of Kansas, says: "**I have sold one hundred Sharpeners in four days.**" Hobart Kerr, of Md., writes: "The women can hardly wait till they get them." Herbert Cain, of Ky., sold nine after supper. At the end of his first day, J. W. Gordon, of Pa., writes: "I sold two dozen, and **I sold to every one I saw.**" Wm. G. Hall, of N. J., says: "I think it is great. I sold six in about one-half hour. The machine is a mighty fine proposition. **I am a mechanic and I know what I am talking about.**" Peter Courtland, of Mich., writes: "I received your sharpener and opened it in a barber shop. I ground his shears and I got an order for one right on the spot." H. A. Henkel, of Va., says: "I have examined it and find it a wonderful little machine. **The workmanship is simply perfect.**" Frank King, Colo., says: "Sample received Saturday. Sold ten today. Sell to most every house." Forest Webb, of Pa., says: "Went out Monday afternoon for about three hours and received one dozen orders. **Profit \$12.00.**" H. Tillery, of Tenn., wrote: "I took three orders first hour. When you sharpen an old, dull knife, dull as a hoe, in less than a minute, **they sit up and look.**" Ray Carter, of Mass., writes: "I went out two days and have orders for thirty sharpeners." **Profit \$30.00 for first two days.** John Durr, of Wis., also says: "**I have sold thirty in two days.**"

You can make this money. **Send now. Territory free.**

**GET BUSY. WRITE TODAY.**

**The Quickedge Sharpener Company**  
No. 637 Sharpener Building  
215 N. Desplaines St., Chicago, Ill.

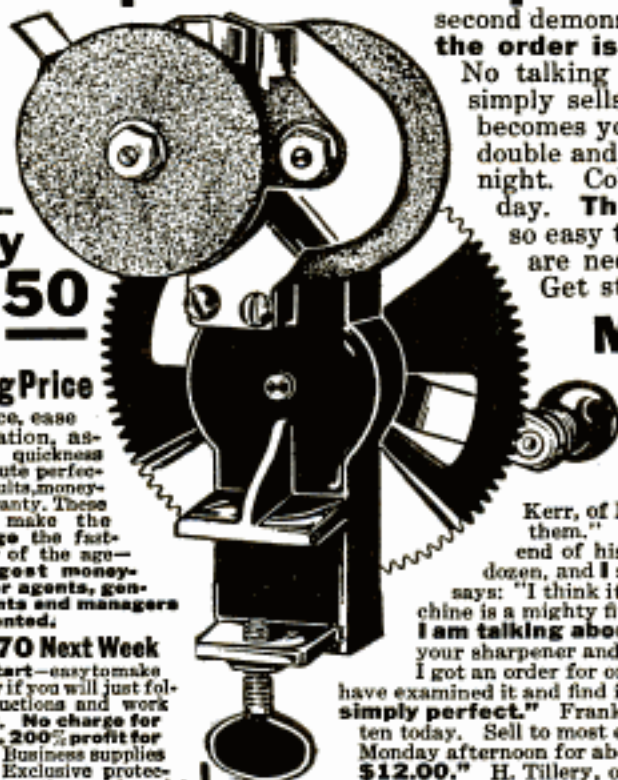

Only  
**\$1.50**

Selling Price

Low price, ease of operation, astonishing quickness and absolute perfection of results, money-back guaranty. These things make the **Quickedge** the fastest seller of the age—the biggest money-maker for agents, general agents and managers ever invented.

### Make \$70 Next Week

**Easy to start**—easy to make big money if you will just follow instructions and work faithfully. **No charge for territory. 200% profit for agents.** Business supplies capital. Exclusive protection, co-operation and assistance. Failure impossible. Nothing to risk. Success assured.

**Easy to demonstrate**—and every woman is anxious to see it work—then she would not do without it. No talking necessary. Just show the machine and take the order—**one dollar profit on every call you make.**

Send for application blank and complete information today—**free**. Investigate. **Get the proof.** Don't delay. Write a postal card or letter right now. **Territory is being assigned very fast.** Get your county now—**free**. Write today.

**The Quickedge Knife and Shear Sharpener**

Grinds any Kitchen Knife or Shears in 10 Seconds

**Absolutely Guaranteed**



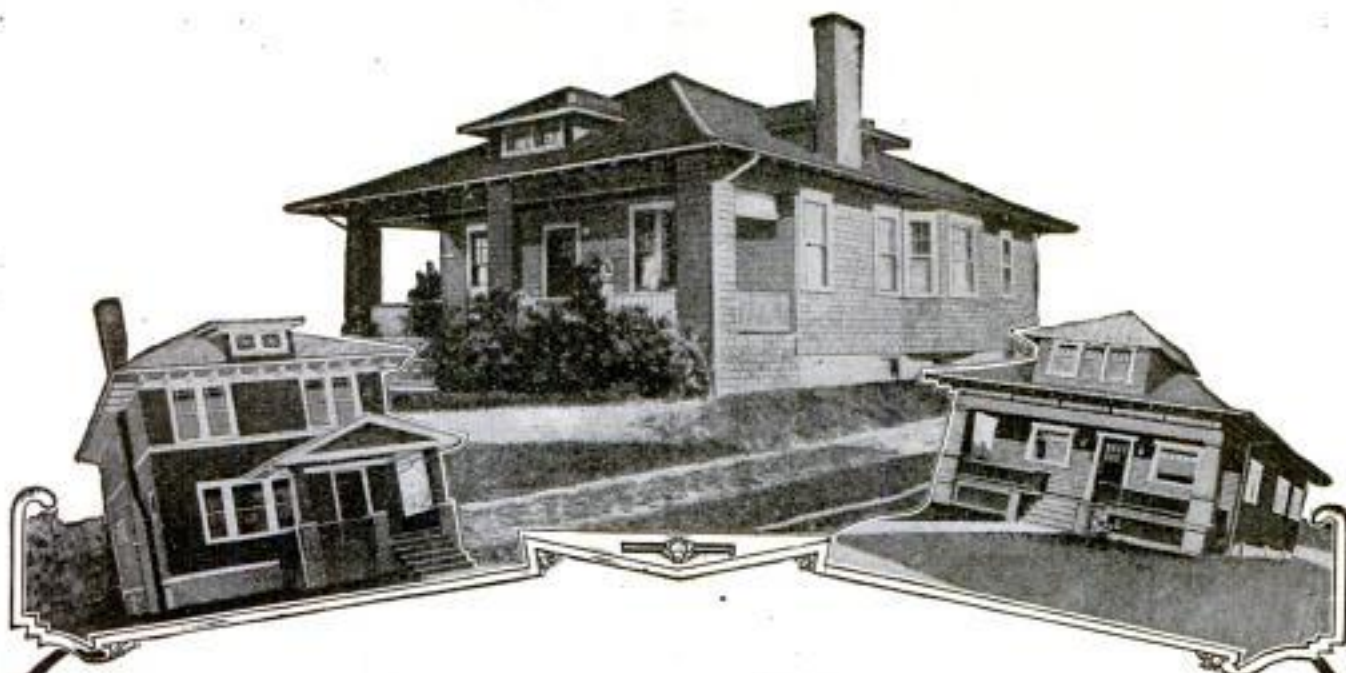

## Save on Your New Home

Build by the Sterling System. Save all the waste of time and material that you pay for if you build the old way. The Sterling System brings your house to you all ready to put on the foundation. No handsaw work in carpenter shop or on the lot. Every board and beam cut exactly to fit in its proper place. You also save in time and cost of work of erection. The Sterling System home can be put up in one-third the time spent by the ordinary way. That saves you rent, and you get into your new home much sooner. Mail coupon for Plan Book.

The saving of time and material means a big saving to you on cost. That proved in thousands of cases by buyers. Reports show from \$200.00 to \$800.00 saved according to style and size of house. Look into this before you build. Be sure to get our big book. (See below.) Tells all about the Sterling System and shows exactly how it saves you money. Send for this book today. Clip the coupon and put it in the mail today. See the Sterling plans before you build.

# Sterling System of Home Building

Over fifty master designs of able architects are shown in our book. You should see these designs. Examine the floor plans. Then read how we prepare all the material ready for erection. No slow handsaw work. All done on automatic machines which work to exactness. The book tells you just what you ought to get no matter how you build. Full specifications for modern homes. Every page filled with information you really must have if you want to build in the right way.

Let us tell you all about this Sterling System of home building. Learn about our positive guarantee of satisfaction. Place no contracts for building until you have at least got the information we have to give on this Sterling System, and until you have seen these master home designs. Post yourself on home building. Whether you decide on a Sterling System home or not, you should have this book and the facts which we will send you on request.

### "Saved \$800"

Says N.B. of Washington, D.C.  
Others say:

- "Saved \$200 building this way."—W. R., Michigan.
- "My saving on carpenter bill alone is \$273."—M. L. H., Illinois.
- "Saved \$100 on carpenter and \$200 on lumber."—Mrs. M. C., Indiana.
- "Will save between \$400 and \$500."—D. G., Michigan.
- "Saved \$325.00."—J. N. P., Michigan.
- "Saved nearly \$300.00."—W. G., Ohio.
- "Saved about \$700 over estimate of house built the usual way."—L. C. W., Penn.
- "Saved at least \$450.00 on material."—F. J. J., Penn.

Names of these and other buyers furnished on application. Write to them and get the facts direct. But first get the book which tells all about the Sterling System.

## Send Coupon for Book of Sterling System Homes

Sign and mail this coupon with 10 cents to pay for postage and wrapping. Let this book help you to solve the problem of getting your new home at the lowest cost. It will tell you hundreds of building secrets. After you have read it, you can think and talk with intelligence on this subject. You will know just how a house ought to be built, what ought to go into it and what it ought to cost. All that valuable information yours if you send this coupon. Do not put this off—sign it and mail it today—now.

**International Mill and Timber Company**  
Dept. 1191 Bay City, Mich.

**International Mill and Timber Co.**  
Dept. 1191—Bay City, Mich.

I want all the information I can get on building, especially if it will save me money. Please send me your book, "The Sterling System of Home Building." I enclose ten cents for postage and wrapping.

Name.....

Address.....



# BLUE STREAKS



## These Tires Bear a Jealously Guarded Name

Superiority shall not go unrecognized.

That is the reason why you will see more Goodyear Blue Streak Motorcycle Tires in use than any other tire made.

That is the reason why Uncle Sam selected them to carry the heavy machine guns on the Mexican border.

That is the reason you will find them on racing motorcycles, and on pleasure and commercial vehicles, where speed, freedom from tire trouble and low cost per mile are considerations.

Goodyear Blue Streaks will render *you* the same good service.

They are built to do credit to the name of Goodyear—a name so jealously guarded that no unworthy product may bear it.

The Goodyear Tire & Rubber Company  
Akron, Ohio

GOOD  YEAR  
AKRON



# Play Real Billiards On Your Dining Table

## Great Home Sport for 10c a Day



*"Quick Demountable"  
Billiard Top for Dining  
or Library Table*

This Brunswick "Quick Demountable" Billiard Top can be set on your dining or library table in a jiffy. Screw blocks at each corner enable you to adjust the playing surface to a perfect level.

Fast Monarch rubber cushions, high class billiard cloth and accurate angles produce the scientific playing qualities that have made the name Brunswick stand for super-excellence around the world.

### Playing Outfit FREE

Balls, Cues, Markers, Spirit Level, Chalk, Tips, Cue-Clamps, expert book of 33 games, etc., all included *without extra cost!* Write today for our handsome color-illustrated billiard book that gives full details, low prices and easy terms.

## Brunswick Home Billiard Tables

**\$5 Brings One On 30 Days' Trial**

These are not toys—but *real* Carom and Pocket Billiard Tables. They aid digestion, relax the mind and keep boys off the street.

Thousands supplying endless entertainment in homes all over America. Indorsed by ministers, praised by parents and urged by doctors.

### Send for Catalog FREE

See all styles of Brunswick Home Billiard Tables, the famous "Baby Grand," "Convertible" Dining and Library Billiard Tables and "Quick Demountables" with folding or removable legs. Sizes to fit all homes pictured and fully described.

Our catalog—"Billiards—The Home Magnet"—has been sent to thousands. Interesting and

valuable. Tells how you can play while you pay. Don't wait—send for this book at once. It's free.

**The Brunswick-Balke-Collender Co.**  
Dept. 43N, 623-633 S. Wabash Av., Chicago

THE BRUNSWICK-BALKE-COLLENDER CO. [654]

Dept. 43N, 623-633 S. Wabash Av., Chicago

Send free, postpaid, your color-catalog—

**"Billiards—The Home Magnet"**

and tell about your easy payment plan and home trial offer.

Name .....

Address .....

Please Mention Popular Mechanics



# SAVE 1/2 - INSTALL YOUR OWN PLUMBING AND HEATING

NEW HARDIN EASY WAY **HARDIN-LAVIN CO**  
CHICAGO

## No More Cold Bathrooms

Nothing makes home more inviting or more healthful during the cold winter months than warm, toasty, even heat. Keeps everybody healthy and happy. Install one of our

## Heating Plants Cut-to-Fit

No loss or waste—hot water, steam, or air. Send for our free estimate. We can save you 1/2. We furnish simplified installing plans, specifications, and instructions, and lend you the tools. Any handy man can do the installing the new Hardin Easy Way.

*If Your Bathroom is Modern so is Your Home*



## Mail Coupon for Free "HANDY-MAN" Book



New  
Tankless  
Flush-  
ometer



Drop  
Apron  
Lava-  
tory



BATH TUB

Every House Owner, Factory, Hospital, Hotel, Office Building, Farmer, Engineer, and Mechanic needs one. It shows a complete line of all the Latest Improvements and Different Designs in Guaranteed heating and plumbing outfits, water supply systems, sinks, roughing-in-goods, pipe, fittings, valves, etc., and all parts and repairs at Wholesale Prices. It also contains practical and exclusive information on How to Do Your Own Plumbing and Heating our new Hardin Easy Way.

## Let Our Service Dept. Help You

Draw a rough sketch of your plan for any heating or plumbing installation, and our staff of engineers will show you the easiest, cheapest way, and supply easy installing plans absolutely free to YOU. Any handy man can do the work with the help of our engineers and save all plumbing bills. We make all shipments promptly, direct from our nearest factory.

## Highest Quality—Wholesale Price

Remember, everything we sell is Grade A. Highest Quality Guaranteed Goods at prices that will surprise you. You save not only on the cost of the goods but on the cost of labor. Our practical experience of 40 years enables us to furnish heating plants with new, original features, combining quality, economy, simplicity, easy installing, and lasting durability.

## Handy-Man Free Book

This book has been written for the handy man about the home. Aside from being our Catalogue, it contains many pages of practical information and money-saving suggestions pertaining to home improvements. It's worth a dollar of any man's money, but if you are interested in up-to-date plumbing and heating goods, we send it FREE. Send for this valuable book and learn how to buy all plumbing and heating supplies on a time-saving, labor-saving, money-saving basis.

## Immediate Delivery This is as much a 40 Years in Business

at the same address is a record to be proud of. It speaks volumes for our wholesale, price policy and money-back guarantee. Send for free "HANDY-MAN" Book, and full particulars. \$500,000 plants behind our guarantee.

**The Hardin-Lavin Co.**  
40 Years at 4540-50K Cottage Grove Ave.  
CHICAGO

## BONDED GUARANTEE

Our guarantee label appears on every fixture we ship. It is your assurance of a square deal. We will replace, without cost to you, any fixture or part that proves defective or not as represented. We guarantee satisfaction. Everything we sell is grade A. "Highest Quality at Wholesale Price" is our motto.



P. M.  
JAN.

FREE  
"Handy-Man"  
BOOK COUPON

The Hardin-Lavin Co.  
4540-50K Cottage Grove  
Ave., Chicago

Please send me your  
"Handy-Man" Free Book  
showing everything in plumbing  
and heating outfits at lowest  
wholesale prices. (This "Handy-  
Man" Book contains much valuable  
information of interest to every handy  
man.)

Name

Address

**HANDY-MAN  
BOOK**

**SIGN, TEAR OFF AND MAIL**

Hardin-  
Lavin  
Co.





## “How An Oliver Agency Made My Whole Business Grow—

“I own a bookstore in a town of 11,000 people. Three years ago I became the local agent for the Oliver Typewriter Company. It was a lucky day for me. Not merely because I have sold one Oliver for every fifty inhabitants in this town, and made the large commission, but because I became a part of the Oliver sales organization. That means that the company has given me advantages which I could not have gained elsewhere. In other words, they enrolled me in their sales school and gave me a new business education. They told me how other men had made successes and how to avoid common difficulties. The Oliver traveling representatives came to see me and gave me additional pointers. They gave me a bigger and broader vision of modern business, and I learned the value of getting ideas from others. With some of my first earnings I took a trip to Chicago to visit the general offices and to get a lot of ideas from the big bookstores in the city.

“All this experience has been of great value to me and I now do the biggest business in a town of this size for many states around. Oliver gave me the big idea and I have applied it not only to the Oliver agency but in my own line.”

This is merely one of many stories that might be told by Oliver agents. Others will tell of the things they have bought with Oliver commissions. Some might tell how the Oliver paid for a college education. Thousands of Oliver agents in all parts of the country have shared in the millions of dollars earned

in commissions. The new Oliver Nine is a big seller and makes lots of friends. Hundreds of thousands of Olivers are in use.

Many of the greatest businesses of the country use Olivers throughout. We permit agents to sell on our famous 17-cents-a-day plan. To ambitious men and women we offer exclusive territories, which means that inquiries and prospects therein are given to them. We do not compete with our agents—we cooperate with them.

The Oliver  
Typewriter Co.  
1413 Oliver  
Typewriter Bldg.  
Chicago, Ill.

I want to know more about an Oliver agency, as I believe I could handle one successfully.

Our national advertising campaign reaches practically every town in this country and Canada.

If you want to begin to win, write to us today for our proposition. If your territory is open and you can show us that you are responsible, you may get the local agency for the Oliver typewriter. Of course, in each case it is first-come, first-served, so we suggest no delay. Someone might get ahead of you. Quick action generally pays—**SO ACT NOW.**

(557)

Name.....

Address.....

City.....State.....



# Williams'

## Shaving soaps

stick  
powder  
cream  
liquid

### SHAVING STRATEGY

Don't try to bluff your beard—trick it. The Williams' Big Stick is a paradox. It's husky to look at but it yields a lather so soft and gentle and soothing that it sneaks in on Mr. Beard unawares and puts him in the discard.

The Williams' Holder Top Shaving Stick gives you this magic lather in a nickel container with a metal grip for your fingers that grows in your affections as the stick wears itself away in your interest.

*Williams' Shaving Soap comes in several convenient forms:*

Stick, Powder, Cream, Liquid  
and in round cakes

Send 12c. in stamps for a trial size of the four forms shown here. Then decide which you prefer or send 4c. in stamps for any one.

J. B. Williams Co.  
Dept. A, Glastonbury, Conn.

*Add the finishing touch to  
your shave with Williams'  
luxurious Talc Powder*

